

Technical and Bibliographic Notes / Notes techniques et bibliographiques

The Institute has attempted to obtain the best original copy available for scanning. Features of this copy which may be bibliographically unique, which may alter any of the images in the reproduction, or which may significantly change the usual method of scanning are checked below.

L'Institut a numérisé le meilleur exemplaire qu'il lui a été possible de se procurer. Les détails de cet exemplaire qui sont peut-être uniques du point de vue bibliographique, qui peuvent modifier une image reproduite, ou qui peuvent exiger une modification dans la méthode normale de numérisation sont indiqués ci-dessous.

- | | | | |
|-------------------------------------|---|-------------------------------------|---|
| <input type="checkbox"/> | Coloured covers /
Couverture de couleur | <input type="checkbox"/> | Coloured pages / Pages de couleur |
| <input type="checkbox"/> | Covers damaged /
Couverture endommagée | <input type="checkbox"/> | Pages damaged / Pages endommagées |
| <input type="checkbox"/> | Covers restored and/or laminated /
Couverture restaurée et/ou pelliculée | <input type="checkbox"/> | Pages restored and/or laminated /
Pages restaurées et/ou pelliculées |
| <input type="checkbox"/> | Cover title missing /
Le titre de couverture manque | <input checked="" type="checkbox"/> | Pages discoloured, stained or foxed/
Pages décolorées, tachetées ou piquées |
| <input type="checkbox"/> | Coloured maps /
Cartes géographiques en couleur | <input type="checkbox"/> | Pages detached / Pages détachées |
| <input type="checkbox"/> | Coloured ink (i.e. other than blue or black) /
Encre de couleur (i.e. autre que bleue ou noire) | <input checked="" type="checkbox"/> | Showthrough / Transparence |
| <input type="checkbox"/> | Coloured plates and/or illustrations /
Planches et/ou illustrations en couleur | <input checked="" type="checkbox"/> | Quality of print varies /
Qualité inégale de l'impression |
| <input checked="" type="checkbox"/> | Bound with other material /
Relié avec d'autres documents | <input type="checkbox"/> | Includes supplementary materials /
Comprend du matériel supplémentaire |
| <input type="checkbox"/> | Only edition available /
Seule édition disponible | <input type="checkbox"/> | Blank leaves added during restorations may
appear within the text. Whenever possible, these
have been omitted from scanning / Il se peut que
certaines pages blanches ajoutées lors d'une
restauration apparaissent dans le texte, mais,
lorsque cela était possible, ces pages n'ont pas
été numérisées. |
| <input checked="" type="checkbox"/> | Tight binding may cause shadows or distortion
along interior margin / La reliure serrée peut
causer de l'ombre ou de la distorsion le long de la
marge intérieure. | | |
| <input checked="" type="checkbox"/> | Additional comments /
Commentaires supplémentaires: | | Continuous pagination. |

The Canadian Patent Office

RECORD





Vol. XXI.—No. 12.

DECEMBER 31st, 1893.

{ Price free by post in Canada and the United States, \$2.00.
SINGLE NUMBERS, - - - 20 Cts.

NOTICE.

All solicitors, agents or attorneys who, in circulars or advertisements, or otherwise, refer to the Commissioner or Deputy Commissioner of Patents, or to any other official of the Patent Office, for evidence of their professional standing, do so without authority.

INVENTIONS PATENTED.

NOTE.—Patents are granted for 18 years. The term of years for which the fee has been paid, is given after the date of the patent.

No. 44,800. Garden Cultivator. (*Cultivateur de jardin.*)

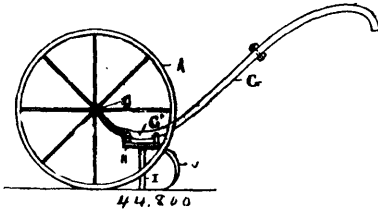

Robert C. Buckley, Peoria, Illinois, U.S.A., 1st December, 1893; 6 years.

Claim.—1st. In a two wheel straddle row cultivator, a pair of wheels, an axle C, having a bracket or hanger D, secured thereto, a pair of handles secured to said hanger D, said handles having their forward portions curved downward to near the ground and forming supports for the hangers H, to which are bolted the cultivator teeth. 2nd. In a wheel cultivator an independence of the right from the left tooth support, thus giving open space from the ground tooth axle.

No. 44,801. Warehouse for Grain.

(*Entrepôt pour le grain.*)

Daniel R. Bowker, Brooklyn, New York, U.S.A., 1st December, 1893; 6 years.

Claim.—1st. A building having an outer wall and an inner wall, the spaces between the walls having galleries extending entirely around the inner building, and grain bins within the inner building, substantially as set forth. 2nd. A building having double outer walls, with an air space between them, inner walls, a series of galleries between the outer double walls and the inner walls, extending entirely around the building, and grain bins within the inner walls, substantially as set forth. 3rd. A grain bin having a sampling tube extending from the exterior of its lower part, up through the grain, said tube having a series of valves opening into it, within the same bin, at different elevations, which are operated from the exterior of the bin, a separate opening for drawing off the grain from the bin, substantially as set forth. 4th. A grain bin having a sampling tube extending from the exterior of its lower part up through the grain and provided with a series of valve couplings with the bin, and valves operated by rigid rods which extend to the exterior of the bin, adapted to pull the valves open and push them shut, and a separate opening for drawing off the grain, substantially as set forth. 5th. A grain bin having a sampling tube which extends from the

exterior of the bin through the grain, provided with valves operated by rigid rods which extend through the stuffing boxes on the bottom

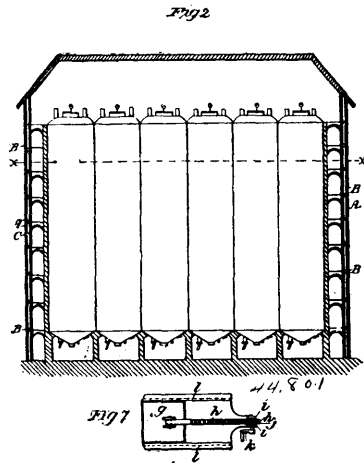

of the bin, and means whereby air may be prevented from entering the test tube, substantially as set forth. 6th. A grain bin having exhaust pumps at its upper part, a vacuum gauge, means for preventing the entrance of air to the bin, a sampling tube extending from the exterior of the lower part of the bin through the grain, provided with a removable air-tight cap, to prevent the air from entering the bin through the sampling tube, and valves for admitting the grain to the sampling tube operated by rods from the exterior of the bin, substantially as set forth. 7th. A grain bin comprising essentially vertical walls, a wooden lining for the walls and non-conducting material between the wooden lining and the walls of the bin, substantially as set forth. 8th. A grain storage warehouse comprising essentially a series of bins, each bin having a wooden lining, an air exhaust pump, a vacuum gauge, a sampling tube and means for forcing air through the grain, substantially as set forth. 9th. A grain storage warehouse, comprising essentially a series of bins each provided with an air exhaust pump, a sampling tube provided with valves at different heights in the tube, and means whereby air may be prevented from entering the tube, substantially as set forth. 10th. A storage warehouse for grain, comprising a series of bins having an air exhaust pump, a vacuum gauge, means for forcing air through the grain, a sampling tube extending from the exterior of the bins through the grain, valves in the tube, rigid rods extending from the valves to the exterior of the bin, and means to prevent air from entering the tube, substantially as set forth.

No. 44,802. Tedder Fork. (*Fourche de faneuse.*)

George M. Baker, Dayton, Ohio, U.S.A., 1st December, 1893; 6 years.

Claim.—1st. In a tedder fork, the combination, with the arm having lugs on its sides, of a spiral spring encircling said arm and bearing on said lugs, a fork having a loop and two eyes formed in the body thereof and terminating in tines, said fork having a pivotal connection with the arm by means of bolts or lugs penetrating the eyes, a coupling link having a loop at one end encircling the arm

and enclosing the spring and a hook at the other end to engage with the loop on the fork, substantially as described. 2nd. The combi-

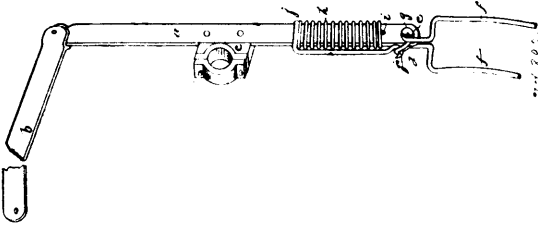

nation of the fork provided with the loop *d* and eyes *c c*, the coupling link *j* provided with a loop *j'*, and a hook *j''*, the fork arm *a* with lugs thereon, the spiral spring *h*, encircling said arm and having a bearing on the lugs thereon, all arranged substantially as herein described.

No. 44,803. Support for Bicycle Saddles.

(*Appui pour selles de bicycle.*)

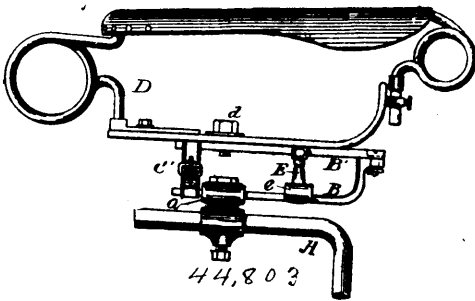

Elial M. Staples, Elizabeth, New Jersey, [U.S.A., 1st December, 1893; 6 years.

Claim.—1st. A bicycle saddle support, consisting of two parts having a pivotal connection at their forward ends so that the rear ends of the upper part may swing laterally relative to the lower part, the rear ends of such parts being loosely connected together by a device which limits the lateral movements of the swinging part. 2nd. A support for bicycle saddles, consisting of two parts pivotally connected together at their forward ends so that the rear end of the upper part may swing laterally relative to the lower part and loosely connected together at their rear ends by a device which limits the swinging movements of the upper part, combined with an interposed brace or vertical post arranged between the front and rear ends of the saddle support. 3rd. A support for bicycle saddles, consisting of two parts pivotally connected together at their forward ends so that the rear end of the upper part may swing laterally relative to the lower part and loosely connected together at their rear ends by a device which limits the swinging movements of the upper part, combined with an interposed brace or vertical post arranged between the front and rear ends of the saddle support, the said brace or vertical post having a rounded top and a curved lower portion to permit the upper part of the saddle support to rock thereon, and to allow said brace or vertical post to rock on the lower part of the saddle support. 4th. A bicycle saddle support, consisting of two separate bars or plates attached together by a pivot or pivots affording a universal joint and connected by a limiting device at their rear ends, combined with a brace interposed between said bars or plates, and having at its upper end a universal joint bearing and resting at its lower end upon the lower bar or plate. 5th. A bicycle saddle support, consisting of two separate bars or plates attached together at their forward ends and connected by a limiting device at their rear ends, combined with a brace or vertical support interposed between said bars or plates intermediate of their ends. 6th. A bicycle saddle support, consisting of two separated bars or plates attached together at their forward ends by a vertical pivot and connected by a limiting device at their rear ends combined with a longitudinally adjustable brace or vertical support interposed between said bars or plates intermediate of their ends. 7th. A spring support for bicycle saddle, consisting of the steel bars or plates *B* and *B'*, separated from each other, as shown, and connected together at their forward ends by a vertical pivot bolt *b'*, combined with the brace or post *E*, interposed between said bars or plates intermediate of their ends and constructed to rock laterally, as set forth, and a limiting device joining the rear ends of said bars or plates, and serving to limit the sidewise swinging movement of the upper bar or plate *B'*, to which the saddle is to be attached.

No. 44,804. Sleigh Attachment for Wheeled Vehicles. (*Accessoire de traîneau pour voitures à roues.*)

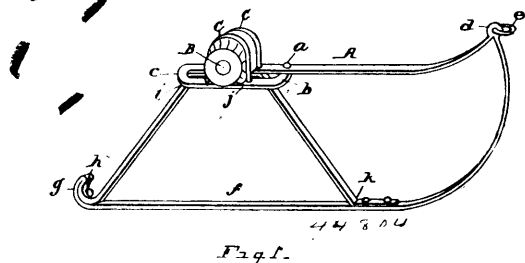

George P. Askin, Detroit, Michigan, U.S.A., 1st December, 1893; 6 years.

Claim.—1st. A sleigh bob formed of a single piece of flat metal and consisting of the lateral extension forming the hub bed, the bob parallel therewith, the runner and the diagonal braces connecting the bob and runner. 2nd. A sleigh bob formed of a single piece of metal, formed first to provide the lateral extension next the bob and parallel therewith, then the runner, and terminating in the inclined braces connecting the top to the runner, and a hub secured on the extension, substantially as described.

No. 44,805. Process of and Apparatus for Amalgamating Ores. (*Procédé et appareil pour amalgamer les minerais.*)

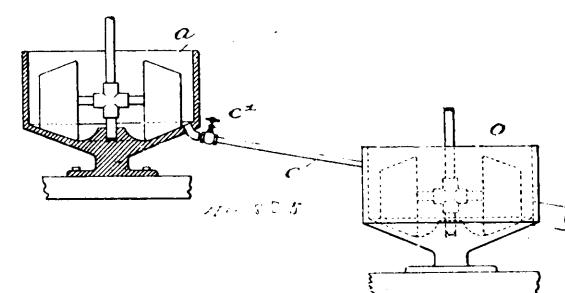

Hanson Gregory, Boston, Massachusetts, and Henry L. Gregory, Rockland, Maine, both in the U.S.A., 1st December, 1893; 6 years.

Claim.—1st. The improved process of treating ores, which consists in alternately reducing separated charges of ore, arresting one charge while being reduced, and at the same time discharging the other charge which has been reduced to an amalgamator. 2nd. An apparatus for treating ores, the same comprising reducing mills, an amalgamating mill, and separate valved passages connecting the latter with the reducing mills respectively.

No. 44,806. Truck for Railway Cars. (*Châssis de char de chemin de fer.*)

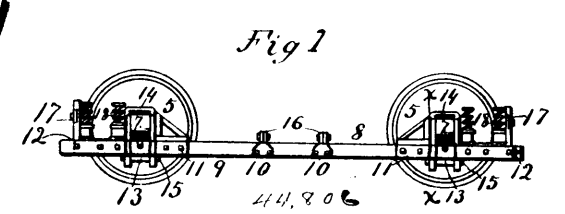

The Sheppard Manufacturing Company, assignee of Antoine B. du Pont, all of Louisville, Kentucky, U.S.A., 4th December, 1893; 6 years.

Claim.—1st. The combination in a railway car truck, of a pair of equalizing bars each comprising two parallel rods and a series of blocks fixed between them, axle bearings fitted to rest on top of the said bars, and inverted U-shaped clips fitting over the bearings and passing down between the pairs of rods at each side of a fixed block, and a bolt or key through the ends of each clip beneath and binding upon the said block, substantially as described. 2nd. The combination in a railway car truck, of a pair of equalizing bars each comprising two parallel rods and a series of blocks fixed between them, axle bearings fitted to rest on top of said bars and to be secured

thereto, that one of the said blocks next to each bearing and between the bearings, having an upward projection serving as a brace to the bearing, and a block at the outer side of each bearing having an upward projection, and a cross-bar attached thereto as a support for the brake, substantially as described.

No. 44,807. Process of Obtaining Pure Sulphate of Nickel. (*Procédé pour obtenir le sulfure de nickel pur.*)

The Orford Copper Company, Constable Hook, New Jersey, assignee of Charles C. Bartlett, New Brighton, New York, all in the U.S.A., 4th December, 1893; 6 years.

Claim.—1st. The hereinbefore described method of producing and separating sulphide of nickel, consisting in smelting the ores, mattes, or other bodies containing nickel, with a flux composed of nitre cake, salt cake, nitrates or carbonates of alkaline bases, or a mixture of two or more of the same, substantially as described, whereby sulphide of nickel is formed, which is of greater specific gravity than the remainder of the mass, and settles to the bottom of the same, while the copper, iron and salts of other metals rise to the top and may be separated in any convenient manner. 2nd. The hereinbefore described method of producing sulphide of nickel, consisting in smelting the ores, mattes or other substances containing nickel, with a flux composed of nitre cake, salt cake, nitrates or carbonates of alkaline bases or a mixture of two or more of the same, substantially as described, in separating out the sulphide of nickel resultant from the operation, from the smelted mass, and in resmelting the bottoms rich in sulphide of nickel with the same or substantially the same flux, and separating the resultant sulphide of nickel from the sulphides of the other metals present, and in repeating the operation until a commercially pure residue of sulphide of nickel is obtained. 3rd. The hereinbefore described method of producing and separating sulphide of nickel, consisting in smelting the ores, mattes or other substances containing nickel, with a flux composed of nitre cake, salt cake, nitrates or carbonates of alkaline bases or a mixture of two or more of the same, substantially as described, in separating out the bottoms rich in sulphide of nickel resultant from the separation, by specific gravity, and in subjecting the separated bottoms to repeated smelting with the same or substantially the same flux, and subsequent separation by specific gravity, until a commercially pure residue of sulphide of nickel is produced.

No. 44,808. Electric Car Fender. (*Défense pour chars électriques.*)

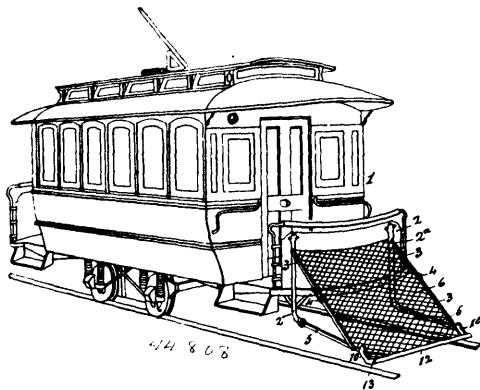

Thomas Ira McMacken and Charles F. Thomson, assignees of Robert Bustin, all of Boston, Massachusetts, U.S.A., 4th December, 1893; 6 years.

Claim.—1st. In a railway car, having propulsion by electricity, or by cable traction, the combination with the end guards, of two downwardly and forwardly inclined sustaining arms, each composed of two members united by a rule joint, two stretcher bars pivotally connected at their rearward ends to the lower ends of upright bars rigidly mounted upon said end guards and pivoted at their forward ends to the lower and forward ends of the jointed sustaining arms, and a net sustained by said parts, substantially as described. 2nd. In a railway car, having propulsion by means of electricity, or by cable traction, the combination with an end guard or dashboard, having upright bars rigidly mounted thereon, of sustaining bars having a forward and downward inclination, each being composed of two members united by a rule joint, the upper and rearward ends of said jointed bars being pivoted to the upper portions of the upright bars, stretcher bars pivotally connected at their rearward ends to the lower curved ends of said upright bars and at their forward ends to the lower, forward extremities of the sustaining bars, locking bolts movable in keepers arranged upon both sides of the rule joints and a net sustained by said parts, substantially as described. 3rd. In a railway car, the combination

with a net supporting frame, which comprises two sustaining bars, each composed of two members connected by a rule joint, of a sliding lock bolt movable in keepers arranged upon both sides of each rule joint, substantially as described. 4th. In a railway car, the combination with a folding, or collapsible and extensible frame, extended forwardly, of an independently folding and extensible forward section, pivotally connected to the lower and foremost extremity of said frame, and having lateral sustaining arms extending downward and forward from said extremity, of the extensible frame, the lower and forward ends of said lateral sustaining arms being connected by a revoluble roll, padded with elastic, or yielding material, substantially as described. 5th. In a railway car, the combination with an end guard or dashboard, of sustaining bars, each formed in two parts connected by a rule joint, a locking bolt movable in keepers arranged on both sides of each rule joint, stretcher bars pivotally connected to the lower ends of rigid supports on the end guard, the upper ends of the sustaining arms having pivotal support below the top of the end guard and a section composed of short lateral arms to the far ends of the stretcher bars, and inclined downwardly and forwardly, a padded roll having its journals supported in the lower forward ends of said lateral arms, and a net sustained by said parts, the padded roll and its supporting arms being capable of an independent rising and falling movement, substantially as described. 6th. In a railway car, the combination with a folding and extensible frame projecting from the end guard, said frame comprising two sustaining arms, each formed in two parts united by a rule joint, of a locking bolt mounted upon each of said arms and movable in keepers arranged upon both sides of each rule joint, said bolt having a knob at its upper end by which it is moved, said knob resting, when the frame is extended, against the rearward keeper, and being maintained in such position by gravity, substantially as described.

No. 44,809. Shingle Bunch and Binder. (*Manière d'attacher et de mettre le bardeau en paquets.*)

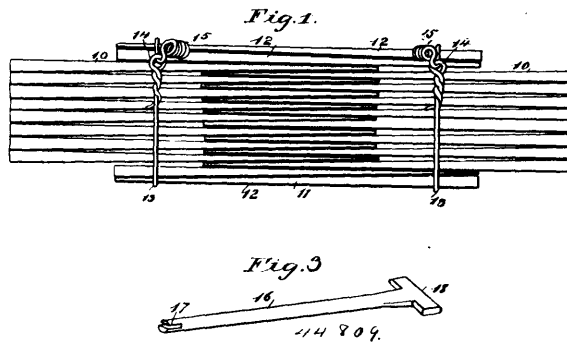

William J. Munro, Joseph Hart, David Batey, all of Sedro, Washington, U.S.A., 4th December, 1893; 6 years.

Claim.—1st. As an improved article of manufacture, a shingle bunch, comprising a plurality of shingles arranged in substantially the usual way, with overlapping thin edges, a series of shingles laid butts and points on the centre and upper and lower sides of the bunch, and wire binders encircling the bunch near the ends of the outer layers of shingles, substantially as described. 2nd. A shingle bunch, comprising a plurality of shingles arranged in substantially the usual way with overlapping thin edges, a series of shingles laid butts and points on the centre and upper and lower sides of the bunch, wire binders encircling the bunch near the ends of the outer layers of shingles, said wires each having a loop at one end through which the other end is passed, and a coil on the non-looped end projecting at an angle to the loop, substantially as set forth.

No. 44,810. Plaster for Walls. (*Plâtre pour les murs.*)

John Quincy Chase, Grand Rapids, Michigan, U.S.A., 4th December, 1893; 6 years.

Claim.—The herein described composition of matter consisting of lime, plaster of paris, oil cake meal, oxide of lead, dextrine, carbonate of soda and cream tartar, in the proportions substantially as described.

No. 44,811. Catch Basin Water-closet. (*Bassin d'attrappe pour latrines.*)

Henry C. Buddenberg, Cincinnati, Ohio, U.S.A., 4th December, 1893; 6 years.

Claim.—1st. In a catch basin water-closet, the combination of a seat 7, a catch basin below it, a water supply pipe 5, a hopper 8 below the catch basin, a combined trap and outlet pipe 9, a valve 11, which controls the outlet, and an overflow 21, 22, all as substantially shown and described. 2nd. In a catch basin water-closet, the combination of a seat 7, a catch basin below it, a water supply pipe 5, a hopper 8 below the catch basin, a combined trap and outlet pipe

9, a valve 11, which controls the outlet, a valve rod 17, whereby the valve is operated, a bearing 20, which keeps the valve rod in proper position, a pipe 18, leading up to the surface, through which the

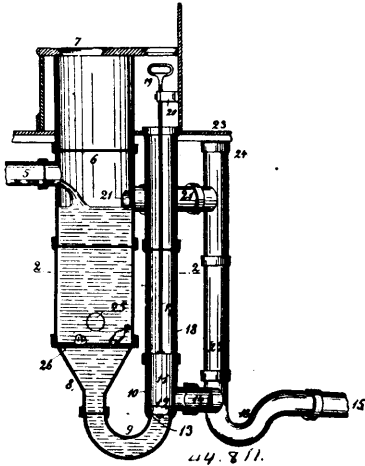

valve may be removed and access gained to parts below and an overflow 21, 22, all as substantially shown and described. 3rd. In a catch basin water-closet, the combination of a seat 7, a catch basin below it, a water supply pipe 5, a hopper 8 below the catch basin, a combined trap and outlet pipe 9, a valve 11, which controls the outlet, an outlet 14, 15, which leads to the sewer, a trap 16, and an overflow 21, 22, connecting the catch basin with the sewer outlet, the upright portion 22, leading to the surface and provided with the hand hole opening 24, through which access to trap 16 may be had, all as substantially shown and described. 4th. In a catch basin water-closet, the combination of a seat 7, a catch basin below it, a water supply pipe 5, a hopper 8 below the catch basin, a grate above the hopper, a combined trap and outlet pipe 9, terminating in its rising branch into a valve chamber 10, a narrow ridged valve seat 13, within this valve chamber, and a rubber or leather seated valve 11, all as substantially shown and described. 5th. In a catch basin water-closet, the combination of a seat 7, a catch basin below it, a water supply pipe 5, a hopper below the catch basin, a combined trap, outlet pipe and valve chamber 9, 10, a valve 11, provided with a valve rod 17, a pipe 18, leading to the surface and permitting access to the valve chamber and parts below, a sewer outlet 14, 15, a trap 16, provided in the same and an overflow 21, 22, connecting the catch basin with the sewer outlet, its upright portion 22, leading to the surface and having hand hole opening 24, by which access to trap 16, is had, all as substantially shown and described. 6th. In a catch basin water-closet, when arranged in series, the combination of the seats 7, catch basins below them, pipes 25, connecting all the catch basins, hoppers below the catch basins, outlet pipes 9, connecting to the hoppers, valves 11, controlling the passage from outlet pipe 9, sewer outlets 14 and 15, provided with traps 16, a water supply pipe 5, connecting to one of the series of catch basins, and an overflow connecting the series with one of the sewer outlets, all as substantially shown and described. 7th. In a catch basin water-closet, the combination of a seat 7, a catch basin below it, a water supply pipe 5, a hopper 8, below the catch basin, a combined trap and outlet pipe 9, a valve 11, located externally from the catch basin and connected with it by pipe 9, and an overflow, all as substantially shown and described. 8th. In a catch basin water-closet, the combination of a seat 7, a catch basin below it, a water supply pipe 5, a hopper 8 below the catch basin, a combined trap and outlet pipe 9, a valve 11, located externally from the basin and connected with it by a pipe 9, an external passage 18, reaching up to the surface, and an overflow, all as substantially shown and described.

No. 44,812. Hydro Carbon Burner.

(Alimentateur à hydro-carbure.)

Emmet B. Raymond, St. Louis, Missouri, U.S.A., 4th December, 1893; 6 years.

Claim.—1st. The improved oil vaporizer and burner made up of screw-threaded pipe and fittings, with a single generating chamber 2, and separate exit nozzles 1, applied one adjacent each end of said generating chamber, and a supply pipe 7, communicating with said generating chamber at a point intermediate of the connections of said exit nozzles therewith, substantially as herein specified. 2nd. In a burner, the generating chamber 2, having within it a horizontal tube 14, the opposite ends of which are open, in combination with an oil supply pipe projecting within said chamber and supporting said tube 14, substantially as herein specified. 3rd. A burner, having a single generating chamber composed of a cross-shaped coupling 3, pipes 4, threaded into said coupling, a supply pipe connected to said generating chamber, and separate burners having

exit nozzles and applied one beneath each of said pipes 4, substantially as herein specified. 4th. In a burner, generating and super-

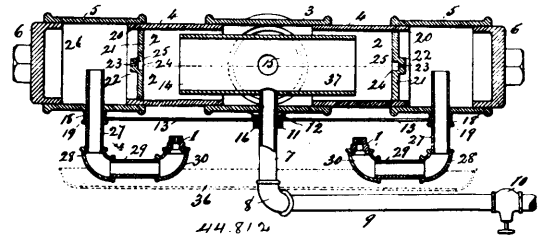

heating chambers locate on opposite sides of a supply pipe connection and formed of T-couplings 5, having nipples 18 upon their lower sides, said nipples having annular projections 19, adjacent their lower ends, exit nozzles connected to said nipples so as to discharge flame upward beneath said chambers and the spreaders 12 and 13, having terminal recesses 17, engaging said nipples, and supported intermediate of their ends by the oil supply pipe of the burner, substantially as herein specified. 5th. In an oil burner, the exit nozzle 1, having a restricted discharge orifice 32, terminating at one end in an enlarged recess 33, and said nozzle having a screw-threaded exterior, substantially as herein specified. 6th. In an oil vaporizer and burner, the combination of a generating chamber a superheating chamber, a burner applied to said superheating chamber to heat both chambers, and a partition separating said generating chamber from said superheating chamber, and provided with a restricted discharge orifice, substantially as herein specified.

No. 44,813. Electric Smelting of Refractory Ores.
(Procédé pour la fonte des minerais réfractaires par l'électricité.)

Thomas Leopold Willson, Leakville, North Carolina, U.S.A., 4th December, 1893; 6 years.

Claim.—1st. The process of reduction of a pulverized metallic compound, which consists in first impregnating it with a reducing agent by saturating it therewith while the latter is in liquid condition, and then subjecting the impregnated compound to the heating action of the electric current. 2nd. The process of reduction of a pulverized metallic compound, which consists in first impregnating it with a reducing agent by boiling it therein, and then subjecting the impregnated compound to the heating action of an electric current. 3rd. The process of reduction of a pulverized metallic oxide, which consists in first impregnating it with a reducing agent in the nature of a hydrocarbon, which is liquid when heated by introducing the oxide into a heated bath of the reducing agent until sufficient of the latter has been absorbed by the metallic compound, then drying the latter by heat, and finally subjecting the impregnated compound to the heating action of an electric current. 4th. The process of reduction of a pulverized metallic oxide, which consists in introducing it into boiling coal tar, drying it by heat to expel the volatile constituents of the tar, and then subjecting the tar impregnated oxide to electric smelting.

No. 44,814. Steam Generator. (Générateur à vapeur.)

FIG. 3

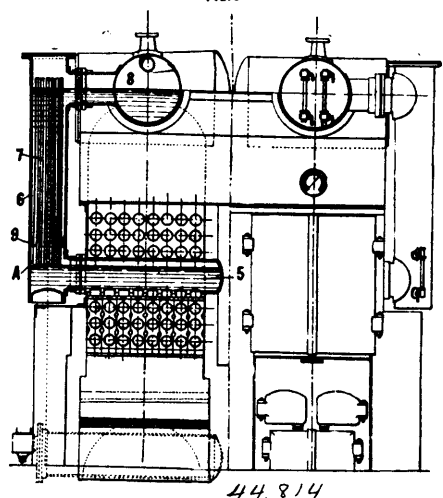

Paul Dubiau, of Marseilles, France, 4th December, 1893; 6 years.

Claim.—1st. In a steam generator, an apparatus or means for collecting or accumulating the whole or part of the steam generated

at a point below the normal level of the water in a steam generator, by the introduction of a division or partition forming a steam space (as at A), for the purpose of obtaining a flow or circulation of the water, substantially as hereinbefore described with reference to the accompanying drawings. 2nd. In a steam generator, an arrangement for establishing communication between the steam space under the partition or division (A) referred to in the preceding claiming clause, and the ordinary steam space above the level of the main body of water in the boiler by means of mixing tubes (B) of small diameter, extending to a suitable depth into the lower water space or chamber, and opening at or above the normal level of the main body of water in the upper space or chamber, as and for the purpose hereinbefore described with reference to the accompanying drawings. 3rd. The arrangement and combination of parts constituting the improvements in or connected with steam generators, substantially as hereinbefore described with reference to the accompanying drawings.

No. 44,815. Insulator for Telegraph Wires.

(*Isoloir pour les fils télégraphiques.*)

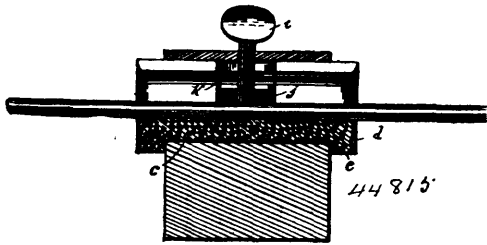

Joseph F. Wright, Colorado Springs, Colorado U.S.A., 4th December, 1893; 6 years.

Claim.—1st. In an insulator for electrical wires, the combination of a non-conducting tube or holder, and a thumb-screw having a non-conducting button on its lower end operating therewith. 2nd. In an insulator for electrical wires, the combination, with the cross-beam of a pole or support, of a non-conducting tube countersunk in the face of said cross-beam and having an opening in its side for the admission of the wire, and a thumb-screw provided with a non-conducting button on its lower end, for securing the wire in place. 3rd. In an insulator for electrical wires, the combination of a non-conducting tube countersunk in the face of the cross-beam to which it is attached, an opening in the side of said tube, a lid hinged to the tube, a thumb-screw working in the lid and in conjunction with the opening in the tube, and a fastening button for the lid. 4th. In combination, with an insulator, a hinged clamp and button, as set forth. 5th. In an insulator for electrical wires, the combination of a tube or holder having a longitudinal opening through its side, and a thumb-screw having a button on its end operating therein, substantially as described.

No. 44,816. Fender for Street Cars.

(*Défense pour chars urbains.*)

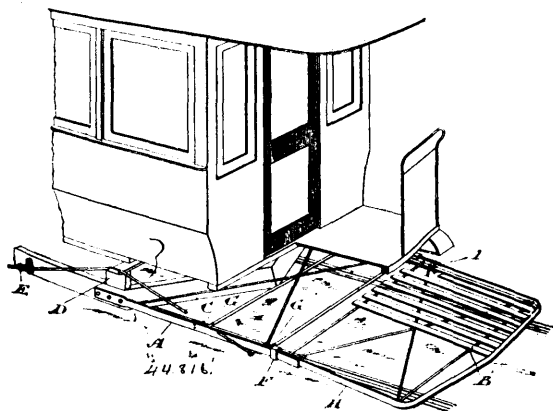

Charles H. Stainton, Toronto, Ontario, Canada, 4th December, 1893; 6 years.

Claim.—1st. A street car fender composed of a guard of suitable width arranged to slide in a stationary frame connected to the car body or truck so that the said guard may be extended beyond the end of the car or slid back beneath it as may be desired, substantially as and for the purpose specified. 2nd. The stationary frame A, having its outer ends turned slightly downwards in combination with the guard B, sliding thereon and the clips F, substantially as

and for the purpose specified. 3rd. The stationary frame A, having its outer ends turned slightly downwards, in combination with the guard B, clips F, and means for holding the guard in its extended position, substantially as and for the purpose specified. 4th. In a street car fender, a guard having its frame formed of a continuous piece of angle iron, the forward end having the angle turned upward sufficient to present an inclined surface to the ground, substantially as and for the purpose specified. 5th. In a street car fender, a guard having its frame formed of a continuous piece of angle iron, the forward end being slightly V-shaped and having the angle of the iron, of which it is formed, turned upward sufficiently to present an inclined surface to the ground, substantially as and for the purpose specified. 6th. The combination of the stationary frame A, having its outer ends turned slightly downwards, the guard B, clips F, stops G, and means for holding the guard in its extended position, substantially as and for the purpose specified. 7th. In a street car fender, a guard having its frame formed of a continuous piece of angle iron and filled in with longitudinal slats, the forward end having the angle turned upward sufficiently to present an inclined surface to the ground, substantially as and for the purpose specified. 8th. A street car fender, composed of a guard of suitable width arranged to slide in a stationary frame connected to the car body or truck in combination with a truss rod connected to the stationary frame, and to the car body or truck, and means to adjust the said truss rod to raise or lower the outer end of the stationary frame, substantially as and for the purpose specified.

No. 44,817. Underground Conduit for Electric Wires.

(*Conduit souterrain pour fils ou câbles électriques.*)

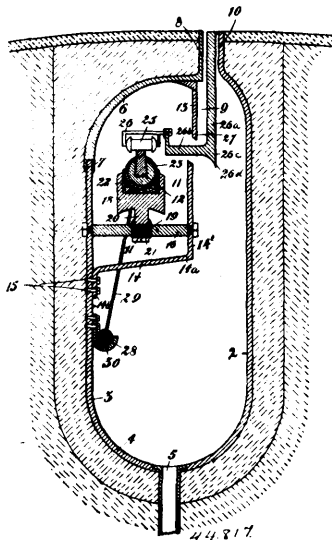

Phelan McCullough, Toronto, Ontario, Canada, 4th December, 1893; 6 years.

Claim.—1st. In an underground conduit for trolley wires, the combination of a subway, a top for the subway having an opening at or adjacent to one side thereof, and a conductor within the subway located between the said opening and the opposite side of the said subway, substantially as set forth. 2nd. In an underground conduit for trolley wires, the combination of a subway, a top for the subway, said top having an opening into the subway, a compartment within the said subway between the opening and the side of the subway, said compartment having an opening from the subway into the interior thereof, and a conductor within the compartment substantially as set forth. 3rd. In an underground conduit for trolley wires, the combination of a subway, a top for the subway, said top having an opening into the subway, a downwardly projecting flange from the underside of the top, located between the said opening and opposite side of the subway, and a conductor in the subway between the flange and the said opposite side, substantially as set forth. 4th. In an underground conduit for trolley wires, the combination of a subway, a top for the subway, having an opening at or adjacent to one side thereof, a conductor within the subway between the side opening and said side, and an insulator of solidified sulphur for said conductor, substantially as set forth. 5th. In an underground conduit for trolley wires, the combination of a subway, a cover for the subway, said cover having an opening into the subway at or near one side thereof, a compartment within the subway between the opening and the opposite side of the subway, a conductor within the compartment and insulated supports for the conductor, substantially as set forth. 6th. In an underground conduit for trolley wires, the combination of a subway, a cover for the subway, said cover having an opening into the subway at or near one side thereof, a downwardly projecting flange

secured to the underside of the cover between the said opening and opposite side, an L-shaped plate, one branch of which is secured to the said opposite side, whilst the other branch extends vertically towards the said cover, the said vertical branch being located between the said flange and said opposite side with an opening between the said flange and vertical branch to admit of the entry of the trolley carrying arm to the compartment formed by the said flange and L-shaped plate, brackets within the compartment, a support connected to each bracket, insulators held by said supports, a trolley rail or wire set in said insulators, a conductor within said subway and connections between the conductor and the trolley rail or wire, substantially as set forth. 7th. In an underground conduit for trolley wires, the combination of a subway, a cover for the subway, said cover having an opening into the subway at or near one side thereof, a downwardly projecting flange secured to the under side of the cover between the said opening and opposite side, an L-shaped plate, one branch of which is secured to the said opposite side, whilst the other branch extends forward towards the cover, the said vertical branch being located between the said flange and said opposite side, with an opening between the said flange and vertical arm to admit of the entry of the trolley carrying arm to the compartment formed by the said flange and L-shaped plate, stays within the compartment, a support connected to each stay, an insulator of mica held by and forming part of each support, an insulator of sulphur held in said mica insulator, and a trolley rail or wire supported in said sulphur insulator, substantially as set forth.

No. 44,818. Locomotive Boiler.

(*Chaudière de locomotive.*)

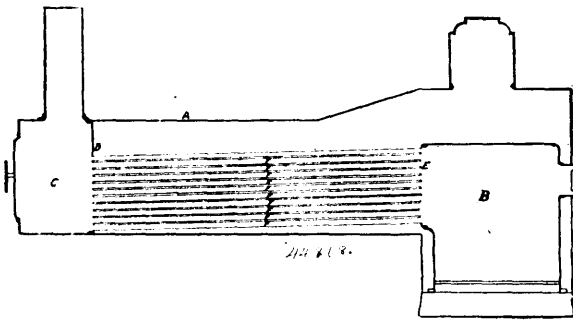

Robert Rushton, St. Thomas, Ontario, Canada, 4th December, 1893; 6 years.

Claim.—The combination in a locomotive boiler of the flue sheets with the flues in such a manner that the said flues shall be higher in the rear flue sheet than in the front flue sheet, substantially as and for the purpose hereinbefore set forth.

No. 44,819. Method of Making Yeast.

(*Manière de faire le levain.*)

Jacob Blumer, Brooklyn, and Charles Schlagenhauser, New York, both in the State of New York, U.S.A., 4th December, 1893; 6 years.

Claim.—1st. The method of making yeast, which consists in extracting the soluble parts of unmalted starch bearing materials with a suitable liquid and at a temperature low enough to leave the starch intact, separating such extract from the solid material, fermenting the clear wort, thereby forming yeast, and separating the yeast, substantially as described. 2nd. The method of making yeast, which consists in extracting the soluble parts of unmalted starch bearing materials with a suitable liquid and at a temperature low enough to leave the starch intact, separating such extract from the solid material, sterilizing the extract, separating the coagulum, fermenting the clear wort, thereby forming yeast, and separating the yeast, substantially as described. 3rd. The method of making yeast, which consists in extracting the soluble parts of unmalted starch bearing materials with a suitable liquid and at a temperature low enough to leave the starch intact, separating such extract from the solid material, sterilizing the extract, adding an alkali to the extract to reduce its acidity, separating the coagulum, fermenting the clear wort, thereby forming yeast, and separating the yeast, substantially as described. 4th. The method of making yeast, which consists in extracting the soluble parts of unmalted starch bearing materials with a suitable liquid and at a temperature low enough to leave the starch in said materials intact, separating such extract from the solid material, sterilizing the extract and coagulating albuminous substances by raising its temperature above mashing temperature, preferably to 100° Centigrade, separating the coagulated albuminous substances before fermentation of the extract, fermenting such extract with the assistance of a small amount of malted grain at a temperature of about 30° Centigrade, thereby forming yeast, and separating the yeast, substantially as described. 5th. The method of making yeast, which consists in extracting the

soluble parts of unmalted starch bearing materials with a suitable liquid at a temperature low enough to leave the starch intact, separating such extract from the solid material, combining the extract with the more or less solid residues which are left after the starch bearing material has served the purpose of starch manufacturing, sterilizing the mixture, adding malted grain, fermenting it, thereby forming yeast, and separating the yeast, substantially as described. 6th. The method of making yeast, which consists in extracting the soluble parts of unmalted starch bearing materials with a suitable liquid, separating such extract from the solid material, combining the extract with the more or less solid residues which are left after the starch bearing material has served the purpose of starch manufacturing, sterilizing the mixture, adding malted grain, separating the clear wort, fermenting it, thereby forming yeast, and separating the yeast from the wort, substantially as described.

No. 44,820. Trunk Lock. (*Serrure pour valises.*)

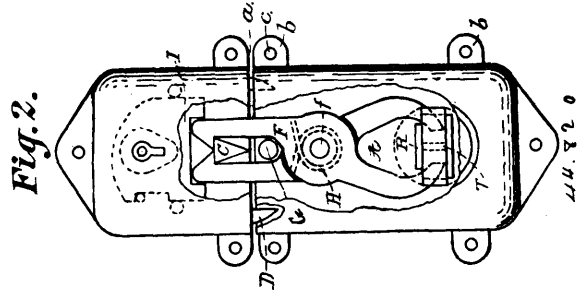

William John Henry, Portland, Maine, U.S.A., 4th December, 1893; 6 years.

Claim.—1st. In a trunk fastening, the herein described cross arms F, pivotally connected to the back plate and having suitable spring mechanism in the arbours about the pivot point for automatically drawing the extremities of the cross arms together when the same are forced apart, and the press bolt having guide standards provided with bevelled faces to engage the lower bevelled extremities of said cross arms, substantially as herein set forth. 2nd. In a trunk fastening, the combination of the cross arms F, pivotally connected to the back plate and having suitable spring mechanism in the arbours about the pivot point for automatically closing the extremities of said cross arms when forced apart by a press bolt, the press bolt essentially as described, and the cross-bar T for carrying said press bolt, substantially as set forth. 3rd. In a trunk fastening, the pivotally operating cross arms F, the actuating spring f, the press bolt composed of the button K and standards L, L, the V-shaped stop C, the lock bolt I, with attendant locking mechanism, substantially as set forth. 4th. In a trunk fastening, the combination with the spring actuated arms F, of the herein described press bolt, provided with guide projections or standards L, L, having the bevelled face M, M, for spreading apart the cross arms F, and holding said cross arms apart, substantially as set forth.

No. 44,821. Axle Bearing for Wheels.

(*Coussinet d'essieu pour roues.*)

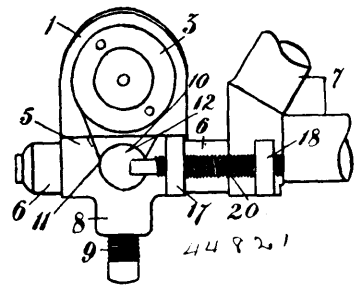

Charles F. Lavender and Thomas Fane, both of Toronto, Ontario, Canada, 5th December, 1893; 6 years.

Claim.—The combination of a bearing case 1, having a threaded aperture formed therethrough, the adjusting cones within the threaded aperture, a collar 5 secured to the bearing case 1 and fitted to receive the shank of the frame, means for securing the collar to the shank, said collar having an opening formed in the side, a movable piece of metal 13 located between the threaded aperture and opening in the collar hinged to the bearing case, and adapted to bear against the adjusting cones and form a lock therefor, substantially as set forth.

No. 44,822. Screen. (Ecran.)

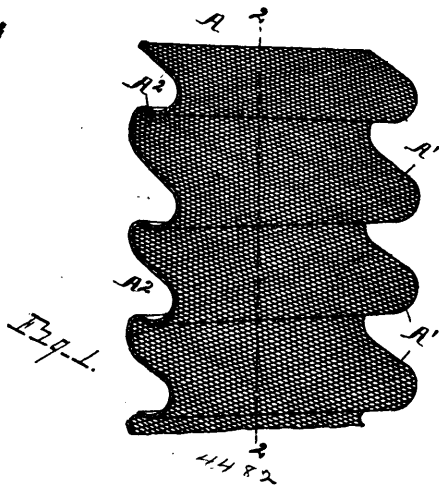

David J. Davidson, Abraham S. Martin and Stephen G. Martin, all of Port Huron, Michigan, U.S.A., 5th December, 1893; 6 years.

Claim.—A corrugated screen, substantially as set forth.

No. 44,823. Separator and Grader.

(Appareil de nettoyage et de gradation des grains.)

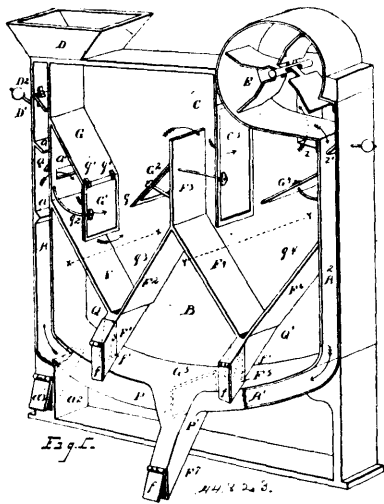

David J. Davidson, Abraham S. Martin and Stephen G. Martin, all of Port Huron, Michigan, U.S.A., 5th December, 1893; 6 years.

Claim.—1st. A vertical or perpendicular purifier, separator and grader, arranged and provided with means to effect a continuous air current therein, the desired separations of the stock supplied thereto being effected by gravity in connection with said air current, substantially as set forth. 2nd. A vertical or perpendicular purifier, separator and grader, provided with a vertical air trunk to receive the stock, and means for effecting an air current in said air trunk, substantially as set forth. 3rd. A vertical or perpendicular purifier, separator and grader, provided with vertical communicating air trunks into one of which the stock is fed, and means to provide an air current in said air trunks, substantially as set forth. 4th. A vertical or perpendicular purifier, separator and grader, constructed with a vertical air trunk, a fan to effect an air current therein and means to diminish the force of the air current, and thereby cause a separation of the stock, substantially as set forth. 5th. In a purifier, separator and grader, the combination of a fan, an interior air chamber communicating with the interior of the fan case, a feeding device, and a continuous air passage leading from the fan to said feeding device and communicating with said interior air chamber, substantially as set forth. 6th. In a purifier, separator and grader, the combination of a fan, an interior air chamber com-

municating with the interior of the fan case, a feeding device, and a continuous air passage leading from the fan downward underneath the air chamber, and upward to the feeding device and communicating with said air chamber, substantially as set forth. 7th. In a purifier separator and grader, the combination of multiple communicating air trunks, an interior air chamber communicating therewith, and a fan to produce an air current through said air trunks and chamber, substantially as set forth. 8th. In a purifier, separator and grader, the combination of an interior air chamber, a fan, a continuous air passage leading from the fan case and communicating with said air chamber, and a feeding device communicating with the air trunk, provided with a valve to control the passage of stock into the air trunk, substantially as set forth. 9th. In a purifier, separator and grader, an interior air chamber, a fan, a feeding device, a continuous air passage leading from the fan to said feeding device and communicating with said air chamber, and an automatic valve to control the feed of the stock into said air passage, substantially as set forth. 10th. In a purifier, separator and grader, an interior air chamber, a fan, a feeding device, a continuous air passage leading from the fan to the feeding device and communicating with said air chamber, said air passage beneath the feeding device, provided with breakers to throw the stock into the centre of the air passage, substantially as set forth. 11th. In a purifier, separator and grader, the combination of an interior air chamber, and multiple communicating air trunks forming a continuous air passage, said air trunks provided with discharge ducts or outlets, substantially as set forth. 12th. In a purifier, separator and grader, the combination of an interior air chamber, vertical or perpendicular air trunks A, A², an air trunk A¹, connecting the air trunks A, A², a feeding device communicating with the trunk A, and a fan having its case communicating with the air trunk A² and with the interior air chamber, the trunk A communicating with the air chamber, substantially as set forth. 13th. In a purifier, separator and grader, the combination of a fan, an interior air chamber communicating with the interior of the fan case, a continuous air passage leading from said fan case and communicating with said chamber, a series of separating devices located within said air chamber, and means of discharging the products separated within said air chamber, substantially as set forth. 14th. In a purifier, separator and grader, the combination of an interior air chamber, air trunks A, A¹, A², of a feeding device communicating with the upper end of the trunk A, and a fan having the interior of its case communicating with the upper end of the trunk A², the trunk A provided with a discharge opening at its base, substantially as set forth. 15th. In a purifier, separator and grader, the combination of an interior air chamber, air trunks A, A¹, A², communicating one with the other, the fan having its case communicating one with the other, the fan having its case communicating with the interior chamber and with the trunk A², the trunks A, A² provided with discharge ducts or outlets, substantially as set forth. 16th. In a purifier, separator and grader, the combination of an interior air chamber, air trunks A, A¹, A², a fan to produce an air current through said air trunks and air chamber, and a valve located within the trunk A² to control the air current, substantially as set forth. 17th. In a purifier, separator and grader, the combination of a fan, an interior air chamber communicating with the fan, a feeding device, a continuous air passage leading from the fan to the feeding device and communicating with the interior chamber below the feeding device, an interior cant board within the air chamber below the inlet orifice, a diaphragm supported above the cant board and forming a passage therebetween, a discharge duct or outlet located at the base of said cant board, and means to control the discharge through said outlets, substantially as set forth. 18th. In a purifier, separator and grader, the combination of a case forming an interior air chamber, a fan having its case communicating with said chamber, a feeding device, and a continuous air passage leading from the fan to the feeding device, and communicating therewith below the interior air chamber, a series of cant boards located within the air chamber provided with corresponding diaphragms thereabove, said cant boards and diaphragms arranged substantially as and for the purposes set forth. 19th. In a purifier, separator and grader, the combination of a case forming an interior air chamber, air trunks communicating one with another and with the interior chamber, a feeding device communicating with the air trunks, a fan communicating with the interior chamber, the interior chamber provided with cant boards F, F², discharge duct F¹ at the base of said cant boards and diaphragms G¹, G² supported above said cant boards, substantially as set forth. 20th. In a purifier, separator and grader, the combination of a case forming an interior air chamber, air trunks communicating one with another and with the interior chamber, a feeding device communicating with the air trunks, a fan communicating with the interior chamber, the interior chamber provided with cant boards F, F², and discharge duct F¹ at the base of said cant boards, diaphragms G¹, G² supported above said cant boards, a division wall at the upper end of the cant board F², additional cant boards F⁴, F⁶ provided with a discharge outlet at their base and diaphragms G³, G⁴ located above the cant boards F⁴, F⁶, substantially as set forth. 21st. In a purifier, separator and grader, the combination of an enclosing case forming an interior air chamber, vertical air trunks A, A², an air trunk A¹, connecting the lower ends of the trunks A¹, A², discharge outlets leading from said latter air trunks, and separating diaphragms and cant boards located within the air chamber and provided with corresponding

discharge outlets, the air trunk A communicating with the interior chamber adjacent to one of said diaphragms, and a fan to produce a continuous air current within the air trunks and air chamber, substantially as set forth. 22nd. In a purifier, separator and grader, the combination of an interior air chamber, communicating with air trunks A, A¹, A², a fan to produce an air current through said air trunks and air chamber, the trunk A¹ provided with cant boards P, P¹, an intervening diaphragm and a discharge outlet, substantially as set forth. 23rd. In a purifier, separator and grader, an air chamber into which stock is admitted, a fan to produce a current of air therethrough, and means to diminish the force of the air current at a desired point within said air chamber to effect a gravity separation of the stock, substantially as set forth. 24th. In a purifier, separator and grader, an air chamber, an air belt communicating therewith, a fan to produce an air current through said air belt and air chamber, and means to diminish the force of the air current at desired points, and thereby effect a gravity separation of the stock, substantially as set forth. 25th. In a purifier, separator and grader, an air chamber, an air belt communicating therewith, a fan to produce an air current through said air belt and air chamber, means to diminish the force of the air current at desired points and thereby effect a gravity separation of the stock, and devices to collect and discharge desired grades or separations of the stock, substantially as set forth. 26th. In a purifier, separator and grader, the combination of an air trunk, an air chamber communicating therewith, and a fan to provide an air current through said air trunk and chamber, substantially as set forth.

No. 44,824. Sieve Cut-off. (Détente de crible.)

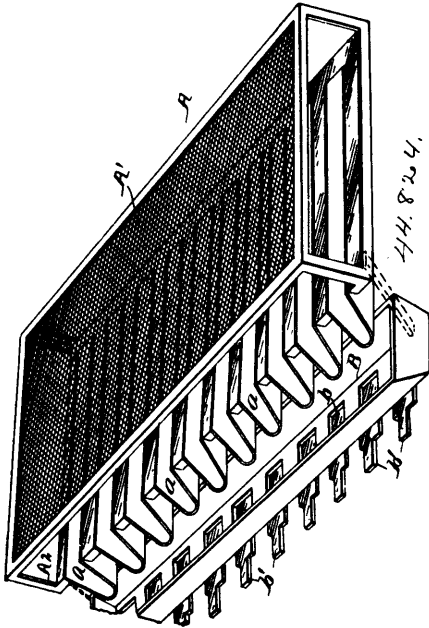

David J. Davidson, Abraham S. Martin and Stephen G. Martin, all of Port Huron, U.S.A., 5th December, 1893; 6 years.

Claim.—1st. The combination of an agitable sieve, of a series of spouts or conveyors, a cut-off box into which said spouts or conveyors discharge, said box constructed with a series of discharge orifices and provided with valves or slides to control said orifices, substantially as set forth. 2nd. The combination, with an agitable screen, of a series of spouts or conveyors located therebeneath and agitable therewith, and a cut-off box into which said spouts discharge, said box constructed with a series of discharge orifices and provided with valves or slides to control said openings, substantially as set forth. 3rd. The combination, with an agitable sieve, of a series of spouts located therebeneath, an agitable cut-off box, into which said spouts discharge, said box constructed with discharge openings and provided with valves or slides to control said openings, substantially as set forth. 4th. The combination, with a sieve or screen, of a cut-off box into which the products passed through the screen are discharged, said box constructed with a series of discharge openings and provided with a corresponding series of valves or slides to control said openings, substantially as set forth. 5th. The cut-off box herein described, constructed with a series of discharge orifices and provided with a series of corresponding valves or slides to control said orifices, substantially as set forth. 6th. The combination, with a sieve or screen, of a series of spouts or conveyors located therebeneath and agitable therewith, substantially as described.

No. 44,825. Sieve Cut-off. (Détente de crible.)

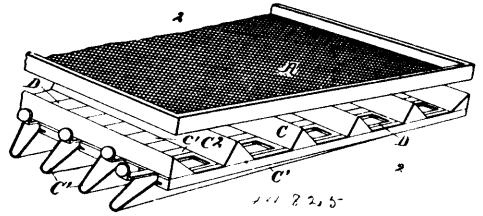

W. Allen Pendry, Detroit, David J. Davidson, Abraham S. Martin and Stephen G. Martin, of Port Huron, all in Michigan, U.S.A., 5th December, 1893; 6 years.

Claim.—1st. The combination, with a screen, of an independent cut-off bottom provided with a series of discharge orifices and means to control said orifices, substantially as set forth. 2nd. The combination, with a screen of an independent cut-off bottom whereby the commodity passed through the screen may be cut off at any desired point, substantially as set forth. 3rd. The combination, with a screen, of an independent cut-off bottom provided with discharge orifices, and means for controlling said orifices, and the series of spouts located below said orifices, substantially as set forth. 4th. The combination, with a screen, of an independent cut-off bottom provided with a series of discharge orifices, and means to control said orifices, the discharge orifices of each series arranged in line, substantially as set forth. 5th. The combination, with an agitable sieve, of an independently agitable cut-off bottom, substantially as set forth.

No. 44,826. Multiple Telephone Switchboard System.

(Système de plaques multiples pour commutateurs.)

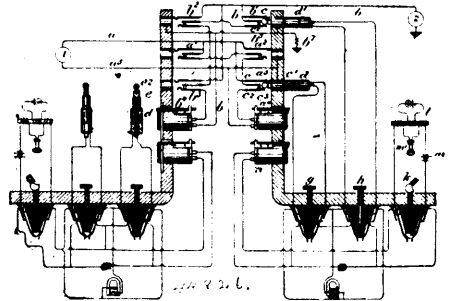

The Bell Telephone Company of Canada, Montreal, Quebec, Canada, assignee of Charles E. Scribner, Chicago, Illinois, U.S.A., 5th December, 1893; 6 years.

Claim.—1st. A connecting plug consisting of a central conducting core, a conducting sleeve concentric with and insulated from said core and of such length as to leave a portion of said core exposed, and an insulated tip secured to said core, substantially as described. 2nd. The combination, with a spring-jack having a line-spring and a test-ring or frame insulated therefrom and an auxiliary spring and contact-anvil insulated from both line springs and test-rings, of a plug having one contact piece making contact with the test-ring, and another contact-piece making contact with the line-spring and insulated tip entering under one end of the auxiliary spring and raising it from a contact-anvil, substantially as described. 3rd. The combination, with a telephone line extending from a substation, of spring-jacks at a central station, each consisting of a line-spring, a test-ring insulated therefrom, and auxiliary springs and contact-anvils, as described, said line-springs and test-rings being connected with the two sides of line, respectively, and a conductor joining the two sides, including in series an annunciator and all the auxiliary springs and contacts, substantially as specified. 4th. The combination, with a line-circuit extending from a substation to switchboards at a central station and connected at each board to a spring-jack having a test-ring, a line-spring insulated therefrom, and an auxiliary spring and contact, said line-springs and test-rings being connected to the sides of the line, respectively, and said auxiliary springs and contacts being normally included in series with an annunciator in a branch connection between the two sides, of a plug inserted into one jack, having contact-pieces making contact with the test-ring and the line-spring of the jack, respectively, and a tip separating the auxiliary spring from its anvil and a test-battery and responsive device included in a circuit between the two contact-pieces of the plug, substantially as described.

No. 44,827. Multiple Telephone Switchboard System.
(*Système de planches multiples pour commutateurs.*)

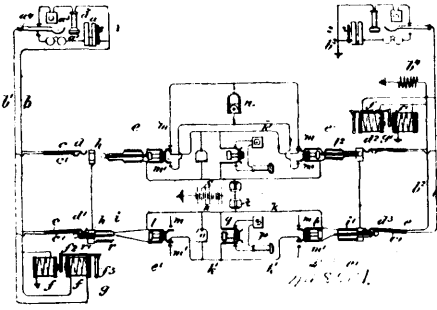

The Bell Telephone Company of Canada, Montreal, Quebec, Canada, assignees of Charles E. Scribner, Chicago, Illinois, U.S.A., 5th December, 1893; 6 years.

Claim.—1st. The combination, with a line circuit extending from a substation to a central station, of an individual annunciator at the central station having two coils adapted to act differentially or oppositely through suitable mechanism upon an indicator, one of said coils being included in the said telephone line circuit and the other being included in a branch from one side thereof to earth, substantially as described. 2nd. The combination, with a telephone line extending from a substation to a central station, of an individual annunciator at the central station provided with two coils adapted to act differentially or oppositely upon an indicator, one of said coils being included in the said line-circuit, and the other being included in a branch, therefrom, to earth, and means for connecting a grounded source of electricity to that side of the line to which the grounded coils is attached, substantially as described. 3rd. In combination, with a telephone line circuit, spring-jacks, each having two contact-pieces connected to the different sides of each line, respectively, an individual annunciator having two electro-magnets adapted to act oppositely or differentially upon indicating mechanism, one of said electro-magnets being included in said line-circuit, and the other being included in a branch from one side of said line to earth, and a connecting-plug adapted for insertion into a spring-jack of the line and having a contact-piece connected to one terminal of a source of electricity whose other terminal is connected to earth adapted to make contact with that line-contact which is connected through a coil of the annunciator to earth, substantially as described. 4th. The combination, with a telephone line circuit extending from a substation to an exchange, of spring-jack at the exchange, each having two contact-pieces connected to the different sides of the line-circuit, respectively, an individual annunciator having two electro-magnets, one being included in the line-circuit and arranged to actuate a suitable indicator when energized, and the other being included in a branch from one side of the line-circuit and arranged to prevent the operation of said indicator when energized, a connecting-plug having two contact-pieces adapted to make contact with the line-contacts of a spring-jack, respectively, and a source of electricity having one of its terminals grounded and the other connected to that contact-piece of the plug which connects with the said grounded coil, substantially as described. 5th. The combination, with a telephone line-circuit extending from a substation to a central station, of spring-jacks at the central station, each having two contact-pieces connected to the two sides of line, respectively, an individual annunciator having two electro-magnets, one included in the line-circuit, adapted to actuate a suitable indicator when energized, and the other included in a branch from one side of the line to earth, and arranged to prevent the actuation of said indicator when energized, a connecting-plug having two contact-pieces making connection with the two line-contacts of a spring-jack, respectively, a source of electricity having one of its terminals connected to that contact-piece of the connecting-plug which connects with the grounded coil of the annunciator, and its other terminal connected to earth, and a clearing-out annunciator included in a conductor joining the different contact-pieces of the plug, substantially as described. 6th. In combination, with a telephone line extending from a substation, to a central station, spring-jacks at the central station, each having three insulated contact-pieces, two of said contact-pieces being connected to the two sides of the line-circuit, respectively, and the remaining contact-pieces of all the line-jacks being connected together, an individual annunciator having two electro-magnets arranged to act differentially upon a suitable indicating mechanism, one of said electro-magnets being included in the line-circuit and the other in a branch from one side of the line-circuit to earth, a connecting-plug having two contact-pieces, one adapted to make contact with one of the line-contacts of the jack, and with the extra contact or test-ring, and the other adapted to make contact with the remaining line-spring of the spring-jack, and a source of electricity having one of its terminals connected to that contact-piece of the connecting-plug which touches

the test-ring of the jack, and its other terminal connected to ground, substantially as described. 7th. In combination, two telephone lines extending from a substation to a central station, two groups of spring-jacks each spring-jack having two contact-pieces connected to the different sides of one of the lines, two individual annunciators, each having two coils arranged to act oppositely upon a common armature, one of said magnets of each annunciator being included in its particular line-circuit, and the other being included in a branch from one side of its particular line to earth, a connecting-plug in a spring-jack of each line, each plug having two contact-pieces making contact with the two line-contacts of the spring-jack, respectively, conductors joining like contact-pieces of the two plugs, a clearing-out annunciator in circuit between the different contact-pieces of the plugs, and a source of electricity having one of its terminals connected to the ground, and the other connected to the conductor joining those contact-pieces of the two plugs which make connection to the grounded coils of the individual annunciators, whereby the individual annunciators of two connected lines are rendered unresponsive to subsequent signalling-currents and the clearing-out annunciator is connected with the lines to respond to such subsequent signals, substantially as described.

No. 44,828. Multiple Switchboard System for Telephone Exchanges.
(*Système de planches multiples pour commutateurs d'échanges de téléphone.*)

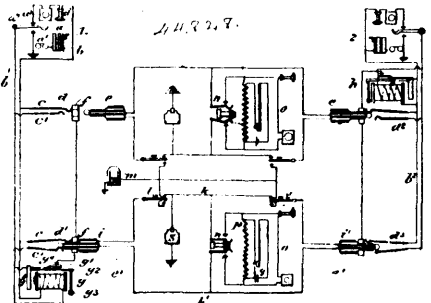

The Bell Telephone Company of Canada, Montreal, Quebec, Canada, assignee of Charles E. Scriber, Chicago, Illinois, U.S.A., 5th December, 1893; 6 years.

Claim.—1st. The combination, with an individual annunciator, of an electro-magnetic switch adapted to close the circuit when energized, a shunt or short circuit about the said annunciator normally open at two points, adapted to be closed at one point by the said electro-magnetic switch, and means for closing the short circuit at another point when connection is made with the line, substantially as described. 2nd. The combination, substantially as hereinbefore described, in a telephone switch board, of a series of main telephone circuits, a call receiving annunciator for each circuit, a shunt circuit round such annunciator, having gaps in its continuity at two points, a circuit closer for the said two gaps respectively, one operative by the act of making a connection, and the other responsive to the action of call currents traversing the line, whereby the call annunciator is prevented from responding to outgoing calls, or disconnection signals. 3rd. The combination, with a telephone line circuit, of an annunciator, included in circuit therewith, an electro-magnetic switch also in circuit between the different sides of line, adapted to close the circuit when energized, a shunt or short circuit about the said annunciator normally open at two points, but connected with the said electro-magnetic switch to be closed at one point when said switch is actuated, and means for closing the short circuit at the remaining break when connection is made with the line, substantially as described. 4th. The combination, with a telephone line circuit, of an individual annunciator included therein, contact points upon said annunciator adapted to be closed together when the magnet of the annunciator is energized, a shunt or short circuit about the annunciator normally open at two points, connected with the contact points of said annunciator so as to be closed at one point when said annunciator is energized, and means for closing the remaining break when connection is established with the line, substantially as described. 5th. The combination, with a telephone line extending from a substation to an exchange, of spring-jacks at the exchange, each having two contact-pieces connected with the different sides of the line-circuit, respectively, and a third contact piece insulated from the said line-contacts, a connecting plug inserted in the said spring-jack having two contact-pieces, one making contact with one of the line-contacts and the other with the remaining line-contact and the extra contact-piece of the spring jack, an individual annunciator having its electro-magnet coil included in circuit between the different sides of the line-circuit and provided with contact points adapted to be closed by the first movement of the annunciator and circuit connections joining one of the said contact points with the extra contact-piece upon all the spring-jacks of the line and the other point with that side of the

line-circuit which is not crossed with the said extra contact-piece, substantially as described. 6th. The combination, with a telephone line extending from a substation to an exchange, of spring-jacks at the exchange, each having two line-contacts connected with the different sides of the line-circuit, respectively, and a third piece normally insulated from the line-contacts, and an individual annunciator having its coil included in the line-circuit, provided with an armature and with contact points adapted to be closed by the first movement of the armature, and an indicator adapted to be actuated by a subsequent movement of the armature, circuit connections joining one of said contact points with the normally insulated contact-piece upon the different spring-jacks and joining the remaining contact point with one side of the line-circuit, and a connecting plug inserted into the spring-jack having two contact-pieces, one making contact with that line contact which is connected with one of the said contact points and the other to cross together the remaining contact-pieces of the jack, substantially as described. 7th. The combination, with a source of calling current at a substation, of the line circuit extending therefrom to an exchange, spring-jacks connected with the line-circuit at the exchange, an individual annunciator thereat, a shunt circuit about said annunciator normally open at two points, contact-points upon the spring-jacks adapted to close the said shunt circuit at one point when connection is established with the line, an electro-magnetic device adapted to be actuated by the signalling current to close the remaining break of the shunt circuit, substantially as described. 8th. The combination, with an individual annunciator, of an electro-magnetic device adapted to prevent the actuation of the indicator thereof when energized, a local circuit including a source of electricity and the said electro-magnetic device normally open at two points, means for closing the local circuit at one point when a connection is established with the line, and at electro-magnetic switch adapted to be actuated by calling currents in the line circuit and when actuated to close the remaining break of the said local circuit, substantially as described. 9th. The combination, with a telephone line, of spring-jacks connected therewith and an individual annunciator in circuit therein, an electro-magnetic device adapted to prevent the actuation of the indicator thereof, a local circuit including the said electro-magnetic device with a source of electricity normally open at two points, contact-pieces upon the spring-jacks adapted to be crossed together when connection is made with the line, and an electro-magnetic switch in the line-circuit adapted to close the remaining break in the local circuit when actuated, substantially as specified. 10th. The combination, with a telephone line, of spring-jacks connected therewith and an individual annunciator in circuit therein, an electro-magnetic device adapted when energized to prevent the actuation of the indicator of the annunciator, a local circuit including the said electro-magnetic device, and a source of electricity normally open at two points, contact points upon the spring-jacks forming the terminals of one of the breaks in the local circuit, an electro-magnetic device in the line-circuit, and contact points thereon adapted to be closed together when said device is energized, said contact-points forming the terminals of the remaining break in the local circuit, substantially as specified. 11th. The combination with a telephone line, of spring-jacks connected therewith, an annunciator in circuit therein, an electro-magnet adapted when energized to restore the indicator of the annunciator to its normal position, a local circuit including the said electro-magnet, and a source of electricity normally open at two points, contact-pieces upon the spring-jacks adapted to be crossed together by a plug inserted into the jack, and when crossed together to close one of the breaks in the local circuit, contact points upon the annunciator adapted to be closed together by the first motion of the annunciator, and when so closed to complete the remaining break of the said local circuit, substantially as described.

of the subscriber's telephone line, of the clearing out drop included with the condenser in a bridge wire between the strands of the cords, said cords and their terminal plugs, the retardation coil in the branch leading to the retaining battery, and said battery, whereby the individual annunciator is prevented from being thrown down when generator current is sent to line from the subscriber's station, while the clearing out drop is traversed by such generator current and operated thereby, substantially as described. 2nd. The combination, with a battery O^5 , of branch circuits o^1, p^2 , each including a retardation coil, and a set of plugs with double stranded cords for each branch circuit, and a clearing out annunciator and a condenser in a bridge wire between the strand of each set of cords substantially as specified.

No. 44,830. Switch for Telephone Exchanges.

(Commutateur pour échanges de téléphone.)

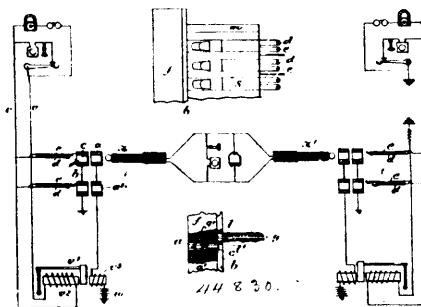

The Bell Telephone Company of Canada, Montreal, Quebec, Canada, assignee of Charles E. Scribner and William R. Patterson, both of Chicago, Illinois, U.S.A., 5th December, 1893; 6 years.

Claim.—1st. In a spring-jack switch, the combination with the test thimble provided with the oblique extension of the tubular piece adapted to be connected to ground, which tubular piece is insulated from the test thimble, and the pair of springs insulated from one another with their free ends presented to the plug hole, one of said springs being longer than the other, and a plug provided with three contacts, one contact being adapted to connect together the thimble and tubular piece, another contact being adapted to connect with the longer of the springs, while the third contact or tip of the plug is adapted to form an electrical connection with the shorter of said springs when the plug is inserted, substantially as and for the purpose specified. 2nd. In a spring-jack switch, a pair of springs or contact pieces insulated from one another by a strip of rubber or other insulating material, said material extending throughout such lengths of the springs as are straight lines, and adapted to flex when the springs are flexed, whereby said contact springs are insulated from one another and adapted to move together when flexed, substantially as described. 3rd. In a strip of spring-jack switches, the combination with the rubber front provided with test thimbles having extensions, of the comb carrying the pairs of contact springs of the switches, and provided with slots for the extensions from the test thimbles, and an intermediate bar provided with tubular extensions, one tubular extension corresponding to each test thimble, substantially as specified. 4th. In a spring-jack switch, a test thimble provided with an oblique terminal extension, and a tubular portion, said thimble and tubular portion being insulated from one another, in combination with contact springs having their free ends presented to the plug hole formed by said thimble and tubular piece, and a plug adapted to be inserted therein to connect the thimble and tubular piece together and make separate connection with the insulated contact pieces, substantially as specified. 5th. A spring-jack switch, having the thimble or test piece thereof provided with a rearwardly projecting extension, in combination with a tubular portion corresponding in position to the said thimble, said tubular portion being connected with ground, and provided with a perforation larger than the terminal extension from the thimble through which said extension piece passes, whereby the insulation of the thimble or test piece is secured, substantially as specified. 6th. In a strip of spring-jacks, the combination with a strip of insulating material, of test thimbles inserted in perforations therein, and provided with shoulders adapted to rest against the bottoms of counter sunk portions of said perforations, and a metallic bar having cylindrical extensions projecting into the same perforations from the opposite side of the strip, substantially as described.

No. 44,831. Machine for Suspending Hogs, Cattle, &c. (Machine pour suspendre les porcs, le bétail, etc.)

Charles A. Donnelly, Hamilton, Ontario, Canada, 6th December, 1893; 6 years.

Claim.—1st. The base B, the standards A having open bearings, the bars E, the braces C, in combination with the longitudinal winding shaft F, provided with a series of fastenings H, for cords I and hooks J, and having ratchet teeth K, the dog L, the cross

No. 44,829. Telephone Exchange Apparatus.

(Appareil d'échange de téléphone.)

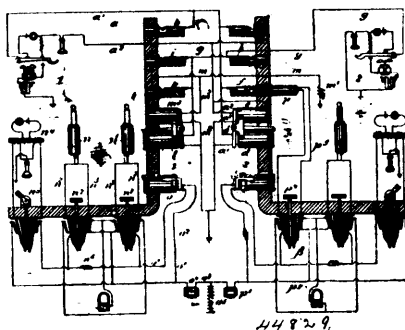

The Bell Telephone Company of Canada, Montreal, Quebec, Canada, assignee of Charles E. Scribner, Chicago, Illinois, U.S.A., 5th December, 1893; 6 years.

Claim.—1st. The combination with the individual annunciator provided with two electro-magnets connected to different branches

handles M, and the pin P, substantially as described and set forth. 2nd. The combination with the general frame work having a series

Fig 1

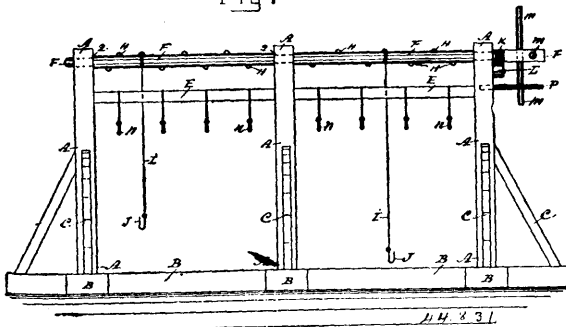

of hooks N, suspended from the longitudinal bars E, substantially as described and set forth. 3rd. The framework of the machine having open bearings, and provided with dog L, and pin P, the shaft F having ratchet teeth K, fastenings H, cords I, hooks J, and the cross handles M, in combination with the bars E, provided with a series of suspended hooks N, substantially as described and set forth.

No. 44,832. Pump. (Pompe.)

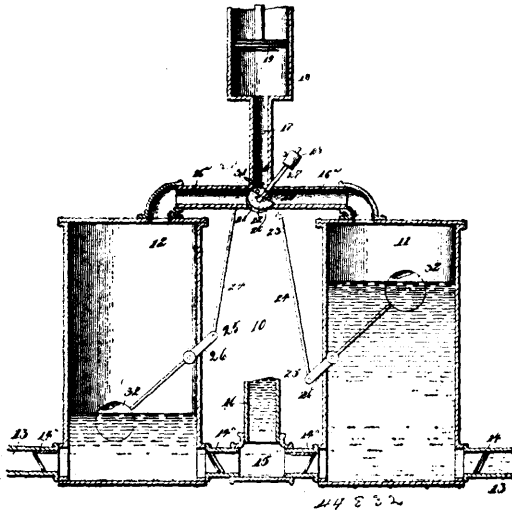

Melchi M. Groove, Garfield, Washington, U.S.A., 6th December, 1893; 6 years.

Claim.—1st. A pump comprising chambers having valved inlets and outlets at their lower ends, and an air pipe having branches connected with the upper ends of the chambers, of an air inlet valve at the juncture of the two branches to divert air into either chamber, floats pivoted within the said chambers, and connections between the floats and the said valve, substantially as specified. 2nd. A pump comprising chambers having valve controlled inlet and outlet openings, a pipe having branches connected respectively with the upper ends of the chambers, and said pipe connecting also with an air pump, and being provided with an adjacent exhaust, a three way valve arranged in the air pipe at the juncture of its two branches, and adapted to divert air to either chamber and simultaneously connect the other chamber with said exhaust, floats arranged in the chambers, and connections between the floats and said valve whereby the latter is reversed as the chambers are alternately filled and emptied, substantially as specified. 3rd. A pump comprising chambers having valve controlled inlet and outlet openings, a pipe having branches connected respectively with the chambers, and said pipe connecting also with an air pump, a valve arranged in the air pipe at the juncture of its branches, and adapted to divert air to either chamber, floats arranged in the chambers, a tilting gravity arm fulcrumed concentrically with the valve, pins carried by the valve in the path of said arm, and a rocking lever operatively connected to the floats, and provided with studs to engage said arm, substantially as specified. 4th. The combination with the chambers provided with suitable valved inlet and outlets, and an air pipe connected at an intermediate point to an air pump and at its ends to said chambers, of a valve arranged in said air pipe to divert the air into either chamber, floats arranged in the chambers, a rocking lever fulcrumed upon the spindle of said valve and connected at its extremities to said floats, a weighted lever fulcrumed upon the spindle of the valve, pins carried by the valve in

the path of said arm, and lugs carried by the rocking lever to engage the arm and reverse its position, substantially as specified.

No. 44,833. Milk Agitating Machines.

(Agitateur pour le lait.)

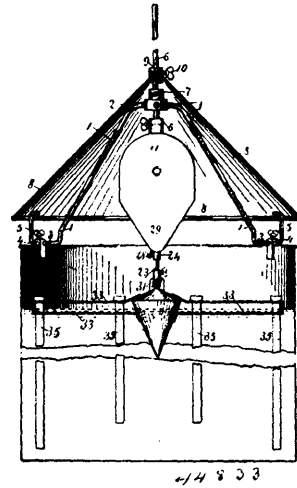

Benjamin Ewing, Brighton, Ontario, Canada, 6th December, 1893; 6 years.

Claim.—1st. In a milk agitating machine, the float constructed of buoyant material or of materials in the form to give sufficient displacement for buoyancy, said float having arms provided with means to carry pendent strips to be immersed and having at its top means whereby it is connected to be operated, substantially as and for the purpose set forth. 2nd. In a milk agitating machine, the supporting frame or tripod composed of legs as described and provided with clamps whereby they are secured to a milk can, substantially as and for the purpose set forth. 3rd. In a milk agitating machine, the combination of the supporting frame having means whereby it is secured on a milk can, the vertical rod carried by the central hub of said frame, and the shield as specified and secured adjustably on said vertical rod, substantially as shown and described. 4th. In a milk agitating machine, the combination of the supporting frame having means whereby it is secured on a milk can, the vertical rod adjustably secured in the hub of said frame, and the clockwork motor secured to the lower end of said rod, substantially as shown and described. 5th. In a milk agitating machine, the combination of the supporting frame having means whereby it is secured on a milk can, the vertical rod adjustably secured in the hub of said frame, the shield adjustably secured on said vertical rod, and the clockwork motor secured on the lower end of said vertical rod, substantially as shown and described. 6th. In a milk agitating machine, the combination of the supporting frame having means whereby it is secured on a milk can, the vertical rod adjustably secured in the hub of said frame, the shield adjustably secured on said rod above said frame, the clockwork motor secured to the lower end of said rod, the float having radial arms carrying immersed strips, and means on said float whereby it is connected to said motor, substantially as shown and described.

No. 44,834. Cultivator. (Cultivateur.)

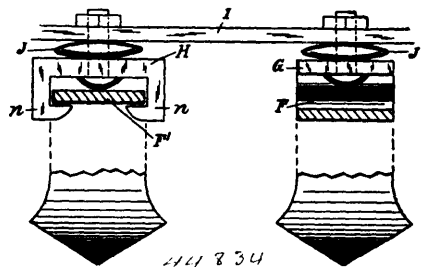

William Hewitt, Brantford, Ontario, Canada, 6th December, 1893; 6 years.

Claim.—1st. The socket arm E, formed with the sockets b and c, and means for pivotally securing and supporting said arm, in combination with a tooth F, substantially as set forth. 2nd. The socket arm E, formed with the sockets b and c, and means for pivotally securing and supporting said arm, in combination with the tooth F, and spring G, substantially as set forth. 3rd. A tooth holder H, formed with the downwardly and inwardly projecting arms n, n,

and suitable means for supporting said holder, in combination with a spring cultivator tooth, substantially as set forth. 4th. An elliptical or rounded washer J, inserted between and in combination with the pressure bar I, and the cultivator tooth, and means for holding them together, substantially as set forth. 5th. An elliptical or rounded washer J, in combination with the pressure bar I, tooth holder H, and means for holding them together, and tooth F¹, substantially as set forth. 6th. An elliptical or rounded washer J, in combination with a pressure bar I, spring G, and means for holding them together, and the tooth F, substantially as set forth. 7th. The socket arm E, and means for pivotally securing and supporting said arm and the tooth F¹, in combination with the holder H, pressure bar I, and means for applying pressure to the latter, substantially as set forth. 8th. The socket arm E, and means for pivotally securing and supporting said arm and the tooth F, and spring G, in combination with the pressure bar I, and means for applying pressure to the latter, substantially as set forth. 9th. The frame C, pivotally secured to the axle B, and the wheels A, and the shaft D, supported in said frame C, in combination with the socket arms E, teeth F¹, holder H, elliptical or rounded washer J, and pressure bar I, and means for applying pressure to the latter, substantially as set forth. 10th. The frame C, pivotally secured to the axle B, and wheels A, and the shaft D, supported by said frame C, in combination with the socket arms E, teeth F, springs G, elliptical or rounded washers J, and pressure bar I, and means for compressing the latter, substantially as set forth. 11th. A cultivator, consisting of one or more sections having teeth of graduated lengths, and means for connecting said teeth with a suitable support, the short teeth being provided with a spring G, and the longer teeth with a holder H, and a pressure bar I, and means for applying pressure to the latter, substantially as set forth. 12th. A cultivator, consisting of one or more sections, having teeth of graduated lengths, and means for connecting said teeth with a suitable support, the short teeth being provided with a spring G, and the longer teeth with a holder H, elliptical or rounded washers J, inserted between the springs G, and holder H, respectively, and the pressure bar I, and means for applying pressure to the latter, substantially as set forth. 13th. A cultivator, consisting of one or more sections, having socket arms E, and means for pivotally supporting said arms, teeth of graduated lengths, the short teeth being provided with a spring G, and the longer teeth with a holder H, and a pressure bar I, and means for applying pressure to the latter, substantially as set forth. 14th. A cultivator, consisting of one or more sections, having the socket arms E, and means for pivotally supporting said arms, teeth of graduated lengths, the short teeth being provided with a spring G, and the longer teeth with a holder H, elliptical or rounded washers J, inserted between the springs G, and holder H, respectively, and the pressure bar I, and means for applying pressure to the latter, substantially as set forth.

No. 44,835. Signal Buoy. (Bouée de signal.)

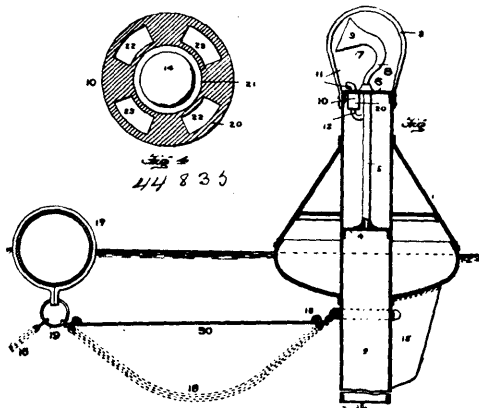

James Bigler, Newburg, New York, U.S.A., 6th December, 1893; 6 years.

Claim.—1st. The combination with a buoy, and a depending water tube containing a diaphragm, of a single fixed air tube opening through said diaphragm and provided with a sounding device, and a valved air supply chest connected to said air tube below the sounding device, as and for the purpose described. 2nd. The combination with a buoy, and a depending water tube, of a fixed diaphragm within said tube above the mean level of the water column therein, a single air tube provided at its upper end with a siren horn, and an air inlet chest connected to said air pipe below the siren horn, and containing an interior automatic valve, substantially as and for the purpose described. 3rd. The combination with a buoy and a depending water tube containing a diaphragm above the mean water level therein, of a single air tube fixed at its lower end and opening through said diaphragm and provided at its upper end with a siren horn, and a valved air chest, having an exposed inlet mouth and a pipe that is coupled to the air tube below the siren horn, substantially as described. 4th. The combination

with a buoy, of a depending tube, having a diaphragm, the single air tube, the siren horn mounted thereon, and the valve chest connected to the air tube and provided with the internal chamber having the valve seat, the valve seat thereon, and the isolated inlet and egress passages communicating with said internal chamber, and having connection, respectively, with said air inlet and exit ports of the valve shell, substantially as described. 5th. The combination with a buoy and a depending water tube containing a diaphragm, of an air tube connected with said diaphragm, a siren horn carried by the air tube, and an automatic inlet chest connected to said air tube at a point between said diaphragm and the siren horn, for the purpose described, substantially as set forth. 6th. The combination with a buoy, the water tube having its ends extended through said buoy and provided with the fixed support at its upper end and with a diaphragm at an intermediate point of its length, an air tube connected at its lower end to said diaphragm and stayed at its upper end by the fixed support, the siren horn fixed to the upper end of said air tube, and the valved air inlet chest fixed to the support, and having a discharge pipe coupled to the air tube at a point between the siren horn and the diaphragm, substantially as and for the purpose described. 7th. The combination of a buoy, a depending water tube containing a diaphragm, a rudder fixed to the buoy and a tube on one side thereof, an air tube connected to said diaphragm, a siren horn communicating with the air tube and having its open mouth facing toward the side of the buoy to which the rudder is secured, and a valved air chest coupled to the air tube below the siren horn, substantially as and for the purpose described. 8th. The combination of a buoy, a water tube having its ends extended through said buoy and provided with a diaphragm, the open hood or guard fixed to the upper end of said water tube, an air tube connected at its lower end to the diaphragm, a siren horn fixed to the upper end of the air tube and arranged wholly within the guard, a valved air chest also arranged within the guard and connected to the air tube below the siren horn, and a rudder fixed to the buoy and water tube on the side toward which faces the open mouth of the siren horn, substantially as and for the purpose described.

No. 44,836. Folding up Steam Bath. (Bain à vapeur pliant.)

(Bain à vapeur pliant.)

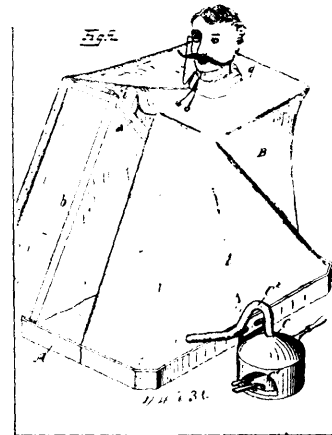

Gustav Heinrich Heinsius von Mayenburg, of Dresden-Neustadt, in the Empire of Germany, 6th December, 1893; 6 years.

Claim.—1st. A frame for steam baths, consisting of the bars *a*, the doors *b*, the cover racks *i*, which hold the cloth cover, and which are adjustable through the support bars *m*, and the cross-bars *k*, which can be connected by means of the socket *l*, these parts folding together flat in consequence of the employment of the hinges *g*, *n*, *o*, *p*, as and for the purpose set forth. 2nd. In a steam bath frame, the arrangement of a trunk-shaped under-part A, which by means of the hinges *h*, is joined to the arms *c*, of the bars *a*, holding the folded up frame, as well as all hathing accessories, as described. 3rd. In the frames of steam baths, the arrangement of doors *b*, which are at the top joined to the frame by the double joint *f*, *g*, and at the lower part turning with their pivots *e*, in the sockets *d*, of the under-part A, thus enabling a convenient entry into the apparatus, as set forth.

No. 44,837. Sign. (Enseigne.)

Alonzo L. Brumfield, Paterson, New Jersey, U.S.A., 6th December, 1893; 6 years.

Claim.—1st. An illuminating sign consisting of a box, opaque sign plates secured thereto, and having blank letter spaces, a series of prismatic tubes adapted to be revolved between said sign plates, and means for revolving said series of tubes, substantially as set forth. 2nd. An illuminating sign consisting of a box, opaque sign plates secured thereto, and provided with blank letter spaces, a series of transparent tubes adapted to be revolved between said sign

plates, pieces of glass of various colours placed in said tubes, and means for revolving said tubes. 3rd. An illuminating sign consist-

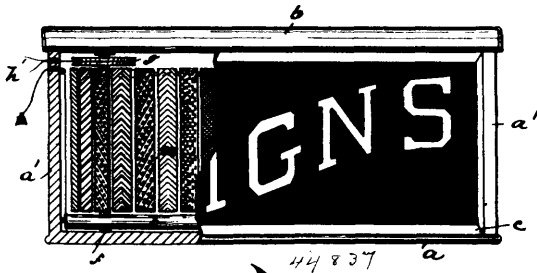

ing of a box, opaque sign plates secured thereto, and provided with blank letter spaces, a transparent background arranged between said sign plates, means for revolving said background, and a movable opaque background arranged between the transparent background and the sign plates. 4th. An illuminating sign consisting of a box, opaque sign plates secured thereto, and provided with blank spaces, a series of tubes adapted to be revolved between said sign plates, means for revolving said series of tubes, and a curtain or shade arranged between said tubes and sign plates, and adapted when operated to give a plain background to the letters on the sign plates, substantially as described and for the purposes set forth.

No. 44,838. Siphon. (Siphon.)

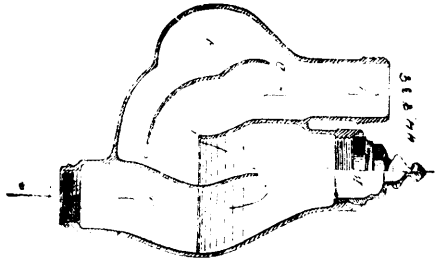

Théophile Lessard, Montreal, Quebec, Canada, 6th December, 1893; 6 years.

Résumé.—La combinaison d'un siphon profond, d'un bouchon également profond B, et d'une chambre à air A, tels que ci-dessus décrits et pour les fins indiquées.

No. 44,839. Change Maker.

(Appareil pour changer la monnaie.)

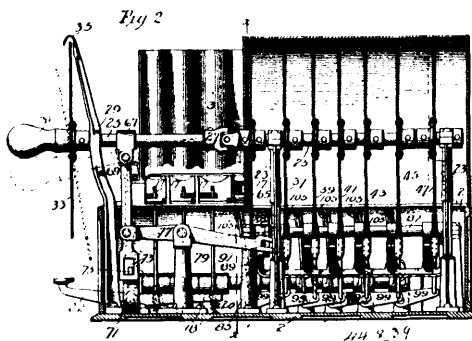

Charles Leslie, Travis, Minneapolis, Minnesota, U.S.A., 7th December, 1893; 6 years.

Claim.—1st. The combination in a change maker, of a series of coin receptacles, a series of slides for ejecting the coins therefrom, means for operating said slides, a series of covering discs, each of said discs controlling the movement of the slide or slides from one receptacle, and means for setting said discs so as to cause any desired combination of slides to be operated, substantially as described. 2nd. The combination in a change maker, with a series of coin receptacles, a series of slides therefor, operating levers for moving said slides, means for operating said levers, a series of governing discs controlling the engagement of said levers with said slides, and means for setting said discs to cause any desired combination of slides to be operated, substantially as described. 3rd. In a change maker, the combination with a rotary shaft provided with a series of governing discs, a series of coin receptacles, slides for said receptacles, each disc controlling the movement of the slide or slides for one receptacle, and means controlled by said discs for operating

said slides, substantially as described. 4th. The combination in a change maker, of a series of coin receptacles, coin ejecting slides therefor, operating levers for moving said slides, means for moving said levers, and a series of governing discs for causing one or more of said levers to engage said slides, substantially as described. 5th. The combination in a change maker, with a series of coin receptacles, of slides for ejecting coins therefrom, operating levers, means for operating said levers, and governing discs for causing the levers of the slides that are to be moved to be brought into engagement with the slides, and those of the slides that are not to be moved to be held out of engagement therewith, substantially as described. 6th. In a change maker, the combination with a series of coin receptacles, and a series of slides therefor, a series of operating levers, means for simultaneously moving all of said levers, and a series of governing discs and connecting means for engaging one or more of said levers with the corresponding slide or slides, substantially as described. 7th. The combination in a change maker, of a series of coin receptacles, a series of slides therefor, a rotary shaft provided with a governing disc for the slide or slides of each receptacle, and with an indicating dial, operating means connecting said shaft with said slides, and governing devices between said discs and said slides, substantially as described. 8th. The combination with a series of coin receptacles, the slides therefor, a rotary shaft provided with a series of governing discs, a series of levers for operating said slides, means connected with said discs for governing the position of said levers, and means for simultaneously moving all of said discs, substantially as described. 9th. The combination with a coin receptacle 3, and slides 11, provided with the L-shaped slot, the operating lever 17 engaging said slide in said slot, means for giving a longitudinal movement to said lever, and means for giving a lateral movement to said lever to cause it when desired to move into the short part of the slot and thereby cause said slide to move with it in its longitudinal movement, substantially as described. 10th. The combination, with the coin receptacles 3 and the coin ejecting slide 11, provided with the L shaped slot, of the lever 17 projecting into said slot and capable of both a longitudinal and lateral movement to bring it into the short part of the slot, and means for giving a longitudinal movement to the lever, whereby, when the lever moves in the long part of the slot the slide remains stationary, and when the lever is in the short part of the slot the slide moves with it, substantially as described. 11th. The combination, with the coin receptacle 3 and the slide 11, of the operating lever 17 adapted to move without engaging said slide, or to engage said slide and move it with it, a governing disc connected with said lever so as to govern its engagement with said slide, and means for operating said lever, substantially as described. 12th. The combination, with the coin receptacles, provided with a series of slides 11 having L-shaped slots therein, the operating levers 17 projecting into said slots, a rotary shaft consisting of two parts joined together, one of said parts being capable of downward movement in addition to its rotary movement, a series of governing discs mounted upon the stationary part of said shaft, an indicating dial mounted upon said movable part, means connecting said discs with said levers 17 for causing said levers to be simultaneously moved when said shaft is depressed, substantially as described. 13th. The combination, with the coin slides and the operating levers, of the series of governing discs provided with recesses or notches in their peripheries, means for giving said levers 17 a lateral movement, and means for giving said levers a longitudinal movement, the lateral movement of said levers being governed by said discs, substantially as described. 14th. The combination, with the coin receptacles provided with a suitable slide, of the operating lever 17 secured upon the rock shaft 19 and capable of a lateral and a longitudinal movement, a governing disc provided with one or more recesses in its periphery, means for turning said shaft 19, and means governed by said disc for giving a lateral movement to said lever 17, substantially as described. 15th. The combination, with the coin slide, of the operating lever 17, arranged to move longitudinally and laterally in respect to said slide, the rock shaft 19 for imparting a longitudinal movement to said slide, the lever 93, means for moving said lever into engagement with the periphery of said disc, and means connecting said lever with said lever 17, for the purpose set forth. 16th. The combination, with the coin slide and its operating lever 17, of the governing disc, the lever 93 arranged to engage the periphery of said disc and have its movement limited thereby, the yoke 89 provided with a rod passing through a loop on said lever, the spring 113 engaging said lever and said yoke, the bail 103 engaging the lever 17 and a connection between said lever 93 and said bail, for the purpose set forth. 17th. The combination, with a coin receptacle, of two or more slides 11 connected therewith and provided with L-shaped slots, the long part of said slots being successively withdrawn in the upper slides, an operating lever projecting into said slot and capable of moving laterally and longitudinally in respect to the slide, and means governing the lateral movement of the slide, whereby it is caused to move without moving either slide or to move one or more of the slides as may be desired, substantially as described. 18th. The combination, with the ledge or plate 6, of the series of coin receptacles 3, having open fronts and arranged upon said plate, so as to cause the coins resting thereon to partially project over the front edge of the ledge, whereby the coins may be removed by grasping the upper and lower coins, substantially as described. 19th. The combination, with the coin receptacle 3, of the slide 11, provided with the guard 13, projecting partially around the front end of the

slide, for the purpose set forth. 20th. The combination, with the coin receptacle 3, of the slide 11, provided with the guard 13, projecting partially around the front end of the slide, and the guard 15, secured upon the receptacle 3, and projecting partially around its front directly above said slide, for the purpose set forth. 21st. The combination, with the ledge or plate 6, of a series of coin receptacles having open fronts arranged upon said plate, so as to cause the coins resting thereon to partially project over the front edge of the plate, the slides 11, and the guards 15, secured upon said receptacles and projecting partially around the front thereof directly above said slides, substantially as and for the purpose set forth. 22nd. The combination, with the coin receptacle and the series of slides 11, provided with the L-shaped slots, the operating lever 17, projecting into said slot, means for moving said lever both laterally and longitudinally in said slot, the locking plate 18, arranged to engage one or more of said slides, and adapted to partake of the lateral movement of said lever, for the purpose set forth. 23rd. The combination, with the coin receptacle arranged with an open front and adapted to hold the coins so that they project beyond the bottom of the receptacle, of the guard 15, secured upon said receptacle and projecting partially around the front of the receptacle, and the slide 11, arranged below said guard, substantially as described. 24th. The combination, with a rotary shaft 25, formed in two parts, connected by universal joint, one part of said shaft being mounted in standards 23, and provided with a series of governing discs, the other part of said shaft being mounted in a yielding standard and provided with an indicating dial and an operating handle a series of coin receptacles, coin slides connected therewith, means controlled by said discs for determining the slides that are to be moved, and means operated by the movable part of said shaft for moving said slides, substantially as described. 25th. The combination with a rotary shaft, provided with a series of governing discs and an indicating dial, of a series of coin receptacles, and a corresponding series of coin slides, each of said discs controlling the movement of the slide or slides for one receptacle, and means for operating said slides, whereby the slides will be moved to eject from the coin receptacles the amount of money indicated by the position of the said dial, substantially as described. 26th. The combination with the rotary shaft, provided with a series of governing discs and with an indicating dial, of a series of coin receptacles and a corresponding series of coin slides, a series of operating levers for moving said slides, and means for first locking said discs after the dial has been turned to indicate the amount of change wanted, second, moving the operating levers into position to engage the slides that must be moved to give the amount of change indicated by the dial, and third, moving said levers and the slides that they engage to eject the necessary coins, substantially as described. 27th. The combination with a shaft 25 formed in two parts, connected together by a universal joint, one part of said shaft being mounted in standards 23, and provided with a series of governing discs, and a locking device for engaging one of said discs, arranged to be operated by the downward movement of the other part of the shaft, substantially as described. 28th. The combination with a shaft 25 and the series of discs mounted thereon, one of said discs being provided with a series of holes 38, the locking pins 40 arranged to engage any one of said holes, the movable standards 69 connected to said shaft, the lever 77 connected to said standard, the slotted plate 42 connected to said lever and also connected to said pin, whereby as said lever is moved the pin is projected into engagement with said disc, substantially as described. 29th. The combination with the coin receptacles and their slides, of the rotary shaft provided with a series of governing discs, means controlling said slides from said discs, and the indicating or index dial provided with two series of oppositely arranged figures or numbers and operatively connected with said discs, for the purpose set forth. 30th. The combination with the coin receptacles and the operating slides, and means for operating said slides and the governing discs, of the indicating or index dial operatively connected with the governing discs, and provided with an outer series of numbers running from 1 to 99, and an inner series of oppositely arranged figures running from 1 to 99, substantially as described. 31st. The combination with the coin receptacles and slides, and means for governing and operating said slides, of the indicating or index dial operatively connected with the governing means, and provided with a series of figures or numbers running from 1 to 99, and arranged near the edge of the disc, a series of numbers running from 1 to 99 arranged opposite said outer series, the lowest figure in one series being arranged opposite the highest figure in the other, a third series of figures running from 1 to 49 arranged with its lowest number opposite the 49 in the outer series, and its highest number opposite the 1, in the outer series, and a fourth series of numbers running from 1 to 24, arranged with its highest number opposite the lowest number of the outer series, and its lowest number opposite the 24, in the outer series, substantially as described. 32nd. The combination, with a series of coin receptacles, their slides, and the governing discs, and means for controlling said slides from said discs, of means for independently changing the connection between the governing discs and one of said slides, for the purpose set forth. 33rd. The combination, with the coin receptacles, the slides, the governing discs, and operating means for said slides controlled by said discs, and means for independently changing the connection between the dollar slide and the dollar disc, so as to cause the dollar slide to be operated to eject one or more coins therefrom in addition

to those that are ejected from the other receptacles, substantially as described. 34th. The combination, with the coin receptacles, the slides, and the operating lever, of the governing disc 47, the lever 93, connected with the operating mechanism and having its movement controlled by said disc 47, the movable plate 115 provided with a series of steps 117, arranged upon said lever and adapted to be brought into contact with the periphery of the disc, and means for changing the adjustment of the plate 115, for the purpose set forth.

No. 44,840. Last for Boots and Shoes.
(*Forme de chaussure.*)

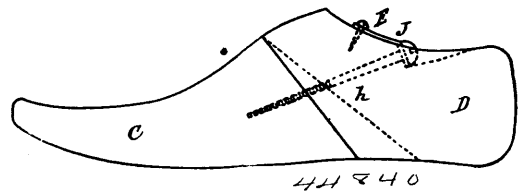

Lucien Laporte, Bord-aux, France, 7th December, 1893; 6 years.

Claim.—1st. A jointed or divided last consisting of two irregular parts fitting together by a slanting dove-tailed joint angular or V-shaped in section, and fixed in place by a screw and holding plate, substantially as set forth. 2nd. A jointed or divided last in three sections, comprising two specially jointed parts, metal plate, screw, connecting screw together with the special wedge piece connecting up and tightening the whole, and fixed by a holding pin and screw, substantially as set forth.

No. 44,841. Spring for Vehicles. (*Ressort de voiture.*)

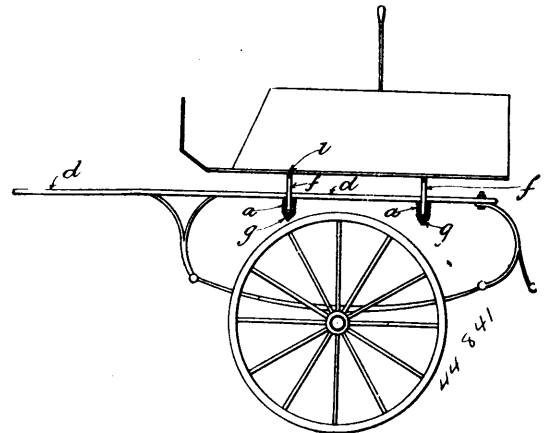

James Joseph Duffy, Carrickmacross, Ireland, 7th December, 1893; 6 years.

Claim.—A vehicle spring, comprising two circular pieces, having a thread or groove on their circumferences to receive the ends of the spring and a screw threaded aperture in their centres for the reception of bolts, a coil spring, a bracket carrying said spring and attached to the body of the vehicle, all in combination and substantially as described.

No. 44,842. Combined Clod Crusher and Land Roller.
(*Brise-motte et rouleau d'agriculture combinés.*)

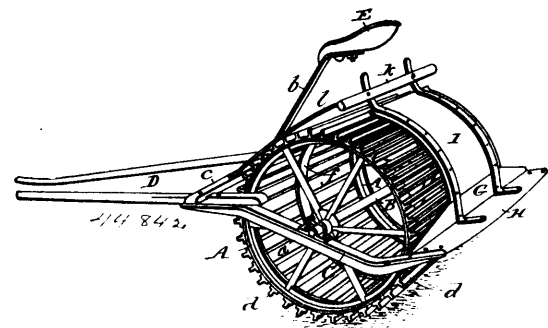

Herman F. Dornell, Athens, New York, U.S.A., 7th December, 1893; 6 years.

Claim.—1st. The combination with the frame, of a drum consisting of wheels connected by T-shaped bars having their web portions

projecting outward to constitute teeth or cutters, boards fitting between said web portions and supported throughout their length upon the lateral portions of the bars, and cleats adapted to engage said lateral portions and detachably secure the boards thereto, substantially as described. 2nd. The combination of the frame, the drum, the step in rear of the drum, the continuous scraper blade secured to the forward edge of the step and extending entirely across the drum, the shield supported upon the step above the scraper and secured at its upper end to a cross-bar carried by brace rods, substantially as described. 3rd. A double combined clod crusher and land roller, having the side and central supports for the drums and plates provided with ball and socket journal bearings for the drum shafts adjustably secured to the supports, substantially as described.

No. 44,843. Thill Coupling. (*Armon de limonière.*)

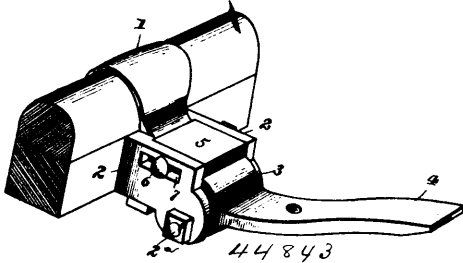

Jacob R. Mikesell, Charlotte, Michigan, U.S.A., 7th December, 1893; 6 years.

Claim.—A combined coupling and anti-rattler, comprising an axle clip provided with forwardly extending side plates having depending ears and provided above the same with horizontal slots, a coupling bolt, an eccentric eye pivotally mounted between the ears by the coupling bolt, an elastic cushioning block arranged in rear of the eccentric eye and engaged by the same when the eye is in operative position, and a securing bolt passing through the adjustable cushioning block, and arranged in said slots, and holding the cushioning block at any desired adjustment, substantially as described.

No. 44,844. Roller Bearing. (*Coussinet à rouleaux.*)

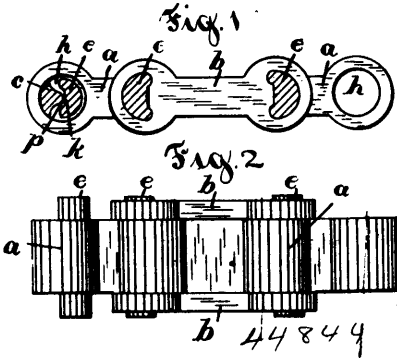

Everett F. Morse, Trumansburg, New York, U.S.A., 7th December, 1893; 6 years.

Claim.—1st. The combination with the parts connected by an oscillating joint, of a seat and a rolling pin, one of said pins being longer than the other and securely attached to one of said connected parts and extending through a suitable hole provided in the other of said parts, the shorter of said pins being arranged within said hole at one side of the longer pin, said pins being provided, one with a bearing surface parallel to its length near the middle of said hole and facing the other pin, the other with a curved rolling surface pressing against the bearing surface of the other pin, substantially as described. 2nd. The combination with the parts connected by an oscillating joint, of a seat pin securely attached to one of said connected parts and extending through a suitable hole provided in the other of said parts, said seat pin having a bearing surface parallel to its length and facing the force of the joint, a rolling pin arranged within said hole at one side of said seat pin, said rolling pin having a curved rolling surface, bearing against the bearing surface of the seat pin and a suitable base opposite said curved surface to bear against the walls of said hole, substantially as described. 3rd. The combination with the parts connected by an oscillating joint, of a seat pin securely attached to one of said connected parts and extending through a cylindrical hole provided in the other of said parts, said seat pin having a plane bearing surface parallel to its length and facing the force of the joint, a rolling pin arranged within said cylindrical hole at one side of said seat pin, said rolling pin having a curved rolling surface pressing against the bearing surface of the seat pin, sides extending from said curved surface and a curved base opposite to said rolling surface fitting and

bearing against the walls of said cylindrical hole, substantially as described. 4th. In a driving chain composed of alternate central and side links, a seat pin having its ends held firmly in the side links and extending through the central links, said seat pin having a substantially plane bearing surface perpendicular to the length of the side links, a rolling pin arranged within the central links at one side of the seat pin and having a curved rolling surface pressing against the bearing surface of the seat pin, and a suitable base opposite said curved surface bearing against the walls of the hole containing it, substantially as described. 5th. In a driving chain composed of an alternative central and side links, said central links having cylindrical holes in each of their ends, two pins arranged within each of said holes side by side, one of said pins being longer than the other and extending through the side links, said pins being provided, one with a plane bearing surface and the other with a curved bearing surface arranged to roll, one on the other, substantially as described.

No. 44,845. Music Leaf Turners.

(*Tourne-feuille de musique.*)

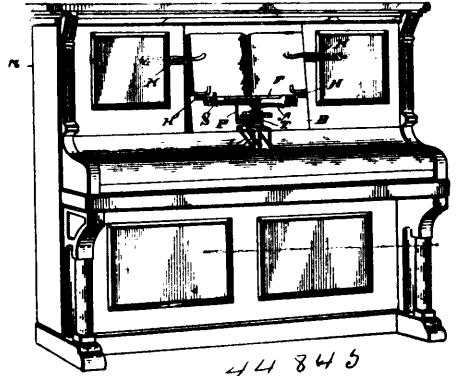

John H. Redfield and Samuel H. Redfield, both of Medford, Oregon, U.S.A., 7th December, 1893; 6 years.

Claim.—1st. The combination with the leaf-turning mechanism of a music rack comprising a foot, and a back consisting of a stationary half, a movable half having screws projecting loosely through horizontal slots in the body of the back, the latter having a socket, and a spring located in said socket, and having one end connected to the movable half, and music clamping devices mounted on the rack, substantially as described. 2nd. In a leaf-turner, the combination with a pair of brackets connected by an upright rod, and a back and foot, of discs mounted on said rod, pawls connected with the discs, means for operating the latter, sleeves having heads engaged by said pawls, arms projecting from said sleeves, and sheet holding devices at the outer ends of said arms, as and for the purpose set forth. 3rd. In a leaf-turner, the combination with a vertical rod, nested sleeves thereon, a leaf-turning arm projecting from the upper end of each sleeve, and a head at the lower end of each sleeve having a double faced tooth, of a disc journaled on said rod, a spring actuated pawl on said disc having a stepped face adapted to engage the lowermost tooth first, a second disc journaled on said rod, a spring actuated pawl on this disc having an oppositely stepped face adapted to engage the uppermost tooth first, and means for independently oscillating said discs, substantially as described. 4th. In a leaf-turner, the combination with a vertical rod, nested sleeves thereon, a leaf-turning arm projecting from the upper end of each sleeve, a spring bearing the arm in one direction, and a head at the lower end of each sleeve, said head having a tooth, of a disc journaled on said rod, a spring actuated pawl connected with said disc and having a stepped face adapted to engage the lowermost tooth first, and means for oscillating the disc, substantially as described. 5th. In a leaf-turner, the combination with a vertical rod, nested sleeves thereon, a leaf-turning arm projecting from the upper end of each sleeve, a spring bearing the arm in one direction, and a head at the lower end of each sleeve, said head having a tooth, of a disc journaled on said rod, a spring actuated pawl connected with said disc and having a stepped face adapted to engage said teeth successively, a gear on the hub of said disc, a toothed segment engaging said gear, a spring bearing said segment in one direction, and a lever for moving it in the opposite direction, substantially as described. 6th. In a leaf-turner, the combination with an upright rod, a sleeve thereon, a leaf-turning arm carried by said sleeve, the latter having a head provided with a tooth, and a pawl adapted to engage said tooth, of a horizontal rod below the upright rod, a bell-crank lever mounted at its angle on said horizontal rod, a rod having a knob at its lower end, its body moving through a suitable guide, and its upper end being connected with one arm of said lever, and connections, substantially as described, between the other arm of said lever and the pawl, as and for the purpose set forth. 7th. In a leaf-turner, the combination with a vertical rod, a sleeve thereon, a leaf-turning arm carried by said sleeve, a spring bearing the arm in one direction, and a head on said sleeve having a tooth, of a disc journaled on the rod, a spring

actuated pawl connected with the disc and adapted to engage said tooth, a gear on the hub of said disc, a pivoted segment having a toothed face engaging said gear, a horizontal rod below the segment, a bell-crank lever mounted at its angle on said rod, its upper end being loosely connected with the segment, a rod depending from its lower end, and a knob at the lower end of said pendent rod, as and for the purpose set forth. 8th. In a leaf-turner, the combination, with an upright rod, a sleeve thereon, an arm carried by said sleeve, an S-shaped spring holding said arm yieldingly in either of two positions, a leaf-turning arm projecting from said arm, and a head on said sleeve having a double-faced tooth, of two pivoted segments, one on each side of said rod, independent means for operating said segments, spring actuated pawls adapted to engage the opposite faces of said tooth, and connections substantially as described between each pawl and one of the segments, as and for the purpose set forth. 9th. In a leaf-turner, the combination, with an upright rod, nested sleeves thereon, a leaf-turning arm projecting from the upper end of each sleeve, and a head at the lower end of each sleeve having a double-faced tooth, of three discs journaled on said rod, spring actuated pawls connected with two of said discs and having oppositely stepped faces engaging the opposite faces of said teeth, an arm projecting from the third disc and having an upturned end adapted to engage all of said leaf-turning arms, and means for independently oscillating said discs, as and for the purpose set forth. 10th. In a leaf-turner, the combination, with an upright rod, sleeves journaled thereon, and leaf-turning arms carried by said sleeves, of a disc journaled on said rod and having a geared hub, an arm projecting from this disc, and having an upturned end adapted to engage all of said leaf-turning arms, a second disc having a geared hub, connections between this disc and said sleeves, pivoted segments having toothed faces respectively engaging said hub, and levers for oscillating said segments, one of the latter being slotted for the passage of the lever which operates the other segment, as and for the purpose set forth.

3rd. In a builder's scaffold, substantially as described, the combination, with the shaft A, of the lifting mechanism consisting of the yoke C, the lever D, pivoted therein, the oppositely inclined clutch members G and J, having screw shanks projected from opposite sides thereof, the link arms E and E', the screw nuts F, and the detachable weights, all arranged substantially as shown and for the purpose described. 4th. The combination with the base B, formed of the swinging sections B', having upper and lower apertured bearing members b' b', of the shaft A vertically movable in the members b' b', the yoke C, held about the shaft between the members b' b', the oppositely inclined clutch collars G and J, the lever D, pivoted in the yoke, and the link arms E and E', connected at their upper ends with the lever D on opposite sides of the pivot, and with the opposite ends of the collars G and J, substantially as shown and described. 5th. In a scaffold support, substantially as described, the combination, with the shaft A, of the bracket Mx, supported thereon, consisting of an upper section M, a downwardly extending portion M', and an outwardly extending section M'', as and for the purpose described. 6th. The combination of a pair of supporting shafts, the brackets held thereon, the plates P, having concave portions adapted to fit the bearing bars of the said brackets and upwardly projecting lugs p' and the planks held on said plates P, all arranged as shown and described.

No. 44,848. Means for Displaying Samples.
Moyen d'étaler des échantillons.)

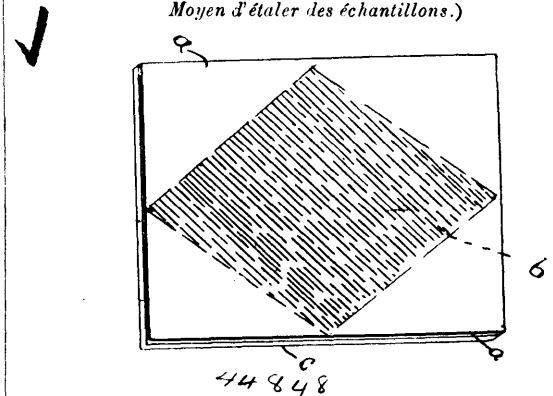

Alexander Ramsay & Son, assignees of Edwin Dowsley, all of Montreal, Quebec, Canada, 9th December, 1893; 6 years.

Claim.—1st. As a new article of manufacture, a display tablet for samples of paint and the like, consisting of a strip of flexible transparent material having a layer or coating of the paint, of which it is a genuine sample, on one side thereof. 2nd. As a new article of manufacture, a display tablet for samples of paint and the like, consisting of a strip of collodion sufficiently thin to be flexible and transparent, having a layer or coating of the paint composing the sample on one side thereof. 3rd. As a new article, a display tablet for samples of paint and the like, consisting of a strip of flexible transparent material, having a layer or coating of the paint, of which it is a genuine sample on one side thereof, and a backing or covering over such sample, as shown and described.

No. 44,849. Clothes Pin. (*Eping'e à linge.*)

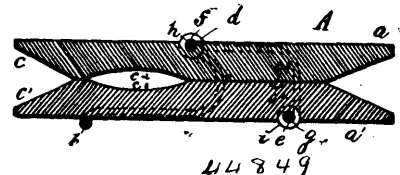

James H. Russell, Manistee, Michigan, U.S.A., 9th December, 1893; 6 years.

Claim.—1st. The combination with the two fingers, of the clamping spring applied thereto and arranged to bear on one of the fingers near its end, and on the other finger between its ends. 2nd. The combination with the two fingers, one having a transverse notch in its outer side near one end, and the other a notch also in the outer side near its centre, of the spring formed with an integral bar b, at one end, eyes or loops in the two arms near the centre and at the free ends, and the transverse pins f, g, supported in said eyes or loops and seated in the transverse notches of the fingers, the bar b, and the pin g, lying against one finger, and the bar f, against the other. 3rd. The combination with the two fingers provided on their upper and under sides with recesses, of the clamping spring extending on opposite sides of the fingers, and provided with the horizontal portion b, bearing on the under side of one of the fingers near its forward end, and with the eyes, and the pins seated in the recesses and extending into the eyes. 4th. The combination with the two fingers provided in their upper and under sides with recesses,

No. 44,846. Hay Press. (*Presse à foin.*)

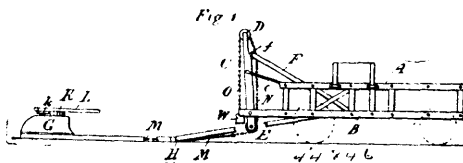

Louis Primeau, Beauharnois, Quebec, Canada, 7th December, 1893; 6 years.

Claim.—1st. In a hay press, the combination, with the box A, having long sills B, carrying the standard C, of the pulley D and E, journaled in the said standard, the wire cord O, and weight W, the plunger rod F, and means for depressing the end of the said plunger rod, substantially as set forth. 2nd. In a hay press, the combination, with the box A, sills B, standard C, and plunger rod F, of the horse power consisting of the vertical shaft I, carrying at its lower end the crank J, and the ratchet-wheel K at its upper end, the lever L, and pawls k, engaging said ratchet-wheel, the rods or chains M, N, connecting the said crank to the said plunger rod, and means for raising the said plunger rod.

No. 44,847. Scaffold. (*Echafaud.*)

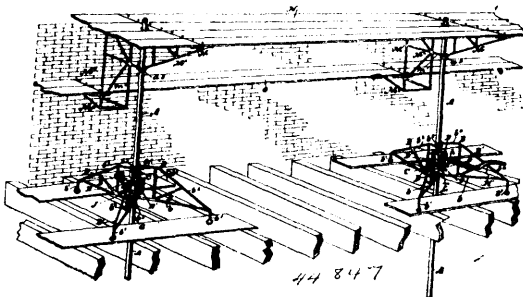

John Elzear Ennis, Duluth, Minnesota, U.S.A., 9th December, 1893; 6 years.

Claim.—1st. A builder's scaffold comprising a main frame or support, a shaft having a collar near one end reversibly mounted on said frame, a bracket loosely mounted on the shaft and a clutch mechanism adjustably mounted on the shaft, said mechanism including reversible clutch members, whereby such mechanism is adapted to move the shaft and the bracket or be movable on the shaft to raise the bracket, substantially as and for the purpose described. 2nd. In a builder's scaffold, in combination with a main frame or support, a shaft movable vertically in such frame, a platform bracket supported on the upper end of the shaft to turn thereon and a clutch mechanism located within the main frame, engaging the shaft, substantially in the manner and for the purpose described.

of the clamping spring consisting of the single piece of wire formed with the horizontal portion *b*, to bear on the under side of one of the fingers near its forward end, and with the eyes *d*, *d'*, and *e*, *e'*, arranged in rear of the horizontal portion at the upper and under sides of the fingers, and the transverse pins seated in the said recesses and extending into the eyes in the spring, substantially as shown and described.

No. 44,850. Marine Vessel. (*Vaisseau marin.*)

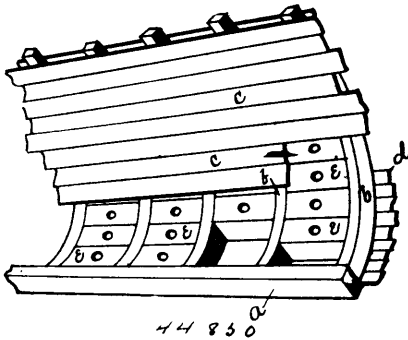

John Black Davids, North Dartmouth, Massachusetts, U.S.A., 9th December, 1893; 6 years.

Claim.—1st. In combination, with a marine vessel, a series of independent air holding reservoirs, composed of non-corrosive material, and adapted to be contained in the space between the outside and inside planking, and between the ribs of said vessel, as and for the purpose shown and described. 2nd. In combination with a marine vessel, a series of independent air reservoirs, composed of non-corrosive material and adapted to fit in the space between the inside and outside planking of said vessel, between the deck beams and other practically waste spaces which would become filled with water when the vessel was partially or wholly submerged, as and for the purpose described.

No. 44,851. Cap for Flues and Ventilating Shafts.

(*Bonnet pour têtes de tubes et puits de ventilation.*)

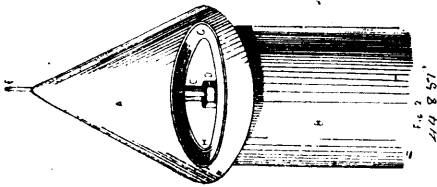

William Edwin Watson, Orangeville, Ontario, Canada, 9th December, 1893; 6 years.

Claim.—1st. The combination of the opening *G*, *H*, with the flue cap *A*, substantially as and for the purpose hereinbefore set forth. 2nd. The combination, with the flue cap *A*, and the opening *G*, *H*, of the spark trap *J*, *K*, substantially as and for the purpose hereinbefore set forth.

No. 44,852. Lawn Sprinkler.

(*Appareil pour arroser le gazon.*)

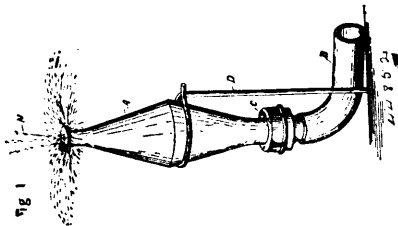

George Steinnetz, Berlin, Ontario, Canada, 9th December, 1893; 6 years.

Claim.—1st. A lawn spindler comprising a wire rod *F*, with disc *K*, substantially as and for the purpose hereinbefore set forth. 2nd. A lawn sprinkler, comprising a soft copper cross bar *G*, which is soldered to case *A*, at ends, and to which is also soldered wire rod *F*, substantially as and for the purpose hereinbefore set forth.

No. 44,853. Sewing Machine. (*Machine à coudre.*)

Felix Maginn, and James Shovelton, both of Manchester, England, 9th December, 1893; 6 years.

Claim.—1st. In a sewing machine, a lever or levers mounted upon and actuated by an excentric or crank, and transmitting motion

therefrom to the loop forming device, feed motion, needle bar, and thread lift, constructed and arranged substantially as hereinbefore

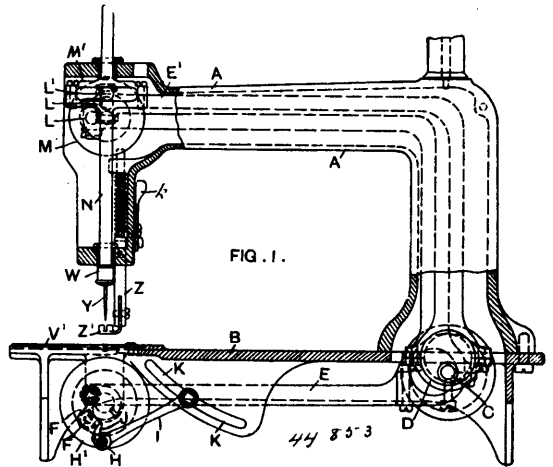

described and as illustrated by the accompanying drawings. 2nd. In a sewing machine of the type set forth, a spool case consisting of two concentric parts fitting one within the other and provided with passages for the thread, the two parts being relatively adjustable so as to increase or diminish the distance between the thread passages, constructed substantially as hereinbefore described and as illustrated by the accompanying drawings. 3rd. The combination and arrangement with the spool case *S*, of a holder *T T'*, one part of which is movable, and the stud *U* having a head and a projection to engage with a fixed part of the machine in the working position of the holder, substantially as hereinbefore described and as illustrated by the accompanying drawings. 4th. The combination and arrangement, with the spool case *S*, of a holder consisting of a relatively fixed and a relatively movable annular or concave part *T T'*, substantially as hereinbefore described and as illustrated by the accompanying drawings. 5th. The combination and arrangement, with the spool case holder *S*, and holder *T T'*, of a light pliable spring *s* adjustably secured so as to be brought into or removed from the path of the needle loop, substantially as and for the purpose hereinbefore described and as illustrated by the accompanying drawings. 6th. In sewing machines of the type set forth, the light bar *I*, pivoted upon a crank pin of the transverse spindle *G*, and having its motion guided by the slot *K*, in combination with a hook fixed thereon and extending to some distance from the axis of the crank pin, and bar and hook reciprocating at right angles to the axis of the horizontal spool case, constructed and arranged substantially as hereinbefore described and illustrated by the accompanying drawings. 7th. In combination, with the needle bar of a sewing machine, a vertical hole pierced in the lower end of the bar, and a disc in the cap-nut adapted to engage with the lower end of the bar and having a passage through it shaped to fit the enlarged non-circular end of the needle, substantially as hereinbefore described and as illustrated by the accompanying drawings.

No. 44,854. Wagon End Gate.

(*Arrière panneau de tombereau.*)

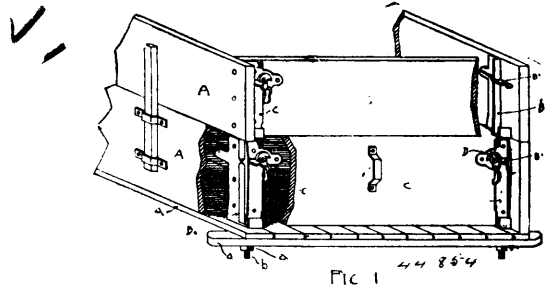

The Acme End Gate Manufacturing Company, assignee of Joseph F. Senn, all of Chicago, Illinois, U.S.A., 9th December, 1893; 6 years.

Claim.—1st. The combination of a brace secured to the sides of the wagon body, and having at its upper portion a rearwardly projecting notched arm, and at its lower part a rearwardly projecting portion for engagement with the end gate plate, with an end gate having transversely secured thereto near each end a wing or piece *E'*, the suspending devices *E''*, secured at the upper ends of the pieces *E'*, and to the braces, a plate secured to each end of the end gate, and having an aperture to receive the notched arm, a locking cam, provided with a lever arm, and fulcrumed to the end gate plate, substantially as described. 2nd. The combination of a brace,

secured to the sides of the wagon body, and having at its upper portion a rearwardly projecting notched arm, and at its lower part a rearwardly projecting portion for engagement with the end gate plate, with an end gate having transversely secured thereto near each end a wing or piece E¹, said wings being rigidly secured to the upper part of the end gate and detachably secured at its lower part, the suspending devices E², secured to the wings and braces, a plate secured to each end of the end gate, and having an aperture to receive the notched arm, a locking cam provided with a lever arm and fulcrumed to the end gate, substantially as described. 3rd. The combination of a rectangular brace, secured to the sides of the body and having at its upper portion the arm B¹, having the notch b², and at its lower part the horizontal portion b⁴, and screw threaded rod b¹, with an end gate plate C², hinged at its bottom to the part b⁴, and having the aperture c, to receive the arm B¹, and the lever operated locking cam D, fulcrumed thereto, secured to each end of the end gate, all constructed, arranged and operating, substantially as and for the purpose set forth. 4th. The combination of a rectangular brace secured to the sides of the body and having at its upper portion the arm B¹, having the notch b², and at its lower part the horizontal portion b⁴, and screw threaded rod b¹, with an end gate plate C², hinged at its bottom to the part b⁴, and having the aperture c, to receive the arm B¹, and the bevelled locking cam D, having the weighted lever D¹, fulcrumed thereto, secured to each end of the end gate, substantially as and for the purpose set forth. 5th. The combination of a brace provided with ribs or webs h, secured to the sides of a wagon body, and having at its upper portion a rearwardly projecting notched arms, and at its lower part a rearwardly projecting portion for engagement with the end gate plate, with a securing plate attached to each end of the end gate, and having an aperture to receive the notched arm, and a lever operated cam fulcrumed to the end gate, a locking device composed of the hooks g and g¹, rod H, and ring H¹, adapted to engage the ribs or webs h, of the braces, and to secure the sides A¹, and side extensions A² together, substantially as described. 6th. The combination of a brace secured to the sides of the body, and having a rearwardly projecting portion formed with a recess or notch, with a securing plate attached to each end of the end gate, and having an aperture to receive the notched end of the brace arm, and a lever operated cam fulcrumed to the securing plate, substantially as described. 7th. The combination of a brace secured to the sides of the body, and having a rearwardly projecting portion provided with a recess or notch, with a securing plate attached to each end of the end gate, and having an aperture to receive the notched end of the brace arm, and a bevelled lever operated cam fulcrumed to the securing plate, substantially as described.

and rafter-gage, the two blades whereof are integral and extend out at right angles with each other, and wherein one blade has a projec-

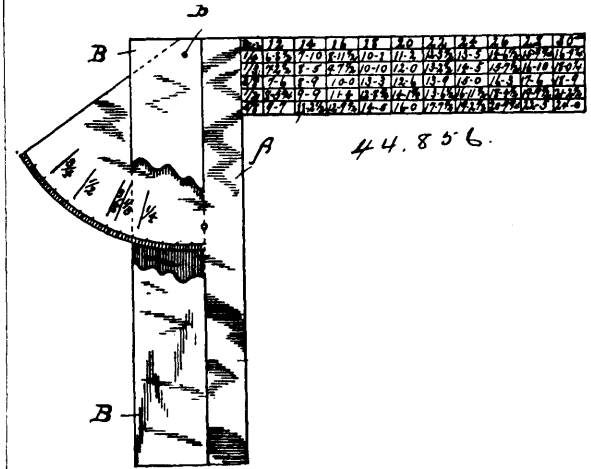

tion on its outer edge upon which are desired markings, and a stock pivoted thereto and adapted to swing over said projection and in varying relations to said blade, substantially as set forth.

No. 44,857. Track Cleaner. (Nettoyeur de voies.)

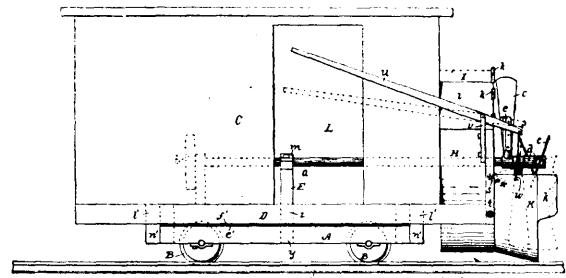

George W. Ruggles, Charlotte, New York, U.S.A., 11th December, 1893; 6 years.

Claim.—1st. A snow clearing device for railways, consisting of a car provided with a driving shaft and means to rotate it, a bucket-wheel secured to the driving shaft in front of the car, and a wheel house for the bucket-wheel, in combination with a series of blades secured to the shaft in front of the bucket-wheel, each held in an independent hub and arranged one forward of another on the shaft, the axes of said blades being at right angles with the shaft, substantially as shown and described. 2nd. A snow cleaning device for railways, consisting of a car or vehicle having a shaft, a bucket-wheel secured to said shaft in front of the car, and a wheel-house for the bucket-wheel, in combination with a series of inclined blades on the driving shaft in front of the bucket-wheel, the wheel-house having an opening next the blades, and a circumferential opening with means to rotate the shaft, the blades being held in hubs on the shaft, and made shiftable in the hubs, substantially as and for the purpose set forth. 3rd. A device for clearing snow from railway tracks, consisting of a car or vehicle having a longitudinal shaft, a bucket-wheel on the shaft forward of the car, and a house for the bucket-wheel, in combination with a series of inclined blades mounted in independent hubs on the shaft forward of the bucket-wheel, the blades being shiftable in the hubs, and the latter being formed with shoulders or stops to control the positions of the blades, with means to drive the shaft, substantially as shown and described. 4th. A device for clearing snow from railway tracks, consisting of a car or vehicle having a longitudinal rotary shaft, a bucket-wheel on the shaft forward of the car, and a house for the bucket-wheel, in combination with a series of blades on the shaft forward of the bucket wheel with means to drive the shaft, the bucket-wheel being formed with radial arms having tapered or spear-shaped ends and buckets secured to said tapered ends to face in opposite directions, substantially as and for the purpose set forth. 5th. A snow clearing device for railways, consisting of a car body mounted upon a truck frame, said body having a longitudinal rotary shaft, a bucket-wheel on the shaft forward of the car, and a house for the bucket-wheel, in combination with inclined blades on the shaft coaxing with the bucket-wheel, and means to drive the shaft, said car body and the truck frame being formed with a mutual centre bearing, substantially as and for the purpose set forth. 6th. A snow clearing device

No. 44,855. Wire Connector.

(Appareil pour relier le fil de fer.)

FIG. 2.

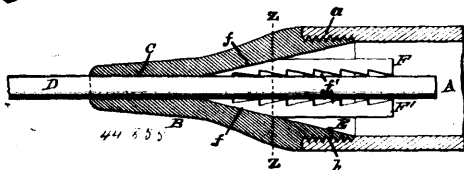

William S. Kisinger, Bantam, Ohio, U.S.A., 9th December, 1893; 6 years.

Claim.—1st. The combination in a coupling for wires, etc., of a tube having converging ends, and a set of bodily detachable keys whose outer edges are tapered and their inner edges provided with teeth, for the purpose described. 2nd. The combination in a coupling for wires, etc., of the tube A, screw threaded at a, the sleeve B, screw threaded at b, and having a bore C communicating with the flaring socket E, and the bodily detachable keys F, F' whose outer edges taper at f, f', and their inner edges having teeth f¹, f¹', for the purpose described.

No. 44,856. Combined Try Square and Bevel.

(Equerre simple et beauveau combinés.)

George A. Topp, Indianapolis, assignee of Thomas R. Cook, Richmond, both in Indiana, U.S.A., 9th December, 1893; 6 years.

Claim.—1st. A combined tool, as described, consisting of a square having a projection upon the outer edge of one of its blades, provided with markings corresponding to the various pitches of roof, and a stock pivoted to and adapted to swing over said blade and its projection, whereby rafters can be marked for any required pitch of roof by the use of said tool without calculation, substantially as set forth. 2nd. In a combination tool, a square having a sector-like projection on the outer edge of one blade, provided with markings, as specified, a stock pivoted thereto and adapted to swing over the same, and a table on the other blade of the square, bearing the same markings in a vertical column, the widths of the building in a horizontal row, and the lengths of the required rafters at intersecting points of lines projected from said vertical column and horizontal row, substantially as set forth. 3rd. As a new article of manufacture, the tool described, consisting of a combined try square, bevel

for railways, consisting of a car body mounted upon a truck frame and having a longitudinal rotatory shaft, a bucket-wheel on the shaft forward of the car, and a house for the bucket-wheel, in combination with inclined blades on the shaft coacting with the bucket-wheel, and means to drive the shaft, said car body and the truck frame being faced with iron at their adjacent parts and joined by a central pivoted bolt or bearing, substantially as shown and described. 7th. A snow clearing device for railways, consisting of a car body mounted upon a truck frame, said body having a longitudinal rotatory shaft, a bucket-wheel on the shaft forward of the car, and a house for the bucket-wheel, in combination with inclined blades on the shaft coacting with the bucket-wheel, and means to drive the shaft, said car body and the truck frame being joined by a threaded swivel bolt, a threaded nut for the bolt held by the car body, and a plate in the truck frame beneath said nut, the bolt being provided with an enlarged part to bear upon said plate, substantially as shown and for the purpose set forth. 8th. A device for clearing snow from railway tracks, consisting of a car body mounted upon a truck frame, and having a longitudinal rotatory shaft, and a bracket-wheel on the shaft forward of the car, in combination with inclined blades held by the shaft to coact with the bucket-wheel, and means to drive the shaft, the car body being adapted to turn horizontally upon the truck, and stops to hold the car body in different positions relative to the truck, substantially as and for the purpose set forth. 9th. A snow clearing device for railways, consisting of a car or vehicle provided with a driving shaft, a bucket-wheel on the driving shaft in front of the car and a wheel-house, in combination with a series of blades on the shaft forward of the bucket-wheel, and arranged in order from front to rear, with means to rotate the driving shaft, and a scoop forward of the wheel-house having the lower part of its cutting edge back of the cut or sweep at the forward blade and the upper part of the cutting edge, on either side in advance of said blade, substantially as shown and described. 10th. A snow clearing device for railways, consisting of a car provided with a driving shaft, a bucket-wheel on the driving shaft in front of the car, and a wheel-house, in combination with a series of blades on the shaft forward of the bucket-wheel, arranged in order from front to rear, with means to rotate the driving shaft, and a scoop forward of the wheel-house having the lower part of its cutting edge back of the sweep of the forward blade, and the upper part of its cutting in advance of said blade, said scoop being hinged at its upper side to move in a vertical plane, and levers at the sides of the car connected with the scoop to control it, substantially as shown and described. 11th. A snow clearing device for railways, consisting of a car or vehicle provided with a driving shaft, a bucket-wheel on the driving shaft in front of the car, and a wheel-house, in combination with a series of blades on the shaft forward of the bucket-wheel, with means to rotate the driving shaft, and a scoop forward of the wheel-house, said bucket-wheel being provided with pairs of arms having double inclined or spear-shaped heads provided with oppositely faced buckets, substantially as shown and described.

No. 44,858. Wheel Journal. (Tourillon à roue.)

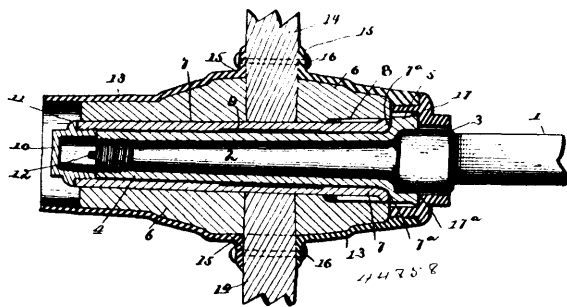

William J. Miller, Colorado, Texas, U.S.A., 11th December, 1893; 6 years.

Claim.—1st. The combination of a spindle provided at its inner end with an enlargement, a sleeve removably secured to the spindle, and provided at its inner end with an enlargement or cup to fit around said enlargement of the spindle, a hub provided with a box fitting rotatably upon said sleeve, and extending at its outer end beyond the extremity of the same, a hollow cap fitting in the outer end of the bore of the box, and provided with an inlet opening which is normally closed and concealed by the box and is adapted to be exposed by partly unscrewing the same, and an adjusting nut detachably secured to the hub and provided with a shoulder abutting against the inner end of the enlargement or cup of the sleeve, substantially as specified. 2nd. The combination of a spindle provided at its inner end with an enlargement 3, a sleeve having its bore threaded at the outer end to engage a threaded portion of the spindle and provided at its inner end with an enlargement or cup 5, to receive the enlargement of the spindle, a box rotatably fitted upon the sleeve, extended at its outer end beyond the extremity of said sleeve and having its bore channelled to form a cavity 9, a hub having a body portion secured to and carried by the box, a shell enclosing said body portion and extending at its extremities beyond

the inner and outer ends of the body portion, a cap 10 threaded in the bore of the box beyond the outer end of the sleeve and having a peripheral flange 11, to abut against the extremity of the box, and an adjusting nut 17 threaded in the extended inner end of the shell and provided with a shoulder abutting against the inner extremity of the enlarged portion or cup of the sleeve, substantially as specified.

No. 44,859. Curtain Hanger. (Console.)

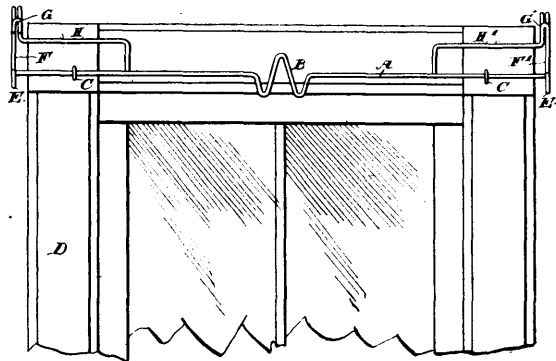

William H. Case, South Oil City, Pennsylvania, U.S.A., 11th December, 1893; 6 years.

Claim.—1st. A curtain and shade hanger, formed of a single piece of wire formed at its ends with integral brackets provided with curtain pole and shade roller brackets, the wire between the brackets being corrugated vertically to provide for lengthening or shortening the hanger, substantially as set forth. 2nd. A curtain and shade hanger formed of a single piece of wire, and comprising the longitudinal member A, forwardly projecting brackets E, E', at the ends of the member A, formed by looping the wire to receive the bearings of a shade roller, an upper set of brackets F, F', formed with concave roller receiving loops G, G', at their outer ends, and the braces, H, H', formed by the extremities of said single wire, said extremities extending inwardly from the loops G, G', parallel with the member A, and then downwardly to and connected with said member A, substantially as set forth.

No. 44,860. Steam Turbine. (Turbine à vapeur.)

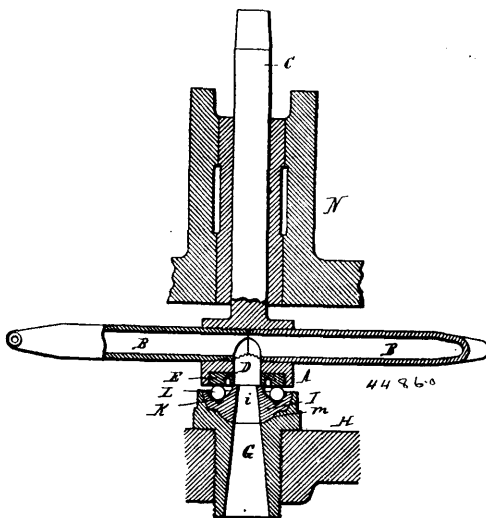

Frederick Hart, Poughkeepsie, New York, U.S.A., 11th December, 1893; 6 years.

Claim.—1st. The combination with the turbine, having a flat bearing surface on its lower side, of a nozzle arranged below said bearing surface, an annular groove formed in the upper surface of said nozzle around the opening thereof, and anti-friction balls arranged in said groove and supporting the flat bearing surface of the turbine, substantially as set forth. 2nd. The combination with the turbine, having a flat bearing surface on its lower side, of anti-friction balls supporting said surface and a nozzle arranged below said bearing surface and having an annular ball groove formed in its upper surface around its orifice, and having between said orifices and said groove a flat face arranged, substantially in the plans of contact, of the flat bearing surface of the turbine with the balls, substantially as set forth. 3rd. The combination with the turbine, having a flat bearing surface on its lower side, of a nozzle arranged below said bearing surface and having in its upper surface an annular groove surrounding its orifice and on its under-

side a spherical knuckle, a supply pipe provided with a seat in which said knuckle rests, and anti-friction balls arranged in said groove and supporting the flat bearing surface of the turbine, substantially as set forth. 4th. The combination with the supply pipe and the turbine, of a removable nozzle provided on its under side with a spherical knuckle resting in a spherical seat in the supply pipe and provided in its upper side with an annular groove, anti-friction balls arranged in said groove, and a flat wear plate secured to the underside of the turbine and bearing on said balls, substantially as set forth.

No. 44,861. Grain Drill. (Semoir en ligne.)

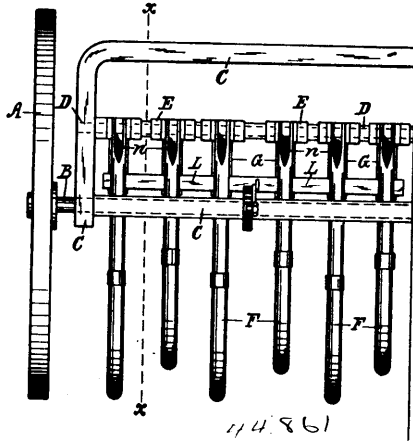

William Hewitt, Brantford, Ontario, Canada, 11th December, 1893; 6 years.

Claim.—1st. A grain tube or spout F, and means for pivotally securing it to a suitable support, in combination with a spring G, formed with an opening O, and pivotally secured to a suitable support, and a pressure bar L, and means for applying pressure to the latter, and a connecting bar H, formed with the perforations J, and the pins I, I, substantially as set forth. 2nd. A grain tube or spout F, a coupling E, formed with the sockets b, c, and a shaft D, in combination with a spring G, formed with a curved portion d, a pressure bar L, and means for compressing the latter, and the connecting bar H, substantially as set forth. 3rd. A grain tube or spout F, a coupling E, formed with the sockets b, c, and a shaft D, in combination with the spring G, formed with an opening O, and curved portion d, pressure bar L, and means for compressing the latter, the connecting bar H, formed with the pin holes J, and the pins I, I, substantially as set forth. 4th. The frame C, pivotally secured to the axle B, the wheels A, the shaft D, the couplings E, and the grain tube or spout F, in combination with a spring G, a pressure bar L, and means for compressing the latter, and the connecting bar H, substantially as set forth. 5th. The frame C, pivotally secured to the axle B, the wheels A, the shaft D, the couplings E, formed with the sockets b, c, and the grain tube or spout F, in combination with the spring G, formed with an opening O, and a curved portion d, a pressure bar L, and means for compressing the latter, the connecting bar H, formed with the pin holes J, the pins I, I, and the clip K, substantially as set forth.

No. 44,862. Self-Locking Hoisting Device.

(Arrêt automatique pour ascenseurs.)

Albert Hillerscheidt, Berlin, Prussia, 11th December, 1893; 6 years.

Claim.—1st. In combination, the pulley-block, the chain-wheel carried thereby, a loosely journalled rotary brake device, also carried by the said block, a brake lever normally in connection with the said rotary device and under tension of the load, whereby the said device will be held stationary normally, and a pawl and ratchet connection between the said rotary brake device, and the chain-wheel and arranged to turn the said device upon the fall of the load when the pressure of the brake-lever is relieved, and the means for operating the brake-lever to release the rotary brake device and allow it to turn more or less freely under the action of the pawl and ratchet connections, constructed and arranged substantially as hereinbefore described. 2nd. In combination, the pulley-block and its chain-wheel, the brake-lever and the rotary brake device in connection with each other normally, the said rotary part being loosely mounted on the block, the chain having one end supporting on the brake-lever to apply a tension thereto, and the pawl and ratchet connection between the rotary brake device and the chain-wheel and arranged to turn the brake device as the load descends upon the release of the brake-lever, and means for controlling the pressure of the brake-lever on the rotary brake device, constructed and arranged substantially as hereinbefore described. 3rd. In combination, the pulley-block, the chain-wheel, the brake device independent thereof, the lever having one arm connected with the brake device, the

hoisting chain supported on the other arm, and the manual operating means for the lever, constructed and arranged substantially as

Fig. 1.

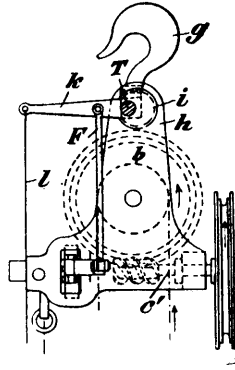
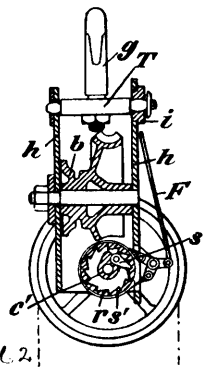
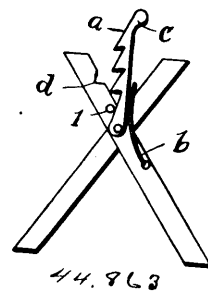

Fig. 2.



hereinbefore described. 4th. In combination, the pulley-block and brake device, the pivoted lever connected with said brake device, the hoisting chain connected with the lever, and the means for adjusting the leverage, constructed and arranged substantially as hereinbefore described. 5th. In combination, the pulley-block and brake device, the pivoted lever connected with the brake device, the chain connected with the lever, and the screw w for adjusting the said lever, constructed and arranged substantially as hereinbefore described. 6th. In combination, the pulley-block, the shaft c', carrying a toothed-wheel and a loose pawl support, the brake-block to bear against said support, the pivoted lever connected with the brake-block, the hoisting chain connected with said lever, and the manual connections for operating the lever, constructed and arranged substantially as hereinbefore described.

No. 44,863. Saw Horse. (Chevalet.)



Joseph Chattaway, Petoskey, Michigan, U.S.A., 11th December, 1893; 6 years.

Claim.—In combination, with a saw buck, a toothed dog pivoted to the cross-legs at or near the intersection thereof and extending vertically between them when in normal position and under spring tension, substantially as described.

No. 44,864. Brake for Wagons. (Frein de voiture.)

Fig. 1.

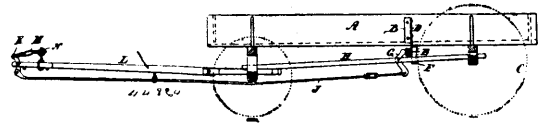

Wilhelm Plotz and Robert Watt, both of Plevna, Ontario, Canada, 11th December, 1893; 6 years.

Claim.—The combination with a wagon A, and draft tongue L, provided with a neck yoke N, of the lever K, fulcrumed to said tongue and connected to the neck yoke, a lever G fulcrumed to the reach bar H, of the wagon, said levers connected by a rod J, a brake beam E hung from the sides of the wagon by strings D, and carrying brake shoes F, having contact with the rear wheels C, when the neck yoke is pulled by the resistance of the horses to the progress of the wagon, as set forth.

No. 44,865. Metallic Fencing. (Clôture métallique.)

Hiram A. Harrington, Anoka, Minnesota, U.S.A., 11th December, 1893; 6 years.

Claim.—1st. The combination with the main posts, of the wires strung thereon, the supports having the flat sheet metal bases 5,

means for securing said bases on the ground, and means for attaching the wires to the upper parts of said supports, substantially as

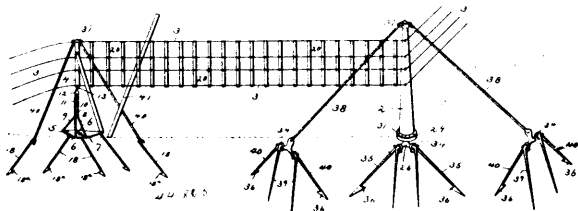

described. 2nd. The combination with the main posts and the wires strung thereon, of metallic slats consisting of the strips 21, the vertical wires 23 embraced thereby, the ends of said wires being secured upon the fence wires, and means for attaching the intermediate fence wires to said strips, substantially as described. 3rd. The combination with the fence wires, of the supports consisting of the metallic strip 4, the two metallic loops 8 and 9, the upper ends of one of said loops being embraced in the curled edges of said strip, the curled lower end 16 of the strip, said loops twisted about one another, the plate 5 secured between the lower ends of said loops, and having the notches, and the metallic barbed pegs 18 extending therethrough and having the hooked ends, substantially as described. 4th. The combination with the wires 3, of the strip 4, the short loops 17 for fastening the wires thereon, the main loops 8 and 9 twisted together at 11, and having the straight lower sides, said loops soldered at 12, the metallic base plate 5 having the curled edges 7, the hooked barbed pegs to secure the base and the lower end of said loops, the upper ends 13 of one of said loops embraced by the curled edges of the strips 4, and means for securing the top and bottom wires thereon, substantially as described. 5th. The combination with the base of the metallic post, of a vertical fastening therefor, the base plate 20, having the ratchet feet 31, and the gravity pawl or pawls 32 provided on the post to engage the same, substantially as described. 6th. In a fence, the combination with a fence post, of the brace inclined therefrom, the anchoring fork connected to the brace, and the hooked and barbed anchoring bars engaging the fork, substantially as described. 7th. In a fence, the posts and inclined braces, combined with the inclined guard stakes located at the sides of the stakes, substantially as described.

No. 44,866. Generator for Steam. (Générateur à vapeur.)

FIG. 1.

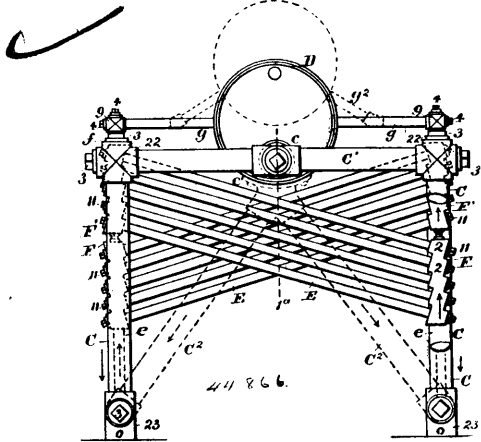

Edward E. Roberts, Red Bank, New Jersey, U.S.A., 11th December, 1893; 6 years.

Claim.—1st. In a steam generator, the combination with the steam and water drum, the two lower drums and the connecting down flow pipes, of a series of alternating sets of return tubes, each set connected at one end to a vertical header in communication with one of the lower drums, and the opposite end with a substantially horizontal header in turn connected with the steam and water drum, substantially as described. 2nd. In a steam generator, the combination with the steam and water drum, the lower water drums and the connecting down flow pipes, of a series of alternating sets of return tubes consisting of horizontal and vertical portions, vertical headers in communication with the lower water drums with which the horizontal portions connect, and horizontal headers in communication with the steam and water drum with which the vertical portions of said sets of tubes connect, substantially as described. 3rd. In a steam generator, the combination with the steam and water drum, of the down flow pipe, the inclined gangs of tubes united at each end in substantially vertical headers, the two upper cross pipes C', in connection with said drum, and four vertical pipes C connecting with the ends of said cross pipes extend-

ing to the base of the generator, as set forth. 4th. In a steam generator, the combination with a plurality of inclined gangs of tubes E, crossing each other within the fire chamber, headers F, F', for each gang of tubes, two longitudinal pipes G, connecting pairs of pipes C at front and rear, vertical pipes e, leading downward from one header of each gang of tubes to connection with said longitudinal pipes, vertical pipes f, leading upwards from the opposite headers, and return tubes g, leading from said pipes f, to the steam and water drum, all substantially as and for the purpose described. 5th. In a steam generator, the combination with the steam and water drum, and circulating pipes of the gang of tubes united at their opposite ends in headers and interposed between the drum and circulating pipes, one of the headers having a horizontal off-set providing a space above it, and between the headers and the generator casing for the superheater coils, substantially as described.

No. 44,867. Sifter for Ashes. (Crible à cendre.)

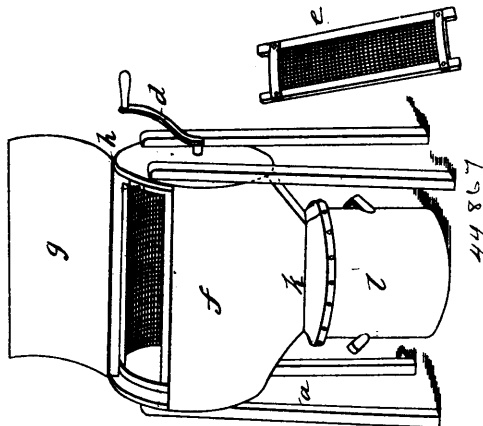

Carey Fletcher Abbott, Chicopee, Massachusetts, U.S.A., 11th December, 1893; 6 years.

Claim.—1st. An ash sifter comprising in its construction a casing and ash discharging chute composed of sheet metal integrally connected as described. 2nd. An ash sifter comprising in its construction a sheet metal casing and cover, the upper portion of the former and the cover being formed on the arc of a circle so as to have to all intents and purposes a cylindrical form, and the lower central portion formed into a tapering ash delivering chute, as and for the purpose described. 3rd. An ash sifter provided with a flexible can cover attached at its inner edges to the lower end of the ash delivering chute and extended out over the top of the can, the outer edge of the cover having a weighted hoop or band connected therewith, substantially as and for the purpose described.

No. 44,868. Wind Engine. (Machine à vent.)

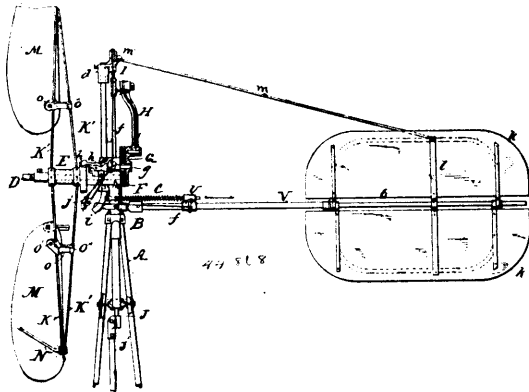

Samuel Webb Martin, Springfield, Ohio, U.S.A., 11th December, 1893; 6 years.

Claim.—1st. In a wind engine, the combination with a wheel hub, of spokes mounted in said hub, their inner ends being separated axially and their outer ends approaching each other, the rear spokes thus bracing the front spokes, independent cross stays or rods connecting each pair peripherally, angle brackets having an inclined face and each carried by, and connecting as a brace, each pair of the said spokes, blades secured to said angle brackets and normally flat, but shaped to curve when mounted according to the inclination of said bracket faces, and adjunctive devices connecting to said blades and frame to maintain the blades in their curved position. 2nd. In a wind engine, the combination with a wheel hub, of a series of front and rear spokes mounted on said hub, with their inner ends separ-

ated axially, and their outer ends approaching each other, straight cross stays or rods directly connecting said spokes at their outer ends from pair to pair, a stud bolt passing through and securing said spokes and stays at one common fastening point on one end of the bolt, the bolt extending forward substantially as shown, to support a portion of a blade or wing on the other end of the bolt, and blades or wings mounted on said frame and stud bolts, substantially as shown and described. 3rd. In a wind engine, the combination with a skeleton wheel frame, of brackets each embracing a front and a rear spoke and having an inclined face at one end, substantially as shown, the said incline of the bracket giving the shape to the blade or wing bolted thereto at the inner end, flexible blades normally flat when detached, but shaped for proper form when mounted on said angle brackets, and supporting stays to maintain said blades in their bent up operative position on said wheel. 4th. In a wind engine, the combination with a skeleton frame, a wind-wheel consisting of pairs of front and rear spokes, respectively, inclined toward each other, and a stay brace between adjacent pairs at their outer ends, the said stays and spokes having eyes or hooks at their outer ends, of flexible blades perforated at their outer ends, a supporting stud bolt, one end passing through and connecting at one common point, a pair of spokes, the stay braces therefor and the outer end of a corresponding blade, and the other end extending forward and engaging with a succeeding blade, substantially as shown, and means to secure the remaining portions of said blade in suitable operative positions. 5th. In a wind engine, the combination with a wheel hub and a skeleton frame supported thereby, consisting of a double series of spokes radiating from said hub and connected at their outer ends, cross-stays for said spokes, angle brackets having inclined faces for the blades, and each mounted on one pair of said double series of spokes, flexible blades secured to said inclined faces of the brackets, stud bolts connecting said outer ends of the spokes by one end, and staying a portion of the respective blades at the other end, and a tie brace secured to each blade at an intermediate point, and to its respective cross stays, whereby each blade is stayed outward by its bracket and stud bolt, and bent inward by its intermediate tie brace. 6th. In a wind engine, the combination with a wind-wheel, and blades or wings carried thereby, of a hook brace consisting of a threaded hook bolt adapted to embrace a portion of the frame at one end and be bolted to a blade at the other end, and having an enclosing sleeve provided with a notch for said hook end, whereby the hook brace will act both as a tie and a brace for said blade, and the sleeve be prevented from turning by said notched engagement. 7th. In a wind engine, the combination with a turntable, a rotatable head and a wind-wheel mounted thereon, of a folding tale vane connected to said head, and means to maintain it in its open position, whereby said vane may be folded for transportation. 8th. In a wind engine, the combination with a turntable, a rotatable head therefor, and a wind-wheel mounted on said head, of a folding tail vane connected to said head and consisting of members hinged together whereby it may be folded, and a detachable extension of the stem of said vane, whereby the vane may be uncoupled and folded for transportation, and means to secure it in its coupled and unfolded position. 9th. In a wind engine, the combination with a wind-wheel frame, and brackets on said frame adapted to support and shape wings or blades detachably secured thereto by bolts and nuts, of flexible wings or blades mounted on said brackets and bent to suitable shape by being so mounted, and normally flat in their mounted condition, whereby said blades may be shipped in their flat, spread-out form, and be readily bent to shape in the act of mounting. 10th. In a wind engine, a wind-wheel consisting of pairs of front and rear radiating spokes approaching each other, cross-stays at their outer ends, sheet metal wings or blades substantially of the shape shown, a stud-bolt securing the outer end of the blade to the meeting ends of the pair of spokes and their stay-rods, and extending forward as a brace for the middle of the succeeding blade, a hook-bolt carried by each of said cross-stays and engaging with its blade between two adjacent stud bolts, to draw the blade inward, and an angle bracket having an inclined face and carried by each pair of spokes near the centre of the wheel, to bend the inner end of its blade to suitable shape and hold it outward, substantially as shown and described. 11th. In a wind engine, the combination, with a turn-table and a head mounted thereon, a wind-wheel carried by said head, and a tailvane rotatively connected to the turn table on the same axis, of a coiled spring interposed between said tailvane and said head, and adapted to be compressed when the head and the wind-wheel are rotated under the wind pressure, and then to return said head and wheel to their normal position, and a connection running upward from said tailvane to a point above and on the other side of the vertical axis of the head and the tailvane from the side to which the vane turns, whereby the rear end of the vane is raised when the wheel turns out of the wind, and the weight of the vane returning will pull on the said connection, and assist the spring in returning the head and the wheel to their normal positions. 12th. In a wind engine, the combination with a turn-table and a rotatable head mounted thereon, of a tailvane rotatively connected to said head and extending directly rearward, the vertical axes of the head and vane lying in substantially the same vertical plane, a connection from the rear of the tailvane to a fastening point on the head at one side of the vertical axis of the vane, and a spring acting at the other side of the vertical axis and against the tailvane, and tending to return the vane to the side at which said connection is fastened,

the location of said connection point with regard to the vertical axis of the vane causing the vane to rise when it turns to one side and compresses the spring and the gravitating tendency of the vane on its return to normal position acting to assist the spring in so returning it.

No. 44,869. Wood Wall Covering.

(Couverture pour murs en bois.)

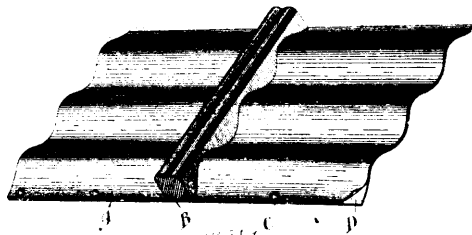

Hugh Silver, Lindsay, Ontario, Canada, 11th December, 1893; 6 years.

Claim.—1st. The combination with a wall or similar substantially flat surface W, of the covering of veneer A, corrugated in line with the grain thereof and having some of the bottoms of the corrugations secured to said wall or surface, substantially as and for the purpose specified. 2nd. The combination with a wall or similar substantially flat surface W, of sheets of veneer A, corrugated in line with the grain thereof, and having some of the bottoms of the corrugations nailed to said wall, and a moulding B whose under surface fits the corrugations, set over the joint between the sheets, substantially as described.

No. 44,870. Steam Boiler. (Chaudière à vapeur.)

FIG. 1.

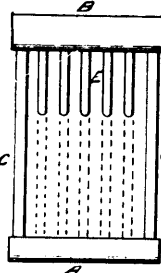
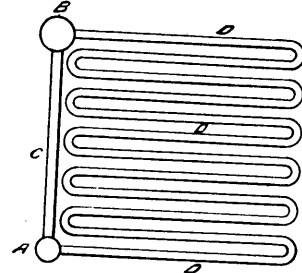

FIG. 2.



44 870

Dixon Best and James H. Metherell, both of Peterboro', Ontario, Canada, 11th December, 1893; 6 years.

Claim.—1st. The boiler front A, B, C, C, substantially as and for the purpose hereinbefore set forth. 2nd. The combination of side generating coils D, D, D, and upper generating coils E, and water grate F, with said boiler front A, B, C, C. 3rd. The combination of water grate F, with upper generating coils E.

No. 44,871. Canopy Top for Vehicles.

(Ciel pour dessus de voiture.)

Jesse U. Tabor, Los Angeles, California, U.S.A., 11th December, 1893; 6 years.

Claim.—1st. In a canopy top, the combination of a support pivoted at its lower end to a vehicle and adapted to stand upright to support the canopy, and to be lowered to lower the canopy, and a suitable supporting hinge brace pivoted at one end to a vehicle, and pivoted at its other end to the support, and adapted to hold the support upright and to allow it to be swung upon its pivot to lower the canopy, a main canopy body attached to the top of such support and extending across the vehicle, two canopy shade leaves hinged respectively one upon each side of such main body, and adapted to stand at an angle with such canopy support and to be folded upon such support, and suitable means adapted and arranged to hold such leaves elevated and to allow them to be folded upon the support. 2nd. In a canopy top having a suitable support hinged at its lower end to a vehicle, and having a hinge brace pivoted at one end to the vehicle, and pivoted at its other end to the support, and adapted to hold such support upright and to allow it to be swung upon its pivot to lower the canopy, and having a canopy shade leaf adapted to be folded upon such support or to be held at an angle thereto, the combination therewith of a canopy shade leaf hinge brace pivoted at one end to such shade leaf and having its other end operatively connected with the canopy support hinge brace, and adapted and arranged to be operated by such brace to cause the leaf to stand at an angle to the support when the support is in its upright position, and to

cause such leaf to fold against the support when the support is lowered. 3rd. In a canopy top, the combination of the canopy support

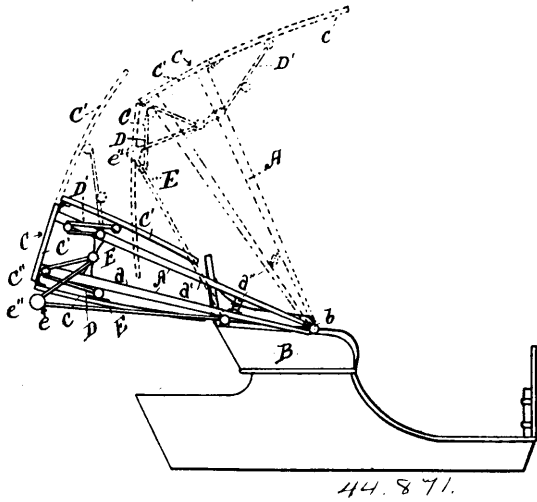

44.871.

pivoted at its lower end to a vehicle and adapted to stand upright to hold the canopy elevated and to be swung upon its pivot to lower the canopy, a suitable hinge brace pivoted at one end to the vehicle and pivoted at its other end to the support, and adapted to be extended to hold the support in its upright position and to double upon itself to allow the support to be swung upon its pivot to lower the canopy, a suitable canopy secured to such support and comprising a main body and a leaf hinged to such main body, such leaf being adapted and arranged to stand at an angle to the support and to be folded there against, and suitable operative means adapted and arranged to hold such leaf at an angle with such support when the support is in its upright position, and adapted and arranged to hold such leaf folded against the support when such support is in its lowered position. 4th. In a canopy top, the combination of the canopy support pivoted at its lower end to a vehicle, and adapted to stand upright to hold the canopy elevated and to be swung upon its pivot to lower the canopy, a suitable hinge brace pivoted at one end to the vehicle, and pivoted at its other end to the support, and adapted and arranged to hold the support in its upright position, and to allow it to be swung upon its pivot to lower the canopy, a suitable canopy secured to such support, and comprising a main body and a leaf hinged to such main body, such leaf being adapted and arranged to stand at an angle to the support and to be folded there against, suitable operative means connecting such leaf with the support hinge brace, and adapted and arranged to cause such support hinge brace to operate to hold such leaf at an angle with the support when the support is in its upright position, and to fold such leaf against the support when the support is in its lowered position. 5th. In a canopy top, the combination of the two canopy supports arranged one upon each side of a vehicle, and each pivoted at its lower end to the vehicle, and adapted to stand upright to hold the canopy elevated, and to be swung upon its pivot to lower the canopy, two suitable hinge braces arranged one upon each side of the vehicle, and each pivoted at one end to the vehicle, and pivoted at its other end to its respective support, and adapted to be extended to hold such support in its upright position, and to double upon itself to allow such support to be swung upon its pivot to lower the canopy, a canopy comprising a main body and two leaves, such leaves being hinged respectively one upon each side of such main body, the main body being secured to the canopy supports, and such leaves being adapted to stand at an angle to such supports, and to be folded there against, and suitable operative means adapted and arranged to hold such leaves at an angle to the supports and to allow them to be folded thereagainst. 6th. In a canopy top, the combination of the two canopy supports arranged one upon each side of a vehicle and each pivoted at its lower end to the vehicle and adapted to stand upright to hold the canopy elevated and to be swung upon its pivot to lower the canopy, two suitable hinge braces arranged one upon each side of the vehicle and each pivoted at one end to the vehicle and pivoted at its other end to its respective support and adapted to be extended to hold such support upright and to double upon itself to allow the support to be swung upon its pivot to lower the canopy, a canopy, comprising a main body secured to the upper ends of such supports and a front and a rear leaf, hinged respectively one upon the front side of said main body and one upon the rear side of such body, and each adapted and arranged to stand at an angle with the supports and to be folded against such supports, suitable means arranged to hold the front leaf at an angle with the supports and to allow it to fold thereagainst, and suitable operative means connecting the rear leaf with each of the support hinge braces and adapted and arranged to be operated by such hinge braces to hold such leaf at an angle with the supports when the supports are in their upright position, and to fold such leaf against the supports when such supports are lowered. 7th. In a folding canopy top, the

combination of the canopy supports arranged one upon each side of a vehicle and each having its lower end pivoted to such vehicle, and adapted and arranged to stand upright to hold the canopy elevated and to swing upon its pivot to lower the canopy, two canopy support hinge braces, arranged one upon each side of such vehicle and each having its lower end pivoted to the vehicle and having its upper end pivoted to its respective canopy support and adapted and arranged to hold such support in its upright position and to allow it to swing upon its pivot to lower the canopy, a canopy, comprising a body provided with a rear canopy shade leaf hinged to such body and adapted to stand at an angle to the canopy supports and to be folded thereagainst, two canopy shade leaf hinge braces, each pivoted at one end to the rear shade leaf, and pivoted at its other end upon the upper pivot of its respective canopy support hinge brace, the brace connection comprising a collar adapted to fit upon the upper pivot of the support of the hinge brace and provided upon one side with a suitable seat adapted and arranged to seat the canopy support hinge brace arm therein, and provided upon its other side with a seat adapted and arranged to seat the canopy leaf hinge brace arm, one of such seats being wider than its respective arm to allow a slight rotation of one brace with relation to the other brace. 8th. In a folding canopy top, the combination of the main body, the canopy shade leaf hinged to such main body by a hinge arranged on the lower side of such body, a joint closing strip having one of its edges secured to the top of the main body, and having its other edge secured to the top of the leaf, and having its body folded upon itself and arranged depending between the opposing edges of the main body and the leaf, and the moulding, arranged to cover the joint between the body and the leaf when the leaf is raised. 9th. In a canopy top, the combination of the main body, the canopy shade leaf hinged to such body and provided at each end with the joint stop projecting from the inner edge of such leaf to engage the main body to hold the edges of the members apart intermediate the stops. 10th. In a folding canopy top, having a canopy support hinge brace and a canopy shade leaf hinge brace each pivoted by one end upon the same pivot, the brace coupling comprising a collar adapted to fit upon said pivot between the two braces and provided in one side with the brace receiving seat adapted to receive and seat the shade leaf hinge brace therein, and provided upon its other side with the brace receiving seat adapted and arranged to receive and seat the canopy support hinge brace therein, one of such brace seats being larger than its respective brace and arranged and adapted to allow slight rotation of one brace arm with relation to the other brace arm.

No. 44,872. Method of attaching Pneumatic Tires to Runs. (*Méthode d'assujétir les bandages pneumatiques aux jantes de roues.*)

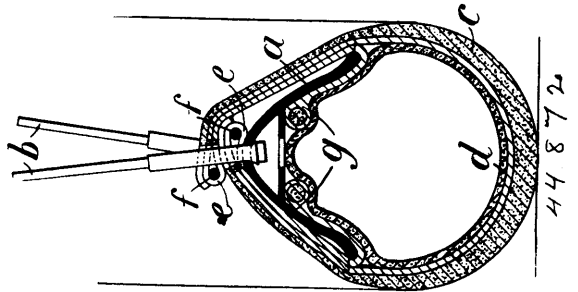

44 872

John Samuel Smith, Christopher John Tate and George Edward Tate, all of London, England, 13th December, 1893; 6 years.

Claim.—1st. A jacket or cover for a pneumatic tire having the edges divided into a series of attachment flaps furnished with loops or pockets through which wires are passed for the attachment of the jacket to the rim of the wheel, each edge of the cover being separately secured with its own set of wires which engage with the spokes of the wheel and one series of flaps overlapping the other, substantially as described. 2nd. The combination of rim, air tube, and jacket with its loops and wires, each edge of the jacket being separately secured with its own set of wires, substantially as described.

No. 44,873. Heating Apparatus. (*Appareil de chauffage.*)

John William Hilton, Charles Richard Mullen and Nicholas Sattler, Cincinnati, Ohio, 13th December, 1893; 6 years.

Claim.—1st. The combination, in a heating apparatus, of a reciprocating grate supported by a counter-balance, and a cut-off, which is automatically opened when said grate is elevated and closed when the latter is lowered, for the purpose described. 2nd. The combination, in a heating apparatus, of a reciprocating grate, inside connections that support it by a counter balance, and a cut-off automatically operated by said grate, substantially as herein described, and for the purpose stated. 3rd. The combination, in a heating apparatus, of the reciprocating grate F f, chains I, I', connecting said grate with a weight box L, and rollers J, J', K, K', over which said chains pass, for the purpose described. 4th. The combi-

nation, in a heating apparatus, of the chute B, cut-off C, at the delivery end of said chute, pivoted levers D d, D' d', coupled to

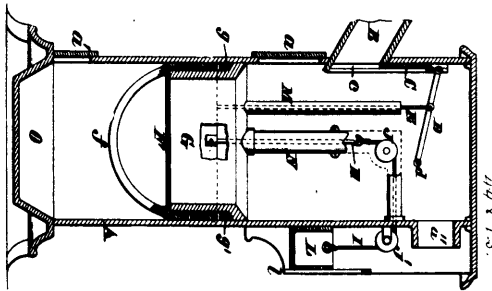

said cut-off and the interior of the shell, and rods E, E', that connect said levers to a reciprocating grate F f, for the purpose stated.

No. 44,874. Cultivator. (Cultivateur.)

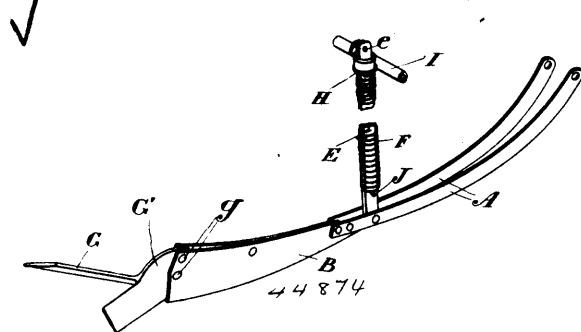

Thomas James McBride, Winnipeg, Manitoba, Canada, 13th December, 1893; 6 years.

Claim.—1st. In a cultivator or seeding machine, having a series of independent drag-bars and shoes attached thereto, the combination with the drag-bar, and shoe having a sharp bottom cutting edge, of a weed cutter comprised of two laterally extending knives attached to the rear of the shoe, as and for the purpose specified. 2nd. In a cultivator or seeding machine, having a series of independent drag-bars and shoes attached thereto, the combination with the drag-bar and shoe having a sharp bottom edge, of a weed cutter comprised of two laterally extending knives preferably slanting slightly upwardly towards their outer ends and to the rear, the cutting edges of the knives being preferably situated at an obtuse angle to the side of the shoe, and the knives being secured to the rear end of the shoe through their upward extensions G¹, which are held between the sides of the shoe, as and for the purpose specified. 3rd. In a cultivator or seeding machine, having a series of independent drag-bars and shoes attached thereto, the combination with the drag-bar and shoe having a sharp bottom cutting edge, of a weed cutter G, secured to the rear end of the shoe and means whereby a pressure is exerted upon the shoe so as to maintain the bottom of the shoe, as it moves forward, at a uniform depth in the ground, as and for the purpose specified. 4th. In a cultivator or seeding machine, having a series of independent drag-bars and shoes attached thereto, the combination with the drag-bar and the shoe having a sharp bottom cutting edge, of a weed cutter G, secured to the rear end of the shoe, the bar g, pivotally connected within the drag-bar and extending through the socket H, attached to the pressure-bar and the spring F, located on the bag E, as and for the purpose specified. 5th. In a cultivator or seeding machine mounted on wheels, a series of draw-bars having runners or shoes with laterally projecting knives attached, for the purpose described. 6th. In a cultivator mounted on wheels, the combination of a series of draw-bars having lateral cutting blades at the lower end thereof and rolling coulters, connected to the draw-bars in front of the blades, substantially as shown.

No. 44,875. Nut Lock. (Arrête-écrou.)

Alexander A. Johnson and Franklin S. Beaumont, Clarksville, Tennessee, U.S.A., 13th December, 1893; 6 years.

Claim.—1st. In a nut lock, the combination of a bolt, provided at the outer end of its curved portion with ratchet grooves, a nut, and a coiled locking spring carried by the nut and encircling the bolt, and having its inner portion closely hugging the same and having its outer portion slightly offset from the bolt and engaging the grooves thereof, substantially as described. 2nd. In a nut lock, the combination of a bolt, provided at the outer end of its threaded portion with ratchet grooves, a nut provided at its interior with a groove and having a branch thereof at its inner face, a coiled spring encircling the bolt and having its inner portion closely hugging the same and provided with a stem arranged in the

grooves of the nut and being substantially L-shaped, the outer portion of the coiled spring being slightly offset from the bolt, and

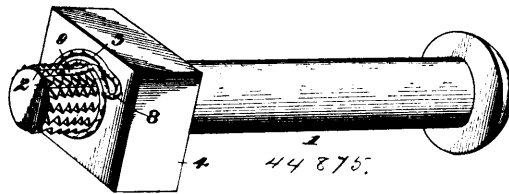

provided with an integral handle portion and a projection to engage the grooves of the bolt, substantially as described.

No. 44,876. Refrigeration and Storage.

(Réfrigération et emmagasinage.)

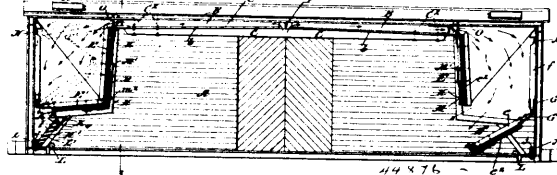

Charles Saunders Hardy, San Diego, California, U.S.A., 14th December, 1893; 18 years.

Claim.—1st. The combination, of a refrigerating chamber, having in its top a draft flue arranged at its inlet end to take the air from the said chamber, and an ice box arranged at the opposite or discharge end of said draft flue and made in sections hinged and adapted to fold, one of its members being arranged to fold upward into approximately the plane of the flue, substantially as set forth. 2nd. The combination, of a refrigerating chamber, and an ice box having hinged members, one of which is arranged to fold upward, and a counterbalance weight connected with said member, substantially as set forth. 3rd. A refrigerating device comprising the combination set forth, of two hinged or pivoted ice receptacle forming members, and the supplemental hinge member hinged by one end to the edge of one of such ice receptacle forming members and hinged by the other to the other member, substantially as set forth. 4th. In a refrigerating and storage device, the combination set forth, of the swinging pendant wall, the pivoted ice receptacle floor, and the supplemental hinge member hinged at one end to the pendant wall between the top and the bottom thereof, and hinged at its other end to the ice receptacle floor, substantially as set forth. 5th. The combination of the swinging pendant wall, the pivoted ice receptacle floor, the hinge member secured to the swinging wall, the supplemental hinge member hinged to the ice receptacle floor, and suitable means to secure the two said hinge members to each other. 6th. A refrigerating chamber provided at its top with longitudinal flues opening at their mouths or inlet ends adjacent to each other at the middle of the car, and ceiling and joists forming such flues, and with ice receptacles supported at their tops by said flues, and arranged at opposite ends of the car in communication with the discharge ends of the flues, and formed with hinged members arranged and adapted to fold when not in use within the plane of the flues, all substantially as set forth. 7th. A refrigerating device having draft flues, and inclined draft plates arranged beneath such flues respectively, sloping from the discharge mouths of such flues upward to the intake mouths of such flues, respectively, and having a folded receptacle to fold into the space at the discharge end of such flues above the lower ends of the draft plates and beneath the ceiling of the chamber. 8th. The combination of the refrigerating chamber, and an ice receptacle arranged at one end thereof, and having a side member pivoted or hinged at its upper edge and arranged to fold upward toward the top of the chamber, a bottom member hinged at one edge to and arranged to fold upward against the end of the chamber, and a connection between said bottom and side members, said connection being adjustable whereby it may be employed to connect the members in both the folded and open positions thereof, substantially as set forth. 9th. The combination of the refrigerating chamber, the side cleats, and the hinged floor and wall of the ice box or receptacle, said wall and floor being arranged to open or turn outward against the side cleats and to be sealed thereby when so adjusted, all substantially as and for the purposes set forth. 10th. A refrigerating chamber having a longitudinal draft flue, and having at one end of said flue a section joined to and forming practically a hinged extension of the lower wall of said flue, all substantially as shown and described. 11th. The combination of the refrigerating chamber, the side cleats, and the hinged wall and floor of the ice box and receptacle, said wall and floor being arranged to open or turn outward against said side cleats and to be supported thereby when so adjusted, all substantially as and for the purposes set forth. 12th. In a refrigerating apparatus, substantially as described, the combination of an ice box or receptacle, and a slatted drain guard arranged below the bottom or floor

thereof, substantially as set forth. 13th. In a refrigerating and storage apparatus, the combination with an ice box or receptacle armed with hinged members adapted to fold, of a drain guard arranged below said box and supported to fold or swing into and out of position for use, substantially as set forth. 14th. In a refrigerating and storage apparatus, the combination of the hinged side and floor of the ice box, the hinged drain guard, and a connection between the floor and guard whereby the latter will be adjusted by the movement of the floor, substantially as set forth. 15th. The combination of the hinged side and floor of the ice box, the side cleats sustaining the same, the drain guard, and side cleats sustaining such guard, substantially as set forth. 16th. In a refrigerating apparatus, the combination with a series of cleats attached to the vertical wall and spaced apart, of the ice box floor hinged thereto, and having a series of transverse cleats which are similarly spaced but arranged alternating with the vertical cleats to enable them to fold between said vertical cleats, substantially as set forth. 17th. In a refrigerating apparatus, the combination with the cleats attached to the vertical wall of a car, and the floor section having transverse cleats, of the two sets of V-hinges applied to the ends of the cleats and connected by a pintle which is located in line with the longitudinal centre of the said cleats, substantially as and for the purposes set forth. 18th. In a refrigerating apparatus, the combination with the hinged side and floor sections, of the hinge devices connecting said parts and composed of sections one of which has an eye at its outer end, and the other of which has a socket plate having holes located at different distances from its ends, and a pin adapted to be inserted in said holes to lock the bar at different points in the socket as required for securing the box sections in the open or folded position, as set forth. 19th. The combination with the hinged and folding ice box sections, of the means of detachable and adjustable connection between the floor and the side section, which consist of an angular plate attached to and projecting over the free edge of the floor section, a bar hinged to the outer end of the angular plate, and a socket plate attached to the edge of the adjacent side section, substantially as shown, whereby when the floor section is folded in vertical position the said bar lies horizontally and supports the free edge of the section. 20th. The combination with a refrigerating chamber, the foldable ice box sections, and the connecting and suspending devices comprising a series of aligned and jointed plates which are attached to said sections and to the top or roof of the car, substantially as shown and described. 21st. The combination with a refrigerating car having the end ice boxes or receptacles, and provided just below its roof or top with longitudinal air flues leading thereto, of the truss beam extended longitudinally between the opposite end boxes and rigidly connected with the car top, substantially as set forth.

No. 44,877. Friction Clutch. (Embrayage à friction.)

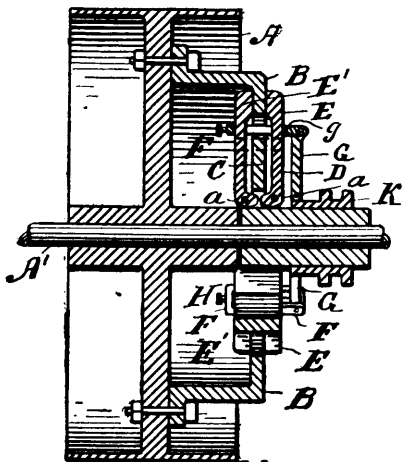

Wilson Richard Smith, Beloit, Wisconsin, U.S.A., 14th December, 1893; 6 years.

Claim.—In a friction clutch, the combination, with the pulley having the grip rim thereon, of the clutches or grips comprising each a pair of oscillatory jaws E, E', pivoted at their inner ends in sockets in the hub of the driver, said driver and its rim having seats for said jaws, the clevis or link embracing said jaws near their upper ends, and held to the jaw E, by a set screw, said link or clevis at its other end being loosely connected to a lever G, having an eccentric portion G, and a sliding sleeve, to which the inner ends of said levers are connected, substantially as specified.

No. 44,878. Sleigh. (Traineau.)

Friederich August Schaefer, Truckee, California, U.S.A., 14th December, 1893; 6 years.

Claim.—1st. A sleigh provided with a drive wheel comprising spokes, brackets extending from the spokes, rings connecting the

brackets with each other, paddles secured between the rings, and a circular band connecting the ends of the spokes with each other, the

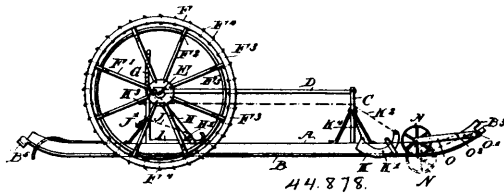

said band terminating a suitable distance from the inner edges of the said paddles, substantially as shown and described. 2nd. In a sleigh, the combination with a platform, of arms held on posts on the said platform, a drive wheel journaled in the said arms, downwardly and forwardly extending arms pivotally connected with the said journal arms of the wheel, a friction wheel held in the said last mentioned arms and adapted to roll on bearings fixed on the said platform, and a rope or cord connected with the said friction wheel arms, substantially as shown and described. 3rd. A sleigh provided with main runners, auxiliary runners adapted to be fastened at their ends to the said main runners, and longitudinal wires or rods secured to the under surface of the said auxiliary runners, substantially as shown and described. 4th. The combination, with the main runner having a recess and boss at its respective ends, of the auxiliary runner having a hook and threaded portion at its respective ends, substantially as shown and described. 5th. In a sleigh, the combination, with a platform provided with runners, drive wheels held vertically adjustable on the sides of the said platform, curved rudders pivoted to the front ends of the said runners, a spring connected with each of the said runners, and a cord or rope connected with the said pivoted rudders and under the control of the operator, substantially as shown and described. 6th. A sleigh comprising the box or frame, provided with runners and vertically adjustable driving wheels mounted at the rear end of the box or frame to engage the snow or ice, substantially as set forth. 7th. A sleigh comprising the box or frame provided with runners, vertically adjustable side driving wheels mounted at the rear end of the box or frame to engage the snow or ice, and a brake L extending through the rear end of the sleigh and operated by the operator's foot, substantially as set forth. 8th. A sleigh comprising the box or frame provided with runners, vertically adjustable side driving wheels, the brake L and the rudders Q¹, provided with foot levers Q², Q³, substantially as set forth. 9th. A sleigh, comprising a box, beams pivoted near the front end of the said box and extending longitudinally, paddle wheels journaled near the rear ends of the said beams and extending down the side of the box, means, substantially as described, for rotating the said paddle wheels from within the box, and wheels mounted on pivoted arms arranged on the front end of the box, substantially as shown and described. 10th. A sleigh, comprising a box, beams pivoted on the front end of the said box, bearings for the said beams, and secured to the sides of the box, paddle wheels journaled on the said beams, and means, substantially as described, for fastening the said beams in place in the said bearings, substantially as described. 11th. A sleigh provided with a paddle wheel comprising a hub, spokes extending from the said hub and each formed at its free end with a fork, rings secured to the prongs of the said forks, and paddles extending transversely and secured to the said rings, substantially as shown and described. 12th. A sleigh provided with a paddle wheel comprising a hub, spokes extending from the said hub and each formed at its free end with a fork, rings secured to the prongs of the said forks, paddles extending transversely and secured to the said rings, each of the said paddles being formed with serrations at its outer edge, substantially as shown and described.

No. 44,879. Fender for Cars. (Défense pour chars.)

Louis Emile Dubois, Toronto, Ontario, Canada, 14th December, 1893; 6 years.

Claim.—1st. In a life saving guard for cars, the combination with the car of a spindle pivotally connected to the car, a framework connected to and carried with the spindle, a balance connected to the spindle and adapted to counter balance the framework, a netting secured to the framework and to the car, and a lever for operating the framework, substantially as described. 2nd. In a life saving guard for cars, the combination of the hangers secured to the under side of the platform, a spindle mounted in the bearings of the hangers, a framework connected to the spindle and adapted to be raised into a vertical position or lowered into a horizontal position, a balance mounted on the spindle and adapted to counter balance the framework and other parts, a bell crank lever connected to the spindle, a foot lever connected to the bell crank lever, and a netting connected to the framework and to the car, substantially as described. 3rd. In a life saving guard for cars, the combination of the car hangers connected to the under side of the platform of the car having bearings to receive a spindle, a spindle mounted in the bearings of the hangers, a bracket connected to each end of the spindle, a framework comprised of two side bars the ends of which

are connected to the said brackets, and a cushioned front, a spindle connected to the front end of the side bars, wheels mounted on the

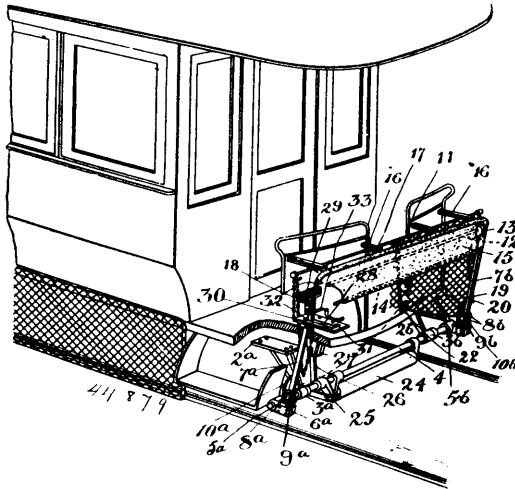

spindle, a canvas covering connected to the side bars on the front forming a platform, arms connected to the outer side of the dashboard, a cross-bar carried by said bars, a netting, the upper end of which is secured to the cross-bar and the lower end connected to the framework, a chain connected to each end of the cross-bar and to the framework, an elastic cord connected to the middle of the cross-bar and to the framework, a balance weight connected to the spindle and adapted to counterbalance the guard, a bell crank lever connected to the spindle, a foot lever passing through the platform the lower end of which is connected to the bell crank lever and the upper end fitted with a pedal, substantially as described. 4th. In a life saving guard for cars, the combination with the car of hangers secured to the under side of the platform of the car, bearings forming part of the hangers, a spindle mounted in said bearings and extending across the car, a bracket mounted on each end of the spindle, a framework, the ends of the side bars of which are mounted in said brackets, spring connected to side bars and bearing against said brackets, a cushioned front connected to the said bars, a spindle connected to the front of said bars, wheels mounted on said spindle, a canvas covering connected to the side bars and to the front, a netting connected to the front of the framework and to the cross-bar held by arms connected to the car, an elastic cord connected to the cross bar and to the front of the framework, stay or guy ropes connected to the cross-bar and to the front of the framework, chains connected to the ends of the cross bar and to the framework, a balance weight connected to the spindle and adapted to lift the guard into a vertical position, a compound lever connected to the spindle, a foot lever passing through a slot in the platform, the lower end of the foot lever connected to the compound lever, a plate enclosing the slot having a corresponding slot therethrough and recesses at each end of the slot, springs to throw the foot lever into either of said recesses, a switch, a spring connected to the foot lever adapted to move the switch, to either cut in or out the current to the motor, substantially as specified.

No. 44,880. Device for Raising and Lowering Electric Lamps. (*Appareil de suspension de lampe électrique.*)

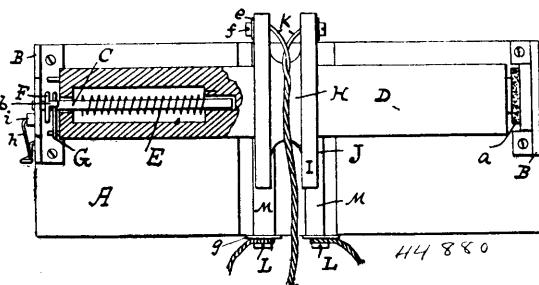

William Doran, Skowhegan, Maine, U.S.A., 14th December, 1893; 6 years.

Claim.—In a hanger for incandescent electric lamps, the combination of an attaching plate, a shaft journalled at one end in a hanger and bearing at its opposite end upon a fixed shaft, the lateral studs extending from one end of the pulley shaft, the said fixed shaft keyed in a hanger, the arm carrying a stud adapted to retain the fixed shaft in its seat, the disc fixed upon the fixed shaft and having lugs adapted to engage a gravitating cam, the said gravitating

cam having a shoulder adapted to engage the lateral lugs of the pulley shaft, the parallel flexible metallic shoes connected to the attaching plate and with wires leading from a dynamo, the pulley on the pulley shaft provided with flanges having metallic peripheries adapted to engage the flexible metallic shoes, and wires connecting the peripheries of the pulley flanges with a lamp, all adapted to operate, substantially as specified.

No. 44,881. Harrow. (*Herse.*)

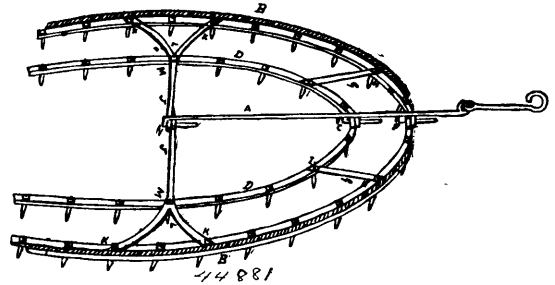

Hiram Chamberlain, Leamington, Ontario, Canada, 14th December, 1893; 6 years.

Claim.—1st. A harrow comprising outer curved bars or frame B, inner curved bars or frame D, braces or stays connecting the outer and inner curved bars and pivoted in the longitudinal centre of the harrow to the draw bar A, substantially as and for the purpose hereinbefore set forth. 2nd. A harrow, the outer side bars of which are curved as shown, and having an outside wooden sheath, covered or not covered by leather or its equivalent, substantially as and for the purpose hereinbefore set forth.

No. 44,882. Vehicle Spring. (*Ressort de voiture.*)

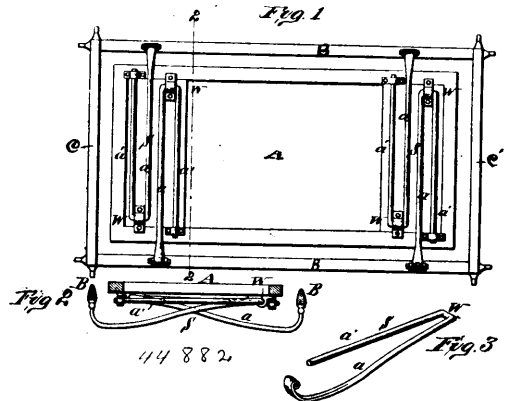

Henry Timken, St. Louis, Missouri, U.S.A., 14th December, 1893; 6 years.

Claim.—1st. The combination, with the running gear and body of a vehicle, of a spring consisting of a wrist portion journalled to said body, and flexible arms united to said wrist portion and extending laterally therefrom, the outer end of one of said arms being attached to the said running gear and the second arm being movably connected to said body, substantially as described. 2nd. The combination, with the running gear and body of a vehicle, of a spring consisting of a wrist portion journalled to said body, and flexible arms united to said wrist portion, and extending laterally therefrom, the outer end of one of said arms being attached to said running gear, and the outer end of the other arm resting on a bearing projecting from the under side of said body, substantially as described.

No. 44,883. External Joint for Escape Pipes, etc.

(*Joint extérieur pour tuyaux de trop-plein, etc.*)

Frederick R. Nies and Francis J. Linnehan, Swampscott, Massachusetts, U.S.A., 14th December, 1893; 6 years.

Claim.—1st. In an external joint for escape pipes, etc., a surrounding upwardly extended hub and a flanged base to rest upon the roof, combined with a sleeve having an returned flange adapted to surround the pipe and support the packing and joint at the upper end of said hub and above the roof, substantially as described. 2nd. An external joint for escape pipes, etc., consisting of a cylindrical upwardly extending hub having a base integral therewith, combined with a concentric metallic sleeve provided with an returned flange to surround the pipe at the upper end of said hub and sustain the packing and joint between the pipe and sleeve at such point above the roof, substantially as described. 3rd. An external joint for escape pipes, etc., consisting of a cylindrical hub and base of malleable metal, combined with a rigid concentric metallic sleeve having

an inturned flange, and an upwardly extended portion to surround the pipe, to form the bottom and outer wall for the joint, substan-

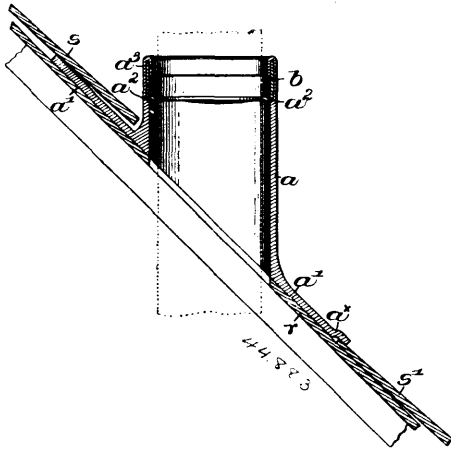

tially as described. 4th. An external joint for escape pipes, etc. consisting of a recessed cylindrical hub an extended base, combined with a rigid metallic sleeve having an annular flange to surround the pipe, and an outwardly turned flange to enter the recessed hub, substantially as described.

No. 44,884. Sleigh. (Traineau.)

Fig. 1.

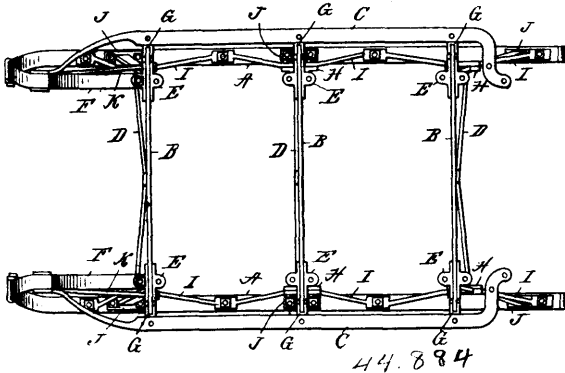

Henry Umphrey and James Weekes, both of Carleton Place, Ontario, Canada, 15th December, 1893; 6 years.

Claim.—The running gear for sleighs, consisting of a bar B, provided with connections E and G, legs secured to said connections E, foot connections J, secured to the lower ends of the legs for securing the legs to the runners, a stay or bar C, secured to the upper curved ends of the runners and to the connections G for keeping the benches in proper position, braces D, for preventing the spreading of the runners, a curved bar F, attached to the runners by a triangular connection and secured to the connections E, by means of a bolt or otherwise, and a bar k, passing through the connections E, and secured by a bolt, the other end of said bar being connected to the runner, all substantially as and for the purposes described.

No. 44,885. Caster. (Roulette de meuble.)

James H. Russell, Manistee, Michigan, U.S.A., 15th December, 1893; 6 years.

Claim.—1st. In a furniture caster, the combination of a casing provided with a cavity and a continuous channel disposed in a vertical plane and communicating therewith, a series of balls moving in said channel, and a sphere mounted in the cavity. 2nd. In a furniture caster, the combination of a casing provided with a cavity in its under side a series of continuous circular channels disposed in vertical planes communicating therewith, a series of balls mounted in the channels, and a sphere mounted in the cavity. 3rd. In a furniture

caster, a casing consisting of the four members, provided in their contiguous faces with circular channels adapted to receive a series of

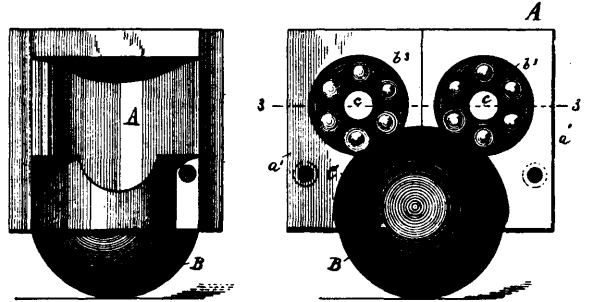

balls, and in their under sides with recesses adapted to receive a sphere.

No. 44,886. Optical Instrument. (Instrument optique.)

Fig. 1

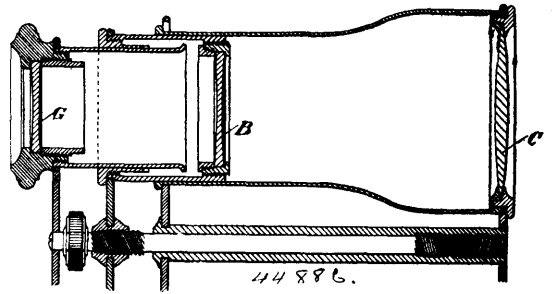

Alfred Conrad Biese, Berlin, Prussia, 15th December, 1893; 6 years

Claim.—1st. A process for producing the gradual enlargement or diminution of images by means of optical instruments of any kind characterized by the arrangement of an adjustable optical system acting as a dispersing lens between the lens producing the image, as for instance, an objective glass and the observing or receiving lens or its equivalent, such as an ocular eye glass or a sensitised photographic plate, constructed and arranged substantially as hereinbefore described. 2nd. An optical instrument such as described, for enabling the image formed to be always presented in the same position and to be consequently observed through the eye glass, or the like, in all positions of the device B so as to be sharply defined, the construction being such as to provide means for moving the object glass or projecting lens forwards or backwards correspondingly to the enlargement obtained by the position of the device B, constructed and arranged substantially as hereinbefore described. 3rd. In optical systems or instruments, such as described, an arrangement for adjusting the object glass or projecting lens simultaneously with the device B in order to obtain the requisite sharpness of definition, the said arrangement consisting of a transmitting device or gear such as a screw spindle with threads adapted to effect the proper relative displacements of the device B and the object glass or projecting lens, constructed and arranged substantially as hereinbefore described.

No. 44,887. Spring Mattress and Frame. (Sommer élastique et cadre.)

Adelbert H. Gale and Francis G. Gale, Waterville, Quebec, Canada, 15th December, 1893; 6 years.

Claim.—1st. As an article of manufacture, the herein described mattress fabric for beds, consisting of short central sections or meshes of heavy wire woven across from side to side of the said fabric, terminated at the sides by longer sections of heavier wire, or one continuous heavier side wire, with or without the short arm at each end, or wire of a uniform gauge, terminated at each end by one or more tier of V-shaped hooks C, and chain links d, or without the same, and tension springs, also with the metal frame, as described, all combined and arranged, as set forth. 2nd. The herein described sections of V-shaped links, as followed each way towards the ends of the fabric by sections of V-shaped links b, all interwoven across from side to side, uniform in length, that is, b or uniformly increasing in length towards the ends of the bed fabric, and

terminated by one or more tier of separate V-shaped links C, with or without the introduction of *d*, in connection with the tension

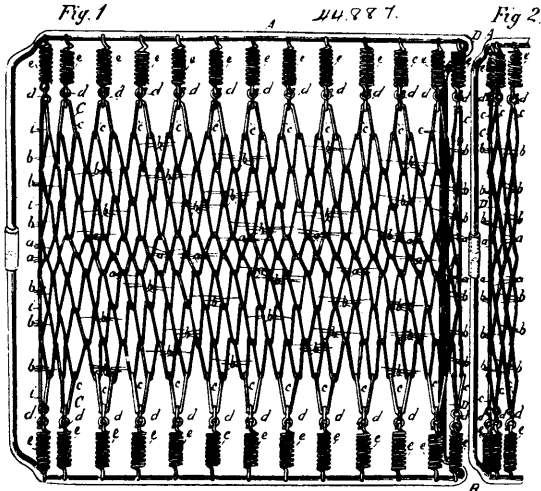

springs, all substantially as and for the purpose set forth. 3rd. The short V-shaped sections woven across from side to side of the mattress, interwoven and followed by the long links *b*, engaging with separate V-shaped heavier links C, joined by means of links or chains *d*, and tension springs, all as and for the purpose set forth. 4th. A mattress fabric, in which the herein described woven sections *a* and *b*, are of uniform length and size of wire, as in fig. 5, connecting with one or more tier of separate V-hooks C, of proper length and size, to connect with one or more tier of chain links *d*, and terminal side wires to be proper size of wire and the most convenient form, all as and for the purposes set forth. 5th. A mattress fabric, in which the herein described V-shaped sections *a* and *b* are of uniform length and size of wire, engaging with one or more tier of separate V-hooks C, of proper size wire and length, to connect directly with the tension spring *c*; the terminal side wires to be of sufficient size to hold, and of most convenient form, all substantially as and for the purposes set forth. 6th. A mattress in which the herein described woven sections *a* and *b*, are of uniform size of wire and length and of a sufficient size wire to engage directly with the tension springs *c*; the last tier of woven sections to be of equal length, longer or shorter and larger or smaller wire than the remaining woven sections, all substantially as and for the purposes set forth. 7th. A spring mattress fabric, composed of the herein described section *a* and *b*, followed by the separate hooked sections *c*, or one or more tier of same, of sufficient length and size of wire to properly connect with the end springs *c*, all substantially as and for the purpose set forth. 8th. A spring mattress fabric composed of the hitherto described interwoven sections *a* and *b*, in which *b*, the last tier of same, are of sufficient length and size to connect with the end tension springs *c*, all substantially as and for the purpose set forth. 9th. A spring mattress composed of wire woven from side to side of a bed and attached at the sides to suitable wires, and connected at each end by one or more tiers of V-shaped links *c* or *d*, either or neither or any combination of same, of suitable length and size to connect with the terminal springs *c*, or as referred to connect with the terminal springs *c*, leaving out *c* and *d*, or either, all substantially as and for the purpose hereinbefore set forth. 10th. A spring mattress metallic bed frame, having its ends raised above the side rails arching upward and outward towards their centres, substantially as and for the purpose hereinbefore set forth. 11th. A spring mattress bed frame having the sides connected by adjustable or mortice couplings, substantially as and for the purposes hereinbefore set forth. 12th. A spring mattress bed frame having its ends and sides connected by adjustable or mortice couplings, substantially as and for the purposes herein set forth. 13th. A spring mattress bed frame formed of one continuous piece of metal having its ends coupled together, and the portion forming the end rails of the frame arched upward and outward, substantially as and for the purposes herein set forth. 14th. A spring mattress bed frame composed of two pieces connected at their sides by adjustable or mortice couplings, substantially as and for the purposes herein set forth. 15th. A spring mattress bed frame composed of two pieces, connected at their ends substantially as and for the purposes herein set forth. 16th. A spring mattress bed frame composed of four pieces connected at their sides and ends, substantially as and for the purposes hereinbefore set forth. 17th. A spring mattress bed frame having corner pieces or couplings as shown and set forth connecting sides and ends of frame, all substantially as and for the purposes hereinbefore set forth. 18th. A spring mattress bed frame having its end rails arching outward and connected to its side rails by adjustable or mortice couplings, all substantially as and for the

purposes hereinbefore set forth. 19th. A spring mattress bed frame having its end rails arching upward and connected to its side rails by adjustable or mortice couplings, all substantially as and for the purposes hereinbefore set forth. 20th. A spring mattress bed frame having its end rails arching upward and outward, and connected to its side rails by adjustable or mortice couplings, all substantially as and for the purposes herein set forth. 21st. A spring mattress bed frame having its side rails arching or bent upward, all substantially as and for the purposes hereinbefore set forth. 22nd. A spring mattress bed having its side rails arching or bent outward, all substantially as and for the purposes herein set forth. 23rd. A spring mattress bed frame having its side rails arching or bent outward and upward, all substantially as and for the purposes herein set forth. 24th. A spring mattress bed frame having its ends arching or bent upward, and its sides connected by adjustable or mortice couplings, all substantially as and for the purposes herein set forth. 25th. A spring mattress bed frame having its ends arching or bent outward, and its sides connected by adjustable or mortice couplings, all substantially as and for the purposes hereinbefore set forth. 26th. A spring mattress bed frame having its ends arching or bent upwards and outwards, and its sides connected by adjustable or mortice couplings, all substantially as and for the purposes hereinbefore set forth. 27th. In a wider or especially strong spring bed, the end rails made stronger or larger in their central parts, and attached to the side rails by adjustable or mortice couplings, all substantially as and for the purposes hereinbefore set forth. 28th. A spring mattress metal tubing frame with thin metal inserted into or flanged into same, all substantially as and for the purposes hereinbefore set forth.

No. 44,888. Cash Register. (Régistre de monnaie.)

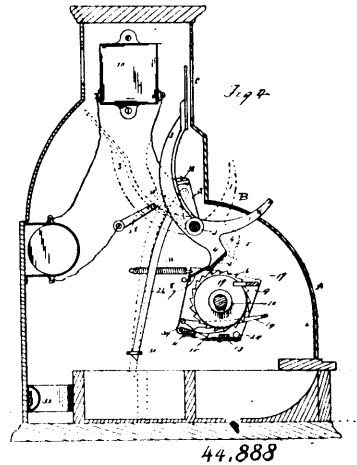

William T. McGraw, Plymouth, Michigan, U.S.A., 15th December, 1893; 6 years.

Claim.—1st. In a cash register, in combination with actuating keys, a screw, and registering wheels adapted to traverse said screw and to be actuated by the depression of said keys, substantially as described. 2nd. In a cash register, the combination of keys, a screw, registering wheels adapted to traverse said screw and to be actuated by said keys, and a scale, arranged to indicate the revolutions of the wheel on the screw, substantially as described. 3rd. In a cash register, the combination of a key, a rocking frame and a screw mounted therein, and registering wheels adapted to traverse said screw and to be actuated by said key, substantially as described. 4th. In a cash register, the combination of a key, a rocking frame and a screw mounted therein, registering wheels adapted to traverse said screw and to be actuated by said key, a stop forming part of said framework and adapted to prevent the overthrow of said key, substantially as described. 5th. In a cash register, the combination of a register wheel, a screw traversed thereby, a spring pawl held on a rocking support, and a pressure spring adapted to hold said support with the spring pawl in contact with the register wheel, substantially as described. 6th. In a cash register, the combination of a key, an electric alarm bell, a contact piece adapted to be thrown out of contact by the depression of the key, a readjusting lever arranged to unbolt the cash drawer and to readjust said key, thereby making electric contact with the alarm bell, substantially as described. 7th. In a cash register, the combination of a screw, a register wheel adapted to traverse said screw and to be actuated by a key of said register, an index bar lying parallel with said screw and provided with teeth extending inward parallel with the radius of said register wheel, a pin projecting from the face of such register wheel, adapted to engage with the teeth from the index bar, substantially as described.

No. 44,889. Seed Planter. (Semoir.)

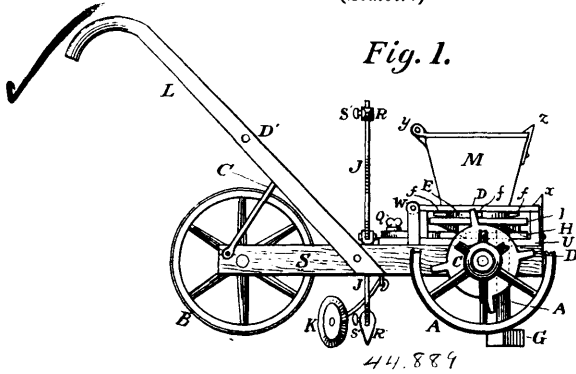

Francis W. Banan, Knox, Maine, U.S.A., 15th December, 1893; 6 years.

Claim.—The combination, in a seed planter of the measuring disc E, with the plate I, having on its under side the inclined planes m , m , m , m , which rest on the inclined planes m^1 , m^1 , m^1 , m^1 , in plate H, substantially as shown and set forth.

No. 44,890. Refrigerator. (Refrigérant.)

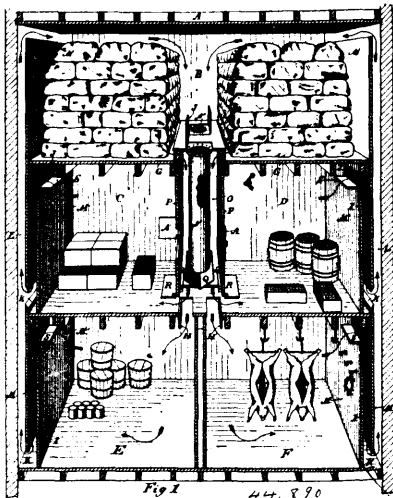

Avelyn J. Dexter, Nauwatosa, Wisconsin, U.S.A., 15th December, 1893; 6 years.

Claim.—1st. The combination in a refrigerator or cold storage building having an ice storage apartment, produce apartments located below said ice apartments, and upward and downward air flues or passages communicating between said ice and said produce apartments, of a chemical refrigerator located in the downward air flue communicating from said ice apartment to said produce apartments, said chemical refrigerator being adapted to additionally cool the air in its passage through said downward flue and accelerate its movement, substantially as and for the purpose specified. 2nd. In a refrigerator or cold storage building, the combination of an ice storage apartment, produce apartments located below said ice apartment, an upward air duct communicating from the upper part of said lower apartments with the upper part of said ice apartment, a downward air flue communicating from the lower part of said ice apartment to the lower part of said produce apartment, and a chemical refrigerator located in said downward air flue, adapted to intensify the cold air as it falls from said ice storage apartment to the produce apartment, substantially as set forth. 3rd. In a refrigerator or cold storage building, the combination with the ice apartment and the produce apartments located below said ice apartment, having upward and downward air flues communicating between said apartments, of a series of metallic ice receivers suspended at their upper ends from the floor of said ice apartments and extending downward into said produce apartment, all substantially as and for the purpose specified. 4th. In a refrigerator or cold storage building, the combination of an ice storage room, one or more produce storage rooms located below said ice storage room, a cold air flue communicating from said ice storage room provided with air distributing ducts, and adjustable doors communicating with several produce rooms or apartments, warm air ducts communicating from the upper part of said storage apartments to the ice storage room, and an artificial refrigerator located in said air flue adapted

to lower the temperature of the air in its downward course from the ice storage room, while the same is subdivided and distributed by said air distributing ducts to one or more of the storage rooms, substantially as and for the purpose specified. 5th. In a refrigerator or cold storage building, the combination of an ice storage room, one or more produce storage rooms located below said ice storage room, downward cold air flues communicating from said ice storage room to said produce rooms, and heat intercepting flues communicating first downward and then upward from the upper parts of said produce storage rooms to said ice storage room, substantially as and for the purpose set forth. 6th. In a refrigerator or cold storage building, the combination of an ice storage room, one or more produce storage rooms located below said ice storage room, a cold air distributing flue communicating from said ice storage room with the several produce rooms, an artificial refrigerator located in said air distributing flue, and heat intercepting flues located within the exterior walls of the several apartments communicating first downward and then upward from the upper part of said produce storage rooms to said ice storage room, all substantially as and for the purpose set forth.

No. 44,891. Pilot Car. (Char pilote.)

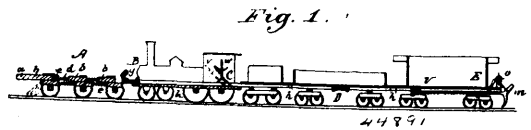

Gustav Link, Duff, Nebraska, U.S.A., 15th December, 1893; 6 years.

Claim.—1st. The combination, with a train or car, of a pilot car consisting of spring-connected trucks and movable connecting rods, and the sliding spring-connected plates and movable rods, substantially as specified. 2nd. The combination, with the pilot car and its spring-connected trucks and plates and movable rods, of the movable rods extending to the rear of the train and connected to the throttle valve rod of the locomotive and the air brakes of the train, substantially as and for the purposes as specified. 3rd. The combination, with the rear car and the movable spring-controlled rods, of the pivoted anchors and windlass and its details, the connecting chains and trip lever, the whole arranged to operate to lock the train to the road bed, substantially as specified. 4th. The combination, with the pilot car, having spring-connected trucks and sliding plates, with movable connecting rods, of a pilot or cow catcher located on the front truck whereby obstructions will be swept or thrown from the track, substantially as specified.

No. 44,892. Tug Clip for Hames. (Crochet d'attelle.)

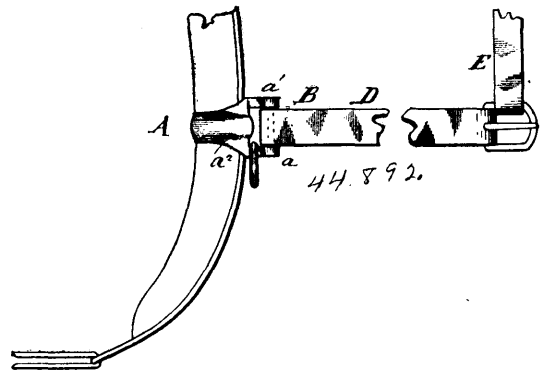

James Scott, Byron, California, U.S.A., 15th December, 1893; 6 years.

Claim.—The hame tug clip A, having ears a a^1 , apertured to receive a screw bolt B, and one threaded to form a nut therefor, a cavity to fit snugly around the hame, a side a^2 , with interior thread to receive a screw F, and a movable elastic side a^3 , with a countersunk bolt hole, whereby the clip may be opened at the side so as to be adjusted on the hame or taken therefrom or inserted thereon.

No. 44,893. Tire for Bicycles. (Bandage pour bicycles.)

Stanley Cooper Peuchen, Toronto, Ontario, Canada, 15th December, 1893; 6 years.

Claim.—1st. In a tire, an outer rim, and an inner rim or felloe, in combination, with elastic sides connected to the rim and laced around the felloe, substantially as and for the purpose specified. 2nd. In a tire, an outer rim, and an inner rim or felloe, in combination, with elastic sides connected to the rim and laced round the felloe, steadying springs being arranged between diagonally opposite sides of the rim and felloe, substantially as and for the purpose specified. 3rd. The felloe A, and outer rim B, in combination,

with the elastic-sided rubber tire C, and lacing D, substantially as and for the purpose specified. 4th. The felloe A, and outer rim B,

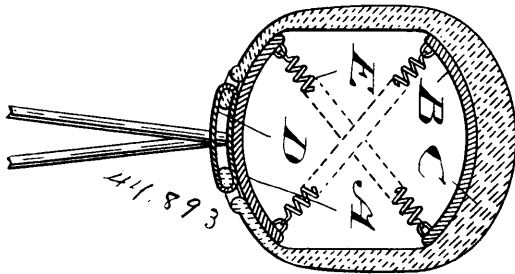

in combination, with the elastic-sided rubber tire C, lacing D, and steadying springs E, substantially as and for the purpose specified.

No. 44,894. System of Heating and Ventilation.

(Système de chauffage et de ventilation.)

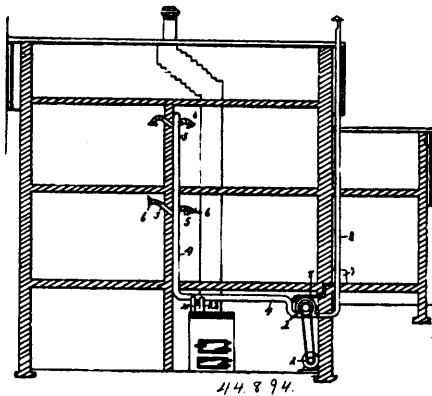

Joseph McCreery, Toledo, Ohio, U.S.A., 16th December, 1893; 6 years.

Claim.—1st. The combination, with the main supply pipe, of a blower connected with said supply pipe, and a series of branch pipes extending from the main pipe, said branch pipes terminating in a series of rigid sections articulated together and adapted to be adjusted in any desired position, and a valve, arranged in one of the said rigid sections, whereby the supply of air is regulated. 2nd. The combination of the main supply pipe, of a blower connected with said supply pipe, and a series of branch pipes extending from said supply pipe, said branch pipes terminating in a series of rigid sections articulated together and adapted to be adjusted in any desirable position, as set forth. 3rd. The combination of a main supply pipe and a blower connected therewith, branch pipes connected with the main pipe, and having at their ends adjustable nozzles, a heater, and a pipe leading from the main pipe to said heater, the nozzles being above the heater, whereby the heated air which rises from the heater will be commingled with the air which issues from the nozzles, as explained. 4th. The combination, with a furnace, of an essentially right angled pipe, the end of the horizontal arm being projected into the combustion chamber of the furnace, the lower end of the vertical arm resting adjacent to the floor upon which the furnace rests, the temperature and draught within the furnace being adapted to cause a suction at the outer end of the pipe.

No. 44,895. System and Means of Ventilation and Purification.

(Système et moyen de ventiler et purifier.)

Joseph McCreery, Toledo, Ohio, U.S.A., 16th December, 1893; 6 years.

Claim.—1st. In combination, a rotatable fan, an induction and an eduction pipe communicating with the fan, the eduction pipe provided with a joint of sound non-conducting material interposed therein, substantially as described. 2nd. In combination a rotatable fan, eduction and induction pipes, communicating therewith, one of said pipes provided with a joint of felt or analogous material, substantially as and for the purpose described. 3rd. In combination a rotatable fan, induction and eduction pipes communicating therewith, and an air flue having several inlets, said eduction pipe communicating with said air flue above the topmost inlet of said flue, substantially as and for the purpose specified. 4th. In combination a rotatable fan, induction and eduction air pipes communicating therewith, a heater provided with a hot air chamber communicating

with the eduction pipe, and pipes K primed led to the remote parts of the room in which the heater is located, said latter pipes communi-

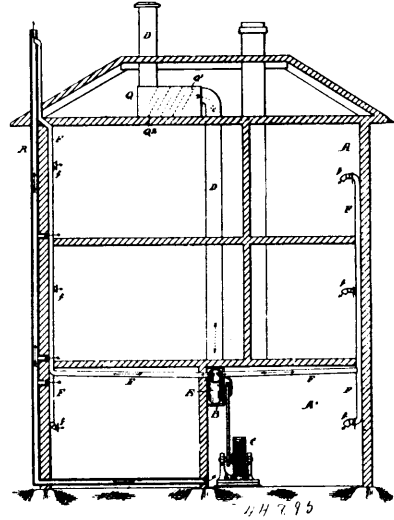

cating with said room and with a base or combustion chamber of the heater, the air admitted into said hot air chamber emitted therefrom in a heated condition, substantially as described. 5th. In combination a rotatable fan, an induction pipe leading to said fan, and an eduction pipe leading therefrom and an air cleansing device interposed in said induction pipe, such cleansing device having a pipe leading into it and containing a liquid, the induct and educt pipes of the cleansing device so communicating with the latter that the air passes through the liquid, substantially as described. 6th. In combination a rotatable fan, induction and eduction pipes communicating therewith, branch pipes connected with eduction pipes, and a perforated pipe, communicating with said branch pipe, substantially as described.

No. 44,896. Shipping Device for Bricks and Similar Articles.

(Appareil pour transporter la brique et autres objets semblables.)

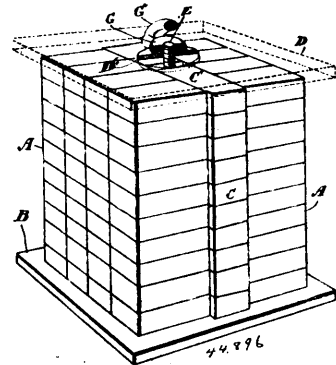

Thomas Parker, John D. Wright, Francis F. Stuart and Alexander M. Colquhoun, Toronto, Ontario, Canada, 18th December, 1893; 6 years.

Claim.—1st. The method herein described, of packing bricks consisting in piling them upon a board, so as to form an opening through the centre of the pile and passing through the top and bottom boards and central opening a bolt, which is caused to clamp the top and bottom boards so as to hold the pile firm by a nut screwed on to the top of the bolt, as and for the purpose specified. 2nd. An improved device for shipping bricks, consisting of a top and bottom board, central bolt passing through a central opening within the pile of bricks, and a ring or clevis nut G¹, screwed on to the top of the bolt, as and for the purpose specified. 3rd. An improved device for shipping bricks, consisting of a top and bottom board, central bolt passing through a central opening within the pile of bricks—a ring or clevis nut G¹, screwed on to the top of the bolt and top and bottom washers D¹, and B¹, surrounding the bolt and situated between the nut G, and the head of the bolt, respectively, as and for the purpose specified.

No. 44,897. Rotary Engine. (Machine rotatoire.)

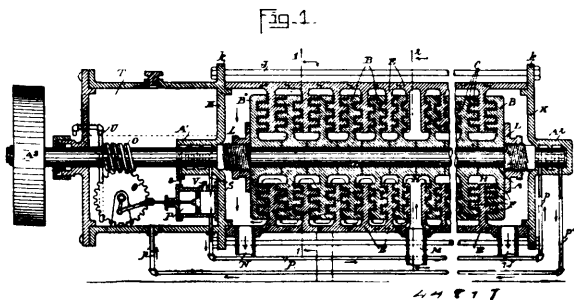

The Consolidated Car Heating Co., assignee of James F. McClory, Albany, New York, U.S.A., 18th December, 1893; 6 years.

Claim.—1st. In a rotary engine, a series of annular discs, projecting rings extending laterally from said discs, a shaft to which said discs are keyed, a V-shaped passageway extending through each of said rings, substantially as described and for the purpose set forth. 2nd. In a rotary engine, a shaft, a series of discs keyed to said shaft, a series of stationary discs, a series of projecting rings attached to each of said discs, arranged in such a manner that said rings intermesh, the stationary with the movable, with passageways for the operating fluid through each of said rings, substantially as described and for the purpose set forth. 3rd. In a rotary engine, a shaft, a series of annular discs secured thereto, a series of rings projecting laterally from each of said discs, a series of stationary discs provided with laterally projecting rings arranged to mesh with said first mentioned rings, a communication between the two adjacent series of discs at each end thereof, substantially as described and for the purpose set forth. 4th. In a rotary engine, a shaft, a series of discs secured thereto, said discs provided with annular projections, passageways cut through said projections, a series of stationary discs with annular projections meshing with said first mentioned annular projections, so arranged that the operating fluid shall pass from near the centre of the discs laterally into the movable projections and the stationary projections toward the circumference of the discs and then be returned through the passageways in the adjacent series of discs toward the centre of the discs, substantially as described and for the purpose set forth. 5th. In a rotary engine, a lubricating device consisting of a worm on a shaft, a gear wheel operating the pump by means of which the lubricating fluid is forced to the journal boxes, substantially as described and for the purpose set forth. 6th. In a rotary engine, a lubricating device consisting of a worm on a shaft, a gear wheel operating the pump by means of which the lubricating fluid is forced to the journal boxes, return pipes from the journal boxes to the tank, with a discharge pipe for eliminating the water of condensation from the tank, substantially as described and for the purpose set forth.

No. 44,898. Harness Loop Attachment.

(Attache de joint pour harnais.)

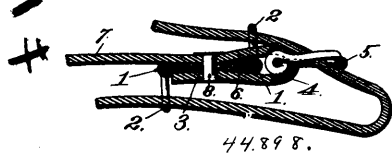

Jay Reed and George Pratt Wyatt, Butler, Missouri, U.S.A., 18th December, 1893; 6 years.

Claim.—1st. In a harness loop attachment, the combination, with a metallic plate provided with a large hole or aperture, of one or more loops carried by said plate, substantially as set forth. 2nd. In an ordinary loop attachment, the combination, with a metallic plate, provided with a large central hole or aperture, and bent to form an eye at each end, of a loop, of wire or equivalent material, pivotally mounted or hinged in each eye of said plate, substantially as set forth. 3rd. In a harness loop attachment, the combination, with a metallic plate bent to form an eye at each end, and provided with a large central hole or aperture, and loops pivotally carried in said eyes, of a strap, a rivet diametrically smaller than the said hole or aperture, passing through said strap and also through said hole or aperture to secure the plate rigidly to the strap, substantially as and for the purpose set forth. 4th. A harness loop attachment, comprising a plate provided with a large central hole or aperture, and loops pivotally carried at each end of said plate, and a rearwardly extending hook carried by said plate to receive the same loop, in combination with a strap passed through said loops, and around the hook portion, and a rivet securing said strap firmly to the plate, substantially as set forth. 5th. In a harness

loop attachment, the combination, with a plate of one or more loops carried thereby, either pivotally or rigidly, of a strap, passing through said loops, and riveted to secure the plate carrying the loops securely in position, as arranged and shown in the various figures, substantially as and for the purpose set forth.

No. 44,899. Crank Shaft. (Arbre à manivelle.)

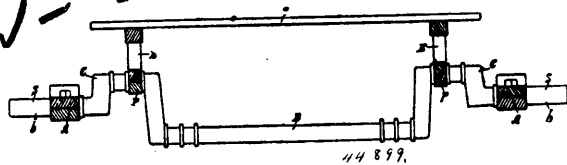

John P. McCloskey, Sarnia, Ontario, Canada, 18th December, 1893; 6 years.

Claim.—1st. As a new article of manufacture, a crank shaft S, supporting and operating a straw or other deck or other operative portion of a thrashing machine and formed with a portion B, weighted to be heavier than the remaining portion of said crank shaft, substantially as and for the purposes set forth. 2nd. As a new article of manufacture, a crank shaft S, supporting and operating a straw or other deck or other operative portion of a thrashing machine, and formed with a portion B, out of line with the journals b, of said crank shaft, substantially as and for the purposes set forth. 3rd. As a new article of manufacture, a crank shaft S, supporting and operating a straw or other deck or other operative portion of a thrashing machine, and formed with a portion B, weighted to be heavier than the remaining portion of said crank shaft, and said portion B, formed out of line with the journals b, of said crank shaft, substantially as and for the purposes set forth.

No. 44,900. Carriage Brake. (Frein de voiture.)

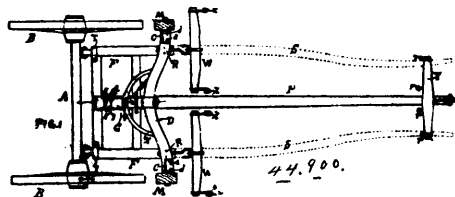

John B. Crosby, Bonshaw, Prince Edward Island, Canada, 18th December, 1893; 6 years.

Claim.—1st. In a carriage brake of the character described, the combination of the following instrumentalities, to wit, an axle, wheels mounted on said axle, a frame fixed to said axle, a pole, a doubletree fitted to slide with said pole on said frame, and adjacent to said wheels and furnished with whiffletrees, cranks mounted on the ends of said doubletree, brake shoes fitted to turn on and by means of said cranks, attachments to said doubletree to limit its longitudinal and circular movement, a yoke fitted to slide on said pole, near its forward end, and provided with hooks for the breeching straps, a bar attached to said frame, permitting the sliding of the said pole thereon, said bar being connected with said yoke, all substantially as set forth. 2nd. In a carriage brake of the character described the combination of the following instrumentalities, to wit, an axle, wheels mounted on said axle, a frame fixed to said axle, a pair of shafts, a tree fitted to slide with said shafts on said frame and adjacent to said wheels and provided with cranks mounted on the ends of said tree, brake shoes fitted to turn on and by means of said cranks, attachments to said tree to limit its longitudinal and prevent its circular movement, substantially as set forth. 3rd. The improved carriage brake herein described, the same consisting essentially of the pole P provided with the sheave m, and attached to the sliding plate G, by means of the bolt b, the shafts S provided with suitable attachments, the sliding doubletree D provided with the bolt b, and the curved plate or segment X furnished with the slot t, and the washer Z adapted to fit said slot, the whiffletrees W provided with the hooks x, the cranks C provided with turned up end a and mounted on said doubletree, the shoes M attached to the cranks C and fitted to turn on said cranks, the frame F provided with sockets T, the plate H attached to said frame and provided with the guides g, g', and the hooks j, the bolt K passing through the guides g and provided with its link L, the sliding plate G provided with its hook h and the projection f, and fitted to clasp said doubletree, the bar N connected with the frame F, by means of the socket T, and fitted to allow said pole to slide thereon, said bar being attached to the yoke Y by means of a chain n passing over said sheave, a yoke Y having the hooks r, and fitted to slide on said pole, all being constructed, combined and arranged to operate, substantially as described.

No. 44,901. Purifier, Grader and Separator.
(*Epurateur et séparateur.*)

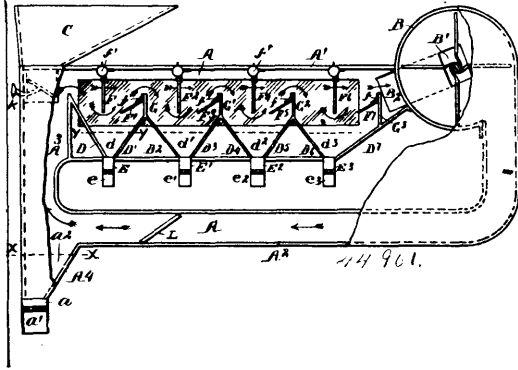

David J. Davidson, Stephen C. Martin and Abraham S. Martin, all of Port Huron, Michigan, U.S.A., 18th December, 1893; 6 years.

Claim.—1st. A purifier, separator and grader, arranged and provided with means to effect an air current therein whereby desired separations of the stock supplied thereto may be effected by gravity in combination with said air current, substantially as set forth. 2nd. A purifier, separator and grader, provided with separating devices to effect desired separations of the stock, and means of producing an air current therein, substantially as set forth. 3rd. In a purifier, separator and grader, an air trunk and means to effect an air current within said trunk, substantially as set forth. 4th. In a purifier, separator and grader, an air trunk provided with separating devices, and means to produce a current of air in said air trunk whereby the desired separations of the stock may be effected by gravity, in combination with the air current, substantially as set forth. 5th. In a purifier, separator and grader, an air trunk into which the stock is fed, separating devices located in said air trunk, and a fan to produce an air current in said trunk, whereby the desired separations of the stock may be effected by gravity in combination with said air current, substantially as set forth. 6th. In a purifier, separator and grader, an air trunk provided with multiple separating devices to effect multiple separations of the stock, and means to produce an air current within said trunk whereby the desired separations of the stock may be effected, in combination with said air current, substantially as set forth. 7th. A horizontal purifier, separator and grader, having in combination therewith means to effect a continuous air current therein, the purifier, separator and grader constructed and arranged to effect desired separations of the stock supplied thereto, by gravity in combination with said air current, substantially as set forth. 8th. A purifier, separator and grader having in combination a fan provided with a fan case, a horizontal air trunk leading from said fan case and back thereto, and separating devices located within said air trunk, substantially as set forth. 9th. A purifier, separator and grader provided with an air trunk to receive the stock and means of affecting desired separations of the stock within said air trunk, and independently discharging said separations, substantially as set forth. 10th. A purifier, separator and grader provided with an air trunk into which the stock is fed, formed of horizontal communicating legs, separating devices located in one of said legs, and means to provide an air current in said air trunk, substantially as set forth. 11th. A horizontal purifier, separator and grader, constructed with an air trunk into which the stock is fed, means of producing an air current in said trunk, and separating devices arranged to diminish the force of the air current to effect the desired separations of the stock, substantially as set forth. 12th. In a purifier, separator and grader, an air trunk and means to produce an air current therein, the construction and arrangement being such that the air current will strike the entering stock supplied thereto opposite the direction of the air current whereby the heavier stock will be separated by gravity, and the lighter portion of the stock will be carried forward, substantially as set forth. 13th. In a purifier, separator and grader, means of producing an air current therein, and separating devices to effect a gravity separation of the stock in combination with said air current, substantially as set forth. 14th. In a purifier, separator and grader, means of producing an air current therein, separating devices to effect gravity separations of the stock in combination with the air current, and discharge outlets for each of said separations, substantially as set forth. 15th. In a purifier, separator and grader, an air trunk or chamber, and means for effecting an air current therein, said air trunk or chamber provided with one or more dead air chambers, substantially as set forth. 16th. In a purifier, separator and grader, a fan, an air passage through which a current of air is directed from the fan back thereto, a cant board located within said air passage, a diaphragm located above said cant board, and a discharge outlet located at the lower end of the cant boards, substantially as set forth. 17th. In a purifier, separator and grader, an air passage,

means of effecting an air current therein, a cant board, a diaphragm, and a discharge outlet at the base of the cant board, said cant board and diaphragm the one adjustable in relation to the other, substantially as set forth. 18th. In a purifier, separator and grader, an air passage, means of effecting an air current therein, a series of cant boards, diaphragms suspended above the cant boards and discharge outlets at the lower ends of the cant boards, substantially as set forth.

No. 44,902. Car Brake. (*Frein de chars.*)

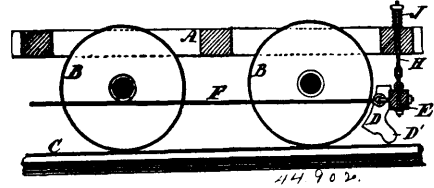

William H. Brownlow, Brockville, and John F. Wood, Ottawa, all in Ontario, Canada, 18th December, 1893; 6 years.

Claim.—1st. The combination with a car truck of a brake beam carrying brake shoes D, having a projection D¹, to have frictional contact with the rails on which the truck wheels run when said shoes are in frictional contact with the wheels, as set forth for the purpose described. 2nd. The combination with a brake operating mechanism, of brake shoes D, having a portion D¹, to engage the rails when the brakes are applied to the wheels of the car truck or engine, and means, such as rods H, and springs J, to lift said brake beams after the shoes have been released, as set forth, for the purpose described. 3rd. The combination with a car truck of brake operating mechanism, and brake beams E having shoes D, engaging the wheels of the car truck and the rails on which said wheels run, and spring devices lifting the brake beam when the brakes are off to raise said shoes clear of the rails, substantially as set forth, for the purpose described. 4th. A brake beam E, having brake shoes D, and hung to a truck and operated by suitable brake mechanism, whereby the brake shoes will have contact with the wheels of a car or engine and with the top of the rails on which said wheels run simultaneously, when the mechanism is operated to apply the brakes, as set forth.

No. 44,903. Roofing and Roofing Tile.
(*Toiture et tuile pour toitures.*)

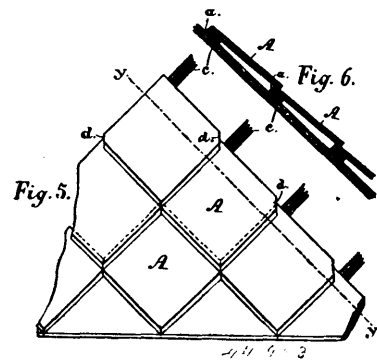

Johan M. Olsen, Hans P. Olsen and Franz W. Bronn, all of Christiana, Norway, 18th December, 1893; 6 years.

Claim.—1st. A covering for roofs consisting of sloping laths c, and rectangular flat tiles A, one edge furnished with a rib d, and having two corners d, removed or oblique, as set forth. 2nd. A rectangular roofing tile A, having a rib d, at one edge and two oblique or removed opposite corners d, as set forth.

No. 44,904. Agricultural Boiler and Feed Steamer.
(*Chaudière d'agriculture et appareil pour passer à la vapeur.*)

Edward Foster and Jefferson J. Foster, both of Leamington, Ontario, Canada, 18th December, 1893; 6 years.

Claim.—1st. In a feed steamer, a firebox located immediately below the boiler, the firebox being connected with the lower plate of the boiler by means of rods hooked on to lugs on the lower plate, and passing through the base of the boiler and secured thereto from below by nuts, means for strengthening the upper and lower plates and of attaching thereto the sheet metal boiler, flues or pipes passing through the upper and lower plates and secured to the said plates so as to enable the said plates to resist the expansion of the steam, a chamber and smoke pipe, a safety valve and water pipe, and a pipe proceeding from the steam boiler to the feed tank provided with a perforated point, through the perforations of which

the steam may escape into the feed in the feed tank, and a removable end on the perforated point, substantially as described and specified. 2nd. In a feed steamer, the base of the firebox 30, in

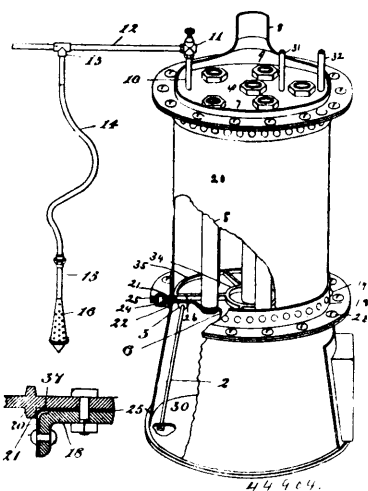

combination with the rods 2 secured thereto, as well as lugs 3 in the lower plate 6, of the boiler and the stop ring 22, substantially as described and specified. 3rd. In a feed steamer, the lower plate 6, with a projection 21, formed thereon, in combination with the sheet metal cylinder 20, bent round at 37, under the bracket ring 18, the packing 25, and the said angle iron bracket ring 18 secured to the bottom plate 6, by the bolt 23, and nut 24, and to the sheet metal side 20, by the rivet 19, substantially as described and specified. 4th. In a feed steamer, a sheet metal boiler secured to the upper and lower plates as specified, in combination with flues passing through the same and secured thereto so as to resist the expansion of the steam, a smoke chamber and smoke pipe, a safety valve and water pipe, and a pipe for carrying the steam to the feed tank, substantially as specified. 5th. In a feed steamer, a sheet metal boiler located on top of the firebox, in combination with a steam pipe 10, provided with a valve 11, a pipe 12, provided with a T-connection 13, a flexible tube 14 connected with the pipe 15, and the perforated point 16, substantially as specified. 6th. A pipe 15, designed for insertion into the feed in the feed tank, in combination with an enlarged nozzle or lower end 16, provided with perforations through which the steam from the boiler may escape into the feed tank, and a removable end 33, substantially as specified. 7th. A plate 6, provided with an inner rim 34, and outer rim 35, and radiating tapering ribs 26, connecting the inner and outer rims, substantially as described and for the purpose specified.

No. 44,905. Rail Joint. (Joint de rail.)

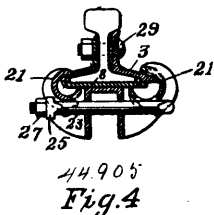

The Heath Rail Joint Company, assignee of Frederick H. Heath, all of Minneapolis, Minnesota, U.S.A., 18th December, 1893; 3 years.

Claim.—1st. The base-plate 5, formed of sheet metal and having the struck trusses extending longitudinally thereof, in combination with the angle-iron plate secured to said base-plate, and provided with the angle portion struck up from the main body of the plate and adapted to fit against the web of the rail. 2nd. The combination with the base-plate, formed of sheet metal and having the longitudinal trusses formed integrally therewith, with the angle-iron plate secured thereto and provided with the angle portions 15 and 17, adapted to fit against the web of the rail. 3rd. The combination with the rails, of the base-plate 5, formed of sheet metal, provided with the longitudinal trusses 13, at right angles to said plate, the angle-iron plate 8, provided with the angle portions 15 and 17, and riveted to said base-plate, the angle-iron 3, the bolts 21, clamps 21 and bolts 23, substantially as described. 4th. The combination with the rails, of a combined trussed base-plate and angle-iron composed of the parts 15 and 17, in combination with the rail or rails to rest upon said plate, and means for securing said rails to the

part 17, of the angle-iron, and said angle-iron engaging the web only of the rail, substantially as described. 5th. The combination, with the wrought metal plate 8, provided with the integral angle-iron or bar of the rail or rails to rest upon said plate, a separable angle-bar, bolts for securing said bar and the rails to said integral angle-iron, and the vertical part of the integral iron being alone in engagement with the rail or rails, substantially as described. 6th. The combination, with the sheet metal plate 8, of the integral angle-iron struck up from the edge thereof and provided with the slot 19, the rail or rails, means for securing the same to said angle-iron, and clamps for securing the rails upon said plate, one of said clamps extending through said slot 19, into engagement with the flange of the rail, substantially as described. 7th. The combination, with the wrought metal plate 8, having the slot 19, of the trussed base-plate secured to the underside of said plate 8, and having the integral trusses 13, the rails, means for securing the rails to said angle-bar or iron, and clamps for securing the rail or rails upon the plate 8, one of said clamps extending through the slot 19, in the integral angle-bar, substantially as described. 8th. The combination with the plate 8, having the integral angle-iron provided with the slot 19, of the plate 5, attached to the bottom of said plate 8, and having the integral middle trusses 13, said trusses provided with the bolt holes, the rails secured to said angle-iron, the clamps, one of which extends through said slot 19, into engagement with the flange of the rail, and the connecting bolts of said clamps, said bolt extending through said holes in said trusses, substantially as described. 9th. The combination with the wrought metal plate 8, provided with the integral angle-iron, of the wrought metal plate 5, provided with the integral trusses 13, said plates being secured together, the rails, the separable angle-iron 3, the bolts 21, for securing the same, and the rails to the said integral angle-iron, the curved rocker clamps engaging the flange of the rail and the top of the separable bar 3, and the connecting tension bolt 23, of said clamps, said bolt extending through holes provided in said trusses 13, substantially as described.

No. 44,906. Rail Joint. (Joint de rail.)

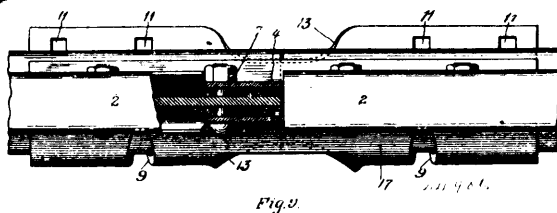

The Heath Rail Joint Company, assignee of Frederick H. Heath and Edward P. Caldwell, all of Minneapolis, Minnesota, U.S.A., 18th December, 1893; 6 years.

Claim.—1st. The combination, with the rails, and an angle-iron fitting upon one side of the rails, of a combined trussed base-plate and angle-iron formed integrally of wrought iron and bolts securing said angle-irons to the rails, substantially as described. 2nd. As a new article of manufacture, the herein described combined base-plate and angle-iron consisting of a single sheet having the longitudinal trusses formed therein, and with the angle-portion adapted to fit against the side of the rails, substantially as described. 3rd. The combined base-plate and angle-iron consisting of the sheet metal plate having depending trusses formed integrally therewith and with the angle-iron portion also formed integrally with said plate and adapted to fit against the flange and side of a rail, substantially as and for the purpose set forth. 4th. The combination, with the rails, of a trussed base-plate, the angle-iron secured to the rails by bolts, the clamping bolt 19', having a hooked end to engage the truss of said plate, and having its upper end secured by a nut in the projecting edge of the angle-bar, substantially as described. 5th. A combined base-plate and angle-iron, consisting of a sheet metal plate, an integral angle iron portion formed on said plate, and depending sheet metal trusses, substantially as and for the purpose specified. 6th. The combined base-plate and angle-iron or bar consisting of a sheet metal plate provided with the integral longitudinal trusses 13, 13, and the integral angle-iron or bar provided with the horizontal, the inclined and the vertical parts in cross section, substantially as described. 7th. The combination, with the rail or rails, of a sheet metal base-plate whereon the rails are adapted to rest, the integral depending trusses provided on said plate, the integral angle-iron formed by bending up one edge of said plate, the separable angle-iron 4, short bolts for securing the same and said integral bar to the rails, said part 4 provided with a short projection extending over the middle portion of the plate, and the hooked clamping bolt 19, secured in said projecting part and hooked beneath the adjacent truss, substantially as described. 8th. The combination, with the rails and an angle-bar fitting upon one side of the rails, of a combined trussed base-plate and angle-iron formed integrally of wrought iron and of the same length as the said plate, and bolts for securing the said angle irons to the rails, substantially

as and for the purpose set forth. 9th. As a new article of manufacture, the herein described combined base-plate and angle-iron, consisting of a single sheet of metal having the longitudinal trusses formed therein, and with the angle-iron portion adapted to fit against the side of the rails and of the same length as the plate, substantially as and for the purpose set forth. 10th. The combined base-plate and angle-iron, consisting of the sheet metal plate having depending trusses formed integrally therewith, and with the angle-iron portion also formed integrally with said plate and adapted to fit against the flange, and side of a rail, and of the same length as the plate, substantially as and for the purpose set forth. 11th. As an article of manufacture, a rail-joint consisting of a flat rail-plate to be secured upon the ties and having depending trusses formed integrally therewith, the inside truss being straight and the outside truss curved as described, and the integral angle-iron to engage the rail or rails, substantially as described. 12th. As an article of manufacture, the rail-joint consisting of the rail-plate portion provided with spike holes 11 and having the integral depending trusses, and the integral angle-bar provided with the spike-head slots, the whole being formed of sheet metal, and said angle-bar and plate portions being of the same length, substantially as and for the purpose set forth.

No. 44,907. Method of and Apparatus for Coiling Wire and Inserting it into Fabrics.
(Méthode et appareil pour lover le fil de fer et l'insérer dans les tissus.)

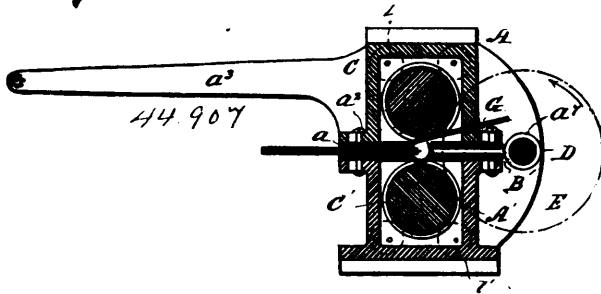

Calvin Jackson and James H. Sternbergh, both of Reading, Pennsylvania, U.S.A., 18th December, 1893; 6 years.

Claim.—1st. In a wire coil machine the combination with the geared rollers and a mandrel F, located between said rollers, of a forming device T, secured to the machine frame and provided with a grooved concave face arranged contiguous to said mandrel, substantially as set forth. 2nd. In a wire coil machine, substantially as described, the combination with one or more rollers supported in a fixed frame of one or more similar rollers supported in a movable frame pivoted to the fixed frame, said rollers being geared with a gear-wheel having its centre at said pivotal point, substantially as set forth. 3rd. In a wire coil machine, substantially as described, the combination with the fixed frame, the movable frame hinged thereto, and the rollers supported in said frames, of clamps adjustably secured to the meeting faces of said frames, the inner edges of said clamps being brought close to the wire coil and holding the material through which the coil is to be inserted, substantially as and for the purpose set forth. 4th. The method of strengthening or uniting softer materials by means of wire which consists first in forming the wire into a spiral coil, and second in permanently combining said coiled wire with the aforesaid material by rotating the coil and passing the pointed end thereof successively through a series of punctures made in the material, substantially as set forth. 5th. The method herein described of continuously forming wire into a spiral coil and combining the same with a softer material which consists first, in simultaneously forming said wire into a spiral coil and advancing the pointed end of the same by means of exterior rotary pressure thereon, and second, in simultaneously puncturing and inserting the coil into the material, substantially as set forth. 6th. In a wire coiling and inserting machine the combination of the geared rollers, the mandrel F located between said rollers, a forming device T contiguous to said mandrel, and the clamps for holding the material through which the coil is to be inserted, all arranged and adapted to operate substantially as set forth.

No. 44,908. Metallic Flux for Refining Iron.
(Flux métallique pour le raffinage du fer.)

Robert L. Sentinella and Edgar W. Beckingsale, all of London, England, 18th December, 1893; 6 years.

Claim.—1st. The hereinbefore described alloy adapted to be used as a flux for the purification of iron or of steel and consisting of the metal, sodium, sodium chloride and iron chloride or chlorides. 2nd. The hereinbefore described process of effecting the alloying of sodium and iron, consisting in heating iron or steel in a crucible to a semi-fluid or plastic condition, stirring sodium chloride into the mass, increasing the heat until a portion of the chloride formed and the dissociated sodium are alloyed with the iron.

No. 44,909. Test System for Multiple Switch-boards.
(Système d'épreuve pour tableaux d'aiguille multiple.)

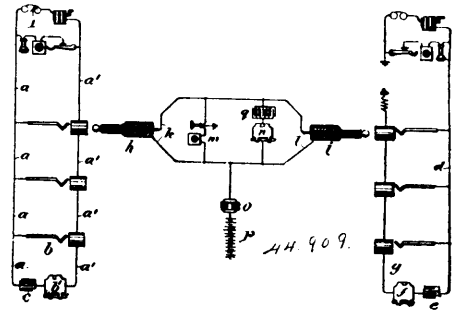

The Bell Telephone Company of Canada, assignees of Charles Ezra Scribner, Chicago, Illinois, U.S.A., 18th December, 1893; 6 years.

Claim.—1st. The combination, with a telephone line having one limb or portion thereof permanently connected with the springs of the switches of the line, and by the other limb or portion thereof with the frames or test pieces of the same switches, of a wire permanently connecting said limbs together at the central office, said connecting wire including a condenser and an individual annunciator. 2nd. The combination with a telephone line extending from the subscriber's station to the central office, of switches upon different switch-boards, each switch being provided with a switch lever and frame insulated from one another, one portion of the telephone line being permanently connected with the springs of said switches, and the other portion being connected with the frames or test pieces thereof, a wire at the central office connecting the two portions of telephone line together, and an individual annunciator and a condenser included in said connecting wire, substantially as and for the purpose specified. 3rd. The combination with a telephone line extending from the subscriber's station to the central office, of switches upon different switch-boards, each switch being provided with a switch lever and frame insulated from one another, one portion of the telephone line being permanently connected with the springs of said switches, and the other portion being connected with the frames or test pieces thereof, a wire at the central office connecting the two portions of telephone line together, and an individual annunciator and condenser included in said wire, and switching apparatus consisting of pairs of double pointed plugs and cords. one strand of said cords (the strand connecting the sleeves thereof) being connected to ground through a retardation coil and battery, a listening end key for bridging the telephone between the strands, and a bridge wire including a clearing out annunciator, permanently connected between said strands. 4th. The combination with a telephone line extending from the subscriber's station to the central office, of switches upon different switch-boards, each switch being provided with a switch lever and frame insulated from one another, one portion of the telephone line being permanently connected with the springs of said switches, and the other portion being connected with the frames or test pieces thereof, a wire at the central office connecting the two portions of telephone line together, and an individual annunciator and condenser included in said wire, and switching apparatus consisting of pairs of double pointed plugs and cords, one strand of said cords (the strand connecting the sleeves thereof) being connected to ground through a retardation coil and battery, a listening in key for bridging the telephone between the strands, and a bridge wire including a clearing out annunciator and a condenser permanently connected between said strands.

No. 44,910. Multiple Switch-board System.
(Système de tableau d'aiguille multiple.)

The Bell Telephone Company of Canada, Montreal, Quebec, assignee of Charles E. Scribner, Chicago, Illinois, U.S.A., 18th December, 1893; 6 years.

Claim.—The combination with a telephone line extending from the subscriber's station to the central office, of two or more switches one portion of the line being permanently connected with the springs of said switches and the other portion or branch thereof being connected with the test pieces of said switches, and an individual annunciator included between said branches or portions of the telephones lines, said individual annunciator being wound differentially and provided with a branch connection to ground, substantially as specified. 2nd. A telephone line connected with an individual annunciator at the central office in two branches or limbs, each branch or limb including a different differential winding of said individual annunciator, whereby current sent over one limb will operate the annunciator, while current sent over both limbs will render said individual annunciator neutral and prevent the operation thereof, substantially as specified. 3rd. A telephone line extending from the subscriber's station to the central office, one

portion being connected with the spring or springs of one or more switches and the other portion thereof connected with the test piece

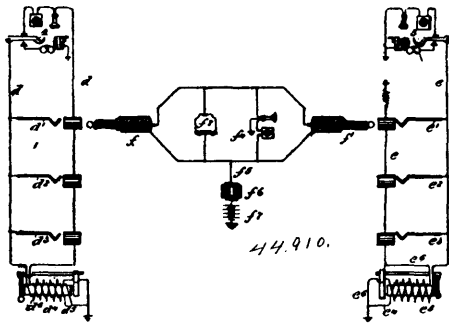

or test pieces of the same switches, and an individual annunciator wound differentially, one differential winding being included in one portion of the telephone line and the other differential winding thereof being included in the other portion thereof, said differential coils being provided with a ground connection, in combination with a connecting device for insertion in one of the switches, and a clearing out annunciator connected in a bridge between the contacts of said connecting device, whereby current sent to line from subscriber's station will be directed through both the differential windings of the individual annunciator, substantially as specified. 4th. The combination with two telephone lines, each connected with switches on different switch-boards, and each including a different individual annunciator wound differentially and provided with a ground connection, as described, of an operator's outfit, including a pair of double pointed plugs and cords and an individual annunciator bridged between the two sets of said cords, whereby on connecting two lines together, current sent from either subscriber's station will be sent in derived circuit through both of the windings of each of the individual annunciators to render the same neutral, while the clearing out annunciator will be operated, substantially as specified.

No. 44,911. Combination Joint.

(Joint à combinaison.)

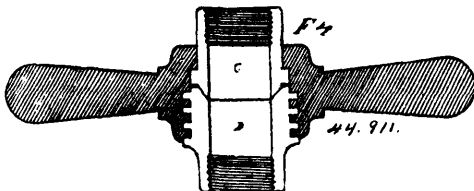

Elie Depeyre, Quebec, Canada, 19th December, 1893; 6 years.

Résumé.—1° La combinaison par les deux douilles C' et B', en position de C et D, dans la section transversale, verticale, par une saillie à l'extérieur de la douille C, s'appuyant sur l'épaulement laissé à l'intérieur de la boîte contenant le joint de la combinaison assemblée en C, D. 2° La combinaison qui s'opère par la douille B', qui est à l'extérieur à fil en saillie coupé à vis, et par inter-sections comme démontré, cette douille est introduite dans la boîte, les parties à vis par les rainures E, E, E, et librement, les lettres sont les pas, l'intersection des rainures faites pour l'accouplement du joint des deux douilles C et D, la douille B', en position de D, laquelle est tournée un sixième de tour à droite, par les poignées le mouvement à gauche l'opération des fils dans les pas F, F, F, produit la pression demandée sur le siège de la douille C, rend le joint par le fait tel que ci-dessus décrit pour les fins indiquées.

No. 44,912. Fence Post. (Pôteau de clôture.)

David Rogers, Bridge Hampton, New York, U.S.A., 19th December, 1893; 6 years.

Claim.—1st. In a fence, the combination, with a series of clamping posts, of a series of intermediate wire supporting posts, the same being provided coincident with the clamps with pairs of independent brackets, the upper bracket of each pair being triangular, and the lower bracket inclining from its post toward the triangular bracket forming a concave wire receiver and terminating short of the upper bracket, outwardly extending lugs perforated and formed upon the

ends of the brackets, and combining to form an entrance to the wire receivers, removable nails passed through the receiving brackets,

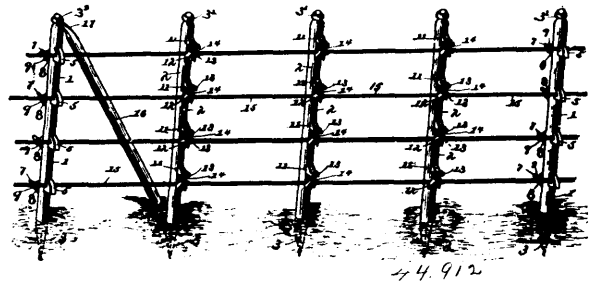

and wires located in the brackets and clamps, substantially as specified. 2nd. A fence post having an upper annular groove and below the same provided with a series of wire clamps, the said groove being adapted to receive the upper forked end of a temporary brace, substantially as specified.

No. 44,913. Apparatus for Attaching Calks and Hobnails. (Appareil pour assujétir les crampons et clous.)

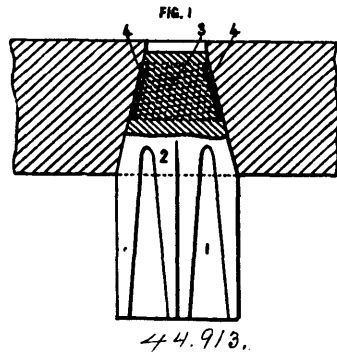

George de Roussy de Sales, Sainte Menehould, France, 19th December, 1893; 6 years.

Claim.—The means of attaching calks or hobnails to the shoes of horses or other animals, or to boots and shoes, consisting in the interposition of a metallic wire or split ring between the calks and the walls of the holes in the horse-shoe or other shoe, substantially as herein described.

No. 44,914. Method of Producing Sterilized Condensed Milk, etc. (Appareil pour stériliser le lait condensé.)

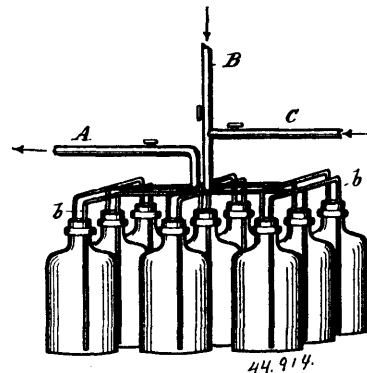

August Fjelstrup, Nybrogate 24 Copenhagen, Denmark, 19th December, 1893; 6 years.

Claim.—The herein described improved method of producing sterilized condensed milk and other similar substances, which con-

thereto and nearly parallel therewith, a rigid spreader between said wires, and a cross wire connected to said spreader between said

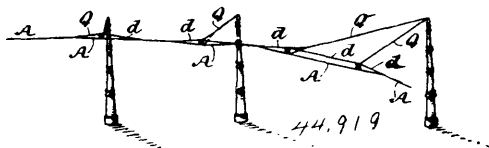

working and second wires, substantially as and for the purposes described. 2nd. In overhead conductors for electric railroads, the combination, with the working wire, of a second wire attached thereto and nearly parallel therewith, a rigid spreader of insulating material between said wires, and a cross wire connected to said spreader between said working and second wires, substantially as and for the purposes described.

No. 44,920. Process of Extracting Fatty Matter.
(*Procédé pour extraire des corps gras.*)

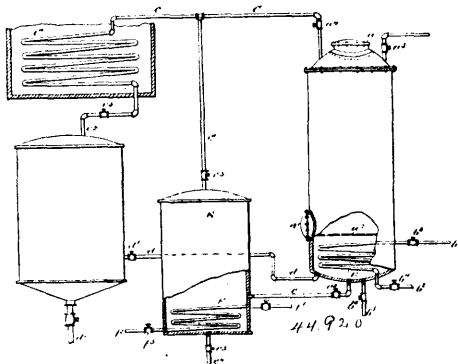

Adolph Schweiser and William F. Jobbins, both of Chicago, Illinois, U.S.A., 20th December, 1893; 6 years.

Claim.—1st. The herein described process for extracting the fatty and oily elements from bones, vegetable and animal substances, the same consisting in first, boiling the material in a fat solvent of higher boiling point than water (100° C.), and simultaneously drying the material from which the fatty elements have been extracted and then evaporating the solvent from the fat liquid and from the dry residuum of the treated substances, substantially as described. 2nd. In a process for extracting the fatty elements from bones, animal and vegetable matter, the herein described method of removing the water and forming a liquid mixture of the fats, the same consisting in boiling the matter in a closed vessel in a solvent, having a boiling point higher than that of water (100° C.), whereby the water is evaporated and driven off, substantially as described. 3rd. In a process for extracting the fatty or oily elements from animal or vegetable matter, the herein described method of separating and recovering the solvent, the same consisting in evaporating the solvent from the fatty substances mixed therewith in a suitable evaporator conducting the vaporized solvent to and re-liquifying it in a suitable condenser connected with the evaporator, and in collecting the said liquid from the condenser in a suitable receiver, substantially as described. 4th. In a process for extracting the fatty elements from bones, animal and vegetable matter, the herein described method of obtaining a dry residuum, freed of all the solvent, the same consisting in, first, boiling the matter in a fat solvent in a closed tank, and drawing off the liquid fatty mixture thus formed and then evaporating any solvent remaining in the dry residuum, substantially as described.

No. 44,921. Lath. (*Latte.*)

The International Sheathing Lath Company, assignee of Squire Toney, both of Viroqua, Wisconsin, U.S.A., 20th December, 1893; 6 years.

Claim.—1st. A lath or sheathing having a face other than a plane, and on the opposite side a recess or recesses, with parallel side walls, so that when applied the side walls of the recess or recesses will be caused to incline. 2nd. A lath or sheathing having an inner face other than plane, the outer face having a recess or recesses with parallel side walls, said lath or sheathing when applied bringing the inner face to a plane, so as to form a locking recess or recesses for the plaster. 3rd. A lath or plastering strip of equal thickness having the front and rear sides each oppositely inclined from the centre, and having a channel or recess the side walls of which are parallel. 4th. A lath or plastering strip having a body portion which inclines from the edges to the centre, and a recess with parallel side walls, said recess reducing the thickness of the lath, so

that it will bend or break at the base of the recess, and incline the side walls thereof. 5th. A lath or sheathing having parallel front

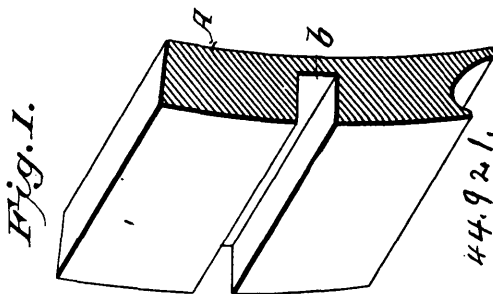

and rear sides, both of which are inclined from edge to centre and a channel or channels in one side with parallel side walls one or both edges of the lath having a groove. 6th. An improved article of manufacture, a plastering strip or lath having a concave back and a concave face, and a channel or channels formed in the convex face. 7th. A sheathing lath having its two surfaces bevelled laterally from towards the longitudinal centre downward and outward forming an obtuse angle on the under surface in cross-section intermediate the edges of the lath, the upper surface of said lath provided with a longitudinal groove intermediate the edges thereof. 8th. In combination, with a series of sheathing laths, each grooved on one or both of its edges to form a portion of a dove-tail recess and constructed with a channel or recess in one of its surfaces, the lath being bevelled on parallel planes from towards the centre outwardly forming an obtuse angle in cross-section on the under surface of the lath beneath the longitudinal centre of said surface groove, each lath being adapted to be sprung inwardly at the centre changing the said surface groove or recess into a dove-tail recess, and bending, cracking or breaking the lath beneath the recess, the series of laths when nailed edge to edge forming dove-tail recesses between them, for the purpose set forth.

No. 44,922. Station Apparatus for Telephonic and Telegraphic Purposes. (*Appareil de station à l'usage de téléphone et télégraphique.*)

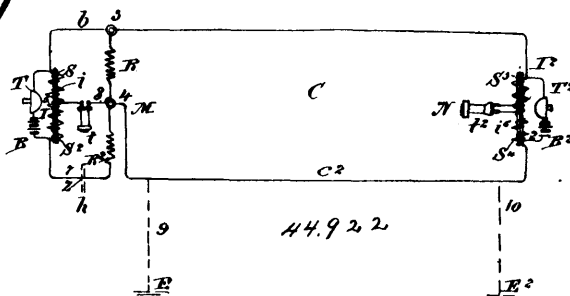

The Bell Telephone Company of Canada, assignee of Theodora Spencer, Cambridge, Massachusetts, U.S.A., 20th December, 1893; 6 years.

Claim.—1st. The combination in an electric circuit of a receiving telephone, and a transmitting telephone at the same station, with means for preventing the side tone in the said receiver when the transmitter is operated, said means comprising balancing resistances and circuit connections for the said receiver, whereby the said receiver is connected between substantially equi-potential points of the circuit with respect to outgoing currents, regardless of variations in the electric condition of the main circuit conductors. 2nd. The combination in an electric telephone circuit, of a station apparatus comprising a receiving telephone, a transmitting telephone and an induction coil therefor, having its secondary helix serially connected in said circuit, with means for rendering the said receiver null or irresponsive to the outgoing currents developed by the said transmitter, the said means consisting of a greater resistance uniting directly the terminals of the circuit, and shunting said secondary helix, a lesser resistance interposed between one of the said circuit terminals and its corresponding secondary helix terminal, and a branch circuit including the receiving telephone connected between the same circuit terminal and the centre of the said secondary helix, substantially as hereinbefore described. 3rd. In an electric telephone station apparatus, the combination of main circuit terminals, a telephone transmitter and an induction coil therefor, having its secondary helix looped to said main circuit terminals, a high resistance directly uniting the said circuit terminals in parallel with the said secondary helix, a lesser resistance approximately balancing the joint resistance of the greater resistance and the external circuit, interposed between one end of the said secondary helix and its corresponding main circuit terminal, and a receiving telephone in a branch circuit connecting the said corresponding main circuit terminal with

the centre of said secondary helix, whereby the said receiving telephone is rendered neutral or irresponsive to the voice currents of its associated transmitter, while remaining perfectly responsive to incoming voice currents, substantially as specified. 4th. In a system of electrical communication, a circuit arrangement for rendering the receiving instrument irresponsive to the sending of its associated transmitter, consisting of the external circuit, a high resistance uniting the terminals thereof, and connected in parallel therewith or as a shunt thereof, three other resistances connected in series between the said terminals, two of which are substantially equal to one another, and the third substantially equal to the joint resistance of the external circuit and its shunting resistance, and a bridge or branch conductor uniting a point between the said two equal resistances to a point at the junction of the shunt resistance and the equalizing resistance, and including the said receiving instrument, substantially as and for the purposes specified. 5th. The combination in an electric circuit, of a receiving telephone and its associate transmitter so connected in such circuit that the operation of said transmitter determines equality of electrical potential at both terminals of said receiver, the line being arranged as one factor of a joint resistance constituting an element of the balanced potential, whereby disturbances of the said balance due to the varying electrostatic condition of the line are minimized, substantially as described.

No. 44,923. Wheel. (Roue.)

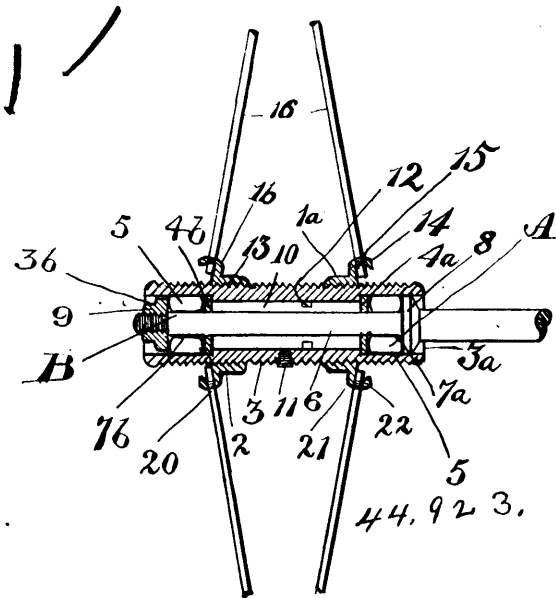

Edgar Descum Misner, Brantford, and William H. Hanes, Lynden, all in Ontario, Canada, 20th December, 1893; 6 years.

Claim.—1st. In a wheel the combination of a sleeve, bearing boxes within the sleeve, a hub composed of two or more hub sections, fitted on the sleeve, means for securing the box to the hub sections, a rim, means for securing the spokes to the rim, and means for moving the hub sections on the sleeve towards or away from each other, substantially as described. 2nd. In a wheel the combination of a sleeve, journal boxes within the sleeve, a hub composed of two or more hub sections fitted on the sleeve, the rim, the spokes, one end of the spokes fitted to the rim, and the other end of the spoke detachably connected to the hub sections, a screw thread cut in the bore of each section of the hub, a screw thread cut on the outer face of the sleeve and means in said sleeve to receive a tool to turn the said sleeve when screwing on the said hub sections, substantially as specified. 3rd. In a wheel the combination of a sleeve having a screw threaded cut on its outer face, bearing boxes within the said sleeve, the hub comprised of two or more sections, each section having spoke sockets to receive the inner ends of the spokes, the rim, the spokes, one end of the spokes connected to said rim, and the other end of the spokes fitted in said spoke sockets, a screw thread formed in the bore of each of said sections engaging with the screw thread on the outer face of the sleeve, the axle, roller bearings in the bearing box in the sleeve, running on the axle, substantially as specified. 4th. In a wheel the combination of a sleeve having a screw thread cut on its outer face, a hub, comprised of two or more hub sections, a screw thread cut in the bore of each hub section engaging with the screw thread on the face of the sleeve, each hub section composed of a collar and an outwardly extending flange, spoke sockets cut in the side face of the flange of each of the hub sections to receive the ends of the spokes, the rim, the spokes, the spokes connected to the rim and hub sections, the axle roller bearings in the bearing boxes in the sleeve, and running on the axle, and means for turning the sleeve to screw on the various hub sections, substantially as specified.

No. 44,924. Method of Making Waterproof Paper Articles. (Méthode de fabriquer des objets en papier imperméable.)

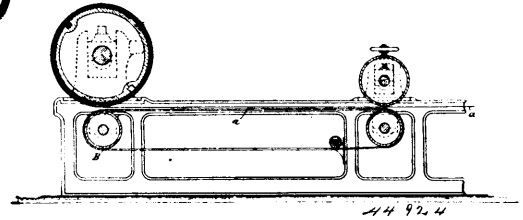

Julius Goldberg, Weissensee, Victor Benedix and August de Bary, both of Berlin, all in Prussia, 20th December, 1893; 6 years.

Claim.—1st. The process for manufacturing waterproof paper and paper articles, consisting in making up sheets from paper pulp, into which water repellent and cementing substances are incorporated, and in pressing such sheets together, substantially as described. 2nd. The herein described process of manufacture of waterproof paper material, by forming sheets of paper pulp intimately mixed with waterproofing and binding agents (such as oils, fats, solutions of resin and gutta percha, casein, marine glue, chrome glue and the like) passing such sheets before the waterproofing and binding agents have set or dried between two pressure rollers, and coiling them in any spiral manner upon one of the rollers in such a manner that the loose layers of paper are pressed singly and in succession upon the layers of paper that have already been pressed, and thus been rendered hard so as to serve as a support, for the purpose of obtaining a thoroughly dense and homogeneous product.

No. 44,925. Electric Engine. (Machine électrique.)

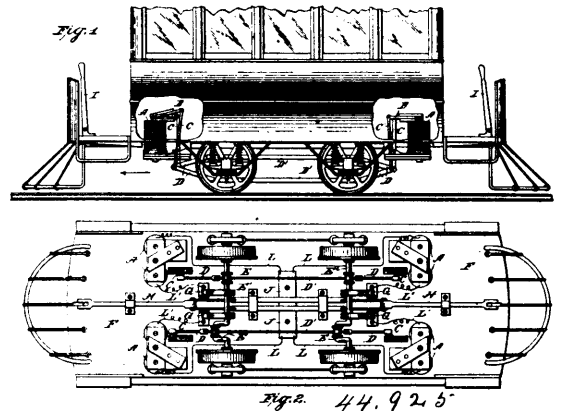

The Lawrence Electric Company, assignee of William Lawrence, all of New York, State of New York, U.S.A., 20th December, 1893; 6 years.

Claim.—1st. In an electric propelling apparatus one or more pairs of electro-magnets secured in and to a suitable bed, an armature for said magnets, an arm connected to and operated by said armature, a rod pivotally secured to the lower end of said arm and connecting with a rod, which is journaled to the cranks formed directly on the axles, substantially as and for the purposes shown and described. 2nd. In an electric propelling apparatus, an electro-magnet secured in and to a suitable bed, an armature for said magnet, an arm connected to and operated by said armature, a rod pivotally secured to said arm and connecting with cranks for turning axles, contact points suitably secured to the axles for opening and closing circuits, electric contact brushes secured to the bed, and a rod or bar for operating said brushes, and levers connected with said rod or bar for controlling the movement of same, and thereby the current of electricity, substantially as shown and described. 3rd. In an electric propelling apparatus one or more pairs of electro-magnets secured in and to a suitable bed, an armature for said magnets, an arm connected to and operated by said armature and magnets, a rod pivotally secured to the lower end of said arm, and connecting with a rod which is journaled to the cranks formed directly on the axle, contact points suitably secured to the axle for opening and closing the circuits, electric contact brushes secured to the bed and operated by a rod or bar and levers and controlling the movement of said brushes, substantially as shown and described. 4th. The improvements in electric controlling apparatus consisting of a forked brush formed from a continuous strip or piece, an arm connected with said brush for moving the latter, a rod or bar connected with said arm and adapted to be operated from either end, and a lever for operating said rod or bar to control the movement of the apparatus, and also the current of electricity, substantially as shown and described. 5th. The improvements in electric controlling apparatus consist

of a forked brush formed from a continuous strip or piece pivoted to the bed of the machine, an arm secured to said pivot for moving the brush vertically, which arm is connected to a rod or bar and adapted to be operated from either end of the apparatus by a lever, and thereby control the movement of the apparatus, substantially as shown and described. 6th. Four or more sets of magnets, armatures and said cranks, said cranks being set at angles to each other, combined with contacts and brushes therefor, said brushes being arranged to be moved to bring one member at a time into engagement with said contacts, whereby the cranks will be moved in opposite directions according to the positions of said brushes, substantially as described.

No. 44,926. House for Cooling Milk.
(Appareil réfrigérant pour le lait.)

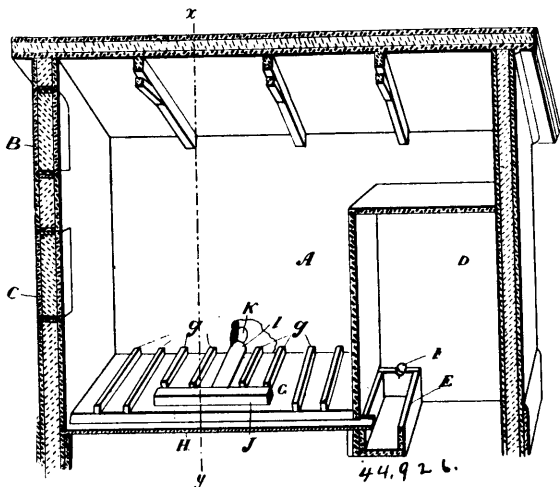

Elias Meek, Freeport, Ontario, Canada, 20th December, 1893; 6 years.

Claim.—1st. The combination, with the cooling compartment having a receiving trough for milk cans and an overflow for such trough, of the ice compartment provided with a suitable flooring and draining trough leading through the partition of the cooling compartment into and above the level of the receiving trough as and for the purpose specified. 2nd. The combination, with the cooling compartment having a receiving trough for milk cans and an overflow for such trough, of the ice compartment having the slanting sectional bottom flooring provided with ribs and terminating in the centre in a draining trough, which leads into the receiving trough in the cooling compartment, as and for the purpose specified. 3rd. The combination, with the cooling compartment having a receiving trough for the milk cans, and an overflow for such trough, of the ice compartment provided with slanting sectional floor leading to the draining trough and air tubes I, and J, leading from the outside house and provided with stops for closing the tubes, as and for the purpose specified.

No. 44,927. Ink Bottle. (Encrier.)

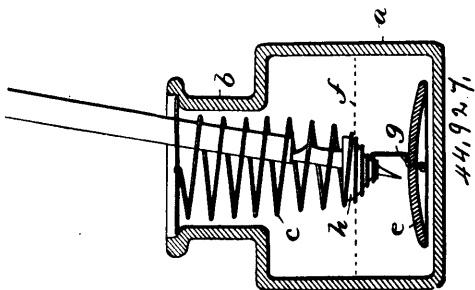

Burt Ramsay, Attleborough, Massachusetts, U.S.A., 20th December, 1893; 6 years.

Claim.—1st. The attachments for ink bottles which consist in the combination of the spring, substantially as described, the valve carried thereby and the pen guide carried by the spring and arranged to move the valve, substantially as described. 2nd. The ink bottle attachment, comprising the volute spring having the valve, and a pen guide attached to one end of the spring, substantially as described. 3rd. The bottle attachment, composed of the volute spring having one end arranged to rest on the top or mouth of the bottle, and a disc valve attached to the other end of the spring, substantially as described. 4th. The herein described

article for the purpose described, composed of a spring having one end formed to rest on the top or mouth of the bottle, and a disc valve secured to the opposite end of the spring whereby in use the coiled spring is located in the neck of the bottle, and holds the valve yieldingly to close the bottom of the neck, substantially as described. 5th. The herein described article consisting of the convolute spring having its large inner end arranged to rest on the top of the neck of the bottle the tapered pen guide secured to the small end thereof, and the disc valve secured to the spring a distance below the pen guide, substantially as described. 6th. The article for the purpose described consisting of the convolute spring having the large ring at one end to rest on the mouth of the bottle, the valve controlled by said spring and the cup-shaped pen guide having the small end of the spring secured around the central opening of the guide, substantially as described. 7th. The article for the purpose set forth consisting of a convolute spring having an arm extending downwardly from the small end thereof to one side of the longitudinal centre of the spring and the valve in the shape of a disc secured to said arm and controlled by the spring, substantially as described. 8th. The herein described article composed of the reversible volute spring, the pen guide secured to the small end thereof as set forth, the end of the spring extending downwardly from the pen guide at one side of the longitudinal centre of the spring, and having the offset at the lower end of the disc valve secured to the extremity of said arm or end with said offset bearing on the upper face of the valve as set forth.

No. 44,928. Border and Protector for Graves.
(Bordure et protection pour fosses.)

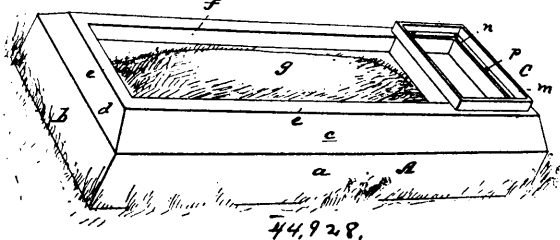

George R. Mease, Frank E. Dumm, and Avery Henderson, all of Upper Sandusky, Ohio, U.S.A., 20th December, 1893; 6 years.

Claim.—1st. The grave mound border and protector, comprising side and end walls, inwardly extending horizontal walls, a cross-bar *q*, a stone socket having a vertical marginal flange and a horizontal flange, and bolts taking through the said horizontal flange of the socket, and the horizontal wall and cross-bar, in combination with the anchor supports having the legs connected in pairs by cross-bars and provided with flat horizontal feet *i*, and flanges *j*, disposed at right angles to each other so as to enter the solid earth at the corners of a grave, and bolts for connecting the said anchor supports to the border or protector, substantially as specified. 2nd. The combination, with a grave mound border and protector, of anchor supports comprising legs having flat horizontal feet *i*, and flanges *j*, disposed at right angles to each other so as to enter the solid earth at the corners of a grave, and cross-bars connecting the said legs in pairs, and a suitable means for connecting the said anchor supports to the border or protector, all substantially as and for the purpose set forth.

No. 44,929. Skate. (Patin.)

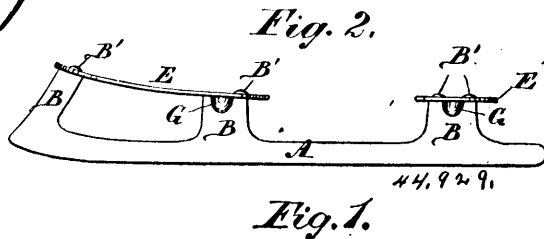

The Starr Manufacturing Company, Halifax, assignee of Thomas Harrison, Dartmouth, all in Nova Scotia, Canada, 20th December, 1893; 6 years.

Claim.—1st. The improvement in fastening sole and heel plates having a slotted depression *G*, to the runner of skates, which consists in slotting said plates outside or off set from said depression, in alignment with the runner, and providing the runner with rivet stubs fitting into said slots, and riveting said stubs by upsetting or swaging the end, as set forth. 2nd. In a skate having the runner fitting into a slotted depression *G*, in the sole and heel plates *E, E'*, said plates having a slot or slots *H*, outside of or off set from said depression, and the runner *A*, provided with rivet stubs *B'*, fitting into said slots, and rivetted by upsetting or swaging the end, as set forth, to secure said plates to the runner, as described for the purpose set forth.

No. 44,930. Oil Injector. (*Injecteur à huile.*)

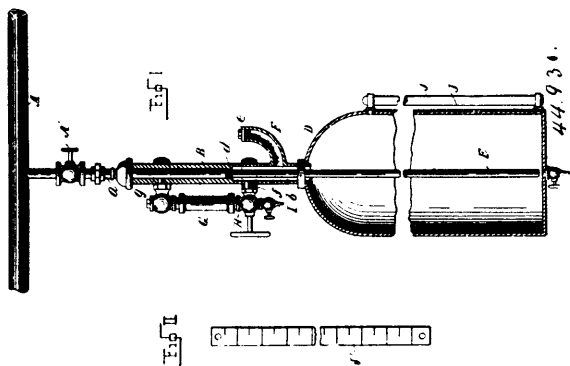

Frank Henry Cornell, New York, State of New York, U.S.A.,
20th December, 1893; 6 years.

Claim.—1st. In an oil injector, the combination with a reservoir or chamber, of a pipe entering the same, said pipe having two compartments, one for the supply of water and the other for the exit of oil, and a separate by pass pipe connecting the latter compartment with the former, substantially as described. 2nd. In an oil injector, the combination of an oil reservoir D, with a pipe B entering the same, a pipe E secured in pipe B, and projecting therefrom into reservoir D, and forming a space *b* and with a pipe G connecting at opposite parts with said space *b* and with pipe B, and a regulator H, connected with pipe G, substantially as described. 3rd. In an oil injector the combination of an oil reservoir with a pipe B, a pipe E therein forming a space *b*, a pipe G, tubes *f* and *g*, extending from pipe G to space *b*, and pipe B, respectively, and a regulator H, substantially as described.

No. 44,931. Fountain Attachments for Pens.

(*Attache pour plumes à réservoir.*)

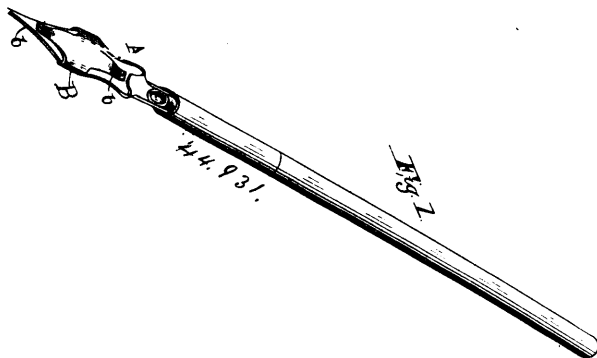

Ernest W. Bradford, Indianapolis, Indiana, U.S.A., 20th December,
1893; 6 years

Claim.—1st. A fountain attachment for pens consisting of a band of elastic material to embrace the pen having projections extending out therefrom towards the end of the pen, substantially as set forth. 2nd. A fountain attachment for pens, consisting of an elastic band with a projection on each end and the same side thereof, substantially as set forth. 3rd. The combination of the pen A, and the fountain attachment B, mounted thereon, said attachment consisting of an elastic band embracing said pen formed with a projection on each end of its under side, the end of each projection being held in close proximity to the under side of the pen by the inherent tension of the material, substantially as set forth.

No. 44,932. Spacing Attachment for Type Writers.

(*Appareil à espacer pour clavigraphes.*)

Charles Oscar Erwin and Frank Winkler, both of Kansas, State of
Kansas, U.S.A., 20th December, 1893; 6 years.

Claim.—1st. In a spacing attachment for type writers, the combination, with a rotatable cylinder of a penetrable disc secured to one end of said cylinder, and a slidable frame having a locking disc adapted to engage the penetrable disc, to prevent the rotatable movement of the cylinder, substantially as set forth. 2nd. In a spacing attachment for type writers, the combination, with a rotatable cylinder having a penetrable disc at one end and a ratchet-wheel at the other, of a slidable frame carrying a locking disc adjacent to the penetrable disc of the cylinder, and a spring actuated pawl engaging the ratchet-wheel, and means to move and hold said spring actuated pawl out of engagement with said ratchet to allow the spring actuated frame to cause the locking disc to engage the pen-

trable disc carried by the rotatable cylinder, substantially as set forth. 3rd. In a spacing attachment for type writers, the combina-

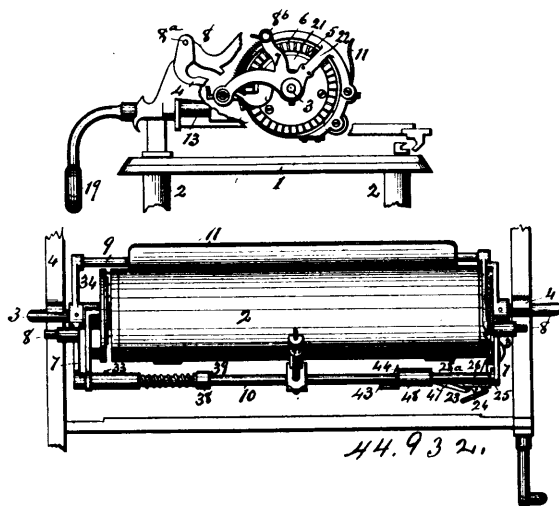

tion, with a rotatable cylinder having a penetrable disc secured at one end, of a spring actuated sliding frame carrying a locking disc adjacent to the penetrable disc carried by the cylinder, and means by which said locking disc may be moved and held out of engagement with the penetrable disc, substantially as set forth. 4th. A spacing attachment for type writers, comprising a rotatable cylinder, a penetrable disc secured to one end of said cylinder, a supporting bracket at each end of said cylinder, connected at the front side of said cylinder by a tubular and slotted tie-rod, a yoke frame comprising a tubular or sleeve section enclosing said tubular rod near one end and carrying the locking disc, a slide rod fitted within said tubular rod and a set screw passing through the slotted end of said tubular rod and connecting the sleeve section of the sliding frame with the slide rod, a lever pivoted within the opposite and slotted end of the tubular rod having a cam face at its other end, adapted when operated to engage and longitudinally move the slide rod within the tubular rod, substantially as set forth. 5th. A spacing attachment for type writers, comprising a rotatable cylinder having a ratchet-wheel at one end, a spring actuated pawl engaging said ratchet-wheel, a tubular and longitudinally extending rod slotted at each end at the front side of said cylinder, and connecting supporting brackets at each end of said cylinder, a tripping dog pivoted within the slotted tubular rod having a notch formed in its rear end, a lever pivoted within said slotted and tubular rod, having its free end engaging the notch of the tripping dog, and a slidable sleeve mounted upon said tubular rod and adapted to pivotally operate said lever to cause the tripping dog to raise and hold the locking pawl out of engagement with the ratchet-teeth at the end of the cylinder, substantially as set forth. 6th. In a spacing attachment for type writers, the combination of a rotatable cylinder having a penetrable disc at one end and a ratchet-wheel at the other end, of a spring actuated locking pawl adapted to engage the teeth of the ratchet-wheel, a longitudinally extended tubular rod at the front side of the cylinder, a sliding frame mounted to slide thereon and carrying a locking disc adjacent to the penetrable disc of the cylinder, a slide rod within said tubular rod and connected to the sliding frame, a tripping dog pivoted within the tubular rod and engaging the spring actuated locking pawl, a lever pivoted within said tubular rod, and adapted to engage the slide rod, and a lever pivoted within the tubular rod, and adapted to operate the tripping dog, and a slidable sleeve mounted upon said tubular rod and adapted to pivotally operate the lever to move the locking disc from engagement with the penetrable disc or to operate the lever to actuate the tripping dog, to move and hold the locking plate out of engagement with a ratchet-wheel, as desired, substantially as described. 7th. In a spacing attachment for type writers, a combination with a revoluble cylinder, having a penetrable disc secured at one end, of a tubular rod having a collar secured thereon, and a sliding yoke frame also mounted upon said tubular rod and carrying a locking disc adjacent to the penetrable disc of the cylinder, and a contracting spring spirally encircling the tubular rod, and secured at its opposite ends to the collar and to the tubular sleeve section of the yoke frame mounted upon the tubular rod, and adapted to hold the locking disc in engagement with the penetrable disc to prevent the revolution of the cylinder, substantially as set forth.

No. 44,933. Lamp. (*Lampe.*)

John U. Bauchelle, Elizabeth, and Thomas M. Fell, Tenafly, all of
New Jersey, U.S.A., 20th December, 1893; 6 years.

Claim.—1st. A self-feeding oil reservoir or fount, provided with one or more burners extending horizontally, or approximately so, therefrom, each burner being provided with a globe surmounted by

a chimney, so that the flame of the burner will be drawn outwardly and upwardly in a curved form in such a manner that the light

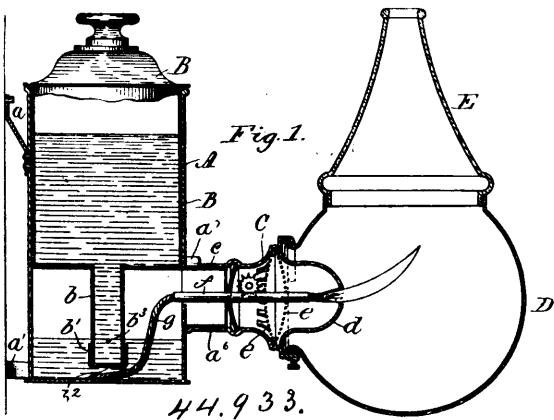

thereof will shine downward so that the lamp will cast no under shadow, substantially as set forth. 2nd. The combination with a receptacle closed at its bottom and open at its top, of a self feeding fount or reservoir closed at its top and arranged to discharge into said receptacle, and one or more burners extending outward horizontally, or approximately so, from said receptacle, and communicating with the latter so as to be supplied with the oil discharged from said self-feeding fount or reservoir, substantially as set forth. 3rd. A lamp comprising a receptacle, closed at its bottom and having attached thereto near its lower part one or more outwardly extending horizontal burners communicating with said receptacle, and an oil fount or reservoir closed at its top and fitting in said receptacle, said fount or reservoir being provided at its lower end with a reduced portion, having oil outlet and air inlet passages, substantially as set forth. 4th. A lamp comprising an oil fount or reservoir provided with a burner extending horizontally, or approximately so therefrom, and a globe support attached to said burner by a vertical hinge, whereby the globe is adapted to be swung horizontally when the lamp is to be lighted, and danger of tipping off or breaking the chimney by which the globe is surmounted is avoided, substantially as set forth. 5th. A lamp burner provided beneath the cone thereof with two foraminous plates or discs constructed and arranged to form an air chamber between them, whereby the inflow of air to the flame is rendered more steady and flickering of the flame is avoided, substantially as set forth.

No. 44,934. Check, Order, Etc.

(Chèque, livre de commandes, etc.)

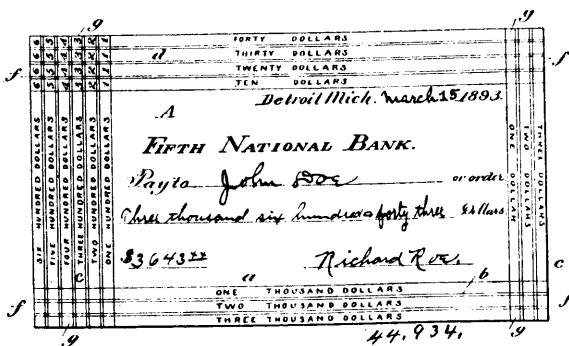

Lumus C. Newton, Detroit, Michigan, U.S.A., 20th December, 1893; 6 years.

Claim.—A blank check, draft or similar instrument, having a series of marginal lines along its edges and ends, numerical values expressed on said lines, and each series being complete in itself and respectively of different values, and corner sections having squares thereon formed by the extension and intersection of the marginal lines, and numerals printed on the said squares corresponding to the values printed on the marginal lines, substantially as and for the purpose specified.

No. 44,935. Wrench. (Clé à écrou.)

Theodore C. Lippitt, Shenandoah, Iowa, U.S.A., 20th December, 1893; 6 years.

Claim.—1st. The combination in a screw wrench, of a bar with an offset head at one end and a handle at the other, a loose jaw parallel with the head, a pair of parallel links pivoted at their ends respect-

ively to the bar and the loose jaw, a screw fitted to slide freely in the handle, a nut threaded upon the screw and located to revolve

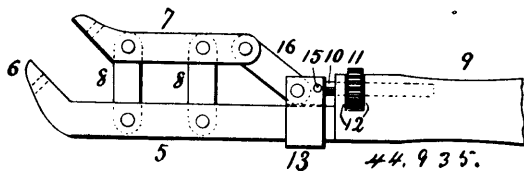

between end bearings in the handle, a carriage fitted to slide upon the bar and rigidly connected with the screw, and a brace pivoted to and connecting the carriage with the loose jaw, substantially as described. 2nd. The combination in a screw wrench of a bar having a head at one end, a loose jaw, a pair of links pivoted to the bar and loose jaw, a carriage fitted to slide upon the bar, a brace pivoted to the carriage and to the loose jaw and means for sliding the carriage, substantially as described. 3rd. The combination in a screw wrench, of a bar with a fixed jaw and a handle, a carriage to slide upon the bar and a movable jaw connected with the carriage, a screw rigidly fixed to the carriage and a nut located in end bearings relative to the handle and threaded to revolve upon the screw, substantially as described. 4th. The combination of a wrench bar having a fixed jaw, a movable jaw, links having integral trunnions on their sides to pass through the loose jaw and through the wrench bar, and means for swinging the loose jaw upon its links, substantially as described. 5th. The combination in a wrench of a pair of nut wrench jaws each perforated through, and a toothed pipe jaw made socket shaped to fit upon and around the edge of each wrench jaw and provided each with a fixed stud to engage the perforation in the wrench jaw, substantially as described.

No. 44,936. Shingle. (Bardeau.)

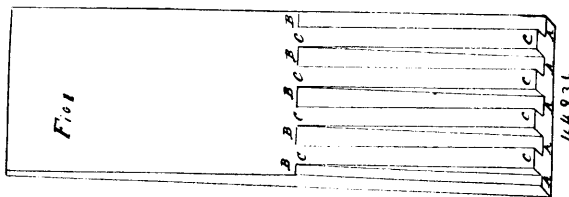

Cyril Demers, St. Flavien, Lotbinière, Québec, Canada, 20 Décembre, 1893; 6 ans.

Résumé.—Les rainures ou passages d'air dans le bardeau à toiture, que ces rainures soient de forme ronde, carrée ou toute autre forme, tel que décrit et pour les fins indiquées.

No. 44,937. Switch and Frog for Railways.

(Aiguille et rail de croisement pour chemins de fer.)

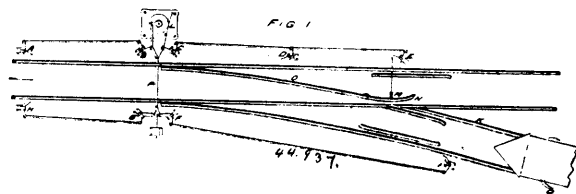

L. Henry Véronneau, Montréal, Québec, Canada, 20 Décembre 1893; 6 ans.

Résumé.—1° La disposition des leviers coudés et leur mode de fonctionnement. 2° La fermeture automatique composée d'une tige percée reposant sur une plaque, guidée au moyen d'une boîte et maintenue dans les deux positions au moyen de deux ressorts, la boîte servant aussi à protéger le mécanisme. 3° Le cœur composé de rails fixes et d'un bout de rail mobile, tournant autour d'une charnière. La pointe est supprimée au point de rencontre du rail principal et du rail de la voie d'évitement, grâce à l'entaille pratiquée dans le rail principal, livrant passage au boudin de la roue.

No. 44,938. Revolving Sole Plate for Ploughs.

(Plaque tournante pour charrues.)

Adam Murchey, and Robert Orr, both of Guelph, Ontario, Canada, 21st December, 1893; 6 years.

Claim.—1st. The new or improved attachment for ploughs, consisting of wheels B, B', situate in the body of the plough on a hollow axle cast in one piece with, or otherwise secured to the land side, or the mould board, or both, in lieu of a bed or sole plate, for the purpose of reducing friction, and thus lessening the draught of the plough, as hereinbefore described and illustrated in the drawing. 2nd. The combination, with the wheels B, B', revolving on horizontal hollow axles C, in lieu of a bed or sole plate, for lessening the draught of

ploughs, of the scrapers S, and guard plates F, cast on or otherwise secured to the land side or mould board, for the purpose of keeping

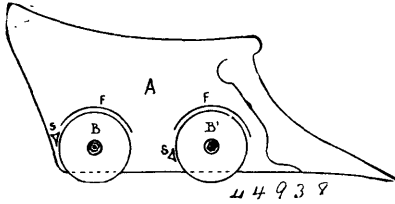

the wheels free from soil or dirt, as hereinbefore described and illustrated in the drawing.

No. 44,939. Pneumatic Tire. (*Bandage pneumatique.*)

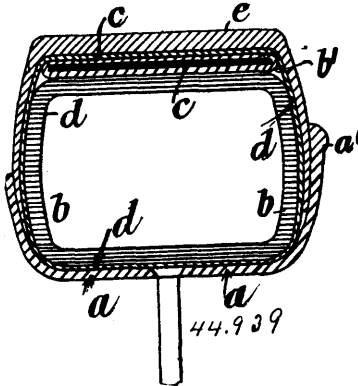

Arthur Matthy, London, England, 21st December, 1893; 6 years.

Claim.—1st. A pneumatic tire consisting of an inflatable air tube suitably made of rubber or canvas rubber, an outer hoop made of very thin finely tempered steel or other suitable elastic material of such a diameter as to give the air tube when inflated a flat outer circumference, a flexible but practically inelastic envelope of canvas or the like placed over the hoop and over the sides of the air tube, and tightly connected to the rim of the wheel so as to maintain concentricity of the hoop and the wheel rim when running, and an outer cover of rubber or the like, substantially as and for the purposes described. 2nd. A pneumatic tire consisting of the inflatable air tube *b*, the outer hoop *c*, the flexible but practically inelastic envelope *d*, which is tightly secured to the wheel rim *a*, and thereby maintains concentricity of the hoop *c*, and the wheel rim *a*, and the outer cover *e*, of rubber or the like, substantially as and for the purpose hereinbefore set forth.

No. 44,940. Mowing Machine. (*Faucheuse.*)

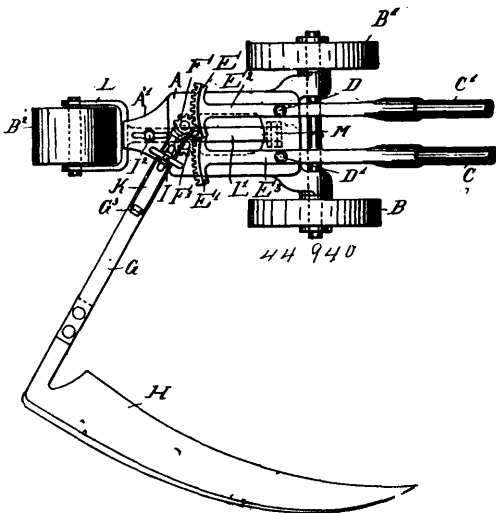

Carl Halverscheid, Hagen, Prussia, German Empire, 21st December, 1893; 6 years.

Claim.—1st. In a mowing machine, the combination with a wheeled frame, and with hand rod or rods adapted to drive said frame, of a movable scythe held by the latter, the hand rod or rods having a movement of their own, and being adapted thereby to operate said scythe, for the purpose hereinbefore set forth. 2nd. In a mowing machine, the combination with a wheeled

frame, and with a hand rod or rods adapted to drive said frame, of a lever having a scythe blade at its front end and a cog-wheel at its fulcrum, the hand rod or rods being connected with movable toothed sectors gearing with said cog-wheels, substantially as and for the purpose hereinbefore set forth. 3rd. In a mowing machine, the combination with a wheeled frame, of two double armed levers E^2, E^3 , held by said frame, said levers carrying at one end hand rods C, C^1 , adapted to turn cog-wheels F, F^1 , meshing with each other, one of said cog-wheels forming the fulcrum part of a lever carrying a scythe blade at its free end, substantially as and for the purpose hereinbefore set forth. 4th. In a mowing machine, the combination with a wheeled frame, of two double armed levers E^2, E^3 , held by said frame, said levers carrying at one end hand rods C, C^1 , adapted to drive the machine, and at the other end toothed sectors E, E^1 , adapted to turn cog-wheels F, F^1 , meshing with each other, cog-wheel F , forming the fulcrum part of a lever G^1 , carrying at its free end a double armed lever G, G^2 , arm G , of said lever holding a scythe blade, arm G^2 , of the same extending below lever G^1 , and being adjustable by a screw I , held by the latter, substantially as and for the purpose hereinbefore set forth. 5th. In a mowing machine, the combination with a wheeled frame, of two double armed levers E^2, E^3 , held by said frame, said levers carrying at one end hand rods C, C^1 , adapted to drive the machine, and at the other end toothed sectors E, E^1 , adapted to turn cog-wheels F, F^1 , meshing with each other, cog-wheel F , forming the fulcrum part of a lever G^1 , carrying at its free end a double armed lever G, G^2 , arm G , of said lever holding a scythe blade, arm G^2 , of the same extending below lever G^1 , and being adjustable by a screw I , held by the latter, said screw having a nut I^1 , adapted to alter the tension of a spring K , acting on the scythe, substantially as and for the purpose hereinbefore set forth. 6th. In a mowing machine, the combination with a transportable frame, having an adjustable front wheel, and with hand rod or rods adapted to drive said frame, of a movable scythe held by the latter, the hand rod or rods having a movement of their own, and being adapted thereby to operate said scythe, substantially as and for the purpose hereinbefore set forth. 7th. In a mowing machine, the combination with a transportable frame, having an adjustable front wheel, and with hand rod or rods adapted to drive said frame, of a lever, having a scythe blade at its front end, and a cog-wheel at its fulcrum, the hand rod or rods being connected with movable toothed sectors gearing with said cog-wheel, substantially as and for the purpose hereinbefore set forth. 8th. In a mowing machine, the combination with a transportable frame A , having an adjustable front wheel B^2 , of two double-armed levers E^2, E^3 , held by said frame, said levers carrying at one end hand rods C, C^1 , adapted to drive the machine, and at the other end toothed sectors E, E^1 , adapted to turn cog-wheels F, F^1 , meshing with each other, one of said cog-wheels forming the fulcrum part of a lever carrying a scythe blade at its free end, substantially as and for the purpose hereinbefore set forth. 9th. In a mowing machine, the combination with a transportable frame A , having an adjustable front wheel B^2 , of two double-armed levers E^2, E^3 , held by said frame, said levers carrying at one end hand rods C, C^1 , adapted to drive the machine, and at the other end toothed sectors E, E^1 , adapted to turn cog-wheels F, F^1 , meshing with each other, cog-wheel F , forming the fulcrum part of a lever G^1 , carrying at its free end a double-armed lever G, G^2 , arm G , of said lever holding a scythe blade, arm G^2 , of the same extending below lever G^1 , and being adjustable by a screw I , held by the latter, substantially as and for the purpose hereinbefore set forth. 10th. In a mowing machine, the combination, with a transportable frame A , having a hinged rod L^1 , holding a single front wheel B^2 , and having a projection A^1 , holding an adjusting screw I^2 for said front wheel, of the two double armed levers E^2, E^3 , held by said frame, said levers carrying at one end hand rods C, C^1 , adapted to drive the machine, and at the other end toothed sectors E, E^1 , adapted to turn cog-wheels F, F^1 , meshing with each other, cog-wheel F forming the fulcrum part of a lever G^1 , carrying at its free end a double armed lever G, G^2 , arm G of said lever holding a scythe blade arm G^2 , of the same extending below lever G^1 , and being adjustable by a screw I held by the latter, said screw having a nut I^1 , adapted to alter the tension of a spring K acting on the scythe, substantially as and for the purpose hereinbefore set forth.

No. 44,941. Snow and Ice Velocipede.

(*Vélocipède pour la neige et glace.*)

D. G. Bolton, Cooperstown, New York, U.S.A., 21st December, 1893; 6 years.

Claim.—1st. A snow and ice velocipede, comprising single front and rear runners supporting the frame, and a propeller chain mounted to travel along the rear runner and driven from the pedal or crank shaft, substantially as shown and described. 2nd. A snow and ice velocipede, provided with auxiliary frames, and single runners held adjustable in the said auxiliary frames, substantially as shown and described. 3rd. A snow and ice velocipede, comprising auxiliary frames having forked bottom parts, a main frame supported on the said auxiliary frames, runners fitted in the forked bottom parts of the said auxiliary frames, links held on the said auxiliary frames and connected with the said runners, and means, substantially as described, for adjusting the said links to move the runners in or out of the forked bottom parts

of the said auxiliary frames, substantially as shown and described.
 4th. A snow and ice velocipede, comprising a main frame, auxiliary

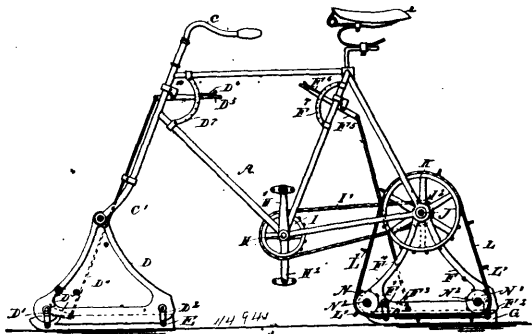

frames jointed on said main frame, runners held adjustable in the said auxiliary frames, a propelling chain adapted to be driven from the pedal or crank shaft and provided with spikes or blades, and sprocket-wheels held in the rear auxiliary frame and under which passes the said propelling chain, to cause the latter to extend horizontally alongside the rear runner between the said sprocket-wheels, substantially as shown and described. 5th. A snow and ice velocipede, comprising a main frame, auxiliary frames jointed on said main frame, runners held adjustable in the said auxiliary frames, a propelling chain adapted to be driven from the pedal or crank shaft and provided with spikes or blades, sprocket-wheels held in the rear auxiliary frame and under which passes the said propelling chain, to cause the latter to extend horizontally alongside the rear runner between the said sprocket-wheels, and means, substantially as described, for operating the said propelling chain from the pedal shaft, as set forth.

No. 44,942. Spring for Watch Cases, Locketts and the Like. (*Ressort pour boîtes de montre, loquet, etc.*)

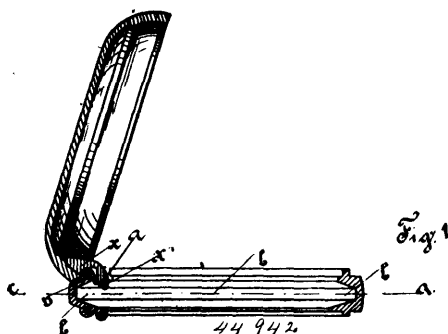

Frederick Emil Lange, Glashuette, Saxony, German Empire, 21st December, 1893; 6 years.

Claim.—1st In a lid lifting device for watch cases, lockets, and the like, a spring wire whose ends bear against the inner side of the watch case, in combination with a tongue extending from the watch lid, whose end bears against the spring wire, substantially as set forth. 2nd. In a lid lifting device for watch cases, lockets, and the like, a watch case having an annular recess, a spring wire arranged in said recess, in combination with a tongue extending from the watch lid, whose end bears against the spring wire. 3rd. In a lid lifting device for watches, lockets, and the like, the combination of a spring wire having a central bend whose ends bear against the inner sides of the watch case, in combination with a tongue extending from the watch lid and provided with a recess at its end, the central bend of the spring wire fitting into the recess of the tongue, substantially as set forth. 4th. In a watch case, the combination of the following parts:—A case provided with an inner annular recess, a lid hinged thereto, a tongue attached to the lid above the hinge, extending down into the watch case and having a recess at its end, a spring wire having a central bend and rounded bent ends bearing against the walls of the annular recess of the watch case, the central bend of the spring wire fitting into the recess in the tongue, substantially as set forth. 5th. As an article of manufacture, a lid lifting spring consisting of a piece of spring wire, having a central bent portion, substantially as set forth. 6th. As an article of manufacture, a lid lifting spring, consisting of a piece of spring wire having a central bend and bent and rounded ends, substantially as set forth.

No. 44,943. Machine for Preparing Gas.
 (*Machine pour la préparation du gaz.*)

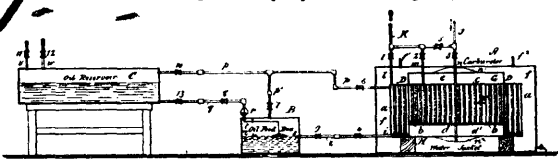

Minian Calvin Smillie, M.D., Gaspé Basin, Quebec, Canada, assignee of Robert Southworth Lawrence, London, England, 22nd December, 1893; 6 years.

Claim.—1st. In an apparatus for carbureting or enriching gas, or air, the combination of an enriching chamber receiving the gas, or air, and the enriching medium, a stripping or equalizing chamber wherein super carbon is chilled or stripped out, and a mixing chamber wherein the enriched gas or air is atomized, and the operating of chilling and mixing is completed, and from which the gas, or air is discharged or distributed to the burners, substantially as set forth. 2nd. In an apparatus for carbureting or enriching gas, or air, the combination of an enriching chamber receiving the gas, or air, and the enriching medium, and containing a series of perforated tubes or compartments filled with an absorbent material, a stripping and equalizing chamber in communication with said enriching chamber and containing similar tubes or compartments filled with a suitable stripping material, and a mixing chamber having pipes or tubes in communication with said stripping chamber so arranged that as the carburetted gas or air is discharged into such mixing chamber it shall be atomized, said mixing chamber containing also perforated tubes or chambers filled with material which is a bad conductor of heat, and from which the enriched and finally chilled gas or air is led or distributed to the burners, substantially as set forth. 3rd. In an apparatus for carbureting or enriching gas or air, the combination with an oil reservoir, of a carburetor consisting of three concentric communicating chambers, the outer of said chambers containing perforated tubes filled with absorbent material, the intermediate chamber containing perforated tubes filled with a suitable stripping material, and the inner or central chamber having atomizing devices and filled with non-conducting material, and layers of cloth or other fabric upon which the lower ends of all of said tubes rest, the whole being connected and arranged with suitable inlets and outlets, substantially in the manner set forth. 4th. In a carburetor, the combination, with the three concentric chambers *a, b,* and *c,* having the perforated tubes with their filling material arranged substantially as described, of the non-conducting chambers *d* and *e,* the surrounding water jacket, and suitable inlets and outlets, substantially as and for the purpose set forth. 5th. The combination, with an oil feed box, of the carburetor made up of the external water jacket, the three concentric chambers having the tubes with their filling material, and the layers of cloth on the bottoms of said chambers, and suitable inlet and outlet pipes, substantially as and for the purpose described. 6th. In a carburetor, the combination, with the mixing and chilling chamber, of an atomizing device, substantially as set forth. 7th. In a carburetor, the combination, with the stripping chamber and the final mixing and chilling chamber of a series of grouped pipes or tubes discharging from said stripping chamber, into said mixing chamber so arranged that the streams of gas or air issuing from the individual pipes of each group will impinge upon each other by crossing each others paths, substantially as and for the purpose set forth. 8th. In a carbureting apparatus, the combination with the carburetor proper, and an oil reservoir, of an oil feed box connected to said reservoir and carburetor, and a valve located outside of said feed box and capable of being adjusted to regulate the depth of oil maintained in the carburetor, substantially as described and shown. 9th. The combination with the oil feed box and its valve, of a plate located within said box and sustained by a spring directly underneath the valve, and a bell or other alarm device actuated by the oil falling upon said plate, substantially as and for the purpose set forth. 10th. In an apparatus for enriching or carbureting gas, or for carbureting air, the combination with a carburetor, of an oil feeding box provided with a valve by which the amount of oil feed to the carburetor can be regulated, a water jacket surrounding said carburetor on all sides and provided with means for causing the circulation of the water in said jacket, a pipe through which the gas or air to be carbureted passes into the enriching chamber of the carburetor, a pipe through which the gas or air may be introduced directly into the intermediate or equalizing chamber of the carburetor, and a pipe through which the gas or air may be caused to pass directly to the burners without passing through the carburetor, the whole being combined so that the operator may vary at pleasure the illuminating power of the gas supplied to the burners, and also supply the burners with gas of a given illuminating power, substantially as described.

No. 44,944. Heater. (*Appareil de chauffage.*)

Evan Alfred Edwards, Chicago, Illinois, U.S.A., 22nd December, 1893; 6 years.

Claim.—1st. In an atmospheric heater, the combination with a chamber for the products of combustion and a heating chamber

above and separated from said first mentioned chamber by an imperforate diaphragm and an air duct for said heating chamber

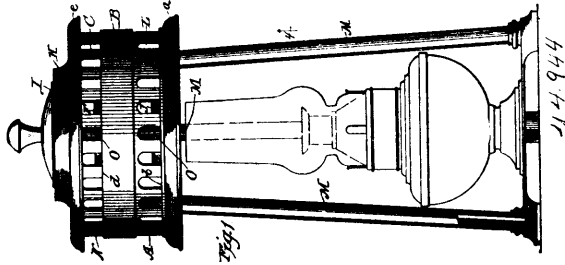

extending through but having no communication with the combustion chamber, substantially as described. 2nd. In an atmospheric heater the combination with a chamber for the products of combustion and a heating chamber above and separated from said combustion chamber by an imperforate diaphragm, of air ducts for said heating chamber extending through but having no communication with the combustion chamber, substantially as described. 3rd. In an atmospheric heater the combination with a chamber for the products of combustion and a main heating chamber above but separated from the combustion chamber by a perforated diaphragm, and air ducts opening into the main heating chamber but having no communication with the combustion chamber, substantially as described. 4th. In an atmospheric heater, the combination with a chamber and a main heating chamber above and separated therefrom by an imperforate diaphragm, of an auxiliary heating chamber above the main heating chamber and separated therefrom by a perforated diaphragm, and air ducts opening into the main heating chamber, substantially as described. 5th. In an atmospheric heater, the combination, with a chamber for the products of combustion, and a main heating chamber above, but separated from said first mentioned chamber by an imperforate diaphragm, of an auxiliary heating chamber above the main heating chamber and separated therefrom by a perforated diaphragm, air ducts opening into the main heating chamber, and passing through but having no communication with the chamber for the products of combustion, and air tubes or flues passing through all of said chambers without communication therewith, substantially as described. 6th. In an atmospheric heater, the combination, with a chamber for the products of combustion and a heating chamber above and separated from said first mentioned chamber by a diaphragm having a central opening closed by a removable cap or plate of air ducts for said heating chamber, substantially as described. 7th. In an atmospheric heater, the combination, with a chamber for the products of combustion, and a heating chamber above, and separated from said first mentioned chamber by a diaphragm having a central opening closed by a removable cap or plate of air ducts opening into the heating chamber, and passing through the chamber for the products of combustion but having no communication therewith, substantially as described. 8th. In an atmospheric heater, the combination, with a chamber for the products of combustion, and a main heating chamber above and separated from the first mentioned chamber by a diaphragm having a central opening closed by a removable cap, and air ducts opening into the main heating chamber, substantially as described. 9th. In an atmospheric heater, the combination, with a chamber for the products of combustion, and a heating chamber above, and separated therefrom by an imperforate diaphragm, of hollow legs opening at their upper ends into the heating chamber and constituting air ducts therefor, substantially as described. 10th. In an atmospheric heater, the combination, with a chamber for the products of combustion, and a heating chamber above, and separated from the first mentioned chamber by an imperforate diaphragm, of the hollow legs extending through the combustion chamber and opening at their inner ends into the heating chamber constituting an air duct therefor, substantially as described. 11th. In an atmospheric heater, the combination, with a chamber for the products of combustion, and a heating chamber above, and separated from said first mentioned chamber by an imperforate diaphragm of an auxiliary heating chamber above the main heating chamber and separated therefrom by a perforated diaphragm, and hollow legs extending through the chamber for the products of combustion and opening into the main heating chamber, constituting air ducts therefor, substantially as described. 12th. In an atmospheric heater, the combination, with a chamber for the products of combustion, and a main heating chamber above, and separated from the first mentioned chamber by an imperforate diaphragm, of an auxiliary heating chamber above the main heating chamber and separated therefrom by a perforated diaphragm, air flues or tubes open at each end and extending through all of said chambers with-

out communication therewith, and hollow legs passing through the products of combustion, and opening into the main heating chamber, constituting air ducts therefor, substantially as described. 13th. An atmospheric heater composed of four sections, the lower one comprising the diaphragm J, the next resting thereon and comprising the diaphragm D, with the perforated side walls of the chamber for the products of combustion, the next resting on the diaphragm D, and comprising the diaphragm F, and the imperforate side walls of the main heating chamber, and the next resting on the diaphragm F, and comprising the cover H, and the perforated side walls of the auxiliary heating chamber, in combination with the air flues or tubes O, and air ducts for the main air chamber substantially as described.

No. 44,945. Calk. (Crampon.)

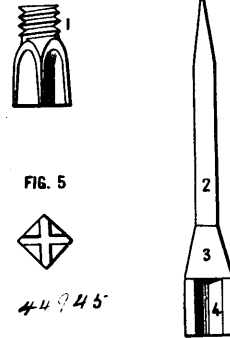

Georges de Roussy de Sales, Sainte-Ménéhould, France, 22nd December, 1893; 6 years.

Claim.—1st. The improved calks or hobnails for the shoes of horses and other animals, or for boots and shoes for personal wear, having their heads formed like a cross or star in cross-section, and thereby enabling them to present a minimum bearing surface while constantly retaining their sharp edges and angles to prevent slipping, substantially as herein described, said calks, or hobnails, being secured to the animal's hoof either directly or by means of a shoe, or to boots and shoes, by screwing, nailing, rivetting, soldering or otherwise, as set forth.

No. 44,946. Lock for Mail Bags.

(Cadenas pour sacs à lettres.)

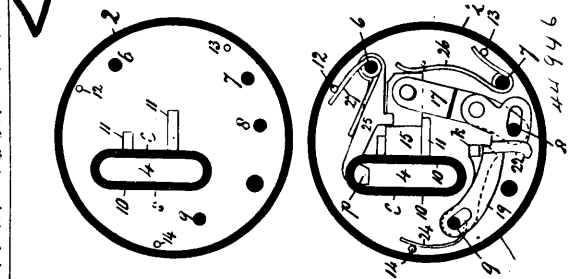

George Low, Ottawa, Ontario, Canada, 23rd December, 1893; 6 years.

Claim.—1st. The combination with the lock case having a bar entrance or aperture 4, and provided with a key hole 3, of the spring locking bolt 15, to engage a bar B, and a spring pawl 25, engaging said bolt, the lever bar 17, hung to said bolt and pivoted to the lock case, the slotted push bar 19, pivotally connected to said lever bar 17, and a tumbler 23, engaging said push bar, whereby the introduction of a bar B, into the lock operates said combination, to lock said bar, and unlocking is effected by partially turning a key inserted in the key hole 3, in the lock case, as set forth. 2nd. The combination of a bar B, having a tapering or semi-circular end provided with a hole B³, and a shoulder B¹, and loop B², at the opposite end, a lock case A, having an aperture 4, to receive said tapering or semi-circular end of said bar, spring mechanism within said case acted upon by the introduction of said bar to effect self locking, and a key to react said mechanism, to effect unlocking, as set forth.

No. 44,947. Tight Joint for Windows.

(Joint serré pour fenêtres.)

Johannes Ehreke, Badresch, Meklenburg Strelitz, German Empire, 23rd December, 1893; 6 years.

Claim.—1st. The arrangement for forming tight joints for windows consisting of a central bar *a* attached to one of the casements of the window in such a manner as to become jammed between the said two casements through the action of a handle *b* in connection with a pin *c* and racks *d*, *e*, having bent ends *x*, acting upon

bolts *f* and *g*, which are adapted to slide in guides *h*, constructed and arranged, substantially as hereinbefore described. 2nd. The

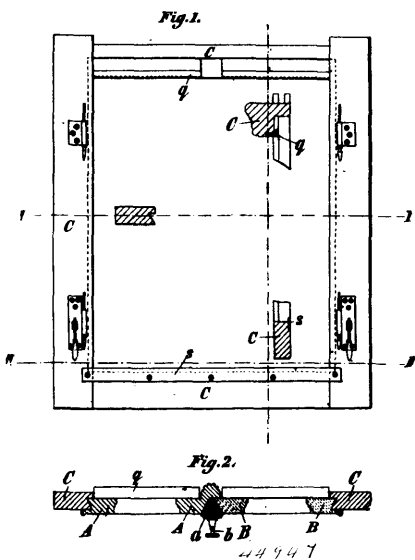

combination, with the central bar *a*, handle *b*, pin *c*, racks *d*, *e*, having bent ends *s*, acting upon bolts *f* and *g*, adapted to slide in guides as specified, of means for securing tight joints at the top and at the bottom of the casements consisting of a device for lifting the hinges by means of eccentrics *l* working in suitable slots in the hinge plates *n*, so as to disengage and engage the casements of the window from the respective bars at the top and bottom constructed and arranged, substantially as hereinbefore described. 3rd. In combination, with windows of the character herein referred to, a hinge composed of two movably connected hinge parts *v* and *w* for the purpose of enabling the window casements to be pressed tightly against the sides of the frame, as also a bayonet lock *u* for the purpose of allowing the casements to be lifted out of their hinges only when opened at right angles to the frame constructed and arranged, substantially as hereinbefore described.

No. 44,948. Cheese Case. (Boîte à fromage.)

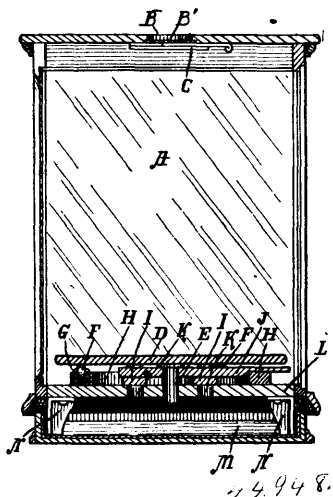

Henry D. Streator, Galesburg, Michigan, U.S.A., 23rd December, 1893; 6 years.

Claim.—1st. In a cheese case, in combination, with a case having a top opening and a water tray beneath the case, a turn-table, a centre pin, a ring beneath said table having rolls supporting said turn-table, parallel openings in the bottom of the case at each side of said pin, strips covering said openings, and a bar attached to said strips having an opening engaging said pin, said bar also extended above and outside of said ring, substantially as described. 2nd. In a cheese case, in combination, with a case having top openings and a water tray beneath said case, a turn-table having a centre pin, parallel elongated openings at each side of said pin, strips covering said openings, and a transverse bar attached to said strips and having an opening engaging said pin, said bar also prolonged at one end beyond the edge of said turn-table, substantially as described.

3rd. In a cheese case, in combination, with a case having a top opening and adjustable bottom openings, and a water tray beneath said case, a turn-table, a centre pin, roller supports for said turn-table, substantially as described. 4th. In a cheese case, the combination of a suitable case having adjustable top and bottom openings, a water tray beneath, and a turn-table within the case for the purpose set forth.

No. 44,949. Explosive. (Explosif.)

Charles E. Munro, Washington, District of Columbia, U.S.A., 23rd December, 1893; 6 years.

Claim.—1st. The method of making explosive material which consists in mixing and incorporating with gun cotton a liquid colloiding agent which is capable of converting at ordinary temperatures the higher cellulose nitrates into viscous form and then acting upon it with heated liquid or vapour to indurate it, substantially as set forth. 2nd. The method of making explosive material which consists in extracting from gun cotton the lower products of nitration, then mixing and incorporating with it a liquid colloiding agent which is capable of converting at ordinary temperatures the higher cellulose nitrates into viscous form, and then indurating it, substantially as set forth. 3rd. The method of making explosive material which consists in extracting from gun cotton the lower products of nitration, then mixing and incorporating with it a liquid colloiding agent which is capable of converting at ordinary temperatures the higher cellulose nitrates into viscous form, and then acting upon it with heated liquid or vapour to indurate it, substantially as set forth. 4th. The method of making explosive material which consists in extracting from gun cotton the lower products of nitration, then mixing and incorporating with it nitro-benzene, and then indurating it, substantially as set forth. 5th. The method of making explosive material which consists in first extracting from gun cotton the lower products of nitration, then mixing and incorporating with it nitro-benzene, and then acting upon it with heated liquid or vapour to indurate it, substantially as set forth. The method of making explosive material which consists in first extracting from gun cotton the lower products of nitration, then mixing and incorporating with it a liquid colloiding agent which is capable of converting at ordinary temperatures the higher cellulose nitrates into viscous form, then forming the material into pieces of the desired form, such as grains or strips, and finally indurating the material, substantially as set forth. 7th. The explosive material consisting wholly of cellulose nitrates of the higher orders in a colloided and indurated condition, substantially as set forth.

No. 44,950. Device for Utilizing Water Power.

(Appareil pour utiliser les pouvoirs d'eau.)

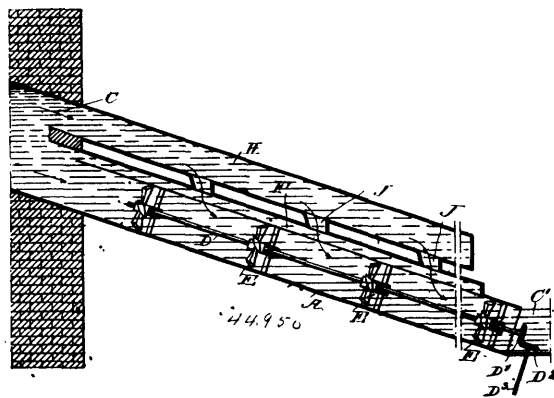

Thomas Anthony Macdonald, Paterson, New Jersey, U.S.A., 23rd December, 1893; 6 years.

Claim.—1st. A device for utilizing water power, comprising a race-way containing the water motors and arranged in an inclined position, and a pressure box opening into the race-way throughout its length, the said race-way and its pressure box being connected with the intake at their upper ends, substantially as shown and described. 2nd. A device for utilizing water power, comprising an inclined race way containing the water motors and connected at its upper end with the intake and at its lower end with a discharge, and a pressure box set on the race-way and opening into the same throughout its length, the lower end of the said pressure box being closed, while the upper end opens into the intake for the race-way, substantially as shown and described. 3rd. A device for utilizing water power, comprising an inclined race-way containing the water motors and connected at its upper end with the intake and at its lower end with a discharge, a pressure box set on the race-way and opening into the same, the lower end of the said pressure box being closed, while the upper end opens into the intake for the race-way, a pipe connected with the intake for the race-way, and branch pipes leading from the said pipe down into the pressure box, substantially as shown and described. 4th. A device for utilizing water power, com-

prising an inclined main race-way, an auxiliary race-way arranged alongside the said main race-way, pressure boxes arranged on the said race ways and in communication with the same, the lower ends of the said pressure boxes being closed, while their upper ends open into the intake for the race-ways, and motors arranged in the said main race-way, substantially as shown and described. 5th. A device for utilizing water power, comprising an inclined main race-way, an auxiliary race-way arranged alongside the said main race-way pressure boxes arranged on the said race-ways, and in communication with the same, the lower ends of the said pressure boxes being closed, while the upper ends open into the intake for the race-ways, motors arranged into the said main race-way, and means for discharging the water from one part of the race-way into part of the other race-way, substantially as shown and described. 6th. A device for utilizing water power, comprising an inclined main race-way, an auxiliary race-way arranged alongside the said main race-way, pressure boxes arranged on the said race-ways and in communication with the same, the lower ends of the said pressure boxes being closed, while the upper ends open into the intake for the race-ways, motors arranged in the said main race-way, pipes leading from the intake for the race-way over the latter, and branch pipes extending downwardly from the said pipes to the pressure boxes for the race-ways, substantially as described.

No. 44,951. Knitting Machine. (Machine à tricoter.)

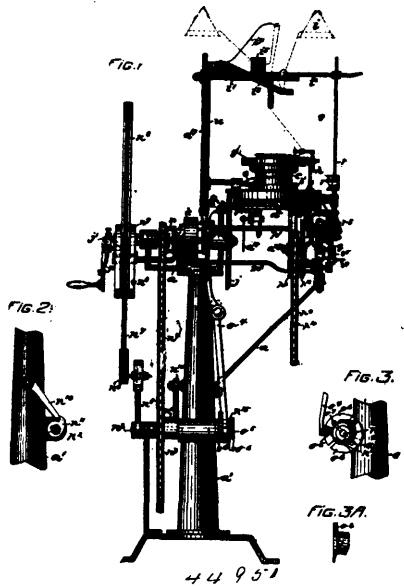

Emil John Franck, Philadelphia, Pennsylvania, U.S.A., 23rd December, 1893; 6 years.

Claim.—1st. A knitting machine provided with a driving-shaft, a counter-shaft, a driving pulley, mechanism for imparting rotary motion from the pulley to the counter-shaft, an arm and its accessories actuated by the counter-shaft and adapted to reciprocate the driving-shaft, and pawl and ratchet connections for preventing retrograde movement of the counter-shaft, substantially as and for the purposes set forth. 2nd. A knitting machine provided with a driving-shaft, a counter-shaft having a crank, a reciprocating rod actuated by said crank and provided with connections for oscillating the driving-shaft, a tooth on said counter-shaft, and a detent for engaging said tooth, substantially as and for the purposes set forth. 3rd. A knitting machine provided with a counter-shaft, a pivotal bar having its respective extremities connected with pawl-bars, a centrally pivoted link having one extremity in engagement with the pivotal bar, and a cam on the counter-shaft engaging the other extremity of the link, substantially as and for the purposes set forth. 4th. A knitting machine provided with a counter-shaft, a pivotal bar having its respective extremities connected with pawl-bars, a centrally pivoted link having one extremity in engagement with the pivotal bar, a cam on the counter-shaft engaging the other extremity of the link, and set screws for limiting the range of motion of the pivotal arm, substantially as and for the purposes set forth. 5th. A knitting machine provided with a pivotal bar having its respective extremities connected with pawl-bars, a centrally pivoted link having one extremity thereof in engagement with the pivotal bar, a counter-shaft and segmental plates adjustably connected with the counter-shaft and provided with cams for engaging the other extremity of said link, substantially as and for the purposes set forth. 6th. A knitting machine provided with a pivotal bar having its respective extremities connected with pawl-bars, a centrally pivoted link having one extremity thereof in engagement with the pivotal bar, a counter-shaft, segmental plates adjustably connected

with the counter-shaft and provided with cams for engaging the other extremity of said link, and set screws for limiting the range of motion of the pivotal arm, substantially as and for the purposes set forth. 7th. A knitting machine provided with a pivotal bar having its respective extremities connected with pawl-bars, a centrally pivoted link having one extremity thereof in engagement with the pivotal bar, a counter-shaft, a sleeve keyed to the counter-shaft, and segmental plates adjustably connected with the sleeve and provided with cams for engaging the other extremity of said link, substantially as and for the purposes set forth. 8th. A knitting machine provided with a driving-shaft having a crank arm, a driving drum loose on the driving-shaft and provided with a recess, a spring controlled pin carried by the handle and adapted to engage said recess, and means for shifting the drum, substantially as and for the purposes set forth. 9th. A knitting machine provided with a driving-shaft having a crank arm, a driving drum loose on the driving-shaft and provided with a recess and its complementary cam surface, a spring controlled pin carried by the handle and adapted to ride on the cam surface and snap into the recess, and means for shifting the drum, substantially as and for the purposes set forth. 10th. The combination, in a knitting machine, of a driving-shaft geared to the cam cylinder, stop motion mechanism, an eccentric fast on said shaft and adapted to supply power to the stop motion mechanism, a bar on the hub of the eccentric, a pulley afforded end play on the shaft and provided with spring controlled pins for engaging said bar and means for shifting said pulley, substantially as and for the purposes set forth. 11th. A knitting machine provided with a sinker bed, sinker bars working in said bed, a revoluble sinker head, a washer interposed between the sinker head and bars, and means for actuating the sinker head, substantially as and for the purposes set forth. 12th. A knitting machine provided with a thread carrier, needles, needle cams, sinker bars adapted to pass under the thread after it is laid on to the needles and having inclined edges for drawing the thread upwards to expand the stitches, and means for operating the sinker bars, needle cams and thread carrier, substantially as and for the purposes set forth. 13th. In a knitting machine, needles and sinker bars having inclined working edges adapted to co-operate with the needles in expanding the stitches, substantially as and for the purposes set forth. 14th. A knitting machine provided with latch needles, a revoluble sinker head having a downwardly projecting ear adapted to ride over and open the latches of the needles, and means for actuating the needles and sinker head, substantially as and for the purposes set forth. 15th. A knitting machine provided with a needle cylinder, a split ring provided with a downwardly projecting finger, a wedge for clamping said ring in the cylinder, and a bed having means for supporting said finger, substantially as and for the purposes set forth. 16th. A knitting machine provided with a needle cylinder, a split ring provided with a downwardly projecting finger and with recessed extremities, a wedge adapted for insertion in said recesses to clamp the ring in the needle cylinder, and a bed having means for supporting said finger, substantially as and for the purposes set forth. 17th. A knitting machine provided with an axially grooved needle cylinder, needles working in said grooves and provided with bits, a sinker bed fitted on wide portions of the webs between said grooves, a sectional ring detachably fitted into notches in said webs beneath the wide portions thereof and adapted to serve as a gauge for the sinker bed and to permit of the removal of needles, substantially as and for the purposes set forth. 18th. A knitting machine provided with needles, a thread carrier and a complementary ring adapted to open the latches of the needles and adjustably connected with the pivotal portion of the thread carrier, the construction being such that the ring may be turned clear of the needles to permit of the application of a transfer frame, substantially as and for the purposes set forth. 19th. A knitting machine provided with needles, a post connected with the cam cylinder, a thread carrying arm hinged to said post, a ring adapted to open the latches of the needles and adjustably attached to said hinged arm, and an adjusting screw interposed between the post and arm, substantially as and for the purposes set forth. 20th. A knitting machine provided with needles, a post connected with the cam cylinder, a thread carrying arm hinged to said post, and a complementary ring adjustably connected with the hinged arm and provided with an integral plate having its lower edge adapted to open the latches of the needles, substantially as and for the purposes set forth. 21st. A knitting machine provided with fashioning needle controlling cam carriages, pawls for actuating said carriages, and racks detachably connected with said carriages, substantially as and for the purposes set forth. 22nd. A knitting machine provided with fashioning needle controlling cam carriages, racks provided with slots, set screws working in said slots and connected with the cam carriages, and pawls engaging said racks, substantially as and for the purposes set forth. 23rd. A knitting machine provided with knitting cams, a set of fashioning needles movable out of range of the knitting cams, carriages provided with a recess closed at the bottom and having a seat for the fashioning needles, and cam plates applied to the edges of said recess and forming two openings, whereof each is co-extensive with the set of fashioning needles, and said plates operating upon both sides of the shanks of all the needles of the set, substantially as and for the purposes set forth. 24th. A knitting machine provided with knitting cams, sets of fashioning needles movable out of range of the knitting cams, a carriage pertaining to each set of fashioning needles and provided with cam plates

extending beyond one of the ends of the carriages, and the projecting extremities of the cam plates of one carriage off-set for the accommodation of the cam plates of the other carriage, substantially as and for the purposes set forth. 25th. A knitting machine provided with a needle cylinder having a retaining spring, needles some of which have longer bits than others, and curved shanks for engaging said spring, a pivotal switch-plate adapted to engage the long bits and shift the corresponding needles out of and into engagement with said spring, a rock-shaft carrying said switch plate, a pin or projection on said rock-shaft, and a spring acting upon said pin or projection and serving to retain it in its extreme position, substantially as and for the purposes set forth. 26th. A knitting machine provided with a needle cylinder having axial grooves at the top thereof, and having a less number of axial grooves at the bottom thereof, needles working in the top grooves and connected in pairs with jacks working in the bottom grooves, and means for operating the jacks, substantially as and for the purposes set forth. 27th. A knitting machine provided with a needle cylinder, a pair of needles having bent shanks adapted to interlock with each other, a jack provided with a recess for engaging the interlocked shanks, and means for operating the jack, substantially as and for the purposes set forth. 28th. A knitting machine provided with needles connected with a jack, and a needle cylinder having axial grooves at the top for the reception of the needles, axial grooves at the bottom for the reception of the jacks, and a peripheral groove for the accommodation of the couplings of the jacks and needles, substantially as and for the purposes set forth. 29th. A knitting machine provided with fashioning needles and their complementary cam carriages, a vibrating arm, pawl-bars, ball and socket connections between the bars and arm, and means for elevating and depressing the pawl-bars and for affording the same a range of side-wise motion, substantially as and for the purposes set forth. 30th. A knitting machine provided with a main-shaft, a drum movable endwise on said shaft, a counter-shaft provided with a crank, a reciprocating arm connected with said drum by straps, and a ball and socket joint interposed between the crank and arm to accommodate the endwise movement of the drum, substantially as and for the purposes set forth. 31st. A knitting machine provided with a driving pulley and its complementary shipper, a rod and a bell-crank for actuating the shipper, a continuously operated shaft having two tappet arms, a bar adapted to be shifted endwise by said tappet arms, means for lifting and depressing said arm, and a ball and socket joint interposed between the bell-crank and bar, substantially as and for the purposes set forth. 32nd. A knitting machine provided with a driving pulley and its complementary shipper mechanism, an oscillating shaft provided with tappet arms, a bar co-operating with the tappet arms and connected with the shipper mechanism, a pattern chain provided with a projection, a shaft provided with a spring controlled arm for locking said bar and with an arm disposed in range of said projection, substantially as and for the purposes set forth. 33rd. A knitting machine provided with a driving pulley and its complementary shipper mechanism, an oscillating shaft provided with tappet arms, a bar co-operating with the tappet arms and connected with the shipper mechanism, a pattern chain provided with a projection, a plate depending from said arm and provided with a recess, a spring controlled shaft provided with an arm having a lip for engaging said recess and with an arm disposed in range of said projection, substantially as set forth. 34th. A knitting machine provided with a driving pulley and its complementary shipper mechanism, an oscillating-shaft having tappet arms, a bar co-operating with the tappet arms and connected with the shipper mechanism, a pattern chain provided with a projection, a shaft provided with an arm adapted to lock said bar, a back stop for said arm, a spring tending to draw said arm into engagement with its seat and with said bar, and a second arm on said shaft disposed in range of said projection, substantially as and for the purposes set forth. 35th. A knitting machine provided with a driving pulley and its complementary shipper mechanism, an oscillating-shaft provided with tappet arms, a bar co-operating with the tappet arms and connected with the shipper mechanism, a pattern chain, a plate depending from said bar and provided with a recess, a shaft provided with an arm having a lip for engaging said bar, a second arm on said shaft, a lever for locking the last mentioned arm, and a lug on the pattern chain for releasing the lever and operating the shaft, substantially as and for the purposes set forth. 36th. A knitting machine provided with a driving pulley and its complementary shipper mechanism, an oscillating-shaft provided with tappet arms and connected with the tappet arms and connected with the shipper mechanism, a pattern chain, a plate depending from said bar and provided with a recess, a shaft provided with an arm having a lip for engaging said bar, a second arm on said shaft, a lever for locking the last mentioned arm, and a lug on the pattern chain for releasing the lever and operating the shaft, substantially as and for the purposes set forth. 37th. A knitting machine provided with stop motion mechanism having a bar and its complementary tappet arms and pattern chain, a shaft having an arm, a back stop, a spring for soliciting said arm into engagement with the bar and back stop, a second arm on said shaft, a lever normally locking the last mentioned arm, and a lug on the pattern chain for releasing said lever and operating the shaft, substantially as and for the purposes set forth. 28th. A knitting machine provided with stop motion mechanism comprising a pattern chain, an arm, a lug on the chain, and a lever normally locking said arm and disposed in range of said lug, substantially as and for the purposes set forth. 39th. A knitting machine provided with reversing mechanism

having tappet arms, a bar co-operating with the tappet arms and adapted to operate the link connected with the belt shipper of said mechanism, a bell-crank operated by said link, a thread controlling device provided with take-up and clamping arms, connections between the take-up arm and bell-crank, a rod attached to the clamping arm and provided with a pin working in a slot in the bar, a pivotal lever having one extremity attached to said rod, and a wheel provided with a cam in range of the other extremity of the pivotal lever, substantially as and for the purpose set forth. 40th. A knitting machine provided with a thread controlling device having clamping and take-up arms, automatic reversing mechanism having tappet arms and a link and bar connected by a bell-crank, a rod connected with the clamping arm and bar, a second bell-crank provided with a rod connected with the take-up arm, and a slotted plate engaging the last mentioned bell-crank and carried by said link, substantially as and for the purposes set forth. 41st. A knitting machine provided with a thread controlling device having a take-up arm, reversing mechanism having a link, a bell-crank lever, a rod connected with one arm of the bell-crank lever and with the take-up arm, a slotted plate engaging the other arm of the bell-crank lever and carried by said link, and an adjustable back stop for the bell crank lever, substantially as and for the purposes set forth. 42nd. A knitting machine provided with a thread controlling device having a clamping arm, reversing mechanism having a bar and tappet arms, a rod connected with said bar and arm, a lever and connections for operating said rod, a cam-wheel for controlling said lever and means, substantially as described, for intermittently rotating said cam-wheel, substantially as and for the purposes set forth.

No. 44,952. Governor for Engines.
(Gouverneur pour machines.)

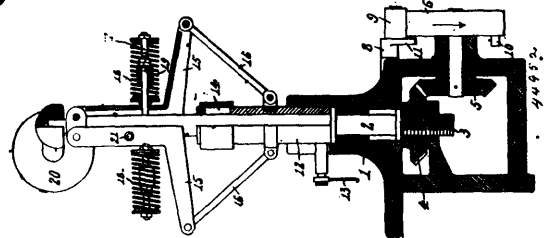

Julius Begtrup and James H. McEwen, both of Ridgeway, Pennsylvania, U.S.A., 23rd December, 1893; 6 years.

Claim.—1st. In a revolving pendulum governor for engines, a pair of centrifugal arms combined with an inertia-weight connected with said arms and adapted for a motion of partial rotation with reference to said arms. 2nd. In a revolving pendulum governor for engines, an inertia-weight combined with a dash-pot. 3rd. In a revolving pendulum governor for engines, a pair of centrifugal arms pivoted to the governor spindle and having the form of elbows with portions projecting parallel with the spindle and portions projecting outwardly therefrom. 4th. In a revolving pendulum governor for engines, a rod extending horizontally across the axis of the governor spindle and provided with springs acting inwardly upon the centrifugal arms of the governor. 5th. In a governor for steam engines a screwed driving gear combined with an arresting stop held normally out of action by the presence of the driving belt of the governor, whereby the breaking of the belt arrests the driving gear and causes the governor spindle to unscrew and effect the stopping of the engine.

No. 44,953. Last. (Forme.)

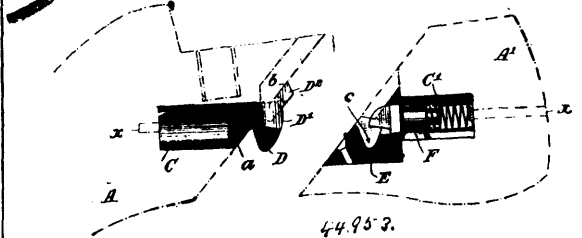

Harry William Mobbs and Alfred Lewis, both of Kettering, Northumberland, England, 23rd December, 1893; 6 years.

Claim.—1st. The method of adapting a wooden last to receive a locking device, which method consists in boring a straight hole from the heel and inward lengthwise of the last, dividing the last into two parts by a cutting transversely of said hole, and concentrically enlarging the respective holes, in the two parts, inward from the two interior faces formed by the cutting to receive co-acting parts of the locking device formed to fit the concentric enlargements and be secured therein. 2nd. A locking device, for a divided wooden last, in which the two parts of the locking device are provided with rearwardly extending stems intended to fit corresponding holes in the

No. 44,957. Wrench. (Clé à écrou.)

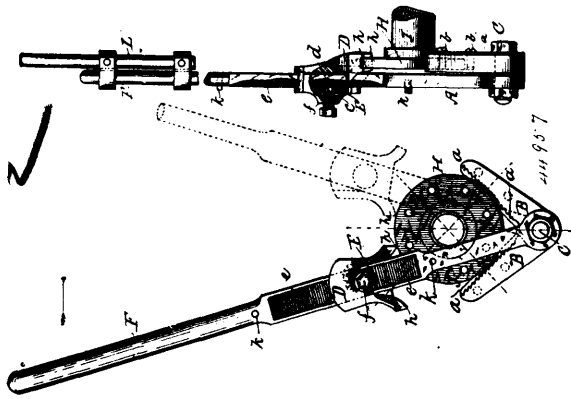

Minnie E. Kellam, assignee of Julius W. Kellam, both of Brooklyn, New York, U.S.A., 26th December, 1893; 6 years.

Claim.—1st. In a flange wrench, a bar in one rigid piece adapted to extend across the face of a flange, with suitable means attached thereto for engaging the flange rim on one side and with a dog having a biting edge adapted to automatically engage with such rim on the opposite side of the flange by the act of turning the long arm of the bar in the direction that the flange is to be turned all arranged for joint operation, substantially as herein described. 2nd. In a flange wrench, a bar A, in a single rigid piece adapted to extend across the face of a flange, in combination with a duo-formed jaw B, for taking hold of the flange rim at two points and with a reversible dog D, for taking hold of such rim on the opposite side, the dog having a biting edge adapted to engage reliably with the edge of a round flange in turning it in either direction, all arranged for joint operation, substantially as herein specified. 3rd. In an adjustable flange wrench, the combination of a double right angled integral swivel jaw pivoted to the lower end of a straight lever bar extended across the face of the flange when applied with a suitable movable adjustable dog carried by said lever bar, substantially as and for the purposes shown and described. 4th. In an adjustable flange wrench, the combination of a double right angled integral swivel jaw pivoted to the lower end of a straight lever bar extended across the face of the flange when applied with a movable duo-formed adjustable dog and means of clamping the same to said lever bar, constructed and to operate substantially as and for the purposes shown and described. 5th. In an adjustable flange wrench, the combination of a double right angled integral swivel jaw provided with a lip to overhang the rim of the flange, pivoted to the lower end of a lever bar extended across the face of the flange when applied, when a movable adjustable dog carried by said lever bar, substantially as and for the purposes shown and described. 6th. In an adjustable flange wrench, the combination of a lever bar extended across the face of the flange when applied and a right angled serrated swivel jaw pivoted to the lower end thereof with an adjustable movable dog pivoted with biting edges operating in the same plane as the jaw, substantially as and for the purposes shown and described. 7th. In an adjustable flange wrench, the combination of a lever bar extending across the face of the flange when applied and a right-angled serrated swivel jaw pivoted to the lower end of the same with an adjustable movable duo-formed reversible dog and means of clamping the latter to said lever bar, substantially as and for the purposes shown and described. 8th. As a new article of manufacture, the herein described adjustable flange wrench, consisting of the lever bar A, swivel angular jaw B, secured to the lower end of said lever bar by pivotal bolt C, said jaw having lip a, adjustable movable reversible dog D, morticed to slide upon said lever bar and provided with biting edges or edge h, h, clamping disc E, set screw f, for securing the same, and stops k, k, the whole constructed, arranged, and to operate substantially as and for the purposes shown and described.

No. 44,958. Saw-set. (Fer à contourner.)

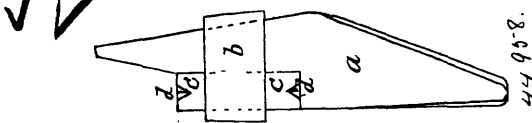

Jacob P. Haynes and Alexander McMullan, both of St. Catharines, Ontario, Canada, 26th December, 1893; 6 years.

Claim.—A saw-set c with the gullets or grooves d in the manner hereinbefore described, cut into the four sides and two ends of the set c and fastened with the fastener b to the stake a, substantially as and for the purposes hereinbefore set forth.

No. 44,959. Electric Railway. (Chemin de fer électrique.)

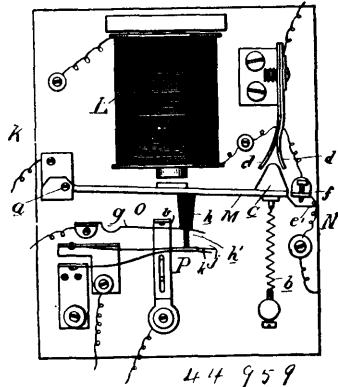

Thomas Harris, Detroit, Michigan, U.S.A., 26th December, 1893; 6 years.

Claim.—1st. In an electric railway system, the combination with a continuous power line, of a working conductor composed of sections normally disconnected from said power line, a switch line and a return switch line extending along the working conductor from a stationary source of electricity, an electro-magnet for each section of the working conductor, the armature of which is adapted to connect the section with the power line and with the switch line, two energizing circuits for each magnet one connecting the section of the working conductor with the return switch line through a normally open and a normally closed break controlled by the next adjacent magnets respectively, and the other connecting the two switch lines through the normally closed break of the other circuit and a normally open break controlled by the magnet itself, and a contact on the car adapted to connect two adjacent sections of the working conductor, substantially as described. 2nd. In an electric railway system, the combination with a continuous power line, of a working conductor composed of sections normally disconnected from said power line, a contact on the car, a switch and a return switch line extending along the working conductor from a stationary source of electricity, an electro-magnet for each section of the working conductor, the armature of which is adapted to connect the section with the power line and with the switch line, and two energizing circuits for each magnet, one connecting the section of the working conductor with the return switch line and including a normally closed break controlled by the succeeding magnet, and a normally open break controlled by the preceding magnet, and by a push button for the initial magnet, and the other circuit connecting the two switch lines and including the normally closed break of the other circuit, and a normally open break controlled by each magnet itself, substantially as described. 3rd. In an electric railway system, the combination, with an insulated power line, and an insulated return power line, of the two exposed working conductors composed of corresponding sections normally disconnected from the power lines, and with which the cars are adapted to travel in multiple connection, a contact on the car adapted to connect the adjacent ends of the sections of one of the working conductors, a switch line and a return switch line extending along the working conductors from a stationary source of electricity, an electro-magnet for each two corresponding sections of the working conductors, two armatures for each magnet, one adapted to connect the section of one working conductor to the return power line, and the other armature being adapted to connect the corresponding section of the other working conductor to the power line, and to the switch line, two energizing circuits for each magnet, one connecting the sections of one working conductor (that which is adapted to be connected with the switch line) with the return switch line including a normally closed break, and a normally open break respectively controlled by the adjacent magnets, and the other energizing circuit connecting the switch lines, and including the normally closed break of the other circuit, and a normally open break controlled by each magnet itself, substantially as described. 4th. In an electric railway system, the combination, with a continuous power line, of a working conductor composed of sections normally disconnected from said power line, a contact on the car adapted to connect one section with the adjacent section of said working conductor in the travel of the car, a switch line, and a return switch line extending along the working conductor from a stationary source of electricity, two switch magnets for each section of the working conductor, the armatures of each of which are adapted to connect said section with the power line, and with the switch line, and two energizing circuits for each magnet, one adapted to connect the magnet in multiple between the return switch line, and its section of the working conductor and including a normally open, and a normally closed break controlled by the magnets of the adjoining sections of the working conductor respectively in reverse order in the two magnets of each section, and the other circuit adapted to connect the magnet in multiple with the switch lines, and including the normally closed break of the other

circuit, and a normally closed break controlled by the magnet itself, substantially as described. 5th. In an electric railway system, the combination, with a continuous power line, of a working conductor composed of sections normally disconnected from said power line, a contact on the car adapted to connect the end of adjoining sections of the working conductor, a switch magnet for each section of the working conductor, the armature of which is adapted to connect the section with the power line, a source of electricity adapted to operate said switches and having one pole connected to the power line and the other to a return switch line extending along the power line, and connections whereby each magnet is comprised in two circuits, one in multiple between the return switch conductor and the section of the working conductor, which the magnet controls and including a normally open and a normally closed break controlled respectively by the magnets of the adjacent sections and the other circuit in multiple between the power line and the switch return line and including the normally closed break of the other circuit and a normally open break controlled by the magnet itself, substantially as described. 6th. In an electric railway system, the combination of two working conductors each composed of corresponding sections, a continuous insulated power line, and a continuous insulated return power line, both normally disconnected from said working conductors, cars adapted to travel in multiple connection with corresponding sections of the two working conductors, and provided with a contact or contacts adapted to connect the adjoining ends of the sections of one of the working conductors, a switch magnet for each two corresponding sections of the working conductor, provided with two armatures one adapted to connect the sections of one of the working conductors with the power line and the other adapted to connect the corresponding section of the other conductor with the return power line, a source of electricity adapted to operate said switches and having one pole connected to the power line and the other to a return switch line extending along the power line, and connections whereby each magnet is comprised in two circuits, one in multiple between the return switch conductor and the section of the working conductors which the magnet is adapted to connect with the power line and including a normally open and a normally closed break controlled respectively by the magnets of the adjacent sections and the other circuit in multiple between the power line and the switch return line and including the normally closed break of the other circuit and a normally open break controlled by the magnet itself, substantially as described.

No. 44,960. Ticket and Machinery for Issuing Tickets. (*Billet et appareil pour l'émission des billets.*)

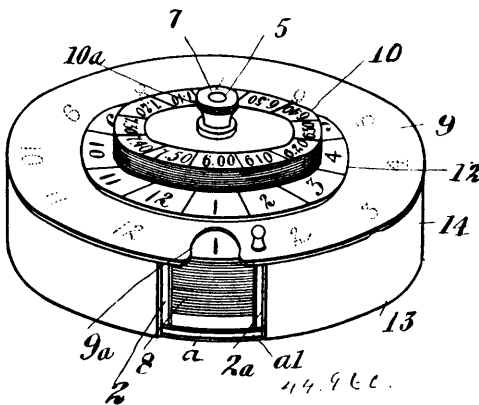

John Duncan, Toronto, Ontario, Canada, 26th December, 1893; 6 years.

Claim.—1st. In a ticket issuing apparatus the combination of a case, means for dividing the case into a series of compartments, tickets within each of said compartments, means for said case indicating the time when said tickets are to be used, and means for holding said tickets within said compartments, substantially as set forth. 2nd. In a ticket issuing apparatus, the combination of a case, means within said case for dividing it into a series of compartments, a parcel of tickets within each compartment, a post passing through the said case and projecting above and below the same, a series of time dials mounted on the upper end of the said post, and means for securing the dials in place. 3rd. In a ticket issuing apparatus, the combination of a case, composed of a bottom having a countersunk central portion, and an upwardly extending flange surrounding its outer edge, an outer casing enclosing said case composed of a bottom having a countersunk central portion, an upwardly extending flange surround the outer edge of the bottom, and having a portion of the flange cut away to allow of the insertion or removal of the tickets, a post passing through the central part of the case, and casing, and extending above and below the same, a thumb-screw fixed to the lower end of the post, an indicating disc revolving around the upper end of the post, and riding above the top of the tickets when in place, a series of time dials mounted on said post above said indicat-

ing disc, and means for securing said time dials in place, substantially as set forth.

No. 44,961. Track for Sliding Doors.

(*Coulisse pour portes glissantes.*)

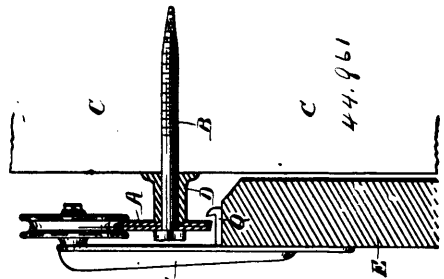

Riley J. Hosner, Romeo, Michigan, U.S.A., 26th December, 1893; 6 years.

Claim.—1st. A track for sliding doors having multiple sections constructed to be spliced together at their adjacent ends, said ends perforated to register the one with the other to receive an attaching screw or bolt whereby the adjacent sections may be united together end to end and engaged upon the building, substantially as set forth. 2nd. A track for sliding doors having multiple sections constructed to be spliced together at their adjacent ends, and an attaching screw or bolt passed through the spliced ends of adjacent sections to unite said sections together and to engage the track upon the building, substantially as set forth. 3rd. A track for sliding doors having in combination multiple sections constructed to be spliced together at their adjacent ends, an attaching bolt or screw passed through the spliced ends of adjacent sections to unite said sections together, and to engage the track upon the building, and a bracket engaged upon said bolt or screw to space the track from the building, substantially as set forth. 4th. A track for sliding doors having in combination multiple sections constructed to be overlapped and spliced together at their adjacent ends, and an attaching bolt or screw passed through the over-lapping ends of the adjacent sections whereby the sections are united together, and the track engaged upon the building, the upper and lower edges of the track being free from obstructions, substantially as and for the purpose set forth.

No. 44,962. Door Hanger. (*Ferrure de porte glissante.*)

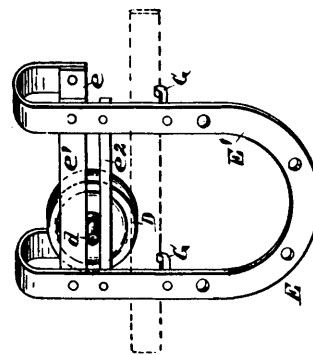

Riley J. Hosner, Romeo, Michigan, U.S.A., 26th December, 1893; 6 years.

Claim.—1st. A door hanger for sliding doors consisting of a roller to engage the track a bracket and a retaining hook, substantially as set forth. 2nd. A door hanger for sliding doors consisting of a roller to engage the track a hanger bracket and a retaining hook located below the roller, said bracket constructed of a metal strip E¹, provided with cross-bars e, e¹, above the axis of the roller. 3rd. A door hanger for sliding doors consisting of a roller to engage the track a hanger bracket and a retaining hook located below the roller, said bracket constructed of a metal strip E¹, provided with cross-bars e, e¹, above the axis of the roller, and a cross-bar e² located beneath the strip e¹ to hold the roller in engagement with the hanger, substantially as set forth. 4th. In combination, a track, a roller having its tread upon the upper edge of the track, a door hanger bracket and a retaining hook located under the lower edge of the track and projecting upward adjacent to the inner face of the track, substantially as set forth.

No. 44,963. Stay Roller. (*Rouleau immobile.*)

Riley J. Hosner, Romeo, Michigan, U.S.A., 26th December, 1893; 6 years.

Claim.—1st. A stay roller for sliding doors consisting of a screw to enter the building and a rotatable roller engaged upon the outer

end of the screw, said roller provided with a rim or flange extending upward above the lower edge of the door when in place, substantially

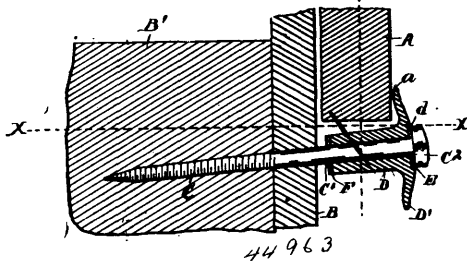

as set forth. 2nd. A stay roller for sliding doors consisting of a screw provided with a rotatable roller at its outer end, said roller provided with a flange or rim concave on its inner surface toward the body of the rim, substantially as and for the purpose set forth. 3rd. A stay roller for sliding doors consisting of a screw, a rotatable roller engaged thereupon provided with a flange or rim at its outer end and a device to hold the roller from sliding longitudinally upon the screw, substantially as set forth. 4th. In combination the screw C provided with a round shank C¹, and a head C 2, a rotatable roller D engaged upon the screw provided with an annular flange D¹, a washer located between the roller and the head of the screw and a retaining device located upon the screw at the opposite end of the roller, substantially as set forth. 5th. The combination with the building provided with a sliding door of a stay roller consisting of a screw and a rotatable roller journaled thereupon provided with an annular flange, said screw entered into the building at a descending angle, substantially as set forth.

No. 44,964. Sheet Metal Vessel.

(Ustensile en feuille de métal.)

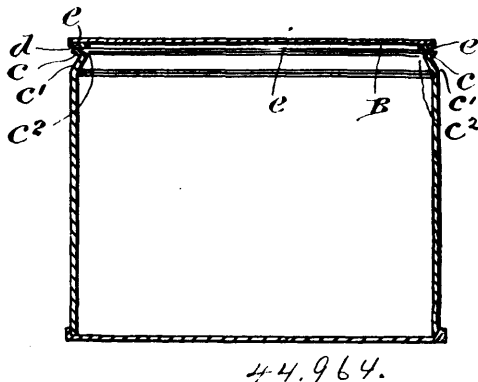

William Pratt, of Montreal, Quebec, Canada, 27th December, 1893; 6 years.

Claim.—1st. A sheet metal vessel of the class described having a shield for the purpose set forth. 2nd. A sheet metal vessel having a portion formed to collapse, and cause a centripetal movement of such portion into contact with a non-collapsible portion of the vessel upon the application of force for the purpose set forth. 3rd. A sheet metal vessel having a line of rupture for the purpose set forth, and one or more portions formed to collapse and secure a centripetal movement of the part or parts into contact with a rigid portion of the vessel, upon the application of force as described for the purpose set forth. 4th. A sheet metal vessel having a line of rupture for the purpose set forth, and an inwardly and irregularly bent collapsing section adapted upon the application of force as described to bend to a differing angle, and cause a centripetal movement of such section for the purpose set forth. 5th. A sheet metal vessel having a line of rupture, upon which the vessel after sealing is opened by hammering, and a collapsing section adjacent to said line of rupture caused by such hammering to collapse and act as a guard or covering for the opening or openings formed along said line of rupture for the purpose set forth. 6th. A sheet metal vessel having a line of rupture upon which the vessel after sealing is opened by hammering and a collapsing section, adjacent to said line of rupture formed by a circumferential bend or indentation, in the metal characterized by opposite sides or portions of differing sizes, and caused by such hammering to collapse, and act as a guard or covering for the opening or openings formed along said line of rupture, for the purpose set forth. 7th. A sheet metal vessel having a line of rupture upon which the vessel after sealing is opened by hammering, and a bend or indentation characterized by opposite sides or portions of differing widths, and the narrower side being contiguous to said line of

rupture, all for the purposes herein set forth. 8th. A sheet metal vessel having a line of rupture in the body adjacent to the cover thereof, a collapsing section in the body adjacent to said line of rupture, and a cover having a lateral flange or extension acting, in conjunction with said collapsing section, upon the application of force as described, to prevent the escape of the contents of the vessel through the opening or openings formed along said line of rupture.

No. 44,965. Fluid Distributor.

(Appareil pour la distribution des fluides.)

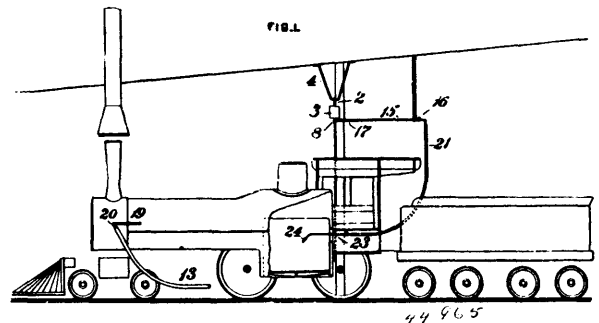

James McNaughton, Waukesha, Wisconsin, U.S.A., 27th December, 1893; 6 years.

Claim.—1st. The combination in a fluid distribution apparatus for kindling locomotive engine fires, of means for supplying combustible fluid to a storage receptacle of determined capacity by the action of a fluid under pressure, means for thereafter discharging said combustible fluid therefrom by gravity, and means for coincidentally with such discharge, forcing it into a fuel charged locomotive engine fire-box, by the action of a fluid under pressure, substantially as set forth. 2nd. The combination, in a fluid distribution apparatus for kindling locomotive engine fires, of means for supplying combustible fluid to a storage receptacle of determined capacity by the action of a fluid under pressure, means for thereafter discharging said determined quantity of combustible fluid by gravity, and means for coincidentally with such discharge forcing it, commingled with a fluid under pressure, into a fuel charged locomotive engine fire-box, by the action of a fluid under pressure, substantially as set forth. 3rd. The combination, in a fluid distribution apparatus for kindling locomotive engine fires, of a series of independent storage receptacles of determined capacity, for the delivery of combustible fluid to locomotive fire-boxes, means for supplying combustible fluid to each of said receptacles by the action of a fluid under pressure, and means for independently discharging said receptacles, substantially as set forth. 4th. The combination in a fluid distribution apparatus for kindling locomotive engine fires, of means for supplying combustible fluid to each of a series of independent storage receptacles of determined capacity, by the action of a fluid under pressure, means for thereafter discharging the contents of any selected one or more of said receptacles by gravity, and means for coincidentally with such discharge, forcing the combustible fluid so discharged into a fuel charged locomotive engine fire-box or fire-boxes by the action of a fluid under pressure, substantially as set forth. 5th. In a fluid distribution apparatus for kindling locomotive engine fires, the combination of a main or supply reservoir, one or more service reservoirs of substantially equal capacity located above the level of the main reservoir, a fluid service pipe connecting the main reservoir with the service reservoir or reservoirs, and a supply pressure pipe leading into the main reservoir, substantially as set forth. 6th. In a fluid distribution apparatus for kindling locomotive engine fires, the combination of a main or supply reservoir, one or more service reservoirs of substantially equal capacities located above the level of the main reservoir, a fluid service pipe connecting the main reservoir with the service reservoir or reservoirs, a supply pressure pipe leading into the main reservoir, a pressure reservoir connected near its lower end to the fluid service pipe, and a service pressure pipe leading from the main reservoir to the pressure reservoir at or near the upper end thereof, substantially as set forth. 7th. In a fluid distribution apparatus for kindling locomotive engine fires, the combination of a main or supply reservoir, one or more service reservoirs of substantially equal capacities located above the level of the main reservoir, a fluid service pipe connecting the main reservoir with the service reservoir or reservoirs, a supply pressure pipe leading into the main reservoir, a pressure reservoir connected near its lower end to the fluid service pipe, and a service pressure pipe leading from the main reservoir to a connec-

tion with the fluid service pipe, delivery pipes leading from the service pressure pipe, substantially as set forth. 9th. In a fluid distribution apparatus for kindling locomotive engine fires, the combination of a main or supply reservoir, one or more service reservoirs of substantially equal capacities located above the level of the main reservoir, a valve controlled fluid service pipe connecting the main reservoir with the service reservoir or reservoirs, a valve controlled supply pressure pipe leading into the main reservoir, a valve controlled service pressure pipe leading from the main reservoir to a connection with the fluid service pipe, valve controlled delivery pipes leading from the service reservoirs, and valve controlled delivery pipes leading from the service pressure pipe, substantially as set forth. 10th. In a fluid distribution apparatus for kindling locomotive engine fires, the combination of a main or supply reservoir, one or more service reservoirs located above the level of the main reservoir, a valve controlled fluid service pipe connecting the main reservoir with the service reservoir or reservoirs, a valve controlled supply pressure pipe leading into the main reservoir, a valve controlled service pressure pipe leading from the main reservoir to a connection with the fluid service pipe, valve controlled delivery pipes leading from the service reservoirs, valve controlled delivery pipes (one for each service reservoir) leading from the service pressure pipe, and supplemental or service delivery pipes (one for each service reservoir) leading from the service pressure pipe, substantially as set forth. 11th. In a fluid distribution apparatus for kindling locomotive engine fires, the combination of a service reservoir, means, substantially as described, for feeding a fuel oil thereto by air under pressure, valved delivery pipes for the discharge of oil from the reservoir, and air under pressure, to a connection with a mixer or burner insertible in a locomotive fire-box, and a valved delivery pipe for the discharge of air under pressure into a locomotive smoke-box, substantially as set forth. 12th. The combination, in a fluid distribution apparatus for kindling locomotive engine fires, of means for forcing a jet of combustible fluid, commingled with air under pressure into a fuel charged locomotive fire-box, and means for forcing a jet of air under pressure into the smoke-box of the locomotive engine, to exert draft in the fire-box, substantially as set forth. 13th. In a fluid distribution apparatus, the combination of a main or supply reservoir, a supply pressure pipe leading thereinto, a fluid service pipe leading therefrom, a service pressure pipe connected with the supply pressure pipe, delivery pipes leading from the fluid service pipe, and service pressure pipe respectively, and a supplemental or blower service delivery pipe leading from the service delivery pipe leading from the service pressure pipe, substantially as set forth. 14th. In a fluid distribution apparatus, the combination of a main or supply reservoir, a pipe leading thereinto for the supply of air under pressure, valved delivery pipes for the discharge of oil from the reservoir, and air under pressure, to a connection with a mixer or burner insertible in a locomotive fire-box, and a valved delivery pipe for the discharge of air under pressure into a locomotive smoke-box, substantially as set forth.

No. 44,966. Bookcase. (Bibliothèque.)

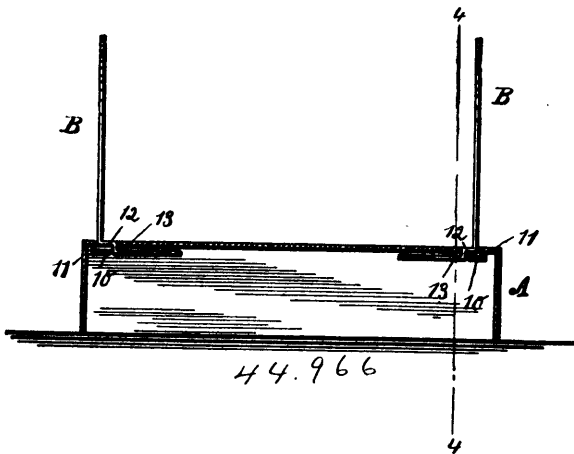

James Stinson, Watsonville, California, U.S.A., 27th December, 1893; 6 years.

Claim.—1st. A bookcase or stand, comprising a base, having its top supported some distance above the object upon which the base rests, and provided with a transverse slot at each end, and L-shaped clamping arms having their lower members of equal width throughout and projecting through the slots of the base, the said lower members being provided with offsets or steps, substantially as described. 2nd. A bookcase, the same consisting of a base, having slots near its ends and recesses adjacent to the slots, and angular arms pivotally located in their slots, the inner members of the arms being formed near their junction with the outer members with depressions adapted to enter the depressed surfaces in the base, as and for the purpose specified. 3rd. In a bookcase or stand, the com-

bination with a base provided with slots near its ends and recesses adjacent to the slots, of arms angular in cross section, one member being longer than the other, the shorter member of each arm being introduced into the slots in the base, the inner members of the said arms being also provided with a depression and a step near the depression, the depressed surface of the arms being adapted to engage with the depressed surfaces of the base, substantially as and for the purpose set forth,

No. 44,967. Pattern for Sleeves.

(*Patron pour manches.*)

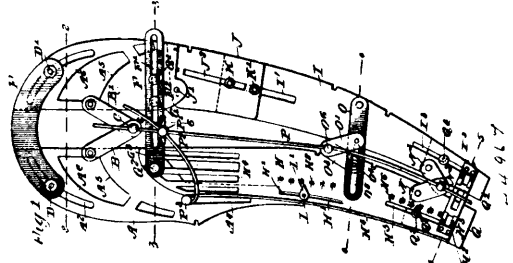

Simon Christiansen, New York, State of New York, U.S.A., 27th December, 1893; 6 years.

Claim.—1st. A sleeve pattern, provided with adjustable sections for obtaining the outline for the upper sleeve, and rods automatically controlled by the said sections for obtaining the outlines for the undersleeve, substantially as described. 2nd. A sleeve pattern comprising two upper sections pivotally connected with each other by pivoted links, and a slotted bar secured on one section and guided in and adapted to be fastened in place in the other section, substantially as shown and described. 3rd. A sleeve pattern, comprising two upper sections and two lower sections, and links pivotally connecting the upper sections with each other, and likewise the lower sections with each other, substantially as shown and described. 4th. A sleeve pattern, comprising two upper sections pivotally connected with each other, two lower sections pivotally connected with each other, and of which one section is fitted to slide on the corresponding section, and the other lower section is fitted to slide on an intermediate piece pivoted to the corresponding upper section, substantially as shown and described. 5th. A sleeve pattern, comprising a slide, and two rods fitted to slide in the said slide, and having each one end fastened so that the movement of the slide changes the position of the rods, substantially as shown and described. 6th. A sleeve pattern, comprising two upper sleeve sections connected with each other by links, having a pivotal connection, two lower sleeve sections connected with each other by sets of links, having pivotal connections, a bar fastened on one upper sleeve section and guided in the other upper sleeve section, a slide fitted to slide on the said bar, a rod loosely engaged by the said slide and engaged by the several pivotal connections of the said links, and a second rod held on one upper sleeve section and likewise loosely engaging the said slide, substantially as shown and described.

No. 44,968. Garment Fitting Pattern.

(*Patron pour l'ajustage des vêtements.*)

Simon Christiansen, New York, State of New York, U.S.A., 27th December, 1893; 6 years.

Claim.—1st. A garment fitting pattern, comprising a series of plates adapted to be held on the wearer's body, one alongside the other, each plate being provided with an adjustable strip adapted to fit with its outer edge the free edge of the adjacent plate, so as to form a drawing edge for marking on the goods to be cut, and articulated connections between the strip and the corresponding plate to permit of moving any part of the strip inward or outward, to properly fit the strip with its outer edge on the adjacent edge of the next following plate, substantially as shown and described. 2nd. A garment fitting pattern, comprising a series of plates adapted to be held on the wearer's body, one alongside the other, one side of each plate forming a drawing edge, a strip held adjustably on the opposite side of the plate, and adapted to fit the adjacent drawing edge of the next following plate, so as to form a second drawing edge to mark on the goods to be cut, and articulated connections between each strip and the corresponding plate, to move the strip inward or outward by opening or closing the said connection, substantially as shown and described. 3rd. A garment fitting pattern, comprising a series of plates adapted to be held on the wearer's body, one alongside the other, one side of each plate forming a drawing edge, a strip held adjustably on the opposite side of the plate and adapted to fit the adjacent drawing edge of the next following plate, so as to form a second drawing edge to mark on the goods to be cut, and articulated connections between each strip and the corresponding plate to move the strip inward and outward by opening

or closing the said connections, and separate adjustable strips held on some of the said plates and forming part of the first named

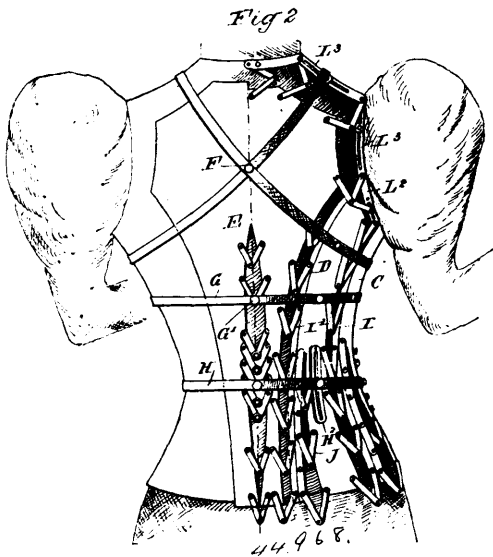

drawing edge, and articulated connections between the separate adjustable strips and their plates, substantially as shown and described. 4th. A garment fitting pattern, comprising a series of plates adapted to be held on the wearer's body, one alongside the other, one side of each plate forming a drawing edge, a strip held adjustably on the opposite side of the plate, and adapted to fit the adjacent drawing edge of the next following plates, so as to form a second drawing edge to mark on the goods to be cut, articulated connections between each strip and the corresponding plate, to move the strip inward or outward by opening or closing the said connections, and separate adjustable strips formed of links pivotally connected with each other, one end of each adjustable strip being pivoted on the corresponding plate, and articulated connections between the said separate adjustable strips and their plates, substantially as shown and described. 5th. A garment fitting pattern, comprising a series of plates adapted to be held on the wearer's body, one alongside the other, shoulder strips made in sections held adjustable one on the other, and articulated connections between the said shoulder strips and the corresponding plates, substantially as shown and described. 6th. A garment fitting pattern, comprising a series of plates adapted to be held on the wearer's body, one alongside the other, one side of each plate forming a drawing edge, a strip held on the opposite side of the plate and adapted to fit the adjacent drawing edge of the next following plate, so as to form a second drawing edge to mark on the goods to be cut, articulated connections between the said strips and their plates, separate adjustable strips held on some of the plates and forming part of the first named drawing edge, articulated connections between the said separate adjustable strips and their plates, shoulder strips held adjustable on the upper ends of the said plates and pivotally connected with the said first named strips, and articulated connections between the said shoulder strips and their plates, substantially as shown and described. 7th. A garment fitting pattern, comprising a series of plates adapted to be held on the wearer's body, one alongside the other, one side of each plate forming a drawing edge, a strip held on the opposite side of the plate and adapted to fit the adjacent drawing edge of the next following plate, so as to form a second drawing edge to mark on the goods to be cut, articulated connections between the said strips and their plates, separate adjustable strips held on some of the plates and forming part of the first named drawing edge, articulated connections between the said separate adjustable strips and their plates, shoulder strips held adjustable on the upper ends of the said plates and pivotally connected with the said first named strips, articulated connections between the said shoulder strips and their plates, and bands adapted to engage pins on the several plates to hold the latter in place on the wearer's body, as set forth.

No. 44,969. Processes for Obtaining Para-phenetol-carbamide. (*Procédé pour obtenir du carbamide de para-phénétole.*)

Hermann Thoms, Berlin, Germany, 27th December, 1893; 6 years.

Claim.—1st. The process for obtaining para-phenetol-carbamide, which consists in heating equimolecular quantities of di-para-phenetylurea or of para-phenetidid-hydrochloride and common urea or the carbamide of ammonia, or commercial ammonium carbonate, between 150° and 160°, for several hours, in a closed retort, substantially as described. 2nd. The process for obtaining para-

phenetol carbamide, which consists in boiling an aqueous solution of para-phenetidid-hydrochloride with common urea, in the proportions of 3 molecules of the former to 2 molecules of the latter, substantially as described. 3rd. The process for obtaining para-phenetol-carbamide, which consists in heating equimolecular quantities of di-para-phenetol-carbamide and dry ammonia to 170° C. in a closed space.

No. 44,970. Autographic Telegraph.

(*Télégraphe autographique.*)

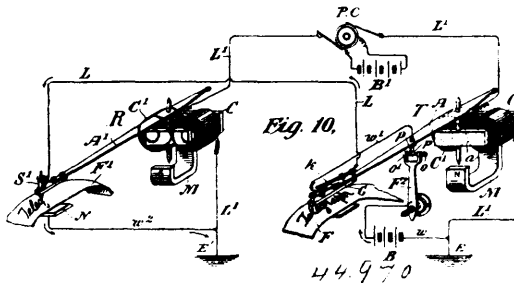

Sylvester P. Denison, Belleville, New Jersey, U.S.A., 27th December, 1893; 6 years.

Claim.—1st. In an autographic or copying telegraph, a transmitting stylus or needle carried by an arm controlled in its movements by electro-magnetic means, and having motion in a lateral direction, said needle or stylus being located in a vertically disposed shoe, and adapted to move simultaneously in a vertical direction, substantially as described. 2nd. In an autographic or copying telegraph, a message blank having the message indented in one face thereof, in combination with a sliding stylus or needle carried by a vibrating arm controlled by electro-magnetic means, said stylus having motion also in vertical direction, and operatively connected with a circuit making and breaking device, and to a transmitting battery, the circuit making and breaking device being also carried by the vibrating arm, substantially as described. 3rd. In an autographic or copying telegraph, a vibrating transmitting arm carrying a sliding stylus operatively connected with a circuit interrupter, also carried by the transmitting arm, in combination with a second circuit interrupter adapted to close the circuit of the transmitting battery during one portion only of its complete vibratory movement, substantially as described. 4th. A receiving stylus autographic or copying telegraphs made of conducting material surrounded by a coating of wax or paraffine, substantially as described. 5th. A receiving stylus for autographic or copying telegraphs, consisting of a metal core surrounded by a cylinder of paraffine or wax, substantially as described. 6th. A receiving stylus for autographic or copying telegraphs consisting of a metal core surrounded by wax or paraffine, and enclosed in a holder or case, substantially as described. 7th. A receiving stylus for autographic or copying telegraphs consisting of a metal core surrounded by wax or paraffine, and enclosed in a holder or case, and provided with means for forcing it forward as it wears away, substantially as described. 8th. In an autographic or copying telegraph, a message fillet or strip having the message indented or depressed in one of its faces, a vibrating transmitting arm carrying a sliding shoe, and a transmitting stylus having sliding movement through the shoe, and operatively connected with a circuit breaker carried by the same arm, the arrangement being such that the sliding shoe carries the stylus over the face of the message, and allows it to drop into and rise out of the indentations in the record surface, substantially as described. 9th. A transmitter for an autographic or copying telegraph having a vibrating arm provided with a sliding shoe, adapted to ride over the surface of the message fillet, in combination with a stylus or needle having sliding movement through the shoe, and a circuit breaker having operative connections with the sliding needle, substantially as described.

No. 44,971. Box for Mathematical Purposes.

(*Boîte à l'usage des mathématiques.*)

Newton Z. Fulton, Gumison, Colorado, U.S.A., 27th December, 1893; 6 years.

Claim.—1st. The cube box herein described consisting of a hollow receptacle made in the form of a cube with an adjustable flush door or lid, combined with three hinged folding external sections of the same square dimensions as the box having supplemental hinged sections equal in length to sides of the box and of square cross section, one of said supplemental folding sections being provided with a hinged block forming a perfect cube whose square is equal to the square cross section of the supplemental hinged sections, substantially as and for the purpose described. 2nd. The cube box herein described consisting of a hollow receptacle made in the form of a cube with an adjustable flush door or lid, combined with three hinged folding external sections of the same square dimensions as the box two of said hinged sections having a supplemental folding

section on their free edges parallel to the hinges, and the third section having a folding supplemental section on its edge at right

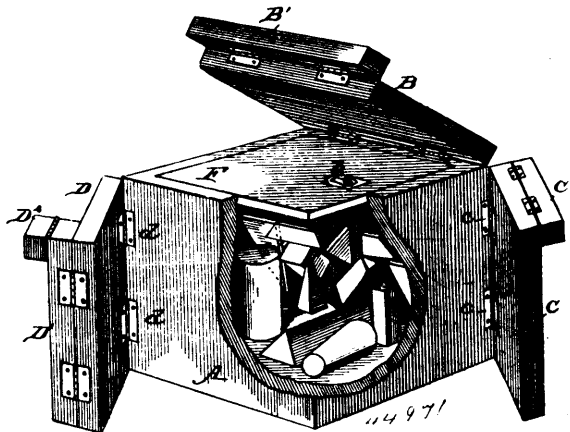

angles to its hinged edge, and one of said hinged supplemental sections having a hinged cube whose square equals the cross section of the supplemental sections, substantially as and for the purpose described. 3rd. The cube box herein described consisting of a hollow receptacle made in the form of a cube with an adjustable flush door or lid, combined with three hinged and folding sections of the same square dimensions as the box, and having supplemental hinged sections equal in length to the sides of the box and of square cross section, one of said supplemental folding sections being provided with a hinged block or cube whose square is equal to that of the cross sections of the supplemental hinged sections, catches or fastenings for holding these hinged sections in locked position, and a handle for lifting and transporting the entire device, substantially as and for the purpose described.

No. 44,972. Machine for Working Wire Fabric.
(*Machine pour la fabrication des tissus métalliques.*)

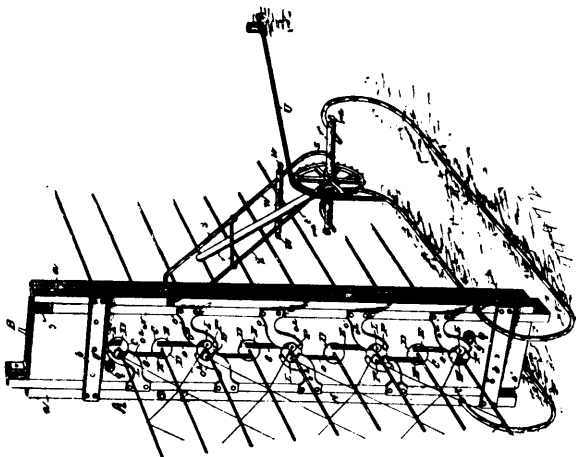

Alva L. Kitselman, Ridgeville, Indiana, U.S.A., 27th December, 1893; 6 years.

Claim.—1st. In a wire fabric machine, a series of intergearing twisters mounted for fixed rotation, and having central perforations adapted to receive the warp wires, and also parallel notches at each side of the central perforations adapted to be aligned with each other, and weft wire carriers mounted in the notches of said twisters and adapted to be shifted from one to the other when said notches are aligned, substantially as set forth. 2nd. In a wire fabric machine, a series of intergearing twisters having separate parallel notches or slots adapted to align respectively with the corresponding notch or slot of the twister directly above and below, weft wire carriers registering in said notches of the twisters, and adapted to move in separate vertical planes, and means for shifting said carriers, substantially as set forth. 3rd. In a wire fabric machine, the combination of a series of directly intercommunicating slotted twister-wheels mounted for a fixed rotation and provided with cog flanges formed integrally on the periphery thereof, said cog flanges meshing with the flanges of the adjacent wheels and being interrupted at the slots, and shiftable single arm weft wire carriers adapted to be carried in the slots of said twister-wheels, and pro-

vided with weft wire guides, substantially as set forth. 4th. In a wire fabric machine, the combination with a frame or casing having a series of bearing openings and a vertical series of slots connecting the same, and out of alignment with each other, a series of twister-wheels mounted in said bearings of the frame or casing, and having separate parallel notches or vertical series of disconnected slots adapted to align with the slots connecting the bearings, weft wire carriers registering with the notches in the twisters, and shifting devices for said carriers, substantially as set forth. 5th. In a wire fabric machine, the opposite adjacent frame, boards or plates having an aligned series of circular bearing openings, and slots connecting such bearing openings, a series of shaftless twister-wheels mounted for a fixed rotation between the frame boards or plates, and provided with integral peripheral cog flanges meshing directly with the flanges of the adjacent wheels, the hub portions at both sides of said cog flanges being journaled in said circular bearing openings of the frame boards or plates, and weft wire carriers mounted in said twister-wheels, and adapted to be shifted from one to the other, substantially as set forth. 6th. In a wire fabric machine, a series of sectional twisters comprising separate superposed halves having oppositely arranged notches or slots, and meeting cog flanges interrupted at said notches or slots, and weft wire carriers arranged to be carried in the notches or slots of the twisters and adapted to be shifted from one to another, substantially as set forth. 7th. In a wire fabric machine, the sectional twisters comprising separate superposed halves having notches or slots and meeting cog flanges the teeth of one flange being out of line with those of the other flanges, the weft wire carriers adapted to be carried in the notches or slots of said twisters, and means for shifting the carriers, substantially as set forth. 8th. In a wire fabric machine, a series of sectional twisters comprising separate superposed hollow sections provided with aligned oppositely disposed notches or slots, meeting cog-flanges registering with the corresponding flanges of the adjacent twisters, said superposed sections also having at their meeting edges interlocking notches and lugs, the shiftable weft wire carriers arranged in the notches of the twisters, and means for shifting the said carriers, substantially as set forth. 9th. In a wire fabric machine, the frame having a series of connected bearing openings, a series of sectional twisters mounted in said bearing openings and having separate oppositely disposed and parallel notches or slots, meeting cog flanges interrupted at said notches or slots, and locking devices for holding the two sections together, shiftable weft wire carriers and guides registering with the notches or slots in said twisters, and means for shifting the carriers from twister to twister, said twisters being inter-gearing, substantially as set forth. 10th. In a wire fabric machine, the combination of the opposite frame bearing boards provided with a series of circular bearing openings, intermediate slots connecting said openings with each other, and upper and lower filling slots, a series of inter-gearing twisters, mounted for fixed rotation in said circular bearing openings and provided with central perforations to receive the warp wires, and separate oppositely disposed and parallel notches or slots adapted to align at the same time with the two slots leading from the bearing openings, combined weft wire carriers and guides mounted for rotation with the twister-wheels, and means for shifting the carriers and guides above and below its twister at the same time, substantially as set forth. 11th. In a wire fabric machine, opposite frame boards or plates having bearing and slots connecting the bearings, a series of twister-wheels mounted for fixed rotation in said bearings and provided with oppositely disposed notches or slots adapted to align with those of the frame boards or plates, warp wire perforations, and inter-meshing peripheral cog flanges, one of said twister-wheels being further provided with a supplemental bevel cog-ring inside of the adjacent frame board or plate, a suitably arranged operating crank shaft, a pinion on said shaft projecting through a slot in one of the frame boards or plates and meshing with said bevel cog-ring, and the shiftable weft wire carriers, substantially as set forth. 12th. In a wire fabric machine, a series of inter-gearing twisters mounted for fixed rotation and each having separate oppositely disposed and parallel notches or slots adapted to align with the corresponding notches or slots, of the twisters above and below it, weft wire carrier arms provided with flattened wire guide ends, registering with the notches or slots in said twister-wheels, so as to be carried therewith, weft wire spools or bobbins mounted for rotation on one end of said arms, and means for shifting the arms through the aligned slots, substantially as set forth. 13th. In a wire fabric machine, the combination with the inter-gearing and inter-communicating notched or slotted twisters, of the shiftable combined weft wire carriers and guides, comprising a single arm having flattened shouldered ends adapted to fit in the notches of the twisters, the shoulders being disposed at both sides of the twisters, perforated guide lugs at such shoulders ends to receive and guide the weft wire, and a right angularly disposed journal or spindle at the opposite end adapted to receive the spool or bobbin of weft wire, substantially as set forth. 14th. In a wire fabric machine, the combination, with the frame, a series of inter-meshing and inter-communicating twisters mounted for fixed rotation in the frame, and weft wire carriers adapted to be arranged for movement with the twisters, of oppositely moving slides, and shifting plates attached to both sides of said slide on both sides of the frame and embracing the projecting ends of said weft wire carriers, substantially as set forth. 15th. In a wire fabric machine, the combination, with the inter-

communicating twister-wheels, and the shiftable weft wire carriers, of the oppositely moving shifting sides carrying notched shifting plates embracing the projecting ends of the carriers, and adapted to move the same from twister to twister, substantially as set forth. 16th. In a wire fabric machine, the combination, with the frame having opposite vertical guides or ways, a series of notched inter-meshing and inter-communicating twisters mounted in the frame, weft wire carriers registering with the notches in the twisters and projecting beyond opposite sides of the same, oppositely moving slides arranged to work in said vertical guides or ways, and having at their upper inner end rack bars meshing with opposite sides of a spur-wheel at the upper end of the frame, one of said slides being provided with a second rack bar, a suitably arranged shifting lever carrying a toothed segment meshing with said second rack bar to operate the slides, and shifting plates secured to both sides of said slides, and embracing the projecting ends of said weft wire carriers, substantially as set forth. 17th. In a wire fabric machine, a series of notches inter-meshing and inter-communicating twister-wheels, combined weft wire carrier and guides, mounted in said wheels and adapted to be shifted from one to the other, oppositely moving shifting slides, and shifting plates attached to both sides of said slides, and extended arms provided with notches adapted to embrace the projecting portions of the carriers, substantially as set forth. 18th. In a wire fabric machine, the combination of the opposite frame boards or plates having bearing openings and connecting slots, and concentric grooves upon their inner faces around certain of said bearing openings, and the twisting-wheels mounted in said bearing openings for a fixed rotation, some of said twisting-wheels being provided with circular retaining or strengthening ribs moving in said grooves, substantially as set forth. 19th. In a machine of the class described, the combination, with the machine frame, of a stationary rod or shaft braced from one side of the machine frame, and having perforated ends, laterally swinging slide runners having curved ends, one of which ends is threaded and passed through the machine frame, while the other unthreaded end of each runner passes through a perforated end of said stationary rod or shaft, binding nuts engaging the threaded ends of said runners and working against the machine frame, and set screws adapted to work in the extremities of said rod or shaft and on to the runner ends therein, substantially as set forth. 20th. The combination with a weaving machine of the class described, of the brace rods connected to and extending out from the front of said machine, a stationary rod or shaft secured to the lower outer ends of said brace rods and having perforated ends, laterally swinging slide runners adjustably connected at one end to the machine body, and at their other ends in the perforated ends of said rod or shaft, and combined propelling and mesh regulating devices arranged on said rod or shaft, substantially as set forth. 21st. In a machine of the class described, the combination with the runner supported machine, of a stationary shaft at the front ends of said runners, a chain-wheel loosely mounted on said shaft provided with a ratchet face on one side, a spring pressed pawl lever loosely mounted on said shaft alongside of the wheel and normally held in engagement with the ratchet teeth thereof, a chain engaging the upper portion of said chain-wheel and anchored stationary a distance in front of the same, and a check pawl for said chain-wheel, substantially as set forth. 22nd. In a machine of the class described, the combination with the runner supported machine, of parallel rods extended from said machine and having lower curved ends, a stationary shaft connected to the lower ends of said rods, a combined drag and mesh regulating device on said shaft, and having a pawl lever moving between said rods, a fixed stop connecting said brace rods to limit the movement of the pawl lever in one direction, and an adjustable regulating stop bar arranged to work over the curved ends of said rods to regulate the movement of the pawl lever in the other direction, substantially as set forth.

No. 44,973. Cigar Bunching Machine.

(Machine à lier les cigares.)

John H. Abraham, Philadelphia, Pennsylvania, U.S.A., 27th December, 1893; 6 years.

Claim.—1st. In a cigar bunching machine, the combination with the feed belt, and mechanism for imparting an intermittent motion thereto, of the hopper provided with a movable bottom *t*, and mechanism for operating said movable bottom at intervals corresponding with the intermittent motions of the belt, substantially as and for the purpose set forth. 2nd. In a cigar bunching machine, the combination with the endless feed belt of the fixed receiving table provided with a slotted cover *J*², and fingers *O* arranged to ride in said slotted cover, substantially as set forth. 3rd. In a cigar bunching machine, the combination with the endless feed belt, of the fixed receiving table provided with a slotted cover *J*², and fingers *O* arranged to rise and fall through the slotted cover, said fingers having also a forward and backward motion, substantially as set forth. 4th. In a cigar bunching machine, a series of feeding fingers *O*, mounted in a sliding frame and capable of independent adjustment, substantially as set forth. 5th. In a cigar bunching machine, a series of feeding fingers *O*, mounted in a sliding frame and capable of independent adjustment, said sliding frame having also an intermittent tilting motion to raise and lower said fingers, substantially as set forth. 6th. In a cigar bunching machine, the tilting frame *M*, having mounted thereon a sliding frame provided

with independently adjustable fingers *O*, in combination with mechanism for successively operating said frames, substan-

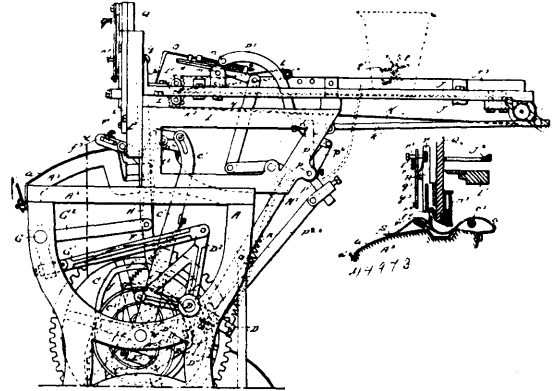

tially as set forth. 7th. In a cigar bunching machine, the combination with plunger *Q*, of the carrier box mounted thereon and provided with an adjustable forward wall *r*⁶, substantially as and for the purpose set forth. 8th. In a cigar bunching machine, with plunger *Q*, of the carrier box mounted thereon and provided with a vertically slidable rear wall and spring for normally raising the same, substantially as set forth. 9th. In a cigar bunching machine, the combination with plunger *Q*, having guideways and projection *q*³ on arm *q*², of the carrier box *R*, mounted in said ways and provided with clip *r*¹, and stop *r*² and the fixed bar *i*¹, all adapted to operate substantially as set forth. 10th. In a cigar bunching machine, the combination with the intermittently operated feeding mechanism, of the plunger *Q*, and carrier *R*, operating at right angles thereto, said carrier being mounted in slideways in the plunger and provided with a vertically slidable rear wall *R*², a spring bottom *r*⁴, adapted to permit the passage of the plunger blade and suitable stops regulating the return movements of the plunger and carrier, all substantially as set forth. 11th. In a cigar bunching machine, the combination with the carrier and the binding table and apron, of the bunching roller *e*², and binder holder *F*¹, carried respectively by levers *c*¹, and *F*, said lever *F*, being pivoted to the lever *c*¹, and normally held in contact therewith by a spring, substantially as set forth. 12th. In a cigar bunching machine the combination with the endless feeding belt and feeding fingers of shafts *P* and *N*, and levers thereon operatively connected to said feeding belt and fingers and to the main operating shaft, substantially as set forth. 13th. In a cigar bunching machine, the combination with the rotating motor shaft *C*, and the rocking shaft *D*, operated thereby, of the bunch rolling mechanism carried by levers *c*¹, and *F*, loosely mounted upon said rotating shaft *C*, and operated by a fixed arm *D*², on said rocking shaft, substantially as set forth. 14th. In a cigar bunching machine, the combination with the rotating motor shaft *C*, and the rocking shaft *D*, operated thereby, of plunger *Q*, bell crank *D*², loosely mounted upon said rocking shaft and operatively connected to the plunger, and *e*, cam *c*², on said rotary shaft, all adapted to operate, substantially as set forth. 15th. In a cigar bunching machine, the combination with the rotating motor shaft *C*, and the rocking shaft *D*, operated thereby, of the feeding fingers and the arm *D*¹, for rocking the same mounted on said shaft *C*, and operated by a cam *C*², on the rotary shaft, said arm *D*¹, being normally held in contact with said cam by a spring *n*¹, substantially as set forth.

No. 44,974. Vehicle Hub. (Moyeu de roue.)

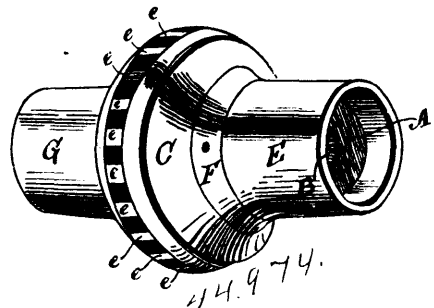

Robert G. Petway, White Bluffs, Tennessee, U.S.A., 27th December, 1893; 6 years.

Claim.—In a vehicle hub, the clamping plate and interposed screw nut between it and the nose-band, in combination with the

tube, having exterior screw threads at its end and cast with an annular flange having upon its inner side suitable lugs for the spokes to abut against, an annular screw threaded rim and shoulder to receive a suitable nose-band, substantially as and for the purpose set forth.

No. 44,975. Tool. (Outil.)

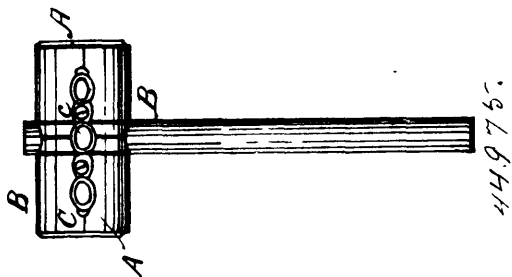

James Alfred Crane, Vila Road, Handsworth, Stafford, England, 27th December, 1893; 6 years.

Claim.—1st. In hand tools for fitting up metallic bedsteads, cots and the like, and for other suitable purposes, the combination consisting of a mallet A, with the addition of a strip or plate of metal B, having suitable holes therein C, for the purpose herein set forth. 2nd. In hand tools for fitting up metallic bedsteads, cots and the like, and for other suitable purposes, the combination consisting of a mallet D, with the addition of a hook or hooks, lever, or wrench or similar tool E, for the purpose set forth.

No. 44,976. Lawn Mower. (Fauçeuise de pelouse.)

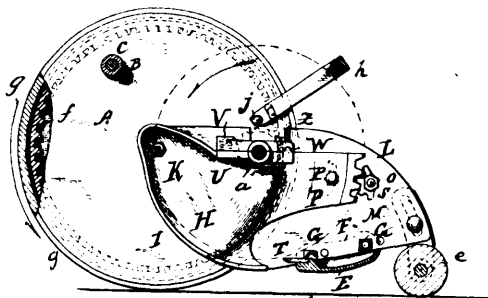

Sammel W. Martin, Springfield, Ohio, U.S.A., 28th December, 1893; 6 years.

Claim.—1st. In a lawn mower, the combination, with end plates, a connecting bar or rod, and a fixed blade-bar rigidly and non-adjustably secured to the plates, of adjustable bearing plates secured to the end plates and forming supports for the reel shaft, and a fastening device to hold the plates against slipping except when adjusted, and adjusting devices. 2nd. In a lawn mower, the combination, with an end plate, of a bearing plate, and fastening devices to secure it. 3rd. In a lawn mower, the combination, with an end plate, of a toothed bearing plate adjustably secured thereto, and a toothed device to engage said teeth and adjust the plates. 4th. In a lawn mower, the combination, with an end plate, struck-up of sheet metal, of a bearing plate of cast metal secured thereto, and acting to reinforce the struck-up plate. 5th. In a lawn mower, the combination, with an end plate, struck-up of sheet metal, of a bearing plate adjustably secured thereto, and acting to reinforce the struck-up plate, and to afford a bearing for the reel. 6th. In a lawn mower, the combination, with an end plate, of a bearing plate frictionally secured thereto and a fastening device to hold the plate against slipping except when purposely adjusted. 7th. In a lawn mower, the combination, with an end plate, of a bearing plate, an axle stud binding them together, a gear-wheel on said axle stud, a reel with the shaft mounted in said bearing plate, a fastening device to secure the two plates against the slipping of the bearing plate except when purposely adjusted, and a fixed blade carried by the end plates. 8th. In a lawn mower, the combination, with an end plate, struck-up of sheet material, of a bearing plate of cast material frictionally secured to the struck-up plate and adapted to reinforce it. 9th. In a lawn mower, the combination, with an end plate, and a bearing plate adjustably secured thereto, and an adjusting device adapted to move the bearing plate slowly and positively in either direction. 10th. In a lawn mower, the combination, with an end plate, and a bearing plate adjustably secured thereto, and having cog-teeth, of a toothed segment mounted

on the end plate and engaging with said teeth. 11th. In a lawn mower, the combination, with a journal bearing box composed of a fixed and a movable part, a spring holding them apart and sustaining the weight of one of them, and an adjusting screw to draw the movable plate down against the spring and into direct contact with the journal or bearing. 12th. In a lawn mower, the combination, with a fixed bearing plate, an upper movable bearing plate recessed, a spring in the recess on the fixed plate, an interlocking joint between the plates at the other end and a screw to draw them together. 13th. In a lawn mower, the combination, with an end plate and driving gear, of a ground-wheel separate therefrom and clutched thereto with a flange extending inward from the tread of the wheel to near the end plate, the width of the flange varying with the excess of diameter of the ground-wheel over the gear-wheel. 14th. In a lawn mower, the combination, with an end plate and driving gear-wheel, of a ground-wheel of more or less excessive diameter over the gear-wheel, and having a flange from its rim to near the end plate, the width of the flange varying with such excess of diameter.

No. 44,977. Propeller and Brake for Vehicles.

(Propulseur et frein de voiture.)

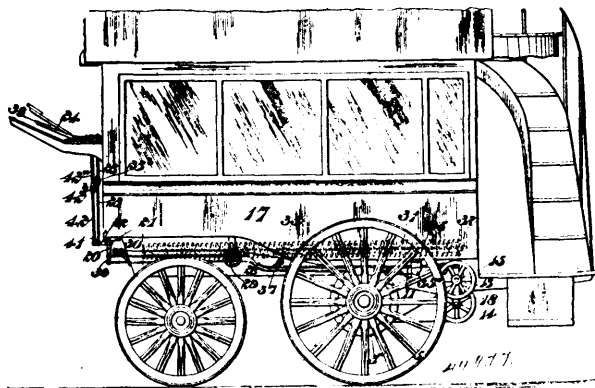

Harriet Carmont, Helmsdale, Kingston-on-Thames, Surrey, England, 28th December, 1893; 6 years.

Claim.—1st. In apparatus serving as a combined starter or propeller and brake for vehicles, the combination with fast and loose drums connected respectively with one of the rotary wheels or axles of the vehicle, and with a spring wherein energy is stored when the apparatus is acting as a brake, and means whereby said loose drum will become automatically connected with said wheel or axle when it is rotated by said spring, of a flexible connector such as a rope so wound upon said drums that when it is tightened thereon to cause the apparatus to act as a brake, the fixed drum will rotate the loose one in the opposite direction, and cause energy to be stored in said spring, and means such as an adjustable tightening pulley around which said connector or rope passes, and whereby the same can be tightened on said drums when desired, substantially as herein described for the purpose specified. 2nd. In apparatus serving as a combined starter and propeller and brake for vehicles, the combination with fast and loose drums connected respectively with one of the rotary wheels or axles of the vehicle, and with a spring wherein energy is stored when the apparatus is acting as a brake, and means whereby said loose drum will become automatically connected with said wheel or axle when it is rotated by said spring, of a flexible connector such as a rope so wound upon said drums that when it is tightened thereon to cause the apparatus to act as a brake, the fixed drum will rotate the loose one in the opposite direction, and cause energy to be stored in said spring, means for tightening said flexible connector or rope on said drums, and means for automatically preventing the second or loose drum being rotated by said spring until it is required to restart the vehicle by the energy stored in said spring, substantially as herein described. 3rd. In apparatus serving as a combined starter or propeller and brake for vehicles, the combination with fast and loose drums connected respectively with one of the rotary wheels or axles of the vehicle, and with a spring wherein energy is stored when the apparatus is acting as a brake, and means whereby said loose drum will become automatically connected with said wheel or axle when it is rotated by said spring, of a rope so wound upon said drum that when tightened thereon the fixed drum will rotate the loose one in the opposite direction, an adjustable tightening pulley around which said rope passes, a rope clutch adapted to automatically grip said rope, or the rope connecting said loose drum with said spring, when said spring tends to rotate said loose pulley, and means for releasing said clutch when the energy stored in said spring is to be utilized to restart or propel the vehicle, substantially as described. 4th. In apparatus serving as a combined starter or propeller and brake for vehicles, the combination with fast and loose drums connected respectively with one of the rotary wheels or axles of the vehicle and with a spring

through a rope, and a toothed wheel fixed to said wheel or axle, and with which said loose drum is caused to engage when rotated by said spring, of a third drum fixed upon another rotary wheel or axle of the vehicle, a rope so wound upon said drums that when tightened both of the fixed drums will act to drive the loose one in the reverse direction, an adjustable tightening pulley for said rope, a rope clutch adapted to engage one of said ropes when moved by said spring, and means for throwing said clutch out of action, substantially as herein described. 5th. In apparatus serving as a combined starter or propellor and brake, the combination with one of the wheels or axles of the vehicle, of the drums 3 and 7, and toothed wheel 2, arranged thereon as described, the coiled spring 33, rope 25, connecting the spring with said drum 7, and provided with a device such as the link 27, with projection 28, for permitting a pawl carried by said drum 7, to engage said toothed wheel, a rope 11, having its ends connected to said drum 7, and wound upon the two drums 3 and 7, in the manner described, guide pulleys 13 and 14, for said rope 11, lever 18, for carrying said pulley 14, a rope clutch 35-35a, arranged to grip said rope 11, and mechanism under the control of the driver of the vehicle for operating said lever 18, and rope clutch, substantially as herein described, for the purposes specified. 6th. The combination with a tram-car, of two sets of apparatus serving as combined starters or propellers and brakes, one set being arranged for use when the car is travelling in one direction and the other for use when travelling in the opposite direction, and each comprising drums 3 and 7, and toothed wheel 2, on one car axle, a drum 3a, fixed on the other car axle, rope 11, wound on said drums, as described, adjustable tightening pulley 14, and rope clip 35-35a, for said rope, mechanism under the control of said driver for operating said pulley and clutch, and a suitable guide rope 25, connecting said drum 7, to one end of a spring, the other end of which is connected with the other set of apparatus, substantially as described.

No. 44,978. Travelling Hanger for Doors.

(*Ferrure de porte glissante.*)

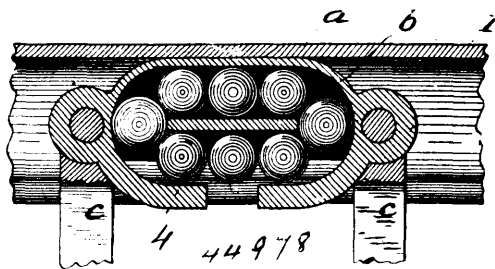

James Thomas McCabe, Toronto, Ontario, Canada, 28th December, 1893; 6 years.

Claim.—1st. In travelling hanger for doors, curtains, etc., the combination of a track, a series of independently moving balls running upon said track, and means for independently attaching the supported object to the balls, substantially as specified. 2nd. In a travelling hanger for doors, curtains, etc., the combination of a track, composed of a tube having a longitudinal slot and balls travelling along said bearing surfaces, and the supported object carried by said balls, substantially as specified. 3rd. In a travelling hanger for doors, curtains, etc., the combination of a track composed of a tube, having a longitudinal slot formed therein, a curved bearing surface arranged on either side of the longitudinal slot, bearing balls travelling along said bearing surfaces, a hanger supported and carried by said balls, substantially as specified. 4th. In a travelling hanger for doors, curtains etc., the combination of a track composed of a tube having a longitudinal slot formed therein and bearing surfaces arranged on either side of the slot, bearing balls running upon the bearing surfaces, a carriage supported by said bearing balls, a depending arm from the carriage, and means for attaching the depending arm to the object to be supported.

No. 44,979. Electric Cutting Machine.

(*Machine à couper électrique.*)

Arthur Kinsky Thyll, New York, U.S.A., 28th December, 1893; 6 years.

Claim.—1st. In an electric cutter the combination with a movable casing, of an electromotor and cutting device mounted therein and means for connecting the armature shaft and the cutting device, substantially as and for the purpose set forth. 2nd. In an electric cutter the combination with a movable base or foot and a standard extending upward from the same, of an electromotor and a cutting device mounted in said standard for connecting the armature shaft and cutting device, substantially as and for the purpose set forth. 3rd. In an electric cutter the combination with an electromotor of a recessed standard supporting said motor, a cutting disc mounted in a bearing in said standard and a connecting mechanism between

the armature shaft and the cutting disc, said mechanism being partly located in the recess of the standard, substantially as set forth.

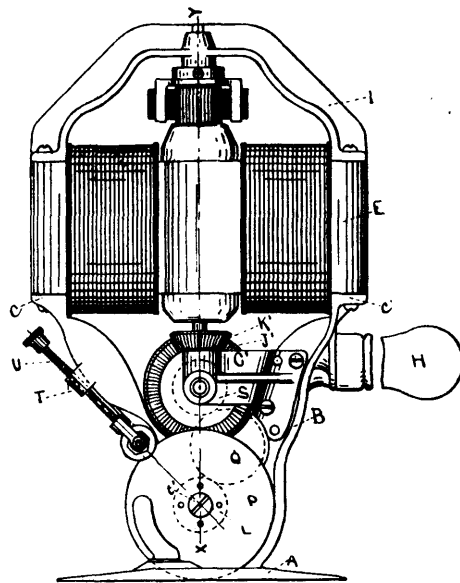

4th. In an electric cutter the combination of an electromotor having two armatures with bevel gears on said armature shafts and bevel gears meshing therewith and mounted on a transverse shaft, a pinion attached to said transverse shaft between the bevel gears thereon, an intermediate shaft provided with a gear meshing with said pinion and the cutting disc fastened to another gear-wheel meshing with the gear-wheel of the intermediate shaft, substantially as set forth. 5th. In an electric cutter the combination of a standard with a double electromotor supported thereon and bearings in said standard for the two armature shafts of the electromotor and a cutting device and suitable gearing connecting said cutting device with the armature shafts, said cutting device and connecting mechanism being mounted in said standard, substantially as and for the purpose set forth. 6th. The combination of a standard provided with a flattened base portion or foot, a rotary cutting disc located at the lower part of the standard and a gear or sprocket-wheel attached to said cutting disc and serving as the bearing for the same, substantially as set forth. 7th. The combination of a standard having a flattened foot or base portion, a rotary cutting disc located at the lower part of the standard, a gear-wheel fastened to said disc and a bushing inserted in the bore of said gear-wheel and fitting over a stud fastened to the standard, substantially as set forth. 8th. The combination of a standard provided with a flattened foot or base portion, a rotary cutting disc located at the lowest part of the standard, a gear-wheel fastened to said disc and having a hub, a stud secured in a nut fastened to the standard and a bushing between the stud and the gear-wheel, said nut having a recess for the hub of the gear-wheel, substantially as set forth. 9th. In an electric cutter the combination of a standard having a supporting foot or base with a rotary cutting device journaled at the lower part of the standard, a connecting mechanism joining said cutting device to the shaft or shafts of an electromotor said electromotor being mounted in said standard and a movable rod mounted in said standard and carrying a grinding disc fitted to rotate therein, said grinding disc being located in proximity to said rotary knife, substantially as set forth. 10th. In an electric cutter, in combination a suitable standard, a rotary cutting disc journaled in said standard and suitable means for driving said cutting disc, a movable rod mounted in the standard having an adjustable collar and spring thereon, and two grinding discs mounted on said rod and adapted to embrace the rotary knife, substantially as set forth. 11th. The combination of a rotary cutting disc, a standard and base supporting same, and a plate fastened to the base, and bevelled in front, and having two upwardly extending fingers following the periphery of the cutting disc, and enclosing the same on both sides, substantially as and for the purpose set forth. 12th. In an electric cutter, in combination, a movable frame or support, a double electromotor mounted upon the same having three poles, one of which poles serves for both armatures of the motor, substantially as and for the purpose set forth.

No. 44,980. Bicycle. (Bicycle.)

Samuel A. White, Harrisburg, Pennsylvania, U.S.A., 28th December, 1893; 6 years.

Claim.—1st. The herein described mechanism for propelling bicycles and similar vehicles, consisting of the pedal lever and the

supplementary adjustable lever arranged, and adapted to increase or diminish the power and accelerate or retard the speed of the

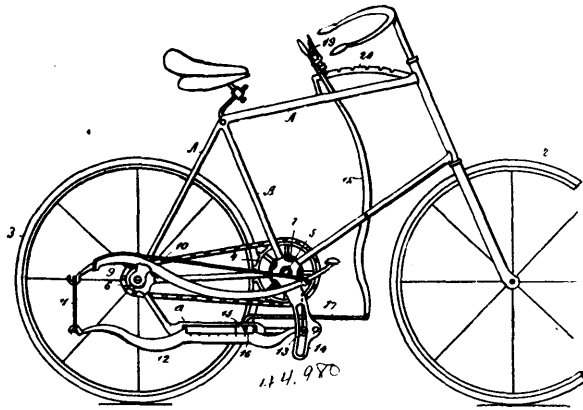
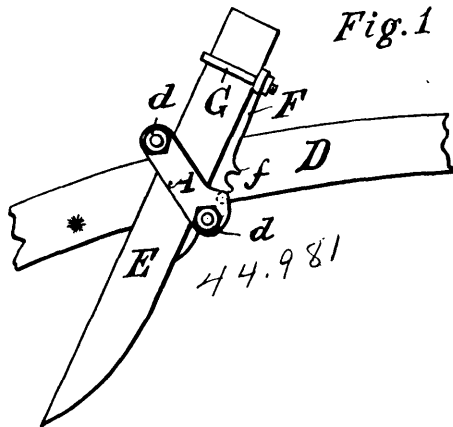

Fig 1

vehicle, substantially as herein set forth. 2nd. In a device for propelling bicycles and similar vehicles, the combination, with the driving wheel and pedal lever, of the herein described supplementary lever, the movable fulcrum with its adjuncts adapted to alter the adjustment of the supplementary lever, substantially as and for the purpose herein set forth..

No. 44,981. Holder for Plough Colters.
(*Porte-coute de charrue.*)



William H. Perrin, Merrickville, Ontario, Canada, 28th December, 1893; 6 years.

Claim.—In a device for holding the colter to the plough beam, the combination, with the plate A, having studs *a*, wedge-shaped portions B, and the clip C, of the rack F, having the clip G, at one end and the teeth *f*, at the lower end, substantially as set forth.

No. 44,982. Car Coupler. (*Attelage de chars.*)

Joseph L. Sowell, Althouse, Oregon, U.S.A., 28th December, 1893; 6 years.

Claim.—1st. In a car coupling, the combination of a draw-head provided in the bottom of its longitudinal opening with a coupling pin perforation, a coupling pin arranged in the perforation and extending above the bottom of the longitudinal opening of the draw-head, a weighted lever connected with the coupling pin and holding the latter normally elevated, and a link guiding plate arranged in the draw-head and having its rear end connected to the upper end of the coupling pin and its lower end arranged on the bottom of the longitudinal opening of the draw-head, substantially as and for the purpose described. 2nd. In a car coupling, the combination of a draw-head provided in the bottom of its longitudinal opening with a longitudinal recess and having a coupling pin perforation at the rear terminus of the recess, a coupling pin arranged in the perforation and projecting above the bottom of the opening of the draw-head, a link guiding plate having its front end arranged in said recess and its rear end hinged to the upper end of the coupling pin, a transverse bar connected to the lower end of the coupling pin and arranged beneath the draw-head, and a weighted lever connected with the transverse bar, substantially as described. 3rd. In a car coupling, the

combination of a draw-head provided in its sides with vertical grooves and having a coupling pin perforation, a coupling pin

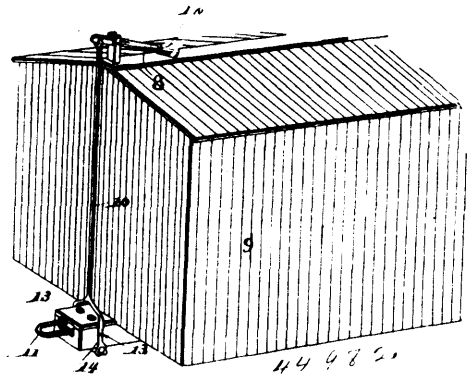

arranged in the perforation and extending above the bottom of the longitudinal opening of the draw-head, a link guiding plate having its rear end connected to the upper end of the coupling pin, a transverse bar connected to the lower end of the coupling pin and arranged beneath the draw-head, a weighted lever fulcrumed on the car, and a rod having its upper end connected to the lever and provided at its lower end with a fork having sides arranged in the grooves of the draw-head and connected to the ends of the transverse bar, substantially as described.

No. 44,983. Hoisting Machinery. (*Vindas.*)

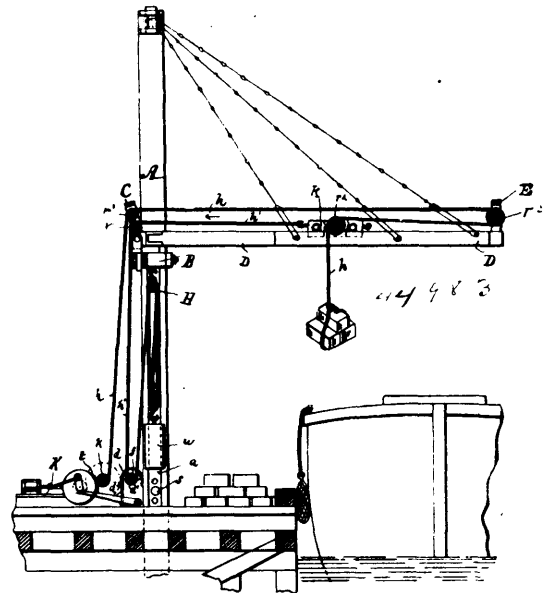

John E. Walsh, New York, State of New York, U.S.A., 28th December, 1893; 6 years.

Claim.—The combination of a mast erected on a dock or other place, arms supported thereon and adapted to be swung around in different positions, trolleys travelling upon said arms, hoisting machines for working the hoisting ropes, tackle ropes passing each from one end of a trolley over a pulley or pulleys to and around a drum connected with a brake and from there over the pulleys of the two blocks of a hoisting tackle, to one of which blocks the other end of a tackle rope is secured, and weights guided in the mast and suspended each from one of the blocks, while the other is secured to the mast, as and for the purposes herein shown and described.

No. 44,984. Electric Motor. (*Moteur électrique.*)

Imle E. Storey, Brooklyn, New York, U.S.A., 28th December, 1893; 6 years.

Claim.—1st. In an electric motor, a field-magnet consisting of a cylinder surrounding a coil or coils of wire, in combination with pole-pieces extending from opposite points at the edges of the cylinder around the coil or coils and toward each other, and other pole-pieces extending inward from a point or points about midway between the edges of the cylinder, and extending in both directions

toward the edges of the cylinder and embracing the coils, substantially as described. 2nd. The combination, with an armature, of a

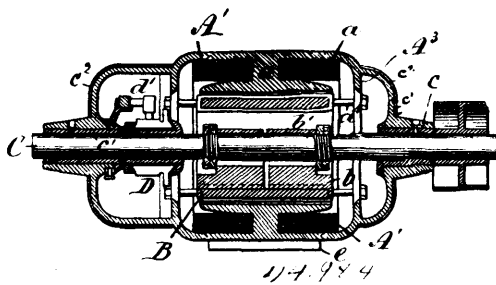

multipolar field-magnet, consisting of a cylinder surrounding the armature, and having pole-pieces projecting from its edge inward and other pole-pieces projecting from its middle portion inward, the different pole-pieces alternating with one another around the armature, and exciting coils confined between the cylinder and the pole-pieces. 3rd. The combination, with the cylinder A, provided with one set of pole-pieces, of the end rings provided with the inward projections, constituting the other set of pole-pieces, as set forth. 4th. The combination, with the cylinder A, provided with one set of pole-pieces, of the end rings provided with the inward projections constituting the two other set of pole-pieces, and bolts as a', connecting the two rings and securing them to the cylinder, substantially as described.

No. 44,985. Machine for Nailing Boots.
(Machine à clouer les chaussures.)

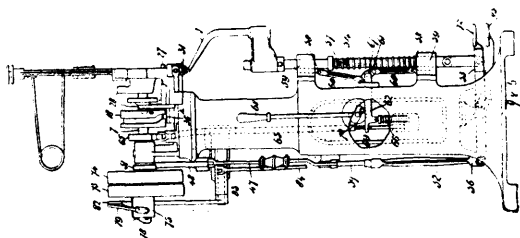

Richard W. Bateman, Halifax, York, England, 28th December, 1893; 6 years.

Claim.—1st. In a boot nailing machine, and in combination, a fixed shear box 20, shear block 22, stud 23, and stud disc 26, operating the block 24, shaft 27, lever 28, and friction roller 29, for operating the disc, and so sliding the shear block, nail carrier 31, piece 34, connected thereto, bar 35, and cranked lever 26, having friction roller 36, for sliding the nail carrier, and a cam having separate grooves for engaging with the friction rollers 29 and 36, and means for operating the cam, substantially as described. 2nd. In a boot nailing machine, and in combination, a vertical slide piece 4, a horizontal slide piece 8, adapted to move in the piece 4, a friction roller 5, and a pricker carried by said piece 8, a supplementary slide piece 10 for operating on the piece 8, pin 9, on piece 10, slotted lever 11, and means for operating the latter, a fixed block 13, adapted to be struck by the friction roller 5, means for reciprocating the plate 4, and means for retracting the piece 8, substantially as described. 3rd. In a boot nailing machine, and in combination, the horn 1, horn spindle, a light spring for raising the latter, wedges for securing same in position, means for holding the spindle, toggle levers for inserting and withdrawing the wedges, means for operating said toggle levers, means for lowering the spindle, and means for pricking and pegging the sole on said horn, substantially as described. 4th. In a boot nailing machine and in combination, the horn 1, horn spindle 54, spring 57, sockets 59, wedges 58, toggle levers 60, link 61, pivoted lever 62, connected to same, means for rocking the lever to operate the wedges through the toggle levers, and a treadle connected to the spindle for depressing the latter, substantially as described. 5th. In a machine of the character described, the combination of the pivoted lever 62, toggle link, toggle levers, wedges and horn spindle, rod 63 connected to lever 62, the main shaft, a cam on same for operating the rod, and a spring 66 connected to lever 62. 6th. In a machine of the character described the combination of the pivoted lever 62, toggle links, toggle levers, wedges and horn spindle, the hand lever 68, dix 69, eccentric pin 70 for bearing on lever 62, and spring 66 for operating the wedges by hand, substantially as described. 7th. In a boot nailing machine, and in combination, the horn spindle 54, a foot lever connected thereto at one end, a rod connected to the other end, a strap and weight or its equivalent connected to the rod, a pulley over which the strap passes, means

for holding the strap fixed on the pulley, and means for raising the latter so that the horn spindle may be lowered to permit of the feed or movement of the boot, substantially as described. 8th. In a boot nailing machine, and in combination, the horn spindle 54, a foot lever connected thereto at one end, a rod 52, connected to the other end, a strap 39, and spring 38, or its equivalent, connected to the rod, a pulley over which the strap passes, a pivoted arm or fork 41 in which the pulley is mounted, a link 46 pivoted on the arm or fork, means operated by the link for jamming the strap into the pulley, a rod 47 attached to the link, a cranked lever 48 attached to the rod, the main shaft and a cam on same for operating the lever 48 to lift the pulley, and so lower the horn spindle, substantially as described.

No. 44,986. Horse-shoe. (Fer à cheval.)

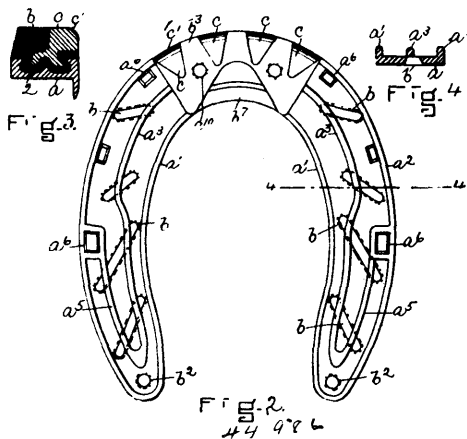

Myron L. Chamberlain, Boston, Massachusetts, U.S.A., 29th December, 1893; 6 years.

Claim.—1st. A compound horse-shoe consisting of a metal frame composed of a plate or web having one or more ribs and provided with locking apertures, and a wearing surface composed of an elastic substance vulcanized on to the said web or plate and enveloping the said rib, the said plate forming a substantially wide solid backing for the elastic wearing surface, substantially as described. 2nd. A compound horse-shoe consisting of a metal frame or shoe, an elastic wearing surface, and a cushioned guard locked to the metal frame or shoe, and having its wearing surface substantially flush with the elastic wearing surface, substantially as described. 3rd. A compound horse-shoe consisting of a metal frame composed of a web or plate having side or edge flanges, one or more ribs secured to or forming part of the said web or plate between the said edge flanges, and a wearing surface of elastic material secured to the said plate or web between the side flanges, substantially as described. 4th. A compound horse-shoe consisting of a metal frame, composed of a web or plate having side or edge flanges and provided with locking apertures, a wearing surface of rubber or like elastic material vulcanized on to the said frame and extended below the side flanges, and one or more metal surfaces embedded in the elastic wearing material and substantially flush with the same, to protect the elastic material from wear, substantially as described. 5th. A compound horse-shoe consisting of a copperized metal frame composed of a plate or web, one or more ribs secured to or forming part of the web or plate between its edges and extended for the whole or a portion of its length, as described, and a wearing surface of rubber or like elastic material vulcanized on to the said copperized plate or web, substantially as described. 6th. A compound horse-shoe consisting of a copperized metal frame or shoe, a wearing surface of rubber or like elastic substance vulcanized on to the said copperized metal frame or shoe, and one or more metal wearing surfaces locked to the metal frame or shoe and embedded in the elastic wearing substance and substantially flush with the same, substantially as and for the purpose specified. 7th. A compound horse-shoe consisting of a metal frame composed of a plate or web provided with a plurality of countersunk holes or openings forming locking apertures, one or more ribs attached to the lower surface of the plate between its sides, and a rubber wearing surface secured to the lower surface of the plate and extended into the countersunk holes and enveloping the said rib, substantially as described. 8th. A compound horse-shoe consisting of a copperized metal frame composed of a plate or web provided with a plurality of countersunk holes, and having one or more ribs attached to the lower surface of the plate or web and extended across the said countersunk holes, and a rubber wearing surface vulcanized on to the lower surface of the copperized plate or web, filling the countersunk holes and enveloping the said rib, substantially as described. 9th. A compound horse-shoe, consisting of a copperized metal frame composed of a plate or web, having locking apertures, and one or more ribs attached to the lower surface of the

said plate and extended across the said locking apertures, and a wearing surface composed of rubber vulcanized on to the copperized lower surface or web, substantially as described.

No. 44,987. Fire Extinguisher.

(*Extincteur d'incendie.*)

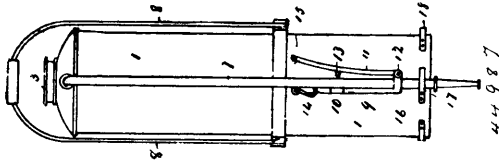

Thomas F. Handly, Allegheny, Pennsylvania, U.S.A., 20th December, 1893; 6 years.

Claim.—1st. In a fire extinguisher, the combination with the receptacle I, designed to be inverted for use, and a hose connected with said receptacle, of an acid receptacle supported within said receptacle near the top thereof, and a stopper for said receptacle, said stopper having a projection extending within said acid receptacle, and of a greater length than the distance between the top of said acid receptacle and adjacent wall of the receptacle I, as and for the purpose described. 2nd. In an apparatus for the purpose described, the combination, consisting of the receptacle I, having a bale pivoted below the centre of the gravity of the same, an acid bottle attached in the interior of the apparatus, having a heavy elongated stopper capable of being removed partly from the mouth of the bottle by gravity, a means for making the bail rigid with the body of the apparatus when the same has been reversed, a hose connected with the fire extinguisher, and a means for closing the same by compression, substantially as described.

No. 44,988. Electric Motor. (*Moteur électrique.*)

Fig. 1.

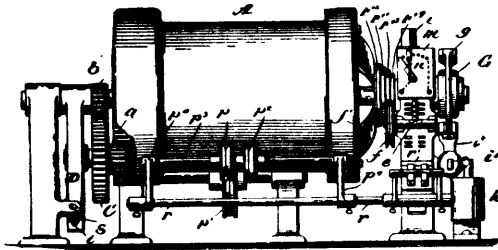

Ernest Richard Esmond, New York, State of New York, U.S.A., 29th December, 1893; 6 years.

Claim.—1st.—In an electric elevator or hoisting apparatus, an electric motor, comprising a field and armature, both of them

rotatable, an intermediate pinion, geared on the one hand to the armature and on the other hand to the field, and a hoisting drum mounted on or formed with the field, substantially as hereinbefore set forth. 2nd. In an electric elevator or hoisting apparatus, an electric motor, comprising a field and an armature, both of them rotatable, an intermediate pinion geared on the one hand to the armature and on the other hand to the field a carrier for said intermediate vibratory upon an axis coincident with that of the armature, and a hoisting drum mounted on or formed with the field, substantially as hereinbefore set forth. 3rd. An electric motor comprising a field and armature, both of them rotatable, in combination with intermediate gearing connecting the two, and a carrier for said gearing hung upon an axis, on which it can vibrate to permit swinging movement of the gearing carried by it, substantially as and for the purposes hereinbefore set forth. 4th. The intermediate and its pendulous spring or weight controlled carrier, in combination with the rotatable field and rotatable armature, of an electric motor, substantially as and for the purposes hereinbefore set forth. 5th. The combination, in an electric motor, having a rotatable field and rotatable armature, with the internal spur wheel a, and the pinion b, of an intermediate C, meshing with said wheel, and pinion, and a carrier for said intermediate pivoted to move upon an axis coincident with that of the wheel and pinion, between which the intermediate is placed, as set forth.

No. 44,989. Separator. (*Séparateur.*)

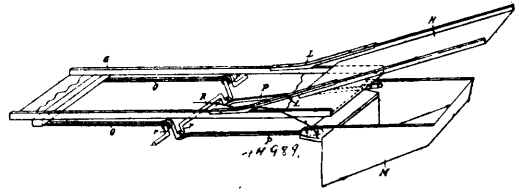

William J. Borland and William Smith, London, Ontario, Canada, 29th December, 1893; 6 years.

Claim.—1st. In a separator, a double throw crank shaft F, in combination with and operating the straw decks B and C, and means for supporting the outer ends of the latter, substantially as and for the purposes set forth. 2nd. In a separator, a crank shaft F, formed with the double throw cranks f f, in combination with and operating the straw decks B and C, and the hangers D and E, substantially as and for the purposes set forth. 3rd. In a separator, a double throw crank shaft R, and connecting bars O and P, in combination with and operating the grain deck G, shoe M, and shoe guard H, the latter being connected to the grain deck G, by the connecting bars L L, and means for supporting said grain deck shoe and shoe guard, substantially as and for the purposes set forth. 4th. In a separator, a crank shaft R, formed with the double throw cranks r r, and the connecting bars O, P, in combination with and operating the grain deck G, shoe M, and shoe guard H, the bars L L, and the hangers I, J, and S, K, and N N, substantially as and for the purposes set forth. 5th. In a separator, a crank shaft R, and connecting bars O O, in combination with and operating a grain deck G, and shoe guard H, the connecting bars L L, and the hangers I, J, and S, K, substantially as and for the purposes set forth.

CERTIFICATES OF THE PAYMENT OF FEES FOR FURTHER TERMS HAVE BEEN ATTACHED TO THE FOLLOWING PATENTS.

3184. CHARLES S. ROE, 2nd and 3rd five years of No. 30,330, from the 5th day of December, 1893. Improvements in Smoke Stacks, 5th December, 1893.
3185. DAVID CARLAW, 2nd five years of No. 30,344, from the 6th day of December, 1893. Improvements in Letter-press Printing and Numbering Machines, 5th December, 1893.
3186. JAMES CURRIE, 3rd five years of No. 18,314, from the 15th day of December, 1893. Improvements in the Attachment of Horses to Vehicles, 5th December, 1893.
3187. WILLIAM B. SENIOR, 2nd five years of No. 30,547, from the 14th day of January, 1894. Improvements in Shoe Clasps, 5th December, 1893.
3188. JAMES MOSS and CHARLES B. HUNT, 2nd five years of No. 30,427, from the 18th day of December, 1893. Improvements in or connected with Sewing Machines, 5th December, 1893.
3189. THE WIDDIFIELD ELECTRIC BRAKE COMPANY, (assignees) 2nd five years of No. 30,424, from the 18th day of December, 1893. Improvements in Electric Brakes for Railway Trains, 6th December, 1893.
3190. THE DOMINION FIRE ESCAPE COMPANY, (assignees), 3rd five years of No. 18,297, from the 14th day of December, 1893. Improvements in Fire Escape Ladders, 6th December, 1893.
3191. GEORGE W. COPELAND, 2nd five years of No. 30,421, from the 17th day of December, 1893. Improvements in Tack Driving Machines, 9th December, 1893.
3192. THE CANADIAN GENERAL ELECTRIC COMPANY, (assignees), 2nd five years of No. 30,366, from the 11th day of December, 1893. System of Electrical Distribution, 9th December, 1893.
3193. THE CANADIAN GENERAL ELECTRIC COMPANY, (assignees), 2nd five years of No. 30,367, from the 11th day of December, 1893. Improvements on Electric Motors, 9th December, 1893.
3194. LUTHER M. BISSELL, 2nd five years of No. 30,402, from the 14th day of December, 1893. Improvements in Whiffletrees, 11th December, 1893.
3195. MILO COVEL, 3rd five years of No. 18,280, from the 11th day of December, 1893. Improvements in a Saw Sharpening Machine, 11th December, 1893.
3196. SHEPARD W. CATELY, 2nd five years of No. 30,398, from the 14th day of December, 1893. Improvements in Carriage Top Springs, 12th December, 1893.
3197. EDWARD CLAYTON and WILLIAM J. CLAYTON, 3rd five years of No. 18,836 from the 10th day of March, 1894. Improvements in Clothing Samples, 14th December, 1893.
3198. A. M. PERKINS (A.M.) & SON, 2nd five years of No. 30,711, from the 5th day of February, 1894. Improvements in Refrigerating and Freezing Apparatus, 14th December, 1893.
3199. EDWIN NORTON and OLIVIER W. NORTON, 2nd five years of No. 30,475, from the 24th day of December, 1893. Improvements in Machines for Soldering Side Seams of Cans, 14th December, 1893.
3200. THE AMERICAN ARITHMOMETER COMPANY, (assignees), 2nd five years of No. 30,577, from the 16th day of January, 1894. Improvements in Mechanical Accountants, 15th December, 1893.
3201. THE VACUUM BRAKE COMPANY (assignees), 2nd five years of No. 30,993, from the 22nd day of March, 1894. Improvements in or Applicable to Vacuum Brake Apparatus, 18th December, 1893.
3202. MELVIN B. CHURCH, 2nd five years of No. 30,437, from the 19th day of December, 1893. Improvements in Enamel Surfaces for Carriages and the like, 19th December, 1893.
3203. FREDERICK R. FARWELL and FOSTER P. RHINES, 2nd and 3rd five years of No. 30,537, from the 12th day of January, 1894. Improvements in Barley Flakes and the Process of Producing the same, 19th December, 1893.
3204. ALEXANDER M. AMOS, 2nd five years of No. 30,521, from the 31st day of December, 1893. Improvements in Steam Cookers, 19th December, 1893.
3205. LEVI L. BURDON, 2nd five years of No. 30,452, from the 20th day of December, 1893. Improvements in Ingot for making Seamless Plated Wire, 20th December, 1893.
3206. JOSEPH VOWLES, 2nd five years of No. 30,482, from the 26th day of December, 1893. Improvements in Wheel Harrows and Cultivators, 26th December, 1893.
3207. JAMES LYALL, 2nd five years of No. 30,646, from the 28th day of January, 1894. Improvements on Twine and in the Device for making same. 27th December, 1893.
3208. FARQUHAR McRAE, 2nd five years of No. 30,504, from the 27th day of December, 1893. Cow Stable Cleaner. 27th December, 1893.
3209. JASPER BATES, 3rd five years of No. 27,109, from the 2nd day of July, 1897. Improvements in Manual Powers. 28th December, 1893.
3210. THE PHONOPORE SYNDICATE (assignees), 2nd and 3rd five years of No. 31,115, from the 11th day of April, 1894. Apparatus for the employment of Vibratory Electricity in Telegraphy. 28th December, 1893.
3211. THE LANSTON TYPE MACHINE CO. (assignees), 2nd five years of No. 30,581, from the 17th day of January, 1894. Improvements in the Art of forming Justified Lines of Types. 29th December, 1893.
3212. THE LANSTON TYPE MACHINE CO. (assignees), 2nd five years of No. 30,582, from the 17th day of January, 1894. Improvements in the Art of forming Justified Lines of Types. 29th December, 1893.
3213. THE LANSTON TYPE MACHINE CO. (assignees), 2nd five years of No. 30,583, from the 17th day of January, 1894. Improvements in the Art of forming Justified Lines of Types. 29th December, 1893.
3214. THE LANSTON TYPE MACHINE CO. (assignees), 2nd five years of No. 30,584, from the 17th day of January, 1894. Improvements in the Art of forming Justified Lines of Types. 29th December, 1893.
3215. CHARLES CLUTHE, 2nd five years of No. 30,507, from the 31st day of December, 1893. Improvements in Hernia Trusses. 29th December, 1893.
3216. ROBERT B. CODLING, 2nd five years of No. 30,519, from the 31st day of December, 1893. Improvements in Machines for Turning Articles of Metal, &c. 30th day of December, 1893.

TRADE MARKS

Registered during the month of December, 1893, at the Department of Agriculture—
Copyright and Trade Mark Branch.

4809. HARDING & SMITH, of St. John, N.B. Flour, 2nd December, 1893.
4810. } WHEATLEY & BATES (LIMITED), of Napier Street, and 5 and 6 Corn
4811. } Exchange Buildings, Sheffield, England. Liquors, such as Hop
Bitter Ale, Hop Beer, Hop Stout, and Hop Bitters, and also all
descriptions of Beverages and Cordials, 4th December, 1893.
4812. }
4813. } J. H. TODD & SON, of Victoria, B.C. Canned Salmon, 5th December, 1893.
4814. }
4815. JOSEPH SMITH, of London, Ont. Cigars, 5th December, 1893.
4816. E. J. WALKER, of Halifax, N. S. Carbonated Beverages, such as Lemonade,
Ginger Ale, Cream Soda, Orange Phosphate and Soda Water,
6th December, 1893.
4817. COUTTS & SONS, of Toronto, Ont. Medicine, 6th December, 1893.
4818. GEO. H. HARPER & CO., of West Flamboro Township, Wentworth County,
Ont. Flour, 6th December, 1893.
4819. THE E. B. EDDY CO., LTD., of Hull, Que. Printing, Type-writer,
Writing and other Papers, 6th December, 1893.
4820. M'KESSON & ROBBINS, of New York, N.Y., U.S.A., General Trade Mark,
7th December, 1893.
4821. } HARTLAND LAW & HERBERT EDWARD LAW, of San Francisco,
4822. } California, U.S.A., trading as the VIAMI COMPANY. General
Trade Marks, 9th December, 1893.
4823. WILLIAM THOMAS GOFFE, of Montreal, Que. Preparations for the Cure
of Rheumatism, 14th December, 1893.
4824. S. DAVIS & SONS, of Montreal, Que. Cigars, Cigarettes and Tobacco, 14th
December, 1893.
4825. THE MONTREAL CHEMICAL CO., of Montreal, Que. Remedies and
Preparations having an action upon the Skin, 16th December,
1893.
4826. J. E. H. SIBBALD, of St. Joseph, Missouri, U.S.A. Flour, 18th December,
1893.
4827. THE TROMMER EXTRACT OF MALT CO., of Tremont, Ohio, U.S.A.,
Medical Compounds, 19th December, 1893.
4828. ISAAC BLUMENSTIEL, of Hamilton, Ont. Cigars, 20th December, 1893.
4829. DANIEL JAMES CALLARD, RALPH CALLARD & JAMES PERCY
CALLARD, of Duke's Road, London, W.C., England. Trading
as CALLARD & BOWSER. Butterscotch and other Sweet-
meats, 20th December, 1893.
4830. WILLIAM FREDERICK JACKSON, of Brockville, Ont. Pills, 22nd
December, 1893.
4831. FELLAY, LAVINE & CO., of Montreal, Que. Cigars, 26th December, 1893.
4832. RICHARD VANCE WINCH, DAVID SAVOY HENNESEY & GEORGE
ALEXANDER, trading as the CANADIAN PACIFIC
PACKING CO., of Lulu Island, Fraser River, B.C. Canned
Salmon, 26th December, 1893.
4833. THE A. A. GRIFFING IRON CO., of Jersey City, New Jersey, U.S.A.
Radiators, 29th December, 1893.
4834. STEWARD & MERRIAM, of Peoria, Illinois, U.S.A. Rolled Oats, 30th
December, 1893.

COPYRIGHTS

Entered during the month of December, 1893, at the Department of Agriculture—
Copyright and Trade Mark Branch.

7150. GORDON POLKA. By I. W. Russell, Ottawa, Ont., 2nd December, 1893.
7151. MEMOIRS OF THE LIFE OF DONALD CAMERON, with Remarks by his son Archibald. Archibald Cameron, Vellore, York County, Ont., 3rd December, 1893.
7152. AROUND THE WORLD POLKA. By William Grimshaw. The Anglo-Canadian Music Publishers' Association, Ltd., London, England, 4th December, 1893.
7153. COURTSHIP AND MARRIAGE AND THE GENTLE ART OF HOME-MAKING. By Annie S. Swan. William Briggs (Book-Steward of the Methodist Book and Publishing House), Toronto, Ont., 4th December, 1893.
7154. CAROLS OF CANADA. By Mrs. McLeod. Elizabeth S. McLeod, Charlottetown, P.E.I., 4th December, 1893.
7155. FRANKINCENSE AND MYRRH. Selections from the Poems of the late Mrs. William Lawson (M.J.K.L.) Selected and Edited by Harry Piers and Constance Fairbanks. Morton & Co., Halifax, N.S., 4th December, 1893.
7156. IRON PIPE TABLES. John Brown, Toronto, Ont., 5th December, 1893.
7157. WEEKLY INVESTMENT STOCK CIRCULAR OF THE YORK COUNTY LOAN AND SAVINGS COMPANY. Joseph Phillips, Toronto, Ont., 6th December, 1893.
7158. APPLICANT'S BLANK, CHURCH'S AUTO-VOCE METHOD. Samuel T. Church, Toronto, Ont., 7th December, 1893.
7159. ENTRANCE AGREEMENT, CHURCH'S AUTO-VOCE SCHOOL FOR THE CURE OF STAMMERING. Samuel T. Church, Toronto, Ont., 7th December, 1893.
7160. ENTRANCE MEMORANDUM, CHURCH'S AUTO-VOCE SCHOOL FOR THE CURE OF STAMMERING. Samuel T. Church, Toronto, Ont., 7th December, 1893.
7161. INFORMATION FOR STAMMERERS. CHURCH'S AUTO-VOCE METHOD. Samuel T. Church, Toronto, Ont., 7th December, 1893.
7162. NORWAY; INTERESTING FACTS ABOUT THE LAND OF THE MIDNIGHT SUN. By an American Traveller. Scott & Bowne, Belleville, Ont., 7th December, 1893.
7163. PIERRETTE. Air de Ballet. Pour Piano, Op. 41, par C. Chaminade. The Anglo-Canadian Music Publishers' Association, Ltd., London, Eng., 9th December, 1893.
7164. AIR DE BALLET. Pour Piano, Op. 30, par C. Chaminade. The Anglo-Canadian Music Publishers' Association, Ltd., London, Eng., 9th December, 1893.
7165. CARD SHOWING THE MAIN FEATURES OF A NEW MUSICAL SYSTEM. John Crampton Wilson, Lindsay, Ont., 11th December, 1893.
7166. TWO DREAMS. Song. Words by Rev. Chas. D. Andrews. Music by J. Lewis Browne. The Anglo-Canadian Music Publishers' Association, Ltd., London, England, 11th December, 1893.
7167. A HISTORY OF UPPER CANADA COLLEGE, 1829-1892. Compiled and Edited by George Dickson, M.A., and G. Mercer Adam. George Dickson, Toronto, Ont., 12th December, 1893.
7168. THE BATTLE MARCH OF DELHI. Arranged for Piano by J. Pridham. The Anglo-Canadian Music Publishers' Association, Ltd., London, England, 12th December, 1893.
7169. VALSE CAPRICE. Pour Piano. Op. 33. Par C. Chaminade. The Anglo-Canadian Music Publishers' Association, Ltd., London, England 12th December, 1893.
7170. INTERNATIONAL MECHANICAL AND LABOUR TIME BOOK. Charles J. Jones, Toronto, Ont., 12th December, 1893.

7171. YE SONS OF ENGLAND. Song and Chorus. Words by E. Boyne. Music by E. Parry. Edward Boyne, Toronto, Ont., 13th December, 1893.
7172. THE CARMELA POLKA. For Piano. By Herbert L. Clarke. Whaley, Royce & Co., Toronto, Ont., 14th December, 1893.
7173. CAPE BRETON ILLUSTRATED. HISTORIC, PICTURESQUE AND DESCRIPTIVE. By John M. Gow. Illustrated by Jas. A. Stubbert. William Briggs (Book-Steward of the Methodist Book and Publishing House), Toronto, Ont., 14th December, 1893.
7174. THE CANADIAN LAW TIMES, VOLUME XII. Edited by E. Douglas Armour, Q.C. The Carswell Co., Ltd., Toronto, Ont., 15th December, 1893.
7175. ADMIRALTY LAW, CANADA. The Rules, 1893. Annotated with Forms, Tables of Fees and Statutes. By Alfred Howell. The Carswell Co., Ltd., Toronto, Ont., 15th December, 1893.
7176. COUNTY CONSTABLES' MANUAL; or, HANDY BOOK. Compiled from the Criminal Code, 1892-93. By J. T. Jones. The Carswell Co., Ltd., Toronto, Ont., 15th December, 1893.
7177. HIGGINS' ANALYSIS OF "LEAKE ON CONTRACTS" AND "BENJAMIN ON SALES." The Carswell Co., Ltd., Toronto, Ont. 15th December, 1893.
7178. APPLICATION AND CONTRACT WITH YORK COUNTY LOAN AND SAVINGS COMPANY. Joseph Phillips, Toronto, Ont., 15th December, 1893.
7179. A SAILOR'S LOVE. Song. Words by C. D. Bingham. Music by F. Boscovitz. The Anglo-Canadian Music Publishers' Association, Ltd., London, England, 15th December, 1893.
7180. THE OLD HORSE-SHOE. Song. Words by C. D. Bingham. Music by F. Boscovitz. The Anglo-Canadian Music Publishers' Association, Ltd., London, England, 15th December, 1893.
7181. PROSE COMPOSITION. By M. F. LIBBY, B.A. The Copp-Clark Co., Ltd., Toronto, Ont., 15th December, 1893.
7182. THE BELL TELEPHONE COMPANY OF CANADA, LIMITED, TORONTO, AND TORONTO JUNCTION EXCHANGES, SUBSCRIBERS' DIRECTORY, ONTARIO DEPARTMENT, NOVEMBER, 1893. The Bell Telephone Company of Canada, Ltd., Montreal, Que., 16th December, 1893.
7183. THE RIGHT HONOURABLE SIR JOHN THOMPSON, PREMIER OF CANADA, (photo-engraving). The Empire Printing and Publishing Co., Ltd., Toronto, Ont., 18th December, 1893.
7184. WILLIAM R. MEREDITH, Q.C., LL.D., (photo-engraving). The Empire Printing and Publishing Co., Ltd., Toronto, Ont., 18th December, 1893.
7185. THE THREE JOLLY BRITONS (English, Irish and Scotch.) A New National Song, by George Ware. The Anglo-Canadian Music Publishers' Association, Ltd., London, England, 18th December, 1893.
7186. RECEIPTS FOR ASSESSMENTS AND DUES FROM MEMBERS OF THE C.M.B.A. Thomas Coffey, London, Ont., 18th December, 1893.
7187. HISTORY OF THE TOWNSHIPS OF DARTMOUTH, PRESTON AND LAWRENCETOWN, HALIFAX COUNTY, NOVA SCOTIA, 1750-1893. By Mrs. Wm. Lawson (Mary Jane Katzmann.) The Board of Governors of King's College, Windsor, N.S., 20th December, 1893.
7188. MOUNTAIN VIEW WALTZ. By Robert Dick. The Anglo-Canadian Music Publishers' Association, Ltd., London, England, 20th December, 1893.
7189. ON LIDO WATERS. Song. Words by Frederic E. Weatherly; Music by F. Paolo Tosti. The Anglo-Canadian Music Publishers' Association, Ltd., London, England, 21st December, 1893.
7190. THE STAR ALMANAC AND CANADIAN YEAR BOOK WITH A CALENDAR for 1894. Hugh Graham, Montreal, Que., 21st December, 1893.
7191. THE ONTARIO LEGAL CHART, 1894. Henry Ryerson Hardy, Toronto, Ont., 22nd December, 1893.
7192. MY DREAMS. Song. Words by Frederic E. Weatherly; Music by F. Paolo Tosti. The Anglo-Canadian Music Publishers' Association, Ltd., London, England, 23rd December, 1893.
7193. STUDENT AND MINSTREL SONGS AND CHORUSES. I. Suckling & Sons, Toronto, Ont., 26th December, 1893.

7194. ABERDEEN WALTZ. For Piano, by B. Forder. Bertie Forder, Toronto Ont., 26th December, 1893.
7195. BEHIND THE VEIL. By James De Mille. T. C. Allen & Co., Halifax, N.S., 26th December, 1893.
7196. TABLES OF RATES AND ESTIMATED RESULTS ON SAVINGS BANK POLICIES, John Francis Matheison, Montreal, Que., 26th December, 1893.
7197. SYLLABAIRE, OU PREMIER LIVRE DE LECTURE, par Philippe, C.S.V. Les Clercs de St. Viateur, Joliette, Que., 26th December, 1893.
7198. McPHILLIPS BROS.' CITY ATLAS OF WINNIPEG, MANITOBA. Compiled by R. C. McPhillips, D. & P. L. S.; Robt. Chas. McPhillips, Winnipeg, Man., 26th December, 1893.
7199. ILLUSTRATIONS OF THE POEM "MOUNT ROYAL" (by W. N. Evans) by Elizabeth Warren & Arthur B. Clarkson, Montreal, Que., 26th December, 1893.
7200. CANADA'S INTELLECTUAL STRENGTH AND WEAKNESS. By John George Bourinot, C.M.G., &c., Ottawa, Ont., 27th December, 1893.
7201. LOCAL TIME TABLE, PRINCE EDWARD ISLAND RAILWAY, WINTER ARRANGEMENT, 1893-4, CHARLOTTETOWN. Horace Haszard, Charlottetown, P.E.I., 27th December, 1893.
7202. LOCAL TIME TABLE, PRINCE EDWARD ISLAND RAILWAY, WINTER ARRANGEMENT, 1893-4, SUMMERSIDE. Horace Haszard, Charlottetown, P.E.I., 27th December, 1893.
7203. CATÉCHISME DES LOIS SCOLAIRES. A L'USAGE DES CANDIDATS AUX BREVETS D'ENSEIGNEMENT. Par l'Abbé Th. G. Rouleau, Québec, Que., 27 décembre, 1893.
7204. REALITY VERSUS ROMANCE IN SOUTH CENTRAL AFRICA. By James Johnston, M.D. The Star Printing and Publishing Co., Toronto, Ont., 28th December, 1893.
7205. CHIPPEWA POLKA. Op. 2. By Will J. Carkeek. The Anglo-Canadian Music Publishers' Association, Ltd., London, England, 28th December, 1893.
7206. ENFANT CHÉRI. Morceau Élegant, pour Piano, par C. Bohm. The Anglo-Canadian Music Publishers' Association, Ltd., London, England, 29th December, 1893.
7207. A PRACTICAL TREATISE ON THE OFFICE AND DUTIES OF CORONERS (Third Edition). By William Fuller Alves Boys, LL.B. The Carswell Co., Ltd., Toronto, Ont., 30th December, 1893.

INDEX OF INVENTIONS.

Arc lamp. Arthur S. Atwater.....	44,916	Land roller: See clod crusher, etc.	
Autographic telegraph. Sylvester P. Denison.....	44,970	Last for boots and shoes. Harry W. Mobbs, et al.....	44,953
Axle bearing. Charles F. Lavender, et al.....	44,821	Last for boots and shoes. Lucien Laporte.....	44,840
Bath. Gustav H. H. Von Mayenburg.....	44,836	Lath. Squire Toney.....	44,921
Bevel: see Square and bevel.		Lawn mower. Samuel W. Martin.....	44,976
Bicycle. Samuel A. White.....	44,980	Loader: See hay loader.	
Boiler: see Locomotive boiler.		Lock for mail bags. George Low.....	44,946
Boiler. Dixon Best, et al.....	44,870	Lock for trunks. William J. Henry.....	44,820
Boiler and feed steamer. Edward Foster, et al.....	44,904	Locomotive boiler. Robert Rushton.....	44,818
Book case. James Stimson.....	44,966	Mattress. Adelbert H. Gale, et al.....	44,887
Boot nailing machine. Richard W. Bateman.....	44,985	Metallic fencing. Hiram A. Harrington.....	44,865
Box for mathematical purposes. Newton Z. Fulton.....	44,971	Metallic flux for refining iron. Robt. L. Sentinella, et al.....	44,908
Brake: see Propeller and brake. Wagon brake.		Milk agitating machine. Benjamin Ewing.....	44,833
Brake for carriages. John B. Crosby.....	44,900	Milkhouse. Elias Meck.....	44,926
Brake for railway cars. William H. Brownlow, et al.....	44,902	Milk. Method of producing sterilized condensed. August Fjelstrup.....	44,914
Bricks. Device for shipping. Thomas Parker, et al.....	44,896	Motor: See electric motor.	
Buoy. James Bigler.....	44,835	Mowing machine. Carl Halverscheid.....	44,940
Burner for hydro-carbon. Emmet B. Raymond.....	44,812	Multiple switch-board system. Charles C. Scribner.....	44,910
Calk for horse-shoes. Georges de Roussy de Sales.....	44,913	Nut lock. Alexander A. Johnson, et al.....	44,875
Cap for flues, &c. William E. Watson.....	44,851	Oil injector. Frank H. Cornell.....	44,930
Car: see Pilot car.		Optical instrument. Alfred C. Biess.....	44,886
Car coupler. Joseph L. Sowell.....	44,982	Ore. Electric smelting of refractory. Thos. L. Wilson.....	44,813
Car truck. Antoine B. Du Pont.....	44,806	Ore. Process of and apparatus for amalgamating. Hanson Gregory, et al.....	44,805
Caster. James H. Russell.....	44,885	Paper articles. Process of manufacturing waterproof. Julius Goldberg, et al.....	44,924
Cattle, &c. Machine for suspending. Charles A. Donnelly.....	44,831	Para-phenetol carbamide. Process of obtaining. Hermann Thoms.....	44,969
Change maker. Charles L. Travis.....	44,839	Pattern. Simon Christiansen.....	44,967
Check, order, &c. Lumus C. Newton.....	44,934	Pens. Fountain attachment for. Ernest W. Bradford.....	44,931
Cheese case. Henry D. Streator.....	44,948	Pilot car. Gustav Link.....	44,891
Cigar bunching machine. John H. Abraham.....	44,973	Plaster. John Q. Chase.....	44,810
Clod crusher and land roller. Herman F. Darnell.....	44,842	Plough. Adam Murchey, et al.....	44,938
Clothes pin. James H. Russell.....	44,849	Pneumatic tire. Arthur Maltby.....	44,939
Conduit: see Underground conduit.		Propeller and brake for vehicles. Harriet Carmont.....	44,977
Cultivator. Robert C. Buckley.....	44,800	Protector for cars. Carl Jung.....	44,954
Cultivator. Thomas J. McBride.....	44,874	Pump. Melchi M. Groove.....	44,832
Cultivator. William Hewitt.....	44,834	Purifier, grader and separator. David J. Davidson, et al.....	44,901
Cutting machine: see Electric cutting machine.		Railway: See electric railway.	
Door hanger. James T. McCabe.....	44,978	Refrigerator. Avelyn I. Dexter.....	44,890
Door hanger. Riley J. Hosner.....	44,962	Refrigerator. Charles S. Hardy.....	44,876
Door hanger. Track for. Riley J. Hosner.....	44,961	Register for cash. William T. McGraw.....	44,888
Drill: see Grain drill.		Roller: See stay roller.	
Electric cutting machine. Arthur K. Thyll.....	44,979	Roller bearing. Everett F. Morse.....	44,844
Electric lamps. Device for raising and lowering. William Doran.....	44,880	Roofing tile. Johan M. Olsen, et al.....	44,903
Electric motor. Ernest R. Esmond.....	44,988	Rotary engine. James F. McElroy.....	44,897
Electric motor. Imle E. Storey.....	44,984	Samples. Method of displaying. Edwin Dowsley.....	44,848
Electric railway. Thomas Harris.....	44,959	Saw buck. Joseph Chattaway.....	44,863
Engine: see Wind engine.		Saw set. Jacob P. Haynes, et al.....	44,958
Engine. William Lawrence.....	44,925	Sawing machine. Lyman Cooper.....	44,955
Explosive. Charles E. Munroe.....	44,949	Scaffold. John E. Ennis.....	44,847
External joint for escape pipes. Frederick R. Nies, et al.....	44,883	Secondary battery. James H. Mason.....	44,917
Fats from bones. Process of extracting. Adolph Schmeizer.....	44,920	Seed planter. Francis W. Banan.....	44,889
Feed steamer: see Boiler and feed steamer.		Separator. William J. Borland, et al.....	44,989
Fence post. David Rogers.....	44,912	Separator and grader. David J. Davidson, et al.....	44,823
Fencing: see Metallic fencing.		Sewing Machine. Felix Maginn, et al.....	44,853
Fender for street cars. Charles H. Stainton.....	44,816	Sheet metal vessel. William Pratt.....	44,964
Fender for street cars. Louis E. Dubois.....	44,879	Shingle. Cyril Demers.....	44,936
Fender for street cars. Thomas I. McMacken, et al.....	44,808	Shingle bunch and binder. William J. Munro, et al.....	44,809
Fire extinguisher. Thomas F. Handly.....	45,987	Sieve. David J. Davidson, et al.....	44,822
Fluid distribution apparatus. James McNaughton.....	44,965	Sieve cut-off. David J. Davidson, et al.....	44,824
Flux: see Metallic flux.		Sifter for ashes. Cary F. Abbott.....	44,867
Friction clutch. Wilson R. Smith.....	44,877	Sign. Alonzo L. Brumfield.....	44,837
Gas apparatus. Ninian C. Smillie, et al.....	44,943	Skate. Thomas Harrison.....	44,929
Gas engine. Maurice Lorois.....	44,918	Sleigh. Friederick A. Schaefer.....	44,878
Generator for steam. Edward E. Roberts.....	44,866	Sleigh. Henry Umphrey, et al.....	44,884
Governor for engines. Julius Begtrup, et al.....	44,952	Sleigh attachment for wheel vehicles. George P. Askin.....	44,804
Grain drill. William Hewitt.....	44,861	Spring for vehicles. Henry Timken.....	44,882
Grave border and protector. George R. Mease, et al.....	44,928	Spring for vehicles. James J. Duffy.....	44,841
Hanger. William H. Case.....	44,859	Spring for watch cases. Friederick E. Lange.....	44,942
Harness loop attachment. Jay Reed, et al.....	44,898	Sprinkler for lawns. George Steinmetz.....	44,852
Harrow. Hiram Chamberlain.....	44,881	Square and bevel. Thomas R. Cook.....	44,856
Hay loader. Fletcher M. Bird.....	44,956	Starch. Method of making. Jacob Blumer, et al.....	44,819
Hay press. Louis Primeau.....	44,846	Station apparatus for telegraphic and telephonic circuits. Theodore Spencer.....	44,922
Heater. Evan A. Edwards.....	44,944	Stay roller. Riley J. Hosner.....	44,963
Heating and ventilating. System of. Joseph McCreery.....	44,894	Steam generator. Paul Dubiau.....	44,814
Hoisting apparatus. John E. Walsh.....	44,883	Stove and heater. John W. Hilton, et al.....	44,873
Hoisting device. Albert Hillerscheidt.....	44,862	Sulphide of nickel. Process of obtaining pure. Charles C. Bartlett.....	44,807
Holder for plough coulters. William H. Perrin.....	44,981	Support for bicycle saddles. Elial M. Staples.....	44,803
Horse-shoe. Myron L. Chamberlain.....	44,986	Suspender for electric railway wires. Alexander Philpborn, et al.....	44,919
Hub for vehicles. Robert G. Petway.....	44,974	Switch and frog for railways. L. Henry Veronneau.....	44,937
Ice velocipede. Dam G. Bolton.....	44,941	Switch-board: see Multiple switch-board.	
Injector: see Oil injector.		Switch-board system. Charles E. Scribner.....	44,826, 44,827, 44,828
Ink well. Burt Ramsay.....	44,927	Switch-boards. Test system for multiple. Charles E. Scribner.....	44,909
Insulator for telegraphic wires. Joseph F. Wright.....	44,815	Syphon. Theophile Lessard.....	44,838
Joint: See external joint		Teddar fork. George M. Baker.....	44,802
Joint. Elie Depeyre.....	44,911	Telegraph: see Autographic telegraph.	
Joint for railway rails. Frederick H. Heath.....	44,905, 44,906	Telephone exchange apparatus. Charles E. Scribner.....	44,829
Journal for wheels. William J. Miller.....	44,858		
Knitting machine. Emil J. Franck.....	44,951		
Lamp. John W. Bauchelle, et al.....	44,933		

Telephone exchanges. Spring jack switch for. Charles E. Scribner, et al.	44,830	Case, William H. Hanger.	44,859
Thill coupler. Jacob R. Mikesell.	44,843	Chamberlain, Hiram. Harrow.	44,881
Threshing machine. Crank shaft for. John P. McCloskey	44,899	Chamberlain, Myron L. Horse-shoe.	44,986
Ticket and means for issuing same. John Duncan.	44,960	Chase, John Q. Plaster.	44,810
Title: see Roofing tile.		Chattaway, Joseph. Saw buck.	44,863
Tire for bicycles. Stanley C. Penchen.	44,893	Christiansin, Simon. Pattern.	44,967
Tires to their rims. Method of attaching pneumatic. John S. Smith.	44,872	Colquhoun, Alexander M., et al. Device for shipping bricks.	44,896
Tool. James A. Crane.	44,975	Consolidated Car Heating Co. Rotary engine.	44,897
Track cleaner. George W. Ruggles.	44,857	Cook, Thomas R. Square and bevel.	44,856
Tug clips for hames. James Scott.	44,892	Cooper, Lyman. Sawing machine.	44,955
Turbine, Frederick Hart.	44,860	Cornell, Frank H. Oil injector.	44,930
Turner for music leaves. John H. Redfield, et al.	44,845	Crane, James A. Tool.	44,975
Type writer. Spacing attachment for. Charles O. Erwin, et al.	44,932	Crosby, John B. Brake for carriages.	44,900
Underground conduit for electric wires. Phelam McCulloch.	44,817	Davias, John B. Vessel.	44,850
Vehicle top. Jesse N. Tabor.	44,871	Davidson, David J., et al. Purifier, grader and separator.	44,901
Ventilation and purification. System and means of. Joseph McCreery.	44,895	Davidson, David J., et al. Separator and grader.	44,823
Vessel: see Sheet metal vessel.		Davidson, David J., et al. Sieve.	44,822
Vessel. John B. Davids.	44,850	Davidson, David J., et al. Sieve cut-off.	44,824
Wagon brake. Wilhelm Plotz, et al.	44,864	De Bary, August, et al. Process of manufacturing water proof paper articles.	44,924
Wagons. End gate for. Joseph F. Senn.	44,854	Demers, Cyril. Shingle.	44,936
Wall covering. Hugh Silver.	44,869	Denison, Sylvester P. Autographic telegraph.	44,970
Warehouse for storing grain. Daniel R. Bowker.	44,801	Depeyre, Elie. Joint.	44,911
Water closet. Henry C. Buddenberg.	44,811	Dernell, Herman F. Clod crusher and land roller.	44,842
Water power. Device for utilizing. Thomas A. Macdonald.	44,950	De Sales, George de Reussy. Calk for horse-shoes.	44,945
Wheel. Edgar D. Misner, et al.	44,923	Dexter, Avelyn I. Refrigerator.	44,890
Wind engine. Samuel W. Martin.	44,868	Donnelly, Charles A. Machine for suspending cattle, etc.	44,831
Windows. Close joint for. Johannes Ehrcke.	44,947	Doran, William. Device for raising and lowering electric lamps.	44,880
Wire connector. William S. Kisinger.	44,855	Dowsley, Edwin. Method of displaying samples.	44,848
Wire fabric machine. Alva L. Kitzelman.	44,972	Dubiau, Paul. Steam generator.	44,814
Wire. Method of and apparatus for coiling. Calvin Jackson, et al.	44,907	Dubois, Lewis E. Fender for street cars.	44,879
Wood for protection from teredo. Method of treating. Francis Hall.	44,915	Duffy, James J. Spring for vehicles.	44,841
Wrench. Minnie E. Kellam.	44,957	Duncan, John. Ticket and means for issuing same.	44,960
Wrench. Theodore C. Lippitt.	44,935	Dumm, Frank, E., et al. Grave border and protector.	44,928
		Du Pont, Antoine B. Car truck.	44,806
		Edwards, Evan A. Heater.	44,944
		Ehrcke, Johannes. Close joint for windows.	44,947
		Ennis, John E. Scaffold.	44,847
		Erwin, Chas. O., et al. Spacing attachment for type writers.	44,932
		Esmond, Ernest R. Electric motor.	44,988
		Ewing, Benjamin. Milk agitating machine.	44,833
		Fane, Thomas, et al. Axle bearing.	44,821
		Fell, Thomas M., et al. Lamp.	44,933
		Fjelstrup, August. Method of producing sterilized condensed milk.	44,914
		Foster, Edward and Jefferson J. Boiler and feed steamer.	44,904
		Franck, Emil J. Knitting machine.	44,951
		Fulton, Newton Z. Box for mathematical purposes.	44,971
		Gale, Adelbert H. and Francis G. Mattress.	44,887
		Goldberg, Julius, et al. Process of manufacturing water proof paper articles.	44,924
		Gregory, Hanson and Henry L. Process of apparatus for amalgamating ores.	44,805
		Groove, Melchi M. Pump.	44,832
		Hall, Francis. Method of treating wood for protection from teredo.	44,915
		Halverscheid, Carl. Mowing machine.	44,940
		Handley, Thomas F. Fire extinguisher.	44,987
		Hames, William H., et al. Wheel.	44,923
		Hardy, Charles S. Refrigerator.	44,876
		Harrington, Hiram A. Metallic fencing.	44,865
		Harris, Thomas. Electric railway.	44,959
		Harrison, Thomas. Skate.	44,929
		Hart, Frederick. Turbine.	44,860
		Hart, Joseph, et al. Shingle bunch and binder.	44,809
		Haynes, Jacob P., et al. Saw set.	44,958
		Heath, Frederick H. Joint for railway rails.	44,905
		Henderson, Avery, et al. Grave border and protector.	44,928
		Henry, William J. Trunk lock.	44,820
		Hewitt, William. Cultivator.	44,834
		Hewitt, William. Grain drill.	44,861
		Hillerscheidt, Albert. Hoisting device.	44,862
		Hilton, John W., et al. Stove and heater.	44,873
		Hosner, Riley J. Door hanger.	44,962
		Hosner, Riley J. Stay roller.	44,963
		Hosner, Riley J. Track for door hanger.	44,961
		International Sheating Lath Company. Lath.	44,921
		Jackson, Calvin, et al. Method of and apparatus for coiling wire.	44,907
		Jobbins, William F. Process of extracting fats from bones.	44,920
		Johnson, Alexander A., et al. Nut lock.	44,875
		Jung, Carl. Protector for ears.	44,954
		Kellam, Minnie E. Wrench.	44,957
		Kisinger, William S. Wire connector.	44,855
		Kitzelman, Alva L. Wire fabric machine.	44,972
		Lange, Friedrich E. Spring for watch cases.	44,942
		Laporte Lucien. Last for boots and shoes.	44,840
		Lawrence Electric Company. Engine.	44,925
		Lawrence, Robert S., et al. Gas apparatus.	44,943
		Lavender, Charles S., et al. Axle bearing.	44,821

INDEX OF PATENTEES.

Ablott, Carey F. Sifter for axles.	44,867
Abraham, John H. Cigar bunching machine.	44,973
Acme End Gate Manufacturing Company. Endgate for wagons.	44,854
Askin, George P. Sleigh attachment for wheeled vehicles.	44,804
Atwater, Arthur S. Arc lamp.	44,916
Baker, George M. Tedder fork.	44,802
Banan, Francis W. Seed planter.	44,889
Bartlett, Charles C. Process of obtaining pure sulphide of nickel.	44,807
Bateman, Richard W. Boot nailing machine.	44,985
Bauchelle, John W., et al. Lamp.	44,933
Beaumont, Franklin S., et al. Nut lock.	44,875
Beckingsale, Edgar W., et al. Flux for refining iron.	44,908
Beckingsale, Edgar W., et al. Metallic flux for refining iron.	44,908
Beltrup, Julius, et al. Governor for engines.	44,952
Bell Telephone Company of Canada. Multiple switch-board system.	44,910
Bell Telephone Company of Canada. Spring-jack switch for telephone exchanges.	44,830
Bell Telephone Company of Canada. Station apparatus for telephone and telegraphic circuits.	44,922
Bell Telephone Company of Canada. Switch-board system.	44,826
Bell Telephone Company of Canada. Telephone Exchange apparatus.	44,827, 44,828
Bell Telephone Company of Canada. Test system for multiple switch-board.	44,829
Benedix, Victor, et al. Process of manufacturing water-proof articles.	44,924
Best, Dixon, et al. Boiler.	44,870
Biese, Alfred C. Optical instrument.	44,886
Bigler, James. Buoy.	44,835
Bird, Fletcher M. Hay loader.	44,956
Blamer, Jacob, et al. Method of making starch.	44,819
Bolton, Dam G. Ice velocipede.	44,941
Borland, William J., et al. Separator.	44,989
Bowker, Daniel R. Warehouse for storing grain.	44,801
Bradford, Ernest W. Fountain attachment for pens.	44,931
Brown, Franz W., et al. Roofing tile.	44,903
Brownlow, William H., et al. Brake for railway cars.	44,902
Brumfield, Alonzo L. Sign.	44,837
Buckley, Robert C. Cultivator.	44,800
Buddenberg, Henry C. Water closet.	44,811
Carmont, Harriet. Propeller and brake for vehicles.	44,977

Lawrence, William. Engine.	44,925	Redfield, John H., and Samuel H. Turner for music leaves.	44,845
Lessard, Theophile. Syphon	44,838	Reed, Jay, et al. Harness loop attachment.	44,898
Lewis, Alfred, et al. Last for boots and shoes.	44,953	Reichel, Walter, et al. Suspender for electric railway wires.	44,919
Link, Gustav. Pilot car.	44,891	Roberts, Edward E. Generator for steam.	44,866
Linneham, Francis J., et al. External joint for escape pipes	44,883	Rogers, David. Fence post.	44,912
Lippitt, Theodore C. Wrench.	44,935	Ruggles, George W. Track cleaner.	44,857
Lervis, Maurice. Gas engine	44,918	Rushton, Robert. Locomotive boiler.	44,818
Low, George. Lock for mail bags.	44,946	Russell, James H. Caster.	44,885
Macdonald, Thomas A. Device for utilizing water power.	44,950	Russell, James H. Clothes pin.	44,849
Magim, Felix, et al. Sewing Machine	44,853	Sattler, Nicholas, et al. Stove and heater.	44,873
Malsby, Arthur. Pneumatic tyre.	44,939	Schaefer, Friederick A. Sleigh	44,878
Martin, Abraham S. and Stephen C., et al. Purifier, grader and separator.	44,901	Schlagenhauser, Charles, et al. Method of making starch.	44,819
Martin, Abraham S. and Stephen G., et al. Separator and grader.	44,823	Schweizer, Adolph, et al. Process of extracting fats from bones.	44,920
Martin, Abraham S. and Stephen G., et al. Sieve.	44,822	Scott, James. Tug clip for hames.	44,892
Martin, Abraham S. and Stephen G., et al. Sieve cut-off.	44,824	Scribner, Charles E. Multiple switch-board system.	44,910
Martin, Samuel W. Lawn mower.	44,976	Scribner, Charles E., et al. Spring-jack switch for telephone exchanges.	44,830
Martin, Samuel W. Wind engine.	44,868	Scribner, Charles E. Switch-board system.	44,826, 44,827, 44,828
Mason, James H. Secondary battery.	44,917	Scribner, Charles E. Telephone exchange apparatus.	44,829
Massey-Harris Company, Cultivator	44,874	Scribner, Charles E. Test system for multiple switch-boards	44,909
Mease, George R., et al. Grave border and protector.	44,928	Senn, Joseph F. End gate for wagons.	44,854
Meck, Elias. Milk house.	44,926	Sentinella, Robert L., et al. Flux for refining iron.	44,908
Metherel, James H., et al. Boiler.	44,870	Sheppard Manufacturing Company. Car truck.	44,806
Mickesell, Jacob R. Thill coupler.	44,843	Shovelton, James, et al. Sewing machine.	44,853
Miller, William J. Journal for wheels.	44,858	Silver, Hugh. Wall covering.	44,869
Misner, Edgar D., et al. Wheel.	44,923	Smillie, Ninian C., et al. Gas apparatus.	44,943
Mobbs, Harry H., et al. Last for boots and shoes.	44,953	Smith, John S. Method of attaching pneumatic tires to their rims.	44,872
Morse, Everett F. Roller bearing.	44,844	Smith, Wilson R. Friction clutch.	44,877
Mullen, Charles R., et al. Stove and heater.	44,873	Smith, William, et al. Separator.	44,989
Munroe, Charles F. Explosive.	44,949	Sowell, Joseph L. Car coupler.	44,982
Munroe, William J., et al. Shingle bunch and binder.	44,809	Spencer, Theodore. Station apparatus for telephonic and telegraphic circuit.	44,922
Murhey, Adam, et al. Plow.	44,938	Stainton, Charles H. Fender for street cars.	44,816
McBride, Thomas J. Cultivator.	44,874	Staples, Elial M. Support for bicycles saddles.	44,803
McCabe, James T. Door hanger.	44,978	Starr Manufacturing Company. Skate.	44,929
McCloskey, John P. Crank shaft for threshing machines.	44,899	Steinmetz, George. Sprinkler for lawns.	44,852
McCreery, Joseph. System and means of ventilation and purification.	44,895	Sternbergh, James H., et al. Method of and apparatus for coiling wire.	44,907
McCreery, Joseph. System of heating and ventilating.	44,894	Stimson, James. Bookcase.	44,966
McCullough, Phelam. Underground conduit for electric wires.	44,817	Storey, Inle E. Electric motor.	44,984
McElroy, James F. Rotary engine.	44,897	Streator, Henry D. Cheese case.	44,948
McEwen, James H., et al. Governor for engines.	44,952	Stuart, Francis F., et al. Device for shipping bricks.	44,896
McGraw, William T. Register for cash.	44,888	Tabor, Jesse N. Vehicle top.	44,871
McMacken, Thomas I., et al. Fenders for street cars.	44,808	Thoms, Hermann. Process for obtaining para-phenetal carbamide.	44,969
McMillan, Alexander, et al. Saw set.	44,958	Thomson, Charles F., et al. Fender for street cars.	44,808
McNaughton, James. Fluid distribution apparatus.	44,965	Thyll, Arthur K. Electric cutting machine.	44,979
Newton, Lunus C. Check, order, &c.	44,934	Timken, Henry. Spring for vehicles.	44,882
Nies, Frederick R., et al. External joint for escape pipes.	44,883	Toney, Squire. Lath.	44,921
Olsen, John M., and Hans P., et al. Roofing tile.	44,903	Topp, George A. Square and bevel.	44,856
Orford Copper Company. Process of obtaining pure sulphide of nickel.	44,807	Travis, Charles L. Change maker.	44,839
Orr, Robert, et al. Plough.	44,938	Umphrey, Henry, et al. Sleigh.	44,884
Parker, Thomas, et al. Device for shipping bricks.	44,896	Von Mayenburg, Gustav H. Bath.	44,836
Patterson, William R., et al. Spring-jack switch for telephone exchanges.	44,830	Veronneau, L. Henry. Switch and frog for railways.	44,937
Penchen, Stanley C. Tire for bicycles.	44,893	Walsh, John E. Hoisting apparatus.	44,983
Pendry, W. Allen, et al. Sieve cut-off.	44,825	Watson, William E. Cap for flues, &c.	44,851
Perrin, William H. Holder for plough coulter.	44,981	Watt, Robert, et al. Wagon brake.	44,864
Petway, Robert G. Hub for vehicles.	44,974	Weekes, James, et al. Sleigh.	44,884
Philipsborn, Alexander, et al. Suspender for electric railway wires.	44,919	White, Samuel A. Bicycle.	44,980
Plotz, Wilhelm, et al. Wagon brake.	44,864	Willson, Thomas L. Electric smelting of refractory ore.	44,813
Pratt, William. Sheet metal vessel.	44,964	Winkler, Frank, et al. Spacing attachment for type writers.	44,932
Primeau, Louis. Hay press.	44,846	Wood, John F., et al. Brake for railway cars.	44,892
Ramsay, Burt. Ink well.	44,927	Wright, John D., et al. Device for shipping bricks.	44,896
Ramsay, (Alexander) & Son. Method of displaying samples.	44,848	Wright, Joseph F. Insulator for telegraphic wires.	44,815
Raymond, Emmet B. Burner for hydro-carbon.	44,812	Wyatt, George P., et al. Harness loop attachment.	44,898