

Technical and Bibliographic Notes / Notes techniques et bibliographiques

The Institute has attempted to obtain the best original copy available for filming. Features of this copy which may be bibliographically unique, which may alter any of the images in the reproduction, or which may significantly change the usual method of filming, are checked below.

L'Institut a microfilmé le meilleur exemplaire qu'il lui a été possible de se procurer. Les détails de cet exemplaire qui sont peut-être uniques du point de vue bibliographique, qui peuvent modifier une image reproduite, ou qui peuvent exiger une modification dans la méthode normale de filmage sont indiqués ci-dessous.

Coloured covers/  
Couverture de couleur

Covers damaged/  
Couverture endommagée

Covers restored and/or laminated/  
Couverture restaurée et/ou pelliculée

Cover title missing/  
Le titre de couverture manque

Coloured maps/  
Cartes géographiques en couleur

Coloured ink (i.e. other than blue or black)/  
Encre de couleur (i.e. autre que bleue ou noire)

Coloured plates and/or illustrations/  
Planches et/ou illustrations en couleur

Bound with other material/  
Relié avec d'autres documents

Tight binding may cause shadows or distortion along interior margin/  
La reliure serrée peut causer de l'ombre ou de la distorsion le long de la marge intérieure

Blank leaves added during restoration may appear within the text. Whenever possible, these have been omitted from filming/  
Il se peut que certaines pages blanches ajoutées lors d'une restauration apparaissent dans le texte, mais, lorsque cela était possible, ces pages n'ont pas été filmées.

Additional comments:  
Commentaires supplémentaires:

Coloured pages/  
Pages de couleur

Pages damaged/  
Pages endommagées

Pages restored and/or laminated/  
Pages restaurées et/ou pelliculées

Pages discoloured, stained or foxed/  
Pages décolorées, tachetées ou piquées

Pages detached/  
Pages détachées

Showthrough/  
Transparence

Quality of print varies/  
Qualité inégale de l'impression

Continuous pagination/  
Pagination continue

Includes index(es)/  
Comprend un (des) index

Title on header taken from:  
Le titre de l'en-tête provient:

Title page of issue/  
Page de titre de la livraison

Caption of issue/  
Titre de départ de la livraison

Masthead/  
Générique (périodiques) de la livraison

This item is filmed at the reduction ratio checked below/  
Ce document est filmé au taux de réduction indiqué ci-dessous.

10X	12X	14X	16X	18X	20X	22X	24X	26X	28X	30X	32X
<input type="checkbox"/>	<input type="checkbox"/>	<input type="checkbox"/>	<input type="checkbox"/>	<input type="checkbox"/>	<input type="checkbox"/>	<input type="checkbox"/>	<input type="checkbox"/>	<input type="checkbox"/>	<input type="checkbox"/>	<input checked="" type="checkbox"/>	<input type="checkbox"/>

# The Canadian Engineer

Vol. III.—No. 7.

TORONTO, NOVEMBER 1895.

PRICE, 10 CENTS  
\$1.00 PER YEAR.

## The Canadian Engineer.

ISSUED MONTHLY IN THE INTERESTS OF THE

CIVIL, MECHANICAL, ELECTRICAL, LOCOMOTIVE, STATIONARY,  
MARINE AND SANITARY ENGINEER, THE MANUFACTURER,  
THE CONTRACTOR AND THE MERCHANT IN THE  
METAL TRADES.

SUBSCRIPTION—Canada and the United States, \$1.00 per year, Great Brit-  
ain, 6s. Advertising rates on application.

OFFICES—62 Church Street, Toronto; and Fraser Building, Montreal.

BIGGAR, SAMUEL & CO., Publishers,  
Address—Fraser Building,  
MONTREAL, QUE.  
E. B. BIGGAR  
R. R. SAMUEL  
Toronto Telephone, 1892. Montreal Telephone, 2589.

All business correspondence should be addressed to our Mont-  
real office. Editorial matter, cuts, electrots and drawings should  
be addressed to the Toronto office.

### CONTENTS OF THIS NUMBER :

PAGE	PAGE
American St. Ry. Convention, 173-181	Horseless Carriages in England... 174
Ball Nozzle Fire Jet ..... 186	Industrial Notes ..... 191
Boilers, Facts About ..... 173	Lever Safety Valve..... 163
Bridge and Trestle Timbers,	McMaster, John..... 171
Strength of ..... 174	Metal Imports from Great Britain. 190
Can. Society Civil Engineers..... 186	Metal Trade Review ..... 185
Can. Ass'n of Stationary Engineers 183	Mining Matters ..... 194
do. New Constitution of..... 188	Moto-Cycle Notes..... 190
Canadian Nickel in Naval Work. 180	Moto-Cycle Race at Chicago..... 172
Concrete Construction ..... 176	Patents ..... 186
Electric Supply, Consolidation of	Personal ..... 183
two Systems..... 184	Plumbago, Uses of ..... 185
Electric Flashes..... 183	Pumps, The M. T. Davidson ..... 187
Fires of the Month..... 190	Railway and Marine ..... 185
Gas Engines for Electric Light and	Safety Valves ..... 168
Power ..... 167	Tidal Motor ..... 180
Grip Socket Case..... 186	Toronto Technical School..... 170

For THE CANADIAN ENGINEER.

### ECONOMICAL ELECTRIC LIGHT AND POWER.

BY J. H. KILLEY, HAMILTON.

The city of Belfast has a population of 275,000 souls. The corporation owns and operates the gas works, and in order to prevent an electric lighting monopoly they took that matter into their own hands and have put into operation the most economical plant now known. This was secured by running their dynamos by new and very powerful gas engines. Those now in position and working are capable of developing 500 h.p., with room for a large addition when needed. Builders of first-class engines will now guarantee to develop one horse-power from every pound of coal used. Thus, for a 500-h.p. gas engine only 500 lbs. of coal per hour would be used, as against double the quantity required by the most economical compound condensing engine, and three and one-half times the quantity in the best automatic cut-off high pressure engine, with the most economical boiler in use to generate steam. By means of this gas engine, the electric lighting plant could operate five hundred 2,000-candle-power arc lamps for eight hours, with 4,000 lbs. (two tons of coal), or six thousand 16 candle-power incandescent lights, with the same amount of coal. If power were sold to those requiring it from such a plant, it could be done much more cheaply than is possible with steam, where the current is supplied to motors of the most approved design. Among other advantages this economical power can be placed in the centre of distribution, which is impossible with a compound condenser of the same power as the gas engine. A compound condenser of the same power as the Belfast gas engine would require 900 gallons of water for the boilers and 20,000 gallons for the condenser per

hour. This would necessitate the proximity of the engine to so large a supply of cold water as is not often available in a city, and could not be taken from the city waterworks. A further advantage of placing the dynamo at the centre of consumption is that a smaller quantity of copper-conducting wire is required, lessening the first cost, and the reduced resistance giving increased light with less electric potential at source of supply. There is also the cost, danger, depreciation and maintenance of boilers, not less than six in number of 100 h.p. each, and the cost of increased labor required to run them, to be considered. Not only is this power suitable for the production of electricity, but it is equally applicable to pumping the water supply of a town or city.

### GAS ENGINES FOR POWER PUMPS.

Our readers will be interested in some account of the large gas engines recently built to the order of the River Wear Commissioners, England, to pump out their new dry dock for the examination and repair of ships and steamers. These engines, rated at 250 horse-power, are attached direct to two centrifugal pumps, built and erected by Tangye Brothers, engineers, of Birmingham. This firm guarantees to build gas engines that will run with less than one pound of coal per brake horse-power per hour; this is more than an indicated horse-power. These engines and pumps were recently tested and were in every respect an entire success, as they worked more economically and pumped out the dock in less time than the contractors guaranteed, their pumping capacity equalled 10,500 tons of water, lifted about thirty feet high at finish, in two hours, emptying the dock in that time. In addition to the main gas engines and pumps there are auxiliary engines and pumps of smaller size to keep the docks clear of water when vessels are docked in it. The gas mains to the engines are attached to the ordinary gas mains of the district, and the gas is supplied at a comparatively low price, as there is plenty of gas coal in the neighborhood.

If the dock had to be pumped out by steam power at least four large boilers would have been required, these would require the fires to be started about two hours before the time the pumps would be in operation, and one boiler would have to maintain steam the whole time the dock would be occupied. The cost of the gas to pump out the dock would not exceed the cost of the coal used to get up steam before the engines were started, the gas engines could be started in ten minutes from the time of receiving the order, and the cost for labor and gas being less than one-half of that by steam, as the cost of gas and labor only commences with the working of the pumps and ceases as soon as they stop. Nothing is clearer than the fact that power for most purposes can be produced at much less cost than steam power by aid of the most modern and approved form of gas engines and gas plant. There is also, it is asserted, less cost of plant and maintenance, and no danger of disastrous explosions.

### THE LEVER SAFETY VALVE.\*

BY CAPTAIN JAMES WRIGHT, MONTRÉAL.

Any person who has been present during an examination of engineers by a board of Government inspectors, will have observed the general promptitude and confidence with which questions are replied to relating to the details of every-day practice, or what should be done in case of emergency or accident.

But sometimes a change comes over this state of affairs, when the candidate is asked to solve arithmetical questions relating to the strength or staying of boilers, and other allied questions. A want of self-confidence at once sets in; he is in a fog, and it is sometimes disagreeable to be a witness. I have observed that questions about safety valves presented the greatest difficulty. This should not be. It is not the fault of the candidate; the fault lies in the obscure and perfunctory manner in which he has been instructed. The mere learning of abstract truths may qualify a student for college honors, but the mechanical engineer, before he can master the subject, must experimentally demonstrate each truth with his own hands, and under every possible variation in detail that he can think of.

The safety-valve problem is generally solved in accordance with the principle of virtual velocities. I prefer to treat it as a simple case of parallel forces in equilibrium on the axis of the valve, which is necessarily true in any position of the pea or weight when at work. There have been ideas patched on the lever which answered as puzzles or conundrums. I prefer to take the common safety valve as I find it, with the lever hinged at one end, the pin forming a fixed point on which the lever is free to turn. The downward parallel forces in the system are the weight of the valve, the lever, the pea or weight, and the pressure of the lever on the pin. Acting parallel to but directly opposed to these forces is the steam pressure in the boiler, the purpose of the arrangement being that the downward forces in the system shall resist and overcome a pressure of steam, up to a certain pressure per square inch on the surface of the valve exposed to this pressure; and if the pressure of the steam rises above this, the valve is lifted from its seat and steam escapes from the boiler.

To prepare the way towards an arithmetical solution of questions in connection with a safety valve, and that might be presented by a board of examiners, I have considered it best to briefly exhibit a few common mechanical truths that bear upon the question; they can be experimentally proven at any time, and I will use no other data in the solution of the question.

I have said that I would treat the safety-valve problem as a case of parallel forces. The acting forces are first, the weight of the parts; second, the resulting or equivalent pressure due to the pin, which varies according to the position on the lever of the pea or weight, and third, the pressure of the steam on the exposed surface of the valve. The directional lines of force are parallel to each other in a properly made safety valve, and all systems of parallel forces have a centre or resultant. Take any weights at hand, hammers, sledges, bricks or stones, and place them at random here and there on the face of a two or three-inch plank. It is evident and indisputable that there is some intermediate place between the ends of the plank where it would balance on the edge of a fulcrum. When in

equilibrium, if we imagine a vertical plane passing through the edge of the fulcrum on which the plank rests, the centre of the parallel forces in the system, and its centre of gravity, lies somewhere on that plane. On this subject there are niceties and refinements that for the solution of our question it is unnecessary to detail. All that is required is to balance a safety-valve lever on the edge of a cold chisel, and when in equilibrium, a vertical line drawn on the lever from the edge of the chisel locates for all practical purposes the position of the centre of force, or the resultant due to gravitation.

It is evident that in equilibrium the lever acts as if its whole weight was concentrated at a point on the plane that is vertical to the fulcrum edge on which it rests. This is a universal law of all bodies or systems of bodies under the influence of gravity. And it is for this reason that in the safety-valve problem a single force equal to the weight of the lever is supposed to act at the place where it balanced on the edge of a fulcrum.

To master a question such as the one on hand, it is necessary that we be able to see the "reason why" in every step of the solution. The word resultant is simply the result as a whole, and in this case there is associated with it the idea of direction with the amount. Returning to our experimental plank balanced on a fulcrum, if it was suspended by a cord from the same place that it rested on the fulcrum, it would be in balance still, and the vertical line of the cord points out the location and direction of the resultant, which in amount is equal to the weight of the plank with all the bodies resting on it. If the weight of the plank with everything on it is 75 pounds, then the resultant is equal to 75 pounds, whether it be in the form of a pressure on a fulcrum or a tension on a wire or cord. This can be proven by making an experiment on the platform of a scale, or suspending it from a steelyard. The valve in place acts as a direct weight, and being of a regular figure its resultant coincides with its axis. If the pea or weight is a ball, its resultant passes through its centre, or if of any other regular figure the resultant passes through its geometrical centre.

The resultant of the parallel forces in any form or design of lever safety valve, is necessarily located at some intermediate position on the lever. We have now arrived at a general principle of the lever when the forces are parallel, that in equilibrium the intermediate weight pressure or tension is equal to the sum of the outside ones. This generalization presents a simple solution of all lever safety valve problems.

A vertical to the axis of the valve indicates the point where, in equilibrium, the steam pressure must be equal to the sum of the opposing forces in the system. If the area of the valve is six square inches, the total pressure of steam on the valve at 80 pounds per square inch, is 480 pounds. To be in equilibrium, the weight of valve, lever and pea added to the pressure, or its equivalent weight at the pin, must equal 480 pounds. Let the weight of valve, lever and pea be 75 pounds, then the required pressure at the pin is 405 pounds, and the question now takes this simple form: Where must the pea be placed on the lever to produce that pressure, or be in balance with a weight of 405 pounds, hung from the pin hole?

Here we come in contact with the principle of the "equality of moments" on both sides of a fulcrum when the lever is balanced. To find the equivalent weight of a pressure is a case of equality of moments.

\*This paper was originally prepared for THE CANADIAN ENGINEER, but first read before the Canadian Association of Stationary Engineers at the Ottawa Convention.

In mechanics the term "moment" means the product of a weight in pounds multiplied by its distance in inches from the fulcrum. Some engineers have objected to this term, and it has been proposed to call this product lever inch pounds, and in preference I will use it. If a weight of 27 pounds is placed on a lever at 10 inches from the fulcrum, the inch pounds are 270. This means that 270 pounds placed on a lever at one inch from the fulcrum, produces the same statical effect as 27 pounds at 10 inches from it—or looking at it from another standpoint, if these weights are placed at their respective distance from, but on opposite sides of a fulcrum, they are in equilibrium. If in a question it was found that the lever inch pounds on one side of the fulcrum was 1,386 and on the other 1,322, a difference of 64, it follows that the lever is not in equilibrium, but that 64 pounds placed one inch from the fulcrum, on the 1,322 side, would make it. Or, in this case, the number 64 divided by any other weight in pounds, gives the distance in inches from the fulcrum where that weight must be placed to effect the same object.

In our common engineers' handbooks the principles of the lever are treated in an obscure and indirect manner. Mechanical writers have pointed this out. The only reason they could give for its perpetuation was the simplicity of the question, and that men competent to deal with it did not consider it worth their while. The handbooks tell us that there are three kinds or classes of levers. I intend to prove that they are alike in principle, and one rule governs and controls all of them.

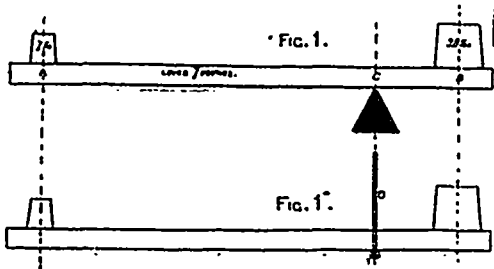

In the so-called first class there is a weight at each end of the lever, and the fulcrum is intermediate. Let the lever weigh 7 pounds, the small weight *A* 7 pounds, and the large weight *B* 28 pounds, the whole of the parts weighing 42 pounds. Balance the system on the fulcrum *C*; it will then be found that the system is in conformity with the law of the equality of inch pounds on each side of the fulcrum, and if one pound is placed on either side of the fulcrum, equilibrium is destroyed and motion would take place. But what I wish to call particular attention to is that here the pressure on the fulcrum is 42 pounds, that being the sum of the weights resting on it. No person can doubt this; it can be visibly proven on the platform of a scale; and if one of the weights is shifted on the lever the other must be shifted to maintain a balance. And still the pressure on the fulcrum is 42 pounds. It follows from this that when the pressure on the fulcrum and the weight on one side of the fulcrum are known, then the weight on the other side of the fulcrum is found by subtracting the last quantity from the first. The weight or pressure on the fulcrum is equal to the sum of all the others. This principle is an important factor in our question. It will be observed (Fig. 1) that if the system, instead of resting on a fulcrum, was suspended from the same place that it rested on the fulcrum, the balance would be undisturbed, and what was formerly a pressure of 42 pounds is now a tension of the same amount.

The division of levers into three classes is more nominal than real. All of its applications can be resolved under one general rule. If, as in Fig. 2, we

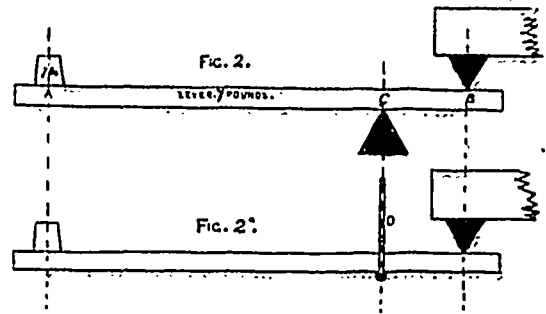

introduce a fulcrum, or more properly, a fixed or immovable point acting at the same place on the lever that the 28-pound weight did, and with the 7-pound weight at the same position of equilibrium on the lever, the pressure at *B* is equal to a weight of 28 pounds, and the pressure at the intermediate fulcrum *C* remains 42 pounds, or, if suspended from *C* and the intermediate fulcrum removed as in Fig. 2a, the tension on the rod *D* is also 42 pounds. This can be proven by making the experiment on the platform of a scale, or suspending the system from a steelyard.

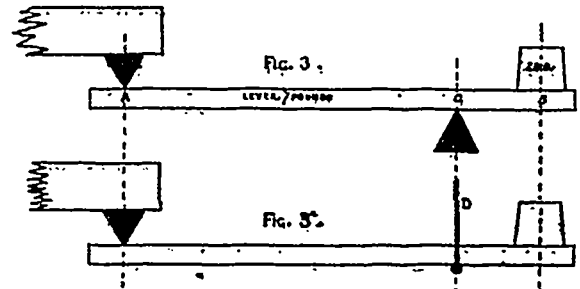

Again in Fig. 3, the intermediate fulcrum and the 28 pound weight are retained in their former position on the lever; but a fulcrum or fixed point is substituted for the 7 pound weight at *A*. No change has taken place; the pressure at *A* is equal to a weight of 7 pounds, and, as formerly, 42 pounds at *C*. The results are the same if suspended from *C* as in Fig. 3a.

From this it will be readily understood that *A*, *B* or *C* may be considered at option, either fulcrum, weight or power, according to the requirements of the mechanism, and that a change in name, or the substitution of an equivalent pressure or tension for a weight, entails no change in principle.

In accordance with the above, the intermediate force in the lever safety valve is the pressure of steam on the valve that acts vertically and in line with its axis, and directly opposed to all the others. The resultant of the system is on this line, and all measurements required in calculating lever inch pounds are taken from it. The opposing forces that are to be in equilibrium with a given steam pressure, are the weight of the lever, the valve, the pea, and the pressure of the lever on the pin, which is a variable quantity depending on the position of the pea on the lever, and in the solution of this question it has to be found, which is easily done by subtracting the known weights from the total required.

In an actual working valve the lever weighed 9½ pounds; it balanced at a point 16½ inches from the centre of pin hole, or 11½ inches from the valve axis, the distance between the valve axis and centre of pin hole being 4½ inches. The weight of the valve and an intermediate piece between it and the lever was 4½ pounds, and the weight of the pea 62 pounds. Total

weight of these parts, 76 pounds. The valve was  $3\frac{1}{2}$  inch diameter. Where should the pea be placed on this lever to be in equilibrium with a steam pressure of 60 pounds per square inch?

Area of  $3\frac{1}{2}$  inch valve is 7.76 square inches; total pressure on it at 60 pounds per square inch is 460.2 pounds. This is the resultant or intermediate force in the system, and, according to the principle set forth, is equal in amount to the sum of all the others, of which one, viz., the pressure on the pin or its equivalent weight, is not given, but is found by subtracting the sum of the known weights, in this case 76 pounds, from the total of 460.2 required; the remainder, 384.2, is the equivalent pressure in pounds due to the resistance of the pin.

The question now becomes, where should the pea or weight of 62 pounds be placed on this lever to be in equilibrium with a weight or pressure of 384.2 pounds placed on the lever at a distance of  $4\frac{1}{2}$  inches from the axis of the valve, or fulcrum, if you please to call it? This is solved on the principle of the equality of inch pounds on each side of a lever in equilibrium. In this case there is one product on one side of the fulcrum and two on the other.

Inch pounds on the pin side of the fulcrum:  $384.2 \times 4.625$ , is equal to 1776.925. On the other side of the fulcrum the sum of the inch pounds of the two components must be the same. Lever 9 $\frac{1}{2}$  pounds, balancing at 11 $\frac{1}{2}$  inches from the axis of valve, is equal to 106.078125. Subtracting this from 1776.925, leaves 1670.846, which is the product of the weight of the pea by its distance in inches from the axis of the valve. Then 1670.846 divided by 62, gives a quotient of 26.94, which is the answer to the question in inches from the axis of the valve, or 31.57 inches if measured from the centre of the pin-hole.

In this manner any similar question is answered. Sometimes government examiners put the question in this form: On the same valve the pea weighing 62 pounds is placed at 35 inches from the centre of pin hole. At what pressure will it be ready to blow off? Here the pea is located at 30 $\frac{1}{2}$  inches from the valve axis. The sum of the inch pounds on that side of the fulcrum or valve axis is 1989.33; this divided by 4 $\frac{1}{2}$ , the distance in inches between the valve axis and centre of pin-hole, gives us 430.125, which is the pressure in pounds at the pin due to the weight being placed at 35 inches from the pin-hole. The total weight or pressure on the "sit" of the valve is 506 $\frac{1}{2}$  pounds, this being the sum of the weight of the parts and the pressure on the pin, and this amount divided by the area of the valve in square inches, gives us 65.987 pounds per square inch, which is the answer to the question.

A neat and clever solution of this problem is based on an extension and application of the same principles. The centre of gravity of a body or a system of bodies is merely a particular case of parallel forces. It is an acknowledged truth that as far as gravity is concerned a body or a system of rigid bodies acts as if its whole weight was concentrated at its centre of gravity. This method begins with an abstraction, or a supposition merely, for the purpose of making a start, but it is soon wiped out. No attention is paid to the individual weights of the pieces or where they balance. The collective weight of all is only required, and as I shall use the data given in the first problem, this amounts to 76 pounds. Imagine lever pea and valve to be in position, but without weight; where should a weight of 76

pounds be placed on the lever, to be in equilibrium with a pressure of 60 pounds per square inch on a  $3\frac{1}{2}$  valve, or to put a pressure of 460.2 pounds on the "sit" of the valve.

It was found in the first problem that in effecting this result there was 1776.925 inch pounds on each side of the axis of the valve. This amount remains a constant for that valve, as long as we are dealing with a pressure of 60 pounds per square inch. Now, 1776.925 divided by 76 gives us 23.38, which, under the supposition made, is the distance in inches from the valve axis that a 76-pound weight should be placed on the lever, to be in equilibrium with a pressure of 60 pounds per square inch. Or to put this in another form, in producing a pressure of 460.2 pounds on the "sit" of the valve, the distributed effect of the weight of the parts in the system is the same as if the whole weight of 76 pounds was concentrated at a point on the lever 23.38 inches from the axis of the valve. Here a reasonable question might be asked: What is the use of this in an engine room? It has a use. This distance of 23.38 inches from the axis of the valve is to be accurately marked on the lever, and with the valve placed on the lever in its working position, or, if necessary, hung by a string from the axis line of the valve; place the 23.38-inch mark on the edge of a fulcrum, or the edge of a cold chisel held in a vice. Next hang the pea on the hook end of the lever, and move it backwards or forwards until the system balances with the 23.38-inch mark on the edge of the chisel or fulcrum, as in Fig. 4.

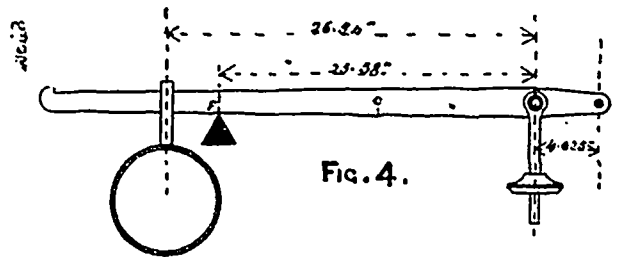

Practically and mathematically this is the true position of the pea on the lever when in equilibrium with a 60-pound pressure, and, as before, it will be found that the pea is 26.947 inches from the axis of the valve.

Looking at a model or drawing of this arrangement, it is evident that when the system is balanced and at rest its whole weight and statical effect is concentrated on the edge of the fulcrum. This is the most simple and accurate solution of the problem that the writer is acquainted with, and is far superior to the graphical method, which in this case has no advantages, and it is easier solved in other ways.

#### THE TORONTO TECHNICAL SCHOOL.

This school was established in January, 1892. Its principal promoters were the late ex-Ald. Gillespie, who died before the school was started, ex-Ald. Dr. J. Orlando Orr, who was the Board's first chairman, and who is at present chairman of that body; the late J. A. Wills and A. M. Wickens. At first it was felt to be somewhat of an experiment, but the success of the school has placed it in a more definite position. It is situated on College street, at the head of McCaul street, and directly to the south of the School of Practical Science, in what was formerly Wycliffe Hall. Permanent quarters have been secured here and the building so fitted as to be better adapted to the requirements of the school.

It is maintained entirely by the City of Toronto,

and is under the control of a Board of Directors composed of seventeen members. Five of these are members of the City Council, five represent the Trades and Labor Council, two the Stationary Engineers, two the Architects, two the Educationalists and one the Manufacturers. Regular meetings of the Board are held on the fourth Tuesday in each month during the session, which begins with October and ends with April.

The classes are free to all residents of the city of Toronto who wish to avail themselves of its privileges. The course of study to be pursued by any one is optional, and registration and entrance to any class can be made at any time during the session. It is desirable, however, to enter the classes at the beginning of the session.

The school has a staff of nine teachers, and the classes are from 7.45 to 9.45 p.m. each week day evening excepting Saturdays.

The design of the school is to aid those who have not had the advantages of an education in the boyhood period of life. It is especially intended for the artisans, tradesmen, mechanics, laborers, etc., and those who follow the usual occupations of an industrial community.

The nature of the work done is very different from that usually taken up by the ordinary commercial schools or colleges. An enumeration of the subjects taught will give some idea of the work it is endeavoring to do. They are arithmetic and mensuration, algebra, Euclid, descriptive geometry, perspective drawing, mechanics, chemistry, practical chemistry, in each of which there are both junior and senior classes. Besides these there are courses as complete as the time will permit in applied electricity, heat, hydrostatics, steam and steam engine, hydraulics, light, sound, practical geometry, freehand drawing, mineralogy and geology, and modelling in clay. In the draughting room a numerous group of subjects is taken up, as machine and architectural drawing, industrial design, shading, lettering, machine construction, etc.

That the school is doing an important and useful work, and that it is appreciated by the young men of the city, are attested by the fact that the average nightly attendance for the whole session was 286. There are no fees for attendance on any of the classes, and each student can take any subject which he chooses, or any group of subjects that the time-table will permit.

Considerable improvement was made during the holidays by the remodelling of the building and the addition of new class rooms. The school is now fairly well provided with apparatus in the more important departments for the practical illustration of the various physical subjects taught. It is intended that the work shall be as practical as possible, and that the students shall be aided personally with their individual difficulties. The practical and useful side of all subjects will receive free consideration, to the exclusion, as far as advisable, of the theoretical and fanciful. At the end of the session, or of the work in any subject, examinations are held in the various branches, and certificates are granted to those who succeed. A diploma is also given by the school to those who complete certain definite courses of study. This work, it is thought, will require from three to four years on the part of a student with average ability, and with but meagre attainments at his entrance upon the course. A goodly number of prizes are going to be offered for competi-

tion in the different subjects at the spring examinations.

Three new teachers have recently been appointed to the staff, and one of the old teachers, Dr. J. McMaster, selected as principal. We understand that already about 450 students have registered for attendance this session.

The prospectus of the school, which gives a brief outline of the work done in each subject, as well as other relative information, can be had by addressing the secretary, A. G. Horwood, who resides in the building.



JNO. M'MASTER, B.A., M.D., C.M.

The subject of this sketch was born in the county of Simcoe, Ont., in 1857. As a boy he was mechanically inclined, and his desire as a youth was to be an engineer and machinist.

With money he earned working on a farm and in a saw mill he resolved to begin his own education. After six months in a public school he passed the entrance to the High School and very shortly afterwards—three months—obtained a second-class B certificate. His means being exhausted he went to work and soon secured enough to fit him for teaching. His earliest professional training was obtained at the Barrie Model School and the Toronto Normal School. By alternately teaching and studying he succeeded in obtaining in succession all the different certificates granted by the Educational Department. A degree in Arts next became the object of his desire. But where or how to get the necessary funds was the serious question. Books had to be bought, fees paid and maintenance for a four-year course provided for. By the judicious handling of what he could earn in the holidays and by persevering application, he was enabled to become the happy possessor of a degree in Arts, and after having taken a full honor course in Mathematics and Physics at Toronto University, he graduated in 1886. While an undergraduate in Arts, he did not confine himself exclusively to Mathematics, but with the view of enlarging his field of knowledge, he took partial courses in Science, Metaphysics and English Literature. After graduating, he married and settled in Belleville, becoming the teacher of Science in the High School there. After teaching in different places for a few years, and not being satisfied with his attainments in life, he resolved to take up the study of medicine, and so took the regular course in Medicine, graduating at Trinity University in the spring of 1894. While an undergraduate in Medicine, he won considerable distinction as a student among his classmates, taking several of the scholarships, etc. He also took the Fellowship in connection with Trinity Medical College.

Before the Toronto Technical School began, Mr.

McMaster was engaged as a teacher in the city night schools for several years, and when that institution was opened, in January, 1892, he was engaged as one of the teachers. Since that time he has remained on the staff, chiefly being engaged in teaching the mathematical subjects. The Principalship of the school was declared vacant at a meeting of the board in August last, and after advertising for applications, Mr. McMaster was selected from among a number. He began his duties as Principal at the opening of the school on the 1st of October.

#### THE MOTO-CYCLE RACE AT CHICAGO.

For some time before the date of the horseless carriage race at Chicago, announced for the 2nd inst., all preparations were made to insure its being carried out in an equitable manner. Although it is but a day since attempts have been made to manufacture these vehicles in the United States, nearly ninety moto-cycles were entered in the competition. In the history of mechanical science there has not on any occasion been as much interest taken in any invention, nor as much done in a short time, as has been done by United States mechanics and inventors to contest for the \$5,000 in prizes offered by the *Times-Herald* newspaper, very little more than three months past.

The judges selected are gentlemen of high standing in the States; they are Major-General Wesley Merrit, commander of the Department of the Missouri, Professor John P. Barret, city electrician, Chicago, and Henry Timpkin, president of the National Carriage Builders' Association, residing in St. Louis. These gentlemen had power to employ any outside or expert help that they might desire to settle any difference arising. It was intended that the conveyances would have a man, selected by the judges, on them to report progress, and to see that the rules governing the competition were strictly followed.

On the 28th, 29th and 30th of October a preliminary test of the vehicles took place, the carriages and machinery being examined by the judges and their assistants, to determine as to whether they were eligible to run in the race or not, by being in line with what is required to make a useful and safe vehicle for the services they were designed for. The mere fact that a light and unsafe machine might be fortunate enough to come in first would not determine the competition in their favor, as a safe and well-designed one carrying a greater weight, yet behind in its time of arriving, might get a prize. The motor-cycles started separately with some time between each, so as to avoid danger or interference at the start. Nothing could better illustrate the great interest in the motors than the fact that there are now in the States two journals entirely devoted to the introduction of the horseless vehicles. The result of this competition will be looked to both in the United States, Canada and Europe with great interest, to determine the question as to whether the inventive American can improve on the heavy European designs or not. They are now building gasoline farmers' traction engines in Kansas of from 12 to 25 h.p., that are guaranteed to handle the largest threshing machine built in the States in an effective manner; the advantages of such are obvious, as there is no fire or sparks, no horses and very little water required. It is stated that no accident from fire has ever taken place on motor-cycles in France and Germany.

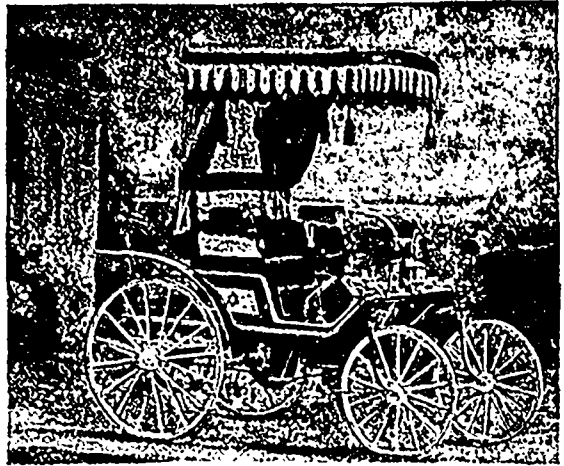

A MOTOR CARRIAGE BUILT IN GERMANY FOR THE SULTAN OF MOROCCO.

Interest in the Chicago competition continues to grow, not only among the manufacturers and merchants, but among the people. While accepting the French as the real inaugurators of the horseless vehicles, the Chicago contest is confidently expected to lead to a number of important improvements on them, and it will also afford the first real test on this continent of the practicability of substituting mechanical power for horse power on ordinary vehicles. It was an unusual sight to see the start of the carriages from the Chicago Midway Plaisance, as also the finish at Lincoln Park, but to the engineer and artisan it possesses a far broader significance than a mere spectacle to the sight-seer. It means the beginning of a bloodless revolution at the end of the 19th century, conducive to great changes in transportation, and to a new industry that will soon employ hundreds of thousands of men. If a moiety of the results expected to follow this test are achieved, the labor, time and cost expended in preparations, etc., will yield large rewards, not only to the builders of the machines, but also to the general public. Farms that are unprofitable can be made to pay by the aid of this power, as horses for transit purposes will not be necessary, the cost and maintenance of such being added in a large degree to the profits of the farmer. Further, less time will be required to get to market and home again. If necessary, the machinery in the carriage can

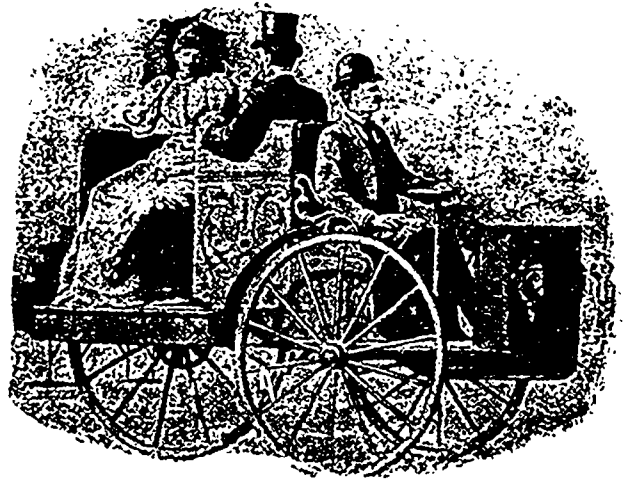

SALISBURY PETROLEUM MOTO-CYCLE.

be applied to run light farm machinery also, without removal from the vehicle, or for pumping purposes if desired. The time may not be far distant when the horseless vehicle in some form may be made to do the ploughing on the farm. It would be useless to enumerate the advantages to be derived from this departure, as it affects more or less all ages and conditions of men.

A number of the vehicles entered for the Chicago test are already in daily operation. They are of a light and symmetrical appearance, and are very much admired in contrast with the heavy French designs.

The judges of the moto-cycle contest have had a dynamometer machine introduced for the purpose of testing the power of motors attached to each carriage, and the amount of oil or other fuel used to give an indicated horse-power; they could not fairly award the prizes without knowing the relation between the fuel and the power of each machine.

One vehicle has arrived that is worthy of more than passing notice, inasmuch as with one motor and front wheels, it can be separated from the body of the vehicle in a few minutes, and attached to a pleasure rig, or to a wagon body for merchandise or other purpose, or can be taken from the body part, drawn into a barn or other building and attached to farm machinery.

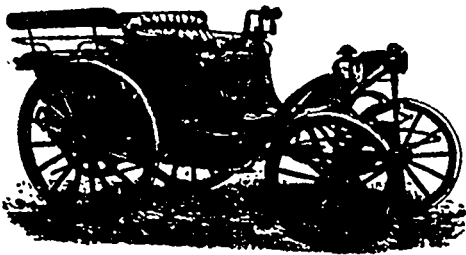

DELAHAYE'S ELECTRIC CARRIAGE.

In an article on horseless carriages, J. Brisben Walker, in the *Cosmopolitan Magazine*, traces the evolution of the means of transport in the history of man in this order: 1st, floating log; 2nd, sledge down hill; 3rd, animal's back; 4th, canoe; 5th, ox cart; 6th, chariot; 7th, oared galley; 8th, sedan chair; 9th, sailing vessel; 10th, horse carriages; 11th, steam carriages; 12th, steamships; 13th, Pullman cars; 14th, bicycles; 15th, cable cars; 16th, electric cars; 17th, horseless carriages. Speculating on the revolution in social life to be wrought by the horseless carriage, Mr. Walker foresees the time when men will again shift back to the country, instead of crowding into the noisy, and more or less unsanitary city. In ancient and medieval days they built cities for protection; and in more recent years, the cities grew because of the bad country roads and the consequent inconvenience and high cost of transporting themselves and their goods. "With the bicycle and horseless carriages," says Mr. Walker, "good roads will jump into the first order of importance, and we may expect to see within the next ten years hundreds of millions of dollars devoted to the levelling and macadamizing of country highways, or, perhaps, even to the construction of asphalt roadways. With these advantages, country life will become quite a different matter, and small communities will multiply rapidly. The day will undoubtedly arrive when great establishments employing many clerks and workmen will ask themselves whether it is worth while to put up with narrow quarters, high rentals, insufficient light and bad air, while the advantages of sunlight, health, and economical conditions are within such easy reach elsewhere." It will even affect our political condition as well as our social, for as the need of concentration behind fortified walls gave Europe its feudal system, so the dispersion of men and industries and the ability to travel long distances on one's own account, will now emancipate the individual as a wage-earner as well as a citizen, and lead up to higher ideals of self-government. The bicycle has

placed it within the power of man to travel 50 to 100 miles a day; but the horseless carriage, with roads properly constructed, will enable him to make a trip of 400 or 500 miles delightfully and inexpensively; while according to Prof. Langley, the aeroplane will accomplish yet greater feats in rapid transit. These things must mean a social, as well as mechanical, revolution in the conditions of life.

In conclusion, THE CANADIAN ENGINEER proposes the inauguration of a public exhibition and test of horseless vehicles for Canada, to be held say in Toronto on the 24th May, 1896, and will be prepared by next issue with proposals as to a committee and other details. If this idea is favorably received, the editor will be glad to receive suggestions from anyone interested. This date will not only insure good weather, but it will give time for foreign exhibitors to compete, and thus the Canadian exhibition of horseless vehicles should be the most comprehensive and interesting yet held, for since the tests in France, England, and this present one in Chicago, more developments will have been made, and their manufacture will have been commenced in Canada.

[Since the above was in type, the Chicago race has been postponed till Nov. 28th, for reasons mentioned elsewhere.]

#### AMERICAN STREET RAILWAY CONVENTION.

One could not better realize the marvelous development of electric railways on this continent than by attending the Convention of the American Street Railway Association in Montreal last month. The association was named "American," so as to include members in Canada, Mexico or any other country on this continent, but this was the first year in which the convention was held outside the United States. It is pleasing to know from the remarks of the delegates that the choice of Canada has not been regretted, and that almost without exception they were pleased with the hospitalities of Montreal. The attendance was variously estimated at 800 to 1,000, the membership including scientific men interested in electric railway work, and wealthy corporations from all over the United States. The aggregate capital represented at this convention was enormous, and indicated in a striking way the evolution of the electric railway on this continent. It is only eight or ten years ago that papers were read before this association including such subjects as "Horseshoeing"; while now the horse is completely banished, and even the cable car will soon be displaced in favor of the electric. Two monthly journals, the *Street Railway Journal*, of New York, and the *Street Railway Review*, of Chicago, published magnificent special editions of about 150 pages each as souvenirs of the convention, while among other electric papers, the *Street Railway Gazette*, of New York, was represented not only with its regular weekly edition, but had a daily supplement printed in the city during the convention. The Victoria Skating Rink was set apart as an exhibition building, and from 100 to 200 firms were represented in the exhibits of street railway equipment, the large building being crowded. Practically the whole of this interesting collection of appliances refers to street railways operated by electricity; and the variety of the exhibits, and the great capital employed by many of the firms represented, shows what a revolution the electric railway has made in the world in ten short years.



### THE HORSELESS CARRIAGE IN ENGLAND.

The town of Tunbridge Wells was all excitement on the appearance there of horseless carriages and motor tricycles which were exhibited at the fair grounds last month. Large crowds came to the town to witness an exhibition which will help to mark another step in the progress of civilization from every side. The signs are coming that the days of the horse's usefulness are passing away. Sir David Solomon appeared in a horseless carriage, known as a "vis-a-vis." It was covered with morocco, with a movable hood. The motor was behind, the driver sat on the back seat, steering and governing being effected by means of a handle bar as on a bicycle. This regulated the speed, etc. Another handle was used to back it. On a stop the carriage was stationary, yet the motor continued to work. The motor is  $\frac{2}{3}$  of a h.p. It can travel on a good road at 20 miles per hour, and average 12. It carries enough benzine to run it 200 miles. It weighs 1,200 pounds on the road. Another much larger carriage was exhibited to carry a heavy load at a slower speed, also a barouche with a petroleum motor on small wheels in front. Great interest was taken in the tricycles, of which several were exhibited. One worked with a petroleum motor ignited by an electric spark. It weighed 90 pounds, and behaved successfully. It is regulated by handles, the pedals being necessary for starting, but while in motion they are not used. A speed of 30 miles an hour can be maintained on good roads. Another was exhibited of  $\frac{2}{3}$  of one h.p. It ran by mineral naphtha. It also made good time, but was not considered as good as the former one. The *London Chronicle* had long articles on the exhibition, showing the advantages of these vehicles, and urging their adoption in England.

### STRENGTH OF BRIDGE AND TRESTLE TIMBERS.

THE CANADIAN ENGINEER is indebted to Walter G. Berg, assistant engineer of the Lehigh Railway, for the following valuable report of the committee on the above subject, of which Mr. Berg was chairman:

Your committee appointed to report on "Strength of Bridge and Trestle Timbers," with special reference to southern yellow pine, white pine, fir and oak, desires to present herewith, as part of their report, the very valuable data compiled by the chairman of the committee, relative to tests of the principal American bridge and trestle timbers, and the recommendations of the leading authorities on the subject of strength of timber during the last twenty-five years, embodied in the appendix to this report, and tabulated for easy reference in the accompanying tables I. to IV.

The uncertainty of our knowledge relative to the strength of timber is clearly demonstrated after a perusal of this information, and emphasizes, better than long dissertations on the subject, the necessity for more extensive, thorough, and reliable series of tests, conducted on a truly scientific basis, approximating as nearly as possible actual conditions encountered in practice.

The wide range of values recommended by the various recognized authorities is to be regretted, especially so when undue influence has been attributed by them in their deductions to isolated tests of small-size specimens, not only limited in number, but specially defective in not having noted and recorded properly the exact species of each specimen tested, its origin, condition, quality, degree of seasoning, method of testing, etc.

The fact has been proved beyond dispute that small-size specimen tests give much larger average results than full-size tests, owing to the greater freedom of small selected test pieces from blemishes and imperfections, and their being, as a rule, comparatively drier and better seasoned than full-size sticks. The exact increase, as shown by tests and by statements of different authorities, is from 10 to over 100 per cent.

Great credit is due to such investigators and experimenters as Professors G. Lauza, J. B. Johnson, H. T. Bovey, C. B. Wing, and Messrs. Onward Bates, W. H. Finley, C. B. Talbot and others, for their experimental work and agitation in favor of full-size tests. Professors G. Lanza, R. H. Thurston, and Wm. H. Burr have contributed valuable treatises on the subject of strength of timber. The extensive series of small and full-size U. S. Government tests, conducted in 1880 to 1882 at the Watertown Arsenal, under Col. T. T. S. Laidley, and more recently the very elaborate and thorough timber tests being conducted by the U. S. Forestry Division under Dr. B. E. Fernow, Chief, and Prof. J. B. Johnson, of Washington University, St. Louis, afford us to-day, in connection with the work of the above mentioned experimenters, our most reliable data from a practical standpoint.

The test data at hand and the summary criticisms of leading authorities seem to indicate the general correctness of the following conclusions:

1. Of all structural materials used for bridges and trestles, timber is the most variable as to the properties and strength of different pieces classed as belonging to the same species, hence impossible to establish close and reliable limits of strength for each species.

2. The various names applied to one and the same species in different parts of the country lead to great confusion in classifying or applying results of tests.

3. Variations in strength are generally directly proportional to the density or weight of timber.

4. As a rule, a reduction of moisture is accompanied by an increase in strength; in other words, seasoned lumber is stronger than green lumber.

5. Structures should be, in general, designed for the strength of green or moderately seasoned lumber of average quality, and not for a high grade of well-seasoned material.

6. Age or use do not destroy the strength of timber, unless decay or season-checking takes place.

7. Timber, unlike materials of a more homogeneous nature, as iron and steel, has no well-defined limit of elasticity. As a rule, it can be strained very near to the breaking point without serious injury, which accounts for the continuous use of many timber structures with the material strained far beyond the usually accepted safe limits. On the other hand, sudden and frequently inexplicable failures of individual sticks at very low limits are liable to occur.

8. Knots, even when sound and tight, are one of the most objectionable features of timber, both for beams and struts. The full-size tests of every experimenter have demonstrated not only that beams break at knots, but that invariably timber struts will fail at a knot or owing to the proximity of a knot, by reducing the effective area of the stick and causing curly and cross-grained fibres, thus exploding the old practical view that sound and tight knots are not detrimental to timber in compression.

9. Excepting in top logs of a tree or very small and young timber, the heart-wood is, as a rule, not as strong as the material farther away from the heart.

This becomes more generally apparent, in practice, in large sticks with considerable heart-wood cut from old trees in which the heart has begun to decay or been wind-shaken. Beams cut from such material frequently season-check along middle of beam and fail by longitudinal shearing.

10. Top logs are not as strong as butt-logs, provided the latter have sound timber.

11. The results of compression tests are more uniform and vary less for one species of timber than any other kind of test; hence, if only one kind of test can be made, it would seem that a compressive test will furnish the most reliable comparative results.

12. Long timber columns generally fail by lateral deflection or "buckling," when the length exceeds the least cross-sectional dimension of the stick by 20, in other words the column is longer than 20 diameters. In practice the unit stress for all columns over 15 diameters should be reduced in accordance with the various rules and formulæ established for long columns.

13. Uneven end-bearings and eccentric loading of columns produce more serious disturbances than usually assumed.

14. The tests of full-size long compound columns composed of several sticks bolted and fastened together at intervals, show essentially the same ultimate unit resistance for the compound column as each component stick would have, if considered as a column by itself.

15. More attention should be given in practice to the proper proportioning of bearing areas, in other words the compressive bearing resistance of timber with and across grain, especially the latter, owing to the tendency of an excessive crushing stress across grain to indent the timber, thereby destroying the fibre and increasing the liability to speedy decay, especially when exposed to the weather and the continual working produced by moving loads.

The aim of your committee has been to examine the conflicting test data at hand, attributing the proper degree of importance to the various results and recommendations, and then to establish a set of units that can be accepted as fair average values, as far as known today, for the ordinary quality of each species of timber, and corresponding to the usual conditions and sizes of timbers encountered in practice. The difficulties of executing such a task successfully cannot be overrated, owing to the meagreness and frequently the indefiniteness of the available test data, and especially the great range of physical properties in different sticks of the same general species, not only due to the locality where it is grown, but also to the condition of the timber as regards the percentage of moisture, degree of seasoning, physical characteristics, grain, texture, proportion of hard and soft fibres, presence of knots, etc., all of which affect the question of strength.

Your committee recommends, upon the basis of the test data at hand at the present time, the average units for the ultimate breaking stresses of the principal timbers used in bridge and trestle constructions shown in the accompanying table.

In addition to the units given in the table, attention should be called to the latest formulæ for long timber columns, mentioned more particularly in the appendix to this report, which formulæ are based upon the results of the more recent full-size timber column tests, and hence should be considered more valuable than the older formulæ derived from a limited number of small-size tests. These new formulæ are Professor Burr's,

App. I.; Professor Ely's, App. J.; Professor Stanwood's, App. K.; and A. L. Johnson's, App. V.: while C. Shaler Smith's formulæ will be better understood after examining the explanatory notes contained in App. L.

Attention should also be called to the necessity of examining the resistance of a beam to longitudinal shearing along the neutral axis, as beams under transverse loading frequently fail by longitudinal shearing in place of transverse rupture.

In addition to the Ultimate Breaking Unit Stress, the designer of a timber structure has to establish the Safe Allowable Unit Stress for the species of timber to be used. This will vary for each particular class of structures and individual conditions. The selection of the proper "Factor-of-Safety" is largely a question of personal judgment and experience, and offers the best opportunity for the display of analytical and practical ability on the part of the designer. It is difficult to give specific rules. The following are some of the controlling questions to be considered.

The class of structure, whether temporary or permanent, and the nature of the loading, whether dead or live. If live, then whether the application of the load is accompanied by severe dynamic shocks and pounding of the structure. Whether the assumed loading for calculations is the absolute maximum rarely to be applied in practice, or a possibility that may frequently take place. Prolonged heavy, steady loading, and also alternate tensile and compressive stresses in the same place will call for lower averages. Information as to whether the assumed breaking stresses are based on full-size or small-size tests, or only on interpolated values, averaged from tests of similar species of timber, is valuable in order to attribute the proper degree of importance to recommended average values, the class of timber to be used and its condition and quality. Finally, the particular kind of strain the stick is to be subjected to, and its position in the structure with regard to its importance and the possible damage that might be caused by its failure.

In order to present something definite on this subject, your committee presents the accompanying table showing the average safe allowable working unit stresses for the principal bridge and trestle timbers, prepared to meet the average conditions existing in railroad timber structures, the units being based upon the ultimate breaking unit stresses recommended by your committee, and the following factors of safety, viz.:

Tension, with and across grain .....	Ten.
Compression, with grain .....	Five.
"    across grain .....	Four.
Transverse rupture, extreme fibre stress .....	Six.
"    "    modulus of elasticity .....	Two.
Shearing, with and across grain .....	Four.

In conclusion, your committee desires to emphasize the importance and great value to the railroad companies of the country of the experimental work on the strength of American timbers being conducted by the Forestry Division of the United States Department of Agriculture, and to suggest that the American Association of Railway Superintendents of Bridges and Buildings endorse this view by official action, and lend its aid in every way possible to encourage the vigorous continuance of this series of government tests, which bids fair to become the most reliable and useful work on the subject of strength of American timbers ever undertaken. With additional and reliable information on this subject, far reaching economies in the designing of timber structures can be introduced, resulting not only in a great pecuniary saving to the railroad companies, but also offering a partial check to the enormous consumption of timber, and the gradual diminution of our structural timber supply. Walter G. Berg, chairman; J. H. Cummin, John Foreman, H. L. Fry.

AVERAGE ULTIMATE BREAKING UNIT STRESSES IN POUNDS PER SQUARE INCH.

Recommended by the Committee on "Strength of Bridge and Trestle Timbers"

AMERICAN ASSOCIATION OF RAILWAY SUPERINTENDENTS BRIDGES AND BUILDINGS.—5TH ANNUAL CONVENTION, NEW ORLEANS, OCT., 1895.

KIND OF TIMBER.	TENSION.		COMPRESSION.			TRANSVERSE RUPTURE.		SHEARING.	
	With Grain.	Across Grain.	With Grain.		Across Grain.	Extreme Fibre Stress.	Modulus of Elasticity.	With Grain.	Across Grain.
			End Bearing.	Columns under 15 Diam.					
White Oak.....	10,000	2,000	7,000	4,500	2,000	6,000	1,100,000	800	4,000
White Pine.....	7,000	500	5,500	3,500	800	4,000	1,000,000	400	2,000
Southern Long Leaf or Georgia Yellow Pine.....	12,000	600	8,000	5,000	4,400	7,000	1,700,000	600	5,000
Douglas, Oregon and Wash- } Yellow Fir.....	12,000	.....	8,000	6,000	1,200	6,500	1,400,000	600	.....
ington Fir or Pine. } Red Fir.....	10,000	.....	.....	.....	.....	5,000	.....	.....	.....
Northern or Short Leaf Yellow Pine.....	9,000	500	6,000	4,000	1,000	6,000	1,200,000	400	4,000
Red Pine.....	9,000	500	6,000	4,000	800	5,000	1,200,000	.....	.....
Norway Pine.....	8,000	.....	6,000	4,000	800	4,000	1,200,000	.....	.....
Canadian (Ottawa) White Pine.....	10,000	.....	.....	5,000	.....	.....	.....	350	.....
Canadian (Ontario) Red Pine.....	10,000	.....	.....	5,000	.....	5,000	1,400,000	400	.....
Spruce and Eastern Fir.....	8,000	500	6,000	4,000	700	4,000	1,200,000	400	3,000
Hemlock.....	6,000	.....	.....	4,000	600	3,500	900,000	350	2,500
Cypress.....	6,000	.....	6,000	4,000	700	5,000	900,000	.....	.....
Cedar.....	8,000	.....	6,000	4,000	700	5,000	700,000	.....	1,500
Chestnut.....	9,000	.....	.....	5,000	900	5,000	1,000,000	600	1,500
California Redwood.....	7,000	.....	.....	4,000	800	4,500	700,000	400	.....
California Spruce.....	.....	.....	.....	4,000	.....	5,000	1,200,000	.....	.....

AVERAGE SAFE ALLOWABLE WORKING UNIT STRESSES IN POUNDS PER SQUARE INCH.

Recommended by the Committee on "Strength of Bridge and Trestle Timbers."

AMERICAN ASSOCIATION OF RAILWAY SUPERINTENDENTS BRIDGES AND BUILDINGS.—5TH ANNUAL CONVENTION, NEW ORLEANS, OCT., 1895.

KIND OF TIMBER.	TENSION.		COMPRESSION.			TRANSVERSE RUPTURE.		SHEARING.	
	With Grain.	Across Grain.	With Grain.		Across Grain.	Extreme Fibre Stress.	Modulus of Elasticity.	With Grain.	Across Grain.
			End Bearing.	Columns under 15 Diam.					
Factor of Safety.	Ten.	Ten.	Five.	Five.	Four.	Six.	Two.	Four.	Four.
White Oak.....	1,000	200	1,400	900	500	1,000	550,000	200	1,000
White Pine.....	700	50	1,100	700	200	700	500,000	100	500
Southern Long-Leaf or Georgia Yellow Pine.....	1,200	60	1,600	1,000	350	1,200	850,000	150	1,250
Douglas, Oregon and Wash- } Yellow Fir.....	1,200	.....	1,600	1,200	300	1,100	700,000	150	.....
ington Fir or Pine. } Red Fir.....	1,000	.....	.....	.....	.....	800	.....	.....	.....
Northern or Short-Leaf Yellow Pine.....	900	50	1,200	800	250	1,000	600,000	100	1,000
Red Pine.....	900	50	1,200	800	200	800	600,000	.....	.....
Norway Pine.....	800	.....	1,200	800	200	700	600,000	.....	.....
Canadian (Ottawa) White Pine.....	1,000	.....	.....	1,000	.....	.....	.....	100	.....
Canadian (Ontario) Red Pine.....	1,000	.....	.....	1,000	.....	800	700,000	100	.....
Spruce and Eastern Fir.....	800	50	1,200	800	200	700	600,000	100	750
Hemlock.....	600	.....	.....	800	150	600	450,000	100	600
Cypress.....	600	.....	1,200	800	200	800	450,000	.....	.....
Cedar.....	800	.....	1,200	800	200	800	350,000	.....	400
Chestnut.....	900	.....	.....	1,000	250	800	500,000	150	400
California Redwood.....	700	.....	.....	800	200	750	350,000	100	.....
California Spruce.....	.....	.....	.....	800	.....	800	600,000	.....	.....

FOR THE CANADIAN ENGINEER

CONCRETE CONSTRUCTION.

BY MAJOR HENRY A. GRAY, M. INST. C.E., M. CAN. SOC. C.E., ENGINEER IN CHARGE PUBLIC WORKS OF CANADA, DISTRICT OF WESTERN ONTARIO.

During my visit to the old country this last summer I visited several works and places where concrete was being used for different structures—especially breakwaters, piers and docks—and I succeeded in obtaining a large and valuable amount of information with respect to the same, which I have endeavored to give from my notes in the following form: I acknowledge with many thanks the aid given me by James Forrest, secretary of the Institution of Civil Engineers, London, who directed my attention to the best sources, i.e., papers presented to the institution, from which to

obtain accurate and reliable data, as well as to a number of my professional friends, civil and military, who gave me the result of their experience.

Concrete was extensively employed by the Romans for building purposes, but for some unexplained cause fell into disuse, and until the last few years its use has been almost entirely confined to the making of monolithic masses placed underground to act as foundation substructures for stone or brick superstructure. The French engineers appear to have been the first to discover the value of beton or concrete, for harbor works on the sea coast. At first, in its use for such works, natural hydraulic limes were employed as the cementing material with the addition of pozzolana. In the course of time, and when the manufacture of Portland cement had improved, the use of concrete in the con-

struction of all descriptions of buildings became general. It can be made, under almost any circumstances and at any place, at a moderate cost, and it is easily shaped into any form or size of block that may be found useful; it can be deposited in moulds in the exact position it is permanently intended to occupy; and when carefully made, with the proper admixture of materials—which is, of course, of vital importance—results have proved that it possesses under the most trying circumstances all that is necessary for strength and durability.

Before deciding to use concrete for a structure, a careful consideration of the locality, the nature of the materials at or near the place, and cost of transport of same, is necessary.

One great advantage of using such a material as concrete, instead of wood, is that it does not decay, and consequently renewals and repairs are less frequent, nor can it be attacked by the teredo or the white ant; it is not subject to contraction or expansion, and its strength, especially in damp localities, becomes greater with age. Objections have been made to the finished appearance of structures built with concrete, but it is not at all difficult to produce a fair and finished surface too on the exposed faces of concrete, as shown in many of the large engineering works which I have visited. It is even possible, in fact easy, with a little attention, not only to produce a fair surface, but to form mouldings and even tracery and ornaments and at the same time to make the face work as durable as any other part of the block. At Chatham an experiment was made in 1874 which has proved conclusively that the common concrete could be faced by superior concrete a thickness of nine to ten inches. In this case the special face concrete was composed of four parts of slag from the dockyard furnaces, used in the remanufacture of wrought iron, and broken by a stone crusher into pieces about  $\frac{3}{4}$  inch cube. To this was added two parts of coarse, sharp river sand and one part of Portland cement. This was mixed in the usual manner and placed in position by a simple contrivance. A plank  $1\frac{1}{2}$  inches thick, 10 feet long and 11 inches wide, was furnished with rope handles attached to one edge of each plank. Two distance pieces from 9 to 10 inches long were inserted loosely between the face shutter and the plank, which was placed on edge to keep the proper distance from the facing. The common concrete was then put in from the back of the plank to the back face of the wall, while the slag concrete was filled in between the face of the wall and the face of the plank. The face concrete was then thoroughly worked by a shovel against the facing shutter until all air was expelled from it, when the plank was lifted and the two concretes well rammed together. The result is a smooth face, as if plastered upon the common concrete wall, and is quite inseparable from it. If furnace slag cannot be obtained, an admirable aggregate for facing concrete, if not quite as good as slag, is found in granite, limestone, or other stone chips, or of large gravel broken in a stone crusher to a range of  $\frac{1}{4}$  to  $\frac{3}{4}$  inch cube. Face concrete, formed of any of these materials in the proportions of 4 parts of the aggregate, two parts of sand and 1 part of Portland cement, becomes so hard that it may be cut into for receiving bolts of any kind just as if it were stone.

It is the practice at Chatham and Woolwich to let in ring-bolts, bollards and mooring-posts into the liquid concrete as the work is carried up. The ironwork gets

as good a hold in the wall as if set in granite, and at a cost of one-tenth less than that of letting them into stone. At St. Alban's, near London, concrete is used extensively in the construction of ornamental walls for large buildings and residences, and for garden walls with mouldings, caps, etc.

In some cases an attempt has been made to give a face by rendering the structure over with plaster or by grouting with liquid mortar, but these methods are only a veneering easily affected by wet and frosty weather. The best plan, and one that has been followed at a very small cost and with great success in harbor works, both above and below low water, exposed alike to frost, heat, storm and rain, consists in using smooth planed boards for the face of the mould, smeared over with soap before commencing the work, to prevent the mortar adhering; then, in filling the frame, care has to be used that a fine mixture of concrete or coarse cement mortar be laid in with a trowel close to the face boards as the work proceeds, so that the mixture is carried up uniformly with that contained in the body of the work, the whole forming one homogeneous mass, and ensuring the setting process being carried on simultaneously, so that the face is in fact like the skin of an iron casting or the chilled surface of a wheel, actually the strongest portion.

In the formation of concrete a large variety of materials have been experimented with, namely, hard and soft sandstone, whinstone gravel, sand from sand pits, lake and river sand, and sand prepared by crushing stone. The proportions used varied from 5 to 1 to 12 to 1, none being adopted which did not completely fill (1st) the voids in the sand with cement, and (2nd) those in the stones with mortar. These voids in the sand amount to from 33 to 34 per cent.; in the gravel to 34 per cent.; in broken stone of a friable nature 40 to 42 per cent., and in the harder kinds of stone 46 to 50 per cent. Gravel is, therefore, all other things being equal, the most, and hard stone the least, economical material to use.

Much difference of opinion exists as to the best thickness of depositing concrete in such structures as walls, etc., but from actual experience it would appear that 18 inches is a fair and safe thickness, and that it should be deposited, if made with Portland cement, as soon after it is mixed as possible, and at once thoroughly rammed while wet. The more concrete is thoroughly rammed the more sound and impervious the mass is, and consequently the less liable to injury from the action of water. No fall or drop is equal in efficiency to ramming, and granting that it is well rammed, the fall or drop may be dispensed with. Cement concrete may be either made by hand or by one or other of several machines. If by hand, the material should be turned over at least three times dry, the water in fixed proportions being then added through a "rose," and turned over three or four times wet. The machines used for mixing are the pug-mill, a horizontal trough with a screw turning the materials over and working them forward, or, for large quantities, McKinnel's machine. This class of machine consists of a cylinder revolving upon a spindle, which traverses the cylinder diagonally. When the cylinder is revolved, the materials are by the resulting eccentric motion thrown backwards and forwards as the ends are alternately above and below the centre of revolution, while at the same time they are being turned over in a lateral direction by the revolution of the barrel. There is an advantage in using a shovel or barrel for filling in con-

crete: the large stones are not so apt to separate from the finer gravel as when it is shot in a continuous stream out of a trough.

In general practice it is considered sufficient to have the materials turned over twice, and then to apply water through the rose of a watering-can, turning over the materials three different times in the process of wetting. Some engineers demand that for wetting the concrete only the smallest quantity that will suffice for wetting shall be used, but there can be no doubt that an excess of water is beneficial rather than injurious to the concrete, for in getting concrete into position much water passes away by absorption, by evaporation, or by actual leakage, so that in many instances the concrete is left too dry to allow of its setting perfectly. When concrete is made thoroughly wet it can bear to part with some of the surplus water by absorption, etc.; all the rest rises to the surface without bringing with it any portion of the cement. When put in wet the concrete admits of being rammed thoroughly solid against the sides or framing, while the matrix never fills in the interstices in the aggregate so thoroughly as when water is freely used in mixing. No cement sets better than such as is covered by the tide almost immediately after it is put in place. It is needless to say that in frosty weather excess of water in mixing concrete is to be avoided.

The shingle used at Chatham is dredged from the bed of the River Medway; it contains a certain amount of loam. When the quantity of loam is small, twelve parts of the shingle to one part of cement makes not only a good hard, but a very tough concrete; but an excess of loam is injurious, and as the workmen say, "kills" the cement. In winter the slightest excess of loam in the gravel renders the concrete liable to injury from frost for a long time after it is made. Sand, if too fine, although it may be sharp and clean, is often little better than dust and acts in the same way as loam.

The most convenient size for a depositing box for placing concrete below water, is one with a capacity of about sixteen cubic feet. In Blyth harbor, where large quay walls were built in 1884, it was found that the cost per cubic yard, for concrete, was as follows:—

ABOVE LOW WATER LEVEL.—PROPORTIONS 7 TO 1.

Cement, 4 0 cubic feet, = 0.16 ton .....	s. d.
Stone and sand .....	5 9
Breaking stone and incidental expenses .....	2 3
Mixing and wheeling.....	1 2
Planking .....	2 4
Per cubic yard .....	1 0
.....	12 6

BELOW LOW WATER LEVEL.—PROPORTION 6 TO 1.

Cement, 4.5 cubic ft. = 0.18 ton .....	s. d.
Stone and sand .....	6 6
Breaking stone and incidental expenses .....	2 3
Mixing and wheeling.....	1 2
Planking (fixed by diver) .....	2 4
Depositing by crane .. .. .	4 0
Dive depositing in place .....	0 9
.....	2 0
.....	19 0

Below is the cost of a cubic yard of concrete at Chatham, formed of 12 parts of shingle to 1 part of Portland cement, calculated carefully in detail at ordinary rates for material and labor:—

1 1-5 cubic yard gravel (including 16 per cent. for shrinkage and 4 per cent. for waste), per cubic yard, 2s....	s. d.
2 1-16 cwt. Portland cement (including allowance for waste and use of bags), per cwt., 1s. 6. ....	2 5
50 gallons water (including allowance for wasteband use of service-pipe), per 1,000 gallons, 10d.....	3 1
.....	0 0½

1 cubic yard mixing concrete and depositing in work, per cubic yard, 1s. 1d. ....	s. d.
1 1-5 cubic yard wheeling gravel (including use of crane and depositing in trucks), per cubic yard, 3d. ....	1 1
2 1-16 wheeling cement, placing in store, loading at store, unloading at work and use of store shed, per cwt., 3s. 4.....	0 3½
1½ cubic yard transport of concrete to work (including use of trucks, roads, banking, etc.), per cubic yard, 1d. ....	0 1½
.....	7 2

The cost so estimated of 1 cubic yard of concrete is 7s. 2d. Calculated on the same basis a yard of 9 parts of shingle to 1 part of cement will cost 8s. 2½d., and of 6 parts of shingle to 1 part of cement 10s. 3d. A cubic yard of slag concrete (6 to 1) used in facing costs about 12s. 2d. per yard; if flint face concrete about 14s. 2d. The proportions of slag concrete, at 12s. 2d. required for facing is so small that the whole cost of the concrete on a lineal foot of wall is only increased about 2½d. per cubic yard, making the entire cost of the wall, including staging and framing, about 7s. 10d. per cubic yard.

(Concluded in next issue).

FACTS ABOUT BOILERS.

ARTICLE No. 3.

THE AGGREGATION OF PIPE AND FITTINGS.

This stage of boiler making occupies the same plane in boiler development that the rotary engine does in its field. Most everybody has been touched by the disease. The materials are all at hand, and the details can be mostly bought ready made. By the addition of another elbow, coupling or return bend, the budding genius of a boiler inventor sees the heights of fame and dollars within his reach.

It would be more charitable to simply place *Punch's* remark, "Don't," under a picture of these seductive pieces. But facts will out, and a few "horrible examples" will suffice to illustrate.

As a rule it can be said that the later the date of the attempt the worse the results. They are all based on the following recipe:

First. Crowd in the greatest possible amount of heating surface, no matter how or at what sacrifice of other equally necessary requirements.

Second. The more bends and right angles so placed as to obstruct circulation the better.

Third. On the same basis that a steam engine will run more regularly without than with a fly wheel, cut down the steam and water capacity to the lowest possible limit.

Fourth. Make it as far as possible out of pipes and fittings screwed together, and place the fittings and joints in the hottest position.

Fifth. Firmly take the position that it will never need repairs, and render them difficult to make.

Sixth. Assert that it will never need internal cleaning, and avoid all facilities for so doing.

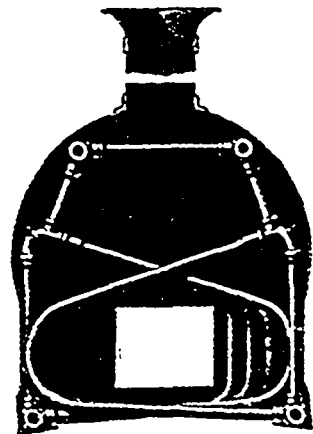

NO. 35. 1833—"ENGINEER," AUG. 17TH, 1894.

Seventh. No matter how closely it copies some other discredited aggregation, give it a new name and it will go for a while.

SIR CHAS. W. DANCE, the inventor of a steam road carriage in England, joined Joshua Field (of Mandsley & Field, the builders) in patenting the first boiler of this description, and can be

considered the father and godfather of troubles in this line. The lower tubes were used as grates, as in Gurney's 1826 design. The familiar "up-flow" and "down-flow" pipes, connected by fittings (made specially, as there were at that time no regular ones on the market), were present. All ideas of the necessity of steam or water capacity, or desirability of access for internal cleaning, were absent. Surface, weight and space occupied dominated the design.

BELLEVILLE, a French engineer, introduced a box coil boiler, made up of bent U pipes screwed into return bends, a series of these coils being placed vertically side by side, connected, connected at the top to a separating drum, and at the bottom to a common feed pipe. It was fitted with various automatic devices for controlling the feed, circulation, blow-off and pressure—the latter as it was found necessary to run the boiler at a higher pressure than that desired in the engine, throttling down to prevent the water from bodily leaving the boiler. They are used principally in marine service.

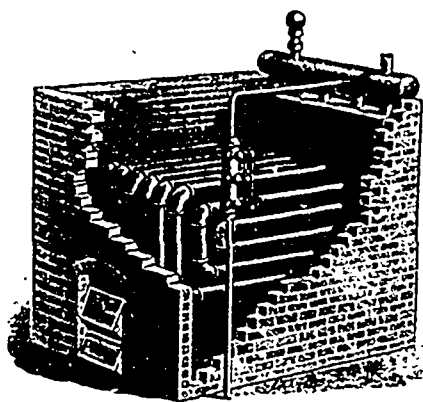

NO. 39. 1876—TRADE CIRCULAR ISSUED IN SENECA, N. Y.

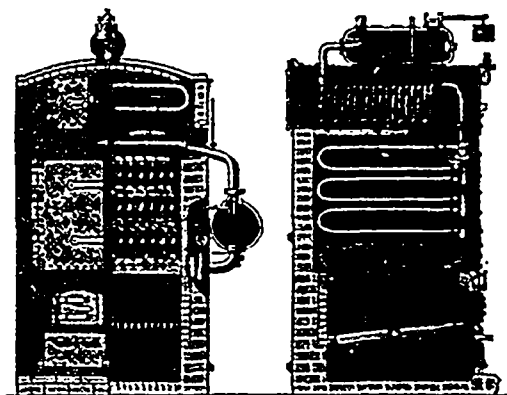

NO. 36. 1865—TRADE CIRCULAR.

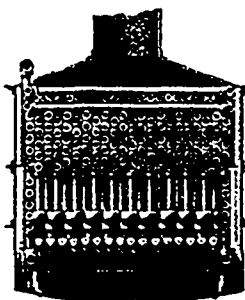

HERRESHOFF rechristened Belleville's 1877 boiler, staggered the tubes, and added a feed-water coil above it made up in the same manner, made of pipes and fittings.

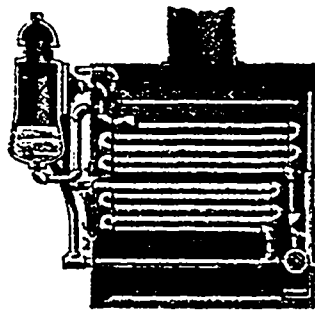

NO. 40. 1890—INTERNATIONAL ENGINEERING CONGRESS, 1894.

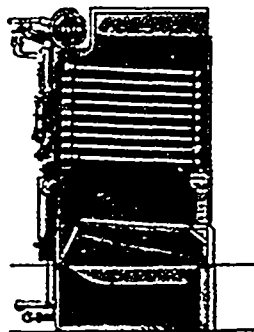

NO. 37. 1877—TRADE CIRCULAR.

About 1877 the bent pipe was discarded and return bends used on both ends of a series of straight tubes. This boiler could be cleaned by taking it all apart. One particular advantage of this boiler seems to be that the steamship owner has the opportunity to constantly displace paying freight by carrying round a mass of brick work.

CHARLES WARD used a vertical cylinder surrounded by a series of concentric coils interrupted twice in their circumference, on opposite sides, by vertical manifolds. These manifolds on one side were connected by a radial pipe to the bottom of the cylinder, and at the other side to a similar pipe connecting near the top of the cylinder.

J. C. KILGORE originated the "Eclipse" boiler, using pipes and fittings to build up his U tube sections; otherwise it was a copy of Allen's 1872 design.

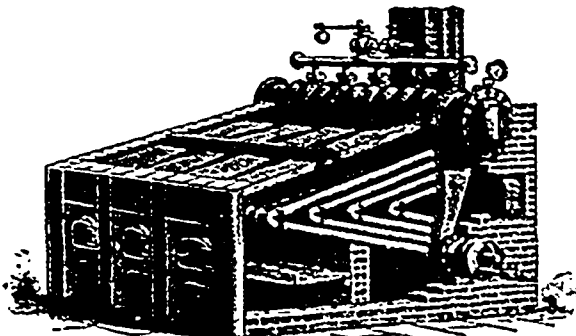

NO. 38. 1874.—TRADE CIRCULAR ISSUED IN PITTSBURG.

JOSEPH SHACKLETON used return bend units connected to vertical manifolds, placed side by side, connected at the top to a steam collector and at their bottom ends to a common feed pipe.

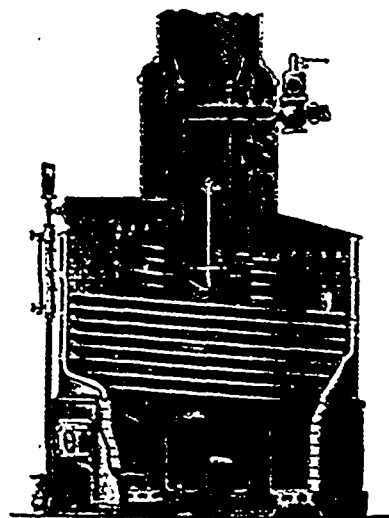

NO. 41. 1879—U. S. NAVAL REPORTS.

E. E. ROBERTS, of New York, bred a cross between Belleville's 1877 and Herreshoff's 1890 boiler, and while "favoring" both its parents, developed outside down-take pipes of its own. Made of pipes and fittings.

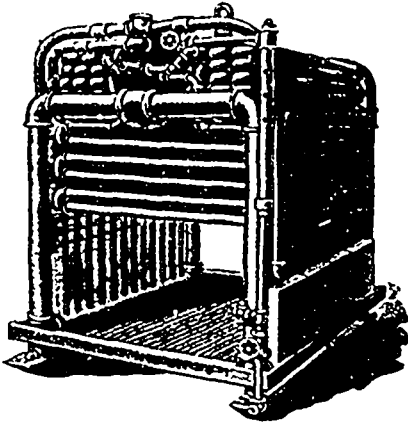

NO. 42. 1887 - TRADE CIRCULAR ISSUED IN NEW YORK

ARMY used straight pipes connected up with elbows and return bends to an overhead steam and water reservoir and bottom connecting pipes

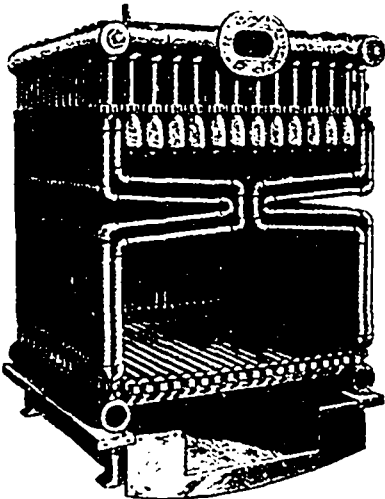

NO. 43. 1890 - U. S. PATENT NO. 434,227.

The above are samples of some of the best aggregations of pipes and fittings. The least objectionable are those having the fewest bends and the least length of pipe, in proportion to the diameters used, between the inlet and outlet of each unit of circulation.

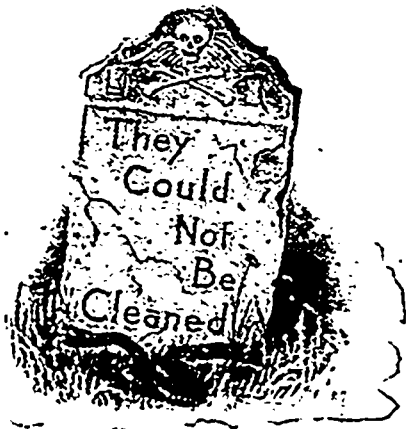

#### CANADIAN NICKEL IN NAVAL CONSTRUCTION.

The recent trial of the torpedo destroyer "Sokol," built for the Russian Government by a British firm, has given the final answer to a problem whose solution means money in the pocket of every Canadian; nickel steel has been proved the most economical material for naval construction.

The details of the trial are given in the *Glasgow Herald* of October 9th. The novelties have been directed towards the reduction in weight so as to secure a high speed with the minimum of power. The result has been most successful. The vessel is 190 ft. by 18½ ft. beam, and her maximum draught to the bottom tip of the blades of the twin-propellers is 7 ft. 6 in., while the full load displacement is 205 tons, of which 30 tons is due to coal, &c. There are two sets of triple expansion engines, the cylinders being 18 in., 26 in. and 39½ in. diameter, with 18 in. stroke. There is no special feature about them, the valves being all of the piston type,

but in many cases naval bronze has been used to reduce weight. The engines are balanced on Yarrow's system, and the proof of efficiency is found in the fact that while running 27 knots on the measured mile, with the engines doing 350 revolutions per minute, afternoon tea was served to ladies on deck. There are eight watertight tube boilers weighing 45 tons with all fittings, and they are equal to sustaining, if necessary, 100 h.p. per ton. On yesterday's trial these were only subjected to ½ inch of air blast, but on the official trial they withstood 1¾ in. without any trouble. Yesterday the trial was practically under natural draught with the engines doing 360 revolutions. The mile was run in one direction in 2 min. 10 sec., and in the other 2 min. 22 sec., the mean speed being 26.7 knots. That was with what the British Admiralty deem natural draught conditions, ½ in. air pressure. But the speed on the official measured mile trial was 30.1 knots. The mile on two days has been covered in 1 min. 52½ sec., equal to 32 knots. On the three hours' trial the speed was 29.777 knots, with the engines making 405.15 revolutions, and the boilers consuming 3 tons 7 cwt. of coal per hour, while the power was under 4,000 h.p., and it is assumed that with only two boilers the loss would be but equivalent to a reduction in speed of one knot.

The distinctive feature of the Russian boat, and the one which contributes most to this great speed for low power, is the adoption of nickel steel. The "Sokol" is the first vessel constructed of this alloy. The nickel steel was constructed at the works of the Steel Company of Scotland. The tensile strength was 40 tons on the square inch, with a maximum extension of about 16 per cent. The thickness of the plates is ¾ down to ¼ of an inch; the ratio of nickel to steel is three per cent. Against the increased price must be placed the fact that the rate of corrosion has been reduced to about one-half, and more important still, the weight of material necessary has been reduced 30 per cent. by reason of the greater strength. In other words, if mild steel had been used, the weight would have been over 42% more than it actually is, so that in part the cost of the material is made up. But, after all, cost is not a great consideration, especially when it is remembered that by the use of nickel steel for the hull, of brass for parts of the engine etc. and of aluminum wherever convenient, it has been possible to get at least two knots more with less power and less coal consumption than with the British destroyers. Even considering the matter of cost, there are possibilities of greater use of nickel steel, for it is cheaper than Siemens' steel was when first made for the British cruiser "Iris." Nickel is now 1s. 6d. per lb. when first bought for experiments six years ago 21s. 6d. would be nearer the price. Then the only supply was from New Caledonia; now immense deposits are being worked at Sudbury, in Canada.

#### THE TIDAL MOTOR.

Editor CANADIAN ENGINEER:

SIR,—I now send you some further advantages of my tidal patent:

1. I claim the English patent for working day and night continuously throughout the year.
2. I also claim an improvement over the old tide mills, by which I can work some hours longer at each rise and fall of the tides than they can do. This is a great improvement, and the present tide mills could be altered to my plan at a very moderate outlay; this would cost much less than the plan for working continuously throughout the year.
3. In many places the continuous plant can be put down nearly costless; also the tides mill, improved plan. This may seem a paradox, but it is absolutely correct.
4. My plants can be erected either on the sea shore or on tidal rivers where there is a tidal flow of a few feet high.
5. A modified form of my plant can be put to work on any river, lake, or other place where there is even a small head of water to be had, and will work with great economy.

Yours truly,

EDWARD DAVIES,  
Harringay Villas, Green Lanes, London N., England,  
Late of Cambridge Cottage, Wood Green, N.

P. S.—In my letter you kindly inserted in your September issue, you have put after "working lifts," etc., the word "towers." It ought to have been "towns."

WITH the increased demand for nickel, interest is being renewed in the Sudbury, Ont., mines. Many first-class nickel mines of the range have lately been bonded by influential American capitalists, who evidently mean to purchase a number of mines within the next few months.

## AMERICAN STREET RAILWAY ASSOCIATION.

The fourteenth annual convention of the American Street Railway Association was held in Montreal from 15th to 19th October, there being about 800 delegates and supply men in attendance.

Among the Canadian delegates and others in attendance were the following: T. C. Lazier, manager Belleville, Ont., Traction Co.; B. E. Charlton, president, and W. W. Dean, electrician, Hamilton Street Railway Co.; John Patterson, Hamilton Radial Electric Railway Co.; F. Nicholls, president Brantford Street Railway Co.; J. M. Campbell, Kingston, Portsmouth and Cataract Railway Co.; Chas. E. A. Carr, manager London Street Railway Co.; G. C. Cunningham, general manager, E. Lusher, secretary-treasurer, J. F. Hill, comptroller, D. McDonald, superintendent, Montreal Street Railway Co.; Louis Beaubien, president, Henry Holgate, manager, J. R. Roy, engineer, A. J. Corriveau, director, Montreal Park and Island Railway Co., Ross Mackenzie, manager, W. Phillips, electrician, Niagara Falls Park and River Railway; J. W. McRae, president, W. Y. Soper, vice-president, T. Ahearn, managing director, J. D. Fraser, secretary-treasurer, J. L. Hutchison, superintendent, Ottawa Electric Railway Co.; W. W. Wylie, superintendent Ottawa Car Co., Ed. A. Evans, Quebec, Montmorency & Charlevoix Railway Co., H. Brown, St. John, N.B., Railway Co., James Gunn, superintendent, J. M. Smith, comptroller, M. Powers, car supt. Toronto Street Railway Company, Charles Morton, Toronto Suburban Railway Co., George H. Penty, Victoria, B.C. Electric Railway Co., M. Coventry, president, Sand-

year being \$276,031,000, and the total profits \$322,000,000. The latter have a capital of \$1,300,000,000, with gross receipts of about \$130,000,000 and profits of \$43,000,000. Among the new branches of business to be cultivated he indicated freight and mail, the delivery of parcels from stores through a system of express, the handling of building material to suburban localities, of milk from near by country districts, and the operation of funeral cars to cemeteries. As to the relation of electric to steam railways, he thought it probable that the former would force an amalgamation of the two systems whereby passengers would be transferred from lines connecting distant points to the suburban systems, carrying the passengers to their destination.

The treasurer's report showed that receipts for the year were \$7,554, and expenses \$7,240.

The first paper was by E. J. Wessels, of New York, on "Air Brakes," which he strongly advocated to replace hand brakes. The street-car air brake has much to contend with. First, the unfamiliarity of the average motorman with the proper use of air is greatly against it. Secondly, the compressor is begrudged space on the car axle. Thirdly, there is the neglect of proper inspection. Fourthly, there is insufficient lubrication. A year ago air brakes were not found on many roads, but where used they had given satisfactory results. They were a great saving in wheels. Mechanical brakes were a failure, and he found that in a tour through Europe compressed air was preferred to steam or any other kind.

In the discussion which followed, Mr. Scullin, of St. Louis,



EXHIBIT OF BABCOCK & WILCOX CO. AND GOUBERT MFG. CO.

wich and Windsor Street Railway Co.; F. W. Atkinson-Bell Telephone Co., Montreal; W. Bellingham, Montreal; K. W. Blackwell, Montreal; W. D. Black, Montreal; W. E. Christie, G. S. Davison, Ottawa; A. W. Dingman, Toronto; Geo. Darling, of Darling Bros., Montreal; A. E. Donville, St. Thomas; F. Fox, E. A. Hewitt and F. J. Green, the Bushnell Co., Montreal; Geo. Hunt, St. Lawrence Machinery Co., Montreal; H. R. Leyden, Montreal; Alex. Macpherson, Montreal; W. T. Bonner and A. McDonnell, Babcock & Wilcox Co., Montreal; Jas. Carroll and Frank Mead, E. F. Phillips Electric Works, Montreal; D. W. McLaren, J. C. McLaren Belting Co., Montreal; A. Roy MacDonald, Montreal; E. S. Piper, Toronto; W. G. Slack, Bell Telephone Co., Montreal; Fred. Thompson, Montreal; C. E. L. Porteous, Toronto.

The chair was occupied by Joel Hurt, of Atlanta, the president, and the proceedings were opened by an address of welcome from Mayor Villeneuve, to which the president replied in appreciative terms.

President Hurt, in his annual address, spoke of the growing importance of the street railway, and the increasing number of men of scientific attainments who were devoting themselves to it. He said there were now in the United States about 179,300 miles of steam railways and 13,500 miles of street railways. The former had a total capital of \$11,000,000,000, the passenger traffic receipts last

said that two years ago they tried two kinds of vacuum brakes, neither of which were a success. In running through suburban parts it worked all right, but in crowded sections, where many stops had to be made, they could not keep up the pressure, the reservoir getting exhausted. Then, also, the brakes failed to work through the wires coming in contact with the piping of the brakes wearing away the insulation and short circuiting, and burning holes through the pipe.

Mr. McCulloch, representing another line in St. Louis, said about two years ago they equipped a car, and it worked so well that they afterwards fitted out a dozen cars with air brakes, but then the bills for repairs began to come in, and became so heavy that they had to be all taken off.

In the afternoon the mayor gave a reception to the members at the city hall, where, after his worship made an address on the benefits of electric over the old horse-car railways, refreshments were served, and afterwards speeches were made by Ald. Stevenson, Nolan and Prefontaine.

On the 16th, after a general discussion on the "Labor Question," a paper was presented by Mr. Baumhoff, of St. Louis, on "Transfers." During the session several gentlemen representing the Dublin Tramways Co. arrived and were invited to seats on the platform.

The report of the executive committee was presented, with



certain amendments to the constitution. The report mentioned that the liabilities of the association exceeded the assets by about \$5,000, and it was thought advisable to raise the amount by subscription among the members. A list was started and the amount soon raised. The new constitution as amended did not provide for the admission of "supply men," and after a warm discussion it was decided to adhere to the present plan of limiting membership to street railway companies.

In the afternoon an adjournment was made to attend a reception given by the governors of McGill College, in the Engineering building, where Prof. Bovey and his staff of professors in the various departments of engineering gave the visitors an interesting exhibition of tests and experiments, which were much enjoyed. After the tests were made the visitors were shown through the departments devoted to electricity, hydraulics, steam and gas engines, wood and iron turning, iron and brass founding, blacksmithing, draughting rooms, cement testing, and the timber and metal testing laboratories. After an address of warm welcome from Prof. Bovey, the visitors were taken upstairs, where an ample spread of refreshments awaited them.

On Thursday morning the president announced the following committees:—

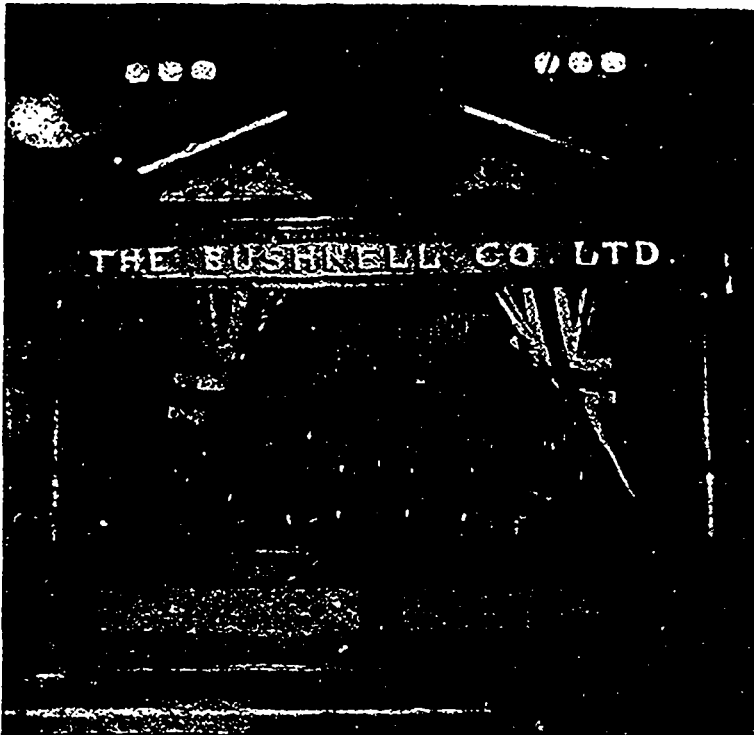

BUSHNELL CO.'S EXHIBIT OF OILS.

*On Ways and Means*—R. B. Harrison, H. M. Littell, T. H. McLain, W. Y. Soper (Ottawa), H. M. Watson, Charles Odell, Charles Green, E. C. Goodrich, T. C. Pennington and John N. Akarman

*On Nominations*—C. D. Wyman, Milwaukee; Charles S. Serant, Boston; John B. McClary, Birmingham; W. J. Thompson, Camden; Edward Lusher, Montreal; John A. Seely, New York; Henry Scullin, St. Louis.

W. J. Hammer, chairman of the Committee on Standard Rules for Electrical Construction and Operation of the Nat. Elec. Light Association, was permitted to present a resolution of that body advocating the formation of a joint committee representing various scientific bodies, and having in view the general adoption of a common code of rules. It was decided to appoint a delegate to this joint committee.

A paper was read by W. L. Brown, of Atlanta, Ga., on "Ties and Poles." He thought six years was the longest that could be expected of pine ties, and eight years of oak ties. Ties in poorly drained roads decay more rapidly than in a well ballasted and drained track. The metal tie, which some engineers strongly advocate, must be well imbedded in concrete, and if it is granted that a concrete foundation is necessary in any really good track, the use of metal may bespeak good judgment. In New Orleans, good results have been obtained with red cypress, under horse tracks, and this is said to have been found sound after twenty-eight years service. White cypress is worthless, but red and black cypress are durable. Timber preservatives such as "brunettizing," or treatment with chloride of zinc, are advisable in dry localities, but not

in wet, for the following reasons; the chloride is easily washed out; leakage currents from the rails may destroy it, and it rusts the nails and spikes. Creosoting is not open to these objections. For a long time the standard size of ties was 6x8 in. by 8 ft. long, but the company with which the writer was associated changed these to ties 5x9 in. by 7 feet long, with good results. As to poles, red cedar has been almost universally used, though in crowded cities iron set in concrete is also used. He estimates the life of cedar poles with large hearts at about 12 years. Some last 20 years, but the life of the pole is limited practically to the life of the sap, as the heart itself is too weak for the service under tension. Properly creosoted pine poles, 30 ft. long and 8 in. diameter at the top, should be superior to any poles on the market, and should cost in the States, when treated with 10 lbs. of creosote per cubic foot, not more than \$5 each, erected. The reason they are not used by the telegraph companies is that being chiefly along the railways and not protected against fire, a creosoted pole being inflammable, would not pay.

The committee on patents, after referring to the trouble companies have over patent law suits, recommended that a bureau similar to that of the Western and Eastern Railway Associations be formed to deal with all patent questions.

It was decided that the next convention should be held at St. Louis.

The officers for the ensuing year were then elected as follows: President, H. M. Littell, vice-president and general manager of Atlantic Avenue Railway, Brooklyn, N.Y.; vice-president, G. C. Cunningham, Montreal Street Railway; second vice-president, Gen. William H. Jackson, president Nashville Street Railway, Nashville, Tenn.; third vice-president, J. W. Morgan, president Camden, Gloucester & Woodbury Railway Company, Camden, N.J.; secretary and treasurer, T. C. Pennington, secretary Chicago City Railway Company; executive committee, Joel Hurt, president Atlanta Construction Railway Company, Atlanta, Ga.; Prentiss Cummings, vice-president West End Street Railway Company, Boston, Mass.; C. G. Goodrich, vice-president, secretary Twin City Railway Company, St. Paul, Minn.; A. Markle, general manager Lehigh Traction Company, Hazleton, Pa.; W. F. Kelly, general manager Columbus Street Railway Company, Columbus, Ohio.

The committee appointed to report on the question of using salt and sand to keep tracks clear in winter, reported as follows:

The use of salt on the rails at certain times and during certain conditions of weather is absolutely necessary in order to clear the rails of a film of ice that will otherwise form on them. Without the use of salt, it would be very unsafe to operate cars on a hilly system during winter, and your committee is of opinion that no road can afford to dispense with its

use. Salt has been used on street railways throughout the United States constantly while horse cars were in vogue, and now more than before is its use imperative in the operation of electric cars. In like manner, sand is a necessity on the rails in order to give the wheel a "proper grip" on the track. In St. Louis, Mo., the quantities of salt dumped on the tracks is in excess of three thousand tons in the course of one winter. There is no objection on the part of the local authorities or health board, to its use, and but for the use of this salt, it would be impossible to operate our cars. The use of sand is also absolutely necessary, and its use is not interfered with in any manner, any more than is the use of salt.

On Friday the topic of "Furnishing Free Music and other Entertainments" was taken up. Mr. McLean, of Indianapolis, said his company owned the only large park in the city, and found it profitable to give entertainments there in the summer, particularly band concerts. No accidents had occurred. Mr. McClary, of Birmingham, said his company had a park of 100 acres, with a lake, and walks and drives, and every week night there is music, while on Sundays there is a sacred concert. It was found profitable.

J. F. McElroy presented a paper on electric heaters for cars, with diagrams showing that the electric heater is a more efficient one than stoves, being set lower and diffusing its heat more evenly through the car.

The banquet was held at the Windsor Hotel, the association's headquarters, on the evening of the 17th, and though it was very largely attended and the speeches were good, the dinner itself and the decorations were not in the style for which the Windsor is reputed among American guests.

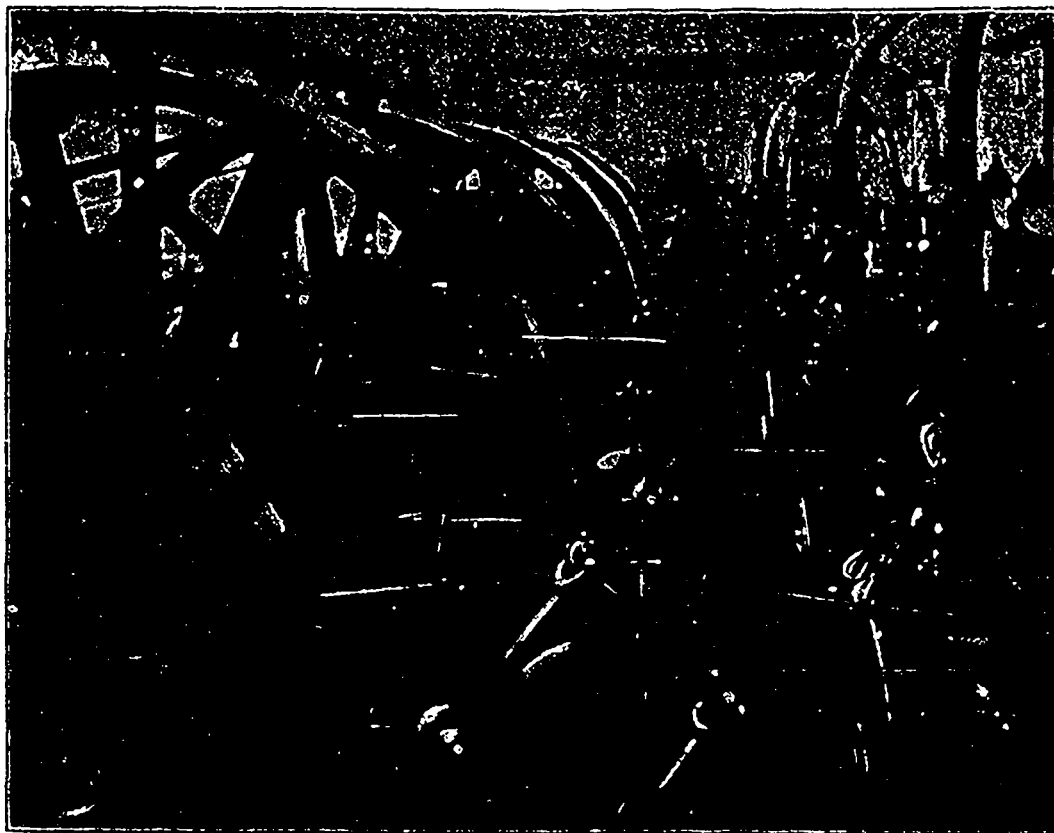

MONTREAL POWER HOUSE—VIEW OF ENGINES BUILT BY LAURIE ENGINE CO.

The exhibition of appliances for street railways and railway equipments was held in the Victoria Skating Rink, which was filled with exhibits, and had large crowds each day. The rink was decorated with the banners of both nations, and in the evening a band was in attendance. We regret that want of space prevents a detailed notice of the exhibits, but among the patrons of THE CANADIAN ENGINEER, in addition to the fine exhibits of the Babcock & Wilcox Co.'s boilers, the Goubert Mfg. Co.'s steam separators, and the Bushnell Co.'s oils, illustrated in this report, our reporter noted the following. Darling Bros., Montreal, Webster feed water heater; James Morrison Brass Manufacturing Co., of Toronto, valves, brass mountings, and trolley fittings, etc.; the St. Lawrence Machinery Supply Co., oils, metallic and other engine packings, boiler coverings, etc.; J. C. McLaren Belting Co., leather belting, the E. T. Burrowes Co. of Portland, Me., car window shades, the Heine Safety Boiler Co. (Geo. Brush, Montreal, agent in Canada), and others. It may here be mentioned that Mr. Peckham, of the Peckham Motor Truck Co., presented a handsome model of his street car motor truck to the engineering department of McGill College.

American friends. No official of either road was wanting in his duty. Stonewall Jackson, as local secretary, had heavy duty to perform, and did it with ability, while M. H. Watts, Mr. Cunningham's secretary, who received the guests and attended to their wants at the headquarters' office, acquitted himself in such a manner as to win the appreciation of all. His work was more exacting than that of any individual at the convention, but his systematic methods and unflinching courtesy carried him through admirably.

Saturday, the last day of the convention, was entirely devoted to sight seeing, the principal events being a fox hunt under the auspices of the Montreal Hunt Club and an excursion to Ottawa. For the latter the visitors were indebted to the munificence and hospitality of James Ross, vice-president of the Montreal Street Railway Co., who at his own expense provided a special train of nine parlor cars to Ottawa and back, with refreshments both ways, and best of all, a splendid luncheon at the Russell House, Ottawa. The excursionists numbered 195, and including Ottawa guests, 250 sat down to the excellently served lunch at the Russell. On behalf of the Ottawa Electric Railway Co., Thos. Abearn and W. Y. Soper thoughtfully provided a train of electric cars and met the



TRAIN OF CARS AT ROCKLIFFE PARK—AM. ST. RY. ASS'N EXCURSION TO OTTAWA.

Great praise should be given to the officials of the Montreal Street Railway Co. and the Montreal Park and Island Ry. Co. for courtesies and attentions they showed to the delegates and visitors. Mr. Cunningham, as one of the officers of the association, and as representing the M.S.R. Co., was everywhere and at everyone's service; while Mr. Corriveau (of the M.P. & I. Ry.), whose enthusiasm and energy in the electrical exhibition of years ago in Montreal was remembered by many, was warmly received among his

party at the station, whence they were conveyed over the city. At Rockcliffe Park, the photograph shown in the accompanying engraving was taken by John Taylor, of the Taylor Truck Co., whose trucks are used on this admirably equipped line. When the party reached the Parliament buildings, they were met in the Senate chamber by the Premier, who gave them a short but hearty address of welcome, which was highly appreciated.

Mr. Ross, who provided this princely treat, was himself absent

in the North-West, but Mrs. Ross attended the party with a number of ladies, and when the train reached the station in Montreal, three rousing cheers were given for her and her husband.

### SOME NOTES ON THE CONSOLIDATION OF TWO SYSTEMS OF ELECTRIC SUPPLY.\*

BY A. A. DION, M.A.I.E.E.

1. The march of electrical progress has been so rapid within the last few years, such marked advances have been made in the methods of supply and distribution of electrical energy for light and power, that central stations, which six or seven years ago were looked upon as the embodiment of the best and latest practice, are already handicapped in the race for wealth, in view of the many improvements which have been made since that time.

2. The constant and rapid increase in the use of electricity in cities has correspondingly increased the difficulties of distribution at constant potential, and new systems have had to be devised to meet the new conditions. Electric supply companies, whose stations were equipped when distribution at one thousand volts seemed like tempting providence, and small generator units were the rule rather than the exception, now find it impossible to adopt more economical systems of distribution without undue sacrifice of apparatus, and must confine their efforts towards the improvement of their services to changes within the limits of existing pressures.

3. The amalgamation of rival electrical interests, which is not infrequent in these times, brings up another and more difficult problem, that of consolidating various and oftentimes conflicting elements to form a single and uniform system. To do this without throwing any apparatus out of service was the task that the writer was lately called upon to undertake.

4. He does not claim originality for any of the features of the plan adopted, but simply states how it was done, in a particular case, believing that in furnishing each other information regarding work done in our respective fields of action, we best carry out the objects of this association, and he trusts that some of the members may be benefited by the discussion which this paper may bring out, if not by the paper itself.

5. The amalgamation above referred to comprised three electric light companies, namely, "The Ottawa Electric Light Company," "The Chaudiere Electric Light and Power Company," and "The Standard Electric Company of Ottawa."

#### THE OTTAWA ELECTRIC LIGHT COMPANY.

6. This was the oldest company, it having commenced business in 1887, and its operations were confined to arc lighting. It owned a substantial stone power house. The motive power was water, and was transmitted through four vertical turbines operating under a head of sixteen feet. The electrical equipment consisted of eighteen T. H. ten ampere generators manufactured by the Royal Co., of Montreal, supplying 325 lights for lighting the streets of the city and 95 lights for private lighting. This company also owned a small workshop for armature and arc lamp repairs.

#### THE CHAUDIERE ELECTRIC LIGHT AND POWER COMPANY.

7. This company was the next in point of age, it having commenced business in 1887. Its business was confined to incandescent lighting and supplying power for motors. Its first plant was a multiple series system, using the well-known U.S. double magnet generators of 25 amperes and 550 volts. The lighting was limited to stores and other public places; five lights were run in series. Each light pendant consisted of two lamps, one above the other. The lower lamp alone normally burned. When, however, it burned out, an electro-magnetic device, contained in the socket, instantly brought the upper lamp in circuit, thereby preserving the continuity thereof.

8. These machines were replaced in 1889 by the Alternating Current Converter system, but were used later for other purposes. The first installation of the latter system consisted of two Westinghouse smooth core alternators of 750 lights capacity each, that were separately excited by small machines of the U.S. type. At the time of amalgamation this company had installed 27,000 incandescent lights and 42 500-volt motors ranging from one and one-half to 20 h. p. and aggregating 320 h. p.

9. This company occupied three power houses, which, for the purpose of this paper, we will designate as *a*, *b*, and *c*.

10. *a* was the original power house, and was operated by water. It contained eight 750 light Westinghouse alternators separately excited. From this station eleven pairs of lighting feeders ran to

various parts of the city. The switchboard was equipped with indicating instruments of the Westinghouse pendulum type—one ampere meter for each pair of feeders and one voltmeter for each alternator—Westinghouse compensators, Wurtz non-arcing lightning arresters, and a large number of double-throw switches, by means of which the feeders and generators were made interchangeable. Some of the longer circuits were supplied with regulators or "boosters."

11. *b* was the next power house to be occupied. It was also a water power station, and was built when the daily loads outgrew the capacity of *a*. The electrical equipment of *b* consisted of a 1,500-light Westinghouse alternator with smooth core armature and a 120 K. W. alternator with toothed core armature, both separately excited, and a 75 K. W. 500-volt U.S. direct current generator of the upright type. The alternators were separately connected by wires to the switchboard in station *a*; some four hundred feet away, and the D. C. generator supplied the motor circuits, two in number, which ran from this station.

12. *c* was a steam power station which had been built in 1893 as an auxiliary, made necessary on account of periodical diminution of the water power through anchor ice and other causes. No place could be found for the steam plant on the premises of the other stations, therefore it had to be erected some distance away on a water course where an abundant supply of water was available for condensing purposes. Additional electrical equipment had therefore to be provided for this station. The building was a one-story brick structure with stone foundation 85 feet by 130 feet. It contained six return tube boilers 14 feet by 60 inches, and a pair of tandem compound condensing engines, rated at six hundred horse-power each. These engines were belted through clutch pulleys to a six-inch shaft running through the building. Two Westinghouse alternators of 240 K. W. capacity, each with toothed armatures, were belted to the shaft, also through clutch pulleys. They were separately connected by wires to the switchboard in station *a*, some two thousand feet distant. In this case pressure wires were run back from the switchboard to the voltmeter in the steam station. Floor and shaft space and stone piers were provided for additional generators.

13. The alternators of this company were run at about 1,100 volts, except those in the steam station, which, owing to their distance from the switchboard, etc., were run at nearly 1,200 volts, when fully loaded, that being their rated capacity. The frequency in every case was about 133 cycles per second. Westinghouse converters—1,000/50 volt—were used, mostly small ones, 1,000 to 2,000 watts, and a few 4,000 watts and 5,000 watts. Over three-quarters of the current output was supplied through meters, the Schallenberger being used exclusively. This company also had a small workshop for re-winding armatures and field coils.

#### THE STANDARD ELECTRIC COMPANY OF OTTAWA.

14. This was the junior company, it having commenced business in 1891. It could thus profit by the experience of others, and it had made provision for considerable extensions of the original plant. It occupied a substantial two-story building with a hydraulic plant consisting of four 66-inch turbines operating under a head of twenty-two feet, with shafting, clutch pulleys, etc., which made each turbine capable of running the whole station or any part of it. This station contained six separately excited alternators of the Royal Company's manufacture, i.e., one of 5,000 lights capacity, one of 2,000 lights capacity, and four of 1,500 lights each, and four sixty-horse-power direct current compound wound generators, also manufactured by the Royal Company. The direct current machines were used for the supply of power for motors; two of them were run in series operating a one hundred horse-power 500 volt motor running an entire flour mill day and night. Another was used to supply 33 250-volt motors ranging from 1/2 h. p. to 20 h. p., and aggregating 105 h. p. The other was held in reserve.

The alternators were run at a frequency of about 133 cycles per second. The lighting switchboard was equipped with T. H. measuring instruments and plug panels which made the ten lighting circuits and the six alternators interchangeable. The voltmeters were connected with the centres of distribution by pressure wires, the distribution being made through T. H. and "Royal" transformers—1040/52 volts: 52 volt lamps and T. H. wattmeters were used throughout the system.

15. There were 18,000 incandescent lights installed.

#### CONSOLIDATION.

16. The plans adopted for consolidating these several systems have not all been carried out at this time. The work is being done in a gradual manner in order to cause no commotion among subscribers, but for the purpose of this paper we will assume that

\* A paper read before the Canadian Electrical Association at the Ottawa Convention.

this work has been completed and speak of things as they will be. As a first step towards carrying out the proposed changes, the small work shops above mentioned were merged into a single one in larger and more commodious premises known as the old arc light station, owned by the company and unoccupied at that time. Some additional tools were provided and a foreman competent to superintend any electrical and mechanical work that might be required, was put in charge.

17 For reasons it was deemed advisable to maintain the arc light service as a department entirely separate from the other branches of the business, for instance, the hours of lighting are limited, and the men connected with this service in most cases have no connection with the other departments. No changes were made in this station beyond the addition of a 60-light Westinghouse arc light machine, in order to increase the reserve and decrease the liability of impaired service from burn-outs, etc.

18 Each circuit is usually run independently from two generators, of a capacity of thirty-five and twenty-five lights respectively, in series.

19 Three patrolmen drive through the streets of the city during lighting hours starting up lamps that have gone out and reporting every morning all lamps out, or requiring the attention of the repairer, as well as cases of improper carboning, etc.

20 These patrolmen also answer all fire alarms during lighting hours, and remain on hand at fires in order to cut wires, if necessary, and perform any other duties which may suggest themselves in the interests of the company. The daily reports of these patrolmen are posted in a book kept for that purpose, in which the history of any particular lamp in the service can be read at a glance.

21. In the attempt to consolidate the two systems of incandescent lighting it soon became evident that all the feeders must be concentrated at one power house, in order that one station only need be kept running during daylight, and water power being cheaper than coal, that station which had the largest water wheel equipment was the most suitable for a central station. The Standard Electric Company's large and commodious power house best answered the requirements, and was selected as the central or distributing station, and the alternators in the other stations were connected, each by a pair of wires, to a central switchboard in this station.

22. In the steam station a 500-volt, direct current, compound generator of 250 h. p. was installed as a part of the power system; to take the place of the 500-volt U. S. machine above referred to.

23. The stations *a*, *b* and *c* of the Chaudiere Company, having become sub-stations, a switchboard panel for each generator was provided in every station. This panel is made of marble set into an iron frame. Each panel contains a T. H. voltmeter connected by pressure wires with the switchboard in the central station, a T. H. ampere meter, alternator field rheostat, main combined switch and cutout, and exciter combined switch and cutout. As these cutouts or fuse blocks, that serve at the same time the purposes of a switch, are also used in the central switchboard, they may be described here.

24. They consist of a block of lignum-vitæ hollowed in the centre so as to form a chamber, air tight but for a small aperture in one side. This chamber contains a fuse of aluminum alloy. The terminals are outside this chamber and fully protected. When a fuse blows the sudden expansion of the air contained in the chamber causes a sudden air blast through the aperture, effectually breaking the arc. The terminals extend outward in the form of metallic plugs, which may be inserted in or withdrawn from spring receptacles set in the switchboard. There are no metal parts exposed on the face of these panels, from which there is danger of receiving a shock or getting burned.

25. Each generator in the steam station is excited by a separate machine, but each of the exciters is of sufficient capacity to excite any two of the generators.

26. Even the most approved water-wheel governors are not sufficiently sensitive or rapid in their action to maintain constant wheel speed under large or sudden changes of load, and the speed of water wheels on power service varies to a considerable extent. To prevent wheels racing when a heavy circuit is opened, hand levers were arranged to throw the governor into faster gear with the gate, so as to close it in a few seconds. While this was an excellent feature as a preventive of accidents, a remedy for the more or less continuous variations of voltage in the circuits had to be found, and for this purpose a separate turbine was set up to run dynamos capable of exciting the fields of not only all the direct current generators, but also those of the alternators in this station. The fields will now remain constant, no matter how the speed may vary, and the fluctuations of E.M.F. will be materially reduced.

27. The machines used as exciters are one of the 250-volt D.C. generators (run at 125 volts) for the alternators, and two of the 550-volt U.S. machines before referred to (run on a three-wire system), for the 250 and 500-volt generators.

28. These exciters are also used to directly supply the motor circuits on Sundays when the load is very light, and the motor wheel which has run day and night during the week is shut down.

29. Each D. C. generator is supplied with a double-throw switch, by means of which its fields may be connected either with the separate exciter or with its own armature. Alternators may also be excited by the common exciter or independently, the change being made through the switchboard.

30. Each of the three companies had pole lines in the same districts, in many cases both sides of a street were occupied by them. The number of poles to be maintained was reduced by placing all the wires running on a street on the best pole line and discarding the other. The lighting districts that were occupied by two different systems were divided in two, so that, while the number of feeders was actually reduced by three pairs, the number of distribution centres was doubled and the line loss between them and the converters was correspondingly decreased.

31. The mains running through contiguous districts are made to overlap, so that all public buildings, such as churches, theatres, halls and hotels have their lights divided between at least two separate circuits and converters. This makes it almost impossible, in case of accident, for all the lights to be out at one time.

32. The size of feeder units had been kept down within the capacity of the smallest generator, but it was found advisable to increase the units for the present to 1,000 and 1,500 lights, which seemed to best fit our generator units.

33. Eight circuit feeders were calculated for an ultimate load of 1,500 lights, and ten for 2,000 lights, this left some margin for extensions.

34. This change made it necessary to run the 750-light machines in pairs as a 1,500-light unit.

35. First parallel running was tried, but it was found that the idle currents were considerable at times, and this method of running was abandoned. Two of the generators were then mounted on iron girders set very accurately, so as to approximate a solid iron base, and flanged pulleys were put on the shafts and bolted together. These generators could thus be driven as a single machine. The armatures were connected in multiple. If this arrangement proves satisfactory, from a mechanical point of view, the other generators in this station will be similarly coupled.

36. It is necessary to the proper working of a lighting and power service, that the losses in the different parts of each circuit should be predetermined and unchangeable. In order to better obtain this result a series of official wiring tables were issued by the company, covering interior wiring services, mains, feeders, etc., together with such printed directions as would secure uniformity in the manner of using the tables, a thing much to be desired but not always obtained. The losses to be 10 per cent. in feeders, 2 per cent. in mains, 1 per cent. in services and 2 per cent. inside buildings calculated.

37. It was also necessary for the convenient working of the lighting system that a uniform voltage should be maintained on all mains, and 1,040 volts was decided upon; it was also decided, however, that 50 volt lamps would be used, experience having taught us that lamps of medium efficiency when run by water power gave the best results for customers and company, when burned somewhat above their normal voltage.

38. The public has come to expect a great deal of light from a 16-candle power lamp. If the lamp is good and the efficiency  $3\frac{1}{2}$  watts per candle or lower, it will maintain its candle power for a considerable time when overrun by four per cent.

39. Converters of 100-light capacity have been introduced wherever the business was sufficiently bunched up, displacing the smaller ones which are used in the districts of more scattered lighting. No doubt still larger ones will be used in time.

40. The compensator system of regulation was adopted in preference to the feeder and pressure wire system. We still have the feeders, and the compensators take care of all the losses between the dynamo and the lamp, while the pressure wires lose their usefulness at the distribution point, although the losses between that point and the lamps may be considerable in some cases.

41. Each circuit is provided with at least three non-arc lighting arresters, one at the station, one at the point of distribution and one or more at the distant ends of the mains. These are carefully grounded, the ground wires being riveted to street railway rails whenever possible.

42. A Bristol recording voltmeter, set up in a case convenient for carrying about, is used to adjust the compensators. The volt-

meter is left at some point of the circuit to be adjusted, for twenty-four hours. This is repeated at different points of the same circuit. The adjustments should be checked once a month.

43. The main switchboard situated in the central station consists of thirty four marble panels set side by side in a framework of angle steel fastened to the stonework of the building. This frame stands at least six feet from the wall, and is supported by soft rubber discs set into iron rings fastened to the floor. These discs have the effect of taking up the vibrations of the floor, and prevent their being communicated to the instruments above. The switchboard is 57 feet long and nine feet in height.

44. There are eight dynamo panels similar to those in the other stations and already described, six for the alternators in this building, and two spare ones.

45. Five motor panels that contain Weston illuminated di-voltmeter, Weston edgewise ampere meters, Westinghouse circuit breakers, ground detector, and jaw switches, through which all the motor circuits and D. C. generators are interchangeable.

46. The twenty feeder panels contain Westinghouse pendulum voltmeters, ampere meters and compensators, throw-over switches, and panels for plug and cable connection with twelve pairs of bus bars and combination switches and fuse blocks, as already described.

47. These twenty panels are divided into two sections of ten, between which a special panel is set up, containing a clock, a ground detector and switch, and other special devices.

48. Directly in front of each section of feeder panels and four feet away from them, stands a table made up of an iron frame work with sides of wire netting and plate glass top set in a polished brass frame. Each of these tables contains ten regulators or "boosters," with a range of 20 per cent. up or down. Each circuit can thus be regulated independently.

49. The attendant at this switchboard controls the whole system. He is also in communication with the attendants at substations and the station superintendent's residence by a private telephone line.

50. For economy in line construction it was decided not to extend the 250-volt motor system except for units of one h. p. or less, and to merge it and the 500-volt service into one single three-wire distribution. The 100 h. p. motor in the flour mill is, however, on a separate circuit, and may, if desired, be run independently of the others. The three wire system is supplied by two of the 250-volt 60 h. p. generators in series, and the 500-volt 250 h. p. generator connected to the + and - wires. The brushes of the 250-volt machines on the + side and the + brush of the 500-volt machine, may be connected together for equalizing purposes. All the D. C. generators are interchangeable through the switchboard.

51. It was found necessary to almost completely reconstruct the motor circuits. Four pairs of +0000 feeders were strung up. As the joints in wire of that size are extremely unsightly a portable welder was constructed for welding the lengths of wire together. A large regulator core was fitted with a primary coil of 368 turns, and a secondary coil of a single turn made up of 12 No. 0000 wires upon the ends of which massive metal jaws were shrunk. These jaws normally stand about four inches apart, but may be pressed closer together by an insulating clamp and screw, the elasticity of the secondary coil causing the jaws to resume their normal position when released. The current is regulated by a T H reactive coil. This apparatus may be attached to any converter on the line as required.

52. Several of the T S dynamos in use for lighting up to 188y have been put in service as motors, two of them running elevators very successfully.

53. The company has lately made what is believed to be an innovation in providing in its office, which is open day and night, a locker with a glass front in which are displayed rubber coats, gloves and shoes. This in addition to the rubber gloves regularly supplied to the linemen. The key of this locker hangs within a little box behind a glass which is to be broken, in case of accident, by anyone requiring the clothing.

### THE BALL NOZZLE "MYSTERY."

Editor CANADIAN ENGINEER:

A correspondent of the *Scientific American*, on the ball nozzle mystery, in last number, page 218, Oct. 5, is right, and the editor wrong. Why does the editor of that paper persist in ignoring my true explanation of the so-called mystery as published in your May (I believe) number last?

C. BAILLAIRGE.

City Engineer's office, Quebec, 1st Nov., 1895.

### USES OF PLUMBAGO.

The use of plumbago in mechanics continues to develop. Originally used for crucible manufacture and as a dry finish or polish its use later led to a marked advance in our wheel grease. Eventually it found its way into the iron foundries as a facing powder next the self lubricating journals marked it a true friend and economiser. Now we have it brought before us as a rust preventer and general preserver of iron surfaces, in which capacity the discussions in the American Painters' Associations show that it far exceeds red lead and iron oxide. Not only does it give a smooth finish fit for a yacht bottom, and slips on with very little brushing effort, but being an inert substance, it is quite unaffected by heat or frost, rain or shine, acid or alkali. It has besides the essential advantage of being cheap.

Its uses are not yet exhausted. Why, for example, should it not be more generally used in packing, if all that is here claimed for it is confirmed, and so far it has never failed. The 'Diamond Graphite' is indigenous to Eastern Canada and is already making its way for extensive use in England and the United States. It is recommended in our advertising columns under the name of 'Diamond Graphite' by the Canada Paint Company, who have introduced it into active service in the engineering world for a variety of purposes.

### METAL TRADE REVIEW.

OCTOBER 31, 1895.

Since last month prices in the metal markets have stiffened up considerably, and there is good prospect of a further advance. Prices are now better than they have been for over a year, and as the advance has been indicated for several months, there is every prospect of a continuance of the present firmness. Notwithstanding the stiffness in prices, the volume of business done in the Dominion during the last month has been small; the same may be said of the United States. This probably indicates that the present boom in South Africa is attracting a great output of goods to that country. Current prices are as follows. Summerlee, \$20 to 20.50; Eglinton, \$18.50; America, \$17.50 to 18; Carnbroe, \$18.50; Ferrona, \$16.50 to 17; Siemens, No. 1, \$16.50 to 17; wrought scrap, No. 1, \$14.50 to 16; bar iron, \$1.60 to 1.65; tin plate cokes, \$2.90; I. C. charcoal, \$3.25 to 3.71; Canada plates, \$2.10 to 2.25;terne plates, \$5.75 to 6. galvanized iron, 4 to 5c., according to brand, Orford copper, 12½ to 13c.; ingot tin, 16 to 16½c.; lead, \$3.15 to 3.25; spelter, \$4.25. sheet zinc, \$4.50; cut nails, \$2.50, black sheets up to 16 gauge, \$2.30; 17 to 24 gauge, \$2.20; 26 gauge, \$2.30; 28 gauge, \$2.40.

### THE GRIP SOCKET CASE.

Editor CANADIAN ENGINEER:

SIR,—We take pleasure in announcing to our customers, and the trade in general, that letters patent have been issued to us on our grip socket under date of October 15th, 1895. We have defended our right to this patent against the most persistent efforts of another party, who set up an interference, claiming priority of invention, and threatening our customers and ourselves with infringement suits. We have received judgments in our favor in every court of appeal, and the final issuing of the patent to us settles the question of our right to manufacture and sell these grip sockets without let or hindrance, and we stand ready, regardless of expense, to defend our rights to the fullest extent of the law.

CLEVELAND TWIST DRILL Co.,  
Cleveland, O.

### CANADIAN SOCIETY OF CIVIL ENGINEERS.

The first meeting of the above society, since the vacation, was held in their hall on the 10th of October, President T. Monro in the chair. There was a fair attendance. A number of applications for membership were considered, and a committee was appointed to select and report on special themes and subjects for discussion and consideration by the members during the coming winter meetings. A paper by J. G. G. Kerry, A.M., entitled, "Some open questions on the minor problems of railroad building," was read. Another meeting of the society was held on the 24th, President T. Monro in the chair. After the minutes had been read the chairman announced that Mr. Kerry's paper, read at the previous meeting, would be discussed. The paper was dissected item by item, and much praise was accorded Mr. Kerry for the thorough manner in which the details of the paper were explained. The paper was vigorously discussed, the following gentlemen taking part: Prof. Cecil Smith, Messrs. Sproule, Kerry and the chairman.

## THE M. T. DAVIDSON STEAM PUMP.

The Davidson Steam Pump is a direct double-acting pump, with single steam end, simple or compound. It is built with a view to simplicity and durability. Its action is regular, and having no dead point, it is absolutely positive, starting from any point, and running full stroke under all conditions. It will pump any fluid, giving a steady and uniform delivery at very slow or high piston speeds. The makers claim that it is the most efficient and economical steam pump made.

The distinctive feature of the steam end of this pump is, that unlike other direct-acting steam pumps, the valve gear consists of only one valve, which is actuated by a positive mechanical connection with the main piston rod of the pump, being assisted in its movements by steam. The accompanying cut represents the valve gear in detail. It consists of the cylindrical steam chest *M*, which is bored out to make a face for the valve *A*, and the piston *B* and *B'*, that assists in operating the valve. The pistons are connected, sufficient space being allowed between them for the valve and steam ports. They are also attached to the slide-valve, all working in the same plane and being of the same diameter, insuring evenness of wear and readiness of access for adjustment, repairs, etc. An examination of the valve will at once suggest the impossibility

exhaust, and secondly, to bring the valve to its closure (mechanically) slightly before the end of the stroke of main piston, thereby causing slight cut-off and compression, next fully opening auxiliary port *e* to steam, and *e'* to exhaust. The admission of steam to one end of valve piston, and the other being open to exhaust, throws the valve in direction shown by arrow, admitting and exhausting steam to and from cylinder for the return stroke.

The main valve being as much under control of the piston rod as is the valve of an ordinary steam engine worked by an eccentric, instead of being independently controlled by an auxiliary valve, secures a positive acting pump, capable of starting from any position, and maintaining a uniform and full stroke.

The pistons are absolutely prevented from striking the cylinder heads by virtue of the mechanical valve closure. This is one of the most important features of the pump.

The water cylinder is of new design. It is beyond question the simplest made; it has but one joint to blow out, and that is in plain sight. The pump is readily inspected, as the water valves and whole inside can be examined by the removal of one plate or bonnet, without breaking any connections of suction and discharge pipes. Each suction and delivery valve is held in place by one valve stem. The pump can be taken apart and put together again in a few minutes. The steam and water cylinders are rigidly con-

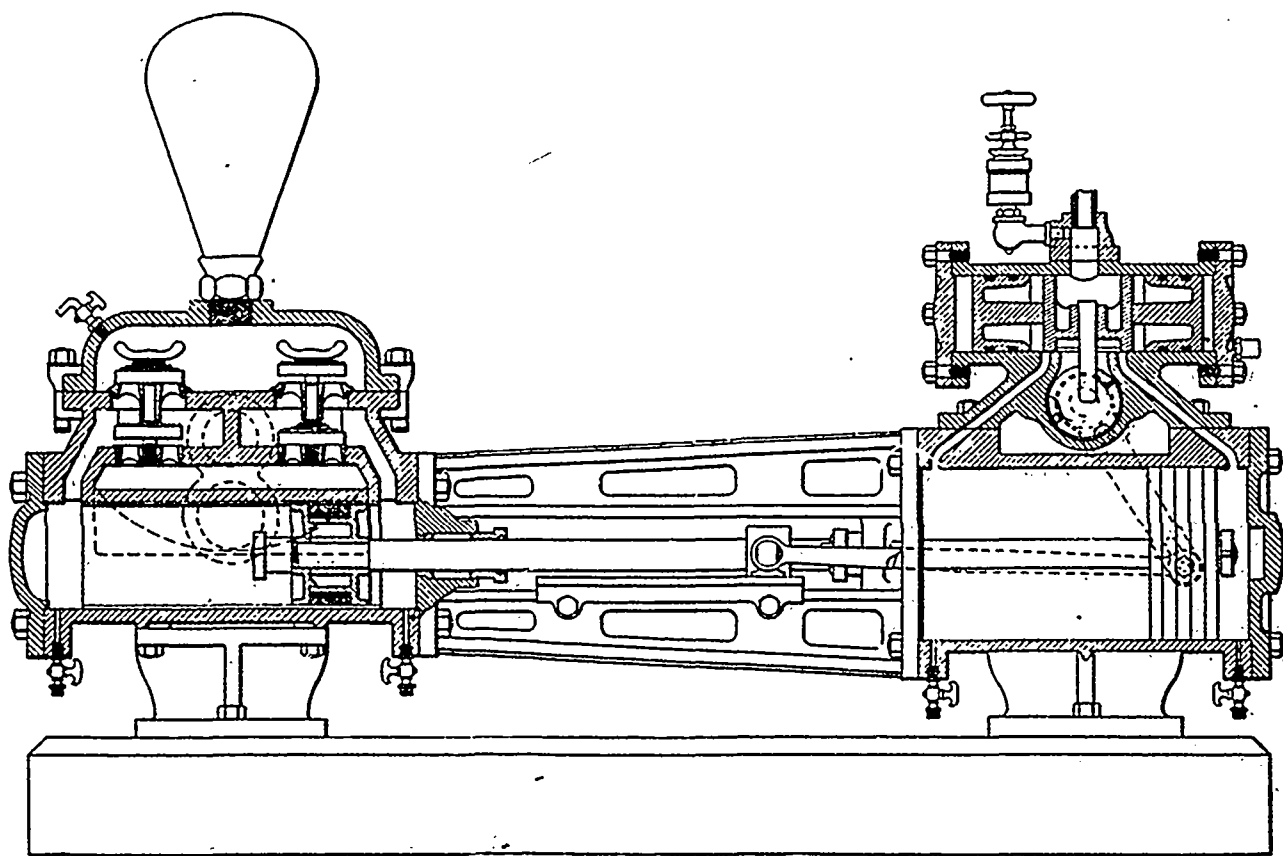

THE M. T. DAVIDSON STEAM PUMP.

of its getting out of order, becoming deranged, or wearing out within the life of any other portion of the pump. The valve is controlled and operated by cam *C* acting on steel-pin *D*, passing through the valve into exhaust port, in which the cam is located. In addition to this mechanical operation, steam is alternately admitted and exhausted to and from the steam chest by ports *e* and *e'*, assisting the movements of the valve by steam actuating the valve pistons *B* and *B'*. When pump is at rest, with valve completely covering main steam ports *f* and *f'*, the cam holds the valve so that steam will be admitted to one end of chest and exhausted from opposite end, by ports *e* and *e'*, throwing the valve and opening main ports *f* and *f'*, admitting steam to and exhausting from steam cylinder. If valve occupies any other position, one of the main steam ports will be open to steam, and the other to the exhaust, insuring the direct supply of steam to one end of cylinder and the rapid release of exhaust steam from other end. It is consequently very evident that the pump must start from any position.

When one of the main steam ports, as *f*, is completely open, admitting steam to cylinder driving main piston, cam and valve in directions shown by arrows, the first movement of the cam will be to oscillate the valve preparatory to bringing it in proper position for the opening of the auxiliary steam port *e*, to live steam, and *e'* to

nected by a substantial frame, designated the intermediate. The intermediate carries a slide for cross-head, preventing vibrations and keeping pump in line. The stuffing boxes of the steam and water cylinders are secured to the heads of the intermediate. They are in plain sight and accessible for adjustment.

The Davidson Steam Pump runs full stroke against the maximum working pressure, and being provided with tightly packed pistons, avoids loss by piston-leakage, and insures a discharge equal to the piston displacement, at its highest speed and greatest pressure. The valve and port areas being very large, allow of the high speeds obtainable by the steam end, securing the greatest pumping capacity with the best economy. The following guarantee is given to purchasers:

"In all cases where I am correctly advised (before shipment) as to the requirements—and possible contingencies—of pumps, I will guarantee satisfaction, or refund the amount of purchase money.

"M. T. DAVIDSON."

The St. Lawrence Machinery Supply Co., Naud, Valiquet & Hunt, of Montreal, have been appointed sales agents for the Davidson pumps in Canada. Their address is 361 a, St. James street, Montreal.

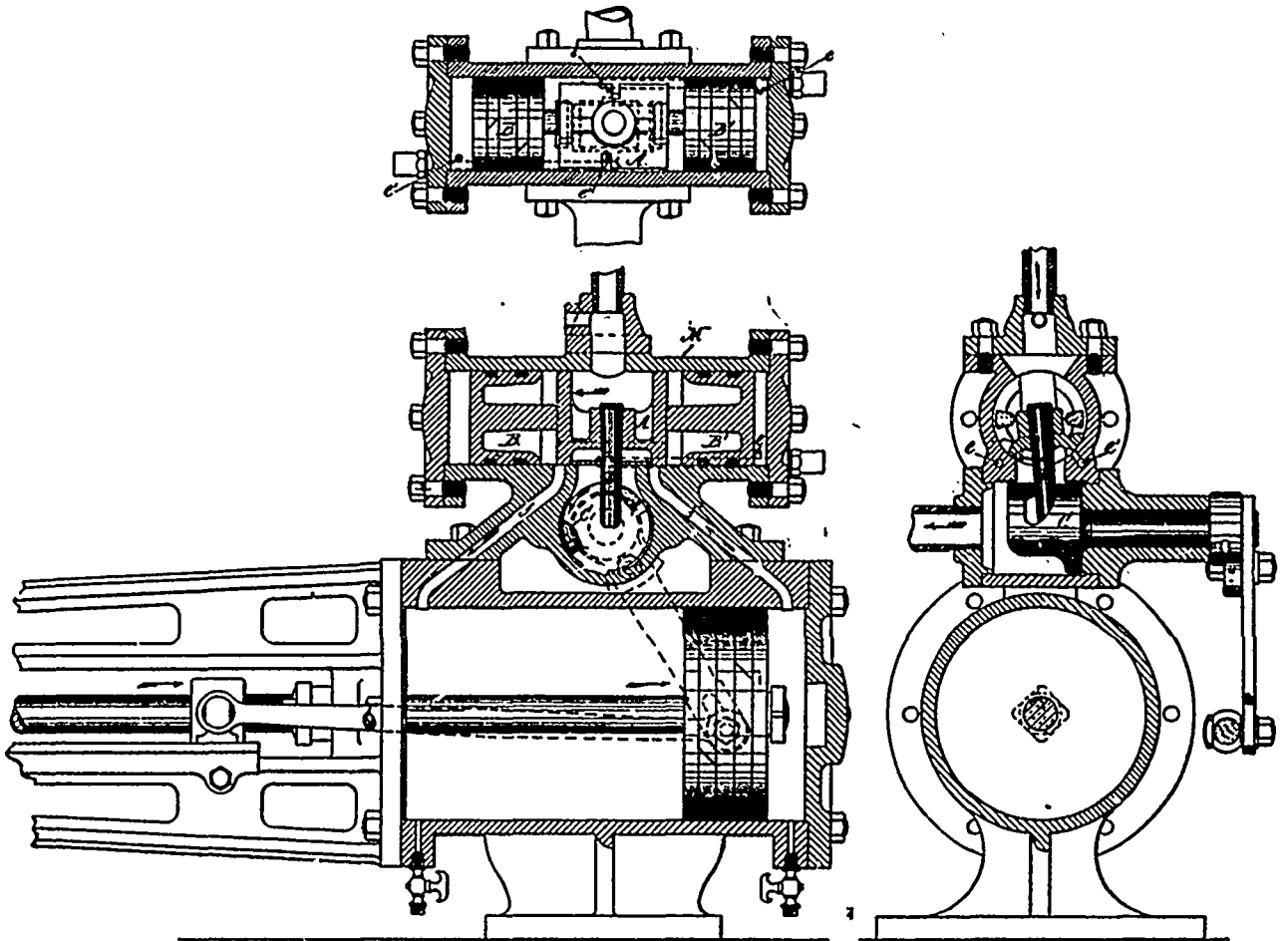

THE M. T. DAVIDSON STEAM PUMP VALVE GEAR.

## CONSTITUTION OF EXECUTIVE COUNCIL C.A.S.E.

AS AMENDED AT THE OTTAWA CONVENTION, 1895.

### ARTICLE I.

SEC. 1.—This Association shall be known as the EXECUTIVE COUNCIL OF THE CANADIAN ASSOCIATION STATIONARY ENGINEERS and shall have supreme control of the business of the Order.

SEC. 2.—The objects of the Executive Council shall be to provide for the formation of Associations under the Charter of the C.A.S.E., and to enact laws for the governing of the same, to assist in the education and elevation of the Stationary Engineer, and by all legitimate means to further their interests.

### ARTICLE II.

SEC. 1.—This Executive Council shall have full supervision over all Associations of the C.A.S.E., and shall have sole power to amend or appeal any part or parts of this Constitution, as also of that governing the C.A.S.E. Associations; it shall be the guardian of all signs, symbols and pass-words, the source of legislation and the final arbiter of all matters in dispute. No change shall be made in any of the signs, symbols or pass-words without its authority. And all By-Laws of the C.A.S.E. Associations must be forwarded to the Secretary, and receive the approval of the President before being passed.

### ARTICLE III.

SEC. 1.—The Executive Council shall be composed of duly accredited representatives from all Associations of the C.A.S.E., and officers elected by such representatives in Convention assembled.

### ARTICLE IV.

SEC. 1.—The officers shall consist of a Past-President, President, Vice-President, Secretary, Treasurer, Conductor and Door Keeper, who shall hold office for one year, or until a successor has been lawfully elected and installed.

### ARTICLE V.

SEC. 1.—The nominations and election of officers shall be made in open convention and a majority of all votes cast will elect; the officers shall be installed as soon after as the convention will direct.

### ARTICLE VI.

SEC. 1.—Each Association shall be entitled to one delegate for each twenty-five members in good standing, or fractional part thereof: Provided, however, that ten or more be that fraction, and that one duly authorized delegate's expenses from each Association be paid by the Executive; all other delegates' expenses are to be paid by the Subordinate Association sending such representatives.

SEC. 2.—Each delegate must be an active member of the Association he represents.

SEC. 3.—All Executive officers, including the District Deputy and representatives, shall receive five cents per mile one way by the most direct route, and two dollars per diem, to be paid by the Executive.

### ARTICLE VII.

SEC. 1.—The revenue of this Executive Council shall be from a per capita tax levied on each member of the C.A.S.E. in good standing, and from the sale of stationery supplies, and fees from the certificates of membership.

SEC. 2.—All Associations shall pay with each semi-annual report, in July and December in each year, 25c. per member reported in good standing on the books, and no Association shall receive the pass word until the Secretary receives their report and per capita tax.

SEC. 3.—The fiscal year shall end the 30th June of each year for the settlement of all accounts from the Subordinate Associations to the Executive Council.

SEC. 4.—All Subordinate Associations neglecting to report and forward per capita tax for the period of six months, shall be suspended, and if a settlement is not made at the expiration of twelve months, their charter, cash and outfit shall be forfeited.

SEC. 5.—Before any changing, revising or altering of this Constitution can take place, there must be presented in writing at the first session of the Convention a notice of such change.

SEC. 6.—This Constitution can only be altered or amended by representatives in Convention and two-thirds of all votes cast in favor. The adoption of this Constitution shall repeal all previous Constitutions.

### ARTICLE VIII.

SEC. 1.—A Board of Arbitration, to consist of the Past-President, Vice-President and Conductor, to whom shall be referred all appeals from the decision of the President.

### ARTICLE IX.

SEC. 1.—The duties of the President shall be to preside at all meetings of the Convention assembled, to sign all charters and issue a semi-annual password. He shall decide all questions of law as laid down by this Constitution, appoint all deputies, not to exceed four for each province, and perform such other duties as the Convention may direct.

SEC. 2.—The Vice-President shall aid the President in the discharge of his duties; take the chair in his absence, and perform such other duties as the Convention may direct.

SEC. 3.—The Secretary shall keep the minutes of all meetings and all other records and books of this Council, receive all moneys and pay the same over to the Treasurer, taking his receipts therefor. He shall render semi-annual reports to the Treasurer of all moneys and vouchers received, and make out a statement of the number of members in good standing reported, also a list of all expulsions, removals and deaths, with the causes thereof, and the reports of all arbitrations. His books and accounts shall be open at all times for inspection by the Executive Officers and Auditors; and he shall, when requested to do so by the Board of Arbitration, give bonds in the sum of \$ . . . ., subject to the approval of the board, and for the performance of his duties he shall be paid the sum of \$ . . . . . per annum.

SEC. 4.—The Treasurer shall receive all moneys from the Secretary, pay all orders signed by the President and countersigned and sealed by the Secretary. He shall have his books open for inspection by the Executive Officers and Auditors at any time. He shall submit to the President an annual statement showing the business and state of the treasury. He shall, when requested to do so by the Board of Arbitration, give bonds in the amount of \$ . . . . . and may receive the sum of \$ . . . . . per year for his services.

SEC. 5.—The Conductor shall assist the President in maintaining order, introduce all delegates, and perform such other duties as the President may direct.

SEC. 6.—The Door-keeper shall keep the door, and shall not allow any member to enter or retire during opening, closing or initiatory ceremonies, or while a member is addressing the chair.

#### ARTICLE X.

SEC. 1.—Each Deputy shall act as organizer in his district, and shall be present, if possible, at the organization of all new Associations. He shall assist by all possible means the working and efficiency of all the Associations in his district; each Deputy shall render to the Secretary one month before Convention meets a full report of all the work done in his district.

#### ARTICLE XI.

SEC. 1.—Upon the application of seven or more Stationary Engineers who have not been rejected or expelled from any other Association of the C.A.S.E., and who have received the consent of the nearest Association, the President shall instruct the nearest Deputy to inquire into their character and qualifications, and upon a favorable report the President shall instruct the Secretary to forward to the Deputy the charter and outfit, who will upon the payment of \$15, institute the Association and report the same with a list of the officers.

#### ARTICLE XII.

SEC. 1.—The annual Convention shall be held on the first Tuesday after the 15th of August each year, and shall last for three days, unless it be found necessary to lengthen or shorten the session by one day; this can only be done by motion.

SEC. 2.—The place for holding the next Convention is to be determined by ballot upon the last session of the Convention.

SEC. 3.—The Auditors for the ensuing year, two in number, are to be appointed by the President after the installation.

SEC. 4.—A quorum of the Executive Council shall consist of seven accredited delegates.

#### RULES OF ORDER.

##### BUSINESS.

1. Roll Call of Officers.
2. Appointment of Committee on Credentials.
3. Welcome Addresses.
4. Report of Committee on Credentials.
5. President's Opening Address.
6. Reading Minutes.
7. Secretary and Treasurer's Report.
8. Appointment of Standing Committees.
9. General Business.
10. Reports of Standing Committees.
11. Election and Installation of Officers.
12. Next Place of Meeting.
13. Any member offering a motion shall put it in writing if requested to do so by the Recording Secretary.
14. No question shall be put by the President unless regularly moved and seconded, nor be open for consideration until so put. No other motion shall be receivable unless it be a motion

SEC. 1.—To adjourn.

SEC. 2.—To lie on the table.

SEC. 3.—To put the previous question.

SEC. 4.—To postpone.

SEC. 5.—To refer.

SEC. 6.—To amend; and such motions shall have precedence in the order stated, and Nos. 3, 4 and 5 thereof shall be decided without debate.

15. "Todd's Parliamentary Practice" shall be the governing law of the Association in all cases not provided for by its own rules.

16. The yeas and nays shall be taken on the call of any Brother in Convention.

#### CANADIAN ASSOCIATION OF STATIONARY ENGINEERS.

At the regular meeting of the Montreal Branch of the Canadian Association of Stationary Engineers on October 3, the members were present in good force to hear the report of the delegates to the Convention at Ottawa. The report was read by Past President Ryan and was very complete, giving detailed accounts of every work of the Convention, and also the many kindnesses received at the hands of the mayor and aldermen and the brothers of the Ottawa branch. It was then resolved to tender a hearty vote of thanks to the delegates for their labors, and also to the members of Ottawa No. 7 for the very kind and efficient manner in which they entertained the members from Montreal. President J. J. York then more fully explained the certificate of membership, after which all present expressed a wish to have one as soon as possible. The president also fully explained what was being done in the insurance scheme, the securing of models, the good points in the school of correspondence at Scranton, and also several other points. All of which went to show the members that their delegates, Bros. Ryan, Smith and Valiquet, had done faithful service in the interest of the branch.

At the previous meeting the report of the pic-nic committee was presented. The pic-nic was held solely with the purpose of starting a library of scientific works and books of reference. The report showed the most encouraging balance of \$247 for the benefit of the library, besides which there were several volumes presented to the library by members and friends of the Association.

The Bushnell Co., Ltd., manufacturers of oils, made two donations to the C.A.S.E. in connection with the last convention—one for the benefit of the Ottawa branch, and one for the executive—amounting in all to over \$50.

It is probable that Toronto Branch, C.A.S.E., will soon have a hall of their own, which will be of special advantage in case of committee meetings, as these now have to be held in private houses. Having got their own room, the next forward step of the Toronto Branch will be a library of engineering books.

In the report of the convention of the C.A.S.E. at Ottawa our reporter misconstrued the remarks of Bro. E. Valiquet on the subject of the secession of St. Lawrence No. 2, of Montreal. The "loss of confidence" spoken of by Bro. Valiquet referred not to the leaders of the movement for separation, but to the question of insurance, which was the rock on which the French-Canadian members split. This explanation is due to Bro. Valiquet, who has been a consistent member of both organizations, and who, like most members on both sides, would like to see a reunion of the divided members.

At the regular meeting of Ottawa No. 7, held on the 8th ult., it was decided that at all future meetings of the association the study of arithmetic should be taken up, beginning with the elementary branches and continuing through the several rules. By so doing we are in hopes of infusing new life into the members and of making them all familiar with this branch, which is of such great importance to all progressive engineers, at the same time subjects in practical engineering will be discussed, thus making our meetings interesting. Votes of thanks were passed to the following gentlemen: His Worship Mayor Borthwick and aldermen of the city of Ottawa, Thos. Ahearn, managing director of the Ottawa Electric Street Railway, and the E. B. Eddy Manufacturing Company, through their manager, George Milne, for the generous treatment which our association received from them during the late convention. The business resulting from the convention being held in this city was also wound up, and resulted in every one getting his just dues and all being well pleased.

At the last regular meeting of Ottawa, No. 7, Canadian Association of Stationary Engineers, the following resolutions were adopted: *Whereas* it has pleased the Lord Almighty to remove from our midst our esteemed and worthy Brother, Duncan Robertson, who has been a most active worker in our organization, seeking, as member and as officer, to advance the interests of this association, and the welfare of its members; therefore, be it *Resolved*, That we place on record our appreciation of his services



as a Brother, as an officer of this organization, and of his merits as a man; that we do most sincerely mourn his loss as a Brother, and that we tender our heartfelt sympathy to the widow and family of our departed Brother in this their hour of great sorrow and loss, and as a tribute of our respect for his memory, the charter of this association be draped in mourning for the period of thirty days. *Resolved*, that a copy of these resolutions be entered on the records of this association, also that a copy be presented to the family of the deceased Brother, and to the city papers and engineering journals for publication. Frank Robert, Thomas Wensley, F. G. Johnson, Wm. Hill, F. W. Donaldson, Committee.

After the Ottawa convention a few of the western delegates went down to Montreal for a short holiday, and were about to leave for home when they were captured by members of Montreal No 1, detained over night, and were given an impromptu banquet in the Queen's Hotel P Cowper, mechanical superintendent Canadian Rubber Co., and Capt J. Wright, consulting engineer, also accepted the brief invitations. At the head of the table sat J. J. York, past-president of the executive council, with the jewelled decoration received at Ottawa shining on his breast; on his right were executive president, W. Blackgrove, and secretary E. J. Philip; on his left side were J Devlin vice-president executive council, and T. Ryan, past-president. The many good things provided by the able manager of the Queen's were thoroughly discussed, after which songs and speeches were in order, and among those who brought down the house were W Blackgrove, J H Garth, D A Starr, George Hunt, A E Edkins, A. M Wickens, and J. Fox. The entertainment was brought to a close with the singing of "God Save the Queen" and "Auld Lang Syne," and the western delegates went home loud in the praises of Montreal No 1.

President Blackgrove has appointed Bro. R. C. Pettigrew, Hamilton, to be executive treasurer in succession to the late Bro. Duncan Robertson.

The annual dinner of the Toronto Branch will be held at the Richardson House on the 20th inst.

METAL IMPORTS FROM GREAT BRITAIN.

The following are the values in sterling money of the imports in the undermentioned metals for the month of August, 1894 and 1895, and for the eight months ending August, 1894 and 1895:—

	Month of August		Eight mos. end'g August	
	1894.	1895.	1894.	1895.
Hardware and Cutlery ....	£5,040	£5,916	£45,467	£34,580
Pig iron.....	1,416	2,301	12,886	16,124
Bar, etc.....	2,315	1,173	14,280	8,702
Railroad .....	36,135	31,118	171,196	84,103
Hoops, sheets, etc.....	10,611	8,912	61,439	33,062
Galvanized sheets .....	5,621	6,176	34,004	41,320
Tin plates.....	14,609	9,184	116,558	82,281
Cast, wrought, etc., iron ..	4,864	5,463	45,930	33,360
Old (for re-manufacture)..	2,681	1,841	10,352	6,573
Steel .....	8,301	10,284	66,645	43,047
Lead .....	1,516	2,339	6,514	14,683
Tin, unwrought .....	2,024	1,384	14,128	15,193
Cement .....	2,368	3,155	23,475	16,893

FIRES OF THE MONTH.

During the past month the following mill and factory fires have occurred in the Dominion: Gillespie foundry, Chatham, N.B.: loss \$12,000, mostly machinery, insurance \$2,675.—J. Middleton's stave mills at Jericho, Ont., insurance, \$1,500. They will be rebuilt.—Brown & Smith's sawmill, Notre Dame, N.B.—W. Wright's evaporator at Conway, Ont.—J. Whitney's sawmill at Belmont, Ont. It will be rebuilt at once.—W. White's sawmill, Mansonville, Que.—J. G. McCrae's barrel factory, Sarnia. Loss \$2,000.—T. Johnson's foundry at Kemptville, Ont. Loss, \$800. To be rebuilt at once.—Jackson & Co.'s sawmill, Tidnish, N.S.—Pictou, N.S., academy. Loss \$20,000; insurance \$12,000. Origin of fire, lightning.—Dominion Lime Co.'s works near Sherbrooke, Que.: loss, \$50,000; no insurance.—Stearns tub factory at Lyndonville, Que., loss \$12,000, insurance \$8,000.—S. S. Cooper's planing mill at Clinton, Ont., October 25th; loss \$6,000; insurance \$2,000.—The sawmill belonging to Goo Dutch & Sons, Black Point, Restigouche, N.B.: no insurance; to be rebuilt at once.—John Bertram & Son's, Dundas, sand shed of tool works. Fired by incendiary Loss reported \$600 to \$1,000; to be rebuilt.

MOTO-CYCLE NOTES.

THE RACE AT CHICAGO POSTPONED TILL THANKSGIVING DAY, NOVEMBER 28TH.

The Maginn Motor Vehicle, built by the Maginn Power Company, of Chicago, has two oscillating cylinders set to act on quartering cranks, which are reversible and geared by chained sprocket wheels to axle of rear wheels. The steering apparatus is attached

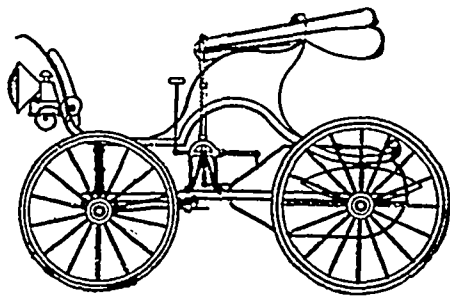

THE MAGINN MOTO-CYCLE.

to the front axle, the wheels of which are loose on the axle. The operator has two levers to handle, that accomplish all the requirements of starting, stopping, reversing, steering and controlling the entire mechanism of a 4 h.p. motor; occupies a space of 18 in. square, it is enclosed, the same covering encloses the transmission gear, and protects it from dust and the weather. It is a favorite for gaining a prize.

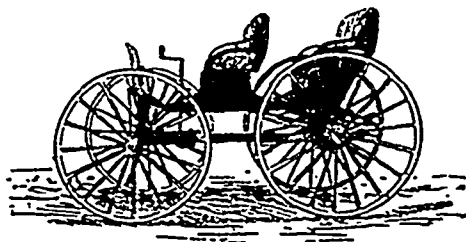

THE R. W. ELSTON MOTO-CYCLE.

This vehicle is equipped with an efficient steering apparatus acting on a segment and two pinions, and a steering port in a convenient position, the carriage is operated from the rear axle and the power distributed equally on both wheels by compensating gear; the advantage of this is apparent—when on turning a corner or going around a circle one wheel travels faster than the other. It has seating capacity for four persons and is propelled by a Kane Pennington Motor of four h.p. The maker claims for it a speed of 25 miles per hour.



THE JOHN W. HALL & SONS' MOTO-CYCLE.

The most attractive carriage to the eye entered shows up in all the beauty that the colored art can design, it is an adjustable vehicle in so far as its seating arrangements go; four can sit in it or it can be folded up to make it applicable to two; the total weight of this carriage is 550 lbs.

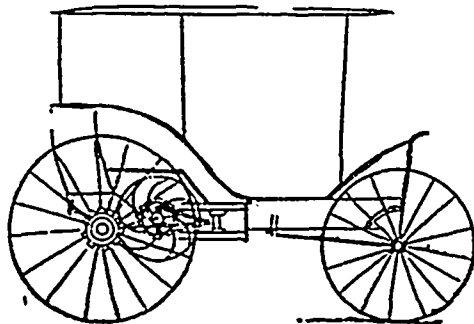

THE GAWLEY MOTO-CYCLE.

This machine, it is claimed by the inventor, is especially applicable to travel over Western States roads; it is propelled by a gas engine of six horse-power; the machinery is well raised above the ground; it is claimed that it will travel from four miles per hour to any speed the operator desires; any person of ordinary intelligence can run it; its total weight is 900 pounds

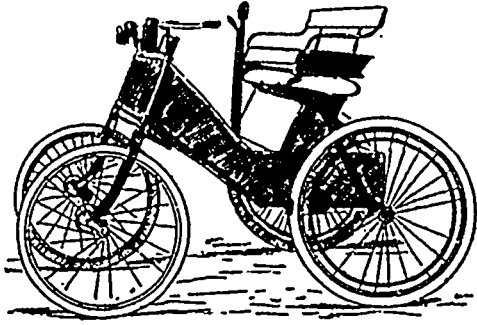

MAX HERTEL'S MOTO-CYCLE.

Two German motors are entered, one of which gained a prize at the Paris-Bordeaux competition. It is claimed that it can travel on fair roads at 30 miles per hour.

Another novelty in motors is entered by Hill & Cummings, of Chicago; the engine has developed five horse-power with all connecting mechanism and gearing to wheels, the total weight is 175 pounds; it is built of aluminum bronze.

There are also a number of tricycle motors entered of three-quarter horse-power, weight from 90 to 110 pounds.

It is proposed in the United States to form an organization of a large number of people interested in the coming revolution in transport, etc., and which will have as its object the furtherance of all details connected with this broad subject, and to hold stated meetings, when papers can be read and discussion followed as to the respective merits of all points in question. Such an organization is now needed, and upon its formation would meet with the hearty co-operation of the friends of good roads, the newspapers, and the public at large. The horseless wagons for merchants' delivery and general purposes have already made their appearance in New York, Boston and Philadelphia, and are highly spoken of.

A remarkably handsome horseless carriage appeared in Chicago on the 29th, from Decatur, Ill., built by the Mueller Manufacturing Company. It was operated by Mr Mueller and his two sons. The streets were lined with thousands of people as it sped along through Michigan Boulevard to Lincoln Park.

Another by Hill & Cummings has also arrived. The engine is built of aluminum bronze, is very light, but powerful. It is noiseless, odorless and canopied, has seats for four persons. This small motor, it is stated, will easily develop five horse power.

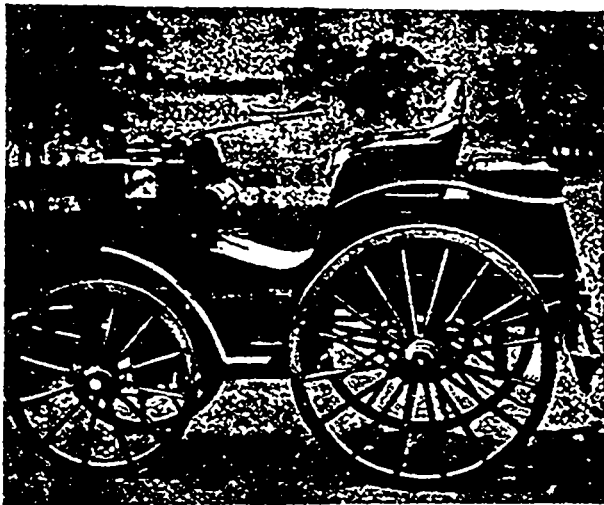

MOTO-CYCLE FOR COUNTRY ROADS.

Another machine has arrived with seating capacity for two, built by Max Hertel. It runs with a double cylinder gasoline motor; it turns completely round in a circle of ten feet. If left to itself it will always run in a straight course. The entire weight of this machine, including fuel and water, is only 220 lbs.

#### CHANGE IN THE RACE-ARRANGEMENTS.

In accordance with the wishes of a large number of manufacturers and inventors who could not complete their machines, and the desire of others who wanted to go over the route and modify their machines to the requirements of the road, the judges put off

the test until November 28th. It was thought this delay would allow sufficient time to complete the motors. It was, however, thought advisable, as Chicago was crowded with people from all parts of the Union and Canada to see the race, that a test of some kind should take place. Six vehicles offered to run for a purse of \$500. These vehicles passed in line through the city, and were admired by countless thousands. When the time for the start arrived the Mueller's Benz carriage was the first to appear, with four passengers. It is an imported German one. The next to get in line was the carriage of Mr. Duryea. They had no competitors. Flanked on both sides by many hundreds of bicycles and other conveyances, and a dense mass of people, they sped on their way. The Mueller machine ran the whole distance of 94 miles without accident in 8 hours and 44 minutes, and the whole cost of the oil, fuel and lubricatory oil for the trip was not more than one dollar. This carriage was admired by all those capable of judging of its merits. The Duryea vehicle did not complete the race. It broke its chain, which detained it 48 minutes, after which, in endeavoring to get out of the way of a farmer's wagon, it was upset in a ditch, breaking one of its wheels. This wagon was built at Springfield, Mass., by a company formed to build it. Great expectations centre on it. The accident referred to might occur to any one. All along the 94 miles the route was crowded by people. After going over the whole course the headlight of the Benz motor-cycle appeared at 20 minutes to 7 p.m., and at 6.43 it stopped in front of the monument. The judges then made their examination and awarded it the \$500 purse.

During the time the carriages were racing others were speeding in Chicago and the parks, not accepting the offer to run that day. It is confidently expected that from 50 to 60 vehicles out of about 90 entered will run in the great race on the 28th of November.

A Moto-cycle Association has been formed in Chicago of various people from all parts of the United States in the interest of the development of the horseless carriage. It is also stated that moto-cycle liveries will be in existence in Chicago and elsewhere next spring.

## Industrial Notes.

G. PREVAT will erect a grist mill at Murillo, Ont.

THE new Jewish Synagogue to be built at Toronto will cost \$25,000.

T. GREENWAY'S mill at Crystal City, Man., is to be enlarged and improved.

A NEW fire station to cost \$45,000 will probably be built at Ottawa in a short time.

THE Union Brewing Co., of Nanaimo, B.C., will erect a brewery at Union, B.C.

PLANS are being prepared for a new Anglican church at Danville, Que., to cost \$6,000.

BRAULT'S mill, at Brault's Mill, near Arthabaska, Que., was destroyed by fire a few days ago.

HINTON & PENNEY'S Victoria Iron Works, at Victoria, B.C., have been purchased by E. Baines & Co.

THE city council of Quelfh have decided to employ an engineer to report on the contemplated sewage system.

JAS. HERRON, Herron's Mills, Lanark township, Ont., has leased the Perth, Ont., grist mill from Hon. John Haggart.

THE Hamilton Bridge Company are working on the addition to the Victoria bridge, London, in connection with the street railway.

THE Maritime Nail Co., St. John, N.B., are applying for incorporation, with a capital stock of \$850,000, to manufacture nails, etc.

THE Dominion Cotton Mill Co.'s mill at Kingston, Ont., was partially destroyed by an electric storm last month. Loss about \$80,000.

THE Bicycle Accident Repair Company, Toronto, is incorporated, with a capital stock of \$10,000, to manufacture and repair bicycles.

A CARRIAGE factory with \$30,000 capital is to be started at Truro, N.S. Mr. Bunker, from Ontario, will put \$4,000 into the enterprise.

WALKER & SONS want the Essex County Council to locate the proposed new county building in Walkerville, Ont., and have offered a free site of seven and one-half acres, worth \$7,000, free gas and water, and \$35,000 in cash.

A NEW canning factory is to be started at Perth, Ont.

T. B. RIDER proposes to establish a flour mill at Magog.

GEO. GILMORE is trying to start a chair factory at Coaticook, Que.

J. W. WELLS will erect a fish and fruit cannery at Hatzic, B. C.

THE C. P. R. will build two new grain elevators at Fort William, Ont.

J. C. McCULLOUGH will establish a bicycle factory at Winnipeg, Man.

THE Nanaimo waterworks purchase by-law was defeated last month by 9 votes.

A GOTHARD will erect a planing mill and sash factory at Rossland or Trail, B. C.

W. SQUIRE, of Ekfrid, Ont., has invented an engine for propelling bicycles by gunpowder.

THE carbon and porcelain works of Peterborough, in spite of their bonus, have gone under.

THE Ontario and Weston Lumber Co. are erecting a sash and door factory at Rat Portage, Ont.

A BUTTER manufactory is to be established at Kingston, Ont.

THE Ross-McLaren Lumber Co are considering the erection of a large mill at Cape Caution, B. C.

SEVERAL new warehouses are to be built on the Napoleon wharf, Quebec, for the Chouinard estate.

Frost's Malleable Iron Works, Smith's Falls, are now being worked by a 25 horse-power electric motor.

THE Lachine, Que., council has passed a by-law authorizing the municipality to borrow \$8,000 for public works.

THE new Jeffrey Hale Hospital, to be built at Quebec, will cost \$10,000. The plans are now being prepared for it.

AN iron bridge is to be built across Badger Creek, near Cartwright, Man. The bridge is to be completed by January 1st.

J. ALLARD, Cookshire, Que., has purchased the machinery of C. W. Taylor's sawmill and will erect a sash and door factory.

THE Cookshire, Que., machine shops and foundry have been closed up. The lack of a practical managing machinist is said to be the cause.

G. W. GREEN, of Millbrook, Ont., has bought out the Payton Pump Works, at Peterborough, and will manufacture pumps and farm machinery.

AUTHORITY has been conferred upon the Hamilton Bridge Company by supplementary letters patent to increase its capital stock from \$100,000 to \$150,000.

OTTAWA is to have extensive additions made to its water system. The additions will include new mains and a new set of pumps, the cost of which will be about \$100,000.

THE Babcock & Wilcox Co., of Montreal, are filling an order from the Oshawa Electric Railway for one of their high pressure 300 horse power wrought steel boilers.

DARLING BROS., Reliance Works, Montreal, have issued a very instructive catalogue containing much valuable information on mechanical subjects. It is sent free to any address.

THE Lunenburg, N.S., *Argus* says that a company has bonded the water power known as Bang's Falls, on the Medway river, N. S., and propose to erect two or three pulp mills.

THE outlook for the Canadian blast furnaces is much improved, and American pig iron has disappeared from the Canadian market, owing to the advance in prices across the line.

R. WOOD, of Snow Road, has sold his steam sawmill to James Cameron, of Fallbrook, Lanark county, Ont., and is putting up a new mill at the Mississippi River, to be run by water power.

TENDERS have been called for by the N. B. Government to build the new bridge over Mill Creek at Campbellton. The total length, including approaches, will be 650 feet, steel work 475 feet.

MANCHESTER, ROBERTSON & ALLISON, dry goods merchants, of St. John, N.B., are about to erect an extension to their building which will cover half an acre of ground. Work will begin at once.

H. McRAE & Co., dealers in cement and contractors' supplies, at Ottawa, have got into financial difficulties. The firm secured an extension some months ago, which they are unable to carry out.

THE business of the British Columbia Pottery and Terra Cotta Company, Ltd., Victoria, has been acquired by J. Hunter and C. A. Vernon, two of the parties most interested in the original organization.

NEW YORK capitalists are negotiating for property at Mink Cove, near Digby Neck, N. S., where they intend to build a summer hotel, at a cost of \$50,000.

RATEPAYERS of Carleton Place, Ont., have voted an additional \$6,000 to be expended on a town and fire-hall. Mr Ryan, Smith's Falls, Ont., has the contract at \$23,500.

THOS. GRAHAM & SON, of the Banner File Works, Almonte, have just received from the Hudson Bay Company an order for all the files that company will require for the next year.

O. S. RIXFORD & Co., of Upper Bedford, Que., are applying for incorporation as the Bedford Manufacturing Company, with a capital stock of \$65,000, to manufacture edge tools, etc.

THE Green Automatic Door-Lock Switch Company, Halifax, N.S., are applying for incorporation, with \$16,000 capital stock, to manufacture the Green automatic door-lock switch, etc.

THE Vernon, B.C., *News* says that the farmers of Spallumcheen and Okanagan will organize a joint stock company to establish a flouring mill, \$10,000 has already been subscribed.

A BRUSH factory to cover 35,000 feet of ground will be erected on Ontario street, Montreal. The directors of the new factory are: R. Forget, Jos. Brunet, H. Laporte, Hon. A. Desjardins and R. Bickerdike.

P. W. ST. GEORGE, city surveyor of Montreal, has sent a report to the Road Committee recommending the construction of new intercepting sewers on a number of principal streets, at a cost of about \$400,000.

J. L. MORRIS, C. E., of Pembroke, has offered to form a Pembroke or Renfrew company to build and operate waterworks in the town of Renfrew, if the council will agree to the necessary conditions and terms.

THE waterproof packing which is being manufactured and put on the market by the Garlock Packing Co., Hamilton, is meeting with great success in the trade. It is a good cold water packing and is capable of resisting a pressure of 2,000 lbs. per square inch.

A PROJECT is on foot to bonus the Peterborough Lock Co., in order to retain it in that town. If the Auburn Woollen Co. can be induced to lease part of their property to the Lock Co. at a sufficiently low rate, they may be included in the bonus.

HENRY F. WHITE, who, last October, was sent to the penitentiary for two years for embezzling funds from the Walkerville Malleable Iron Works, has been pardoned by the Government. White was manager of the works, and months after his departure was arrested in Chicago.

THE Henderson Bicycle Co., with \$100,000 capital, has been successfully floated in Goderich, Ont.; \$55,000 has now been paid up. The company are building the factory, which will employ 75 men. The new firm will have an agency and repair shops in Brantford, Winnipeg and Toronto.

A TERRIBLE accident took place recently in a manufacturing establishment on St. Catherine street, Montreal. A workman named Albert Vautier was engaged polishing a piece of iron, when a large emery wheel, making two thousand revolutions a minute, burst, striking the unfortunate man to the floor. Vautier's head was terribly crushed, and he died shortly after from his injuries.

AT the annual meeting of the Sherbrooke Gas and Water Co., R. W. Heneker was re-elected president, and T. J. Tuck vice-president. E. F. Waterhouse was re-appointed as secretary-treasurer, and Andrew Sangster as superintendent. It is understood that the company has procured new plant for supplying motive power, and that it will be in operation shortly. A dividend of 3 per cent. for the last half year was declared.

THE cycle manufacturers and jobbers of Canada have organized a Canada Cycle Board of Trade. The organization is represented by manufacturers in Montreal, Toronto, London, Kingston, St. Catharines, and other places. The following are the officers: President, J. N. Shenston, Massey-Harris Company, vice-president, D. F. Maguire, Griffiths Corporation, secretary, J. Miln. Executive committee, H. E. Walton, Kingston, T. Fane, Toronto, Mr Knowles, Brantford; Mr. Chapman, St. Catharines.

A CHANGE has been announced in the firm of Naud & Valiquet, Montreal. George Hunt, who was executive president of the Canadian Association of Stationary Engineers in 1893, has joined the firm, now known as the St. Lawrence Machinery Supply Co. Mr Valiquet is vice-president of Montreal Branch, No. 2, of the C.A.S.E., and Mr Naud, while connected with the firm of R. W. Richardson & Co., made many friends among machinists and engineers, so that all the members of the new firm start with practical experience. Particulars of the specialties they deal in will be found in the advertising pages.

THE Gardner Tool Co., of Brockville, is desirous of locating its factory at Sherbrooke, Que., and has asked the city councillors of that place for inducements to do so. The company pays about \$35,000 in wages.

THE mayor of Perth, Ont., has received a letter from the company that undertook to build a system of waterworks in that town, explaining the cause of their delay, and stating that they will soon begin work.

THAT it will create a revolution in the running gear of bicycles, is what Isaac Patton, of Smith's Falls, Ont., claims for his new bicycle. The chain gear is done away with and a peculiar wheel and pinion gear takes its place. It is said to gain four or five feet every revolution of the pedal over anything now in use.

IT is said that Messrs Radcliff and Baldwin, of New York, and Hickson, of Buffalo, after visiting Port Burwell and looking over the harbor, have instructed Mr. Hogg, chief engineer of the T. L. E. & P. R., to make a survey of its harbor, with a view to establishing a ferry route for transferring loaded coal cars from some convenient U. S. point to Port Burwell.

THE building of the great power dam at the outlet of the Lake of the Woods at Portage, Ont., across the Winnipeg River, is progressing rapidly. It is said by experts that this dam will raise the water in the lake to an additional height of four feet. The raising of the water in the Lake of the Woods will cause an overflow into what is known as Great Swamp, overflowing immense timber, hay and agricultural tracts of land in Beltrami and Rosseau counties, Minnesota. It is estimated that not less than 70,000 acres will be ruined utterly. Already many thousands of acres of valuable land have been rendered unfit for cultivation. Agents of the United States are on the way to make investigations. The dam has already cost \$300,000.

DARLING BROS., engineers and machinists, Montreal, record the following recent shipments of their special machines: Brackman & Kerr Milling Co., Victoria, B.C., one 75 h.p. Webster Heater; Lang Packing and Provision Co., Montreal, one 400 h.p. Webster Heater; British American Dyeing Co., Montreal, one 200 h.p. Webster Heater, Montreal Cold Storage and Freezing Co., Montreal, one 400 h.p. Webster Heater, Dominion Coal Co., Montreal, one 50 h.p. Webster Heater, Dominion Glass Co., Montreal, one 75 h.p. Webster Heater, H. R. Ives & Co., one 75 h.p. Webster Heater; Canadian Bridge and Iron Co., Montreal, one 50 h.p. Webster Heater, Toronto Paper Mfg. Co., Cornwall, Ont., 2 Webster Oil Extractors, Standard Life Assurance Co., Montreal, one Webster Oil Extractor. All of the above machines were furnished under guarantee that they would effect a saving in fuel of 10 per cent. over and above any coil heater in the market, and have effected the desired saving.

A PLANT is to be erected in Halifax for the purpose of furnishing gas and coke, and "for the extraction of more valuable substances." By the new process, says the report, gas will play a secondary, though important part. The other articles to be produced are to be the source of profit. Nova Scotia coal has a high percentage of sulphur, which will be extracted at a profit. Dr. Slocum, of Pittsburg, is the chemist of the new company, which has obtained incorporation with extensive powers from the Provincial Government, and which has obtained the right from the city council of Halifax to lay mains throughout the streets. Dr. Slocum is in Halifax deciding on a location. A contract has been given to a Nova Scotia iron firm for \$45,000 worth of pipe. Dr. Slocum; J. D. Weeks of the *American Manufacturer and Iron Worker*; Mr. Dunkirk of the Eureka Coal Company of Pittsburg; F. S. Pearson and Mr. Dimock of New York; H. M. Whitney of Boston; W. B. Ross of Halifax and other moneyed men, are pillars of the company. Halifax now pays \$2.50 a thousand feet for gas, less 20 per cent., if paid within a certain date, and the new company undertakes to supply it for \$1.50.

## Electric Flashes.

A WINDING UP order has been issued by the Superior Court against the St. Jean Baptiste Electric Light Company of Montreal.

THE breaking of the main shaft in the Hamilton, Ont., Electric Light Works, left the city in darkness for a couple of nights recently.

EGANVILLE is soon to have the electric light. McRae & McKenzie, millers, have ordered a plant, and will operate it by water power.

IN Toronto there are 117 miles of underground electric light and telephone wires, while the total length of overhead wires is 4,288 miles.

W. Ross is again endeavoring to obtain an electric lighting franchise for Rat Portage, Ont. The council is considering the application.

THE Halifax Street Railway Co. saved \$14,000 by a timely purchase of 2,000 tons of rails. Rails are selling at an advance of \$7 per ton.

A PROJECT is on foot for the construction of an electric railway line from Pogamasing, Ont., to Biscotasing, Ont., for the convenience of cutlers.

THE people of Pembroke are agitating for an electric railway to connect their town with Beachburg, Foresters' Falls, Westmeath and Eganville.

THE Electric Light Company, Niagara town, has bought land on which to build an 80 x 100 brick power house to cost \$10,000, and the machinery about \$25,000.

A. M. SCHOFIELD, engineer of the Carleton Place electric light works, has gone to Detroit to engage in electrical work. He is succeeded by John E. Bennett.

J. B. McDIARMID, manager of the electric light plant at Aylmer, Ont., was killed recently by the breaking of a 30-inch wooden pulley, which struck him on the side of the head.

THE Lunenburg, N.S., *Argus* understands that an engineer is examining the route from Port Medway, N.S., for the proposed electric line for carrying pulp to a port of shipment.

JUDGMENT has been given for the plaintiff, with costs, in the suit Brantford Electric Light Co. vs. Wood. It was an action to determine the rights of different users of a water power.

THE Underwriters' Association have been pressing the Government to extend the cable to Belle Isle, owing to the numerous wrecks that take place in the Gulf. The cost would be \$200,000.

THE Hamilton, Grimsby and Beamsville Electric Railway has just completed the first year of its history, and during the year it has carried 220,894 passengers and 15,042 tons of freight. The road is only eighteen miles long.

NEGOTIATIONS are in progress for an electric road between Renfrew, Ont., and Portage du Fort. The distance is eight miles, and water power will generate the electricity. A. C. Wright, of Renfrew, is interested in the project.

THE Barrie and Allandale Electric Street Railway Co., with a total capital of \$50,000, in \$50 shares, has been incorporated. The promoters propose to lay out a park on the shore of Kempenfeldt Bay, a mile and a half from the town, and run cars out there.

JAS. A. BAYLIS, electrician of the Bell Telephone Co., in Toronto, has been removed to Montreal, where he takes the position of chief electrician. The employees of the B. T. Co. in Toronto made a presentation to Mr. Baylis before his departure.

THE Fraserville Electric Power Company, Fraserville, Que. is applying for incorporation, with a capital stock of \$25,000, to operate telephones, and do electric lighting and supply electric motors for commercial purposes in Kamouraska and other counties in the Province of Quebec.

D. H. KEELY, superintendent of the Government telegraph service, has gone to the Maritime Provinces to superintend the repairs to the Government cables at present out of order between Meat Cove and St. Paul's Island, and between Grand Manan and New Brunswick.

A PARTY of the directors of the United Tramways Company of Dublin, Ireland, have been inspecting the principal electric street railway systems of Canada and the States, with a view to establishing an electric system in their city. The party is composed of Wm. Carte, president; Wm. Anderson, manager; Wm. M. Murphy and John R. Wigham, directors.

THE Gorge electric railway line on the American side, at Niagara, is now under construction, and life on the Canadian side has been endangered by the careless blasting. Several large rocks were blown over to the Canadian side; one weighing 30 pounds crashed through the roof of the Canadian Customs office and narrowly missed killing the officer on duty. Action has been taken against the company.

AT the next sitting of Parliament the Canadian Electric Railway and Power Company of Toronto will ask for power to build, operate and maintain an electric railway from Montreal to Windsor, running through Brockville, Kingston, Belleville, Toronto and London, with power to build branch railways within a radius of 25 miles from the main line. If the company's scheme materializes, a new invention by Nikola Tesla, by which electric power may be transmitted along a wire for 200 miles, will be used.

It is said that one result of the new management of the G.T.R. will be the substitution of electricity for steam in the St. Clair tunnel. The system decided on is said to be a modification of that used by the Baltimore and Ohio Railway in the great tunnel at Baltimore. The trolley system is used, and trains weighing 1,400 tons are taken up an 8 per cent grade with ease. On the level a speed of 60 miles an hour has been attained.

PRESIDENT MILES, of the Hamilton, Grimsby and Beamsville Railway, has requested the Hamilton aldermen to grant an extension of the time for earning the \$5,000 bonus offered by the city for the completion of the line to Beamsville. The additional five miles of road Mr Miles says, will mean an increase of \$13,000 in the yearly working expenses, and he does not think the extension will prove a profitable one for the company. If the extension is built a new power house and car barn, and a lot of new cars, will have to be built, bringing the total cost of the extension up to about \$75,000.

THE eleventh annual report of the Royal Electric Company, Montreal, shows that the net gain on the fifteen months' operations was \$106,209.14, out of which five quarterly dividends of 2 per cent. each, amounting to \$99,900.10, have been declared, the remainder going to swell the balance of \$308,758.98. The lights on the direct current arc system have been increased from 1,617 to 1,666; the lights on alternating current incandescent system from 40,013 to 53,977, and the motors from 347 to 688 horse-power. Reference was made to the faithful service of Charles W. Hagar, who recently retired from the position of secretary and manager, and a tribute paid to the experience and business ability of his successor, Wm. H. Browne.

THERE has been on exhibition in the Montreal *Star* office window a model of a new electric snow-plough, to be used on street railways. It has attracted much attention, and has been endorsed by the city engineer. A steel scoop placed in front collects the snow. The scoop can rapidly be raised or lowered, leaving required depth of snow on street and between the rails. It can also be drawn across to right or left by chain working on shaft. The scoop projects about six feet over the side of road from the rails, and clears the street for the vehicles. The removing plates are placed on endless chain running around sprocket wheels placed at each end of scoop, and running across scoop, draw the snow thus collected to the side of road. Power to run the removing plates is taken from electric motor placed on platform of car and conveyed by chain to sprocket wheel on the horizontal shaft, and thus by gear wheels to vertical shafts, on which are fixed the sprocket wheels, and around which the endless chain with plates runs. One scoop only is used at a time. On the return trip the car is switched on to the other track, and the back scoop, which is similarly fitted with plates, is used.

## Mining Matters.

NATURAL gas is reported from Iberville, Que.

MUCH material is being extracted from the asbestos mine in the township of Denholme, Que.

THE Coe Hill, Ont., iron mines were re-opened a few days ago. The mines have been closed for several months.

NEARLY three hundred tons of phosphate were shipped from the High Rock mines, Buckingham, Que., in one week recently.

ASBESTOS in large deposits of excellent quality has been discovered on a claim at Bear Creek, B.C., near the Tulameen River.

THE gas well struck lately on the Homer Cutler farm near Ridgeway Ont. is estimated to have a flow of 2,000,000 feet a day.

THE Canadian Mica Co. has acquired mining properties at Wilson's Corners and Cascades, Que., and will begin operations at once.

THE Kingston and Pembroke Railway Co. has undertaken to supply ore for the Hamilton blast furnace from the iron mines along its line.

A WELL owned by the Central Oil Co., at Dunnville, Ont., is producing amber crude oil which is said to be equal to the finest American amber.

GENERAL WILKINSON has promised to give the first gold brick which the Regina mine produces to the establishment of a hospital at Rat Portage.

THE Canadian Oil Co. has assigned to C. Mackenzie, Saruia, Ont. Mr. Mackenzie has recently bought the Oil Springs property of the Walford syndicate for \$4,000.

A VALUABLE seam of coal has been discovered at Grand Lake near St. John, Nfld. The coal discovered is hard and bright, and approaches the nature of anthracite.

THE Credit Forks Mining and Manufacturing Company, Toronto, are applying for incorporation, with a capital stock of \$10,000, to manufacture lime, bricks, terra cotta, etc.

C. F. SCOTT, of the Anglo-American Gold Mining Company, of British Columbia, was in Ottawa recently, and reports a successful season at the company's claim in the Similkameen district.

A. BLUE, Director of the Ontario Bureau of Mines, says that Canadian capital could be turned to excellent profit by investing in the numerous gold properties on the Seine River, Rainy Lake, or Lake of the Woods.

THE Kingston School of Mining has reopened for the season. Since last session many additions have been made to the appointments of the school, including a new 60 x 40 geology room and museum.

C. B. KINGSTON, B.A., B.A.S.C., a graduate in mining engineering at McGill University, in 1892, has left Canada for London, whence he will sail for Australia to become manager of the mining properties of a large London company.

PROF. H. MONTGOMERY, of Trinity University, Toronto, and his son, have made a trip up the Gatineau in search of minerals. He says there is no other district in Canada so rich in minerals as the East Templeton and Gatineau districts.

THE gold find at Seymore Creek, North Vancouver, about ten miles from the city of Vancouver, is reported to be most valuable. While boring for water John McLeod struck flake gold, and six feet lower crush quartz which is said to assay \$11,000 to the ton.

IT is likely that a smelter will be erected in Vancouver at an early date. G. F. Monckton has offered to erect and operate one if the city will give him a \$5 a ton bonus for the first 5,000 tons smelted. A mining school will be established in connection with the smelter.

IT is reported from Port Arthur, Ont., that the Bethlehem, Pa., Iron Co. have secured the option of properties believed to contain hematite in Mattawan iron range. Hitherto the company has imported hematite from Cuba, but owing to the war they have turned their attention to Canada.

MUCH interest is taken in the future of Alberta coal as a source of coke supply. There is no coking coal anywhere in the West, Montana smelters bringing their coke all the way from Virginia. It is claimed that the coal at Sheep Creek and the upper Red Deer is suitable for the purpose. If the experiments are successful, the discovery will be of great value to British Columbia.

L. J. MORKHILL, civil engineer and miner, of Lyster, Que., has gone to California to take a position as superintendent of the Anaconda Mining Co. He is of the opinion that there is as much gold within easy reach of Sherbrooke, Que., as there ever was in Australia or California. He exhibited nuggets found at Maynard Brook, Que., and along the Chaudiere, Gilbert and St. Francis Rivers.

A CONE and bar of gold weighing in all 2,435 ozs., valued at \$41,857, are to be exhibited in Montreal. They are the result of the clean up at the famous Cariboo mine, in Golden, after twenty-nine days run, and the Horse Fly, a sister mine, after forty days run. This is considered very satisfactory, as the cleaning up of the cuts was not made and the bed rock was not cleaned. During the clean up a cave-in at number two pit of the Cariboo mine covered up and killed a miner named A. Budden.

IT has been reported from Port Arthur that a wonderful gold discovery has been made in the mountains near Jackfish Bay, Lake Superior, about five miles from the Canadian Pacific Railway, where it skirts the shore at that point. The vein or ledge has been traced for one and one-half miles, it having a width of from sixteen to twenty-five feet and conservative estimates are that it carries from \$3 to \$10 per ton in free gold, besides the sulphurates. A syndicate is being formed in Ottawa to work the vein.

THE commissioners appointed by the N.S. Government to inquire into the history, cause and effect of the coal mine fires of Pictou county, Nova Scotia, have just finished taking evidence. The work of the commission was directed mainly to an investigation of the Foord pit. This mine has been on fire in one place or another since the fifties, and it is burning yet. The object of the commission is to learn whether something cannot be done to save so valuable a property as the Foord pit. The pit will probably be worked again in the near future.

It is understood that the farms of Wain, Downey, Turner, Dean, McDonald and others, in North Sannich, Vancouver Island, in all about 2,000 acres, have been bonded by C. McK. Smith and Beaumont Boggs, of Victoria, for the purpose of prospecting them for coal. It is well known that the indications are good, and it is almost a certainty that coal will be found in paying quantities at no very great depths. The quality of the coal, as far as it has been examined, is the same as that mined at Nanaimo

## Railway and Marine News.

THE C.P.R. car shops at Perth are closed down for an indefinite period.

THE C.P.R. last month ordered thirty-five additional locomotives to cope with the grain shipments from the North West.

A GANG of men are at work on the Tilsonburg, Lake Erie & Pacific Railway, which will run from Tilsonburg to Port Burwell Ont.

THE Crossan Car Co., of Cobourg, Ont., has received the contract for seventy-five platform cars for the use of Government railways.

SEVEN hundred men who during the summer have been employed on the Newfoundland railway construction, have returned to the cities.

THE Tring Branch of the Quebec Central Railway was opened last month. The line is sixty miles in length and connects Quebec and Lake Megantic.

CLARKE & CONNOLLY have sub-let their contract for the River Aux Raisin drainage in the township of Osnabruck to W. J. Brennan, of Cornwall.

STOCK to the amount of \$76,000 has been subscribed for the Facer Carwheel Co. of Perth, Ont., and tenders are called for the erection of the necessary buildings.

HOWARD, LEAMY & MURPHY, contractors, have entered an action claiming \$35,000 from the Chateauguay and Northern Railway Company for breach of contract.

LAST month at the Michigan Central level crossing at Essex, Ont., three people in a wagon were instantly killed by a passing train and two others seriously injured.

THE first train went over the completed part of the Coast Railway of N.S. on Oct. 24. The work will now be pushed rapidly to completion with the aid of construction trains.

L. MERRITT and his brothers, A., A. R., J. E. and L. F., of St. Paul, Minn., have filed articles of incorporation to build a railroad from Duluth through the Mesaba range to Winnipeg.

THE schooner "Osceola," which was in a collision at Chatham, N.B., with the steamer "Miramichi," whereby three lives were lost, has arrived in Halifax, N.S., and an investigation is being made.

THE C.P.R. Company has leased the branch line running from Renfrew, Ont., to Eganville, to the Atlantic and North-West Railway Company, for 999 years. The price to be paid was \$16,000 per mile.

THE famous Government steamship "Alert," which has made a number of Arctic expeditions, was sold at Quebec recently. She was bought for \$4,000 by a ship-builder of St. John, N.B., for the sake of her old metal, etc.

THE T. H. & B.'s request for a further bonus of \$200,000 from the City of Hamilton as a condition upon which that railway will be extended to Toronto, has been unanimously rejected by the finance committee of the Hamilton City Council.

THE contract for construction of a lighthouse at Cabot Head, Georgian Bay, has been awarded to John George, of Port Elgin, Ont. Two foghorn machines from Carrier, Laine & Co., Levis, Que., have been sent up to this place. The new lighthouse at Double Top Rock, Georgian Bay, is completed.

THE special committee of the Brantford city council, appointed to consider the letter of the general manager of the G.T.R. regarding the cut off from Lynden to the Harrisburg branch, have decided to ask the company just what bonus they want, and what equivalent they will give before further steps are taken.

APPLICATION will be made at the next session of Parliament for a charter for the Hamilton, Brantford and Pacific Junction Railway Co. to build a road from a point on the Toronto, Hamilton and Buffalo Railway, at or near Copetown, to a point on the

Canada Pacific Railway, at or near Schaw Station. Both Hamilton and Brantford capital is interested, and an engineer, says the *Hamilton Times*, is now making preliminary survey. The new line will be twelve miles long and is expected to be of easy construction.

It is probable that the level crossing on the Grand Trunk Railway tracks, at St. Henri, Montreal, will be done away with in a short time and a raised crossing built. The cost of such a work would be \$916,450 with wooden floor, and \$1,033,450 with an iron one. The matter is now being considered by the Montreal City Council.

THE St. Lawrence & Adirondack Railway are building their line between Caughnawaga and Beauharnois on the charter which was secured some years ago for the Southwestern Railway. Cameron & Fitzpatrick have the contract for the thirteen miles between the two towns, and will finish the work by July 1st, '96. The track is now being laid on the three miles of line connecting the St. L. & A. with the Beauharnois Junction Railway at Beauharnois. Dr. Seward Webb, of New York, is president, and R. W. Leonard, of Kingston, Ont., has been appointed chief engineer.

APPLICATION is being made for charters for a number of new railways in the North-West. One is proposed from Winnipeg to the Saskatchewan at Grand Rapids, thence to Hudson's Bay, with a branch to the boundary, and also a branch from Grand Rapids to Edmonton. Another intends to construct railways from Edmonton (a) southerly to the Calgary and Edmonton Railway; (b) north-westerly to a point on the Athabaska River, near Fort Assiniboine, with a branch to Stony Plains; (c) easterly to Fort Saskatchewan, with a branch to Sturgeon River.

THE Dominion Government seized the other day, at Kingston, the big steel dredge of Larkin, Connolly & Co., valued at \$85,000, in satisfaction of the \$35,000 judgment held against them. The sheriff of Montreal, acting upon instructions from the Dominion Government, also served a writ of re-vestigation on the Richelieu & Ontario Navigation Company, to seize all stock held by the Messrs. Connolly. The bailiff demanded a certificate of the amount of such stock, but the secretary refused to give the information on the ground that he had no authority to do so. The writ was returned to Ottawa with the remark that the information required was refused, but it appears that the company has since decided to furnish the figures asked.

## Personal

THOS. AHEARN, of Ahearn & Soper, Ottawa, leaves this month for a tour through Australasia lasting four or five months.

HUGH P. HAZEN, C.E., of Montreal, Que., is at present engaged on the engineering staff of the St. Lawrence and Adirondack Railway.

JAMES MANSERGH, C.E., the English hydraulic engineer, has arrived in Toronto with his son, and is now at work on his report on the Toronto waterworks system.

A WIDELY published rumor that the office of assistant general manager of the Grand Trunk Railway was abolished has been contradicted by Mr. Wainwright, who occupies that position.

J. PATTON, Yarmouth, N.S., was accidentally shot dead at a shooting gallery in that place a few days ago by a boy named J. L. Roy. Deceased was 21 years of age and an employe of the Burrill-Johnson Iron Co.

C. M. HAYS, vice-president and general manager of the Wash Ry Co., has been appointed general manager of the Grand Trunk. More extended reference to the changes in the Grand Trunk will be made in our next issue.

WILLIAM STAFFORD, proprietor of the Lancaster, Ont., machine works, was fatally injured on the G.T.R. track near Lancaster on October 14th. Mr. Stafford was an Englishman by birth, but had been in business in Lancaster for fifteen years and in Montreal for fourteen years previous to his death.

G. D. CORRIGAN, Palmer & Corrigan, civil engineers, Vancouver, B.C., was killed on Oct. 9th, by the accidental discharge of a gun in his own hands. Mr. Corrigan graduated from the School of Practical Science, Toronto, in 1888, was engaged with the Union Pacific Railway, in Oregon and Washington, for two years, since that has been in business in Vancouver. He has been carrying on a trigonometrical survey for the Government of British Columbia for the past three years.

We regret to announce that Duncan Robertson, who was stricken with paralysis at Ottawa while attending the meeting of the C.A.S.E., as reported in last issue of THE CANADIAN ENGINEER, has since died. Mr Robertson was an Oddfellow and a Mason, and was much respected both in his business and social relationships.

W. J. CARRUTHERS-WAIN, C.E., president of the Tramways Institute of Great Britain and Ireland, represented that body at the Street Railway Convention in Montreal. Mr. Wain, who is now taking a trip through Canada, informed a representative of THE CANADIAN ENGINEER that he was much pleased with the progress we are making in street railway affairs.

A COMMITTEE of the Canadian Electrical Association, consisting of A. B. Smith (president), J. J. Wright, A. M. Wickens, Joseph Wright, A. J. Kammerer and C. H. Mortimer, surprised K. J. Dunstan, the past president, with a present of an enlarged photograph of the group of members taken at the Ottawa convention. The gift was accompanied by a handsome opera glass for Mrs. Dunstan.

CECIL B. SMITH, M.A.E., late lecturer in Civil Engineering at McGill College, has been promoted to be assistant professor of the same, his special duties being to instruct in railroad engineering, structural designing and testing laboratories. The following other changes in the teaching staff of the Applied Science Faculty of McGill University, have been made by the Board of Governors: W. A. Carlyle, M.A.E., lecturer in mining, to be professor in the same subject; Mr. Guest, to be assistant professor in mechanical engineering; W. A. Duff, science, '94, to be demonstrator in the thermo laboratory; Louis Herdt, science, '93, to be demonstrator in the dynamo room, and J. G. G. Heny, M.A.E., to be lecturer in descriptive geometry and surveying.

## The Patent Review.

- 48,252 G. H. Moore, London, Ont., process of refining petroleum.  
 48,253 W. McNames, Scatterwood, S. Dak., car coupler.  
 48,257 J. D. Sinclair, Caledonia, N. Y., car coupler.  
 48,282 C. G. Richardson and C. Riordon, both of Toronto, and J. R. Barber, Georgetown, Ont., process of refining nickel, etc.  
 48,254 T. Manley, Prince Albert, N. W. T., machine for operating the valves of feed spouts of conveyors of sawdust to furnaces.  
 48,274 L. Sennett, Russell, Kentucky, air brake coupler.  
 48,281 E. R. Johns, New York, method of electro-plating metals.  
 48,263 The Homstead Manufacturing Company, Homstead, Penn., ice scraper for trolley wires.  
 48,269 W. H. B. Lyons, Goshen, Ind., fuel saver.  
 48,271 J. G. Pennycuik, Toronto, Ont., apparatus for lighting, heating and cooking.

- 48,285 J. B. Cooper, Minneapolis, Minn., device for stopping a leak in hose.  
 48,295 A. Schram, Toronto, Ont., water tap attachment.  
 48,303 C. Rutkoskie, Benton Harbor, Mich., hydro-carbon heater.  
 48,308 J. M. Elder, Indianapolis, Ind., gate closer for elevators.  
 48,320 I. Pierce, West Bay City, Mich., method of packing valve stems.  
 48,327 H. L. Boyle, Grand Rapids, and F. Gates, Owosso, Mich., gas engine.  
 48,330 M. E. McKee, St. Paul, Minn., brake adjuster.  
 48,331 J. M. Isgrig, Traverse City, Mich., shaft-aligning device.

## AMERICAN PATENTS.

The following is a list of patents recently granted in the United States to Canadians. This list is furnished to THE CANADIAN ENGINEER by Hanbury A. Budden, patent solicitor, Montreal.

- 545,948 William DeLany, Cobourg, bicycle.  
 546,232 Wilber R. Hitchcock, Cornwall, assignor of one-half to A. W. Andrews and J. D. Miller, Wallingford, Vermont, insulator, conductor, and conduit for electrical wires and cables.  
 546,048 Charles Kelly, Toronto, envelope.  
 546,238 Frank S. Mead, Montreal, electric igniter for gas engines.  
 546,244 Frederick W. Owen, Toronto, bill file.  
 546,188 Charles F. Pym, Windsor, assignor of one-half to J. F. Sedgwick, Cottam, lasting jack.  
 546,552 Benjamin C. Pettingell, assignor to J. Pettingell, Victoria, blasting powder.  
 546,566 Alexander A. Vernon, assignor to himself and A. Green, Owen Sound, napkin holder.  
 546,355 James M. Smith, Galt, truss.

MARINE ENGINEER, aged 38, first-class certificate Board of Trade, England, trained on the Clyde, with considerable experience on ocean-going steamers, wants a situation on shore or afloat. Has references. P.O. Box 408, St. John, New Brunswick.

CIVIL ENGINEER, age 31, with good experience in railroad and general engineering, wants position of any sort. Has instruments and first-class references. Box 195, Collingwood, Ont.

MICHIGAN MINING SCHOOL, HOUGHTON, MICH. A high grade technical school. Practical work, Elective system. Summer courses. Gives degree of S. B. E. M. and Ph. D. Laboratories, shops, mill, etc., well equipped. For catalogues write to the secretary.  
 M. E. WADSWORTH, Ph. D., Director.

## FOR SALE (good as new)

20,000 feet 3-in. Boiler Tubes; 20,000 feet 4-in. Boiler Tubes; large quantity Steam Pipe 1-in. to 9-in.; large stock second-hand Rails; Pulleys, Hangers, Shafting, Valves, Gauges, Hercules Rabbit Metal, Solder, etc.

**FRANKEL BROS.,**

METALS, SCRAP IRON, COTTON WASTE, ETC. 116-130 GEORGE STREET, TORONTO

A COPY  
OF OUR  
LARGE  
BOOK

# STEAM

WILL  
BE  
SENT

# FREE

UPON  
APPLI-  
CATION  
TO

**WM. T. BONNER, GENERAL CANADIAN AGENT FOR THE . . . BABCOCK & WILCOX BOILERS**  
 415 BOARD OF TRADE BLDG., MONTREAL

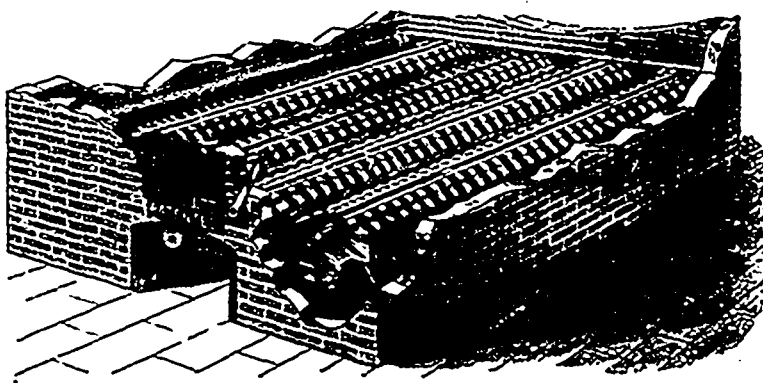

From HUNT BROS., Millers, London, Ont.

We have had the Heeson Rocking Grate in use for over a year and like it very much, and consider it the best grate of the kind made in Canada.

## The Heeson Rocking Grate Bars

Will be placed on trial under any boiler in the Dominion for thirty days, at the end of which time, if they are not satisfactory, we will remove them and return the old bars to their place free of expense.

**THE HEESON ROCKING GRATE BAR CO.**  
OF TORONTO (Limited)

Office: Mall Building, cor. King and Bay Sts.