

ICE FORMATION

WITH SPECIAL REFERENCE TO

ANCHOR-ICE AND FRAZIL

BY

HOWARD T. BARNES, M.A.Sc., D.Sc., F.R.S.C.

Associate Professor of Physics, McGill University, Montreal

FIRST EDITION

FIRST THOUSAND

NEW YORK

JOHN WILEY & SONS

LONDON: CHAPMAN & HALL, LIMITED

1906

GB2429

B37

1906

Copyright, 1906
BY
HOWARD T. BARNES

ROBERT DRUMMOND, PRINTER, NEW YORK

TO

Professor Hugh E. Callendar, F.R.S.,

WHO BY HIS TEACHING AND EXAMPLE STIMULATED
ME WITH A LOVE FOR RESEARCH,

THIS BOOK IS DEDICATED

On
regard
develo
the St
from p
ing fri
which
river-i
during
print.

In
better
ing an
which
though
for a g
when c
through
additio

The
measur
has bee

PREFACE.

ON account of the wide demand for definite information in regard to ice phenomena, especially in connection with hydraulic development in the North, I decided to give the ice story of the St. Lawrence River as it has presented itself to me, both from personal observation and from intercourse with engineering friends. The present book is really the result of the need which has arisen for the republishing of my various papers on river-ice formation, which have appeared from time to time during the past ten years, and many of which are now out of print.

In attempting a work of this kind I found that it would be better to present the facts as completely as possible by including an account of the elementary laws of heat-transmission, which bear particularly on the ice problem. It has also been thought wise to add a chapter on the physical constants of ice, for a great deal of valuable work has now been done which, when collected together from the original memoirs scattered through various scientific publications, forms an important addition to the study.

The description of the methods for precise temperature measurements by the platinum resistance thermometer, which has been added by request, may prove useful to any desiring

to observe the small temperature deviations in water accompanying the formation or disintegration of ice.

I have every confidence that a thorough understanding of the laws underlying the formation of ice will lead to methods, as it has already done in part, which will so temper the effects of ice in our northern rivers as to render them no longer a bar to the full development and utilization of our vast water-powers.

It is a pleasant duty here to record my indebtedness to many engineering friends who have aided me in my ice study. I may mention with special regard Mr. John Kennedy, chief engineer of the Harbour Commission Works, Montreal; Mr. T. C. Keefer, C.M.G., of Ottawa; Mr. W. J. Sproule, engineer Harbour Commission Works, Montreal, and Mr. John R. Freeman, of Providence, R. I., President of the American Society of Mechanical Engineers.

MACDONALD PHYSICS BUILDING,
MCGILL UNIVERSITY, MONTREAL,
September, 1906.

INTR

PHYS

t

PHYS

I

t

r

I

V

FORM

C

C

SHEET

P

R

S

CONTENTS.

	PAGE
INTRODUCTION.....	1
CHAPTER I.	
PHYSICAL LAWS GOVERNING THE TRANSFER OF HEAT.	4
Radiation. Surface Emissivity and Solar Radiation. Conduction. Convection.	
CHAPTER II.	
PHYSICAL CONSTANTS OF ICE.....	30
Density. Maximum Density of Water. Heat of Fusion or Latent Heat. Specific Heat of Ice. Specific Heat of Water and the Thermal Unit. Thermal Conductivity of Ice and Snow. Thermal Conductivity of Water. Coefficient of Expansion. Relative Hardness or Penetrability. Plasticity. Elasticity. Viscosity. Vapor-pressure of Ice and Supercooled Water. Electric Properties.	
CHAPTER III.	
FORMATION AND STRUCTURE OF ICE.....	74
Crystalline Structure. Snow-crystals. Structure of Solid Ice. Quincke's Theory. Regelation. Spontaneous Crystallization. Glacier Motion. Modifications of Ice. Supercooling of Water.	
CHAPTER IV.	
SHEET, FRAZIL, AND ANCHOR ICE.....	98
Sheet Ice. Rate of Growth of Surface-ice. Frazil-ice. Artificial Production. Anchor-ice. Historical. Distinguished from Frazil. Radiation as the Cause of Anchor-ice Formation. Ice-floods in the St. Lawrence.	

	PAGE
CHAPTER V.	
PRECISE TEMPERATURE MEASUREMENTS	136
The Platinum Resistance Thermometer. Mercury Thermometer Compared. Method of Measurement. Refinement of Apparatus. Sample Results showing Accuracy Attained.	
CHAPTER VI.	
RIVER TEMPERATURES	149
Instruments used in Investigations of River Temperatures. First Series of Results under Surface-ice. Second Series of Tests at the Lachine Rapids. Details of the Observations. General Considera- tions. Freezing-point Diagram. Conditions which Govern the For- mation of Frazil and Anchor-ice.	
CHAPTER VII.	
THEORIES TO ACCOUNT FOR FRAZIL AND ANCHOR-ICE	185
Early Theories of Arago, Eisdale, and Farquharson. Later Theories of Francis, Bell, Hunt, Henshaw and Lord Kelvin. Discus- sion of Henshaw's Paper. Views of Keefer. Extract from Article on Anchor-ice from the Montreal Flood Commission Report. Depth of Formation of Anchor-ice in Fresh and Salt Waters.	
CHAPTER VIII.	
METHODS OF OVERCOMING THE ICE PROBLEM IN ENGINEERING WORK . . .	226
Construction and Situation of Power-works. When a Surface- sheet is Valuable and when not. Vulnerable Spots in a Power-house. Artificial Heating and Steam-injection. Electric Heating of Racks. Effect of Head of Water. Effect of Rapid Fall on Temperature Con- ditions. Volume of Ice Formed by Radiation. Erosive Velocity of Water and its Probable Effect on Anchor-ice Formation.	
DESCRIPTION OF PLATE	249

FIG.
1. D
2. A
3. D
4. D
5. C
6. W
7. D
8.
9.
10.
11. A
12. C
13. V
14. A
15. B
16. C
17. C
18. C
19. Id
20. R
21. L
22. R
23. A
24. D
25. C
26. A

LIST OF ILLUSTRATIONS.

FIG.	PAGE
1. Distribution of heat in the spectrum.	8
2. Absorption-bands observed when light is passed through iodine vapor.	14
3. Diagram of ether spectrum.	17
4. Diurnal waves of heat in the earth.	25
5. Convection currents in water.	28
6. Water circulating in pipe by convection currents.	28
7. Dilatometer of Plücker and Geissler.	32
8. " " Kopp.	33
9. " " Bunsen.	34
10. " " Nichols.	35
11. Apparatus of Barnes and Cooke.	39
12. Calorimeter used by A. W. Smith for latent heat of water.	49
13. Variation of the specific heat of water.	54
14. Andrews's curve for the relative hardness of ice at different temperatures.	66
15. Bunsen ice-calorimeter.	89
16. Curve showing rate of growth of ice in the Bunsen ice-calorimeter.	91
17. Curves of boundary conditions for ice, water, and vapor.	93
18. Clear block of St. Lawrence River ice showing structure and refraction.	104
19. Ideal picture of sheet-, frazil-, and anchor-ice, as they are usually found near the foot of a rapid.	114
20. Railroad track across the St. Lawrence River in winter.	117
21. Locomotive and freight cars on the ice-track	119
22. Result of an ice-shove opposite Montreal before the construction of the guard-pier.	121
23. Another view of the ice-shove.	123
24. Diagram of differential platinum thermometer connections.	140
25. Cabin on the guard-pier where the measurements of the temperature of the water under the surface ice were made.	157
26. Attendant placing thermometer through hole cut in surface ice. End of shanty on guard-pier shown.	159

LIST OF ILLUSTRATIONS.

FIG	PAGE
27. Observation cabin at the Lachine Rapids where temperature measurements were made.	162
28. Attendant about to place thermometer in water. Frazil may be seen running in the open water	164
29. Mass of anchor-ice brought up by sun's rays seen floating down in the current.	169
30. Freezing-point diagram.	176
31. Artificial channel blasted through the headrace of a large power company to allow of sufficient waterflow	228
32. Blasting operation. Men prying off lump which has been cracked off by blast. Frazil underneath.	229
33. Iron rack which has been submerged during the night previous by adhering frazil stopping the flow. Large masses are still seen clinging to the bars.	233
34. Horizontal steam-pipes shown in place on the same iron rack previous to lagging. Electric scraper shown for removing frazil from rack.	235
35. Same iron rack heavily lagged with tar paper and wood over the steam-pipes.	236
36. Penstock or wheel-house which has been blocked by frazil drawn in through the racks. The ice has been mostly removed previous to the photograph.	237
37. Steam injection for rendering turbines free from the adhesion of frazil-ice.	239
38. Effect of an ice-shove from accumulated masses of frazil below the Cedar Rapids, St. Lawrence River. Poplar tree overturned	245
39. Farmhouse overturned in a similar way by an ice-shove.	247
40. Folder plate with four sections of the St. Lawrence River in winter, showing the accumulations of frazil-ice under the surface-ice.	

ICE FORMATION.

INTRODUCTION.

NOWHERE can man witness a more wonderful sight of the delicate poising of the forces of Nature than in the spectacle of one of our northern rivers in winter. The full magnitude of the struggle which goes on between ice and water is only realized in its entirety where an engineering problem has to be met and the ice conditions studied. The steadiness of the temperature of the water throughout the winter is a matter of great interest. It never varies more than a few thousandths of a degree from the freezing-point, even though the temperature of the air may be 30 or 40 degrees lower. As a constant temperature thermostat we have nothing to equal it, even with all the appliances of one of our modern laboratories.

Evidence shows that the great bulk of our water-power lies in the northern portion of the American Continent, from the great lakes and along the St. Lawrence valley through the snow belt. Hence, as water-power development advances, the circumstances under which ice formation takes place become more and more important. To the hydraulic engineer the question of ice formation is of vital importance, and too much attention cannot be given to this matter for a more thorough understanding of the problems involved. What presents itself during the summer months for consideration is nothing to what must be met during the winter months, when ice is forming rapidly, and

ice bridges, dams, and shoves may change the whole character of the levels and channels in a single night. Rivers are thus known to have been turned entirely out of their course into new channels during a winter of unusual severity, and in some instances the reversal of a rapid is of yearly occurrence.

No one set of conditions may be said to hold from year to year, on account of the variations in the severity of the winters. Therefore, before an engineering scheme is carried out, a careful study should be made of neighboring conditions, previous summer and winter levels, and deductions made from a consideration of the native traditions over an extended region round about. Indeed, where possible, at least two years should be devoted to the study of the ice conditions at any particular locality where it is desired to erect an expensive plant. It is a well-known law of Nature that any change in a system in equilibrium due to outside conditions brings about a change within the system in a reverse direction. To convert a substance of higher energy-content (water) into one of lower energy-content (ice), a large amount of energy is liberated in the form of heat to resist that change. Water differs from ice in possessing a store of energy latent in itself and which we measure as heat. The magnitude of this energy may be realized when we remember that, in the passage of water into ice, enough heat is liberated to warm 143 times its own mass one degree on the Fahrenheit scale above the freezing-point.

A study of ice formation means a study of heat transfer, and of the physical laws governing its movement from one body to another. It is my intention, therefore, before considering the practical details of river-ice formation, to run over, in as brief a manner as possible, the laws governing heat transfer. A review of this kind is important at the outset, in order that the essential points of the subject in hand may be made clear in the light of modern ideas of physics.

The position occupied by water in the economy of Nature is most remarkable, and everywhere we see natural conditions influenced and moulded by its wonderful properties.

It has the highest capacity for heat of any substance, and it is this which governs to a large extent the temperature of the earth. It tempers the seaboard and equalizes the climates of the earth in a way which no other known substance could do. The remarkable increase in thermal capacity as the freezing-point is reached makes it more difficult for water to be cooled to that critical point; and when the freezing-point is reached ice can form only at the expense of a large amount of latent heat, larger than any other known substance.

Composing three quarters of the earth's surface, eighty per cent of the animal body and about ninety per cent of the vegetable, water may be said to largely control the conditions of life.

The expansion of water as the freezing-point is reached, and the position of maximum density, protect our lakes and rivers from becoming entirely solid. The large expansion in the passage of water into ice provides a protective coat to our waterways, and lessens the growth of ice. Where this protective coat is not possible, as in a rapidly flowing river we meet with the worst effects from the presence of ice.

Water is of all substances the best solvent, and has thereby exerted a tremendous influence in altering the crust of the earth, and in the formation of minerals and rocks, in which it is usually found combined. Water is thus worthy of our highest consideration; and a careful study of the conditions under which Nature seeks to preserve this important substance, and prevent its passage into a form useless to her many and varied needs, is of the utmost importance.

CHAPTER I.

PHYSICAL LAWS GOVERNING THE TRANSFER OF HEAT.

Radiation. Surface Emissivity and Solar Radiation. Conduction.
Convection.

THE fundamental conception in connection with ice formation is that the mass formed is dependent on the amount of heat lost. This involves a knowledge of the conditions which will bring about an abstraction of heat. In all cases we have the same laws obeyed, and the same forces operative, in the largest lake or river as in the most delicate laboratory experiment. The great variety of conditions in Nature give rise to many ice forms, but in all cases the manner of heat transfer is the most important determining factor.

Few subjects give rise to so many and varied theories, which are due, no doubt, to the peculiar character of the observational evidence at hand. If we sift such evidence down, however, it must be possible in all cases to find adequate explanation in the fundamental laws of heat transmission.

It must be acknowledged at the outset that to the physicist these fundamental laws are not by any means so well known as is desired, when they come to be applied to any particular group of conditions. Future study will doubtless enable a more complete application to be made, when it will be possible to offer a more perfect explanation in every instance.

If in this chapter I treat the subject of heat transfer in too

P.
elem
be t
fresh
1
from
radi
pera
equa
fer.
of h
cond
of th
consi
moti
body
mole
ordin
heat.
is de
heat
estab
state
conve
T
You
waves
well
as di
appe
takes
space
With
laws

elementary a way, I prefer to err in this direction; for we cannot be too careful at the outset to have the fundamental principles fresh in our minds.

The physicist recognizes three ways in which heat travels from a body of high to one of low temperature. These are by radiation, conduction, and convection. A difference of temperature existing between two bodies brings about an effort at equalization by one, two, or all three of these methods of transfer. This does not mean that there are three different kinds of heat, one variety always travelling by radiation, one by conduction, and another by convection. Heat is a measure of the internal energy of the molecules of a body. All bodies consist of molecules in a state of vibration, and the energy of motion of these molecules determines the temperature of the body. At the absolute zero of temperature the motion of the molecules is supposed to be incapable of bringing about the ordinary sensation of heat, and the body is said to possess no heat. It is at the lowest possible temperature as temperature is defined, i.e., with reference to its power of communicating heat to other bodies (Maxwell). The dynamical theory of heat, established by the experiments of Rumford, Davy, and Joule states that heat is a result of motion and that they are mutually convertible.

The development of the wave theory of light by Fresnel and Young involved also the idea of the transmission of heat by waves, for it is by the same means of conveyance that heat, as well as light, reaches us from the sun. The process of radiation, as distinguished from conduction and convection, does not appear to depend in any way on the presence of matter. It takes place through the best vacua, and through interstellar space with the enormous velocity of 187,000 miles per second. Without any hypothesis as to the nature of radiant heat, the laws of its reflection and refraction may be studied. Whatever

the mechanism, we have abundant experimental evidence that the process is precisely the same as that of the propagation of light. What it is that is propagated is energy.

A difference of temperature between two bodies merely means that a difference exists in the energy of the molecules of the two bodies, which may be equalized with lapse of time by radiation, conduction, and convection until equilibrium results. The conditions may be such as to allow of only one, or of two, or of all three of these methods to become operative.

Radiation.—In general we speak of radiant energy as including all classes of ether-waves set up by the energy of molecular or atomic vibration. Thus all bodies radiate and are the recipients of energy in the form of waves. In a perfectly elastic medium, such as the ether is supposed to be, the velocity of the various wave-motions set up in it by whatever source remains the same. Thus the electric waves, the heat-waves, the visible light-waves, and the ultra-violet or chemical rays all possess the same velocity, which has been found to be very nearly 187,000 miles per second, or 3×10^{10} cm. per second.

The number of waves produced per second determines the length of the wave, the familiar expression connecting these with the velocity being $v = nl$, where v is the velocity, n is the number per second, and l is the length of the wave. Molecules vibrating rapidly produce shorter waves of greater rapidity than molecules vibrating more slowly.

The visible rays extend over only a very short range, from about .4 thousandths of a millimeter to .8 thousandths. These, on account of the greater ease of study, are by far the best known; but beyond these limits, on either side, waves exist which are detected by other physical properties. Beyond the violet we have a series of waves made familiar by their chemical action. The shortest of these waves which we have yet detected are probably the X-rays, or γ -rays from

F
radi
of 1
urec
blar
unti
mill
nize
one
less-
wav
long
as y
of w
?
conc
light
unde
?
(an
that
the 1
is sh
mop
to r:
heat
reac
nerv
heat
the 1
E
as ra
as a
ture

radium. Beyond the red rays we find longer waves, capable of producing the sensation of heat. These have been measured as far as about 60 thousandths of a millimeter. A blank then follows of several octaves, using a musical simile, until we come to the shortest electrical waves of about 4 millimeters. Then follows a series of waves which are recognized by their electrical properties, until we produce waves one to four miles long from the large oscillators in the wireless-telegraph stations. We have no reason to doubt that waves exist, or are capable of being produced, between the longest heat and the shortest electrical waves, but we have not as yet discovered any physical property of the waves by means of which they can be measured.

The heating properties of the waves are those we are chiefly concerned with here; but it is only by comparing them with light-waves, which we are more familiar with, that we can understand them.

An examination of the spectrum of light with a thermopile (an instrument sensitive only to heat-waves) reveals the fact that the heating power of the rays increases rapidly towards the red end and passes through a maximum just beyond. This is shown in Fig. 1, where the relative heating effect on a thermopile, which has been moved through the spectrum from ray to ray, is illustrated by a curve. This shows clearly that the heating effect of the rays is greatest just before the rays are reached which are capable of producing an effect on the optic nerve. The red, orange, and yellow rays produce considerable heating effect as well as visible effects. The heating power of the rays falls off rapidly towards the violet end.

Every body at a stationary temperature must be regarded as radiating energy at a constant rate; it must also be regarded as absorbing energy at the same rate, otherwise its temperature would fall. Thus a body suspended in a room, at the same

temperature as its surroundings, radiates to, and is the recipient of, waves from other sources at the same rate. The higher the temperature of a body with respect to its surroundings the faster it radiates energy. A sufficient elevation of temperature brings about an emission of the luminous rays of least refrangibility, and it is said to be red-hot. As the temperature

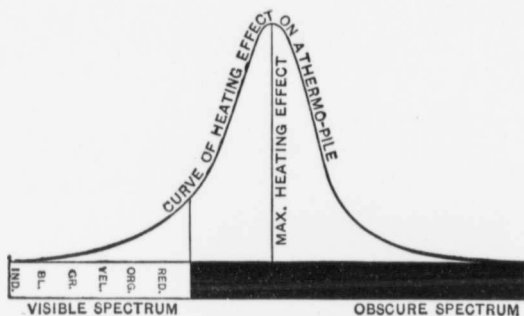

FIG. 1.—Distribution of Heat in Spectrum.

is raised some of the rays of higher refrangibility are produced, and the body is said to become white-hot, producing a mixture of all the rays which are visible, as well as the heat-rays. In a vast mass of vibrating, moving molecules it could not be expected that all would possess the same period of vibration, or be homogeneous. We therefore find that any source of rays gives out mixed rays, or rays of different wave-length. Thus a highly incandescent body gives out white light from the mixture of all the spectral colors, as well as the shorter heat-waves beyond the red. Just what combination of causes determines the number or limit of the rays produced is not known. It is evident that temperature has the predominating influence. Illuminators of low temperature are reddish yellow; others, of high temperature, as the arc-light, are white, possessing a large number of the ultra-violet rays as well. Such a light as the mercury-vapor lamp is poor in red and yellow rays and rich in

green
small
effici

T
is w
flame
the f
from
radia
wave
length
the 1
exten

In
that :
surfac
incide
Kirch
radiat
the p
posses
black
or tub
found
of thi
nothin

In
earth
waves
waves.
a trap
the sh
throug

green, blue, and ultra-violet rays. This light emits a very small proportion of heat radiation, and is therefore the most efficient form of light yet devised.

That temperature alone is not the sole determining factor is well illustrated by placing a platinum spiral in a Bunsen flame, and comparing the radiation produced with that from the flame alone. The spiral cannot well differ in temperature from the flame in which it is immersed, but the character of the radiation is decidedly different. The spiral absorbs the heat-waves from the flame and converts them into waves of shorter length, including light-waves as well. Thus the surface, and the medium setting up the radiation determine to a large extent the character of the radiation.

In a study of the radiation of various bodies it was found that all types had to be referred to that from a perfectly black surface. It is only such a surface that absorbs all the rays incident on it, and correspondingly emits all the rays. Thus Kirchhoff conceived the idea of a "perfectly black body," the radiation of which would possess a character independent of the property of any particular substance. Since we do not possess a body which fulfils such requirements, the "perfectly black body" was found to be that represented by an enclosure, or tube closed at one end and blackened on the inside. It was found that the radiation within a uniformly heated enclosure of this kind depends on the temperature of the enclosure and nothing else.

In the same way that we receive heat from the sun, the earth is continually losing heat by radiation into space. Heat-waves from terrestrial sources are, however, longer than solar waves. This is well illustrated in the way greenhouses act as a trap for the sun's heat. Glass has the property of allowing the short heat-waves and the luminous waves to pass freely through, but is fairly opaque to the long heat-waves. The

solar rays readily pass through the glass and are absorbed by the earth and vegetation, thereby raising their temperature. The return radiation from the warmed earth consists of much longer waves from a low-temperature source, as compared to the sun, and are in consequence unable to penetrate the glass outwards. They are therefore radiated back again, and the whole interior of the greenhouse is warmed.

Bodies differ a great deal in their power of absorbing or transmitting heat-waves. Many bodies which freely transmit light are exceedingly opaque to the heat-waves. Other bodies, on the other hand, transmit heat but are opaque to the light-waves. It seems that the transmission of any particular type of ether-waves by matter depends on the relation of the vibration of the molecules to the period of the waves. Thus we might expect to find in nature bodies which absorb and others which transmit the same rays. Some bodies absorb several different types of rays and transmit freely intermediate waves. Such bodies are said to exhibit selective absorption. We usually speak of a body which freely transmits heat-waves as a diathermanous body, and that which is opaque to the rays as athermanous. Drawing a simple comparison from what we can easily observe in the case of light-waves, we know that red glass absorbs all the rays but the red, green glass all but the green, and so on for the various colors. A solution of permanganate of potash allows free passage to both ends of the spectrum, i.e., the red and the violet, but stops off by absorption all the intermediate rays.

Considering the heat spectrum, we are prepared to find that bodies may transmit portions of it and absorb others, but less is known about this on account of the greater difficulty of the experiments. The selective absorption of bodies for the heat-waves was first established by De la Roche. It is to the elaborate researches of this investigator and to Melloni that we owe most of our knowledge of the transparency of bodies for heat-

P
 way
 wor
 was
 and
 pas
 eith
 mat
 ingl
 and
 scar
 lam
 per
 380
 wat
 for
 a p
 spir
 spir
 and
 7
 by l
 fron
 TABL
 —
 —
 Rock
 ..
 Icelan
 Mirro
 Carbo
 Emer
 Ambe
 Alum
 Melte
 Ice (v
 —

waves. The general method which was adopted by these workers may be briefly described: the source of heat-waves was placed at one side of a screen provided with an aperture, and a thermopile was placed at the other. The radiation, after passing through the aperture, fell upon the face of the pile, either unobstructed or after passing through a thin plate of the material under test. It was found that rock salt was exceedingly diathermanous, transmitting over 90 per cent of the rays, and that plates of alum and pure water of the same thickness scarcely transmitted the tenth part of the radiation from a lamp-flame, and almost none of the radiation from a low-temperature source, such as a blackened copper ball heated to 380° Cent., or from the face of a Leslie cube containing boiling water. In all, the transparency of various materials was studied for the rays from a Locatelli lamp without a glass chimney, a platinum spiral heated to incandescence in the flame of a spirit-lamp, a copper plate heated to nearly 400° Cent. by a spirit-lamp, and a thin copper vessel blackened on the outside and filled with boiling water.

The following table contains a few of the materials studied by Melloni, and selected from the well-known table compiled from his researches:

TABLE OF TRANSPARENCY OF DIFFERENT MATERIALS FOR RADIANT HEAT.

Thickness, 2.6 mm.	Locatelli lamp.	Incandescent platinum.	Blackened copper heated to 400° Cent.	Blackened copper heated to 100° Cent.
Rock salt (clear)	92	92	92	92
" " (dull)	65	65	65	65
Iceland spar	39	28	6	0
Mirror-glass	39	24	6	0
Carbonate of lead	32	23	4	0
Emerald	19	13	2	0
Amber (natural)	11	5	0	0
Alum.	9	2	0	0
Melted sugar	7	0	0	0
Ice (very pure)	6	0	0	0

A similar table was compiled for liquids, using an Argand burner with a glass chimney. Every liquid was enclosed in a glass cell with parallel faces:

TABLE OF TRANSPARENCY OF LIQUIDS FOR RADIANT HEAT.

Liquid thickness, 9.21 mm.	Per cent of rays transmitted.	Liquid thickness, 9.21 mm.	Per cent of rays transmitted.
No screen.	100	Nitric acid.	15
Mirror-glass.	53	Alcohol.	15
Turpentine.	31	Sugared water (colorless)	12
Naphtha.	28	Alum-water.	12
Sulphuric ether.	21	Salt water.	12
Pure sulphuric acid.	17	Distilled water.	11
Ammonia.	15		

This table shows that pure water is exceedingly opaque to the particular type of radiant heat from a luminous source, and that salt in solution, as well as alum, slightly increases rather than decreases the diathermancy.

It was found that bodies which absorbed a large proportion of the heat-rays were exceedingly transparent to such rays that succeeded in passing through them. This sifting of the rays, as it is called, was also studied by Melloni. Thus a plate of alum, which transmits only 9 per cent of the heat from a naked flame, transmits 90 per cent of the rays which emerge from an alum plate. This is what we might expect when we consider that the absorption of rays means the transformation of the ether-pulse into molecular vibration, and such waves as are found to penetrate a body are those out of tune with the molecules and not influenced by them. The emergent waves are those which have been sifted by the particular body, and are little affected by again passing through the same material.

An examination of the diathermancy of gases and vapors was first successfully carried out by Tyndall in 1859, after a long series of trials. In general he showed that air, oxygen, hydrogen, and nitrogen, when carefully purified, showed no

sensible absorption of heat. The vapor of ammonia was found to absorb a large proportion of the heat-waves. Ozone was found to behave in the same way. Special attention was given by Tyndall to the absorption by aqueous vapor, for the high absorptive power of water led him to conclude that the vapor would act in the same way. The question was one of the greatest importance in meteorology. He found that the ordinary air from a room absorbed 72 times as much heat as the air when purified and dried. It was concluded that moisture in the small proportion found in the air, and the presence of carbon dioxide, was sufficient to increase the absorption by this large amount. The high absorptive power of moisture was further established by examining air with high degrees of humidity.

The experiments of Magnus, in 1861, tended to refute the conclusions of Tyndall in regard to moisture; but it seems from later results that pure air is highly diathermanous, and that carbon dioxide and moisture, present in ordinary air, possess a well-marked absorptive power, thus confirming the experiments of Tyndall.

The temperature of the source of radiation has, as we have been led to expect, a well-marked influence on the transmission of the heat-waves, inasmuch as temperature determines to a large extent the character of the waves emitted. Take ordinary glass, for an example; it allows the free passage of the luminous and short heat-waves, which are transmitted by the sun, but is highly opaque to the obscure or ultra-red rays. A plate of glass only one tenth of an inch thick intercepts all the radiation from a source at 100° Cent., and transmits only 6 per cent of the radiation from a source at 400° Cent. It is for this reason that glass is extensively used as a fire-screen.

Much experimental work has yet to be done as to the character of the absorption of the long heat-waves emitted by bodies at ordinary temperatures, and from very cold bodies. This affects

the question of terrestrial radiation very considerably; for in this case we are dealing with the radiation of the comparatively cool earth into space, which we consider to be at the absolute zero of temperature. It is therefore of little use to apply our study of hot-body radiation to terrestrial problems. It is not to be supposed, because a substance like water has been found to be highly opaque to the radiation from hot bodies, that it will be the same for cold-body radiation. We shall see later on that the whole question of the formation of anchorage depends on admitting that the long heat-waves can penetrate freely through water. It is probable that water possesses an absorption-band for the shorter heat-waves, but may become perfectly transparent for the longer heat-waves. It is to Rubens and Aschkanass, in 1898, that we owe our knowledge of the existence of an absorption-band in the case of water. These investigators observed a well-marked band at about 50 thousandths of a millimeter (50μ , $\mu = .001$ mm.). For the sake of comparison I show in Fig. 2 the absorption-spectrum for iodine



FIG. 2.—Absorption-bands observed when Light is Passed through Iodine Vapor.

vapor. In this we see exhibited in the case of light-waves what takes place for many substances for the heat-waves as well. The well-defined dark bands show where the particular radiation has been removed from the light during its passage through the vapor. With the exception of the bands, light is transmitted freely. In the case of water it may yet be proved that, beyond the absorption-band of Rubens and Aschkinass, the heat-waves are transmitted without sensible absorption. Drude has shown (1898) that water is opaque to

the short electrical waves. In his experiments he used waves from 9 to 10 cm. long, which were strongly absorbed. On the other hand, he found that waves of the order of 60 cm. were freely transmitted. It appears, then, that the transmission of water for ether-waves shows the presence of absorption-bands. In consequence we have no more reason for supposing that the absorption-band for the waves of 50 thousandths runs continuously into the band for waves of 9 cm., than we have for supposing that waves between these, possessing heating properties, have the power of penetration. When we consider the very latest evidence, the balance of proof seems to point to the latter as being correct, that water is transparent to the very long rays.

I have recently made some experiments on the absorption of terrestrial radiation, and, although they are not yet by any means complete, they point very strongly to the fact that water, and especially clear ice, is transparent to a large proportion of the radiation from the earth into space. Two platinum coils were made, wound on flat mica frames and blackened, and each enclosed in a box blackened on the inside. On leaving one coil uncovered to the sky at night, during the winter-time, it was found to become cooler than the uncovered coil by from 5° to 9° Fahrenheit. A block of clear ice 2 inches thick placed over the open thermometer cut off only a small percentage of the radiation. Glass, 2 mm. thick, cut off a much larger proportion of the rays, but not all of them. A box with a glass bottom was constructed, in which was placed a layer of salt solution, 1 cm. thick, and then another glass was placed over this to prevent evaporation. Radiation was found to take place through all of these materials, although it would have been quite sufficient to have cut off all of the radiation from a source at 100° Cent. or 400° Cent. The explanation of this cooling of the thermometer can only be made on the assumption that it

was emitting rays which could penetrate the glass and water. The almost perfect transparency of the ice for the radiation into space, makes it appear probable that water also would be much more transparent if the rays had not to first pass through the glass plate. In the case of ice formation in nature, we are always dealing with radiation from a surface at 32° Fahr., or below, into space through an atmosphere almost devoid of water-vapor.

During recent years several very important investigations have been made on the long heat-waves by Rubens and Aschkinass and Nichols, who have experimented with prisms of rock salt, fluor-spar, sylvine, and quartz. They have succeeded in extending the important researches of Langley, and carrying the results farther into the region beyond the red to as far as 60 thousandths of a millimeter.

A very good statement of the limits of our present knowledge in regard to the long heat-waves has been given by Professor E. F. Nichols, of the University of Columbia, in a paper entitled "The Unobtained Wave-lengths between the Longest Thermal and the Shortest Electric Waves yet Measured," which was presented at the International Electrical Congress at St. Louis in 1904. In considering the present boundaries he points out the great advance which has been made in the measurement of the long waves by successive reflection from crystalline surfaces, such as quartz. After five reflections on sylvine surfaces, waves of 61μ in length have been isolated and measured. In character these long waves resemble electric waves more closely than they do light-waves. All metallic surfaces reflect them about equally and almost entirely. The relations between reflecting power and electric conductivity, and between refractive index and dielectric constant, hold more rigidly than in light-waves. It has been possible to demonstrate, with conducting areas of suitable dimensions, the same laws of resonance for

heat-waves which were known previously only for electric waves.

Professor Nichols further questions how much farther the method of isolation by multiple reflection, which has yielded so much, can be carried. Substances are known which should have regions of absorption and metallic reflections beyond 60μ ; but the difficulty of experimenting is very great. Rubens has calculated that from a black body at 2000° Cent. the intensity of the radiation of waves of the length of 1.5μ is 800,000 times greater than for waves of 60μ . If the total energy between wave-lengths 50μ and 60μ be taken as unity, the total energy between 60μ and 100μ will be 0.7, and between 100μ and 1000μ only about 0.2. It will be seen, then, how small a proportion of the very long waves exist compared to the shorter waves.

Turning to the electric spectrum, Professor Nichols points out that, beginning with the 60-cm. waves of Hertz, investigators like Righi, Lebedew, and Lampa have successively reduced them. Lampa, using an apparatus differing in no essential respect from the infra-red grating spectrometer, was able to obtain and make measurements with waves only 4 mm. long.

Summing up the complete ether spectrum, Professor Nichols

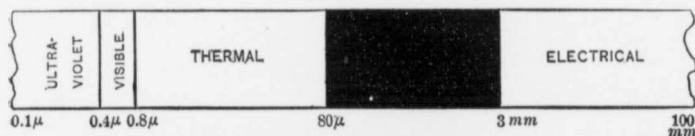

FIG. 3.—Diagram of Ether Spectrum.

shows that, beginning with Schumann's and Lyman's short ultra-violet waves of the order of 0.1μ , we have about two octaves in the ultra-violet, one in the visible, and six in the infra-red spectrum, making nine in all. The shortest electric

waves yet produced begin about six octaves lower in the scale. See Fig. 3.

Surface Emissivity and Solar Radiation.—It is of importance to know, with a certain amount of approximation, the quantity of heat emitted by radiation from a surface in a given time. The laws of cooling were worked out very completely by Dulong and Petit in 1817, who experimented with bodies heated above their surroundings, and suspended in a closed space exhausted of air. They found that the velocity of cooling depended on some function of the temperature, this function being determined by the character of the surface. Thus we find that different surfaces differ in their power of radiating heat, and complicate an otherwise simple problem.

In 1871, Macfarlane first gave us trustworthy results of surface emissivity in absolute measure. The method adopted consisted in observing the cooling of a copper sphere, about 4 centimeters in diameter, which was suspended in a double-walled vessel. The interior surface was coated with lampblack, and the ball was tried, in the one case, when polished, and, in the other, coated also with lampblack. He found that the emissivity, in calories per square centimeter per second, per degree difference in temperature for temperature differences of from 6 to 60 degrees centigrade, varied from .000178 to .000226 for the polished surface, and from .000252 to .000328 for the black surface.

Bottomley's experiments (1887) on the energy radiated from a bright platinum wire per square centimeter, in calories, gave as a result .03788 at 408° Cent., and .07261 at 505° Cent.

For ordinary materials it is not easy to select a suitable value for the rate of emission of heat-energy. We have to assume that the surface is a black one, which will give the maximum effect, and then correct it as best we can from a

comparison of Macfarlane's experiments. This gives at least an outside estimate, and yields approximate results.

The amount of heat which we receive from the sun is a matter of great interest, and has been the subject of countless researches. The solar constant, as it is called, is defined as the amount of heat received per minute on a perfectly absorbing surface, of one square centimeter, presented normally to the sun's rays at his mean distance. The surface is supposed to be situated just outside our atmosphere. Crova found (1900) from his experiments, carried out at various places, such as Mont Blanc, Mont Ventoux, and Montpellier, that the solar constant cannot be less than 3 calories. He used an actinometer or pyroheliometer, which consists of a small calorimeter blackened externally and exposed alternately to sunshine and shade. Biot's formula was applied in correcting for the amount of atmosphere traversed. Violle found 2.5 calories on Mont Blanc, Langley, 3 calories on Mount Whitney, and numerous other experimenters range from 2.8 to 3.4 calories. A recent result by Hansky (1905), using Crova's method on Mont Blanc, is 3.29.

It is probable, however, that this constant is not in reality a constant quantity, for it cannot be assumed that the successive portions of the sun's surface presented to us have all the same radiating power. It is probable, also, that the heating power of the sun undergoes a periodic variation, corresponding to the variation in the area of the sun-spots, the period being roughly about 35 years.

The amount of heat actually received on the earth's surface is less than 3 calories, owing to the absorption in the air by the water-vapor, and the obliquity of the radiation.

The temperature of the sun, as deduced by the latest methods, based on the laws obtained for "black-body radiation," is just about 6000 degrees centigrade, and although very varying results have been obtained from time to time

by different observers, this seems to be the most trustworthy value.

The earth is in temperature equilibrium only with a portion of the sun's radiation, for the energy it receives from the sun consists of shorter waves than it emits. Many of the shorter waves are absorbed by the atmosphere and are radiated back again into space, while the longer waves emitted by the earth are more freely transmitted outward without being absorbed.

We know, however, from Professor Rutherford's researches, that heat produced by the radium-content of the earth is more than enough to make up for the loss of heat from the earth by radiation, and the temperature of the earth is by this means a little higher than it otherwise would be, and compensates somewhat for the unequal exchange of energy.

Conduction of Heat.—Conduction of heat differs from radiation in that it is an exceedingly slow process. Whereas radiant energy is transmitted with the tremendous velocity of 187,000 miles per second, conduction of heat is often an appreciable time in travelling a short distance. We generally regard conduction as the transfer of heat from particle to particle of a body, or from one body to another by contact. Thus, when a metal rod is thrust into boiling water, the heat gradually travels along the bar, part being absorbed in raising the temperature of the bar and part being lost by radiation from the surface. When the steady state has been reached, that is, when all parts of the bar have been raised to a steady temperature, as much heat is radiated away as is being supplied from the heated end. Since the increased temperature in the bar means an increase in the molecular vibration of the bar, we see that the travelling of the heat is merely a travelling outward of the molecular vibration.

The simplest explanation of the phenomenon of conduction is that of the radiation of heat through an absorbing medium;

but it is sometimes regarded as the result of the direct action of molecules colliding with others owing to greater activity. It can hardly be said, however, that this last explanation is satisfactory, for we cannot well imagine a system of molecules in such close proximity as to touch without some sort of disturbance of the homogeneity of the material.

Moreover, the medium, which it has been found necessary to invent as being the vehicle of conveyance of the radiating energy-waves, we consider also as penetrating the intermolecular spaces of all matter. A wave-motion can therefore penetrate into a body, and produce a secondary action by influencing and setting in motion the molecules of the body. A molecule set in more rapid vibration would also have an influence on the ether directly surrounding it, which in turn influences the neighboring molecules. The collision of the molecules likely produces a change in the molecular arrangement, resulting in greater freedom of movement, and a different physical state of the body. It is simpler to consider the conduction of heat from the standpoint of the radiation through an absorbing material, and the rise of temperature merely as the increase in the vibration of the molecules.

The wave-motion, as it penetrates into the body, is absorbed by the comparatively heavy molecules, and as it proceeds farther and farther into the body it leaves behind trains of molecules with augmented vibration. Outwardly we observe a temperature elevation which proceeds along the bar, giving rise to what we term the conduction of heat. The process would naturally be a slow one, on account of the inertia of the molecules, and would be different for different bodies. A very clear mental picture can be obtained by considering a train of waves rolling into a quiet harbor from a storm at sea. In the harbor are several parallel rows of boats, at anchor. The first wave, as it rolls under the first row of boats, is absorbed in setting the

boats in motion, and is so far depleted as hardly to affect the second row. The second wave increases the motion of the first row of boats, but is less absorbed by them, and passes on to be absorbed in setting the second row of boats in motion. So each succeeding wave penetrates farther and farther into the harbor, and finally all the rows of boats are rocking in tune with the waves. The energy absorbed, now that the steady state has been reached, is that required to keep the boats in motion. In this simile the boats represent the molecules of matter anchored in the ocean of the ether, and the ocean waves the ether waves passing through.

It is immaterial whether we imagine the body to receive the heat-waves from incident radiation, such as a sunbeam, or ray from a fire, or whether the body is partially thrust into a hotter body, where the proximity of neighboring molecules in more rapid vibration sets up the heat-waves. In the same way that heat-waves are absorbed by producing increased vibration in the molecules, molecular vibrations are themselves centres of disturbance in the ether and produce waves.

The most elementary experiments show us that bodies differ very greatly in their conducting power. Thus wood conducts heat at a very much slower rate than silver, copper, or iron. A wooden rod, heated at one end, conducts heat so badly that all of the heat is dissipated from the end before any of it is conducted down the rod. In the case of a copper rod the heat is conducted away from the heated end fast enough to render the rod sensibly hot for a long distance. A very striking fact is brought out by a comparison of the conducting power of different materials for heat and for electricity, in that a table for one, arranged in the order of ascending or descending power, is also the table for the other. Unlike electrical conductivity, however, we have no material which is an absolute non-conductor for heat. Substances like silk are very perfect insulators

for heat, and yet we know that we can observe the passage of heat through silk, whereas the passage of electricity through silk is not possible in the ordinary sense of being conducted through.

The measurement of the conducting power of a substance is done in various ways. The conductivity for heat is defined as the quantity of heat in calories which passes across a cube of unit edge (1 cm.) in unit time (1 second), under a uniform temperature gradient of one degree centigrade per centimeter. Thus, if Q be the total quantity of heat passing between two surfaces of area A and distance apart D , and under a temperature difference dT in time t seconds, then

$$K = Q \frac{d}{dTtA},$$

where K is the conductivity after the steady state has been reached. Before the steady state has been reached part of the heat is absorbed in producing molecular vibration and raising the temperature of the body. The conductivity is then called thermometric conductivity, or simply diffusivity, k . Then $k = \frac{K}{c}$, where c is the specific heat of unit volume of the substance.

The diffusivity of heat through the earth is of great importance in dealing with ground temperatures, and much work has been done in determining the conductivity of the earth's crust. One of the standard methods for determining thermal conductivity is that of periodically heating and cooling a body, and tracing the course of the heat-waves by means of thermometers set at intervals in the body. This method is employed in the case of soil-temperature investigation by placing thermometers at different depths in the ground. The waves set up on the surface by the alternate heating and cooling of the seasons, and the daily variations can be traced into the soil, and the conductivity obtained. The diurnal

waves cannot be traced to very great depths, but the yearly waves are only lost at depths of about 50 feet. At this depth the mean temperature of the earth remains very constant. Beyond this depth, depending on the locality, and character of the earth, the temperature begins to increase. Roughly speaking, the rate of increase is about 1° Fahr. for every 50 or 60 feet of descent, although this falls as low as 30 or 40 feet in some places, and in others rises to as much as 120 or 130 feet. In this way there is a slow conduction of heat to the surface of the earth. Lord Kelvin has calculated that the diffusivity of garden sand is of the order of .0087 in C.G.S. units, and that of sandstone, .0231.

In the experiments of Professors Callendar and McLeod at McGill University in 1895-96, made with platinum thermometers buried at various depths in the earth, it was found that the old river-sand composing the bed of the College grounds had a diffusivity of .0043 in C.G.S. units. This is of importance as indicating the rate of transmission to the bed of a river of the heat of the earth, although moisture increases this to a certain extent.

One of the most interesting facts brought out by the experiments of Callendar and McLeod on soil temperatures is the remarkable steadiness of the temperature of the earth during the winter-time. This is due to the protective effect of the snow-covering, and is followed by an extremely rapid rise as soon as the snow disappears and the ground is thawed.

It was found that the annual mean temperature of the soil is nearly 5° Fahr. above the mean temperature of the air, as a result, probably, of the protection afforded by the snow.

Some typical diurnal curves are shown in Fig. 4 for five very hot days in May. The change from hot to cold at night is sharper at that season of the year. It will be observed that the waves, which are well marked on the thermometer buried

a
in
20
th
60
30
M
Fr
the
tion
I
of th
C
Z
B

at a depth of 4 inches, become much less apparent on the 10-inch thermometer, and disappear almost entirely at a depth of 20 inches.

The effect of a thunder-shower on the 7th is apparent by the diminution of the amplitude of the wave following. This,

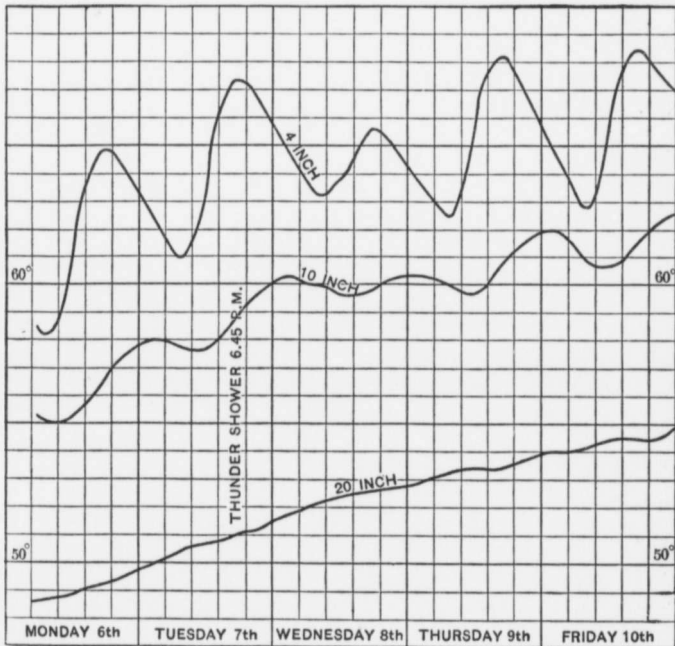

FIG. 4.—Diurnal Waves of Heat in the Earth. Callendar and McLeod.

the authors consider, may have been due to a check to radiation by the cloudiness of the sky.

I give here a few values showing the conductivities of some of the more common materials, including ice :

TABLE OF ABSOLUTE CONDUCTIVITIES, C.G.S. UNITS.

Copper.....	1.108	Iron.....	.164
Zinc.....	.307	Ice.....	.005
Brass.....	.302	Water.....	.00136

The values represent the amount of heat in calories which is conducted across a cube of one centimeter edge in one second, with a difference of temperature at the boundary faces of one degree centigrade.

It will be observed how much better a conductor of heat ice is than water, and how poor both materials are, compared to the good conducting metals.

Gases are much poorer conductors of heat than either solids or liquids. The difficulty of making accurate measurement is very great, on account of the change in density which takes place when the temperature changes, giving rise to convection currents. Satisfactory results have been obtained from the experiments on cooling, and also from the kinetic theory of gases.

If we take the conductivity of air to be 1, then water is 30, iron is 3500, and copper as much as 20,000 times better. It will be seen, then, that air is one of the best non-conductors of heat that we have.

Convection of Heat.—The movement of portions of matter at a higher temperature than their immediate surroundings, and the consequent conveyance of heat from one place to another, is what is termed convection of heat. It is brought about entirely by the change of density which takes place with a change of temperature.

All bodies expand on heating, and in the case of such mobile bodies as liquids and gases, the heated portions rise under the action of gravity on the heavier portions at a lower temperature. It will be seen, then, that a study of the thermal conductivity of liquids and gases is a matter of some difficulty, since there is, besides the ordinary process of conduction, a diffusion of the heated matter upwards, giving rise to the convection currents before mentioned. This is of course overcome, to a large extent, by applying the heat from above, in which case the movement of the heated layers is reduced

to a minimum. Convection is an exceedingly important method of heat transfer, as it includes, directly or indirectly, by far the greater part of meteorology, as well as being the basis of all our methods of heating and ventilation. Since convection deals with the motion of fluids, it is properly a branch of hydrokinetics. More experimental data are required for the complete treatment of this subject, but we must be content to indicate some of the results in a very general way. It is one of the most simple subjects in dealing with the fundamental principles, but presents great difficulties when actually applied to general problems in nature, owing to the great complexity of almost every one of its effects.

In summer weather, in the vicinity of the seacoast, we have examples on a large scale of the process of convection, due to the large changes of temperature of the land, while the sea remains nearly constant in temperature during the whole day and night. As the land is heated by direct sunshine on a clear day, the heated air rises, and its place is taken by a horizontal inrush of cold air. This gives rise to the sea-breeze. After sunset the land grows cold by radiation, and the air above becomes colder than that over the sea. The air rushes out to sea to take the place of the warmer air, and gives rise to the land-breeze.

The rising of heated air may be shown very well by observing the upward rush of air around a spirit-flame, or Bunsen burner, when smoke is allowed to mingle with the inrushing cold air. Where a flame is supplied with a chimney, as in an ordinary coal-oil lamp, the upward rush of hot air is considerably increased. This illustrates our methods of ventilation by means of air-shafts or chimneys. The great increase in the draught of a fireplace after the fire at the base has been lighted is familiar to every one.

Water heated in a flask by a flame at the bottom is set

in rapid motion by the rising of the heated portions, and these currents can be traced by means of sawdust or bran. A constant circulation can thus be maintained by keeping the outside of the flask cool. This is shown in the accompanying figure, where the arrows represent the direction of the convection currents.

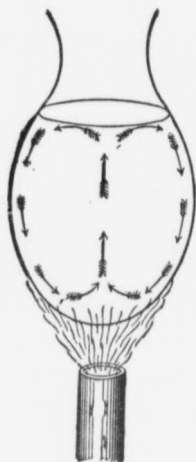

FIG. 5.—Convection Currents in Water.

A system of hot-water heating depends on convection currents. The heat generated from the burning coal is distributed throughout a large area by means of water or air conveyed in pipes or shafts. In the case of water, the cool water returns to the furnace, or source of supply, by the force of gravity, and, after gathering a fresh store of heat, rises again through the network of pipes. In Fig. 6 is shown how water may be made to circulate in a closed pipe by heating on one side. An open fireplace is an excellent illustration of the method

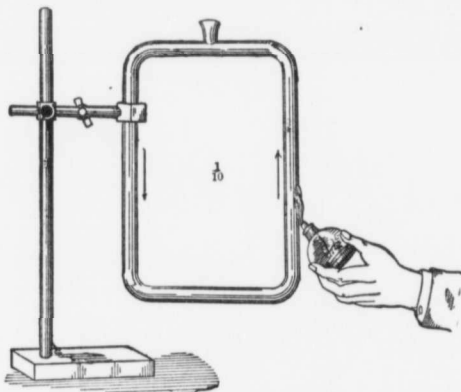

FIG. 6.—Water Circulating in Pipe by Convection Currents.

of heat transfer by all three methods. The heat, resulting

from the combustion of the wood or coal, is partly carried up the chimney by convection, is partly radiated out in the room, and is partly carried out by conduction along the hearth.

The importance of convection in equalizing the climates of the earth cannot be overestimated. Thus the Gulf Stream and the trade-winds bring the cool of the arctic regions to temper the heat of the tropics, setting up vast chains of moving masses of matter.

The presence of water-vapor in the air has a very important influence on the great convection currents rising from the surface of the earth. Tremendous heating and cooling effects are brought about by the rapid condensing and expansion of the mist in the atmosphere; and we know that the evaporation of large masses of water, and its subsequent carriage by convection currents of air to be again liberated in cooler regions, have a great deal to do with problems of meteorology. The convective equilibrium of a moist atmosphere is not a simple question, although vastly easier than a study of its complicated motions.

In the sun's atmosphere convection currents of extraordinary magnitude have been observed, and speeds of 100 miles per second have been measured by perfectly trustworthy methods.

CHAPTER II.

PHYSICAL CONSTANTS OF ICE.

Density. Maximum Density of Water. Heat of Fusion, or Latent Heat. Specific Heat of Ice. Specific Heat of Water, and the Thermal Unit. Thermal Conductivity of Ice and Snow. Thermal Conductivity of Water. Coefficient of Expansion. Relative Hardness or Penetrability. Plasticity. Viscosity. Vapor-pressure of Ice and Supercooled Water. Electric Properties.

Density of Ice.—The earliest determination of the density of ice was made by Robert Boyle (1772), and the method employed was to observe the difference in volume of a certain quantity of water contained in a calibrated receptacle, first in the liquid and then in the solid state, and from this to calculate the density of the ice. The vessel used was a glass one, with a long narrow neck on which the graduations were marked. This was filled with water exhausted under an air-pump and so comparatively free from air. A freezing-mixture was then applied to the vessel from below, moving the mixture up as congelation took place, which by this method did not involve the fracture of the glass. In this way the volume of the water when frozen was observed to increase 11.12%, which gives the value for the density of ice as 0.903. No great scientific value was aimed at here, the strains undergone by the glass during the formation of the ice rendering the results most uncertain, apart from the probable presence of minute cracks in the ice formation, a difficulty exceedingly hard to guard against in determinations involving the use of artificial ice. There were several other early determinations made by Williams, Heinrich,

Dumas, Osann, and others, and results obtained at various values ranging from 0.905 to 0.950. These, however, do not call for any special attention, as they were for the most part derived from investigations carried on in a comparatively rough way, and often involving corrections of such a nature as to render the results quite useless from a scientific point of view.

During the last century there were many accurate determinations of the density of ice.

The first of these was performed by the German physicist Brunner (1845). His method consisted of weighing ice in different media, whose densities could be accurately determined.

For this purpose he prepared pieces of river-ice, formed during very sudden and severe cold weather. This ice he found could be procured in sizes suitable for his experiments, without flaw or crack of any description. He devoted some time and attention to the production of artificial ice free from air, but was not successful in obtaining any sufficiently free from the flaws and cracks which usually characterize this kind of ice.

The weighing was first conducted in air, corrections being made for air-displacement. Then the specimen, which was suspended from the arm of the balance by a single human hair, was immersed in refined petroleum-oil. The specific gravity of this oil was determined with the utmost accuracy, the method employed being that of weighing in air and in the petroleum a piece of glass of which the coefficient of expansion had been determined very carefully. The loss of weight undergone by the specimen of ice when immersed in this liquid afforded the data for the computation of its density, which was found to be 0.9180 ± 0.000039 .

It is worthy of note here that this series of experiments, while involving the determination of the ice density, was not undertaken for this especial purpose, but rather for the refutation of a statement that the density decreased with a decrease

in temperature. This, needless to say, was entirely disproved, the linear coefficient of expansion obtained being 0.0000375. (Experiments carried on at -1° to -20° C.)

A short time after Brunner, the next experimenters of note to undertake determinations of this quantity were Plücker and Geissler. The principle employed by them was essentially that of Robert Boyle, to whose experiments reference has been made, the method of course being subjected to refinements not attempted in the earlier experiments.

The instrument employed was a dilatometer of exceedingly delicate construction, as shown in Fig. 7. First, the instrument was completely filled with mercury, after which water was introduced through the small opening at *C*; when the inner bulb, *B*, had been almost completely filled with water, the inlet *C* was sealed off in a flame.

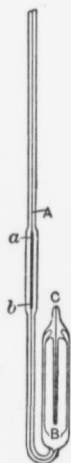

FIG. 7.
Plücker and Geissler's Dilatometer. The introduction of the water into the instrument forced the mercury up into the capillary tube *A*, which had previously been very carefully calibrated. The instrument was now ready for use and was placed in a bath at 0° Cent., and the height to the mercury-thread noted; then the apparatus was transferred to a freezing-mixture, composed of alcohol cooled by ice and calcium chloride. As one would expect, the walls of the instrument gave way under the strain when congelation took place; however, the mercury was forced up in the capillary tube *A*, and the movement was a direct measure of the expansion of the water on freezing. Only three determinations of this kind were made, probably owing to the fact that a new instrument had to be prepared for each experiment.

The mean value obtained by these three determinations was 0.91580 ± 0.000008 .

The determination made by Kopp in 1855 is scarcely worthy of mention. His method included the use of a dilatometer (Fig. 8), but one of poor design and involving probable errors of such a nature as to render his results quite worthless. His values came much lower than those of the preceding men, a result which might have been anticipated from the fact that in every specimen of ice experimented on, obtained of course by artificial freezing, a small bubble was noticed. The value obtained was 0.907 ± 0.0007 .

In 1860 Dufour undertook a new determination of the density of ice. His method differed from both the preceding ones, but was incapable of the same degree of accuracy obtained by weighing, or by the dilatometric method.

The method consisted of submerging ice in a liquid of which the density could be varied; then, by adjusting this, a point could be reached where the density of the liquid was identical with that of the ice, this being ascertained by observing when the ice was in equilibrium in the liquid. The specific gravity of the liquid was then accurately determined, and the ice density thus arrived at. In his first series of experiments a solution of alcohol and water was used. Here, however, the results were indirect, as the alcohol attacked the ice when the mixture was at 0° Cent., rendering it necessary to carry on the experiments at lower temperatures than this, and then allow for the cubical expansion of the ice, adopting the coefficient obtained by Plücker in his experiments, namely, 0.000158. From twenty-two experiments he obtained the value 0.9175 ± 0.0007 , the probable error here being the same as that of Kopp's results.

The year following the publication of these results, Dufour again set himself to solve the same problem, using the same



FIG. 8.
Kopp's Di-
latometer.

method, but employing a mixture of chloroform and petroleum, neither of which attacks ice. Here again he worked at temperatures below the freezing-point, the results obtained being slightly higher than those of the first set of experiments,— 0.9178 ± 0.0005 .

We now come to the work of Bunsen, who began his determinations in 1870. The method employed involved the use of a dilatometer of special design (Fig. 9), the increase in volume being measured by the quantity of mercury expelled from a capillary point in the apparatus, the general principle being identical with that of the weight-thermometer, without, of course, involving the coefficient of expansion for the glass dilatometer, as the observations before and after were both taken at zero centigrade. Three determinations were made, the results showing a remarkable agreement, ranging from 0.91682 to 0.91667, the mean value being 0.91685 ± 0.00003 .

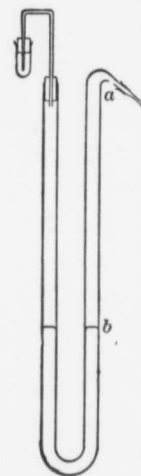

FIG. 9.—Bunsen's Dilatometer.

This value, determined by three observations alone, has been the accepted value for the density of ice since 1870. This quantity, however, is of great importance, especially in connection with the use of the Bunsen ice-calorimeter, and this fact led to a redetermination of this value in 1892 by J. v. Zakrzewski.

The method used by Zakrzewski was to fill a long thin-walled glass tube with air-free water by boiling out in the usual way. The tube, which was 14 cm. high and 1.5 to 1.8 cm. in diameter, was held vertically, and fused below to a fine tube of one millimeter bore. This capillary tube was bent in such a way as to contain a quantity of mercury. Enough mercury was added as a seal to allow of suitable measurements of any expansion or contraction of the water in the large tube. After cooling the water to the freezing-point, a small quantity of ice was

produced at the upper end by subjecting the glass to the action of a mixture of ether and solid carbon dioxide. Before commencing an experiment, all the ice, with the exception of a small trace, was melted. The tube was then buried in a mixture of ice and water, leaving a small portion of the upper end protruding into a vessel fitted with a stirrer. A salt mixture was added to the vessel and kept carefully at -0.7° Cent. Freezing set in slowly, and continued by raising the tube higher and higher into the salt mixture until the entire quantity of water was frozen. The tube was then seen to be filled with clear ice with a conical core. Accurate account was made of all mercury expelled during the freezing.

The tube was removed, and by gentle application of heat the ice was melted. Account was again kept of all the mercury drawn into the tube. It was found that the amount expelled and drawn in agreed to a milligram. From these determinations at -0.7° he obtained the values 0.916710, 0.916713, and 0.916708, giving a mean value of 0.916710. One determination made at -4.72° gave 0.916995, giving a value of the cubical expansion of ice, 0.000077. Correcting his result to 0° Cent., his value was 0.916660.

In 1899 a very careful series of measurements was made by Prof. E. L. Nichols of Cornell University. Professor Nichols's first determinations were made by the dilatometer method, using a specially prepared instrument, closely resembling a combination of both a specific-gravity bottle and a Bunsen ice-calorimeter (Fig. 10). The principle employed in freezing the water was identical with that of the Bunsen calorimeter, and the method of observing the increase in volume of the water was the same as that used by Bunsen in his density-of-ice determinations, the density being arrived at by two different methods of calculation from the different weighings, both



FIG. 10.—Nichols's Dilatometer.

results, however, being obtained from the identical experiments. These two values, 0.92154 and 0.91631, are far from showing good agreement, this fact being especially pointed out by Nichols, and used as an argument against the dilatometer method when mercury is used to fill the instrument. Also, the great divergence shown by these two results is probably due in a large measure to the deformation of the walls of the instrument caused by filling the dilatometer completely and afterwards partially with mercury.

These considerations led Nichols to abandon this method, and to devise another in which the results would be more certain and consistent. The next method tried was that of weighing, first in air and then in refined petroleum. Great precautions were taken in the details of the experiments, the density of the petroleum being found by weighing a piece of glass in distilled water and then in the petroleum, the coefficient of expansion of the materials being allowed for. All the weighings were likewise reduced to weights "in vacuo."

The main object of this series of experiments was to determine the variation in density, if such existed, of specimens of ice formed under different conditions and obtained from different sources. Four varieties of ice were thus experimented on, and results obtained ranging from 0.91816 to 0.91590, these being given in the following table:

RESULTS OF NICHOLS ON THE DENSITY OF ICE.

Kind of ice.	Temperature of weighings.	Density at 0 in terms of that of water.	Means.
Ice-mantles (CO and ether).....	-1.6	0.91619	} 0.91615
	-1.5	0.91590	
	-0.6	0.91636	
Natural ice (icicles).....	-1.9	0.91816	} 0.91807
	-1.6	0.91801	
Natural ice (pond-ice newly cut).....	-0.7	0.91804	
Natural ice (pond-ice one year old).....	-1.8	0.91644	

Nichols then proceeded to compare the results obtained, with the values given by the other observers, for similar specimens of ice, and showed that there is a remarkably good agreement and one that evidently points to real differences in the densities of the specimens, and not errors in the methods.

The importance of these considerations led Nichols to devise another and independent method by which these results could be checked and verified. The plan decided on was as follows: a small iron box was constructed, built up of slabs of iron with the faces planed and polished, with an accurately fitting slab of iron as a cover. After having brought the box to the temperature of the room, it was filled with mercury, and from the weight of the mercury required to completely fill the box its cubical content was found, the volume being computed for zero by allowing for the cubical expansion of the iron and mercury. The box thus having been measured, a piece of ice, newly cut from a reservoir, was placed in it, the ice being of such a size as to have a small margin all around it when in position in the box (the interstices being filled with mercury). The lid, which was formed of a planed slab of iron fitting accurately on to the planed tops of the four sides of the vessel, was then pressed down, forcing out parts of the mercury and leaving in the box only mercury and ice. From the weight of the ice, determined beforehand, and the cubic content of the box, and the amount of mercury necessary to fill the space around the ice in the box, the density of the ice could be computed. The value obtained was 0.91772.

Nichols concludes his paper by pointing out the strong evidence which his experiments bring to support the theory that there is an actual discrepancy between the absolute values of the density of specimens of ice formed under different conditions; the artificial ice experimented upon being formed similarly to the ice-mantles in the Bunsen ice-calorimeter.

In reviewing these experiments, it will at once be seen that there are three general methods of determining ice-density, i.e., equilibrium, dilatometric, and weighing methods.

In the first two methods, obviously, great accuracy cannot be obtained. Of the two experimenters using the first method, Dufour obtained by far the most accurate results, and yet it is stated by him that the density of the liquid was always between 0.914 and 0.922.

The dilatometric methods used by Kopp, Plücker and Geissler, and by Bunsen, also have some uncertain features peculiar to the particular instrument used.

The objections to the method of weighing are that the experiments are not carried on at zero, and the density of the liquid has to be determined by a separate experiment. The application of the coefficient of expansion in order to reduce the density to zero is not a serious objection, though it may be possible that this coefficient, which was determined for temperatures ranging from -1° to -20° Cent., may not hold between, say, -1° and 0° , owing to 0° being the point where a change of state takes place; nor is the separate experiment for determining the specific gravity of the liquid a serious objection, as this is done by the same method as the ice-density determinations and is capable of the same degree of accuracy.

From this it will be seen that it is the method of weighing from which one would expect the most accurate results, and as a matter of fact, as Nichols has also pointed out, it is the only one that has yielded consistent results in each of its applications to the measurement of ice-density, and it is evidently to this method that one must look for a final determination of the absolute value.

It was owing to a consideration of these facts that the method of weighing was adopted in the series of ice determinations carried out in 1900-01 by Barnes and Cooke.

The objection to which former methods of weighing were open, that the ice during the experiments was not at the temperature for which the density was required, was eliminated by the arrangement employed in these determinations, the ice first being weighed in air at zero and then in water at the same temperature, the water being unable to act upon the ice without the access of heat, which was prevented by the experimental arrangements. A description of the experiments is as follows, the ice is placed in a weighted grip which is suspended from the arm of a sensitive balance by a fine wire. This wire passes through a long, narrow tubular opening in the cover of a copper vessel, which is surrounded by a mixture of pure snow and water, and the entire contents thus brought to zero. After the ice has been weighed, pure water at zero temperature is admitted into the vessel, and after this has completely covered the suspended ice the weight is again taken, and from the loss due to immersion the density of the ice is calculated, due corrections being made for the weight of the suspension and grip, and for the density of the water.

The general arrangement of the apparatus is shown in Fig. 11.

The grip was made of flexible brass wire about a millimeter and a half in diameter, the three prongs being very carefully soldered to the end of the suspending wire. To the lower end of each prong a short piece of fine lead tubing was then soldered, to counteract the tendency of the ice to rise to the surface, when immersed in the water. The greatest care was taken in the soldering to prevent cracks or inequalities of the surface upon which bubbles

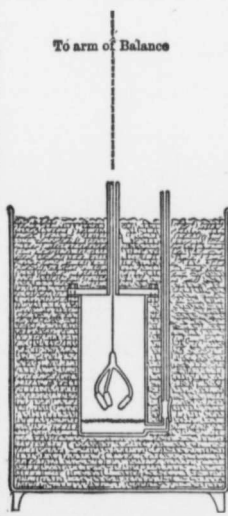

FIG. 11.—Apparatus of Barnes and Cooke.

of air might have lodged during immersion. The upper end of the wire ended in a hook, by which it could be attached to the arm of the balance.

The copper vessel inside which the grip was suspended was about 15 cm. in diameter and 40 cm. high. The top could be securely bolted down, and was rendered water-tight by means of a leather washer. A brass tube about $1\frac{1}{2}$ cm. in diameter and 30 cm. long was soldered in an upright position into a hole in the centre of this cover, forming a long narrow neck through which the suspension-wire could hang freely from the balance-arm down into the interior of the vessel. This long neck also rendered it possible to completely immerse the vessel in the mixture of snow and water. In the lower part of the vessel an outlet was constructed of a bit of bent brass tubing soldered in position. To this orifice a very long piece of brass tubing was attached by means of a rubber neck, this tubing projecting above the snow and water and preventing this mixture from entering at the lower opening. By pulling out this tubing the water was allowed to enter the vessel and cover the suspended specimen of ice. In case the inflow of water should carry in small particles of snow, which would tend to vitiate the observations, a piece of fine wire gauze was fastened to the inside of the vessel, just above the inlet, which therefore cleared the water of all particles of snow before it reached the specimen of ice.

The outside vessel, which contained the snow-and-water mixture, was of copper and about 60 cm. in diameter by 70 cm. high. Thus, when the inner vessel containing the specimen was imbedded in this mixture, it was surrounded by a wall of snow and water ranging in thickness from 15 to 20 cm., more than sufficient to prevent any possibility of transmission of heat from the outside.

The balance used was one constructed by Oertling, and

very sensitive. A hole was bored in the bottom of the case, and also through the supporting table, to allow the free passage of the suspension to the rest of the apparatus, which was placed under the table during the weighings.

The following was the method of carrying out an experiment, a piece of ice was cut from the solid block a little larger than required. This was then reduced by washing in cold water, which removed all traces of chipping and crevices due to the cutting. It was then put aside and allowed to come to zero temperature, shown by its tendency to melt. Meanwhile the mixture of snow and water was prepared, the inner vessel imbedded in it with the top off and the apparatus taken into the open air, the temperature during the days of the experiments never being far from 0° Cent. The specimen was then taken outside, carefully dried with filter-paper and a linen rag, caught in the weighted grip, and placed inside the inner vessel, the specimen never being touched by the bare hand during these operations. The cover was then securely bolted on, the end of the suspension passing up through the tubular opening, and, after having completely covered the main body of this inner vessel to a depth of about 10 or 15 cm., the whole apparatus was carried in to the laboratory and placed under the table on which the balance rested. After passing the suspension up through the table and balance-case, it was attached to the arm of the balance, and the vessel beneath adjusted till it was hanging freely. Before taking the weight, the specimen was allowed to remain thus suspended for about 15 minutes so as to accurately assume the temperature of the surrounding mixture. After the weight had been carefully taken to 0.1 of a milligram, the water was allowed to enter the inner vessel from the surrounding mixture and the weight again taken; the density of the ice being calculated from the loss of weight owing to the immersion in the water.

The weight and density of the suspension had to be allowed for in these calculations, and they were determined in the same manner as the ice-density, the experiment being carefully repeated on the suspension and grip after each ice-density experiment, and using the same water for immersion. The density of the water in the inner vessel was then compared with that of distilled water, by means of a pyknometer. All the weighings were corrected to weight in vacuum.

One of the primary objects of these experiments was to determine the variation in the density of old and new ice in case any such difference existed, and, with this end in view, the specimens experimented upon were cut from blocks of ice taken from the St. Lawrence River during the winters of '99, '00, and '01, and kindly supplied by Mr. Becket from the warehouses of the City Ice Company. However, no systematic difference was noticed in these three kinds of ice; and it is safe to assume that, for ice similar in formation to these (i.e., formed on the lower surface of a thick field of ice covering the river), no such variation exists. Nichols's experiments, however, clearly showed that, on the specimens used in his determinations, age certainly acted in such a manner as to cause the density to continually approach the value, which he assumes as the normal.

The following is a table of the results obtained by the method which has just been described:

DENSITY OF ICE. METHOD OF WEIGHING IN WATER AT 0° C.

Date.	Year of formation.	Density.	Difference from mean.
March 9th.	1901	.91684	.00023
" "	1901	.91665	.00004
" "	1900	.91661	.00000
" 16th.	1900	.91642	.00019
" "	1899	.91650	.00011
" "	1899	.91648	.00013
" 23d.	1900	.91678	.00017

Mean = 0.916611 ± 0.000065.

In order to check the accuracy of the method, two determinations were made upon the same specimen (the 1899 ice), the ice being removed, washed, and the whole experiment repeated. The two results agree to 2 parts in 90,000. All the other determinations were made with different specimens of sizes ranging from 150 to 200 grams.

From these experiments it appears that the density of the St. Lawrence River ice may be taken as

$$0.91661 \pm 0.00007,$$

a value agreeing very closely with Nichols's value for old river-ice, but considerably lower than his value for natural ice newly cut. It also agrees very closely with Bunsen's result (2 in 10,000), which is the generally accepted value.

Quite recently (1902), experiments have been carried out by J. H. Vincent on the density and cubical expansion of ice. His method consisted in weighing water in mercury. The water was weighed both as liquid at 0° Cent. and as solid at several temperatures below the freezing-point. It was necessary for him to assume values for the density of water and mercury at 0° Cent. The density of ice at 0° Cent. was then calculated, assuming that the densities of ice and mercury are linear functions of the temperature. The measurements are therefore not direct, but depend on certain prearranged assumptions.

The mean value of the density of ice at 0° Cent. was found by Vincent to be 0.9160. The variations of the individual computations, which had to be made in order to arrive at a value of the density at 0° Cent., are of the order of 1 in 1000; but the work was very carefully performed and is entitled to much weight.

The latest determinations of the density of ice are those of A. Leduc (1906), who made a special point of boiling the water used for the ice-masses in order to get rid of all traces

of dissolved air. This is a very important point, and one that has been overlooked in all previous determinations of ice-density. Water always contains a large amount of dissolved air, and in freezing it is a question whether it discharges more than a small part of this air. Even boiling water retains some of the air, and I have shown ("Mechanical Equivalent of Heat and Specific Heat of Water,") 1902 that it is necessary to condense the steam from boiling water under oil before all traces of air can be eliminated. Leduc seems to have met the same difficulty, and adopted practically the same method of procedure in preparing the water for his experiments. Using about 99 grams of ice prepared in this way, Leduc finds a density that is not less than 0.9172. He finds that this increases as greater efforts are made to remove the dissolved gases. Although unable to get rid of all traces of gases, he concludes that the density of perfectly gas-free ice at 0° Cent. is 0.9176. He considers that water, which has been merely boiled, as Bunsen used in his determinations of the density of ice, still contains about 1 cc. of gas per liter at atmospheric pressure.

The values found by Barnes and Cooke are somewhat lower than this, but the difference may be due to the presence of dissolved air in the natural ice used in their experiments.

From a careful study of the large amount of data available, it is evident that the density of ice is subject to small variations of the order of 1 or 2 parts in 1000, as Nichols showed in his work. These variations are due probably to the manner of formation, and are the result of strains set up in the ice. Nichols considered that these strains disappear in time, and the density reaches then a final value. It is probable, also, from the work of Leduc, that the presence of varying quantities of dissolved gases may account for most of the differences found by various observers, and for a gradual change taking place in the ice after formation. It is quite conceivable that the manner

of formation of artificial ice would lead to a greater or less amount of air being frozen in with the ice, and might also account for the difference found by Nichols for new and old natural ice.

Maximum Density of Water.—The occurrence of the maximum density of water, at a temperature above the freezing-point, is one of the most important facts to be met with anywhere in nature. In our study of ice formation we shall repeatedly have occasion to point out how important it is, and for this reason we must devote some attention to the way it has been determined.

The determination of the density of water near the freezing-point, has attracted a great deal of attention, and many beautiful experiments may be performed to show that water ceases to contract at 4° Cent. or 39° Fahr., and expands from there far below 0° Cent. The classical experiment of Thos. Chas. Hope in 1805, which is familiar to every one, is one of the best.

Among the first precise experiments on the density of water, we may mention the work of Hälström in 1825.

Despretz, in 1840, made accurate measurements with pure air-free water, which, when enclosed in a dilatometer, he succeeded in cooling to -20° Cent., and found a perfectly regular expansion to this point. The sudden change of volume of water in solidifying at zero was shown to be a leap, as it were, to the gradual change of volume taking place when the water was supercooled. The temperature found by Despretz for the maximum density-point was, from the mean of his experiments, 4.007° Cent.; Hälström found for the same point 4.108° ; Kopp found 4.08° , and Pierre 3.92° . Rosetti, in 1867-69, gives a summary of the various values found, and from this it may be concluded that 4° is as near the true point as the errors of the various experiments will allow us to come.

M. Chappuis, in 1897, determined the variation in the den-

sity of water very accurately by the dilatometer method, using an iridio-platinum vessel similar to the bulb of a gas-thermometer.

Some of the values he obtained are given in the following table:

DENSITY OF WATER AT ATMOSPHERIC PRESSURE. AFTER CHAPPUIS.

Temp.	Density.	Temp.	Density.
0° Cent.....	.9998674	6° Cent.....	.9999681
1° "9999272	7° "9999294
2° "9999682	8° "9998760
3° "9999923	9° "9998085
4° "	1.0000000	10° "9997272
5° "9999918		

It was shown by Chappuis that the expansion cannot be accurately represented by a formula. M. Amagat, in 1893, in an exceedingly interesting paper, showed that, when the pressure is increased, the temperature of maximum density recedes towards zero, the amount being .025° Cent. per atmosphere. At 144.8 atmospheres the maximum density-point was reduced to 0.6° Cent.

Many other accurate determinations have been made of the expansion of water, notably those of Marek in 1889, Thiesen in 1889, and K. Scheel in 1892, all showing good agreement.

Heat of Fusion of Ice.—The heat of fusion of ice, or, as we also say, of the latent heat of water, is the energy in the form of heat which it is necessary to supply in order to convert unit mass of ice into water at 0° Cent. Conversely, it is the heat-energy liberated from unit mass of water in freezing. A knowledge of this constant is important in many ways, for by it we can determine the amount of ice that may be formed under given cooling conditions. We also look for an accurate measure of it in order that the subject of latent heat calorimetry may be placed on a more satisfactory basis.

A number of investigators have devoted time to this work, and several methods have been devised for the measurements. Black of Edinburgh, in 1762, was the first to draw attention to the "latent" properties of the heat in the melting of ice. He gave a first rough measurement of this to be 79.7 calories, by mixing a known quantity of ice with an equal quantity of water, and noting the number of degrees through which the water was cooled.

Lavoisier and Laplace, in 1780, determined the constant by means of their familiar double-walled calorimeter. The amount of ice melted by a known weight of water, cooling through a known interval of temperature, gave the necessary data for the calculation of the constant. The heated water was enclosed in a thin metal ball, which could be separately studied as to heat capacity. It took sixteen hours for the heated ball to come to the temperature of the ice after dropping it into the calorimeter. The value they obtained was 75 calories per gram of ice melted, and this remained the standard for sixty years. In 1842 Regnault commenced his classical work on this subject. His first experiments were with snow cooled slightly below 0° Cent. On placing the snow in the calorimeter it melted so quickly that it lessened the chances of error. The result obtained was 79.2 calories. Further experiments with small blocks of ice gave 79.06 calories.

The determinations in 1843 of La Provostaye and Desains were carried out at the same time as the experiments of Regnault. The method employed was the common one of adding a known weight of ice to a known weight of water, and measuring the drop in temperature of the mixture. Their result came to 79.01 calories. The authors devoted a great deal of time to the elimination of errors, such as evaporation and the usual heat corrections of radiation and conduction. They seemed, however, to be somewhat uncertain of the amount of

moisture adhering to their ice before introducing it into the calorimeter.

Hess, in 1848, avoided the uncertainty of using wet ice by using ice cooled several degrees below freezing. The value he obtained was 80.3 calories. Person, in 1850, made a determination by the method of mixture, and found 80.0 calories. In the work of both of these last investigators measurements had to be made of the specific heat of the ice, cooled below zero.

In 1870 the ice-calorimeter of Bunsen was devised, and was used primarily for the study of specific heats. Determinations of the latent heat were made by placing water at the boiling-point in the inside tube, and observing the amount of ice melted. Further on is shown a diagram of a typical Bunsen ice-calorimeter. The change in volume on the melting of the ice is shown by the movement of a thread of mercury adjusted in the fine tube to some suitable zero. The mercury extends down the tube to the bottom of the calorimeter and acts as a trap for the water, which has to be carefully boiled and otherwise treated to expel air. The calibration of the fine horizontal tube has to be done with great care, since by means of the change of reading, the volume change is determined, and the amount of melted ice estimated.

What we may safely regard as the best and most accurate determination of the heat of fusion of ice was made by Professor A. W. Smith of the University of Michigan, in 1903. The method employed by Professor Smith may be described briefly as follows, the ice is broken into small pieces, and cooled several degrees below zero. It is then transferred to a calorimeter, containing light oil, also cooled below 0° Cent. The calorimeter is then warmed slowly by a feeble electric current until the temperature is about 1° Cent. below zero. A larger current is then applied for a sufficient time to melt the ice, and raise the resulting water to half a degree above zero.

The electric energy has then been expended in raising the temperature of the ice and calorimeter from -1° Cent. to 0° Cent., in melting the ice, and in raising the water and calorimeter to 0.5° Cent. In addition some heat is lost by radiation, conduction, and convection. By suitable arrangements of the experimental conditions, all of these quantities may be determined. Thus everything in the nature of a correction was small compared to the heat absorbed in melting the ice.

By the kindness of Dr. Smith we reproduce the figure out of his paper illustrating the general arrangements of his apparatus (Fig. 12). He describes his calorimeter as follows: "The dimensions of this chamber are 35 cm. in depth by 23 cm. diameter, it being circular in section. The larger vessel, *E*, is 70 cm. deep and 45 cm. in diameter, it also being circular in section. Both

of these vessels were made of heavy galvanized iron. The space between them was filled with broken ice, making a layer 11 cm. in thickness around the sides of the inner chamber, and about twice this thickness over the top and bottom, thus maintaining the temperature of the interior chamber very closely to 0° Cent. The top of this chamber is a removable cover, made with an outside flange to prevent water from gaining access to the inside. At the center of this cover is a tube 4 cm. in diameter and 20

cm. in length, which extended through the broken ice to the outside, and through which passed the thermometer, stirrer-

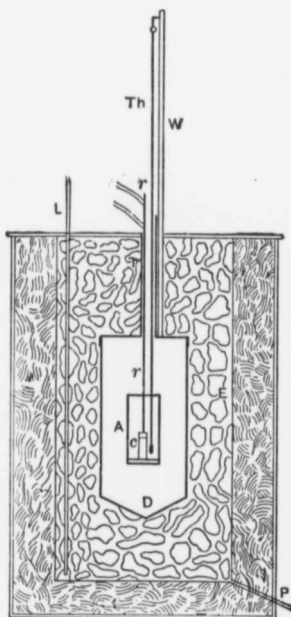

FIG. 12.—Calorimeter used by A. W. Smith for Latent Heat of Water.

rod, current-wires, etc. In order to protect this broken ice as much as possible from outside heat, the vessel *E* was placed within an extra-large barrel with the intervening space packed with excelsior. With this protection the amount of ice melted was about 10 kilos per day, this amount being added each morning. The total quantity of ice required for this packing around the chamber was about 60 kilos. As fast as it melted, the water was drained away through the tube *P*. Over the barrel was a wooden cover through which projected the tube *T*, the wooden post *W*, which served as a support for the thermometer when in use, and the thermometer-case *L*, in which the thermometer was kept during the time between experiments."

The value which he obtained, i.e., 79.896 calories, depends on the relation of the electrical and thermal units, but this relationship is now known with an accuracy which warrants us in regarding his measurements as the nearest to the truth.

A summary of the values which have been obtained for the latent heat of fusion of ice is given in the following table:

VARIOUS VALUES OBTAINED FOR THE LATENT HEAT OF WATER.

Observer.	Date.	Latent heat in calories per gram.
Black.....	1762	79.7
Lavoisier and Laplace.....	1780	75
Provostaye and Desains.....	1843	79.1
Regnault.....	1842	79.24
".....	1843	79.06
Hess.....	1848	80.24
Person.....	1850	80.0
Bunsen.....	1870	80.02
Smith.....	1903	79.896
Leduc.....	1906	79.2

I have added Leduc's value, which he considers to be the most probable, but I do not think that it is entitled to nearly as much weight as the value of Smith.

Person calculated that the heat of fusion of a body is smaller, the lower the temperature becomes. Pettersson verified this in the case of ice, and found that for 1° Cent. lowering of the melting-point of ice, the heat of fusion was decreased by 0.59 calorie, as against 0.5 by the theory. At -6.5° Cent. observation gave a value of 76.0 calories.

Specific Heat of Ice.—The specific heat of ice has received of late very little attention, and further careful determinations are required in order that the results may be expressed in more precise units. Of the early experimenters who turned their attention to this, we may pass over the work of Desormes and Clement and of Avogadro as being too inaccurate to be included with the later work. Thus the former obtained the values 0.75 and 0.70, and the latter 0.92 by somewhat similar methods.

The two general methods which have been used in the later work are, in one case the mixing of ice cooled below the freezing-point, with warm water, and after correcting for the heat of fusion, to estimate the specific heat. The other is to mix cooled ice with oil of turpentine, and arrange that the minimum temperature of the mixture shall not be above the melting temperature. By this means a knowledge of the heat of fusion is avoided, but, on the other hand, an accurate knowledge of the specific heat of turpentine at different temperatures is required.

Person, in 1850, found between -21° Cent. and -2° Cent. the value 0.480, which agrees with the value of Regnault (1843), between -78° and 0° Cent. Over the interval between -20° and 0° Cent. Person also found the value .504, which led him to the opinion that the specific heat near to the melting-point was increased slightly by the latent heat. According to his view, then, from -2° to 0° Cent. a portion of the ice was melted, giving rise to a higher value of the specific heat. If this is true, it is in accord with the view that a blending of the two phases,

ice and water, occurs at 0° Cent. We shall see presently that there is evidence to show that ice exists in solution in water, for a considerable distance above the freezing-point, which gives rise to the rapid drop in the specific heat of water as the temperature rises from 0°. If the specific heat of ice falls off below zero, it would indicate the presence of water in solution in the ice. Other physical properties of ice undergo remarkable changes as the freezing-point is reached, which may be associated with the same phenomenon. Later determinations seem to indicate, however, that there is no appreciable change in the specific heat of ice in the neighborhood of the freezing-point, but it is a matter which might well receive special investigation.

Desains, in 1843, found the value of the specific heat between -20° and zero to be 0.513; another value by him is given as 0.47, from which he concludes that the correct value is 0.51. Hess found, for an interval of temperature between -14° and zero, the value 0.533. His work was carried out in 1848. Both these latter determinations are in accord with Person's views. A valuable comparative measure of the specific heat of ice at different temperatures very near the freezing-point was made by A. W. Smith in 1903. It was necessary for him to gain an accurate knowledge of the mode of variation of the specific heat near the freezing-point in order to correct his value of the latent heat of fusion of ice. He consequently measured between -1.40 and 0°. He found that there was no measurable change in the heat capacity of the ice, which he used

TABLE OF SPECIFIC HEAT OF ICE.

Date.	Observer.	Range.	Specific heat.
1843.....	Regnault	-78° to 0° Cent.	0.474
1843.....	Desains	-20° " 0° "	0.513
1848 to 1851....	Hess	-14° " 0° "	0.533
1850.....	Person	-21° " -2° Cent.	0.480
1850.....	"	-20° " 0° "	0.504

in his experiments between these limits. If Person's views are correct, we should expect an increase in the specific heat from -2° to zero.

In the table are included the various values which have been obtained for the specific heat of ice.

The Specific Heat of Water.—The specific heat of water, owing to its great importance, has been the subject of much study. The exact relation between the mechanical and electrical units depends on it, and the selection of the thermal unit is still a matter for an international committee to decide on.

It would be a matter of comparative simplicity to select such a unit, if the specific heat of water were constant throughout the entire range of temperature, or even over a short range at ordinary temperatures, but all the best determinations show that a wide variation occurs between 0° Cent. and 100° Cent. The variation is not a simple one, and from 0° Cent. to 40° Cent. the specific heat drops rapidly, passing through a minimum value near 40° , and then increases up to, and beyond the boiling-point. In Fig. 13 the mode of variation over the range of temperature from -10 to 100° Cent. is shown.

Various points have been decided on for the selection of the thermal unit, and it seems that the best one is the temperature at which the specific heat is equal to its mean value between 0° and 100° Cent. It will be seen by inspection of the curve that this occurs between 15° and 16° . The one-hundredth part of the specific heat between 0° and 100° being taken as unity, then that between 15° and 16° Cent. is equal to 1.0002.

In the table on page 54 the specific heat of water is given in terms of such a unit.

The specific heat of water is of special interest in the neighborhood of the freezing-point. I have made several determinations of this, not only by an absolute method down to a few degrees of the point, but by a method of mixtures, to tempera-

TABLE OF SPECIFIC HEAT OF WATER.

- 5° Cent.....	1.0158	50° Cent.....	0.9980
0° ".....	1.0094	60° ".....	0.9991
10° ".....	1.0023	70° ".....	1.0004
20° ".....	0.9989	80° ".....	1.0017
30° ".....	0.9976	90° ".....	1.0031
40° ".....	0.9974		

tures several degrees below zero. In these latter experiments I had to supercool water, and in so doing it was shown that the

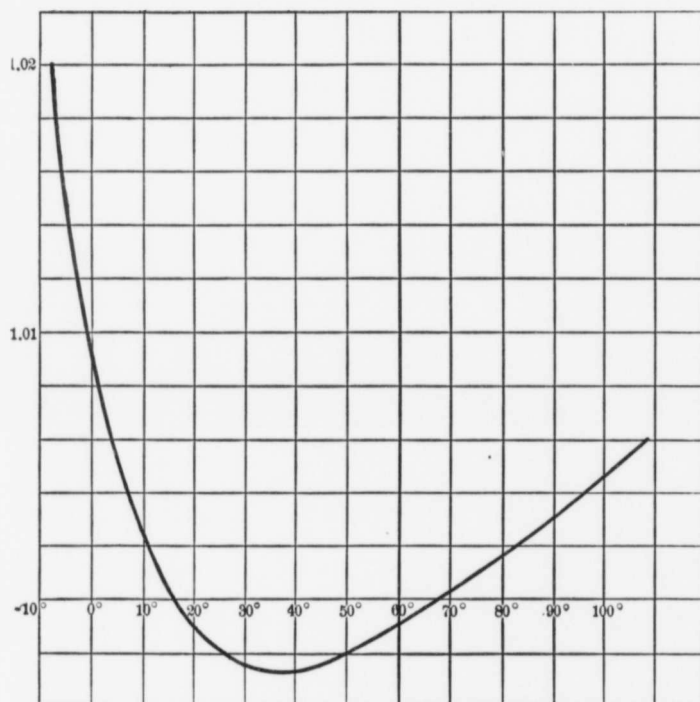

FIG. 13.—Variation of the Specific Heat of Water. (Barnes.)

variation curve which had been deduced for large ranges of higher temperatures was continued regularly below zero. This is shown in the figure just given, where it will be seen that the

curve is continued below zero without any anomalous point being shown. It is of great interest to observe the change in the character of the specific-heat curve from 40° downwards towards the freezing-point. It will be seen what a rapid rise takes place as zero is reached. The best explanation of this is along the lines suggested by Sutherland and myself,—that at the lower points an aggregation of the molecules takes place, whereby the formation of a different physical state of the water is indicated. It is possible that this represents the actual formation of the solid phase, which will enable us to say that water below 40° Cent. contains ice-molecules in solution. As the temperature falls lower and lower the strength of the solution and hence the percentage of ice-molecules to water-molecules increases. At the freezing-point the ice-molecules are capable of forming a crystalline structure, and the remaining water-molecules pass over into the solid phase with loss of heat.

From our point of view, water at 0° Cent. is a saturated solution of ice-molecules. Whatever the difference in physical structure may be between the water-molecules and the ice-molecules, the latter represents the phase of less energy-content, the difference between the two phases being measured as heat-energy in the heat of fusion.

The presence of the ice-molecules in solution completely explains the rapid decrease in the specific heat of water as the temperature rises, as well as the position of maximum density. In the first case, superimposed on the heat-energy necessary to cause an expansion of the molecules as the temperature rises, we have the heat absorbed in breaking up the molecules of ice to form water-molecules. The relative amount of ice-molecules grows less as the temperature rises, and consequently the specific heat apparently grows less. At 37.5° there is an exact balance between the two effects, the normal increase in the specific heat, and the decrease in the heat absorbed in

breaking up the ice-molecules. Shortly above 40° the ice-molecules probably disappear altogether, and the specific-heat curve becomes normally that for a simple liquid.

In the second case, dealing with the position of the point of maximum density, we are observing the resultant of two effects,—one the change in volume of the water due to the decreasing number of ice-molecules, and the other the natural increase in volume due to the increased space required by the molecules of water as the temperature rises. We presume in this example that the ice-molecules occupy a greater space, or are of greater volume, than the water-molecule, just as they do when formed into a crystalline structure.

From 0° Cent. up there are so many ice-molecules present that we find an apparent decrease in volume. At 4° there is a balance of the two effects, to be followed by an increase in volume as the temperature rises, the normal thermal expansion masking the effect of the ice. The position of maximum density occurs therefore at 4° Cent. or 39° Fahr., while above and below this temperature the density decreases.

The effect of pressure on the viscosity of water can also be explained by the ice simile. It was observed by L. Hauser (1901) that below 30° Cent. an increase of pressure decreases the viscosity of water, whereas above this temperature the reverse is the case. No precise point was obtained for the balance of the effects, but the author places it at about 30° . It is well known that the effect of pressure on a mixture of ice and water is to melt some of the ice. Pressure here changes the ice-molecules into the less viscous water-molecules, and we find the effect apparent on the water below 30° . At or near this temperature there is a balance between the decrease in viscosity due to the squeezing back of the ice-molecules into water-molecules, and the normal increase in the viscosity due to increasing pressure.

From a consideration of these various explanations, from the point of view of the presence of ice-molecules in the water, the old idea, still retained by some, of the presence of a point of maximum specific heat at the point of maximum density, is no longer necessary; which fact has been abundantly verified by experiment.

Thermal Conductivity of Ice and Snow.—A knowledge of the thermal conductivity of ice and snow is of great importance in many problems of meteorology. The protection to the ground afforded by a layer of snow or ice against the severe temperatures of northern winters has, as we have shown, considerable bearing on practical questions. Thus the character of the underground temperatures in the crust of the earth, is influenced to a large extent by the thickness of ice or snow that accumulates over the ground in winter. The nocturnal cooling of the soil by radiation, which goes on to so large an extent under ordinary conditions of soil-exposure, is practically without influence when the ground is covered with snow.

The loss of heat from a river is checked by the rigidity of the surface-sheet of ice, which prevents the direct contact of air and water, and reduces the loss to that of conduction through a mass of ice. And, although ice is a better conductor of heat really than water, the process of conduction-loss is so slow, compared to convection and wind-currents that the heat-loss is checked at once. As the ice-sheet grows thicker the heat-loss grows slower. Accumulations of snow, fallen, blown, and drifted over the ice-sheet, still further reduce the loss of heat, as it is a poorer conductor than solid ice, and it checks radiation through the clear ice.

An accurate knowledge of the conductivity of ice and snow is not an easy matter to gain, on account of the many difficulties in carrying out the experiments at a sufficiently low temperature.

A number of investigators have turned their attention to the problem of snow, and much fewer to ice. In the former case, no doubt, the direct bearing of the results on meteorological problems, as I have just indicated, explains the matter; but in the latter case we are beginning to find the need of a more accurate knowledge of the conductivity of ice, in order to form an estimate of the protective value of ice-sheets in engineering work. It does not take much error in the determination of the constant of conductivity, to make a large difference in the questions that often arise.

The conductivity of ice was first determined by Principal Forbes, and the results of his experiments were described in 1874, although the observations were made about ten years earlier. The method he used was one suggested by Lord Kelvin. A disc of ice was formed, 12 inches in diameter, by a freezing-mixture placed above a vessel of water kept constantly at 0° Cent. The thickness of the ice could be measured fairly accurately to 1/80th of an inch. With suitable thermometers in the ice disc the value for the conductivity, K , which he found, was the following:

Along the principal axis.	0.134
Perpendicular to axis.	0.128

The results are expressed in centimeter, gram, degree centigrade, minute units, which means that for a temperature gradient of one degree centigrade per centimeter 0.134 calorie of heat will flow across each square centimeter of surface per minute in the direction of temperature fall, when this is along the principal axis. Perpendicular to the principal axis 0.128 calorie passed under the same conditions.

The next determination is that of Mitchell, in 1885, who used Ångström's method of periodically heating and cooling the end of a bar of ice, and determining the period of the waves

of heat set up in the bar. This method was a favorite one for metals, and had been used extensively. Its application to bars of ice seems to be more to test the method than to make a determination of the conductivity. There are many things which recommend the method as a general one, and in the case of bars of good conducting material, such as the metals, it is found to yield consistent results. When applied to ice it is not so satisfactory, and the value obtained by Mitchell cannot be expressed very precisely. He found, in C.G.S. units, the value 0.005 for the conductivity.

Among the numerous investigators who employed the periodic method for determining the conductivity of materials, F. Neumann stands out as one of the principal workers. In the case of poor conducting materials such as ice, however, he formed spheres, and determined the temperature at the centre and at the outside. For ice he found for the diffusivity the value 0.01145, and for K the value 0.00573.

Straneo, in 1897, using the ordinary guard-ring method, found values for the conductivity of ice, in two directions as follows:

Along principal axis	0.30 to 0.31
Perpendicular to axis	0.308

The units are the centimeter, gram, deg. centigrade and minute. Making a summary of the various values, we find, with the exception of Forbes's, a fairly good agreement (see table on page 60).

A comparison of the thermal conductivities of ice and snow was made in 1885 by T. Andrews. This investigator worked at the Sheffield Iron-works, during the winter which was of some severity. His method was to enclose a mass of water in a circular tank, and convert it into ice by means of a suitable freezing-mixture. When the whole mass had come to 0° Fahrenheit and become solid, as shown by mercury thermom-

SUMMARY OF OBSERVATIONS ON THE THERMAL CONDUCTIVITY OF ICE.

Observer.	Date.	<i>K</i> in C.G.S. units.
Forbes.	1874	.0022
"	1874	.0021
Mitchell.	1885	.005
Neumann.00573
Straneo.	1897	.0052
"	1897	.0051

eters placed in the ice through long iron tubes frozen in place, the surroundings were changed to 32° Fahr., and the time noted for the mass to come to the freezing-point. The block was 2 feet 1½ inches in diameter, and somewhat over 2 feet high. It was found that 73½ hours were required in point of time, for the mass to rise from 0° Fahr. to 32° Fahr. Similar experiments made with snow packed in the cylinder showed a much longer period. Starting with 0° Fahr., the time taken for the snow to rise from 0° Fahr. to 32° Fahr. was found to be 165½ hours. The conductivity of the ice was thus found to be about 122 per cent greater than that of the snow.

In 1889, S. A. Hjelström determined the conductivity of snow by burying four thermometers at different depths, and following the temperatures by observation from time to time. The depths were 1, 11, 21, and 31 centimeters respectively. Taking the specific heat of ice as 0.50, and the density of the snow as .183, he found as a mean the value .0304 in cm., gram, deg. Cent., minute units. This he finds is seven times worse than moist clay, which he gives as 0.226 in the same units.

In 1891, Abels found that the conductivity was proportional to the square of the density of the snow, or that $K=0.406d^2$. Similar to Hjelström, he employed thermometers buried at different depths in the snow, but the observations were not so satisfactory as might be desired.

M. Jansson in 1901 determined the conductivity of snow

by considering it as a fine powder and applying a method which had been worked out by C. Christiansen in 1881 for such cases. The snow was placed between three circular copper plates into which thermo-junctions were inserted. The outer plates were maintained at the required temperatures in order to cause a measurable flow of heat across the snow, and the temperature drop was measured from the second plate. It was found that the conductivity K could be represented by the following expression:

$$K = 0.00005 + 0.0019d + 0.006d^4,$$

in C.G.S. units, where d is the density of the snow.

It was further found that the result depended on the form of the crystals and the size of the grains.

In February of last year (1905) Okada published, in the Journal of the Meteorological Society of Japan, some measurements of the thermal conductivity of snow by burying thermometers at different depths. He found that the density of the snow varied a good deal with the depth, and according to the following order:

at 5 cm.....	0.13
25 cm.....	0.24
34 cm.....	0.29
45 cm.....	0.35

For the depth between 10 and 20 cm. the diffusivity was found to be 0.0031, and the value of K was 0.00028 in C.G.S. units. For a depth of 20 to 30 cm. the diffusivity was 0.0038 and $K = 0.00045$.

The specific heat was taken as 0.508 in the calculations, and the value of the diffusivity was obtained by applying the usual formula to the case of heat-waves passing through a body in one dimension only, i.e., directly down, as indicated by the thermometers.

Okada found that Abels' formula, which is $K = 0.0068d^2$ in C.G.S. units, gives, for his values of the density, the value of K as 0.00022 in the one case, and 0.00039 in the other. This shows fairly satisfactory agreement, much better than is shown by reference to the formula of Jansson, which is not in such good accord.

It will be observed that the conductivity of snow is very much less than that of pure solid ice, and shows what an important influence the accumulation of the winter's snow must have on the thickness of the ice-sheet on a lake or river.

The winter just passed in Canada (1906), which will probably long be remembered by the inhabitants as a most remarkable one from the scarcity of snow, was unusually mild throughout the ice-region, and yet it was observed that the ice-sheet, over many of the smaller lakes and rivers was unusually thick and clear, and quite free from snow. This condition was undoubtedly brought about by the exposure of the ice-sheet, and the more rapid heat-loss from the water by conduction through the ice.

The protective action of the snow on the ground cannot be overestimated, and in the dry state in which it usually exists during the severest weather, it is equal to the best non-conductor of heat.

Conductivity of Water.—The first absolute measurement of the conductivity of water was made by Lundquist of Upsala, in 1869, who obtained, by a method due to Ångström and used by him for metals, the value 0.0933 at a temperature of 40.8° Cent., in C.G. minute units.

Winkelmänn in 1874, using Stefan's method for gases, obtained the value 0.0924 in the same units.

In two papers which were published in 1880 by H. F. Weber there is described a very careful series of measurements of the conductivity of water, and several other liquids. He placed

the liquid between copper plates, which were maintained at a steady difference of temperature, and had suitable thermometers immersed in the liquid. A most careful study of the method was made previous to, and during the course of the work, and many possible sources of error corrected for. He found that the conductivity decreased rapidly as the temperature was lowered, but the results are expressed in terms of the specific heat equal to unity over the range of his experiments. He determined the diffusivity $\left(\frac{K}{ds}\right)$ at 4.1° Cent. to be 0.15619, which is a mean of ten determinations. Taking with him $d=1$, $s=1$, the value of K comes out to be 0.0745 in C.G. minute units. At 23.67° Cent. he finds for the diffusivity, 0.17909, a mean of ten determinations, which gives for K the value 0.0857, taking d as 0.998 and s as 1.

When we take the true value of the specific heat of water, for the two temperatures at which Weber worked, we find at 4° Cent. his value changed to 0.0741, and for 23° Cent. 0.0859, the correction being to increase the difference between the values. In a third paper, published in 1880, Weber compares his results with those of Lundquist and Winkelmann, and in the case of the former investigator, he shows a very good agreement. After deducing a linear expression from his two measurements at 4° and 23° Cent., Weber extrapolated to 40.8° Cent., the temperature of Lundquist's experiments, and obtained the value 0.0953, or, corrected for the specific heat, the value 0.0950. This is quite close to Lundquist's value, which was 0.0937.

Winkelmann's value, which was 0.0924, does not agree with Weber's for the same temperature, which was 0.0745, or, corrected for specific heat, 0.0741.

A later determination of the thermal conductivity of water has recently been made by R. Weber (1903). He found the value 0.00131 in C.G.S. units between 35° and 12° Cent. The

method employed was the usual one, and the author tried a large number of liquids as well as water.

TABLE OF THERMAL CONDUCTIVITY OF WATER.

Name.	Date.	Temperature.	Value C.G.S. units.
Lundquist.....	1869	40.8° Cent.	.00156
Winkelmann.....	1874	4.0° "	.00154
H. F. Weber.....	1880	4.0° "	.00124
".....	"	23.6° "	.00143
R. Weber.....	1903	24.0° "	.00131

Coefficient of Expansion of Ice.—The earliest determinations of the expansion of ice were made by Brunner in 1845, who obtained the value 0.0001125; by Struve in 1845, who obtained 0.0001593; by Marchand in 1845, who found 0.0001050; and by Plücker and Geissler in 1852, who found 0.0001585. These values represent the cubical expansion for ice near to the freezing-point.

Petterson of Stockholm, in 1883, found that ordinary distilled-water ice had a linear expansion of 0.000053 between -12° and -2° Cent. He also claims that ice begins to contract at some point between -0.35° and -0.25° . With ice made from the purest water the coefficient between -17° and -10° , which was found to be 0.000055, increased to 0.000057 between -4° and -3° , and then decreased until it changed sign at a point just near the freezing-point.

While carrying out his experiments on the comparison of the thermal conductivity of snow and ice in 1885, T. Andrews measured the dilatation of ice, and extended his measurements to very low temperatures. To do this he surrounded his ice-cylinder with a freezing-mixture of 3 parts crystallized calcium chloride and 2 parts snow, which gave a temperature of -39° Fahr. The following results were obtained by Andrews in the course of his work:

Thel 0000065

PHYSICAL CONSTANTS OF ICE.

Linear coefficient for 1° Fahr. between	16° and 32° F.	0.0000408
“ “ “ 1° “ “	0° “ 16° F.	0.0000280
“ “ “ 1° “ “	-21° “ 0° F.	0.0000204
“ “ “ 1° “ “	-30° “ -21° F.	0.0000197

It will be seen from these results that the coefficient of expansion increases rapidly towards the freezing-point and becomes quite small at low temperatures.

Zakrzewski, in 1892, determined the cubical expansion by the method described under Density of Ice, and found 0.000077, which is obviously too small.

Later determinations of the coefficient of expansion of ice, have been made by Nichols during the progress of his work on the density of ice in 1899, and by Vincent in connection with his work on the same subject in 1902 already described.

Nichols found 0.0001620 for the volume expansion per degree centigrade, and Vincent found a rather smaller value, i.e., 0.000152.

In the following table will be found a summary of the various results reduced to the same standards:

Name.	Date.	Cubical expansion per degree centigrade.
Brunner.	1845	0.0001125
Struve.	1845	0.0001593
Marchand.	1845	0.0001050
Plücker and Geissler.	1852	0.0001585
Pettersson.	1883	0.000168
Andrews.	1885	0.0002203 (highest)
“	1885	0.0001064 (lowest)
Nichols.	1899	0.0001620
Vincent.	1902	0.000152

Taking a mean of Andrews' results, which comes to 0.0001633, the last five values in the table agree remarkably well, and with the result of Struve. If there is such a wide variation in the coefficient with the temperature, as Andrews shows in his

work, then some of the variations in these results may be due to temperature.

I have not included Zakrzewski's value in the summary, because I believe it to be insufficiently determined. It depends on two determinations of the ice-density at -0.7° and -4° . While his method might yield good results at the former temperature, I do not consider it trustworthy at the latter.

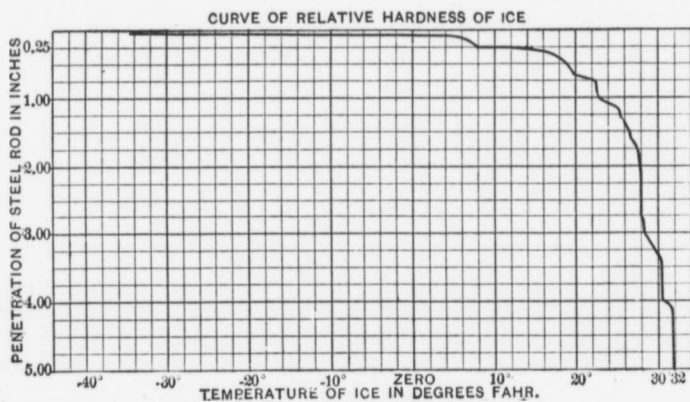

FIG. 14.—Andrews's Curve for Relative Hardness of Ice at Different Temperatures.

Relative Hardness or Penetrability of Ice.—This was determined by Andrews in 1885, while engaged in measuring some of the other physical properties of ice. The results, although very simple, are exceedingly interesting. The observations were taken at intervals during the gradual warming of his large ice-cylinder from -35° Fahr. to 32° Fahr. To carry out his experiments on the relative hardness of his ice-block, he used a polished-steel rod 16 inches long by 0.292 inch in diameter. This rod was made blunt at the end, and rested under a weight of $181\frac{1}{2}$ pounds; this served to press it into the ice at a rate depending on the hardness. The depth to

which the rod penetrated the ice under the varied conditions of temperature, compared with the penetrability at 32° Fahr., afforded a means of calculating the relative hardness of the pure ice. The curve of his results is so striking that I reproduce it here (Fig. 14). An interesting feature of the work is that the ice appears to maintain its almost impenetrable hardness from -35° to about 10° Fahr. to 20° Fahr., after which its power of resistance rapidly decreases, giving way almost entirely at the melting-point, where it becomes very soft indeed.

The Plasticity of Ice.—McConnell and Kidd in 1888, and McConnell alone in 1891, proved the plasticity of ice under tension to be true. They showed that an ordinary bar of ice, composed of several crystals, will yield continuously either to pressure or tension. They found, however, that a bar, cut from a single crystal, with its length at right angles to the optic axis, showed no signs of continuous stretching, even under half the breaking tension; and this was also true of pressures, a crystal yielding in neither direction, for forces applied at right angles to the optic axis. A single crystal of ice has been termed by McConnell to be of perfect "brittleness."

The explanation offered by James Thomson, to account for the plasticity of ice, in the light of what is termed regelation, that is, the melting of ice under pressure, and the water flowing to other parts of the crystal to freeze again when relieved of the pressure, was found not to accord with McConnell's experiments. This was especially so for his experiments carried out at very low temperatures.

The bending of a bar of ice was shown to take place by the sliding of a number of layers of finite thickness. To account for the distortion of the ice-bars in his experiments, McConnell was led to believe that a sheer or slipping of the planes took place, giving rise to the observed plasticity. He proved this by

obtaining the direction of the optic axis of the various crystals by polarized light.

One of the most interesting features of McConnell's work is the large amount of bending and recovery of ice, which was out of all proportion to known effects in other substances.

According to Moseley's work in 1871, Young's modulus for ice is 92,700 kilos per square centimeter. In McConnell's experiments, when the effect of the plastic strains is neglected in one bar of ice used in his work, the elastic depression under 2.5 kilos should have been 0.00138 cm., which is less than one-seventh of the recovery observed. Allowing for some uncertainty in the measurements, he was unable to devise any system of elastic strains which could possibly make his bar rise 0.01 cm., and he concluded that he had to deal with a real tendency for the forcibly displaced sliding layers to slip back. It would be a matter of great interest to study this effect further in our northern latitudes, where weather conditions in the winter conduce to greater ease and accuracy of measurement than can possibly be found in England, where McConnell's experiments were carried out. The peculiar molecular effect observed, should be tested for the bending of ice at low temperatures.

McConnell determined from his experiments what he called the plastic coefficient, or inverse of the viscosity. He gives as a value for this coefficient the number $A \times 10^{-11}$ cm. gm.⁻¹ sec., where A lies between 1 and 10.

Elasticity and Viscosity of Ice.—Hans Hess, in 1902, made an extended study of glacier ice, and found some interesting results. An ice-bar cut from a block, when loaded in the middle, showed a slow settling with time, after the first small deflection due to bending had taken place. The slow change went on regularly with the time, and represented the gradual sheering of the ice-crystals. The rate of change due to the sheer, was widely different for different loads. On removing the

*McConnell's work
Recovery of ice
1871-1872*

load the bar recovered somewhat at once, and then continued to recover slowly for a few minutes. This slow recovery was put down by Hess to residual elasticity, but probably corresponds to the slipping back of the sliding layers, observed by McConnell.

The great value of the work of Hess lies in the careful study he made of the effects in various directions, with respect to the optic axis. The bars of ice he used were about 1.2 cm. thick, 2.5 cm. wide, and from 4 to 16 cm. long. The loads varied from 1 to 5 kilos.

Bars were cut with the crystalline axis parallel to the width, to the length, and to the thickness. Determinations of the modulus of elasticity showed that this varied in the proportion of 1 to 3 to 5 for the cases where the principal crystalline axis, was at right angles to the plane of the bending force, in the direction of the bending force, and when the plane of the axis was at right angles to the direction of bending force; that is to say, with the axis parallel to l , to a , or to b .

The values tabulated on page 70 for the modulus of elasticity E , bending moment, and the viscosity μ , were obtained.

As a rule, what Hess terms "squashing" was only observed when the main axis was parallel to a or to b .

The plasticity of the ice was shown in two different ways, —in planes which are at right angles to the main axis of the crystal, when sheering only takes place, that is, the ice moves only in the direction of the bending force; and in planes which contain the main axis, when side movements take place, giving rise to the phenomenon of "squashing." Experiments made on grained ice gave the same results as for the crystals.

Very little was done by Hess in determining the effect of temperature on the viscosity of ice, but the experiments of Andrews (Fig. 14) would indicate that for very low temperatures quite different results would be obtained.

1 dyne = $\frac{1}{981}$ of the weight of 1 gram.

AXIS PARALLEL TO LENGTH, *L*.

Load.....	2000 grams	5000 grams	6000 grams
Bending moment...	1350 cm. gr.	3400 cm. gr.	4000 cm. gr.
μ 15 sec.....	6.5×10^{10}	10.5×10^{10}	0.55×10^{10}
μ 60 ".....	17.5	11.5	3.6
μ 120 ".....	10.0	13.0	3.65
μ 300 ".....	11.0	16.6	3.5
μ 1200 ".....	12.0
<i>E</i>	5.4×10^9	7.0×10^9	7.5×10^9

AXIS PARALLEL TO THICKNESS, *a*.

Load.....	1000 grams	1500 grams	2000 grams
Bending moment...	1600 cm. gr.	2350 cm. gr.	3100 cm. gr.
μ 15 sec.....	7.5×10^{10}	10.0×10^{10}	8.0×10^{10}
μ 60 ".....	7.5	11.0	7.0
μ 120 ".....	7.5	9.0	11.0
μ 300 ".....	8.0	12.0	12.0
<i>E</i>	1.6×10^{10}	2.0×10^{10}	2.0×10^{10}

AXIS PARALLEL TO WIDTH, *b*.

Load.....	1000 grams	1500 grams	2000 grams	3000 grams
Bending moment.	1500 cm. gr.	2250 cm. gr.	3000 cm. gr.	4450 cm. gr.
μ 15 sec.....	3.7×10^{10}	3.7×10^{10}	2.4×10^{10}	11.0×10^{10}
μ 60 ".....	8.0	11.0	6.0	9.0
μ 120 ".....	12.0	10.0	10.0
μ 300 ".....	21.0	19.0	17.6
<i>E</i>	3.5×10^{10}	3.0×10^{10}	2.9×10^{10}	4.0×10^{10}

For all experiments undertaken by Hess, it was found that, with measurable loading, the coefficient of viscosity increases with the duration of the experiments, and, even after only five minutes, is about proportional to the time. For large loads near to the breaking-point, the viscosity coefficient decreases with the duration of the experiment.

Observations were made by Hess to determine the dependence of the velocity of flow on the pressure. For this purpose an iron tube 25 cm. long and 6 cm. wide, with a conical orifice running down to 4.5 cm., was arranged. Pure air-free water was frozen in the tube, and a piston was fitted in one end to which a long arm, weighted with 87.5 kilograms, was attached. During the experiment the tube was surrounded with pure snow. The flow was found to increase very rapidly with increased

Young's E = 11.0×10^{10} C.G.S. units

E = 11.0×10^9
 E = 11.0×10^{10}
 E = 11.0×10^{10}

pressure, and it was found that, once the flow had started, a comparatively small pressure was sufficient to maintain it.

With a pressure increasing 28.6 to 42.0 kilograms per square centimeter, the piston moved from 0.000013 cm. per second after the first four minutes, to 0.00717 cm. per second after four hours. The portion of the ice forced out of the narrow orifice was found to be quite different in structure to the ice inside the cylinder. The latter was clear and homogeneous, while the expelled ice was cracked and broken into grains.

After long-continued pressure, however, the outflowing ice was as compact and clear as that in the cylinder, which must indicate some definite change in structure with time under the increased pressure.

Similar to the experiments of Hess, and at about the same time (1902), G. Tammann studied the velocity of flow of ice, during the course of his experiments on the flow of crystalline substances. It was clearly demonstrated that the plasticity of ice is relatively small, but that near the melting-point it rapidly increases. Like Hess, he enclosed ice in a steel cylinder with a small orifice at one end, out of which it was made to flow under pressure. It was observed that, no matter what the temperature, a constant slow increase in flow took place, with increasing pressure, up to the pressure corresponding to the melting-point for the particular temperature of the experiment, when a sudden rapid increase in flow took place.

He obtained the following results for different temperatures indicated in the table:

Temperature.	Pressure in kilos per sq. cm.	Highest pressure of steady flow.	Melting pressure in kilos per. sq. cm.
- 5.7° Cent.	665	642	678
-10.7° "	1130	1116	1225
-15.7° "	1729	1611	1681
-21.7° "	2100	2000	2070
-27.6° "	2240	2220

The second column shows the pressure at which the rapid increase of flow took place, and represents very nearly the pressure which would be required to bring ice down to the melting-point corresponding to the temperature of the experiment. The third column represents the highest pressure of steady flow corresponding to the particular temperature, and, by comparison with the second, shows how suddenly the ice yields. The last column gives the pressure from the melting-curve.

No better illustration of this could be given than in the curve of Andrews, which we have referred to so often and reproduced in Fig. 14. Had Andrews carried out his experiments, on the rate of penetration of the steel rod, with ice under greater pressures than the atmospheric pressure, the yield would have been observed sooner, and his whole curve would have been displaced in the diagram to the left.

The viscosity of ice was the subject recently of a careful research by B. Weinberg (1905). Ice was cut into cylinders and prismatic rods, with their lengths parallel to the optic axis. One end of the rod was fixed and the other was subjected to a twist.

The coefficient of viscosity was studied in its relation to temperature, and an expression of the following form was given:

$$\mu = (1.244 - 0.502 T + 0.0355 T^2) \frac{10^{13} \text{ grms.}}{\text{cm. sec.}}$$

Young's modulus was found to be of the order of 10^9 gm./cm. sec², or 5×10^9 at a temperature of -1° Cent.

Vapor-pressure of Water and Ice.—For some purposes it is a matter of importance to know the vapor-pressure of water near the freezing-point and of ice below that point. It is well known that much evaporation goes on from the surface of the snow at quite low temperatures.

Measurements have been made by Regnault, Juhlin, and

Marvin and Thiesen. Karl Scheel, in a paper before the German Physical Society in 1905, quotes the best values which have been obtained, and shows that the results may be calculated by a formula proposed by Hertz. I merely reproduce here the table given by Scheel as representing the best values of all the investigators on the subject.

TABLE OF VAPOR-PRESSURES FOR WATER AND ICE.

Water.		Ice.	
Temp. Cent.	<i>P</i> in mm. of mercury.	Temp. Cent.	<i>P</i> in mm. of mercury.
+20°	17.406	0°	4.579
+10°	9.179	-10°	1.974
0°	4.579	-20°	0.787
-10°	2.159	-30°	0.292
-20°	0.960	-40°	0.104
		-50°	0.034

These values show that the vapor-pressure of pure ice is below that of water.

Electrical Properties of Ice.—Ice has been shown to be one of the most perfect insulators known. Thus telephone cables, which are defective in insulating properties through moisture, become perfectly right when the air temperature falls below freezing.

The dielectric constant of ice at -24° Cent. has been found to lie between 60 and 78, values not far from pure water.

CHAPTER III.

FORMATION AND STRUCTURE OF ICE.

Crystalline Structure. Snow-crystals. Structure of Solid Ice. Quinke's Theory. Regelation. Spontaneous Crystallization. Glacier Motion. Modifications of Ice. Supercooling of Water.

IN the neighborhood of the poles and on high mountains, there exist often immense masses of permanent ice; and in some districts of Siberia, where a kind of culture of the soil is practicable in summer, there are found below the surface of the earth strata of ice mingled with sand. In sinking a well at Yakutsk the soil was found frozen hard to a depth of 382 feet, and consisting in some parts entirely of ice. These permanent masses of ice must be classed with rocks as among the solid constituents of the globe.

The hardness and strength of ice is very great at low temperatures, and it is reported that cannon of the calibre of six-pounders were made in St. Petersburg in 1740. They stood an explosion of a charge of a quarter of a pound of powder with hemp or iron ball, although the thickness of the ice was only four inches.

Crystalline Structure of Ice.—Ice, treated as a mineral in Dana's Mineralogy, is shown to crystallize in the hexagonal system, probably hemimorphic. Distinct faces are rare and difficult to measure. The hardness is placed at 1.5, fracture conchoidal, and lustre vitreous. It is colorless to white when pure, and pale blue in large masses. Being transparent to light it is optically uniaxial, and shows a positive character as regards its indices of refraction. According to Reusch (1864)

the indices of refraction are, for the ordinary ray, using red light, 1.30598; green light, 1.3120; violet light, 1.317; and for the extraordinary ray for the same three colors, 1.30734, 1.3136, and 1.321 respectively. The refractive index decreases slightly with temperature.

Snow-crystals are the usual forms met with, and these assume many beautiful shapes. According to Dana, the crystals are generally six-rayed stellate forms of great variety and delicacy. Hail appears sometimes in hexagonal crystals projecting from a solid nucleus, and rarely as distinct quartzoids.

A very complete study of snow-crystals has been made by Wilson A. Bently in the *Monthly Weather Review* (1904), who has taken a large number of negatives. His results are of so much interest that I reproduce the following extracts from the *National Geographic Magazine*:

"Snow-crystals are divided into two great classes,—those columnar in form and those of a tabular form. These two fundamental types are in turn divided into many sub-varieties. . . .

"The forms vary according to the wind, the height of the clouds, the degree of cold, the amount of water in the air, etc. Crystals formed in cold weather or in high clouds are usually columnar or solid tabular. Those formed in moderate weather and light winds or in low clouds are apt to have frail branches and to be of a feathery type. Mixed forms grow partly in low and partly in high clouds. High winds give broken and irregular forms, and much moisture the very granular crystals.

"These heavy granular-covered crystals are peculiarly a product of the lower or intermediate cloud strata, and especially of moist snowstorms. In intense cold they are rare, while the columnar and solid tabular then become common.

"About four fifths of the perfect forms occur within the west and north quadrants of great storms.

"The most common forms outlined within the nuclear or central portions of the crystals are a simple star of six rays, a solid hexagon, and a circle. The subsequent additions assume a bewildering variety of shapes, each of which usually differs widely from the one that preceded it and from the primitive nuclear form at its centre.

"By bearing in mind the fact that crystals evolved within the upper clouds tend towards solidity, and the crystals formed in lower clouds tend toward open branches and feathery forms, it is possible to trace the history and travels of a great many of the crystals.

"Columnar forms or solid tabular are naturally heavier than the open forms. They are not, therefore, likely to be wafted about in so many directions, and hence to be modified and become so intricate as the light, feathery crystals.

"Perfect crystals are frequently covered over and lines of beauty obliterated by granular coatings. Such heavy granular-covered crystals possess great interest for many reasons. They show when the character of the snow is due to the aggregation of relatively coarse cloud-particles or minute raindrops, and not to the aggregation of the much smaller molecules of water presumably floating freely about between them. They also offer a complete explanation of the formation and growth of the very large raindrops that often fall from thunder-clouds and other rainstorms, if we accept the conclusion that such large drops result from the melting or merging together of one or more of the large granular crystals.

"While most granular forms possess true crystalline nuclei, there is reason to suppose that they sometimes form directly from the particles of cloud or mist.

"Minute inclusions of air prevent a complete joining of the water-molecules; the walls of the resultant air-tubes cause the absorption and refraction of a part of the rays of light entering

the crystal, hence those portions appear darker by transmitted light than do the other portions. The softer and broader interior shadings may perhaps also be due, in whole or in part, to the same cause; but if so, the corresponding inclusions of air must necessarily be much more attenuated and more widely diffused than in the former cases. We can only conjecture as to the manner in which these minute air-tubes and blisters are formed.

“As no one can ever actually see the extremely minute water-particles rush together and form themselves into snow-crystals, the material and the manner in which the molecules of water are joined to form snow-crystals is largely a matter of speculation. While it is true that the snow-crystals form within the clouds, it does not therefore follow that they are formed from the coarse particles of which the clouds are composed in cold weather.

“We have good grounds for assuming that the true snow-crystals are formed directly from the minute invisible atoms or molecules of water in the air, and not from the coarse particles in the clouds, as it is unlikely that these coarse particles could unite into snow-crystals in so perfect a manner as to leave no trace of their union even when examined under powerful microscopes.”

Structure of Solid Ice.—The method of studying the crystalline structure of a solid block of ice was given us by Tyndall. Slabs or plates of ice, about half an inch in thickness, were cut parallel to the freezing-planes, and rendered flat by levelling and reducing by means of a warm and smooth metal plate. The planes of freezing were found by observing the direction of the bubbles in the ice, which were either arranged in striæ at right angles to the surface, or collected in groups parallel to the surface of the water. A beam of sunlight was then focussed by a lens on points in the interior of the slab. The position

of the focus was first found in the air, the lens was then screened and the ice placed in position, the screen was removed and the effect watched through an ordinary pocket-lens. By this means the path of the heat-ray was instantly studied by a great number of little luminous points resembling shining air-bubbles. When the beam was sent through the edge of the plate, the path of the beam could be traced by these brilliant spots.

In lake-ice the planes of freezing are easily recognized by the stratified appearance, which the distribution of the air-bubbles gives to the substance. When surfaces perpendicular to the planes of freezing were examined by a lens, after exposure to the light, they were found to be cut by innumerable small parallel fissures, with here and there minute spurs shooting from them, which gave the fissures, in some cases, a feathery appearance. When ordinary light from the window was allowed to fall on the ice at a suitable incidence, the interior of the mass was found filled with little flower-shaped figures. Each flower was found to consist of six petals, and at its centre was a bright spot which shone with bright metallic lustre. It was found that these petals were composed of water. Tyndall found that the relation between the planes of these flowers, and the planes of freezing was perfectly constant. They were always parallel to each other. Further, it was found that the development of these flowers was independent of the direction in which the beam traversed the ice. Hence the direction of freezing could always be told in an irregular-shaped mass of ice by sending a sunbeam through it.

A mass of ice may be thus shown to be crystalline in structure, and to be entirely analogous to crystalline solids formed from a saturated solution. The work of Sir David Brewster long ago proved it to be uniaxial, the axis being perpendicular to the surface of freezing.

Theory of the Formation of Ice Due to Quincke (1905).

—For a great many years Professor G. Quincke of the University of Heidelberg has made a study of colloidal mixtures of silicic acid, glue, etc., evaporated to form gelatinous masses, or thin films and develop fissures. He has shown that these viscous oily films of more concentrated solution exist in a less concentrated solution of the same substance, and form folds, straight and twisted tubes, cylinders or cones, spheres and bubbles, open and closed foam-cells with visible and invisible foam-walls. Thin solid films were shown to behave like films of very viscous liquid. Depending on the viscosity of the oily liquid, the oily films form tubes or bubbles and foam-cells joining on to one another. The mutual inclination of the foam-walls and their surface tensions was shown to continually change as the concentration of the oily liquid changes, and in the case of invisible foam-walls may depend also on the thickness of the oily film. When the oily film is very thin, its surface tension diminishes with diminishing thickness of the film.

Oily foam-walls formed against solid surfaces are normal to these surfaces. It is shown that three oily foam-walls meet in a common edge at equal angles of 120° when they have equal surface tensions.

It is shown that foam-cells of a liquid jelly, immersed in water, can increase or diminish in volume by the diffusion of water through the foam-walls inwards or outwards, that is to say, the liquid jelly can swell or shrink. Two clots of liquid jelly can coalesce into one, which does not occur with clots of solid jelly, nor can these latter swell or shrink.

In general it is shown that a liquid jelly becomes, for the time being, positively or negatively doubly refracting when the viscous walls, or the viscous contents of the foam-cells, are expanded or compressed. A jelly may remain permanently

doubly refracting when the walls or the contents of the foam-chambers solidify while in an expanded condition.

In this connection the author describes an oily liquid as one which has a surface tension in the common surface with other liquids with which it may be in contact. A solution of any salt, then, must be regarded as an oily liquid in comparison with pure water or a weaker salt solution. An emulsion is described as a watery liquid containing suspended drops of oily liquid, or drops of any sort enclosed in an oily skin. These drops can coalesce into larger drops, or the oily skins can join on to one another and form a continuous mass of bubbles or foam. Foam, then, consists of portions of watery liquid enclosed in partitions of oily liquid. Each space so enclosed is called a foam-cell, and the enclosing partition the foam-wall.

A jelly is described as being liquid when the foam-cells are very small, and the fluid foam-walls very thin. A jelly is solid when the walls or the contents of the foam-cells or both have become solid or stiff. It is well known that water is only rarely obtained in a state of absolute purity. Even pure distilled water shows a measurable electric conductivity, showing the presence of a very minute trace of foreign material. Water contained in glass vessels dissolves sufficient of the glass to materially lower its resistance. Natural waters of lakes or ponds always contain varying amounts of salts in solution, and in the case of sea-water a very considerable proportion.

On examining pure-water ice, and ice frozen from water containing added quantities of dissolved salt, melting in the dark, in open air and in sunlight, the author has observed precisely the same group of phenomena, which he met with in his study of gelatinous mixtures. For this reason he suggests a theory of ice formation based on his previous knowledge. Ice is treated as a liquid jelly, with foam-walls of concentrated oily

salt solution, which enclose foam-cells containing viscous, doubly refracting, pure or nearly pure water, the terms being used strictly as given above.

The further the temperature of the ice falls below 0° Cent., the greater the viscosity of the liquid in the walls, and in the interior of the foam-cells. This is shown by the plasticity becoming less. The breaking of the ice with conchoidal fracture at very low temperatures, occurs at the surface of the invisible spherical foam-walls which have contracted differently from their contents. An explanation is given of the well-known appearance of "glacier grains," which are supposed to be foam-cells filled with pure or nearly pure ice, and separated from one another by visible or invisible walls of oily salt solution.

The phenomenon of regelation is explained as the running together of two gelatinous clots, containing liquid foam-cells and liquid cell-contents. Similar effects have been obtained with silicic acid or glue. In the formation of ice we have to do with the separation of pure ice-crystals and mother liquor rich in the dissolved salt, which is always present to a greater or less extent in the water. Since a surface tension exists at the boundary of separation, invisible foam-walls are formed. As the freezing proceeds, the mother liquor continually becomes more concentrated and the foam-walls thinner. Finally, the mother liquor also freezes to ice and solid salt. Air in the water, like the dissolved salts, separates out at short intervals and gives rise to the white places in ice. The air accumulates at the places rich in salt solution. Since the foam-walls, or parts richest in salt, possess a lower melting-point than pure ice, these melt first when an ice-block is subjected to the action of sunlight, or any radiant heat-energy, and give rise to the beautiful liquefaction figures of Tyndall. Artificial ice is seen to be traversed by many horizontal tubes, normal to the surface,

which are especially numerous in the diagonal and median planes of the ice-block where the mother liquor had accumulated.

The small spherical bubbles which are often noticed in an ice-block subjected to melting are tubes of melted salt solution which have broken up with contraction of volume; these may be vacuus or full of air. Some judgment can be made on the velocity of freezing, for the more rapidly water solidifies the more numerous are the foam-cells. By repeated fractional freezing and melting of the ice-crystals formed, the author succeeded in obtaining purer and purer ice with increasingly large foam-cells or glacier grains. He states, however, that he has not succeeded in obtaining by this means ice free from foam-walls or from glacier grains.

A study of separate glacier grains in artificial ice shows that it contains a differently orientated crystal of ice, whose optic axis is very seldom normal to the surface.

When in natural ice the optic axis of the separate crystals in the different grains is found to be normal or parallel to the free surface of the water, the separation of orientated crystals of ice may have been started by the contact action of ice-crystals or snowflakes falling on the surface of the supercooled water, and swimming thereon in a horizontal position.

The more slowly artificial ice is frozen, and the less salt it contains, the more transparent and rigid it is, and the more difficult to split with a knife.

The planes of easiest cleavage in natural ice are those due to invisible layers of liquid salt solution, which are embedded in the crystals. In this respect the under-surface of a solid sheet of river-ice several feet thick should be particularly firm and free from foam-walls; for the freezing goes on with great slowness, and all the dissolved salt should be expelled and carried away by the undercurrents bathing the surface.

Regelation.—Whenever a liquid expands in passing over to the solid state, the effect of increased pressure is to lower the normal freezing temperature. The reverse is the case where a contraction on solidification sets in. The lowering of the temperature of a mass of ice and water under pressure, is brought about by the passage of a sufficient amount of ice into liquid to cause the necessary abstraction of heat from the mixture. Under the new pressure the mixture possesses a freezing temperature of $32^{\circ} - t$, instead of 32° . Attention was first directed to the influence of pressure on the melting-point in 1849, by James Thomson, brother of Lord Kelvin. He showed from thermodynamic principles that it should be so, and calculated that one atmosphere additional pressure lowered the freezing-point 0.0075° Cent. This was verified by Lord Kelvin in 1850, who obtained experimental results very near the theoretical value. In 1880, Dewar obtained an accurate measurement of this temperature depression, and showed that it amounted to 0.0072° Cent. per atmosphere.

The melting of ice under pressure, and the resolidification when the pressure is removed, is observed in nature in many ordinary occurrences, such as the making of a snowball, the passage of a runner of a sleigh along a road, and in the movement of glaciers. Greater pressure is required the colder the snow or ice. Tyndall has shown that when placed in a press, snow may be squeezed into water, which immediately solidifies into a cake or ball of clear ice when the pressure is removed. In this way rods of ice may be squeezed out of small openings in the end of a compression cylinder (see Chapter II). One of the most beautiful experiments illustrating the melting of ice under pressure is that due to Bottomley. A loop of wire is placed around a solid cake of ice a foot thick, and is attached to a heavy weight. Gradually the wire will cut its way through the ice without cracking it. Under the wire the ice is melted

by pressure; the resulting water flows around the wire, and, being freed from the pressure on the upper side and being below its normal freezing temperature, at once solidifies.

J. Joly (1886) has pointed out that the slipperiness of ice in skating, is due to the fact that under pressure of the body, the ice melts and lubricates the skate. This does not take place when the ice is very cold.

It was Faraday (1850) who first observed the phenomenon of the freezing together of two pieces of *melting* ice. So slight is the pressure necessary that a train of floating ice-blocks may be made by touching the leader with the second block, and the second with the third, and so forth, until a number are obtained in line capable of being led about.

Many explanations have been made of this remarkable experiment. Faraday himself attempted to explain it by assuming that the particles on the exterior of a block of ice are held by cohesion on one side only. When the temperature is at the freezing-point, these exterior particles, being partly free, are the first to pass into the liquid state, and a film of water is produced over the ice. In the interior of the block the particles are bounded on all sides by solid ice. The force of cohesion is then a maximum, leaving the interior ice with no tendency to pass into a liquid. When the interior is exposed by fracture, a liquid film at once covers the surfaces, lessening the cohesive force. On placing the two moist pieces together again, the liquid films become bounded by ice on both sides, and, being excessively thin, the force of cohesion is able to act across, drawing the film back again into the solid state. This theory must have given rise to the view advanced by Faraday that a small quantity of water, surrounded on every side by ice, has a natural tendency to become ice.

Professor James Thomson, in 1860, endeavored to explain Faraday's experiment by capillary action, but Faraday showed

this could not be, because the blocks froze together in water as well as in air. Thomson was forced to give other explanations, and he pointed out that the analogy might be found in the crystallization of salts from their aqueous solutions. It is quite conceivable, as we shall see, that a mass of ice in water just at the freezing-point has a natural tendency to further crystallization.

Tyndall, who gave the name "regelation" to Faraday's experiment, was led to believe, from his observations on the internal cavities formed in ice, that the melting-point of ice was not the same in the interior of the mass as on the surface, and that this temperature lay considerably below the normal freezing temperature. In this manner he accounted for the appearance of water-cavities in the interior of a mass of ice at 32° Fahr., which are sometimes seen. He also, with Forbes, accounted for the phenomenon of regelation by the same idea. Thus two pieces of ice, brought into intimate contact on the melting surface, at once froze together. The surfaces of contact were transferred by this means to the interior between two blocks, and, the melting temperature being lower, the water-film of separation was at once frozen. There are some objections to this theory which may be raised, but the main objection seems to be the want of evidence which is available to prove it. No experimental data have ever been obtained, which would indicate a lower melting temperature in the interior.

We are now in a position to see that the term regelation has been generally applied to two classes of phenomena. In one, we have the effect observed by Thomson of the lowering of the melting-point by pressure and the consequent melting of the ice so compressed; and in the other, we have the freezing together of two moist ice surfaces when brought in intimate contact, but without the application of pressure. The word regelation itself implies that a previous frozen state has existed,

and is therefore well applied to the freezing of the water formed from the melting ice in Thomson's experiment, after the pressure has been removed. In Bottomley's experiment we have the phenomenon of regelation perfectly illustrated.

In Faraday's experiment I believe that the use of the term "regelation" is at once inaccurate and tending to ambiguity. The water in this case need not have been previously frozen. It is erroneous to apply the term to all cases in which water, however previously existing, is frozen by the effect of contiguous ice. The general application of the term to all cases has already given rise to much discussion, if one is to judge by the numerous papers published by Thomson, Faraday, Forbes, Tyndall and Herschel, to account for the various facts.

It was clearly demonstrated by these eminent investigators, that pressure is not essential to the solidification of two moist-ice surfaces. A striking experiment was carried out by Forbes and described by him thus: "Two slabs of ice, having their corresponding surfaces ground perfectly flat, were suspended in an inhabited room upon a horizontal glass rod passing through two holes in the plates of ice, so that the plane of the plates was vertical. Contact of the even surfaces was obtained by means of two very weak pieces of watch-spring. In an hour and a half the cohesion was so complete that, when violently broken in pieces, many portions of the plates (which had each a surface of twenty or more square inches) continued united; in fact it appeared as complete as in another experiment, where similar surfaces were pressed together by weights." In repeating this experiment, Thomson found that the watch-springs were really not necessary, and that the pieces of ice united strongly in a few hours.

Faraday held strongly to the view that ice possessed the property of tending to solidify water in contact with it, and the tendency was stronger when water was in contact with ice

on all sides. An observation made by Forbes seems to have shown that ice has more than a *tendency* to solidify water, for he found that, if a small quantity of water be enclosed in a cavity in ice, it will gradually turn to ice. Apart from the effects produced by pressure, to which I think we should restrict the term regelation, it is evident that ice possesses some power of increasing at the expense of the water in contact with it. The conditions must of course be that the ice and water are at the freezing-point exactly, neither gaining nor losing heat, and when this persists we have a parallel to the case of a crystal growing in a saturated solution of the salt composing it.

We have already seen that there is a considerable amount of evidence to support the view that at the freezing-point there are ice-molecules already present in the water, or, in other words, that water at 0° Cent. is a saturated solution of ice. Thus two pieces of ice with moist surfaces, brought in close contact, would fulfil the conditions for freezing along the touching planes.

Ice on both sides, surrounding water at 0° Cent. would grow together by natural crystallization from a saturated solution, and would completely account for Faraday's experiment without the necessity of introducing the effect of pressure.

In 1904 some experiments were carried out by Mr. A. S. B. Lucas, under my direction, with the Bunsen ice-calorimeter, leading to the same conclusion. The ice-mantle formed around the interior tube of the calorimeter is in contact with water at 0° Cent., and the bulb itself is usually surrounded by a jacket of ice and water. Where the calorimeter is buried sufficiently deep to prevent the ingress of heat by conduction from the outside air, the ice-mantle is in contact with water at zero. It is a very well known fault with the Bunsen ice-calorimeter that one never obtains absolutely steady readings. All workers seem to agree that it has to do with the impurities in the out-

side mixture of ice and water, and have devised methods for overcoming this.

Mr. Lucas endeavored to obtain steady readings by paying particular attention to the purity of the materials composing the ice-jacket, but without success.

In order to obtain steady readings when the ice-calorimeter is to be used for delicate work, some surround the calorimeter proper by an air-jacket, which is in turn surrounded by a freezing-point mixture. They thus allow a sufficient amount of heat to enter from the outside through the air-jacket to balance the steady growth of ice that goes on. The thickness of the air-mantle is regulated until the readings become steady. Others put the interior of the calorimeter under a sufficient head of mercury to lower the freezing temperature to a point where it lies below that of the surrounding ice-jacket. This is generally accomplished by elevating the column leading to the capillary tube.

In Mr. Lucas's experiments the bulb of his calorimeter (Fig. 15) was filled with boiled distilled water, and closed by pure, freshly distilled mercury. The expansion or contraction of the mercury took place along a horizontal capillary tube, fitted to a three-way glass tap. The thread could thus be regulated and brought to any convenient position for observation. The capillary tube was 35 cm. long and had a volume of 0.0006619 c.c. per millimeter. The elevation of the capillary tube was 35 cm. The ice-mantle in the bulb was therefore under a pressure of half an atmosphere, which lowered the freezing-point appreciably.

A large copper vessel, perfectly clean, was used to enclose the ice-jacket surrounding the calorimeter, which was completely buried up to the three-way tap. The top and sides of the vessel were padded heavily with thick felt and cotton-wool. The whole apparatus was kept in a room at about 10° Cent.,

so as to preserve the mixture as long as possible. The observations extended over several days, and the ice-jacket was always kept firm and compact.

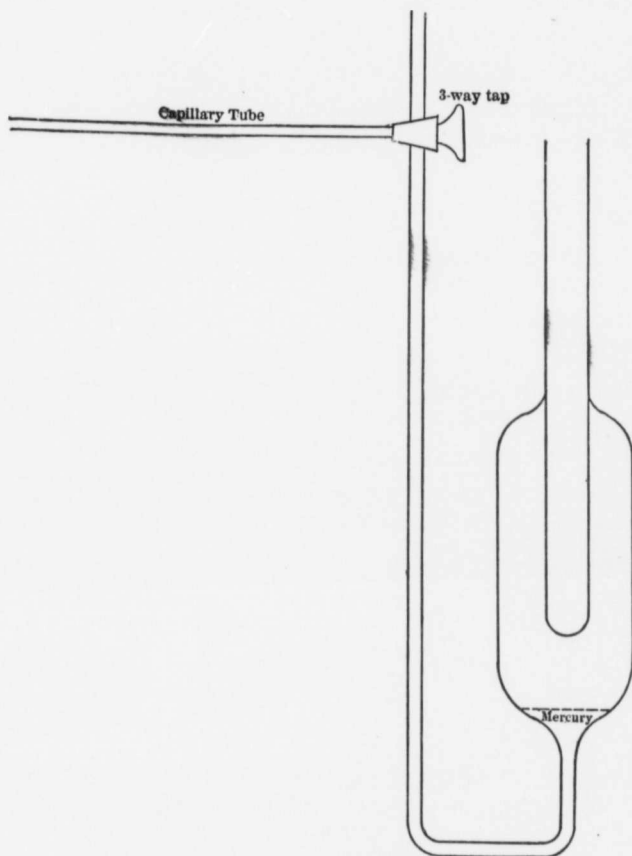

FIG. 15.—Bunsen Ice-calorimeter.

Four sets of experiments were obtained which all agreed very well.

In one set clean, freshly fallen snow was selected, of which there is usually a great plenty in Montreal during the winter-

time, and this was moistened with tap-water. In the other sets, clean cracked river-ice was used, which was obtained from the large clear blocks cut from the underside of the surface-sheet. The ice was moistened in some cases with distilled water, and in others with river-water.

The ice-mantle was prepared in two ways: One, by pouring into the inside tube of the calorimeter, after the contents had been brought to 0° Cent., a little liquid air; the other, by using less severe a treatment in the form of a mild refrigerant of salt and snow. The mantles in the two cases were quite different in appearance. The one from the liquid air was as clear as crystal at first and difficult to see, but soon formed radial cracks as though passing through a change of structure, or yielding to internal strains. The mantle formed by the salt and snow was mottled and milky in appearance, as though freezing about innumerable air-bubbles.

In all the experiments a rapid increase in reading set in, which was followed in one case for 200 hours with no sign of abatement. Bunsen remarks that the increase in reading at first, results from the fact that the mantle is colder after its experience with the freezing-mixture, and that before reaching zero, ice forms. This, he says, may go on for 114 hours, after which it becomes steady. We found no sign of the thread becoming steady. The results for the liquid-air mantle are shown by the curve in Fig. 16. Identical results were obtained for a second set of readings using a mantle formed by liquid air. In two cases, where the mantle was formed by salt and snow, the rate of increase was greater.

The explanation for this difference is not apparent, unless a change in the ice-density is taking place with lapse of time, as suggested by Nichols in his work on the Density of Ice. The increase in thickness of the two liquid-air-formed mantles was 0.021 cm. in eight days; the rate for the other mantles was

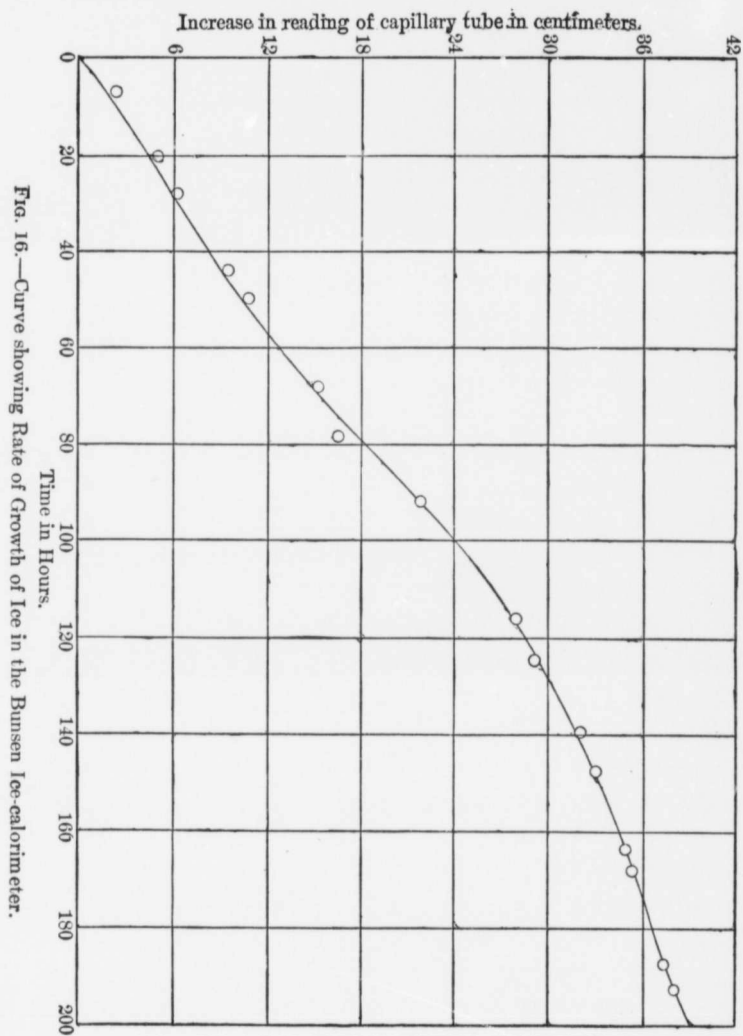

FIG. 16.—Curve showing Rate of Growth of Ice in the Bunsen Ice-calorimeter.

nearly double this amount. Recently (1905) I have measured the difference in temperature, between the inside of the ice-mantle formed by liquid air, and the outside ice-jacket during the time that the ice was actually growing. Very sensitive differential platinum thermometers were used (see Chapter V). Under the conditions of the experiments, carried out with great care, the difference from zero was $+0.0009^{\circ}$ Cent., whereas a difference of about 0.0031° should have been recorded to account for the growth from the loss of heat alone to the jacket. In any case the temperature of the mantle would be slightly higher than the jacket from the heat disengaged during the formation of the ice.

Further experiments will be carried out on this important point to determine more exactly the character of the ice-growth.

Glacier Motion.—The gradual motion of a glacier takes place under the pressure of the accumulation of heads of snow and ice in the north.

A full explanation of glacier motion is very complicated, and cannot be set down to any one cause. Several actions are in operation, and each plays a part in the motion. Thus, while the downward movement of the mass may be explained by pressure, there is probable sheering due to the mass being somewhat viscous. Variations of temperature influence the motion, and cause a downward creeping as well as longitudinal and lateral fissures.

Tyndall considered that in no case have we an example of an ice-block yielding under tension without rupture. The only example he gives of this is in glacier motion. Whenever the banks of the glacier bed narrow, the ice is observed to squeeze together very slowly in parallel lines of flow, just as water forms stream-lines. Quite a different condition is noted where the banks widen. In this case the ice might be expected to widen out in a mass, but instead we find that the ice breaks and forms crevasses, yielding under the state of strain by rupture. An

angular change of three to five degrees is sufficient to form these crevasses, and the suddenness of their formation, and the slowness with which they widen, are a demonstration of the non-viscosity, as Tyndall puts it, of the ice. Had the ice been capable of stretching even at the small rate at which the crevasses widen, there would be no necessity for their formation. Whenever pressure comes into play we observe the effect of viscous flow, but whenever tension is produced we have cracking and rupture.

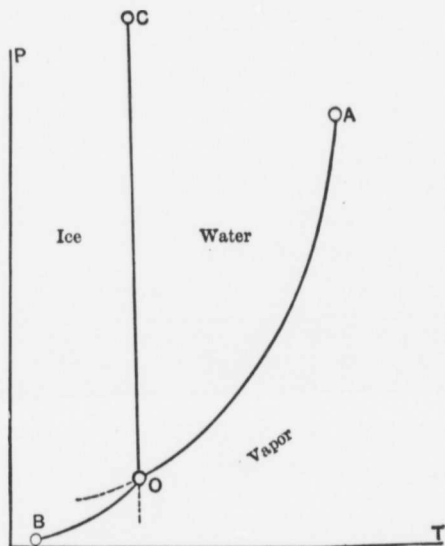

FIG. 17.—Curves of Boundary Conditions of Ice, Water, and Vapor.

OA Vapor Pressure Curve for Water. OB Vapor Pressure Curve for Ice.
OC Boundary Line for Ice and Water.

In the preceding chapter we found abundant evidence of the viscosity of ice and that it yields under tension. The lowering of the freezing-point by pressure is very much more effective an agent in compressing a glacier than the small effect of viscosity. The coefficient of viscosity of ice is large, and probably has

little or nothing to do with glacier flow. The tendency to form crevasses when the ice is under tension can be well explained by the reverse of regelation, without having to jump to the conclusion that ice is only viscous under pressure. Under tension the ice must tend to pass over into vapor, which would cause the ice to become much more brittle in the glacier mass. Diminution of pressure, or a negative pressure such as a tensile stress, tends to vaporize the ice in its interior, just as an augmentation of the pressure liquefies the ice in its interior. The consequence of this is the rupture of the ice-mass along lines of least resistance, which may be along lines of different temperatures. By referring to the curves of boundary conditions for ice, water, and vapor this may be seen (Fig. 17).

Further Modifications of Ice.—Tammann (1902) has shown as a result of his classical researches that for temperatures under -20° Cent., and high pressures of at least 2200 to 2700 atmospheres, two kinds or modifications of ice may be formed, differing in specific volume from ordinary ice. He calls these different kinds of ice, ice II and ice III. By lowering the temperature from -30° to -60° Cent. and raising the pressure to 2400 atmospheres, ice III is formed; but on lowering the temperature to -80° Cent. with the same pressure, ice II appears.

A volume change of 0.171 cubic centimeters per gram at -76° takes place in transforming ice II to ice I or vice versa. The volume change in ice III is more difficult to measure, but the author found the contraction in the passing of ice I to ice III, at -35° , 0.193, and at -40° to -50° , 0.192. The bounding conditions for water and ice Tammann shows to contain three triple points: 1, the ordinary melting-point; 2, the point at -22.0° and 2200 atms. in which the water exists with ice I and ice III in equilibrium; and, 3, the point at -22.4° and 2230 atms. in which the water exists in equilibrium with ice I and ice II. The author shows that ice II may be formed

with explosive violence, with decrease in pressure, when ice I is carried over into the region in which ice II is stable. Ice III is formed with less violence. Ice II and III can be carried over into the ice I region only to about 300 atms.

Supercooling of Water.—Water crystallizes on solidification, and therefore, like all other liquids which form crystalline solids, possesses a fixed and definite freezing-point. It is a matter of great difficulty cooling such a liquid below its normal freezing-point without the solid forming. It is possible, however, in the case of water, if carefully and slowly cooled, to reduce its temperature much below the freezing-point. This anomalous condition is exceedingly unstable, and, if the supercooled water be disturbed by a sudden shock, or a minute piece of ice be dropped into it, solidification at once sets in, and continues until the temperature rises to the freezing-point.

The phenomenon of surfusion, as it is termed, was noticed as early as 1724 by Fahrenheit. He found that a glass bulb filled with water and hermetically sealed could be cooled below 32° and remain in this state. On breaking off the sealed stem, however, the mass at once solidified.

Gay-Lussac, in 1836, observed that water under a layer of oil remained liquid at -12° Cent., but a slight shake was sufficient to start solidification. Uncovered water when very pure may be supercooled several degrees, but it is a very difficult and tedious operation, and can be seldom carried more than four or five degrees. Mechanical action, such as vibration, or the mere touching of a glass rod or the bulb of a thermometer against the side of the containing vessel, suffices to start the process of freezing. As soon as solidification sets in there is an evolution of heat, and this continues until sufficient heat is liberated to raise the temperature of the mass to the freezing-point. Further solidification then ceases, unless the mass continues to lose heat. By immersing small globules of water in

a mixture of chloroform and almond-oil, sufficient to free them from gravity, Dufour succeeded in cooling them to -20° Cent. without freezing.

I have succeeded in cooling pure distilled water—as free as it is possible, with ordinary methods of double-distilling, to free water from dust—in open flasks to -6° Cent., but had no success beyond this point. Solidification invariably set in. Curiously enough, once the freezing-point was passed in the process of supercooling, it was certain that several degrees below that point would be reached without ice forming, and at -3° or -4° quite violent agitation was required for solidification to take place. Time and again ice would form around the sides of the flask immersed in the salt and snow mixture, and the temperature remain at 0° Cent. But whenever the thread of the mercury thermometer was seen to fall below 0° Cent., then it was considered certain that as much as four or five degrees of supercooling would be reached with little danger from freezing.

Whatever form of instability exists in supercooled water, when once this is set up by as much as a few tenths of a degree, it almost invariably persists for several degrees farther on. It seems harder to pass the freezing-point without ice forming than to continue the cooling beyond this temperature. The degree of instability reaches such a critical state, however, beyond five or six degrees, that extraordinary precautions have to be taken for further cooling. With agitation, and the presence of dust or suspended matter, and particularly with dissolved air in the water, supercooling without ice forming may be said to be impossible. Indeed, it may safely be said that the process is entirely one for a laboratory experiment, and is seldom met with in nature. It may happen that a very quiet pool or pond of water may become supercooled during a time of great cold and no wind agitation. Such a phenomenon is

met with in nature occasionally with the advent of a cold wave. A pool of clear, quiet water has been observed to suddenly form a considerable quantity of surface ice, which probably indicated a state of supercooling. In the presence of ice, supercooling, except to a minute extent, is absolutely impossible. The formation of ice, which takes place when water is cooled, keeps the temperature apparently from falling below 32° Fahr., but is not sufficient to keep the temperature quite up to that point. The deviations are comparatively small, and never more than a few thousandths of a degree, and depend on the rate of cooling. This is discussed fully in Chapter VI.

CHAPTER IV.

SHEET, FRAZIL, AND ANCHOR ICE.

Sheet Ice. Rate of Growth of Surface-ice. Frazil-ice. Artificial Production. Anchor-ice. Historical. Distinguished from Frazil. Radiation as the Cause of Anchor-ice Formation. Ice-floods in the St. Lawrence.

Sheet Ice.—The formation of a surface-sheet of ice on an expanse of quiet water, with the advent of cold weather, is exceedingly beautiful. As the season advances, the mass of the water drops in temperature, lagging somewhat behind the temperature of the air. The loss of heat to the cool atmosphere takes place by radiation and conduction from the surface. In the interior the convection currents play the most part in causing the temperature to fall, and result in a fairly uniform distribution of temperature throughout the mass. The currents of cooled water sink slowly downwards, while the lower layers rise to the surface to be in turn cooled. Thus a chain of moving water is set up, and gradually the heat of the water is given up to the air.

The convection process stops when 4° Cent. or 39° Fahr. is reached and passed, so that the colder layers remain at the top. The surface in contact with the air then becomes cooled more than the interior, and finally reaches the freezing-point.

The abstraction of heat from the surface goes on at a rate much faster than can be kept up from the interior of the mass, and very soon long needle-crystals of ice shoot out over the top of the water from the banks towards the centre. These ramify and divide and form lateral crystals until the whole

surface becomes coated with ice. The process of solidification then proceeds, the surface layer becoming more compact, until the water is entirely protected by a thin blanket of ice. Thickening of the ice-sheet takes place downwards by conduction of heat through the ice, and to a certain extent upwards by accumulations of snow.

It is a most interesting sight to observe the approach of the ice-mantle from all sides towards the centre. In the case of very large bodies of water, it happens that frequently the border-ice never meets, being prevented from doing so, either by the mildness of the climate, or by continual wind agitation. The formation of ice near the shores first is an evidence of the rapid convection of heat by the air. The cold currents of air, being warmed by the water, rise rapidly from the centre, and are replaced by cold air which sweeps in from the sides. On account of the increased temperature which the air attains as it moves over the open surface towards the centre, it follows that the centre is subjected to less cooling than the edges, over which the cold air sweeps from the countryside. Without doubt the direction of wind affects the conditions, and its direction may often be observed in the formation of the first ice on an open lake or river.

The conduction of heat away from the water to the shore, which has been given as the cause of the formation of border ice, can have but an infinitesimal effect when compared with the immense stream of convection currents. We have seen what bad conductors rock and sand are, and what a small quantity of ice could be formed by conduction of heat to the edges.

It is probable that the crystallization commences on the edges because of the continual agitation always present there. In order to start freezing, some agitation or nucleus must be present, and nothing is so efficient as a minute crystal of ice. The spray from a small wave breaking on the shore, and freezing

to ice by intimate contact with the cold air before it falls back, produces the necessary first ice, over which the convection currents of air carry the necessary chill for the ice-crystals to spread.

The ice-sheet, once formed, is seldom disturbed until the advent of mild weather in the spring, when it melts away as quickly as it came, under the influence of warm rains and sunshine. The ice-sheet grows continually in thickness as the winter advances, and this growth is brought about almost solely by conduction. Radiation ceases when the ice forms, because it is seldom clear, and is usually covered by snow. The heat-rays do not penetrate such an opaque mass, but are reflected back again by the irregular masses of ice-crystals or snowflakes. Were the ice-sheet clear and solid it would readily transmit some of the heat-rays, and the loss of heat would go on at a greater rate. It seldom happens to be perfectly clear, however, and therefore conduction plays the chief part. As the surface-ice thickens, the growth becomes less rapid, for the heat has to travel a longer distance to the cold air above.

We have seen in Chapter II that the conduction of heat through ice is very small, and, were it not for the accumulation of snow and rain on the surface and the freezing to the under side of fine crystals of ice carried under by currents in a river, the ice-sheet would grow in thickness very slowly.

It is possible to calculate approximately the rate at which a sheet of ice will thicken by conduction alone to a cold atmosphere.

The problem has been attacked by Dr. S. Tetsu Tamura, in a paper on "The Mathematical Theory of Ice Formation," published in the *Monthly Weather Review* for February, 1905. The author shows how difficult it is to obtain an adequate mathematical expression which can be applied to actual conditions in nature.

Considering a surface of open water subjected to a cold atmosphere, the problem is to calculate the thickness of ice, E , which will form in a time t . After the first formation of ice the sheet increases in thickness by conduction through the ice. If it is assumed that the temperature of the ice increases uniformly from its upper surface downwards, the quantity of heat, $\frac{K\theta}{E}dt$, will flow upwards through the ice in a time dt . In the same interval of time a layer of ice whose thickness is dE is formed. Here K represents the thermal conductivity of the ice, and θ the temperature of the air, or upper surface of the ice, which must be less than 0° Cent. The quantity of heat, $\frac{K\theta}{E}dt$, is drawn from the water which is in contact with the ice at 0° Cent., and is equal to $LSdE$, where L is the heat of fusion, and S is the density of ice.

Therefore

$$\frac{K\theta}{E}dt = LS dE,$$

from which

$$E^2 = \frac{2K}{LS} \int_0^t \theta dt.$$

As long as θ remains constant,

then
$$E = \sqrt{\frac{2\theta Kt}{LS}},$$

a simple formula for calculation.

I have obtained a useful formula, also a simple one for calculation, which is based on a mathematical analysis of the actual observed data for the growth of an ice-sheet, and which I have

found to hold very accurately for fairly large temperature differences.

This formula reads:

$$t = \frac{LSE}{K\theta} \left(1 + \frac{E}{2} \right),$$

where t is the time in seconds for the ice-sheet to attain a thickness E centimeters;

L is the heat of fusion, 80 calories;

S is the density of ice, 0.9166;

K is the conductivity of ice, 0.0057 calorie per degree difference of temperature, per square centimeter, per second;

θ is the difference in temperature, centigrade, between the under side of the ice-sheet, 0° , and the air temperature. (Equivalent simply to the air temperature.)

More experimental data are required before a satisfactory solution of the problem can be obtained. The experiments will prove vastly easier to obtain than a correct mathematical solution.

In the following table will be found the time taken for an ice-sheet to grow in thickness, indicated in the first column, when the air temperature is that given by the upper line.

Intermediate values may be interpolated from those given. The calculations are made from the second formula, and are on the assumption that the surface is clear of snow.

The table might be useful as giving an approximate value for the thickness of ice that would form at any place, having found the mean air-temperature over the period of time considered.

Where great thicknesses of snow intervene a correction must be applied, but this, of course, cannot be given by a formula, on account of the variation in the amount deposited.

RATE OF GROWTH OF ICE-SHEET.

Thickness of ice.	Temperature.			
	-10° Cent.	-20° Cent.	-30° Cent.	-40° Cent.
1 inch.	2.06 hours	1.03 hours	41.2 min.	30.9 min.
6 inches.	1.95 days	23.41 "	15.61 hours	11.71 hours
10 "	5.19 "	2.60 days	1.73 days	1.29 days
1 foot.	7.38 "	3.69 "	2.46 "	1.85 "
2 feet.	28.60 "	14.30 "	9.53 "	7.15 "
3 "	63.69 "	31.85 "	21.23 "	15.92 "

A section of a great ice-block taken from the river presents an interesting appearance. The hardened layer of superimposed snow, frozen by rains and packed close by the winter's accumulation of snow, shows successive layers of mottled, coarse-grained ice. The under portions are usually hard, clear ice, one or two feet in thickness, produced by the freezing of successive layers of water bathing the under side. This ice is the most perfect that can be produced, and the most highly prized. It is formed slowly under the most advantageous circumstances, and without stress of any kind to disturb the symmetry. It is that which can be preserved for the greatest length of time, and which resembles more nearly firm rock. It is only in northern lands that such ice is formed, and differs very greatly in its endurance from artificially prepared ice.

In Fig. 18 is shown a block of perfect St. Lawrence River ice as it appears when taken from the river, previous to being hauled to the ice-storage warehouses. This ice-block measured 3 feet long, by 40 inches high, and 26 inches thick. To show the clearness, Mr. Becket, who kindly supplied me with the photograph, placed some reading matter behind the block. The high refractive power of the ice is well shown.

Frazil-ice.—Frazil is a French-Canadian term for fine spicular ice, from the French for forge-cinders, which it is supposed to resemble. It is always formed in an open channel,

where the current is flowing too swiftly for the border-ice to meet over the surface, and is often called "slush-ice." It is a surface-formed ice, which cannot remain attached and freeze into a surface-sheet. It occurs in varying degrees of fineness, depending on the degree of agitation of the water. On a smooth gliding surface flat plates of ice may be formed, and give rise to the term "plate ice." In rapids, or at the foot of waterfalls,



FIG. 18.—Clear Block of St. Lawrence River Ice, showing Structure and Refraction.

very fine particles of ice are formed in minute needle crystals, which grow in bulk when carried far in open water.

Artificial frazil-ice may be formed by subjecting water to rapid agitation in a cold atmosphere. A tub of water placed out-of-doors in winter and rapidly stirred, soon turns to slush by the copious growth of these fine crystals. It is safe to say that a long stretch of open water becomes loaded to the bottom

with slush-ice during a period of intense cold and great wind agitation, frequently occurring in our northern rivers in winter. During such a time the water appears dull in color, presenting an appearance of being mixed with fine sand. At any time during cold weather, the water may be seen to be harboring numerous fine crystals by withdrawing a sample in a clear glass for inspection. The amount it may contain will depend entirely on the weather conditions. A dull, stormy day, with a wind that blows against the current, is productive of the greatest amount. This is the result of the surface agitation, together with the rapid extraction of heat. A bright, sunny day, although very cold, does not show much formation, on account of the absorption of the sun's rays near the surface, offsetting the cooling effect of the air. At night, under a clear sky with wind agitation, a large amount will be formed, depending on the temperature of the air. In this case, both conduction to the air, and radiation from the bottom and volume of the water are operating. Very little radiant heat is stopped by the atmosphere, on account of the minute amount of water-vapor present in the air under these circumstances (see Chapter II). A stretch of open water makes a very much greater quantity of ice in the form of frazil crystals than could be produced as a surface-sheet, if the water were sufficiently quiet to allow such to grow. It is this which causes an open channel to be of so much trouble to engineering operations whenever frost occurs; for, although a surface-sheet may form lower down, the fine ice is carried far under the surface-ice by the currents. Serious changes of level often occur in a river, by the damming up, or complete stoppage of a channel by frazil carried under the surface-ice, and building down on both sides of the channel. Great masses of frazil accumulate in the quiet bays by the drifting in of the fine crystals, and their subsequent settling upwards to the under side of the surface-sheet. The crystals

soon become attached to the surface-ice, and attain depths reaching to the bottom of the river; in some cases we have observed a depth of 80 feet.

In taking soundings through the ice, the lead may usually be sunk through the masses of frazil, but often these become frozen together so hard as to resist all efforts at penetration. The distance to which frazil-ice will be carried depends on the swiftness of the currents, and the amount of open channel above. In the St. Lawrence River, at Montreal, the frazil, generated for the most part in the Lachine Rapids, is found attached as far down as Verrens, some twelve miles below. In this case the river is open above the rapids, as far as Lake St. Louis, seven miles above.

An appropriate term, nucleation, might be applied to the formation of ice-crystals throughout the volume of the water, on nuclei supplied by fine particles of sand, when the water is slightly undercooled by radiation or wind agitation. This term is applied by Professor Carl Barus of Brown University to describe the formation of condensation nuclei in air.

Anchor-ice.—The form of ice which has attracted the most attention of all the forms to be met with in nature, is that known in this country as anchor-ice. As its name implies, it is ice which is found attached or anchored to the bottom of a river or stream. It seems to have been observed in nearly all countries where river-ice is formed, and goes by the name of ground-ice, bottom-ice, ground-gru,—a name given it by the inhabitants of Aberdeenshire,—and lapped ice by the people of the south of Scotland, who apply the epithet to the natural coagulation of milk. In France it goes by the name of *glace-du-fond*, and in Germany as *Grundeis*. The French-Canadian expression is *moutonne*, as it resembles the white backs of sheep at rest.

The phenomenon of ice forming on the bottom of rivers has been known for a very long time, and, although the majority of

the early philosophers of France denied its existence, it was perfectly well known to every peasant.

In 1788 M. Beaun wrote several papers to establish the existence of ground-ice from his personal observations. He reports that the fishermen on the Elbe used to find the baskets, which they let down into the river for the purpose of catching eels, were often, when brought up to the surface, incrustated with ice. Anchors used for mooring their boats, when lost during the summer, frequently appeared in the following winter, being raised by the mass of ice which had formed about them. Their signal-buoys sometimes became displaced from the raising of the large stones by the ground-ice, and caused great inconvenience.

Desmarest, a member of the French Academy of Sciences, was among the first of the scientists to make observations on the formation of ground-ice. He reports having observed flakes of ice, formed at the bottom of running streams, increase in thickness five or six inches in a single night.

In Ireland's "Picturesque Views of the River Thames," published in 1792, where he speaks of the ground-ice of that river, he states: "The watermen frequently meet the ice-meers, or cakes of ice, in their rise, and sometimes in the under side enclosing stones and gravel brought up by them *ad imo*."

In February of 1827 M. Hugj, President of the Society of Natural History at Soleure, reports that while standing on the bridge over the Aar, when the river was clear of ice, he observed large ice-tables continually rising from the bottom in a vertical direction, and with such buoyancy as to rise considerably above the surface, when they immediately sank into a horizontal position, and floated down-stream.

This is in almost perfect accord with what takes place in our northern rivers, during the daytime under a bright sun or during mild weather.

In 1833 the great philosopher, M. Arago, published an interesting paper on the subject in the *Annuaire du Bureau des Longitudes*. He mentions the following rivers where ground-ice was met with, and the date of such observations: In the Thames, by Hales, in 1730; in the river Déonie, France, in 1780, in the Elbe, by Beaun, in 1788; in the Teine, Herefordshire, in 1816; in the Rhine, at Strassburg, in 1829; and in the Seine in 1830.

In the *Edinburgh Philosophical Journal* for 1834 there is an interesting paper on "Observations on Ground-ice," by the Rev. Mr. Eisdale, who attempts to explain the phenomenon by an original theory of his own. He states that the ice commences on the bottom and extends upwards to the surface, and is produced only in the most rapid and most rugged streams.

The Rev. Dr. Farquharson published two important papers on ground-ice in the *Philosophical Transactions* of 1835 and 1841. His observations were made of the ice in the rivers Don and Leochal in Aberdeenshire. The conclusions he arrived at are that ground-ice is formed by radiation, and he endeavored to substantiate his reasoning upon the principle of the formation of dew. A further discussion of the theories advanced by these men will be reserved for Chapter VII.

The first mention of the name *anchor-ice*, which I have been able to find is in the *Encyclopædia Americana*, published by Carey and Lea, of Philadelphia in 1831. Under the article on Ice, the author, after referring to ground-ice, states that "a kind called anchor-ice appears to be formed at the bottom, or at least under the surface of rapid rivers, perhaps owing to the comparatively slow motion of the water at the bottom of a stream."

The term anchor-ice, then, seems to have originated in America, and is applied to ice anchored on the bottom of streams and rivers, flowing too swiftly for surface-ice to form. Much confusion exists in regard to the relation of this ice to frazil-ice,

brought about partly by a misuse of terms, and partly from the fact that immense quantities of frazil-ice become attached to the bottom by freezing to the layers of ice already formed there. The term anchor-ice we shall use to designate all ice found attached to the bottom, irrespective of its nature of formation. Thus, frazil becomes anchor-ice when it attaches itself to the bottom. The birth of frazil is in the water itself by surface-cooling, through wind or rapid agitation, and by radiation. Anchor-ice may form *in situ* on the bed of a river, and may grow by attaching to itself frazil-crystals brought down by currents, and by the process of radiation.

In the report of the Montreal Flood Commission we have the terminology clearly defined, and it cannot be too strongly emphasized, the importance of adhering to this distinction, for clearness of expression. Thus, referring to the important report published by the Commission as early as 1888, we find the following: "Frazil as distinguished from anchor-ice is formed over the unfrozen surface above and below Lachine Rapid (St. Lawrence River at Montreal), between Prescott and tide-water, and wherever there is sufficient current or wind agitation to prevent the formation of bordage-ice."

We find that as early as 1810, writers of that time drew a distinction between three kinds of river-ice, if we may judge from an early edition of the Encyclopædia Britannica published at that date. Under the article on Ice we find the following: "Ice forms generally on the surface of the water, but this, too, like the crystallization, may be varied by an alteration in the circumstances. In Germany, particularly the northern parts of that country, it has been observed that there are three kinds of ice: 1. That which forms on the surface; 2. Another kind formed in the middle of the water, resembling nuclei or small hail; 3. Ground-ice, which is produced at the bottom, especially where there is any fibrous substance to which it may

adhere. This is full of cells like a wasp's nest, but less regular, and performs many strange effects in bringing up very heavy bodies from the bottom by means of its inferiority in specific gravity to the water in which it is formed. The ice which forms in the middle of the water rises to the top, and there unites into large masses; but the formation both of this and the ground-ice takes place only in violent and sudden colds, where the water is shallow and the surface is disturbed in such a manner that the congelation can not take place. The ground-ice is very destructive to dykes and other aquatic works. In the more temperate European climates these kinds of ice are not met with."

These three kinds of ice are what we term sheet, frazil, and anchor ice.

The worst effects which are met with in engineering works are from frazil-crystals formed during extreme weather, when anchor-ice is frozen down and rapidly growing, and not, as is sometimes supposed, when moderate weather occurs, and these huge lumps become loose and rise to the surface. Thus it is often thought that it is useless distinguishing frazil- from anchor-ice, unless it were possible to tell them apart when seen together at the foot of a stretch of open water, where they accumulate at the edge of the barrier-ice. They are certainly both ice, but the conditions under which anchor-ice will form are not the same as for frazil, and vice versa. Methods of construction to obviate the one will not meet the exigencies of the other. So long as the ice problem lasts we shall find circumstances conducive to the formation of either one, or the other, or both. We should therefore keep clearly in our mind how each is likely to be formed in order to be prepared to distinguish the conditions most likely to favor the growth of either. In a shallow, smooth-flowing river we are more likely to have anchor-ice formed in excess, whereas in a deep and turbulent

stream we are likely to have more frazil. It is hardly likely, however, that there will be a great difference in the amount of frazil formed in either case; it will probably be that more or less anchor-ice will appear in proportion. In a river 30 or 40 feet deep, anchor-ice is almost unknown, although large quantities of frazil are met with.

Everything seems to point to radiation as the cause of anchor-ice, and it is a great question whether it would form at all, or except in exposed or exceedingly shallow rapids, unless the first coating of ice was placed over the rocks by the radiation of heat.

Consider the circumstances: the water flowing over the rocks at the bottom of a river is always very close to the freezing-point. The deviations from the freezing-point, as we shall see later, are probably seldom, if ever, as great as $1/100^{\circ}$. The bottom is continually being warmed to a small degree by the conduction of heat from the earth. It is, therefore, difficult to see how ice can form on it by heat-loss directly to the water. The utmost frost that we have ever observed is only .006 of a degree, which would have a small influence in cooling the bed directly. Unlike open ground subjected to extremely cold air, the bed of a river cannot become frozen to any depth.

The radiation of heat from the bed of a river must go on all the time to the colder air above, and to the much colder space. During the daytime under a clear sky we have the sun's heat radiated down through the water, and offsetting the cooling effect produced by the space radiation; and on a cloudy day we have the heat-rays reflected back again by the clouds. On a clear night in winter, with little or no motion in the air, the circumstances are entirely conducive to excessive radiation. We have seen, from what knowledge we have of the radiation from hot bodies like the sun, that only a small proportion of

the heat can penetrate a layer of water. Hence the heat of the sun is mostly absorbed in the first few feet of water. Only a small proportion of the rays ever reach the bottom. On the other hand, the radiation from the bottom is quite different, and consists of long rays which we have every reason to believe penetrate the water much more easily. It might at first sight appear that there was a much larger amount of heat radiated to the bottom of a river by the sun, whose temperature is so high, than is radiated out of the river into space. This is apparently quite true, and, but for the absorption by the water of the greater part of the sun's heat, and the consequent lessening of the heat which actually reaches the bottom, it is a question whether anchor-ice would ever form. It has been pointed out in a previous chapter how little is known in regard to cold-body radiation, and it is not impossible that little or no heat is absorbed by the water, if radiated from the bottom into space at absolute zero.

The influence of the sun is everywhere observed in the formation of both frazil- and anchor-ice. In the former by warming the water, and preventing it from becoming undercooled, and in the latter by loosening the masses of anchor-ice, and causing them to rise. Frazil is never observed to have a bad effect under a strong sun.

That portion of the heat from the sun, the long waves that penetrate the water, is effective in melting off the hold which anchor-ice has on the bed of a river. A common sight in the early morning, after a cold clear night, when the sun rises, is the appearance of masses of anchor-ice. These rise and float down with the current in great quantity. Boatmen are very careful when crossing a river not to go when these masses are rising, from the danger of being surrounded and caught in a mass of anchor-ice and carried down helpless by the stream into the rapids.

If we sum up the various facts of common observation in connection with anchor-ice, we see that everything points to radiation as the prime cause. Thus we find that a bridge or cover prevents the ice forming underneath. Such a cover would act as a check to radiation, and reflect the heat-waves back again to the bottom. Anchor-ice rarely forms under a layer of surface-ice. It forms on dark rocks more readily than on light ones, which is in accord with what we know in regard to the more copious radiation of heat from dark surfaces. Anchor-ice never forms under a cloudy sky either by day or night, no matter how severe the weather, but it forms very rapidly under a clear sky at night. Anchor-ice is readily melted off under a bright sun. It seems highly probable, then, that radiation of heat supplies the necessary cooling to the bottom of a river to form the first layers of ice, after which the growth or building-up of the ice is aided by the entangling and freezing of frazil-crystals which are always present in the water.

The growth of anchor-ice is exceedingly beautiful, taking place in arborescent forms and resembling bushy weeds. So hard and thick does it become that it is often very difficult to thrust a sounding-rod through it. It is very granular in structure, as is shown by an examination of the masses which rise to the surface. Through clear water the ice looks weed-like, with long tentacles rising up out of the mass. It often has immense power in lifting rocks and boulders up bodily, and many of these are carried far down-stream attached to irregular masses of ice. The spongy character of adhering frazil-crystals attached to anchor-ice, or the underside of a surface-sheet, causes them to accumulate slime and infusorial growths from the water. A very characteristic color of these masses is brown. When melted in a vessel the slime settles to the bottom, when it is seen to be of a very fine structure, consisting probably largely of infusorial growth. In Fig. 19 is shown an ideal pic-

ture of the position in which ice is usually found at the foot of a rapid near the barrier-ice.

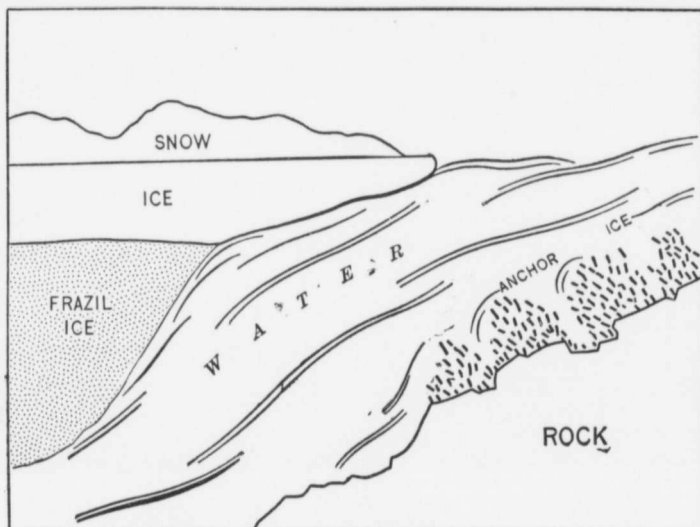

FIG. 19.—Ideal Picture of Sheet, Frazil, and Anchor Ice as they are usually found near the foot of a Rapid.

Ice-floods in the St. Lawrence.—On account of the peculiar nature of the ice-growth along the St. Lawrence River, floods are experienced in certain sections during the period of the formation of ice and the break-up of the winter. In Montreal, before the construction of the dyke and guard-pier along the harbor front, the ice-floods used to do much damage. The whole question of examining into the nature of the floods was given to a Commission in 1886, consisting of Thos. C. Keefer, Henry F. Perley, John Kennedy, and P. W. St. George, who made a most careful survey of the river along the flood area. The most elaborate and painstaking observations were made of the ice, and a large number of charts were prepared showing the thickness of the ice, the extent of the ice-sheet, and permanent open water.

Soundings were taken through the ice, and it was shown to what a large extent frazil-ice, manufactured in the rapids, was carried under the ice and deposited in the quieter water. I reproduce, through the kindness of Mr. Keefer and Mr. Kennedy, several of the charts which tell more than any description (see *Plate*) how enormous the accumulation of frazil-ice may become. Needless to say, the Commission did not have to seek far for the cause of the floods, when it was seen how solidly the frazil-ice became packed in almost every available space, and what an enormous quantity was let loose in the spring at the time of the breaking-up of the surface-sheet. The narrow portions of the river just below Montreal are entirely inadequate to carry off these large quantities of ice, and a consequent damming of the waters annually occurs.

As to the character of the floods, I cannot do better than to quote from the Report of the Flood Commission: "The St. Lawrence River is not subject to floods in the ordinary sense in which this term is applied to other rivers, such as the Ohio and Mississippi. The floods with which we have to deal are not due to excessive quantity of water but of ice, and are entirely local, being confined to a comparatively insignificant extent of the river. Although due to ice formation, they differ from ice-gorges in the more Southern rivers, which are of short duration and often more destructive, and are produced only by the breaking-up and departure of the ice. In the St. Lawrence, on the contrary, there is a permanent elevation of the river-level in the affected districts, while the volume of the flow is diminishing, which elevation, though not maintained at maximum height, continues throughout the winter. Although this takes place every winter, and the wharves of Montreal are submerged about four months in the year, this winter rise of the river is not always accompanied by what may be called a

flood. The river reaches its highest winter level from the packing of the ice in December or January, and its highest spring level, arising from the breaking-up and departure of the ice, in March and April. The spring break-up resembles the ice-gorges of other rivers, in that it is an accompaniment of the departure of the ice, but this winter elevation is peculiar to the more Northern rivers, and, when it reaches the proportions of a flood, is the result of an unusual burden of ice-blocking the channels and requiring a temporary rise before the river can force open a larger area of waterway and settle down to its winter bed."

The strength of the water-current really determines the formation of a continuous surface-sheet, and the barrier-ice, which forms at the foot of rapids where the river widens out, encroaches on or recedes from the open water in direct proportion to the severity of the weather. It is when the strong floating ice meets the barrier-ice that the winter packing sets in. The packed surface of the channel presents a ragged section both in air and water. All interstices are filled with frazil, which is also drawn in under by the current, but very soon rises to the under side of the ice and freezes there. So deep and firm becomes this accumulation of frazil that at one time it was the custom of the railroads to construct a track across the river for the carriage of freight.

In the accompanying photographs (Figs. 20 and 21) will be seen the track so placed, and a locomotive and freight-cars such as were used at that time. It is a most magnificent sight in the spring of the year to witness what is termed an "ice-shove," when the ice begins to move out of the river in a mass. So great is the quantity of ice let loose all at once that, in the narrow portions of the river, immense piles of huge ice-blocks rise in a few moments. I reproduce two photographs (Figs. 22 and 23) taken opposite Montreal before the guard-pier

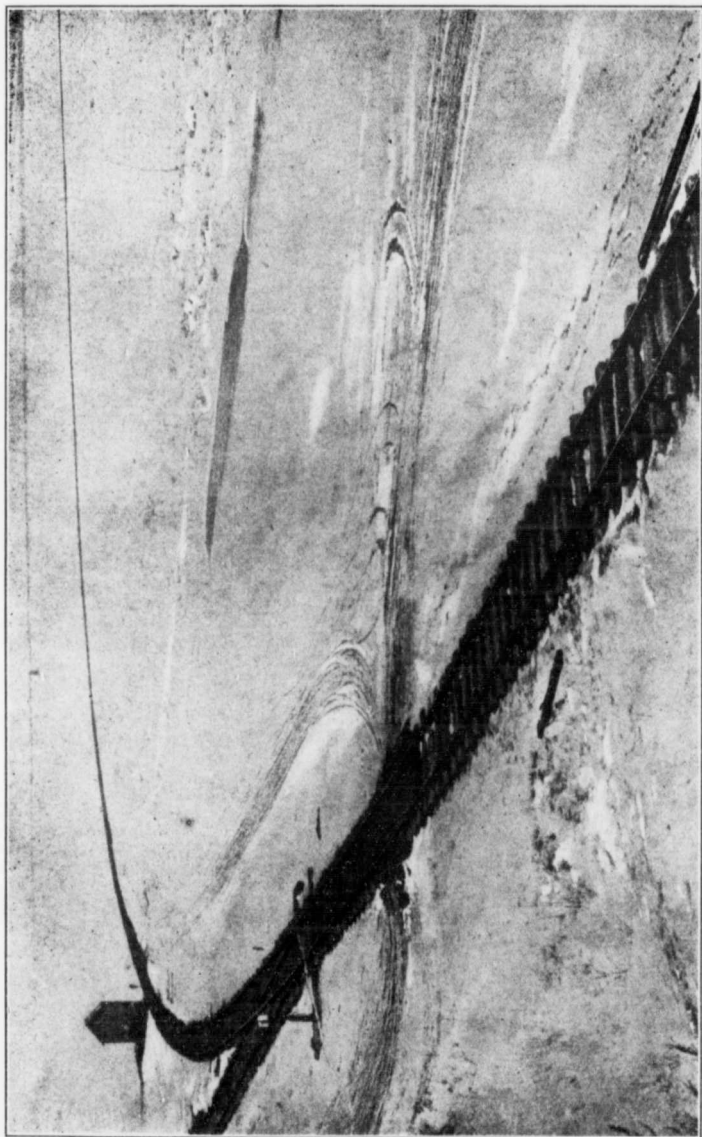
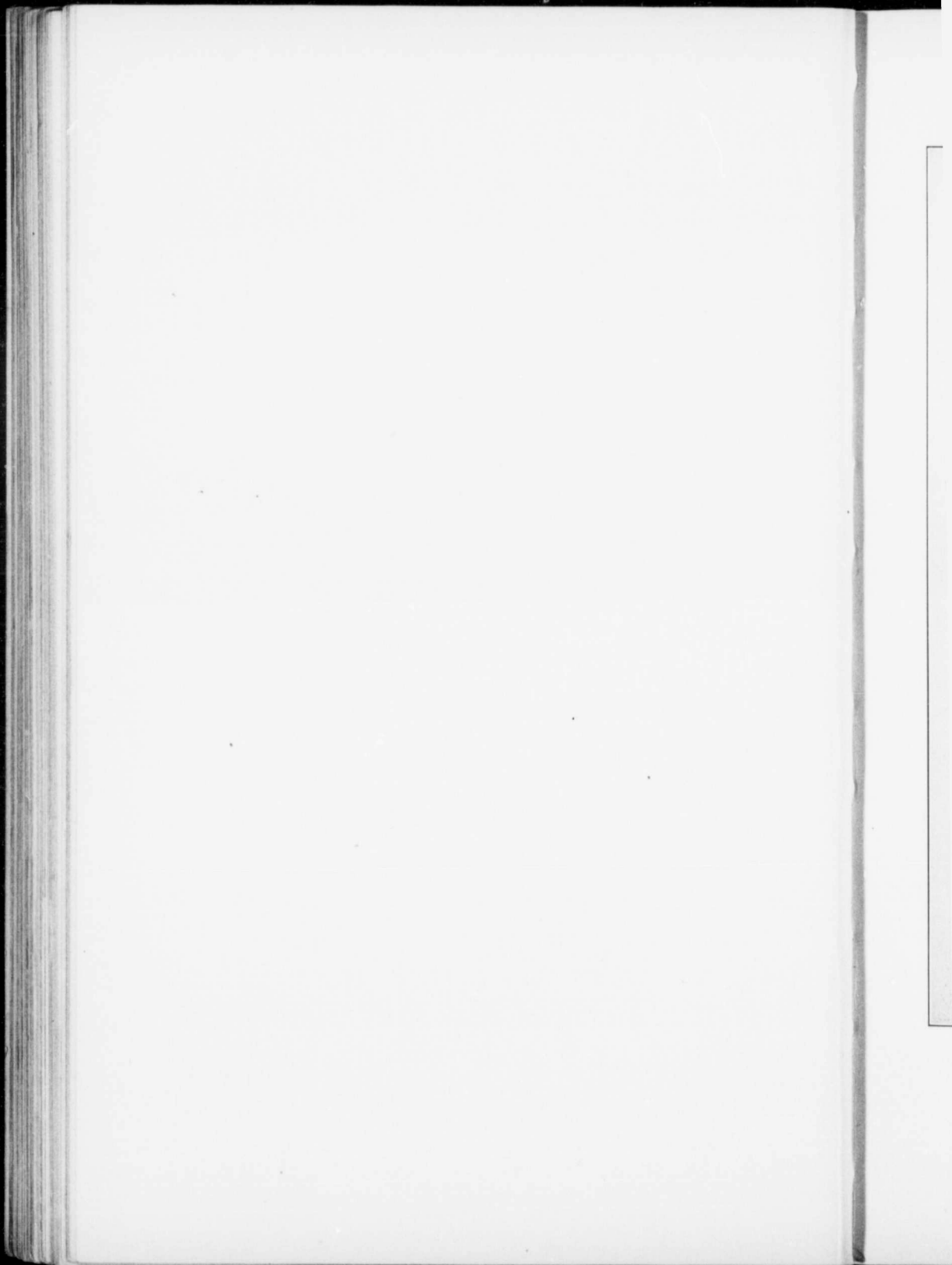

FIG. 20.—Railroad-track Laid across the St. Lawrence River in Winter.



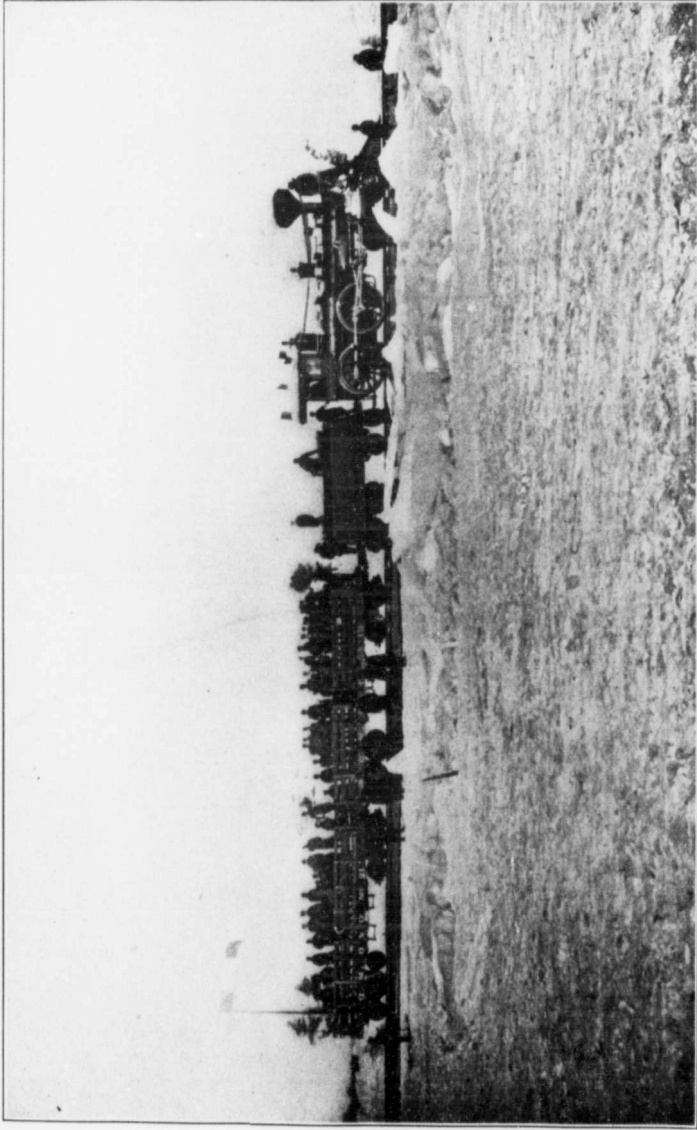
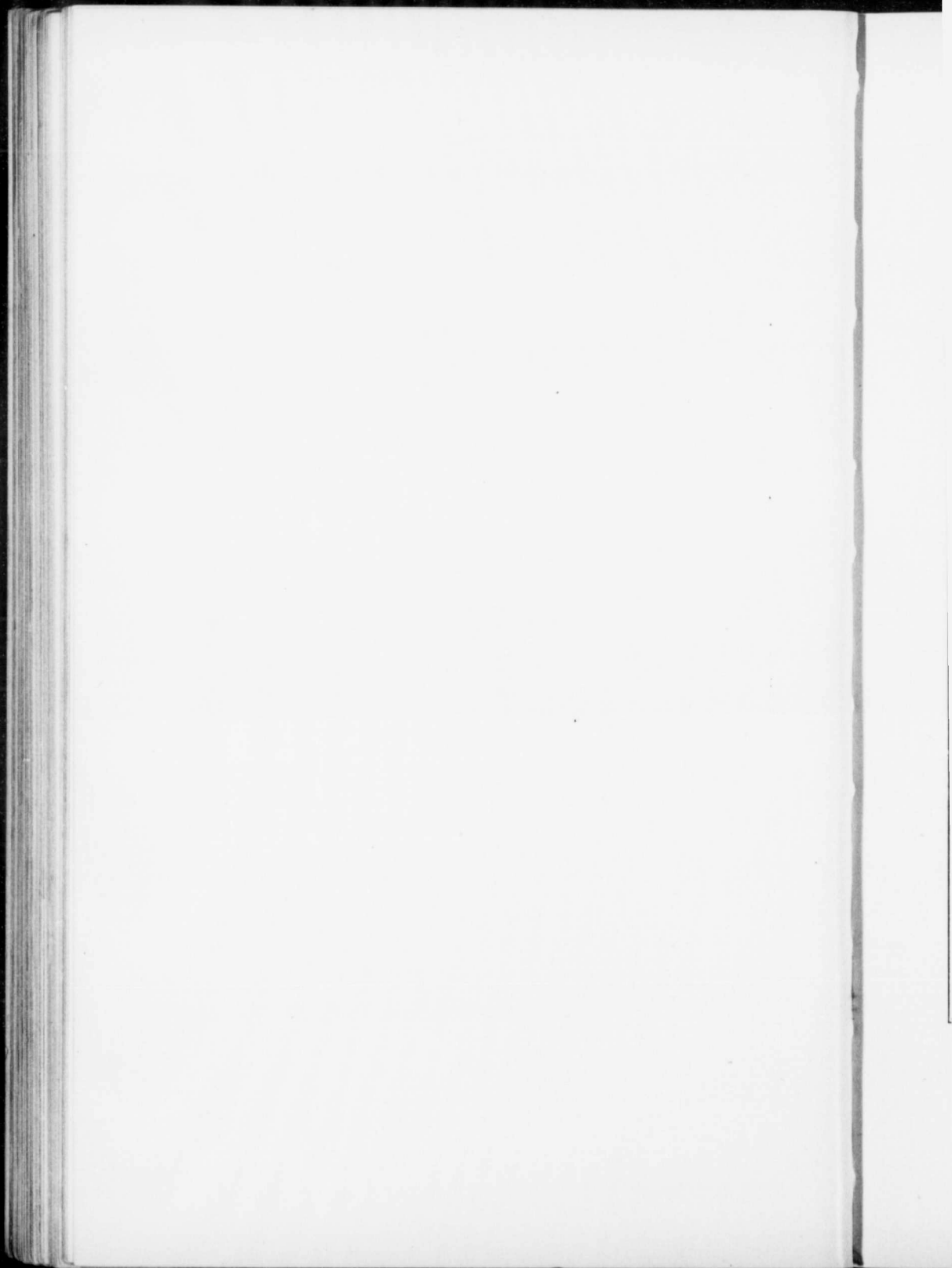

Fig. 21.—Locomotive and Freight-cars on the Ice-track.



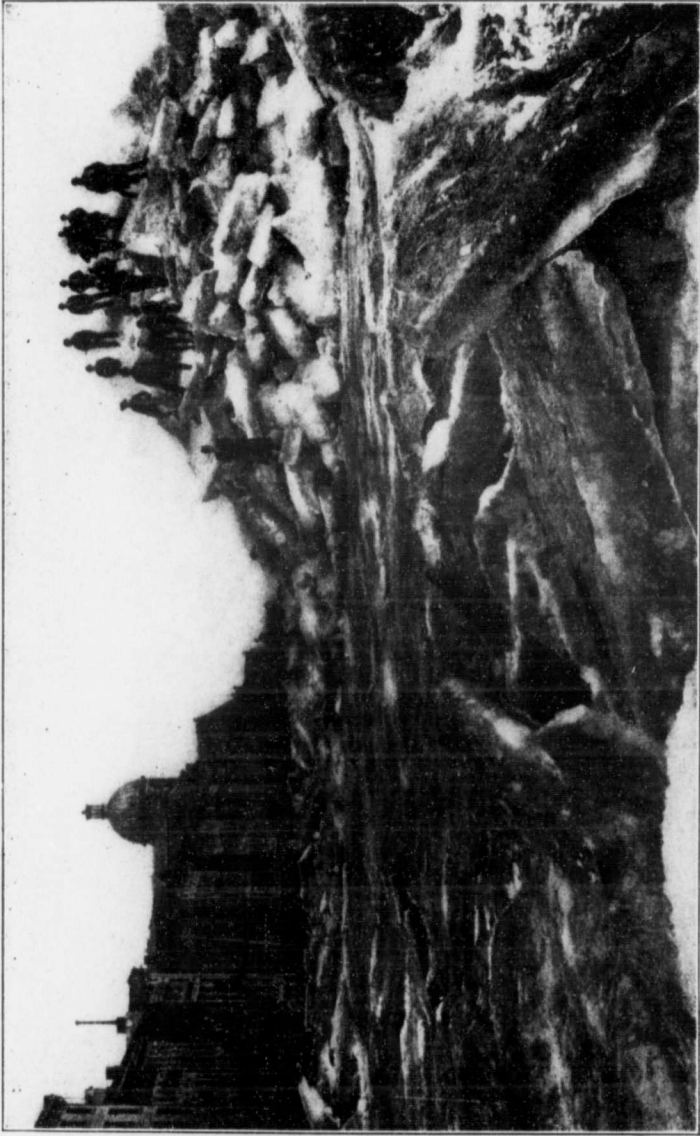

FIG. 22.—Result of Ice-shove opposite Montreal before Construction of Guard-pier.

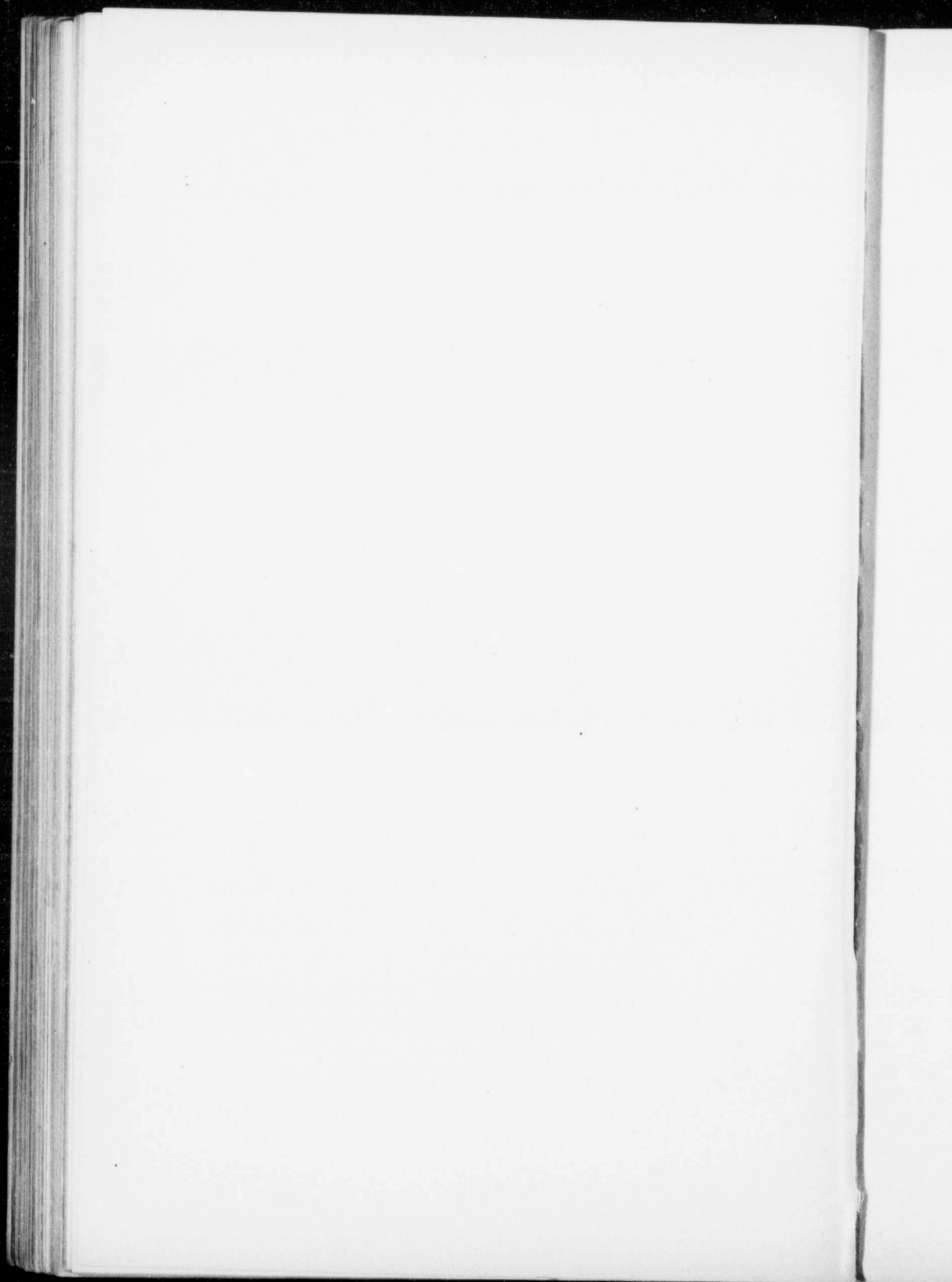
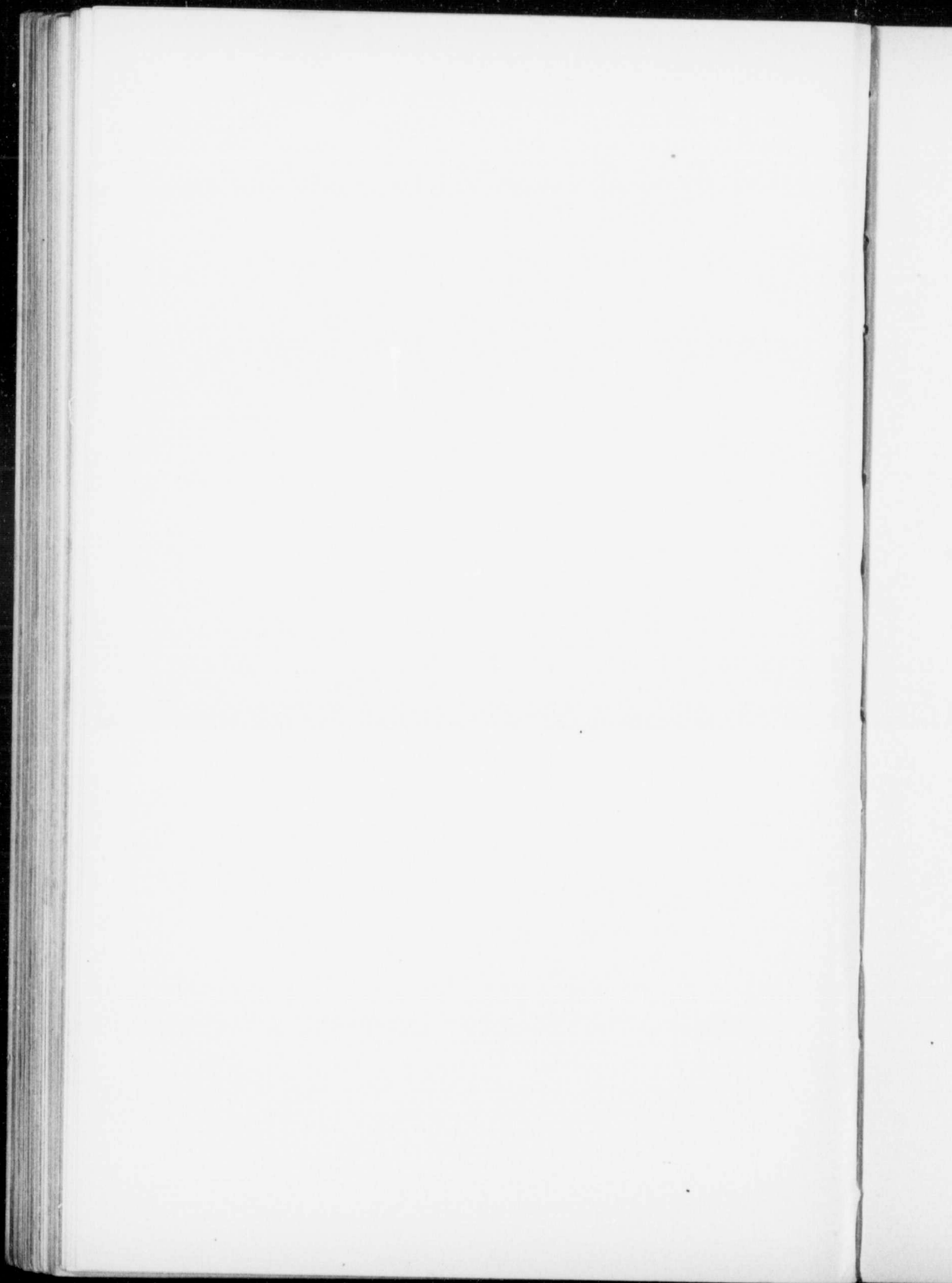



FIG. 23.—Another View of the Ice-shove.



was constructed, just after such a shove had taken place, which will convey some impression of the magnitude.

The accumulated mass of frazil, though porous and saturated with water, is as effective an obstruction to the flow of a river, with respect to the area occupied by it, as so much rock. The obstruction it creates may be inferred from the fact that it compels so great a river as the St. Lawrence to back up in winter fifteen feet at one point below Montreal before it can force sufficient way for its low-water discharge through "these miles of monstrous tubercular growths within its ice-covered bosom."

The ice story told by the Flood Commission of the St. Lawrence River is of so much interest that I reproduce parts of it here, in order that a better knowledge may be gained of the conditions to be met with in a river subject to winters of great severity.

EXTRACT FROM THE REPORT OF THE MONTREAL FLOOD
COMMISSION.

The St. Lawrence is a river of such width and depth that, notwithstanding the great volume of water which it carries (its low-water discharge above Lake St. Peter being 315,000 cubic feet per second), its extreme range between highest and lowest water-marks is only about six feet, or one-tenth that of the Ohio at Cincinnati. Wherever this range is exceeded, as at Cornwall, Beauharnois, and Montreal, it is only in winter, and is due to the packing of the ice. The river below Montreal is affected by ice from tide-water to the foot of the Lachine Rapids—a distance of eighty miles—and, with the exception of what are called air-holes, the whole surface is covered with ice. But above the Lachine Rapids the winter level is only elevated by ice for a short distance opposite Cornwall and Beauharnois. All the remainder, embracing both open-water river sections and

ice-covered lake ones, with rare local exceptions, maintains the ordinary level. The exceptions are where an ice-bridge or -jam may occur in the narrower channels above the Cornwall Canal in very severe winters, or where a bridge is formed artificially by sawing off enough bordage-ice and swinging it across the channel to an island, to give communication with the mainland. These bridges do not affect the river-levels at their site, but by arresting floating-ice may advance the bridge up-stream to a point where shallower water and a swifter current may cause a pack and form a dam. The open-water sections are about forty miles in length between Cornwall and Prescott, about fifteen miles between Lakes St. Francis and St. Louis, and about ten miles between the ice-covered portion of the latter and the foot of the Lachine Rapids. There is no case of a permanent winter dam where there is open water immediately below it (as in the case of a gorge at the break-up of the ice), but the permanent winter rise at Cornwall and Beauharnois takes place under the same conditions as that at Montreal, namely, the junction of a river section open in water with one which is closed, and of a strong current with comparatively dead water.

At the outset of the winter there is every reason to believe that ice which has been formed as high up as Prescott reaches Montreal or passes out to sea before the river is boomed by an ice-bridge in Lakes St. Francis and St. Louis, but, when these lakes and the river above Prescott are frozen over, the local accumulation of ice at Cornwall, Beauharnois, and Montreal is restricted to that which can be supplied from the open-water sections above each. Without these lakes the whole winter output of ice below Prescott would be deposited opposite the Island of Montreal, and in all probability would render a large portion of the lower banks of the St. Lawrence as uninhabitable as Ile Ronde is now, by permanently submerging

them during the winter. These lakes generally close permanently in December.

History of the Floods.—There is no record of any gauging of water-levels of the St. Lawrence at Montreal previous to 1852. Since that year daily measurements, showing the depth of water on the lower sill of Lock No. 1, Lachine Canal (which gives the harbor-level at this lock) have been made. The mean summer level of the harbor is taken as a depth of nineteen feet on this sill, ordinary low water seventeen feet, and extreme low water fifteen feet and five inches. The top of the revetment wall or level of Commissioners Street is thirty-eight feet six inches above the lock-sill, or nineteen feet six inches above mean summer level of the harbor. This wall was completed in 1841, and was no doubt expected to be above all ordinary floods, but its height was evidently limited by that of adjacent streets, Custom House Square, McGill, and parts of St. Paul streets. As a matter of fact, the water has only gone over it once in the winter months since 1848, namely, in 1886, but has done so seven times in the spring month of April. This April flooding commenced in 1861 and continued at regular intervals of four years until 1873, when there was a cessation for twelve years until 1885, since then it has gone over the wall three years in succession. Many cellars were always flooded, and some portions of the lower streets in many of these years were covered by water backed up through the drains before the river reached the top of the revetment wall, but, as this influx of water is limited by the size of these drains and can be cut off and handled by pumps, we have assumed the top of the revetment wall as flood-level, and count only those as flood years in which the river has overflowed this wall, because when this takes place flooding commences and pumping is out of the question.

Of floods previous to 1852 there is little information extant,

as only in the case of one, that of January, 1838, is the height given with reference to any known elevation. The first winter rise of the St. Lawrence which has been recorded was at Christmas, 1643, when the first white men wintered here under Maison-neuve. An ice-flood then drove this pious soldier out of his cantonments to prayer and pilgrimage, as recorded by Père Barthélémy Vimont, S. J., in the "Relations des Jésuites."

In 1819 "Commissioners Street was overflowed opposite the new market (the 'new market' was on what is now Jacques Cartier Square, and the 'old market' on what is now Custom House Square) and planking injured by an ice-shove." Commissioners Street was then several feet lower than its present level; there is therefore no mention of a flood in other parts of the city. On April 10th, 1823, there was "the greatest ice-shove since 1798." The house occupied by Sharp, in the rear of the old mansion house, was blocked by ice to the third-story windows, out of which the inmates escaped. The American mail was stopped by the overflow of the road from Laprairie to St. John's, but there is no reference to a flood of water in the city.

In January, 1883, there were two feet of water in cellars in St. Paul Street (the part of the street is not mentioned), canoes were used in St. Anne's suburb, and the top of the arch of the bridge over the creek at the foot of McGill Street was covered. All this could have taken place without the river reaching as high as the top of the revetment wall. In the following April Griffintown was "flooded as usual."

On April 25th, 1836, there was a great ice-shove. Handy-side distillery at Pointe à Callière was levelled, as well as a stone-shed at the mouth of "Little Creek," from which point to Cringan's stores, at what is now the north corner of St. Peter and Common streets, near the foot of Port Street. The ice piled thirty feet high. A man named White, his wife and

three children, were crushed to death in their shanty, upon which ice two feet thick was piled fourteen feet high. The creek overflowed several streets in Griffintown, most probably in consequence of its outlet being dammed up by this great shove of ice. There is no mention of a flood except in Griffintown in connection with this "shove."

Then followed the distressing January floods of 1838, 1840, and 1841, three within four years, in consequence of which a public meeting was held on January 8th, 1841.

In 1848 the water rose on January 4th over the revetment wall, McGill Street was flooded as high up as College Street, and Mountain Street as high up as Torrance's garden. The houses on the lower side of Bonaventure Street were flooded and the furniture damaged. St. Paul and Commissioners streets were to a great extent under water and remained so until the 9th, five days of a winter flood. This was not of so long duration as in January, 1838, when the inundation lasted fourteen days. Since 1848 the level of floods is known by the gaugings at the canal-lock taken daily, but only at noon, and commencing in 1852. Recently a self-registering gauge for floods has been established at the harbor commissioner's office, by which the exact time at which highest water is reached is recorded.

From 1848 until 1861 the water did not reach the top of the revetment wall. The highest spring flood did not come within nearly two feet of it, but in January, 1854, it rose within nine inches, and in January, 1858, within five inches of the top of this wall. In April, 1861, 1865, 1869, 1885, 1886, and 1887 the water went over this wall; and in April, 1873, reached its top level. There was no winter flood between 1848 and 1886, although in January, 1867, the water came within ten inches; and in January, 1858, and also January, 1884, within two inches of the top of the revetment wall. It is remarkable that previous to 1850 all the floods were winter ones, and that this was

followed by an exemption for thirty-eight years, or until January, 1886, when the next winter flood took place; while, on the other hand, since 1850 there have been six spring floods, all in the month of April, besides one year in which the water rose in that month to the level of the top of the revetment wall. It is also noteworthy that, although the river has reached its highest stage since the gaugings commenced in 1852, eight times in December and three times in March, there never has been a flood in either of these months, nor has the water in either of these months, during the eleven years in which the ice took and departed in them, reached within two feet of the top of the revetment wall. This proves that the early closing and the early breaking-up of winter means immunity from ice-floods.

The commissioners have obtained the gaugings in the Ottawa River and St. Lawrence, as well as those of Lake Ontario, and also the temperatures of these winters from the McGill College Observatory, in the hope of establishing some relation between these and the flood, as well as the non-flood years, but without much success. While high water in the St. Lawrence and the Ottawa must intensify the April flood, they are unable to say that in any instance it has been the direct cause of one, though April floods have occurred, as might be expected, generally when the St. Lawrence and Ottawa were rising; and the highest flood at Montreal was coincident with the highest level at Ottawa, and also on Lake Ontario on the same date, as was the case during the greatest flood, that of 1886, and no doubt was the cause of its excessive range; but there has been high water at Ottawa when the St. Lawrence broke up at low level at Montreal, and a flood at Montreal when the Ottawa was at an average height only. Nor have we been able to trace any relation between the severity of the winters and the flood years, or the mildness of the winters and the non-flood years, although it is evident that the floods are a question of ice and,

they believe, of ice only, however much they may be increased by an unusual volume of water in April. High water in the St. Lawrence and Ottawa occurs long after the departure of the ice, and seldom reaches within ten feet of the ice-flood level. The river is so large and its banks of such height that, when relieved of ice, the greatest known height of water cannot flood Montreal. Even when covered with ice it is only when this covering conceals a much larger body of other submerged ice, as at Montreal, Beauharnois, and Cornwall, that flooding is caused by it.

The records of the thermometer for past years, or of high and low stages of the St. Lawrence, are less important for this question than that of the daily condition of the river as to the formation, movement, and distribution of the ice which it carries. In order to explain this, it is necessary to describe somewhat minutely the process by which the river disposes of the ice derived from an enormous surface and produced in great abundance, even in mild winters—sometimes in greater abundance in these than in more severe winters, owing to the more frequent breaking-up and re-forming of the ice over the same surface.

The Ice-pack.—In the latter part of November ice formation begins at the shores of the mainland and islands and upon the shoals, which latter are more or less numerous and extensive, according to the stage of the river. This "bordage-ice" pushes outward as the water becomes colder and thickens, unless a wind, which in such wide water is always accompanied with more or less sea, breaks off this glacial fringe and sends it down the stream. If the bordage is already strong enough to resist the lighter waves the latter thicken and strengthen it, and, as it widens and encroaches upon the main channel, light, floating ice is drawn under it and there arrested by friction, and cemented by frost to its undersurface. When from

increasing cold the water of the main channel is cooled down sufficiently (which is generally zero weather), the whole surface of the river is covered with moving ice of a peculiar character, known as "frazil-" and "anchor-ice." It has a dull leaden hue when afloat, like saturated snow, and floats in patches of varying area, in the interior of some of which there may be unfrozen water like tiny lakelets; in others thin plates or scales of true transparent ice are seen, apparently formed in the calm water produced by the surrounding boom of "slush-ice," as this formation is also called; in others may be found ice of bordage origin, from shoals or boulders, which has been swept away by the frazil in its downward march. This might properly be designated "current-ice" to distinguish it from that found at the bottom, as it forms only where there is sufficient current or wind agitation to prevent the surface from freezing over. With a certain temperature the whole unfrozen surface of the river is covered with it, and this condition at the setting-in of the winter applies to a continuous open channel between the bordages (wherein is the deepest water and strongest current), from Prescott to tide-water, a distance of over 190 miles. From the first appearance of this ice-flood until a portion of it is arrested by the closing of the lakes above Montreal a week or more may elapse; and, since there is an average current velocity between Prescott and Montreal, produced by a fall of over 200 feet in a little over 100 miles, or about two miles per hour, it is quite possible that in many winters ice derived from 100 miles of river may pass Montreal to winter below it.

This abundant and incessant flow of slush-ice, mingled with more or less of detached bordage-ice, and receiving accessions from every part of the open channel both of sheet-ice and frazil formed there, is checked and then arrested in the open channel through Lake St. Peter, where it first feels the effects of tide. Massed across the outlet of this lake, and abutting on the shoals

which flank the ship channel there, it is quickly frozen together, and a bridge is formed. Meanwhile the bordage, thickened by frost and by snow (made heavier by thaws or occasional rain, as well as the filling up underneath by frazil), begins to encroach upon the waterway, causing a gradual rise of the surface. This rise of water lifts the bordages and often detaches them from the shore, when, in favorable positions and aided by wind and current, they move down the main channel until arrested by the ice-bridge. After Lake St. Louis has been closed by the severity of the weather and no more floating ice descends from its covered spaces, a thaw may set in which, aided by a northeast wind, will break up the ice there from all but the land-locked bays, and send it in large fields over the Lachine Rapids, where it is more or less broken up. With colder weather the surface is again covered with frazil and thin plate ice, the bordages lifted and broken, and the three kinds of ice move down to the bridge below. It is when the strong floating ice meets this bordage that the winter packing begins, very slight at first in the weaker currents of the lake, but heavier where the current is stronger in the river sections. At the first formation of the bridge the floating cakes are thin and often tilted on edge by the current, projecting vertically and irregularly above and below the surface several feet, also against the edges of the solid bordages, which resist side pressure from the descending flood of ice. The packed surface of the channel presents a ragged section both in air and water. All interstices are filled with frazil, which on the first obstruction is drawn under by the current, but immediately rises to the underside of the ice, where it is soon arrested by the ragged outlines of the ice-bridge. This arrested channel-ice is quickly frozen together and over it the winter road is formed. The downward flow of ice varies with the supply, which is dependent on the weather, and the upward march of the ice-bridge is governed by this

flow, but not everywhere proportional to it, because more ice is drawn under the bridge where the current is strong and where the ice is thin, and less where the latter is thick or the current weak. With continued cold weather, producing an abundant supply of floating ice, the upward march between Lake St. Peter and Montreal is rapid, averaging four miles per day, until the foot of St. Mary's Current is reached. The river in this forty-five miles has an average fall of 1.06 inches per mile, and an average channel velocity of two and one-quarter miles per hour in summer. This is increased opposite the city by the St. Mary's Current at St. Helen's Island and the Sault Normand, at the reef extending across the river from Moffatt's Island to Point St. Charles, just below the Victoria Bridge. The summer fall in the river from Victoria Bridge to the foot of the St. Mary's Current is nine feet in three miles, and the velocity of current four to eight miles an hour.

The upward march of the ice-bridge is not only arrested or delayed by mild weather, but there may be gaps in it caused by a jam between the bordages at some point above, forming a temporary bridge there, leaving more or less open-water space between it and the permanent one below. This space is generally filled by the giving way of the upper bridge from increasing pressure against it. The downward flow of ice may move at the rate of one and a quarter to two miles per hour, and the upward march of the ice-bridge may average one and a half miles per hour at particular times.

Above Varennes (which is twelve miles below Montreal) the packing becomes more severe and the rise of the water greater, and this increases from that point to Montreal. In addition to the gradual rise, due to the bordages, the ice-bridge, and floating ice, a special and temporary rise or fluctuation of the river-level takes place as the ice-bridge advances, and within a short time after the ice has taken and the bridge permanently

established from point to point the water falls about two feet.

It is when the ice-bridge approaches the St. Mary's Current, and this rapid is apparently fighting for its life, that the grandest effects of its convulsive efforts are seen. The large ice-floes, as they approach the ice-bridge, are nipped between it and the moving ice behind them and are broken, tilted on edge, forced under the bridge, or packed against it. When this moving mass is excessive it grounds on to the shoals and piles in the channel, thus throttling the only waterways left to the river; the latter then rises rapidly, backing up to deliver an effective blow and drives the obstruction before it and on to the bordages or under them out of the channel. Sometimes the solid bordages are lifted, cracked, and the edges driven over each other or on the shore, where piles of great height and volume are suddenly formed, sweeping everything movable before them.

These collections of frazil are the most important factor of the flood question, and, indeed, it may safely be asserted that they are the sole cause of them. In other words, if there were only field- or bordage-ice to deal with, no matter how often they were broken up or broken off by wind or thaw, there would be no floods, because it is inconceivable that in a river over a mile in width, with a channel half a mile wide and thirty feet deep, enough of this ice could be sunk to raise the water to such an extent as to produce a flood. The tendency of field- or bordage-ice is to float, and it resists submersion with great force, while the tendency of frazil- and anchor-ice is to sink upon the slightest provocation and follow submerged channels, taking all the windings of the currents until grounded in shallow water or arrested against the under side of the fixed ice, to which it freezes and forms a nucleus for further accessions of the same material, until this spongy downward growth reaches many times the thickness of the surface-ice to which it is attached.

CHAPTER V.

PRECISE TEMPERATURE MEASUREMENTS.

The Platinum Resistance Thermometer. Mercury Thermometer Compared. Method of Measurement. Refinement of Apparatus. Sample Results showing Accuracy Attained.

BEFORE proceeding to the experimental portion of the present study of ice formation, it seems advisable to include here a brief outline of the best methods for accurately measuring temperature. It will be seen that in order to understand the various conditions in which frazil-, or anchor-ice is met with, it is necessary to understand how the minute temperature differences are set up in the water, and how these are measured. The steadiness of a mixture of ice and water has already been explained, but we find, on more careful inquiry, that this is only a question of degree; that beyond $1/100^{\circ}$ Fahrenheit variations occur which are brought about by a rapid process of formation or melting.

It is true that the temperature is kept steady when heat is abstracted rapidly from water at the freezing-point by the latent heat liberated, but we find that in order to establish the process of growth or decay, a minute temperature difference must exist to initiate the flow of heat.

It is probable that the crystallization of ice takes place at a measured rate, and that if the abstraction of heat from a mass of water and ice is very rapid the temperature depression is increased. Likewise, if a mass of water and ice be subjected

to rapid melting the temperature of the mixture will be not 32° Fahr. or 0° Cent., but a small fraction of a degree above.

The measurement of these small temperature differences is one of great difficulty, even under the most favorable laboratory surroundings. When applied to actual conditions in nature it becomes more difficult still. The reason why attention has not been directed more to these measurements is on account of the inadequacy of our ordinary temperature-measuring instruments. Repeated attempts have been made to connect the formation of ice in a river with the temperature of the water. The Montreal Flood Commission devoted a great deal of attention to this, but it cannot be said that they obtained anything more definite than to say that the temperature of the water was never very different from 32° Fahr. throughout the winter.

To actually record the small differences requires most sensitive thermometers which would be capable of measuring to the 1/10,000 part of a degree. The ordinary mercury thermometer is well enough to 1/100 of a degree under laboratory conditions with some care, but to go beyond this only leads to complications, and errors far exceeding the measurements.

Only in the hands of an expert can the mercury thermometer be used to 1/1000 of a degree, and no one can expect such a thermometer to be constant in its zero to much better than 1/10°. Moreover, such errors as a change of zero, pressure on the bulb, capillary and stem corrections are so large as to make the readings far from reliable.

The change in resistance of a pure metal with temperature, has been the subject of much study, and it has been found that with a metal like platinum very reliable measurements can be made. Especially in the measurement of small differences in temperature the change in resistance of a platinum wire affords by far the most accurate results. It will be seen to resolve itself into merely a measurement of minute differences

in resistance which, as is well known, can be done with a precision equalled only by the use of the sensitive chemical balance.

The laws governing the change in resistance with temperature of pure platinum have been most carefully worked out, and the method of reduction, to obtain the reading of temperature on the standard nitrogen or hydrogen gas thermometer, has been carefully studied and repeatedly verified.

With the resistance thermometer we still have to deal with the question of a change in zero and a stem correction, but these are so small that with care they may be eliminated altogether. In measuring temperatures in the river during the winter, when no great variation has been observed to occur from the freezing-point, the platinum thermometer is very suitable. It may be read from any convenient location with the bulb actually in the water, and hence does not require to be withdrawn from the water and read in an atmosphere cooled down many degrees below freezing. The differential platinum thermometer is in addition exceedingly useful, in that the one measurement gives any deviations which may occur from a carefully prepared mixture of ice, snow, and water at the freezing-point.

The measurement of temperature by means of a platinum wire, as originally suggested by Siemens, has been carefully worked out by Professor Callendar of the Royal College of Science, London, and formerly of McGill University. His classical researches on the subject are too well known to make it necessary for me to dwell on the fundamental part of them. The introduction of the idea of a platinum temperature which depends on the term

$$pt = \frac{R_t - R_0}{R_{100} - R_0} \times 100,$$

where R_0 , R_{100} , and R_t are the measures of the resistance of

any one particular sample of platinum wire at 0° , 100° Cent., and at a temperature t , has been now almost universally accepted.

The reduction of the platinum temperature to the air-scale was obtained from a series of comparisons with the nitrogen air-thermometer at three fixed points, 0° , 100° , and 444° Cent., which led to the well-known parabolic formula

$$t - pt = \delta \left(\frac{t^2}{100^2} - \frac{t}{100} \right),$$

where t is the air temperature and δ a constant depending on the purity of the platinum wire, the same for any particular purity of wire.

I propose to describe here some tests made on various thermometers used during the course of my researches. Before doing so, I must briefly describe the resistance-boxes and method usually used for compensating the change in resistance in the wire due to a change of temperature.

The general plan of Wheatstone's bridge connections for the thermometer-circuit is the usual one (Fig. 24). The wires leading to the bulb of the thermometers A and B are compensated for a change in resistance due to a change in temperature by similar wires placed side by side with them, but connected to the opposite arms of the bridge-circuit a and b . The change in resistance in either thermometer is compensated by resistance-coils on an opposite arm of the bridge, and a final adjustment made on a short bridge-wire, of which the coils are suitable multiples. A change in resistance is referred to a change in units of the box, rather than measured in ohms. It is evident that a change in the temperature of the resistance-coils, while compensating a change in resistance in the thermometer, will produce an apparent change in the thermometer reading. This

can be corrected by either taking the temperature of the coils in air, or by immersing them in oil at a constant temperature. For very accurate work, however, it is better to introduce a different arrangement. If each resistance-coil on the bridge is wound with another coil, which has the same temperature coefficient but a different specific resistance, then, if these second coils are connected with an opposite arm of the bridge system, any change in temperature of the bridge-coils cannot affect the balance point on the bridge-wire. This

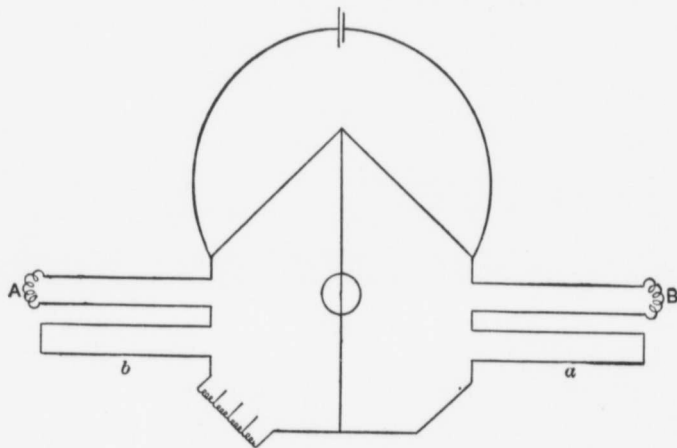

FIG. 24.—Diagram of Differential Platinum Thermometer Connections.

method, which was devised by Callendar, works exceedingly well.

Besides the compensated resistance-coils, the special feature of this box is the bridge-wire scale, which has a compensating device for a change in length due to a change in temperature, so that the galvanometer contact point always reads at the same point on the scale. The resistance-coils are multiples of the bridge-wire, commencing from the smallest coil, which is equivalent to 10 cm. of bridge-wire, and doubling always as

the coils become larger, i.e., 10, 20, 40, 80, 160, etc., up to 2580. The resistance of the bridge-wire is 0.0088 ohm per centimeter, so that the ten-coil is rather less than 0.1 ohm. The bridge-wire scale is of brass, very carefully divided to half-millimeters, and supplied with a vernier with lens reading to 0.01 mm. The total length of bridge-wire is 40 cm., but it could be read only between 6 and 34 cm., leaving a margin of 6 cm. at each end.

Each of the larger coils, before putting in place in the box, was tested for compensation in a specially constructed oil-bath, the temperature of which could be changed quickly at will. Each coil was also made of either two or three wires in parallel, 0.15 mm. in diameter, so as to avoid current heating. They were specially designed for immersion in oil when in place in the box, but this was not found necessary. It was not deemed necessary to test the small coils, from 10 to 40, for compensation, as the test of the larger coils showed that the calculation of the lengths of wire necessary was so nearly correct as to leave little room for error in the smaller coils over a wide range of temperature. The ratio-coils in the box were made from 0.15-mm. platinum-silver wire wound in parallel on a mica frame, and were carefully adjusted to equality. The resistance-coils were connected to mercury-cups and short-circuited when not in use by thick copper connectors.

The calibration of the box consisted in determining the errors in the different box-coils and the calibration of the bridge-wire and scale.

In determining the total change in resistance of the thermometers between 0° and 100° , which is termed the fundamental interval, or, briefly, F.I., the largest that it was necessary to use was coil 640. It was evident that, provided this coil is accurately compensated, it is the best one to which to refer the F.I. It is entirely unnecessary to know its absolute

value in ohms, provided we assume it equal to 640 even units, and refer the other coils, including the bridge-wire, to it.

From 640 down every coil differs from the sum of all the rest by very nearly 10 cm. of bridge-wire, or the size of the smallest coil. If we compare the lengths of bridge-wire obtained by differencing the coils in this way, we obtain the usual series of equations of the form

$$640 - \text{sum}_1 = a_1; \quad 320 - \text{sum}_2 = a_2; \quad 160 - \text{sum}_3 = a_3, \text{ etc.},$$

where a_1 , a_2 , and a_3 are very nearly 10 cm. and involve the coil errors.

If we eliminate the sum from any two equations, remembering that the next lowest sum differs from the one before by the lesser coil, then we have a series of the form

$$640 - 2 \times 320 = a_1 - a_2; \quad 320 - 2 \times 160 = a_2 - a_3, \text{ etc.},$$

which should equal 0 if $a_1 = a_2 = a_3$.

If we let the error in 640 be equal to 0, then the error in $320 = \frac{1}{2}(a_1 - a_2)$ in terms of 640 even units; then

$$160 = \frac{1}{2} \left\{ \frac{1}{2}(a_1 - a_2) - a_2 - a_3 \right\},$$

and so on for all the coils.

The error in the bridge-wire, which we call the bridge-wire correction, is determined from the error in coil 10 obtained in terms of 640 even units. The calibration of the bridge-wire was done by inserting a small resistance, equal to about 3 cm. of bridge-wire, into the bridge-circuit, so that by short-circuiting it by a heavy copper connector placed in mercury-cups, the bridge-wire reading could be shifted the same amount at any part of the wire. The reading was found to vary 0.0005 cm. per centimeter on either side of the middle point 19, in such

a way as to increase towards 30 and decrease towards 0. This showed that the wire was slightly smaller towards the zero end, and hence its resistance greater. As the equivalent length of 10 cm., obtained in the calibration of the box-coils, never occurred at exactly the same spot on the bridge-wire, there is a small correction to be applied to the values of a_1 , a_2 , and a_3 due to their position. The correction is worked out so as to reduce the values to a length of bridge-wire extending over the middle point, between 14 and 24. The correction is very small, however, and would produce no appreciable error to the results if neglected altogether.

In Table A is given a complete series of readings taken to determine the coil corrections in the first box. In Table B a summary of tests is given extending over a period of a year.

The signs are affixed to the corrections in the way they should be applied to the reading. The bridge-wire correction is given per centimeter of length. In taking the readings a low-resistance galvanometer was used which had a high figure of merit. The sensitiveness was obtained so as to give from 40 to 50 scale-divisions per millimeter of bridge-wire on reversing the current. For the small coils an external resistance of 350 ohms was required, which was reduced gradually to 150 ohms for the 640 coil in order to preserve the same sensitiveness throughout the test, with one accumulator. The galvanometer contact was arranged so that it could be held in contact with the bridge-wire. Therefore, instead of obtaining an exact balance and reading the vernier, the contact was placed to the nearest millimeter or half-millimeter mark on the scale, with the help of the vernier, and the deflection of the galvanometer recorded. Accurate account was always kept by repeated verification of the sensitiveness of the galvanometer, which never altered as much as one scale-division when external disturbances were absent.

TABLE A.—SET OF READINGS FOR DETERMINING BOX-COIL CORRECTIONS.

Coils.	640-sum.	320-sum.	160-sum.	80-sum.	40-sum.	20-sum.	10-sum.
Reading of bridge-wire. {	24.979	21.970	20.645	19.711	25.113	27.640	28.787
	14.950	12.096	10.631	9.815	15.135	17.624	18.911
Equivalent length.	10.029	9.874	10.014	9.896	9.978	10.016	9.876
Correction to mean bridge-wire.	0	+ .002	+ .003	+ .004	- .001	- .002	- .004
Corrected length.	10.029	9.876	10.017	9.900	9.977	10.014	9.872
Differences, 640-2×320, etc.	—	+ .153	- .141	+ .117	- .077	- .037	+ .142
Correction in terms of 640 coil.	0	- .077	+ .032	- .043	+ .017	+ .027	- .057

TABLE B.—BOX-COIL CORRECTIONS IN TERMS OF 640 EVEN UNITS.

Date.	320.	160.	80.	40.	20.	10.	Bridge-wire.
1898.							
May 6th.	-.087	+ .027	-.038	+ .021	+ .034	-.050	+ .008
" 21st.	-.072	+ .028	-.038	+ .018	+ .026	-.055	+ .007
" 25th.	-.077	+ .027	-.036	+ .017	+ .028	-.051	+ .007
1899.							
January 7th.	-.055	+ .033	-.044	+ .019	+ .030	-.051	+ .007
" 9th.	-.063	+ .040	-.042	+ .020	+ .030	-.050	+ .007
" 12th.	-.069	+ .029	-.045	+ .019	+ .024	-.055	+ .008
April 27th.	-.077	+ .032	-.043	+ .017	+ .027	-.057	+ .007
Means.	-.071	+ .030	-.040	+ .019	+ .029	-.053	+ .007

Referring again to the diagram of the complete thermometer-circuit, Fig. 24, the position of the resistance-coils in the bridge system is shown, and the position of the ratio-coils and bridge-wire. When differential thermometers are used we have them connected on opposite arms of the bridge, at *A* and *B*, and arranged so that the compensating-leads for thermometer *A* are in series with thermometer *B*, and the compensating-leads for *B* connected with *A*. Where *A* and *B* are at the same temperature and of the same resistance, it is evident that the bridge system is in equilibrium with the galvanometer contact at the middle of the bridge-wire. For

a change in the temperature of either *A* or *B* the bridge reading was shifted either to the right or left, and, when too great to be read on the wire, was compensated by the resistance-coils. A change of temperature in *A* higher than *B*, however, could not be recorded beyond the bridge-wire. It was therefore necessary to arrange that *B* should always be used for measuring a change in temperature higher than *A*. The resistance-coils were brought into the circuit by removing the heavy copper contacts from the mercury-cups. When these contacts were removed, the contacts of each corresponding compensating-coil were removed at the same time. To obtain the fundamental constant ($R_{100} - R_0$) or interval, F.I., both *A* and *B* are balanced when immersed in melting ice, and then with *A* in ice and *B* in steam. To obtain the difference between the intervals of the two thermometers both were read when in steam. This gives the data required for converting into degrees a change of resistance in *B* relative to *A*.

The usual way of making a platinum thermometer is to wind the fine wire of about 6 mils (thousandths of an inch) on a light mica frame. The ends of the coil, which is wound double, are soldered or fused to heavy platinum, platinum silver, or copper leads, which are bare and insulated by passing through mica disks or washers. Each mica disk has four holes punctured through it, and four equal wires are threaded through these holes. Two of these wires form the connecting-leads for the coil and two form the compensating-leads, and are usually merely soldered or fused together at the point where the main leads join the fine coil.

In differential temperature measurement at low temperatures, insulated wire may be used for the leads, and the mica disks avoided. The platinum wire forming the coil may be silk covered and bunched together, which is a more compact construction. The connecting cable, running from the resist-

ance box to the thermometer bulb, may be of any length and consists of four wires well insulated.

As an example of the method of calibrating a pair of differential platinum thermometers, I reproduce here a sample set of readings which were taken by me on a pair which I used in my determinations of the specific heat of water between 0° and 100°. (Phil. Trans., Vol. 199, p. 149, 1902.)

SEPTEMBER 26TH, 1899.

First determination.

Both in ice, reading of bridge-wire..... 23.173. No coils.
A in ice; *B* in steam..... 23.757 + coils, 640 + 320 + 10.

Second determination.

Both in ice, reading of bridge-wire..... 23.175, 23.172. No coils.
A in ice; *B* in steam..... 23.646 + coils, 640 + 320 + 10.
 Both in steam..... 25.143. No coils.

Barometer in first determinations: Uncorrected, 75.073 cm. at temp. 18.9°; corrected, 74.851.

Barometer in second determinations: Uncorrected, 75.092 cm. at temp. 18.8°; corrected, 74.870.

	In first determination.	In second determination.
Bridge-wire.....	-0.584	-0.473
Bridge-wire correction.....	4	3
	-0.588	-0.476
Coils.....	969.876	969.876
	969.288 in box units.	969.400 in box units.
Barometer correction...	+ .4093°	+ .4025°
F.I.....	97.3381 in degrees.	97.3425 in degrees.
Mean value.....	97.3403.	

The wire used in making each thermometer of the pair was drawn down to 4 mils from some 6-mil platinum wire. The resistance of the thermometers was about 25 ohms each, and gave a F.I. about 970 units of the box. The bulbs are about 7 mm. in diameter and about 6½ cm. long, and were made of the bare wire wound on a mica frame. The first arrangement was with the platinum wire fused to about No. 18 copper wire, which in turn was soldered to the copper leads about 6 cm. above the bulb. This was changed by having the wire fused to

much longer copper wires, which were soldered to the leads at a point considerably beyond the glass tubes containing the bulbs. This avoided the changing of the temperature of the solder-joints in the glass tube. The final arrangement was to have the wire gold-soldered to heavy platinum wires, which in turn were fused to copper wires about 6 cm. above the bulbs. These wires were then soldered to the main leads at a point sufficiently beyond the glass tube, so as to remain unaffected by a change in temperature in the interior of the glass tube. All these changes were made to improve the thermometers, although the last one was not really necessary. A very considerable uncertainty was introduced with the first arrangement, which was corrected on removing the solder-joints from the interior of the thermometer tubes.

The fixed points, 0° and 100° , upon which the accuracy of the F.I. depends, were obtained as usual with a mixture of finely cracked ice and water, and the usual form of hypsometer. In regard to the constancy of these points, the former depends on the percentage of ice or water present in the mixture and its rate of melting, while the latter depends on the accuracy of reading of the barometer, accepting in both cases the purity of the ice or water. Great care was always taken with the freezing-point mixture, to have it compact and firmly placed in a copper vessel, heavily lagged, and in which water could be made to circulate through the ice around the thermometer bulbs. The thermometers were so far as possible placed side by side, separated only by a thin partition of ice.

After obtaining the balance point with both thermometers in ice, one, *B*, was removed to the steam-jacket, leaving the other, *A*, still in ice. The change in resistance in *B* was compensated by the resistance-coils until the reading was brought on to the bridge-wire. When a sufficient time was allowed (about 15 minutes was generally ample) for the attainment

of a steady temperature to $1/10,000^{\circ}$, as shown by the steadiness of the balance-point, the reading of the bridge-wire was recorded. Thermometer *B*, was then returned to the ice-bath, and the first reading repeated, which gave a measure of any change of zero in *B*. The sensitiveness of the galvanometer changed slightly between the two points, owing to the increase in resistance in the two arms of the bridge system, but this was determined always at both points.

In the tests an external resistance of at least 40 ohms was inserted in the battery-circuit, which was supplied from one accumulator. The current was never as much as 0.02 ampere in each thermometer, and current-heating could be safely neglected. In view, however, of a possible effect of current-heating on the differential readings, the F.I. was determined for different external resistances, but no effect could be measured. The current was left continuously running during a test.

To show the order of agreement to be obtained in using platinum thermometers, the following readings were obtained at totally different times, with the pair of thermometers described:

F.I. corrected to 76.00 cm. barometer.

90.5009

90.5006

90.5037

90.4994

90.5062.

The maximum deviation here is 4 parts in 90,000, and the mean much less. Such deviations as are here shown result as much from an error in reading the barometer in determining the true temperature of the steam-jacket as from any want of steadiness of the platinum thermometer.

CHAPTER VI.

RIVER TEMPERATURES.

Instruments used in Investigations of River Temperatures. First Series of Results under Surface-ice. Second Series of Tests at the Lachine Rapids. Details of the Observations. General Considerations. Freezing-point Diagram. Conditions which Govern the Formation of Frazil- and Anchor-ice.

I SHALL in this chapter devote some space to a description of the experiments which have been made by me to determine the temperature of the water of the St. Lawrence during the winter months. I shall quote extensively from my published papers, which have mainly appeared in the Transactions of the Royal Society of Canada of 1896, 1897, 1899, 1904. Many of the earlier papers are now practically out of print, and as the experiments described there were of considerable importance to the better understanding of the conditions governing the formation of frazil- and anchor-ice, I give them here in some detail.

The work divides itself into two groups, which comprise the experiments of 1896, made in the quiet water under the surface-ice opposite Montreal, and the experiments made the winter following in the open water of the Lachine Rapids. Both sets led to the same conclusions, and were confirmatory of the opinion which had been formed from theoretical considerations as to the non-existence of any large variations in temperature from the freezing-point. The final result, which consisted in connecting the formation and agglomeration, the disintegration and

decay of the ice, with small deviations, negative or positive from that point, was entirely unlooked for, and has been already fruitful of much practical benefit in engineering work.

The experiments were undertaken at the suggestion of Mr. John Kennedy, Chief Engineer of the Harbor Commissioners' Works at Montreal, who, as member of the Montreal Flood Commission, became interested in an endeavor to determine with some refined instruments the exact nature of the deviations from the freezing-point in winter, and the relation of these variations to the formation and agglomeration of frazil-ice.

Attempts had been made to carry out this work by means of mercury thermometers by members of the Flood Commission, and among the appendices to their report we find the following account of their experiments:

"Date, 26th February, 1887. Time, 1.30 to 2 P.M. Reading of thermometer opposite Caughnawaga in open water about 1000 feet from bordage-ice, at surface or at any depth to 15 feet, 32.3° F. -0.5° =corrected, 31.8° F., also when weighted and settled into frazil at bottom (15 feet depth), and allowed to remain there five or ten minutes, reading the same; corrected, 31.8° F., bulb probably settled into frazil four inches. Frazil 0 to 4 feet or more depth on bottom. Observed within easy range of vision during two hours and a half, seven masses of frazil rise from the bottom. Temperatures taken in the open running water.

"Date, 1st March; time, 10.30 A.M.; temperature, at same place and positions as on 26th February, found the same, namely, 31.8° F.

"Observed two masses of frazil (anchor-ice) rising in one hour.

"Temperature of water taken through the ice in the channel of Lake St. Louis, depth of water 31 feet, about one mile above Chateauguay, time 3.30 P.M., 1st March, was at any

depth 31.8 degrees F. to 31.9 degrees F., seeming to be slightly higher than in the open water opposite Chateauguay at 10.30 A.M., but it was difficult to read with certainty to one tenth of a degree at the positions 32.3 degrees and 32.4 degrees on the scale where the thermometer stood uncorrected by 0.5 degrees. Thermometer tested within a few days of taking these observations by Professor C. H. McLeod of McGill College Observatory, and correction given as 0.5 degrees; also tested by standing in a tub of frazil and water in the basement of the Harbor Commissioners' building for three hours and reading it at intervals, the reading being always 32.5 degrees, this giving a correction of 0.5 degrees.

"So far as these observations of the temperature go, they appear to show that the temperature of the open water and the frazil (anchor-ice) on the bottom opposite Caughnawaga was, at the time of observation, slightly below 32.0° F.

"It is seen from the air temperatures given that the weather was variable, and that high temperatures occurred not long previously to the time of observation, and at the hours of observation the air temperature was rising and frazil (anchor-ice) was rising from the bottom. It is therefore not improbable that during a long interval of frost and before the temperature began to rise there might be found lower temperatures in open water and frazil than those here recorded.

"The thermometer used in these observations was enclosed in a water-tight tin tube, with glass face and valve in bottom, so that it could be brought up full of water from any desired depth and read before the enclosed water was appreciably affected by the temperature of the air."

We find here that an apparent undercooling of the river water by two tenths of a degree was observed. The thermometer used, which was designed by Mr. Sproule, assistant engineer of the Harbor Commissioners, was protected by a column

of water drawn up from the river, and was therefore not subject to so severe variations from the low temperature of the air as it otherwise would have been. It was an ordinary thermometer with degree graduations, and the reading was estimated to tenths. It is a question whether its readings, when withdrawn from the water, might not have been influenced by the cold air, and it seems that Mr. Sproule felt somewhat uncertain as to the reality of these variations recorded, from a conversation which I had with him on the matter during the time of my first series of measurements.

Records have been kept by other observers, who have shown that large variations from the freezing-point took place. Thus in the chart of air and river temperatures now in the possession of Mr. John Kennedy, which was made by the late T. D. King for the Grand Trunk Railway during the time of the construction of the Victoria Tubular bridge at Montreal, will be found variations in the temperature of the river water under the surface ice, amounting to several degrees either way from the freezing-point. The readings were made with a mercury thermometer probably withdrawn from the water without protection, and read in a cold atmosphere.

It will be seen how much more suitable an electrical thermometer is for measuring the temperature of the water. Its chief advantage, outside of its far greater possibilities in point of refinement, lies in the fact that it need not be withdrawn from the water when a reading is made. The observer is also protected from the cold by a suitable shelter, and is therefore in a better position to make accurate measurements.

Instruments Used in my Investigations.—In both series of experiments a special form of platinum resistance thermometer was used, which was designed by Professor Callendar who was then at McGill University. The coils of wire forming the sensitive bulbs, were each 50 ohms, and composed of silk-covered

platinum wire of 6 mils diameter. The wire was bunched together in an elongated coil, and placed in a protecting lead tube about 8 inches long and $\frac{1}{4}$ inch in diameter. The lead was pressed flat over the wire for greater sensitiveness. The coils of wire were each connected to compensated leads in the usual way (Chap. V), which were enclosed in lead-composition tubing $\frac{1}{2}$ an inch in diameter. The length of the leads for one coil was made 100 feet, in order to reach far enough into the river, and the length of the other was only 10 feet. The shorter end was always kept in a suitable shelter in the form of a cabin or shanty, where the readings were made. The long end passed out through a hole in the side of the cabin. The ends of the lead tubing were soldered together inside the cabin, out of which the wires passed to the measuring bridge. The coil from the short end was kept immersed in a carefully prepared mixture of snow and river water, kept in the cabin, and from time to time the long end was brought up from the river and immersed side by side with it in order to check the zero-reading on the bridge.

On account of the compensating device the reading of the bridge was never influenced by changes in temperature of the long leads, which were exposed to all the severity and variation of the temperature of the winter air. The bridge, upon which the differences in resistance of the two coils were measured, was the one devised by Callendar, and described in the last chapter. On account of the compensation of its coils it was practically unaffected by changes in temperature inside the cabin.

The galvanometer presented the most difficulty, since it was one of the low-resistance Thomson type of reflecting instrument. The needle being under the influence of the control-magnet and earth's field was subject to continual variation. The movement of a mass of iron caused a variation in the zero-reading that could only be rectified by adjusting the control-magnet.

This necessitated a redetermination of the sensitiveness, that is, of the number of scale-division deflection, read by means of a telescope with micrometer eyepiece, which corresponded to a shift of one millimeter of the contact-piece on the bridge-wire. The difficulty of this will be appreciated when it is realized that many of the measurements were so small as to be seen only by a change in deflection on reversing the current in the battery-circuit. To distinguish between a real variation from the zero-reading, due to the change in the river temperature, from a change produced by the alteration of the magnetic field was often a matter of great difficulty.

A number of magnetic articles were distributed both inside and outside of the cabin, while the mass of iron contained in the heating-apparatus alone was enough to disturb the galvanometer. The sensitiveness had to be continually determined and zero-readings obtained. A far greater number of readings had to be discarded than recorded. Usually one dry cell served to supply the current for the bridge system.

Under suitable laboratory conditions it is possible to measure to the ten thousandth part of a degree. In the present case, owing to the many variables, no attempt was made closer than one thousandth. A much more suitable galvanometer to use would have been a sensitive low-resistance permanent magnet one of the D'Arsonval type. When the measurements were made, however, in 1896, we did not possess such an instrument comparable in sensitiveness with the Thomson galvanometer. To-day a D'Arsonval galvanometer can be procured of almost any desired sensitiveness.

A difference of one degree centigrade in the temperature of the thermometer bulbs produced a change in the resistance of the platinum coils, which covered a length of bridge-wire equal to 20 cm. (8 inches). The galvanometer sensitiveness was arranged to be nearly 50 scale-divisions for each centimeter,

so that each galvanometer division was approximately one thousandth of a degree.

FIRST SERIES OF TESTS.

Under Surface-ice.—On the 15th day of February, 1896, the complete outfit, consisting of the differential thermometer with the accompanying set of instruments, was set up in the watchman's cabin (Fig. 25), situated on the end of the guard-pier about half a mile from the harbor front, opposite Montreal. The guard-pier, which has proved to be such an effective barrier to the disastrous ice-shoves, which were of yearly occurrence in the harbor (Figs. 22 and 23), was then nearing completion.

Having set up the instruments satisfactorily, one of the ends of the thermometer was placed through a hole cut in the ice on the outside of the pier, and from that date on for over four weeks daily readings were taken, with the exception of two short stops. The first stop was caused by a solder joint giving out on one of the ends of the thermometer, making it necessary to completely renew this end; this caused the loss of two days. The other stop was caused by the breaking of the galvanometer suspension, which caused the loss of one day. During the time of the experiments it may be said that the most severe part of the winter occurred. The temperature of the outside air varied from -28° to $+40^{\circ}$ Fahr., including several cold dips, from 20° to 30° above zero to several degrees below.

It was found necessary to make some alterations to the cabin, and this was done through the kindness of Mr. Kennedy. The chief change was the erection of a stand for the instruments, with its foundation on the solid earth of the pier. This effectually prevented vibrations from disturbing the galvanometer-readings.

A large puncheon was provided in the cabin for holding the freezing-point mixture of ice and water. This was filled every day with fresh clean snow off the river, and moistened with clean river water mixed with frazil drawn from a hole cut in the ice. Fig. 26 shows the attendant about to place the long end of the thermometer in the water.

Results of the Observations.—During the complete series of experiments no difference of as much as a hundredth of a degree from freezing was recorded.

From February 15th to 17th the greatest variation in river temperature took place, when the air sunk from 0° to -28° Fahr. It is possible to limit this within one hundredth of a degree. During this time a large amount of frazil was found accumulated under the surface-ice.

During February 18th no reading of any value could be obtained, owing to the giving out of the solder join already mentioned. The entire day of February 19th was employed in renewing one of the ends of the thermometer.

During milder weather, from February 20th to 22d, the water remained almost steadily at the freezing-point. Careful reading gives a difference from the freezing-point of $+0.0015^{\circ}$ Cent. From February 23d to 24th the air did not sink below $+10^{\circ}$ Fahr., while the highest it attained was $+35^{\circ}$ Fahr. During this time there was some rain. The river did not show any greater variation from the freezing-point, but a decrease in the amount of frazil was noticed.

From February 25th to 27th a cold dip of -10° Fahr. caused the river to sink slightly below the freezing-point. Observation gives -0.005° Cent. During the time from February 28th to March 3d the temperature of the air varied from $+42^{\circ}$ to $+16^{\circ}$ Fahr., never sinking below the latter point. The river remained at the freezing-point with variations slightly above.

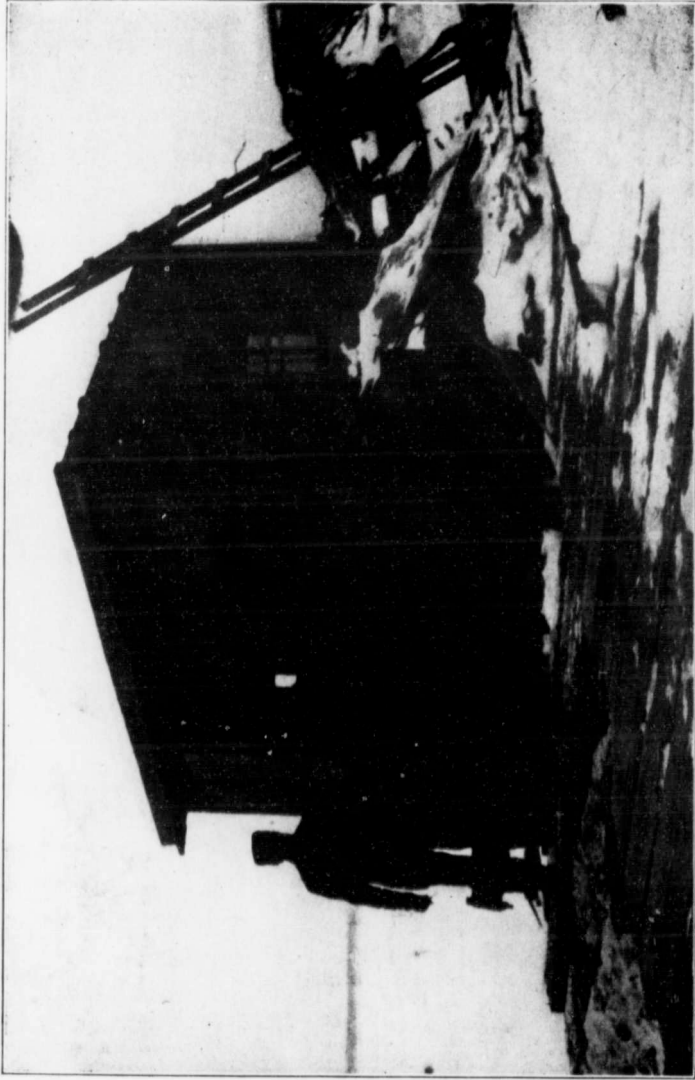
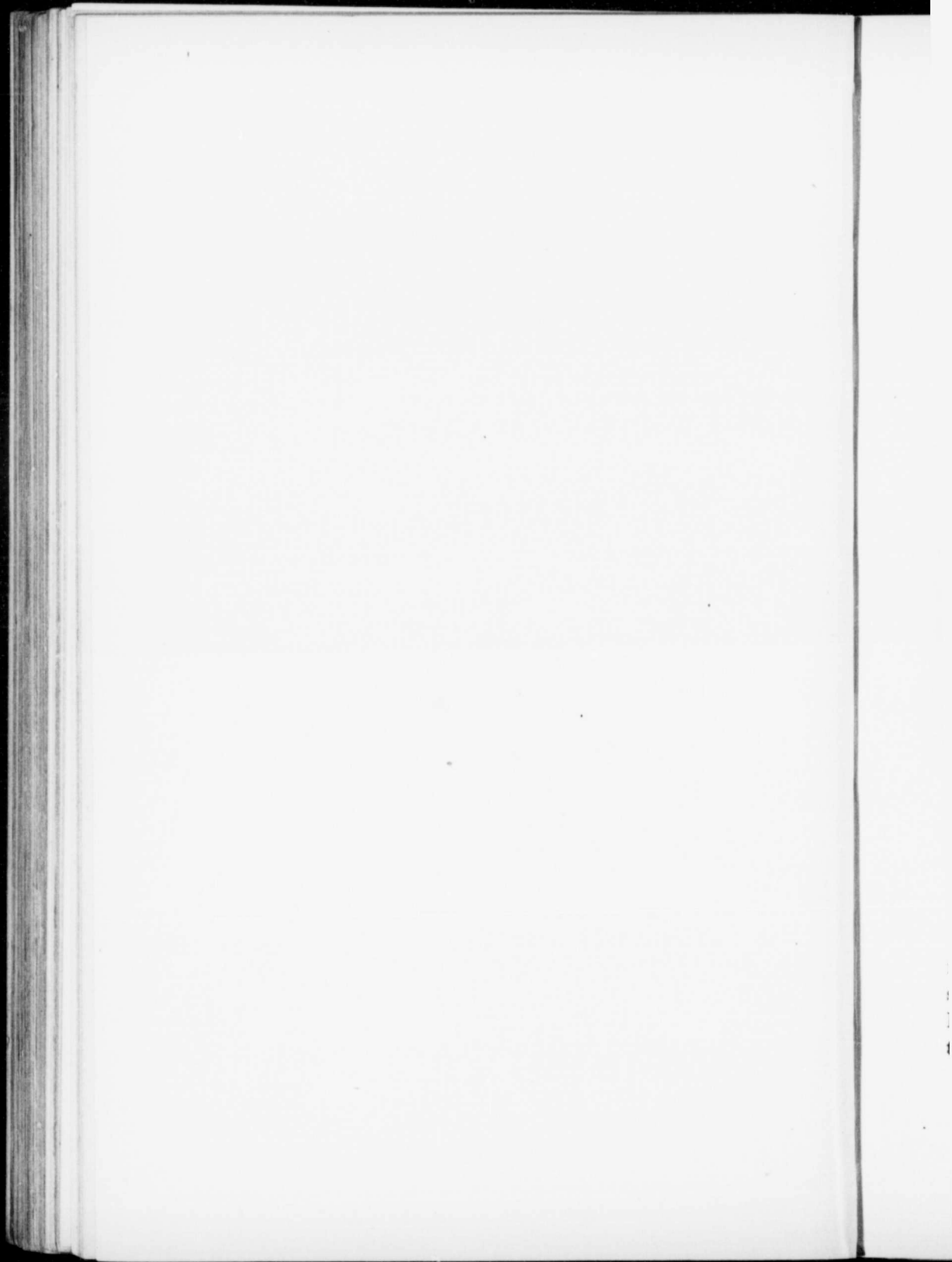

FIG. 25.—Cabin on the Guard-pier where the Measurements of the Temperature of the Water under the Surface-ice were made.



On March 4th the air temperature went suddenly down to zero. This had the effect of lowering the river temperature 0.0057° Cent. below freezing. On the following day the undercooling was only 0.0004° Cent., while an increase in the amount of frazil was noticed. This was found clinging to the lead tube leading to the thermometer.

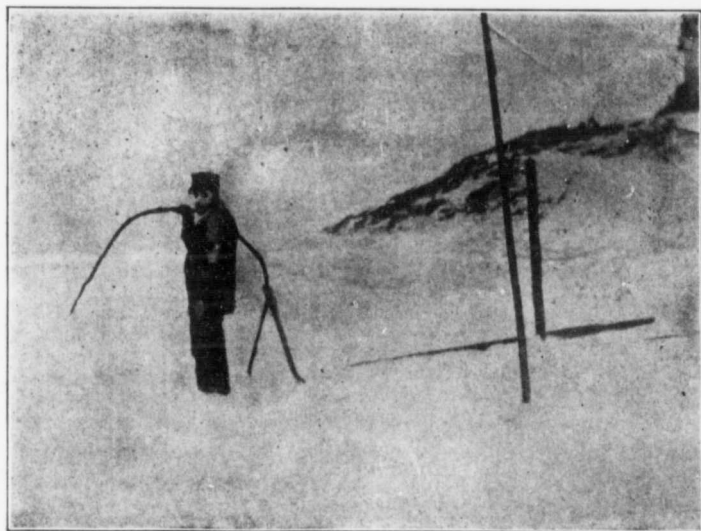

FIG. 26.—Attendant placing Thermometer through Hole Cut in Surface-ice. End of Shanty on Guard-pier Shown.

From March 6th to 10th there was warmer weather, to be followed on March 11th by another cold dip, -8° Fahr. This also had a slight effect on the water, sending it down from $+0.0005^{\circ}$ to -0.0039° Cent.

From March 12th to 16th the air temperature remained fairly uniform, rising during the day to about $+20^{\circ}$ Fahr., and sinking during the night to a few degrees either way from 0° Fahr. The river temperature showed but slight variations from the freezing-point.

During the milder weather, and in general, the river from six to eight feet below the surface-ice was warmer than that at a depth of two feet, although by only one or two thousandths of a degree.

SECOND SERIES OF TESTS.

Measurements of River Temperatures at the Lachine Rapids, 1897.—In the present series of tests a number of observations were made, during the winter of 1897, of the temperature of the Lachine Rapids, in continuation of the measurements made under the surface-ice at the guard-pier, opposite Montreal.

It was considered almost certain, a priori, that the temperature of the open water in the Lachine Rapids could not differ to any large extent from the freezing-point. But, as a matter of further interest, it was deemed important to establish this by direct experiment, and to determine, as far as possible, the relationship between the formation of frazil-ice and the temperature of the water.

Place of Observation.—It was difficult to choose a place for making the measurements which would present a sufficient variety of conditions in the state of agitation of the water, to enable the readings to be of value in determining any inequality in temperature throughout the mass of the river.

The first locality selected was at the foot of the rapids, between the north shore of the river and Île Héron, at the spot where the main current runs under the barrier-ice. It was soon seen, however, that this would prove to be a most dangerous place in which to leave the observation-shanty and instruments, on account of the continually shifting surface-ice. A shove of considerable size might at any moment take place here during extreme cold weather, owing to the complete blockage of the channels under the ice by frazil. A place was finally selected higher up, which, from the solidity of its foundation

and the character of the water in the immediate vicinity, made it as suitable as could well be desired.

The Lachine Hydraulic Company, their works being then under construction, had built out from the north shore, for a considerable distance, a coffer-dam of earth and stone, which, with the outer dam of the same material extending down to the power-house, served to turn aside an immense volume of water, otherwise to be employed for power purposes. Just at the corner where this coffer-dam joins the outer dam, the water attained a considerable velocity, with a great deal of surface agitation in parts. It was decided to locate the observation-shanty at this point in preference to any other for the following reasons: The shanty would be on the solid earth of the pier, and hence remain steadier for the measurements; the water was in nearly every state of agitation within easy reach of the thermometer stem; and the depth of water varied so in the immediate vicinity that while in some parts it was sufficiently shallow to permit of observations being made of the growth of anchor-ice in others it attained a depth of nearly 20 feet. Moreover, the current sweeping around the point caused a large sheet of comparatively quiet backwater to work up from a considerable distance below. This remained open, except in the severest weather, when frazil, swept in from the currents aided by surface-formed ice, became compacted into a thin moving heterogeneous surface-sheet, soon dispersed in milder weather. The especial advantage of having this quiet water and the swift current in juxtaposition was to enable the measurements to be made at close intervals of the temperature of the water in such different conditions, coming together from opposite directions (see Fig. 27).

The river in winter above the place where the shanty was located, is open for a distance of six or eight miles, and flows so swiftly that it is being continually stirred to the bottom by

surface currents carried down and lower layers brought to the surface. All along the bottom there are formed immense quantities of anchor-ice, and, owing to the surface agitation, large quantities of fine floating ice as well. The conditions are as favorable, therefore, at this point for producing an extreme temperature in the water as they might ever be expected to be.



FIG. 27.—Observation Cabin at the Lachine Rapids where Temperature Measurements were Made.

Instruments Used in the Investigation.—The instruments used in the present series are the same as those already described, and consisted of the differential thermometer, compensated-wire resistance-box, low-resistance galvanometer, reversing-key and battery.

The observation-shanty was provided by the Harbor Commissioners of Montreal, through the kindness of Mr. Kennedy, the chief engineer, and, although smaller than the one provided the previous winter, served the purpose sufficiently well. It

was necessary to provide a smaller cabin than that of the previous winter, owing to the difficulty of transportation to and from the city, a distance of five miles, and of placing it in a suitable position on the end of the pier. The services of a watchman were also procured to protect the instruments, and to prevent them from freezing.

Method of making the Measurements and Accuracy of the Readings.—The method of making the measurements consisted, as in the previous experiments, of immersing the two stems of the thermometer in a carefully prepared mixture of snow and water contained in the shanty, and obtaining by this means a zero-reading, or reading on the bridge-wire when both ends were at 0° Cent. Leaving the shorter end in the mixture, the longer end was passed out of the shanty into the river (Fig. 28), and any difference in temperature, from the mixture of snow and water, was indicated by a change in reading on the bridge-wire. One millimeter then corresponded to 0.005° Cent. It was possible, as in the previous experiments, to measure to the ten-thousandth part of a degree, but it was exceedingly difficult to be accurate to more than one thousandth. As before the peculiar want of proper laboratory conditions in the observation-cabin, together with the care that had to be exercised in making the mixtures of snow and water for the steady end of the thermometer, rendered the work much longer and more tedious than would have been the case under a more favorable environment. The mixtures had to be prepared of sufficient magnitude to avoid errors of conduction, and of sufficient uniformity to avoid errors of temperature throughout their mass. It was possible, however, by taking proper precautions, to prepare mixtures of snow and water that would be, within the limits of these measurements, sufficiently uniform. The same procedure was carefully followed in every case, and was essentially as follows: To a large cask provided for the

purpose were added two or three buckets of snow. This was pounded down by means of a flat-ended club, and enough river water added to moisten the whole mass. The "slush" thus produced was then further worked down, excess of water poured off, and continually beaten until the mass became firm and solid throughout. This was repeated with every successive batch of snow until the cask was nearly full of a firm mass of

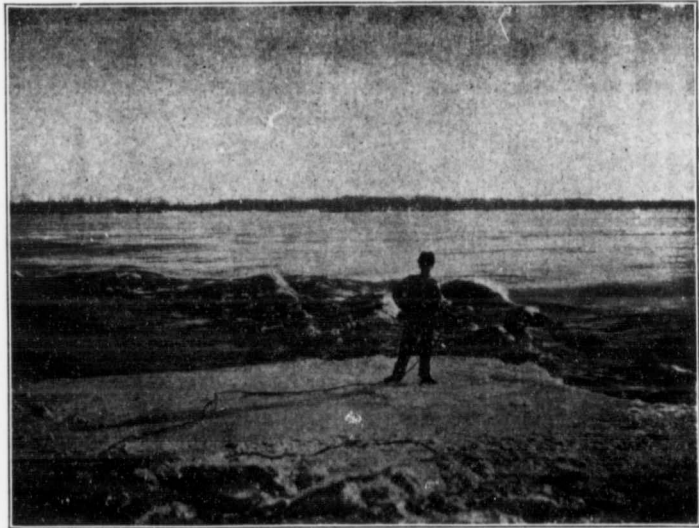

FIG. 28.—Attendant about to Place Thermometer in Water. Frazil may be seen Running in the Open Water.

moist snow. River-water was then added in sufficient quantity to permeate the whole mass. This mixture would remain good for several hours, and a much longer time, of course, if the temperature of the shanty was so regulated as to be only a little above 0° Cent. Where sets of readings were separated by several hours a fresh mixture had to be prepared, in order to secure absolute uniformity of temperature throughout the mass. The snow remaining in a mixture that had already been pre-

pared, served as a beginning for a fresh supply, by pouring off all excess of water and working down until thoroughly firm and compact. The time required to make one of these mixtures, of sufficient uniformity to be relied upon to 1/1000 of a degree, was from one half to three quarters of an hour.

The following table will show the probable error to be found in carefully prepared freezing-point mixtures, as determined by a number of zero-readings at different times:

Same mixture.	Different mixtures.
$\pm .00045^{\circ}$ Cent	$\pm .00090^{\circ}$ Cent.
$\pm .00070^{\circ}$ “	$\pm .00020^{\circ}$ “
$\pm .00020^{\circ}$ “	$\pm .00065^{\circ}$ “
$\pm .00025^{\circ}$ “	$\pm .00085^{\circ}$ “

These differences may be regarded as satisfactory, when it is considered under what unfavorable circumstances they were taken.

In determining differences in temperature of the various parts of the water at short intervals of time, all errors due to the freezing-point mixture, and cabin end of the thermometer were eliminated. Errors of 0.005° Cent., and even greater, were obtained in cases where the freezing-point mixtures were carelessly made, and not sufficiently compact, or when attempts were made to use old mixtures. These either contained an excess of water through melting, or were being converted into solid ice on the bottom, from the fact that the floor of the shanty was at a temperature below freezing.

To avoid errors of conduction along the thick lead tube containing the connecting-leads, a length of about 18 inches was buried in the snow with the thermometer stem, and about a foot more was protected by building up snow around it. When both stems were immersed at the same time they were, as far as possible, buried together. From time to time, while

readings were being obtained, the immersed end, or in the case of a zero-reading each end, was stirred, and snow repacked around it.

To ensure more perfect uniformity, it would have been better to arrange some form of helical pump, by which water could have been set in circulation through the snow around the thermometer stems by drawing it from the bottom to the surface. A greater degree of accuracy could have been thus attained, but, owing to the want of space in the shanty, it was thought that serious difficulties might have arisen, which would outweigh the advantages to be gained. Then, again, unless the other conditions in the shanty, such as its being unprotected from the wind, and the proximity of magnetic bodies to the galvanometer, could have been rectified, it was useless aiming at greater refinement in the freezing-point mixture.

On account of the refinement of the temperature measurements, great care had to be taken with the thermometer to avoid sharply bending the stems, or otherwise straining the fine platinum coils. When this took place during a set of readings, it was necessary to redetermine the zero-point.

Time of the Observations.—The cabin was put in place on the first day of February, 1897, and on the third the instruments were taken out and observations commenced, lasting over an interval of nearly six weeks. It was impossible to obtain readings every day, on account of the length of time required to reach the cabin from the city. Delays occurred through the occasional giving out of the apparatus, and the necessity of removing it to the city for repairs. College duties also prevented me being at Lachine every day during the time. Nevertheless, a great many observations were obtained, including night-readings, which will, it is hoped, throw considerable light on river-ice formation.

It is to be regretted that the extreme weather, which was

experienced the winter before could not have been repeated, as, owing to the mildness of the winter, the air did not fall more than 10° Fahr. below zero during the entire time of the experiments. A great many readings were obtained on what may be termed "zero" days, when the temperature was a few degrees either way from 0° Fahr. Observations were also taken during stormy, cloudy, and bright weather, showing that all these conditions have an important influence in determining the temperature of the open water.

Details of the Observations.—The amount which the open river may become cooled below the freezing-point, appears to be of the same order as under the surface-ice, but the extent to which it may be warmed by sun and rain, is much larger than could be expected under a surface-sheet.

Many observations were destroyed during the taking, owing to the many disturbing influences, and were never recorded; while others had to be discarded for the same reason, even after the work had been completed. The following table will, however, give a few of the observed differences on various dates, worked out to the ten-thousandth place. I feel confident that they were measured under as steady and uniform

TABLE OF OBSERVATIONS OF THE TEMPERATURE OF THE LACHINE RAPIDS.

Date.	Air temp., Fahrenheit degrees.		Sun- shine in per cent pos- sible.	Sky.	Wind in miles per hour.	Difference from freezing-point in degree centigrade	
	Max.	Min.				Current.	Quiet water.
Feb. 3d . . .	+20	+10	89	Clear.	28.6	0
" 5th... . .	+32	-3	88	"	9.7	+0.0215
" 7th... . .	+38	+27	00	Raining.	13.1	+0.0197	+0.0182
" 8th... . .	+34	+28	00	"	16.3	+0.0547	+0.0415
" 11th... . .	+18	-3	94	Clear.	6.5	+0.0137	+0.0151
" 12th... . .	+11	-2	00	Stormy.	21.1	-0.0065	-0.0068
" 13th... . .	+17	0	100	Clear.	15.1	+0.0186
" 15th... . .	+33	+24	67	Clear to cloudy.	17.6	+0.0280	+0.0423
March 1st . .	+22	-10	25	" " "	16.8	0

conditions as was possible to produce in the observation shanty, and necessary to maintain for an accuracy of one-thousandth of a degree.

The records of sunshine, and velocity of wind were taken from the monthly reports of the McGill College meteorological observatory. Most of the maximum and minimum air temperatures were measured at the rapids, with a suitable registering thermometer. The column of differences contains temperatures for both the swift current and quiet backwater.

It will be seen that during the warm, rainy weather the current was a little warmer than the quiet water; while during the clear weather, with a large percentage of sunshine, the current was colder. These readings were all taken during the day, and show what an enormous influence the sun had in warming the water, although the air temperature remained cold. The wind had a marked influence in cooling the water, especially when it was blowing against the current, as on February 12th. On this date the largest difference below freezing was recorded. It is interesting, from purely theoretical considerations, to see that the water, being vigorously churned and mixed with air, showed an indication of being warmer than the quiet water. Immense quantities of ice were manufactured on this date throughout the mass of the river, giving a general *brown, sandy color to the water*, more especially in the swifter currents.

A shallow portion of the current near the shanty gave excellent opportunity for studying the growth of anchor-ice. When the temperature observations were commenced on February 3d large masses of anchor-ice were located there. These were disintegrated and otherwise completely cleared away, during the warm, rainy weather from February 6th to 9th. On the nights of February 10th and 12th anchor-ice appeared again growing *in situ, and in greater abundance on the darker rocks*. On February 12th, owing to the slight undercooled state of the

water, floating ice carried down by the currents stuck in quantities to the anchor-ice, causing it to grow to a great thickness. Large islands of ice appeared also scattered through the rapids in the shallower parts. In this state the worst effects of frazil are to be met with, due to its agglomerating. In making one of the measurements on this day, the thermometer bulb was placed so as to rest on some anchor-ice. When attempts were

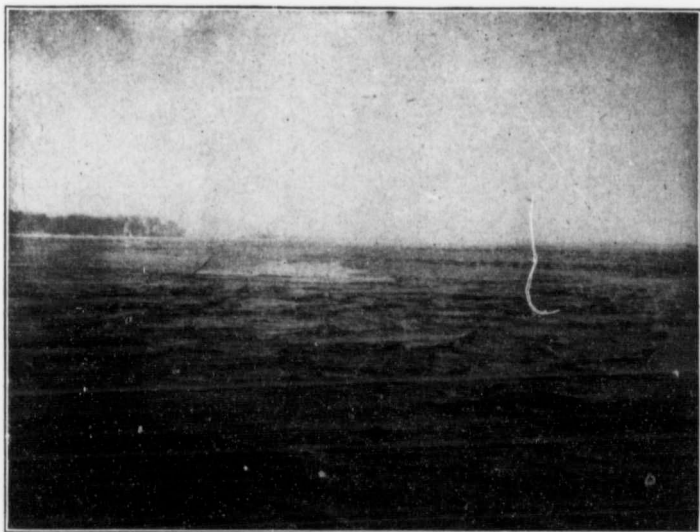

FIG. 29.—Mass of Anchor-ice, brought up by the Sun's Rays, Seen Floating Down in the Current.

made to take it up for other measurements it was found frozen down and could only be removed with great difficulty. On February 13th, although the air temperature still remained cold, the bright sun served to warm the water, and to bring up a great deal of ice. The river was of an entirely different color, and there was apparently no ice forming in the water, beyond a small amount of fine ice in the currents, produced by extreme agitation. Early in the morning there were also no blocks of

anchor-ice visible, but, as the sun became stronger, immense quantities of this ice were brought up, and floated down (Fig. 29). During the remaining time of the experiments there was a continual formation of ice on the bottom, near the shanty on the cold clear nights, and a corresponding melting by the heat of the sun's rays penetrating the water, during the days following.

In order to test the effect of radiation in the water, both during the day and night, some readings were taken on February 13th, 15th, and 26th. On February 13th and 15th, the readings were taken at noon, with the sun at its brightest, in the quiet water just over the edge of some border-ice formed out from the pier. By this means the stem of the thermometer could be placed at any distance in the water down to a depth of about five feet. It could also be bent so as to pass under the border-ice, and thus be somewhat protected from the direct rays of the sun. On February 26th the readings were made at night, under similar conditions.

The following readings on February 13th and 15th were obtained:

Date.	Sun- shine %.	Locality.	Diff. from 0° C.	Air temp.
Feb. 13th.	100	5 ft. from surface (bottom).	+ .0186	+16° Fahr.
"	"	1 " " "	+ .0474	"
"	"	8 in. " "	+ .0741	"
"	"	Shallow current.	+ .0461	"
Feb. 15th.	67	3 ft. from surface.	+ .0423	30° Sky clear
"	"	8 in. " "	+ .0819	" "
"	"	Just under edge-ice.	+ .0292	" "
"	"	Deep current.	+ .0280	" "
"	"	Bottom of backwater, sun clouded.	+ .0112	" Cloudy

Had the stem of the thermometer been painted black no doubt it would have indicated a higher temperature. On the bottom, in the quiet water, the lower temperature suggests the

presence of a layer of anchor-ice, made very probably by the clear nights previous. The rapidity with which the temperature approached the freezing-point on February 15th, when the sky became clouded over, also indicates this. The observation given of the temperature of the backwater, with the sun clouded over, was made about one hour after the previous set of readings.

On February 26th, a successful set of night-readings was obtained, which will illustrate to a moderate extent the effect of a clear, cold atmosphere. The maximum and minimum temperatures for that date are recorded as 9° and -4° Fahr., with a temperature during the night of about 0° Fahr., and towards morning of a little above. The sky was not so clear as could be desired during the earlier part of the night, but towards midnight it became very clear, and remained so for the greater part of the night. Readings were started at 4.30 in the afternoon of February 25th, and were continued at intervals of every two hours until 7 o'clock the following morning.

The freezing-point mixture had to be repaired and renewed at intervals all night, to ensure sufficient uniformity. The measurements commenced by showing the water to be slightly above freezing, owing to the influence of a bright sun all day. Towards evening it became colder, and remained practically at the freezing-point until after midnight, when it became cooled slightly below the freezing-point. The currents and quiet water showed very little difference in temperature.

About 6.40 p.m. the following readings were obtained, which will serve to show how uniformly the temperature of the river was falling to the freezing-point:

Quiet water down 3 feet.....	.0037° Cent.
“ “ “ 8 inches.....	.0034° “
Current.....	.0037° “

This tends to show that the cooling by the surface abstraction of heat, which would cause the upper layers of water to be cooler than the lower layers, was also probably aided by radiation, which would cause the mass to sink more uniformly.

Later readings between 7 and 11 p.m. showed that the temperature was practically at 0° Cent. At midnight, when the sky was about at its clearest, experiments were tried with the thermometer stem at different depths in the quiet water. The temperature at the bottom was, as near as could be measured, at the freezing-point. Differing the other readings from the reading of the thermometer on the bottom we have:

Within 1 foot of surface.	- .0016° Cent.
Same reading 15 minutes after; stem not dis-	
turbed.	- .0023° “
At 3 feet.	- .0018° “

These observations apparently show that the thermometer, when left undisturbed, was being actually cooled by radiation below the temperature of the surrounding water, a condition further borne out by the *formation of ice actually on the stem itself*. At about 3 a.m. measurements were made of the difference in temperature of the backwater and current. The quiet water was apparently colder than the current by 0.0058° Cent. The only difference in the temperature of the two bodies of water, seems to be explained best in admitting again the possibility of radiation influencing the readings of the thermometer. This is a condition not so easily attained in the swift current. Several times I was obliged to remove ice from the stem of the thermometer which, from its nature, had undoubtedly formed *in situ*.

During this night the radiation was not so strong as it is sometimes, as was shown by the small amount of ice made on the bottom. The radiation, although small in amount,

became strong at times when the sky was clearest, and had an important influence in determining the temperature of the water, as already shown.

Towards morning the current became cooled slightly below the freezing-point. Observations at 5.50 A.M. gave -0.0058° Cent., and at 6.30 A.M. gave -0.0046° Cent. This was no doubt due to the continued action of the cold atmosphere, as well as to the effect of many hours of radiation. Curiously enough, about this time the quiet water became warmer than the current by 0.0033° Cent., showing a difference itself from the freezing-point of -0.0022° Cent. The question suggests itself, whether there was any natural cause for this change, and the only answer seems to be, that there was some possible check to radiation occurring in the atmospheric conditions towards morning. As a matter of fact, as the light grew stronger, the conditions were such as to suggest a dull day, although during the night the sky had been mostly clear. Heavy banks of clouds were noticed, which cleared away, however, as the day advanced.

A great deal of fine ice was noticed coming down in the currents especially during the early morning, when the water was slightly undercooled.

Attempts were made to obtain similar readings on a number of other occasions, but, owing to practical and experimental difficulties, no other all-night readings could therefore be obtained.

The coldest day on which measurements were made was on March 1st in the morning, when the air temperature went down to -10° Fahr. after a few days of mild, rainy weather. Many of these readings were rendered valueless by the fact that a block of ice, coming down in the current, so bent the stem of the thermometer as to sever a wire in the fine platinum coil. Enough has been recorded, however, to show that the

temperature of the river did not vary to any extent from the freezing-point, certainly not more than has already been found.

Later readings during March are not given on account of experimental difficulties. It may be said that up to the middle of that month, when the readings were discontinued, the temperature of the river-water showed no larger variations from the freezing-point. It was always possible, by noting the conditions of the weather, to foretell with considerable exactness, the temperature of the water.

General Considerations.—The extreme steadiness of the temperature of the river, both in open water and under the surface-ice, is a matter of great interest.

From theoretical reasoning it is impossible to imagine water cooled much below the freezing-point. Under favorable laboratory conditions water, free from ice and dissolved air, has been brought to several degrees below (Chap. III). On the introduction of the smallest crystal of ice, however, the whole mass comes to the freezing-point with the formation of ice. The solution can no longer be cooled below the freezing-point while any water remains.

The condition of the frazil-ice is determined entirely by the temperature of the water, which in turn is regulated by the severity of the weather. With a cold atmosphere, and strong wind, the water becomes thrown into a slightly undercooled state, during which time it is struggling to maintain its equilibrium by manufacturing ice, and liberating the store of its own heat. The evidence of rapid growth is everywhere apparent. The frazil-ice freezes to objects which may be immersed in the water and also freezes together into large lumps.

Each crystal of ice appears to be growing rapidly, and innumerable new crystals are being born from the mass of the water, springing from minute forms of matter as a nucleus around which they grow.

When the rapid loss of heat is checked by the sun's rays, or by the advent of mild weather, the temperature of the water rises to the freezing-point, or a little above, and the process of frazil manufacture ceases. Under the influence of mild weather and especially with rain, the process of disintegration of the ice goes on, and the temperature remains above the freezing-point. We see, then, that so delicate is the poising of the temperature conditions about the freezing-point, that the balance has only to be upset a few thousandths of a degree either way to bring about tremendous physical effects.

That the apparent isothermal change of ice into water, or water into ice, is dependent on minute temperature differences in its mass has already been claimed by some authorities; and that the temperature of a mixture of ice and water depends on the relative amounts of ice or water present has also been stated. The experiments conducted by me, although not undertaken to prove any such supposition, yet directly support it. The fact that, in the measurements of the temperature of the water under the surface-ice, the water commenced, after a sudden cold dip, by being in a slightly undercooled state, and that, after the proportion of ice increased, the temperature gradually came to the freezing-point, would tend to show this. In the open channels, where the quantity of water is very great compared to the ice, a slightly larger difference has been observed than was possible under the ice. The more water is being churned up and mixed with air and ice, the less can its temperature fall below the freezing-point.

It appears that there may be drawn certain conclusions relative to the temperature of a mixture of water and ice, when the transformation is going on either one way or the other, that is,

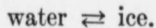

If we imagine a quantity of water subjected to a uniform

and definite loss of heat at the freezing-point and continuously stirred, so as to produce intimate mixing between the ice and water, then it is probable that the temperature will fall slightly below the freezing-point of the order of a few thousandths of a degree; will gradually approach the freezing-point as the quantity of ice grows, until finally, as the ice predominates over the water, the temperature will drop again. Conversely, if we imagine a quantity of ice melting, and if possible subjected to constant stirring, then the temperature will rise slightly above the freezing-point, depending on the amount of heat being absorbed. The temperature will then drop more and more, approaching the freezing-point as the quantity of water increases, until the quantity of water begins to predominate, and then will rise again.

Schematically the complete process may be represented as in the figure by following the arrows:

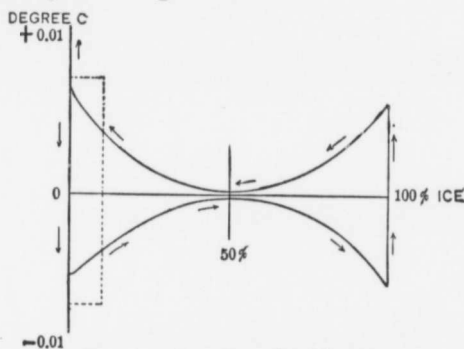

FIG. 30.—Freezing-point Diagram.

To obtain any idea of the amount of variation beyond 50 per cent of ice, there is required more experimental knowledge. The dotted rectangle roughly represents the extent of the range during the winter, at a point like the Lachine Rapids, where the percentage of ice never reaches a very high figure. Within this range the measurements show the sort of variation to be

expected. On February 12th, 1897, with rapid formation of ice under a strong wind at a temperature of -2° Fahr., the water showed a temperature

of -0.0065° Cent.
and -0.0068° “

On February 7th, under a cloudy sky and air temperature slightly above freezing, the temperature recorded was

$+0.0197^{\circ}$ Cent.
 $+0.0182^{\circ}$. “

This was slightly higher than could be expected, on account of the rain during the day. The effect of the rain was shown the next day, also a cloudy, rainy day, when the temperature reached

$+0.0547^{\circ}$ Cent.
 $+0.0415$. “

During this time the ice was very thoroughly cleared out of the rapids. On the other days, with a bright sun, the temperatures measured were affected by the absorption of the solar heat in the water.

To fix the freezing-point of water for accurate temperature measurements it is necessary to define the quantity of ice and water, and the rate of loss or gain of heat to the surroundings. With an even mixture it is not certain whether the two branches of the curve for a gain or loss of heat will meet, or whether they will still be separated by a minute temperature difference. It is probable they will be, and in that case a freezing-point mixture must be defined as an intimate and equal mixture of ice and water, neither gaining nor losing heat.

Artificial Production of Frazil-ice.—Some experiments were tried to test this point in regard to the temperature differences

observed in the water, and in the winter of 1904, with the assistance of Mr. Lucas, I succeeded in reproducing exactly the conditions of frazil manufacture in the laboratory, and in connecting this formation with the temperature of the water.

The obvious way was to pass a stream of cold air rapidly through the water, but no method of precooling the blast proved effective. On the introduction of the Hampson-Linde liquid-air plant in the laboratory, however, a method at once suggested itself, and was put into successful operation.

Liquid air, enclosed in a suitable vessel, was made to boil vigorously, and the cooled air led directly by suitable tubes into the water, and allowed to bubble through. The water experimented with was enclosed in a glass vessel immersed in a freezing-point mixture of snow and water, and cooled to zero. The liquid air was placed in another vessel, through the bottom of which two glass tubes protruded. These tubes passed from the space above the liquid air to the water below. The chilled air was thus conveyed as directly as possible into the water. In addition to the stirring, produced by the rapid bubbling, a glass stirrer was provided. The obvious advantage of this method over any means of external cooling is that the ice that is formed is of the fine needle variety, exactly similar in appearance to frazil, instead of a cake of ice that, by the external method, would be formed around the sides of the vessel. Some difficulty was encountered in the freezing of water in the tubes conveying the chilled air, but with a strong blast this was of small amount. In order to measure the small difference of temperature between the water in which ice was being formed, and a uniform mixture of snow and water, so protected as to be neither gaining nor losing heat, a pair of differential platinum thermometers was used, having a scale of ten centimeters to a degree centigrade. It was therefore possible to measure to the 1/10,000 of a degree with comparative ease, and a difference of 1/100 produced a

large deflection. The differences, which it was expected would be observed, were of the order of a few thousandths; it was therefore necessary to pay particular attention to the readings. The method of carrying out an experiment was such that direct observation of the difference was obtained. One reading was made with the two thermometers in the snow-mixture, and the second reading with one thermometer in the snow-mixture and the other in the water.

It was possible to obtain at once a check of the ice-point by stopping the flow of chilled air, when the temperature of the water immediately rose to the zero-point. In all cases this corresponded with the reading when both thermometers were together in the snow-mixture.

Preliminary measurements were made with a Beckmann thermometer, graduated to hundredths and reading to thousandths. At the outset, when the first ice-crystals were forming, the temperature sank over a hundredth below freezing, which was measurable, but when larger quantities of ice-crystals were present the instrument was not sensitive enough.

An effort was made to obtain readings with definite quantities of ice present. It was impossible to form an estimate of the quantity of ice formed by the chilled air, but clean dry snow was weighed outside the building and added to a known weight of water. In our two series of tests, one set with the Beckmann and the other set with the platinum thermometers, we used different weights of water. The differences observed were practically the same in both cases. The rate at which the chilled air was passed through was also the same. The differences observed were in practical agreement with the measurements made during the severe weather in the open water in the Lachine Rapids.

It was found that with the Beckmann thermometer the temperature of the water just at the time when the first ice-

crystals were formed was of the order of a hundredth of a degree. On adding successively 5, 10, and 20 parts by weight of ice the difference was reduced. This showed us that with very rapid cooling, the temperature of the water never fell much below the freezing-point. After repeating our experiments several times, we replaced the mercury thermometer with the differential platinum thermometers, and used a larger supply of water, about 400 c.c. The readings we obtained were as follows:

Ice just forming.	-0.0140° Cent.
Ice, 20%.	-0.0060° "

These measurements were checked several times, and all the conditions of the experiment were such as to warrant entire confidence in the results.

During the time in which the water was in this undercooled state the fine needle-crystals exhibited very completely the phenomenon of agglomeration. They appeared to be in a very adherent state, as shown by the formation of spongy masses, and their accumulation about the thermometer bulb and stirrer. They adhered, of course, to the tubes leading in the chilled air, but not to the wall of the vessel, which was surrounded by the snow and water.

On withdrawing the vessel and examining the ice formed, it was found to resemble very closely the natural frazil-crystals from the river. It was in a flocculent state, floating low in the water, thoroughly "water-logged," and easily kept under by the light masses at the surface.

The Main Conditions which Cause the Formation of Frazil- and Anchor-ice.—I shall now briefly consider the main facts in connection with the formation of frazil- and anchor-ice.

The experimental evidence is now sufficiently great to enable us to recognize two distinct agencies at work in the production of these two forms of river-ice. In the first case, we

have the production of frazil by the direct contact of the water with the cold air, whereby the heat is abstracted by agitation either by wind, or flowing over rapids. Its formation is the accompaniment of a small temperature depression in the water, which increases with the degree of atmospheric cold. The appearance of the frazil is the relief offered by Nature to offset the excessive cooling of the water, and the extent of undercooling of the water is an indication of the amount of ice being formed. Another form of relief supplied by Nature is the absorption of a portion of the sun's heat in the water during such time as it is clear. By this means the surface-cooling effect is offset by the powerful volume effect of the sun's rays. No bad effects of frazil are ever noticed under a bright sun, and, indeed, very little frazil is then produced, no matter how low the air temperature may be.

The agglomeration of the frazil is a result of the undercooling in the water, whereby each little crystal of ice becomes the centre or nucleus for further ice-growth. Two such crystals coming in contact at once freeze together, and very soon firm compact lumps are formed. Some particle of denudated material in the water becomes the nucleus of an ice-crystal, and the heart of a frazil-crystal may often be seen to contain a bit of stone, particle of mud, or portion of vegetable matter.

With the advent of warm weather, and especially under the influence of rain, the temperature rises slightly above the freezing-point, but remains very nearly at that point so long as any ice lasts.

The second great cause of river-ice formation is that of terrestrial radiation, whereby an immense quantity of heat is radiated off into space under a clear sky. This gives rise to the anchor-ice which grows to such great thicknesses on the bottom of our northern rivers, which flow too swiftly for surface-ice to form.

The subject of anchor- or ground-ice has attracted the attention of scientists for over a hundred years, and even so eminent a philosopher as Arago was completely led astray as to the cause of its formation.

A full discussion of the various theories which have been advanced will be given in the next chapter. I must mention the name of one gentleman, to whom we have already referred, the Rev. James Farquharson of Alford, Aberdeenshire, who, by his accurate observation of the conditions in Nature and his marvellous powers of deduction manifested in his early writings, was undoubtedly the first to satisfactorily bring forward radiation as the cause of anchor-ice formation. His remarks and observations are so convincing that, without further study, one is led with him to the same conclusion. He wrote at a time when a considerable controversy was going on over the existence of ground-ice, and of the cause of so remarkable a phenomenon of a river freezing on the bottom instead of the surface, and he stood almost alone, as we shall see in the next chapter, in his conclusions.

We have never, to my knowledge, observed the formation of anchor-ice under a layer of surface-ice, although there is no valid reason why it should not form in a shallow river, provided the ice is clear and free from snow, and the water is flowing sufficiently rapid to be at or very near the freezing-point along the bed. Usually this is not the case and anchor-ice is not formed. It is reported, however, in 1730 and quoted in a paper on "Ground-ice" by M. Arago in 1833 that, "during an atmospherical temperature of 15.8° Fahr., Hales saw at Teddington the surface of the Thames, near the banks, covered with a layer of ice one third of an inch in thickness. There was also, at the same time, a second layer below, of greater thickness, which followed the depth of the river as it adhered to the bottom. This sheet was united to the upper one even on the

waterside, but it was gradually separated in proportion, as, in proceeding into the river, the depth of the water increased. It was not so solid as the first, and was mixed with sand and even stones, which the flakes sometimes carry with them in their movement upwards."

Again, we find quoted by the same authority, that in the beginning of February, 1830, M. Duhamel, on breaking the ice which covered the surface of the Seine, a short way below the bridge at Grenelle about 10 feet from the banks, found a layer of continuous ice 4 cm. thick. The water was upwards of a yard deep. At every depth the water was found to be at zero, and the current was tolerably rapid. In both these observations no means are available for us to find out whether the ground-ice was formed previous to the formation of the surface-sheet or after. It is quite possible that the river was open, and, after becoming cooled to zero, ice was formed on the bottom during the earlier part of the night by radiation. The surface-sheet may have been of a later growth, formed more slowly from the sides, and of sufficient clearness to admit of radiation. On the other hand, the surface-sheet may have been formed first and the ground-ice later, although the thickness of the surface-ice, which was found to be $\frac{1}{2}$ inch, indicated a very recent formation. Both rivers were shallow, and it is unlikely that there was any accumulation of snow on the surface of the ice, which, as we have seen, is the chief obstacle to the heat-loss.

Another case is quoted by Mr. Farquharson in his second communication to the Royal Society, 1841, as observed by Colonel Jackson, of the presence of ground-ice in the Neva, under three feet of ice and three feet of snow. He considers, however, that ground-ice was formed previous to the surface-ice, and, on account of the severity of the weather, the mean temperature there being only 38.75° Fahr., it had not been dislodged during the time of formation of the surface-sheet.

In my experiments to detect the cooling of the bulb of the thermometer, when left undisturbed at night in the water, the temperature was observed to fall one thousandth of a degree in 15 minutes, and when the bulb was withdrawn ice was seen to have formed on it. I have also observed that ice grows more readily and to greater depths on dark-colored rocks, which is in accord with what we know of the greater radiating power of dark objects. This was also observed by Farquharson. It is also well known that anchor-ice does not grow on cloudy nights, although frazil may be produced at such times.

In the experiments on the absorption of the earth's radiation in water and in ice, to which I have already referred in Chapter I, it was seen that a considerable amount of heat can penetrate through water and a larger amount can penetrate clear ice. Having established the fact that some of the heat-rays can penetrate, we would naturally turn to the question whether such heat-loss would be shown by its effects on the bed of a river in contact with ice-cold water. It requires a cooling of only a thousandth of a degree to initiate the formation of ice, and it would be a matter of some surprise if the radiation did not produce this minute effect. In deep rivers anchor-ice is unknown, the limit of formation appearing to be from 40 to 45 feet. The depth, however, would depend on the clearness of the water.

CHAPTER VII.

THEORIES TO ACCOUNT FOR FRAZIL- AND ANCHOR-ICE.

Early Theories of Arago, Eisdale, and Farquharson. Later Theories of Francis, Bell, Hunt, Henshaw, and Lord Kelvin. Discussion of Henshaw's Paper. Views of Keefer. Extract from Article on Anchor-ice from the Montreal Flood Commission Report. Depth of Formation of Anchor-ice in Fresh and Salt Waters.

IN the discussion now before us of the various views which have been advanced from time to time to account for the curious phenomena of natural-ice formation, I shall adhere closely to the distinguishing terminology, which has already been adopted in this book, to designate frazil- and anchor-ice. The need of such a separation will, I believe, impress itself more and more on practical men as time goes on.

In 1901 I endeavored to bring about an official confirmation of my views in a paper on "Ice Formation in Canadian Waters," before the Canadian Society of Civil Engineers. Although the Society made no official move, it was a matter of satisfaction to observe, in the discussion following the paper, that every one taking part fell in with the suggestion, consciously or unconsciously, and clearly made the desired distinction in describing personal experiences. It is important, I think, to have a name for the two forms of ice, being as they are products of two totally different agents of heat transfer, and I have adhered to the term "frazil" because it is one universally accepted in Canada. Going back in history, we find the first ones to apply a name to the ice found on the bed of a river were the

Germans, who called it *Grundeis*. Following from this suggestion later writers adopted the name ground-ice. The name anchor-ice originated in North America, and I have chosen to use this name in preference to the much older one—ground-ice, because I think it more perfectly fits the facts of the case. Ground-ice might be ice formed anywhere on the ground, but anchor-ice readily suggests ice which is held down or anchored to the bottom.

The need of a distinctive name is more readily seen after considering the facts brought forward by a number of observers. In quoting the personal experiences of any author I shall, where it may be necessary, add in parentheses the true term to the author's use of the word frazil- or anchor-ice, according as it appears to represent either form of ice contrary to the terminology of this book.

It will be necessary now to briefly consider the various theories which have been advanced from time to time to account for river-ice formation.

About the beginning of the last century a great deal of interest was taken in ground-ice, and it appears that so sceptical were the philosophers of that date of its formation, although it was a common tradition among the boatmen and sailors, that so eminent a man as M. Arago devoted a large amount of time in collecting evidence, and deducing a theory to account for it. He states, in his paper referred to in the last chapter, that "Sailors for the most part believe that the flakes of ice are formed at night on the bottom of rivers by the action of the moon, and it is the sun which attracts them to the surface on the following day."

It is a strange thing that a man of so great understanding, and scientific training should have missed so completely the true cause of anchor-ice. He was very adverse to the idea of radiation, which had been partially suggested as influencing the

formation of ground-ice by a Mr. McKeever, an Irish philosopher, for he says: "According to this author, the rocks, stones, and gravel which generally cover the bottom of rivers have powers of radiation superior to those of mud, perhaps on account of their peculiar nature, but chiefly because they have rough surfaces. Thus rocks, in large or small masses, will become much cooler in consequence of radiation. When the atmospheric temperature is very low, they will, of course, freeze the water which touches them." Continuing, M. Arago says: "It is unnecessary to examine here whether heat radiates through a thick layer of water, as Mr. McKeever supposes, as the most simple observation is sufficient to overthrow it."

He then expresses himself very strongly, for we find the following in reference to the above: "Let us throw aside all these absurd explanations and, for want of better, analyze perspicuously the physical condition of the question."

All through the paper we find Arago's mind influenced by his opinion that water is opaque to the heat-rays, and therefore radiation can play no part in ground-ice formation. He seems to have set himself stubbornly against the idea, contrary to the true scientific mind, which is open to consider all alike, abandoning none until proof is found to the contrary. In no place can he prove that the cause which renders the dew and hoar frost possible on the earth may not influence the bed of a river. He refers to the fact that "We have no observations which prove that this kind of ice is seen, until the temperature of the whole of the water is at zero." He might equally well have said that we have no observations which prove that radiation from the bottom of the river may not, partially at least, penetrate the few feet of clear water with which most of his observations have to do.

Had he pondered over the sailors' traditions he might have had some trace of consideration for the radiation theory, for

the influence which they ascribed to the moon was, of course, a consequence of a clear sky when radiation is at its height, and the influence of the sun's rays, the reverse process by radiation to the earth.

An explanation is offered by Arago for the appearance of ground-ice, which he attributes to three circumstances: 1st, the inversion, by the motion of the current, of the hydrostatic order; by which the cold layers at the surface below the point of maximum density become thoroughly mixed with the warmer layers below, and the whole body of the water becomes cooled to the freezing-point; 2d, the aptitude to the formation of crystals of ice on the stones and asperities of the bottom in the water wholly cooled to 32° Fahr., similar to the readiness with which crystals form on pointed and rough bodies in a saturated saline solution; 3d, the existence of a less impediment to the formation of crystals in the slower motion of the water at the bottom than in the more rapid one near or at the surface. Of these circumstances, the first is, of course, a necessary condition. The second endeavors to account for the ice by the spontaneous crystallization which is, as we have seen, entirely too slow to account for the immense thickness to which anchor-ice grows, even apart from the possibility of the bed of the river becoming cooled below 32°, when the tendency is for it to be slightly above, by the slow conduction of heat from the earth. The third is not in accord with common observation, when we witness the ready formation of ground-ice in rapids, where the current is swiftest. None of these circumstances supply sufficient reason for the initiation of the ice-crystals, except the idea of the spontaneous crystallization, for which he certainly had less ground for belief and proof to support, than the idea of radiation which was already known to exert its influence on the earth.

In the paper on "Ground-ice," by the Rev. Mr. Eisdale, we

find the explanation given that it is the result of frozen spicules from the atmosphere, analogous to hoar frost, falling into the river, and there forming nuclei, around which the water freezes at the bottom. Here we find the idea of radiation influencing the formation, but only in so far as it produces the hoar frost. Mr. Eisdale's theory will hardly stand the test of rigorous application to the many observations of the formation of immense quantities of ground-ice when no hoar-frost is produced at all.

Mr. Weitz, author of a paper on "Ground-ice of the Siberian Rivers" in the Journal of the Geographical Society, says that which he noticed at the bottom of the Kann, near Krasnojarsk, was of a greenish tinge and resembled patches of the *confer-voidæ*. I have been unable to obtain further reference to these observations.

We now come to a discussion of the two papers by Mr. Farquharson. The first one deals mostly with his own personal experiences and the reasons which led him to the conclusion that radiation is the main cause of the production of ground-gru. The second paper contains further observations in support of his theory, and was written to offset the severe criticism he received at the hands of a writer in the *Penny Cyclopædia* of that date, 1835. Having been so greatly struck by the important bearing which these papers have on the conditions to-day, and from the fact that nowhere in the modern literature on the subject have I seen reference to them, or a better presentation of the subject, I feel justified in extracting portions of them here. One is often surprised to find buried in rare volumes of original memoirs treasures of greatest value, and I do not know a more perfect illustration of this than in the two papers before us. Written seventy years ago by a clergyman in a quiet country parish, they stand to-day without a rival in point of usefulness in helping to give us a better knowledge of present-day problems.

I take the following extract from his papers:

"The ice formed at the bottom does not resemble the solid glass-like plates which are formed on the surface. It has nearly the aspect of the aggregated masses of snow as they are seen floating in rivers during a heavy snow-shower; but, on taking it out of the water, it is found to be of a much firmer consistence than these, although never approaching to the firmness and solidity of surface-ice. It is a cavernous mass of various-sized, but all small, pieces or crystals of ice, adhering together in an apparently irregular manner by their sides or angles or points promiscuously. Both the firmness of the adhesion and the dimensions of the interstices (the latter filled with water, and their volume easily estimated by the quantity of it which is discharged when the ice is lifted out of the stream) are, however, greatly modified by the intensity and continuance of the previous cold. When the ice begins first to form on the bottoms of the streams it presents a rudely symmetrical appearance which, for illustration, may be compared to little hearts of cauliflowers fixed on the bottom, having a similar uniform circular outline and protuberance in the centre, with coral-like projections. These pieces have a shining silvery aspect; they are dispersed, at first irregularly, in small numbers, but increase, both in size and numbers, till the whole bottom is covered, and, if the frost continues severe, grow in height, but in a very irregular manner, so as to obliterate the earlier somewhat symmetrical shapes, till the streams are raised high above their former levels, and frequently made to overflow their banks.

"In a district where it occurs almost every winter, and often repeatedly during that season, and where many of the rivers are crossed by means of fords, its existence influences too much their economical arrangements not to excite their particular attention, especially as many horses refuse to enter any stream even slightly impeded by it, being greatly alarmed by

the pieces which break and float up from the bottom by the action of their feet. A body with which all are so well acquainted is known by an appropriate name. They call it ground-gru; gru being the term by which they designate snow saturated with or swimming in water. I shall venture to use their term for the ice formed at the bottom.

"It will be better here also to state, generally, the conditions of temperature and phases of the weather under which the ground-gru is formed. I have seen it occur only when the temperature of the whole mass of water was reduced to, or nearly to, 32° Fahr., and when the temperature of the air was several degrees below that point. I have observed it an invariable condition, that it was preceded by a continuance, for some time, of a clear, or very nearly clear, state of the sky.

"The following observations were made in the rivers Don and Leochal. The former having an easterly course is about 120 feet broad and a foot deep at the shallows. Both rivers possess a like character of very clear water and alternating rapids and pools. The rapids in the Don are reaches, where the water falls two or three or more feet from a higher to a lower level, within a distance of fifty or a hundred or sometimes two or three hundred yards. They are generally impeded with many large stones, some of them projecting above the water. The depth varies greatly, but seldom exceeds two or three feet. The pools between the rapids are on an average much longer reaches, in which there is little fall and a greatly diminished velocity of the stream, which often in them flows so equably as to give rise to no ripple on the surface. They, too, have in them large stones, but fewer in number. The depth in them, too, varies greatly, from two or three to four or five feet. The rapids and pools in the Leochal are of a similar kind, but both much less deep in this smaller stream. The bed of this river has, however, on the whole, a steeper descent, and owing to

this there is more broken water and spray in the rapids. The character of alternating rapids and pools in both streams is owing to the varying hardness of the granitic and micaceous-schistose rocks in which their beds are formed. Where the rocks are hard there is a rapid; where more friable a pool. In the parts of the rivers observed, the original rocks themselves do not anywhere form the immediate bed of the stream. That, to the depth of two or three or more feet, is composed of the debris of these rocks, broken up and sometimes much water-worn, and reduced to the size of a very large gravel by the action of the stream, but not so small as to deserve to be named sand. No part of the bottom is muddy.

“On the night between the 31st of December, 1834, and the 1st of January, 1835, after the mean temperature of the air had continued for three days at 47° Fahr., and when there had been little frost in the season before, there commenced a hard frost, with a calm and perfectly cloudless sky, which continued with little abatement till the 5th of January at 10 A.M. On the night between the 3rd and 4th the temperature of the air was 23° Fahr.; and on the 4th the bottoms of the rapid in the Leochal were seen coated in some places with silvery cauliflower-shaped clusters of ground-gru. I neglected at this time to examine the temperature of the water.

“Between the 4th and 5th the temperature of the air was down to 19° Fahr.; and on the 5th I examined the Don and the Leochal along half a mile of each, beginning the examination at half-past 8 o'clock A.M. The examination began at the bridge of Alford, built of granite over the Don, in the middle of one of the rapids. At this rapid, the whole bottom, with the exceptions to be immediately stated, was covered with silvery gru, appearing from two or three to five or six inches deep. My attention was particularly directed to the exceptions, as throwing a clear light on the question of the radiation of heat

from the bottom. Round each of the piers, and in front of the abutments of the bridge, there was a space quite clear of all frozen matter, excepting at a side of one pier under an arch, where a piece of very still water, caused by an obstruction at the bottom, was covered by clear sheet ice. On the south side of the river two embanking-walls, one up and the other down the stream, each twelve yards long, are built in a line with the watercourses of the abutment. Close to the bridge these walls are eight feet high from the bottom of the stream, but as they recede from the bridge the masonry slopes gradually to a lower level till the extremities are little above the level of the water. The bottom in front of these walls was clear of ground-gru, as well as that in front of the abutments; but the breadth of the clear space in front of the walls narrowed gradually towards their extremities, in proportion as the masonry became lower, till at the extremity of the downward wall especially, which ends at a sloping gravelly bank, the gru came to the edge of the water. The space of the bottom clear of gru was about five or six feet broad at the high parts of the walls next the bridge; and the water runs on the place at the medium depth and velocity of the rapid. There was another clear space in the bottom of this rapid. About twenty-five yards above the bridge there is, in the middle of the stream, a piece of still water, caused by an elevated bed of gravel just below it, over which the stream is very shallow. The still water, for an extent of two or three square poles, was covered with sheet ice, and that again covered by a very thin, but white, opaque deposition of hoar frost. From under this ice the water, flowing rapidly over the gravel-bed below, had no ground-gru for a space of eight or ten yards downwards.

“Above this rapid a pool of moderate stillness, about three or four feet deep, extends a hundred and fifty yards in length. Over the bottom of this there were scattered, in an irregular

manner, many cauliflower-shaped clusters of silvery gru, most of them very small, and none that were observed covering more of the bottom than a square foot or two at one place. In the deepest and stillest part of the pool there were several tufts of water starwort, with sooty-colored decaying leaves, forming the darkest-colored objects seen at the bottom. These were all densely tangled with fringes of silvery gru. At the head of the pool, where the velocity acquired by the water in the rapid immediately above it was not yet greatly diminished, an appearance of a different kind presented itself. There are here several large stones in the bed of the stream, but none of them projecting above the water. On the faces of these opposed to the stream there were seen quantities of gru of a different aspect from that further down. It was not arranged in the same cauliflower shapes, but in angular masses, like wreaths of snow blown by the wind. It wanted, too, the silvery glance of the other, and had more the appearance of a pale ash-colored mud. On reaching it with the end of a pole, its consistency was found to be less firm; in fact, it was only a heap of detached uncemented spiculæ pressed against the stones, and retained there mechanically by the action of the water in a certain modified state of its velocity. The source of these heaps of uncemented spiculæ will soon be noticed. This pool, as indeed was the case with all the pools in the river, had at its edges and in its little bays narrow pieces of surface-ice, extending a foot or two from the banks.

“The rapid immediately above this, not unlike that at the bridge, was covered at the bottom with silvery gru, with one exception. The river was low at the time from long-continued deficiency of rain, and the water had deserted the south side of the channel, leaving many little pools among the stones, communicating more or less freely by irregular little currents with the main stream. The pools were covered over with sheet

ice, and that with a thin opaque deposit of hoar frost like snow. In the little currents returning from under this ice there was no frozen matter.

“At the head of this rapid there is a pool much deeper and stiller than that above the bridge rapid already described. The depth is five feet, and the stillness such that, at many points of it, there is no ripple or wave on the surface. None of the silvery cauliflower-like ice was seen on the bottom here; but near the head of it, in a modified state of the current pouring in from the rapid above it, there were, on the faces of several large stones opposed to the stream, collections of uncemented icy spiculæ.

“The source of these collections was very readily observed in a great rapid immediately above this. In that rapid the water has a much quicker descent than in the others referred to. It is about a hundred yards long, and cumbered with many large stones, over which, at many points through its whole length, the water breaks with a great deal of spray. Here an immense quantity of gru occupied the bottom, impeding much the course of the stream. At the time of observation many pieces of this gru were seen edging up, and in some instances breaking quite away from the bottom, apparently by the increasing pressure of the water, as it became dammed back by the increase of the gru itself. This at least was the appearance, although there may have been another cause for the disengagement of it from the bottom, and that is the impeding, by the imperfectly translucent gru, of that radiation of heat from the bottom which, I trust in conclusion to demonstrate, is the immediate chief agent in the whole phenomenon.

“It is now to be observed that a number of pieces of loose gru, the origin of which was so clearly ascertained at this last rapid, were floating down in all parts of the river. In passing through the rapids they were broken into fragments, and,

where the fall was violent, shivered into minute pieces. The larger pieces that remained after passing through the rapids floated at the surface, immediately as they got into the uniformly flowing currents at the heads of the pools; but the minuter ones, mixed with the water to all depths by the plunging whirls in the rapids, not being so speedily disentangled from their cohesion with the water by the action of gravity, floated for a greater distance immersed in the water, and were intercepted by, and mechanically retained against, the faces of the stones by the action of the stream at the heads of the pools. Further down and in stiller water, where no such intercepted heaps were seen, their buoyancy had, no doubt, by degrees overcome the cohesion and raised them to the surface; and, in fact, in the still water many minute icy fragments were floating in the surface.

“In the smaller stream of the Leochal the quantity of ground-gru was comparatively much more abundant, occupying the bottoms both of the pools and rapids in close masses, and, in the latter, at many parts forming such an impediment as to urge the water over its usual banks. But there were two remarkable exceptions: One of the pools flows close to the foot of a steep bank about fifteen feet high, and in the side next the bank there was little ground-gru. In a rapid, which at a turn of the river has an easterly course, there was a very dense fringe of *Phalaris arundinacea* standing, with its dense foliage of withered leaves in the south edge of the water. Its height was four feet, and it extended fourteen feet in length along the stream. At the foot of it the bottom of the rapid was clear of ground-gru to the breadth of three feet.

“The temperature of the air and water at the time of these observations was particularly ascertained. That of the air at sunrise, about an hour before the observations commenced, had been 23° Fahr.; but it was rising rapidly during their progress,

and was at 36° Fahr. before their conclusion. The temperature of the water in the Don varied from 32° to 33° Fahr.; but the variation could not be distinctly traced as depending on the depth or velocity, as there was a temporary variation in the same place, both in the pools and rapids. At one of the small streams, returning from under the sheet ice on the little pools at the edge of one of the rapids, the temperature was nearly steady at 33° Fahr. In the Leochal the temperature was nearly steady everywhere at 32° Fahr.

“By 10 o'clock A.M. on the same day a cloud obscured the whole sky, and at 2 o'clock P.M. the temperature of the air was 40° Fahr. At this time much gru rose from the bottom and floated down the streams of both rivers. The relaxation of the frost, however, was of very brief continuance. Before sunset the temperature of the air was again down to 31° Fahr., with a perfectly calm air and clear sky; and the clear sky continued till the evening of the 7th of January, the thermometer during the two intermediate nights being at 23°, and during the intermediate day at 26°.

“The same parts of the Don and Leochal were again examined at 10 o'clock A.M. on the 7th. In the Don the ground-gru now covered all the bottoms of the pools as well as of the rapids. It was of less depth in the deep still pool below the great rapid; but everywhere else it formed a great impediment to the stream, raising it so much above its former level that it covered deeply the pieces of sheet ice formed at the edge on the 5th. New pieces of similar ice were now forming at the same places on the more elevated surface. The Leochal was still more impeded by the gru than the Don.

“But, what is worthy of particular notice, the clear spaces of the bottom, at the piers, abutments, and embanking-walls of the bridge on the Don, and at the Phalaris grass in the Leochal, still continued so, but were now considerably narrowed in their

lateral dimensions, the ground-gru having encroached upon them on the sides next the streams. The temperature of the air was 24° Fahr., of the water everywhere nearly steady at 32°.

“Several circumstances occurred on some subsequent days which deserve to be noticed, as throwing light, by the contrast which they exhibit, on the phenomenon now under consideration. On the 8th of January there occurred a thaw, when the thermometer suddenly rose to 47° Fahr. The rivers were speedily cleared of ice and ground-gru, which last rose from the bottom and floated away with the stream. The atmosphere at the time was considerably clouded, with a brisk SW wind. On the 9th of January the temperature of the air fell to 36° Fahr.; and on the morning of the 10th of January, with a temperature of the air at 29° Fahr., there was a fall of snow of about an inch deep, which ceased by 8 o'clock A.M. The snow that fell into the rivers was observed to be entangled, and stuck fast in irregular crushed masses in many parts of the rapids; and there were collections formed of loose spiculæ of a muddy aspect at the sides of the stones opposed to the streams, in the heads of the pools, where the velocity of the currents was intermediate between that of the rapids and that of the stiller parts of the pools; but there was no appearance on any part of the bottom resembling the symmetrical cauliflower-shaped ground-gru. On the evening of the 10th the temperature of the air fell to 23°, and continued at from 23° to 21° till the morning of the 12th, with a densely clouded state of the sky. During this time extensive sheets of surface-ice were formed on the pools of the Don, and many of the pools of the Leochal were quite frozen over, but the ground-gru was nowhere renewed; on the contrary, the masses of snow entangled in the rapids on the 10th disappeared to a great extent, obviously floating away in the stream. In this state of the river and weather, the collections of uncemented spiculæ, on the faces of the stones opposed

to the streams in the heads of the pools, appeared in their places the same as before, neither increasing nor diminishing in size.

“The cooling of the surface of the ground by radiation, discovered by Dr. Wells, takes place only under a clear sky. It is therefore greatly modified on parts of the ground screened from a part of the sky by opaque objects, as walls, trees, hedges. In illustration of the extent to which a screening or shading body near at hand modifies the radiation, I shall detail some observations I made on the 7th of January last, incidentally in the first instance, but then extended, in reference to the observations on the ground-gru which I was making at the time. Having occasion that day to dig into recently hoed ground, in the middle of a garden remote from shade, the soil was observed to be frozen to the depth of four inches by the clear frost, which had continued from the 1st of January, with the trifling intermission above mentioned. On digging into similar ground at the north base of a wall six feet high the soil was found, close at the foot of the wall, frozen to the depth of only half an inch; at a foot distance from it about an inch; at two feet little more; and it was only at the distance of ten or twelve feet that it was frozen hard to the depth of three inches. A similar modification of the effect of radiation was observed in the shade of trees. Under the Scotch fir the soil, slightly covered with decaying herbage, was not at all frozen; although in similar ground similarly covered, but remote from shade, it was hard frozen to the depth of two or three inches.

“Now the ground-gru in the rivers was modified in a way strictly similar by the effect of shade. The bridge of Alford, over the Don, is happily situated for illustrating this, being on one of the rapids, where the ground-gru is earliest and most abundantly formed. While the other rapids, and the unshaded parts of this one, were quite occupied by gru on both the 5th

and 7th of January, spaces in the shade of the masonry at this bridge were quite clear of it. It cannot be admitted as an explanation of this fact, that heat may have been there laterally transmitted to the water by contact with the piers and walls; for if this took place, why then did the clear spaces on the bottom narrow gradually towards the low extremities of the embanking-walls? Besides, the transmission of heat laterally had not hindered the formation of surface-ice, in contact with a pier, on a piece of still water under one of the arches. The modification of the radiation by shade was also exhibited in the absence of all gru on the bottom, along the foot of the dense tuft of Phalaris grass in the Leochal, where there could be no more transmission of heat laterally, than at the general line of the grassy banks of this stream.

“The water, too, returning warmer from under the surface-ice on the little pools at the edge of one of the rapids, is another instance of the modification of the radiation by shade. The thin white opaque covering of hoar frost on the ice prevented radiation, at least in a great measure, and the heat of the bed of the river, in the course of continual transmission upwards from strata not yet cooled to much depth by the frost, finding no outlet by the radiation, was expended in heating the water by contact.

“There was another phenomenon observed on the 5th of January (although no longer seen on the 7th, being then concealed by the immense formation of gru), which can be readily explained by the admission of the radiation of heat through the water, and therefore goes to support the justness of the theory. The tufts of water-starwort, in the deepest and stillest parts of one of the pools, were the darkest-colored objects seen at the bottom, and they were fringed in every part with spiculæ of gru, at a time while it yet occupied little of the bottom of this pool. The experiments of Boyle, Franklin, Rumford,

Leslie (although he denies the conclusion himself), Davy, and Stark appear too uniform in their results to leave any doubt remaining that dark-colored bodies both absorb and radiate heat more freely than those which are light-colored. It is in consistency, then, with an ascertained law of the radiation of heat, that the very dark-colored tufts of the water-starwort should have been the first bodies in the pool cooled to a very low temperature, and of course first covered with gru."

Later Work on River-ice Formation.—Turning our attention now to the more modern papers on the subject, we find several valuable ones written from 1881 to 1887. These are all descriptive of the ice problem as it has presented itself to the practical engineer in the development of water-power, or water-works in this country.

Naturally the conditions of formation have been more severe and the ice-growth on a much vaster scale than could be expected in the countries where—like England, France, or Germany—the winters are comparatively mild, and the rivers small. In Russia, no doubt, much attention has been devoted to this problem, but, on account of the difficulty of securing reliable information, I am unable here to add anything authoritative on the subject.

In all the papers that I have seen, no mention is made of the work of the European writers, and I have therefore thought it worth while to dwell at some length on these papers before commencing a survey of the more recent ones which bear more directly on the subject which we have to consider.

In 1881, at Montreal, in the presidential address before the American Society of Civil Engineers, Mr. J. B. Francis devotes a short section to a consideration of anchor-ice. He makes no mention of the term "frazil," but states in regard to anchor-ice: "The ice is formed in small needles on the surface, which would remain there and form a sheet if the surface was not too much

agitated." He then goes on to explain the production of whirls and eddies and the general mixing of the currents, whereby these needles of ice are carried to the bottom and adhere there by regelation. As an explanation of regelation, he refers to the observations of Faraday and Forbes (Chap. III). To explain why the small crystals freeze so readily, as compared to a larger mass of ice, he says: "In the minute needles formed at the surface of the water the tendency to adhere would be much the same as in larger masses touching at points only, while the external forces acting upon them would be extremely small in proportion." Thus they would become frozen down more easily.

He states that the adherence of the ice to the bed of the stream or other objects is always down-stream from the place where they are formed, which is true, of course, in respect to the freezing down of frazil-crystals. He then goes on to say that in large streams it is frequently many miles below, which is quite correct, but he overlooks the growth of anchor-ice in places where frazil-ice is formed only in small quantity, and immediately swept away by currents running from under the barrier-ice. After speaking of the agglomeration of these needles (frazil) into spongy masses drifting along with the current, causing troublesome impediments to the use of water-power, he points out the value of having water-powers supplied directly from ponds, rivers or canals frozen over for a long distance immediately above the places from which the water is drawn. In the entire paper no reference is made to the effect of radiation.

Dr. Robert Bell published a paper in 1886, in the Transactions of the Royal Society of Canada, on "Ice Phenomena," and in it devotes some space to a discussion of frazil- or anchor-ice. He points out many facts in support of the radiation theory of anchor-ice, which he states was first suggested by

Dr. T. Sterry Hunt, who mentioned to him that he regarded it as analogous to the formation of hoar frost. Dr. Bell considers that the surface-formed ice in the rapid may aid the formation by being carried down by currents. He speaks of the excavation caused by the removal of stones and boulders by anchor-ice. Dr. Hunt has been given the credit for suggesting radiation as the cause of anchor-ice formation. We have no means of knowing whether he was familiar with Farquharson's papers, or whether he came to the same conclusion independently.

The first paper to be written solely about frazil-ice, to my knowledge, is that of Geo. H. Henshaw, in the Transactions of the Canadian Society of Civil Engineers for 1887. The paper is on "The Nature of Frazil and the Prevention of its Action in Causing Floods." Written at the time of the work of the Montreal Flood Commission, it is of value in bringing out expressions of opinion on the subject from well-known engineers, and of offering a theory to account for its varied formation.

After complaining that in a study of this kind, which is more physical than engineering, the scientific men neglect the subject or "leave us in the dark," he points out "that the haziest notions, if any, regarding it prevail among our highest scientific authorities." As an illustration, he refers to the explanation offered by Sir William Thomson (Lord Kelvin) of frazil-ice, when president of the British Association Meeting in Montreal in September, 1884. This explanation was that it was supposed to be the product of currents of water passing over and disintegrating solid anchor-ice, exposing its "bones," just as a rock is worn into irregular forms by the removal of its softer parts. The incorrectness of this explanation is manifest to any one who has experienced this kind of ice.

All through Mr. Henshaw's paper we find the terms frazil- and anchor-ice used in the exact sense of the terminology

adopted in this book, and it is only in the discussion following the paper that any confusion arises. The author gives his opinion that ice (frazil) never forms in water without an independent nucleus and that, like anchor-ice, it may form below the surface of the water. When it appears free on the surface the nuclei are supplied by minute particles of vapor, which, becoming frozen in their ascent and falling back upon the water, form the stars seen in Tyndall's experiment, when the sun's rays are focussed in the interior of a block of ice. The author refers then to the observations of Mr. Frank Gilbert, engineer and contractor, who was engaged in deepening the channel through the Gallops Rapids, showing the presence of masses of frazil frozen down to the anchor-ice on the bottom. He says that it covered the bottom in dense masses of a spongy appearance, through which his pole swept with scarcely perceptible impediment. Masses of frazil cannot be described better than looking "spongy." Any one who has dislodged this ice from the under side of surface-ice where it has accumulated, and seen it rise slowly to the surface, cannot mistake it. It can readily be distinguished from anchor-ice by its much more feathery texture. Anchor-ice is coarser and full of grains formed of much larger crystals. Mr. Henshaw offers an explanation of frazil in order to account for its formation at some points more readily than others. He considers generally that frazil-ice is formed in currents cold enough not only to preserve its crystals, but to induce their formation.

On account of the irregular nature of the bed of a river Mr. Henshaw considers that there are formed currents and streams of different velocity to the surrounding layers, just as in a wind-storm the snow is drifted and sweeps in long lines, or streaks, with bare places between. Thus there may be formed in a rapidly flowing river streaks composed of currents colder than their surroundings. He regards these currents as forming

“an irregular network with meshes of every size and threads of every thickness.” The frazil appears in the currents, which he calls supercooled by the “sudden cooling of the water upstream.” At the same time he is careful not to commit himself to the statement that the water itself is below the freezing-point. He considers that such water is always charged with minute icy particles, which may cause in themselves the refrigeration of the bottom. Objects found in the threads of colder water become nuclei about which ice forms, and masses of frazil are produced. Similarly, when warm weather sets in, these currents become warmer than their surroundings, and the ice is dislodged.

The main idea connected with Mr. Henshaw's explanation is quite correct, that is, the existence at certain times of currents of different temperature, and no doubt the slight undercooling of the water set up at the surface of an eddy results in a colder current passing downwards. To go further and state that his theory has “at least the merit of accounting for all known facts in connection with the nature and action of frazil” is wholly incorrect. All that he attempts to do is to try and explain why frazil appears to mass at some points and not at neighboring places; to do this he produces from his imagination a picture of a river, divided off into innumerable parts, separated by a skeleton of ice-laden, supercooled water. The remainder of the paper is devoted to a discussion of the ice-floods along the St. Lawrence, and of methods to obviate them.

The discussion which follows Mr. Henshaw's paper is of a very interesting character. It brings out, better than anything else I have ever seen, how different observers may arrive at totally different conclusions about the same phenomenon. The collection of facts here found is of the greatest value, and I shall give, as far as possible, the essential points in connection with it as follows:—

Mr. Herschel states that anchor-ice is the New England equivalent of frazil, which is probably correct, owing to the lack of terms then existing. Frazil is wholly of Canadian origin. Mr. Herschel then goes on to describe conditions for the formation of anchor-ice (frazil), where he had observed it in the Connecticut River, and at the Detroit Water-works. He observes that it forms in the river only at times when there is no covering of solid ice, and generally, only for the 12 to 24 hours just preceding the formation of such a covering. He gives as its most distinguishing characteristics, its low specific gravity, and its adhesiveness. The first is obviously his way of describing the fact that masses of frazil float low in the water, to which we have already referred and explained; and the second is probably the result of having always observed frazil on days when it was forming.

Mr. G. W. Ranney stated that frazil was never observed by him to form in still water or smooth current. He considers that it is formed in rapids where the water is broken up and intermixed with air. Referring to personal observations at Cow Bay, Mr. Ranney says: "At 0° Fahr. prisms of ice begin to form about 200 feet down-stream from the surface-ice. The anchor-ice (frazil) begins to form as soon as the rapid commences, but does not adhere to the bed of the river until it has travelled 500 to 600 feet down the rapid, and commences to settle on the bed of the river and adhere to everything with which it comes in contact."

This is no doubt all correct, for the water would require an appreciable time to become sufficiently undercooled for the frazil to form after flowing from under the surface-ice. And its adhesive properties would be very much increased after travelling 500 feet down the rapid in contact with a cold atmosphere.

Dr. Robert Bell brought forward the idea of radiation as

the real origin of frazil (anchor-ice), and stated the necessary conditions for its formation.

Mr. Hannaford stated that frazil-ice is to be found at the foot of rapid currents, and in broken and shallow water, rather than in currents of great depth. He says that frazil-ice (anchor-ice) is practically unknown at the Niagara River. He then compares the conditions at Montreal, and speaks of the ice-floods.

Mr. Lesage described the conditions at the Montreal Water-works' aqueduct above the Lachine Rapids, where the river in winter is always open for a distance of seven miles to Lake St. Louis. Immense masses of frazil- and anchor-ice are drawn into the aqueduct, and frequently completely cut off the supply of water. So much trouble was experienced that the mouth of the aqueduct was moved higher up to a bay, and a large basin was formed by part embankment and part cribwork, which allowed the surface-ice to be formed over an area of about 10 acres, and no further trouble has been experienced. This general method is now recognized as an effective prevention of the ice trouble under certain conditions. Mr. Lesage's personal observations are of the greatest value, from the wide experience he has had in handling the ice problem for the Montreal Water-works.

He has observed large masses of anchor-ice attached to boulders, the general bed of the river, and in all places where there were eddies. "It assumes a fungus shape," he says, "gradually growing upwards." A rise of a few degrees in the air temperature will cause the whole mass to break away from its anchorage, often carrying with it a boulder or any substance to which it is attached. He has observed that sometimes the river is nearly covered with these floating masses, plainly showing that they had formed in the open water of the river. "The formation was most marked on cold bright days, and the frazil (anchor-ice) rose to the surface on a cloudy day, with a slight

rise of temperature. Every year," he states, "when ice first covers the aqueduct, frazil forms in the settling-basin and is carried into the wheels, which have to be stopped a few hours until the ice has covered the basin."

Mr. Poole related one of his experiences at the Acadia Colliery, N. S., when the feed-pipe, supplying the boilers from an artificial pond, was stopped up in the morning after a clear, cold night, and a wind sufficient to prevent surface-ice from quickly forming. It was found that the netting was coated over with coarse crystals of ice and the sponges were solid lumps. He says "the crystals of ice had every appearance of growing *in situ*." The current was so weak that he considers they could not have been drawn down. This observation of Mr. Poole's is clearly one of radiation.

Mr. Murdock stated that he had never seen anchor-ice on clay bottoms, but only on shallow rapid rivers with rocky beds. Frazil, he considers, the same as anchor-ice and has the property of floating under the surface of running water. He speaks of the case of the uplift and overflow of the Saskatchewan by the anchor-ice, which came under his notice.

Mr. Steckel remarked on the origin of the word "frazil" and considered it to be a purely French-Canadian expression for "slush-ice." He advised adopting a name common to both French and English and suggested "Frasis."

Mr. Sproule then followed, and remarked that only a small part of the frazil blocking the channels has at any time been attached to the bottom. He considered that frazil is formed only at very low temperatures, and seems to differentiate it from a surface-ice film, which is forming all the time when the temperature is a few degrees below the freezing-point. It is the disintegration of this surface-ice that he thought caused the the most obstruction. We cannot see where to draw the line of separation in Mr. Sproule's suggestion. Frazil is distinctly

a product of surface agitation as well as, what we have termed, nucleation in the mass of the river when undercooled, so that no distinction really exists.

There is no doubt that Mr. Sproule was entirely correct in attributing to frazil the main agent at work in obstructing river channels.

Mr. Keefer, after describing anchor-ice and frazil and the meaning of the terms, gave some of the conditions necessary for their formation. He says: "Anchor-ice will form on the bottom in shallow streams whenever there are about 15 degrees of frost or more." At Montreal he considers that there is little doubt that the depth of formation extends in severe weather to 45 feet. The thickness to which it will grow depends on the duration of the cold. In comparing his observations of anchor-ice and frazil, Mr. Keefer refers to the fact that there is often an abundant formation of slush-ice (frazil) on the surface in the main channel at the setting-in of winter, which collects in masses by mutual attraction or cohesion of the spicules. He goes on to say: "If this be the raw material from which the growth of anchor-ice is made at the bottom, the fact still remains that this ice is most abundant on the surface when there is no anchor-ice at the bottom; on the other hand, the growth of anchor-ice at the bottom is most rapid when and where there is no visible ice of any kind floating upon the surface." He considers that it may be possible for surface-formed crystals to build up anchor-ice, but the first layers must be formed on the bottom *in situ*. He then goes on to give his reasons for holding the radiation theory. He states that intelligent and reliable mill-owners assert that this troublesome ice is never found in their mill-races—no matter how cold the weather is—whenever the sun is shining or whenever there is a cloudy sky at night.

In concluding his remarks, Mr. Keefer stated that anchor-

ice is not an unmixed evil; from the large amount produced and the enormous quantity of heat set free in its formation, he considers that it plays a very important part in tempering the severity of the climate. A closed river or lake is practically shut off from heat-loss, while an open river is an abundant source of heat.

Sir William Dawson stated that the best name for frazil would be "spicular ice," which is used by geologists in discussing the subject. He also pointed out that fishermen and boatmen on the coast called it "lolly." It floats in the water and is perfectly soft and mobile. "Such ice," he said, "may consist of thin blades or needles of a crystalline character, which may form in a separate or detached manner in water, which is cooled below the freezing-point, and which is agitated by the wind, or by a rapid current, so that the ice cannot become compact." The spicular ice may further grow on the bottom in the manner in which crystalline needles form in some saturated saline solutions. He stated further: "The fact that it forms most readily in open water without any covering of ice, and in clear cold weather, indicates that radiation from the bottom has an important influence in its formation, but where the water is sufficiently cold it may crystallize on any nucleus presented to it; and more especially, it would seem, on metallic bodies and stones which are good conductors of heat. Hind states that on the coast of Newfoundland anchor-ice forms in large masses in the sea, at depths of sixty and seventy feet, and it has been known to raise stones and anchors from the bottom, and to freeze around fish caught in nets. He also states that when the salt water has been cooled below the freezing-point, the fresh water of streams pouring into it from the land is at once converted into lolly or floating frazil. In this last action there is something analogous to what takes place when water at about the temperature of 32° is tossed about in a rapid and

mixed with air at a still lower temperature, perhaps below zero. These are merely desultory observations from the point of view of a geologist; but they may serve to show that there are different kinds of spicular ice, and that they may be formed in various ways. It seems certain that several of these modes of formation are concerned in the production of the spicular ice so troublesome in our river, so that it is not prudent to limit ourselves merely to one theory of formation, any farther than the general principle that they all depend on the somewhat rapid crystallization of water, under circumstances in which it tends to form groups of spicular crystals rather than solid sheets."

Mr. Tate remarked that whenever water, at a temperature of 32° Fahr. or less, was passing over the river-bed at a higher temperature, a formation of ice might occur after the manner of hoar frost, possessing great cohesiveness and tenacity, until disturbed by a higher temperature or other forces.

Mr. W. Bell Dawson pointed out the influence which the point of maximum density would have on the formation of ice in quiet waters, and the absence of this condition in a rapid, tended to make ice crystallize on the bottom and sides. He considers that the frazil in the water is produced mostly from crystals so formed.

Mr. T. Guerin gave as his theory of frazil that it consisted of particles which must have been frozen separately. To bring this about, the water must have been divided into distinct particles at the time of freezing, such as when violently agitated into foam and spray. He did not believe that frazil is always formed at the bottom. We notice here the confusion of terms. He also found it difficult to believe in the amount of frazil (anchor-ice) observed lying on the bottom near the Canadian Pacific Railway bridge at Lachine.

Mr. P. A. Peterson, in reply to Mr. Guerin, described his personal observations of the anchor-ice at the C. P. R. bridge.

He stated that in taking soundings in depths of water varying from five to forty feet, the bottom of the river was frequently covered over its entire area with frazil (anchor-ice) from two to three feet in thickness; when the sounding-rod was let down upon it the frazil (anchor-ice) was of such a consistency as to sustain the rod, which could be forced through it by a couple of strong men without much difficulty. He described the rise of the ice in mild weather, when it could be seen all over the open surface of the river. He observed that it formed during a period of intense cold, when the thermometer was below zero.

Mr. W. McLea Walbank described the anchor-ice as being visible at Lachine in the open water on a clear day, and that it always came up to the surface on cloudy days, turned upside down.

Mr. Irwin considered that air mixing with water was the main factor in the production of frazil-ice. Such ice, he thinks, would be very cold and therefore dense enough to sink and be carried to the bottom. Under surface-ice frazil does not form, which Mr. Irwin considers is in direct support of his theory. It is not clear whether he refers to air absorbed by the water or air which has become churned up with it. In any case, it is impossible to conceive of an ice-crystal forming, and being so cold that it sinks readily in the water. How could it be so cold, is a question we may well ask ourselves. If the cold of the air-bubble forms the ice-crystal, why should the crystal not grow by the addition of more ice, rather than remain below the freezing-point.

In his concluding remarks Mr. Henshaw stated that frazil- and anchor-ice were of common origin. Anchor-ice, he thinks, forms when the current is too swift to allow "efflorescence," and may be likened to "an accumulation of roots when branches and foliage have been swept away." He does not consider that

the loose masses seen floating in our rivers can ever have been attached to the bottom, "even if it is assumed that the nuclei have, by some means, reached the necessary temperature, and still more so that the particles from the surface should arrange themselves in forms suggestive of luxuriant vegetable growth."

I have devoted considerable space to bringing forward this discussion, and in some cases I have added a word of comment. It may be seen how varied are the views brought forward by men, all of whom have been brought face to face with the various forms of ice.

We must now turn to the very valuable report of the Flood Commission, and there we find a section devoted to a discussion of anchor-ice, as it presented itself to the engineers in charge of the work.

I regard their observations of such value that I take the opportunity of reproducing this section, since the report is rare and difficult to obtain.

ARTICLE ON ANCHOR-ICE, EXTRACTED FROM THE REPORT OF
THE MONTREAL FLOOD COMMISSION, 1886-87.

"The terms 'anchor-ice' and 'frazil' (cinder-ice) are indifferently applied to the same material, but the first evidently is most applicable to this ice when found in the bottom of the river. Large quantities are formed by a comparatively moderate degree of cold upon the surface of the open water and never reach the bottom, but a still larger quantity in the same area and with much greater rapidity becomes attached to the bottom in the coldest weather only, and leaves it on the approach of a higher temperature. In one respect the two are identical, that is, both are exclusively the production of open water. There is no formation of either when and where the surface is covered with ice, and, whereas large formations of

both take place in the beginning of winter over the vast surface below the Lachine Rapids, the further formation of this ice ceases as soon as and wherever the ice-bridge is formed. Frazil, as distinguished from anchor-ice, is formed over the whole unfrozen surface above and below Lachine Rapids between Prescott and tide-water, and wherever there is sufficient current or wind agitation to prevent the formation of bordage-ice, while anchor or anchored ice, except in the shallowest portions of the current, does not appear in the deeper water until zero weather sets in.

“This continued low temperature brings the whole body of the water to or even below the freezing-point, and it is then filled with needles of ice, which are carried from the surface to the bottom and from the bottom to the surface by the rolling motion of the descending water. The contact of this frigid current with the bottom brings the latter into a condition when this form of ice adheres to and commences to grow rapidly upon it, as an icy fungus or moss attaining a growth of several feet in depth within the duration of a severe cold term, which may extend from three to five days. On the approach of mild weather it becomes detached from the bottom, sometimes bringing up with it gravel and stones, and may be seen a dark-colored mass bursting up all over the open surface with considerable force and with a hissing sound, which rises a foot or more above the surface, but falling back shows only a few inches floating above it. Out of the portion above the surface the water quickly drains and it becomes as white as snow. The river surface then presents the appearance of a meadow dotted with low white haycocks, which pass over the Lachine Rapids and go under the fixed ice below. This is repeated several times during the winter, the number of the ‘crops’ and the thickness of each depending on the severity of the winter.

“One of the principal objects of our survey has been to

ascertain what became of this anchor-ice, as well as of the surface-formed frazil, after they disappeared under the ice-bridge. Holes were cut through the ice in March last and lines of cross-sections, over fifty in number, were taken at various points between Lake St. Peter and the Lachine Rapids. Through these holes the thickness of solid ice and of frazil, as well as the depth of water underneath both, were ascertained. The frazil- or anchor-ice, was always found immediately underneath the solid ice and attached to its under side. Chopping was always necessary to get through the solid ice, but as soon as the frazil was reached the water came up to its winter level. A pole could be forced through the frazil and a heavy sounding weight could be 'churned' through it until the clear water was reached, or the bottom of the river, where, as in some cases, this deposit extended to the bottom. The first trial cross-sections showed that the deposit of frazil was comparatively small in quantity below Varennes. The cross-sections, therefore, were taken chiefly above Varennes, and more frequently where the greater deposit was found. The great bulk of the frazil was found above Longue Pointe, and above that point, therefore, the great majority of the cross-sections were taken. The greatest quantity in proportion to the free water was found in the Laprairie Basin. Here there was more frazil than clear water, the proportions being one hundred and seventy millions of cubic yards of frazil to one hundred and thirty millions of cubic yards of water. The next greatest quantity was found between Ile Ronde and Longue Pointe, where there was about half as much frazil as clear water, the proportion being forty-five millions of cubic yards of frazil to ninety-one millions of water. The next most congested section of the river was that between the Victoria Bridge and Ile Ronde, where there was found about thirty per cent of frazil. The next in order of congestion was between Longue Pointe and Pointe aux Trem-

bles, where the frazil was about twenty-seven per cent of the clear water. The last section measured was between Pointe aux Trembles and Varennes, where the frazil was reduced to a little over six per cent of the clear water.

“These proportions of ice and water are confined to the frazil alone, and do not include the solid-ice covering of the river, which, weighed down by snow, thaw, and rain, is thereby depressed below winter water-level, and by so much encroaches on the discharge at its widest point. In these comparative quantities no account is taken of the water with which the frazil is saturated when suspended in the channel and underlaid with clear water. When grounded and compressed by the weight of the solid ice overhead, little water can penetrate it, and this grounding is shown by ‘hummocks’ on the river surface where the frazil is holding up the crust when elsewhere it has been lowered by the falling of the water.

“The greatest depth of frazil below Montreal was found immediately opposite Longue Pointe. Here the downward growth from the under side of the solid-ice covering of the river extended to a depth of thirty-five feet. It was found nearly as deep at the foot of the Lachine Rapids. In these cases it reaches nearly to the bottom, but, of course, not all the way across the channel, otherwise the river would be driven out of its banks. Opposite this great ‘undergrowth’ at Longue Pointe the main channel is about sixty feet deep, overhung with about twenty feet of frazil, but having a clear waterway under it nearly forty feet deep, through which it finds relief. That this downward growth of frazil is, in the situations most favorable for its accommodation, only limited by the depth of water seems probable from the results of our soundings above Beauharnois, where the enormous winter run of frazil between Lake St. Francis and Lake St. Louis is arrested as soon as the latter is permanently closed. Here we found the undergrowth

over eighty feet deep and reaching within a few feet of the bottom" (see plate of cross sections).

"On the basis of our cross-sections the estimated quantity of frazil between the Lachine Rapids and Varennes, in March last, was two hundred and fifty-three million cubic yards. Besides this frazil, there were one hundred millions of cubic yards of surface-ice between the Lachine Rapids and Varennes, making a total of ice in this section exceeding three hundred and fifty millions of cubic yards. Of this amount two hundred and twenty millions were above the line between Moffatt's Island and Windmill Point, but as the ice went partially out of Lachine Basin before the flood and shoved in front of the city, about half of this two hundred and twenty millions of cubic yards must have slipped down below Ile Ronde before the ice-bridge gave way, and thus contributed to the flood of April last. The quantities of March, 1887, were probably in excess of average winters; but our investigation of temperature shows as severe winters not followed by flood. There may have been as great, or even greater, quantities of frazil in some non-flood years, when it was differently distributed, or when it moved off in different order.

"We endeavored to ascertain whether there was any diminution of this body of frazil before the ice went out, for which purpose it was remeasured up to the last day on which it could be safely done. Warmer land-water is coming in, it may be weeks before the ice goes out, but apparently it had no effect upon the frazil or upon the channel-water, which maintained a temperature almost at the freezing-point to the last.

"Thus there was in April last, during the flood, about three millions of cubic yards of ice massed in that portion of the river extending from Montreal to Varennes, forcing the river to rise over nine feet higher than when the ice-bridge formed at Hoche-

laga in the end of December, 1886. Probably one third of this total had been let down below St. Helen's Island from that portion of the river between it and the Lachine Rapids, which contained over two hundred millions of cubic yards of ice. This was an obstruction compared with which St. Helen's Island, Ile Ronde, and Moffatt's Island are insignificant. The whole cubical contents of these islands above low-water mark is under twelve millions of cubic yards.

"This ice obstruction causes the river to rise until its increased sectional area and additional head give the necessary discharge, and, whereas the river, when not burdened with ice, varies its sectional area, surface slope, and velocity, as it narrows or widens, shoals or deepens, we find that when congested with ice, with all lengths of cross-sections and all depths of frazil, there was remarkable uniformity in the area of the free water-way left, everywhere between Lachine Rapids and Varannes. The river evidently disposes of the down-coming frazil, where it will be least in the way. A very large proportion of that we found in March, perhaps the greater portion, had been carried down there after the ice-bridge was formed. All through the winter we found from observations at the air-holes that frazil was passing down below the city. This undoubtedly had come over the Lachine Rapids and had gone through the whole length of the Laprairie Basin. How far it travels from Montreal we cannot determine. It probably follows the main-channel current until it is wheeled out of line by some eddy or counter-current, and is thrown into lower water, where it will be allowed time enough to attach itself to the ice overhead. There is no means of getting current velocities under the frazil, but the presumption is that when this encroaches upon the channel to a certain extent, the local current is quickened and no more frazil allowed to stop there. In whatever way it is done the cross-sections prove that the river, like a judicious

stevedore, disposes of the frazil as it arrives, and so places it as to maintain a thoroughfare for its water.

"Uniformity of water-section suggests uniformity of current during this state of ice congestion, which we know does not exist when the river is free from ice. The summer current opposite Montreal is much stronger than it is in the Laprairie Basin above or in the river below Hochelaga. The one is reduced and the other increased by the ice-pack, and it is owing to this increase of current in Laprairie Basin chiefly that so much frazil is carried down below Montreal and so far below that city.

"The sources from which this enormous amount of frazil is derived are. first, the whole river above Montreal until Lake St. Louis is closed, then the river-section below this lake as far as Laprairie Basin, with its twenty-nine square miles of water surface, nineteen square miles of which remained open until the ice-pack from below ascended to the Victoria Bridge. After this space is filled up with ice the open area from the foot of the Lachine Rapids to Lake St. Louis above Ile Dorval, containing about twelve square miles, remains open all winter. Lake St. Francis is permanently closed in December, but the fifteen square miles of open water between it and Lake St. Louis sends down the frazil in such quantities that the channel opposite Beauharnois is blocked, raising the water about thirteen feet, the flow of the Ottawa River on the Vaudreuil side of Ile Perrot is stopped, the current reversed, and large quantities of St. Lawrence water pour into the Lake of Two Mountains, some of which flows down the Back River (the main stream of the Ottawa), and re-enters the St. Lawrence at Bout de l'Ile, fifteen miles below Montreal." (Compare plate of cross-sections.)

Mr. T. C. Keefer, C.M.G., C.E., in his presidential address before Section III of the Royal Society of Canada in 1898, took as his subject, "Ice-floods and Winter Navigation of the

Lower St. Lawrence." No one is more competent to speak to us on the subject of the ice problem than Mr. Keefer, whose vast experience in handling the matter has won for him the greatest praise. As one of the prominent engineers of the Flood Commission, he aided in bringing about a most complete understanding of the conditions giving rise to the floods, we have already described, out of which have developed effective methods of prevention.

The illustrations which I have reproduced of the ice-shoves in the harbor of Montreal (Figs. 22 and 23) were taken, by the kindness of Mr. Keefer, from his report. The destructive action of these piles of ice have been now completely removed by the construction of the guard-pier, which is a long narrow artificial island, placed in the middle of the river opposite the harbor, and turns the main current of the river away from the city.

Mr. Keefer devotes a section of his paper to the subject of anchor-ice, and in this we find what he terms a supplement to the paper by Dr. Bell, which we have already referred to. The points brought out are so important that I cannot do better than reproduce them here. "1. The greater formation of anchor-ice, both in area and thickness, is often in the deeper open water above the rapids. In the shallower rapids it forms and rises more frequently, and in less severe frosts, probably because radiation is more rapid and sun penetration greater in shoal than in deep water, and from the more rapid flow of the ice-cold water chilling the stony bottom. In long-continued, extremely cold spells of several days' duration it may grow, in a rapid, to a very considerable depth and form a dam, raising the whole water-surface. When this gives way we are not able to say whether it has yielded before the increased head of water, or from the relaxation of its hold upon mother earth, which follows a change of temperature.

"2. It has been known to continue for days and nights on

the bottom and attain great thickness, without a clear sky overhead, but with the thermometer always below zero, Fahr.'

"3. The very large boulders which are picked off the shoals below the rapids and dropped in the ship-channel below Montreal are lifted (I believe) by anchor-ice lodged under the surface-ice. By the sudden, and often considerable, elevation of the field-ice to which it is attached (which may be caused by a 'shove' before the river 'takes' in January), the whole may be driven upon or over a boulder shoal and settle down with the falling water enveloping a boulder with its saturated slush, out of which all water is expressed, by downward pressure of the surface-ice, during the winter fall of river-level and thus form a solid mass. These icy 'islands' are seen as 'hummocks' after the winter lowering of the river, when the compressed anchor-ice beneath holds up the surface-ice much above the water-level. When the whole field is lifted by the spring rise of water the boulder accompanies it (a mere pebble in proportion to the size and lifting-power of acres of ice perhaps twenty feet thick in some places), and is dropped as soon as warmer water in the river releases it from its icy matrix.

"4. It is not only 'in the rapids,' but everywhere where there is open water in the river, that the colder surface-water is carried to the bottom. Anchor-ice has been found at least two feet in depth on the bottom in over twenty feet of water in the river above the Lachine Rapids. This is only during the severest weather. Although the temperature of the water may not descend perceptibly below the freezing-point, while that of the air is over twenty below zero, it is under these circumstances this deep river-bottom produces anchor-ice, and when this ice rises, as it does in floes of considerable size, it does so with decided force from such a depth, projecting its top into the air and falling back with a hissing sound due to the rapid drainage of its above-water portion. It is also known

that at the time of this formation upon the river-bottom, the flowing water is loaded with fine ice-crystals (to the formation of which, I think, the cold surface-air is a necessary factor) and, as these are carried to the bottom, the presumption is that they are picked up by a condition of river-bottom which does not exist at other times, which, if not actually frozen, has this power of attraction for these passing crystals by which alone, I believe, anchor-ice is formed. Whether the river-bottom is frozen by radiation into space or into an intensely cold atmosphere at the surface of the water, or whether this is produced by the continued friction of an ice-laden current of the coldest possible water, the result is the same and is fortunately limited to short and infrequent periods of severe winters.

“After the spring break-up, when large masses of ice are driven ashore by the final ‘shove,’ ice-floes have been found on the beach, partly composed of several feet of anchor-ice, to the bottom of which frozen gravel was attached.”

A most interesting observation is reported by Mr. Keefer, which illustrates the immense growth of frazil-crystals in the water during a very cold day. He describes crossing over the river below the Lachine Rapids in an open boat, when the thermometer was twenty below zero, Fahrenheit, and noticing the frazil-ice spiculæ so thick that their resistance to the paddle could be felt, and when the paddle was withdrawn the needle-like spiculæ stood out at right angles to it. The crystals seemed to be attached only by the point, like iron-filings to a magnet.

During this time the river must have been slightly under-cooled and the frazil forming rapidly. The constant withdrawing of the paddle into the cold atmosphere chilled it to such an extent that these crystals at once attached themselves, and grew to considerable dimensions.

Mr. Keefer refers to the disastrous effects of anchor-ice, during a winter of great severity, in driving a river out of its

bed, and this, he thinks, accounts for some of the "ancient channels," "lost channels," and "high-water channels" to be found near some cataracts and rapids.

He draws attention to the yearly closing of the outlet of the St. Lawrence at the head of Lake St. Louis by the frazil manufactured in the Cedar Rapids (compare p. 219), and the consequent overflow of the St. Lawrence around the head of Ile Perrot into the channel of the Ottawa. This is noticed every year by Montrealers, who comment on the clear qualities of the water supplied by the water-works in February and March, as contrasted to the water at other times. The Ottawa, flowing into Lake St. Louis, passes down the river by the north bank, and supplies the aqueduct at the head of the Lachine Rapids. During the winter the Ottawa is compelled to pass almost entirely by the channel to the north of the Island of Montreal, known as the Back River, while its place is taken, along the north shore, by the St. Lawrence flowing around Ile Perrot. Thus the aqueduct is fed by the clear blue waters of this river during the greater part of the winter months. The waters of the two rivers are so different that, in summer, the line of separation may readily be seen. The blue waters of the St. Lawrence pass the south shore, and the brown waters of the Ottawa the north shore, before they become mixed farther down.

Depth of Formation of Anchor-ice in Fresh and Salt Water.

—The depth to which anchor-ice will grow seems to be about the same in the clear waters of the ocean, according to the observations recorded by Captain Robert F. Scott, in his "Voyage of the Discovery," as we observe it in our northern rivers. In his log of September 12th, 1902, we find that his attention was drawn to the fact that his nets and ropes, whilst under water, became coated over with ice-crystals. He describes it as "a very curious phenomenon." One line, only an inch in circumference, was pulled up covered with a cylinder of flaky

ice nearly a foot in diameter. This cylinder of attached ice extended five or six fathoms (30 to 36 feet) below the surface, after which it gradually dwindled away. Captain Scott describes the ice as very delicate and of a flaky structure, the axes of the leaves being at right angles to the rope, while their planes were inclined and intersected at an angle of crystallization of 60° . The whole thing, he says, "looks like some beautiful lace fabric, and, held up to the light, we can see through it the most gorgeous prismatic coloring. It falls to pieces at a touch, and each leaf can be split to the thinnest layers." The likeness to anchor-ice, as we observe it, is at once apparent.

He further describes similar crystals formed on the tow-nets, where each minute fibre forms a nucleus for the ice to grow around.

Temperatures were taken of the water at the time, which indicated something below the freezing-point of the salt water, but he did not place much reliance on these readings, for he says, "I do not know that they (the temperatures) are very reliable for such small differences." At a later date he states that the explanation was given to him as due to the supercooling of the sea, when ice would form around nuclei, such as the ropes and nets, "just as a saturated solution can be made to crystallize." "In this light," he says, "it would be natural enough that the effect should increase as the water grew colder towards the spring, and it is interesting to note that Hodgson found that at one time these crystals formed as deep as 17 fathoms (102 feet) below the surface."

It is quite possible that the open sea, not being affected by currents of any magnitude nor agitated in its depth, might become supercooled, but with the presence of so much ice it is difficult to imagine it so. Captain Scott's most frequent observations were made of the flaky ice which diminished beyond 40 feet, which is quite in accord with the data we have in regard

to non-formation of anchor-ice beyond 40 or 45 feet in our rivers. If radiation played no part in the formation of the ice around his ropes and nets, then it is difficult to see why the ice should not form beyond this depth if it grows in the way he suggests. It is possible that the sea was above the freezing-point at these depths, but there is certainly a close agreement with well-existing data for anchor-ice. The one observation of ice at 102 feet is very interesting, but this was not observed by Captain Scott personally.

It was pointed out by Sir Wm. Dawson, in the discussion of Henshaw's paper on page 210, that on the coast of Newfoundland anchor-ice is known to grow in large masses at a depth of 60 or 70 feet in the sea. This compares with the observation of ice at a depth of 102 feet. Sea water is usually very clear, and will permit of the transmission of radiant heat from a greater depth than in the case of the more turbulent waters of a river.

To account for anchor-ice and the fact that spongy masses of frazil crystals float low in the water, it has been suggested that the density of these forms of ice was greater than normal. The production of a very dense ice that apparently sank in the water of an ordinary cryophorus was recorded by Professor John Cox in 1902. All efforts, however, by the author to repeat this interesting observation were unsuccessful. Experiments made of the density of frazil-ice, directly withdrawn from the water, which were made by Mr. John R. Freeman, yielded in every case normal results. This taken in connection with the known buoyancy of anchor-ice leaves little doubt that the ice which is commonly met with in nature is of ordinary density.

CHAPTER VIII.

METHODS OF OVERCOMING THE ICE PROBLEM IN ENGINEERING WORK.

Construction and Situation of Power-works. When a Surface-sheet is Valuable and when not. Vulnerable Spots in a Power-house. Artificial Heating and Steam-injection. Electric Heating of Racks. Effect of Head of Water. Effect of Rapid Fall on Temperature Conditions. Volume of Ice Formed by Radiation. Erosive Velocity of Water and its Probable Effect on Anchor-ice Formation.

It is my intention now to devote some space to a consideration of the various methods which have been resorted to from time to time, to overcome the bad effects resulting from the excessive production of ice, in a few of the cases which have come under my notice. It is generally not a difficult matter to find out precisely the nature of the ice troubles in the case of most of the big hydraulic works, for, as a rule, they are affected in well defined spots. I believe that by a careful study of the problem it will be possible to so temper the effects of the ice that little or no difficulty need be encountered, but the need of all the evidence available is obvious. Changes of climate, however, bring about variations of the conditions in any locality, which complicate the problem as it is presented to the engineer. It is only by gathering experience, and interpreting such experience in the light of our present knowledge of ice formation, that we may expect to do the most good, and I hope that it will be no longer necessary for water-power users to view with alarm the advent of cold weather with its consequent production of frazil.

It is now universally recognized that, when possible, the water at the intake of a power-house should be covered by a layer of surface-ice. The ideal condition for this is when works are supplied by water from a river completely frozen over. The most effective prevention to the formation of both frazil and anchor-ice is the protection afforded by a surface-sheet, and under these conditions no trouble need be expected. This condition may not always hold, however, if there are stretches of open water situated in the river above the surface-ice. In all open waterways large quantities of frazil and, during mild weather, anchor-ice are carried down by the currents under the surface-sheet, and deposited along the under side of the ice. An excessive accumulation of this undergrowth may result in either the stoppage of the channel, or a very serious reduction of the volume of water conveyed. Ice-shoves, or flooding, may occur and so alter the head of water at the power-house as to temporarily cause inconvenience or loss. This contingency must be carefully considered in the location of any power-plant, where a temporary shutting-down of the works means delay to others depending on them.

When located at the foot of rapids, or at the head of a rapid with a stretch of open water above, means should be taken to construct a headrace of sufficient magnitude to serve as a settling-basin for the ice drawn in. Even in this case, the greatest judgment must be exercised, in order that the headrace may not become blocked at the mouth by frazil. I have personal experience of such cases, where a channel has to be blasted in the surface-sheet in order to allow of sufficient current for the turbines during the severest weather. Men are kept at work during such time clearing out the frazil from the channel in order that it may not close again.

The construction of booms, or cribwork, at the intake of such a channel may serve to deflect much of the ice. A large

power company, situated near Montreal at the Lachine Rapids, has successfully employed such construction. In the accompanying photograph (Fig. 31) will be seen a channel which is kept open by artificial means by men constantly employed to clear the sides of ice by axes and blasting, and where the frazil, which has been drawn in at the intake, continually accumulates along the under side of the surface-sheet fringing the edges. Blasting is resorted to, as will be seen by the efforts of



FIG. 31.—Artificial channel blasted through the head-race of a large Power Company to allow of sufficient water-flow.

men (Fig. 32) to dislodge a block of ice cracked off by the force of the explosion immediately underneath. So deep and thick is the frazil that it is with great difficulty the block is pried off, and it is buoyed up by this spongy ice much beyond its natural state. Even after this block has been sent floating down with the stream, long bars are necessary to scoop up the frazil still remaining attached to the masses adhering further down in the water.

It will take but a single cold night to completely cover the

channel with surface-formed ice, so that men are kept at work continually blasting the edges of the ice, and paring with axes.

A long narrow canal, which is fed from a stretch of open water or rapids, is one of the most troublesome of all forms of construction. We cannot hope to draw in water separated from frazil under such circumstances, and every means should be provided to pass it on as quickly as possible. A surface-



FIG. 32.—Blasting Operation. Men prying off lump which has been cracked off by blast. Frazil underneath.

covering is only useful for preventing the ice forming. If it has formed, then the addition of a little more can do no further harm, and the ice-sheet is not only useless but detrimental in forming a means for the massing of the crystals into lumps. It is much better not to have a covering at all than one which will act as a filter for the ice-laden water.

Although a power-house may be most conveniently located at the base of a river normally frozen over, there are times when the ice problem may become very serious. One of the

worst times is the interval before the surface-ice permanently forms in the early winter, when the water has dropped to zero and a sudden cold dip, with high wind, produces a choppy surface and plenty of fine frazil-ice. This condition may not occur every year, and yet means must be taken to handle the ice should such a contingency arise. The best way to treat such a state of affairs is to handle the ice at the power-house and pass the frazil through, after rendering it harmless by artificial heat, either in the racks, or directly in the turbines, or both. This expedient, although at first sight seeming impossible, on account of the large amount of energy required to warm water, is, I thoroughly believe, a practical one, and one which I have long wanted to see put in practice. When we remember that a thousandth of a degree is often sufficient to stop the formation of ice and prevent its adherence to surrounding objects, a simple calculation will show that an artificial heating-plant is quite within the realms of possibility. We do not need to warm the entire volume of water which passes through the wheel-house, that would be an absurd notion, nor could we cope with Nature in such a way, but we can apply the heat where it is needed, and by so doing prevent the first ice-crystals from gaining a foothold. It does not take long for the crystals to build up an impenetrable barrier when once the first layer of ice has adhered to the gates, racks, or metal surfaces of the wheels.

It happens that a large number of power-houses have continually to meet the ice trouble whenever cold weather arrives, since the presence of rapids or open water above supplies the necessary frazil. Such plants should be supplied with a heating system, which can be turned on at once to the affected spots.

We can place the most vulnerable spots in a power-house at the gates, the rack used for removing logs or wood from the water, and the wheel itself.

In the first, a freezing of the gates may prevent them from

being closed when necessary. This occurs all too frequently, and I have in mind a large power company that recently lost a unit, which ran away on the refusal of the gates to close. Enough damage was then done to pay many times over the cost of a heating-plant. Usually salt is applied in large quantities to the frozen parts, or they are left alone until they remedy themselves, as is usually the case when the conditions change and the water rises slightly in temperature (perhaps only two or three thousandths of a degree). The greatest agent in thawing out a frozen gate is the direct action of the sun, whose influence may be seen to be that of the absorption of the heat-rays in the water, thus acting around the affected part. Probably it raises the temperature of the metal surfaces the necessary amount to cause the loosely adhering masses of frazil to break away.

The racks are a continual source of trouble, and men are usually kept busy cleaning them off with long rakes. During the severest weather this is sometimes not effective, and a complete block of the waterway results. Usually the racks are metal bars passing into the water and freely exposed to the cold air. Such a construction is to be avoided under all circumstances, unless the ends of the rack can be made so as to protrude under cover in a warm atmosphere, or be artificially heated. In this case they are a decided advantage.

When the frazil is in the agglomerating state, and ready to adhere to everything in its path which is also below the freezing-point, the long iron bars of the rack act as a magnet to iron-filings, and the frazil-crystals soon mass about them. So firm do they freeze that they cannot be dislodged while the cold weather lasts without temporarily shutting down, and cleaning off with salt.

I have a photograph (Fig. 33) of a rack which shows the massing of the ice about the bars. It was taken in the morning

after a cold night, when the rack was completely blocked by frazil. The shutting-down of the plant resulted, and, as several other plants were similarly affected, the water rose and almost covered the rack completely, depositing frazil nearly to the top. The air temperature at the time of the photograph, 11 A.M. of the morning following, was 20° Fahr., but the sun was shining brightly. It will be observed that the ice no longer holds to the rack, for a clear line is visible along the water's edge. The effect of the sun on the water is well shown, and was the successful agent in relieving the situation.

The two following photographs (Figs. 34 and 35) show a method of heating which has been successfully applied at the Ottawa Electric Company's No. 1 power-house, and was designed and placed by Mr. John Murphy, late mechanical superintendent and now electrical engineer to the Department of Railways and Canals, Ottawa, to whom I am indebted for the pictures. To my knowledge, Mr. Murphy is the first one to successfully apply such a method, and he deserves all the credit for demonstrating its applicability. The first photograph shows the line of steam-pipes laid against the face of the rack, which consists of parallel iron bars, $\frac{1}{8}$ inch thick and 18 feet long, with about two feet always above water. The second shows the insulating material, consisting of tar paper and grooved and tongued lumber, which was used. No trouble has been experienced since this method has been applied, and the ice caught by the rack may easily be cleaned off, since it is impossible for it to freeze to the iron bars.

Another method of preventing the accumulation of agglomerated ice in the wheel-pits has been applied by Mr. W. L. Bird, mechanical superintendent at the Lachine Hydraulic Works, with much success. During the winter the iron racks are removed, and the housing completely closed around the wheel-pits, and free access of heat allowed from the generator-rooms.

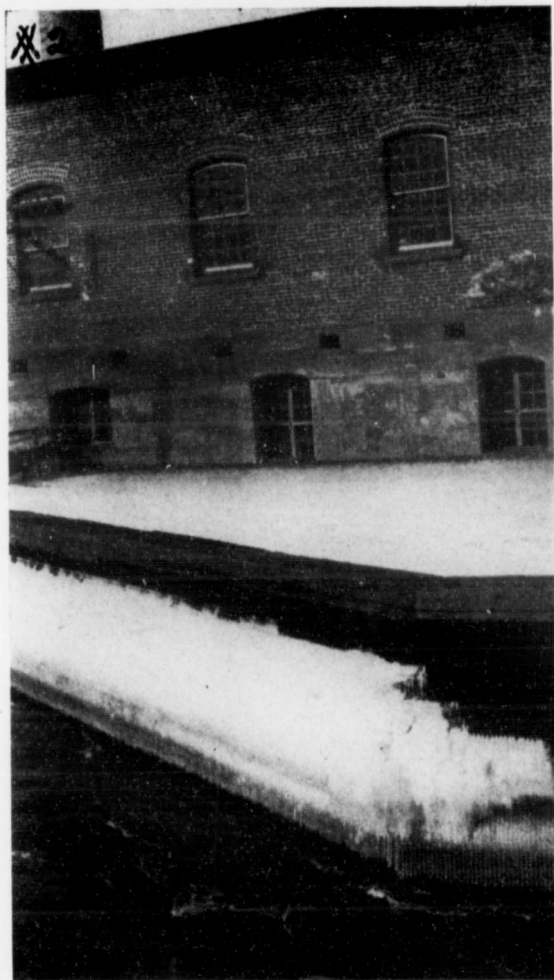
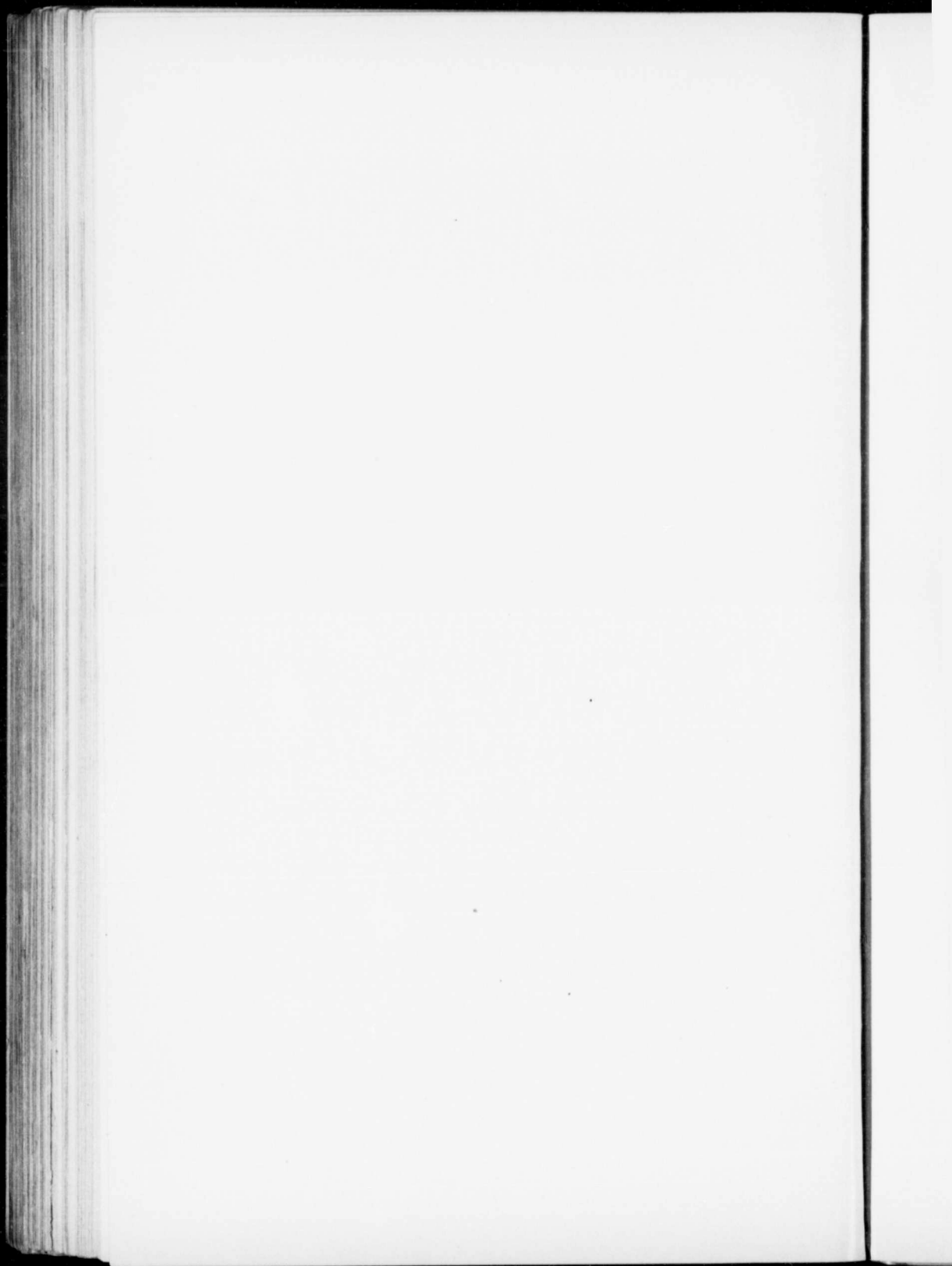

FIG. 33 —Iron Rack which has been submerged during the night previous by adhering Frazil stopping the flow. Large masses are seen still clinging to the bars.



The result is that no ice forms there, and ice drawn in may be passed directly through without agglomerating.

The Lachine Company has constructed a long head-race which freezes completely over, and at the intake, which is fed from a long stretch of open water, a boom is arranged so as to deflect most of the large floating ice down-stream. Thus such water as they use is drawn under 2000 feet or so of surface-

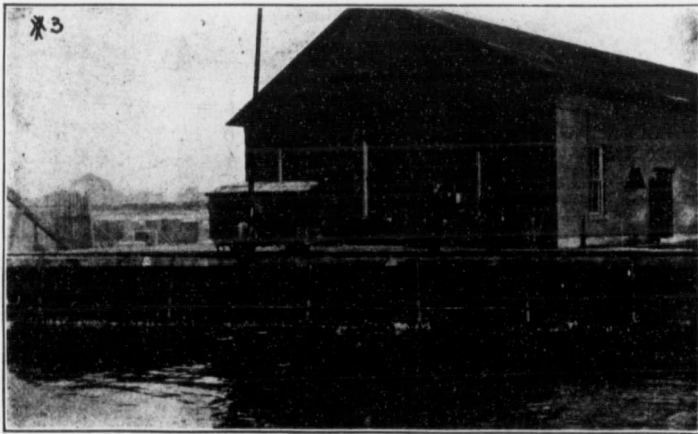

FIG. 34.—Horizontal steam-pipes shown in place on the same iron rack previous to lagging. Electric scraper shown for removing frazil from the rack.

ice, and is comparatively free of frazil when it reaches the power-house.

At the Ottawa Power Company's works the water is open, and large quantities of frazil are made in the rapids above the Chaudière Falls, which have to be passed through the turbines. It has been demonstrated by Mr. Murphy that this may be successfully accomplished in the severest weather, by a system of steam-injection.

The following photograph (Fig. 36) is taken of the interior of one of their penstocks or wheel-pits, after frazil had stopped

the operation of this set of wheels, and it was found necessary to shut out the water by putting in the stop-logs at the mouth of the penstocks. The picture was taken after more than one half of the frazil had been removed by men who were obliged to dig their way in. After the ice has been removed the wheel-gates have to be treated to a liberal application of salt, in order to render them free enough to operate.



FIG. 35.—Same iron rack heavily lagged with tar paper and wood over steam-pipes.

It is reported that on occasions a power user builds a fire out of oily waste and wood around the wheel-cases, in order to get them running again, otherwise the usual thing is to wait until the sun relieves the agglomerating masses. I am indebted to Mr. Murphy for a description of a method which he has devised, and patented for overcoming this trouble, and he assures me that since it has been put in operation not the slightest difficulty has been met with.

Fig. 37 shows the method of injecting steam into the water-wheel case. The object is the correct one of keeping the surface of the metal sufficiently warm to prevent the ice from attaching,

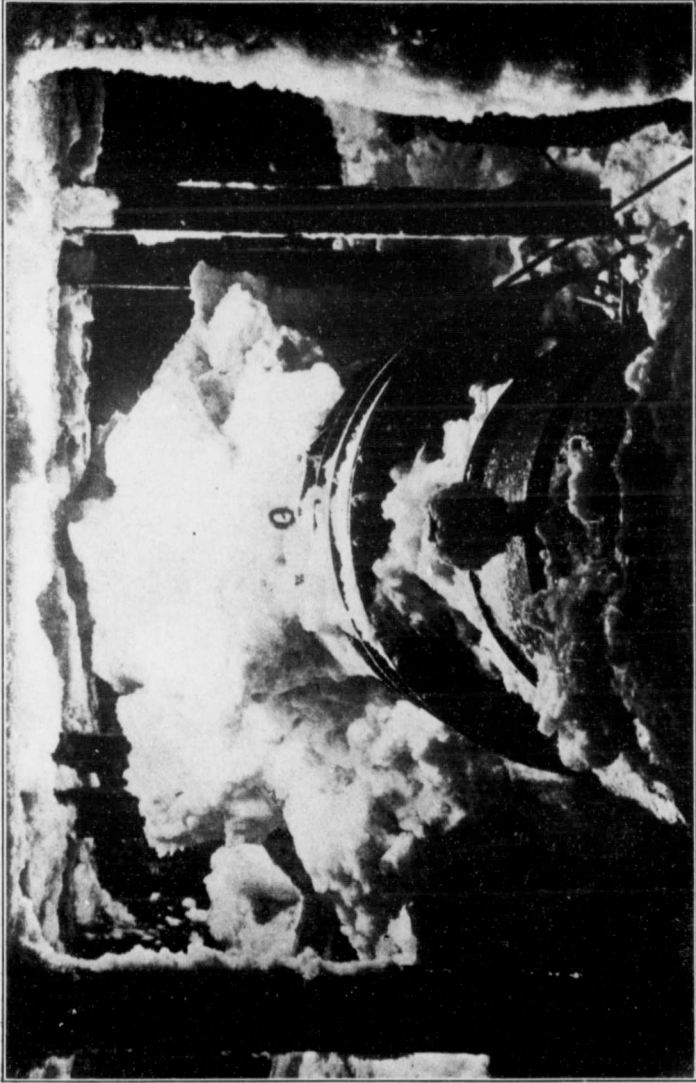
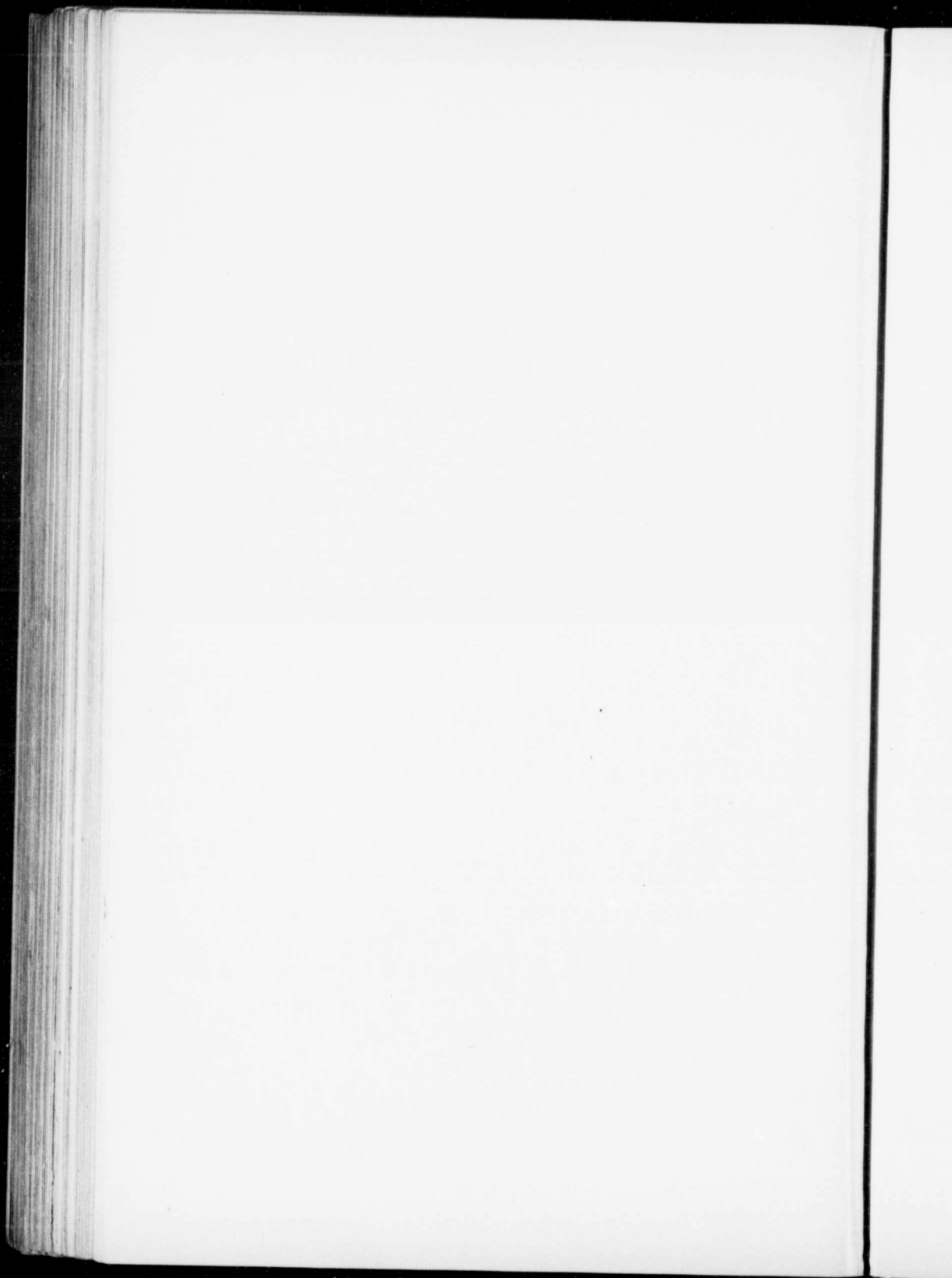

FIG. 36.—Penstock or Wheel-house which has been blocked by frazil drawn in through the racks. The ice has been mostly removed previous to the photograph.



or forming there. The steam-pipes are also run into the manhole covers or water-wheel domes, with which the cylinder-gates are

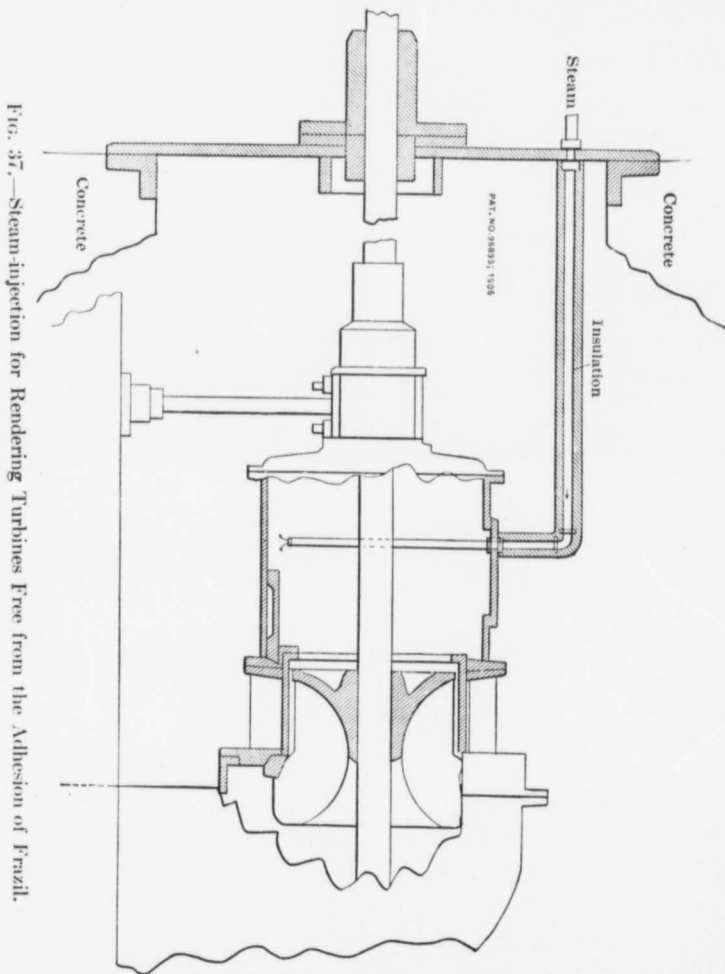

Fig. 37.—Steam injection for Rendering Turbines Free from the Adhesion of Frazil.

moved when they are opened. Steam is admitted when the gates begin to freeze, and immediate relief is always afforded.

Holes were bored through the end plates which serve the purpose of keeping the water in the penstocks from entering the power-house, and which also form the bearing through which the turbine-shaft runs, and through these holes steam-pipes were led. Steam is admitted when a unit begins to lose capacity, and normal load is picked up again within five minutes of the time of the admission of the steam. Water-wheels, which were shut down during the night when frazil was running in great quantities, have been started up as soon as steam was injected, in spite of the fact that the frazil had filled the penstock and settled on the wheel-cases, and blocked up the openings between the chutes. Mr. Murphy informs me that only twenty tons of coal have been used during four months of the past year, with eleven days of frazil fighting, as against one or two bad days in previous years, and that they have had a clean running sheet. All of this work has been done at the No. 1 power-house of the Ottawa Electric Company's central station, where there are three sets of horizontal turbines, each set consisting of three 39-inch wheels, operating under 30-foot head. The volume of water passed is about 100,000 cubic feet per minute. It was possible to turn steam into any set of wheels from the power-house at will, by means of globe-valves beside each set. An old horizontal boiler, rated from 20 to 35 H.P., was used to supply the steam.

It is not necessary to keep steam passing all the time, but only on such occasions, usually at night, when the frazil is agglomerating and in an adhesive state. The occasional injection of steam is often all that is necessary.

Experiments have been tried at the Ottawa Power Company on the electric heating of the racks. Mr. Murphy, in a personal letter to me, thus describes his tests, which he kindly informs me I am at liberty to make use of, together with other information which has proved most useful and instructive.

"We have made with a couple of bars of the rack the following trials." (The rack is the same one subjected to the steam-tests.) "They (the bars) were covered with hard ice above the water-line, and also for a short distance below it. Two heavy iron wedges, used as 'terminals,' were driven between them—care being taken not to crack the ice—and current from an exciter sent through the bars. Ten minutes after the current was started the ice was removed with a pocket-knife, while the adjacent bars could only be cleaned with much difficulty with a heavy chisel. 600 amperes at 0.3 volt, i.e., 180 watts, were used for this trial. The temperature of the air was just about the freezing-point, and so also was that of the water. Here I may mention that for the past two winters we daily took water temperatures with a registering thermometer, and persistently got for our pains nothing but 32° F. Another day when the air was at 15° F. ice was immediately melted from a single rack-bar by sending 500 amperes through it. Both of these trials went to show that if a small amount of energy was continuously applied to the bars, ice would not form on them, and that the amount of energy would be lessened very considerably if the bars were kept away from the cooling effect of the atmosphere."

There is doubtless much to be done in perfecting this artificial method of heating in order to meet all cases, but I am convinced more than ever, by the valuable results gained at the Ottawa Power Company's Works, that it will be possible to so temper the effects of frazil-ice as to render it harmless in a large majority of cases. It is too soon to say that the ice problem can be overcome in all cases. By patient investigation, and a better understanding of the conditions governing the formation, and disintegration of ice much has been accomplished, and there is every hope for the future. If we cannot cope with Nature in preventing the production of ice, by intelligent and

wise planning, we may expect its presence to be no longer a detriment to the water-power development of our country.

In conclusion, there are certain factors to be considered in the study of ice conditions, which may be shown to exert an important influence in Nature. The effect of pressure has a direct bearing on the question of the state of the ice at different hydraulic depths. We have seen in Chapter III that the effect of pressure is to lower the freezing-point of water. One hundred and fifty atmospheres lower it one degree centigrade. We see, then, that for every foot of immersion in the water the freezing-point is lowered 0.00022° Cent. or 0.0004° Fahr. At a depth of 5 feet the normal freezing temperature is one thousandth of a degree lower than at the surface, which is quite comparable with the undercooling observed in the water when the ice is agglomerating. This means that the undercooled layers, if submerged deep enough, would be at or near their freezing temperature. The ice-crystals, which on the surface would stick together from the fact of their being below their normal freezing temperature, would not stick together at a great depth. Radiation, however, being a volume effect, would not be influenced by this.

Undercooling in the water may be offset to a certain extent by a sudden fall. Water falling one foot is heated 0.0013° Fahr. or 0.0007° Cent. At the base of a waterfall, the water may acquire a considerable rise in temperature, although this is counteracted by the cooling effect of the air. In the case of a gradual fall the latter effect would be very much greater, and probably the former would never be noticed. It is a matter which requires some further experimental work before the precise influence could be determined. It should be borne in mind, however, and suggests some advantage in operating turbines under as high a head as possible.

Some simple calculations of the amount of ice formed by

radiation reveal the fact that under ordinary conditions, this must exert an important influence in the formation of ice. The calculations have to be based on assumptions which seldom hold rigidly in actual conditions. The mathematical treatment of radiation effects is exceedingly complicated, and can only be solved under special conditions. Generally we find that from a body of water at 32° Fahr., radiating heat to an atmosphere at 0° Fahr., only about four and one-half pounds of ice would be formed per square yard per hour. This would be in addition to the ice formed by purely surface-contact effects with the cold air. At night, if we consider the radiation into space at the absolute zero of temperature, we would find as much as eighty pounds per square yard per hour formed. Allowing for the absorption of the heat-rays by the water, as determined in Melloni's researches, we should find one inch of solid ice formed on the bed of the river in about six to six and one-half hours. We have seen, however, in Chapter II, that the water is much more transparent to the long heat-rays, and therefore such a calculation gives us an amount far too small, but even on the basis of an eleven per cent transmission, which Melloni found, a considerable amount of ice would be formed.

Calculation of the heat transmitted to the bed of a river by conduction alone from the earth, shows that in one hour, there would be enough to melt a layer of ice only a thousandth of an inch in thickness.

It would be an interesting experiment to measure the velocity of water in places where anchor-ice was known to grow, and to compare this with the known erosive action of water flowing over channel-beds of different materials. We know that anchor-ice sometimes forms on rocks rather than on sandy or gravelly beds within the immediate vicinity.

The following table I have taken from Professor H. T. Bovey's treatise on Hydraulics, p. 269:

Nature of Channel-bed.	Erosive Velocity of Water along Bottom in Feet per Second.
Soft and clayey soils.	0.26
Rich clay.	0.52
Firm sand.	1.02
Gravel.	2.30
Broken stone.	3.08
Soft schist.	4.90
Stratified rocks.	6.00
Hard rocks.	10.3

It is well known that velocities above 2 to 3 feet per second will prevent the formation of weeds. It seems likely that anchor-ice would have great difficulty in gaining a foothold along the bed of a river where the velocity exceeded the erosive velocity. Radiation might, however, accomplish this on hard or stratified rocks.

The question of the existence of a thin skin of stationary water on the surface over which water was flowing, is one upon which I have been unable to obtain reliable data. Some authorities assert that such does not exist. If it does, even to a minute extent, it would be subject to cooling effects of radiation and probably become frozen, thus forming the basis for the adherence of frazil-crystals in water flowing with considerable rapidity. Above the erosive velocity it is possible that a skin no longer exists. The existence of a skin seems very likely, so long as the water is flowing over the bottom in stream-lines.

There are doubtless questions of practical interest which I have overlooked in the preceding pages. I have endeavored to embrace as many of the points as possible which have been raised during the past few years, through correspondence and personal conversation with engineering friends, who have taken an interest in this work.

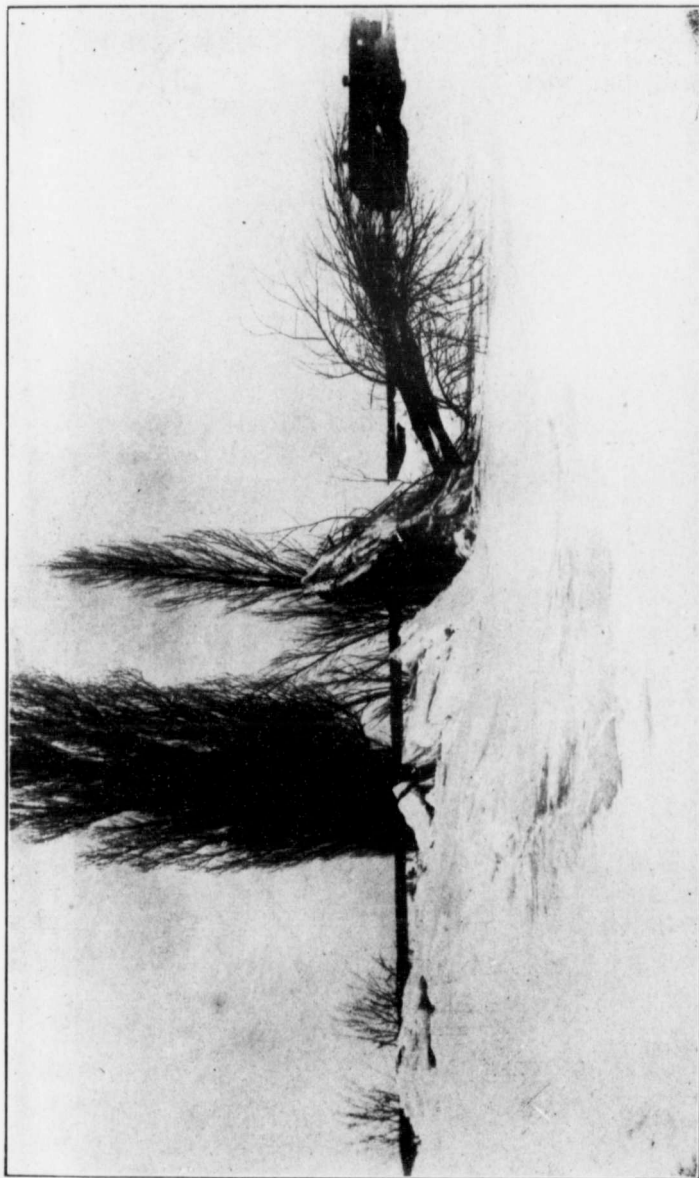
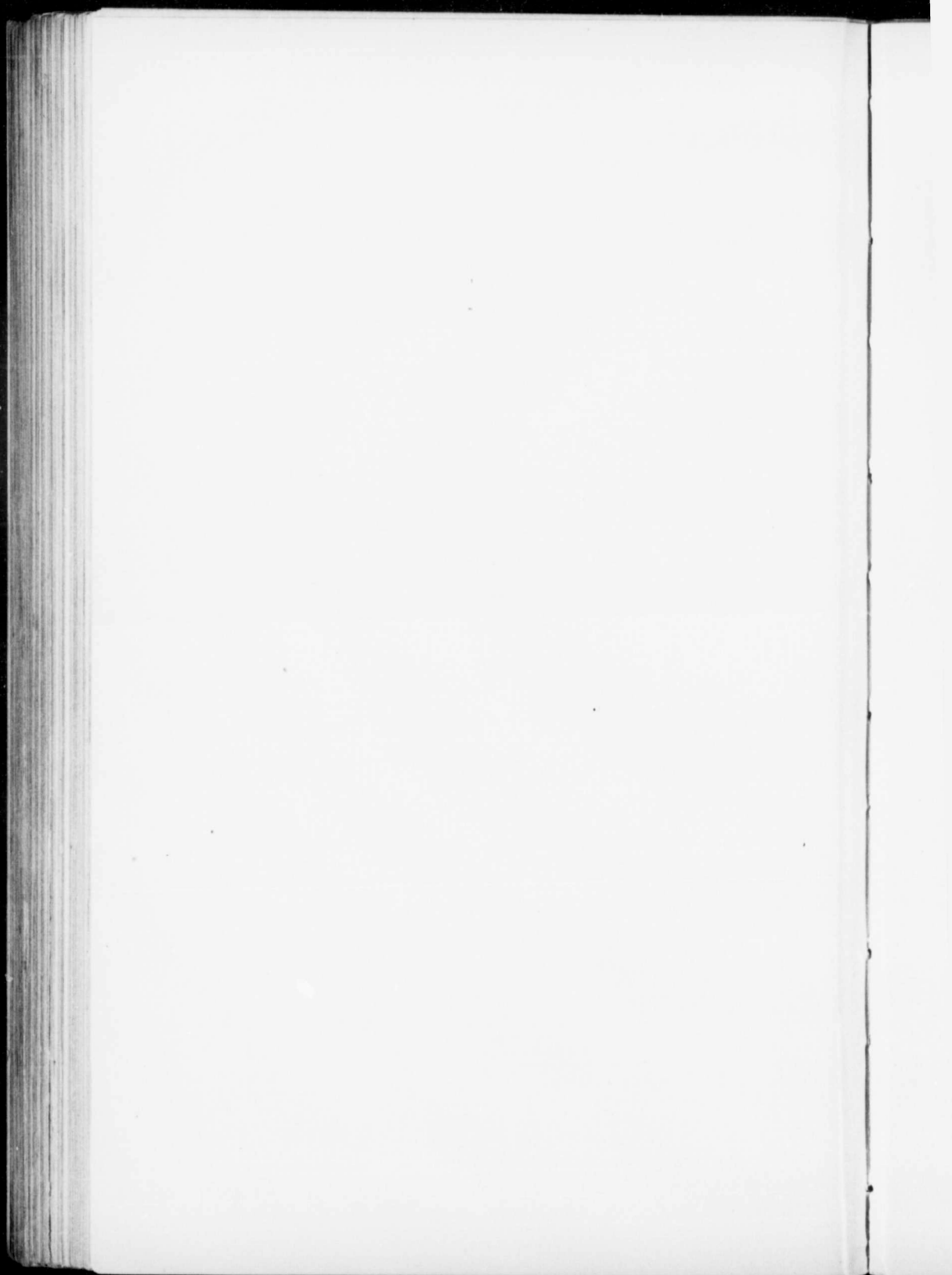

FIG. 38.—Effect of an Ice-shove from Accumulated Frazil below the Cedar Rapids, St. Lawrence River. Poplar-tree overturned on the bank of the river at the foot of Isle Perrot. (Compare Plate for location.)



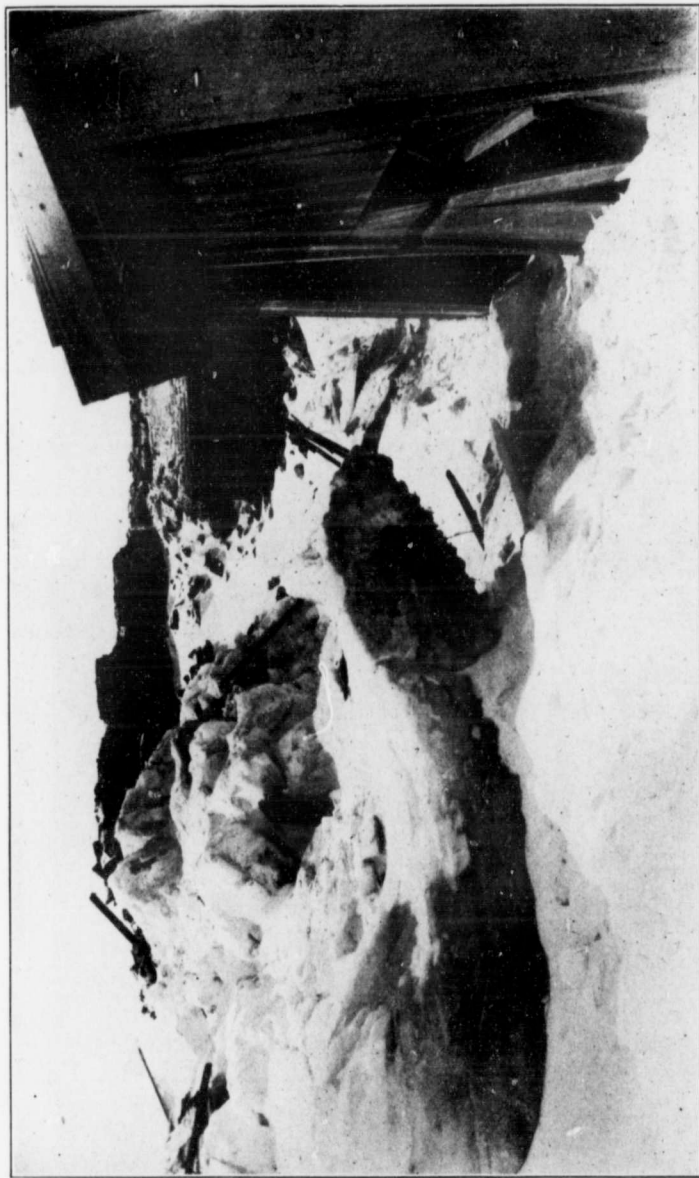
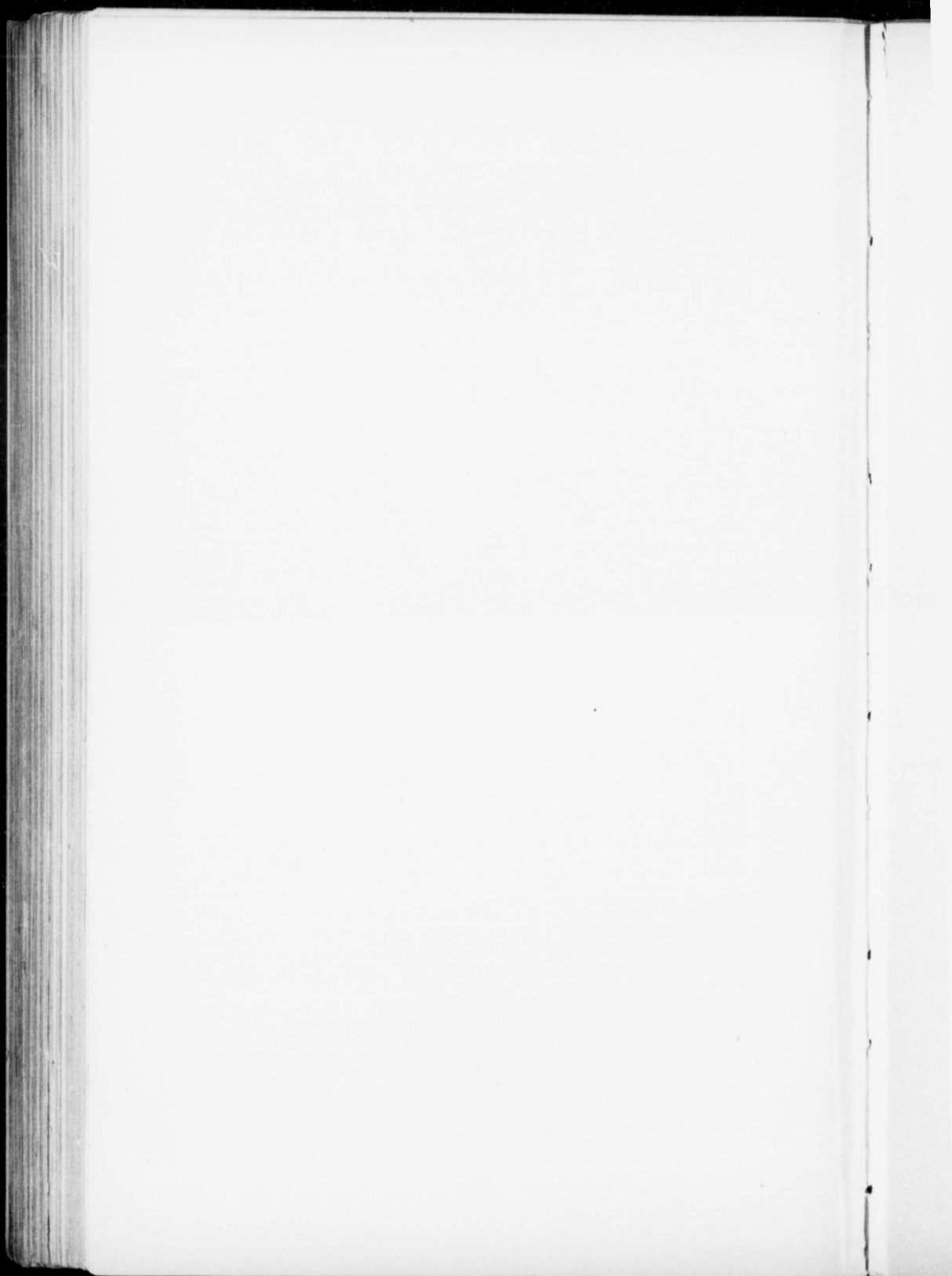

FIG. 39.—Farm-house overturned in a similar way by an ice-shove on the Banks of Isle Perrot, below the Cedar Rapids.
(Compare Plate.)



DESCRIPTION OF PLATE.

The four sections shown in the accompanying plate were taken from the Report of the Montreal Flood Commission, and were drawn from data obtained in elaborate soundings and measurements of the state of the ice between the head of Lake St. Louis and as far down as Varennes, twelve miles below Montreal. It will be observed that the Commission altered the word frazil by spelling it frasil. A map is added of Lake St. Louis, through which the direction of the two upper diagrams are shown. The waters of the St. Lawrence enter the lake through the Cedar Rapids, to the right of Ile Perrot, and it is here that the vast quantity of frazil-ice is made during the winter. The channel becomes completely blocked by the accumulation under the surface-ice of the lake, and the waters of the St. Lawrence are forced around the head of Ile Perrot into the channel of the Ottawa River at St. Anne. The longitudinal and cross-section both show the depth of accumulated frazil to a vertical scale of 60 feet to an inch, and a horizontal scale of 3000 feet to an inch. In some places the frazil was so dense that it was found impossible to reach the river-bottom.

The two lower diagrams illustrate the extent of accumulated frazil below the Lachine Rapids, which is manufactured in the water flowing out from the surface-ice, below Lake St. Louis in the open reach between this point and the barrier-ice at the foot of the rapids, a distance of 8 or 10 miles.

One diagram shows the general distribution of frazil com-

pared to the free waterway occupied by the swiftest currents, and the other is a typical longitudinal section drawn over the same track, showing the irregular massing of the ice-crystals. The City of Montreal lies between Victoria Bridge (Grand Trunk Railway entrance to city) and Hochelaga.

As an example of the devastation sometimes caused by an ice-shove, I reproduce two photographs, figs. 38 and 39, showing how the surface ice has been pushed over the banks by the force of the water in its endeavor to clear a channel for itself through the accumulation of frazil under the barrier ice. In one case a poplar tree was overturned, and in the other a farm house, situated near the shore, was demolished. These examples are the result of the masses of frazil which are shown in the first two sections of the plate. I am indebted to Dr. G. P. Girdwood for the excellent photographs.

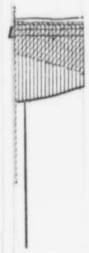
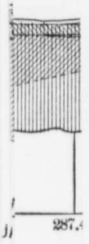

PLAN

SECTION

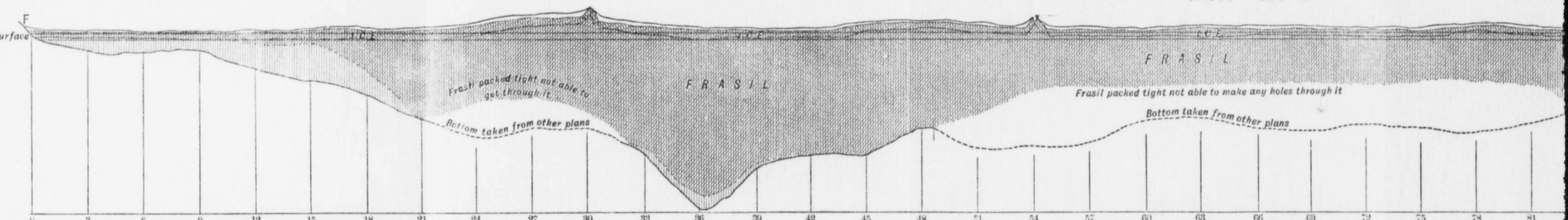
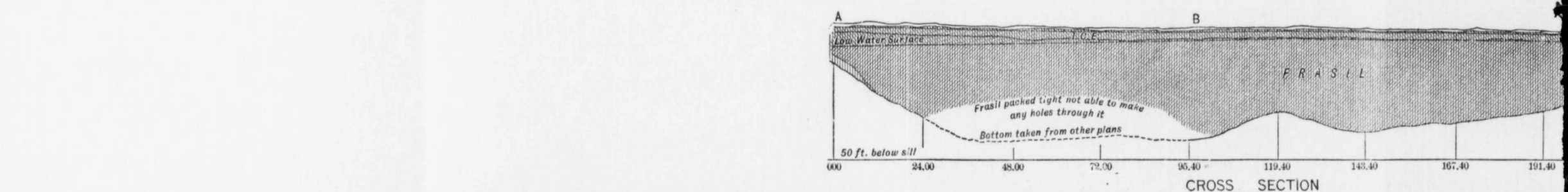
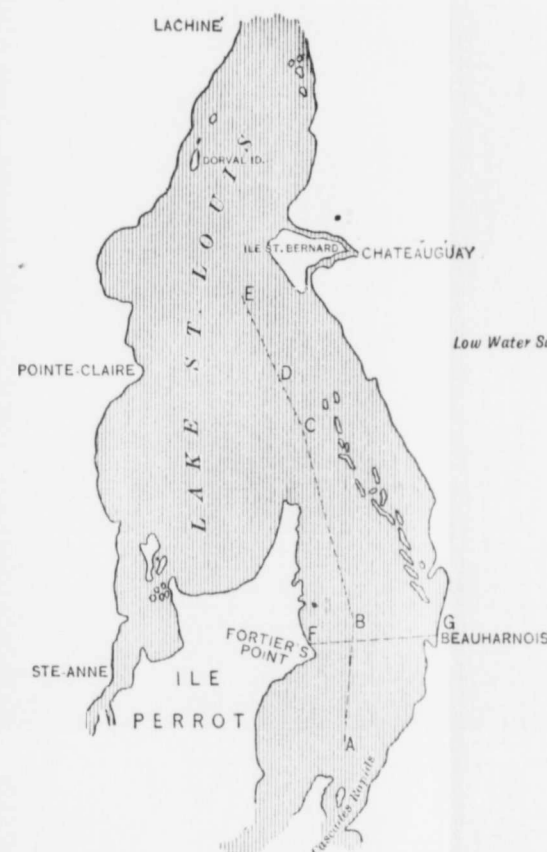

DIAGRAM SHOWING DISTRIBUTION OF FRASIL AND REMAINING FREE WATER WAY. MARCH 15TH 1887.

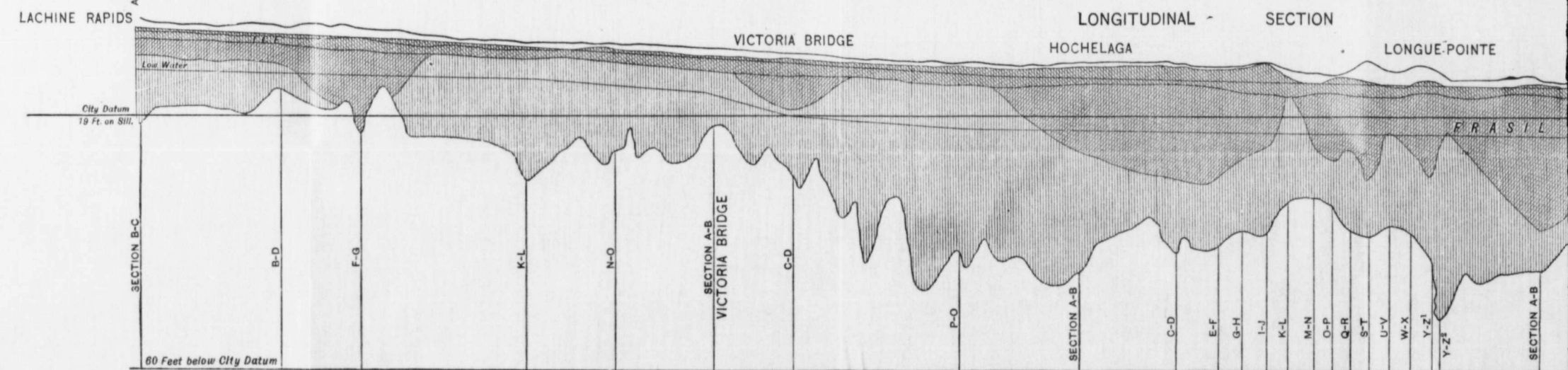
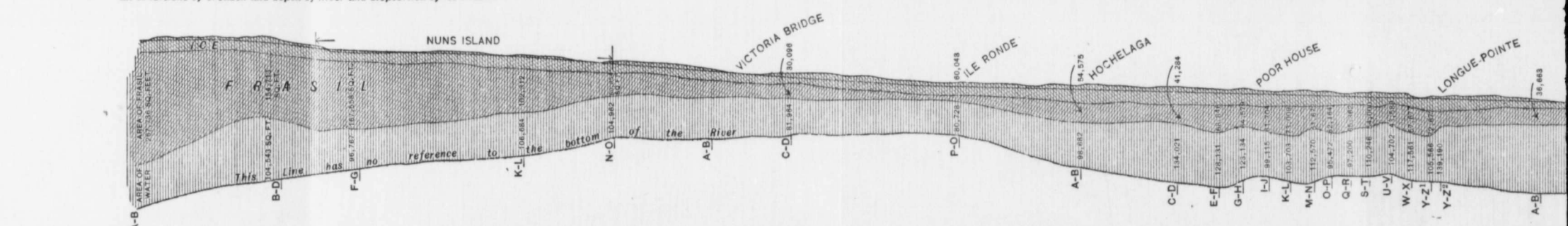

FIG. 40. Four sections of the St. Lawrence River in winter, showing the accumulations of frazil-ice under the surface-ice.

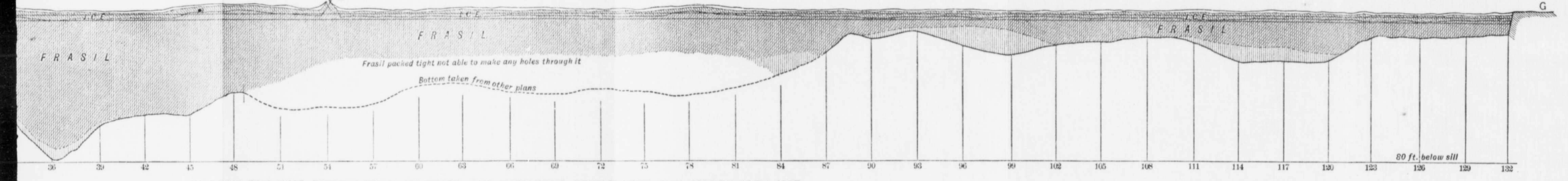

DIAGRAM SHOWING DISTRIBUTION OF FRASIL AND REMAINING FREE WATER WAY. MARCH 15TH 1887.

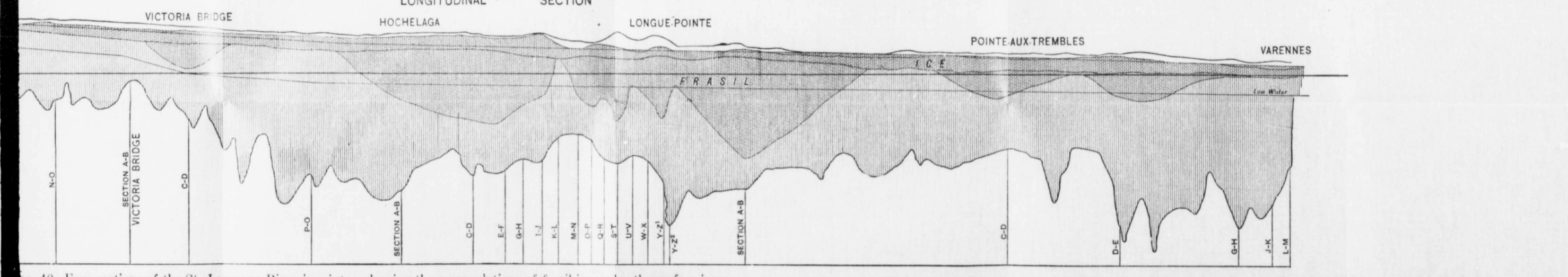
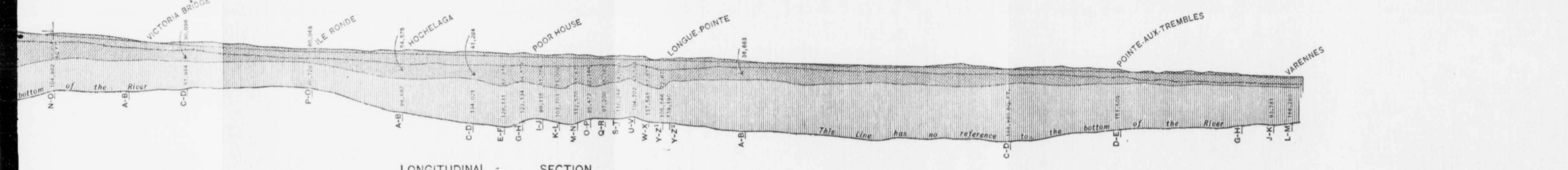
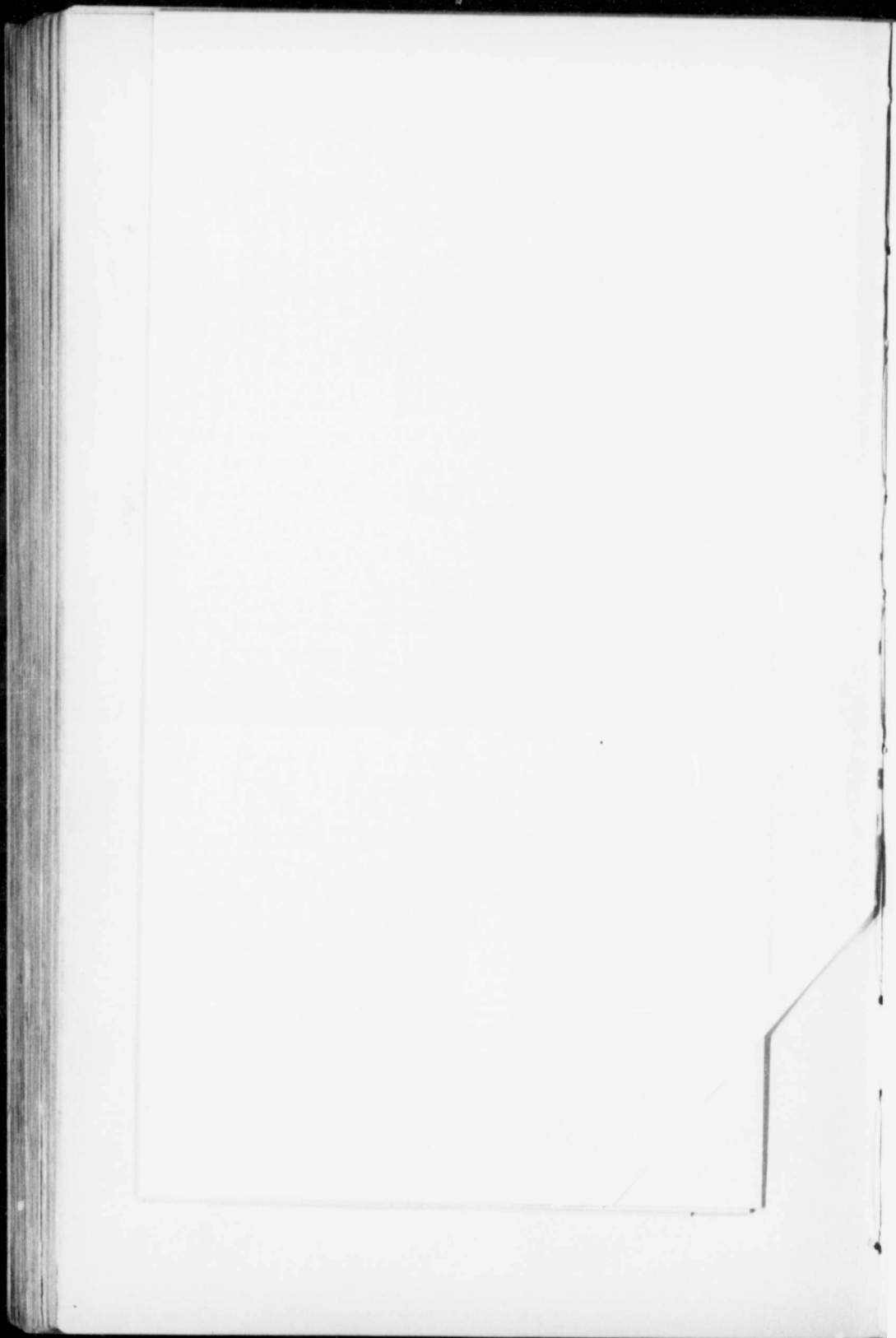

FIG. 40. Four sections of the St. Lawrence River in winter, showing the accumulations of frazil-ice under the surface-ice.



INDEX OF SUBJECTS.

- Absorption bands, 14
selective, 10
and transmission of heat, 10, 11, 12, 14, 15, 16
- Adhesion of frazil-ice, 230
- Anchor-ice, accumulation of, 215
appearance of, 113, 190, 204, 207, 212, 213, 224
buoyancy of, 107, 112, 135, 150, 207, 208, 212, 214, 221, 225
depth of formation of, 209, 210, 211, 212, 223
distinguished from frazil, 108, 109, 110, 185, 204, 208, 209, 212
effect of, on river channels, 2, 222, 223
formation of, 106, 108, 109, 110, 111, 168, 201, 207, 208, 220, 244
melted by heat of earth, 243
radiation the cause of, 108, 111, 113, 170, 171, 172, 181, 184, 187,
190, 193, 199, 200, 203, 206, 208, 209, 210, 222, 225
theories of, 186, 201, 202, 208, 209, 210, 211, 213, 220
value of a surface sheet in preventing the formation of, 113,
182, 183
- Artificial channel in surface-ice, 227, 228
heat applied to frazil-ice, 230
production of frazil-ice, 104, 177
- Athermancy, 10
- Bending moment of ice, 70
- Black-body radiation, 9, 17, 18, 19
- Blasting an ice-channel, 228
- Booms to deflect frazil-ice, 227, 235
- Bordage-ice, 132 (see also Border-ice)
- Border-ice, 99
- Bottom-ice, 106
- Boundary curves of ice, water, and vapor, 93
- Bridge, ice, 126, 134, 135
- Bunsen ice calorimeter, 48, 87
- Calorimeter, Bunsen ice, 48, 87
Lavoisier and Laplace's, 47

- Capacity for heat of water, 3, 53
Channel, artificial, in surface-ice, 105, 227, 228
 blasting an ice, 228
 effect of anchor-ice, in a river, 2, 222, 223
Coefficient of expansion of ice, 64
Color of ice, 74
Conditions governing the formation of river-ice, 180
Conduction of heat, 20
Conductivity of the soil and earth's crust, 24, 243
 thermal, of ice, 57, 60
 of snow, 57, 60
 of water, 62
Construction of power works, 2, 227
Cribwork to deflect frazil-ice, 227
Crystalline structure of ice, 74, 77
Current-ice, 132

Density of ice, 30
 new and old, 36, 42
 variations in the, 44
 of water, maximum, 45, 56
 of St. Lawrence River ice, 42
Depth of formation of anchor-ice, 209, 210, 211, 212, 223
Diathermancy, 10
 of gases and vapors, 12
 of ice, 15
 of water, 14, 184
Dielectric constant of ice, 73
Diffusivity of heat, 23

Elasticity of ice, 68
Electric heating of racks, 240
Electrical thermometer, 137
Electrical waves, 7, 17
Emissivity, surface, 18
Erosive velocity of water, 244
Ether waves, velocity of, 6
Expansion of water near the freezing-point, 3, 45, 56

Falling water, heat generated by, 242
Floods, ice, in the St. Lawrence, 114, 205, 207, 219, 220
Flow of ice under pressure, 70, 71
Foam cells and walls in ice, 80
Fracture of ice, 74, 81
Frazil-ice, accumulation of, 105 115, 116, 125, 132, 135, 207, 208, 215-
 219, 227, 249
 adhesion of, 230, 231
 agglomeration of, 169, 174 181, 202

- Frazil-ice and anchor-ice, conditions governing the formation of, 180
 appearance of, 113, 132, 168, 204
 artificial heat applied to, 230
 artificial production of, 104, 177
 booms or cribwork to deflect, 227, 235
 buoyancy of, 135, 180, 206, 208, 225
 disintegration of, 175
 distinguished from anchor-ice, 108, 109, 110, 185, 204, 208, 209,
 212, 214
 effect of sun on, 112, 181
 formation of, 103, 109, 110, 111, 174, 201, 206, 207, 210
 in penstocks or wheel-pits, 235
 steam injection for relief from, 236
 theories of, 201, 202, 203, 209, 210, 211, 212, 213
 value of surface-ice as a protection from, 105, 229, 235
- Freezing-point diagram, 176
 mixture, 164
 of water, general considerations as to, 136, 174, 175, 176, 177,
 180
- Gases, diathermancy of, 12
- Gates, freezing of, 230
- Glacé-du-fond, 106
- Glacier grains, 81, 82
 motion, 92
- Ground-gru, 106, 190
- Ground-ice, 106, 190
- Growth, rate of, for sheet-ice, 101, 102
- Gru, ground, 106, 190
- Grundeis, 106, 190
- Hardness, relative of ice, 66, 74
- Headrace, artificial channel in, 227, 228
- Heat, absorption and transmission of, 10, 11, 12
 artificial, applied to frazil-ice, 230
 conducting power of different materials, 25, 26
 conduction of, 20
 convection of, 26
 diurnal waves of, in the earth, 25
 of fusion of ice, 46
 generated by falling water, 242
 radiation of, 6, 7
 radiation of, from black body, 9, 17, 18, 19
 relation of, to light, 5, 67, 16
 physical laws governing the transfer of, 4
 waves, relation to electrical waves, 16
 theory of, 5
- History of the ice floods in the St. Lawrence, 127

- Ice, anchor-, formation of, 106, 108, 109, 110, 111, 168, 201, 207, 208, 220, 244
- bending moment of, 70
 - bordage, 132 (see also Border)
 - border, 99
 - bottom, 106
 - bridge, 126, 134, 135
 - calorimeter, 47, 48, 87
 - channel, blasting of, 228
 - coefficient of expansion of, 64
 - color of, 74
 - crystalline structure of, 74, 77
 - current, 132
 - density of, 30
 - of new and old, 36, 42
 - of St. Lawrence River, 42
 - diathermancy of, 15
 - dielectric constant of, 73
 - elasticity of, 68
 - floods in the St. Lawrence, 114, 205, 207, 219, 220
 - flow of, under pressure, 70, 71
 - foam cells and walls in, 80
 - formation due to Quincke, 79
 - fracture of, 74, 81
 - frazil, formation of, 103, 109, 110, 111, 174, 201, 206, 207, 210
 - ground, 106
 - heat of fusion of, 46
 - index of refraction of, 75
 - insulating properties of, 73
 - lapped, 106
 - lustre of, 74
 - modifications of, 94
 - molecules in solution, 55, 87
 - moutonne, 106
 - pack in the St. Lawrence, 132
 - penetrability of, 66
 - physical constants of, 30
 - plasticity of, 66, 69
 - plate, 104
 - by radiation to air, 243
 - space, 243
 - relative hardness of, 66, 74
 - sheet or surface, formation of, 98, 99, 100, 132
 - shoves, 220, 222, 227, 250
 - slush, 104, 132
 - specific gravity of, 30
 - specific heat of, 51
 - spicular, 210

- Ice, spontaneous crystallization of, 84, 87
 - thermal conductivity of, 57, 60
 - vapor pressure of, 72
 - variation in the density of, 44
 - viscosity of, 68
 - Young's modulus of, 68, 72
- Index of refraction of ice, 75
- Instruments used in investigations of river temperatures, 152, 162
- Insulating properties of ice, 173

- Lapped ice, 106
- Latent heat of water, 46
- Lustre of ice, 74

- Maximum density of water, 45, 56
- Mercury thermometer, accuracy of, 137
- Modifications of ice, 94
- Montreal Flood Commission, 109, 137, 150, 213, 220, 249
- Montreal Flood Commission Report, 114, 115, 125
 - the history of the floods, 127
 - the ice-pack, 132
 - river temperatures, 150
 - frazil- and anchor-ice, 213

- Moutonne-ice, 106

- Nucleation, 106, 209

- Penetrability of ice, 66
- Penstocks or wheel-pits, frazil-ice in, 235
- Physical constants of ice, 30
- Physical laws governing the transfer of heat, 4
- Plasticity of ice, 66, 69
- Plate ice, 104
- Platinum thermometer, 137, 152
 - construction of, 145
 - calibration of, 146
- Power-house, vulnerable spots in, 230
- Power-works, construction of, 227
 - situation of, 227, 229
- Pressure, effect of, on state of ice at different depths, 242

- Racks, adherence of frazil-ice to, 231
 - blockage of, by frazil-ice, 231
 - electric heating of, 240
 - steam heating of, 232
- Radiation, black body, 9, 17, 18, 19
 - cause of anchor-ice formation, 108, 111, 113, 170, 171, 172, 181, 184, 187, 190, 193, 199, 200, 203, 206, 208, 209, 210, 222, 225
 - quantity of ice formed by, 243

- Radiation of heat, 6, 7
 - solar, 18
 - terrestrial, 15
- Rate of growth of sheet ice, 101, 102
- Regelation, 81, 83
- River temperatures, 149
 - instruments used in investigations of, 152, 162
 - under surface-ice, 155
 - in the Lachine rapids, 160
- Selective absorption, 10
- Sheet ice, formation of, 98, 99, 100, 132
 - rate of growth of, 101, 102
 - section of, 103
- Shoves, ice, 220, 222, 227, 250
- Situation of power-works, 227, 229
- Slush-ice, 104, 132
- Snow crystals, 75
 - thermal conductivity of, 57, 60
- Soil, conductivity of, 24
- Soil temperatures, 23, 24, 25
- Solar radiation, 18
- Solvent, influence of water as a, 3
- Specific gravity of ice, 30
- Specific heat of ice, 51
 - of water, 53
 - variation of, 54
- Spectrum, ether, 16, 17
 - heat of the, 7, 8
- Spicular ice, 210
- Spontaneous crystallization of ice, 84, 87
- Steam heating of racks, 232
 - injection for relief from frazil-ice, 236
 - in wheel-pits, 236
 - in turbines, 239
- Structure, crystalline, of ice, 74, 77
- Sun, temperature of, 19
- Supercooling of water, 95, 174
- Surface emissivity, 18
- Surface-ice, temperature of water under, 155
 - value of, as a protection from frazil- and anchor-ice, 105, 113 182
 - 207, 208, 212, 229, 235
- Temperature of the earth, 20
 - earth's crust and the soil, 23, 24, 25
 - influence of, on radiation, 8, 9, 13
 - precise measurements of, 136
 - of water in Lachine rapids, 160

- Temperature of water under surface-ice, 155
Terrestrial radiation, 15
Thermal conductivity of ice, 57, 60
 of snow, 57, 60
 of water, 62
Thermometer, mercury, accuracy of, 137
 platinum electrical, 137, 152
Transmission and absorption of heat, 10, 11, 12
Turbines, steam injection in, for relief from frazil, 239

Ultra-violet waves, 17

Vapor-pressure of ice and water, 72
Velocity of ether waves, 6
Viscosity of water, effect of pressure on, 56
 of ice, 68
Visible waves, 6
Vulnerable spots in a power-house, 230

Water, capacity for heat of, 3
 diathermancy of, 14, 15
 in the economy of nature, 3
 effect of pressure on the viscosity of, 56
 erosive velocity of, 244
 expansion of, near the freezing-point, 3
 falling, heat generated by, 242
 freezing-point of, 174
 influence of, as solvent, 3
 latent heat of, 46
 maximum density of, 45, 56
 specific heat of, 53
 supercooling of, 95, 174
 thermal conductivity of, 62
 vapor pressure of, 72
 variation of the specific heat of, 54
Wave theory of heat, 5, 6, 7
Wheel-pits or penstocks, accumulation of frazil-ice in, 235

X-rays, 6

Young's modulus for ice, 68, 72

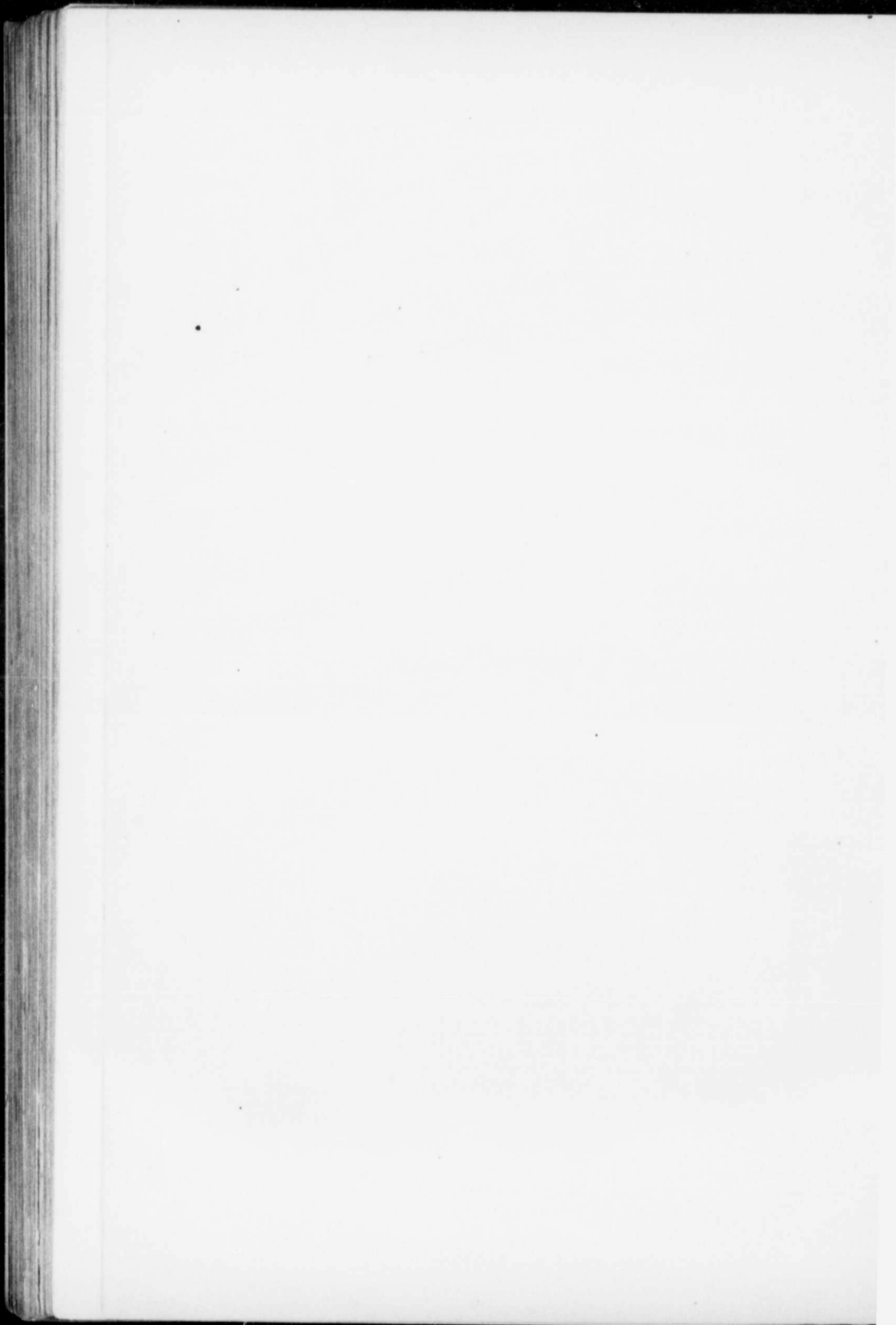

INDEX OF NAMES.

- Abels, H., 60, 62
 Andrews, T., 59, 64, 65, 66, 69, 72
 Ångström, A. J., 58, 62
 Arago, D. E. J., 108, 182, 185, 186, 187, 188
 Aschka s 14, 16
 Avogadro, A., 51
- Barnes, H. T., 38, 44, 54
 Barus, C., 106
 Beaun, 107, 108
 Becket, 42, 103
 Bell, R., 185, 202, 203, 206, 220
 Bently, W. A., 75
 Bird, W. L., 232
 Black, J., 47, 50
 Bottomley, J. T., 18, 83, 86
 Bovey, H. T., 243
 Boyle, R., 30, 32, 200
 Brewster, Sir D., 78
 Brunner, C., 31, 64, 65
 Bunsen, R., 27, 34, 35, 38, 43, 44, 48, 50, 87, 90, 91
- Callendar, H. L., 24, 138, 140, 152, 153
 Chappuis, P., 45, 46
 Christiansen, C., 61
 Clément, 51
 Cooke, H. L., 38, 44
 Cox, J., 225
 Crova, A., 19
- Dana, E. S., 74, 75
 Davy, Sir H., 5, 201
 Dawson, Sir Wm., 210, 225
 Dawson, W. Bell, 211
 De la Roche, F., 10
 Desains, P., 47, 52
 Desmarest, 107
 Desormes, C. B., 51
 Despretz, C., 45
 Dewar, J., 83
- Drude, P., 14
 Dufour, L., 33, 38, 96
 Duhamel, J. M. C., 183
 Dulong, P. L., 17
 Dumas, J., 31
- Eisdale, E., 108, 185, 188, 189
- Fahrenheit, G. D., 95
 Faraday, M., 84, 86, 87, 202
 Farquharson, J., 108, 182, 183, 184, 185, 189, 203
 Forbes, J. D., 58, 59, 60, 86, 87, 202
 Francis, J. B., 185, 201
 Franklin, B., 200
 Freeman, J. R., 225
 Fresnel, A. J., 5
- Gay Lussac, L. J., 95
 Geissler, 32, 38, 64, 65
 Gilbert, F., 204
 Girdwood, G. P., 250
 Guerin, 211
- Hales, 108, 182
 Hälström, G. G., 45
 Hannaford, 207
 Hansky, 19
 Hauser, L., 56
 Heinrich, 31
 Henshaw, G. H., 185, 203, 204, 205, 212, 225
 Herschel, Sir J., 86
 Herschel, 206
 Hertz, 17, 73
 Hess, G. H., 48, 50, 52
 Hess, H., 68, 69, 70, 71
 Hind, 210
 Hjelström, 60
 Hodgson, 224
 Hope, T. C., 45
 Hugl, 107
 Hunt, T. Sterry, 185, 203

- Ireland, 107
 Irwin, 212

 Jackson, Col., 183
 Jansson, M., 60, 62
 Joly, J., 84
 Joule, J. P., 5
 Judin, 72

 Keefer, T. C., 114, 115, 185, 209, 219, 220
 Kelvin, Lord, 24, 58, 185, 203
 Kennedy, J., 114, 115, 150, 152, 155, 162, 222
 Kidd, 67
 King, T. D., 152
 Kirchhoff, G., 9
 Kopp, H., 33, 38, 45, 83

 Lampa, 17
 Langley, S. P., 19
 Laplace, P. S., 47, 50
 Lavoisier, A. L., 47, 50
 Lebedew, 17
 Leduc, A., 43, 44, 50
 Lesage, 207
 Leslie, Sir J., 201
 Lucas, A. S. B., 87, 88, 178
 Lundquist, G., 62, 63, 64
 Lyman, 17

 Macfarlane, D., 18
 McConnell, J. C., 67, 68, 69
 McKeever, 187
 McLeod, C. H., 24, 151
 Magnus, G., 13
 Marchand, 64, 65
 Marek, 46
 Marvin, 73
 Maxwell, J. C., 5
 Melloni, M., 10, 243
 Mitchell, 58, 59, 60
 Moseley, 68
 Murdock, 208
 Murphy, J., 232, 235, 236, 240

 Neumann, F. E., 59, 60
 Nichols, E. F., 16, 17
 Nichols, E. L., 35, 36, 37, 38, 42, 43, 44, 45, 65, 90

 Okada, 61, 62
 Osann, 31

 Perley, H. F., 114
 Person, C. C., 48, 50, 51, 52

 Peterson, P. A., 211
 Petit, A. T., 17
 Pettersson, 51, 64, 65
 Pierre, 45
 Plücker, J., 32, 33, 38, 64, 65
 Poole, H. F., 208
 Provostaye, F. de la, 47, 50

 Quincke, G., 74, 79

 Ranney, G. W., 206
 Regnault, V., 47, 50, 51, 52, 72
 Reusch, 74
 Righi, 17
 Rosetti, F., 45
 Rubens, H., 14, 16, 17
 Rumford, Count, 5, 200
 Rutherford, E., 20

 St. George, P. W., 114
 Scheel, K., 46, 73
 Schumann, 17
 Scott, R. F., 223, 224, 225
 Siemens, C. W., 138
 Smith, A. W., 48, 49, 50, 52
 Sproule, W. J., 151, 152, 208, 209
 Stark, 201
 Steckel, 208
 Stefan, J., 62
 Straneo, 59, 60
 Struve, 64, 65
 Sutherland, 55

 Tammann, G., 71, 94
 Tamura, S. T., 100
 Tate, 211
 Thiesen, M., 46, 73
 Thomson, J., 67, 83, 84, 86
 Tyndall, J., 12, 13, 77, 78, 81, 83, 86, 92, 93, 204

 Vincent, J. H., 43, 65
 Violle, J., 19

 Walbank, W. McLea, 212
 Weber, H. F., 62, 63, 64
 Weber, R., 63, 64
 Weinberg, B., 72
 Weitz, 189
 Wells, 199
 Williams, 31
 Winkelmann, A., 62, 63, 64

 Young, Thos., 5
 Zakrzewski, J. v., 34, 65, 66