

**CIHM  
Microfiche  
Series  
(Monographs)**

**ICMH  
Collection de  
microfiches  
(monographies)**



**Canadian Institute for Historical Microreproductions / Institut canadien de microreproductions historiques**

**© 1996**

## Technical and Bibliographic Notes / Notes techniques et bibliographiques

The Institute has attempted to obtain the best original copy available for filming. Features of this copy which may be bibliographically unique, which may alter any of the images in the reproduction, or which may significantly change the usual method of filming are checked below.

- Coloured covers / Couverture de couleur
- Covers damaged / Couverture endommagée
- Covers restored and/or laminated / Couverture restaurée et/ou pelliculée
- Cover title missing / Le titre de couverture manque
- Coloured maps / Cartes géographiques en couleur
- Coloured ink (i.e. other than blue or black) / Encre de couleur (i.e. autre que bleue ou noire)
- Coloured plates and/or illustrations / Planches et/ou illustrations en couleur
- Bound with other material / Relié avec d'autres documents
- Only edition available / Seule édition disponible
- Tight binding may cause shadows or distortion along interior margin / La reliure serrée peut causer de l'ombre ou de la distorsion le long de la marge intérieure.
- Blank leaves added during restorations may appear within the text. Whenever possible, these have been omitted from filming / Il se peut que certaines pages blanches ajoutées lors d'une restauration apparaissent dans le texte, mais, lorsque cela était possible, ces pages n'ont pas été filmées.
- Additional comments / Commentaires supplémentaires:

L'Institut a microfilmé le meilleur exemplaire qu'il lui a été possible de se procurer. Les détails de cet exemplaire qui sont peut-être uniques du point de vue bibliographique, qui peuvent modifier une image reproduite, ou qui peuvent exiger une modification dans la méthode normale de filmage sont indiqués ci-dessous.

- Coloured pages / Pages de couleur
- Pages damaged / Pages endommagées
- Pages restored and/or laminated / Pages restaurées et/ou pelliculées
- Pages discoloured, stained or foxed / Pages décolorées, tachetées ou piquées
- Pages detached / Pages détachées
- Showthrough / Transparence
- Quality of print varies / Qualité inégale de l'impression
- Includes supplementary material / Comprend du matériel supplémentaire
- Pages wholly or partially obscured by errata slips, tissues, etc., have been refilmed to ensure the best possible image / Les pages totalement ou partiellement obscurcies par un feuillet d'errata, une pelure, etc., ont été filmées à nouveau de façon à obtenir la meilleure image possible.
- Opposing pages with varying colouration or discolourations are filmed twice to ensure the best possible image / Les pages s'opposant ayant des colorations variables ou des décolorations sont filmées deux fois afin d'obtenir la meilleure image possible.

This item is filmed at the reduction ratio checked below /  
Ce document est filmé au taux de réduction indiqué ci-dessous.

10x	12x	14x	16x	18x	20x	22x	24x	26x	28x	30x	32x
<input type="checkbox"/>	<input type="checkbox"/>	<input type="checkbox"/>	<input type="checkbox"/>	<input type="checkbox"/>	<input type="checkbox"/>	<input checked="" type="checkbox"/>	<input type="checkbox"/>	<input type="checkbox"/>	<input type="checkbox"/>	<input type="checkbox"/>	<input type="checkbox"/>

The copy filmed here has been reproduced thanks to the generosity of:

National Library of Canada

The images appearing here are the best quality possible considering the condition and legibility of the original copy and in keeping with the filming contract specifications.

Original copies in printed paper covers are filmed beginning with the front cover and ending on the last page with a printed or illustrated impression, or the back cover when appropriate. All other original copies are filmed beginning on the first page with a printed or illustrated impression, and ending on the last page with a printed or illustrated impression.

The last recorded frame on each microfiche shall contain the symbol  $\rightarrow$  (meaning "CONTINUED"), or the symbol  $\nabla$  (meaning "END"), whichever applies.

Maps, plates, charts, etc., may be filmed at different reduction ratios. Those too large to be entirely included in one exposure are filmed beginning in the upper left hand corner, left to right and top to bottom, as many frames as required. The following diagrams illustrate the method:

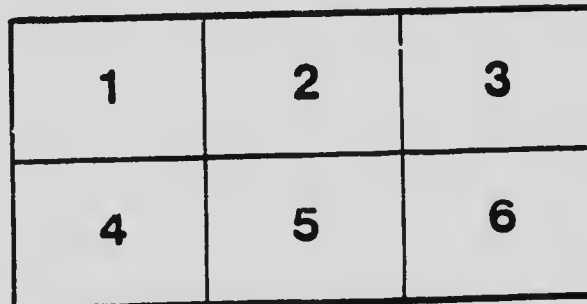
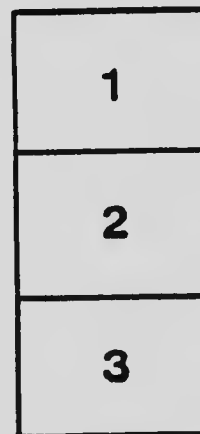
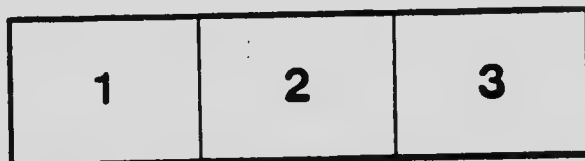

L'exemplaire filmé fut reproduit grâce à la générosité de:

Bibliothèque nationale du Canada

Les images suivantes ont été reproduites avec le plus grand soin, compte tenu de la condition et de la netteté de l'exemplaire filmé, et en conformité avec les conditions du contrat de filmage.

Les exemplaires originaux dont la couverture en papier est imprimée sont filmés en commençant par le premier plat et en terminant soit par la dernière page qui comporte une empreinte d'impression ou d'illustration, soit par le second plat, selon le cas. Tous les autres exemplaires originaux sont filmés en commençant par la première page qui comporte une empreinte d'impression ou d'illustration et en terminant par la dernière page qui comporte une telle empreinte.

Un des symboles suivants apparaîtra sur la dernière image de chaque microfiche, selon le cas: le symbole  $\rightarrow$  signifie "A SUIVRE", le symbole  $\nabla$  signifie "FIN".

Les cartes, planches, tableaux, etc., peuvent être filmés à des taux de réduction différents. Lorsque le document est trop grand pour être reproduit en un seul cliché, il est filmé à partir de l'angle supérieur gauche, de gauche à droite, et de haut en bas, en prenant le nombre d'images nécessaire. Les diagrammes suivants illustrent la méthode.

# MICROCOPY RESOLUTION TEST CHART

(ANSI and ISO TEST CHART No. 2)

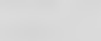
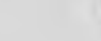
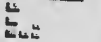
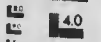
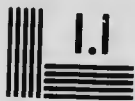
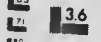
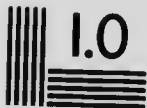

APPLIED IMAGE Inc

1653 East Main  
Rochester, New York 14609 USA  
(716) 482 - 0300 - Phone  
(716) 288 - 5989 - Fax

# THE HOUSE & ITS FURNISHING.



Alfred G. Bell

I remember, I remember  
The house where I was born,  
The little window where the sun  
Came peeping in at morn."

# THE HOUSE *and* ITS FURNISHING.



Abbie DeLury

“I remember, I remember  
The house where I was born,  
The little window where the sun  
Came peeping in at morn.”

00938247

University of Saskatchewan  
College of Agriculture

---

THE HOUSE AND ITS  
FURNISHINGS

By Abbie DeLury.

---

"Mine be a cot beside the hill;  
A beehive's hum shall smoothe my ear;  
A willowy brook that turns a mill,  
With many a fall shall linger near.

"The swallow oft, beneath my thatch,  
Shall twitter from her clay-built nest;  
Oft shall the pilgrim lift the latch,  
And share my meal a welcome guest.

"Around my ivied porch shall spring  
Each fragrant flower that drinks the dew;  
And Lucy, at her wheel shall sing  
In russet-gown and apron blue."

---

BULLETTEN No. 4.  
SASKATOON, SASKATCHEWAN  
1914.



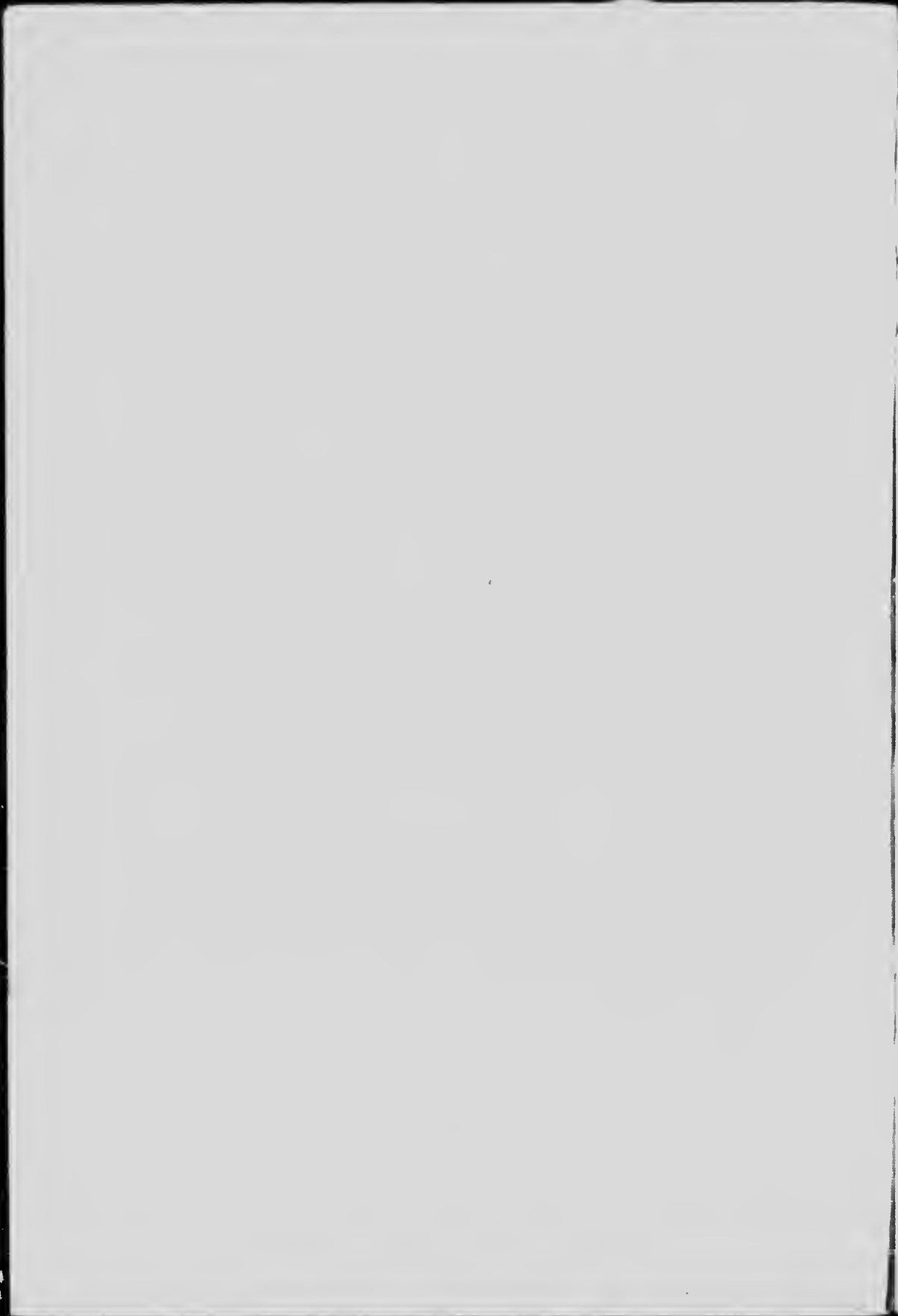

## GENERAL REMARKS

---

People, in general, are coming to a realization of the influence of environment on character and personality; ugly, sordid and slipshod surroundings are sure, in most cases, to produce similar characteristics in the natures of those who live in the midst of them. A clean, orderly, harmonious environment must necessarily have a refining and soothing effect. So, too, we must consider the character of the surroundings a person creates for himself as being, in large measure, an expression of what he is himself,—"Houses are like the human beings who inhabit them."

It lies within the reach of nearly all people to create about them an atmosphere of cleanliness, order and beauty. Luxurious surroundings are not necessarily beautiful, nor are plain and simple surroundings necessarily unbeautiful. The essentials of beauty lie within almost everyone's reach.

The first essential is **cleanliness**, which implies fresh air and sunlight, freedom as far as possible from dust, absence of flies and other household pests and other conditions that breed these, both within and outside of the house. To maintain these last mentioned conditions, it may often be the duty of the housewife to interest herself actively in the affairs of the community, to see that sanitary precautions are taken and sanitary measures enforced. In such cases, the housewifely conscience cannot confine itself merely "to the home." Conditions of cleanliness in and about the house can be reached and maintained with the merely putting forth of effort, without which, nothing of value can be reached. With system, the effort may be greatly minimized so that one does not become a slave to the brush and broom. **Order**, the next essential, naturally follows its twin-sister, cleanliness, and has a valuable ally in systematized work. **Cleanliness** and **order** lay the foundation for the third essential, **beauty**. Beauty, besides resting on these, also implies simplicity and harmony. This is the lesson taught us by every leaf and twig and flower.

It is a combination of all these which produces that indefinable something in the home that gives the feeling of comfort, good cheer and happiness which makes us speak of a "homey" home. It is the aim of every true woman to surround her family and herself with that atmosphere of peace and happiness and comfort which comes, often as much from beautiful and harmonious appointments as from the nature and character of the inmates, the two being interdependent.

It shall be the aim of the following pages to make some practical application of the foregoing remarks. The different parts of the house will be considered as to plan and furnishing.

# THE BASEMENT

---

A light, airy, well-planned basement that is easily kept in a sanitary condition is a part in the building of the house that one cannot afford to dismiss carelessly—better let some of the more ornamental parts of the house go, than not have a well planned and well equipped basement. The facilities it affords and the amount of labor that it saves are incalculable to say nothing of its part in helping to maintain healthful conditions in the house. It is labor-saving in the sense that many of the household occupations, such as washing, that cannot be carried on without a certain amount of litter, can be performed there; many household appliances that are not used daily and crowd the kitchen and pantry causing a great deal of extra cleaning and moving, can be kept in the basement; and if it is kept clean, it means much less dust and dirt to be contended with in the house.

The ideal which lies within the reach of most people, seems to be the basement with concrete floor and walls or walls of white brick. It has the advantage of being of reasonable cost; it is also kept clean and sanitary with little effort and even in a country house without plumbing, arrangements can be made for carrying off water.

Allowance should be made for plenty of window space to ensure a sufficiency of light and air; the windows should be placed on opposite sides to allow for air circulation, necessary to keep air dry and pure. They should be provided with substantial, well-fitting screens for the summer, when plenty of air in the basement is necessary and yet insect life has to be rigidly excluded.

The height of basement walls should be sufficient to have the basement airy, and enough of the height above ground to accommodate good sized windows. A good average height from floor to ceiling of basement is eight feet with two and a half to three feet above ground.

The basement plan (Fig. 1) given on page 8, allows for nearly all conveniences and necessities but a plan will always have to

conform to conditions. The plan is drawn on scale of one-eighth inch to a foot. Coal shutes are at the back of the coal bins. Larder and root cellar are provided with windows for ventilation.

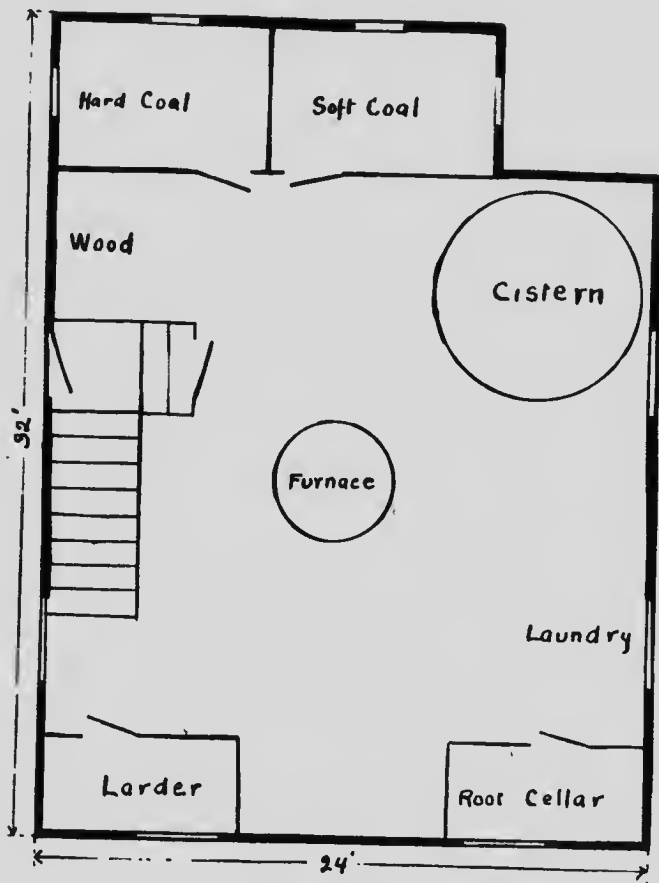

Fig. 1

# THE KITCHEN

---

"The scrubbing's done; my kitchen stands arrayed  
In shining tins, and order reigns supreme.  
Here on the table, like a fairy dream,  
A row of pies and cakes, all freshly made  
And full of spicy odors, stand displayed.  
While from the oven, like a rising stream  
Of incense, comes an odor, warm supreme,  
The bread, its final browning still delayed.  
Now while I wait beside the oven door,  
I take up my guitar upon my knee,  
And singing the old songs I knew of yore,  
My happy youth comes back to me.  
Music and incense rising in the air.  
Courage is mine and all the world is fair.

1. **Desirable qualities**—The kitchen should be airy and fitted up in such a way that it can be kept clean without too much labor. It is not well to have it too large, so increasing the amount of work necessary to keep it in good condition and causing an unnecessary amount of walking in the performance of duties. On the other hand it is well not to have it so small that the movements of the housekeeper have to be cramped and it should not be so small as to be difficult to keep airy; a stuffy kitchen is very tiring. There ought to be space enough for the worker in the kitchen to sit down and sew or read, or merely to sit down during intervals of waiting, however short they may be.

There seems to be quite a general impression that it is not essential to aim at attractiveness in the kitchen appointments; that, as the homelier duties are performed there, it need lend itself only to utility. But, it must be borne in mind that the housewife, and others of the household often also, spend a large part of their lives there and surely it is worth while to have surroundings

as cheerful and pleasant as is practicable. It makes a wonderful difference in the worker's attitude toward her work and in her general habit of mind and disposition if her kitchen surroundings are agreeable or otherwise. "The bec is a housewife; her song is a grumble;"—wretched working surroundings are largely accountable for this unenviable reputation of the housewife.

2. **Fittings**—(1) Walls—it is well to have the walls and ceiling of a kind that can be easily cleaned and kept free of dust; colors cheery and soft, clean and cool looking. Painted or tinted walls in soft, flat colors answer the purpose very well.

Wall oil-cloths or papers with varnished surface are prettier and daintier than painted walls. If varnished over they keep their colors unfaded and are all the more easily washed off. Blue and white as colors seem to fulfil all the conditions necessary, provided the blue is of a soft neutral tint. Some of the patterns in these colors are very beautiful as are also some of those in green and white. Often green and white patterns have touches of brighter color, very desirable for cheeriness, especially if the kitchen happens to be not a very bright one. Oil-cloth is very satisfactory. There is no danger of tearing or cracking and it will with care, keep in good condition for almost any length of time. It can be bought at from three to four cents a square foot. The paper with varnished surface can be bought at about one cent a square foot. It is not as durable as oil-cloth but it can be wiped off and kept fresh and clean.

(2) Woodwork—baseboard, cupboards etc., should be painted in a color that harmonizes with the other color schemes; sometimes it is difficult to get nice soft shades in paint. Some of the blues are very glaring. A very nice shade may be obtained by mixing one of the light shades with one of the soft gray shades. One can experiment until the desired tint is obtained. Blue may also be toned with orange. A soft shade of green may be obtained by adding a little red; a soft shade of red by adding green, etc.

After being once well painted a fresh coat every spring will usually suffice to keep a surface in good condition. It is easily cleaned by using warm water with a few drops of ammonia in it; soap is hard on paint. The floor may be painted in the same color as woodwork but a few shade darker. The ideal floor covering is a good linoleum. It is expensive at first for it pays

to get the best quality, but it is economical in the long run because of its durability, in which it is unmatched by anything else. Its pattern and colors may be kept as nice as new for years by giving it a coat of varnish every few months, this also makes it much easier to wash off. If desired, a tile pattern may be chosen. It gives a kitchen a nice, cheerful look. Many of the patterns that imitate the different woods are good and seem to make, perhaps, a more natural looking floor.

Linoleum has the advantage of being easy on the feet of the worker, also on the whole body because of its yielding qualities; it is easily kept clean, is durable in itself and also preserves the floor underneath; it is warm also. If found beyond one's means at time of fitting, oil-cloth will do. It may be preserved in pattern and color by a coat of varnish, just as the linoleum is, but will need to be replaced many times more. It is not quite so easy on the feet, is not so warm and does not look so well, and is more inclined to warp. Both linoleums and oil-cloths come in nice grass color designs so that they resemble matting in appearance.

3. **Furnishings**—will always, in large measure, depend on circumstances, whether city conveniences or not, size of family etc., but in any case, all should be plain and substantial. The stove particularly should be devoid of ornament and it usually looks better for being so, as also being easy to clean.

The kitchen work table may be either plain white natural wood or may be covered with aluminum, zinc or oil cloth. The zinc and aluminum have the advantage of being durable, easily kept clean and cannot be injured by heat.

A cupboard of some description is a positive necessity unless a pantry is situated very conveniently to the kitchen. The size and kind will always depend on circumstances—whether there is pantry space, size of family, character of meals, etc. Where there is no pantry and the kitchen is large enough (and it should be large enough in such a case) a cupboard that will answer every purpose can be built in. It will be found just as convenient, if not more so, than a pantry and assuredly will take less trouble to keep in order. A plan for such a cupboard is given with the paragraph on the pantry. It allows for space above for dishes and below for utensils and supplies. There are drawers for knives, towels, cloths, etc., a bakeboard and table space for working and serving. The window in the middle provides for good light. A division for writing, keeping account books, etc., could be made.



The practice of keeping utensils hanging about is, in general, not a good one. There is always a certain amount of unavoidable dust, which, of course, will settle on the exposed utensils so that there is extra cleaning required to make them fit to use. There may be a few that are in such constant use that dust has not much chance to settle upon, otherwise all things should be protected. A few things may be kept near the stove for convenience when cooking, such as, a covered salt box, salt and pepper shakers, perhaps cans of different seasonings which are often in use. A shelf to accommodate them can be put up near the range.

A chair or stool should stand near the work table. If it is not there, the worker will in all probability, stand at her work and thus lose many an opportunity of resting.

A small table for work-basket and a rocker near a window should be a part of the furnishings. The housekeeper can often snatch a few minutes' rest or recreation in intervals of waiting on some of the household processes or where some watching of things is necessary (and there are many such occasions) and where otherwise, she would perhaps, just weary herself standing about. It is wise to keep book or paper or mending at hand.

Hangings are not appropriate in the kitchen but plain, simple muslin or cheese cloth curtains for the windows are not objectionable but add greatly to the attractiveness and to the general look of cleanliness and they are so easily kept clean that they can hardly be considered as adding to the work of the household.

Pictures on the walls are out of place and could not very well be kept in good condition in a place where cooking and such like processes are being carried on.

There is no objection to a flowering plant or two in the kitchen window and it adds much to the cheerful appearance of the kitchen.

4. **Utensils**—These should be of the best quality and it pays to buy such. In general, enamel and granite are the most satisfactory ware within the reach of all but only the best should be purchased. Aluminum is durable, light to handle and easy to heat. It is expensive at first but lasts so well with care that it is cheap in the end.

It is not wise to have an overstock of implements to work with; they are often unnecessarily brought down, adding to

the work of dish-washing and there are always that many more to handle and put away. On the other hand, many housekeepers add greatly to their work and often fail to have variety in their cookery by not having a sufficiency of conveniences. It is poor economy to save on utensils at the expense of one's strength. It is a housewife's need to have as many as possible of the labor saving conveniences; it adds much more to her comfort and happiness and that of her family to sacrifice some of the less important things to having good things to work with in the kitchen.

The following is a list of articles with their prices, that are needful in any average household and the cost is not much to be reckoned with; the quality at the price is good. The list can be added to or some articles eliminated to suit particular cases. Choose articles that are easily kept clean and in repair, avoid utensils with seams.

1 granite dish pan.....	75
1 rinsing pan.....	75
1 tea-kettle.....	1.00
1 large stew-kettle with lid.....	1.00
1 roasting pan.....	75
1 double boiler.....	60
1 large lipped saucepan with lid.....	60
1 medium saucepan.....	45
1 three quart granite pitcher.....	60
1 one quart granite pitcher.....	30
1 large pudding dish.....	25
1 medium pudding dish.....	20
1 steamer.....	60
1 muffin tin.....	40
2 large pie plates (tin).....	20
1 large earthen mixing bowl.....	40
1 medium mixing bowl.....	30
1 granite colander.....	50
1 potato masher (wire).....	20
1 potato ricer.....	25
1 flour sifter.....	25
1 coarse wire strainer.....	25
1 fine wire strainer.....	10
1 vegetable grater.....	20
1 nutmeg grater.....	10
1 granite funnel.....	25
1 tin skimmer.....	10

1	biscuit cutter	10
1	lemon squeezer (glass)	10
1	pair salt and peppers	20
1	meat board	50
1	round cake-tin	40
1	square cake-tin	40
2	loaf tins	80
1	frying pan	50
1	meat board	50
1	rolling pin	40
1	dozen earthen cups	60
2	asbestos mats	10
1	jelly mould	25
1	kneading pan	1.00
1	ibre pail	30
1	granite soap dish	20
1	wooden chopping bowl	40
1	chopping knife	20
1	set jelly cake tins	30
1/2	doz. German silver teaspoons	25
3	German silver tablespoons	20
3	forks (nickel)	45
2	wooden spoons	20
1	dover egg beater	10
1	can opener	25
1	cork screw	25
1	French knife	50
1	spatula	50
2	paring knives	30
1	Scales	5.00
1	meat grinder	1.50
2	tin measuring cups	20
1	vegetable brush	10
1	bread knife	75
		<hr/>
		Total \$29.15

5. **The Fireless Cooker**—The fireless cooker has now become so generally recognized as a saver of material and energy in cooking that a little treatment of the subject will not be out of place in a discussion of kitchen requirements. We may choose

from a range including the home-made hay box to the most elaborate manufactured article, but, in any case, the saving of time and labor will amply repay the effort or cost.

The principle of the cooker is the retention of heat: it follows that the article to be cooked must first be heated to boiling point, or perhaps cooked for some time (depending on the article to be cooked) before being put in the cooker; or, in the case of those fitted with soap-stones, the soap-stones have first to be heated very hot, placed in the cooker and the article put in to cook. The degree to which the soap-stones are heated can be so great that any of the processes of cooking, baking, roasting etc. can be carried on. The soap-stone cooker is more expensive but has the advantage of being available for more general use and there is no upholstery—it is very sanitary. Many of the cheaper kinds have upholstery and care must be taken to keep them well ventilated.

Prices for the manufactured article range from ten dollars upward depending too, upon size and make.

It is the kind that can be made at home that shall be considered here.

For the purpose, a convenient sized packing box or an old steamer trunk can be utilized.

To make—(1) See that there are no cracks or holes of any kind in the box; if so, have them filled up. Everything must be done to prevent escape of heat.

(2) In the case of a box get a well fitting lid, secure it with strong hinges. It can be fastened down firmly when in use with hooks or other strong fasteners. With a trunk the question of a practically air-tight lid is settled.

(3) Line the box and lid with a layer of asbestos sheeting which can be easily obtained at a very slight cost. If not convenient to get, sheets of paper (newspaper or any other kind) will answer the purpose. Use twenty to twentyfive layers of the paper, being careful to overlap the edges.

(4) For packing, use hay, excelsior, shavings or any light, loose material. The packing should be put in closely but not too solidly and nests made to accommodate the cooking utensils. In this way it can be changed frequently.

(5) If a more permanent and neater sort of padding is desired, the packing may be kept in place with heavy denim, cotton or ticking. To do this—

(a) Cut a piece of cloth the size of the top of box, allowing an inch or more on all sides for lapping, etc.

(b) Have ready chosen, utensils the size that it is judged will be needed; these should be straight sided, and have close fitting lids—lids can be obtained provided with firm fasteners.

(c) Using the lids as guides cut circles from the cloth in the positions that utensils will fit into the box.

(d) Cut rectangular pieces of cloth of the same width as the height of utensil and of same length as its outside circumference, allowing for a seam.

(e) Sew the circumference edge around the circle, thus forming a nest to accommodate the utensil. If the edges are put together with a piece of strong tape, it will be firmer and allow room for the utensil to slip in.

(f) Sew the other circumference edge to the edge of the cloth where the circle was cut out, using tape in the same way. Now the rectangular piece of cloth will fit over the top of the packing, utensils can be placed in several cavities and the packing put around them.

Packing—(1) Place packing to the depth of four or five inches in the bottom of the box.

(2) Put cotton batting to the depth of two inches just beneath where the utensils are to go.

(3) Place the utensils in their cavities and stand them in the cooker where they are to fit.

(4) Place around the utensils an inch thickness of cotton batting; then arrange the packing in the box in the spaces between utensils, folding back the top piece of cloth for the purpose.

(5) When packed up to the level of the top of the utensils, turn the top cloth back, draw firmly and smoothly and tack edges to the sides of the box. The top of utensils should come to at least six inches below the top of the box. If utensils are of different depths, they can be brought to the same level at the top by packing higher at the bottom.

(6) Now make one, two or three cushions (according to the size of the box) mattress-like (see Fig. 2) to fit into the spaces left above the surface of the utensils, so that when the lid is closed down, these will fit tightly over the top. The utensils are thus enclosed on all sides by a packing of non-conducting material.

Fig. 3 shows the cavities for utensils.



FIG. 2.

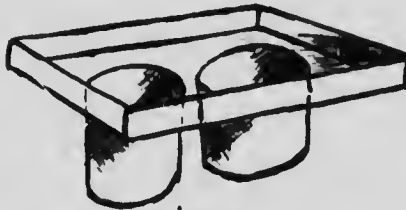

FIG. 3.

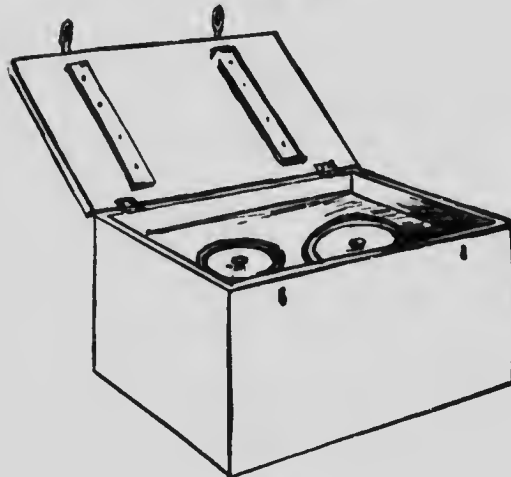

FIG. 4.

Fig. 4 shows the completed cooker with utensils in place

Care—

(1) This kind of cooker should be left open in the air

and sunshine when not in use; cushions should be taken out and hung in the air, otherwise the odor of cooking will linger about them.

(2) During use, the cooker may be kept in the basement if it is in the way in the kitchen.

(3) Do not leave food in the cooker long after it is cooked. It will reach the temperature at which food spoils quickly.

Note—This kind of cooker is useful only for slow cooking processes, like steaming and stewing.

Advantages of fireless cooker.—

(1) The odor of cooking does not escape through the house.

(2) There is no burning of food; no watching is required.

(3) It is a saving of fuel and in warm weather it makes much cooking over a hot fire unnecessary.

(4) No food material is wasted.

(5) On days when top of range is much in use, as it often is on wash day or canning day, the cooker can be used for preparing all or the greater part of the meal.

(6) It is a great saver of time and energy for people who are wage earners outside of home and who do their own cooking; they can come in and find the greater part of their meal entirely cooked for them.

(7) It is good in cases where food has to be carried distances, as it is often with men working in the fields, workmen in cities, etc. Something hot and appetizing can thus be conveyed to them.

(8) It is likely that it will in future be an established feature in the lunches of school children.

(9) Hot water may be kept on hand when fires are not kept up.

(10) Wear and tear on kitchen utensils is lessened and they are easier to wash.

6. Arrangement.—

There are two types of kitchen which seem to be the most general: (1) the usually rather small kitchen built into the body of the house, (2) the kitchen built as a rear attachment to the house.

The latter is, of course, to be preferred on account of its lending itself to easy ventilation and plenty of light and sunshine can be obtained; also, (its comparative isolation from the living-rooms, from which kitchen odors can be more easily kept is another advantage).

Fig. 5, illustrates a plan for a kitchen of the former class, where usually only one window is possible. In the plan given the table is placed under the window to give good light while working.

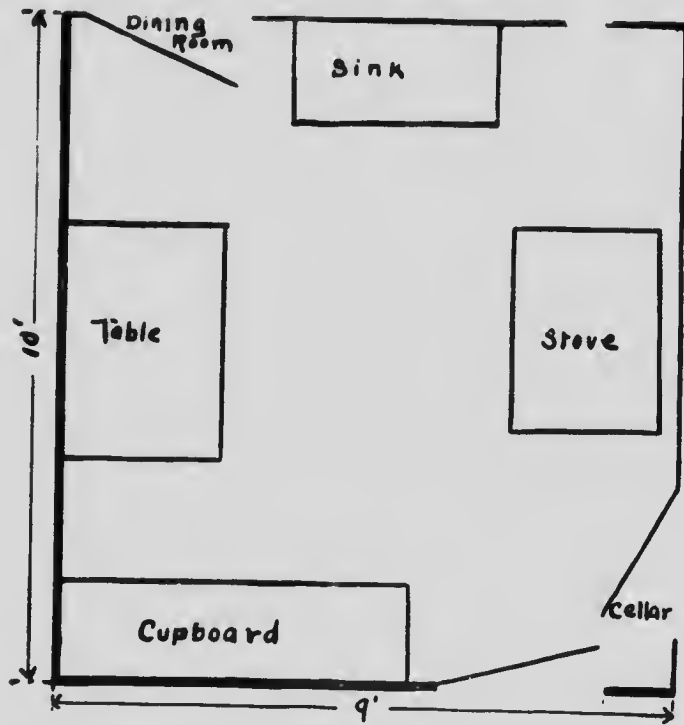

Fig. 5

Fig. 6, is a plan for the built-on kitchen. It contains a cupboard of the kind illustrated in Fig. 7, and so renders a pantry unnecessary. The side of the kitchen opposite the cupboard allows for a very wide window and on that side is sufficient room for a table and chair well removed from the stove. The sink is placed so that it is convenient to both dining-room and cupboard. The stove is placed near the cupboard and is where it is not exposed to draughts if windows are opened.



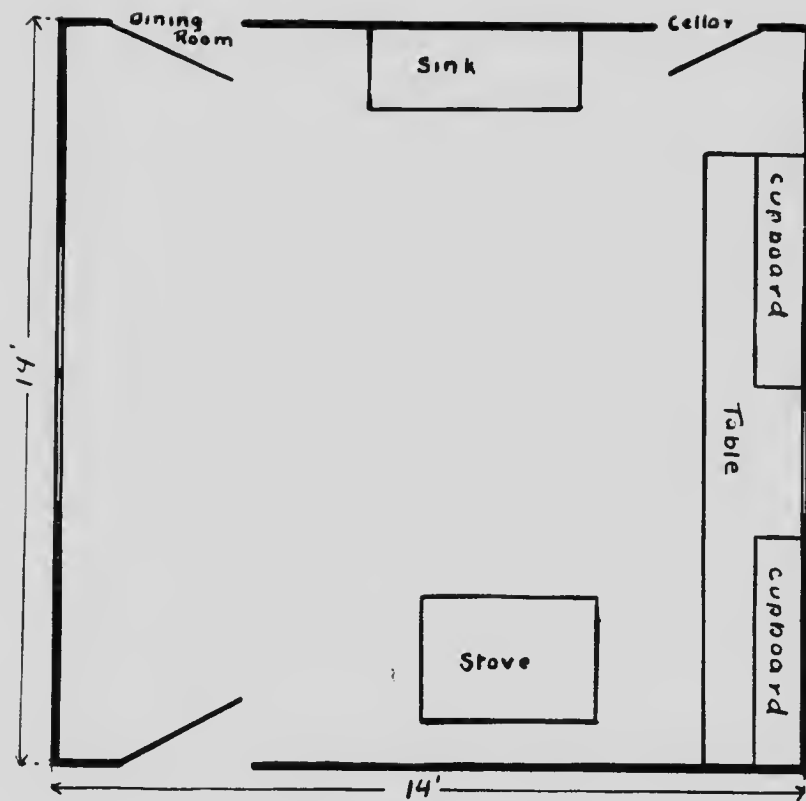

Fig. 6

It is wise to avoid extra additions in the way of sheds built on to the house, in as far as possible. Such places are liable to become littered with all sorts of odds and ends and often make a lot of unnecessary work, in keeping them clean and tidy.

If things go wrong in the household,  
 As they often will you know,  
 Or you're worried out with cares that vex,  
 And the children try you so,  
 Don't sit in the vale of shadows  
 Or stoop to be a scold.  
 'Twill only make bad worse, you see,  
 While you grow gray and old.

—Helen Rich.

Finish every day and be done with it. You have done what you could. Some blunders and absurdities, no doubt, crept in; forget them as soon as you can.

—Emerson.

# THE PANTRY

---

And what most of all, a person might laugh at, not indeed a grave person, but a jester, I say that pots have a graceful appearance when they are placed in regular order.

—Zenophon.

A pantry is not an essential if the kitchen is provided with a capacious built-in cupboard similar to that shown in Fig 7; this cupboard can be used for dishes and utensils, for serving, and provided with a kneading board, can be used for some baking operations.

A long, narrow pantry provided with such a cupboard is often found a convenient and secluded place in which to do serving and cookery and makes a good division between kitchen and dining-room. The floor space need be sufficient only for standing to work and for passing through from kitchen to dining-room.

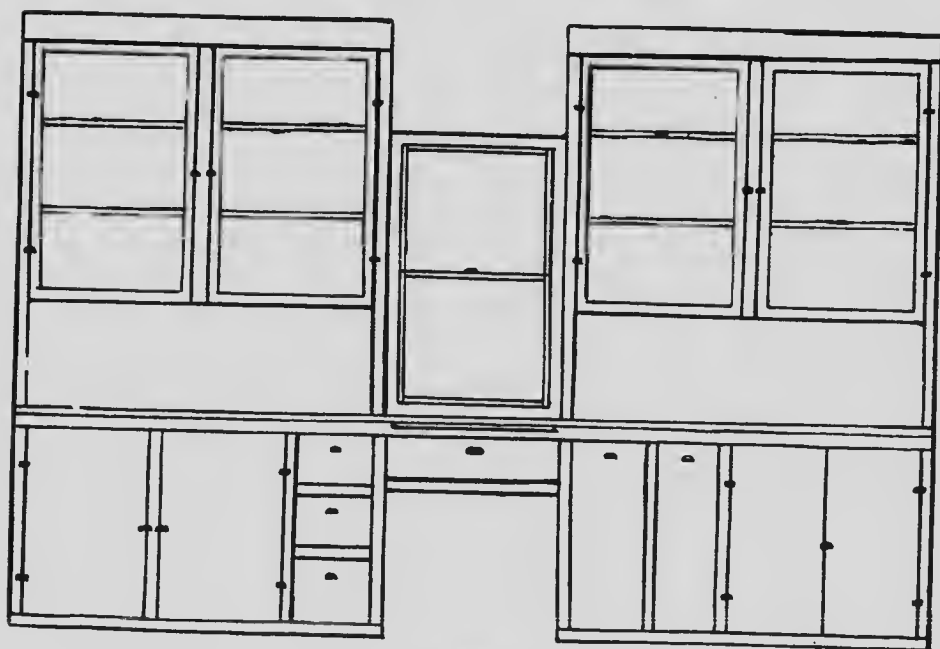

Fig. 7

## THE DINING-ROOM

---

An' all the time the wind blowed there,  
An' I could feel it in my hair,  
An' ist smell clover ever' where;-  
An' a' old red-head flew  
Purt' nigh wite over my high-chair,  
When we et on the porch.

—James Whitcomb Riley.

The dining-room should, if at all possible, be situated so as to receive a large amount of sunshine: cheeriness and brightness are great aids to digestion. Its general appearance should be plain and dignified yet cheery and comfortable. This effect can be obtained by using plain, rich colorings for floor and walls and by having well-made suitable furniture, devoid of ornamentation.

The best floor is of polished hard-wood. A few rugs will add to the comfort of the room. If hardwood floors are not possible, some staining and polishing can make an ordinary wood floor look very well. A large rug or a few small ones will save the floor and improve its appearance. Where there are children, linoleum in some dark dull wood design is more serviceable and more easily kept in good condition. A few rugs may also be used.

Walls should be tinted or papered in plain rich colors. figured wall-papers should be avoided, at least, those with very decided figures. The warm browns and greens seem to be the most fitting. Floor, woodwork and walls should harmonize. The plate-rail is not approved of by everyone but it can be made a very attractive addition to the room. If it is made a catch-all for every kind of ornament, then it ceases to be an attraction. If used for its only and original purpose—to exhibit a few pieces of china of special beauty or rarity, it is an embellishment. For furniture—choose with regard to the use it is to be put to; do not buy things merely because they are ornamental. The very plainest chairs, table, side-board or whatever else is used, will

be found to be the most useful and beautiful. Do not put any thing in the way of furniture in dining-room but what is intended for dining-room use.

Flowers for decoration are pleasing—either cut flowers or a pot or two of ferns or flowers. Flowers for the table are sometimes spoiled by the desire to use too many for the vase, giving them a crowded appearance.

In Fig. 8, by placing only the one spray in the vase, the full beauty of every part—stem, leaf and flower and their relation to one another is fully brought out.

In Fig. 9, by trying to place too many in the space, the beauty of each spray is largely lost, beside the crowded appearance of all gives a feeling, almost of discomfort.



Fig. 8



Fig. 9

## THE LIVING ROOM

---

I once gave a lady two-and-twenty recipes against melancholy; one was a bright fire, another, to remember all the pleasant things said to her; another to keep a box of sugar-plums on the chimney-piece and a kettle simmering on the hob. I thought this mere trifling at the moment, but have in after life discovered how true it is that these little pleasures often banish melancholy better than higher and more exalted objects; and that no means ought to be thought too trifling which can oppose it either in ourselves or in others.

—Sidney Smith.

The living-room will, of course, be the most spacious room in the house. It will be much better to sacrifice two or three smaller parlors or sitting-rooms to having the one large family room. It will be here that the leisure hours of the family are spent. It should therefore be sunny and bright during the afternoon and early evening hours. A western aspect will ensure this. The floors and walls should be in soft and restful colors, such as, some of the warmer shades of brown, grayed greens, tans with touches of color like the deep reds and terra cottas. The furniture should suggest comfort and be of a build that can stand constant use. There should be nothing fragile-looking but everything appearing as if it were intended for service. Chairs and tables should be solid-looking and steady. It is desirable to have a large table for general use and one or more smaller tables for the use of individuals—it may be for their work, for many work-hours will probably be spent here—the housewife with sewing or darning, the children with their books, etc. It will be the part of the house often resorted to for reading—this makes bookshelves and places for magazines a necessity. A couch, preferably a leather-covered one, or one in denim with cushions of a serviceable kind, means a look of rest and comfort. The cushions may be used to add touches of color. For decoration, here again, one can ask nothing better than flowers or ferns. One or two potted plants will be quite sufficient with a vase or bowl of cut flowers or sprays. During a large part of the year something for

the vase can be obtained: flowers or twigs, leaves or berries.

Fig. 10. shows an arrangement of the common yellow petalled daisies which grow on the prairies.

Fig. 11, shows some twigs of the pussy-willow which with their brown stems and buds of many delicate hues leave nothing to be desired in the way of beauty.

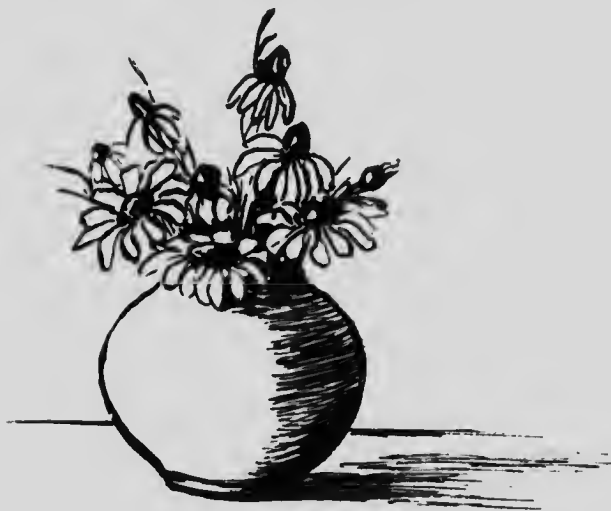

Fig 10



Fig. 11

In both cases, the use of dishes of graceful and suitable form and good arrangement of the flowers make for the beauty of the whole.

For pictures, it is better to have only one or two good ones, suitably framed, than to have several of a poor sort. Let the children of the family have the best obtainable before them. Good copies of the works of the masters can be procured in these days at reasonable cost; pay good attention to the proper hanging. Fig. 12, shows poor hanging on account of the slanting lines formed by the wire. Fig. 13, shows a picture properly hung, the wires forming vertical lines. Better still, hang on a picture-hook or small nail behind the picture.

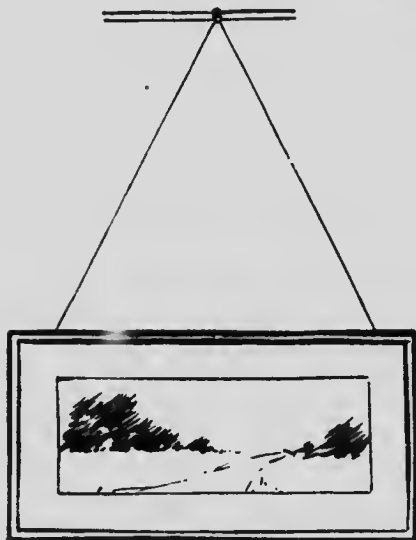

Fig. 12



Fig. 13

If ornaments are used at all, let them be few in number and of good form and quality. Better have none than some of the ornate and tawdry kind that are often seen for sale. Simplicity of form and subdued coloring are to be observed here as in the other appointments of the room. In Fig. 14, are shown some ornaments which need only be seen for us to recognize and feel their beauty and what could be simpler in design? Seen beside those pictured in Fig. 15, is to bring out their beauty in contrast to the crudity and elaborateness of those shown there.

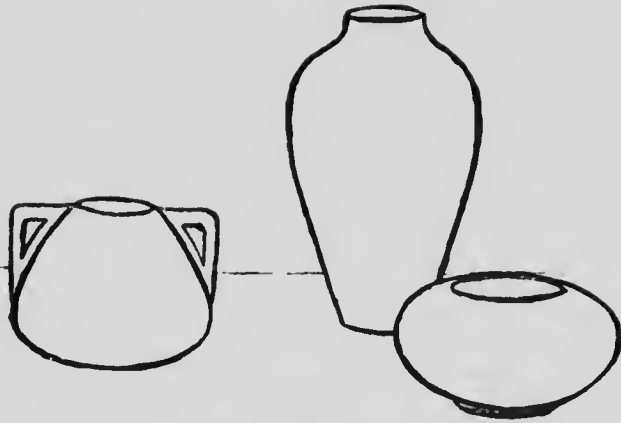

Fig. 14



Fig. 15

Choose hangings of the best material that circumstances will allow, always of course considering that they be in keeping with the other furnishings. They should be in harmony with the dominant color of the room, not in any way suggesting that they are used for decoration, but, serving a purpose, whatever that purpose is. Therefore avoid obtrusiveness in color and design.

For window curtains, it is always safe to choose creams, or ecrus in small and plain designs whatever the color scheme of the room. If side-hangings are desired, have them carry out or harmonize with the prevailing color note. Hang them so that they fall in straight lines and reaching to, or a little below, the bottom of the window-frame.

A floor of polished hard-wood with some small rugs or



one large rug is most beautiful and most sanitary. A linoleum of inconspicuous design may be necessary where there are a number of children.

And the fireplace must not be forgotten. It will be greatly worth while to make many sacrifices for this luxury. With an open fireplace of brick, one can afford to do without many of the pictures and ornaments that we usually consider so essential; the fireplace can more than make up for any scarcity of other decoration. Avoid the up-to-date one with its small provision for a fire and its precautions for shutting off what fire there is, from view. The little extra labor required to keep it cleaned out is more than repaid by the pleasure and comfort derived; the open fireplace has been in the past one of the greatest factors in fostering the love of reading and literature, a fact worth noting.

**"The beautiful is not to be stared at but to be lived with."**

**—Macaulay.**

## THE BED-ROOM

---

But how beautiful an appearance it has too; when shoes, for instance, of whatever kind they are, are arranged in order; how beautiful it is to see garments, of whatever kind, deposited in their several places.

—Xenophon.

In the bed-room, if anywhere in the house, simplicity should reign. Have only what is necessary—nothing more. A bed, dresser, two or three chairs (one of them an easy chair), a small table, perhaps a washstand, constitute almost all that is necessary.

The general atmosphere should be one of airiness and cleanliness.

The bed of brass or iron is to be preferred to the wooden bed as being more easily kept clean and affording fewer lodging places for dust. It pays to buy good mattresses: they can be cleaned and overhauled occasionally and so made to last a long time. They should be protected from dust by a cover made of unbleached cotton. A good spring of woven wire is necessary for comfort. Blankets or comforters for covering are warm and light. Heavy-weight coverings, like heavily padded quilts of heavy and stiff material are very undesirable. They are not warm, prevent the entrance of air and interfere with circulation. For counterpane, a white one that can be easily washed is most sensible.

A lounge or couch-bed is usually a very acceptable piece of furniture in the bed-room. For rest during the day, it is more convenient than the bed and it can be utilized for the nurse in case of sickness.

Closets—and every bed-room should have one—may be provided with shelves for boxes, shoes, etc. and a bar on which to hang clothing to prevent its being crushed is a great convenience.

The closet ought to be well-aired and, usually the only means of doing this is through the bed-room. For this reason, the closet door can be left open when the room is not in use.

Woodwork done in white or some other light, delicate color is much favored for bed-rooms on account of the air of daintiness and cleanliness which it imparts to a room. Light-colored papers are popular for the same reason. Blue is a favorite bed-room color. It is a cool and restful color for summer, but in a cold climate is rather chilly-looking for the winter. If used, it should be toned down to softness. A soft olive green is a good bed-room color because of its restfulness. For northern rooms, creams or buffs add the required touch of warmth and cheerfulness. Some of the warm grays and pinks beside being dainty are warm and cheerful and probably to be preferred in the colder climates.

The ideal floor for a bed-room is, of course, one of polished hardwood, but few people can have the luxury. Any floor can be painted in a color that harmonizes with the other room colorings. Few care to dispense with rugs or a large rug and it assuredly adds to the comfort. If shaken frequently, nothing can be said against rugs as regards being sanitary.

Curtains of some light washable material are to be preferred. Heavy window hangings should be avoided. Green window shades for shutting out too strong light are necessary for rest and sleep. Shades that are white or cream on the outside and a soft green shade on the inside are easily procured.

As a rule, pictures on the bed-room walls, unless it is a bed sitting-room, need not be a part of the furnishing. It might seem, however, to be the place for family portraits and those of near friends. Small knick-knacks should be shunned as gatherers of dust and as adding to the labor of cleaning. For the same reason, toilet articles should be few and of a simple kind.

Frequently, the girls of the household are given some choice about their bed-room appointments and they should be encouraged to take an interest in keeping all in nice dainty condition and in exercising their taste in fitting up and in taking a part in the work of it. It is not so often the boys have anything to say about their rooms—anything is supposed to do and the result is that they are careless and untidy about their rooms and their belongings. It is a good plan to enlist their interest in furnishing and fixing-up: it will have its result in seeing them anxious to keep everything in good order. They will even be-

come interested in making things such as shelves for their books, places for their boots, sporting things, etc. Such an interest is likely to extend itself to the whole house and its surroundings, and to create an attachment for the home place.

"The filth or poverty permitted or ignored in the midst of us are as dishonorable to the whole social body, as in the body natural it is to wash the face, but leave the hands and feet foul."

"When men do not love their hearths, nor reverence their thresholds, it is a sign that they have dishonored both."

