

PER
S
671
C34

THE CANADIAN THRESHERMAN & FARMER

CANADA'S FARM MACHINERY MAGAZINE
WINNIPEG CANADA

JUNE, 1913



E.H. Heath COMPANY Publishers
LIMITED
ELEVENTH YEAR

JOHN DEERE IMPLEMENTS

Dain Vertical Lift Mower

STRENGTH, ease of management, durability, light draft and superior cutting qualities characterize DAIN MOWERS. Frame made from one solid piece of iron. Only three pieces comprise the gear mechanism.

A coil spring working with the lifting apparatus makes control of the cutter bar either by hand or foot-lift very simple.

A small boy can easily lift the bar for turning corners or passing obstructions and can raise it to a vertical position for transporting without leaving the seat.

DAIN MOWERS cut easy and clean at all times.

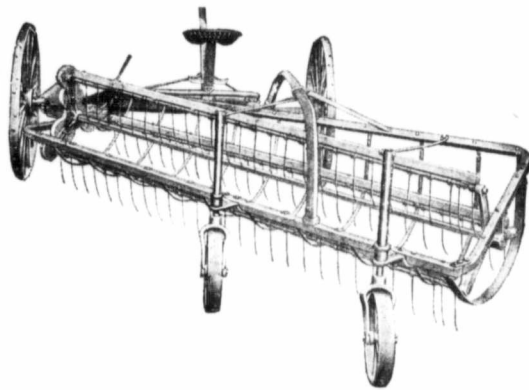

Dain Hay Loader

WITH a DAIN HAY LOADER, one man can easily load a wagon in a few minutes. The "force-feed" delivery pushes the hay forward on the load within easy reach.

DAIN HAY LOADERS enable the user to harvest his hay in less time with much less help.

All parts are hammock-mounted and slow-driven. Consequently, DAIN HAY LOADERS are light draft and easy to operate.

Being mounted on wheels lessens the draft. This, with many other light-running qualities, explains why the Dain requires less power to operate it and is the most popular Rake Loader built.

Couples to any height of wagon without any adjustments.

The ground wheels are set under the deck. Therefore, DAIN HAY LOADERS can be operated up close to obstructions and will gather all the hay cut by the mower.

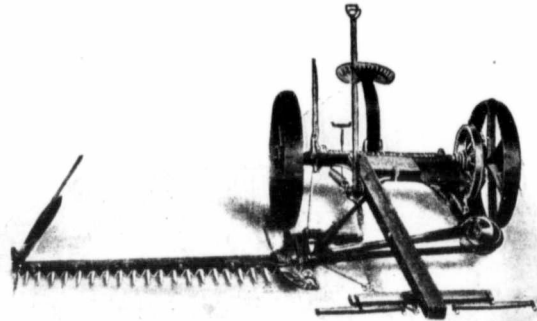

Dain Side Delivery Rake

IT WORKS around the field the same as a mower, gently gathering the hay into loose fluffy windrows through which the air can circulate freely. Hay raked with DAIN SIDE DELIVERY becomes thoroughly air-cured and not sun-burned and discolored. None of the feeding value is lost.

Two swaths of hay are raked at a time. Two windrows may be laid together for convenience when loading with a loader. The raking is notably clean.

The reel on the DAIN SIDE DELIVERY consists of three bars on which flexible teeth are mounted. It revolves slowly and uniformly. The teeth have a forward and upward movement which picks up the hay instead of dragging it along the ground.

DAIN SIDE DELIVERY RAKES will not wrap or wind with hay.

They will rake light or heavy hay equally well without picking up trash.

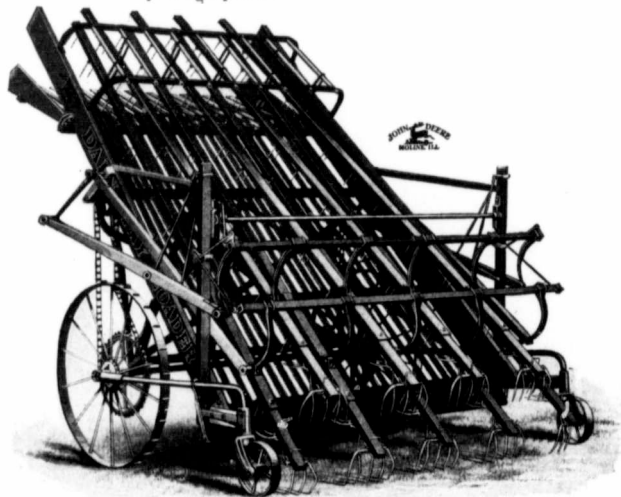

JOHN DEERE PLOW COMPANY, LIMITED
WINNIPEG REGINA CALGARY SASKATOON EDMONTON LETHBRIDGE

JOHN DEERE IMPLEMENTS

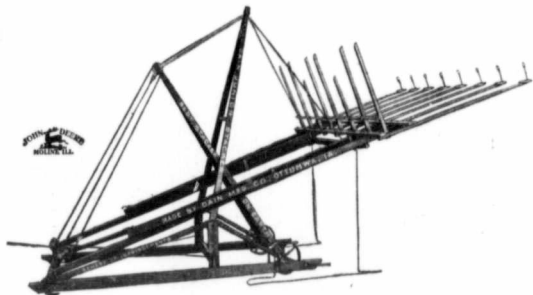

Dain Junior Mounted Stacker

There are many reasons why this stacker is so popular. Mounted on wheels, it is easily transported.

The hoisting gear is connected with both sides of the stacker head. The head does not sag or tilt while being elevated, letting the hay slip off.

Pitcher teeth are adjustable to hold the hay while topping off the stack.

Stacker teeth equipped with spring hay retainers prevent the scattering around of loose hay.

Large compression springs act as cushions. When the load is being dumped, they relieve the stacker of any sudden strain. These springs return the stacker from its dumping to receiving position.

The DAIN JUNIOR is strong and simple in construction, light of draft and easy to operate. Thousands of farmers the world over will attest to its satisfactory service.

Dain Truss-Frame Sweep Rake

This rake is constructed flexibly. The teeth will, therefore, conform to the uneven surface of the ground. CLEAN WORK IS THE RESULT.

Teeth are equipped with metal socket points, preventing them from damage, when coming in contact with any obstruction.

Sliding seat enables the operator to balance the load, thus relieving the pressure on the points of the teeth, REDUCING THE DRAFT.

Frame is trussed, a channel steel truss over the rake head equalizes the weight and PREVENTS SAGGING.

Hinged tongues make it easy for the team, as movement of the rake DOES NOT EFFECT TONGUE.

For an all-purpose sweep rake, the DAIN TRUSS FRAME has no equal. IT IS WELL CONSTRUCTED, NICELY FINISHED AND WILL GIVE A LONG SATISFACTORY SERVICE.

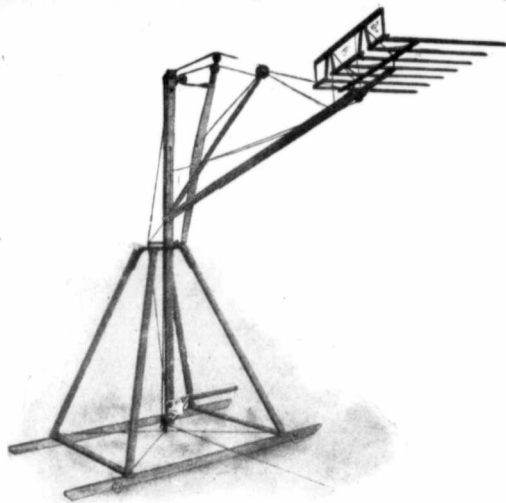

Dain Universal Swing Around Stacker

With this stacker a load can be taken up from any side of the stacker and deposited on the stack. The construction permits the swinging of the load either way around the entire circle.

The construction is substantial. It will carry the load at all points without any undue strain. The four posts which form the tower are tied together at the base with strut rods. They converge toward the top and are connected to the turn table with steel trusses.

A paralleling device working automatically maintains the teeth in a level position, while the load is being lifted, even though the load is unevenly placed on the teeth. After being dumped, the teeth return to proper position to receive the next load.

As a swing around stacker, the DAIN UNIVERSAL has no equal.

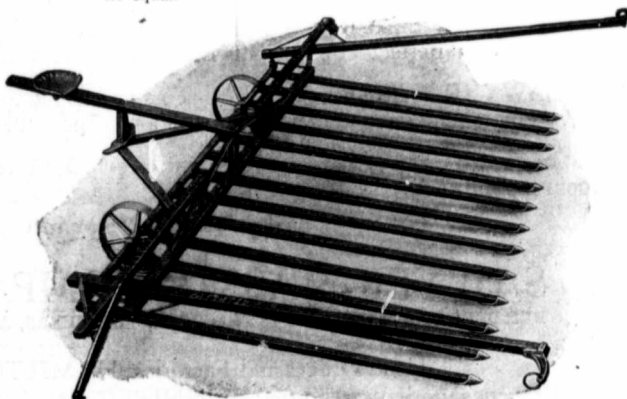

JOHN DEERE PLOW COMPANY, LIMITED
WINNIPEG REGINA CALGARY SASKATOON EDMONTON LETHBRIDGE

1836

1913

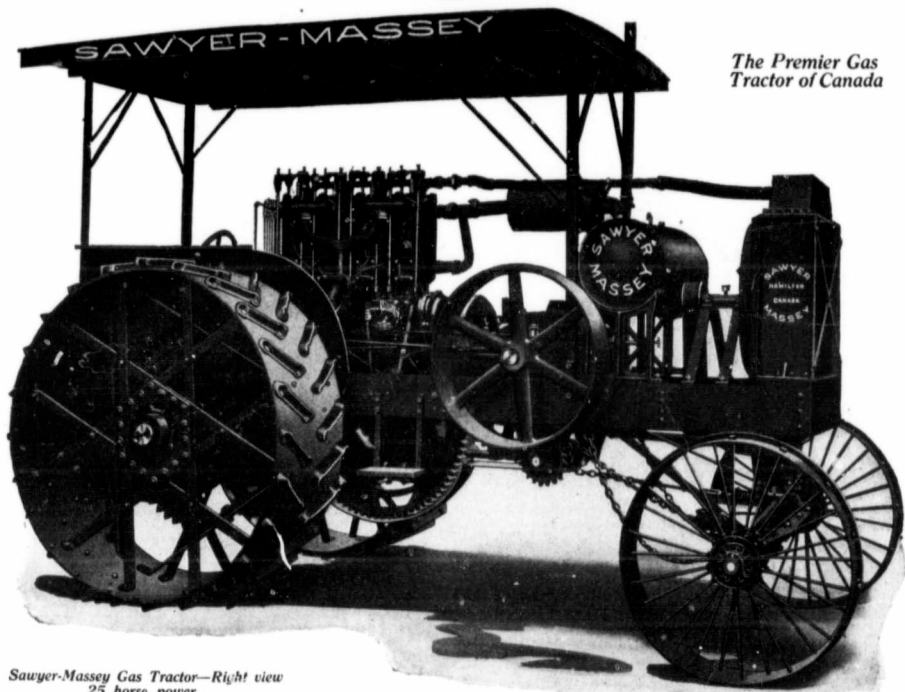

The Premier Gas Tractor of Canada

Sawyer-Massey Gas Tractor—Right view
25 horse power.

ECONOMY—RELIABILITY—POWER

The **SAWYER-MASSEY** "25" Gas Tractor excels in these three essentials.

Simple construction and perfect co-ordination of parts insure economy of gas and oil and the greatest ease in handling and keeping in repair.

Correct design, the best of materials, skilled workmen and competent supervision in manufacture insure absolute reliability and the maximum of service.

Rated at 25 Nominal and 45 Brake Horse Power, the **SAWYER-MASSEY** Gas Tractor develops 52 Actual Brake Horse Power. It has power for the heaviest work, and such power as comes only from perfect construction throughout the whole mechanism.

The **SAWYER-MASSEY** "25" Gas Tractor has demonstrated its superiority in Canada. It will give efficient service under any conditions, and will easily prove its superiority anywhere.

We have an attractive proposition for Dealers in Foreign Countries, and invite correspondence.

Write for our Illustrated Catalogue

SAWYER-MASSEY COMPANY LIMITED

BUILDERS OF STEAM AND GAS TRACTORS, THRESHERS, AND ROAD-MAKING MACHINERY.

Head Offices and Factories: HAMILTON, ONTARIO.

Branches and Warehouses: WINNIPEG, Manitoba, REGINA, Saskatchewan

SAWYER-MASSEY

"THE PREMIER COMPANY"

"THE PREMIER GOODS"

You saw this advertisement in this magazine. Don't forget to say so when writing.



Vol. XVIII.

WINNIPEG, CANADA, JUNE, 1913.

No. 5

OUR PRE-HISTORIC ALFALFA

PUBLIC interest in the growing of alfalfa in Western Canada has of late become so intensified we have thought that a few facts which are not generally known as to the history and distribution of the plant might not be unacceptable. Still more interesting may the reading of this brief article prove when we state at the outset that there are few things within the range of field husbandry that have a more remote ancestry, that carry a more dependable record, or that can be more successfully wooed by what often seems the most forbidding circumstances of soil and climate.

As a matter of fact, there appears to be no time in the world's history at which this wonderful legume was not known, used and esteemed as one of the most valuable of all field crops. Since men were able to live and leave a record behind them, alfalfa has been as commonly used in the feeding of all herbivorous animal life as wheat and oats are in sustaining human flesh today.

Its native soil (so far as it can be traced) was Central Asia where, as Mr. Coburn says: "it possibly afforded the herbage which sustained Nebuchadnezzar in his humiliating exile and eventually restored him to sanity and manhood." However that may be, we know that it was carried by the Persians into Greece with the invasion of Xerxes in 490 B. C., utilized by the Romans in their conquest of Greece and carried to Rome in 146 B. C. Pliny and other writers praise it as a forage plant, and it has been in cultivation in parts of Italy con-

tinuously from its introduction. The name "alfalfa" is an Arabic term meaning "the best fodder," and if the ancients of the Old World realized its value to the extent this indicates, it is an amazing circumstance that with all our development in Western Canada, the plant is only of recent date in our midst and only yet is being seriously "tried" as a crop that can be depended upon

to Belgium and England, and one of our English writers of the Plantagenet period speaks of it in glowing terms as a food plant for cattle.

But to the Spaniards is due the gratitude of the Western Hemisphere for the circumstance that it now is what it is all over North and South America. Not in the interests of "intensive farming" but in one of the most bloody

1853 or the following year was it introduced into Northern California (from Chili, it is said), but it had been grown by the Spaniards and Indians in Southern California for probably a hundred years, having had a gradual migration from Mexico.

While it is even now discussed as a new plant on the Atlantic Coast, it has been in cultivation on a small scale in the Carolinas, New York and Pennsylvania for probably a century and a half. There are, of course, small fields in those States that have been producing for over sixty years, and there are records of it showing that it had been known and duly attested before that. In a book written in 1793 by one named Spurrier and dedicated to Thomas Jefferson, the writer enthusiastically speaks of it as "lucerne," tells how it should be cultivated, and gives the information that three crops of valuable hay could be cut from it annually.

From time to time since then it crops up in the "transactions" of one Agricultural Society or another, and in one case the statement is made as to its yielding six to nine tons of hay per acre "under the best cultivation and plentiful manuring." Yet its cultivation did not spread. The indifference of the real "old timers" of the early days to any new idea in crop cultivation must have been more pronounced than even the sluggishness and hidebound incredulity of these days.

According to this Spurrier, the difficulties of propagation were not considered greater than we estimate them now. He said one planting would survive many



A Few Thousand Dollars Worth of Perfectly Cured Alfalfa Hay

and that can be profitably grown. It is known in France and England as lucerne, why, we cannot say. Some writers assume that it is thus named from the Swiss Canton, Lucerne, but this cannot be the case as it was not known there until long after it was cultivated in France and England.

It is generally believed that the Moors introduced it into Spain from northern Africa at the time of the Moorish Conquest of Spain about 711 A.D. At all events it was imported into France, later

raids recorded in history did Cortes bring it with his company of cut-throats to Mexico in 1519 and in less than twenty years afterwards (also in the train of ruthless warfare) was it imported by the Spaniards into Peru and Chili where it has ever since luxuriantly flourished.

If it was planted on the United States Atlantic seaboard in that century, it does not appear to have been appreciated by the Indian aborigines nor even by the early European settlers. Not till



years, and the yield was three times as great as that of any other forage plant. We know that alfalfa is very longlived. Fields in Mexico, it is claimed, have been continuously productive without re-planting for over two hundred years, and others in France are known to have flourished for more than a century. Its usual life in the United States is reckoned as probably from ten to twenty-five years, although there is a field in New York state that has been mown successively for over 60 years. Mr. Coburn in his "Book of Alfalfa" suggests that "under its normal conditions and with normal care it would well-nigh be, as it is called, everlasting."

The Wonderful Root System

The root growth of alfalfa is probably the greatest of wonders. While it usually grows no higher than 4 or 5 feet (although it has been known to reach more than 10 ft.)

and its normal height is about three feet, its roots go down ten, twenty or more feet, and one case is reported in Nevada where the roots were found penetrating through crevices in the roof of a tunnel one hundred and twenty nine feet below the surface of an alfalfa field! Professor W. P. Headden of Colorado found roots nine feet long from alfalfa only nine months old, and another reports seventeen inches long of but four weeks' growth, the plants being but six inches high. It usually has a slender top-root, with many branches tend-



ing downwards, yet with considerable lateral growth. As the tap-root is piercing the earth it is also sending out new fibrous roots, while the upper ones, decaying, are leaving humus and providing innumerable openings for air, the rains and fertilizing elements from the surface soil. The mechanical effect of this root growth and decay in the soil constitutes one of the greatest virtues of the plant, and by its roots alfalfa becomes self-acting, by far the most efficient, deep reaching sub-soiler and renovator known to agriculture.

The botanical name of alfalfa is "Medicago sativa." There are some 50 species of this genus, Medicago, that are known, but alfalfa and one or two others are all that are of practical value as

made, we believe, of a far more thorough and painstaking character which tend to discredit the slipshod experiments made by some growers who were entrusted with seed brought back by Professor Hansen.

It is not within the scope of this article to give the extended reports of our own Canadian experiments, such as were so exhaustively made last year under the direction of Professor Bedford, Deputy Minister of Agriculture in Manitoba and of the Saskatchewan Department, and which are being continued on a still more extended scale this year. These will be found elsewhere in the "Canadian Thresherman and Farmer" in due course, as well as all else that can be gathered as to the ascertained quali-

ties and the limitations of different varieties. Acclimation of alfalfa is a slow process, and numerous close observers think there are too many radical differences in climate and possibly of soil between Turkestan and New Mexico, Manitoba or Saskatchewan to admit of this variety's becoming a pre-eminently valuable acquisition to North America generally. It is thought more reasonable to let the American-grown alfalfa gradually accustom itself, as it will, to any particular region, sowing seed from nearly the same latitude, and grown under as nearly as possible the conditions it will encounter in its new environment.

Experts Refuted

Not many things in the progress of agricultural science have more frequently upset the pronouncement of "experts" than alfalfa growing has done. While certain oracles have been declaring that alfalfa would only grow in certain soils and in certain climates, it has again and again shown its adaptability to nearly all climates and mostly all soils. It produces with a rainfall as scant as 14 inches and in the Gulf States of America flourishes with 65 inches. It gives crops at an elevation of 8000 feet above sea level, and in Southern California it grows below sea level to a height of 6



The Larger the Stack the Less Waste of Hay from Exposure to the Weather

feet or over, with nine cuttings a year, aggregating ten to twelve tons!

Another authority positively announced "it will grow wherever corn will grow," and hardly had he said it when men from New York and Louisiana came forward and said they were growing it where corn would not grow. Another declares: "it will not grow over a hardpan or gumbo soil," and at once still another man from the Atlantic coast reports a good field of alfalfa with roots fifteen feet long that pass through six inches of hardpan which was so hard that it had to be broken with a pick axe in following the root!

A Kansas man writes that he has eighty acres which had stood 5 years at the time of writing and promises to continue indefinitely, yielding 4½ tons from 3 cuttings a year, and the whole of it on gumbo soil where corn raising

feet or over, with nine cuttings a year, aggregating ten to twelve tons!

Among other claims for Turkestan as distinguished from the ordinary alfalfa, the U. S. government officials in charge of its introduction and exploitation aver that its seed will germinate much quicker and the plants start into growth earlier under the same conditions than common alfalfa. The plants are more leafy, grow more rapidly and have a stronger, more vigorous root system. Another advantage which the Turkestan variety has is that the stems are more slender and less woody, the plants making a more nutritious hay of finer quality. That it will withstand drought under the same conditions better than ordinary alfalfa seems certain from the reports of the experimenters. In the West and Northwest, at least, it seems to be more productive both with and without irrigation."

Another authority positively announced "it will grow wherever corn will grow," and hardly had he said it when men from New York and Louisiana came forward and said they were growing it where corn would not grow. Another declares: "it will not grow over a hardpan or gumbo soil," and at once still another man from the Atlantic coast reports a good field of alfalfa with roots fifteen feet long that pass through six inches of hardpan which was so hard that it had to be broken with a pick axe in following the root!

A Kansas man writes that he has eighty acres which had stood 5 years at the time of writing and promises to continue indefinitely, yielding 4½ tons from 3 cuttings a year, and the whole of it on gumbo soil where corn raising

feet or over, with nine cuttings a year, aggregating ten to twelve tons!

was a failure. Still another expert declares: "it must have a rich, sandy loam," and forthwith from the deserts of Nevada, the sand hills of Nebraska, and the thin, worn, clay soils of the South come reports of satisfactory yields! Such results are significant, indicating better returns than any other crop brings from these varied soils, and that few farmers are justified in postponing the addition of alfalfa to their agriculture because of supposed hindrance of soil and climate.

These testimonies, together with what have been published of our local experiments, show that there are no greater barriers to success with alfalfa at almost any point in Western Canada than what are imposed on the crop by the men who are growing it. Last year reports of the Manitoba experiments were most encouraging in view of the fact that the crop was to a great extent left to "fend for itself" after it had been seeded. Had the professor's instructions and hints been more carefully followed and greater interest taken in safeguarding the experiments for the purposes of accurate returns, the results would certainly have justified almost any hope as to its future.

Authorities and humble experimenters alike seem to agree that there are

only two things that alfalfa cannot stand, and these are wet feet and abnormal acidity in the land. It never seems to do well where the water is nearer to the surface than six feet, or where in winter water will stand on the ground for over forty-eight hours. If water flows over the field for some such time due to a freshet, the alfalfa is often found uninjured if too much soil has not been deposited on and around the plants. Even in such instances, fields have been saved by a disking once or twice, but it is wholly unwise to sow on a field subject to overflow, or one where water rises to the surface in winter or spring; likewise on a field so flat that water will not run off in time of a heavy rain or promptly drain out through the sub-surface.

The alfalfa roots will find their way to moisture if given the right surface conditions. There are profitable alfalfa meadows in parts of Kansas where it is eighty

feet to water, but there has not yet been found one that is prosperous where water comes close to the surface, or where it stands on the ground in winter.

The other neighbor that alfalfa will not tolerate is an excess of acidity in the soil. This often happens where corn and wheat have been raised for many years, thus robbing the soil of much lime—a condition that may be remedied by an application of lime to the land just before sowing to alfalfa, harrowing it in beforehand, or, if the seed is to be broadcasted, the lime may be applied just before sowing, when once harrowing will suffice for both, or it may be sown with a drill—500 to 1,000 pounds per acre.

A simple test for acidity is to make a deep cut in the ground with a knife, pressing the earth slightly apart, then push a piece of litmus paper into the opening

in clods and baked soil. Alfalfa is a child of the sun; permanent shade from any source is its enemy, and when young it is not a good fighter against adversaries of any sort. More failures are due to weeds than to any other cause, and unfortunately all the weeds do not grow on the land of the farmer who is shiftless or neglectful.

Alfalfa in Comparison with Other Feeds

The feeding value of alfalfa is largely in its chemical compound known as protein; its extreme digestibility is another desirable quality to be considered, and not least is its appetizing character. Not only do all animals like it, but when given in moderate quantities it seems to increase the general appetite for more fat-making feeds. Steers beginning to "fall off" on a heavy diet of corn, or in fact of anything else will come to



food and 6.95 pounds of proteids, while 100 pounds of alfalfa contain 54.43 pounds of digestible food and 11.22 pounds of proteids. Another station reports that the average yield per annum of green clover to the acre is 14,000 pounds, and of green alfalfa 36,500 pounds. The protein in the clover is 616 pounds, and in the alfalfa 2,214 pounds; one ton of alfalfa has 265 pounds of protein, and clover only 246 pounds.

But alfalfa will produce, two, three or more cuttings each year

while clover will produce but one or two at most. Further, clover will ordinarily survive but two years, while alfalfa will last from ten to one hundred, thus saving many plowings and seedings.

It is also estimated that the stubble and outgrowth of alfalfa are worth at least four times as much for humus as are those of clover, while the mechanical and other beneficial effect of the long alfalfa roots far excel those of clover.

The alfalfa field is green for pasture a month earlier in the spring than clover and may be mowed a month earlier. It starts a vigorous growth at once after cutting, covering the ground with its luxuriant foliage before the second growth of clover has made any substantial progress.

We cannot at this writing do justice to its marketing advantages. The records are most voluminous where it has been handled persistently. One man writes from Lincoln County, Kansas, that from five acres he received in one season \$100 for hay, \$150 for seed and \$20 for straw.



Dinner Time in Old Devon

and press the earth together. Leave the paper there for a few hours. If upon examination the litmus paper has a pink appearance it is proof of acidity, and this, as already said, may be remedied with lime.

Forward Preparation

Many of the most successful growers of alfalfa begin preparations two or three years before they sow the seed, and having regard to the perennial if not everlasting nature of the subsequent crops, this or any preparation cannot be grudged. There must be, by rights, the most perfect physical condition of the soil. It should have been plowed deep for at least two years, and, generally speaking, a two or three inch sub-soiling along with a seven or eight inch plowing will be very helpful.

The soil's condition should be like that of a garden. Care should be taken never to work with the ground when too wet, as such working almost inevitably results

their appetites after being fed only a few pounds of alfalfa daily.

Alfalfa alone is not a fat-making food. Animals fed upon it grow in weight, but the weight is principally of bone, blood and muscle. It is without a sufficiency of fat and carbohydrates, and these should be added in such food as corn, corn meal, etc. When alfalfa is fed alone, all the protein cannot be digested, and therefore it is always economical to add some carbonaceous food, if animals are fattening for market.

Many things are understood best through contrasts with others better known. In every part of an agricultural country certain crops are considered standard, and all others are judged by comparison with these. For example, red clover almost everywhere is ranked the best yielding forage, and the fertilizer and renovator par excellence.

After a series of tests, one report says 100 pounds of clover contain 47.49 pounds of digestible

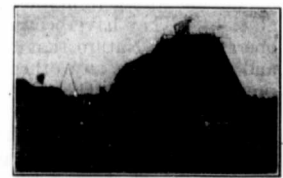



"Everything Begins and Ends with the Soil"

The CANADIAN THRESHERMAN & FARMER

CANADA'S LEADING AGRICULTURAL MAGAZINE

PUBLISHED MONTHLY BY

E. H. HEATH COMPANY, Limited, WINNIPEG, CANADA

E. H. HEATH, PRESIDENT E. W. HAMILTON, MANAGING DIRECTOR F. C. BRAY, TREASURER
J. D. DUTHIE, EDITOR C. B. FULLER, FIELD REPRESENTATIVE
(MEMBERS WESTERN CANADA PRESS ASSOCIATION)

AUTHORIZED BY THE POSTMASTER GENERAL, OTTAWA, CANADA, FOR TRANSMISSION AS SECOND CLASS MATTER

JUNE, 1913

SUBSCRIPTION RATES

Postage prepaid, Canada and Great Britain, \$1.00 Per Year.

Postage prepaid, United States and Foreign Countries, \$2.00 Per Year.

Failing to receive paper, you should notify the office at once, when mistakes, if any, will be corrected immediately.

All Subscriptions must be paid for in advance and are positively discontinued at date of expiration unless renewed.

Advertising copy in order to secure good position should be in our hands not later than the 15th of the month preceding date of issue.

Advertising rates furnished on application

TIME IN THE BILL OF COSTS

THERE IS ONE ITEM in the price of all success, of every development that is not always taken into account—Time. If it is not actually forgotten, it is astonishing how universally it is grudged when one comes to "foot the bill." And yet it is the tool of all others that Nature positively refuses to work without. "All men in their haste" would seek to rob her of it, but in every case the end is disaster, the experiment is the worst of all abortions and the impatient mortal who tries it has to begin all over again.

TIME FLIES: "it's a way time has," said Artemus Ward, but the implied idea of rapid flight has no part in Nature's working plan. Time "flies" only to the man who can't or wont keep step with Time's unhalting yet unresting progress, and the meaning of this need never be explained to the man who knows the sin of procrastinating. With a congenital disposition to "put off," he knows, in a

way which no language can accentuate the tragic side of this experience—the commonest, perhaps, of all human experience.

the natural product. Men can assist Nature and men have produced wonderful variations in the prehistoric fruits—working all the time, however, in unison with Nature, but with all her kindly co-operative spirit, *she will not be rushed.*

"THE GAS ENGINE IS A FIZ-ZLE," said a good friend the other day. He had tried it on his farm, and the result had been anything but satisfactory. "You can't make poultry pay in Manitoba" was the solemn affirmation of two others who had been in the hen game but who ought to have been the last men in the province to make the statement. In all of these cases wherein "it can't be done" there were two elements that scored against success: first, the business of handling the engine and farming the poultry had been delegated to another; and second, the time allowance was something like that of the boy who planted an acorn on his birthday and a week later worked his way down to the seed to find how it was getting on.

HOW LONG AGO IS IT since the internal combustion engine was as crude and incomprehensible to even a trained mechanic of the day as are the principles of wireless telegraphy to an ordinary school child of today? We know quite a number of men who have had the same disappointing experience with their gas machinery but they all frankly admit that the engine may be and probably is all right, but they had been unfortunate with their men. Or if they had handled it themselves, they are free to admit that their knowledge was at the most fragmentary—acquired, perhaps, from a couple of demonstrations at the factory or the trial ground of the branch house where the engine was purchased.

NOW A MACHINE THAT COSTS in the neighborhood of \$2500 is worth the expenditure of some time in acquiring a familiarity with its parts and with its habits before taking it out to the serious business of breaking or plowing. At all events it is as unreasonable to "pass up" the experiment as it is to condemn a 15-jewelled modern watch because some ignoramus had taken it to pieces and found it impossible to replace its parts. Knowledge and time are as necessary an accompaniment to any bargain in farm machinery as sunshine and rain are to the growing of the crops. If you haven't got it, you've got to buy the experience. The cheapest purchase in experience is to pay the market value for it.

THE LIE IS GIVEN to the complaint of these men by an overwhelming mass of evidence. In Manitoba we have many scores of men who have scarcely wasted a dollar on their gas engine experiments and who have had a record of unbroken, paying success since they bought their equipment. And we know nearly as many men and at least one celebrated woman in Manitoba who are making poultry not only "pay," but by intelligent treatment of the birds and shrewd marketing practice are making a big income from this one source. If in doubt—please communicate.

A CHINESE AMBASSADOR was sent by his Emperor to every point of the civilized globe he could reach. The stolid celestial was after information, but he found that the "heathen Chink" could give pointers to many nations in which his country and its traditions was a by-word; to men who were bursting with self-complacency in their superior intelligence, having nothing to gain of educational value from the benighted oriental. When he returned to Peking, the English attache asked him whether there was any trait he had observed in his travels which was peculiar to all men in every country he had visited. "Yes," he replied, "me tink all men love lazy."

ONE EMINENT JURIST has said that downright laziness on the part of men and the desire to possess and to get off without paying the price is the tap-root of all the crime that had ever come before him. It seems to be in the blood of all men, and it certainly has become thoroughly inoculated into Canadian life. Not that the hustling Western people are kleptomaniacs suffering from that itching to appropriate something to which they have no right, but they are awful sinners when it comes to meeting an obligation in which time is an item which cannot be set aside without prejudice.

IN THINGS WHICH THEY HAVE GOT TO KNOW about, like the germination and growth of wheat, they are all right. They have been taught by years of the invariable operations of Nature that they cannot force wheat to grow and ripen within any other point of time than Nature has prescribed for it. Of course they can "force" rhubarb and produce hot-house strawberries in a week or two ahead of their natural out-door date, but when ever did "forced rhubarb" or the results of any other hurried experiment compare with

OUR GUARANTEE

No advertisement is allowed in our columns until we are satisfied that the advertiser is absolutely reliable and that any subscriber can safely do business with him. If any subscriber is defrauded E. H. Heath Co., Ltd., will make good the loss resulting therefrom, if the event takes place within 30 days of date advertisement appeared, and complaint be made to us in writing with proofs, not later than ten days after its occurring, and provided, also, the subscriber in writing to the advertiser, stated that his advertisement was seen in "THE CANADIAN THRESHERMAN AND FARMER." Be careful when writing an advertiser to say that you saw the advertisement in "THE CANADIAN THRESHERMAN AND FARMER."

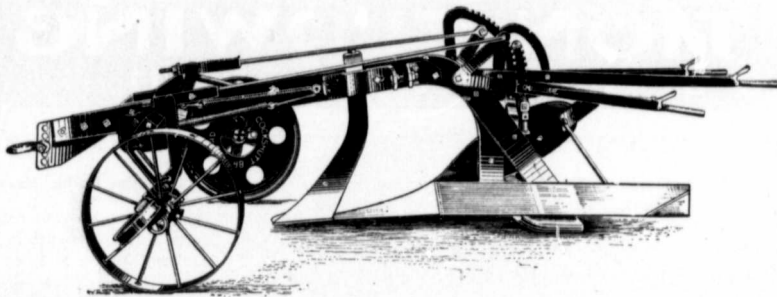

**New
Features
that save time
and give you
Better Results**

Cockshutt Engine Scrub Breaker

AN improvement over any brush breaker now on the market. Read this advertisement, then see one, and place your order early.

There is three inches more clearance under the beam—a valuable feature when working in heavy brush.

The shares are made thicker and stronger to stand the heavy work. Note the heavy construction throughout. This Brush Breaker is built to do good work in the heaviest and roughest land.

The furrow wheel is set at an angle, obviating any tendency to climb the furrow. This also allows more clearance between the wheel and the mouldboard for getting away brush.

Makes Heavy Work Easy

The levers are spring balanced, making easy control of the wheels in entering and leaving the furrow.

In addition to the regular levers there is a third one by which the rear end of the plow can be instantly raised on a shoe for transportation. This shoe is on a swivel and swings around, allowing the plow to freely follow the tractor. When starting the furrow this shoe is quickly thrown up clear of the ground with the lever. A very handy arrangement and a time saver, no heavy lifting or loss of time, simply pull the third spring-balanced lever.

Cockshutt Plow Company, Limited

BRANCHES:

WINNIPEG REGINA CALGARY SASKATOON

DISTRIBUTING POINTS:

Red Deer Lethbridge Edmonton Brandon Portage la Prairie

TRACTION PLOWING

AS TOLD BY THE MEN WHO DO IT

Tractor Must be Looked After

Your letter of recent date received, and will give you a little of my experience, although I have only had my outfit for one year.

I have a 15-30 Oil Pull engine, Rumely make, and will say that I am well pleased with it, and am satisfied that it can do as much as or a little more than any other

many horses and men to do the same amount of work, and then you would have the horses on your hands the rest of the time.

In harrowing, I use two gangs of harrows, one behind the other, covering about 26 feet. This does great work at three miles an hour. I did this before and after seeding with good results, not using the

small or medium outfits do better work and make more money for the man that runs it.

I really think there would be fewer engines sold if men were more plentiful, and horses not so high priced, but as things are now, the farmers in order to get the amount of work done, and to get it done at the right time, can-

Engine Rather Heavy

In response to your request regarding my experience in traction farming will say that we have a steam plowing outfit, 32 h.p. Case engine with a 12-bottom Cockshutt plow. We use ten plows for sod but put on two more for old ground.

In breaking sod I run with a crew of seven men and a cook. Engineer, fireman, plowman, night-man, blacksmith, tankman with two horses and a coal hauler with four horses. We plow 4 1/2 inches deep and average about 27 1/2 acres per day. We have the night man to get up steam, coal and oil up and get everything ready for the crew to start at 5.15 in the morning. We run till 12 o'clock and then the nightman comes on while the crew eat their dinner. The crew start again and run till 7.30 when they quit work, eat supper and go to bed if they like.

We aim to pay good wages, feed well, treat our men white and work accordingly. It takes three tons of coal, 3,400 gallons of water and \$3.00 for oil. We find this size engine very good for plowing any land, but mighty heavy for wet places. I do not think that it is a success for discing, spring plowing or for summer fallow discing. When discing we pull eight 16 x 16 disc harrows and six sections of lever harrows behind. For seeding it would ridge the ground too much.

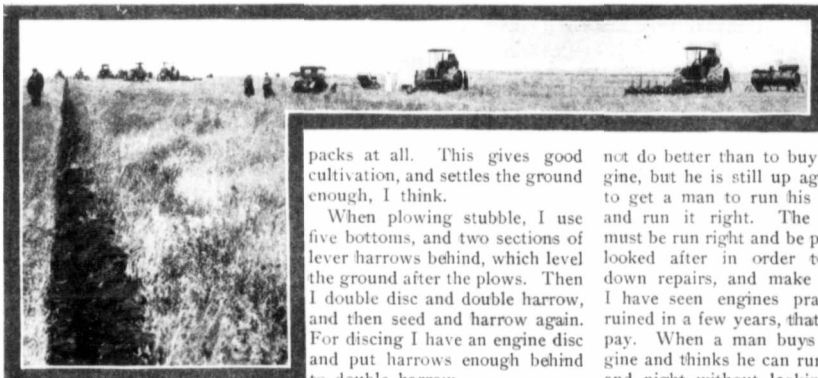

packs at all. This gives good cultivation, and settles the ground enough, I think.

When plowing stubble, I use five bottoms, and two sections of lever harrows behind, which level the ground after the plows. Then I double disc and double harrow, and then seed and harrow again. For discing I have an engine disc and put harrows enough behind to double harrow.

I am not in favor of using an engine for seeding and cutting, unless one has no horses at all, but I think it is a paying proposition to keep horses as well as the engine. There are too many parts to be looked after when seeding and binding, consequently when one puts several of them after an engine they are more or less neglected, and break down or do poor work, but by taking the heavy work away from the horses they will be in shape to do the seeding and cutting in less time, that is, one can drive faster, and do a greater distance during that time, and can also do better work.

I think it is a good idea to do the discing and harrowing with the horses right after the plows, as that kind of work is hard on an engine on account of the dust and grit. By doing each piece of work separately better work can be done, than when doing them all together.

In regard to running the engine on plowed land, I would rather work it down with horses, as I think the engine packs the ground too much. I also think that there is a limit to the size of the engine. I think a 15-20 h.p. engine is big enough for one man to handle, and to do good work, that is, for the average farmer with about a section or so of land.

In regard to threshing, I think

not do better than to buy an engine, but he is still up against it to get a man to run his engine, and run it right. The engine must be run right and be properly looked after in order to keep down repairs, and make it last. I have seen engines practically ruined in a few years, that do not pay. When a man buys an engine and thinks he can run it day and night without looking after it, sooner or later he will find out that he has made a mistake, but often he blames the engine, and not himself. An must be looked after properly in order to do good work, just the same as a horse. If not, they will soon show it, as at first a few weak parts will break, and after a while the whole engine is a wreck, and has not made the money that its owner thought it would make when he bought, but that is not the en-



gine's fault. My idea is to combine the work of the engine with that of the horses. Do the hard work with the engine, and then finish with the horses. This gives time to look after them all, and keep them in good shape.

Yours very truly,
B. Wolff,
Liberty, Sask.

No, I do not consider it detrimental to plowing old ground. In old ground I think with the twelve plows we can plow 50 acres per day.

By using a night man we can get at least two hours more work done per day besides save the crew ever so much. Last season we paid the engineer, \$6.00 per

make of engine, taking all things into consideration.

Now as to fuel, I have never taken particular notice, as to how much oil I used per day, as it is hard to tell just how much is left in the tank, and we do not always do the same distance each day, but I can say that I did not use three gallons per acre, when breaking heavy clay land, and pulling five bottoms.

I then shipped my engine to Brock on the Goose Lake line, where the soil is very heavy, and the engine could only pull four bottoms and naturally took a little more oil, but not so much as three gallons per acre. I had no men or horses with my outfit, as I handled both the engine and plows myself, and had the oil and water hauled by the load.

In regard to the cost per acre when plowing, discing, and harrowing, I am not able to say much, as I worked mostly by myself, and put in a lot of broken time, as I had other things to look after, but would say that I would not try to farm on a big scale, that is a half section or more without an engine. An engine will do good work, and needs little repair if properly handled. You can also do it in much shorter time, than if you had horses, as you would require too

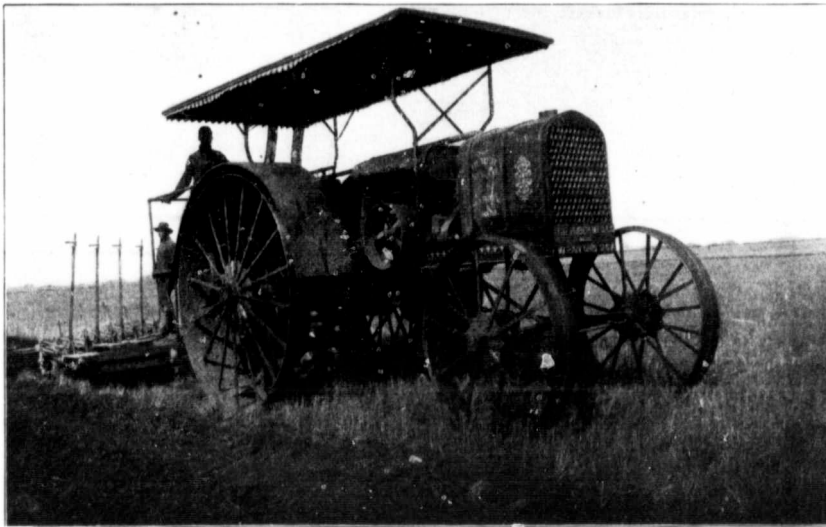

Use a Huber Gas Tractor For Your Plowing or Threshing

It is built for the big work of Western Canada. Capable of meeting the most exacting requirements. Motor is of the four-cylinder type; drive wheels eight feet high; gearing of the strongest construction. No tractor has stronger pulling power; is more adaptable or more lasting. These facts are best demonstrated by actual use of the outfit. We urge your careful attention to the proposition we have to offer in this HUBER "THIRTY-SIXTY" TRACTOR. Prompt deliveries assured.

You need a threshing machine of large capacity for your work. We have the machine for you. Has every good cleaning, grain-saving and labor-reducing device. It is a machine that will make money for you every day, giving the biggest output of cleaned grain.

A HUBER THRESHER, run by a HUBER TRACTOR, puts you in position where you can run your business at a profit. You will not be trying out a new thing; but an outfit that has been tested for years in every kind of work, and that has invariably given satisfaction to users.

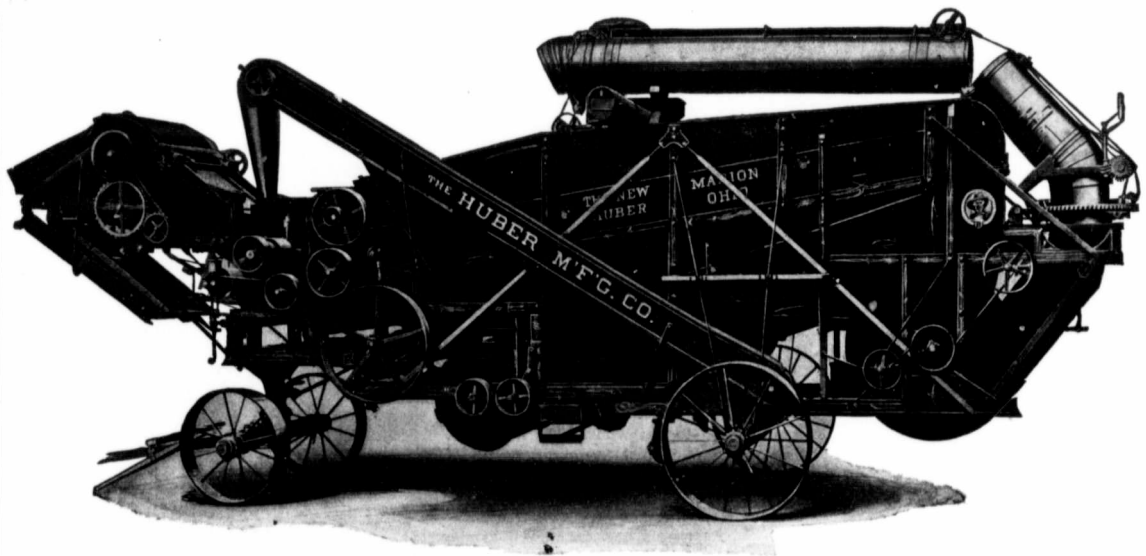

THE HUBER MANUFACTURING CO.

MARION, OHIO, U.S.A.

Canadian Headquarters: Corner Logan and Arlington St., WINNIPEG, MANITOBA

You saw this advertisement in this magazine. Don't forget to say so when writing.

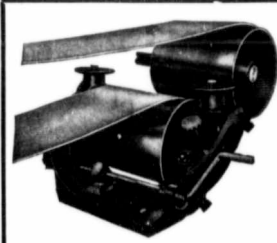

LOOK AT THESE

THE OLD RELIABLE DEPENDABLE CASWELL ADJUSTABLE BELT GUIDE.

Holds the belt steady in every wind that blows. As necessary as a self-feeder. Always on the job. Saves the belt. It has been saving time, labor, belts, and money, for thousands of threshers for over a decade. **LET IT SAVE YOURS.**

THE CASWELL AUTOMATIC BINDER HITCH
Simple. Easily Attached. Cheap.

Each binder steers itself and cuts an even swath all the time on in-curves, out-curves, round corners, square corners, and points, without any attention whatever.

After two years of success everybody says "The best at any price."

CASWELL MFG. CO.

Cherokee, Iowa U.S.A.

"I sold five of your binder hitches this year and the parties that bought them are well satisfied with them, in fact they give better satisfaction than the higher priced hitches."
C. K. CHRISTENSEN,
Carpis, N. Dak., Dec. 11th, 1912.

We also manufacture a full line of **Power Farming Equipment** including **Wagons, Packers, Disc and Seeder Hitches, etc.** Write us to-day for catalog and prices. Also see your dealer. Dealer business solicited.



You saw this advertisement in this magazine. Don't forget to say so when writing.

day, tank man, \$2.50 per day, coal hauler, \$40 per month, blacksmith, \$80 per month and the rest received \$3.00 per day and received \$3.50 per acre and 50c for pulling the packer behind the plows.

The following are my expenses:

Engineering	4.50
Fireman and waterman	3.00
Coal	8.00
Oil and blacksmith	1.50
Board for team and men	2.50
Team	2.00
	\$21.50

Traction Farming Has Come to Stay

I will try and tell you my experience with a traction engine. Last spring my brother and I bought an outfit consisting of a 30-60 h.p. Hart-Parr engine and an eight-furrow J. I. Case engine gang. Owing to the very wet spring we did not get started very early. In stubble plowing we pulled eight plows, which was a very light load for the engine, consequently we did not use much more than a barrel of kerosene per day, and about a barrel of water.

In breaking we pulled six plows 14-inch, and used one and a half barrels of kerosene and one and a half barrels of water according to the weather. We also used from three to five gallons of gasoline per day. The more stoppages we had, the more gasoline we use. We ran our engine about twelve hours per day and our best record per day was fifteen acres in ten hours with six plows. While breaking we had three men on the outfit, my brother ran the engine and we had one man on the plows and one man to draw oil and water, do the cooking, blacksmithing and make himself generally useful, which kept him pretty busy. We are going to put four men on this summer so that we can

mostly breaking, I have tried to figure out the cost per acre.

Engineer per day	\$ 3.00
Plowman per day	1.50
Oilman per day	1.50
Board three men	1.50
Kerosene per day	8.70
Gasoline72
Grease and oil	1.00
Team	1.50
Depreciation	1.00
Interest	1.00
	\$21.42

This makes the average cost per acre about \$1.80. I figure it costs about \$2.00 per acre to plow wild prairie and I do not think it can be broken any cheaper with horses as we have broken lots with horses and oxen too.

In my opinion traction farming has come to stay and provided the land is not too wet, the modern tractor can be depended on just as much as horses to get the crop in. We have practically no trouble at all with our engine, which speaks well for the Hart-Parr, as my brother has never run an engine before and only had a couple of days assistance from the expert at the start.

I do not think a tractor has any detrimental effect on plowed land as once last spring we ran our engine through a field of wheat and when the grain was up a couple of inches, at harvest time we could not notice where the engine had been.



Hoping this information will be satisfactory, I am,
Yours truly,
Mason Morris,
De Winton, Alta.



A Good Average

I received your letter the other day asking for my experience in traction work.

I have a 25 h.p. Case steam tractor, and a Cockshutt ten-furrow 14-inch plow, which my engine handles nicely. In regard to expense, I hired my men by the month during the summer, paying \$37.50 per month, which would work out to about \$1.50 per day.

I buy my coal by the car load, paying \$7.90 a ton, and when I am plowing, I run the engine myself. One man looks after the plows, while another man hauls the water, and the coal, so that two men and myself can run the outfit.

I plow on an average 30 acres per day, using about 2,200 pounds of coal at 7.90 per ton, which would cost about \$8.00 per day, \$1.00 for oil, and two men costing me \$3.00. Total expense \$12.00, and plowing costs on an average of 40c per acre.

They break about 15 acres per day on job work, for which I got \$4.00 per acre, which earned me \$60.00, which after deducting \$21.50 would leave me a profit of \$38.50 per day.

I do not use the engine for any other farm work other than threshing. I have a Waterloo separator 36 x 56, which my engine runs with ease. I averaged about 1,500 bushels a day at 5 1/2c per bushel, which earned me \$82.60, and my expenses per day were:

Engineer	6.00
Fireman	2.75
Water man	4.75
Four pitchers	11.00
Oil	1.00
Myself (running separator)	6.00
	\$31.50

which deducted from \$82.60 would leave me a profit of \$51.10, and as I put in thirty days threshing, the total profit would be \$1,533.00.

I think this is all I have to say this time. This is my first season with my engine, but I have had no breaks at all, and my engine is very little the worse for wear. Hoping that these few lines will be of some use to you, I am,

Yours truly,
S. E. Nichol,
Bagot, Man.

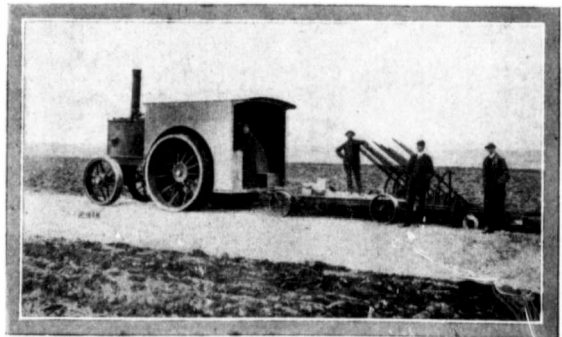

work longer hours. We had a team with us all the time and had our own caboose, in which we slept and had our meals. We also carried our own blacksmith outfit with us, as our work was

I hope to be able to send you a better account of our next season's work. With best wishes to your valuable paper, I am,
Yours truly,
Emmons Bros.



↑ It's an **AULTMAN-TAYLOR 30-60** ↑

You need to complete your equipment of modern farm machinery. Not until you are an owner of one of these wonderful money-making, labor-saving farm tractors will you have fully realized its real worth as a profit producer. You can plow, break, disk, pack, drill, harrow, harvest, build roads and do numerous other jobs about the farm quicker, easier and better, and at a tremendous saving over doing the work with animal power and hired help. With an **AULTMAN-TAYLOR 30-60** you can cultivate a large acreage, consequently increase production. The soil can be more thoroughly prepared than by any other process. You can plow deeper, thus reaping the full benefits of the rich sub-soil. You can gather your crops when they are ripe at the lowest cost. You can harvest, thresh and haul your crops to market with the same machine. For belt work, such as threshing, etc., its powerful long stroke four-cylinder motor furnishes abundant power for all stationary work. Uses less fuel per developed horse power than one and two-cylinder types of engines.

Get in on this big money-making proposition. Start right now to farm the **AULTMAN-TAYLOR** way. On thousands of farms throughout America **AULTMAN-TAYLOR** tractors are increasing production, reducing its cost, making farming easier and proving a mighty profitable investment for their owners. Make up your mind today to start farming for bigger profits. Buy an **AULTMAN-TAYLOR 30-60** and you'll have the most efficient tractor built. It's the one tractor that will stand the grind of hard and continuous service. It's

BUILT FOR HARD WORK AND LOTS OF IT

Every feature in its construction, from its drivers to the top of its radiator, has been tried and proven. Every tractor is fully guaranteed. The **AULTMAN-TAYLOR 30-60** uses either gasoline, kerosene or distillate with unequalled efficiency and economy. At the Winnipeg Contest this famous tractor established a world's economy record in plowing, by delivering to the draw bar more draw bar horse power hours per unit of fuel than any other internal combustion engine ever entered in any official test. Its performance in the field since that time has earned for it a still greater reputation.

WRITE TODAY FOR CATALOG. We have the tractor that will do your work better and more economically than any other. All we ask is that you investigate. You be the judge. Don't wait, but write today.

The Aultman & Taylor Machinery Co.

Lock Box No. 64. MANSFIELD, OHIO.

BRANCHES: Minneapolis, Minn., U.S.A. Calgary, Alta. Regina, Sask., Canada



"FLOUR CITY TRACTORS"



Illustrating the "Flour City" 20, 30, and 40 H. P. in field work.
The "Flour City" has the endorsement of all who have used them.

Embodying units of power, suitable for any size farm.
It is a successful tractor, backed by safe and sane business methods.

Gas Easier than Steam

We bought a Hart-Parr tractor in the spring of 1912, which is rated at 30 h.p. tractive, and 60 h.p. trake test. This we think is a conservative rating.

We broke about 1,500 acres with it, and disced 150 acres, before we went threshing. The plowing was done in very heavy gumbo soil, yet we could pull six Cockshutt plows at all times if the footing was good, yet we never hauled six plows except on two or three occasions, as we did not want to load our engine anywhere near its capacity. We hauled five 14-inch bottoms all summer in discing, and we hauled six discs and six sections of harrows, this being a very small load for the engine.

We used 135 gallons of coal oil, and eight gallons of cylinder oil for cylinder bearing, and gears. We found it paid best to use the best. We also used 100 gallons of water. These figures are for twenty-four hours, as we ran night and day when the weather permitted running at all. Thirty-two acres was our biggest day's work, and we generally made 30 acres when everything went right, but had to keep going pretty nearly all the time to do it with one man running, while the other got his meals.

We never had more than four men on our outfit, and sometimes three, and did our own blacksmithing, and our own cooking most of the time. We did not have any horses on our outfit, as we had a tank of oil, and a tank of water hauled on the field for us at the rate of two tanks of oil, and one of water every week.

Our cost of operating was about \$1.25 per acre, not counting our own wages, but counting them would bring it up to \$1.75 per acre. We were both experts in either steam or gas engines, and could get the highest wages if we worked out.

We did very well threshing, considering the scarcity of labor, and high price thereof. We had a 36-56 Waterloo separator, and

threshed 70,000 bushels of wheat and oats, my brother running the engine, and myself running separator. We did some odd jobs such as moving grain bins with engine, and had good luck at that also.

A gas engine is a very delicate machine, and one should understand them to make a success of it. A very little thing will cause them to use one-third more fuel than they should use, and in oil engines especially, one should try and get water free from alkali, as the mineral deposits in water will form a coating on the valve stems, which will not permit them to close properly. This causes

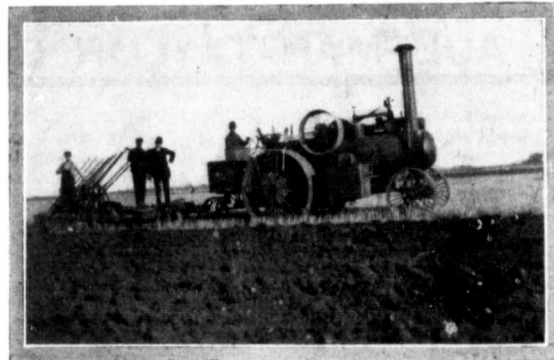

a great waste of fuel, and soon stops the engine, and makes grinding the valves necessary.

We had had no experience in harvesting or seeding, but from observance, would state that the engine is detrimental to a well worked seed bed, unless there are two discs pulled directly behind the drive wheels to loosen up the soil before the drills.

Hoping this will meet your requirements as far as work goes, we would say that a gas engine is very easily operated compared with steam, as they do not bury down in the mud so bad when they get stuck, and for many other reasons, which would fill a book.

Yours respectfully,
Grant Bros.
Mosten, Sask.

Tractor not for Small Farmer

We have an Aultman & Taylor gasoline engine 30-60 four cylinder, bought last spring, and with a few defects in the construction of the engine I like it very well. We did not have much trouble with it, the most was in the water supply pump, and that is remedied for 1913, and we feel that we have the best engine we have seen so far.

But all of them are most too complicated for the average man, and will give lots of trouble until they are made more simple, and you will have to have an expert to get satisfaction, and re-

ground got harder, we had to drop off some of them, and finally finished with eight plows, and packer. We had some trouble of course, on account of ignorance in not knowing how to manipulate it, but on the whole, did fairly well.

In stubble ground we used four double discs, two drag harrows, two wheat drills and packer, making about 35 acres per day, and used from 45 to 50 gallons of oil at 26½¢ and four gallons of lubricating oil at 46½¢, and engineer, and one man to look after the drills and other machinery. Then we had a man that would take out three barrels of water per day, and the wheat in the wagon ready for the man to fill up, which would take about three hours. I paid about \$8.00 and board for labor, or about 75¢ per acre.

Our ideal of farm power on a small farm, outside of the horse, would be a simple one cylinder engine, not too big, and in which you could use any kind of combustible fuel, with two speeds, that would do what 20 horses would, where one man could use in plowing, discing or anything to get the ground ready. The worst trouble with a big engine is that you have to lead them to get results, then you have so many things hitched on that you cannot turn easily, without missing so much at the corners, and one man cannot watch them all, and unless your ground is in first class condition and clean, you clog up, and a lot of poor work is being done. On the other hand if you are farming on a big scale, take the big engine, and let it do the breaking, and get the ground ready, then follow with horses.

We threshed with ours using a 36-60 separator, and threshed out 40,000 bushels of wheat and 15,000 bushels of oats in 26½ days. We did not have any trouble to speak of, and made some money, and think it is as cheap as any power,

Yours truly,
Bowman Bros.,
Carmangay, Alta.

It is a question if any of them, no difference whose make, will pay on a small place, and unless one farms at least a thousand acres or more, he should figure close before he buys, and from our experience and observation, we would buy a one cylinder small engine 15-30 or 20-40, that could use both gasoline and kerosene. That is one fault with ours, as we can only use gasoline, and at 30½¢ per gallon it has to do the work to pay.

We used three gallons per acre in summer fallowing, and drew a packer, and but little more in breaking. In the spring we had eight plows, drag harrow, nine feet of wheat drill, and packer, and made 15 to 20 acres per day, and the wheat average 22 bushels per acre No. 2, but when the

The Premier Company

The Premier Goods

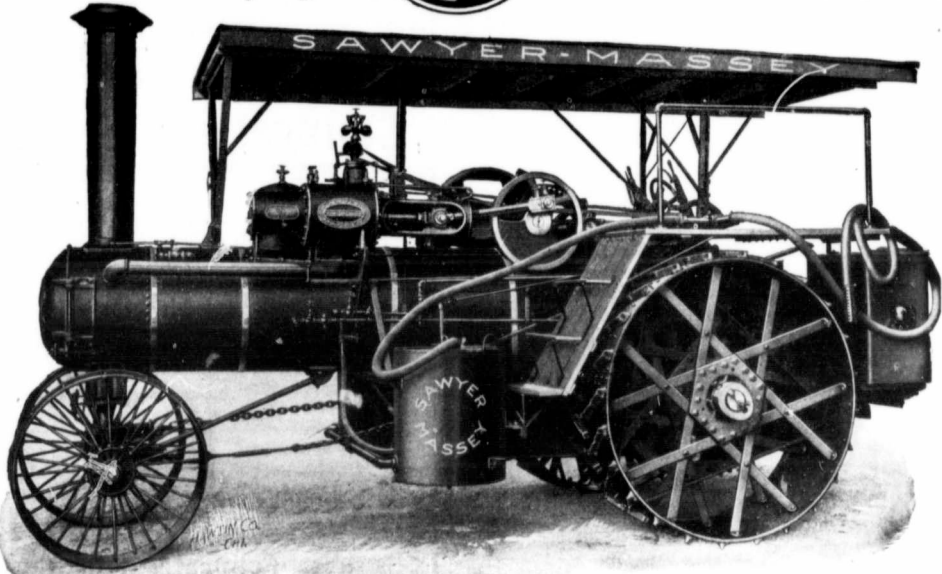

THE FARMER'S TIRELESS HELPER

The SAWYER-MASSEY Steam Tractor develops easily and cheaply all the power required for the largest farm. It is economical of fuel and water and easy to operate, and in plowing and threshing will give the greatest satisfaction.

SAWYER-MASSEY Class "C" Compound Steam Tractors are built in 27 and 32 H.P. sizes, developing 82 and 100 brake H.P. respectively. Also built in 22-25 and 35 H.P. Simple.

The SAWYER-MASSEY "Great West" Thresher is designed especially for use in the Great Canadian West. It is strongly built and compact, and has the greatest possible efficiency. Furnished in five sizes varying from 25 inch cylinder x 42 inch body to 40 inch cylinder x 64 inch body.

SAWYER-MASSEY Machinery is built by a Company with 77 years of successful manufacturing experience, and is designed especially to meet Canadian requirements. It will give satisfaction in every respect.

We have an attractive proposition for Dealers in Foreign Countries, and invite correspondence.

Write for Catalogue

SAWYER-MASSEY COMPANY LIMITED

BUILDERS OF STEAM AND GAS TRACTORS,
THRESHERS AND ROAD-MAKING MACHINERY.

Head Offices and Factories :: :: HAMILTON, ONTARIO

Branches and Warehouses: Winnipeg, Manitoba; Regina, Saskatchewan

SAWYER-MASSEY

Questions and Answers For Gas Engine Operators

This is a department for gas engine operators similar to that which we have so successfully carried on for the past few years for those interested in steam. We invite your questions and will give them our best attention. Just tell us your troubles or ask us about any point upon which you desire information. We have secured the services of a competent expert who can handle gas engine queries intelligently and to the complete satisfaction of all concerned.

Ques. What causes a leaky piston?
Ans. Worn or broken piston rings; shifting of the position rings so as to bring the openings on their circumferences into line.

Ques. How should the length of the valve stem be adjusted?
Ans. If too long, the end of the valve stem should be filed until a card can be inserted between the stem and the end of the push rod.

Ques. How is the formation of carbon within the cylinder usually indicated?
Ans. By the frequent occurrence of pre-ignition, due to projecting points of red hot carbon within the cylinder.

Ques. What causes the formation of carbon in the cylinder?
Ans. Too rich a mixture almost invariably results in the formation of carbon, which also follows upon the use of oils that do not stand high enough temperatures, or that are otherwise of poor quality. The formation of carbon is also caused by delayed opening of either exhaust or inlet valves, not providing enough time for the exhaust.

Ques. Describe the action of carbon in a cylinder?
Ans. Carbon, when present in lumps, will tend to become red hot and cause pre-ignition. Small particles may catch on the valve seats, holding the valves open and causing loss of compression and power. The carbon that catches in the piston rings and their grooves may so bend the rings as to prevent their even contact with the cylinder walls so essential to good compression, and, in addition, may score the cylinders.

Ques. How may carbon be removed from the cylinder?
Ans. It is scraped off with hard, sharp edged tools. For cleaning out the ring grooves a special tool should be used, made to fit so closely as to leave no deposit under its end or by its edges. Keeping the deposits moist with kerosene will facilitate their removal; soaking with kerosene for hours or even days will be still better. For surfaces that can be reached in this manner,

and that will not be injured by the wear it will cause, finishing may be done with coarse emery cloth, held at the head or around a stick.

Ques. What precaution should be taken to reduce the formation of carbon?
Ans. To keep it to a minimum, the often recommended process of coal oiling the cylinders from time to time is to be advised, but even with this preventive regularly applied, it occasionally becomes necessary to take off the cylinder, scrape out the combustion chambers, and clean the valves and pistons. The formation of carbon can be largely avoided by close attention to the carbureter, the lubricating, and ignition systems.

Ques. Why does a smoky exhaust cause considerable trouble?
Ans. The soot formed is liable to take fire and smolder, causing pre-ignition, or even back firing, especially under heavy loads; moreover the operator in some restricted sections is liable to arrest.

Ques. What does dark colored smoke in the exhaust indicate?
Ans. An over rich mixture which ignites imperfectly.

Ques. What causes dense white smoke?
Ans. An excess of cylinder oil with a resulting deposit of carbon soot in the cylinder, or a poor oil.

Ques. What does a thin, blue or nearly invisible smoke indicate?
Ans. A correct mixture and good ignition.

Ques. What should be done in case of smoke in the exhaust?
Ans. The cylinder oil feed or the carbureter should be adjusted according as the color of the smoke indicates too much oil, or an over rich mixture.

Ques. Explain the usual cause of after firing.
Ans. After firing or "barking" is commonly caused by misfires, in one or more cylinders, which results from an accumulation of unburned gas in the muffler that is ignited by heat of the walls or by the exhaust of may be due to a mixture, that is firing cylinders. Sometimes it

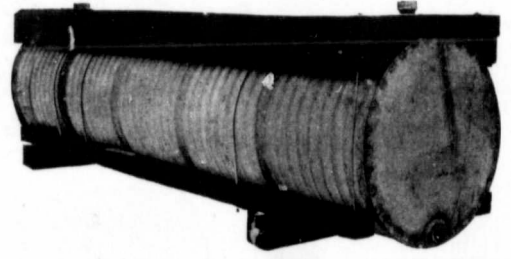

Corrugated Wagon Tanks

This Tank can be used for Gasoline, Coal Oil or Water. Every Tank Guaranteed. Capacity 10 bbls., weight 500 lbs. Ready to set on your wagon at a right price. Think it over and see if you can't save money by having one of our tanks.

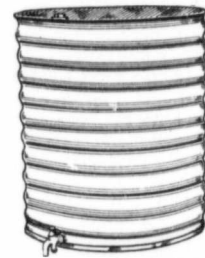

Gasoline and Oil Storage Tanks

MADE IN TWO SIZES:
46 and 56 Gallons

Price for Larger Tanks on application.

CALL, WIRE OR WRITE

Canadian Corrugated Pipe Co., Limited
PORTAGE LA PRAIRIE, MAN.



You've observed—that in front of the finest homes Ford cars are numerous. We are selling an ever increasingly greater part of our gigantic output to experienced automobile owners who have tired of the exorbitant expense of big car up-keep.

Our factories have produced more than a quarter of a million Model T's. Prices: Runabout, \$675, Touring Car, \$750; Town Car, \$1000—f. o. b. Walkerville with all equipment. For particulars get "Ford Times"—an interesting automobile magazine. It's free—from Walkerville factory. Ford Motor Company of Canada, Limited.

FARM FOR SALE—A SNAP

N.E. 1/4 Sec. 30. Tp. 8. Range 33 W. 1.

MUNICIPALITY OF ANTLER, SASK., REDVERS P.O.

160 ACRES, 80 of which have been in cultivation for several years. The other 80 acres suitable for pasture. Has Hay Patches and Stream with Trees.

8 Good Buildings—inclusive price \$25.00 per acre.
Address: Box 3164, Winnipeg.



Just a Moment!

Mr. Traction Owner. We wish to announce that we can now fill your orders for our new product

REX MOTOR SPIRIT

Specially distilled for Gasoline Tractors, Motor Trucks or any Combustible Engine using low grade fuel. *Costs Less Than Gasoline—Something New.*

Literature and Prices Mailed Upon Application to

Canadian Oil Companies Limited : : WINNIPEG, REGINA, CALGARY : : NELSON : :

You saw this advertisement in this magazine. Don't forget to say so when writing.

too rich or too weak, which burns slowly, continuing its combustion after passing into the exhaust. It also occurs frequently, when the spark is retarded, especially with heavy loads.

Q

Ques. In a multi-cylinder engine, explain a method of testing for a missing cylinder.

Ans. In practically all four cylinder engines the cranks of the second and third cylinders are in line, and are set at 180 degrees to the cranks of the first and fourth, which are also in one line. Consequently, the pistons of the second and third cylinders make their "in" strokes at the same time as the first and fourth make their "out" strokes. As a rule, the order of ignition is: first, third, fourth, second, which is also the order in which the primary circuit is closed by the timer, closing the circuits through the primary winding of each coil, in succession. In order, therefore, to determine which cylinder, if any, be missing fire, it is necessary only to open the throttle and advance the spark lever to the running position, giving the engine good power, and to cut out three of the four cylinders by depressing their coil vibrators.

If the engine continues to run with coils 2, 3 and 4 cut out, cylinder 1 is evidently working properly. Depressing vibrators of 1, 3 and 4 shows whether 2 is working; of 1, 2 and 4 whether 3 is working; and of 1, 2 and 3 whether 4 is working. On discovering the faulty cylinder, its plug may be tested and the fault corrected.

A similar method may be fol-

lowed in the search for a missing cylinder of a three or six cylinder engine.

Q

Ques. What sometimes causes the engine to run while the switch is off?

Ans. It occasionally happens that the switch becomes defective so that it does not break the circuit when in its "off" position. A most common cause for running with open switch is red hot plug points, also the heating to incandescence of some small particle in the cylinder, either loose or attached to the interior surfaces.

Q Q Q

The Second "Made-in-Canada" Train

The splendid success of the "Made-in-Canada" exhibition tour through Manitoba, Saskatchewan and Alberta last year is responsible for the Canadian Home Market Association's decision to repeat the enterprise this year, only on a larger, improved scale. Another fact that leads to the repetition of the experimental tour of 1912 is the industrial activity which followed in the wake of the train in its course across the prairie last year. The establishment of several factories and warehouses in prairie cities may be traced directly to the "Made-in-Canada" train. An even greater impetus may be expected this year, for any defects or weaknesses discovered in the initial trip have been strengthened or remedied in the train of 1913. All the exhibits will be different from those in last year's train, and the

comfort of the visiting public has been provided for by better entrance and exit facilities, more lighting and better display signs.

The tour will be organized on practically the same basis as that of 1912, and will cover about 120 cities and towns in the West, occupying about 52 days. The train will leave Montreal on May 14th, and after visiting half a dozen cities in Ontario, will exhibit in Winnipeg about May 21st, proceeding westward, and returning to Montreal about July 5th. The itinerary will embrace the principal points on the lines of the Canadian Pacific Railway, the Canadian Northern Railway and the Grand Trunk Pacific, west of Winnipeg.

The train will be electric lighted throughout, and the cars will be arranged with the aisles along the side, leaving the greatest possible width for the exhibit booths. Stops will vary from two hours to forty-eight hours each, depending on the size of the town or city visited.

The route, after visiting Montreal, Ottawa, Toronto and Sudbury, will be along the main line of the C.P.R. to Winnipeg, making stops at Port Arthur, Fort William, Dryden, Kenora and Keewatin. After leaving Winnipeg, it will spend a day in Brandon, and will then proceed along the Souris line, via Arcolet to Regina, touching all the principal towns en route. After leaving Regina, it will proceed along the main line of the C.P.R. to Medicine Hat, making stops at all the principal intermediate points. Leaving Medicine Hat, it will follow the Lethbridge line, making a side trip to Raymond, Magrath and other towns in that

district. Leaving Lethbridge, it will touch Macleod and all the principal points from Macleod to Wetaskiwin. Leaving Wetaskiwin, it will proceed eastward on the C.P.R., making several stops before Macklin, and also touching the principal points on the new line from Macklin to Moose Jaw. After four weeks on the C.P.R. it will be turned over to the C.N.R., who will handle the train from Regina to Prince Albert and from Warman to Edmonton, where they will transfer it to the G.T.P., who will operate it over their system from Tofield to Alix, and from Edmonton to Melville, and from Melville to Canora. At the latter point it will be turned over to the C.N.R. again. Making stops at Dauphin and intermediate points, the train will proceed to Winnipeg, where the exhibits will be dismantled. This is a much more comprehensive tour than that of last year, and practically all the points covered, except the larger cities, will be new ones.

One of the features of this year's trip will be a moving picture show. In addition to the lantern views, which were shown last year, there will be two or three moving picture films of Canadian scenes, which are bound to prove of interest to those who visit the train. As last year, the lecture will be given in the open or in some suitable hall at all evening stops, but in the daytime it will be given in a special car which will be equipped for this purpose.

No exhibit will attract greater interest than that of Ontario fresh fruit and dairy products, splendidly arranged in one of the cars by the Agricultural Department of Ontario.

Course in Gas Engineering

Conducted by D. O. BARRETT

Fuel Consumption

WHY is it that one man with a certain size of standard make of engine is well pleased with the power it develops and the low fuel consumption, while another man with the same make and size of engine declares that the engine does not develop the power at which it was sold, and that it uses much more fuel than it was represented to him would be used? The engines are the same size and make, yet one may be developing half the power of the other, but with twice as great a fuel consumption. The power developed and the fuel consumption may, at first thought, appear to be only distantly connected, or if connected at all the connection may be expressed by "more fuel, more power." Right here is one of the stumbling blocks of the inexperienced operator of a gas engine. What more natural thing in the world than to give the engine a little more fuel when you see the load is too heavy for the engine and it is beginning to slow down?

But let us consider for a few moments how a gas engine operates. In the previous chapter attention was called to the fact that the gas or gas line and air must be mixed in certain proportions in order to ignite at all, and in one certain or definite proportion to give the greatest possible power or explosive pressure. Roughly speaking, about one volume of gas to seven of air is found to give the best results, although this depends on the quality of the gas. For economical fuel consumption, then, we must have this mixture at each explosion.

At this point enters the question of throttling and hit-and-miss engines. With the latter type the mixture of fuel always remains the same, and when the engine gets above speed, one or more charges are "cut out" until the speed drops to or below normal, when another charge is taken in this way the greatest possible pressure is secured from each charge, which is taken in. With the throttling engine there are two types. In both, the intention is to take an impulse at every opportunity, i.e., on every revolution or every other one according as it is a two or four cycle engine. If the speed gets above the normal the charge is decreased in size so as not to give as strong an impulse to the piston. In one type, however, the mixture

remains the same, that is, the proportion of air and gas is the same, the size of the charge being diminished. However, as the charge is decreased, the compression is less, and therefore the explosive pressure is not so high. With the other type of throttling or graduated charge engine the amount of air for a charge remains the same, but the amount of gas or gas line is graduated. This, as will be seen, at once destroys the ratio of the mixture from which the greatest force is derived, and therefore causes increased fuel consumption, because the maximum possible power is not secured from the fuel used. Further than this, if the speed gets too high, the amount of gas or gas line admitted to the cylinder is made very small. When the ratio of gas gets beyond a certain limit, say 1 of gas to 15 of air, the charge fails to explode, and the fuel is therefore exhausted, unignited, and is wasted. To remedy this waste, the manufacturer of such an engine resorts to cutting out the charge after reaching a certain limit, but in so doing he adopts the hit-and-miss principle, which he otherwise condemns.

Taking a hit-and-miss engine, however, and having a proper mixture to give the greatest power, suppose the engine stalls and we want more power. If we give it a large-sized charge we at once destroy the ratio that gives the greatest force, and we therefore get less instead of more power from the charge. If, on the other hand, we decrease the amount of fuel, we likewise decrease the proper ratio and also get less power. Getting less power from each charge, it is necessary for the engine to take more frequent charges in order to maintain the speed. We therefore have the unlooked-for, but perfectly natural, result of using more fuel and getting less power.

Suppose we have a throttling engine of the type which keeps the ratio of gas or gasoline to air the same and regulates the speed by decreasing the size of the charge or increasing it. Suppose the engine is so adjusted that the most advantageous ratio is not secured. At once the power from each charge is decreased, and more of the larger-sized charges will, therefore, be taken, resulting in increased fuel consumption to maintain the load and speed.

It will thus be seen that no matter what kind of an engine we

Let a Cushman Engine Run your Binder—Saves a Team

4 Gives you more power, smoother, steadier. **4**
Sickle never stops when bull wheel skids or
H. P. in turning. Weight of engine only 167 lbs. Cycle

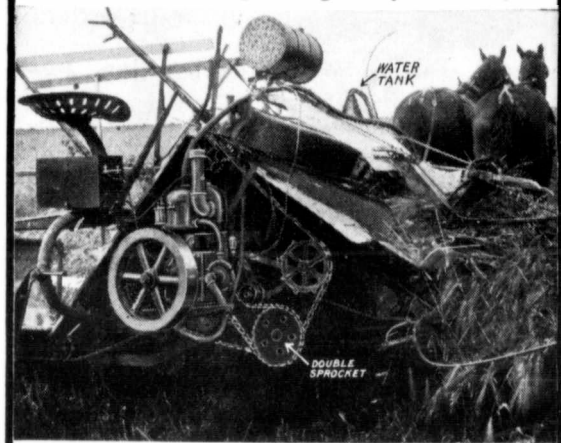

Easily and quickly attached. Our universal adjustable brackets do the trick. Anyone can run this simple 4-H. P. engine on the binder. It runs the reel and sickle, elevates, binds and delivers the grain. Team simply draws the machine. Don't overstrain your horses. Sickle continues to run when the bull wheel skids. Cut your grain when ripe. Wet weather, muddy fields have no harm where the Farm Cushman engine is used.

Farm Cushman The Original Binder Engine

See Your Dealer Now—Write Us Today

This is a personal appeal to you. Insure your harvest. We cannot guarantee deliveries on orders in the rush season. Scores of farmers and dealers last year ordered too late to be delivered. Write now and make sure to get yours. See your dealer. If he does not handle the Farm Cushman, write us. Accept no substitute. Don't wait. Do it now.

Remember, the Farm Cushman is the all-purpose engine. Best for running the *grindstone, pump, corn sheller, wood saw, feed grinder, washer, separator, etc.* Runs at any speed, throttle governed. Change speed at any time without stopping. We also build 2-cylinder special heavy duty engines. 6 to 20 h. p., for use in the Corn Belt, for silo filling, operating large balers, grinding and sawing. Tell us your needs. Start the binder engine matter to-day. Catalog free.

Cushman Motor Works of Canada Limited

202 Chambers of Commerce

WINNIPEG : : MAN.

Cheaper Power for Every Purpose

Ask for New Booklets of Waterloo Boy Light Weight Caterpillar Type Oil Tractors, three sizes—15 H.P. and 25 H.P. Double Cylinders and 30 H.P. 4 Cylinders. These Tractors are exceptionally Light Weight. The 30 H.P. weighs less than 9000 lbs. Practically every part is made of steel.

The WATERLOO BOY GASOLINE ENGINE will run all day without attention, furnish exactly the power you need, maintain a uniform speed and save you money every hour it works.

Use either Kerosene or Gasoline for fuel—equipped for both at no extra charge.

The recent award of Gold Medal at Budapest, Hungary, in open competition with the best engines of all countries is clinching proof that the Waterloo Boy leads the World in Construction, Power, Service and Durability.

Has many important exclusive features—Speed Lever works like throttle on a locomotive; oil reliable fly ball governor; automatic feed regulation, open jacket, standard in Winter, interchangeable parts, etc.

Lowest in price because made in largest quantities, at low manufacturing costs. Guaranteed 5 Years. Book free. Write today.

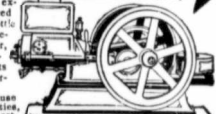

Awarded Gold Medal First Prize at the International Gasoline & Oil Engine Show Budapest, Hungary

Heavy Weight Tractors pack the ground and injure it, they cannot get around over soft ground and they waste fuel moving useless dead weight. "Waterloo Boy Caterpillar Type" Oil Tractors are guaranteed to work on any ground that is in condition to be worked with horses. Mr. Farmer, this is just the tractor you have been looking for, for Spring Plowing.

Burrige-Cooper Co., Ltd.

Engine, Gang Plows, Peerless Separators, Traction Engines, Grain Grinders and Power Washing Machines.

Winnipeg, Manitoba

Regina, Saskatchewan

You saw this advertisement in this magazine. Don't forget to say so when writing.

The "Dreadnoughts" of the Prairies

Marshall's High-Class Gasoline Tractors

Made in Two Sizes:
16 H.P. Tractive
30-35 Brake H.P.

32 H.P. Tractive
60-70 Brake H.P.

For Plowing,
Threshing and
Hauling, Road
Grading, &c.

Economical,
Durable, Reliable

Thoroughly Tested
Before Leaving
The Works

Best Material
and Workmanship

Prompt Mechanical
Service by Skilled
Engineers

Guaranteed to
Give Satisfaction

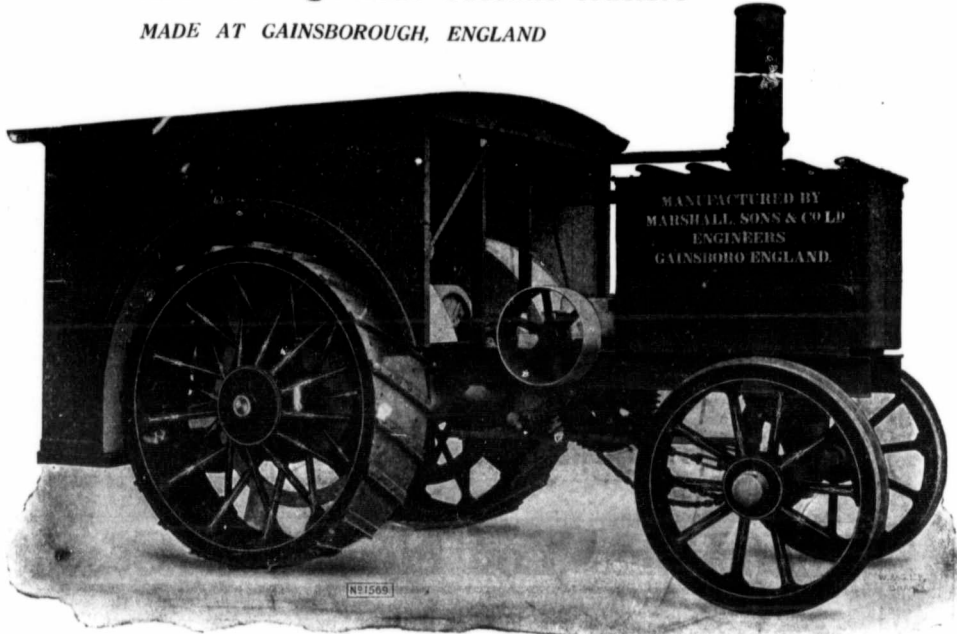

CATALOGUE GIVING FULL DETAILS FREE ON REQUEST

All Owners of "Marshall"
Tractors Please Communi-
cate

Marshall Sons & Co. of Canada Ltd.

1020 Twentieth Street W.

SASKATOON

Complete Line of Spare
Parts Kept in Stock

You saw this advertisement in this magazine. Don't forget to say so when writing.

have, there is a possibility of getting the charges too rich, and in the hit-and-miss type of getting them too weak, either of which means a higher consumption of fuel for a given load and speed than would be necessary if the proper adjustments were made.

Granting this, how are we to know when we have secured the adjustment which gives the best results? By watching the results is the best way. The perfect mixture will give perfect combustion. Perfect combustion gives a clear exhaust. Whenever a gas or gasoline engine gives a smoky exhaust it is due to one or two things. First, too much fuel may have been supplied the engine, resulting in imperfect combustion. Second, too much lubricating oil may have been fed, the surplus not used in lubricating the cylinder being burned and making a smoky exhaust, as well as clogging and gumming up the piston rings, exhaust ports, exhaust valve, stem, etc. If you have a smoky exhaust, therefore, look first at your lubricator and if, after cutting down the supply of oil the smoke does not stop, look

at your fuel valve. If the condition is due to too much lubricating oil and has existed for some time, it may take several days to overcome the smoking, as the oil, which has been deposited in the exhaust passages, may be several days getting burned out.

Another way to tell whether you are using too much fuel is to note your fuel bills for each month and compare them with each other. Of course, in a place where the load is quite variable, this cannot be done successfully. But even then you can generally tell whether your load for one month has been very much more or less than the previous month. Bear this in mind and determine in the best way you can about how one month compares with another, and then compare the fuel bills. If one fuel bill is very much larger than another and the load has been approximately the same, probably there has been some waste of fuel.

There is one very good way in which to secure fuel economy if you are hiring a man to take care of your engine and if your load is approximately the same right

along. Suppose your fuel bill has been running about \$20 per month. If, by any means, you could get it down to \$10 per month or less, would it not be worth while for you to pay your engineer a few dollars more per month? Tell him that if he can get the cost of fuel per month under \$20 you will give him half what he saves. It will surprise you what the result will be. He will study the engine as he never did before. He will see where this piece is out of adjustment, or that piece is worn out, or the battery is weak and fails to ignite every charge, and so on. He will keep the engine clean and in nice shape, knowing that everything counts in lowering the consumption, and that of every dollar saved half will be his.

It must not be understood, however, that high fuel consumption is due entirely to improper regulation of the fuel valve. If the engine fails to ignite a charge because of weakness of the battery, or failure of the igniter to work at the proper instant, the charge is exhausted unexploded. This of course increases the con-

sumption because more charges are taken and some of them are not exploded in the cylinder. These unignited charges which are exhausted remain in the exhaust pipe, and as soon as the next charge, which is ignited, is exhausted, the hot flame ignites the charge in the pipe, causing an explosion which is often regarded as dangerous to persons near. As the exhaust pipe, however, is always as strong as the engine cylinder, it is ample to contain these pipe explosions, which usually result in nothing but a little scare and increased consumption of fuel.

Furthermore, a bad exhaust system may produce this increase in consumption. If, for any reason, the burned gases cannot readily escape from the cylinders there results considerable back pressure with an excessively large amount of these gases remaining in the cylinder. The result is that the incoming charges are so polluted by the burned gases as to destroy their effectiveness. Sometimes this occurs to such an extent that the charges fail to ignite

Continued on page 18

YOU BUY AN ENGINE WITH THE OBJECT OF

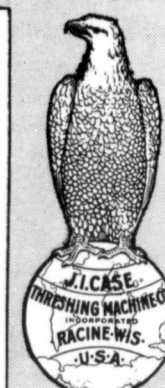
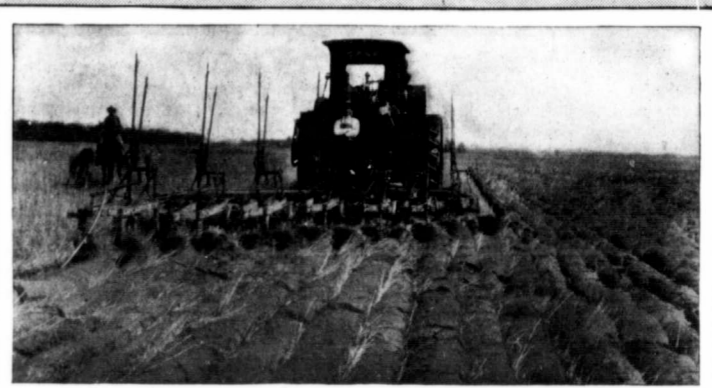

Then What You Need is a "Case" Engine

The Money-Making Ability of an Engine is determined by what it costs to "Operate" it, how much "Power" you can get out of it and "how Long it Lasts." Those are the things you want to consider when you buy an Engine.

You must remember that every Expense must be deducted from your Profits to determine the final Money-Making Ability of your Engine. There is a Big Difference in Engines when you come to figure what it costs to keep them going. It costs a great deal more to operate and Maintain some Engines than others without any corresponding Advantage.

Fuel Economy is the big thing in keeping down Expenses—and that's one of the strongest features about the Case Engine. In the Case Engine you get a Wonderful Power on a Wonderfully Small Fuel Consumption, in fact, more Power on Less Fuel than any other Steam Engine. In the Winnipeg Motor Contest, the Case Steam Engine has repeatedly Plowed on 60 to 90 per cent less Coal per Acre than its nearest competitor. That proves Case Economy in Fuel Consumption.

"Power" and "Durability" depend upon Careful Designing, Care in Building and the Use of only the very Best Materials. You can't buy more Power and Durability than the Case Engine will give you at any price, but you can pay more and get less of both. More Case Steam Engines are sold than all other makes combined for these very reasons and you can't do better than accept the Judgment of the Majority as your Guide.

The attached Blank is for your Convenience in writing for Information. FILL IT IN AND MAIL IT TODAY.

Case Engines Furnish Economical Power for Every Purpose

30 H. P., 7 1/4 x 10-inch Cylinder Simple Traction Engine—

Very powerful. Easy to operate. For driving small Threshing Machines, Corn Shellers, Feed Grinders, Rock Crushers and Saw Mills. The greatest Traction Engine of its size on the market.

40 H. P., 8 1/4 x 10-inch Cylinder Traction Engine—

This Engine is very powerful, easy to handle, economical in fuel consumption, well adapted for driving moderate size Threshing Machines, Plowing and Hauling.

50 H. P., 9 x 10-inch Cylinder Traction Engine—

A reliable, powerful engine for general use. Takes small amount of coal and water, is an easy steamer and strong puller under belt and on the road. The greatest hill climber ever built.

60 H. P., 10 x 10-inch Cylinder Traction Engine—

This is Our General Purpose Engine. For Plowing, Threshing, Hauling, Grading, Moving Buildings, Pulling Stumps, Driving Rock Crushers and Husker-Shredders. A reliable, powerful Engine with a capacity for doing a continuous and heavy volume of work on a minimum fuel and up-keep expense.

75 H. P., 11 x 11-inch Cylinder Traction Engine—

In the various tests with engines of equal size, this 75 H. P. Case Engine has developed more power, at the same time showing greater economy in the use of fuel than its competitors. It is designed for threshing and plowing and all-around work.

80 H. P., 11 x 11-inch Cylinder Traction Engine—

This engine is particularly well adapted for steam plowing, working well in breaking virgin soil or stubble land. It also will drive our largest threshing machine. In the Winnipeg Motor Contest it showed remarkable economy in fuel consumption, using only 97.5 pounds of coal to plow one acre of ground. In its class it stands without equal as a plowing engine.

110 H. P., 12x12-inch Cylinder Simple Traction Engine—

The Four-time winner of the Gold Medal and First Prize in Steam Plowing at the Winnipeg Industrial Exhibition in competition with both compounded and double cylinder Engines of various Makes. As a result of the achievements of this Engine, more Case Engines are used for plowing than all other Makes combined.

J. I. CASE THRESHING MACHINE COMPANY INC.

CANADIAN BRANCHES, TORONTO, WINNIPEG,

MAKING MONEY WITH IT!

No Other Engine Approaches the "Case" for Steam Plowing

The Records of the Case Engine in Economical Steam Plowing have never been equaled. Twice in the Great Winnipeg Steam Plowing Contest the Case has Completely Out-Distanced all others. In the last Contest only one Engine dared to compete with the Case—and that one was Completely Out-Classed.

The Economy of the Case Engine in Steam Plowing is a Matter of Record that you can verify for yourself. Examine the records of the Winnipeg Contest and you will see that no Engine in the Steam Plowing Contest has used less than 120 lbs. of Coal per acre. You will see that Case Engines have repeatedly demonstrated their ability to plow on less than 100 lbs. per acre. *Ninety Nine and Two-Tenths* pounds per Acre in 1910 and *Ninety Nine and Three-Tenths* pounds per acre in 1912 for the Case 110 H. P. is a record in Low Fuel Consumption never approached by any other Steam Plowing Outfit.

It stands to reason that the cheaper you can plow the more Profitable your Plowing becomes. Can you afford to burn up Money at the rate of 10 to 50 pounds more Coal to the Acre than is necessary in your Plowing? No matter what you pay you can't buy any Plowing Engine so Economical to operate, so well Built and Powerful as the Case. Every Part and Every Feature of its Construction has been Time-Tried and Time-Proven.

Case 110 H. P. Steam Plowing Engine Gold Medal Winner at Winnipeg.
Also Awarded the SWEEPSTAKE HONORS in the 1913 Winnipeg Motor Contest

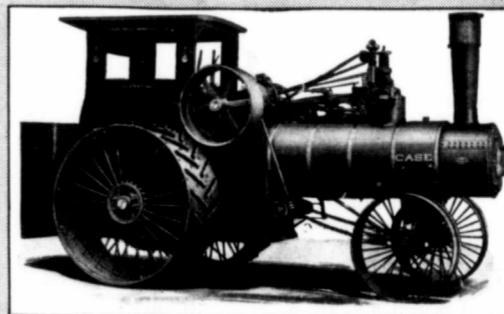

You would never forgive yourself if, in buying your Power Plowing Outfit, you overlooked the most Economical one of them all. So you owe it to yourself to at least investigate the Case before you buy. We are willing to trust the verdict to your good judgment. Sign and send the Coupon.

REMEMBER

A request for information does not obligate you to buy. It simply gives us a chance to put before you facts to your best interest to consider.

REQUEST FOR CATALOG

J. I. Case Threshing Machine Co., Racine, Wis.
Please send your STEAM ENGINE CATALOG and full information regarding the Economy of Case Steam Engines for
Name _____
P. O. _____
State _____

741 - 791 STATE ST. RACINE, WIS. U.S.A.

SASKATOON, REGINA & CALGARY



Farm Building Construction

By Prof. L. J. Smith

FRAMING (Continued)

EXCEPT for very short and small buildings where one length of 2 x 4 or 2 x 6 will be long enough for the plate without splicing, two pieces of 2-inch stuff should be used, as there is a strong tendency for the plate to bow out at the centre on account of the outward pressure at the foot of the rafters. If the plate is not strong enough, and bows out as described, the middle of the peak of the roof sags down, giving a very unsightly appearance to the building. This trouble can be largely overcome and a good deal of this outward thrust taken off the plates by nailing 1 x 4 or 1 x 6 stuff to the under side of the rafters, having the pieces run diagonally upwards from the plate near the corners, to the middle of the peak of the roof.

Often the plate runs around all sides of the building. Then at the ends, short pieces of studding are toenailed to the top of the plate directly above the longer studding, and run up to the end pairs of rafters as already described. The plates are joined at the corners as in figure 12. The piece "C" does not rest on the 2 x 4's forming the corner post, but is simply spiked to the upper horizontal 2 x 4.

Figure 13 is a sectional drawing of the side of a small barn or farm building, showing the inside and outside finish. The parts already named are not designated.

- The new names are as follows:
- 9 Water table
 - 10 Cap.
 - 11 Inside Shiplap Sheathing.
 - 12 Siding.
 - 13 Ceiling.
 - 14 Rough Flooring
 - 15 Frieze.
 - 16 Fascia.
 - 17 1x2 Strapping.
 - 18 Roof Boards.
 - 19 Shingles.

The finish shown makes a very warm barn. A shed where heat was not required might have no sheathing on the inside and only a layer of siding on the outside of the studding. The barn could be made still warmer by nailing another layer of shiplap or tongue and grooved stuff over the shiplap already on the inside of the studding, and putting a layer of good building

paper between. It would also make the stable a little warmer if pieces of one inch material were fitted closely between the studding just behind the ledger board.

It will be noticed in the figure that the outer edge of the sill is not flush with the outside of the concrete wall, but is set in just

then be nailed directly to the studding. The joint at "C" would need to be tight to keep out the rain. It would make a better job to have the cap come up behind the siding as shown at "D."

The finish of the overhang of the roof in Figure 13 is very sim-

ilar to the roof boards and the shingles to help keep the cold out and, equally important, the heat in. Instead of roof boards, narrow one inch strips may be nailed to the rafters to nail the shingles to. These strips should be laid the same distance on centers as the butts of the shingles are apart, or "to the weather,"—in the shop language of the builder. If roof boards are used, it is well to lap one past the other at the peak as shown. The tips of the shingles are sawed off flush with the peak, then the ridge-boards "R B" are nailed on. They are 1 x 4 to 1 x 6 stuff, depending on the size of the building. One ridge-board is made the thickness of the board wider than the other, on account of the one overlapping the edge of the other when put on the peak. The high edge of the narrow board should be planed to the proper level, in order to make a good fit and keep out the rain. If the work is properly fitted and nailed, this finish, which is the one in most common use, will keep out the weather. A better

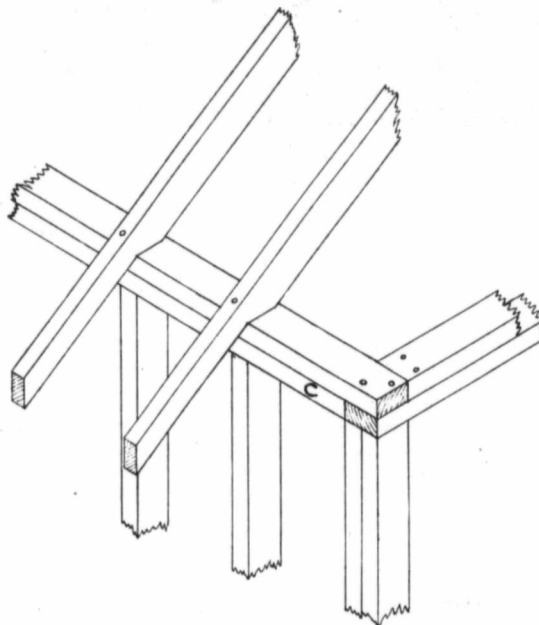

Fig. 12

the thickness of the outside shiplap. This allows the watertable to come down over the wall, thus insuring a warm finish at this point. The flooring in the loft may be rough or finished on one side as desired. It should fit in between the studding right up against the outer shiplap, to make a warmer finish, and to keep the dirt from getting down between the joists. The outside shiplap need run only to the floor joist, for it is not essential to have the loft warm. There should be a layer of good building paper between this shiplap and the siding. Where the shiplap ends, 1 x 2 inch strapping is nailed to each studding, in order to fill out for the siding. This however, is not essential. The shiplap and siding could be finished off with a cap as in Figure 14, and the siding above the cap could

be and inexpensive, yet gives a good appearance. The two or three lower roof boards fit together tightly. The lower ends of the rafters are not covered by the regular soffit or plunger board, but are left exposed as is often done in bungalow construction. The frieze fits tightly up between the rafters and against the under side of the roofing to keep the wind from blowing into the loft. This practice is not necessarily followed in milder climates, for these openings between the rafters give pretty good ventilation to fresh hay when it has just been placed in the mow.

Figure 15, illustrates the finish of the peak of the roof. It shows the roof boards nailed against each other, which makes a warmer construction. In house building, heavy paper is often put between

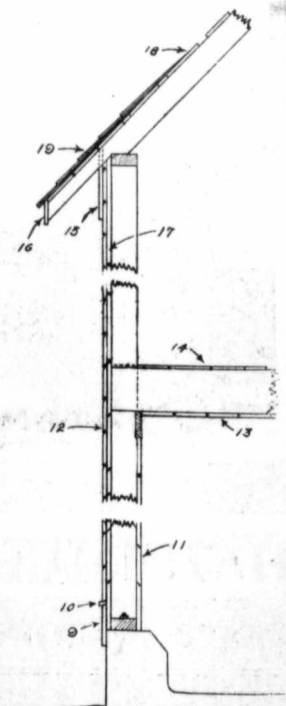

Fig. 13

*There's Only One
OilPull -
Rumely, La Porte*



Big grain crops mean Big Profits—

The wise Thresherman will have a *Big Separator* and a *Big Power*.

CANADIAN-RUMELY IDEAL SEPARATORS—OILPULL 30-60 CANADIAN ADVANCE SEPARATORS

A small fortune awaits the man who decides at once that this year is the right time to get a BIG threshing outfit. The grain harvest will be a record-breaker this year—and the big per-acre yield means record-breaking runs for threshing outfits. The owner of a Rumely outfit will be limited in his money-making only by the number of hours of daylight.

The Rumely OilPull Tractor runs just as regular as clockwork. You can overload your big separator one minute and let it run empty the next—the big 30-60 OilPull will not vary its speed 2 per cent. That's STEADY power! Just what every experienced thresherman knows is necessary in order to clean and save the grain. The OilPull uses kerosene all the time—overload or all load off, high speed or low speed. The OilPull also uses distillates and the heavier crudes. The low running expense and the steady, reliable power furnished

have made users enthusiastic about the OilPull—because it has made money for them.

The Canadian-Rumely Ideal and Canadian-Advance Separators have many big threshing records. They've given years of satisfactory service in all parts of the Dominion. The Ideal is especially built to get the grain before it goes far into the machine. Because of a 100 per cent threshing cylinder, a winged heater, and an inclined chain rake it separates 95 per cent of the grain before it has gone 3 feet from the cylinder.

The Canadian-Advance Separator is noted for its good work in even the toughest jobs. The teeth on the cylinder and concaves, because of their shape and size, give unusually long service and do thorough threshing in Turkey-red wheat and other tough grains. Reverse the teeth, and you have a new set.

Decide on the big outfit now and have it in good time for the earliest threshing profit.

Write today for OilPull and Separator Booklet.



Rumely Products Co.

(INCORPORATED)

POWER FARMING MACHINERY

La Porte

::

::

Indiana

Canadian Branches

WINNIPEG, Man.
SASKATOON, Sask.
REGINA, Sask.
CALGARY, Alta.
VANCOUVER, B.C.
BRANDON, Man.
YORKTON, Sask.
ESTEVAN, Sask.
EDMONTON, Alta.
TORONTO, Ont.

THIRTY-EIGHT YEARS' EXPERIENCE

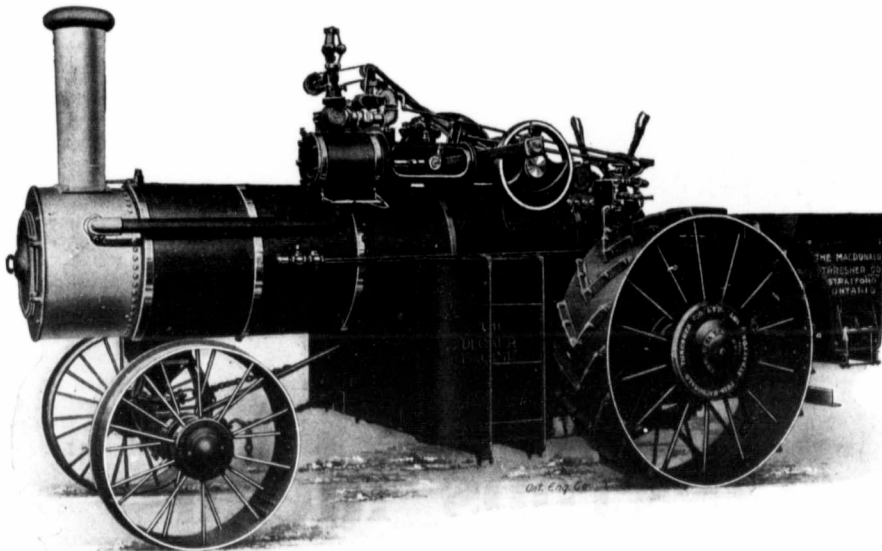

Manufacturing the famous "Decker" line of Threshing Machinery. Engines in sizes as follows:

18, 20, 22 and 25 h.p.

Boilers command 175 lbs. steam pressure. "Decker" Valve Gear, superior to all devices used for the purpose, heavy gear suitable for hard work. Plowing engines a specialty.

"Decker" Separators

made in the following sizes:
24-46, 28-50, 32-54 and 36-60.

Well adapted for gas power, being easy to drive. A marvel of simplicity; efficient in separation and convenient to handle. Wind Stackers, Feeders, Baggers and a full line of thresher supplies.

Write for Catalogue.

THE MACDONALD THRESHER CO. Limited

Western Branch: Winnipeg, Man.

Box 1296

Head Office and Factory: Stratford, Ontario, Canada.

You saw this advertisement in this magazine. Don't forget to say so when writing.

finish can be had by nailing on a ridge roll "R R." This is simply a three-quarter round large enough to cover well the crack where the ridge-boards meet.

Roofs

Having covered briefly the framing and finish of a small farm

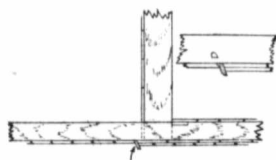

Fig. 14

building, we will consider the larger structures. While the same principles and terms apply alike to all buildings, the larger and wider buildings vary mainly as to the shape and bracing of the roof. It is well to take up the names of the different common types of roofs in order to clear up any wrong use of the terms; and then study the various methods of framing and bracing barn roofs. Figure 16 illustrates a number of common types of roofs. There are three common types used on barns, namely: the shed or lean-to roof "A", sometimes called a shanty roof; the common shaped roof called the saddle or

gable roof "b" and "d", used mostly on ordinary sized buildings; and the gambrel roof "e," now most commonly used on the larger barns, and beginning to be used to quite an extent on smaller ones.

The other common roofs are the hip roof "c," and the mansard roof "f." Most houses have the gable or the hip roof or various modifications of the two. The mansard roof is not now used so much for houses, but is used largely on public buildings.

The gambrel roof has two slopes or pitches from the eaves to the peak; the lower being quite steep and the pitch to the peak being of a gentle incline pitch. The point at which these two pitches meet is called the

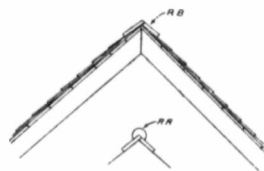

Fig. 15

curb, "c." The mansard roof is quite similar to the gambrel, yet there is no need for their being confused; for while the mansard roof, named after a Frenchman of that name, has two pitches, it

slopes up from the four sides instead of but the two as is the case with the gambrel. The lower pitch is generally steeper than that of the gambrel, while the upper part of the roof is more nearly flat and is called the deck. The lower part of the mansard roof has dormer win-

rafters under the deck.

The gambrel roof is sometimes called a curb roof and there is some reason in such a name, although the mansard roof has a curb also. Again, the gambrel roof is in many localities called a hip roof, which is of course absolutely incorrect. A hip roof "C" slopes

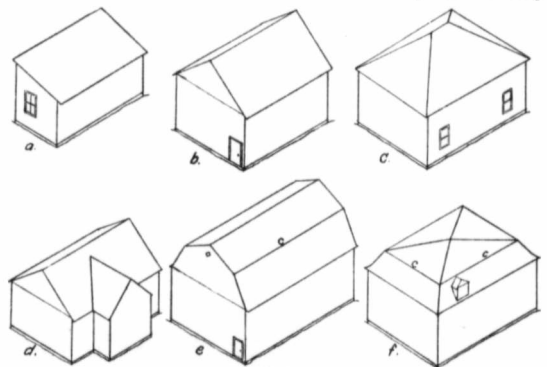

Fig. 16

downs in it. In the gambrel roof, the rafters of the two parts of the roof should be equal or nearly equal in length, though the proper practice is not always followed, in which case the lower rafter is generally made longer than the upper. In the mansard roof, the lower pitch has short rafters as compared with the length of the

up to the peak from all four sides. The rafter underneath the line where any two of these parts of the roof meet, is called a "hip rafter" by all English speaking builders so far as I have been able to learn; and this without doubt gave the roof its name. The parts of the hip roof sloping

Continued on page 62

The Only Flax Feeder on the Market

Attaches to any Separator. Is made of **Steel** and is backed by our **Iron Clad** warrant, that you get feeder satisfaction or your money.

It simmers itself right down to a matter of investigation, puts it up to you to **know** where you are "at" before placing your order.

An Ounce of "Prevention" is worth a Pound of "Cure"

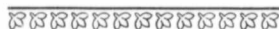

The Garden City Feeder has Two governors, one to keep the cylinder clear when starting or stopping, and the other to Prevent any Variation in the speed of the machine: You don't have to knock out the motion of Anything, in order to get the governor to work.

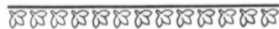

A separator fed by a Garden City Feeder maintains a **Uniform Speed**. No "Ups" or "Downs," just one steady hum all the time, that's the way a separator Should run, and **Must** run, in order to do Good and Fast work; that's why Every Thresherman Needs a "Garden City."



The Garden City Feeder

At work on the Rumely Separator of Smith Bros. at Sedly, Sask., fall 1912. Taking care of FLAX as fast as FOUR men can supply it. The **PROOF** of the Feeder is the Feeding. Smith Bros. were obliged to throw off a—Feeder that had been used but ONE SEASON, because it could not feed FLAX.

This is Our Ironclad Warrant

The GARDEN CITY FEEDER is positively warranted to feed any separator to its full capacity, with any kind of grain in any condition, without slugging the cylinder, breaking any concaves or spokes, winding on any part, littering underneath the feeder, or causing any burned belts; and to deliver all bundles to the cylinder **END FIRST**, regardless of how they are piled upon the carrier.

No other guarantee covers so many points. No other guarantee means one-half so much. No other feeder can make good on that guarantee. Every claim can be tried out on YOUR separator. **NO "IFS" or "ANDS"** about it. **NO EXCEPTIONS, NO CLAIMS THAT CANNOT BE DEMONSTRATED, NO "CRAWFISHING,"** just "**PLAIN TALK**" that means exactly what it says. That's the guarantee printed in every order for a Garden City Feeder; that's the guarantee that **PROTECTS YOU**. If the Garden City Feeder fails to "**MAKE GOOD**" on it, your money or notes will be immediately returned to you.

Wouldn't You Like to Try One?

It will Pay You to do so.

Write today for terms and prices

THE GARDEN CITY FEEDER CO., LTD.

REGINA ❖ ❖ ❖ SASK.

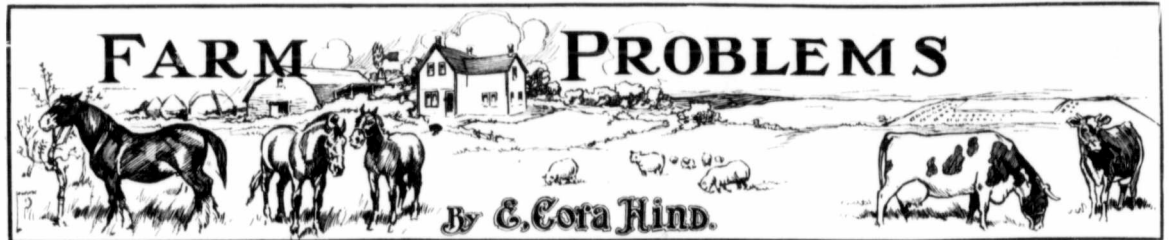

A great deal has been said about winter wheat as a suitable crop for Alberta, but the experience of five years has been such as to raise the question whether or not it is profitable to grow winter wheat in Alberta. The recent census bulletin from Ottawa makes the very startling statement that 43.6 per cent. of the area sown to winter wheat in Alberta last season has been winter killed, and that the present standing of the crop is only 76. The winter killing has reduced the acreage from 1,086,800 acres to 825,500.

The average yield of winter wheat in Alberta has never gone over 20 bushels to the acre, which is very low indeed for winter wheat and has oftener ranged between 20 and 22. Every spring there is the same story of winter killing, and while there is no doubt that southern Alberta can raise as fine a sample of winter wheat as has ever been produced on the continent of America, even here the results of five years cannot be said to be wholly satisfactory. Even where the wheat is not winter killed, it is subject to many vicissitudes, especially near the mountains where quite often even in July a cold wind, frost laden, will come down from the mountain passes and catch the tender grain, frequently just as it is in the blossom. This wind may not last more than a couple of hours,—may come in the night time when the farmer is asleep. When he gets up again in the morning, there is nothing to show that this killing wind has passed by, but a little later he finds that, in spite of the promise of the blossom, his wheat does not fill.

I have seen fields where the stand was certainly good for 45 or 50 bushels to the acre, which did not thresh 5 bushels to the acre. These winds from mountain passes and the winter killing are two conditions against which the best farmer in the world has no defence, but it would seem that the time had about arrived when the farmers of Alberta would have to decide whether or not the winter wheat is a paying proposition. With 43 per cent winter killed it certainly cannot be a good investment in the present year.

There are districts of course which seem to be almost, if not

entirely, exempt from either winter killing or damage during the flowering period in the summer. Some of this land is found south of Cardston, Macleod and in the Pincher Creek Valley, but speaking generally the districts along the line of the Macleod and Calgary branch—east as far as Medicine Hat—and south to the Crow's Nest Pass, line (the big triangle), have not given a good account of themselves in the matter of winter wheat, while to the north the averages for five years run as low as 15 bushels in some districts.



Never Despise the Day of "Small Things"

Many crops are raised in southern Alberta that thresh as high as 65 bushels to the acre, but the fact that the five year average of the Province is not over 22 shows that the general conditions for the production of winter wheat cannot be satisfactory. Many of the farmers are themselves realizing this and a considerable proportion of the land which last year was intended to be sowed to winter wheat in 1913 will be sowed to alfalfa instead.

Fall Wheat in Manitoba

The province of Saskatchewan has so far done very little in the matter of the growing of winter wheat, though some fairly successful, if somewhat tentative experiments have been carried on. Manitoba, and especially Northern Manitoba, is growing winter wheat successfully in small areas, and will no doubt steadily increase the acreage. There is much land which lends itself specially to the cultivation of this

wheat, for example the Dauphin country and the Swan River Valley.

These lie behind the Riding Mountains, and have each year not only a heavy snowfall, which acts as a blanket to the winter wheat, but the shelter of the mountain prevents the drifting of snow, which is so noticeable in the open prairie sections, in fact it may be said that when winter wheat is planted in Swan River Valley the snow comes down and covers it, and that blanket is never shifted or moved until the heat of the spring sun is

could not be exported to eastern biscuit manufacturers, or even to Great Britain.

The man who is intending to try winter wheat this coming summer would do well to make enquiry as to just what is the record in the district where he proposes to grow it. While there is undoubtedly a market for the high grade Alberta red winter wheat, there is not sufficient demand for the soft wheat produced in northern Manitoba to warrant the growing of it, excepting in limited areas, until such time as a market is more fully assured. Winter wheat is not really a profitable crop unless a man is sure of from 35 to 40 bushels to the acre. One of its chief advantages in this country is of course the fact that under ordinary conditions it is ready to cut from a week to ten days earlier than the spring wheat crop.

Alfalfa

It seems as if it was almost impossible to pick up a paper at the present time, or to listen to the conversation in a crowded street car, without hearing something about alfalfa; it is almost as universally discussed as the doings of the militant suffragettes. "Milling," which is the official organ of the British milling trade, in a recent editorial, takes up the question of alfalfa growing (or lucerne, as they call it) in the Argentine. Cattle are very scarce in the Argentine, owing to the drought of the past four years, and there is a great shortage of animals for their export trade in chilled meats.

During the past year the rain was sufficient, but the effect of previous dry seasons was still felt, and arable land has also gone up in price. While the advance in the cost of arable land is expected to increase wheat growing, in some of the drier sections specially where drought resisting wheats are being introduced, at the same time the growing of alfalfa will be extensively carried on in order to revive the cattle industry, which is extremely profitable to Argentina, especially in view of the possible free entry of meat into the United States.

Alfalfa in South Dakota

The State of South Dakota is also devoting much attention to

sufficient to melt it. In this way the young plants are protected and do not suffer from the freezing and heaving so common on the open prairie, where there is no shelter of any kind. So far, winter wheat grown in Northern Manitoba has not proved so hard and flinty a berry as that grown in Alberta, but it is the class of wheat which experts state makes the very best kind of biscuit flour.

For years the Canadian West has been shipping in its biscuit flour from St. Louis. Biscuit manufacturers in Winnipeg, however, have made a very thorough test of the baking qualities of winter wheat from Northern Manitoba, and reported "quite as satisfactory as the St. Louis product." This opens up not only a possibility of a local market for flour made from winter wheat, but if the article produced from it is of a superior quality there is no reason why, when the supply runs beyond local demands, it

This Hart-Parr Drive Wheel Unbroken By A Pile Driver Blow Of 216,000 Pounds

The drive wheels on our small, light oil tractor are not built as we once might have built them, and as other manufacturers of small tractors still build them.

Painstaking experiments and rigid tests showed us the fallacy of trying to make any built up wheel do efficient reliable duty on a small tractor. For the drive wheels must be light to keep down weight, and still be strong enough to stand up under the constant, racking strains of every-day field service. And so, before we even offered our small tractor for sale, we experimented, at our own expense, and discarded the various drive wheels commonly used, and which other tractor builders still cling to.

How Hart-Parr Drive Wheels Are Built

The drive wheels on the small, light Hart-Parr Oil Tractor are Solid Steel Castings—not built up or pieced. Casting them of tough steel does away with hundreds of small parts and insures lightest weight, yet greatest strength. Moreover, these drive wheels are cast with our wonderful, self-cleaning wave form lugs, which afford a bull dog grip on soft ground, but do not injuriously pack the soil. No built up drivers on a small tractor combine all these vital, necessary features.

Hub Undented By A 216,000 Pound Blow

One of these steel drive wheels was picked at random from a batch of 50 or more, made during an ordinary day's work in our steel foundry. This drive wheel was placed on a solid foundation, absolutely without give, and laid in the position shown in the illustration to the right. A 3,600 pound cast iron weight was then dropped from a height of 60 inches, full on to the hub of the driver. As it fell, it gathered speed and struck the hub a crushing blow of 216,000 pounds. Close inspection of the hub showed hardly a dent in it. The wheel was uninjured.

Here's What Happens In Field Service

In actual service, the tractor travels over rough roads and uneven fields, many of them with quite deep ruts. When it hits the bottom of these hollows, the drive wheels are compelled to sustain the tractor's weight exactly in the same manner as the driver, on test,

A Size For Every Farm

Hart-Parr Oil Tractors are built in three sizes, and are big money makers on farms of 100 acres or 1,000 acres. They are strictly One-Man Outfits, use cheapest KEROSENE for fuel at all loads, and are oil cooled.

Get Our Literature

Consult us on your power requirements. We'll gladly send you our fine catalog and other interesting literature on power farming costs, and advise you the size tractor best suited for you.

Hart-Parr Company

30 Main Street, Portage la Prairie, Man.
57 West 23rd Street, Saskatoon, Sask.
1616 8th Avenue, Regina, Sask.
The Chapin Co., 325 8th Ave. W., Calgary, Alta.

The Tests We Made

The remarkable strength, toughness and durability of these all-steel, single piece Hart-Parr drive wheels, are clearly shown by severe drop tests recently conducted at our works. These tests will interest every farmer who intends buying a power equipment.

Rim Stands 216,000 Pound Blow Without A Crack or Break

This same wheel was then placed upright, as shown in the illustration to the left. The 3,600 pound weight was again dropped from a height of 60 ins., striking the rim a 216,000 pound blow. Careful examination

of every inch of the wheel showed not a break or crack anywhere. Rim, spokes and hub—all remained absolutely unharmed. The tests this wheel withstood would send an ordinary wheel to the scrap pile.

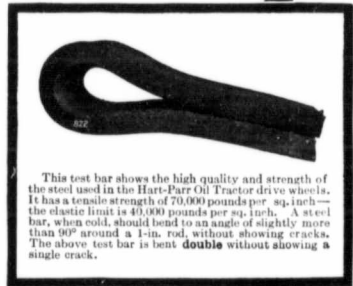

This test bar shows the high quality and strength of the steel used in the Hart-Parr Oil Tractor drive wheels. It has a tensile strength of 70,000 pounds per sq. inch—the elastic limit is 40,000 pounds per sq. inch. A steel bar, when cold, should bend to an angle of slightly more than 90° around a 1-in. rod, without showing cracks. The above test bar is bent double without showing a single crack.

Big Margins Of Safety and Strength

We could build cheaper drive wheels. We could even build a smaller margin of strength and safety into them and still make them as good as the drivers found on other makes of small tractors. But our policy and aim is to give the farmer the best that can be had in material, workmanship, efficiency and reliability. And it's just the same with every other part of this small, light Hart-Parr Oil Tractor. No skimping in quality—nothing left undone which will ensure the farmer the utmost in tractor satisfaction. The reason Hart-Parr Oil Tractors are superior to all others is because they are built so from the drive wheels, up.

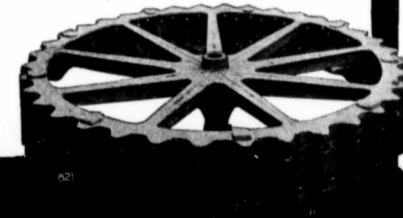
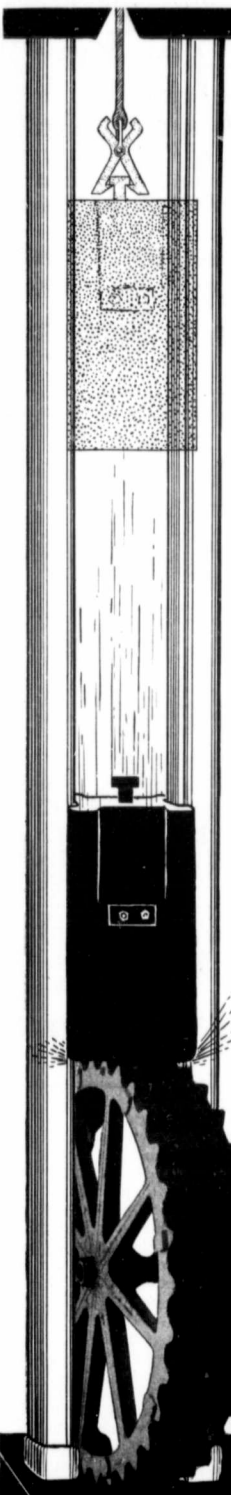

Position of Wheel—Second Test

Position of Wheel—First Test

You saw this advertisement in this magazine. Don't forget to say so when writing.

the growing of alfalfa, having the ambition to become the leading alfalfa state of the union. Professor N. E. Hansen, of the South Dakota Agricultural College, who is known as the "alfalfa wizard" of the United States, has on several occasions been sent as a representative of the United States department of agriculture, to Siberia and other countries in search of alfalfas which would be hardy enough for the northern states. Seed gathered by him on these trips has been developed into large alfalfa fields in many of the western and northwestern states.

Those who visited the Dry Farming Congress at Lethbridge last year had an opportunity of seeing not only specimens of the alfalfa produced from seed, introduced by Professor Hansen, but also of seeing large photographs of the remote and even barren looking regions from which the seed had been brought. He is setting out almost immediately on another trip to western Africa, the South Dakota Legislature, at its recent session, having voted \$10,000.00 for this trip.

The special purpose is to secure alfalfa seed which will be adaptable to western South Dakota, where the rainfall is not as ample as it is in the eastern or older section. The legislature also voted an additional \$15,000 to be used in the propagation of alfalfa in western South Dakota, which was the great cattle ranching section of the state, and which in recent years has been homesteaded.

Professor Hansen will go directly to Russia, and from there his objective will be eastern Mongolia, where he has learned that there are alfalfas that thrive on the hard dry uplands, with little moisture, and with hot summers and very cold winters. In some of the territory to be visited by Professor Hansen the temperatures range from 120 above in summer to 65 below in winter and the rainfall is less than 9 inches. He hopes to bring back with him two tons of seed. This expedition is of great moment to Western Canada, as the conditions in western South Dakota correspond very closely to conditions in southern Saskatchewan and parts of southern Alberta—sections which were all cattle ranches until within the last few years.

If Professor Hansen succeeds in getting hardy alfalfas that will grow in western South Dakota, there is no doubt that they can be grown in any part of southern Saskatchewan and Alberta. There are large stretches of land in these districts which have been recently homesteaded, or where men have bought farms and are attempting to grow grain with

Do they Use Pedlar Culvert on Your Roads?

Use It On the Farm, Too

Pedlar Culvert makes farm bridges at ditches, gates, etc. Time saving, frost-proof. It never washes out. Lasts for years. Sizes 8 inches to 7 ft. in diameter.



Put the small sizes in your open drains like this everywhere needed on your farm.



Or use it under your gateway bridge, or as a well curbing, if desired.

Instead of doing statute labor, year after year, on a rotting bridge, throw it out and install our Pedlar Culvert in a few hours.

Nested bundles like this

make interlocking sections which—

—a man clamps—

In Toncan Metal

Pedlar Culverts are not made in ordinary metal, and do not corrode. Toncan is a peculiar anti-rusting metal. It is used only in Pedlar Culverts. It makes the culvert good for years to come.

There are imitations. Be sure and get the genuine Pedlar Culvert, which will not corrode. Write us at our nearest branch for full details.

A Sample of Pedlar Culvert and a Special Book about it to every Farmer or Reeve or Municipal Officer —

FREE

THIS culvert is made in sizes from 8 inches up to 7 ft. It is very strong. It is proof against ice, frost, freshets, and corrosion. It saves road troubles and excavating. Does your township use it?

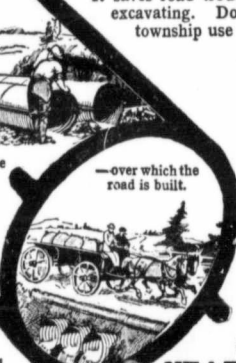

—over which the road is built.

OUR NEAREST BRANCH WILL TAKE CARE OF YOU

SEND for our Free Sample of Pedlar Culvert and Book to-day to the nearest branch below.

TORONTO 112 Bay Street 321-3 Craig St.
MONTREAL 86 King Street 432 Sussex St.
LONDON 200 King St. W.
OTTAWA 422 St. James St. W.
CEATHAM 127 Rue du Port
QUEBEC 563 3rd St. W.
EDMONTON 1282 1st Ave. So.
LETHBRIDGE



PORT ARTHUR 45 Cumberland St.
MOOSE JAW 302 Fairford St.
WINNIPEG 16 Lombard St.
MEDICINE HAT -- Toronto St.
SASKATOON Box 168
CALGARY Box 7, Crown Block
VANCOUVER 108 Alexander St.
VICTORIA 454 Kingston St.

WRITE NEAREST BRANCH FOR CULVERT BOOK \$36

Yo saw this advertisement in this magazine. Don't forget to say so when writing.

somewhat indifferent success. It is known now that some of these lands ought always to have been left for cattle ranches, but cultivation once having started, it is hardly likely they will ever go back to merely grass ranches again.

The finding of an alfalfa that can be grown without difficulty in these semi-arid districts would mean that it would speedily become much more profitable to turn these sections into stock farms than to retain them as purely grain farms, and in this way the cattle industry of Western Canada would not only receive an immense impetus, but would be established on a very much more certain and profitable foundation.

Alfalfa in Manitoba

Little old Manitoba is not going to be behind in the alfalfa game, thanks to the enterprise of

Professor Bedford, deputy minister of agriculture. He is busy at the present time locating alfalfa testing plots in the Red River Valley. A short time ago he visited St. Pierre Jolys and made a selection of land there for the purpose. The preparation of the land and the sowing of the seed will be superintended by Mr. Harrison of the Agricultural college. The soil in this district is very rich, but is well drained, and promises to produce very heavy crops.

Another field selected for a test plot is on the farm of J. H. Irwin, one mile south of Neepawa. This land was last year in fodder corn, and is in excellent shape for the seed. Professor Bedford says that the department proposes to thoroughly test the growing of alfalfa in every part of the province, and the hardiest varieties are being planted, sown in rows three feet apart, in order that the crop may be kept free from weeds. It is

intended to prove that not only alfalfa, but alfalfa seed, can be raised to advantage.

It will be seen from the foregoing that alfalfa production is in the very air, and it is to be hoped that every farmer will become inculcated with the idea, and will speedily proceed to prepare and put in a small patch of alfalfa. Between now and the end of the first week in June is the time when alfalfa should be sowed. While seed at the present time is expensive it will only take a few dollars to secure seed enough to plant a small area; if nothing else is available, last year's potato plot would answer as a starting point. Alfalfa growing, with its sure accompaniment of cattle, hogs and sheep, is the best possible solution of the 50c a bushel wheat problem.

The province at the present time is paying half a million dollars for seed. Small quantities of seed which have been raised in the province have proved of excellent quality.

GOOD TIME—BAD WORDS

Fly Like Sparks From The Anvil When The Belt Breaks

One can BUY a reputation but character cannot be bought by any process of squaring or boosting. It must be FOUNDED and BUILT from something so good that it cannot be wrecked. Our friends have taken care of our reputation. Had there been a loose joint in the character of our belts at any time, our foes and astute competitors would have buried us long ago.

OUR Belts are Known as the



LION BRAND

Rubber Belts

and the



MAPLE LEAF

Endless Thresher Belts

The very finest grade of material only is used in every detail carried out in our factories; the best workmen employed in this industry and the experience of a long lifetime are co-operated and concentrated on the one business of making these goods. The result is--belts that GRIP, belts that PULL and belts that WEAR, and they have stood the test of more threshermen in Western Canada than all other brands put together.

With That New Outfit For 1913

See that it is provided with a

“Lion” or “Maple Leaf” Brand

Any Thresher Company can supply you with our Belt. In fact the majority use them exclusively. Don't accept a substitute, you will regret it just when you most need belt service. If you have any difficulty in getting our goods, write direct to the

Gutta Percha and Rubber Limited

WINNIPEG

NOT IN ANY TRUST OR COMBINE

CALGARY

FARMING A HALF SECTION OF LAND

The First Three Years' Program for a Half-Section of Land

By H. Hudson

IN the locality of Lloydminster, a fair sized town in Central Saskatchewan, is to be found some of the most fertile land in the country. The surface soil is a heavy black loam about ten inches deep on an average, the sub-soil being a medium heavy clay. The land around is a rolling bluffly prairie. A few trees grew here and there at one time, but they have long since been chopped down or burned. The value of unbroken land in the vicinity of the town is \$15 per acre. Taking up a half-section of land two and a half miles to the north-east of the town we have some splendid soil with suitable surroundings. There are but few stones on the land and these will come in handy for building purposes. A lake is half a mile away which is two miles long and half a mile wide, a splendid place for boating and bathing in the summer time and for skating in the winter. Its greatest advantage, however, is that stock can be watered there the year round. The climatic conditions of this part of the country are favorable, as the Battle River 40 miles south and the North Saskatchewan River 25 miles to the north carry away most of the destructive storms, and the country in between fares well with a moderate amount of rainfall and sunshine. The land is best suited for mixed farming, but as grain growing brings quicker returns, it is better for the settler, as the brotherly love. This is an English settlement and the community is made up mainly of sons and daughters of the Old Country. This is beneficial for the settler as the brotherly love of the Briton is extended to at least all English people who come within his bounds. His interests are looked after with fraternal pride, and he joins them in their efforts to give back to Canada the best of her products for what she has done for them.

A man and his wife arriving on this farm in the spring have ample opportunity of showing their skill in developing the natural resources of the soil and bringing forth an economical profit for their labors. To do this the man needs to have a fair education which will enable him to work out the most economical and scientific method of procedure. His wife will need to be well versed in the principles of domestic science, to

be able to manage household affairs to the best advantage. Taking a young couple with such abilities we will place them on this farm and watch the method of cultivation for the first three years. They arrive about March 25th with a capital of \$4,000 and personal effects enough to last them for at least eighteen months. The land is bought, and \$100 is paid extra for the breaking up and cultivating of 20 acres; \$750 is paid down in cash, the remainder to be paid in 5 equal annual payments of \$832 each with interest at 7 per cent. The second payment has to be made at the end of 18 months.

The farmer immediately sets to work to dig a cellar on the site he locates for his house. The weather being mild and with good sharp implements he soon has a

80 bushels of grain. The pickling is done as a guard against smut, and is done about twelve hours before seeding. About the middle of April he borrows a drill and puts in ten acres of wheat, sowing two bushels of seed to the acre. He then harrows the field to cover up all the seed and to form a mulch. By this time the carpenter has the stable well under way and in about ten days' time the building is completed. In size it is 28 feet by 14 feet and 7 feet to the plates with a half pitch roof. Dismissing the carpenter, the farmer then hires another man to help to put up a fence. Barb wire and willow posts are bought, and in three days' time they have a two-wire fence up around an area containing twenty acres. The man is then put to digging a well. In

During the latter part of May he plants some potatoes and sows his vegetable seed. The first week in July is spent in hauling stones off the breaking. Then he starts discing, overlapping as he goes lengthways of the field. About July 20th, he leaves off discing to put up hay. After building a rack he makes an agreement with a neighbor that they shall put up hay together, he furnishing the horses while his neighbor supplies the implements. They select a spot, where there is an abundance of good prairie wool and very little spear-grass, and commence haying. In two weeks they have twenty loads each stacked alongside of their respective stables. Discing is again continued till August 12th, when he puts in four days roadwork, with one team, to pay off his land taxes. Then the crop is ready to cut, so, borrowing an eight-foot binder he sets to harvest his crop. The sheaves are then stooked into long stooks containing about ten sheaves each. Discing is again resumed and early in September, his hundred acres of breaking have been disced twice lengthways and twice crossways. The farmer then hires a man to help him to stack his grain. The stacks are built close to the stable so that straw will be handy for winter use. They both join on to a threshing outfit and put in, altogether, thirty days' work each. The man drives a team and stook wagon, while the farmer himself works his team on the water tank. About the end of September his own threshing is done. The grain turns out well; the wheat averaging twenty-five bushels to the acre, while the oats go about seventy bushels to the acre. Just about this date the potatoes and garden vegetables are dug up and stored away in the house cellar. Threshing is continued till the end of the season. The man is then paid off. The farmer harrows his breaking twice, bringing it to a fine condition for the next year's crop. He also plows up his twenty acres of stubble land, so that the frost will disintegrate any clods of earth that are turned up. Then he helps his neighbors to haul grain, to pay off the debts he has made by borrowing implements, etc. About November 10th, the ground freezes up, making further work upon the land impossible. The farmer then turns his attention to getting his buildings ready for the winter. His grain is stored in bins in the stable,



'All Over' in a Fine Hay Season.

hole dug 7 feet deep by 6 feet square. He then buys a team of four horses, harness and a wagon with a double box. With his plans for the buildings made he purchases the required amount of lumber, nails, etc., and hauls it out to his future home. Over the cellar he erects a comfortable two-roomed house which, with the aid of a carpenter, takes about two weeks to build. In dimension it is 24 feet by 16 feet and 7 feet up to the gables with half pitch roof. His wife then moves in, having in the meantime been boarding with a neighbor. He then buys such implements as smoothing harrows, disc harrows and a sulky plow. The latter is soon put to use to plow a double fire-guard, each 6 feet wide with an equal space in between, around the farmyard. The seeding season is now approaching so he buys some well cleaned pure Red Fife wheat. This he pickles by dipping a bag half full of wheat into a barrel containing a formalin solution of 1 lb. of formaldehyde to 40 gallons of water. This solution is enough to pickle about

two days the well is dug to a depth of 14 feet and is 4 feet square. A wooden crib is put in it and three feet of pure clean water comes into the well which is sufficient for household purposes. The man is then paid off. The farmer buys some well cleaned Abundance oats and a cow, which has just commenced her lactation period. About the end of April he pickles the oats in the manner already described and a drill is borrowed. Nine and a half acres are sown with two and a half bushels to the acre. The land is then harrowed. Early in May the farmer sets out to do his breaking with his four horses, a pick-axe, and a sulky plow. The pick-axe is used to pick out the stones, that are a nuisance, as he goes along. With fine weather, a good machine, and willing horses he breaks on an average 2 acres per day. This he continues with an occasional stop till the end of the breaking season which is about July the first. The breaking is done about three inches deep and is turned over flat so that the sod will rot well.



MAYTAG^{CO} LTD



Do Not Make A Mistake This Year

When it comes to buying a Self Feeder. We believe what you all want is a Feeder that for more than the past ten years has been doing good, satisfactory work in the CANADIAN FIELDS. A Feeder may do good work in South America, Russia, or even in the United States and then fail to handle the Canadian crops right. Without hesitation we refer anyone intending to get a new Feeder this year to any one of the Eight Thousand Threshermen in Canada who are using the

RUTH FEEDER

THE RUTH has been tried out and proven to be the only Feeder that can make good under any and all conditions. Wheat, Oats, Barley, Rye and Flax all look alike to the Ruth. Millions of acres are being sown to FLAX this year, so be sure and get the Feeder that likes it. THERE IS NO FEEDER IN THE WORLD THAT EQUALS THE RUTH when it comes to feeding flax. Take no chances. Buy the Feeder that has been proven out IN CANADA. If ever one has it is THE RUTH. Do not buy an experiment. BUY A RUTH. Below is the RUTH WARRANTY; please read it carefully. We not only carry a full stock of Feeders and Repairs at Winnipeg, but they can be had of any of our branches as shown below.

THE RUTH WARRANTY

"The RUTH Feeder is Warranted to Feed any make or size of Separator to its full capacity, with any kind of grain in any condition whatsoever, bound, loose, straight, tangled, stack burned, wet or dry, PILED ON THE CARRIER IN ANY WAY YOU PLEASE, without slugging the separator cylinder or loosening a spike, and to do a faster, cleaner and better job of feeding and to WEAR LONGER AND COST LESS FOR REPAIRS than any Feeder manufactured by any other Company in the World. We further Guarantee it to be made of the best material obtainable by the most skillful workmen, and if WITHIN THREE YEARS FROM DATE OF SALE (if our instructions are carried out) any part of the above described Feeder (except webs and belts) should break or in any way incapacitate the Feeder owing to defect in material or workmanship, and not on account of carelessness on the part of the user, we will replace such part or parts ABSOLUTELY FREE OF COST, on return of defective parts F.O.B. Winnipeg, Man."

Repairs and Extras

While it is an undisputed fact that the RUTH FEEDER REQUIRES LESS REPAIRS THAN ANY OTHER FEEDER IN THE WORLD, the cost per machine for repairs during the past 10 years averaged less than \$2.00, an occasional piece is needed, and when the accident does happen it is wanted quick. We understand this and in order to make it more than ever to your interest to buy a RUTH, we are doing something that no other Feeder Company has ever done, and that is we will have a good stock of repairs this year and in all the years to come at central points throughout Canada. This year you can get them from

H. A. KNIGHT at REGINA, and INTERNATIONAL HARVESTER at SASKATOON, Sask.
The W. S. COOPER Co. at CALGARY, and GEO. THOMAS & Co. at WEYBURN, Sask.

Do not forget that

Any Threshing Machine Company doing business in Canada can supply you with a RUTH Feeder, and we FURNISH THE ATTACHMENTS TO PUT THEM ON SO THAT THEY FIT PERFECTLY. When we say ANY Thresher Company, we had in mind more especially any of the following. We are not only willing but anxious to fill all orders they may favor us with during the coming season.

Sawyer & Massey Co.
International Harvester Co.
Waterloo Manufacturing Co.
Fairbanks-Morse Co.
American Abell E. & T. Co.
Haug Bros. & Nellermeoe Co.

Gaar Scott & Co.
Burrledge Cooper Co.
Buffalo Pitts Co.
Canadian Port Huron Co.
The Rumely Co.
Robert Bell E. & T. Co.

Geo. White Sons & Co.
Nichols & Shepard Co.
Reeves & Co.
J. I. Case Threshing Machine Co.
John Goodison Thresher Co.
Aultman & Taylor

Minneapolis Thr. Machine Co.
W. S. Cooper Co.
Compagnie des Jardins
Matthew Moody & Sons
A. & T. B. Farquhar
C. Smith & Sons

Huber Manufacturing Co.
Geiser Threshing Machine Co.
McDonad Thresher Co.

REMEMBER, that should you buy a Separator of ANY COMPANY whose name DOES NOT appear above, that we can and will furnish the proper attachments to equip it with a RUTH FEEDER.



MAYTAG



COMPANY, LIMITED

WINNIPEG, MANITOBA

You saw this advertisement in this magazine. Don't forget to say so when writing.



CANADIAN INDUSTRIAL EXHIBITION



WINNIPEG, JULY 8-16, 1913

Send your entries for the biggest and best year of the West's biggest and best

LIVE STOCK SHOW

In all classes in every section except dogs

Entries Close June 21st.

\$75,000 IN PRIZES, PURSES AND AMUSEMENTS.

HUGE AGRICULTURAL MOTOR CONTEST

Every farmer should see this, the greatest contest of its kind in the world. Highly instructive — of tremendous educational value to all.

ORIGINAL GRAIN CLEANER CONTEST

The first fanning mill contest ever held. Perfection in grain cleaners means no docking at the elevators. This contest will show you the best grain cleaner on the market.

FRONTIER DAYS EXPOSITION

The finest and best attraction to be seen in the West this summer. Nothing to equal it. Bucking bronchos; outlaw horses; thrilling Indian scenes. Come and see the cowboy at home.

SIR WILLIAM WHYTE
President

F. J. C. COX
Vice-President

W. H. EVANSON
Treasurer

A. W. BELL
Secretary

You saw this advertisement in this magazine. Don't forget to say so when writing.

and with the threshing bill paid up and no bad debts on his books his mind is at ease, and he looks into the face of the forthcoming winter with a spirit of repose and contentment. However, he is by no means an idle man, so he takes a brush hook and spends about two weeks brushing out some of the willow scrub on his farm. Then the snow gets too deep for this work, so he buys a set of bob-sleighs and starts hauling fuel from the woods 20 odd miles distant. Six good loads are hauled before Christmas and another six after that date. During the time he is away a neighbor's boy attends to the two horses and cow left at home. Early in the spring he sells six tons of hay for a good price. About the middle of February, the farmer hauls out lumber from town to build a granary. This he puts up as a permanent building alongside of his stable. When finished it is 16 feet by 14 feet and 7 feet to the eaves, and capable of holding about 1,250 bushels of grain. During odd days through the winter, he cuts his fuel with a buck-saw and splits a great deal of it, so that by the spring he has enough chopped wood to last all through the summer. He buys a fanning mill and fans his seed oats and all his wheat. The balance of his wheat not wanted for seed or feed, is

sold as seed wheat. He gets his implements and horses in good shape for the spring work and buys a 20 single disc drill. It may be well to explain here some of the minor details which have not been mentioned. The poultry are looked after by the lady of the house, under whose supervision they thrive well. About forty chicks are raised, half of these of course are of the male sex and they are useful to grace the table as a change from the ordinary fare. The farmer attends to the milking of the cow, hoeing the garden, and all such chores outside of the house. The ration for the horses while working is 1 lb. of hay per day per 100 lbs. live weight, and a mixture of 3 parts of whole oats and 1 part of bran—3 gallons per horse per day. When not working, the grain ration is reduced to one-third of this amount. Salt is given twice a week. The horses are watered in a slough near the farmyard for the most part of the summer. When it goes dry a tank has to be made and water hauled from the lake half a mile distant. In the winter, water is hauled for the stock in barrels every third day.

The following is the cash account recording the expenditure and the income of the farmer for his first year.

Cash Account of First Year.		Dr.	Cr.		285
By cash on hand			4000	To one set of bob-sleighs ..	30
To cash payment on land ..	750			To lumber for rack and well	
To four horses at \$200 each	800			crib	16
To two sets of harness at				To boy during winter, 30	
\$35 per set	70			days at 30c per day	9
To lumber, nails, etc. for				To disc drill	130
house	350			To lumber for granary	65
To wagon with double box ..	91			To fanning mill	45
To lumber, nails etc. for				To school taxes	24
stable	200			To household expenses	300
To wages for carpenter, 24				By wheat sold for seed, 90	
days at \$3 per day	72			bus. at \$1	90
To cook stove	25			By hay sold, 6 tons at \$6 ..	36
To feed oats 100 bus. at 30c	50.70			By interest on money in	
To hay, 2 tons at \$6 per ton	12			Bank	24
To bran 1600 lbs. at \$1 per				To sundries	50
100 lbs.	16			To balance, cash in hand ..	815.60
To fence posts, 300 at 7c					
per post	25.20			\$4435.00	4435
To barb wire, 900 lbs. at \$4					
per 100 lbs.	36				
To man for fencing and dig-					
ging well, 5 days at \$1.50	7.50				
To seed wheat, 20 bus. at \$1					
per bus.	20				
To seed oats, 24 bus. at 30c					
per bus.	7.20				
To 25 head of poultry, 40c					
per bird	10				
To one cow	30				
To potatoes and garden seed					
for garden	5				
To cord wood, 7 cords at \$5					
per cord	35				
To coal, 6 tons at \$5 per ton					
.....	30				
To harrows, 5 sections	27				
To disc harrows	44				
To sulky plow, 16 in. with					
stubble and breaker bot-					
tom	65				
To tools, shares and repairs					
To binder twine, 50 lbs. at					
10c per lb.	5				
To machine oil	1				
To threshing wheat, 250 bus.					
at 5c per bus.	12.50				
To threshing oats, 665 bus.					
at 3 1/2c per bus.	23.30				
To man for stacking, 2 days					
at \$2.50	5				
To man for driving stock					
team, 30 days at \$2.50 ..	75				

The soil becomes workable about April 8th, and the farmer harrows his twenty acres of fall plowing. The wheat is then pickled and eighty acres are sown with two bushels of seed to the acre. The land is then harrowed. Directly this is done he commences breaking and keeps at it till about April 26th. He then pickles and puts in the remaining forty acres to oats; sowing two and a half bushels to the acre and harrowing immediately after drilling. He resumes his breaking, and continues more or less till July 1st. Near the end of May he plants his potatoes and sows his garden seed on his fireguard. Altogether he breaks one hundred acres and then he plows a fire-guard around his pasture and farmyard.

"The Great Minneapolis Line"

COURTESY THE LINE OF EVER INCREASING POPULARITY FAIRNESS

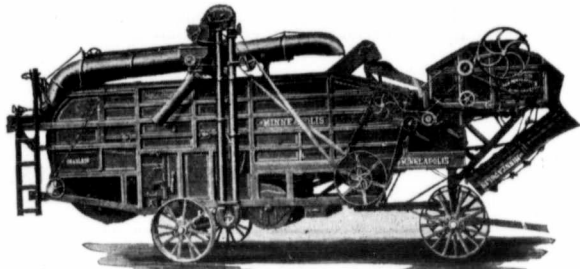

STANDARD SEPARATOR

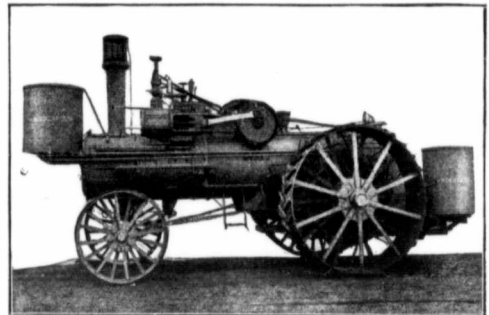

STEAM ENGINE

Always Ready

It Saves the Farmers' Grain

Runs Steady

Without an Equal for Durability and Efficiency

The Minneapolis Separator has won its place in the hearts of American farmers and threshermen absolutely on its merits. It will stand the hardest kind of usage and thresh, save and clean in a satisfactory manner any and all kinds of grain and seeds.

The Minneapolis Steam Engine has for years been a favorite with threshermen of the West and Northwest, because of its ability to develop extraordinary power economically, and to stand up to the most severe work.

WATCH THE STRAW STACK—ASK OUR CUSTOMERS

It is very simple in design, handsomely finished, a free, easy steamer, in short, an engine that will please the most exacting.

THE MINNEAPOLIS 20 H. P. Universal

is the most popular light-weight gas tractor on the market. We lead where others follow. The "following" is excellent proof of our ability to design and build well.

Let your order be for a **MINNEAPOLIS UNIVERSAL** and you will have no regrets.

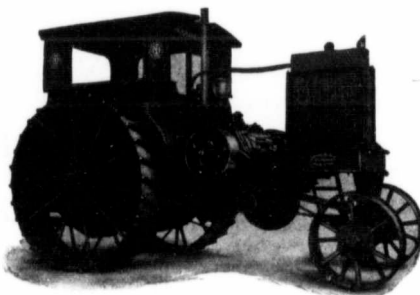

40 H. P. MOTOR

THE MINNEAPOLIS 25 H. P. Farm Motor

has made for itself an enviable reputation. It will do the work of 24 horses with ease and at a much less cost. It is guaranteed not to balk and eats only when at work. It does not require an expert to run a Minneapolis farm motor or a repair shop to keep it running.



UNIVERSAL TRACTOR

King of all Gas Tractors—THE MINNEAPOLIS 40

Of practically all steel construction
All parts easily accessible
Gas power is cheaper than horse power
Tractors that are durable, efficient and reliable
The kind you should buy for heavy work
MINNEAPOLIS 40

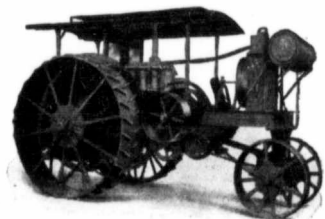

25 H. P. MOTOR

"It doesn't matter so much what you pay for what you get, as what you get for what you pay"

The Minneapolis Threshing Machine Co.

HOME OFFICE AND FACTORY

West Minneapolis (Hopkins P.O.), Minn., U.S.A.

REGINA - WINNIPEG - CALGARY - EDMONTON

THE MINNEAPOLIS THRESHING MACHINE CO.
West Minneapolis, Hopkins P.O., Minn., U.S.A.

Gentlemen:

Please mail to me free, printed matter as checked below:

Large General Catalog. _____

Threshers' Account Book. _____

Wall hanger of the Great Minneapolis Line in colors. _____

I will be in the market for.....

about.....1913.

Name

Town

C. T. F. Province

NOT IN ANY TRUST OR COMBINATION

You saw this advertisement in this magazine. Don't forget to say so when writing.

285
90
36
24
.60
.00 4435
rkable
farmer
of fall
then
sown to
the
rowed.
com-
s at it
then
aining
g two
re and
after
aking
ss til
lay he
vs his
l. Al
ndrec
i fire
: and

The stones are hauled off the plowing and the farmer starts discing, which he continues till about July 20th. After making another agreement with his neighbor, they put up fifty loads of hay, which are equally divided between them. Four days' road-work is the next item, which he does to pay off his land taxes. Discing is again continued, to be stopped once more by the harvest. The oats are ready to cut about August 18th, so the farmer borrows an eight-foot binder and begins reaping. He hires a man to do the stooking and inside of eight days his whole crop is in the stook. The man is then dismissed. The remainder of the discing is now done and by about September 10th, all the breaking has been disc'd four times. He then has his crop threshed from the stook. The grain turns out well, the wheat averaging 25 bushels to the acre, and the oats yielding 65 bushels to the acre. Hiring a man they work out on a threshing outfit the same as the previous year. They put in 25 days' work, threshing altogether. One car-load of wheat of about 1,000 bushels is loaded from the machine and shipped to the Grain Growers Grain Co. The farmer and his man haul grain for the neighbors in return for their labor and for implements borrowed. Early in October the potatoes and garden truck are dug up and stored away in the cellar. The man is paid off and the farmer harrows his breaking twice. About ten days are spent fall plowing. The freeze up then puts a stop to all work on the land about November 1st. Forty acres of fall plowing are done and one hundred acres of breaking are in good shape for the future crop. He then puts up a poultry house, as he has now about one hundred fowl, and he gets his building into good trim for the winter. About two weeks are spent in brushing down some scrub. Six tons of hay are sold during the winter and a dozen loads of wood are hauled. A great deal of the wood is cut and split into convenient fuel for the fire. Near the end of March a small car of oats of 1,600 bushels is shipped to the company already mentioned. The remaining 350 bushels of oats which he has to spare are sold at the elevator. His extra wheat, amounting to 700 bushels, is sold partly for seed and partly to the elevator. He now has two hundred and twenty acres of his land broken, but the scrubby parts are as yet untouched. He therefore invests in a brush breaker plow and also buys another team of horses. These animals are of a heavier draft type than the ones he has. One of them is a grade Clydes-

dale mare weighing about 1,500 pounds, the other is a grade Clyde a little less in weight. He also buys a couple of pure bred Yorkshire sows, about 16 months of age, which are due to farrow in April. Lumber is bought and a piggery is built of the "A" shaped type, a hog fence is also invested in. The seed grain is cleaned and everything is put in order for the spring. The following is the cash account recording the expenditure and income of the farmer for his second year.

To be concluded in July issue.

The Only Culvert for a Good Road

The past winter and early spring has demonstrated in a most significant and in many cases the folly of taking chances with "any old" idea for a culvert. All sorts of cheap make-shifts have been resorted to, but the best yet in a really effective provision for carrying superfluous water under a roadway is the corrugated galvanized culvert.

These light, and easily handled culverts are capable of resisting enormous pressure. The "trick" is in the construction and of course quality of metal used. Several makers are now pushing them to the front and from all experience there is nothing as yet in the field that can come near them when it comes to something that will give perfect service and refuse to collapse under almost any circumstance. We have pleasure in calling attention to the advertisement of the Canadian Corrugated Pipe Co., of Portage la Prairie who are manufacturers of the "genuine Open Hearth Iron" Culverts, and are now shipping them East and West of that point in large orders. As a rust-resisting medium, this metal is unequalled and has been thoroughly tested and approved by the leading road-builders, architects, engineers and scientific men.



"Did you ever meet my brother Dennis?" asked Pat. "He has just won a gold medal in a Marathon race."

"That's fine," said Mike. "But did I ever tell you about my uncle at Dublin?" Pat agreed that he could not call him to mind. "Well," continued Mike, "he's got a gold medal for five miles and one for wrestling, and a lot of badges for boxing and cycling."

"He must be a great athlete, indeed," said Pat.

"You're wrong," cried Mike. "He keeps a pawnshop!"

INEXPENSIVE, HIGHEST QUALITY WEDDING GIFTS

You are in a "fix" as to what you shall give the June Bride. To get rid of the difficulty, write for our new illustrated booklet (free to any address) of a specially selected group of highest quality jewellery, silverware and dainty articles of household utility. Most of these are made by ourselves in our own Canadian factories. They are unusually handsome goods, and the remarkably low prices will astonish you.

We guarantee safe delivery and perfect satisfaction or money will be instantly refunded.

Henry Birks & Sons Limited

WINNIPEG JEWELLERS & SILVERSMITHS MANITOBA

You saw this advertisement in this magazine. Don't forget to say so when writing.

125,000 People will see CALGARY INDUSTRIAL EXHIBITION JUNE 30 - JULY 5

\$110,000 will be expended to help them enjoy it

Reduced Passenger Rates. Freight paid on Alberta Exhibits. Live Stock unexcelled in the West.

Splendid programme of Music, Vaudeville, Fireworks, Races.

I. S. G. VAN WART, President. M. L. RICHARDSON, Manager, Calgary.

You saw this advertisement in this magazine. Don't forget to say so when writing.



The Best
Farm Lubricants

STANDARD
Gas Engine Oil

Used and recommended by the leading engine builders all over the country. Keeps its body at high temperatures. Equally good for external bearings.

PRAIRIE
Harvester Oil

A heavy-bodied oil, suitable for all kinds of farm machinery. Withstands weather, and is unaffected by moisture.

POLARINE
For Tractor and Automobile Lubrication

Silver Star Engine Kerosene

Eldorado Castor Machine Oil	Imperial Motor Gasoline
Capitol Cylinder Oil	Thresher Hard Oil
Eureka Harness Oil	Mica Axle Grease

Stock carried in 300 tank and warehouse stations in Western Canada. For prices at nearest warehouse, write any agency.

THE IMPERIAL OIL COMPANY
Limited
Main Office:
WINNIPEG
Regina, Moose Jaw, Saskatoon, Calgary
Edmonton, Lethbridge, Vancouver.



The "Associated Line" for 1913

Is Bigger, Better, More Complete than ever before

Quality Counts with You, Us and Everybody.

Quality, the ear-mark by which all standards are gauged, has been the prime factor in the unprecedented success of the Associated Manufacturers' Co.

From our infancy up we have pounded on the one subject—quality! quality!! quality!!!—until now it is a watchword everywhere—in our immense factories—in our general offices—and in the minds of every dealer who handles our goods—and the best of it is, this condition could not exist—especially as regards the dealers—if the engines themselves that we build and deliver, did not by their own demonstration in actual work back up our every claim to quality.

Associated Engines are built just as good as the finest of material and the most expert workmanship can make them. The question of price is never allowed to enter until the finished product is perfected, and that accounts for the important fact that you will find Associated Engines all over the world standing up and delivering the goods to the entire satisfaction of the purchaser.

We do not claim to build the only good engine on earth—that would be unjust and untrue. But we do claim that no engine could be built better—of better material or workmanship, and that the conditions in our immense factories make it absolutely impossible for any other concern in the world to meet our price.

Starting years ago in a small way, this factory has grown steadily

until now its many buildings of permanent fireproof construction cover acres of ground.

In this factory have been installed the most modern and specially-built automatic and self-regulating machines that money could buy to reduce the cost and make more perfect the parts that go into the building of Associated Engines.

These machines have revolutionized the building of engines; they have made possible the interchangeable-part system which means that all parts of any one size engine are made just alike and can be slipped into place without the old-time method of filing and fitting, so common with most makes of engines. This feature is best appreciated by the man who is obliged at some time or other to order a new part or repair for his engine.

But it is the wonderfully reduced cost of production that counts most with these new machines. It is the fact, that we are now enabled to almost double our production with practically the same amount of help. Now we are dividing this great saving with our customers, and giving them the highest quality of engines possible to produce at a price that enables them to beat any and all competition, and this fact has kept our factories running day and night where others have been forced to cut down their working hours and lay off their men. These engines combine best of materials, highest quality of workmanship, absolute interchangeability of parts, simplicity, economy of operation and low price and are without a doubt the best engine proposition on the market today.

The Factory That Stands Behind Associated Engines

Built More Engines in 1912 Than Were Built in Any Other One Gasoline Engine Factory.

A Factory Noted for its Honesty, Integrity and Square Dealing

The Associated Manufacturers' Co. was the first great, big, broad-gauged and broad-minded concern on earth that came out with a strictly high grade line of engines and other articles to be sold at prices that would enable dealers to meet any and all kinds of competition. Take the engines we show on the two following pages. Look at the 1½ h.p. Chore Boy, the 2¼ h.p. Hired Man, the 4 h.p. Farm Hand or the famous Six Mule Team, the Foreman and Twelve Mule Team. Nowhere can you find a line of engines of equal quality, and the prices are lower than others.

Then, another thing, "Associated" engines are built in a responsible factory—a factory that for years has stood on the same grounds it stands today, and where it will stand for years to come. You will never have trouble in getting repairs or new parts for any engine that ever comes through their doors, and this fact alone is worth the price of any engine.

Remember, the country is today flooded with engines of all kinds that

are made in little "catch penny" factories that are in existence today and gone tomorrow. There are other factories that put out the same engine under a dozen different names, possibly changing the shape of the water pot and name plate. There are sales organizations, and some of them doing a good business, too, that are selling any old line of engines, under some high sounding name, that they have bought cheap and that they have figured would catch the farmer. There is no telling how long these companies will exist, nor how long you will be able to get repairs and new parts from them.

These are the sort of engines that we say no man can afford to buy. Know your engine, and, above all, know the factory and company from which it comes. Remember, there is much more to an engine than the mere substance of iron and material that goes into it, or the labor that goes into its construction.

WRITE to either of the concerns named below for Catalogue and prices. You will be surprised to find how much money they can save you and give you a better Engine than you have been buying

Associated Manufacturers' Co., Waterloo, Iowa, U.S.A.

World's Largest Engine Builders

DAVID MAXWELL & SONS, St. Mary's, Ontario.

JAS. F. VANBUSKIRK, Fredericton, New Brunswick.

CRANE & ORDWAY COMPANY, Winnipeg, Manitoba. BRUCE STEWART & CO., Ltd, Charlottetown, Prince Edward Island.

P. T. LEGARE, Quebec, 273-287 Rue St. Paul; 32-38 Rue St. Valier.

BLIGH & PRINCE, Truro, Nova Scotia

Highest in Quality

The Great Associated Line

Lowest in Price

Associated Portable Line

This illustrates our Six Mule Team mounted on our Special All Steel Flexible Trucks. Nothing better made.

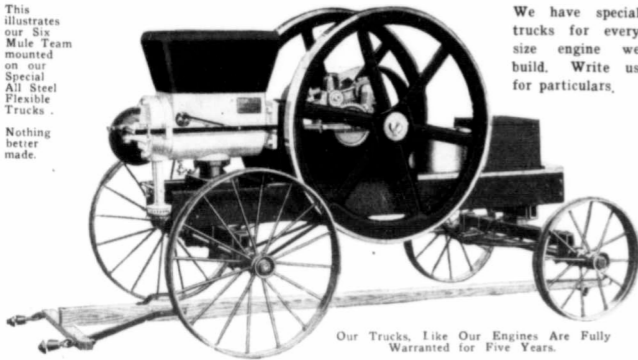

Our Trucks, Like Our Engines Are Fully Warranted for Five Years.

We have special trucks for every size engine we build. Write us for particulars.

The Chore Boy, 1 1/4 H.P.

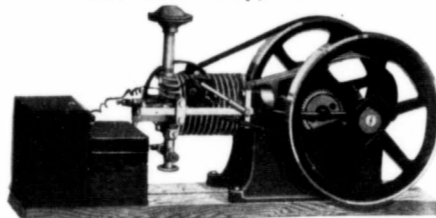

SPECIFICATIONS: Speed, 450 R. P. M.; Cylinder Bore, 3 1/2; Stroke, 5; Fly Wheel Diameter, 17; Face, 2 1/4; Fly Wheel Weight, 40 pounds; Pulley Diameter, 6; Face, 4; Shaft Diameter, 1 1/2; Length, 24; Over all Length, 48; Width, 24; Over all Height, 20; Base Size, 9 1/2 x 19; Weight, 320 pounds; Colors, Red and Black; Mounting, No. 1, 2, or 3 Truck.

The Associated Complete Sawing Outfits

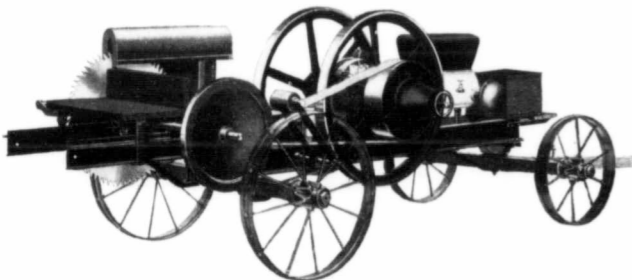

Either 4, 6, or 8 H.P. Engines used in making these mounted Sawing Outfits, with proper sized Saw and Tilting or Sliding Table

Our "Six Mule Team." The Engine that has made Waterloo Famous

The World's Greatest Engine Valve

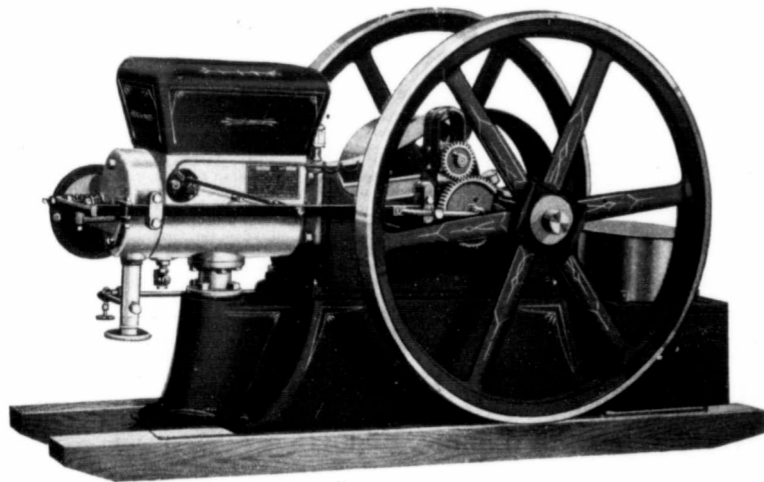

SPECIFICATIONS: Speed, 300 R. P. M.; Cylinder Bore, 6 inches; Stroke, 10 inches; Fly Wheel Diameter, 40 inches; Face, 3 inches; Weight, 250 pounds; Pulley Diameter, 16 inches; Face, 6 inches; Shaft Diameter, 2 1/4 inches; Length, 38 inches; Over all Length, 84 inches; Width, 40 inches; Height, 44 inches; Base Size, 19 x 38 inches; Weight, 1,500 pounds; Color, Red.

Besides the samples shown on these pages the Associated Line comprises Continuous and Batch Concrete Mixers, mounted and on skids, Feed Grinders, Stationary Saws, Line Shafts and many other items that will be explained if you will write your nearest Jobber for Catalogue.

The Six Mule Team is a wonderful engine. It is designed right, built right, and of the best material and workmanship. It is the simplest engine on the market—there being less parts to it to get out of order and cause trouble.

While this engine is only rated at 6 h.p. it actually develops much more than that and it equals the majority of engines that are today sold with a 7 1/2 h.p. rating.

You saw this advertisement in this magazine. Don't forget to say so when writing.

The Farm Hand, 4 H.P.

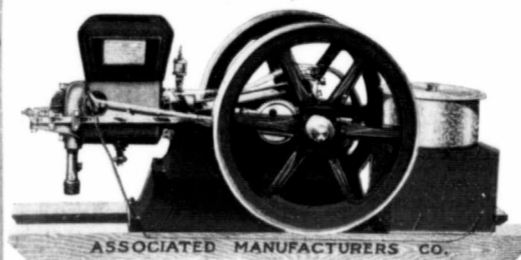

SPECIFICATIONS: Speed, 400; Cylinder Bore, 4 1/4; Stroke, 8; Fly Wheel Diameter, 27; Face, 2 1/2; Weight, 135 pounds; Pulley Diameter, 12; Face, 6; Shaft Diameter, 1 1/2; Length, 32 1/2; Length over all, 72; Height over all, 32; Base size, 12 x 22 1/2; Weight, 800 pounds; Color, Red.

The 12 Mule Team

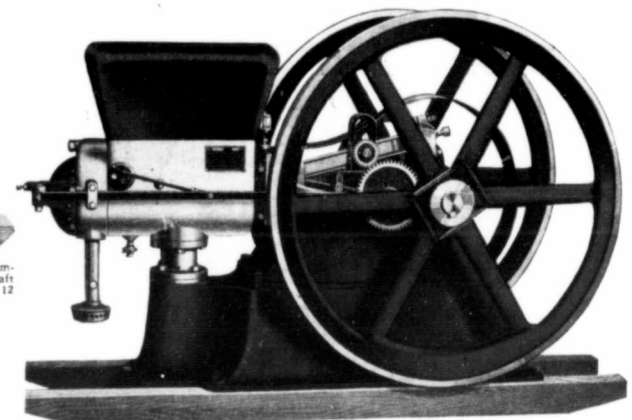

SPECIFICATIONS: Speed, 250; Cylinder Bore, 8; Stroke, 13; Fly Wheel Diameter, 48; Face, 3; Weight, 500; Pulley Diameter, 24; Face, 8; Shaft Diameter, 2 1/4; Length, 44; Length over all, 90; Width, 46; Height, 54; Base Size, 22 x 48; Weight, 2,700; Color, Red.

Associated Engines are Engines of Service

The 8 H.P. "Foreman"

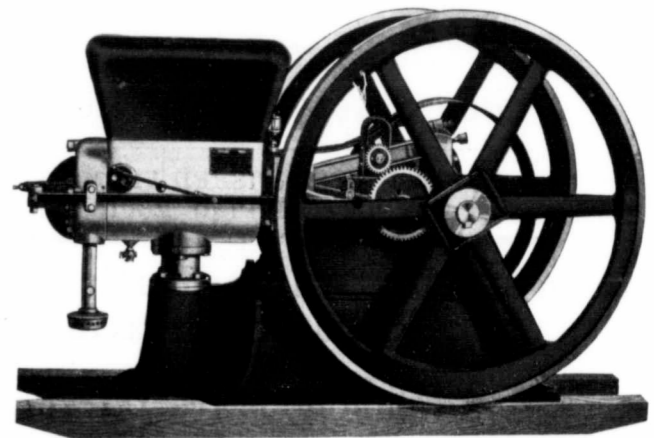

SPECIFICATIONS: Speed, 275; Bore, 6 1/4; Stroke, 10; Fly Wheel Diameter, 42; Face, 3; Fly Wheel Weight, 260; Pulley Diameter, 20; Face, 6; Shaft Diameter, 2 1/4; Length, 38; Length over all, 84; Width, 40; Height, 46; Base Size, 19 x 38; Weight, 1,820; Color, Red.

The Hired Man, 2 1/4 H.P.



SPECIFICATIONS: Speed, 450; Cylinder Bore, 4; Stroke, 5; Fly Wheel Diameter, 18; Face, 2 1/4; Fly Wheel Weight, 50 pounds; Pulley Diameter, 6; Face, 4; Shaft Diameter, 1 1/2; Length, 24; Over all Length, 48; Width, 24; Height, 20; Base Size, 9 1/2 x 19; Weight, 400 pounds; Colors, Red and Black; Mounting, No. 1, 2 or 3 Truck.

Associated Manufacturers' Co., Waterloo, Iowa

WORLD'S GREATEST ENGINE BUILDERS

DAVID MAXWELL & SONS, St. Mayr's, Ontario.

CRANE & ORDWAY CO., Winnipeg, Manitoba

P. T. LEGARE, Quebec, 273-287 Rue St. Paul, 32-38 Rue St. Valier

JAS. F. VANBUSKIRK, Fredericton, New Brunswick.

BRUCE STEWART & COMPANY, LTD., Charlottetown P.E.I.

BLIGH & PRINCE, Truro, Nova Scotia.

You saw this advertisement in this magazine. Don't forget to say so when writing.



OUR LINE



BRASS AND IRON VALVES

FOR ALL PRESSURES AND PURPOSES

Malleable and Cast Iron Screwed Fittings

Drainage Fittings

Hydraulic Valves and Fittings

Flanged Fittings of every description

Pipe Fitters' Tools and Engineers' Supplies

STEAM SPECIALTIES

Automatic Stop Check Valves

Emergency, Exhaust Relief and Back
Pressure Valves

Steam and Oil Separators

Steam Traps

Pop Safety and Relief Valves

ESTIMATES FURNISHED FROM DRAWINGS SUBMITTED
ON COMPLETE PIPING EQUIPMENT, PIPE BENDS, Etc.

Steam and Hot Water Heating Boilers, Tank Heaters,
Radiators, Heating Specialties

Plumbing Material for all purposes

GASOLINE ENGINES, SAW OUTFITS, CONCRETE
MIXERS, PUMPS, THRESHER SUPPLIES

Crane & Ordway Co.

93 Lombard Street

Winnipeg, Manitoba

Good Roads in Western Canada

BY A. C. EMMETT

The writer of these articles (which will be continued from month to month throughout the year) has had a wide and severely practical experience and is specially engaged on the "Good Roads" movement.

ONE of the best features in connection with the Good Roads movement in Manitoba at the present time, is the way in which farmers are coming to the front as advocates for improved highways. It has taken considerable time and earnest effort on the part of the good roads missionaries to bring about this desirable state of affairs, but now that the farmers have seen what bad roads cost them, they are amongst the keenest advocates for immediate improvements.

The Farmers Association of Osborne, Man., is particularly active and is using every endeavor to obtain improvement of the main roads between Winnipeg and Morris. President Inwood and Secretary Peache take every opportunity to impress upon the municipal councils the benefits that farmers would receive if provided with good roads, and the members of the association are willing and anxious to be shown the quickest way in which they can secure action to attain this much-desired improvement.

Municipal elections will have Good Roads as a strong party slogan during 1913, and the progressive councillor who is awake to the trend of feeling in this direction, is the man who will be selected to take care of the interests of the farmers who honor them with their confidence and support.

Manitoba's Need

Many residents in Manitoba who spent some time in California during the winter months, have become good roads enthusiasts by reason of the object lessons provided by the splendid roads which traverse California in every direction. One citizen of Winnipeg in particular is emphatic on the subject, and in speaking of his journeys in California he stated that all the main highways were equal to the best of Winnipeg's asphalt streets.

One of the greatest drawbacks to Manitoba, said this gentleman, is the great neglect, and the utter unconcern shown in respect to its highways by the provincial government and the municipalities.

The province, he believes, would be rapidly settled if the authorities turned their attention to the building of proper roads, as undoubtedly the unsightly highways, often almost impassable, was the greatest drawback to the intending settler or investor.

May Be Improvement

It is interesting to note in connection with the remarks quoted above, that the municipalities in the immediate neighborhood of Winnipeg, have realized the advantage of good highways and are taking advantage of the legislation brought into effect by the government at the last session providing assistance where the highway to be built is to be of a permanent nature and constructed under the supervision of the Highways Commissioner.

No less a sum than \$78,000 has been voted for road improvement on the highways between Winnipeg and Selkirk and the work will be carried out this year by the

shape than they were in 1911, it will surely give them a poor opinion of the progressiveness of Manitoba, and may lead to the loss of a large amount of capital which would otherwise be invested in farm land immediately adjacent to Winnipeg.

When it is remembered what vast sums are spent every year in bringing in farm and dairy produce from the United States, the folly of holding back the development of the vast acreage near Winnipeg, for the purpose of supplying this demand locally, by failure to provide means of communication between the farm and the city, is at once apparent and shows a sad want of foresight on

market. When this call becomes a little more general the government will find it an advantage to study the requirements of the farmer in this direction as Good Roads will in future election campaigns be one of the strongest platforms for the parties to work on.

Railways Offer Comparison

There is an interesting parallel in regard to road construction in the history of railways. When at first locomotives and railway coaches were small and light, iron rails, which lasted only a short time, were considered sufficiently strong. But when the demands of traffic necessitated the use of heavier rolling stock and locomotives steel rails began to be used, until now they have entirely superseded the old iron rails of some 50 years ago. Gradually also steel rails have become heavier and heavier in section, until at present on some of the best railway sections weighing well over 100 lb. to the yard are used, and it is admitted that these are none too heavy for the fast and heavy traffic which they have to bear.

Pursuing this parallel, it may be asked whether, in consequence of the changed character of road traffic, there should not be a radical revision of the system, so that at least on main roads some more permanent form of surface will be used. Whether it be asphalt, sand and bitumen, or wood paving, or something in the nature of metal plates or concrete blocks, something stronger and more durable than ordinary road metal is needed to bear the strain. Most people are familiar with the limited use of plate-ways which are still found over certain bridges, in the neighborhood of some factories, and in private yards of manufacturing concerns where heavy material has to be moved on tracks and where rails and flanged wheels are not convenient. But the public are probably not so well acquainted with the fact that on a 24 ft. road—a reasonable average width to take for the main roads of this country—only something like 6 in. is used out of the 24 ft. by most of the vehicles which pass over it. In fact, in the case of horse-drawn vehicles with narrow iron tires perhaps as little as 2 in. out of the 24 ft. has to bear the strain of the load, while the rest of the road—that is, the middle and the two outsides—has to bear scarcely any traffic, a fact which ac-



A Strip of Good work in Old Kildonan

Highways Commissioner's department. Concrete bridges will replace the tumbledown wooden structures at present in existence and when completed, the work will leave this road in good shape for all classes of traffic.

With the ever-growing use of motor vehicles for commercial purposes, the necessity of roads suitable for carrying this class of traffic has become apparent, and if the market gardener and the dairyman is to be encouraged in the local production of dairy and garden produce for the Winnipeg market, the municipalities must provide roads fit for them to haul their produce over at any time during the year.

The scene of the motor plowing contest is on the road to Stony Mountain and is the same spot that was used for the competition in 1911. There were hundreds of prominent manufacturers and visitors who made trips to the contest ground over the supposed graded roads and if they are to find them in no better

the part of those who should take a pride in the development of Manitoba.

The experience of the past two years has taught the American road builders that there is a necessity for a better class of road than has been built in the past. This is due to the ever-increasing use of motor trucks which are now used to carry freight over long distance hauls instead of as before only on the streets of the cities or towns.

Although at the present time Canada does not have the same use for so many motor trucks as are used in the States, there is nevertheless a time coming when the truck will be just as well used in this country, and for this reason those responsible for the building of the Canadian highways should look to the future and see that roads are built which will carry the traffic. Even now the farmer is calling for a better road which will allow of the use of the gas tractor in hauling wheat and other farm produce to

counts for the common phenomenon of a road wearing gradually into a shape represented by a central hump—two ruts and two gentle slopes towards each side and the ditches. In the case of motor cars, the wear of a pneumatic tire, whether studded or plain, is rather wider, especially in the case of cars of the larger sizes. But even then the surface of the road actually under compression and wear does not amount to more than 3 in. to 4 in. at the most in each wheel track, or for both wheels 6 in. to 8 in. out of the 288 in. which is the total width of a 24 ft. road.

Taking these facts into consideration it would appear possible to make 2 sets of tracks, one for up and one for down traffic, from one of the most suitable materials instead of going to the expense of covering the entire road. Only time and experiment will however settle the vexed problem of the most suitable roadway for the increasing volume of traffic.

Itinerary—Better Farming Demonstration Specials—June, 1913

(Note—The stops are listed in chronological order, viz.: 9 a.m. to noon; 2 p.m. to 5 p.m.; and 7 p.m. to 10 p.m.)

Date	C.P.R.	C.N.R.
June 3	Austin Carberry Alexander	
June 4	Griswold Oak Lake Virden	
June 5	Hargrave McAuley Elkhorn	
June 6	Wheatlands Harding Lenore	
June 7	Moore Park Brookdale Wellwood (Sunday)	
June 9	Hamiota Miniota Crandall	
June 10	Oak River Rapid City Minnesoda Russell	Letellier St. Jean Emerson Myrtle
June 11	Binscarth Foxwarren Solsgrith	Roland Miami Somerset
June 12	Strathclair Newdale Neepawa Arden Gladstone	Swan Lake Baldur Belmont Ninette Margaret
June 14	Gunton Balmoral Stonewall (Sunday)	Minto Elgin Cromer
June 16	Starbuck Elm Creek Carman Troherne Holland	Beulah Isabella McConnell Eden Birnie
June 17	Glenboro Reston Pipestone Souris Hartney	Kelwood Erickson Elphinstone Oakburn Rossburn
June 19	Broomhill Tilson Pierson Melita Napinka	Angusville Shellmouth Roblin Grandview Gilbert Plains
June 21	Lyleton Waskada Deloraine (Sunday)	Sifton Fork River Winnipegosis
June 23	Boissevain Ninga Killarney	Ethelbert Mintonas Swan River



"Here is the New Way to Get a Better Barn at Lower Cost"

"I Want to tell You about the New 'George' Shingle for Barns"

"YOU can now buy my big 'George' Shingle. It makes a quick-laid metal roof that is good for 100 years, is easy to lay, and non-corroding. It makes a perfect roof for any building of large size. It is lightning and fire-proof; it needs no skilled labor; each shingle locks into the others around. "Use it. Lay it, and your barn will not leak. Lay it, and you save days of wages against cedar shingle. Lay it, and you are done with repairs or further attention. Your barn is perfect."

"I want to save you money. My roof for barns is the most economical made. It is sold all over the world in 16 x 20 inch size, but from now on, you can buy it in 'George' Size, 24 x 24 inches to a single shingle, as well. Write my nearest branch and learn about why I made it."

"Remember, I make metal culvert, managers and troughs, portable buildings and granaries in metal, metal tile, metal walls, ceiling and siding for farm houses, etc. Write me if you need any of these things."

"I have seen an astonishing thing happen in Canada, the land of lumbering. This is it. Lumber is getting so poor and costly, and labor so high priced, that you actually save money by using corrugated iron (galvanized) for your barn walls, and metal shingle for the roof. This is the new way to build barns."

"Use my galvanized, corrugated iron in 8 ft. sheets, and my big 'George Shingle' instead of wood and cedar on your barn. At one stroke you get a lower cost than a wooden barn painted. This is because I save you wages in erection, make repairs needless, make leaky roof and walls impossible, make painting unnecessary, and give you a lightning-proof, fire-proof barn into the bargain. Write me.

G. H. Pedlar



SEND FOR MY NEW PEDLAR BOOK, FREE

"I have written a little book telling how a modern barn is built, and showing it, step by step, in pictures. It uses my galvanized, corrugated iron and 'George' Shingle, instead of wood. Send for the book to my nearest branch. It may save you thousands of dollars. Write to-day, friends, and read about a barn that saves cost."

331

The Pedlar People Limited

TORONTO 113 Bay Street
MONTREAL 321-3 Craig St.
ST. JOHN, N.B. 42-46 Fr. William St.
OTTAWA 432 Sussex St.
PORT ARTHUR 45 Cumberland St.
MOOSE JAW WINNIPEG MEDICINE HAT LONDON EDMONTON HALIFAX
202 Fairford St. 76 Lombard St. -- Toronto St. 86 King St. 563 3rd St. W. 16 Prince St.
SYDNEY SASKATOON CALGARY CHATHAM QUEBEC
194-208 George St. Box 1645 Rm. 7, Crown Block 209 King St. W. 127 Rue du Pont
VANCOUVER VICTORIA LETHBRIDGE OSHAWA, CAN.
108 Alexander St. 434 Kingston St. 1262 1st. Ave. So.

Address nearest Office for "George Shingle," Book No. 166

You saw this advertisement in this magazine. Don't forget to say so when writing.



Date	C.P.R.	C.N.R.
June 24	Holmfild Cartwright Mather	Bowman Durban Benito
June 25	Clearwater Pilot Mound Snowflake	Dauphin Ochre River Ste. Rose du Lac
June 26	Manitou Winkler Morris	McCreary Glenella Plumas
June 27	Tyndall Beausejour Whitemouth	P'te. la Prairie Oakville Sanford

The Agricultural Motor Competition Its Growth and Importance

If there is one thing which stands out prominently as having helped to focus the eyes of the agricultural world on Winnipeg

it is the annual Farm Motor Contest inaugurated by the Canadian Industrial Exhibition Association some five years since. From an insignificant commencement it has sprung rapidly into importance until it is now an event of world-wide magnitude. In fact it set the world's standard for this class of machinery. At no other event in the world is there gathered together so many of the big men in the implement world. In addition to these gentlemen there are, as a rule, representatives of several governments and delegates from every Agricultural College in Canada and the United States, while the awards made by the judges are eagerly awaited all over Europe.

The wonderful benefit the Dominion has derived from this competition may be estimated from the Minister of Customs reports. The year before this event was started, the total amount expended in importing these engines was \$588,000 last year (1912) \$5,250,000 was spent. This shows clearly that the farming community have been made to realize the marvelous development made possible on our wide prairies upon a scale never before approached in the history of the world through the introduction of these great machines, and the exhibition association should certainly be given all credit for the quick teaching of this great lesson.

Mileage Records make Sales Records

Tires are no longer bought for what they are; they are bought for what they will do.

Men buy the tires that have given them the most mileage in the past.

Men who have never used automobile tires ask to see their friends' tire-mileage records.

In a market like this, a tire that increases tire-mileage is bound to win. See what mileage-buying has done for No-Rim-Cut Tires.

Canadian Sales Jumping Along

In the Fall of 1910 we started to make No-Rim-Cut Tires in Canada. Our out-put was 25 tires a day. In scarcely more than two years after entering the Canadian market we have increased our tire out-put to 500 tires per day.

In that short time from a standing start, we have jumped our total Canadian sales to over 90,000 tires. That is equipment for over 20,000 cars.

It is clear that these Tires are saving money for car-owners.



The Town of Goodyear

1911 and 1912 have seen some changes over in Bowmanville.

To increase our output of tires from 25 to 500 per day in scarcely more than two years involved bringing in hundreds of men and their families.

In that time our pay roll has increased nearly seven fold. In 1911 we employed 89 men. To-day over 600 punch the clock.

This little community of men work in a factory plentifully supplied with light and pure air.

At the same time as we have been building factory additions, we have built homes for these Goodyear men. Last year we built 50, and we realize that this is just a start.

The Balmoral Hotel has just been bought and turned into a Goodyear Club, with swimming tank, billiard room and reading rooms.

The little Town of Goodyear has its own sporting organizations—ball clubs—hockey team—bowling clubs—gun clubs—and its own athletic grounds.

Goodyear men build brains as well as muscle into No-Rim-Cut Tires. We want their home-life to be happy and comfortable.

GOOD YEAR

No-Rim-Cut TIRES

Save Rim-Cutting Cost

Not one No-Rim-Cut Tire has been ruined by rim-cutting. This feature alone has made a tremendous saving to over 20,000 Canadian motorists. Ask one of them.

10% Oversize Adds to Mileage

Add 10% to the air capacity of a tire and you add 30% to its mileage. That is what tire experts have figured. No-Rim-Cut Tires have on an average 10% greater air capacity than ordinary tires. We claim that with the average car this adds 25% to the mileage of the tires—a conservative estimate. Ask a friend if this provision for overloading has not increased his tire mileage.

These money saving tires fit most every style of rim.

Look up the Goodyear Dealer.

169

THE GOODYEAR TIRE & RUBBER CO. OF CANADA
Head Office, TORONTO LIMITED Factory, Bowmanville

BRANCHES at Victoria, Vancouver, Edmonton, Calgary, Regina, Winnipeg, Hamilton, London, Toronto, Montreal, St. John.

All kinds of Rubber Belting, Hose, Packing, Bicycle and Motor Cycle Tires, Truck Tires.

PRACTICAL TALKS TO THRESHERMEN

CONDUCTED BY PROFESSOR P. S. ROSE

Talk No. LXX

Note.—The term "gas engine" in these lessons will be used indiscriminately in speaking about all internal combustion engines.

THE development of the petroleum industry and that of the gas engine industry go hand in hand. Drake struck oil near Titusville, Pennsylvania, August 28, 1858. Previous to that time what little petroleum was produced in this country or in the

usual method of transportation now is by pipe line. Some of these lines are hundreds of miles in length and extend across a number of states.

When the oil reaches the refinery the different commercial products such as kerosene, benzine, etc., are separated out by what is called fractional distillation. Roughly speaking, this process consists in heating the oil through a given narrow range of temperature and condensing the vapor given off while the temperature passes through the given range. In this way there is separated out first the very volatile substances including the light naphthas, then the heavier products until when the temperature reaches four or five hundred degrees the lubricating oils begin to distill off. The residue left consists of a heavy tar which is used for a variety of purposes. The asphaltic tars are used for oiling roads, roofing, etc.

A portion of the paraffine tars are used for the same purpose and another portion goes to the chemical works to be worked up into a great variety of substances. There are two distinct kinds of crude oil, the one having paraffine base and the other an asphaltic base. The paraffine oils are found east of the Mississippi River and the asphaltic oils west. The oils of Kansas, Texas and California are all of asphaltic base and yield only a small percentage of gasoline, usually not more than three per cent. The eastern oil yields as high as fifteen per cent.

In the beginning of the petroleum industry and for many years thereafter gasoline was practically worthless. No use had been discovered for it which would utilize the entire product. The tendency of the refiners was to turn out kerosene with a low flashing test in order to utilize as much of the gasoline as possible and laws had to be enacted to regulate the product placed on the market in the interests of public safety. The oil companies spent every effort toward finding a market for gasoline, but succeeded only partially.

It is said that thousand's of barrels were actually thrown away. With the beginning of the gasoline engine industry the market for gasoline gradually broadened, but it did not assume large proportions until the automobile came into use. From that time until the present the refiners have been straining every effort to supply the demand for gasoline.

It has come to be the principal product and kerosene the bi-product as far as demand is concerned. The trouble is not to find a market for gasoline at the present time, but to get enough from the crude to supply the demand.

It is estimated there are 670,000 automobiles in the United States and a million and a half other gasoline engines. The total horse power as near as can be estimated is well upwards of twenty-five million. This will be augmented during the present year by between six and seven million horse power additional, making a total at the end of the year 1913 of considerably more than thirty million horse power. At this rate, gasoline cannot be used for fuel very many more years. We shall have to depend upon kerosene and low grade distillates especially, for all our heavier machines, and the time is not very far distant perhaps when some other liquid fuel such as alcohol will have to be manufactured to supply the rapidly increasing demand.

It requires about one-eighth of a gallon of gasoline or kerosene per horse power hour. A 1-horse power engine, therefore, running eight hours would require one gallon of fuel. The large gas tractors in plowing require from sixty to seventy gallons of fuel per day. In 1910 there were produced in the United States 209,556,048 barrels of oil and in 1911 about 217 million barrels, fully two-thirds of which came from fields west of the Mississippi River, where the content of kerosene and gasoline is rather low. We may not yet have reached the maximum of petroleum production but it is inconceivable that it can be greatly increased.

Many of the fields are practically worked out. The world's supply of petroleum, just as the supply of coal or iron, is limited. We are rapidly approaching the time when gasoline cannot be used and then kerosene and distillates will have to take its place. Then, sometime in the more distant future when oil production begins to decline, another product will have to be used for all liquid fuel engines. It is likely that time will come within the present century when we consider the rapid production of the liquid fuel engine and the demand which will be made for fuel within the next few years.

The tractor people are meeting

the problem designing engines to use kerosene and other cheaper distillates. These fuels are eminently satisfactory for that purpose and no radical changes need be made to adapt gasoline tractors to use heavier fuel with fair economy. The automobile people are studying the subject of fuel with a great deal of concern. Their business depends at the present time upon gasoline and it is imperative that they find a suitable means for carbureting the heavier fuels. Ordinary farm engines, even those that are designed for gasoline, can easily be turned into kerosene burners and it would pay most users of such engines to make the change. At the present time alcohol is too expensive to be considered with the petroleum products at market

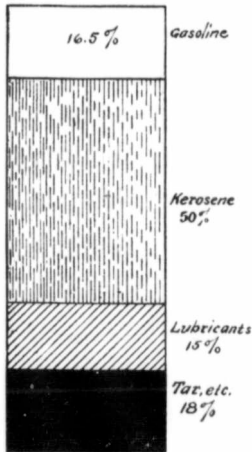

The percentages of the different products vary greatly. Some crude can be used for illuminating purposes and some as a lubricant. The chart is supposed to represent average conditions.

Fig. 154

world for that matter, came from bituminous shale or slatey coal, hence the name coal oil. It was not used for power at all and only a little for illumination. Since that date the petroleum industry has reached its present proportions and the gas engine industry has been born and developed. The first workable gas engine was produced about 1860 but it was eight years later before the Otto engine was developed. By that time there was plenty of liquid fuel available. The liquid fuel engine could not have appeared any sooner than it did both for lack of fuel and lack of lubricating oil. Lubricating oils, previous to the discovery of mineral lubricants were not suitable for high temperature.

Petroleum, as it is pumped from the ground, is a dark brown ill smelling liquid containing a large number of different compounds, all belonging to the same chemical group. The crude oil is pumped from the wells and either pumped through long pipe lines to the refiners or carried in tank cars to the same place. The

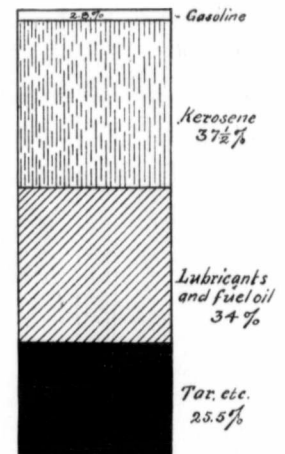

The line of demarcation between gasoline and kerosene is not as clearly marked as in the chart. The lowering of the Beaumé test and application of destructive distillation methods have increased the gasoline to some extent at expense of two lower orders.

Fig. 155

prices. There is no doubt, however, that in time great alcohol factories will be established. It is said that enough alcohol could be made from the corn stalks grown each year to run all our power machinery and heat and light all our dwellings.



Blusterers are like a caravan of empty wagons going down hill, the less load the more noise they make.

It Saves the Farmer's Thresh Bill!

The wastage of grain by the average Threshing Machine is far more than many suppose. The Operator usually knows it, but he can't help it with that kind of Machine, so he covers it up all he can and lets it go at that. The Farmer suspects it, but thinks he has to put up with it, and much of his hard-earned money goes over into the straw stack.

This great wastage is the result of employing an incompetent type of Threshing Machine that rushes the straw to the stack, but does not beat the grain out of it.

THE RED RIVER SPECIAL WORKS ON AN ENTIRELY DIFFERENT PRINCIPLE OF SEPARATION from any other make of Threshing Machine. It **beats it out** while other makes hurry the straw to the stack and expect the grain to fall out, which it does not do.

Note carefully the following illustrations:



This is the way to Separate by hand with a pitchfork

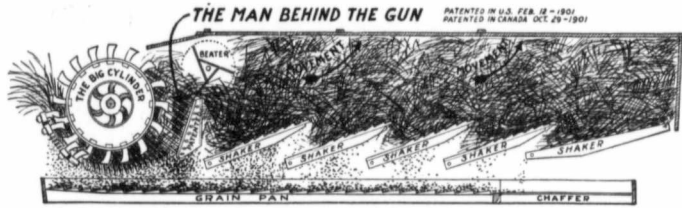

This is the way the RED RIVER SPECIAL Separates IT BEATS IT OUT—like you do with the pitchfork



This is the way the Lazy Man tries to Separate with a pitchfork

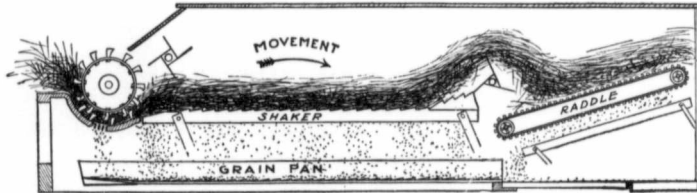

This is the way OTHER KINDS try to separate THEY DON'T BEAT OUT THE GRAIN

The Red River Special is the only Threshing Machine that uses the true and sure method of separation by beating the grain out of the straw just as you would do with a pitchfork.

The Big Cylinder, the Man Behind the Gun, with the Patent Grate and Check Plate, and the Uplifting Shakers that toss the straw up and beat it as you would do with a pitchfork save the grain that others waste, whether it be wheat, oats, rye, barley, flax, peas, rice, alfalfa, timothy or other grains or seeds.

WE HAVE THOUSANDS OF TESTIMONY LIKE THE FOLLOWING:

Joseph Rinkenberger, H. J. Meyer, Godfrey Ginzler and sixteen other farmers of Gridley, Ill., say: "We know from experience that your Red River Special Separator, when properly managed, will save enough extra grain that other machines waste to pay our thresh bills each year just as you advertise." The Girard Threshing Company, consisting of R. H. Syth, James McConnell, Louis Decker, Ira Allen, Will Syth, Oscar Kippenham and A. Redmond, of Girard, Mont., with our 25 H. Double Cylinder Engine and 4050 Red River Special Separator, say: "The whole rig has given entire satisfaction: it cleans easily, pulls well, and the Red River Special does all that is claimed for it in threshing fast and saving the grain." H. W. Herren and H. E. Smith, of Hastings, Nebr., say: "The new 36 x 56 Red River Special Separator bought of you last July does fine work in any kind of grain; it is a good cleaner and a very fast thrasher. We have operated

two or three other makes of machines, but your Red River Special just beats them all." Mr. M. Spangenberg, of Elgin, N. Dak., says: "Anybody who has worked with your new Red River Special will think a long time before he will buy any other make of machine, for it will save all the grain from the straw pile and cannot be equalled for fast and clean flax threshing." The Wieland Thresher Company, of Glen Ullin, N. Dak., says: "Your Red River Special Separator is the best we have ever run and we have done threshing for the last ten years. It surely does save the farmer's thresh bill and does all you claim for it. We thought we had used good separators before and felt satisfied with their work, but since we have run the Red River Special we have just learned to know what a good machine is." Peter Junk, L. Hummelster, W. H. Rankin, W. H. Robinson, G. F. Thompson, Mat Merz and ten other farmers of Downs, Osborne Co., Kans.,

say: "We had our threshing done this year by your Red River Special Separator owned by C. E. Brake, and are entirely satisfied with it, and believe it saved enough grain that other machines would have wasted to pay our several thresh bills." Wm. Bronner, Peter Hanson, Ed. Brande, M. I. Grass, Geo. Fries, all farmers of Andover, S. Dak., say: "Your Red River Special run by Wm. Roth threshed our grain this year and did a very fast and clean job in threshing, taking all the grain out of the head, separating it from the straw, cleaning it perfectly and saving all the grain." Mr. Claus Anderson, of Wilmar, Minn., says: "Your Red River Special Separator that you sold Peter Erickson this year has threshed for me, and I am well pleased because it cleans well, threshes all the grain from the head, runs right along from morning until night as steady as you could wish, and more than all that, it saved all my grain."

Write us, or any of our customers, or call on our Branch House or Dealer for proof that **It Saves the Farmer's Thresh Bill.**

NICHOLS & SHEPARD COMPANY, Battle Creek, Michigan

IN CONTINUOUS BUSINESS SINCE 1848

The only builders of the Red River Special Line of Threshers, Self-Feeders, Wind Stackers, Weighers, Traction Steam Engines, Oil-Gas Tractors and Everything for the Thresherman.

BRANCH HOUSES, with Repairs, at Kansas City, Mo.; Minneapolis, Minn.; Billings, Mont.; Indianapolis, Ind.; Madison, Wis.; Lincoln, Nebr.; Fargo, N. D.; Regina, Sask.; Des Moines, Iowa; Peoria, Ill.; Winnipeg, Man.; Nashville, Tenn.; Dallas, Texas; Spokane, Wash.; Salt Lake City, Utah.

You saw this advertisement in this magazine. Don't forget to say so when writing.

"Waterloo" Steam Tractor

Built on over Sixty Years' Experience

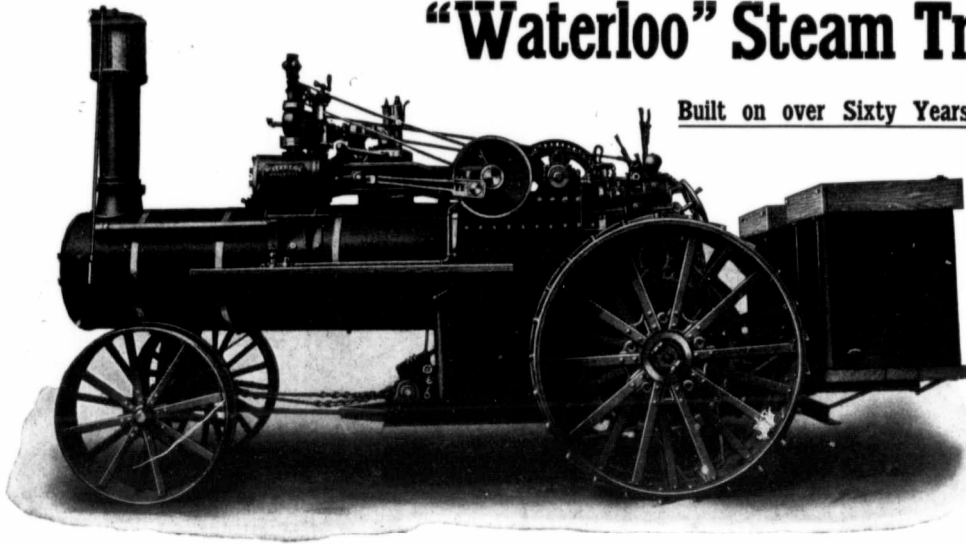

Made
in
Canada

Sold
on its
Merits

27 H.P. "REAR MOUNTED" TRACTION ENGINE

Boiler conforms to every government requirement, commanding 175 lbs. steam pressure. Centre Mounted "Link" Type Valve Gear insures the most economical and efficient handling of steam in the cylinder. Heavy gear of a semi-steel mixture insures strength and the best of wearing qualities. Let us send you our Catalogue on complete line of Threshers and Engines—A postal will bring it.

The Waterloo Manufacturing Company Limited

Western Headquarters: PORTAGE LA PRAIRIE, Man. Head Office and Factory: WATERLOO, Ont. Branch Warehouse: REGINA, Sask

this boiler was sagged two inches or more between all of the stay bolts. Is there no law in North Dakota against running a boiler in such a condition?

A. There are quite a good many so-called engineers who refuse to run with a soft plug. They are usually careless fellows and fellows who know very little about a boiler or an engine, and certainly nothing about the danger of a boiler explosion. They have probably been caught once or twice with no water, due to failure of the tank team to get in on time, or have tried to go down a steep hill with a heavy fire and have had the soft plug melt out. Another thing in your part of the country where water is strongly alkaline and it is necessary to carry water quite low, there is more liability of melting out the soft plug than where the water is better. In the first instance that you mention where the top of the plug did not come up to the upper surface of the crown sheet it is more than likely the plug would melt out even with plenty of water, because mud and scale would collect in the pocket just above the plug and insulate it from the water. To be effective, the top of the plug should be slightly above the upper surface of the crown sheet, then there is no danger of mud or

scale collecting over its upper surface. There is no law in North Dakota in regard to boiler inspection.

Q. H.J.J. 1. What makes the valve gear on the small cylinder side of a Reeves engine clatter all the time? I have tightened all the boxes, but it does not seem to help it any.

2. How much lubricating oil should a Reeves engine have in a day of ten hours?

3. Which is considered the best separator, the Case or the Advance, for all kinds of grain, and which is the easiest of upkeep, that is, with belts and all moving parts?

A. 1. We can't tell you definitely where the trouble is but there is no question if the valve gear clatters that there is lost motion at some of the joints. There are a great many joints in a Reeves valve motion and very little lost motion in one or two places is sure to make a racket. Possibly the trouble is with the cross shaft which passes under the engine beds. We have seen this get quite loose and cause annoyance.

2. The amount of oil any engine should have depends upon the condition the engine is in, the load it carries and the kind of

They Win Their Way Because They Pay

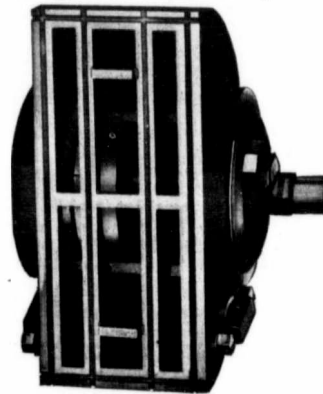

The Baker Balance Valve is considered by all mechanics to be the finest principle of a balance valve in existence, and will increase the power of the engine from 20 to 30%. The Baker Valve can be attached to any kind of slide valve type of engine without facing the valve seat. Note the soft metal packing around the face of cage.

They pay for themselves in a short time in actual saving of oil, fuel and water. Read what Mr. Partridge says about them. He is only one of hundreds.

Baker Valve Co., Winnipeg, Man.

Oakburn, Man., March 6, 1911

In reply to your letter of March 3rd, would say that I did not have a single complaint last fall from any customer using the Baker Valve. In fact every man was more than pleased with the results gained by using the Baker Valve. The engines use much less water and by so doing steamed much easier. A child can reverse the engine under full head of steam. I might say that I had about ten of these valves on my territory last season.

Yours truly,
J. W. Partridge.

We want agents everywhere. We want you to sell them in your locality. Write us to-day. We pay a liberal commission.

BAKER VALVE COMPANY

100 James Street

Winnipeg, Man.

water used. Ordinarily ten to fifteen drops per minute are enough. This would require about two gallons of oil a day. Engines are often run with considerably less, but for rough

traction work it often requires two gallons.

3. We never make any inquiry in regard to the comparative merits of different machines and cannot answer this question.

Course in Gas Engineering

Continued from page 19

at all. Ordinarily, however, it simply results in less power developed and more fuel used.

Huge fuel consumptions, then, may mean that the igniter is in need of attention, or that the exhaust system is defective, as well as the fuel valve may be improperly adjusted. Each particular part must be carefully examined, and the defect, wherever it exists, located and remedied.

Referring again to the question of throttling and hit-and-miss engines, which is the better? This is largely a matter of personal opinion and it is practically impossible to answer the question to the satisfaction of everyone. A great deal depends on the conditions under which the engine is installed. Manufacturers of hit-and-miss engines claim that the consumption of the throttling engine is enormous. Their competitors claim that the variation in speed of a hit-and-miss engine is likewise enormous. Both deny the claims made against their own engines. As a matter of fact, a great many hit-and-miss engines are doing electric light and other work requiring a very close regulation, and are doing it satisfactorily. On the other hand, some gasoline engines of the throttling type have a very satisfactory consumption. It is all the more difficult to decide the matter from the statements of some engine operators, because if one man says his speed is very irregular, or another his consumption is very high, how are we to know whether or not they have their engines in proper adjustment to secure the best results? Might not better results be secured if some one else were in charge of the engines?

Eternal vigilance is the price to be paid for some things besides liberty. It certainly is the price that must be paid by all business men in the period of competition now existing. The power plant is one of the fixed charges which every factory of any size, or any building devoted to office purposes, must endure. It may be regarded as a necessary evil, but it is there and the best thing to do is to make it cost as little as possible. Constant study and effort to reduce the fixed cost of operation is one of the ways to reduce the fixed cost of the power plant. We have seen how, with a gas or gasoline engine, we can in some measure accomplish this result.

☺ ☺ ☺

The Wary Constable

The Prisoner: "There goes my hat. Shall I run after it?"

Policeman Casey: "Phwat? Run away and never come back again? You stand here, and I'll run after your hat."

New Sales Manager for J. I. Case T. M. Co.

One of the most important recent announcements in the manufacturing world is that of the appointment of W. W. Ramsey as General Sales Manager of the J. I. Case T. M. Company, Inc., of Racine, Wis. Mr. Ramsey succeeds C. L. Farney, who becomes assistant treasurer.

Mr. Ramsey's period of service with the company dates back to 1893. On January 15th of that year he was given a position at the Nashville, Tenn., branch house. The next year he was appointed manager of this branch, which position he held until 1900, when he was transferred to Dallas, Texas, as branch house manager. Here he remained until 1903, when the company called him to the home office at Racine to fill the position of Assistant



W. W. Ramsey

Sales Manager. In 1905, by another upward step, he became Division Sales Manager. It is from this position that he now assumes the duties of General Sales Manager.

Further announcements are those of the appointments of F. R. Washburn, former branch house manager at Spokane, Wash., as Division Sales Manager to succeed Mr. Ramsey, and of Stephen Bull II, grandson of Stephen Bull, one of the founders of the company, as assistant sec-

☺ ☺ ☺

A Descriptive Reply

A young teacher, whose efforts to inculcate elementary anatomy had been unusually discouraging, at last she asked in despair:

"Well, I wonder if any boy here can tell me what the spinal cord really is?"

"The spinal cord is what runs through you. Your head sits on one end, and you sit on the other."

GANDY

THRESHER BELT

NOW is the time for you to be thinking seriously about your thresher belt. Have you seen a sample of GANDY BELTING yet?

You just have time to get a sample, put it through some tests of your own and decide, before the season will be upon you. The

Gandy Thresher Belt

is the choice of 20,000 American threshermen, who demand the best belt that can be manufactured. It is built for hard service, and will stand the roughest weather. It grips like a clinging vine, even when wet.

We always keep thousands of GANDY Thresher Belts in stock and ship the same day the order is received. The GANDY Thresher Belt is "The Red Belt with the Green Edge."

Write today for free sample and full information
THE GANDY BELTING CO., 733 W. Pratt St., BALTIMORE, MD.
 New York Office: 88-90 Reade Street

Sawyer-Massey Co.

NOT IN A COMBINE!

You saw this advertisement in this magazine. Don't forget to say so when writing.

Steam or Gas Tractors

Equipped with

PICKERING

"THE GOVERNOR WITHOUT JOINTS"

give greater efficiency

Equally satisfactory for STEAM and GAS TRACTORS

Patent Ball Ranger Speed Changer Supplied on all Genuine Pickering Governors. Will increase speed 50% or more.

The Pickering Governor Co.

PORTLAND CONN., U.S.A.

You saw this advertisement in this magazine. Don't forget to say so when writing.

Does your Oiling System Work Satisfactorily?
Do you get Plenty of Oil at the Right Time?

IF NOT

Get a Madison Kipp Force Feed Oil Pump



A Madison Kipp Oil Pump is guaranteed to work satisfactorily at any time, and deliver any amount of Oil when desired.

A Madison Kipp Oil Pump will more than pay for itself in a short time, because it does not waste oil and will keep your engine properly lubricated at all times.



Get our Catalog, it costs you nothing

Canadian Agents: THE MAYTAG COMPANY, Winnipeg, Man.

MADISON KIPP LUBRICATOR COMPANY

MADISON

::

::

WISCONSIN

Manitoba Summer Fairs 1913

Emerson	July 7-8
Morris No. 2	July 1-2
Roland	July 2-3
Miami	July 3-4
Glenboro	July 1
Dufferin	June 30-July 2
Neepawa	June 30-July 2
Carberry	July 3-4
Cypress River	July 7-8
Winnipeg	July 8-16
Wawanesa	July 8-9
Elgin	July 10-11
Carillon	July 15
Brandon (Dominion Fair)	July 15-26
Mordei	July 21-22
Cartwright	July 22-23
Minnedosa	July 24-25
Deloraine	July 28-29
Kiuarney	July 29-31
Waskada	July 29-30
Roston	July 29
Souris	July 29-31
Hartney	July 31, Aug. 1
Gladstone	July 28-29
Anscaeth	July 30-31
Bossburn	July 31, Aug. 1
Oak Lake	July 29-30
Elkhorn	July 30-31
MacGregor	Aug. 5
Verden	Aug. 5-6
Miniota	July 28-29
Rivers	July 29-30
Hamiota	July 30-31
Harding	July 31, Aug. 1
Russell	Aug. 4-5
Boisevain	Aug. 4-5
Manitou	Aug. 5-6
Pilot Mound	Aug. 6-7
Shoal Lake	Aug. 5-6
Birtle	Aug. 6-7
Strathclair	Aug. 7-8
Swan River	Aug. 4-5
Dauphin	Aug. 5-6
Roblin	Aug. 6-7
Gilbert Plains	Aug. 7-8
Arthur	Aug. 4-5
Teherne	Aug. 6-7
Swan Lake	Aug. 7-8
Crystal City	Aug. 4-5
Oak River	Aug. 4-5
Rapid City	Aug. 5-6

Fa. Fairs.

St. Vital	Aug. 26-27
Kildonan & St. Pauls	Sept. 10-11
Headingley	Sept. 12-13
Springfield	Sept. 17-18
Rockwood	Sept. 23-24
Argyle, Woodlands & Woonona	Sept. 26
Beausejour	Sept. 27-28
Gironx	Sept. 29-30
Plumas	Sept. 29-30
McCreary	Oct. 1
Woodlands No. 2	Oct. 1
Woodlands No. 1	Oct. 2
Ste. Rose du Lac	Oct. 2
Kelwood	Oct. 2-3
Morris No. 1	Oct. 7

The feminist movement is making women so much more confident of themselves that the horse which will be perfectly safe for a woman to drive and which, at the same time, a man will not be ashamed to drive is now thought to be a possibility.



The Link Wind Stacker Hood

GUARANTEED

To Remove the Dust, Rust and Refuse from the Straw.

Attached by anyone in fifteen minutes.

The Straw Cleaner Sold on Trial

Send for particulars to

LINK MANUFACTURING COMPANY, KANSAS CITY, MO., U.S.A.

The Rockwood Paper Drive Pulley

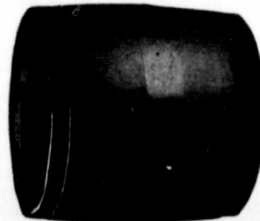

We know you will buy when you learn the facts. At present you're skeptical—think we may be over enthusiastic or exaggerate in our claims.

That's not the case—we're honest—we know the Paper Drive Pulley is better and want to convince you.

May we send you a copy of our book "Here's the Proof?" It's chock full of letters from real live Threshermen in the United States and Canada giving their experiences.—Shall we send it?

THE ROCKWOOD MFG. CO. 1928 English Ave. Indianapolis, Ind., U.S.A

RUMELY
LA PORTE

RUMELY
LA PORTE

Canadian Power, Seed and Soil

VOL. 1.

LA PORTE, INDIANA.

June, 1913.

No. 6.

THRESHING WORDS

How Ten Men Spent a Whole Week Writing Six Words

Ten men sat the other day around a table in the Rumely Club at La Porte, Ind., and listened while their chief, the advertising manager, announced that a crop of sentences was to be raised from the dictionary, and that after the crop had been harvested, it would be thoroughly threshed to find the best possible words to express an idea.

"Our company has one big fact to tell to everybody everywhere. It is up to us to find the best words to use—the words which will express the idea forcibly, clearly, and simply. Let each of us, one week from tonight, bring in six short sentences or phrases telling this big fact."

All agreed, and the big idea was explained in detail. The Rumely Company made an oil-burning internal-combustion tractor which used oil at all loads or all load off, in any and all temperatures and climates. This was the only engine which would do this. And, further, this Rumely engine was called "OilPull." This name was copyrighted and could be used by no other engine maker. There was but one oil-pulling engine and but one OilPull name.

Must Use Few Words

"It's easy enough," said the advertising manager, "to tell our story in four or five sentences, but it must be told in one, and that one must not be longer than seven or eight words."

At the week end there was a large

crop of sentences all telling the same story with more or less force, clearness and simplicity.

Then harvesting was necessary. The advertising manager called his crew together to thresh out the best six or seven words from among the several hundred.

Eleven busy men put in two whole evenings and many hours in between just to select a half dozen words. It must have been important—and it was. Other makers of internal-combustion tractors were saying their engines would burn kerosene under all conditions. The Rumely OilPull used the Secor-Higgins fuel system, an automatic control of all variable conditions. This fuel system was patented and could be used by no one else, and it was the only system which would actually work. The Rumely Company knew the other engines could not do what the OilPull would. So it is easy to see that these few words were important.

Name Doesn't Apply to All

And, also, people were coming to use the word "OilPull" when they really were talking about some other engine which was supposed to burn oil. If an engine used oil under the best possible conditions, it was called by some an "OilPull." A lot of different engines will use oil when all conditions are favorable, and these were all becoming confused with the real OilPull which burns oil anywhere any time.

Two things were to be overcome. The first was the exaggerated claims for other engines, and the second was the unintentional misuse of the word "OilPull." Both of these conditions resulted in loss to the Rumely Company and also to farmers.

The evening of threshing out the many sentences finally resulted in the selection of these words:

"There's Only One OilPull, Rumely La Porte."

These six words will be in Rumely ads hereafter and will tell over and over again the one big fact about the Rumely OilPull. This Rumely slogan is not a combination of nice-sounding words which mean nothing; it is a slogan designed to fit into a definite place already existing and to carry a specific message.

POWER FARMING

A Book written by an Expert, Being Given Away by Rumely Products Co.

For tractor users, a new book of instruction and information has just been issued by the Rumely Products Company of La Porte, Ind'ana. The book is written and prepared by Raymond Olney, power-farming expert. It is called "Power-Farming." It contains much information and many suggestions which the farmer who owns or operates a tractor will find of very great value.

The book will be sent without charge to tractor owners or operators or to anyone who is thinking of using one. Requests should be mailed to the Rumely Products Company, La Porte, Ind., asking for their book "Power-Farming."

"How to Farm with a Tractor" is told in considerable detail in this new Rumely book. Some of the different phases discussed are: Combining field operations; plowing; power-farming equipment; the automatic plow; adjustment and alignment of plows; hitching the plows to the engine; laying out the field for plowing; tillage operations and seeding; equipment for seeding and tillage; hitches; methods of seeding; the tractor in the harvest field.

Tractor-owners, and especially farmers thinking of getting a tractor, will find a lot of valuable facts in this book which they can apply to every-day work to advantage.

The Rumely Company also will be glad to answer any questions about power-farming — questions which come up in the course of experience in the field. You can write them on any power-farming problems and their expert will advise you.

Three hours of human labor were required to produce one bushel of wheat in 1830. Now it takes ten minutes.



OILPULL, WINNIPEG

Gold Medal Tractor will Again Compete in Big Contest

The Rumely OilPull Tractor will defend its title to the Gold Medal again at the sixth annual International Motor Contest at Winnipeg, next month, July 4 to 19. Two engines will be entered—the type "E" 30-60 h.p., and the type "F" 15-30 h.p.

At the Winnipeg contest last year the OilPull was given first place over all other internal-combustion engines. The OilPull "E" won the gold medal in its class, and it scored the highest total

Unvarying Power

The Rumely Oil Pull tractor gives a belt power exceptionally good for threshing. The speed does not vary 2 per cent. from normal.

This is a big, important fact for threshermen. Just set your blast so it will properly clean the grain you are handling—and then you can go about other work. The Oil Pull will keep the speed just the same—it matters not whether the separator is crowded or empty.

Write for OilPull Book No. 353



Rumely Products Co.
(INCORPORATED)
Power-Farming Machinery
La Porte :: Indiana

CANADIAN ADVANCE SEPARATOR

has a large grate surface, which joins the concave and is really a continuation of the concave. The forks rake the straw up the side of this grate and most of the grain falls out there.

The straw racks have just the right "throw" to keep the straw moving in a thin, even sheet.

Write for Catalog of Advance Steam Engines and Separators.



Rumely Products Co.
(INCORPORATED)
Power-Farming Machinery
La Porte :: Indiana

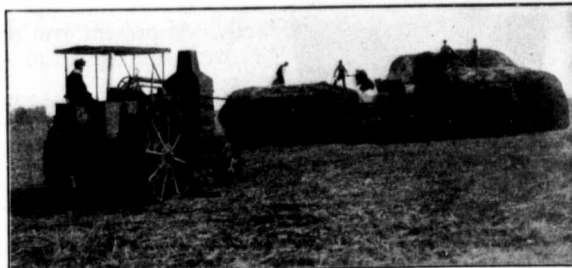

number of points in the economy brake test and the plowing contest of any internal-combustion tractor. The OilPull "F" won the silver medal in its class and scored the highest number of points in the maximum brake test of any internal-combustion tractor.

The OilPull tractors will be in charge of W. H. C. Higgins, manager of the Rumely Company's experimental department. Mr. Higgins is the inventor of the carburetor which forms a part of the Secor-Higgins fuel system used in the OilPull. He says he is confident the OilPull will again make a creditable showing against its competitors.

CANADIAN POWER, SEED AND SOIL

Canadian Power, Seed and Soil
Vol. 1. Established 1913 No. 6

Published Monthly by
RUMELY PRODUCTS CO., INC.
La Porte Indiana

THERE'S ONLY ONE OILPULL

(The following editorial is reprinted from The Gas Review for April, 1913.)

A gas engine show was held at the University of Wisconsin last month which was intended to illustrate the various uses for the different kinds of internal combustion engines. The different types were very well represented and included tractors, farm stationary engines, marine motors, aeroplane engines, motorcycles and auto-cycles.

In the farm engine section the most striking feature observed was the pla-

there is even no change made in the amount of compression.

There have been a number of costly and serious blunders made in the gas engine business since it started, but none more serious than the present one ever confronted the trade. It would be a mighty good thing if a committee of reputable engineers would lay down a few of the essentials of a kerosene burning engine. It seems about the only way to save the situation from the wildest statements of a lot of trade mongers who merely appear to want to grab their share of the trade while the grabbing is good rather than go a little more slowly and build securely for the future.

There is no intention to criticise the engines exhibited at the University, but rather the general tendency toward misrepresentation brought about by the exigencies of trade and to point out the danger there is in pursuing such a

There's only One OilPull Rumely, La Porte

card universally displayed saying, "this engine burns kerosene." Every manufacturer of farm engines realizes that the time has arrived when, if he is to meet the demands of his customers, he must sell a kerosene engine. For years these engines have been advertised to burn gasoline, kerosene, alcohol or distillate. The time is now here when these claims must be substantiated. When gasoline was low in price little risk was run in making almost any statement as to what kind of fuel an engine could use, but with gasoline going upward in price so rapidly it will take more than a placard or the statement of a catalog to satisfy the buyers. In other words, the engines must actually do what they are advertised to do and do it successfully, or the business will be badly injured.

It is a fact that many of the so-called kerosene engines now on the market are not suited to kerosene at all. They are pretty good gasoline engines, but the manufacturers have no right to advertise them as suitable for kerosene. Most of them are not even fitted with a double system of fuel supply enabling the operator to start on gasoline and then switch over to kerosene after the cylinder gets warm. Few of them are fitted with a water spray and in many

course. What is needed at the present time, perhaps more than ever before, is absolute honesty of statement in regard to what kinds of fuel an engine is capable of handling. It is a well-known fact among gas engineers that an engine to be successful must be designed particularly for the fuel it is to use. Versatile engines capable of utilizing any fuel may be built, but they are mighty scarce.

COULDN'T PLUG A GAAR-SCOTT

Six pitchers found it impossible to "plug" a 40 x 60 Gaar-Scott Separator run by a 25 h.p. Gaar-Scott double cylinder engine at Wardenville, Sask. The outfit is owned by Barclay Brothers. "An iron brace accidentally broke off the dividing board and before we could stop the machine it had gone through," writes W. G. Barclay, one of the brothers. "Judging from the present shape of this brace, we should think the Gaar-Scott Separator equal to anything which required threshing. The only damage to the separator resulting from this iron going through was a few teeth broken and bent."



THRESHERMEN PLEASED

The Story of a Few Letters Taken from the Tops of Our Files

Rumely and Advance Separators and Engines have pleased threshermen for many years. What threshermen have said during the past five years illustrate what they have always thought of these machines.

1908

Albert Alfson, Binford, N. D. says: "I bought a complete Rumely Outfit in 1908—not a cylinder tooth loose all fall and not a cent in repairs—all repairs for engine was governor speeder spring 40c.

1909

James McDougall, Nokomis, Sask., says: "I think the Rumely Separator has no equal for fast or clean threshing. It ran thirty-eight days without a tooth getting bent, loose or broken. It has better separating capacity over the rack and more room over the shoe than any separator I ever ran.

1910

D. E. Cloud, Inavale, Neb., says: "My 16 h.p. Rumely engine and 34 x 56 Separator with Ruth Feeder and Gearless Wind Stack make the completest outfit I ever saw. I can stand off fifty yards and watch her run and hear nothing but the light exhaust of the engine and the hum of the stacker."

1911

E. W. Aikers, Derby, Ohio, says: "I have used Advance Thresher Machinery for the last fifteen years, and have found it the best. I am now using engine and separator that has been out and threshing nine years and I think I can use it successfully for four or five more."

1912

C. H. Weatherman, Spring Valley, Wash., says: "My outfit consists of a 22 h.p. Advance Engine (straw burner) 34 x 56 Rumely Ideal Separator, Ruth Feeder, Iowa Special Bagger and Gearless Wind Stack. I have threshed for many years and have never operated an outfit that gave as good satisfaction to myself or those I threshed for. We ran about 25 days and frequently threshed over four thousand bushels in one day."

Canadian Made Separators

Both the Advance Separator and the Rumely Ideal Separator are made in Canada. They are manufactured in a plant at Toronto, formerly the American-Abell Company, but now owned and operated by the Canadian Rumely Company, Ltd.

For The Smaller Threshing Jobs

The Rumely Gas Pull tractor (15-30 h.p.) and the Canadian-Rumely Ideal Junior Separator (sizes 18-24 and 24-48) make an excellent outfit for a locality where the fields are small. The Junior is a duplicate of the larger Ideal.

And this handy size Gas Pull Tractor will do a lot of other jobs on the medium size farm.

Write for Catalog

Rumely Products Co.
(INCORPORATED)
Power-Farming Machinery
La Porte :: Indiana



THIS IS THRESHING CLEAN

To ship four cars of wheat and not be docked a single pound on account of dirt, seeds, or chaff is a threshing record to be proud of. Yet this was the experience of W. J. Newman of Belle Plaine, Sask., operating a Rumely Ideal Separator. "I hardly know where to begin to mention the good points of the Rumely Ideal Separator," writes Mr. Newman. "I did not lose three hours on account of the separator during the thirty-four days. The straw carrier just back of the cylinder helps wonderfully in separation. I also like the Ideal decks the best of anything I have seen, and I think the hard-oil cups a great advantage."

A PARTNERSHIP OUTFIT

John Brothers and four neighboring farmers near Harvey, N. D., bought in partnership a 30 h.p. Advance Engine and a 40 x 64 Advance Separator. "Our outfit is working fine," writes Mr. Brothers. "Farmers are always pleased when they can get an Advance outfit to do their threshing."

Separates 95 p.c. In First 3 Feet

Canadian-Rumely Ideal Separators, by a 100 per cent. threshing cylinder, a winged beater, and a wide inclined chain rake, separate 95 per cent. of the grain before it has gone three feet from the cylinder.

The rest of the Separator (13 ft. 9 in.) goes after the other 5 per cent.—and gets it.

Canadian Rumely Steam Engines economically furnish steady, reliable power for threshermen.

Write for Catalog

Rumely Products Co.
(INCORPORATED)
Power-Farming Machinery
La Porte :: Indiana



ELY
A PORTE
No. 6.
VIPEG
ill Again
or will de-
edal again
ional Mo-
xt month.
ill be en-
., and the
year the
over all
nes. The
lal in its
est total
wer
Pull
belt
nally
hing-
not
from
port-
ther-
your
pro-
rain
ig—
go
The
the
le—
ther
wd-
353
Co.
ry
ana
brake
ny in-
OilPull
class
points
ny in-
charge
of the
l de-
ventor
part
used
fident
itable
rs.



The Old Time Breeds of Poultry in North America

By MICHAEL K. BOYER, *Hammonden, N.J.*

IN the days of our forefathers, many of the breeds of the present day were unknown. On the other hand, many of the breeds of today originated from some very popular variety in our grandfather's days.

From date at hand we learn that about 1850 there was a breed known as the "Bucks County Breed," it being a cross made by the poultry fanciers of Bucks County, Pennsylvania. Like all new breeds it was claimed to be a good layer, good setter, and good mother; the eggs large and nutritious; the flesh white, firm, tender, and fine flavored. It was also said to be the equal of the Dorking fowl, the pride of England, and at that time very much thought of by American poultrymen. In the States of New Jersey and Pennsylvania the breed was prized for caponizing, in weight running from 16 to 18 pounds to the pair.

From what can be learned, the Bucks County Breed was bred in a variety of colors—Felch says they were Buff mongrels, an extraction from Buff Cochins or Buff Shanghai on native stock. According to Bement (a well known authority of his day) he secured a pair which had a different plumage. The color of the cock was a dark blue-black, with the ends of the feathers tipped with white; wings tinged with a yellow or golden color; hackles dark glossy blue; rose or double comb, and large wattles, bold, lively carriage and a stately walk. The hen did not differ much from the cock in color, and was very similar in form, being deep, plump and thickset in body; short legs, of medium size and dark color; high, single comb, serrated, falling over to the side, and large wattles. It is plain that Mr. Felch knew what he said when he declared them to be mongrels, as they neither bred true to comb nor had a fixed color.

Originally, we are told, this cross was known as the ostrich fowl, probably on account of its

size, but later on it assumed the local title.

Even with all its shortcomings from a breeding standpoint, its fame spread, and it became popular in parts of New England. Mr. Bement secured the pair referred to from a gentleman in Boston. Dr. Kettridge of New Hampshire, then more or less prominent in poultry matters, purchased some stock from a breeder in Montgomery county, Pennsylvania, but he said that at that time the variety was known as the "Bobby fowl."

The Bucks County Breed received its fatal blow when the Asiatic varieties became more generally known and popular. This was about 1860, and from then on we can find no trace of the cross.

Four varieties of the Asiatic family were known and bred in America about 1860, viz., the Cochins, the Dark Brahma, the Chittagong and the Shanghai. Prior to that George P. Burhham, of Massachusetts, originated and bred what he called the Gray Shanghai, and in 1852 he sent nine of these birds to England, as a present to her late Majesty, the Queen Victoria.

The impression, in some way or other, became general that the Light Brahmas sprang from these Gray Shanghais, but that was a mistake, as in 1896 I. K. Felch exhibited at the Boston show a stuffed carcass of a Light Brahma cockerel that came direct from England.

The following interview between the writer and Mr. Felch took place shortly after that show, and appeared in the Farm Poultry of March, 1896:

In reply to a number of questions, Mr. Felch said: "It will be remembered by those long interested in the Brahmas, that in 1863 to 1865, and later, there was quite a paper war as to the first Brahmas having pea or single combs—Mr. Burhham and the Kerr faction claiming that they had single combs. Thus were they striving to secure to the Grey Shanghai or Chittagong breeds the credit of producing the Brahmas. To keep in evidence the fact that the Chamberlain strain, the birds that Knox found

IF ALFALFA

REPLACED A FEW ACRES ONLY OF THE LAND YOU NOW SOW TO WHEAT, AND A

"MAGNET" Cream Separator



filled the position now held by any other separator in your dairy—you have got the key to the best money-coining end of agriculture all experience knows of up to this date.

If you have cows that give milk — good quality and in reasonable quantity — the "Magnet" will give you the last particle of the product that can be converted into cash.

The "Magnet" leaves everything out of sight when it comes to clean skimming—structural simplicity, and therefore ease in operating. It is as firm on its feet as a granite rock and every movement is as silent and smooth as the course of nature.

Our Slogan is "TO SATISFY"—and we will do it at all costs.

We will prove every point we claim for the superiority of the "Magnet" on your farm—at our expense.

The Petrie Mfg. Co., Ltd.

Head Office and Factory: HAMILTON, ONT.
Winnipeg, Calgary, Regina, Vancouver, Montreal, St. John, N.B.
Edmonton, Alta.

You saw this advertisement in this magazine. Don't forget to say so when writing.

Get The Most For Your Cream!

Ship to us and receive highest prices. We furnish tags and cans free and pay all charges. Some of the best-known shippers have been dealing with us for years.

We pay CASH for every can of cream received and remit the same day. Cans promptly returned. Write us and let us put you in a position to get the most for your cream.

The Brandon Creamery & Supply Company
BRANDON MANTOBA

Tie This Tag to Your Cans

Brandon Creamery & Supply Company
BRANDON, MAN.

You saw this advertisement in this magazine. Don't forget to say so when writing.

Patronize those who patronize this Magazine

on the India ship in New York harbor, in 1847, and their subsequent progeny, were pea comb. I had this bird set up, when some years old, although it was late, and the plumage all discolored and falling off of him.

"He was hatched in 1850, a descendant of those New York lot of birds, and when he was set up, the work made him so much of a Game shape that we never took care of him.

"I bought the bird for one dollar, and sold thirteen of his descendants for \$1300. It is safe to say that were there a truthful record kept, more Brahmans in the United States could trace their lineage to him than to any other Brahma of the past time."

The Shanghai seemed to be in the front seat in 1860, but it was closely crowded by the Brahmans and Cochins. The Shanghai was then the largest fowl in the country, weighing from 22 to 26 pounds to the pair at maturity.

There was considerable controversy at that time whether the Shanghais, Brahmans and Cochins, were varieties of the same class, or distinct breeds. Bement said they were different varieties of the same breeds, claiming that fowls imported from China, whether feather-legged or smooth legged, whether dark or light in plumage, came either directly or indirectly from Shanghai or its vicinity.

The Chittagongs came next in line, and it must be said of them they bred very uniform in both color and shape. At one time, too, it was said that the Hoang Ho fowls were the most valuable of the Asiatic breeds, but we have so little reliable data that we cannot venture an opinion.

In the early sixties the White Faced Black Spanish were very popular throughout New Jersey, Pennsylvania and Ohio, noted for large white eggs, and the number of them that they produced.

At the present day, with the exception of the Brahmans and Cochins, and with a limited number of breeders of Black Spanish, none of the old time breeds are with us. Of the remaining breeds, the Brahmans, especially the Light Brahmans, are the only ones that have not only held their own, but are still forging ahead. The Cochins are less bred than they were 10 years ago, and the Black Spanish variety is seldom advertised.

Simply because an egg is fertile is no guarantee of it hatching out a chick. Weak germs cannot hatch, and this weakness being caused by the hen being out of condition, may cause the chicks to die in the shell. A hen may be in good condition today and in a bad state tomorrow.

While it must be admitted that no incubator is able to do as good

work as a hen, yet in hatching large quantities of eggs it would be too expensive to solely rely on hens. A machine is ready when broody hens are very scarce, and if run properly, the machine will give almost as good a percentage of strong chicks as will hens. But much depends upon the work of the man in charge. Hens cannot always be relied upon. At times they give up the notion in the midst of the hatch; some hens impart too much heat, and some not enough. Some hens are restless and break eggs, and many more things are apt to go wrong at a critical time. Both hens and incubators need watching.

If common sense, and less doctoring, were applied to ailing hens, there would be less spread of contagion. When hens are busy they are as a rule healthy. Nip a cold in the bud, and there will be no need for roup cures. Keep the premises in a strict sanitary condition, and there need be no fear of cholera. Nearly all of the diseases that affect poultry are the effects of unsanitary surroundings, due to carelessness. In general, the treatment of diseases is not so satisfactory as preventive measures. Nowhere more than in the poultry business does that old adage apply; "An ounce of prevention is worth a pound of cure."

France classes the worth of a hen more for the production of meat and eggs than she does for fine feathers or Standard looks. Some years ago the poultrymen aimed for show records, and while they no doubt gained their point, they at the same time ruined the stamina and thrift of the hen for commercial purposes. Today it is different. Utility has taken a front seat, and all breeds are bred up to conform with the ideas of the market poultryman.

No successful poultry plant was ever established with mongrel stock. Dunghill fowls, like incompetent labor, are not worth having around. Thoroughbred fowls, like skilled labor, are sure to create a profit for the farm.

There is but one way to build up the utility of a flock, and that is by proper selection. If each year the eggs from only the best layers are used for hatching purposes, each generation will become the more prolific; and this can also be greatly assisted by securing new males from some strain that has been likewise carefully selected. In this work of selection the trap nest is the only reliable indicator.

"How many hens should be placed in a pen with a male bird for good fertility?" That question is asked time and again by beginners, and it is interesting to note the difference of opinion:

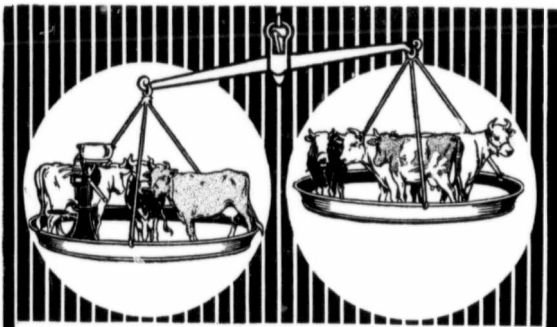

Three cows and a DE LAVAL CREAM SEPARATOR will make more money than four cows with gravity setting

Thousands upon thousands of cow owners have already proved this statement; any experienced dairyman will verify it for you. With such a big saving it is hard to understand why any cow owner should try to get along without a De Laval Cream Separator. If you are selling cream or making butter, and have no separator, or else an inferior machine, we know if we could put a De Laval on your place we would be doing you a personal favor. If you haven't a separator don't make the mistake of starting with a "cheap" or inferior machine. When you do buy a separator—as soon or later you surely will—be sure to get the best—the De Laval. Remember, you can't make money by trying to save money in the purchase price of a cream separator. A De Laval costs only a little more than the cheapest and will save you twice as much and last five to ten times as long as other separators.

DE LAVAL DAIRY SUPPLY CO., LIMITED
MONTREAL PETERBORO WINNIPEG VANCOUVER

Dr. Thomas' Electric Oil
Relieves all Pain in Man or Beast
25 Cent Bottles at all Dealers

GENUINE GREGG EVENERS
SIMPLEST AND STRONGEST MADE

MADE for two, three, four and five horses abreast, for Wagons, Manure Spreaders, Gang, Sulky and Disc Plows; also five and six Horse Tandem for Gang and Sulky Plows. These are made of one-quarter inch heavier wood stock than similar eveners now on the market. Ironing extra heavy. Look for the name **Genuine Gregg** on every Evener. Ask your hardware or implement dealer. Write for Catalogue "T."
GREGG MFG. CO. Ltd., Winnipeg, Man. IF IT COMES FROM GREGG IT MUST BE WELL MADE

HAIL INSURANCE!

The State Farmers' Mutual Hail Insurance Co. of Waseca, Minnesota have a big surplus of funds and are in excellent standing as a business concern. Expense ratio is under 30 per cent. Eighteen years in business, have always paid losses in full and never pro-rated. Company carries the risk to extent of \$10 per acre. No increase in rates during continuance of policy—Assets \$500,000—See the Waseca agent in your district or write Smith & Home, Provincial Managers of

State Farmers' Mutual Hail Insurance Company
—WASECA MINN.—

You saw this advertisement in this magazine. Don't forget to say so when writing.

A
Y OF
TO
T
other
he key
culture
- good
- the
of the
clean
it is
it and
gnet"
N.B.
riting.
3
T
e

Holmes says two males for each pen, using them on alternate days. For a half dozen hens or less, allow the male with them but a half day at a time. Professor Wheeler says the best results he has ever had, were 10 hens mated with a year-old male. The hens were in three pens, four in one, and three in each of the others. The male was in each pen one day in three. Stevenson says by keeping about 30 to 40 hens in one pen, with two vigorous cockerels, allowing only one of them with the hens at a time,

changing them every day. Mount prefers using enough hens for one cock in each pen—with a small active breed, such as Leg-horns, Minorcas, etc., 20 hens to one cock are about the number and with the larger breeds, such as Wyandottes, Plymouth Rocks, etc., 15 hens; with Brahmas and all very large breeds, 10 hens. Fred Grundy says small, penned-up flocks, comprising six to 12 females and one male, will give 60 to 80 per cent fertile eggs, and strong chicks, for 15 to 25 days at the beginning of the season. After that the per cent. of fertility decreases rapidly, and the chicks are invariably weak, and never make good, vigorous breeding stock. It pays well to have two male birds for each pen and alternate them. It is a practice the writer has used in his yards for years with marked success.

table, it is easily seen how sickness and diseases are carried. Don't let a single fly escape. Use Tanglefoot liberally wherever you see a fly, and you will avoid discomfort and ill-health throughout the summer.

Work at Ottawa for the Live Stock Industry

For a number of years until a few months ago, the work of the Live Stock and Health of Animals Branches of the Department of Agriculture at Ottawa was carried on under one head. The work embraced a very extensive field, involving an expenditure of a sum annually of considerably more than half a million of dollars.

According to the annual report of the united branches for the year ending March 31st, 1912, just issued, three more or less distinct lines of effort are carried on. A well organized system is in operation to protect the live stock of the country from disease, not only guarding against its introduction from abroad, but by preventing the spread of infection already existing among Canadian herds and flocks. In this division regulations are enforced to deal with such diseases as hog cholera, tuberculosis, glanders, dourine, mange, anthrax, sheep scab, and rabies, any of which uncontrolled might cause very serious losses to the farming industry.

The meat inspection division seeks by wise regulations, carried out by an extensive, well trained staff, to prevent diseased or otherwise unwholesome meats from being sent from one province to another or out of the country. It also compels operators of food canning establishments to maintain their factories in a sanitary condition, and to put up only sound goods. During the year reported it is shown that 6,151 carcasses of cattle, 241 of sheep, and 2,832 of hogs, as well as many portions of carcasses and 12,702 lbs of poultry were condemned. The report names the diseases and conditions responsible for these losses.

The work of the Live Stock branch is shown to be of an entirely different character. In a number of ways efforts are made to throw light upon the paths of the stock raisers and to encourage the extension and improvement of the live stock industry. Reference is made to a comprehensive investigation of the market conditions affecting wool and mutton carried on by a commission. To improve the light horse stock of the country bonuses are paid to owners of thoroughbred stallions, used for service. To assist dairy farmers in ascertaining where high producing breeding stock may be secured, a Record of Performance has been established for pure-bred dairy cattle. The report just issued shows that 801 cows entered for

The Tent Caterpillars

The Division of Entomology of the Experimental Farms Branch of the Dominion Department of Agriculture, Ottawa, has recently issued a circular on "Tent Caterpillars" by Mr. J. M. Swaine, Assistant Entomologist for Forest Insects, in the Division of Entomology.

This publication discusses the defoliating Tent Caterpillars which were so extremely numerous in parts of Eastern Canada during the season of 1912. A description is given of the different stages of the insects, and their life histories and habits are discussed in considerable detail. The American Tent Caterpillar constructs the large silken tents in May and June, so well known by all owners of fruit trees, and from these retreats the caterpillars emerge to feed upon the nearby foliage. This species is found most commonly in orchards, although it also infests various shade trees. The Forest Tent Caterpillar spins no tent, but feeds in groups of several scores upon the foliage, and rests at intervals massed upon the trunk or lower branches. This species feed chiefly upon deciduous forest trees, such as poplar and birch. Both these species were very abundant last season, particularly in Quebec Province, and their ring-like masses of eggs are to be seen in immense numbers upon the twigs of fruit trees and deciduous shade trees and forest trees in many districts. The circular referred to above gives a very complete account of the measures to be adopted in controlling these important insect enemies. They are, briefly, the removal and destruction of egg masses, spraying infested trees with lead arsenate or Paris green, and banding the trees to prevent reinfestation by wandering caterpillars. Formulae for the spray mixture are given and directions for their preparation.

Copies of this publication, Entomological Circular No. 1, Experimental Farms, may be obtained from the Publications Branch, Department of Agriculture, Ottawa.

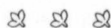

Knavery may serve a term, but honesty is the best in the long run. Trickery comes back to its master.

Kill Flies Early

One Destroyed Now Prevents Countless Millions Later.

"One dead fly in the spring is worth a million in the summer," say scientists. "A mature fly in April may be the ancestor of over six billion flies by the first of September, according to a careful scientific calculation. The young flies killed in April have had few offspring and that is the time they should be annihilated. The killing of all the winter flies would do away with the great work required in the summer."

Now that house-cleaning time is upon us and doors and windows are left wide-open, we are subject to the pest in numbers. One of the easiest ways of preventing discomfort and fly-infection is to spread a sheet of old-fashioned Tanglefoot in the window. Pull down the shades and leave the sheet of Tanglefoot in the edge of the sunlight where the flies will be attracted. This is a most effective method, as the sticky coating on the paper not only kills the fly, but covers it with a varnish which also destroys the germ on the fly.

The use of poisons is risky, especially where there are children. So many fatalities have been reported from their use that in several states their sale is forbidden except by registered pharmacists.

In regions infested by fleas, a small piece of liver laid in the center of a sheet of Tanglefoot will effectually rid one of these pests.

There are a number of different species of flies, but the one known as the house fly, or musca domestica, is most frequently found in the house. These flies usually breed in manure piles, garbage cans, etc. Coming from these places to your dining room



"INTERNATIONAL FLY WAY" Prevents the Tremendous Loss from Flies

Flies cost the Farmers of Canada millions of dollars annually by retarding the growth or fattening of animals and by greatly reducing the production of milk by constantly annoying the animal all summer. Every farmer or stockman knows this statement to be true from his own experience.

Flies also cause a great loss of life by spreading Disease from farm to farm. "International Fly Way" will keep flies off your animals and give them perfect rest from these pestiferous insects, which will make you more money in a larger production of milk or much quicker growth of all animals.

SAVE YOUR STOCK By Using "INTERNATIONAL FLY WAY"

It is positively guaranteed to be effective in Driving Away Flies, Mosquitoes, and other insects which worry stock and reduce their eating capacity. It is harmless to the hair and skin and will be found perfectly satisfactory when used according to directions.

We place our twenty years of reputation behind "International Fly Way" and ask you to test it on our positive guarantee.

FOR SALE BY ALL DEALERS. INTERNATIONAL STOCK FOOD CO. Limited, TORONTO No. 74

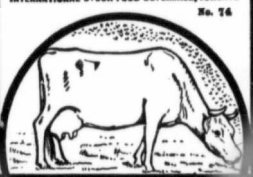

Mention this magazine when writing advertisers

DR. WARNOCK'S ULCERKURE

The wound healing wonder. Heals without leaving a scar or the usual aftergrowth of white hairs. Ulcerkure is the surest and safest of all antiseptics.

Sold in bottles, 50 cents and \$1.00

Western Veterinary Co.

Sole Proprietors

P.O. Box 2132. Winnipeg, Canada

Mention this magazine when writing advertisers



ABSORBINE

TRADE MARK REG. U.S. PAT. OFF.

Removes Bursal Enlargements, Thickened, Swollen Tissues, Curbs, Filled Tendons, Soreness from any Bruise or Strain; Stops Spavin Lameness. Allays pain. Does not Blister, remove the hair or lay up the horse. \$2.00 a bottle, delivered. Book 1 K free.

ABSORBINE, JR., the antiseptic liniment for mankind. For Syphilis, Strains, Gouty or Rheumatic deposits, Swollen, Painful Varicose Veins. Will tell you more if you write. \$1 and \$2 per bottle at dealers or delivered. Manufactured only by W. F. YOUNG, P.O. 112 Lyman's Bldg., Montreal, Can. Also furnished by Martin Ross & Wynn Co., Winnipeg, The National Drug and Chemical Co., Winnipeg and Calgary, and Henderson Bros. Co., Ltd., Vancouver. Mention this magazine when writing advertisers

ARE YOU USING MOLASSINE MEAL

*Made in
England*

The Food Discovery of the Age

Owing to so many of the British Settlers who have moved to Western Canada writing us asking where they can get **Molassine Meal**, as they have been accustomed to using it in the Old Country, we have now arranged to bring this famous food to your door.

Every reputable food dealer in the West will soon be selling this food and able to supply all demands.

MOLASSINE MEAL

is a scientific combination of molasses and vegetable matter, specially treated and cooked by a patented process that nullifies the potash salts.

The success of **Molassine Meal** has been so great that many other sugar preparations have been put on the market which are purely and simply imitations and do not contain any **antiseptic, digestive and worm-destroying properties.**

Molassine Meal is the only safe way to feed molasses to livestock.

Molassine Meal may be fed in large quantities to any animal all the year round to advantage and profit.

Molassine Meal is not only a good food in itself, but owing to its antiseptic properties, it keeps the stomach and blood of the animals fed regularly with it in a healthy condition, thus enabling them to derive the whole of the nutrition from other rations.

Molassine Meal prevents and eradicates worms and prevents colic.

Molassine Meal, by keeping the stomach and blood in perfect health, enables the animal to avoid diseases, for the same reason that a healthy human being is able to resist all attacks of germ diseases.

Molassine Meal is guaranteed to contain no drugs, acids or medicaments of any kind.

Molassine Meal is the best all-year-round food known to science to-day for

HORSES CATTLE SHEEP PIGS POULTRY DOGS

Molassine Meal is guaranteed by the makers to keep in good condition for any length of time.

Ask your nearest dealer and if he cannot supply you let us know.



See that this Trade Mark is on every bag



GOVERNMENT ANALYSIS

Write to the Department of Inland Revenue, Ottawa, for their Bulletin No. 241, on Registered Stock Foods, and see the Government analysis of MOLASSINE MEAL. It is better than its guarantee and away ahead of any other Molasses Food.

ROYAL WARRANT



After supplying the Royal Stables for several years, His Majesty King George V has granted a Royal Warrant to the makers of MOLASSINE MEAL.

THE MOLASSINE CO. LTD.

St. John, N. B.

Please send me full particulars regarding Molassine Meal, particularly for (mark X opposite livestock you are particularly interested in).

MILCH COWS _____ My dealer is _____
 STEERS _____ Name _____
 SHEEP _____ Address _____
 PIGS _____
 HORSES _____
 NAME _____
 ADDRESS _____

The Molassine Co. of Canada Limited

St. John—Montreal—Toronto

For sale in Western Canada by
The A. Macdonald Co., Ltd.
 Winnipeg, Man.

test for this record during the year.

In addition to the report of the Veterinary Director General and Live Stock Commissioner, the volume, which contains almost 500 pages including many illustrations, embodies 24 appendices including reports of officers and a number of publications that have appeared as separate works, including Report No. 4 of the Record of Performance, Bulletin No. 15 of the Live Stock Branch, the Report of the Third General Convention of the National Live Stock Association, the Report of the National Record Committee, and others. The selling price of this blue book is fixed at forty cents, but provision has been made for supplying copies free to those who apply for them to the Chief Officer of the Publications Branch of the Department of Agriculture at Ottawa.

Co-operative Egg Farming

Co-operative egg farming is carried on in parts of England which gives a method for disposing of eggs to a good advantage. It is a plan especially beneficial to the farmers of the district as, no matter how few dozen they may have for sale, the same market rate can be realized as if they had a large quantity to ship.

The Framlingham and District Co-operative Society, Limited, of Suffolk, England, takes the eggs from the farmers, tests them, and then ships the entire lot to market, giving an official stamp of guarantee of quality, which finds for them a ready sale.

The society receives eggs only of good size and quality. Each egg must weigh not less than two ounces, and a deduction of two cents in price is made for every ten coming under the weight of two ounces each.

Each farmer is supplied with a small rubber stamp, with which he must stamp each egg before it will be received for shipment. All eggs coming to the shipping house are tested by experts, who can tell pretty closely the age and condition.

The exactness of the society has been the means of inducing the farmers to improve their stock, and mate for good sized eggs, and they are careful to bring only the strictly fresh article to market.

Each offering stands upon its own merits. There is no limit to quantity, quality alone being the consideration. A dozen or a hundred eggs will receive the same kind of attention, and given the same advantage of sale, as will a thousand, provided, of course, they are properly stamped by the farmer from whose yard they

have come, and meet the requirements of the official test.

The society guarantees to dispose of the eggs, no matter in how large quantities they may be offered, at the best prices obtainable.

In Paris markets the eggs are dated, and one pays according to the freshness, so that it is possible to be certain of newly-laid eggs; or, if it is necessary to be economical, yesterday's eggs, or the day's before, are offered at a reduction.

Here the American farmer and poultryman can find an object lesson. Especially in communities more or less remote from a good market, it would be profitable for farmers and poultrymen to unite and form a society similar to that in Framlingham, and in this way not only put more money in the producers' pockets, but improve the grade of fowls and the quality of eggs, and in this way secure the best prices for furnishing the consumers' eggs of superior size, flavor and condition.

The common practice of farmers carting their eggs to the village store to be traded off for groceries is an unwise act for both the farmer and the consumer. In the first place, the farmer is indifferent as to the age and condition of his eggs. During a scarcity he will save up his eggs until he has a sufficient number of dozens to make it an object to "go to town." If a society would exist in the locality that would test the eggs, the farmer would soon learn that condition meant money to him and would take greater care. By such a practice there would be less bad eggs on the market, and if this co-operative principle would become general there would soon be a scarcity of preserved or pickled eggs, or eggs from cold storage plants, on the winter markets, to compete with the fresh-egg trade, and the housewife would no longer look upon an egg with suspicion whenever she came to use one.

There used to be a theory, and with some it is still believed, that the presence of a small pigeon-sized egg means that that particular hen has laid out her litter and will not begin again for some time. That theory has been exploded by the aid of the trap nest. The records kept by the writer show that on February 17, Brahma hen No. 27 laid a small, pigeon-sized egg; the next day she laid another small egg, but somewhat larger than the one of the day before. Two days later she laid a regular sized egg, and continued doing so until the 26th of the month, when she laid a double-yoked egg, which proved that both the pigeon-sized and double-yoked eggs are the pro-

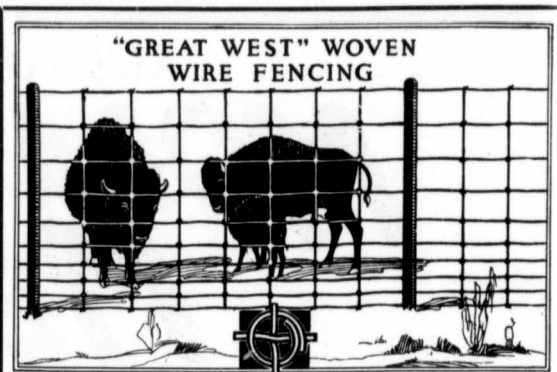

Economy

is not governed by the price you pay but by the VALUE you receive and the results obtained. For every dollar spent on "Great West" Wire Fence you will get a dollar's value, and be more than repaid by results. Send for Illustrated Catalogue.

THE GREAT WEST WIRE FENCE CO. LIMITED
76-82 LOMBARD STREET, WINNIPEG, MAN.

Distributing Agencies—Edmonton, Alta., Race, Hunt & Giddy; Calgary, Alta.: Reynolds & Jackson; Saskatoon, Sask.: Plasterers' & Builders' Supplies Ltd.

You saw this advertisement in this magazine. Don't forget to say so when writing.

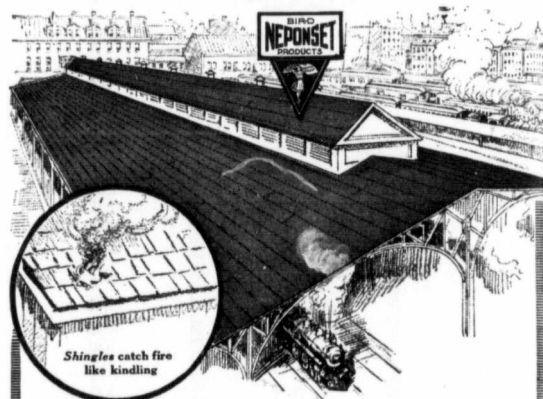

This Roofing Used Twice!

Most roofs have but "one life." This roof pictured above had "two lives." When the Old Wells Street Station of the Chicago and Northwestern R. R. in Chicago was torn down, its roof of NEPONSET Paroid, after fighting smoke, burning cinders and storm for eight years, was rolled up and used to roof other stations.

It's still giving perfect service. NEPONSET Paroid Roofing is constantly doing this—giving better, longer and safer service than you would think it possible for any roofing to give.

"Covered with NEPONSET Paroid" means that you have protected your stock, implements, grain, etc., with the safest, sanest and surest product which the development of prepared roofing affords. It's a quality product. Anyone can lay it.

NEPONSET

Waterproof Building Products

Roofings
NEPONSET roofings are a fire protection, leak-proof and long lived. Anyone can lay them. NEPONSET Paroid Roofing is for general use. NEPONSET Protective Roofing is an ornamental roofing for dwellings. Attractive colors.

Building Papers
If NEPONSET Waterproof Building Papers are built into walls and floors, the building will be warmer, will cost less to heat and will last years longer. Recommended by architects, engineers and building owners everywhere.

Wall Board
NEPONSET Wall Board is a scientific product which takes the place of lath and plaster, comes in sheets 32 inches wide. Remember, it is the only wall board with waterproofed surfaces that requires no further decoration. Anyone can put it up.

Are you going to build? Write for more facts about the products in which you are interested. Send for Samples, free booklet and name of nearest NEPONSET dealer.

BIRD & SON Est. 1895 862 Heintzman Building, Hamilton, Ont.
[F. W. BIRD & SON] Montreal St. John, N. B. Winnipeg Vancouver

You saw this advertisement in this magazine. Don't forget to say so when writing.

Remember to renew your Subscription

INSURE YOUR CROPS

WITH

The Canada Hail Insurance Company

GUARANTEED BY THE LONDON MUTUAL FIRE INSURANCE COMPANY OF CANADA

Combined assets over One Million Dollars. Our Policy Contract guarantees positive protection to Policyholders

FULL DOMINION
GOVT. DEPOSIT

LOWEST POSSIBLE RATES

LOSSES PAID IN FULL

PROMPT SETTLEMENTS

HEAD OFFICE
WINNIPEG, MAN.

Rates based under the Graduated or Classification System

Application for Agencies Invited

Apply General Agents: Matthews, Wrightson & Co. (Canada) Limited

722-8 Union Bank Building, Winnipeg, Man.

The London Mutual Fire Insurance Company of Canada

CONTINUOUS OPERATION FOR 54 YEARS

ESTABLISHED 1859

A GENERAL FIRE INSURANCE BUSINESS TRANSACTED

OUR FARM POLICIES contain many features which are very advantageous to the assured, the most important being the blanketing of all contents of a house or barn under one item. The only property on a farm which we ask for specific insurance on, being live stock.

AUTOMOBILE INSURANCE—This policy covers against loss or damage by fire and/or explosion and self-ignition to the body, machinery and equipment of automobile while in the Dominion of Canada. Insurance covers cars while en route or while kept in private garage, barn or stable. Permission given to keep automobile in any public garage for a stated period free of charge.

CONSULT ANY OF OUR 500 AGENTS IN WESTERN CANADA. OR APPLY TO

General Agents: Matthews, Wrightson & Company (Canada) Limited, 722-8 Union Bank Building, Winnipeg

You saw this advertisement in this magazine. Don't forget to say so when writing.

duct of hens that are too fat. This hen in question was very fat.

Meat in some form must be fed poultry. Fowls on free range, especially in an orchard, gather a vast amount of bugs, worms and insects that furnish them all the meat food required. But very few flocks have the advantage of an orchard range, and as the majority of flocks are kept in confined quarters, the question of a meat-supply must be carefully considered. The green bone cutter has done much in solving this important question, but an injudicious use of green bone has caused troubles in other ways. It developed worms in fowls, and it produced irritableness in the stock. In young, growing stock it caused a too-rapid development of the comb and wattles. A fresh meat diet should be given cautiously — not more than an ounce for each hen, and no oftener than every other day. An excellent substitute for green bone is the commercial meat sold by poultry supply houses. Being thoroughly cooked and dried, it is in a safe condition for feeding and can be safely fed at the rate of 12 to 15 per cent.

While we believe in breeding up for heavy records, at the same time we would rather have our hens average 120 eggs a year, and remain in robust health, than to

have their systems drained of vitality in the race to pass the 200 mark. There is reason in all things. If we are to forge our stock ahead to be champion layers, we are going to do it at the sacrifice of something else. What will become of our meat supply if we are going to put all the forces to work on eggs? When we spend our food and attention on the fowl with a view to creating an ideal carcass, do we not make the egg yield suffer? Will not this unnatural flow of eggs tend to cripple fertility and make weak, puny chicks? Why not work for both eggs and meat? Why not have a limit? If we can gradually increase the powers of a hen so that she will average 200 eggs a year, and still maintain health and meat qualifications, it is advisable to go ahead. But to build up the one at the expense of the others will eventually produce a delicate race. We want the 200-egg hen if we can get her within reason.

Growing ducklings thrive best on a feed of equal parts, by measure, of corn meal, ground peas, bran and middlings, all made into a thick mash, either with scalding hot water or milk, the latter being the best. The mash is improved by adding short-cut green grass, clover or some other green

stuff, and a few handfuls of coarse sand.

A writer some years ago truthfully said that more is lost to the producer of dressed poultry, eggs, butter, vegetables and fruit, through sending them to market in improper condition, than would be required to pay the national debt.

Ducks and geese require drinking vessels, especially if reared and kept on land. Unless the vessel is deep enough so the fowl can get its entire head under water, and thus wash its eyes, dust or dirt will settle in the eyes, making them sore, and often resulting in blindness. A three-gallon water pail is the best drinking vessel for either ducks or geese.

A very successful, and at the same time well-balanced whole grain ration for egg production, is composed of equal parts, by measurement, of Indian corn, wheat and oats, well mixed.

With the end of the Hebrew holidays in October, the demand for live poultry lessens, and consequently sells at a lower figure, until after Christmas. Shippers should arrange to market their surplus stock before this time.

Authorities do not all agree whether a chicken should be allowed to perch early in life, or

be compelled to squat on the ground. One writer says Nature is a very reliable guide. When the wing feathers have sufficiently developed to allow the bird to use them, then perching is at once indicated. That, no doubt, is true, but, on the other hand, if birds perch while young, the breast bone, which is little more than gristle, is easily bent. But after it has taken on its firm, bone-like condition, it requires considerable pressure to bend it. In the young bird the crookedness is not caused by a break, but rather by pressure on the shape moulded. This is generally brought about by small, round roosts, the breast bone being brought down on the keen edge, and the pressure caused by the head counter-balancing the tail, thus gradually forcing the bone out of its keep shape, and the indentation becomes permanent as the bone hardens. This is especially so with chickens from inbred stock. The writer has a different method for this perching, using low, wide perches, so the chickens must squat, and thus the breast bone is protected by the legs, which will not permit it to come in contact with the perch.

The practice of allowing fowls to squat on the floor, is not advisable, for the reason that the

Continued on page 62

It is with a great deal of pleasure that we announce the opening of Messrs. Marshall Sons & Co. Ltd., of Gainsborough, England, in a Canadian branch of their already enviable business. Their goods are not unknown to the Canadian farmer, for already many of their famous Colonial tractors have been purchased by farmers in Western Canada.

The business in Canada will be under the direct charge of Mr. H. E. Lambe, as managing director of the Canadian concern. Mr. Lambe has spent considerable time in the Canadian West, and is very enthusiastic over the business prospects here.

Upon his departure for Canada a very fitting banquet was held at the Gainsborough Constitutional Club, on which occasion Mr. Lambe was presented with a beautiful gold hunter watch in recognition of his services as honorary treasurer of the club and as a mark of esteem. Mrs. Lambe was also remembered by being presented with a beautiful silver tea service.

In the course of Mr. Lambe's remarks at the presentation, he said, "It may possibly interest you to hear something about the future plans of Messrs. Marshall Sons & Co. I may tell you that they have decided to establish a depot in the city of Saskatoon in the Province of Saskatchewan in our great Dominion of Canada. It is a very prosperous city with 27,500 inhabitants, beautiful wide streets, electric street cars, all modern conveniences, electricity at very cheap rates, both for heat and power, and a splendid river something like a quarter of a mile or more wide, which makes our something like a quarter of a mile thing like a little stream.

"I have been fortunate enough to secure a most excellent building site, and I believe there are bright prospects for the success of the firm of Messrs. Marshall Sons & Co. of Canada Limited. This Company will be controlled by the parent company in Gainsborough, and I have been invited to the important position of Manager in Canada. I know perfectly well that there will be plenty of work and plenty of difficulties, but I believe that with the good quality of materials and excellent workmanship for which Messrs. Marshall & Sons are famed the world over, we will be able to overcome these difficulties.

"It is difficult to foretell what this great Dominion of Canada will come to, but in my own humble opinion, I believe that in the space of fifty years or so it will probably equal the wealth and population of the United States of America. That is saying a great deal, but Canada is growing so fast and there are such vast pos-

First British Tractor Concern Established in Canada

sibilities in front of it, that I feel I am right in saying so. Messrs. Marshall & Sons are, I believe, the first British firm of machinery manufacturers and general engineers to go out to this great Dominion to be established in the far West. It is a venture, and I can only hope it will be successful. I shall do my best, and I wish to thank you again heartily for all your good wishes."

In view of the fact that Messrs. Marshall & Sons Co. have become one of our permanent institutions, we deem it advisable for the benefit of our readers to give a brief description of the works of the parent Company of Gainsborough.

The now vast concern, with branch offices in London, Calcutta, Bombay and other cities abroad, was originally founded on the present site by Mr. William Marshall at about the close of 1855. Rather more than a year later his son, Mr. James Marshall, joined him in the business, followed by the co-partnership of Mr. Henry Marshall during 1861. Some twelve months afterwards the enterprise was made into a joint-stock company, which was just before the inauguration of the first Limited Liability Companies Act of 1862. Mr. William Marshall commenced his notable career by purchasing an old millwright's business in Gainsborough, doing mainly in oil and flour mill work, to which he added later threshing machines, fixed and portable engines.

The Britannia and Trent Works now occupy about 31 and 9 acres respectively, and further extensions are still under construction. The engineering productions proper are executed in the former factory, the latter being exclusively confined to wooden products, such as the frames and carriages of their threshing machines. The works are served by the River Trent and by direct connection with the main line of the Great Central and Great Northern Railway systems and their ramifications. Upwards of a million pounds sterling are now profitably invested in this prosperous undertaking, the weekly wages bill amounting on average to about \$25,000 to \$30,000.

The main machine shop is a large hall some 350 feet long by 165 feet wide, provided with a gallery all round same. On the ground floor all the heavy plant

is located, the lighter machinery being installed in the gallery. Here a very wide range of English and foreign made tools, some 400 in number, are to be seen at work.

In the brassworking shop, a great number of special turret lathes, many having been built by Messrs. Marshall themselves. Some of them are fitted with an ingenious revolving chuck device of their own design, by which cocks, valves and the like are entirely machined at one setting. Obviously, the products of the firm involve a very large amount of brass fittings. Grinding ma-



H. E. Lambe

chines find here a large scope of employment, the buffing being done in a separate department, like the screwing and tapping work.

In the automatic machine room, we saw such familiar types of machines as those by Messrs. The Cleveland Company, Spencer, Pratt & Whitney, Ludw. Loewe, etc. There are 16 machines of the kind running on small repetition work, e.g. producing screws, bolts, nuts, studs, etc.

The engine erecting and fitting shop is about 275 feet long by 130 feet wide, suitably served by cranes and transporting plant of modern designs. At the south side of the works is located the department in which the threshing machines are built. The main erecting shop is 310 feet by 62 feet, with an extension of 120 feet by 40 feet.

The spacious and well-lighted pattern shop provided forms the subject of another of our illustra-

tions. This is equipped with efficient machinery, electrically driven in groups from shafting, or by separate motors; and in connection with this, as in other departments, the systematic way of storing and labelling articles is a noteworthy feature.

The foundry covers an area of about 2 acres. Here are installed three 4 ft. and one 3 ft. cupolas. The average total weight of castings turned out per day sometimes amounts to over 50 tons. 1-30 tons, 2-25 tons, 2-5 tons and 3-1 ton electrical cranes are provided, also numerous hand and power jib cranes and smaller ones operated by hand or pneumatic power. The floor is formed of iron plates, furnished with tramways, upon which the castings and materials are conveyed. In this manner large ladles of molten metal are run about the foundry on suitable trolleys to the various moulds. A portion of this department is devoted to an ingenious arrangement of plant for pneumatic moulding, which we examined with much interest. By this means the sand is delivered from an overhead hopper into moulds beneath, which in turn are rammed by a flexible head, much like a water-mattress, which exerts the necessary yielding pressure for the purpose. The whole outfit is pneumatically operated. The sand elevators, as also the moulding apparatus, are discernible in the background of the illustration. To the extreme left hand may be noticed a tramway with trucks standing thereon. About 400 hands are employed in this branch.

An additional foundry has been built on the south side of the works, measuring 160 ft. by 80 ft. This has two cupolas. In this foundry are cast the travelling wheel centres and freitars.

A brass foundry also forms a part of these extensive works, where a deal of plate moulding is carried out.

The smithy is equipped with a number of flexibly connected drop stamps, hammers, forging machines, bolt and nut making plant, etc., of modern types.

All the engines or machines and their working parts made on the premises are thoroughly tested under power before being dispatched to customers. This work is carried out in three or more separate departments allotted and equipped for the special purpose.

The boiler shop covers an area of some 250 feet by 250 feet square, and the mounting department about 220 feet by 60 ft. The materials are transported by tramways and cranes. Numerous plate furnaces, hydraulic flanging presses, drilling, milling, riveting, etc., machines are installed here. Portable pneumatic



"He's Hailed Out - and not a Cent of Insurance"

Best Service at Lowest Possible Cost

THE CENTRAL CANADA INSURANCE COMPANY
BRANDON - CANADA

INSURANCE AGENCIES LIMITED
General Agents
Jos. Cornell
General Manager

THE SASKATCHEWAN INSURANCE COMPANY
SASKATCHEWAN - CANADA

THE ALBERTA-CANADIAN INSURANCE COMPANY
EDMONTON - CANADA

13

THE pity of others more fortunate than himself is of no avail to the man who has lost his all through neglect to insure.

Help from the neighbors, trifling loans, collections for his benefit—all these things, however kindly offered and well meant are galling to the self-reliant independent man, and the thought that but for his own improvidence such things would not be necessary does not make the pill less bitter.

The best way is to take your own measures for protection beforehand. Years of experience and carefully kept records prove that no district offers a guarantee against hail. Some localities are less subject to it than others, that is all. In such districts we insure crops at a lower rate than others. We return all premiums if your crop is a failure and you plow it down.

Write any of the Companies for information as to our rates and service, see one of our 1,500 Local Agents or consult

Insurance Agencies, Limited

WINNIPEG	REGINA	EDMONTON
BRANDON	SASKATOON	CALGARY

You saw this advertisement in this magazine. Don't forget to say so when writing.

Fast Threshing Complete Separating Thorough Cleaning

"Why do men buy threshing machines?" says the old farmer. No, he was not asking a conundrum. We were talking seriously about threshermen's reasons for buying certain machines. "In the long run," he continued, "every so-called buying reason leads up in one or another to a combination of three features, fast threshing, complete separating, thorough cleaning. Every thresher does one of these. Most threshers do two of them. There are a few that do all three, and when a thresherman finds one of the latter machines he is ready to spend his money. Light running, ease of transportation, and



the threshers we sell. There are individual reasons for the purchase of each of the threshers, but all combine the three important specifications. I H C local agents will give you complete thresher information, and will supply you with catalogues. See them, or, if you prefer, write to us for particulars.

other lesser considerations are relative. The 3-sided combination I have mentioned is what every thresherman is looking for."

Fast threshing, complete separating, thorough cleaning of the grain, not one or two, but all three are combined in

INTERNATIONAL HARVESTER COMPANY OF CANADA LTD.

Brandon, Man.

Calgary, Alta.
Regina, Sask.

Edmonton, Alta.
Saskatoon, Sask.

BRANCH HOUSES AT

Estevan, Sask.
Winnipeg, Man.

Lethbridge, Alta.
Yorkton, Sask.

North Battleford, Sask.

You saw this advertisement in this magazine. Don't forget to say so when writing.

hoists, tools and plant of various kinds are also brought into requisition. An even more extensive shop, 400 feet by 150 feet, with mounting bay 275 feet by 40 feet has been erected at the south end of the factory, where a large new power house has been constructed.

The general movement of the raw materials to be manufactured products in these exemplary works takes a progressive course in the direction of north-east to south-east, where the manufactured machinery is delivered to the trucks on the Great Central Railway. The foundry supplies are obtained from the eastern side. This general outlay of the works will be better understood upon reference to plan, which forms the subject of our first illustration.

It may be casually mentioned that in connection with the threshing machine department there is an enormous dipping tank which holds about 20 tons of paint, and by the exercise of this process a large saving of labor is achieved over painting by hand to say nothing of the wearing out of brushes.

The steam power employed in the Britannia Works amounts to an aggregate of about 3,500 h.p.

including electric lighting and driving requirements.

The timber used in the construction of the threshing machines is stored and worked at the Trent factory before mentioned, where the machine shop, equipped with the most modern sawing, planing and wood-working plant, covers an area of 325 feet long by 100 feet wide. All the machines are electrically driven by generators and motors placed in the basement, and run from compound engines directly coupled to two Crompton dynamos.

Those who have had the opportunity of inspecting these vast and important works and of observing the methodical organization, progressive practices, and equipment which characterize the same will, we believe, freely allow that they constitute a laudable pillar of industry which any country may be gratified to have in its midst.

A new department has been added to the Britannia Works for the machining and erecting of Oil Tractors and Gas Engines about 250 feet by 100 feet.



Instead of all the world's being a stage, it's a treadmill.

Co-operative Egg Farming

Continued from page 57

floor is generally cold, and there is always more or less current of air moving close to the ground, which is apt to chill the stock.

No turkeys should be allowed to perch before they are fully three months old; four months would be better. Even when it is a case of weight for weight, a nice straight-breasted bird with the flesh laid evenly alongside it has the appearance, if not the actual fact, of carrying more meat, and no one can deny the fact that it is much easier to carve.



When Jack London, the author, was recently introduced to a certain musician, he got home with a neat piece of leg-pulling. "I am myself a musician in a small way," said London. "My musical talent was once the means of saving my life."

"There was a great flood in the town of my boyhood," explained London. "When the water struck our house, my father got on a bed and floated with the stream until he was rescued."

"And you?"

"Well," smiled London, "I accompanied him on the piano."

Farm Building

Continued from page 24

up to the peak from all four sides may meet at one point or may form a short ridge as in the figure, depending on whether the building is square or not, and whether the two pairs of slopes of the roof have the same pitch. Sometimes this type of roof has a small deck, but this deck would be small as compared with the one on the mansard roof for the same sized building.

A hip roof is sometimes called a cottage roof, probably because the roofs of so many cottages are a combination of a hip and a gable roof, the back part over the kitchen being hipped.



"Now, boys, what is the axis of the earth?"

"The axis of the earth," said Johnny, "is an imaginary line which passes from one pole to another, and on it the earth revolves."

"Very good, Johnny," said the teacher. "Could you hang clothes on that line?"

"Yes, sir."

"Oh, indeed; and what sort of clothes, may I ask?"

"Imaginary clothes, sir."

—London Daily News.

"Honi Soit Qui Mal-y Pense"

A story is told in Scotland of a gentle old minister, Dr. Erskine, who frequently, much against his will, was set in judgment over some frail offender from his parish, who by feminine gossip had been adjudged a reprobate. One day before him and a row of grim elders a sixteen-year-old girl was brought to task.

"What are ye up here for, Eppie, lass?" asked the kindly old man.

She could not speak for sobs. An austere deacon answered for her. She was foun' last nicht, sir, dauncin'—dauncin' wi' the ungodly. My ain wife caught her."

"Ay, dauncin'," the voice of the old minister grew gentler. "Luik up at me, lassie, ye ken for an auld frien' o' yer ain an' yer father. Noo, tell me jist ae thing. What were ye thinkin' o' while ye daunced?"

The girl lifted a sweet, tear-stained, innocent face to his. "Sir I was thinkin' nae ill o' ony ane."

Dr. Erskine stretched out his hands to the well-filled church. "Here, my people," he cried, "Here's a lesson for ye. Ane an' a' o' ye tae yer feet—up an' dance!"

The Winning Home of "Rex Motor Spirit"

Realizing that gasoline was getting almost prohibitive in price for traction owners, and after months of experimenting, the Canadian Oil Companies Limited, are offering an entirely new substitute for gasoline, viz: Rex Motor Spirit.

Rex Motor Spirit is designed to take the place of gasoline entirely for gasoline tractors and motor trucks. It is pure white in color, extremely volatile and has a pleasant odor. We understand that it will sell for about three cents per gallon below the price of gasoline, and is thereby a boon to traction owners everywhere, and will no doubt receive a warm reception as it will reduce the cost of operating to a very large extent.

The Winnipeg Manager of the Company, Mr. Ira T. Peacock, when approached by our representative asking as to whether they could supply the demand, made the following statement:

"For the past year our Company have been experimenting along this line, and it has taken us over ten months to perfect our new product, Rex Motor Spirit.

Our Saskatchewan storage capacity was doubled early in the spring, and our new station at Brandon will be completed with-

Threshing From Stook In June!

Several fields in the neighborhood of Sperling, Manitoba, carried the grain in the stook throughout the winter of 1912-1913. When the snow went, the crop presented a sorry spectacle—an apparently hopeless task for any crew of pitchers to handle. They did not attempt it—the sheaves having loosened up and scattered in many cases. What human hands could never have done, the

Stewart Sheaf Loader

accomplished and left a field as clean of grain and straw as if it had been swept with a broom. This was done in the end of May and beginning of June, 1913, and the wheat fetched about 15 cents a bushel more than had it been shipped tough in the previous fall.

We Do Not Of Course Advocate This System Of Farming, But It Shows What The Stewart Sheaf Loader Can Do Under The Most Adverse Conditons

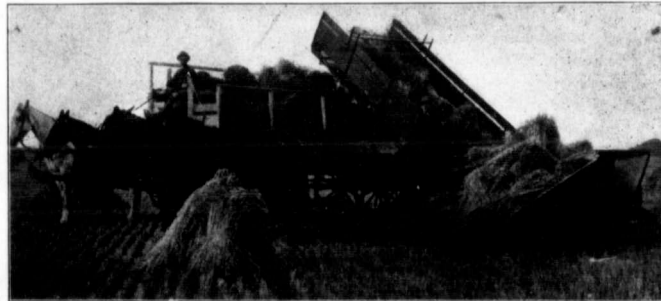

Mr. FARMER!

In a few weeks you will be up against the most heart breaking experience of your life—a big crop of grain (your year's income) and you can't hire the men to gather it, even at ruinous cost.

With a

STEWART SHEAF LOADER you no longer face the labor problem and by using it instead of the big bunch of boarders you take on at harvest time, you will get cleaner fields, you will gather the crop in a fraction of the time, and you will positively

SAVE FROM \$25.00 TO \$40.00 PER DAY

Write at once for particulars, if you will be in time for the 1913 crop.

The Stewart Sheaf Loader Co., Ltd. 804 TRUST AND LOAN BUILDING WINNIPEG



in thirty days time. We can take care of all orders right now.

"We have had Rex Motor Spirit tried out in Winnipeg by three experts, and they pronounce it perfect."

Imperial Bank of Canada

PROCEEDINGS

OF THE

Thirty-Eighth Annual Meeting of the Shareholders

Held at the Banking House of the Institution in Toronto, on Wednesday, 28th May, 1913, at 12 Noon

The Thirty-eighth Annual General Meeting of the Imperial Bank of Canada was held, in pursuance of the terms of the Charter, at the Banking House of the Institution, 28th May, 1913.

THE REPORT

PROFIT AND LOSS ACCOUNT

Dividend No. 88, for three months at the rate of 12 per cent per annum (paid 1st of August, 1912).....	\$ 182,678.88	Balance at credit of account 30th April, 1912, brought forward.....	\$1,022,787.88
Dividend No. 89, for three months at the rate of 12 per cent per annum (paid 1st November, 1912).....	195,298.22	Profits for the twelve months ended 30th April, 1913, after deducting charges of management and interest due depositors, and after making full provision for all bad and doubtful debts and for rebate on bills under discount.....	1,125,971.61
Dividend No. 90, for three months at the rate of 12 per cent per annum (paid 1st February, 1913).....	199,689.85	Premium received on new Capital Stock.....	788,169.18
Dividend No. 91, for three months at the rate of 12 per cent per annum (paid 1st of May, 1913).....	203,001.96		\$2,936,928.67
	\$ 780,668.91		
Special contribution to Officers' Pension and Guarantee Fund.....	\$ 20,000.00		
Annual Contribution to Officers' Pension and Guarantee Fund.....	7,500.00		
Transferred to Reserve Fund.....	1,000,000.00		
Written off Bank Premises and Furniture Account.....	124,771.21		
Balance of Account carried forward.....	1,003,988.55		
	\$2,936,928.67		

RESERVE FUND

Balance at credit of account, 30th April, 1912.....	\$6,000,000.00
Premium received on new Capital Stock.....	788,169.18
Transferred from Profit and Loss Account.....	211,830.22
	\$7,000,000.00

D. R. WILKIE
General Manager.

LIABILITIES

Notes of the Bank in circulation.....	\$ 5,803,794.00
Deposits not bearing interest.....	\$12,300,587.23
Deposits bearing interest (including interest accrued to date.....)	44,600,524.63
Deposits by other Banks in Canada.....	56,802,111.86
	224,075.36
Total Liabilities to the public.....	\$62,829,981.42
Capital Stock (paid up).....	6,788,169.17
Reserve Fund Account.....	\$7,000,000.00
Dividend No. 91 (payable 1st May, 1913) for three months at the rate of 12 per cent per annum.....	203,001.96
Rebate on Bills discounted.....	138,967.00
Balance of Profit and Loss Account carried forward.....	1,003,988.55
	8,145,957.51
	\$77,964,108.10

ASSETS

Gold and Silver Coin.....	\$ 1,624,796.87
Dominion Government Notes.....	10,830,331.75
Deposit with Dominion Government for security of note circulation.....	\$12,455,128.62
Notes of and Cheques on other Banks in Canada.....	4,171,844.16
Balance due from other Banks in Canada.....	307,424.50
Balance due from Agents in the United Kingdom.....	97,551.62
Balance due from Agents in Foreign Countries.....	2,497,522.89
	2,345,084.93
	\$22,754,556.72
Cash Reserves—36 1-5 per cent of Liabilities.....	\$ 566,986.99
Dominion and Provincial Government Securities.....	1,519,307.72
Loans to Provincial Governments.....	
Canadian Municipal Securities, and British or Foreign or Colonial Public Securities other than Canadian.....	4,197,948.27
Railway and other Bonds, Debentures and Stock.....	730,152.68
	7,014,395.66
Call and short loans on stocks and bonds in Canada.....	3,135,507.37
Call and Short Loans on Stocks and Bonds elsewhere than in Canada.....	2,000,000.00
Total Liquid Assets—55% per cent of Liabilities.....	\$34,904,459.75
Other Current Loans, Discounts and Advances.....	40,502,609.92
Overdue Debts (loss provided for).....	71,105.93
Real Estate (other than Bank premises).....	97,252.72
Mortgages on Real Estate sold by the Bank.....	468,597.25
Bank Premises, including Safes, Vaults and Office Furniture, at Head Office and Branches.....	1,900,000.00
Other Assets not included under foregoing heads.....	20,082.53
	\$77,964,108.10

D. R. WILKIE,
General Manager

E. HAY,
Assistant General Manager.



MANY BRANDS OF BAKING POWDER CONTAIN ALUM WHICH IS AN INJURIOUS ACID. THE INGREDIENTS OF ALUM BAKING POWDER ARE SELDOM PRINTED ON THE LABEL IF THEY ARE, THE ALUM IS USUALLY REFERRED TO AS SULPHATE OF ALUMINA OR SODIC ALUMINIC SULPHATE.

MAGIC BAKING POWDER CONTAINS NO ALUM

THE ONLY WELL-KNOWN MEDIUM-PRICED BAKING POWDER MADE IN CANADA THAT DOES NOT CONTAIN ALUM, AND WHICH HAS ALL ITS INGREDIENTS PLAINLY STATED ON THE LABEL.

E. W. GILLETT COMPANY LIMITED
WINNIPEG TORONTO, ONT. MONTREAL.

You saw this advertisement in this magazine. Don't forget to say so when writing.

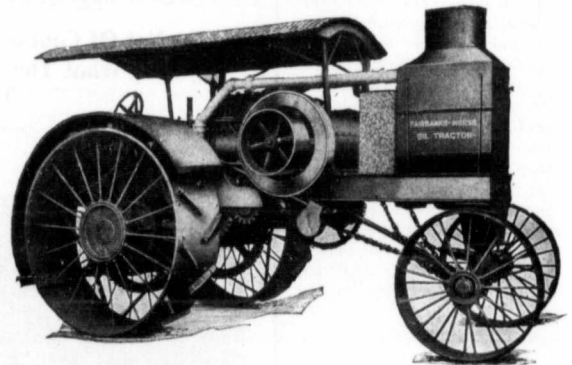

FAIRBANKS-MORSE OIL TRACTOR

In All Ways Best For Canada's West
Dependable, Economical and Fully Guaranteed. Booklet FREE on Request.

WE MANUFACTURE

Fairbanks-Morse Oil Tractors, 15-30, 20-40, 20-40 H.P. Gasoline Engines (all types), Portable and Stationary, 1 to 500 H.P. Marine Engines, 2 and 4 Cycle, 1 to 4 Cylinders. Binder Engines, adapted to all makes of Binders. Hand and Power Pumps for every purpose. Truck and Pitless Wagon Scales.

The Canadian Fairbanks-Morse Co., Limited
WINNIPEG - REGINA - SASKATOON - CALGARY
Montreal - St. John - Ottawa - Toronto - Vancouver - Victoria

You saw this advertisement in this magazine. Don't forget to say so when writing.

Acetylene Headlights for Traction Engines

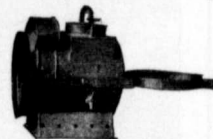

Complete in one apparatus. The best on the market. Indispensable for plowing at night or moving over rough fields, and bad roads. Attachments for all makes of engines. Projects a light 400 feet. Will not jar out. Runs ten hours with one charge. Write for catalog. Agents wanted.

AMERICAN ACETYLENE STOVE CO.

510 Masonic Temple

MINNEAPOLIS, MINN.

You saw this advertisement in this magazine. Don't forget to say so when writing.

La Compagnie Desjardins Famous Small Threshing Machines

"THE CALL OF THE WEST" Sold by

A. STANLEY JONES :: North Battleford, Saskatchewan

General Sales Agent for Saskatchewan and Manitoba

Offices: "The Industrial Spur East" Phone 223 and 220

Prices from \$425.00 to \$680.00 including engine, separator and all belts, carriage paid to any point in SASKATCHEWAN. It can all be mounted on one good wagon complete. Capacity from 400 of wheat to 600 or 700, and of oats from 700 to 1500 and more according to size taken. The \$680.00 outfit will easily thresh 600 of wheat and as much as 1500 of oats if in average grain and fed properly, although only sold to thresh 600 to 800 of grain. If you have any size farm your usual threshing bill will be more than your payment on this machine. La Compagnie Desjardins have made these machines since 1864 and were the original makers of the Champion, but owing to the makers of other machines calling their Champions we have called ours by what it proved to be last year—

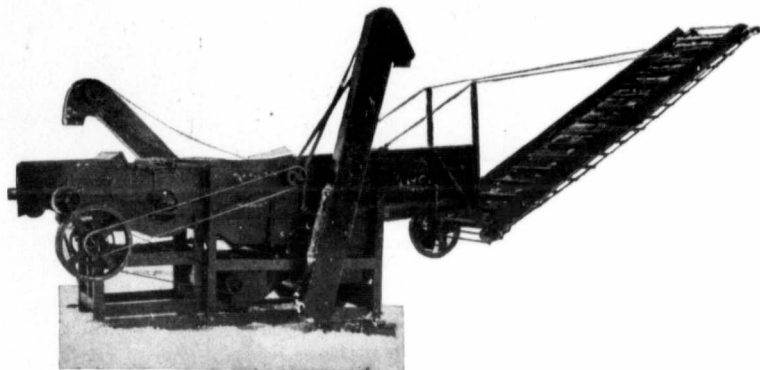

"THE CALL OF THE WEST"

We make every bit of it. Don't buy any other machine or any sort of small outfit till you have had my prices. Outfits on show in running order at North Battleford. Drop a card RIGHT NOW.

You saw this advertisement in this magazine. Don't forget to say so when writing.

FORAGE crops include those plants the roots, stems, leaves or seeds of which are used for animal food. As ordinarily used, this term applies only to the "roughage" and does not include "concentrates" or seeds. We shall have in mind the latter meaning in our discussion of this subject in its relation to Saskatchewan Agriculture.

There are several means of providing summer forage for dairy cattle: 1. Pasture, including native or virgin pasture, annual pasture and semi-permanent pastures of improved or cultivated grasses.

- 2. Soiling Crops.
- 3. Ensilage.

Pastured land produces less forage than cultivated land, but since the cost of production is very much less the pasture continues to be used to furnish a large part of the summer forage for dairy cows, particularly where land is cheap or native pasture abundant. The commonly used pasture plants do not produce large returns under semi-arid conditions, and we find, therefore, that the productiveness of pastures in the plains areas of our province is short lived. The yield of forage, as of wheat, is limited by the precipitation. Our best pastures, both native and im-

~~~~~

### Forage for Dairy Cattle

JOHN BRACKEN.  
From an address given before the Saskatchewan Dairymen's Convention at Saskatoon in February, 1913.

~~~~~

proved, are found in the northern and eastern parts of the province where the rainfall is greater.

The native grasses and legumes furnish rich and palatable food for stock and the forage of the virgin prairie or park land should not be despised by the stockman. Our native pastures are often mismanaged and there is little that can be done to improve them once they have been destroyed by over-grazing early in the spring and late in the fall for a number of years. In such pastures the more palatable grasses will generally be found to have given way to the coarser, more persistent types or even to worthless forms such as wormwood or other weeds. The life of a native pasture may be prolonged by judicious management, keeping the cattle off it in early spring and late fall and never allowing it to be cropped off too close. This is particularly important on areas that for various reasons may not be suitable for cultivation.

as yet with grasses or grasses and clovers for pasture purposes. The little that has been done leads us to believe that our two best hay grasses, Western Rye and Brome, should also form a large part of the pasture. The latter is a better pasture grass than the former, but its use should probably be confined to the open plains areas and drier parts of the province. Other good pasture grasses that might be mixed in small quantities with one or other of the above, are Meadow Fescue, Red Top and Kentucky Blue. In feeding value, Red Top is inferior to either of the other two, but in moist, low lying areas, yields considerably more than Kentucky Blue. Of the clovers, White or Dutch is perfectly hardy, Alsike semi-hardy, and Red even less hardy than Alsike. White Clover is a perennial, Red a biennial usually, and Alsike is of intermediate duration. Small amounts of each or all of these increase the cost of the pasture, but also increase the amount and quality of it. White and Alsike are more suitable for permanent pastures than Red, on account of their greater hardiness and longer duration. The clovers are better suited to the more moist north and east and it is quite probable that alfalfa will be

Annual pasture crops are relatively expensive, but yield much more pasturage than permanent ones. Generally speaking, they should not be included in the permanent cropping plan of a dairy farm, on account of the expense of production and the waste in pasturing. They, however, serve a useful purpose in furnishing green succulent food at a time in the summer when other pastures are short and brown from want of moisture. When labor is scarce and expensive, annual pastures may take the place of soiling crops in supplying green, succulent food in the dry season.

Among the crops suitable for annual pasture are Winter Rye, Beardless or Success Barley, Oats or Oats and Pease, and the Millets. Oats and Winter Vetch furnishes a good yield of excellent forage, but the cost of the vetch seed is rather too high to warrant its extensive use.

Very little experimental work has been done in Saskatchewan

ING
HIGH
IN-
ING
ITED
THE
TO
OR

ER

IUM-
E IN
LUM,
NTS

FED
REAL.

ring.

ring.

E

est
klet

oline
o En-
to all
truck

ited
ARY
toria

ring.

ines

se best
wing at
und bad
engines.
ar out-
rite for

MINN.

ring.

KEEP YOUR THRESHING MACHINE GOING THROUGH THE BUSY SEASON

If there is one thing more than another which gives the thresherman the right to express himself in plain language, it is an engine breakdown in a busy season with no repairs at hand.

The purchase of an I H C engine or tractor puts you in the best possible position when accident occurs. We don't claim that our machines will not break down, but we do arrange to prevent annoyance to you as far as is humanly possible. Here is our claim. Ask any thresherman or farmer who operates an I H C engine or tractor whether we make good or not.

I H C engines do as much work as any other—often times more. I H C engines and tractors cost no more to operate than any other—in many cases less. I H C engines and tractors are dependable; they rarely give trouble. I H C



local dealers and general agents keep very complete repair part stocks on hand, so that it is possible to keep an I H C engine or tractor in good running order practically all the time.

There is a policy in our business which we refer to as I H C service. It means the selling of machines made as well as such machines can be

made. It means that we stand behind them after we make the sale and see to it that they do the work we sold them to do. Our motto is "Satisfy the Customer." See the I H C local agent and get from him a confirmation of this story. If you are interested in an engine or tractor, he will see that you get complete information, or you can get it by addressing a letter to us.

International Harvester Company of Canada, Ltd.

BRANCH HOUSES AT

Brandon, Man.

Calgary, Alta.
Regina, Sask.Edmonton, Alta.
Saskatoon, Sask.Estevan, Sask.
Winnipeg, Man.

Lethbridge, Alta.

North Battleford, Sask.
Yorkton, Sask.

You saw this advertisement in this magazine. Don't forget to say so when writing.

found a satisfactory substitute in pasture mixtures for the plains.

The three crops best suited for soiling dairy cattle are—alfalfa, corn, and pease and oats mixed. The alfalfa will be ready for cutting by the third week in June generally, the pease and oats soon after, and the corn when dry, warm days of July and early August have lessened the growth of grass in the pastures. These are all quite easily grown. The corn is liable to injury by late spring and early fall frosts and in the northern areas will for this reason not give as good results as in the south or on lighter land. Alfalfa is a perennial crop and will grow quickly after the first cutting is made, unless the season is particularly dry at that time. The green alfalfa is more valuable for milk production, pound for pound, than either of the others, and the pease and oats on account of low cost and earlier maturity, are more popular than corn. All of these crops should, of course, be sown on well prepared land if good results are to be secured.

Ensilage is as yet very little used in Saskatchewan. The most suitable crop for preserving in the silo is corn, and except in the south and southwest it often fails to mature sufficiently to make a good quality of silage. Ensilage

will take the place of soiling crops and tide the stock over periods of drought with no decrease in the milk production. The cost of the silo and the cost of ensilage are factors that will prevent the use of this method of preserving forage on most farms for some time. In the meantime, information will be secured regarding the relative value and cost of ensilage from our more or less immature corn.

The roughage for winter feeding of dairy cattle may consist of any or all of the following:

1. Hay—Native, cultivated, mixed grass and legumes, cereal or millet.
2. Straw from cereals, or fodder from corn.
3. Roots.
4. Ensilage.

When cut at the right time and properly cured, the native upland prairie hay is at least equal to the best cultivated grass hay in feeding value. When it is allowed to become ripe before cutting, its palatability, as well as its digestibility, is lessened, and prairie hay that is frozen when partly green, is of very much less value than the same hay unfrosted.

Of the cultivated grasses, those most suited for hay production in Saskatchewan are Western Rye Grass, Brome Grass,

Meadow Fescue and Timothy. Western Rye Grass and Brome yield more than any others. They are both hardy and drought resistant, and generally Brome yields slightly more than Western Rye. Brome is, however, difficult to eradicate and in the more humid parts, on account of its leafiness, is less easily cured than Rye. Rye should be cut early or the hay will be found to be fibrous and weedy. Meadow Fescue is hardy, drought resistant and produces hay of excellent quality. Timothy is hardy, but ill-suited to the drier portions of the province. It does quite well in the north and northeast, but should not be used alone in the southwest or central part of the province.

For dairy cattle the hay crop should not consist of grasses only, but these should be mixed with some of the clovers. The latter increase the protein content of the hay, thus increasing its value for milk production and flesh formation. It is true that as yet our knowledge of the management of clovers is limited and our choice of varieties restricted, nevertheless, we know that even now some of the legumes can be used with success. White clover, as has been pointed out, is perfectly hardy, but is not suited to hay production on account of

its short growth. Alsike is semi-hardy and in the more moist regions may be used in small quantities in mixtures either for hay or pasture. Red clover is not commercially successful on the plains areas as yet. In the protected parts of the north and northeast it usually does better. A small sprinkling of Red clover seed in a grass mixture is justified by the added quality it will give to the first crop of hay, and by its influence in gradually inoculating the soil, thus making it more suitable for future crops of clover. It is the opinion of some, that lack of inoculation is the principal reason why Red clover is at first not as hardy as we could desire. But while our clovers are not as suitable as we could hope, it has been demonstrated beyond reasonable doubt, that alfalfa has come to stay. Some varieties are perfectly hardy and a pound or more added to the grass seed will be found to give very satisfactory results.

Cereal hay, such as oat sheaves, cut on the green side, is a common form of winter forage for all classes of stock. When cut green, it compares favorably with the best grass hay and when slightly more mature, the straw becomes less and the grain more valuable. This class of hay is available to

Continued on page 67



MOGUL AUTOMATIC LIFT ENGINE GANG PLOW

**SIMPLE
DEPENDABLE
DURABLE**

AFTER putting it to the most rigid tests for strength and dependability, we are glad to offer to the trade our new Mogul Automatic Lift Plow. It is one of our policies to do our experimenting at our own expense, and we never place an implement on the market until we feel that it is mechanically perfect. We believe that the popularity of our line is largely due to this policy.

And so we are offering you the new plow with full confidence in its ability to stand any test to which it may be put.

The P. and O. Automatic Lift is not only a power lift plow, but embraces practically every feature of the Regular Mogul, most important being the individual levers by which the depth of any bottom may be instantly adjusted without stopping the engine, or using a wrench.

THINK

What it means to be able to raise all of the bottoms a trifle when going up a steep grade in order to ease up on the engine.

What it means to be able to raise one of the bottoms over an obstruction without raising all of them.

What it means to raise one or more bottoms instantly when plowing in tough soil where the engine cannot pull all of them.

All of these advantages are found on no other power lift plow, but are possible because of



The Ideal One-Man Outfit

the independent levers on the P. and O. Mogul Automatic Lift.

Other features found on this plow which have proven so popular on the regular Mogul are: Same style of carrying frame; same heavy beams; cone couplings, pin-break; spacing blocks between beams to assure perfect alignment.

In building the Automatic Lift we have adhered to our old policy of strength and simplicity. The power for raising the bottom is transmitted from one of the carrying wheels to a clutch wheel on the cam shaft. When the operator desires to lower the bottoms a slight pull on the rope throws the clutch into engagement, causing the cam shaft to revolve, dropping the bottoms one at a time on a straight line at right angles to the course of the plow, which makes a square land instead of having a saw toothed effect at each end of the field, as is the case with rigid bottom plows.

In raising the bottoms, the operation is the same. From this description it is evident that the matter of operating the plow is extremely simple. The trip ropes can be tied anywhere to suit the convenience of the engine operator, so that he can keep one hand on the steering wheel when tripping the plow.

The platform covers the frame, including the lifting mechanism. This platform is hinged in front, and can easily be raised up to expose the frame for oiling or inspecting the lifting parts.

At the field tests which were held before this plow was placed on the market, men who have worked for years with agricultural machinery were surprised, we might even say amazed, at the accuracy and ease with which the lifting device raised and lowered the bottoms. Each bottom being dropped exactly on time, and when the bottoms were raised, the additional draft on the engine was so slight that the keenest observer could notice no difference in its performance.

The P. and O. Automatic Lift is made in 4, 5 and 6-furrow sizes, and makes the ideal one-man outfit. If you are interested in engine plows, it will pay you to write for more detailed information, which we will gladly furnish upon request.

Bear in mind that this is a P. and O. plow, and that every P. and O. tool is backed by an absolutely unqualified guarantee.

Made By

PARLIN & ORENDORFF CO., CANTON, ILL., U.S.A.

International Harvester Co. of Canada Ltd.

SALES AGENTS FOR CANADA

You saw this advertisement in this magazine. Don't forget to say so when writing.

A Syndicate of Sympathy

One's faith in human nature does at times receive a shock, but in the end, and when we have reached the heart of things, it will be found that after all, human nature is really very kind; is, in fact, under certain conditions the

was to one who in seven short years had built up his little property in the neighborhood, was as nothing to the poignancy of the man's feelings as he contemplated the way in which his faithful brute friends had met their fate.



Mrs. Junkin's Neighbors who helped her to Feed the Boys of the Plowing Bee. Courtesy of the Farmer's Advocate

softest, most pliant and responsive of all things made.

These "conditions" need be nothing more than the simple recurrence of some phase of that experience that comes into every life—"When a feller needs a friend."

There is sufficient of the principle of good even in the worst of men to disarm all hostility in the hour of disaster. However, the wicked may "spread himself like a green bay tree" and ride roughshod over every neighbor, even the most vindictive of men cannot withhold some measure of sympathy when he is struck down and held by the heel of calamity.

If it is so in the case of the "wicked," what will not ordinary men do, and feel in inexpressible sympathy for a good neighbor when he is suddenly overtaken by misfortune?

George Junkin, farmer of Sanford, Manitoba, had a taste of this the other day which he will never forget or fail to pass on however long he may live; neither will any of the press boys (among them the writer) who, by the good offices of Alick McCurdy, had the privilege of witnessing what took place. The simple facts are these.

Early on Tuesday morning May 20, George's barn containing 17 head of fine draft horses (ten of which he had bred himself) and six head of cattle was completely wiped out by fire. Left safe and comfortably bedded for the night by his own careful hand but a few hours before, he was awakened to find that not a shred of his barn and its priceless contents were beyond the reach of the flames.

The financial loss, great as it

\$500 insurance on the building was the only monetary redress he had, but that unhappy circumstance did not break his sturdy determination to bury his regrets and strike out anew.

And his neighbors did not waste any time whatever in tearful requiems over their friend's bereavement. Hardly had the intelligence been flashed around when it occurred to some of them that as the only "help" George's independence wanted was just the means to help himself, they put their mouths and their ears together over the telephone, and before sundown every man who could be reached had willingly committed himself to a friendly conspiracy of which George was to be the "victim."

The "plot" was to get their teams and their implements to George's farm next day, do the plowing and the seeding (already belated) and now brought to a



After Lunch. Lined Up for the Camera.

standstill so far as his own means would enable him to cover the land. Not a man said "nay," and only one neighbor was amissing from the round up, solely because of sickness in his team.

Tom Rodgers, E. J. Heney, J. C. Elves and John Blanco became a self-constituted Council of War, and when the press boys arrived at the lunch hour, the farm yard was packed in every corner with heavy draft horses munching their mid-day meal with an instinctive knowledge of the grand work in which they were taking part and looking the picture of eagerness to get to it again.

The little home was crowded with lusty, hungry fellows, and a brave little army of hustling women were piling anew the fast clearing tables with every wholesome eatable and liquid refreshment one would expect to find at a farm home. It looked as if a marriage feast or the home-coming of the bride was in progress; it looked anything but a house of mourning, least of all did it bear the impress of a funeral.

By an official census made on the spot, exactly 78 men were present—ranging from the plow-boy of 14 to the grey bearded veteran of three score and over. Something like 250 horses responded to their names and when lined up on the field there were 49 gang plows at work, six seeders and four sets of harrows.

It was a brave sight and one which cannot be outlined by any language that has ever been constructed to convey man's thoughts. Metaphorically speaking, one did not have an adjective to his back, but he felt a lump in his throat now and again, and a tear of gladness that could not be repressed as he contemplated the wealth of kindly feeling in the unselfish zeal of these great-hearted sons of the soil.

When all was done, over 150 acres had been prepared for or actually laid under crop. There was no flag-flying or public utterance of any sort. Plain folk and especially the rank and file of Canadian life don't find expression to their feelings at such a

time in set speeches or votes of thanks. One of their pet aversions is to be "caught in the act" of rendering a neighborly service, and to find it gibbeted before the eyes of the world.

Oil Your Engine Cylinders With A

PRACTICAL FORCE-FEED OIL PUMP

"The Great Cold-Weather Lubricator"

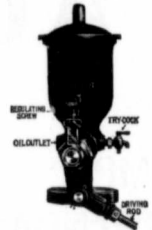

Note how simple it is constructed.

It has no ratchet wheel, pawls, springs or anything of that sort, and has only two working parts that do the pumping, the rocker shaft and pump plunger; the shaft rocking back and forth carries the oil from the reservoir to the outlet and the plunger screwing in and out does the pumping. Nothing could be more simple—the entire pump can be taken apart and put together in ten minutes, a monkey wrench the only tool needed.



The rocker-shaft and pump plunger. These two pieces do the pumping.

You can pipe from either side of the pump, whichever way is more convenient. The pump has ample feed capacity for and can be used on any engine of any make or size, single, double or compound. Not affected by changes in temperature—will work equally as well in extreme cold weather as in hot weather. Nothing to freeze—no draining to be done.

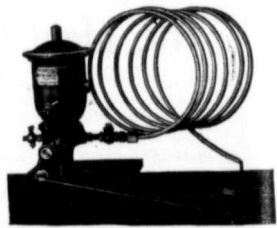

Pumping frozen cylinder oil through 16 ft. of tubing; a demonstration which proves its superiority as a cold weather lubricator.

The Oil bowl is easily filled—just lift off the lid and pour the oil in. Feed is regulated while engine is running. Adjust the feed, keep the oil bowl filled and the pump does the rest.

Sold with or without sight-feed attachment.

Write for catalog, prices and full information.

McCullough Manufacturing Co. Minneapolis, Minnesota, U.S.A.

CRANE & ORDWAY CO. WINNIPEG MAN.

Distributing Agents for Western Canada

Mention this magazine when writing advertisers

Forage for Dairy Cattle

Continued from page 66

all and where a plentiful supply of grass hay is not procurable, oats or barley may be grown. The quality will be much improved by adding an equal quantity of field peas to the oats. On heavier soils or on fallow, this amount of peas should perhaps be reduced in order to lessen the danger of lodging. On the other hand, it may be increased for lighter soils and on spring or fall plowing.

The millets are not popular for the reason that they are annuals. They, however, furnish quick growing, heavy yielding "catch" crops and are frequently useful in dry seasons when the hay crop promises to be short. They can be sown late and still give large yields. Among the best varieties are Hungarian, Kursk, Siberian and common.

But winter forage for dairy cattle is not satisfactory without some form of succulent feed. This can be supplied by using either roots or ensilage. Both of these foods come at considerable cost per acre, but at low cost per ton. Corn under good management should yield 10 to 20 tons of green forage, mangels 15 to 35, turnips the same, and sugar beets and carrots from 5 to 15. Larger yields than the largest of these have been reported from Indian Head. On our farm here the largest yields above mentioned have been surpassed without the aid of fertilizers. It should be remembered that these crops, carry approximately nine-tenths of their weight in the form of water, and that, therefore, the yields should not be compared with the "dry weight" of the hay crop. Nevertheless, "succulence" in winter forage is a valuable quality and it can only be secured by using succulent feeds such as roots or ensilage.

Calgary Fair

Visitors at the Calgary fair this year will be treated to one of the best arranged list of attractions which this exhibition has ever presented. Music by the 91st Highlanders' Band of Hamilton and some of the best Western bands in addition to the famous Titus Grand Opera Quartette will appeal to the lovers of melody. Two diving horses, one of which takes a daring plunge into a tank of water with a lady on its back, will furnish a thrill which will be remembered. Ramona Ortez does things on a slender steel wire that the ordinary person would not attempt on a six foot sidewalk. These are only a couple of the nine big acts which will be imported for the exhibition.

FARQUHAR THRESHERS

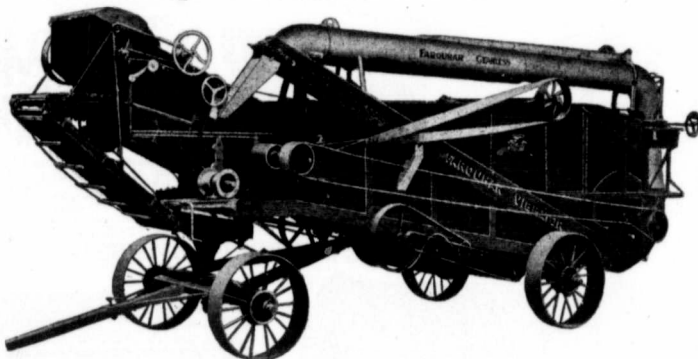

Handle all grains perfectly. Made in 3 styles, 20 to 40 inch. Work Fast, Run Easy, Save Power, Separate Clean, Have Fewer Parts, Outwear Others. Send for Free Illustrated Catalogue.

THE CANADIAN FAIRBANKS-MORSE CO., LIMITED
 WINNIPEG REGINA SASKATOON CALGARY
 Montreal St. John Ottawa Toronto Vancouver Victoria

You saw this advertisement in this magazine. Don't forget to say so when writing.

Concrete is the best building material

A BROAD statement—Yet literally true. The aim of man from the beginning has been to make his building materials as nearly like natural stone as possible. The great labor required to quarry stone led him to seek various manufactured substitutes. The only reason he ever used wood was that it was easiest to get and most convenient to use. Wood is no longer easy to get. Like most building material, its cost is increasing at an alarming rate. The cost of concrete is decreasing. So, from the standpoint of either service or economy, Concrete is the best building material. Canada's farmers are using more concrete, in proportion to their numbers, than the farmers of any other country. Why? Because they are being supplied with

Canada Cement —



Without this label it is not "Canada" Cement.

Write for our Free 160-page book "What The Farmer Can Do With Concrete" —No farmer can afford to be without a copy.

Canada Cement Company Limited - Montreal

You saw this advertisement in this magazine. Don't forget to say so when writing.

ENGINEER with papers, wishing a job on gasoline plow. Reply, stating wages to, Clifford Jordan, 223 Smith St., Winnipeg. Mention this magazine when writing advertisers.

GASOLINE ENGINEER seeks position, international preferred. State wages. Apply, Box 3164, Winnipeg. Mention this magazine when writing advertisers.

FOR SALE—1 Hart-Parr gas engine, 25-45 h.p.; good condition, plowed less than 200 acres. \$1,800 F.O.B. Stonewall, Jno. Harmer Estate, 182 Princess St., Winnipeg. Mention this magazine when writing advertisers.

FREE TO THRESHERMEN Our Large Catalog of Supplies Write for it Today



Our "Veteran" is the best, strongest and heaviest canvas belt on the market. Fully guaranteed.

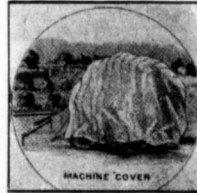

Our prices on Canvas Covers are very low. Get them at once.



Washington's Superior Pulley Covering consists of canvas and a specially prepared cement. Is more durable than a leather covering. Put up in outfits of 3 different sizes.

- No. 1—Sufficient for 50 sq. feet. \$12.00
- No. 2—Sufficient for 20 sq. feet. 6.00
- No. 3—Sufficient for 10 sq. feet. 3.50

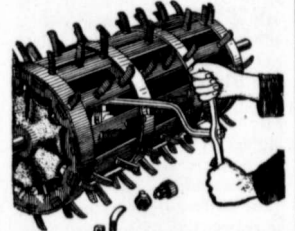

Tiger Adjustable Ratchet Cylinder Wrench. Quickly pays for itself. Fully warranted. Our price, only \$2.00

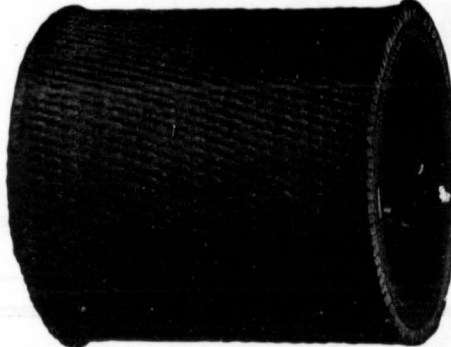

Our price for the best 2-in. Canvas Covered Suction Hose with woven jacket is only 60c. per foot. Plain 2-in. Suction Hose, only 37c. per foot.



Headquarters for Galvanized Steel Thresher Tanks. Write for Catalogs giving full description and prices.

Send for Catalog Do It Now It means Dollars in Your Pocket

Windsor Supply Co., Windsor, Ont.

You saw this advertisement in this magazine. Don't forget to say so when writing.

OWING to the success of the experimental alfalfa plots sown under the direction of the Provincial Department of Agriculture during the year 1911, the Minister of Agriculture has thought it advisable to continue the experiments this year. It is thus hoped to provide a thorough test in every district in the province.

From ten to fifteen different fields will be sown this year, representing a range of soil from the stiff clay loams of the Red River Valley, at an altitude of between 700 and 800 feet, to the lighter soils of the Souris plateau. It is intended to test the growing of alfalfa even on the highest portion of the Riding Mountains at an altitude of over 2,000 feet.

The results of these experiments will undoubtedly establish the status of alfalfa-growing in Manitoba and the range of the Department's efforts will enable every farmer in every district to ascertain whether or not alfalfa will prove a success with him. Besides accomplishing this, the alfalfa plots of the Department will place inoculated alfalfa soil within easy reach of every farmer. To obtain it from near-by farms instead of from the Agricultural College at Winnipeg or the Experimental Farm at Brandon will mean the elimination of long hauls; hitherto about the only two sources of supply in the

Better Farming in Manitoba Official Tests Being Undertaken on behalf of the Manitoba Farmer's Pocket-Book are of Vital Interest to Every Farmer in the Province

Province have been the Agricultural College and the Experimental Farm.

During the past month plots for the growing of fodder have been established at St. Pierre Jolys, Binscarth and Dougald. In addition to these, the Minister has decided that it is advisable to attempt the growing of alfalfa seed in Manitoba. Decidedly interesting is the fact that over half a million dollars is annually sent out of the country to foreign parts for the purchase of alfalfa seed which, Hon. Mr. Lawrence believes, can be produced equally well by the farmers right here in Manitoba. This is a saving which alone justifies the Department in conducting the most exhaustive experiments.

For testing the growing of alfalfa seed, therefore, ten acres of farm land, belonging to J. H. Irwin, of Neepawa, were selected and purchased by the Department. They have been sown with the highest grade of alfalfa seed in rows from thirty to thirty-six inches apart. This plot will be cultivated between the rows and hoed between the plants in the

row to ensure the product being perfectly free from weed seeds.

While travelling through the Neepawa district in search of a suitable field for the above seed-growing test, Mr. S. A. Bedford, Deputy Minister, noticed that certain forms of couch grass were very prevalent and that farmers were complaining bitterly of the difficulty in eradicating it. The Deputy Minister therefore selected ten acres which were badly infested with couch grass and a practical demonstration in the eradication of this noxious weed will be undertaken by the Department.

This land was plowed last week, harrowed, disced and packed and each day's plowing was sown before night with six-rowed barley, three bushels to the acre. It is expected that this will give a prompt and strong germination of barley and will result in choking out the couch grass, at the same time producing a good crop of barley.

The farmers of the Neepawa district are taking a great interest in the experiment and it is to be hoped that it will prove a suc-

cess and lead the way to a better system for the eradication of this weed.

The particular couch grass prevalent in the district mentioned is known as "sweet grass." There are two other forms of couch grass with which Mr. Bedford proposes to experiment during the year.

The manner in which the Provincial Department of Agriculture and the Manitoba Agricultural College are being conducted is highly commendable. If a list of all the different avenues of effort being expended were to be compiled it would represent a sum of tangible results that would perhaps be no less surprising than gratifying. The point is that the work is of a very practical nature, and it is the practical which is of use to the Manitoba farmer. It is therefore a source of satisfaction that so practical and experienced a man as Mr. Bedford is Deputy Minister to a man as wide-awake as Hon. George Lawrence has proved himself to be. With such men in the Department under whose jurisdiction falls that important institution, the Manitoba Agricultural College, the best interests of the Manitoba agriculturist will be properly looked after, and in this connection President W. J. Black of the Agricultural College also provides efficiency that rounds out a perfect organization.

1913 MADE-IN-CANADA

Exhibition Tour

COME SEE WHAT CANADIAN WORKMEN ARE MAKING

THIS is the most realistic demonstration of Canada's advance to leadership in manufactures. What the Agricultural shows prove of the Dominion's pre-eminence in the fields—the Made-in-Canada Exhibition Train does for her development in the Factories.

TEN CARS FULL OF INTERESTING EXHIBITS

From the leading Canadian Manufacturers we have gathered exhibits of what is newest and best for farm and home. Just a walk through the train will be an education and delight. Make especial note to see the Exhibit of Produce from the Mixed Farming Districts of Ontario.

EVERYONE WELCOME

ADMISSION FREE

The Made-in-Canada Tour was a tremendous success last year in every town on the route. Don't miss it this year! It has been improved in many ways.

MAKE THE EXHIBITION A FAMILY HOLIDAY

There will be FREE MOVING PICTURES and LANTERN SLIDES. Nearly 100 Fascinating Exhibits.

TIME TABLE

June 11	MACKLIN, LUBELAND, KERROBERT, PLENTY	June 15	HANLEY, DUNDURN, SASKATOON, KOSTEEN, DUCK LAKE, PRINCE ALBERT, LANGHAM, RADISSON, NORTH BATTLEFORD, BATTLEFORD, LASHBURN, LLOYDMINSTER, VERMILION, YEGREVILLE, HILLIARD, LAMONT,	June 21	FORT SASKATCHEWAN, EDMONTON, CAMROSE, NEW NORWAY, MIRROR, ALIX, TOFIELD, HOLDEN, VIKING, WAINWRIGHT, UNITY, SCOTT, BIGGAR, ASQUITH, WATROUS.	June 27	NOKOMIS, REMANS, KELLIHER, MELVILLE, YORKTON, CANORA, KAMSACK, TOGO, ROBLIN, GRAND VIEW, GILBERT PLAINS, DAUPHIN, GLENELLA, GLADSTONE, PORTAGE LA PRAIRIE, WINNIPEG, (Unload).
" 12	ROBETOWN, BOUNTY, CONQUEST, OUTLOOK, HAWARDEN, ELBOW, TUGASKE, BROWNLEE, KEILS, LUMSDEN, CRAIK, DAVIDSON,	" 17		" 23		" 28	
" 13		" 18		" 24		" 30	
" 14		" 19		" 25		July 1	
" 16		" 20		" 26		" 2	



DON'T MISS THIS UNIQUE TREAT!

You saw this advertisement in this magazine. Don't forget to say so when writing.

Supplies
Wrench
Catalog
It Now
means
Dialers in
Your
Pocket

Ont.

to a better
ion of this

ch grass
rict men-
et grass.
forms of
Mr. Bed-
ment dur-

the Pro-
Agricul-
Agricul-
conducted

If a list
ues of ef-
ere to be
resent a
ilts that
s surpris-
e point is
ery prac-
practical
Manitoba
a source
practical
as Mr.
ister to a
as Hon.

proved
h men in
whose ju-
rtant in-
Agricul-
interests
urist will
t, and in
at W. J.
l College
y that
nization.

An example of the initiative which justifies this meed of praise is found in the proposal which the Department is making to establish a number of Boys' and Girls' Clubs throughout the farming community. These Clubs will compete in the growing of grains and vegetables and in the production of poultry, the products being shown at Juvenile Exhibitions in the fall. It is expected that by this means interest in farm life will be stimulated among the young people and that the tendency of the day to drift toward town will be checked. One of these Clubs has already been started at Starbuck and it is hoped to establish nine others.



"My son wants to marry your daughter. Does she know how to cook a good dinner?"
"Yes, if she gets the materials for one. Does your son know how to supply them?"

Oxy-Acetylene Welding

Save your cracked or broken castings from the scrap heap. We weld cylinders, crank shafts, gears, levers, etc., retain original form and strength at a small cost. Metal added to worn out parts. All metals welded satisfactory.

The Manitoba Welding & Mfg Co.
62, PRINCESS STREET, WINNIPEG

"Alfalfa Inoculation"

Bulletin Issued by the Bacteriological Department and Field Husbandry Department, Manitoba Agricultural College.

The Manitoba Agricultural College investigations show that many of the failures in growing alfalfa in the province are due to the fact that the soil or seed was not inoculated with nitrogen fixing bacteria. These small organisms living in nodules on the roots of the plant, have the faculty of being able to convert the nitrogen of the soil air into a form that can be used by the plant. This is very necessary, as the soil under ordinary conditions is not rich enough in the above element to supply the needs of this highly nutritious legume. It is therefore necessary to have these germs present in the soil, if success is to be insured. In some districts they are found naturally in the soil, but on the average farm they have to be introduced in some way. This point was illustrated quite clearly on several of the demonstration plots in the province. The first year little difference could be noticed in the treated and untreated portions; however, the plant roots on one area produced

nodules, and the plants on the uninoculated tract did not. The second year there was an appreciable difference, the inoculated soil producing much more vigorous plants and giving a higher yield of hay.

There are two ways of insuring this success, or in other words, there are two methods of inoculation. The first is called "seed inoculation with nitro-culture," and consists in applying the bacteria to the alfalfa seed. The germ in this case is grown on a jelly-like substance called gelatine, and is put up in small bottles. There is enough material in each bottle to inoculate 60 lbs. of seed. In using the culture the following rules should be observed:

1. Do not open the bottle of culture until you are ready to inoculate the seed, and do not inoculate more seed at one time than can be sown in a day.
2. The whole contents of the bottle may be used on a small amount of seed without doing harm.
3. To treat the seed, put in a clean dish one pint of sweet skimmed milk and four tablespoonfuls of sugar. Heat the milk to the boiling point, stirring occasionally, and boil it for a minute or two. Let it stand un-

til the milk is cold. If less than a bushel of seed is to be treated, proportionally less milk and sugar may be used.

4. When the milk is cold, pour a little into the bottle of culture, replace the cork and shake the bottle vigorously. Pour this portion of the milk from the bottle back into the dish. Repeat this at least six times. The jelly in the bottle will not dissolve, but should be broken up with a clean stick and mixed with the milk. The bacteria are on the surface of the jelly, hence it is not necessary that the latter be dissolved.

5. Heap the seed on a clean floor or table, pour the mixture over it and mix thoroughly with the hand or shovel until each seed is wet. It is important that this mixing be done very thoroughly so that each seed will be inoculated.

6. Spread the seed in a layer a few inches thick, out of the sunlight, handling over at intervals until it is dry enough to sow. This will not usually take over half an hour.

7. The seed should be sown immediately after treatment.

The second method is known as "soil inoculation," and consists of spreading broadcast on the land which has been prepared for seeding, some soil from a field of

SOME REAL FARMERS' FRIENDS

The Western Wagon Tank



T 44. Made of 20 gauge galvanized steel, 14-in. manhole, 1-in. flange fitted in rear end with plug; tank is securely bolted into steel cradle, with channel irons to fit over boiler, also fitted with side rails to protect tank, on the inside we place slush boards. This is one of the most durable tanks on the market, capacity 350 gallons, shipping weight 550 lbs. Price **\$35.00.**

Tank Pump

CAPACITY 3 BARRELS PER MINUTE

5.95
No other style low-down pump has stood the tests of time like this one. It has the greatest strength. Is the **SIMPLEST**, and handles more water with less labor than any other low-down pump. Can be successfully used for filling thresher tanks, washing out boilers, for use in shallow stock wells, draining cellars or irrigation purposes.
Double acting—draws water on each stroke of the lever. The cylinder is 5 inches in diameter, bored on a lathe and polished; has 2-inch stroke and 2-inch openings for suction and discharge. The plunger is solid; no valves to get out of order. Handles valve-seats, and fitted with drain cocks to prevent freezing. Never wears out. New leathers, easy to replace, make it new. Union Nuts and Attachments are extra heavy and will not break...

T 31. Price complete as shown in cut and including 2-in. round self-fastening strainer, nozzle and hose band. Weight 95 lbs. Price **\$5.95**

Common Sense Flue Cleaner



B 16. The best Flue Cleaner made; it is adjustable to wear, will clean the flues perfectly.
Size, inches..... 1 1/2 2 2 1/4 2 1/2 3
Price, each..... **\$2.00 2.25 2.50 2.50 3.00**

Absolute Satisfaction Guaranteed or Your MONEY REFUNDED

You Cannot Buy The Quality - Elsewhere At The Price -

"Yellow Jacket" Wire-Lined Suction Hose



This is what we recommend for all Tank Pumps, we have perfect hose that will stand the racket of the water. We have found it in the celebrated "Yellow Jacket." It is made of the very best material—a heavy flat wire lining, 4-ply of heavy canvas, and a composition containing more pure rubber than is used in any hose on the market. It is covered on the outside with a tight woven yellow cotton jacket; this outside woven jacket takes all the strain in bending, coiling and handling the hose—making it almost impossible to wear out this hose. It has the cotton jacket, which makes it last three times as long. In 20 and 25-ft. lengths only.

This is the hose we furnish with Tank-Pump Outfits. **T 42.** and **T 43.**

T 28. "Yellow Jacket" 2 in. Wire-Lined Suction Hose. Length, 20 ft.; diam. 2 in.; Weight 50 lbs. Price **\$9.50.** Length 25 ft.; diam. 2 in. Weight 60 lbs. Price **\$12.00.**

1 in. Wire-Lined Injector Hose, length 12 1/2 ft. Price **\$3.00.** 1 in. Discharge Hose, 4-ply. Price, per ft. **15c.** 3/4-in. Water Hose. Price, per ft. **10c.**

Endless Stitched Canvas Belts



T 10. Our "Reliable" Belts are the heaviest and most durable offered. They are made on full weight 32-oz. duck. They are filled with pure lined duck, pressed with the new and improved hydraulic machine process, making the belt exceptionally pliable and durable. They are impervious to heat, cold, steam, gas or acid fumes. All belts will stretch some. The "Reliable" will stretch but little. It is made on a special weave of duck of proper width for each size belt, giving a proper salvage and even strain on both edges. You will find our "Reliable" Drive Belts the best and most durable and pliable you ever used

100 ft., 7 in. x 4-ply....	\$26.00	120 ft., 8 in. x 4-ply....	\$36.00
100 ft., 7 in. x 5-ply....	\$22.00	120 ft., 7 in. x 5-ply....	\$25.00
100 ft., 8 in. x 4-ply....	\$30.00	150 ft., 7 in. x 4-ply....	\$39.00
100 ft., 8 in. x 5-ply....	\$38.00	150 ft., 7 in. x 5-ply....	\$45.00
120 ft., 7 in. x 4-ply....	\$39.00	150 ft., 8 in. x 4-ply....	\$50.00
120 ft., 7 in. x 5-ply....	\$47.00	150 ft., 8 in. x 5-ply....	\$49.00

Catalog of Full Line of Thresher Supplies sent to your address free

Bemis & Call's Pipe Wrench

(Long Nut) **\$1.60**

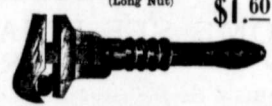

This wrench not only combines the superior quality of a gas pipe wrench, but also all the requisite combinations of a regular nut wrench. The long nut enables you to attain a good grip with the hand, and holds the jaw perfectly rigid. Weights range from 2 1/4 to 4 1/2 lbs. each. Number Size Takes Pipe Each

B 19 12 in. 1/2 to 1 1/2 in. **\$1.60**
B 20 15 in. 3/4 to 2 1/2 in. **2.10**

PENBERTHY AUTOMATIC INJECTOR

B 10. Acknowledged as the best injector on the market, a style left and back.

Style B, for 3/4 in. pipe, each, **\$8.40.**

Style BB for 3/4 in. pipe, each, **\$10.00.**

Style C, for 1 in. pipe, each, **\$13.50.**



Wizard Low Tension Magnetos

Designed for use with single cylinder engines, and are equipped with governor which maintains a constant speed regardless of engine; they are driven by friction of pulley against fly wheel of engine, or can be equipped with belt drive. We send complete instructions for installing our magnetos which include wiring diagram. This is one of the finest magnetos manufactured, and is sure to give satisfaction.

B 21. For Make and Break Engines, **\$14.00.**
B 22. For Jump Spark, **\$15.00.**

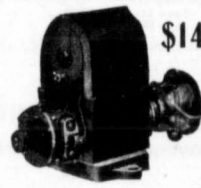

C. S. JUDSON CO., LTD., 181 Market Street WINNIPEG, Man.

You saw this advertisement in this magazine. Don't forget to say so when writing.

vigorous growing alfalfa. There are a few points to be observed when this system is used.

1. Soil should be from a field that is producing nodule bearing alfalfa plants.

2. The soil should be fresh and should not be exposed to strong sunlight or allowed to dry out.

3. Best results are obtained when the soil is applied at time of planting.

4. It is preferable to spread it on a cloudy day and harrow the field immediately.

5. It should not be applied in quantities of less than 100 lbs. per acre.

Both of the above plans have given good satisfaction where care has been taken in doing the work. The first has the advantage where a large acreage is to be sown and there are no alfalfa fields in the vicinity. The cost of shipping large quantities of soil increases the expense of getting a stand of alfalfa. With the nitro-culture there is also less danger of introducing weed seeds. The soil method, however, usually gives better results with the

average grower as there is less danger of sowing dead germs. If the bacteria are living when received, and the directions are carefully followed, there is no reason why the nitro-culture will not give just as good results as the soil inoculation process. Some growers to make things doubly sure, use both methods.

Both the nitro-culture and the soil can be obtained from the Manitoba Agricultural College, Winnipeg. The nitro-culture may be secured by sending an application to the Bacteriological Department, Manitoba Agricultural College, enclosing twenty-five cents, which pays for the postage and bottle. There is no charge made for preparing the culture.

The soil is shipped out in 100 lb. sacks by freight. Individual shipments will be limited to 200 lbs. which will provide enough soil to inoculate two acres. All applications for soil should be sent to the Field Husbandry Department, Agricultural College, Winnipeg. It will cost fifty cents to pay the freight on each ship-

ment of 100 lbs., and a charge of twenty-five cents will be made for each sack; hence a money order to the amount of seventy-five cents should be mailed with each application if a single sack is required. Where two sacks are required, the money order should be increased to one dollar and fifty cents.

Getting Rid of the Weeds

By T. N. WILLING, Saskatchewan University.

The majority of farmers have heard lectures and read bulletins, newspaper articles, etc., on the subject of weeds, but how very few put into practice in an effective way the advice thus showered upon them! They have the opportunities, for the weeds are there at hand to be pulled, harrowed or plowed as may be judged best. Why is there not more effective work? Is there too much blind following of rules and too little consideration given to why one method or another should be adopted? Many fail who mean well.

A weed may be pulled out and cast aside, but that does not always mean that it is destroyed, for many plants have sufficient sap within them to mature the seeds that were perhaps already well filled.

Land may be harrowed and yet not accomplish the desired result, the work having been done at the wrong time, as the weeds have either not started growth or were too well rooted. After plowing for a summer fallow the harrows may not be put on soon enough and the result is a poor seed bed for starting the weed seeds, and clods to prevent effective harrowing later. There may be too frequent harrowing of a summer fallow and no opportunity given for weed seeds to start the growth which is necessary so that we may destroy them. Plowing for summer fallow is frequently begun as too late a date and weeds are left with heads sticking up between the furrows to ripen and increase. Two plowings for a summer fallow sometimes cause seeds to be buried too deeply to grow until brought up by the second plowing.

Continued on page 75

Better Farming Demonstration SPECIALS LEAVE WINNIPEG JUNE 3rd

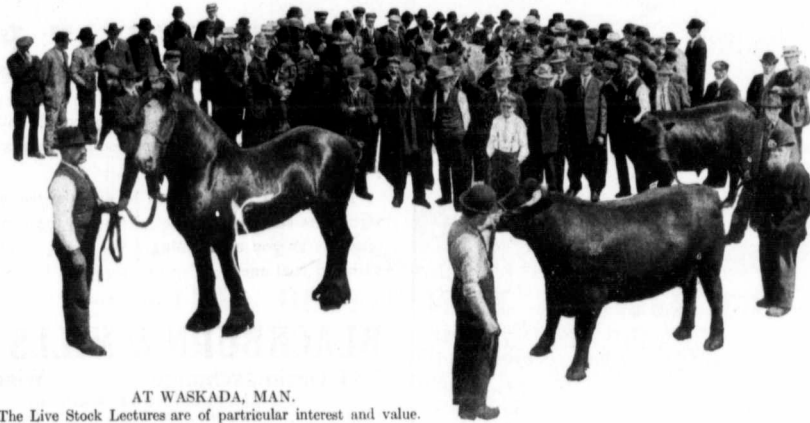

AT WASKADA, MAN.
The Live Stock Lectures are of particular interest and value.

Of Exceptional Interest This Year To Every Farmer And His Family

The Provincial Department of Agriculture takes pleasure in announcing the despatch on June 3rd of a Better Farming Demonstration Special over the lines of the Canadian Pacific Railway within the boundaries of the province and a similar Special over the Canadian Northern lines, leaving Winnipeg on or about the same date. Each train will be on the road three weeks. Local posters will announce the date of arrival at the various stops, and a cordial invitation is extended to every farmer in every community in Manitoba to be at the nearest station with his family when the Special arrives.

The Better Farming Demonstration Specials this year will have many distinctive, interesting and valuable features. No expense or effort is being spared to make their success greater than ever. The staff of the Agricultural College, who will be in charge, are making enthusiastic preparations and the program will be so varied and complete that nobody will fail to be entertained and instructed.

Farm Mechanics

Would you like to see models of up-to-date farm buildings? Is there anything to interest you in a demonstration of modern conveniences for the farm home? Do concrete and engine work mean anything to you?

You will be shown washing machines at work, churns busy, farm water supply, foundation work and building floors, how to produce electric light for the house and many other things.

That boy of yours with the mechanical turn of mind will become absorbed in the baby gasoline engines. Bring him along.

Poultry

Professor Herner of the Poultry Department of the Agricultural College will have a car to himself in keeping with the importance of this industry to Manitoba farmers.

The car will be fitted up with models of poultry houses, incubators, brooders, fattening and feeding crates, shaping boards, etc. Samples of mixed feeds, etc., will also be displayed.

A practical demonstration of killing and dressing poultry will be included at every stop and Professor Herner will be glad to answer any questions which may bear upon the discussion.

Animal Husbandry

On the C. P. R. train special attention will be devoted to Hog Raising and two representatives of six different breeds of hogs will be carried for demonstration purposes. There will also be samples of feeds and charts of feed values to illustrate the discussion which will be of particular value.

On the C. N. R. train lectures will be given at each place on farm horses, dairy and beef cattle and different types of these animals will be carried for practical demonstration.

Field Husbandry

The Field Husbandry cars will be fitted up with samples of weeds, grains and fodders and the subject of rotations and cultivation of all farm crops suitable to Manitoba will be clearly illustrated.

Special emphasis will be laid upon Barley growing for animal feed and weed destruction. How to eradicate weeds and grow a crop of Barley at the same time and how to convert barley into prime bacon will form a basis for an interesting discussion. Questions may be asked and will lead to a discussion of difficulties and their practical solution.

Home Economics

On both the Better Farming Demonstration Specials there will be an entire car devoted to an exhibition of sewing, dress-making and house-furnishing.

Every farmer's wife and daughter should see this Exhibit. The discussion which will take place in the Home Economics car between the ladies assembled will prove exceptionally interesting and profitable.

Other Features

There will be a special Dairy car on the Canadian Northern train, but it was found impossible to carry it on the C. P. R. train this year in view of the accommodation required by the Farm Mechanics and other Departments. The Canadian Pacific train will lay emphasis upon demonstrations and exhibits, while on the C. N. R. special lectures will be given by members of the College staff.

EVERYBODY WELCOME

Watch The Posters

For Exact Date of Arrival in Your District



SINCE early May, the outstanding feature of the Winnipeg market has been the steady rise in the price of contract wheat, despite good crop prospects and extreme bearishness up until a few days ago in American markets, where the winter wheat crop has recently generally deteriorated. While now estimated at 510,000,000 bushels, and still a big one, the winter wheat crop is not yet entirely reaped and will likely suffer some more in the harvesting. What amounts to practically a corner in our May wheat was run here, resulting in the contract grades selling in the last half of the month at prices away above export basis. Still exporters were fair buyers of cash grain, having made arrangements of boat space which they had to fill, rather than be penalized for freight, when, had they no such contracts, they would have been ready resellers at a good profit on this market. Dry weather in Kansas and Oklahoma has been the slogan of the Bulls, and with encouragement resulting from the success of the May corner, there is already a well developed corner in the July option here, and while persistent effort might send July wheat considerably higher yet, farmers holding grain in store or now shipping same should note that our market is in an inflated and therefore unhealthy position, being several cents above export basis. Naturally one asks; what are stocks in our Terminals? On May 31, contract wheat, One Northern, Two Northern and Three Northern, totalled 7,132,614 bushels. The natural inference is that the party operating the July "squeeze" will have big stocks of contract wheat to take care of, especially since seven weeks will yet elapse before the life of the option expires. Selling on these markets therefore seem advisable.

A persistent oversold condition of the market right down to May, probably accounts for at least a good portion of the increase. It cannot be said that the advance is due to export demand, as this has been poor and intermittent for several weeks past, though millers have been fair buyers.

Our 1912 crop inspections to date are slightly less for wheat

than in 1911, but greatly ahead in other grains. They are:

Wheat, 1912	130,379,625 bus.
Oats, 1912	50,113,500 bus.
Barley, 1912	13,527,800 bus.
Flax, 1912,	18,603,900 bus.

Estimates of 1912 crop now range around 178,000,000 to 180,000,000 bushels.

New crop estimates show acreages seeded, as compared with 1912, as follows: Wheat, 4 per cent increase; Oats, 8 per cent increase; Barley, 17 per cent increase; Flax, 21 per cent decrease. Prospects are generally excellent at this date, yet growers should by no means sell their wheat for October delivery at these prices.

While the Continent has been a heavy buyer of wheat for weeks past, she has been taking cheaper American and Argentine wheat. Crop conditions are generally good over there, though reserves are small. Yet it seems scarcely likely they will take much of our wheat at these prices. The weather conditions will henceforth affect the market from day to day.

In coarse grains, steady prices have prevailed, yet it seems as if our oats are too low considering the fact that Chicago oats are about five cents over ours. Moreover, their oat crop has very seriously deteriorated recently. But the Eastern demand for our oats has been slow and stocks have piled up. Large quantities of tough oats which have to sell at a considerable discount have lately been filling the demand. Farmers holding oats in granaries should examine them carefully as all last crop oats are rather juicy and so poor keepers. Oats and barley should be sold on any upturns in prices.

Flax has been held quite steady despite tremendous receipts. Note the inspections above. Yet, now that flax seeding is about over, it seems certain that the flax acreage in the Dakotas and Western Canada are 25 per cent to 30 per cent less than in 1912 and if the farmers sell readily their present holding in the next few weeks, it is likely the big Eastern crushers having acquired the flax, will use the smaller acreage as a good excuse for boosting flax so that they may sell, at an enhanced price, the oil made from the flax they have so advantageously bought.

FARMERS! SHIP YOUR GRAIN

TO THE

CANADIAN ELEVATOR CO. LTD.

GRAIN COMMISSION MERCHANTS, WINNIPEG

It is as much our business to give satisfaction as to secure grain shipments. We watch the grading of each car and allow liberal advances on all bills of lading.

You saw this advertisement in this magazine. Don't forget to say so when writing.

BETTER WHEAT PRICES

The old story again, those who could hold their wheat, are now getting the better prices. More than ever, does it pay to ship your grain.

First class attention paid by experienced men to your consignments sent this House. For very best results phone or write us as you are loading. We have already a host of satisfied customers. Try our service FOR RESULTS.

BLACKBURN & MILLS (A. M. Blackburn) (D. K. Mills)

531 Grain Exchange Winnipeg, Man.

TELEPHONE MAIN 46

Licensed Reference: The Royal Bank of Canada Bonded

You saw this advertisement in this magazine. Don't forget to say so when writing.

UNION BANK OF CANADA

Established 1865

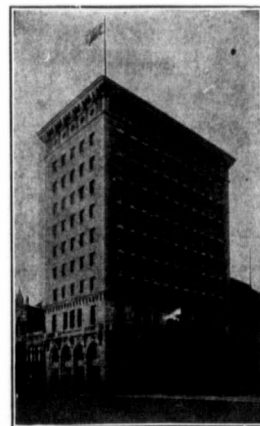

Head Office Winnipeg

Paid-up Capital \$5,000,000
 Reserve and Undivided Profits \$3,375,000
 Total Assets, over 70,000,000
 Hon. President - HON. J. SHARPLES

PRESIDENT - JOHN GALT

VICE-PRESIDENTS
 W. PRICE R. T. RILEY

DIRECTORS

W. R. ALLAN S. HAAS
 S. BARKER, M.P. F. E. KENASTON
 M. B. L. J. CARSON G. P. RILEY
 Lieut-Col. J. CARSON G. H. THOMSON
 E. L. DREWRY W. SHAW
 E. E. A. DU VERNET, K.C.

G. H. BALFOUR, General Manager.
 H. B. SHAW, Assistant General Manager.
 F. W. S. CRISPO, Superintendent of Branches and Chief Inspector.

London, England, Branch No. 51 Threadneedle Street, E.C.

This Bank, having over 300 branches in Canada, extending from the Atlantic to the Pacific Coasts, offers excellent facilities for the transaction of every description of banking business. It has correspondents in all cities of importance throughout Canada, the United States, the Continent of Europe, and the British Colonies. Collections made in all parts of the Dominion, and returns promptly remitted at lowest rates of exchange.

Head Office, Winnipeg.

SPECIAL ATTENTION GIVEN TO FARMERS' BUSINESS Interest Allowed on Deposits. Grain Drafts Negotiated.

Branches and Agencies West of Great Lakes:

Manitoba—Baldur, Birtle, Boissevain, Brandon, Carberry, Carman, Carroll, Clear water, Crystal City, Cypress River, Dauphin, Deloraine, Jansen, Kerrobert, Kindersley, Landis, Lang, Langan, Killarney, Manitow, Melita, Minnedosa, Minto, Morden, Neepawa, Newdale, Nings, Rapid City, Roblin, Russell, Shoal Lake, Souris, Strathclair, Virden, Waskada, Wawanesa, Wellwood, Winnipeg.

Saskatchewan—Adanac, Alsaak, Arcola, Asquith, Bounty, Buchanan, Cabri, Canora, Carlyle, Craik, Cupar, Cut Knife, Esterhazy, Eyebrow, Fillmore, Gravelbourg, Gull Lake, Herbert, Humboldt, Indian Head, Jansen, Kerrobert, Kindersley, Landis, Lang, Langan, Leville, Lemberg, Lumsden, Luseland, Macklin, Maple Creek, Maryfield, Milestone, Moose Jaw, Moomsinn, Netherhill, Neudorf, Ogema, Outlook, Osbow, Pense, Perdue, Plenty, Qu'Appelle, Regina, Roseville, Roseworth, Saskatoon, Scott, Simpson, Simons, Sisseton, Strassburg, Swift Current, Teasler, Theodora, Toza, Tompkins, Vanguard, Viceroy, Wapella, Warota, Watrous, Webb, Weyburn, Wilkie, Windthorst, Wolseley, Yorkton, Zealandia.

Alberta—Airdrie, Alox, Barons, Bashaw, Bassano, Bellevue, Blaskie, Blairmore, Bowden, Bow Island, Brooks, Calgary, Carbon, Cardston, Carleton Place, Carstairs, Clearwater, Consort, Cowley, Didsbury, Edmonton, Fort Saskatchewan, Grande Prairie, Grassy Lake, High River, Hillcrest, Innisfail, Irvine, Lascombe, Langdon, Lebberidge, Macleod, Medicine Hat, Okotoks, Pasmag, Pincher Creek, Seven Persons, Strathmore, Swallow, Three Hills, Wainwright.

British Columbia—Enderby, Hazelton, Nanaimo, New Hazelton, Prince Rupert, Telkwa, Vancouver, Vernon, Victoria.

Winnipeg Branch, D. M. NEEVE, Manager. F. E. WILSON, Asst.-Manager. F. J. BOULTON, Manager Fortage Ave. Branch, corner Garry (adjoining Post Office).

You saw this advertisement in this magazine. Don't forget to say so when writing.

Getting Rid of Weeds

Continued from page 72

and then the weather and soil may be too dry and these seeds, wild oats perhaps, may not germinate until the following spring with the newly sown crop. Such a summer fallow has been a waste of time and opportunity.

Reader—ask yourself these few questions and consider:

Have I weeds in my crop?

Is there any profit in growing them?

If they do not pay for their keep, why am I growing them?

Am I really trying to quit the weed growing habit, or am I content to be called an incompetent and slovenly farmer who grows what he does not want and what no one else wants?

**"He's a Rider!
He's a Rider!!"**

The cry of forced admiration came from a hundred cowboys as Tom Three Persons rode the wild horse "Cyclone." In the competition for the world's championship there had been splendid riding before—men holding miraculously to bronchos that reared and bucked, that dashed forward and came to sudden, body-jerking stops. But there has been nothing like this. It seemed that Cyclone's every movement was anticipated by the Indian on his back. The wild horse swerved, the man was ready for him. As the other cowpunchers watched they realized the prize must go to Indian, and when he threw himself from the saddle, Charlie Tipton, who had himself ridden everything brought forward, remarked simply, as he turned over his quid, "I'll meet you again next year."

All this happened at the Stampede of 1912, and now Charlie Tipton is getting ready to make good his promise. This August the Stampede is to be held at Winnipeg, and Tipton is coming to wrest that title of champion rider from Tom Three Persons if he can. There are huge prizes given for this and other contests, but more than the money what Tipton wants is "to beat the Indian." To Winnipeg Stampede, in August, Ropers are coming in numbers. Henry Gramer, of Kaw City, Oklahoma. Joe Gardiner, from Sierra Blanca, Texas. Rafael Frasto, from Sanora, Old Mexico. The Weir Boys, from Monument, New Mexico. These Weir boys thought themselves the greatest ropers in the world until last year. Then they met Clay McGonigal and Ed. Echols—and well the Weir boys declare they will reserve the decision this year. McGonigal, in the last compe-

DON'T WORRY ANY MORE

About Your Threshing



THIS OUTFIT WILL ANSWER THE PURPOSE

This is our No. 8 Thresher, 28 inch Cylinder, with Straw Carrier, Tailings Elevator and Grain Bagger

Thresherman like this size because it has a large capacity, does a first class job, does not throw any dust to the operator, is strongly made and easy to move

We manufacture this machine to run with 4, 5 and 8 H.P. Engines. We also manufacture the One and Two Horse Tread Powers

WRITE TODAY FOR CATALOGUE
and prices to the manufacturers of the Genuine AMERICAN CHAMPION Threshing Machines

WE WANT A GOOD RESPONSIBLE AGENT IN YOUR DISTRICT

P. T. LEGARÉ, LIMITÉE,

273, 287 St. Paul Street, QUEBEC.

Six Reasons Why You Should Have The Morris Improved Beading Tool



1. Because it can be used in any and all makes of boilers.
2. Because it does not require an experienced hand to operate it.
3. Because it expands the flue at the same time as beading.
4. Because it compels you to treat all parts of bead alike.
5. Because it expands under a spring pressure, allowing flue to upset and reinforce in flue sheet, instead of being crushed away as by other expanders.
6. Because flues beaded with the Morris Improved Beading Tool will last three times as long as flues beaded in the old way.

Dear Sir:—
The beading tool I purchased from you has given me entire satisfaction. I used it in refitting my engine. I consider that by using your Improved Beader on this job only, that I saved three times its purchase price. Every man that owns a boiler should own a Morris Improved Beading Tool. I would not part with it for \$100 if I could not get another.

Yours truly,
CHAS. H. SCHROEN.
Chatsworth, Ill., March 24, 1913.

AGENTS WANTED EVERYWHERE.

BAKER VALVE CO., Canadian Agents : : **WINNIPEG, Man.**

GILSON ENGINE "GOES LIKE SIXTY"



Anybody can operate the simple "GOES LIKE SIXTY" Engine. Ready for work the moment you set it. Built strong and sold to last a lifetime. Will give long, unflinching satisfaction. Gas, gasoline or kerosene can be used for fuel. Gilson quality gives full value for your money—dependable service, great durability, highest economy and perfect satisfaction; freedom from trouble, delays and expense.

Every engine ABSOLUTELY GUARANTEED. You can try this engine on your own farm before setting for it. You take no chance. The "GOES LIKE SIXTY" Line has an engine for every purpose. All styles and sizes from 1 to 40 h.p. Write for catalogue.

GILSON MANUFACTURING CO., LIMITED
66 York Street : : : : Guelph, Ont.

tion threw his steer in 21 seconds. That is, he raced after the steer as it came to the "shoot" whirled his "lariat," caught the brute with a lightening twirl, entangled its legs, and by a jerk threw it to the ground. Then leaping from his horse, he tied securely the legs of the fallen beast.

That in 21 seconds. No wonder an old timer was heard to ruminate, "That boy is right smart."



**Portable
Corrugated
Granaries**

This is the only thoroughbred Granary with a real pedigree.

Write today for full particulars.
WINNIPEG SEILING AND ROOFING CO., LTD.
P.O. Box 2185 G. : : : : WINNIPEG, Man.



Fish Bite Like hungry wolves if you use **Magie-Fish-Lure**. Best fish bait ever discovered. Keeps your lousy pulling them out. Write to-day and get a box to help introduce it. Agents wanted.

J. P. Gregory, Dept. 85, St. Louis, Mo

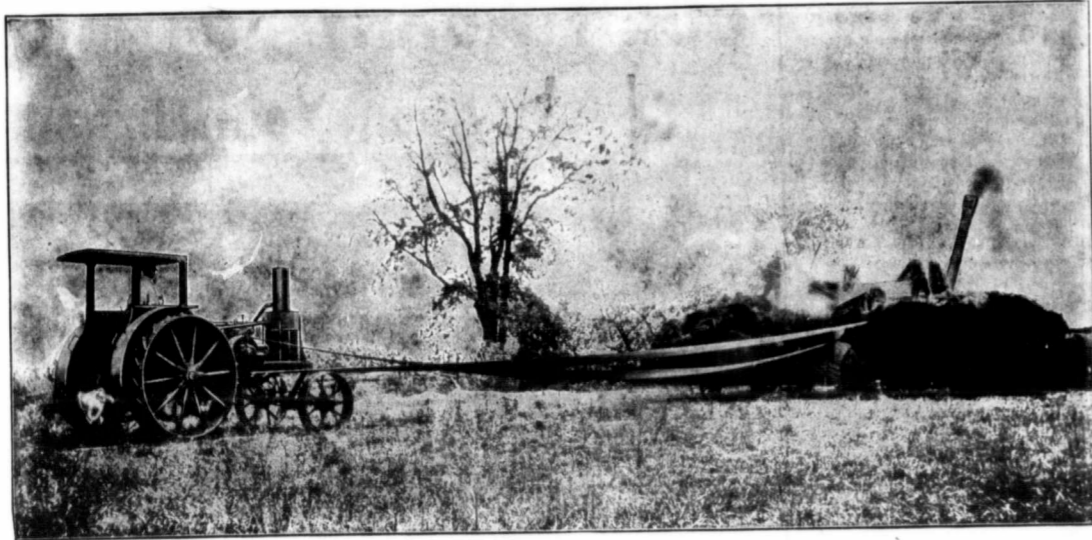

Buy a Machine with Quality of Work and Durability Guaranteed

ONE of the things of most importance to you in buying a machine is the question of how long it will last. It's the policy of the Avery Company to stand right square back of its machines and to give you definite guarantees which you will find in our printed matter. Some of these guarantees are given straight from the shoulder. These guarantees put the Avery Company squarely behind every machine they apply.

Guarantees on Avery Double Under-mounted Steam Engines

We guarantee against breakage for a period of one year following date of purchase, all gearing and shafting, including crank shaft (not only on our plowing engines, but all of our engines). We guarantee to replace, free of charge, not at the factory, but freight prepaid to the owner, anywhere in the United States or Canada, and supply a mechanic, if necessary, free of charge, to install any gearing or shafting, including the crank shaft, broken during any usual or unusual use of the engine, upon receipt of notice that such replacements are required.

All Avery Under-mounted Engines are warranted for one year, or longer, against leaky cap screws attaching any brackets to the boiler, and defects of such nature will be made good free of charge.

Guarantees on Avery "Yellow-Fellow" Separators

Our cylinder is guaranteed to thresh One Hundred Thousand (100,000) bushels of grain without breaking or losing a single tooth, and any replacements necessary to make good this warranty will be made free of charge, and any replacements on account of wear will be made with the same proportionate discount from the list price. Avery Jumbo Teeth are further warranted for five years or longer against breakages caused by pitchforks, bolts, spades or other foreign materials accidentally entering the cylinder.

The Separating Device will shake out 99 52-100 per cent. or more of the loose grain that is in the straw, the grain to be dry and in fit condition to thresh. When desired we will submit the machine to test.

Guarantees on Avery "Light-Weight" Tractors

We guarantee against breakage for a period of one year following date of purchase, all gearing and shafting, including crank shaft, broken during any usual use of the Tractor, and will replace any broken parts free of charge.

Avery Tractors are guaranteed to develop more than their rated horse power either in the belt or on the draw bar.

When you get an Avery machine you know positively that the Avery Company will stand behind it. That's what a man wants when he buys. Write today for complete Steam Engine, Tractor or Separator Catalogue. Use the coupon or write us a letter or postal. Address:

Avery Company, 675 Iowa Street, Peoria, Ill.

Western Canadian Distributors: Haug Bros. & Nellermore Co., Winnipeg, Regina, Calgary

Get An Avery Bull Dog : : Watch Fob : :



It's a Dandy Representation of the Famous Avery Bull Dog Trade-mark.

Send us the lists of names mentioned below, together with 10 cents in stamps or silver, and we will mail same at once.

These are the lists of names to send:

1. List of Threshermen in your neighborhood.
2. List of Plow Outfit Owners in your neighborhood.
3. List of those talking of buying an Engine, Separator or Plow this year (if you know of any).

Names, initials and addresses must be correctly given.

Address your letter as follows:

Avery Company
675 Iowa St., Peoria, Ill.

Avery Company, 675 Iowa St., Peoria, Ill.
Gentlemen—Please mail catalogs checked below:

- Steam Engine
- Gas or Oil Tractor
- Separator
- Engine Gang Plow

Are you in the market?

Name..... Date.....

Town..... State.....

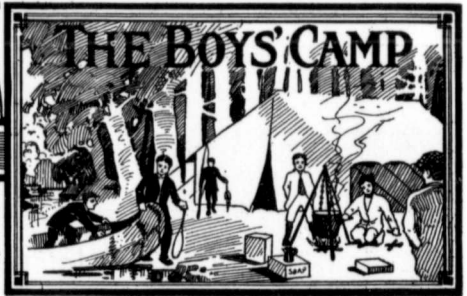

The Coster and His Best Friend



Top Notch of the Horse Show

This is a humble costermonger who makes his living by peddling flowers, fruit and vegetables in the streets of London. He looks a very plain sort of chap and not in the least bit "chesty," although he has won first prize in the great contest for the best bred and the best kept donkey. This is one of London's biggest shows which is held in Regents Park every year on "May Day," and when thousands of the great folks (many of them Lords and Ladies, Dukes and Duchesses) turn out to see what the great-hearted plain people can do in exhibiting the finest horse flesh in the world. The animals are not merely "Show" horses, but are the intelligent, plodding friends of the people, who work hard six days of the week at least for an honest living. The man in the picture has spent nothing on his own get-up but he has decorated his faithful friend with the finest rosette his wife or "gal" could make. If he is afflicted with personal vanity, you can't see any of it, but that honest, serious looking face is the mirror of his soul, and beneath that time-worn waistcoat (short of an unnecessary button or two) there beats a heart as loyal to his four-footed friend and his two-legged "pals" as ever throbbed in human breast. All the world knows that a London Coster will count no sacrifice too great for his work-a-day chum—the "Moke."

Girls' Prize Letter

Cochrane, Alta.
Dear Cousin Doris:—This is the first letter I have written to your club but I read the letters every month and think they are fine. How many members like reading? I love it. I have read four of the Elsie books and am going to send for one or two more and I have read several other ones too. We have been having bad weather lately

but it is lovely now. We have a big family; there are twelve at home and two or three away, so there is a lot of work to do. My sister's husband has a motor car and he runs passengers. I have had quite a few rides in it. I stopped going to school last fall as there was too much work for mother. I was in the fifth class when I left. There are about sixteen going to school now.

How many of the members see any harm in dancing? We have had two or three dances around here at the neighbors' this winter. Last summer when Mother was sick I kept house for quite a while. I liked it all right but there was so much to do, I like cooking the best. I can make quite a few cakes and biscuits. I tried making bread and got on pretty good. I will give the recipe for one or two cakes. For jelly cake, take butter about the size of an egg and melt it a bit, mix one cup of sugar beat two eggs up good in it I cup of milk and two spoonfuls of baking powder and flour enough to make a batter, put in two cake tins and bake in a moderate oven. When baked and cold put some jam between it and mix some icing sugar and cream and spread over the top. This makes a very nice cake. I will give more if this one is all right. We live four miles from town and our school house is about one hundred yards from our door.

We had a concert and a Christmas tree the Thursday night before Christmas, and the school house was packed and refreshments were served afterwards then they sang "God Save the King," and all left for home. We have church in the school house once every Sunday. My father is one of the trustees for the school. Do any of the members do fancy work? I am going to get my aunt to teach me, she does quite a bit of it. They have just got the phone in and they think it is fine. She says it is just like talking to someone at the door. We have had it in quite awhile. Well I hope my letter will escape the W. P. B. sitting over in the corner so I guess I will have to say Good-Bye, hoping to get a prize and wishing the club success. I remain, Yours Truly, Sara Callaway.

Mozart, Sask.

Dear Cousin Doris:—I thought I would write to your club. I am 9 years old. I have 3 sisters and 5 brothers. We have got 14 horses and 15 head of cattle, and thirty-five pigs and about 100 hens. We live on a farm about 7 miles from town. I go to school in summer but I don't go in winter. I would like to see my letter in print and to receive a book. Your cousin, Elsie Isfeld.

Lembar, Sask.

Dear Cousin Doris:—I wrote to your charming club before, but I guess it was lost. I like reading the girls' letters, they are very interesting. The boys' do not seem to be as interested in letters as the girls do.

I am nearly thirteen years old, five feet, three and a half inches tall. We have not gone to school since New Years because we have not had any teacher. I am in grade five. My sister who is two years older is with me. Jennie Gooding says she likes riding horse back for one, and I do for another. We have two horses we can ride. My older brothers and sisters can ride horse back real well.

I will close wishing the club every good success. I hope my letter will escape the W. P. B. I remain your Cousin, Mattie Laughlin.

Lampman, Sask., Jan. 1, 1913.

Dear Cousin Doris:—This is my first letter to your interesting club. My father takes the Thresherman and Farmer. I like to read the girl's Cozy Corner page. I am 9 years old. I go to school. Our school is closed now. Our teacher's name was Mr. MacInnis. I have two sisters. We have a threshing machine (The Aultman Taylor) it is a gasoline one. I lived two miles from town.

We have a telephone and like it. Well I guess I will close. Hope to see my letter in print in the next paper, so good bye, from Gerlie Moynes.

Strassburg, Sask., Jan. 20, 1913.

Dear Cousin Doris:—I have always been reading the letters in your society so I thought I'd let you read my letter. I go to a country school winter and summer. I am in grade V now. I am twelve now, my birthday is on the 24th of December.

I live a mile and a half from a town. I was born in Canada, my parents came to Canada twenty-six years ago. It is very cold now, the thermometer went down to forty-nine; the snow is not very deep around here. We had a snow storm a few days ago.

I have four sisters and one brother, one of my brothers died last winter, my mother's grandfather died a few days ago.

I will close now, wishing your club much success, Christina Moelder.

Reid Hill, Alta., Feb. 26, 1913.

My Dear Cousin Doris: This is my first letter to your Club. My father takes the Canadian Thresherman and Farmer.

I delight in reading the little stories. We live on a farm eight miles from town. Our nearest town is Vulcan. I have two brothers and one sister. We have about forty chickens and ten cows and three hogs and nine little pigs. They are one week and a half old and we have thirteen head of horses. Mamma has thirteen ducks and she is going to trade one for a rooster. We go to school every day. We have a lady teacher. I am in the fifth grade. We drive three miles and one half to school. We go to the Sunny Glen school. Our horse's name we drive is Susie. We can ride her too. Our old dog Hero goes to school with us. We have two cats and three dogs, one little dog Bousser shakes hands and sets up in a corner. My sister and I have two dolls nearly twenty in. tall. My Papa has a threshing outfit. Last summer we had many pretty flowers. My grandpa from Ill. came to see us. "hat fun we had he loved Mamma's flowers and ducks. He is coming this year again. This summer we'll be glad to see him. I will close ending with a riddle. What animal rains down from the sky. Ans. Rain-dear. I will close hoping to get a prize. Mayme Forsyth.

Maymont Sask.

Dear Cousin Doris:—Will you let me join your Cozy Corner. We have taken this paper for a long time but I never got enough courage to write before. We live four miles from Maymont. It is not a big place yet, there are three general stores, two elevators, one post-

office, a station, two livery stables, two churches and two blacksmith shops. My father owns one of them, there is a school there too. I have not been going lately on account of the winter but I will start soon. I am in the fifth grade and my studies are as follows: Reading, writing, spelling, geography, grammar, arithmetic and composition.

This has been a nice winter. I have skated twice. I am only learning. How many of the girls are book-worms. I am for one. I have read a lot of books such as, Little Men, Little Women, Eight Cousins, Jane Eyre, Villet and a lot of others. Mother thinks I read too much. I have read every story book in the house. We have four pets, two kittens whose names are, Nimrod and Cleopatra, a cat called Toot, and a dog called Suavy. This is all for this time so good bye Cozy Corner. I would like to hide the W. P. B. when you see this letter. Your truly, Elna Davison.

Out Knife, Sask., Feb. 1, 1913.

Dear Cousin Doris: I have not written to the Cozy Corner for a long time. I enjoy reading the letters very much. I am interested in cooking and all kinds of house work. My sisters are away so I have quite a lot of experience now. I have only tried making bread several times. Here is a good recipe for chocolate creams: The white of an egg, 1 tablespoon water, 1 teaspoon cream. Stir together but do not beat, add enough powdered sugar to make it stiff enough to knead. Add flavoring. Turn out on a clean board and knead. Mould in balls and let dry. Drop into melted chocolate. It will be ready to eat the next day. To melt the chocolate cut it in bits in a dish then place the dish in a dish of hot water. Use a fork to take the chocolates out.

I have just finished making a sofa cushion. I have another one to make. I am not going to school now as our school hasn't a teacher yet. When I go to school I am in grade VIII. My studies are, Arithmetic, reading and literature, British and Canadian history, geography, spelling, agriculture, drawing and grammar.

My mother, and two of my sisters were out to the mountains this summer. They had a splendid trip.

I am five feet, five inches tall. I am dark complected and I have black hair. I am rather stout. I will be fourteen years old, Easter Sunday. Hoping I will see my letter in print I remain, Your Loving Cousin—Jamett Munsell.

Vegreville, Alta., Jan. 30, 1913.

Dear Cousin Doris:—This is my first letter to your charming circle but I have been an interested reader for some time. I think that "The Girls' Cozy Corner" is a lovely name for our corner. It sounds very cheery and inviting, especially in winter time. I always read the little poems in our corner each month and several of them I have cut out.

I have not gone to school for over a year. I was taking my first year in High School when I stopped. I am staying in at home and studying music and keeping house. Just at present Mother is in Eastern Ontario, visiting and I am keeping house for my father and two brothers. It is quite new experience for me for I never kept house for any length of time before. I get along fine, however, though I get pretty tired at times.

I am very fond of reading and I very much prefer such books as "Rebecca of Sunnybrook," "Little Women" and "Mother Carey's Chickens" to the "Elmer" Books and others of that kind. I always thought "Elmer" was too "weepee" and "goody goody," though their are some who don't agree with me. What do you think, Cousin Doris?

I would like very much if Vera M. Porter would write to me for I liked her letter very much and I think our tastes are somewhat in common. I would be glad to have any of the Cozy Corner Girls write to me and I would answer their letters.

I am very fond of outdoor sports as I think most girls of my age are. Skating and horseback riding are my favorites. There is going to be a Masquerade Carnival in Vegreville soon and I am going to costume as Snow-Shoe Girl. I have taken prizes for riding at our last three fairs.

Say, Cousin Doris, have you ever put your picture in the Cozy Corner? If you have I have never seen it and I would like very much to see it and little Monona's too. How old is Monona? Is she big enough to write a little letter to the Cozy Corner? I suppose not for I imagine her a little bit of a girlie, about two or three years old.

Well I guess I'd better close for I can almost see Cousin D. glancing over this disjointed epistle and then tossing it over into the W. P. B. and honestly I would not blame her if she does.

Well, this is all for this time. Wish me all success to the Girls' Cozy Corner. I remain, Yours Sincerely, Irene Kennedy. Age 14.

(Yes, I prefer the books you mention. No, Monona is too young to write a letter. My picture has never been in the Cozy Corner. C. D.)

Carry, Sask.

Dear Cousin Doris:—Could you Cozy Corners crowd a little closer and make room for me? This is my third letter to Cozy Corner. I have not seen any of my letters in print. So I thought I would try again.

My brother takes the Canadian Thresherman and Farmer. He has taken it for over 3 years and we all like it fine. I have two brothers and no sisters. I am 14 years old, my birthday is the 9th of March. I ride on horse back to school every day. I live 2 miles from school. I live on a farm and we have 6 miles to our nearest town named Parry. We have 10 horses and 5 cows, and a lot of chickens. We have 2 dogs and 4 cats. Well I will close and I hope to see my letter printed. I am your cousin, Helga Malm.

Golden, B. C.

Dear Cousin Doris:—This is my first letter to the Cozy Corner and if you will allow me I will come in for a chat.

I have just read the letters in the Canadian Thresherman. I like reading the letters. I would like to have a dialogue from some of the members, I wish Vera M. Porter would send me hers.

My father is working with the C.P.R. and we are living in one of the houses. I am a bookkeeper. I like it very well. We have an Edison Phonograph. We live a mile from our town. I have got to get a tooth out today. I think I will close for this time for my letter is getting quite long. Your Cousin,—Eleanor Johnston.

Golden, B. C.

Dear Cousin Doris:—This is my first letter to the Cozy Corner. I take great interest in reading the letters. I came from the East to the West. It was nicer in the East than here. We go to Mr. Landell's school now.

We have got a nice Edison Phonograph, and some lovely pieces, we have Warner My God to Thee. It is a lovely hymn. I am eleven years old and I am four feet and a half tall. Would any of the readers send me the song of Casey Jones? Well my letter is getting too long. Hoping to see my letter in print. Emma M. Johnston.

Canora, Sask., Feb. 25, 1913.

Dear Cousin Doris:—This is my first letter to your Club and I hope to see it in the Canadian Thresherman and Farmer. My father gets the Canadian Thresherman and Farmer every week and I like it very much. As soon as we get

it I take it and run with it in the other room and read the Girls' Cozy Corner. I like it very much. We live two miles from town, our school is in the town, but I do not go to school now because it is too cold. It is a little warmer now than it was. The coldest day I think was 36 below zero. All the names of the newspapers that we get are, Canadian Thresherman and Farmer, The Family Herald and Weekly Star, The Canadian Farmer, The Grain Growers' Guide, The Farmers' Weekly Telegram, The Good Stories, The Canada Advertiser, and the Nor-West Farmer. I hope to win a prize too. I will close with a few riddles. What can turn around and will not move. Ans.—Milk. A riddle, a riddle, a farmer's fiddle, alive on both ends and dead in the middle. Ans.—A man plowing. What makes one track around the house. Ans.—A snake. Humpty dumpty sat on the wall. Humpty dumpty had a great fall, all the king's horses and all the king's men, could not put humpty dumpty together again. Ans.—An egg. When is a hen not a hen. Ans.—When she is dead. Black, white and green all over. Ans.—A newspaper. What swims beneath the water and will not drown. Ans.—A fish. Wishing Cousin Doris a happy Easter. Hedwig Hoehn.

Would you draw any drawings if I would send some? Hoping to win a prize. Yes! Send me the best you can draw. C.D.

Rock Dell, Sask., March 3, 1913.

Dear Cousin Doris, I have long been a silent reader so will now ask the girls if they will please move over and make room for a new member. We live on a farm twenty-two miles west of Yorkton and fourteen miles north of Birmingham, which is our shipping point for nearly all our grain for about the past five years as it is a much shorter haul and return trip is quite easily made in one day. The past summer the Canadian N. others surveyed a new line through which crossed two of our quarters to the north a half mile, and is to be completed this season. Our school opens tomorrow again for a year. Has been closed the past two months, but as a rule the doors are kept open all the year. Mr. Scott is to be our teacher. We do quite a bit of ranching here as well as farming. Have seventy-six head of cattle, forty-two horses, sixteen pigs, sixty chickens and three ducks.

There are a nice lot of cherry trees around our place, are very pretty when in bloom. The different kinds of fruit growing here are, raspberries, gooseberries, saskatoons, choke cherries, and nin cherries, and strawberries. We also have a large tame garden of fruit such as plums, apples, black caps, gooseberries and strawberries, which we find very successful and covers a space of at least two acres and I bears very plentiful. The post office is at our place and mail comes through twice a week by stage on Tuesday and Fridays. We have had rather a steady cold winter with lots of snow, which is about four feet on the level, but had very mild weather before the New Year.

My father owns a M. Rumely engine, Sawyer & Massey separator, and Cock-shutt plows, all giving satisfaction. I have four sisters, three of which are married, also seven brothers, four being married. I will close hoping to receive a prize, and wishing the members every success with best wishes to Cousin Doris. I remain, very sincerely yours, Mary Griffith.

Lots of fun may be had at a Vegetable Party with dry beans. For one contest, have a bag bowful of the beans, and let each guest slide his hand through it, trying to pick up as many beans on the back of his hand as possible. When he has all that he can possibly hold, let him run around the room with the beans on his hand. His score will be determined by the number still remaining on his hand at the end of his journey. Give an appropriate prize to the boy and girl with the highest scores.

Lee MacMahan, a twelve-year-old boy, is the champion speller of the state of Oklahoma. He spelled against forty-one picked spellers, and had to spell off 5,000 words in eight hours. He won a gold medal.



Peerless Presentation of the Pioneer Past

A Pageant! A Contest! A Historic Prospective!

- Q The last thrilling panorama of a stage and a day in the history of our country that is disappearing forever. The epic of the frontier, the Saga of the Cowboy—the Benediction of the wild, haunting, mysterious West.
- Q The spirit of the grim, fierce, naked Rockies, frowning from their ramparts athwart a hundred centuries of time. The spirit of the wild, wide, yawning plains. The spirit of the great ribbons of water and the long, lonesome trails.
- Q The spirit of the wind, the buffalo, the Indian, the discoverer, the pioneer, the adventurer, the administrator, the missionary, the statesman, the plainsman, the rider, the railroad, the tractor, the wheat.
- Q The spirit that thrills and pulsates in us and our West today. The Story of Yesterday brought in a whirling, swirling picture of its last truthful reproduction, to Winnipeg.

WINNIPEG
 One Wild Delirious Week
AUGUST 9-16, 1913
 Write for "The Cowboy Dictionary" It's free. Ask your Agent about Rates
STAMPEDE HEADQUARTERS
FORUM BUILDING WINNIPEG
GUY WEADICK, Manager



Womans' Department

Conducted by PEARL RICHMOND HAMILTON

A HOUSEHOLD FORUM FOR THE DISCUSSION OF EVERYTHING THAT PERTAINS TO THE HOME



Life's Lesson

A child came close to his teacher's side,
His book tight clasped in his little hand.

"Teacher," he said, with wistful eyes,
"We're coming to words I don't understand."

I've turned the pages o'er and o'er,
And the words are so big, and they're all so new,

When we come to the lessons where they are put,
Oh, teacher, I don't know what I'll do."

The teacher smiled at the troubled face,
And tenderly stroked the curly head.

"Before we reach them I think you will learn

The way to read them," she gently said;

"But if you shouldn't I'll help you then.
And don't you think that the wisest plan

Is to learn the lesson that comes today,
And learn it the very best you can?"

And it seems to me it is so with us,
We look at the days that are still ahead—

The days that, perchance, may never be ours—
With—a pitiful longing and nameless dread.

But surely the Father who gives the task

Will lovingly watch, as we try to read
With faltering tongue and tear-dimmed eyes.

And will help his children in time of need.

Home Economics

Patriotism

By Mrs. Young of Manitou.

This excellent paper was read at the Manitou meeting of Home Economics Society

When we hear that word, what a motley array of images pass before our mental vision. Yet I fear that for most of us the first pictures are those on battlefields, political declaiming, floating flags, beating drums, perhaps even clamor and bloodshed. We look first to our soldiers and famous statesmen, and our gala day platform speakers. Yet among all our patriotic writings few are so often quoted or so widely popular as those lines by Walter Scott—

"Breathes there a man with soul so dead
Who never to himself hath said, as
home his footsteps he has turned
From wandering on a foreign strand
This is my own, my native land."

"My native land," not necessarily the land where my birth took place, but my home land, the land where body and soul are most truly themselves, the land where the body finds fulfillment of its most ardent desires, and the soul expounds to its noblest attainments. Here am I a part of all things and all things are a part of me.

Yet it is to himself that Walter Scott's patriot expresses his joy in this home land. He may proclaim it to others, but first he must feel it in that inner consciousness which is his trust in being.

Of the more or less silent citizens, must the great body of our patriotic army be found, expressing their loyalty by the manner of their lives, serving silently, almost unconsciously, but serving as truly and as nobly and unselfishly as the men whose deeds are subjects of song and story.

There is no need to mention the value of the patriotic spirit; it is too generally recognized that "the soul is dead" in the citizen who loves not the name of his native land. He cannot love his fellow men or his Creator. "The wretch concentrates all in self," says his own personal advancement, fills his own pockets, let it be at whose expense it may. But there can be no love without service, as service is the fruit of love. So is it its promoter. I love, I serve, I serve, I love.

Perhaps no country has to face the menace of a lack of loyalty as has this glorious prairie land in which we live. The "Lure of the Golden West" brings among us many home seekers, but it brings also many who are anxious to grasp the opportunities she offers to speedily gather together an abundance which in an older land would require a lifetime. Then, having secured this comparative affluence, to pass on to other climes to enjoy it, or go back to the old land, and there set up the home that has thus been made possible. This is the Great West robbed of her rights; so she becomes a land of sojourners.

However we look at this it is bad. The country is robbed, a spirit of unrest is generated in our youth, and the real foundations of the nation are being undermined.

Since time immemorial it has been recognized as necessary that man should have a settled plan of abode. He needs a native land just as surely as the native land needs him.

God gave unto his chosen people a goodly land, that they might enter in and possess it, they and their children and their children's children.

We, too, have given unto us a goodly land. Let us hope that we may enter in and possess it for generations yet to be, that the souls of our citizens may have an abundance of life, and that the land may prosper in the truest sense of the word. In other words may we be able to make it a land of homes—homes wherein are growing up the noble, patriotic citizens who are to make this western prairie the gem of the British Empire.

And this is the great task, as well as the splendid privilege of our women. I do not wish to be misunderstood; our women may add to this what duties they will, for no good work can suffer from a worthy woman's sharing in its accomplishment; but even this is her greatest and best work—this making of good homes throughout our lands, and the rearing therein of noble, patriotic God-fearing citizens.

Happy is the man whose early thoughts are guided into safe upward leading channels, who is taught as Old Nokomis taught the little Hiawatha, who early learns to look for the first wild flower and to welcome each of its successors until autumn frosts tint the leaves, and golden harvests are gathered in, who listens to the first robin's note and the farewell honk of November's wild goose, who knows the habits of the folk of feathers and of fur, and who through these has communion with the great author of them all.

Happy is he who early learns that liberty is not licence, but that law is liberty.

Children take to these things naturally if they are but guided a little. Every home has its rules whether recognized openly or not, and the boy or girl does not find it hard to see that there are mutual agreements for mutual benefit; that they are evidence of man's superiority, of his relationship to God himself. From the little home rules it is only a step to the village or municipal councils, and so on until the ins and outs, as well as the usefulness of government are mastered. The child who has mastered the why of a law will be little tempted to break it. For then human law is merely consideration for fellow men in a concise form; while God's law is guiding hands placed all along our path by a kindly, loving Father, lest we err, and erring, suffer.

In the home, too, should be learned the first lessons of service. The lad who helps his father, who knows his plans, and is encouraged to express his own

ideas, on the farm or in the business, and who having thought and helped shares the benefits is getting ready to take his place in the planning, and helps along the work of the nation.

The girl who helps her mother, who plans for others, and for whom others plan, is preparing for a broad and useful womanhood.

This greatest privilege is ours that we rear a nation of home makers, rendering our people strong and honorable, a nation without a peer. This is our patriotic service.

It was proposed that we hold several picnics next month, the proceeds to go to the rest room fund.

A song from Miss Andrew was a delightful conclusion to the intellectual part of the programme.

Refreshments were served, and a few minutes of social chat indulged in before the members dispersed.

OAK LAKE.

Mrs. Hamilton, Can. Thresherman, Winnipeg, Man.

Dear Madam,—Our April meeting was one of the best we have had—a good attendance and splendid program. The principal items of interest were two addresses given by two local ladies on "Systematic management of the home" and "The place work should have in a woman's life." The addresses were witty, interesting and instructive. We are discovering some splendid speakers among our members.

Nine new members joined, and we had a social hour and lunch together at the close of the program.

Yours truly,
Mrs. Cochrane, Corr. Sec.

WAWANESA.

A number of the ladies of Wawanesa and surrounding district have organized themselves into a home economics society. Several meetings have been held since the convention in Winnipeg in February, and interesting programmes have been carried out. The society now numbers thirty-seven members, and bids fair to becoming larger, as its aims and objects become more widely known.

The last meeting, held on May 3rd, was honored by the presence of Mrs. E. C. Salisbury, Prof. of Household Science, who completed the organization of society, and gave an interesting talk on the lines of work which might be taken up by the members.

The officers are as follows:—President, Mrs. J. Dent; vice-president, Mrs. J. C. Illife; sec.-treasurer, Mrs. J. E. Allison; directors, Mesdames Bertrand, Banting, H. Downie, R. C. Rutledge, J. Mayhew, Sweeney and C. R. Rogers.

MINNEDOSA.

The Home Economics Society of Minnedosa held a most interesting meeting on the afternoons of April 24 and 25.

The Rest Room is not as yet ready for the formal opening, but it was sufficiently far advanced to enable us to hold the meetings there.

The society was fortunate in being able to procure the services of Miss Kennedy and Miss McKee, of the Agricultural College.



A Happy Toiler
A Lancashire Lass who Spins Cotton for the World's Millions

ideas, on the farm or in the business, and who having thought and helped shares the benefits is getting ready to take his place in the planning, and helps along the work of the nation.

The girl who helps her mother, who plans for others, and for whom others plan, is preparing for a broad and useful womanhood.

This greatest privilege is ours that we rear a nation of home makers, rendering our people strong and honorable, a nation without a peer. This is our patriotic service.

MANITOU H. E. S.

Our May meeting was the largest this year. As it came so near Empire Day, "patriotism" was made the theme of two excellent papers given by Mrs. Young and Mrs. Kitson. Though embodying some of the same ideas, the papers were quite unlike and very interesting. The writers agreed that the finest patriotism is shown, not in great military or political achievements, but



BISCUITS MUST BE FRESH
TO BE PALATABLE
MOONEY'S BISCUITS
ARE THE FRESH BISCUITS

Fresh enough to take the place of the bread and biscuits you bake yourself.

Because the **MOONEY** system is so perfect that every biscuit is shipped the same day it leaves the oven.

The big Winnipeg factory is so close that your Grocer gets **MOONEY'S** in a few hours—no long haul—no deterioration.

Besides the demand for **MOONEY'S**—the popular biscuit—is so great that his stock is always changing.

MOONEY'S never grow stale on the grocers' shelves, That's one reason why



MOONEY'S
PERFECTION
SODA BISCUITS

are fresher, crisper and more appetizing.

Ask for the big package or a sealed tin and judge for yourself

"LET MOONEY DO IT"



You saw this advertisement in this magazine. Don't forget to say so when writing.

common beauties land, and his must the finest e—let us

ry Farm-ould help Those ess to do send one. lack was on "Why?" This sent con- members Kennedy's ed with

d several ds to go vas a de- tellectual nd a few in before

sherman, sting was good at- m. The s two ad- dies on he home" ld have sses were ive. We speakers

d we had er at the

rr. Sec.

Vawanesa organized economies been held tipeg in aggrammes siety now and bids aims and town. May 3rd. f Mrs. E. d Science. on of so- talk on be taken

President. Mrs. J. C. Allison; Banting Mayhew.

y of Min meeting i and 25 ready for 'as suffi us to hold

in being Miss Ken: Agricul

Miss Kennedy gave a splendid practical demonstration in cutting and fitting a simple house dress. The work dress is too often neglected on the old principle that anything will do for working in.

Miss Kennedy showed how it is quite possible to have a practical well-fitting house dress at a very small outlay. The most minute details were carefully explained, and nothing was left to chance in either cutting or fitting. Miss Kennedy gave many helpful hints, and her demonstration was very much appreciated.

Miss McKee followed with a talk on invalid cookery and some simple desserts. Invalid cookery is a branch of cooking that is too often neglected, and there is quite an art in preparing everyday dishes in a tempting manner. As Miss McKee had prepared most of the dishes she mentioned the members were able to sample them.

It is hoped that these lecturers will be able to visit Minnedosa again shortly, as everyone voted these meetings a great success.

In my next report I hope to be able to give you an account of the opening of the Rest Room.

E. M. Ewens,
Sec. Treas., Minnedosa H. E. S.,
Bethany, Man.

PILOT MOUND

The May meeting of the Home Economics Society was well attended, although the threatening appearance of the weather doubtless kept a few away. The subject for the afternoon was "Forestry," and an interesting paper on "The Farm Plantation" was read by Mrs. R. J. Stephenson. A short discussion followed.

The business part of the meeting included some interesting correspondence. An announcement was made that there would be a public meeting on Wednesday, May 28, at 3 p.m., in the Old Fellows hall, when Miss Kennedy, of the M.A. College staff, would lecture on "Household Decoration," illustrating different color schemes by means of materials, etc. Members were urged to do all in their power to make the meeting on May 28th a success.

At the request of the Town Council a committee was appointed to superintend arrangements for Tag Day, June 7th.

SWAN LAKE

The regular meeting of the Swan Lake H.E. was held on Saturday, April 26th. After the reading of the minutes of the last meeting, the Cor. Sec. read a letter from Mrs. Charlton Salisbury referring to the practical help which the Extension Dept. of the Agricultural College is prepared to give the H.E. Societies, and after discussion the various subjects which the society wished to take up were found to stand in the following order:—1st, dressmaking and plain sewing; 2nd, food and its preparation; 3rd, home nursing and hygiene; and Mrs. Langridge was directed to write to Mrs. Salisbury and ask for full particulars as to the method of taking up these subjects.

The question of Tag Day was then discussed, and a committee of Mesdames Geo. Crouch, W. E. Gardner, W. F. Hartwell, Geo. Crawford, H. Dodd, B. Langridge, with Mrs. G. B. Gordon as captain, was appointed to take this matter up in due course.

The programme which followed was bright and varied; each item breathed the spirit of spring and was much enjoyed. Two ladies, Mrs. A. E. Downey and Mrs. J. Herbert, provided substitutes. The opening selection was a duet by Misses Mahel Simpson and May Sanson, and was nicely and clearly sung. This was followed by a very interesting paper read by Mrs. A. E. Peniston emphasizing the need for a careful selection of color when repapering and painting the house during the spring cleaning. Certain colors produce certain effects—red is never a suitable color for a room as it causes a headache and eyestrain. Yellow increases vitality and mental activity for a time, but excites the restless and mischievous propensities in children. The wisest selections can be made by following the festive tones in nature, pale green, grey, and blue being the most suitable colors for all scheme decor-

ation. The paper read by Mrs. S. P. Hodgson, written by Mrs. Pearl Richmond Hamilton, was on Springtime. It was divided into two parts. Miss V. Gordon kindly read the second. This paper laid stress upon the need for a bright and cheerful spirit at all times, but more especially in Springtime, when all nature is smiling and full of promise. The Misses H. Hodgson, L. Blair and Myrtle Herbert also sang of spring and gave much pleasure with their trio. Mrs. Robb substituted for Mrs. Downey, who had chosen a poem from Tennyson, entitled "Early Spring," which was read with emphasis and effect. After the roll call and the serving of lunch the meeting adjourned to meet again on Saturday, May 31st.

Visiting Delegates from the Extension Department.

The Agricultural Extension department conducted a splendid series of visitations during the month of May. Mrs. Charlton Salisbury and Miss Kennedy, of the Agricultural College, both of whom are gifted women and splendid speakers, visited the societies in Manitoba. They gave lecture demonstrations on "Methods of cooking," "House furnishings" and "Dressmaking."

Miss Kennedy visited Emerson, Miami, Swan Lake, Carman, Headingly, Deloraine, Pilot Mound, La Riviere and Manitoba.

Reports from these places state their great appreciation of Miss Kennedy's visits. Not only were the women pleased to meet Miss Kennedy personally, but they were greatly helped by her demonstrations. Mrs. Salisbury spoke at Russell, Birtle, Valley River, Benito, Swan River, Hamiota, Oak Lake and Verdun.

Mrs. Salisbury's addresses are full of interest and instruction along practical lines, and her visits were also very much appreciated. These visitations bring the work of the college to the women of the province in a highly commendable way.

I appreciate very much the honor conferred on me by the Morris society. This month a very kind note reached me from Morris stating that they had elected Mrs. Colin H. Campbell, Mrs. Lipssett Skinner and Pearl Richmond Hamilton honorary members. This recognition pleases me more than I can express in writing. I ask the Morris society to kindly accept my very sincere expression of gratitude for their kindness.

P. R. H.

Mrs. Dayton, president of the Manitoba Home Economics Society, attended the Homemakers' Convention of Saskatchewan, accepting the invitation extended to her by the department of agriculture of Saskatchewan.

Mothers' Corner

MOTHER

Mother—That precious name,
For evermore the same.

Earth's sweetest word!
Though ages past have flown,
No sound was ever known
Like that dear name alone.

Or ever heard!

From childhood's earliest day,
She guarded all our way.

With tenderest care,
She shared our every woe,
Each cherished hope did know,
Of childish prayer.

Through the long hours of night,
When tears bedimmed her sight,
Our pain she soothed;

Never of self a thought!
Always for us she wrought;
With tireless love she sought
Our paths to smooth.

Wondrous, oh, wondrous love,
Most like to that above,
She gave alone!

Shame! that our lips we seal
From loving words which heal
Each headache, and reveal
Love oft unknown.

Oh, what a debt we owe!

Our grateful love we'll show!

While now we may;

More tender yet to be;

Thoughtful and eagerly

Her slightest need to see

Each passing day.

Our mother's God, to thee,
In deep humility,

We lift our prayer;

Keep those we love the best

Through every trial and test.

And may they ever rest

Safe in thy care.

A Jewish rabbi said at a meeting of mothers not very long ago: "Let the mother have religion, and her every word, kiss and embrace, will unconsciously become an act of religion to her child; her devotion and sacrifice at the side of the cradle will become a divine service, her lullaby will become a hymn of praise, her every prayer will rise upward as a supplication, and sink deep into the heart of the child as a prophecy. With the child's love of its mother there will spring up unconsciously the child's love of God, to whom it sees its mother turn with thanksgiving in the hour of joy, with supplication in the hour of sorrow, and whom she seeks to serve by loving what is right, by cherishing what is beautiful. With religion in the mother's heart, the very nursery becomes a sanctuary, and play itself becomes an act of devotion."

NOTICE

The booklet entitled "Helps for Expectant Mothers" I am pleased to send to any wife who requests it—free of cost. I am sure this booklet is helping scores of mothers. One has just written me that she could get no neighbor to help her until she gave me the booklet to read. The neighbor promised to help her after reading the booklet, and they got along very nicely by following the instructions carefully.

P. R. H.

THE MOTHER OF HENRY WARD BEECHER

Here is a pretty little story of the mother of Henry Ward Beecher and Harriet Beecher Stowe, told by the latter:

"Our mother," says Mrs. Stowe, "was an enthusiastic lover of plants and flowers, and her brother, John, in New York, upon one occasion, had just sent her a parcel of fine tulip bulbs. I remember rummaging the bulbs out of an obscure corner of the nursery one day when she was out, and, being strongly seized with the idea that they were good to eat, I used all the little English I then possessed to persuade my brothers that these were onions such as grown people ate, and that they would be very nice for us.

"So we fell to and devoured the whole lot, and I remember being somewhat disappointed in the odd, sweetish taste, and thinking that, after all, onions were not as nice as I had imagined.

"Then mother's face appeared at the nursery door, and we all ran toward her, telling of our discovery and what we had done. We had found a bag of onions and eaten them all up!

"I remember that there was not even a momentary expression of impatience, but that she sat down and quietly said: 'My dear children, what you have done makes mamma very sorry. Those were not onions, but the roots of beautiful flowers, and, if you had only left them alone, we should have had next summer in the garden great, beautiful, red-and-yellow flowers such as you never saw.' "That was all. There was no explosion of anger, no clonding at the brow, no ugly threats of punishment, but only that gentle look and words of love."

Mrs. Beecher is said to have been a woman of "strange, restful, sympathetic nature, and endowed far beyond the common in the matter of breadth and soundness." Lyman, Beecher, her husband, persistently declared she was his superior, not only in the graces of the heart, but in intellectual ability, and that in "nearly all matters her judgment was almost perfect."

Inheriting such a royal nature, the abilities of the famous preacher and his no less famous sister are scarcely to be wondered at.

BE CHEERFUL

In a quaint New England village there stands in the churchyard a monument bearing four simple words: "She was Always Cheerful." What a life story!

Every mother knows what it means to have the day start wrong. How the appearance at the breakfast table of a "grouch" member will overshadow the entire day, and often tax her ingenuity to dispel the influence before its closing hours.

A cheerful mother is the home's greatest blessing—more to be desired than a scientific economist. But it is no paradox to say that one is usually the complement of the other, for system and order bring serenity, and serenity assures good cheer. The nervous, emotional woman cannot be always cheerful, therefore the mother should look well to her health. She should take a little time each day for herself, even if some household duty is neglected. Time will regulate and repair the little domestic omissions, but it will never make over an overworked woman. In the time she sets aside for herself she should do the purely personal things which all women need and many busy mothers neglect, such as caring for her hair and nails or her complexion, never forgetting that her husband and children will repay her in admiration for all the care she puts on herself. She should also take time for reading. Select good, cheery, optimistic literature, and try to live by its guidance. The works of Van Dyke, Trine or Hillis will lift up any woman who is downcast or broken in spirit. The expenditure of this time may seem impossible to many mothers. But all could do it if they would, and they would do it if it was necessary for the welfare of some other member of the family. There is where the unselfishness of a mother's life is revealed. She can always take up new duties for a new baby, a sick child, or at the request of her husband, but for herself, too often, there is no time allotted.

Haydn, a deeply religious and devout man, said: "There are but few contented and happy men here below; everywhere grief and care prevail. Perhaps my labors may one day be the source from which the weary and worn, or the man burdened with affairs, may derive a few moments' rest and refreshment." None of us may ever give the world another "Creation," but we can make our own little creations—our home nests—the place where one man, burdened with the care of the world, may find rest and repose, especially if a cheery voice and a radiant smile be always his greeting.—Maggie Wheeler Ross.

Haydn, a deeply religious and devout man, said: "There are but few contented and happy men here below; everywhere grief and care prevail. Perhaps my labors may one day be the source from which the weary and worn, or the man burdened with affairs, may derive a few moments' rest and refreshment." None of us may ever give the world another "Creation," but we can make our own little creations—our home nests—the place where one man, burdened with the care of the world, may find rest and repose, especially if a cheery voice and a radiant smile be always his greeting.—Maggie Wheeler Ross.

SOME HELPFUL ADVICE FOR HOME ECONOMY

By Dr. H. W. Wiley

A penny saved has not as much value as a penny well spent.

True economy does not begin with laying a penny aside, day by day, but in knowing what is secured with the pennies expended.

A close, intelligent buyer finds that the pennies accumulate anyway.

The greatest source of home waste is found in the kitchen and the table it serves. This is due to ignorance in buying and waste in cooking.

Intelligence in buying and control of the kitchen can come only through patient study, but the reward of this intelligence lies in reduced expenses and improved family health.

Quality of food and style of cooking should always rank higher than quantity of supply.

All butchers, bakers and grocers are not dishonest, but dishonest ones are discouraged when they see that the purchaser knows what he or she wants.

A home garden is a source of economy and health for those who care for it. The more a home garden is able to produce for itself, the less the cost of maintaining that home.

High prices of food products come and go with the years, but the kitchen and table waste of a home governed by lack of intelligence or extravagance goes on forever.

Laws can partly or wholly suppress dishonest manufacturers or merchants, but they cannot reach the home whose expenditures are regulated by desires and not educated judgment.



The Two-piece Firepot



Three-sided Grate Bars

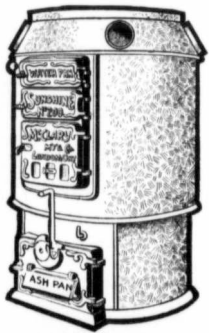

Install A Modern Furnace

One With Latest Features, And Built To Last

CONSIDERING its extra weight, the superior quality of the materials, the skill and experience put into it, McClary's Sunshine furnace is the cheapest furnace on the market. You get more value for every dollar you invest in the Sunshine than you do in any other furnace.

McClary's Sunshine Furnace is the product of the largest stove and furnace makers in the British Empire. It has labor-saving, health-producing and fuel-economizing features—the result of long experience—that no other furnace has.

It has, for instance, the "rocking-down" system which eliminates the old-time back-breaking, dirty shaking. It has a conveniently located water-pan over the fuel door. It has a sure-acting dust-flue to prevent dust from falling ashes getting into the house. It has an almost straight-sided fire-pot to prevent ashes forming "pockets" and deadening the fire. And some coal-economizing features our agent will be glad to tell you about.

But, too important to overlook, is the fact that the Sunshine furnace is built to last. The materials are the best, and every piece of metal is tested. Every operation in the making is inspected, too. Nothing is left to chance.

As an example of the quality of materials used, take the fire-pot. This is of semi-steel—not gray iron as are other fire-pots. Semi-steel is not affected by sulphur fumes from burning coal. In addition, a semi-steel fire-pot weighs twenty per cent. more than the same size and pattern in gray iron.

But that's not all. The fire-pot is in two pieces to prevent it cracking from extreme expansion or contraction. One-piece fire-pots are continually cracking, having to be replaced.

Then take the grate bars. Those on the Sunshine are very heavy and have three sides—three lives. By exposing a different side to the fire every few days, the life of the grates is greatly prolonged.

Examine the dome, too. It is of heavy steel, as is also the radiator. The frame of the ash-pit, the doors on the furnace, the casing—every part of the furnace is of the most durable material. All joints are accurately fitted together, and rendered dust-tight by a special cement originated by McClary's.

Last, but not least, the McClary Company place the services of their corps of experienced installation men at your disposal. These men will assist you and the McClary agent in your locality to plan the arrangement of your heating system. They will also co-operate with you in other ways to insure the proper installation of your furnace.

Furthermore, the Sunshine furnace is guaranteed to heat your house to your satisfaction, if installed according to the directions of the McClary experts. You therefore run absolutely no risk in having one installed.

Send your name and address to our nearest office, with particulars about the size of your house, and we will tell you about how much it will cost to install a McClary's Sunshine in your home. The latest Sunshine booklet is also free on request.

McClary's Sunshine Furnace

LONDON ST. JOHN, N.B. TORONTO HAMILTON MONTREAL CALGARY WINNIPEG SASKATOON VANCOUVER EDMONTON

336

You saw this advertisement in this magazine. Don't forget to say so when writing.

HOME MAKERS' DEPARTMENT

Conducted by Edith Charlton Salisbury.

In their Work in the Homes Women have much to do in Making Sure the Success of Canada—the Young People's Opportunities.

What Has Been Done in Manitoba.

It is less than two years since the first Home Economics Society was organized in Manitoba. The societies are still in their infancy, but already their influence for good has been felt throughout the province. The women who are enrolled as members in these societies are beginning to realize as they never have before how great are their opportunities for the upbuilding and strengthening of home, community and national life through their efforts. Already they have accomplished much: in the future, as the number of societies increases, the membership enlarges, and individual effort becomes more general, they will become a still greater power. Already the societies have done much to dispel that narrowness of view which is the natural result of living too much

to one's self, whether it be in the country or city. Petty jealousies and factions cannot exist in the same locality with the wide-awake progressive Home Economics Society—for all personal differences will be submerged or forgotten in the work of the organization. A peep into the future reveals many important improvements in home and community life which may be directly traced to the influence of the societies. Lift the curtain, and look on some of these changes which will be wrought in Manitoba. The busy house mother claims first attention, for it was in her domain that a new order of things was especially needed. She performs her work in a more systematic manner and with less labor, while her family is better nourished than formerly, but at less expenditure of money and effort. With less manual labor and a little more

study the family is accomplishing more and actually producing more in dollars and cents from the farm. Also, there is more time for recreation and social intercourse, and a keener appreciation of the advantages of rural life under modern conditions. The new interest of the mother in her home duties extends to each member of the family, and we find a fuller enjoyment of life in the entire home. There is an apparent interest and desire from the youngest to the eldest to make the most of opportunities that fit for practical living.

Looking at the community at large, we find the earmarks of contented, thrifty living on every hand. The farmers are marketing more butter and eggs of better quality and are receiving a better price for their produce. There is greater pride in surroundings and the farmstead has been made more attractive, more home-like, and, at the same time, more valuable by planting trees and laying out vegetable and flower gardens and beautifying it in many ways. A healthier, more wholesome atmosphere pervades the community. All that tends towards the general comfort and well-being of the inhabitants is encouraged, while those things which

hinder advancement are discouraged and soon cease to exist.

Another benefit accruing to the account of the Home Economics Societies, we see in the life and habits of the thousands of emigrants who come to Manitoba to make their home. Members of the societies, themselves loyal Canadians, willingly assume their part in the country's responsibility to encourage these people to become English-speaking Canadian citizens, intelligent and educated. The Home Economics Societies can do much to lessen the loneliness and strangeness of a foreign country and encourage new settlers to become industrious, useful citizens of this country.

No country is any better than its homes, and the quality of the homes, as well as the character of its inmates, depends largely on the efforts of the women who have been entrusted with the keeping of these homes. Co-operation is the key of success in any line of work; the home, where every member is united in effort and interest, is the really successful home; and the community in which there is co-operation and continued effort towards a better standard of living is the most successful

The home economics society and the agricultural society are the factors that stand for successful and progressive living in the province of Manitoba.

Getting Help From Everyone.

If a word of advice is necessary or timely to the members of societies who have charge of arranging programmes, it would be to use your persuasive powers to have some of the quiet, reserved women take part occasionally. There will always be in every society some women who find it easier "to speak in meetin'" than others. But the silent member may have the wisdom of Solomon in her mind; the big concern for herself and the entire society is that she give utterance to this wisdom.

All cannot read papers, or lead in discussion, but every woman has some thought, some discovery, an interesting bit of personal experience concerning any home subject which cannot fail to be helpful to some one in the society. Or, if she has nothing to give, she may have a question to ask that may lead to most instructive discussion. The best meetings are those in which there is a mutual exchange of questions and answers, and in which many persons have something to give — even the widow's mite.

It is well to vary each programme with vocal and instrumental music, readings or recitations, and for these features to enlist the services of the young women and girls in the locality. The programme committee of each society is advised to not only bring into frequent use the capabilities and accomplishments of all the members of the society, but to occasionally invite the school teachers, butchers, bakers, physicians, bankers, dentists and ministers of the community to give addresses on topics of interest to the homemaker.

Let Progress be the Watchword.

It is being realized more clearly every day that the business of housekeeping has not kept pace with the great advancement in other lines of human endeavor; that the wonderful discoveries in science, and developments in the arts, have only been partially applied, and that very slowly, to the problems of personal health and the home life. We are yet only in the early morning of progress in homemaking and housekeeping. Hundreds, yes thousands, of women are still unaware of the sunrise of greater possibilities in woman's greatest work — that which concerns the home and the family; and the dawn of hope for better living has not yet touched their horizon.

Why should not women study their business of homemaking with the same view to its economic value as men give to their special lines of work? If it is true that 90 per cent. of the wages of working people and 75 per cent. of the incomes of the leisure class is in the hands of the women who have charge of the homes, it is certainly of first importance that every woman should know how to spend this money to the best advantage. So far in the history of the world, especially of the Western Continent, it has been found that half the cost of living is the cost of food, and also that the cost is not so much for that which is actually expended for necessary food, shelter, clothing, etc., as it is the cost of waste—waste of everything which enters into material life, waste of human energy, waste of health. In handling the 75 or 90 per cent. of the commercial profits of the country to the best advantage women certainly have entrusted to them a work which calls for their best and most rational endeavor.

As Outsiders See Us.

A few months ago a young woman travelled from the East coast to the West through the Canadian Northwest. Her home was in Boston, that centre of culture, refinement and education; that wonderful city which some of us in the West are eager to visit when we get particularly hungry for what we call the finer things of life. This young woman had been surrounded by such things all her life; she had been brought up on music, art, literature and high

ideals; she had been a near neighbor to the best the world has to give all her days. Some of us out here might have envied her. One day — her last in Western Canada—she took a long drive over the prairie, "to say good-bye to the plains," she said, and her farewell had in it a message to all the young people of the West. That message, spoken from the heart of a thoughtful woman, seems to me the best word I can give you for the gazette.

"There are no individuals in the world more fortunate than the young people of this great new country," she said as her eyes followed the setting sun on his trail far across the prairie. "Think of their opportunities! A country to make a nation build! What a glorious chance to do something worth while! Back East all the making and building were done years before my time. Customs have become established, ideas fixed, the roads to right and wrong clearly blazed; there seems so little that one individual can do back there. But out here everything is in the beginning; nothing is finished; individual efforts and opinions will surely show in results. I wonder if they know, these lucky young people, what a grand chance to make good has been given to them? Tell them, wherever you go and whoever they are, tell them no one ever had a bigger, better opportunity than is theirs. No one is more to be envied than the boys and girls of these new provinces."

My acquaintance with this young woman makes me quite sure of what she meant by "opportunity to do things." She was not thinking entirely of wealth, as she looked over the vast wheat fields, though she is ambitious, and I have seen her eyes darken and glow when some one told of fortunes made in real estate. Life means more than dollars and fame, or even a career, to this woman. Knowing her so well, I think I can truthfully interpret her message for you. One big opportunity which I know she thinks has been given to you young men and young women is that of nation-building in this new country; building so strong and true and dependable that all other nations will respect it and love it.

In days of youth, while habits and opinions are only in the formative shape, it is comparatively easy to make changes, to drop old habits, to take on new ones. In a new country, where affairs, institutions and customs are still in the making, where in many places both good and evil are waiting at the door for an invitation to enter—it rests with the young men and women to say which shall be the intimate friend of the country. In fact, to sum it all up into one sentence, the future of the Northwest rests with its young people.

There is no better place to define nation-building than in the individual home, for true it is that the strength and unity of a nation depend on the strength and unity of the family. Those things which tend to elevate ideals and improve conditions in the home tend to make a nation more powerful.

There are certain qualities which one always looks for in the well-rounded character. Among these are honesty, energy, enthusiasm, human interest, broadness of vision, kindness, tolerance and sweetness of disposition. It seems to me all of these qualities should be essentials in the character of the new race that is to come out of the new West. Especially should this be true when we consider the diversity of people, customs, opinions and ideals, gathered from everywhere under the sun, which will be factors in this new race.

The formation of character should begin in the home, since it is the young people who are organizing our Western homes; on them rests largely the responsibility of the kind of people we shall have in future years.

The institutions of any community reflect to a certain extent the moral tone of that community. Shall we have institutions that stand for uprightness and integrity? Shall these things that are "lovely and of good report" be pre-eminent throughout these provinces, or will a greedy desire for gain at any cost become a national trait? It rests with the young people to decide. Manners



Mason & Risch Pianos

"Factory to Home"

17 Western Branch Stores

It has always been our most serious endeavor to make the MASON & RISCH PIANO the best Piano in the world's workshop. This is the basic principle upon which its towering supremacy rests. Few Pianos make so intimate and so general an appeal as the MASON & RISCH.

If you have no Piano you certainly want one. To be without is almost a reproach. And surely if you buy one now you want the BEST—THE MASON & RISCH—for half a century foremost in the minds of all who appreciate a perfect instrument.

Write us for Catalogue No. 28 showing 1913 designs and ask for full details of our "Factory-to-Home" selling plan. Also send for bargain list of used instruments.

Mason & Risch Limited

Factory Branch:

274 Portage Ave., Winnipeg

You saw this advertisement in this magazine. Don't forget to say so when writing.



In this warfare on flies, nothing has been found so effective as Tanglefoot.

Now, each year 300,000,000 sheets are used in households all over America during the fly-season.

Swatting Won't Do

Don't trust to half-way methods. With the first fly get Tanglefoot.

Put a sheet wherever you see a fly. Each early fly may breed millions of you wait. By using Tanglefoot now, you prevent countless armies of flies.

Avoid Poisons

In several states the sale of poison is forbidden except by registered pharmacists.

Poisoned flies drop into your food, into the baby's milk, everywhere. And the poison does not kill the germ on the fly. Fly-traps, too, are unsanitary and disgusting to care for.

A Double Protection

Tanglefoot is non-poisonous. It not only catches and kills the fly, but seals it over with a varnish which destroys the germ as well as the fly.

Each sheet of Tanglefoot can catch 1,000 flies. Have a supply always on hand, and enjoy freedom from flies and fleas the summer through.

Millions Know This Trademark



Tanglefoot contains one-third more sticky compound, hence it lasts longer than ordinary sticky fly-papers. Get a supply of Tanglefoot from your druggist or grocer today for this season's warfare on flies.

Made Only by THE O. & W. THUM CO., Grand Rapids, Mich.

A little gasoline quickly removes Tanglefoot from clothes or furniture

are a fairly true indication of the common attitude of members of a family to each other and of the regard human beings have for each other. Politeness, the basis of good manners, is only another term for human interest, consideration, justice and unselfishness. It is a quality of mind which permits one individual to look after his own welfare and interests, at the same time granting the same privileges to other people. It is a rare quality, but whenever sufficiently developed as to be noticeable in any community, it always insures success and prosperity to that community. It will be worth while—an effort well expended for the young people of the West — to cultivate this politeness, which may win for them the title of the most prosperous race on the continent — in other words, the most united.

RECIPES

Berry Cake

Sift a teaspoonful of soda and two teaspoonfuls of cream of tartar into three cups of flour, add half a teaspoonful of salt, one cup of sugar and one and one-half cups of berries. Mix with milk a little softer than you would for biscuits, a piece of butter or other shortening the size of a walnut. An egg may be used, if desired, but it is not necessary. This makes a very large sheet of cake.

Spice Loaf

Cut very fine three pounds of beef, add a cup of crackers rolled fine, one egg, one and one-half teaspoonful of salt, one-half teaspoonful of cloves and pepper. Mold into a loaf and bake one hour.

Salad

A delicious luncheon or supper salad is made of asparagus tips and shrimps. Drain a can of the tips and a can of shrimps. Use half as much of shrimps as asparagus and toss them together with a seasoning of salt and pepper. Make a French dressing and beat with it the yolks of two or three hard boiled eggs that have been rubbed through a sieve. Turn it over the salad before it goes to the table.

Pickled Nasturtiums

When the seeds are green, but full grown, pick and place in a fruit jar, cover with strong salt and water for twenty-four hours, then pour off, rinse well, drain and place in a heated jar with scalding vinegar poured over them. Bottle tightly.

They are often used in place of capers in mixed pickles.

Apple Compote

Core, without paring, enough "Talmont-sweet" apples to arrange without crowding in a baking dish.

Have ready a cupful of English walnut meats ground or pounded fine, mixed with three tablepoons of fine sugar.

Fill the hollow cores with this mixture and sprinkle three tablepoons of sugar over and about them, and add cold water to half cover them.

Cover pan closely, and bake one hour or until tender without breaking to pieces.

Let them cool in the dish with the syrup around them.

When thoroughly chilled, serve with whipped cream, or roll each apple in coconut and use the rich syrup as a sauce.

Stuffed Round Steak

Make tender young steak, criss-cross thoroughly; spread with good bread stuffing, roll, tie, bake in slow oven three hours, basting often; or, cover with seasoned tomatoes and bake. This, as also the round steak breaded and sautéed round steak, depends for success on the original tenderness of the steak.

DOMINION EXHIBITION

Brandon, Manitoba.

July 15th. to 25th. 1913

THE Fair To See **The Best In The West**

\$50,000.00 Prize List
\$20,000.00 In Speed Events

REDUCED RATES ON ALL RAILROADS

FARMERS!

We have the most liberal premium list offered in Canada. Refund of 50 per cent of freight on live stock and poultry without restrictions as to where else exhibits are shown. Transfer track delivers all live stock right to Exhibition Barns. **A PREMIUM WON AT BRANDON WILL BE WORTH HAVING.** Send for Prize List.

ENTRIES CLOSE JULY 1st.

EVERYBODY! Brandon has now the most beautiful exhibition grounds in Canada, covering 106 acres. We have spent \$150,000 on new buildings for the Dominion Exhibition. In visiting Brandon you come to the most beautiful city in the West. Ample provision has been made for the accommodation of the record crowds that will attend. Municipality owned street car system right to the grounds.

MANUFACTURERS!

Your opportunity is here. Free space for outside exhibits and special building for Manufacturers, Automobiles and Motor Trucks.

See that YOU have the space; WE'LL have the crowds. Fair and courteous treatment assured to all exhibitors.

ENTRIES CLOSE JULY 1st.

Canada's Greatest Live Stock Show

Some of the Attractions

Grand Fireworks Display, picturing "THE NAVAL BATTLE IN THE NORTH SEA," a stupendous spectacle 200 feet long, portrayed in brilliant colored fires. A vivid presentation of modern naval warfare.

Beautifully illuminated grounds with spacious promenades. Music by the best bands in Western Canada. High class attractions from Europe and America's leading amusement centres. Bobber Ben Ali's Whirlwind Arabs, 12 people; the famous Rex Comedy Circus; Modelsky's Russian Troupe of 8 people; The Barkers; Fire Divers; Performing Elephants; Daring Aviation Flights by Monoplane twice a day, and other events.

The Midway with eighteen new attractions and the best of the old. High-class, Clean Entertainment by the Great Patterson Shows. TRAVELLER'S DAY, MONDAY, JULY 21st.

THE EXHIBITION THAT DOES CANADA CREDIT!

P. PAYNE, President

W. I. SMALE, Secretary and Manager

You saw this advertisement in this magazine. Don't forget to say so when writing.

Egg Baskets

Cut hard boiled eggs in halves lengthwise. Remove the yolks and keep the whites hot by placing in hot water. Mix the yolks with a cream sauce, season with salt and pepper, and stir until smooth and light. Fill the whites with the mixture. Make handles of thin celery. These are a pretty garnish for any sort of vegetable salad.

Little Fruit Cakes

Cream together three-fourths cup of butter and add two of sugar, add well beaten eggs; then one-half teaspoonful of ground clove, one-fourth teaspoonful of ground mace, and one teaspoonful of allspice. Mix and sift together with one teaspoonful of cream tartar and three cups of flour. Dissolve three-fourths teaspoonful of soda in a

cup of milk. Add part of the flour to the egg mixture, then the milk and the remainder of the flour. Dredge with the flour one cup of sliced citron and two cups of seeded raisins and add to the batter. Bake in small tins in a moderate oven.

A good motto for creamery patrons—clean cream, sweet cream, frequent delivery.

NEVER SATISFIED

"Some men," writes a correspondent, "are never satisfied. I was talking to an old farmer about his bumper crop of hay.

"You've broken all records, haven't you?" I said.

"Yes sir," he answered; "I've broken all records for hay, and no mistake."

"Good!" said I. "Good! And

let me tell you it's a pleasure to meet for once a perfectly satisfied farmer."

"The old man chewed a straw meditatively.

"Well, I don't go so far as to say I'm perfectly satisfied," he replied. "You see, I ain't got a bale of bad hay this year to feed the dry cows on."

THE MAN IN CANVAS

By RICHARD HARDING DAVIS

In their home town of Keepsburg the Keeps were the reigning dynasty, socially and in every way. Old man Keep was president of the tramway line, the telephone company, and the Keep National Bank. But Fred, his son, and the heir apparent, did not inherit the business ability of his father; or, if he did, he took pains to conceal that fact.

When Fred arranged an alliance with Miss Winnie Platt, who also was of the innermost inner circle of Keepsburg, everybody said Keepsburg would soon lose them. And everybody was right. When single, each had sighed for other social worlds to conquer, and when they combined their fortunes and ambitions they found Keepsburg impossible, and they left it to lay siege to New York.

The point from which the Keeps elected to launch their attack was Scarborough-on-the-Hudson. They selected Scarborough because both of them could play golf, and they planned that their first skirmish should be fought and won upon the golf links of the Sleepy Hollow Country Club. But the attack did not succeed. Something went wrong. They knew no one and no one knew them. That is, they did not know the Van Wardens; and if you lived at Scarborough and were not recognized by the Van Wardens, you were not to be found on any map.

Since the days of Hendrick Hudson the country seat of the Van Wardens had looked down upon the river that bears his name, and ever since those days the Van Wardens had looked down upon everybody else—except Harry Van Warden, and he lived in New York at the Turf Club.

Harry, according to all local tradition—for he frequently motored out to Warden Koopf,

the Van Warden country seat—and according to the newspapers, was a devil of a fellow, and in no sense cold or unsociable. So far as the Keeps read of him, he was always arrested for speeding, or breaking his collar bone out hunting, or losing his front teeth at polo.

"If you would only play polo or ride to hounds, instead of playing golf," sighed Winnie Keep to her husband, "you would meet Harry Van Warden, and he'd introduce you to his sisters, and then we could break in anywhere."

"If I was to ride to hounds," returned her husband, "the only thing I'd break would be my neck."

The country place of the Keeps was completely satisfactory. The house was one they had rented from a man of charming taste and inflated fortune; and with it they had taken over his well-disciplined butler, his pictures, furniture, family silver, and linen. It stood upon an eminence, was heavily wooded, and surrounded by many gardens; but its chief attraction was an artificial lake well stocked with trout, that lay directly below the terrace of the house and also in full view from the road to Albany.

This latter fact caused Winnie much concern. In the neighborhood were many Italian laborers, and on several nights the fish had tempted these born poachers to trespass.

"It makes me nervous," complained Winnie. "I don't like the idea of people prowling around so near the house. And think of those twelve hundred convicts, not one mile away, in Sing Sing. Most of them are burglars and if they ever get out ours is the first house they will break into."

"I haven't caught anybody in this neighborhood breaking into our house yet," said Fred, "and

You Will Notice the Difference The First Cup of



BLUE RIBBON TEA will show you its delightful quality. So sure are we that you will be pleased with it, that we authorize your grocer to refund the full purchase price if you are not entirely satisfied. On this condition we ask you to say definitely "Blue Ribbon" when next you order tea.

You saw this advertisement in this magazine. Don't forget to say so when writing.

The Canadian Housewife's Choice

Benson's Prepared Corn
For Culinary Purposes

Silver Gloss Starch
For Home Laundering

Benson's and Silver Gloss have led for over half-a-century

The Canada Starch Co. Limited

Manufacturers of **EDWARDSBURG** BRANDS

Montreal Cardinal Toronto Brantford Vancouver

You saw this advertisement in this magazine. Don't forget to say so when writing.

REGISTERED TRADE MARK
JOSEPH RODGERS & SONS, Limited
SHEFFIELD, ENG.
Avoid imitations of our CUTLERY by Seeing that This EXACT MARK is on Each Blade.
SOLE AGENTS FOR CANADA
JAMES HUTTON & CO., MONTREAL

I'd be glad to see even a burglar."
They were seated on the brick terrace that overlooked the lake. It was just before the dinner hour, and the dusk of a wonderful October night had fallen on the hedges, the clumps of evergreens, the rows of close clipped box. A full moon was just showing itself above the tree tops, turning the lake into moving silver. Fred rose from his wicker chair and crossing to his young bride, touched her hair with the tips of his fingers.

"What if we don't know anybody Win," he said, "and nobody knows us? It's been a perfectly good honeymoon, hasn't it? If you just look at it that way, it works out all right. We came here really for our honeymoon, to be together, to be alone--"

Winnie laughed shortly. "They certainly have left us alone!" she sighed.

"But where else could we have been any happier?" demanded the young husband loyally. "Where will you find any prettier place than this, just as it is this minute, so still and sweet and silent? There's nothing the matter with the moon, is there? Nothing the matter with the lake? Where's there a better place for a honeymoon? It's a bower--a bower of peace, solitude--a bower of--"

As though mocking his words there burst upon the sleeping countryside the shriek of a giant siren. It came sharply as a scream of terror, it continued in a bellow of rage. Then, as suddenly as it had cried aloud, it sank to silence; only after a pause of an instant, as though giving a signal, to shriek again in two sharp blasts. And then again it broke into the hideous, long scream of rage, insistent, breathless, commanding; filling the soul of him who heard it, even of the innocent, with alarm.

"In the name of heaven," gasped Keep, "what's that?"

Down the terrace the butler was hastening towards them. When he stopped he spoke as though he were announcing dinner. "A convict, sir," he said, "has escaped from Sing Sing. I thought you might not understand the whistle, and that perhaps you would wish Mrs. Keep to come indoors."

"Why?" asked Winnie Keep. "The house is near the road, madam," said the butler. "And there are so many trees and bushes. Last summer two of them hid there, and the keepers--there was a fight."

The man glanced at Keep. Fred touched his wife on the arm. "It's time to dress for dinner, Win," he said.

"And what are you going to do?" demanded Winnie.

"I'm going to finish this cigar



It fits better

That perfect fit and comfort which you are assured when you ask for your size in Pen-Angle Underwear (the kind knit to fit) greatly improves the look of your outer garments, and gives you a feeling of being well-dressed from the skin out. Other underwear is more or less of a makeshift--it bulges, sags, loses shape, shrinks,--but

Pen-Angle Underwear

hasn't even one of the faults you are used to paying good money to bother with. Just try Pen-Angle once and learn how it surely does solve the underwear question for man and woman and child. Ask the store you trade at.

PENMANS LIMITED, PARIS, CANADA
HOSIERY, SWEATERS, UNDERWEAR

You saw this advertisement in this magazine. Don't forget to say so when writing.

first. It doesn't take me long to change." He turned to the butler. "And I'll have a cocktail, too. I'll have it out here."

The servant left them, but in the French window that opened from the terrace to the library, Mrs. Keep lingered irresolutely. "Fred," she said, "you--you're not going to poke around in the bushes, are you--just because you think I'm frightened?"

Her husband laughed at her. "I certainly am not," he said. "And you're not frightened either. Go in. I'll be with you in a minute."

But the girl hesitated. Still shattering the silence of the night, the siren shrieked relentlessly; it seemed to be at their very door, to beat and buffet the window-panes. The bride shivered and held her fingers to her ears.

"Why don't they stop it?" she whispered. "Why don't they give him a chance!"

When she had gone Fred pulled one of the wicker chairs to the edge of the terrace, and leaning forward with his chin in his hands, sat staring down at the lake. Somewhere near at hand a criminal--a murderer, burglar--was at large, and the voice of the prison he had tricked still bellowed in rage, in amazement, still clamored not only for his person, but perhaps for his life. The whole countryside heard it; the farmers bedding down their cattle for the night; the guests of the Briar Cliff Inn, dining under red candle-shades; the "joy-riders" from the city, racing their cars along the Albany road.

From within the prison, from within the grey walls that made

the home of the siren, each of twelve hundred men cursed it with his soul. Each clinging to the bars of his cell, each trembling with a fearful joy; each, his thumbs up, urging on with all the strength of his will the hunted, rat-like figure that stumbled panting through the crisp October night, bewildered by the strange lights, beset by shadows, staggering and falling, running like a mad dog in circles, knowing that wherever his feet led him the siren still held him by the heels.

As a rule, when Winnie Keep was dressing for dinner Fred, in the adjoining room, could hear her unconsciously and lightly heartedly singing to herself. It was a habit of hers that he loved. But on this night, although her room was directly above where he sat on the terrace, he heard no

singing. He had been on the terrace for a quarter of an hour. Gridley, the aged butler who was rented with the house, and who for twenty years had been an inmate of it, had brought the cocktail and taken away the empty glass. And Keep had been alone with his thoughts. They were entirely of the convict. If the man suddenly confronted him and begged his aid, what would he do? He knew quite well what he would do. He considered even the means by which he would assist the fugitive to a successful get-away.

The ethics of the question did not concern Fred. He did not weigh his duty to the state of New York or society. One day, when he had visited the "institution" as a somewhat sensitive neighborhood prefers to speak of it, he was told that the chance of a prisoner escaping from Sing Sing and not being at once taken was one out of six thousand. So with Fred it was largely a sporting proposition. Any man who could beat a six-thousand-to-one shot commanded his admiration.

And, having settled his own course of action, he tried to imagine himself in the place of the man who at that very moment was endeavoring to escape. Were he that man, he would first, he decided, rid himself of his tell-tale clothing. But a man without clothes would be quite as conspicuous as one in the purple-grey cloth of the prison. How could he obtain clothes? He might hold up a passerby, and, if the passerby did not flee from him or punch him into insensibility he might effect an exchange of garments; he might by threats obtain them from some farmer; he might despoil a scarecrow.

But with none of these plans was Freddy entirely satisfied. The question deeply perplexed him. How best could a naked man clothe himself? And as he sat pondering that point, from the bushes a naked man emerged. He was not entirely undraped, for around him he had drawn a canvas awning. Fred recognized it as having been torn from one of the rowboats on the lake. But, except for that, the man was bare to the heels. He was a young man of Fred's own age. His hair was cut close, his face smooth-shaven, and above his eye was a half-healed bruise. He had the sharp, clever, rat-like face of one who lived by evil knowledge. Water dripped from him, and, either from that reason or from fright, the young man trembled and, like one who had been running, breathed in short, hard gasps.

Fred was astonished to find that he was not in the least surprised. It was as though he had

"There's nothing to pay"



SIMPSON'S PAY DELIVERY CHARGES

THE gratifying experience illustrated in the above picture will be yours if you shop by mail at the SIMPSON Store. Your purchase, whether for fifty cents or fifty dollars, will arrive all delivery charges paid. You will have "nothing to pay."

You will know before mailing your order, exactly what it will cost after you receive it, for the price quoted in the SIMPSON Catalogue is all you send to have any article delivered free.

Not only is there "nothing to pay" when your parcel arrives, but there's "nothing to pay" if you wish to return your purchases. Send them back at our expense.

The fact that we are parties to a one-sided contract like this—bringing the goods to your door and taking them away again if you are not pleased—makes it imperative that in our catalogue all illustrations be exact and descriptions truthful. Every article is carefully selected—each garment must be Fashion's "last word" in style—each item of merchandise must represent the one best value of its kind.

We guarantee satisfaction, or your money back

OUR SPRING AND SUMMER CATALOGUE is now being mailed. Send for a free copy. Just write your name and address on a Post Card and ask for Catalogue Number 276

THE ROBERT SIMPSON COMPANY LIMITED
TORONTO



You saw this advertisement in this magazine. Don't forget to say so when writing.

Join the Good House-Keepers Club

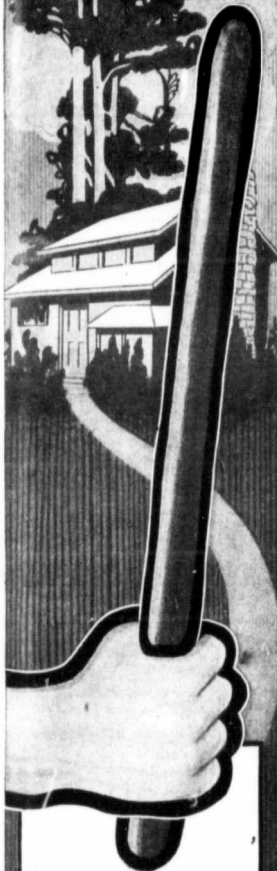

For perfect cleaning in all parts of the house this "club" is famous. Where there is cleaning to do, Old Dutch Cleanser does it easily, thoroughly, quickly — does it with real economy and satisfaction; without hard rubbing or scrubbing.

Many uses and Full Directions on Large Sifter Can—10c.



been waiting for the man, as though it had been an appointment.

Two thoughts alone concerned him that before he could rid himself of his visitor his wife might return and take alarm, and that the man, not knowing his friendly attentions, and in a state to commit murder, might rush him. But the stranger made no hostile move, and for a moment in the moonlight the two young men eyed each other warily.

Then taking a breath, and with a violent effort to stop the chattering of his teeth, the stranger launched into his story.

"I took a bath in your pond," he blurted forth, "and—and they stole my clothes! That's why I am like this."

Fred was consumed with envy. In comparison with this ingenious narrative, how prosaic and commonplace became his own plans to rid himself of accusing garments and explain their absence! He regarded the stranger with admiration. But, even though he applauded the other's invention, he could not let him suppose that he was deceived by it.

"Isn't it rather a cold night to take a bath?" he said.

As though in hearty agreement, the man burst into a violent fit of shivering.

"It wasn't a bath," he gasped. "It was a bet."

"A what?" exclaimed Fred. His admiration was increasing. "A bet? Then you are not alone?"

"I am now—Confound them!" exclaimed the canvas-clothed one. He began again reluctantly. "We saw you from the road, you and a woman sitting here in the light from that room. They bet me I didn't dare strip and swim across your pond with you sitting so near. I can see now it was framed up on me from the start. For when I was swimming back I saw them run to where I'd left my clothes, and then I heard them crank up, and when I got to the hedge the car was gone!"

Keep smiled encouragingly. "The car!" he assented. "So you've been riding in the moonlight."

The other nodded, and was about to speak when there burst in upon them the scream of the siren. The note was of a deeper rage, and came in greater volume. Between his clenched teeth the stranger cursed fiercely, and then, as though to avoid further questions, burst into a fit of coughing. Trembling and shaking, he drew the canvas cloak closer to him. But at no time did his anxious, prying eyes leave those of Keep.

"You—you couldn't lend me a suit of clothes, could you?" he stammered. "Just for tonight? I'll send them back. It's all right,"

FIRE INSURANCE

The Liverpool-Manitoba Assurance Co.

All Policies Guaranteed by

THE LIVERPOOL AND LONDON AND GLOBE INSURANCE COMPANY, LTD.

Northwest Branch - WINNIPEG, Canada

Agents wanted in unrepresented districts. S. N. RICHARDS, Local Manager

The Occidental Fire Insurance Co.

Head Office: WAWANESA, MAN.

A. NAISMITH, President R. M. MATHESON, Vice-President
A. P. KEMPTON, Sec. and Mgr. C. D. KERR, Treasurer

Subscribed Capital \$500,000.00
Security to Policy-holders 640,817.29

Full Deposit with Dominion Government
Agents wanted in unrepresented districts

Alex. Naismith, Pres. S.H. Henderson, Vice-Pres. C. D. Kerr, Treasurer

The WAWANESA MUTUAL INSURANCE COMPANY

HEAD OFFICE: WAWANESA, MAN.
A. F. KEMPTON, Secretary-Manager

Amount of Insurance in force Dec. 31st, 1912 \$54,606,660.00
Assets over Liabilities \$587,537.67

THE NUMBER OF FARMERS INSURED, 31st. Dec. 1912, 23,261

The Largest Farmers Mutual Fire Insurance Company in Canada. Agents wanted in unrepresented districts

INSURANCE—INSURANCE

FRED W. PACE F. J. HARRISON F. GRANT MILLAR

PACE, HARRISON & MILLAR

Keewaydon Building - Portage Ave., East

General Agents:

<p>NATIONAL FIRE INSURANCE COMPANY of Hartford, Conn.</p> <p>Assets Exceed \$12,000,000.00</p>	<p>GENERAL FIRE ASSURANCE COMPANY of Paris, France.</p> <p>Assets Exceed 7,500,000.00</p>
----------------------------------------------------------------------------------------------------	-----------------------------------------------------------------------------------------------

Adjustment and payment of losses arranged from our office. Liberal contracts to live agents. WRITE FOR AGENTS.

Mackenzie, Brown, Thom & McMorran Mackenzie, Brown, MacDonald & Bastedo

Barristers, Solicitors, &c.
Regina, Saskatchewan, Canada

Norman MacKenzie, K.C. Hon. George W. Brown Douglas J. Thom
T. Sydney McMorran Hector Y. MacDonald Frank L. Bastedo

General Solicitors in Canada for the National Thresher Manufacturers' Association of America
General Solicitors in Canada for the American Collectors' Association.
General Solicitors in Saskatchewan for Fifteen Canadian and American Thresher and Implement Companies.

National Trust Company, Ltd.

TORONTO, WINNIPEG, EDMONTON, MONTREAL, REGINA, SASKATOON

Capital and Reserve, \$2,800,000.00

The strain and worry of managing Estates will all be borne for you by this Company.

A PRIVATE Executor may die or become incapable of acting before the completion of the Trust. A Trust Company is PERMANENT and will survive the longest Trusts.

This Company's financial strength and expert staff ensure responsible and capable administration.

We act as Trustee, Executor, Administrator, Guardian, Liquidator, Assignee, Financial Agent

SAFE DEPOSIT VAULTS SAVINGS DEPARTMENT MONEY TO LEND

D. H. COOPER, Manager, Winnipeg Branch, 323-325 Main Street.
C. Y. STAINER, Secretary.

CHALLENGE

WATERPROOF

GOLLARS

THE ACME OF COMFORT
is assured to every wearer of
"CHALLENGE"
Collars and Cuffs

They have the same dull finish, texture and fit as the best linen collar, and won't wilt or crack. "Challenge" Collars can be cleaned with a rub from a wet cloth.

Always smart—always dressy.

If your dealer doesn't sell "Challenge" Brand, send us 25c for collar or 50c for pair of cuffs. You'll be delighted.

New style book sent free on request.

THE ARLINGTON COLLAR CO. OF CANADA Ltd.
54-56 Fraser Ave., Toronto, Can.
Y 10

You saw this advertisement in this magazine. Don't forget to say so when writing.

WE WANT AGENTS
 Everywhere in Western Canada
 for
 C.O.W.L. Brand Ranch & Farm Remedies. (Preparations made from refined Coal-Tar and blended with suitable emollient oil).
Liberal Commissions
 Full particulars, prices etc., on application.
The Carbon Oil Works, Limited
 WINNIPEG - CANADA
 Write to Dept. "T" Remedies.

Mention this magazine when writing advertisers.

SYNOPSIS OF CANADIAN NORTH-WEST LAND REGULATIONS

Any person who is the sole head of a family or any male over 18 years old, may homestead a quarter-section of available Dominion land in Manitoba, Saskatchewan or Alberta. The applicant must appear in person at the Dominion Lands Agency or Sub-Agency for the district. Entry by proxy may be made at any agency, on certain conditions, by father, mother, son, daughter, brother or sister of intending homesteader.

Duties—Six months residence upon and cultivation of the land in each of three years. A homesteader may live within nine miles of his homestead on a farm of at least 80 acres solely owned and occupied by him or by his father, mother, son, daughter, brother or sister.

In certain districts a homesteader in good standing may pre-empt a quarter-section alongside his homestead. Price \$3.00 per acre. Duties—Must reside six months in each of six years from date of homestead entry (including the time required to earn homestead patent) and cultivate fifty acres extra.

A homesteader who has exhausted his homestead right and cannot obtain a pre-emption may enter for a purchased homestead in certain districts. Price \$3.00 per acre. Duties—Must reside six months in each of three years, cultivate fifty acres and erect a house worth \$300.00.

W. W. COREY,

Deputy of the Minister of the Interior
 N.B.—Unauthorized publication of this advertisement will not be paid for.

Mention this magazine when writing advertisers

Making High-Priced Pork while Grinding their own Feed.



AGENTS WANTED
 in Every Town and District

Shipments made from Galt, Ont. and Winnipeg, Man.

Address to Head Office

Canadian Hog Motor Co. Ltd.

372 Portage Ave.

Winnipeg, Man.

Mention this magazine when writing advertisers.

Make Farm Work Easy For Man and Horse.



Under evenest distribute the load so ever; horse pulls an equal share. That means better work from each horse, easier work for you. They are made for 2, 4, 6 or 8 horses. The 4 horse plow ever works four horses abreast on gang, sulky and disk plows. 1 horse in row, 1 on unplowed ground. Heider shows ever for wagon, manure spreader, grain drill, or any implement with pole.

The famous Heider four-horse Plow Ever.

Heider Byeners
 Made right work right without side draft. Will last a lifetime.

Sold by dealers everywhere. If your dealer has none in stock don't accept any other. Write us for free catalogue.
HEIDER MFG. CO.
 Main St., Carroll, Iowa.

Mention this magazine when writing advertisers.

In Answering Advertisements in this Magazine be sure and mention where you saw the advt. Remember we guarantee the reliability of all our advertisers.

he added reassuringly. "I live near here."

With a start Keep raised his eyes, and, discovered by his look, the young man continued less confidently.

"I don't blame you if you don't believe it," he stammered, "seeing me like this; but I do live quite near here. Everybody around here knows me, and I guess you've read about me in the papers, too. I'm—that is my name—"Like one about to take a plunge, he drew a short breath, and the rat-like eyes regarded Keep watchfully. "My name is Van Warden. I'm the one you read about—Harry; I'm Harry Van Warden!"

After a pause, slowly and reprovingly Fred shook his head; but his smile was kindly, even regretful, as though he were sorry he could not longer enjoy the stranger's confidences.

"My boy," he exclaimed, "you're more than a Van Warden! Your a genius!" He rose and made a peremptory gesture. "Sorry," he said, "but this isn't safe for either of us. Follow me, and I'll dress you up and send you where you want to go." He turned and whispered over his shoulder: "Some day let me hear from you. A man with your nerve—"

In alarm the other, with a gesture, commanded silence.

The library led to the front hall. In this was the coatroom. First making sure the library and hall were free of servants, Fred tiptoed to the coat-room and, opening the door, switched on the electric light. The canvas-clad man, leaving in his wake a trail of damp footprints, followed close at his heels.

Fred pointed at golf-capes, sweaters, great-coats hanging from hooks, and on the floor at boots and overshoes.

"Put on that motor coat and the goloshes," he commanded. "They'll cover you in case you have to run for it. I'm going to leave you here while I get you some clothes. If any of the servants butt in, don't lose your head. Just say you're waiting to see me—Mr. Keep. I won't be long. Wait."

"Wait!" snorted the stranger. "You bet I'll wait!"

As Fred closed the door upon him the stranger was rubbing himself violently with one of Mrs. Keep's golf jackets.

In his own room Fred collected a suit of blue serge, a tennis shirt, boots, even a tie. Underclothes he found ready laid out for him, and he snatched them from the bed. From a roll of money in his bureau drawer he counted out a hundred dollars. Tactfully he slipped them into the serge suit, and with the bundle of clothes under his arms raced downstairs

Your Money Back If My Gopher Poison Doesn't Kill Gophers-for Less Than 1c Per Acre



I do not claim—I do not promise—I absolutely and unreservedly guarantee that Mickelson's Kill-Em-Quick Gopher Poison is the surest, quickest and cheapest method in the world for killing gophers.

It is the only gopher poison in the world that does what it is supposed to do. It is the only gopher poison that is guaranteed to do what is claimed for it. It is the only gopher poison that you can buy with absolute assurance that it will kill the gophers—kill them quick and sure. You take no risk when you buy Kill-Em-Quick. The actual proofs of what others have done and the guarantee that goes with every box makes you sure that Kill-Em-Quick will either do the work claimed for it or your money will be refunded.



Mickelson's Kill-Em-Quick

It is the result of a ten years study of the habits, likes, tastes and haunts of gophers. Out on the farms I have watched them and the effect that various poisons had on them. It took me a long time to finally discover the combination that I am now offering you.

Kill-Em-Quick is different from anything else ever prepared to poison gophers with. It is attractive to their sense of smell and it tastes so good that they eat it greedily.

Once they get it into their mouths, they are sure to swallow it, and it is so powerful that the smallest particle causes instant death. It is easy to mix and easy to use. Simply soak the grain in water over night, then drain water off and mix with Kill-Em-Quick. Mix it with wheat, oats, oatmeal, corn, shorts or bran. For immediate use, soak grain in hot water for ten minutes and mix as above.

All old fashioned poisons are hard to mix, are distasteful to gophers and are applied in such a weakened state that they cannot possibly accomplish their purpose. The gophers do not eat enough of it to hurt them.

Get This Coin Purse Free

The handiest coin purse you ever saw. Free with the coupons found in each package of Kill-Em-Quick. One in every package. Send two from packages and coupon printed in this ad, and I will send the coin purse free.

Anton Mickelson, President
 Mickelson-Shapiro Co., Dept. C Winnipeg, Man.

Free Coin Purse

This coupon and two coupons from Mickelson's Kill-Em-Quick entitles you to one leather coin purse free. Send no money—just this coupon and two coupons from Kill-Em-Quick packages. Dept. C

Mickelson-Shapiro Co., Winnipeg, Man.

You saw this advertisement in this magazine. Don't forget to say so when writing.

WHY THE HECLA FURNACE SAVES ONE TON OF COAL IN SEVEN

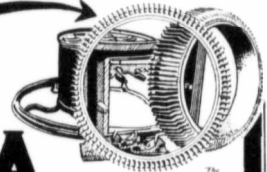

When you Buy a Furnace you get no more than you pay for:

But

some furnaces gobble up coal at such an extravagant rate, or are so complicated in construction that the average householder condemns the plant before it has been in use six months.

The Hecla Furnace

Eliminated trouble—its mechanical construction is simple—no dust—no escaped gas, and besides, it Saves One Ton of Coal in Every Seven you buy.

Write for our booklet *Comfort and Health*—it will interest you. The Hecla Furnace is "Comfort Insurance."



CLARE & BROCKEST LTD.
 WINNIPEG CANADA

You saw this advertisement in this magazine. Don't forget to say so when writing.

Be sure To Renew Your Subscription Before It's Too Late

YOU MUST

realize that with a "Barth" Jack you save time. Saving time means more work. More work means more profit. Ask your dealer for this Jack. Write us for catalogue.

BARTH MFG. CO.
166 L. St. MILWAUKEE, WIS.



Mention this magazine when writing advertisers

**CHEW
MAPLE
SUGAR
TOBACCO**

MILD, SWEET, MELLOW AND JUICY

Manufactured by
ROCK CITY TOBACCO CO.
Quebec Winnipeg

Mention this magazine when writing advertisers.

WANTED — SALESMAN AND SALESWOMAN—Hundreds of good positions now open paying from \$1,000.00 to \$5,000. a year. No firm experience required to get one of them. We will teach you to be a high grade Traveling Salesman or Saleswoman by mail in eight weeks and help you to secure a good position where you can make good wages while you are learning. Practical Remuneration. Write today for full particulars and testimonials from hundreds of men and women who have recently placed in good positions; also list of good positions open. Address Dent, 279, NATIONAL SALESMEN'S TRAINING ASSOCIATION, 806 Kent Building, Toronto, Ont. Mention this magazine when writing advertisers

and shoved them into the coat-room.

"Don't come out until I knock," he commanded. "And," he added in a vehement whisper, "don't come out at all unless you have clothes on!"

The stranger grunted. Fred rang for Gridley and told him to have his car brought around to the door. He wanted it to start at once—within two minutes. When the butler had departed, Fred, by an inch, opened the coat-room door. The stranger had draped himself in the underclothes and the shirt, and at the moment was carefully arranging the tie.

"Hurry!" commanded Keep. "The car'll be here in a minute. Where shall I tell him to take you?"

The stranger chuckled excitedly; his confidence seemed to be returning. "New York," he whispered, fast as he can get there! Look here," he added doubtfully, "there's a roll of bills in these clothes."

"They're yours," said Fred. The stranger exclaimed vigorously, "You're all right!" he whispered. "I won't forget this, or you either. I'll send the money back same time I send the clothes."

"Exactly!" said Fred. The wheels of the touring car crunched on the gravel drive, and Fred slammed the door to, and like a sentry on guard, paced before it. After a period which seemed to stretch over many minutes there came from the inside a cautious knocking. With equal caution Fred opened the door the width of a finger and put his ear to the crack.

"You couldn't find me a button-hook, could you?" whispered the stranger.....

Indignantly Fred shut the door and, walking to the veranda hailed the chauffeur. James, the chauffeur, was a Keepsburg boy, and when Keep had gone to college James had accompanied him. Keep knew the boy could be trusted.

"You're to take a man to New York," he said "or wherever he wants to go. Don't talk to him. Don't ask any questions. So, if you're questioned, you can say you know nothing. That's for your own good."

The chauffeur mechanically touched his cap and started down the steps. As he did so the prison whistle, still unsatisfied, still demanding its prey, shattered the silence. As though it had hit him a physical blow, the youth jumped. He turned and lifted startled, inquiring eyes to where Keep stood above him.

"I told you," said Keep, "to ask no questions."

As Fred re-entered the hall Winnie Keep was coming down

BELL ENGINES AND THRESHERS

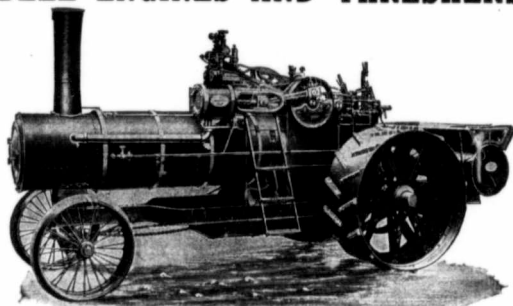

Our 26 and 30 h.p. Rear Mount Plowing Engine. 175 lbs. steam pressure under Alberta Specifications. No Brackets attached to boiler with Stud Bolts or Cap Screws. Engine and Gearing mounted on separate Steel Frame. No strain on the boiler. Gearing, open heart Cast Steel, guaranteed against breakage until worn out. Made to Plow without lost time through breaks or boiler troubles. Enquire about it.

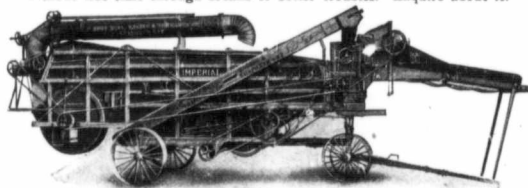

Imperial Separators. Sizes: 28 x 42, 32 x 54, 36 x 60. Improved for 1913. Good in all kinds of grain. A wonder in Flax. Handsome, Speedy and Durable. Write for further information.

The ROBT. BELL ENGINE & THRESHER CO. LTD.

Branches: Winnipeg, Man. Saskatoon, Sask.

Factory: Seaforth, Ont.

SPARK ARRESTER

One that gets all the sparks without clogging or interfering with the draft. Fits any engine. Screens adapted to any fuel.

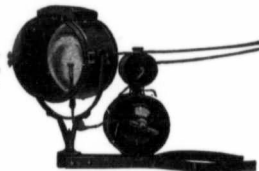

ACETYLENE GAS HEADLIGHT

Turns night into day. Bracket to fit any make of engine. Throws light 400 feet. Operating expense about 1c. per hour.

FLUE CUTTER

You need this tool to get ready for your Spring Plowing. Is adjustable in length and size. Cuts the flue without burring the end. Try it.

Estate of E. M. POPE, Watertown, S. Dakota, U. S. A.
Send for Catalogue and Price List to

THE MAYTAG COMPANY, LIMITED, Winnipeg, Man

CAEW
"BAT"
PLUG TOBACCO
THE ROCK CITY TOBACCO CO. LIMITED - QUEBEC.

The "Eagle" Steel Scrub Cutter
(Built in 3 sizes.)

No. 1 cuts 4 feet swath for use with 4 to 6 horses.
No. 2 cuts 5 1/4 feet swath for use with tractor of 20-25 h. p.
No. 3 cuts 6 1/4 feet swath for use with the heaviest tractor.
The best solution of the problem of cleaning scrub land in a cheap, rapid and satisfactory manner, saving at least 75% of the cost of hand labor.

The Eagle Manufacturing Company
Dauphin, Man.

FARMERS ATTENTION

Canadian-American farmers and your sons, who have for 18 years been buying Rawleigh's Medicines, Extracts, Spices, Etc., in the United States on Rawleigh's Pay-After-You-Are-Satisfied Plan are all invited to call and see us at our new Canadian factory in Winnipeg.

FARMERS' SONS and OTHERS
who want to make not less than

\$100 PER MONTH CLEAR PROFIT

above all expenses selling our goods direct to farmers from wagons should write us at once for our matchless offer to salesmen.

NO DUTY OR LONG HAUL FREIGHT petition. We are the only large Company of our kind in Canada. Every farmer in Canada needs and uses our kind of goods.

We want a man at once in every locality to represent the greatest buying, manufacturing, distributing and selling organization in North America. Established 18 years. Capital and surplus now \$2,000,000. Reference: Canadian Bank of Commerce. Address

The W.T. Rawleigh Medical Company
IMPORTERS - CHEMISTS - MANUFACTURERS
94 Bannell St., W. WINNIPEG,
MANITOBA



\$35 DOMINION BICYCLES FOR \$26.50

BIGGEST AND BEST VALUE IN BICYCLES EVER OFFERED



THEY have mud guards, wood rims, Dunlop style tires, roller chain, New Departure coaster brake, large rubber pedals, pump & tools

Retail Price - - - \$35.00
Mail Order Price - \$26.50

SUNDRIES AND TIRES at Prices entirely unheard of in the West before. Send for large illustrated Catalog. It is free.

DOMINION CYCLE COMPANY
224-6 LOGAN AVE., WINNIPEG



Dealers Increase Your Sales!
Take a Look at the **Strite Governor Pulley** It's the original and the only thing for driving cream separators with guarantee. Once tried, always used. **TRY ONE.** More in use than all others combined. Costs no more than imitations. Also ask about our friction clutch pulleys.

STRITE GOVERNOR PULLEY CO., 310 S. 3RD ST., MINNEAPOLIS

THE Double Track Route TO

Detroit, London, Hamilton, Toronto, Montreal and New York via Niagara Falls

Smooth road-bed, polite employees, unequalled dining-car service, and latest standard equipment

AGENTS, COOK'S TOURS AND ALL STEAMSHIP LINES

Rates, reservations and all particulars at Ticket Office

Phone Main 7098 260 Portage
WINNIPEG

Mention this magazine when writing advertisers

the stairs toward him. She had changed to one of the prettiest evening gowns of her trosseau, and so outrageously lovely was the combination of her gown and herself that her husband's anxiety fell from him, and he was lost in admiration. But he was not for long lost. To his horror, the door of the coat-room opened towards his wife and out of the room the stranger emerged. Winnie, not accustomed to seeing young men suddenly appear from among the dust-coats, uttered a sharp shriek.

With what he considered great presence of mind, Fred swung upon the visitor.

"Did you manage it?" he demanded.

The visitor did not heed him. In amazement, in abject admiration, his eyes were fastened upon the beautiful and radiant vision presented by Winnie Keep. But he also still preserved sufficient presence of mind to nod his head dully.

"Come," commanded Fred.

"The caris waiting." Still the stranger did not move. As though he had never before seen a woman, as though her dazzling loveliness held him in a trance, he stood still, devouring Winnie with his eyes. In her turn, Winnie beheld a strange youth who looked like a groom out of livery, so overcome by her presence as to be struck motionless and inarticulate. For protection she moved in some alarm towards her husband.

The stranger gave a sudden jerk of his body that might have been intended for a bow. Before Keep could interrupt him, like a parrot reciting a lesson he exclaimed explosively:

"My name's Van Warden. I'm Harry Van Warden."

He seemed a little convinced of the truth of his statement though he had announced that he was the Czar of Russia. It was as if the stage manager had drilled him in the lines.

But upon Winnie, as her husband saw to his dismay, the words had produced an instant and appalling effect. She fairly radiated excitement and delight. How her husband had succeeded in capturing the social prize of Scarboro she could not imagine, but, for doing so, she flashed towards him a glance of deep and grateful devotion.

Then she beamed upon the stranger. "Won't Mr. Van Warden stay to dinner?" she asked.

Her husband emitted a howl. "He will not!" he cried. "He's not that kind of a Van Warden. He's a plumber. He's the man that fixes the telephone."

He seized the visitor by the sleeve of the longmotor coat and dragged him down the steps.

THE STOVER!

Is the Very Best Engine to Buy

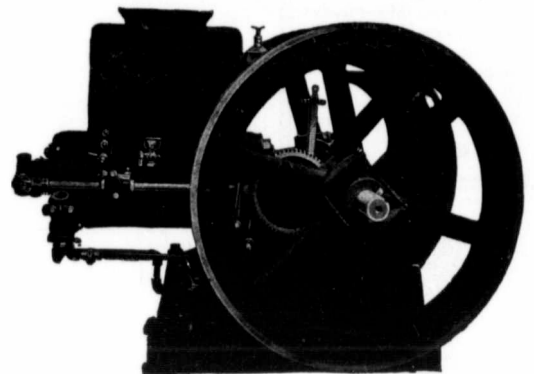

Write for our Extraordinary Prices of

Dry Cells, Crusher Plates, Harness, Oils, Plow Shares, Bag Holders, Scales, Buggies, Cultivators, Plows, Harrows, Thrashers, Belting, Grain Crushers, Pole Saws Etc., Etc.

NOTE: OUR PRICE for 12-inch plow shares is **\$2.25**, for 14-inch plow shares is **\$2.50**, for 16-inch plow shares is **\$2.75**. All Guaranteed.

We Can Save You Money

Canadian Stover Gasoline Engine Co., Ltd.
EIGHTH and PACIFIC AVENUE, BRANDON
The Original Farmers' Company

You saw this advertisement in this magazine. Don't forget to say so when writing.

2 IN 1 10 CT

SHOE POLISH

Gives a Quick, Brilliant Polish That Lasts

Easier to Use Better for the Shoes

No Turpentine

You saw this advertisement in this magazine. Don't forget to say so when writing.

Sporting Goods That Are Fit For Sport

Everything for the sportsman or athlete. Pocket Flash-Lights from 75c. to \$2.75. Send for one of our Baseball Annuals containing every detail and record of baseball interest. Price 5c. per copy. Also New Baseball Score Counter. Send us your name and address together with 10c. and we will mail you one. State your needs and we will send complete information free by return.

Sportmen's Headquarters
P. J. Cantwell & Co., Ltd.
346 Portage Ave., Winnipeg
DEPT. B.

ICY-HOT



The Bottle That Keeps Hot Liquids Hot 24 Hours Cold Liquids Cold 3 Days

Hot or cold drinks when needed while traveling, fishing, hunting, motoring, picnicing, etc.

Keep baby's milk at right temperature, or invalid's hot or cold drink by the bed, all night, without heat, ice or leeches.

Icy-Hot Jars—one and two quart—keep stew, vegetables, etc., hot without fire—disinfects or ice cream acid without loss.

Accept No Substitute
There's No Bottle Just As Good
Inexpensive glass bottle easily removed, sterilized if broken. Perfectly sanitary—liquids touch only glass. Handsome nickel plated and leather cases.

Many New and Exclusive Features



You saw this advertisement in this magazine. Don't forget to say so when writing.

CORRUGATED IRON SHEETING

If you want a strong, durable, inexpensive Wall and Roof covering, use **CORRUGATED IRON**. If you want the best quality corrugated galvanized iron, use that manufactured by us. Write to-day for free booklet. 704

THE METALLIC ROOFING CO. LIMITED
MANUFACTURERS
TORONTO & WINNIPEG

Western Canada Factory
 797 Notre Dame Ave.
WINNIPEG MAN.



The Biggest Thing in the Clock Business

Big Ben is the biggest thing today in the alarm clock business.

He is only two years and a half old, but he's already getting more work from the Dominion than any clock alive.

In two years and a half time, 6,000 Canadian dealers have adopted him. Nearly half of the families in Canada leave it to him to call them up in the morning; nearly half the families in Canada use him all day long to tell the right time by. He is really two good clocks in one—a crackerjack of a time-keeper and a crackerjack of an alarm.

Big Ben stands seven inches tall. He is triple nickel-plated and wears an inner vest of steel that insures him for life. His big, bold figures and hands are easy to read in the dim morning light. His large, comfortable keys almost wind themselves. He rings five minutes steadily or ten intermittently. If he is oiled every other year, there is no telling how long he will last.

Big Ben's price is \$1.00 anywhere in Canada. If you cannot find him at your dealer's, a money order sent to Windsor, La Salle, Illinois, will bring him to you, carefully packed and duty charges paid.

BIG BEN

Big Ben Alarm Clocks

Are illustrated in the catalogue of

D. R. Dingwall, Limited
 JEWELLERS. WINNIPEG

Write for a copy of this book

Reluctantly, almost irresistibly, the visitor stumbled after him casting backward amazed glances at the beautiful lady. Fred thrust him into the seat beside the chauffeur. Pointing at the golf-cap and automobile goggles which the stranger was stupidly twisting in his hands, Fred whispered, fiercely:

"Put those on! Cover your face! Don't speak! The man knows what to do."

With eager eyes and parted lips, James the chauffeur was waiting for the signal. Fred nodded sharply, and the chauffeur stooped to throw in the clutch. But the car did not start. From the hedge beside the driveway, directly in front of the wheels, something on all fours threw itself upon the gravel. Something in a suit of purple-grey; something torn and bleeding, smeared with sweat and dirt; something that cringed and crawled, that tried to ride and sank back upon its knees, lifting to the glare of the headlight the white face and the white hair of a very old, old man. The kneeling figure sobbed, the sobs rising from far down in the pit of the stomach, wrenching the body like waves of nausea. The man stretched his arms towards them. From long disuse his voice cracked and broke.

"I'm done!" he sobbed. "I can't go no farther! I give myself up!"

Above the awful silence that held the four young people the prison siren shrieked in one long, mocking howl of triumph.

It was the stranger who was the first to act. Pushing past Fred, and slipping from his own shoulders the long motor-coat, he flung it over the suit of purple grey. The goggles he clapped over the old man's frightened eyes, the golf cap he pulled down over the white hair. With one arm he lifted the convict and with the other dragged and pushed him into the seat beside the chauffeur. Into the hands of James he thrust the money.

"Get him away!" he ordered. "It's only twelve miles to Connecticut line. As soon as you're across, buy him clothes and a ticket to Boston. Go through White Plains to Greenwich—and then you're safe!"

As though suddenly remembering the presence of the owner of the car, he swung upon Fred. "Am I right?" he demanded.

"Of course!" roared Fred. He flung his arm at the chauffeur as though throwing him into space. "Get out of here!" he shouted.

The chauffeur, by profession a criminal but by birth a human being, chuckled savagely, and this time threw in the clutch. With a grinding of gravel the racing car leaped into the night, its ruby red lamp winking in fare-

WINCHESTER

Loaded Shells and Cartridges

To end ammunition troubles use Winchester make of loaded shells and cartridges. The Winchester name and trademark on a box of loaded shells or cartridges mean that they are accurate, reliable and uniform, in a word the best that can be made. They are a guarantee that the long experience, great skill and unequalled facilities of the Winchester Repeating Arms Company—the largest manufacturers of guns and ammunition in the world—were all efficiently employed in making them. Winchester loaded shells and cartridges develop the greatest possibilities of any shotgun, rifle or revolver in which they are used. They are sold by all dealers, and are the best sellers everywhere. Accept only Winchester make

TO GET THE LIMIT OF SATISFACTION

W TRADE MARK

You saw this advertisement in this magazine. Don't forget to say so when writing.

Be Sure of Your Separator Oil

STANDARD Hand Separator Oil

Standard Hand Separator Oil is the perfect lubricant for cream separators. Reduces friction and jarring to a minimum, so that greatest cream yield is insured.

Never gums, rusts or corrodes. Lengthens the life of the separator.

One gallon cans. All dealers.

THE IMPERIAL OIL CO., Limited
 Main Office: WINNIPEG
 Regina, Moose Jaw, Saskatoon, Calgary, Edmonton, Lethbridge, Vancouver.

You saw this advertisement in this magazine. Don't forget to say so when writing.

Remember to Renew Your Subscription

METALLIC WALLS FOR THE HOME



"METALLIC" Ceilings are artistic, sanitary and will last as long as the building.

In the kitchen and bathroom they are of particular sanitary value as they can be easily cleaned and are absolutely rust-proof.

While inexpensive, they give an air of distinction to any home.

Write us for free booklet.

690

THE METALLIC ROOFING CO. LIMITED
MANUFACTURERS
TORONTO & WINNIPEG

Western Canada Factory: 767 Notre Dame Ave. WINNIPEG, MAN.

Enough to Make a Cat Laugh



Tempting

The burly prisoner stood unabashed before the judge. "Prisoner at the bar," asked the clerk of the arraigns, "do you wish to challenge any of the jury?"

The prisoner looked them over carefully.

"Well," he replied, "I'm not exactly wot you'd called in training, but I wouldn't mind a round or two with that there fat old joser in the corner."

The Only Thing

An emigrant to the States was being examined on landing by the authorities, to discover to what nationality he belonged; but, try him as they would, he could not tell them. To find out, they asked him if he had read the Bible, or Shakespeare, or the Koran. But he hadn't read any of these. The inspector lost his temper at last.

"What have you read, then?" he asked him, and the man answered:

"I've just red hair on my head."

More or Less

A lady who had not enjoyed the advantages of a liberal education, but whose natural shrewdness had led her to see the value of life assurance, had been asked by the agent who was filling up the proposal if she had had this, that, and the other illness or disorder.

"No! No! No!" she had replied wonderingly to question after question, until a light dawned on her:

"Say, mister, would I get more or less if I'd had all them things?"

Extreme Penalty

Lord Russell of Killowen, years before he was a judge, was sitting in court, when another barrister, leaning across the benches during the hearing of a trial for bigamy, whispered: "Russell, what's the extreme penalty for bigamy?" "Two mother-in-laws," replied Russell.

DON'T WAIT

but order early your supply of

Drewry's Bock Beer

The Spring Tonic for which there is always a big demand.

Ladies', Gentlemen's and Children's Clothing

Spring and Summer clothing for ladies, gentlemen and children. Do not fail to send for our handsome illustrated book of this season's fashions. You will find our prices most interesting.

Metropolitan Mfg. Co. Limited
Toronto, Ont.

Ontario Wind Engine & Pump Company's
LINES ARE SUPREME

Be Successful

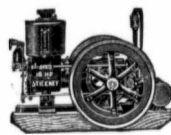

Success is not "getting what you want," it is getting what you ought to have. That's why users of the O. W. E. & P. Co.'s Engines with outside Ignitors; Engines with ball bearing cams; Windmills that operate with a breeze and stand a gale; Pump Jacks that pump; Grinders with both capacity and efficiency; Water Basins that supply the cow with fresh water; Stanchions that let her sleep; Well Drills that earn from \$20 to \$50 a day. They've got what they ought to have and are successful. The O. W. E. & P. Co.'s machines are what you should have.



If your dealer does not handle our lines, write the
Ontario Wind Engine & Pump Co., Ltd.

AT
MONTREAL TORONTO WINNIPEG OR CALGARY

You saw this advertisement in this magazine. Don't forget to say so when writing.

Bakes Bread to Perfection

New Perfection
WICK BLUE FLAME
Oil Cook-stove

Cleaner than coal or wood. Cheaper than gas.

For best results use ROYALITE Oil.
Stock carried at all chief points.



THE IMPERIAL OIL COMPANY Limited
Winnipeg Toronto Halifax
Montreal Vancouver St. John

You saw this advertisement in this magazine. Don't forget to say so when writing.

THE BEST LINIMENT

OR PAIN KILLER FOR THE HUMAN BODY

**Gombault's
Caustic Balsam**

IT HAS NO EQUAL

For the Human Body
—It is penetrating, soothing and healing, and for all Old Sores, Bruises, or Wounds, Painful Swellings, Cancers, Boils, Corns and Bunions. CAUSTIC BALSAM has no equal as a Liniment.

We would say to all who buy it that it does not contain a particle of poisonous substance and therefore no harm can result from its external use. Persistent, thorough use will cure many old or chronic ailments and it can be used on any case that requires an outward application with perfect safety.

A Perfectly Safe and Reliable Remedy for Sore Throat Chest Cold Backache Neuralgia Sprains Strains Lumbago Diphtheria Sore Lungs Rheumatism and all Stiff Joints

REMOVES THE SORENESS—STRENGTHENS MUSCLES
Dorhill, Tex.—"One bottle Gombault's Balsam did my rheumatism more good than \$100.00 paid in doctor's bills."
Price \$1.50 per bottle. Sold by Druggists, or sent by express prepaid. Write for Booklet No. 1.
The LAWRENCE-WILLIAMS COMPANY, Toronto, Can.

Mention this magazine when writing advertisers.

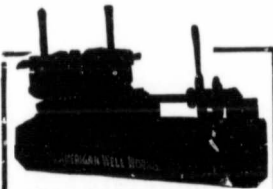

\$1500 to \$5000 Per Year

have been made by hundreds of people operating the "American" Drilling Machines, 40 years' experience, 59 regular styles and sizes and the output of the world's largest manufacturers of this kind of machinery make "AMERICAN"

MACHINES STANDARD

Made in types for every kind of earth and rock drilling or mineral prospecting, equipped with any power, or operated with your traction engine. Our new 1918 page Catalog Free.

THE AMERICAN WELL WORKS

General Office and Works:

AURORA
ILL., U. S. A.

Chicago Office: First Nat. Bk. Bldg.

Mention this magazine when writing advertisers

PATENTS TRADE MARKS AND DESIGNS

Write for booklet, circulars, terms, etc.

FETHERSTONHAUGH & CO.

FRED. E. FETHERSTONHAUGH, F. C. M. E.
GERALD S. ROXBURGH, E. A. Sc.

Portage Avenue, WINNIPEG.
209-10 Bank of Nova Scotia

Mention this magazine when writing advertisers

ERZINGER'S No. 2 CUT PLUG

Leads them all. It's the Best Dollar Tobacco sold anywhere.

JOHN ERZINGER

McIntyre Bldg. - 293 Portage Ave.
Phone 69 Phone 2677

Mention this magazine when writing advertisers.

Interested Advice

Two young men were talking together when George, the older of the two, became suddenly very confidential.

"I am much bothered," he said. "I can marry a wealthy widow whom I don't love or a poor girl that I do love intensely. What shall I do?"

"Listen to your heart," advised his companion, "and marry the one you love."

"You are right, my friend. I shall marry the girl."

"Then can you give me the widow's address?"

Finding a Name for Baby

She: "They haven't found a name for that baby in the flat upstairs yet."

He: "The one that cries so?"

"Yes."

"Well, that's strange! The neighbors have called it everything they could think of!"

Not Proven

"She claims to have a perfect alibi."

"What is her alibi?"

"She says that she can prove that at the time the crime was committed her maid was brushing her hair."

"That proves an alibi for her hair, but how about herself?"

His Soul's Revelation

"Do you know," said a Sunday school teacher, addressing a new pupil in the infant class, "that you have a soul?"

"Course I do," replied the little fellow, placing his hand over his heart. "I can hear it tick."

The Successful Hunter

Daughter: "Why, papa, you are improving. You've shot a rabbit."

Papa (City magnate who has bought a country estate and is trying to live up to it): "Well, I didn't exactly shoot it, Gwen. I slipped climbing a fence, and fell on it."

Not What He Went For

"Been to the theatre this week?"

"Yes."

"What did you see?"

"A black velvet bow, some tortoise-shell combs, a couple of plumes, a chiffon knot, and a stuffed bird about the size of a hen."

Unfortunate

Owner: "How did you come to puncture the tyre?"

Chauffeur: "Ran over a milk bottle."

Owner: "Didn't you see it in time?"

Chauffeur: "No; the kid had it under his coat."

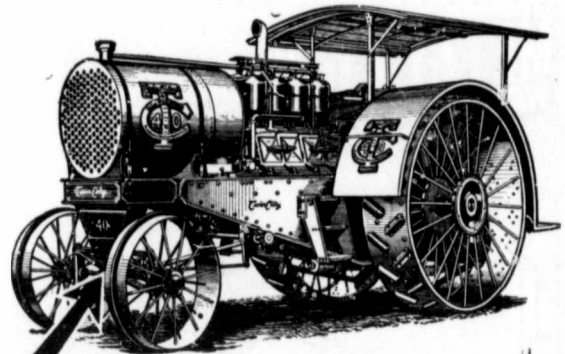

Under Perfect Control

At all times—under all conditions; a giant steel horse that responds instantly to every move of the throttle and steering gear—a worker that never tires, never balks, never goes lame.

Twin City Tractors

Two Sizes—25 and 40 Tractive H.P.

Burn Kerosene or Gasoline

Its three-point suspension maintains steady balance while travelling over rough ground—prevents strain to all working parts.

The front wheels turn on automobile knuckle joints—insuring easy steering.

The fly-ball governor controls the engine within a few revolutions from full load to no load by regulating the fuel supply. An accurate, positive adjusting device on the governor makes a steady motion for operating a thresh-

ing machine, cornsheller, feed grinder and other farm machinery.

A hand throttle gives the operator control of the motor while running. There are many other points of excellence in the Twin City Tractor, which make it stand head and shoulders above all other makes. They are all explained in our Tractor book 10H. Our book 12H tells of some of the remarkable achievements of the Twin City Tractor. Both books are free. Write for them.

Minneapolis Steel & Machinery Co. of Canada, Limited
Regina, Saskatchewan

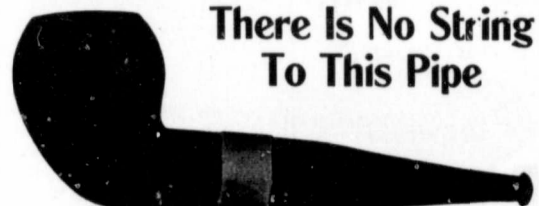

There Is No String To This Pipe

It is absolutely FREE to subscribers who take advantage of this offer

The Weekly Free Press and Prairie Farmer
Winnipeg

The Canadian Thresherman and Farmer

Both including Pipe for **\$1.25**
the nominal sum of

The lowest price at which these two papers will be offered this year is \$1.25. It makes no difference whether you take the pipe or not, the price is the same. While the supply of these pipes lasts they will be given away free to all who subscribe. Better get your order in early and be sure of a good smoke.

1911.

Weekly Free Press and Prairie Farmer,
Winnipeg, Man.

Find enclosed \$1.25, for which send the "Weekly Free Press and Prairie Farmer" one year, and the "Canadian Thresherman and Farmer" one year, together with pipe, to the following address:

Name _____
Town _____
Province _____ P.O. Box _____

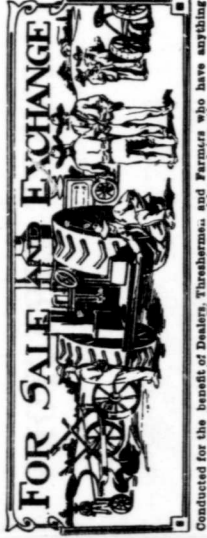

Conducted for the benefit of Dealers, Threshermen, and Farmers who have anything to sell or exchange. There exists a world for each illustration.

MACHINE SHOPS. Practical mechanics... Machine shops, practical mechanics... Machine shops, practical mechanics...

SALESMEN WANTED. Threshermen or... Salesmen wanted, threshermen or...

FOR SALE—45 H.P. 2-cylinder gas engine... For sale, 45 H.P. 2-cylinder gas engine...

FOR SALE—Caddy steam plowing outfit... For sale, Caddy steam plowing outfit...

FOR SALE—Caddy steam plowing outfit... For sale, Caddy steam plowing outfit...

FOR SALE—Caddy steam plowing outfit... For sale, Caddy steam plowing outfit...

FOR SALE—Caddy steam plowing outfit... For sale, Caddy steam plowing outfit...

FOR SALE—Caddy steam plowing outfit... For sale, Caddy steam plowing outfit...

WANTED—Good engine for plowing... Wanted, good engine for plowing...

POSITION WANTED AS FIREMAN... Position wanted as fireman...

WANTED—Position of a gas engine... Wanted, position of a gas engine...

WANTED NOW—For Western Trade... Wanted now, for western trade...

WANTED—POSITION AS ENGINEER... Wanted, position as engineer...

FOR SALE—One 25 horse J. I. Case... For sale, one 25 horse J. I. Case...

FOR SALE—One 30 H.P. Double... For sale, one 30 H.P. Double...

FOR SALE—Caddy Patent Engine... For sale, Caddy Patent Engine...

FOR SALE—One 30 H.P. American... For sale, one 30 H.P. American...

WANTED—POSITION AS ENGINEER... Wanted, position as engineer...

FOR SALE—One 30 H.P. American... For sale, one 30 H.P. American...

FOR SALE—One 30 H.P. American... For sale, one 30 H.P. American...

TWO EXPERIENCED ENGINEERS... Two experienced engineers...

FOR SALE—110 horse power... For sale, 110 horse power...

FOR SALE—One 30-40 horse power... For sale, one 30-40 horse power...

43 VARIETIES, poultry, pigeons... 43 varieties, poultry, pigeons...

FOR SALE—Large Wind Mill and... For sale, large wind mill and...

FLOWING OUTFIT—Having sold my... Flowing outfit, having sold my...

WANTED POSITION—on other steam... Wanted position, on other steam...

FOR SALE—Big "Dutchman" Engine... For sale, big "Dutchman" engine...

FOR SALE—One 30 H.P. underrated... For sale, one 30 H.P. underrated...

WANTED—Position as engineer for... Wanted, position as engineer for...

FOR SALE—International 20 H.P. gas... For sale, International 20 H.P. gas...

WE DUPLICATE ALL INVENTIBLE... We duplicate all inventible...

ENGINEER—Wants position on steam... Engineer, wants position on steam...

WILL OIL—Full Rummy 30-40 H.P. Tractor... Will oil, full Rummy 30-40 H.P. tractor...

FOR SALE—Three sections P. & O... For sale, three sections P. & O...



REIGNER'S SITUATION WANTED... Reigner's situation wanted...

GASOLINE ENGINE expert desires... Gasoline engine expert desires...

LIGHT BRAEMAS—The real Canadian... Light braemas, the real Canadian...

WANTED—To buy from contact who... Wanted, to buy from contact who...

PRAMONT FLAX—Grown on fallow... Pramont flax, grown on fallow...

GASOLINE ENGINE expert desires... Gasoline engine expert desires...

LIGHT BRAEMAS—The real Canadian... Light braemas, the real Canadian...

FOR SALE—One 30 H.P. Case... For sale, one 30 H.P. Case...

KUD WELDING CO. OXY-ACETYLENE... Kud welding co. oxy-acetylene...

WANTED—Position as steam engineer... Wanted, position as steam engineer...

FOR SALE—One 30-40 horse power... For sale, one 30-40 horse power...

FOR SALE—Having rented my farm... For sale, having rented my farm...

WANTED—Steamy, suitable for ten... Wanted, steamy, suitable for ten...

REBUILT 25 H.P. Minneapolis outfit... Rebuilt 25 H.P. Minneapolis outfit...

FOR EXCHANGE—Imported Cleveland... For exchange, imported Cleveland...

FOR EXCHANGE—Imported Cleveland... For exchange, imported Cleveland...

FOR EXCHANGE—Imported Cleveland... For exchange, imported Cleveland...

WESTERN CANADIAN IMPLEMENT DIRECTORY

EXPLANATION.—First find the Implement Wanted and the Number opposite will be the Number of the Concern, in the first column, that handles it.

1-AULTMAN & TAYLOR MACHINERY CO., Regina, Calgary, Saskatchewan.
2-BEATTY BROS., Brandon.
3-BELL ROBT. ENGINE & THRESHER CO., Winnipeg.
4-BRANDON PUMP & WIND MILL WORKS, Brandon.
5-BRITISH CANADIAN AGRICULTURAL TRACTORS, Saskatoon.
6-BUFFALO PITTS CO., Moose Jaw.
7-BURRIDGE-COOPER CO., Winnipeg.
74-Canadian Armstrong Quam Co., Saskatoon.
74a-Canadian Corrugated Pipe Co., Fortage la Prairie.
74b-Canadian CUSHMAN CO., Winnipeg.
8-CANADIAN FAIRBANKS CO., Winnipeg, Calgary, Saskatoon Vancouver.
9-CANADIAN HOLT CO., Calgary.
10-CANADIAN MOLINE PLOW CO., Winnipeg.
11-CANADIAN RUBBER CO., Winnipeg, Vancouver.
12-CANADIAN STOVER CO., Brandon.
13-CANADIAN SWENSONS CO., Winnipeg.
14-CASE, J. I. T. M. Co., Winnipeg, Regina, Calgary, Saskatoon.
15-COCKSHUTT PLOW CO., Winnipeg, Regina, Calgary, Edmonton.
16-CRANE & ORDWAY, Winnipeg.
17-DEERE, JNO. PLOW CO., Winnipeg, Regina, Calgary, Edmonton Saskatoon, Lettbridge.
18-DE LAVAL SEPARATOR CO., Winnipeg.
19-DOMINION SPECIALTY CO., Winnipeg.
20-DUIS GEO. & CO., Winnipeg.
201-EMERSON BRANTINGHAM IMPLEMENT CO., Winnipeg, Regina, Calgary, Saskatoon.
21-EMPIRE CREAM SEPARATOR CO., Winnipeg.
214-GARDEN CITY FEEDER CO., Regina.
22-GAS TRACTION CO., Winnipeg, Saskatoon, Calgary.
23-GENERAL SUPPLY CO., Winnipeg.
24-GOODYEAR TIRE & RUBBER CO., Winnipeg, Regina, Calgary.
24 1/2-GOULD, SHAPLEY & MUIR, Winnipeg, Regina.
25-GRAY-CAMPBELL CO., Winnipeg, Brandon, Moose Jaw, Calgary.
26-HACKNEY MFG. CO., Winnipeg.
26-HAUG BROS. & NELLERMOE CO., Winnipeg, Calgary, Regina.
27-HARMER IMPLEMENT CO., Winnipeg.
28-HART PARR CO., P. la Prairie, Regina, Calgary, Saskatoon.
29-HERO IMPLEMENT CO., Winnipeg.
291-HUBER MFG. CO., Winnipeg, Saskatoon, Brandon.
292-INT. HARVESTER CO., Winnipeg, Regina, Calgary, Edmonton, Saskatoon, Brandon.
31-LISTER R. A. & CO., Winnipeg.
32-LOUEN HARDWARE & SPECIALTY CO., Winnipeg.
33-MANITIBA ENGINES LTD., Brandon.
34-MASSEY-HARRIS CO., Winnipeg, Regina, Calgary, Edmonton, Saskatoon.
35-MAYTAG CO., Winnipeg.
36-McLAUGHLIN CARRIAGE CO., Winnipeg.
37-McRAE ALEX., Winnipeg.
38-MELLOTTE CREAM SEPARATOR CO., Winnipeg.
39-MINNEAPOLIS STEEL AND MACH. CO., Regina.
39 1/2-MINNEAPOLIS THRESHING MACHINE CO., Winnipeg, Regina, Calgary.
40-MOODY MATHEW & SONS, Winnipeg.
41-NEEPAWA MFG CO., Neepawa.
42-NICHOLS & SHEPARD CO., Regina, Winnipeg.
43-ARMSTRONG MANUFACTURING CO., Saskatoon.
44-PETRIE MFG. CO., Winnipeg, Regina, Calgary, Vancouver, Edmonton.
45-PIONEER TRACTOR CO., Calgary.
46-RAYMOND MFG. CO., Winnipeg.
47-REEVES & CO., Regina.
48-RENFREW MACH. CO., Saskatoon.
49-RHSBURY PUMP CO. LTD., Brandon.
50-RUMELY M. CO., Winnipeg, Calgary, Saskatoon, Regina.

51-SAWYER & MASSEY CO., LTD., Winnipeg.
52-SHARPLES SEPARATOR CO., Winnipeg.
53-STEVENS BRUSH CUTTER CO., Odessa.
54-STEWART SHEAF LOADER CO., Winnipeg.
55-TUDHOPE-ANDERSON CO., Winnipeg, Regina, Calgary, VIRDEN MFG. CO., Virden.
7-VULCAN IRON WORKS, Winnipeg.
WATERLOO MFG. CO., P. la Prairie, Regina.
80-WATSON JNO MFG. CO., Winnipeg.
61-WESTERN FOUNDRY CO., Saskatoon.
62-WESTERN STEEL & IRON CO., Winnipeg.
63-WHITE, GEO. & SONS, Brandon.
63 1/2-WINNIPEG CEILING & ROOFING CO., Winnipeg.
64-WINNIPEG RUBBER CO., Winnipeg.

BUGGIES AND CUTTERS.
Armstrong Buggies and Cutters. 15
Bays Buggies and Cutters. 16
Bayne Carriages Co. 37
Brookville Buggies and Cutters. 17
Dominion Carriage Transfer Agents. 6
Emerson. 209
Gray Buggies and Cutters. 24
Greer Buggies. 62
Henry Buggies. 10
McLaughlin Buggies and Cutters. 36
Munro-Melntosh Buggies & Cutters 10
Renfrew Buggies. 17
Tudhope Buggies and Cutters. 55

CREAM SEPARATORS.
Blue Bell. 30
Champion. 55
Dairy Maid. 55
De Laval. 18
Empire. 21
Magnat. 44
Massey-Harris. 34
Mellotte. 31
National. 36
Renfrew Standard. 18
Sharpley. 48

CULTIVATORS AND STUMP PULPERS.
China's Stiff Tooth Cultivators. 15
Cockshutt Cultivator. 15
Deere No. 2 Cultivator. 17
Deering Cultivator. 30
E. J. (2 Horse) Cultivator. 15
Emerson. 201
Fleury's Cultivator. 17
Frost & Wood Seedling. 15
Hilborn Stump Puller. 64
K. A. (2 Horse) Cultivator. 21
McCormick Cultivator. 30
Massey-Harris Corn Cultivator. 45
Paris Scuffer. 39
Sveinvald Cultivator. 34
Verity Cultivator. 34

DISC AND DRAG HARROWS.
Ajax Drag. 17
Bissell Disc. 17
Boss Drag. 50-62-60
Canadian Moline Boss Drag. 10
Canon Disc. 35
Case, J. I. Disc and Drag. 27
Champion Wheel Disc. 17
Cockshutt Disc and Drag. 15
Cockshutt Lever and Clip. 17
Deer Disc and Drag. 17
Deere Steel Boss. 17
Deering Disc Harrow. 30
Jefferson Jr. Disc. 62
Economy Disc. 10
Emerson Disc and Drag. 64
Evans Disc. 30
Fleury's Steel Channal Drag. 17
Fleury's Clipped Drag. 17
Fleury's Disc. 17
Fuller and Johnston. 61
Grand Detour Drag and Disc. 60
Hosmer Wheel Disc. 17
International Diamond and Lever. 30
Massey-Harris Disc and Drag. 34
Emerson Rake. 20
Moline Flexible Drag and Lever. 10
Nixon Disc and Drag. 64
Harris Disc and Drag. 64
Scott Diamond Drag. 17
Superior Wheel Disc. 30
Universal Drag. 17
Universal Traction Truck for Discs. 1
Harrow. 17
Louden Hay Rake. 20
Louden Hay Tools. 32
Massey-Harris Mower. 34
Massey-Harris Steel Roller. 34
Massey-Harris Hay Tedder and Leader. 34
McCormick Hay Stacker. 30
McCormick Mower. 30
McCormick Sweeper & Hay Rake. 20
Noxon Mowers & Rake. 55
Reeves Hay Tools. 201
Stewart Wheel Loader. 17
Success Hay Lozer. 34
Watson's Root Pulper. 60

FRED AND ENRIQUE CUTTERS AND PULPERS.
Cockshutt Feed Cutters. 15
McCormick Pulper. 30
Fleury's Feed Cutter. 17
Geiser Feed Cutter and Grinder. 7
Massey-Harris Feed Cutter. 24
Watson's Feed Cutter. 60
Watson's Root Pulper. 60

FEED GRINDERS.
Brandon. 6
Challenge. 6 & 27
Cyclone. 7
Daisy. 7
Diamond Air Spray. 55
Fleury's. 17
Good Shapley & Muir. 15
Manitoba. 37
Maple Leaf. 44
Ontario. 43
Scientific Regina. 30
Stover Ideal. 10
Tanner. 30
Victor. 30
Watson's Ideal. 60

GARDEN IMPLEMENTS, INCUBATORS AND POULTRY SUPPLIES.
Chatham Incubator. 25
Cyphers' Incubator. 60
Fountain Incubator. 60
Iron Age (Garden Implements). 63-61
Maxwell. 55
Plank Jr. Garden Tools. 41-55

CLEANERS, FANNING MILLS AND PICKERS.
Acme Pickler. 6
Automatic. 19
Chatham Fanning Mill. 25
Fossten Fanning Mill. 17
Hero Fanning Mill. 29
Hero Roller. 29
Superior Fanning Mills. 27
Webber Grain Cleaner. 10
Wonder. 15

GASOLINE ENGINES.
Aultman & Taylor (Gas Tractor). 1
Avery Tractor. 26
Brandon. 6
Buffalo (Tractor). 6
Cater. 4
Case Tractor. 14
Cashman. 71
Fairbanks (Stationary Portable Tractor). 43
Flour City (Tractor). 8
Gads. 7
Gas Pull (Tractor). 20
Gas Tractor ("Big & 30"). 22
Gelsco (Stationary Portable Tractor). 7
Gilson. 48
Hilborn. 254
Holt-Farr Tractor. 28
Holt Caterpillar. 9
Huber (Gas Tractor). 201
Ideal. 24 1/2
International. 30
International (Tractor). 30
Manitoba. 33
Minneapolis. 30
New York. 60
Nichols & Shepard (Tractor). 42
Ohio (Tractor). 48
Pioneer (Gas Tractor). 57
Massey-Harris Olds. 34
Massey-Harris. 45
Renfrew Standard. 201
Rustin Procter (Tractor). 5
Sawyer-Massey (Tractor). 43
Stover (Stationary, Portable, Tractor). 12
Twin City (Tractor). 38
Universal (Gas Tractor). 59
Waterloo Boy. 7

HARVESTING MACHINES.
Champion. 30
Deering. 30
Frost & Wood. 15
North Star. 27
Fagus. 30
Winnipeg Colling & Roofing Co. 63
Wizard. 27

HAY LOADERS, HAY PRESSES, HAY TOOLS, MOWERS, RAKES, SWEEP RAKES, HAY STACKERS AND BRUSH LOADERS.
Admiral Hay Press. 15
B.T. 2
Buffalo Hay Press. 51
Canton Hay Press. 30
Champion Hay Rake. 30
Champion Mower. 30
Champion Side Delivery Rake. 35
Dain Hay Loader and Stacker. 17
Dain Hay Press. 17
Dain Side Delivery. 17
Deere Hay Loader. 17
Deering Hay Stacker. 30
Deering Sweep & Hay Rake. 30
Deering Mower. 30
Emerson Hay Loader. 201
Emerson Mower. 201
Emerson Rake. 20
Frost & Wood Mower. 15
Tedder. 15
Frost & Wood Sweep & Hay Loader. 15
International Hay Stacker. 30
International Sweep & Hay Rake. 30
International Hay Press. 30
Jenkins Sweep Rake. 10
Keystone Hay Rake. 30
Louden Hay Tools. 32
Massey-Harris Mower. 34
Massey-Harris Steel Roller. 34
Massey-Harris Hay Tedder and Leader. 34
McCormick Hay Stacker. 30
McCormick Mower. 30
McCormick Sweeper & Hay Rake. 20
Noxon Mowers & Rake. 55
Reeves Hay Tools. 201
Stewart Wheel Loader. 17
Success Hay Lozer. 34
Tiger Steel Rake. 15

HORSE POWERS AND JACKS, SAW MILLS, WOOD SAWS AND TREAD POWERS.
Caters Wood Saws and Jacks. 4
Cockshutt Horse Power. 15
Fleury's Horse Power and Jacks. 17
Fleury's Wood Saws and Tread Powers. 17
Gas Scott Saw Mills. 60
Geiser Saw Mills and Horse Powers. 7
Good Shapley & Muir Wood Saws. 15
Horse Powers, Road Powers Bevel Jacks. 15

LAND ROLLERS AND PULVERIZERS.
Acme Pulverizers. 17
Canton Land Roller. 30
Canton Packer. 30
Cantrell Sub-Surface Packer. 30
Cockshutt Land Roller. 15
Cockshutt Pulverizer. 15
Cockshutt Combined Pulverizer and Sub-Soil Packers. 15
Deere Land Roller. 17
Emerson Roller Pulverizer. 201
Fleury's Pulverizer. 17
Pulsons' Sub-Surface Packer. 10
Hilborn. 35
Hilborn Pulverizer. 17
Moline Fertilizer Pulverizer. 10
Verity Wheel Roller. 34
Verity Pulverizer. 10
W. S. O. Flexible Pulverizer. 60
Watson's Land Roller. 60
Western. 61

MANURE SPREADERS AND LITTER CARRIERS.
B.T. 2
Clover Leaf. 30
Cockshutt. 30
Emerson Low Down. 201
Huskey. 35
Kent. 10
Mand. 7
Louden. 32
Massey-Harris. 34
National. 34
Success. 17

GANG PLOWS, ETC.
Canton. 30
Case, J. I. 27
Case, J. I. Engine Gang. 27
Canton Mogul Engine Gang. 30
Cockshutt. 15
Cockshutt Engine Gang. 17
Deere. 17
Deere Engine Gang. 17
Emerson Engine Gang. 55
Emerson Engine Gang. 55
Grain Engine Gang. 7
Grand Detour. 60
Jamesville. 34
Massey-Harris Engine Gang. 39
Moline. 10
Moline Engine Gang. 30
Oliver Engine Gang. 30
Paris. 49
Verity. 201
Railroad Grading & Rooter Plows. 58
Verity. 34

POTATO AND BEET MACHINERY.
Aspinwall Potato Planters and Sprayers. 15
Aspinwall Assoverters and Cutters. 15
Deere Potato Diggers and Beet Tools. 17
Hamilton Wagon. 30
Egan Potato Sprayer. 43
Evans Potato Planter. 30
Eureka Potato Planter. 17
Hoover Potato Digger. 15
Moline Knocker Potato Digger. 10
Splitstator Sprayer. 17

RIDING ATTACHMENTS, HARROW CARTS, WHEEL BARROWS AND HAND CARTS.
Cockshutt Wheel Harrow. 15
Cockshutt Harrow Cart. 15
Deere Harrow Cart. 17
Eclipse High Harrow Cart. 27
Emerson Harrow Cart. 55
Fleury's Wheel Harrow. 17
Fuller & Johnston Harrow Cart. 61
Kramer Rotary Harrow. 17
Naylor Harrow Attachment. 27
P. & O. Harrow Cart. 30
P. & O. Hand Cart. 30
Racine Rotary Harrow. 14
Success Harrow Cart. 10
Verity Wheel Barrow. 34
Watson's Wheel Barrow. 60

ROAD SCRAPERS AND ROAD MACHINES.
Cockshutt Scrapers. 18
Crosby Road Machinery. 58
Indiana Road Machine. 55
Russell Elevator. 32
Stacy Road Scrapers. 61
Toronto Pressed Steel Scrapers. 61
Sawyer & Massey Reversible Grader. 51

SEEDING MACHINES.
Cockshutt. 15
Deering. 30
Frost and Wood Champion. 15
Hosmer. 30
Kentucky. 30
Massey-Harris. 39
McCormick. 30
Monitor. 10
Superior. 30
Sveinvald. 55
Van Brunt. 17

THRESHING MACHINERY, SELF FEEDERS, WIND STACKERS AND ATTACHMENTS.
Advance. 60
American Abell. 60
Aultman & Taylor. 60
Avery. 60
Bell Robt. 3
Cuddy. 14
Dakota Weicher (Ask Any Thresher Co.). 82
Dreadnought Engine Guide. 80
Garr Scott. 60
Geiser. 60
Geiser's Weicher. 60-68
Garden City Feeder. 214
Hawkeye Feeder. 35
Harley Weicher. 66-67
Huber (Gas Tractor). 201
Minneapolis. 301
Nichols & Shepard. 42
Nichols & Shepard. 42
Parson's Feeder. 35
Perfection. 60
Perfection (Ask Any Thresher Co.). 17
Perfection (Ask Any Thresher Co.). 17
Reeves. 35
Ruth Feeder. 35
Sawyer Massey. 51
Watson. 69
Whiteford Justice Measure. 66
White G. & Sons. 63
White Wings Feeder. 35

THRESHERS' SUPPLIES.
Brown Wing Carrier (Ask Any Thresher Co.). 17
Canadian Fairbanks. 6
Canadian Rubber. 34
Crane & Ordway. 17
Deering Stephen. 17
General Supply Co. 23
Goodyear Tire & Rubber Co. 24
Thresher Supplies Carried in West-Canada. 64
Cos. 17
Madison Kipp Lubricators. 35
Massey-Harris. 35
Maytag Co. 35
Ohio Injection Co. (Ask any Thresher Co.). 35
Penberthy Injector & Brass Goods Handled by all Leading Jobbers and Thresher Carriers. 64
Winnipeg Rubber. 64

WAGONS AND SLEIGHS.
Adams Farm Trucks. 15
Adams Lorry. 15
Gears. 15
Adams Wagons & Sleighs. 15
Anders Trucks. 55
Avery Wagons & Grain Trucks. 58
Bain Wagons & Sleighs. 39
Canadian Crescent Wagon. 39
Chatham Wagon. 10-64
Cockshutt Metal Wheel Truck. 15
Columbus Wagon. 30
Davenport Wagon. 17
Electric Steel Wheel Trucks. 27
Fish Bros. (Racine) Wagon. 55
Gennie T. G. Mandis Wagon. 10
Grand Detour. 60
Gray Light Farm Sleigh. 25
Hamilton Wagon. 30
Hamburg American Wagon. 64-60
Metal Wheel Truck. 17
Millburn Wagon. 36
New Deal Wagon & Sleigh. 17
New Deal Farm Truck. 17
New Moline Wagon. 17
Northern Sheet Metal Wheel Truck. 17
Old Dominion Wagons & Sleighs. 30
Patrol Wagon & Sleigh. 30
Rushford Wagon. 36
Stone & Gravel Spreading Wagon. 36
T. G. Mandis Sleigh. 10
Weber Wagon. 30
Winona Wagon. 30

WELL DRILLING MACHINERY.
Austin. 7
Armstrong. 71
Brandon. 6
Stans. 8
Stans. 43

WINDMILLS, TANKS AND PUMPS.
Caters Pumps. 4
Chicago Air Motor. 43
Chicago Aerometer. 27-7
Florman Pump. 44
Goold Shapley & Muir Wind Mill and Pumps. 241
Harris Pumps. 34
Louden Pump. 34
Manitoba Pumps & Wind Mill. 33
Manitoba Tanks. 33
Ontario Pumps. 34
Risbury Pumps. 49



Hart-Parr Oil Tractor Operating Blade Grader

Make Big Money Building Good Roads
It's spare-time work, which will net you a nice profit if you own a

HART-PARR -OIL TRACTOR-

☞ The owner of a Hart-Parr Tractor never experiences a non-productive, in-between season, waiting for crops to mature. For aside from farming with the tractor at a big profit, he earns big money with it in many other ways. Making good roads is one of them.

☞ When field work is slack and you are feeding your hard earned money into only half worked or idle horses, the merry hum of a Hart-Parr Oil Tractor is heard on many a highway. And its owner wears a satisfied smile.

☞ For just about the time you are losing time and money, the Hart-Parr Oil Tractor farmer is busy making good roads for his neighbors—in-between season work—which nets him a nice profit without requiring one dollar of additional investment.

☞ The reason is this:—Horse built roads are costly to build, do not last under modern traffic, and require a heavy outlay each season for up-keep and repairs. Roads built the Hart-Parr Oil Tractor way, are lasting and beautiful. They stand up well under constant travel. The initial cost is small and the yearly up-keep cost is almost nothing.

☞ These are facts now clearly recognized by progressive communities and road officials everywhere. That's why countless Hart-Parr Oil Tractors are in great demand

at roadbuilding time. And that's why you can keep your power plant busy in slack seasons and pocket easily earned profits if you own a Hart-Parr Oil Tractor.

☞ They are ideal outfits for every kind of power work on farm or road. They never tire, handle easier and cover more ground than 12 to 30 good horses. They will operate blade graders, elevating graders, drags, levelers and rollers, with steady even power—are fine for haulage purposes, will run stone crushing plants, plow up new roadways, pull stumps and, in addition, do all your heavy power work on the farm. They are handy, general purpose outfits.

☞ Hart-Parr Oil Tractors have fewer parts than other tractors of equal power, hence are easy to operate and care for. They are strictly one-man outfits, use cheapest kerosene for fuel, and are oil cooled—a feature which insures perfect operation in coldest or hottest weather.

☞ We want you—the farmer or road official who is reading this ad—to write us at once for our big, free catalog and booklet, "Making and Maintaining Good Roads." The latter, especially, contains many interesting road building illustrations, convincing figures on road making costs with Hart-Parr Oil Tractors, and shows how others have made and saved a lot of money in this line of work. So write today and let us tell you the many profit making ways you can use a Hart-Parr Oil Tractor, both on and off the farm.

HART-PARR COMPANY

30 Main St., Portage la Prairie, Man.
57 West 23rd St., Saskatoon, Sask.

1616 8th Ave., Regina, Sask.
The Chapin Co., 325 8th Ave. West, Calgary, Alta.

WHAT YOU GET IN THE "CASE" GAS TRACTOR

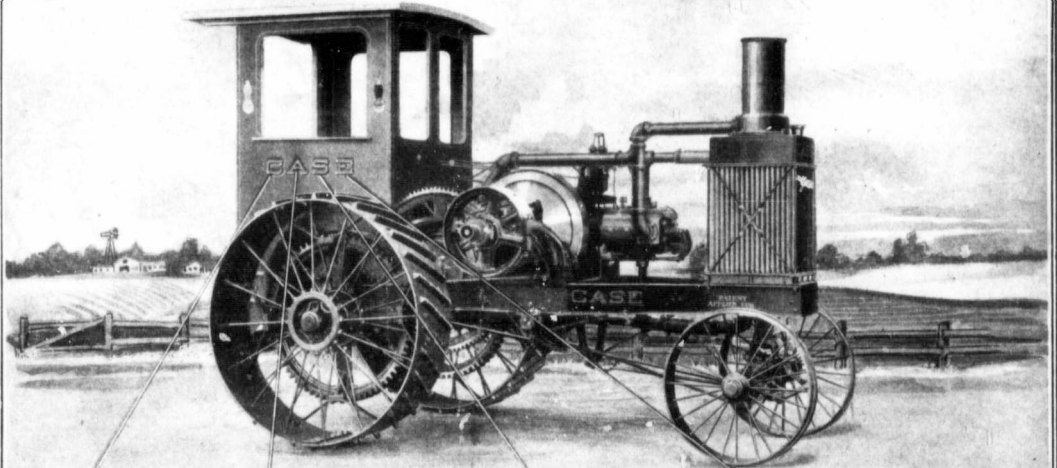

CAPACITY-ACCESSIBILITY-SIMPLICITY-ECONOMY



THAT'S THE WHOLE STORY OF THE
"CASE" 40 GAS TRACTOR
IN FOUR WORDS.

WHAT MORE CAN WE GIVE YOU
WHAT MORE CAN YOU ASK

WRITE FOR CATALOGS OR BETTER STILL,
CALL AT OUR NEAREST BRANCH HOUSE
AND SEE THEM DEMONSTRATED ~



J.I. CASE THRESHING MACHINE CO.
741-791 STATE ST. RACINE, WIS. U.S.A. (INC.)

CANADIAN BRANCHES, TORONTO, WINNIPEG, SASKATOON, REGINA & CALGARY