

Please read and send in as full a  
discussion as possible at earliest date.

## The Canadian Society of Civil Engineers.

INCORPORATED 1887.

**ADVANCE PROOF**—(*Subject to revision.*)

---

N.B.—This Society, as a body, does not hold itself responsible for  
the statements and opinions advanced in any of its publications.

---

### ELECTRICAL EQUIPMENT FOR CORNWALL CANAL.

By F. H. LEONARD, Jr.

(Read before the Electrical Section, 24th March, 1904.)

The electrical equipment for the Cornwall Canal is supplied with current from the power house of Mr. M. P. Davis, near Mille Roches, on the Cornwall Canal. Messrs. T. Pringle & Son were the engineers and the electrical equipment was installed under the personal supervision of the writer.

We have fully described the hydraulic and generating equipment for this plant in the "Canadian Engineer" and in the "Electrical World and Engineer," but to obtain a comprehensive grasp of the complete plant we will again recite some of the particular features in connection with it.

The plant is situated just below the lower dam on the Cornwall Canal, near the Village of Mille Roches, and takes water from the upper level, which is an artificial lake made by the construction of a dam across the former river bed. The tail water empties into the old river bed which was left dry—except at certain seasons of high water—by the construction of this dam. There is obtained by this means a head, under ordinary circumstances, of about thirty feet, but on account of high back water the plant was designed for operation temporarily on a minimum head of eighteen feet.

The intake is short and cut at about right angles to the weir channel at the south end of the dam built to take care of the overflow from the upper level.

The fine racks and stop log checks are built in one frame of structural steel in front of the entrance to the concrete wheel chambers. Besides the stop logs, head gates are provided opening in two halves by means of worm geared head gates winches. Two large manholes over the centre of each pair of wheels provide for access to the wheel chambers and are large enough to pass the runners through in case of repairs.

The power house partly covers the wheel chambers, the concrete top of which makes a portion of the switch board gallery which is widened at the centre by a platform extending three feet beyond the face of the bulk head wall.

The power house foundation rests on the solid rock, the wheel pit being excavated to a depth of about ten feet below the surface of the bed rock. The arches over the wheel pit are of concrete but faced on the outside with rough picked masonry of large dimensions, which gives to the entire structure a very substantial appearance. The power house is constructed on a steel frame having brick walls and heavy plank roof.

A hand power crane of twenty-five ton capacity with two trolleys having a span of thirty-eight feet is provided for erecting and handling the machinery. (See photo on next page.)

Provision was made for four hydraulic units, giving an ultimate capacity of approximately 6,000 H.P. Each unit consists of 5-35" New Sampson wheels by Wm. Hamilton & Co., with horizontal shafts directly coupled to a 1,000 K.W. Bullock Generator operating at 2,200 V at 180 R.P.M. and 60 cycles.

The switchboard gallery is about nineteen feet above the main floor of the power house and accessible by means of a flight of iron steps in the centre and two iron ladders at either end of the power house.

At present but one unit is installed with 2-50 KW. exciters 285 R.P.M. Switchboard panels are provided for the control of the generators, exciters and the various feeders.

The arc lights, of which 225 are located along the bank of the canal, were furnished by the G. I. Co., of New York. A three panel switchboard controls the operation of these lamps and each circuit is regulated by a 100 light G. I. regulator capable of maintaining practically constant current with any number of lamps in circuit from 1 to 100—its full capacity.

The current for these circuits is stepped up from 2,200 V. by means of transformers of 60 K.W. each—the transformers being

provided with intermediate taps so that besides the full voltage of 11,000 V., if a smaller number of lamps are required, either 4,400 or 6,600 V., can be used, thus reducing the re-actance necessary to maintain a proper voltage and permitting of a higher P.F. under the conditions of partial load.

Current for the power circuits, three in number, is obtained by stepping up from the generating voltage to 11,000 V. by means of 3-150 KW. transformers which supply the 3 P. transmission lines reaching various locks along the eleven miles of canal.

The primaries of both arc lighting and power transformers are controlled by oil switches connected to the bus bars on the main switchboard, a separate panel being provided for each class of service. The power circuits are passed through a separate high potential switchboard which connects the transformers to the three separate 3-phase power lines. A 2,200 V. line also provides Mille Roches with light and power service.

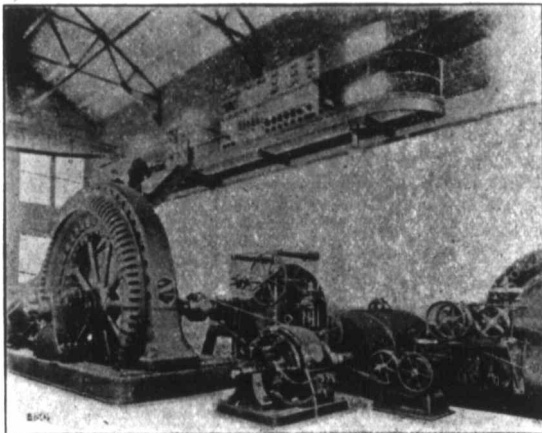

Lightning arresters and choke coils are provided for the various circuits. The wiring of the station between generator and switchboards to the wire tower, from which the circuits are fanned out to different pole lines, is all carried in three conductor cables lead encased, suitable trenches being provided in the concrete floors allowing ample space for additional cables.

The pole lines for the lighting and power circuits are of substantial structure, an exceedingly straight lot of cedar poles being used. These range from 30 to 50 ft. in height, none having less than 7" tops on which are mounted special cross arms provided with hickory

pins which were boiled in steric acid. 5½" Triple petticoat glass insulators being used with satisfactory results with the 11,000 V. circuits. Bare copper conductor is used spaced 16" on centres, and on account of the low current per line no attempt was made to use the triangular arrangement of conductors, the three wires of each circuit being arranged side by side without transposition.

The 3-phase power circuits occupy the upper arms and on the lower arms are located the single phase arc circuits. The main lines occupy the south bank of the canal.

Crossings are made at the Mille Roches bridge in armoured paper cables, one for three phase 2,200 V. power and lighting circuits and another for the single phase 11,000 V. arc circuit. Another crossing is made at lock 18, which provides for 3-phase power circuit, as well as another 11,000 V. arc circuit to provide for power and lighting on the north bank below this point.

At the Stormont Bridge, near Cornwall, another 11,000 V. arc cable provides for lighting the two piers at the bridge and an emergency cable is laid just above lock 17 so that in case of accident to any of the other crossings or a break in the line, emergency connection can be made in the houses covering the cable heads on the bank of the canal.

While in some cases, sawed octagon poles have been used for a similar purpose, yet the shaved cedar poles selected in this case, present an exceptionally pleasing appearance. Extreme care has been taken in locating and setting out the line and a transit has been used for the work, making the alignment and location almost perfect.

The line is well guyed on the curves with galvanized signal strand well anchored, or, in some cases, tied to a heavy guy stub. On the sharp curves, poles are double armed to provide for the severe strain.

#### LIGHTING.

The lighting of the canal is carried out in a very liberal manner, an arc lamp being located on every fourth pole and the poles averaging about one hundred feet apart. At the locks, as many as twelve or fourteen lamps are located so as to brilliantly illuminate both ends of the locks, as well as the intervening space and the regulating weirs—most of which are located beside the locks.

The lamps are hung from iron pipe brackets which pass through the pole and are held in place by a collar at the front side and a lock nut at the back and braced on the under side by an iron pipe strut fastened to the face of the pole by two lag screws. An insulated hanger is used at the outer end of the bracket (2'-6" from the pole) which, together with the insulators on the lamps, renders danger

from grounding in the lamp frame and bracket extremely remote. The lamps are trimmed from the pole without lowering; pole steps are driven in each lamp pole.

Loops are cut in from transposition insulators by means of No. 8 Flexible rubber covered conductor soldered to the bare copper line conductors, particular care being taken to support the connection at the lamp so as to avoid any possible danger of the swing of the lamp causing a break at the binding post. Some trouble of this character was at first experienced but was soon overcome by the above provision.

At the lower end of the canal, where three sets of locks are grouped together, the illumination is very brilliant, and viewed from the Stormont Bridge at Cornwall—taking in at a single glance some sixty arc lamps reflected in the still waters of the canal—the sight is most impressive in its quiet brilliancy.

A description of the illumination of one of the locks will convey a very clear idea of them all.

A light is located at the piers as the lock is approached from below, and an arc lamp is also located at each side of the lock just below the gate; two more lamps are located at the middle of each lock and two at the upper end of the lock just at the lock gates. There are also two more at the upper piers and as two locks are located side by side, it is easy to imagine that the illumination would almost rival day light.

Below lock 18 both banks are illuminated all the way by lamps located 400 ft. apart. Above lock 18 the lamps are located on the south side of the canal only, with the exception of prominent points, bridges, etc., where lamps are provided on both sides.

The upper level broadens into a lake of considerable proportions, about thirty feet deep near the lower end the dam retains the water between Sheik's Island and the Canadian shore, making a broad and easily navigable waterway of about three miles to the upper dam. The lamps are here less frequently located on the prominent points on the south side until the upper dam is reached when the canal again narrows to the usual dimensions.

The lamps are again located about four hundred feet apart on the south bank up to lock 21, which is a guard lock, there being very little difference between the upper canal level and the St. Lawrence River at this point. On the long pier on the south side protecting the canal entrance lamps are placed, as well as on the north bank as far up as Dickinson's Landing.

An illumination so perfect as above described, makes navigation as easy at night as in day light and lockages are performed as rapidly and as easily as they could be in the day time.

## LOCK HOUSES.

At the upper end of each lock on the south bank there is located a small switchboard cabin, 7'-0" x 9'-0" ; on the little island between the two locks is located another switchboard cabin and at the upper end of the lock on the north side of the second lock is another cabin.

In the first of those above mentioned are placed three transformers connecting to the 11,000 V. mains, which step the voltage from the line pressure to 550 V., and it is at this pressure that the motors operate. A high tension fuse board is provided to take care of the primary connections to the transformers. The long enclosed fuse has friction contacts at either end and by pulling these fuses out of the end clips by means of a wooden stick with a hook at the end, the circuit can be opened in case of temporary trouble, or for any purpose when it becomes necessary to disconnect the transformers. The secondary of the transformers passes through the switch on the switchboards which distributes the secondary current to the motors, two of which are located on each side of the lock. Armoured cable with paper insulation is used to conduct the current from the switch cabin to the motors located on the same side of the lock.

The connection for motors on the opposite side is carried through armoured cable which leads down through the floor of the switch cabin and passes through a hole drilled in the stone coping of the lock to the upper stop log check—there being two checks cut in the masonry. This leaves one which could be utilized for stop logs in case it ever became necessary to keep the water out of the lock during repairs. The cable turns over a radius of 16" at the top and passes down the check, being protected by a piece of oak plank which is grooved in the centre to take the cable, the plank being fastened by drift bolts to the stone work and protected at the edges with iron strips. As the plank does not come above the edges of the check in the stone work, there is practically no danger of the cables ever being injured by a boat in entering or leaving the locks.

Where the cable crosses on the lock bottom a timber is held on top grooved on the bottom side to receive the cable, and as the top of this timber is well below the breast wall at the entrance of the lock, there is no danger of the cable ever being disturbed.

Rising on the opposite side of the lock in the stop log check, the cable again passes through a hole drilled in the stone coping until it comes out of the earth back of the masonry under the next switch cabin, from this switch cabin the cable is carried into the third switch cabin on the north side of the old locks.

You will bear in mind that the new locks were built on the south side of the old locks, and are about 70 feet longer, the old locks be-

ing 55 feet wide and 200 feet long inside the gates and the new locks 45 feet wide and 270 feet long inside the gates and 14 feet over sills.

On the switchboards in each of the cabins are placed the motor starting switches connected to auto starters which control the motors on one side of each lock. From the switch cabin on the south side are operated two motors, the first motor being connected by armoured cable reaching from the switch cabin underground to the first motor. The second motor is reached by conductors running from the switch cabin overhead to a pole very near the motor at the lower end of the lock, armoured cable connecting from the pole underground as far as the masonry and checked into the masonry where it passes over to the motor.

The switch cabin on the little island between the two locks controls the two motors on the north side of the new locks and two motors on the south side of the old locks. The third switch cabin controls the motors on the north side of the old locks, as well as the motor operating the weir gate mechanism.

The arrangement is identical in all the locks with the exception of No. 15 and old lock 16, which are not provided with weir gates.

The equipment for operating the lock gates and weirs was adapted for use in connection with the winches and weir gate mechanism already installed without disturbing their capability for hand operation should occasion require.

When these devices were operated by hand, the lockmen laboriously turned a crank on the winches at the two opposite sides of the lock gates, utilizing one winch for opening and the other for closing the gates. Four winches were located at each end of the lock, two on each side, one of which handled the chain to close the opposite gate, the other to open the gate on the side at which these winches were located.

Across the top of each gate is a bridge on which is mounted the worms and rods for opening the two valves in each of the gates when required to fill or empty the lock.

The electrical equipment utilized practically all of this machinery as it stood with only the necessary changes to make the mechanical connections with the electrical drive.

In order to keep the speed down to approximately what was obtained by hand operation, a very material reduction in motor speeds was necessary. To obtain this and cover the other points, special apparatus was devised and patented by Mr. Alex. Pringle and myself, apparatus was devised and patented by Mr. Alex. Pringle and the writer, which are shown in the drawings attached.

The motors selected were all of 5 H.P. for both the lock gates and weir mechanism. Some question as to whether a 3 or 5 H.P. motor should be adopted arose, but the matter was decided in favour

of the 5 H.P. motor on account of its lower speed, and while the capacity of this motor is never exceeded except for a few seconds, the balance of the time running considerably under load, yet the whole arrangement is simple and while somewhat stronger than absolutely required, the interchangeability and greater durability it was thought justified the slight additional expense.

To operate the two winding winches which control the chains for opening and closing the gates, one motor is located near the hollow coil at the heel of the lock gate, which is coupled by means of short length of shafting and friction clutch coupling to the winch near this point, and by means of another friction clutch and length of shaft sufficient to reach the other winch, supported at intermediate points by pedestals carrying journal boxes mounted on cut stone blocks jointed to the coping, making a practically continuous stone foundation for the mechanism.

The arrangement of the motor bed, gearing and speed reduction will be more clearly understood by referring to the drawing showing the casing for the worm gear and motor bed.

As there is a reduction of about 42 to 1, which gives a speed of about 26 revolutions for the operating shaft, it was decided to use the worm gear rather than a more complicated triple reduction by means of spur gears. A sub-base extends under the motor and also carries the casing for the worm and worm gear. The worm runs in oil, the thrust being taken up by alternate steel and bronze collars and thrust discs, adjustable at one end by means of set screws and check nut to compensate for wear.

The motor, which runs at 1,200 R.P.M., is coupled directly to the worm shaft, the worm being cut out of solid steel and meshing into a hobbled bronze wheel turning on a shaft mounted on babbitted bearings. The projection at one end of this shaft having mounted upon it the friction coupling controlled the working shafts. The opposite end being coupled to a short length of shaft which carries a chain wheel similar to a sheave in a chain hoist and from this point by means of a welded link chain made endless is turned at an angle to the main working shaft, the supplementary shaft for operating the valves in the lock gates. This shaft is supported on bearings secured to the coping of the lock and placed about  $\frac{1}{2}$ " above its surface and continued under the bridge on the lock gate, a universal coupling being utilized at a point near the gate pivot so that the travel of this joint is minimized.

The arc of the circle through which this coupling passes is provided for by a swivel box carrying the end of the driven shaft and the travel in and out is allowed for by having the chain sheave run free on the shaft except when engaged by a jaw clutch keyed to the shaft so as to allow the shaft to run in and out as it passes through



this arc and engage or disengage the clutch at the proper time for controlling the valve mechanism. The clutch being disengaged, allowed the driving sheave to run loose on the shaft, the shaft itself remaining idle during the time the gate is open and is only put into operation when the gate is swung to the closed position.

The valves are operated by bevel gear reversing mechanism, which allows the operator to either close or open the valves in the gates by throwing the shipping lever which engages a jaw clutch with one of the bevels required to operate the valve stem in the desired direction. The travel of this stem, however, is limited by an automatic stop consisting of a loop and bell crank operated by a pin in the cross head travelling with the valve system so that at the lower or upper limit of travel, the pin trips the bell crank connecting with the shipping lever so as to throw the clutch out of engagement with the bevel gear which produces the motion.

This mechanism permits of much more rapid lockage than could be carried out by hand and reduces the necessary force of lockmen to one-half the crew formerly required.

#### LOCKAGES.

While the usual lockage is, perhaps, a familiar sight, many possibly do not understand it, and a short description will not be out of place.

Let it be assumed that a barge is proceeding up the canal, following another which has previously passed in the same direction.

The lock would, of course, be full of water up to the level of the section above. As the barge approaches the lock, the lockmaster starts the motors at the lower end by means of the starting switch on the switchboard in the lock house, and two of the lockmen proceed to the lower gate and open the valves, which allows the lock to empty into the lower reach; the mechanism is started on all four valves one after the other. One of the lockmen crosses to the south side and the other to the north side. The mechanism operating the valve stems continues to operate until the valves are wide open and the pin trips the operating mechanism, leaving the valves in this condition until the water within the lock has reached approximately the level of the lower reach.

The lockmen on each side of the canal then throw in the friction clutch which connects by means of a short shaft to the pinion meshing into the large spur wheel on the winch. This winds up the slack on the chain which runs through the chain well over a roller and out to a hook about four feet above the sill at the outer end of the lock gate.

As soon as the slack is wound up, the chain commences to move the gate, opening it until it leaves the passage free for the entrance of the barge into the lock. As soon as the boat is moved into position and made fast, the gate is closed by throwing in the opposite clutch which operates the winch at the opposite end of the shaft and closes the gate—the clutch on the first winch being released, of course, allows the chain to pay out as quickly as required to permit the gate to close.

As soon as the gates are closed, the clutch operating the shaft which drives the valve mechanism has moved into engagement and starts the valve driving mechanism, the lockmen throw the lever starting the two valves in each of the lock gates to close and immediately walk over to the other end of the lock; before they reach it, however, these valves have closed and the tripping mechanism has thrown the clutch out of gear. The valves in the gates in the upper end of the lock are then opened in a manner similar to that described in connection with the opening of the lower gates, allowing the barge to proceed on its journey.

#### WEIRS.

To keep the various levels of the canal normal, on account of excessive flow of water from above or any heavy draught of power used on a level or by lockages, the flow of water has to be compensated for by adjusting the weir gates.

These gates are operated by worm and segment, or, in some cases, by raising or lowering the valves in a manner similar to that on the lock gates, the operating of which is carried out in much the same way as described in connection with the gates.

As there are a number of weir gates or valves which must be capable of independent operation, provision is made by means of a double jaw clutch engaging with either one or the other of two bevelled gears on a horizontal shaft which meshes into a third bevelled gear on a shaft of the worm for operating the segment which drives the valve stems.

The operator only has to throw the clutch into engagement so as to move the valve in the desired direction and as soon as the gate has opened or closed sufficiently for the purpose of regulation, the lever is thrown out of engagement with the gear. A friction clutch is placed between the shaft of the worm wheel driven by the motor so that in case of accident resulting in jamming any of the parts, the friction clutch will slip before any serious breakage occurs.

## BRIDGES.

The equipment for the bridges is operated by a motor driving the mechanism through worm gears, the same power unit being utilized as for the operation of the lock gates and weirs, an extension of the interchangeable idea. Aside from the first speed reduction, however, the gearing is quite different, though in the case of both the Mille Roches and the Stormont bridges the arrangement is worked out on similar lines.

The bridge at Mille Roches is 179 x 12 and has the motor swung under the bridge just outside of the turn table, being counter-balanced by weights at the opposite end of the bridge. I beams support the motor and worm gear case, the shaft of which drives the gearing communicating the motion to a pinion meshing with the rack which turns the bridge.

A friction clutch communicates the power from the motor driven worm shaft to one or the other of a pair of bevels turning the bridge in whichever direction the operator desires. The clutches are operated by two removable levers coming up through the bridge floor so that the bridge tender has ready control of both.

To swing the bridge, the operator first starts the motor, then throws the lever which withdraws the bolts unlocking the bridge. One of the clutch levers is then operated so as to engage the bevel gear required to turn the bridge in the desired direction for opening. The friction slips for a while until it gets the bridge under motion, then it swings rapidly until it is nearly open when the operator uses the other friction clutch (which tends to turn the bridge in the opposite direction) as a brake to retard the speed and gradually bringing the bridge to rest in the open position.

The reverse motion is used for closing and is operated in very much the same way.

The control of the Stormont Bridge is very similar to that of the Mille Roches Bridge, the only difference in the mechanism being that the power unit is mounted inside the drum of the turn table on I beam frame, which does not require to be balanced.

The power is communicated with a large intermediate gear so as to reach the gearing originally utilized in turning the bridge by hand.

The Stormont Bridge is very much heavier than the Mille Roches Bridge, but the operation is very satisfactory. The normal full load current is only exceeded for a few seconds in starting.

As in both cases, the motors are mounted under the deck of the bridge, little protection is required but a galvanized iron cover is provided so that drip from the underside of the planking is prevented from reaching the motors. The motors alongside the locks

are also protected with easily removeable galvanized iron hoods or covers. This is the only protection from the weather, which has been provided for the motors, and they have been left in their position without any other cover for the last two winters.

The hardiness of the motor used has been well demonstrated by the fact that the motors start up every season without any trouble. The only serious trouble with the machines occurred after a heavy storm which brought the 11,000 V. primaries in contact with the 550 V. secondaries for a few seconds, resulting in a burn out of half a dozen motor coils in one of the machines. Lightning has occasionally given slight trouble but nothing of a very serious character has occurred.

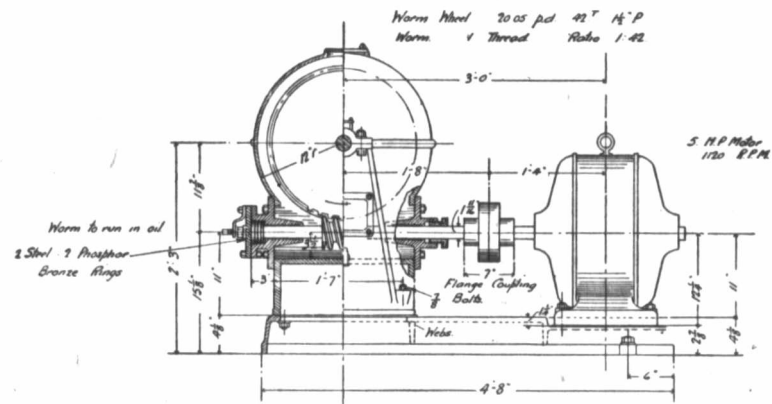

Elevation

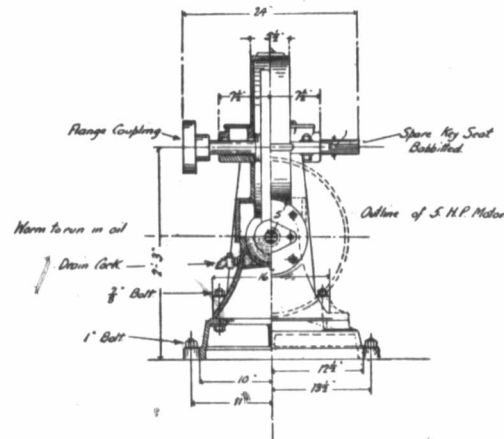

End Elevation

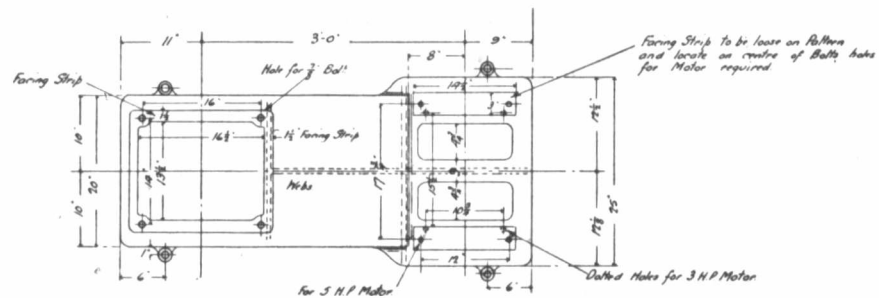

Plan of Base

DETAILS OF HOUSING  
FOR WORM GEARING  
DIRECT-CONNECTED TO MOTOR



Scale.  
Designed to suit both 3 & 5 HP Motors

**CORNWALL CANAL**  
**ARRANGEMENT — OF — MACHINERY**  
**USING ELECTRIC POWER**

FIGURE 1.

7

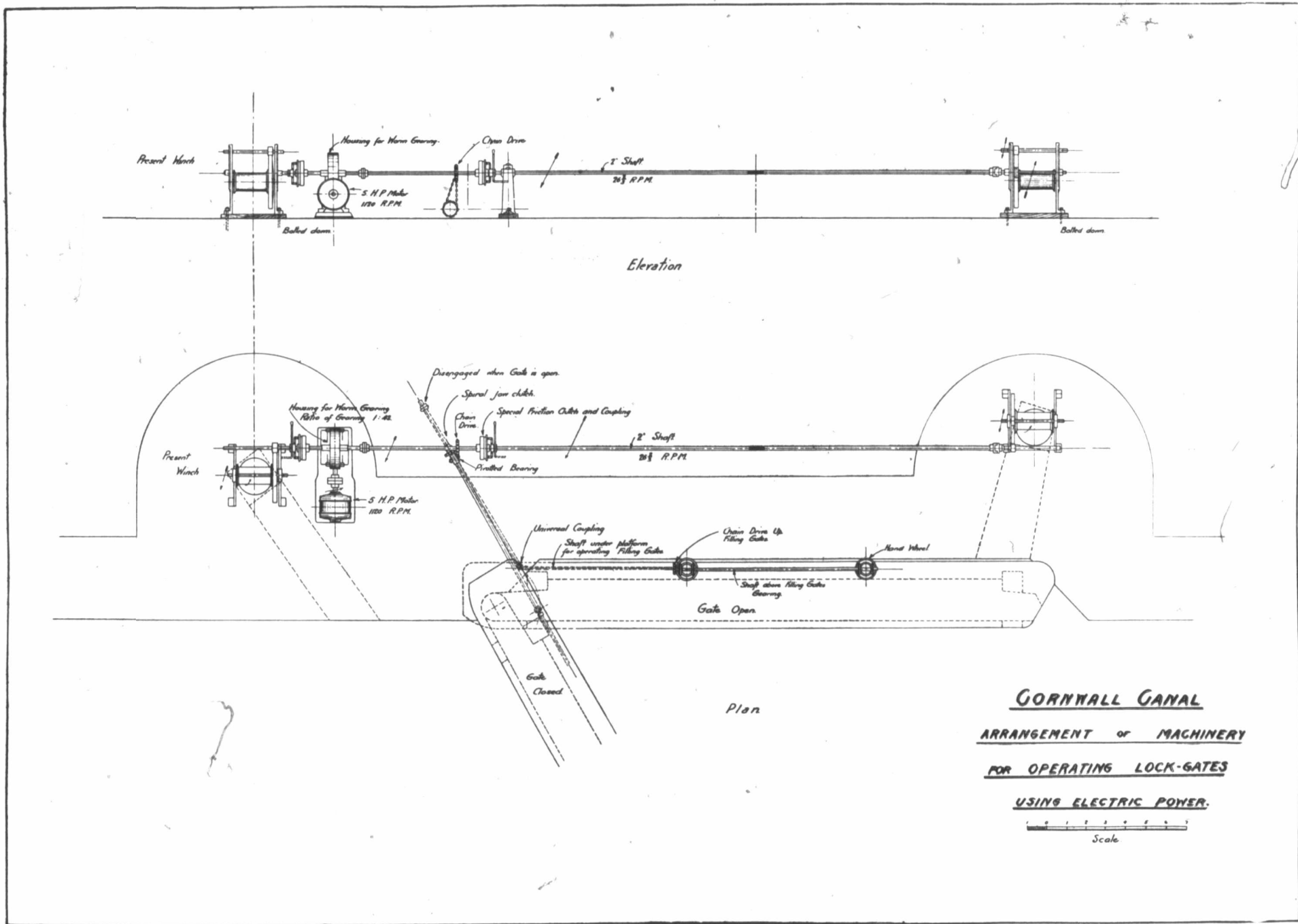
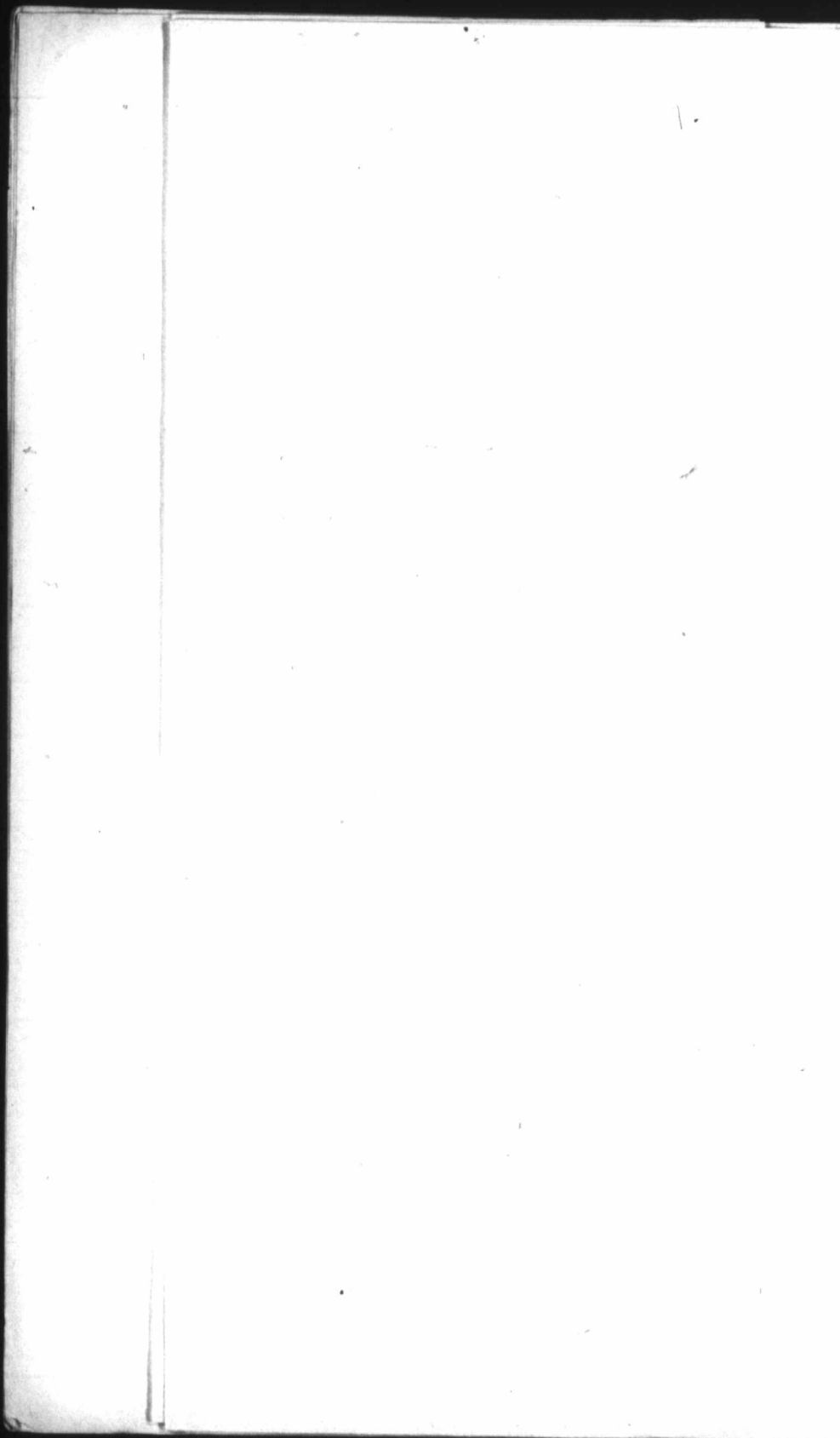

FIGURE 2.





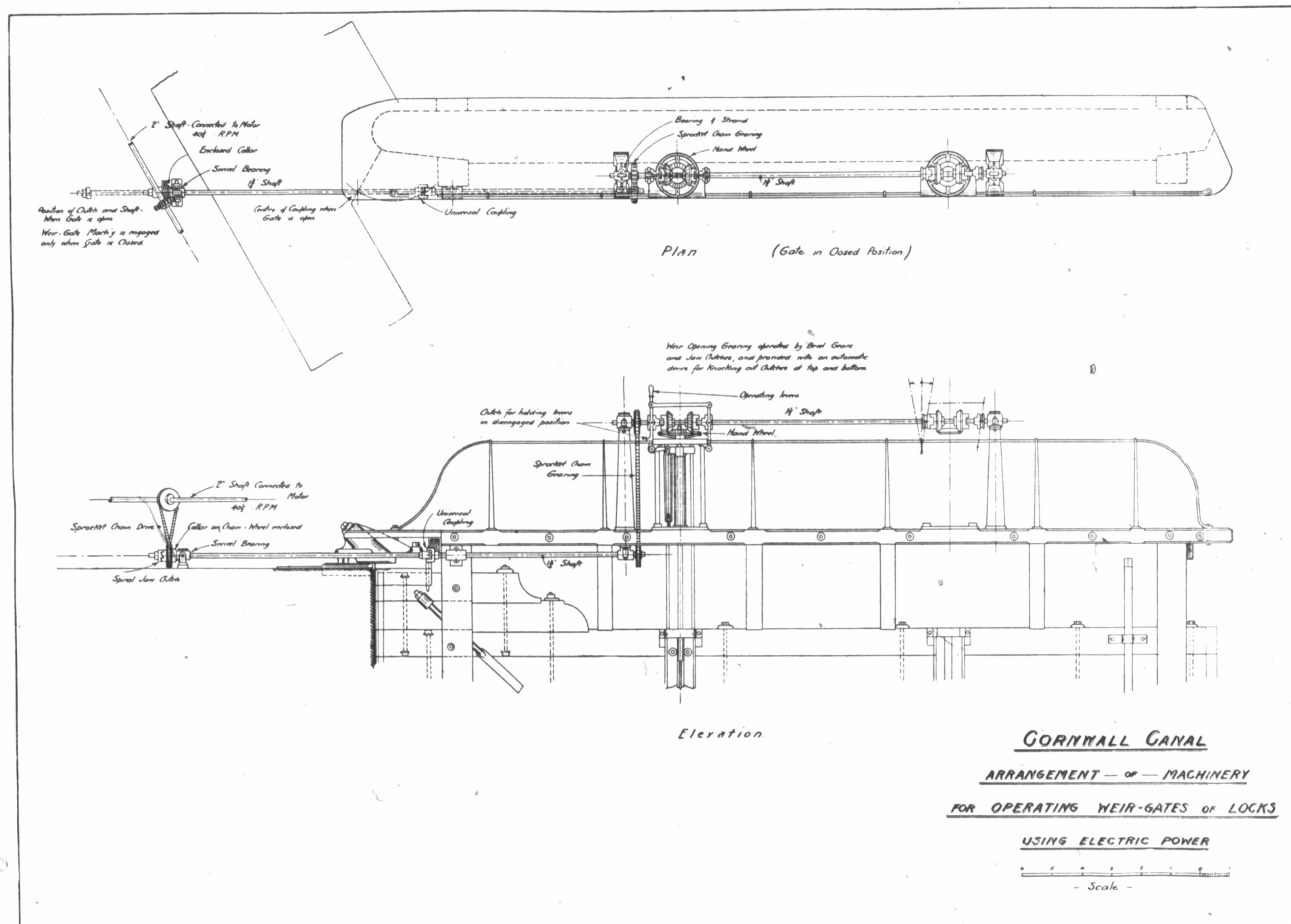
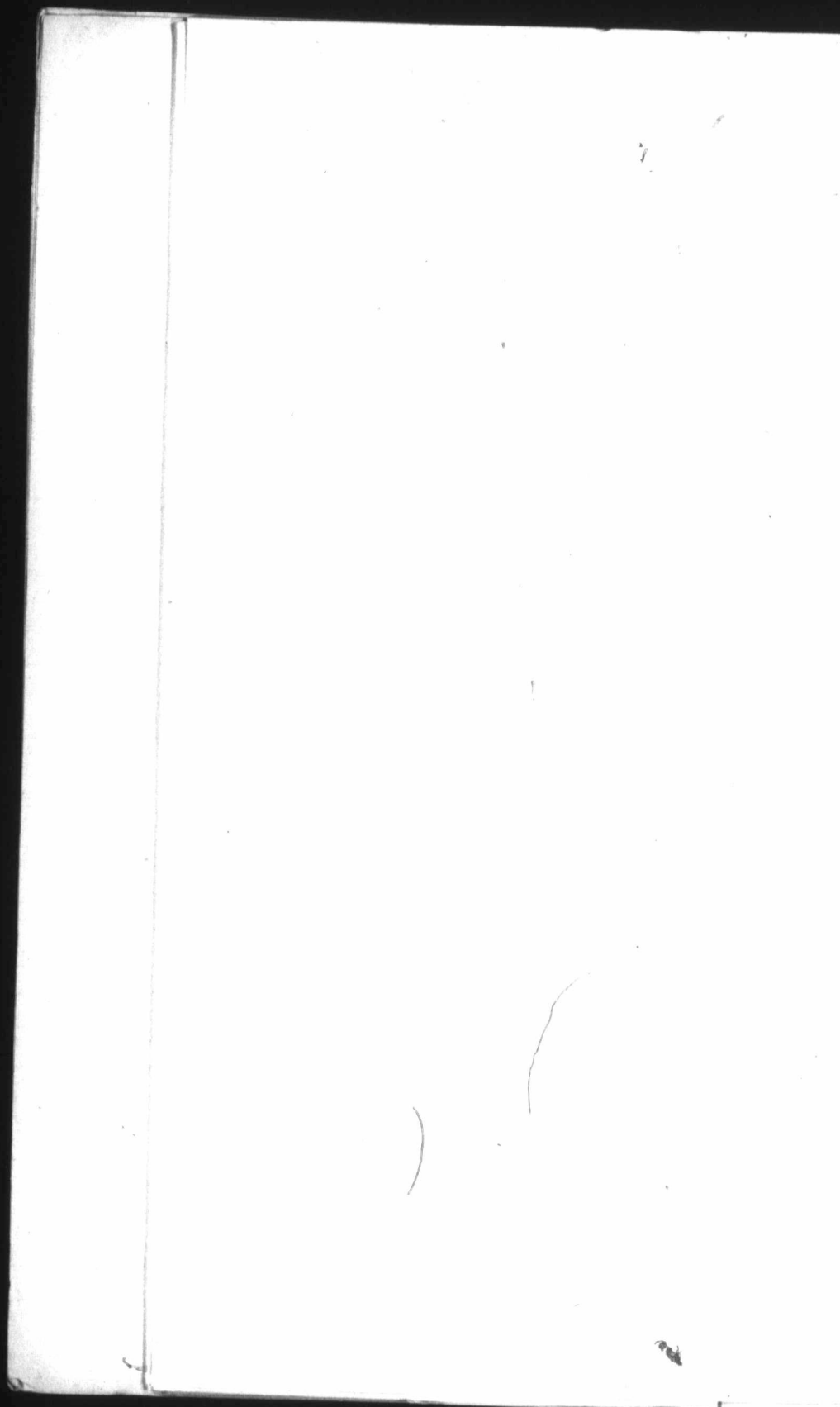
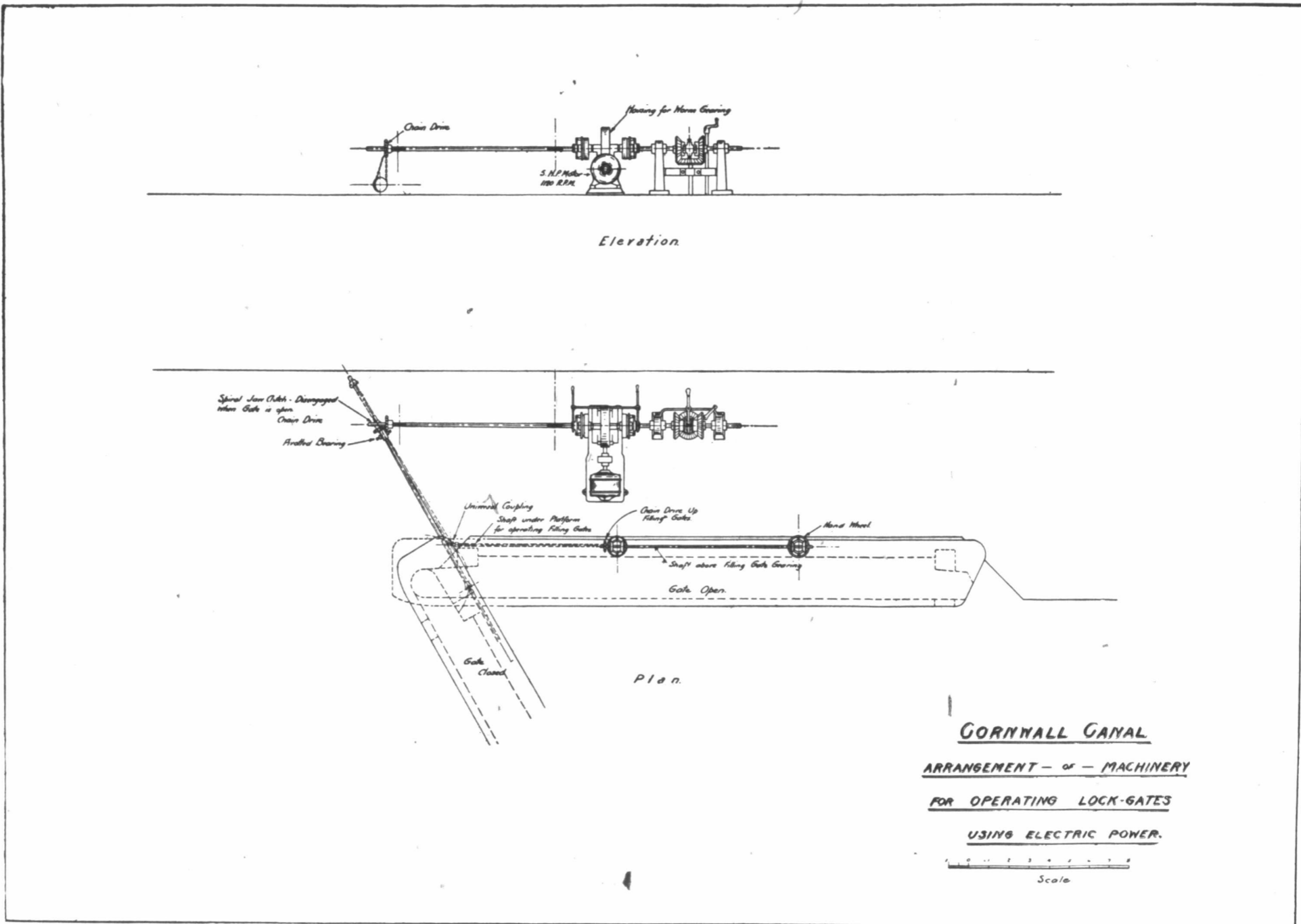

FIGURE 3.





**GORNWALL CANAL**  
**ARRANGEMENT - of - MACHINERY**  
**FOR OPERATING LOCK-GATES**  
**USING ELECTRIC POWER.**

Scale

FIGURE 4.

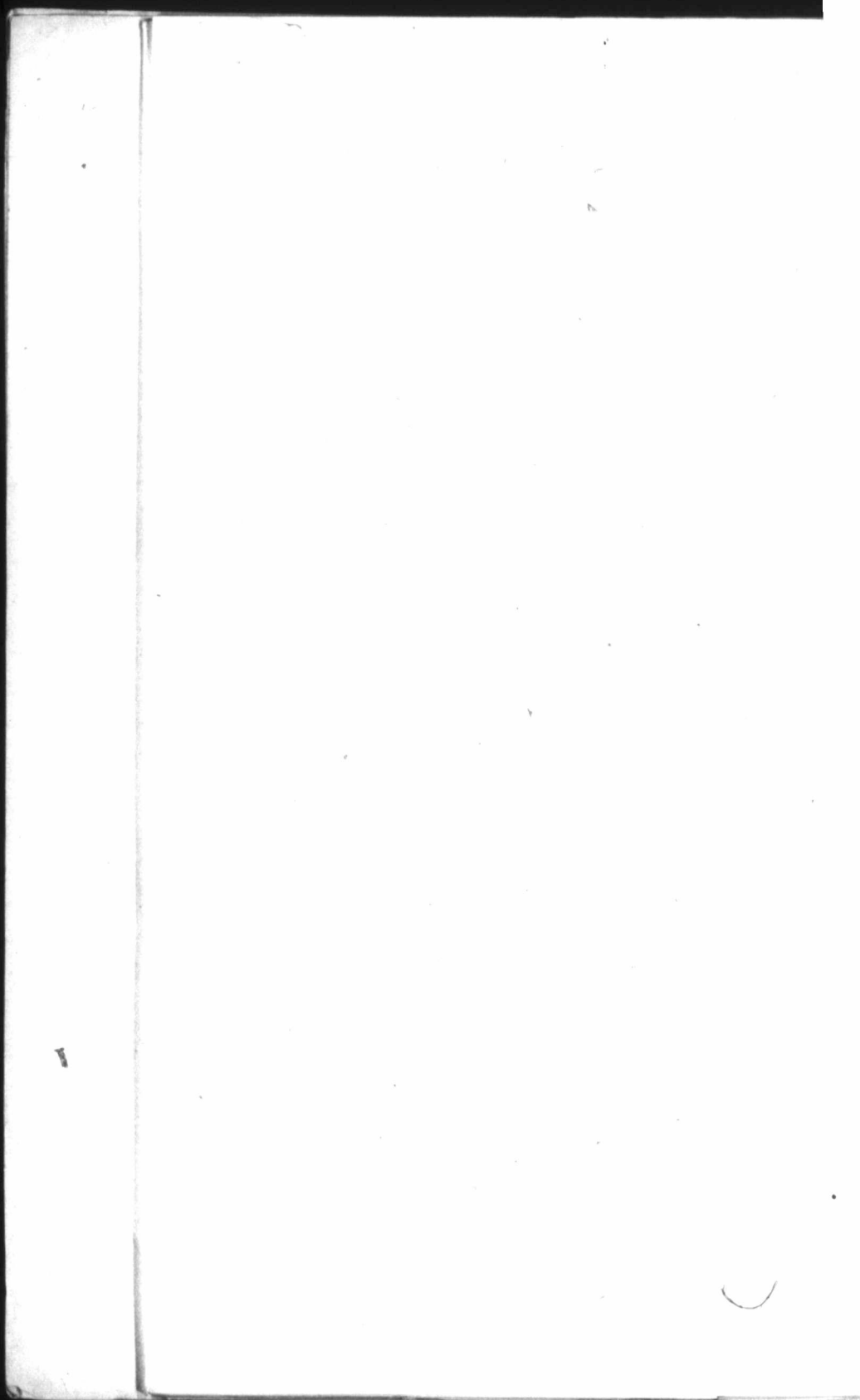

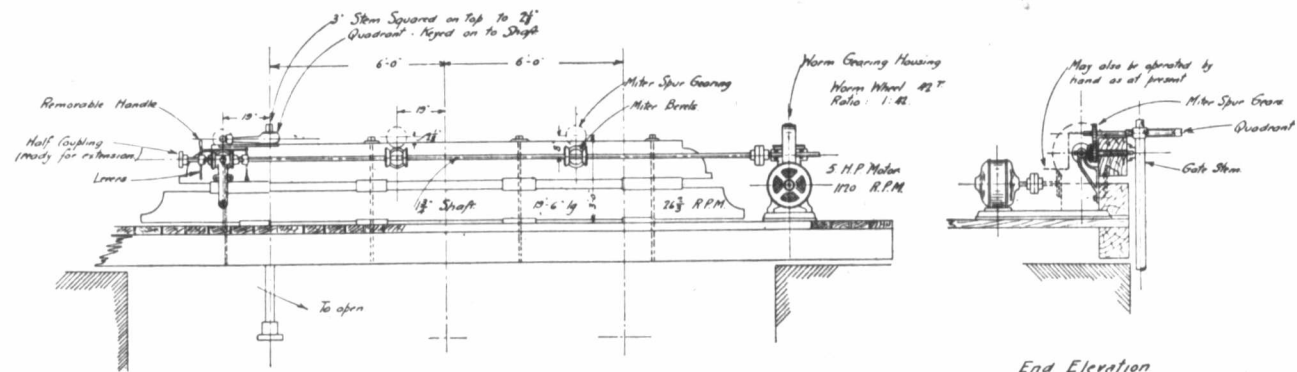

Elevation (looking from side towards Canal)

End Elevation

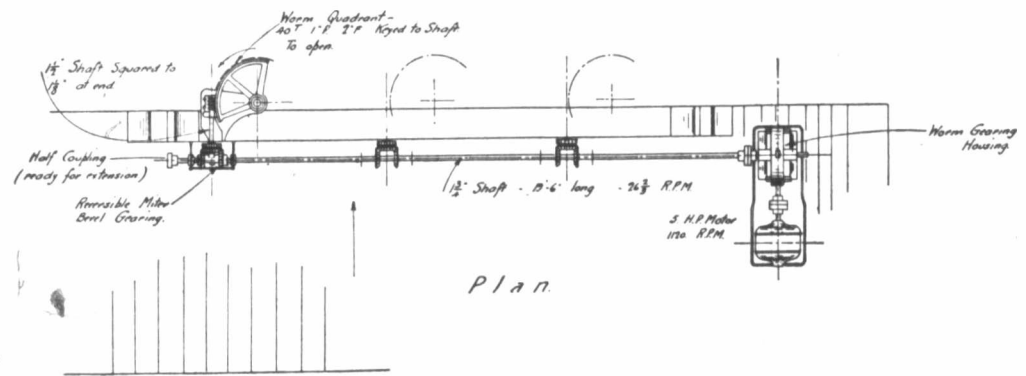

Plan.

**GORNWALL CANAL**  
ARRANGEMENT — OF — MACHINERY  
FOR OPERATING WASTE-WEIR GATES  
USING ELECTRIC POWER  
 Scale: \_\_\_\_\_

FIGURE 5.

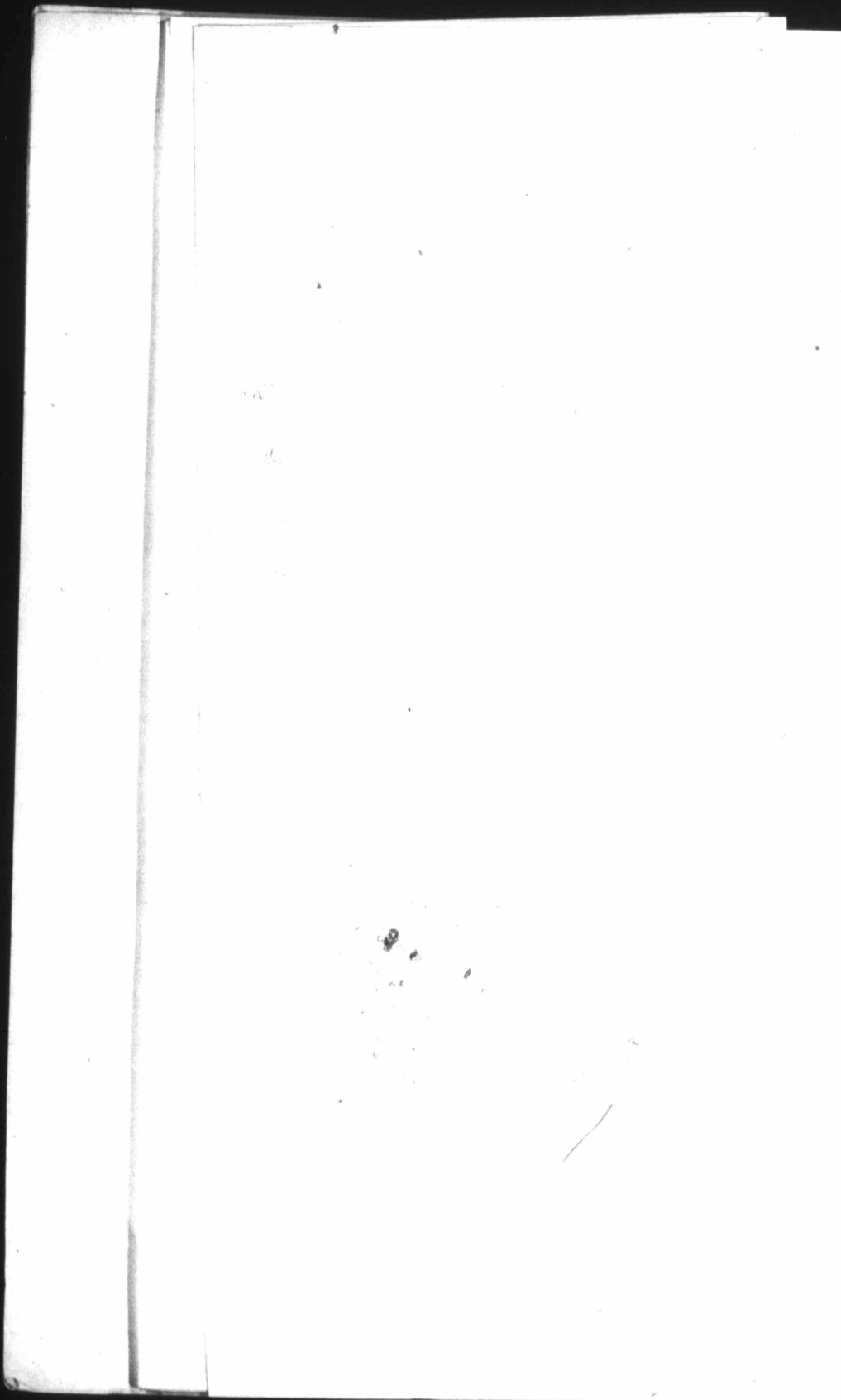

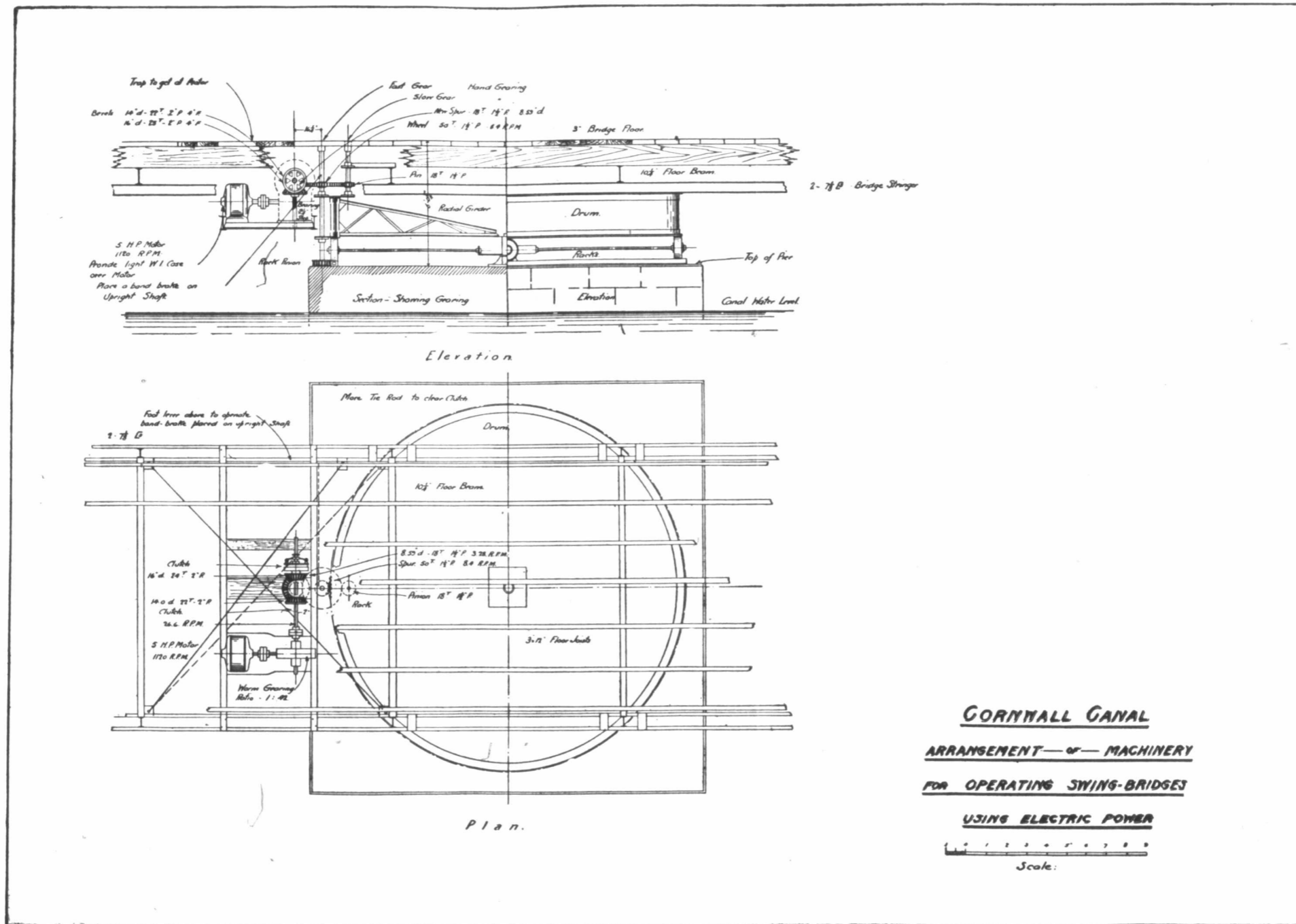

FIGURE 6.