

FARMER'S ADVOCATE

AND HOME JOURNAL

THE ONLY WEEKLY AGRICULTURAL PAPER IN WESTERN CANADA

REGISTERED IN ACCORDANCE WITH THE COPYRIGHT ACT OF 1875

MAY 15, 1907

WINNIPEG MANITOBA

VOL. XLII, NO. 764

For
Table Use—
For Kitchen Use—
For the Dairy—
**Windsor
Salt**
is Best. Pure—fine
—well-savoured.
Grocers'—
everywhere.



**"HINGE-STAYS" MAKE DILLON
TWICE AS STRONG**

Short, stiff, hard, steel wire stays make a "hinge-like" joint at every lateral wire on the Dillon fence. These "Hinge-stays" give our fence a greater degree of elasticity—enable it to withstand greater strain. They set like, and really are, hinges—make our fence swing or spring back into shape after receiving a heavy blow, or the unusual pressure caused by a furious bull or other animal endeavoring to push his way through to freedom. Catalogue tells more about this "twice as strong" fence.

The Owen Sound Wire Fence Co., Limited,
Owen Sound, Ont.

**DILLON HINGE-STAY
FENCE**

GASOLINE TRACTIORS
WE HAVE THEM
3, 12, 16, 20 and 25 HORSE POWER
WRITE
The Portage Iron & Machine Co. Ltd.
Portage la Prairie, Man.
Founders Machinists Boltermakers

FRUIT LAND IN KOOTENAY B. C.
Farm of 290 acres with Railway and Steamer shipping facilities. Land is level, soil is good and plenty of water for irrigation. Suitable for subdivision. Deal with owner and save agent's commission. Price only \$25.00 per acre for quick sale.
F. J. WATSON, Fernie, B. C.

**FIRES ARE
NUMEROUS**
DELAYS are DANGEROUS
Losses promptly adjusted if you are Insured in the
Hudson Bay Insurance Co. Ltd.
Address P.O. Box 1059, MOOSE JAW, Sask.
Live Agents wanted in unrepresented districts

ALEX. NAISMITH, President. WM. PATERSON, Vice-President. C. D. KERR, Treasurer

The Wawanesa Mutual Insurance Co.
HEAD OFFICE: WAWANESA MAN.
A. F. KEMPTON, SECRETARY-MANAGER

Amount of insurance in force Dec. 31st, 1906 - - - - \$17,447,679.00
Assets over Liabilities - - - - - 224,096.56

The Number of Farmers Insured Dec. 31st, 1906, over 15,248
Over 15,248 farmers Insured. The largest agricultural Fire Insurance Company west of Lake Superior. Agents wanted in unrepresented districts.

PLANT POTATOES
They pay better than wheat. We are open for unlimited quantities now and at all times. Feed the small and rotten ones to the swine and forward choice stock to the WINNIPEG market for good returns.
WILTON BROS.
1427 Erin Street, Winnipeg
Licensed and Bonded Grain Buyers

**We Own 80,000 Acres of the
Best Wheat Land
in Western Canada.**
Prices from \$7.00 per Acre up.
We can sell you a farm cheaper than any real estate firm in the West, simply because the land we sell is our own; you do not need much cash to buy from us; write for particulars
FARMER'S COLONIZATION and SUPPLY COMPANY,
6 Stanley Block, Winnipeg, Man.

NOTICE.
If you are at all interested in having your stock thrive better, your cows give more and richer milk, it will pay you to write us for our special offer.

The Peel Richards Co.
Manufacturers Peel Stock Food.
Box 362, Winnipeg, Man.

PILES CURED IN 6 TO 14 DAYS
PAZO OINTMENT is guaranteed to cure any case of Itching, Blind, Bleeding or Protruding Piles in 6 to 14 days or money refunded. 50c

DID YOU GET ONE
of those Farms on a 10% basis?

If not you will regret it. The chance does not occur every day to buy improved farms on the same terms as School Lands, viz.: 10% cash, and the balance in nine equal annual instalments with interest at 6% on deferred payments. Write us for maps, etc.

McINNIS & CLARK
Box 6 BRANDON, MAN.

POTATOES
and consignments of EGGS, BUTTER, GRAIN, on commission. We are open for car lots of POTATOES. If you are going to load a car write or wire us, or ship it in our car. References—Bank of Hamilton (Grain Exchange Branch, Winnipeg); Bradstreet's or R. G. Dunn & Co.
LAING BROS., 234 & 236 KING ST., WINNIPEG

**Your Watch
Wanted**
Send us your watch by mail for repair. A post card will bring a small box for mailing; and we will report cost of work. If you are satisfied we will repair it and return it to you post paid. Your watch will receive prompt and careful attention. All work is guaranteed.
D. E. BLACK,
Expert Watchmaker
and Manufacturing Jeweler.
The largest Repair Trade in Alberta
130 8th Ave. East, Calgary, Alta.

Prices are Good—Take advantage of them by Shipping through us.
Write To-day for Prices and Shipping Directions.

O A T S

Thompson, Sons and Company
Commission Merchants
P.O. Box 77B, WINNIPEG Can.



VICTORIA DAY EXCURSIONS
Fare and One-Third
 For the round trip
 between the stations on the
CANADIAN NORTHERN RY

Tickets good to go May 22nd to
 May 24th inclusive.
 Return until May 27th, 1907.

Any Canadian Northern Railway
 Agent will be more than pleased to
 furnish fullest information.



It dries them up.
COMMON SENSE
EXTERMINATOR

**Kills Roaches, Bed-bugs, Rats
 and Mice**

All Dealers and 377 Queen St. W.,
 Toronto, Ontario.
 Write for Testimonials.

DOMINION EXPRESS
**Money Orders and
 Foreign Cheques**

The Best and Cheapest System of
 Sending Money to any place
 in the World.

A receipt is given purchaser. If order
 or cheque is LOST or DESTROYED the
 amount will be promptly REFUNDED.
 No Red Tape. Full information from any
 local Agent Dom. Exp. Co. or C.P.R.



**SYNOPSIS OF CANADIAN
 NORTH-WEST HOMESTEAD
 REGULATIONS**

ANY even numbered section of Dominion
 Lands in Manitoba, Saskatchewan and
 Alberta, excepting 8 and 20, not reserved, may
 be homesteaded by any person who is the sole
 head of a family, or any male over 18 years of
 age, to the extent of one-quarter section of 160
 acres, more or less.

Entry must be made personally at the local
 land office for the district in which the land is
 situated.

The homesteader is required to perform the
 conditions connected therewith under one of the
 following plans:

- (1) At least six months' residence upon and
 cultivation of the land in each year for three
 years.
- (2) If the father (or mother if the father is
 deceased) of the homesteader resides upon a
 farm in the vicinity of the land entered for, the
 requirements as to residence may be satisfied
 by such person residing with the father or mother.
- (3) If the settler has his permanent residence
 upon farming land owned by him in the vicinity
 of his homestead, the requirements as to residence
 may be satisfied by residence upon the said land.
 Six months' notice in writing should be given
 to the Commissioner of Dominion Lands at
 Ottawa of intention to apply for patent.

W. W. CORY,
 Deputy of the Minister of the Interior.
 N. B.—Unauthorized publication of this
 advertisement will not be paid for.

ALL ADVERTISING CONTRACTS ARE MADE SUBJECT
 TO A GUARANTEE OF 20,500 SWORN CIRCULATION

Farmer's Advocate
 and Home Journal

The Only Weekly Farm Journal in Western Canada.

PUBLISHED EVERY WEDNESDAY BY THE
 FARMER'S ADVOCATE OF WINNIPEG, LIMITED.
 GENERAL OFFICES:

14 and 16 Princess Street, Winnipeg, Man.

Branches at London, Ont. and Calgary, Alta.

BRITISH AGENCY—W. W. CHAPMAN, Mowbray House, Norfolk Street, W. C., London, Eng.

TERMS OF SUBSCRIPTION.—In Canada, England, Ireland and Scotland, \$1.50 per year in
 advance; \$2.00 when not paid in advance. In the United States, \$2.50 per year in advance.
 All other countries, \$3.00.

ADVERTISING RATES—Single insertion, 15 cents per line, agate. Contract rates furnished on
 application.

REMITTANCES should be made direct to this office, either by Express or P. O. Money Order or
 Registered letter, which will be at our risk. When made otherwise we will not be responsible.
 THE DATE ON YOUR LABEL shows to what time your subscription is paid.

CHANGE OF ADDRESS—Subscribers when ordering a change of address should give the old as
 well as the new P. O. address.

WE INVITE FARMERS to write us on any agricultural topic. We are always pleased to receive
 practical articles. For such as we consider valuable we will pay ten cents per inch printed
 matter. Contributions sent us must not be furnished other papers until after they have appeared
 in our columns. Rejected matter will be returned if accompanied by postage.

ANONYMOUS communications will receive no attention.

LETTERS intended for publication should be written on one side of the paper only.

THE FARMER'S ADVOCATE is sent to subscribers until an explicit order is received for its discon-
 tinuance. All payments of arrearages must be made as required by law.

Address all communications to
 FARMER'S ADVOCATE OF WINNIPEG, LIMITED,
 WINNIPEG, MAN.

Contents of this Issue.

ILLUSTRATION		
Miss Trout	725	Mr. Mackay's Opinion of Cultivating Crops
A Comfortable Abode. The Farm Home of J. Uren, Adair, Sask.	727	Agricultural Legislation at Ottawa Session of 1906-7
Ideal for a Picnic. On the Farm of W. Clark, St. Adair, Sask.	730	Building a Rural Telephone Line
A Picnic Party on the Little Red Deer, Alta.	738	Every Enterprising Farmer Should Take the M. A. C. Course
		Larger Machinery should Increase Wages An Old Country Judge for the Winnipeg Industrial
EDITORIAL		
Telephones for the Farm	723	DAIRY
Develop More Live Stock Judges from Our Own Men	723	Avoiding Udder Troubles
The Live Stock Trade Taking Life	723	Milk For Town and City
No More Bucket Shop Deals for a While	723	POULTRY
Keep the Standard Up for Clydesdale Registration	724	Feeding Many Chicks Easily
Keep the Four Year Course in Agriculture for the Future	724	How Hens Were Cured of Egg Eating
		A Few "Don'ts" for the Poultry Man
STOCK		
Beef Cattle Feeding in Manitoba	724	HORTICULTURE AND FORESTRY
Calf Raising by Hand	724	Source of Lumber Supply in Central Canada
Experiences of Successful Pig Raisers	724	In Order to Ensure a Crop of Strawberries Fruit Farm for the North
HORSE		
No Quarter to Typical Reactors to Mallein Test for Glanders	725	FIELD NOTES
Three-horse Eveners and Lines	726	Events of the Week
Keep up the Stud Fees	727	Alberta Central Stock Growers will Hold Picnic Convention
FARM		Spraying With Chemicals to Kill Weeds
Suggestion to Farmers' Elevator Companies	727	A Great Road Improver
Enjoyed His Course at the M. A. C.	727	Things to Remember
That Saskatchewan Wolf Bounty	727	Beef Ring Charts
Cultivation of a Growing Crop	728	MARKETS
"A Reader" Gives Specific Data	728	HOME JOURNAL
		GOSSIP
		QUESTIONS AND ANSWERS

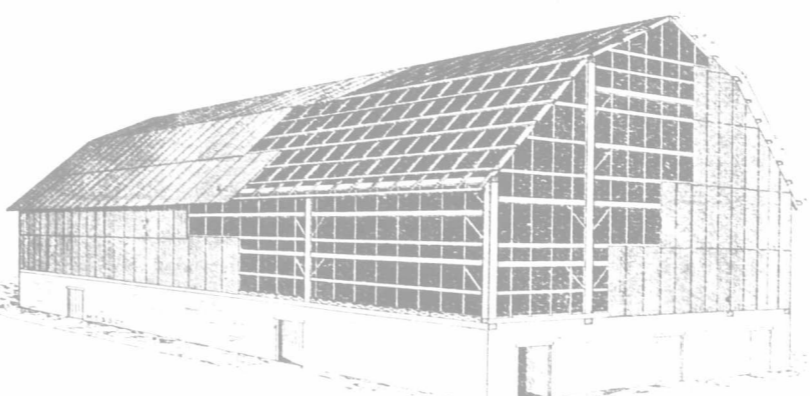

This cut shows an up-to-date Barn Construction, 40 feet x 70 feet, and the method of covering with Corrugated Sheets. The framework is light, as the corrugated sheets, when nailed in place, make the building very rigid. This drawing is made from actual plans and the barn has been built many times with splendid results.

The saving of wood sheeting, as compared with the ordinary barn construction, will cover the difference in cost between wooden shingles and our "Acorn Quality" Corrugated Galvanized Sheets.

This galvanized covering protects your building from lightning, prevents fires from the outside, is easily and cheaply applied, and OUTLASTS A GENERATION.

Do not make a mistake and put up an old style barn, when you can secure a better and more durable construction for less money.

See the page of barn illustrations in our new catalogue, and write for our book of testimonials with list of users.

CLARE & BROCKEST
 WINNIPEG.

The
BLUE
RIBBON
COOK
BOOK
 Should
 be in
 every
 home in
 Western
 Canada

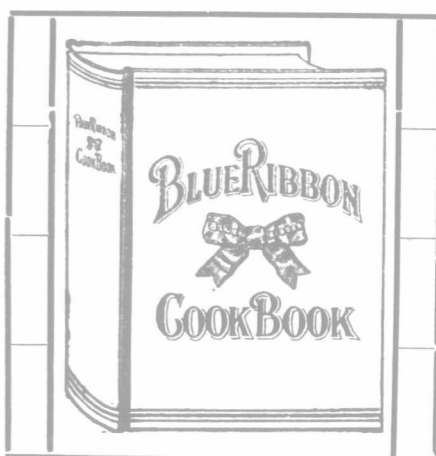

The price puts it within
 the reach of all. A good
 cook book is a necessity
 —not a luxury.

YOU CAN HAVE IT
 FOR ONLY

35c

Or if you are already a
 subscriber to the FARMER'S
 ADVOCATE, send us the
 name of ONE new balance
 of the year subscriber, at
 the special price of **75c**,
 and we will mail you the
 Cook Book, postpaid.

It is only necessary to show
 a copy of the FARMER'S
 ADVOCATE to your friends
 to secure numerous sub-
 scribers.

Address—
 The
Farmer's Advocate
 WINNIPEG, MAN.

OATS	Ship your WHEAT, OATS, BARLEY, FLAX to us and obtain highest prices	WHEAT
G. B. MURPHY & CO., Winnipeg, Man.		

"PAGE FENCES WEAR BEST"

Made of High Carbon Wire,—we'll prove it to you. COILED—not crimped. This makes it still stronger in service. It stays taut. Painted WHITE over heavy GALVANIZING—rust proof. Experienced dealers to erect it. Leads all in sales 209 —as in merit. Get illustrated booklet and 1907 prices before buying. **THE PAGE WIRE FENCE COMPANY, LIMITED, Walkerville, Toronto, Montreal, St. John, Winnipeg**

Robson the Cream of the KOOTENAY

Robson, B. C., 22-1-07
Messrs. McDermid & McHardy, Nelson, B. C.

Dear Sirs:—
I bought a lot from you 1st Jan., 1907, not seeing it until I moved on it 27th March. I wish to state the quality of soil, and the location of the property far surpasses my greatest expectations. I have lived on the prairie for twenty years, in southeastern Saskatchewan. I travelled over a considerable portion of B. C. before locating here. People on the prairie imagine living in the Rockies means obtaining a very short glimpse of the sun during the daytime. In fact, according to their ideas, the length of time it takes the sun to traverse the space from behind one mountain until it hides itself in obscurity behind the next, is all the sunshine we are entitled to. I was agreeably surprised myself to find we have just as bright sunny days here at Robson as we had on the Prairie.

People in the East, who are intending moving to some other part of the country, where they can enjoy a more favorable climate, and surroundings, would save themselves a great deal of expense and travel, if they would come to Robson. After they had thoroughly examined the property, and the location, they would undoubtedly conclude, "They could not possibly wish a better place to live."

I find all prices for produce, and the general description of the property, exactly as stated in advertising matter, and not in the least exaggerated.

Yours sincerely,
(Signed,) H. Hedley.

LET US SELECT A ROBSON LOT FOR YOU

Illustrated Booklet Free on application

McDermid & McHardy
NELSON, B. C.

MENTION THIS PAPER

THE J.B. ARMSTRONG CO. LIMITED
GUELPH CANADA
ESTABLISHED 1834 INCORPORATED 1876
ARMSTRONG STANDARD BUGGY
CARRIAGE BUILDERS
COCKSHUTT PLOW CO., Agents Western Canada

Going to School or Learn a Trade?
Write for our fine new catalogue giving complete information about the special opportunities offered for obtaining an education in almost any subject and learning some of the best trades. Address
G. H. Longwell, Pres. Highland Park College, Des Moines, Ia.

Four Cows Will Earn You MORE Money Than EIGHT Cows Earn You Now

Tell me to show you how to get over thirty dollars a year more out of each cow you keep. Make me prove that four cows AND a Capital Separator will actually earn you —YOU, PERSONALLY—more money in cold cash profits than an EIGHT-cow herd and no Capital Separator. Don't take my say-so for it. Don't wrap yourself up in your own belief that it can't be done. It CAN be done, and I can PROVE it to you, in a practical, hard-sense fashion, with figures and facts that you won't want to dodge. Write to me and see.

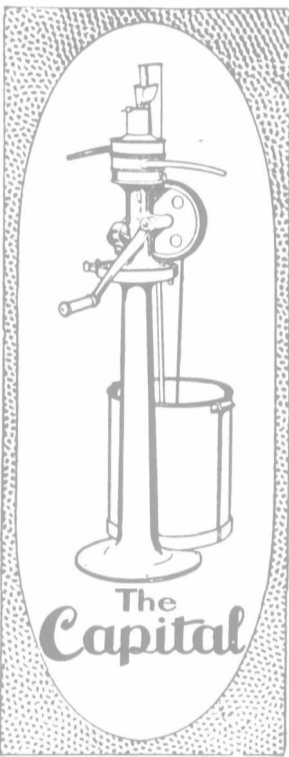

Let's get the thing clear to start with. Here is what I say I can show you: That with four good cows and my method of separating, making butter—and selling butter—you can make more money in one year than eight cows will make you without my method.

If I do that,—if I do show you a difference of over thirty dollars profit a year on every cow you keep,—then I want to talk business with you. I don't want a cent of your money until you are satisfied that I have made good every word I say and everything I promise. I don't want to sell you a Capital Separator until you ask me to,—I shan't importune you, nor bother you. All I want to know is your name and address, and how many cows you keep. When I get these facts, I'll tell you some things you haven't heard before. I'll show you not only why you need a Capital Separator, but why you can make more money by my method of selling butter than you'll make any other way. It won't be all separator talk I'll talk to you,—you've read reams of separator argument, but you haven't heard yet about the right way to

make butter and the right way to SELL butter. Tell me to tell you about it,—there's nothing to pay.

Why don't I tell you right here in print? Simply because I am not giving "blanket" advice. What might be a good plan for a man in Ontario wouldn't work in Manitoba,—and I propose to advise each dairyman according to his location and other vital details. Naturally, I want to sell Capital Separators. I am no philanthropist. But I will sell them faster because I can tell people how to make them pay,—and that's something new in this business.

I don't care what your experience with dairying has been, nor what with separators. You may have what you think is the best separator there is. Or you may believe, as many do, that there isn't any real profit in dairy-farming. I can show you where you're wrong in either case. Do I get the chance to do that? Will you listen to the mere, sheer, downright facts? Just write to me and say so.

I don't care whether you feel able to buy a Capital Separator or not. It won't be a hard matter, once you get to the buying point, to make terms with me. Some of my friends—I don't consider them merely my customers—take three years' time to pay in. Some of them pay in three months. Doesn't make any difference to me, because I know, and I can prove to you, that my Separator will buy itself the first year you have it. It will save you enough money and trouble, to pay for itself twice over in that time. And I can prove that, too,—just write and ask me to.

I've got a machine here, and a method, that will open your eyes to what there really is in keeping cows for profit. Maybe you are one of the few that know that already. Even if you are, you won't be any the poorer for reading what I'll write you. Let me tell you about the easiest separator to run you ever saw, the easiest to buy,—the separator that skims cleanest and does it easiest,—the one with the really low-down can,—and about the method that makes more butter, makes better butter, and gets better prices for it the whole year round. Just write to me—address as follows:

Robert Ferguson

National Manufacturing Co., Limited
51 Mail and Empire Building, TORONTO, ONT.

When writing to advertisers please mention the Farmer's Advocate.

Should be in every home in Western Canada

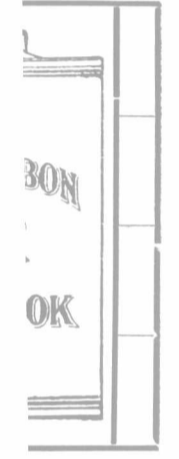

within A good necessity

WE IT Y

ready a ARMER'S as the balance ber, at 75c, ou the id.

o show RMER'S friends s sub-

ocate

De Laval Cream Separators

are in use in a vast majority of dairies throughout the world, and many users of inferior machines, who would like to change for a De Laval do not understand that while such second-hand machines possess no saleable value, the De Laval Company makes very fair "trade" allowances for them. This is simply to get them out of the way, and by means of practical illustration of the difference between good and poor separators, stop the sale of others like them in the neighborhood. Nobody is injured by the resale of these old machines, as they are "scrapped" for their old metal value.

The De Laval Separator Co.

MONTREAL

WINNIPEG

VANCOUVER

REPRESENTATIVES EVERYWHERE

KINGSTON

TORONTO

WINNIPEG

Jas. Richardson & Sons

Highest prices paid for all kinds of

GRAIN in carload lots. Special attention paid to low grade samples WHEAT, OATS, BARLEY, FLAX. Write for shipping instructions and price circulars.

Real Estate Guide

Saskatchewan and Alberta

100,000 acres choice wheat land in the Goose Lake and Eagle Lake Districts.

Several choice sections on the main line of the Can. Northern Ry. at Humboldt, Quill Lake and Wadena.

Improved and unimproved lands in the Regina District and on the Prince Albert, Arco and Soo lines.

Regina City Property

We own property in all parts of the city, also two of its best additions.

We have 160 acres adjoining Regina which will make a splendid sub-division.

For full particulars re any of the above write the owners,

C. W. Blackstock & Company REAL ESTATE

Head Office, ROSE STREET, REGINA, Sask.

Branch Office, 76 Fort St., Victoria, B.C. Branch Office, 20th St., Saskatoon, Sask.

British Columbia

Timber Limits on Vancouver Island

The City of Victoria

A city of beautiful homes, the playground of the Dominion and the tourist's paradise.

Thousands of Canadians, Englishmen and even Americans are making Victoria their winter home, owing to its semi-tropical climate.

The coming two years will see an enormous increase in property values in Victoria.

BUY NOW. We have recently purchased two of the finest sub-divisions in the city and are offering lots for sale at prices and terms which cannot fail to appeal to you.

Telephone Instruments

for

Rural Party Lines

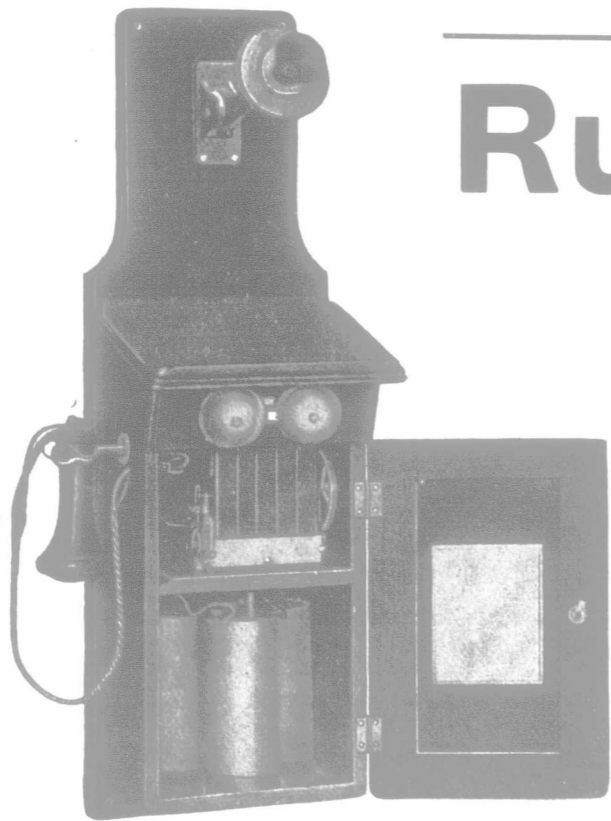

We make a specialty of High Grade Telephones for Rural Telephone Lines and can supply you with everything needed to build Telephone Lines.

Our Telephones and Switchboards are made of the very best materials obtainable and are assembled in our factory in Montreal. If there is anything you require for a telephone system we have it for you.

The No. 501A subscriber's station is an instrument that has been designed to meet the demands of rural party line service. It is equipped with a powerful five bar generator which will ring, under favorable conditions, thirty or more bells on a single line.

Write To-Day For Bulletin No. 2

We are the only Manufacturers in Canada who can supply you with anything or everything for a Telephone System

The Northern Electric & Mfg. Co. Limited

181 Bannatyne Ave., Winnipeg.

Cor. Notre Dame and Guy Streets, Montreal.

Farmer's Advocate and Home Journal

REGISTERED IN ACCORDANCE WITH THE COPYRIGHT ACT OF 1875.

May 15, 1907.

WINNIPEG, MANITOBA.

Vol. XLII. No. 764

EDITORIAL

Telephones for the Farm.

Rural telephones are beginning to be considered necessities. Every community that has passed the bustling days of pioneering and has settled into the long stride of substantial development thinks about or talks over rural telephones. The construction and installation of country lines is conducted upon two different plans. One is to induce the Bell Telephone Company to extend its line from the nearest town at so much per year for each subscriber, and the other is to organize a local company to install and operate the rural telephone system, the principle of the arrangement being purely co-operative. The former plan has its advantages, which are freedom of responsibility, a satisfactory service maintained, and connection with long distance lines without unnecessary bickering. The only objection we have ever heard raised to a rural Bell system is its cost and, conversely the great argument in favor of organizing a local company to conduct the telephone business is the reduction of cost. As for service it has seldom been the case but what a local company could do as well as the Bell, but there is invariably trouble getting the long distance connections. This by the way, is one of the outstanding instances of the intolerable self-complacency and arrogance which characterize so many of our large corporations and which drive the public to expensive independence when a mutual arrangement would be better for all concerned.

In the Farm department of this issue we publish an article on the construction and operation of local telephone systems from which we trust that those who may in the future be interested in such concerns may derive much benefit. This subject is worthy of considerable study and the article might well be preserved for future reference.

Develop More Live Stock Judges From Our Own Men.

The season has about arrived when fair boards and superintendents of fairs begin to scurry around for judges for the coming summer fairs. Of late years great improvement has been noted at the smaller fairs, for as a result of the work of the Dominion and the various Provincial Departments of Agriculture, the old jury system has been abandoned and the single judge system followed, and as a consequence we hear fewer complaints of the integrity and competency of judges than ever before. This much accomplished, we must look for fresh fields to conquer, and right here we might mention one; viz., the bringing forward and development of home talent. At some of the agricultural colleges the best student judges were tried out from time to time at fairs, and after culling severely a number of good men were secured for permanent use. We should like to see something of the same idea put into practice in the West. Alberta made a start the coming winter and incurred an expense of several thousand dollars, sending out a staff of itinerant lecturers (seven), three herdsmen and several specimens of live stock. The work attempted was not with a view to developing expert judges of live stock solely for fairs, but for all, when the outlay of time and money is considered, there ought, we submit, to be some who, having undergone the refining fires of the fortnightly stock judging and lecture periods, can now be trusted, as a noted animal husbandry authority puts it, "to tell where the ribbons should go" and that without any great play to the gallery. We do not think that any attempt to bring the profession of expert judging to agricul-

tural college men should be made, but plead for a greater catholicity of taste, so that it may be possible to secure, without going far afield and at great expense, live stock judges from among the breeders and young men of Western farms. Occasionally one notes at shows an occurrence which any upright, self-respecting judge detests, the rushing forward to congratulate a judge when he gives a decision which agrees with your own. It is a species of impertinence and is usually done for a purpose, and places the judge in an unenviable position before the spectators and unsuccessful exhibitors. Even if you are an exhibitor the limit to which you may reasonably go is to quietly leave the ring with one word of thanks. These are days when every man's actions are scanned and watched closely, and an exhibitor has no justification for toadying round a judge, to whom generally the attentions are exceedingly distasteful, besides giving others the impression that there is an understanding between them. It will generally be found that the exhibitor quickest to congratulate a judge because he has won, will be the loudest to condemn if a loser. Fortunately judges as a rule award the prizes to the animals submitted, for if otherwise, the congratulating exhibitor would, we opine, after his first offence be likely to fall short, or to use a slang phrase, "be apt to get it in the neck."

The Live Stock Trade Taking Life.

The conditions operating to affect the meat trade this season are significant enough to give us pause. They are immediate and certain, and more distant and probable. At present we have a continuously large increase in our population, with a scarcity of butcher products and an ascending market. Practically anything and everything that will make meat is eagerly bought. In the trade it is freely admitted that between now and the time the first cattle come off the grass prices will have to go higher, and there is no prospect that either hogs or cattle can be imported in sufficient quantities and at low enough prices to materially affect the markets here, although that is done to some extent. Farther distant, prospects do not point to cheaper meat, but rather to higher. Without giving credence to alarmist stories, we must admit that conditions on the range have been severe and that cattle will not come forward in such high fit and probably not in so large numbers as could be expected in ordinary seasons.

The situation is one upon which the mixed farmer should cogitate. There is an opportunity to take advantage of the adverse circumstances of the rancher and the rising tide of market prices and the mixed farmer is in the best position to move quickly to take advantage of them. The supply of meat products will in the future be drawn more and more from the farms and less from the ranges. Even now it is not too soon to prepare for the possibility of having to make the best use of a supply of unmarketable wheat and the certainty of a larger proportion than ever before, of barley and oats, since seeding has been so long delayed.

Naturally enough most farmers want to see in conjunction with their efforts to produce stock some improvement in the handling of cattle and hogs at the central markets of Calgary and Winnipeg. The conviction is firmly fixed that the methods in vogue upon these markets have not tended to foster the live stock business, but rather to restrict it and to render producers indifferent to the trade. The appointment of the commission which has just begun its inquiry is the outcome of this sentiment, and it is to be hoped that when their investigations have been completed, the public will be in a better position to decide what attitude to present toward the buyers.

Another favorable circumstance is also about to operate to improve market conditions for the feeders and shippers, particularly of Manitoba

and eastern Saskatchewan. We refer to a movement among certain dealers (we are not in a position to say whom, but it is not the canning company) to organize a stock yard company with all necessary facilities for trade, including feed yards, commission offices, banks, auction rooms, etc., to be located in some convenient city. The movers in this enterprise are most anxious to facilitate the placing of two and three-year-old feeders upon the grain farms of Manitoba, and for this purpose have the promise of a banking institution that money will be furnished at reasonable rates to any person who wishes to feed steers to enable him to buy them and carry them over.

From more than one direction, therefore, it appears that circumstances and efforts are operating to give to live stock raising and feeding a better standing and to make it a more profitable adjunct to farming. The moral is, if you have young cattle this spring keep them, and if you have not, consider the advisability of getting a few.

Some Conclusions Upon the Threshing Problem.

The season for machinery buying, like the poor, is always with us. Consequently the discussion upon threshing which has been conducted in these columns the past few weeks has been relevant, especially as this is, more particularly, the time when a man makes up his mind about buying a thresher. The threshing problem has probably received as much study as any other of those that confront the farmer, and the opinions that have been expressed in this discussion are those to which most students of the question have come.

Threshing as an operation looks expensive when considered in two aspects, the cost per bushel and the total cost, especially upon a farm of more than half a section in extent. Thus from the standpoint of a farmer, unless he is also a thresherman doing custom work, threshing looks like a costly job. With the owner of a large outfit who does custom work in threshing season, does it well, and then puts his machine away, threshing does not look so much like a "pay streak." The difference of opinion is due to the fact that risk, interest on money, wear and tear, and numerous other expenses in connection with threshing, are not visible to the farmer, while they are a present thorn in the side of the thresher and almost invariably cost him more than they would the farmer. The problem of threshing has been the difficulty of adjusting these risks and expenses and ultimately compensating the man who carries them. In any case this is the farmer, but often he pays the cost in the form of five or seven cents per bushel for his threshing, and as one correspondent puts it, "pays for the machine but does not get it," but when the machine has moved away he has nothing but the results of its work to show for his expense. This is the phase of threshing that has touched the man who now advocates the smaller outfit.

From the nature of the work threshing machines should belong to the men who grow the grain, because it always adds to the cost of producing when grain has to be handled by labor or machinery that are not strictly of the farm, but the expense of a machine being great and the risk of keeping it heavy it naturally follows that unless these are borne cooperatively, the latter in the form of security provided, the expense of threshing will come heavy. But because partnership ownership and management are less satisfactory than private ownership and management, the object should be to get an outfit the cost and risk of which will be distributed over as much land as possible, but the management of which will be in as few hands as possible.

"Reader," who writes from Virden, Man., seems to us to have found the best plan for the average farmer, and this plan might be adopted upon smaller farms where the means and the

ability of the owner warrants, or upon two small farms where the owners are not averse to partnership arrangements, and where other uses than threshing can be made of the engine.

Some of the positive conclusions emphasized in the discussion are these: That a large outfit owned conjointly by a number of small farmers is not satisfactory; that owing to the cost of an engine other work than threshing should be found for it; that a large outfit owned by two or more men who farm on a large scale may prove satisfactory under able management and mutual arrangement; that where extra men have to be hired or come to the farm at threshing time the expense and inconvenience of threshing is very much increased; that where threshing is done by custom work, the thresher furnishing men and taking all risks, the cost of threshing is too high; and that the gas motor will, when commonly used on small or average sized outfits, very much facilitate threshing.

Keep the Standard up for Clydesdale Registration.

The Canadian Clydesdale Association made a distinct forward move recently, when its executive passed a resolution in which was included the basis on which imported horses would be registered in future. Some parties have objected to the more stringent rule, but we trust their views will not be considered to the extent that the new regulation will be withdrawn. It seems inconsistent that Canadian breeders should insist on four straight crosses for mares and five for stallions in order to register in the Canadian book, and also that Shorthorn cattle that do not trace to the first thirty volumes of Coates' (the English) Herd Book should be barred and yet be willing to take in short pedigreed horses simply because such have crossed the "briny." The volume of horse trade between Great Britain and Canada has been very large of late years, but it is open to question whether the improvement in horse-flesh in Canada is commensurate with the numbers imported. If that is so, and it appears to be, what reasons are there for such lack of, or tardiness in, the improvement of our horse stock? Is it not a fact that many of the short pedigreed fellows, many of them good individuals, are by reason of their mixed ancestry lacking in prepotency, the power to impress upon their progeny their own characteristics? Some horsemen say that Clydesdale stallions are lacking in masculinity and that such is the reason for the weak impress left upon the graded stock of the country, the main feature from the use of many purebred draft stallions being their ability to splash white over the faces and legs of their progeny.

Keep the Four Year Course in Agriculture for the Future.

Our readers will have noticed the letters published in our columns from a number of students from Western farms, young men fortunate enough to have had one term at the Manitoba Agricultural College the past winter. All those attending are agreed that the course has been one of great benefit, that it is inexpensive and that it develops the ethical as well as the material in them. Fortunately the college, as far as we know, has outlined courses designed for farmers' sons to go back to the farms, and has no intention at present of turning out graduates in agriculture with a university degree. We trust that for some time to come—or never—no attempt will be made to turn out young farmers whose anxiety will be to leave the farm for positions as professors or lecturers or even editors of agricultural or other journals. It would mean a lot of expense to the province and the game would not be worth the candle. Candidly we believe that for many years hence, Guelph can do all the manufacturing of agriculturists with the university brand upon them. We would suggest that arrangements might be made so that W. A. C. students on completion of their second year of work could drop into the third year at Guelph should they desire to acquire the degree of bachelor of the science of agriculture. Rather than increase the number of degree conferring institutions, sometime vellept universities, we should use all means to strengthen and improve those now existing. One big institution can get better equipment and bigger men than can a half dozen smaller institutions. Provincial pride sometimes needs holding in check so that the exercise of common sense may be permitted.

STOCK

Beef Cattle Feeding in Manitoba

The opinion has often been advanced by men who have made a study of the entire question that Western cattle are rarely finished as they should be in order to secure the top price of the market, and that instead of shipping cattle in the usual condition, the grass fed stuff should be made grain finished and thus put on the market in a better condition than now obtains. It is common knowledge that the average feeder of cattle on the farms of Manitoba just gets his beef cattle to the point where they are starting to be finished; he rarely if ever finishes the stuff, and markets them in such a condition that he fails to get the most money out of them, the cattle having reached a stage in feeding which the Chicago and other U. S. markets describe as "warmed-up."

Occasionally one finds a person profiting by these circumstances, buying the warmed up stuff to finish it. At Gladstone this method is being carried out as a big undertaking by P. Galloway, who winters a large number to fill his railroad and other beef contracts. At the Gladstone yards on the banks of the White Mud we saw recently several hundred being fed, indoors—beef cattle of a better type than one usually sees. The steers were in very good order and are fed hay (wild) and chop (a mixture of bran, oats, barley and screenings), getting in all about three gallons (in three feeds) a day, with water in front of them. The passages of the cattle and their condition showed that the diet was not very far wrong. As many as 600 head have been at the feeding grounds during the winter, large drafts being made from time to time as the markets demanded.

While the Galloway method is an object lesson from which many deductions may be drawn, there are two other systems of feeding being followed in close proximity to the town of Newdale which are even more interesting and provocative of thought on the whole work of feeding cattle for beef, especially so as the lines of endeavor followed are such as may be adapted to the conditions of many Manitoba and Northern Alberta farmers. At Mr. Jas. Young's some forty-five steers are being fed, ten of which had been recently tied up. The outside stuff is doing better than those tied, the latter being restless and not filled up as they should be to make profitable gains. The steers are three off and went into feeding quarters at 1,212 pounds, most being Shorthorn grades. In the bunch were noticed some Whitefaces and some Blacks, very good stuff, the Whitefaces being tidy stuff and a shade smaller than the others. An interested onlooker and one-time feeder of cattle under similar conditions, Wm. Grayston, gives it as his opinion that the Shorthorn grades are the best, but he has noticed that while the Whiteface and Black grades usually seen are the get of purebred bulls, the average Shorthorn grade of the country is the product of a grade Shorthorn bull and as a consequence the reputation of the reds, white and reans has suffered. There is abundant need for more good purebred bulls and when such are available a more liberal use of them by the farmers of the West is in order, if the beef cattle trade of Canada is to grow.

At Mr. Young's, as has been stated, the cattle being fed are running loose outside; they have a shed into which they can go, and have the shelter of a bluff in which they spend some time. The yard in which they are fed is well sheltered and plenty of straw is supplied, lots of water, salt at hand all the time, both rock and barrel, the former being preferred. When put in, Oct. 20th, the cattle got straw and sheaf oats and January 1st were started on grain, made up of barley chop three parts, bran one, low grade flour one. These cattle were given eight pounds of the mixture a day, increased to about ten pounds at the present time. These cattle will go on pasture the middle of the month and to the market about June 15th to 20th and by appearances all will be export stuff and should average over 1,400 lbs. They averaged when put in, the weight given above. Their coats were long, but they were very thrifty looking cattle, well fleshed and filled up and were contented. They came in at three and a quarter cents and will go out two cents better.

margin that gives a pretty fair leeway on which to do a profitable business.

The conditions under which this bunch of cattle are being fed can, we believe, be duplicated on dozens of farms in Manitoba and Northern Alberta, and when such results as were seen by us are possible after the winter experienced, there is to our mind a field worth exploring by many farmer feeders. Given shelter and plenty of water, we cannot see any justification for following the laborious feeding methods of some, of having cattle tied up all winter, with the extra trouble of cleaning out stables every day. At the Cook ranch ninety steers were seen, not one of which had been under cover all winter. They had access to abundance of water from springs in a sheltered ravine, but were fed up on high grounds, albeit well sheltered by bluffs; they were put in at similar weights to the Young bunch and will go out in June. In December the cattle were fed four pounds, in January and February eight and in April ten pounds per day of a mixture of two thirds barley and one third bran. When the cattle go on pasture middle of the month low grade flour will be added, such keeping their appetites from flagging. The outdoor method of feeding has the further advantage that the cattle do not shrink to nearly the same extent when shipped as the confined stuff does. Last year (as reported in the market columns of a Toronto paper) four cars were shipped by Mr. Cook to the Queen City. Such weighed 1,508 pounds at home, at Toronto 1,475 pounds. The market reporter stated that these cattle were the best ever seen from the West and were sold at \$5.12½ per cwt. This year's output will, judging by the markets, hardly get past Winnipeg, for the buyers do not worry a particle at paying five cents and up some for the right stuff. The advocates of feeding cattle loose are certainly borne out in their contention by the results as seen by the FARMER'S ADVOCATE recently at Newdale.

Calf Raising by Hand

EDITOR FARMER'S ADVOCATE:

Last July it was my fortune or misfortune to take a trip by wagon of one hundred and twenty-five miles across country from the Blindman district southeast to the Red River. I saw on the journey many things of interest, but I believe the one thing that impressed me most was the poor little skim-milk calves seen by the way. While in a few places where the big creamery cans were seen, the calves looked as if they had reasonable care, in most places they were a disgrace to the place and generally at these places the pigs were rolling fat, showing plainly where the bulk of the milk was going to.

I have for the last fifteen years raised from seven to twelve calves by hand each year, and in that time have never lost a single calf while feeding, and have always had good, growthy calves. My plan is if the cow is very gentle and has been milked several seasons to leave the calf with her for the first two days, as then the calf will get what milk it requires in the natural way; then remove the calf out of sight of the cow and commence feeding by giving one quart of milk three times daily. I give my fingers to suck at first, but teach it to drink out the last of the pail, as it will then learn that the milk comes from the pail and not your fingers. Do not be impatient with them; they will learn in time. Increase the amount daily until you give them two gallons a day. After the first two weeks feed twice a day; then begin feeding a little skim or separator milk, commencing with about one quart mixed with three of fresh milk and increase the amount until at the end of five weeks feed only skimmed milk. Place in reach of the calves sweet green hay and you will be surprised to see how soon they will learn to eat it. Place a small amount of oats or oat and barley chop in a pail where they are fed, but do not mix anything with the milk, as all the experiments I have tried in that line have only resulted in scouring them badly. I have mixed well cooked flour starch with the milk with good results and one season fed ten calves with the milk of eight cows by boiling about three fourths of a teacupful of flax seed in two gallons of water until about one gallon remained and mixing with milk, but this is a troublesome method, especially in the morning, and I think equally as good results can be obtained by carefully feeding the skimmed milk and being sure it is warm enough. My experience has taught me to keep the milk warm, not too cold and patiently watch them to eat a little dry chop or oats

and turning them out to grass as soon as the grass is large enough. Never stop giving them their birthright until they are six months old. I was told quite recently by a neighbor, "I never feed a calf longer than three months," but I have seen the calves that were weaned at three and four months of age, and none of them for me!

Mrs. Wm. Richards.

Alta.

Experiences of Successful Pig Raisers.

EDITOR FARMER'S ADVOCATE:

We have not had any such losses of spring pigs as complained of in a recent issue of the FARMER'S ADVOCATE for some years and do not know what to attribute it to in cases where the sows have been running out during the winter, as some of your correspondents quote. In some cases it might be caused by heavy feeding of barley chop. Barley chop is not a good feed for young pigs if fed exclusively, and I do not like it for sows either, when approaching farrowing time. Perhaps if I give you our methods of handling brood sows it might be helpful to some of your inquirers, as we have had good success during the last few years raising pigs.

We breed the sows in the fall so as to bring them in anywhere from January to March or April, according as we have room and feed, etc. The sows generally run the pasture or stubble during the fall and are not penned at all during winter. We have a shed over which we thresh straw and they make their beds in this straw stack all winter. Sometimes if it is very cold they do not come out for two or three days. They are fed dry chop in the open air, and as they approach farrowing we gradually change from all barley to barley and oat chop with

EDITOR FARMER'S ADVOCATE:

I have had the best of success with my pigs this spring I ever had. I have not lost a pig only one that got killed with cattle in getting out of the pen. I never had a better lot of young pigs and better doers. I saw your letter in the ADVOCATE re seed grain. I may say that the wheat I showed at Brandon and got first prize with out of thirty-five exhibits I have been growing for twenty-one years and the barley that was first for twenty years and it is better now than when I got it.

W. H. ENGLISH.

EDITOR FARMER'S ADVOCATE:

Re losses of young pigs. My first three sows did very well in March. One young sow in April had ten, only two having hair on. These lived and the balance died. My idea is that during the long, cold winter the sows got almost no exercise, which is the cause of pigs coming very fat and with no hair on. These pigs cannot be raised. Sometimes they live some days, but die in the end. Roots, bran, etc., may be better where there is little exercise, but good pigs come with any kind of feed if the sows have lots of exercise.

My average so far is eight pigs to each sow.

There is a heavy loss throughout this part from mares slipping foals, both those in the stable and on the prairie. Many mares are out all winter.

A. B. POTTER.

EDITOR FARMER'S ADVOCATE:

I have followed with great interest the articles which appear from time to time in your paper on pigs. I remember some time ago a neighbor wishing to ship a car of hogs to Winnipeg writing to some of the principal dealers of that city for prices and he got the same reply from all of them, offering so much for "choice" hogs weighing from 150 to 225

We heard a great deal about losses of young pigs this year and think the main cause is from want of exercise and too heavy feeding of the wrong kind of feed for the sows when pregnant. Our sows, without exception, as well as our herd boars, wintered outside, and were fed almost entirely on oats either whole, chopped or boiled, to give a little variety. Whether or not this is scientific feeding we are not prepared to say, but we are entirely satisfied with the result so far.

The demand for young stock has been splendid and it is keeping up well, and we do not anticipate having many youngsters with us after they are old enough to ship.

E. R. JAMES.

HORSE

No Quarter to Typical Reactors to Mallein Test for Glanders.

The V. D. G. states that "up till Aug. 31st, 1906, 15,505 horses have been tested and that 18,117 mallein tests have been made.

"The marked disproportion between the number of horses tested and the number of tests made is attributable to the fact that from 1902 to 1904 we followed a retesting policy.

"I propose to refer first to the danger inseparable from the keeping alive of ordinary non-clinical reactors. I am not in a position to furnish any great amount of statistical information, for the reason that from the very beginning of our present operations animals of this class falling into our hands have been, except in the case of a few which early became ceased reactors, so dealt with to prevent the possibility of their coming into contact, direct or indirect, with healthy horses.

"When engaged in private practice, I had an opportunity of forming an opinion on the subject, for although, after the use of mallein was adopted, which, with me, was in the year 1893, I invariably advised my clients to destroy all typical reactors; the law did not make their slaughter compulsory and many were permitted to live. Not a few subsequent outbreaks of which I was cognizant were undoubtedly due to the retention and distribution of infection by these apparently healthy animals.

"As a matter of fact there has never been, at least among intelligent and single-minded veterinarians, any great tendency to believe in the harmlessness of horses which continue to give typical reactions to mallein, even when they present no visible symptoms of glanders. The Departmental Committee appointed in 1901 by the Board of Great Britain for the purpose of conducting experimental investigations with regard to this and kindred subjects, reached the conclusion that these apparently healthy reactors are capable of transmitting glanders. The Committee in question comprised the late Mr. A. C. Cope, Mr. Wm. Hunting, Sir John McFadyean and Dr. James McL. McCall, all men of high professional attainments and great experience in dealing with glanders. One of the points dwelt upon by them; viz., the suddenness with which a reactor may become clinically glandered, is worthy of special note. Our experience in Canada has demonstrated beyond question the danger arising from this liability of reactors to suddenly develop acute symptoms, and has shown further that a considerable proportion of these superficially healthy animals are in reality clinical cases.

"As under our present regulations such horses are slaughtered, opportunities for post mortem examination have not been wanting, and in many cases showing absolutely no external symptoms, extensive ulcerations have been found high up in the nasal passages, while the presence in this situation of minute nodular lesions, undoubtedly specific, has been strikingly frequent. These discoveries bear out the opinion which I have long held and frequently expressed regarding the importance, from an infective point of view, of enlarged submaxillary glands in reacting animals. There is never smoke without fire, and these glands are not likely to show tumefaction without a definite pathological reason. Leaving nasal lesions aside, it is well known that in typical reactors glanders nodules are invariably found in the lungs, and not unfrequently in other organs.

"Before mallein was heard of, in spite of all our efforts and precautions, case after case, and outbreak after outbreak, of glanders would occur in the same stable. After each fresh outbreak the most thorough disinfection was practised, and all the surviving horses subjected to careful scrutiny and continued close observation. Six months, or perhaps a year, would elapse and then another case or series of cases would occur. We blamed the stables; we thought the contagion, or, as we then called it, the virus, was immortal and indestructible. Now we know that, outside of the animal body, the life of the bacillus mallei is, under the most favorable conditions, limited to three or four months. In the animal body it is a different matter, and the cause of the mysterious recurrent outbreaks was the chronic latent case

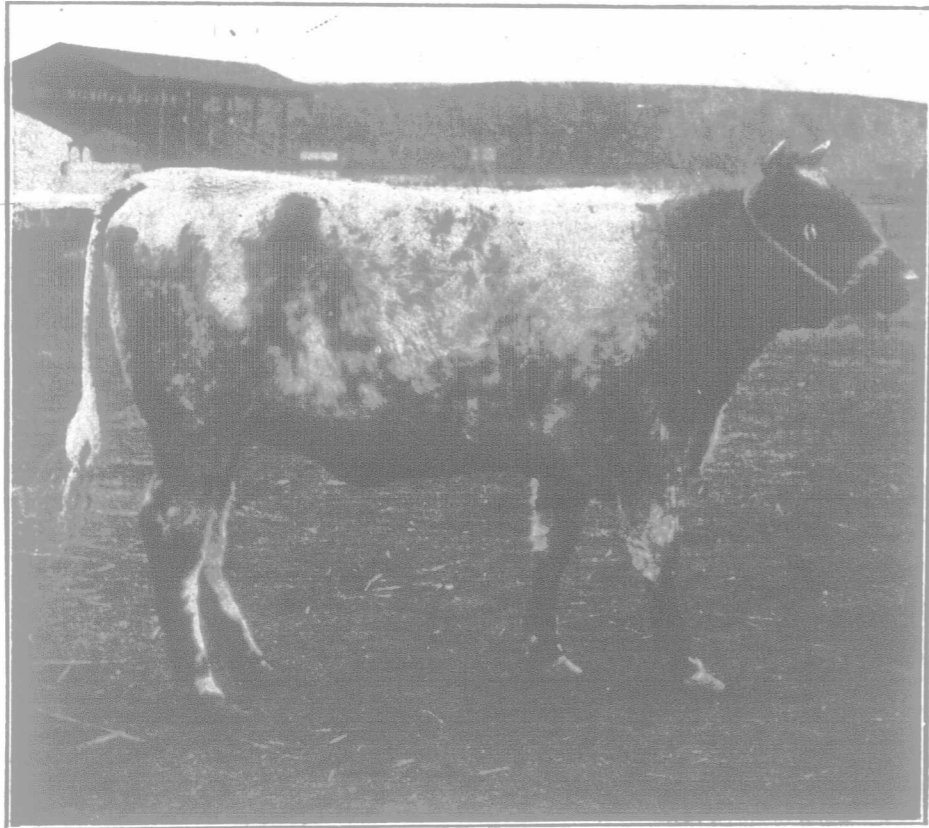

MISS TROUT.

Champion of the Calgary Fat Stock Show shown by E. D. Adams, Calgary.

a little bran and sometimes a little shorts, the oat chop being in increasing proportion. A week or ten days before parturition we place the sows in pens and commence feeding slop, oat chop, bran, shorts and a little barley chop. When they are ready to farrow they do so without any trouble, as their bowels are lax, and they are strong and hardy from their winter in the straw stack. The pigs come strong and we usually raise from eleven to thirteen after killing off the runts of the litter.

Last year we raised forty-seven pigs in four litters and lost thirteen pigs in the same four litters. That was 78.3 per cent. raised, from an average litter of fifteen pigs. This spring we are raising 74.5 per cent. from an average litter of 15.5.

The drop in percentage raised this spring I attribute to our own fault, not the sows, as the pigs all came strong, but the sows were in too small quarters.

During the summer the sows have the run of a brome grass pasture. I do not think there is anything more harmful for a brood sow than being penned up during the greater part of the year, especially when our feeds in this country are so high in carbohydrates.

Grass or roots, laxative feed, a good run, and a stray shed are some of the essentials in successful swine raising; and about the surest road to failure is keeping the sows in a close, warm pen the year round.

H. CLENDENNING.

on foot and a cent less for light weights and heavy ones, and not one of them mentioned bacon hogs, and I know that we all got the same price whether they were long hogs or the short, thick type. I would far sooner have the short pig because it is easier to keep.

Last year I had a young sow farrow eleven, which I sold at different ages and in the fall sold the sow for \$24 and cleared a good hundred on the family. I consider it was the easiest earned hundred dollars I ever made.

I don't believe in winter feeding, but like the pigs to come in February or early in March and have them ready to sell shortly after the freeze up.

S. D. C.

EDITOR FARMER'S ADVOCATE:

With regard to the spring farrowings, we beg to say that we have had practically no losses of young pigs coming in March and April of this year. Out of eighty-four young pigs farrowed in March and April only two came dead. We have lost one or two others from the sows either lying or tramping on them, but we have never had a better lot of strong, healthy, large litters of uniform pigs than we have got this year. In the smallest litter there were eleven pigs and the others ranged from that to fourteen. We consider that a litter of ten or eleven good, strong, even pigs is more profitable than some of the larger litters that you hear about.

of glanders, then unrecognized, but now, through the agency of mallein, marked down and known as a reactor.

"In tracing the origin of primary outbreaks in hitherto uninfected localities, we almost invariably find that the disease has been introduced not by a well marked case of glanders, but by a non-clinical contact horse, often a reactor, generally purchased by an unsuspecting farmer ignorant of the fact that his new bargain has recently come from an infected district, and possibly from a badly infected stud.

"Ceased reactors so called should, in the light of our experience, be divided into three distinct classes:

"1. Those which, while not properly reacting to mallein, are, owing to a slight thermal rise or a septic infection, more or less serious at the point of injection, erroneously classed as reactors by the veterinarian making the test.

"2. Actual ceased reactors, comparatively few in number, and almost invariably, in our experience, consisting of horses tested when in the incipient stages of glanders, or at any rate when but slightly affected, as evidenced by the fact that their original reactions, though typical, are not so well marked either thermally or locally, as those given by clinical cases or by these animals which, while perhaps not showing external symptoms, are suffering from the disease in an advanced form.

"3. Those which having on one or more occasions definitely reacted, develop an acquired tolerance to the test, the latter being, however, of a temporary character, so that after the lapse of a varying period, generally from six to twelve months, a typical reaction again follows the injection of mallein. The first-mentioned class are of but little importance, and demand no attention at our hands.

"The second class is naturally much more interesting, consisting as it does of horses which actually overcome the infection of glanders either through the action of mallein or by the efforts of nature unaided, or at least aided only by favorable physical conditions.

"We have in Canada under supervision at present a considerable number of horses which have at one time or another, during the past four years, given a typical reaction to mallein, but which are now, so far as we can ascertain by periodical inspection and repeated testing, absolutely free from glanders. These animals, however, constitute a lamentably small proportion of the total number which reacted without showing clinical symptoms in the two years during which we followed the retesting system. Two years ago I stated that about 25 per cent. of our non-clinical reactors had ceased to react, and were apparently free from glanders. At the time I expressed my great disappointment with the small return which this percentage gave for the risk and labor involved in carrying on the retests, and announced that it was our intention to discontinue that method of dealing with glanders and adopt the plan which we are now following.

"I am sorry to have to tell you that in classing all these horses as safely ceased reactors we were seriously in error. During the intervening period many of them have rejoined the reacting ranks, and have been condemned as diseased. There are still, however, a number which have continued to stand not only the mallein test, but the test of time. These give absolutely no indication of being other than healthy horses, and thus, so far as can be seen at present, there is no reason to doubt that, in a proportion of comparatively mild cases of glanders, recovery may and does take place.

"We have found, moreover, that while it is not by any means possible to tell at the first, or even at the second test which of the affected horses will eventually become permanent ceased reactors, we can at one or other of these stages make reasonably certain of those which will not do so.

"Animals which, on being first tested, show a thermal rise exceeding 104° Fahrenheit, accompanied by a characteristic reaction, those which give more a pronounced reaction to a second or subsequent test than they do to the first, and those which suddenly cease to react without showing a gradual lowering of the temperature and a corresponding abatement of the local reaction are not likely to become permanent ceased reactors.

"Having now dealt with the suppositious ceased reactors and with those which appear to make an actual and permanent recovery, it becomes our duty to discuss those animals, and they are, in our experience, by far the most frequently encountered, and needless to say the most dangerous, which acquire a temporary tolerance to mallein, but which again give a definite reaction when tested, after sufficient time has elapsed to nullify the effects of previous injections. In the report of the Special Committee appointed by the British Board of Agriculture, already referred to, the records given indicate that all the ceased reactors dealt with in the experiments showed an abnormally high temperature when tested with mallein some time after they had apparently ceased to react. I considered this a very suspicious circumstance, and one which furnished food for serious thought. In order to discover, if possible, the reason of this peculiar phenomenon I determined to again submit to the mallein test a number of horses which had been kept for varying periods under supervision as ceased reactors. The results were

very interesting, as may be gathered from the reports. I do not think it necessary to make any extended comment on the facts brought to light by this series of retests. So far as the possibility of the latter reactions being due to reinfection is concerned, I would say that this danger was fully considered and guarded against. If reinfection occurred in any of these cases it was through one or other of the so-called reactors, and not from any outside source.

(Continued on page 752)

Three-horse Eveners and Lines.

A reader in Saskatchewan asks for information on how to arrange eveners and lines for three-horse teams when hitched to a tongue. The diagrams given below have all been found to give satisfaction, but there may be others that work equally as well. In figure 7, showing an arrangement of the lines, the short cross line from each outside horse to the center one may be attached to the hame. We have also used just the two-horse leather lines from bit to bit; but this was on well broken horses.

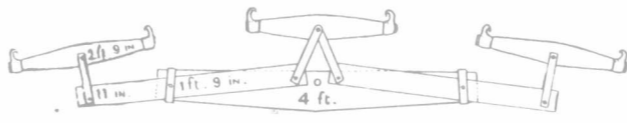

FIG. 1.

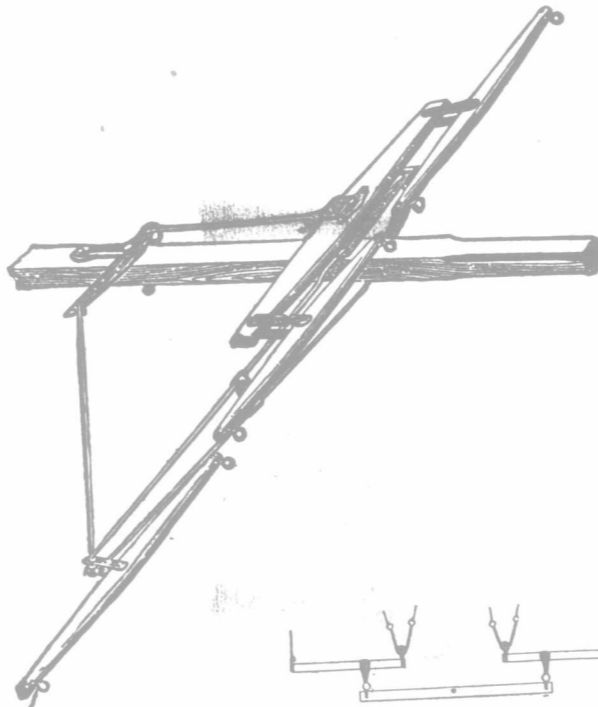

FIG. 2.

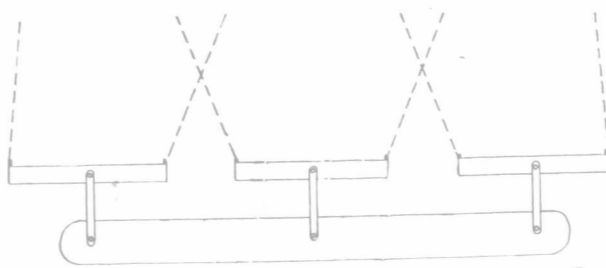

FIG. 3.

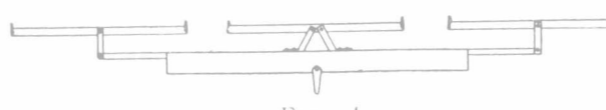

FIG. 4.



FIG. 5.

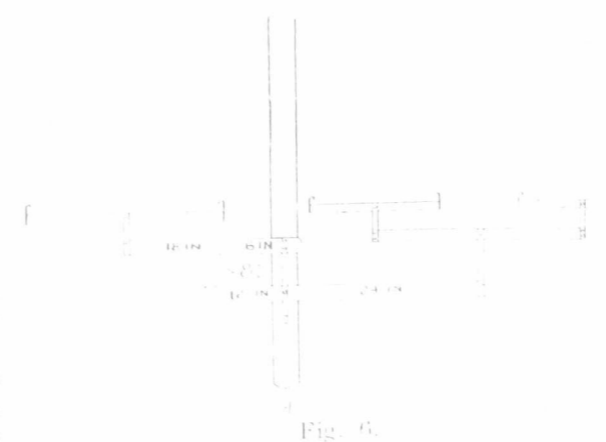

FIG. 6.

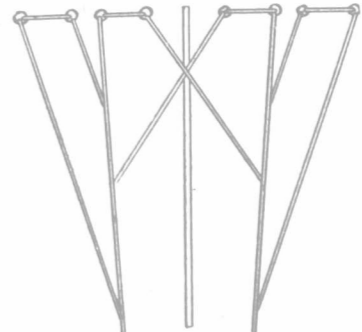

FIG. 7.

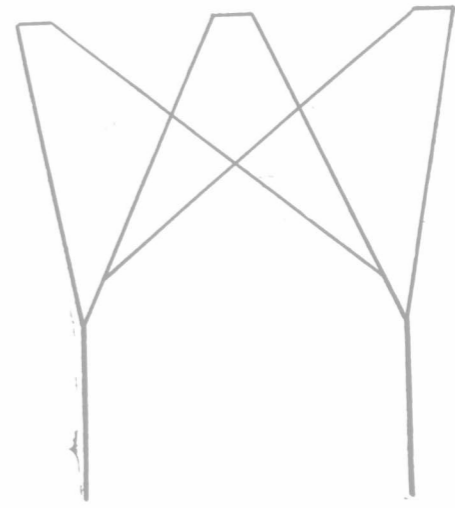

FIG. 8.

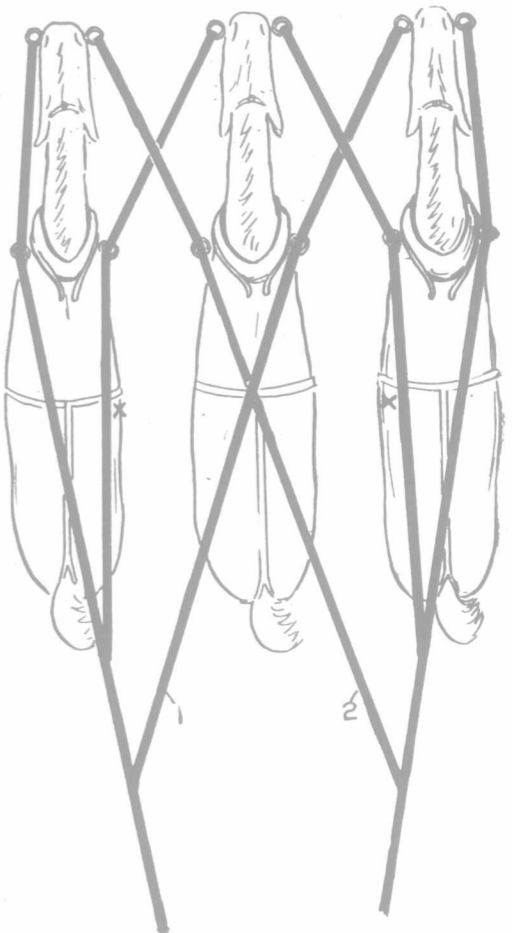

FIG. 9.

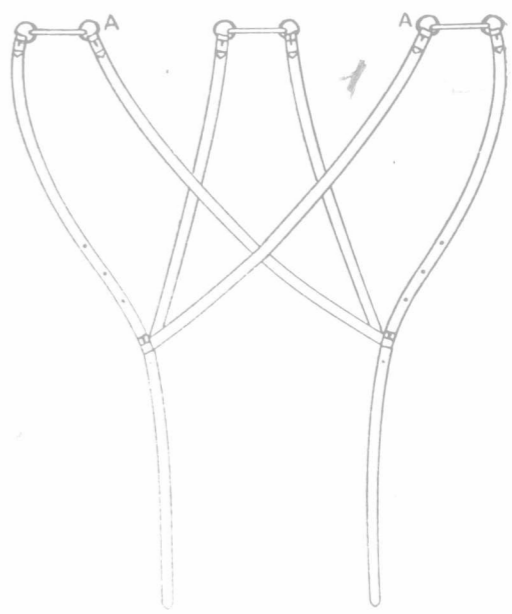

FIG. 10.

M
r
ti
lc
tl
g
ar
he
th
su
cc
pi
m
th
fo
Tl
m
It
lic
bu
ge
ou
so
aff
in
pe
av
ref
un
for
sta
wa
a
set
th
suc
us

S
Ed
I
s
in
of
the
the
gra
tha
am
for
gra
I w
I th
in t
quit
con
succ
to g
In
alor
doir
incc
thre
whe
alth
in g
the
char
held
Besi
doll
of t
lost
we
advi
this
A
othe
gene
our
past
has
our
pelle
some
hous
com
thing
inve
will
ators
it h
the l
If
mon
recei
a go

Keep Up the Stud Fees.

Several horsemen, individual owners and members of syndicates, have drawn our attention to the attempt on the part of some men to lower stallion fees. We believe it is admitted that the average fee (insurance) cannot be let go below \$15 if the owner or owners of the horse are to come out even. To expect the use of a horse costing \$2,000 and up for less money is in the end bound to result in the withdrawal of such horses from the district in which bargain counter-fees are negotiated. When present prices for work horses are considered, the fee mentioned is very reasonable, but for all, many men do not seem to appreciate the fact that three or four dollars on a stud fee may mean forty to sixty dollars on the foal when marketed. The product of the low fee horse costs just as much to raise as the one from the costlier horse. It is proverbial amongst farmers that the stallion owning business is a money losing game, but the farming community cannot very well get along in its horse breeding operations without stallions, and the best are none too good, so that it appears to us that the farmer can well afford to carry out the following suggestions, in favor with the horsemen; viz., pay twenty per cent. of the insurance fee at the first service; avoid over-doing the stallion being used by refraining from bringing to him non-breeders or unhealthy mares; by returning mares regularly for trial; and by refusing to patronize scrub stallions or those whose owners are known to waste them by breeding to too many mares in a season. Good farmers want their mares settled to the best horses, but must remember that all breeding operations are more or less successful depending on the co-operative efforts used.

FARM

Suggestion to Farmers' Elevator Companies.

EDITOR FARMER'S ADVOCATE:

If you will kindly allow space in your valuable paper I should like to add something to the discussion in your columns on the question of the organization of farmers' elevator companies. I believe that there should be such companies formed at all of the wheat markets, as far as possible, all over the grain growing section of the country. I believe that such organizations could and would do a great amount of good in the way of securing better prices for and better facilities for the handling of our grain. I made the statement in an article which I wrote you re "Co-operation in Threshing," that I thought "farmers were the hardest class of people in the world to organize." Still I have known of quite a number of successful farmers' elevators companies and believe that they can be made a success wherever the farmers have enterprise enough to go at it and organize.

If any community has any idea of doing anything along that line this summer it is time to be up and doing, as it takes quite a long time to organize, incorporate and build to be ready for the grain when threshing begins. We found this out to our loss when we built our house at Midale last season, for, although we began early, the delays that occurred in getting a suitable site on which to build, in getting the organization completed, obtaining the necessary charter, etc., and the lumber which to build, held the work back until after harvest began. Besides we had to pay our contractor two hundred dollars more than the original contract price because of the advance in the price of labor. And we also lost two or three weeks of the threshing season when we could have done a good business. So I would advise all who wish to do anything towards building this season to get to work at once.

As for the success of our company here and of others in which I have been interested I will say in general they are a good investment. Of course our Midale company have been handicapped the past winter like all other elevator companies, as it has been impossible to get cars to ship grain, so that our house together with all the rest has been compelled to close. We have at this writing, May 1st, something like 10,000 bushels of wheat still in the house and we cannot tell just how our business will come out this year. I think though, taking every thing into consideration, that it will be a paying investment even this year. One thing is sure: It will be a good thing for the vicinity if the incorporators do not make a cent out of it themselves, for it has been the means of making our town one of the best markets in this part of the country.

If it does not pay the promoters a dividend on the money invested in any other way, we shall have received enough more on our own grain to pay us a good interest, and not only the members of the

company, but all the farmers in the vicinity will have profited thereby as well. And right at this point I wish to say that when an organization of this kind is started everything should be done to get all the farmers to go into it, but, there are always some who will hang off. They are of the class usually that wish to profit at someone else's expense, or at least to share in the profits, but let someone else take all the risks. We have had them say when we asked them to take stock, "No, you go ahead and build your elevator. We will get as much good out of it as though we paid our \$25.00 or more, and we won't be running any risk." We think that is a very pessimistic view to take of the question.

Another thing that would not be out of place to mention here is, don't let any one person take too much of the stock. One man offered last summer to take all of the stock on which the promoters guaranteed 6 per cent. interest. It is always advisable to have the stock limited to a few shares to each and thereby get as many members into the company as possible and to cover as wide a territory as possible. Of course there is always more or less opposition to a farmers' elevator company. Even some of the commission firms in Winnipeg tried to dissuade us from building last summer, saying that we "couldn't make it pay," "or," they said, "the old line houses will combine and boost the prices so you will have to quit the business." We said to ourselves, "All right, let them boost as much as they please. We shall be the gainers thereby, for we have wheat of our own to sell. If they pay more than we can afford to pay, well and good, we can let them have the grain."

on hand, but wait many times until the last ton of coal is sold before ordering more, and in consequence causing much inconvenience and suffering in some instances to the would-be consumers.

I should like to add a word of warning to any who may go into an enterprise of this kind in regard to the selection of a buyer or agent for the company. Very much, indeed nearly everything, depends on the buyer, whether a grain company is successful or not. In this country, where there are nearly a dozen different grades of wheat it is a different proposition to grade it correctly to what it was down in the States where there were not half so many different grades, and a man who could grade grain properly down there might fall down on it here. I think as far as possible all organizations of that kind shall employ good, honest, and thoroughly competent Canadian grain buyers, even if they have to pay high wages—it will pay in the long run. I think any company who wish to organize will find the following by-laws a help.

Sask. E. P. M.

(Continued on page 745.)

Enjoyed His Course at the M. A. C.

EDITOR FARMER'S ADVOCATE:

I have just finished my first winter in the Manitoba Agricultural College, and I am more than pleased with the course and the way it is presented. It is not a technical course devised for the benefit of would-be professors, but a course that is practical, and which will have the effect of keeping the boys on the farm and making farming the most paying and pleasant of the professions. The lectures are not



Photo by W. O. Baber.

A COMFORTABLE ABODE. THE FARM HOME OF J. UREN, ADAIR, SASK.

Our company here is organized upon a different plan to most of such companies and slightly different to the one of which the by-laws at the close of this article were the rules of. That company was organized in a town in Minnesota and has been in successful operation now for nearly or quite ten years. They have had a dividend every year of from nine per cent. (the last) to as high as twenty-five or thirty per cent, and that on a margin of about one cent per bushel.

Our company was organized and incorporated by ten men. They had the complete control of it and each of the ten took fifteen shares at \$25.00 each. These shares are called preferred stock and the ten that hold them are called the promoters. We (the promoters) guarantee the holders of the balance of the shares, called common stock, 6 per cent. per annum regardless of whether the house makes it or not. If there is anything left after paying all the share holders 6 per cent. on their money invested, then the promoters are paid 10 per cent. on their money invested, and if there is still a balance it is divided equally among all the shareholders.

There are 400 shares issued in all, 150 preferred and 250 common. We limited the number of common shares to five for each person. We built a 35,000 bushel capacity house and the cost was something over \$5,000.00. We incorporated so that we could handle rural telephone lines. We expect to handle fuel the coming season. The present lumber and fuel companies doing business here are owned and controlled by out of town corporations that operate a number of houses up and down the road, and it seems a good many times as though they do not make the effort they should to keep a supply

cut and dried material taken from text books that are not suitable to our Western conditions, but are the applications of the sciences to the prevailing conditions as observed throughout the West by both professors and students.

All the subjects taken up were so interesting and important that it is very difficult to say which one appealed most to me. If there were one that appealed more than another I think it was Agriculture. It was the subject I was most conversant with before going to college, and during the entire course the discovery of the causes that had produced the effects that I had noticed in my farm experiences, kept the subject a continual source of interest to me.

The cost of the course was much lower than I had anticipated. It was as follows:—Board \$63.75; tuition \$10.00; books \$6.63; laundry \$7.24, or a total of only \$87.62.

I think considering the signs of the times, the cheapness and efficiency of the course, also the slack time at which it is given, that the young farmers of Manitoba and the Northwest, who do not take a course in the M. A. C. are in a fair way to be left at the foot of the ladder of success.

W. E. AUGUST.

That Saskatchewan Wolf Bounty

Our apologies are due to the Chief Game Guardian and Government of Saskatchewan for the inadvertent statement which appeared in our April 17th number, page 572, to the effect that a bounty of \$5 would be paid for the killing of a pup of a timber wolf. The bounty, where the district is gazetted as a wolf bounty district, is only \$1 for pups of either prairie or timber wolves, \$1 for a mature prairie wolf and \$5 for an adult timber wolf.

Cultivation of a Growing Crop

EDITOR FARMER'S ADVOCATE:

I have tried cultivating a crop after it was up and with good results, particularly with wheat crops. Oats were improved by it too, but the barley was too tender; at least for the heavy harrow that I used. A light weeder or harrow might be more successful. I tried it first in the spring of 1903, on a wheat crop in which the soil had become slightly baked during a dry spell succeeding some heavy May rains. For a time the harrowed part looked thin and badly shaken up, but it gained steadily; the blades became broader and healthier looking than the unharrowed part, and in harvest time the heads were better filled and the straw was longer and stronger than the unharrowed crop. This was a dry year and I was satisfied that the cultivation checked evaporation until the young plants sheltered the ground.

The following year I tried it on a wheat field that had a patch of stink weed, to see what effect it would have in destroying weeds. This field had been well harrowed after the seeder to kill all weeds that had germinated and give the wheat a fair start. When the stink-weeds were nicely started and the wheat was coming into its third blade, the field was harrowed lengthwise with the drills. The crop came on well after it. Many of the weeds were killed and those that escaped never appeared above the crop.

I am convinced that in many cases the harrow can be used with benefit on a wheat or oat crop after it is up; both in the way of conserving moisture and destroying weeds. It should, of course, be used with judgment. The crop should be in the second blade at least to give the roots a good hold on the soil, before the harrow is used. It should not be cultivated while the surface soil is very damp and the day should be clear and sunny. I should like to hear the opinion of others on this subject, and in each case would like to know the conditions under which it is practised. I believe it would be more in vogue were it not for the scarcity of time in seeding.

Lisgar, Man.

C. L. S.

"A Reader" Gives Specific Data.

EDITOR FARMER'S ADVOCATE:

In your issue of April 24th, I see a letter by "Another Reader" re gasoline outfit.

This man is looking at it from a professional thresher's side and his argument is good, but only proves what I said to be correct, even taking his extreme price.

His figures prove that it is a good paying way to thresh; the farmer keeps this money at home, pays for the machine, covers all expenses and has nothing to kick at. He would be quite willing to work for this pay all the year around. But here, buy a farm, hire horses, men, machinery and all work done by the day, and how much money will you make raising wheat? By owning the machinery, horses, etc., and hiring your men by the month you can make as good living and a little more. Just so with the small thresher; by owning the rig, horses, etc., and doing the work with your own help you save all the time and there is your profit again.

My rig cost \$1,650, instead of \$2,000 and a rig costing \$1,400 will thresh 600 bushels of wheat per day at a cheaper rate per bushel than mine. I stated 600 and would say the bushels were large; this was run over more often than under. I have noticed cases where it took 1,200 bushels thresher measure to fill 1,100 bushels in a car. I got this size machine so I can push more through if I wish by enlarging the gang.

If you hire a big machine you have a lot of trading work to get your own help. You get all kinds of dirt drawn on to your farm. The waste in feeding a gang of horses and men is large. I have kept an outfit three weeks to get five days work done (note E. P. M. in April 24th issue). You have to turn the house upside down and hire extra help in the house.

You let your crop sit out in the weather until someone comes and you generally prepare two or three times before he does come. Your big machine is crowded to the full capacity and over, therefore there is more thrown over in the straw pile.

Now with the little outfit you have most of the help by the month. You have the horses also and it comes a little easier for you than paying out the hard costs. I figure this way:

3 Stook Teams	\$12
1 Pitcher	2
1 Man at Machine	2
Myself	5
Gasoline	4
Oil, etc	1
	—
	\$26

There is no need of a \$5 per day man as you can feed 100 bushels per day into any machine, but the man at \$2 can be there anyway. Now this outfit will pay for herself in three years and pay wages too by threshing two good sized crops each year, and then you have the use of it for seven years for the expense of repairs, supposing it only lasts ten years.

Ours threshed last year:

13,000 bushels of wheat @ 7 cents	\$910.00
7,000 bushels of oats and barley @ 5 cents	350.00
	—
	\$1,260.00

I paid wages for 28 days. 28 days at \$26 per day is \$728. This leaves \$532 profit. Now the question is how much money did I lose?

How many of us could have threshed clean out and saved a grade while waiting our turn for a machine?—Note Harold S. Miller in April 24th. As for interest on the outfit, it is hardly fair to put it all on one month's work. You can run the engine on a chopper and it will put through 30 bags of grain per hour. This we have done all winter with a 12-inch plate Fleury, and have done over 900 bags custom work this winter, besides all the chopping for ourselves. Figure that at 7 or 8 cents per bag.

A farmer needs some power and this seems to me to be the most satisfactory.

I always looked at it in this way. I paid out about \$500 per year to get threshed; then we traded work to get help and it always took about three weeks of time. Now I thought that \$500 might as well go into a machine that I would soon own and then my threshing will come pretty cheap. You must remember the other man is not threshing for fun; he is going to get enough out of you to pay wages and pay for his machine and as much more as he can get. I do not mind help paying for the machine, but when it is paid for I do not see why he should have it instead of me. "Another Reader's" remarks about beating the thresher out of his pay I take as a joke. If he likes that work he had better start a bucket shop where he can do it on a large scale and he will have no thresher tracking him wherever he goes; but if he really means that, it only makes me feel more satisfied than ever, because if a thresher has to thresh 700 bushels to get paid for 600, then the man who pays, pays for both, and I object to paying my neighbor's threshing account.

The gasoline has an advantage over steam on the small outfit, though I think steam will be better on a large machine at present. The gasoline will cost about 30 cents per day per horse power used and there the expense ends. With a steamer there is engineer \$5, fireman \$2, waterman \$4 and fuel man part of time.

Man.

A READER.

Mr. Mackay's Opinion of Cultivating Crops.

EDITOR FARMER'S ADVOCATE:

With regard to the use of the weeder, I have to say that the implement does good work when used at the proper time, but is of no use when weeds are large, or the land is hard from rains or other causes. To do effectual work it must be used just as the young weeds are appearing, and where at all numerous the land should be gone over two or three times. We find, however, that an ordinary light iron harrow as a rule gives better results than the weeder. It destroys more weeds, and leaves the soil in a better condition.

Where a crop is intended to be harrowed, half a bushel more seed per acre should be sown, and sown from two and a half to three inches deep. The extra seed will permit of many plants being destroyed, and leave sufficient without causing too much stooling, which must be avoided if possible. The deep seeding will put the roots out of the way of the harrow teeth, and cause the minimum amount of injury.

A weeder has advantages over a harrow. First, it does not destroy any of the grain, and secondly it can be used earlier and later in the crop. These advantages, however, are of no account unless the weeds are just appearing and the soil in a favorable condition when used.

I do not know of any farmer having a weeder in this district, but have seen a good many crops on stubble land harrowed when above ground. I have seen good, as well as poor results from harrowing. The good results were caused by extra seed being sown, permitting two to four strokes of the harrows; the poor results from weeds being too far advanced.

I should advise using a light harrow, just as the weeds appear, even if the grain is only just coming above the ground.

AUGUS MACKAY,

Superintendent, Exp. Farm, Indian Head.

Agricultural Legislation at Ottawa
Session of 1906-7.

While practically all of the legislation that has been put through by the Dominion Government during the session that has been in progress during the past five months has more or less of interest to the agriculturist, in common with other classes of the community, three of the measures that have been enacted have a direct bearing on agriculture. These are the Cold-storage Act, the Meat and Canned Foods Act, and the Customs Tariff Revision of 1907.

The Cold-Storage Act is in accordance with the policy of the Minister of Agriculture, formulated some years ago, for the purpose of aiding the export trade in perishable food products. Commencing with the assistance to steamship companies towards the installation of cold chambers for the carrying of fruit, dairy products, etc., the work was extended to the provision of an ice-car service during the heated months for butter, then for cheese; the construction and operation of illustration cooling rooms; and the bonusing of cheese and butter factories for the construction of refrigerators according to plans recommended by the Department. This still left the weak link of a lack of cold-storage facilities for the cooling and holding of such products as fruits, dressed poultry, etc., until these could be forwarded to the market by cool cars and steamships.

This bill provides for the granting of subsidies to persons who may enter into contracts with the Governor-in-Council for the construction, equipment and maintenance in good and efficient working order, of public cold-storage warehouses equipped with mechanical refrigeration, in Canada, and suitable for the preservation of all food products.

Upon the approval of the Governor-in-Council of the details of plans, specifications, location and amount to be expended upon every such warehouse, the Minister of Agriculture grants towards the construction and equipment of such warehouse a subsidy of thirty per cent. of the cost thereof in five instalments, as follows: 15 per cent. upon the completion of the cold storage and its satisfactory operation; 7 per cent. at the end of the first year following; 4 per cent. at the end of the second year; and 2 per cent. at the end of each of the two succeeding years; provided the warehouse is maintained and operated to the satisfaction of the Minister of Agriculture.

The Meat and Canned Food Act is a measure that should very materially assist the export trade in meats, vegetables, fruits and fish. Its purpose is to safeguard the trade in these products from charges of unwholesomeness, and in this way establish the same measure of confidence for these goods as already exists in Canadian cheese and butter. A meat inspection measure has been recommended by the Veterinary Director-General for two or three years, but not until the effect of the revelations of conditions at Chicago packing-houses became apparent did such legislation appear necessary in Canada. The publicity given the findings of the inspection commission appointed from Washington, gave all canned goods and products of meat-packing plants a name so bad in the minds of consumers wherever American foods reached, that the sale for them fell off greatly in all the leading markets of the world. To insure confidence in Canadian dressed, cured and canned meats, etc., the new measure was enacted.

To the great satisfaction of the Government, an inspection of all the meat-packing plants in Canada, preparing food for either export or interprovincial trade by an official of the Department of Agriculture revealed a generally satisfactory condition. The plants themselves, and the manner in which they were found to be operated, were calculated to turn out wholesome food in an attractive form. It was to insure a continuation of this condition, and to have the products of Canadian factories marketed bearing the seal of Governmental inspection that the Meats and Canned Food Act was introduced and made law by the Parliament of Canada.

There are two main divisions to the bill. The provisions in regard to meats, including dressed carcasses, cured bacon, hams, dressed poultry, sausages, and all canned or bottled meat products, are a little more drastic than the provisions which apply to fruits, vegetables and fish. In plants where the former are prepared, one or two duly qualified Government inspectors are to be constantly employed to inspect the animals alive and again after slaughter, and the spots thereof in the course of curing or canning. That found healthy and fit for food shall be so marked by the inspector, which mark it shall be a guarantee that the product is wholesome. Provision is made for

ing a weeder
l many crops
bove ground.
results from
e caused by
two to four
results from

row, just as
is only just
MACKAY.
n Head.

Ottawa

that has been
nt during the
ing the past
the agricult-
community,
nacted have
ese are the
med Foods
f 1907.
ice with the
formulated
g the export
Commencing
nies towards
he carrying
as extended
during the
se; the con-
ding rooms;
ories for the
3 to plans
his still left
facilities for
s as fruits,
e forwarded

subsidies to
h the Gov-
equipment
king order,
ipped with
ad suitable

-Council of
ation and
warehouse,
s the conse-
a sub-e of
in five
the com-
tory opera-
following;
and 2 per
ling years;
operated to
ure.

asure that
trade in
purpose is
m charges
ablish the
as already

A meat
d by the
ree years,
conditions
rent did
ida. The
tion com-
ll canned
s a name
American
ff greatly
To insure
d canned

ment, an
Canada,
provincial
griculture
on. The
hey were
turn out
t was to
to have
l bearing
Meats
made law

ill. The
dressed
poultry,
ucts, are
h apply
here the
ed Gov-
oyed to
ughter.
ing cr
od shall
mark it
hat the
ade for

re-inspection before shipment, if considered necessary, with a view to determining whether the product has undergone deterioration since the first inspection.

Carcasses or portions thereof considered unhealthful or unfit for food, or which contain such ingredients or preservatives for food, shall be marked by the inspector in such a manner as to indicate their condition, when they shall be disposed of as regulations provide.

In the case of fruits, vegetables and fish, the bill provides for sufficiently frequent and thorough inspection of packing plants to ascertain whether these are kept in a sanitary state, and whether the products prepared and packed for export are sound, wholesome and fit for food. Factories conducted in accordance with regulation shall be granted permission to use such marks as will indicate that their products are sound and good. A plant that is not so conducted may be closed and its packed goods confiscated. All unsound or unwholesome products discovered in packing plants by inspectors shall be confiscated or destroyed.

Penalties ranging up to five hundred dollars are provided for false marking, tampering with marks, obstructing inspectors, and other violations of the Act. The Governor-in-Council may suspend the operations of any sections of the Act until the beginning of the year 1908.

The industry to be safeguarded by this Act is now worth about twenty millions of dollars annually for export alone, while the interprovincial trade in these products is enormous. It is calculated that some \$60,000 will be required to carry out this inspection the first year. This will include the salaries and expenses of from 35 to 40 inspectors, in addition to the bonus of \$100 granted to each candidate who chose to prepare himself for inspection work by taking a special course in meat inspection at Chicago. At the present time there are in Canada from 15 to 20 meat-packing plants that will require constant inspection, and from 60 to 70 canneries that will need occasional supervisory inspection.

THE TARIFF CHANGES.

The Customs Tariff Act of 1907 differs from tariff measures previously enacted by the Parliament of Canada. Heretofore one specified general tariff was provided for, while the Act of 1907 makes provision for three separate specific tariffs; viz.: British Preferential, Intermediate and General.

The British Preferential Tariff applies to goods produced or manufactured in the following British countries when imported direct to a Canadian port: The United Kingdom, Bermuda, British West Indies, British Guiana, British India, Ceylon, Straits Settlements, New Zealand, Cape of Good Hope, Natal, Orange River Colony, Transvaal, and Southern Rhodesia. Any other British Colony may be admitted to this preference by an order-in-council, and the preference may be withdrawn by the same procedure from and after, in either case, the publication of the Order-in-Council in the Canadian Gazette.

In the old tariff of 1897, which remained in operation until the present one came into force in November, 1906, the British Preference amounted to a reduction of 25 per cent. of the general tariff on all British goods, with the exception of certain spirituous liquors, medicines, tobaccos, etc. This preference, by the Act of 1907, is set at a fixed amount or percentage for each article specified.

The Intermediate Tariff shall apply to goods the produce or manufacture of any British or foreign country, to which country the benefits of it shall have been extended by the Governor-in-Council, in consideration of favors granted the products of Canada. By this process articles shall be transferred from the general to the intermediate classification. This transfer shall have effect simultaneously with the publication of the Order-in-Council in the Canadian Gazette. Provision is made for the withdrawal of this benefit at the discretion of the Governor-in-Council.

This intermediate tariff has not yet been put into operation with any country. It is purely a provision for a reciprocal arrangement that may be entered into between the Governor-in-Council and a country seeking better terms than the general tariff affords.

In order to guard against the effects of undervaluation of imports, provision is made in the Tariff Act for levying a special duty ("Dumping Duty") on such articles equal to the difference between the said selling price for the articles for export and a fair market value for home consumption. This special duty is limited to fifteen per cent., ad valorem. Exempted goods under this provision include sugar refined in the United Kingdom, and binder twine made from certain grasses or fibres and measuring not exceeding 600 feet to the pound.

Again, a surtax is provided to apply to the goods of any foreign country which treats imports from Canada less favorably than these from other countries. The amount of the surtax when imposed shall be one third of the duty specified in the general tariff. This is a continuation of the amendment to the customs tariff, assented to in October, 1903.

The tariff schedule of articles of general farm use was published in our January 9th issue and only comparatively small modifications have since been made.

APPROPRIATIONS

The fiscal year now ends on March 31st, instead of June 30th, as formerly. The following are estimates for agriculture, for the year ending March 31st, 1908.

Experimental Farms	17 months 1907-8	\$140,000
Additional Branch Farms		40,000
Publications of Bulletins and Reports		8,000
Fumigation Stations		4,500
Exhibitions		250,000
Dairying, Fruit and Trade Extension		115,000
Cold Storage		150,000
Seeds		50,000
Live Stock		45,000
Health of Animals		350,000
Food Inspection		75,000

It will be seen that an extension of service is being provided for in most of the Departments. It is expected that branch experimental farms will be put into operation in Central and Southern Alberta during the present season. An additional vote of thirty thousand dollars, not shown in the above table, is for a new horticultural building and cattle stable at the Central Farm.

The work of the Dairy Commissioner is being extended in the direction of supervising and assisting the export butter trade. For this work Mr. Geo. H. Barr, formerly Chief Dairy Inspector in Western Ontario, has been appointed a place on the staff of this Branch of the Department of Agriculture.

The enforcing of the Seeds Act in the various provinces, and the establishing of a seeds laboratory at Calgary for the Western provinces, call for an increased expenditure of money in the branch of the Seed Commissioner.

The Cold-storage Bill, already described, explains the disposition of \$100,000 of the grant for cold storage purposes.

The Health of Animals Branch, which is now associated with the Live Stock Branch, will administer the inspection of meats and canned goods, as provided in the bill already described. During the session a grant of \$5,000 was voted to Dr. Grenfel, the Labrador missionary, towards the importation of reindeer from Northern Europe to the Canadian Labrador, to provide flesh, milk and clothing for the inhabitants of that barren country.

Building a Rural Telephone Line.

The most essential element to first class telephone service is good outside construction. Poor construction is always dear. Not alone will it prove a source of annoyance and loss of service, but at the same time, the entire work will have to be gone over a second time, adding doubly to the cost, unless first class work is done. It might be added that poor construction is worse than no line at all, for when it is expected that the line may be depended upon, just when they are most needed they are down.

There are two kinds of telephone line suitable to rural requirements; viz., metallic circuit, and grounded bridging telephone lines.

A grounded line (Fig. 2) consists in running one wire in the poles and using the earth for the return path of the current. Grounded lines prove quite satisfactory, providing good ground connections are obtained, where there are no trolley wires, electric-light circuits or telegraph wires running very close to the line.

The metallic circuit (Fig. 3) consists in running two wires on the same set of poles, one for the outgoing current and one for the return current. Metallic circuits are always preferable to grounded lines, as the service is always superior, being free from noise caused from earth currents, and the liability of damage to apparatus by lightning is much less.

Where several metallic currents are run on the same set of poles, they should be transposed; that is the wires of each circuit should be crossed and recessed, as shown in Fig. 1, which is done to prevent cross-talk between the different circuits. The most common practice is to transpose lines every half mile, though no definite rule can be given for this crossing and recessing.

Poles.—For rural lines poles should be at least, twenty-five feet long, and five or six inches in diameter at top; cedar is the best timber. They will cost from \$1.25 to \$1.60 per pole, f. o. b. the receiving station of shipment, in car lots of about one hundred and thirty to the carload; i. e., at consumer's station.

Staking.—The first thing to do is to stake out the line. This should be done with care so as to get the poles in perfect alignment. If the line is crooked, every pole will have to be guyed in order to keep the wires from pulling it over. The guying of a line is what makes it expensive to build. In consequence, the straighter a line can be staked out, the better for economy's sake. Stakes should be set from ten to eleven rods apart, or closer in going over hills or where the ground is uneven.

Setting Poles.—Poles should be set one-seventh of their length in the ground, and the earth well tramped in. Use short poles in going over hills and long poles in the valleys, so that the top of the line will be as level as possible.

Railroads.—In crossing railroads, the telephone company must make application to the Board of Railway Commissioners for Canada, sending to the Secretary of the Board with the application a plan and profile in duplicate. Profile must show the distance between the railway and the telephone wires, which

must be at least three feet apart. Wires of telephone company should be at least twenty-five feet above tracks, and firmly secured to double cross-arms.

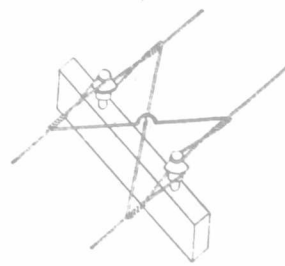

FIG. 2.

Guying.—Before stringing in wires, all poles not in perfect alignment should be thoroughly guyed. All corners should be extra well guyed. Do not guy to fences or trees, as they are not permanent, and the swaying of the trees will break the wires. Where guying is necessary, set a strong post in the ground, or bury a "dead man." This latter consists of a log or large stone buried fully five feet deep, to which the guy is attached.

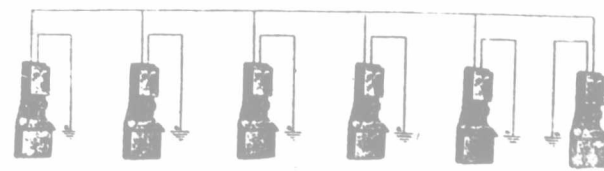

FIG. 3.

Corners.—Heavy poles should be selected for corners, being able to stand the strain better than others.

Wire.—No. 12 B. B. galvanized iron telephone wire is the proper kind to use. It costs about \$3.30 per cwt. delivered. Requires about one hundred and sixty-five pounds of wire to the mile, of three hundred and thirty pounds for one mile metallic circuit.

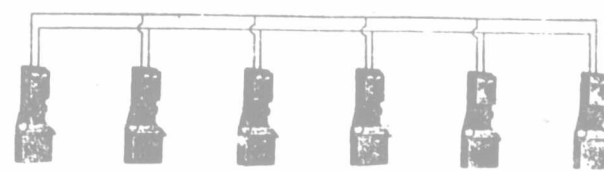

FIG. 1.

Stringing wires.—In putting up two or more wires be careful to draw them all the same tension, the rule being from twelve to fifteen inches sag in a ten-rod span. This is equally true whether the line is held on brackets or cross-arms. Use side blocks and glass insulators.

Insulation.—The insulation of the telephone line means its insulation from anything that would tend to conduct the electricity direct to the earth instead of passing through the telephones in such proportion-

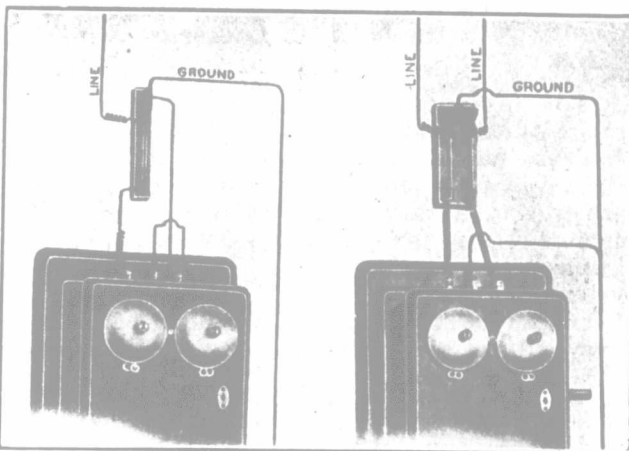

FIG. 4.

FIG. 5.

ate quantities as it should. Telephone lines must not be allowed to touch or come in contact with ice-cops, for the trees and leaves would tend to ground the lines and interfere with the service.

Telephones.—It is always best to purchase bridging telephones, with the ringer wound to 1,600 ohms resistance, a five-bar generator, and where a metallic circuit is used and a switch-board required, have a push-button installed in the instrument so that the subscriber can call central without any other subscriber knowing that the ring has gone through. With these telephones in use as many as twenty or thirty can be successfully used on one bridging party line. These telephones will cost from \$14 to \$15 each, delivered. There are now at least three firms who are manufacturers of telephone apparatus located in Canada, the Northern Electric and Manufacturing Company of Montreal, the Century Telephone Construction Company, and the Scrubbing-Carlson Telephone Manufacturing Company of Rochester N. Y. These firms are strictly independent, and

so far as our dealings with either of them are concerned, have proven very satisfactory.

Brackets are made usually of oak, and have a thread on the upper end, upon which is fastened the glass insulator. Where only one or two wires are to be carried on the poles, brackets serve the purpose very satisfactorily. They should be at least eighteen inches apart. The upper bracket should be eight inches from the top of the pole, and the other twenty or twenty-four inches below it on the opposite side. Brackets should be nailed to the pole with one six-inch and one five-inch spike nail. The quickest way to erect a line is to do all the work on the poles such as attaching brackets, etc., before the poles are set in the holes.

Every tenth pole should be equipped with a lightning rod, made of No. 9 wire, stapled on the side of the pole with half inch galvanized iron staples. The wire should be carried on the top of the pole, and have two hand-turns under the bottom end of the pole. This precaution will protect the poles to a great extent from injury by lightning.

Where three or more wires are run on the same set of poles, cross-arms should be used. These cross-arms are made of pine, three by four inches, and bored for one and one-quarter inch pins. Never use cross-arms with less than six pins. Have the spaces between the pins not less than one foot; a greater distance is better. On lines where the distance between poles are equal, the cross-arms should be placed on alternate sides of the poles.

Drawing up and Tying Wires.—When a wire is drawn, you should first make sure that the head pole or end of line is properly guyed to prevent it from being pulled over. Both ends of the tie wire should pass under the line wire and make two and one-half complete turns. There is no way to overcome cross-talk on grounded lines where they are run for any distance side by side. By transposing metallic lines, cross-talk can be eliminated. You can always talk much rather than you can ring. All telephones upon one line must have ringers of the same resistance; this is imperative. This is the only way to secure satisfactory results. Only the most powerful instruments, with 1,600-ohm ringers, should be used where there are more than ten phones on a line. Ringers of 1,600-ohms resistance have been found by actual practice to be best suited for rural bridging party lines having from ten to twenty-five instruments thereon.

Connecting Telephones.—When the line is built, place the telephone on the wall as near the outside line wire as possible. Insulated copper wire should be used to run from the telephone to the line wire and to the ground. In single-wire grounded circuits avoid making the ground wire extend from the phone to the ground any longer than absolutely necessary. Always take the covering from the wire where it goes under the bridging posts, and scrape the wire bright and clean. Screw tight the bridging posts on the telephone and on the batteries, so that they will make good connections. In all saddle staples should be used to fasten the wires to the walls of the house. Never drive a staple over two wires together, and in driving staple do not injure covering of wire.

(Continued on page 750.)

Every Enterprising Young Farmer Should Take the M. A. C. Course.

EDITOR FARMER'S ADVOCATE:

As to my opinion of the course at the Manitoba Agricultural College for young men on Manitoba farms, I am quite pleased to state that I believe it is one every enterprising young farmer should take. It enlarges one's views, inspires esteem for our profession, arouses enthusiasm and cultivates observation and systematic study.

It is somewhat difficult in speaking of a course every subject of which was fraught with interest

and practical value, to particularize and state which subjects appealed most strongly to a student. To me, however, animal husbandry, field agriculture and farm mechanics appeal strongly.

Another part of the course that I believe is well worthy of mention is the literary society. In its weekly meetings the students were required to participate in debates. The progress made by many, in this line, was truly astonishing, and manifested some worthy talent which otherwise would have lain dormant.

Perfect friendliness existed in the college halls through the entire course. A spirit of good-will and helpfulness seemed to pervade the atmosphere, while the moral tone was worthy of admiration.

The cost of board, tuition fees, books, etc., is to my mind extremely low. For the foregoing, \$90 covered my expenditure. Apart from this, of course, some students spend more than others. Actual expense in connection with the course, however, is seen to be no great amount.

Wishing your paper every success and hoping to meet many at the M. A. C. next fall.

GORDON A. TODD.

Larger Machinery Should Increase Wages.

EDITOR FARMER'S ADVOCATE:

From a hired man's point of view, I take objection to "O. K.'s" remarks in your issue of April 17th, page 595. Some years ago farmers were content to pay a man twenty dollars a month to take a two horse team and work on an average ten hours a day with wet days off and a moderate amount of chores. Now-a-days a man takes out four or six horses which necessitates more chores, and in most cases works wet or fine and also full ten hours a day. Now sir, is it not natural that a man should ask for higher wages? Again, does not the farmer profit by the extra work done and if a farmer runs his farm in a proper manner should not his profits increase in a larger proportion than his expenses? One man now drives the same number of horses as two used to do. Is not that a saving in the board bill? As for doing the least work possible for the highest wages, it is a slander. I know a large number of hired men through the country and with perhaps the exception of about two they are conscientious, hard-working men. When O. K., affirms that hired men are wasters and that the hotel men and storekeepers are the only ones that profit by the high wages, he shows how little he uses any sound judgment he may possess. Visit any part of the Northwest and see how many of the present-day farmers were once hired men. Could the hotel-keepers have got all their wages? If it is possible enquire at the local bank and see how many hired men have banking accounts. Is that possible with wasters? Perhaps if O. K. were to go and hire out for a summer or two he might find that hiring out is not all honey, especially with a certain class of men.

Cannington Manor, Sask.

HIREDMAN.

An Old Country Judge for the Winnipeg Industrial.

Arthur S. Gibson of Ruddington, Notts., will it is expected judge the Clydesdales, Shires and Shorthorns at the Winnipeg Industrial in July. Mr. Gibson was for years manager of the Philo Mills studs, herds and flocks, and had during his management that great Shorthorn Marengo in service and has officiated as judge at several

big shows, being taken to Buenos Ayres a year and a half ago for that purpose. Previous to taking over management the late Philo Mills estate, Mr. Gibson was a successful breeder and exhibitor of Shorthorns, Yorkshires, Shropshires and draft horses in Great Britain. He is a brother of Messrs. Richard, William and John T. Gibson, well known in Eastern Canada.

DAIRY

Avoiding Udder Troubles

EDITOR FARMER'S ADVOCATE:

As the season of the year is about due when cows are freshening, I will give your readers some of my experience with udders and how we avoid trouble with them.

Caked udder—so called—I consider to be the normal condition of good cows when in good condition at freshening. It is to be hoped that large udders are on the increase as it means better cows. I have had people come to the stable when the cow is freshening, and, consequently, having a very large udder, and think there is something wrong with them, and want to know what I would do for it, while that same udder was just what I was working for. Poor cows are not troubled with caked udder, and good cows in poor condition are not so troubled. A good large udder, which is necessarily somewhat caked, does not alarm the man who keeps good cows. Of course, in reaching this desirable end, trouble may come to the inexperienced; and if the udder should appear to be rather hard, or if the cow is in a very flush condition, there is nothing better to soften up the cow's udder before freshening than to put a halter on her and give her a mile or so of exercise—slow walk. Then, of course, she must be put in a fairly warm place after exercising else she will catch cold after the warming up.

A cow's udder is really a complicated piece of machinery, and if there has been any trouble with her udder before, it is likely to be aggravated when freshening again. In this case, besides exercising, it would be well to give a cow a good dose of salts—one and half pounds to the does—followed up by a tablespoonful of saltpetre once or twice a day, as the case may seem to call for, in her feed. Saltpetre is a mild purge, and cooling to the blood. It is for this reason that a good dose of salts, given promptly upon any appearance of trouble, so quickly relieves the soreness of the udder.

Another prolific cause of udder trouble or garget is often carelessness in milking—not milking clean. Take a poor milker in a stable, and he will be having trouble all the time, while a good, thorough milker will not have any trouble, when the cows are otherwise all under the same conditions. If, however, garget strikes in, from neglect or any other cause, it should be attended to at once by purging the cow with a good dose of salts. If allowed to go on even one day, it may result in a partial loss of that quarter of the udder.

There is considerable trouble from cow pox, which is a different "pox" than we were used to some years ago. That is, we have had of late years what we may call a species of cow pox that is very similar to a boil. It forms a hard lump, and inflames the spot larger than an egg, and after a number of days it will gather and break. In the treatment of this it is not well to go squeezing this lump before it is "ripe." It is something, in this respect, like a boil. Then, when it breaks, or is ready to break, the putrid stuff will come out, and there is a "core" as in a boil, that comes from it. This complaint will spread from cow to cow, and the best way to keep it out is to use disinfectants strongly about: nothing better than diluted carbolic acid to fill up the sore after the "core" is out, and rub around the udder for a few days. This complaint is not likely to be of any permanent injury to the cow, although it is very painful, and, to very nervous cows, makes them touchy to milk. Some cows it does not bother at all, or lower their milk yield.

The treatment for a shrunken quarter, as recommended by the Nebraska Experimental Station, and using it with a bicycle pump, might in some cases be of benefit. If the trouble with the udder has been so serious as to make the appearance of that udder practically dead, any treatment is likely to be very effective. We



Photo by W. C. Baber.

IDEAL FOR A PICNIC. ON THE FARM OF W. CLARK, ST. ADAIR, SASK.

have known cases, though, where a cow has nearly lost part of her udder, and has had this damaged part brought back to use by commencing on the cow a couple of weeks before she freshens with massage on that part of the udder, and stripping and bringing it to milk before the other parts of the udder have started. In some cases this has worked out all right, and in others it has been impossible to bring the part of the udder back to life again. It all depends, seemingly, upon how much injury to the udder has been done while the udder was in an inflamed state.

The most important point in case of any udder trouble is to act at once. Garget and similar troubles can be scatted—warded off—by giving immediately on the appearance a big dose of Epsom salts. If a cow trembles—appears in pain, with no apparent cause—it's garget coming, and give her a purge at once. Prevention is better than cure. Prompt treatment comes next.

Milk for Town and City.

EDITOR FARMER'S ADVOCATE:

In your issue of April 24th, Mr. N. J. Davis reports me as having admitted in April 3rd issue that it takes more labor and care than can be generally exercised in the production of milk for the supply of cities in the province of Manitoba. But that is incorrect. My statements were: But it requires much more labor and care than (is) generally exercised in the province of Manitoba. The majority of purchasers of milk I believe are aware of the risk they run in buying doubtful milk, but the almighty dollar is worshipped as much in Manitoba as it is in the United States. But people that will not pay a reasonable price for a first class article, strange to say, will pay any price to obtain any kind of milk when it is very scarce and difficult to obtain, and without a murmur. Mr. Munroe is quoted by Mr. Davis as speaking of the difficulty under our climatic conditions of keeping healthy cows free from tuberculosis, but so far I found no difficulty in that respect. I think it very important to study Nature's laws in feeding cows, and housing must be given second place.

I had but one cow, a purebred Holstein that I was doubtful if I could cure or not. I knew she was badly diseased after I had bought her and eventually sold her conditionally for \$10. I kept her alive for three years by careful feeding and fed her milk to calves and they thrived remarkably on it.

I have no doubt the Royal Commission on tuberculosis in Copenhagen would find cows affected with tuberculosis, but tuberculosis seldom if ever enters the lactiferous ducts, so they might consider their investigations futile as far as milk for food is concerned.

I think there is a very small percentage of infant mortality due to tubercular bacillus. The greatest mortality among infants is doubtless due to *cholera infantum*, and I think it's quite possible to cause that by feeding food such as milk at too low a temperature; or it may be caused by anything which interferes with the normal operations of the digestive apparatus. It's quite possible Prof. Bitter has proved that heating 15 minutes to 154° F. kills typhus bacillus, but Professor Bitter should try killing typhus bacilli in a quantity of milk, and it would be a more difficult thing to do at that temperature.

Prof. Woll in saying an obligatory heating of milk for sanitariums is practiced, does not mean, as I understand it, to pasteurize or sterilize it, but simply to warm the milk to feed. I also contend that milk must be fed to children at the normal temperature. But the safest and best way is to pour a little boiling water into enough milk required at a time for feeding. Professors Farrington and Well say the selection of the best kind of milk is especially important in pasteurizing milk. The acidity test should be used for the selection of milk best adapted for pasteurizing. I think this is contrary to most advocates of pasteurizing. When pasteurizing of milk was first introduced it was considered to be almost a panacea for all ills. Scientists were elated over results. But if they had fed the same milk without pasteurizing the results would have been more satisfactory. The reason was milk was produced under strictly sanitary conditions; the results thus favored pasteurized milk. But many of the large cities in the United States pasteurize now all kinds of milk and practically all their milk is so treated or sterilized, and it's quite evident the results are very unsatisfactory, as the following article plainly proves that in New York at least specialists are in a dilemma as to what to recommend. They evidently have grave doubts about the beneficial results from pasteurized milk.

J. J. White.

The latest spring in the memory of the "oldest inhabitant"! Yet there should be no anxiety for awhile at least, for late seedings in other years have invariably been followed by good, heavy big harvests. Also before the days of farming in the Northwest we are told that in some years there was no summer at all.

POULTRY

Feeding Many Chicks Easily.

To grow rapidly and make good broilers or winter layers, chicks need all they will eat till matured. There is no danger of over eating if dry feed is placed before chicks when first fed and always kept before them. To do this easily and save a great deal of time, take any kind of box about two feet square—the size is of little consequence. Split out a crack in the bottom large enough to let in the light; split off enough of each side to let a chick crawl under when the box is turned upside down. The ends, of course, must not be cut. Place the feed in a small basin or empty cigar box under the middle of the box. The chicks can go in and get food as they like without being molested by grown fowl and the larger birds cannot eat the feed. If given all the dry feed they will eat and fed wet mash at the same time, chicks may be troubled with indigestion, as the wet mash tempts them to eat when they are not really hungry, but they never have any trouble when fed all the dry feed they want when mash is omitted.

Crossfield, Alta.

W. I. THOMAS.

How Hens were Cured of Egg Eating.

EDITOR FARMER'S ADVOCATE:

A number of your patrons seem troubled with hens eating eggs. Where nests are to the open it's somewhat tedious to break the habit. It generally commences by accident in quarreling over the nest. The hens perhaps need the shell and the moisture, the former in lieu of gravel, plaster, coal, ashes, etc., the inside instead of water. By accident they discover where they can supply the want, and then learn how to smash a shell, especially if the shell is only weak. I have had mine start several times. Where a building or part is used exclusively as a hen-house, I find a row of nests along the wall partitioned off in about foot spaces, the front boarded about eight inches high and the wall answering as the back, the best arrangement. The top is put high at the back and slanting towards the front; the first board nailed stationery, the next fastened by hinges to it; a projection of six or eight inches in front of nests level with the bottom as a landing to hens coming to the nest. The lid can be closed right down on this if necessary, or raised just enough to admit the fowl and hung by a strap to the wall at the back. This winter my hens commenced eating their eggs, but I had been leaving the lid thrown back, with the eggs in the light. I dropped the lid to about five inches from the landing, hung on a curtain of old bagging, leaving about three inches in the center open and put a board from the ground directly in front of the opening to walk up on. Then I sewed potato in cotton, one or two for every nest, and threw them in, and we had no more trouble. Why? The eggs and hens were in partial darkness, did not fight over nests and when ready for off were eager to get to daylight. Have tried it several times. When the eggs were open the temptation to the hen was like some men and their whiskey, too strong to be resisted, but when the temptation was not too direct the desire was forgotten. This conquered the hen and it's a pity a like scheme could not be applied to the weak inebriate.

TEMPERATE FARMER.

A Few "Don't's" for the Poultry Man.

EDITOR FARMER'S ADVOCATE:

Don't expect your fowl to lay so well in the cold weather unless you give them a little extra care.

Don't close your brooder up tight because it's cold; your chicks will do better with fresh air.

Don't forget a load of good, sharp gravel drawn when you have an idle team will pay good wages.

Don't think because you cannot see it your poultry don't pay; try keeping track of them for one year.

Don't think a mongrel male in your flock is as good as a purebred; there will often be a difference of three pounds each on the surplus stock in the fall, and if you want lots of eggs the difference is even greater, to say nothing of extra vigor.

Don't expect too much of that setting of eggs you sent away, for remember they pass through a great many hands.

Don't forget that if you are not satisfied with the hatch and write to the man you bought them of, he will generally meet you half way.

Don't forget that if you hatch one good cockerel you may easily get your money back.

Don't forget that now is the time to force along the young chicks; they will show better returns now than in the winter, if you wait until then to let them get their growth.

Don't be afraid of feeding them too much if on free range; they can stand it better now than in the winter when they cannot get exercise and have their growth.

Don't forget to be like Eavesdropper (who wrote a short article in the FARMER'S ADVOCATE) and prick up your ears when anyone is talking poultry; you may not learn anything, but the chances are you will.

Holmfild.

H. E. WABY.

Horticulture and Forestry

Source of Lumber Supply in Central Canada

An English reader asks what resources of forest and timber there are in Canada convenient to the great wheat fields of the prairie.

By reference to the map some idea of the extent or the timbered regions west of Lake Superior and east of the Rocky Mountains and therefore contiguous to the great grain fields of Canada is gained. Between Port Arthur and the boundary between Ontario and Manitoba and from the height of land on the north just above the C. P. R. main line south into the United States, is one continuous stretch of virgin forest, grown so thickly in most places that it is difficult to traverse. This forest is mostly of pine, the most valued of woods for building purposes. In extent it is some four hundred miles from east to west and averages about one hundred miles in width. West of Winnipeg there is not much wooded country until the Riding Mountain district is reached. From here is northwards wherever there are hills and streams, there is timber until the Saskatchewan and its tributaries are reached, and then is marked the beginning of one of the largest tracts of spruce timber in the world. Only the edges of this forest have been skirted as yet, but that has revealed its extent and value. Following west along the Saskatchewan River this tract gradually blends into the unexplored forests of the mountainous country of British Columbia and north to the gold fields of the far-famed Yukon and into the region of perpetual snow.

With these immense resources of timber lying along the north and east sides of the great grain growing prairies, it is very natural that large industrial concerns should spring up for the conversion of the raw material into commercial lumber and building material, and this is what has been done. At intervals along the railways mills have been built and towns have sprung up about those centers of industry. In the pine woods districts there are mills at Port Arthur, Kenora, Mine Center, Rainy River and Winnipeg. In the northwestern spruce district there are mills at Grandview, Red Deer, Lake Dauphin, Greenbush, Prince Albert, etc., and numerous small mills, set back from the railway lines, which move from place to place as this timber is cut.

For the finished lumber of these mills there is an ever expanding market in the cities, towns and farms of the grain belt and in the trade it comes in competition with the product of the Pacific coast and mountain mills which supply the greater part of the demand in Canada. To the settlers in the newer parts of Canada this lumbering industry is of incalculable value. It furnishes besides building material large supplies of fuel from its refuse, gives employment to a vast army of men during the winter when the demand for men on the farm is practically nil, and so gives the man who is willing to work profitable employment during the dull seasons.

In Order to Ensure a Crop of Strawberries.

The accompanying illustrations and explanation may be the means of enlightening some people who have attempted strawberry growing with poor results. It is essential with strawberries as with other things where production is wanted, that proper matings should be made. One wants more than a flower bed, more than blossoms—he wants fruit. A writer in *The Strawberry* says:

"I discovered that even bisexuals were greatly benefited by setting them beside other bisexuals of the same season. This is because the stigmas of the flowers of many bisexuals are not receptive to the pollen given off by the anthers of their own flowers. In making this experiment I took a number of different bisexuals and set them in alternate rows. In other plots I grew the

same varieties alone where they had to depend upon the pollen from their own flowers. All plots received the same care and treatment. At fruiting time the difference in yield and perfection of fruit were quite noticeably in favor of the plot containing the several bisexuals where they were mated together. Here there were very few barren blossoms, and the berries seemed to be as near perfection as it is possible to get them. In the plots where the same bisexuals were set alone there were a large number of barren flowers, as well as many deformed and imperfect berries.

"I also have spent much time in experimenting in the mating of pistillates and discovered that it was better to use two bisexuals with each pistillate. By placing the pistillates in rows between two bisexuals, one a little earlier and the other a trifle later than the pistillate, perfect pollination will be insured, as the early bisexual flowers are almost sure to open with the early flowers of the pistillate, while the later flowers of the pistillate will open with the flowers of the later bisexuals, thus having a large number of anthers bursting and throwing pollen just when the stigmas are most receptive, insuring perfectly developed berries and lots of them. This method of mating not only aids to increase the yield of the pistillate varieties, but the exchange of pollen between bisexuals adds greatly to their yield, as well as encouraging better formed berries."

Fruit Farm for the North.

A press report says that the Alberta Government has decided to establish a fruit experiment farm at Vegreville and that H. T. Payne will conduct the experiments upon his own farm.

FIELD NOTES

Events of the Week.

CANADIAN.

Calgary is to have a new \$150,000 city hall, and the plans of a local architect, Wm. Dodd, have been selected.

Hon. G. W. Ross of the Ontario senate was married to Miss Mildred Peel of London, Ont., a sister of Paul Peel, the artist.

The trouble between men and operators in Western coal mines has been settled and the men have resumed work.

Local option has again been sustained in Neepawa, Man., by a fifty-one per cent. vote in its favor.

Dr. Hutchison, the well-known physician, died at his home in Grenfell, Sask. He was much interested in agricultural matters and a director of the Grenfell Agricultural Society.

Ernest Thompson Seton is planning to spend the summer in an exploring tour that will take him a thousand miles north of Edmonton. He thinks that a great deal of that country will be found to be habitable.

Henceforth, by an agreement between the Chinese and Canadian Governments, all Chinese lepers will be returned to China at the expense of that Government.

T. W. Crothers of St. Thomas was chairman of the recent Text Book Commission in connection with the Ontario Education Department. A cheque for \$2,000 was sent to him for his services and was returned, Mr. Crothers stating that he felt himself amply repaid by the honor of the appointment, and that he wished nothing but payment for actual expenses incurred, some two hundred dollars in amount.

BRITISH AND FOREIGN.

Rioting in San Francisco led to the death of several persons.

Disturbances still continue at Lahore, India, and a native outbreak seems imminent. Bands of peasants armed with clubs are said to be pouring into the city. The Bengal district is also disaffected.

France still occupies Oudja, on the Moroccan frontier, while waiting a settlement of her demand for satisfaction for the murder of Dr. Mauchamp in March. Arms and ammunition are being shipped in for the use of the Moors.

The new Irish Home Rule bill has come before the British House of Commons for its first reading. Ardent Home Rulers claim that it gives practically no adequate measure of home rule to Ireland, but the Unionists consider it a step in the right direction. Its chief points are five: Irish Members of Parliament will retain their connection with the Imperial body. The Crown will retain control of five of the eight Departments into which the Government is divided, including the constabulary. An Administrative Council for Ireland is to be formed, to consist of eighty-two elective members and twenty-four nominated by the Crown. A fund in excess of twenty millions will be created for the purpose of carrying the law into effect. No preference for any religious denomination shall be shown in appointments and if existing officers of Departments are retired by the Council they must be given full pensions.

Alberta Central Stock Growers will Hold Picnic Convention.

Preparations for the first annual meeting of the Central Alberta Stock Growers' Association, to be held at Erskine, June 5th and 6th, are well under way.

The program promises to be especially strong, consisting of speakers well up in Dominion politics, prominent railroad officials, notable cattle men from the United States and members of the Canadian agricultural press.

The meeting will be held at the outskirts of the town on the shore of a beautiful little lake, which will be well stocked with boats. The evening of each day will be devoted to sports and music.

It is to be a picnic affair. Everyone, whether or not members of the Association, is cordially invited to attend and bring tents, lunch baskets and blankets. A comfortable tent, furnished for the use of the press will be provided. There will be a reception and rest tent for ladies.

Ship your tents, properly labelled, not later than June 1st, and you will find them pitched ready for occupancy on your arrival.

Full program later.

A Great Road Improver.

In many parts of the south and east the implement illustrated below is now in general use. It has been discovered to be of particular value in keeping clay roads in a good state of repair, and making them less liable to become cut up in wet weather. The implement is used to level and grade the road and in doing this regularly after rains the ordinary clay of the surface is worked into a sort of cement, which makes the road much less pervious to water. The time to use the drag is when the clay of the road is wet enough to form a mud when the drag is drawn over it.

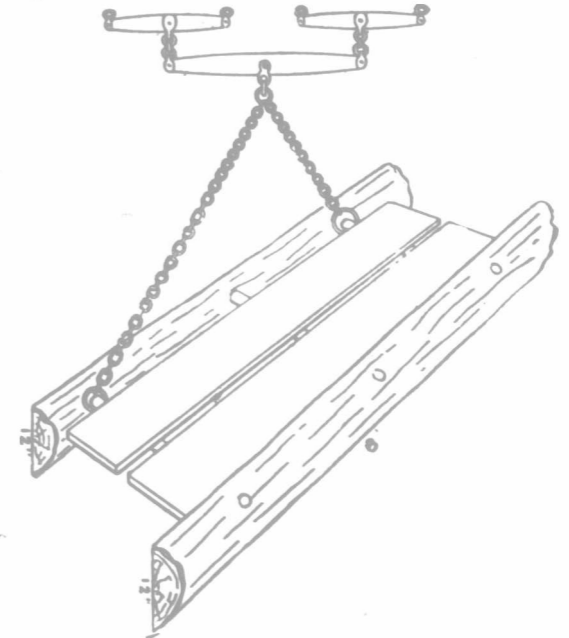

The operation is less effective where the surface has become drier, but is better than to leave it cut with wagon tracks and hoof prints which make the surface rough between rains and form receptacles to hold water on the road when rain comes. The first principle in road making is to get a dry surface. The drag makes this possible by rounding up the crown and by making a material to cover it that turns the water. The latter is really the valuable function of the drag it forms, when used early after a rain, a material that is water resistant. We should like to learn of the drag being used on some of our heavy clay roads. No one can deny they need it badly enough.

Spraying with Chemicals to Kill Weeds.

This method of ridding fields of weeds has been experimented with for some time and has apparently been more successful with some of the mustard family, charlock especially, than others. The Old Country investigators have relied upon bluestone (copper sulphate) solutions hitherto, but some recent work by the Agronomist of the Wisconsin Experiment Station seems to indicate that copperas (sulphate of iron) is equally useful for the purpose of weed killing and has the advantage of being a great deal cheaper. Prof. R. A. Moore, the agronomist, in a letter states that "we were able to exterminate or partly exterminate many other noxious weeds, in addition to eradicating mustard from grain fields. I expect to carry on extensive experiments this year to see if we cannot in some way put Canada thistles under control." He summarizes the work done under his direction in the following sentences.

"In various parts of the state, grain fields were found to be so contaminated with wild mustard that it was impossible to eradicate it by hand pulling. By spraying these grain fields at the proper time with a 20 per cent. solution of iron sulphate when conditions were proper, the mustard plants were practically all destroyed.

"The spraying should be done on a calm, bright day after the dew has disappeared, as the work is more effective if the solution is put on in the warm sunlight. When rain follows the spraying within a few hours, the extermination of the mustard will not be complete.

"The grain fields should be sprayed when the mustard plants are in the third leaf, or before the plants are in blossom, in order to have the spray do the most effective work. The day following the spraying, the tips of the blades of the grain may be somewhat blackened, but no detrimental effects can be noticed, either to the crop or grasses seeded with it, two weeks after spraying.

"Daisies, cocklebur, bind weed, rag weed, chickory, sheep sorrel, yellow dock, wild lettuce, and many other weeds were partially or wholly eradicated from the fields where tests were made for the extermination of the mustard.

"Iron sulphate can be purchased for about eleven dollars per ton in small quantities, and in bulk for considerably less. One hundred pounds of iron sulphate will make sufficient solution of the proper strength to spray approximately one acre. From twenty to twenty-five acres of land can be covered in a day where the sprayer is kept in continual use.

"The iron sulphate solution is not poisonous and can be readily handled without injury. White clothing coming in contact with it will be discolored, but not harmed.

"The solution is made by emptying a hundred pounds of iron sulphate (copperas or ferrous

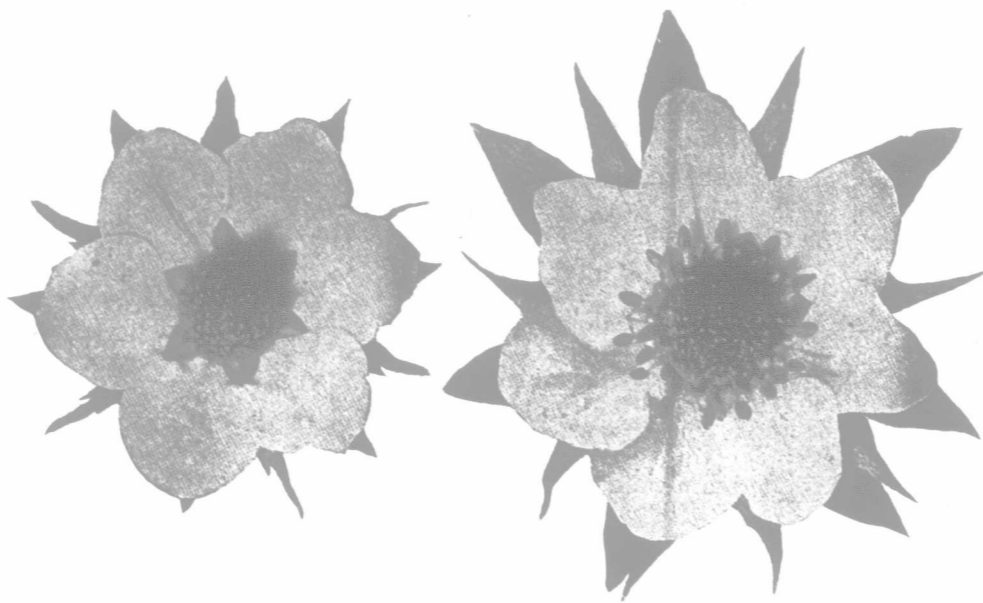

BLOSSOM OF THE MALE OR BISEXUAL.

BLOSSOM OF THE FEMALE OR PISTILLATE.

With this illustration before him it will be easy for even an amateur to determine the difference between the male and female varieties. The male (bisexual) blossom is on the left. It is larger in every way than the female (pistillate) which is on the right. Note the anthers on the male blossom surrounding the center cone. The white spots in the center are the stigmas. When the anthers burst the pollen settles on the end of the stigmas. The germ of this pollen finds its way down into the ovary of the pistillate, and seed development at once begins, if the stigma is receptive. If only a part of the stigmas are receptive the berry will be a deformed berry; if none of the stigmas are receptive a blank blossom is the result. On the other hand, if all the stigmas are receptive to the pollen at the time the anthers burst, the berry will be fully developed and perfectly smooth. The pistillate blossom (on the right) has no anthers and must receive its pollen from some nearby male or bisexual. Hence the necessity of proper mating.

MARKETS

sulphate) into an ordinary 52 gallon cask (a coal oil barrel is of that capacity) and then stirring the chemical into solution with water for seven to ten minutes, when it will be found to have been dissolved. The solution made in this way is approximately twenty per cent., although some German investigators have had good results with 15 per cent. solutions. It is necessary to watch the machines used for spraying, as the nozzles are apt to clog in some machines. Iron sulphate in a commercial form is obtained as a by-product in the manufacture of steel and wire fencing. Canada thistles that received the iron sulphate spray solution seemed to be badly scorched and further experiments will be made in the hope of subduing such pests."

New Appointment at Regina

John Bracken, B. S. A. who has been in charge of the seed division of work in Manitoba, has been selected by the Saskatchewan Department of Agriculture to succeed Mr. Jas. Murray, recently resigned, to take charge of the Brandon farm.

Things to Remember.

- Purebred Cattle Sale, Brandon May 30
Central Alberta Stock Growers' Association Meets and Picnic at Erskine, June 5 and 6
Shorthorn Cattle Sale, Hon. Thos. Greenway, Crystal City June 13
Winnipeg Horse Show June 13, 14 and 15
Shorthorn Sale, A. & G. Mutch, Regina Exhibition Grounds June 26
Calgary Exhibition July 9, 10, 11 and 12
Portage la Prairie Exhibition July 9, 10, and 11
Hackney Sale, Rawlinson Bros., Calgary July
Winnipeg Exhibition July 13 to 20
Regina Exhibition July 30, August 2

SASKATCHEWAN FAIRS.

- Lashburn September 18
Lloydminster September 19 and 20
Radisson September 24
Quill Lake September 26
Watson September 27
N. Battleford October 1 and 2
Duck Lake October 4
Kinistino October 8
Tisdale October 10
Melfort October 15 and 16
Battleford July 24, 25 and 26
Hanley July 30
Prince Albert August 1 and 2
Saskatoon August 6, 7 and 8
Rosthern August 8 and 9
Indian Head August 13 and 14
Ft. Qu'Appelle July 31
Santaluta August 2
Moosomin August 6 and 7
Grenfell August 8

Beef Ring Charts.

Information is again asked upon the methods of conducting beef rings. In the first place, it is necessary to decide how many shares there will be in the ring; then secure the necessary number of contributors; sometimes one share being sufficient for two small families. Rules are then made to cover the transactions. A certain age and weight of animal is agreed upon and two members of the ring nominated to inspect each animal provided a few weeks before it is to be killed. Lots are then drawn to decide the order in which the animals are to be taken. A butcher is appointed and the day of the week arranged for killing. The butcher should be able to kill and handle quickly and should keep a record of the cuts each patron receives. For this purpose he can arrange shelves or baskets numbered and so rotate the cuts that each patron will receive a full carcass at the end of the sixteen or twenty weeks over which the ring runs. In response to different enquiries we give charts to guide the butcher in cutting carcasses.

These charts were supplied us by the butchers for two different rings. The one describing the sixteen share chart is much more explicit than the other, especially in the matter of the disposition of the shoulder, but by the exercise of a little ingenuity as equal a distribution could be made of a carcass when cut into twenty shares.

SIXTEEN-SHARE BEEF RING

Fig. 1.—Represents one-half of beef lying on a table ready for the saw. Before letting this half down divide it in the middle, by running a saw across at "a" between roasts 4 and 5, leaving two ribs on the hind quarter. After laying both quarters on the table, divide the fore quarter at line "b."

No. 9—Represents neck. Saw neck off, leaving three joints on it.

No. 1—Represents roast No. 1. Saw roast No. 1 off, leaving three joints on it.

No. 2—Represents roast No. 2. Saw roast No. 2 off, leaving three joints on it.

No. 3—Represents roast No. 3. Saw roast No. 3 off, leaving three joints on it.

No. 4—Represents roast No. 4. Saw roast No. 4 off, leaving four joints on it.

No. 11—Represents front shank. Saw front shank off above upper joint.

No. 14—Represents second rib cut. Saw it off, leaving five ribs on it.

No. 13—Represents first rib cut. Saw it off, leaving four ribs on it.

No. 10—Represents brisket.

No. 12—Represents shoulder, which lies directly under brisket, as represented in Fig. 1.

Then take the hind quarter, and divide at the line "d."

No. 15—Represents flank. Cut flank off at line "c."

No. 5—Represents roast No. 5. Saw roast No. 5 off, with three joints on it.

Nos. 6, 7 and 8—Represents sirloin, rump No. 2 and rump No. 1, respectively. Divide these three as near to the same weight as possible.

No. 17—Represents steak. Cut steak into slices, giving a slice to each person.

No. 16—Represents hind shank after steak is taken off.

After this half of the beef has been cut up it is divided between the first eight persons, as shown by time-table, giving each person a roast, a boil-piece, and a slice of steak. Then the other half of the beef is taken down and cut up in the same manner. This table gives the cuts for each patron:

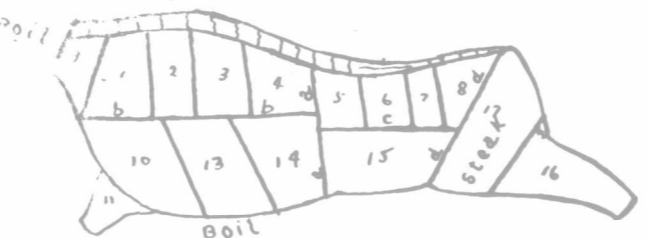

FIG. 1

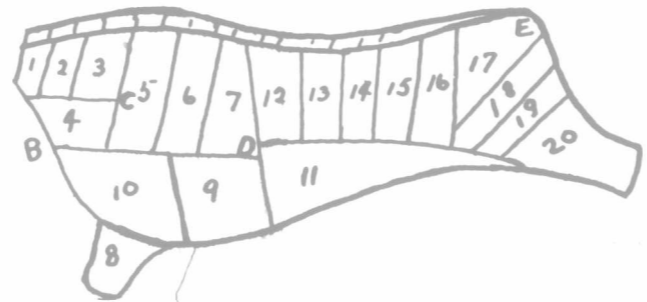

FIG. 2

Table with 2 columns: Nos. 10 and 5, and Boil and Roast. Lists numbers 1 through 13 and their corresponding cuts.

Fig. 2—Represents half a carcass to be cut into twenty shares. To give each party a boil and a roast, it must be divided after the beef is cut down in halves. Cut it across Nos. 7 and 12, leaving four ribs of the hind quarter. After laying the front quarter on the table for cutting up, cut off front shank No. 8; then cut from line B making two pieces (Nos. 10 and 9); then take off neck No. 1; then take roast No. 7 (3 ribs in it); roast No. 6 (2 ribs); roast No. 5 (2 ribs); then cut across to line C, taking piece No. 4 (boiling piece); then No. 3 (2 ribs in it); leaving piece No. 2. After cutting up the two fore quarters, let down the hind quarter on the table, and cut from line D leaving flank No. 11; then cut roast No. 12 (3 ribs in it); then follow along 13, 14, 15, 16; then cut across line E (rump roast) No. 17; then cut off Nos. 18 and 19, leaving hind shank, No. 20.

Table with 2 columns: Nos. 1 and 18, and Boil and Roast. Lists numbers 1 through 10 and their corresponding cuts.

The weight of the beef is supposed to be not less than 400 lbs. and not to exceed 500 lbs. all to be cut up and divided into 20 shares.

The backward season continues to exercise a bullish effect upon the market; in fact most people are becoming decidedly uneasy with the prospects so dull. Some of the more optimistic had set May 15th as the ultimate extreme of the beginning of seeding, but when the 10th passed and temperatures still remained low, their predictions took on a little more earnestness than was intended. However, the consolation remains that the bad seasons in the past were not those of the latest seedings. The best that can be said of the weather conditions is that the markets are benefiting immensely by them. No one can tell how dull wheat might have been with the country so full of it, and prospects bright for another big crop.

During the past week the tendency was continually upward with an occasional break for a session or two. Primary receipts are liberal and the visible supply is on the increase, but cables have been stronger and navigation being open trade is more free. Millers have raised the price of flour 10 cents per bag on all the leading brands. Quotations on the Winnipeg market are:

Table of market prices for various commodities like No. 1 Hard, No. 1 Northern, No. 2 Northern, No. 3 Northern, No. 4, No. 2 White Oats, No. 3 Barley, No. 1 Flax.

PRODUCE (WHOLESALE PRICES).

Table of wholesale prices for produce including Bran, Shorts, Chopped Feeds, Hay, Potatoes, Creamery Butter, Dairy Butter, Cheese, Eggs, and Poultry.

LIVE STOCK.

Cattle were more plentiful than ever last week and as a result a most unexpected drop in prices took place for stuff offered at Winnipeg. What are called best were in keen enough demand, but only a few were really top notchers.

Hogs continue strong, with only a few coming in. Prices are quoted as follows:

Best butchers, 5 1/2c.; bulk of butchers offered, 4 1/2c to 5c.; cows 2 1/2c. to 3c.; bulls, 2c. to 3c.; sheep 5c. to 6c.; lambs 6c. to 6 1/2c.

Hogs, 125 to 250 lbs., \$7.75 per cwt; rough heavy, \$6.75 to \$7.25.

TORONTO.

Export cattle, \$5.15 to \$5.85 for best; \$4.75 to \$5.00 for medium. Butchers best \$5.25, medium, \$4.40 to \$5.00. Hogs \$6.50.

CHICAGO.

Beeves \$4.30 to \$6.45; good prime steers \$5.40 to \$6.45; stockers and feeders \$2.90 to \$5.10. Hogs, mixed, \$6.25 to \$6.50; heavy, \$6.35 to \$6.45; bulk of sales, \$6.40 to \$6.47.

President Fallieries, accompanied by the representatives of France and foreign nations, inaugurated the spring Salon of the Society of French Artists in the Grand Palace. It is the universal verdict of critics that the exhibition of paintings and sculpture surpasses any seen in a dozen years. America for the first time leads all foreign countries, both in the number and in the excellence of works displayed. This is recognized and a prominent place has been accorded to American canvasses. The entire exhibition is remarkable for the uniformly high standard of the works. Only 1,000 pictures are shown, the jury having rejected over 4,100 aspirants. All paintings of the decadent or the impressionistic schools have been rigorously excluded.

HOME JOURNAL

Life, Literature and Education

IN THE WORLD OF LITERATURE AND ART.

Miss Mollot, a Manitoba girl, is gaining fame by her piano playing in Paris.

* * *

Ellen Terry, the great English actress, was married in Pittsburg recently to James Carew, her leading man.

* * *

Helen H. Watson is the author of a new work of fiction, "Andrew Goodfellow," a tale of 1805, in which Admiral Nelson figures as the friend of the hero, whose name provides the title. It is an interesting story of an interesting period of English history.

* * *

Mr. H. J. Rose, the Rhodes scholar at Oxford from McGill, has won the chancellor's Latin essay prize. He has already won the Craven and Ireland scholarships.

* * *

St. Andrews' Church, Toronto, is installing the largest organ in Canada. It will have eighty-five speaking stops and will be supplied with electric power.

* * *

What is believed to be a genuine specimen of Watteau's art has been found in a private house in Dunedin, New Zealand. It was given to a hotel landlord in discharge of a debt forty years ago.

* * *

The Dominion Department of the Interior has published a new Canadian atlas of such high quality that Lord Grey is placing a copy in each university, large public library and important club in the United Kingdom.

* * *

Professors Porter and Bell, with a party of eighteen students of the mining department of McGill University, are making a five weeks' tour of Western mining centers for geological purposes.

* * *

Dr. John Watson, better known as Ian McLaren, died at Mount Pleasant, Iowa, on the sixth of May. Dr. Watson had been on a lecturing tour in Canada and United States, when he was attacked by tonsillitis, followed by blood poisoning which resulted in his death. He was born in Essex, England, in 1850 and was educated in Edinburgh and Germany and ordained in 1875. He was pastor of Sefton Park Presbyterian Church, Liverpool, from 1880 to 1950. Popular as a preacher and lecturer he was best and most widely known by his books "Beside the Bonny Briar Bush" and "Days of Auld Lang Syne," which have taken firm hold on the hearts of all English-speaking people.

NOTHING GAINED BY CONCEALMENT.

During the past winter with its unusual severities some Canadians were indignant that Western papers reported cases of great hardship which were copied in the East and abroad. Their wrath was kindled because they thought that when nothing good could be said the proper thing was silence. They said that the country was being given a bad reputation by its own papers, and intending emigrants reading these accounts would refuse to leave their own land or would seek another of more genial climate.

Western Canada is still very new and those coming into it to take up land are pioneers and must endure for a few years at least some of the inconveniences of pioneer life. There is nothing to be gained by playing the ostrich and trying to deceive not only ourselves, but outsiders, into believing that life out West is a bed of roses with the thorns snipped off, that "the thermometer drops pretty low, but you don't really feel the cold," that the presence of railway ties and steel argues prompt transportation for the farmer. These things are not invariably so and in trying to pretend that they are we are in danger of living into our land under false pretences, a class of people who are no use to the country in its present condition and to whom the country yields nothing of happiness or prosperity. Canada loses more than the wackings who come here under the

impression that life is going to be easy and who fall down before the unsuspected difficulties, than she would from attracting a smaller number of men of a kind that are strong enough to face a struggle for a comparatively short period.

A man with some brains, a fair amount of health and a heap of courage, can take up land in the West and be on the highway to prosperity with most of his troubles behind him within five or six years. Even with a previous knowledge of the hardships to be endured before success becomes apparent, he will not hesitate to face the hard work and loneliness of the present to secure a home and independence for the future. And that is the kind of man Canada needs right now. But if he lacks those qualities he will throw up the game in disgust, or become a mental and physical wreck in the endeavor to cope with Nature in a struggle for which he is not adequately equipped. And when he fails he will blame the country, not himself. This great West will have a place for such men in the future, but now the battle is to the strong and only harm can come of inducing the weak to enter the fight by hiding from them the dangers of the field.

OUR EDUCATIONAL SYSTEM TOO BOOKISH.

EDITOR FARMER'S ADVOCATE:

I have been much interested in articles on education, that have appeared from time to time in your valuable magazine, particularly those by "Winnipegger" and "Hobbs, et al." Leaving for the present the defects in our rural school system, it appears to me that our leaders in matters educational display a great lack of resourcefulness in not investigating the sociological conditions affecting the intellectual life of people living in our great centers; and an equal lack of progressiveness in not providing a system of education that will meet demands in this regard.

From the time a child enters school till he or she emerges from our higher institutions, the training consists almost solely in acquiring pure knowledge; yet there has been no period when the science of education should be more directed towards intellectual growth by providing a variety of activities so arranged as to suit the mental and physical standing of the pupil. How many pupils to-day are compelled to memorize rules, and fit them on as best they may, instead of these rules being skillfully developed in practical work? How many experiments in agriculture are loosely fitted on to conditions, instead of these being simply regarded as handmaids in the process of investigating actual natural conditions? Sociological conditions to-day demand a radical change along these lines, if we are to avert degeneracy. In fact, judging from my experiences with the average product of our city institutions and with those engaged in treadmill occupations, it appears to me that symptoms of degeneracy are already manifesting themselves.

There are two features in modern society that have no parallel in history, and whose influence on the intellectual life of the people "Winnipegger" does not appear to have even observed, much less to have grasped their significance. This is distinctively an age of complex machinery and division of labor in our industrial life, and of books in our educational life. Unveil the story of the past and you will see the sturdy yeomanry of England after three or four generations in industrial centers transformed into mental and physical dwarfs compared with their antecedents. If such were true under more primitive conditions when production and barter were largely the result of individual effort, and only about three per cent. of the population lived in these centers, what are we to expect under conditions to-day with one-third of our population engaged in treadmill occupations; such as filling up blanks in offices, handling a lever, attending to a wheel, or some other monotonous round of duty from one year's end to another? This one idea must in course of time be stamped on the minds of the men and women so engaged; and if we allow the enormous wealth we produce to be concentrated into the hands of a few, instead of lessening the hours of labor of the mass and thus allowing time for mental and physical

recuperation and development, we destroy the manhood of the few by excessive dissipation and idle living, and that of the many by excessive toil and poverty. The drift towards degeneracy or a more progressive civilization hinges on education.

It seems like sacrilege to say anything derogatory of books. Do we misuse them? And what effect has this misuse on our mental status? In early days the written scroll was read by the few. The books from which the youth of the past learned their lessons were nature and society; yet we are informed by our best authorities that the average intelligence of the early Greek citizen was higher than that of the members of the modern British House of Commons. James Mill, realizing the stunting influence of our book system of instruction, personally supervised the training of his son, directed him in observing closely nature and society and used books simply as aids in solving the problems he thus observed; with the result that John Stuart Mill stood in the front rank of the investigators of his time, has left us the best book extant on inductive logic, as well as other books of great value to the student.

In the present reign of books, from the time a child enters school till he or she emerges from our higher institutions, it is books, books, books. The environs are books; the source of all knowledge, books. Book ideas are the be-all and the end-all of our instructional system; and the mental training consists largely of such as will fit the young man or woman for storing up these ideas—good, bad and indifferent, and for reproducing them in neat form on a sheet of foolscap. Who can blame the young man or woman in after life for being simply imitators and for resorting to books for an answer to all problems that confront them? The onus of criticism for any defects in our educational system generally falls on the young schoolgirl. Why blame her? What are the great masters in our higher institutions doing? Is there any more attention paid by them to directing an investigation of actual conditions in nature and society, and to training the higher faculties of the mind for self-reliant action in investigating these conditions? Ask a bunch of B. A.'s and B. S. A.'s when they emerge from their alma mater what they know of the great economic problems they will be called upon to deal with as citizens, problems on the solution of which may hinge their own happiness, the well-being of their fellow citizens and the progressiveness of our civilization. Ask them to define a syllogism, to state the canons of Aristotle, give them a few sophisms to analyze and to point out the fallacies. They will stand aghast and tell you these subjects were not in their course. They may be able to read Greek and Latin, tell you the great battles of history (with dates) the choice cuts on a beef animal and the way moisture rises by capillary attractions; but they have yet to connect their education with the problems they are up against, and they are handicapped for lack of training in the science of sound reasoning to guide them in solving these problems.

The misuse of books weakens instead of developing our powers of observation and independent thinking. The athlete training for a race does not enter a motor car; neither does the subject for developing powers of independent thinking read a book. There is no thinking required in reading a book; nor in reproducing the ideas thus obtained. Yet this is the mental operation that fills in the time of the great majority. The imagination leads the way in independent thought, and like a searchlight flashes into the dark unknown, revealing the hitherto unobserved. The reasoning powers follow, analyze, separate the true from the false, the sound from the unsound. This is thinking; these are the mental powers that make us progressive beings. But these powers through our exclusive system of book instruction are weakened. And its evils are much more apparent in cities than in rural districts, where children and adults spend the greater part of their time in the activities of farm life, which often calls for independent thinking.

I recently visited our Agricultural College, and to say the least the conditions there for the development of our young farmers can be made ideal if the staff of the institution is equal to the conditions. What is required to improve on present methods is less instruction and more education, less pure science and more applied science, less book learning and more experience, less memorizing and more sound reasoning. "Winnipegger" would make improvements along these lines he would be doing something to avert the degeneracy of his fellow citizens.

A FARMER.

THE QUIET HOUR

BE COURTEOUS

— 1 St. Peter iii. : 8.
Courtesy is not a falsehood or grimace it need not be such.—"Bending before men," is a recognition that there does dwell in that presence of our Brother something Divine.—Carlyle.

In the R. V. the words I have chosen as the text are translated, "Be humbledminded." So, also, where it is stated—in Acts xxvii—that a Roman centurion "courteously entreated Paul," the revised translation is "treated Paul kindly." It would seem, then, that true courtesy includes humility and kindness, and it is a grace well worth cultivating. The Roman soldier's unexpected courtesy and kindness to one of the prisoners in his charge is still remembered in his honor, long centuries after his acts of bold daring have been forgotten by the world. And other acts of courteous kindness still stand out in bold relief, though performed many centuries before Rome was even thought of. Look at that tableau in Genesis xxiv. An elderly, travel-stained man, hot and tired and thirsty, goes up to a fair young girl and says: "Let me, I pray thee, drink a little water of thy pitcher."

How graceful and kind is her ready response as she quickly lets down her pitcher upon her hand, saying, "Drink, my lord"; and, as if that were not enough to satisfy her desire to show hospitality, she adds, "I will draw water for thy camels also, until they have done drinking." And this was not a mere Oriental parade of grand and meaningless words, for "she hastened, and emptied her pitcher into the trough, and ran again unto the well to draw water, and drew for all his camels." Though that little scene was acted about 4,000 years ago, it is not, nor ever will be, out of date or old-fashioned. Example is always more influential than precept, and Rebekah's little thought that her sweet courtesy to a dusty stranger by the well would inspire other maidens to do likewise until the end of time. If she had not been humbled-minded, thinking of the needs of another rather than of the beauty of her own action, her courtesy would have been only superficial, and would have had no "salt" to preserve its freshness during all these long centuries.

In the second chapter of Exodus, we find another picture of graceful courtesy. Seven shepherdesses fill the troughs to water their flocks, and some rude, uncourteous shepherds interfere and drive them away. Then Moses proves himself to be a gentleman, keeping his courtly manners even in the wild wilderness, for he instantly stands up in defence of the weak. He delivers them out of the hand of the shepherds, draws water for them and helps them to water their flocks. Now it is not for nothing that these and similar pictures of courtesy are given a place in God's Great Book. Courtesy is not only a matter of birth, breeding or education; and it should always be more than "skin deep." Real courtesy—including humility and kindness—is a very important part of Christian character. It springs naturally from the "recognition that there does dwell in that presence of our Brother something Divine."

We sometimes see men and women who are good and honorable, and who yet bring discredit on their Christian profession by the roughness and rudeness of their manners—especially in the home circle. They seem to think that courtesy of word or act is out of place in the easy familiarity of the home atmosphere. They speak rudely or shortly to those they love best, though probably any stranger will be treated with courtesy and attention.

To cure this sin of discourtesy by outside means might result in a superficial polish, which would be little better than the former rudeness. But real Christian courtesy springs from within, being the direct result of having the eyes open to see Him Who is always with us. Those who have learned to recognize Christ in everyone will find discourtesy almost impossible. Think of the little children or

the troublesome, noisy boys and girls who so often hear rough words addressed to them by those who love them best. They may grow accustomed to being considered of little consequence, may care little for a slighting word or a hasty slap; but if God considers an act of courtesy to be worthy of a place of honor in His Word, surely He does not overlook the countless acts of discourtesy which seem to pass unheeded.

Our Lord gratefully accepted the precious ointment which was poured lavishly on His head and feet, and declared that this courteous attention should always be remembered by His Church. But the discourtesy shown by Simon the Pharisee was keenly felt by the loving heart of Jesus, and the Church can never forget that either. Simon neglected the customary signs of welcome which any honored guest had a right to expect. No water was provided to wash the weary feet; there was no kiss of greeting, and no anointing oil was poured on the head. Discourtesy to the King is no light offence on the part of a subject. It is a great mistake to fancy that a rude or unkind speech to a child is a matter of slight consequence. Our Lord's warning words bear witness to the gravity of the offence. "Take heed," He says, "that ye despise not one of these little ones." And he makes it very plain that any kindness or unkindness shown to a child is accepted by Him, for He says: "Whosoever shall receive one of such children in My Name, I receive Me; and whosoever shall receive Me, I receive not Me, but Him that sent Me." If we see Christ in everyone, we cannot be discourteous.

Then we must always remember that a rude, unattractive Christian will tend to drive others away from Christ, making them dislike the very name of Christianity. And terrible indeed is the warning against dragging down Christ's little ones. "Whoso shall cause one of these little ones which believe on Me to stumble, it is profitable for him that a great millstone should be hanged about his neck, and that he should be sunk in the depth of the sea." Holiness says that our Lord's command regarding children—"Forbid them not!"—must refer also to the "forbidding face," because children are great readers of faces, and "a face bright with looking unto Jesus must carry in its impressions to those who look upon it. We may be unconscious of it, but if we have been on the Mount with God, others will see it. God works through features, and sometimes we are responsible for the impressions conveyed through our faces."

If we are often on the Mount with God, our eyes will be clear enough and our hearts pure enough to see Him everywhere. As Christ is in His brethren here in the world, the least discourtesy to them must touch Him, and cannot be lightly regarded by those who love and honor Him.

Anyone can be polite to strangers—that fleeting courtesy requires little effort and deserves little praise. But to be bright and pleasant and courteous all day and every day, when other people are unreasonable or complaining, cross or disagreeable, rude or unkind, is by no means so easy. For true courtesy must go under the surface. To be rude in thought and put on a smooth, polite manner, is to be very untrue; and it is also generally very irritating to the other person, who instinctively feels that he is being smoothed down and cajoled. We can generally feel each other's thoughts, and are not easily deceived by outside manners. As Christians we are especially bound to be kind to those who are not particularly attractive to us. "If ye do good to them which do good to you, what thank have ye? for sinners also do even the same," says our Lord. To meet unkindness with cheerful kindness, and to meet rudeness with winning courtesy—not once, but continually—is to be sure of victory in the end, and no ignoble victory either. Love is stronger than hate, good can overcome evil, life must prevail over

death. Enemies can, by persistent kindness, be transformed into friends. As God sends His rain and sunshine to carry healing and life to the evil as well as the good, so His children must be ready to show kindly courtesy to all around them. Those who do not seem to deserve, or even appreciate it, may yield quite unexpectedly and turn towards the Sun of Righteousness whose light they see always reflected in a sunny, loving face. Courtesy, like sunshine, may win them, but certainly coldness and discourtesy never will. "By love serve one another," writes St. Paul, and humility grows in lov-

ing service; until to "serve one another" becomes a most glorious vocation, and we can understand how our Master and Lord was exalted by His life of lowly ministry. He is always ready to reach out with kindest courtesy to the meanest creature He has made; and how then can we venture to look down with lofty condescension or disdain on any of our brothers and sisters.

The only possible root of true Christian Courtesy is LOVE, which is the grand foundation as well as the crown of everything worth having. "Familiar acts are beautiful through Love." HOPE.

The Literary Society

PRIZE ESSAYS FOR THE LAST COMPETITION.

Second Paper.

ACCUMULATION AND DISTRIBUTION OF WEALTH.

This topic in some respects is a matter affecting every individual, less or more, and a topic that an essay of your limit of 600 words would scarcely preface; but as different contributors will bring forward different ideas they may fairly well represent and partially cover the ground. Before attempting the distribution of wealth it might be wise to investigate the accumulation of wealth. What are or what have been the principal prominent tactics which have resulted in the enormous wealth that some men possess at the present day, whether it be counted in thousands or millions? Not taking into consideration the handing down from generation to generation of fortunes or accumulation of legacies, let us take men of our own time or the last seventy years and watch those who were once poor and see what they individually have accomplished. Some cases point to circumstantial happenings not premeditated, but an unseen natural worldly or providential course of events. As an illustration I would point to the present time when the development of this Western country is bringing wide margins to individual men on real estate and investments which were not at all in sight eight or ten years ago. Sometimes we find the reason to be a clear-headed premonition of what is coming to pass in the future and a shaping of a course in the proper channel and which we might term "acute foresight." There are others again who make money the chief end of man, who have no consideration outside their own aim, right or wrong, social or business, widows, orphans or needy poor. Their pocket has always a gaping mouth and so long as money is running in they have no concern where or how it has been gotten, and this is what we term "gall." There are some who have honestly earned a fortune, who have labored hard mentally and physically to master a thoroughness and system where small profits and volume of business caused the accumulation of wealth. This we call "systematic executive ability." At the present time we have a system known as a "trust," "combine" or "merger" which is generally supposed to be a means of accumulating wealth to the few at the expense of the masses and we call it 1 Hard theft. There are many different ways whereby wealth has accumulated, each one varying in some distinct feature from the others; some circumstantial, some premeditated, some by scheming and gall, some by an excessive sense or tact in one particular undertaking and a push or grit which will never down. What would tend to counteract any of those influences? We say more education, either moral or mental, better both. The first if cultivated to a high degree would influence the user to be satisfied with decent remuneration or return the overplus again into circulation; it would or should show a man that every time an addition is made to a mass of wealth somebody is poorer. That must be a fact, but human nature seldom looks at it thus. If man makes money he calls it "business" and there is no distinction generally between a small or large margin, value or no

value, justice or roguery—its just "business." Mental and moral education would tend to make what might be termed an equal distribution of brains by bringing the ignorant into a better position to stand on an equal footing in the race with the educated. The distribution of wealth is now being partially effected by the action of labor unions. By co-operative action, to a certain extent, they deter capital from too much accumulation, and when not allowing themselves to become frenzied or riotous and disorderly, we believe they perform a certain function in the distribution of wealth. The G. G. Ass'n. of the West, the Society of Equity in the United States and some portions of Canada, and such like organizations, have for their object the equal distribution of wealth or at least the object of destroying its accumulation at the hands of the capitalists. Mr. Campbell mentions those, but thinks they have not attained much prominence. Neither have they if results mean absolute success. Why? Because every man has not done his best privately and publicly towards that end. There are master mechanics at the helm of finances whose keenness and astuteness outwit their competitors. Mr. Campbell alludes to the agricultural situation as travelling to destruction, labor going off the land, people accumulating in towns and centers. We believe he is right. Every time such happens it decreases the productiveness of the farms. It makes living on them more expensive, as it causes railway carriage and expenses, wholesale and retail margins and business to spring up, calling for more middlemen. If those large centers were in rural locations, distributed every few miles, the trade would be done directly from producer to consumer. Where manufacturers locate tradesmen, builders, mechanics and laborers also locate for employment, and we believe he is right when he says the wealth goes off the farm, and shorter hours of toil, more leisure, more chances of pleasure, draw the young people off the land. Why are not those requisites more plentiful on the farm? We must say that because there is not enough attention given to home attractions, not enough wealth (margins over cost of production), to practically give every boy and girl a wage they can secure elsewhere. We believe a better study of home economics, a better business understanding of money matters, profit or loss, system, and higher agricultural education and practice, might counteract some of the trek into business centers. Not only that, but the agriculturists do not get the advantage of cheap money. Anyone knows that money borrowed on farm property is not carried so cheaply as banks and corporations secure it. Why? Do we not first produce the commercial stuff that keeps most of the manufacturers going, either as producers or buyers? Then why are chances of cheap money not ours? If we secure wealth or a fair share on the farm we must have close study of home economics, profits over cost, cheaper interest on capital borrowed, independence as much as possible of outside concerns from which we have to buy, attractions and interest to counteract alien magnetism and an organized system of controlling prices the same as manufacturers control theirs.

GEO. ARMSTRONG.

Something to Please Everybody!

Stephens HOUSE PAINT

THE PRODUCT OF OUR TWENTY
YEARS' EXPERIENCE

These paints will protect your property against all weather conditions, at the same time imparting an artistic and lasting finish.

We have prepared some interesting paint information in booklet form, and will be pleased to mail same on request. When writing ask for Booklet No. 7.

G. F. STEPHENS & CO. Ltd.

PAINT MAKERS
WINNIPEG, CANADA

The "Royal Jewel" Steel Range

THE IDEAL COOKING APPARATUS



The Range that saves you money, in fact, the Range that wears and always looks well.

Note the large, roomy oven—well ventilated and evenly heated. One of the most important considerations in the purchase of a Range.

Possesses many other valuable advantages which are fully described in our new booklet—write for it.

MERRICK, ANDERSON CO.
WINNIPEG, Man.

INGLE NOOK CHATS

Household Sanitation.

BY MARY E. ALLEN-DAVIDSON M.D.

(Continued from page 661.)

CHAPTER V AND LAST

FOOD CONTAMINATION. PERSONAL
CLEANLINESS.

Food may be contaminated in several ways, as, by fermentation or decay of meats, vegetables, fruits, milk, butter; by lack of care in storing, as when flour, meal, etc., becomes damp, mouldy, wormy, or mixed with foreign matter, e.g., dust. By want of inspection, and also of cleanliness in preparation children and adults too often eat food that is so contaminated as to be positively dangerous. They eat fruit that is partially decayed. They buy and eat it direct from the shop. Now fruit is handled in a very slovenly way, with never a thought as to cleanliness. It is exposed uncovered on the streets in front of shops, and in shop windows where all sorts of abominations in the way of street dust settle on it and where flies loaded with the horrors of back lanes crawl over it at will. Is it any wonder that children contract diarrhoea in the fruit season? Take note of this; never allow your children to eat fruit that you have not inspected. Explain fully and enlist their co-operation so that they will not be tempted to eat forbidden fruit. Give them plenty of fruit that you have cleansed. Let them buy if they wish, only let them bring all to you to be inspected. Take care to wash all fruit first; then pare what can be pared and scald off the outer skin of fruit that will permit of this treatment. Take time to pick out the choicest, ripest and freshest fruit for the children's eating and then you need not fear diarrhoea from this source.

Never eat tainted meat. Fermentation in meat develops animal poisons called ptomaines. This is specially true of canned goods. Since Upton Sinclairs' revelations in "The Jungle" one feels like a cannibal every time he thinks of eating canned meats. Even with the most liberal allowances for reform since then, canned meats should be tabooed, at least for children. Let grown ups make a cemetery of their stomachs if they will. Buy fresh meat and prepare it yourself. Be wary of Hamburg steak. Too many fag ends go to its composition. Cook all meats thoroughly to guard against tape worm, and to kill any other disease germs, as tubercle bacilli. It would be much safer in summer not to use meat at all. It is not fit to eat, as it taints so quickly and the temptation to "doctor" it with vinegar, spices, etc., so as not to "waste" it is hard to resist. In such a state it is still more harmful. Don't be tempted. There is more waste in doctor's bills, lost time and sometimes a dead human, than in a lump of dead cow or sheep or hog. You may have eaten tainted meat and escaped with perhaps an unnoticed general uneasiness of body or a sharp attack of diarrhoea. You may so escape ninety-nine times, but one time in a hundred is enough to get a fatal dose of ptomaine poison. You will be as dead as if you had never eaten bad meat before. The next time may be the hundredth. Moral. Don't let there be a next time.

Milk is easily contaminated by lack of care in handling and storing. It is responsible for much disease in children; such as stomach derangements, with their accompanying train of mouth throat, skin troubles and even graver complications, as convulsions and diarrhoea, dysentery, etc. I have seen mothers fish flies out of the milk before giving to the children. In homes where children are to be the largest users of milk, special care should be

taken in its selection and care. The cow supplying the milk should be young, healthy and fresh every year, the milk from a farrow being undesirable. They should be given the milk of that one cow, not mixed milk, nor changed from the milk of one cow to that of another. The cow should be tested for tuberculosis, for Koch to the contrary notwithstanding, an Old Country commission of expert bacteriologists and physicians have put on record their conviction that tuberculosis can be transmitted from cattle to humans, through milk, and infected meat. Cows should be kept in clean, well-ventilated stables, should be well watered and carefully fed, giving a proper supply of salt. Don't feed kitchen slops, that is dish water, to a cow. It vitiates her taste and makes her less nice in the selection of her food, and is undesirable for other reasons. Great care should be used in milking. Wipe or wash off the udder to remove dust and soil. Always milk with dry hands. Do not set the pail directly under the cow, so that you can prevent dust or other particles from falling into the milk. Strain the milk at once through a wire strainer and several thicknesses of butter cloth. This finely divides and aerates the milk, besides removing any solid particles, some of which will dissolve if not removed at once. All milk for children's use should be sterilized by heating to 150° after all animal heat has passed off. After straining wash out pails and strain cloths in warm, soapy water. When all milk is removed, scald thoroughly with boiling water. Do not use a cloth to dry out milking utensils after scalding, as the cloth may not be absolutely "fit," but turn down and leave in the sunlight for a time. The hot pails will soon dry off.

If children have contracted diarrhoea, stop all milk absolutely for a day or two, nourish with white of egg beaten up with water and a little lemon juice, with barley water or with weak meat juice or broth. When starting on milk again, sterilize as above and peptonize for a few days.

If you have the slightest suspicion of the water, which should be clear without visible impurity and without taste or odor, boil the water. Do this anyway as a routine procedure if there is any diarrhoea or typhoid in your vicinity, but above all keep out flies.

Boiled water is insipid and flat. Aerate by pouring from a height through a fine strainer from one vessel to another. This will restore it somewhat. The boiling drives off the air and carbonic acid gas; hence the flatness. Add a little lemon or pineapple juice to make more palatable. Both these juices in weak mixtures are said to kill the typhoid bacillus as also the germ that causes diarrhoea.

Keep flour, meal, rice, sugar, in a dry place thoroughly protected from dampness, mice and worms. The storage rooms of provision men should be often and thoroughly inspected and the law should compel safe storage of food stuffs. I have bought rice that was stained from mice and that had a perceptible odor of mice upon it.

The time is coming when the process of mixture and manufacture of such foods as jellies, breakfast-foods, etc., will be rigidly inspected and the horror of throwing these down on dirty floors and men getting in feet and all and mixing with a hoe will not be tolerated.

A word or two about candy. Don't buy your candy. You don't know the uncleanly handling it has received. Make your own candy. The taste for sweets should be indulged, but never before meals or between meals. Give after meals and not too much. Children will soon cease to crave an over supply. Always wash teeth and mouth with clear water and prevent fermentation and so injury to the teeth, after eating candy.

(To be continued.)

"SEVENTEEN" WOULD NOT EXCLUDE BACHELORS.

Dear Dame Durden:—Here is another inquirer, if so I may call myself. I do so enjoy reading those letters sent to your Ingle Nook by the Western people, especially the bachelor friends. I am sure they will find your Ingle Nook of great value. I am one of those many cooks who have been much "tempted and tried," although I think I am rather a young cook. I am only seventeen, but still I think I may enter your corner, may I not? In the number for April 17th I noticed a recipe for Angel Food Cake, and allow me to thank you for it and also the other cake for which we could use the yolks of the eggs. I have never attempted anything fancy in the baking line yet, but some day I hope to, and then will you wish me success?

Allow me to here say that in the FARMER'S ADVOCATE we found a recipe for cough medicine. I do not know what number it was in because we lost two or three papers, but if anyone would like to get this recipe it will be found of great value. At least we found it so. Mother had a very bad cough and this cough cure was of great use to her. It is quite a long recipe and I will not put it in my letter to-day, but if any from our Nook care to ask for it I will send it.

I see that quite a few of our friends in the Ingle Nook are English and I am glad to see them here. It must be very lonesome for them to leave their homes and loved ones to come here to Canada to seek new homes for themselves. But they have our sympathy and we shall make them our friends. I am not an English girl, but a Canadian, and have a warm spot in my heart for the English. We have quite a few English people around here. I have only been personally acquainted with two English women, and with them I spend many a "merry moment" and many a "useful moment" also. The rest of my acquaintances among the English are gentlemen. Almost every Sunday evening they gather here at our home and we sing hymns and spend the evening in this way. We have had many happy times, but they are drawing to a close, for the men are going to be "bachelors" henceforth in the far West. I see, Dame Durden, that you wish to know whether the members wish to have the bachelors excluded. For my part, I say let them stay, and we will make them feel welcome. I enjoy their letters so much. Now I am afraid my letter is too long, but if it is just let me know and I will try to be more careful in future. In closing, Dame Durden, may I ask for a recipe for rust stains on linen?

SEVENTEEN.

(You are one of the graduates from the Children's Corner, aren't you? It is a pleasure to know that our readers when advanced beyond one department are ready to pass on to one fitted for the more mature instead of dropping out. You can hold yourself in readiness to send that cough cure, for someone will be almost sure to send for it.

To take rust from linen, moisten oxalic acid (salts of lemon) in a little water and spread it on the spot. Leave for a few hours and then rinse in pure water to which has been added a few drops of ammonia. I have heard that common table salt moistened with lemon juice and applied to the spot will remove the rust. But someone told me the other day that it removed the spot by removing the goods, so you had better experiment on a small patch first.—D. D.)

MORE ABOUT GARDENS.

Dear Dame Durden:—Seeing the letters in the Ingle Nook written by B. S. and Tweedside, and being very much struck by some of their ideas on farmers' homes, gardens and children, I thought I would give vent to my thoughts, which have been cooped up for so long that they may sound rather rusty and crusty as well.

It is indeed very true that some farmers do not seem to care in the least what kind of home they have so long as their meals are ready and their beds comfortable, but many, I know, are very careful to keep the animals out

of their yards and to clean their feet before they enter the house. In some cases it would not be wise for them to neglect doing so. I believe some women drive their husbands to be careless by their whining and nagging, but most of them, if they really see that their wives wish to have things nice, will take pleasure in doing things for their comfort.

A man in his right senses surely would not object to a garden unless he had to attend to it all by himself. For my part I do not want a man in my garden, after it is plowed and harrowed, although he may have anything eatable in it if he likes. Tweedside wonders what kind of children grow in houses such as she describes. I can easily answer that as I am one of them, though in my case things were not in quite so bad a shape as she makes out. However, I have grown up and can say that that kind of thing only made me more determined not to have a home like that, and I am now supposed to be a good house-keeper, cook, and a credit to the social world as well.

To Lonesome I would like to say that I intend trying his recipe for sour-dough sinkers. I assure you they'll be good though if I make them. I also know a good recipe for kisses of a sensible kind—cakes, I mean.

Now, Dame Durden, I hope you do not think this letter worthy of the waste basket, but if you do please put it there. I have been wanting to write to you for ever so long, to tell you how much I enjoy the different features of the FARMER'S ADVOCATE, the Veterinary column especially, and the Ingle Nook. Now since I have begun you will likely hear from me again when I have something more sensible to write about.

NEDDY OF THE HILLS.

TABLE LINEN.

Dear Dame Durden:—I am sending in a recipe for a rolled jelly cake. Take 3 eggs, beat well; mix in 1½ cups of sugar, a cup of milk, 1 teaspoon of baking powder, and 2 cups of flour. This will make a very large cake. It may be filled with jam or lemon cheese. I prefer the latter.

Will you please tell me what articles of table linen are required to lay a table, and how it should be arranged? I do a great deal of fancy work and can make tray cloths, doilies and table mats, but I do not know just what I should use. Also, how should bread be arranged on the tray? I am afraid that this sounds terribly ignorant, but I have a lot to learn yet. I have not commenced housekeeping yet, but when that happy(?) day comes I shall wage war against great breadths of carpets, heavy mats and the "accumulation of rags," which are the bane of women's lives. Why can they not comprehend how much healthier, and consequently happier they would be without having to wear themselves out sweeping dirty, dusty carpets and shaking and beating rugs! This is especially true on the farm, where we cannot expect to confine men to the kitchen when they are in the house.

KIDDY.

(To begin with, if your table has a polished top buy a silene cloth for it. This padded cloth is rather expensive, but it will last for years. It protects the table from the marks of hot dishes, makes the table cloth lie smoother and wear longer, and does away with the sound of the dishes.

Buy the best linen you can afford for table cloths as a matter of economy. The best wears longer and does up so much better, and one is less apt to grow careless over its treatment. Do not be lavish in the use of doilies, mats, etc. A few spotless pieces are more effective than a large number. A centerpiece on which to place flowers or a potted plant, a tray cloth of good size under the tea things and another under the meat platter are enough, unless you are serving hot vegetables, when the crocheted mats should be used under the vegetable dishes. A tea cosy is a convenience and is best made of some dark color in saten padded well. Then have a linen cover which can easily be removed to be laundered. Embroider in white all

pieces that are to be used constantly, as the colored ones are so apt to fade or run. Embroidery cotton, pearl lustre or mercerized cotton are better than silk in white, as the latter is apt to turn yellow. I had almost forgotten the table napkins. Have a dozen or so of the large-sized ones in good linen, embroidered with your initial (your maiden surname) for very special occasions, but for every day use have only a medium size and not too heavy in texture. If each member of the family has a napkin ring of some kind the daily use will not add greatly to the laundry, as a napkin can be used for three or four days without changing.

As for the bread, there is no hard and fast rule for its arrangement. Do not cut the slices too thick, and if they are from a large loaf cut them in two. If much bread is needed it is better to have it on two plates, the slices piled evenly. If you use an oval or oblong tray let the slices lie overlapping one another. My own preference, when the family is small, or at meals where not much bread is eaten, is to have the loaf uncut, on a bread board at the corner of the table, and slices cut off with a bread knife as they are required. By this method there are no pieces left over to get dry and be thrown out.

I'm with you in regard to the heavy carpets and other non-essentials in furnishings, and hope the happy day will soon come when you can carry out these good ideas in your own home.—Dame Durden.)

PECULIARITIES OF ENGLISH.

- You cannot cure hams with a hammer,
- You can't weigh a gram with a gram-mar,
- Mend socks with a socket,
- Build docks with a docket,
- Nor gather up clams with a clamor.
- You can't pick locks with a pickle,
- You can't cure the sick with a sickle,
- Pluck figs from a figment,
- Drive pigs from a pigment,
- Nor make your watch tick with a tickle.
- You can't make a mate of your mater,
- You can't get a crate from a crater,
- Catch moles from a molar,
- Bake rolls with a roller,
- But you can get a wait from a waiter.
- You cannot raise crops from a cropper,
- You can't shave your chops with a chopper,
- Break nags from a nagger,
- Shoot stags with a stagger,
- Nor pop to a girl with a popper,
- You can't grow beeves from the beaver.
- You can't catch the heaves from a heaver,
- Get grains from a grainer,
- Draw strains from a strainer,
- Nor cleave to your wife with a cleaver.
- A bat can't be made out of batter
- A flat's not a thing that can flatter,
- A pond does not ponder,
- A wand will not wander,
- And so that's the end of our patter.

TRANSCRIPT.

"THE BEST RESULTS OBTAINABLE"

In acknowledging receipt of his Policy for a large amount, a prominent Winnipeg Architect wrote to the Great-West Life Assurance Company as follows:

"The particular reason why I gave this Insurance to the Great-West Life is because I know that this Company has been well conducted, and will bring me ultimately the very best results obtainable."

This is the experience of every Great-West Policyholder. Not only are the rates charged for Insurance unusually LOW, but the profits paid to Policyholders are remarkably HIGH.

Full information on request.

THE GREAT-WEST LIFE ASSURANCE CO.

Head Office - - WINNIPEG



Field Erected with No. 9 Galvanized Coiled Steel Wire

Heavy coiled steel wire fence, hard steel wire lock that does not rust or slip and kinks both wires. All heavily galvanized and is replacing other makes of fencing using lighter gauged wire. Can be erected as cheaply as barb wire and

DOES NOT INJURE STOCK

WRITE FOR CATALOGUE BUY THE BEST AGENTS WANTED

THE GREAT WEST WIRE FENCE CO. LTD.
76 LOMBARD STREET, WINNIPEG, CANADA



STATELY HALLWAYS

when decorated with **Alabastine** have a lustrous richness. Our illustrated book, "Homes, Healthful and Beautiful," tells why **Alabastine** is the most durable of all wall-coverings—how it destroys disease germs, and how you can decorate your home with **Alabastine** at much less cost than with any other material.

Send ten cents for a copy of "Homes, Healthful and Beautiful," with many dainty, new ideas for the decoration of your home.

Alabastine is sold by hardware and paint dealers everywhere—a 5 pound package for 50 cents.

Ask your dealer for tint card. NEVER SOLD IN BULK.

THE Alabastine Co. LTD
175 WILLOW STREET. PARIS. ONT.



No More Drudgery Housework Made Easy With The Chatham Kitchen Cabinet

JUST think what a saving in time and labor you can make with a Chatham Kitchen Cabinet—the number of steps you save in a day—the ease with which you can prepare a meal! With the Chatham every ingredient and every cooking utensil you need in the preparation of a meal is right within reach of your hand and there is no constant running back and forth from kitchen to pantry for first one article and then another.

The **Chatham Kitchen Cabinet** enables you to get a meal—stir up a cake—or mix a batch of bread in just half the time—with half the labor that it takes you in the old way—running back to the pantry every minute or two for first, the salt—then the spice—next the flavoring—and so on. Now you can get this wonderful work-saver at a very reasonable price on my

Liberal Time Payment Plan

So if it isn't convenient for you to pay all cash, you can pay for the Cabinet on such easy terms that you'll never miss the money—while all the time you can be enjoying its benefits. And my Kitchen Cabinet is not only useful—but ornamental as well—and any woman will be proud to own one. It not only simplifies cooking—but it keeps your kitchen always neat and tidy and does away with all the clutter of cooking and baking.

If you are thinking of replenishing your home furnishings you cannot invest in anything that will give as much genuine help in your housekeeping as the Chatham Kitchen Cabinet—and once you use it you'll find the regular weekly—monthly—and yearly housecleaning is no longer a bugbear. Your kitchen and pantry take the biggest part of your time—and make the hardest part of your housework—but if you'll use my Cabinet you can cut out all the kitchen drudgery and use the extra time for pleasanter work or recreation.

Now you should get my **FREE KITCHEN CABINET CATALOGUE** at once—and you can get it, postpaid, by writing a postal. Send for it today without fail. It's a handsome book that shows beautiful photographs of the Chatham Kitchen Cabinet and gives my prices and terms.

It's free for the asking. Write for it today. Address me personally.

MANSON CAMPBELL
President,
The Manson Campbell Company,
Ltd.
Dept.
Chatham,
Ont.

Sold Direct From Factory On Time—ON TRIAL—and Fully Guaranteed.



Stocks Carried at Montreal, Brandon and Calgary

Address all inquiries from Western Canada to my Company to Brandon, Moose Jaw or Calgary

CHILDREN'S CORNER

PRIZE WINNERS FOR APRIL.

The prizes for the best written and most interesting letters appearing in the April issues have been awarded to Kathleen Kinley and Peter Dunlop. If Archie Rankin had given his age the awards might have been different, but we did not know to which class he belonged. Other good letters were by Louise Trenholme, Florence Spicer, Chirp, Caroline Brink and Clarence Burry.

Cousin Dorothy.

A TOWN IN THREE YEARS.

Dear Cousin Dorothy:—When we came out here three years ago there was nothing to be seen but the prairie. Now we have the town of Earl Grey only a mile south of our place.

I haven't gone to school since Christmas because it was too cold. It has been very stormy this last winter. I have two dogs and two cats. The big dog's name is Nero, and the little one's name is Spry. The old cat's name is Kitten, and the little one's name is Tibby.

MERLE HAGER.

A LAP DOG.

Dear Cousin Dorothy:—We came to Saskatchewan in 1904, and I like it well. I have one sister married and five at home, but no brothers. My father has two quarter sections of land. We have eight cows and eleven calves, four horses and two colts and five pigs. I have two cats called Tipe and Dick and a lap dog called Mickie. We live about eighty rods from the school. One sister and myself go to school. She is in the fifth grade. I am in the third. My teacher's name is Miss A. A. I like her well.

WILBERT KNOX. (11)

LIKES UNITED STATES BETTER.

Dear Cousin Dorothy:—I look for the paper every week and we always get it. We have a farm twenty miles north of Calgary, Alberta. I live in a city called Calgary. I have a brother named Harold and a sister named Alma. I came from the United States of America to Canada and do not like it here so well as I do the States.

VERNAL G. FOX. (10)



A PICNIC PARTY ON THE LITTLE RED DEER, ALTA.

A LITTLE SISTER GONE.

Dear Cousin Dorothy:—My little sister Margaret died the 14th of January. She wrote to the Children's Corner when she was sick in bed.

I have two little rabbits and when I go to feed them and they see me coming they always come to meet me, and stand on their hind legs and eat from my hands. I have a pup and everybody that goes by, he wants to go too. We have to keep him tied up. We haven't any school here now as our 1st teacher went to British Columbia. I am ready for the fourth reader.

We are six miles from the Earlville post office. The mail comes in twice a week. We are three miles from the Earlville creamery.

My mother has taken the FARMER'S ADVOCATE for quite awhile. I would like very much to correspond with any of the other girls of the Children's Corner, if they would correspond with me.

ESTHER E. GARRETT. (12)

A NARROW ESCAPE.

Dear Cousin Dorothy:—I have always been a reader of the paper ever since we have taken it, and that is five years.

I will tell you about our place. It is in the Moose Mountains, six and a half miles from the town of Arcola. We have a quarter section of land. It is a very pretty place, is covered with timber and there is a small lake in front of the house. There are people come from town in the summer and they have built three cabins as a summer resort. One of them has a little cripple girl named Jean, and they named the lake "Lake Jean." They have a row boat on it. I have been out on it three or four times and it is real nice. They had a picnic here on the fifth of July, so we had it pretty close. We had our pictures taken and had a good, big supper.

I will relate a narrow escape from drowning last summer. My brother and his school mate went in bathing just after supper, and he either got too far out into the water or else took cramps. The other little boy saw him go under and he tried to get him out, but it was too far out for him. He got ashore and ran to the cabins for help. There was a big crowd out from town that night, and when they got to the place where he had gone under they couldn't see any thing but the crown of his head. They got him out and there was not a bit of life in him. The men began to work on him, but they were doing no good. There happened to be a nurse there and she brought him back about an hour. If she hadn't been there he would have died. He was in the water for fifteen minutes.

LOST SOME CATTLE.

Dear Cousin Dorothy:—This is my first letter to the FARMER'S ADVOCATE. Papa has taken it for over one year and likes it fine. I found it very interesting to read the letters in it, so I thought I would write too.

We live thirty-three miles north of Lipton, but there is a store two miles and a half east of here. We have three horses, thirty-four hens and four pigs. We have one cow. We lost the head of cattle. Our horses' names are La Vie Belle and...

We came to and I like it married and others. My lions of land. eleven calves, and five pigs. pe and Dick ie. We live the school. o to school. I am in the is Miss A. A.

KNOX. (11)

BETTER.

I look for l we always wenty miles I live in a e a brother named Alma. l States of o not like it es. J. Fox. (10)

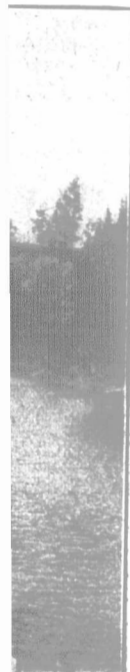

ave always ever since five years. place. It six and a of Arcola. land. It vered with ke in front ople come and they a summer little cripp-ey named y have a out on it real nice. re fifth of lose. We id a good,

ape from brother a bathing ither got else took saw him him out. He got or help. m town e to the r they e crown out and m. The but they appen ed broug ht e had n ed. H minutes



Gold Standard BAKING POWDER

"Guaranteed The Best"

There's nothing like a test in your own oven to prove the Strength, Purity and Value of Gold Standard Baking Powder.

Just buy a tin from your grocer, take it home and try it yourself.

Gold Standard is a pure, wholesome Baking Powder and is in every way the equal of those sold at more than twice the price.

Sixteen Ounce Tins 25 Cents.

FILL OUT THE BLANK BELOW AND RETURN IT TO US AND WE WILL MAIL YOU OUR NEW 80 PAGE COOK BOOK FREE.

Codville Georgeson Co. Ltd.
Dept. A.
Winnipeg, Man.

Please mail me a free copy of your Cook Book.

My name is

My address is

My grocer is

His address is



You cannot possibly have a better Cocoa than

EPPS'S

A delicious drink and a sustaining food. Fragrant, nutritious and economical. This excellent Cocoa maintains the system in robust health, and enables it to resist winter's extreme cold.

COCOA

Sold by Grocers and Storekeepers in 1/2-lb. and 1/4-lb Tins.

He has never been in the water since. It was a good lesson for him. He was ten years old and the other boy was nine years old.

EMMA BUTT. (13)

MOTHER GETS UPSET.

Dear Cousin Dorothy:—We have two dogs; their names are Billy and Renie. We have six horses, two colts, and about one hundred chickens. I don't go to school in the winter. I have a little sleigh. We give my mother a ride on it and tip her off sometimes in a snow bank. She likes going down hill. I like reading the comic section and the FARMER'S ADVOCATE too. This is my first winter in Canada. We came last May from England. I draw wood on my sleigh and sometimes it goes over. I have a horse called Frank. We are milking ten cows. We have one kitten and three cats. I have one sister eight years old. She goes to school and is in the second book. Santa Claus brought me some slippers full of nuts and a box of tools. He has six reindeers and a sleigh. He comes down the chimney so fast you can't see him.

GILBERT WIDDOWSON. (9)

DR. DRUMMOND'S LAST POEM.

The following verses were read at St. Patrick's Day banquet in Montreal last month by the deceased poet, Dr. Drummond, and comprise the last poem given to the public from his famous pen:

What means this gathering to-night?
What spirit moves along
The crowded hall, and touching light
Each heart among the throng,
Awakes as though a trumpet blast
Had sounded in their ears
The recollections of the past,
The memories of years?

O! 'tis the spirit of the West,
The spirit of the Celt,
The breed that spurned the alien breast,
And every wrong has felt—
And still, though far from fatherland,
We never can forget
To tell ourselves with heart and hand
We're Irish yet! We're Irish yet.

And they outside the Clan of Conn,
Would understand, but fail,
The mystic music plays upon
The heart-strings of the Gael—
His ear, and his alone can tell
The soul that lies within,
The music which he knows so well,
The voice of Kith and Kin.

He hears the tales of old, old days,
Of battle fierce by ford and hill,
Of ancient Senachie's martial lays,
And race unconquered still—
It challenges with mother's pride
And dares him to forget
That tho' he cross the ocean wide
He's Irish yet! He's Irish yet!

His eye may never see the blue
Of Ireland's April sky,
His ear may never listen to
The song of lark on high;
But deep within his Irish heart
Are cloisters, dark and dim,
No human heart can wrench apart,
And the lark still sings for him.

We've bowed beneath the chastening
rod,
We've had our griefs and pains,
But with them all, we still thank God,
The blood is in our veins;
The ancient blood that knows no fear,
The Star p is on us set,
And so, however foes may jeer,
We're Irish yet! We're Irish yet!

Village Dame—"Ah, I do think as gentlefolk don't know what trouble be. There's my darter now, just lost the last one of seven, she 'ave, after all the trouble she've took wi' 'em, feeding 'em on the best. But 'twere no use; they've a' died one after t' other." Squire—"Dear, dear! I'd no idea your daughter had so many children." Dame—"Children! I be talkin' o' pigs!"

"Miriam," said her mother, "have you ever given young Mr. Stapleford any reason to believe you cared for him enough to marry him?"

"He seems to think so," answered the daughter, "because I told him the other evening that he was sending me too many costly flowers and ought to begin to save his money."



There are different ways of doing things

PROFITABLE and UNPROFITABLE!

Do you know what you received last month for your butter?

We know what we paid our patrons, and if you knew you might be surprised at what you lost by not coming with us.

If you were to test your cows with a

BABCOCK TEST

you would dispose of the unprofitable one.

If you tested our method of dealing with our patrons you would never think of staying in the old rut.

ALL WE WANT IS A SQUARE TRIAL!

A TEST IS CONVINCING

We could not hold our patronage and keep on increasing our business if we weren't proving ourselves peerless prosperity promoters for the best farmers of the country.

It's easy enough to get all the work you want without churning your own cream.

Business is business, and we can give satisfaction that satisfies.

Resolve to throw aside the old way—try the new—send a few cans to the Brandon Creamery, and you will become a permanent patron, we know you will.

The Brandon Creamery

(Dept. B)

BRANDON, Man.

CENTURY 100 PER CENT. GOOD

THE WILLIAMS-ABBOTT ELECTRIC CO.

Cleveland, O., U.S.A., April 1st, 1907

To the Trade:

We have sold to The Century Telephone Construction Company of Buffalo, N.Y., our entire plant, including our machines, tools, dies, patterns, etc.

This transfer includes all the valuable improvements developed on Williams-Abbott apparatus during ten years active connection with the telephone business, during which time, our patrons will agree with us, we have built up a line of apparatus that has an enviable reputation.

We have sold the Century Company our materials manufactured and unmanufactured, our patents, and the good-will of the business. Our patrons can thus get a complete variety of apparatus, both common battery and magneto, and it will be to your interest to deal with one concern.

All orders for repairs and renewals as well as for additional apparatus of the Williams-Abbott make should be sent to the Century Telephone Construction Company at Buffalo.

While our factory here in Cleveland was a large one, the new factories of the Century Company at Buffalo are three times as large, and our old patrons will be promptly supplied with the same apparatus as formerly whenever they specify it, as the entire line will continue to be manufactured the same as formerly, and under the same factory foremen who have moved to Buffalo.

Mr. Wright who was our salesmanager is now a part of the Century sales organization and we know that any orders for Williams-Abbott materials will have his personal attention and that they will treat you right.

We thank the trade for the patronage that they have favored us with during the past several years and which has been the basis for the large business we have carried on.

Yours truly,

The Williams-Abbott Electric Co.

(Sgd.) L. SANDS, Pres't.

Century Telephone Construction Company
53 Adelaide St., West, Toronto, Ont.

**GOOD
BAKERS**

**Cheapest!
Cleanest!
Safest!**

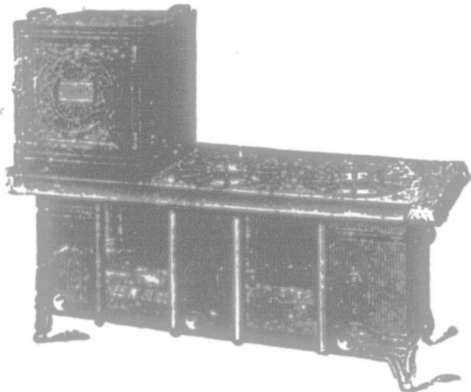

**GOOD
COOKERS**

**Not like those
Sold in Stores,
Absolutely Safe
from Explosion.**

Burns Barrels of Air

The Most Wonderful Stove Ever Invented

CAN'T CLOG UP!

Causing great excitement wherever exhibited. Fuel drawn principally from atmosphere. Uses 395 barrels of air while consuming one gallon of oil. Wood, coal and oil cost money. Only free fuel is air. Supply is unlimited. No trust in control. Air belongs to rich and poor alike.

Harrison Valveless, Wickless, Automatic Oil-Gas and Air Burner Stove

Automatically generates gas from Coal Oil, mixing it with air. Burns like gas. Intense hot fire. Combustion perfect. To operate turn knob, oil runs into burner, touch a match, it generates gas, which passes through air mixed, drawing in about a barrel of air to every large spoonful of oil consumed. That's all. It is self regulating. No more attention. Same heat all day or all night. For more or less heat simply turn knob. To put fire out simply turn knob. As near perfection as anything in this world. Not like those sold in stores. No leaks, nothing to clog up. No wick, not even a valve; yet heat is under perfect control. Cheapest fuel on earth. The only stove absolutely guaranteed to be safe from explosions. No hot fiery kitchens. Not dangerous like gasoline. Simple, durable, lasts for years. Prices, one burner, \$3.75; two burners, \$7.50; three burners, \$11.50. Write to-day. All orders receive prompt attention.

International Supply Co.

Suite 3, McKay Block

299 Portage Avenue

WINNIPEG

MANITOBA

Bob, Son of Battle

(Continued from page 705)

He began by saying that he spoke "as representing all the tenants"—but he was interrupted.

"Na," came a shrill voice from half-way down the table. "Ye'll except me, James Moore. I'd as lief be represented by Judas!"

There were cries of "Hold ye gab, little mon!" and the squire's voice "That'll do, Mr. M'Adam!"

The little man restrained his tongue, but his eyes gleamed like a ferret's, and the Master continued his speech.

He spoke briefly and to the point, in short phrases. And all the while M'Adam kept up a low-voiced, running commentary. At length he could control himself no longer. Half rising from his chair, he leant forward with hot face and burning eyes, and cried: "Sit doon, James Moore! Hoo daur ye stan' there like an honest man, ye whitewashed sepulchre? Sit doon, I say, or"—threateningly—"wad ye hae me come to ye?"

At that the Dalesmen laughed uproariously, and even the Master's grim face relaxed. But the squire's voice rang out sharp and stern.

"Keep silence and sit down, Mr. M'Adam! D'you hear me, sir? If I have to speak to you again it will be to order you to leave the room."

The little man obeyed, sullen and vengeful, like a beaten cat.

The Master concluded his speech by calling on all present to give three cheers for the squire, her ladyship, and the young ladies.

The call was responded to enthusiastically, every man standing. Just as the noise was at its zenith, Lady Eleanour herself, with her two fair daughters, glided into the gallery at the end of the hall; whereat the cheering became deafening.

Slowly the clamor subsided. One by one the tenants sat down. At length there was left standing only one solitary figure—M'Adam.

His face was set, and he gripped the chair in front of him with thin nervous hands.

"Mr. Sylvester," he began in a low, clear voice, "ye said this is a free country and we're a' free men. And that bein' so I'll tak' the liberty, wi' yer permission, to say a word. It's maybe the last time I'll be wi' ye, so I hope ye'll listen to me."

The Dalesmen looked surprised, and the squire uneasy. Nevertheless he nodded assent.

The little man straightened himself. His face was tense as though strung up to a high resolve. All the passion had fled from it, all the bitterness was gone; and left behind was a strange, ennobling earnestness. Standing there in the silence of that great hall, with every eye upon him, he looked like some prisoner at the bar about to plead for his life.

"Gentlemen," he began, "I've bin amang ye noo a score years, and I can truly say there's not a man in this room I can ca' 'Friend.' He looked along the ranks of upturned faces. "Ay David, I see ye, and you, Mr. Hornbut, and you, Mr. Sylvester—ilka one o' you, and not one as'd back me like a comrade gin a trouble came upon me." There was no rebuke in the grave little voice—it merely stated a hard fact.

"There's I doot no one amang ye but has some one—friend or blood—whan he can turn to when things are sair wi' him. I've no one."

"I bear alane my lade o' care"—alane wi' Wullie, who stands to me, blaw or snaw, rain or shine. And whiles I'm feared he'll be took from me." He spoke this last half to himself, a grieved, puzzled expression on his face, as though lately he had dreamed some ill dream.

"Forbye Wullie, I've no friend on God's earth. And, mind ye, a bad man aften mak's a good friend—be ye never given me the chance

It's a sair thing that, gentlemen, to ha' to fight the battle o' life alane; no one to pat ye on the back, no one to say 'Weel done.' It hardly gies a man a chance. For gin he does try and yet fails, men never mind the failin'—they only mark the failin'."

"I dinna blame ye. There's something bred in me, it seems, as sets iver one agin me. It's the same wi' Wullie and the tykes—they're doon on him the same as men are on me. I suppose we was made so. Sin' I was a lad it's aye bin the same. From school days I've had iver one agin me."

"In ma life I've had three friends. Ma mither—and she went; then ma wife"—he gave a great swallow—"and she's awa'; and I may say they're the only two human bein's as ha' lived on God's earth in ma time that iver tried to bear wi' me;—and Wullie. A man's mither—a man's wife—a man's dog! it's aften a' he has in the ward; and the more he prizes them the more like they are to be took from him." The little earnest voice shook, and the dim eyes puckered and filled.

"Sin' I've bin amang ye—twenty-odd years—can any man here mind speakin' any word that wasna ill to me?" He paused; there was no reply.

"I'll tell ye. All the time I've lived here I've had one kindly word spoke to me, and that's a fortnight ago, and not by a man then—by her ladyship, God bless her!" He glanced up into the gallery. There was no one visible there; but a curtain at one end shook as though it were sobbing.

"Weel, I'm thinkin' we'll be gaein' in a wee while noo, Wullie and me, alane and thegither, as we've aye done. And it's time we went. Ye've had enough o' us, and it's no for me to blame ye. And when I'm gone what'll ye say o' me? 'He was a drunkard.' I am. 'He was a sinner.' I am. 'He was ilka thing he shouldna be.' I am. 'We're glad he's gone.' That's what ye'll say o' me. And it's but ma deserts."

The gentle, condemning voice ceased, and began again.

"That's what I am. Gin things had been differ', aiblins I'd ha' bin differ'. D've ken Robbie Burns? That's a man I've read, and read, and read. D've ken why I love him as some o' you do yer Bibles? Because there's a humanity about him. A weak man hissel', aye slippin', slippin', slippin', and tryin' to haud up; sorrowin' ae minute, sinnin' the next; don't ill deeds and wishin' 'em undone—just a plain human man, a sinner. And that's why I'm thinkin' he's tender for us as is like him. He understood. It's what he wrote—after ain o' his troubles, I'm thinkin'—that I was goin' to die ye."

"Then Gently seen yer brother man, Still gentler sister woman."

Though they may gang a kennin' wrang.

To step aside is human— the doctrine o' Charity. Gie him his chance, says Robbie, though he be a sinner. Mone a man'd be differ', mone bad'd be guid, gin they had but their chance. "O' them their chance, says he; and I'm a' for it. As 'tis, ye see me here, a bad man wi' still a streak o' good in him. Gin I'd had ma chance, aiblins I'd be a good man wi' just a speck o' the devil in him. A' the differ' betime what is and what might ha' bin."

(To be continued.)

Had Moran, in a recent address on insurance, said of a certain proposed company:

"This would not be an economy, but an economy in the long run. It would save the money and the jam."

It would save the boy's mother,

and the extra agance to eat

the economy, the

the economy, the



Are You The Man?

For an Ideal Home in the glorious
KOOTENAY FRUIT LAND

Have you been dreaming of a home in an environment where you could live by the way as you journey through life? Let your dream come true.

The Opportunity

The famous Cold Spring Ranch, the most extensive improved property in the Kootenay, is now being subdivided. It is on far-famed Kootenay Lake, eighteen miles from Nelson, the capital of the Kootenay, on a Canadian Pacific transcontinental route; rail and water transportation at the door. Wild land, cleared land, orchard land from which to choose. Any size lot from three acres up. Abundance of water—springs and running streams. Prices average about \$100.00 per acre. Easy terms. Orchards will net \$200 to \$500 an acre within three years. No worry from coal strikes—unlimited supply of wood. A big income from vegetables and berries while the orchards are growing. Poultry, too—eggs 75c. a dozen in Nelson.

Place for a Colony

Cold Spring Ranch makes a splendid location for a colony or neighborhood group. The ranch home is the most comfortable, convenient and modern farm home in the Kootenays. Piped with spring water, good plumbing, large rooms, wide verandas. It has a slightly elevated overlooking Kootenay Lake. Trains stop at the gate and steamboats land right in front of the house. Large greenhouses. Plenty of water for forcing vegetables. A group of friends or associates, religious or otherwise, would find this property ideal for a home.

Ideal Climate

is claimed for the Kootenay country of British Columbia. Just winter enough for a tonic and to give quality to fruit. Just altitude enough to escape excessive moisture. Warm summer days, cool nights. No blizzards, no mosquitos, no sandstorms, no cyclones or terrifying thunder storms. Grand mountain lake scenery. Freedom from fruit pests. Irrigation unnecessary.

Finest Temperate Zone Fruits

Apples, pears, peaches, cherries, prunes, plums, strawberries, raspberries, gooseberries of this district unrivalled. First place in competition with all the British Empire.

Best Fruit Market in the World

Stiff duty on U. S. fruit, rigid inspection of importations, and an area to supply of a million square miles that cannot raise fruit and into which 300,000 people are going annually. High prices, quick sales. Excellent transportation facilities. Very limited area of good fruit land. Big demand, small supply.

Act Quickly

Choose your piece and "get busy" at once. Don't put off the day of your happiness or lose the first selection of the famous Cold Spring subdivisions.

At present all applications for a subdivision of this property will be received subject to preference for applicants for the farm house piece and their friends and associates. If you and your neighbors are thinking of a new money-making location in a mild climate with grand and beautiful natural surroundings, write at once for particulars.

HANSEL, LANGAN, KNAPPEN CO.

38 Aikins Building, Winnipeg, Manitoba
Victoria Building, Nelson, B. C.

SUGGESTIONS TO FARMERS ELECTOR COMPANIES.

(Continued from page 727.)

[In the Midale Company the word "promoters" was substituted for "board of directors" and "company," for "association." With only a few other minor changes the above by-laws were adopted. —Ed.]

—ARTICLE I.—

SECTION 1. The annual meeting of the shareholders of this Association shall be held on the second Thursday in July of each and every year, between the hours of 10 a. m. and 4 p. m., at which there shall be elected nine directors, who shall constitute the Board of Directors. Such other business may be transacted at the annual meeting as may be deemed advisable or necessary.

SEC. 2. Thirty days notice shall be given of the holding of such meeting of shareholders by publishing a notice thereof for three weeks prior to such meeting in a newspaper, or by notice mailed to each shareholder of record, which notice shall especially state the time and place of holding such meeting.

SEC. 3. The Board of Directors, at the request of one-third of the shareholders, shall call a special meeting of shareholders. The notice of said meeting must specify the business to come before such meeting, and must be mailed to every shareholder not less than seven days prior to such meeting. No business shall be finally acted upon or disposed of at such special meeting excepting that designated in the notice, which must specify the purpose of such meeting.

SEC. 4. The President, and in case of his absence, the Vice-President, shall preside at all meetings of the association, and shall cast the deciding vote in case of a tie. Each shareholder shall have one vote only, and no vote shall be cast by proxy.

SEC. 5. The Board of Directors shall meet on the first Mondays of each month for six months, commencing from the first meeting in July, and quarterly thereafter during balance of the year.

SEC. 6. Special meetings of the Board of Directors may be called by the President at any time, and shall be called by him at the request of the Executive Committee or any six directors, and every director shall be notified of such special meeting.

SEC. 7. Six members of the Board of Directors shall constitute a quorum for the transaction of business, and a majority vote of all members present shall be necessary to determine any question under consideration.

SEC. 8. No transfer of the grounds or buildings of the company, either by sale or lease, shall be consummated without an affirmative vote of two-thirds of the shareholders present at a regularly called annual or special meeting.

—ARTICLE II.—

BOARD OF DIRECTORS, DUTIES AND POWERS.

SEC. 1. The Board of Directors shall meet within three days after the annual election and complete its organization by electing from its own members a President, Vice-President, Secretary, Treasurer, and General Manager. They shall also elect two members of the Association who shall, with the General Manager, constitute an Executive Committee.

SEC. 2. The Board of Directors shall fix salaries and rates of compensation of all officers, agents or regular employees of the Association, and shall have power to fill all vacancies that may occur in the Board, or any office thereof.

SEC. 3. The Board of Directors shall cause to be rendered to the annual meeting of shareholders a full detailed account of all business of the Association during the preceding year, with an estimate of the value of all property, both real and personal, owned by the Association. A similar account shall be rendered at any special meeting of shareholders, when required by a majority of the shareholders, a reasonable time being given to prepare the same.

SEC. 4. The Board of Directors shall have power to transact such business and adopt such measures, not inconsistent with the Articles of the Association, as shall seem best calculated to

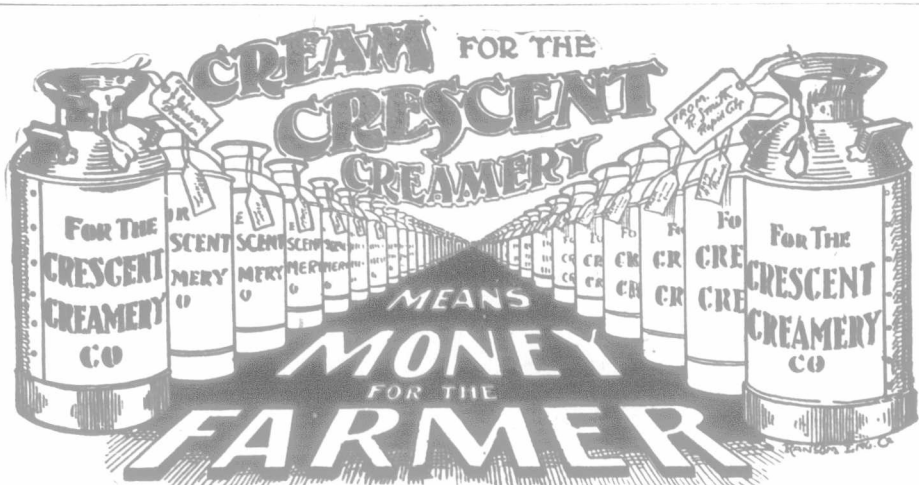

Farmers' Interests
are our Interests

We Originate
Others Imitate

Our system of weighing, sampling and testing each individual can of cream which we receive is as near perfect as can be.

We have facilities not possessed by any other creamery in Manitoba for pasteurizing and ripening all cream we receive. This enables us to turn out a strictly A1 article, thereby ensuring our patrons the highest price at all times.

Highest Prices
Prompt Payments

Accurate Tests
Trial Solicited

CRESCENT CREAMERY CO. LIMITED
WINNIPEG AND BRANDON

WET PAINT

THIS IS THE SIGN OF THE SEASON

We have specially prepared paints for each purpose

**HOUSE PAINTS, FLOOR PAINTS,
BARN PAINTS, ROOFING PAINTS.**

Always INSIST on having paint bearing OUR NAME,
Your local dealer has it for you. Write us for any
information and for color card. Also for our little
illustrated booklet of houses showing effects of
color combinations.

The Canada Paint Co.

Limited

WINNIPEG, Man.

Our Binder Twine Prices



The Twine we sell we guarantee. It contains about 50 per cent. of pure Manila and measures 550 feet to the pound. It can be used in any style of knotter and will give perfect satisfaction.

Our prices are 11½c per lb at Winnipeg, 12c at Brandon, 12½c at Regina, and 12½c at Calgary. To these prices must be added the local freight rates from any one of these points to the point to which you want your twine delivered.

The most economical way to buy Twine is in car-lots. You can get it laid down anywhere in Manitoba for 12c, which is an exceedingly low price for this grade of Twine. Have your neighbors combine with you, and send your orders all together, and even if you have not a full car, send them to us, for it is quite possible that we have other orders for your station that will make up the car-lot. If not we will see that you get the Twine in the cheapest way possible.

There is no object in delaying your order, for in buying from us you are protected by our liberal guarantee.

Should your crop be destroyed by hail or excessive rain or should the Twine be unsatisfactory for any reason, return it to us and we will promptly refund the money.

THE T. EATON CO. LIMITED
WINNIPEG, CANADA

BUTTER WRAPPERS

YOUR BUTTER will bring you a higher price and will also find a ready buyer if properly done up in nicely printed wrappers. We quote the above at the following prices:

	1000	add. 1000		1000	add. 1000
8½ x 11 or 9 x 12			½ x 11 or 9 x 12		
Single Brand 1	\$2.75	\$1.00	Combination S.B. 4	\$1.85	.65
Single Brand 2	2.00	.75	Single Brand 9 up	1.50	.45
Single Brand 4	1.75	.65	Com. Brand S.B. 9 up	1.70	.45

Victoria Printing Company
Box 345, Winnipeg, Manitoba.

promote the interests of the Association; and to that end shall from time to time prescribe such rules and regulations for the management of the business as it may deem expedient.

—ARTICLE III.—

DUTIES OF OFFICERS.

SEC. 1. The President of the Association shall be the presiding officer at all meetings of the Board of Directors and of the shareholders. He shall sign, execute and deliver all deeds of conveyance of real estate which the Association may order executed and shall sign all certificates of stock of the Association; shall countersign all certificates and orders upon the Treasurer, and perform such other duties as the board may direct. In case of the absence or inability to act, the Secretary shall discharge the duties of the President until his return, or until his disability be removed, or the vacancy filled.

SEC. 2. The Vice-President shall attend all meetings of the shareholders, and keep, in a suitable book, the minutes of said meetings. He shall have charge of the records and papers of the Association; shall have charge of and affix the corporate seal to all such documents as may require attestation; shall issue notices of all meetings; and perform all the duties generally incident to the office of Secretary. His records shall be open to the inspection of any of the directors at all proper business hours.

SEC. 3. The Treasurer shall receive all money paid to the Association through the hands of the Secretary, and give his receipt therefor, and shall pay out the same under the direction of the Board of Directors, keeping in a suitable book a true account thereof. He shall make a full detailed report of all receipts and disbursements to the Promoters at their annual meetings, and an annual report of the same. The books of the Treasurer shall at all times be open to the inspection of the promoters. He shall also furnish such bonds as the Managers may require.

SEC. 4. The Executive Committee shall have control of the warehouses or elevators of the company, and employ competent and suitable agent, or agents, to properly operate the same, which agent, or agents, shall be directly responsible to and under the direction of such Executive Committee; shall cause to be kept a true and complete record of all business transacted by such agent, or agents, or by the committee; shall preserve for the use of the Association all important correspondence, and shall submit a report of these transactions to the Board of Directors at every regular meeting, or whenever required to do so, at any special meeting. Such report shall specify the amount of wheat purchased, stored, handled or shipped, and the grades thereof, as far as practicable; as also the amount of other grains or products purchased, stored or shipped. They shall closely and carefully supervise the business and property of the company, and from time to time, and at least monthly, carefully examine the books, records and accounts of the agent, or agents. They shall submit a full and complete financial and business report of the business of the company at the annual meeting of the shareholders.

—ARTICLE IV.—

CERTIFICATES OF STOCK.

SECTION 1. The certificates of the capital stock of the Association shall be issued in such form as the Board of Directors may direct, and shall be numbered and registered as issued. They shall exhibit the holder's name, the number of shares, and shall be signed by the President and countersigned and sealed by the Secretary.

SEC. 2. Transfers of stock shall be made only on the books of the Association, in the presence of the Secretary or other authorized officers of the Association, either by the holder in person or by his attorney-in-fact. In case of transfers by executors, administrators, guardians, or by any other legal representative, duly authenticated evidence of such authority shall be produced to the Association. No transfer shall be made until a certificate granted to the transferee is presented up to the Association, and the session of stock shall be held as vesting an owner.

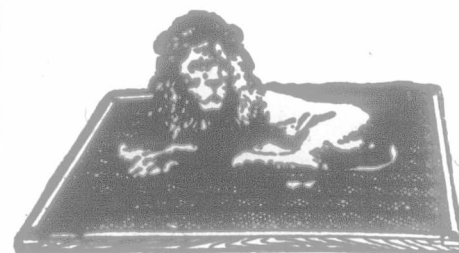

The Guaranteed Hercules Spring Beds Never Sag

—they never stretch out of shape—and never lose their springiness.

For solid comfort—for luxurious sleep—you will find no other bed so lastingly satisfactory. The patent interlacing steel wires preserve the spring and greatly strengthen the bed.

Our 30-days' free trial protects everyone who buys a "Hercules." Look for the name on the frame.

Gold Medal Furniture Mfg. Co., Limited.

Montreal Toronto Winnipeg

T. IE CHOICEST LAND IN THE WHOLE KOOTENAY DISTRICT.

Lands selling at \$125 to \$150 not to be compared with what we offer at \$100 per acre.

We have Water Front property, immediately adjoining the C. P. R. siding, where trains stop for passengers or produce.

Just a few more 10 acre blocks at these prices. Terms easy. Might consider exchange for City Property on this.

BOYLE, HIGGINS & CO.

314 SMITH, ST., WINNIPEG

PHONE 5014



GILSON MFG. CO. Ltd., Dept. A, GUELPH, ONT.

Don't take any Chances, but cut that heavy hay crop of yours with a Massey-Harris Mower

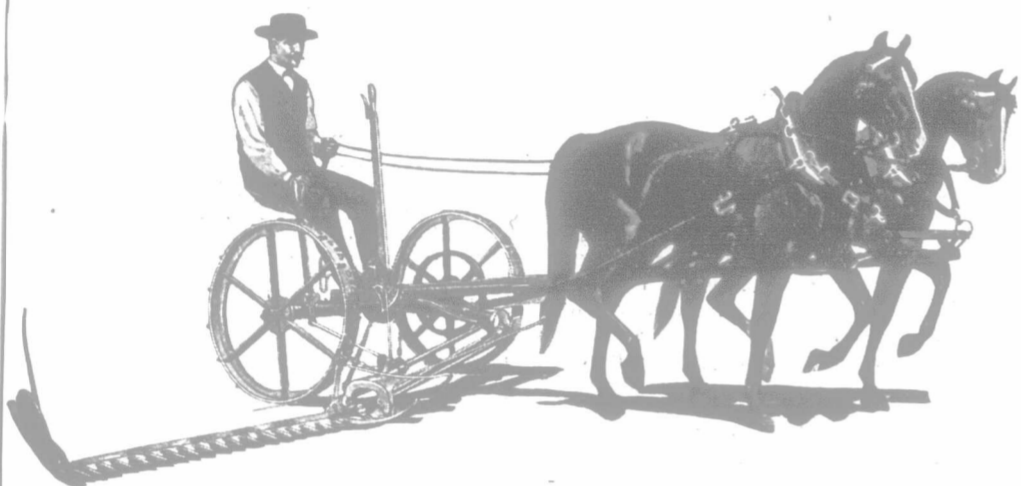

THE MAIN FRAME OF OUR MOWER

has three broad and substantial roller bearings used at points where the strain is heaviest.

The ball bearings at crank shaft (see illustration below) prevent wear and friction.

There are brass bushings at both ends of the crank shaft.

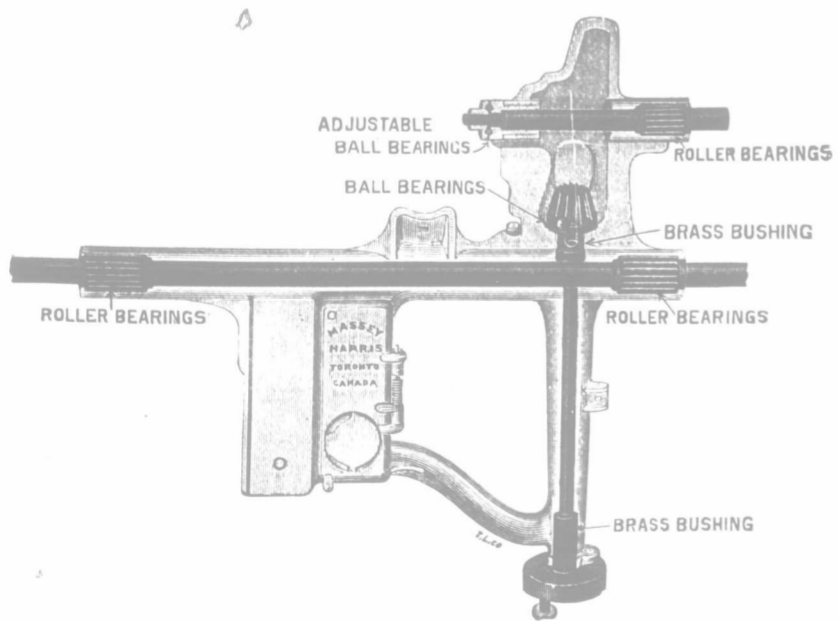

Ask for one of our New Catalogues

MASSEY-HARRIS CO.

LIMITED

in any other than in the person name it is issued as between the Association and such holder), until the transfer be duly made upon the books of the Association as aforesaid.

SEC. 3. No stock shall be transferred upon the books of the Association without the approval of the Board of Directors. On transfer and surrender of any certificate it shall be immediately cancelled and posted in the margin of the certificate book from which it was originally taken, and a regular register shall be kept of every certificate issued, showing the number of shares certified therein, which register shall be kept by the Secretary. On transfer and cancellation of any certificates, the Secretary shall note date thereof on the register of certificates opposite to the proper numbers, and mark such certificates "cancelled." No certificates shall be transferred, or dividends paid thereon, when the holders are in debt to the Association.

—ARTICLE V.—

SECTION 1. These by-laws may be amended at any annual meeting of the shareholders, or at a special meeting called therefor, by an affirmative vote of two-thirds present at such meeting.

SEC. 2. That the question of storage of wheat be left with the Board of Directors, and that the directors be allowed as compensation for their services a commission of 10 per cent. out of the net dividends declared by this Association at the annual meeting.

WINNIPEG EXHIBITION ANNOUNCEMENT.

The Winnipeg Industrial Exhibition, announced to be held July 13-20, has already indicated a purpose and plan that is an assurance of a larger, more comprehensive and more entertaining week than has ever been attempted in the Exhibition's history.

Thoroughly impressed with the importance of adhering to the main object of an Exhibition's existence the management will insist upon making the agricultural features the most prominent and distinctive while at the same time catering to the desire for an entertaining and spectacular program, which will not only brighten the earnestness of the Exhibition, but will be in itself of informing and of sensational interest.

The prize list, in almost every class, has this year been considerably added to and the amounts of the prizes in many instances increased.

So great is it expected that the wheat exhibit will be, that a special building has been set apart for it.

The Winnipeg Exhibition offers the largest prizes for wheat of any exhibition in the world, there being \$500 alone offered in the Red Fyfe class, \$200 of the amount being for first prize.

There are several reasons for the belief that the coming exhibition will attract for competition and exhibition the greatest turn-out of live stock in the history of Western Canada, beyond the fact that Western Canadian purebred stock has been much improved and increased during the last year.

The Shorthorn and heavy draft horse breeders of the West will have an opportunity of having their stock judged by one of the greatest living stock judges and breeders, Arthur S. Gibson, of Ruddington, Nottinghamshire, England, who has accepted the Exhibition Board's invitation to undertake that responsible position.

Recognizing the interest that Western Canada has always taken in the best class of driving and fast horses, the program for the coming Exhibition is one that probably has never been equalled at any race-track in the West. The prizes alone will aggregate \$10,800 in money outside of the cups that will be offered, and will undoubtedly attract the very fastest and best horses, trotting and running, from the United States and Eastern Canada as well as from all parts of the West.

The special features indicated above display the sincerity of the Association in their desire that the coming Winnipeg Exhibition will be the best in the history of the association.

A Magistrate Investigates Zam-Buk

SAYS IT IS A WONDERFUL HEALER AND DOES MORE THAN IS CLAIMED FOR IT.

Probably no household remedy in existence has won such glowing tributes from people in high places as has Zam-Buk. Mr. Roger F. Perry, Justice of the Peace for British Columbia, recently tested this famous balm, and this is what he says of it:

"The Pavilion, Goldfields, B. C.

"To the Zam-Buk Co.

"Gentlemen.—After a very fair trial I have proved Zam-Buk eminently satisfactory. In my case it cured a skin rash of five years standing which no doctor had been able to do any good for.

"I would certainly encourage any person to keep Zam-Buk in their home. It truly does even more than you claim for it. For my own part I would not now be without it in the house. Yours very truly,

(Signed) "Roger F. Perry, Justice of the Peace for B. C."

Zam-Buk differs from ordinary salves and embrocations, for while these mostly contain animal oils and fat Zam-Buk is purely herbal. It closes and heals cuts, festering sores, ulcers, eruptions, boils, eczema, chafing sores etc. In the household it is the handiest possible remedy for burns, scalds, children's injuries. It instantly cleanses any wound to which it is applied; prevents festering, inflammation or blood poison. It cures piles, varicose ulcers, and fistula. All druggists and stores sell at 50 cents a box, or from the Zam-Buk Co., Toronto, for price, 6 boxes for \$2.50.

EE EE

Steedman's
SOOTHING
Powders

Relieve FEVERISH HEAT.
Prevent FITS, CONVULSIONS, etc.
Preserve a healthy state of the constitution during the period of

TEETHING.

Please observe the EE in STEEDMAN.

EE CONTAIN NO POISON EE

Cocoa cannot be made better than

COWAN'S
Perfection
COCOA
(Maple Leaf Label)

The choicest Cocoa grown is used and no pains spared to make it the best. It is healthful, nutritious and very digestible.

The Cowan Co. Ltd. Toronto

nteed
es
g
ag
h out of
lose their
for luxul
l find no
satisfac
nterlacing
he spring
n the bed.
trial pro-
buys a
for the
urniture
ited.
Winnipeg

LAND
E
STRICT.

25 to
pared
er at

Front
ately
P. R.
rains
rs' or

acre
ices.
light
for
this.

& CO.
NIPEG

\$65
GILSON
GASOLINE
ENGINE
Pumping, Cream
urns, Wash Ma-
FREE TRIAL
catalog-all sizes
ELPH, ONT.

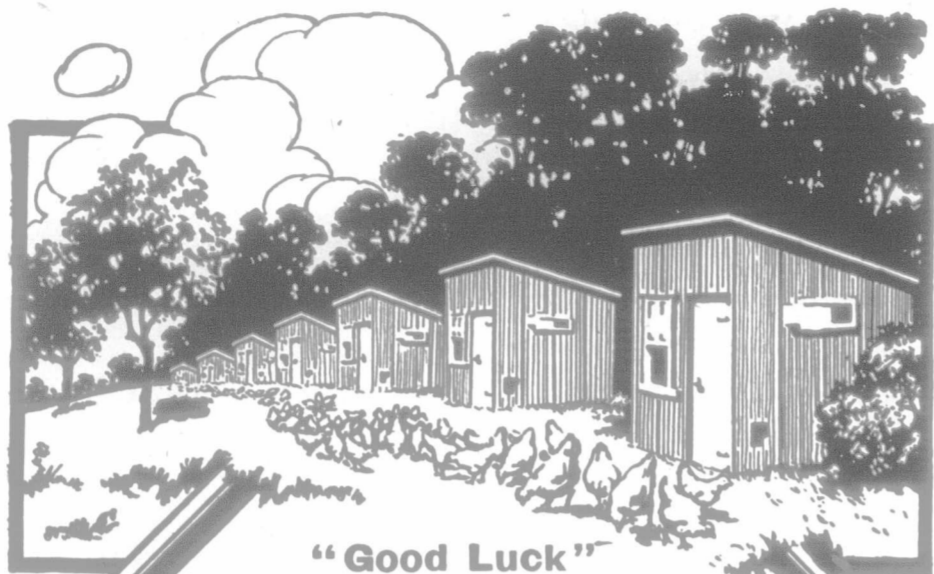

"Good Luck" in Poultry Raising

is not "good luck," but good management. Diseases in poultry are due to poor feeding and poor protection. Rex Flintkote will absolutely protect from cold, heat and wet. Let us prove to you that

REX FLINTKOTE ROOFING

is the wisest purchase for top or siding. We can prove it.

We Will Send You Free Samples to Test

together with our valuable roofing booklet, on receipt of postal request. Our complete book, "Making Poultry Pay," will be sent for 4c. in stamps. It is very useful to the poultry raiser.

J. A. & W. Bird & Co.
21 India St., Boston, Mass.
Agents: Mackenzie Bros.
Winnipeg and Calgary



GOSSIP

M. J. Henry, the Vancouver nursery and seed man, sends us one of the third edition of his catalog, together with excerpts from an address he gave before the Pacific Coast Association of Nurserymen, which we publish herewith:

"Our method is simply to use printer's ink instead of paying a commission to one agent for selling, to another to deliver and collect. Keep your business before the people, in the papers you consider best for the purpose, and keep at it. Do not be discouraged if you do not receive an order from every reader of a paper in which you advertise, for they may not need anything in your line this year, nor possibly next, but you may rest assured that the intelligent reading public will bear you in mind and eventually trial orders will come. If you send what is asked for or explain the reasons why, they will come again.

"If people can send their orders by mail to department stores, seed houses or jewelry merchants, why should they not make up an order from a nursery catalog, inclose their money and receive their goods by mail, express or freight, as they do from other business houses? By this method the nursery-man is certainly doing a much safer business than through canvassers, for he is not obliged to send out one dollar's worth of stock until payment is received (unless he is so inclined), therefore not obliged to charge his good cash customers an extra price to cover the losses he will surely sustain if he undertakes to ship out his stuff and collect on delivery or at some later time.

"By adding an extra planter tree of some surplus stock, you do yourself no injury and help to please your customers.

"You need not expect to please everybody; the person who has done that lies up in the cemetery with an obituary on his tombstone, but you will get your share of the trade. Always remember that a pleased customer is one of your best advertisements."

GOOSE WHEAT.

The *Northwestern Miller* is a staunch supporter of all that is best in the department to which it devotes its pages. Beyond that, again, it does not flinch from exposing faults and frauds wherever found, and it is doing a grand service to millers and farmers in exposing the misleading and pernicious advice of those in high places. We in this journal have time and again warned the American farmer against the growing of goose wheat; we have also warned that country's millers against using it for flour-making purposes, and we endorse all that our contemporary has to say on the same subject. Apparently, however, neither pleadings nor warnings have had any appreciable effect, and in a recent issue our Minneapolis friend has put it on record that when the day of judgment comes—as come it will—those who are responsible for advising farmers to grow the class of wheat we are dealing with will not be allowed to escape. To us it is almost incredible that the so-called macaroni grain should be boomed by the Department of Agriculture, and farmers advised to grow it in place of that grand, reliable berry we call No. 1 Spring; and yet that is the truth. Canada is rapidly perfecting her brands and sticking loyally to the strength element which goose wheat does not possess. Russia, on the whole, breeds true; we in England also are trying to improve that same content, and are succeeding; but in the home of the nitrogen element, from the place where the world learnt how to value it, there is obvious evidence that those whose duty it is to preserve the one thing which has made her flour famous throughout the world are encouraging a retrograde movement which is certain to end in a national disaster. *The Miller*, British

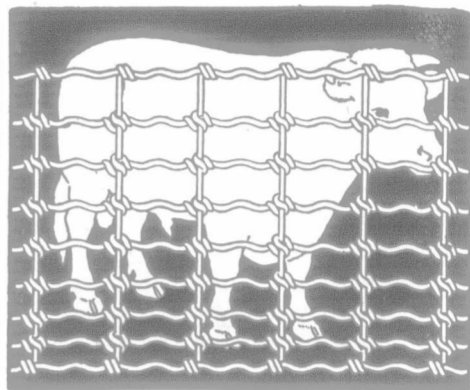

No. 9 Hard Steel Wire

from top to bottom. Does it look strong? Do you know what No. 9 hard steel wire means? It means double the strength and durability of light wire fences. Means the toughest thing known to fence builders. Means the biggest and heaviest wire used for fencing in Canada.

Mr. Fence Builder, just stop one moment and think. You don't want to do the job over again year after next. Take a lesson from some of the two-year old fences you know. They are usually made, or partly made, of light, soft wires that break easily—of poorly galvanized wires that rust soon eat up—of poorly fastened wires that slip. Your experience tells you these are the things to look out for. Keep them in mind and take a good look at

Ideal Fence

Look at one that's been up two, three, four or five years. If you'll examine carefully, we'll be satisfied with your judgment. Don't forget to look at the lock. It grips the wire on FIVE bearing points. We show it good and large below so you'll be sure to see it. No. 9 wires, No. 9 stays, locked as Ideal locks them at every crossing, there's no going to be any slips or breaks or holes in your fence and there's no going to be any sagging.

The railroads know how to fence for permanency. They are buying more Ideal than any other make. Farmers are following suit, fencing their farms to stay.

Take a little time to think of the essentials of good fencing before you buy. The Ideal has them all. We know you'll want Ideal when you know about it. Let us talk Ideal fence personally to you for a few minutes. Write in and give us the chance. We'll send you a little book with the particulars to start with.

The Ideal Fence Company, Ltd.

Dept. B Winnipeg, Man.

NOTE THE LOCK



"Only One" "BROMO QUININE"

That is LAXATIVE BROMO QUININE. Similarly named remedies sometimes deceive. The first and original Cold Tablet is a WHITE PACKAGE with black and red lettering, and bears the signature of E. W. GROVE. 25c.

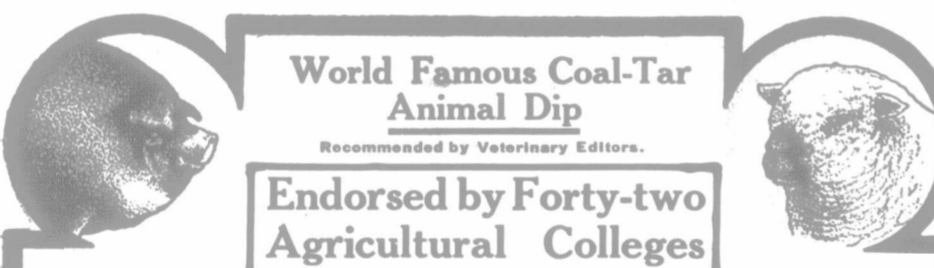

World Famous Coal-Tar Animal Dip

Recommended by Veterinary Editors.

Endorsed by Forty-two Agricultural Colleges

Used by Many Thousand Stock Growers.

Disinfectant Lice Killer
Mange Cure Antiseptic

ZENOLEUM

For Cattle, Horses, Hogs, Sheep, and Poultry

We honestly believe *Zenoleum* is the best general live stock remedy for lice and vermin on all animals and a positive disinfectant and cure for skin troubles and internal parasites in hogs and sheep.

OUR ABSOLUTE GUARANTEE—If *Zenoleum* is not all we say it is, or even what you think it ought to be, you can have your money back. No talk, No letters—just money.

AT ALL DEALERS—Four sizes: eight ounce tin, 25 cents; thirty-two ounce—50 cents; medium tin, 90 cents; large tin, \$1.50. Nearly any dealer in Canada will supply you with *Zenoleum*. If not, send to us. **ASK YOUR DEALER FIRST.**

ZENOLEUM VETERINARY ADVISER

64 pages of interesting matter for farmers and stockmen—written by authorities at Agricultural Colleges—positively free for a postal card.—Ask now. We'll send it.

Zenner Disinfectant Co.,

114 Lafayette Avenue,
Detroit, Michigan

We Edit, Compile and Print
Live Stock Catalogs

WRITE FOR
PARTICULARS

The Farmer's Advocate of Winnipeg, Limited, Winnipeg, Manitoba

LOSSES PAID IN FULL

283 Loss Claims Paid by this Company Last Year Amounting to \$51,421.17

\$2,700,000
INSURANCE NOW IN FORCE

RATE OF ASSESSMENT LAST YEAR, 14 CENTS PER ACRE

Assets, \$121,000
Which includes available revenue for 1907, on Insurance in force.

Total losses paid for years 1905 and 1906, \$144,000
Average rate of Assessment last 4 years 15 1/2 cts. per acre. Over 3,750 farmers now insured with us. For further particulars write the Company.

The Manitoba Farmers' Mutual Hail Insurance Company

W. C. GRAHAM, Manager - Box 513, WINNIPEG

BACON HOGS IN DAKOTA.

According to bulletin No. 63 of the Grand Rapids, North Dakota, station, in the past year 28 pigs were raised on the farm from 3 sows. They were farrowed April 1st. From May 1st to September 1st their feed was skim milk and clover pasture with but a small quantity of shorts. September 1st they were divided into two lots 12 of the least desirable for breeding purposes being put on a fattening ration. They were fed barley, peas, shorts, and boiled roots and had access to clover pasture till October 15th. They were killed November 1st and sold on the local market. Their average dressed weight was 135 pounds. They sold for 8 1/2 cents a pound, bringing \$11.47 apiece. The cost of feed, including the skim-milk and pasture, and the cost of keeping the brood sows through the year added to this was \$6.37 apiece, leaving a net profit of \$5.10 apiece, or a profit of over 80 per cent.

These are not large figures, nor on a big scale, but they show what by-products and northern grown grains can do in one kind of pork growing. The Large Improved Yorks are kept at this place, and their popularity in Canada is commented upon both for grading up and crossing. It is claimed for them that they are much more prolific than the lard breeds for the section, and take better to pasture.

The director of the station says: "A bacon breed should be kept in preference to a lard breed for the reason that in the absence of corn a first class lard hog cannot be produced, while the feed that produces the choicest bacon can be grown in abundance—barley, peas, clover, roots, etc. Clover pasture greatly reduces the cost of feed, and stimulates a greater growth and vigor in the pigs than is possible to secure in confinement. The pigs should be had to come in early spring and disposed of in November. At 7 months they can be made to weigh between 180 and 200 pounds."

With corn hogs in the more southern parts, and bacon hogs grown on barley, speltz, peas and pasture in the north, it begins to look as though the Dakotas and tributary country were strictly in it for all that hogs can bring.

STRAIGHT SCOTCH.

Thirty-two directors of the Highland Agricultural Society of Scotland met together, some of them coming from a considerable distance, to determine the weighty question as to the kind of whiskey that shall be sold at the coming fair in Scotland. These same directors last winter inaugurated a "temperance" reform by forbidding exhibitors to treat visitors to the show. The caterers, it seems, had become acquainted with the American brand that passes under the various names of red-eye, tangle-foot, etc., and the result was that many of the visitors were not in shape to go home to their wives and mothers and sisters. Inasmuch as the Scotchman has not been very thoroughly inoculated with the temperance microbe, it seemed necessary to these grave and dignified gentlemen to provide a bet-

Bonded Bankers; Bank of British North America Licensed

Farmers! Ship your Grain to the GRAIN GROWERS' GRAIN CO. Ltd.

Commission Merchants, Track Buyers and Exporters
Wheat, Barley, Oats and Flax bought on track or handled on commission

We would ask every farmer, whether a shareholder or not, to consign his grain to us or wire for bids when car is loaded. Let every farmer take a share or shares in the Company and increase our working capital. The larger the Company the greater the economy in operation and ease in maintaining satisfactory export connections. Although enjoying the privileges of membership on the Winnipeg Grain and Produce Exchange, we will take every opportunity to enlarge our export connections and trade in Eastern Canada and the Old Country.

You must pay someone for the service of handling your grain. The Company will employ part of the profits of the business in spreading the organization, improving conditions and developing markets; the balance of profits will be available in the payment of dividends on paid-up capital. Those of our subscribers who have only paid 10% on shares had better meet the 20% call since made, at once, and so share to a greater extent in the profits of this season's business.

Get your neighbors as shareholders, if possible; if not, try and induce them to patronize the Company.

Bill your grain to the order of the Grain Growers' Grain Co., at Fort William or Port Arthur, according as you are on the Canadian Pacific or Canadian Northern railway system

Write across the bill "Advise Grain Growers' Grain Co., 5 Henderson Block, Winnipeg."



Ringbone

There is no case so old or bad that we will not guarantee Fleming's Spavin and Ringbone Paste to remove the lameness and make the horse go sound. Money refunded if it over fails. Easy to use and one to three 45-minute applications cure. Works just as well on Sidebone and Bone Spavin. Before ordering or buying any kind of a remedy for any kind of a blemish, write for a free copy of Fleming's Vest-Pocket Veterinary Adviser. Ninety-six pages of veterinary information, with special attention to the treatment of blemishes. Durably bound, indexed and illustrated. Make a right beginning by sending for this book. FLEMING BROS., Chemists, 45 Church Street, Toronto, Ontario.

The Ancient Order of United Workmen of the Canadian Northwest.

Issues Certificates for \$500.00, \$1000.00, and \$2000.00

- A purely Western Fraternal Protection Association.
- Has paid out to the widows and orphans of its deceased members over \$600,000.00, without disputing one single claim.
- Has its Surplus Benefit Fund amounting to \$125,000.00 invested in Western securities at interest compounded half-yearly.
- Its rates are adequate, and it is governed by its member on the Lodge system.
- If you are interested write for particulars and rates to _____ or _____

C. H. Jefferies, Rev. C. Endicott
Grand Recorder, Grand Master Workman,
P. O. Box 1290, Winnipeg, Man. P. O. Box 152, Arcola, Sask.

Enquire of the officers of the Lodge in your locality.

ONE MAN MADE \$10,000 on HALF AN ACRE

of ground, growing Ginseng. Another is making hundreds of dollars per year growing Mushrooms in an ordinary cellar. Others are making big money growing Golden Seal and other medicinal plants, of which the wild supply is fast becoming extinct and prices rapidly advancing. YOU CAN DO THE SAME. Our new monthly magazine, PROFITABLE HOME INDUSTRIES, tells you all about it; full details; letters from successful people. If you want to make money, write us to-day. Price \$1.00 per year, 3 months trial 25 c., sample copy 10 c.

Address: PROFITABLE HOME INDUSTRIES, 165 Thomson Bldg., Scranton, Pa.

PIANOS and ORGANS

Highest grades only
Prices reasonable and easy.

J. MURPHY & COMPANY
CORNWALL ST. REGINA.

steel
e
Does it look what No. means? It length and nces. Means wn to fence biggest and fencing in
st stop one i don't want ar after next, s of the two- z. They are ade, of light, ily—of poorly st soon eats res that slip. u these are Keep them d look at
al
ce
to two, three, 'll examine d with your look at the FIVE beared and large ee it. No. 9 d as Ideal sing, there's or breaks or there's not
to fence for uying more s. Farmers their farms
think of the before you n all. We n you know fence per- utes. Write We'll send riculars to
Fence Ltd. g, Man.
OCK
SLIP
"VINE" Quinine, Sim deceive. The is a WHITE lettering, and VE. 25c.

WANTS & FOR SALE

Advertisements will be inserted under this heading, such as Farm Property, Help and Situations Wanted, and miscellaneous advertising.

TERMS—Two cents per word each insertion. Each initial counts for one word and figures for two words. Names and addresses are counted. Cash must always accompany the order. No advertisement inserted for less than 50 cents.

ON CROP PAYMENTS. 200 deep soil farms for sale on crop payments, these farms are ready for the breaker, and close to Yorkton, Saltcoats, Rokeby and Wallace, Saskatchewan, and Reston, Manitoba; first payment after you sell the first crop. Apply now, James Armstrong, 4 East Richmond street, Toronto. 22-5

RENT FOR TERM, option of purchase, 489 acres about 200 cultivated, 100 meadow, rest bluff, and scrub. Creek through center. Brick veneered, twelve roomed house. Good buildings, etc., tennis lawn. Quarter section joining with shack and stable, creek, 25 acres cultivated, rest meadow and pasture. One mile from Austin, C. P. R. Half mile from G. T. P. Apply, Vavasour, Austin, Manitoba. 11-5

WANTED—Persons to grow mushrooms for us in their own homes. Waste space in cellar, garden or barn can be made earn \$15 to \$25 per week. Send stamp for illustrated booklet and full particulars. Montreal Supply Co., Montreal. 22-5

HOLSTEINS FOR SALE—Young stock of both sexes, including this spring's calves, also a few cows. Prices reasonable. W. H. Mullins, Ponoka, Alta. 29-5

POULTRY and EGGS

Rates—Two cents per word each insertion. Cash with order. No advertisement taken under fifty cents.

W. C. TAYLOR, Dominion City—Barred Plymouth Rocks, Buff Cochins, Black-breasted Red Game, Eggs for setting.

FOR SALE—Choice Indian games, Golden Wyandottes, Buff Orpingtons, Plymouth Rocks. S. Ling, 128 River Ave., Winnipeg

AT MAW'S Poultry Farm, Parkdale Post Office near Winnipeg. Acclimatized utility breeds: turkeys, geese, ducks, chickens, incubators and poultry supplies. Large catalog mailed free.

ADDRESS YOUR CORRESPONDENCE to the Eden Rest Poultry Farms, P. O. Box 333, Lethbridge, Alberta, when you want eggs for hatching from pure bred, barred white and Buff Rocks, White and Buff Wyandottes, S. C. White and Brown Leghorns and Buff Orpingtons. Eggs \$1.50 per setting. E. J. Cook, Mgr. 26-4

FOR SALE—Barred Plymouth Rock and Mammoth Pekin duck eggs for setting. T. E. Bowman, High River, Alta. Box 81. 15-7

H. E. HALL, Headingly, Man. Pure-bred Barred Rock Eggs for sale. \$1.50 for 15. Incubator lots, \$7.00 per 100 eggs. 26-6

BUFF ORPINGTON Eggs a specialty \$1.50 per setting. McNaughton Bros., Didsbury, Alta. 15-5

INCUBATOR lots of eggs for sale at \$10.00 per 100. Barred and White Plymouth Rocks and Buff Orpingtons. All birds selected from trap nest record laying stock of A. W. Foley, Dominion Government Poultry Breeding Station, Bowmanville, Ont. Eggs from choice stock, \$2.00 per setting. Address, Northern Nursery Co., Drawer L, Edmonton, Alta. 29-7

BARRED AND WHITE ROCKS, White Wyandottes and Buff Orpingtons. Eggs \$2.00 per setting; am booking others now, catalog and prize list sent on application. Address: Old Chief Poultry Yards, Lethbridge, Alta. 15-7

PORTAGE POULTRY YARDS—Ringlet Barred Rocks and Single Comb Rhode Island Reds, Eggs \$2 per 15. Joseph Campbell, Portage la Prairie, Box 281. 15-5

WHITE WYANDOTTES, White Rocks, Black Minorcas. Eggs \$1.50 for 15. Mammoth Bronze Turkeys, great laying strain. Eggs \$2.00 for 10. J. B. Gamble, Lemberg, Sask. 29-5

BARRED ROCKS exclusively. Eggs \$1.00 per thirteen, \$5.00 per hundred from utility stock, \$2 per thirteen, \$10 per hundred from fancy stock. All breeding stock selected for laying by Hogan system. Ship C. P. R. or C. N. R. Mrs. A. Cooper, Treesbank, Man. 15-5

ELMER SELLER, proprietor Last Mountain Valley Poultry Farm, Strasbourg, Sask.; Harry Latta, Manager. Breeders of Buff Orpingtons exclusively. Our pens contain some noted prize winners from Canada and the United States; eggs, \$2.00 per 13, \$8.00 per 100. Satisfaction guaranteed. 22-5

THOMAS COMMON, Hazel Cliffe, Sask.—Eggs for hatching from Prize Winning White Plymouth Rock, \$3 sitting Barred Rocks, \$2 general purpose, \$1 sitting, \$1.75 two, \$5 hundred eggs. 15-5

FOR SALE—Pekin Duck and Single Comb Brown Leghorn eggs at \$1.00 per setting. Thos. Y. Hurton, Carman, Man. 22-5

S. C. BUFF ORPINGTONS from Cooks' famous strain, Brown Leghorns, Pekin Ducks, Eggs, two and three dollars per setting. R. Hall, Woodleigh, Wapella. 15-5

W. F. SCARTH & SON'S S. C. Buff Orpingtons. Eggs from carefully selected hens mated with first prize cock, Manitoba Poultry Show, 1907, \$2.00 per 13. Box 706, Virden.

EGGS FOR SALE from E. B. Thompson strain Barred Plymouth Rocks. Choice matings, \$1.50 per 15. Utility stock \$5.00 per 100. Mrs. Jas. McPee, Jr., Headingly, Manitoba. 22-5

CHOICE SINGLE COMB Snow-white Leghorn eggs from carefully selected pens of choicest matings. Bred for heavy layers and typical beauty. Testimonials report excellent hatches. Selected eggs reduced to \$1.50 per setting. Good hatch guaranteed. Orders filled promptly. Honest dealings. G. Norman Shields, 29 Close Ave., Toronto, Ont. 22-9

BARRED ROCK Eggs from carefully selected pens of choicest matings. Leading strains of America. Selected for their choice barring and heavy laying of large brown eggs, and headed by cockerels, vigorous, blocky, and beautifully barred. I expect grand results from my Barred Rocks this season. Testimonials report excellent hatches. Eggs carefully selected from choicest matings reduced to \$1 per setting or \$1.50 per two settings. Good hatch guaranteed. Orders filled promptly. Honest dealings. G. Norman Shields, 29 Close Ave., Toronto, Ont. 22-9

"PRIDE OF MANITOBA"—Rhode Island Reds and Buff Rocks. "Greatest laying combination on earth." "Bred for Western climate," Catalog free—Maple Leaf Yards, Oakville, Man. 5-6

A LAYING STRAIN of White Wyandottes, selected by trap nests. Eggs, \$2.50 a setting. W. I. Thomas, Crossfield, Alta. 15-5

Breeders' Directory

Breeders name, post-office address, class of stock kept, will be inserted under this heading at \$4.00 per line per year. Terms cash strictly in advance. No card to be less than two lines or more than three lines.

POPULAR GROVE HEREFORDS, A number of young cows, heifers and bulls now for sale from this famous herd at low prices. I. E. Marples Deleau, Man. Buff Orpington Eggs. A carload of 2-year-old BULLS and HEIFERS will be at Medicine Hat for sale about the first week of June.

A. & J. MORRISON, Glen Ross Farm, Homewood Man., Clydesdales and Shorthorns.

JAMES WILSON, Grand View Stock Farm Innisfail, Alta.,—Breeder of Shorthorns.

H. H. KEYS, Penac, Sask.—Aberdeen Angus Cattle and Buff Orpington Chickens for sale.

GUS. WIGHT, Napinka, Man.—Clydesdales and Shorthorns for sale. Evergreen Stock Farm

WA-WA-DELL FARM.—Leicester sheep and Shorthorn Cattle. A. I. Mackay, Macdonald Man.

O. KING, Wawanesa, Man.—Breeder of Yorkshires, Barred and white Rock Powl and Toulouse geese.

MERRYFIELD FARM, Fairville, Thos. Brooks breeder of Clydesdales and Shorthorns. Box 13, Penac Sask.

CLYDESDALES, Shorthorns and Tamworths T. E. M. Banting & Sons, Banting, Man. Phone 85, Wawanesa.

STRONSA STOCK FARM—Well bred and carefully selected Shorthorns and Berkshires. David Allison, Roland, Man.

SHETLAND PONIES and Hereford Cattle, finest in Canada. Write or come and see them. J. E. Marples, Poplar Grove Farm, Deleau, Man.

JOHN GARDHOUSE & SONS, Highfield P. O. Ont.—Breeders of Scotch and Scotch-topped Shorthorns, Lincoln and Leicester sheep and Shire horses.

R. A. & J. A. WATT, Salem, Elora Station, G. T. and C. I. R. R.—Champion herd at Toronto and New York State fairs, 1905, also Grand Champion females, including both Senior and Junior Honors at both fairs. Write your wants.

BROWNE BROS., Ellisboro, Assa.—Breeders of Polled Angus cattle and Berkshire swine. Stock of both for sale.

ASHCROFT, W. H. NESBITT, Roland, Man. Clyde and Hackney mares and Stallions, work horses in car lots, Ayrshires. Our motto, Live and let Live.

BERKSHIRES.—Gold Medal Herd, Neepawa Manitoba. Address, J. A. McGill.

WOODMERE FARM.—Clydesdales, Shorthorns and Yorkshires. Pigs at 8 weeks, f. o. b. Neepawa, \$8 apiece. S. Benson.

GEORGE LITTLE, Neepawa, Man.—Shorthorns of best Scotch type.

BELLEVUE HERD of Yorkshires—Boars in service: Oak Lodge Gamester, Summerhill Oak and others. Young stock got by the above boars out of choice sows ready to ship soon. Eight litters to select from, order early. Oliver King, Wawanesa, Man. 5-6

WATER! WATER!!

LISTOWEL

Drilling Machine Co.

Manufacturers of well drilling machinery and drilling tools. The most efficient and best equipped outfit in Canada to-day. Catalogue and full particulars on application.

Listowel, - Ont.

Here are the FACTS, not "Claims"

The "claims" of the Empire are facts—proved by tens of thousands of cow owners, by years of experience.

The Improved Frictionless Empire Cream Separator

Is the easiest to turn, the easiest to wash, requires the fewest repairs, lasts the longest, and makes the most dollars for you. These are facts proved by the Empire in actual use. We want to give you the proofs and show you why. It's to your interest to investigate before you buy. Don't fail to get our new catalogue.

ONTARIO WIND ENGINE & PUMP CO., Ltd., Winnipeg, Manitoba, Canada.

THE FARMER'S ADVOCATE

\$1.50 A YEAR

Office—14-16 Princess Street

Winnipeg, - Manitoba.

ter class of whiskey, or rather, to act upon the report of the committee previously appointed. This committee reported that whiskey should not be less than four years old, of the best quality, of reasonable strength, and that it should be tested by an expert.

Next week we will carry a large advertisement of a sale of Hackney horses to be held by Mr. Douglas H. Grand, formerly of Grand's Repository, Toronto and New York, at London, Eng. on June 17th. The lot is a most select one, including breeding stock and prize winning harness horses. They are down from the stud of R. G. Heaton, Cambridgeshire and are got by such well known sires as Garton, Duke of Connaught, Mathias, St. Thomas and others. This is the stud that produced Forest King, the champion harness horse of America. By mentioning the FARMER'S ADVOCATE interested parties may secure a catalogue of the sale from Mr. Heaton, Charlton, Eng. or orders to Mr. Grand will receive prompt attention.

THE USE OF THE FARMER'S ADVOCATE has become general and many of our informed stallion owners are giving the great help of their stallions to breeding and their sires to their sons. They derive from the FARMER'S ADVOCATE its use. The S.A. is a most valuable

ING OUTFIT, advertised in this issue is guaranteed to produce results, is made and sold by I. O. Crittenden, 44 Fox Building, Elyria, Ohio, for \$7.50. His descriptive circular, giving full details, is convincing.

A "DURABLE" PEOPLE.

The Comment of a Boston Writer Concerning Longboat and Other Canadians.

Boston papers are commenting on the wonderful endurance of Longboat, the Indian, who won the Marathon race. One writer says that, judging by the performance of Longboat, Sherring, Caffrey and others, these Canadians are "a durable people." Certainly if the objects of the Y. M. C. A. are achieved the young men of this country will be noted for their durability, physical, moral and intellectual. It is not surprising that after a General Secretary of the Y. M. C. A. has spent years endeavoring to make men durable he should demand similar characteristics in the inanimate articles surrounding him. Accordingly when the Secretary of the Victoria Y. M. C. A. wanted a piano some three years ago he purchased a Goulay. So satisfied has he been with the instrument that recently when his Board desired a new piano for the parlors of the Victoria Y. M. C. A. he recommended the purchase of a Goulay. The recommendation carried, in spite of the fact that nineteen other instruments were under consideration. Recently the firm of Goulay, Winter & Leeming received the following letter from him: "The piano arrived safely and is in splendid tune. Our Directors are justly proud of it, and think it away ahead of all competitors." The Secretary of the Edmonton branch of the Y. M. C. A. joins the chorus of approbation with the following letter: "The piano ordered from you arrived in first-class order. It came through the coldest of the winter and landed here without showing the least sign of an effect from the cold either upon case or action." Canadians are durable, and the Goulay piano is a true Canadian. Adv.

A little book which our readers have seen mentioned frequently in advertisements and in live stock discussions, called the "Zenoleum Veterinary Adviser," holds much that is of interest to farmers and stockmen, whether owners of few or many animals. It is valuable because it gives methods of treating troubles that all classes of live stock are heir to. The book is carefully indexed, and was designed primarily to show the relation of the celebrated Zenoleum Animal Dip and Disinfectant to domestic husbandry economy. Zenoleum has come to be a very popular thing among owners of live stock in every state in the Union, in Canada and other foreign countries.

The Zenoleum Veterinary Adviser gives many descriptions of diseases and ailments, their causes and symptoms, etc., that could hardly be had in such compact and reliable form in any other book we can now call to mind. There are sixty-four pages, splendidly printed in large readable type, and well bound in a serviceable cover.

This book can be had free by any reader of this paper by writing to the Zenner Disinfectant Company, 114 Lafayette Avenue, Detroit, Mich., for it.

During some manoeuvres a lieutenant was shot in the leg. They took him to the hospital, where the doctors began to cut his leg. After bearing it in silence for some time he asked:

"What are you doctors butchering me like this for?"

"We're looking for the bullet one answered.

Bullet? Why didn't you tell me before? I've got it in my pocket."—*Bocian.*

"We never openly complain about any of our cooking," began Mrs. Subbubs, who was taking Citiman home to dinner, for fear the cook will get mad and leave."

"Subbubs" protested Citiman, "you can't expect me to do anything like—" "I'll do it of course you're too polite, but I'll guarantee you particularly about the cooking or she'll demand a divorce."—*Philadelphia Press.*

in this issue is
sults, is made
nden, 44 Fox
or \$7.50. His
g full details,

OPPLE.

Writer Con-
Other Cana-

enting on the
ongboat, the
rathon race.
ing by the
u, Sherring,
Canadians
Certainly if
l. C. A. are
this country
bility, physi-
d. It is not
eneral Secre-
s spent years
durable he
characteristics
surrounding
he Secretary
A. wanted a
go he purch-
ished has he
hat recently
ew piano for
Y. M. C. A.
chase of a
dation carb-
at nineteen
ider consid-
of Gourlay,
ed the fol-
"The piano
lendid tune.
proud of it,
of all com-
of the Ed-
M. C. A.
bation with
The piano
in first-class
the coldest
here with-
of an effect
on case or
urable, and
Canadian.
Adv.

eaders have.
in adver-
discussions,
eterinary
is of inter-
n, whether
imals. It
methods of
classes of
he book is
s designed
tion of the
il Dip and
husbandry
ome to be
owners of
the Union,
countries.
y Adviser
of diseases
and symp-
lly be had
le form in
all to mind.
splendidly
type, and
cover.
ee by any
ing to the
pany, 114
lich, for it.

lieutenant
ook him to
tors began
g it in sil-

chering me
bullet one
ell me be-
"Bocian.

about any
Subbubs,
to dinner,
mad and

pan, "you
ing like—"
polite, but
rly about
ll demand
Press.

POTAGE FAIR.

The directors of the Portage la Prairie Industrial Exhibition Association have met and formulated plans to make the Portage and Lakeside fair an occasion of considerable festivity. Three days will be given up to the event and \$20,000 is appropriated for prizes, horse races, attractions, etc. Some of the best track horses in the country are expected to "throw dust" and the good old method of entertaining by platform attractions, bands, fireworks, etc., will be utilized to the extreme limit of feasibility. Portage has had an experience of running a fair without special attractions, but it is not one that business men like to reflect upon.

More money is to be spent upon the buildings and grounds which are now the most convenient and pleasant in the country, so that altogether "all of us" may look forward to a jolly holiday on the 9th, 10th, and 11th of July. A week before Winnipeg.

POTATO SCAB.

"The plant pathologist of the Idaho Experiment Station, L. F. Henderson, has issued a bulletin on the results of some of his work in treating potatoes for scab and has the following to say with regard to the planting of scabby seed treated with formalin.

"It was my desire to find out whether by planting very scabby potatoes, which had been well treated, in ground several hundred yards away from that in which my former experiments had been conducted, I could get a crop absolutely free from scab. Formalin alone was used; in this case a pint to about fifteen gallons of water, and the tubers were immersed in the sacks, and left soaking for fully two hours. Large potatoes alone were used, but some of them were so gnarled by the scab as hardly to be recognizable. The ground was plowed, then harrowed, then cross plowed and again harrowed. The seed was planted deep while the ground was then heaped above them, and they were thus left until the young weeds started. The harrow was then put upon the ground, and the whole harrowed till the surface was perfectly level. At this time the tubers had started growth, but were still well covered. The value of this method was shown at digging time when hardly a sunburnt potato could be found. Cultivation was given the patch three times with a cultivator, and twice with a hoe, keeping out nearly all weeds. A magnificent yield, both in size and quantity, was the result. The crop was practically free from scab. I say "practical," for though thirty rows did not yield me a single scabby potato, three rows at one end gave a half sack of scabby tubers. Why it should have been at this place and at no other, I am at a loss to understand, for I am sure that every sack of seed had the same treatment. These three rows had, at this end, been more or less disturbed, and the young tubers uncovered, by the ground squirrels. Whether a few floating spores from the old ground had blown over and thus inoculated the young tubers is possible, but too improbable to take into account. As the patch of ground planted yielded about sixty sacks of potatoes, large and small, and the scabby ones filled a sack barely half full, the ratio was one to 120. This would mean over ninety-nine per cent. of potatoes were free from scab, while the seed from which they were raised had been unusually scabby."

SCRUB STALLION COMPETITION

EDITOR FARMER'S ADVOCATE:

I am in favor of the stallion enrolment system all right, but I think only pure-breds should be enrolled or allowed to stand for public service. There are still far too many mongrel stallions being used, which makes it difficult for a neighborhood to support a good horse, as the fees of the scrub are low and farmers will patronize such a horse with the result that there are a lot of poor colts and a cheap class of horses raised. In such cases a man who wishes to improve his own stock and that of his district cannot afford to buy a first-class stallion and compete in prices with a poor mongrel horse. I have parties now who wish to use my horse, but tel-

me where there is another they can get for \$5 and think I ought to stand my horse for the same, although the other is worth from \$150 to \$200, while mine is a \$2,000 horse. Farmers are only half awake to their own interests. They think they will "get a pretty good colt anyway from the other horse."
Sask. J. C. MOONEY.

COST OF THE THAW TRIAL.

"To those who have not thought of sensational court cases in their industrial aspects it may prove astonishing to read some estimates of the cost of the Thaw trial to the newspapers," says the *Saturday Evening Post*, Philadelphia.

"From the news standpoint this was unquestionable the most valuable trial of the sort that has ever been held in this country. It involved not only persons in high life on both sides of the Atlantic, but was also without precedent in the matter of feminine interest—which comes pretty near being news interest at the last analysis. Had all the newspaper editors assembled in convention for the express purpose of planning a murder trial that would have maximum market value, they could hardly have designed one so ample in its main currents of morbid public interest. The very bigness of the case was such that editors were stunned for a day or two after the actual murder.

"The Associated Press spent three hundred thousand dollars to cover the Cuban war. That much was spent on this trial by New York State and the defence alone. It took the prosecution but half a day to enter actual proof of the murder. But the State laid out more than one hundred thousand dollars in costs, and the defendants nearly two hundred thousand dollars for legal talent and sundries.

WORK FOR SEVENTY STAR REPORTERS.

"What the newspapers spent may be estimated roughly by considering the way in which the trial was covered. When the prisoner entered court on February 4th, dressed in clothes carefully made for the occasion, there was a clamoring mob of newspaper representatives of all kinds, several hundred in number. A strong force of police separated those who had bona fide admission cards. Seventy reporters and artists from the New York papers got in, and others connected with press associations, outside newspapers and foreign journals brought the total up to more than a hundred. Some of these reporters were highly paid special writers of reputation, receiving twenty dollars a day or more. With the plain garden variety of reporter, the sketch artist, the news photographer and the specialists in women's gowns, this insular aggregation of talent probably embodied a salary expense of one thousand dollars a day.

"The trial was a big event in New York. But no more so than in Pittsburgh. It was a big event in the courtroom, but also a big one in a hundred places outside. Battalions of reporters doing what is called leg-work covered the hotels where witnesses and principals were stopping. Reporters skilled in psychological minutiae were detailed to watch principals in other cities, give them facilities for obtaining instant details over the long-distance telephone hot from the courtroom and wire the effect of evidence upon them. News was as eagerly watched in Europe as on Park Row. These outside workers probably cost two thousand dollars per day.

"Then there were cable and telegraph tolls. The press associations wired from two to three columns to two thousand daily papers every day, while fifty large dailies took from four columns to a page. At a minimum estimate of six dollars per column the transmission of this news cost not less than twenty-five thousand dollars a day, allowing for variations.

"For six weeks of the actual trial it is a conservative estimate to place this expense of reporting and wires at one million dollars.

"But that represented only the cost of reporting a climax that had, for more than six months, been carefully worked up by newspaper accounts of the prisoner's diet, plans, relatives and legal

Get Ready for Spring Roofing

When you build, you want the roofing that will give you the *best service*—that will last so long that its cost *per year* is less than any other.

Paroid has proved in actual use on farm and dairy buildings, on factory and railway buildings, on government buildings at home and abroad, to cost less *per year* than any other roofing.

There are good reasons for it:

It is better made and is made of better materials. Its basis is a better, tougher, more durable felt—made in our own mills. (Established in 1817.) We are in position to *know* that it is. You cannot afford to buy a roofing made from a cheap felt nor from a

PAROID

manufacturer who does not make his own felt.

Paroid has a thicker, smoother, more pliable coating than any other ready roofing. It is better all the way through. You can see and feel the difference.

It is the only roofing laid with square, rust-proof caps which do not rust nor work loose and which have the largest binding surface. Read our offer and let us *prove* to you its superiority. If your dealer cannot supply you, don't take a substitute. Write to us direct.

Send Now For Free Samples

and find how to save money on your roofing. If you enclose 4c in stamps for postage we will send you free our new 48 page book of *Complete Plans For Farm, Poultry, Dairy and Live Stock Buildings*. It will save you money.

F. W. BIRD & SON,
(Established in U. S. A. in 1817)
WINNIPEG OFFICE: 817, 819, 821, 823, 825, 827, 829, 831, 833, 835, 837, 839, 841, 843, 845, 847, 849, 851, 853, 855, 857, 859, 861, 863, 865, 867, 869, 871, 873, 875, 877, 879, 881, 883, 885, 887, 889, 891, 893, 895, 897, 899, 901, 903, 905, 907, 909, 911, 913, 915, 917, 919, 921, 923, 925, 927, 929, 931, 933, 935, 937, 939, 941, 943, 945, 947, 949, 951, 953, 955, 957, 959, 961, 963, 965, 967, 969, 971, 973, 975, 977, 979, 981, 983, 985, 987, 989, 991, 993, 995, 997, 999, 1001, 1003, 1005, 1007, 1009, 1011, 1013, 1015, 1017, 1019, 1021, 1023, 1025, 1027, 1029, 1031, 1033, 1035, 1037, 1039, 1041, 1043, 1045, 1047, 1049, 1051, 1053, 1055, 1057, 1059, 1061, 1063, 1065, 1067, 1069, 1071, 1073, 1075, 1077, 1079, 1081, 1083, 1085, 1087, 1089, 1091, 1093, 1095, 1097, 1099, 1101, 1103, 1105, 1107, 1109, 1111, 1113, 1115, 1117, 1119, 1121, 1123, 1125, 1127, 1129, 1131, 1133, 1135, 1137, 1139, 1141, 1143, 1145, 1147, 1149, 1151, 1153, 1155, 1157, 1159, 1161, 1163, 1165, 1167, 1169, 1171, 1173, 1175, 1177, 1179, 1181, 1183, 1185, 1187, 1189, 1191, 1193, 1195, 1197, 1199, 1201, 1203, 1205, 1207, 1209, 1211, 1213, 1215, 1217, 1219, 1221, 1223, 1225, 1227, 1229, 1231, 1233, 1235, 1237, 1239, 1241, 1243, 1245, 1247, 1249, 1251, 1253, 1255, 1257, 1259, 1261, 1263, 1265, 1267, 1269, 1271, 1273, 1275, 1277, 1279, 1281, 1283, 1285, 1287, 1289, 1291, 1293, 1295, 1297, 1299, 1301, 1303, 1305, 1307, 1309, 1311, 1313, 1315, 1317, 1319, 1321, 1323, 1325, 1327, 1329, 1331, 1333, 1335, 1337, 1339, 1341, 1343, 1345, 1347, 1349, 1351, 1353, 1355, 1357, 1359, 1361, 1363, 1365, 1367, 1369, 1371, 1373, 1375, 1377, 1379, 1381, 1383, 1385, 1387, 1389, 1391, 1393, 1395, 1397, 1399, 1401, 1403, 1405, 1407, 1409, 1411, 1413, 1415, 1417, 1419, 1421, 1423, 1425, 1427, 1429, 1431, 1433, 1435, 1437, 1439, 1441, 1443, 1445, 1447, 1449, 1451, 1453, 1455, 1457, 1459, 1461, 1463, 1465, 1467, 1469, 1471, 1473, 1475, 1477, 1479, 1481, 1483, 1485, 1487, 1489, 1491, 1493, 1495, 1497, 1499, 1501, 1503, 1505, 1507, 1509, 1511, 1513, 1515, 1517, 1519, 1521, 1523, 1525, 1527, 1529, 1531, 1533, 1535, 1537, 1539, 1541, 1543, 1545, 1547, 1549, 1551, 1553, 1555, 1557, 1559, 1561, 1563, 1565, 1567, 1569, 1571, 1573, 1575, 1577, 1579, 1581, 1583, 1585, 1587, 1589, 1591, 1593, 1595, 1597, 1599, 1601, 1603, 1605, 1607, 1609, 1611, 1613, 1615, 1617, 1619, 1621, 1623, 1625, 1627, 1629, 1631, 1633, 1635, 1637, 1639, 1641, 1643, 1645, 1647, 1649, 1651, 1653, 1655, 1657, 1659, 1661, 1663, 1665, 1667, 1669, 1671, 1673, 1675, 1677, 1679, 1681, 1683, 1685, 1687, 1689, 1691, 1693, 1695, 1697, 1699, 1701, 1703, 1705, 1707, 1709, 1711, 1713, 1715, 1717, 1719, 1721, 1723, 1725, 1727, 1729, 1731, 1733, 1735, 1737, 1739, 1741, 1743, 1745, 1747, 1749, 1751, 1753, 1755, 1757, 1759, 1761, 1763, 1765, 1767, 1769, 1771, 1773, 1775, 1777, 1779, 1781, 1783, 1785, 1787, 1789, 1791, 1793, 1795, 1797, 1799, 1801, 1803, 1805, 1807, 1809, 1811, 1813, 1815, 1817, 1819, 1821, 1823, 1825, 1827, 1829, 1831, 1833, 1835, 1837, 1839, 1841, 1843, 1845, 1847, 1849, 1851, 1853, 1855, 1857, 1859, 1861, 1863, 1865, 1867, 1869, 1871, 1873, 1875, 1877, 1879, 1881, 1883, 1885, 1887, 1889, 1891, 1893, 1895, 1897, 1899, 1901, 1903, 1905, 1907, 1909, 1911, 1913, 1915, 1917, 1919, 1921, 1923, 1925, 1927, 1929, 1931, 1933, 1935, 1937, 1939, 1941, 1943, 1945, 1947, 1949, 1951, 1953, 1955, 1957, 1959, 1961, 1963, 1965, 1967, 1969, 1971, 1973, 1975, 1977, 1979, 1981, 1983, 1985, 1987, 1989, 1991, 1993, 1995, 1997, 1999, 2001, 2003, 2005, 2007, 2009, 2011, 2013, 2015, 2017, 2019, 2021, 2023, 2025, 2027, 2029, 2031, 2033, 2035, 2037, 2039, 2041, 2043, 2045, 2047, 2049, 2051, 2053, 2055, 2057, 2059, 2061, 2063, 2065, 2067, 2069, 2071, 2073, 2075, 2077, 2079, 2081, 2083, 2085, 2087, 2089, 2091, 2093, 2095, 2097, 2099, 2101, 2103, 2105, 2107, 2109, 2111, 2113, 2115, 2117, 2119, 2121, 2123, 2125, 2127, 2129, 2131, 2133, 2135, 2137, 2139, 2141, 2143, 2145, 2147, 2149, 2151, 2153, 2155, 2157, 2159, 2161, 2163, 2165, 2167, 2169, 2171, 2173, 2175, 2177, 2179, 2181, 2183, 2185, 2187, 2189, 2191, 2193, 2195, 2197, 2199, 2201, 2203, 2205, 2207, 2209, 2211, 2213, 2215, 2217, 2219, 2221, 2223, 2225, 2227, 2229, 2231, 2233, 2235, 2237, 2239, 2241, 2243, 2245, 2247, 2249, 2251, 2253, 2255, 2257, 2259, 2261, 2263, 2265, 2267, 2269, 2271, 2273, 2275, 2277, 2279, 2281, 2283, 2285, 2287, 2289, 2291, 2293, 2295, 2297, 2299, 2301, 2303, 2305, 2307, 2309, 2311, 2313, 2315, 2317, 2319, 2321, 2323, 2325, 2327, 2329, 2331, 2333, 2335, 2337, 2339, 2341, 2343, 2345, 2347, 2349, 2351, 2353, 2355, 2357, 2359, 2361, 2363, 2365, 2367, 2369, 2371, 2373, 2375, 2377, 2379, 2381, 2383, 2385, 2387, 2389, 2391, 2393, 2395, 2397, 2399, 2401, 2403, 2405, 2407, 2409, 2411, 2413, 2415, 2417, 2419, 2421, 2423, 2425, 2427, 2429, 2431, 2433, 2435, 2437, 2439, 2441, 2443, 2445, 2447, 2449, 2451, 2453, 2455, 2457, 2459, 2461, 2463, 2465, 2467, 2469, 2471, 2473, 2475, 2477, 2479, 2481, 2483, 2485, 2487, 2489, 2491, 2493, 2495, 2497, 2499, 2501, 2503, 2505, 2507, 2509, 2511, 2513, 2515, 2517, 2519, 2521, 2523, 2525, 2527, 2529, 2531, 2533, 2535, 2537, 2539, 2541, 2543, 2545, 2547, 2549, 2551, 2553, 2555, 2557, 2559, 2561, 2563, 2565, 2567, 2569, 2571, 2573, 2575, 2577, 2579, 2581, 2583, 2585, 2587, 2589, 2591, 2593, 2595, 2597, 2599, 2601, 2603, 2605, 2607, 2609, 2611, 2613, 2615, 2617, 2619, 2621, 2623, 2625, 2627, 2629, 2631, 2633, 2635, 2637, 2639, 2641, 2643, 2645, 2647, 2649, 2651, 2653, 2655, 2657, 2659, 2661, 2663, 2665, 2667, 2669, 2671, 2673, 2675, 2677, 2679, 2681, 2683, 2685, 2687, 2689, 2691, 2693, 2695, 2697, 2699, 2701, 2703, 2705, 2707, 2709, 2711, 2713, 2715, 2717, 2719, 2721, 2723, 2725, 2727, 2729, 2731, 2733, 2735, 2737, 2739, 2741, 2743, 2745, 2747, 2749, 2751, 2753, 2755, 2757, 2759, 2761, 2763, 2765, 2767, 2769, 2771, 2773, 2775, 2777, 2779, 2781, 2783, 2785, 2787, 2789, 2791, 2793, 2795, 2797, 2799, 2801, 2803, 2805, 2807, 2809, 2811, 2813, 2815, 2817, 2819, 2821, 2823, 2825, 2827, 2829, 2831, 2833, 2835, 2837, 2839, 2841, 2843, 2845, 2847, 2849, 2851, 2853, 2855, 2857, 2859, 2861, 2863, 2865, 2867, 2869, 2871, 2873, 2875, 2877, 2879, 2881, 2883, 2885, 2887, 2889, 2891, 2893, 2895, 2897, 2899, 2901, 2903, 2905, 2907, 2909, 2911, 2913, 2915, 2917, 2919, 2921, 2923, 2925, 2927, 2929, 2931, 2933, 2935, 2937, 2939, 2941, 2943, 2945, 2947, 2949, 2951, 2953, 2955, 2957, 2959, 2961, 2963, 2965, 2967, 2969, 2971, 2973, 2975, 2977, 2979, 2981, 2983, 2985, 2987, 2989, 2991, 2993, 2995, 2997, 2999, 3001, 3003, 3005, 3007, 3009, 3011, 3013, 3015, 3017, 3019, 3021, 3023, 3025, 3027, 3029, 3031, 3033, 3035, 3037, 3039, 3041, 3043, 3045, 3047, 3049, 3051, 3053, 3055, 3057, 3059, 3061, 3063, 3065, 3067, 3069, 3071, 3073, 3075, 3077, 3079, 3081, 3083, 3085, 3087, 3089, 3091, 3093, 3095, 3097, 3099, 3101, 3103, 3105, 3107, 3109, 3111, 3113, 3115, 3117, 3119, 3121, 3123, 3125, 3127, 3129, 3131, 3133, 3135, 3137, 3139, 3141, 3143, 3145, 3147, 3149, 3151, 3153, 3155, 3157, 3159, 3161, 3163, 3165, 3167, 3169, 3171, 3173, 3175, 3177, 3179, 3181, 3183, 3185, 3187, 3189, 3191, 3193, 3195, 3197, 3199, 3201, 3203, 3205, 3207, 3209, 3211, 3213, 3215, 3217, 3219, 3221, 3223, 3225, 3227, 3229, 3231, 3233, 3235, 3237, 3239, 3241, 3243, 3245, 3247, 3249, 3251, 3253, 3255, 3257, 3259, 3261, 3263, 3265, 3267, 3269, 3271, 3273, 3275, 3277, 3279, 3281, 3283, 3285, 3287, 3289, 3291, 3293, 3295, 3297, 3299, 3301, 3303, 3305, 3307, 3309, 3311, 3313, 3315, 3317, 3319, 3321, 3323, 3325, 3327, 3329, 3331, 3333, 3335, 3337, 3339, 3341, 3343, 3345, 3347, 3349, 3351, 3353, 3355, 3357, 3359, 3361, 3363, 3365, 3367, 3369, 3371, 3373, 3375, 3377, 3379, 3381, 3383, 3385, 3387, 3389, 3391, 3393, 3395, 3397, 3399, 3401, 3403, 3405, 3407, 3409, 3411, 3413, 3415, 3417, 3419, 3421, 3423, 3425, 3427, 3429, 3431, 3433, 3435, 3437, 3439, 3441, 3443, 3445, 3447, 3449, 3451, 3453, 3455, 3457, 3459, 3461, 3463, 3465, 3467, 3469, 3471, 3473, 3475, 3477, 3479, 3481, 3483, 3485, 3487, 3489, 3491, 3493, 3495, 3497, 3499, 3501, 3503, 3505, 3507, 3509, 3511, 3513, 3515, 3517, 3519, 3521, 3523, 3525, 3527, 3529, 3531, 3533, 3535, 3537, 3539, 3541, 3543, 3545, 3547,

Power Spramotor

SPRAYS 250 TREES PER HOUR.
16 to 30 nozzles with 125 lbs. pressure. Automatic, compensating, single or double speed. Strains its own mixture and fills its own tank in 10 minutes. New patented nozzles that spray all parts of the tree from below or above as shown. 2 1/2 horse-power motor can be used for all kinds of work when not spraying—20 to 30 a day.

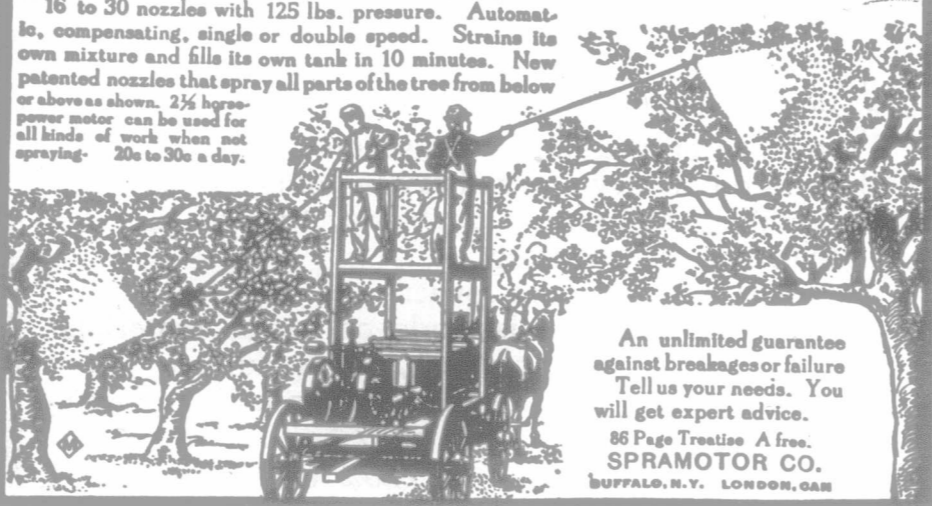

An unlimited guarantee against breakages or failure. Tell us your needs. You will get expert advice.
86 Page Treatise A free. SPRAMOTOR CO. BUFFALO, N. Y. LONDON, CAN.

Make Sure

—of Success

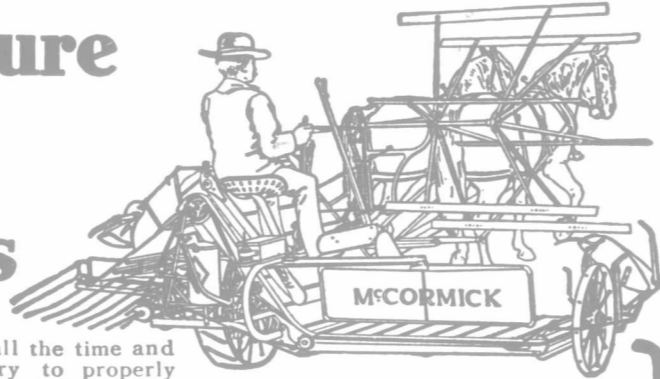

AFTER spending all the time and money necessary to properly prepare the soil, and after finishing the work of seeding, you cannot afford to take any chances on harvesting the crop.

The great element of safety and success in this work depends upon selecting the proper harvesting machine.

Taking everything into account, the McCormick binder will meet the most exacting requirements.

This is true not only because of the cutting and binding capacity of the machine, but also because of its easy draft, ease in handling and its remarkable strength and durability.

It is impossible in this small space to set forth the meritorious features of the McCormick binder in detail.

Someone in every community has a McCormick. Before you buy a binder ask this man about it.

Ask him if it has not given better service than any other binder he ever owned.

Ask him if it has not always been ready for work, and if it has not worked well in all kinds and conditions of grain.

It has been well said of the McCormick that "You see them wherever you go, and they go wherever you see them."

This is a well deserved compliment to the reliability of the McCormick.

The McCormick line of harvesting machines is complete and includes, besides grain and corn harvesting machines, binder twine, mowers, tedders, sweep rakes, side delivery rakes, hay loaders, stackers. Also a complete line of tillage implements and seeding machines, comprising disk drills, shoe drills, hoe drills, cultivators and seeders, smoothing, spring-tooth and disk harrows, land rollers and scuffers. Also gasoline engines, cream separators, hay presses, wagons, sleighs and manure spreaders.

The McCormick line is the O. K. line and is stenciled with the seal of excellence.

For detailed description of any or all of these machines, see illustrated catalogues.

Call on the local McCormick agent for information, or write nearest branch house for catalogue.

CANADIAN BRANCH HOUSES: Calgary, London, Montreal, Toronto, Regina, St. John, Winnipeg, Ottawa.
INTERNATIONAL HARVESTER COMPANY OF AMERICA,
(INCORPORATED)
CHICAGO, U. S. A.

HIDES AND FURS

The season for heavy receipts in Hides and Furs will soon commence. Remember that we are large exporters and make a specialty of consignments. Do not fail to communicate with us when you have any to offer :: :: :: :: ::

THE LIGHTCAP HIDE & FUR CO., LTD.

P. O. Box 484, 172 to 176 King Street

WINNIPEG

Write for Price List

MANITOBA

DONALD MORRISON & CO. 414 Grain Exchange

GRAIN COMMISSION

Winnipeg Reference: Bank of Toronto

Consign your grain to us to be sold at best possible prices on arrival or afterwards, as you may elect. Liberal advances on bills of lading. Prompt returns. Futures bought and sold. Twenty years experience in grain commission business.

LICENSED AND BONDED.

CORRESPONDENCE SOLICITED

organization. If this preparatory work cost only five thousand dollars a day, it still ran to nearly another million dollars.

A STUDY IN BREEDS OF SWINE.

An instructive pamphlet devoted to the breeds of swine has been issued from Ottawa as Bulletin No. 11 of the Live Stock Branch. It deals with the history, characteristics and points of excellence of the six principal breeds reared in Canada. Commencing with a review of the origin of domestic swine the bulletin teaches that the many varieties that are found in various parts of the world are all descended from one original stock of wild hogs. The varieties that were effected by domestication upon the progenitors of our present breeds are followed out briefly. It is pointed out that confinement along with an ample supply of food soon affected great and lasting changes in conformation, disposition and aptitudes of the animals. With these changes there came about a breeding to type and color in various localities as suited the requirements and desires of the hog raisers, resulting in the course of time in establishing the present pure breeds.

The breeds described in the bulletin, and represented by illustrations of typical animals, are the Yorkshire, the Tamworth, the Berkshire, the Chester-White, the Poland-China, and the Duroc-Jersey. The first and second are described as bacon breeds, the third and fourth as midway between the bacon and the lard type, and the two remaining breeds as belonging to the lard producing class of hogs.

The improvement of the Yorkshire is traced down from 1760, the time of Robert Bakewell. It was not until 1860 that this breed was given a separate classification at English shows. Among the chief classifications of the Yorkshire of the present day are its docility, vigor, muscular development and its excellent crossing qualities. They are said to be early maturing, reaching with good care a marketable condition, weighing from 180 to 220 pounds at from six to seven months old.

The Tamworth which is also described as belonging to the large breeds is traced from about 1815, when it is said to have been introduced into England from Ireland by Sir Robert Peel. The author of the bulletin claims that this breed is purer than any of the others, inasmuch as its improvement has been brought about almost entirely by selection of animals within the breed itself. It is stated to have received little attention outside of the counties of Leicestershire, Staffordshire and North Hamptonshire until about 1870, when the bacon curers of England commenced a campaign against the then fashionable short, fat and heavy shouldered pig, which they found quite unsuitable for bacon production. The Tamworth then came into prominence as an improver of some of the other English breeds. It seems to have maintained from the first its disposition to put on lean meat during its growth.

The Berkshire is stated to have assumed a fairly uniform and desirable type about the year 1825. It was at that time a fine appearing animal, very hardy, of good size and length without coarseness. Unfortunately owing to a fashion which prevailed some years afterwards, the Berkshire was developed on into a thick, short animal with heavy jowl, thick neck and fat back. Later this type of hog became unpopular and the attention was again given to developing greater length, symmetry and fleshiness. As now found the Berkshire exhibits desirable qualifications as a packer's animal.

The history of the Chester-White is extremely interesting. It is said to trace back to a pair of white hogs imported into Chester county, Pa. from England in 1816. This importation made a marked change in the swine of the district with the result that the Chester-White rapidly grew in favor. In its early years it was a fairly lengthy type of hog, but for many years past it has been classed as a compact hog of the thick backed sort. The breeders in Canada have been endeavoring to develop the Chester-White into a lard producing animal, and to some extent they have been successful.

by the packers and to some extent they have been successful.

The Poland-China and Duroc-Jersey have during the past ten years grown less and less popular in Canada, according to the author of the bulletin. In 1905 only eight members of the Dominion Swine Breeders' Association bred Poland-China, and three bred Duroc-Jerseys.

With the description of each breed is published a scale of points by which, with the illustration of typical animals, a valuable service is afforded in teaching the correct ideals to be looked for in selecting breeding animals. The author of the bulletin is Mr. J. B. Spencer, B.S.A., who has in this work presented a systematic study of swine that should be highly appreciated not only by students of animal husbandry, but by swine raisers in all parts of Canada. Copies of the bulletin are obtainable by applying to the Live Stock Commissioner at Ottawa.

The following is what the *Scottish Farmer*, the editor of which is secretary of the Clydesdale Horse Society of Great Britain, has to say regarding the late decision of the executive of the Canadian Clydesdale Association in regard to restricting the recording of short pedigreed fillies from Scotland.

"Clydesdale breeders in this country have got a nasty knock from their Canadian customers. It is no surprise to the writer that the check has come. Breeders here are to pay the penalty for neglect of registration. On and after the first day of June, 1907, only animals registered in the Clydesdale Stud Book here and out of mares registered in the Stud Book here, will be eligible for record in the Canadian Clydesdale Stud Book. But not only so; the sire and dam of the sire, and the sire and dam of the dam, must also be registered. This makes the Canadian rules parallel with those of the United States, and the fate of the short pedigreed filly is sealed so far as Canada is concerned. No blame can be attached to the Canadian. He knows that the Clydesdale Stud Book has been published for twenty-nine years, and its thirtieth volume has now been opened. To him it appears absurd that animals of pure breeding should in this country only show a bare three cross pedigree. He means to protect himself, and after 1st June there will be no more free importation of short pedigreed fillies. Home breeders had better, therefore, hustle, or the Canadian market is gone as the American went before it."

GETTING RID OF TUBERCULOSIS IN CATTLE.

If once cattle are rid of tuberculosis a big step in advance towards preventing the disease in the human family will have been made, is the conclusion one arrives at from the latest investigations and deductions therefrom. Various methods have been tried, of which the use of *tuberculin* was the most noteworthy as its use rendered possible early detection of the disease. Once detected measures could be employed to limit its ravages in herds, the most acceptable being the Bang system by which affected cows are segregated, and their calves taken from them at birth and raised by healthy cows. At Ottawa the Veterinary Director General reports encouraging results from the fresh air treatment, and now we have the method spoken of as *bovo-vaccination*.

Professor Von Behring of Marburg is a celebrated scientist who has to his credit the discovery of the antitoxines of lockjaw and diphtheria, and who is strenuously working towards eventual protection of man against the "great white plague" (tuberculosis). Unlike Koch, who astonished the world by announcing that human and bovine tuberculosis are not intercommunicable and who since has been proved incorrect in such a conclusion, Von Behring considers the milk of tuberculous cattle a source of human consumption, and has discovered that a preparation of the attenuated *Bacillus* of human tuberculosis when injected into the nose of a three weeks' old calf, and repeated every month, will protect that calf after one year, from contracting bovine tuberculosis. The protec-

extent they

Duroc-Jersey
years grown
Canada, accord-
bulletin. In
of the Domin-
association bred
bred Duroc-

each breed is
ts by which,
pical animals,
ded in teach-
be looked for
nimals. The
s Mr. J. B.
in this work
udy of swine
reciated not
husbandry,
all parts of
bulletin are
to the Live
taw.

the Scottish
is secretary
Society of
egarding the
tive of the
ociation in
e recording
m Scotland.
this country
from their
no surprise
k has come.
penalty for
n and after
only animals
Stud Book
tered in the
eligible for
esdale Stud
he sire and
re and dam
registered.
les parallel
States, and
igreed filly
concerned.
the Canad-
Clydesdale
lished for
s thirtieth
pened. To
animals of
is country
s pedigree.
, and alter
more free
eed fillies.
therefore,
ket is gone
e it."

ULOSIS IN

erculosis a
preventing
... will
... one
estigations
various
which the
most note-
1 possible
use. Once
employed
the most
system by
egregated,
them at
cows. At
or General
from the
we have
no-vaccin-

Marburg
has to his
ntitoxines
and who
rds even-
against the
rculosis),
the world
id bovine
nunicable
ed incor-
Behring
ous cattle
tion, and
ration of
human
into the
calf, and
tect that
contract-
2 protec-

London and Lancashire Life

HEAD OFFICE FOR CANADA:
MONTREAL

This Company is paying on
matured policies the full
amount of estimated profits

Liberal Contracts to Suitable Representatives

B. HAL BROWN, Gen. Mr.
Montreal

W. R. ALLAN - - - - Agent
L. W. HICKS - Branch Manager
WINNIPEG

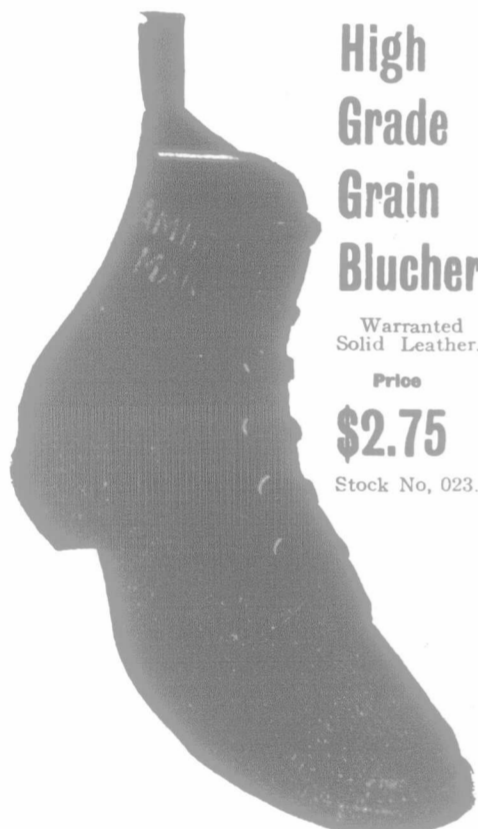

**High
Grade
Grain
Blucher**

Warranted
Solid Leather.

Price
\$2.75

Stock No. 023.

Save Your Repairing Bill. Buy the Best.
If Amherst make is not sold in your town
write
E. J. BLAQUIER, Box 683, Brandon, Man
m. If sent by parcel post 50c. extra.

Imperial Bank of Canada

HEAD OFFICE: TORONTO
Capital (Paid-up) \$4,700,000
Reserve Fund \$4,700,000
D. R. WILKIE, President and Gen'l Manager
Hon. ROBT. JAFFRAY, Vice-President.
AGENTS GREAT BRITAIN—Lloyd's Bank
Limited, Head Office, Lombard Street, London
BRANCHES in Manitoba, Saskatchewan, Al-
berta, British Columbia, Quebec, and Ontario.
WINNIPEG BRANCHES
North End—Corner Main street and Selkirk
avenue. F. P. JARVIS, Mgr.
Main Office—Cor. McDermot Avenue and Albert
Street. N. G. LESLIE

Select Farms

IN LOWER FRASER VALLEY
British Columbia's
Richest Farming
District
I publish a real-estate bulletin
giving description and prices
of some of the best farms in
the Valley. Send for one (it
will be of value to anyone
interested in this country, or
looking for a chance to better
their present conditions) to
T. R. PEARSON
NEW WESTMINSTER, BRITISH COLUMBIA

tive preparation or substance is entirely
harmless to the calf, and may be safely
handled by the veterinarian and is
injected directly into the jugular vein
by means of a hypodermic needle and
syringe. The calf then is kept away
from tuberculous cattle, out of infected
places and is fed milk known to be free
from tuberculosis bacilli. In three
months a second injection is made and
the calf again is protected against con-
tact with the disease germs or affected
cattle and at the end of a year is con-
sidered immune so that it will not con-
tract the disease from association with
tuberculous cattle or living in an
infected environment. If tuberculin
is used after the year of probation is
ended it fails to cause a reaction (rise
in temperature) but if infected prior
to that time and before the animal
therefore, has been immunized fully, a
reaction may occur although the calf
is not affected by tuberculosis, the
reasons being that the injection of the
protective substance renders the animal
peculiarly sensitive (hypersensi-
sitive) to tuberculin. When immuni-
zation is complete the animal, it is
claimed, is safe against bovine tuber-
culosis for the balance of its life.

Seventy thousand head are said to
have been immunized, and it is said
that the results are eminently satis-
factory, no reactions being obtained
in heads which formerly gave eighty
to one hundred per cent. The outdoor
life of our Canadian cattle is largely
responsible for their freedom from
this insidiously fatal disease.

Not far from the village of Newdale
on the M. and N. W. division of the
C. P. R. is Mount Pleasant, the
farm of Wm. Grayston, on which he
has started a small Shorthorn herd
with females from the Lynch herd, West-
bourne. The cows are low-set, thick
fleshed and well covered; and carry the
blood of Village Hero and Scottish
Canadian.

ADAMSON BROS'. SHORTHORNS.

Adamson Bros., Gladstone, are into
the breeding of Shorthorns, and have
had for some time as the head or their
herd Marquis of Lungburn, by Marquis
of Nenda (imp.). This bull, which by
the way is to be disposed of having been
in the herd for some time, is an impres-
sive sire, a good handler, possessed of
a good constitution. The light roan
Ambassador, a deep melow feshow
with plenty of constitution, was also
seen in the boxes. A new acquisition
is Topman's Heir, a light roan bred by
John G. Barron, a very deep, low set
bull, which will be remembered in the
two-year-old class at last season's
shows. He is a lengthy, thick-hearted,
good handling chap, that may be heard
from in the ring the coming season.
The females are all in breeding condi-
tion, testimony further borne out by
the calves filling the boxes. A show
heifer is the light roan Vivian.

ONE OF THE POSSIBLES—WATCH FOR HIM.

Andrew Graham, Pomeroy, Man., has
just returned from the East on a pur-
chasing tour for the stallion syndicate
of which he is a member. He bought
Vigorous, four years, a dark bay, ratch
on face, one fore and both hind feet
white. This horse was imported by
T. H. Hass, Millbrook, Ont. Vigorous
is by Up-to-Time and is therefore a
grandson of Baron's Pride. Vigorous
won first at Paisley, Bishopton, Barr-
head, East Kilbride. He was first in the
three-year-old class at Toronto Exhibi-
tion, and at the Toronto Spring Show
in March he was second. Mr. Graham
had looked other horses over when in
the East, but considered this horse the
most promising and therefore bought
him for the Carman. Vigorous weighed
1925 lbs. the day he was purchased and
is good mover and has plenty of con-
stitution.

EASTERN PUREBRED STOCK FOR THE WEST.

A couple of carloads of miscellaneous
purebred stock arrived in Winnipeg
yards (C. P. R.) for Western men, billed
from Ontario breeders of registered
stock. Included in the lot was a Short-
horn bull from Robt. Miller, for C. A.



We are the People

Who for Twenty Years have supplied
the West with the Best

**PUMPS
WINDMILLS and
GASOLINE ENGINES**

OUR GOODS ARE THE STANDARD OF QUALITY

BRANDON PUMP & WINDMILL WORKS

Box 410

Start the Bowels

When you suffer with sick headache, biliousness, torpid liver,
tainted breath or stomach ills—start the bowels. Health demands
that they move naturally at least once a day; otherwise poisons
are thrown back into the blood and the whole body becomes a
lodging place for disease. Keep the bowels open with

BEECHAM'S PILLS

when there is the slightest evidence of irregularity, and you will be
free from the complaints caused by sluggish bowels or an inactive
liver. The action of Beecham's Pills is gentle but thorough. Fifty-
six years before the public, their wonderful success as liver and
bowel correctives, has won first place for them as

Nature's Constipation Cure

In boxes with full directions, 25c.

THE CANADIAN BANK OF COMMERCE

HEAD OFFICE, TORONTO

CAPITAL, - \$10,000,000 REST, - \$5,000,000

B. B. WALKER, President **ALEX. LAIRD, General Manager**
A. H. IRELAND, Superintendent of Branches

ONE HUNDRED AND SIXTY-EIGHT BRANCHES IN CANADA, THE
UNITED STATES AND ENGLAND

BRANCHES IN THE CANADIAN WEST:

- | | |
|---|--|
| BAWLIF, Alta.
A. E. D. Band, Manager | MOOSE JAW, Sask.
E. M. Saunders, Manager |
| BRANDON, Man.
A. Maybee, Manager | MOOSOMIN, Sask.
D. I. Forbes, Manager |
| CALGARY, Alta.
C. W. Rowley, Manager | NANTON, Alta.
C. F. A. Gregory, Manager |
| CANORA, Sask.
G. G. Bourne, Manager | NEEPAWA, Man.
C. Ballard, Manager |
| CARMAN, Man.
D. McLennan, Manager | NORTH BATTLEFORD, Sask.
A. S. Horton, Manager |
| CLARESHOLM, Alta.
W. A. Cornwall, Manager | NORWOOD, Man.
W. H. Switzer, Manager |
| CROSSFIELD, Alta.
James Cameron, Manager | PINCHER CREEK, Alta.
W. G. Lynch, Manager |
| DAUPHIN, Man.
D. H. Downie, Manager | PONOKA, Alta.
E. A. Fox, Manager |
| EDMONTON, Alta.
T. M. Turnbull, Manager | PORTAGE LA PRAIRIE, Man.
A. L. Hamilton, Manager |
| ELGIN, Man.
H. B. Haines, Manager | PRINCE ALBERT, Sask.
C. D. Nevill, Manager |
| ELKHORN, Man.
R. H. Brotherhood, Manager | RADISSON, Sask.
C. Dickinson, Manager |
| GILBERT PLAINS, Man.
E. J. Meek, Manager | RED DEER, Alta.
D. M. Sanson, Manager |
| GLEICHEN, Alta.
F. J. Turner, Manager | REGINA, Sask.
H. F. Mitten, Manager |
| GRANDVIEW, Man.
A. B. Sturmet, Manager | SASKATOON, Sask.
W. P. Kirkpatrick, Manager |
| HIGH RIVER, Alta.
C. R. W. Pooley, Manager | STAVELY, Sask.
Thos. Andrews, Manager |
| HUMBOLDT, Sask.
F. C. Wright, Manager | STONY PLAIN, Alta.
C. S. Freeman, Manager |
| INNISFAIL, Alta.
H. L. Edmonds, Manager | STRATHCONA, Alta.
G. W. McTavish, Manager |
| INNISFREE, Alta.
W. P. Perkins, Manager | SWAN RIVER, Man.
F. J. Macoun, Manager |
| KAMSACK, Sask.
G. G. Bourne, Manager | TREHERNE, Man.
J. S. Munro, Manager |
| KINISTINO, Sask.
E. R. Jarvis, Manager | VEGREVILLE, Alta.
W. P. Perkins, Manager |
| LANGHAM, Sask.
W. J. Savage, Manager | VERMILION, Alta.
A. C. Brown, Manager |
| LASHBURN, Sask.
S. M. Daly, Manager | VONDA, Sask.
J. C. Kennedy, Manager |
| LEAVINGS, Alta.
Thos. Andrews, Manager | WADENA, Sask.
W. E. D. Farmer, Manager |
| LETHBRIDGE, Alta.
C. G. K. Nourse, Manager | WATSON, Sask.
A. L. Jensen, Manager |
| LLOYDMINSTER, Sask.
S. M. Daly, Manager | WETASKIWIN, Alta.
H. I. Millar, Manager |
| MACLEOD, Alta.
H. M. Stewart, Manager | WEYBURN, Sask.
J. D. Bell, Manager |
| MEDICINE HAT, Alta.
F. L. Crawford, Manager | WINNIPEG, Man.
John Aird, Manager |
| MELFORT, Sask.
E. R. Jarvis, Manager | YELLOWGRASS, Sask.
C. Hensley, Manager |

BANKING BY MAIL

Business may be transacted by mail with any of the branches of this Bank
in Canada and the United States, accounts being opened, deposits made or
funds withdrawn in this way with equal facility. Every possible attention is
paid to out-of-town accounts and general farmers' business. Notes discounted,
sales notes collected, etc. 77

THIRD ANNUAL BULL SALE

under the auspices
of the

**CATTLE BREEDERS' ASSOCIATION
OF MANITOBA**

will be held at

BRANDON
Thursday, May 30th, 1907

Catalogues ready May 1st

Animals delivered to purchaser's nearest station
in Manitoba for \$2.00 per head.

Cheap passenger rates on
certificate plan from all stations.

A. W. BELL
Secretary

1001 Union Bank Building
Winnipeg

Hooper, Holland Man., a Hereford bull from W. H. Hunter, for Jno. Wallace, Cartwright, Man.; three Clydesdale stallions from Oswald Sorby, Guelph; Duncan McLaughlin, Winnipeg; Shorthorn bull from A. W. Smith, for Duncan Stewart, Westbourne; four Berkshires from Thos. Teasdale, for J. A. McGill, Neepawa; four Yorkshires from Glenhudson farm for Jno. Graham, Burnside; one Shorthorn bull (white) from Robt. Miller to Jno. G. Barron, Carberry; Shorthorn bull from McDermott for J. Gill, Oak River; Aberdeen-Angus for John Gill, Oak River; Aberdeen-Angus bull from W. R. Bowman to Chas. Lawley, Melita; Clydesdale stallion for Jno. L. Salkeld, Wapella; four horses for John Cowan, Whitewood, Sask; one Clyde stallion for H. H. Cayford, Lashburn, Sask.; Hereford bull for O. Olafson, Caron; Clydesdale stallion for J. Stevenson, Lamerton, Alta.; Shorthorn cow and bull calf for Dr. A. G. Hopkins, Winnipeg, Man.; one bull and three Berkshires for B. E. Husband, Carstairs; Shorthorn bull for Jno. Potts, Morley, Alta; turkeys for Jonathan Batty, Vegreville, Alta.

RANGE CATTLE TO MOVE LATE.

R. Ironside in an interview at Chicago states that the range cattle will not move East much before September. It estimates the minimum range loss as twenty-five per cent., and says his estimate is a very conservative one.

Sam McLean has purchased Silver Light, an imported Clydesdale stallion from Alex. Galbraith & Son and has sold his Hackney stallion Confident Squire.

The Elgin Clydesdale Horse Association has sold Lambton Lothian (imp.) to Tolley and Chambers.

D. J. Louttit, Elgin, Man., has purchased the Clydesdale stallion Baron Templeton (imp.), from Alex Galbraith & Son, Brandon.

Geo. Bothwell's dispersion sale of Shorthorns brought an average of \$159.30, for fifty-nine head.

A. T. Gordon, Combscausway, N. B., son of A. M. Gordon, noted as the owner of Corner Stone, will judge the Shorthorns at Toronto, Ont.

BUILDING A RURAL TELEPHONE LINE.

(Continued from page 730.)

Lightning Arrestors.—In order to protect telephones from discharges of lightning and from heavy discharges of atmospheric electricity, it is customary and usually necessary to intervene between the telephone and the main line some protective device in the nature of a fusible wire and a narrow air-gap between the line and the ground. This air-gap is formed by two pieces of block carbon, separated by a thin strip of perforated mica. Figs. 4 and 5 show such a device properly installed on a ground return line or a metallic circuit.

The most prolific source of trouble on telephone lines is bad ground wires. The most common practice of making a good ground connection is to take a sharp rod, seven feet long by half an inch in diameter, having a hole about three inches from the sharpened end. Through this hole pass an end of a piece of line wire, and wind this wire around the rod from bottom to top, having two or three loose feet of wire left. Now drive the rod into the earth in some damp place. Then connect the covered wire from the middle post of the telephone to the ground wire attached to the ground rod. The conductivity of the earth being mainly due to the presence of moisture therein, it is absolutely necessary that the ground wire, or its rod or plate, should come in contact with the earth, which is damp continually and not for a few months in the year.

As all telephone instruments and lines are exposed to the action of the elements, and to careless usage, so all telephone apparatus will occasionally have something the matter with it. Do not expect good service when the lines are grounded or crossed, and do not blame the telephone when the batteries are run down. Good, dry batteries should last, with ordinary treatment, from six months to a year. On a new line the second set of batteries almost invariably lasts longer than the first set.

CLYDESDALE STALLIONS and MARES



Out of a carefully bred and selected lot I am offering a five-year-old stallion, a three-year-old, a two-year-old, two yearlings, and several mares and fillies. Will sell quick before seeding. Farm (Meadow Lawn) convenient to Regina. Full details given on application. Address

J. D. TRAYNOR

Condie P. O., Sask.

A. & G. Mutch Craigie Mains LUMSDEN, SASK.

Importers and Breeders of Clydesdale Horses

We have handled two large importations of Clydesdales since last fall and have good ones always on hand. We buy and sell our own horses by this means saving to our customers all high commission and expenses. We also sell on small margins above cost. We will quote you prices on Clydesdales of all ages.

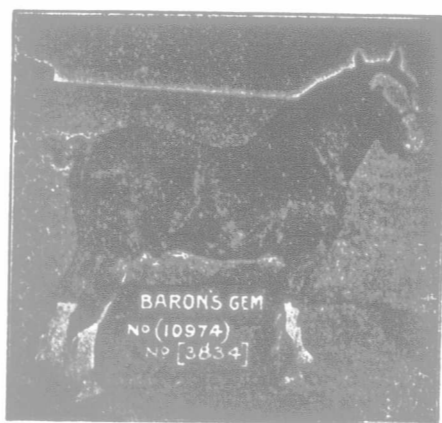

A SNAP To MAKE ROOM. Will take \$50 per head for 10 nice choice, blocky Hereford Bulls 12 to 15 months old. All in good condition. Bred from imported stock. Also choice heifers and cows for sale.

A. S. HUNTER, - Durham, Ont.



SAFETY IMPREGNATING OUTFIT
Gets to heat all mares bred with it and greatly increases their income from your stallion. Durable, easily used and GUARANTEED to produce results. A necessity for every horse breeder. Cost 1/20th of the cost of a cow. Price, \$7.50. Write for details to J. O. CRITTENDEN, 44 Fox Bldg., Elyria, Ohio, U.S.A.



Are a True Heart Tonic,

Nerve Food and Blood Enricher. They build up and renew all the worn out and wasted tissues of the body, and restore perfect health and vigor to the entire system. Nervousness, Sleeplessness, Nervous Prostration, Brain Fog, Lack of Vitality, After Effects of La Grippe, Anemia, Weak and Dizzy Spells, Loss of Memory, Palpitation of the Heart, Loss of Energy, Shortness of Breath, etc., can all be cared by using

Milburn's Heart and Nerve Pills.

Price 50c. a box or 3 for \$1.25. All dealers or THE T. MILBURN CO., LIMITED, Toronto, Ont.

ABSORBINE

Will reduce inflamed, swollen Joints, Bruises, Soft Bunches, cure Boils, Fistula, or any unhealthy sore quickly; pleasant to use; does not blister under bandage or remove the hair, and you can work the horse. \$2.00 per bottle delivered. Book 8-B free. ABSORBINE, JR., formankind, \$1.00 per bottle. Cures Varicose Veins, Strains, Bruises, Etc. M.D. only by

W. F. YOUNG, P. D. F., 46 Belmont St., Springfield, Mass. LYMAN SONS & CO., Montreal, Canadian Agents. Also furnished by Martin Bole & Wynne Co., and Palford Leonard Drug Co., Winnipeg, The National Drug & Chem. Co. Winnipeg and Calgary, and Henderson Bros. Co. Ltd., Vancouver.

Money Saved BY Dealing with us

We Save you from 25 to 50c. on every Dollar you spend for Groceries, Hardware, Clothing, Shoes, etc.

We deliver FREIGHT PREPAID to any railway station in Manitoba, Saskatchewan, Alberta, British Columbia and West Ontario.

WRITE FOR OUR PRICE LIST IT IS FREE

If you want to know who we are ask your neighbors, some of them are surely patronizing us.

WE OFFER FIRST-CLASS GOODS ONLY TRY US AND BE CONVINCED

NORTHWESTERN SUPPLY HOUSE

259-261 Stanley St. WINNIPEG, Man.

Kettle Valley Irrigated FRUIT LANDS Company

have large acreage of subdivided fruit lands now for sale. Prices \$100 to \$150 per acre. Ample supply of water for which NO RENT is charged. Soil a rich sandy loam which produces the finest apples, small fruits and vegetables. Valuable local market in surrounding mining towns. Splendid climate and excellent railway facilities. Apply to

W. O. Wright, Managing Director
MIDWAY, B. C.
Winnipeg Agents B. M. TOMLINSON & CO.
Edward Bldg., Opp. Eatens, Winnipeg, Man.
Phone 5710

MILK CANS ROB YOU

Look through a microscope at milk set to cream in pans or cans and you'll see how they rob you. You'll see the caseine—the cheese part—forming a spider web all through the milk. You'll see this web growing thicker and thicker until it forms solid curd. How can you expect all the cream to rise through that? It can't. This



caseine web catches a third to half the cream. You stand that loss just as long as you use pans or cans for they haven't enough skimming force to take out all the cream. But, just the minute you commence using Sharples Dairy Tubular Cream Separator, you stop that loss.

Sharples Dairy Tubular Cream Separators have 10,000 times more skimming force than pans or cans, and twice as much as any other separator. They get all the cream—get it quick—get it free from dirt and in the best condition for making Gilt Edge Butter. Caseine don't bother the Tubular. The Tubular is positively certain to greatly increase your dairy profits, so write at once for catalog I-188 and our valuable free book, "Business Dairying."

The Sharples Separator Co.
West Chester, Pa.
Toronto, Can. Chicago, Ill.

VETERINARY ADVICE FREE

Dr. S. A. Tuttle, a veterinary surgeon of long experience has written a book entitled "Veterinary Experience" on the diseases of horses, giving symptoms and treatment in plain terms. It is fully illustrated with diagrams showing the skeleton and circulatory and digestive systems with references that make them plain. Tells how to buy a horse and know whether it is sound or not. Every horse owner should have one. It is sent to any one.

TUTTLE'S ELIXIR
is the only guaranteed cure for Colic, Curb, recent Shoe Bells and Callous. It locates lameness, relieves and cures Spavin, Ring Bone, Cockle Joints, Grease Heel, Scratches, Cataract, etc. Send today and get the book free and information about Dr. Tuttle's specific.
TUTTLE'S ELIXIR CO.
66 Beverly Street, Boston, Mass.
Canadian Branch, 32 St. Gabriel St., Montreal, Quebec.

CUSHING BROS. CO., LTD.

THE GREATEST SASH AND DOOR HOUSE IN THE WEST.

Doors
Windows
Plate Glass

Shingles
Lumber
Lath

FACTORIES: Calgary, Edmonton, Regina
BRANCHES: Strathcona, Red Deer, Fort Saskatchewan

ADVERTISE IN THE ADVOCATE

After a rural party line has been in operation for a while, it frequently happens that so many telephones are connected to it that it becomes overloaded, making it difficult for parties at opposite ends of the line to ring each other. When a line has reached this condition it is necessary to divide it into two or more telephone sections, and use some switching device for connecting one section with the other. It is obvious that the party who is going to make connections must be able to communicate verbally with the subscribers of both lines. Therefore, the operator's station, as we will call it, has to be equipped with a complete 'phone. Where sufficient interest warrants the organization of a company, and a sufficient number of people take telephones, it is advisable, in fact, necessary, to establish a telephone exchange or central office.

Just here I might add that parties should consider carefully future growth when purchasing a telephone exchange or central office equipment, for it is the case almost invariably that original equipments are purchased for too small a capacity. The telephone exchange, or central office, consists of a collection of apparatus called a switchboard, whereby numerous lines coming in from the subscribers may be connected together at the order of the subscribers, so that one may talk with another, and be disconnected when conversation is finished, leaving these lines ready for other connections.

A switchboard consists of terminals and associated signals for each line, and a suitable number of pairs of flexible connecting cord circuits for connecting any one of these lines with another.

The terminals are called spring-jacks, and consist of tubular openings, containing electrical contacts, made of German silver springs, so that a plug thrust into it makes contact with these springs.

The signal associated with the spring-jack is usually of the shutter type, called a "drop" or a "polarized ringer." Where all lines used are bridging grounded, it is advisable to use the polarized ringer signal, as also in regular bridging metallic circuits, for in either of these cases all the rings on each line pass through central, and with a drop it would fall with each ring whether central was wanted or not, but with the polarized ringer the central can recognize her ring, even when her duties do not compel her to remain seated at the central. Where metallic circuits are used, and the bridging telephone with push-button to ring central is supplied to the subscribers, then the more satisfactory switchboard is the one equipped with the drop or other similar device, for with this push-button telephone, a subscriber can ring any other subscriber without calling central, or can ring central without disturbing any other subscriber on the line. When a subscriber wishes to call central he presses the button and calls in the usual way. When calling a subscriber the button is not used. A central board wired for this kind of bridging telephone, will give the best of satisfaction to the subscribers and the minimum of labor at the central. Where the drop is used it will have a night bell installed in connection therewith. In purchasing a central board always have it wired for full capacity of board, but not necessary to have all the drops or jacks installed. It is just as cheap to buy a fifty-line board fully wired as to buy the same size board wired for only twenty-five lines. The main cost is in the number of jacks and drops or polarized ringers installed. Extra drops and jacks can be purchased at any time as your number of lines increase, and it is an easy matter for any person to install in the board fully wired. Be sure to have plenty of cord circuit on your rural boards, as the tendency of the manufacturer or salesman is to have too few cord circuits.

It is necessary in installing a central board to protect it from the effects of lightning discharges, and for this purpose it is well to have two sets of lightning arresters installed in connection with the board. One arrester in the cable pole box placed on the pole just outside the central office and the second arrester in the building. Good grounds must be provided for these arresters, to make them efficient. Place a copper plate eight feet in the

DISPERSION SALE

of Purebred Shorthorn

Cattle

at

Regina, on June 26

We will sell our entire herd of Shorthorns at the City Amphitheatre, Regina, on the above date. In the lot are 6 bulls and 22 females, most of the latter being cows with calves at foot. Catalogs giving full information and lengthy notes on the breeding of the cattle are ready and will be sent upon request.

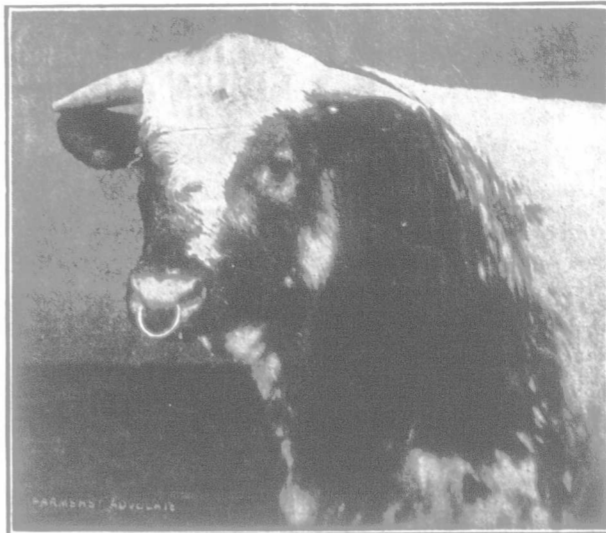

GEO. P. BELLOWES, MISSOURI, AUCTIONEER. A. & G. MUTCH, LUMSDEN, SASK.

10,000 Well-Bred Cattle For Sale

Owing to the curtailment of their range by settlement, the New Walrond Rancho Company, Livingston, Alberta, intends to offer during the coming summer their entire herd of Shorthorn, Hereford and Galloway Cattle for sale.

Owing to the winter feeding and careful handling these cattle are semi-domestic, the young heifers are easily made gentle. For settlers they are the most desirable imaginable, being absolutely free from tuberculosis and other diseases common among dairy breeds, and while they are high-class beef cattle, they yield a large quantity of very rich milk.

When necessary to car them, neighbors should combine so as to purchase a train-load, say 300 to 400, smaller numbers cannot be handled profitably.

Bulls will also be disposed of.

For particulars apply to

THE LOCAL MANAGER
NEW WALROND RANCHE CO. LTD.
Livingston P. O., Alberta

R. P. Stanley, Moosomin, Sask.

Breeder and Importer of Percheron and Hackney Horses

Percheron stud headed by Berenger, winner of first prize at three years old at Paris, France, in 1905.

My new importations are now in their new quarters on farm. They are a very choice lot and doing finely and are all for sale at reasonable prices.

Every horse sold under a warranty Terms easy. Correspondence solicited. Barns 1/2 mile of station.



WE BUY DRY HIDES G. S. HIDES FURS PELTS

McMILLAN FUR & WOOL CO. 228 King St., WINNIPEG, MAN. Write For Prices.

Kootenay Fruit Lands HIGH-CLASS PHOTOGRAPHS

For Sale 160 acres in Slovan Valley, no waste land, no stone; all level; soil first class, 2 nice streams. Close to school, P.O., Ry Signal. 7 acres cleared 100 fruit trees, some are bearing. Good log buildings. \$4000.00 Cash.

Geo. G. McLAREN, Box 654, NELSON, B.C.

For first class and up-to-date photographs, go to E. B. CURLETTE'S New Studio in the Allan Block. Only one grade of work turned out, and that the best. No stairs to climb. All on the ground floor. Location: First door south of Post Office, Calgary, Alta.

E. B. CURLETTE

If Your Horse Gets Hurt?

If one of the horses should be kicked—cut a knee—strain a shoulder—go lame—have you the remedy at hand to CURE the injury?

Kendall's Spavin Cure

ought to be in every stable and barn in Canada. It prevents little horse troubles from becoming big ones—and takes away all signs of lameness. With a bottle of Kendall's Spavin Cure handy, you are prepared for accidents that may happen at any time.

CROSSFIELD, Alta., Jan. 14 '06
"I have used Kendall's Spavin Cure with great success in many things, such as Barb Wire Cuts and Raw Sores."
M. J. MORRISON.

Don't be without it another day. Get a bottle at your dealers. \$1. or 6 for \$5. Our "Treatise On the Horse" tells just what you ought to know about horses, their diseases, and how to cure them. Write for free copy.

DR. B. J. KENDALL CO., ENOSBURG FALLS, VERMONT, U.S.A. 35



JOHN A. TURNER, SALGREGGAN STOCK FARM, CALGARY P. O. Box 472
Importer and Breeder of Clydesdales, Hackneys, Shorthorns and Shropshire Sheep.

New importation from Scotland has just arrived. *Scottish Farmer* reports—"Altogether this makes up one of the grandest shipments on 'e this eventful year." A large number of excellent males of the above breeds to select from, both home bred and imported. Also a few stallions suitable for range purposes. Quality and breeding of the best. Prices defy competition. No agents or commission men—business conducted personally. Sales speak for themselves—35 stallions sold last season. Anyone wishing a show stallion or filly can have a greater choice here than in any other breeding establishment in Canada. Orders for stock carefully filled. Visitors all made welcome.

FAIRVIEW SHORTHORNS

SIX YEARLING BULLS, fit to head herds. Sired by Nobleman, Meteor and Topman's Duke. Also some cracking BULL CALVES by Meteor. Some females (Cows and Heifers) in calf; just the stuff to lay the foundation of a herd with.

NOW IS THE TIME TO BUY

Cattle are going up in price. I shall not hold a sale this year, but parties will have abundant opportunities to buy by private treaty

CARBERRY—C.P.R. and C.N.R.
FAIRVIEW—C.N.R.

JNO. G. BARRON

Alex. Galbraith & Son
BRANDON, MAN.

ARE OFFERING

CLYDESDALE STALLIONS and MARES

of the highest merit and choicest breeding at lower prices than all competitors.

New Shipment just arrived containing several sons of the noted Baron's Pride.

A few choice Suffolks, Percherons and Hackneys on hand
EVERY ANIMAL GUARANTEED. WRITE FOR PARTICULARS.
26 YEARS in the front rank of importers.

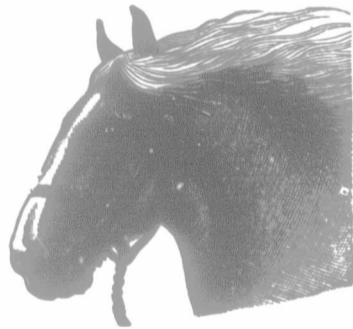

CLUB STABLES

12th STREET, (Box 483) BRANDON

MacMillan, Colquhoun & Beattie

Importers and Breeders of

Clydesdale, Percheron and Hackney Stallions

THE MOST FASHIONABLE STRAINS OF BREEDING ALWAYS ON HAND

GOLDEN WEST STOCK FARM

Clydesdales and Shorthorns

Stallions and mares of excellent breeding, of all ages, for sale

Also some choice young bulls fit for service and a number of cows and heifers of noted Scotch strains.

Many of them Leading Prize Winners at the big Western Fairs.

P. M. BREDT

Regina, Sask.



ground, to which is attached a large-sized insulated copper wire, which attaches to the carbon discharge point of the arrestor.

When a metallic circuit is joined to a grounded line the connection is not made direct, but through a repeating coil. This is done to prevent the balance of the circuit being destroyed by an uneven arrangement of lines. It has been found that a short line, subject to disturbances, if joined to a metallic circuit, will cause the whole line to become noisy and difficult to talk over. By making connection through a repeating coil, the disturbance is eliminated and a quiet line throughout is obtained.

W. DOAN, M.D.
Manager Harrietsville Telephone Association, Ltd.

NO QUARTER TO TYPICAL REACTIONS TO MALLEIN TEST.

(Continued from page 726)

THE REACTION TO THE TEST DANGEROUS

Further proof of the dangerous character of these horses, which, through an acquired tolerance to mallein, are erroneously classed as ceased reactors, is, I am sorry to say, furnished by our own official records, several instances having occurred in which horses held under supervision for periods deemed sufficient to ensure safety, were permitted to mingle with healthy animals, with disastrous results.

Not the least remarkable feature of these cases is the fact that they seldom develop clinical symptoms themselves, although, beyond doubt, many of them are capable of transmitting infection to others.

What constitutes an actual and typical mallein reaction? Ability to deteriorate with certainty, at least in the majority of cases, between typical and non-typical reactions, is, for obvious reasons, perhaps the most important factor in the use of mallein.

In horses affected with glanders from the 4th to the 15th hour after the injection of the usual dose of reliable mallein a distinct rise of temperature takes place, except in certain cases which will be specially mentioned later. The temperature gradually rises until the 14th or 15th hour after injection, when, after remaining at about the same height for a longer or shorter period, it gradually declines, the downward course being not unfrequently preceded by a slight secondary elevation.

This thermal disturbance should, under ordinary circumstances, indicate a rise of at least 2.5 degrees Fahrenheit over the highest control temperature taken before injection. The wide variation in normal temperature shown by the equine species, especially in Western America, demands the application to this rule of certain definite limitations. For instance, if invariably followed, a horse having a pre-injection temperature of, say, 99°, would be condemned at 105.5°, which might be well within his normal range. On the other hand, an animal with a pre-injection temperature of 102°, which is not at all strikingly abnormal in the West, would be allowed to reach without condemnation 104.4°, a point entirely outside of the normal range.

Other things being equal, 103° Fahrenheit would appear to indicate the danger line, but no fixed rule can possibly be adopted, close observation and sound judgment in the operator being of more importance than hard and fast ruling.

The thermal rise is accompanied, or rather followed, by a hard, tense and exceedingly painful swelling at the point of injection. This swelling is usually circular, and shows a tendency to increase from the eighth hour after injection, at the same time becoming more painful, affecting the muscles and causing marked lameness in the forelimb of the side on which the injection was made. It is often accompanied by swelling of the surrounding lymphatics, which also become intensely painful.

The local reaction does not, as a rule, entirely disappear for several days.

Properly the thermal reaction is a condition of the disease, and is not a symptom of it, and is not a reliable guide to the extent of the infection.

Warranted to Give Satisfaction.

Gombault's Caustic Balsam



Has Imitators But No Competitors.

A Safe, Speedy and Positive Cure for Curb, Splint, Sweeney, Capped Hock, Strained Tendons, Founder, Wind Puffs, and all lameness from Spavin, Ringbone and other bony tumors. Cures all skin diseases or Parasites, Thrush, Diphtheria. Removes all Bunches from Horses or Cattle.

As a Human Remedy for Rheumatism, Sprains, Sore Throat, etc., it is invaluable. Every bottle of Caustic Balsam sold is warranted to give satisfaction. Price \$1.50 per bottle. Sold by druggists, or sent by express, charges paid, with full directions for its use. If send for descriptive circulars, testimonials, etc. Address

The Lawrence-Williams Co., Toronto, Ont

FOR SALE

The Imported Suffolk Stallion



DEPUTY (3203)

using three years old. Sire, Warrior 3rd (2845); Dam, Depper (4695). A handsome, whole colored, dark chestnut with heavy bone, grand set, strong joints, good action. The acme of strength and quality combined. Sound and all right and price right. Correspondence solicited

Mossom Boyd Co. Bobcaygeon, Ont.

CLYDESDALES

Catalog on application

W. H. BRYCE

Doane Lodge Stock Farm
Arcola, Sask.

An Ideal Stock Farm For Sale

960 acres in Block. 7 1/2 miles from town; all fenced. Running Water and Springs. Good House and Barns. Write for full particulars. This is one of our many good buys.

CANADIAN AMERICAN REAL ESTATE CO. Ltd.
LACOMBE, Alberta

WINDMILLS

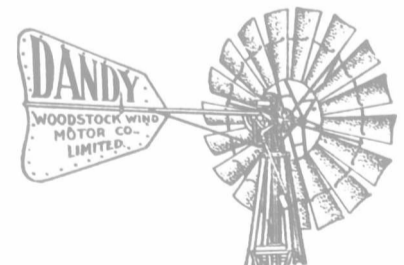

Grain Grinders, Tanks, Water Boxes and Foundry Supplies. Write for our free catalogue. Estimates cheerfully given.

WOODSTOCK WIND MOTOR CO. Limited
Woodstock, Ont.

FERGUSON & RICHARDSON

Barristers, Solicitors, Etc.

Canada Life Building Winnipeg, Canada
Solicitors for Farmer's Advocate

R. FERGUSON W. W. RICHARDSON

Disinfection.
It's
Salmon
 ve Cure for
 peed Hook,
 er, Wind
 r Spavin,
 r Tumors,
 Parasites,
 nodes all
 the.
 Rheumatism,
 is invaluable.
 Is sold for
 Price \$1.50
 or sent by ex-
 press for
 five circulars,
 Toronto, Ont

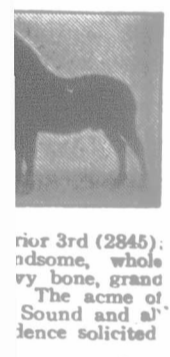

rior 3rd (2845).
 handsome, whole
 body bone, grand
 The acme of
 Sound and all
 Hence solicited

aygeon, Ont

SALES
 CE
 k Farm

Farm
 7 1/2 miles
 Running
 and House
 full par-
 of our

CO. Ltd.

.LS



er Boxes
 Write for
 es cheer-

OR CO.

ROSON

eg, Canaca
 ate
 CHARDSON

Too Rapid Feathering



Spring chickens often show positive weakness as the result of too rapid feathering. This checks the development of the chick, and may result in loss. If you begin the care of the young brood by giving daily a little of

DR. HESS POULTRY PAN-A-GE-A

In the morning find these difficulties will be avoided. It contains bitter tonics to increase digestion, iron to make blood, and nitrates to help the fowl to throw off poisons from the system. By increasing digestion you increase growth and egg production, as all development depends absolutely upon the digestion. Besides this it has a principle peculiar only to itself—it has the power of destroying the little germs of disease, cleansing and purifying the system generally. Poultry Pan-a-ge-a is the prescription of Dr. Hess (M.D., D.V.S.). It makes eggs in abundance when given to laying hens, and hastens the fattening of market stock. Endorsed by leading poultry associations in United States and Canada. Costs but a penny a day for 30 hens, and is sold on a written guarantee.

1 1/2 lb. package, 35c. 12 lbs. \$1.75,
 5 lbs. 85c. 25-lb. pail, \$3.50.

Send 2 cents for r. Hess 48-page Poultry Book, FREE.

DR. HESS & CLARK
 Ashland, Ohio, U.S.A.
 Instant Loose Killer Kills Lice

If you want feeders that will graze you must have with the best, for sale.

HEREFORD

blood in them. I can supply you with the best, for sale. Shetlands and White Leghorns
JAS. SHAY, Portage la Prairie



A. W. Caswell, Neepawa, Man.

NEEPAWA STOCK FARM

FOR SALE—Shorthorns, combining milk and beef, and prize winning Tamworths, pigs of both sexes. Write me.

The Best in the KOOTENAY

52 acres of splendid fruit land only 20 minutes from the centre of the City of Nelson. First-class wagon road through property.

5 acres under the very best of cultivation and 13 acres almost ready for planting.

1/4 of an acre bearing strawberries.

500 raspberry bushes. 150 apple trees. 50 cherry trees. All the very best varieties.

Last year 4 1/2 TONS of finest tomatoes were raised from half an acre of new ground on this sunny property and marketed at good prices.

Small frame house and good frame barn.

\$100 per acre on easy terms.

Wolverton & Co.
 NELSON, B.C.

THE JOHN ABELL ENGINE AND MACHINE WORKS CO. Ltd.

Rebuilt Engines in all sizes.
 Rebuilt Separators 30x56, 36x60, 40x60
 Write for prices or call and see the goods, the success of our prices will tempt every farmer to be his own thrasher. All engines and separators are put in first class running order.
 760 Main St. P.O. Box 481, Winnipeg, Man.

respiration are increased, rigors are frequent, sometimes slight, but occasionally violent, and continuing throughout the whole reaction. There is great depression, while loss of appetite, staring coat and disinclination to move are also commonly noted.

In clinical cases reaction is, as a rule, early and well marked, and most of our inspectors agree that the severity of the reaction is in direct ratio to the degree of infection or the stage which the disease has reached. Clinical symptoms not infrequently make their first appearance during the test, generally from 24 to 30 hours after injection. In advanced cases they may persist, the animal rapidly breaking down, while in incipient cases they may gradually recede, the animal regaining a normal and comparatively healthy appearance. Clinical symptoms already evident are almost invariably aggravated by the test. One especially noteworthy feature is that in animals showing only a slight enlargement of the submaxillary lymphatic glands, these will become tense, swollen and painful as the test progresses. This also applies to other enlarged nodes.

Occasionally all evidences of reaction are present, except the thermal rise, while in others the opposite is the case, and it may be noted that these eccentricities are not infrequently shown by all the horses tested in certain outbreaks, and further that they persist throughout repeated tests of the same animals, although, under ordinary conditions, the local reaction has a tendency to become less well marked with each succeeding test.

In animals in the last stages of glanders, old horses, young foals and others of inferior vitality, a lowering of temperature not infrequently follows the injection of mallein. This is especially noticeable in advanced cases where the temperature is high at the time of injection. In actual outbreaks, contact horses, even when showing no clinical symptoms, but having a high initial temperature, dropping or remaining stationary after injection, should be condemned, especially when a local reaction occurs. In fact it may be said down as a general rule that a typical local reaction is proof positive of the existence of glanders, even when no thermal disturbance takes place.

There is not, as a rule, much difficulty in distinguishing between a typical and a non-typical reaction. The former has been already described. In the latter the thermal rise seldom exceeds 20°, and reaches its greatest height at or before the 12th hour, returning to normal before the 20th hour.

The swelling, when circular, rarely exceeds three inches in diameter. It is only slightly painful, is quite superficial, soft and movable, does not increase after the 8th hour, and is rapidly absorbed during the course of the second day. It never affects the action of the muscles, nor does it cause lameness. Sometimes a fluctuating dependent swelling of considerable size follows careless or unskillful injection, but this, as a rule, is absorbed rapidly during the first 24 hours.

With ordinary precautions septic infection seldom takes place, and abscess formation is rare except in typical reactors, when it is not uncommon. Occasionally considerable swelling, sometimes accompanied by a thermal rise, will occur in horses suffering from influenza and similar affections. Such so-called reactions are not typical, and should not be ascribed to the action of mallein, but to the already existing febrile condition of the animal.

Cases sometimes occur in which, at the end of 24 hours after injection, neither thermal nor local conditions are sufficiently definite to enable the veterinarian to reach a decision. In these circumstances the animal should be kept under close observation for a further period of 24 hours, when, if it is diseased, the increased swelling and marked lameness which almost invariably follow will remove any possible doubt. Suspected cases which have failed to give a decided reaction will not infrequently develop clinical symptoms if put to hard work immediately after being tested.

Reaction, both thermal and local, but especially the latter, is not so well

ALBERTA-CANADIAN INSURANCE CO.

AUTHORIZED CAPITAL \$500,000.00
 FULL GOVERNMENT DEPOSIT

HEAD OFFICE: EDMONTON, ALTA
 HEDLEY C. TAYLOR, President JOSEPH H. GARIFFY, Vice-President
 EDGAR A. BROWN, Secretary

Agents Wanted in Unrepresented Districts

Scarcliffe Herefords

Do you want to grow CATTLE that go to market early, that make the BEST use of their feed, and so leave the largest PROFIT to the feeder? Then use Hereford Blood. Use young stock offered for sale. Herd headed by Simpson 1st. Get my quotations.

H. M. BING, GLENELLA, Man.

PREVENT BLACKLEG BLACKLEG VACCINE FREE

Introduce, we will send one 10-dose package (value \$1.00) of

OUTTER'S BLACKLEG PILLS

"CALIFORNIA STOCKMEN'S FAVORITE"
 Had our booklet on Blackleg and Anthrax FREE to each stockman who sends the names and addresses of 20 cattle-raisers; if you do not want Vaccine, send us your name and address on a post card and we will promptly send the booklet. It is up-to-date, valuable and interesting. Mention this paper Address
THE OUTTER LABORATORY
 BERKELEY, CAL

Saskatchewan Valley Stock Farm.

Largest Herd of Pure Bred SHORTHORNS in northern Saskatchewan. Winners of Imperial Bank Cup. Best herd any breed 1904, 1905 and 1906
 Stock for Sale Farm adjoins city
R. S. COOK, Prince Albert, Proprietor

Sittyton Shorthorns

The Champion Herd at Regina and Calgary, 1906. At present all my bulls are sold but I can supply a number of first-class females of all ages and of most approved breeding. My old stock bull, Sittyton Hero 7th, has left a good mark. Get my prices for females before closing elsewhere.
GEO. KINNON, COTTONWOOD, Sask.
 Lumsden or Pense stations.

Lump Jaw

The first remedy to cure Lump Jaw was
Fleming's Lump Jaw Cure
 and it remains today the standard treatment, with years of success back of it, known to be a cure and guaranteed to cure. Don't experiment with substitutes or imitations. Use it, no matter how old or bad the case or what else you may have tried—your money back if Fleming's Lump Jaw Cure ever fails. Our fair plan of selling, together with exhaustive information on Lump Jaw and its treatment, is given in
Fleming's Vest-Pocket Veterinary Adviser
 Most complete veterinary book ever printed to be given away. Durable bound, indexed and illustrated. Write us for a free copy.
FLEMING BROS., Chemists,
 45 Church Street, Toronto, Ontario

The Regina Veterinary Stock Food

A scientific Stock Food prepared by leading Veterinarians. Prevents Contagious Abortion, Swamp Fever, Equine Typhoid, Pink Eye, Strangles, Indigestion, Hidebound and all blood and skin diseases of Live Stock.
 Endorsed by prominent stock men.
 Manufactured by **THE REGINA VETERINARY STOCK FOOD COMPANY, Box 547 Regina Sask**

B. P. RICHARDSON

BARRISTER, SOLICITOR
 NOTARY PUBLIC
 Solicitor for the FARMER'S ADVOCATE for Alberta and Saskatchewan
GRENFELL, SASK.

LANDS FOR SALE

ISLAND PARK HEREFORDS

ships and one grand championship.
 Address: **J. A. CHAPMAN, ISLAND PARK FARM, BERESFORD MAN.**

At MAPLE SHADE

JOHN DRYDEN & SON
 Stations: Brooklin, G.T.R.

Sold Out, But Still In The Business

We have no more Yorkshires or Berkshires for sale until the Spring litters come in. Send your order now and avoid disappointment. We expect a grand lot of young stuff from imported and prizewinning sires.
 Several excellent Shorthorn Bulls and Heifers for sale. Some of these are extra quality.
WALTER JAMES & SONS Rosser, Man

WOOL CALFSKINS & C. FURS

Write for Prices or
 Ship direct to
T. CARTER & Co. Toronto

RED POLLED CATTLE

The Grain Grower's Cow

YORKSHIRE HOGS

Spring Pigs \$10 apiece when weaned. You can save money both on price and freight by ordering now. Remember, we raise the big litters.

Shorthorn Bulls, Heifers and Hefifer Calves for Sale.

The get of Sir Colin Campbell (imp)—28878—and General—30399—. Cows all ages in calf or calf at foot. Seventy head to choose from. Young stock for sale; two and three years old. Also mares and fillies. Leicester Sheep, both sexes. Stock always on hand.
Geo. Rankin & Sons, Hamiota, Man

SHORTHORNS

Ranchers and farmers need the red, white and roans if you wish to breed the best and most profitable cattle. Can supply you with tip-top stuff. Am offering two-year-old Bull—herd header—and 14 yearling Bulls; also Cows and Heifers
JOHN RAMSAY, Priddie, Alta.

Forest Home Farm

FOR SALE two right good Clydesdale Stallions, rising two years. Shorthorn Bulls and Heifers, one and two years old. Yorkshire Pigs (fall and spring litters), and a grand lot of Barred Rock Cockerels.
 All at moderate prices
ANDREW GRAM Pomeroy P.O.
 Garman or Roland Stations, O.P.K., C.N.R. or G.N.R.

Terra Nova Stock Farm

HERD OF
ABERDEEN-ANGUS CATTLE
 All the best families represented. Some fine young bulls for sale from both imported and home bred cows. Prices reasonable.
S. MARTIN, Rounthwaite, Man.

The Champion Herd at Winnipeg and Brandon for three years.

This year won nine first prizes out of ten competed for. At Winnipeg, three champion A few good young females for sale.
PARK FARM, BERESFORD MAN.

Our young bulls are the best that our herd has ever produced.

We can furnish Guickstank bulls of high quality to head the best herds and some that will produce prime steers. We have a bull catalog—send for one.
Brooklin Ont. Myrtle, C.P.R.

We Challenge Comparison

There is no Breakfast Food as good as "B & K" OATS. None equal in delicacy of flavor, in purity, in wholesomeness.

Our 25 years' experience in Milling is behind this statement, and our guarantee goes with every sack.

TRADE MARK
B & K
REGISTERED

A High Grade Cereal made from
Selected White Northwest Oats

Your Grocer Sells it or can get it for you
Once Used ————— Always Used

The Brackman-Ker Milling Co. Ltd.

Calgary, Alberta

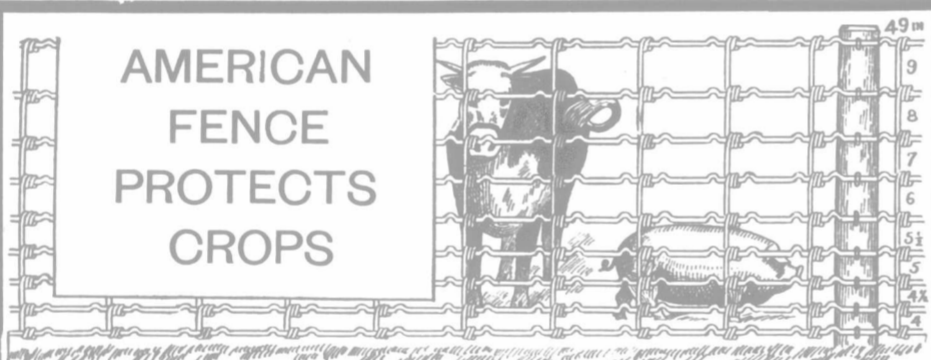

SPECIAL STEEL SPECIAL GALVANIZING
ALL No. 9
HARD, STIFF, SPRINGY WIRE
USED IN THE

American Woven Wire Fence

Tension Curves prevent stays from slipping.



Hinge joint allows the American to fit the Hills and Hollows.

The Canadian Steel & Wire Co. Limited
HAMILTON, CANADA

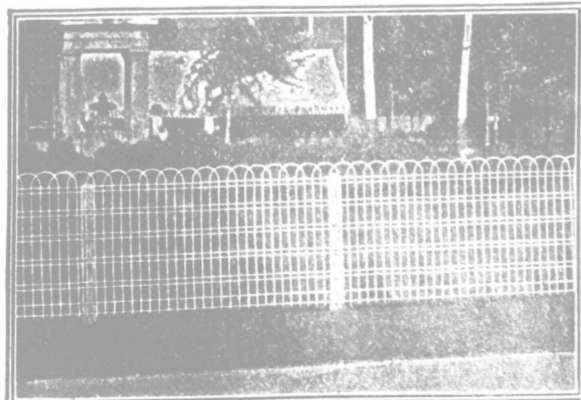

PAGE ACME White Fences

Any height to 8 ft. Any length you say. From 16 cents a foot. Gates to match, from \$2.25. Last longer. Easy to put up. Get booklet.

PAGE WIRE FENCE CO., Limited
Walkerville - Toronto - Montreal
St. John - Winnipeg

marked in mules as in horses, but as in the former acute symptoms are more likely to develop early in the course of the disease, the risk from latent cases is less serious.

"It may be laid down as a general rule that while an apparent improvement in health and condition may, and frequently does, follow the application of the test in mild or incipient cases, the effects of mallein on animals in advanced stages of the disease are invariably bad, and that the testing of such cases hastens a fatal termination.

"Local reactions are more pronounced in hot weather than when the atmospheric conditions are moderate. In connection with this statement I would call attention to the fact that under temperate weather conditions, as, for instance, on the pacific slope, the prevailing type of glanders, while decidedly infectious, is much milder than that seen in most other parts of the country.

"Sudden changes of weather seem to favor the development of acute cases, while under steady heat or cold the disease frequently remains dormant. For this reason serious outbreaks are with us more common in spring and fall than in the steady weather of winter and summer.

"I need hardly point out that, in order to secure satisfactory results, the conditions surrounding the animals should be normal while the test is being conducted. The administration of water, and even of food, the regulation of body heat and of ventilation, must all be carefully watched, in view of their relation to thermal change. For the same reason no exercise whatever should be permitted while the test is being carried on.

"In conclusion I would say that the operations which we have conducted, and their results, have shown in the most convincing manner the great value of mallein as a diagnostic agent when intelligently used by careful and experienced veterinarians. The expressed views of our inspectors on this point indicate that it can be absolutely relied upon in about 98 per cent. of the animals submitted to its action.

"On the occasion of the last annual meeting of the American Veterinary Medical Association, held in New Haven, Conn., August, 1906, the facts as above were set forth with the result that the following resolution was unanimously passed by the association.

"Whereas, in the presentation of Canadian state control work with glanders by Veterinary Director-General Dr. J. G. Rutherford, it is apparent that the Canadian Government has undertaken control work with infectious diseases of animals upon a scale that is highly creditable and in a way commensurate with the importance of the work, and

"Whereas, actual results shown in this report plainly justify the heavy expenditures incurred; therefore be it

"Resolved, That we commend those in higher Canadian Government authority for thus generously supporting this work, and commend the general organization and plan of the Canadian work to the consideration of the Federal authorities and to our various state authorities in so far as it may be applicable to their conditions and not already in force."

An old-time barrister was John Williams, a sarcastic wit, and a bachelor with an intense prejudice against marriage. His clerk one day asked him for a holiday to get married, and some months afterward on entering his chambers, Williams found his dead body suspended from the door. He engaged another clerk and asked him if he were married.

"No," replied the clerk, but thinking Williams would regard marriage as a guarantee of steadiness, he added, "but I'm going to be."

"Very well," replied Williams, "but understand this—when you hang yourself, don't do it here"—*Argument.*

"Do you believe that story about the goose that laid the golden egg?" queried the young lady.

"Certainly," replied the man, with the new suit. "It was a turkey's egg."—*Chicago News.*

See that Lock

It is the perfect fitting, patented side lock on

EASTLAKE METALLIC SHINGLES

no other shingles have it. This famous device makes Eastlake Shingles the easiest and quickest laid—and also insures the roof being absolutely leak proof. Eastlake Shingles are fire, lightning and rust proof.

OUR GUARANTEE—We guarantee Eastlake Metallic Shingles to be made of better material, more scientifically and accurately constructed, more easily applied and will last longer than any other. Eastlake Shingles have been made since 1886.

Our cheapest grade will last longer and cost less than the best wooden shingles. Our best Metallic Shingles should not be mentioned in the same breath with any other roof covering, shingles, slate or tin. Write us for reasons.

The Metallic Roofing Co., Limited,
Manufacturers, Toronto and Winnipeg

WOOD SHEETING
"AQUAPROOF" PAPER

Does Your FOOD Digest Well?

When the food is imperfectly digested the full benefit is not derived from it by the body and the purpose of eating is defeated; no matter how good the food or how carefully adapted to the wants of the body it may be. Thus the dyspeptic often becomes thin, weak and debilitated, energy is lacking, brightness, snap and vim are lost, and in their place come dullness, lost appetite depression and languor. It takes no great knowledge to know when one has indigestion, some of the following symptoms generally exist, viz.: constipation, sour stomach, variable appetite, headache, heartburn, gas in the stomach, etc.

The great point is to cure it, to get back bounding health and vigor.

BURDOCK BLOOD BITTERS

a constantly effecting cures of dyspepsia because it acts in a natural yet effective way upon all the organs involved in the process of digestion, removing all clogging impurities and making easy the work of digestion and assimilation.

Mr. R. G. Harvey, Ameliasburg, Ont., writes: "I have been troubled with dyspepsia for several years and after using three bottles of Burdock Blood Bitters I was completely cured. I cannot praise B.B.B. enough for what it has done for me. I have not had a sign of dyspepsia since."

Do not accept a substitute for B.B.B. There is nothing "just as good."

ED. H. DAWSON
Notary Public, Accountant
DAYSLAND, ALTA.
LANDS FOR SALE

If you are doing an Agricultural, Ranching or Commercial business, advertise in the Farmer's Advocate.

SEWING MASHINES

THE RIGHT KIND AT LESS THAN WHOLESALE PRICES.

An absolute 10 year Guarantee with every machine. Three Months Free Trial Before You Decide to Keep it or Not. Positively a Saving of \$15 to \$40. Strictly High Grade Sewing Machines, None better Made. These machines are sold through the Retailer at double our prices under another name. Why pay more when you can get the best machine made at so great a saving? Thousands now in use and every one giving perfect satisfaction.

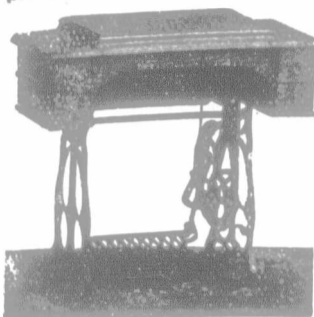

\$18 Buys the economy 5 drawer drop head Solid Oak Cabinet, the best machine in the world for the money. While the price is extremely low, some might think it too cheap to be good, yet we guarantee it to do the work required of a machine equal to any you can buy elsewhere for \$65. It is made to last and give good satisfaction.



For \$26.50 We offer the Wingold High Arm Automatic Lift, Ball Bearing, Five Drawer, Drop Head Cabinet the most beautiful French Polished Oak Cabinet, most handsomely finished in every detail, a regular \$75 machine for only \$26.50, fully guaranteed for 10 years and three months free trial before you decide whether you keep the machine or not. We consider this one of the Greatest Bargains in Sewing Machines over heard of. It is made by one of the largest and most reliable manufacturers. If you want something good, this will please you.

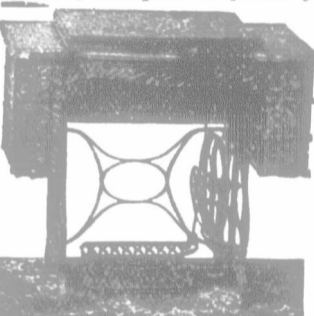

\$27 Buys the Winnipeg Ball Bearing, Automatic Lift, Seven Drawer, Drophead Sewing Machine. Elegantly designed, exquisitely finished, brilliantly hand polished. A most beautiful and desirable Serpentine Front Cabinet, equipped with the latest and the most complete, the most durable, as well as the Handsomest Machine ever offered at any price. The Head is designed on symmetrical lines, high arm and full length, made of the very best materials and all wearing parts Case Hardened. Latest Improved in every detail, a complete set of Most Modern Steel Attachments and a full set of accessories makes this the Simplest, Easiest Operated Machine made.

OUR OFFER! Mail us your name and address saying you would like to have our New Sewing Machine Offer, and you will receive by return mail FREE the most LIBERAL OFFER ever heard of. Don't buy a Sewing Machine of any kind on any kind of terms until after you receive our offer. Write to-day for further particulars.

THE WINGOLD STOVE CO. Dept. F. A. 245 NOTRE DAME AVENUE, WINNIPEG



HIT!

It's the long shot that shows up the quality of both gun and shells.

DOMINION AMMUNITION

will stand the severest test. Ask your dealer for Crown Shells loaded with the Hamilton Powder Co's "Snap Shot" Black Powder, or Sovereign (Nobel's Empire Bulk Smokeless.) Each in its class is ahead of competition. The "less the duty price" is an added consideration. The quality is guaranteed by this trademark. If your dealer cannot supply you—write us. Dominion Cartridge Co., Ltd. 3-07 MONTREAL.

We Do Job Printing Right on Time Right on Quality Right on Price Farmer's Advocate of Winnipeg, Limited

QUESTIONS AND ANSWERS.

TROUBLE WITH YOUNG PIGS.

I have a young sow that pigged about six weeks ago and had six pigs. Three were big, fat and hairless, and the other three were deformed. Should you advise breeding the sow again and should I obtain good results. I see several of your correspondents are having trouble with their pigs this year. I have lost twenty-one little ones and one sow up to the present.

W. B.

Ans.—Would suggest that you breed the sow again, and with summer care and exercise things may be all right next time. Breed her any time now.

PARTIALLY EMASCULATED.

Have a two-year-old colt, which I had castrated last June. The man that did the job only took one testicle and said if he took it the other one would come down quicker. The colt is a nuisance to handle, and I should like to know if it would be safe to have a vet. take the other one when it cannot be felt.

M. J. M.

Ans.—Yes; the other may be removed if reasonable precautions are taken. It will be necessary to throw and tie the colt so that the hocks are flexed and the legs kept well apart. If so tied there will probably be no difficulty experienced in securing the missing seed.

FEARS SPAVIN.

I am desirous of buying a good mare for spring work. I have seen one that suits in every way, but has had her hock joint strained in the deep snow. The joint swelled up to twice its natural size, was blistered twice and is almost natural now and the mare is not at all lame. Do you think there is any chance of this leg developing a spavin? The mare is worth \$200.00 if it does not, but I should not like to put that money in her if it did. The swelling is soft and she notices it only on account of blister.

Sask. J. J. A.

Ans.—Of course it is impossible to tell positively, but if she comes well again we should not hesitate to take the risk. In the meantime she should have plenty of chance to recover before being put to hard work. The danger lies in putting her to work before the joint is perfectly well; after that with ordinary treatment she should be a good investment.

HOMESTEAD FOR WIDOW.

Will you kindly inform me through the columns of your valuable paper: First, if a man took up a homestead in Sept., 1905, moved on with his family immediately and in March, 1907 died suddenly can widow prove up in husband's name right away or must she put in regular time on same homestead in order to obtain patent? Second, can widow take up homestead in her own name this spring?

Sask. WIDOW.

Ans.—Make an explanation of the circumstances to the land office where homestead was filed and you will in all probability be granted the time your husband put in on the homestead. In that case you could not secure another, but if the first were abandoned you could probably get another under the circumstances.

UNTHRIFTY CALF.

I have a calf about nine months old which would scarcely eat or drink anything and got very thin. It did not appear to be sick, but is a very poor doer.

Man. N. H.

Ans.—Some animals are just naturally poor feeders and when they will not eat very little can be done with them. The way to avoid such stock is to breed to stock that are good feeders and easy keepers. Improved stock are not merely a fancy; they are called improved or pure bred or whatever name one likes to attach to them, because the poor feeders are culled out

STOP!

Before you finally buy that new Pump and ask yourself whether it is not better to get a Pump that has proved itself superior to all other Wood Pumps by years of hard test in the extreme temperatures of Western Canada.

FLORENCE WOOD PUMPS

ARE BEST BY TEST

MELOTTE CREAM SEPARATORS

are the most durable and efficient Cream Separators on the market. Built to last a lifetime. Saves work, money and worry because it is easy to turn, easy to clean and easy to buy. Write us to-day.

Agents for "Ideal" Gasoline Engines

Melotte Cream Separator Co. Ltd.

W. ANTLIFF, Manager

WINNIPEG

CALGARY

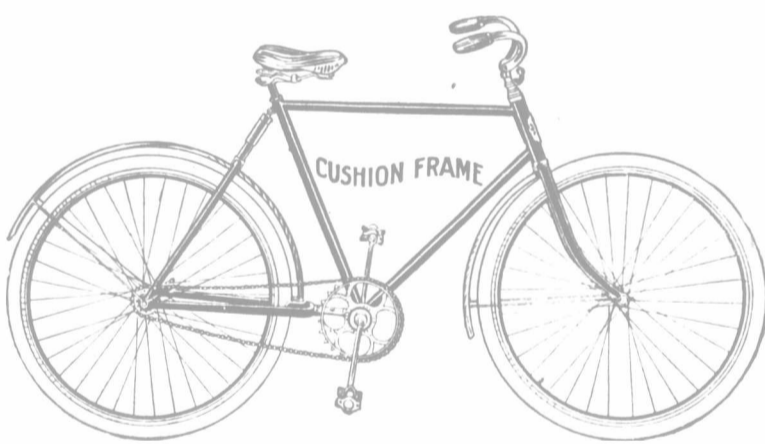
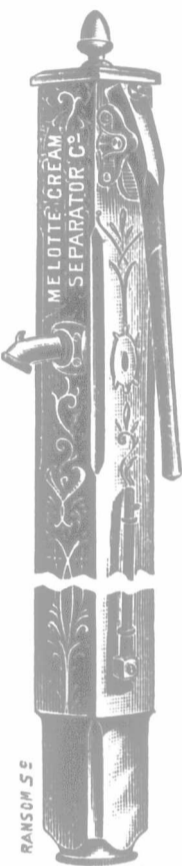
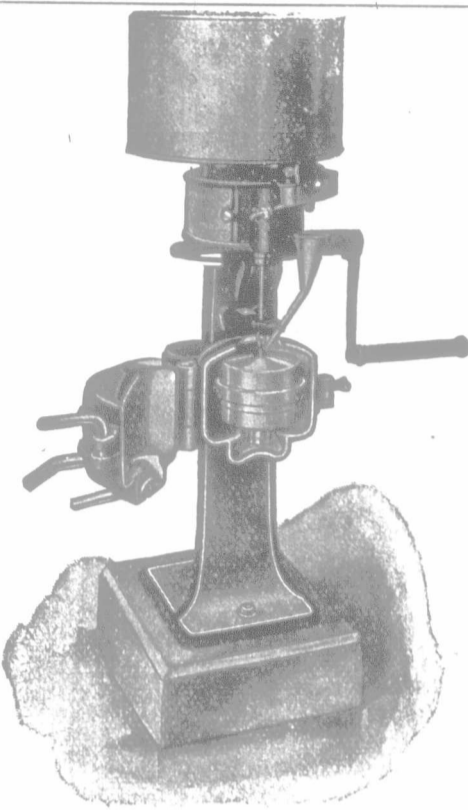

Cleveland Massey Brantford Rambler Imperial Perfect

In purchasing a bicycle be sure you get one of the above. There are no better made and repairs for these are always carried in Winnipeg. We do not handle one make of bicycle one year and another make the next year, but have manufactured the above lines for years. Inquire of the dealer in your own town or if we are not represented send for catalogue.

Canada Cycle & Moter Co., Winnipeg, Man.

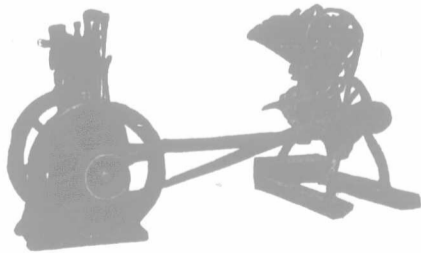

The Farmer's Friend

For Grinding, Pumping, Churning, and General Farm or Machine Shop Work, the Fairbanks-Morse Gasoline Engine

holds the lead. It will do more work than any other Gasoline Engine of same horse power

For Sale by Dealers Everywhere.

Or cut out complete advertisement and send to

THE CANADIAN FAIRBANKS COMPANY, LTD. 92-94 Arthur St., Winnipeg.

Please send me illustrated Catalogue No. Gasoline Engines. I may want..... H. P. Engine to run Name Town Province

THE MANITOBA WINDMILL AND THE MANITOBA GASOLINE ENGINE

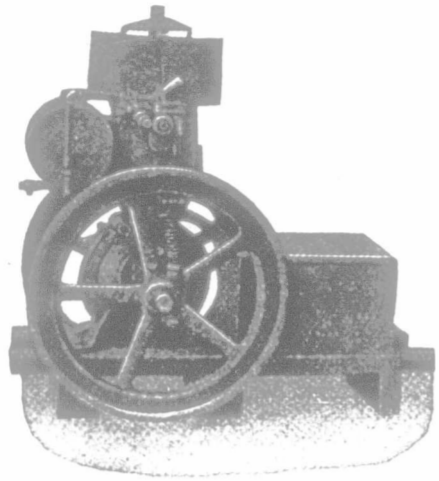

**Efficient in Service.
Honest in Workmanship.
Built for Business.**

They are the ideal machines for the progressive farmer.

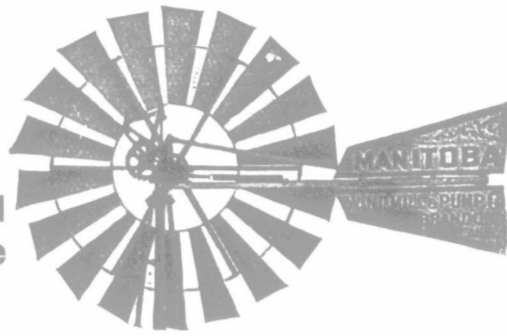

Our Catalogue Will Tell You all About it

Manitoba Windmill and Pump Co. Ltd.

MANUFACTURERS, Box 301, BRANDON, Man.

THIS IS TO YOU

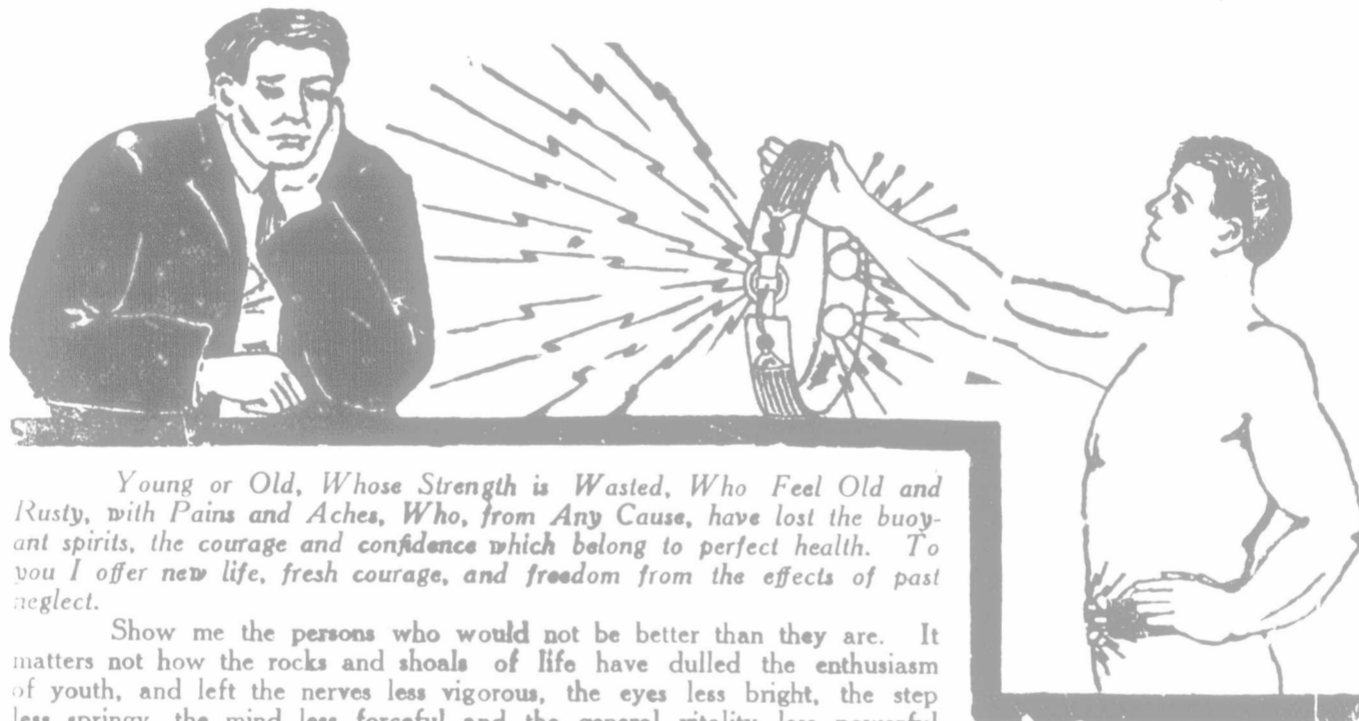

Young or Old, Whose Strength is Wasted, Who Feel Old and Rusty, with Pains and Aches, Who, from Any Cause, have lost the buoyant spirits, the courage and confidence which belong to perfect health. To you I offer new life, fresh courage, and freedom from the effects of past neglect.

Show me the persons who would not be better than they are. It matters not how the rocks and shoals of life have dulled the enthusiasm of youth, and left the nerves less vigorous, the eyes less bright, the step less springy, the mind less forceful and the general vitality less powerful than they ought to be at your age, you want to be strong.

Hard work wears, dissipation and worry, disappointment and the other cares of life drain away the vim and snap of perfect health. Electricity applied my way restores them. It makes you feel young, it renews the fire of youth, the spice of life.

Dr. McLaughlin's Electric Belt

Has made thousands of homes happy. It is as good for women as for men. Man and wife can use the same Belt. The regulator makes it strong or mild to suit the wearer. It is the only Electric Belt in the world that can be regulated while on the body. You feel the power, but it does not burn and blister, as do the old-style bare metal electrode belts. If you are weak or in pain it will cure you. Will you try it?

I HAVE AN ELECTRIC BELT THAT DOES CURE, and I am offering it to you in such a way that you take no chances whatever. Give me your name and address, with a statement of your case, and I will at once arrange a Belt suitable for your case, and

When You Are Cured, Pay Me

All I ask is reasonable security for my Belt while you are wearing it.

Dr. McLaughlin, Dear Sir: I purchased one of your Belts some time ago, and it has done me a great deal of good. I did not think anything would help me as it has done. I have told nearly every one that I know of your wonderful Belt, and a lot of them have got one, and are not disappointed. Yours truly, MRS. J. D. B. T. K.

I am fully satisfied with my Belt. It is a real cure. I am stronger in every way, and I thank you very much for your Belt. WILLIAM J. PEARSON, 1121 York St., Sask. 354 Donald Street, Brandon, Man.

Dear Sir: I have worn your Belt for one month and am very much pleased with it. The varicocoe is relieved, I always feel fine when I get up in the morning. I am much stronger, able to stand up much straighter than I did. Yours truly, J. D. B. T. K.

**CALL TO-DAY
FREE Consultation
Book Test**

**If You Can't Call Send
Coupon for Free Book**

DR. M. D. McLAUGHLIN
112 YORGE STREET, TORONTO.

Dear Sir, - Please forward me one of your Books, as advertised.

NAME _____

ADDRESS _____

Office Hours: 10 a.m. to 9 p.m., Wednesday and Saturday

as much as possible. Wild cattle and scrubs have by natural selection and environment developed an ability to keep body, bones and hide together on very little feed, to such an extent that their systems will not utilize feed for meat production. On the other hand improved stock are bred and trained to make use of their feed.

Give the calf some flax seed and chopped oats with clean chaff or hay and get as much flesh on him as possible; then turn him over to the butcher.

REGISTERING MORTGAGE.

A buys a farm from B and gives B a mortgage for \$1,000. B registers the mortgage in his name. The wife of B refuses to live with him unless he transfers the mortgage over to her. B gives her the transfer. Is it legal if she does not register it? Can B collect the money on it if she neglects to register it? Would the fact of A paying her one payment on it be the same as registering it? Can she will it to whom she pleases as things now are? She has not yet received any payment on mortgage.

Sask. F. W.

Ans.—The transfer of the mortgage to B's wife is apparently capable of being set aside by B, there being no consideration for it, but apart from that question B's wife by reason of the fact that she has not registered cannot claim to have the farm as security for the money advanced. See Mortgage Act, R. S. M. 1902 c. 115 S. 2; nor can she acquire any rights over a subsequent mortgagee, who advanced his money without knowing that she was then the holder of the transfer of the mortgage. Registry Act, R. S. M. 1902 c. 150, s. 69. Of course, B's wife can bequeath the transfer of mortgage by will for what it is worth.

WEIGHT OF BUSHEL.

Kindly tell me the exact number of pounds in a bushel of potatoes. Cypress Municipality, A. M. Man.

Ans.—Sixty pounds is the legal weight of potatoes, turnips, parsnips, carrots, and beets.

PUTTING CULVERT IN RAILROAD.

The railroad runs through my farm. There is one sluice or culvert in my farm and now the water is running from the neighbor's fields and flooding my farm, by the railroad keeping it in. Can I make the railroad people put in more culverts, or is there any rule how far apart they should be? Can I make them get it done in time to seed as they will be busy putting them in near the town? This one culvert is not enough.

Sask. T. E. W.

Ans.—A railway company is bound to construct and maintain suitable culverts and outlets to drain and carry off water, the flow of which is obstructed or impeded by the railway. The landowner whose lands are injuriously affected may apply to the Board of Railway Commissioners for the construction of necessary culverts and on enquiry the Board may order how, when and by whom the work is to be done. See Canadian Railway Act, 1903, S. 190.

DAMAGE TO OATS.

A threshes oats and leaves them in a pile on the stubble. B owns adjoining farm and his cattle stray over and get at the oats on A's place. The cattle from three other farms also stray over and help to injure the pile. A sends B a lawyer's letter telling him that if he does not make good 200 bushels of oats he will sue him for same. B is positive that his cattle were not at the pile long enough to do more than 25 bushels at the most.

What is the evidence in the case of legal liability? A could make good his oats if he had proof that other cattle were not at the pile.

A. B. C.

Ans.—It is the evidence by the parties in the case.

M
or
wi
he
be
th
bl
po
in
fr
wi
pu
pa
he
It
til
th
th
otl
fro
qu
to
the
tur
blo
vet
wit
wa
to
is
gre
of
son
chr
vis
apr
the
whi
blo
chic
rem
wal
for
can
ente
car
unti
diar
ister
of
prop
This
and
that
best
Co
wha
man
hors
last
and
ever
wate
oats
peav
all
l
Hav
abou
ends
oil
a
horse
I
hav
all
w
the
thick
to
pe
sum
petre
of
su
one
p
salt
a
tab
for
tl
also
l
They
bowe
but
t
Sas
An
your
adv
mash
then
Barb
one
d
suffic
fodde
After
food,

Wild cattle natural selection developed an ability to hide together such an extent not utilize feed On the other are bred and their feed.

LUMPS ON NECK.

I have a mare with a large, hard lump on each side of her neck near the top where the collar sits. She can't get her head over to eat grass and pulls back on her halter.

Alta. J. A. M. Ans.—Keep all pressure away from the lumps and apply the following blister:—Binioidide of mercury, 2 drams; powdered cantharides, 3 drams; vaseline, 4 ounces; mix. Cut the hair closely from the parts and rub the above well in with the fingers for ten minutes. If pus is forming the blister will bring it quickly to a head.

BLOATING, DROPSY.

Will you inform me in your valuable paper of the cause and cure for young heifers one to three years old bloating? It comes on gradually and they eat well till a day or so before they die, when they quit eating and bloat so much that they can hardly walk. We opened two that died, one in February, 1906, the other in May. We made an incision in front of the hip bone and found a great quantity of clear water, which appeared to be between the wall of the body and the bowels. Do you think it was a tumor? There is one beginning to bloat now and was examined by a veterinarian who said to physic her with salts. The first was treated that way but it did no good. Would like to have your opinion and know if there is any cure. By so doing you will greatly oblige.

Ans.—An abnormal accumulation of fluid in the abdominal cavity is sometimes found in connection with chronic disease of some of the internal viscera. It is sometimes, however, apparently the result of weakness of the coats of the minute blood vessels, which exude the watery parts of the blood, of which the effused fluid is chiefly composed. This fluid may be removed by tapping the abdominal walls about seven or eight inches in front of the udder, with a trocar and canula. When the instrument has entered the cavity of the belly the trocar is withdrawn and the canula left in until the water has escaped. After diuretics and tonics should be administered, such as sulphate of iron, iodide of potassium and digitalis, in doses in proportion to the age of the animal. This condition usually occurs in lean and unthrifty animals. It is seldom that entire success will follow even the best professional treatment.

UNTHRIFTY HORSES.

Could you kindly give me any advice what to do with a team of horses, one mare rising four years and one aged horse? I arrived here from Manitoba last spring. My horses then were fat and healthy, but have gradually failed ever since. They have had good well water and are getting six gallons of oats a day with highland hay, mostly peavine. They were on good pasture all last summer with bran and oats. Have passed a few large white worms about six inches long, tapered at both ends. I gave about one quart of linseed oil and two ounces of turpentine to each horse, but they did not pass any worms. I have fed linseed meal and a little salt all winter. I think there is trouble in the kidneys, as their urine is always thick and yellow and sometimes difficult to pass. I gave sweet nitre during last summer and this winter. I have fed saltpetre for a time; then made a powder of sulphur, four pounds; baking soda, one pound; cream of tartar, half pound; saltpetre, half pound; mixed and fed a tablespoon to each horse once a day for three days; then miss three. I have also fed boiled oats about twice a week. They have a sort of rolling noise in their bowels, and they are getting very poor, but they eat well.

Ans.—The nutritive assimilation of your horses appears to be faulty. Would advise you to feed exclusively on a bran mash diet for at least sixteen hours, and then give to each horse the following:—Barbadoes aloes, 7 drams; calomel, one dram; ground ginger, 2 drams; soap, sufficient to form a ball. Give no fodder until physic has ceased to operate. After this give morning and evening in food, or on tongue with tablespoon,

one of the following powders:—Sulphate of iron, bicarbonate of soda, nitrate of potassium, of each, four ounces; powdered nux vomica, three ounces. Mix thoroughly and divide into forty powders. Would advise you to give a moderate ration of boiled wheat, in place of a feed of oats, once daily for two weeks.

DELAYED GESTRUM.

Young mare four years old never came in season last year nor this spring so far. Is there anything I could give her to make her come that way?

Ans.—If your mare is very plethoric, would advise you to reduce her condition by lower feeding and regular exercise. A dose of purgative medicine might, under the circumstances, be beneficial; i. e., Barbadoes aloes, one ounce; ground ginger, seven drams; soap, sufficient to make a ball. Withhold all fodder for at least sixteen hours before administering the ball. Feed exclusively on bran mash until physic has ceased to operate. On the other hand if the mare is in low condition, try to improve it by good feeding, good grooming and general good care.

TRAIN ON CROSSING: PROPERTY.

1. How long can a train hold a crossing to keep teams from passing? 2. Can a boy under age hold stock in his own right when he works out and buys it himself? 3. If A enters a homestead in his own name can he have the Government deed to the same to his wife, and can she hold the same regardless of any debts he may owe?

Ans.—1 Only five minutes, except in cases of necessity. 2. Yes. A boy under age can hold any amount of property, but he is not liable for debts contracted in purchasing the property, unless it be necessary to his maintenance. 3. Yes, but why put it in the wife's name? The husband can hold the homestead himself, not withstanding his debts, as the homestead is exempt from execution.

STOCK RUNNING AT LARGE.

I should like to know something about the stock law for this province (Sask.). If hay is not fenced during winter months, can owner collect damages done by neighbor's stock?

Ans.—For the purpose of protecting growing crops from stock running at large the old Northwest Territories Government passed the Herd Ordinance. This act provides for the establishment of herd districts, that is, certain districts may be declared to be under the Herd Ordinance. The Herd Ordinance provides that stock shall not run at large without being accompanied by a herder between the 15th of May and the 30th of October inclusive. Before and after these dates stock may roam at will at the owner's risk, but he is not responsible for damage they may do to grain or stacks that are not surrounded by lawful fences. If it is found that stock break through a lawful fence and do damage, then the owner of the fence may recover. But if his stacks or grain are not protected after the expiry of the Herd Ordinance dates, they are at his own risk. The act is a compromise between the grain growers and stock raisers and to protect the grain growers from themselves so that every man will not be compelled to fence or herd stock all the year around. A full copy of the act may be obtained from the Government at Regina.

WEED SEEDS IN SHORTS

Is it unlawful for a grist mill to sell shorts in which are uncrushed weed seeds. If so whom should I notify in the matter.

Ans.—We are not aware that this is an indictable offence. Full particulars in the matter could be obtained from the chief weed inspectors in the different provinces. Mr. T. N. Willing, Regina, is Saskatchewan's; Arch. Mitchell, Edmonton, is Alberta's; and Robt. O'Malley, Winnipeg, is Manitoba's.

WINNIPEG FAIR

July 13th to 20th, 1907

The annual outing for Western Canada's agriculturists.

The display of live stock unexcelled.

Largest prizes ever offered by any Fall Fair for Clydesdales, Heavy and Agricultural teams of horses.

Splendid programme of races.

Entries close July 1st.

GEO. H. GREIG, President.

A. W. BELL, Manager.



A REMARKABLE INVENTION FOR THE Culture of Hair

THE EVANS VACUUM CAP is a practical invention constructed on scientific and hygienic principles by the simple means of which a free and normal circulation is restored throughout the scalp. The minute blood vessels are gently stimulated to activity, thus allowing the food supply which can only be derived from the blood, to be carried to the hair roots, the effects of which are quickly seen in a healthy, vigorous growth of hair. There is no rubbing, and as no drugs or chemicals of whatsoever kind are employed there is nothing to cause irritation. It is only necessary to wear the Cap three or four minutes daily.

60 DAYS' FREE TRIAL!

The Company's Guarantee:

An EVANS VACUUM CAP will be sent you for sixty days' free trial. If you do not see a gradual development of a new growth of hair, and are not convinced that the Cap will completely restore your hair, you are at liberty to return the Cap with no expense whatever to yourself. It is requested, as an evidence of good faith, that the price of the Cap be deposited with the Chancery Lane Safe Deposit Company of London, the largest financial and business institution of the kind in the world, who will issue a receipt guaranteeing that the money will be returned in full, on demand, without questions or comment, at any time during the trial period.

The eminent Dr. I. N. LOVE, in his address to the Medical Board on the subject of Alopecia (loss of hair) stated that if a means could be devised to bring nutrition to the hair follicles (hair roots), without resorting to any irritating process, the problem of hair growth would be solved. Later on, when the EVANS VACUUM CAP was submitted to him for inspection, he remarked that the Cap would fulfil and confirm in practice the observations he had previously made before the Medical Board.

Dr. W. MOORE, referring to the invention, says that the principle upon which the Evans Vacuum Cap is founded is absolutely correct and indisputable.

An illustrated and descriptive book of the Evans Vacuum Cap will be sent post free, on application.

THE SECRETARY, EVANS VACUUM CAP CO. LTD. REGENT HOUSE, REGENT STREET, LONDON, ENG.

From the Cow to the Pail, From the Pail to the Cans
 of
The National Creamery & Produce Coy., Ltd.

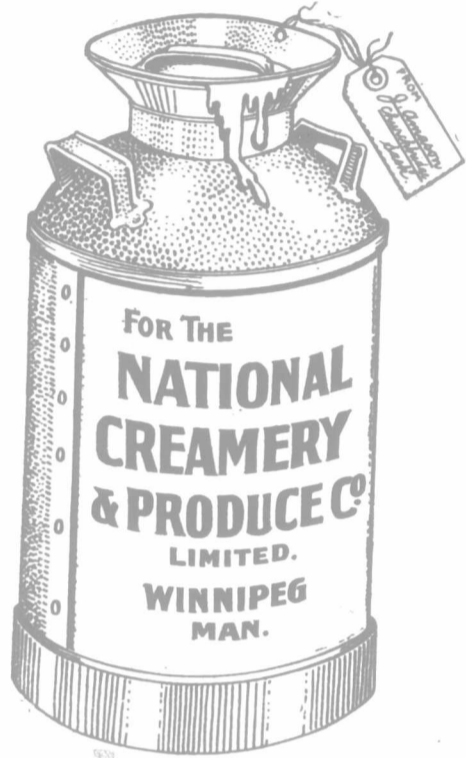

Is the simple labor-saving, money-making, comfort-giving solution of the dairy problem in the Province of Manitoba.

We are the only Creamery Company that insures patrons against loss by paying by Express Money Orders, always paying the highest prices and paying promptly on the 1st and 15th of each month.

We have the largest and most sanitary Creamery in the Province, with a churning capacity of over 25,000 pounds per day.

We have the only Creamery in Canada equipped with a Cold and Pure Air Circulation System. This Air is purified by a washing process which it undergoes in passing through a spray of brine which passes over ammonia coils, thus removing all bad odors from our Creamery room and cooling our room down to a low temperature. This enables us to keep our Cream room in a perfectly sanitary condition, therefore, enables us to make the best product on the Western market, thereby commanding the highest market prices at all times.

We test every can of Cream separately and guarantee our tests to our patrons, and any farmer wishing to do so, may have the Dairy Superintendent call at our Factory, test his Cream and send him an official test of same.

Ship us a few cans of Cream on trial, so that we can show you how satisfactory are our methods of doing business.

WRITE FOR PARTICULARS

The National Creamery & Produce Co., Ltd.
WINNIPEG, MANITOBA.

Hail Insurance

INSURE YOUR CROPS WITH

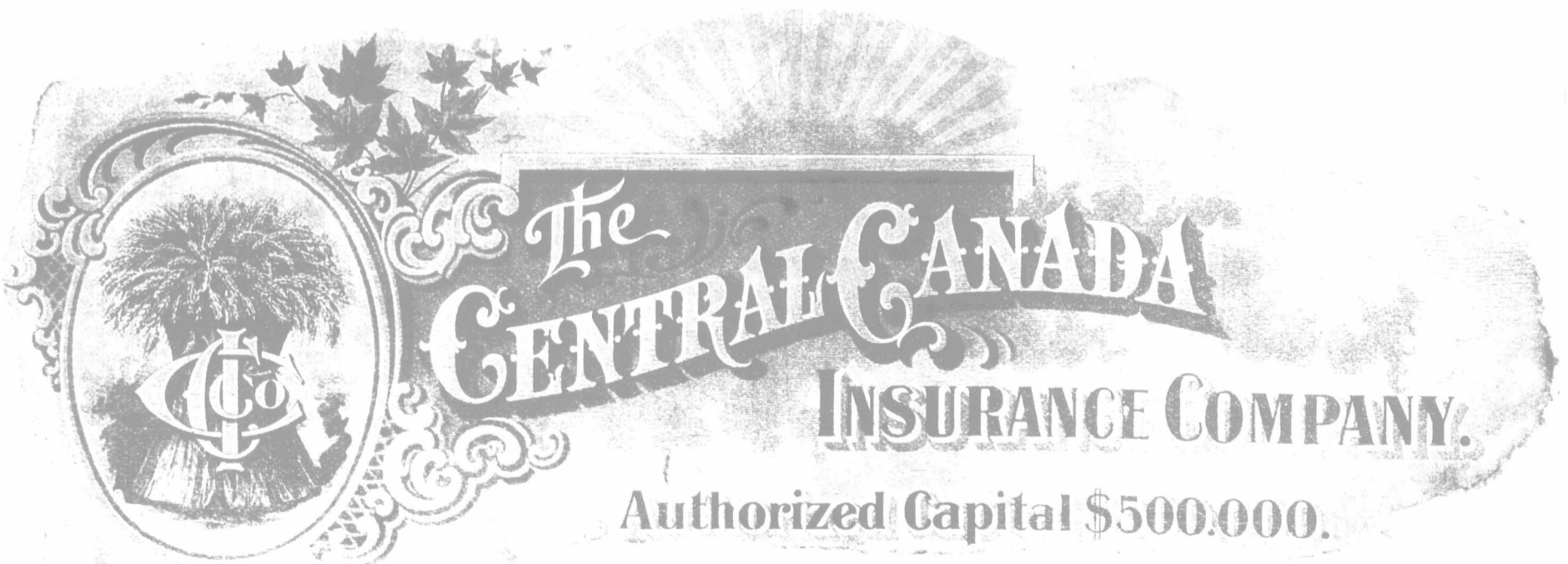

HEAD OFFICE
 BRANDON, MANITOBA.

Authorized Capital \$500,000.

YOU PAY THE PREMIUM

And give you a policy that guarantees prompt
 and full settlement of your loss.

WE CARRY THE RISK

A CONTRACT THAT GUARANTEES NOTHING IS NOT
 INSURANCE AND IS DEAR AT ANY TIME.

Full information on application to any local
 agent or our Head Office.

JOS. CORNELL, Manager, Brandon, Man.