

Technical and Bibliographic Notes / Notes techniques et bibliographiques

The Institute has attempted to obtain the best original copy available for scanning. Features of this copy which may be bibliographically unique, which may alter any of the images in the reproduction, or which may significantly change the usual method of scanning are checked below.

L'Institut a numérisé le meilleur exemplaire qu'il lui a été possible de se procurer. Les détails de cet exemplaire qui sont peut-être uniques du point de vue bibliographique, qui peuvent modifier une image reproduite, ou qui peuvent exiger une modification dans la méthode normale de numérisation sont indiqués ci-dessous.

- Coloured covers /
Couverture de couleur
- Covers damaged /
Couverture endommagée
- Covers restored and/or laminated /
Couverture restaurée et/ou pelliculée
- Cover title missing /
Le titre de couverture manque
- Coloured maps /
Cartes géographiques en couleur
- Coloured ink (i.e. other than blue or black) /
Encre de couleur (i.e. autre que bleue ou noire)
- Coloured plates and/or illustrations /
Planches et/ou illustrations en couleur
- Bound with other material /
Relié avec d'autres documents
- Only edition available /
Seule édition disponible
- Tight binding may cause shadows or distortion
along interior margin / La reliure serrée peut
causer de l'ombre ou de la distorsion le long de la
marge intérieure.
- Additional comments /
Commentaires supplémentaires:

Continuous pagination.

- Coloured pages / Pages de couleur
- Pages damaged / Pages endommagées
- Pages restored and/or laminated /
Pages restaurées et/ou pelliculées
- Pages discoloured, stained or foxed/
Pages décolorées, tachetées ou piquées
- Pages detached / Pages détachées
- Showthrough / Transparence
- Quality of print varies /
Qualité inégale de l'impression
- Includes supplementary materials /
Comprend du matériel supplémentaire
- Blank leaves added during restorations may
appear within the text. Whenever possible, these
have been omitted from scanning / Il se peut que
certaines pages blanches ajoutées lors d'une
restauration apparaissent dans le texte, mais,
lorsque cela était possible, ces pages n'ont pas
été numérisées.

The Canadian Patent Office

RECORD

Vol. X.—No. 2.

FEBRUARY, 1882.

{ Price in Canada \$2.00 per An.
United States - \$2.80 }

CONTENTS.

INVENTIONS PATENTED.....	31
INDEX OF INVENTIONS.....	XLVIII
INDEX OF PATENTEES.....	XLIX
ILLUSTRATIONS.....	LIII

INVENTIONS PATENTED.

No. 13,917. Improvements on Electric Circuits. (*Perfectionnements aux circuits électriques.*)

Francis Blake, Weston, Mass., U. S., 2nd January, 1882; for 15 years.

Claim.—1st A number of metallic plates and a number of insulated plates of substantially the same dimensions alternating in a pile, in combination with a number of smaller plates, one for each of the electric circuits between which connections are to be made, a peg hole in and through each smaller metallic plate extending also through all the larger plates, whether metallic or insulating. 2nd. A metallic peg with two flanges, whereby it is adapted to make connections between two of several insulated metallic plates placed in a pile, and two only for the purpose specified. 3rd. The combination, with large insulated connecting plates and smaller line plates perforated, of several pairs of contact pegs, the contact portions of said pegs being at equal distances apart in pegs of the same pair, but at unequal distances apart in pegs of different pairs, whereby each pair of pegs may be used with any and all the line plates, but with only one and the same connecting plate.

No. 13,918. Adjustable Seat Rail for Carriage Tops. (*Barre mobile de siège pour les soufflets des voitures*)

Daniel Conboy, Uxbridge, Ont., 2nd January, 1882; (Re-issue of Patent No. 10,150.)

Claim.—1st. In a carriage top in which the bottom of the back curtain is fastened to a rail or bar extending across the rear of the seat, the combination of a device arranged to secure the said rail to the seat in such a manner that it may be vertically adjusted, for the purpose of permitting the top to be tilted without disconnecting the back curtain from the said rail.

No. 13,919. Method of Removing Iron from Ferruginous Aluminous Solutions. (*Méthode pour enlever le fer des solutions ferrugineuses aluminiques.*)

Conrad Semper and Constantine Fahlberg, Philadelphia, Pa., U. S., 2nd January, 1882; for 5 years.

Claim.—1st. The method of removing iron from a ferruginous solution of the salt of a metal-alkali or alkaline earth, which consists in treating said ferruginous solutions with plumbic dioxide. 2nd. The method of manufacturing sulphate of alumina or aluminous cake free, or almost free from iron, which consists in treating ferruginous aluminous solutions with plumbic dioxide. 3rd. The process of purifying waste plumbic dioxide and ferric plumbate, produced in the process of precipitating iron from ferruginous solutions, which consists in treating said waste mass with vitric or other acid or acid salt, for the removal of the iron therefrom.

No. 13,920. Improvements on Steam Rock Drills. (*Perfectionnements aux forêts de mine à vapeur.*)

The Rand Drill Company, (Assignee of Joseph C. Gittens,) New York, N. Y., U. S., 2nd January, 1882; for 5 years.

Claim.—1st. In a column for the support of a rock drill, the elongated radius bar *b*, in combination with the jack screws *a* inserted through the platform *A*, and the column *A*. 2nd. The column

A provided with the adjustable shoulder *C* composed of the two curved jaws *c*, which embrace the column upon opposite sides and are clamped thereon by the transverse clamping bolts *e*, provided with the nuts *e*, for the purpose of affording a vertically adjustable bearing for the lower end of the hub *D* of the lateral arm *D*. 3rd. The bearing for the drill cylinder carriage composed of a number of equidistant elevations *g* arranged radially with relation to the bolt which constitutes the axis of oscillation for the carriage. 4th. The arrangement of the steam valve *H* having its stem projecting laterally from the side of the steam chest *F* and provided with a lever or handle in convenient position to be reached by one hand of the operator, while his other hand is grasped upon the crank of the feed screw. 5th. The axially split crank nut *K* provided with the transverse clamping screw bolt *k*, in combination with longitudinal feed screw *L*. 6th. The chuck *M* provided upon its inner end with the transverse clamping bolt *m* and having a female screw thread formed upon its middle section only, and having its inner section sufficiently large in diameter to embrace the shank of the piston rod, above the portion upon which the male screw thread is cut.

No. 13,921. Improvements on Corn Mills.

(*Perfectionnements aux moulins à blé-d'inde.*)

Albert E. F. Chattaway, Wixford, Eng., 2nd January, 1882; for 5 years.

Claim.—The arrangement and combination of the several parts or appliances by which to drive the lower stone at a high speed, without disturbing the position of either of the stones relatively, namely: mounting the lower stone *G* in a frame *D* capable of adjustment and fixing on bearings *L*, or similarly mounting the upper stone *H* together with the several parts *R* *S*, by which such adjustment and fixing are effected.

No. 13,922. Improvements on Steam Boiler Cleaners. (*Perfectionnements aux nettoyeurs des chaudières à vapeur.*)

Christ Reiser, Prairie du Chien, Wis., U. S., 2nd January 1882; for 5 years.

Claim.—1st. In combination with the tubes *a* of a steam boiler, the chamber *B* having inlet pipe *D*, trough *E*, plates, pans or traps *F* *G* *H* and pipes *I*. 2nd. A steam boiler cleaner composed of the following separable and detachable parts, namely: the lower trough or pan *H* having the overflow pipes *I*, the trough or plates *G* *F* *E* and feed pipe *D*. 3rd. In combination with a steam boiler cleaner, the pipe *K* with its connections and cock.

No. 13,923. Improvements on Head Lights for Locomotives. (*Perfectionnements aux lanternes des locomotives.*)

Irvin A. Williams, Utica, N. Y., U. S., 2nd January 1882; for 10 years.

Claim.—1st. The combination of a burner, a head light case and a reflector provided with means whereby access from the outside of the reflector and in rear of its front edge or flanges afforded for either lighting, trimming or cleaning the burner within the head light case without removing the reflector from the case, and without moving the burner from its normal position, or a portion of the reflector as an adjunct of the burner, away with the burner from the position of use within the case. 2nd. The combination of a head light case, a reflector movable within the case and a burner, whereby the reflector can be moved out of the range of the burner and the burner either cleaned, trimmed or lighted without removing the reflector from the case. 3rd. The combination of a head light case, a burner movable in the case, a reflector and means whereby the burner can be lighted, or cleaned or trimmed within the head light case without removing the reflector from the case, and without moving a portion of the reflector, as an adjunct of the burner, away with the burner from its position of use within the case. 4th. The combination of a head light case, a reflector, a removable burner and means whereby the burner can be removed out of the case without removing the reflector from said case, and without moving a portion of the reflector as an adjunct of the burner, away with the burner from its position of use within the case. 5th. A head light provided with a reflector, which is movable in the head light case out of the range of the burner in said case.

No. 13,924. Improvements on Head Lights for Locomotives. (*Perfectionnements aux lanternes des locomotives.*)

Irvin A. Williams, Utica, N. Y., U. S., 2nd January, 1882; for 10 years.

Claim.—1st. The combination of a reflector provided with means whereby it is connected to its support and is allowed to tilt out of the range of the burner, a burner and a head light case. 2nd. The combination of a reflector provided with means whereby it is connected to its support and is allowed to slide upward, out of the range of the burner, a burner and a head light case. 3rd. The combination of a reflector provided with means whereby it is connected to its support and is allowed to slide and tilt, out of the range of the burner, a burner and a head light case. 4th. The combination of a reflector having a chimney attachment and provided with means whereby it is made movable within the head light case, out of the range of the burner, a burner and a head light case. 5th. The combination of a removable burner, a head light case and a reflector provided with means whereby it is connected to its support and is allowed to have a tilting movement, out of the range of the burner. 6th. The combination of a removable burner, a head light case and a reflector provided with means whereby it is connected to its support and is allowed to have an upward sliding movement out of the range of the burner. 7th. The combination of a removable burner, a head light case and a reflector provided with means whereby it is connected to its support and is allowed to have a tilting and a sliding movement, out of the range of the burner. 8th. A reflector provided with means whereby it is permanently supported and allowed a tilting forward movement out of the range of the burner while in the head light case.

No. 13,925. Improvements in the Art of Raising Bread. (*Perfectionnements dans l'art de faire lever la pâte.*)

Charles E. Avery, Boston, Mass., U. S., 2nd January, 1882; for 5 years.

Claim.—1st. The improved baking powder, or cream of tartar substitute described, composed of an acid lactate with an alkaline carbonate or bicarbonate. 2nd. A bread-raising composition composed of acid lactate of calcium and an alkaline bicarbonate or carbonate.

No. 13,926. Improvements in Straw-Cutters. (*Perfectionnements aux coupe-pailles.*)

Cornelius Shepardson, Czajenovia, N. Y., U. S., 2nd January, 1882; for 5 years.

Claim.—1st. In combination with the gate B arranged to reciprocate vertically across the end of the box A, the knife C having V-shaped teeth, and the cutting edges thereof formed by a continuous bevel at the front, and a short level around the points at the rear. 2nd. In combination with the box A and the knife C, the gauge D having ears *a*, adjustably connected with the brackets *b* having slot *c*. 3rd. The combination, with the box A provided with vertically reciprocating knife C, of the plate E, sustained by the downward projecting arms *d* having lugs *e*, and the bolts passing through said lugs. 4th. In combination with the knife C operated by the foot lever F, the apron G.

No. 13,927. Improvements in Hot Water Heating Apparatus. (*Perfectionnements aux calorifères à eau.*)

John Pye, Quebec, Que., 2nd January, 1882; for 5 years.

Claim.—1st. The boilers B B having return water inlets Q, intervening fire chambers E, coil pipes or sections I rising transversely over the fire chamber and connecting the boilers B B with horizontal tubular headers J J having branches *o* within the walls K K enclosed by top L, whereby, when distributing pipes are connected to the branches *o* and inlets Q, the circulation of water will be carried through the coil headers and distributing pipes, and returned to the boilers. 2nd. A series of sectional pipes or coils I, each section independently connected to a boiler arranged on both sides of the fire chamber and with tubular headers H common to all the sections of one boiler, the whole enclosed by walls K and top L. 3rd. The combination, within suitable sides and top of the boilers B B, intervening fire chamber E, tubular headers H, connecting sectional pipes or coils I with a series of distributing pipes connecting the header and boiler. 4th. The shaker composed of triangular bars R, intervening the grate bars mounted on transverse bars S and reciprocated by lever T.

No. 13,928. Improvements in the Method of, and Apparatus for Breaking Down and Getting Coal and other Minerals in Mining. (*Perfectionnements dans la méthode de briser ou extraire le charbon et autres minéraux en minant, et dans les appareils pour cet objet.*)

Charles S. Smith, Leicester, and Thomas Moore, Shipley, Eng., 2nd January, 1882; for 5 years.

Claim.—1st. The method of breaking down or getting coal and other minerals by the introduction into bore holes of caustic lime, which, after compression and confining by lamping or otherwise, is brought into contact with water or other suitable liquid along the entrance or greater part of the length of the charge so as, by the expansion of the lime and pressure of the steam generated, to produce sufficient force for breaking down the mineral. 2nd. In breaking down or getting coal or other minerals, a cartridge formed of compressed caustic lime having one or more longitudinal grooves or passages, to serve as channels for the introduction of water. 3rd. In combination with cartridges or charges of caustic lime, a perforated or slotted or permeable tube placed along the side or through the body thereof and serving to bring water into intimate contact therewith. 4th. In combination with the perforated or slotted tube for lime cartridges, a

covering of woven fabric for preventing the lime from entering the holes of the tube.

No. 13,929. Improvements on Door Knobs. (*Perfectionnements aux boutons des portes.*)

George M. Hathaway, Jersey, N. J., U. S., 2nd January, 1882; for 5 years.

Claim.—The knob shank C having one internal side inclined as at *c* and inclined seat *e*, and the knob D having a central counter-sunk aperture *d* and inclined surface *d* to correspond with the seat *e*, combined with the wedge F having perforated arm F and the screw E adapted to serve with the spindle A.

No. 13,930. Improvements on the Process of Tanning Hides. (*Perfectionnements dans les procédés de tannage des peaux.*)

Robert F. Dobson, Darlington, Wis., U. S., 2nd January 1882; for 5 years.

Claim.—The improved process of tanning hides which consists, first, in immersing them for five or ten days or thereabout, in a bath formed of strong brine and tanning extract, or of strong brine alone, second, in placing them in an air tight compartment and subjecting them to the action of fumes of sulphur therein for twelve or twenty-four hours.

No. 13,931. Improvements on Car-Couplings. (*Perfectionnements aux accouplages des chars.*)

James E. Smith, Wilkesbarre, Pa., U. S., 2nd January 1882; for 5 years.

Claim.—1st. The combination, with the longitudinally slotted draw-head provided with bearings C, of the transverse shaft D to which is detachably secured the angular coupling pin I. 2nd. As an improvement in car-couplings, the combination of the longitudinally slotted draw-head A having eyes or bearings C, shaft D having crank E and detachable angular pin I, lever G and chain F or its equivalent. 3rd. The combination, with the draw-head formed with the slots B, of the transversely arranged shaft D journaled in the bearing C, that is secured directly to the draw-bar, the bent pin I secured to said shaft and arranged to work in the slots of the draw-head, the crank arm F upon one end of the shaft C and connecting with the operating lever, and the dog G pivoted to the side of the draw-head in position to be brought against the crank.

No. 13,932. Improvements on Vacuum Dredges. (*Perfectionnements aux dragues à vide.*)

Abel C. Whittier, Boston, Mass., U. S., 2nd January, 1882; for 5 years.

Claim.—The steam vacuum chamber provided with trunnions and supported in bearings, to be tipped backward and forward and having the draft pipe *g g* combined with the second turn-table.

No. 13,933. Improvements in Flower Crock. (*Perfectionnements aux pots à fleurs.*)

Amelia D. Polsgrove and Benjamin R. Davis, Catawissa, Penn., U. S., 2nd January, 1882; for 5 years.

Claim.—1st. The combination of the pot A having tube B and base N, the lining G provided with tube H, and the cup E. 2nd. The combination, with the flower pot or crock A provided with a screw collar D, of the cup E provided with a screw collar F. 3rd. The combination of the flower crock or pot A provided with a screw collar D, and a tube B of the cup E provided with a screw collar F. 4th. The combination, with the flower pot or crock A, of the lining G provided with a tube H projecting from its bottom.

No. 13,934. Improvements on Door Checks. (*Perfectionnements aux arrête-portes.*)

The Norton Door Check and Spring Company, Portland, Me., (Assignee of Lewis C. Norton, Boston, Mass.,) U. S., 2nd January, 1882; for 5 years.

Claim.—1st. The combination of the cylinder C with its cap *c* and piston *d*, the three parts forming a chamber for the compression of air, which chamber is provided with two outlets, one adjustable by hand and the other automatically. 2nd. The door check consisting of the cylinder C, piston *d* and cap *c* with its automatically adjustable valve. 3rd. The adjusting device consisting of the hollow screw E and the adjusting screw F. 4th. The combination of the cylinder C, cap *c*, piston *d*, spring E, cap *c* with its valve, and the adjusting device F. 5th. The valve consisting of the cap *c* provided with the hole *f* and ridge or shoulder *g*, and the flexible disk *i* provided with slots *h*. 6th. In combination with a door and its frame of a door check in which the forward stroke of the piston is controlled by compressed air, provided with an arm whereby its piston rod may be operated, a guide rod whereby the stroke of its piston will be controlled, and suitable devices for the attachment of said arm guide rod and door check to the said door or its frame. 7th. The combination of the door check C, D, hinge plate J, guide rod H and the arm G provided with a suitable device for attaching it to the door or its frame. 8th. The combination of the piston rod D, guide rod H and arm G with its adjusting disk K.

No. 13,935. Composition to be Used as Paint. (*Composé à peinture.*)

Anthony W. Burke, Stayner, Ont., 2nd January, 1882; for 5 years.

Claim.—A compound composed of resin, shellac, camphor, castor oil and glycerine dissolved in methylated spirits and colored with lamp black or any other coloring, the whole compound in the manner and in the proportions specified.

No. 13,936. Improvement on the Method of Producing Rotary Motion. (*Perfectionnement dans la méthode de produire le mouvement rotatoire.*)

John J. Read, Dublin, Ireland, 2nd January 1882; for 5 years.

Claim.—The method of converting reciprocating and alternating rectilinear motion into continuous rotary motion by the arrangement of cog wheels, pulleys or drums combined with ratchet wheels, pawls, springs and rack frames.

No. 13,937. Improvement on Toe Calks for Horse Shoes. (*Perfectionnement aux pinces des fers à cheval.*)

Peter Routledge, King, Ont., 2nd January, 1882; for 5 years.

Claim.—The addition of a piece of iron at the inner angle formed by the intersection of the calk and shoe, and the welding of the same to the calk and shoe.

No. 13,938. Improvements on the Process of Manufacturing Food or Beverages Containing, or Formed in Part of Coffee. (*Perfectionnements dans le procédé pour préparer des aliments ou breuvages contenant du café, ou composés en partie de café.*)

Arthur Conroy and Michael Conroy, Liverpool, Eng., 2nd January, 1882; for 5 years.

Claim.—1st. The process of manufacturing a coffee mixture consisting in taking malt and coffee, roasting them, grinding them and mixing them one with another before, during or after the roasting or grinding. 2nd. As a new article of manufacture, a combination of coffee and of malt roasted in a similar manner and extent to that in which coffee is roasted.

No. 13,939. Improvements on Injectors.

(*Perfectionnements aux injecteurs.*)

Wallace E. McDonald, Sandy Lake, Pa., U.S., 2nd January, 1882; for 5 years.

Claim.—1st. The combination, with the steam and water tubes, of regulating or grading valve. 2nd. The stem valve *d* combined with the steam and water tubes *a b*.

No. 13,940. Improvements on Means of, and Apparatus for Increasing the Illuminating Power of Coal Gas. (*Perfectionnements aux moyens d'augmenter la puissance d'éclairage du gaz de houille, et aux appareils pour cet objet.*)

John McDonald, London, Eng., 2nd January 1882; for 5 years.

Claim.—1st. Constructing a carburetter in such a way that only a small proportion of the carburetting material contained therein shall be exposed at one time to the action of the gas. 2nd. In combination with the carburetter, a heating coil of equivalent means for heating the carburetted gas. 3rd. Heating the coal gas before being carburetted, and causing it to enter the carburetter hot, in combination with the retort for heating the carburetted gas. 4th. Passing carburetted coal gas through an absorbent material.

No. 13,941. Improvements on Wire Staples.

(*Perfectionnements aux crampes en fil métallique.*)

Patrick Dunn and Thomas Harris, Cote-St. Paul, Que., 2nd January, 1882; for 5 years.

Claim.—1st. As an improved article of manufacture a wire staple having the crown or head depressed or indented. 2nd. A wire staple formed by bending the wire rectangularly, depressing the head or crown and pointing the ends by a bevelled cut, one of which points its end inwardly.

No. 13,942. Improvements in Fire proof Compositions. (*Perfectionnements dans les composés réfractaires.*)

Charles C. Gilman, Hardin County, Iowa, U.S., 2nd January, 1882; for 5 years.

Claim.—A composition of matter to be used for fire-proofing and other purposes, consisting of kaoline clay, free from sand or sandy-clay, and resinous saw-dust prepared with water, machine pressed, dried, burned, and subsequent to firing, sawed or wrought with edge tools.

No. 13,943. Improvements on Cancelling Stamps. (*Perfectionnements aux timbres à maculer.*)

Leonard Tilton, Brooklyn, N. Y., U.S., 2nd January 1882; for 5 years.

Claim.—The means for sustaining and obtaining universal movement consisting of the stamp carrying arm *l* provided with rollers *n*, the hub *a* provided with the arms *h i* and rollers *l i*, and the swivelling standard *c* carrying the hub.

No. 13,944. Improvements in Gas Motor Engines. (*Perfectionnements aux machines à gaz.*)

Augustin Fiddes, Bristol, Eng., 2nd January, 1882; for 5 years.

Claim.—1st. The use of the slide or piston valve *F* made to work in the cylinder *A* in such a manner as to fully compress the charge, by travelling in the same direction as the piston *B*, and to maintain the charge so compressed up to time of firing. 2nd. The arrangement of parts in the cylinder *A*, in combination with the slide or piston valve *F* working therein, whereby the said slide or piston valve is made to admit the gas and air at the proper time for acting on the piston *B*, so that the engine may be worked without a separate external slide valve. 3rd. The admission and employment of a small quantity of water in the cylinder *A* at the time of firing, so as to be converted into steam and act expansively. 4th. The combination of parts shewn and employed for firing the charge. 5th. The respective combination of parts constituting improvements in the gas motor engine.

No. 13,945. Improvements in Chain Belts.

(*Perfectionnements aux courroies chaînes.*)

James M. Dodge, Chicago, Ill. U. S., 2nd January 1882; for 5 years.

Claim.—A drive belt adapted to engage with a wheel having metallic or other rigid tapering peripheral bearing surfaces, said belt having tapering lugs which form bearing surfaces corresponding in taper to the taper of the peripheral bearing surfaces of the wheel, for which the belt may be designed, and each made of such a width (or extent in the direction of the length of the belt) relatively to the wheel as to practically come in contact, throughout the whole extent of its bearing surfaces with the peripheral bearing surfaces, of said wheel.

No. 13,946. Improvements on Nut Locks.

(*Perfectionnements aux arrête-écrous.*)

James A. Soley, Winnipeg, Man., 2nd January, 1882; for 5 years.

Claim.—1st. The combination of the two straight locking plates *B B* fitted with the oblong holes *E* to admit of expansion, and contraction of the rails and provided with the transverse bars *H H H H* on the inner sides. 2nd. The combination of two locking bolts similar to *C* that passes through the holes *D D* in the outer fish-plate, which bolts have heads that countersink flush with the inner side of the plate and pass through the plates *B B*, securing them with the collar *G* and the spring or other key *F*.

No. 13,947. Improvements in the Construction of Rolling Stock for Railways. (*Perfectionnements dans la construction du matériel roulant des chemins de fer.*)

Auguste Estrade, Perpignan, France, 2nd January, 1882; for 5 years.

Claim.—1st. In the rolling stock of railways, a frame within which the body of the vehicle, engine or tender is suspended by springs or their equivalents, and which in its turn is supported by other springs upon the wheels. 2nd. A locomotive engine having its body suspended by springs within a frame that is carried by other springs upon the wheels, the rollers *f* carried by the said frame and bearing against rails or ribs *e* on the body. 3rd. A locomotive engine having its body suspended by springs within a frame that is carried by other springs upon the wheels, the connection of the cylinders *A* with the body *A* by means of the plate *E* and frame *F*.

No. 13,948. Improvement on Lighting Apparatus. (*Perfectionnement des appareils d'éclairage.*)

William Wheeler, Concord, Mass., U. S., 2nd January, 1882; for 5 years.

Claim.—1st. The holophote consisting of the prolate ellipsoidal reflector *B*, convex levers *F* and concave lens *G*. 2nd. The combination of the hemispherical reflector *K* with the reflector *B* and the lenses *F G*. 3rd. The combination of the ring *H* provided with glass disks, the spaces between said disks being filled with an athermanous liquid, or the latter and a fluorescent liquid arranged between such disks with the holophote consisting of the reflector *B* and the lenses *F G*. 4th. The holophote *B* and reflector *K* provided with the interchangeable connecting hinges *d e* and pin *f*, such admitting of the reflector being removed from the holophote in order for the latter to be connected with another holophote. 5th. The combination of the holophote constructed of the reflector *B* and lenses *F G*, with tubes having inner reflecting surfaces. 6th. The combination of a holophote constructed of the reflector *B* and lenses *F G*, with one or more tubes having inner light reflecting surfaces, and with one or more reflecting prisms arranged in such tube or tubes and to reflect light into or through such as explained. 7th. The combination of the hemispherical reflector *K* provided with the sight hole *g*, with the holophote consisting of the reflector *B* and the lenses *F G*. 8th. A light transmitting tube consisting of a tube of glass, a metallic reflecting coating encompassing its outer surface and a circumscribing coating of asphalt or varnish, and an additional metallic coating surrounding the asphalt or varnish coating. 9th. The combination of the covered tubular couplings *L* with a series of prisms bevelled on their ends and with a compression block and binding screws arranged with such couplings and prisms. 10th. The combination of a covered tube *L* provided with openings on its sides with one or more reflecting prisms arranged in such openings. 11th. In two light reflecting prisms or sets of such, arranged and provided with a passage in or between them for the transmission of light. 12th. The combination of the adjustable tube *U* provided with one or more lateral openings and means of adjusting it, and with one or more reflectors or prisms with an encompassing tube *T* and one or two lateral passages or branch tubes *M* *M* leading from such tube *T*. 13th. The combination of a series of reflecting prisms arranged above a common axis, with a main tube having its axis in prolongation, with the axis of the prisms and with a series of branch tubes extending from the prisms. 14th. The combination of a light dispenser *Y* with a tube *z*, for transmitting light in a pencil or beam of rays to such dispenser. 15th. The combination, with a light transmitting tube, of a series of curved light reflecting branches arranged with such light transmitting

Claim.—1st An illuminating candle composed of a flat wick surrounded by a flattened or elliptical body. 2nd. The combination of animal charcoal and carbon oil with wax or its equivalent. 3rd. The composition of matter to be used for the manufacture of candles composed of carbon oil, animal charcoal and wax in the proportions specified or any modification of them. 4th. In the manufacture of an illuminating composition of matter, the employment of animal charcoal.

No. 13,960. Improvements on Fruit Dryers.

(*Perfectionnements aux séchoirs à fruits.*)

Horace M. Dake, Nimda, N.Y., U.S., 9th January, 1882; for 5 years.

Claim.—1st. In an apparatus for drying fruits, vegetables, &c., in combination with the closed water bottom A, steam chambers B and tray spaces C, the pipes b and d for returning the condensed steam to the bottom A, the upper part b divided from the lower part d by a partition i, and receiving the steam from the dryer through pipe c. 2nd. The combination of the dryer A B C having the alternate steam connecting pipes a a, the stay pieces f f, the combined steam and condensed steam pipe b b, steam pipe c and steam valve d.

No. 13,961. Improvement in Device for Catching and Holding Hogs.

(*Perfectionnement des appareils à prendre et retenir les porcs.*)

Orville Ewing, Decatur, Ill., U.S., 9th January, 1882; for 5 years.

Claim.—The hollow metallic tube consisting of the curved mouth or end A with concave lug B, side bars C C and the handle G, combined with the cord G and movable handle H.

No. 13,962. Improvements in Saddle Girths.

(*Perfectionnements aux sangles des selles.*)

William McNaught, jr., Cartersville, Ga., U.S., 9th January, 1882; for 5 years.

Claim.—The combination, with the girth sections A and B, of the pulleys F and G and the rope H or equivalent, the ring J and the hooks L.

No. 13,963. Improvements in Disintegrating Mills.

(*Perfectionnements aux moulins à désagréger.*)

Lewis J. Bennett, Buffalo, N. Y., U.S., 9th January, 1882; for 5 years.

Claim.—1st. In a disintegrating mill, the combination of two or more concentric rows of square disintegrating pins arranged with their edges facing each other and shafts which cause the several rows of pins to rotate in opposite directions, whereby the flat working faces of the pins in the inner row drive the material squarely against the flat working faces of the pins in the next outer row, and whereby rapidly contracting and enlarging spaces are formed between the pins which insure a thorough disintegration of the material, and prevent the material from lodging between the pins. 2nd. The combination, with the disks E and F and ring H supported on the disk F, of the square pins G G₂ G₃ and rings O P M attached respectively to the disk E and ring H, and provide I with square recesses in which the pins are removably secured. 3rd. The combination, with a stationary breaker arm I, of an endless row of separate disintegrating pins G arranged alternately at a greater and less distance from the axis of rotation, the breaker arm being arranged within the endless row of pins, whereby shoulders of unequal depth are successively formed between the rotating pins and breaker arm, and the thorough breaking of the material and its escape outward through the spaces between the pins is insured. 4th. The combination, with the disk F and annular plate H, of the protecting plate H₁, pins G G₂, sectional cast rings m m₂ and wrought rings m m₃. 5th. The combination, with the disk E provided with protecting plate E₁, of the pins G₁ G₂, sectional cast rings o o₃ and wrought rings o₁ o₂. 6th. The combination, with the disk of a disintegrating mill, of a marginal protecting ring provided with one or more removable balancing plates Q forming part of the protecting ring, and provided with depressions for the reception of balancing material. 7th. The combination, with the disk E, of the ring P applied to the inner side of the disk near the edge thereof, for the reception of the outer row of disintegrating pins, and the protecting ring P₁ attached to the outer side of the disk E near the edge thereof. 8th. The combination, with the lower side pieces A A₁ provided with flanges r₁ and recesses r₂, of the upper side pieces R provided with angle irons r, and projecting edges r₂ entering the recesses r₂. 9th. The combination, with the side pieces R R provided with rings T having grooves t, of the hoop S provided on its inner side with a removable wear plate S₁, and fitted in said grooves and secured by bolts v.

No. 13,964. Improvements on Animal Traps.

(*Perfectionnements aux pièges.*)

John H. Morris, Thomas D. Morris, Seward, Neb., U. S., (and the said John H. Morris, Administrator to the goods, chattels and effects of William Morris.) 9th January, 1882; for 5 years.

Claim.—The jaw A with its extended back plate a and treadle E, in combination with jaw A with its extended back B provided with the latch b.

No. 13,965. Single Plate Carriage Spring.

(*Ressort de voiture à une seule lame.*)

The Guelph Carriage Goods Company, (Assignee of John B. Armstrong.) Guelph, Ont., 9th January, 1882; (Extension of Patent No. 7012.)

No. 13,966. Improvements in the Manufacture of Boots and Shoes.

(*Perfectionnements dans la fabrication des chaussures.*)

Willard Comey, Westboro, Mass., U.S., 9th January, 1882; for 5 years.

Claim.—1st. The improved turned shoe described having its sole A channelled from, or near the edge inwards to the upper by a line of stitches passing through the upper and through that part of the sole under the channel flap a. 2nd. The improved mode of manufacturing turned shoes consisting in channelling the sole from or near its edge inwards, then folding back the channel flap towards the middle of the sole, then lacing the shoe with the channel flap of the sole against the sole of the last, then drawing the last and sewing, turning and finishing the shoe. 3rd. The improved shoe composed of the inner sole A channelled on the grain side, the upper B, the welt or middle sole and the outer sole F, the welt or middle sole, upper and inner sole being connected by stitches passing through the welt and upper and through the flesh part only of the inner sole, the lip of the channel on the grain surface of the inner sole lying over the loops of the stitches which connect the welt, upper and inner sole, and the outer sole being connected with the welt by a second line of stitches which pass through the flesh part only of the outer sole, the lip of the channel on the grain surface of the outer sole lying on the loops of the stitches which connect the welt and the outer sole. 4th. In a boot and shoe sewing machine, the combination, with a gauge or rest for the edge of the welt and the upper of a boot or shoe, of a sliding bar H adapted to be brought down upon the welt and having a lateral movement for pushing or pressing the welt outward, against the gauge or rest, and keeping it constantly in contact therewith. 5th. The combination, with the work supporting horn D and stitch forming devices, of the longitudinally and laterally moving push bar H and flanged guide roll M, adapted to form separate gauges for the outer edge of the welt and the contiguous edge of the upper or vamp, whereby the welt is maintained at the proper distance from the vamp throughout its entire length. 6th. The sliding push bar H with its spring p adapted to be moved downward in guides on the frame G, by the contact of projection with the spring, and upward by the contact of a projection 12 with a projection 13 on the bar H, in combination with the piece q having an inclined face 16, whereby the lower end of the bar H is caused to move obliquely to push the welt outward from the sole and keep it constantly in contact with the inner portion 18 of the gauge roll M. 7th. The combination, with the horn B and the sliding push bar H, of the guide roll M, with its central portion 18 and upper and lower flanges V W mounted upon a supporting arm L made adjustable on the frame work. 8th. The guide M, in combination with the tip of the horn, the one forming an outer and the other an inner guide, between which the upper of the shoe passes.

No. 13,967. Improvement in the Art of Brushing Gold Leaf from Book Covers.

(*Perfectionnement dans l'art de brosser l'or en feuille des couvercles de livres.*)

James B. Waterston and William Zimmerman, Chicago, Ill., U. S., 9th January, 1882; for 5 years.

Claim.—1st. In a book binder's gold brushing machine, consisting of a box or chamber provided with a cylindrical revolving brush working over an adjustable platform, a longitudinal slot immediately above and parallel to said platform and an air escape. 2nd. The chamber A provided with cylindrical revolving brush B, in combination with the adjustable platform D, drawer or receptacle C and screened cover E. 3rd. The box or chamber A provided with cylindrical revolving brush, adjustable platform D, receptacle or drawer C, slot G provided with hinged door or valve e. 4th. A box or chamber A provided with a revolving brush B, elastic and adjustable platform D, receptacle C, slot G and an air escape guarded by screens. 5th. A box or chamber A provided with a revolving brush B, adjustable platform D, receptacle C, slot G provided with valve e, and air escape guarded by screens. 6th. A box or chamber provided with a revolving brush working over an adjustable platform, said platform made of open or wire work, a longitudinal slot immediately above and parallel to the platform and provided with a valve and an air escape.

No. 13,968. Improvements in Knit Fabrics.

(*Perfectionnements dans les tricots.*)

John Penman, Paris, Ont., (Assignee of John Nelson, Rockford, Ill., U. S.) 9th January, 1882; for 15 years.

Claim.—A knit fabric composed of yarns differing in size or color interchanged in the fabric, with their ends overlapping, whereby a smooth even fabric is produced.

No. 13,969. Improvements on Grain Gleaners and Binders.

(*Perfectionnements aux engins pour les lieuses.*)

John F. Mahon, London, Ont., 9th January, 1882; for 5 years.

Claim.—1st. The application, to a grain binding machine, of the shaft r and the teeth K. 2nd. The application of the gear wheel S, in combination with the gear wheel t, the rollers l m and elevators n. 3rd. The application of the loose pinion u coupled with the fixed pinion t and stop pawl v, in combination with the gear wheel r. 4th. The application of the toothed segment e working in combination with the pinion f, the eccentric and pitman z and the rack g. 5th. The application of the stop pawl u and clutch u.

No. 13,970. Improvements on Freight Transfers.

(*Perfectionnements aux passe marchandises.*)

Alexander E. McDonald, Brooklyn, N. Y., 9th January, 1882; for 5 years.

Claim.—1st. A transfer for freight or other service consisting of a platform or its equivalent, for the load mounted on the upper end of a supporting lever or levers, the said lever being hinged, pivoted, or steered at its foot. 2nd. A platform or its equivalent, a supporting lever or levers and a cushion spring to check the descent of the load. 3rd. The transfer consisting of the platform, or its equivalent, mounted on the supporting lever or levers, in combination with the sides of the slots in which the lever or levers play, adapted to form guides for said levers. 4th. The combination, with the transfer, of the means for operating it from within doors. 5th. The device for covering slot in the walk, in combination with the transfer. 6th. The locking device whereby the platform is held when down on the step. 7th. The construction of the platform with one part fixed and one part hinged thereto.

No. 13,971. Improvements on Thill Couplings. (*Perfectionnements aux armons des limonnières.*)

Henry T. Perram, Stamford, Ont., 11th January, 1882; for 5 years.

Claim.—In a thill coupling in which the end of the thill B is inserted in the usual way into the ordinary socket B, a coupling pin C provided with a head D having a slotted groove *a*, in combination with a detachable hook bracket F and spring E, one end of the latter fitting into a hole *b* in the detachable bracket F, and its other end slipped into the slotted passageway *a* in the head D, the centre of the spring being sprung over an elastic block G.

No. 13,972. Explosive Powder.

(*Poudre explosible.*)

L. A. M. C. S. Robert, Paris, France, 11th January, 1882; for 5 years.

Claim.—1st. The use of salt in the form of a limpid solution. 2nd. The use of a natural cellulose which is at the same time porous, elastic and homogeneous in all its parts. 3rd. Obtaining an explosive by simple drying after absorption of the saline solution by a porous body, without recourse to any mechanical process.

No. 13,973 Improvements in the Manufacture of Hose. (*Perfectionnements dans la fabrication des bas.*)

William B. Pollock, Montreal, Que., 11th January, 1882; for 5 years.

Claim.—As a new article of manufacture, a woven or knitted hose or stocking decreased at the ankle by stitching E.

No. 13,974. Improvements in Skirt Adjusters. (*Perfectionnements aux pince jupons.*)

Nannie C. Greene, South Brooklyn, N. Y., U. S., 11th January, 1882; for 5 years.

Claim.—As an improved article of manufacture, the skirt adjuster consisting of two straight pieces of webbing A B provided with rings or eyelets C on their inner edges, and with spring clasps E on their outer edges, and the lacing string D, the said clasps being adapted to be clasped upon the side seams of the back breadth of a skirt.

No. 13,975. Improvements on Waggons.

(*Perfectionnements aux wagons.*)

James Cruickshank, Weston, Ont., 11th January, 1882; for 5 years.

Claim.—A wagon having an ordinary bolster, brackets fitted to the end of the said bolster and provided with projecting arms arranged to carry adjustable clevises, in combination with elliptic springs arranged to support the body of the wagon, and detachably connected to the said clevises by a bolt or bolts.

No. 13,976. Improvements on Metallic Coffins. (*Perfectionnements aux cercueils métalliques.*)

William D. McGloghlon, London, Ont., 11th January, 1882; for 5 years.

Claim.—The air tight burial casket or coffin A stamped in one piece out of iron or other metal, and having a metallic lid B provided with glazed opening C D and metallic covering plate B', said lid being soldered down to upper edges of coffin after the body is placed therein.

No. 13,977. Improvements on Milk Coolers.

(*Perfectionnements aux garde lait.*)

Alfred Allaire and François Allaire, St. Lin, Que., 11th January, 1882; for 5 years.

Resume.—1o. L'arrangement et la combinaison avec le bassin à lait A muni du tuyau de décharge a, du bain B, ayant une cloison b, couvercle c, une boîte a glace d, un tuyau e et des arêtes f. 2o. La combinaison du bassin à lait A avec le bain B ayant la doublure C, les trous d'épanchement h et le tuyau de décharge.

No. 13,978. Improvements on Fanning Mills.

(*Perfectionnements aux tarares cribleurs.*)

William C. Howarth, St. Thomas, Ont., 11th January, 1882; for 5 years.

Claim.—1st. The slide P. 2nd. The crankshaft E. 3rd. The shoe G provided with the distributors T T. 4th. The combination of the cog wheels B B, rod D and crank shafts E E. 5th. The combination of the shoe G and slide P. 6th. The combination of the shoe G, and the crank shafts E E.

No. 13,979. Improvements on Injectors.

(*Perfectionnements aux injecteurs.*)

The Hancock Inspirator Company, (Assignee of John T. Hancock,) Boston, Mass., U. S., 11th January, 1882; (Extension of Patent No. 7011.)

No. 13,980. Improvements in the Manufacture of Hubs. (*Perfectionnements dans la fabrication des moyeux.*)

George W. Bentley, Atha, Ont., (Assignee of Chauncey H. Guard, Dayton, Ohio, U. S.,) 16th January, 1882. for 5 years.

Claim.—The construction of a carriage wheel hub in which a lamina composed of wood veneer, cloth or thread and glue is wound around the body of the hub prepared therefor, which, when so wound, forms the bulge or swell of the hub, whereby the laminated body of the said hub becomes encased within a band which renders it impervious to the weather and other causes of decay.

No. 13,981. Improvements on Current Wheels. (*Perfectionnements aux éleveurs d'eau.*)

Alexander D. Clark, Omaha, Neb., U. S., 16th January, 1882; for 5 years.

Claim.—1st. The combination, with the raft floated by air containing tubes, of the horizontal current wheel and the pump, and devices for conveying power from the wheel to the pump. 2nd. The combination, with the raft having the opening B₁ of the wheel supported upon a vertical shaft located in said opening and removable bearings for said shaft. 3rd. The wheel C consisting of the hinged vanes C₂, and the open frame work composed of the bands c c, hub plates c₁ upon the wheel shaft, vertical braces c₂ c₃ and radial arms c₄ c₅.

No. 13,982. Improvements in Guards for Circular Saws. (*Perfectionnements aux garde-scies rondes.*)

Richard W. Taylor, Bury St. Edmunds, Eng., 16th January, 1882; for 5 years.

Claim.—A metal curved plate or plates suspended over the periphery or edge of the saw and in the same plane as the saw, but permitted to move in a circle concentric, or nearly concentric with the saw, and mechanism for restoring the same automatically to its normal position.

No. 13,983. Improvements in Railway Brakes. (*Perfectionnements aux freins des railroutes.*)

Carl F. Sim and William Studer, Montreal, Que., 16th January, 1881; for 5 years.

Claim.—1st. A railway brake in which the brake shoes are in their normal position in contact with the wheel tires and removed therefrom by the action of the braking mechanism. 2nd. The combination of the bent lever N N pivoted to ear, connected at one end with brake lever and with its other end normally held down by weight P. 3rd. A brake mechanism operated either by hand or power composed of a rod passing beyond and under the draw-bar and connected by a chain or rope with a hand brake or fixed point, and a rod passing out beyond the other end of the car and connected by a rope or chain with mechanism for operating the brake lever, each of these chains or ropes passing over a separate sheave and both sheaves being carried in a sliding hanging frame. 4th. The combination of the lever L acted upon by traction on either of the chairs E I, the chain M passing over sheave m, and the lever N N, carrying weight P and connected with brake lever.

No. 13,984. Improvements on Apparatus for Carrying Eggs. (*Perfectionnements aux appareils à transporter les oeufs.*)

John Halley and Alexander Barr, Glasgow, Scotland, 16th January, 1882; for 5 years.

Claim.—An egg holder having holding members or fringes made of spring wire and shaped with upper parts closing or contracting over the egg, but with the extreme upper ends flared or bent outwards and forming inclined by acting on which the egg opens the holder, when being inclined.

No. 13,985. Improvement in Tobacco Caddies. (*Perfectionnement des boîtes à tabac.*)

George T. Tuckett, Hamilton, Ont., 16th January, 1882; for 5 years.

Claim.—A sheet metal box A for packing tobacco constructed with the V-shaped notches a at the corners forming the projections b b b b, in combination with the cover B as constructed with notches c c c c at the corner flanges d d d d to fit under, and be overlapped by projections b of the box.

No. 13,986. Improvements in Ploughs.

(*Perfectionnements aux charrues.*)

William Sanderson, Eramosa, Ont., 16th January, 1882; for 5 years.

Claim.—1st. A share point A constructed with perforations b in its rear end, so that a pin F, placed in one of the perforations b and bearing on a shoulder piece G constructed on the plough head, will secure in the said share point from being moved backwards, when at work in the field. 2nd. A landside D constructed with a clamp H on its interior surface, in which a share point A is moved backward and forward as required, and permits of a wedge B passing through the same and above the share point and into the groove h h which, when the set screw is tightened, will prevent any vibration in the share point A. 3rd. The landside of a plough constructed with a groove G in the h h in its interior surface, and a projecting shoulder piece G in the rear end of the plough head having a lateral slot h therein, in which groove and slot the share point A can be moved backward and forward as required, a pin F placed in the share point A in front of the shoulder piece G, and a wedge B placed above the same in groove h h with set screw in rear end, when tightened, will prevent any slipping

or vibration of the share point when at work. 4th. In combination with a plough having a movable adjustable share point A in a groove *h h*, cast in the interior surface of the landside D, and also a lateral slot formed in a shoulder piece G, the wedge B with set screw in rear end clamp H, and pin F.

No. 13,987. Improvement in Open Back Saws. (*Perfectionnement des scies sans dossières.*)

Lewis Lawson, New York, U. S., 16th January, 1882; for 10 years.

Claim.—1st. The slitted limb C with rigid jaws *n* in combination with the adjustable horizontal screw bolt E with jaws *n*, set nut and threaded end R operating in the square eye X to adjust and secure the saw S in a right line, by means of the stop pins P P passing through the ends of the blade and held in the jaws *n*. 2nd. The combination of the saw blade having a stationary pin P P at each end thereof, with the jaws *n* and adjustable screw bolts E to either tighten or loosen the blade.

No. 13,988. Improvements on Vegetable Soup Compounds. (*Perfectionnements à la soupe aux légumes en conserve.*)

John D. Warren, Lyndonville, N. Y., U. S., 16th January, 1882; for 5 years.

Claim.—A dry compound for use as vegetable soup composed of vegetables commonly used in such soup, such as potatoes, corn, cabbage, celery, carrots, etc., cut into small squares and thoroughly evaporated, combined with salicylic acid and sulphite of soda to preserve the same, and ground celery seed, ground parsley and vegetable flour for flavoring the compound.

No. 13,989. Improvement on Ore Separators. (*Perfectionnement des séparateurs de minerais.*)

Charles G. Buchanan, Brooklyn, N. Y., U. S., 16th January, 1882; for 5 years.

Claim.—1st. A magnetic ore separator having two inductively magnetized rolls forming a magnetic field between them. 2nd. As a means for separating the magnetic from the non-magnetic portions of the ore, the magnetized parallel rolls of opposite polarities revolving near each other in opposite directions. 3rd. A magnetized roll adapted and arranged to revolve in front of another magnet of opposite polarity, and thereby create a magnetic field between their opposed faces, whereby the magnetic ore particles attached to the roll in the magnetic field ore as the roll revolves separated from the non-magnetic ore particles and carried to a point opposite the magnetic field where they are discharged by their own gravity. 4th. As a means for equalizing the magnetic force and for increasing the conductive capacity of the rolls throughout the length of the magnetic field, a magnet or magnetized roll having an elliptical or oval core or hollow centre. 5th. A roll capable of inductive action revolved in the field of a magnet of opposite polarity. 6th. The combination of two parallel and contiguous rolls supported on standards of opposite polarities and adapted to be magnetized by induction from said standards. 7th. A magnetic ore separator constructed with a pair of parallel rolls capable of inductive action, adapted to revolve and supported on suitable standards, and devices adapted to convey by induction electricity of opposite polarities to said rolls. 8th. Electro magnetic standards A A, insulated wires C C, P U, hollow rolls B B, collars K, frame A₂, upper E and chutes.

No. 13,990. Improvements in Machines for Cutting Ice. (*Perfectionnements aux machines à couper la glace.*)

Félix L. D. Pearson, Montreal, Que., 16th January, 1882; for 5 years.

Claim.—1st. The combination of the saws N with an operating mechanism, and traction wheels D simultaneously operated to move the machine forward, and runners B. 2nd. The combination of the saws N, wheels D, runners B and operating mechanism by which the saws and wheels D are simultaneously operated, and guides B₂. 3rd. The combination of the saws N, wheels D, runners C and operating mechanism by which the saws and wheels D are simultaneously worked. 4th. The combination of the platform A provided with runners B C, wheels D, track H and guides B₂, also jacking device for raising the wheels D with the saws N, and operating mechanism for simultaneously working the said saws and wheels.

No. 13,991. Improvements in the Manufacture of Hubs. (*Perfectionnements dans la fabrication des moyeux.*)

George W. Bentley, Atha, Ont., (Assignee of Chauncey H. Guard, Dayton, Ohio, U. S.) 16th January, 1882; for 5 years.

Claim.—A hub constructed with wood pins laminated with linen or hemp fibre, and glue inserted diagonally through the said hub, in perforations prepared therefor, and subsequently placed in a tapered tube and subjected to pressure, under hydraulic or under mechanical power, whereby the pores of the wood are closed and the fibres thereof so compressed that the wood becomes a solid hard substance equal to that of our best native woods, and suitable for the manufacture of such hubs.

No. 13,992. Improvements on Car-Couplers. (*Perfectionnements aux accouplages des wagons*)

Andrew Zettel, Formosa, Ont., 16th January, 1882; for 5 years.

Claim.—1st. The new buffer A or outside frame which is large enough to hold the slide or pin holder and is also deep enough to hold the pin upright, when not entered into the link. 2nd. The sliding pinholder B, which supports the pin when not holding the link and

which, when struck by the link in the approaching buffer, slides back and allows the pin to fall into the opening of the link to receive it. 3rd. The handle C attached, either at the sides or at the bottom of the arm, to the pinholder B to move it forward, under the pin E¹, so as to hold the pin up until the cars come together. 4th. In a new kind of link D on one end of which is a heel to hold it high enough to enter itself without being held by a brakeman, when the cars are shunted against each other and which enters the hole in the opposite buffer shoves back the sliding pin holder, when the pin falls into the space in the link and the cars are coupled without requiring a brakeman to go between the cars and thus endangering his life.

No. 13,993. Device for Drawing Screw Pattern from the Mould. (*Appareil pour tirer du moule les gabarits des vis.*)

William A. Ingalls, Providence, R. I., U. S., 16th January, 1882; for 5 years.

Claim.—1st. The combination of a mould board or table with screw pattern provided, exteriorly of the mould, with a screw thread which is held in a guiding nut, the screw thread of which is separated from the sand in the mould by an intervening guide chamber inclosing the screw pattern. 2nd. The combination of a mould board or table with a screw-pattern provided, exteriorly of the mould, with a screw thread held in a guiding nut, the screw thread of which is intersected with an opening *k* for the escape of loose sand. 3rd. The combination of a mould board or table with a screw pattern provided, exteriorly of the mould, with a screw thread held in guiding nut made in two parts, whereby the screw pattern can be properly withdrawn from the mould and then again inserted in proper position for forming a new mould by opening the guiding nut.

No. 13,994. Improvements on Lasting Machines. (*Perfectionnements aux machines à enformer.*)

Solomon B. Ellithorp, Rochester, N. Y., U. S., 16th January, 1882; for 5 years.

Claim.—1st. A lasting machine composed of a suitable frame A, last seat B, curved levers E E, templet G provided with hooks and clamps H I respectively, eccentric levers L L, connecting rods A K, holding bolts *n* and gathering cord O. 2nd. The combination, with the clamps I, of screws p, hooks H and the adjustable templet G to regulate the action of said clamps. 3rd. In a means for stitching and holding the leather F on the last C, the combination with the clamps I and holding screws N, of the gathering cord O. 4th. In a means for stretching, forming and holding the leather F on the last C, the combination, with the clamps I and holding screws N, of the curved levers E E.

No. 13,995. Improvements in the Process of Making Soap. (*Perfectionnements dans le procédé de fabrication du savon.*)

Charles S. Higgins, Brooklyn, N. Y., U. S., 16th January, 1882; for 15 years.

Claim.—1st. The process of making soap, viz: the saponification of fats and resins and subsequent solidifying, the same by stearic acid or stearine. 2nd. As a new article of manufacture a resin soap composed of tallow or its equivalent, resin, a caustic alkali and stearic acid or stearine. 3rd. As a composition of matter, a soap composed of saponified tallow, saponified resin and unsaponified stearic acid or stearine. 4th. The use, in the manufacture of resin soap, of stearic acid or stearine at a period subsequent to the saponification of its acid ingredients, for the purpose of hardening the saponified resin.

No. 13,996. Improvements in Locomotive Smoke Stacks. (*Perfectionnements aux cheminées des locomotives.*)

George S. Strong, Philadelphia, Pa., U. S., 16th January, 1882; for 5 years.

Claim.—1st. The mode of equalizing the draft in the stack, said mode consisting in dividing the blast at the exhaust nozzle and admitting a portion of the exhaust steam near the lower end of the smoke box, and conveying another portion upward into the chimney near the upper end of the stack. 2nd. The combination of the smoke box, the stack and the exhaust nozzle opening into the smoke box, with an annular chamber opening into the interior of the stack at the upper end and with pipes whereby a portion of the exhaust steam is conveyed to the said annular chamber. 3rd. The combination of the stack having a deflector F, with the funnel G having pipe *d* and the steam nozzle *f*, whereby the sparks and cinders, thrown into the funnel by the deflector, are caused to pass through the pipe. 4th. The combination of the deflector, F the funnel G and its discharge pipe and jet nozzle, with the stack having an annular steam chamber *a* at the upper end.

No. 13,997. Improvements on Trunks. (*Perfectionnements aux malles.*)

Frank H. Ransom, Buffalo, N. Y., U. S., 16th January 1882; for 5 years.

Claim.—A trunk provided with the flanges G, in combination with a tray C provided with projections F.

No. 13,998. Improvements in Pipe Wrenches. (*Perfectionnements aux clés à tuyaux*)

Timothy D. Mernan and Allan H. G. Hardwicke, Buffalo, N. Y., U. S., 16th January, 1882; for 5 years.

Claim.—1st. The combination, with the lever B having a perforation *d*, of a chain adapted to be drawn through said perforation, and means whereby one end of the chain can be fastened to the body thereof. 2nd. A chain pipe wrench, the combination, with a lever B provided with a perforation *d*, of a chain E adapted to be drawn through the perforation of the lever and provided at one end with a hook *f*.

No. 13,999. Improvements in Looms.*(Perfectionnements dans les métiers à tisser.)*

George Keighley, Burnley, Eng., 16th January, 1882; for 5 years.

Claim.—In combination with a loom and as a substitute for the usual breast beam, a roller operating to exert a tension upon the cloth and take up slack between the reed and cloth roller.

No. 14,000. Improvements on Hot Water Stoves. *(Perfectionnements aux calorifères à eau.)*

Edouard Bellavance, Montréal, Que., 16th January, 1882; for 5 years.

Résumé.—1o. Le déplacement du réservoir à eau chaude, tel qu'aujourd'hui placé dans l'intérieur du foyer d'une fournaise ordinaire, et sa mise endessus de ce même foyer. 2o. Dans une fournaise dite "Self Feeder," ou autre, la conversion du tube central ou alimentateur en un réservoir cylindrique ou de forme quelconque devant servir à recevoir l'eau à être échauffée et donner ainsi un appareil de chauffage à l'eau chaude. 3o. Dans une fournaise dite "Self Feeder," ou autre, le remplacement du tube central ou alimentateur par un serpentín ou une série de tubes verticaux devant servir à l'échauffement de l'eau et transformant la fournaise ordinaire en appareil de chauffage à l'eau chaude.

No. 14,001 Improvements on Nut Locks.*(Perfectionnements aux arrêts-écrous.)*

Samuel S. Smith, Bryan, Ohio, U. S., 16th January, 1882; for 5 years.

Claim.—The plate D having the nib c, V-shaped notch b and perforation to receive the bolt C and adapted to be bent upon itself, in combination with said rail a, fish plates B, bolt C and nut a.

No. 14,002. Improvements on Automatic Regulators. *(Perfectionnements aux régulateurs automatiques.)*

Alexander M. Kerr, Westminster, Ont., 16th January, 1882; for 5 years.

Claim.—The combination of the regulator A and the wire E or its equivalent, with the door G or its equivalent.

No. 14,003. Improvements on Skates.*(Perfectionnements aux patins.)*

Henry Bezer, London, Eng., 16th January, 1882; for 5 years.

Claim.—1st. The vertically adjustable spring bearing plate s. 2nd The combination, with the vertically adjustable spring bearing plate s, of the screw m, collar r, plate f, plate y, pin z and runner a. 3rd. The combination, with the sliding heel piece i, of the sliding plate f, lever n and cam l. 4th. The combination with the bearing plate s, of the sliding heel piece i, sliding plate f, lever n, cam l, screw m, inclined slots t t, headed adjustable u u and slotted clip plates v v.

No. 14,004. Improvements on Harrows.*(Perfectionnements aux herses.)*

John H. Smale, St. Thomas, Ont., 16th January, 1882; for 5 years.

Claim.—1st. The wrought iron teeth E having diamond-shaped pieces of wrought steel F welded on to said teeth, which are attached by bolts C passing through them and clipped on two bars A by groove a and shoulders b c. 2nd. In combination with the above, the wrought iron bars A, braced by tubes B and connected by bolts and nuts C D.

No. 14,005. Improvements on Ploughs.*(Perfectionnements aux charrues.)*

Fremont Simonds, Grand Island, N. Y., U. S., 16th January, 1882; for 5 years.

Claim.—1st. A mould-board for ploughs having a spiral face of a gradually increasing pitch and its surface straight on lines drawn radially across its face. 2nd. A mould-board A in which the furrow turning portions of the surface are straight, in combination with the plough share B having a similar furrow turning surface but sharper or having less pitch, so as to start the turning of the furrow more gradually. 3rd. The combination of a mould-board having a straight lower edge and a removable shoe attached to said edge near the heel. 4th. The standard D having a ton bearing, in combination with the beam D2 clamped directly to said bearing by a bolt I2 and swinging on the latter for the purpose of adjusting it to one side or the other. 5th. The land side C, the bottom of which acts as a shoe, in combination with a mould-board, the base or lower part of which is arranged parallel, or substantially so, with the land side and adapted to act as or to receive a shoe. 6th. The combination of a mould-board, a share secured to said mould-board and provided with a rib on its under side, extending from near its front and back to the landside. 7th. The combination, with a plow, of the pivoted handles secured respectively to the mould-board and land side, and intermediate plate L. 8th. The bolts K, slotted handle plates I II, bolts m m, landside C, mould-board and handles M, in combination with the angle plate L, for the purpose of holding the handles and all the parts together.

No. 14,006. Improvements on Wheels.*(Perfectionnements aux roues.)*

Robert Gowans, Scarborough, Ont., 16th January, 1882; for 5 years.

Claim.—In a wheel composed wholly of metal, a rim formed out of a U-shaped bar of metal, and a hub having flanges forming a central recess around its circumference, corresponding with the recess in the U-shaped rim, in combination with curved spokes having hooked or

eye-shaped ends arranged to fit in the recesses in the rim and hub, and held in position by bolts or rivets.

No. 14,007. Improvements on Wind-Mills.*(Perfectionnements aux moulins à vent.)*

Clarence J. Hamilton, Plymouth, Mich., U. S., 16th January, 1882; for 5 years.

Claim.—A wind-mill wherein the sails automatically controlled and governed with relation to the force of the wind, by the centrifugal action of the weights which turn the sails upon their arms. 2nd. In combination with the plate I and its connections, the laterally moving ring N, and frame O secured to the yoke R by means of the bars P, said yoke being secured to a lever S and by means of which the said ring and its frame are projected or retracted, for the purpose of operating the lever M fulcrumed on the plate I.

No. 14,008. Improvement on Curtain Rollers. *(Perfectionnements aux bâtons des rideaux.)*

Hugh Farley, Philadelphia, Pa., U. S., 16th January, 1882; for 5 years.

Claim.—1st. Mechanism to support a curtain roller and allow it to rotate freely, which retains its position against the window frame by friction alone. 2nd. A support for curtain rollers, in combination with means to create a friction between said support and the window frame. 3rd. The combination of the roller A and pivot projection C, with pivot recessed caps D or their equivalent, and a spring F.

No. 14,009. Improvements in the Manufacture of Articles from Plastic Materials. *(Perfectionnements dans la fabrication des objets en matières plastiques.)*

Joseph Naylor, Sterling, N. J., U. S., 16th January, 1882; for 5 years.

Claim.—1st. The method of making or preparing rolls, sticks, or cylinders of plastic material from the ends of which are to be cut blanks to form buttons or other articles or veneers for the same, which consists in placing together side by side sticks, sheets or elements of the plastic material of different colours, and then consolidating the same, whereby a finished cylinder or stick is formed, transverse sections of which, taken at any point, present the same design in the same colours. 2nd. The improvement in the manufacture of articles from plastic materials which consists in, first, producing or forming a stick or cylinder of the plastic material having a design in different colours or tints running through it from end to end, second, consolidating said stick or cylinder, third, cutting from the end of said completed stick or cylinder, disks or blanks of the proper thickness and, fourth, pressing said blanks in moulds or dies, whereby they are given the required shape.

No. 14,010. Improvements in Pavements.*(Perfectionnements dans le pavage.)*

Antonio Pelletier, Washington, D.C., and Tranquillo Luna, Los Limas, N.M., U. S., 16th January, 1882; for 15 years.

Claim.—1st. Paving blocks formed of concrete having their upper and lower longitudinal and transverse edges bevelled, so as to form, when laid, V-shaped channels running at right angles to each other, and adapted to be reversed at will. 2nd. The foundation formed of concrete blocks at right angled parallelogram form, laid with relation to each other in such a manner that each paving block will bear upon three or more of the said foundation blocks. 3rd. The pavement formed of the paving blocks D having upper and lower bevelled edges a, in combination with the foundation formed of blocks B arranged in relation to the said paving blocks in such a manner that each of the latter will bear upon three or more of the foundation blocks B and with an intervening layer of sand. 4th. The combination of the foundation formed of series of strips of wood, laid upon the road bed, crossing each other at angles so as to form diamond or rectangular shaped spaces, said spaces filled with concrete or beton, the strips forming part of the foundation, the paving blocks formed of concrete, with bevelled upper and lower edges, and a cushion layer of sand interposed between said foundation and the paving blocks.

No. 14,011. Improvement on Sawing Machines. *(Perfectionnement aux scieries.)*

William Hamilton, Peterborough, Ont., 16th January, 1882; for 5 years.

Claim.—The placing of the levers laying down horizontally at each end of frame, the set works column and rack bar, with notch bar and shifting gauge block and gauge bails attached, the use of a mill front cast ways, the using of the steam cylinder on this kind of a mill by adapting it as a frame to hold ways, also the drop dog for holding logs.

No. 14,012. Improvements in Oil Lamps.*(Perfectionnements aux lampes à huile.)*

Francis J. Hamilton, Orillia, Ont., 16th January, 1882; for 5 years.

Claim.—The slotted tube A provided with a wick, in combination with the burner B.

No. 14,013. Improvements on Skates.*(Perfectionnements aux patins.)*

The Starr Manufacturing Company, (Representing John Forbes.) Halifax, N. S., 16th January, 1882; (Extension of Patent No. 1344.)

No. 14,014. Improvements on Steam Apparatus for Supplying Heat and Power. (*Perfectionnements aux appareils à vapeur pour le chauffage et la force motrice.*)

Eugene F. Osborne, St. Paul, Min., U.S., 19th January, 1882; for 5 years.

Claim.—1st. The combination, with a main or general steam supply pipe, a local distributing pipe, having no interior connecting with said supply pipe, and apparatus for transmitting heat from the contents of the former to the contents of the latter, operating to condense the steam of the supply in the act of transmission, of mechanism whereby the amount of heat transmitted may be varied at will, and a meter arranged to pass the water so condensed. 2nd. In a general steam heating system, the combination, with a street or main supply pipe connected with the steam space of a generator, of a local distributing pipe situated in a building to be heated, the contents or circulation of said local distributing pipe being separate from that of the main supply pipe, apparatus for transmitting heat from the contents of the main to the contents of the local pipe, operating to condense the supply-steam in the act of transmission, and a meter arranged to pass the water of condensation from the supply-steam. 3rd. The combination, with a steam supply pipe, a local distributing circuit and apparatus for transmitting heat from the former to the latter, of regulating mechanism adapted to be set at will to secure the transmission of any desired amount of heat from the steam of the supply pipe to the contents of the local distributing circuit, and also adapted to automatically maintain a practically constant pressure or heat in the local distribution of the degree required. 4th. In combination with the steam supply pipe, a closed local circuit, and apparatus for transmitting heat from the steam of the supply-pipe to the contents of the local circuit, a device or devices actuated by the heat of the local circuit to control the amount of heat transmitted to the contents of said local circuit from the steam of the main supply. 5th. In a general steam heating system, a main circuit comprising a steam generator, a steam supply pipe or pipes, a pipe or pipes for the return of water of condensation, and apparatus for forcing the water of condensation from the return pipe back to the generator, the pipes of said main circuit extending in proximity with each other, from the steam source of the building or buildings to be heated, and combined with local heating apparatus, either for steam or hot water, located in said building or buildings. 6th. In a steam heating system for large districts, the combination, with the main circuit containing a steam generator, a steam supply pipe, and a condense-water return pipe, said pipe being arranged in proximity throughout the heated district, and connected at the several buildings heated, of a local circuit situated in a building to be heated and adapted to be closed, so as to continually circulate its contents, means for transmitting heat from the main circuit to the local circuit, and means for measuring the amount of heat transmitted. 7th. The combination, with a steam generator, a steam supply pipe, and a condense-water return pipe belonging to a steam heating main circuit, said pipes being arranged in proximity throughout the heated district, and with a local heating apparatus, having a circulation distinct from that of the main circuit, of a transmitter placed at the junction of the main circuit, with the local heating apparatus, connected to receive, and operating to condense the steam from the supply main, and also connected to discharge the condense-water into the return main, and a meter arranged to pass the condense-water after it has left the transmitter and before it enters the return main. 8th. The combination, with a steam supply pipe, a local heating apparatus operating to condense the steam supplied and a meter arranged to pass the condense-water, of a pipe or passage *n7* conducting steam from said supply pipe to the meter or to the condense-water pipe leading to the meter, for the purpose of restoring to the condense-water the temperature and volume lost subsequently to condensation in its passage through the heating apparatus, and thereby securing accurate measurement of the heat supplied. 9th. In the measurement of heat supplied from steam to a heating apparatus, by metering the water of condensation, the method described, which consists in practically restoring the condense-water after it leaves the heating apparatus, and before it passes the meter, to its original temperature and volume at the instant of condensation. 10th. In combination with the generator *S* and the duplex system of mains *A B*, the tank *F* and the pump *P* connected between the return *S*, the pump *P* and the tank *F*, the latter directly furnishing water for the generator through said pump, mechanism adapted to automatically control the speed of the pump in accordance with the quantity of water in said tank. 11th. The combination, with the generator *S*, tank *F* and pump *P*, of the steam pump supply pipe *S1 S2*, having the valve chamber *C* and valve *C2*, the latter being worked by the float *F2* within the tank *F*. 12th. In combination with the generator *S*, the tank *F*, the source of the water supply *W* having a pressure greater than that of the tank *F* and automatic mechanism controlling the passage of water from the tank to the generator, mechanism whereby the passage of water from the source *W* to the tank is controlled by the height of the water in the generator. 13th. In combination, with the tank *F*, generator *S*, pump *P* and automatic mechanism for regulating the speed of the pump, of the water source *W* connected with the tank through the pipe *W1 W2* and the float valve *U* in the said connecting pipe, said valve being controlled by the float *U3* in the chamber *U* connected with the generator in such a manner as to have a common water line therewith. 14th. The combination, with the steam supply main *A* and the return main *B*, of the main circuit, embracing the tank *F* and the generator *S*, a *d* mechanism for forcing the water of condensation from the tank to the generator, the connecting pipe *A2* having the reducing valve *L*, and the supply *A* at the head of the main circuit. 15th. The combination, with the tank *F* and the supply *A* of the main circuit described, of

the pipe *A2* having the valve *L*, the diaphragm regulator *L2* of which the weight arm *L1* is arranged to bear on the valve rod *L* and in which the diaphragm is exposed on one side to the pressure of the tank, and on the other to that of the supply main *A* at a chosen point on said main. 17th. The main circuit of a general steam heating system, the supply main *A* and the return main *B* arranged one above the other in the box *X*. 18th. In combination with the mains *A B* arranged one above the other, the rollers *A4 B4* and the saddles *I I1* constructed and combined to retain the mains in proper relation, and at the same time permit longitudinal movement. 19th. In combination with the thick covering of the main pipe and the supporting roller, the interposed saddle *I* having the projections *i* which pass through the pipe covering and bear upon the pipe itself. 20th. In combination with the mains *A B* arranged one above the other, the saddles *I I1* of the lower pipe, extended about the pipe to afford mutual support to each other. 21st. The slip joint fitting *J* having the packing bulb *J1* provided with a curved chamber *J2* narrowed towards the central pipe passage, and with packing screw *J3*. 22nd. The combined slip and flexion joint fitting *J* having the packing bulb *J1* chambered at one end, and the spherical bulb *J6* at the other end, whereby the fitting is adapted to be combined with a suitable socket to make a flexion joint. 23rd. The combination, with the duplex main system, of the coupling *D* having the chambers *D1 D2* and adapted to receive the mains *A B* one above the other. 24th. The double chambered coupling *D* combined with the mains *A B* and adapted to afford communication between these mains by the plugged opening *D4*. 25th. The double chambered coupling *D* adapted to be connected flexibly with the mains *A B* at one or both ends, combined with said mains. 26th. In combination with the steam supply main and water return main *B*, the double chambered coupling *D* having its chambers connected by a pipe or passage *D5 D6 D7* provided with a valve controlled by a float in the steam chamber of the coupling, whereby the coupling may serve as a drip transfer, automatically discharging the water of condensation from the main *A* into the return *B*. 27th. In combination with the double chambered coupling *D* rigidly connecting the mains *A B*, the anchor bar *D11*. 28th. The double chambered coupling *D* provided with the hand hole *D9* opening into the lower chamber *D1*, combined with the mains *A B*. 29th. The duplex main pipe system, consisting of the supply main *A* and the return main *B* arranged parallel with each other and in proximity, said pipes being rigidly connected with each other at intervals, and provided with slip joints between the points of connection. 30th. In a system of general steam heat supply, the combination, with the supply main, of a supply branch leading from said main and extending around an entire square or block of buildings, whereby all the buildings in said square or block are supplied from a single connection with the main, said branch being arranged beneath the walk or buildings, so that the connections with the interior heating apparatus of the several buildings are accessible without opening the street. 31st. In combination with the supply main of a general steam heating system, two or more supply branches connected with said main, at the intersection of streets, and each leading to and around an adjacent square to serve as a general branch supply furnishing heat to all the buildings in the square heated from said system, said branches being arranged beneath the walk or buildings. 32nd. In combination with the general supply main having provision made at the intersection of streets for the connection of branches thereto, one or more branches connected with said main at said intersection, extending parallel with the main until opposite the square, and thence leading to and about the square beneath the walk or buildings. 33rd. In a general steam heating system, the apparatus comprising the tank trap *K*, transmitter *T*, meter *N* and connections for the admission and passage of steam into the transmitter through the tank trap, and the water of condensation from the transmitter through the meter and tank trap, said transmitter being adapted to be connected with a local distribution system. 34th. The analyzer *K1* combined with the supply pipe *A1*, transmitter *T* and meter *N*. 35th. In combination with the tank trap *K* connected to receive the pressure of the steam supply pipe *A1*, and also connected to receive the water of condensation from the transmitter *T* or the meter *N*, the discharge *B3* having the valve *K2* operated by a float and located beneath the water line of said tank. 36th. In combination with the transmitter *T* having the passage *r* in the main circuit through or contiguous to the chamber *T1* in the local circuit, the valve *G1* in the discharge pipe *B3* of the main circuit, governed by the pressure in the chamber *T1* so as to raise or lower the water of condensation in the passage *r* and thereby expose more or less of the surface of said passage to the steam of the main circuit. 37th. In combination with the local hot water circuit having a pipe extending a suitable distance above the highest radiator in the circuit, said pipe being either open at the top or provided with a valve, whereby it may be opened or closed, the transmitter *T* connected with said circuit, and also with the steam supply or return pipes, and the regulator *G* connecting, as indicated, with the transmitter and with the return steam pipe, whereby varying pressure in the local hot water circuit arising either from the varying column due to change of temperature therein, or from the confine *it* of its contents, operates to control the heating effect of the transmitter. 38th. In combination with the meter *N* receiving the discharge from the transmitter *T* and discharging into the tank *K*, the latter being subject to the pressure of the steam supply, the pipe or passage *n7* connecting the tops of said meter with the pipe *A5*, or other pipe or space having the pressure of the steam supply. 39th. In combination with the meter *N* connected at its top to receive steam from the steam supply pipe, the trap bend *n8* in the pipe *B3* discharging into the meter. 40th. In combination with the main steam supply, or with the main circuit, the local hot water circuit, combined with the compression tank *W4*, open pipe *n4* and cock *n5*. 41st. In combination with a general steam source and a transmitter connected therewith, an engine having its steam supply connected with the transmitter, a local heating circuit supplied from the exhaust of the engine, connected to force the water of condensation from the exhaust heating circuit mentioned back into the transmitter. 42nd. In combination with the transmitter *T* connected with the main circuit or steam supply and with the engine *O*, pump *P2* and tank *T4* respectively connected, the safety relief trap *H* connected with the tank *F4* and provided with a discharge pipe *h* arranged in the said trap. 43rd. In combination with the radiators *R1 R2* the supply pipe *a* and return pipe *b*, the connecting pipes *c3 c4* and the air valve *n5* on the return *b*.

No. 14,015. Improvements on Arithmetical Frames. (*Perfectionnements aux tables d'arithmétique*)

John Gould, Chatham, N. J., U. S., 19th January, 1882; for 5 years.

Claim.—1st. An arithmetical device having a frame A provided with a series of slates B capable of being revolved at will and controlled in position by a vertical slot or groove *a*. 2nd. The combination with an arithmetical device having a frame A provided with a series of slates B capable of being revolved at will and controlled in position by a vertical slot or groove *a*, of the projecting axis *b*, washers *d*, springs E and handles C. 3rd. The combination, with an arithmetical device provided with a frame A and slates B operated and controlled as described, of the cross bars A₁ A₂ provided with complex fractions or numbers and fractions.

No. 14,016. Improvements in Car Heaters.

(*Perfectionnements aux calorifères des chars.*)

Miles C. Root, Toledo, Ohio, U. S., 19th January, 1882; for 5 years.

Claim.—1st. A heating apparatus of cars consisting of the heater A provided with a shell or jacket B, having air ducts B₁ adapted to fit into corresponding sized openings *a*, in the false jamb F, in such a manner as to take the cold air from the bottom of the car and return it back again in the body of the car in a heated condition. 2nd. A smoke pipe E pivoted at *b* to the short pipe H₁, which is provided with the lug *c* for engagement with the fork J and chimney I, in combination with the pipe D of the heating apparatus. 3rd. In a car heater, the combination of the heater A provided with the shell or jacket B having air ducts B₁, with the false jamb F having openings *a* adapted to receive the air ducts B₁.

No. 14,017. Improvements in Projectiles.

(*Perfectionnements aux projectiles.*)

Herman Gruson, Buckau, Prussia, Albert Hellhoff, Mayence, Hesse, and Josef Halbmayr, Marianbad, Bohemia, 19th January, 1882; for 15 years.

Claim.—1st. A projectile divided by one or more partition walls or the walls of two or more vessels, into two or more compartments adapted to contain the component parts of an explosive substance, the discharge of the projectile from the gun, causing the said walls to be broken, or openings in them to be uncovered. 2nd. In combination with a projectile in which the component parts of the charge are contained in separate vessels or chambers, the detonating fuse containing a primer E and gunpowder D. 3rd. In combination with a projectile in which the component parts of the charge are contained in separate vessels or chambers, the firing device consisting of piston T and perforated cup K.

No. 14,018. Improvements in Wash Basins, etc. (*Perfectionnements aux cuvettes des laburos, etc.*)

Abraham Edwards, (Assignee of Joseph Bennor), Philadelphia, Pa., U. S., 19th January, 1882; for 5 years.

Claim.—1st. In a mercury seal joint or stench trap having an induction and an ejection pipe and an enlarged intervening chamber, whereby the mercury which forms the seal will, under superposed fluid pressure in the induction pipe, be lifted into and dispersed over the bottom of said chamber, permitting the discharge of such fluid, such mercury automatically sealing the trap after said discharge and rising on a solid column in the ejection pipe under back pressure. 2nd. In combination with the induction pipe M having a bend or neck *m*, a platform N which forms the bottom of the mercury spreading chamber. 3rd. In combination with induction and ejection pipes M O and a platform N, a removable cap or section forming, with said platform, a mercury spreading chamber, and means for clamping or securing the same in position. 4th. In combination with induction and ejection pipes and an intermediate mercury spreading chamber, a ledge *a* projecting for preventing mercury from being forced into ejection pipe by violence of flow or pressure in the induction pipe.

No. 14,019. Improvements on Reapers and Mowers. (*Perfectionnements aux faucheurs-moissonneurs.*)

Jay C. Meyers and Robert Banker, Bayfield, Ont., 19th January, 1882; for 5 years.

Claim.—1st. The roller cam J. 2nd. The adjustable cam lever K. 3rd. The combination of the cam J lever K and axle-tree A. 4th. The combination of the cam J and lever K. 5th. The combination of the finger bar Q, knife sections N and pivot straps *a*, or their equivalent, for giving the knife sections a circular cutting motion. 6th. The guards P. 7th. The combination of the connecting bar R, shoe S and knuckle joint couplings T. 8th. The axle-tree A. 9th. The combination of the axle-tree A, gear wheels H H₁ H₂, crank F and the ratchets B₁ B₂ or their equivalent.

No. 14,020. Improvements on Boots and Shoes. (*Perfectionnements aux chaussures.*)

Oliver W. Ketchum, Toronto, Ont., 19th January, 1882; for 5 years.

Claim.—1st. A boot having a lap over instep one or more straps A secured at one end to said lap and adapted to pass through one or more staples C on the quarter D, and provided with an extension E adapted to pass beneath the lap, around the front of the ankle or instep, through the whole P on the opposite quarter, thence around the back of the ankle to a buckle F. 2nd. A boot having a lap over instep the straps A, each adjustably secured at one end of the lap by a buckle B and adapted to pass through staples C, in combination with, and fastened to the strap E adapted to pass around the front of the ankle through the hold P, thence around the back of the ankle to a

buckle F. 3rd. The straps A in combination with straps C secured to the quarter D by the staples L, which are laced and secured to the sole at M. 4th. In a boot having a lap over instep forming an integral part of the inside quarter, the combination of the strap A secured at one end to the lap by a buckle B and adapted to pass through staples. 5th. In a boot provided with a strap or straps arranged to bind down the lap over instep, the combination of a buckle B provided with a rivet *b* which passes through the leather of the boot, thence through a hole in the buckle projecting beyond it and forming a pin, which passes through a hole in the straps A.

No. 14,021. Improvements on Piano-fortes. (*Perfectionnements aux pianos.*)

Theodore A. Heintzman, Toronto, Ont., 19th January, 1882; for 5 years.

Claim.—In a piano provided with a solid metal bridge; vertically projecting lips extending along the outer edges of the bed plate of the said bridge and forming ringing points for the strings passing over them, in combination with a bearing bar provided with a ridge forming a ringing point, and situated between the ringing points of the bed plate.

No. 14,022. Improvements on Gasoline Stoves. (*Perfectionnements aux poêles à gaz.*)

Fordyce A. Lyman, Cleveland, Ohio, U. S., 19th January, 1882; for 5 years.

Claim.—1st. The cylinder E and air chamber therein provided with a perforated bottom and closed top pipe G having an aperture *d*, cross pipe *m* with its respective stop cocks and set screw K, in combination with an oil fount or reservoir of a gasoline cooking stove. 2nd. In an apparatus for producing a pressure of air, the combination of the cylinder E having therein an air chamber provided with a perforated bottom and closed top, air pipe and aperture *d*, cross pipe *m* and its respective stop cocks and set screws.

No. 14,023. Improvements on Relay Telephones. (*Perfectionnements aux téléphones à relais.*)

Henry C. Strong and Llewellyn H. Lloyd, Chicago, Ill., U. S., 19th January, 1882; for 5 years.

Claim.—1st. In a telephone, the bevelled bar magnet A carrying the spools B and C, in combination with the iron tube D, casing E and F and the double diaphragms I J K. 2nd. In combination with the magnet A, spools B and C, tube D and casing E F, the adjusting cup G carrying the double diaphragms I J. 3rd. The bevelled bar magnet, in combination with the spools B and C securing nut *h*.

No. 14,024. Improvements on Horse-Power Links. (*Perfectionnements aux chaînes des manèges.*)

Bernard L. Olds, St. Albans, Vt., U. S., 13th January, 1881; for 5 years.

Claim.—1st. The horse-power link provided with a rigid loop of stirrup *c* for connection of the wooden lag. 2nd. The combination of the link A provided with loop *c*, and the lag B provided with mortises that receive the loop.

No. 14,025. Improvements on Speed Regulators for Horse-Powers. (*Perfectionnements aux régulateurs de la vitesse des manèges.*)

Bernard L. Olds, St. Albans, Vt., U. S., 19th January, 1881; for 5 years.

Claim. 1st. In speed regulators the weighted arms *a*, lever *e*, rod *k*, spring *m*, loose disk *c* and rope *p* connected to a brake lever, combined together with the fly wheel A. 2nd. The plate C provided with stud *b*, the loose winding disk *c* having a tubular hub, spring actuated lever *e* connected with centrifugal acting weights, and rope *p* connected to the winding disk and brake lever.

No. 14,026. Improvements in Clocks.

(*Perfectionnements dans les horloges.*)

William N. Miller, Toronto, (Assignee of John F. Lash, Hamilton), Ont., 19th January, 1882; for 5 years.

Claim.—1st. The combination, with the pendulum P having loop G, of the adjustable spring coil H having hook I carrying the ball or weight J. 2nd. A pendulum formed with a loop, and having a laterally adjustable ball or weight. 3rd. The combination of a pendulum having a laterally adjustable weight, and provided with a laterally extending finger, or index, and an index secured upon the inside of the clock case. 4th. A pendulum rod formed with a loop, for a laterally adjustable hooked tension coil and with a finger or index.

No. 14,027. Improvements on Clothes Wringers. (*Perfectionnements aux essoreuses à linge.*)

Daniel F. Babb, Kingsville, Ont., 19th January, 1882; for 5 years.

Claim.—1st. The mode of construction of lever bars D D and the combination of the same with the springs C C and bearings F F, and spring supports I I. 2nd. The shape of the springs C C bearings F F and spring supports I I.

No. 14,028. Improvements on Horse Shoes.*(Perfectionnements aux fers à cheval.)*

Theodore S. Very, Boston, Mass., U. S., 19th January, 1882; for 5 years.

Claim.—1st. The method of making horse shoes, by rolling a straight bar to form the creases and nail cavities, and secondly, bending the prepared bar into horse shoe form. 2nd. The method of preparing blanks for horse shoes, by rolling a bar to form nail hole cavities in one surface, and elongated cavities in the opposite surface, coinciding with said nail cavities. 3rd. The improved rolled and bent horse shoe having nail hole cavities formed in one side and coinciding elongated cavities formed in the opposite side. 4th. The manufacture of horse shoes having the usual nail cavities *c c* in one side, the forming, in the hoof bearing face of such shoes, of the cavities *e e* elongated into continuous grooves, disposed to meet the nail holes punched through the cavities *c c* from the other side, to thereby insure the longitudinal coincidence of the upper and lower end of the nail holes and correct any imperfection of punching. 5th. A horse shoe or horse shoe blank having the usual nail cavities in one side, and provided with the cavities *e e* elongated into continuous grooves and arranged in the hoof bearing surface of the shoe. 6th. A horse shoe having elongated cavities *e e* formed in its loop bearing surface said cavities, preventing direct contact between the metal of the shoe and the nail receiving portions of the bottom of the hoof.

No. 14,029. Improvements on Machines for Bearding Barley.*(Perfectionnements aux machines à barber l'orge.)*

Francis W. Brenton, Foxboro, Ont., 19th January, 1882; for 5 years.

Claim.—The combination of the plates B and E, the teeth C and F, rake G and wire H.

No. 14,030. Improvements on Machines for Turning Tree Nails.*(Perfectionnements aux machines à tourner les gournables.)*

Francis Lighthody, Bath, Me., U. S., 19th January, 1882; for 5 years.

Claim.—1st. The machine for forming tree nails from blanks consisting of a chuck mounted on shaft G, for carrying the blank gearing, for causing said chuck to revolve a transverse shaft L, carrying a drum *m* and operated, through a spur wheel J, by the revolution of shaft G, all in combination with a sliding cutter-head connected to the said drum by a belt, whereby the revolution of the chuck and blank accomplishes also the positive feeding of the cutter *z* to the said blank. 2nd. The combination, with the shaft G having the worm L of the vertically adjustable shaft I and the spur wheel J and the drum *m* connected to the sliding cutter-head. 3rd. The combination of the sliding cutter-head the shaft G having the worm I, vertically adjustable shaft L having the spur wheel J, the pivoted lever *m* and the trip catch 10.

No. 14,031. Improvements in Gate Rollers and Hinges.*(Perfectionnements aux roulelles et aux pentures des barrières.)*

Selwin B. Pratt, Canandaigua, N. Y., U. S., 19th January, 1881 for 5 years.

Claim.—The combination, with the gate A, of the pivoted hinge consisting of the standards C, roller D, guide pin K and step *i*, and the pivoted hanger B.

No. 14,032. Improvements in Spring Tooth Harrows.*(Perfectionnements aux herces à dents élastiques.)*

Oscar J. Panches, Plymouth, Mich., U. S., 19th January, 1882; for 5 years.

Claim.—1st. A double harrow tooth formed of a bar of curved spring metal with a rigid cutting tooth in front and a spring tooth in rear. 2nd. A double harrow tooth formed of a bar of curved spring metal with a rigid cutting tooth in front and a spring tooth in rear, flat portion of the spring-tooth being twisted so as to present its edge to the rigid cutting tooth *c*, with its plane perpendicular to the flat portion of the spring-tooth *b*. 3rd. The curved double harrow-tooth B having the spring point *b*, twist *a*, perforated socket *h* and rigid cutting teeth *c*, with its plane perpendicular to the flat portion of the spring tooth *b*. 4th. The combination, with a harrow frame A, of the curved double harrow tooth B having the spring point *b*, twist *a*, rigid cutting tooth *c* and pivoted bolt *i*.

No. 14,033. Improvements on Fire Grates.*(Perfectionnements aux grilles des foyers.)*

Adam C. Engert, Bromley-by-Bow, England, 19th January, 1882; for 15 years.

Claim.—1st. Open domestic fire grates, kitcheners and ranges having at the back, in the position usually occupied by a fire lump, a chamber *e* opening into the fire place and provided with a movable plate or pusher *f* by which, when it is desired to feed the fire, the fuel may be pushed forward out of the chamber *e* into the fire place. 2nd. The combination of the parts *e h* and K. 3rd. Closed fire grates consisting in combining with them the chamber *e* and back plate or pusher *f*.

No. 14,034. Improvements on Machines for Collecting Mill Dust.*(Perfectionnements aux machines à ramasser la fuller-farine.)*

Samuel L. Bean, Washington, D. C., U. S., 19th January, 1881; for 5 years.

Claim.—1st. The combination of a stellated dust catching balloon and an automatically operated cut-off or gate within the same, which

periodically cuts off the air current from a portion of the angles or separating chambers of the balloon, to permit the dust to be shaken from the cloth sides of such cut-off angles. 2nd. The combination of a stellated dust catching balloon and travelling gate within the same, for cutting off the air current from successive angles of said balloon. 3rd. The combination of a stellated dust catching balloon, a travelling gate within the same for cutting off the air current from successive angles of said balloon and a travelling knocker.

No. 14,035. Improvements on Gas Consuming Furnaces.*(Perfectionnements aux foyers fumivores.)*

Kingsbury M. Jarvis, Peabody, and Albert F. Upton, Boston, Mass., U. S., 19th January, 1882; (Extension of Patent No. 6984.)

No. 14,036. Improvements on Horse Rakes.*(Perfectionnements aux râtes à cheval.)*

William H. Field, Portchester, (Assignee of William J. Lane, Millbrook, N. Y., U. S., 19th January, 1882; (Extension of Patent No. 6976.)

No. 14,037. Single Plate Carriage Spring.*(Resort de voiture d'une seule lame.)*

The Guelph Carriage Goods Co.'s, (Assignee of John B. Armstrong.) Guelph, Ont., 19th January, 1882; (Extension of Patent No. 7012.)

No. 14,038. Improvements on Liquid Filters.*(Perfectionnements aux filtres.)*

Thomas Cushing, (Representative of James Foley.) Montreal, Que., 19th January, 1882; (Extension of Patent No. 6967.)

No. 14,039. Improvement on Hammers for Dressing Stones.*(Perfectionnement des marteaux à rhabiller les meules.)*

Alexander McDonald, Belmont, Mass., (Assignee of John Hartnoll, Mason, N. H.,) U. S., 19th January, 1882; (Extension of Patent No. 6975.)

No. 14,040. Improvement in Snow Shovels.*(Perfectionnement des pelles à neige.)*

Henry W. Searle, Hamilton, Ont., 19th January, 1882; (Extension of Patent No. 7001.)

No. 14,041. Improvements on Sleigh Knees.*(Perfectionnements aux courbes des traîneaux.)*

Peter Filman, Barton, Ont., 19th January, 1882; (Extension of Patent No. 6996.)

No. 14,042. Improvements on Mining Machines.*(Perfectionnements aux machines à miner.)*

Francis M. Lechner, Waynesbury, and Joseph A. Jeffry, Columbus, Ohio, U. S., 21st January, 1882; (Extension of Patent No. 12,537.)

No. 14,043. Improvements on Railway Cars.*(Perfectionnements aux chars des railroutes.)*

The La Mothe Manufacturing Company, (Assignee of Bernard J. La Mothe,) New York, N. Y., U. S., 21st January, 1882; (Extension of Patent No. 7005.)

No. 14,044. Improvements on Boot and Shoe Heels.*(Perfectionnements aux talons des chaussures.)*

Joseph Kieffer, Montreal, Que., 25th January, 1882; for 5 years.

Claim.—1st. A heel shell made of a single piece of leather, or like substance, and having its upper edges turned down so as to form a channel for the stitching securing it to the upper. 2nd. In combination with the shell of a boot heel, the sole secured thereto by stitching on the turned down edge of the front. 3rd. In combination with a boot heel provided with a turned up rim and the covering piece, the metal plate provided with projections secured to the one, and holding the other in place. 4th. In combination with the turned up rim of the outer shell of a boot heel, a metal plate forming the bottom of the heel, secured to said rim by serrated projections and provided with suitable projections underneath. 5th. A combined leather and metal lift in which the metal plate is adapted to be fastened to the top lift, by means of circumferential edge projections, and is also provided with upward projections adapted to secure the plate to the heel proper. 6th. The plate D' with edge projections or serrations *d*.

No. 14,045. Improvements on Sash Cord Fasteners.*(Perfectionnements aux arêcorons des jalousies.)*

Thomas Morton, New Windsor, N. Y., U. S., 25th January, 1882; for 5 years.

Claim.—1st. The suspending device F composed of a single piece of wire having loop *c* and hooks *a a*. 2nd. The combination, with the chain E and weight D, of the suspending device F constructed or provided with hooks *a a* and loop *c*. 3rd. The combination, with the chain E and sash A, of the corrugated curved plate or key seat *t* fitting within the circular recess H in the sash and provided with a hole *f* through which the chain is passed, and the ring-shaped key I inserted in the chain link and fitting in the corrugation of said plate.

No. 14,046. Improvements on Water Closets.*(Perfectionnements aux cabinets d'eau.)*

Abraham Edwards, Philadelphia, Pa., U. S., 25th January, 1882: for 5 years.

Claim.—1st. The combination, with a water-closet bowl having on or around its upper edge, a trough for the reception of mercury or other fluid, or a packing to form a valve seat, of a cap or valve provided with a vertical spindle or axis of rotation, whereby it is designed and adapted to form a cover of said bowl and to be removed therefrom by being lifted and swung. 2nd. The combination, with a water-closet bowl having a fluid trough or packing receptacle on or around its upper edge, of a cap or cover for said bowl having a flange or rib corresponding to the bowl trough and adapted and designed to enter the same, and means for moving said cap vertically and swinging it laterally.

No. 14,047. Improvements in the Manufacture of Pigments. *(Perfectionnements dans la préparation des couleurs.)*

John B. Orr, London, Eng., 25th January, 1882: for 15 years.

Claim.—1st. The production of a white pigment from the precipitate obtained by treating solutions of sulphide of strontium with solution of zinc salts, usually the sulphate. 2nd. The production of a white pigment by calcining a precipitate consisting of strontic sulphate and zinc sulphide.

No. 14,048. Improvements in the Manufacture of Lactates. *(Perfectionnements dans la préparation des lactates.)*

Charles Avery, Boston, Mass., U. S., 25th January, 1882: for 5 years.

Claim.—The method of manufacturing lactic acid and lactates by the fermentation of a sugar of vegetable origin with a lactic ferment in the presence of nitrogenous matters chiefly of vegetable origin and of a substance suitable to gradually neutralize the acid as fast as formed, whereby time is economized, putrefaction prevented, and purification rendered simple and unexpensive.

No. 14,049. Improvements in Roof Brackets.*(Perfectionnements aux supports des toitures.)*

Hardy M. Hoerner, Fowler, Mich., U. S., 25th January, 1882: for 5 years.

Claim.—The roofing bracket A B C D E having teeth or points F, and provided with a spring clasp G having downward projecting teeth or points H.

No. 14,050. Process and Apparatus for Reclaiming Lowlands Adjacent to the Tide Water Beaches. *(Procédé et appareil de rehaussement des bas-fonds contigus aux grès baignés par la mer.)*

George Howell, Philadelphia, Penn., U. S., 25th January, 1882: for 5 years.

Claim.—1st. In dredging at suitable points along the shore the sand or mud from below high water mark conveying it over the said low lands, the resupply of sand or mud to the excavated places being caused by the action of the tide. 2nd. The combination, with endless apron or conveyer E, of an anchored support F carrying a pivoted frame P adapted and designed to rise and fall with the tides. 3rd. The combination of an excavating and lifting conveyer E with a distributing conveyer N, engine Q, and intermediate gearing, whereby both the excavating and distributing apparatus are driven by said engine, while the distributor may be shifted into different positions. 4th. The combination, with excavating conveyer E, incline L, and distributing conveyer N, of the swivelled hopper M.

No. 14,051. Improvements on Iron Fence Posts. *(Perfectionnements aux pieux des clôtures en fer.)*

James S. Fox, Port Hope, Ont., 25th January, 1882: for 15 years.

Claim.—1st. A tubular fence post composed of two parallel vertical bars c c of angle iron, or iron of semi-circular or curved form, in cross section, fitted together to form a tube. 2nd. The combination, with a tubular fence post composed of two parallel vertical bars of angle iron or iron, of semi-circular or curved form, in cross section fitted together, of the pointed shoe B formed of two separate plates or portions e e bent at their sides to form flanges 10 and secured to the lower ends of the bars c c. 3rd. A tubular fence post A composed of a single bar of angle iron, or iron of semi-circular or curved form in cross section bent double at b to form two parallel vertical bars or portions c c, in combination with the pointed shoe B composed of two separate plates or portions e e, bent to form flanges 10 and secured to the lower ends of the bars c c. 4th. The clamping or fastening device consisting of the collar C made adjustable upon the post A and provided with a projection g having two holding or bearing edges 15 15, between which, and the post the barbed wire D is held, whereby the wire is bent at an angle over the bearing edges or points when the collar is clamped upon the post. 5th. The combination, with a fence post, of the collar C made adjustable thereon and provided with a projection g having two holding or bearing edges 15 15, between which and the post the barbed wire is bent, and the wedge E for clamping the collar upon the post and bending the wire over the holding edges. 6th. In a clamp for securing barbed wire to fence posts, the combination, with the collar C and fence post A, of the wedge E provided with guides i k adapted to fit the edge or corner of the post and keep the wedge in position.

No. 14,052. Improvements on Extension Tables. *(Perfectionnements aux tables à rallonge.)*

William B. Crich, Clinton, Ont., 25th January, 1882: for 5 years.

Claim.—In a table prepared with beads or moulds or prepared in the form shown in Fig. 4, for the reception of metal slides, in combination with metal slides prepared to fit over and work on the beads or moulds formed in the wooden slide bars.

No. 14,053. Improvements in Machines for Sewing Buttons. *(Perfectionnements aux machines à coudre les boutons.)*

James H. Morley, Holyoke, Mass., U. S., 25th January, 1882: for 15 years.

Claim.—1st. The combination, in a machine for sewing shank buttons to fabrics, of button feeding mechanism appliances for passing a thread through the eye of the buttons and locking the loop to the fabric and feeding mechanism. 2nd. A needle and operating mechanism appliances for bringing the buttons successively to positions to permit the needle to pass through the eye of each button, and means for locking the loop of thread carried by the needle to secure the button to the fabric. 3rd. The combination, in a sewing machine, of two independent needle bars, needles and operating devices, a movable frame carrying both needle bars at an angle to each other and arranged so that the needles shall penetrate the cloth at different points on lines transverse to the line of feed. 4th. The combination, with the frame A, needle bar frame D pivoted to frame A, and adjustable cam bearings z z, of the shaft b₂, cams 7 8 on said shaft, and a suitable spring to swing said frame D towards said cams. 5th. The combination, with the needle bar frame D, of the needle bars 14 15, the eyed needle a₁, the hook needle z z, the cast off a₁, presser foot a₁ and devices for operating said parts. 6th. The combination, with the swinging needle bar frame D and the needle bars 14 15, of the crank 10, shaft b₁ and the studded crank disk on said shaft pitman 17 and the cam plate 13. 7th. In a needle feed sewing machine, the combination, with the cloth plate b₄ and the slotted presser foot supported upon and operating in the frame of the machine, of the needle bar frame D, needle bars 14 15 and their needles and the cast off a₁, adapted to be oscillated by and with the needle bar frame and actuating mechanism. 8th. The combination, in a machine for sewing buttons to fabrics, of button feeding and sewing appliances and feeding appliances, and operating mechanism whereby the feeding devices are moved alternately different distances to alternate short button stitches with long stitches between the buttons. 9th. The combination, with the frame A, swinging needle bar frame D, needle bars 14 15 and their needles carried thereby, said frame D being provided with thread guides and adapted to swing in frame A with different degrees of oscillation, of the thread take up z₂ adapted to swing with regular vibratory movement and appliances for operating the frame D, needle bars and take up. 10th. The cloth plate b₄, constructed with an unobstructed passage in it from the point between the needles, where the stitch is formed, to the outer edge thereof, combined with devices for feeding buttons above said plate and presser foot below the same. 11th. The combination with cam b₁ shaft b₁, lever d₁, the button carrier h having pin e₁ therein and having button clamping devices in one end thereof and the spirally slotted sleeve e₂. 12th. The combination, with button sewing appliances, of a trough appliance for carrying the buttons successively from the trough to the sewing devices, and mechanism for operating said appliances and sewing devices. 13th. The combination, with frame A and the button feed trough d₁ pivoted to said frame, of the lever d₄ having the cam slot a therein, to receive stud a on said trough, and operating mechanism. 14th. The combination, with the trough d₁ adapted to convey buttons therein, of the corrugated button turner e₂ connected with lever d₂ and mechanism for imparting a reciprocating longitudinal movement to said strip over the said trough. 15th. The hopper B having the button rim c therein, the upper bottom c₁ having an opening therein over the trough d₁, the perforated button gate e₂ and mechanism to intermittently rotate said gate and the button guard e₃ to partly cover some of the perforations in said gate. 16th. The combination, with the trough d₁ and with the hopper bottom c having an opening therein to let buttons drop through, of the ejector e₄ and appliances for imparting to said ejector a reciprocating motion under said hopper bottom. 17th. The ejector and pawl carrier e₅ having the arm e₆ thereon, the lever d₃ and appliances for oscillating the latter, the slotted connecting rod J and spring d₃. 18th. The button carrier h having a socket at one end to receive the socket end of the carrier and having the finger lever pivoted thereto, the slotted button plate and the button finger capable of movement by appliances from and towards said slotted button plate. 19th. The combination, with the button finger, the slotted button plate and the finger lever, of an adjustable inclined surface in the form of a wedge against which the finger lever strikes, when the button carrier h moves towards the end of the button trough. 20th. The presser foot b₁ supported in the frame of the machine the cam e₆ and mechanism for imparting an intermittent reciprocating motion to said presser foot b₁, independent of either needle bar. 21st. The combination, with the button carrier h and with the sleeve f₂ fitted loosely through d₃ of the spring e₆. 22nd. The combination, with the button trough d₁ of the cap e₄ secured adjustable on said trough. 23rd. In combination, with the button trough d₁, the stop spring e₅ and the button carrier h supporting button clamping devices thereon. 24th. The cast off bar 16 supporting in the swinging needle bar frame, in combination with which appliances, for frictionally sustaining said bar in positions to which it is moved to operate the cast off. 25th. In combination with needle bar 15, the yoke 18 secured to said needle bar, the cast off bar 16 passing loosely through said yoke and having the collars s x thereon, the pitman 17 secured to said yoke for rotating said crank. 26th. In a machine for sewing buttons on to fabrics provided with devices for automatically feeding said buttons to sewing devices, the combination, with sewing and button feeding appliances, of the connecting device f connected by mechanism with the driving shaft of the machine. 27th. In combination, the hook needle a₁, the eyed needle a₁, the cast off a₁ and operating devices.

No. 14,054. Improvements on Cigar Machines. (*Perfectionnements aux machines à cigares*)

Oscar Hammerstein, New York, U.S., 25th January, 1882; for 5 years.

Claim.—1st. The hopper E containing vertically reciprocating plunger G, in combination with the horizontally reciprocating plunger F and receiving chamber D. 2nd. The combination of the hopper E with the vibrating scoop H, vertically reciprocating plunger G, horizontally reciprocating plunger F and receiving chamber D. 3rd. The combination of the hopper E which has an aperture b with a receiving chamber D placed out of line with said apertures and with two plungers, one of which crowds the contents of the hopper into and through the aperture, whereupon the other crowds it into the receiving chamber. 4th. The combination of the scoop H and its crank d, and link e with the lever f, cam g and with the slide G and the connections thereof with the tappet m, all arranged so that the cam g will move the scoop and the slide G in succession. 5th. The combination of the plunger F with the link o, bell crank p, rod q lever r having pin s with rotating cam t. 6th. The combination of the plunger F with the plunger G and with mechanism for moving them at right angles to one another so that, when the plunger G descends, the plunger F will move away from beneath the plunger G and so that, when the plunger G ascends, the plunger F will move under the path of the plunger G. 7th. The combination of the hopper E, receiving chamber D and air pipe J, with the charging plunger F and mould m₁, and with mechanism for twice opening the valve of the air pipe while the chamber D is closed by the slide F, so as to permit the charge of the chamber F first to be blown into the mould I and the remnants next into the hopper E. 8th. The vertically reciprocating receiving mould I, in combination with the chamber D and with the air pipe J, and with the vertically reciprocating pipe L and hopper E. 9th. The air pipe J leading into the chamber D, in combination with a valve and with mechanism for opening said valve twice, and with the slide F. 10th. The combination of a receiving chamber D of a cigar mould, with the air pipe J and with the rotating wire or wires n arranged within said chamber D. 11th. The combination of the receiving mould I with the intermediate mould M, and main cigar mould N. 12th. The combination of the cylinder l² carrying mould chamber m², with the supporting disks k² and with mechanism for imparting intermittent rotary motion to the cylinder l. 13th. The mould chamber m² constructed of side wings, and reciprocating bottom n² fitted upon a cylinder l², in combination with the reciprocating bolt d², for moving the bottom n² and ejecting the contents of the mould chamber. 14th. The mould chamber m² combined with the swinging cap P and fixed blade m³, and with mechanism for rotating the mould and swinging the cap. 15th. The combination of the mould chamber m² on the ring l² with the hinged cap P, spring l³ and stationary projection k³ for moving the cap. 16th. The combination of the mould chambers m² and their carrying cylinder l² with the pawl e², bell crank p², lever q² and actuating cam r². 17th. The main cigar mould N constructed with the recesses or notches c₃ on the same side on which it has the mould cavities, for the purpose of being moved by the intermediate mould M. 18th. The combination of the intermediate mould M with mechanism for imparting intermittent rotary motion to it, and with the projecting noses b₃ and the main cigar mould N having notches c₃. 19th. The intermittently rotating ring or cylinder l³ carrying mould chamber m², in combination with mechanism for moving it, and with the bolt n² for locking it in its terminal positions, and with the lever n² for unlocking it. 20th. The mould chamber m² constructed of fixed checks or side pieces and provided with movable bottom n², in combination with the spring o² for holding said bottom normally in such position as to enable the mould chamber to receive its entire charge. 21st. The main cigar mould N placed in a housing O and held thereby, friction springs a₃ in combination with the rotating mould M, which is provided with means for moving the main cigar mould N and with a plunger or plungers, for discharging its contents into the cavities of the main cigar mould N. 22nd. The combination of the mould m² having a movable bottom n² and spring o² and secured on rotating ring l², with the reciprocating slide d² and oscillating crank shaft p². 23rd. The combination of a table or support adapted to receive and maintain a wrapper, with mechanism for applying air pressure to such wrapper and holding it in place. 24th. The perforated table A₆ adapted to receive the wrapper of a cigar or cigarette, in combination with the conduit C₆ and air propelling apparatus D₆. 25th. The perforated table A₆ combined with apparatus for creating suction of air through the perforations and provided with the projecting pin e₆. 26th. The table A₆ having apparatus a₆ that lead to the air suction apparatus, in combination with the projecting pin e₆ and gauge f₆. 27th. A table A₆ perforated and combined with air suction apparatus, and provided with the depression or groove g₆.

No. 14,055. Improvements on Buffing Machines for the Soles of Boots and Shoes. (*Perfectionnements aux machines à polir les semelles des chaussures*.)

John H. Stevens, Lynn, Mass., U.S., 25th January, 1882; for 5 years.

Claim.—1st. The rotating spindle and its attached flexible disk to receive an abrasive pad or surface. 2nd. The shaft K, its flexible pad b and washer m, combined with the abrasive pouch or pad applied thereto. 3rd. As an improved article of manufacture, an abrasive pouch or pad composed of cloth adapted to be applied to the foot and to be gathered or contracted about and above the disk l. 4th. The arm a, case or shell c forming a part thereof, the shell b connected with shell e, and the rotating spindle and foot composed of a disk and an abrasive pouch or pad combined with the exhaust fan and with the draft pipe, having its mouth 5 located just at the rear of and above the bottom of the foot to leave an unobstructed space all about the edge of the said foot, to permit the boot or shoe to be moved freely under the said foot.

No. 14,056. Improvements on Window Shade Rollers. (*Perfectionnements aux bâtons des rideaux*.)

Edward R. O'Brien, Toronto, Ont., 25th January, 1882; for 5 years.

Claim.—A window shade roller in which the roller is caused to revolve by the action of a spring, a pin fitting loosely in a hole made through a stationary spindle arranged to support one end of the roller without being directly connected to it, in combination with ratchet formed slots cut longitudinally in a sleeve secured to the end of the roller and caused to revolve on the spindle.

No. 14,057. Improvements in the Manufacture of Tobacco. (*Perfectionnements dans la fabrication du tabac*.)

Isaac Lindsley, Pawtucket, and Socrates Schofield, Providence, R.I., U.S., 25th January, 1882; for 5 years.

Claim.—1st. The process of manufacturing tobacco which consists in compressing one charge of tobacco upon a previously compressed charge in an open ended die, by means of a plunger, and forcing the same through the said die. 2nd. Compressing one charge of tobacco upon a previously compressed charge in the large chamber of a die by means of a plunger, and forcing the said charges as they advance into and through a smaller chamber, whereby the said charges are more effectually joined to each other. 3rd. A bar of compressed tobacco having a transverse grain hollowed or made V-shaped in axial section throughout the bar. 4th. A bar of compressed tobacco having a friction hardened or polished longitudinal surface, and a transverse grain hollowed or made V-shaped in axial section throughout the bar.

No. 14,058. Improvements in Saw-Mills.

(*Perfectionnements dans les scieries*.)

Thomas Moore, St. Thomas, Ont., 25th January, 1882; for 5 years.

Claim.—The combination and arrangement of the pulleys E E F F G G H H and the belts K K L L M M, with the cones C₁ and C₂ with the rod N N, shifter O O, chain wheel P P, sheaves R R, shafts S S, hand wheels T T and U U with the frames A A and B B, the top saw mandrel V V with the frame B B, pulley W W and X X, slots Y Y, screws a a and b b, brackets c c, guides d d, tightener f f, belt j j connecting rod k k, the feed shaft H₁ and the friction I I and J J with shaft l l.

No. 14,059. Improvement on Fence Bars.

(*Perfectionnement des pointes de clôtures*.)

Wellington P. Chisholm, Chicago, Ill., U.S., 25th January, 1882; for 5 years.

Claim.—The barb blank B cut from a sheet metal strip, said blank having its opposite ends alike and formed by a zig-zag cut beginning at one side of the blank extending obliquely to the middle thereof, then backward centrally and longitudinally of the blank and then obliquely to the opposite margin of the barb, thus forming two points on each end of the blank.

No. 14,060. Improvements on Machines for Making Paper Tags. (*Perfectionnements aux machines pour faire des étiquettes en papier*.)

William C. Wildman, (Assignee of Charles M. Richardson,) Bridgeport, Ct., U.S., 25th January, 1882; for 5 years.

Claim.—1st. The combination of a feeding device to deliver the paper dies to cut and punch the tags, with the foot E₃ and head F' to hold the tag after the dies have separated, and the fingers h h i to take the tag from between the head and foot. 2nd. The combination of dies to cut and punch the tags, fingers h h i to take the tag with mechanism to present and introduce the cord through the hole in the tag, grasp the end of the cord and draw it through, and cutter and jaws j j to take the end of the cord, the said jaws j j and the fingers h h i moving together away from the dies which cut the tag. 3rd. The combination of dies to cut and punch the tags, fingers h h i to take the tag with mechanism to present and introduce the cord through the hole in the tag, grasp the end of the cord and draw it through, and cutter and jaws j j to take the end of the cord, and the revolving horn r moving with the said jaws j j, and the said fingers advanced to give sufficient slack for the horn to form the loop and knot. 4th. The combination of dies for cutting the tag mechanism to present and introduce the cord through the hole in the tag, and mechanism to take the two ends of the cord and form a knot. 5th. The combination of mechanism for holding the tag, the reciprocating tube a, fingers b, cutter j, divided revolving horn c, the two parts of the horn arranged to separate and close upon the ends of the cord, after it has formed the loop for the knot, and the jaws j j. 6th. The combination of mechanism for holding the tag, reciprocating tube a and fingers b, jaws j j and cutter j. 7th. The combination of mechanism for holding the tag, reciprocating tube a and fingers b with the feed e₆ to advance the cord. 8th. The combination of mechanism for holding the tag with the reciprocating tube a, jaws j j, revolving horn c and lifter l. 9th. The combination of the feed rolls, the punch and die, and the laterally moving tag carrier. 10th. The combination of mechanism for holding the tag, reciprocating tube a and fingers b, with the feed e₆ to advance the cord, and fingers h h i to hold the tag.

No. 14,061. Improvement in the Process of Manufacturing Iron Directly from the Ore. (*Perfectionnement dans le procédé de fabrication du fer directement du minerai*.)

George Beals, Buffalo, N.Y., U.S., 25th January, 1882; for 5 years.

Claim.—Placing the mixture of iron bearing material and fuel into a reverberatory or ordinary puddling furnace in a sloping mass or masses, leaving a free space on the hearth upon which the iron may be balled, and then raking down the metallic iron from the sloping surface or surfaces, when it has come to nature, and balling the same on the free space of hearth.

No. 14,062. Improvements in the Manufacture of Sugar. (*Perfectionnements dans la fabrication du sucre.*)

Emil Fleischer, Dresden, Saxony, 25th January, 1882; for 5 years.

Claim.—1st. The method of extracting sugar from saccharine liquids such as syrup, treacle, etc., consisting in producing a bibasic saccharate of stromtia, and then separating the sugar and stromtia by crystallization. 2nd. The method of producing bibasic saccharate of stromtia (C₁₂ H₂₂ O₁₁ X 2 S r O) by making a solution of saccharine matter and of stromtia, and raising the temperature of this solution to the boiling point. 3rd. The method of purifying the bibasic saccharate of stromtia, by pouring a hot solution of stromtia over and drawing this solution through it in some suitable manner. 4th. The method of repeatedly precipitating the bibasic saccharate of stromtia in the same mother liquid, and adding fresh stromtia and fresh saccharine liquid after each precipitation for the purpose of obtaining a concentrated mother liquid. 5th. As a new chemical product in bibasic saccharate of stromtia (C₁₂ H₂₂ O₁₁ X 2 S r O) made by mixing saccharine matter and stromtia in solution and boiling this solution. 6th. An apparatus for separating precipitated sugar from the mother liquid made and consisting of a flat vessel with a perforated or like bottom resting upon a vessel connected with an air exhaust pump, the precipitated sugar being placed upon the perforated floor and a vacuum created in the lower vessel, causing the liquids to pass from the precipitated sugar through the perforated floor into the lower vessel. 7th. In an apparatus for the manufacture of sugar, the combination with the vessel A, of the perforated floor a, the wire netting b, the fabric c, the strips e and the clamps d.

No. 14,063. Improvements in Tassel Clamps for Window Curtains. (*Perfectionnements aux pûtes des glands de rideaux.*)

Henry M. Wells and Thomas R. Fuller, Toronto, Ont., 25th January, 1882; for 5 years.

Claim.—The curtain tassel clamp composed of the grooved longer lever A, the shorter claw-shaped lever B, their connecting pin or rivet i and the spring k.

No. 14,064. Improvements on Bolt Threading Machines. (*Perfectionnements aux machines à fileter les boulons.*)

William H. Price, (Assignee of Levi W. Stockwell,) Cleveland, Ohio, U.S., 25th January, 1882; for 5 years.

Claim.—The link c₂ in combination with sliding collar a₂, ring a₁ and scroll ring c₁.

No. 14,065. Improvement on Voltaic Plasters. (*Perfectionnement des emplâtres voltaïques.*)

Warren B. Potter, Boston, Mass., U.S., 26th January, 1882; (Extension of Patent No. 7034.)

No. 14,066. Set Gear for Circular Saw-Mills. (*Engrenage des scieries à scies circulaires.*)

Hector Gawley, Maidstone, Ont., 26th January, 1882; (Extension of Patent No. 7041.)

No. 14,067. Improvements in the Construction of Chairs. (*Perfectionnements dans la fabrication des chaises.*)

Joseph S. Anthes, Berlin, Ont., (Representing Joseph Tees, Montreal, Que.,) 26th January, 1882; (Extension of Patent No. 7044.)

No. 14,068. Improvements on Spring Bed Bottoms. (*Perfectionnements aux sommiers élastiques.*)

Horace J. Beemer and John Sullivan, Montreal, Que., 26th January, 1882; (Extension of Patent No. 7070.)

No. 14,069. Improvements in Means for Transmitting Power. (*Perfectionnements dans les moyens de transmission du mouvement.*)

Anthony Jarolimek, Hainburg on the Danube, Austria, and John G. Avery, Spencer, Mass., U.S., 26th January, 1882; for 5 years.

Claim.—1st. As an improvement in means for transmitting power, a hollow round band composed of wires coiled dense or close, the successive coils of one wire overlaying and supporting those of another. 2nd. A hollow round band composed of wires in the form of a dense or close double spiral coil, in combination with grooved pulleys for transmitting power. 3rd. A hollow round band composed of one or more wires in the form of a dense or close spiral coil, the same being provided at each extremity with an eye-piece screwed into the same, longitudinally and flexibly coupled with a like eye piece at the other extremity of the band, by means of a link.

No. 14,070. Improvement on Hydraulic Rams and Water Wheels. (*Perfectionnements aux bétiers et aux roues hydrauliques.*)

George Yellott, Towson, Ind., U.S., 26th January, 1882; for 5 years.

Claim.—1st. In combination with the ram chamber of a hydraulic ram, a water wheel adapted in its revolution to alternately open and close the waste water orifice in the said chamber and thereby effect

the alternate movement of the water from the drive pipe towards the ram delivery pipe and to said wheel, whereby, in the latter action of the water, the said wheel is caused to revolve. 2nd. In combination with the ram chamber of a hydraulic ram, a water wheel having at its periphery a series of bucketed and a series of plain sections, the said plain sections being adapted as valves to cut off the discharge of waste water from the said chamber, and thereby conduct the body of water from the draw pipe of the ram towards the air vessel of the same, and the said bucketed sections to receive the waste water and thereby effect the revolution of the said wheel. 3rd. A hydraulic ram, the chamber of which has a circular concave surface adapted to fit practically water tight the circumference of a water wheel, the said concave surface having therein an orifice for discharging water from the said chamber to the said wheel.

No. 14,071. Improvements in Sewing Machines. (*Perfectionnements dans les machines à coudre.*)

Christopher Lockman, Hamilton, Ont., 26th January, 1882; for 5 years.

Claim.—1st. In combination with a sewing machine, the driving of the same by means of an endless belt over pulleys on the shafts. 2nd. In combination with a sewing machine, the pulleys E F on the upper and lower shafts respectively and provided with notches H, the endless band G passing over the same and provided with projections I to fit in said notches. 3rd. The combination, in a sewing machine, of the pulleys E F and metallic endless belt G for driving the same. 4th. In combination with a sewing machine, the shuttle carrier frame C₁ made to slide in a groove d of the lug j on one side, and to slide on the rod D₁ on the opposite. 5th. The combination of the shuttle carrier frame C₁, crank L, tablet M, grooved projection N, rod D and slot d in lug J₁. 6th. In combination with the feed dog G₁ and feed bar j, the slotted adjustable plate k for taking up the wear of the feed dog.

No. 14,072. Improvements in the Art of Freezing Fish. (*Perfectionnements dans l'art de geler le poisson.*)

Samuel L. Kelly, Victoria, B. C., 26th January, 1882; for 5 years.

Claim.—The preserving of each fish in a separate solid block of ice, the air having been extracted from the fish while the block is freezing, also as a new article of commerce, a block of ice with a fresh fish frozen in the centre.

No. 14,073. Improvement on Brick Machines. (*Perfectionnement des machines à briques.*)

Lewis B. Kennedy, Keokuk, Iowa, U. S., 26th January, 1882; for 5 years.

Claim.—1st. The combination of a revolving table B bearing brick moulds, with bent frame A and connecting bolt C through the table B. 2nd. The combination, in a brick machine, of levers F F₁ connected with upper and lower plungers, and counter weight F₁ r, with a drawing shaft or wheel so connected and adapted as to drive the plungers and permit them to be idle alternately by continuous motion. 3rd. The combination, with upper and lower plungers and a horizontally revolving table, of levers F F₁, drive wheel M and slotted connecting bar d. 4th. The combination of a drive wheel and a connecting bar with connected levers F F₁ having pivots connected with frame A, and with bars connected with plungers above and below, arranged so that the mould and series of pivots and parts will come into direct line between the pivots in frame A, at the point of greatest pressure upon the brick.

No. 14,074. Improvements in Devices for Removing Impurities from the Water of Steam Boilers. (*Perfectionnements aux appareils pour enlever les impuretés de l'eau des chaudières à vapeur.*)

Allen S. Fisher, Clinton, Ont., 26th January, 1882; for 5 years.

Claim.—1st. In combination with a steam boiler reservoir or setting chamber E or E¹ or E² connected with the water in the boiler as follows: 1st. by flow pipe f through which the impurities raised to the surface of the water by ebullition are forced into said setting chamber where the current of the water is deflected and the impurities or sediment precipitated; 2nd. the return pipe g passing from said chamber through the shell or flue sheet into the water will flow into the boiler, while the impurities in the lower part of the chamber can be ejected through blow-off pipes h by opening valve i. 2nd. In combination with a steam boiler device B or C, having an enlarged receiving area for collecting the sediment and suspended within the boiler by means of flow-pipe passing outwardly through the shell or flue sheet thereof, the said device constituting the induction channel for the upward current carrying the sediment combined with a setting chamber E or E¹ or E², and a return pipe boiler at from same into the boiler water, which pipe may enter the boiler at any desired part of shell or flue sheet. 3rd. In combination with a steam boiler flow-pipe/ reservoir or setting chamber E or E¹ or E², return pipe g in combination with check valve O, and blow-off pipe f provided with valve i. 4th. In combination with steam boiler flow-pipe f, any exterior reservoir or setting chamber return pipe g, in combination with steam pipe j conveying live steam therein, and blow-off pipe h with valve i.

No. 14,075. Combined Low Water Alarm and Safety Valve for Steam Boilers. (*Indicateur du niveau de l'eau et soupape de sûreté combinés, pour les chaudières à vapeur.*)

George Wilson, Old Kent Road, London, Eng., 26th January, 1882; for 5 years.

Claim.—A dome mounted in the boiler divided horizontally by diaphragm D on which is mounted the adjustable steam safety valve H, and in which is formed a seat for the valve rod *f* carried by float E resting on the water in the boiler.

No. 14,076. Improvements in Grain Cleaners. (*Perfectionnements aux nettoyeurs des grains.*)

William L. Peter, Philadelphia, Pa., U. S., 26th January, 1882; for 5 years.

Claim.—1st. Heating the grain and then treating it to friction or attrition. 2nd. Heating and steaming the grain and then treating it to friction or attrition. 3rd. Heating the grain and then treating it to friction or attrition and currents of air, and constantly heating said grain during its subjection to friction. 4th. The apparatus for cleaning grain which consists of the combination of a heater, an attrition machine and a finishing machine, the two latter being adapted to air currents of air sucked through all or part of them. 5th. In the apparatus for cleaning grain, the combination of heater A, conveyer B with its steam axle C, conveyer D, attrition surface *g* and its steam box G, brush H, adapted to springing action casing J, fan Q and pipe S. 6th. In the apparatus for cleaning grain, the combination of heater A, conveyer B with its steam axle C, conveyer D, attrition surface *g* and its steam box G, brush H adapted to spring action fan Q, casing J, pipe S, conveyer K, brushes M N, both adapted to springing action, casing J, pipe S and a heater T. 7th. The combination of heater A, conveyer B, steam pipe W and attrition machine F.

No. 14,077. Improvements on Pen-Holders.

(*Perfectionnements aux porte-plumes.*)

James Palmer, Point Edward, Ont., 26th January, 1882; for 5 years.

Claim.—As a new article of manufacture, a pen-holder flattened where it is grasped by the thumb and fingers and having its shank for holding the pen barrel set at such an angle that the pen nib shall be inclined in the direction of the travel of the pen for the purpose of inducing the ink to flow more freely.

No. 14,078. Improvements on Wood Working Machines. (*Perfectionnements aux machines à travailler le bois.*)

Freeman Hanson, Hollis, Me., U. S., 26th January, 1882; for 5 years.

Claim.—1st. A wood working machine in which are combined the following elements or parts: a train of gear at each end of the main driving shaft, a frame to hold the wood to be cut, moulded or carved and having a revolving spindle, a cutting knife on a swinging frame, an oval cog wheel on the band wheel shaft, a swinging arm with wheel for many-sided work, a swinging arm with wheel for oval work, and a pawl and ratchet for star and crescent work. 2nd. In a wood working machine which, by mere transposition of its parts or by the addition of certain specified and conveniently arranged adjuncts, can be transformed at will from a machine to cut, mould or carve, or to do many-sided or oval work, or star or crescent work. 3rd. A wood working machine in which is combined the mechanism for cutting, carving and moulding.

No. 14,079. Improvements on Mechanical Movements. (*Perfectionnements aux mouvements mécaniques.*)

William F. Cochrane, Indianapolis, Ind., U. S., 26th January, 1882; for 5 years.

Claim.—1st. The combination, in mechanism for converting a rotary into reciprocating movement, of a driving shaft and suitable intermediate gear with a shaft carrying upon one of its ends, a wheel for imparting motion thereto, and upon its opposite end, a crank for converting the rotative movement of said shaft into a reciprocating movement, said crank being arranged within a spherical joint. 2nd. A spherical joint for permitting the change of angle of a cutter-bar, a saw or other reciprocating device, as required, through the walls of which a rotating shaft passes and within which such rotative movement is converted into a reciprocating one by means of a crank or other suitable device and through the walls of which said movement is communicated to the device to be moved. 3rd. The combination, in a device for producing a mechanical movement, of a driving shaft having upon it wheels for imparting movement to the mechanism, said wheels deriving movement from the driving shaft and another shaft, the outer end of which enters a hollow spherical joint, a crank for converting the rotative movement of the driving shaft into a reciprocating one, a connecting rod and a sliding guide with a cutter-bar, saw or other device to be moved.

No. 14,080. Improvements on Force Pumps.

(*Perfectionnements aux pompes foulantes.*)

John Sanders, Toronto, Ont., 26th January, 1882; for 5 years.

Claim.—1st. In a force pump in which a double piston ended plunger, having valves in each piston, is operated by a forked rod extending to the top of the well and worked by a pivoted lever, the combination of a slotted passage way cut through the barrel of the cylinder, to admit the water and allow the pin connecting the piston and forked rod to operate. 2nd. In a force pump having a double piston ended plunger, the annular groove *a* cut around the circumference of the piston, for the purpose of forming a water joint between the working piston and cylinder of the pump, in combination with a pump cylinder having a slotted passage cut in through it, between the head of the plunger to admit the water.

No. 14,081. Improvements in Earth Closets.

(*Perfectionnements aux cabinets à la terre sèche.*)

James H. McNairn, (Co-inventor with John Cameron,) Toronto, Ont., 26th January, 1882; for 5 years.

Claim.—1st. The attachment of the lever and operating machinery E to the fixture D on the closet. 2nd. The attachment of the seat connection to a projecting arm or rod. 3rd. The guide A for directing the fall of earth. 4th. A metal spout in connection with reciprocating valves. 5th. The earth chamber C built into and forming part of the closet.

No. 14,082. Improvements on Portable Engines. (*Perfectionnements aux machines portatives.*)

Thomas McGregor, Dayton, Ohio, U. S., 26th January, 1882; for 5 years.

Claim.—1st. In a steam engine, the combination, with the bed plate or heater, of the fly wheel shaft journalled at one end upon the heater, and at the other upon a shifting pillow or box united to said heater by a steam pipe, whereby the true alignment of the shaft is always maintained under the expansion or contraction of the heater. 2nd. The cross head K provided with shoulders *i*, and adjustable pads *l* fitted over said shoulders and rendered adjustable by set screws *h*. 3rd. The slide valve seat provided with live steam chambers whose superficial arc is about equal to the arc of the exposed upper surface of the valve. 4th. The slide valve seat provided with live steam chambers, the outer ones of which are on a line with the induction ports.

No. 14,083. Improvements on Sap Spouts.

(*Perfectionnements aux gouttières d'eau d'érabie.*)

Godson J. Alford, Bastard, Ont., 25th January, 1882; for 5 years.

Claim.—The tapered end E with the thread C, in combination with the outer end A and groove B.

No. 14,084. Improvements in Needles for Knitting Machines. (*Perfectionnements aux broches des machines à tricoter.*)

Samuel Peberly and Jacob S. Duvall, Philadelphia, Pa., U. S., 26th January, 1882; for 5 years.

Claim.—1st. The needle A having integral therewith the pin or pivot C, and the bent up jaws B B' jointly with the latch D. 2nd. The process of forming a knitting machine needle by striking up the pivot C upon the inner face of the flap or jaw B' simultaneously with the flattening of the jaws B B', inserting the pivot through the eye or hole in the heel of the latch and bending up the flaps or jaws B B', to hold the latch in place between them, whereby the end of the latch pivot is protected from outside friction.

No. 14,085. Improvement on Saw Handles.

(*Perfectionnement aux manches des scies.*)

Roswell H. Smith, St. Catharines, Ont., 26th January, 1882; for 5 years.

Claim.—A saw handle with adjustable plate C with seats or notches *c* and *h*, in connection with the other parts.

No. 14,086. Improvements on Car Couplings.

(*Perfectionnements aux accouplages des chars.*)

John H. Putnam, Tioga, Pa., U. S., 26th January, 1882; for 5 years.

Claim.—1st. The combination, with the draw-head B and link *a* of a freight car, of the rod C c c' bent and held in suitable hangers *d d* attached to the ends of the car and which allow an upward movement and side play to said rod, and operated by the handle *e* forming part of said rod. 2nd. In combination with a draw-head B and link *a* of a freight car, the bent rod C c c' for coupling cars having the projections *e e'* in the horizontal part *e*, for holding the coupling link therein.

No. 14,087. Improvement on Fruit Dryers

(*Perfectionnement des séchoirs à fruits.*)

Leslie E. Woodruff, Harry P. Wheeler and John Pearson, Howell, Mich., U. S., 26th January, 1882; for 5 years.

Claim.—1st. A furnace constructed with an open top and with projecting flanges, and adapted to receive and hold in place a water receptacle. 2nd. In combination with a furnace and water receptacle, a series of steam boxes connected together and with the water receptacle. 3rd. The furnace A, water receptacle E, steam boxes G, connected together and with such water receptacle, and the drawers J.

No. 14,088. Improvements on Trolling Spoon Baits.

(*Perfectionnements aux appâts pour troller.*)

Samuel Alcock, Charles Laight and Benjamin Westwood, Toronto, Ont., (Assignees of William T. J. Lowe, Buffalo, N. Y., U. S.) 28th January, 1882; for 5 years.

Claim.—In a spoon bait, the combination of a wire spring rigidly connected at one end to the spoon, and having an eye formed at its other end to fit upon the bait wire.

No. 14,089. Improvements on Screw Plates.

(*Perfectionnements aux filières à vis.*)

William H. Price, (Assignee of Levi W. Stockwell,) Cleveland, Ohio, U. S., 28th January, 1882; for 5 years.

Claim.—1st. The dies *a* having notches *a'* in combination with a cam disk L provided with eccentric cams in such relative positions to the dies that, by turning the cam disk, they will successively enter the

dies. 2nd. The combination of notched dies *a* with eccentric cams *c* of unequal length. 3rd. The dies *a* and cam disk *d* having the notch *e*, in combination with the adjustable spring stop *e*.

No. 14,090. Improvements on Cooking Stoves. (*Perfectionnements aux fourneaux de cuisine.*)

Giles F. Filley, St. Thomas, (Assignee of David H. Nation, St. Louis, Mo., U.S., 28th January, 1882; for 5 years.

Claim.—1st. In a stove *A*, the combination of the flues *C* and *H*, the escape *N*, said flues being separated and said escape being arranged as described. 2nd. In a stove *A*, the combination of the flues *C D D E E F G H* and the escape *N*, damper *M* and strips *K K*.

No. 14,091. Improvements in Lumber Dryers. (*Perfectionnements aux sécheres à bois.*)

George W. Reid, (Assignee of Philip Pfeffer,) New York, U. S., 30th January, 1882; (Extension of Patent No. 7047.)

No. 14,092. Improvement in Registering Dynamometers. (*Perfectionnement des dynamomètres-compleurs.*)

The Transmitting Dynamometer Company, New York, (Assignee of Hamilton Ruddick, Brooklyn,) N.Y., U.S., 30th January, 1882; for 5 years.

Claim.—1st. The automatically registering rotating dynamometer which consists of the pencil-holder or marker *F G*, in combination with the rotating circular dial *H* and with mechanism for vibrating said pointer and for imparting independent slow rotation to said dial plate, within the rapidly revolving carrying wheel *C*. 2nd. In combination with the shaft *A* and its rotary projecting arm *B*, the loose pulley or wheel *C*, spring or springs *D*, and the pencil-holder *G* which is connected to said arm *B* and to said pulley for marking the dial *H*. 3rd. The combination of the wheel or pulley *C* and its shaft *A* with the reciprocating pawl carrying bar *L*, ratchet or friction wheel *J*, intermediate differential transmitting gear and loose toothed wheel *I*, all arranged so that said wheel *I* will have a slow independent rotary movement imparted to it, within the rapidly revolving wheel *C*. 4th. In a rotating dynamometer, the combination of the power transmitting arm *B*, power receiving arm *E* and intervening spring *D* which bears directly against both of said arms and with the adjusting screw *a*, all arranged so that, by means of said screw, the tension of the spring is regulated. 5th. The recording rotary dynamometer consisting of the combination of the shaft *A*, its arm *B* and spring *D* with the pulley or wheel *C*, loose dial plate *H*, reciprocating bar *L*, ratchet wheel *J*, intermediate transmitting gear to convey motion from the wheel *J* to the disk *I* that carries the dial, and with the pencil carrying bar *G* which is connected to the arm *B* and to the pulley.

No. 14,093. Improvements in Iron Fences. (*Perfectionnements aux clôtures en fer.*)

Jacob G. German, St. Mary, Ont., 30th January, 1882; for 5 years.

Claim.—1st. The combination of the two iron rods *a* and *a*, to form a wire fence post. 2nd. The turned iron pieces *c*. 3rd. The iron rod braces *e*.

No. 14,094. Improvement in the Lacing of Boots and Shoes. (*Perfectionnement dans les chaussures à lacets.*)

Ewen C. C. Henderson, Pictou, and Thomas A. McDonald, Durham, N.S., 30th January, 1882; for 5 years.

Claim.—1st. The fastener composed of the three eyelets *E F G* and the threading of the eyelets *E F G* with the lacing cord *B*, forming the loop *H* and firmly holding the lacing cord *B*. 2nd. The combination of the above fastener with a single lacing cord and the hooks or buttons *c*, of the fastening eyelets *E F G* with the lacing cord and the loops.

No. 14,095. Improvements in the Manufacture of Boot and Shoe Heels. (*Perfectionnements dans la fabrication des talons de chaussures.*)

John Kelsey, Montreal, Que., 30th January, 1882; for 5 years.

Claim.—1st. The novel method of cutting from a piece of stock a number of pieces, whereby the stock ordinarily required for a top lift is made to serve with the supplementary pieces of sheet rubber for a number of top lifts. 2nd. The combination of a part of stock or sole leather and a central rubber part agreeing therewith, with an ordinary heel the whole constructed and arranged.

No. 14,096. Improvements on Snow Clearers. (*Perfectionnements aux chasse-neige.*)

John Coxen, San Francisco, Cal., U.S., 30th January, 1882; for 5 years.

Claim.—1st. A spirally tapering blade or screw having a cutting bit or edge and surrounded by, or contained within a pipe or container, and arranged to operate in an inclined position to cut or carve the body or breast of snow against which it is progressed and convey it up the spiral screw to discharging pipe in the manner specified. 2nd. In combination with a spiral blade or screw adapted to cut or displace the material against which it is rapidly revolved, the funnel or open mouthed hood for receiving and compressing the body of snow taken into the hood and present it to the revolving blade or screw in a compact form, constructed and arranged to operate in the manner specified. 3rd. The combination and arrangement of the flaring mouthed hood, the iron or steel bed, or supporting plate, or

proW suitably connected together by bolts with the spiral screw surrounded by a containing pipe and operated in an inclined position by means of a shaft stepped at its lower end, and a bevelled wheel upon its upper end, said spindle or shaft working in a bearing or boxing on the side of the screw container. 4th. The combination and arrangement of the screw carrying pipe with the conducting pipe adapted to be raised and lowered or turned to the right or left, by means of the bolt or round joint crown wheel and toothed gears. 5th. The means for operating the screw of a snow clearer which consists of the internally toothed gears upon the driving wheels of the dummy, and intermediate spur wheel connecting with the toothed wheel of the driving shaft of the screw, and operated by suitable connections with an engine or locomotive. 6th. The combination of a metal bed plate with a truck dummy or car carrying a snow clearer and upon which the operating parts are mounted, whereby a firm proW is provided and the working parts of the snow clearer held firmly, and the car or truck weighted.

No. 14,097. Improvements in Apparatus for Heating, Cooling and Other Purposes. (*Perfectionnements aux appareils pour le chauffage, le refroidissement et autres fins.*)

Joseph E. Culver, Jersey City, N.J., U.S., 30th January, 1882; for 5 years.

Claim.—1st. The combination of the inner compartment composed of a series of tubes and of chambers connecting the tubes, the inlet and outlet pipes to the inner compartment connected to the chambers respectively, the outer compartment entirely enclosing the inner compartment, and the inlet and outlet pipes to the outer compartment connected to the top and bottom parts thereof respectively. 2nd. The combination of the inner compartment composed of a series of tubes and of chambers connecting the tubes, the outer compartment entirely enclosing the inner compartment, the inlet and outlet pipes to the inner and outer compartment respectively, and the furnace communicating with the inner compartment through its inlet pipe. 3rd. The combination of the inner compartment composed of a series of tubes, the outer compartment, the furnace communicating with the inner compartment and the inlet and outlet pipes to the inner and outer compartments respectively, said pipes being provided with suitable valves to regulate the flow of the fluent bodies, the outlet pipe of the outer compartment extending or discharging into the outlet pipe of the inner compartment.

No. 14,098. Improvement in Telephones. (*Perfectionnements dans les téléphones.*)

Amos E. Dolbear, Somerville, Mass., U.S., 30th January, 1882; for 15 years.

Claim.—1st. The apparatus or instrument composed of the plates *a b*, mounted in a suitable case and adapted to operate in combination with the secondary coil of an induction coil. 2nd. The combination of two primary coils, each connected with a battery and a transmitter, whereby the receiver at the sending station and the coil at the receiving station are switched out of line. 3rd. The combination of a primary coil in circuit with a battery and a transmitter, and a secondary coil with its enlarged terminal *a* mounted in a suitable case and arranged to vibrate or to cause vibrations in the plate *b*. 4th. The combination of the coils *F P*, each in circuit with a battery and each arranged to act as a primary coil, while the other acts as a secondary coil.

No. 14,099. Improvements in the Art of, and Apparatus for Making and Revivifying Bone Black. (*Perfectionnements dans le procédé et les appareils de fabrication et de révivification du noir animal.*)

Robert A. Chesebrough, New York, N.Y., U. S., 30th January, 1882; for 5 years.

Claim.—As an improvement in the art of making and revivifying bone black, subjecting the bone or bone black to the burning or reburning operation in pots or receptacles placed on a car or carriage, which is run into and from the oven.

No. 14,100. Improvements in Blind Hinges. (*Perfectionnements aux pentures des jalousies.*)

Félix Ménard, Montreal, Que., 30th January, 1882; for 5 years.

Résumé.—Le taquet *d* arrêé 3 et les parties 4 et 5 qui servent à empêcher la persienne de se dépendre complètement lorsque l'on veut la fermer.

No. 14,101. Improvements in Rail Chairs. (*Perfectionnements aux coussinets des rails.*)

Michael R. Perkins, Portsmouth, N. H., U. S., 30th January, 1882; for 5 years.

Claim.—1st. A metal plate covering and partially unclosing a plate of wood, or other suitable material, intervening between the metal and the cross tie. 2nd. A metal plate provided with a wooden plate intervening between the metal and the cross tie. 3rd. The combination of plate *A*, flanges *B B*, plate *C* and spikes and cross tie.

No. 14,102. Improvements in Washing Machines. (*Perfectionnements aux lavesuses.*)

George T. Murphy, Toronto, Ont., (Representing Almon H. Calkins, Chicago, Ill., U. S.) 30th January, 1882; (Extension of Patent No. 7037.)

No. 14,103. Improvements on Harvesting Machines. (*Perfectionnements aux moissonneuses.*)

George Sweet, Dansville, N. Y., U. S., and John Watson, Ayr, Ont., 30th January, 1882; (Extension of Patent No. 7050.)

No. 14,104. Improvements in Apparatus for Butting and Dressing Timber. (*Perfectionnements aux appareils à recevoir et retailer le bois equarri.*)

William H. King, Quebec, Que., 31st January, 1882; (Extension of Patent No. 7140.)

No. 14,105. Improvements on Freezers. (*Perfectionnements aux congélateurs.*)

Charles Boss, Bathurst, N. B., 31st January, 1882; (Extension of Patent No. 7334.)

No. 14,106. Improvements on Machines for Cutting Pills. (*Perfectionnements aux machines à tailler les pilules.*)

Thomas Daniels, Toledo, Ohio, U. S., 31st January, 1882; for 5 years.

Claim.—1st. In a pill machine, the base A in combination with the movable frame C, and the rings or washers K. 2nd. The base B in combination with the movable frame H, and the rings or washers K. 3rd. The rolling pin E in combination with the base A, the movable frame C, and the rings or washers K. 4th. The cutting frame F for cutting the sheet of pill mass into a square cake. 5th. The plate G with numerous consecutive calls. 6th. The strips of metal or other substances J with their attachments in combination with the roller cutter I, the movable frame H and the celled plate G. 7th. The combination of the base B with the movable frame H, the celled plate G, the strips and attachments J and the roller cutters I.

No. 14,107. Improvements on Fruit Barrels. (*Perfectionnements aux barils à fruits.*)

Charles E. Bartram, Fredonia, N. Y., U.S., 31st January, 1882; for 5 years.

Claim.—A fruit package or barrel constructed on staves or slats A held in position by wires a a or equivalent, and with separating pieces c thereon between each slat, leaving a space b, and with heads b held together and fastened in the ends of said barrel by the metal straps d d d in connection with loops e e, and the wooden pieces f f.

No. 14,108. Improvements in Bulletin Boards. (*Perfectionnements aux tableaux à bulletins.*)

Albert D. Marble, Scandia, Ks., U. S., 31st January, 1882; for 5 years.

Claim.—A rectangular box provided with a series of horizontal compartments into which are adapted to fit a series of cubical blocks with the necessary blank lettered or figured faces, the said compartments being provided with springs at one end and set screws at the other, whereby the blocks are confined by adjustable spring pressure, so that they may readily be removed and changed.

No. 14,109. Improvements on Mowing and Reaping Machines. (*Perfectionnements aux faucheuses moissonneuses.*)

Charles J. F. Wilkins, Windsor, N. S., 31st January, 1882; for 5 years.

Claim.—1st. Circular cutter plates C forming any desired number of blades or cutters secured by rivets or otherwise to chain pulley D. 2nd. Guards F, each having two separate sets of cutter plates on different levels. 3rd. The system of placing cutter-plates C consecutively on finger bar E, so that, when said plates revolve, every alternate plate will revolve above the plate on either side of it or lower plates, the plate on either side of it or upper set will revolve beneath consequently every alternate plate in lower set will revolve beneath guards with guard plates a b to suit cutter plates C. 4th. The movable slide H. 5th. The arrangement for operating chain pulley D by endless chain I from chain wheel K together with combination of cutter plates C, roller D, guards F, tubes N and cap Q, and slide H with finger bar E.

No. 14,110. Improvements on Door Hangers. (*Perfectionnements dans la suspension des portes.*)

Samuel Ide, Metina, N. Y., U. S., 31st January, 1882; for 5 years.

Claim.—The track or way composed of the two independent and separate bars A C, the screws a a and the dividers b b interposed between the bars, whereby the outer bar which supports the roller G

may be adjusted out or in, to increase or lessen the width of the slot or to straighten the bar. 2nd. The combination of the track composed of the two independent bars A C separated by dividers b b and having a slot c between them and the hanger D and roller G, the latter running on the outer bar and having a double bevelled flange m which runs in the slot between the bars and allows free movement to the roller.

No. 14,111. Improvements on Horse Collars. (*Perfectionnements aux colliers de cheval.*)

Stephen Peace, London, Ont., 31st January, 1882; for 5 years.
Claim.—A sweat collar made of rubber or rubber cloth, for placing between the ordinary draft collar and the horse's shoulders.

No. 14,112. Improvements on Blowers. (*Perfectionnements aux soufflets.*)

Wright D. Smith, Detroit, Mich., U. S., 31st January, 1882; for 15 years.

Claim.—1st. A case for rotary blowers consisting of an inner scroll C and an outer scroll A, both scrolls starting from opposite sides of the case and ending with the outlet of said case. 2nd. The case A consisting of two scrolls A C starting from opposite sides of the fan chamber, and each having an independent outlet, in combination with the frame I J.

No. 14,113. Improvements in the "Boss Washing Machine." (*Perfectionnements dans la machine à laver dite "Boss."*)

Owen Harris, Kingsville, Ont., 31st January, 1882; for 5 years.
Claim.—1st. The combination of the jaws B B connected by the brace D. 2nd. The combination of the jaws B B with the ways a a and the hook C. 3rd. The way in which the hanger is fastened on the tube by the screws E E E E.

No. 14,114. Improvements in Spark-Arresters. (*Perfectionnements aux arrête-flammèches.*)

James K. Taylor, Boston, Mass., U.S., 31st January, 1882; for 5 years.

Claim.—1st. In a locomotive spark arrester, the spark receiving reservoir placed in front of, and separated from the smoke box proper by the partition M. 2nd. The combination of the spark receiving reservoir with the smoke box, the blast and lifting pipes, the deflecting cone and the pipes by which the sparks are conveyed from the stack to the reservoir. 3rd. The combination, with the spark reservoir C and smoke box J separated by partition M, of the smoke stack B, blast pipe H, lighting pipe F and conducting pipes A D. 4th. The combination, with the spark reservoir C, having outlet gate E and separated from the smoke box J by a partition M having a shield G, of the conducting pipes A D. 5th. The combination, with the spark reservoir C having outlet gate E, of the conducting pipes A D and the shield G attached to partition M.

No. 14,115. Improvements in Car-Couplings. (*Perfectionnements aux accouplages des chars.*)

Wallace C. Kelly, Hastings, Mich., U. S., 31st January, 1882; for 15 years.

Claim.—1st. In combination with the recessed draw-bar A, the pivoted stop B provided with a curved or cam face to support the coupling pin. 2nd. The recessed draw-bar A, in combination with the pivoted stop B provided with a cam face, and having a groove a in said face.

No. 14,116. Improvements on Presses. (*Perfectionnements aux presses.*)

John H. Brinkop, Quincy, Ill., U.S., 31st January, 1882; for 5 years.

Claim.—1st. The combination of a reciprocating plunger, movable end blocks and a hinged apron forming the front wall. 2nd. The combination of a reciprocating plunger, adjustable sides and the hinged apron. 3rd. The combination of the reciprocating plunger and the adjustable sides provided with levers and end blocks, said parts acting in connection with the front and rear walls of the press box. 4th. The combination, with the reciprocating plunger and front and rear walls, of the end blocks E, levers D, sliding blocks c and connecting bars, whereby the end blocks are operated. 5th. The combination, with the sides N, of the reciprocating plunger B, movable end blocks and apron A. 6th. The combination of the plunger B, sides N, hinged apron A, levers D and locking lugs 16. 7th. The combination of the plunger B, sides and hinged apron and the adjustable rear wall R. 8th. The combination of the plunger B, cross-bar b, arms G, rock shaft p, arms P and treadle lever. 9th. The combination of the plunger B and cross-bar b, arms G and the posts 20. 10th. The combination of the plunger 23, levers 25 and depressing knob K.

Patents issued up to 6th March, 1882, Claims and Drawings of which will appear in a subsequent number of the Patent Record.

- No. 14,141. A. J. Rice, Sodus, N. Y., "Apple Slicer," Feb. 8th, 1882.
- No. 14,142. L. Low, Ryegate, Vermont, "Carpenter's Squares," Feb. 8th, 1882.
- No. 14,143. H. Whitehead, Bucknall, and T. Dodd, Winsford, Eng., "Railway Points," Feb. 8th, 1882.
- No. 14,144. T. Tanner, Osage, Nebraska, "Window Light Fastener," Feb. 8th, 1882.
- No. 14,145. W. H. Rhodes, Elyna, Ohio, "Post Hole Digger," (Extension of Patent No. 7057,) Feb. 9th, 1882.
- No. 14,146. R. Mitchell, Montreal, Que., "Service Box," (Extension of Patent No. 7064,) Feb. 9th, 1882.
- No. 14,147. H. Milsom, Buffalo, N. Y., "Generator," (Extension of Patent No. 7056,) Feb. 9th, 1882.
- No. 14,148. F. B. Ide, Troy, N. Y.; A. H. Sims, Montreal, Que., "Method of Making Collars and Cuffs," Feb. 9th, 1882.
- No. 14,149. I. R. Laux, B. Gunsaulis, Wadsworth, Ohio, "Wringer and Bench," Feb. 9th, 1882.
- No. 14,150. W. Greene, St. Lawrence, Eng., "Soap," Feb. 9th, 1882.
- No. 14,151. E. T. Gilliland, Indianapolis, Ind., "Telephone," Feb. 9th, 1882.
- No. 14,152. W. Hadden, Brooklyn, N. Y., "Distributer," Feb. 9th, 1882.
- No. 14,153. J. Whitney, Franklinville, N. Y., "Collar Pad," Feb. 9th, 1882.
- No. 14,154. S. Welte, Harriston, Ont., "Lathe," Feb. 9th, 1882.
- No. 14,155. T. Genin, F. C. Charbonneau and J. B. Genin, Montreal, Que., "Scies," Feb. 9th, 1882.
- No. 14,156. C. Beall, Fairview, W. Virginia, Assignee, "Extension Table," Feb. 9th, 1882.
- No. 14,157. J. Watson, Ayer, Ont., Assignee, "Harvesting Machines," Feb. 9th, 1882.
- No. 14,158. W. H. R. Toye, New York, N. Y., "Ornamental Fabrics," Feb. 9th, 1882.
- No. 14,159. W. H. Taylor, Baldwinville, N. Y., S. Taylor, Hamilton, Ont., "Gig Saddle Tree," (Extension of Patent No. 7076,) Feb. 9th, 1882.
- No. 14,160. D. A. Ritchie, Charleston, Mass., "Metallic Pipe," (Extension of Patent No. 2061,) Feb. 9th, 1882.
- No. 14,161. A. Huff, Chatham, Ont., "Milk Can," (Extension of Patent No. 7110,) Feb. 9th, 1882.
- No. 14,162. E. S. Lenox, New York, N. Y., Assignee, "Wire Bale Tie," (Extension of Patent No. 7042,) Feb. 9th, 1882.
- No. 14,163. E. S. Lenox, New York, N. Y., Assignee, "Wire Bale Tie," (Extension of Patent No. 7042,) Feb. 9th, 1882.
- No. 14,164. The Canadian Telephone Company, Limited, Assignee, Montreal, Que., "Transmitter," (Extension of Patent No. 11,737,) Feb. 9th, 1882.
- No. 14,165. The Canadian Telephone Company, Limited, Assignee, Montreal, Que., "Transmitter," (Extension of Patent No. 11,737,) Feb. 9th, 1882.
- No. 14,166. F. Bramer, Assignee, Little Falls, N. Y., "Harrow," (Extension of Patent No. 7230,) Feb. 10th, 1882.
- No. 14,167. H. Squier, Grand Haven, Mich., "Ship Fastenings," (Extension of Patent No. 7129,) Feb. 10th, 1882.
- No. 14,168. J. C. Dietrich, Waterloo, Ont., "Saws," (Extension of Patent No. 9222,) Feb. 10th, 1882.
- No. 14,169. F. Bramer, Little Falls, N. Y., Assignee, "Harrow," (Extension of Patent, No. 7230,) Feb. 11th, 1882.
- No. 14,170. H. Squier, Grand Haven, Mich., "Ship Fastenings," (Extension of Patent No. 9222,) Feb. 11th, 1882.
- No. 14,171. J. B. Dietrich, Galt, Ont., "Saw," (Extension of Patent No. 9222,) Feb. 11th, 1882.
- No. 14,172. J. F. Walmisley, London, Ont., "Metallic Fence Fastening," Feb. 11th, 1882.
- No. 14,173. W. A. Cooper and J. E. McLeod, Topeka, Kansas, "Head Chairs for Railroad Switches," Feb. 11th, 1882.
- No. 14,174. W. Deering, Chicago, Ill., Assignee, "Harvesters," (Extension of Patent No. 7122,) Feb. 11th, 1882.
- No. 14,175. W. V. Ferry, Chicago, Ill., "Car Coupling," Feb. 11th, 1882.
- No. 14,176. H. Lee, New York, N. Y., "Plate Printing Machines," Feb. 14th, 1882.
- No. 14,177. H. S. Smith and H. W. Shipman, Brooklyn, N. Y., "Veneer Cutter," Feb. 13th, 1882.
- No. 14,178. N. A. Richardson, Bridgeport, Conn., "New Process for Sharpening Files," Feb. 13th, 1882.
- No. 14,179. N. A. Richardson, Bridgeport, Conn., "New Process for Sharpening Files," Feb. 14th, 1882.
- No. 14,180. T. L. Wilson, Hamilton, Ont., "Electric Lamp," Feb. 15th, 1882.
- No. 14,181. S. B. Hart, Peoria, Ill., "Fertilizer Distributor," Feb. 15th, 1882.
- No. 14,182. J. R. Carter, Toronto, Ont., "Copying Books," Feb. 15th, 1882.
- No. 14,183. L. J. Cadwell, Chicago, Ill., "Desiccating Eggs," Feb. 15th, 1882.
- No. 14,184. J. Maunder, Little Britain, Ont., "Iron Harrows," Feb. 15th, 1882.
- No. 14,185. W. Hodge, Uxbridge, Ont., "Adjustable Carriage and Buggy Top," Feb. 15th, 1882.
- No. 14,186. T. T. Marshall, Jarvis, Ont., "Boots," Feb. 15th, 1882.
- No. 14,187. C. B. Thompson, St. Catharines, Ont., "Winders," Feb. 15th, 1882.
- No. 14,188. T. C. Hewitt, London, Ont., "Fences," Feb. 15th, 1882.
- No. 14,189. T. C. Hewitt, London, Ont., "Fences," Feb. 15th, 1882.
- No. 14,190. The Canadian Telephone Company, Limited, Montreal, Que., "Speaking Telegraph," (Extension of Patent No. 9922,) Feb. 17th, 1882.
- No. 14,191. The Canadian Telephone Company, Limited, Montreal, Que., "Speaking Telegraph," (Extension of Patent No. 9922,) Feb. 18th, 1882.
- No. 14,192. S. Johnston, Brockport, N. Y., "Grain Binders," Feb. 18th, 1882.
- No. 14,193. D. Smith, Litchfield Corner, Maine, "Egg Preservers," Feb. 18th, 1882.
- No. 14,194. J. D. Arnold, and W. H. Southworth, Holley, N. Y., "Tanks," Feb. 18th, 1882.
- No. 14,195. E. G. Parkhurst, Hartford, Conn., "Packing Box for Ammunition," Feb. 18th, 1882.
- No. 14,196. W. C. Parmenter, Toronto, Ont., "Creamers," Feb. 18th, 1882.
- No. 14,197. E. B. Hughes, Toronto, Ont., Assignee, "Gloves and Mitts," Feb. 18th, 1882.
- No. 14,198. W. Beattie, Portage, Wis., "Leg and Foot Protector," Feb. 18th, 1882.
- No. 14,199. E. Peerless, Toronto, Ont., "Stoves," Feb. 18th, 1882.
- No. 14,200. G. K. Flower, Pittsburg, Penn., "Horse Shoes," Feb. 18th, 1882.
- No. 14,201. D. Vaughan, Bangor, Wis., "Millstone Dresser," Feb. 18th, 1882.
- No. 14,202. J. D. Pierce, Milwaukee, Wis., "Stoves," Feb. 18th, 1882.
- No. 14,203. H. P. Edmands, Covington, Kentucky, "Grain Separators and Graders," Feb. 18th, 1882.
- No. 14,204. W. C. Cross, Boston, Mass., "Satchel Bottom Paper Bags," Feb. 18th, 1882.
- No. 14,205. W. C. Cross, Boston, Mass., "Satchel Bottom Paper Bags," Feb. 18th, 1882.
- No. 14,206. L. H. Spaulding, Chicago, Ill., "Heating and Ventilating System," Feb. 18th, 1882.
- No. 14,207. R. W. Anderson, Toronto, Ont., "Sofa Bed," Feb. 18th, 1882.
- No. 14,208. C. La Dow, Albany, N. Y., "Sulky Harrow," Feb. 18th, 1882.
- No. 14,209. The Canadian Telephone Company, Limited, Montreal, Que., "Speaking Telegraph," (Extension of Patent No. 9923,) Feb. 18th, 1882.
- No. 14,210. The Canadian Telephone Company, Limited, Montreal, Que., "Speaking Telegraph," (Extension of Patent, No. 9923,) Feb. 20th, 1882.
- No. 14,211. O. E. Lewis, Urbana, Ohio, "Boots and Shoes," Feb. 20th, 1882.
- No. 14,212. C. E. Bourne and W. Bourne, Boston, Mass., "Piano Case," Feb. 20th, 1882.
- No. 14,213. G. H. P. Flagg, Boston, Mass., "Rolls," Feb. 20th, 1882.
- No. 14,214. G. Price, Birmingham, Eng., "Door Furniture," Feb. 20th, 1882.
- No. 14,215. T. C. Fields, St. Andrews, Que., "Medicinal Compound," Feb. 20th, 1882.
- No. 14,216. C. W. Peterson, San Francisco, Cal., "Air Ships," Feb. 20th, 1882.
- No. 14,217. Sir M. Parker, Cooksville, Ont., Assignee, "Boiler Compound," (Extension of Patent No. 7145,) Feb. 20th, 1882.
- No. 14,218. G. W. Copeland, Malden, Mass., Assignee, "Lasting and Tacking Devices," Feb. 20th, 1882.
- No. 14,219. H. Rogers, Jamesville, Wis., and J. H. Rogers, Springfield, Mass., "Shaking and Dumping Grate," (Extension of Patent No. 7135,) Feb. 20th, 1882.
- No. 14,220. H. Rogers, Jamesville, Wis., and J. H. Rogers, Springfield, Mass., "Shaking and Dumping Grate," (Extension of Patent No. 7135,) Feb. 21st, 1882.
- No. 14,221. J. M. Wescott, Wilton, Ind., "Adjustable Feed Seeding Machine," (Extension of Patent No. 7441,) Feb. 21st, 1882.
- No. 14,222. C. W. Levalley, St. Paul, Minn., "Mowing Machines," Feb. 21st, 1882.
- No. 14,223. J. T. Gurney, S. Little, Boston, Mass., "Slides," Feb. 21st, 1882.
- No. 14,224. M. D. Temple, Chicago, Ill., "Chain Pumps," Feb. 21st, 1882.
- No. 14,225. E. M. Fox, New York, N. Y., "Electric Lamps," Feb. 21st, 1882.
- No. 14,226. W. F. Berry, Martinsburgh, West Virginia, "Door Hangers," Feb. 21st, 1882.

- No. 14,227. S. Wheeler, Albany, N. Y., "Portable Writing Cases," Feb. 21st, 1882.
- No. 14,228. J. H. Lux, Earville, Iowa, "Horse Hay Forks," Feb. 21st, 1882.
- No. 14,229. M. Hill, Vanessa, Ont., "Fruit Evaporator Tray," Feb. 21st, 1882.
- No. 14,230. J. S. Trites, Moncton, N. B., "Railway Frogs," Feb. 21st, 1882.
- No. 14,231. S. Phelps, Norwick, Ont., "Paint for Covering Roofs," Feb. 21st, 1882.
- No. 14,232. J. P. Burnham and O. G. Burnham, Chicago, Ill., Feb. 21st, 1882.
- No. 14,233. T. L. Wilson, Port Hope, and E. H. Davis, Toronto, Ont., Feb. 21st, 1882.
- No. 14,234. J. M. Rowe, Clailbourne, Ohio, "Fences," Feb. 21st, 1882.
- No. 14,235. T. L. Wilson, Hamilton, Ont., "Dynamo Electric Machines," Feb. 21st, 1882.
- No. 14,236. W. J. Boland, Chicago, Ill., and M. Byrnes, Hull, Que., "Steam Engines," Feb. 21st, 1882.
- No. 14,237. H. Kurth and R. H. Thompson, New York, N. Y., "Anti-friction Oil," Feb. 21st, 1882.
- No. 14,238. L. C. Eggert, Walkerton, Ont., "Washing Machines," Feb. 21st, 1882.
- No. 14,239. J. B. Fischer, Hamilton, M. Bare, Cincinnati, and W. Bare, Hamilton, Ohio, "Ice Tools," Feb. 21st, 1882.
- No. 14,240. E. Kriehhoff and W. K. Kains, London, Ont., "Chairs," Feb. 21st, 1882.
- No. 14,241. J. Watson, Ayer, Ont., Assignee, "Hay Rake," Feb. 21st, 1882.
- No. 14,242. J. P. Manny, Rockford, Ill., "Harvesters," Feb. 24th, 1882.
- No. 14,243. J. P. Manny, Rockford, Ill., "Harvesters," Feb. 24th, 1882.
- No. 14,244. J. P. Manny, Rockford, Ill., "Harvesters," Feb. 24th, 1882.
- No. 14,245. The American Stove Manufacturing Company, Belleville, Ill., Assignee, "Cook Stove," Feb. 24th, 1882.
- No. 14,246. The McDonald Manufacturing Company, Fond du Lac, Wis., Assignee, "Thrasher and Separator," Feb. 24th, 1882.
- No. 14,247. C. E. Bourne, W. Bourne, Boston, Mass., "Upright Pianos," Feb. 24th, 1882.
- No. 14,248. J. T. Gurney, S. Little, Boston, Mass., "Refrigerators," Feb. 24th, 1882.
- No. 14,249. J. T. Gurney, S. Little, Boston, Mass., "Refrigerator Waggon," Feb. 24th, 1882.
- No. 14,250. O. Sherwood, East Fairfield, Vermont, H. R. Bartlett, Brouton, Min., "Fire Truck and Ladder," Feb. 24th, 1882.
- No. 14,251. C. Taylor, Montreal, Que., "Amalgamator," Feb. 24th, 1882.
- No. 14,252. O. D. Orvis, Chicago, Ill., "Steam Boiler Furnaces," Feb. 24th, 1882.
- No. 14,253. E. A. Cullerton, Toronto, Ont., "Furnaces," Feb. 24th, 1882.
- No. 14,254. A. F. Macdonald, Winnipeg, Manitoba, "Nut Locks," Feb. 24th, 1882.
- No. 14,255. J. B. Barnes, Fort Wayne, Indiana, "Railroad Spikes," Feb. 24th, 1882.
- No. 14,256. T. Tarble, Swanton, Vermont, Assignee, "Car Coupling," Feb. 24th, 1882.
- No. 14,257. J. Lockwood and C. McIntire, Sullivan, Ind., "Door Securer," Feb. 24th, 1882.
- No. 14,258. H. A. Clark, Boston, Mass., "Wires," Feb. 27th, 1882.
- No. 14,259. H. A. Clark, Boston, Mass., "Process of Desulphurizing and Devulcanizing Waste Vulcanized India Rubber," Feb. 27th, 1882.
- No. 14,260. I. Promoti, L. Huebner, Munich, Germany, "Brick Slabs, Paving Stones," Feb. 27th, 1882.
- No. 14,261. G. R. McCrea, Bowmanville, Ont., "Carriages," Feb. 27th, 1882.
- No. 14,262. F. Barr, Captain in the Revenue Marine of the U. S., "Automatic Signal Buoys," Feb. 27th, 1882.
- No. 14,263. J. H. Dadds, Portsmouth, Ont., "Machine for Making Brushes," Feb. 27th, 1882.
- No. 14,264. J. Dewe, Ottawa, Ont., "Chromoscope," Feb. 27th, 1882.
- No. 14,265. M. V. B. Eichlberger, Dayton, Ohio, "Manufacture of Pulp," Feb. 27th, 1882.
- No. 14,266. G. E. Beach, Marshalltown, Iowa, "System of Water Works," Feb. 27th, 1882.
- No. 14,267. A. D. Tingley, "Device for feeding and Watering Stock in Cars," Feb. 27th, 1882.
- No. 14,268. J. Wood, Red Bank, N. J., "Snow Plow," Feb. 27th, 1882.
- No. 14,269. V. W. Mason, Providence, R. I., "Reversing Mechanism for Elevators etc.," Feb. 27th, 1882.
- No. 14,270. E. McCoy, Detroit, Mich., "Lubricator," Feb. 27th, 1882.
- No. 14,271. J. J. Lafleur, Hyde Park, Ill., "Champion Tag," Feb. 27th, 1882.
- No. 14,272. C. D. Murdock, Nashville, Tenn., "Bed Comforts, etc.," Feb. 27th, 1882.
- No. 14,273. R. M. Bidelman and O. Webster, Adrian, Mich., "Stove Board," Feb. 27th, 1882.
- No. 14,274. J. M. Taylor, Fredericton, N. B., "Window for Locomotive Cabs," Feb. 27th, 1882.
- No. 14,275. E. Caswell, Lyons, N. Y., "Hub Borer and Box Setter," Feb. 27th, 1882.
- No. 14,276. F. K. Collier, Litchfield, Mich., "Fire Shrinker," Feb. 27th, 1882.
- No. 14,277. O. C. Ross, Penfield, N. Y., "Fellve Connection," Feb. 27th, 1882.
- No. 14,278. T. Smith, London, Ont., "Sliding bar Buggy Top," Feb. 27th, 1882.
- No. 14,279. W. Schenck, St. Paul, Minn., "Stove Back," Feb. 27th, 1882.
- No. 14,280. J. W. Kenna, Chicago, Ill., "Tilting Chair," Feb. 27th, 1882.
- No. 14,281. H. L. Palmer, Brooklyn, N. Y., "Kettles," Feb. 27th, 1882.
- No. 14,282. T. Chohey, Hamilton, Ont., "Sewing Machine Belt Screw Fastener," Feb. 27th, 1882.
- No. 14,283. E. Oppenheim, San Francisco, Cal., "Vehicle Seat," (Extension of Patent No. 7158.) Feb. 28th, 1882.
- No. 14,284. A. M. Colt, Bataria, N. Y., "Clamps for Wood Working," Feb. 28th, 1882.
- No. 14,285. V. A. I. Cawood, Marshall, Mich., "Elevating Bagging and Weighing Attachments," Feb. 28th, 1882.
- No. 14,286. A. Delone, Palmerston, Ont., "Window Shades," Feb. 28th, 1882.
- No. 14,287. J. A. Burns, Sharpsburg, Penn., "Car Coupling," Feb. 28th, 1882.
- No. 14,288. H. Leiser, Cincinnati, Ohio, "Garment Sample," Feb. 28th, 1882.
- No. 14,289. A. Iske and A. Ishe, Lancaster, Penn., "Volatile Motor," Feb. 28th, 1882.
- No. 14,290. C. F. Godley, Philadelphia, Penn., "Lubricators for Car Axle Boxes," Feb. 28th, 1882.
- No. 14,291. E. W. Blackhall, Toronto, Ont., "Ruber and Head Line Holder," Feb. 28th, 1882.
- No. 14,292. G. J. Fritz, St. Louis, Mo., "Doctor Engine," Feb. 28th, 1882.
- No. 14,293. J. Roberts, New York, N. Y., "Washer," Feb. 28th, 1882.
- No. 14,294. J. Budd, Boston, Mass., "Ornamental Glass," Feb. 28th, 1882.
- No. 14,295. G. W. Daily and E. D. Plimney, Aurora, Ill., "Horse Collar," Feb. 28th, 1882.
- No. 14,296. J. McMahon, Westcot, Richmond, Ind., "Fertilizer Distributors for Grain Drills," Feb. 28th, 1882.
- No. 14,297. T. A. Jebb and W. T. Jebb, Buffalo, N. Y., "Manufacture of Distilled Spirits," Feb. 28th, 1882.
- No. 14,298. L. Cassier, Minooka, Ill., "Wind Mill," Feb. 28th, 1882.
- No. 14,299. H. McNally, Woohouse, Ont., "Improvement for Attaching Animals to Loads," Feb. 28th, 1882.
- No. 14,300. J. S. Brooks, New York, N. Y., "Fire Proof Fabrics and Shields for Buildings," Feb. 28th, 1882.
- No. 14,301. T. R. Ferrall, Boston, Mass., "Anti-frictional Bearings," Feb. 28th, 1882.
- No. 14,302. W. Castle, Rochester, N. Y., Assignee, "Boiler," Feb. 28th, 1882.
- No. 14,303. G. F. McCombs, Washington, Penn., "Sewing Machine," Feb. 28th, 1882.
- No. 14,304. H. M. Pierce, Grand Rapids, Mich., "Method of Extinguishing Fires and Cooling the Charges of Kilns," Feb. 28th, 1882.
- No. 14,305. H. M. Pierce, Grand Rapids, Mich., "Manufacture of Charcoal," Feb. 28th, 1882.
- No. 14,306. W. Nevins, Fitusville, Penn., "Seed Planter," (Extension of Patent No. 7150.) Feb. 28th, 1882.
- No. 14,307. E. H. Arms and R. J. Quingley, Toronto, Ont., "Watch Case," Feb. 28th, 1882.
- No. 14,308. J. J. McIntire, Oakland, Cal., "Egg and Fruit Carriers," March 3rd, 1882.
- No. 14,309. C. Grattan, Stockton, Cal., "Gang Plow," March 3rd, 1882.
- No. 14,310. J. Donder, New Orleans, Louisiana, "Steam Trap," March 3rd, 1882.
- No. 14,311. H. F. W. Mechanic and W. L. Tay, Elyria, Ohio, "Carriage Bow," March 3rd, 1882.
- No. 14,312. C. E. Williams, Wingham, Ont., "English White Oil," March 3rd, 1882.
- No. 14,313. C. A. Storey, Halifax, N. S., "Flower Stand," March 3rd, 1882.
- No. 14,314. W. A. Allen, Jersey, N. J., "Machine for Binding Kindling Wood," March 3rd, 1882.
- No. 14,315. W. A. Allen, Jersey, N. J., "Machine for Sawing Kindling Wood," March 3rd, 1882.
- No. 14,316. L. Shutte, Philadelphia, Penn., "Injector," March 3rd, 1882.
- No. 14,317. J. Webster, Solihull, Warwick, England "Alumina," March 3rd, 1882.
- No. 14,318. F. Hanson, Hollis, Maine, "Moulding Machine," March 3rd, 1882.
- No. 14,319. L. B. Villebonnet, Nancy, Rep. France, "Rotary Apparatus," March 3rd, 1882.
- No. 14,320. W. Hubbard, Elgin, Ill., "Telephone," March 3rd, 1882.

- No. 14,321. E. L. Miller and W. H. Bohrer, Washington, D. C., "Pamphlet Cover Roller," March 3rd, 1882.
- No. 14,322. H. F. Gaines, Rouse's Point, N. Y., U. S., "Hand Stamp," March 3rd, 1882.
- No. 14,323. S. Kinder, Amherst, (Assignee of D. O. Parker, Liverpool, N. S., (Extension of Patent No. 1,357), March 3rd, 1882.
- No. 14,324. W. S. Garrison, Cedar Falls, Iowa, "Bay Window," March 6th, 1882.
- No. 14,325. G. Dec, Discon, Ill., "Stove Carrier and Lifter," March 6th, 1882.
- No. 14,326. T. A. and W. T. Jebb, Buffalo, N. Y., "Manufacture of Grape Sugar," March 6th, 1882.
- No. 14,327. C. A. N. C. de Winter, Paris, France, "Improvements on Ships or Vessels," March 6th, 1882.
- No. 14,328. N. Weber, La Porte, Ind., "Middlings Purifier," March 6th, 1882.
- No. 14,329. J. D. Billings, New York, N. Y., "Horse Shoes," March 6th, 1882.

- No. 14,330. T. A. Blake, New Haven, Ct., "Pig Iron Breaker," March 6th, 1882.
- No. 14,331. Sir J. Anderson and B. Smith, London, Eng., "Electric Telegraph," March 6th, 1882.
- No. 14,332. C. A. Crengeyer, Detroit, Mich., "Door Fastening," March 6th, 1882.
- No. 14,333. J. Miller, Canton, Ohio., "Grain Thrashing and Separating Machine," March 6th, 1882.
- No. 14,334. E. Ross, Wauseon, Ohio., "Embroidering and Ornamenting Rugs," March 6th, 1882.
- No. 14,335. G. W. Dudley, Waynesborough, Va., "Rotary Engine," March 6th, 1882.
- No. 14,336. D. M. Macpherson, Lancaster, Ont., "Milk Cooler," March 6th, 1882.
- No. 14,337. J. A. Awalt, Anderson, Ind., "Regulators for Watches," March 6th, 1882.

THE CANADIAN PATENT OFFICE RECORD.

ILLUSTRATIONS.

Vol. X.

FEBRUARY, 1882.

No. 2.



13917 Blake's Improvements on Electric Circuits.

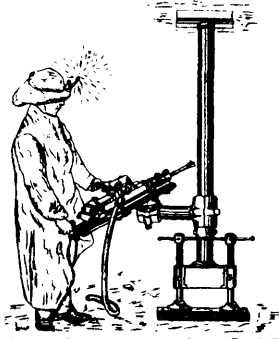

13920 Gibbens's Improvements on Steam Rock Drills.

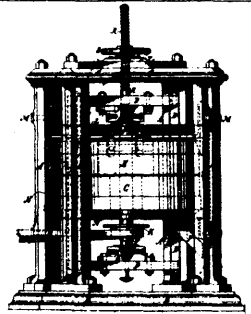

13921 Chattaway's Improvements on Corn Mills.

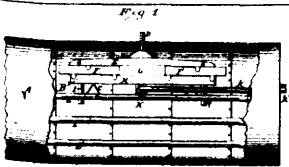

13922 Reiser's Improvements on Steam Boiler Cleaners.

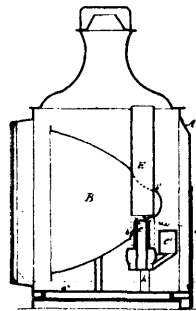

13923 Williams's Improvements on Head Lights for Locomotives.

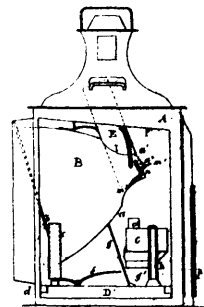

13924 Williams's Improvements on Head Lights for Locomotives.

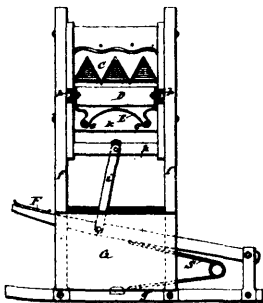

13926 Shepardon's Improvements in Straw-cutters.

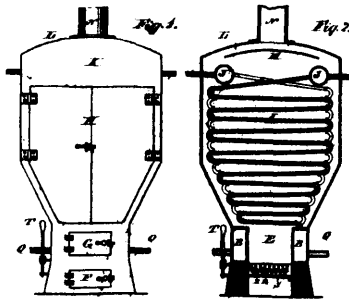

13927 Eye's Improvements in Hot Water Heating Apparatus.

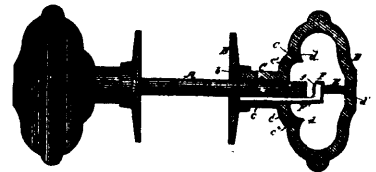

13929 Hathaway's Improvements on Door Knobs.

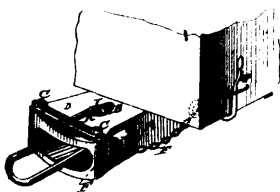

13931 Smith's Improvements on Car-couplings.

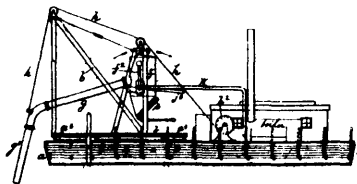

13932 Whittier's Improvement on Vacuum Dredges.

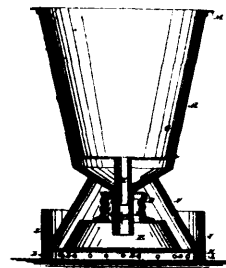

13933 Folsgrove's Improvements in Flower Cocks.

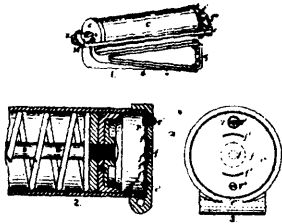

13934 Norton's Improvements on Door Checks.

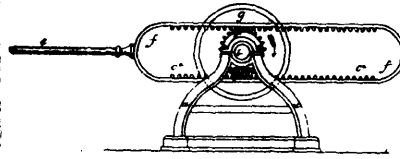

13936 Read's Improvements on the Method of Producing Rotary Motion.

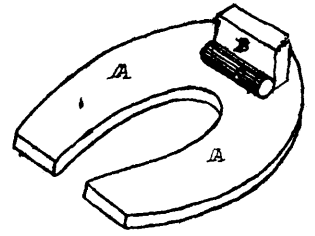

13937 Routledge's Improvement on Toe Calks for Horse Shoes.

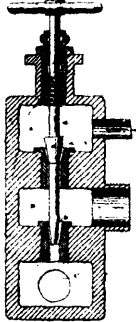

13938 Macdonald's Improvement on Injectors.

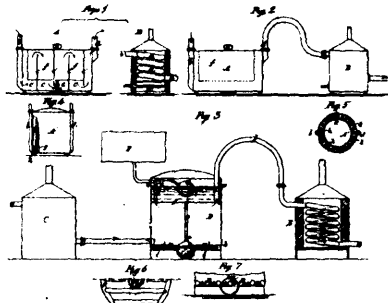

13940 Macdonald's Improvements on Means of, and Apparatus for Increasing the Illuminating Power of Coal Gas.

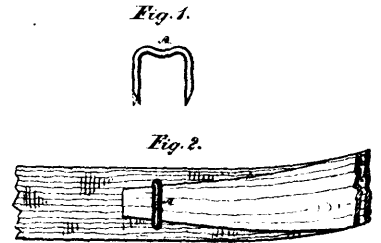

13941 Dunn & Harris's Improvements on Wire Staples.

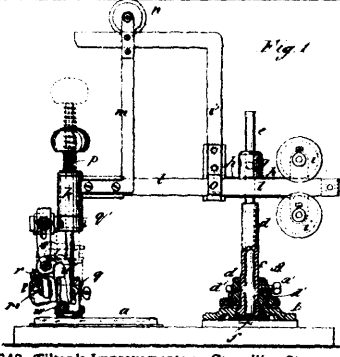

13943 Tilton's Improvements on Cancelling Stamps.

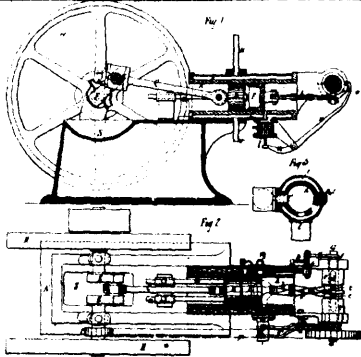

13944 Fiddes's Improvements in Gas Motor Engines.

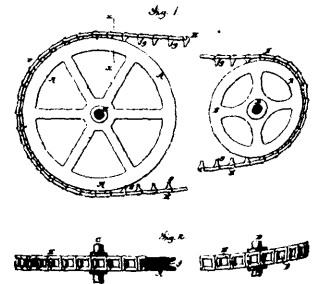

13945 Dodge's Improvements in Chain Belts.

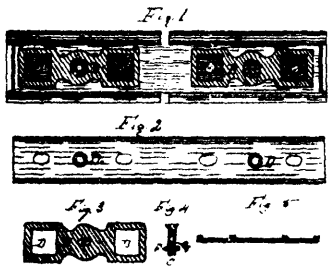

13946 Soley's Improvements on Nut Locks.

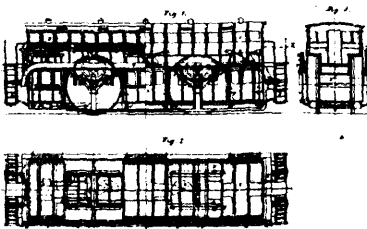

13947 Estrade's Improvements in the Construction of Rolling Stock for Railways.

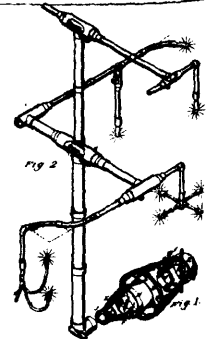

13948 Wheeler's Improvement on Lighting Apparatus.

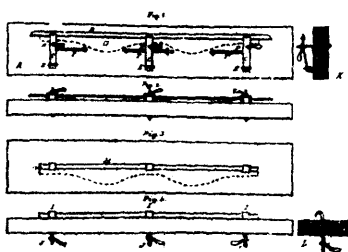

13949 Newton's Improvements on Machines for Stuffing Horse Collars.

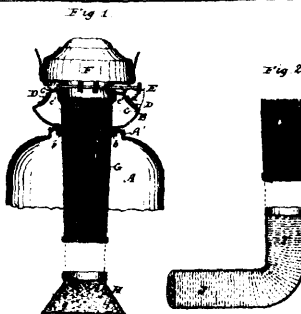

13950 Newton's Improvements on Lamps.

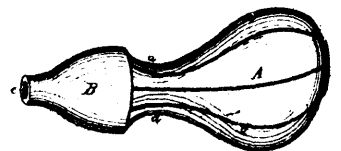

13951 Withoff's Improvements on Vaginal Syringes.

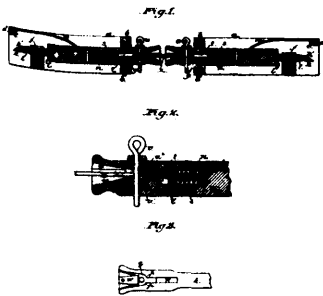

13962 Lewallen's Improvements in Car-Couplings.

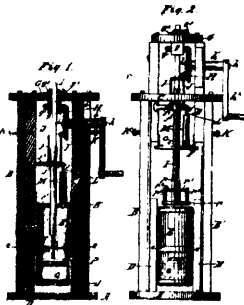

13953 Gates's Improvements on Churns.

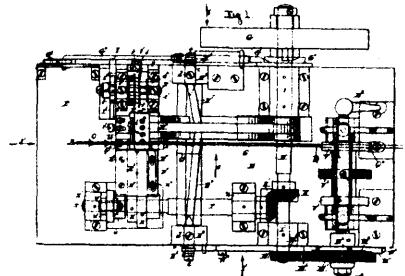

13966 Stover's Improvements on Machines for Manufacturing Barbed Metallic Strand Fencing.

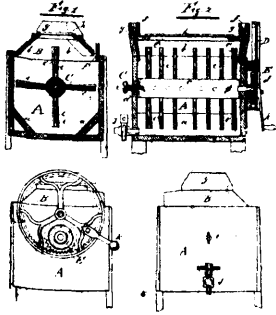

13967 Van De Water's Improvements in Churns.

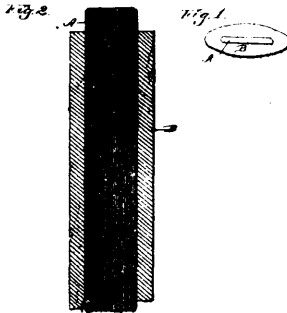

13969 Loper's Improvements in Candles.

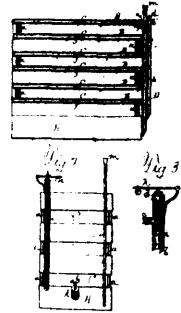

13980 Dake's Improvement on Fruit Dryers.

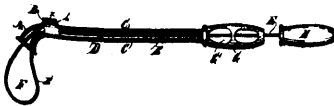

13961 Ewing's Improvements in Device for Catching and Holding Hogs.

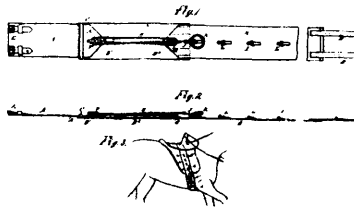

13962 McNaught's Improvements in Saddle Girths.

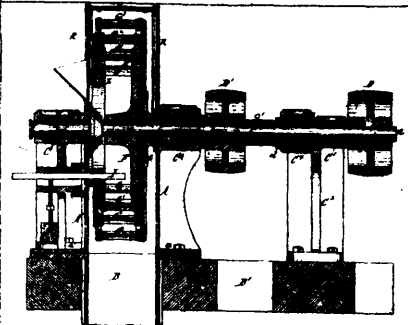

13963 Bennett's Improvements in Disintegrating Mills.

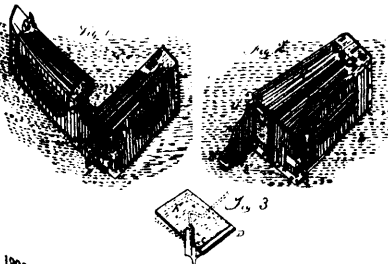

13964 Morris's Improvements on Animal Traps.

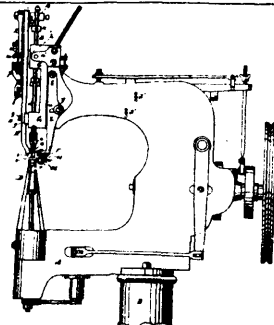

13966 Comey's Improvements in the Manufacture of Boots and Shoes.

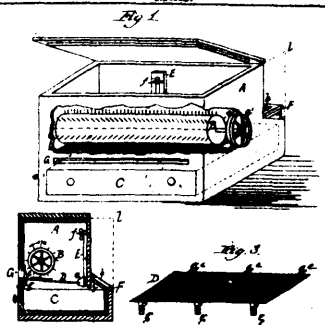

13967 Waterston & Zimmerman's Improvement in the Art of Brushing Gold Leaf from Book Covers.

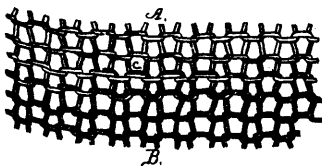

13968 Nelson's Improvements in Knit Fabrics.

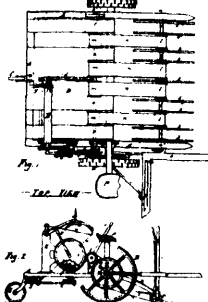

13969 Mahon's Improvements on Grain Gleaners and Binders.

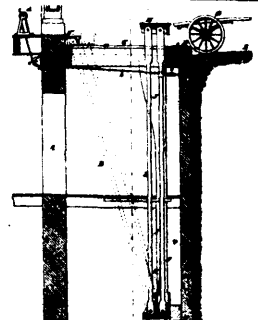

13970 McDonald's Improvements on Freight Transfers.

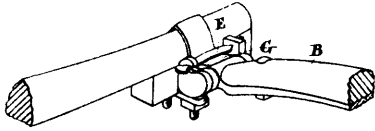

13971 Ferram's Improvements on Thill Couplings.

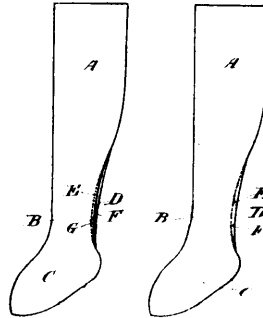

13973 Pollock's Improvements in the Manufacture of Hose.

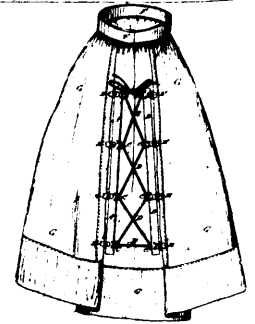

13974 Greene's Improvements in Skirt Adjusters.

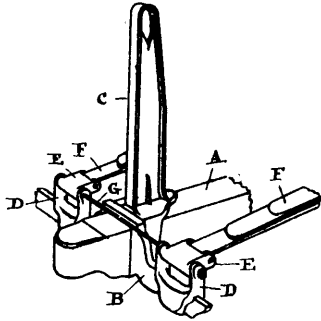

13975 Cruickshank's Improvements on Waggon's.

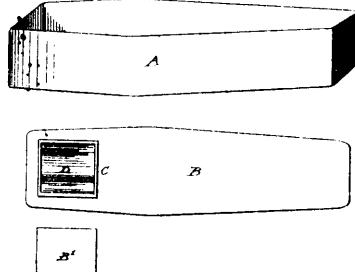

13976 McGloghlon's Improvements on Metallic Coffins.

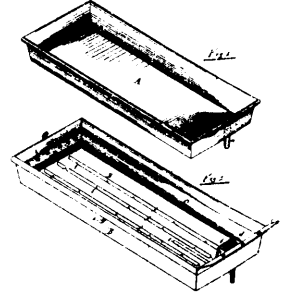

13977 Allaire's Improvements on Milk Coolers.

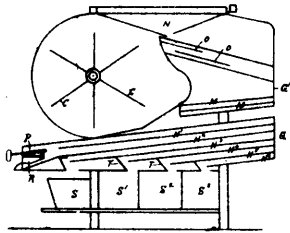

13978 Howarth's Improvements on Fanning Mills.

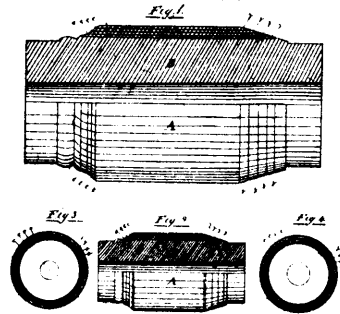

13980 Guard's Improvements in the Manufacture of Hubs.

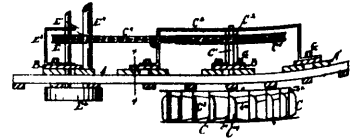

13981 Clark's Improvements on Current Wheels.

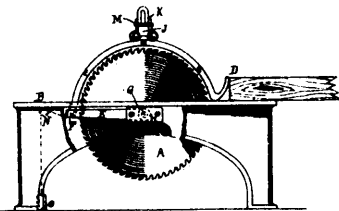

13982 Taylor's Improvements in Guards for Circular Saws.

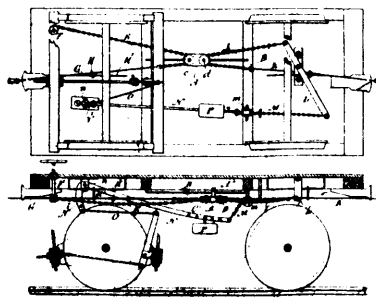

13983 Sinn & Studer's Improvements in Railway Brakes.

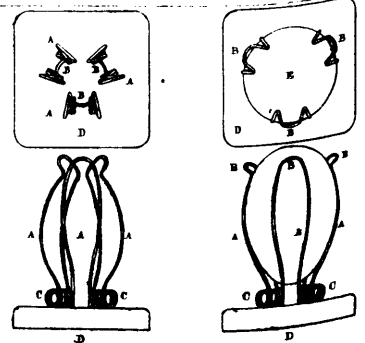

13984 Halley & Barr's Improvements on Apparatus for Carrying Eggs.

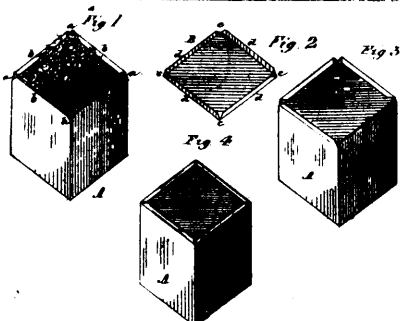

13985 Tuckett's Improvements in Tobacco Caddies.

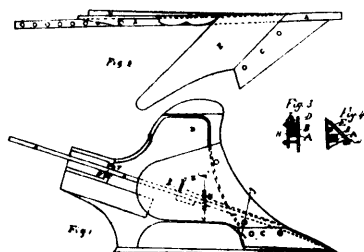

13986 Sanderson's Improvements in Ploughs.

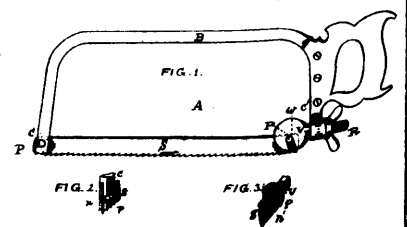

13987 Lawson's Improvements in Open Back Saws.

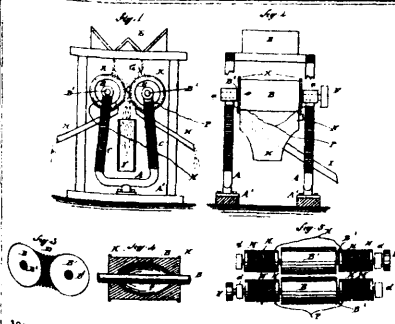

13989 Buchanan's Improvements on Ore Separators.

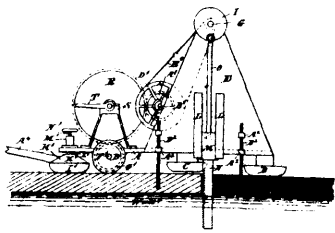

13990 Pearson's Improvements in Machines for Cutting Ice.

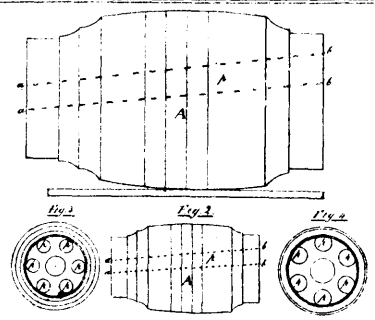

13991 Guard's Improvements in the Manufacture of Hubs.

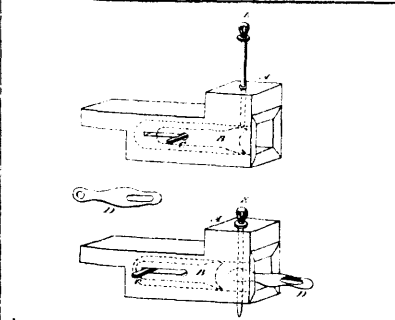

13992 Zettel's Improvements on Car-couplers.

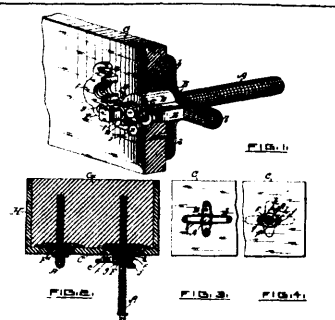

13993 Ingalls's Device for Drawing Screw Patterns from the Mould.

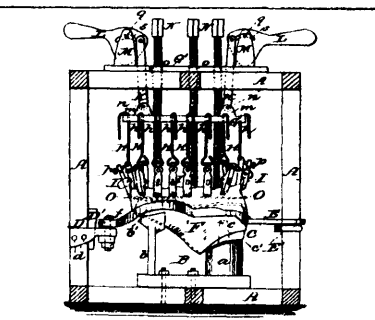

13994 Ellithorp's Improvements on Lasting Machines.

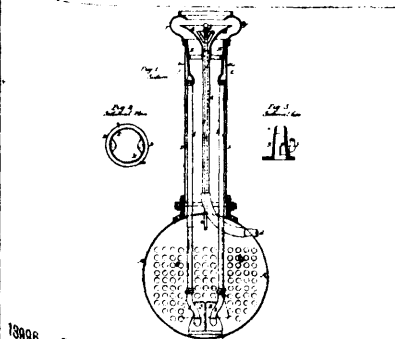

13986 Strong's Improvements in Locomotive Smoke Stacks.

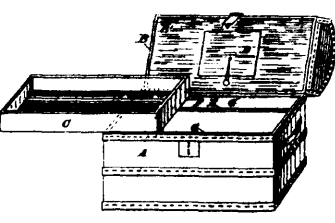

13997 Ransom's Improvements on Trunks.

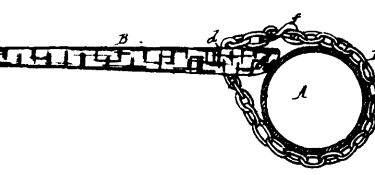

13998 Mernan's Improvements in Pipe Wrenches.

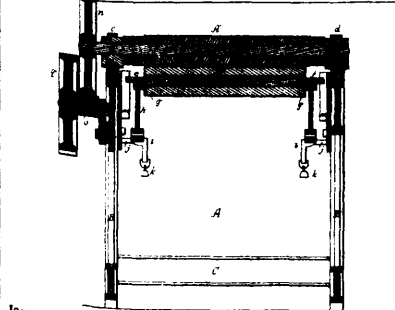

13999 Keigley's Improvements in Looms.

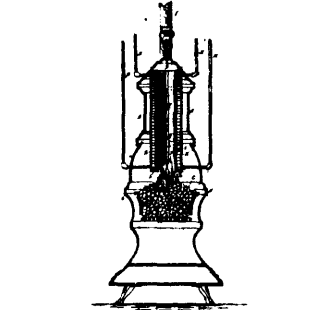

14000 Bellavance's Improvements on Hot Water Stoves.

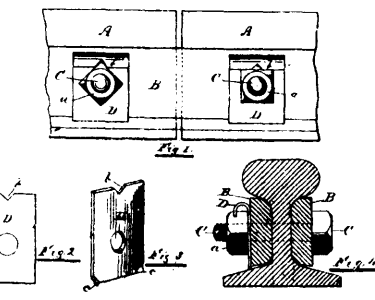

14001 Smith's Improvements on Nut Locks.

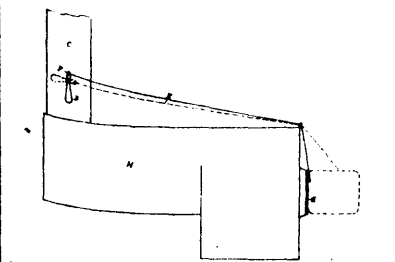

14002 Kerr's Improvements on Automatic Regulators.

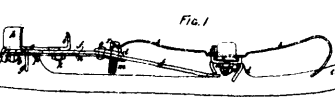

14003 Bezer's Improvements on Skates.

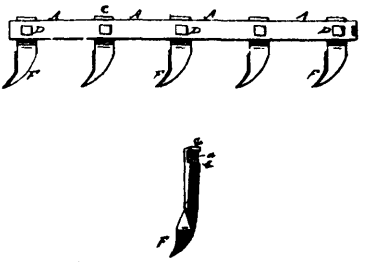

14004 Smale's Improvements on Harrows.

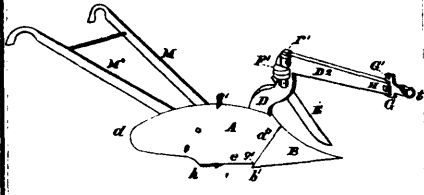

14005 Simonds's Improvements on Ploughs.

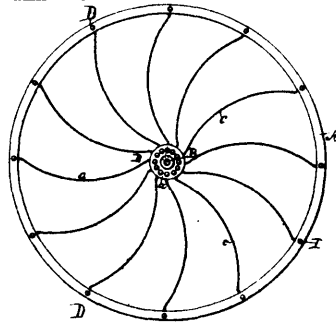

14006 Gowans's Improvements on Wheels.

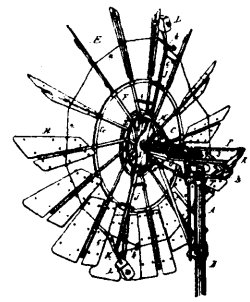

14007 Hamilton's Improvements on Wind-mills.

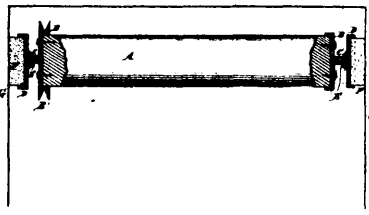

14008 Farley's Improvements on Curtain Rollers.

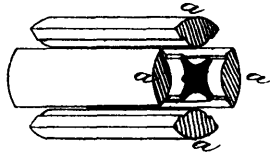

14009 Naylor's Improvements in the Manufacture of Articles from Plastic Materials.

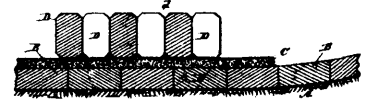

14010 Pelletier's Improvements in Pavements.

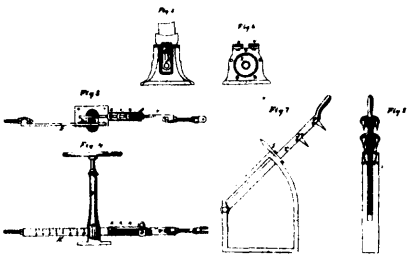

14011 Hamilton's Improvements on Sawing Machines.

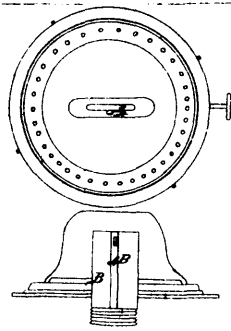

14012 Hamilton's Improvements in Oil Lamps.

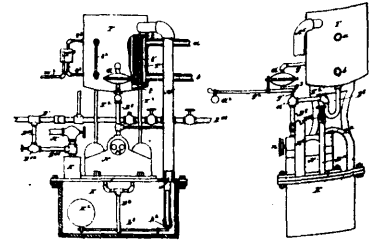

14014 Osborne's Improvements on Steam Apparatus for Supplying Heat and Power.



14015 Gould's Improvements on Arithmetical Frames.

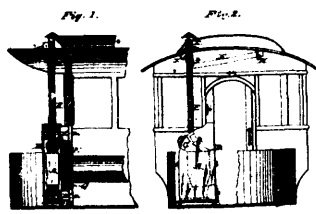

14016 Root's Improvements in Car Heaters.

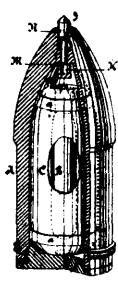

14017 Gruson's Improvements in Projectiles.

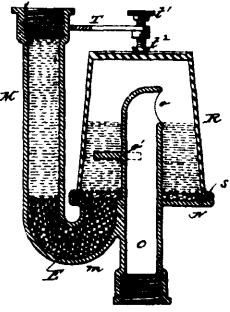

14018 Bennor's Improvements in Wash Basins, etc

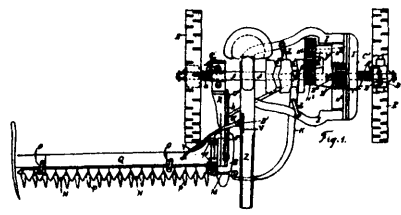

14019 Meyors & Barker's Improvements on Reapers and Mowers.

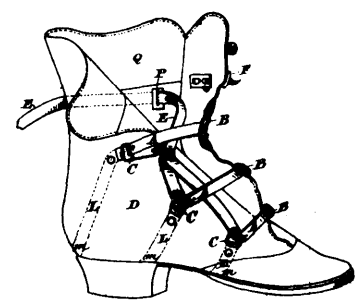

14020 Ketchum's Improvements on Boots and Shoes.



14021 Heintzman's Improvements on Piano-fortes.

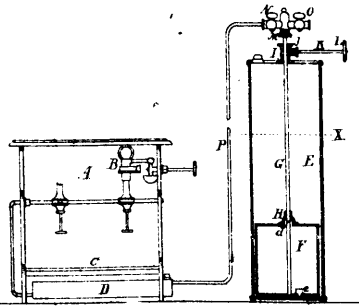

14022 Lyman's Improvements on Gasoline Stoves.

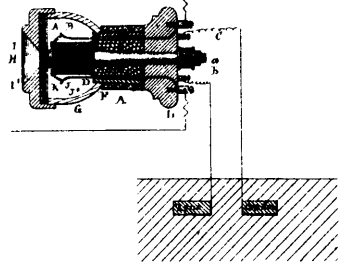

14023 Strong's Improvements on Relay Telephones.

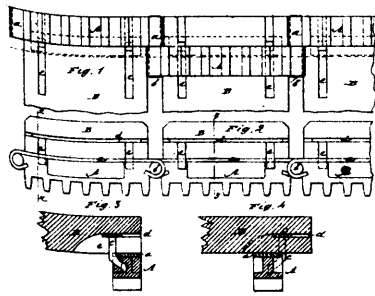

14024 Olds's Improvements on Horse power Links.

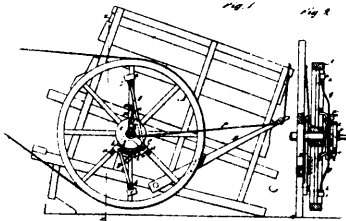

14025 Olds's Improvements on Speed Regulators for Horse-power.

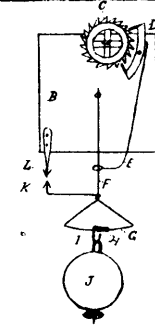

14026 Lash's Improvements in Clocks.

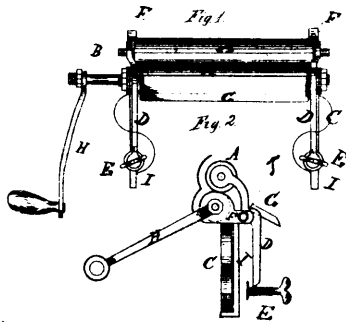

14027 Babb's Improvements on Clothes Wringers.

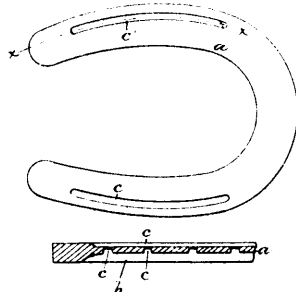

14028 Very's Improvements on Horse Shoes.

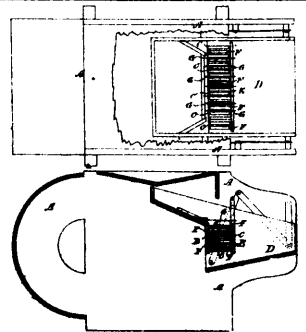

14029 Brenton's Improvements on Machines for Bearding Barley.

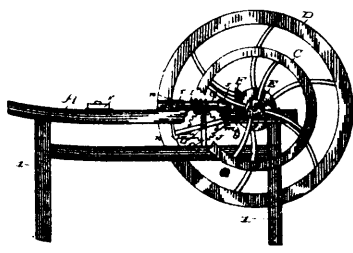

14030 Lightbody's Improvements on Machines for Turning Tree Nails.

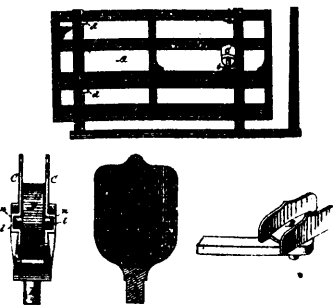

14031 Pratt's Improvements in Gate Rollers and Hinges.

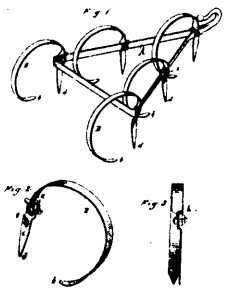

14032 Panches's Improvements in Spring Tooth Harrows.

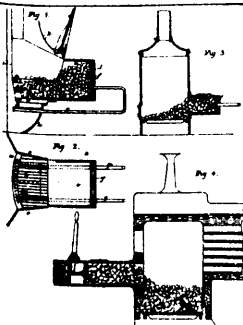

14033 Engert's Improvements on Fire Grates.

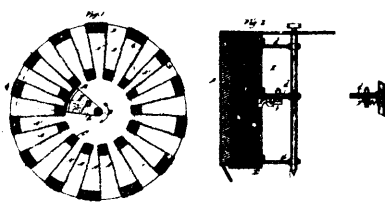

14034 Bean's Improvements on Machines for Collecting Mill Dust.

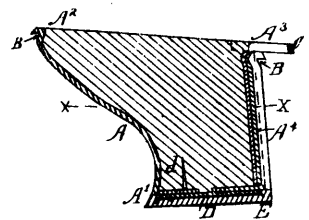

14044 Kieffer's Improvements on Boot and Shoe Heels.

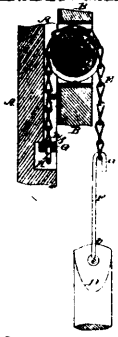

14045 Morton's Improvements on Sash Cord Fasteners.

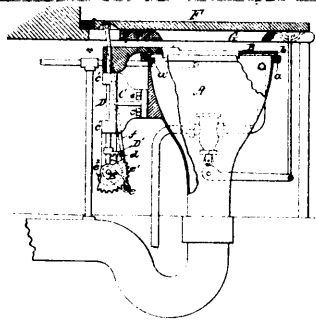

14046 Edwards's Improvements on Water Closets.

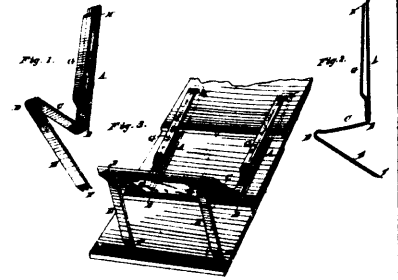

14049 Hoerner's Improvements in Roof Brackets.

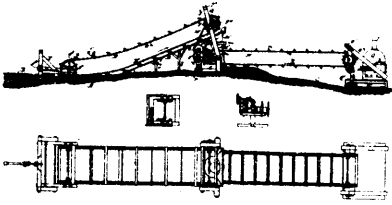

14050 Howell's Process and Apparatus for Reclaiming Lowlands Adjacent to the Tide Water Beaches.



14051 Fox's Improvements on Iron Fence Posts.



Fig. 1.

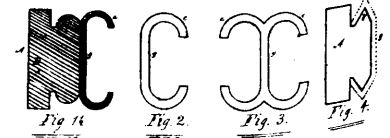

14052 Crich's Improvements on Extension Tables.

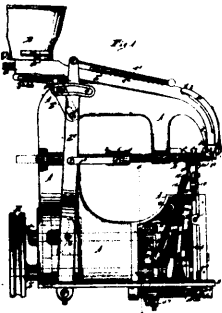

14053 Morley's Improvements in Machines for Sewing Buttons.

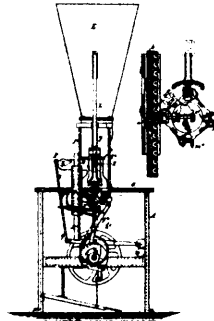

14054 Hammerstein's Improvements on Cigar Machines.

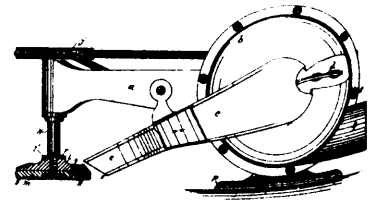

14055 Stevens's Improvements on Buffing Machines for the Soles of Boots and Shoes.

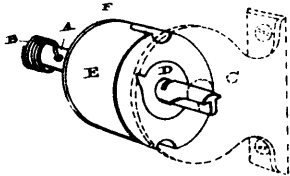

14056 O'Brien's Improvements on Window Shade Rollers.

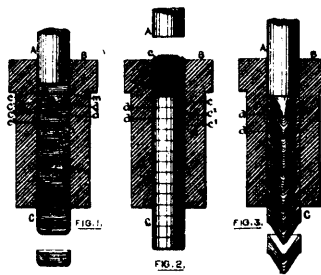

14057 Lindsley's Improvements in the Manufacture of Tobacco.

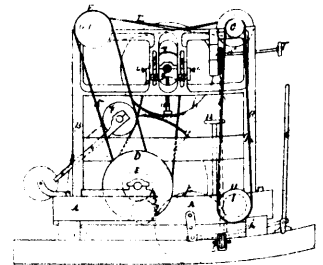

14058 Moore's Improvements in Saw Mills.

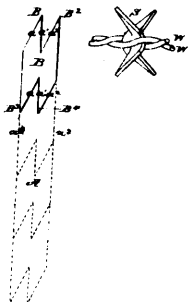

14059 Chisholm's Improvements on Fence Barbs.

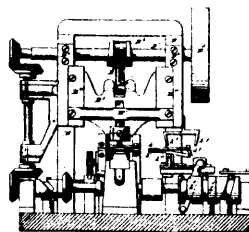

14080 Richardson's Improvements on Machines for Making Paper Tags.

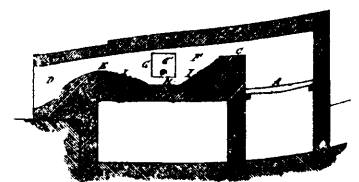

14061 Beale's Improvement in the Process of Manufacturing Iron Directly from the Ore.

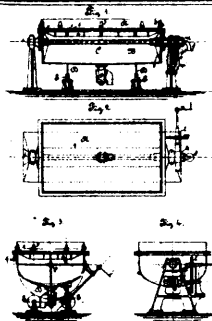

14082 Fleischer's Improvements in the Manufacture of Sugar.

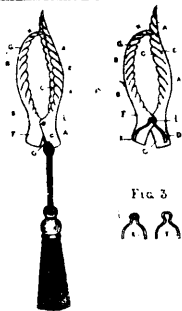

14063 Wells & Fuller's Improvements in Tasseel Clamps for Window Curtains.

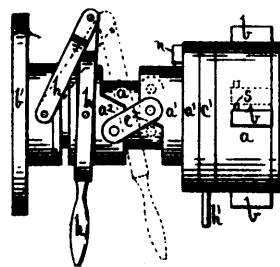

14064 Stockwell's Improvements on Bolt Threading Machines.

Fig. 1.



Fig. 2.

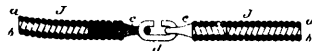

14068 Jarolimek & Avery's Improvements in Means for Transmitting Power.

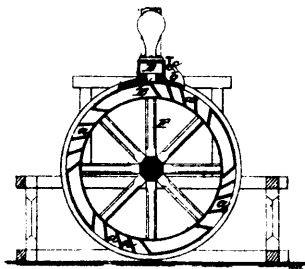

14070 Yellott's Improvement on Hydraulic Rams and Water Wheels.

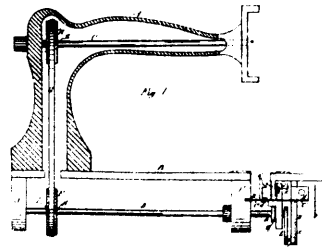

14071 Lockman's Improvements in Sewing Machines.

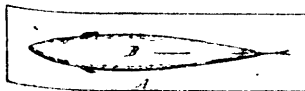
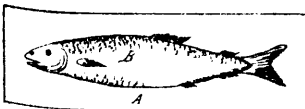

14072 Kelly's Improvements in the Art of Freezing Fish.

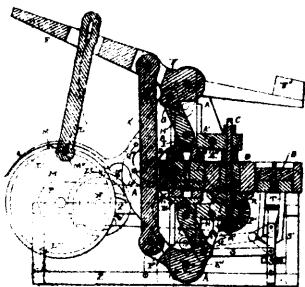

14073 Kennedy's Improvement on Brick Machines.

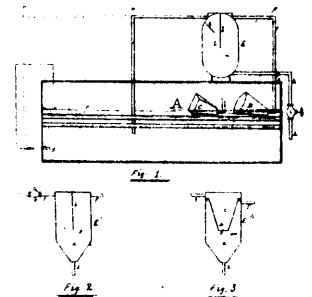

14074 Fisher's Improvements in Devices for Removing Impurities from the Water of Steam Boilers.

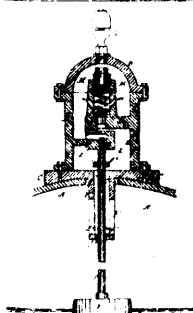

14075 Wilson's Combined Low Water Alarm and Safety Valve for Steam Boilers.

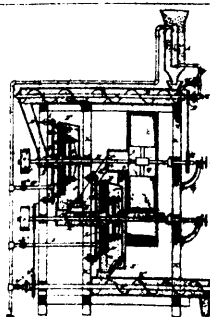

14076 Teter's Improvements in Grain Cleaners.

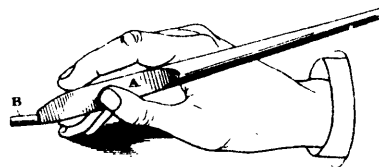

14077 Palmer's Improvements on Pen-holders.

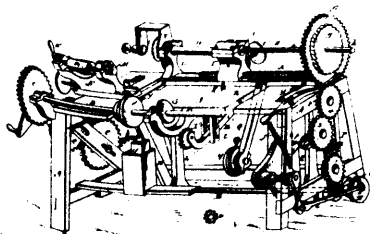

14078 Hanson's Improvements on Wood Working Machines.

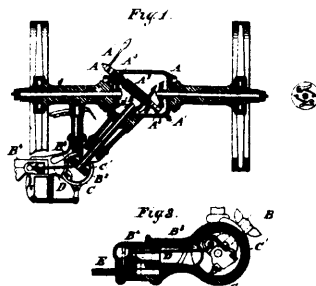

14079 Cochrane's Improvements on Mechanical Movements.

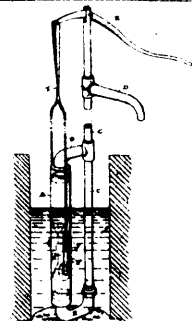

14080 Sanders's Improvements on Force Pumps.

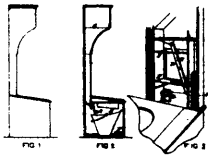

14081 McNairn & Cameron's Improvements in Earth Closets.

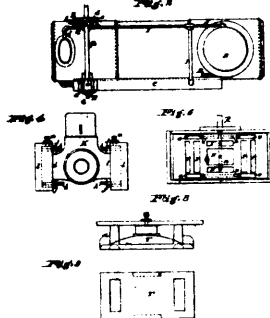

14082 McGregor's Improvements on Portable Engines.

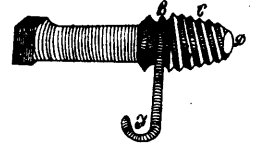

14083 Alford's Improvements on Sap Spouts.

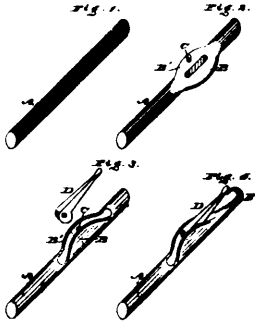

14084 Feberdy & Duvall's Improvements in Needles for Knitting Machines.

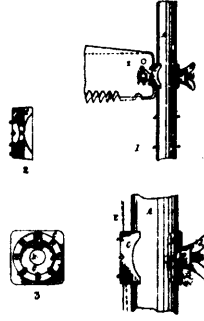

14085 Smith's Improvements on Saw Handles.

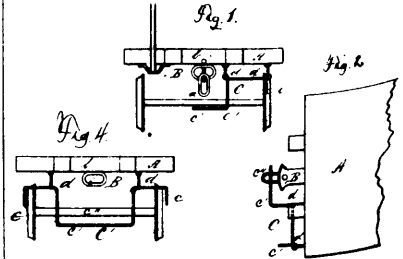

14086 Putnam's Improvements on Car-couplings.

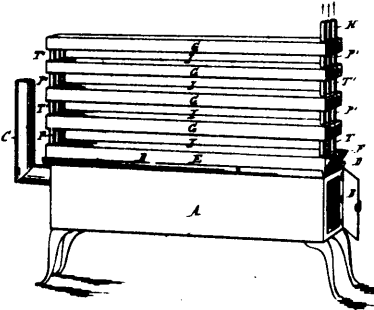

14087 Woodruff, Wheeler & Pearson's Improvement on Fruit Dryers.



14088 Lowe's Improvements on Trolling Spoon Baits.

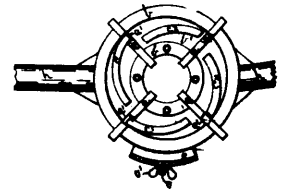

14089 Stockwell's Improvements on Screw Plates.

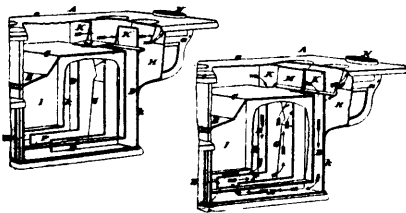

14090 Filley's Improvements on Cooking Stoves.

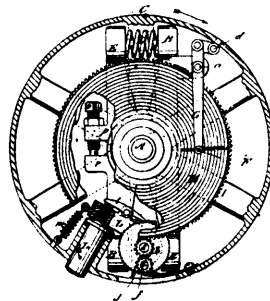

14092 Ruddick's Improvement in Registering Dynamometers.

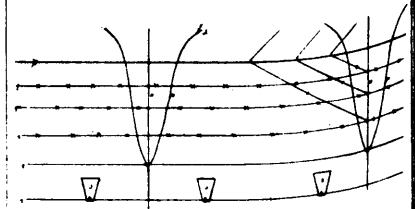

14093 German's Improvements in Iron Fences.



14094 Henderson & McDonald's Improvement in the Lacing of Boots and Shoes.

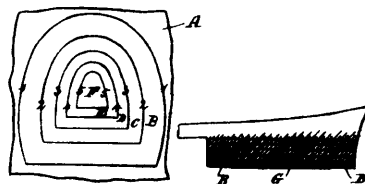

14096 Kelsey's Improvements in the Manufacture of Boot and Shoe Heels.

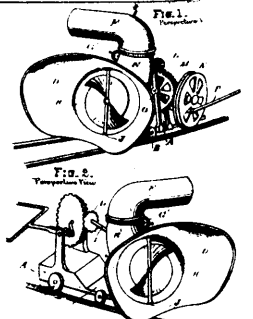

14098 Coxen's Improvements on Snow Clearers.

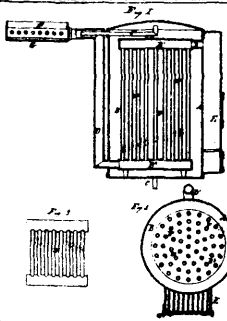

14097 Culver's Improvements in Apparatus for Heating, Cooling and other Purposes.

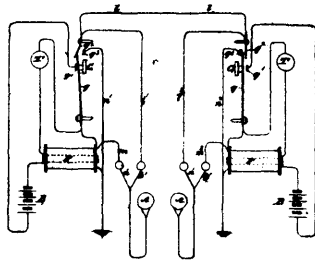

14098 Dolbear's Improvement in Telephones.

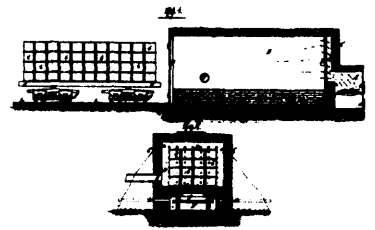

14099 Chesebrough's Improvements in the Art of, and Apparatus for Making and Revivifying Bone Black.

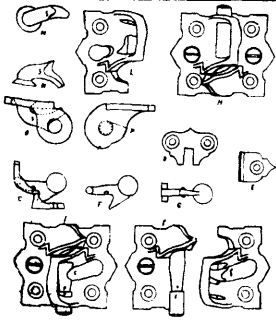

14100 Ménard's Improvements in Blind Hinges.

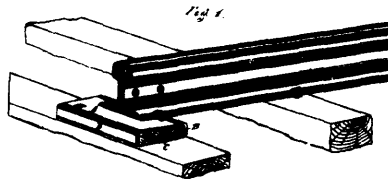

14101 Perkins's Improvements in Rail Chairs.

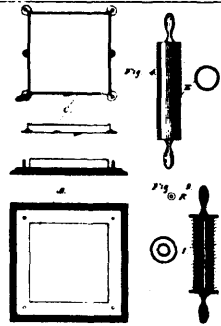

14106 Daniels's Improvements on Machines for Cutting Pills.

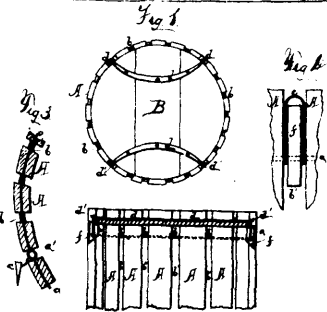

14107 Bartram's Improvements on Fruit Harrels.

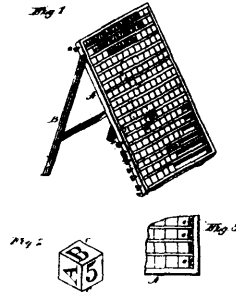

14108 Marble's Improvements in Bulletin Boards.

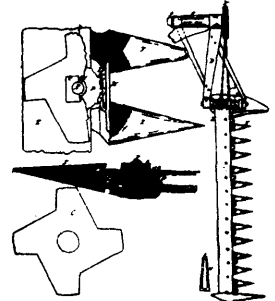

14109 Wilkins's Improvements on Mowing and Reaping Machines.

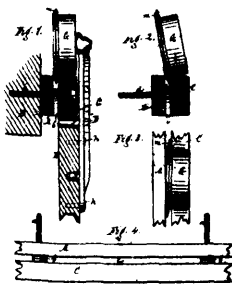

14110 Ide's Improvements on Door Hangers.

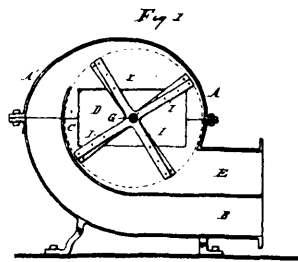

14112 Smith's Improvements on Blowers.

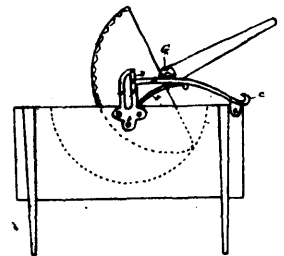

14113 Harris's Improvements in the "Boss Washing Machine."

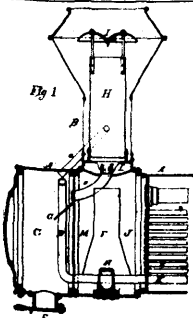

14114 Taylor's Improvements in Spark Arresters.

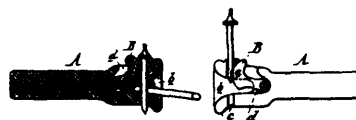

14115 Kelly's Improvements in Car-couplings.

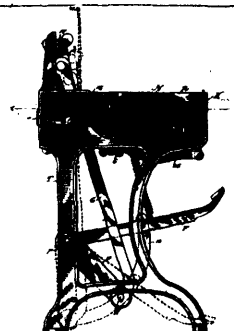

14116 Brunkop's Improvements on Presses.