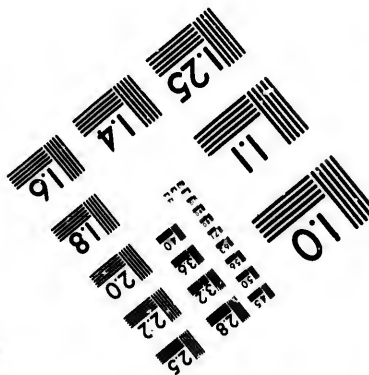
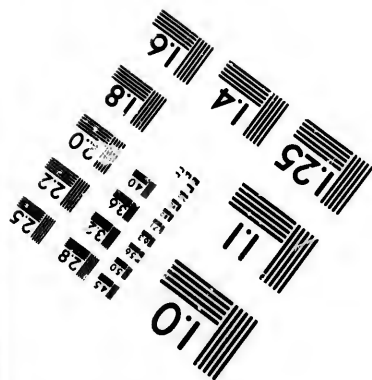
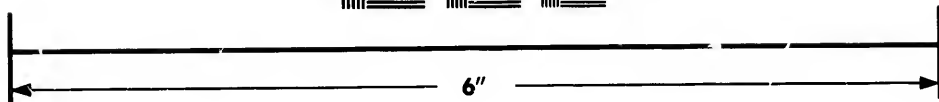
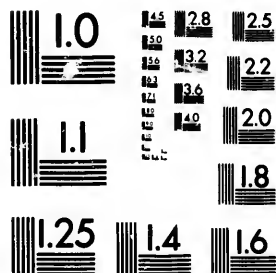

**IMAGE EVALUATION
TEST TARGET (MT-3)**



**Photographic
Sciences
Corporation**

23 WEST MAIN STREET
WEBSTER, N.Y. 14580
(716) 872-4503

25
28
32
36
22
20
18

**CIHM/ICMH
Microfiche
Series.**

**CIHM/ICMH
Collection de
microfiches.**



Canadian Institute for Historical Microreproductions / Institut canadien de microreproductions historiques

10
01

© 1981

Technical and Bibliographic Notes/Notes techniques et bibliographiques

The Institute has attempted to obtain the best original copy available for filming. Features of this copy which may be bibliographically unique, which may alter any of the images in the reproduction, or which may significantly change the usual method of filming, are checked below.

- Coloured covers/
Couverture de couleur
- Covers damaged/
Couverture endommagée
- Covers restored and/or laminated/
Couverture restaurée et/ou pelliculée
- Cover title missing/
Le titre de couverture manque
- Coloured maps/
Cartes géographiques en couleur
- Coloured ink (i.e. other than blue or black)/
Encre de couleur (i.e. autre que bleue ou noire)
- Coloured plates and/or illustrations/
Planches et/ou illustrations en couleur
- Bound with other material/
Relié avec d'autres documents
- Tight binding may cause shadows or distortion
along interior margin/
La reliure serrée peut causer de l'ombre ou de la
distortion le long de la marge intérieure
- Blank leaves added during restoration may
appear within the text. Whenever possible, these
have been omitted from filming/
Il se peut que certaines pages blanches ajoutées
lors d'une restauration apparaissent dans le texte,
mais, lorsque cela était possible, ces pages n'ont
pas été filmées.
- Additional comments:/
Commentaires supplémentaires:

L'Institut a microfilmé le meilleur exemplaire qu'il lui a été possible de se procurer. Les détails de cet exemplaire qui sont peut-être uniques du point de vue bibliographique, qui peuvent modifier une image reproduite, ou qui peuvent exiger une modification dans la méthode normale de filmage sont indiqués ci-dessous.

- Coloured pages/
Pages de couleur
- Pages damaged/
Pages endommagées
- Pages restored and/or laminated/
Pages restaurées et/ou pelliculées
- Pages discoloured, stained or foxed/
Pages décolorées, tachetées ou piquées
- Pages detached/
Pages détachées
- Showthrough/
Transparence
- Quality of print varies/
Qualité inégale de l'impression
- Includes supplementary material/
Comprend du matériel supplémentaire
- Only edition available/
Seule édition disponible
- Pages wholly or partially obscured by errata
slips, tissues, etc., have been refilmed to
ensure the best possible image/
Les pages totalement ou partiellement
obscurcies par un feuillet d'errata, une pelure,
etc., ont été filmées à nouveau de façon à
obtenir la meilleure image possible.

This item is filmed at the reduction ratio checked below/
Ce document est filmé au taux de réduction indiqué ci-dessous.

10X	14X	18X	22X	26X	30X
<input type="checkbox"/>	<input type="checkbox"/>	<input type="checkbox"/>	<input checked="" type="checkbox"/>	<input type="checkbox"/>	<input type="checkbox"/>
12X	16X	20X	24X	28X	32X

The copy filmed here has been reproduced thanks to the generosity of:

National Library of Canada

The images appearing here are the best quality possible considering the condition and legibility of the original copy and in keeping with the filming contract specifications.

Original copies in printed paper covers are filmed beginning with the front cover and ending on the last page with a printed or illustrated impression, or the back cover when appropriate. All other original copies are filmed beginning on the first page with a printed or illustrated impression, and ending on the last page with a printed or illustrated impression.

The last recorded frame on each microfiche shall contain the symbol \rightarrow (meaning "CONTINUED"), or the symbol ∇ (meaning "END"), whichever applies.

Maps, plates, charts, etc., may be filmed at different reduction ratios. Those too large to be entirely included in one exposure are filmed beginning in the upper left hand corner, left to right and top to bottom, as many frames as required. The following diagrams illustrate the method:

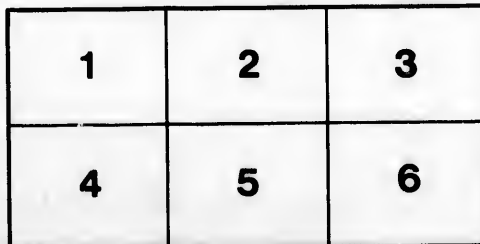
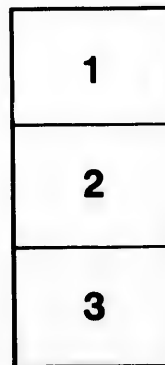

L'exemplaire filmé fut reproduit grâce à la générosité de:

Bibliothèque nationale du Canada

Les images suivantes ont été reproduites avec le plus grand soin, compte tenu de la condition et de la netteté de l'exemplaire filmé, et en conformité avec les conditions du contrat de filmage.

Les exemplaires originaux dont la couverture en papier est imprimée sont filmés en commençant par le premier plat et en terminant soit par la dernière page qui comporte une empreinte d'impression ou d'illustration, soit par le second plat, selon le cas. Tous les autres exemplaires originaux sont filmés en commençant par la première page qui comporte une empreinte d'impression ou d'illustration et en terminant par la dernière page qui comporte une telle empreinte.

Un des symboles suivants apparaîtra sur la dernière image de chaque microfiche, selon le cas: le symbole \rightarrow signifie "A SUIVRE", le symbole ∇ signifie "FIN".

Les cartes, planches, tableaux, etc., peuvent être filmés à des taux de réduction différents. Lorsque le document est trop grand pour être reproduit en un seul cliché, il est filmé à partir de l'angle supérieur gauche, de gauche à droite, et de haut en bas, en prenant le nombre d'images nécessaire. Les diagrammes suivants illustrent la méthode.

**WORKS OF
PROF. HENRY T. BOVEY**

PUBLISHED BY

JOHN WILEY & SONS.

A Treatise on Hydraulics.

8vo. cloth, \$4.00.

Strength of Materials and Theory of Structures.

830 pages, 8vo. cloth, \$7.50.

2 003

THEORY OF STRUCTURES

AND

STRENGTH OF MATERIALS.

WITH

DIAGRAMS, ILLUSTRATIONS, AND EXAMPLES.

BY

HENRY T. BOVEY, M.A., D.C.L., F.R.S.C.,

PROFESSOR OF CIVIL ENGINEERING AND APPLIED MECHANICS, M'GILL UNIVERSITY, MONTREAL.
MEMBER OF THE INSTITUTION OF CIVIL ENGINEERS; MEMBER OF THE INSTITUTION OF MECHANICAL ENGINEERS; LATE FELLOW OF QUEENS' COLLEGE, CAMBRIDGE (ENG.).

SECOND EDITION, REVISED AND ENLARGED.

FIRST THOUSAND.

NEW YORK:

JOHN WILEY & SONS.

LONDON: CHAPMAN & HALL, LIMITED.

1896.

COPYRIGHT, 1893,
BY
HENRY T. BOVEY.

ROBERT DRUMMOND, ELECTROTYPYER AND PRINTER, NEW YORK.

DEDICATED

TO

William C. McDonald,

WHOSE BENEFACTIONS TO M'GILL UNIVERSITY
HAVE DONE SO MUCH TO ADVANCE THE CAUSE OF
SCIENTIFIC EDUCATION.

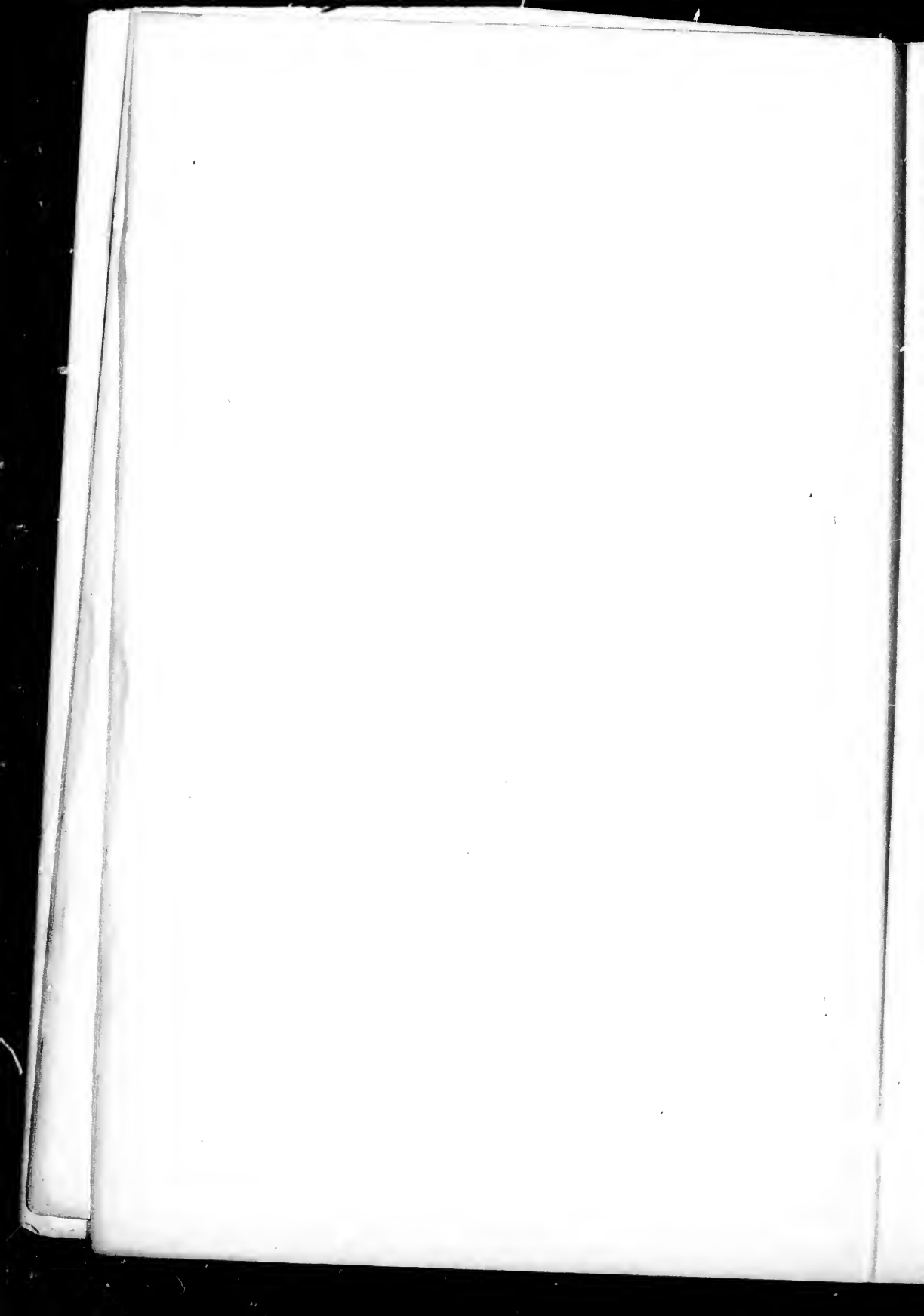

PREFACE.

THE present work treats of that portion of Applied Mechanics which has to do with the Design of Structures.

Free reference has been made to the works of other authors, yet a considerable amount of new matter has been introduced, as, for example, the Articles on "Surface Loading" by Carus-Wilson, "The Flexure of Columns" by Findlay, and "The Efficiency of Riveted Joints" by Nicolson; also my own Articles on "Maximum Shearing Forces and Bending Moments," "The Flexure of Long Columns," "The Theorem of Three Moments," etc.

I am much indebted to Messrs. C. F. Findlay and W. B. Dawson for valuable information respecting the treatment of Cantilever Bridges, Arched Ribs, and the Live Loads on Bridges.

To Messrs. J. M. Wilson, P. A. Peterson, C. Macdonald, and others, many thanks are due for data respecting the Dead Weights of Bridges.

I am under deep obligation to my friend Prof. Chandler, who has kindly revised the proof-sheets, and who has made many important suggestions.

I have endeavored so to arrange the matter that the student may omit the advanced portions and obtain a complete elementary course in natural sequence.

At the end of each chapter, a number of Examples,

selected for the most part from my own experience, are arranged with a view to illustrating the subject-matter—an important feature, as it is admitted that the student who carefully works out examples obtains a mastery of the subject which is otherwise impossible.

The various Tables in the volume have been prepared from the most recent and reliable results.

A few years ago I published a work on "Applied Mechanics," consisting mainly of a collection of notes intended for the use of my own students. The present volume may be considered as a second edition of that work, but the subject-matter has been so much added to and rearranged as to make it almost a new book. I venture to hope that this volume may prove acceptable not only to students, but to the profession at large.

HENRY T. BOVEY.

MCGILL COLLEGE, MONTREAL,
November, 1892.

PREFACE TO SECOND EDITION.

IN this edition many corrections have been made, new examples have been added, and an Appendix to Chap. I., illustrating Bow's method of lettering, has been introduced.

HENRY T. BOVEY.

MCGILL COLLEGE, MONTREAL,
November, 1896.

CONTENTS.

CHAPTER I.

FRAMED STRUCTURES.

	PAGE
Definitions.....	I
Frames of Two or More Members.....	2
Funicular Polygon.....	3
Polygon of Forces.....	4
Line of Loads.....	5
Mansard Roof.....	6
Non-closing Polygons.....	7
Funicular Curve.....	10
Centre of Gravity.....	11
Moment of Inertia.....	12
Cranes, Jib.....	13
" Derrick.....	16
" Composite.....	31
Shear Legs.....	17
Bridge Trusses.....	17
Roof Trusses.....	19
King-post Truss.....	21
Incomplete Frames.....	27
Queen-post Truss.....	31
Composite Frames.....	32
Roof-weights.....	37
Wind-pressure.....	38
Distribution of Loads.....	39
Examples of Roof Trusses.....	41
Examples of Bridge Trusses (Fink, Bollman, Howe, Bowstring, Single-intersection, etc).....	52
Method of Sections.....	62
Piers.....	65

	PAGE
Tables of Roof-weights and Wind-pressures.....	67
Examples.....	70

CHAPTER II.

SHEARING FORCES AND BENDING MOMENTS.

Equilibrium of Beams.....	93
Shearing Force.....	95
Bending Moment.....	96
Examples of Shearing Force and Bending Moment.....	97
Relation between Shearing Force and Bending Moment.....	108
Effect of Live (or Rolling) Load.....	111
Graphical Representation of Moment of Forces with Respect to a Point... 116	116
Relation between Bending Moments and Funicular Polygon.....	118
Maximum Shear and Maximum Bending Moment at any Point of an Arbitrarily Loaded Girder.....	121
Hinged Girders.....	126
Examples.....	131

CHAPTER III.

GENERAL PRINCIPLES, ETC.

Definitions.....	140
Stress, Simple.....	140
" Compound.....	140
Hooke's Law.....	141
Coefficient of Elasticity.....	141
Poisson's Ratio.....	142
Effect of Temperature.....	142
Specific Weight.....	143
Limit of Elasticity.....	143
Breaking Stress.....	147
Dead and Live Loads.....	143
Repeated Stress Effect.....	145
Wöhler's Experiments.....	145
Testing of Metals.....	147
Launhardt's Formula.....	159
Weyrauch's Formula.....	153
Unwin's Formula.....	159
Flow of Solids.....	162
Work, Internal and External.....	168
Energy, Kinetic and Potential.....	167
Oblique Resistance.....	169
Values of k	174
Momentum. Impulse.....	176
Angular Momentum.....	177

CONTENTS.

ix

PAGE		PAGE
67	Useful Work. Waste Work.....	175
70	Centrifugal Force.....	181
	Impact.....	184
	Extension of a Prismatic Bar.....	189
	Oscillatory Motion of a Weight at the End of a Vertical Elastic Rod.....	190
	Inertia.....	198
93	Balancing.....	198
95	Curves of Piston Velocity.....	205
96	Linear Diagrams of Velocity.....	206
97	Curves of Crank-effort.....	207
108	Curves of Energy.....	207
111	Fluctuation of Energy.....	207
116	Tables of Strengths, Elasticities, and Weights of Materials.....	210
118	Tables of the Breaking Weights and Coefficients of Bending Strengths of Beams.....	213
121	Table of the Weights and Crushing Weights of Rocks, etc.....	214
126	Table of Expansions of Solids.....	215
131	Examples.....	216

CHAPTER IV.

STRESSES, STRAINS, EARTHWORK, AND RETAINING WALLS.

140	Internal Stresses.....	235
140	Simple Strain.....	235
140	Compound Strain.....	230
141	Principal Stresses.....	240
141	Curves of Maximum Shear and Normal Intensity.....	240
142	Combined Bending and Twisting Stresses.....	244
142	Combined Longitudinal and Twisting Stresses.....	247
143	Conjugate Stresses.....	247
143	Relation between Principal and Conjugate Stresses.....	247
147	Ratio of Conjugate Stresses.....	250
143	Relation between Stress and Strain.....	251
145	Rankine's Earthwork Theory.....	255
145	Pressure against a Vertical Plane.....	257
147	Earth Foundations.....	258
159	Retaining Walls.....	260
153	Retaining Walls. Conditions of Equilibrium.....	260
159	Rankine's Earthwork Theory applied to Retaining Walls.....	264
162	Line of Rupture.....	265
168	Practical Rules respecting Retaining Walls.....	267
177	Reservoir Walls.....	271
179	General Case of Reservoir Walls.....	275
174	General Equations of Stress.....	276
176	Ellipsoid of Stress.....	281
177	Stress-strain Equations.....	281

	PAGE
Isotropic Bodies	283
Relation between A , λ , and G	285
Traction	287
Torsion.....	288
Work done in the Small Strain of a Body (Clapeyron).....	292
Examples.....	294

CHAPTER V.

FRICTION.

Friction.....	300
Laws of Friction.....	300
Inclined Plane.....	301
Wedge	302
Screws.....	306
Endless Screw.....	309
Rolling Friction.....	310
Journal Friction.....	312
Pivot.....	316
Cylindrical Pivot.....	316
Wear.....	318
Conical Pivot.....	319
Schiele's Pivot (<i>anti-friction</i>).....	320
Belts and Ropes.....	321
Brakes.....	323
Effective Tension of a Belt.....	324
Effect of High Speed.....	325
Slip of Belts.....	326
Prony's Dynamometer	327
Stiffness of Belts and Ropes.....	327
Wheel and Axle.....	329
Toothed Gearing.....	331
Bevel-wheels.....	335
Efficiency of Mechanisms.....	335
Table of Coefficients of Journal Friction.....	336
Examples.....	337

CHAPTER VI.

TRANSVERSE STRENGTH OF BEAMS.

Elastic Moment.....	340
Moment of Resistance.....	340
Neutral Axis.....	340
Transverse Deformation.....	344
Coefficient of Bending Strength.....	344

PAGE.		PAGE
283	Equalization of Stress.....	349
285	Surface Loading.....	350
287	Effect of Bending Moment in a Plane which is not a Principal Plane.....	354
288	Springs.....	355
292	Beams of Uniform Strength.....	358
294	Flanged Girders.....	365
	Classification of Flanged Girders.....	365
	Equilibrium of Flanged Girders.....	366
	Moments of Inertia of I and other Sections.....	371
	Design of a Girder of I-section.....	381
	Deflection of Girders.....	384
	Camber.....	387
	Stiffness.....	389
	Distribution of Shearing Stress.....	391
	Beam acted upon by Forces Oblique to its Direction.....	396
	Similar Girders.....	401
	Allowance to be made for Weight of Beam.....	405
	Examples.....	407

CHAPTER VII.

TRANSVERSE STRENGTH OF BEAMS—(Continued.)

320	General Equations.....	428
321	Interpretation of the General Equations.....	432
323	Examples—Cantilever.....	435
324	" Girder upon Two Supports.....	439
325	" " fixed at One End and resting upon Support at the	
326	Other.....	442
327	" " fixed at Both Ends.....	445
327	" " upon Two Supports not in the same Horizontal Plane.....	446
329	" Neutral Axis of Arbitrarily Loaded Girders.....	448
331	" Cantilever with Varying Section.....	455
335	" Girder Encastré at the Ends.....	458
335	Springs.....	456
336	Work done in bending a Beam.....	460
337	Transverse Vibrations of a Beam supported at Both Ends.....	461
	Imperfect Fixture.....	461
	Continuous Girders.....	463
	Theorem of Three Moments.....	463
	Swing-bridges.....	470
	Maximum Bending Moment at the Points of Support of a Continuous	
	Girder of n Spans.....	475
	General Theorem of Three Moments.....	484
	Comparative Merits of Continuous Girders.....	486
	Examples.....	490

CHAPTER VIII.

PILLARS.

	PAGE
Classification of Pillars.....	513
Form " ".....	514
Failure " ".....	515
Uniform Stress.....	516
Uniformly Varying Stress.....	517
Hodgkinson's Formulæ.....	520
Gordon's Formula.....	522
Values of the Coefficients (a and f) in Gordon's Formula.....	523
Graphical Representation of Strength of Pillars.....	524
Rankine's Modification of Gordon's Formula.....	526
Formula for Safe Working Stress.....	526
Value of "Radius of Gyration" for Different Sections.....	526
American Iron Columns.....	532
Long Thin Pillars.....	534
Long Columns of Uniform Section (Euler's Theory).....	538
Resistance of Columns to Buckling (Weyrauch's Theory).....	550
Baker's Formulæ.....	549
Flexure of Columns.....	554, 557
Examples.....	563

CHAPTER IX.

TORSION.

Definition.....	563
Coulomb's Laws.....	568
Torsional Strength of Shafting.....	569
St. Venant's Results.....	572
Torsional Rupture.....	572
Resilience of Shafting.....	574
Effect of Combined Bending and Twisting.....	574
Distance between Bearings for Shafting.....	575
Efficiency of Shafting.....	577
Spiral Springs.....	577
Figures illustrating the Distortion produced by twisting Round, Square, and Rectangular Iron Bars.....	585a, 585b
Examples.....	58c

CHAPTER X.

CYLINDRICAL AND SPHERICAL BOILERS.

Cylinders.....	586
Efficiency of Riveted Joints in Boilers.....	587

CONTENTS.

xij

	PAGE
Thick Hollow Cylinder.....	588
Spherical Shells.....	591
Practical Formulæ.....	592
Examples.....	594

CHAPTER XI

BRIDGES.

Classification.....	597
Curved and Horizontal Flanges.....	597
Depth of Girders (or Trusses).....	597
Position of Platform.....	598
Comparative Advantages of Two, Three, and Four Main Girders.....	600
Dead Load.....	600
Live Load.....	600
Trellis (or Lattice) Girder.....	600
Warren Girder.....	603
Howe Truss.....	611
Single-intersection Truss.....	616
Double-intersection Truss.....	616
Whipple Truss.....	618
Linville Truss.....	618
Post Truss.....	618
Quadrangular Truss.....	618
Bowstring Truss.....	618
Bowstring Truss with Isosceles Bracing.....	624
Bowstring Suspension-bridge (Lenticular Truss).....	626
Cantilever Trusses.....	627
Curve of Cantilever Boom.....	634
Deflection of Cantilevers.....	638
Pollers.....	639
Wind-pressure.....	651
Regulations respecting Wind-pressure.....	653
Lateral Bracing.....	654
Chords.....	655
Stringers.....	656
Maximum Allowable Working Stresses.....	657
Camber.....	659
Rivet Connections between Flange and Web.....	660
Eye-bars, Pins, and Rivets.....	661
Steel Eyebars.....	665
Rivets.....	666
Dimensions of Rivets.....	667
Strength of Punched and Drilled Plates.....	668
Riveted Joints.....	668
Theory of Riveted Joints.....	671

PAGE
513
514
515
516
517
520
522
523
524
526
526
526
532
534
538
550
549
557
563

60
68
99
2
2
4
4
5
7

	PAGE
Covers.....	675
Efficiency of Riveted Joints.....	676
Tables of Weights of Actual Bridges.....	682-687
Table of Loads for Highway Bridges.....	688
Examples.....	689-702

CHAPTER XII.

SUSPENSION-BRIDGES.

Cables.....	703
Anchorage.....	704
Suspenders.....	706
Curve of Cable (<i>catenary</i>).....	706
Link "Cable".....	709
Length of Cable.....	712
Weight of Cable.....	713
Deflection due to Change of Length.....	714
Pressure upon Piers.....	718
Stiffening Truss.....	719
Stiffening Truss hinged at the Centre.....	725
Suspension-bridge Loads.....	730
Modifications of the Suspension-bridge proper.....	731
Examples.....	734-739

CHAPTER XIII.

ARCHED RIBS.

Definitions.....	740
Equilibrated Polygon (Line of Resistance).....	741
Polygon of Pressures.....	743
Linear Arch.....	743
Conditions of Equilibrium.....	745
Joint of Rupture.....	747
Minimum Thickness of Abutment.....	749
Empirical Formulæ.....	750
Linear Arch in Form of a Parabola.....	750
" " " " " Transformed Catenary.....	750
" " " " " Circular Arc.....	753
" " " " " Elliptic Arc.....	753
Hydrostatic Arch.....	757
Geostatic Arch.....	759
General Arch Theory.....	760
Arched Ribs.....	762
Bending Moment and Thrust at any Point of an Arched Rib.....	763
Rib with Hinged Ends.....	764

	PAGE
Semicircular Rib with Hinged Ends.....	765
Graphical Determination of the Thrust at any Point of an Arched Rib....	767
Rib in Form of a Circular Arc.....	769
Rib with Fixed Ends.....	771
" " " " in Form of a Circular Arc.....	773
" " " " " " " Semicircle.....	775
" " " " " " " Parabola.....	775
Effect of a Change of Temperature.....	777, 786
Deflection of an Arched Rib.....	780, 802
Elementary Deformation of an Arched Rib.....	781
Rib of Uniform Stiffness.....	788
Parabolic Rib of Uniform Depth and Stiffness.....	789, 795, 800
Arched Rib of Uniform Stiffness with Fixed Ends.....	804
Stresses in Spandril Posts and Diagonals.....	804
Maxwell's Method of Determining the Stresses in a Framed Arch.....	806
Examples.....	809-812

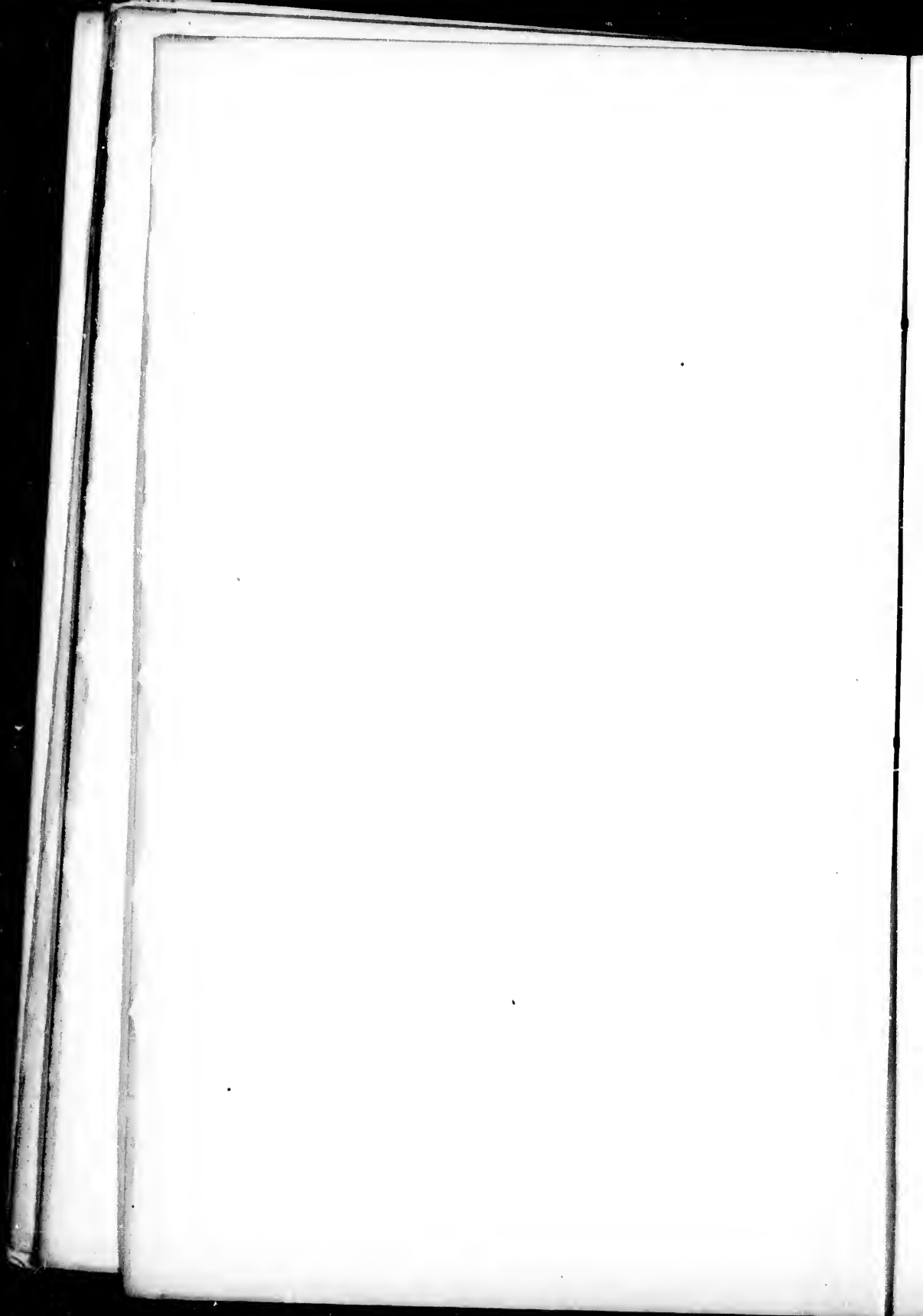

THEORY OF STRUCTURES.

CHAPTER I.

FRAMES LOADED AT THE JOINTS.

✓ 1. **Definitions.**—*Frames* are rigid structures composed of straight struts and ties, jointed together by means of bolts, straps, mortises and tenons, etc. *Struts* are members in compression, *ties* members in tension, and the term *brace* is applied to either.

The external forces upon a frame are the loads and the reactions at the points of support, from which may be found the resultant forces at the joints. The greatest care should be exercised in the design of the joints. The resultant forces should severally coincide in direction with the axes of the members upon which they act, and should intersect the joints in their centres of gravity. Owing to a want of homogeneity in the material, errors of workmanship, etc., this coincidence is not always practicable, but it should be remembered that the smallest deviation introduces a bending action. Such an action will also be caused by joint friction when the frame is insufficiently braced. The points in which the lines of action of the resultants intersect the joints are also called the *centres of resistance*, and the figure formed by joining the centres of resistance *in order* is usually a polygon, which is designated the *line of resistance* of the frame.

The *position* of the centres should on no account be allowed to vary. It is assumed, and is practically true, that the joints of a frame are flexible, and that the frame under a given load

does not sensibly change in form. Thus an individual member is merely stretched or compressed in the direction of its length, i.e., along its line of resistance, while the frame as a whole may be subjected to a bending action.

The term *truss* is often applied to a frame supporting a weight

2. Frame of Two Members.— OA , OB are two bars jointed at O and supported at the ends A , B . The frame in

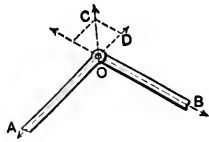

FIG. 1.

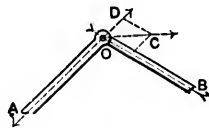

FIG. 2.

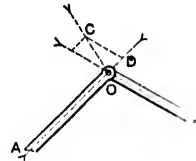

FIG. 3.

Fig. 1 consists of two ties, in Fig. 3 of two struts, and in Fig. 2 of a strut and a tie.

Let P be the resultant force at the joint, and let it act in the direction OC . Take OC equal to P in magnitude, and draw CD parallel to OB . OD is the stress along OA , and CD is that along OB .

Let the angle $AOB = \alpha$, and the angle $COD = \beta$.

Let S_1 , S_2 be the stresses along OA , OB , respectively.

$$\therefore \frac{S_1}{P} = \frac{OD}{OC} = \frac{\sin(\alpha - \beta)}{\sin \alpha}, \quad \text{and} \quad \frac{S_2}{P} = \frac{CD}{OC} = \frac{\sin \beta}{\sin \alpha}.$$

3. Frame of Three or More Members.—Let A_1, A_2, A_3, \dots be a polygonal frame jointed at A_1, A_2, A_3, \dots . Let P_1, P_2, P_3, \dots be the resultant forces at the joints A_1, A_2, A_3, \dots , respectively. Let S_1, S_2, S_3, \dots be the forces along A_1A_2, A_2A_3, \dots , respectively.

Consider the joint A_1 .

The lines of action of three forces, P_1 , S_1 , and S_2 , intersect in this joint, and the forces, being in equilibrium, may be represented in direction and magnitude by the sides of the

triangle Os_1s_2 , in which s_1s_2 is parallel to P_1 , Os_1 to S_1 , and Os_2 to S_2 .

Similarly, P_2, S_1, S_2 may be represented by the sides of the triangle Os_2s_3 , which has one side, Os_2 , common to the triangle Os_1s_2 , and so on.

Thus every joint furnishes a triangle having a side common to each of the two adjacent triangles, and all the triangles together form a *closed* polygon $s_1s_2s_3 \dots$. The sides of this polygon represent in magnitude and direction the resultant

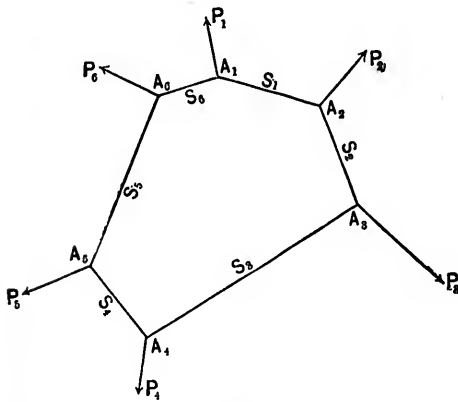

FIG. 4.

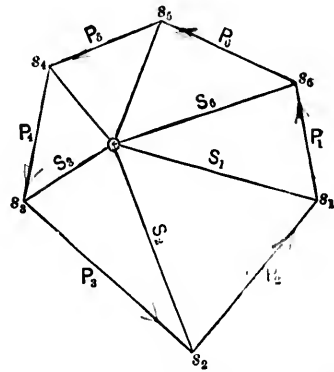

FIG. 5.

forces at the joints, and the radii from the pole O to the angles $s_1s_2s_3, \dots$ represent in magnitude, direction and character, the forces along the several sides of the frame $A_1A_2A_3 \dots$. The polygon $A_1A_2A_3 \dots$ is the line of resistance of the frame, and is called the *funicular polygon* of the forces P_1, P_2, P_3, \dots with respect to the pole O .

The two polygons are said to be *reciprocal*, and, in general, two figures in graphical statics are said to be *reciprocal* when the sides in the one figure are parallel or perpendicular to corresponding sides in the other.

A triangle or polygon is also said to be the reciprocal of a point when its sides are parallel or perpendicular to corresponding lines radiating from the point. Thus the triangle Os_1s_2 is

the reciprocal of the point A_1 , and the polygon $A_1A_2A_3 \dots$ is the reciprocal of the point O .

If more than *two* members meet at a joint, or if the joint is subjected to more than *one* load, the resulting force diagram will be a quadrilateral, pentagon, hexagon, . . . according as the number of members is 3, 4, 5, . . . or the number of loads 2, 3, 4, . . .

In practice it is usually required to determine the stresses in a number of members radiating from a joint in a framed structure. If the reciprocal of the joint can be drawn, its sides will represent in direction and magnitude the stresses in the corresponding members.

Corollary.—The converse of the preceding is evidently true. For if a system of forces is in equilibrium, the polygon of forces $s_1s_2s_3 \dots$ must close, and therefore the polygon which has its sides respectively parallel to the radii from a pole O to the angles s_1, s_2, s_3, \dots and which has its angles upon the lines of action of the forces, must also close.

EXAMPLE 1. Let O be a joint in a framed structure, and let Os_1, Os_2, Os_3, \dots be the axes of the members radiating from it. The polygon $A_1A_2A_3 \dots$ is the reciprocal of O , the side A_1A_2 representing the stress along Os_1 , the side A_2A_3 that along Os_2 , etc.

EX. 2. Let the resultant forces at the joints be parallel. The polygon of forces becomes the straight line s_1s_6 ,

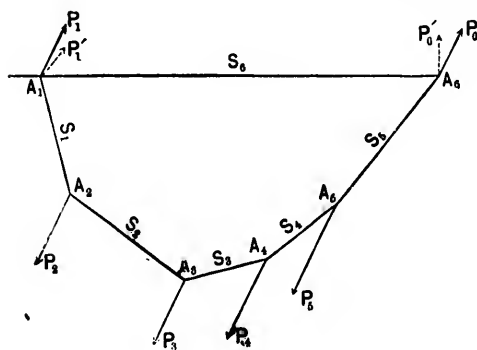

FIG. 6.

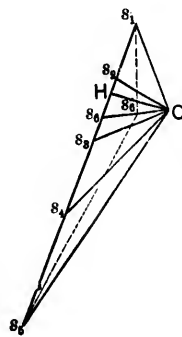

FIG. 7.

forces will remain the same, and the frame will be in equilibrium under the *given* loads. The equilibrium, however, is unstable as the chain, and consequently the inverted frame will change form if the weights vary. Braces must then be introduced to prevent distortion.

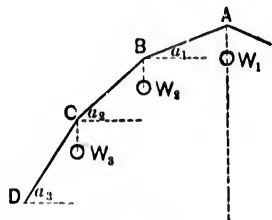

FIG. 9.

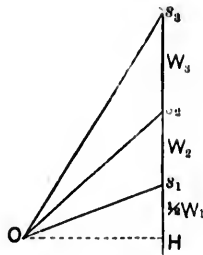

FIG. 10.

Take the case of a frame $DCBA \dots$ symmetrical with respect to a vertical through A , and let the weights at A, B, C, \dots be W_1, W_2, W_3, \dots , respectively.

Drawing the stress diagram in the usual manner, OH represents the horizontal thrust of the frame.

The portions s_1, s_2, s_3, \dots of the line of loads give a definite relation between the weights for which the truss will be stable. The result may be expressed analytically, as follows:

Let $\alpha_1, \alpha_2, \alpha_3, \dots$ be the inclinations of AB, BC, CD, \dots , respectively, to the horizontal.

Let the horizontal thrust $OH = H$. Then

$$H = \frac{W_1}{2} \cot \alpha_1 = \left(\frac{W_1}{2} + W_2 \right) \cot \alpha_2 = \left(\frac{W_1}{2} + W_2 + W_3 \right) \cot \alpha_3 = \dots$$

$$\text{If } W_1 = W_2 = W_3 = \dots$$

$$\cot \alpha_1 = 3 \cot \alpha_2 = 5 \cot \alpha_3 = \dots$$

If there are two bars only, viz., AB, BC , on each side of the vertical centre line, the frame will have a double slope, and in this form is employed to support a *Mansard* roof.

4. **Non-closing Polygons.**—Let a number of forces P_1, P_2, P_3, \dots act upon a structure, and let these forces, *taken in order*, be represented in direction and magnitude by the sides of the unclosed figure $MNPQ\dots$. This figure is the unclosed

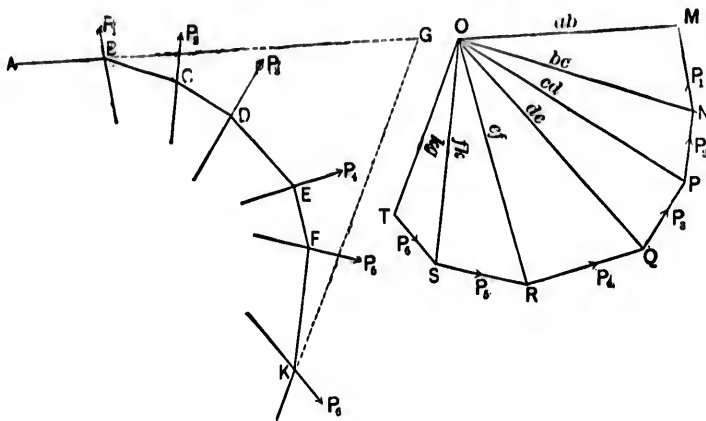

FIG. 11.

polygon of forces, and its closing line TM represents in direction and magnitude the resultant of the forces P_1, P_2, P_3, \dots .

For PM is the resultant of P_1 and P_2 , and may replace them; QM may replace PM and P_3 , i.e., P_1, P_2 , and P_3 ; and so on.

Take any point O and join OM, ON, OP, \dots .

Draw a line AB parallel to OM and intersecting the line of action of P_1 in any point B . Through B draw BC parallel to ON and cutting the line of action of P_2 in C . Similarly, draw CD parallel to OP, DE to OQ, EF to OR, \dots . The figure $ABCD\dots$ is called the *funicular polygon* of the given forces with respect to the pole O . The position of the pole O is *arbitrary*, and therefore an infinite number of funicular polygons may be drawn with different poles.

Also the position of the point B in the line of action of P_1 is arbitrary, and hence an infinite number of funicular polygons with their corresponding sides parallel, i.e., an infinite number of *similar* funicular polygons, may be drawn with the *same* pole.

5. To show that the Intersection of the First and Last Sides of the Funicular Polygon (i.e., the Point G) is a Point on the Actual Resultant of the System of Forces P_1, P_2, P_3, \dots .—First consider two points P_1, P_2, MNP being the force and $ABCD$ the funicular polygon.

Let AB, DC , the first and last sides of the latter, be pro-

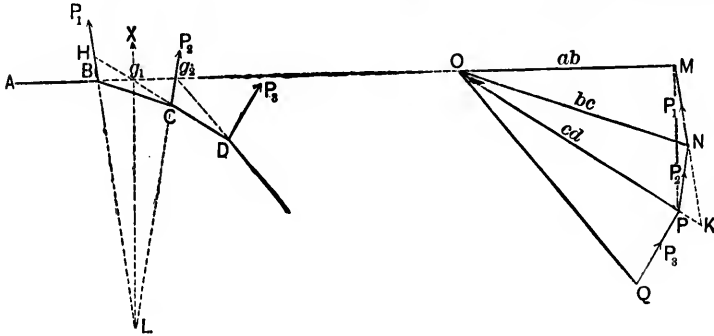

FIG. 12.

duced to meet in g_1 ; also let DC produced meet the line of action of P_1 in H .

Produce OP and MN to meet in K .

Let the lines of action of P_1 and P_2 meet in L .

By similar triangles,

$$\frac{KP}{KN} = \frac{HC}{HL}; \quad \frac{KN}{KO} = \frac{HB}{HC}; \quad \frac{KO}{KM} = \frac{Hg_1}{HB}.$$

Hence

$$\frac{KP}{KN} \frac{KN}{KO} \frac{KO}{KM} = \frac{HC}{HL} \frac{HB}{HC} \frac{Hg_1}{HB},$$

or

$$\frac{KP}{KM} = \frac{Hg_1}{HL},$$

and therefore, since the angle H is equal to the angle K , the line PM is parallel to the line Lg_1 .

But PM represents in magnitude the resultant of the forces P_1, P_2 , and is parallel to it in direction.

Therefore Lg_1 is also parallel to the direction of the resultant.

But L is evidently a point on the *actual* resultant of P_1, P_2 . Hence g_1 must be a point on this resultant.

Next, let there be three forces, P_1, P_2, P_3 .

Replace P_1, P_2 by their resultant X acting in the direction Lg_1 . The force and funicular polygons for the forces X and P_3 are evidently MPQ and Ag_1DE , respectively; and g_2 , the point of intersection of Ag_1 and ED produced, is, as already proved, a point on the actual resultant of X and P_3 , i.e., of P_1, P_2 , and P_3 .

Hence the *first* and *last* sides, AB, ED , of the funicular polygon $ABCDE$ of the forces P_1, P_2, P_3 , with respect to the pole O , intersect in a point which is on the *actual* resultant of the given forces.

The proof may be similarly extended to four, five, and any number of forces.

If the forces are all parallel, the force polygon of the two forces P_1, P_2 becomes a straight line, MNQ . Draw the funicular

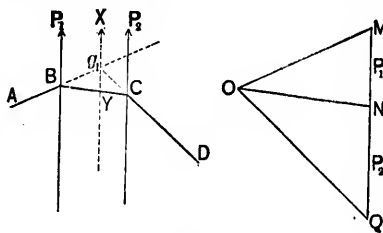

FIG. 13.

polygon $ABCD$ as before, and through g_1 , the intersection of the *first* and *last* sides, draw g_1Y parallel to MQ , and cutting BC in Y .

By similar triangles,

$$\frac{P_1}{ON} = \frac{MN}{ON} = \frac{g_1Y}{BY} \quad \text{and} \quad \frac{P_2}{ON} = \frac{QN}{ON} = \frac{g_1Y}{CY} :$$

$$\therefore \frac{P_1}{P_2} = \frac{CY}{BY}.$$

Hence Yg_1 , which is parallel to the direction of the forces P_1, P_2 , divides the distance between their lines of action into segments which are inversely proportional to the forces, and must therefore be the line of action of their resultant. The proof may be extended to any number of forces, as in the preceding.

Funicular Curve.—Let the weights upon a beam AB become infinite in number, and let the distances between the weights diminish indefinitely.

The load then becomes continuous, and the funicular polygon is a curve, called the funicular curve.

The equation to this curve may be found as follows:

Let the tangents at two consecutive points P and Q meet in R . This point is on the vertical through the centre of gravity of the load upon the portion MN of the beam.

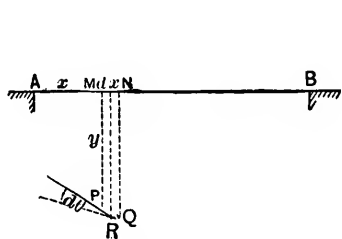

FIG. 14.

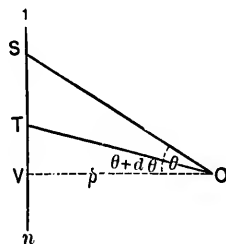

FIG. 15.

Let w be the line of loads, and let OS, OT be the radial lines from O , the pole, parallel to the tangents at P and Q . Take A as the origin.

Let θ be the inclination of the tangent at P to the beam, and let the polar distance $OV = p$.

$w dx$ = the load upon the portion MN . Then

$$w dx = ST = SV - TV = p \tan \theta - p \tan (\theta + d\theta) \\ = -p d\theta, \text{ approximately.}$$

$$\therefore -w = p \frac{d\theta}{dx} = p \frac{d^2 y}{dx^2}, \text{ since } \theta = \frac{dy}{dx}.$$

Integrating twice,

$$py = -\iint w dx^2 + c_1 x + c_2,$$

c_1 and c_2 being constants of integration.

If the intensity, w , of the load is constant,

$$py = -\frac{wx^2}{2} + c_1x + c_2,$$

and the curve is a parabola.

6. Centres of Gravity.—Let it be required to determine the centre of gravity of any plane area symmetrical with respect to an axis XX . Divide the area into suitable elementary areas a_1, a_2, a_3, \dots having known centres of gravity.

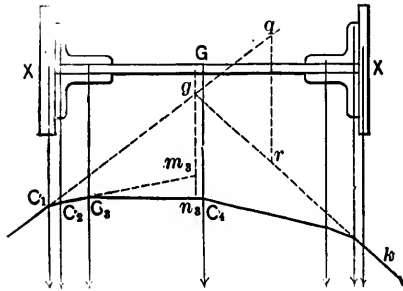

FIG. 16.

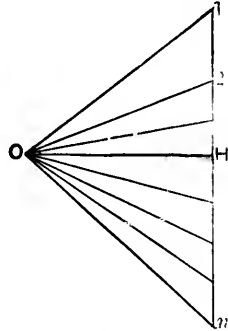

FIG. 17.

Draw the force (the line mn) and funicular polygons corresponding to these areas, and let g be the point in which the first and last sides of the funicular polygon meet. The line drawn through g parallel to mn must pass through the centre of gravity of all the elementary areas and, therefore, of the whole area. Hence it is the point G in which this line intersects the axis XX .

Rail and similar sections may be divided into elementary areas by drawing a number of parallel lines at right angles to the axis of symmetry, and at such distances apart that each elementary figure may, without sensible error, be considered a rectangle of an area equal to the product of its breadth by its mean height.

In the case of a very irregular section, an accurate template of the section may be cut out of cardboard or thin metal. If the template is then suspended from a pin through a point near the

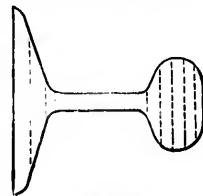

FIG. 18.

edge, the centre of gravity of the section will lie in the vertical through the pin. By changing the point of suspension, a new line in which the centre of gravity lies may be found. The intersection of the two lines must, therefore, be the centre of gravity required. Another method of finding the centre of gravity is to carefully balance the template upon a needle-point.

The area of such a section may be determined either by means of a planimeter or by balancing the template against a rectangle cut out of the same material, the area of the rectangle being evidently the same as that of the section.

7. Moment of Inertia of a Plane Area.—Let any two consecutive sides, C_1C_2 , C_2C_3 , of the funicular polygon meet line gG in the points m_1 , n_1 .

Let x_1 , x_2 , x_3 , . . . be the lengths of the perpendiculars from the centres of gravity of a_1 , a_2 , a_3 , . . ., respectively, upon gG .

Draw the line OH perpendicular to the line of loads, and let $OH = p$.

By the similar triangles $C_1m_1n_1$ and OH .

$$\frac{m_1n_1}{x_1} = \frac{34}{p} = \frac{a_1}{p}, \quad \text{or} \quad m_1n_1 = \frac{a_1x_1}{p};$$

$$\therefore \frac{a_1x_1^2}{p} = m_1n_1 \frac{x_1}{2} = \text{area of triangle } C_1m_1n_1.$$

But the total area A bounded by the funicular polygon $C_1C_2C_3 \dots$ and the lines gC_1 , gk is the sum of all the triangular areas C_1gm_1 , $C_2m_1n_1$, $C_3m_1n_1$, . . . described in the same manner as $C_1m_1n_1$.

$$\therefore A = \frac{a_1x_1^2}{p} + \frac{a_2x_2^2}{p} + \dots = \frac{\Sigma(ax^2)}{2p}.$$

The sum $\Sigma(ax^2)$ is the moment of inertia, I , of the plane area with respect to gG . Hence,

$$A = \frac{I}{2p}, \quad \text{or} \quad I = 2Ap.$$

The moment of inertia I_y of the area, with respect to a parallel axis at distance y_1 from gG , is given by the equation

$$I_y = I + Sy_1^2,$$

where $S = A_1 + A_2 + \dots$

Let the new axis intersect C_1g and kg in the points q and r . The triangles qgr and OIn are similar.

$$\therefore \frac{qr}{y_1} = \frac{in}{p} = \frac{S}{p};$$

and, therefore, the area A' of the triangle qgr

$$= \frac{qr}{2}y_1 = \frac{Sy_1^2}{2p}.$$

Hence

$$I_y = 2pA + 2pA' = 2p(A + A').$$

Note.—If p be made $= \frac{in}{2} = \frac{A}{2}$,

$$I = A^2 \quad \text{and} \quad Sy_1^2 = AA',$$

and

$$\therefore I_y = A(A + A').$$

The angle IOn is also evidently a right angle.

8. Cranes.—(a). *Jib-crane.*—Fig. 19 is a skeleton diagram of an ordinary jib-crane. OA is the post fixed in the ground at O ; OB is the jib; AB is the tie. The jib, tie, and gearing are suspended from the top of the post by a cross-head, which admits of a free rotation round the axis of the post.

Let the crane lift a weight W .

Three forces in equilibrium meet at B ; viz., W , the tension T in the tie, and the thrust C along the jib.

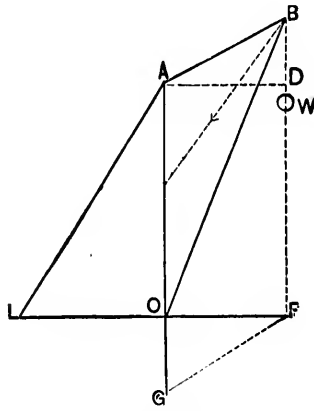

FIG. 19.



FIG. 20.

Draw the reciprocal figure SS_1S_2 of B, S_1S_2 representing W .

$$\frac{T}{W} = \frac{SS_2}{S_1S_2} = \frac{AB}{AO} \quad \checkmark$$

and

$$\frac{C}{W} = \frac{SS_1}{S_1S_2} = \frac{BO}{AO} \quad \checkmark$$

The load is not suspended directly from B , but is carried by a chain passing over pulleys to a chain-barrel usually fixed to the crane-post. The stress S in the chain depends upon the system of pulleys, and is, e.g., $\frac{W}{n}$, if n is the number of falls of chain from B and if *friction is neglected*. In order to obtain the true values of T and C this tension S must be compounded with W .

Draw S_1k parallel to the direction in which the chain passes from B to the chain-barrel, and take S_1k to represent S in.

magnitude. The line S_k evidently represents the resultant force at B due to W and S .

Draw kt parallel to AB .

The tension in the tie and the thrust in the jib are now evidently represented by tk , tS , respectively.

Generally the effect of chain-tension is to *diminish* the tension of the tie and to *increase* the thrust on the jib.

The vertical component of T , viz., $T \frac{BD}{AB} = W \frac{BD}{AO}$, is transmitted through the post.

The total resultant pressure along the post at O

$$= -T \sin BAD + C \sin BOF = -W \frac{BD}{AO} + W \frac{BO}{AO} \frac{BD + AO}{BO} = W.$$

The pull upon the tie tends to upset the crane, and its moment with respect to O is

$$T \cos BAD \times AO = W \frac{AB}{AO} \frac{AD}{AB} AO = WAD = WOF,$$

OF being the horizontal projection of AB .

OF is often called the radius or throw of the crane.

If the post revolves about its axis (as in *pit-cranes*), the jib and gearing are bolted to it, and the whole turns on a pivot at the toe G . In this case, the frame, as a whole, is kept in equilibrium by the weight W , the horizontal reaction H of the web-plate at O , and the reaction R at G . The first two forces meet in F and, therefore, the reaction at G must also pass through F .

Hence, since OFG may be taken to represent the triangle of forces,

$$H = W \frac{OF}{OG} \quad \text{and} \quad R = W \frac{GF}{OG}.$$

In a portable crane the tendency to upset is counteracted by means of a weight Q placed upon a horizontal platform OL attached to the post and supported by the tie AL .

The horizontal projection tm of tk represents the horizontal

pull at A , and if tn be drawn parallel to AL , the intercept mn cut off on the vertical through m by the lines tm and tn represents the counter-weight required at L .

(b) *Derrick-crane.*—The figure shows a combination of a der-

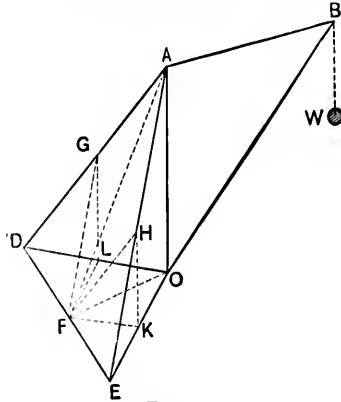

FIG. 21.

rick and crane, called a derrick-crane. It is distinguished from the jib-crane by having two back-stays, AD , AE . One end of the jib is hinged at or near the foot of the post, and the other is held by a chain which passes over pulleys to a winch on the post, so that the jib may be raised or lowered as required.

The derrick-crane is generally of wood, is simple in construction, is easily erected, has a vertical as well as a lateral

motion, and a range equal to a circle of from 10 to 60 feet radius. It is therefore useful for temporary works, setting masonry, etc.

The stresses in the jib and tie are calculated as in the jib-crane, and those in the back-stays and post may be obtained as follows :

Let the plane of the tie and jib intersect the plane DAE of the two back-stays in the line AF , and suppose the back-stays replaced by a single tie AF . Take OF to represent the horizontal pull at A . The pull on the "imaginary" stay AF is then represented by AF and is evidently the *resultant* pull on the two back-stays. Completing the parallelogram $FGAH$, AH will represent the pull on the back-stay AE , and AG that upon AD , their horizontal components being OK , OL , respectively. The figure $OKFL$ is also a parallelogram.

If the back-stays lie in planes at right angles to each other,

$$OL = OF \cos \theta = T \sin \alpha \cos \theta, \text{ and is a max. when } \theta = 0^\circ,$$

and

$$OK = OF \sin \theta = T \sin \alpha \sin \theta, \text{ and is a max. when } \theta = 90^\circ,$$

θ being the angle FOL , and α the inclination of the tie to the vertical.

Hence the stress in a back-stay is a maximum when the plane of the back-stay and post coincides with that of the jib and tie.

Again, let β be the inclination of the back-stays to the vertical. The vertical components of the back-stay stresses are

$$T \sin \alpha \cos \theta \cot \beta \quad \text{and} \quad T \sin \alpha \sin \theta \cot \beta;$$

and, therefore, the corresponding stress along the post is

$$T \sin \alpha \cot \beta (\cos \theta + \sin \theta),$$

which is a maximum when $\theta = 45^\circ$.

9. Shear Legs (or Shears) and Tripods (or Gins) are

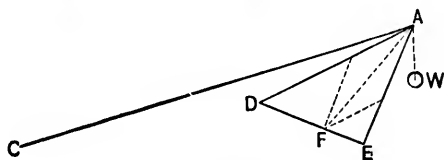

FIG. 22.

often employed when heavy weights are to be lifted. The former consists of two struts, AD , AE , united at A and supported by a tie AC , which may be made adjustable so as to admit of being lengthened or shortened. The weight is suspended from A , and the legs are capable of revolving around DE as an axis. Let the plane of the tie and weight intersect the plane of the legs in AF , and suppose the two legs replaced by a single strut AF . The thrust along AF can now be easily obtained, and hence its components along the two legs.

In tripods one of the three legs is usually longer than the others. They are united at the top, to which point the tackle is also attached.

10. Bridge and Roof Trusses of Small Span.—A single girder is the simplest kind of bridge, but is only suitable for

very short spans. When the spans are wider, the centre of the girder may be supported by struts OC, OD , through which a portion of the weight is transmitted to the abutments.

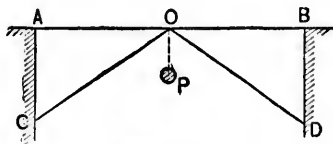

FIG. 23.

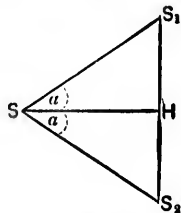

FIG. 24.

Take the vertical line S_1S_2 to represent P , the weight at O . Draw SS_1 parallel to OC , and SS_2 to OD .

Draw the horizontal SH , and let the angle $AOC = \alpha$.

$$\text{The thrust along } OC = S_1S = S_1H \operatorname{cosec} \alpha = \frac{P}{2} \operatorname{cosec} \alpha.$$

$$\text{The tension along } OA = SH = S_1H \cot \alpha = \frac{P}{2} \cot \alpha.$$

The horizontal and vertical thrusts upon the masonry at C (or D) are $\frac{P}{2} \cot \alpha$ and $\frac{P}{2}$, respectively.

If the girder is uniformly loaded, P is one half of the whole load.

II. In the figure a *straining cill*, EF , is introduced, and the girder is supported at two intermediate points.

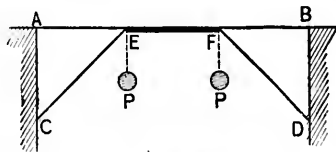

FIG. 25.

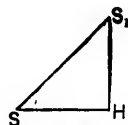

FIG. 26.

Let P be the weight at each of the points E and F . Draw the reciprocal SS_1H of the point E , S_1H representing P .

The thrust in EC (or FD) = $SS_1 = P \frac{SS_1}{S_1H} = P \frac{EC}{AC}$, and the horizontal thrust in the straining piece = $SH = P \frac{SH}{S_1H} = P \frac{AE}{AC}$.

If a load is uniformly distributed over AB , it may be assumed that each strut carries one half of the load upon AF (or BE), and that each abutment carries one half of the load upon AE (or BF).

By means of straining cills the girders may be supported at several points, 1, 2, . . . , and the weight concentrated at each may be assumed to be one half of the load between the two adjacent points of support. The calculations for the stresses in the struts, etc., are made precisely as above.

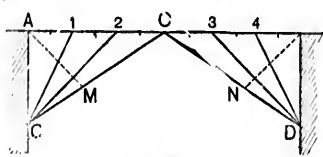

FIG. 27.

If the struts are very long they are liable to bend, and counterbraces, AM, BN , are added to counteract this tendency.

12. The *triangle* is the only geometrical figure of which the form cannot be changed without varying the lengths of the sides. For this reason, all compound trusses for bridges, roofs, etc., are made up of triangular frames.

Fig. 28 represents the simplest form of roof-truss. AC, BC are rafters of equal length inclined to the horizontal at an angle α and each carries a uniformly distributed load W .

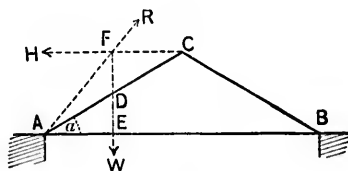

FIG. 28.

The rafters react horizontally upon each other at C , and their feet are kept in position by the tie-beam AB . Consider the rafter AC .

The resultant of the load upon AC , i.e., W , acts through the middle point D .

Let it meet the horizontal thrust H of BC upon AC in F . For equilibrium, the resultant thrust at A must also act through F .

The sides of the triangle AFE evidently represent the three forces. Hence

$$H = W \frac{AE}{EF} = \frac{W AE}{2 DE} = \frac{W}{2} \cot \alpha;$$

$$\begin{aligned} R &= W \frac{AF}{EF} = W \sqrt{\frac{AE^2 + EF^2}{EF^2}} \\ &= W \sqrt{1 + \frac{1}{4} \left(\frac{AE}{DE}\right)^2} = W \sqrt{1 + \frac{\cot^2 \alpha}{4}}. \end{aligned}$$

The thrust R produces a tension H in the tie-beam, and a vertical pressure W upon the support.

Also, if γ is the angle FAE ,

$$\tan \gamma = \frac{EF}{AE} = 2 \frac{DE}{AE} = 2 \tan \alpha.$$

If the rafters AC , BC are unequal, let α_1 , α_2 be their inclinations to A , B , respectively.

Let W_1 be the uniformly distributed load upon AC , W_2 that upon BC .

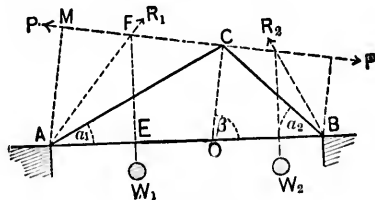

FIG. 29.

Let the direction of the mutual thrust P at C make an angle β with the vertical, so that if CO is drawn perpendicular

to FC , the angle $COB = \beta$; the angle $ACF = 90^\circ - ACO = 90^\circ - (\beta - \alpha_1)$.

Draw AM perpendicular to the direction of P , and consider the rafter AC . As before, the thrust R_1 at A , the resultant weight W_1 at the middle point of AC , and the thrust P at C meet in the point F .

Take moments about A . Then

$$P \cdot AM = W_1 AE.$$

But $AM = AC \sin ACM = AC \cos(\beta - \alpha_1)$,

and $AE = \frac{AC}{2} \cos \alpha_1.$

$$\therefore P = \frac{W_1 \cos \alpha_1}{2 \cos(\beta - \alpha_1)}.$$

Similarly, by considering the rafter BC ,

$$P = \frac{W_2 \cos \alpha_2}{2 \sin(\beta + \alpha_2 - 90^\circ)} = -\frac{W_2 \cos \alpha_2}{2 \cos(\beta + \alpha_2)}.$$

Hence

$$\frac{W_1 \cos \alpha_1}{2 \cos(\beta - \alpha_1)} = P = -\frac{W_2 \cos \alpha_2}{2 \cos(\beta + \alpha_2)},$$

and therefore

$$\tan \beta = \frac{W_1 + W_2}{W_1 \tan \alpha_2 - W_2 \tan \alpha_1}.$$

The horizontal thrust of each rafter = $P \sin \beta$.

The vertical thrust upon the support $A = W_1 - P \cos \beta$.

The vertical thrust upon the support $B = W_2 + P \cos \beta$.

13. King-post Truss.—The simple triangular truss may be modified by introducing a king-post CO , which carries a portion of the weight of the beam AB , and transfers it through the rafters so as to act upon the tie in the form of a tensile stress.

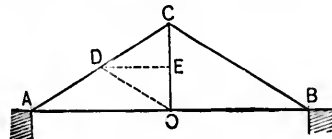

FIG. 30.

Let P be the weight borne by the king-post; represent it by CO .

Draw OD parallel to BC , and DE parallel to AB .

$DC = \frac{CE}{\sin \alpha} = \frac{P}{2} \operatorname{cosec} \alpha$ is the thrust in CA due to P , and is of course equal to DO , i.e., the thrust along CB .

$DE = CE \cot \alpha = \frac{P}{2} \cot \alpha$ is the horizontal thrust on each rafter, and is also the tension in the tie due to P .

Let W be the uniformly distributed load upon each rafter.

The total horizontal thrust upon each rafter $= (W + P) \frac{\cot \alpha}{2}$.

The total vertical pressure upon each support $= W + \frac{P}{2}$.

If the apex C is not vertically over the centre of the tie-beam take CO , as before, to represent the weight P borne by the king-post; draw OD parallel to BC , and DE parallel to AB .

The weight P produces a thrust CD along CA , DO along CB , and a horizontal thrust DE upon each rafter.

CE is the portion of P supported at A , and EO that supported at B .

DE , and therefore the tension in the tie AB , diminishes with AO , being zero when AC is vertical.

Sometimes it is expedient to support the centre of the tie-beam upon a column or wall, the king-post being a pillar against which the heads of the rafters rest.

Consider the rafter AC .

The normal reaction R' of CO upon AC , the resultant weight W at the middle point D , and the thrust R at A meet in the point F .

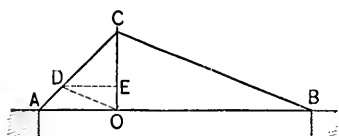

FIG. 31.

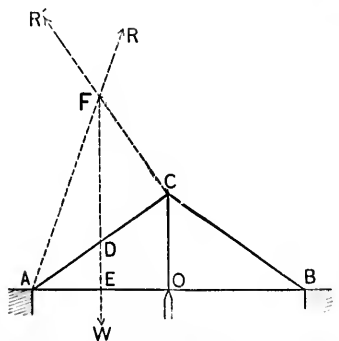

FIG. 32.

Take moments about *A*. Then

$$R'AC = W \cdot AE, \text{ or } R' = \frac{W}{2} \cos \alpha.$$

Thus the total thrust transmitted through *CO* to the support at *O* is $2 \frac{W}{2} \cos \alpha \cdot \cos \alpha = W \cos^2 \alpha$.

The horizontal thrust upon each rafter

$$= \frac{W}{2} \cos \alpha \sin \alpha = \frac{W}{4} \sin 2\alpha.$$

14. If the rafters are inconveniently long, or if they are in danger of bending or breaking transversely, the centres may be supported by struts *OD*, *OE*. A portion of the weight upon

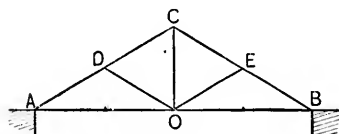

FIG. 33.

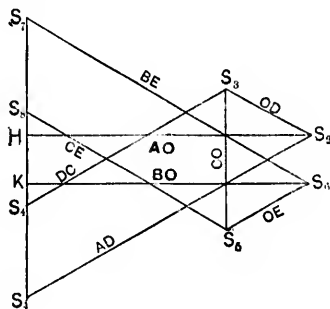

FIG. 34.

the rafters is then transmitted through the struts to the vertical tie (king-post or rod) *CO*, which again transmits it through the rafters to act partly as a vertical pressure upon the supports, and partly as a tension on the tie-beam. The main duty, indeed, of struts and ties is to transform transverse into longitudinal stresses.

This king-post truss is the simplest and most economical frame for spans of less than thirty feet. In larger spans two or more suspenders may be introduced, or the truss otherwise modified.

Let there be a load $2W$ uniformly distributed over the rafters AC, BC , and assume it to be concentrated at the joints A, D, C, E, B , in the proportion $\frac{W}{4}, \frac{W}{2}, \frac{W}{2}, \frac{W}{2}, \frac{W}{4}$.

Also, let the load (including a portion of the weight upon the tie-beam AB , and the weights of the members OD, OE, OC) borne directly at O be P .

The *total* reaction at each support is $W + \frac{P}{2}$, and acts in an opposite direction to the weight $\frac{W}{4}$ there concentrated.

Hence the *resultant* reaction at a support is $\frac{3}{4}W + \frac{1}{2}P$. Thus, the weights at the points of support A and B are taken up by the abutments, and need not be considered in determining the stresses in the several members of the frame.

Draw the reciprocal S_1H, S_2 of A . Then

$$S_1H = \frac{3W}{4} + \frac{P}{2}; \quad H, S_2 = \text{tension in } AO;$$

$$S_2S_1 = \text{compression in } AD.$$

Draw the reciprocal $S_1S_2S_3S_4$ of D . Then

$$S_2S_3 = \text{compression in } OD; \quad S_3S_4 = \text{compression in } DC;$$

$$S_1S_4 = \frac{W}{2} = \text{weight at } D,$$

Draw the reciprocal $S_1S_2S_3S_4S_5$ of C . Then

$$S_1S_5 = \text{tension in } CO = \frac{W}{2} + P; \quad S_4S_5 = \text{compression in } CE;$$

$$S_2S_5 = \frac{W}{2} = \text{weight at } C.$$

Draw the reciprocal $S_6S_5S_4S_3S_2$ of E . Then

S_6S_5 = compression in OE : S_5S_4 = compression in BE ;

$$S_4S_3 = \frac{W}{2} = \text{weight at } E.$$

Draw S_6K horizontally. Then

S_6KS_5 is evidently the reciprocal of B ; $KS_5 = \frac{3}{4}W + \frac{1}{2}P$, being the reaction at B , and S_6K the tension in the tie BO . The reciprocal of O is also the figure $S_7HKS_6S_5S_4$, and $HK = P$.

15. Collar-beams (DE), queen-posts (DF, EG), braces, etc., may be employed to prevent the deflection of the rafters. The complexity of the truss necessarily increases with the span and with the weight to be borne.

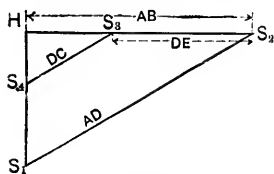

FIG. 35.

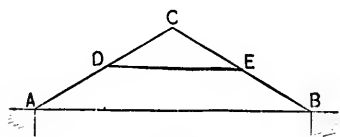

FIG. 36.

With a single collar-beam and a uniformly distributed load, S_1HS_2 is the reciprocal of A , and $S_1S_2S_3S_4S_5$ the reciprocal of D ; S_1H being the reaction at A , and S_4S_5 the weight at D .

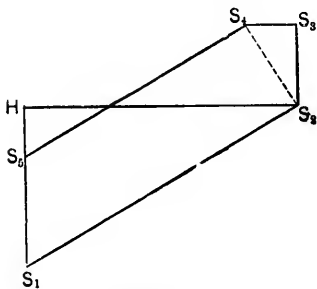

FIG. 37.

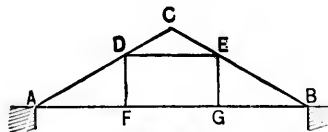

FIG. 38.

With a collar-beam DE , two king-posts DF, EG , and a uniformly distributed load, the stresses at the joints D and E

As in the preceding case, this truss will be found *incomplete* if the load is unevenly distributed, and the reciprocals of D and E will not close. In practice, however, the friction at the joints, the stiffness of the several members, and the mode of construction render the truss sufficiently strong to meet the ordinary variations of load.

17. General Remarks.—In the trusses described in Arts. 13 and 14 the vertical members are ties, i.e., are in tension, and the inclined members are struts, i.e., are in compression. By inverting the respective figures another type of truss is obtained in which the verticals are struts while the inclined members are ties. Both systems are widely used, and the method of calculating the stresses is precisely the same in each.

In designing any particular member, allowance must be made for every kind of stress to which it may be subjected. The collar-beam DE , for example, must be treated as a pillar subjected to a thrust in the direction of its length at each end; if it carry a transverse load, its strength as a beam, supported at the points D and E , must also be determined. Similarly, the rafters AC , BC , etc., must be designed to carry transverse loads and to act as pillars. But it must be remembered that struts and queen-posts provide additional points of support over which the rafters are continuous, and it is practically sufficient to assume that the rafters are divided into a number of short lengths, each of which carries *one half* of the load between the two adjacent supports.

When a tie-beam is so long as to require to be spliced, allowance must be made for the weakening effect of the splice.

18. Incomplete Frames.—The frames discussed in the preceding articles (excepting those referred to in Art. 15) will support, *without change of form*, any load consistent with strength, and the stresses in the several members can be found in terms of the load. It sometimes happens, however, that a frame is *incomplete*, so that it tends to change form under every distribution of load. An example of this class is the simple trapezoidal truss, consisting of the two horizontal members AB , DE , and the two equal inclined members AD , BE , Fig. 41.

First, let there be a weight W at each of the points D , E .

The triangles of forces for the joints D and E , viz., SS_1H and SS_2H , can be drawn, and hence it follows that there must be

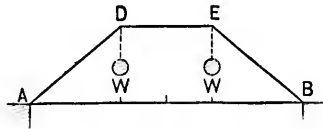

FIG. 41.

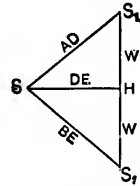

FIG. 42.

equilibrium. This is also evident from the symmetrical character of the loading.

The same triangles represent the forces at the points of support A, B .

$$\therefore \text{reaction at } A = S_1H = W = S_2H = \text{reaction at } B.$$

Next, let there be a weight W_1 at D and a weight W_2 ($< W_1$) at E .

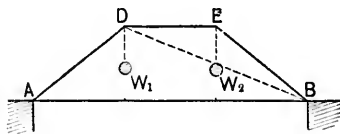

FIG. 43.

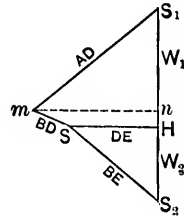

FIG. 44.

It will now be found that the diagram of forces will not close, so that there cannot be equilibrium. The joint D will be pushed in and the frame distorted. The distortion may be prevented by introducing a brace from A to E or from B to D . In the latter case $S_1mSS_2S_1$ represents the stress-diagram, the triangle S_2HS being the reciprocal of the joint E , and the quadrilateral SmS_1H that of the joint D . Drawing the horizontal mn , the triangle mnS_1 and the quadrilateral mSS_2n are evidently the reciprocals of A and B , respectively.

$$\therefore nS_1 = \text{reaction at } A \quad \text{and} \quad nS_2 = \text{reaction at } B.$$

In practice the loads are usually transmitted to D and E by means of two vertical *queen-posts* (*queen-rods* or *queens*) DF, EG .

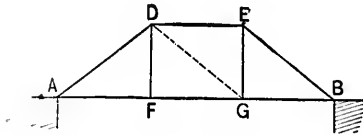

FIG. 45.

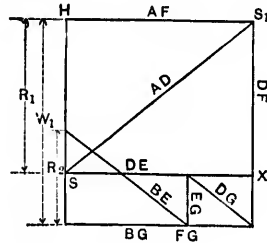

FIG. 46.

If there are no diagonal braces DG, EF , the distortion of the frame under an unevenly distributed load can only be prevented by the friction at the joints, the stiffness of the members, and by the queens being rigidly fixed to AB at F and G .

Let W_1 be the load at F transmitted through the queen FD to D .

Let W_2 ($< W_1$) be the load at G transmitted through the queen GE to E .

If the frame is rigid, the reactions R_1 at A and R_2 at B , which will balance these weights, can easily be found by taking moments about B and A , successively. Thus,

$$R_1 l = \frac{W_1}{2}(l + c) + \frac{W_2}{2}(l - c)$$

and

$$R_2 l = \frac{W_1}{2}(l - c) + \frac{W_2}{2}(l + c),$$

where $AB = l$ and $FG = c$.

Draw the triangle of forces SHS_1 for the joint A , SH representing R_1 .

The triangle SS_1X is the reciprocal of the joint at D , and the tension in FD should, therefore, be $XS_1 = SH = R_1$. But the

tension in FD is actually W_1 , so that there is an *unbalanced* force,

$$= W_1 - R_1 = \frac{W_1 - W_2}{2} \cdot \frac{l - c}{l},$$

acting along FD .

To take up this unbalanced force and render the frame rigid the diagonal DG is introduced, and the stress for which it should be designed is evidently

$$(W_1 - R_1) \sec FDG = \frac{W_1 - W_2}{2} \frac{l - c}{l} \frac{s}{d},$$

s being the length of the diagonal and d the depth of the truss. The complete stress diagram is as shown in Fig. 46.

Cor. 1. The manner in which distortion is prevented by the stiffness of AB may be shown as follows:

Let x be the force of resistance which AB , by its stiffness, can exert at F or G against any load which tends to make it deviate from the horizontal.

If W is the load at F , the actual downward pull upon D is $W - x$; this must necessarily produce an equal upward pull at E , which must be balanced by the force of resistance x at G ,

$$\therefore W - x = x,$$

and

$$x = \frac{W}{2}.$$

Thus the beam AB will be acted upon by an upward pull $\frac{W}{2}$ at F and an equal downward pull at G , forming a couple of moment $\frac{W}{2}c$, and showing that equilibrium is impossible.

The *upward* reaction R_1 at A is

$$R_1 = \frac{1}{l} \left(\frac{Wl + c}{2} - \frac{Wl - c}{2} \right) = \frac{Wc}{2l}$$

= downward reaction at B , and the moment at F (or G)

$$= \frac{W}{2} \frac{c}{l} \frac{l-c}{2} = \frac{W}{4} \frac{c}{l} (l-c).$$

Cor. 2. Let a weight W be supported at the joint D of any quadrilateral frame $ADEB$. Draw the reciprocal SS_1S_2 of D ,

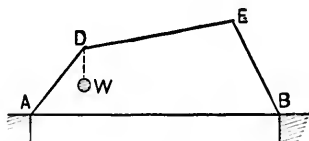

FIG. 47.

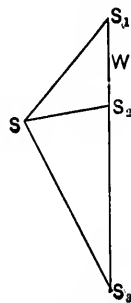

FIG. 48.

S_1S_2 representing W . Draw SS_3 parallel to EB and intersecting the vertical S_1S_2 produced in S_3 . The weight which can be borne at E consistent with equilibrium is represented by S_3S_2 .

19. Composite Frames or Trusses (i.e., frames made up of two or more simple frames).—An example of this class has already been given in the case of the king-post roof (Art. 13).

Bent Crane.—Fig. 49 shows a convenient form of crane when much head-room is required near the post. The crane is merely a semi-girder, and may be tubular with plate-webs if the loads are heavy, or its flanges may be braced together as in the figure for loads of less than ten tons. The flanges may be kept at the same distance apart throughout, or the distance may be gradually diminished from the base towards the peak.

Let the numbers in Fig. 50 denote the stresses in the corresponding members. *Three* forces, S_1 , C_2 , and W , act through the point (1), so that S_1 and C_2 may be obtained in terms of W ; *three* forces, S_1 , S_2 , T_2 , act through (2), so that S_2 and T_2 may be obtained in terms of S_1 and therefore of W ; *four* forces, S_2 , C_1 , S_3 , C_4 , act through (3), and the values of S_1 , C_2

being known, those of S_1, C_1 may be determined. Proceeding in this way, it is found that of the forces at each succeeding joint only two are unknown, and the values of these are consequently determinate.

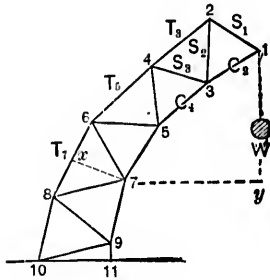

FIG. 49.

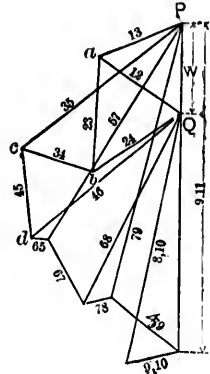

FIG. 50.

The calculations may be checked by the *method of moments* and by the stress diagram (Fig. 50).

E.g., let $W = 10$ tons.

Take moments about the point (7). Then

$$T_7(x7) = 10(y7) \text{ or } T_7 = \frac{3.25}{1.25} = 26 \text{ tons} = (68) \text{ in Fig. 50.}$$

No other forces enter into the equation of moments, as the portion of the crane above a plane intersecting (68) and passing through (7) is kept in equilibrium by the weight of 10 tons and the stresses T_7, S_6, C_6 ; the moments of S_6 and C_6 about (7) are evidently zero.

In the stress diagram (Fig. 50) PaQ is the reciprocal of the point 1, abQ of the point 2, $PcbQ$ of 3, $Qbcd$ of 4, and so on.

Other examples of composite roof and bridge frames will now be given.

20. Roof-trusses.—A roof consists of a covering and of trusses (or frames) by which it is supported. The covering is generally laid upon a number of *common rafters* which rest.

upon horizontal beams (or *purlins*), the latter being carried by trusses spaced at intervals varying with the type of construction but averaging about 10 ft. The truss rafters are called *principal rafters*, and the trusses themselves are often designated as *principals*.

In roofs of small span the trusses and purlins are sometimes dispensed with.

Types of Truss.—A roof-truss may be constructed of timber, of iron or steel, or of these materials combined. Timber is almost invariably employed for small spans, but in the longer spans it has been largely superseded by iron, in consequence of the combined lightness, strength, and durability of the latter.

Attempts have been made to classify roofs according to the mode of construction, but the variety of form is so great as to render it impracticable to make any further distinction than that which may be drawn between those in which the reactions of the supports are vertical and those in which they are inclined.

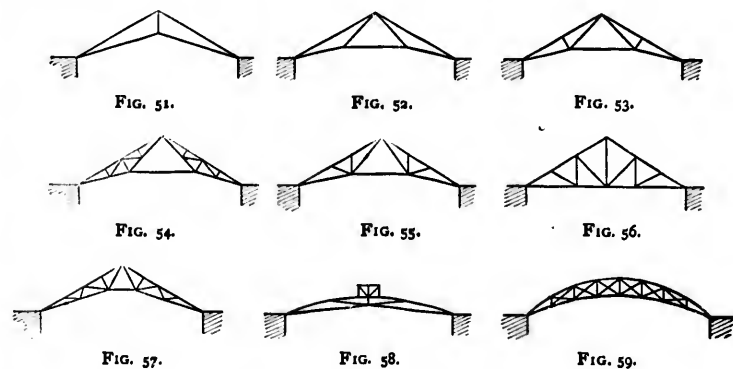

Fig. 51 is a simple form of truss for spans of less than 30 ft.

Fig. 52 is a superior framing for spans of from 30 to 40 ft.; it may be still further strengthened by the introduction of struts, Figs. 53 and 54, and with such modification has been employed to span openings of 90 ft. It is safer, however, to limit the use of the type shown by Fig. 53 to spans of less than

60 ft. Figs. 55, 56, 57, 58, and 59 are forms of truss suitable for spans of from 60 to 100 ft. and upwards.

Arched roofs, Figs. 58 and 59, admit of a great variety of treatment. They have a pleasing appearance, and cover wide spans without intermediate supports. The flatness of the arch is limited by the requirement of a minimum thrust at the abutments. The thrust may be resisted either by thickening the abutments or by introducing a tie. If the only load upon a roof-truss were its own weight, an arch in the form of an inverted catenary, with a shallow rib, might be used. But the action of the wind induces oblique and transverse stresses, so that a considerable depth of rib is generally needed. If the depth exceed 12 in., it is better to connect the two flanges by braces than by a solid web. Roofs of wide span are occasionally carried by ordinary lattice-girders.

Principals, Purlins, etc.—The principal rafters in Figs. 51 to 57 are straight, abut against each other at the peak, and are prevented by tie-rods from spreading at the heels. When made of iron, tee (T), rail, and channel (both single — and double][) bars, bulb-tee (T) and rolled (I) iron beams, are all excellent forms.

Timber rafters are rectangular in section, and for the sake of economy and appearance, are often made to taper uniformly from heel to peak.

The heel is fitted into a suitable cast-iron skew-back, or is fixed between wrought-iron angle-brackets (Figs. 60, 61, 62), and rests either directly upon the wall or upon a wall-plate.

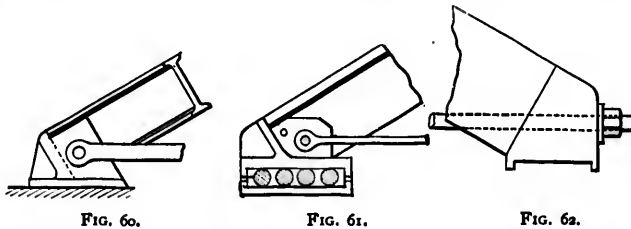

FIG. 60.

FIG. 61.

FIG. 62.

When the span exceeds 60 ft., allowance should be made for alterations of length due to changes of temperature. This

may be effected by interposing a set of rollers between the skew-back and wall-plate at one heel, or by fixing one heel to the wall and allowing the opposite skew-back to slide freely over a wall-plate.

The junction at the peak is made by means of a casting or wrought-iron plates (Figs. 63, 64, 65).

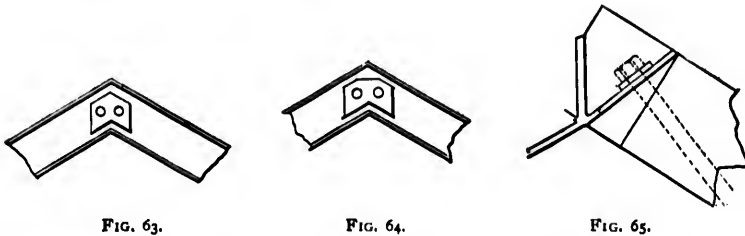

Light iron and timber beams as well as angle-irons are employed as purlins. They are fixed to the top or sides of the rafters by brackets, or lie between them in cast-iron shoes (Figs. 66 to 71), and are usually held in place by rows of tie-

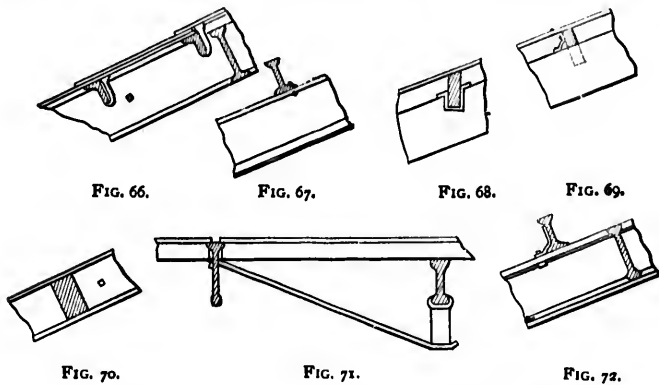

rods, spaced at 6 or 8 ft. intervals between peak and heel, running the whole length of the roof.

The sheathing boards and final metal or slate covering are fastened upon the purlins. The nature of the covering regulates the spacing of the purlins, and the size of the purlins is governed by the distance between the main rafters, which may

vary from 4 ft. to upwards of 25 ft. But when the interval between the rafters is so great as to cause an undue deflection of the purlins, the latter should be trussed. Each purlin may be trussed, or a light beam may be placed midway between the main rafters so as to form a supplementary rafter, and trussed as in Fig. 72.

Struts are made of timber or iron. Timber struts are rectangular in section. Wrought-iron struts may consist of L-irons, T-bars, or light columns, while cast-iron may be employed for work of a more ornamental character. The strut-heads are attached to the rafters by means of cast caps, wrought-iron straps, brackets, etc. (Figs. 73 to 76), and the strut-feet are easily designed both for pin and screw connections (Figs. 77 to 80).

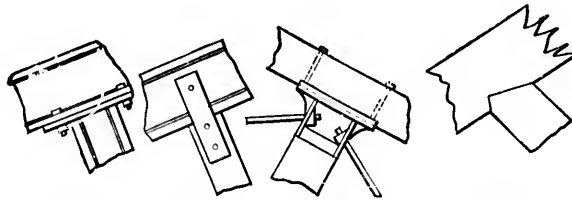

FIG. 73.

FIG. 74.

FIG. 75.

FIG. 76.

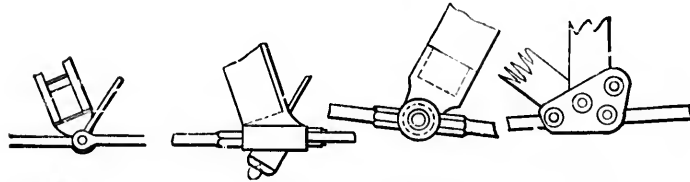

FIG. 77.

FIG. 78.

FIG. 79.

FIG. 80.

Ties may be of flat or round bars attached either by eyes and pins or by screw ends, and occasionally by rivets. The greatest care is necessary in properly proportioning the dimensions of the eyes and pins to the stresses that come upon them.

To obtain greater security, each of the end panels of a roof may be provided with lateral braces, and wind-ties are often made to run the whole length of the structure through the feet of the main struts.

Due allowance must be made in all cases for changes of temperature.

21. Roof-weights.—In calculating the stresses in the different members of a roof-truss two kinds of load have to be dealt with, the one *permanent* and the other *accidental*. The permanent load consists of the *covering*, the *framing*, and *accumulations of snow*.

Tables at the end of the chapter show the weights of various coverings and framings.

The weight of freshly fallen snow may vary from 5 to 20 lbs. per cubic foot. English and European engineers consider an allowance of 6 lbs. per square foot sufficient for snow, but in cold climates, similar to that of North America, it is probably unsafe to estimate this weight at less than 12 lbs. per square foot.

The *accidental* or *live* load upon a roof is the wind-pressure, the maximum force of which has been estimated to vary from 40 to 50 lbs. per square foot of surface *perpendicular to the direction of blow*. Ordinary gales blow with a force of from 20 to 25 lbs., which may sometimes rise to 34 or 35 lbs., and even to upwards of 50 lbs. during storms of great severity. Pressures much greater than 50 lbs. have been recorded, but they are wholly untrustworthy. Up to the present time, indeed, all wind-pressure data are most unreliable, and to this fact may be attributed the frequent wide divergence of opinion as to the necessary wind allowance in any particular case. The great differences that exist in all recorded wind-pressures are primarily due to the unphilosophic, unscientific, and unpractical character of the anemometers which give no correct information either as to pressure or velocity. The inertia of the moving parts, the transformation of velocities into pressures, and the injudicious placing of the anemometer, which renders it subject to local currents, all tend to vitiate the results.

It would be practically absurd to base calculations upon the violence of a wind-gust, a tornado, or other similar phenomena, as it is almost absolutely certain that a structure would not lie within its range. In fact, it may be assumed that a wind-pressure of 40 lbs. per square foot upon a surface

perpendicular to the direction of blow is an ample and perfectly safe allowance, especially when it is remembered that a greater pressure than this would cause the overthrow of nearly all the existing towers, chimneys, etc.

22. Wind-pressure upon Inclined Surfaces.—The pressure upon an inclined surface may be obtained from the following formula, which was experimentally deduced by Hutton, viz. :

$$p_n = p \sin \alpha^{1.84 \cos \alpha - 1}; \quad (A)$$

p being the intensity of the wind-pressure in pounds per square foot upon a surface perpendicular to the direction of blow, and p_n being the normal intensity upon a surface inclined at an angle α to the direction of blow.

Let p_h, p_v be the components of p_n , parallel and perpendicular, respectively, to the direction of blow.

$$\therefore p_h = p_n \sin \alpha, \quad \text{and} \quad p_v = p_n \cos \alpha.$$

Hence, if the inclined surface is a roof, and if the wind blows horizontally, α is the roof's pitch.

Again, let v be the velocity of a fluid current in feet per second, and be that due to a head of h feet.

Let w be the weight of the fluid in pounds per cubic foot.

Let p be the pressure of the current in pounds per square foot upon a surface perpendicular to its direction.

If the fluid, after striking the surface, is free to escape at right angles to its original direction,

$$p = 2hw = \frac{v^2}{g}w.$$

Hence for ordinary atmospheric air, since $w = .08$ lb., approximately,

$$p = \frac{.08}{32}v^2 = \left(\frac{v}{20}\right)^2. \quad (B)$$

When the wind impinges upon a surface oblique to its direction, the intensity of the pressure is $\left(\frac{v \sin \beta}{20}\right)^2$, v being the absolute impinging velocity, and β being the angle between the direction of blow and the surface impinged upon. (See chapter on Bridges.)

Tables prepared from formulæ A and B are given at the end of the chapter.

23. Distribution of Loads.—Engineers have been accustomed to assume that the accidental load is uniformly distributed over the whole of the roof, and that it varies from 30 to 35 lbs. per square foot of covered surface for short spans, and from 35 to 40 lbs. for spans of more than 60 ft. But the wind may blow on one side only, and although its direction is usually horizontal, it may occasionally be inclined at a considerable angle, and be even normal to a roof of high pitch. It is therefore evident that the horizontal component (p_h) of the normal pressure (p_n) should not be neglected, and it may cause a complete *reversal* of stress in members of the truss, especially if it is of the arched or braced type.

If P_n is the total normal wind-pressure on the side of a roof of pitch α , its horizontal component $P_n \sin \alpha$ will tend to push the roof horizontally over its supports. This tendency must be resisted by the reactions at the supports.

In roofs of small span, the foot of each rafter is usually *fixed* to its support, and it may be assumed that each support exerts the same reaction, which should therefore be equal to $\frac{P_n \sin \alpha}{2}$.

In roofs of large span the foot of one rafter is fixed, while that of the other rests upon rollers. The latter is not suited to withstand a horizontal force, and the whole of the horizontal component of the wind-pressure must be borne at the fixed end, where the reaction should be assumed to be equal to $P_n \sin \alpha$.

In designing a roof-truss it is assumed that the wind blows on one side only, and that the total load is concentrated at the joints (or points of support) of the principal rafters.

E.g., let the rafters AB, AC of a truss be each supported at

two intermediate points (or joints), D, E and F, G , respectively, and let the wind blow on the side AB .

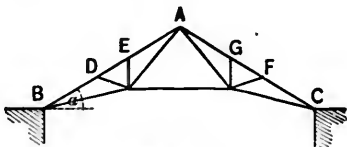

FIG. 81.

Take $BD = CF = l_1$, $DE = FG = l_2$, $EA = GA = l_3$; and let $l_1 + l_2 + l_3 = l$; $\therefore BC = 2l \cos \alpha$, α being the angle ABC .

Let W be the permanent (or dead) load per square foot of roof-surface.

Let p_n be the normal wind-pressure per square foot of roof-surface.

Let d be the horizontal distance in feet from centre to centre of trusses.

The total normal live load concentrated

$$\text{at } B = p_n d \frac{l_1}{2}; \quad \text{at } D = p_n d \frac{l_1 + l_2}{2};$$

$$\text{at } E = p_n d \frac{l_2 + l_3}{2}; \quad \text{at } A = p_n d \frac{l_3}{2}.$$

The total vertical dead load concentrated at D and $F =$

$$wd \frac{l_1 + l_2}{2}; \text{ at } E \text{ and } G = wd \frac{l_2 + l_3}{2}; \text{ at } A = wd l_3.$$

Let R_1, R_2 be the *resultant* vertical reactions at B and C , respectively (i.e., the total vertical reactions less the dead weights ($wd \frac{l_1}{2}$) concentrated at these points).

Take moments about C .

$$\begin{aligned} \therefore R_1 2l \cos \alpha &= \text{sum of moments of live loads about } C + \text{sum} \\ &\quad \text{of moments of dead loads about } C, \\ &= \text{moment of resultant wind-pressure about } C \\ &\quad - \text{moment of resultant dead load about } C, \\ &= p_n l d \left(\frac{l}{2} + l \cos 2\alpha \right) + wd(l_1 + 2l_2 + 2l_3) l \cos \alpha, \end{aligned}$$

where $\frac{l}{2} + l \cos 2\alpha$ is the perpendicular from C upon the line of action of the resultant wind-pressure which bisects AB normally.

(N.B. The moment of the horizontal reaction at B or C about C is evidently nil.)

R_2 may be found by taking moments about B .

To determine the stresses in the various members of a roof-truss two methods may be pursued :

(x) A single stress diagram may be drawn to represent the combined effect of the live and dead loads. This will be found to be the quickest and most useful method.

(y) The normal wind-pressure (p_n) may be resolved into its vertical (p_v) and horizontal (p_h) components; p_v may then be combined with the dead load W , and a stress diagram drawn for the vertical loads only. A second diagram may be drawn for the horizontal loads. The resultant stresses will be the algebraic sum of the corresponding stresses in the two diagrams.

A third method will be referred to in a subsequent article.

24. EX. I. Method (x) applied to the roof-truss ABC , Fig. 82.

The dead load = wld concentrated at A .

The live loads = $p_n \frac{ld}{2}$ acting at each of the points A and

B normally to AB .

The vertical reaction at B

$$= R_1 = \frac{wld}{2} + \frac{p_n ld}{\cos \alpha} \left(\frac{1}{4} + \frac{\cos 2\alpha}{2} \right).$$

Let rollers be placed underneath *C*.

The total horizontal reaction = $p_n l d \sin \alpha$, and is wholly borne at *B*.

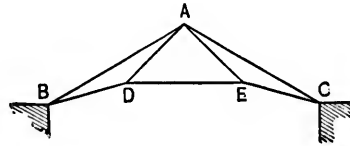

FIG. 82.

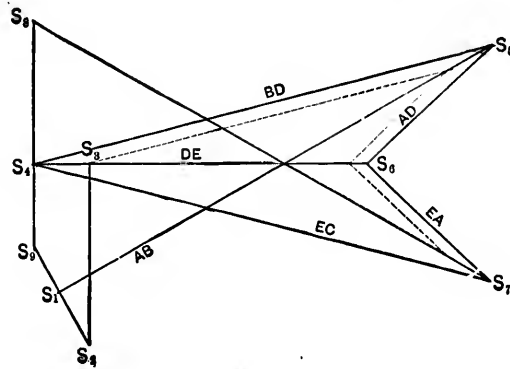

FIG. 83.

At *B* there are *five* forces in equilibrium, of which three are known, and the reciprocal of *B* may be thus described :

Draw S_1S_2 to represent the normal wind-pressure ($p_n \frac{ld}{2}$) at *B*; S_2S_3 to represent R ; S_4S_5 to represent the horizontal reaction ($p_n l d \sin \alpha$); S_1S_3 parallel to *BD*; S_5S_7 parallel to *AB*.

The closed figure $S_1S_2S_3S_4S_5S_6S_7$ is the reciprocal required, and the stresses in *BD*, *AB*, at *B*, are represented by S_1S_3 , S_5S_7 , respectively, being a tension and a thrust.

At *D* there are three forces in equilibrium, of which the tension in *DB* has been found. Drawing S_3S_4 horizontally and S_6S_7 parallel to *AD*, the triangle $S_3S_4S_6$ is evidently the reciprocal of *D*, the stresses in *DA*, *DE* being represented by S_3S_6 , S_4S_6 , respectively, and being both tensions.

Again, the triangle $S_4S_5S_6$ is the reciprocal of E , the stresses in EC , EA being represented by S_4S_5 , S_5S_6 , respectively, and being both tensions.

At A there are *six* forces in equilibrium, of which two, viz., the normal pressure, $(\frac{p_n ld}{2})$, and the dead weight, (wld), are given, while the stresses in AB , AD , AE have been found.

Draw S_4S_5 to represent $\frac{p_n ld}{2}$, and S_5S_6 to represent wld .

Five of the forces at A are therefore represented by the following lines, taken in order: S_4S_5 , S_5S_6 , S_1S_2 , S_2S_3 , S_3S_4 .

Hence the closing line S_4S_6 must necessarily represent in direction and magnitude the force in AC at A , and it is a thrust.

Also, $S_4S_5S_6$ must be the reciprocal of C , and therefore S_4S_6 represents the reaction at C .

The resultant reaction at B is represented in direction and magnitude by S_4S_5 .

The line S_4S_6 must pass through the point S_4 , as S_5S_6 , the horizontal reaction, is merely the horizontal projection of S_4S_6 , the total wind-pressure.

The dotted lines show the altered stresses if rollers are under B , the end C being fixed. The stress in each member is diminished, and as the truss should be designed to meet the most unfavorable case, the stresses should be calculated on the assumption that the rollers are on the leeward side.

This may be considered an invariable rule for roof-trusses.

EX. 2. Method (x) applied to the roof-truss ABC , Fig. 84.

The vertical dead load $= \frac{wld}{2}$ at each of the points F , A , G .

The live load, acting normally to AB , $= \frac{p_n ld}{4}$ at each of the points B and A , and $= \frac{p_n ld}{2}$ at F .

The vertical reaction R_1 at B

$$= \frac{1}{2}wld + \frac{p_n ld}{2 \cos \alpha} (\cos 2\alpha + \frac{1}{2}).$$

The horizontal reaction at $B = p_n l d \sin \alpha$, rollers being under C as before.

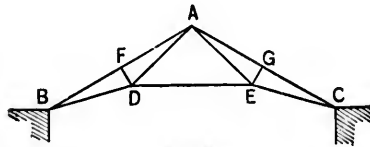

FIG. 84.

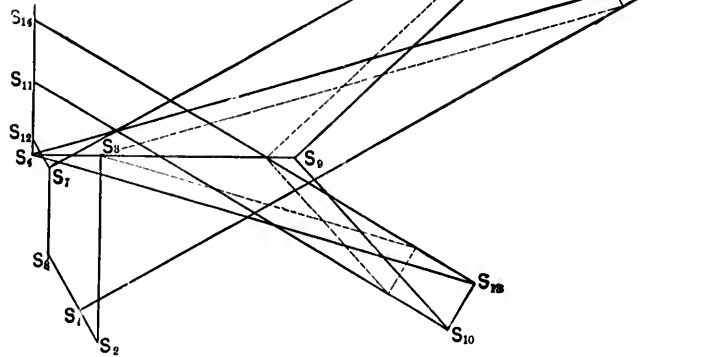

FIG. 85.

Describe the stress diagram in precisely the same manner as in Ex. 1.

Taking $S_1 S_2$ to represent the normal wind-pressure at B ,
 $S_2 S_3$ " " " vertical reaction R_1 at B ,
 $S_3 S_4$ " " " horizontal reaction at B ,

$\therefore S_1 S_2 S_3 S_4 S_1$ is the reciprocal of B ,
 $S_1 S_5 S_6 S_7 S_8 S_1$ " " " F ,
 $S_5 S_4 S_5 S_6 S_6$ " " " D ,
 $S_7 S_6 S_7 S_{10} S_{11} S_{12} S_7$ " " " A ,
 $S_{11} S_{10} S_{12} S_{14} S_{11}$ " " " G ,
 $S_2 S_4 S_{13} S_{10} S_2$ " " " E ,
 $S_4 S_{14} S_{13}$ " " " C .

$S_2 S_4$ is the horizontal projection of $S_2 S_3 + S_3 S_4 + S_4 S_{13}$, i.e., of the total normal wind-pressure, and therefore the vertical through S_{11} must pass through S_4 .

The dotted lines show the altered stresses if rollers are under *B*.

The resultant reaction at *B* is represented in direction and magnitude by S_1S_1' .

EX. 3. Method (x) applied to the truss represented by Fig. 86.

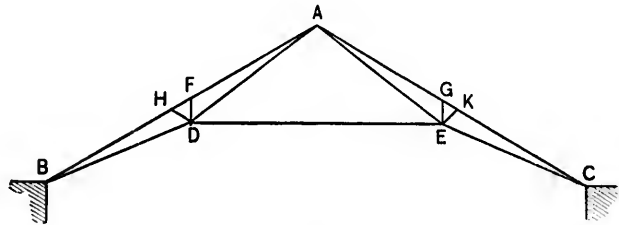

FIG. 86.

Data.—Pitch = 30° ; $AD = BD = AE = CE = 23$ ft.; trusses 13 ft. centre to centre; dead weight = 8 lbs. per square foot of roof-surface; wind-pressure on one side of roof (say *AB*) normal to roof-surface = 28 lbs. per square foot; $DF = DH = EG = EK$; *DF* and *EG* are vertical; rollers under one end, say *C*; span = 79 ft.; $AF \cong BH = 21$ ft., nearly; $FH = 3\frac{1}{2}$ ft., nearly.

Total *live* load = 4459 lbs. $\left(= \frac{24\frac{1}{2}}{2} \cdot 13 \cdot 28 \right)$ at each of the points *F, H,*

and = 3822 lbs. $\left(= \frac{21}{2} \cdot 13 \cdot 28 \right)$ at each of the points *A, B.*

Total *dead* load = 1274 lbs. $\left(= \frac{24\frac{1}{2}}{2} \cdot 13 \cdot 8 \right)$ at each of the points *F, H, K, G,*

and = 2184 lbs. $(= 21 \cdot 13 \cdot 8)$ at the point *A.*

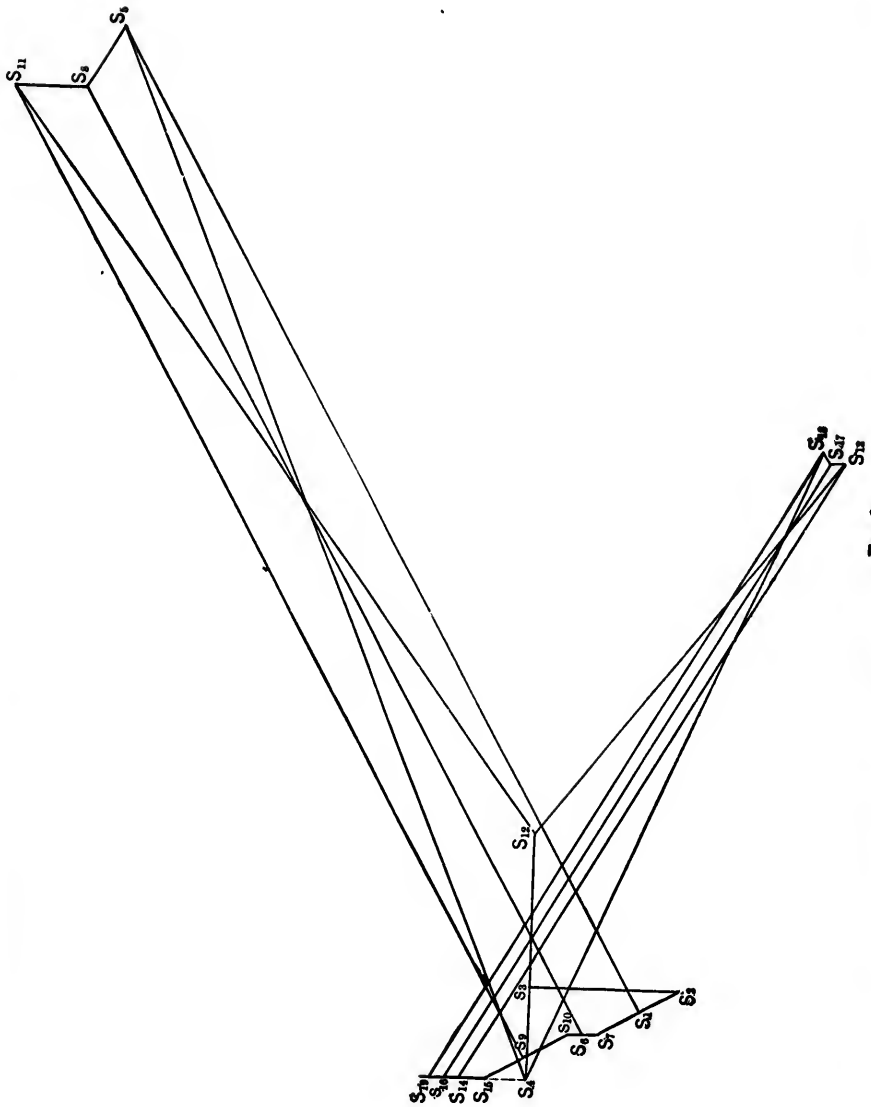

FIG. 87.

Resultant vertical reaction at B

$$= \frac{1}{2}(4 \times 1274 + 2184) + \frac{16562}{\sqrt{3}} = 13201.8 \text{ lbs.}$$

Horizontal reaction at $B = 16562 \sin 30^\circ = 8281 \text{ lbs.}$

Let 1 inch represent 16,000 lbs., and on this scale draw

$S_1S_2 = 3822 \text{ lbs.}$, the normal wind-pressure at B ;

$S_2S_3 = 13201.8 \text{ lbs.}$, the vertical reaction at B ;

$S_3S_4 = 8281 \text{ lbs.}$, the horizontal reaction at B ;

S_4S_5 parallel to BD , and S_1S_5 parallel to BA .

The figure $S_1S_2S_3S_4S_5$ is the reciprocal of B .

The stress diagram can now be easily completed, the reciprocals of the points H, F, D, A, G, K, E , and C being

$S_2S_7S_1S_6S_8S_7$, $S_3S_{10}S_6S_9S_{11}S_9$, $S_4S_9S_{12}S_{11}$, $S_5S_{11}S_{12}S_{13}S_{14}S_{13}S_9$,
 $S_{10}S_{14}S_{13}S_{17}S_{16}$, $S_{17}S_{16}S_{10}S_{18}S_{17}$, and $S_{18}S_{16}S_4S_{17}$, respectively.

S_4 , as before, is in the vertical line $S_{10}S_{16}$ produced.

On the assumed scale,

$S_4S_5 =$ the tension at BD ;	$S_1S_5 =$ thrust in BH ;
$S_{11}S_{12} =$ " " " AD ;	$S_6S_9 =$ " " HF ;
$S_4S_{12} =$ " " " BE ;	$S_6S_{11} =$ " " AF ;
	$S_6S_8 =$ " " DH ;
	$S_6S_4 =$ " " DF .

These are the maximum stresses to which the members of *one half* of the truss can be subjected, and for which they should be designed. It is also usual, except in special cases, to make the two halves symmetrical.

S_2S_3 is the *resultant reaction* at B .

If the end C is fixed and rollers placed under B , the reduced stresses may be shown by dotted lines as in Exs. 1 and 2.



FIG. 87.

EXS. 4 and 5. Method (x) applied to the trusses represented by Figs. 88 and 90.

It is assumed, as before, that there is a normal wind-pressure upon AB , and that rollers are under C .

Figs. 89 and 91 are the maximum stress diagrams corresponding to Figs. 88 and 90, respectively, and are drawn in precisely the same manner as described in the preceding examples.

Remark on Fig. 88.—The stresses at the joints F and D are indeterminate, and it is *assumed* that the stress in FL

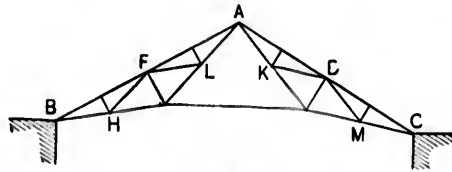

FIG. 88.

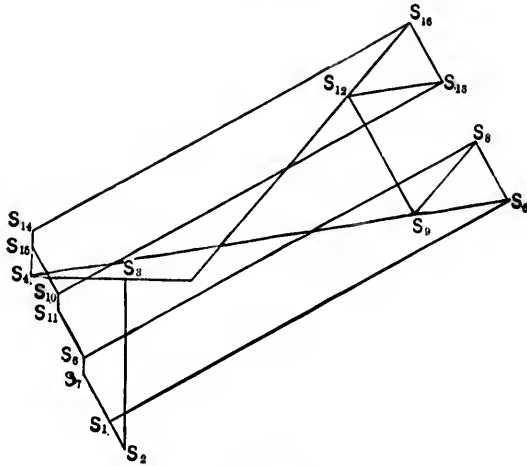

FIG. 89.

is equal to that in FH . The reciprocal of F thus becomes $S_1, S_{11}, S_6, S_3, S_2, S_{12}, S_{13}, S_{11}, S_{12} (= S_6, S_3)$ being the stress in FL . This truss is an example of a frame with *redundant* bars, in which the stresses can only be determined when the relative *yield* of the bars is known.

Remark on Fig. 90.—The stress-diagram, Fig. 91, for each of the joints in the horizontal BC (Fig. 90) is closed by the return of one side upon another. Thus at D the stress diagram is $S_0S_4S_3S_6$, the closing line S_6S_0 (the tension in DE) returning

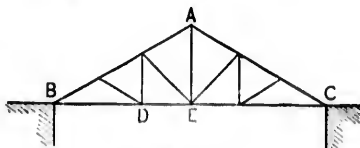

FIG. 90.

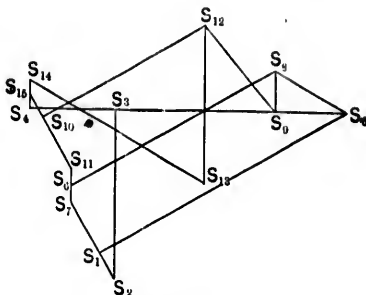

FIG. 91.

upon S_0S_4 (the tension in DB). The total stress in AE is evidently represented by $S_{12}S_{13}$, the reciprocal of A being $S_{14}S_{15}S_{10}S_{12}S_{13}S_{14}$.

Ex. 6. A truss with curved upper and lower chords, the portions, however, between consecutive joints being assumed straight.

Under a uniformly distributed load the truss (Fig. 92) is evidently incomplete, and the stress diagrams at the joints in the lower chord will not close, so that equilibrium is impossible. The frame is made complete and the stresses determinate by introducing ties as in Fig. 93, the corresponding stress diagram for one half the truss being shown by Fig. 94.

Next, let there be a wind-pressure on the side AB of the truss. In order to prevent a reversal of stress in the diagonal ties on the side AC (Fig. 93), additional ties DE, FG , called *counter-braces*, are introduced as in Fig. 95. Fig. 96 gives the

stress diagram due to wind-pressure only, it being assumed that the end C rests upon rollers and that B is fixed.

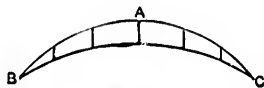

FIG. 92.

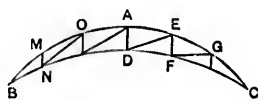

FIG. 95.

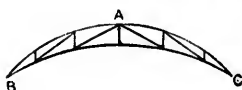

FIG. 93.

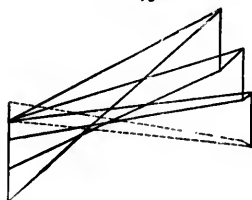

FIG. 94.

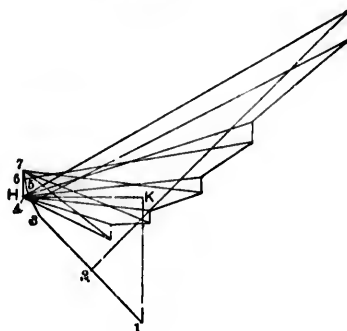

FIG. 96.

Note.—21 = wind-press. at $B = \frac{1}{2}$ wind-press. upon BM ,
 23 = " " $M =$ " " BM ,
 34 = " " $M =$ " " MO ,
 45 = " " $O =$ " " MO ,
 56 = " " $O =$ " " OA ,
 67 = " " $A =$ " " OA .

$\uparrow K$ = vertical reaction at B ,
 HK = horizontal reaction at B .

EX. 7. A single example will serve to illustrate method (γ). Take the truss represented by Fig. 97. Let $BF = AH$, and $CG = AK$.

Fig. 98 is the stress diagram due to the vertical load upon the roof, viz., the dead weight + vertical component of wind-pressure. pq is the vertical reaction at B and is

$$= \frac{p_w \cos \alpha}{4} (3BH + AH)d + \frac{w}{4} (4BH + 2AH)d.$$

qm is the weight at F and is

$$= \frac{p_n \cos \alpha + w}{2} BH = \text{weight at } H = mn.$$

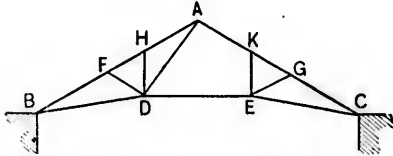

FIG. 97.

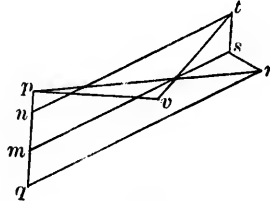

FIG. 98.

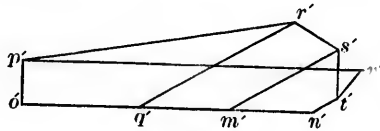

FIG. 99.

Fig. 99 is the stress-diagram due to *horizontal* component of wind-pressure, rollers being placed under B and the end C being fixed.

$$p'o' = \text{downward reaction at } B = \frac{p_n d \sin^2 \alpha}{4 \cos \alpha};$$

$$o'q' = \text{horizontal force of wind at } B = \frac{p_n d \sin \alpha}{2} BF;$$

$$q'm' = m'n' = \text{horizontal force of wind at } F \text{ or } H = \frac{p_n d \sin \alpha}{2} BH.$$

Total resultant stresses in the members $BF, FH, HA, DF, DH, DB, DA, DE$ are represented by $qr - q'r', ms - m's', nt - n't', sr - s'r', st - s't', pr - p'r', tv - t'v', pv - p'v'$, respectively.

Note.—The stress diagrams for trusses with both of the lower ends of the principal rafters *fixed*, are drawn in precisely the same manner as described in the preceding examples.

Thus, in Fig. 100, $S_1S_2S_3S_4S_5$ is the reciprocal of A, S_3S_4 , representing the portion of the horizontal wind-pressure borne

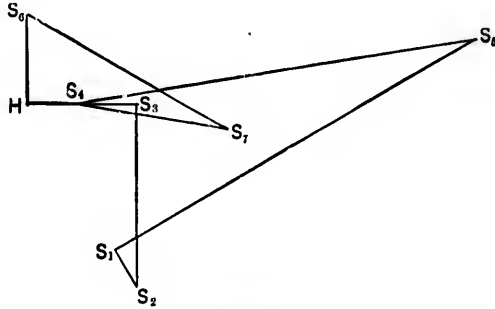

FIG. 100.

at A . Again, $HS_6S_7S_1H$ is the reciprocal of B, HS_4 , representing the portion of the horizontal wind-pressure borne at C . $HS_6 = HS_4 + S_4S_3 =$ total horizontal wind-pressure, S_3S_7 representing the vertical reaction at B , and HS_6 that at C .

25. Bridge-trusses.—A bridge-truss proper consists of an upper *chord* (or *flange*), a lower *chord* (or *flange*), and an intermediate portion, called the *web*, connecting the two chords. Its depth is made as small as possible consistent with economy, strength, and stiffness. Its purpose is to carry a distributed load, which, as in the case of roof-trusses, is assumed to be concentrated at the joints, or *panel-points*, of the upper and lower chord. Trussed *beams* are also employed for the same object, and examples of simple frames of this class have already been given.

The following are bridge-trusses of a more complex character.

EX. 1. The beam BC (Fig. 101) is supported at three points by the vertical struts DF, AK, EG , which are tied at the feet by the rods DB, DK, AB, AC , and EK, EC . Let W_1, W_2, W_3 be the loads concentrated at the joints F, K, G , respectively. Draw the *line of loads* S_1S_2, S_2S_3 being $W_1, S_2S_3 = W_2$, and $S_3S_4 = W_3$.

Describe the funicular polygon with any pole O , and draw OH parallel to the closing line MN of this polygon. Then

HS_1 is the reaction at B and HS_2 the reaction at C (Art. 3).
 HS_1S_6 is the reciprocal of B , S_1S_6 being the thrust along FB , and S_6H the tension along BD .

$S_1S_7S_2S_8$ is the reciprocal of F , S_1S_7 being W_1 , the weight at F , S_7S_8 the thrust along KF , S_8S_2 the thrust along DF .

$HS_2S_9S_3H$ is the reciprocal of D , S_2S_9 being the tension along DK , and S_9H the tension along DA .

HS_1S_9H is the reciprocal of A , S_1S_9 being the thrust along KA , and S_9H the tension along AE .

So, $S_2S_9S_0S_4S_5S_6S_2$, $S_7S_2S_{10}S_8S_9$, $S_9S_{10}HS_8S_9$, and S_1HS_{10} are the reciprocals of K , G , E , and C , respectively, the closing line $S_{10}S_4$ being necessarily horizontal and representing the stress in GC .

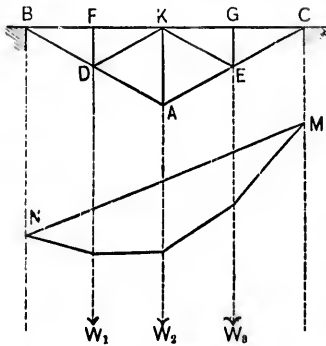

FIG. 101.

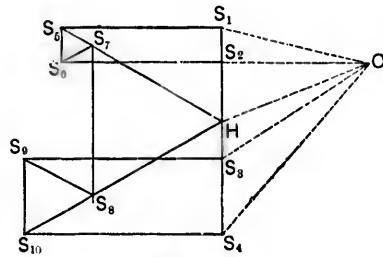

FIG. 102.

This truss *inverted* is often used for bridge purposes in districts where timber is plentiful, as it may be constructed entirely of wood. The stresses in the several members of the inverted truss are of course reversed in kind but unchanged in magnitude, and are given by the same stress diagram.

Note.—The reactions HS_1 , HS_2 may be obtained at once by the method of moments. Thus, by taking moments about C , the reaction R_1 at B is

$$R_1 = \frac{2}{3}W_1 + \frac{1}{2}W_2 + \frac{1}{4}W_3;$$

and by taking moments about B , the reaction R_2 at C is

$$R_2 = \frac{1}{4}W_1 + \frac{3}{8}W_2 + \frac{3}{4}W_3.$$

EX. 2. In the truss represented in the accompanying figure, the length of the beam AB is so great that the single triangular truss ACB with a single central strut CO is an insufficient support. The two halves are therefore strengthened by the simple triangular trusses AGO with a central strut GF and BPO with a central strut PN .

Again, each quarter-length, viz., AF , FO , ON , NB , is similarly trussed. The subdivisions may, if necessary, be carried still farther. This truss in *four, eight, sixteen, . . .* divisions or

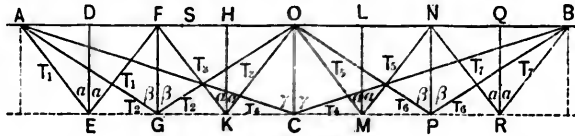

FIG. 103.

panels is known as the Fink truss, and has been widely employed in America, the number of panels usually being eight or sixteen.

The members shown by the dotted lines may be introduced for stiffness, and the platform may be either at the top or bottom. The weight directly borne by a strut is usually determined from the loads upon the two adjacent panels by assuming the corresponding portions of the beam to be independent beams supported at the ends. Thus if there be a weight W at the point S in the panel FH , the portion of W borne by the strut GF at F is

$$W \frac{SH}{FH},$$

and the portion borne by the strut KH at H is

$$W \frac{FS}{FH}.$$

Let $W_1, W_2, W_3, W_4, W_5, W_6, W_7$ be the weights upon the struts (or posts) $DE, FG, HK, OC, LM, NP, QR$, respectively.

Let $P_1, P_2, P_3, P_4, P_5, P_6, P_7$ be the compressions to which these posts are severally subjected.

Let α, β, γ be the inclinations to the vertical of AE, AG, AC , respectively.

Let T_1, T_2, T_3, \dots be the tensions in the ties, as in Fig. 103.

The tensions in the ties meeting at the foot of a post are evidently equal.

Each triangular truss may be considered separately.

From the truss AEF , $2T_1 \cos \alpha = P_1 = W_1$;

from the truss AGO , $2T_2 \cos \beta = P_2 = W_2 + (T_1 + T_2) \cos \alpha$;

from the truss FKO , $2T_3 \cos \alpha = P_3 = W_3$;

from the truss ACB ,

$2T_4 \cos \gamma = P_4 = W_4 + (T_2 + T_3) \cos \beta + (T_1 + T_4) \cos \alpha$;

from the truss OMN , $2T_5 \cos \alpha = P_5 = W_5$;

from the truss OPB , $2T_6 \cos \beta = P_6 = W_6 + (T_5 + T_6) \cos \alpha$;

from the truss NRB , $2T_7 \cos \alpha = P_7 = W_7$.

Hence

$$T_1 = \frac{W_1}{2} \sec \alpha,$$

$$T_2 = \frac{1}{2} \left(W_2 + \frac{W_1 + W_3}{2} \right) \sec \beta,$$

$$T_3 = \frac{W_3}{2} \sec \alpha,$$

$$T_4 = \frac{1}{2} \left(W_4 + \frac{W_2 + W_6}{2} + \frac{W_1 + 3W_3 + 3W_5 + W_7}{4} \right) \sec \gamma,$$

$$T_5 = \frac{W_5}{2} \sec \alpha,$$

$$T_6 = \frac{1}{2} \left(W_6 + \frac{W_5 + W_7}{2} \right) \sec \beta,$$

$$T_7 = \frac{W_7}{2} \sec \alpha,$$

and the values of P_1, P_2, P_3, \dots can be at once found.

Again, the thrust along $AF = T_1 \sin \alpha + T_2 \sin \beta + T_3 \sin \gamma$;
 " at $F = T_2 \sin \beta + T_3 \sin \gamma$;
 " along $FO = T_2 \sin \beta + T_3 \sin \gamma + T_4 \sin \alpha$;
 " at $O = T_3 \sin \gamma$;
 etc., etc.

If the truss carries a uniformly distributed load W ,

$$W_1 = W_2 = W_3 = W_4 = W_5 = W_6 = W_7 = \frac{W}{8} ;$$

$$T_1 = T_2 = T_3 = T_4 = \frac{W}{16} \sec \alpha,$$

$$T_5 = T_6 = \frac{W}{8} \sec \beta, \quad T_7 = \frac{W}{4} \sec \gamma.$$

If the above diagram is inverted, it will represent another type of truss in which the obliques are struts and the verticals ties.

Note.—The stresses in the several members of each of the trusses due to the weight it is designed to carry, may of course be easily determined *graphically* in the manner already described in previous articles.

EX. 3. Fig. 104 represents a beam trussed by a number of *independent* triangular trusses, the vertical posts being

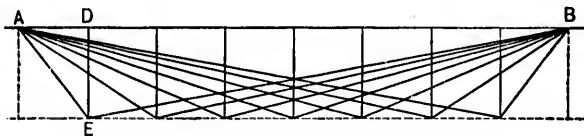

FIG. 104.

equidistant. The weight concentrated at the head of each post may be found by the method described in Ex. 2, which in fact is generally applicable to all bridge and roof trusses.

Let T_1 , T_2 be the tensions in AE , BE , respectively.

Let W_1 be the weight at D .

Let α_1, α_2 be the inclinations of AE, BE , respectively, to the vertical.

$$T_1 = W_1 \frac{\sin \alpha_2}{\sin (\alpha_1 + \alpha_2)}, \quad T_2 = W_1 \frac{\sin \alpha_1}{\sin (\alpha_1 + \alpha_2)}.$$

Similarly, the stress in any other tie may be obtained.

The compression in the top chord is the algebraic sum of the horizontal components of all the stresses in the ties which meet at one end.

The verticals are always struts and the obliques ties.

This truss has been used for bridges of considerable span, but the ties may prove inconveniently long.

EX. 4. The figure $SANT$ represents an ordinary triangular truss of the Warren type, supported at the ends S and T .

Draw the *line of loads* 16, 12 being the weight at B , and 23, 34, 45, 56 the weights at D, F, K, M , respectively.

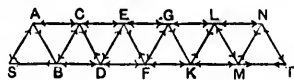

FIG. 105.

With any pole O describe the funicular polygon and draw OP parallel to its closing line QR .

$\therefore 1P$ is the reaction at S , and $6P$ that at T .

The reciprocal of S is the triangle PS_1S_2 ; $1S_1$ being the tension in SB , and S_1P the compression in AS .

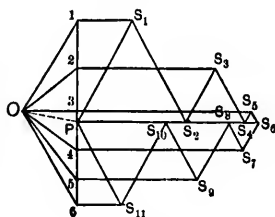

FIG. 106.

The reciprocal of A is the triangle PS_1S_2 ; S_1S_2 being the tension in AB , and S_1P the compression in CA .

The reciprocal of B is the figure $S_112S_2S_3S_4$; $2S_3$ being the tension in BD , S_3S_4 the compression in CB , and 12 the weight at B .

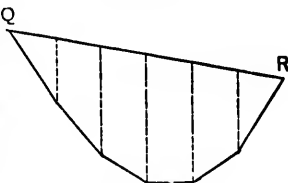

FIG. 107.

The reciprocal of C is the figure $PS_2S_3S_4P$; S_3S_4 being the tension in CD , and S_2P the compression in EC .

The reciprocal of D is the figure $S_423S_5S_6S_7$; $3S_5$ being the tension in DF , S_5S_6 the compression in ED , and 23 the weight at D .

The reciprocal of E is the figure $PS_1S_2S_3P$; S_1S_2 being the tension in EF , and S_3P the compression in GE .

The reciprocal of F is the figure $S_1S_2S_3S_4$; $4S_4$ being the tension in FK , S_1S_2 the tension in FG , and 34 the weight at F . And so on, the closing line PS_n for the reciprocal of T being necessarily parallel to NT .

The arrow-heads show the character of the stresses in the several members of the truss.

Note.—The reactions may also be at once determined by the method of moments.

Thus $1P = \frac{1}{3}(12) + \frac{1}{3}(23) + \frac{1}{3}(34) + \frac{1}{3}(45) + \frac{1}{3}(56)$,

and $6P = \frac{1}{3}(12) + \frac{2}{3}(23) + \frac{2}{3}(34) + \frac{1}{3}(45) + \frac{1}{3}(56)$.

EX. 5. In the truss represented by the accompanying figure,

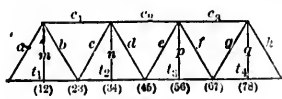

FIG. 108.

the joints in the upper as well as those in the lower chord are loaded, the weights being transmitted to the former by means of vertical suspenders.

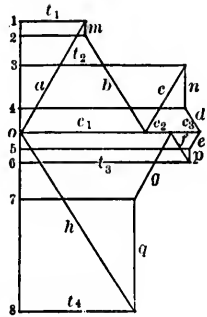

FIG. 109.

Fig. 109 is evidently the corresponding stress diagram.

Note.—In the trusses represented by Figs. 106 and 109, the floor is carried upon the lower chords. If the trusses are inverted, the floor may be carried on the upper chords. The stresses in the several members are evidently the same in magnitude and are only reversed in kind.

EX. 6. The Howe truss represented by Fig. 110 is very widely used and may be constructed of timber, of iron, or of timber and iron combined.

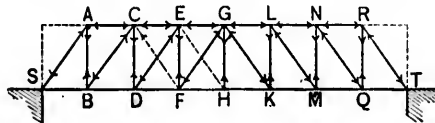

FIG. 110.

Let there be a *uniformly* distributed load upon the truss consisting of a weight W at each of the joints B, D, \dots in the lower chord.

The reaction at each support $= 3\frac{1}{2}W$.

Fig. 111 is the stress diagram, and the several members of the truss are indicated on the lines representing the stresses to

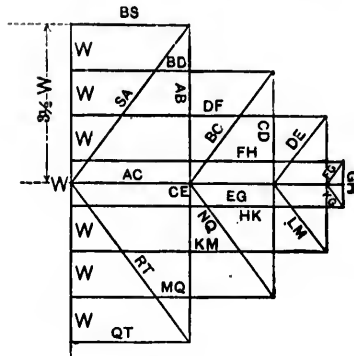

FIG. 111.

which they are subjected. The *directions* of these stresses at the joints, and hence also their character, are easily determined by following *in order* the sides of the reciprocals. The verticals are evidently all *ties* and the diagonals all *struts*.

If the load is *unevenly* distributed, the stresses in different members may be reversed. For example,

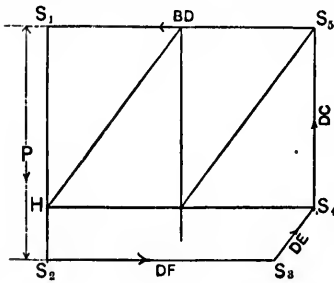

FIG. 112.

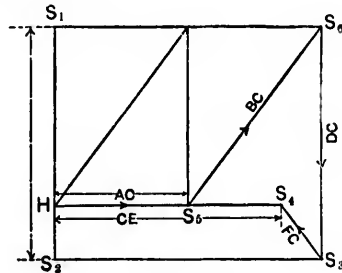

FIG. 113.

Let the truss carry a single weight P at any point D . The reciprocal of D is $S_1, S_2, S_3, S_4, S_5, S_1$ (Fig. 112), S_1, S_2 represent-

ing P , and the arrow-heads showing the directions of the forces now acting at D . Thus the force in DE at D , represented by S_1S_1 , acts from D towards E , and is, therefore, a tension.

Hence, in order that DE may not be subjected to a tensile force, counterbraces CF , EH are introduced so that the portion of P borne on the support at T may be transmitted through the system $CFEH$ to H and from H to T through the regular system $HGKLMNQRT$. The reciprocal of D is now $S_1S_1S_1S_1$ (Fig. 113), and the reciprocal of C the figure $HS_1S_1S_1H$, the arrow-heads showing the directions of the forces at C . It will be at once observed that FC must be a strut.

In order to make provision for a varying load, as when a train passes over a bridge, counterbraces are introduced in the panels on both sides of the centre, and although they may not be necessary in every panel, they will give increased stiffness to the truss.

Note.—Generally speaking, a panel is that portion of the bridge-truss between two consecutive verticals, and the ends of the verticals are called panel-points.

Ex. 7. Fig. 114 represents a Pratt truss, and is merely an inverted Howe truss. The diagonals become ties and the



FIG. 114.

verticals struts. Counterbraces are introduced to resist the action of a varying load, precisely as described in Ex. 6.

Ex. 8. The bowstring truss in its simplest form is repre-

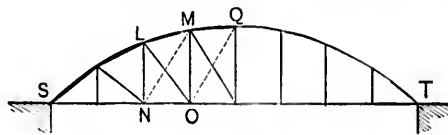

FIG. 115.

sented by Fig. 115. Assuming that the portions of the upper chord between consecutive joints are straight, the stress dia-

gram for a *uniformly* distributed load and for one half the truss is Fig. 116.

The panels, however, are *incomplete* frames, and if the truss

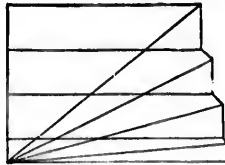

FIG. 116.

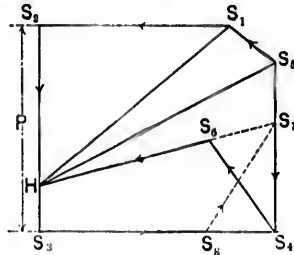

FIG. 117.

has to carry an *unequally* distributed load, ties similar to that shown by the dotted line *MN* must be introduced in the several panels in order to prevent distortion.

For example, let there be a single load *P* at the joint *N*, and let there be no brace *NM*. The stress in the first vertical is evidently *nil*. The reciprocal of *N* is $S_1S_2S_3S_4S_5S_6S_1$, Fig. 117, S_2S_3 , representing *P*. The reciprocal of *L* is $HS_6S_7S_6H$, and the arrow-heads show the *directions* of the forces at *H*.

Thus the force in *OL*, which is represented by S_1S_6 , acts from *O* towards *L*, and is, therefore, a *compression*. But, under a uniformly distributed load, the diagonals are all ties, and *NM* is introduced to take up that portion of *P* which would be otherwise transmitted through *LO* in the form of a compression. In this case the reciprocal of *L* is HS_6S_7H , since the stress in *LO* due to *P* is assumed to be *nil*. Also the reciprocal of *N* is $S_1S_2S_3S_4S_5S_6S_1$. The stress in *NM*, represented by S_1S_2 , acts from *N* to *M* and is a tension.

Hence the diagonals *NM* are also ties, and the portion of the weight *P* borne at *L* is carried to *Q* through the system *NMOQ*.

Ex. 9. Fig. 118 is a bowstring truss with isosceles bracing. Under an arbitrary load Fig. 119 is the stress diagram, the loads at *a, b, c, d, e, f, g* being 12, 23, 34, 45, 56, 67, 78, respectively. As in the Warren girder, the diagonals may, under the action of a varying load, be subjected to both tensile and com-

pressive stresses. They must, therefore, be designed to bear such reversal of stress.



FIG. 118.

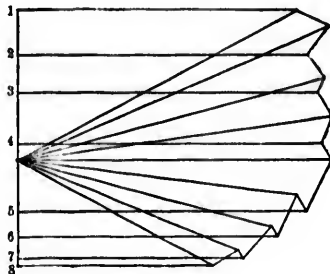

FIG. 119.

It is assumed, as before, that the portions of the upper chord between consecutive joints are straight.

Note.—The design of bridge-trusses will be further considered in a subsequent chapter.

26. Method of Sections.—It often happens that the stresses in the members of a frame may be easily obtained by the method of sections. This method depends upon the following principle:

If a frame is divided by a plane section into two parts, and if each part is considered separately, the stresses in the bars (or members) intersected by the secant plane must balance the external forces upon the part in question.

Hence the *algebraic* sums of the horizontal components, $\Sigma(X)$, of the vertical components, $\Sigma(Y)$, and of the moments of the forces with respect to any point, $\Sigma(M)$, are severally zero; i.e., analytically,

$$\Sigma(X) = 0, \quad \Sigma(Y) = 0, \quad \text{and} \quad \Sigma(M) = 0.$$

These equations are solvable, and the stresses therefore determinate, if the secant plane does not cut more than three members.

Ex. 1. ABC is a roof-truss of 60 ft. span and 30° pitch.

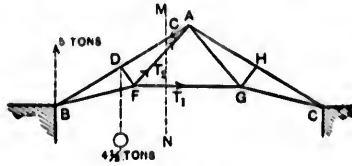

FIG. 120.

The strut $DF = GH = 5$ ft.; the angle $FDA = 90^\circ$. Also $AF = FB = AG = GC$.

The vertical reaction at $B = 5$ tons. The weight concentrated at $D = 4\frac{1}{2}$ tons.

Let the angle $ABF = \alpha$.

$$AB = 30 \sec 30^\circ = 20\sqrt{3}; \quad \cot \alpha = \frac{10\sqrt{3}}{5} = 2\sqrt{3},$$

$$\therefore \sin \alpha = \frac{1}{\sqrt{13}}; \quad \cos \alpha = \frac{2\sqrt{3}}{\sqrt{13}}$$

If the portion of the truss on the right of a secant plane MN be removed, the forces C , T_2 , T_1 in the members AD , AF , FG must balance the external forces 5 tons and $4\frac{1}{2}$ tons in order that the equilibrium of the remainder of the truss may be preserved.

Hence, resolving horizontally and vertically,

$$T_1 + T_2 \cos(\alpha + 30^\circ) - C \sin 60^\circ = 0;$$

$$T_2 \sin(\alpha + 30^\circ) - C \cos 60^\circ + 5 - 4\frac{1}{2} = 0.$$

Taking moments about F ,

$$C \cdot 5 - 5BF \cos(30^\circ - \alpha) + 4\frac{1}{2}DF \sin 30^\circ = 0.$$

But

$$\cos(\alpha + 30^\circ) = \frac{5}{2\sqrt{13}}, \quad \sin(\alpha + 30^\circ) = \frac{3\sqrt{3}}{2\sqrt{13}}, \quad \cos(30^\circ - \alpha) = \frac{7}{2\sqrt{13}}.$$

$$BF = BD \sec \alpha = 5\sqrt{13}, \quad \text{and } DF = 5 \text{ ft.}$$

$$\therefore T_1 + T_2 \cdot \frac{5}{2\sqrt{13}} - C \cdot \frac{\sqrt{3}}{2} = 0;$$

$$T_2 \cdot \frac{3\sqrt{3}}{2\sqrt{13}} - C \cdot \frac{1}{2} + \frac{1}{2} = 0.$$

$$C \cdot 5 - 5 \cdot 5\sqrt{13} \cdot \frac{7}{2\sqrt{13}} + 4\frac{1}{2} \cdot 5 \cdot \frac{1}{2} = 0.$$

Hence $C = 15\frac{1}{4}$ tons, $T_1 = 9.89$ tons, and $T_2 = 6.35$ tons.

EX. 2. The figure represents a portion of a bridge-truss cut off by a plane MN and supported at the abutment at A .

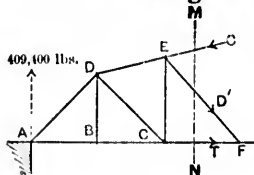

FIG. 121.

The vertical reaction at A
 $= 409,400$ lbs.
 The weight at $B = 49,500$ lbs.
 " " " $C = 38,700$ lbs.

$$AB = BC = 24 \text{ ft.}; \quad BD = 24 \text{ ft.}; \quad CE = 29\frac{1}{8} \text{ ft.}$$

The forces C' , D' , T in the members met by MN must balance the external forces at A , B , C .

Revolving horizontally and vertically,

$$T + D' \cos \alpha - C' \cos \beta = 0;$$

$$D' \sin \alpha + C' \sin \beta - 409400 + 49500 + 38700 = 0;$$

α and β being the inclinations to the horizon of EF , DE , respectively.

Taking moments about E ,

$$- T \times 29\frac{1}{8} + 409400 \times 48 - 49500 \times 24 = 0.$$

But $\tan \alpha = \frac{29\frac{1}{2}}{24} = \frac{11}{9}$ and $\tan \beta = \frac{5\frac{1}{2}}{24} = \frac{2}{9}$.

$\therefore \sin \alpha = \frac{11}{\sqrt{202}}$, $\cos \alpha = \frac{9}{\sqrt{202}}$, $\sin \beta = \frac{2}{\sqrt{85}}$, $\cos \beta = \frac{9}{\sqrt{85}}$.

Hence $T = 629,427\frac{2}{11}$ lbs.;

$C' = \frac{9814500}{117} \sqrt{85} = \frac{1090500}{13} \sqrt{85}$ lbs.;

$D' = \frac{1994600}{13} \sqrt{202}$ lbs.

27. Piers.—To determine the stresses in the members of the braced piers (Fig. 122) supporting a deck bridge.

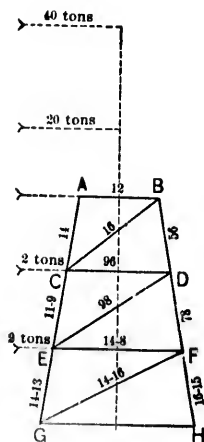

FIG. 122.

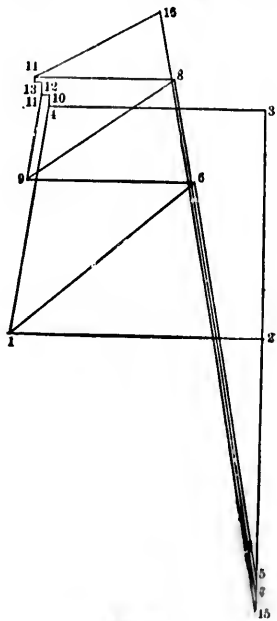

FIG. 123.

Data.—Height of pier = 50 ft.; of truss = 30 ft. Width of pier at top = 17 ft.; at bottom = 33 3/8 ft.

The bridge when most heavily loaded throws a weight of 100 tons on each of the points *A* and *B*.

Weight of half-pier = 30 tons.

The increased weight at each of the points *C*, *D* and *E*, *F*, from the portions *AD* and *CF* of the pier = 5 tons.

Resultant horizontal wind-pressure on train = 40 tons at $87\frac{1}{2}$ feet above base.

Resultant horizontal wind-pressure on truss = 20 tons at 65 feet above base.

Resultant horizontal wind-pressure on pier = $2\frac{1}{2}$ tons at each of the points *C* and *E*.

With the wind-pressure acting as in the figure, the diagonals *CB*, *ED*, and *GF* are required. When the wind blows on the other side, the diagonals *D* to *A*, *F* to *C*, and *H* to *E* are brought into play. The moment of the couple tending to overturn the pier

$$= 40 \times 87\frac{1}{2} + 20 \times 65 + 4 \times 25 = 4900 \text{ ton-feet.}$$

The moment of stability = $(200 + 30) \times \frac{33\frac{3}{8}}{2} = 3871\frac{3}{8}$ ft.-tons.

Thus the difference, = $4900 - 3871\frac{3}{8} = 1028\frac{1}{8}$ ft.-tons, must be provided for in the anchorage. The pull on a vertical anchorage-tie at *G* = $\frac{1028\frac{1}{8}}{33\frac{3}{8}} = 30\frac{55}{101}$ tons.

Again, if *H* be the horizontal force upon the pier at *A* due to wind-pressure,

$$H \times 50 = 40 \times 87\frac{1}{2} + 20 \times 65 = 4800;$$

$$H = 96 \text{ tons.}$$

The stress diagram can now be easily drawn.



The reciprocals of the points *A*, *B*, *C*, *D*, *E*, *F* are 4321, 2561, 11-10-4169, 65789, 13-12-11-98-14, and 87-15-16-14, respectively. In the stress diagram 43 = 96 tons, 32 = 25 = 100 tons, 57 = 7-15 = 4-10 = 11-12 = 5 tons, and 10-11 = 12-13 = $2\frac{1}{2}$ tons. The stress in *EG* is of an opposite kind to the stresses in *AC*, *CE*.

Note.—In computing the stresses in the leeward posts of a braced pier, it is usual in American practice to assume that the maximum load is upon the bridge and that the wind exerts a pressure of 30 lbs. per sq. ft. upon the surfaces of the train and structure, or a pressure of 50 lbs. per sq. ft. upon the surface of the structure alone. The negative stresses in the windward posts of the pier are determined when the minimum load is on the bridge, the wind-pressure remaining the same.

TABLE OF WEIGHTS OF ROOF-COVERINGS.

Description of Covering.	Weight of Covering in lbs. per sq. ft. of Covered Area	Dead Weight of Roof in lbs. per sq. ft. of Covered Area
Boarding (¾-inch)	2.5 to 3	
Boarding and sheet-iron	6.5	
Cast-iron plates (¾-inch)	15	
Copper8 to 1.25	
Corrugated iron and laths	5.5	
Felt, asphalted3 to .4	
Felt and gravel	8 to 10	
Galvanized iron	1 to 3	
Laths and plaster	9 to 10	
Pantiles	6 to 10	
Sheet lead	5 to 8	
Sheet-zinc	1.25 to 2	
Sheet-iron (corrugated)	3.4	8 without boards and 11 with boards for spans up to 75 ft.
" " " " "	3.4	12 without boards and 15 with boards for spans from 75 to 150 ft.
Sheet-iron (16 W.G.) and laths	5	
Shingles (16-inch)	2	10 on laths for spans up to 75 ft.
" (long)	3	14 on laths for spans from 75 to 150 ft.
Sheathing (1-inch pine)	3	
" (chestnut and maple)	4	
" (ash, hickory, oak)	5	
Slates (ordinary)	5 to 9	13 without boards or on laths and 16 on 1½-in. boards for spans up to 75 ft.
Slates (large)	9 to 11	17 without boards or on laths and 20 on 1½-in. boards for spans from 75 to 150 ft.
Slates and iron laths	10	
Thatch	6.5	
Tiles	7 to 20	
Tiles and mortar	25 to 30	
Timbering of tiled and slate roofs (additional)	5.5 to 6.5	

WEIGHTS OF VARIOUS ROOF-FRAMINGS.

Description of Roof.	Location.	Covering.	Span.	Width of Bays.		Weight in lbs. per sq. ft. of Covered Area.		Pitch.	
				ft. in.	ft. in.	Framing.	Covering.		
Pent				15	0		3.5		
Common Truss				37	0	5	0	4.6	
" "				40	0	12	0	5.5	
" "				50	0	10	0	3.0	
" "	Liverpool Docks	Felt	53	3	11	0	2.085	5.00	30°*
" "				54	0	14	0	9.5	
" "				55	0	6	6	11.6	
" "				72	0	20	0	7.0	
 Timber rafters and struts, iron ties	Liverpool Docks	Zinc	62	0	12	0	3.013	5.66	30°*
" "	"	Zinc	76	0	25	0	2.6	7.72	30°*
" "	"	Zinc	79	0	13	0	3.86	5.42	30°*
" "	"	Slates	80	8	11	8	4.72	12.1	26° 31'*
 Common Truss				90	2	20	0	13.6	
Common Truss				84	0	9	0	8.5	
" "				100	0	14	0	7.0	
" "				130	0	26	0	6.4	
Bowstring	Manchester		50	0	11	0	9.6		
" "	Lime Street		154	0	26	0	4.9		
" "	Birmingham		211	0	24	0	11.0		
Arched	Strasburg		97	0	13	0	12.0		
" "	Paris		153	0	26	0	15.0		
" "	Dublin		41	0	16	0	10.7		
" "	Derby		81	6	24	0	16.8		
" "	Sydenham		120	0			11.8		
" "	"		72	0			11.3		
" "	St. Pancras		240	0	29	4	24.5		
" "	Cremorne		45	0	14	6	11.5		

* In the roofs designated by * the wind-pressure was taken at 40 lbs. per square foot of vertical surface, and the weights of

Pitch-pine..... at 45 lbs. per cubic foot;

Deals and boarding... " 30 " " " "

Slates on boarding... " 8.4 lbs. per square foot;

Felt with laths..... " 1.0 " " " "

Zinc..... " .66 " " " " " , allowing for 5-in. laps, screws, and corrugation.

TABLE OF THE VALUES OF P_n , P_v , P_h , IN LBS. PER SQ. FT. OF SURFACE, WHEN $P = 40$, AS DETERMINED BY THE FORMULA $P_n = P \cdot \sin a^{1.84} \cos a^{-1}$,

Pitch of Roof.	P_n	P_v	P_h
5°	5.0	4.9	.4
10°	9.7	9.6	1.7
20°	18.1	17.0	6.2
30°	26.4	22.8	13.2
40°	33.3	25.5	21.4
50°	38.1	24.5	29.2
60°	40.0	20.0	34.0
70°	41.0	14.0	38.5
80°	40.4	7.0	39.8
90°	40.0	0.0	40.0

TABLE PREPARED FROM THE FORMULA $p = \left(\frac{v}{20}\right)^2$.

Velocities in feet per second.	Velocities in miles per hour.	Pressure in lbs. per sq. ft.
10	6.8	.25
20	13.6	1.00
40	27.2	4.00
60	40.8	9.00
70	47.6	12.25
80	54.4	16.00
90	61.2	20.25
100	68.0	25.00
110	74.8	30.25
120	81.6	36.00
130	88.4	42.25
150	102.0	56.25

EXAMPLES.

1. Show that the locus of the poles of the funicular polygons of which the first and last sides pass through two fixed points on the closing line, is a straight line parallel to the closing line.

2. The first and last sides of a funicular polygon of a system of forces intersect the closing line in two fixed points. Show that for any position of the pole each side of the polygon will pass through a fixed point on the closing line.

3. Four bars of equal weight and length, freely articulated at the extremities, form a square $ABCD$. The system rests in a vertical plane, the joint A being fixed, and the form of the square is preserved by means of a horizontal string connecting the joints B and D . If W be the weight of each bar, show (a) that the stress at C is horizontal and

$= \frac{W}{2}$, (b) that the stress on BC at B is $W \frac{\sqrt{5}}{2}$ and makes with the ver-

tical an angle $\tan^{-1} \frac{1}{2}$, (c) that the stress on AB at B is $W \frac{\sqrt{13}}{2}$ and

makes with the vertical an angle $\tan^{-1} \frac{3}{2}$, (d) that the stress upon AB at A is $\frac{3}{2}W$, (e) that the tension of the string is $2W$.

4. Five bars of equal length and weight, freely articulated at the extremities, form a regular pentagon $ABCDE$. The system rests in a vertical plane, the bar CD being fixed in a horizontal position, and the form of the pentagon being preserved by means of a string connecting the joints B and E . If the weight of each bar be W , show that the

tension of the string is $\frac{W}{2} (\tan 54^\circ + 3 \tan 18^\circ)$, and find the magnitudes and directions of the stresses at the joints.

5. Six bars of equal length and weight ($= W$), freely articulated at the extremities, form a regular hexagon $ABCDEF$.

First, if the system hang in a vertical plane, the bar AB being fixed in a horizontal position, and the form of the hexagon being preserved by means of a string connecting the middle points of AB and DE , show

that (a) the tension of the string is $3W$, (b) the stress at C is $\frac{W}{2\sqrt{3}}$ and

horizontal, (c) the stress at D is $W \sqrt{\frac{13}{12}}$ and makes with the vertical

an angle $\cot^{-1} 2\sqrt{3}$.

Second, if the system rest in a vertical plane, the bar DE being fixed in a horizontal position, and the form of the hexagon being preserved

by means of a string connecting the joints C and F , show that (a) the tension of the string is $W \frac{1}{\sqrt{3}}$, (b) the stress at C is $W \sqrt{\frac{31}{12}}$ and makes with CB an angle $\sin^{-1} \sqrt{\frac{3}{124}}$, (c) the stress at B is $W \sqrt{\frac{7}{12}}$ and makes with CD an angle $\sin^{-1} \sqrt{\frac{3}{28}}$.

Third, if the system hang in a vertical plane, the joint A being fixed, and the form of the hexagon being preserved by means of strings connecting A with the joints E , D , and C , show that (a) the tension of each of the strings AE and AC is $W \sqrt{3}$, (b) the tension of the string AD is $2W$; and determine the magnitudes and directions of the stresses at the joints, assuming that the strings are connected with pins distinct from the bars.

6. Show that the stresses at C and F in the first case of Ex. 5 remain horizontal when the bars AF , FE , BC , CD are replaced by any others which are all equally inclined to the horizon.

7. If the pole of a funicular polygon describe a straight line, show that the corresponding sides of successive funicular polygons with respect to successive positions of the pole will intersect in a straight line which is parallel to the locus of the pole.

8. A system of heavy bars, freely articulated, is suspended from two fixed points; determine the magnitudes and directions of the stresses at the joints. If the bars are all of equal weight and length, show that the tangents of the angles which successive bars make with the horizontal are in arithmetic progression.

9. If an even number of bars of equal length and weight rest in equilibrium in the form of an arch, and if $\alpha_1, \alpha_2, \dots, \alpha_n$ be the respective angles of inclination to the horizon of the 1st, 2d, \dots , n th bars counting from the top, show that

$$\tan \alpha_{n+1} = \frac{2n+1}{2n-1} \tan \alpha_n.$$

10. Three bars, freely articulated, form an equilateral triangle ABC . The system rests in a vertical plane upon supports at B and C in the same horizontal line, and a weight W is suspended from A . Determine the stress in BC , neglecting the weight of the bars.

$$\text{Ans. } \frac{W}{2\sqrt{3}}.$$

11. Three bars, freely articulated, form a triangle ABC , and the system is kept in equilibrium by three forces acting on the joints. Determine the stress in each bar.

What relation holds between the stresses when the lines of action of

the forces meet (*a*) in the centroid, (*b*) in the orthocentre of the triangle?

12. A triangular truss of white pine consists of two equal rafters *AB*, *AC*, and a tie-beam *BC*; the span of the truss is 30 ft. and its rise is $7\frac{1}{2}$ ft.; the uniformly distributed load upon each rafter is 8400 lbs. Determine the stresses in the several members.

Ans. Stress in *BC* = 8400 lbs., in *AB* = $4200\sqrt{3}$ lbs.

13. *ABCD* is a quadrilateral truss, *AB* and *CD* being horizontal and 15 and 30 ft. in length, respectively. The length of *AC* is 10 ft., and its inclination to the vertical is 60° . A weight W_1 is placed at *C*, and W_2 at *D*. What must be the relation between W_1 and W_2 so that the truss may not be deformed? For any other relation between W_1 and W_2 , explain how you would modify the truss to prevent deformation, and find the stresses in all the members.

$$\text{Ans. } W_1 = W_2 \frac{\sqrt{3} + 1}{2}.$$

14. A Warren girder 80 ft. long is formed of five equilateral triangles. Weights of 2, 3, 4, 5, tons are concentrated, respectively, at the 1st, 2d, 3d, and 4th apex along the upper chord. Determine the stresses in all the members of the girder.

Ans.—*Tension Chord*: Stress in 1st bay = $2\sqrt{3}$; 2d = $5\frac{1}{2}\sqrt{3}$;

$$3d = 7\sqrt{3}; 4th = 6\frac{1}{2}\sqrt{3}; 5th = 2\frac{1}{2}\sqrt{3}.$$

Compression Chord: Stress in 1st bay = $4\sqrt{3}$;

$$2d = 6\frac{1}{2}\sqrt{3}; 3d = 7\frac{1}{2}\sqrt{3}; 4th = 5\frac{1}{2}\sqrt{3}.$$

Diagonals: Stress in 1st and 2d. = $4\sqrt{3}$;

$$3d \text{ and } 4th = 2\frac{1}{2}\sqrt{3}; 5th \text{ and } 6th = \frac{1}{2}\sqrt{3};$$

$$7th \text{ and } 8th = 2\sqrt{3}; 9th \text{ and } 10th = 5\frac{1}{2}\sqrt{3}.$$

15. In a quadrilateral truss *ABCD*, *AD* is horizontal, *AB* and *BC* are inclined at angles of 60° and 30° respectively to the horizontal, and *CD* is inclined at 45° to the horizontal. What weight must be concentrated at *C* to maintain the equilibrium of the frame under a weight *W* at *B*?

If a weight *W* is placed at *C* as well as at *D*, what member must be introduced to prevent distortion? What will be the stress in that member?

$$\text{Ans. First: } W \frac{\sqrt{3} + 1}{2}.$$

Second: Introduce brace *BD* and let $BDA = \alpha$.

$$\text{Then stress in } BD = \frac{W(2 - \sqrt{3})}{2 \sin(60^\circ + \alpha)},$$

16. The boom AB of the accompanying truss is supported at five intermediate points dividing the length into six segments each 10 ft. long. The depth of the truss = 10 ft. Draw stress diagrams for the following cases:

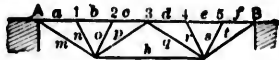

FIG. 124.

- (a) A weight of 100 lbs. at each intermediate point of support.
- (b) Weights of 100, 200, 300, 400, 500 lbs. in order at these points.

Ans. (a) Stress in $a = 375$; $b = 325$; $c = 375$; $d = 450$;

$$m = 125\sqrt{13}; n = 50\sqrt{5}; o = 50\sqrt{5};$$

$$p = 25\sqrt{13} \text{ lbs.}$$

(b) Stress in $a = 875$; $b = 825$; $c = 925$; $d = 1350$; $e = 1325$.

$$f = 1125; g = 1375; h = 50\sqrt{5}; i = 100\sqrt{5};$$

$$j = 141\frac{1}{2}\sqrt{13}; k = 8\frac{1}{2}\sqrt{13}; l = 200\sqrt{5};$$

$$m = 250\sqrt{5}; n = 458\frac{1}{2}\sqrt{13} \text{ lbs.}$$

17. The rafters AB, AC of a factory roof are 18 and 24 ft. in length respectively. The tie BC is horizontal and 30 ft. long. The middle points of the rafters are supported by struts DE, DF from the middle point D of the tie BC ; the point D is supported by the tie-rod AD . The truss carries a load of 500 lbs. at each of the points E, A , and F . Find the stresses in all the members. Secondly, find the stresses in the members when the rafter AB is subjected to a normal pressure of 300 lbs. per linear ft., rollers being at C .

Ans. Stress in $BE = 1112\frac{1}{2}$; $EA = 800$; $CF = 1016\frac{1}{2}$; $FA = 600$;

$$BD = 667\frac{1}{2}; CD = 813\frac{1}{2}; DE = 312\frac{1}{2}; DF = 416\frac{1}{2};$$

$$AD = 502 \text{ lbs.}$$

Stresses due to 300 lbs. in $BE = 1012\frac{1}{2}$; $EA = 1800$;

$$DE = 2812\frac{1}{2}; BD = 3847\frac{1}{2}; AD = 2250;$$

$$DC = 2160; AC = 2700; DF = 0.$$

18. If it be assumed in the first part of the last question that the whole of the weight is concentrated at the points E and F , draw the stress diagram.

19. A triangular truss consists of two equal rafters AB, AC and a tie-beam BC , all of white pine; the centre D of the tie-beam is supported from A by a wrought-iron rod AD ; the uniformly distributed load upon each rafter is 8400 lbs., and upon the tie-beam is 36000 lbs.; determine (a) the stresses in the different members, BC being 40 ft. and AD 20 ft. What (b) will be the effect upon the several members if the centre of the tie-beam be supported upon a wall, and if for the rod a post be substituted against which the heads of the rafters can rest? Assume that the pressure between the rafter and post acts at right angles to the rafter.

Ans. (a) Stresses in $BD = 13200$; $AD = 18000$; $AB = 13200\sqrt{2}$ lbs.

$$(b) \quad " \quad " \quad = 4200; \quad " \quad = 8400; \quad " \quad = 6300\sqrt{2} \text{ lbs.}$$

20. A triangular truss of white pine consists of a rafter AC , a vertical post AB , and a horizontal tie-beam BC ; the load upon the rafter is 300 lbs. per lineal foot; $AC = 30$ ft., $AB = 6$ ft. Find the resultant pressure at C .

Ans. 4409 lbs.

Find the stresses in the several members when the centre D of the rafter is also supported by a strut from B .

Ans. Stress in $BC = 4500\sqrt{6}$; $CD = 22500$; $DB = 11250$;
 $DA = 11250$; $AB = 2250$ lbs.

21. The rafters AB , AC of a roof-truss are 20 ft. long, and are supported at the centres by the struts DE , DF ; the centre D of the tie-beam BC is supported by a tie-rod AD , 10 ft. long; the uniformly distributed load upon AB is 8000 lbs., and upon AC is 2400 lbs. Determine the stresses in all the members.

What will be the effect upon the several members if AB be subjected to a horizontal pressure of 156 lbs. per lineal foot?

Ans. (a) Stress in $BD = 4600\sqrt{3}$; $BE = 9200$; $EA = 5200$;
 $ED = 4000$; $AD = 2600$; $DF = 1200$;
 $AF = 5200$; $CF = 6400$; $CD = 3200\sqrt{3}$.

(b) Tens. in $BE = 520\sqrt{3}$; $AD = 260\sqrt{3}$; compress. in
 $ED = 520\sqrt{3}$; $AC = 520\sqrt{3}$; $DC = 780$.

No stresses in BD , AE .

22. Determine the stresses in all the members of the truss in the preceding question, assuming the tie-beam to be also loaded with a weight of 600 lbs. per lineal foot.

Ans. Stress in AB increased by $6000\sqrt{3}$ lbs.; in BC by 9000 lbs.;
in AD by $6000\sqrt{3}$ lbs.

23. A horizontal beam is trussed and supported by a vertical strut at its middle point. If a loaded wheel roll across the beam, show that the stress in each member increases proportionately with the distance of the wheel from the end.

Ans. Stress in tie-beam (hor.) = $\frac{W}{l}x \cot \theta$; on tie = $\frac{Wx}{l \sin \theta}$;
on strut = $\frac{W}{l}2x$.

24. A frame is composed of a horizontal top-beam 40 ft. long, two vertical struts 3 ft. long, and three tie-rods of which the middle one is horizontal and 15 ft. long. Find the stresses produced in the several members when a single load of 12000 lbs. is concentrated at the head of each strut.

Ans. Stress in horizontal members = 50000 lbs.
" " sloping " = 51420 "
" " struts " = 12000 "

25. If a wheel loaded with 12000 lbs. travel over the top-beam in the last question, what members must be introduced to prevent distortion? What are the maximum stresses to which these members will be subjected?

Ans. 19122 lbs.

26. A beam of 30 ft. span is supported by an inverted queen-truss, the queens being each 3 ft. long and the bottom horizontal member 10 ft. long. Find the stresses in the several members due to a weight W at the head of a queen, introducing the diagonal required to prevent distortion. Also find the stresses due to a weight W at centre of beam.

$$\text{Ans.—1. Stress in } AB = \frac{20}{9}W; \quad AE = 2.32W; \quad EF = \frac{20}{9}W;$$

$$BE = \frac{2}{3}W; \quad BF = 1.16W; \quad BC = \frac{10}{9}W;$$

$$CF = 0; \quad DF = 1.16W.$$

$$2. \text{ Stress in } AB = \frac{5}{3}W; \quad AE = 1.74W; \quad BE = \frac{W}{2};$$

$$EF = \frac{5}{3}W.$$

27. A roof-truss of 20 ft. span and 8 ft. rise is composed of two rafters and a horizontal tie-rod between the feet. The load upon the truss = 500 lbs. per foot of span. Find the pull on the tie. What would the pull be if the rod were raised 4 ft.?

Ans. 3125 lbs.; 6250 lbs.

28. The rafters AB, AC of a roof are unequal in length and are inclined at angles α, β to the vertical; the uniformly distributed load upon $AB = W_1$, upon $AC = W_2$. Find the tension on the tie-beam.

$$\text{Ans. } \frac{W_1 + W_2}{2} \frac{\sin \alpha \sin \beta}{\sin (\alpha + \beta)}$$

29. In the last question, if the span = 10 ft., $\alpha = 60^\circ$ and $\beta = 45^\circ$, find the tension on the tie, the rafters being spaced $2\frac{1}{2}$ ft. centre to centre, and the roof-load being 20 lbs. per square foot.

Ans. 198 lbs.

30. The equal rafters AB, AC for a roof of 10 ft. span and $2\frac{1}{2}$ ft. rise are spaced $2\frac{1}{2}$ ft. centre to centre; the weight of the roof-covering, etc. = 20 lbs. per square foot. Find the vertical pressure and outward thrust at the foot of a rafter.

Ans. Total vertical pressure = $125\sqrt{5}$ lbs. = horizontal thrust.

31. The lengths of the tie-beam and two rafters of a roof-truss are in the ratios of 5:4:3. Find the stresses in the several members when the load upon each rafter is uniformly distributed and equal to 100 lbs.

Ans. Stress in tie = 48 lbs.; in one rafter = 60 lbs.; in other = 80 lbs.



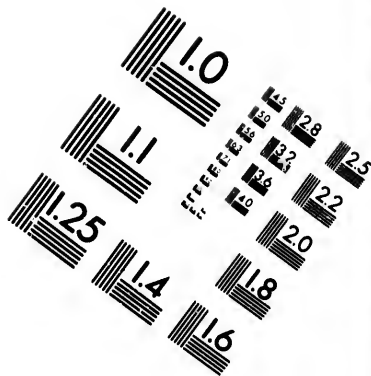
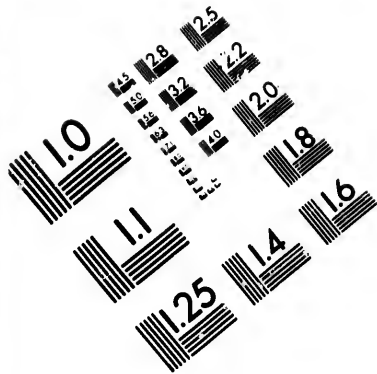

**IMAGE EVALUATION
TEST TARGET (MT-3)**

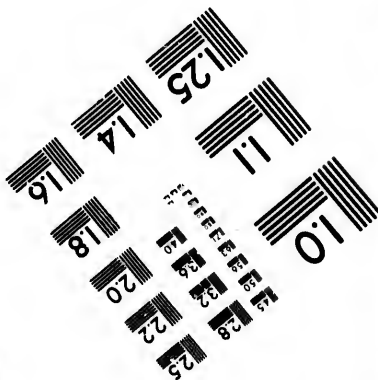
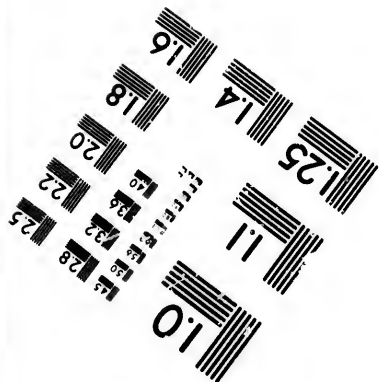
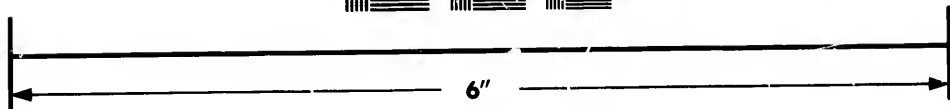
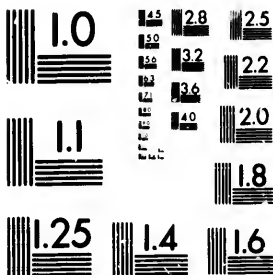

**Photographic
Sciences
Corporation**

23 WEST MAIN STREET
WEBSTER, N.Y. 14580
(716) 872-4503

LE 28 25
23 22
20

10

32. In a triangular truss the rafters each slope at 30° ; the load upon the apex = 100 lbs. Find the thrust of the roof and the stress in each rafter.

Ans. 100 lbs.; 86.6 lbs.

33. A roof truss is composed of two equal rafters and a tie-beam, and the span = 4 times the rise; the load at the apex = 4000 lbs. Find the stresses in the several members.

Secondly, if a man of 150 lbs. stands at the middle of a rafter, by how much will the stress in the tie-beam be increased?

Ans.—1. Stress in tie = 4000 lbs.; in each rafter = $2000\sqrt{5}$ lbs.
2. 75 lbs.

34. A king-post truss for a roof of 30 ft. span and $7\frac{1}{2}$ ft. rise is composed of two equal rafters AB, AC ; the horizontal tie-beam BC , the vertical tie AD , and the struts DE, DF from the middle point D of the tie-beam to the middle points of the rafters; the roof-load = 20 lbs. per square foot of roof-surface, and the rafters are spaced 10 ft. centre to centre. Find the stresses in the several members.

Second, find the altered stresses when a man of 150 lbs. weight stands on the ridge.

Third, find the altered stresses when the tie-beam supports a ceiling weighing 12 lbs. per square foot.

Ans.—1. Stress in $BE = 5625$ lbs.; $BD = 2250\sqrt{5}$ lbs.;
 $AE = 3750$ lbs.; $DE = 1875$ lbs.;
 $AD = 750\sqrt{5}$ lbs.

2. Stresses in BD, BE, AE increased by 150 lbs., $75\sqrt{5}$ lbs., and $75\sqrt{5}$ lbs., respectively; other stresses unchanged.

3. Stresses in AD , tie-beam, and rafters increased by 1800, 1800 and $900\sqrt{5}$ lbs., respectively; other stresses unchanged.

35. The platform of a bridge for a clear span of 60 ft. is carried by two queen-trusses 15 ft. deep; the upper horizontal member of the truss is 20 ft. long; the load upon the bridge = 50 lbs. per square foot of platform, which is 12 ft. wide. Find the stresses in the several members.

Ans. Stress in vertical = 6000 lbs.; in each sloping member = 10000 lbs.; in each horizontal member = 8000 lbs.

36. If a single load of 6000 lbs. pass over the bridge in the last question, and if its effect is equally divided between the trusses, find (a) the greatest stress in the members of the truss, and also (b) in the members which must be introduced to prevent distortion. Also find (c) the stresses when one half the bridge carries an additional load of 50 lbs. per square foot of platform.

- Ans.*—(a) In sloping end strut = $3333\frac{1}{3}$ lbs.; horizontal tie = $2666\frac{2}{3}$ lbs.; horizontal strut = $1333\frac{1}{3}$ lbs.
 (c) In sloping end strut = 6250 lbs.; horizontal tie = 5000 lbs.; horizontal strut = 3000 lbs.
 (b) In case (a) = $1666\frac{2}{3}$ lbs.; in case (c) = 2500 lbs.

37. A roof-truss consists of two equal rafters AB, AC inclined at 60° to the vertical, of a horizontal tie-beam BC of length l , of a collar-beam DE of length $\frac{l}{3}$, and of queen-posts DF, EG at each end of the collar-beam; the truss is loaded with a weight of 2600 lbs. at the vertex, a weight of 4000 lbs. at one collar-beam joint, a weight of 1200 lbs. at the other, and a weight of 1500 lbs. at the foot of each queen; the diagonal DG is inserted to provide for the unequal distribution of load. Find the stresses in all members.

Ans. Stress in $BD = 11733\frac{1}{3}$; $BF = 5866\frac{2}{3}\sqrt{3}$; $DF = 1500$;
 $DA = 2600$; $DE = 3633\frac{1}{3}\sqrt{3}$; $DG = 1866\frac{2}{3}$;
 $GC = 4933\frac{1}{3}\sqrt{3}$; $GE = 2433\frac{1}{3}$; $CE = 9866\frac{2}{3}$;
 $AE = 2600$ lbs.

38. The rafters AB, AC are supported at the centres by the struts DE, DF ; the centre of the tie-beam is supported by the tie AD ; $BC = 30$ ft., $AD = 7\frac{1}{2}$ ft.; the load upon AB is 4000 lbs., that upon AC 1600 lbs. Find the stresses in all the members. By an accident the strut DE was torn away; how were the stresses in the other members affected?

Ans.—Case 1: Stress in $BE = 2400\sqrt{5}$; $BD = 4800$;
 $DE = 1000\sqrt{5}$; $AE = 1400\sqrt{5}$;
 $AF = 1400\sqrt{5}$; $DF = 400\sqrt{5}$;
 $FC = 1800\sqrt{5}$; $DC = 3600$ lbs.
 Case 2: Stress in $BA = 1400\sqrt{5}$; $BD = 2800$;
 $AD = 400$; $AF = 1400\sqrt{5}$;
 $FC = 1800\sqrt{5}$; $DF = 400\sqrt{5}$;
 $DC = 3600$.

39. The platform of a bridge for a clear span of 60 ft. is carried by two trusses 15 ft. deep, of the type shown by the accompanying diagram; the load upon the bridge is 50 lbs. per square foot of platform, which is 12 ft. wide. Find the stresses in the several members.

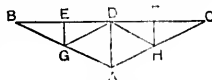

FIG. 125.

Ans. Stress in $BE = 13500$; $BG = 6750\sqrt{5}$; $EG = 4000$;
 $ED = 13500$; $GD = 2250\sqrt{5}$; $GA = 4500\sqrt{5}$;
 $AD = 9000$ lbs.

40. If a single weight of 2000 lbs. pass over a truss similar to that shown in the preceding question, find the stresses in the several members when the load is (1) at E , (2) at D .

Ans.—Case 1: Stress in $BG = 1500\sqrt{5}$; $BE = 3000$;
 $EG = 2000$; $ED = 3000$;
 $GD = 1000\sqrt{5}$; $AG = 500\sqrt{5}$;
 $AH = 500\sqrt{5}$; $DH = 0$; $FH = 0$;
 $DF = 1000$; $FC = 1000$;
 $CH = 500\sqrt{5}$ lbs.

Case 2: Stress in BA and $CA = 1000\sqrt{5}$;
 BD and $DC = 2000$; $AD = 2000$ lbs.,
 and in other members = 0.

41. A white-pine triangular truss consists of two rafters AB , AC , of unequal length, and a tie-beam BC . A vertical wrought-iron rod from A , 10 ft. long, supports the tie-beam at a point D , dividing its length into the segments $BD = 10$ ft. and $CD = 20$ ft. The load upon each rafter is 300 lbs. per lineal ft.; the load upon the tie-beam is 18,000 lbs., uniformly distributed. Determine the stresses in the several members.

Ans. In $AB = 9650\sqrt{2}$ lbs.; $AC = 4825\sqrt{5}$ lbs.; $BD = CD = 9650$ lbs.

42. The post of a jib-crane is 10 ft.; the weight lifted = W ; the jib is inclined at 30° , and the tie at 60° , to the vertical. Find (a) the stresses in the jib and tie, and also the B. M. at the foot of the post.

How (b) will these stresses be modified if the chain has *four* falls, and if it passes to the chain-barrel in a direction bisecting the angle between the jib and tie?

Ans.—(a) Stress in tie = W ; in jib = $W\sqrt{3}$. B. M. = $W\sqrt{3}$ ft. tons.
 (b) “ “ = $.87W$; “ = $1.87W$.

43. An ordinary jib-crane is required to lift a weight of 10 tons at a horizontal distance of 9 ft. from the axis of the post. The hanging part of the chain is in *four* falls; the jib is 15 ft. long, and the top of the post is $16\frac{1}{2}$ ft. above ground. Find the stresses in the jib and tie when the chain passes (1) along the jib, (2) along the tie.

The post turns round a vertical axis. Find the direction and magnitude of the pressure at the toe, which is 5 ft. below ground.

Ans.—(1) Stress in tie = $\frac{30\sqrt{5}}{11}$ tons; in jib = $11\frac{1}{2}$ tons.

(2) “ “ = $\left(\frac{30\sqrt{5}}{11} - 2\frac{1}{2}\right)$ tons; in jib = $9\frac{1}{11}$ tons.

Pressure on toe = $10\sqrt{10}$ tons, and is inclined to vertical at an angle $\tan^{-1}3$.

44. In the crane represented by the figure $AB = AC = 35$ ft.; $BC = 20$ ft.; $BD = 20$ ft.; the weight lifted = 25 tons; AC slopes at 45° ; the chain hangs in four falls and passes from A to D . Find the stresses in all the members and the upward pull at D .

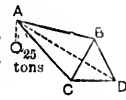

FIG. 126.

Ans. Stress in $BC = 26$; $AC = 47.6$; $AB = 28.4$; $CD = 21.7$ tons.
Vertical pull at $D = 31.3$ tons.

45. The figure represents the framing of an hydraulic crane. $AB = BD = DF = FG = HK = 7$ ft.; $KG = BC = 2\frac{1}{2}$ ft. Find the stresses in the members of the crane when the weight (1 ton) lifted is (a) at A ; (b) at B ; (c) at D . Also (d) find the stresses when there is an additional weight of $\frac{1}{2}$ ton at each of the points B, D, F , and G .



FIG. 127.

Ans.—(a) Stress in tons in $AB = BD = 2$; $DF = FG = \frac{4^2}{11}$;

$$KG = \frac{117}{26}; AC = \sqrt{5}; CE = \frac{20}{9} \sqrt{2};$$

$$EH = \frac{27720}{9009} \sqrt{2}; CD = \frac{5}{9} \sqrt{5};$$

$$DE = \frac{5}{99} \sqrt{317}; EG = \frac{5}{143} \sqrt{317};$$

$$HG = \frac{5\sqrt{5}}{26}; BC = EF = 0.$$

(b) Stress in tons in $AB = 0 = AC$; $BC = 1$; $CE = \frac{10}{9} \sqrt{2}$;

$$HE = \frac{30}{13} \sqrt{2}; DF = FG = \frac{28}{11}; GK = \frac{7}{2};$$

$$CD = \frac{7}{9} \sqrt{5}; DE = \frac{7}{99} \sqrt{317};$$

$$EG = \frac{7}{143} \sqrt{317}; HG = \frac{7\sqrt{5}}{26}.$$

(c) Stress in $AB = 0 = AC = BC = DC = BD = CE$;

$$DF = \frac{14}{11} = FG; DE = \frac{1}{11} \sqrt{317};$$

$$GE = \frac{9}{143} \sqrt{317}; GH = \frac{9}{26} \sqrt{5};$$

$$HE = \frac{20}{13} \sqrt{2}; KG = 2\frac{1}{2}.$$

(a) Stress in tons in $AB = 0 = AC$; $BC = \frac{1}{2} = EF$;

$$FD = \frac{21}{11} = FG; \quad KG = \frac{62}{13}; \quad CE = \frac{5\sqrt{2}}{9};$$

$$HE = \frac{30\sqrt{2}}{13}; \quad DE = \frac{8}{99}\sqrt{317};$$

$$GE = \frac{27}{286}\sqrt{317}; \quad HG = \frac{20}{13}\sqrt{5};$$

$$DC = \frac{7}{18}\sqrt{5}.$$

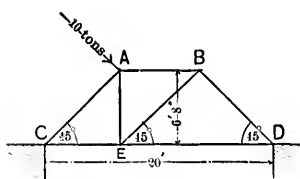

FIG. 128.

46. The inclined bars of the trapezoidal truss represented by the figure make angles of 45° with the vertical; a load of 10 tons is applied at the top joint of the left rafter in a direction of 45° with the vertical. Assuming the reaction at the right to be vertical, find the stresses in all the pieces of the frame.

Ans. Vert. reaction at $D = \frac{10}{3}\sqrt{2}$; stress in $DE = \frac{10}{3}\sqrt{2}$;

$$DB = 6\frac{2}{3}; \quad BE = 6\frac{2}{3}; \quad BA = \frac{20}{3}\sqrt{2}; \quad AE = \frac{10}{3}\sqrt{2};$$

$$AC = \frac{10}{3}; \quad CE = \frac{5}{3}\sqrt{2} \text{ tons.}$$

47. The post of a derrick-crane is 30 ft. high; the horizontal traces of the two back-stays are at right angles to each other, and are 15 ft. and 25 ft. in length. Show that the angle between the shorter trace and the plane of the jib and tie, when the stress in the post is a maximum, is $30^\circ 58'$.

Also find the greatest stresses in the different members of the crane when the jib, which is 50 ft. long and is hinged at the foot of the post, is inclined at 45° to the vertical, the weight lifted being 4000 lbs.

Ans. Stress in jib = 6666 $\frac{2}{3}$ lbs.; in tie = 4768.4 lbs.; max. thrust along post = 10991.5 lbs.; max. stress on long back-stay = 7362.7 lbs.; on short back-stay = 10539 lbs.

48. A queen-truss for a roof consists of two horizontal members, the lower 48 ft. long, the upper 16 ft. long; two inclined members AB , DC , and two queens BE , CF , each 8 ft. long; the points E , F divide AD into three equal segments; the load upon the members AB , BC , CD is 120 lbs. per lineal foot. Find (a) the stresses in the several members. How (b) will these stresses be modified if struts are introduced from the

feet of the queens to the middle points G, H of the inclined members? In this latter case also, determine (c) the stresses due to a wind-pressure of 120 lbs. per lineal ft. normal to AB , assuming that the horizontal reaction is equally divided between the two supports at A and D .

Ans.—(a) Stress in lbs. in $AE = 4066.56 = EF = DF = BC$;
 $AB = 4546.56 = CD$; $BE = 2033.28 = CF$.

(b) Stress in lbs. in $AE = 5139.84 = DF$;
 $BC = 4066.56 = AF$; $AG = 5746.56 = DH$;
 $BG = 4546.56 = CH$; $EG = 1200 = FH$;
 $BE = 536.64 = CF$.

(c) Additional stress in $AG = 1040\sqrt{5}$; $BG = 680\sqrt{5}$;
 $GE = 600\sqrt{5}$; $AE = 2320$; $BE = 600$; $BC = 400\sqrt{5}$;
 $BE = 400\sqrt{5}$; $CF = 400$; $CB = 400\sqrt{5}$; $EF = 1120$;
 $FD = 320$.

(In case (c) the brace BF is introduced to prevent distortion.)

49. A pair of shear-legs, each 25 ft. long, with the point of suspension 20 ft. vertically above the ground surface, is supported by a tie 100 ft. long; distance between feet of legs = $10\sqrt{5}$ ft. Find the thrusts along the legs and the tension in the tie when a weight of 2 tons is being lifted.

Ans. Tension in tie = 1.137 tons; compn. in each leg = 1.87 tons.

50. In the crane ABC , the vertical post $AB = 15'$, the jib $AC = 23'$, and the angle $BAC = 30^\circ$. Find (a) the stresses in the jib and tie, and also the bending moment at the foot of the post when the crane lifts a weight of 4 tons.

The throw is increased by adding two horizontal members CE, BD and an inclined member DE , the figure BE being a parallelogram and the diagonal CD coincident in direction with CA . Find (b) the stresses in the several members of the crane as thus modified, the weight lifted being the same.

In the latter case show (c) how the stresses in the members are affected when the chain, which is in four falls, passes from E to B and then down the post.

Ans.—(a) Tension in tie = $3\frac{1}{2}$ tons; thrust in jib = $6\frac{2}{5}$ tons;
 (b) Stress in $CE = 9.34$; in $ED = 10.16$; in $CB = 13.49$;
 in $CD = 6.15$; in $DA = 10.7$; in $BD = 7$ tons.
 (c) Stress in $CE = 8.9$; in $ED = 10.7$; in $CB = 12.9$;
 in $CD = 5.8$; in $DA = 10.7$; in $BD = 7.4$ tons.

51. The horizontal traces of the two back-stays of a derrick-crane are x and y feet in length, and the angle between them is β . Show that the stress in the post is a maximum when $\frac{\cos(\beta - \theta)}{\cos \theta} = \frac{x}{y}$, θ being the angle between the trace x and the plane of the jib and tie.

52. The two back-stays of a derrick-crane are each 38' long, and the angle between their horizontal traces $2 \tan^{-1} \frac{1}{2}$; height of the crane-post = 32'; the length of the jib = 40'; the throw of the crane = 20'; the weight lifted = 4 tons. Determine the stresses in the several members and the upward pull at the foot of each back-stay when the plane of the jib and post (*a*) bisects the angle between the horizontal traces of the back-stays, (*b*) passes through a back-stay.

Ans. In jib = 5; in tie = 2.52 tons; in back-stay in (*a*) = 2.56, in (*b*) = 4.7 tons.

53. Find the stresses in the members of the crane represented by the figure; also find balance-weight at *C*.

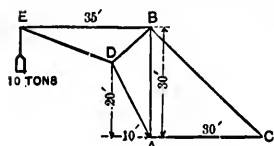

FIG. 129.

Ans. Stress in $BE = 25$; $DE = 26.9$;
 $DB = 21.83$; $DA = 26.08$;
 $BA = 24.3$; $BC = 18.12$ tons.
 Counterweight at $C = 15.14$ tons.

54. Draw the stress diagram for the truss represented by the figure, the load at each of the points *B* and *C* being 500 lbs.

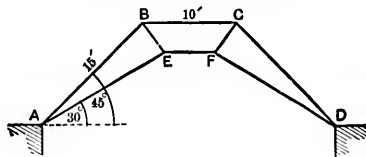

FIG. 130.

Also, if the rafter *AB* is subjected to a nominal wind-pressure of 100 lbs. per lineal ft., introduce the additional member required to prevent deformation, and state in lbs. the stress it should be designed to bear. Draw the stress diagram of the modified truss, assuming that the foot *A* is fixed, and that there are rollers at *D*.

($AB = AE = 15'$; $BC = 10'$; angle $BAD = 45^\circ$; angle $EAD = 30^\circ$.)

55. The post *AB* of a jib-crane is 20 ft.; the jib *AC* is inclined at 30° and the tie *BC* at 45° to the vertical; the weight lifted is 5 tons. Find the stresses in the jib and tie when the chain passes (*a*) along the jib, (*b*) along the tie, (*c*) horizontally from *C* to the post.

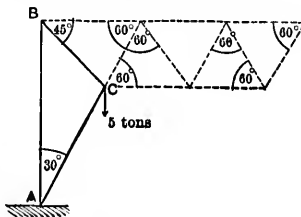

FIG. 131.

The chain has *two* falls.

56. In a mansard roof of 12 ft. rise, the upper triangular portion (of 4 ft. rise) has its rafters inclined at 60° to the vertical. The rafters of the

lower portion are inclined at 30° to the vertical. If there is a load of 1000 lbs. at the ridge, find the load at each intermediate joint necessary for equilibrium, and the thrust of the roof.

A load of 2000 lbs. is concentrated at each of the intermediate joints and a brace is inserted between these joints. Find the stress in the brace.

Ans. 1000 lbs.; thrust = $500\sqrt{3}$ lbs.; $333\frac{1}{3}\sqrt{3}$ lbs.

57. The horizontal boom CD is divided into eight segments, each 8 ft. long, by seven intermediate supports; the depth of the truss at each end = 16 ft.; a weight of 1 ton is concentrated at C and at D , and a weight of 2 tons at each of the points of division. Determine the stresses in the several members.

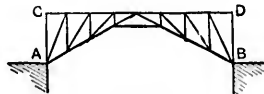

FIG. 132.

58. The figure is a skeleton diagram of a roof-truss of 72 ft. span and 12 ft. deep; G, K, L, O, H are respectively the middle points of AE, EL, EF, LF, FB ; $AE = EL = LF = FB = 20$ ft.; the trusses are 12 ft. centre to centre; the dead weight of the roof = 12 lbs. per sq. ft.; the normal wind-pressure upon AE may be taken = 30 lbs. per sq. ft.; the end A is fixed and B is on rollers. Draw a stress diagram. Show by dotted lines how the stress diagram is modified with rollers under A, B being fixed.

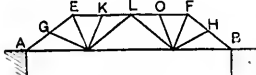

FIG. 133.

59. The platform of a bridge of 84 ft. span and 9 ft. deep is carried by a pair of trusses of the type shown in the figure. If the load borne by each truss is 300 lbs. per lineal ft., find the stresses in all the members.

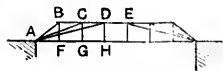

FIG. 134.

Ans. Stress in $AB = 6000$; $AC = 1200\sqrt{73}$; $AD = 3600\sqrt{17}$; $BC = 4800$; $CD = 14400$; $DE = 28800$.

Stress in horiz. chord = 288000; in each vertical = 3600 lbs.

60. The figure represents the shore portion of one of the trusses for a cantilever highway bridge. The depth of truss over pier = 51 ft.; the length of each panel = 17 ft.; the load at A (from weight of centre span) = 16800 lbs.; the width of roadway = 15 ft.; the load per sq. ft. of roadway = 80 lbs. Find the stresses in all the members, assuming the reaction at the pier F to be vertical.

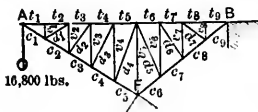

FIG. 135.

Ans. $t_1 = t_2 = 28000$; $t_3 = 36500$; $t_4 = 45000$; $t_5 = 53500$; $t_6 = 55200$; $t_7 = 48400$; $t_8 = 41600 = t_9$; $c_1 = 5600\sqrt{34}$; $c_2 = 7300\sqrt{34}$; $v_1 = 10200$; $v_2 = 15300$; $v_3 = 20400$;

$$\begin{aligned}
 v_4 &= 25500; v_5 = 45900; v_6 = 20400; v_7 = 15300; \\
 v_8 &= 10200; c_2 = 9000 \sqrt{34}; c_3 = 10700 \sqrt{34}; \\
 c_4 &= 12400 \sqrt{34}; c_5 = 77500; c_6 = 69000; c_7 = 60500; \\
 c_8 &= 53000; d_1 = 1700 \sqrt{34}; d_2 = 1700 \sqrt{61}; \\
 d_3 &= 1700 \sqrt{106}; d_4 = 22100; d_5 = 1700 \sqrt{97}; \\
 d_6 &= 3400 \sqrt{13}; d_7 = 8500 \text{ lbs.}
 \end{aligned}$$

61. The inner flange of a bent crane forms a quadrant of a circle of 20 ft. radius, and is divided into *four* equal bays. The outer flange forms the segment of a circle of 23 ft. radius. The two flanges are 5 ft. apart at the foot, and are struck from centres in the same horizontal line. The bracing consists of a series of isosceles triangles, of which the bases are the equal bays of the inner flange. The crane is required to lift a weight of 10 tons. Determine the stresses in all the members.

62. A braced semi-arch is 10 ft. deep at the wall and projects 40 ft. The upper flange is horizontal, is divided into *four* equal bays, and carries a uniformly distributed load of 40 tons. The lower flange forms the segment of a circle of 104 ft. radius. The bracing consists of a series of isosceles triangles of which the bases are the equal bays of the upper flange. Determine the stresses in all the members.

63. The domed roof of a gas-holder for a clear span of 80 ft. is strengthened by secondary and primary trussing as in the figure. The points *B* and *C* are connected by the tie *BPC* passing beneath the central strut *AP*, which is 15 ft. long, and is also common to all the primary trusses; the rise of *A* above the horizontal is 5 ft.; the secondary truss *ABEF* consists of the equal bays *AH*, *HG*, *GB*, the ties *BE*, *EF*, *FA*, of which *BE* is horizontal, and the struts *GE*, *FH*, which are each 2 ft. 6 in. long and are parallel to the radius to the centre of *GH*; the secondary truss *ACKL* is similar to *ABEF*; when the holder is empty the weight supported by the truss is 36000 lbs., which may be assumed to be concentrated at *G*, *H*, *A*, *M*, *N*, in the proportions 8000, 4000, 1000, 4000, and 8000 lbs., respectively. Determine the stresses in the different members of the truss.



FIG. 136.

64. The figure is the skeleton diagram of a cantilever for a viaduct in

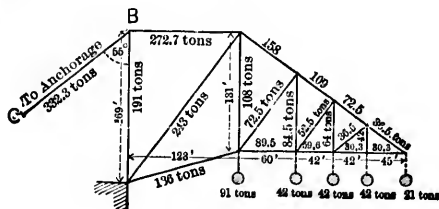

FIG. 137.

India. Determine *graphically* the stresses in the various members under the loading indicated.

65. In the accompanying roof-truss $AB = AC = 30$ ft., and the struts are all normal to the rafters. Find the stresses in all the members, the load at each of the joints in the rafters being 2 tons (angle $ABC = 30^\circ$ and angle $DBC = 10^\circ$). How will the stresses be modified if there is a force of 2 tons acting at each of the points of support between A and B at right angles to the rafter, and a force of 1 ton at A , assuming that the end B is fixed and that C rests upon rollers?

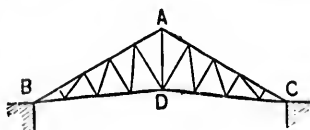

FIG. 138.

66. The figure represents a portion of a Warren girder cut off by the plane MN and supported upon the abutment at A . The reaction at $A = 20$ tons; the load concentrated at each of the points $B = 4$ tons. Find the stresses in each of the members met by MN .

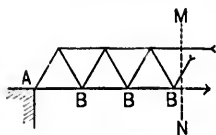

FIG. 139.

Ans. Stress in tension chord = $\frac{104}{3} \sqrt{3}$ tons;

in compression chord = $32 \sqrt{3}$ tons; compression in diagonal = $\frac{16}{3} \sqrt{3}$ tons.

67. The figure represents a portion of a roof-truss cut off by a plane MN and supported at A . The strut DC is vertical; $AD = 23$ ft., and the distance of D from $AC = 7\frac{1}{2}$ ft.; the angle between AC and the horizontal = $\cos^{-1}\frac{4}{5}$; the vertical reaction at $A = 7$ tons; the horizontal reaction at $A = 2\frac{1}{2}$ tons; at each of the points B and C a weight of 4 tons is concentrated. Find the stresses in the members met by MN . (AD and T_1 make equal angles with the rafter and $DB = DC$.)

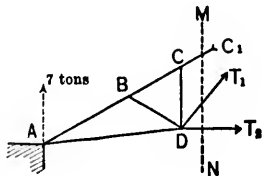

FIG. 140.

Ans. $C_1 = 13.2$ tons; $T_2 = 2.1$ tons; $T_1 = 10.8$ tons.

68. The feet of the equal roof-rafter AB, AC are tied by rods BD, CD which meet under the vertex and are joined to it by a rod AD . If W_1, W_2 are the uniformly distributed loads in pounds upon AB, AC , respectively, and if S is the span of the roof in feet, find the weight of metal (wrought-iron) in the ties.

Ans. $\frac{5}{6} \frac{W_1 + W_2}{f} S \cot \beta$, f being inch-stress in pounds, and β the angle ABD .

(a) If $AB = AC = 20$ ft., $AD = 5$ ft., the angle $BAD = 60^\circ$, find

the stresses in the several members when a weight of 3500 lbs. is concentrated at the vertex.

Ans. 7000 lbs.; 6309.8 lbs.; 3500 lbs.

(b) The roof in (a) is loaded with 10 lbs. per square foot on one side and 33 lbs. per square foot on the other; the trusses being 13 ft. centre to centre. Determine (a) the stresses in the several members. Examine (b) the effect of a horizontal pressure of 14 lbs. per square foot on the most heavily loaded side, assuming that the reaction is equally divided between the two supports.

Ans. (a) 11180 lbs.; 10077.65 lbs.; 5590 lbs.

69. In the truss represented in the accompanying figure, the load on $AB = W_1$, on $AC = W_2$; the angle $ABD = \beta$; $AD = BD = AE = CE$. Find the total weight of metal (wrought-iron) in the tie-rods.



FIG. 141.

Ans. $\frac{5}{6} \frac{W_1 + W_2}{f} S \cot \beta$; S being the span

and f the inch-stress.

(a) If the stress in BD or EC is equal to the stress in DE , show that $\beta = 60^\circ - \frac{\alpha}{3}$; α being the angle ABC .

(b) The trusses are 12 ft. centre to centre; the span is 40 ft.; the horizontal tie is 16 ft. long; the rafters are inclined at 60° to the vertical; the dead weight of the roof, including snow, is estimated at 10 lbs. per sq. ft. of roof-surface. Determine the stress in each member when a wind blows on one side with a force of 30 lbs. per sq. ft. normal to the roof-surface, assuming that the horizontal reaction (1) is wholly borne at B , (2) is equally divided between the supports.

Ans.—(1) Stress in $AB = 8956.8$ lbs.; $BD = 10015.2$ lbs. = EC ;
 $AD = 2503.8$ lbs. = AE ; $DE = 8196$ lbs.;
 $AC = 11356.8$ lbs.

(2) Stress in $AB = 7756.8$ lbs.; $BD = 6840.9$ lbs. = EC ;
 $AD = 1710$ lbs. = AE ; $AC = 10156.8$ lbs.

70. In the truss represented by the accompanying figure, the load upon $AB = W_1$, upon $AC = W_2$; the angle $ABD = \beta$; the span $BC = S$; the ties AD, BD, AE, CE are equal; F and G are the middle points of the rafters. Find the amount of metal in the tie-rods (wrought-iron).

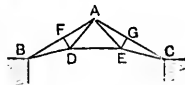

FIG. 142.

Ans. $\frac{5}{6} \frac{S}{f} \frac{W_1 + (W_1 + W_2) \cos^2 \beta}{\sin \beta \cos \beta}$.

(a) The struts DF and EG are each 5 ft.; the angle $ABC = 30^\circ$; the dead weight of the roof, including snow, is 9 lbs. per square foot of roof-surface, and the trusses are 12 ft. centre to centre. Determine the stresses in the several members when a wind blows with a force of 30

lbs. per square foot of roof-surface normal to the side AB . The span = 60 ft., and the end C rests upon rollers.

Secondly, determine the stresses produced in the members of the truss in the preceding question when a single weight of 3000 lbs. is suspended from G .

Ans.—(1) Stresses in BD ; DA ; DE ; EA ; EC ;
 BF ; FA ; FD ; CG ; GA ; GE .
 31238.55; 19852.35; 12633.6; 8113.5; 24379.43;
 29620.44; 28685.16; 7855.2; 22420.44; 21485.16; 1620 lbs.

(2) Stresses in BD ; DA ; DE ; EA ; EC ;
 BF ; FA ; FD ; CG ; GA ; GE .
 375 $\sqrt{39}$; 125 $\sqrt{39}$; 1000 $\sqrt{3}$; 875 $\sqrt{39}$; 1125 $\sqrt{39}$;
 2625; 2625; 0; 7875; 6375; 1500 $\sqrt{3}$ lbs.

(b) The rafters AB , AC are of unequal length and make angles of 60° and 45° , respectively, with the vertical; the strut $DF = 7\frac{1}{2}$ ft.; the tie DE is horizontal; the dead load upon each rafter = 100 lbs. per lineal foot; the wind-pressure normal to $AB = 300$ lbs. per lineal foot, rollers are placed at C . Find the stresses in all the members. The rafter $AB = 45$ ft.

Show by dotted lines how the stress diagram will be modified:

- (1) If the rollers are placed at B .
- (2) If the strut DF is omitted.
- (3) If a single weight of 500 lbs. is concentrated at D .

(c) If it is assumed that the horizontal reaction is equally divided between B and C , show that the stress in DE due to a horizontal wind-pressure upon AB is nil; the angle ABC being 30° .

(d) In a given roof, the rafters are of pitch-pine, the tie-rods of wrought-iron: the span is 60 ft.; the trusses are 12 ft. centre to centre; $DF = 5$ ft. = EG ; the angle $ABC = 30^\circ$; the dead weight of the roof, including snow, is 9 lbs. per sq. ft. of roof-surface; rollers are placed at C ; a single weight of 3000 lbs. is suspended from F , and the roof is also designed to resist a normal wind-pressure of 26.4 lbs. per sq. ft. of roof-surface on one side AB . Determine the stresses in the several members.

71. In the truss represented in the accompanying figure. the struts DF , DH , EG , EK are equal, and the ties BD , AD , EA , EC are also equal; the load upon AB is W_1 , and upon AC is W_2 . Find the weight of metal (wrought-iron) in the ties.

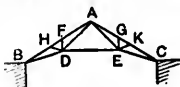

FIG. 143.

$$\text{Ans. } \frac{5}{18} \frac{S}{f} \frac{4W_1 + 3(W_1 + W_2) \cos^2 \beta}{\cos \beta \sin \beta}$$

(a) $AD = AE = BD = EC = 23$ ft.; the angle $ABC = 30^\circ$; the span = 79 ft.; the trusses are 13 ft. centre to centre; the heel B is free to

slide on a smooth wall-plate; the dead weight of the roof, including snow, is 8 lbs. per square foot of roof-surface. Determine the stress to which each member is subjected when the wind blows horizontally with a force of 40 lbs. per square foot of vertical surface (1) upon the side AB , (2) upon the side AC .

Ans. See Ex. 3, Art. 24.

(b) The rafters AB, AC are inclined at 60° to the vertical and are each 40 ft. in length. The foot C rests on rollers, and the foot B is fixed. The strut DF is vertical, is 10 ft. long, and is equal to the strut DE in length. Also $AF = HF = 10$ ft. The dead load carried by the rafters is 120 lbs. per lineal foot. Provision has also to be made for a normal wind-pressure upon AB of 300 lbs. per lineal foot. Draw the stress diagram, and show how it will be modified if the strut DF is removed.

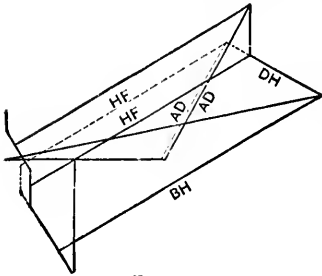

FIG. 144.

Ans. Vertical reaction at $B = 10528$ lbs. both before and after DF is removed.

Horizontal reaction at $B = 6000$ lbs.

The dotted lines show the modified stresses for one half of the truss.

72. The load upon a roof-truss of the accompanying type is 1000 lbs. at each joint; the span 100 ft.; the rise = 25 ft. Find the stresses in

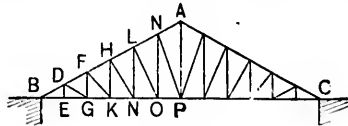

FIG. 145.

the different members. How will the stresses be affected by an additional load of 250 lbs. at each of the joints between the foot and ridge on one side?

Ans. Stress in $BD = 5500\sqrt{5}$; $DF = 5000\sqrt{5}$;
 $FH = 4500\sqrt{5}$; $HL = 4000\sqrt{5}$; $LN = 3500\sqrt{5}$;
 $NA = 3000\sqrt{5}$; $DE = 0$; $FG = 500$; $HK = 1000$;
 $LM = 1500$; $NO = 2000$; $AP = 5000$;
 $BE = 11000 = EG$; $GK = 10000$; $KM = 9000$;
 $MO = 8000$; $OP = 7000$; $DG = 500\sqrt{5}$;
 $FK = 1000\sqrt{2}$; $HM = 500\sqrt{13}$; $LO = 1000\sqrt{5}$;
 $NP = 500\sqrt{29}$ lbs.

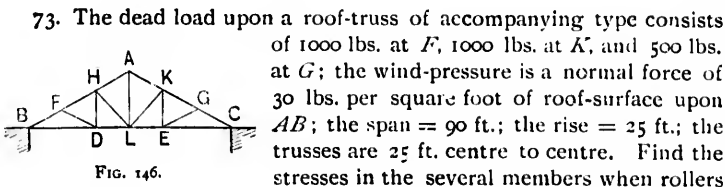

FIG. 146.

73. The dead load upon a roof-truss of accompanying type consists of 1000 lbs. at *F*, 1000 lbs. at *K*, and 500 lbs. at *G*; the wind-pressure is a normal force of 30 lbs. per square foot of roof-surface upon *AB*; the span = 90 ft.; the rise = 25 ft.; the trusses are 25 ft. centre to centre. Find the stresses in the several members when rollers are (a) at *C*, (b) at *B*.

Ans.—(a) Reaction (vertical) at *C* = 12291 $\frac{3}{8}$ lbs.; vertical reaction at *B* = 23958 $\frac{1}{8}$ lbs.; horizontal reaction at *B* = 18750 lbs.

Tension in *BD* = 48625; *DL* = 34475; *LE* = 21675; *EC* = 22125; *DH* = 7861 $\frac{1}{8}$; *AL* = 15888 $\frac{3}{8}$; *KE* = 250 lbs.

Compression in *BF* = 3666 $\frac{3}{8}$ $\sqrt{106}$; *FH* = 2788 $\frac{3}{8}$ $\sqrt{106}$; *HA* = 1977 $\frac{3}{8}$ $\sqrt{106}$; *AK* = 2325 $\sqrt{106}$; *KG* = 2408 $\frac{1}{8}$ $\sqrt{106}$; *GC* = 2458 $\frac{1}{8}$ $\sqrt{106}$; *DF* = 1572 $\frac{3}{8}$ $\sqrt{106}$; *LH* = 1505 $\frac{3}{8}$ $\sqrt{181}$; *LK* = 83 $\frac{1}{8}$ $\sqrt{181}$; *EG* = 50 $\sqrt{106}$ lbs.

(b) Only alteration in stresses is that each stress in the different sections of the horizontal tie is diminished by 18750 lbs.; all the remaining stresses are unchanged.

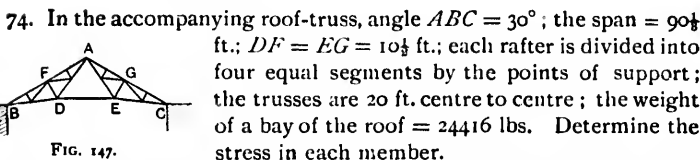

FIG. 147.

74. In the accompanying roof-truss, angle *ABC* = 30°; the span = 90 $\frac{1}{2}$ ft.; *DF* = *EG* = 10 $\frac{1}{2}$ ft.; each rafter is divided into four equal segments by the points of support; the trusses are 20 ft. centre to centre; the weight of a bay of the roof = 24416 lbs. Determine the stress in each member. Also determine the stresses due to a wind-pressure of 30 lbs. per square foot of roof-surface acting normally to *AB*, when rollers are under (a) *C*, (b) *B*.

75. The figure represents a bowstring truss of 80 ft. span, cut off by the plane *MN* and supported at *O*. The upper flange *OCDE* is an arc of a circle of 85 ft. radius; *OA* = *AB* = etc. = 10 ft.; the rise of the truss = 10 ft.; a load of 15 tons is concentrated at each of the points *A* and *B*; the reaction at *O* = 45 tons. Find the stresses in the members cut by the plane *MN*.

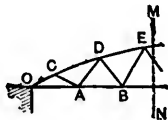

FIG. 148.

76. The figure is a portion of a bridge-truss cut off by the plane MN and supported upon the abutment at A ; $AC = CE = 14\frac{1}{2}$ ft.; the depth $BC = DE = 17\frac{1}{2}$ ft.; in the third panel the compression in the upper chord is 64,600 lbs.; the tension in the lower chord is 53,800 lbs. Find the reaction at A , the equal weights supported at C and E , and the diagonal stress T .

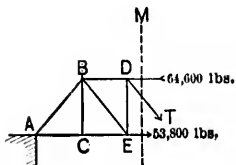

FIG. 149.

Ans. Reaction = 38,943 lbs.; weight at C and at E = 12,954 lbs.; T = 16,578 lbs.

77. The top beam of a roof for a clear span of 96 ft. consists of six bars AB, BC, CD, DE, EF, FG , equal in length and so placed that A, B, C, D, E, F, G are on circle of 80 ft. radius; the lower boom also consists of six equal rods AH, HK, KL, LM, MN, NG , the points H, K, L, M , and N being on a circle of 148 ft. radius; B is connected with H , C with K , D with L , E with M , and F with N ; the opposite corners of the bays are connected by cross-braces; the end A is fixed to its support, G being allowed to slide freely over a smooth bed-plate. Determine graphically the stresses in the various members when there is a normal wind-pressure per lineal foot of 460 lbs. upon AB , 340 lbs. upon BC , and 60 lbs. upon CD .

78. A bowstring roof-truss, with vertical and diagonal bracing, of 50 ft. rise, and five panels, is to be designed to resist a wind blowing horizontally with a pressure of 40 lbs. per square foot. The depth of the truss at the centre is 10 ft. Determine, *graphically*, the stresses in the several members of the truss, assuming that the roof rests on rollers at the windward support.

79. Determine the chord, vertical and diagonal stresses in a Howe truss of 80 ft. span, 8 ft. depth, and ten panels, due to a load of 40 tons (*a*) concentrated at the centre; (*b*) concentrated at the third panel point; (*c*) uniformly distributed; (*d*) distributed so that 5 tons is at first panel point, 10 tons at second, and 25 tons at third.

Ans. Panel stresses in tension chord :

	1st	2d	3d	4th	5th	6th	7th	8th	9th	10th
<i>a</i>	20	40	60	80	100	100	80	60	40	20
<i>b</i>	28	56	84	72	60	60	48	36	24	12
<i>c</i>	18	32	42	48	50	50	48	42	32	18
<i>d</i>	30	55	70	60	50	50	40	30	20	10

Panel stresses in compression chord :

<i>a</i>	20	40	60	80	80	60	40	20		
<i>b</i>	28	56	84	72	42	36	24	12		
<i>c</i>	18	32	42	48	48	42	32	18		
<i>d</i>	30	55	70	60	40	30	20	10		

Stresses in verticals :

<i>a</i>	20	20	20	20	40	20	20	20	20
<i>b</i>	28	28	28	12	12	12	12	12	12
<i>c</i>	18	14	10	6	4	6	10	14	18
<i>d</i>	30	25	15	10	10	10	10	10	10

Diagonal stresses :

<i>a</i>	20	$\sqrt{2}$	tons	in	each	diago	nal.		
<i>b</i>	$28\sqrt{2}$	$28\sqrt{2}$	$28\sqrt{2}$	$12\sqrt{2}$	$12\sqrt{2}$	$12\sqrt{2}$	$12\sqrt{2}$	$12\sqrt{2}$	$12\sqrt{2}$
<i>c</i>	$18\sqrt{2}$	$14\sqrt{2}$	$10\sqrt{2}$	$6\sqrt{2}$	$2\sqrt{2}$	$2\sqrt{2}$	$6\sqrt{2}$	$10\sqrt{2}$	$14\sqrt{2}$
<i>d</i>	$30\sqrt{2}$	$25\sqrt{2}$	$15\sqrt{2}$	$10\sqrt{2}$	$10\sqrt{2}$	$10\sqrt{2}$	$10\sqrt{2}$	$10\sqrt{2}$	$10\sqrt{2}$

80. A Warren girder of 60 ft. span, composed of six equilateral triangles, carries upon its lower chord a weight of 2 tons at the first and second joints, 15 tons at the centre joint, and $7\frac{1}{2}$ tons at the fourth and fifth joints. Find the stresses in all the members.

Ans. Stresses in tension chord : 1st bay = $\frac{1}{2}\sqrt{3}$; 2d = $\frac{1}{2}\sqrt{3}$;
 3d = $\frac{5}{2}\sqrt{3}$; 4th = $\frac{7}{2}\sqrt{3}$;
 5th = $\frac{5}{2}\sqrt{3}$; 6th = $\frac{1}{2}\sqrt{3}$.

Stresses in compr. chord : 1st bay = $\frac{1}{2}\sqrt{3}$; 2d = $\frac{5}{2}\sqrt{3}$;
 3d = $\frac{7}{2}\sqrt{3}$; 4th = $\frac{5}{2}\sqrt{3}$;
 5th = $\frac{1}{2}\sqrt{3}$.

Diag. stresses 1st and 2d bays = $\frac{1}{2}\sqrt{3}$; 3d and 4th = $\frac{1}{2}\sqrt{3}$;
 5th and 6th = $\frac{1}{2}\sqrt{3}$; 7th and 8th = $\frac{1}{2}\sqrt{3}$;
 9th and 10th = $\frac{1}{2}\sqrt{3}$; 11th and 12th = $\frac{1}{2}\sqrt{3}$;

81. Determine the stresses in the members of a Fink truss of 240 ft. span and sixteen panels; depth of truss = 30 ft.; uniformly distributed load = *W*.

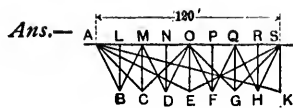

FIG. 150.

Stress in $BA, BM, DM, DO, FO, FQ,$

$HQ, HS,$ same and $= \frac{W\sqrt{5}}{64}$; in

CA, CO, GO, GS same and $= \frac{W}{16}\sqrt{2}$;

in EA, ES same and $= \frac{W}{8}\sqrt{5}$; in $AK = \frac{W}{4}\sqrt{17}$; in $BL,$

$DN, FP, HR,$ same and $= \frac{W}{16}$; in CM, GQ same and $= \frac{W}{8}$;

in $EO = \frac{W}{4}$; in $KS = \frac{W}{2}$; in AM, MO, OQ, QS same and

$= \frac{29}{64}W.$

82. Determine the stresses in the members of a Bollman truss 100 ft. long and $12\frac{1}{2}$ ft. deep, under a uniformly distributed load of 200 tons, together with a single load of 10 tons concentrated at 25 ft. from one end.

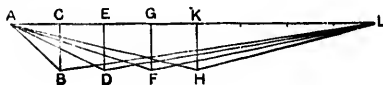

FIG. 151.

Ans. Stress in $AB = 1\frac{1}{2}\sqrt{2}$; $BL = 1\frac{1}{2}\sqrt{2}$; $AD = 1\frac{1}{2}\sqrt{5}$;

$DL = 2\frac{1}{2}\sqrt{37}$; $AF = 1\frac{1}{2}\sqrt{10}$; $FL = 1\frac{1}{2}\sqrt{26}$;

$AH = 2\frac{1}{2}\sqrt{17} = HL$; in $BC = 25 = FG =$

$HK = \text{etc.}; DE = 50 \text{ tons}; \text{compression along}$

$AL = 193\frac{1}{2} \text{ tons.}$

Note.—Questions 53, 54, 57-59, 61, 66, 67, 70, 71, 73, and 74 can be easily solved graphically.

83. Determine the stresses in the several members when the throw of the crane in Question 55 is increased by the introduction of the new members, shown by the dotted lines.

CHAPTER II.

SHEARING FORCES AND BENDING MOMENTS.

Note.—In this chapter it is assumed that all forces act in one and the same plane, and that the deformations are so small as to make no sensible alteration either in the forces or in their relative positions.

I. Equilibrium of Beams.—A *beam* is a bar of somewhat considerable scantling, supported at two points and acted upon by forces perpendicular or oblique to the direction of its length.

CASE I. AB is a beam resting upon two supports in the same horizontal plane. The reactions R_1 and R_2 at the points of support are vertical, and the resultant P of the remaining external forces must also act vertically in an opposite direction at some point C . According to the principle of the lever,

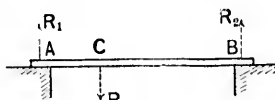

FIG. 152.

$$R_1 = P \frac{BC}{AB}, \quad R_2 = P \frac{AC}{AB}, \quad \text{and} \quad R_1 + R_2 = P.$$

CASE II. AB is a beam supported or *fixed* at one end. Such a support tends to prevent any deviation from the straight in that portion of the beam, and the less the deviation the more perfect is the fixture.

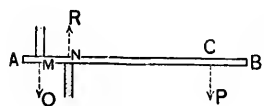

FIG. 153.

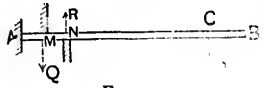

FIG. 154.

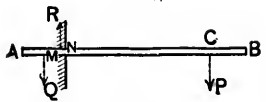

FIG. 155.

The ends may be fixed by means of two props (Fig. 153), or by allowing it to rest upon one prop and preventing upward motion by a ledge (Fig. 154), or by building it into a wall (Fig. 155). In any case it may be assumed that the effect of the fixture, whether perfect or imperfect, is to develop two unequal forces, Q and R , acting in opposite directions at points M and N . These two forces are equivalent

to a left-handed couple $(Q, -Q)$, the moment of which is $Q \cdot MN$, and to a single force $R - Q$ at N . Hence $R - Q$ must $= P$.

CASE III. AB is an inclined beam supported at A and resting upon a smooth vertical surface at B .

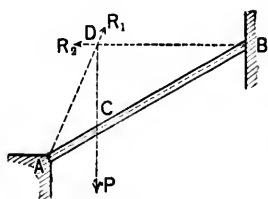

FIG. 156.

The vertical weight P , acting at the point C , is the resultant load upon AB . Let the direction of P meet the horizontal line of reaction at B in the point D .

The beam is kept in equilibrium by the weight P , the reaction R_1 at A , and the reaction R_2 at B . Now the two forces R_2 and P meet at D , so that the force R_1 must also pass through D .

$$\text{Hence } R_1 = P \frac{l}{\cos ADC} \text{ and } R_2 = P \tan ADC.$$

Note.—The same principles hold if the beam in Cases I and II is inclined, and also whatever may be the directions of the forces P and R_2 in Case III.

CASE IV. *In general*, let the beam AB be in equilibrium under the action of any number of forces $P_1, P_2, P_3, \dots, Q_1, Q_2, Q_3, \dots$, of which the magnitudes and points of appli-

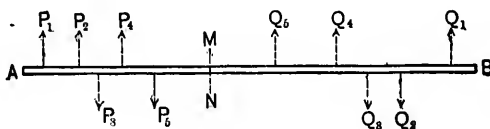
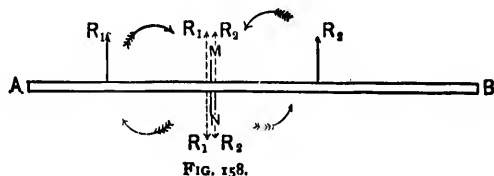

FIG. 157.

cation are given, and which act at right angles to the length of the beam. Suppose the beam to be divided into two segments by an imaginary plane MN . Since the whole beam is in equilibrium, each of the segments must also be in equilibrium. Consider the segment AMN .

It is kept in equilibrium by the forces P_1, P_2, P_3, \dots and by the reaction of the segment BMN upon the segment AMN at the plane MN ; call this reaction E_1 . The forces P_1, P_2, P_3, \dots are equivalent to a single resultant R_1 acting at a point distant r_1 from MN . Also, without affecting the equilibrium, two forces, each equal and parallel to R_1 , but opposite to one another in direction, may be applied to the segment AMN at the plane MN , and the three equal forces are then equivalent to a single force R_1 at MN , and a couple $(R_1, -R_1)$ of which the moment is $R_1 r_1$.



Thus the external forces upon AMN are reducible to a single force R_1 at MN , and a couple $(R_1, -R_1)$. These must be balanced by E_1 , and therefore E_1 is equivalent to a single force $-R_1$ at MN and a couple $(-R_1, R_1)$.

In the same manner the external forces upon the segment BMN are reducible to a single force R_2 at MN , and a couple $(R_2, -R_2)$ of which the moment is $R_2 r_2$. These again must be balanced by E_2 , the reaction of the segment AMN upon the segment BMN .

Now E_1 and E_2 evidently neutralize each other, so that the force R_1 and the couple $(R_1, -R_1)$ must neutralize the force R_2 and the couple $(R_2, -R_2)$. Hence the force R_1 and the couple $(R_1, -R_1)$ are respectively equal but opposite in effect to the force R_2 and the couple $(R_2, -R_2)$; i.e.,

$$R_1 = R_2 \quad \text{and} \quad R_1 r_1 = R_2 r_2; \quad \therefore r_1 = r_2.$$

The force R_1 tends to make the segment AMN slide over the segment BMN at the plane MN , and is called the *Shearing*

Force with respect to that plane. It is equal to the algebraic sum of the forces on the *left* of MN ,

$$= P_1 + P_2 - P_3 + \dots = \Sigma(P).$$

So $R_2 = Q_1 - Q_2 - Q_3 + \dots = \Sigma(Q)$ is the algebraic sum of the forces on the *right* of MN , and is the force which tends to make the segment BMN slide over the segment AMN at the plane MN . R_2 is therefore the *Shearing Force* with respect to MN , and is equal to R_1 in magnitude, but acts in an opposite direction.

Again, let $p_1, p_2, p_3, \dots, q_1, q_2, q_3, \dots$, be respectively the distances of the points of application of $P_1, P_2, P_3, \dots, Q_1, Q_2, Q_3, \dots$ from MN .

Then $R_1 r_1 =$ the algebraic sum of the moments about MN of all the forces on the *left* of MN ,

$$= P_1 p_1 + P_2 p_2 - P_3 p_3 + \dots = \Sigma(Pp),$$

is the moment of the couple ($R_1, -R_1$).

This couple tends to bend the beam at the plane MN , and its moment is called the *Bending Moment* with respect to MN of all the forces on the *left* of MN .

So $R_2 r_2 =$ the algebraic sum of the moments about MN of all the forces on the *right* of MN ,

$$= Q_1 q_1 - Q_2 q_2 - \dots = \Sigma(Qq),$$

is the *Bending Moment*, with respect to MN , of all the forces on the *right* of MN , and is equal but opposite in effect to $R_1 r_1$.

It is seen that the Shearing Force and Bending Moment *change sign* on passing from one side of MN to the other, so that to define them *absolutely* it is necessary to specify the segment under consideration.

Remark.—The reaction E_1 has been shown to be equivalent to the force $-R_1$ and the couple ($-R_1, R_1$). The Moment of this couple may be called the *Elastic Moment*, the *Moment of Resistance*, or the *Moment of Inflexibility*, and is equal in magnitude, but opposite in effect, to the corresponding Bending Moment due to the external forces.

2. Examples of Shearing Forces and Bending Moments.—In each of the following examples the beam is horizontal and of length l .

EX. 1. The beam OA , Fig. 159, is fixed at A and carries a weight P at O .

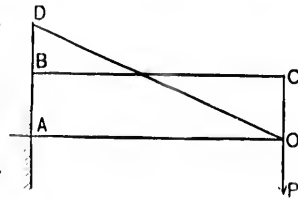

FIG. 159.

The *Shearing Force* (S) at every point of the beam is evidently constant and equal to P .

Upon the verticals through A and O take AB and OC each equal or proportional to P ; join BC . The vertical distance between any point of the beam and the line BC represents the shearing force at that point.

Again, the *Bending Moment* (M) at any point of the beam distant x from O is Px ; it is nil at O , and Pl at A .

Upon the vertical through A take AD equal or proportional to Pl ; join DO . The vertical distance between any point of the beam and the line DO represents the bending moment at that point.

EX. 2. The beam OA , Fig. 160, is fixed at A , and carries a uniformly distributed load, of intensity w per unit of length.

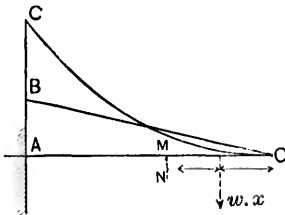

FIG. 160.

The resultant force on the right of a vertical plane MN distant x from O is wx and acts half-way between O and MN .

The *Shearing Force* (S) at MN is therefore wx ; it is nil at O , and wl at A .

Upon the vertical through A take AB equal or proportional to wl ; join BO . The vertical distance between any point of the beam and the line BO represents the shearing force at that point.

Again, the *Bending Moment* (M) at MN is $wx \frac{x}{2} = \frac{wx^2}{2}$; it is nil at O , and $\frac{wl^2}{2}$ at A . Upon the vertical through A take AC equal or proportional to $\frac{wl^2}{2}$.

The bending moment at any point of the beam is represented by the vertical distance between that point and a parabola CO having its vertex at O and its axis vertical.

Ex. 3. The beam OA , Fig. 161, is fixed at A and carries

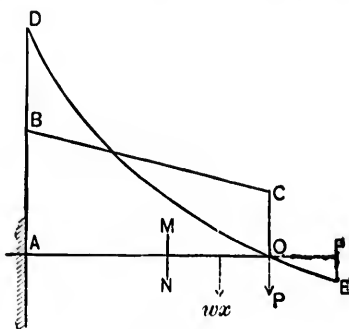

FIG. 161.

a single weight P at O , together with a uniformly distributed load of intensity w per unit of length.

The *Shearing Force* (S) at a plane MN distant x from O is evidently $P + wx$; it is P at O , and $P + wl$ at A .

Upon the verticals through O and A take OC equal or proportional to P , and AB equal or proportional to $wl + P$; join BC . The vertical distance between any point of the beam and the line BC represents the shearing force at that point.

Again, the *Bending Moment* (M) at MN is evidently

$$wx \frac{x}{2} + Px = \frac{wx^2}{2} + Px;$$

it is nil at O , and $\frac{wl^2}{2} + Pl$ at A .

Upon the vertical through A take AD equal or proportional to $\frac{wl^2}{2} + Pl$. The bending moment at any point of the beam is represented by the vertical distance between that point and a parabola DOE having its axis EF vertical and its

vertex at a point E , where $OF = \frac{P}{2w}$ and EF is equal or proportional to $\frac{P^2}{2w}$.

Note.—The ordinates of the line BC in Ex. 3, are equal to the algebraic sum of the corresponding ordinates of the straight lines BC and BO in Exs. 1 and 2. Also, the ordinates of the curve DO in Ex. 3, are equal to the algebraic sum of the corresponding ordinates of the line DO in Ex. 1, and the curve CO in Ex. 2. Hence the same conclusions as in Ex. 3 are arrived at by treating the weight P and the load wl independently, and then superposing the respective results.

EX. 4. The beam OA , Fig. 162, rests upon two supports at O and A , and carries a weight P at a point B , dividing the beam into the two segments OB , BA , of which the lengths are a and b respectively.

The reactions R_1 , R_2 at O and A are vertical, and according to the principle of the lever,

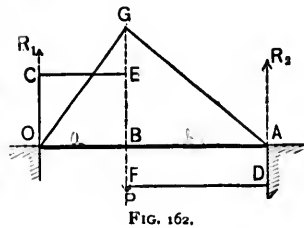

$$R_1 = P \frac{b}{l} \quad \text{and} \quad R_2 = P \frac{a}{l}.$$

The *Shearing Force* (S) at every point between O and B is constant and equal to $R_1 = P \frac{b}{l}$. On passing B the shearing force (S) changes sign, and its value at every point between B and A is constant and equal to $R_1 - P = -P \frac{a}{l} = -R_2$. Upon the verticals through O , B , and A take OC , BE , each equal or proportional to $\frac{Pb}{l}$, and BF , AD , each equal or proportional to $\frac{Pa}{l}$; join CE and DF . The shearing force at any point of the beam is represented by the vertical distance between that point and the broken line $CEFD$.

Again, the *Bending Moment* (M) at any point between O and B distant x from O is $R_1x = P\frac{b}{l}x$; it is nil at O , and $P\frac{ab}{l}$ at B .

The *Bending Moment* (M) at any point between B and A distant x from O is $R_1x - P(x - a) = P\frac{a}{l}(l - x)$; it is $P\frac{ab}{l}$ at B , and nil at A .

Upon the vertical through B take BG equal or proportional to $P\frac{ab}{l}$; join OG and AG . The bending moment at any point of the beam is represented by the vertical distance between that point and the line OGA .

Cor.—If P be at the centre of the beam, $S = \frac{P}{2}$, and M at the centre $= \frac{Pl}{4}$.

EX. 5. The beam OA , Fig. 163, rests upon two supports at O and A , and carries a uniformly distributed load of intensity w per unit of length.

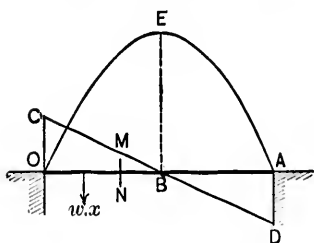

FIG. 163.

The reactions at O and A are each equal to $\frac{wl}{2}$.

The resultant force between O and a plane MN distant x from O is wx , and acts half-way between O and MN . The *Shearing Force* (S) at MN is therefore $\frac{wl}{2} - wx$; it is $\frac{wl}{2}$ at O , nil at the middle point B , and $-\frac{wl}{2}$ at A . Upon the verticals through O and A take OC and AD , each equal or proportional to $\frac{wl}{2}$; join CD . The shearing force at any point of the beam is represented by the vertical distance between that point and the line CD .

Again, the *Bending Moment* (M) at MN is

$$\frac{wl}{2}x - wx\frac{x}{2} = \frac{wl}{2}x - \frac{wx^2}{2};$$

it is nil at O and at A ; it is a maximum and equal to $\frac{wl^2}{8}$ at the middle point B . Upon the vertical through B take BE equal or proportional to $\frac{wl^2}{8}$. The bending moment at any point of the beam is represented by the vertical distance between that point and a parabola OEA having its vertex at E and its axis vertical.

Cor. 1. The shearing force is a minimum and zero at the centre, a maximum and $\frac{wl}{2}$ at the ends, and increases uniformly with the distance from the centre.

Cor. 2. The bending moment is a minimum and zero at the ends, a maximum and $\frac{wl^2}{8}$ at the centre, and diminishes as the distance from the centre increases.

Ex. 6. The beam OA , Fig. 164, rests upon two supports at O and A , and carries a weight P at a point B , together with a uniformly distributed load of intensity w per unit of length.

Let the lengths of the segments OB , BA be a and b , respectively.

The reactions R_1 at O , and R_2 at A , are vertical, and according to the principle of the lever,

$$R_1 = P\frac{b}{l} + \frac{wl}{2}$$

and

$$R_2 = P\frac{a}{l} + \frac{wl}{2}.$$

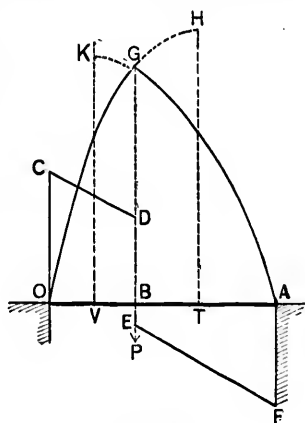

FIG. 164.

The *Shearing Force* (S) at any vertical plane between O and B distant x from O is

$$R_1 - wx = P\frac{b}{l} + \frac{wl}{2} - wx;$$

it is $\frac{Pb}{l} + \frac{wl}{2}$ at O , and $\frac{Pb}{l} + \frac{wl}{2} - wa$ at B .

The *Shearing Force* (S) at any plane between B and A distant x from O is

$$R_1 - P - wx = P\frac{b}{l} + \frac{wl}{2} - P - wx = \frac{wl}{2} - P\frac{a}{l} - wx;$$

it is $\frac{wl}{2} - P\frac{a}{l} - wa$ at B , and $-\frac{Pa}{l} - \frac{wl}{2}$ at A .

Upon the verticals through O , B , and A take OC equal or proportional to $\frac{Pb}{l} + \frac{wl}{2}$, BD equal or proportional to $\frac{Pb}{l} + \frac{wl}{2} - wa$, BE equal or proportional to $\frac{wl}{2} - P\frac{a}{l} - wa$, and AF equal or proportional to $-\frac{wl}{2} - P\frac{a}{l}$; join CD and EF . The shearing force at any point of the beam is represented by the vertical distance between that point and the broken line $CDEF$.

If $\frac{wl}{2} > \frac{Pa}{l} + wa$, BE is positive, and therefore E is vertically above B .

Again, the *Bending Moment* (M) at any point between O and B is

$$\left(P\frac{b}{l} + \frac{wl}{2}\right)x - \frac{wx^2}{2};$$

it is nil at O , and

$$\left(P\frac{b}{l} + \frac{wl}{2}\right)a - \frac{wa^2}{2} \text{ at } B.$$

The bending moment (M) at any point between B and A distant x from O is

$$\left(P\frac{b}{l} + \frac{wl}{2}\right)x - \frac{wx^2}{2} - P(x-a) = \left(-P\frac{a}{l} + \frac{wl}{2}\right)x - \frac{wx^2}{2} + Pa;$$

it is $\left(P\frac{b}{l} + \frac{wl}{2}\right)a - \frac{wa^2}{2}$ at B , and nil at A .

Upon the vertical through B take BG equal or proportional to $\left(P\frac{b}{l} + \frac{wl}{2}\right)a - \frac{wa^2}{2}$. The bending moment at any point of the beam between O and B is represented by the vertical distance between that point and a parabola OGH having its axis HT vertical and its vertex at a point H , where

$$OT = \frac{1}{w}\left(P\frac{b}{l} + \frac{wl}{2}\right)$$

and

$$HT \text{ is equal or proportional to } \frac{1}{2w}\left(P\frac{b}{l} + \frac{wl}{2}\right)^2.$$

The bending moment at any point between B and A is represented by the vertical distance between that point and a parabola AGK having its axis KV vertical and its vertex at a point K , where

$$OV = \frac{1}{w}\left(-P\frac{a}{l} + \frac{wl}{2}\right),$$

and

$$KV \text{ is equal or proportional to } \frac{1}{2w}\left(-P\frac{a}{l} + \frac{wl}{2}\right)^2 + Pa.$$

Cor.—If the weight P is at the centre,

$$S = \frac{P}{2}, \text{ and } M \text{ at the centre} = \frac{Pl}{4} + \frac{wl^3}{8}.$$

Note.—The ordinates of the lines CD and EF in Ex. 6 are equal to the algebraic sum of the corresponding ordinates of the

lines CE , FD in Ex. 4, and the line CD in Ex. 5. Also, the ordinates of the curves OG , AG are equal to the algebraic sum of the corresponding ordinates of the lines OG , AG in Ex. 4, and the curve OEA in Ex. 5. Hence the same conclusions as in Ex. 6 are arrived at by treating the weight P and the load wl independently, and then superposing the respective results.

Ex. 7. In fine, a beam, however loaded, may be similarly treated, remembering that if the load changes *abruptly* at different points, the portions of the beam between the points of discontinuity are to be dealt with separately. For example, the beam OA , Fig. 165, rests upon two supports at O and A , and carries three weights P_1 , P_2 , P_3 at points C , D , E , of which the distances from O are p_1 , p_2 , p_3 , respectively. A point B divides OA into segments $OB = a$ and $BA = b$, which are

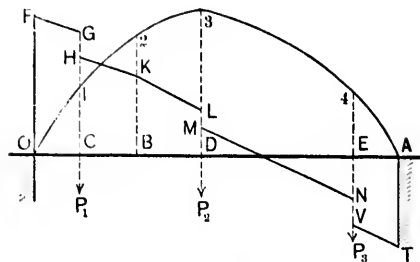

FIG. 165.

uniformly loaded with weights of intensities w_1 and w_2 per unit of length, respectively. The reactions R_1 and R_2 at O and A are vertical, and according to the principle of the lever,

$$R_1 l = P_1(l - p_1) + P_2(l - p_2) + P_3(l - p_3) + w_1 a \left(\frac{a}{2} + b \right) + \frac{w_2 b^2}{2},$$

and

$$R_2 l = P_1 p_1 + P_2 p_2 + P_3 p_3 + \frac{w_1 a^2}{2} + w_2 b \left(\frac{b}{2} + a \right).$$

To represent graphically the *Shearing Force* at different points of the beam :

Upon the verticals through O, C, B, D, E, A , take $OF, CG, CH, BK, DL, DM, EN, EV$, and AT , respectively equal or proportional to

$$R_1, R_1 - w_1 p_1, R_1 - w_1 p_1 - P_1, R_1 - w_1 a - P_1,$$

$$R_1 - w_1 a - P_1 - w_2 (p_2 - a),$$

$$R_1 - w_1 a - P_1 - w_2 (p_2 - a) - P_2,$$

$$R_1 - w_1 a - P_1 - w_2 (p_3 - a) - P_2,$$

$$R_1 - w_1 a - P_1 - w_2 (p_3 - a) - P_2 - P_3,$$

and $R_1 - w_1 a - P_1 - w_2 b - P_2 - P_3 = R_2.$

Join FG, HK, KL, MN , and VT . The shearing force at any point of the beam is represented by the vertical distance between that point and the broken line $FGHKLMNVT$.

To represent graphically the *Bending Moment* (M) at different points of the beam :

$$M \text{ at } O = 0; \quad M \text{ at } C = R_1 p_1 - \frac{w_1 p_1^2}{2};$$

$$M \text{ at } B = R_1 a - \frac{w_1 a^2}{2} - P_1 (a - p_1);$$

$$M \text{ at } D = R_1 p_2 - w_1 a \left(p_2 - \frac{a}{2} \right)$$

$$- w_2 \frac{(p_2 - a)^2}{2} - P_1 (p_2 - p_1),$$

$$M \text{ at } E = R_1 p_3 - wa \left(p_3 - \frac{a}{2} \right) - w_1 \frac{(p_3 - a)^2}{2} - P_1(p_3 - p_1) - P_2(p_3 - p_2);$$

and

$$M \text{ at } A = 0.$$

Upon the verticals through C , B , D , and E take C_1 , B_2 , D_3 , and E_4 , respectively equal or proportional to the bending moments at these points.

The bending moment at any point of the beam is represented by the vertical distance between that point and the parabolic arcs O_1 , 1_2 , 2_3 , 3_4 , and $4A$. The axes of these parabolas are vertical, and the positions of the vertices may be easily found from the several equations.

EX. 8. A beam OA , Fig. 166, of which the weight may be neglected, is 15 ft. long, is fixed at O , and carries a weight of 80 lbs. at A . Determine the bending moment at a point distant 10 ft. from the free end. Also illustrate the shearing force and bending moment at different points of the beam graphically. The required bending moment is $80 \times 10 = 800$ lb.-ft.

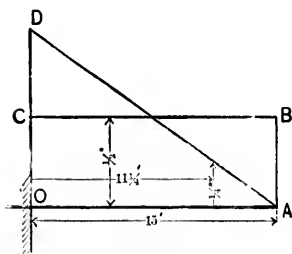

FIG. 166.

The shearing force is the same at every point of the beam, and equal to 80 lbs. Choose a vertical scale of measurement so that half an inch represents 80 lbs.

Upon OA describe a rectangle $OABC$, in which $OC = AB = \frac{1}{2}$ ". The ordinate from every point of BC to AO is $\frac{1}{2}$ ", or 80 lbs., and is therefore the shearing force at the foot of such ordinate.

Again, the bending moment at O is $80 \times 15 = 1200$ lb.-ft. Choose a vertical scale of measurement so that 1 inch represents 1200 lb.-ft. Upon the vertical through O take $OD =$

1 inch; join DA . The ordinate from any point of DA to OA is the bending moment at its foot. For example, at $11\frac{1}{4}$ ft. from O the ordinate is $\frac{1}{4}$ " or 300 lb.-ft., and this is equal to $80 \times 3\frac{3}{4}$, i.e., the bending moment.

Ex. 9. A beam OA , Fig. 167, of which the weight may be neglected, rests upon two supports at O and A , 30 ft. apart, and carries a uniformly distributed load of 200 lbs. per lineal foot, together with a single weight of 600 lbs. at a point B dividing the beam into segments OB , BA , of which the lengths are 10 and 20 ft. respectively. Determine the shearing force and bending moment at the points C and D , distant 5 ft. from the nearest end. Also, illustrate graphically the shearing force and bending moment at different points of the beam.

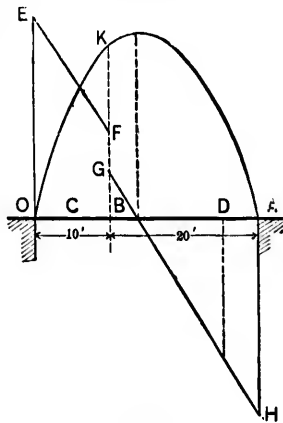

FIG. 167.

Let R_1, R_2 be the reactions at O and A , respectively. Then

$$R_1 \cdot 30 = 600 \cdot 20 + 200 \cdot 30 \cdot 15 = 102000;$$

$$\therefore R_1 = 3400 \text{ lbs.}, \text{ and } R_2 = 200 \cdot 30 + 600 - R_1 = 3200 \text{ lbs.}$$

$$\text{The Shearing Force at } C = 3400 - 200 \cdot 5 = 2400 \text{ lbs.}$$

$$\text{“ “ “ “ } D = 3400 - 200 \cdot 25 - 600 = -2200 \text{ lbs.}$$

$$\text{The Bending Moment at } C = 3400 \cdot 5 - 200 \cdot 5 \cdot \frac{5}{2}$$

$$= 14,500 \text{ lb.-ft.}$$

$$\text{The Bending Moment at } D = 3400 \cdot 25 - 200 \cdot 25 \cdot \frac{25}{2} - 600 \cdot 15$$

$$= 13,500 \text{ lb.-ft.}$$

Next, considering the segment OB , the shearing force at O is 3400 lbs., and at B 1400 lbs.

Considering the segment BA , the shearing force at A is -3200 lbs., and at B 800 lbs.

Choose a vertical scale of measurement so that 1 inch represents 3000 lbs. Upon the verticals through O, B, A take $OE = 1\frac{2}{3}$ "', $BF = \frac{7}{3}$ "', $BG = \frac{4}{3}$ "', and $AH = 1\frac{1}{3}$ "'; join EF and

GII. The ordinate from any point of the broken line $EFGH$ to OA is the Shearing Force at its foot. For example, the ordinate at D is $-\frac{1}{8}''$, or -2200 lbs.

Again, the bending moment at B is $3400 \cdot 10 - 200 \cdot 10 \cdot 5 = 24,000$ lb.-ft. Choose a vertical scale of measurement so that 1 inch represents 24,000 lb.-ft. Upon the vertical through B take $BK = 1$ inch. Draw the parabolas OK, AK , with their vertices at points determined as in Example (6). The ordinate from any point of the curves OK, AK is the bending moment at its foot.

For example, at a point 14 ft. from O the curve ordinate is $1\frac{1}{8}''$, or 25,600 lb.-ft., and this is the Bending Moment at the same point, being also the greatest for the segment BA . The vertex of AK is, therefore, vertically above the point of which the horizontal distance from O is 14 ft.

3. Relation between Shearing Force and Bending Moment.—Let a beam AB be arbitrarily loaded with weights w_1, w_2, w_3, \dots concentrated at the points 1, 2, 3, . . .

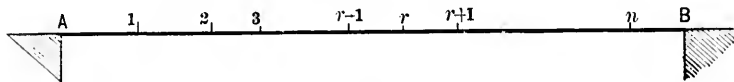

FIG. 168.

Let a_1, a_2, a_3, \dots be the lengths of the segments $A1, 12, 23, \dots$, respectively.

Let M_A, M_B be the moments at A and B . These moments are of course *nil* if the beam merely rests upon supports at its ends.

The reaction R at A is given by the equation

$$Rl = w_1(l - a_1) + w_2(l - a_1 - a_2) + \dots + M_B + M_A,$$

l being the length of the beam.

The *shearing force* S_1 between A and 1 $= R$;

$$\begin{array}{ccccccc} \text{"} & S_2 & \text{"} & 1 & \text{"} & 2 & = R - w_1; \\ \text{"} & S_3 & \text{"} & 2 & \text{"} & 3 & = R - w_1 - w_2; \\ & \cdot & & \cdot & & \cdot & \\ \text{"} & S_n & \text{"} & n-1 & \text{"} & n & = R - \Sigma(w); \end{array}$$

$\Sigma(w)$ denoting the sum of the first $(n - 1)$ weights.

The bending moment

$$M_A \text{ at } A = M_A;$$

$$M_1 \text{ " } 1 = Ra_1 + M_A = M_A + S_1a_1;$$

$$M_2 \text{ " } 2 = R(a_1 + a_2) - w_1a_2 + M_A = M_1 + S_2a_2;$$

$$M_n \text{ " } n = R(a_1 + a_2 + \dots + a_n) - w_1(a_2 + \dots + a_n) - \dots - w_{n-1}a_n + M_A \\ = M_{n-1} + S_n a_n.$$

Hence the difference between the bending moments at the beginning and end of any interval is equal to the product of the shearing force (S) for that interval by the length (a) of the interval.

Let ΔM denote the difference between any two consecutive bending moments; then

$$\Delta M = Sa.$$

This result has been deduced without any assumption as to the number of the loads. They may therefore be infinite in number and in the limit form a continuous load.

Thus, if S be the shearing force at a distance x from A ,

$$\frac{dM}{dx} = S;$$

or, the shearing force at any point is equal to the rate of increase of the bending moment per unit of length.

The above results may also be expressed as follows: The shearing force at any point is measured by the tangent of the slope at the corresponding point of the bending-moment polygon or curve.

The shearing force is positive, zero, or negative according as

$$R \begin{matrix} > \\ < \end{matrix} \Sigma(w);$$

$\Sigma(w)$ being the sum of the weights up to the point under consideration. In the case of a continuous load, of intensity w ,

$$\Sigma(w) = \int_0^x w dx.$$

Thus the bending moment M at the same point is a *maximum* (or a *minimum* in certain special cases) when the shearing force changes sign, i.e., when

$$S = 0.$$

Again, with an arbitrarily distributed load

$$M_n = S_1 a_1 + S_2 a_2 + \dots + S_n a_n + M_A,$$

and with a continuous load

$$M = \int_0^x S dx + M_A.$$

Thus the difference between the ordinates of the bending-moment diagram at any point and A is proportional to the area of the shearing-force diagram between the same points. From this result an important deduction may at once be made.

The bending moment M_x at any point between r and $r + 1$ distant x from r is

$$\begin{aligned} M_x &= R(a_1 + a_2 + \dots + a_r + x) - w_1(a_2 + a_3 + \dots + a_r + x) + \dots \\ &\quad - w_r x + M_A \\ &= M_r + x(R - w_1 - w_2 - \dots - w_r) \\ &= M_r + x S_{r+1}. \end{aligned}$$

Now $M_{r+1} = M_r + a_{r+1} S_{r+1}$, and therefore S_{r+1} is zero if $M_{r+1} = M_r$, and also $M_x = M_r = M_{r+1}$.

Thus, *the bending moment is the same at every point between r and $r + 1$, and the case is one of simple bending without shear, as, e.g., with a carriage-axle.*

4. To Discuss the Effect of a Rolling Load.—CASE I. Let a single weight W travel from left to right over a girder OA of length l , resting upon two supports at O and A .

The reaction R_1 at O , when W is at B distant x from O , is $W\frac{l-x}{l}$ and is the *Shearing Force* for all points between O and B ; it is nil or W according as the weight is at A or O . Upon the vertical through O take OD equal or proportional to W ; join DA . The shearing force at any point of the beam between O and the weight, as the latter travels from A towards O , is represented by the vertical distance between that point and the line AD .

Also, the shearing force at any point between B and A is $R_1 - W = -W\frac{x}{l}$, and is equal or proportional to the vertical distance between that point and the line OE where AE is equal to OD .

Again, the *Bending Moment* at B , when W is at B , is $W\frac{l-x}{l}x$; it is nil at O and at A :

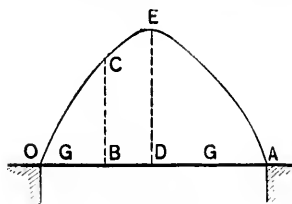

FIG. 170.

it is a maximum and $= \frac{Wl}{4}$ at the middle point D . The bending moment at any point of the beam when the weight is at that point is represented by the vertical distance between the point and the parabola OEA , having its axis vertical and its vertex at E , where DE is equal or proportional to $\frac{Wl}{4}$.

Note.—The shearing and bending actions are symmetrical on both sides of the centre, and it is therefore sufficient to deal with one half of the girder only.

Cor. 1. The shearing force and bending moment at any point are maxima at the instant the weight passes that point.

For example, the shearing force at B for the segment OB ,

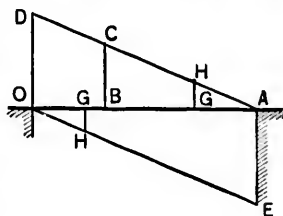

FIG. 169.

when the weight is at B , is equal or proportional to BC (Fig. 169), which is evidently greater than GH , representing the shearing force at B , when the weight is at any other point G .

Again, the bending moment at B (Fig. 170), when W is at B , is $W\frac{l-x}{l}x$. If W is at any other point G distant a from O , the bending moment at B is $Wa\frac{l-x}{l}$ or $Wx\frac{l-a}{l}$, according as $a <$ or $> x$, and in either case is greatest when $a = x$, i.e., when the weight is at B .

Cor. 2. In addition to the rolling load, let the girder carry a permanent weight W' at the centre.

Consider one half of the girder only, and, for convenience, trace the shearing-force and bending-moment diagrams for W' below OA .

The compound diagram for maximum shearing forces is $DTLFD$ (Fig. 171), where KT is equal or proportional to $\frac{W}{2}$, and $KL = OF$ is equal or proportional to $\frac{W'}{2}$.

The maximum shearing force at a point distant x from the centre is represented by $XY = \frac{W}{l}\left(\frac{l}{2} + x\right) + \frac{W'}{2}$.

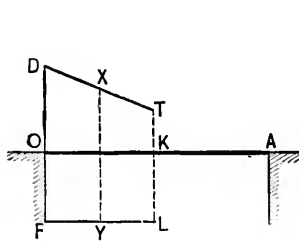

FIG. 171.

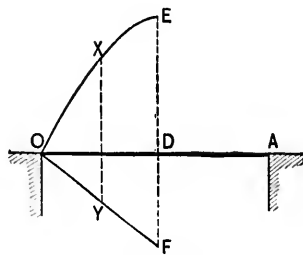

FIG. 172.

Again, the compound diagram for maximum bending moments is $OEFO$ (Fig. 172), where DF is equal or proportional to $\frac{W'l}{4}$, and OF is a straight line.

The maximum bending moment at a point distant x from the centre is represented by

$$XY = \frac{W}{l} \left(\frac{l}{4} - x^2 \right) + \frac{W'}{2} \left(\frac{l}{2} - x \right).$$

Cor. 3. Theoretically, the total volume of material required in the web of the girder in Cor. 2 is equal or proportional to

$$\frac{2 \times \text{area } DTLF}{f_s} = \frac{3}{4} \frac{Wl}{f_s} + \frac{1}{2} \frac{W'l}{f_s},$$

f_s being the web unit stress.

So, if d be the effective depth of the girder, and f the unit stress in one of the flanges, the total volume of metal in that flange is equal or proportional to

$$\frac{2 \times \text{area } OEFO}{fd} = \frac{2}{3} \frac{Wl^2}{4fd} + \frac{W'l^2}{8fd} = \frac{1}{6} \frac{Wl^2}{fd} + \frac{1}{8} \frac{W'l^2}{fd}.$$

CASE II. Let a train weighing w per unit of length travel over the girder from right to left, and let the total length of the train be not less than that of the girder.

The reaction at A , Fig. 173, when the front of the train is at B distant x from O , is $\frac{wx^2}{2l}$, and

is the shearing force for all points between A and B . Upon the verticals through A and O take AD and OE each equal or pro-

portional to $\frac{wl}{2}$. Thus between A and B the shearing force at any point is represented by the vertical distance between that point and a parabola having its axis vertical and its vertex at O .

After the end of the train has passed O , the shearing force at any point of the uncovered portion of the girder is evidently represented by the vertical distance between that point and the parabola AFE , having its axis vertical and its vertex at A .

Again, as the train moves from O towards B , the reaction.

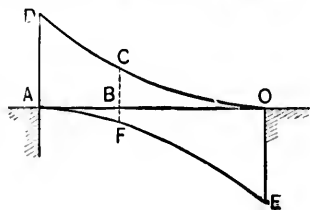

FIG. 173.

at A , and consequently the bending moment at B , continually increase. On passing B , the reaction at A still increases, and the bending moment at B when the train covers a length a of the girder is

$$\frac{wa^2}{2l}(l-x) - \frac{w}{2}(a-x)^2 = \frac{wx}{2l}a(2l-a) - \frac{wx^2}{2}.$$

This expression is evidently a maximum when $a(2l-a)$ is a maximum, i.e., when $a = l$. Hence the bending moment, and therefore the flange stresses, at any point are greatest when the moving load covers the whole girder.

Cor. 1. The shearing force at any point B is a maximum when the train covers the longest segment OB .

This is evidently the case until the train arrives at B , for the reaction at A , and therefore the shearing force at B , will continually increase up to this point. When the train passes B and covers a length $a (> x)$ of the girder, the shearing force at B is $\frac{wa^2}{2l} - w(a-x)$.

But this is $< \frac{wx^2}{2l}$, the shearing force at B when OB is covered, if $\frac{a^2 - x^2}{2l} < a - x$, i.e., if $\frac{a+x}{2l} < 1$, which is evidently the case.

Cor. 2. In designing the flanges of a girder, the rolling load is supposed to cover the whole girder, and may be treated as a uniformly distributed load.

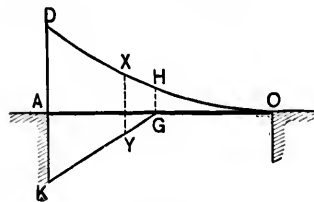

FIG. 174.

Cor. 3. In addition to the rolling load, let the girder carry a uniformly distributed load of w' per unit of length. As before, consider one half of the girder only. Trace the shearing-force diagram for the permanent load below OA . The compound diagram is $DHGK$, where GH and AK are equal or proportional to $\frac{wl}{8}$ and $\frac{w'l}{2}$, respectively.

The maximum shearing force at a point distant x from the centre is represented by XY and is equal to

$$\frac{w}{2l} \left(\frac{l}{2} + x \right)^2 + w'x.$$

Again, the maximum flange-stresses are obtained by assuming the total load upon the girder to be $w + w'$ per unit of length.

EXAMPLE.—The two main girders of a single-track bridge are 80 ft. in the clear and 10 ft. deep. The dead load upon the bridge is 2500 lbs. per lineal foot. If the bridge is traversed by a uniformly distributed live load of 3000 lbs. per lineal foot, determine the maximum bending moment and shearing force at a point of the girder distant 10 ft. from one end.

The bending moment at any point is a maximum when the train covers the whole of the bridge, in which case the total distributed load is 5500 lbs. per lineal foot, of which each girder carries one half.

Thus the reaction at each support = $\frac{1}{2} \cdot 80 \cdot \frac{5500}{2} = 110,000$ lbs., and the *bending moment* at the given point = $110000 \times 10 - 10 \times 2750 \times 5 = 962,500$ lb.-ft.

The *shearing force* at the given point due to the *dead* load = $50,000 - 10 \times 1250 = 37,500$ lbs.

The *shearing force* due to the live load is a maximum when the live load covers the 70 ft. segment, and its value is then

$$\frac{1500 \times 70^2}{2 \times 80} = 45,937\frac{1}{2} \text{ lbs.}$$

Hence the total maximum shearing force

$$= 37,500 + 45,937\frac{1}{2} = 83,437\frac{1}{2} \text{ lbs.}$$

5. Moments of Forces with respect to a given Point Q.
 —First, consider a single force P_1 .

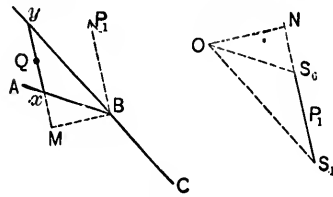

FIG. 175.

Describe the force and funicular polygons, i.e., the line S_1S_0 and the lines AB, BC .

Through the point Q draw a line parallel to S_1S_0 , cutting the lines AB and CB produced in x and y .

Drop the perpendiculars BM and ON upon yx and S_1S_0 produced. Then

$$\frac{xy}{BM} = \frac{S_1S_0}{ON} = \frac{P_1}{ON};$$

$$\therefore P_1 BM = xy \cdot ON.$$

But BM is equal to the length of the perpendicular from Q to the line of action of P_1 , and the product $xy \cdot ON$ is, therefore, equal to the moment of P_1 with respect to Q . Hence, if a scale is so chosen that $ON = \text{unity}$, this moment becomes equal to xy ; i.e., it is the intercept cut off by the two sides of the funicular polygon on a line drawn through the given point parallel to the given force.

Next, let there be two forces, P_1, P_2 .

Describe the force and funicular polygons $S_2S_1S_0$ and $ABCD$.

Let the first and last sides (AB and DC) be produced to meet in G , and let a line through the given point Q parallel to the line S_2S_0 intersect these lines in x and y .

Draw GM perpendicular to xy , and ON perpendicular to S_2S_0 . Then

$$\frac{xy}{GM} = \frac{S_2S_0}{ON} = \frac{\text{resultant of } P_1 \text{ and } P_2}{ON},$$

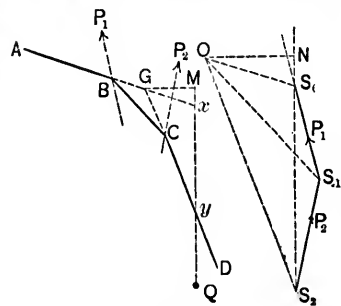

FIG. 176.

and hence

$$(\text{the resultant of } P_1 \text{ and } P_2) \times GM = xy \cdot ON.$$

But GM is equal to the length of the perpendicular from Q upon the resultant of P_1 and P_2 , which is parallel to S_1S_2 and must necessarily pass through G . Hence, if a scale is so chosen that $ON = \text{unity}$, xy is equal to the moment of the forces with respect to Q ; i.e., *it is the intercept cut off by the first and last sides of the funicular polygon on a line drawn through the given point parallel to the resultant force.*

A third force P_3 may be compounded with P_1 and P_2 , and the proof may be extended to three, four, or any number of forces.

The result is precisely the same if the forces are parallel.

The force polygon of the n parallel forces P_1, P_2, \dots, P_n

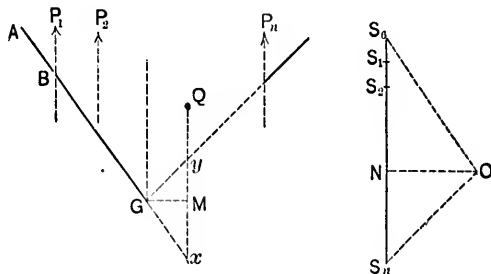

FIG. 177.

becomes the straight line $S_0S_1S_2 \dots S_n$. Let the first and last sides of the funicular polygon meet in G . Drop the perpendiculars GM, ON upon xy and S_0S_n, xy , as before, being the intercept cut off on a line through the given point Q parallel to S_0S_n . Then

$$xy \cdot ON = GM \cdot S_0S_n. \text{ Hence, etc.}$$

Thus the moment of any number of forces in one and the same plane with respect to a given point may be represented by the intercept cut off by the first and last sides of the funicular-

lar polygon on a line drawn through the given point parallel to the resultant of the given forces.

6. Bending Moments.—Stationary Loads.—Let a horizontal beam AB , supported at A and B , carry a number of weights P_1, P_2, P_3, \dots at the points N_1, N_2, N_3, \dots

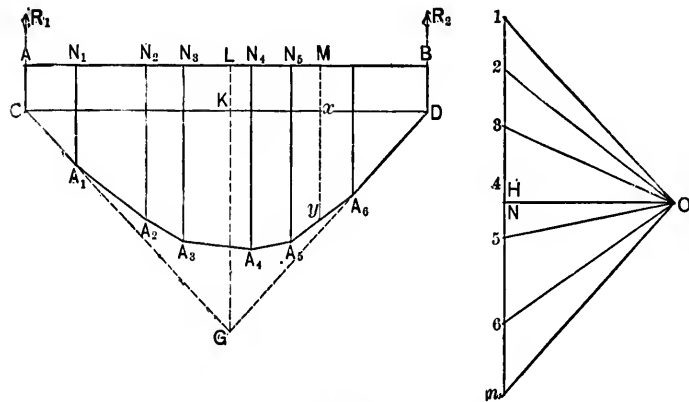

FIG. 178.

The force polygon is a vertical line $1234 \dots n$, where $12 = P_1, 23 = P_2$, etc.

Take any pole O and describe the funicular polygon $A_1A_2A_3 \dots$.

Let the *first* and *last* sides of this polygon be produced to meet in G and to cut the verticals through A and B in the points C and D .

Join CD .

Let the vertical through G cut AB in L and CD in K ; LG is the line of action of the resultant.

Draw OH parallel to CD .

From the similar triangles O_1H and GCK ,

$$\frac{1H}{OH} = \frac{GK}{CK}.$$

From the similar triangles OnH and GDK ,

$$\frac{nH}{OH} = \frac{GK}{DK}.$$

$$\therefore \frac{1H}{nH} = \frac{DK}{CK} = \frac{BL}{AL} = \frac{R_1}{R_2},$$

R_1, R_2 being the reactions at A and B , respectively.

But $1H + nH = 1n = P_1 + P_2 + \dots = R_1 + R_2$.

Hence $1H = R_1$ and $nH = R_2$.

Thus the line drawn through the pole parallel to the closing line CD divides the line of loads into two segments, of which the one is equal to the reaction at A and the other to that at B .

Let it now be required to find the bending moment at any point M of the beam, i.e., the moment of all the forces on one side of M with respect to M .

In the figure these forces are $R_1, P_1, P_2, P_3, P_4, P_5$, and the corresponding force polygon is $H123456$. The first and last sides of the funicular polygon of the forces are CD parallel to OH , and A_5A_6 parallel to $O6$. If the vertical through M meet these sides in x and y , then, as shown in Art. 5, the moment of the forces $R_1, P_1, P_2, P_3, P_4, P_5$ with respect to M , i.e., the bending moment at M , = $ON \cdot xy$, ON being the perpendicular from O upon $1H$ produced.

Hence, if a scale is chosen so that the polar distance ON is unity, the bending moment at any point of the beam is the intercept on the vertical through that point cut off by the closing line CD and the opposite bounding line of the funicular polygon.

7. Moving Loads.—Beams are often subjected to the action of moving loads, as, e.g., in the case of the main girders of a railway bridge, and it becomes a matter of importance to determine the bending moments for different positions of the loads. It may be assumed that the loads are concentrated on wheels which travel across the bridge at invariable distances apart.

At any given moment, let the figure represent a beam 11

under the loads P_1, P_2, P_3, \dots . Describe the corresponding funicular polygon $CC'C'' \dots D$, the closing line being CD .

Let the loads now travel from *right to left*. The result will be precisely the same if the loads remain *stationary* and if the supports 11 are made to travel from *left to right*.

Thus, if the loads successively move through the distances

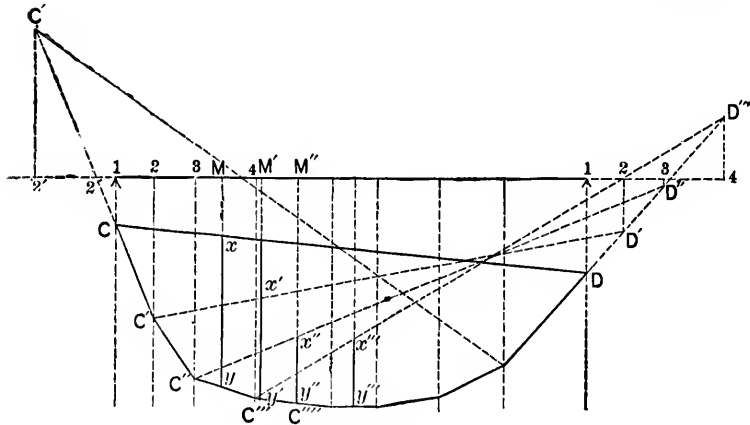

FIG. 179.

12, 23, 34, \dots to the *left*, the result will be the same if the loads are kept stationary and if the supports are successively moved to the *right* into the positions 22, 33, 44, \dots . The new funicular polygons are evidently $C'C'' \dots D'$, $C''C''' \dots D''$, $C'''C'''' \dots D'''$, \dots the new closing lines being $C'D'$, $C''D''$, $C'''D'''$, \dots .

The *bending moment* at any point M is measured by xy for the first distribution, $x'y'$ for the second, $x''y''$ for the third, etc., the position of M for the successive distributions being defined by $MM' = 12$, $M'M'' = 23$, $M''M''' = 34$, \dots .

Similarly, if the loads move from *left to right*, the result will be the same if the loads are kept stationary and if the supports are made to move from *right to left*.

It is evident that the envelope for the closing line CD for all distributions of the loads is a certain curve, called the *envelope of moments*. The intercept on the vertical through any point of the beam cut off by this curve and the opposite bound-

ary of the funicular polygon is the greatest possible bending moment at that point to which the girder can be subjected.

EXAMPLE. Loads of 12 and 9 tons are concentrated upon a horizontal beam of 12 ft. span at distances of 3 and 9 ft. from the right-hand support. Find (a) the B. M. at the middle point

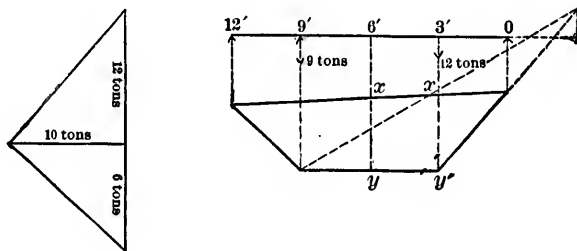

FIG. 180.

of the beam, and also (b) the max. B. M. produced at the same point when the loads travel over the beam at the fixed distances of 6 ft. apart.

Scales for lengths, $\frac{1}{8}$ in. = 1 ft.; for forces, $\frac{1}{16}$ in. = 1 ton.
Take polar distance = $\frac{3}{8}$ in. = 10 tons.

Case a. B.M. = $xy \times 10 = 3.15 \times 10$ tons = $31\frac{1}{2}$ ton-ft.

Case b. B.M. = $x'y' \times 10 = 3.6 \times 10$ tons = 36 ton-ft.

8. Analytical Method of Determining the Maximum Shear and Bending Moment at any Point of an Arbitrarily Loaded Girder AB.—At any given moment let the load consist of a number of weights $w_1, w_2, \dots w_n$, concentrated at points distant $a_1, a_2, \dots a_n$, respectively, from B.

The corresponding reaction R_1 at a is given by

$$R_1 l = w_1 a_1 + w_2 a_2 + \dots + w_n a_n;$$

l being the length of the girder.

Let $W_n = w_1 + w_2 + \dots + w_n$, the sum of the n weights.

“ $W_r = w_1 + w_2 + \dots + w_r$, the sum of the first r w'ts.

The shear at a point P between the r th and the $(r + 1)$ th weights is

$$S_1 = R_1 - w_1 - w_2 - \dots - w_r = R_1 - W_r.$$

Let all the weights now move towards A through a distance x , and let p of the weights move off the girder, q of the weights be transferred from one side of P to the other, and s new weights, viz., $w_{n+1}, w_{n+2}, \dots, w_{n+s}$, advance upon the girder, their distances from B being $a_{n+1}, a_{n+2}, \dots, a_{n+s}$, respectively.

Let $L = w_1 + w_2 + \dots + w_p$, the total weight leaving the girder.

Let $T = w_{r+1} + w_{r+2} + \dots + w_{r+q}$, the total weight transferred from one side of P to the other.

Let $R_p l = w_1 a_1 + w_2 a_2 + \dots + w_p a_p$.

" $R_q l = w_{r+1} a_{r+1} + w_{r+2} a_{r+2} + \dots + w_{r+q} a_{r+q}$.

" $R_s l = w_{n+1} a_{n+1} + w_{n+2} a_{n+2} + \dots + w_{n+s} a_{n+s}$.

Thus R_p, R_q, R_s are the reactions at A due, respectively, to the weight which leaves the girder, the weight which is transferred, and the new weight which advances upon the girder.

The reaction R_2 at A with the new distribution of the loads is given by

$$\begin{aligned} R_2 l &= w_{p+1}(a_{p+1} + x) + w_{p+2}(a_{p+2} + x) + \dots + w_r(a_r + x) \\ &\quad + w_{r+1}(a_{r+1} + x) + \dots + w_n(a_n + x) + w_{n+1}a_{n+1} + \dots \\ &\quad + w_{n+s}a_{n+s} = R_1 l - R_p l + x(W_n - L) + R_s l, \end{aligned}$$

and hence

$$(R_2 - R_1)l = (R_s - R_p)l + x(W_n - L).$$

Also, the corresponding *shear* at P is

$$\begin{aligned} S_2 &= R_2 - (w_{p+1} + w_{p+2} + \dots + w_r + w_{r+1} + \dots + w_{r+q}) \\ &= R_2 - (W_r - L + T). \end{aligned}$$

Hence the *shear* at P with the first distribution of weights is greater or less than the *shear* at the same point with the second distribution according as

$$S_1 \geq S_2,$$

or $R_1 - W_r \geq R_2 - W_r + L - T,$

or $T - L \geq R_2 - R_1,$

or
$$T - L \geq R_1 - R_p + \frac{x}{l}(W_n - L). \quad (A)$$

Note.—When no weights leave or advance upon the girder, R_1 , R_p , and L are severally nil, and hence

$$S_1 \geq S_2,$$

according as
$$\frac{T}{x} \geq \frac{W_n}{l};$$

i.e., according as the weight transferred divided by the distance through which it is transferred is greater or less than the total weight on the girder divided by the span.

Again, let z be the distance of P from B , and let

$$R_1 l = w_1 a_1 + w_2 a_2 + \dots + w_r a_r.$$

The bending moment at P with the first distribution of weights is

$$\begin{aligned} M_1 &= R_1(l - z) - w_1(a_1 - z) - w_2(a_2 - z) - \dots - w_r(a_r - z) \\ &= R_1(l - z) - R_1 l + z W_r. \end{aligned}$$

The bending moment at the same point with the second distribution is

$$\begin{aligned} M_2 &= R_2(l - z) - w_{p+1}(a_{p+1} + x - z) - w_{p+2}(a_{p+2} + x - z) - \dots \\ &\quad - w_r(a_r + x - z) - \dots - w_{r+q}(a_{r+q} + x - z) \\ &= R_2(l - z) - (R_r l - R_p l + R_q l) - (x - z)(W_r - L + T). \end{aligned}$$

Hence the bending moment at P with the first distribution of weights is greater or less than the bending moment at the same point with the second distribution according as

$$M_1 \geq M_2,$$

or

$$\begin{aligned} R_1(l - z) - R_1 l + z W_r &\geq R_2(l - z) - (R_r - R_p + R_q)l \\ &\quad - (x - z)(W_r - L + T), \end{aligned}$$

or

$$zW_r - (R_p - R_q)l + (x - z)(W_r - L + T) \geq (R_n - R_1)(l - z)$$

or

$$\begin{aligned} z(L - T + R_p - R_q) + l(R_q - R_1) + x(W_r - L + T) \\ \geq \frac{x}{l}(l - z)(W_n - L). \dots \dots \dots (B) \end{aligned}$$

Note.—If no weights leave or advance upon the girder K_r , R_p and L are severally nil, and

$$M_1 \geq M_2,$$

according as

$$-zT + lR_q + x(W_r + T) \geq \frac{x}{l}(l - z)W_n.$$

If also the point P coincide with the r th weight, and the distance of transfer, $x_1 = a_r - a_{r+1}$, then

$$R_q l = w_{r+1} a_{r+1}, \quad T = w_{r+1}, \quad \text{and} \quad z = a_r.$$

Hence $M_1 \geq M_2$, according as

$$-w_{r+1} a_r + w_{r+1} a_{r+1} + (a_r - a_{r+1})(W_r + w_{r+1}) \geq \frac{a_r - a_{r+1}}{l}(l - a_r)W_n$$

or

$$\frac{W_r}{l - a_r} \geq \frac{W_n}{l};$$

i.e., according as the sum of the first r weights divided by the length of the corresponding segment is greater or less than the total weight upon the girder divided by the span.

If the weights are concentrated at the panel points of a truss, the last relation may be expressed in the form

$$\frac{\text{first } (r) \text{ weights}}{r \text{ panels}} \geq \frac{\text{total weight}}{\text{total number of panels}}$$

EXAMPLE. A series of loads of 3000, 23,600, 20,100, 21,700,

22,900, 18,550, 18,000, 18,000, and 18,000 lbs. travel, in order, over a truss of 240 ft. span and ten panels.

Let A, p_1, p_2, \dots, B be the truss, p_1, p_2, p_3, \dots being the panel points. Let the loads travel from B towards A , and compare the shear in the panel p_1, p_2 , when the weight of 3000 lbs. has reached p_2 with the shear in the same panel when the weights have advanced another 24 ft.

$$R_1 = \frac{1}{10} \cdot 18550 = 1855 \text{ lbs.}, \quad R_2 = 0, \quad \frac{x}{l} = \frac{1}{10},$$

$$W_n = 91300 \text{ lbs.}, \quad L = 0, \quad T = 3000 \text{ lbs.}$$

Hence $S_1 \geq S_2$, according as (see A)

$$3000 - 0 \geq 1855 + \frac{1}{10}(91300 - 0) \geq 10985,$$

and

$$\therefore S_1 < S_2.$$

Let the weights again advance 24 ft.

$$R_1 = \frac{1}{10} \cdot 18000 = 1800 \text{ lbs.}, \quad R_2 = 0, \quad \frac{x}{l} = \frac{1}{10},$$

$$W_n = 109,300 \text{ lbs.}, \quad L = 0, \quad T = 23,600 \text{ lbs.}$$

Hence $S_1 \geq S_2$, according as (see A)

$$23600 - 0 \geq 1800 - 0 + \frac{1}{10}(109300 - 0), \quad \text{or} \quad 23600 \geq 12730,$$

and

$$\therefore S_1 > S_2.$$

Hence the shear in the panel p_1, p_2 is a maximum when the weight of 3000 lbs. is at p_1 .

Again, let the 3000 lbs. be at p_1 , and compare the bending moment at p_2 with the bending moment at the same point when the weights have advanced first 24 ft. and then 48 ft. towards A .

First. $z = 120 \text{ ft.}, \quad L = 0, \quad T = 22,900 \text{ lbs.}, \quad R_1 l = 18000 \times 24,$

$R_p = 0$, $R_q l = 22900 \times 96$, $x = 24$ ft., $W_r = 68,400$ lbs.,
 $W_n = 145,850$ lbs.

Hence $M_1 \geq M_2$, according as (see B)

$$120(0 - 22900 + 1800 - 0) + 22900 \times 96 - 18000 \times 24 \\ + 24(68400 - 0 + 22900) \geq \frac{24}{240}(240 - 120)(145850 - 0),$$

or

$$1425600 \geq 1750200,$$

and

$$\therefore M_1 < M_2.$$

Second. $z = 120$ ft., $L = 3000$ lbs., $T = 18550$, $R_s = 0$, $R_p l = 3000 \times 216$, $R_q l = 18550 \times 96$, $x = 24$ ft., $W_r = 91,300$ lbs.,
 $W_n = 163,850$ lbs.

Hence $M_1 \geq M_2$, according as (see B)

$$120\left(3000 - 18550 + 0 - 3000 \cdot \frac{216}{240}\right) + 240\left(18550 \cdot \frac{96}{240} - 0\right) \\ + 24(91300 - 3000 + 18550) \geq \frac{24}{240}(240 - 120)(163850 - 3000),$$

or

$$2155200 \geq 1930200,$$

and

$$\therefore M_1 > M_2.$$

Hence the bending moment at p , is a maximum when the weight of 3000 lbs. is at p , i.e., when all the panel points are loaded.

9. Hinged Girders.—Any point of a girder at which the bending moment is *nil* is termed a point of *contrary flexure*, and on passing such a point the bending moment must necessarily change sign.

Consider a horizontal girder resting upon supports at A , B , C , D , and *hinged* at the points E and F in the side spans.

In order that there may be no distortion by the turning of the hinges, the latter must not be subject to any bending action; i.e., they must be points of contrary flexure.

Let $AE = a$, $EB = b$, $BC = c$, $CF = e$, $DF = d$.

Let W_1, W_2, W_3, W_4, W_5 be the loads upon AE, EB, BC, DF, FC , respectively, and let x_1, x_2, x_3, x_4, x_5 be the several distances of the corresponding centres of gravity from the points E, B, C, F, C .

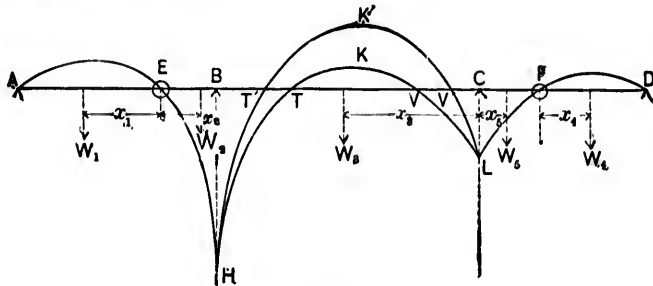

FIG. 181.

The two portions AE and DF are evidently in precisely the same condition as two independent girders of the same lengths, carrying the same loads and supported at the ends. EF may also be treated as an independent girder supported at B and C , carrying the weights W_2, W_3, W_5 , and loaded at the *cantilever* ends E and F with weights equal to the reactions at E and F for the portions AE, DF assumed to be independent girders.

Let R_1, R_2, R_3, R_4 be the reactions at A, B, C, D , respectively. Then

$$R_1 a = W_1 x_1,$$

and

$$R_4 d = W_5 x_5.$$

Hence, since R_1 and R_4 are always *positive*, there can be no upward pull either at A or D , and no anchorage will be needed at these points.

Next, taking EF as an independent girder,

$$\text{the load at } E = W_1 - R_1 = W_1 \left(1 - \frac{x_1}{a}\right);$$

$$\text{“ “ } F = W_5 - R_4 = W_5 \left(1 - \frac{x_5}{d}\right).$$

Take moments about C and B . Then

$$-(W_1 - R_1)(b + c) - W_2(x_2 + c) + R_2c - W_3x_2 + W_3x_1 + (W_4 - R_4)c = 0,$$

and

$$-(W_1 - R_1)b - W_2x_2 + W_3(c - x_2) - R_2c + W_3(x_2 + c) + (W_4 - R_4)(c + e) = 0;$$

two equations giving R_2 and R_3 , since R_1 and R_4 have been already determined.

The pier moments P_1 at B and P_2 at C are

$$P_1 = -(W_1 - R_1)b - W_2x_2 = -W_1\frac{b}{a}(a - x_1) - W_2x_2,$$

and

$$P_2 = -(W_4 - R_4)c - W_3x_2 = -W_4\frac{c}{d}(d - x_1) - W_3x_2;$$

their values depending solely upon the loads on the spans containing the hinges.

The bending moment at any point in BC distant x from B

$$\begin{aligned} &= R_2x - (W_1 - R_1)(b + x) - W_2(x_2 + x) - M \\ &= P_1 + x(R_1 + R_2 - W_1 - W_2) - M; \end{aligned}$$

M being the bending moment due to the load upon the length x .

The shearing-force and bending-moment diagrams for the whole girder can now be easily drawn.

For any given loads upon the side spans, let AEH and DFL be the bending-moment curves for the portions AB , CD ; BH and CL representing the pier moments at B and C , respectively. The bending moments for the least and greatest loads upon BC will be represented by two curves HKL , $HK'L$, and the distances TT' , VV' through which the points of contrary flexure must move, indicate those portions of the girder which are to be designed to resist bending actions of opposite signs.

Again, let the two hinges be in the intermediate span.

Let $AB = a$, $BE = b$, $EF = c$, $FC = e$, $CD = d$.

Let W_1, W_2, W_3, W_4, W_5 be the loads upon AB, BE, EF, CD, CF , respectively, and let x_1, x_2, x_3, x_4, x_5 be the several distances of the corresponding centres of gravity from the points B, B, F, C, C .

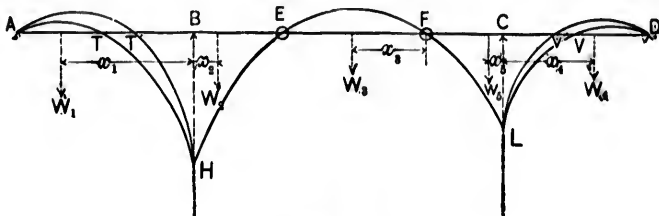

FIG. 182.

EF evidently may be treated as an independent girder supported at the two ends and carrying a load W_3 .

AE and DF may be treated as independent girders carrying the loads W_1, W_2 and W_4, W_5 , respectively, and also loaded at the cantilever ends E and F with weights equal to the reactions at E and F due to the load W_3 upon girder EF , which is assumed to be independent. Thus

$$\text{the load at } E = W_3 \frac{x_3}{c};$$

$$\text{“ “ } F = W_3 \left(1 - \frac{x_3}{c}\right).$$

The pier moments P_1 at B and P_2 at C are

$$P_1 = W_1 x_1 + W_2 x_2 \frac{b}{c}$$

and

$$P_2 = W_4 x_4 + W_5 \left(1 - \frac{x_5}{c}\right) e;$$

their values depending solely upon the loads on the span containing the hinges.

Let R_1, R_2, R_3, R_4 be the reactions at A, B, C, D , respectively, and take moments about the points B, A, D, C . Then

$$\begin{aligned} R_1 a - W_1 x_1 + \left(W_2 x_2 + W_3 x_3 \frac{b}{c} \right) &= 0 = R_1 a - W_1 x_1 + P_1; \\ -R_2 a + W_1(a - x_1) + W_2(a + x_2) + W_3 x_3 \frac{a+b}{c} &= 0; \\ R_3 d - W_3 \left(1 - \frac{x_3}{c} \right) (e + d) - W_4(x_4 + d) - W_4(d - x_4) &= 0; \\ -R_4 d - W_3 \left(1 - \frac{x_3}{c} \right) e - W_4 x_4 + W_4 x_4 &= 0 \\ &= -R_4 d + W_4 x_4 - P_2. \end{aligned}$$

R_2 and R_3 are always *positive*;

R_1 is *positive* or *negative* according as $W_1 x_1 \geq P_1$; and

R_4 " " " " " $W_4 x_4 \geq P_2$.

Thus there will be a downward pressure or an upward pull at each end according as the moment of the load upon the adjoining span is greater or less than the corresponding pier moment. The ends must therefore be anchored down or they will rise off their supports.

The shearing-force and bending-moment diagrams for the whole girder can now be easily drawn.

Let *HEFL* be the bending moment curve for any given load upon the span *BC*, *BH* and *CL* being the pier moments at *B* and *C*, respectively.

The bending-moment curves for the least and greatest loads on the side spans may be represented by curves *ATH*, *AT'H* and *DVL*, *DV'L*, and the distances *TT'*, *VV'* through which the points of contrary flexure move indicate those portions of the girder which are to be designed to resist bending actions of opposite signs.

Reverse strains may, however, be entirely avoided by making the length of *EF* sufficiently great as compared with the lengths of the side spans.

The preceding examples serve to illustrate the mechanical principles governing the stresses in cantilever bridges.

EXAMPLES.

1. A beam 20 ft. long and weighing 20 lbs. per lineal foot is placed upon a support dividing it into segments of 16 and 4 ft., and is kept horizontal by a downward force P at the middle point of the smaller segment. Find the value of P and the reaction at the support.

Show that the required force P will be doubled if a single weight of 150 lbs. is suspended from the end of the longer segment. Draw shearing-force and bending moment diagrams in both cases.

Ans. 1200 lbs.; 1600 lbs.

2. A man and eight boys carry a stick of timber, the man at the end and the eight boys at a common point. Find the position of this point, if the man is to carry twice as much as each boy.

Ans. Distance between supports = $\frac{4}{9}$ length of beam.

3. A timber beam is supported at the end and at one other point; the reaction at the latter is double that at the end. Find its position.

Ans. Distance between supports = $\frac{1}{3}$ length of beam.

4. Two beams ABC , BCD are bolted at B and C so as to act as one beam supported at A and D ; $AB = 12$ ft., $BC = 4$ ft., $CD = 16$ ft.; each of the bolts will bear a bending moment of 100 lb.-ft. Find the greatest weight which can be concentrated on the portion BC .

Ans. $14\frac{7}{12}$ lbs.

5. In the preceding question find the greatest uniformly distributed load which the beam will bear.

Draw the shearing-force and bending-moment diagrams.

Ans. $25\frac{3}{4}$ lbs.

6. A uniform beam $20\sqrt{3}$ ft. in length rests with one end on the ground and the other against a smooth vertical wall; the beam is inclined at 60° to the vertical and has a joint in the middle which can bear a bending moment of 30,000 lb.-ft. Find the greatest load which may be uniformly distributed over the beam. Also find how far the foot of the beam should be moved towards the wall in order that an additional 2000 lbs. may be concentrated at the joint.

Draw curves of shearing force and bending moment in each case.

Ans. 8000 lbs.; distance = 10 ft.

7. A man of weight W ascends a ladder of length l which rests against a smooth wall and the ground and is inclined to the vertical at an angle α . The ladder has n rounds. Find the bending moment at the r th round from the foot when the man is on the p th round from the foot. (Neglect weight of ladder.)

$$\text{Ans. } Wpl \frac{n-r+1}{(n+1)^2} \sin \alpha.$$

8. A regular prism of weight W and length a is laid upon a beam of length $2l (> a)$. If the prism is so stiff as to bear at its ends only, show that the bending action on the beam is less than if the bearing were continuous from end to end of the prism.

$$\text{Ans.} - \text{1st. Max. B.M.} = \frac{2}{l} W \left(\frac{l}{2} - \frac{a}{4} \right)^2;$$

$$\text{2d. " " } = W \left(\frac{l}{2} - \frac{a}{8} \right).$$

9. A railway girder, 50 ft. in the clear and 6 ft. deep, carries a uniformly distributed load of 50 tons. Find the maximum shearing stress at 20 ft. from one end, when a train weighing $1\frac{1}{4}$ tons per lineal foot crosses the girder.

Also find the minimum theoretic thickness of the web at a support 4 tons being the safe shearing inch-stress of the metal.

$$\text{Ans. } 16\frac{1}{4} \text{ tons; } .195 \text{ in.}$$

10. A beam is supported at one end and at a second point dividing its length into the segments m and n . Find the two reactions. Also find the ratio of m to n which will make the maximum positive moment equal to the maximum negative moment.

$$\text{Ans. } \frac{w}{2m}(m^2 - n^2), \frac{w}{2m}(m + n)^2; m : n :: 1 + \sqrt{2} : 1.$$

11. One of the supports of a horizontal uniformly loaded beam is at the end. Find the position of the other support so that the straining of the beam may be a minimum.

$$\text{Ans. Distance from end support} = \frac{\text{length}}{\sqrt{2}}.$$

12. A rolled joist 17 ft. long is supported at one end and at a point 13 ft. distant from that end. Two wagon-wheels 5 ft. apart and each carrying a load of 1300 lbs. pass over the joist. Find the maximum positive and negative moments due to these weights, and also the corresponding reactions.

$$\text{Ans. Max. positive B. M.} = 5512\frac{1}{2} \text{ lb.-ft. ;}$$

$$\text{reactions} = 1550 \text{ and } 1050 \text{ lbs.}$$

$$\text{Max. negative B. M.} = 5200 \text{ lb.-ft. ;}$$

$$\text{reactions} = 1700 \text{ lbs. and } -400 \text{ lbs.}$$

$$\text{or} = 2900 \text{ lbs. and } -300 \text{ lbs.}$$

Denoting the distance from a support by x , the max. positive B. M. diagram for each half of the 13-ft. span is given by $M_x = 100(21 - 2x)x$.

13. A uniformly loaded beam rests upon two supports. Place the supports so that the straining of the beam may be a minimum.

Ans. Distance of each support from centre = $l\left(1 - \frac{1}{\sqrt{2}}\right)$.

14. Two bars AC, CB in the same horizontal line are jointed at C and supported upon two props, the one at A , the other at some point in CB distant x from C . The joint C will safely bear n lb.-ft.; the bars are each l ft. in length and w lbs. in weight. Find the limits within which x must lie.

Ans. $l \frac{wl \pm 2n}{3wl \mp 2n}$.

15. A uniform load PQ moves along a horizontal beam resting upon supports at its ends A and B . Prove that the bending moment at a given point O is a maximum when PQ occupies such a position that $OP : OQ :: OA : OB$.

Draw curves of maximum shearing force and bending moment for all points of the beam.

16. A beam is supported at the ends and loaded with two weights mW and nW at points distant a, b , respectively, from the consecutive supports. Show that the bending action is greatest at mW or nW according as $\frac{m}{n} > \frac{b}{a}$.

17. A wheel supporting 10 tons rolls over a beam of 20 ft. span. Place the wheel in such a position as to give the maximum bending moment, and find its value.

Ans. At the centre; 50 ton-ft.

18. Two wheels a ft. apart support, the one mW tons, the other nW tons, m being $> n$, and roll over a beam of l ft. span. Show that the bending moment is an *absolute* maximum at the centre or at a point whose distance from the nearest support is $\frac{l}{2} - \frac{na}{2(m+n)}$ according as

$l \leq a\left(1 + \sqrt{\frac{m}{m+n}}\right)$, and find its value in each case. ($l < 2a$.)

Ans. $\frac{mWl}{4}$ ton-ft.; $\frac{m+n}{4l}W \left\{l - \frac{na}{m+n}\right\}^2$ ton-ft.

19. Find the max. B. M. on a horizontal beam of length l supported at the two ends and carrying a load which varies in intensity from w at one end to $w + pl$ at the other.

20. Four wheels each carrying 5 tons travel over a girder of 24 ft. clear span at equal distances 4 ft. apart. Determine, graphically, the max. B. M. at 8 ft. from a support, and also the absolute max. B. M. on the girder.

Ans. $2\frac{2}{3}^0$ ton-ft.; $80\frac{1}{3}$ ton-ft.

21. Two wheels each supporting 7 tons roll over a beam of $7\frac{1}{2}$ ft. span. Find the maximum bending moment for the whole span, and also the curve of the maximum bending moment at each point when the wheels are 4 ft. apart.

Ans. Abs. max. B. M. = $24\frac{1}{6}$ ton-ft. at wheel at $2\frac{1}{2}$ ft. from one end. Denoting the distance from support by x , the max.

B. M. curve for the first $3\frac{1}{2}$ ft. is given by

$$M_x = \frac{1}{2}(11 - 2x)x,$$

and for the remaining 4 ft. by

$$M_x = \frac{1}{2}(7\frac{1}{2} - x)x.$$

22. Two wheels supporting, the one 11 tons, the other 7 tons, travel over a beam of $12\frac{1}{2}$ ft. span. Find the maximum bending moment for the whole span, and also the curves of the max. shearing force (both positive and negative) and maximum bending moment at each point when the wheels are 6 ft. apart.

Ans. Abs. max. B. M. = 37.2 ton-ft.

The *max. positive* shearing force at each point is given by the equations

$$S_x = \frac{183 - 18x}{12\frac{1}{2}} \quad \text{and} \quad S_x = \frac{11(12\frac{1}{2} - x)}{12\frac{1}{2}}.$$

The *max. negative* shearing force at each point is given by the equations

$$S_x = -\frac{7x}{12\frac{1}{2}}, \quad S_x = \frac{45\frac{1}{2} - 18x}{12\frac{1}{2}}, \quad S_x = -\frac{42 + 18x}{12\frac{1}{2}}, \quad S_x = -\frac{11x}{12\frac{1}{2}}.$$

The max. B. M. curve is given by the equations

$$M_x = \frac{183 - 18x}{12\frac{1}{2}}x, \quad M_x = \frac{11(12\frac{1}{2} - x)}{12\frac{1}{2}}x, \quad \text{and} \quad M_x = \frac{75x - 18x^2 + 273}{12\frac{1}{2}}.$$

N.B.—In the above cases x is measured from the support to the nearest load.

23. In the preceding example show that the maximum *negative* shear at $4\frac{3}{4}$ ft. from a support, when the 7-ton wheel only is on the beam, is the same as the maximum negative shear at the same point when both of

the wheels are on the beam, and find its value. Also show that the maximum *negative* shear at $9\frac{3}{4}$ ft. from a support is the same when only the 11-ton wheel is on the beam as when the two wheels are on the beam, and find its value.

Ans. $8\frac{3}{4}$ tons; $11\frac{5}{8}$ tons.

24. Solve example 22 when the beam carries an additional load of 1250 lbs. ($=\frac{5}{8}$ ton) per lineal foot.

Ans. Abs. max. B. M. is at 5.291 ft. ($=\frac{7418\frac{1}{2}}{1402}$ ft.) from support.

Max. *positive* shearing-force diagram is given by $S_x = 18.54625 - 2.065x$ from $x=0$ to $x=6\frac{1}{2}$ ft., and $S_x = 14.90625 - 1.505x$ from $x = 6\frac{1}{2}$ to $x = 12\frac{1}{2}$ ft. The max. *negative* shearing-force diagram is given by $S_x = -.56x$ from $x=0$ to $x = 4\frac{3}{8}$ ft.; $= 3.64 - 1.44x$ from $x = 4\frac{3}{8}$ to $x = 6\frac{1}{2}$ ft.; $= 7.54625 - 2.065x$ from $x = 6\frac{1}{2}$ to $x = 9\frac{3}{4}$ ft.; $= 3.90625 - 1.505x$ from $x = 9\frac{3}{4}$ to $x = 12\frac{1}{2}$ ft. Max. B. M. curve is given by $M_x = (18.54625 - 1.7525x)x$, and $M_x = (14.90625 - 1.1925x)x$.

25. Three wheels, each loaded with a weight W and spaced 5 ft. apart, roll over a beam of 18 ft. span. Place the wheels in such a position as to give the maximum bending moment, and find its value.

Ans. Middle weight at centre of beam; $8\frac{1}{2}W$.

26. Place (a) the wheels in the preceding example so that B. M. at any point between the two hindmost wheels may be constant, and find its value. Also (b) determine all the positions of the wheels which will give the same bending moment at 6 and 12 ft. from one end, and find its value.

Ans.—(a) 1st wheel at 1 ft. from support; B. M. $= 7W$.

(b) When distance between end wheel and support is ≥ 2 ft. and ≤ 6 ft.; B. M. $= 7W$.

27. Four wheels each loaded with a weight W and spaced 5 ft. apart roll over a beam of 18 ft. span. Place the wheels in such a position as to give the maximum bending moment, and find its value.

Ans. One wheel off the beam and middle wheel of remaining three at the centre; max. B. M. $= 8\frac{1}{2}W$. If all wheels are on beam, max. B. M. $= 8\frac{3}{4}W$.

28. All the wheels in the preceding example being on the beam, the B. M. at the centre for a certain range of travel is constant and equal to that for a particular distribution of the wheels when only three are on the beam. Find the range, the B. M., and the position of the three wheels.

Ans. While the end wheel travels 3 ft. from the support ; $8W$;
first wheel 5 ft. from the support.

29. A span of l ft. is crossed by two cantilevers fixed at the ends and hinged at the centre. Draw diagrams of shearing force and bending moment (1) for a single weight W at the hinge, (2) for a uniformly distributed load of intensity w .

Ans. Taking hinge for origin, the shearing-force and bending-moment diagrams are given by

$$(1) \quad S_x = \frac{W}{2}; \quad M_x = -\frac{Wx}{2}.$$

$$(2) \quad S_x = wx; \quad M_x = -\frac{wx^2}{2}.$$

30. A beam for a span of 100 ft. is fixed at the ends. Hinges are introduced at points 30 ft. from each end. Draw curves of shearing force and bending moment (1) when a weight of 5 tons is concentrated on each hinge ; (2) when a uniformly distributed load of $\frac{1}{4}$ ton per lineal foot covers (a) the centre length, (b) the two side lengths, (c) the whole span.

Ans. Take a hinge as origin ; the diagrams are given by—

$$(1) \quad \text{For each side span} \quad S_x = 5, \quad M_x = -5x;$$

$$\text{for centre span} \quad S_x = 0, \quad M_x = 0.$$

$$(2)-(a) \quad \text{For each side span} \quad S_x = \frac{5}{2}, \quad M_x = -\frac{5}{2}x;$$

$$\text{for centre span} \quad S_x = \frac{5}{2} - \frac{x}{8}, \quad M_x = \frac{5}{2}x - \frac{x^2}{16}.$$

$$(b) \quad \text{For each side span} \quad S_x = \frac{x}{8}, \quad M_x = -\frac{15}{4}x + \frac{x^2}{16};$$

$$\text{for centre span} \quad S_x = 0, \quad M_x = 0.$$

$$(c) \quad \text{For each side span} \quad S_x = \frac{5}{2} + \frac{x}{8}, \quad M_x = -\frac{25}{4}x + \frac{x^2}{16};$$

$$\text{for centre span} \quad S_x = \frac{5}{2} - \frac{x}{8}, \quad M_x = \frac{5}{2}x - \frac{x^2}{16}.$$

31. If the load on each of the wheels in example 27 is 5 tons, and if the beam also carries a uniformly distributed load of 20 tons, and two loads of 2 and 3 tons concentrated at points distant 5 and 9 ft., respectively, from one end, find the maximum shearing force (both positive and negative) and the maximum bending moment for the whole span ; also find the loci for the maximum shearing force and bending moment at each point.

Ans. Denoting the distance from support by x , the *max. positive* shearing-force diagram is given by $S_x = \frac{3}{8} - \frac{1}{8}x$ from $x = 0$ to $x = 3$; $S_x = \frac{6}{8} - \frac{1}{8}x$ from $x = 3$ to $x = 8$; $S_x = \frac{1}{8} - \frac{1}{8}x$ from $x = 8$ to $x = 13$; $S_x = 5 - \frac{5x}{18}$ from $x = 13$ to $x = 18$ ft. The *max. negative* shearing-force diagram is given by $S_x = -\frac{1}{8}x$ from $x = 0$ to $x = 5$; $S_x = \frac{7}{8} - \frac{1}{8}x$ from $x = 5$ to $x = 10$; $S_x = \frac{2}{8} - \frac{1}{8}x$ from $x = 10$ to $x = 15$; $S_x = \frac{50}{6} - \frac{20x}{18}$ from $x = 15$ to $x = 18$. Max. *positive* shear = $\frac{3}{8}$ tons; max. *negative* shear = $\frac{3}{8}$ tons; *max. bending-moment* curve is given by $M_x = \frac{3}{8}x - \frac{1}{16}x^2$ from $x = 0$ to $x = 3$; $M_x = \frac{3}{8}x - \frac{1}{16}x^2$ from $x = 3$ to $x = 5$; $M_x = \frac{2}{8}x - \frac{1}{16}x^2 - 15$ from $x = 5$ to $x = 8$; $M_x = \frac{1}{8}x - \frac{1}{16}x^2 + 12$ from $x = 8$ to $x = 9$; abs. max. B. M. = 142 ton.-ft.

32. A rolled joist weighing 150 lbs. per lineal foot and 20 ft. long carries a uniformly distributed load of 6000 lbs., and two wheels 5 ft. apart, the one bearing 5000 lbs. and the other 3000 lbs., roll over the joist. Find the maximum shears at the supports, at the centre, and at 5 ft. from each end.

Ans. 10,250 lbs.; 9750 lbs.; 3250 lbs.; 6750 lbs.; 6250 lbs.

33. A beam l ft. long and weighing w lbs. per lineal foot has a load of mW lbs. at a ft. from the left end and a load of nW lbs. at b ft. from the right end. Find the shearing forces and bending moments at the weights and at the middle of the beam, a and b being each $< \frac{l}{2}$.

How will the result be affected if $b > \frac{l}{2}$?

34. A rolled joist weighing 450 lbs. per lineal foot and 20 ft. long carries the four wheels of a locomotive at 3, 8, 13, and 18 ft. from one end. Find the maximum bending moment and the maximum shears, both positive and negative, the load on each wheel being 10,000 lbs.

Ans. Max. B. M. = 123,600 lb.-feet.; max. shears = 23,500 lbs. and 25,300 lbs.

35. Solve the preceding example when a live load of $2\frac{3}{8}$ tons per lineal foot is substituted for the four concentrated weights on the wheels.

36. The loads on the wheels of a locomotive and tender passing over a beam of 60 ft. span are 14,180, 14,180, 21,260, 21,260, 21,260, 21,260, 16,900, 16,900, 16,900, 16,900 lbs., counting in order from the front, the

intervals being 5, $5\frac{1}{2}$, 5, 5, $8\frac{1}{2}$, 5, 4, 5 ft. Place the wheels in such a position as to give the maximum bending moment, and find its value.

Also find the maximum bending moments for spans of 30, 20 and 16 feet.

Ans. For 60-ft. span, max. B. M. is at 5th wheel and = 1,559,925.4 lb.-ft. when 1st wheel is 7.95 ft. from support.

For 30-ft. span, max. B. M. at 5th wheel when 2d wheel is .596 ft. from support and = 436,761.4 lb.-ft.

For 20-ft. span, max. B. M. at centre when 3d wheel is $2\frac{1}{2}$ ft. from support and = 212,600 lb.-ft. = max. B.M. at same point when 4th wheel is 5 ft. from support.

For 16-ft. span, max. B. M. is at 5th wheel and = 132,875 lb.-ft. when 4th wheel is 5 ft. from support.

37. If the 60-ft. beam in the preceding example also carries a uniformly distributed load of 60,000 lbs., find the curves of maximum shearing force and bending moment at each point.

38. If a beam is supported at the ends and arbitrarily loaded, show that the ordinate at the point of maximum moment divides the area of the curve of loads into two parts which are equal to the supporting forces. If a and b are the distances of the centres of gravity of the parts from the ends of the beam, and if W is the total weight on the beam, show that the maximum bending moment is $W \div \left(\frac{1}{a} + \frac{1}{b} \right)$.

39. A span of l ft. is crossed by a beam in two half-lengths, supported at the centre by a pier whose width may be neglected. The successive weights on the wheels of a locomotive and tender passing over the beam are 14,000, 22,000, 22,000, 22,000, 22,000, 14,000, 14,000, 14,000, 14,000 lbs., the intervals being $7\frac{1}{2}$, $4\frac{1}{2}$, $4\frac{1}{2}$, $4\frac{1}{2}$, $10\frac{1}{2}$, 5, 5, 5 ft. Place the wheels in such a position as to throw the greatest possible weight upon the centre pier, and find the magnitude of this weight for spans of (1) 50 ft.; (2) 25 ft.; (3) 20 ft.; (4) 18 ft.

40. Loads of $3\frac{1}{2}$, 6, 6, 6, and 6 tons follow each other in order over a ten-panel truss at distances of 8, $5\frac{1}{2}$, $4\frac{1}{2}$, and $4\frac{1}{2}$ ft. apart. Apply the results of Art. 8 to determine the position of the loads which will give the maximum diagonal and flange stresses in the third and fourth panels.

41. A truss of 240 ft. span and ten panels, has loads of $12\frac{1}{2}$, 10, 12, 11, 9, 9, 9, and 9 tons concentrated at the panel points. Find, by *scale measurement*, the bending moments at the four panel points which are the most heavily loaded, and determine by Art. 8 whether these are the

greatest bending moments to which the truss is subjected as the weights travel over the truss at the panel distances apart.

42. Loads of $7\frac{1}{2}$, 12, 12, 12, 12 tons are concentrated upon a horizontal beam of 25 ft. span at distances of 18, 108, 164, 216, and 272 in., respectively, from the left support. Find, graphically, the bending moment at the centre of the span. If the loads travel over the truss at the given distances apart, find the maximum B. M. at the same section.

43. A beam $ABCD$ is supported at four points A , B , C , and D , and the intermediate span BC is hinged at the two points E and F . The load upon the beam consists of 15 tons uniformly distributed over AB , 10 tons uniformly distributed over BE , 5 tons uniformly distributed over FC , 30 tons uniformly distributed over CD , and a single weight of 5 tons at the middle point of EF . $AB = 15$ ft.; $BE = 5$ ft.; $EF = 15$ ft.; $FC = 10$ ft.; $CD = 25$ ft. Draw curves of B. M. and S. F., and find points of inflexion.

44. Four wheels loaded with 4, 4, 8, and 8 tons are placed upon a girder of 24 ft. span at distances of 3 in., $6\frac{1}{2}$ ft., $8\frac{3}{4}$ ft., and 9 ft. from the left support. Find by scale measurement the bending moment at the centre of the girder. If the wheels travel over the girder at the given distances apart, find the maximum B. M. to which the girder is subjected.

45. Three wheels loaded with 8, 9, and 10 tons and spaced 5 ft. apart, are placed upon a beam of 15 ft. span, the 8-ton wheel being 3 ft. from the left abutment. Determine graphically the B. M. at 6 ft. from the left abutment. Also find the greatest B. M. at the same point when the weights travel over the beam, and the *abs. max.* bending moment to which the beam is subjected.

Ans. $47\frac{3}{8}$ ton-ft.; $53\frac{1}{2}$ ton-ft.; *abs. max.* B. M. = $56\frac{1}{2}\frac{3}{4}$ ton-ft. at 2d wheel when 1st is $2\frac{1}{4}$ ft. from support.

CHAPTER III.

DEFINITIONS AND GENERAL PRINCIPLES.

I. Definitions.—The science relating to the strength of materials is partly theoretical, partly practical. Its primary object is to investigate the forces developed within a body, and to determine the most economical dimensions and form, consistent with stability, of that body. Certain hypotheses have to be made, but they are of such a nature as always to be in accord with the results of direct observation.

The materials in ordinary use for structural purposes may be termed, generally, *solid bodies*, i.e., bodies which offer an appreciable resistance to a change of form.

A body acted upon by external forces is said to be *strained* or *deformed*, and the straining or deformation induces *stress* amongst the particles of the body.

The state of strain is *simple* when the stress acts in *one* direction only, and the strain itself is measured by the ratio of the deformation to the original length.

The state of strain is *compound* when *two* (or *more*) stresses act simultaneously in different directions.

A strained body tends to assume its natural state when the straining forces are removed: this tendency is called its *elasticity*. A thorough knowledge of the laws of elasticity, i.e., of the laws which connect the external forces with the internal stresses, is absolutely necessary for the proper comprehension of the strength of materials. This property of elasticity is not possessed to the same degree by all bodies. It may be almost absolute, or almost zero, but in the majority of cases it has a mean value. Hence it naturally follows that solid bodies may be classified between two extreme, though ideal, states, viz.,

a *perfectly elastic* state and a *perfectly soft* state. Perfectly elastic bodies which have been strained resume their original forms exactly when the straining forces are removed. Perfectly soft bodies are wholly devoid of elasticity and offer no resistance to a change of form.

Bodies capable of undergoing an indefinitely large deformation under stress are said to be *plastic*.

2. Stresses and Strains.—Every body may be subjected to five distinct kinds of stresses, viz.:

- (a) A longitudinal pull, or tension.
- (b) A longitudinal thrust, or compression.
- (c) A shear, or tangential stress, which may be defined as a stress tending to make one surface slide over another with which it is in contact.
- (d) A transverse stress.
- (e) A twist or torsion.

Under any one of these stresses a body may suffer either an elastic deformation, of a temporary character, or a plastic deformation, of a permanent character.

3. Resistance of Bars to Tension and Compression.—

Let a straight bar of homogeneous material and length L be stretched or compressed longitudinally by a force P uniformly distributed over the constant cross-section A of the bar; let the line of action of P coincide with the axis of the bar, and let l be the consequent extension or compression, i.e., the deformation.

If the transverse dimensions of the bar are small as compared with the length, experiment shows that, *within certain limits*, the force P is *directly* proportional to the deformation l and to the area A , and *inversely* proportional to the length L , these quantities being connected by the relation

$$P = EA \frac{l}{L},$$

where E is a constant dependent upon the material of the bar and is called the *coefficient* or *modulus* of elasticity. It is evidently the force which will double the length of a perfectly elastic bar of unit section. Denoting the unit stress $\left(\frac{P}{A}\right)$ by f ,

and the strain per unit of length $\left(\frac{l}{L}\right)$ by λ , the above equation may be written

$$f = E\lambda,$$

or the unit stress = E times the unit strain.

Thus the equation is the analytical expression of Hooke's law, that for a body in a state of simple strain the strain is proportional to the stress.

The longitudinal strain is accompanied by an alteration in the transverse dimensions, the lateral unit strain being $-\frac{\lambda}{m}$, where m is a coefficient which usually varies from 3 to 4 for solid bodies and is approximately 4 for the metals of construction. In the case of india-rubber, if the deformation is small, m is about 2.

Generally the deformation may be calculated per unit of *original* length without sensible error, but for india-rubber it is more accurate to make the calculation per unit of *stretched* length $\left(= \frac{\lambda}{1 + \lambda}\right)$.

The ratio $\frac{1}{m} = \frac{\text{lateral strain}}{\text{longitudinal strain}}$ is called Poisson's ratio.

If the transverse dimensions of a bar under compression are small as compared with the length L , a slight disturbing force will cause the bar to bend sideways, and the bar will be subjected to a bending action in addition to the compression. If the bar is to be capable of resisting a direct thrust only, the ratio of L to its least transverse dimension should not exceed a certain limit depending upon the nature of the material. For example, experiment indicates that this limit should be about 5 for cast-iron, 10 for wrought-iron, 7 for steel, and 20 for dry timber.

If the temperature of the bar is raised t° , the consequent strain is αt , α being the coefficient of linear dilatation; and a stress $E\alpha t^\circ$ will be developed if a change of length is prevented.

4. Specific Weight; Coefficient of Elasticity; Limit of Elasticity; Breaking Stress.—Before the strength of a body can be fully known, certain physical constants, whose values depend upon the material, must be determined.

(a) *Specific Weight.*—The specific weight is the weight of a unit of volume. The specific weights of most of the materials of construction have been carefully found and tabulated. If the specific weight of any new material is required, a convenient approximate method is to prepare from it a number of regular solids of determinate volume and weigh them in an ordinary pair of scales. The ratio of the total weight of these solids to their total volume is the specific weight. It must be remembered that the weight may vary considerably with time, etc.; thus a sample of greenheart weighed 69.75 lbs. per cubic foot when first cut out of the log, and only 57 lbs. per cubic foot at the end of six months. When the strength of a timber is being determined, it is important to note the amount of water present in the test-piece, since this appears to have a great influence upon the results.

The straining of a structure is generally largely due to its own weight.

The *total load* upon a structure includes *all* the external forces applied to it, and in practice is designated *dead* (*permanent*) or *live* (*rolling*), according as the forces are gradually applied and steady, or suddenly applied and accompanied with vibrations. For example, the weight of a bridge is a dead load, while a train passing over it is a live load; the weight of a roof, together with the weight of any snow which may have accumulated upon it, is a dead load; *wind* causes at times excessive vibrations in the members of a structure, and although often treated as a dead load, should in reality be considered a live load.

The dead loads of many structures (as masonry walls, etc.) are so great that extra or accidental loads may be safely disregarded. In cold climates, great masses of snow and the penetrating effect of the frost necessitate very deep foundations, which proportionately increase the dead weight.

(b) *Coefficient of Elasticity.*—Generally speaking, a knowledge of the external forces acting upon a structure, discloses

the manner of their distribution amongst its various members, but the deformation of these members can only be estimated by means of the coefficient of elasticity, which expresses the relation between a stress and the corresponding strain.

In practice it is usually sufficient to assume that a material is elastic, homogeneous, and isotropic, and its deformation under stress may be found, if the coefficients of elasticity, of form, and of volume are known.

In a homogeneous solid there may be twenty-one distinct coefficients of elasticity, which are usually classified under the following heads:

(1) *Direct*, expressing the relation between longitudinal strains and normal stresses in the same direction.

(2) *Transverse*, expressing the relation between tangential stresses and strains in the same direction.

(3) *Lateral*, expressing the relation between longitudinal strains and normal stresses at right angles to the strains; i.e., a lateral resistance to deformation.

(4) *Oblique*, expressing other relations of stress and strain.

If a body is isotropic, i.e., equally elastic in all directions, the *twenty-one* coefficients reduce to *two*, viz., the coefficients of direct elasticity and of lateral elasticity. Such bodies, however, are almost wholly ideal. In a perfectly elastic body E would be the same both for tension and compression. In the

ordinary materials of construction it is slightly less for compression than for tension; but if the stresses do not exceed a certain limit (§ (e), page 145) the difference is so slight that it may be disregarded.

The equation $f = E\lambda$ may be represented graphically by the straight line MON , the ordinate at any point representing the unit stress required to produce the unit strain represented by the corresponding abscissa.

The angle $MOY = \tan^{-1} E = \tan^{-1} \left(\frac{f}{\lambda} \right)$.

Coefficients of elasticity must be determined by experiment.

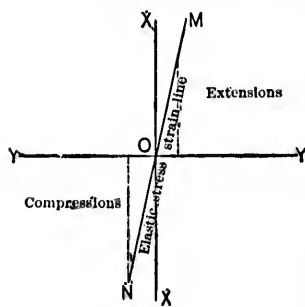

FIG. 183.

The coefficients of direct elasticity for the different metals and timbers are sometimes obtained by subjecting bars of the material to forces of extension or compression, or by observing the deflections of beams loaded transversely. The coefficients for blocks of stone and masonry might also be found by transverse loading; they are of little, if any, practical use, as, on account of the inherent stiffness of masonry structures, their deformations, or *settlings*, are due rather to defective workmanship than to the natural play of elastic forces.

The *torsional* coefficient of elasticity, i.e., the coefficient of elastic resistance to torsion, has been shown by experiment to vary from two fifths to three eighths of the coefficient of direct elasticity.

(e) *Limit of Elasticity*.—When the forces which strain a body fall below a certain limit, the body, on the removal of the forces, will resume its original form and dimensions without sensible change (disregarding any effects due to the development of heat) and may be treated as perfectly elastic. But if the forces exceed this limit, the body will receive a permanent deformation, or, as it is termed, a *set*.

Such a limit is called a *limit of elasticity*, and is the greatest stress that can be applied to a body without producing in it an appreciable and permanent deformation.

This is an unsatisfactory definition, as a body passes from the elastic to the non-elastic state by such imperceptible degrees that it is impossible to fix any exact line of demarcation between the two states. Fairbairn defines the limit more correctly, as the stress below which the deformation is approximately proportional to the load which produces it, and beyond which the deformation increases much more rapidly than the load. In fact, both the elastic and ultimate strengths of a material depend upon the *nature* of the stresses to which they are subjected and upon the *frequency* of their application. For example, in experimenting upon bars of iron having an ultimate tenacity of 46,794 lbs. per sq. in. and a ductility of 20%, Wöhler found that with repeated stresses of equal intensity, but alternately tensile and compressive, a bar failed after 56,430 repetitions when the intensity was 33,000 lbs. per sq. in.; a

second bar failed only after 19,187,000 repetitions when the intensity was 18,700 lbs. per sq. in. ; while a third bar remained intact after more than 132,000,000 repetitions when the intensity was 16,690 lbs. per sq. in. These experiments therefore indicated that the *limit of elasticity* for the iron in question, under repeated stresses of equal intensity, but alternately tensile and compressive, lay between 16,000 and 17,000 lbs. per sq. in., which is much less than the limit under a steadily applied stress. Similar results have been shown to follow when the stresses fluctuate from a maximum stress to a minimum stress of the *same kind*.

Generally speaking, then, the limit of elasticity of a material subjected to repeated stresses, is a certain maximum stress below which the condition of the body remains unimpaired.

Bauschinger's experiments indicate that the application to a body of any stress, however small, produces a plastic or permanent deformation. This, perhaps, is sometimes due to a want of uniformity in the material, or to the bar being not quite straight initially. In any case, the deformations under loads which are less than the elastic limit, are so slight as to be of no practical account and may be safely disregarded.

The main object, then, of the *theory* of the strength of materials, is to determine whether the stresses developed in any particular member of a structure exceed the limit of elasticity. As soon as they do so, that member is permanently deformed, its strength is impaired, it becomes predisposed to rupture, and the safety of the whole structure is threatened. Still, it must be borne in mind that it is not absolutely true that a material is always weakened by being subjected to forces superior to this limit. In the manufacture of iron bars, for instance, each of the processes through which the metal passes changes its elasticity and increases its strength. Such a material is to be treated as being in a new state and as possessing new properties.

The strength of a material is governed by its tenacity and rigidity, and the essential requirement of practice is a *tough* material with a high elastic limit.

This is especially necessary for bridges and all structures

liable to constantly repeated loads, for it is found that these repetitions lower the elastic limit and diminish the strength.

In the majority of cases, experience has fixed a practical limit for the stresses, much below the limit of elasticity. This insures greater safety and provides against unforeseen and accidental loads, which may exceed the *practical* limit, but which do no harm unless they pass beyond the *elastic* limit.

Certain operations have the effect of raising the limit of elasticity: a wrought-iron bar steadily strained almost to the point of its ultimate strength and then released from strain and allowed to rest, experiences an elevation both of tenacity and of the elastic limit.

If the bar is stretched until it breaks, the tensile strength of the broken pieces is greater than that of the bar. A similar result follows in the various processes employed in the manufacture of iron and steel bars and wires: the wire has a greater ultimate strength than the bar from which it was drawn.

Again, iron and steel bars, subjected to *long-continued* compression or extension, have their resistance increased, mainly because time is allowed for the molecules of the metal to assume such positions as will enable them to offer the maximum resistance; the increase is not attended by any appreciable change of density.

Under an increasing stress a *brittle* material will be fractured without any great deformation, while a *tough* material will become plastic and undergo a large deformation.

(d) *Breaking Stress*.—When the load upon a material increases indefinitely, the material may merely suffer an increasing deformation, but generally a limit is reached at which fracture suddenly takes place.

Cast-iron is perhaps the most doubtful of all materials, and the greatest care should be observed in its employment. It possesses little tenacity or elasticity, is very hard and brittle, and may fail suddenly under a shock or an extreme variation of temperature. Unequal cooling may predispose the metal to rupture, and its



FIG. 184.

strength may be still further diminished by the presence of air-holes.

Cast-iron and similar materials receive a sensible set even under a small load, and the set increases with the load. Thus at no point will the stress-strain curve be absolutely straight, and the point of fracture will be reached without any *great* change in the slope of the curve and without the development of much plasticity.

Wrought-iron and *steel* are far more uniform in their behavior, and obey with tolerable regularity certain theoretical laws. They are tenacious, ductile, have great compressive strength, and are most reliable for structural purposes. Their strength and elasticity may be considerably reduced by high temperatures or severe cold.

When a bar of such material is tested, the *stress-strain* curve ($f = \pm E\lambda$), as has already been pointed out, is almost absolutely straight within the elastic limit, e.g., from O to A in

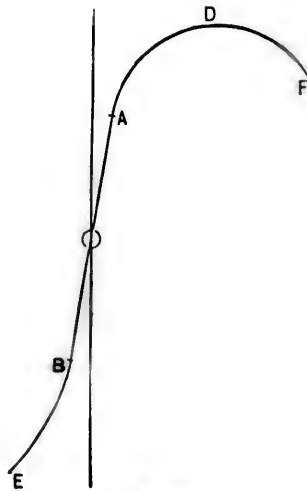

FIG. 184.

tension and from O to B in compression. As the load increases beyond the elastic limit, the increasing deformation becomes plastic and permanent, and the stress-strain diagram takes an appreciable curvature between the limits A and B and the points D and E corresponding to the maximum loads. In tension, as soon as the point D is reached, the bar rapidly elongates and is no longer able to sustain the maximum load, its sectional area rapidly diminishes, and fracture ultimately takes place under a load much less than the maximum load. The point of fracture is represented in the figure

by the point F the ordinate of F being the *actual ultimate final load on the bar*

$$\text{intensity of stress} = \frac{\text{final load on the bar}}{\text{area of fractured section}}.$$

The exact form of the stress-strain curve between D and F is unknown, as no definite relation has been found to exist between the stress and strain during the elongation from D to F .

Ordinarily, the *breaking tensile stress* has been defined to be the *maximum load applied* divided by the *initial sectional area* of the bar; but this, although convenient, is manifestly incorrect.

It is important to note that, as the deformation gradually increases under the increasing load, the molecules of the material require greater or less time to adjust themselves to the new condition.

During the tensile test of a ductile material there is, at some point beyond the elastic limit, an abrupt break GH in the continuity of the stress-strain curve, the curve again becoming continuous from H to D .

The point G has been called the *Yield Point* or the *Breaking-down Point*, and the deformation from H onward is almost wholly plastic or permanent.

In *compression* there is no local stretch as in tension, and there is consequently no considerable change in the curvature of the compression stress-strain curve up to the point of fracture.

Timber is usually tested by being subjected to the action of tensile, compressive, or transverse loads. Other characteristics, however, must be known before a full conception of the strength of the wood can be obtained. Thus the specific weight must be found; the amount of water present, the loss in drying, and the corresponding shrinkage should be determined; the *structural* differences of the several specimens, the rate of growth, etc., should be observed.

The chief object of experiments upon *masonry* and *brick-work* is to discover their resistance to compression, i.e., their crushing strength. In fact, their stiffness is so great that they may be compressed up to the point of fracture without sensible change of form, and it is therefore very difficult, if not impossible, to observe the limit of elasticity.

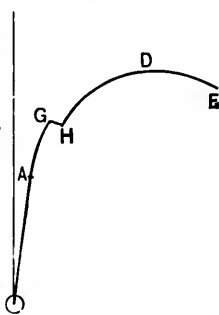

FIG. 186.

The *cement or mortar* uniting the stones and bricks is most irregular in quality. In every important work it should be an invariable rule to prepare specimens for testing. The crushing strength of cement and of mortar is much greater than the tensile strength, the latter being often exceedingly small. Hence it is advisable to avoid tensile stresses within a mass of masonry, as they tend to open the joints and separate the stones from one another. Attempts are frequently made to strengthen masonry and brickwork walls by inserting in the joints tarred and sanded strips of hoop-iron. Their utility is doubtful, for, unless well protected from the atmosphere, they oxidize, to the detriment of the surrounding material, and, besides this, they prevent an equable distribution of pressure. They are, however, far preferable to bond-timbers.

The *working load* (or *stress*, or *strength*) is the maximum stress which a material can *safely* bear in ordinary practice, and depends both upon the *character* (see Art. 5, below) of the stress and upon the ultimate strength of the material, the ratio of the ultimate or breaking stress to the working stress being usually called a *factor* of safety. For example, the factor is about

3 for long-span iron bridges, or bridges having great weight as compared with the *live* load (a moving train).

4 for ordinary iron bridges.

5 for ordinary metal shafting.

8, 10, and even more for long struts and members subjected to repeated stresses of varying magnitude.

10 is also generally taken to be the factor of safety for timber.

Under a *steady*, or a merely statical load, even as great as $\frac{7}{8}$ of the breaking stress, a member of a structure may probably not be unsafe.

5. Wöhler's Law.—It is now generally admitted that variable forces, constantly repeated loads, and continued vibrations diminish the strength of a material, whether they produce stresses approximating to the elastic limit, or exceedingly small stresses occurring with great rapidity. Indeed many engineers design structures in such a manner, that the several

members are strained in one way only, so convinced are they of the evil effect of alternating tensile and compressive stresses. Although the fact of a variable ultimate strength had thus been tacitly acknowledged and often allowed for, Wöhler was the first to give formal expression to it, and, as a result of observation and experiment, enunciated the following law:

"That if a stress t , due to a static load, cause the fracture of a bar, the bar may also be fractured by a series of often-repeated stresses, each of which is less than t ; and that, as the differences of stress increase, the cohesion of the material is affected in such a manner that the minimum stress required to produce fracture is diminished."

This law is manifestly incomplete. In Wöhler's experiments the applications of the load followed each other with great rapidity, yet a certain length of time was required for the resulting stresses to attain their full intensity; the influence due to the rapidity of application, to the rate of increase of the stress, and to the duration of individual strains still remains a subject for investigation.

The experiments, however, show that the rate of increase of repetitions of stress required to produce fracture, is much more rapid than the rate of decrease of the stresses themselves, and depends both upon the *maximum* stress and upon the difference or *fluctuation of stress*.

The effect of repeated stresses of equal intensity, but alternately tensile and compressive, has been already pointed out in Art. 4.

Bars of the same material repeatedly bent in one direction, bore 31,132 lbs. per square inch when the load was wholly removed between each bending, and 45,734 lbs. per square inch when the stress fluctuated between 45,733 lbs. and 24,941 lbs.

The table on page 152 gives the results of similar experiments on steel.

The axle-steel was found to bear 22,830 lbs. per square inch, when subjected to repeated shears of equal intensity but *opposite* in kind, and 29,440 lbs. per square inch, when the shears were of the *same* kind. It would therefore appear that the shearing strengths of the metal in the two cases are about $\frac{1}{4}$

of the strengths of the same metal under alternate bending and under bending in one direction, respectively.

Character of Fluctuation.	Maximum Resistance to Repeated Stresses in lbs. per square inch.	
	Axle-steel.	Spring-steel (un-hardened).
Alternating stresses of equal intensity	29,000, — 29,000	
Complete relief from stress between each bending	49,890, 0	52,000, 0
Partial relief from stress between each bending	83,110, 36,380	93,500, 62,240

From torsion experiments with various qualities of steel, the important result was deduced, that the maximum resistance of the steel to alternate twisting was $\frac{1}{3}$ of the maximum resistance of the same steel to alternate bending.

Wöhler proposed 2 as a factor of safety, and considered that the maximum permissible working stresses should be in the ratios of 1 : 2 : 3, according as members are subjected to alternate tensions and compressions (alternate bending), to tensions alternating with entire relief, or to a steady load.

The weakening of metal by repeated stresses has been called *fatigue*, and is much more injurious to iron and steel under tension than under compression. Egleston's investigations have shown that a *fatigued* metal may sometimes be restored by rest or by annealing.

From the law, however, as it stands formulæ may be deduced which, it is claimed, are more in accordance with the results of experiment, give smaller errors, and insure greater safety than the false assumption of a constant ultimate strength.

The formulæ necessarily depend upon certain experimental results, but in applying them to any particular case, it must be remembered that only such results should be employed, as have been obtained for material of the same kind and under the same conditions as the material under consideration. The effects due to faulty material, rust, etc., are altogether indeterminate, so that no formula can be perfectly universal in its application. Hence the necessity for factors of safety, with values depending upon the class of structure, still exists.

A brief description of the principal of these formulæ will now be given, and in the discussion

t, the *statical breaking strength*, is the resistance to fracture under a static or under a very gradually applied load.

u, the *primitive strength*, is the resistance to fracture under a given number of repeated stresses, the stress in each repetition remaining unchanged in kind, i.e., being due either to a tension, a compression, or a shear.

s, the *vibration strength*, is the resistance to fracture under alternating stresses of equal intensities, but different in kind, due to a vibratory motion about the unstrained state of equilibrium.

b is the admissible stress per unit of sectional area

F is the effective sectional area and is

$$= \frac{\text{numerically absolute maximum load}}{b}$$

6. Launhardt's Formula.—A bar of unit sectional area is subjected to stresses (*B*) which are either wholly tensile, wholly compressive, or wholly shearing, and which vary from a maximum *a*₁ (= max. *B*) to a minimum *a*₂ (= min. *B*).

Let *a*₁ - *a*₂ = *d* = the maximum difference of stress.

Let $\frac{a_2}{a_1} = \frac{\text{min. } B}{\text{max. } B} = \phi.$

If *a*₂ = 0, *a*₁ = *d* = *u*.

If *d* = 0, *a*₁ = *a*₂ = *t*.

By Wöhler's law,

$$a_1 \propto d = fd, \dots \dots \dots (I)$$

f being an unknown coefficient of which the value remains to be determined.

If *d* = 0, *a*₁ = *t* and *f* = ∞.

If *d* = *u*, *a*₁ = *d* and *f* = 1.

Launhardt's assumption, viz., $f = \frac{t-u}{t-a_1}$, satisfies these extreme conditions, and also gives intermediate values of a_1 which closely agree with the results of the most reliable experiments.

Hence (1) becomes

$$a_1 = \frac{t-u}{t-a_1} d = \frac{t-u}{t-a_1} (a_1 - a_2),$$

and

$$\therefore a_1 = u \left(1 + \frac{t-u}{u} \frac{a_2}{a_1} \right) = u \left(1 + \frac{t-u}{u} \phi \right). \quad \dots (2)$$

This is Launhardt's formula, and is an analytical expression of Wöhler's Law.

Wöhler in his bending experiments upon Phœnix axle-iron found that $u = 2195^k$ per cent.* and $t = 4020^k$ per cent.†;

$$\therefore \frac{t-u}{u} = \frac{5}{6}$$

The same iron under tension gave $u = 2195^k$ per cent.‡ and $t = 3290^k$ per cent.‡;

$$\therefore \frac{t-u}{u} = \frac{1}{2}.$$

Choosing the most unfavorable case, and, in order to insure greater safety, taking $u = 2100^k$ per cent.‡, equation (2) becomes

$$a_1 = 2100 \left(1 + \frac{\phi}{2} \right). \quad \dots (3)$$

If 3 is the factor of safety,

$$b = 700 \left(1 + \frac{\phi}{2} \right). \quad \dots (4)$$

* k per cent.‡ is an abbreviation for kilogrammes per square centimetre. One kilogramme per square centimetre is equivalent to 14.2232 lbs. per sq. in.

In his bending experiments upon Krupp cast-steel (untempered) it was found that $u = 3510^t$ per cent.² and $t = 7340^t$ per cent.²;

$$\therefore \frac{t - u}{u} = \frac{7}{6}.$$

But steel varies considerably in strength, and great care must be exercised in its use, especially in bridge construction. For this reason take $u = 3300^t$ per cent.² and $t = 6000^t$ per cent.²;

$$\therefore \frac{t - u}{u} = \frac{9}{11},$$

and (2) becomes

$$a_1 = 3300 \left(1 + \frac{9}{11} \phi \right). \dots \dots \dots (5)$$

If 3 is the factor of safety,

$$b = 1100 \left(1 + \frac{9}{11} \phi \right). \dots \dots \dots (6)$$

EXAMPLE 1.—The stresses upon a bar of Phoenix axle-iron, normal to its cross-section, vary from a maximum tension of 50000^t to a minimum tension of 20000^t. Determine the admissible stress per cent.² and the necessary sectional area.

By (4),

$$b = 700 \left(1 + \frac{1}{2} \frac{20000}{50000} \right) = 840^t \text{ per cent.}^2,$$

and

$$\therefore F = \frac{50000}{b} = \frac{50000}{840} = 59.52 \text{ sq. centimetres.}$$

Let p be the dead load and q the total load, per lineal unit of length, upon the flanges of roof and bridge trusses.

By Minnie

$\therefore \phi = \frac{p}{q}$, and equations (4) and (6) respectively become

$$b = 700 \left(1 + \frac{1}{2} \frac{p}{q} \right), \dots \dots \dots (7)$$

$$b = 1100 \left(1 + \frac{9}{11} \frac{p}{q} \right) \dots \dots \dots (8)$$

EX. 2.—Determine the limiting stress per cent.³ for the flanges of a wrought-iron lattice girder when the ratio of the dead load to the greatest total load is $\frac{1}{3\frac{1}{2}}$.

By (7),

$$b = 700 \left(1 + \frac{1}{2} \frac{1}{3\frac{1}{2}} \right) = 800^t.$$

7. **Weyrauch's Formula.**—Let a bar of a unit sectional area be subjected to stresses which are alternately different in kind, and which vary from an absolute numerical maximum a' ($= \max. B$) of the one kind to a maximum a'' ($= \max. B'$) of the other kind.

Let $a' + a'' = d =$ the maximum numerical difference of stress.

Let $\frac{a''}{a'} = \frac{\max. B'}{\max. B} = \phi'.$

If $a'' = 0,$ $a' = d = u.$

If $a'' = s,$ $a' = s = \frac{d}{2}.$

By Wöhler's Law,

$$a' \propto d = fd, \dots \dots \dots (9)$$

f being an unknown coefficient of which the value remains to be determined.

If $a' = u,$ $f = 1.$

If $a' = s,$ $f = \frac{1}{2}.$



Weyrauch's assumption, viz., $f = \frac{u-s}{2u-s-a'}$, satisfies these extreme conditions, the most reliable results of the few experiments yet recorded, and also Wöhler's deduction that a' diminishes as d increases and *vice versa*.

Hence (9) becomes

$$a' = \frac{u-s}{2u-s-a'}d = \frac{u-s}{2u-s-a'}(a' + a''),$$

and

$$\therefore a' = u \left(1 - \frac{u-s}{u} \frac{a''}{a'} \right) = u \left(1 - \frac{u-s}{u} \phi' \right). \dots (10)$$

This is Weyrauch's formula, and it may be always applied to those cases in which a member is subjected to stresses alternating between tension and compression, or due to shearing actions in opposite directions.

In the Phœnix iron experiments already referred to it was found that $s = 1170^t$ per cent.²;

$$\therefore \frac{u-s}{u} = \frac{7}{15}.$$

Taking $u = 2100^t$ as before, and making $\frac{u-s}{u} = \frac{1}{2}$, (10) becomes

$$a' = 2100 \left(1 - \frac{\phi'}{2} \right). \dots (11)$$

If 3 is the factor of safety,

$$b = 700 \left(1 - \frac{\phi'}{2} \right). \dots (12)$$

Weyrauch considers 3 to be the proper factor of safety for bridges and similar structures. It is also a suitable factor for the parts of machines subjected to determinate straining actions. A larger factor will be required when other contingencies have to be provided against.

In the steel experiments, Wöhler found that $s \approx 2050^k$ per cent.:

$$\therefore \frac{u - s}{u} = \frac{5}{12}.$$

Taking $u = 3300^k$ and $s = 1800^k$,

$$\frac{u - s}{u} = \frac{5}{11},$$

and (10) becomes

$$a' = 3300(1 - \frac{5}{11}\phi'). \dots \dots \dots (13)$$

If 3 is the factor of safety,

$$b = 1100(1 - \frac{5}{11}\phi'). \dots \dots \dots (14)$$

If a very soft steel is employed in the construction of a bridge, it may be advisable to diminish still further the admissible stress per unit of sectional area. For example, it may be assumed that $t = 5200^k$, $u = 3000^k$, and $s = 1500^k$, so that (2) and (10) respectively become

$$a_1 = 3000(1 + \frac{3}{4}\phi) \dots \dots \dots (15)$$

and

$$a' = 3000(1 - \frac{1}{2}\phi'). \dots \dots \dots (16)$$

EXAMPLE.—The stresses in a wrought-iron bar normal to its cross-section, vary between a tension of 40000^k and a compression of 30000^k . Find the sectional area (disregarding buckling).

By (12)

$$b = 700(1 - \frac{1}{2} \times \frac{30000}{40000}) = 437.5^k \text{ per cent.}^2.$$

$$\therefore F = \frac{40000}{437.5} = 91.42 \text{ sq. centimetres.}$$

Shearing Stresses.—For shearing stresses in opposite directions Wöhler found, in the case of Krupp cast-steel (untem-

pered), that $u = 2780^{\text{t}}$ per cent.³ and $s = 1610^{\text{t}}$ per cent.³, or about $\frac{1}{3}$ of the corresponding values for stresses which are alternately tensile and compressive, and it may be generally assumed, that the value of b for shearing stresses, is $\frac{1}{3}$ of its value for stresses which are alternately tensile and compressive, and which have the same ratio ϕ' .

8. Unwin has proposed to include all cases of fluctuating stress in the formula

$$a' = \frac{d}{2} + \sqrt{t(t - nd)},$$

a' being the actual strength, d the fluctuation of stress, t the statical breaking strength, and n a coefficient whose value remains to be determined.

When $d = 0$, the load is steady and $a' = t$.

When $d = a'$, the load alternates with entire relief and

$$a' = 2t(\sqrt{1 + n^2} - n).$$

When $d = 2a'$, the stresses are alternately tensile and compressive and of equal intensity. The stress fluctuates from a' to $-a'$, and $a' = \frac{t}{2n}$.

In these extreme cases, if n is made equal to 1.42 for wrought-iron and to 1.66 for steel, results are obtained almost identical with those given in Arts. 6 and 7. The formula may therefore be assumed to be approximately correct for intermediate cases.

The mean value of n for iron and steel seems to be $\frac{1}{3}$, so that the formula may be written

$$a' = \frac{d}{2} + \sqrt{t(t - \frac{1}{3}d)}.$$

EXAMPLE.—One of the diagonals of a bowstring truss has a sectional area of 3 square inches, and is subjected to stresses

which fluctuate between a tension of 14 tons and a compression of 6 tons. Find the statical strength of the iron.

$$a' = \frac{1}{3}t;$$

$$d = \text{fluctuation of stress} = \frac{14 - (-6)}{3} = \frac{20}{3}.$$

$$\therefore \frac{1}{3}t = \frac{20}{3} + \sqrt{t(t-10)}.$$

$$\therefore t = 10.17 \text{ tons per sq. in.}$$

9. Remarks upon the Values of t , u , s , and b .—As yet the value of u in compression has not been satisfactorily determined, and for the present its value may be assumed to be the same both in tension and compression.

If, as Wöhler states, "repeated stresses" are detrimental to the strength of a material, then the values of u and s diminish as the repetitions increase in number, and are minima in structures designed for a practically unlimited life.

Only a very few of Wöhler's experiments give the values of t , u , s , and a , so that Launhardt's and Weyrauch's assumptions for the value of f must be regarded as tentative only, and require to be verified by further experiments. The close agreement of Wöhler's results from tests upon untempered cast-steel (Krupp), with those given by Launhardt's formula, may be seen from the following:

For $t = 1100$ centners* per sq. zoll, Wöhler found that $u = 500$ centners per sq. zoll. Thus (2) becomes

$$a_1 = 500 \left(1 + \frac{6a_2}{5a_1} \right),$$

and

$$\therefore a_1^2 - 500a_1 - 600a_2 = 0.$$

Hence for $a_2 = 0, 250, 400, 600, 1100,$

Launhardt's formula gives

$$a_1 = 500, 710, 800, 900, 1100;$$

* A centner = 110.23 pounds. A square zoll = 1.0603 square inches.

while Wöhler's experiments gave

$$a_1 = 500, 700, 800, 900, 1100.$$

Again, with Phoenix iron, for $t = 500$ centners per sq. zoll, u was found to be 300 centners per sq. zoll, and

$$\therefore a_1 = 300 \left(1 + \frac{5a_2}{6a_1} \right)$$

or

$$a_1^2 - 300a_1 - 250a_2 = 0.$$

If $a_2 = 240$, $a_1 = 436.8$, which almost exactly agrees with the result given by the tension experiments.

In general, the admissible stress per square unit of sectional area may be expressed in the form

$$b = \tau(1 \pm m\phi), \quad (17)$$

v and m being certain coefficients which depend upon the nature of the material and also upon the manner of the loading. Consider three cases, the material in each case being wrought-iron:

(a) Let the stresses vary between a maximum tension and an equal maximum compression; then

$$\phi = 1.$$

and

$$\therefore b = 700(1 - \frac{1}{2}) = 350^k \text{ per cent.}^2.$$

(b) Let the material be subjected to stresses which are either tensile or compressive, and let it always return to the original unstrained condition; then

$$\text{min. } B = 0, \text{ or max. } B' = 0, \text{ and } \therefore \phi = 0.$$

$$\therefore b = 700(1 \pm 0) = 700^k \text{ per cent.}^2.$$

(c) Let the material be continually subjected to the same dead load; then

$$\text{min. } B = \text{max. } B,$$

and

$$\therefore b = 700(1 + \frac{1}{3}) = 1050^k \text{ per cent.}^2 = 14,934 \text{ lbs. per sq. in.,}$$

which is one third of the ultimate breaking strength, viz., 1050^k per cent.²

Thus in these three cases the admissible stresses are in the ratios of 1 : 2 : 3, ratios which have been already adopted in machine construction as the result of experience.

Wöhler, from his experiments upon untempered cast-steel (Krupp), concluded that for alternations between an unloaded condition and either a tension or a compression, $b = 1100$, and for alternations between equal compressive and tensile stresses, $b = 580$.

In America it has often been the practice to take

$$F = \frac{\text{max. } B + \text{max. } B'}{700} = \frac{a' + a''}{700}$$

for stresses alternately tensile and compressive, it being assumed that if the stresses are tensile only, their admissible values may vary from 0^k to 700^k per cent.²

$$\text{Since } \phi' = \frac{a}{a'}, \therefore a' = \frac{700F}{1 + \phi'}, \text{ and } \therefore b = \frac{a'}{F} = \frac{700}{1 + \phi'}. \quad (18)$$

Comparing this with (12),

	for $\phi' = 0,$	$\frac{1}{4},$	$\frac{1}{3},$	$\frac{1}{2},$	$1,$
(18) gives	$b = 700.$	$560.$	$467,$	$400,$	$350,$
and (12) gives	$b = 700,$	$612,$	$525.$	$437,$	$350.$

10. Flow of Solids.—When a ductile body is strained beyond the elastic limit, it approaches a purely plastic condition in which a sufficiently great force will deform the body indefinitely. Under such a force, the elasticity disappears and the material is said to be in a *fluid* state, behaving precisely like a fluid. For example, it flows through orifices and shows a contracted section. The stress developed in the material is called the *fluid pressure* or *coefficient of fluidity*.

The general principle of the flow of solids, deduced by Tresca, may be enunciated as follows:

A pressure upon a solid body creates a tendency to the relative motion of the particles in the direction of least resistance.

This gives an explanation of the various effects produced in materials by the operations of wire-drawing, punching, shearing, rolling, etc., and in the manufacture of lead pipes. Probably it also explains the anomalous behavior of solids under certain extreme conditions.

Rails which have been in use for some time are found to have acquired an elongated lip at the edge. This is doubtless due to the flow of the metal under the great pressures to which the rails are continually subjected. Other examples of the flow of solids are to be observed in the contraction of stretched bars and in the swelling of blocks under compression. The period of fluidity is greater for the more ductile materials, and may disappear altogether for certain vitreous and brittle substances.

In punching a piece of wrought-iron or steel, the metal is at first compressed and *flows inwards*, while the *shearing* only commences when the opposite surface begins to open. A case brought under the notice of the author may be mentioned in illustration of this. The thickness of a cold-punched nut was 1.75 inches, the nut-hole was .3125 inch in diameter, and the length of the piece punched out was only .75 inch. Thus the flow must have taken place through a depth of 1 inch, and the shearing through a depth of .75 inch. Hence the surface really shorn was $\pi \times .3125 \times .75 = .736$ sq. in. in area, and a *measure* of the shearing action is the product of this surface area and the *fluid pressure*. The nature of the flow may be observed by splitting a cold punched nut in half and treating the fractured surfaces with acid, after having planed them and given them a bright polish. The metal bordering the core will be found curved downwards, the curvature increasing from the bottom to the top, and well-defined curves will mark the separating planes of the plates which were originally used in piling and rolling the iron.

In experimenting upon lead, Tresca placed a number of plates, one above the other, in a strong cylinder, Fig. 188, page 165, with a hole in the bottom. Upon applying pressure the lead was always found to flow when the *coefficient of fluidity*

was about 2844 lbs. per sq. in., the *difference of stress* being double this amount. The separating planes assumed curved forms analogous to the corresponding surfaces of flow when water is substituted in the cylinder for the lead.

The flow of ductile metals, e.g., copper, lead, wrought-iron, and soft steel, commences as soon as the elastic limit is exceeded, and in order that the flow may be continuous the distorting stress must constantly increase. On the other hand, in the case of truly *plastic* bodies, flow commences and continues under the same constant stress. It evidently depends upon the hardness of the material, and has been called the *coefficient of hardness*. The *longer* the stress acts the greater is the deformation, which gradually increases indefinitely or at a diminishing rate.

Experiment shows that there is very little alteration in the density of a ductile body during its plastic deformation, and Tresca's analytical investigations are based on the assumption that the body is deformed without sensible change of volume.

Consider a prismatic bar undergoing plastic deformation.

Let L be the length and A the section of the bar at commencement of deformation.

Let $L + x$ be the length and a the section of the bar at a subsequent period.

Let p be the intensity of the fluid pressure.

Since the volume remains unchanged,

$$LA = (L \pm x)a, \dots \dots \dots (1)$$

the positive or negative sign being taken according as the bar is in tension or compression.

Let P_1 be initial force on bar.

Let P be force on bar when its length is $L \pm x$. Then

$$P_1 = pA,$$

$$P = pa,$$

and hence
$$\frac{P}{P_1} = \frac{a}{A} = \frac{L}{L \pm x} \dots \dots \dots (2)$$

Hence
$$P(L \pm x) = P_1 L = \text{a constant}, \dots \dots \dots (3)$$

and the force *diminishes* as the bar stretches and *increases* as the bar contracts under pressure.

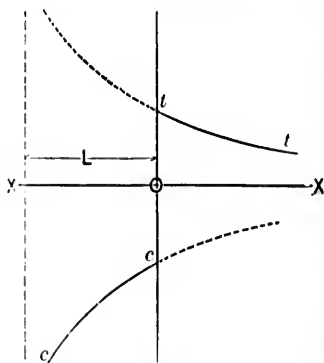

FIG. 187.

If equation (3) be referred to rectangular axes, the ordinates representing different values of P and the abscissæ the corresponding values of x , the stress-strain diagrams, t in tension and c in compression, are hyperbolic curves, having as asymptotes the axis of x , XOX , and a line parallel to the axis of y at a distance from it equal to the length L of the bar.

Next consider a metallic mass (e.g., lead) resting upon the end CD of a cylinder of radius R , and filling up a space of depth D . A hole of radius r is made at the centre of the face CD , through which the mass flows under the pressure of fluidity exerted by a piston. When the mass has been compressed to the thickness $DO = x$, let y be the corresponding length KE of the "jet."

First, assume that the specific weight of the mass remains constant.

If dx be the diminution in the thickness DO corresponding to an increase dy in the length of the jet, then

$$\pi R^2 dx + \pi r^2 dy = 0. \dots (1)$$

Integrating eq. 1, and remembering that $y = 0$ when $x = D$,

$$R^2(D - x) - r^2 y = 0. \dots (2)$$

Second, assume that the cylindrical portion $EFGH$ is gradually transformed into $NMPLKQN$, of which the part $PMNQ$ is cylindrical, while the diameter of the part $PLKQ$ gradually

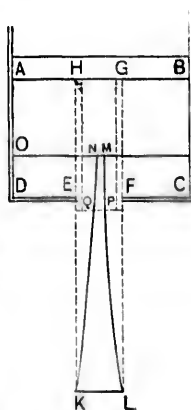

FIG. 188.

increases from the face of the cylinder to $KL (= EF)$, at the end of the jet. Then

$$\begin{aligned} \pi(R^2 - r^2)dx &= \text{amount of metal which flows into the} \\ &\quad \text{central cylinder} \\ &= 2\pi r dr x, \dots \dots \dots (3) \end{aligned}$$

dr being the depth to which the metal penetrates.

Third, assume that the diminution of the diameter of the cylindrical portion $PMNQ$ is directly proportional to the said diameter.

Then, if z be the radius of the cylinder $PQNM$,

$$\frac{dr}{r} = \frac{dz}{z} \dots \dots \dots (4)$$

By eqs. (3) and (4),

$$(R^2 - r^2) \frac{dx}{x} = 2r^2 \frac{dz}{z}.$$

Integrating,

$$(R^2 - r^2) \log_e x = 2r^2 \log_e z + c,$$

c being constant of integration.

When $x = D$, $z = r$,

$$\therefore (R^2 - r^2) \log_e \frac{x}{D} = 2r^2 \log_e \frac{z}{r},$$

or

$$\frac{z}{r} = \left(\frac{x}{D} \right)^{\frac{R^2 - r^2}{2r^2}} \dots \dots \dots (5)$$

By eqs. (2) and (5),

$$\frac{z}{r} = \left(1 - \frac{r^2}{K^2} \frac{y}{D}\right)^{\frac{K^2 - r^2}{2r^2}}, \dots \dots (6)$$

which is the equation to the profile *PL* or *QK*.

Note.—If $R^2 = 3r^2$, eq. (6) represents a straight line.

“ $R^2 = 2r^2$, “ “ “ parabola.

II. Work.—Work must be done to overcome a resistance. Thus bodies, or systems of bodies, which have their parts suitably arranged to overcome resistances are capable of doing work and are said to possess energy. This energy is termed *kinetic* or *potential* according as it is due to *motion* or to *position*. A pile-driver falling from a height upon the head of a pile drives the pile into the soil, doing work in virtue of its motion. Examples of potential energy, or *energy at rest*, are afforded by a *bent spring*, which does work when allowed to resume its natural form; a *raised weight*, which can do work by falling to a lower level; *gunpowder* and *dynamite*, which do work by exploding; a *Leyden jar* charged with electricity, which does work by being discharged; *congl. storage batteries*, a *head of water*, etc. It is also evident that this potential energy must be converted into kinetic energy before work can be done. A familiar example of this transformation may be seen in the action of a common pendulum. At the end of the swing it is at rest for a moment and all its energy is potential. When, under the action of gravity, it has reached the lowest point, it can do no more work in virtue of its position. It has acquired, however, a certain velocity, and in virtue of this velocity it does work which enables it to rise on the other side of the swing. At intermediate points its energy is partly kinetic and partly potential.

A measure of energy, or of the capacity for doing work, is the *work done*.

The energy is exactly equivalent to the actual work done in the following cases:

(a) If the effort exerted and the resistance have a common point of application.

(b) If the points of application are different but are rigidly connected.

(c) If the energy is transmitted from member to member, provided the members do not change form under stress, and that no energy is absorbed by frictional resistance or restraint at the connections.

Generally speaking, work is of two kinds, viz., *internal work*, or work done against the mutual forces exerted between the molecules of a body or system of bodies, and *external work*, or work done by or against the external forces to which the body or bodies are subjected. In cases (a), (b), (c) above, the internal work is necessarily nil.

As a matter of fact, every body yields to some extent under stress, and work must be done to produce the deformation. Frictional resistances tend to oppose the relative motions of members and must also absorb energy. If, however, the work of deformation and the work absorbed by frictional resistance are included in the term *work done*, the relation still holds that

$$\text{Energy} = \text{work done.}$$

A measure of work done is the product of the resistance by the distance through which it is overcome. When a man raises a weight of one pound one foot against the action of gravity he does a certain amount of work. To raise it two feet he must do twice as much work, and ten times as much to raise it ten feet. The amount of work must therefore be proportional to the number of feet through which the weight is raised. Again, to raise two pounds one foot requires twice as much work as to raise one pound through the same distance; while five times as much work would be required to raise five pounds, and ten times as much to raise ten pounds. Thus the amount of work must also be proportional to the weight raised. Hence a measure of the work done is the product of the number of pounds by the number of feet through which they are raised, the resulting number being designated *foot-pounds*. Any other units, e.g., a pound and an inch, a ton and an inch, a kilogramme and a metre, etc., may be chosen, and the work done represented in inch-pounds, inch-tons, kilogram-

metres, etc. This standard of measurement is applicable to all classes of machinery, since every machine might be worked by means of a pulley driven by a falling weight.

12. Oblique Resistance.—Let a body move against a resistance R inclined at an angle θ to the direction of motion (Fig. 189). No work is done against the normal component $R \sin \theta$, as there is no movement of the point of application at right angles to the direction of motion. This component is, therefore, merely a pressure. The work done against the tangential component $R \cos \theta$ between two consecutive points M and N of the path of the body is $R \cos \theta \cdot MN$. Hence the total work done between any two points A and B of the path

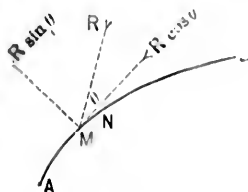

FIG. 189.

$$= \Sigma(R \cos \theta \cdot MN) = \int_0^s R \cos \theta ds,$$

s being the length of AB .

If AB is a straight line (Fig. 190), and if R is constant in direction and magnitude,

$$\text{the total work} = R \cos \theta \cdot AB = R \cdot AC,$$

AC being the projection of the displacement upon the line of action of the resistance. Let the path be the arc of a circle

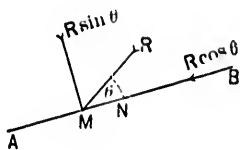

FIG. 190.

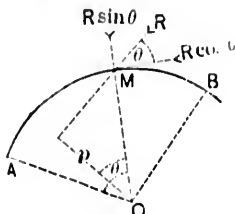
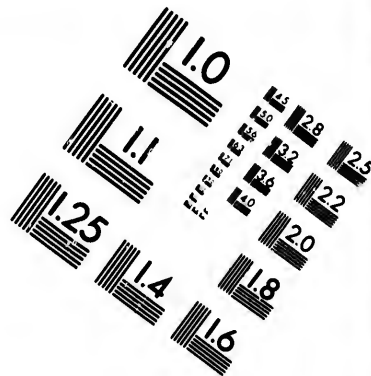
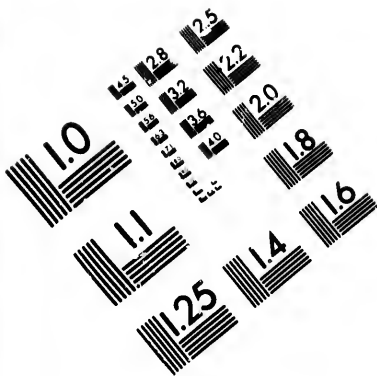

FIG. 191.

(Fig. 191) subtending an angle α at the centre. If R and θ remain constant, the work done from A to B

$$\begin{aligned} = R \cos \theta \text{ arc } AB &= R \cos \theta \cdot Oa \cdot \alpha = R \cdot OM \cos \theta \cdot \alpha \\ &= Rp\alpha = Ma, \end{aligned}$$





**IMAGE EVALUATION
TEST TARGET (MT-3)**

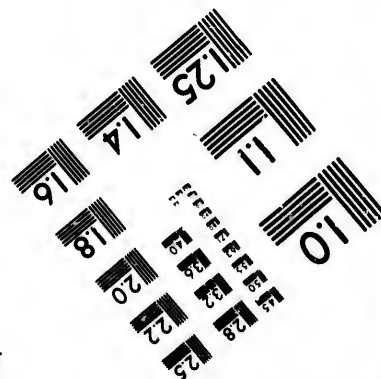
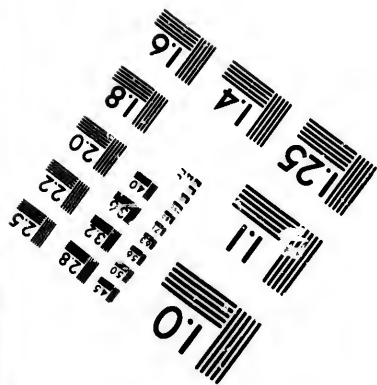
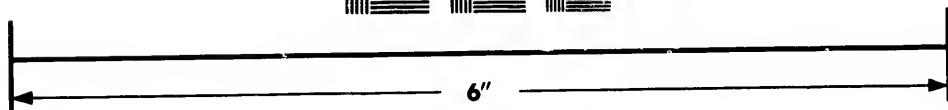
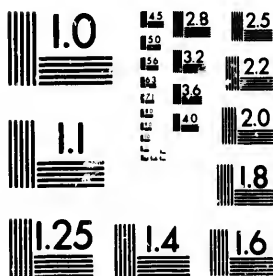

**Photographic
Sciences
Corporation**

23 WEST MAIN STREET
WEBSTER, N.Y. 14580
(716) 872-4503

128
132
122
120
8

10

p being the perpendicular from O upon the direction of R , and $M = Rp$ being the moment of resistance to rotation.

If there are more resistances than one, they may be treated separately and their several effects superposed. In such case, M will be the total moment of resistance and will be equal to the algebraic sum of the separate moments.

The normal component $R \sin \theta$ produces a pressure.

13. Graphical Method.—Let a body describe a path AB

(Fig. 192) against a variable resistance of such a character that its magnitude in the direction of motion may be represented at any point M by an ordinate MN to the curve CD . Let the path AB be subdivided into a number of parts, each part MP being so small that the resistance from M to P may be considered uniform. The mean

value of this resistance = $\frac{MN + PQ}{2}$, and the work done in

overcoming it = $\frac{MN + PQ}{2} \cdot MP$ = the area $MNQP$ in the limit. Hence the total work done from A to B = the area bounded by the curves AB , CD and the ordinates AC , BD .

14. Kinetic Energy.—The velocity v acquired by a body of weight w and mass m in falling freely from rest through the vertical distance h is

$$v = \sqrt{2gh}; \quad \therefore wh = \frac{w}{g} \frac{v^2}{2} = m \frac{v^2}{2}.$$

Thus an amount of work wh is done, and the body possesses the kinetic energy $m \frac{v^2}{2}$.

Again, let v' be the velocity of the body after falling through a further distance x , measured vertically. Then

$$w(h + x) = \frac{mv'^2}{2},$$

and

$$\therefore wx = \frac{m}{2}(v'^2 - v^2).$$

Thus the work done in falling through the vertical distance x is wx , and is equal to the corresponding change of kinetic energy.

15. EXAMPLE I. Let it be required to determine the *work done* in stretching or compressing a bar of length L and sectional area A by an amount l .

Suppose that the force applied to the bar gradually increases from 0 until it attains the value P ; its mean value is $\frac{P}{2}$, and the *work done* is therefore $\frac{P}{2}l$.

But $P = EA\frac{l}{L}$; E being the coefficient of elasticity.

$$\therefore \text{the work done} = \frac{E}{2}A\frac{l^2}{L} = \frac{1}{E}\left(\frac{P}{A}\right)^2\frac{AL}{2}.$$

This formula is only true for small values of the ratio $\frac{l^2}{L}$.

In the case of a compressive force it is assumed that the bar does not bend.

A *suddenly* applied force, $\frac{P}{2}$, will do as much work as a *steady* force which increases uniformly from 0 to P , and hence it follows that a bar requires *twice* the strength to resist with safety the sudden application of a given load than is necessary when the same load is gradually applied.

If f is the *proof stress* or elastic limit per unit of sectional area, $\frac{f}{E}$ is the corresponding *proof strain*, and the work done in producing the latter is called the *resilience* of the bar. According to the above, its value is $\frac{f^2}{E}\frac{AL}{2}$; $\frac{f^2}{E}$ is called the Modulus of Resilience.

EX. 2. A wrought-iron tie-rod, 30 ft. in length and 4 sq. in. in sectional area, is subjected to a longitudinal pull of 40,000 lbs. Determine the unit stress, the strain, and the elongation, the coefficient of elasticity being 30,000,000 lbs.

$$\text{The unit stress is } \frac{40000}{4} = 10,000 \text{ lbs. per sq. in.}$$

Also, from the elastic law, $10000 = 30000000 \times \text{strain}$.

$$\begin{aligned} \therefore \text{the strain} &= \frac{1}{3000} \\ \text{and the elongation} &= \frac{30}{3000} = \frac{1}{100} \text{ ft.} \end{aligned}$$

EX. 3. A steel rod is 15 ft. long and $2\frac{1}{2}$ sq. in. in sectional area. The proof strain of the steel is $\frac{1}{1000}$, and its coefficient of elasticity is 36,000,000 lbs. Find the greatest weight that can be safely allowed to fall upon the end of the rod from a height of 27 ft.

The proof stress = $E \times \text{proof strain} = 36,000 \text{ lbs. per sq. in.}$
The compression of the rod under the proof-stress is

$$\frac{15}{1000} = \frac{3}{200} \text{ ft.}$$

The resilience of the rod

$$\begin{aligned} &= \frac{f^2 AL}{E 2} = \frac{(36000)^2 \cdot 2\frac{1}{2} \times 15 \times 12}{36000000 \cdot 2} \\ &= 8100 \text{ inch-lbs.} = 675 \text{ ft.-lbs.} \end{aligned}$$

Again, let W be the required weight in pounds.

The total distance through which it falls = 27 ft. + compression = $(27 + \frac{3}{200})$ feet, and the corresponding work is $W(27 + \frac{3}{200})$ ft.-lbs. This must of course be exactly equivalent to the resilience of the rod, and

$$\therefore W(27 + \frac{3}{200}) = 675,$$

and

$$W = 24.9 \text{ lbs.}$$

The resilience of the rod may also be at once found from the fact that it is the product of one half of the total stress by the compression, i.e., $\frac{1}{2} \cdot 2\frac{1}{2} \cdot 36000 \times \frac{3}{100} = 675$ ft.-lbs.

EX. 4. Let $w_1, w_2, w_3, \dots, w_n$ be the weights of a system of particles rigidly connected together and at distances $x_1, x_2, x_3, \dots, x_n$, respectively, from a given axis. Let the system revolve around the axis with a uniform angular velocity A .

The kinetic energies of the several particles are

$$\frac{w_1 x_1^2 A^2}{g \cdot 2}, \quad \frac{w_2 x_2^2 A^2}{g \cdot 2}, \quad \dots, \quad \frac{w_n x_n^2 A^2}{g \cdot 2},$$

and therefore the total kinetic energy of the system

$$\begin{aligned} &= \frac{A^2}{2g} \{w_1 x_1^2 + w_2 x_2^2 + \dots + w_n x_n^2\} \\ &= \frac{A^2}{2} \{m_1 x_1^2 + m_2 x_2^2 + \dots + m_n x_n^2\}, \end{aligned}$$

m_1, m_2, \dots, m_n being the masses of the particles.

The sum between the brackets is called the moment of inertia of the system of particles about the axis and is usually denoted by I .

$$\therefore \text{the total kinetic energy} = \frac{A^2 I}{2}.$$

Again, it appears from the definition that every moment of inertia is the product of a mass and the square of a length. This length is called the radius of gyration and is usually designated by the symbol k .

If M be the total mass of the system, and W the total weight,

$$I = M k^2 = \frac{W}{g} k^2,$$

and the total kinetic energy = $M \frac{(Ak)^2}{2} = \frac{W}{g} \frac{(Ak)^2}{2}$, the re-

sult being the same as if the particles were collected in a ring of radius h , sometimes called the equivalent ring or fly-wheel.

Let I_g be the moment of inertia of the system with respect to a parallel axis through the centre of gravity, and let h be the distance between the two axes. Then

$$\begin{aligned} I_g &= m_1(h - x_1)^2 + m_2(h - x_2)^2 + \dots + m_n(h - x_n)^2 \\ &= h^2 \Sigma(m) - 2h \Sigma(mx) + \Sigma(mx^2). \end{aligned}$$

Since the new axis passes through the centre of gravity,

$$\Sigma mx = Mh.$$

Also, $\Sigma(m) = M$ and $\Sigma(mx^2) = I$;

$$\therefore I_g = Mh^2 + I - 2Mh^2;$$

$$\therefore I = I_g + Mh^2.$$

So, if I' is the moment of inertia about another parallel axis at the distance h' from the centre of gravity,

$$I' = I_g + Mh'^2.$$

$$\therefore I - Mh^2 = I' - Mh'^2.$$

Hence, if the positions of two parallel axes relatively to the centre of gravity are known, and if the moment of inertia about one is given, the moment of inertia about the other can be obtained by means of the last formula.

Note.—Nothing has been said as to the number of the particles. They may be infinite in number and infinitely near each other, forming in fact a solid body. The summation $\Sigma(mx^2)$ is then best effected by integration.

16. Values of k^2 .

1. For a rectangular plate of depth d with respect to an axis through the centre perpendicular to the side d $k^2 = \frac{d^2}{12}$.
2. For a circular plate of radius r with respect to a diameter. $k^2 = \frac{r^2}{4}$.

3. For an annulus of external radius r_1 and internal radius r_2 with respect to a diameter... .. $k^2 = \frac{r_1^2 + r_2^2}{4}$.

Note.—If $r_1 - r_2 = t$, and the breadth t of the annulus is small as compared with the radius r_1 , then

$$k^2 = \frac{r_1^2 + (r_1 - t)^2}{4} = \frac{r_1(r_1 - t)}{2}, \text{ approx.,}$$

and the area

$$= \pi(r_1^2 - r_2^2) = 2\pi r_1 t, \text{ approx.}$$

4. For the plates in (2) and (3) with respect to an axis through the centre perpendicular to the plates, the numerators remain the same but the denominator is in each case 2.
5. For a sphere of radius r with respect to a diameter... .. $k^2 = \frac{2}{5}r^2$.
6. For a solid cylinder of radius r with respect to its axis... .. $k^2 = \frac{r^2}{2}$.
7. For an elliptic plate of which the major and minor axes are $2b$ and $2d$ respectively:
- With respect to the major axis... .. $k^2 = \frac{d^2}{4}$.
- With respect to the minor axis... .. $k^2 = \frac{b^2}{4}$.
8. For a triangular plate of height h with respect to an axis coinciding with the base... .. $k^2 = \frac{h^2}{6}$.

17. Momentum—Impulse.—A moving body of weight w and mass m acted upon in the direction of motion for a time t by a force F will acquire a velocity v which is directly proportional to F and to t , and inversely proportional to w . Hence

$$v = n \frac{Ft}{w},$$

n being some coefficient.

If $F = w$, the velocity generated in one second is g .

$$\therefore g = n,$$

and

$$\therefore v = g \frac{Ft}{w} = \frac{Ft}{m},$$

or

$$mv = Ft.$$

This is the analytical statement of Newton's Second Law of Motion, which has been expressed by Clerk Maxwell in the following form: "The *change of momentum* (i.e., the product of the mass and velocity) is numerically *equal to the impulse* (i.e., the product of the force and the time during which it acts) *which produces it, and is in the same direction.*"

Again, let p be the perpendicular from a fixed axis O upon the direction of motion of the body, and let r be the radius OP to the body. Then

$$mv p = Ftp = Fpt = Mt,$$

where $M = Fp$; or *the change of the moment of momentum*, i.e., *of the angular momentum*, is equal to *the moment of impulse*.

The above results are also true for two or more bodies or systems of bodies severally acted upon by extraneous forces, and the equations may be written

$$\Sigma mv = \Sigma Ft, \quad \Sigma mv p = \Sigma Fpt = \Sigma Mt.$$

In words, *the total change of momentum in any assigned direction is equal to the algebraic sum of the impulses in the same direction,*

and the total change of angular momentum is equal to the algebraic sum of the moments of the impulses.

Hence it follows that if two or more bodies or systems of bodies mutually attract or repel each other, and if there are no extraneous forces, the total momentum in any assigned direction is constant (the principle of the conservation of linear momentum), and the angular momentum about a given axis is constant (the principle of the conservation of angular momentum).

Suppose that the velocity of the body of weight w and mass m changes from v_1 to v_2 in the time t under the action of a couple of moment M , and let p_1, p_2 be the corresponding values of p , and r_1, r_2 those of r , Fig. 193.

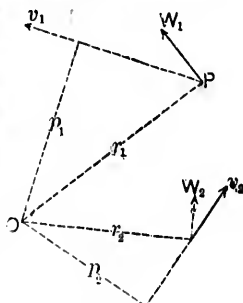

FIG. 193.

$$\therefore m(v_1 p_1 - v_2 p_2) = Mt;$$

or if w_1, w_2 are the components of v_1, v_2 in directions perpendicular to r_1, r_2 , respectively,

$$m(w_1 r_1 - w_2 r_2) = Mt.$$

For example, a weight W of water passing through a turbine of external radius r_1 and internal radius r_2 has its angular momentum changed from $\frac{W}{g} w_1 r_1$ to $\frac{W}{g} w_2 r_2$, w_1, w_2 being the tangential components of the velocity with which the water enters and leaves the wheel. The water, therefore, exerts upon the wheel a couple of moment $\frac{W}{g} (w_1 r_1 - w_2 r_2)$, and if the wheel rotates with an angular velocity A , the work done upon the wheel by the water

$$= \frac{W}{g} A (w_1 r_1 - w_2 r_2) = \frac{W}{g} (w_1 u_1 - w_2 u_2),$$

u_1 and u_2 being the circumferential velocities corresponding to r_1 and r_2 , respectively.

18. Useful Work—Waste Work.—Let a body of mass m and weight w pass over the distance s under the action of a force F acting in the direction of motion for a time t , and let the velocity of the body change from v_1 to v_2 . Assume t to be so small that, for the interval in question, the velocity may be regarded as constant and of the average value $\frac{v_1 + v_2}{2}$;

$$\therefore s = \frac{v_1 + v_2}{2}t.$$

But $Ft = (mv_2 - mv_1)$.

$$\therefore Fts = \frac{m}{2}(v_2^2 - v_1^2)t,$$

or

$$Fs = \frac{m}{2}(v_2^2 - v_1^2).$$

Thus Fs , the work done, is equal to the *change* of kinetic energy in the given interval.

If the body is a material particle of a connected system, a similar relation holds for every other particle of the system, and the total work done = $\frac{1}{2}(\sum mv_2^2 - \sum mv_1^2)$.

A part of this work may be expended in doing what is called *effective* work, i.e., in overcoming (1) an external resistance, or in doing *useful* work, and (2) frictional resistance, or in doing *wasted* work.

Denoting the total *effective* work by T_e and the total *motive* work by T_m , the last equation may be written

$$T_m - T_e = \frac{1}{2}(\sum mv_2^2 - \sum mv_1^2),$$

and the difference between the total motive work and the total effective work is equal to the total change of kinetic energy.

In the case of a machine working at a normal speed the velocities of the different parts are periodic, being the same at the beginning and end of any period or number of periods. For any such interval, therefore, $v_1 = v_2$, and $\therefore T_m = T_e$, so

that there is an equality between the motive work and the effective work.

19. General Case.—Let $\bar{x}_1, \bar{y}_1, \bar{z}_1$ be the co-ordinates of the C. of G. of a moving body of mass M with respect to three rectangular axes at any given instant.

Let $\bar{x}_2, \bar{y}_2, \bar{z}_2$ be the co-ordinates of the same point after a unit of time.

Let x_1, y_1, z_1 be the co-ordinates of any particle of mass m at the given instant.

Let x_2, y_2, z_2 be the co-ordinates of the same particle after a unit of time.

$$\therefore M\bar{x}_1 = \Sigma(mx_1), \quad M\bar{y}_1 = \Sigma(my_1), \quad M\bar{z}_1 = \Sigma(mz_1);$$

$$M\bar{x}_2 = \Sigma(mx_2), \quad M\bar{y}_2 = \Sigma(my_2), \quad M\bar{z}_2 = \Sigma(mz_2);$$

$$\therefore M(\bar{x}_2 - \bar{x}_1) = \Sigma m(x_2 - x_1), \quad M(\bar{y}_2 - \bar{y}_1) = \Sigma m(y_2 - y_1),$$

$$M(\bar{z}_2 - \bar{z}_1) = \Sigma m(z_2 - z_1),$$

or

$$M\bar{u} = \Sigma mu, \quad M\bar{v} = \Sigma mv, \quad M\bar{w} = \Sigma mw,$$

$\bar{u}, \bar{v}, \bar{w}$ being the component velocities of the C. of G. at the given instant with respect to the three axes, and u, v, w the component velocities of the particle m at the same instant.

From these last equations,

$$M\bar{u}^2 = \Sigma mu\bar{u}, \quad M\bar{v}^2 = \Sigma mv\bar{v}, \quad M\bar{w}^2 = \Sigma mw\bar{w}.$$

$$\therefore M(\bar{u}^2 + \bar{v}^2 + \bar{w}^2) = \Sigma m(u\bar{u} + v\bar{v} + w\bar{w}),$$

which may be written in the form

$$\begin{aligned} M(\bar{u}^2 + \bar{v}^2 + \bar{w}^2) + \Sigma m\{(u - \bar{u})^2 + (v - \bar{v})^2 + (w - \bar{w})^2\} \\ = \Sigma m(u^2 + v^2 + w^2), \end{aligned}$$

or

$$MU^2 + \Sigma mV^2 = \Sigma mw^2,$$

U being the resultant velocity of the C. of G. ; v , that of the particle ; and V , that of the particle relatively to the C. of G.

The last equation may be written

$$\frac{MU^2}{2} + \frac{\sum mV^2}{2} = \frac{\sum mv^2}{2}.$$

Thus the energy of the total mass collected at the centre of gravity, together with the energy relatively to the centre of gravity, is equal to the total energy of motion.

If the body revolves around an axis through its C. of G. with an angular velocity A , the second term of the last equation becomes

$$\frac{1}{2} \sum mr^2 A^2 = \frac{A^2}{2} \sum mr^2 = \frac{A^2}{2} I,$$

r being the distance of the particle m from the axis, and I the moment of inertia of the body with respect to the axis.

20. EXAMPLE 1. The charge of powder for a 27-ton breech-loader with a 9-ton carriage is 300 lbs. ; the weight of the projectile is 500 lbs., its diam. is 10 in., and its radius of gyration 3.535 in. ; the muzzle velocity is 2020 ft. per sec. ; the velocity of recoil, $16\frac{1}{4}$ ft. per sec. ; the gun is rifled so that the projectile makes *one* turn in 40 calibres.

Total energy of explosion = energy of shot + energy of recoil ;

Energy of shot = energy of translation + energy of rotation

$$\begin{aligned} &= \frac{500}{32.2} \cdot \frac{(2020)^2}{2} + \frac{500}{32.2} \cdot \frac{1}{2} \cdot \left(\frac{\pi \cdot \frac{10}{2}}{1\frac{1}{2}} \cdot \frac{2020}{40 \cdot \frac{10}{2}} \right)^2 \left(\frac{3.535}{12} \right)^2 \\ &= 31680124.2 + 97758.6 \\ &= 31777882.8 \text{ ft.-lbs. ;} \end{aligned}$$

$$\text{Energy of recoil} = \frac{36 \times 2240}{32.2} \cdot \frac{(16\frac{1}{4})^2}{2} = 330652.1 \text{ ft.-lbs.}$$

Hence, if C be the energy of 1 lb. of powder,

$$\begin{aligned} C \cdot 300 &= 31777882.8 + 330652.1 \\ &= 32108534.9 \text{ ft.-lbs.,} \end{aligned}$$

and hence

$$C = 107028.45 \text{ ft.-lbs} = 47.7 \text{ ft.-tors.}$$

EX. 2. Let W be the weight of a fly-wheel in lbs., and let its max. and min. angular velocities be A_1, A_2 , respectively. The motion being one of rotation only, the energy stored up when the velocity rises from A_2 to A_1 , or given out when it falls from A_1 to A_2 , is

$$\frac{1}{2} (A_1^2 - A_2^2) = \frac{W}{2g} k^2 (A_1^2 - A_2^2) = \frac{W}{2g} (v_1^2 - v_2^2),$$

v_1, v_2 being the linear velocities corresponding to A_1, A_2 , and k being taken equal to the mean radius of the wheel.

It is usual to specify that the variation of velocity is not to exceed a certain fractional part of the mean velocity.

Let V be the mean velocity, and $\frac{1}{\mu}$ the fraction. Then

$$v_1 - v_2 = \frac{V}{\mu}; \quad \text{also} \quad v_1 + v_2 = 2V;$$

$$\therefore \frac{v_1^2 - v_2^2}{2} = \frac{V^2}{\mu}.$$

Hence the work stored or given out = $\frac{W}{g} \frac{V^2}{\mu}$.

21. Centrifugal Force.—A body constrained to move in a plane curve exerts upon the body which constrains it, a force

called *centrifugal force*, which is equal and opposite to the *deviating* (or *centripetal*) force exerted by the constraining body upon the revolving body.

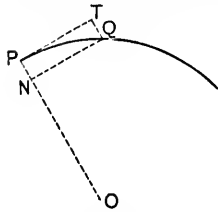

FIG. 194.

Let a particle of mass m move from a point P to a consecutive point Q (Fig. 194) of its path during an interval of time t under the action of a normal deviating force.

Let the normals at P and Q meet in O ; PQ may be considered as the indefinitely small arc of a circle with its centre at O .

If there were no constraining force, the body would move along the tangent at P to a point T such that $PT = vt$, v being the linear velocity at P .

Under the deviating force the body is pulled towards O through a distance $PN = \frac{1}{2}ft^2$, f being the normal acceleration, and QN being drawn perpendicular to OP .

Also, *in the limit*, $PQ = PT = QN = vt$.

$$\text{But} \quad QN^2 = PN \cdot 2OP;$$

$$\therefore v^2t^2 = \frac{1}{2}ft^2 \cdot 2R,$$

R being the radius OP ; and hence

$$f = \frac{v^2}{R} = A^2R,$$

A being the angular velocity.

Hence the deviating force of the mass m

$$= mf = m \frac{v^2}{R} = mA^2R,$$

and is equal and opposite to the centrifugal force.

Again, if a solid body of mass M revolve with an angular velocity A about an axis passing through its C. of G., the total

centrifugal force will be *nil*, provided the axis of rotation is an axis of symmetry, or is one of the principal axes of inertia at the C. of G.

If the axis of rotation is parallel to one of these axes, but at a distance \bar{R} from the C. of G.,

$$\left. \begin{array}{l} \text{the centrifugal force} \end{array} \right\} = \sum mrA^2 = A^2 \sum mr = A^2 M\bar{R} = \frac{W}{g} A^2 \bar{R},$$

r being the distance of a particle of mass m from the axis, and W the weight of the body. Thus the centrifugal force is the same as if the whole mass were concentrated at the C. of G.

If the axis of rotation is inclined at an angle θ to the principal axis, the body will be constantly subjected to the action of a couple of moment $2E \tan \theta$, E being the actual energy of the body.

EXAMPLE.—A ring of radius r rotates with angular velocity A about its centre O . Let ρ be the weight of the ring per unit of length of periphery. Consider any half-ring AFB . The centrifugal force of any element

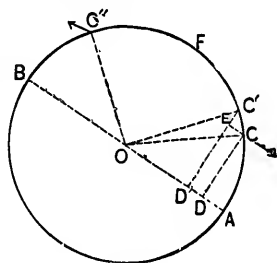

FIG. 195.

$$CC' = \frac{\rho CC'}{g} A^2 r.$$

The component of this force parallel to AB , is balanced by an equal and opposite force at C' , the angle $C''OB$ being = the angle COA . Thus the total centrifugal force parallel to AOB is nil.

The component of the force at C , perpendicular to AB ,

$$= \frac{\rho CC'}{g} A^2 r \sin COD = \frac{\rho CC'}{g} A^2 r \cos C'CE$$

$$= \frac{\rho CC'}{g} A^2 r \frac{CE}{CC'} = \rho \frac{A^2 r}{g} DD'.$$

Hence, the total centrifugal force perpendicular to AB

$$= p \frac{A^2 r}{g} \Sigma(DD') = 2 \frac{p}{g} A^2 r^2.$$

If T is the force developed in the material at each of the points A and B ,

$$2T = 2 \frac{p}{g} A^2 r^2,$$

since the direction of T is evidently perpendicular to AB .

$$\therefore T = \frac{p}{g} A^2 r^2 = \frac{p}{g} v^2,$$

v being the circumferential velocity.

Let f be the *intensity* of stress at A and B , and w the specific weight of the material.

Assuming that T is distributed uniformly over the sectional areas at A and B ,

$$f = \frac{w}{g} v^2.$$

Thus, the stress is independent of the radius for a given value of v , and the result is applicable to every point of a flexible element, whatever may be the form of the surfaces over which it is stretched.

22. Impact.—When a body strikes a structure, or member of a structure, the energy of the blow is expended in

- (1) overcoming the resistance to motion of the body struck;
- (2) deforming the body struck;
- (3) the kinetic energy of either or of both of the bodies after impact, *if the motion is sensible*;
- (4) deforming the striking body;
- (5) producing vibrations.

Generally speaking, the energy represented by (5) is very small and may be disregarded. Also, if the striking body is very hard, the energy (4), absorbed in its deformation, is inappreciable and may be neglected.

First, let a body of weight P fall through a vertical distance h and strike a second body, the point of application moving in the direction of the blow through a distance x against a mean resistance R' . Then

$$P(h + x) = \text{work done} = R'x.$$

Let V be the velocity of the striking body at the moment of impact. Then

$$\text{energy of blow} = \frac{P V^2}{g} = R'x = P(h + x).$$

The actual resistance is directly proportional to the distance through which the point of application moves, *so long as the limit of elasticity is not exceeded*. Its initial value is *nil*, and if R is its max. value, the mean value is $R' = \frac{R}{2}$.

$$\therefore \frac{P V^2}{g} = \frac{Rx}{2} = P(h + x).$$

If $h = 0$, $R = 2P$, or the *sudden* application of a load P from rest, produces a pressure equal to *twice* the load, provided the limit of elasticity is not exceeded.

EXAMPLE. A 1-oz. bullet moving with a velocity of 800 ft. per sec. strikes a target and is stopped dead in the space of $\frac{3}{8}$ inch ($g = 32$). Then

$$\frac{1}{16} \cdot \frac{1}{32} \cdot \frac{1}{32} \cdot (800)^2 = R' \cdot \frac{3}{8} \cdot \frac{1}{16};$$

$\therefore R'$, the mean resistance overcome by the bullet, = 5000 lbs.
The time in which the bullet is brought to rest

$$= \frac{\text{momentum}}{\text{force}} = \frac{1\frac{1}{8} \cdot \frac{1}{32} \cdot 800}{5000} = \frac{1}{3200} \text{ sec.}$$

Next, let a body of weight W_1 , moving in a given direction with a velocity v_1 , strike a body of weight W_2 moving in the same direction with a velocity v_2 . After impact let the bodies continue to move in the same direction with a common velocity v .

$$\begin{aligned} \frac{W_1}{g}v_1 + \frac{W_2}{g}v_2 &= \text{momentum before impact} \\ &= \text{momentum after impact} \\ &= \left(\frac{W_1}{g} + \frac{W_2}{g}\right)v, \end{aligned}$$

or

$$W_1v_1 + W_2v_2 = (W_1 + W_2)v.$$

$$\text{Energy before impact} = \frac{W_1}{g} \frac{v_1^2}{2} + \frac{W_2}{g} \frac{v_2^2}{2}.$$

$$\text{“ after “} = \frac{(W_1 + W_2)v^2}{2}.$$

Energy lost by impact

$$= \frac{1}{2g}(W_1v_1^2 + W_2v_2^2) - \frac{v^2}{2g}(W_1 + W_2)$$

$$= \frac{W_1W_2(v_1 - v_2)^2}{2g(W_1 + W_2)}.$$

If either of the bodies is subjected to any constraint, energy must be expended to overcome such constraint, and the loss of energy by impact will be less.

EXAMPLE 1. Let a weight of W_1 tons fall h ft. upon the head of a pile weighing W_2 tons and drive it a ft. into the ground against a mean resistance of R tons, the head of the pile being crushed for an appreciable length x ft.

Let v be the velocity of the weight when it strikes the pile ;

“ P “ “ mean force of the blow ;

“ y “ “ distance through which pile moves during action of blow ;

“ t “ “ duration of the blow in seconds ;

“ V “ “ common velocity of the pile and weight during action of blow ;

“ z “ “ distance through which pile moves after the blow.

$Px + Ry =$ work done in crushing the pile + work done in overcoming ground-resistance in time $t =$ energy dissipated by blow

$$= W_1 h - \frac{W_1 + W_2}{g} \frac{V^2}{2} \dots \dots \dots (1)$$

Also, considering the change of momentum first of weight and then of pile,

$$Pt = \frac{W_1}{g}(v - V) = Rt + \frac{W_2}{g}V. \dots \dots \dots (2)$$

Again,

$$Rz = \text{work done after blow} = \frac{W_1 + W_2}{g} \frac{V^2}{2} \dots \dots \dots (3)$$

Finally, $y + z = a, \dots \dots \dots (4)$

and

$$v^2 = 2gh. \dots \dots \dots (5)$$

The work done in crushing the pile is Px .
 The work done in overcoming ground-resistance is Ry .
 The total work done is $Px + Ry$.

Thus, if W_1 , W_2 , h , a , and x are known, eqs. (1) to (5) will give P , t , R , y , V , and z .

Ex. 2. Let a hammer weighing W_1 lbs. moving with a velocity of v ft. per sec., strike a nail weighing W_2 lbs. and drive it x ft. into a piece of timber, of weight W_3 , against a mean resistance of R lbs.

First, assume the timber to be fixed in position.

Let V_1 be the common velocity acquired by the hammer and nail.

$$\begin{aligned} (W_1 + W_2) \frac{V_1^2}{2g} &= \text{energy expended in overcoming } R \\ &= Rx. \end{aligned} \quad (1)$$

$$\text{But } \frac{W_1}{g}v = \text{change of momentum} = \frac{W_1 + W_2}{g}V_1. \quad (2)$$

$$\therefore \frac{W_1^2}{W_1 + W_2} \frac{v^2}{2g} = Rx, \quad (3)$$

$$\text{and the time of the penetration} = \frac{x}{\frac{1}{2}V_1} = \frac{W_1 v}{Rg} \text{ sec.} \quad (4)$$

Second, let the timber be free to move, and let V_2 be the common velocity acquired by the hammer, nail, and timber.

$$\begin{aligned} (W_1 + W_2) \frac{V_1^2}{2g} &= \text{energy expended in overcoming } R \text{ plus} \\ &\quad \text{the energy expended in producing the} \\ &\quad \text{velocity } V_2 \\ &= Rx + (W_1 + W_2 + W_3) \frac{V_2^2}{2g}. \end{aligned} \quad (5)$$

$$\text{But } \frac{W_1}{g}v = \frac{W_1 + W_2}{g}V_1 = \frac{W_1 + W_2 + W_3}{g}V_2. \quad (6)$$

Hence, substituting these values of V_1 and V_2 in eq. (5),

$$\frac{W_1^2 W_2}{(W_1 + W_2)(W_1 + W_2 + W_3)} \frac{v^2}{2g} = Rx; \dots (7)$$

also, the *time of the penetration*

$$= \frac{x}{\frac{1}{2}V_1} = \frac{W_1 W_2}{W_1 + W_2 + W_3} \frac{v}{gR} \text{ sec.}, \dots (8)$$

and the distance through which the timber moves

$$= \frac{V_2}{2} t = \frac{W_1^2 W_2}{(W_1 + W_2 + W_3)^2} \frac{v^2}{2gR} \text{ ft.} \dots (9)$$

23. On the Extension of a Prismatic Bar.—The elementary law of extension is sometimes enunciated as follows:

A prismatic bar of length L and sectional area A is stretched, and its length is $L + x$ when the force of extension is P ; if dP is the increment of force corresponding to an increment dx of length,

$$dP = EA \frac{dx}{L + x}.$$

Hence, the force producing an extension l is equal to

$$\int_0^l EA \frac{dx}{L + x} = EA \log_e \left(1 + \frac{l}{L} \right) = P_1, \text{ suppose.}$$

But

$$\log_e \left(1 + \frac{l}{L} \right) = \frac{l}{L} - \frac{1}{2} \left(\frac{l}{L} \right)^2 + \frac{1}{3} \left(\frac{l}{L} \right)^3 - \dots = \frac{l}{L}, \text{ approx.}$$

$$\therefore P_1 = EA \frac{l}{L}.$$

Corollary.—From the last equation, $\frac{dP_1}{dl} = \frac{EA}{L}$, and $\frac{EA}{L}$ is consequently a measure of the longitudinal *stiffness* of a bar, so that for the *same* material, the stiffness varies directly as the sectional area and inversely as the length, while for *different* materials it also varies directly as the coefficient of elasticity.

Work of Extension.—The force producing the increment dx has for its least value $P (= EA \frac{x}{L})$, for its greatest value $P + dP$, and for its mean value $P + \frac{dP}{2}$, so that the *work done* is $(P + \frac{dP}{2})dx = Pdx$, approximately.

Hence the *work done* in stretching the bar until its length is $L + l$ is equal to

$$\int_0^l P dx = \int_0^l EA \frac{x}{L} dx = \frac{EA l^2}{2L}.$$

24. On the Oscillatory Motion of a Weight at the End of a Vertical Elastic Rod.—An elastic rod of natural length $L(OA)$ and sectional area A is suspended from O , and carries a weight P at its lower end, which elongates the rod until its length is $OB = L + l$.

Assume that the mass of the rod as compared with P is sufficiently small to be disregarded, then

$$P = EA \frac{l}{L}.$$

If the weight is made to descend to a point C , and is then left free to return to its state of equilibrium, it must necessarily describe a series of vertical oscillations about B as centre.

FIG. 196.

Take B as the origin, and at any time t let the weight be at M distant x from B ; also let $BC = c$.

Two cases may be considered.

First, suppose the end of the rod to be *gradually* forced down to C and then suddenly released.

According to the principle of the conservation of energy,

$$\begin{aligned} \frac{P}{g} \frac{1}{2} \left(\frac{dx}{dt} \right)^2 &= \text{the work done between } C \text{ and } M \\ &= \frac{EA}{L} \left(\frac{c^2}{2} - \frac{x^2}{2} \right), \end{aligned}$$

or

$$\frac{P}{g} \frac{1}{2} \left(\frac{dx}{dt} \right)^2 = \frac{P}{L} \frac{1}{2} (c^2 - x^2);$$

and hence

$$v, \text{ the velocity of the weight at } M, = \sqrt{\frac{g}{l} (c^2 - x^2)}.$$

Now v is zero when $x = \pm c$, so that the weight will rise above B to a point C_1 , where $BC_1 = BC$.

Again, from the last equation,

$$dt \sqrt{\frac{g}{l}} = \frac{dx}{(c^2 - x^2)^{\frac{1}{2}}},$$

and integrating between the limits 0 and x ,

$$t \sqrt{\frac{g}{l}} = \sin^{-1} \frac{x}{c},$$

and the oscillations are therefore isochronous.

When $x = c$,

$$t = \frac{\pi}{2} \sqrt{\frac{l}{g}},$$

and the time of a complete oscillation is

$$\pi \sqrt{\frac{l}{g}}.$$

Next, suppose the oscillatory motion to be caused by a weight P falling without friction from a point D , and being suddenly checked and held by a catch at the lower end of the rod.

Take the same origin and data as before, and let $AD = h$. The elastic resistance of the rod at the time t is

$$EA \frac{l+x}{L},$$

and the equation of motion of the weight is

$$\frac{P d^2 x}{g dt^2} = P - EA \frac{l+x}{L} = P - \frac{P}{l}(l+x) = -P \frac{x}{l};$$

$$\text{or } \frac{d^2 x}{dt^2} = -\frac{g}{l}x.$$

Integrating,

$$\left(\frac{dx}{dt}\right)^2 = -\frac{g}{l}x^2 + c_1, \quad c_1 \text{ being a constant of integration.}$$

But $\frac{dx}{dt}$ is zero when $x = c$, and $c_1 = \frac{g}{l}c^2$.

Hence

$$\left(\frac{dx}{dt}\right)^2 = \frac{g}{l}(c^2 - x^2) = v^2.$$

This is precisely the same equation as was obtained in the first case, and between the limits 0 and x

$$t \sqrt{\frac{g}{l}} = \sin^{-1} \frac{x}{c},$$

so that the motion is isochronous, and the time of a complete oscillation is

$$\pi \sqrt{\frac{l}{g}}.$$

Cor. 1. When $x = -l$,

$$\left(\frac{dx}{dt}\right)^2 = 2gh,$$

and hence

$$\frac{g}{l}(c^2 - l^2) = 2gh,$$

or

$$c^2 = l^2 + 2lh.$$

Cor. 2. If $h = 0$, i.e., if the weight is merely placed upon the rod at the end A , $c = \pm l$, and the amplitude of the oscillation is *twice* the statical elongation due to P .

Cor. 3. The rod may be safely stretched until its length is $L + l$, while a further elongation c might prove most injurious to its elasticity, which shows the detrimental effect of vibratory motion. If a small downward force Q is applied to P when it has reached the end of its vibration, it will produce a corresponding descent, and the weight P will then ascend an equal distance above its neutral position. At the end of the interval corresponding to P 's natural period of vibration, apply the force again, and P will descend still further. This process may be continued indefinitely, until at last rupture takes place, however small P and Q may be. If Q is applied at irregular intervals, the amplitude of the oscillations will still be increased, but the increase will be followed by a decrease, and so on continually. In practice the problem becomes much more complex on account of local conditions, but experience shows that a *fluctuation* of stress is always more injurious to a structure than the stress due to the maximum load, and that the injury

is aggravated as the periods of fluctuation and of vibration of the structure become more nearly synchronous.

An example of a fluctuating load is a procession marching in time across a suspension-bridge, which may strain it far more severely than a much greater dead load, and may set up a synchronous vibration which may prove absolutely dangerous. In fact, a bridge has been known to fail from this cause.

Cor. 4. The coefficient of elasticity of the rod may be approximately found by means of the formula

$$T = \pi \sqrt{\frac{l}{g}},$$

T being the time of a complete oscillation. For suppose that the rod emits a musical note of n vibrations per second, then

$$\pi \sqrt{\frac{l}{g}} = T = \frac{1}{2n}$$

is the time of travel from C to C_1 ;

$$\therefore l = \frac{g}{4\pi^2 n^2}, \quad \text{and hence} \quad E = \frac{PL4\pi^2 n^2}{A g}.$$

Cor. 5. Suppose that the weight is perfectly free to slide along the rod. When it returns to A , it will leave the end of the rod and rise with a certain initial velocity. This velocity is evidently $\sqrt{2gh}$, and the weight accordingly ascends to D , then falls again, repeats the former operation, and so on. The equations of motion are in this case only true for values of x between $x = +c$ and $x = -l$.

25. On the Oscillatory Motion of a Weight at the End of a Vertical Elastic Rod of Appreciable Mass.—Suppose the mass of the rod to be taken into account, and assume:

(a) That all the particles of the rod move in directions parallel to the axis of the rod.

(b) That all the particles, which at any instant are in a plane perpendicular to the axis, remain in that plane at all times.

As before, the rod OA of natural length L and sectional area A is fixed at O and carries a weight P_1 at A .

Take O as the origin, and let OX be the axis of the rod.

Let ξ , $\xi + d\xi$, and x , $x + dx$, be respectively the *actual* and *natural* distances from O of the two consecutive sections MM , $M'M'$.

Let ρ_0 be the natural density of the rod, and ρ the density of the section MM , distant ξ from O .

The forces which act upon the rod are:

- (a) The upward and constant force P_0 at O .
- (b) The weight P_1 at A .
- (c) The weight of the rod.
- (d) A force X per unit of mass through the slice bounded by the planes MM , $M'M'$, distant ξ and $\xi + d\xi$, respectively, from O .

Suppose the rod, after equilibrium has been established, to be cut at the plane $M'M'$. In order to maintain the equilibrium of the portion $OM'M'$ it will be necessary to apply to the surface of this plane a certain force P , and the equation of equilibrium becomes

$$-P_0 + \int_0^\xi \rho A d\xi X + P + \rho_0 g A x = 0.$$

But if the thickness $d\xi$ of the slice MM' is indefinitely diminished, P is evidently the elastic reaction, and its value is

$$EA \frac{d\xi - dx}{dx} = EA \left(\frac{d\xi}{dx} - 1 \right).$$

Hence

$$-P_0 + \int_0^\xi \rho A X d\xi + EA \left(\frac{d\xi}{dx} - 1 \right) + \rho_0 g A x = 0.$$

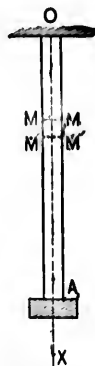

FIG. 197.

Differentiating with respect to x ,

$$\rho AX \frac{d\xi}{dx} + EA \frac{d^2\xi}{dx^2} + \rho_0 g A = 0.$$

But $\rho d\xi = \rho_0 dx$,

$$\therefore \rho_0 AX + EA \frac{d^2\xi}{dx^2} + \rho_0 g A = 0,$$

or

$$X + \frac{E}{\rho_0} \frac{d^2\xi}{dx^2} + g = 0.$$

Also, $\rho_0 A X dx$ is the resistance to acceleration arising from the inertia of the slice, and is therefore equal to

$$- \rho_0 A dx \frac{d^2\xi}{dt^2},$$

so that

$$X = - \frac{d^2\xi}{dt^2}.$$

Hence

$$\frac{d^2\xi}{dt^2} = \frac{E}{\rho_0} \frac{d^2\xi}{dx^2} + g. \dots \dots \dots (1)$$

To solve this equation.—In the state of equilibrium,

$$EA \left(\frac{d\xi}{dx} - 1 \right)$$

is the tension in the section of which the distance from

O is x , and counterbalances the weight P_1 and the weight $\rho_0 A(l-x)g$ of the portion AMN of the rod.

$$\therefore EA \left(\frac{d\xi}{dx} - 1 \right) = P_1 + \rho_0 Ag(l-x),$$

or

$$\frac{d\xi}{dx} = 1 + \frac{P_1}{EA} + \frac{\rho_0 g}{E}(l-x).$$

Integrating,

$$\xi = x + \frac{P_1}{EA}x + \frac{\rho_0 g}{E} \left(lx - \frac{x^2}{2} \right). \dots (2)$$

There is no constant of integration, as x and ξ vanish together.

This value of ξ is a *particular* solution of (1), and is independent of t .

$$\text{Put } \xi = x + \frac{P_1}{EA}x + \frac{\rho_0 g}{E} \left(lx - \frac{x^2}{2} \right) + z,$$

z being a new function of x and t . Then

$$\frac{d^2 \xi}{dx^2} = -\frac{\rho_0 g}{E} + \frac{d^2 z}{dx^2}, \quad \text{and} \quad \frac{d^2 \xi}{dt^2} = \frac{d^2 z}{dt^2}.$$

Hence, from eq. (1),

$$\frac{d^2 z}{dt^2} = \frac{E}{\rho_0} \frac{d^2 z}{dx^2} = v_1^2 \frac{d^2 z}{dx^2}, \quad \text{where } v_1^2 = \frac{E}{\rho_0}.$$

The integral of this equation is of the form

$$z = F(x + v_1 t) + f(x - v_1 t),$$

$v_1 \left(= \sqrt{\frac{E}{\rho_0}} \right)$ being the velocity of propagation of the vibrations.

The full solution of (1) is therefore of the form

$$\xi = x + \frac{P_1}{EA}x + \frac{\rho_0 g}{E} \left(lx - \frac{x^2}{2} \right) + F(x + v, t) + f(x - v, t).$$

omit to end of chapt

26. Inertia-Balancing.—Newton's First Law of Motion, called also the *Law of Inertia*, states that "a body will continue in a state of rest or of uniform motion in a straight line unless it is made to change that state by external forces."

This property of resisting a change of state is termed *inertia* and in dynamics is always employed to measure the *quantity of matter* contained in a body, i.e., its mass, to which the *inertia* must be necessarily proportional. Thus, to induce motion in a body, energy must be expended, and must again be absorbed before it can be brought to rest. The inertia of the reciprocating parts of a machine may therefore heavily strain the framework, which should be bolted to a firm foundation, or must be sufficiently massive to counteract by its weight the otherwise unbalanced forces.

EXAMPLE I. Consider the case of a direct-acting horizontal steam-engine, Fig. 198.

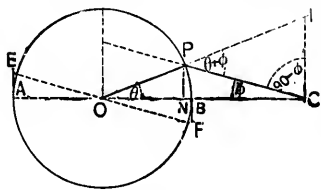

FIG. 198.

At any given instant let the crank OP and the connecting-rod CP make angles θ and ϕ , respectively, with the line of stroke AB .

Let v be the velocity of the crank-pin centre P , and let u be the corresponding piston velocity, which must evidently be the same as that of the end C of the connecting-rod.

Let OP produced meet the vertical through C in I .

At the moment under consideration, the points C and P are turning about I as an *instantaneous centre*.

$$\therefore \frac{u}{v} = \frac{IC}{IP} = \frac{\sin(\theta + \phi)}{\cos \phi}.$$

Let W be the weight of the reciprocating parts, i.e., the piston-head, piston-rod, cross-head (or motion-block), and a portion of the connecting-rod.

Assume (1) that the motion of the crank-pin centre is uniform;

(2) that the obliquity of the connecting-rod may be disregarded without sensible error, and
 $\therefore \phi = 0$.

Draw PN perpendicular to AB , and let $ON = x$; ON is equal to the distance of the piston from the centre of the stroke, corresponding to the position OP of the crank.

The kinetic energy of the reciprocating parts

$$= \frac{W u^2}{g \cdot 2} = \frac{W v^2 \sin^2 \theta}{g \cdot 2} = \frac{W v^2}{g \cdot 2} \left(1 - \frac{x^2}{r^2}\right),$$

r being the radius OP .

\therefore the *change of kinetic energy*, or work done, corresponding to the values x_1, x_2 of x ,

$$= \frac{W v^2}{g \cdot 2} \left(\frac{x_1^2}{r^2} - \frac{x_2^2}{r^2}\right).$$

Let R be the *mean pressure* which, acting during the same interval, would do the same work. Then

$$\frac{W v^2}{g \cdot 2} \frac{x_1^2 - x_2^2}{r^2} = R(x_1 - x_2),$$

and

$$\therefore R = \frac{W v^2}{g \cdot 2} \frac{x_1 + x_2}{r^2}.$$

Hence, in the limit, when the interval is indefinitely small, $x_1 = x_2 = x$, and the pressure corresponding to x becomes

$$R = \frac{W v^2}{g \cdot r^2} x.$$

This is the *pressure due to inertia*, and may be written in the form

$$R = C \frac{x}{r},$$

$C \left(= \frac{W}{g} \frac{v^2}{r} \right)$ being the centrifugal force of W assumed concentrated at the crank-pin centre. R is a maximum and equal to C when $x = r$, i.e., at the points A, B , and its value at intermediate points may be represented by the vertical ordinates to AB from the straight line EOF drawn so that $AE = BF = C$. In low-speed engines, C may be so small that the effect of inertia may be disregarded, but in quick-running engines, C may become very large and the inertia of the reciprocating parts may give rise to excessive strains.

Another force acting upon the crank-shaft is the centrifugal force of the crank, crank-pin, and of that portion of the connecting-rod which may be supposed to rotate with the crank-pin.

Let w be the weight of the mass concentrated at the crank-pin centre which will produce the same centrifugal force as these rotating pieces (i.e., $wr =$ sum of products of the weights of the several pieces into the distances of their centres of gravity from O).

$$\text{The centrifugal force of } w = \frac{w}{g} \frac{v^2}{r}.$$

Thus the total maximum pressure on the crank-shaft

$$= C + \frac{wv^2}{gr} = \frac{v^2}{gr} (W + w) = r(W + w) \frac{A^2}{g}$$

A being the uniform *angular* velocity of the crank-pin.

This pressure may be counteracted by placing a suitable balance-weight (or weights) in such a position as to develop in the opposite direction a centrifugal force of equal magnitude.

Let W_1 be such a weight and R its distance from O . Then

$$RW_1 \frac{A^2}{g} = r(W + w) \frac{A^2}{g},$$

or

$$RW_1 = r(W + w),$$

from which, if R is given, W_1 may be obtained.

During the first half of the stroke an amount of energy represented by the triangle AEO is *absorbed* in accelerating the reciprocating parts, and the *same* amount, represented by the triangle BOF , is given out during the second half of the stroke when the reciprocating parts are being retarded.

During the up-stroke of a *vertical* engine the weights of the reciprocating parts act in a direction opposite to the motion of the piston, while during the down-stroke they act in the same direction.

In AE produced (Fig. 199) take EE' to represent the weight of the reciprocating parts on the same scale as AE represents the pressure due to inertia. Draw $E'O'F'$ parallel to EOF .

During the up-stroke the ordinates of $E'O'$ represent the pressures required to accelerate the reciprocating parts, the pressures while they are retarded being represented by the ordinates of $O'F'$.

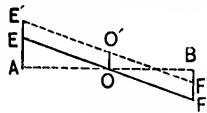

FIG. 199.

The case is exactly reversed in the down-stroke.

N.B.—The formula $R = C \frac{x}{r}$ may be easily deduced as follows :

$$u = v \sin \theta; \text{ the acceleration} = \frac{du}{dt} = v \cos \theta \frac{d\theta}{dt} = \frac{v^2}{r^2} x;$$

$$\therefore \frac{W}{g} \frac{du}{dt} = \text{accelerating force} = \text{force due to inertia}$$

$$= \frac{W}{g} \frac{v^2}{r^2} x = C \frac{x}{r}.$$

Ex. 2. Consider a double-cylinder engine with two cranks at right angles, and let d be the distance between the centre lines of the cylinders (Fig. 200).

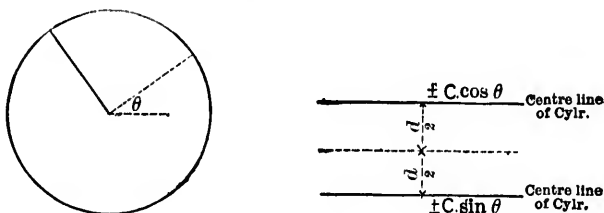

FIG. 200.

The pressures *due to inertia* transmitted to the crank-pins, when one of the cranks makes an angle θ with the line of stroke are

$$P_1 = C \cos \theta \quad \text{and} \quad P_2 = C \sin \theta.$$

These are equivalent to a single alternating force

$$P = C(\cos \theta \pm \sin \theta)$$

acting half-way between the lines of stroke, together with a couple of moment

$$M = P \frac{d}{2} = C \frac{d}{2} (\cos \theta \pm \sin \theta).$$

The force and couple are twice reversed in each revolution, and their maximum values are

$$P_{max.} = C\sqrt{2} \quad \text{and} \quad M_{max.} = \frac{Cd}{2} \sqrt{2}.$$

In order to avoid the evils that might result from the action of the force and couple at high speeds, suitable weights are introduced in such positions that the centrifugal forces due to

their rotation tend to *balance* both the force and the couple. For example, the weights may be placed upon the fly-wheels, or again, upon the driving-wheels of a locomotive.

Let a balance-weight Q be placed nearly diametrically opposite to the centre of each crank-pin (Fig. 201), and let R be the distance from the axis to the centre of gravity of Q .

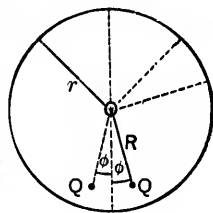

FIG. 201.

Let e be the horizontal distance between the balance-weights.

The centrifugal force F due to the rotation of Q

$$= \frac{Q(\text{velocity of } Q)^2}{gR} = \frac{Q}{g} \frac{R^2}{Rr^2} v^2 = \frac{QR}{gr^2} v^2,$$

and this force F is equivalent to a single force F acting half-way between the weights and to a couple of moment

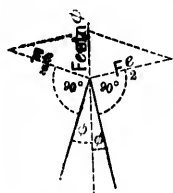

FIG. 202.

$F \frac{e}{2}$. Let ϕ be the angle between the radius to a balance-weight, and the common bisector of the angle between the two cranks (Fig. 202).

Since there are two weights Q , there will

be two couples each of moment $F \frac{e}{2}$, and two

forces each equal to F acting half-way between the weights, the angle between the axes of the couples being $180^\circ - 2\phi$, and that between the forces being 2ϕ . The moment of the resultant couple is $Fe \sin \phi$, and its axis bisects the angle between the axes of the separate couples; the resultant force parallel to the line of stroke $= 2F \cos \phi$.

Q and ϕ may now be chosen so that

$$2F \cos \phi = \text{maximum alternating force} = C\sqrt{2},$$

and

$$Fe \sin \phi = \text{maximum alternating couple} = \frac{Cd}{2} \sqrt{2}.$$

$$\therefore \tan \phi = \frac{d}{e},$$

and

$$F = \frac{C}{e} \sqrt{\frac{e^2 + d^2}{2}};$$

or

$$\frac{QR}{g r^2} v^2 = \frac{W v^2}{g r} \frac{1}{e} \sqrt{\frac{e^2 + d^2}{2}},$$

and

$$\therefore Q = \frac{W r}{e R} \sqrt{\frac{e^2 + d^2}{2}}$$

EX. 3. Again, the pressure C at a dead point may be balanced by a weight Q diametrically opposite.

If R is the radius of the weight-circle, then

$$\frac{W v^2}{g r} = C = \frac{Q R}{g r^2} v^2,$$

and

$$\therefore Q = W \frac{r}{R}.$$

The weight Q may be replaced by a weight $Q \frac{e+d}{2e}$ on the near and a weight $Q \frac{e-d}{2e}$ on the far wheel. Thus, since the cranks are at right angles, there will be two weights 90° apart on each wheel, viz., $Q \frac{e+d}{2e}$ in line with the crank and $Q \frac{e-d}{2e}$. These two weights, again, may be replaced by a single weight B whose centrifugal force is the resultant of the centrifugal forces of the two weights. Thus

$$\left(\frac{B}{g} \frac{v'^2}{R}\right)^2 = \left(\frac{Q}{g} \frac{e+d}{2e} \frac{v'^2}{R}\right)^2 + \left(\frac{Q}{g} \frac{e-d}{2e} \frac{v'^2}{R}\right)^2,$$

v' being the linear velocity at the circumference of the weight-circle.

$$\therefore B^2 = Q^2 \frac{e^2 + d^2}{2e^2},$$

or

$$B = \frac{Q}{e} \sqrt{\frac{e^2 + d^2}{2}}$$

If α is the angle between the radius to the greater weight $\frac{Q(e+d)}{2e}$ and the crank radius,

$$\tan \alpha = \frac{\frac{Q}{g} \frac{e-d}{2e} \frac{v'^2}{R}}{\frac{Q}{g} \frac{e+d}{2e} \frac{v'^2}{R}} = \frac{e-d}{e+d}$$

Note.—In outside-cylinder engines $e - d$ is approximately nil, and $B = Q = W \frac{r}{R}$.

27. Curves of Piston Velocity.—Consider the engine in Ex. 1.

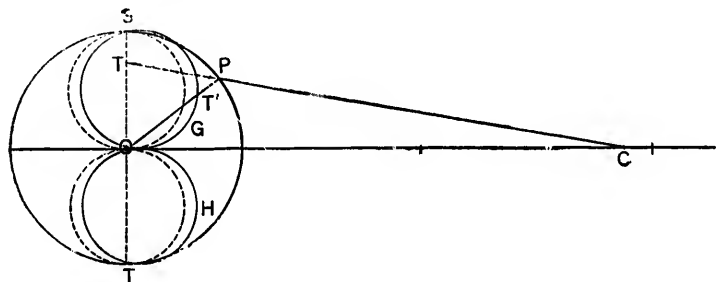

FIG. 203.

Let CP produced intersect the vertical through O in T , and in OP take $OT' = OT$.

The piston velocity u and the velocity v of the crank-pin centre are connected by the relation

$$\frac{u}{v} = \frac{\sin(\theta + \phi)}{\cos \phi} = \frac{OT}{OP} = \frac{OT'}{OP} \dots \dots (1)$$

If the velocity v is assumed constant, and if it is represented by OP , then on the same scale OT' will represent the piston velocity u . Drawing similar lines to represent the value of u

for every position of the crank, the locus of T' will be found to consist of two closed curves OGS , OHT , called the *polar curves of piston velocity*. They pass through the point O and through the ends S and T of the vertical diameter. On the side towards the cylinder they lie outside the circles having OS and OT as diameters, while on the side away from the cylinder they lie inside the circles. If the connecting-rod is so long that its obliquity may be disregarded,

$$\phi = 0 \quad \text{and} \quad u = v \sin \theta,$$

and the curves coincide with the circles.

A *rectangular diagram of velocity* may be drawn as follows:

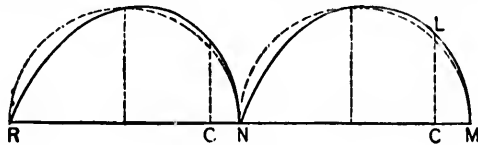

FIG. 204.

Upon the vertical through C , Fig. 204, take $CL = OT$; the locus of L is the curve required for one stroke. A similar curve may be drawn for the return stroke either below MN or upon the prolongation $NR (= MN)$ of MN .

If the obliquity of the connecting-rod is neglected, the curves evidently coincide with the semicircles upon MN and NR , $MN (= NR)$ defining the extreme positions of C . The obliquity, however, causes the actual curve to fall above the semicircle during the first half of the stroke, and below during the second half.

Again, let the connecting-rod (l) = n cranks (r). Then

$$\frac{\sin \theta}{\sin \phi} = \frac{l}{r} = n,$$

and by eq. 1,

$$u = v (\sin \theta + \cos \theta \tan \phi) = v \left(\sin \theta + \frac{\sin \theta \cos \theta}{\sqrt{n^2 - \sin^2 \theta}} \right). \quad (2)$$

If the obliquity is very small,

$$\tan \phi = \sin \phi = \frac{\sin \theta}{n}, \text{ approximately,}$$

and

$$\therefore u = v \left(\sin \theta + \frac{\sin \theta \cos \theta}{n} \right) = v \left(\sin \theta + \frac{\sin 2\theta}{2n} \right).$$

28. Curve of Crank-effort.—The *crank-effort* F for any position OP of the crank is the component along the tangent at P of the thrust along the connecting-rod.

$$\text{This thrust} = \frac{P}{\cos \phi}.$$

$$\therefore F = P \frac{\sin (\theta + \phi)}{\cos \phi}.$$

If the pressure P upon the piston is constant, and if it is represented by OP , then, *on the same scale*, OT' , Fig. 203, will represent the crank-effort. Thus, the curves of piston velocity already drawn may also be taken to represent curves of crank-effort. If the pressure P is variable, as is usually the case, let OP , the crank radius, represent the *initial* value of P . After expansion has begun, take OP' in OP , for any position OP of the crank, to represent the corresponding pressure which may be directly obtained from the indicator-diagram. Draw $P'T'$ parallel to PT , and take $OT'' = OT'$. Then OT'' will represent the required crank-effort, and the linear and polar diagrams may be drawn as already described.

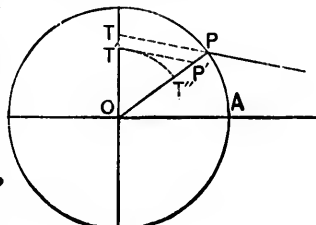

FIG. 205.

29. Curves of Energy—Fluctuation of Energy.—In the curve of crank-effort as usually drawn, the crank-effort for any position OP of the crank is the ordinate $S'H$, the abscissa DH being equal to the arc AP , i.e., to the distance traversed by the

point of application of the crank-effort. Thus, DSE and EVG being the curves,

$$DE = EG = \text{semi-circumference of crank-circle} = \pi r.$$

If the obliquity is neglected, the curves of crank-effort are the two curves of sines shown by the dotted lines.

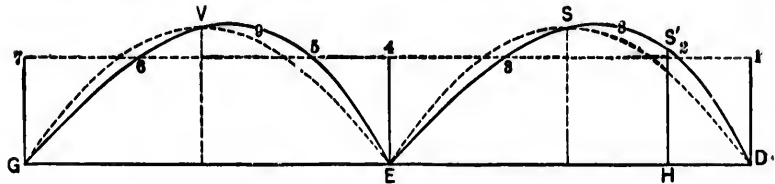

FIG. 206.

The area $DS'H$ also evidently represents the *work done* as the crank moves from OA to OP , and the total work done is represented by the area DSE in the forward and by EVG in the return stroke.

Let F_0 be the *mean* crank-effort. Then

$$F_0 \times 2\pi r = 2P \times 2r,$$

assuming P to be constant.

$$\therefore F_0 = \frac{2P}{\pi}.$$

Draw the horizontal line 1234567 at the distance $\frac{2P}{\pi}$ from DEG , and intersecting the verticals through D , E , and G in 1, 4, and 7, and the curves in 2, 3, 5, and 6. The engine may be supposed to work against a constant resistance R equal and opposite to the mean crank-effort F_0 .

From D to 2, $R >$ crank-effort, and the speed must therefore continually diminish.

From 2 to 3, $R <$ crank-effort, and the speed must continually increase.

Thus 2 is a point of min. velocity, and therefore also of min. kinetic energy.

From 3 to E , $R >$ crank-effort, and the speed must continually diminish.

Thus 3 is a point of max. velocity, and therefore also of max. kinetic energy.

Similarly, in the return stroke, 5 and 6 are points of min. and max. velocity, respectively.

The change or fluctuation of kinetic energy from 2 to 3 = area 283, bounded by the curve and by 23.

The fluctuation from 3 to 5 = area 3E5, bounded by 35 and by the curve.

Again, since $\frac{F}{P} = \frac{Fr}{Pr}$, the ordinates of the curves may be taken to represent the *moments* of crank-effort, and the abscissæ are then the corresponding values of θ .

The work done between A and any other position P of the crank-pin

$$\begin{aligned} &= \int_c^o Frd\theta = Pr \int_0^o \left(\sin \theta + \frac{\sin \theta \cos \theta}{\sqrt{n^2 - \sin^2 \theta}} \right) d\theta \\ &= Pr(1 - \cos \theta + n - \sqrt{n^2 - \sin^2 \theta}). \end{aligned}$$

If there are two or more cranks, the ordinates of the crank-effort curve will be equal to the algebraic sums of the several crank-efforts. For example, if the two cranks are at right angles, and if F_1 , F_2 are the crank-efforts when one of the cranks (F_1) makes an angle θ with the line of stroke,

$$F_1 = P \left(\sin \theta + \frac{\sin 2\theta}{2n} \right)$$

and

$$F_2 = P \left(\cos \theta - \frac{\sin 2\theta}{2n} \right).$$

$$\therefore F_1 + F_2 = P(\sin \theta + \cos \theta) = \text{combined crank-effort,}$$

P being supposed constant.

Note.—In the case of the polar curves of crank-effort, if a circle is described with O as centre and a radius = mean crank-effort = $\frac{2P}{\pi}$, it will intersect the curves in four points, which are necessarily points of max. and min. velocity.

THE STRENGTHS, ELASTICITIES, AND WEIGHTS OF IRON AND STEEL.

Material.	Max. Load on Original Area in lbs. per sq. in.		Yield-point in lbs. per sq. in.	Per cent of Extension.	Per cent of Contraction of Area.	Young's Modulus, E (in lbs.)	Coefficient of Rigidity, $\frac{E}{6}$ (in lbs.)	Weight Per Cubic Foot (in lbs.)
	Tension.	Compression.						
CAST IRON.	17,000	94,000	10,000			14,000,000	6,300,000	430
do. do. (special)	22,400	99,600	11,200					
Wrought-iron.								
Ordinary plate, plates, angles, channels, tees, and other shapes for structural work (e.g., bridges, etc.).	49,000	50,000	40,000	23 on 6"	43	25,000,000	10,500,000	430
Round bars (Low Moor).	49,000		40,000	30 on 10"	56	28,500,000	10,500,000	430
Square bars for spikes.	54,000			30 on 4"	43	31,000,000		430
Massive forgings.	30,000		14,000					
Iron wire.	60,000					23,500,000	10,500,000	
do. do.	44,000							
do. do.	10							
do. do.	114,000							
STEEL.								
Bessemer plate, angles, channels, I-beams, etc., for structural work (e.g., bridges, etc.).	66,000		40,000	26 on 8"	52	25,500,000	13,000,000	439.6
Bessemer bars, round and rectangular.	66,000		39,000	23 on 6"	43	28,500,000	13,000,000	430
Open-hearth plate.	67,000		41,000	26 on 6"	53	28,500,000		
do. angles.	66,000		40,000	26 on 6"	43	28,500,000		
do. channels.	66,000		40,000	26 on 6"	43	28,500,000		
do. bars.	53,000		31,000	23 on 8"	34	23,500,000		
Round bars for bolts.	52,000		31,000	25 on 6"	38	28,500,000		
Locomotive tires.	94,000		36,000	27 on 3"	53		13,000,000	
do. " poor quality.	85,000		42,000	23 on 4"	32			
Rectangular bars for nuts.	85,000		42,000	17 on 4"	19			
Spring steel, unhardened.	59,000		50,000		49	28,500,000	10,500,000	
Cast steel, unhardened and tempered.						23,500,000	10,500,000	
Cast steel, hardened and tempered.						35,000,000	13,000,000	
Steel wire.	164,000							
do. do.	10							
do. do.	204,000							

Alum
Bras
" "
Bra
Copp

Copp
Gun-
Lead
Lead
Phos-
Tin
Zinc
Leath

TH

mos
spec
the
the
log,
wher
very
timb
by a

Descr
Ti

Acacia
Alder,
Apple,
Ash, E
Beech,
Birch,
Box...
Blue gu
Cedar,
Chestn
Ebony,
Elm, C

THE STRENGTHS, ELASTICITIES, AND WEIGHTS OF VARIOUS ALLOYS, ETC.

Material.	Max. Load on Original Area in lbs. per sq. in.			Young's Modulus, <i>E</i> (in lbs.).	Coeff-icient of Rigidity, <i>G</i> (in lbs.).	Weight in lbs. per cu. ft.
	Tension.	Com-pression.	Shear-ing.			
Aluminum.....	28,800			9,600,000	3,600,000	160 to 166
Brass.....	17,000	10,300		9,100,000	3,400,000	487 to 524
(hammered).....				15,000,000	5,600,000	
Brass wire.....	52,000			14,000,000		531
Copper plate, hammered.....				15,000,000	5,700,000	556
annealed.....	30,000	58,000		15,000,000	5,700,000	
Copper wire.....	60,000			17,000,000		555
Gum-metal.....	16,000			9,900,000		529
Lead.....	1,850	7,100		700,000		712
Lead wire.....	3,100			990,000		
Phosphor-bronze.....	57,000			14,000,000	5,250,000	
Tin.....	4,950			5,600,000	2,140,000	456 to 468
Zinc.....	7,500			13,500,000		424 to 449
Leather.....	4,000			25,000		

THE STRENGTHS, ELASTICITIES, AND WEIGHTS OF TIMBERS.

This table contains the results of the most recent and most reliable experiments, but, generally speaking, only small specimens of the material have been tested. It is found that the strength, elasticity, and weight of a timber are affected by the soil, age, seasoning, per cent of moisture, position in the log, etc., and hence it is not surprising that specimens even when cut out of the same log show results which often differ very widely from the mean. Additional experiments on large timbers are needed, and in each case should be accompanied by a complete history of the specimen from the time of felling.

Description of Timber.	Tensile Strength in tons per sq. in.	Com-pressive Strength in tons per sq. in. along Fibres.	Shearing Strength in tons per sq. in. along Fibres.	Young's Modulus, <i>E</i> (in tons).	Coeff-icient of Rigidity, <i>G</i> .	Coefficient of Bending Strength in tons per sq. in.	Weight in lbs. per cu. ft.
Acacia.....		7.1					
Alder.....		3.1					50
Apple.....	4.5 to 6.3						50
Ash, Canadian..	2.45	2.5	.2 to .312	620			47
Ash, English...	5.35 to 7.58	4		723			43 to 53
Beech.....	4.9 to 9.8	3.67		607			43 to 53
Birch.....	6.69	1.47 to 2.27	.25 to .364	734			45 to 49
Box.....	9	4.6		803			64
Blue gum.....	2.7	3.078		509	5.86		
Cedar.....	2.23 to 4.9	2.56		217			35 to 47
Chestnut.....			.308	509			35 to 44
Ebony.....		8.48					
Elm, Canadian..	4.3	2.9		1100			47

THE STRENGTHS, ELASTICITIES, AND WEIGHTS OF TIMBERS
(Continued.)

Description of Timber.	Tensile Strength in tons per sq. in.	Compressive Strength in tons per sq. in. along Fibres.	Shearing Strength in tons per sq. in. along Fibres.	Young's Modulus, <i>E</i> (in tons).	Coefficient of Rigidity, <i>G</i> .	Coefficient of Bending Strength in tons per sq. in.	Weight in lbs. per cu. ft.
Elm, Eng.	5.89	4.6					
Greenheart	2.7 to 4.1	4.46 to 6.5		759			34 to 37 58 to 72
Hawthorn	4.68						
Hazel	8.48					8.15	47½
Hornbeam	9.1	2.6					
Iron bark	7.12	4.54					
Ironwood	4.31	5.21					
Jarrah	1.31	3.2				4.13	
Lancewood	3.6 to 6.7						42 to 63
Larch	3.92 to 4.55	1.42 to 2.45					32 to 38 41 to 83
Lignum vitæ	5.26	4.46		446		7.18	
Locust	4.5 to 6.7	1.33	.535				
Mahogany, Span.	1.7 to 7.3	3.3	3.3			560 to 1339 712 to 879	53 35 49
Maple, Lond.	1.3 to 3.6						
Maple	4.7 to 7.7	2.23					
Mora	4.1	4.4					
* Oak, Am.							
" white	4.46	1.89 to 2.6	.324 to .446	830 577		2.712	57 to 68
" Eng.	8.8	2.84	.335 to .431			4.55	61 61
" Memel	5.4	4.4		664			49 to 58
Pine, Dantzic	3.5			1025			36 34
" Memel	4.5						34
" pitch	4.6	3.5					41 to 58
* " red				670		2.93	34
* " yellow	1.7 to 6.67	2.4 to 3		962		3.71	34
* " yellow				779		3.255	
* " white	2.2 to 6.87	2.4 to 3.6	.227	900		4.51	32
" white				484		2.146	
Plane	1.3 to 5.1	2.24	.119 to .164			3.03	30 40
Poplar	5.4			604			
* Spruce	2.94	1.8		340			23 to 26
* "				594		2.18	
* "	2.99 to 5.97		.113 to .167	438 to 737		1.63 to 2.86	29 to 32 36 to 43
Sycamore	3	3.16		700			41 to 52
Teak	4.7 to 6.7	5.35		1000			38 to 57
Walnut	3.5	2.7					24 to 35
Willow	4.6 to 6.25	1.5		629			

G = E/2 approximately.

* The results for these timbers are deduced from experiments carried out by Bauschinger Lanza, and others, on comparatively large specimens.

THE BREAKING WEIGHTS AND COEFFICIENTS OF BENDING STRENGTH IN TONS (OF 2240 LBS.) OF VARIOUS RECT-ANGULAR BEAMS, THE WEIGHTS HAVING BEEN UNIFORMLY DISTRIBUTED.

Material.	Clear Span between Supports in inches.	Breadth in inches.	Depth in inches.	Mean Breaking Weight of each Joist or Beam.	Coefficient of Bending Strength.
Yellow pine (Quebec), 11 joists	142	3	9	5.66	2.48
" " " 2 beams	142	3½	11	7.89	1.68
" " " 2 beams	126	14	15	60.97	1.83
Fir (Baltic), 2 beams	126	14	14	46.6	1.6
" " " 11 joists	142	3½	11	8.29	2.08
" (Swedish), 2 joists	142	3	9	5.7	2.49
Pine (Baltic), 2 beams	126	13½	13½	58.43	2.24
Baltic redwood deal (Wyberg), 2 joists	142	3	9	5.75	2.52
Spruce deals (St. John), 3 pairs with bridg- ing pieces	142	3	9	6.81	2.98

TH
Yello
Pitch
Baltic
Amer
Red p
N. ments pool
AVER
Dough from dista
Dough
Red p
* Fo Society

THE BREAKING WEIGHTS AND COEFFICIENTS OF BENDING STRENGTH IN TONS (OF 2240 LBS.) OF VARIOUS RECT-ANGULAR BEAMS LOADED AT THE CENTRE.

Material.	Clear Span between Supports in inches.	Breadth in inches.	Depth in inches.	Breaking Weight in tons.	Coefficient of Bending Strength.	Remarks.
Yellow pine.....	129	14	15	38.15	2.34	
" ".....	129	14	15	34	2.09	
" ".....	45	5	7	5.9	1.62	
" ".....	45	5	7	5.7	1.57	Old timber
" ".....	45	5	5	3.1	1.67	" "
" ".....	45	5	5	3.05	1.64	
" ".....	45	2½	3½	.925	2.04	Old timber
" ".....	45	2½	3½	1.075	2.37	" "
Pitch pine.....	129	14	15	59.25	3.64	
" ".....	129	14	15	60.25	3.7	
" ".....	45	5	7	7.8	2.14	
" ".....	45	5	7	9.75	2.68	
" ".....	45	5	7	10.65	2.92	
" ".....	45	5	7	11	3.03	
" ".....	45	2½	3½	1.6	3.52	
" ".....	45	2½	3½	1.35	2.97	
Baltic pine.....	45	5	7	7	1.91	
" ".....	45	5	7	3.5	2.34	
" ".....	45	2½	3½	1.125	2.48	
" ".....	45	2½	3½	1.2	2.64	
American elm.....	45	5	7	14.9	4.1	Old timber
" ".....	45	5	7	15.6	4.29	" "
" ".....	45	2½	3½	2.65	5.84	" "
" ".....	45	2½	3½	2.6	5.73	" "
Greenheart.....	45	5	5	14	7.56	
" ".....	45	2½	7	11.45	6.31	
" ".....	45	3	3	3.85	9.625	
" ".....	45	2½	3½	4.00	8.81	
" ".....	45	2½	3½	3.55	7.82	
" ".....	139	9	8	24.5	8.87	
Red pine.....	147	6	12	7.5	1.91	
" ".....	147	6	12	8.45	2.15	

N.B.—The results contained in the last two tables are mainly deduced from experiments carried out under the supervision of W. Le Mesurier, M.Inst.C.E., Dock Yard, Liverpool

AVERAGE OF THE RESULTS OBTAINED BY THE AUTHOR WITH BEAMS OF LARGE SCANTLING IN THE TESTING LABORATORY, MCGILL UNIVERSITY.*

Canadian Timbers.	Coefficient of Bending Strength in lbs. per sq. in.	Coefficient of Elasticity in lbs.	Weight per cubic ft. in lbs.
Douglas fir—specially selected, free from knots, and cut out of log at a distance from the heart.....	9,000	2,000,000	40
Douglas fir—ordinary first quality.....	6,000	1,430,000	34
Red pine.....	5,100	1,430,000	34.78

* For details of these tests the reader is referred to the Transactions of the Canadian Society of Civil Engineers, Vol. IX, 1895.

THE WEIGHTS AND CRUSHING WEIGHTS OF ROCKS, ETC.

Material.	Weight per cu. ft. in lbs.	Crushing Weight in lbs. per sq. in.
Asphalt.....	156	8,300
Basalt, Scotch.....	184	17,200
" Greenstone.....	181	16,800
" Welsh.....	172	
Beton.....		800 to 1,400
Brick, common.....		550 to 800
" stock (Eng.).....		2,250
" Sydney, N. S.....		2,200
" yellow-faced (Eng.).....	100 to 135	1,440
" Staffordshire blue.....		7,200
" E. c.....		1,700
" pressed (best).....	150	10,200
Brickwork in ordinary lime mortar.....	112	600 to 1,200
Cement, Portland.....	86 to 94	1,700 to 6,000
" Roman.....	100	
Clay.....	119	
Concrete, ordinary.....	119	460 to 775
" in cement.....	137	
Earth.....	77 to 125	
Firestone.....	112	19,600
Freestone.....		3,000 to 3,500
Glass, flint.....	192	27,500
" crown.....	157	31,000
" common green.....	158	31,000
" plate.....	172	
Granite, Aberdeen gray.....	163	10,800
" red.....	165	
" Cornish.....	166	14,000
" Sorrel.....	167	12,800
" Irish.....		10,450
" U. S. (Quincy).....		15,000
" Argyll.....		10,900
Gneiss.....	96 to 175	19,600
Limestone.....	154 to 162	7,500 to 9,000
Lime, quick.....	53	
Mortar.....	86 to 119	120 to 240
" (average).....	106	
Masonry, common brick.....		500 to 800
" in cement.....		760
" rubble.....	116 to 144	$\frac{1}{8}$ of cut stone
Marble, statuary.....	170	3,200
" miscellaneous.....	168 to 170	8,000 to 9,700
Oolite, Portland stone.....	151	4,100
" Bath stone.....	123	
Sand, quartz.....	177	
" river.....	117	
" pit.....	100	
" fine.....	95	
Sandstone, red (Eng.).....	133	5,700
" Derby grit.....	150	3,100
" paving (Eng.).....	156 to 157	5,700 to 6,000
" Scotch.....	153 to 155	5,300 to 7,800
" U. S.....		5,300
Shingle.....	88	
Slate, Anglesea.....	179	10,000
" Cornish.....	157	to
" Welsh.....	180	24,000
Trap.....	170	

FACTORS OF SAFETY

GOOD ORDINARY WORK.

Timber.....	2 to 3 for dead load,	3 to 6 for live load.
Metals.....	3 " " "	6 " " "
Masonry.....	4 " " "	8 " " "

EXPANSIONS OF SOLIDS.

Materials.	Linear Expansion per Unit of Length.		Expansion in Bulk. From 32° F. to 212° F.
	From 32° F. to 212° F.	From 32° F. to 572° F.	
Brass.....	.001868 = $\frac{1}{538}$.0065
Bronze.....	.00182 = $\frac{1}{549}$.0054
Cast-iron.....	.001075 = $\frac{1}{930}$.0033
Copper.....	.001718 = $\frac{1}{582}$.001883 = $\frac{1}{531}$.0055
Fir.....	.00352 = $\frac{1}{284}$		
Glass.....	.00861 = $\frac{1}{1161}$.0027
Gold.....	.001466 = $\frac{1}{682}$		
Gun-metal.....	.00181 = $\frac{1}{552}$		
Iron wire.....	.00144 = $\frac{1}{694}$		
Lead.....	.0002848 = $\frac{1}{351}$.0057
Oak.....	.000746 = $\frac{1}{1340}$		
Platinum.....	.000884 = $\frac{1}{1131}$		
Silver.....	.001909 = $\frac{1}{524}$		
Steel, unhardened.....	.001079 = $\frac{1}{927}$.0036
" hardened.....	.00124 = $\frac{1}{807}$		
Tin.....	.002173 = $\frac{1}{460}$.0066
Wrought-iron (bar).....	.001235 = $\frac{1}{81}$		
" (for smith-work)..	.001182 = $\frac{1}{848}$.001468 = $\frac{1}{681}$.0036
Zinc, cast.....	.002941 = $\frac{1}{340}$.0058
" hammered.....	.003108 = $\frac{1}{322}$		

NOTE.—Crushing strength of ordinary brickwork in Portland cement, 1 to 3, = 1500 to 1700 lbs. per sq. in.

EXAMPLES.

1. How many square inches are there in the cross-section of an iron rail weighing 30 lbs. per lineal yard? How many in a yellow-pine beam of the same lineal weight? *Ans.* 3 sq. in.; 45 sq. in.

2. A vertical wrought-iron bar 60 ft. long and 1 in. in diameter is fixed at the upper end and carries a weight of 2000 lbs. at the lower end. Find the factors of safety for both ends, the ultimate strength of the iron being 50,000 lbs. per sq. in. *Ans.* $19\frac{9}{14}$; $18\frac{3}{17}$.

3. A vertical rod fixed at both ends is weighted with a load w at an intermediate point. How is the load distributed in the tension of the upper and compression of the lower portion of the rod? *Ans.* Inversely as the lengths.

4. Find the length of a steel bar of sp. gr. 7.8 which, when suspended vertically, would break by its own weight, the ultimate strength of the metal being 60,000 lbs. per sq. in. *Ans.* 17,723 ft.

5. The iron composing the links of a chain is $\frac{1}{2}$ in. in diameter; the chain is broken under a pull of 10,000 lbs. What is the corresponding tenacity per sq. in.? *Ans.* $57,272\frac{8}{17}$ lbs.

6. A vertical iron suspension-rod 90 ft. long carries a load of 20,000 lbs. at its lower end; the rod is made up of three equal lengths square in section. Find the sectional area of each length, the ultimate tenacity of the iron being 50,000 lbs. per sq. in., and 5 a factor of safety. *Ans.* $\frac{2}{9}$ sq. in.; $\frac{2}{9}$ sq. in.; $\frac{2000000}{9}$ sq. in.

7. If the rod in the previous question is of a conical form, what should be the area of the upper end? Also find the intensities of the tension at 30 and 60 ft. from the lower end. *Ans.* 2.0407 sq. in.; 9999.612 lbs., 9999.605 lbs. per sq. in.

8. The dead load of a bridge is 5 tons and the live load 10 tons per panel, the corresponding factors of safety being 3 and 6. If the two loads are taken together, making 9 tons per panel, what factor of safety would you use? *Ans.* 5.

9. The end of a beam 10 in. broad rests on a wall of masonry. If it be loaded with 10 tons, what length of bearing surface is necessary, the safe crushing stress for stone being 150 lbs. per sq. in.? *Ans.* $13\frac{1}{2}$ in.

10. Find diameter of bearing surface at the base of a column loaded with 20 tons, the same stress being allowed as in the preceding question. *Ans.* $\sqrt{380.12}$.

11. In the chain of a suspension-bridge five flat links dovetail with four alternately, and a cylindrical pin passes through the eyes. The pull on the chain is 200 tons. Find the area of the pin, the bearing strength of the metal being 6 tons per sq. in. *Ans.* $1\frac{2}{3}$ sq. in.

12. An iron bar of uniform section and 10 ft. in length stretches .12 in. under a unit stress of 25,000 lbs. Find E .
Ans. 25,000,000 lbs.

13. A ship at the end of a 600-ft. cable and one at the end of a 500-ft. cable stretch the cables 3 in. and $2\frac{1}{2}$ in., respectively. What are the corresponding strains? *Ans.* $\frac{1}{2400}$.

14. A rectangular timber tie is 12 in. deep and 40 ft. long. If $E = 1,200,000$ lbs., find the proper thickness of the tie so that its elongation under a pull of 270,000 lbs. may not exceed 1.2 in. *Ans.* $7\frac{1}{2}$ in.

15. A wrought-iron bar 60 ft. long is stretched 5 in. by a pull of 50,000 lbs. Find its diameter, E being 25,000,000 lbs. *Ans.* .59 in.

16. A wrought-iron rod 984 ft. long alternately exerts a thrust and a pull of 52,910 lbs.; its cross-section is 9.3 sq. in. Find the loss of stroke, E being 29,000,000 lbs. *Ans.* 4.632 in.

17. A wrought-iron bar 2 sq. in. in sectional area has its ends fixed between two immovable blocks when the temperature is at 32° F. If $E = 29,000,000$ lbs., what pressure will be exerted upon the blocks when the temperature is 100° F. ? $\alpha = .00125$. *Ans.* 27388 $\frac{2}{3}$ lbs.

18. What should be the diameter of the stays of a boiler in which the pressure is 30 lbs. per sq. in., allowing one stay to each $1\frac{1}{2}$ sq. ft. of surface and a stress of 3500 lbs. per sq. in. of section of iron? *Ans.* $1\frac{1}{2}$ in.

19. A force of 10 lbs. stretches a spiral spring 2 in. Find the work done in stretching it successively 1 in., 2 in., 3 in., up to 6 in. *Ans.* $\frac{5}{2}$, $\frac{20}{3}$, $\frac{45}{2}$, $\frac{80}{3}$, $\frac{135}{2}$, $\frac{180}{3}$ in.-lbs.

20. A roof tie-rod 142 ft. in length and 4 sq. in. in sectional area is subjected to a stress of 80,000 lbs. If $E = 30,000,000$ lbs., find the elongation of the rod and the corresponding work. *Ans.* 1.136 in.; 3786 $\frac{2}{3}$ ft.-lbs.

21. An iron wire $\frac{1}{8}$ in. in diameter and 250 ft. in length is subjected to a tension of 600 lbs., the consequent strain being $\frac{1}{3000}$. Find E , and show by a diagram the amount of work done in stretching the wire within the limits of elasticity. *Ans.* 14,661,818 $\frac{2}{11}$ lbs.

22. A timber pillar 30 ft. in length has to support a beam at a point 30 ft. from the ground. If the greatest safe strain of the timber is $\frac{1}{1000}$, what thickness of wedge should be driven between the head of the pillar and the beam? *Ans.* $\frac{1}{10}$ ft.

23. An hydraulic hoist-rod 50 ft. in length and 1 in. in diameter is attached to a plunger 4 in. in diameter, upon which the pressure is 800 lbs. per sq. in. Determine the altered length of the rod, E being 30,000,000 lbs. *Ans.* .0213 ft.

24. A short cast-iron post is to sustain a thrust of 64,000 lbs., the ultimate crushing strength of the iron being 80,000 lbs. per sq. in. and 10 a factor of safety. Find the dimensions of the post, which is rectangular in section with the sides in the ratio of 2 to 1. *Ans.* 4 in.; 2 in.

25. The length of a cast-iron pillar is diminished from 20 ft. to 19.97 ft. under a given load. Find the strain and the compressive unit stress, E being 17,000,000 lbs. *Ans.* .0015; 25,500 lbs. per sq. in.

26. A rectangular timber strut 24 sq. in. in sectional area and 6 ft. in length is subjected to a compression of 14,400 lbs. Determine the diminution of the length, E being 1,200,000 lbs. *Ans.* .003 ft.

27. Find the height from which a weight of 200 lbs. may be dropped so that the maximum admissible stress produced in a bar of 1 sq. in. section and 5 ft. long may not exceed 20,000 lbs. per sq. in., the coefficient of elasticity being 27,000,000 lbs. *Ans.* $\frac{5}{27}$ ft., or, more accurately, $\frac{4}{27}$ ft.

28. Find the H. P. required to raise a weight of 10 tons up a grade of 1 in 12 at a speed of 6 miles per hour against a resistance of 9 lbs. per ton (ton = 2240 lbs.). *Ans.* 31.3.

29. A square steel bar 10 ft. long has one end fixed; a sudden pull of 40,000 lbs. is exerted at the other end. Find the sectional area of the bar consistent with the condition that the strain is not to exceed $\frac{1}{100}$. $E = 30,000,000$ lbs. Find the resilience of the bar.

Ans. 2 sq. in.; 533 $\frac{1}{2}$ ft.-lbs.

30. How much work is done in subjecting a cube of 125 cu. in. of iron to a tensile stress of 8000 lbs. per sq. in.? $E = 30,000,000$ lbs.

Ans. 11 $\frac{1}{3}$ ft.-lbs.

31. A signal-wire 2000 ft. in length and $\frac{1}{8}$ in. in diameter is subjected to a steady stress of 300 lbs. The lever is suddenly pulled back, and the corresponding end of the wire moves through a distance of 4 in. Determine the instantaneous increase of stress. $E = 25,000,000$ lbs.

Ans. 51 $\frac{1}{2}$ lbs.

32. If the total back-weight is 350 lbs., what is the range of the signal end of the wire? *Ans.* $\frac{1}{16}$ ft.

33. A steel rod of length L and sectional area A has its upper end fixed and hangs vertically. The rod is tested by means of a ring weighing 60 lbs. which slides along the rod and is checked by a collar screwed to the lower end. A scale is marked upon the rod with the zero at the fixed end. If the strain in the steel is not to exceed $\frac{1}{100}$, what is the reading from which the weight is to be dropped? $E = 35,000,000$ lbs.

Ans. Distance from point of suspension = $(\frac{201}{100} - \frac{1}{100}A)L$.

34. A load of 1000 lbs. falls 1 in. before commencing to stretch a suspending rod by which it is carried. If the sectional area of the rod is 2 sq. in., length 100 in., and $E = 30,000,000$ lbs., find the stress produced.

Ans. 17,328 lbs. per sq. in.

35. If the rod carries a load of 5000 lbs., and an additional load of 2000 lbs. is suddenly applied, what is the stress produced?

Ans. 4500 lbs. per sq. in.

36. Steam at a pressure of 50 lbs. per sq. in. is suddenly admitted upon a piston 32 in. in diameter. The steel piston-rod is 48 in. in length and 2 in. in diameter, E being 35,000,000 lbs. Find the work done upon the rod.

Ans. 117.69 ft.-lbs.

37. What should be the pressure of admission to strain the rod to a proof of .001?

Ans. $68\frac{2}{3}$ lbs. per sq. in.

38. A boulder-grappler is raised and lowered by a wire rope 1 in. in diameter hanging in double sheaves. On one occasion a length of 150 ft. of rope was in operation, the distance from the winch to the upper block being 30 ft. The grappler laid hold of a boulder weighing 20,000 lbs. What was the extension of the rope, E being 15,000,000 lbs.?

Ans. $\frac{1}{10}$ ft.

39. The boulder suddenly slipped and fell a distance of 6 in. before it was again held. Find the maximum stress upon the rope.

Ans. $50,452\frac{1}{2}$ lbs. per sq. in.

40. What weight of boulder may be lifted if the proof-stress in the rope is not to exceed 25,000 lbs. per sq. in. of gross sectional area?

Ans. 78,571 $\frac{3}{4}$ lbs.

41. The steady thrust or pull upon a prismatic bar is suddenly reversed. Show that its effect is trebled.

42. A weight W is suspended by a spring, which it stretches. The weight is further depressed 1 ft., when it is suddenly released and allowed to oscillate. Find its velocity at a distance x from the position of equilibrium.

Ans. $\sqrt{10(1-10x^2)\frac{g}{W}}$.

43. If a spring deflects .001 ft. under a load of 1 lb., what will be the period of oscillation of a weight of 14 lbs. upon the spring?

44. Show that the change of a unit of volume of a solid body under a longitudinal stress is $\lambda\left(1 - \frac{2}{m}\right)$, which becomes $\frac{\lambda}{2}$ if $m = 4$, as in metals, and *nil* when $m = 2$, as in india-rubber (page 142).

45. A steel bar stretches $\frac{1}{1000}$ th of its original length under a stress of 20,000 lbs. per sq. in. Find the change of volume and the work done per cubic inch.

Ans. $\frac{1}{3000}$ th; $\frac{1}{5}$ ft.-lb. per cu. in.

46. During the plastic deformation of a prismatic bar, show that the change in sectional area is proportional to the deformation calculated on the altered length of the bar.

47. A prismatic bar of volume V changes in length from L to $L \pm x$ under the "fluid pressure" p . Find the corresponding work.

$$\text{Ans. } pV \log_e(L \pm x).$$

48. Show that the total work done in raising a number of weights through to a given level is the product of the sum of the weights and the vertical displacement of their centre of gravity.

49. An engine has to raise 4000 lbs. 1000 ft. in 5 minutes. What is its H. P.? How long will the engine take to raise 10,000 lbs. 100 ft.?

$$\text{Ans. } 24\frac{2}{3} \text{ H. P. ; } 1\frac{1}{2} \text{ min.}$$

50. How many men will do the same work as the engine in the preceding question, assuming that a man can do 900,000 ft.-lbs. of work in a day of 9 hours?

$$\text{Ans. } 480 \text{ men.}$$

51. Determine the H. P. which will be required to drag a heavy rock weighing 10 tons at the rate of 10 miles an hour on a level road, the coefficient of friction being 0.8. What will be the speed up a gradient of 1 in 50, the same power being exerted?

$$\text{Ans. } 477\frac{1}{3} \text{ ; } 9\frac{1}{4} \text{ miles per hour.}$$

52. Two horses draw a load of 4000 lbs. up an incline of 1 in 25 and 1000 ft. long. Determine the work done.

$$\text{Ans. } 160,000 \text{ ft.-lbs.}$$

53. At what speed do the horses walk if each horse does 16,000 ft.-lbs. of work per minute?

$$\text{Ans. } 2\frac{2}{11} \text{ miles per hour.}$$

— 54. A wrought-iron rod 25 ft. in length and 1 sq. in. in sectional area is subjected to a steady stress of 5000 lbs. What amount of live load will instantaneously elongate the rod by $\frac{1}{8}$ in., E being 30,000,000 lbs.?

$$\text{Ans. } 6250 \text{ lbs.}$$

55. Determine the shortest length of a metal bar a sq. in. in sectional area that will safely resist the shock of a weight of W lbs. falling a distance of h ft. Apply the result to the case of a steel bar 1 sq. in. in sectional area, the weight being 50 lbs., the distance 16 ft., the proof-strain $\frac{1}{100}$, and $E = 35,000,000$ lbs.

$$\text{Ans. } \frac{2EWh}{af^2 - 2Wf}, f \text{ being the safe unit stress; } 11\frac{2}{3} \text{ ft.}$$

56. A shock of N ft.-lbs. is safely borne by a bar l ft. in length and a sq. in. in sectional area. Determine the increased shock which the bar will bear when the sectional area of the last m th of its length is increased to ra .

$$\text{Ans. } N \left(1 - \frac{1}{m} + \frac{1}{rm} \right).$$

57. The bar in Example 12 is 1 sq. in. in section. Determine the work stored up in the rod in foot-pounds and compare it with the work which

would be stored up if for half its length the rod has its section increased to 4 in. *Ans.* 125 ft.-lbs.; $\frac{1}{4}$ of 125 ft.-lbs.

58. If 25,000 lbs. per sq. in. is the proof-stress, find the modulus of resilience for the 1-in. rod. *Ans.* 25 in in.-lb. units.

59. A steel rod 100 ft. in length has to bear a weight of 4000 lbs. If $E = 35,000,000$ lbs., and if the safe strain is .0005, determine the sectional area of the rod (1) when the weight of the rod is neglected; (2) when the weight of the rod is taken into account. Also in the former case, determine the work done in stretching the rod $\frac{1}{10}$ in., $\frac{2}{10}$ in., $\frac{3}{10}$ in., . . . $\frac{10}{10}$ in., successively.

Ans. $\frac{3}{8}$ sq. in.; $\frac{5}{4}\frac{1}{4}$ sq. in.; 33 $\frac{1}{2}$, 133 $\frac{1}{2}$, 300, . . . 1200 in.-lbs.

60. A line of rails is 10 miles in length when the temperature is at 32° F. Determine the length when the temperature is at 105 $\frac{1}{2}$ F., and the work stored up in the rails per sq. in. of section, E being 20,000,000 lbs. $\alpha = .0016$ per 180° F. *Ans.* 10.00653 miles; 338060.8 ft.-lbs.

61. A wrought-iron bar 25 ft. in length and 1 sq. in. in sectional area stretches .0001745 ft. for each increase of 1° F. in the temperature. If $E = 29,000,000$ lbs., determine the work done by an increase of 20° F.

How may this property of extension under heat be utilized in straightening walls that have fallen out of plumb? *Ans.* 7.064 ft.-lbs.

62. Find the work done in raising a Venetian blind, w being the weight of a slat, a the distance between consecutive slats, and n the number of slats.

$$\text{Ans. } wa \frac{n(n+1)}{2}.$$

63. How many $\frac{3}{8}$ -in. rivets must be used to join two wrought-iron plates, each 36 in. wide and $\frac{1}{4}$ in. thick, so that the rivets may be as strong as the riveted plates, the tensile and shearing strength of wrought-iron being in the ratio of 10 to 9? *Ans.* 17 rivets (16.3).

64. A horizontal string, without weight, of length $2a$ and sectional area s , has its two ends fixed in the same horizontal plane. A weight W suspended from its centre draws the string slightly out of the horizontal. Show that, approximately,

$$t = \frac{1}{2} \left(\frac{EW^2}{s^2} \right)^{\frac{1}{2}} \quad \text{and} \quad d = a \left(\frac{W}{Es} \right)^{\frac{1}{2}}$$

t being the intensity of the tension, d the depression, and E the coefficient of elasticity.

65. A heavy wire of length $2a$, sectional area S , and weight W has its ends fixed in a horizontal plane and is allowed to deflect under its own weight. Find the deflection d and the tenacity t (assumed uniform throughout).

66. A length 270 ft. of wire 1 sq. in. in section and of sp. gr. 7.8 is subjected to the above conditions. Find the tenacity of the wire and the deflection, the coefficient of elasticity, E , being 25,300,000 lbs.

67. A brick wall 2 ft. thick, 12 ft. high, and weighing 112 lbs. per cu. ft. is supported upon solid pitch-pine columns 9 in. in diameter, 10 ft. in length, and spaced 12 ft. centre to centre. Find the compressive unit stress in the columns (1) at the head; (2) at the base. The timber weighs 50 lbs. per cu. ft. *Ans.* 507.03 lbs.; 510.5 lbs.

68. If the crushing stress of pitch-pine is 5300 lbs. per sq. in. and the factor of safety 10, find the height to which the wall may be built.

Ans. 12.46 ft.

69. Determine the diameter of the wrought-iron columns which might be substituted for the timber columns in question 67, allowing a working stress in the metal of 7500 lbs. per sq. in. *Ans.* 2.36 in.

70. Find the greatest length of an iron suspension-rod which will carry its own weight, the stress being limited to 4 tons per sq. in. What will be the extension under this load, E being 12,500 tons?

Ans. 2688 ft.; .860 ft.

71. A horizontal cast-iron bar 1 ft. long exactly fits between two vertical plates of iron. How much should its temperature be raised so that it might remain supported between the plates by the friction, the coefficient of friction being $\frac{1}{3}$? *Ans.* $\frac{1}{16}^{\circ}$ F.

72. The fly-wheel of a 40 H. P. engine, making 50 revolutions per minute, is 20 ft. in diameter and weighs 12,000 lbs. What is its kinetic energy?

If the wheel gives out work equivalent to that done in raising 5000 lbs. through a height of 4 ft., how much velocity does it lose?

The axle of the fly-wheel is 12 in. in diameter. What proportion of the H. P. is required to turn the wheel, the coefficient of friction being .08?

If the fly-wheel is disconnected from the engine when it is making 50 revolutions per minute, how many revolutions will it make before it comes to rest?

Ans. 511,260.4 ft.-lbs.; 1.04 ft. per sec.; $\frac{1}{3}$ ths; 169.4.

73. The velocity of flow of water in service-pipe 48 ft. long is 64 ft. per sec. If the stop-valve is closed in $\frac{1}{3}$ of a sec., find the increase of pressure near the valve. *Ans.* 375 lbs. per sq. in.

74. Work equivalent to 50 ft.-lbs. is done upon a bar of constant sectional area, and produces in it a uniform tensile stress of 10,000 lbs. per sq. in. Find the cubic content of the bar, E being 30,000,000.

Ans. 360 cu. in.

75. A fly-wheel weighs 20 tons and its radius of gyration is 5 ft. How

much work is given out while the speed falls from 60 to 50 revolution per minute?

Ans. $94\frac{3}{4}$ ft.-tons

76. The resilience of an iron bar 1 sq. in. in section and 20 ft. long is 30,000 ft.-lbs. What would be the resilience if for 19 ft. of its length it was composed of iron 2 sq. in. in section, the remaining foot being the same size as before?

Ans. 15,750 ft.-lbs.

77. A particle under the action of a number of forces moves with a uniform velocity in a straight line. What condition must the forces fulfil?

Ans. Equilibrium.

78. Determine the constant effort exerted by a horse which does 1,650,000 ft.-lbs. of work in one hour when walking at the rate of 2½ miles per hour.

Ans. 125 lbs.

79. A train is drawn by a locomotive of 160 H. P. at the rate of 60 miles an hour against a resistance of 20 lbs. per ton. What is the gross weight of the train?

Ans. 50 tons.

80. A train of 292½ tons is drawn up an incline of 1 in 75, 5½ miles long, against a resistance of 10 lbs. per ton, in ten minutes. Find the H. P. of the engine. The speed on the level, the engine exerting 769.42 H. P., is 43.4 miles per hour. What is the resistance in pounds per ton?

Ans. 1027 H. P.; 22.7 lbs. per ton.

81. The dead load upon a short hollow cast-iron pillar with a sectional area of 20 sq. in. is 50 tons (of 2000 lbs.). If the strain in the metal is not to exceed .0015, find the greatest live load to which the pillar might be subjected, E being 17,000,000 lbs.

Ans. 205,000 lbs.

82. A steel suspension-rod 30 ft. in length and ½ sq. in. in sectional area carries 3500 lbs. of the roadway and 3000 lbs. of the live load. Determine the gross load and also the extension of the rod, E being 35,000,000 lbs.

Ans. $3\frac{57}{100}$ ft.

83. A steel rod 10 ft. in length and ¼ sq. in. in sectional area is strained to the proof by a tension of 25,000 lbs. Find the resilience of the rod, E being 35,000,000 lbs.

Ans. 178½ ft.-lbs.

84. What form does the useful work done by a hammer take when a nail is driven into any material? What becomes of the rest of the energy of the mass of the hammer after striking the blow?

85. A hammer weighing 2 lbs. strikes a steel plate with a velocity of 10 ft. per sec., and is brought to rest in .0001 sec. What is the average force on the steel?

Ans. 6250 lbs.

86. A hammer weighing 10 lbs. strikes a blow of 10 ft.-lbs. and drives a nail .5 in. into a piece of timber. Find the velocity of the hammer at the moment of contact, and the mean resistance to entry. Also find the steady pressure that will produce the same effect as the hammer.

Ans. 8 ft. per sec.; 240 lbs.; 480 lbs.

87. When a nail is driven into wood, why do the blows seem to have little if any effect unless the wood is backed up by a piece of metal or stone?

88. In Question 86, taking the weight of the nail to be 4 oz. and the weight of the piece of timber to be 100 lbs., find the depth and time of the penetration (*a*) when the timber is fixed; (*b*) when the timber is free to move.

Also in case (*b*) find the distance through which the timber moves.

$$\text{Ans.}-(a) \frac{2}{3} \text{ in.}; \frac{1}{8} \text{ sec.}$$

$$(b) .44245 \text{ in.}; .0009448 \text{ sec.}; .04113 \text{ in}$$

89. Show that the greater part of the energy of impact is expended in local damage at high velocities, and in straining the impinging bodies as a whole at low velocities.

90. A pile-driver of 300 lbs. falls 20 ft., and is stopped in $\frac{1}{10}$ sec. What is the average force exerted on the pile? Ans. 3344 lbs.

91. A weight falls 16 ft. and does 2560 ft.-lbs. of work upon a pile which it drives 4 in. against a uniform resistance. Find the weight of the ram, and the resistance. Ans. 160 lbs.; 7680 lbs.

92. A pitch-pine pile 14 in. square is 20 ft. above ground, and is being driven by a falling weight of 112 lbs. If $E = 1,500,000$ lbs., find the fall so that the inch-stress at the head of the pile may be less than 800 lbs.

Supposing that the pile sinks 2 in. into the ground, by how much would it be safe to increase the fall?

$$\text{Ans. } 7.456 \text{ ft.}; 116.5 \text{ ft.}$$

93. A weight of W_1 tons falls h ft., and by n successive instantaneous blows drives an inelastic pile weighing W_2 tons a ft. into the ground. Assuming the pile and weight to be inelastic, find (*a*) the mean effective resistance of the ground.

If the ground-resistance increases directly as the depth of penetration, find (*b*) how far the pile will sink under the r th blow. If the head of the pile is crushed for a length of x ft., x being very small as compared with the depth $\frac{a}{n}$ of penetration, find (1) the mean thrust, during the blow, between the weight and hammer; (2) the time of penetrating the ground; (3) the time during which the blow acts.

$$\text{Ans.}-(a) \frac{W_1^2}{W_1 + W_2} \frac{nh}{a} + (W_1 + W_2); (b) \{rt - (r-1)t\} \frac{a}{\sqrt{nh}}$$

$$(1) \frac{W_1 W_2}{W_1 + W_2} \frac{h}{x}; (2) \frac{W_1 + W_2}{W_1} \frac{a}{4n \sqrt{h}}; (3) \frac{x}{4 \sqrt{h}}$$

94. An inelastic pile weighing 780 lbs. is driven $3\frac{1}{2}$ feet into the ground by 120 blows from a weight of 112 lbs. falling 30 ft. Find the

steady load upon the pile which will produce the same effect, assuming the ground-resistance to be (a) uniform; (b) proportional to the depth of penetration. If the resistance is uniform, how long (c) does each movement of the pile last? How many blows (d) are required to drive the pile the first half of the depth, viz., $1\frac{1}{2}$ ft., the ground-resistance being 7168 lbs.? How far (e) does the pile sink under the last blow?

Ans. (a) 14,336 lbs.; (b) 28,672 lbs.; (c) .0107 sec.; (d) 30;
(e) .0146 ft.

95. A steamer of 8000 tons displacement sailing due east at 16 knots an hour collides with a steamer of 5000 tons displacement sailing at 10 knots an hour. Find the energy of collision if the latter at the moment of collision is going (1) due west; (2) north-west; (3) north-east.

96. A hammer weighing 2 lbs. strikes a nail with a velocity of 15 ft. per sec., driving it in $\frac{1}{4}$ in. What is the mean pressure overcome by the nail?

Ans. 675 lbs.

97. A beam will safely carry 1 ton with a deflection of 1 in. From what height may a weight of 100 lbs. drop without injuring it, neglecting the effect of inertia?

Ans. 11.2 in.

98. A rifle-bullet .45 in. in diameter weighs 1 oz.; the charge of powder weighs 85 grains; the muzzle-velocity is 1350 ft. per sec.; the weight of the rifle is 9 lbs. Neglecting the twist determine the energy of 1 lb. of powder. If the bullet loses $\frac{1}{4}$ of its velocity in its passage through the air, find the average force of the blow on the target into which the bullet sinks $\frac{1}{4}$ in.

If there is a twist of 1 in 20 in., find the charge to give the same muzzle velocity, the length of the barrel being 33 in.

99. A leather belt runs at 2400 ft. per minute. Find how much its tension is increased by centrifugal action, the weight of leather being taken at 60 lbs. per cubic foot.

Ans. $20\frac{1}{2}$ lbs. per sq. in.

100. Find the centrifugal force arising from a cylindrical crank pin 6 in. long and $3\frac{1}{2}$ in. in diameter the axis of the pin being 12 in. from the axis of the engine-shaft, which makes 100 revolutions per minute. How would you balance such a pin?

Ans. 55.02 lbs.

101. The pull on one of the tension-bars of a lattice girder fluctuates from 12.8 tons to 4 tons. If 24 tons is the statical breaking strength of the metal, 15 tons the primitive strength, determine the sectional area of the bar, 3 being a factor of safety.

Ans. 2.15 sq. in. (Launhardt);

1.87 sq. in. (Unwin).

102. The stress in a diagonal of a steel bowstring girder fluctuates from a tension of 15.15 tons to a compression of 7.65 tons. If the primitive strength of the metal is 24 tons and the vibration strength 12

tons, find the proper sectional area of the diagonal, 3 being a factor of safety. *Ans.* 2.53 sq. in. (Weyrauch);

1.7 sq. in. (Unwin), 40 tons per sq. in. being statical strength.

103. A wrought-iron screw-shaft is driven by a pair of cranks set at right angles. Neglecting the obliquity of the connecting-rods, and assuming that the pull on the crank-pin is constant, compare the coefficients of strength (a' and l) to be used in calculating the diameter of the shaft. How is the result affected by the stopping of the engine?

Ans. $a' = .82l$; $a' = \frac{3}{4}l$.

104. Taking $f = E\lambda$ as the ordinary analytical expression of Hooke's Law, find the value of the modulus of elasticity when calculated (1) from the *actual* stress and the elongation per unit of *initial* length; (2) from the actual stress and the elongation per unit of stretched length.

Ans. (1) $E + f$; (2) $E + f(1 + \lambda)^2 = E + f(1 + 2\lambda)$, if λ is small.

105. In a fly-wheel weighing 12,000 lbs. and making 50 revolutions per minute, the centre of gravity is *one seventeenth* of an inch out of the centre. Find the centrifugal force. *Ans.* 50.4 lbs.

106. In the preceding question, if the axis of rotation is inclined to the plane of the wheel at an angle $\cot^{-1}.001$, find the centrifugal couple, the radius of gyration being 10 ft. *Ans.* 1028.9 ft.-lbs.

107. A cylinder and a ball each of radius R start from rest and roll down an inclined plane without slipping. If V is the velocity of translation after descending through a vertical distance h , show that

$$V^2 = \frac{3}{4}(2gh) \text{ in the case of the cylinder,}$$

and

$$V^2 = \frac{5}{4}(2gh) \text{ in the case of the ball.}$$

108. A wheel having an initial velocity of 10 ft. per sec. ascends an incline of 1 in 100. How far will the wheel run along the incline, neglecting friction? $g = 32.2$. *Ans.* 232.9 ft.

109. A wrought-iron fly-wheel 10 ft. in diameter makes 63 revolutions per minute. Find the intensity of stress on a transverse section of the rim, disregarding the influence of the arms. If the wheel, which weighs W lbs., gives out work equivalent to that done in raising W through a height of $5\frac{1}{4}$ ft. in 1 sec., what velocity will it lose? If the axle of the wheel is 10 in. in diameter and if .08 is the coefficient of friction, show that it will take $\frac{W}{2500}$ H. P. to turn the wheel. ($g = 32.2$)

Ans. 16,335 lbs.; 5.6 ft. per sec.

110. If the earth be assumed to be spherical, how much heat would be developed if its axial rotation were suddenly stopped, a unit of heat corresponding to 778 ft.-lbs.?

Weight of mass of earth = $10^{21} \times 6.029$ tons; diameter of earth = 8000 miles.

111. A body weighing 50 lbs. is projected along a rough horizontal plane, the velocity of projection being 100 ft. per sec. What amount of work will have been expended when the body comes to rest? $g = 32.2$.

If the coefficient of friction is $\frac{1}{4}$, how much work is done against friction in 4 secs., and in what time will the body come to rest? $g = 32.2$.

Ans. 7763.9 ft.-lbs.; 2298 $\frac{1}{2}$ ft.-lbs; 24 $\frac{1}{11}$ secs.

112. A chain l ft. in length and a sq. in. in sectional area has one end securely anchored, and suddenly checks a weight of W lbs. attached to the other end, and moving with a velocity of V ft. per sec. away from the anchorage. Find the greatest pull upon the chain.

$$\text{Ans. Pull} = V\sqrt{\frac{aEW}{lg}}$$

113. Apply this result to the case of a wagon weighing 4 tons and worked from a stationary engine by a rope 3 sq. in. in sectional area. The wagon is running down an incline at the rate of 4 miles an hour, and, after 600 ft. of rope have been paid out, is suddenly checked by the stoppage or reversal of the engine ($E = 15,000,000$ lbs.).

Ans. 26,884 lbs.

114. A chain l ft. in length and a sq. in. in sectional area has one end attached to a weight of W lbs. at rest, and at the other end is a weight of nW lbs. moving with a velocity of V ft. per second and away from the first. Find the greatest pull on the chain.

$$\text{Ans. Pull} = V\sqrt{\frac{aEWn}{lg(n+1)}}$$

115. A dead weight of 10 tons is to act as a drag upon a ship to which it is attached by a wire rope 150 ft. in length and having an effective sectional area of 8 sq. in. If the velocity of the floating ship is 20 ft. per second, and if its inertia is equivalent to a mass of 390 tons, find the greatest pull on the chain ($E = 15,000,000$ lbs.).

Ans. 208 tons.

116. (a) A train weighing 160 tons (of 2240 lbs.) travels at 30 miles an hour against a resistance of 10 lbs. per ton. What H. P. is exerted?

(b) With the same H. P. what will be the speed up a gradient of 1 in 100?

(c) If the steam is shut off, how far will the train run before stopping (1) on the incline; (2) on the level?

(d) If the draw-bar suddenly breaks, in what distance would the carriages (100 tons in weight) be stopped if the brakes are applied immediately the fracture occurs, the weight of the brake-van being 20 tons and the coefficient of friction .2?

(e) If the engine (weight = 60 tons) continued to exert the same power after the fracture, what would be its ultimate speed?

(f) What resistance would be required to stop the whole train after steam is shut off, in 1000 yards on the level?

Ans. (a) 128; (b) $9\frac{3}{7}$ miles per hour; (c) (1) 199.2 ft., (2) 6776 ft.; (d) 680.3 ft. on the level, 52.9 ft. on the incline; (e) 80 miles an hour on the level, 24.6 miles on the incline; (f) 22.58 lbs. per ton.

117. A 4-in. \times 3-in. diameter crank-pin is to be balanced by two weights on the same side of the crank; the length of the crank is 12 in.; the engine makes 100 revolutions per minute; the distance of the C. of G. of each weight from the axis of the shaft is 6 in. Find the weights.

118. A shaft is worked with cranks at 120° . Assuming the pressure on the crank-pin to be horizontal and constant in amount, compare the coefficients of actual and ultimate strength to be used in calculating the diameter of the shaft.

Ans. $a' = .507l$.

119. In a horizontal marine engine with two cranks at right angles distant 8 ft. from one another, weight of reciprocating parts attached to each crank is 10 tons, revolutions 75 per minute, stroke 4 ft. Find the alternating force and couple due to inertia.

Ans. 54.2 tons; 216.8 ft.-tons.

120. An inside-cylinder locomotive is running at 50 miles an hour; the driving-wheels are 6 ft. in diameter; the distance between the centre-lines of the cylinders is 30 in., the stroke 24 in., the weight of one piston and rod 300 lbs., and the horizontal distance between the balance-weights $4\frac{1}{2}$ ft.; the diameter of the weight-circle is $4\frac{1}{2}$ ft. Find the alternating force and couple, and also the magnitude and position of suitable balance-weights.

Ans. 7871 lbs; 9839 ft.-lbs.; 106.5 lbs.; $27\frac{1}{4}^\circ$.

121. The pressure equivalent to the weight of the reciprocating parts of an engine is 3 lbs. per sq. in.; the stroke is 36 in.; the number of revolutions per minute is 45; the back-pressure is 2 lbs. per sq. in.; the absolute initial steam-pressure is 60 lbs. per sq. in.; the rate of expansion is 3. Find the pressure necessary to start the piston, and also the effective pressure at each $\frac{1}{2}$ of the stroke.

122. An engine with a 24-in. cylinder and a connecting-rod = six cranks = 6 ft., makes 60 revolutions per minute. Show that the pressure required to start and stop the engine at the dead-points = $\frac{1}{4}$ of the weight of reciprocating parts.

123. Find the ratio of thrust at cross-head to tangential effort on crank-pin when the crank is 45° from the line of stroke, the connecting-rod being = four cranks.

124. Draw the linear diagram of crank-effort in the case of single crank, the connecting-rod being = four cranks. Assume the resistance uniform and a constant pressure of 9000 lbs. on the piston, the stroke being 4 ft. and the number of revolutions per minute 55. Also find the fluctuation of energy in ft.-lbs. for one revolution.

125. An engine with a connecting-rod = six cranks = 6 ft. receives steam at 70 lbs. pressure per sq. in., and cuts off at *one-quarter* stroke. Find the crank-effort when the piston has travelled *one-third* of its forward stroke. Diameter of piston = 2 ft. Also find the position of the piston where its velocity is a maximum.

126. Data: Stroke = 3 ft. ; number of revolutions per minute = 60 ; cut-off at one-half stroke ; initial pressure = 56 lbs. per sq. in. absolute ; diameter of piston = 10 in. ; weight of reciprocating parts = 550 lbs. ; back-pressure = $1\frac{1}{2}$ lbs. per sq. in. absolute. Find the effective pressure at each fourth of the stroke, taking account of the inertia of the piston. Also find the pressure equivalent to *inertia* at commencement of stroke.

127. A pair of 250 H. P. engines, with cranks at 90° , and working against a uniform resistance and under a uniform steam-pressure, are running at 60 revolutions per minute. Assuming an indefinitely long connecting-rod, find the maximum and minimum moments of crank-effort, the fluctuation of energy, and the coefficient of energy.

128. An inside-cylinder locomotive runs at 25 miles per hour ; its drivers are 60 in. in diameter ; the stroke is 24 in. ; the distance between the centre-lines of the cylinders = 30 in. ; weight of reciprocating parts = 500 lbs. ; horizontal distance between balance-weights = 59 in. ; diameter of weight-circle = 42 in. Find the alternating force, alternating couple, and the magnitude and position of suitable balance-weights.

Ans. 226.8 lbs. ; 4113.8 ft.-lbs. ; $\phi = 26^\circ$.

129. Draw a diagram of crank-effort for a single crank, the connecting-rod being equal to *four* cranks, the stroke 4 ft., and the number of revolutions per minute 55. Assume a uniform resistance and a constant pressure of 9000 lbs. on the piston.

130. A vertical prismatic bar of weight W_1 , sectional area A , and length L has its upper end fixed, and carries a weight W_2 at the lower end. Find the amount and work of the elongation.

$$\text{Ans. Ext.} = \frac{L}{EA} \left(\frac{W_1}{2} + W_2 \right); \text{ work} = \frac{1}{2} \frac{L}{EA} \left(\frac{W_1^2}{3} + W_1 W_2 + W_2^2 \right).$$

131. A right cone of weight W and height h rests upon its base of radius r . Find the amount and work of the compression.

$$\text{Ans. Comp.} = \frac{Wh}{2\pi Er^2}; \text{ work} = \frac{1}{5} \frac{W^2 h}{\pi Er^2}.$$

132. A tower of height h , in the form of a solid of revolution about a vertical axis, carries a given *surchage*. If the specific weight of the

material of the tower is w , and the radius of the base a , determine the curve of the generating line so that the stress at every point of the tower may be f . If the surcharge is zero and the height of the tower becomes infinite, show that its volume remains finite.

$$\text{Ans. } y = ae^{-\frac{wx}{f}}; \text{ vol. of tower of infinite height} = \frac{f}{w}\pi a^3.$$

133. Determine the generating curve when the tower in the last question is hollow, the hollow part being in the form of a right cylinder upon a circular base of given radius R .

$$\text{Ans. } y^2 - R^2 = (a^2 - R^2)e^{-\frac{wx}{f}}.$$

134. A heavy vertical bar of length l and specific weight w is fixed at its upper end and carries a given weight W at the lower end. Determine the form of the bar so that the horizontal sections may be proportionate to the stress f to which they are subjected. (*Note.*—Such a bar is a bar of uniform strength.)

$$\text{Ans. Sectional area at distance } x \text{ from origin} = \frac{W}{f}e^{\frac{w}{f}(l-x)}.$$

135. Find the upper and lower sectional areas of a steel shaft of uniform strength, 200 ft. in length, which will safely sustain its own weight and 100 tons, 7 tons per sq. in. being the working stress. (1 ton = 2240 lbs.)

$$\text{Ans. } 14.3 \text{ sq. in.}; 15 \text{ sq. in.}$$

136. A vertical elastic rod of natural length L and of which the mass may be neglected, is fixed at its upper end and carries a weight W_1 at the lower end. A weight W_2 falls from a height h upon W_1 . Find the velocity and extension of the rod at any time t .

$$\text{Ans. } v^2 = \frac{g}{W_1 + W_2} \left(2W_2h - \frac{EA}{L}x^2 \right) = \left(\frac{dx}{dt} \right)^2,$$

x being measured from mean position of $(W_1 + W_2)$.

137. Determine the functions F and f in Art. 24 when P_1 is zero, and also when the rod is perfectly free; i.e., when $P_0 = 0$ and $P_1 = 0$.

138. An elastic trapezoidal lamina $ABCD$, of natural length l and thickness unity, has its upper edge AB ($2a$) fixed and hangs vertically. If a weight W is suspended from the lower edge CD ($2b$), show that, neglecting the weight of the lamina, the consequent elongation

$$= \frac{1}{2} \frac{W}{E} \frac{l}{a-b} \log_e \frac{a}{b}.$$

If an additional weight is placed upon W and then suddenly removed, show that the oscillation set up is isochronous

$$\text{and that the time of a complete oscillation} = \pi \left\{ \frac{Wl \log_e \frac{a}{b}}{2gE(a-b)} \right\}^{\frac{1}{2}},$$

Examine the case when $a = b$.

$$\text{Ans. Ext.} = \frac{1}{2} \frac{Wl}{aE}; \text{ time of oscillation} = \pi \sqrt{\frac{Wl}{2aEg}}.$$

139. If the specific weight of the lamina in the preceding question is w , find how much it will stretch under its own weight, and also the work of extension. Determine the result when $a = b$.

$$\text{Ans. } \frac{1}{2E} \frac{wb^2l^2}{(a-b)^2} \log_e \frac{b}{a} + \frac{wl^2}{4E} \frac{a+b}{a-b}; \frac{wl^2}{2E}.$$

$$\text{Work} = \frac{w^2l^3}{4E(a-b)^2} \left\{ \frac{a^4 - b^4}{4} - b^2(a^2 - b^2) + b^4 \log_e \frac{a}{b} \right\}; \frac{w^2al^3}{3E}.$$

140. An elastic lamina in the form of an isosceles triangle ABC has its base $AB (= 2a)$ fixed and hangs vertically. If its weight is W , find its elongation. Take coefficient of elasticity $= E$, thickness of lamina $=$ unity, and L the distance of C from AB .

$$\text{Ans. } \frac{WL}{4aE}.$$

141. A metal rod $\frac{1}{4}$ sq. in. in area and 5 ft. long hangs vertically with its upper end fixed and carries a weight of 18 lbs. at the lower end. On striking the rod it emitted a musical note of 264 vibrations per second (middle C of piano-forte). Find the coefficient of elasticity, the weight of the rod being neglected.

$$\text{Ans. } 30,979,160 \text{ lbs.}$$

142. Diameter of a pipe is 18 in. ; at one point it is curved to an arc of 6 ft. radius. Water flows round the curve with a velocity of 6 ft. per second. Determine the centrifugal force per foot of length of bend measured along the axis.

$$\text{Ans. } 20,717 \text{ lbs.}$$

143. A disk of weight W and area A sq. ft. makes n revolutions per second about an axis through its centre, inclined at an angle θ to the normal to the plane of the disk. Find the centrifugal couple.

$$\text{Ans. } \frac{WAN^2}{5.12} \tan \theta \text{ ft.-lbs.}$$

144. In a circular pipe of internal radius r and thickness t , a column of water of length l , flowing with a velocity due to the head h , is suddenly checked. Show that

$$gh = \frac{E\lambda^2}{r} \left\{ 1 + \frac{1}{2} \frac{t}{r} \left(1 + \frac{E}{E_1} \right) + \frac{t^2}{r^2} \right\},$$

E being the coefficient of elasticity of the material of the pipe, E_1 the coefficient of compressibility of the water, and λ the extension of the pipe circumference corresponding to E .

145. A heavy ball attached by a string to a fixed point O revolves in a horizontal circle with a given uniform angular velocity ω . Find the vertical depth of the centre of the ball below the point of attachment.

If a uniform rod be substituted for the ball and string, find its position.

Also find the position when the ball is attached to the fixed point by

a uniform rod; r being the ratio of the weight of the rod to the weight of the ball.

$$\text{Ans. } h = \frac{g}{\omega^2}; \quad h = \frac{3}{2} \frac{g}{\omega^2}; \quad h = \frac{g}{\omega^2} \frac{1 + \frac{r}{2}}{1 + \frac{r}{3}}$$

146. The deflection of a truss of l ft. span is $l \times .001$ under a stationary load W . What will be the increased pressure due to centrifugal force when W crosses the bridge at the rate of 60 miles an hour?

$$\text{Ans. } \frac{242}{125} \frac{W}{l}$$

147. A fly-wheel 20 ft. in diameter revolves at 30 revolutions per minute. Assuming weight of iron 450 lbs. per cu. ft., find the intensity of the stress on the transverse section of the rim, assuming it unaffected by the arms.

$$\text{Ans. } 96 \text{ lbs. per sq. in.}$$

148. Assuming 15,000 lbs. per sq. in. as the tensile strength of cast-iron, and taking 5 as a factor of safety, find the maximum working speed and the bursting speed for a cast-iron fly-wheel of 20 ft. mean diameter and weighing 24,000 lbs., the section of the rim being 160 sq. in.

149. A 60-in. driving-wheel weighs $3\frac{1}{2}$ tons, and its C. of G. is 1 in. out of centre. Find the greatest and the least pressure on the rails.

150. A wheel of weight W , radius of gyration k , and making n revolutions per second on an axle of radius R , comes to rest after having made N revolutions. Find the coefficient of friction.

$$\text{Ans. } \sin \phi = \frac{\pi n^2 k^2}{Ng}, \text{ and coeff. of fric.} = \tan \phi.$$

151. A train starts from a station at A and runs on a level to a station at B , l ft. away. If the speed is not to exceed v ft. per sec., show that the time between the two stations is

$$\frac{l}{v} + \frac{Wv}{g} \frac{P+B}{(P-R)(B+R)},$$

W being the gross weight of the train, P the mean uniform pull exerted by the engine, R the road resistance, and B the retarding effect of the brakes.

Also, if the speed is not limited, show that the *least* time in which the train can run between the specified points is

$$\sqrt{2l \frac{W}{g} \frac{P+B}{(P-R)(B+R)}} \text{ sec.,}$$

and that the *maximum* speed attained is

$$\sqrt{\frac{2gl(P-R)(B+R)}{W(P+B)}} \text{ ft. per sec.}$$

152. A locomotive capable of exerting a uniform pull of 2 tons, with a 24-in. stroke, 20-in. cylinder, and 60-in. driving-wheels, hauls a train between two stations 3 miles apart. The gross weight of the train and locomotive = 200 tons; the road resistance = 12 lbs. per ton (of 2000 lbs.); the brakes, when applied, press with two thirds of the weight on the wheels of the engine and brake-van, viz., 90 tons, the coefficient of friction being .18. Find (a) the least time between the stations; (b) the distance in which the train is brought to rest; (c) the maximum speed attained; (d) the pressure of the steam; (e) the weight upon the driving-wheels.

Ans.—(a) 513.8 sec.; (b) 990 ft.; (c) 42 miles per hour; (d) 25 lbs. per sq. in.; (e) $11\frac{1}{2}$ tons.

153. If the speed in the last question is limited to 30 miles an hour, find (a) the time between the stations; (b) the distance in which the train is brought to rest; (c) the distance traversed at 30 miles an hour.

Ans.—(a) $543\frac{1}{2}$ sec.; (b) $504\frac{1}{2}$ ft.; (c) 7773 $\frac{1}{2}$ ft.

154. If the steam-pressure in the above locomotive is increased to 50 lbs. per sq. in., find (a) the weight of the heaviest train which can be hauled between the stations in 10 minutes, the road-resistance being 20 lbs. per ton (of 2000 lbs.) and the braking power being sufficient to bring the train to rest in a distance of 720 ft.

Also find (b) the braking power; (c) the weight thrown upon the drivers, the coefficient of friction being $\frac{1}{4}$; (d) the maximum speed attained.

Ans.—(a) $310\frac{1}{2}$ tons; (b) 15.6 tons; (c) 24 tons; (d) 36 miles per hour.

155. The weight upon the driving-wheels (D in. in diameter) of a locomotive is W tons; the adhesion = *one fifth*; the cylinders have a diameter of d in. and a stroke of l in. Find the steam-pressure required to skid the wheels.

Ans. $400\frac{WD}{d^2l}$ lbs. per sq. in.

156. Two trains, each with a brake-power of 190 lbs. per ton (of 2000 lbs.), run between Montreal and Toronto, a distance of 333 miles, against an average resistance of 10 lbs. per ton. One train runs through, and the other stops at N intermediate stations. Show that the saving of fuel in the former is $\frac{9N}{25}$ per cent; the speed is not to exceed 30 miles per hour.

157. If the end of a railway wagon exposes a surface of 6×4 ft. to the wind, what is the greatest gradient up which a 20 lb. to the sq. ft. gale will drive it? Take the weight at 10 tons, the friction 10 lbs. per ton.

Ans. 1 in 59.

158. A locomotive and tender weigh 70 tons, of which 26 tons are carried by the driving-wheels. Taking the adhesion at $\frac{1}{4}$, friction 10 lbs. per ton, what maximum gradient can the engine ascend?

Ans. 1 in 16.

159. Given a locomotive with two 18" x 26" cylinders, the connecting-rod = 6 ft., the boiler-pressure = 140 lbs., and driving-wheels of 7' 0" diameter, calculate the adhesion-friction, i.e., the ratio $\frac{\text{force at periphery}}{\text{weight on drivers}}$.

160. A railway wagon weighing 20 tons, with two pairs of wheels 8' 0" centre to centre, and with its centre of inertia 7' 0" above top of rails, has its wheels skidded while running. Take $\mu = 0.15$. Required the total retarding force and pressure of each wheel.

Ans. 7.375; 12.625, and 3 tons on rail.

161. Find (a) the least time in which a locomotive exerting a uniform pull of P tons can haul a train weighing W tons between two stations l ft. apart on an incline of 1 in m , the brake-power being B tons and the road-resistance R tons.

Also find (b) the time between stations when the speed is limited to v ft. per sec.

$$\text{Ans.}-(a) \sqrt{2W \frac{l}{g} \frac{P+B}{(P-A)(B+A)}}; (b) \frac{l}{v} + \frac{Wv}{2g} \frac{P+B}{(P-A)(B+A)},$$

where $A = R + \frac{W}{m}$.

162. A locomotive exerting a uniform pull of 4 tons hauls a train of 200 tons up an incline of 1 in 200, between two stations 2 miles apart, the greatest allowable speed being 30 miles an hour. If the road-resistance is 10 lbs. per ton (of 2000 lbs.), and if the brakes are capable of exerting a pressure of 100 tons, the adhesion being *one fifth*, find (a) the time between the stations; (b) the distance in which the train is brought to rest; (c) the distance traversed at 30 miles.

Also, if the speed is not limited to 30 miles, find (d) the least time in which the distance can be accomplished; (e) the maximum speed attained; (f) the distance in which the train is brought to rest.

Ans.—(a) 5½ min.; (b) 275 ft.; (c) 7260 ft.; (d) 4.87 min.;
(e) 53.8 miles per hour; (f) 880 ft.

163. With the same brake-power, adhesion, and road-resistance, find the weight of the heaviest train which the locomotive in the preceding question, exerting the uniform pull of 4 tons, can haul between the two stations in 6 minutes.

Ans. 360 tons.

164. If the locomotive has 60-in. drivers and 24-in. x 20-in. diameter cylinders, find the weight required upon the drivers when the steam-pressure is 50 lbs. per sq. in.

Ans. 20 tons.

CHAPTER IV.

STRESSES, STRAINS, EARTHWORK AND RETAINING-WALLS.

1. Internal Stresses.—The application of external forces to a material body will strain or deform it, and the particles of the body will be in a state of mutual stress.

In the following calculations it is assumed :

(a) That the stresses under consideration are parallel to one and the same plane, viz., the plane of the paper.

(b) That the stresses normal to this plane are constant in direction and magnitude.

(c) That the thickness of the plane is unity.

Def. The angle between the direction of a given stress and the normal to the plane on which it acts is called the obliquity of the stress.

2. Simple Strain.—The solid $ABCD$ (Fig. 207) of uniform transverse section A is acted upon in the direction of its length by a force P uniformly distributed over its end,

producing an intensity of stress $\frac{P}{A} = p$. At any

other transverse section mn the intensity must be the same in order that equilibrium may be maintained.

Draw an oblique plane $m'n'$, inclined at an angle θ to the axis. The total stress on $m'n' = P$ and necessarily acts in the direction of the axis.

The intensity of the stress on $m'n' = \frac{P}{m'n'} =$

$\frac{P}{mn \operatorname{cosec} \theta} = \frac{P}{A} \sin \theta = p \sin \theta$. The normal component of the intensity on $m'n' = p \sin^2 \theta = p_n'$.

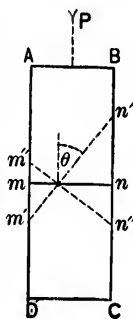

FIG. 207.

The tangential component or shear on $m'n'$

$$= p \sin \theta \cos \theta = p'_t.$$

So, if $m''n''$ is an oblique plane perpendicular to $m'n'$, the normal component of the intensity on $m''n'' = p \cos^2 \theta = p''_n$.

The tangential component or shear on $m''n''$

$$= p \cos \theta \sin \theta = p''_t.$$

$$\therefore p''_n + p''_t = p \quad \text{and} \quad p'_t = p''_t = p \sin \theta \cos \theta = \frac{p \sin 2\theta}{2}.$$

The shear is evidently a maximum when $2\theta = 90^\circ$ or $\theta = 45^\circ$.

3. Compound Strain.—(a) First consider an indefinitely small rectangular element $OACB$ (Fig. 208) of a strained body, kept in equilibrium by stresses acting as in the figure.

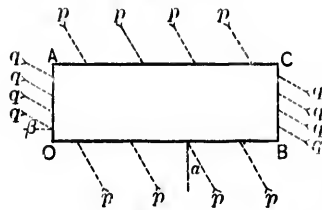

FIG. 208.

p is the intensity of stress on the faces OB, AC , and α its obliquity.

q is the intensity of stress on the faces OA, BC , and β its obliquity.

$OB \cdot p \cos \alpha$, the total normal stress on OB , is balanced by $AC \cdot p \cos \alpha$, the total normal stress on AC .

$OB \cdot p \sin \alpha$, the total shear on OB , is equal in magnitude but opposite in direction to $AC \cdot p \sin \alpha$, the total shear on AC .

These two forces, therefore, form a couple of moment $OB \cdot p \sin \alpha \cdot OA$.

Similarly, the total normal stresses on the faces OA, BC balance and the total shears form a couple of moment $OA \cdot q \sin \beta \cdot OB$.

In order that equilibrium may be maintained the two couples must balance.

$$\therefore OB \cdot p \sin \alpha \cdot OA = OA \cdot q \sin \beta \cdot OB,$$

or

$$p \sin \alpha = q \sin \beta = t, \text{ suppose.}$$

Hence, at any point of a strained body, the intensities of the shears on any two planes at right angles to each other are equal.

(b) Next consider an indefinitely small triangular element OAB (Fig. 209) of the strained body, bounded by a plane AB and two planes OA, OB at right angles to each other.

Let p be the intensity of stress on OB , α its obliquity.

Let q be the intensity of stress on OA , β its obliquity.

Let t be the intensity of shear on each of the planes OA, OB . Then

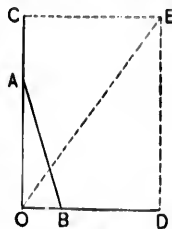

FIG. 209.

$$t = p \sin \alpha = q \sin \beta.$$

$$p_n, \text{ the normal component of } p, = p \cos \alpha.$$

$$q_n, \text{ " " " " } q, = q \cos \beta.$$

Produce OA and take $OC = p_n \cdot OB + t \cdot OA =$ the total force on OB in the direction of OA .

Produce OB , and take $OD = q_n \cdot OA + t \cdot OB =$ the total force on OA in the direction of OB .

Complete the rectangle CD .

OE represents in direction and magnitude the resultant of the two forces OC, OD , and must therefore be equal in magnitude and opposite in direction to the total stress on AB .

Let p_r be the intensity of stress on AB . Then

$$(p_r \cdot AB)^2 = OE^2 = OC^2 + OD^2 = (p_n \cdot OB + t \cdot OA)^2 + (q_n \cdot OA + t \cdot OB)^2;$$

$$\text{or } p_r^2 = p_n^2 \left(\frac{OB}{AB}\right)^2 + q_n^2 \left(\frac{OA}{AB}\right)^2 + 2t \frac{OA \cdot OB}{AB^2} (p_n + q_n) + t^2.$$

Let γ be the angle between AB and OA . Then,

$$p_r^2 = p_n^2 \sin^2 \gamma + q_n^2 \cos^2 \gamma + 2t \sin \gamma \cos \gamma (p_n + q_n) + t^2.$$

This gives the intensity of stress on any plane AB inclined at an angle γ to OA , and in the limit AB is a plane through O .

EXAMPLE.—Consider an indefinitely small triangular element abc (Fig. 210) of a horizontal beam bounded by a plane

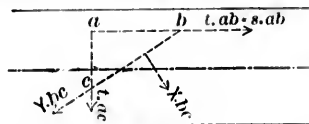

bc inclined at θ to the vertical, the horizontal plane ab , and the vertical plane ac .

The element abc is kept in equilibrium by the stress $p \cdot ac$ upon ac , the shear $s \cdot ab$ ($= t \cdot ab$) along ab , the shear $t \cdot ac$ along ac , and the stress developed in the plane bc . The weight of the element is neglected as being indefinitely small as compared with the forces to which it is subjected. Let the stress upon bc be decomposed into two components, the one $X \cdot bc$ normal and the other $Y \cdot bc$ tangential to bc .

Resolving perpendicular and parallel to bc ,

$$X \cdot bc = p \cdot ac \cos \theta - t \cdot ab \cos \theta - t \cdot ac \sin \theta$$

and

$$Y \cdot bc = p \cdot ac \sin \theta - t \cdot ab \sin \theta + t \cdot ac \cos \theta,$$

or

$$X = p \cos^2 \theta - t \sin 2\theta \dots \dots \dots (1)$$

and

$$Y = p \frac{\sin 2\theta}{2} + t \cos 2\theta \dots \dots \dots (2)$$

The value of θ for which X is a maximum is given by

$$\frac{dX}{d\theta} = 0 = -p \sin 2\theta - 2t \cos 2\theta, \text{ or } \tan 2\theta = -\frac{2t}{p}. \quad (3)$$

Substituting the value of θ in eq. 1, we have

$$\text{max. value of } X = \frac{p}{2} + \sqrt{\frac{p^2}{4} + t^2} \dots \dots (4)$$

The value of θ for which Y is a maximum is given by

$$\frac{dY}{d\theta} = 0 = p \cos 2\theta - 2t \sin 2\theta, \text{ or } \tan 2\theta = \frac{p}{2t}. \quad (5)$$

Substituting the value of θ in eq. (2), we have

$$\text{max. value of } Y = \sqrt{\frac{p^2}{4} + t^2}. \quad \dots \dots \dots (6)$$

Eq. (4) gives the maximum intensity of stress of the *same* kind as p . The maximum intensity of the opposite kind of stress is $\frac{p}{2} - \sqrt{\frac{p^2}{4} + t^2}$.

Eq. (6) gives the maximum intensity of shear.

The position of the planes of principal stress (see following article) is given by $\tan 2\theta = \frac{2t}{p}$.

Let θ_1, θ_2 be the values of θ for which X and Y are respectively maxima. Then

$$\tan 2\theta_1 \tan 2\theta_2 = -\frac{2t}{p} \frac{p}{2t} = -1,$$

and

$$\therefore \theta_1 - \theta_2 = 45^\circ.$$

Hence, at any point, the angle between the plane upon which the normal intensity of stress is a maximum and the plane upon which the tangential intensity of stress is a maximum, is equal to 45° .

Again, t is zero when $\theta_1 = 90^\circ$ or 0° , and p is zero when $\theta_1 = 45^\circ$.

Thus, the *curve of greatest normal intensity* cuts the neutral axis at an angle of 45° , one skin surface at 90° and the opposite at 0° , while the *curve of greatest tangential intensity* cuts the skin surfaces at 45° , and touches the neutral axis.

Fig. 211 serves to illustrate the curves of greatest normal intensity. There are evidently two sets of these curves, referring respectively to direct thrust and direct tension.

Fig. 212 illustrates the curves of greatest *tangential* intensity.

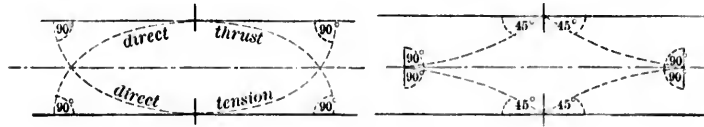

FIG. 211.

FIG. 212.

4. Principal Stresses.—Suppose that there is no shear on *AB*, Fig. 209, and that the stress is wholly normal.

In such a case *OE* must be perpendicular to *AB*.

$$\begin{aligned} \therefore \tan \gamma &= \cot COE = \frac{OC}{CE} = \frac{OC}{OD} = \frac{p_n \cdot OB + t \cdot OA}{q_n \cdot OA + t \cdot OB} \\ &= \frac{p_n \tan \gamma + t}{q_n + t \tan \gamma} \end{aligned}$$

$$\therefore \frac{2t}{q_n - p_n} = \frac{2 \tan \gamma}{1 - \tan^2 \gamma} = \tan 2\gamma. \quad \dots (7)$$

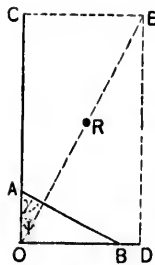

FIG. 213.

Two values of γ satisfy this equation, viz., γ and $\gamma + 90^\circ$.

Hence, at any point of a strained body, there are two planes at right angles to each other, on which the stress is wholly normal.

Such planes are called *planes of principal stress*, and the stresses themselves *principal stresses*.

5. Ellipse of Stress.—At any point of the strained body, consider a small triangular element *OAB* (Fig. 213), *OA* and *OB* being the planes of principal stress

Let p_1 be the principal stress normal to *OB*.

“ p_2 “ “ “ “ “ *OA*.

Complete the construction as before, and let ψ be the angle between OE and OC . Then

$$\left. \begin{aligned} \sin \psi &= \frac{CE}{OE} = \frac{OD}{OE} = \frac{p_2 OA}{p_r AB} = \frac{p_2}{p_r} \cos \gamma, \\ \cos \psi &= \frac{OC}{OE} = \frac{p_1 OB}{p_r AB} = \frac{p_1}{p_r} \sin \gamma; \end{aligned} \right\} \dots (8)$$

$$\therefore \cos \gamma = \frac{p_r \sin \psi}{p_2}, \quad \sin \gamma = \frac{p_r \cos \psi}{p_1}; \text{ and}$$

$$1 = \sin^2 \gamma + \cos^2 \gamma = \frac{(p_r \cos \psi)^2}{p_1^2} + \frac{(p_r \sin \psi)^2}{p_2^2} \dots (9)$$

Take OR to represent p_r in direction and magnitude.

Let X, Y be the co-ordinates of R with respect to O . Then

$$X = p_r \cos \psi, \quad Y = p_r \sin \psi,$$

and eq. (9) becomes

$$1 = \frac{X^2}{p_1^2} + \frac{Y^2}{p_2^2}, \dots (10)$$

the equation to an ellipse with its centre at O , and its axes (equal to $2p_1$ and $2p_2$) lying in the planes of principal stress. This ellipse is called the *ellipse of stress*, and the stress on any plane AB at O is the semi-diameter of the ellipse drawn in a direction making an angle ψ with the axis OC , ψ being given by

$$\tan \psi = \frac{p_2}{p_1} \cot \gamma. \quad (\text{Eq. (8).}) \dots (11)$$

6. Constant Components of p_r . — Take the planes of principal stress as planes of reference (Fig. 214).

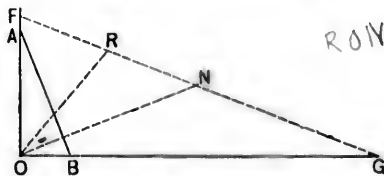

FIG. 214.

Draw ON perpendicular to AB , and take $ON = \frac{p_1 + p_2}{2}$.

Let the obliquity of $OR = \theta = RON = 90^\circ - \psi - \gamma$.

Join NR . Then

$$\begin{aligned} NR^2 &= OR^2 + ON^2 - 2OR \cdot ON \cos \theta \\ &= p_r^2 + \left(\frac{p_1 + p_2}{2}\right)^2 - p_r(p_1 + p_2) \sin(\psi + \gamma). \end{aligned}$$

But $p_r^2 = p_1^2 \sin^2 \gamma + p_2^2 \cos^2 \gamma$, and

$$\sin(\psi + \gamma) = \sin \psi \cos \gamma + \cos \psi \sin \gamma = \frac{p_2}{p_r} \cos^2 \gamma + \frac{p_1}{p_r} \sin^2 \gamma.$$

(See eqs. (8).)

$$\begin{aligned} \therefore NR^2 &= p_1^2 \sin^2 \gamma + p_2^2 \cos^2 \gamma + \left(\frac{p_1 + p_2}{2}\right)^2 \\ &\quad - (p_1 + p_2)(p_1 \sin^2 \gamma + p_2 \cos^2 \gamma) \\ &= \left(\frac{p_1 + p_2}{2}\right)^2 - p_1 p_2 = \left(\frac{p_1 - p_2}{2}\right)^2. \end{aligned}$$

$$\therefore NR = \frac{p_1 - p_2}{2}. \quad \dots \dots \dots (12)$$

Hence, the intensity of stress OR at any point O of the plane AOB is the resultant of two constant intensities

$$ON = \frac{p_1 + p_2}{2} \quad \text{and} \quad NR = \frac{p_1 - p_2}{2},$$

the former being perpendicular to the plane.

7. The Angle $ONR = 2\gamma$ or $180^\circ - 2\gamma$.

$$\frac{\sin ONR}{\sin \theta} = \frac{OR}{NR} = \frac{p_r}{\frac{p_1 - p_2}{2}}$$

But

$$\begin{aligned} \sin \theta &= \cos(\psi + \gamma) = \cos \psi \cos \gamma - \sin \psi \sin \gamma \\ &= \frac{p_1 - p_2}{p_r} \sin \gamma \cos \gamma = \frac{p_1 - p_2}{2p_r} \sin 2\gamma. \end{aligned}$$

$$\therefore \frac{\sin ONR}{\frac{p_1 - p_2}{2p_r} \sin 2\gamma} = \frac{p_r}{\frac{p_1 - p_2}{2}}$$

$$\therefore \sin ONR = \sin 2\gamma, \quad \text{and} \quad ONR = 2\gamma \text{ or } 180^\circ - 2\gamma. \quad (13)$$

Let NR (Fig. 214) produced in both directions meet OA in F and OB in G .

$$\begin{aligned} \text{The angle } OFN &= 180^\circ - ONR - NOF \\ &= 180^\circ - 2\gamma - (90^\circ - \gamma) = 90^\circ - \gamma = FON. \end{aligned}$$

$$\therefore NF = NO: \quad \text{so,} \quad NG = NO = NF.$$

$$\therefore N \text{ is the middle point of } FG.$$

Also

$$RF = FN - NR = ON - NR = p_1$$

and

$$RG = RN + NG = RN + ON = p_2.$$

N. B.—The shear at O

$$= \frac{p_1 - p_2}{2} \cos(2\gamma - 90^\circ) = (p_1 - p_2) \sin \gamma \cos \gamma.$$

8. Maximum Shear.— ON has no component along AB . Hence, the shear on AB is $NR \cos$ (angle between NR and AB), and is evidently a maximum when the angle is nil. Its value is then NR , or $\frac{p_1 - p_2}{2}$.

9. Application to Shafting.—At any point in a plane section of a strained solid, let r be the intensity of stress, and θ its obliquity.

At the same point in a second plane let s be the intensity of stress, and θ' its obliquity.

By Art. 6, r and s are the resultants of two constant stresses

$$\frac{p_1 + p_2}{2} \quad \text{and} \quad \frac{p_1 - p_2}{2}.$$

$$\therefore \left(\frac{p_1 - p_2}{2}\right)^2 = \left(\frac{p_1 + p_2}{2}\right)^2 + r^2 - r(p_1 + p_2) \cos \theta \quad (14)$$

and

$$\left(\frac{p_1 - p_2}{2}\right)^2 = \left(\frac{p_1 + p_2}{2}\right)^2 + s^2 - s(p_1 + p_2) \cos \theta'. \quad (15)$$

Subtracting one equation from the other,

$$\frac{r^2 - s^2}{r \cos \theta - s \cos \theta'} = p_1 + p_2. \quad \dots \quad (16)$$

First. Consider the case of combined torsion and bending, as when a length of shafting bears a heavy pulley at some point between the bearings.

Let p be the intensity of stress (compression or tension) due to the bending moment M_b .

Let q be the intensity of shear due to the twisting moment M_t .

p and q act in planes at right angles to each other.

$$\therefore r \cos \theta = p, \quad r \sin \theta = q = s, \quad \text{and} \quad \theta' = 90^\circ.$$

$$\therefore r^2 = p^2 + q^2 \quad \text{and} \quad s = q.$$

Hence, by eq. (16),

$$p_1 + p_2 = p; \quad \dots \dots \dots (17)$$

and by eq. (15),

$$\left(\frac{p_1 - p_2}{2}\right)^2 = \frac{p^2}{4} + q^2; \quad \dots \dots \dots (18)$$

$$\therefore p_1 = \frac{p}{2} + \sqrt{\frac{p^2}{4} + q^2} \quad \dots \dots \dots (19)$$

and

$$p_2 = \frac{p}{2} - \sqrt{\frac{p^2}{4} + q^2}. \quad \dots \dots \dots (20)$$

$$\text{The max. shear} = \frac{p_1 - p_2}{2} = \sqrt{\frac{p^2}{4} + q^2}; \quad \dots \dots \dots (21)$$

also

$$p = \frac{4M_b}{\pi r^3} \quad (\text{Chap. VI.}) \quad \text{and} \quad q = \frac{2M_t}{\pi r^3} \quad (\text{Chap. IX.})$$

for a shaft of radius r .

$$\therefore p_1 = \frac{2}{\pi r^3} \{M_b + \sqrt{M_b^2 + M_t^2}\}; \quad \dots \dots \dots (22)$$

and

$$\frac{\rho_1 - \rho_2}{2} = \frac{2}{\pi r^3} \sqrt{M_b^2 + M_t^2} \dots (23)$$

Perhaps the most important example of the application of the above principle is the case of a shaft acted upon by a crank (Fig. 215).

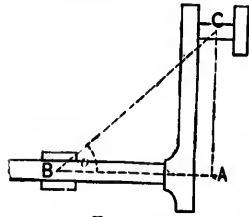

FIG. 215.

A force P applied to the centre C of the crank-pin is resisted by an equal and opposite force at the bearing B , forming a couple of moment $P \cdot CB = M$.

This couple may be resolved into a bending couple of moment $M_b = P \cdot AB = P \cdot BC \cos \delta = M \cos \delta$, and a twisting couple of moment $M_t = P \cdot AC = P \cdot BC \sin \delta = M \sin \delta$; δ being the angle ABC .

$$\therefore \rho_1 = \frac{2}{\pi r^3} \{M \cos \delta + M\} = \frac{4M}{\pi r^3} \cos^2 \frac{\delta}{2}; \dots (24)$$

$$\text{and the max. shear} = \frac{2M}{\pi r^3} \dots (25)$$

If the working tensile or compressive stress (ρ_1) and the working shear stress $\left(\frac{\rho_1 - \rho_2}{2}\right)$ are given, the corresponding values of r may be obtained from eqs. (22) and (23) or eqs. (24) and (25); the greater value being adopted for the radius of the shaft.

Second. Consider the case of combined torsion and tension or compression.

Let the tensile or compressive force be P .

$$\rho, \text{ the intensity of the tension or compression,} = \frac{P}{\pi r^2};$$

$$q, \text{ " " " shear} = \frac{2M_t}{\pi r^3}.$$

$$\therefore p_1 = \frac{1}{2\pi r^2} \left\{ P + \sqrt{P^2 + \frac{16M_t^2}{r^2}} \right\}, \dots (26)$$

and

$$\frac{p_1 - p_2}{2} = \frac{1}{2\pi r^2} \sqrt{P^2 + \frac{16M_t^2}{r^2}} \dots (27)$$

10. **Conjugate Stresses.**—Consider the equilibrium of an indefinitely small parallelepiped *abcd* (Fig. 216) of a strained body, the faces *ab*, *cd* being parallel to the plane *XOX*, and the faces *ad*, *bc* to the plane *YOY*.

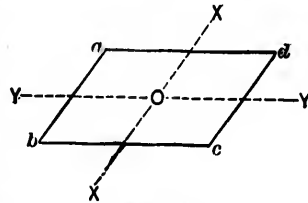

FIG. 216.

Let the stresses on *ab*, *cd* act parallel to the plane *YOY*. The total stresses on *ab* and *cd* are equal in amount, act at the centres of the faces, are parallel to *YOY*, and therefore neutralize one another.

Hence the total stresses on *ad* and *bc* must also neutralize one another. But they are equal in amount, and act at the middle points of *ad*, *bc*; they must therefore be parallel to *XOX*.

Hence, if two planes traverse a point in a strained body, and if the stress on one of the planes is parallel to the other plane, then the stress on the latter is parallel to the first plane.

Such planes are called planes of conjugate stress, and the stresses themselves are called conjugate stresses.

Principal stresses are of course conjugate stresses as well.

Conjugate stresses have equal obliquities, each obliquity being the complement of the same angle.

11. **Relations between Principal and Conjugate Stresses** (Fig. 217).—Take any line $ON = \frac{p_1 + p_2}{2}$.

Prob. - Find the...

With N as centre and a radius $= \frac{p_1 - p_2}{2}$, describe a semicircle.

Let θ be the common obliquity of a pair of conjugate stresses.

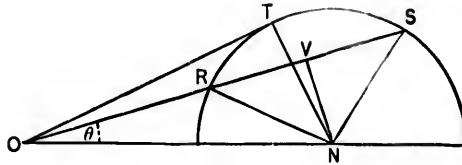

FIG. 217.

Draw ORS , making an angle θ with ON , and cutting the semicircle in the points R and S .

Join NR, NS .

OR and OS are evidently a pair of conjugate stresses.

Draw NV perpendicular to RS and bisecting it in V .

Draw the tangent OT ; join NT .

Let $OR = r, OS = s$. Then

$$rs = OR \cdot OS = OT^2 = ON^2 - NT^2$$

$$= \left(\frac{p_1 + p_2}{2}\right)^2 - \left(\frac{p_1 - p_2}{2}\right)^2 = p_1 p_2, \quad (28)$$

and

$$r + s = 2OV = 2ON \cos \theta = (p_1 + p_2) \cos \theta. \quad (29)$$

The maximum value of the obliquity, i.e., of θ , is the angle TON .

Call this angle ϕ . Then

$$\sin \phi = \frac{NT}{ON} = \frac{p_1 - p_2}{p_1 + p_2} \dots \dots \dots (30)$$

Let OR, OR' be a pair of conjugate stresses (Fig. 218).

Let OG, OH be the axes of greatest and least principal stress, respectively.

Draw ON normal to OR .

Let the angle $GOR = \psi, RON = \theta, HON = GOR' = \gamma$, as before. Then

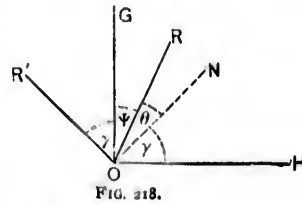

$$\psi = 90^\circ - \gamma - \theta;$$

and by eqs. (8),

$$\frac{p_2}{p_1} \cot \gamma = \tan \psi = \cot (\gamma + \theta);$$

$$\therefore \frac{\cot (\gamma + \theta)}{\cot \gamma} = \frac{p_2}{p_1}.$$

$$\sin \phi = \frac{p_1 - p_2}{p_1 + p_2} = \frac{\cot \gamma - \cot (\gamma + \theta)}{\cot \gamma + \cot (\gamma + \theta)} = \frac{\sin \theta}{\sin (2\gamma + \theta)}.$$

$$\therefore \sin (2\gamma + \theta) = \frac{\sin \theta}{\sin \phi},$$

or

$$\gamma = \frac{1}{2} \left\{ -\theta + \sin^{-1} \left(\frac{\sin \theta}{\sin \phi} \right) \right\} \dots \dots \dots (31)$$

Hence,

$$\text{angle } GON = 90^\circ - \gamma = \frac{1}{2} \left\{ 180^\circ + \theta - \sin^{-1} \left(\frac{\sin \theta}{\sin \phi} \right) \right\} \dots \dots \dots (32)$$

and

$$\text{angle } HOR = \gamma + \theta = \frac{1}{2} \left\{ \theta + \sin^{-1} \left(\frac{\sin \theta}{\sin \phi} \right) \right\} \dots \dots \dots (33)$$

12. Ratio of r to s .

$$\begin{aligned} \frac{r}{s} &= \frac{OR}{OS} = \frac{OV - RV}{OV + RV} = \frac{OV - \sqrt{NR^2 - NV^2}}{OV + \sqrt{NR^2 - NV^2}} \\ &= \frac{ON \cos \theta - \sqrt{NR^2 - ON^2 \sin^2 \theta}}{ON \cos \theta + \sqrt{NR^2 - ON^2 \sin^2 \theta}} \\ &= \frac{\cos \theta - \sqrt{\left(\frac{NR}{ON}\right)^2 - \sin^2 \theta}}{\cos \theta + \sqrt{\left(\frac{NR}{ON}\right)^2 - \sin^2 \theta}}. \end{aligned}$$

But

$$\frac{NR}{ON} = \frac{\rho_1 - \rho_2}{\rho_1 + \rho_2} = \frac{NT}{ON} = \sin \angle TON = \sin \phi.$$

$$\begin{aligned} \therefore \frac{r}{s} &= \frac{\cos \theta - \sqrt{\sin^2 \phi - \sin^2 \theta}}{\cos \theta + \sqrt{\sin^2 \phi - \sin^2 \theta}} \\ &= \frac{\cos \theta - \sqrt{\cos^2 \theta - \cos^2 \phi}}{\cos \theta + \sqrt{\cos^2 \theta - \cos^2 \phi}} \dots \dots (34) \end{aligned}$$

Let $\frac{\cos \phi}{\cos \theta} = \sin \alpha$. Then

$$\frac{r}{s} = \frac{1 \mp \cos \alpha}{1 \pm \cos \alpha} = \tan^2 \frac{\alpha}{2} \quad \text{or} \quad = \cot^2 \frac{\alpha}{2}. \quad (35)$$

If $\theta = 0$, $\alpha = 90 - \phi$.

$$\therefore \frac{r}{s} = \tan^2 \left(45 - \frac{\alpha}{2}\right) \quad \text{or} \quad = \cot^2 \left(45 - \frac{\alpha}{2}\right). \quad (36)$$

If $\theta = \phi$, $\alpha = 90^\circ$.

$$\therefore \frac{r}{s} = 1. \quad \dots \dots \dots (37)$$

13. Relation between Stress and Strain.—Let a solid body be strained uniformly, i.e., in such a manner that lines of particles which are parallel in the free state remain parallel in the strained state, their lengths being altered in a given ratio, which is practically very small. Lines of particles which are oblique to each other in the free state are generally inclined at different angles in the strained state, and their lengths are altered in different ratios.

Let the straining of the body convert a rectangular portion $ABCD$ (Fig. 219) into the rectangle $AB'C'D'$, where $AB' = (1 + \alpha)AB$ and $AD' = (1 + \beta)AD$.

Now α and β are very small, so that their joint effect may be considered to be equal to the sum of their *separate* effects. Hence:

First. Let a simple longitudinal strain in a direction parallel to AB convert the rectangle $ABCD$ into the rectangle $AB'ED$, where $BB' = \alpha \cdot AB$.

A line OF will move into the position OF' , where $FF' = \alpha \cdot DF$, and

$$\begin{aligned} \text{the strain along } OF &= \frac{OF' - OF}{OF} \\ &= \frac{FF' \cos \theta}{OF} = \frac{\alpha \cdot DF \cos \theta}{OF} = \alpha \cos^2 \theta, \end{aligned}$$

θ being the angle OFD .

Also, the “distortion or deviation from rectangularity”

$$= \text{angle } FOF' = \frac{FF' \sin \theta}{OF} = \frac{\alpha \cdot DF \sin \theta}{OF} = \alpha \cos \theta \sin \theta.$$

Second. Let a simple longitudinal strain in a direction parallel to AD convert the rectangle $ABCD$ into the rectangle $ABKD'$, where $DD' = \beta \cdot AD$.

The line OF will move into the portions $O'F''$, where $OO' = \beta \cdot AO$ and $F''F = DD' = \beta \cdot AD$.

$$\therefore \text{ the strain along } OF = \frac{O'F'' - OF}{OF}.$$

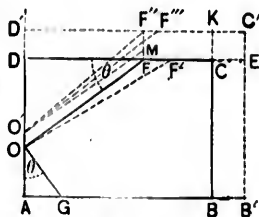

FIG. 219.

Draw $O'M$ parallel to OF . Then

$$\begin{aligned} O'F'' - OF &= O'F'' - O'M = F''M \sin \theta = (F''F - FM) \sin \theta \\ &= (DD' - OO') \sin \theta = \beta(AD - AO) \sin \theta \\ &= \beta \cdot OD \sin \theta. \end{aligned}$$

$$\therefore \text{the strain along } OF = \frac{\beta \cdot OD \sin \theta}{OF} = \beta \sin^2 \theta.$$

The *distortion* = the angle $F''O'M$

$$= \frac{F''M \cos \theta}{OF} = \frac{\beta \cdot OD \cos \theta}{OF} = \beta \sin \theta \cos \theta.$$

Hence, when the strains are simultaneous, the line OF will take the position $O'F'''$ between $O'F''$ and OF' , and

$$\begin{aligned} \text{the total strain along } OF &= \alpha \cos^2 \theta + \beta \sin^2 \theta; \\ \text{the total distortion} &= (\alpha - \beta) \sin \theta \cos \theta. \end{aligned}$$

Again, draw a line OG perpendicular to OF .

The angle $OGA = 90^\circ - \theta$, and hence, from the above,

$$\text{the total strain along } OG = \alpha \sin^2 \theta + \beta \cos^2 \theta,$$

and the corresponding distortion = $(\alpha - \beta) \sin \theta \cos \theta$.

Denote the strain along OF by e_1 , that along OG by e_2 , and each of the equal distortions by t . Then

$$e_1 + e_2 = \alpha + \beta.$$

Again, if OF, OG are the sides of a rectangle enclosed in the rectangle $ABCD$, the straining will convert the rectangle into an oblique figure with its opposite sides parallel. The lengths of adjacent sides are altered by the amounts e_1 and e_2 , and the angle θ by $2t$. The above results may also be considered to hold true if the straining, instead of being uniform, varies continuously from point to point.

Consider a unit cube $ABCD$ subject to stresses of intensity p_1 and p_2 upon the parallel faces AD, BC and AB, DC . By Art. 3, Chap. III,

$$\alpha = \frac{p_1}{E} - \frac{p_2}{mE},$$

$$\beta = \frac{p_1}{mE} + \frac{p_2}{E},$$

and the strain perpendicular to the

$$\text{face } ABCD = -\frac{p_1}{mE} - \frac{p_2}{mE}.$$

If the stresses are of equal intensity but of opposite kind, i.e., if the one is a tension and the other a compression,

$$p_1 = -p_2 = p, \text{ suppose.}$$

$$\therefore \alpha = -\beta = \frac{p}{E} \left(1 + \frac{1}{m} \right), \text{ and the third strain is } ml.$$

Thus the volume of the *strained* solid

$$= (1 + \alpha)(1 - \alpha)(1) = 1 - \alpha^2 = 1, \text{ approximately,}$$

so that the volume is not sensibly changed.

Also, if $OGHF$ is an enclosed square, O being the middle point of AD , $\theta = 45^\circ$, and

$$e_1 = e_2 = \frac{\alpha + \beta}{2} = 0 = \text{strain along } OF \text{ or } OG,$$

and the distortion = change in angle O

$$= 2t = 2 \frac{\alpha - \beta}{2} = 2\alpha = \frac{2p}{E} \left(1 + \frac{1}{m} \right).$$

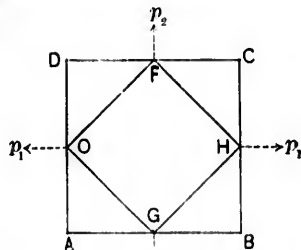

FIG. 220.

This result may be at once deduced from the figure. For

$$\tan \frac{FOG}{2} = \frac{OD}{FD} = \frac{1 + \beta}{1 + \alpha} = \frac{1 - \alpha}{1 + \alpha} = \tan \left(\frac{90^\circ - 2t}{2} \right),$$

or

$$\frac{1 - \alpha}{1 + \alpha} = \frac{1 - \tan t}{1 + \tan t} = \frac{1 - t}{1 + t},$$

since t is very small. Hence

$$t = \alpha.$$

As already shown in Art. 3, shearing cannot take place along one plane only, and at any point of a strained solid the shears along planes at right angles are of equal intensity. The effect of such stresses is merely to produce a *distortion of figure*, and generally without sensible change of volume.

Thus, shears of intensity s along the parallel faces of the unit square $ABCD$ will merely distort the square into a rhombus $ABC'D'$ (Fig. 221). Denoting the change of angle by $2t$,

and assuming that the "stress is proportional to the strain,"

$$s = G \cdot 2t,$$

where G is a coefficient called the *modulus of transverse elasticity*, or the *coefficient of rigidity*, and depends upon a change of form.

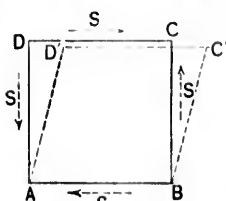

Consider a section along the diagonal BD .

The stresses on the faces AB , AD , and on CB , CD , resolved parallel and perpendicular to BD , are evidently equivalent to nil and a normal force $s\sqrt{2}$, respectively. Thus, there is no sliding tendency along BD , but the two portions ABD and

CBD exert upon each other a pull, or tension, of intensity $\frac{s\sqrt{2}}{BD}$

$$= \frac{s\sqrt{2}}{\sqrt{2}} = s.$$

Similarly it may be shown that there is no tendency to slide along AC , but that the two portions ABC and ADC exert

upon each other a pressure of intensity s . The straining due to the shearing stresses is, therefore, identical with that produced by a thrust and tension of equal intensity upon planes at 45° . Hence, as proved above,

$$s = G \cdot 2t = G \frac{2s}{E} \left(1 + \frac{1}{m} \right),$$

and

$$\therefore G = \frac{E}{2} \frac{m}{1+m} = \frac{s}{2t}.$$

Now m rarely exceeds 4, and hence G is generally $< \frac{2}{3}E$.

Again, the *coefficient of elasticity of volume*, or *cubic elasticity* (Art. 23), is

$$K = \frac{mE}{3(m-2)} = \frac{2}{3} \left(\frac{m+1}{m-2} \right) G,$$

and hence

$$m = \frac{6K + 2G}{3K - 2G}.$$

14. Rankine's Earthwork Theory.—A mass of earthwork tends to take a definite slope.

Rankine assumes, (1) that the stresses exerted in different directions through a particle of a granular mass are subject to the general principles enunciated in the preceding articles; (2) that the cohesion of the particles is gradually destroyed, and that the stability of the mass ultimately depends on friction only.

In the limit, therefore, the face of the mass is inclined to the horizon at an angle equal to the angle of friction, or, as it is sometimes called, the angle of repose.

Adopting *for the present* Rankine's assumptions, the equilibrium of the mass requires that the direction of the mutual pressure between the two parts into which the mass is divided by a plane shall make an angle with the normal to the plane less than the angle of friction.

Denote the angle of friction by ϕ .

The maximum obliquity must be $\leq \phi$.

By eq. (30),

$$\sin \frac{p_1 - p_2}{p_1 + p_2} \leq \phi, \quad \text{or} \quad \frac{p_1 - p_2}{p_1 + p_2} \leq \sin \phi.$$

$$\therefore \frac{p_2}{p_1} > \frac{1 - \sin \phi}{1 + \sin \phi} \dots \dots \dots (38)$$

Thus, if a pressure of intensity p_1 acts through a mass of earthwork, eq. (38) gives the least intensity of pressure p_2 acting in a direction perpendicular to that of p_1 consistent with equilibrium

The limiting ratios of a pair of conjugate stresses in a mass of earthwork may also easily be determined.

By eq. (34),

$$\text{the ratio} = \frac{\cos \theta - \sqrt{\cos^2 \theta - \cos^2 \phi}}{\cos \theta + \sqrt{\cos^2 \theta - \cos^2 \phi}} \dots \dots \dots (39)$$

Hence the ratio cannot exceed

$$\frac{\cos \theta + \sqrt{\cos^2 \theta - \cos^2 \phi}}{\cos \theta - \sqrt{\cos^2 \theta - \cos^2 \phi}};$$

nor can it be less than

$$\frac{\cos \theta - \sqrt{\cos^2 \theta - \cos^2 \phi}}{\cos \theta + \sqrt{\cos^2 \theta - \cos^2 \phi}}.$$

If $\theta = 0$, the ratio becomes

$$\frac{1 \mp \sin \phi}{1 \pm \sin \phi} \dots \dots \dots (40)$$

For example, let the ground-surface be horizontal.

The pair of conjugate stresses become a vertical stress p_1 and a horizontal stress p_2 .

$$\therefore \frac{p_1}{p_2} < \frac{1 + \sin \phi}{1 - \sin \phi} \dots \dots \dots (41)$$

or

$$\frac{p_2}{p_1} > \frac{1 - \sin \phi}{1 + \sin \phi}, \dots \dots \dots (42)$$

as in eq. (28).

Pressure against a Vertical Plane.—Let *ACB* (Fig. 222), the ground-surface of a mass of earthwork, be inclined to the horizon at an angle θ .

Consider a particle at a vertical depth $CD = x$ below *C*.

Let *s* be the vertical intensity of pressure on the particle at *D*.

Let *r* be the conjugate intensity of pressure on the particle at *D*.

This conjugate pressure acts in the direction *ED* parallel to the ground-surface, and its obliquity is θ .

Take *DE* so that

$$\frac{DE}{DC} = \frac{r}{s} = \frac{\cos \theta - \sqrt{\cos^2 \theta - \cos^2 \phi}}{\cos \theta + \sqrt{\cos^2 \theta - \cos^2 \phi}}$$

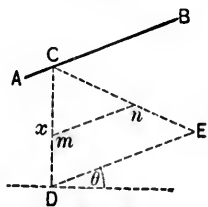

FIG. 222.

Then *w . ED* represents in direction and magnitude the intensity of pressure on the vertical plane *DC* at the point *D*, *w* being the weight of a unit of volume of the earthwork.

Join *CE*.

The intensity of pressure at any other point *m* is evidently *w . mn*, *mn* being drawn parallel to *DE*.

Hence, the total pressure on the plane *DC* = weight of prism *DCE*

$$\begin{aligned} &= \frac{w . DC . DE}{2} \cos \theta = \frac{w . DC^2 r}{2 s} \cos \theta \\ &= \frac{wx^2}{2} \cos \theta \frac{\cos \theta - \sqrt{\cos^2 \theta - \cos^2 \phi}}{\cos \theta + \sqrt{\cos^2 \theta - \cos^2 \phi}} \dots \dots (43) \end{aligned}$$

Again, *s* is the pressure due to the weight of the vertical column *CD*.

$$\therefore s = wx \cos \theta, \dots \dots \dots (44)$$

and

$$r = wx \cos \theta \frac{\cos \theta - \sqrt{\cos^2 \theta - \cos^2 \phi}}{\cos \theta + \sqrt{\cos^2 \theta - \cos^2 \phi}} \quad (45)$$

By means of this last equation the total pressure on CD may be easily deduced as follows:

The pressure on an element dx at a depth x

$$= r dx = wx \cos \theta \frac{\cos \theta - \sqrt{\cos^2 \theta - \cos^2 \phi}}{\cos \theta + \sqrt{\cos^2 \theta - \cos^2 \phi}} dx.$$

$$\therefore \text{total pressure} = \int_0^x r dx = \text{etc.}$$

The total resultant pressure is parallel in direction to the ground-surface, and its point of application is evidently at *two thirds* of the total depth CD .

15. Earth Foundations.—CASE I. Let the weight of the superstructure be uniformly distributed over the base, and let p_0 be the intensity of the pressure produced by it.

If p_h is the maximum horizontal intensity of pressure corresponding to p_0 ,

$$\frac{p_0}{p_h} < \frac{1 + \sin \phi}{1 - \sin \phi}.$$

In the natural ground, let p_v be the maximum vertical intensity of pressure corresponding to the horizontal intensity p_h . Then

$$\frac{p_h}{p_v} < \frac{1 + \sin \phi}{1 - \sin \phi}.$$

Hence

$$\frac{p_0}{p_v} < \left(\frac{1 + \sin \phi}{1 - \sin \phi} \right)^2.$$

If x is the depth of the foundation, and w the weight of a cubic foot of the earth,

$$\begin{aligned} p_v &= wx; \\ \therefore \frac{p_0}{wx} &< \left(\frac{1 + \sin \phi}{1 - \sin \phi} \right)^2 \dots \dots \dots (46) \end{aligned}$$

Let $h + x$ be the height of the superstructure, and let a cubic foot of it weigh w' . Then

$$p_0 = w'(x + h).$$

Hence, a minimum value of x is given by

$$\frac{w'(h + x)}{wx} = \left(\frac{1 + \sin \phi}{1 - \sin \phi} \right)^2 = \frac{1}{k^2}, \text{ suppose;}$$

$$\therefore x = \frac{w'hk^2}{w - w'k^2} \dots \dots \dots (47)$$

CASE II. Let the superstructure produce on the base a uniformly varying pressure of maximum intensity p_1 and minimum intensity p_2 .

By Case I,

$$\frac{p_1}{wx} = \left(\frac{1 + \sin \phi}{1 - \sin \phi} \right)^2 \dots \dots \dots (48)$$

In the natural ground the minimum horizontal intensity of pressure is

$$p_h = wx \frac{1 - \sin \phi}{1 + \sin \phi}.$$

When the foundation-trench is excavated, this pressure tends to raise the bottom and push in the sides. The weight of the superstructure should therefore be at least equal to the weight of the material excavated in order to develop a horizontal pressure of an intensity equal to p_h .

$$\therefore \frac{p_h}{p_1} = \frac{1 - \sin \phi}{1 + \sin \phi}.$$

Combining this with the last equation,

$$\frac{p_2}{wx} > 1. \dots \dots \dots (49)$$

Combining (48) and (49),

$$\frac{p_1}{p_2} < \left(\frac{1 + \sin \phi}{1 - \sin \phi} \right)^2 \dots \dots \dots (50)$$

(Rankine's Civil Engineering, Arts. 237, 239.)

16. Retaining-walls.—Consider a portion $ABMN$ of a wall (Fig. 223).

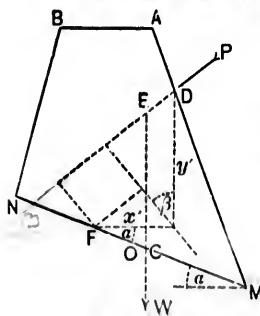

FIG. 223.

Let W be its weight, and let the direction of W cut MN in C .

Let P be the resultant of the forces externally applied to $ABNM$ and tending to overthrow it. Let D be its point of application, and let its direction meet that of W in E .

Let F be the centre of pressure (or resistance) at the bed MN .

Let O be the middle point of MN .

Let $MN = t$, $OF = qt$, $OC = rt$, q and r being each less than unity.

Let x' and y' , respectively, be the horizontal and vertical co-ordinates of D with respect to F .

Let the inclination to the horizon of $MN = \alpha$, of P 's direction = β .

Conditions of Equilibrium.—(a) The moment of P with respect to $F \leq$ the moment of W with respect to F , or

$$P(y' \cos \beta - x' \sin \beta) \leq W(qt \mp rt) \cos \alpha; \dots (51)$$

the upper or lower sign being taken according as C falls on the left or right of O .

In ordinary practice q varies from $\frac{1}{4}$ to $\frac{3}{8}$.

EXAMPLE.—A masonry wall (Fig. 224) of rectangular section, x ft. high, 4 ft. wide, weighing 125 lbs. per cubic foot, is built upon a horizontal base and retains water (weighing $62\frac{1}{2}$ lbs. per cubic foot) on one side level with the top of the wall.



FIG. 224.

$$P = 62\frac{1}{2} \frac{x^2}{2}, \quad W = 125 \times 4x, \quad \alpha = 0, \quad \beta = 0, \quad t = 4 \text{ ft}$$

$$x' = 2 + 4q, \quad y' = \frac{x}{3}, \quad r = 0.$$

$$\therefore 1\frac{3}{4}x^3 \leq 2000qx,$$

or

$$x^2 \leq 192q. \dots \dots \dots (52)$$

If $q = \frac{1}{4}$, $x^2 \leq 48$ and $x \leq 6.928$ ft.

If $q = \frac{3}{8}$, $x^2 \leq 72$ and $x \leq 8.485$ ft.

(b) The maximum intensity of pressure at the bed MN must not exceed the safe working resistance of the material to crushing. The load upon the bed is rarely if ever uniformly distributed. It is practically sufficient to assume that the intensity of the pressure diminishes at a uniform rate from the most compressed edge inwards.

Let f be the maximum intensity of pressure, and R the total pressure on the bed.

Three cases may be considered.

CASE I. Let the intensity of the pressure diminish uniformly from f at M to 0 at N (Fig. 225).

Take MG perpendicular to MN and $= f$; join GN .

The pressure upon the bed is represented by the triangle MGN .

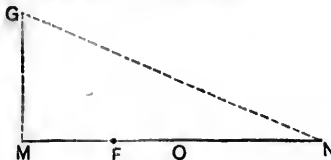

FIG. 225.

$$\therefore R = \frac{1}{2}MG \cdot MN = \frac{1}{2}ft.$$

The ordinate through the centre of gravity of the triangle, parallel to GM , cuts MN in the centre of pressure F .

$$\therefore qf = OF = OM - FM = \frac{f}{2} - \frac{f}{3} = \frac{f}{6}.$$

CASE II. Let the maximum intensity $f > MG$ in Case I.

Take $MH = f$, and the triangle $MHK = R$ (Fig. 226).

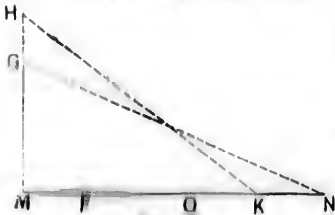

FIG. 226.

The pressure on the bed is now represented by the triangle MHK .

$$R = \frac{1}{2}MH \cdot MK = \frac{1}{2}f \cdot MK.$$

The ordinate through the

Handwritten scribble

Handwritten scribble

centre of gravity of the triangle MHK parallel to HM cuts MN in the centre of pressure F .

$$\therefore qt = OF = OM - MF = \frac{t}{2} - \frac{MK}{3}.$$

But $MK = \frac{2R}{f}$;

$$\therefore qt = \frac{t}{2} - \frac{2R}{3f}; \text{ and hence}$$

$$q = \frac{1}{2} - \frac{2R}{3ft} \text{ and is evidently } > \frac{1}{6}. \quad (53)$$

CASE III. Let the maximum intensity $f < MG$ in Case I. Take $ML = f$, and the trapezoid $MLSN = R$ (Fig. 227).

The pressure on the bed is now represented by the trapezoid $MLSN$.

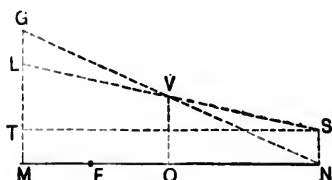

FIG. 227.

$$\therefore R = \frac{1}{2}(ML + NS)MN$$

$$= \frac{1}{2}(f + NS)t.$$

$$\therefore ML + NS = \frac{2R}{t}$$

and

$$NS = \frac{2R}{t} - f.$$

The ordinate through the centre of gravity of the trapezoid parallel to LM cuts MN in the centre of pressure F .

Draw ST parallel to NM .

The moment of $MLSN$ with respect to O

$$= \text{moment of } MTSN \text{ with respect to } O$$

$$+ \text{moment of } LST \text{ with respect to } O,$$

or

$$\frac{1}{2}(ML + NS)MN \cdot OF = 0 + \frac{1}{2}LT \frac{TS^2}{6}.$$

$$\therefore \frac{1}{2} \frac{2R}{t} tqt = \frac{1}{2}(ML - NS) \frac{MN^2}{6} = \frac{1}{2} \left(2f - \frac{2R}{t} \right) \frac{t^3}{6};$$

Hence, $q = \frac{1}{6} \left(\frac{ft}{R} - 1 \right)$, and is evidently $< \frac{1}{6}$ (54)

Now W must be a function of x , the vertical depth of N below B ; P also may be a function of x .

Hence if f is given, and the corresponding value of q from (53) or (54) substituted in (52), x may be found.

When (53) is employed, the value of x found must make $q > \frac{1}{6}$.

When (54) is employed, the value of x found must make $q < \frac{1}{6}$.

EXAMPLE. The rectangular wall in (a), the safe crushing strength of the material being 10,000 lbs. per square foot ($=f$).

$$R = W = 500x.$$

By (53),

$$q = \frac{1}{2} - \frac{x}{120}.$$

Substituting in (52),

$$x^2 \leq 192 \left(\frac{1}{2} - \frac{x}{120} \right) \leq 96 - \frac{2}{3}x;$$

Hence,

$$x \leq 9.03 \text{ ft.}$$

Again, $q > \frac{1}{2} - \frac{9.03}{120} > .4248$, and is *à fortiori* $> \frac{1}{6}$.

If (54) is employed,

$$q = \frac{1}{6} \left(\frac{80}{x} - 1 \right).$$

Hence, by (52),

$$x^2 \leq 32 \left(\frac{80}{x} - 1 \right).$$

By trial x is found to lie between 12 and 13; each of these values makes $q > \frac{1}{6}$, which is contrary to (54).

The first is therefore the correct substitution.

(c) The angle between the directions of the resultant pressure and a normal to the bed must be less than the angle of friction.



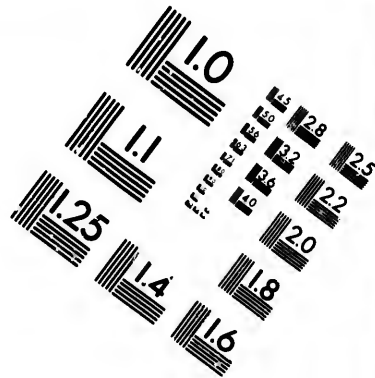
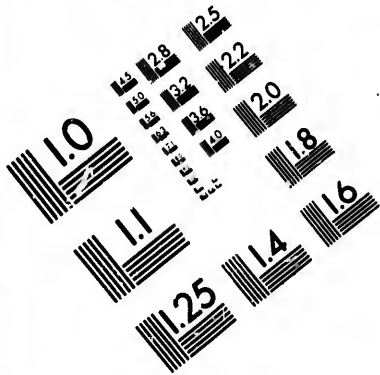

**IMAGE EVALUATION
TEST TARGET (MT-3)**

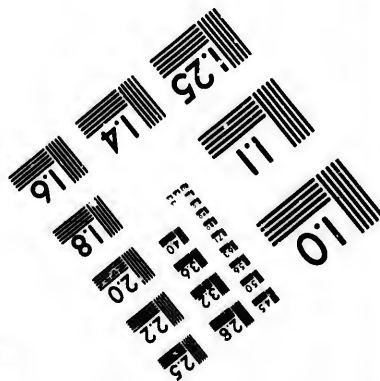
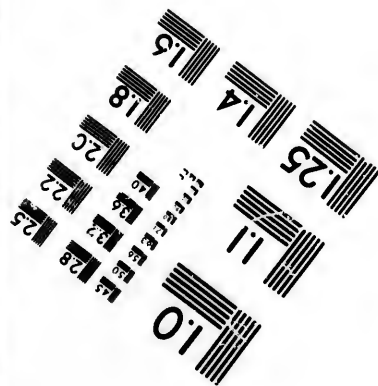
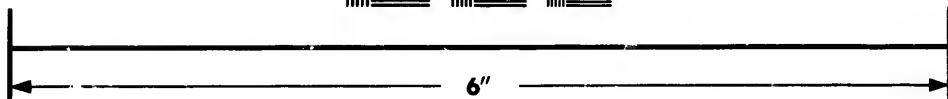
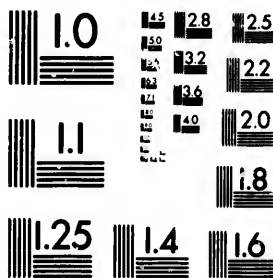

**Photographic
Sciences
Corporation**

23 WEST MAIN STREET
WEBSTER, N.Y. 14590
(716) 872-4503

18
19
20
22
25
28
30
32
34
36
38
40
42
44
46
48
50
52
54
56
58
60
62
64
66
68
70
72
74
76
78
80
82
84
86
88
90
92
94
96
98
100

10
11
12
13
14
15
16
17
18
19
20
21
22
23
24
25
26
27
28
29
30
31
32
33
34
35
36
37
38
39
40
41
42
43
44
45
46
47
48
49
50
51
52
53
54
55
56
57
58
59
60
61
62
63
64
65
66
67
68
69
70
71
72
73
74
75
76
77
78
79
80
81
82
83
84
85
86
87
88
89
90
91
92
93
94
95
96
97
98
99
100

Let ϕ be the angle of friction, R the mutual normal pressure. Resolving along the bed and perpendicular to it,

$$P \cos \overline{\alpha + \beta} - W \sin \alpha < R \tan \phi$$

and

$$P \sin \overline{\alpha + \beta} + W \cos \alpha = R;$$

$$\therefore \frac{P \cos \overline{\alpha + \beta} - W \sin \alpha}{P \sin \overline{\alpha + \beta} + W \cos \alpha} < \tan \phi,$$

which reduces to

$$P(\cos \overline{\beta + \alpha} \cos \phi - \sin \overline{\beta + \alpha} \sin \phi) < W(\sin \phi \cos \alpha + \cos \phi \sin \alpha),$$

or

$$P \cos \overline{\beta + \alpha + \phi} < W \sin \overline{\alpha + \phi},$$

or

$$P(\cos \beta \cos \overline{\alpha + \phi} - \sin \beta \sin \overline{\alpha + \phi}) < W \sin \overline{\alpha + \phi},$$

or

$$\frac{P \cos \beta}{P \sin \beta + W} < \tan \overline{\alpha + \phi}.$$

$$\therefore \tan^{-1} \frac{P \cos \beta}{P \sin \beta + W} - \alpha < \phi. \quad \dots \dots (55)$$

17. Rankine's Theory of Earthwork applied to Retaining-walls.—Fig. 228 represents a

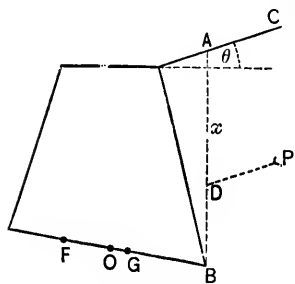

FIG. 228.

vertical section of a wall retaining earthwork. AB is a vertical plane cutting the ground-surface AC in the point A .

Consider the equilibrium of the whole mass of masonry and earthwork in front of AB .

Let the depth $AB = x$.

The total pressure on AB is, by

(43),

$$P = \frac{wx^2}{2} \cos \theta \frac{\cos \theta - \sqrt{\cos^2 \theta - \cos^2 \phi}}{\cos \theta + \sqrt{\cos^2 \theta - \cos^2 \phi}}.$$

Its point of application is D , and $BD = \frac{x}{3}$.

Let W be the weight of the whole mass under consideration, and let its direction cut the base of the wall in the point G . Let F be the centre of pressure in the wall-base. Taking moments of P and W about F ,

$$P \left\{ \frac{x}{3} \cos \theta - \left(qt + \frac{t}{2} \right) \sin(\theta + \alpha) \right\} < W(qt \mp rt) \cos \alpha. \quad (56)$$

The other conditions of equilibrium may be discussed as in Art. 16.

18. Line of Rupture.—Another expression for the pressure on AB may be obtained as follows:

If the whole mass in front of AB (Fig. 229) were suddenly removed, some of the earthwork behind AB would fall away.

Suppose that the volume ABC would slip along the plane CB .

The stability of ABC is maintained by the reaction P on AB , the weight W of ABC , and the frictional resistance along BC .

Let the direction of P make an angle β with the horizon.

Let the angle $CBA = i$.

Let R be the mutual pressure on the plane BC .

Resolving along and perpendicular to BC ,

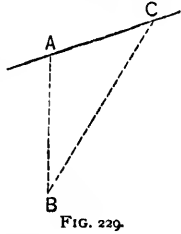

$$- P \cos(90^\circ - i - \beta) + W \cos i = R \tan \phi;$$

and

$$P \sin(90^\circ - i - \beta) + W \sin i = R.$$

$$\therefore - P \sin(\beta + i) + W \cos i = \tan \phi \{ P \cos(\beta + i) + W \sin i \},$$

and

$$P = W \frac{\cos i - \sin i \tan \phi}{\sin(\beta + i) + \cos(\beta + i) \tan \phi} = W \frac{\cos(i + \phi)}{\sin(\beta + i + \phi)}.$$

Also

$$W = w \frac{BA \cdot BC}{2} \sin i = \frac{wx^2 \cos \theta \sin i}{2 \cos(\theta + i)};$$

$$\therefore P = \frac{wx^2 \cos \theta \sin i}{2 \cos(\theta + i)} \frac{\cos(i + \phi)}{\sin(\beta + i + \phi)} \dots \dots \dots (57)$$

The only variable upon which P depends is the angle i .

Differentiating the right-hand side of eq. 57 with respect to i and putting the result equal to zero, a value of i is found in terms of β , θ and ϕ , which will make P a maximum.

The line inclined at this angle to the vertical is called the *line of rupture*.

If the ground-surface is horizontal, $\theta = 0$.

If the face retaining the earth is vertical, *and if it is also assumed that the friction between the face and the earthwork is nil*, P is horizontal and $\beta = 0$. Hence (57) becomes

$$P = \frac{wx^2}{2} \tan i \cot(i + \phi) \dots \dots \dots (58)$$

This is a maximum when $2i = 90^\circ - \phi$, and then

$$P = \frac{wx^2}{2} \tan\left(45 - \frac{\phi}{2}\right) \cot\left(45 + \frac{\phi}{2}\right) = \frac{wx^2}{2} \left(\frac{1 - \tan \frac{\phi}{2}}{1 + \tan \frac{\phi}{2}}\right)^2;$$

or

$$P = \frac{wx^2}{2} \frac{1 - \sin \phi}{1 + \sin \phi}; \dots \dots \dots (59)$$

the same result as that obtained by Rankine's theory.

The following is an easy geometrical proof of eq. (59):

On any line KL (Fig. 230) describe a semicircle.

Draw KM inclined at the angle ϕ to KL , and KN inclined at the angle i to KM .

Join NL , cutting KM in T .

Let O be the middle point of the arc KM .

Join OL , cutting KM in Y .

Draw NV parallel to KM . Then

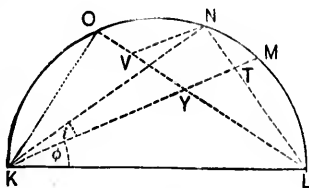

FIG. 230.

$$\tan i \cot (i + \phi) = \frac{NT}{KN} \times \frac{KN}{NL} = \frac{NT}{NL} = \frac{VY}{VL}.$$

The ratio $\frac{VY}{VL}$ is evidently a maximum when N coincides with O , and hence $\tan i \cot (i + \phi)$ is a maximum when KN coincides with KO .

Now the arc $OK =$ the arc OM , and hence the angle $OKM =$ the angle OLK .

Hence, if $OKM = i$, OLK must also $= i$.

But $OKL + OLK = 90^\circ = i + \phi + i = 2i + \phi$.

$$\therefore i = 45^\circ - \frac{\phi}{2}.$$

19. Practical Rules.—When the surface of the earthwork is horizontal and the face of the wall against which it abuts vertical, the pressure on the wall according to Rankine's theory is

$$P = \frac{wx^2}{2} \frac{1 - \sin \phi}{1 + \sin \phi},$$

and the direction of P is horizontal.

This result is also identical with that obtained in Art. 18, on the assumption of Coulomb's wedge of maximum pressure (Poncelet's Theory).

Experience has conclusively proved that the theoretical value of P given above is very much greater than its real value, so that the thickness of a wall designed in accordance with theory would be in excess of what is required in practice. In the deduction of the formula, indeed, the altogether inadmissible assumption is made that there is no friction between the earth-work and the face of the wall. This is equivalent to the supposition that the face is perfectly smooth and that therefore the pressure acts normally to it. Boussinesque, Levy, and St. Venant have demonstrated that the hypothesis of a normal pressure only holds true,

either, first, if the ground surface is horizontal and the wall-face inclined at an angle of $45^\circ - \frac{\phi}{2}$ to the vertical,

or, second, if the wall-face is vertical and the ground-surface inclined at an angle ϕ to the horizon.

When the surface of the ground is horizontal and the face of the wall vertical; and when $\phi = 45^\circ$, the above formula gives the correct *magnitude* of P . Its direction, however, is not horizontal, but makes an angle with the vertical equal to the angle of friction between the earth and the wall. The wall-face is generally sufficiently rough to hold fast a layer of earth, and in all probability Boussinesque's assumption that the friction between the wall and the earth is equal to that inherent in the earth is a near approximation to the truth. The *direction* of P will thus be considerably modified, leading to a smaller moment of stability and a corresponding diminution in the necessary thickness of the wall.

In practice the thrust P may always be made small by carrying up the backing in well-punned horizontal layers.

In order to neutralize the very great thrust often induced by alternate freezing and thawing and the consequent swelling, a most effective expedient is to give a batter of about 1 in 1 to the rear line of the wall extending below the line to which frost penetrates.

The greatest difficulty in formulating a table of earth-thrusts arises from the fact that there is an infinite variety of earth-work. As an example of this, Airy states that he has found

the cohesive power of clay to vary from 168 to 800 pounds per square foot, the corresponding coefficients of friction varying from 1.15 to .36, and that even this wide range is less than might be found in practice.

A correct theory for the design of retaining-walls is as yet wanting. According to Baker, experience has shown that with good backing and a good foundation the stability of a wall will be insured by making its thickness one-fourth the height, and giving it a front batter of 1 or 2 in. per foot, and that under no conditions of ordinary surcharge or heavy backing need its thickness exceed one-half the height. Baker's usual practice in ground of average character is to make the thickness one-third the height from the top of the footings, and if any material is taken out to form a face panel, three-fourths of it is put back in the form of a pilaster.

General Fanshawe's rule for brick walls of rectangular section retaining ordinary material is to make the thickness

24%	of the height for a batter of 1 in	5 ;
25 "	" " " " " " 1 in	6 ;
26 "	" " " " " " 1 in	8 ;
27 "	" " " " " " 1 in	10 ;
28 "	" " " " " " 1 in	12 ;
30 "	" " " " " " 1 in	24 ;
32 "	" " " " " "	for a vertical wall.

The thickness at the footing adopted by Vauban for walls with a front batter of 1 in 5 or 1 in 6 and plumb at the rear, is approximately given by the empirical formula

$$\text{thickness} = .19H + 4 \text{ ft.},$$

H being the height of the wall above the footing. Counterforts were introduced at intervals of 15 feet for walls above 35 feet in height, and at intervals of 12 feet for walls of less height.

The counterfort projects from the wall a distance of $\frac{H}{5} + 3$ ft.

approximately, and the approximate width of the counterfort is

$$\frac{H}{10} + 3 \text{ ft.}, \text{ diminishing to } \frac{H}{15} + 2 \text{ ft.}$$

Brunel curved the face of the wall and made its thickness one-fifth or one-sixth the height. Counterforts 2 ft. 6 in. in thickness were introduced at intervals of 10 ft.

The vast importance of the foundation will be better appreciated by bearing in mind that the great majority of failures have been due to defective foundations. If water can percolate to the foundation, a softening action begins and a consequent settlement takes place, which is most rapid in the region subjected to the greatest pressure, viz., the toe. In order to counteract this tendency to settle, the toe may be supported by raking piles, the rake being given to diminish the bending action of the thrust on the piles. It is also advisable to distribute the weight as uniformly as possible over the base, a condition which is not compatible with large front batters and deep offsets, as they tend to concentrate weight on isolated points. In the case of dock-walls, too, a large front batter will keep a ship farther away from the coping and will necessitate thicker fenders, as well as cranes with wider throws. As an objection to offsets Bernays urges that, in settling, the backing is liable to hang upon them, forming large holes underneath. He therefore favors the substitution of a batter for the offsets. On the other hand, if water stands on both sides of the walls, the hydrostatic pressure on the offsets will greatly increase its stability.

Dock-walls are liable to far greater variations of thrust than ordinary retaining-walls. The water in a dock with an impermeable bottom may stand at a much higher level than the water at the back of the wall, and its pressure may thus even more than neutralize the thrust due to the backing. With a porous bottom the stability of a wall may be greatly diminished by an upward pressure on the base. The experience of dock-wall failures has led to the conclusion that a large moment of stability is not of so much importance as "weight with a good grip on the ground." Many authorities, both practical and theoretical, have urged the great advantages in economy and strength attending the employment of counterforts. The use of Portland cement, or cement concrete, will guard against the breaking away of the counterforts from the main body of

the wall, as has often happened in the case of the older walls. But a uniform distribution of pressure as well as of weight is important, and it therefore seems more desirable to introduce the extra weight of the counterforts into the main wall. Besides, the building of the counterforts entails of itself an increased expense.

20. Reservoir Walls.—Let f be the maximum safe pressure per square foot of horizontal base, at inner face of a full reservoir, at outer face when empty.

Let w be the weight of a cubic foot of the masonry.

Assume that the wall is to be of *uniform strength*, i.e., that the section of the wall is of such form that in passing from any horizontal section to the consecutive one below, the ratio of the increment of the weight to the increment of the surface is constant and equal to f .

Let AB , Fig. 231, be the top of the wall. Take any point O as origin, and the vertical through O as the axis of x .

Let $OA = t_1$, $OB = t_2$, and let

$$T = t_1 + t_2 = AB.$$

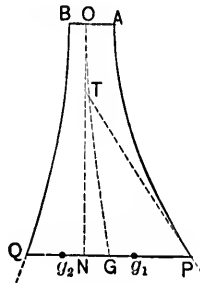

FIG. 231.

For the profile AP consider a layer of thickness dx at a depth x . Then

$$\frac{wydx}{dy} = f, \dots \dots \dots (1)$$

or

$$dx = \frac{f}{w} \frac{dy}{y};$$

$$\therefore x = \frac{f}{w} \log_e y + c,$$

c being a constant of integration.

When $x = 0$, $y = t_1$;

$$\therefore 0 = \frac{f}{w} \log_e t_1 + c,$$

and hence

$$x = \frac{f}{w} \log_e \frac{y}{t_1}, \dots \dots \dots (2)$$

which is the equation to AP and is the logarithmic curve.

It may be similarly shown that the equation to BQ is

$$x = \frac{f}{w} \log_e \frac{y}{t_2}. \dots \dots \dots (3)$$

Equations (2) and (3) may also be written in the forms

$$y = t_1 e^{\frac{w}{f}x} \dots \dots \dots (4)$$

and

$$y = t_2 e^{\frac{w}{f}x}. \dots \dots \dots (5)$$

Corresponding points on the profiles, e.g., P and Q , have a common subtangent of the constant value $\frac{f}{w}$, for

$$NT = PN \tan NPT \left(= y \frac{dx}{dy} \right) = \frac{f}{w} \dots \dots \dots (6)$$

$$\text{Area } PNOA = \int_0^x y dx = t_1 \left(\frac{f}{w} e^{\frac{w}{f}x} - \frac{f}{w} \right) = \frac{f}{w} (Y_1 - t_1), \quad (7)$$

where $PN = Y_1$.

$$\text{Area } QNOB = \int_0^x y dx = \frac{f}{w} (Y_2 - t_2), \quad (8)$$

where $QN = Y_2$.

$$\therefore \text{Area } QPAB = \frac{f}{w} (Y_1 + Y_2 - t_1 - t_2) = \frac{f}{w} (T' - T), \quad (9)$$

where $PQ = Y_1 + Y_2 = T'$.

Thus the area of the portion under consideration is equal to the product of the subtangent and the difference of thickness at top and bottom.

Lines of resistance with reservoir empty. Let g_1 be the point in which the vertical through the C. of G. of the portion $OAPN$ intersects PN . Then

$$Ng_1 \times \text{area } OAPN = \int_0^x y dx \frac{y}{2};$$

$$\therefore Ng_1(Y_1 - t_1) \frac{f}{w} = \frac{1}{2} \frac{f}{w} \int_{t_1}^{Y_1} y dy = \frac{1}{4} \frac{f}{w} (Y_1^2 - t_1^2);$$

$$\therefore Ng_1 = \frac{Y_1 + t_1}{4}.$$

So if g_2 be the point in which the vertical through the C. of G. of the portion $OBQN$ intersects QN ,

$$Ng_2 = \frac{Y_2 + t_2}{4}.$$

Let G be the point in which the vertical through the C. of G. of the whole mass $ABQP$ intersects PQ . Then

$$NG \times \text{area } ABQP = Ng_1 \times \text{area } AONP - Ng_2 \times \text{area } BONQ,$$

or

$$NG \frac{f}{w} (Y_1 - t_1 + Y_2 - t_2) = \frac{1}{4} \frac{f}{w} (Y_1^2 - t_1^2) - \frac{1}{4} \frac{f}{w} (Y_2^2 - t_2^2).$$

$$\therefore NG = \frac{(Y_1^2 - t_1^2) - (Y_2^2 - t_2^2)}{4(Y_1 - t_1 + Y_2 - t_2)}.$$

The horizontal distance between G and a vertical through the middle point of AB

$$= NG - \frac{1}{2}(t_1 - t_2) = \frac{(Y_1 - t_1)^2 - (Y_2 - t_2)^2}{4(Y_1 - t_1 + Y_2 - t_2)} = \frac{(Y_1 - t_1) - (Y_2 - t_2)}{4}$$

= one half of the horizontal distance between the verticals through the middle points of AB and QP .

The locus of G can therefore be easily plotted.

Lines of Resistance with Reservoir Full.—Let R be the centre of resistance in PQ (Fig. 232).

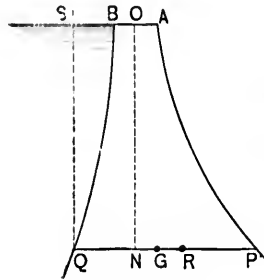

FIG. 232.

Draw the vertical QS , and consider the equilibrium of the mass $QSAPO$.

Let w' = weight of a cubic foot of water.

$$\frac{w'x^2x}{2 \cdot 3} = \text{moment of water-pressure}$$

against QS about R

$$= \text{moment of weight of } QBS \text{ about } R + \text{moment of weight of } QPAB \text{ about } R,$$

or

$$\frac{w'x^3}{6} = \text{moment of } QBS \text{ about } R + \frac{f}{w}(T' - T)w.GR.$$

The first term on the right-hand side of this equation is generally very small and may be disregarded, the error being on the safe side.

In such case

$$GR = \frac{1}{6} \frac{w'}{f} \frac{x^3}{T' - T}.$$

Also the *mean* intensity of the vertical pressure

$$= p_0 = \frac{w \times \text{area } APQB}{PQ} = f \left(1 - \frac{T}{T'} \right),$$

and the *maximum* intensity of the vertical pressure

$$= p_1 = \frac{2R}{\left(\frac{1}{3} - 3q\right)T^2} = \frac{4}{3}f \frac{\left(1 - \frac{T}{T'}\right)}{1 - 2q}$$

or

$$= \frac{R}{T'}(1 + 6q) = f(1 + 6q)\left(1 - \frac{T}{T'}\right).$$

General Case.—Let the profile be of any form, and consider any portion $ABQP$, Fig. 233.

Take the vertical through Q as the axis of x , and the horizontal line coincident with top of wall as the axis of y .

The horizontal distance (\bar{y}) between the axis of x and the vertical through the C. of G. of the portion under consideration is given by the equation

$$\bar{y} \int_0^x t dx = \int_0^x t y dx,$$

t being the width, dx the thickness, and y the horizontal distance from OQ of the C. of G. of any layer MN at a depth x from the top.

When the reservoir is *empty*, the deviation of the centre of resistance from the centre of base

$$= qT = Y - \bar{y} < \frac{T}{6}.$$

When the reservoir is *full*, let $q'T$ be the deviation of the centre of resistance from the centre of the base, and disregard the moment of the weight of the water between OQ and the profile BQ . Then

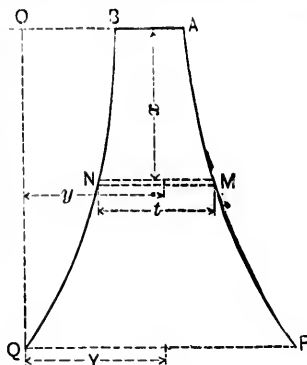

FIG. 233.

$$q'T = \frac{\text{moment of water pr. } \pm \text{ moment of wt. of } OBQ}{\text{weight of } ABQP} \mp Y$$

$$= \pm \frac{1}{\delta} \frac{\tau w' x^3}{\tau w \int_0^x t dx} \pm \bar{y} \mp Y.$$

Hence

$$(q \pm q')T = \frac{1}{\delta} \frac{\tau w' x^3}{\tau w \int_0^x t dx}.$$

21. General Equations of Stress.—Let x, y, z be the co-ordinates with respect to three rectangular axes of any point O in a strained body.

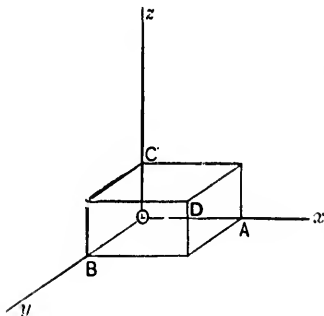

FIG. 234.

Consider the equilibrium of an element of the body in the form of an indefinitely small parallelepiped with its edges $OA(=dx)$, $OB(=dy)$, $OC(=dz)$ parallel to the axes of x, y, z . It is assumed that the faces of the element are sufficiently small to allow of the distribution of stress over them being regarded as uniform. The resultant force on each face will

therefore be a single force acting at its middle point.

Let X_1, Y_1, Z_1 be the components parallel to the axes x, y, z of the resultant force per unit area, on the face BC .

" X_2, Y_2, Z_2 be the corresponding components for the face AC .

" X_3, Y_3, Z_3 be the corresponding components for the face AB .

These components are functions of x, y, z , and therefore become

$$-\left(X_1 + \frac{dX_1}{dx} dx\right), -\left(Y_1 + \frac{dY_1}{dx} dx\right), -\left(Z_1 + \frac{dZ_1}{dx} dx\right),$$

for the adjacent face AD ;

$$-\left(X_2 + \frac{dX_2}{dy}dy\right), -\left(Y_2 + \frac{dY_2}{dy}dy\right), -\left(Z_2 + \frac{dZ_2}{dy}dy\right),$$

for the adjacent face BD ;

$$-\left(X_3 + \frac{dX_3}{dz}dz\right), -\left(Y_3 + \frac{dY_3}{dz}dz\right), -\left(Z_3 + \frac{dZ_3}{dz}dz\right),$$

for the adjacent face DC .

Hence, the total stress parallel to the axis of x

$$\begin{aligned} &= X_1 dydz - \left(X_1 + \frac{dX_1}{dx}dx\right) dydz + X_2 dzdx - \left(X_2 + \frac{dX_2}{dy}dy\right) dzdx \\ &\quad + X_3 dxdy - \left(X_3 + \frac{dX_3}{dz}dz\right) dxdy \\ &= -\left(\frac{dX_1}{dx} + \frac{dX_2}{dy} + \frac{dX_3}{dz}\right) dxdydz. \end{aligned}$$

Similarly, the total stress parallel to the axis of y

$$= -\left(\frac{dY_1}{dx} + \frac{dY_2}{dy} + \frac{dY_3}{dz}\right) dxdydz,$$

and the total stress parallel to the axis of z

$$= -\left(\frac{dZ_1}{dx} + \frac{dZ_2}{dy} + \frac{dZ_3}{dz}\right) dxdydz.$$

Let ρ be the density of the mass at O , and let P_x, P_y, P_z be the components parallel to the axes of x, y, z of the *external* force, per unit mass, at O .

$\rho dxdydz P_x$ is the component parallel to the axis of x of the external force on the element;

$\rho dxdydz P_y$ is the component parallel to the axis of y of the external force on the element;

$\rho dxdydz P_z$ is the component parallel to the axis of z of the external force on the element.

The element is in equilibrium.

$$\left. \begin{aligned} \therefore \frac{dX_1}{dx} + \frac{dY_2}{dy} + \frac{dZ_3}{dz} &= \rho P_x; \\ \frac{dY_1}{dx} + \frac{dY_2}{dy} + \frac{dY_3}{dz} &= \rho P_y; \\ \frac{dZ_1}{dx} + \frac{dZ_2}{dy} + \frac{dZ_3}{dz} &= \rho P_z. \end{aligned} \right\} \dots \dots \dots (1)$$

These are the general equations of stress.

Again, take moments about axes through the centre of the element parallel to the axes of co-ordinates, and neglect terms involving $(dx)^2 dy dz$, $dx(dy)^2 dz$, $dx dy (dz)^2$.

$$\therefore Y_3 = Z_2, \quad Z_1 = X_3, \quad \text{and} \quad X_2 = Y_1. \dots \dots (2)$$

Adopting Lamé's notation, i.e., taking

N_1, N_2, N_3 as the normal intensities of stress at O on planes perpendicular to the axes of x, y, z ;

T_1 as the tangential intensity of stress at O on a plane perpendicular to the axis of x if due to a stress parallel to the axis of y , or on a plane perpendicular to the axis of y if due to a stress parallel to the axis of x ; and T_2, T_3 similarly,—equations (1) become

$$\left. \begin{aligned} \frac{dN_1}{dx} + \frac{dT_3}{dy} + \frac{dT_2}{dz} &= \rho P_x; \\ \frac{dT_3}{dx} + \frac{dN_2}{dy} + \frac{dT_1}{dz} &= \rho P_y; \\ \frac{dT_2}{dx} + \frac{dT_1}{dy} + \frac{dN_3}{dz} &= \rho P_z. \end{aligned} \right\} \dots \dots \dots (3)$$

Next consider the equilibrium of a tetrahedral element having three of its faces parallel to the co-ordinate planes. Let l, m, n be the direction-cosines of the normal to the fourth face.

Also, let X, Y, Z be the components parallel to the axes of x, y, z of the intensity of stress R on the fourth face.

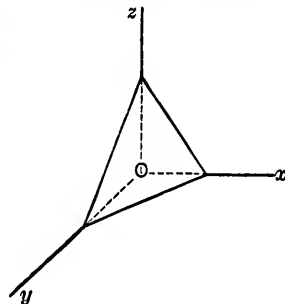

FIG. 235.

$$X = lN_1 + mT_2 + nT_3 + \frac{1}{3}\rho P_x l dx.$$

But the last term disappears in the limit when the tetrahedron is indefinitely small, and hence

$$\left. \begin{aligned} X &= lN_1 + mT_2 + nT_3; \\ Y &= lT_1 + mN_2 + nT_3; \\ Z &= lT_2 + mT_1 + nN_3. \end{aligned} \right\} \dots \dots \dots (4)$$

These three equations define R in direction and magnitude when the stresses on the three rectangular planes are known.

Let it be required to determine the planes upon which the stress is wholly normal. We have

$$X = lR, \quad Y = mR, \quad Z = nR. \dots \dots (5)$$

Substituting these values of X, Y, Z in eqs. (4) and eliminating l, m, n , we obtain

$$R^3 - R^2(N_1 + N_2 + N_3) + R(N_1N_2 + N_2N_3 + N_3N_1) - T_1^2 - T_2^2 - T_3^2 - (N_1N_2N_3 - N_1T_1^2 - N_2T_2^2 - N_3T_3^2 + 2T_1T_2T_3) = 0; \quad (6)$$

a cubic equation giving three real values for R , and therefore three sets of values for l, m , and n , showing that there are three planes at O on each of which the intensity of stress is wholly normal. These planes are at right angles to each other and are called *principal planes*, the corresponding stresses being *principal stresses*. They are the principal planes of the quadric,

$$N_1x^2 + N_2y^2 + N_3z^2 + 2T_1yz + 2T_2zx + 2T_3xy = c. \quad (7)$$

For, the equation to the tangent plane at the extremity of a radius r whose direction-cosines are l, m, n is

$$Xrx + Yry + Zrz = c, \dots \dots \dots (8)$$

and the equation of the parallel diametral plane is

$$Xx + Yy + Zz = 0. \dots \dots \dots (9)$$

The direction-cosines of the perpendicular to this plane are

$$\frac{X}{R} = l, \quad \frac{Y}{R} = m, \quad \frac{Z}{R} = n,$$

so that the resultant stress R must act in the direction of this perpendicular.

Hence the intensities of stress on the planes perpendicular to the axes of the quadric (7) are wholly normal.

Refer the quadric to its principal planes as planes of reference. All the T 's vanish and its equation becomes

$$N_1x^2 + N_2y^2 + N_3z^2 = c. \dots \dots \dots (10)$$

Also, the general equations (3) become

$$\left. \begin{aligned} \frac{dN_1}{dx} &= \rho P_x; \\ \frac{dN_2}{dy} &= \rho P_y; \\ \frac{dN_3}{dz} &= \rho P_z. \end{aligned} \right\} \dots \dots \dots (11)$$

Again,

$$\left(\frac{X}{N_1}\right)^2 + \left(\frac{Y}{N_2}\right)^2 + \left(\frac{Z}{N_3}\right)^2 = l^2 + m^2 + n^2 = 1. \dots (12)$$

Consider X, Y, Z as the co-ordinates of the extremity of the straight line representing R in direction and magnitude. Equation (12) is then the equation to an ellipsoid whose semi-axes are N_1, N_2, N_3 . As a plane at O turns round O as a fixed centre, the extremity of a line representing the intensity of stress R on the plane will trace out an ellipsoid. This ellipsoid is called the *ellipsoid of stress*.

Note 1. The coefficients in the cubic equation (6) are invariants. Thus, $N_1 + N_2 + N_3$ is constant, or the sum of three normal intensities of stress on three planes placed at right angles at any point of a strained body is the same for all positions of the three planes.

Note 2. The perpendicular p from O on the tangent plane, equation (8),

$$= \frac{c}{Rr} = p.$$

$$\therefore R = \frac{c}{pr} \dots \dots \dots (13)$$

Note 3. Let the stress be the same for *all* positions of the plane at O . Then $N_1 = N_2 = N_3$, and the ellipsoid (12) becomes a sphere. The stress is therefore everywhere normal, and the body must be a perfect fluid. Conversely, if the stress is everywhere normal, the body must be a perfect fluid, the ellipsoid becomes a sphere, and therefore $N_1 = N_2 = N_3$.

22. Relation between Stress and Strain.—In Art. 13 it was shown that when the size and figure of a body are altered in two dimensions, there is an *ellipse of strain* analogous to the ellipse of stress. If the alteration takes place in three dimensions, it may be similarly shown that every state of strain may be represented by an *ellipsoid of strain* analogous to the ellipsoid of stress. The axes of the ellipsoid are the principal axes of strain, and every strain may be resolved into three simple strains parallel to these axes.

It is assumed that the strains remain very small, that the stresses developed are proportional to the corresponding strains, and that their effects may be superposed.

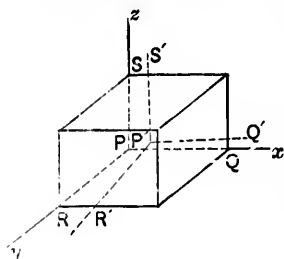

FIG. 236.

Consider an element of the unstrained body in the form of a rectangular parallelepiped, having its edges $PQ (= h)$, $PR (= k)$, $PS (= l)$ parallel to the axes of co-ordinates.

When the body is strained, the element becomes distorted, the new edges being $P'Q'$, $P'R'$, $P'S'$.

Let x, y, z be the co-ordinates of P .

Let $x + u, y + v, z + w$ be the co-ordinates of P' .

By Taylor's Theorem the co-ordinates with respect to P' of

$$Q' \text{ are } h\left(1 + \frac{du}{dx}\right), \quad h\frac{dv}{dx}, \quad h\frac{dw}{dx};$$

$$R' \text{ are } k\frac{du}{dy}, \quad k\left(1 + \frac{dv}{dy}\right), \quad k\frac{dw}{dy};$$

$$S' \text{ are } l\frac{du}{dz}, \quad l\frac{dv}{dz}, \quad l\left(1 + \frac{dw}{dz}\right).$$

$$\therefore \left. \begin{aligned} P'Q' &= h\left(1 + \frac{du}{dx}\right); \\ P'R' &= k\left(1 + \frac{dv}{dy}\right); \\ P'S' &= l\left(1 + \frac{dw}{dz}\right). \end{aligned} \right\} \dots \dots \dots (14)$$

$$\left. \begin{aligned} \text{Hence, strain parallel to axis of } x &= \frac{P'Q' - PQ}{PQ} = \frac{du}{dx}; \\ \text{“ “ “ } y &= \frac{P'R' - PR}{PR} = \frac{dv}{dy}; \\ \text{“ “ “ } z &= \frac{P'S' - PS}{PS} = \frac{dw}{dz}. \end{aligned} \right\} (15)$$

Again, $\cos Q'P'R'$

$$= \frac{\left(1 + \frac{du}{dx}\right) \frac{du}{dy} + \left(1 + \frac{dv}{dy}\right) \frac{dv}{dx} + \frac{dw}{dy} \frac{dw}{dx}}{\left[\left\{ 1 + \left(\frac{du}{dx}\right)^2 + \left(\frac{dv}{dx}\right)^2 + \left(\frac{dw}{dx}\right)^2 \right\} \left\{ \left(\frac{du}{dy}\right)^2 + \left(1 + \frac{dv}{dy}\right)^2 + \left(\frac{dw}{dy}\right)^2 \right\} \right]^{\frac{1}{2}}}$$

In the limit, this reduces to

$$\left. \begin{aligned} \cos Q'P'R' &= \frac{du}{dy} + \frac{dv}{dx} \\ \text{Similarly, } \cos Q'P'S' &= \frac{du}{dz} + \frac{dv}{dx} \\ \cos R'P'S' &= \frac{dv}{dy} + \frac{dw}{dz} \end{aligned} \right\} \dots \dots (16)$$

Volume of unstrained element = hkl ;

$$\begin{aligned} \text{Volume of distorted element} &= hkl \left(1 + \frac{du}{dx}\right) \left(1 + \frac{dv}{dy}\right) \left(1 + \frac{dw}{dz}\right) \\ &\quad \text{multiplied by the cosines} \\ &\quad \text{of small angles} \\ &= hkl \left(1 + \frac{du}{dx} + \frac{dv}{dy} + \frac{dw}{dz}\right), \\ &\quad \text{in the limit.} \end{aligned}$$

$$\therefore \frac{\text{Difference of volume}}{\text{Vol. of unstrained element}} = \frac{du}{dx} + \frac{dv}{dy} + \frac{dw}{dz}, \dots \dots (17)$$

= the *volume* or *cubic* strain.

23. Isotropic Bodies, i.e., bodies possessing the same elastic properties in all directions.

A normal stress of intensity N , parallel to the axis of x produces a simple longitudinal strain $\frac{N_1}{E}$, and two simple lateral strains, each = $-\frac{N_1}{mE}$, parallel to the axes of y and z ,

E being the ordinary modulus of elasticity and $\frac{1}{m}$, Poisson's ratio (Art. 3, Chap. III).

Normal stresses N_2, N_3 parallel to the axes of y and z may be similarly treated.

Let the three normal stresses act simultaneously and superpose the results. Then

$$\left. \begin{aligned} \text{total strain parallel to axis of } x &= \frac{N_1}{E} - \frac{N_2 + N_3}{mE} = \frac{du}{dx}; \\ \text{“ “ “ “ } y &= \frac{N_2}{E} - \frac{N_3 + N_1}{mE} = \frac{dv}{dy}; \\ \text{“ “ “ “ } z &= \frac{N_3}{E} - \frac{N_1 + N_2}{mE} = \frac{dw}{dz}. \end{aligned} \right\} \quad (18)$$

The form in which these equations are given is due to Grashof.

Solving for N_1, N_2, N_3 ,

$$\left. \begin{aligned} N_1 &= \frac{m(m-1)E}{(m+1)(m-2)} \frac{du}{dx} + \frac{mE}{(m+1)(m-2)} \left(\frac{dv}{dy} + \frac{dw}{dz} \right); \\ N_2 &= \frac{m(m-1)E}{(m+1)(m-2)} \frac{dv}{dy} + \frac{mE}{(m+1)(m-2)} \left(\frac{dw}{dz} + \frac{du}{dx} \right); \\ N_3 &= \frac{m(m-1)E}{(m+1)(m-2)} \frac{dw}{dz} + \frac{mE}{(m+1)(m-2)} \left(\frac{du}{dx} + \frac{dv}{dy} \right). \end{aligned} \right\} \quad (19)$$

The last equations may be written

$$\left. \begin{aligned} N_1 &= A \frac{du}{dx} + \lambda \left(\frac{dv}{dy} + \frac{dw}{dz} \right); \\ N_2 &= A \frac{dv}{dy} + \lambda \left(\frac{dw}{dz} + \frac{du}{dx} \right); \\ N_3 &= A \frac{dw}{dz} + \lambda \left(\frac{du}{dx} + \frac{dv}{dy} \right); \end{aligned} \right\} \dots \dots \dots (20)$$

where

$$\frac{dw}{dy} + G \frac{dw}{dy}$$

Similar

G is and is Lamé's μ serve to Ke through Let

Let ments.

∴

For

where $\lambda = \frac{mE}{(m+1)(m-2)}$, is the coefficient of dilatation, and

$$A = \frac{m(m-1)E}{(m+1)(m-2)}$$

Again, the straining changes the angle RPS by an amount $\frac{dv'}{dy} + \frac{dw'}{dz}$, producing two tangential stresses, each equal to $G\left(\frac{dv'}{dy} + \frac{dw'}{dz}\right)$, parallel to the axes of y and z .

$$\begin{aligned} \therefore T_1 &= G\left(\frac{dv'}{dy} + \frac{dw'}{dz}\right). \\ \text{Similarly, } T_2 &= G\left(\frac{du'}{dz} + \frac{dw'}{dx}\right); \\ T_3 &= G\left(\frac{du'}{dy} + \frac{dv'}{dx}\right). \end{aligned} \quad \left. \begin{array}{l} \\ \\ \end{array} \right\} \dots \dots \dots (21)$$

G is called the coefficient of *rigidity* or *transverse elasticity*, and is designated n in Thomson and Tait's notation, and μ in Lamé's notation.

Relation between A , λ , and G .—Equations (20) and (21) preserve the same forms whatever rectangular axes may be chosen.

Keep the axis of z fixed and turn the axes of x and y through an angle α .

Let N_1' be the normal stress parallel to the new axis of x .

$$\therefore N_1' = N_1 \cos^2 \alpha + N_2 \sin^2 \alpha + 2T_3 \sin \alpha \cos \alpha. \quad (22)$$

Let x' , y' and u' , v' be the new co-ordinates and displacements.

$$\therefore N_1' = A \frac{du'}{dx'} + \lambda \left(\frac{dv'}{dy'} + \frac{dw'}{dz'} \right) = (A - \lambda) \frac{du'}{dx'} + \lambda \theta. \quad (23)$$

For $\frac{du}{dx} + \frac{dv}{dy} + \frac{dw}{dz} = \theta = \frac{du'}{dx'} + \frac{dv'}{dy'} + \frac{dw'}{dz'}$, is an invariant.

The values of N_1' given by eqs. (22) and (23) must be identical. Now,

$$\left. \begin{aligned} x &= x' \cos \alpha - y' \sin \alpha, & y &= x' \sin \alpha + y' \cos \alpha; \\ u' &= u \cos \alpha + v \sin \alpha, & v' &= -u \sin \alpha + v \cos \alpha. \end{aligned} \right\} (24)$$

$$\begin{aligned} \therefore \frac{du'}{dx'} &= \frac{du}{dx} \cos \alpha + \frac{dv}{dx} \sin \alpha \\ &= \frac{du}{dx} \cos^2 \alpha + \frac{dv}{dy} \sin^2 \alpha + \left(\frac{du}{dy} + \frac{dv}{dx} \right) \sin \alpha \cos \alpha \\ &= \frac{du}{dx} \cos^2 \alpha + \frac{dv}{dy} \sin^2 \alpha + \frac{T_3}{G} \sin \alpha \cos \alpha; \end{aligned}$$

and by eq. (23),

$$N_1' = (A - \lambda) \left(\frac{du}{dx} \cos^2 \alpha + \frac{dv}{dy} \sin^2 \alpha + \frac{T_3}{G} \sin \alpha \cos \alpha \right) + \lambda \theta. \quad (25)$$

Also by eqs. (20) and (22),

$$N_1' = (A - \lambda) \left(\frac{du}{dx} \cos^2 \alpha + \frac{dv}{dy} \sin^2 \alpha + \frac{2T_3}{A - \lambda} \sin \alpha \cos \alpha \right) + \lambda \theta. \quad (26)$$

Eqs. (25) and (26) must be identical.

$$\therefore G = \frac{A - \lambda}{2} = \frac{mE}{2(m + 1)} = \mu = n. \quad \dots (27)$$

Adding together equations (20),

$$\begin{aligned} N_1 + N_2 + N_3 &= (A + 2\lambda) \left(\frac{du}{dx} + \frac{dv}{dy} + \frac{dw}{dz} \right) \\ &= \frac{mE}{m - 2} \left(\frac{du}{dx} + \frac{dv}{dy} + \frac{dw}{dz} \right). \end{aligned}$$

It may be easily shown that the normal stresses can each be separated into a fluid pressure p and a distorting stress.

Hence, putting

$$N_1 = N_2 = N_3 = p = \frac{mE}{3(m-2)} \left(\frac{du}{dx} + \frac{dv}{dy} + \frac{dw}{dz} \right),$$

the cubic elasticity = $\frac{p}{\frac{du}{dx} + \frac{dv}{dy} + \frac{dw}{dz}} = \frac{mE}{3(m-2)} = K. \quad (28)$

24. Applications.—1. *Traction.*—One end of a cylindrical bar of isotropic material is fixed and the bar is stretched in the direction of its length. The axis of the bar is the only line not moved laterally by contraction.

Take this line as the axis of x .

The displacements u, v, w of any point x, y, z may be expressed in the form

$$u = \alpha x, \quad v = -\beta y, \quad w = -\beta z. \quad \dots \quad (29)$$

By eqs. (20) and (29),

$$N_1 = \alpha A - 2\beta\lambda. \quad \dots \quad (30)$$

$$N_2 = -\beta A + \lambda(\beta + \alpha) = N_3. \quad \dots \quad (31)$$

By eqs. (21) and (29), all the tangential stresses vanish.

Hence, since N_1, N_2, N_3 are constant, and since the equations of internal equilibrium contain only differential coefficients of the stresses, the hypothesis, eq. (29), satisfies these equations.

First. Let $N_2 = 0 = N_3$; i.e., let no external force act upon the curved surface.

$$\therefore -\beta A + \lambda(\beta + \alpha) = 0,$$

or

$$\frac{\beta}{\alpha} = \frac{\lambda}{A + \lambda} = \frac{1}{m}. \quad \dots \quad (32)$$

Thus, the coefficient of contraction is less than the coefficient of expansion.

Again, by eqs. (30) and (32),

$$\frac{N_1}{\alpha} = A - 2\lambda \frac{\beta}{\alpha} = A - \frac{2\lambda}{m} = E. \quad \dots (33)$$

Second. If the bar, instead of being free to move laterally, has its surface acted upon by a uniform pressure P , then

$$N_2 = N_3 = P.$$

By eqs. (31) and (32),

$$\frac{\beta}{\alpha} = \frac{AP - \lambda N_1}{\lambda(N_1 + 2P) - AN_1} \quad \dots (35)$$

For example, let P be sufficient to prevent lateral contraction. Then $\beta = 0$ and, by eqs. (31) and (35),

$$\alpha A = N_1 = \frac{AP}{\lambda} = (m - 1)P.$$

2. *Torsion.*—(a) Let a circular cylinder (hollow or solid) of length l undergo torsion around its axis (the axis of x), and let t be the angle through which one end is twisted relatively to the other. A point in a transverse section distant x from the latter will be twisted through an angle $x \frac{t}{l}$.

The displacements u, v, w of the point x, y, z in this section may be expressed in the form

$$u = 0, \quad v = -zx \frac{t}{l}, \quad w = +yx \frac{t}{l}.$$

By eqs. (20) and (21),

$$N_1 = 0 = N_2 = N_3,$$

and

$$T_1 = 0, \quad T_2 = +Gy \frac{t}{l}, \quad T_3 = -Gz \frac{t}{l}.$$

The algebraic sum of the moments of T_x , T_z with respect to the axis

$$= G \frac{l}{l} (y^2 + z^2) = G \frac{l}{l} r^2,$$

r being the distance of the point (x, y, z) from the axis.

Hence, the moment M , = $l\theta$ (Chap. IX), of the couple producing torsion

$$= G \frac{l}{l} \int r^2 dS = G \frac{l}{l} I = G\theta I,$$

dS being an element of the area at (x, y, z) , I the polar moment of inertia, and θ the torsion per unit of length of the cylinder, or the *rate of twist*.

The torsional rigidity of a solid cylinder

$$= \frac{M}{\theta} = GI = \frac{G}{2} \pi R^4,$$

R being the radius of the cylinder.

(b) Torsion of a bar of *elliptic* section.

The displacements u , v , w may now be expressed in the form

$$u = F(y, z), \quad v = -\theta xz, \quad w = \theta xy.$$

$$\therefore \frac{du}{dx} = 0 = \frac{dv}{dy} = \frac{dw}{dz};$$

$$N_x = 0 = N_y = N_z;$$

$$T_x = 0, \quad T_y = G \left(\frac{du}{dz} + \theta y \right), \quad T_z = G \left(\frac{du}{dy} - \theta z \right). \quad (35)$$

Hence, by the general eqs. (3),

$$\frac{d^2 u}{dy^2} + \frac{d^2 u}{dz^2} = 0. \quad \dots \dots \dots (36)$$

Also, the surface stresses are zero;

$$\therefore T_1 \frac{dz}{ds} - T_2 \frac{dy}{ds} = 0, \dots \dots \dots (37)$$

and hence, by eqs. (35),

$$\frac{du}{dy} dz - \frac{du}{dz} dy = \theta(zdz + ydy). \dots \dots \dots (38)$$

This equation must hold true at the surface.

Let the equation to the elliptic section be

$$\frac{y^2}{b^2} + \frac{z^2}{c^2} = 1. \dots \dots \dots (39)$$

$$\therefore \frac{dz}{dy} = -\frac{c^2 y}{b^2 z}, \dots \dots \dots (40)$$

and by eq. (38),

$$c^2 y \frac{du}{dy} + b^2 z \frac{du}{dz} = -\theta y z (b^2 - c^2). \dots \dots \dots (41)$$

$r = d y z$ satisfies this last equation and also eq. (36), if

$$d = -\theta \frac{b^2 - c^2}{b^2 + c^2}. \dots \dots \dots (42)$$

Again, the algebraic sum of the moments T_1 , T_2 with respect to the axis of x ,

$$\begin{aligned} &= G \left(\frac{du}{dz} + \theta y \right) y - G \left(\frac{du}{dy} - \theta z \right) z \\ &= G \left\{ (d + \theta) y^2 - (d - \theta) z^2 \right\} \\ &= \frac{2G\theta}{b^2 + c^2} (c^2 y^2 + b^2 z^2). \dots \dots \dots (43) \end{aligned}$$

The total moment (M of the couple producing torsion

$$\begin{aligned} &= 2G\theta \int (c^2 y^2 + b^2 z^2) dS \\ &= G\theta \frac{\pi b^3 c^3}{b^2 + c^2}, \end{aligned} \tag{37}$$

and the torsional rigidity

$$\frac{M}{\theta} = G \frac{\pi b^3 c^3}{b^2 + c^2} \dots \dots \dots \tag{38}$$

(c) Torsion of a bar of rectangular section.

As in case (b), u must satisfy the equation

$$\frac{d^2 u}{dy^2} + \frac{d^2 u}{dz^2} = 0 \dots \dots \dots \tag{39}$$

Also, the equations of condition corresponding to eq. (38) are

$$\frac{du}{dy} - \theta z = 0 \quad \text{when } y = \pm b, \dots \dots \tag{40}$$

and

$$\frac{du}{dz} + \theta y = 0 \quad \text{when } z = \pm c; \dots \dots \tag{41}$$

$2b$ and $2c$ ($b < c$) being the sides of the rectangle. The total moment of torsion, viz., $\int (T_y y - T_z z) dS$ is then found to be

$$M = 16b^3 c G \theta \left\{ \frac{1}{3} - \frac{64 b}{\pi^2 c} \sum_0^\infty \frac{\tan h (2n + 1) \frac{\pi c}{2b}}{(2n + 1)^3} \right\} \dots \tag{42}$$

If $b = c$, i.e., if the section is a square, eq. (48) becomes

$$M = .843462 IG \theta, \dots \dots \dots \tag{43}$$

I ($= \frac{1}{3} b^4$) being the moment of inertia with respect to the axes. (See Chap. IX).

If $\frac{b}{c}$ is very small, eq. (48) becomes

$$M = 16b^3cG\theta\left(\frac{1}{3} - .21\frac{b}{c}\right). \dots \dots (50)$$

The torsional rigidity of a rectangular section is sometimes expressed by the formula

$$\frac{M}{\theta} = \frac{5}{18} \frac{b^3c^3}{b^2 + c^2} G. \dots \dots (51)$$

For the further treatment of this subject, the student is referred to St. Venant's edition of Clebsch, and to Thomson and Tait's Natural Philosophy.

3. *Work done in the small strain of a body* (Clapeyron's Theorem) — Multiply eqs. (3) by $u dx dy dz, v dx dy dz, w dx dy dz$, and find the triple integral of their sum throughout the whole of the solid.

The terms involving the components P_x, P_y, P_z may be disregarded, as the deformations due to their action are generally inappreciable.

Also,

$$\begin{aligned} \int \int \int \frac{dN_1}{dx} u dx dy dz \\ = \int \int (N_x' u_x - N_x'' u_x'') dy dz - \int \int \int N_1 \frac{du}{dx} dx dy dz; \end{aligned}$$

N_x', N_x'' being the values of N_1 at the two points in which the line parallel to the axis of x cuts the surface of the body, and u_x', u_x'' the corresponding values of u .

Let dS, dS' be the elementary areas of the surface at these points, and l', l'' the cosines of the angles between the normals to these elements and the axis of x .

The double integral on the right-hand side of the last equation then becomes

$$\int \int (N_x' l' u_x' dS - N_x'' l'' u_x'' dS') = \Sigma (N_1 l u dS).$$

Treating the other terms similarly,

$$\begin{aligned} 0 = \Sigma \{ & (N_1 l + T_1 m + T_2 n) u + (T_1 l + N_2 m + T_1 n) v \\ & + (T_2 l + T_1 m + N_3 n) w \} dS \\ - \iiint dx dy dz \{ & N_1 \frac{du}{dx} + N_2 \frac{dv}{dy} + N_3 \frac{dw}{dz} \\ & + T_1 \left(\frac{dv}{dz} + \frac{dw}{dy} \right) + T_2 \left(\frac{dw}{dx} + \frac{du}{dz} \right) + T_3 \left(\frac{du}{dy} + \frac{dv}{dx} \right) \} \end{aligned}$$

Hence, the work done = $\frac{1}{2} \Sigma (Xu + Yv + Zw) dS$

$$\begin{aligned} &= \frac{1}{2} \iiint dx dy dz \left\{ \frac{\lambda + G}{G(3\lambda + 2G)} (N_1 + N_2 + N_3)^2 \right. \\ &\quad \left. - \frac{1}{G} (N_1 N_2 + N_2 N_3 + N_3 N_1 - T_1^2 - T_2^2 - T_3^2) \right\} \\ &= \frac{1}{2} \iiint dx dy dz \left\{ \frac{(N_1 + N_2 + N_3)^2}{E} \right. \\ &\quad \left. - \frac{N_1 N_2 + N_2 N_3 + N_3 N_1 - T_1^2 - T_2^2 - T_3^2}{G} \right\}, \end{aligned}$$

E being the ordinary modulus of elasticity.

EXAMPLES.

1. At a point within a strained solid there are two conjugate stresses, viz., a tension of 200 lbs. and a thrust of 150 lbs. per square inch, the common obliquity being 30° . Find (a) the principal stresses; (b) the maximum shear and the direction and magnitude of the corresponding resultant stress; (c) the resultant stress upon a plane inclined at 30° to the axis of greatest principal stress.

Ans.—(a) A tension of 204.65 lbs. and a thrust of 146.95 lbs. per sq. in.

(b) 175.8 lbs. per sq. in.; 177.95 lbs. in a direction making an angle of $9^\circ 20'$ with the axis of greatest principal stress.

(c) 163.3 lbs. per sq. in.

2. A wall with a plumb rear face is to be 30 ft. high and 4 ft. wide at the top; the earth slopes up from the inner edge at the angle of 20° , 30° being the angle of repose. Assuming Rankine's theory, determine the proper width of the base, the masonry weighing 144 lbs. per cubic foot, and the earth 110 lbs. *Ans.* 10.94 ft., q being $\frac{1}{4}$.

3. A wall 6 ft. wide at the bottom, plumb at the rear, and with a front batter of 1 in 12, retains water level with the top. Find (a) the limiting position of the centre of pressure at the base so that the stress may be nowhere negative.

How (b) high may the wall be built when subjected to this condition? (a cubic foot of masonry = 125 lbs.).

Ans. (a) 12 in. from middle point of base; (b) height = 8.9 ft.

4. A wall is built up in layers, the water face being plumb and the rear stepped. If l be the thickness of the n th layer and y the depth of water above its lower face, show that width of layer \times thickness of layer = $\sqrt{4 \cdot l^2 + 6Atz + mty^2} - 2A$; A being the sectional area of the wall above the layer in question, z the horizontal distance between the water face and the line of action of the resultant weight above the layer, l the layer's thickness, and m the ratio of the specific weights of the water and masonry.

5. At a point within a strained solid, the stresses on two planes at right angles to each other are a thrust of $30\sqrt{2}$ lbs. and a tension of 60 lbs. per square inch, the obliquities being 45° and 30° respectively. Determine (a) the principal stresses; (b) the ellipse of stress; (c) the intensity of stress upon a plane inclined at 60° to the major axis.

Ans.—(a) A tension of 61.76 lbs. and a thrust of 39.80 lbs.

(c) A thrust of 57.06 lbs.

6. If the principles of the ellipse of stress are applicable within a mass of earth, and if at any point of the mass the stress upon a plane is double its conjugate stress, the angle between the two stresses being $20^{\circ} 28'$, show that the angle of repose of the earth is $27^{\circ} 58'$.

7. The total stress at a point O upon a plane AB is 60 lbs. per square inch, and its obliquity is 30° ; the normal component upon a plane CD at the point O is 40 lbs. per square inch; CD is perpendicular to AB . Find (a) the total stress upon CD , and also its obliquity; (b) the principal stresses at O ; (c) the equal conjugate stresses at O .

Ans.—(a) $\tan^{-1}(\frac{2}{3})$; 50 lbs.
 (b) 76.57 lbs. and 15.39 lbs.
 (c) 34.32 lbs.; obliquity = $41^{\circ} 42'$.

8. Assuming Rankine's theory, find the pressure on the vertical face of a retaining-wall, 30 ft. high, which retains earth sloping up from the top at the angle of repose, viz., 30° .

(Weight of masonry = 128 lbs. per cubic foot.; weight of earth = 120 lbs. per cubic foot.)

Ans. 46,764 lbs.

9. At a point within a strained solid the stress on one plane is a tension of 50 lbs. per square inch with an obliquity of 30° , and upon a second plane is a compression of 150 lbs. per square inch with an obliquity of 45° . Find (a) the principal stresses; (b) the angle between the two planes; (c) the plane upon which the resultant stress is a shear, and the amount of the shear.

Ans.—(a) $p_1 = 179.98$ lbs. (comp.); $p_2 = -46.12$ lbs. (tens.).
 (b) $61^{\circ} 31'$.
 (c) 91.11 lbs.; $\gamma = 26^{\circ} 51'$.

10. At a point within a strained solid the stress on one plane is a tension of 100 lbs. per square inch with an obliquity of 30° , and on a second plane a compression of 50 lbs. with an obliquity of 60° . Find (a) the angle between the planes; (b) the plane upon which the stress is wholly a shear; (c) the planes of principal stress.

Ans.—(a) $50^{\circ} 5'$.
 (b) 64.6 lbs.; $\gamma = 31^{\circ} 16'$.
 (c) $p_1 = 106.46$ (tens.); $p_2 = -39.26$ (compr.).

11. In the preceding question find the conjugate stresses at the given point having the common obliquity 45° .

Ans. 92.63 lbs. (tension) and 45.11 lbs. (thrust).

12. At a point within a strained mass the principal stresses at a given point are in the ratio of 3 to 1. Find the ratio of the conjugate stresses at the same point having the common obliquity 30° . Also find the inclination of the axis of greatest principal stress to the horizontal.

Ans. Equal; 60° .

13. A wall 3 feet thick, of rectangular section and weighing 125 lbs. per cubic foot, is subjected to a horizontal thrust of 800 lbs. per foot run

at its top. What should be the height of the wall in order that all the joints above the base may be frictionally stable? Coefficient of friction = unity. *Ans.* $2\frac{7}{8}$ ft.

14. A wall 12 ft. high, 2 ft. wide at the top, and 3 ft. wide at the bottom, is constructed of masonry weighing 120 lbs. per cubic foot. The overturning force on the rear face of the wall, which is plumb, is a horizontal force P acting at 4 ft. from the base. Find P so that the deviation of the centre of pressure in the base may not exceed $\frac{1}{4}$ ft. The centre of pressure being fixed at 2 in. from the middle of the base, show that $\frac{2}{3}$ of the section may be removed without altering its stability, and find the increase in the inclination of the resultant pressure on the base to the vertical, consequent on the removal.

Ans. 360 lbs.; tangents of angles arc in ratio of 5 to 3.

15. A reservoir wall is 4 ft. wide at top, has a front batter of 1 in 12, a rear batter of 2 in 12, and is constructed of masonry weighing 125 lbs. per cubic foot; the maximum compression is not to exceed $10,526\frac{1}{9}$ lbs. per square foot. Find the limiting height of the wall. *Ans.* 16 ft.

16. A dock-wall, plumb at the rear and having a face with a batter of 1 in 24, is 20 ft. high and 9 ft. wide at the base. Counterforts are built at intervals of 12 ft., projecting 3 ft. from the rear and 6 ft. wide. Determine the thickness of an equally strong wall without counterforts, with the same face-batter and also plumb in the rear.

Ans. 10.95 ft.

17. If the walls in the preceding question are founded in earth weighing 112 lbs. per square foot and having an angle of repose of 32° , find the least depth of foundation in each case, the masonry weighing 125 lbs. per cubic foot.

Ans. 2.72 ft.; 2.71 ft.

18. A vertical retaining-wall is strengthened by means of vertical rectangular anchor-plates having their upper and lower edges 18 and 22 ft., respectively, below the surface. Find the holding power per foot of width, the earth weighing 130 lbs. per cubic foot and having an angle of repose of 30° .

Ans. $27,733\frac{1}{3}$ lbs.

19. Determine the limiting depths of foundation for (a) a wall of rectangular section 20 ft. high; (b) for a wall of trapezoidal section having plumb rear and front faces 4 and 20 ft. high respectively. Angle of repose of earth = 30° ; weight of earth = 112 lbs. per cubic foot; of masonry = 140 lbs.

Ans. (a) 3.22 ft.; (b) 1.93 ft.

20. A wall 20 ft. high and 6 ft. thick retains earth on one side level with the top, and on the other the earth rises up the wall at its natural slope, viz., 45° , to the height of 5 ft. Will the wall stand or fall?

(Weight of masonry per cubic foot = 130 lbs.; of earth = 120 lbs.)

Find the locus of the centres of pressure of successive layers.

Ans. Overturning moment = 4128 ft.-lbs. ; moment of stability = $93600q + 750(\frac{1}{3}^4 - 6q) = 36912\frac{1}{2}$ ft.-lbs if $q = \frac{2}{3}$.
The wall is stable.

21. The upper half of the section of a masonry wall is a rectangle 4 ft. wide, and the lower half a rectangle 6 ft. wide, one face being plumb. Find the height of the wall so that the stress on the base may nowhere exceed 10,000 lbs. per square foot when the wall retains water (*a*) on the plumb face, (*b*) on the stepped face.

(Masonry weighs 125 lbs. per cubic foot.)

Ans. (*a*) 13.08 ft.; (*b*) 12.2 ft.

22. A masonry dam h ft. high is a right-angled triangle *ABC* in section, and retains water on the vertical face *AB*. Show that the thickness t of the base *BC* is given by $t^2 = \frac{4h^2}{5(6q+1)}$, qt being the deviation of the centre of pressure in the base from the middle point.

Also show that the thickness will be given by $t^2 = \frac{4h^2}{3(6q+1)}$ if the rock upon which the wall is built is seamy, and if it is assumed that the communication between the water in the seams, and that in the reservoir produces an upward pressure upon the base *BC*, varying uniformly from that equivalent to the head at *B* to nil at *C*. If $q = \frac{1}{2}$, show that, in order that the wall may slide, the coefficient of friction must be less than 67 per cent in the first and 81 per cent in the second case.

(Weight of a cubic foot of masonry = $2\frac{1}{2}$ × weight of cubic foot of water.)

23. A wall 30 ft. high is of triangular section *ABC*, the face *AB* being plumb, and water being retained on the side *AC* level with the top of the wall; the masonry weighs 125 lbs. per cubic foot. Find the thickness of the base *BC* (*a*) when $q = \frac{2}{3}$; (*b*) when stress in masonry is not to exceed 10,000 lbs. per square foot; (*c*) when $q = \frac{2}{3}$ and the wall also retains earth on the side *AB* level with the top, the angle of repose being 30° . The weight of the earth per cubic foot = 144 lbs.

Ans. (*a*) 17.69 ft.; (*b*) 19.72 ft.; (*c*) 8.52 ft.

24. A wall 4 ft. wide at the top, with a front batter of 1 in 8, and a rear batter of 1 in 12, is 30 ft. high. Will the wall be stable or unstable (1) when it retains water level with the top; (2) when it retains earth?

(Weight of masonry per cubic foot = 125 lbs.; of earth = 112 lbs.; angle of repose = 30° ; and $q = \frac{2}{3}$.)

Ans. (1) Moment of wt. = 128,863 ft.-lbs.; overturning moment = 281,250 ft.-lbs., and wall is therefore unstable.

(2) Moment of wt. = 148,251 lbs.; overturning moment = 168,000 lbs., and wall is therefore unstable.

25. The faces of a reservoir wall 4 ft. wide at top and 40 ft. high have the same batter, and water rises on one side to within 6 ft. of the top. Find the width of base, assuming (*a*) that the pressure on the horizontal

base is to be nowhere negative; (b) that the pressure varies uniformly and at no point exceeds 5068 lbs. per square foot.

(Weight of masonry = 125 lbs. per cubic foot.)

Ans. (a) 24.32 ft.; (b) 30 ft.

26. The faces AB , AC of a wall are parabolas of equal parameters having their vertices at B and C ; water rises on one side to the top of the wall. Determine the thickness of the horizontal base BC , (a) for a wall 50 ft. high; (b) for a wall 100 ft. high, so that the pressure on the base may at no point exceed 10,000 lbs. per square foot. Also (c) compare the volume of such wall with the volume of an equally strong wall of the same height, but with a section in the form of an isosceles triangle with its vertex at A .

(Weight of masonry = 125 lbs. per cubic foot.)

Ans. (a) 32.44 ft.; (b) 90.35 ft.

(c) in case (a) ratio = $7 : \sqrt{114}$;

" (b) " = $\sqrt{130} : 21$.

27. The water-face AC of a wall has a batter of 1 in 10; the width of the wall AD at the top is 6 ft.; the rear of the wall DEF has two slopes, DE , having a batter of 2 in 10, and EF , a batter of 78 in 100; the masonry weighs 125 lbs. per cubic foot, and the maximum compression must not exceed 85 lbs. per square inch. Find the safe heights of the two portions AE and EC .

Ans. 28.5 ft.; 45.7 ft.; total height = 74.2 ft.

28. The section $ABCD$ of a retaining-wall for a reservoir has a vertical face BC and a parabolic water-face AD , with the vertex at D . The width of the base $DC = 4 \times$ width of the top AB . If $AB = 6$ ft., find the height of the wall, and trace the curves of resistance (a) when the reservoir is full; (b) when empty.

(Cubic foot of masonry = $2 \times$ cubic foot of water.)

Ans. 32 ft. if $q = \frac{1}{3}$, and then max. compn. = 8000 lbs. per sq. ft.

29. The figure represents the section of the upper portion of a masonry dam which has to retain water level with the top of the dam. The face AC is plumb for a depth of 73 ft. The width of the section is constant and = $22\frac{1}{2}$ ft. for a depth $AB = 40$ ft.

Find the maximum stress in the masonry at the horizontal bed BF . With the same maximum stress, show that the width of the horizontal bed CG , FG being straight, is 75.386 ft.

(Masonry weighs 130 lbs. per cubic foot.)

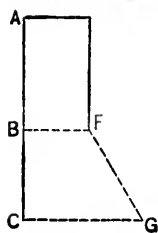

FIG. 237.

Ans. $14,049\frac{9}{188}$ lbs. per sq. ft.

30. A wall of an isosceles triangular section with a base 36 ft. wide has to retain water level with its top. How high may such a wall be built consistent with the condition that the stress in the masonry is nowhere to exceed $10,546\frac{2}{3}$ lbs. per square foot?

(Weight of masonry per cubic foot = 125 lbs.)

Ans. 54 ft., and $q = \frac{7}{36}$.

31. When a cylindrical bar is twisted, show that it is subjected to shears along transverse and radial longitudinal sections, or to tensions and compressions on helices at 45° to the axis.

32. Find the work done in gradually and uniformly compressing a body of volume V_1 to the volume V_2 , p being the final intensity of pressure and k the modulus of compression. Also show that the intensity of stress is constant throughout the body.

$$\text{Ans. } \frac{p^2 V_1}{2k}.$$

33. A bar is stretched under a force of intensity p . If the bar is prevented from contracting, find the lateral stress; also find the extension.

$$\text{Ans. } \frac{p}{m-1}; \quad \frac{p m^2 - m - 2}{E m(m-1)}.$$

34. Taking the value of the coefficient of elasticity (E) and the coefficient of rigidity (G) to be 15,000 and 5750 tons for steel, 13,950 and 5450 tons for wrought-iron, and 9500 and 3750 tons for cast-iron, find the coefficient of elasticity of volume (K), and also the values of the direct elasticity (A) and the lateral elasticity (λ), assuming the metals to be isotropic.

	m	K	A	λ
Ans. Steel.....	$3\frac{2}{3}$	$12777\frac{1}{3}$	$\frac{3}{8}G$	$\frac{1}{8}G$
Wrought-iron...	$3\frac{3}{4}$	$10559\frac{3}{4}$	$\frac{1}{4}G$	$\frac{1}{4}G$
Cast-iron.....	$3\frac{1}{2}$	$6785\frac{1}{2}$	$\frac{2}{7}G$	$\frac{3}{7}G$

35. A body is distorted without compression or expansion; find the work done.

$$\text{Ans. } \frac{1}{4\mu} \int \{N_1^2 + N_2^2 + N_3^2 + 2(T_1^2 + T_2^2 + T_3^2)\} dS.$$

36. Find the work required to twist a hollow cylinder of external radius R_1 , internal radius R_2 , and length l through an angle α .

$$\text{Ans. } \mu \frac{\pi \alpha^2}{4l} (R_1^4 - R_2^4).$$

Prove that torsion is equivalent to a shear at each point.

37. Show that a simple elongation is equivalent to a cubical dilation and a pair of shearing or distorting stresses.

38. Find the resultant shearing stress at any point in the surface of the transverse section of an elliptic cylinder. (Art. 24, Case b .)

$$\text{Ans. } \frac{2\theta G}{p} \frac{b^2 c^2}{b^2 + c^2}, \quad p \text{ being the perpendicular from the centre upon the tangent to the ellipse at the given point, and } 2b, 2c \text{ the major and minor axes.}$$

39. A cylinder undergoes torsion round its axis. Show that the curves of no traction are concentric circles.

Handwritten scribble, possibly "Morse" or "Morse's".

CHAPTER V.

FRICITION.

1. Sliding Friction.—Friction is the resistance to motion which is always developed when two substances, whether solid, liquid, or gaseous, are pressed together and are compelled to move the one over the other. If P is the mutual pressure, and if F is the force which must act tangentially at the point of contact to produce motion, the ratio of F to P is called the coefficient of friction and may be denoted by f . The value of f does not depend upon the nature of any *single* substance, but upon the nature and condition of the surfaces of contact of a *pair* of substances. It is not the same, e.g., for iron upon iron as for iron upon bronze or upon wood; neither is it the same when the surfaces are dry as when lubricated.

The laws of friction as enunciated by Coulomb are :

- (1) That f is independent of the velocity of rubbing; (2) that f is independent of the extent of surface in contact; (3) that f depends only on the nature of the surfaces in contact.

The friction between two surfaces at rest is greater than when they are in motion, but a slight vibration is often sufficient to change the friction of rest to that of motion.

Morin's elaborate friction experiments completely verified these laws within certain limits of pressure (from $\frac{3}{4}$ lb. to 128 lbs. per square inch) and velocity (the maximum velocity being 10 ft. per second), and under the conditions in which they were made.

A few of his more important results are given in the following table :

Material.	State of Surfaces.	Coefficient of Friction.
Wood on wood	dry.....	.25 to .5
Metal on wood	dry.....	.2 " .6
" " "	wet.....	.22 " .26
Metal on metal	dry.....	.15 " .2
" " "	wet.....	.3
Metal and wood on each other } or each on itself }	slightly oily.....	.15
	occasionally lubricated as usual....	.07 to .08
	constantly lubricated.....	.05

The apparatus employed in carrying out these experiments consisted of a box which could be loaded at pleasure, and which was made to slide along a horizontal bed by means of a cord passing over a pulley and carrying a weight at the end. The contact-surfaces of the bed and box were formed of the materials to be experimented upon. The pull was measured and recorded by a spring dynamometer.

More recent experiments, however, have shown that Coulomb's laws cannot be regarded as universally applicable, but that f depends upon the velocity, the pressure, and the temperature. At very low velocities Morin's results have been verified (Fleeming Jenkin). At high velocities f rapidly diminishes as the velocity increases. Franke, having carefully examined the results of various series of experiments, especially those of Poirée, Bochet, and Galton, has suggested the formula

$$f = f_0^{-\alpha v},$$

v being the velocity and f_0 , α , coefficients depending upon the nature and condition of the rubbing surfaces.

For example,

$f_0 = .29$ and $\alpha = .04$ for cast-iron on steel with dry surfaces.

$f_0 = .29$ and $\alpha = .02$ for wrought-iron on wrought-iron with dry surfaces.

$f_0 = .24$ and $\alpha = .0285$ for wrought-iron on wrought-iron with slightly damp surfaces.

Ball has shown that at very low pressures f increases as

the pressure diminishes, while Rennie's experiments indicate that at very high pressures f rapidly increases with the pressure, and this is perhaps partly due to a depression, or to an abrasion of the rubbing surfaces.

2. Inclined Plane.—Let a body of weight P slide uniformly up an inclined plane under a force Q inclined at an angle β to the plane.

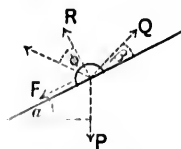

FIG. 238.

Let F be the friction resisting the motion, R the pressure on the plane, and α the plane's inclination.

The two equations of equilibrium are

$$F = Q \cos \beta - P \sin \alpha$$

and

$$R = -Q \sin \beta + P \cos \alpha.$$

$$\therefore \frac{F}{R} = \frac{Q \cos \beta - P \sin \alpha}{-Q \sin \beta + P \cos \alpha} = \text{coefficient of friction} = f.$$

Let the resultant of F and R make an angle ϕ with the normal to the plane. Then

$$\tan \phi = \frac{F}{R} = \frac{Q \cos \beta - P \sin \alpha}{-Q \sin \beta + P \cos \alpha}, \quad \text{or} \quad \frac{Q}{P} = \frac{\sin(\alpha + \phi)}{\cos(\beta - \phi)}.$$

ϕ is called the *angle of friction*. It has also been called the *angle of repose*, since a body will remain at rest on an inclined plane so long as its inclination does not exceed the angle of friction.

$$\text{If } \alpha = 0 = \beta, \text{ then } \frac{Q}{P} = \tan \phi = f.$$

The work done in traversing a distance $x = Q \cos \beta \cdot x$. If Q is variable, the work done = $\int_0^x Q \cos \beta \cdot dx$

3. Wedge.—The wedge, or key, is often employed to connect members of a structure, and is generally driven into posi-

tion by
out mo
ing a p

The
scendin
pressur
motion
which n
Q upon

The
assumed
is unifor
in a stat

Let
tively, th
of frictio

Let
angle bet

Consid
inappreci
Resol

Resolving

R_1

or

R_1

Consid

Resolv

R_1

Assum
and hence

by eq. (2),

tion by the blow of a hammer. It is also employed to force out moisture from materials by inducing a pressure thereon.

The figure represents a wedge descending vertically under a continuous pressure P , thus producing a lateral motion in the horizontal member C , which must therefore exert a pressure Q upon the vertical face AB .

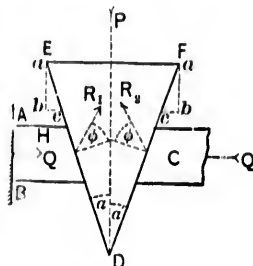

FIG. 239.

The member H is fixed, and it is assumed that the motion of the machine is uniform, so that the wedge and C are in a state of relative equilibrium.

Let R_1, R_2 be the reactions at the faces DE, DF , respectively, their directions making an angle ϕ , equal to the angle of friction, with the normals to the corresponding faces.

Let α be the angle between DE and the vertical, α' the angle between DF and the vertical.

Consider the wedge, and neglect its weight, which is usually inappreciable as compared with P .

Resolving vertically,

$$R_1 \cos(90^\circ - \overline{\alpha + \phi}) + R_2 \cos(90^\circ - \overline{\alpha' + \phi}) = P = R_1 \sin(\alpha + \phi) + R_2 \sin(\alpha' + \phi). \quad (1)$$

Resolving horizontally,

$$R_1 \sin(90^\circ - \overline{\alpha + \phi}) - R_2 \sin(90^\circ - \overline{\alpha' + \phi}) = 0,$$

or

$$R_1 \cos(\alpha + \phi) = R_2 \cos(\alpha' + \phi). \quad (2)$$

Consider the member C , and neglect its weight.

Resolving horizontally,

$$R_2 \cos(\alpha' + \phi) = Q = R_1 \cos(\alpha + \phi). \quad (3)$$

Assuming the wedge isosceles, as is usually the case, $\alpha = \alpha'$, and hence,

$$\text{by eq. (2), } R_1 = R_2, \text{ and by eq. (1), } 2R_1 \sin(\alpha + \phi) = P. \quad (4)$$

Hence, by eqs. (3) and (4),

$$\frac{Q}{P} = \frac{\cot(\alpha + \phi)}{2} = \frac{\text{external resistance overcome}}{\text{effort exerted}} \quad (5)$$

(N.B.—This ratio of resistance to effort is termed the *mechanical advantage*, or *purchase*, of a machine.)

Suppose the motion of the machine reversed, so that Q becomes the effort and P the resistance.

The reactions R_1, R_2 now fall *below* the normals, and the equations of relative equilibrium are the same as the above, with $-\phi$ substituted for ϕ .

Thus,
$$\frac{Q}{P} = \frac{1}{2} \cot(\alpha - \phi). \dots \dots \dots (6)$$

The two cases may be included in the expression

$$\frac{Q}{P} = \frac{1}{2} \cot(\alpha \pm \phi). \dots \dots \dots (7)$$

For a given value of P , Q increases with α .

If there were no friction, ϕ would be zero, and eq. (7) would become

$$\frac{Q}{P} = \frac{\cot \alpha}{2}.$$

Thus, the effect of friction may be allowed for, by assuming the wedge frictionless, but with an angle *increased* by 2ϕ in the *first* case, and *diminished* by 2ϕ in the *second* case.

Again, when P is the effort and Q the resistance, eq. (5) shows that if $\alpha + \phi > 90^\circ$, the ratio $\frac{Q}{P}$ is negative, which is impossible, while if $\alpha + \phi = 90^\circ$, $\frac{Q}{P}$ is zero, and in order to

overcome Q , however small it might be, P would require to be infinitely great. Hence,

$$\alpha + \phi \text{ must be } < 90^\circ,$$

and below this limit $\frac{Q}{P}$ diminishes as ϕ increases.

Similarly, it may be shown from eq. (7) that when Q is the effort and P the resistance,

$$\phi \text{ must be } < \alpha,$$

and that below this limit $\frac{Q}{P}$ increases with ϕ .

Efficiency.—During the uniform motion of the machine, let any point a descend vertically to the point b . The corresponding horizontal displacement is evidently $2bc$.

$$\text{The motive work} = P \cdot ab;$$

$$\text{“ useful work} = Q \cdot 2bc.$$

$$\text{Hence, the efficiency} = \frac{Q \cdot 2bc}{P \cdot ab} = \frac{Q}{P} \cdot 2 \tan \alpha \\ = \tan \alpha \cot (\alpha + \phi), \text{ by eq. (5).}$$

This is a maximum for a given value of ϕ when

$$\alpha = 45^\circ - \frac{\phi}{2},$$

$$\text{and the max. efficiency} = \tan \left(45^\circ - \frac{\phi}{2} \right) \cot \left(45^\circ + \frac{\phi}{2} \right)$$

$$= \left(\frac{1 - \tan \frac{\phi}{2}}{1 + \tan \frac{\phi}{2}} \right)^2 = \frac{1 - \sin \phi}{1 + \sin \phi}.$$

For the *reverse* motion, the efficiency

$$= \frac{P \cdot ab}{Q \cdot 2bc} = \cot \alpha \tan (\alpha - \phi).$$

This is a maximum when $\alpha = 45^\circ + \frac{\phi}{2}$. Thus the

$$\text{max. efficiency} = \cot\left(45^\circ + \frac{\phi}{2}\right) \tan\left(45^\circ - \frac{\phi}{2}\right) = \frac{1 - \sin \phi}{1 + \sin \phi}.$$

4. Screws.—A screw is usually designed to produce a linear motion or to overcome a resistance in the direction of its length. It is set in motion by means of a couple acting in a plane perpendicular to its axis. A reaction is produced between the screw and nut which must necessarily be equivalent to the couple and resistance, *the motion being steady*.

Take the case of a *square**-threaded screw. It may be assumed that the reaction is concentrated along a *helical line*, whose diameter, d , is a mean between the external and internal diameters of the thread, and that its distribution along this line is uniform. It will also be supposed that the axes of the couple and screw are coincident, so that there will be no lateral pressure on the nut.

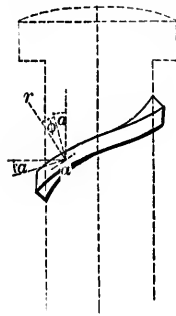

FIG. 240.

Let M be the driving couple.

“ Q “ “ axial resistance to be overcome.

“ r “ “ reaction at any point a of the helical line, and let ϕ be angle between its direction and the normal at a ; ϕ is the angle of friction.

“ α “ “ angle between the tangent at a and the horizontal; α is called the *pitch-angle*.

Since the reaction between the screw and nut must be equivalent to M and Q , then

* Square-threaded screws work more accurately than those with a V-thread, but the efficiency of the latter has been shown to be very little less than that of the former (Poncelet). On the other hand, the V-thread is the stronger, much less metal being removed in cutting it than is the case with a square thread. Again, with a V-thread there is a tendency to burst the nut, which does not obtain in a screw with a square thread.

Q = algebraic sum of vertical components of the reactions at all points of the line of contact,

$$= \Sigma[r \cos (\alpha + \phi)] = \cos (\alpha + \phi) \Sigma(r), \dots (1)$$

and M = algebraic sum of the moments with respect to the axis of the horizontal components of the reactions at all points of the line of contact,

$$= \Sigma\left[r \sin (\alpha + \phi) \frac{d}{2}\right] = \frac{d}{2} \sin (\alpha + \phi) \Sigma(r) \dots (2)$$

Let the couple consist of two equal and opposite forces, P , acting at the ends of a lever of length p , so that $M = Pp$.

Hence, by eqs. (1) and (2),

$$\frac{Q}{M} = \frac{Q}{Pp} = \frac{2}{d} \cot (\alpha + \phi),$$

and the *mechanical advantage*

$$= \frac{Q}{P} = \frac{2p}{d} \cot (\alpha + \phi) \dots (3)$$

If $\phi = 0$, $\frac{Q}{P} = \frac{2p}{d} \cot \alpha$, and the effect of friction may be allowed for, by assuming the screw frictionless, but with a pitch-angle equal to $\alpha + \phi$.

Again, let the figure represent one complete turn of the thread developed in the plane of the paper. CD is the corresponding length of the thread; DE the circumference πd ; CE , parallel to the axis, the pitch h ; and CDE the pitch-angle α .

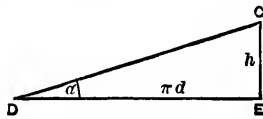

FIG. 241.

The motive work in one revolution = $M \cdot 2\pi = Pp \cdot 2\pi$.

The useful work done in one revolution = Qh .

$$\begin{aligned} \text{Hence, the efficiency} &= \frac{Qh}{Pp \cdot 2\pi} = \frac{2p}{d} \cot (\alpha + \phi) \frac{h}{p \cdot 2\pi} \\ &= \frac{h}{\pi d} \cot (\alpha + \phi) = \tan \alpha \cot (\alpha + \phi) \dots (4) \end{aligned}$$

This is a maximum when $\alpha = 45^\circ - \frac{\phi}{2}$, its value then being

$$\left(\frac{1 - \tan \frac{\phi}{2}}{1 + \tan \frac{\phi}{2}} \right)^2.$$

In practice, however, α is generally much smaller, efficiency being sacrificed to secure a large mechanical advantage, which, according to eq. (3), increases as α diminishes.

If $\alpha + \phi = 90^\circ$, $\frac{Q}{P} = 0$, so that to overcome Q , however small it may be, would require an infinite effort P .

$$\therefore \alpha + \phi < 90^\circ.$$

Suppose the pitch-angle sufficiently coarse to allow of the screw being *reversed*. Q now becomes the effort and P the resistance. The direction of r falls on the other side of the normal, and the relation between P and Q is the same as above, $-\phi$ being substituted for ϕ .

Thus,

$$\frac{Q}{P} = \frac{2p}{d} \cot(\alpha - \phi),$$

and therefore the mechanical advantage

$$= \frac{P}{Q} = \frac{d}{2p} \tan(\alpha - \phi).$$

If $\alpha = \phi$, $\frac{P}{Q} = 0$, and to overcome P , however small it may be, Q would require to be infinite.

$$\therefore \alpha > \phi.$$

If $\alpha < \phi$, reversal of motion is impossible, and the screw then possesses the property, so important in practice, of serving to fasten securely together different structural parts, or of locking machines.

Again, it may be necessary to take into account the friction between the nut and its seat, as well as the friction at the end of the screw. The corresponding moments of friction with respect to the axis are (Art. 8)

$$f \frac{Q d_1^3 - d_2^3}{3 d_1^2 - d_2^2} \quad \text{and} \quad f \frac{Q d'}{3},$$

f being the coefficient of friction, d_1 , d_2 the external and internal diameters of the seat, and d' the diameter of the end of the screw.

5. Endless Screws (Fig. 242).—A screw is often made to work with a toothed wheel, as, for example, in raising sluice-gates, when the screw is also made sufficiently fine to prevent, by friction alone, the gates from falling back under their own weight. The theory is very similar to the preceding. Let the screw drive. A tooth rises on the thread, and the wheel turns against a tangential resistance Q , which is approximately parallel to the axis of the screw.

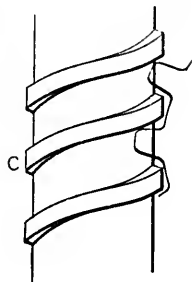

FIG. 242.

Let Fig. 243 represent one complete turn of the thread developed in the plane of the paper, α being the pitch-angle as before.

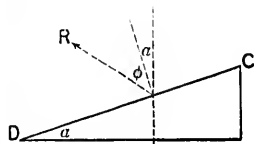

FIG. 243.

Consider a tooth. It is acted upon by Q in a direction parallel to the axis, and by the reaction R between the thread and tooth, making an angle ϕ (the angle of friction) with the normal to the thread CD .

$$\therefore Q = R \cos (\alpha + \phi).$$

Again, the horizontal component of R , viz., $R \sin (\alpha + \phi)$, has a moment $R \sin (\alpha + \phi) \frac{d}{2}$ with respect to the axis of the

screw, and this must be equivalent to the moment of the driving-couple, viz., Pp (Art. 4).

$$\therefore Pp = R\frac{d}{2} \sin(\alpha + \phi).$$

Thus the relation between P and Q is the same as in the preceding article.

Similarly if the wheel acts as the driver,

$$\frac{P}{Q} = \frac{d}{2p} \tan(\alpha - \phi).$$

6. Rolling Friction.—The friction between a rolling body and the surface over which it rolls is called rolling friction. Prof. Osborne Reynolds has given the true explanation of the resistance to rolling in the case of elastic bodies. The roller produces a deformation of the surfaces in contact, so that the distance rolled over is greater than the actual distance between the terminal points. This he verified by experiment, and concluded that the resistance to rolling was due to the sliding of one surface over the other, and that it would naturally increase or diminish with the deformation. In proof of this he found, for example, that the resistance to an iron roller on india-rubber is *ten* times as great as the resistance when the roller is on an iron surface. Hence the harder and smoother the surfaces, the less is the rolling friction. The resistance is not sensibly affected by the use of lubricants, as the advantage of a smaller coefficient of friction is largely counteracted by the increased tendency to slip. Other experiments are yet required to show how far the resistance is modified by the speed.

Generally, as in the case of ordinary roadways, the resistance is chiefly governed by the amount of the deformation of the surface and by the extent to which its material is crushed. Let a roller of weight W (Fig. 244) be on the point of motion under the action of a horizontal pull R .

The resultant reaction between the surfaces in contact must pass through the point of intersection of R and W . Let it also cut the surface in the point B .

Let d be the horizontal distance between B and W .

" p " vertical " " B " R .

Taking moments about B ,

$$Rp = Wd,$$

or

$$R = \text{the resistance} = W \frac{d}{p}.$$

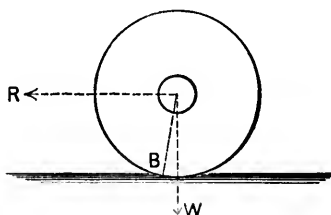

FIG. 244.

Coulomb and Morin inferred, as the results of a series of experiments, that d is independent of the load upon the roller as well as of its diameter,* but is dependent upon the nature of the surfaces in contact.

* Dupuit's experiments led him to the conclusion that d is proportional to the square root of the diameter, but this requires further verification.

Let μ be the coefficient of sliding friction.

The resistance of the roller to sliding is μW , and "rolling" will be insured if $R < \mu W$, i.e., if $\frac{d}{p} < \tan \phi$, which is generally the case so long as the direction of R does not fall below the centre of the roller.

Assume that R is applied at the centre. The radius r may be substituted for p , since d is very small, and hence

$$R = W \frac{d}{r}.$$

An equation of the same form applies to a wheel rolling on a hard roadway over obstacles of small height, and also when rolling on soft ground. In the latter case, the resistance is proportional to the product of the weight upon the wheel into the depth of the rut, and the depth for a small arc is inversely proportional to the radius.

Experiments on the tractional resistance to vehicle^m on ordinary roads are few in number and incomplete, so that it is impossible to draw therefrom any general conclusion.

From the experiments carried out by Easton and Anderson, it would appear that the value of d in inches varies from 1.6 to 2.6 for wagons on soft ground, and that the resistance is not sensibly affected by the use of springs. Upon a hard road, in fair condition, the resistance was found to be from $\frac{1}{4}$ to $\frac{1}{3}$ of that on the soft ground, the average value of d being $\frac{1}{4}$ inch, and was very sensibly diminished by the use of springs.

7. Journal-friction.—Experiments indicate that f is not the same for curved as for plane surfaces, and in the ordinary cases of journals turning in well-lubricated bearings the value of f is probably governed by a combination of the laws of fluid friction and of the sliding friction of solids.

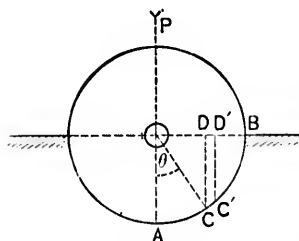

FIG. 245.

Consider a journal in a semicircular bearing with the cap removed. When the cap is screwed on, the load upon the journal will be increased by an amount approximately equal to the tension of the bolts. Let P be the load.

Assume that the line of action of the load is vertical and that it intersects the axis of the shaft. This load is balanced by the reaction at the surface of contact, but much uncertainty exists as to the manner in which this reaction is distributed. There are two extremes, the one corresponding to a normal pressure of constant intensity at every point of contact, the other to a normal pressure of an intensity varying from a maximum at the lowest point A to a minimum at the edge of the bearing B .

Let l be the length of the bearing, and consider a small element ΔS at any point C , the radius OC ($= r$) making an angle θ with the vertical OA .

First. Let p be the constant normal intensity of pressure.

$$P = \int p \Delta S \cos \theta \cdot l = pl \sum (DD') = 2plr.$$

$$\text{Frictional resistance} = \int (fp \Delta S l) = fpl \sum (\Delta S) = fpl\pi r = fP \frac{\pi}{2}.$$

The frictional resistance probably approximates to this limit when the journal is new.

Second. Let $p = p_0 \cos \theta$,
 so that the intensity is now proportional to the depth CD and varies from a maximum p_0 at A to *nil* at B . This, perhaps, represents more accurately the pressure at different points when the journal is worn.

$$\begin{aligned} \therefore P &= \Sigma(p \Delta S \cos \theta \cdot l) = \Sigma(p_0 \Delta S \cos^2 \theta \cdot l) \\ &= 2p_0 l r, \int_0^{\frac{\pi}{2}} \cos^2 \theta \cdot d\theta = p_0 l r \frac{\pi}{2} \end{aligned}$$

and the *frictional resistance* $= \Sigma(fp \Delta S l) = 2fp_0 l r = fp \frac{A}{\pi}$.

Hence, the frictional resistance lies between $fp \frac{\pi}{2}$ and $fp \frac{A}{\pi}$.

It may be represented by μP , μ being a coefficient of friction to be determined in each case by experiment.

The total *moment* of frictional resistance must necessarily be equal and opposite to the moment M of the couple twisting the shaft; i.e.,

$$M = \mu Pr.$$

Thus, the total reaction at the surface of contact is equivalent to a single force P tangential to a circle of radius μr having its centre at O and called the *friction-circle*.

The work absorbed by axle-friction per revolution

$$= M \cdot 2\pi = 2\mu\pi Pr.$$

The work absorbed by axle-friction per minute

$$= 2\mu\pi PrN = \mu P v,$$

N being the number of revolutions and v the velocity per minute.

The work absorbed by frictional resistance produces an equivalent amount of heat, which should be dissipated at once in order to prevent the journal from becoming too hot. This may be done by giving the journal sufficient *bearing surface* (an area equal to the product of the diameter and the length of the bearing), and by the employment of a suitable unguent.

Suppose that h units of heat per square inch of bearing surface (ld) are dissipated per minute.

Let l inches be the length and d inches the diameter of the journal.

hld = heat-units dissipated = heat-units equivalent to frictional resistance

$$= \frac{\mu\pi PdN}{12J} = \frac{\mu Pv}{12J},$$

J being Joule's equivalent, or 778 ft.-lbs.

$$\therefore \frac{12Jh}{\mu\pi} = \frac{PN}{l} \quad \text{and} \quad \frac{12Jh}{\mu} = \frac{Pv}{ld}.$$

Let $\frac{P}{ld} = p$ = pressure per square inch of bearing surface.

$$\therefore pv = \frac{12Jh}{\mu} = \text{a constant.}$$

In Morin's experiments d varied from 2 to 4 in., P from 330 lbs. to 2 tons, and v did not exceed 30 ft. per minute; so that pv was < 5000 , and the coefficient of friction for the given limits was found to be the same as for sliding friction.

Much greater values of pv occur in modern practice.

Rankine gives $p(v + 20) = 44800$ as applicable to locomotives.

Thurston gives $pv = 60000$ as applicable to marine engines and to stationary steam-engines.

Frictional wear prevents the diminution of l below a certain

limit at which the pressure per unit of *bearing surface* exceeds a value p given by the formula.

$$P = pld = pkd^2;$$

where

$$k = \frac{l}{d}.$$

In practice $k = \frac{1}{2}$ for slow-moving journals (e.g., joint-pins), and varies from $1\frac{1}{2}$ to 3 for journals in continuous motion. The best practice makes the length of the journal equal to four diameters (i.e., $k = 4$) for mill-shafting.

Again, if the journal is considered a beam supported at the ends,

$$CPl = \frac{qd^3}{32} \pi,$$

q being the maximum permissible stress per square inch, and C a coefficient depending upon the method of support and upon the manner of the loading.

$$\therefore d^3 \propto \frac{k}{q}.$$

For a given value of P , d diminishes as q increases. Also, it has been shown that the work absorbed by friction is directly proportional to d .

Hence, for both reasons, d should be a minimum and the shaft should be made of the strongest and most durable material. In practice the pressure per square inch of bearing surface may be taken at about 2 tons per square inch for cast-iron, $3\frac{1}{4}$ tons per square inch for wrought-iron, and $6\frac{1}{2}$ tons per square inch for cast-steel.

It would appear, however, from the recent experiments of Tower and others, that the nature of the material *might* become of minor importance, while that of a suitable lubricant would be of paramount importance. They show that the friction of properly lubricated journals follows the laws of fluid friction much more closely than those of solid friction, and that the

lubrication might be made so perfect as to prevent any absolute contact between the journal and its bearing. The journal would therefore *float* in the lubricant, so that there would be no metallic friction. The loss of power due to frictional resistance, as well as the consequent wear and tear, would be very considerably diminished, while the load upon the journal might be increased to almost any extent.

Tower's experiments also indicate that the friction diminishes as the temperature rises, a result which had already been experimentally determined by Hirn. It was also inferred by Hirn that, if the temperature were kept uniform, the friction would be approximately proportional to \sqrt{v} , and Thurston has enunciated the law that, with a cool bearing, the friction is approximately proportional to $\sqrt[3]{v}$ for all speeds exceeding 100 ft. per minute.

With a speed of 150 ft. per minute and with pressures varying from 100 to 750 lbs. per square inch, Thurston found experimentally that f varied inversely as the square root of the intensity of the pressure. The same law, but without any limitations as to speed or pressure, had been previously stated by Hirn.

8. Pivots.—Pivots are usually cylindrical, with the circular edge of the base removed and sometimes with the whole of the base rounded. Conical pivots are employed in special machines in which, e.g., it is important to keep the axis of the shaft in an invariable position. Spherical pivots are often used for shafts subject to sudden shocks or to a lateral movement.

(a) *Cylindrical Pivots.*—If the shafts are to run slowly, the intensity of pressure (p) on the step should not be so great as to squeeze out the lubricant. Reuleaux gives the following rules:

The maximum value of p in lbs. per square inch should be 700 for wrought-iron on gun-metal, 470 for cast-iron on gun-metal, and 1400 for wrought-iron on lignum-vitæ.

For rapidly-moving shafts,

$$d = c\sqrt{Pn},$$

n being
to be det
and P th

Supp
divided
rings be

In on
by the fr

Hence th

$$= \int_a^b$$

where

d d_1 , d_2
face in co

If the
work abso
Again

and the t

If $d_2 =$

Thus,
times the

n being the number of revolutions per minute, c a coefficient to be determined by experiment ($=.0045$), and P the load upon the pivot.

Suppose the surface of the step to be divided into rings, and let one of these rings be bounded by the radii $x, x + dx$.

In one revolution the work absorbed by the friction of this ring

$$= \mu p \cdot 2\pi x \cdot dx \cdot 2\pi x.$$

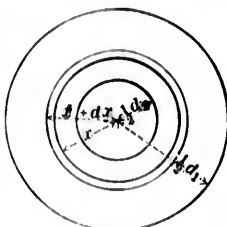

FIG. 246.

Hence the *total* work absorbed in one revolution

$$= \int_{\frac{d_2}{2}}^{\frac{d_1}{2}} 4\mu p \pi^2 x^2 dx = \frac{\mu p \pi^2}{6} (d_1^3 - d_2^3) = \frac{2}{3} \mu \pi P \frac{d_1^3 - d_2^3}{d_1^2 - d_2^2},$$

where

$$P = \frac{p\pi}{4} (d_1^2 - d_2^2),$$

d_1, d_2 are the external and internal diameters of the surface in contact.

If the *whole* of the surface is in contact, $d_2 = 0$, and the work absorbed $= \frac{2}{3} \mu \pi P d_1$.

Again, the *moment* of friction for the ring

$$= \mu p \cdot 2\pi x \cdot dx \cdot x = 2\mu p \pi x^2 \cdot dx,$$

and the total moment

$$\begin{aligned} &= \int_{\frac{d_2}{2}}^{\frac{d_1}{2}} 2\mu p \pi x^2 dx = \frac{2}{3} \mu p \pi \frac{d_1^3 - d_2^3}{8} \\ &= \frac{\mu p \pi}{12} (d_1^3 - d_2^3) = \frac{\mu P}{3} \frac{d_1^3 - d_2^3}{d_1^2 - d_2^2}. \end{aligned}$$

If $d_2 = 0$, the moment $= \frac{\mu P}{3} d_1$.

Thus, in both cases, the work absorbed by friction $= 2\pi$ times the moment of friction.

Let D be the *mean* diameter of the surface in contact

$$= \frac{d_1 + d_2}{2}.$$

Let $2y$ be the width of the surface in contact $= d_1 - d_2$.
Then

$$\text{work absorbed} = \mu\pi P \left(D + \frac{y^2}{3D} \right).$$

Sometimes shafts have to run at high speeds and to bear heavy pressures, as, e.g., in screw-propellers and turbines. In order that there may be as little vibration as possible, p must be as small as practicable, and this is to some extent insured by using a collar-journal.

Let N be the number of collars, and let d_1, d_2 be the external and internal diameters of a collar.

Then work absorbed by friction per revolution per collar

$$= \frac{\mu p \pi^2}{6} (d_1^3 - d_2^3) = \frac{2}{3} \mu \pi \frac{P}{N} \frac{d_1^3 - d_2^3}{d_1^2 - d_2^2} = 2\pi \times \text{moment of friction.}$$

According to Reuleaux, the mean diameter of a collar

$$= D = \sqrt[3]{\frac{Pn^2}{N^2}},$$

n being the number of revolutions per minute.

Also, the *width* of surface in contact $= d_1 - d_2 = .48 \sqrt{D}$,
and the maximum allowable pressure per square inch

$$= p = \frac{46940}{n}.$$

(b) *Wear*.—The wear at any point of the elementary ring must necessarily be proportional to the friction μp , and also to the amount of rubbing surface which passes over the point in a unit of time, i.e., the velocity Ax ; A being the angular velocity of the shaft.

Hence, the wear at any point is proportional to $\mu p A x$.

(c) *Conical Pivots.*—As before, suppose the surface of the step to be divided into a number of elementary rings. Two cases will be discussed :

First. Assume that the normal intensity of pressure p at the surface of contact is constant.

Let $x, x + dx$ be the distances of D and E , respectively, from the axis.

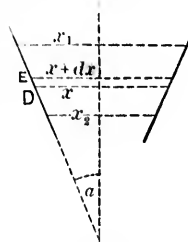

FIG. 247.

The total moment of friction

$$\begin{aligned} &= \int_{x_2}^{x_1} \mu p DE \cdot 2\pi x \cdot x = \frac{2\mu p \pi}{\sin \alpha} \int_{x_2}^{x_1} x^2 dx \\ &= \frac{2}{3} \frac{\mu p \pi}{\sin \alpha} (x_1^3 - x_2^3), \end{aligned}$$

x_1, x_2 being the radii of the top and bottom sections of the step.

Also, P , the total load on the pivot,

$$\begin{aligned} &= \int_{x_2}^{x_1} p DE \sin \alpha \cdot 2\pi x = 2\pi p \int_{x_2}^{x_1} x dx \\ &= \pi p (x_1^2 - x_2^2). \end{aligned}$$

$$\text{Hence total moment of friction} = \frac{2}{3} \frac{\mu P}{\sin \alpha} \frac{x_1^3 - x_2^3}{x_1^2 - x_2^2}.$$

Second. Assume that the wear is of such a nature that every point, e.g., D , descends vertically through the same distance.

Thus, the normal wear $\propto \sin \alpha$,

$$\text{or } \mu p A x \propto \sin \alpha,$$

$$\text{or } p x \propto \sin \alpha.$$

In the present case α is constant, and hence $p x =$ a constant.

Thus, total moment of friction

$$\begin{aligned} &= \int_{x_2}^{x_1} \mu p DE \cdot 2\pi x \cdot x = \frac{2\mu p x \pi}{\sin \alpha} \int_{x_2}^{x_1} x dx \\ &= \frac{\mu p x \pi}{\sin \alpha} (x_1^2 - x_2^2). \end{aligned}$$

$$\begin{aligned} \text{Also, } P &= \int_{x_2}^{x_1} p DE \sin \alpha \cdot 2\pi x \\ &= 2\pi p x \int_{x_2}^{x_1} dx = 2\pi p x (x_1 - x_2). \end{aligned}$$

$$\text{Hence total moment of friction} = \frac{\mu P}{2 \sin \alpha} (x_1 + x_2).$$

(d) *Schiele's Pivots*.—The object aimed at in these pivots is to give the step such a form that the wear and the pressure are the same at all points.

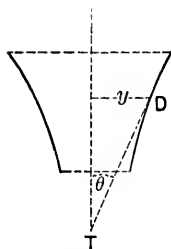

FIG. 248.

Let θ be the angle made by the tangent at any point of the step with the axis.

Let y be the distance of the point from the axis. Then

$$py \propto \sin \theta;$$

and hence if p is constant,

$$y \propto \sin \theta \quad \text{or} \quad y \operatorname{cosec} \theta = \text{a const.}$$

is the equation of the generating line of the step. This line is known as the *tractrix* and also as the *anti-friction curve*. If the tangent at D intersects the axis in T ,

$$DT = y \operatorname{cosec} \theta = \text{a const.}$$

The curve may be traced by passing from one point to another and keeping the tangent DT of constant length.

The above equation may be written

$$y \frac{ds}{dy} = \text{a const.} = a,$$

or

which
equati

Schiele
have no

9. I
movabl
upon b
of the c

In o
arrow, I
the fric
ance to b

Const
ance, and
point of s

Any
the belt
gential to
tangential
reaction e
at the mi
gential fo
 $\mu R ds$.

Let th
gle BOB'
Resolv

or

$$\frac{ds}{dx} = \frac{a dy}{y dx} = \sqrt{1 + \left(\frac{dy}{dx}\right)^2},$$

which may be easily integrated, the result being the analytical equation to the curve, viz.,

$$x = a \log_e \left(\frac{a - \sqrt{a^2 - y^2}}{y} \right) + \sqrt{a^2 - y^2} + a \text{ const.}$$

Schiele or anti-friction pivots are suitable for high speeds, but have not been very generally adopted.

9. Belts and Ropes.—Let the figure represent a pulley movable about a journal at O , and let a belt (or rope), acted upon by forces T_1, T_2 at the ends, embrace a portion ABC of the circumference subtending an angle α at the centre.

In order that there may be motion in the direction of the arrow, T_1 must exceed T_2 by an amount sufficient to overcome the *frictional resistance* along the arc of contact and the *resistance to bending* due to the stiffness of the belt.

Consider first the frictional resistance, and suppose the belt to be *on the point of slipping*.

Any small element BB' ($= ds$) of the belt is acted upon by a pull T tangential to the pulley at B , a pull $T - dT$ tangential to the pulley at B' , and by a reaction equivalent to a normal force Rds at the middle point of BB' , and a tangential force, or frictional resistance, μRds .

Let the angle $COB = \theta$, and the angle $BOB' = d\theta$.

Resolving normally,

$$(T + T - dT) \sin \frac{d\theta}{2} - Rds = 0. \quad \dots (1)$$

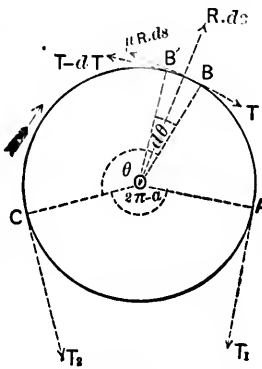

FIG. 249.

This is Poncelet's Problem
on the end of 13

$$(T + T - dT) \sin \frac{d\theta}{2} - R ds = 0 \quad (1)$$

Resolving tangentially,

$$(T - \overline{T - dT}) \cos \frac{d\theta}{2} - \mu R ds = 0, \quad \dots \quad (2)$$

μ being the coefficient of friction.

Now $d\theta$ being very small, $\sin \frac{d\theta}{2}$ is approximately $\frac{d\theta}{2}$, $\cos \frac{d\theta}{2}$ is approximately *unity*, and small quantities of the second order may be disregarded.

Hence, eqs. (1) and (2) may be written

$$T d\theta - R ds = 0, \quad \dots \quad (3)$$

and

$$dT - \mu R ds = 0. \quad \dots \quad (4)$$

$$\therefore dT = \mu T d\theta, \quad \text{or} \quad \frac{dT}{T} = \mu d\theta. \quad \dots \quad (5)$$

Integrating,

$$\log_e T = \mu \theta + C,$$

C being a constant of integration.

When $\theta = 0$, $T = T_2$, and hence $\log_e T_2 = C$.

$$\therefore \log_e \frac{T}{T_2} = \mu \theta,$$

$$\text{or} \quad \frac{T}{T_2} = e^{\mu \theta}. \quad \dots \quad (6)$$

When $\theta = \alpha$, $T = T_1$, and hence

$$\frac{T_1}{T_2} = e^{\mu \alpha}, \quad \dots \quad (7)$$

e being the number 2.71828, i.e., the base of the Napierian system of logarithms.

If $e^{\mu \theta}$ tin
 progre
 progre
 corres
 contac
 for th
 surplus
 A
 of an
 again,
 of iron
 and joi
 about
 cumfere
 drum.
 is secur
 lever A
 A will c
 tion whi
 Let a
 is applie
 Let A
 its axis.
 The k
 When
 tion of th
 be T_1 , T_2
 Let n
 brought to
 d being th
 Also, if
 perpendicu
 respectivel

If α is increased by β , the new ratio of tensions will be $e^{\alpha\beta}$ times the old ratio; so that if α increases in arithmetical progression, the ratio of tensions will increase in geometrical progression. This rapid increase in the ratio of the tensions, corresponding to a comparatively small increase in the arc of contact, is utilized in "brakes" for the purpose of absorbing surplus energy. For example:

A flexible brake consisting of an iron or steel strap, or, again, of a chain, or of a series of iron bars faced with wood and jointed together, embraces about three-fourths of the circumference of an iron or wooden drum. One end of the brake

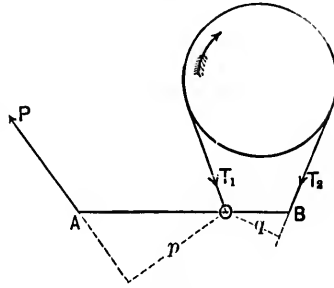

FIG. 250.

is secured to a fixed point O and the other to the end B of a lever AOB turning about a fulcrum at O . A force applied at A will cause the brake to clasp the drum and so produce friction which will gradually bring the drum to rest.

Let ω be the angular velocity of the drum before the brake is applied.

Let I be the moment of inertia of the drum with respect to its axis.

$$\text{The kinetic energy of the drum} = \frac{I\omega^2}{2}.$$

When the brake is applied, the motion being in the direction of the arrow, let the greater and less tensions at its ends be T_1, T_2 , respectively.

Let n be the number of revolutions in which the drum is brought to rest. Then

$$\frac{1}{2}I\omega^2 = (T_1 - T_2)\pi dn, \quad \dots \dots \dots (8)$$

d being the diameter of the drum.

Also, if P is the force applied at A , and if p and q are the perpendicular distances of O from the directions of P and T_2 , respectively,

$$Pp = T_2q. \quad \dots \dots \dots (9)$$

Again,

$$T_1 = T_2 e^{\mu\alpha}, \dots \dots \dots (10)$$

α being the angle subtended at the centre by the arc of contact.
Hence, by eqs. (8), (9), (10),

$$n = \frac{qI\omega^2}{2Pp(e^{\mu\alpha} - 1)\pi d} \dots \dots \dots (11)$$

If the motion of the drum were in the opposite direction, q would be the perpendicular distance of O from the direction of T_1 , and then $Pp = T_1 q$.

Proceeding as before,

$$n' = \frac{qI\omega^2 e^{\mu\alpha}}{2Pp(e^{\mu\alpha} - 1)\pi d}$$

and therefore the number of turns in the second case, before the drum comes to rest, is $e^{\mu\alpha}$ times the number in the first, which is consequently the preferable arrangement.

The coefficient of friction μ varies from .12 for greasy shop belts on iron pulleys to .5 for new belts and hempen ropes on wooden drums. In ordinary practice, an average value of μ for dry belts on iron pulleys is .28, and for wire ropes .24; if the belts are wet, μ is about .38.

Formulae (6) and (7) are also true for non-circular pulleys.

10. Effective Tension.—The pull available for the transmission of power = $T_1 - T_2 = S$. Let HP be the horsepower transmitted, v the speed of transmission in feet per second, a the sectional area of the rope or belt, and s the stress per square inch in the *advancing* portion of the belt.

Then, if T_1 and T_2 are in pounds,

$$HP = \frac{(T_1 - T_2)v}{550} = \frac{Sv}{550}, \text{ and } T_1 = as.$$

The working tensile stress per square inch usually adopted for leather belts varies from 285 lbs. (Morin) to 355 lbs. (Claudel),

an average value being 300 lbs. In wire ropes, 8500 lbs. per square inch may be considered an average working tension.

Hempen ropes for the transmission of power generally vary from $4\frac{1}{2}$ to $6\frac{1}{2}$ in. in circumference.

II. Effect of High Speed.—When the speed of transmission is great, the effect of centrifugal force must be taken into account.

The centrifugal force of the element $ds = \frac{wads v^2}{g r}$, w being the specific weight of the belt or rope, and r the radius of the pulley.

Eq. (3) above now becomes

$$T d\theta - R ds - \frac{wads v^2}{g r} = 0,$$

or

$$T d\theta - \frac{wad\theta}{g} v^2 - R ds = 0;$$

and hence, by eq. (4),

$$\frac{dT}{T - \frac{wa}{g} v^2} = \mu d\theta.$$

Integrating,

$$\log_e \frac{T - \frac{wa}{g} v^2}{T_2 - \frac{wa}{g} v^2} = \mu \theta$$

since $T = T_2$ when $\theta = 0$.

Also, $T = T_1$ when $\theta = \alpha$, and therefore

$$\frac{T_1 - \frac{wa}{g} v^2}{T_2 - \frac{wa}{g} v^2} = e^{\mu \alpha},$$

or

$$T_1 = T_2 e^{\mu \alpha} - \frac{wa}{g} v^2 (e^{\mu \alpha} - 1).$$

The work transmitted per second

$$= (T_1 - T_2)v = \left(T_2v - \frac{wa}{g}v^2\right)(e^{\mu\alpha} - 1),$$

which is a maximum and equal to $\frac{2}{3}T_2(e^{\mu\alpha} - 1)v$ when $v = \sqrt{\frac{T_2g}{3wa}}$, and the two tensions are then in the ratio of $2e^{\mu\alpha} + 1$ to 3.

The speed for which no work is transmitted, i.e., the limiting speed, is given by

$$T_2v - \frac{wa}{g}v^2 = 0, \quad \text{or} \quad v = \sqrt{\frac{T_2g}{wa}}$$

12. Slip of Belts.—A length l of the belt (or rope) becomes $l\left(1 + \frac{p_1}{E}\right)$ on the *advancing* side and $l\left(1 + \frac{p_2}{E}\right)$ on the *slack* side, where $p_1 = \frac{T_1}{a}$ and $p_2 = \frac{T_2}{a}$, E being the coefficient of elasticity. Thus, the advancing pulley draws on a greater length than is given off to the driven pulley, and its speed must therefore exceed that of the latter by an amount given by the equation

$$\frac{\text{reduction of speed, or slip}}{\text{speed of driving pulley}} = \frac{l\left(1 + \frac{p_1}{E}\right) - l\left(1 + \frac{p_2}{E}\right)}{l\left(1 + \frac{p_1}{E}\right)} = \frac{p_1 - p_2}{E + p_1}.$$

The slip or creep of the belt measures the loss of work. In ordinary practice the loss with leather belting does not exceed 2 per cent, while with wire ropes it is so small that it may be disregarded.

13. **Prony's Dynamometer.**—This dynamometer is one of the commonest forms of friction-brake. The motor whose power is to be measured turns a wheel *E* which revolves between the wood block *B* and a band of wood blocks *A*. To

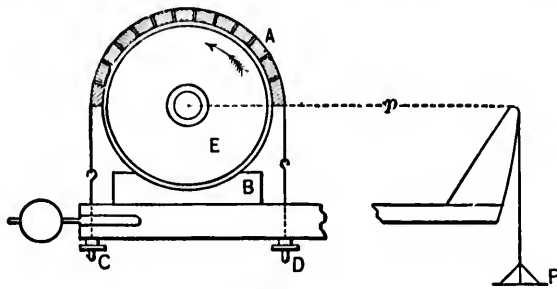

FIG. 251.

the lower block is attached a lever of radius *p* carrying a weight *P* at the free end. By means of the screws *C*, *D* the blocks may be tightened around the circumference until the unknown moment of frictional resistance *FR* is equal to the known moment *Pp*.

The weight *P*, which rests upon the ground when the screws are slack, is now just balanced.

The work absorbed by friction per minute = $2\pi RFn = 2\pi Ppn$,

n being the number of revolutions per minute.

14. **Stiffness of Belts and Ropes.**—The belt on reaching the pulley is bent to the curvature of the periphery, and is straightened again when it leaves the pulley. Thus, an amount of work, increasing with the stiffness of the belt, must be expended to overcome the resistance to bending. As the result of experiment, this resistance has been expressed in the form $\frac{aT}{bR}$, *T* being the tension of the belt, *a* its sectional area, *R* the radius of the pulley, and *b* a coefficient to be determined.

According to Redtenbacher, *b* = 2.36 in. for hempen ropes.

“ “ “ *b* = 1.67 “ “ “ “
 “ “ Reuleaux, *b* = 3.4 “ “ leather belts.

Let the figure represent a sheave in a pulley-block turning in the direction of the arrow about a journal of radius r .

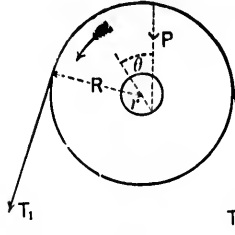

FIG. 252.

Let T_1 be the effort, T_2 the resistance.

The resistance due to the stiffness of the belt may be allowed for

by adding $\frac{aT_2}{bR}$ to the force T_2 . The frictional resistance at the journal-surface is $P \sin \phi$ or fP , P being the resultant of T_1 , T_2 .

The motion being steady, taking moments about the centre,

$$T_1 R = \left(T_2 + \frac{aT_2}{bR} \right) R + fPr,$$

or

$$T_1 = T_2 + \frac{aT_2}{bR} + f \frac{r}{R} P.$$

If T_1 and T_2 are parallel, $P = T_1 + T_2$, and the last equation becomes

$$T_1 = T_2 + \frac{aT_2}{bR} + f \frac{r}{R} (T_1 + T_2).$$

Let the pulley turn through a small angle θ .

The *counter-efficiency* of the sheave

$$= \frac{\text{motive work}}{\text{useful work}} = \frac{T_1 \theta}{T_2 \theta} = \frac{T_1}{T_2} = 1 + \frac{2fr}{R - fr} + \frac{a}{b} \frac{1}{R - fr}.$$

In the case of an endless belt connecting a pair of pulleys of radius R_1 , R_2 , the resistance due to stiffness may be taken equal to $\frac{aT}{b} \left(\frac{1}{R_1} + \frac{1}{R_2} \right)$, T being the mean tension $\left(= \frac{T_1 + T_2}{2} \right)$.

The resistance due to journal-friction = $f r P \left(\frac{1}{R_1} + \frac{1}{R_2} \right)$.

The useful resistance = $T_1 - T_2 = S$.

Hence, the counter-efficiency

$$= 1 + \left(\frac{1}{R_1} + \frac{1}{R_2} \right) \left(\frac{aT}{bS} + 2fr \frac{P}{S} \right).$$

In wire ropes the stress due to bending may be calculated as follows:

Let x be the radius of a wire. The radius of its axis is sensibly the same as the radius R of the pulley.

The outer layers of the wire will be stretched, and the inner shortened, while the axis will remain unchanged in length.

Hence,

$$\frac{x}{R} = \frac{\text{change of length of outer or inner strands}}{\text{length of axis}} = \frac{\text{unit stress}}{E},$$

$$\text{and the unit stress due to bending} = E \frac{x}{R}.$$

15. Wheel and Axle.—Let the figure represent a wheel of radius p turning on an axle of radius r , under the action of the two tangential forces P and Q , inclined to each other at an angle θ .

The resultant R of P and Q must equilibrate the resultant reaction between the wheel and axle at the surface of contact.

Let the directions of P and Q meet in T .

If there were no friction, the resultant reaction and the resultant R would necessarily pass through O and T .

Taking friction into account, the direction of R will be inclined to TO

Let its direction intersect the circumference of the axle in the point A . The angle between TA and the normal AO at A , the motion being steady, is equal to the angle of friction; call it ϕ .

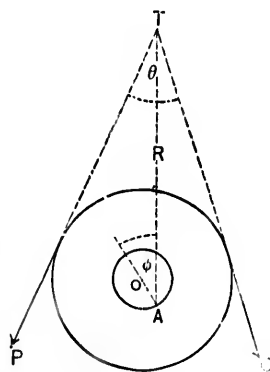

FIG. 253.

Taking moments about O ,

$$Pp - Qq - Rr \sin \phi = 0. \quad \dots \quad (1)$$

Also,

$$R^2 = P^2 + Q^2 + 2PQ \cos \theta. \quad \dots \quad (2)$$

Let $f = \sin \phi = \frac{\mu}{\sqrt{1 + \mu^2}}$, μ being the coefficient of friction.

Eq (1) may now be written

$$Pp - Qq - fRr = 0. \quad \dots \quad (3)$$

If P and Q are parallel in direction,

$$\theta = 0 \text{ and } R = P + Q.$$

Let the figure represent a wheel and axle.

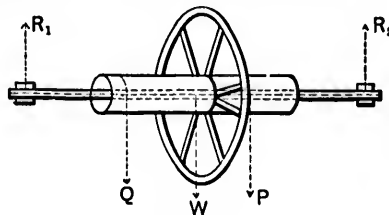

FIG. 254.

Let P be the effort and Q the weight lifted, the directions of P and Q being parallel.

Let W be the weight of the "wheel and axle."

Let R_1 and R_2 be the vertical reactions at the bearings.

Let p be the radius of the wheel.

Let q " " " axle.

Let r " " " bearings.

Take moments about the axis. Then

$$Pp - Qq - R_1 r \sin \phi - R_2 r \sin \phi = 0. \quad \dots \quad (4)$$

But

Hence,

or

P

Effici

and the r

16. T
partly rol
garded, as

Let the
point B tou
reaching th
approach.

But

$$R_1 + R_2 = W + P + Q. \dots \dots \dots (5)$$

Hence,

$$Pp - Qq = (W + P + Q)r \sin \phi = (W + P + Q)fr,$$

or

$$P(p - fr) = Q(q + fr) + fWr. \dots \dots \dots (6)$$

Efficiency.—In turning through an angle θ ,

$$\text{motive work} = Pp\theta,$$

$$\text{useful work} = Qq\theta,$$

$$\therefore \text{efficiency} = \frac{Qq\theta}{Pp\theta} = \frac{Qq}{Pp},$$

and the ratio $\frac{Q}{P}$ is given by eq. (6).

16. Toothed Gearing.—In toothed gearing the friction is partly rolling and partly sliding, but the former will be disregarded, as it is small as compared with the latter.

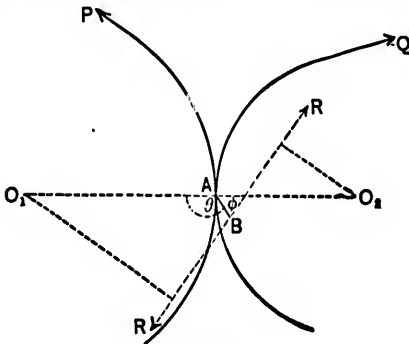

FIG. 255.

Let the pitch-circles of a pair of teeth in contact at the point \$B\$ touch at the point \$A\$; and consider the action *before reaching* the line of centres \$O_1O_2\$, i.e., along the arc of approach.

The line AB is normal to the surfaces in contact at the point B .

Let R be the resultant reaction at B . Its direction, the motion being steady, makes an angle ϕ , equal to the angle of friction, with AB .

Let θ be the angle between O_1O_2 and AB .

Let the motive force and force of resistance be respectively equivalent to a force P tangential to the pitch-circle O_1 , and to a force Q tangential to the pitch-circle O_2 .

Let r_1, r_2 be the radii of the two wheels.

The work absorbed by friction in turning through the small arc ds

$$= (P - Q)ds. \dots \dots \dots (1)$$

Consider the wheel O_1 , and take moments about the centre.

$$Pr_1 = R\{r_1 \sin (\theta - \phi) + x \sin \phi\}, \dots \dots (2)$$

where $AB = x$.

Similarly, from the wheel O_2

$$Qr_2 = R\{r_2 \sin (\theta - \phi) - x \sin \phi\}. \dots \dots (3)$$

Hence,

$$\frac{Q}{P} = \frac{\sin (\theta - \phi) - \frac{x}{r_2} \sin \phi}{\sin (\theta - \phi) + \frac{x}{r_1} \sin \phi}, \dots \dots \dots (4)$$

and therefore

$$P - Q = Q \frac{\left(\frac{1}{r_1} + \frac{1}{r_2}\right)x \sin \phi}{\sin (\theta - \phi) - \frac{x}{r_2} \sin \phi} \dots \dots \dots (5)$$

Hence, the work absorbed by friction in the arc ds

$$= Q \frac{\left(\frac{1}{r_1} + \frac{1}{r_2}\right)x \sin \phi ds}{\sin (\theta - \phi) - \frac{x}{r_2} \sin \phi} \dots \dots \dots (6)$$

In precisely the same manner it can be shown that, *after leaving* the line of centres, i.e., in the *arc of recess*,

$$\frac{Q}{P} = \frac{\sin(\theta + \phi) - \frac{x}{r_2} \sin \phi}{\sin(\theta + \phi) + \frac{x}{r_1} \sin \phi}, \dots \dots \dots (7)$$

and the work absorbed by friction in the arc ds

$$= Q \frac{\left(\frac{1}{r_1} + \frac{1}{r_2}\right)x \sin \phi ds}{\sin(\theta + \phi) - \frac{x}{r_2} \sin \phi}, \dots \dots \dots (8)$$

The ratio $\frac{Q}{P}$ and the *loss of work* given by eqs. (4) and (6) are respectively greater than the ratio $\frac{Q}{P}$ and the *loss of work* given by eqs. (7) and (8), and therefore it is advisable to make the arc of approach as small as possible.

Again, by eq. (4), motion will be impossible if

$$\sin(\theta - \phi) + \frac{x}{r_1} \sin \phi = 0;$$

i.e., if $\cot \phi = \cot \theta - \frac{x}{r_1 \sin \theta},$

and this can only be true if the direction of R passes through O_2 .

Simple approximate expressions for the *lost work* and efficiency may be obtained as follows:

θ differs very little from 90° , and x is small as compared with r_2 , and differs little from the corresponding arc s measured from A .

Hence the work absorbed by friction in the arc ds

$$= Q \tan \phi \left(\frac{1}{r_1} + \frac{1}{r_2}\right) s ds = Q \mu \left(\frac{1}{r_1} + \frac{1}{r_2}\right) s ds,$$

and the work lost in arc of approach s_1 ,

$$= \int_0^{s_1} Q\mu \left(\frac{1}{r_1} + \frac{1}{r_2} \right) s ds = Q\mu \left(\frac{1}{r_1} + \frac{1}{r_2} \right) \frac{s_1^2}{2}. \quad (9)$$

The useful work done in the same interval = Qs_1 .

The counter-efficiency (reciprocal of efficiency)

$$= \frac{Qs_1 + Q\mu \left(\frac{1}{r_1} + \frac{1}{r_2} \right) \frac{s_1^2}{2}}{Qs_1} = 1 + \mu \left(\frac{1}{r_1} + \frac{1}{r_2} \right) \frac{s_1}{2}. \quad (10)$$

Similarly for the arc of recess s_2 ,

$$\text{the lost work} = Q\mu \left(\frac{1}{r_1} + \frac{1}{r_2} \right) \frac{s_2^2}{2}, \quad (11)$$

$$\text{and the counter-efficiency} = 1 + \mu \left(\frac{1}{r_1} + \frac{1}{r_2} \right) \frac{s_2}{2}. \quad (12)$$

If $s_1 = s_2 = \text{pitch} = p = \frac{2\pi r_1}{n_1} = \frac{2\pi r_2}{n_2}$, n_1, n_2 being the number of teeth in the driver and the follower, respectively, the expressions for the lost work given by eqs. (9) and (11) are identical, and those for the counter-efficiency given by eqs. (10) and (12) are also identical.

Thus, the whole work lost during the action of a pair of teeth

$$= Q\mu \left(\frac{1}{r_1} + \frac{1}{r_2} \right) p^2, \quad (13)$$

and the counter-efficiency

$$= 1 + \mu \left(\frac{1}{r_1} + \frac{1}{r_2} \right) \frac{p}{2}, \quad (14)$$

$$= 1 + \mu\pi \left(\frac{1}{n_1} + \frac{1}{n_2} \right). \quad (15)$$

This last equation shows that the efficiency increases with the number of teeth.

If the follower is an annular wheel, $\frac{1}{r_1} - \frac{1}{r_2}$ must be substituted for $\frac{1}{r_1} + \frac{1}{r_2}$ in the above equations. Thus, with an annular wheel the counter-efficiency is diminished and the efficiency, therefore, increased.

It has been assumed that R and Q are constant, as their variation from a constant value is probably small. It has also been assumed that only one pair of teeth are in contact. The theory, however, holds good when more than one pair are in contact, an effort and resistance, corresponding to P and Q , being supposed to act for each pair.

17. Bevel-wheels.—Let IA, IB represent the developments of the axes of the pitch-circles II_1, II_2 of a pair of bevel-wheels when the pitch-cones are spread out flat, O_1, O_2 being the corresponding centres.

The preceding formulæ will apply to bevel-wheels, the radii being O_1I, O_2I , and the pitch being measured on the circumferences IA, IB .

18. Efficiency of Mechanisms.
—Generally speaking, the ratio of the effort P to the resistance Q in a mechanism may be expressed as a function of the coefficient of friction μ . Thus,

$$\frac{P}{Q} = F(\mu).$$

If, now, the mechanism is moved so that the points of application of P and Q traverse small distances $\Delta x, \Delta y$ in the directions of the forces,

$$\text{the efficiency} = \frac{Q\Delta y}{P\Delta x} = \frac{1}{F(\mu)} \frac{\Delta y}{\Delta x}.$$

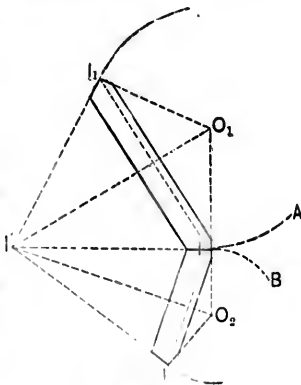

FIG. 256.

But the ratio $\frac{\Delta y}{\Delta x}$ depends only upon the geometrical relations between the different parts of the mechanism, and will therefore remain the same if it is assumed that μ is zero. In such a case the efficiency would be perfect, or the motive work ($P\Delta x$) would be equal to the useful work ($Q\Delta y$), and therefore

$$I = \frac{1}{F(0)} \frac{\Delta y}{\Delta x}.$$

Hence, the efficiency

$$= \frac{F(0)}{F(\mu)}.$$

TABLE OF COEFFICIENTS OF AXLE-FRICTION.

	Dry.	Greasy and Wet.	Ordinary Lubrication.	Continuous Lubrication	Pure Carriage-grease.	Lard and Plumbago.	Grease.
Bell-metal on bell-metal.....			.097				
Brass on brass.....			.070				
Brass on cast-iron.....			.072	.040			
Cast-iron on bell-metal.....	.194	.161	.075	.054	.065		.16
Cast-iron on brass.....	.194		.075	.054			
Cast-iron on cast-iron.....		.137	.075	.054			.14
Cast-iron on lignum-vitæ.....	.185		.1	.092		.11	.14
Lignum-vitæ on cast-iron.....			.116	.17			.15
Lignum-vitæ on lignum-vitæ.....				.07			
Wrought-iron on bell-metal.....	.251	.189	.075	.054	.09	.11	
Wrought-iron on cast-iron.....			.075	.054			
Wrought-iron on lignum-vitæ.....	.187		.125				

1. I
P' to r
that th
raised

Find th
2. F
by a 15-
diameter
friction.

3. A
10 H. P.
diameter

4. A $\frac{1}{2}$
 $\frac{1}{2}$ in.; the
of the pul
for stiffne

Hence

5. If t
slack tens
 $\frac{1}{2}$ and the

6. Sho

will be a m

being the s

The tigh
ference of t
transmit, th
per cubic in

7. In an
150 lbs., the
arc of conta
larger wheel
the efficienc
of the belt.
elasticity in

EXAMPLES.

1. In a pair of four-sheaved blocks, it is found that it requires a force P' to raise a weight $5P'$, and a force $5P'$ to raise a weight $15P'$. Show that the general relation between the force P' and the weight W to be raised is given by

$$P = \frac{2}{5}W - P'.$$

Find the efficiency when raising the weights $5P'$ and $15P'$.

2. Find the mechanical advantage when an inch bolt is screwed up by a 15-in. spanner, the effective diameter of the nut being $1\frac{1}{8}$ in., the diameter at the base of the thread .84 in., and .15 being the coefficient of friction.

3. A belt, embracing one-half the circumference of a pulley, transmits 10 H. P.; the pulley makes 30 revolutions per minute and is 7 ft. in diameter. Neglecting slip, find T_1 and T_2 ; μ being .125.

Ans. 1541 $\frac{1}{8}$ lbs.; 1041 $\frac{1}{8}$ lbs.

4. A $\frac{1}{2}$ -in. rope passes over a 6-in. pulley, the diameter of the axis being $\frac{1}{2}$ in.; the load upon the axis = 2 \times the rope tension. Find the efficiency of the pulley, the coefficient of axle-friction being .08 and the coefficient for stiffness .47.

Hence also deduce the efficiency of a pair of three-sheaved blocks.

5. If the pulleys are 50 ft. c. to c. and if the tight is three times the slack tension, find the length of the belt, the coefficient of friction being $\frac{1}{3}$ and the diameter of one of the pulleys 12 in.

6. Show that the work transmitted by a belt passing over a pulley will be a maximum when it travels at the rate of $\sqrt{\frac{T_2}{3m}}$ ft. per sec., T_2 being the slack tension and m the mass of a unit of length of the belt.

The tight tension on a 20-in. belt, embracing one-half the circumference of the pulley, is 1200 lbs. Find the maximum work the belt will transmit, the thickness of the belt being .2 in. and its weight .0325 lb. per cubic inch. (Coefficient of friction = .28.) *Ans.* 68.75 H. P.

7. In an endless belt passing over two pulleys, the least tension is 150 lbs., the coefficient of friction .28, and the angle subtended by the arc of contact 148° . Find the greatest tension. The diameter of the larger wheel is 78 in., of the smaller 10 in., of the bearings 3 in. Find the efficiency. A tightening-pulley is made to press on the slack side of the belt. Assuming that the working tension is to the coefficient of elasticity in the ratio of 1 to 80, find the increment of the arc of contact

on the belt-pulley, the tension of the slack side, and the force of the tightening-pulley. *Ans.* 309 lbs.

8. A belt weighing $\frac{1}{4}$ lb. per lineal foot, connects two 42-in. pulleys, one making 240 revolutions per minute. Find the limiting tension for which work will be transmitted. Also find the tight and slack tensions and the efficiency when the belt transmits 5 horse-power. Diameter of axle = 2 in.; coefficient of friction = .28. *Ans.* 301 lbs.; 137 lbs.; 741 lbs.

9. A circular saw makes 1000 revolutions per minute and is driven by a belt 3 in. wide and $\frac{1}{8}$ in. thick, its weight per cubic inch being .0325 lb. The belt passes over a 10-in. pulley, embracing one-half the circumference, and transmits 6 H. P. Find the tight and slack tensions, the coefficient of friction being .28. *Ans.* 1431 lbs.; 67.5 lbs.

10. A flexible band, embracing three-fourths of the circumference of a brake-pulley keyed on a revolving shaft, has one extremity attached to the end *A* of the lever *AOB*, and the other to the fixed point *O* (between *A* and *B*) about which the lever oscillates. The pressure between the band and pulley is effected by a force applied at right angles to the lever at the end *B*. Show that the time in which the axle is brought to rest is about $2\frac{1}{2}$ times as great when revolving in one direction as in the opposite ($f = .2$).

11. In a Prony-brake test of a Westinghouse engine, the blocks were fixed to a 24-in. fly-wheel with a 6-in. face, and the balance-reading was 48 lbs.; the distance from centre of shaft to centre of balance, measured horizontally, was 30 in., and the number of revolutions per minute was 624. Find the H. P. *Ans.* 14.3.

12. An engine makes 150 revolutions per minute. If the diameter of the brake-pulley is 45 in. and the pull on the brake is 50 lbs., find the B. H. P. *Ans.* 2.67.

13. A small water-motor is tested by a tail dynamometer. The pulley is 18 in. in diameter; the weight is 60 lbs.; the spring registers a pull of 50 lbs.; the number of revolutions per minute = 500. Find the B. H. P. *Ans.* $\frac{3}{4}$.

14. The power of an engine making n revolutions per minute is tested by a Prony brake having its arm of length r connected with a spring-balance which registers a force P . The arm is vertical and the weight W of the brake is supported by a stiff spring fixed vertically below the centre of the wheel. What error in B. H. P. would be introduced by placing the spring x ft. away from the central position?

$$\text{Ans. } \frac{B W x}{P r}, B \text{ being the B. H. P.}$$

15. Find work absorbed by friction per revolution by a pivot 3 in. long and carrying 6 tons, its upper face being 6 in. in diameter, coefficient of friction .04, and $2a$ being 90° .

16. the di
17. ute is
units o
heat b
18.
10 rev
coeffic
friction
will the
19.
10 ft. is
revoluti
coefficie
20. A
diameter
 $\frac{1}{16}$. Find
of the jo
21. A
cient of
ton.
22. A
of 50 tons
Find the
23. A
makes 60
oil. How
being .08
24. A p
of the tee
proach = a
and find th
25. Fin
of teeth in
wheel, whic
26. The
an addendu
recess are ca
cient of fric

16. The diameter of a solid cylindrical cast-steel pivot is $2\frac{1}{4}$ in. Find the diameter of an equally efficient conical pivot.

17. The pressure upon a 4-in. journal making 50 revolutions per minute is 6 tons, the coefficient of friction being .05. Find the number of units of heat generated per second; Joule's mechanical equivalent of heat being 778 ft.-lbs.

18. A water-wheel of 20 ft. diameter and weighing 20,000 lbs. makes 10 revolutions per minute; the gudgeons are 6 in. in diameter and the coefficient of friction is .1. Find the loss of mechanical effect due to friction. If the motive power is suddenly cut off, how many revolutions will the wheel make before coming to rest? *Ans.* $\frac{3}{8}$ H. P.; 10.9.

19. A fly-wheel weighing 8000 lbs. and having a radius of gyration of 10 ft. is disconnected from the engine at the moment it is making 27 revolutions per minute; it stops after making 17 revolutions. Find the coefficient of friction, the axle being 12 in. in diameter. *Ans.* .2325.

20. A railway truck weighing 12 tons is carried on wheels 3 ft. in diameter; the journals are 4 in. in diameter, the coefficient of friction $\frac{1}{8}$. Find the resistance of the truck so far as it arises from the friction of the journals. *Ans.* $37\frac{1}{2}$ lbs.

21. A tramcar wheel is 30 in. in diameter, the axle $2\frac{1}{2}$ in.; the coefficient of axle-friction .08, of rolling friction .09. Find the resistance per ton. *Ans.* 28.37 lbs.

22. A bearing 16 in. in diameter is acted upon by a horizontal force of 50 tons and a vertical force of 10 tons; the coefficient of friction is $\frac{1}{8}$. Find the H. P. absorbed by friction per revolution. *Ans.* .906 H. P.

23. A steel pivot 3 in. in diameter and under a pressure of 5 tons makes 60 revolutions per minute in a cast-iron step well lubricated with oil. How much work is absorbed by friction, the coefficient of friction being .08?

24. A pair of spur-wheels are 4 in. and 2 in. in diameter; the flanks of the teeth are radial; the larger wheel has 16 teeth; the arc of approach = arc of recess = $\frac{1}{3}$ of the pitch. Show how to form the teeth, and find their efficiency. (Coefficient of friction = .11.)

25. Find the work lost by the friction of a pair of teeth, the number of teeth in the wheels being 32 and 16, and the diameter of the larger wheel, which transmits 3 horse-power at 50 revolutions per minute, 3 ft.

26. The driver of a pair of wheels has 120 teeth, and each wheel has an addendum equal to .28 times the pitch; the arcs of approach and recess are each equal to the pitch; the tooth-flanks are radial. (Coefficient of friction = .106.) Find the efficiency.

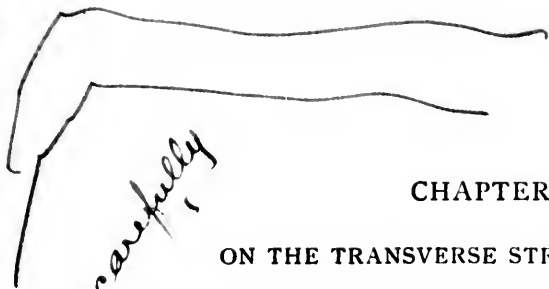

CHAPTER VI.

ON THE TRANSVERSE STRENGTH OF BEAMS.

1. To determine the Elastic Moment.—Let the plane of the paper be a plane of symmetry with respect to the beam $PQRS$.

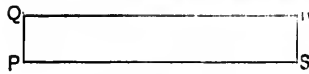

FIG. 257.

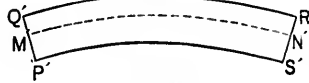

FIG. 258.

If the beam is subjected to the action of external forces in this plane, $PQRS$ is bent and assumes a curved form $P'Q'R'S'$. The upper layer of fibres, $Q'R'$, is extended, the lower layer, $P'S'$, is compressed, while of the layers within the beam, those nearer $P'S'$ are compressed and those nearer $Q'R'$ are extended. Hence, there must be a layer $M'N'$ between $P'S'$ and $Q'R'$ which is neither compressed nor extended. It is called the *neutral surface* (or *cylinder*), and its axis is perpendicular to the plane of flexure. In the present treatise it is proposed to deal with flexure in one plane only, and, in general, it will be found more convenient to refer to $M'N'$ as the *neutral line* (or *axis*), a term only used in reference to a *transverse section*.

If a force act upon the beam in the direction of its length, the lower layer $P'S'$, instead of being compressed, may be stretched. In such a case there is no neutral surface *within* the beam, but theoretically it still exists somewhere *without* the beam.

Let $ABCD$ be an indefinitely small rectangular element of the unstrained beam, and let its length be s . Let $A'B'C'D'$, Fig. 260, be the element after deformation by the external forces.

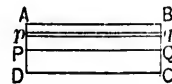

FIG. 259.

pre
and

line
curv

Z
sma
may
layer
tions
with

T
(a)
respe
(b)
genco
(c)
plane
(d)
ing str
notwit
layers.
(e)
freely
Cor
area a,
Let
Fro

 $\frac{Op'}{OP'} =$

Also

$P'Q'$, the neutral line, being neither compressed nor extended, is unchanged in length and equal to $PQ = s$.

Let the normals at P' and Q' to the neutral line meet in the point O ; O is the centre of curvature of $P'Q'$.

Also, as the flexure of the element is very small, the normal planes through OP' and OQ' may be assumed to be perpendicular to all the layers which traverse the corresponding sections of the beam, so that they must coincide with the planes $A'D'$ and $B'C'$, respectively.

The assumptions made in the above are:

(a) That the beam is symmetrical with respect to a certain plane.

(b) That the material of the beam is homogeneous.

(c) That sections which are plane before bending remain plane after bending.

(d) That the ratio of longitudinal stress to the corresponding strain is the ordinary (i.e., Young's) modulus of elasticity notwithstanding the lateral connection of the elementary layers.

(e) That these elementary layers expand and contract freely under tensile and compressive forces.

Consider an elementary layer $p'q'$, of length s' , sectional area a_1 , and distant y_1 from the neutral surface.

Let $OP' = R = OQ'$.

From the similar figures $OP'Q'$ and $Op'q'$,

$$\frac{Op'}{OP'} = \frac{p'q'}{P'Q'}, \text{ or } \frac{R + y_1}{R} = \frac{s'}{s}, \text{ and therefore } \frac{y_1}{R} = \frac{s' - s}{s}.$$

Also, if t_1 is the stress along the layer $p'q'$,

$$t_1 = Ea_1 \frac{s' - s}{s} = Ea_1 \frac{y_1}{R} = \frac{E}{R} a_1 y_1,$$

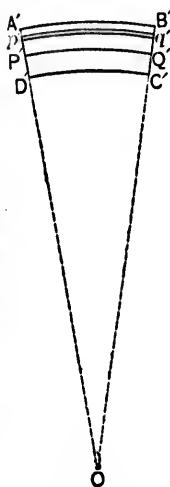

FIG. 260.

E being the coefficient of elasticity of the material of the beam.

So, if $t_1, a_1, y_1, t_2, a_2, y_2, \dots$ are respectively the stress, sectional area, and distance from the neutral surface, of the several layers of the element,

$$t_1 = \frac{E}{R} a_1 y_1, \quad t_2 = \frac{E}{R} a_2 y_2, \quad \dots$$

The *total* stress along the beam is the algebraic sum of all these elementary stresses,

$$= t_1 + t_2 + t_3 + \dots = \frac{E}{R} (a_1 y_1 + a_2 y_2 + \dots) = \frac{E}{R} \Sigma (ay).$$

Again, the moment of t_1 about $P' = t_1 y_1 = \frac{E}{R} a_1 y_1^2$;

$$\text{“ “ “ } t_2 \text{ “ “} = t_2 y_2 = \frac{E}{R} a_2 y_2^2;$$

$$\text{“ “ “ } t_3 \text{ “ “} = t_3 y_3 = \frac{E}{R} a_3 y_3^2;$$

and so on.

Thus, the *Elastic Moment* for the section $A'D'$ = the algebraic sum of the moments of all the elementary stresses in the different layers about P' ,

$$\begin{aligned} &= t_1 y_1 + t_2 y_2 + t_3 y_3 + \dots = \frac{E}{R} (a_1 y_1^2 + a_2 y_2^2 + \dots) \\ &= \frac{E}{R} \Sigma (ay^2). \end{aligned}$$

beam
thro
flexu
I or
gyrat

Bu
mome
He

Now
braic,
therefo
face to



Fig.

As be

Now, $\Sigma (ay^2)$ is the *moment of inertia* of the section of the beam through $A'D'$, with respect to a straight line passing through the neutral line and perpendicular to the plane of flexure, i.e., the plane of the paper. It is usually denoted by I or Ak^2 , A being the sectional area, and k the radius of gyration. Thus,

$$\text{the elastic moment} = \frac{E}{R} I = \frac{E}{R} Ak^2.$$

But the elastic moment is equal and opposite to the bending moment (M) due to the external forces, at the same section.

Hence

$$\frac{E}{R} I = \frac{E}{R} Ak^2 = M.$$

Note.—It is necessary in the above to use the term *algebraic*, as the elementary stresses change in character, and therefore in sign, on passing from one side of the neutral surface to the other.

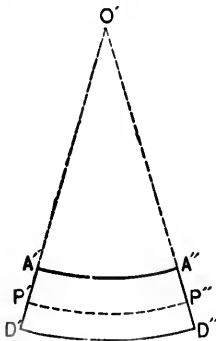

FIG. 261.

Cor. 1. Bearing in mind assumption (e), the figure represents on an exaggerated scale the *transverse* section of the beam at $A'D'$, the upper and lower breadths of the beam, $A'A''$ and $D'D''$, being respectively contracted and stretched, and being also arcs of circles having a common centre at O' .

Let R' be the radius of the arc $P'P''$, whose length remains unchanged.

Let mE be the lateral coefficient of elasticity, m being a numerical coefficient.

As before, for any layer at a distance y from $P'P''$,

$$\frac{mE}{R'} = \frac{t}{ay} = \frac{E}{R}.$$

$$\therefore R' = mR.$$

Thus, *within the limits of elasticity*, the curvature of the breadth is $\frac{1}{m}$ that of the length, and does not sensibly affect the resistance of the beam to bending. The influence, however, upon the bending may become sensible if the breadth is very large as compared with the depth, as, e.g., in the case of iron or steel plates.

Cor. 2. If the resolved part of the external forces in the direction of the length of the beam is *nil*,

the total longitudinal stress = $\frac{E}{R} \Sigma(ay) = 0$, or $\Sigma(ay) = 0$,

showing that P' must be the centre of gravity of the section through $A'D'$. Hence, when the external forces produce no longitudinal stress in the beam, the neutral line is the *locus* of the centres of gravity of all the sections perpendicular to the length of the beam.

Cor. 3. If t , a , y be, respectively, the stress, sectional area, and distance of a fibre from the neutral line, then

$$\frac{E}{R} ay = t, \text{ or } \frac{E}{R} y = \frac{t}{a} = \text{intensity of stress} = f, \text{ suppose,}$$

$$\therefore \frac{f_y}{y} = \frac{E}{R}, \text{ and } \frac{E}{R} I = M = \frac{f_y}{y} I.$$

EXAMPLE 1. A timber beam, 6 in. square and 20 ft. long, rests upon two supports, and is uniformly loaded with a weight of 100 lbs. per lineal foot. Determine the stress at the centre at a point distant 2 in. from the neutral line.

Also find the central curvature, E being 1,200,000 lbs.

$$I = \frac{6.6^3}{12} = 108, \quad M = 1000 \times 10 - 1000 \times 5 = 5000 \text{ ft.-lbs.} \\ = 60,000 \text{ inch.-lbs., and } y = 2 \text{ in.}$$

Hence from the above equations,

$$\frac{1200000}{R} \times 108 = 60000 = \frac{f_y}{2} 108.$$

Thus $R = 2160$ in. = 180 ft., and $f_y = 1111\frac{1}{2}$ lbs. per sq. in.

EX. 2. A standpipe section, 33 ft. in length and weighing 5720 lbs., is placed upon two supports in the same horizontal plane, 30 ft. apart. The internal diameter of the pipe is 30 in., and its thickness $\frac{1}{2}$ inch. Determine the additional uniformly distributed load which the pipe can carry between the bearings, so that the stress in the metal may nowhere exceed 2 tons per square inch.

Let W be the required load in pounds.

The weight of the pipe between the bearings = $\frac{30}{33} \cdot 5720$
= 5200 lbs.

Thus, the total distributed weight between the bearings
= $(W + 5200$ lbs.)

Now
$$M = \frac{f_c}{c} I,$$

and the stress in the metal is necessarily greatest at the central section.

$$M, \text{ at the centre, } = \frac{W + 5200}{8} \cdot 30 \cdot 12 \text{ inch-lbs.};$$

$$f_c = 2 \times 2240 \text{ lbs.}, \text{ and } \frac{I}{c} = \pi r^3 t = \frac{22}{7} \cdot 15^3 \cdot \frac{1}{2}.$$

$$\therefore \frac{W + 5200}{8} \cdot 30 \cdot 12 = 2 \cdot 2240 \cdot \frac{22}{7} \cdot 15^3 \cdot \frac{1}{2} = 72000 \times 22,$$

and hence $W = 30,000$ lbs.

Cor. 4. The beam is strained to the limit of safety when either of the extreme layers $A'B'$, $D'C'$ is strained to the limit of elasticity. In such a case, the least of the values of $\frac{f_y}{y}$ for the extreme layers $A'B'$, $D'C'$ is the greatest consistent with the strength of the beam; and if f_c and c are the corresponding intensity of stress, and distance from the neutral axis,

$$\frac{E}{R}I = M = \frac{f_c}{c}I.$$

EXAMPLE.—Compare the strengths of two similarly loaded beams of the same material, of equal lengths and equal sectional areas, the one being round and the other square.

Let r be the radius of the round beam; f_r , the intensity of the skin stress.

Let a be a side of the square beam; f_a , the intensity of the skin stress. Then

$$\pi r^2 = a^2; \quad I, \text{ for round bar,} = \frac{\pi r^4}{4}, \text{ and for square bar} = \frac{a^4}{12}.$$

Also, since the beams are similarly loaded, the bending moments at corresponding points are equal.

$$\therefore \frac{f_r}{r} \frac{\pi r^4}{4} = M = \frac{f_a}{a} \frac{a^4}{12},$$

so that

$$\frac{f_r}{f_a} = \frac{2}{3} \frac{a^2}{\pi r^2} = \frac{2}{3} \sqrt{\frac{22}{7}} = \sqrt{\frac{88}{63}}.$$

Thus, under the same load, the round beam is strained to a greater extent than the square beam, and the latter is the stronger in the ratio of $\sqrt{88}$ to $\sqrt{63}$.

Cor. 5. The neutral surface is neither stretched nor compressed, so that it is not subjected to any longitudinal stress. But it by no means follows that this surface is wholly free from stress, and it will be subsequently seen that the effect of a shearing force, when it exists, is to stretch and compress the different particles in diagonal directions making angles of 45° with the surface.

Cor. 6. For a rectangular beam, $I = \frac{bd^3}{12}$, and $c = \frac{d}{2}$.

$$\therefore M = \frac{f}{c}I = \frac{f}{\frac{d}{2}} \frac{bd^3}{12} = \frac{f}{6}bd^2.$$

If the beam is fixed at one end and loaded at the other with a weight W , the maximum bending moment = Wl .

If the beam is fixed at one end and loaded uniformly with a weight $wl = W$, the maximum bending moment

$$= \frac{wl^2}{2} = \frac{Wl}{2}.$$

If the beam rests upon two supports and carries a weight W at the centre, the maximum bending moment = $\frac{Wl}{4}$.

If the beam rests upon two supports and carries a uniformly distributed load of $wl = W$, the maximum bending moment = $\frac{wl^2}{8} = \frac{Wl}{8}$.

Hence, in the first case, $W = \frac{f}{6} \frac{bd^3}{l}$;

“ “ second “ $W = \frac{f}{6} 2 \frac{bd^3}{l}$;

“ “ third “ $W = \frac{f}{6} 4 \frac{bd^3}{l}$;

“ “ fourth “ $W = \frac{f}{6} 8 \frac{bd^3}{l}$.

$$\frac{f}{6} = \frac{W}{1} = \frac{W}{R}$$

In general,
$$W = \frac{f}{6} q \frac{bd^3}{l};$$

q being some coefficient depending upon the manner of the loading.

Now, if the laws of elasticity held true up to the point of rupture, these equations would give the *breaking weights* (W), corresponding to different ultimate unit stresses (f), but the values thus derived differ widely from the results of experiment. It is usual to determine the breaking weight (W) of a rectangular beam from the formula $W = C \frac{bd^3}{l}$, where C is a constant which depends both upon the manner of the loading and the nature of the material, and is called the *coefficient of rupture*.

The *modulus of rupture* is the value of f in the ordinary bending-moment formula ($M = \frac{f}{c} I$) when the load on the beam is its breaking load.

The preceding equations, however, may be evidently employed to determine the breaking weights in the several cases by making $\frac{f}{6} q = C$. In this case f is no longer the *real* stress, but may be called the coefficient of bending strength.

The values of C for iron, steel, and timber beams, supported at the two ends and loaded in the centre, are given in the Tables at the end of Chapter III.

The corresponding value of f is obtained from the equation

$$\frac{f}{6} 4 = C;$$

or

$$f = \frac{3}{2} C.$$

EXAMPLE.—Determine the central breaking weight of a

red-pine
support
The

the

2. I

beam u
from th
ceeded.
way. I
increas
produci
the dist
slower.
sion acc
increasi
the poin
metal o
stress is
equaliza
an incre
the incr
ductility
For
compress

represent
section v
this lim

red-pine beam, 10 in. deep, 6 in. wide, and resting upon two supports 20 ft. apart.

The value of C for red pine is about 5700. Hence,

$$\text{the breaking weight} = W = 5700 \frac{6 \cdot 10^3}{20 \times 12} = 14,250 \text{ lbs.}$$

2. Equalization of Stress.—The stress at any point of a beam under a transverse load is proportional to its distance from the neutral plane so long as the elastic limit is not exceeded. At this limit materials which have no ductility give way. In materials possessing ductility, the stress may go on increasing for some distance beyond the elastic limit without producing rupture, but the stress is no longer proportional to the distance from the neutral plane, its variation being much slower. This is due to the fact that the portion in compression acquires increased rigidity and so exerts a continually increasing resistance (Chap. III) almost if not quite up to the point of rupture, while in the stretched portion a flow of metal occurs and an approximately constant resistance to the stress is developed. Thus, there will be a more or less perfect equalization of stress throughout the section, accompanied by an increase of the elastic limit and of the apparent strength, the increase depending both upon the form of section and the ductility.

For example, if the tensile elastic limit is the same as the compressive, the shaded portion of Fig. 262 gives a graphical



FIG. 262.



FIG. 263.



FIG. 264.

representation of the total stress in a beam of rectangular section when the straining is within the elastic limit. Beyond this limit, it may be represented as in Fig. 263, and will be

intermediate between Fig. 262 and the shaded rectangle of Fig. 264 which corresponds to a state of perfect equalization.

3. Surface Loading.*—It may be well to draw attention to another important assumption upon which is based the mathematical treatment of the problem of Beam Flexure.

It has been assumed that the external forces acting on a beam can be so applied that they may be considered as distributed uniformly over the whole section. Thus when a beam encastré is loaded at the free end, Fig. 265, the load P is as-

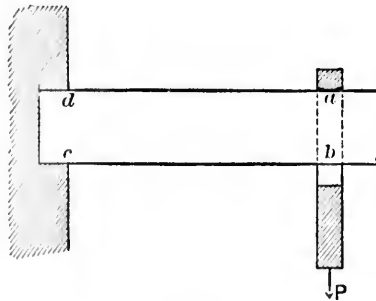

FIG. 265.

sumed to be uniformly distributed over the section ab , i.e., each element in the section is supposed to experience the same amount of strain due to the load, and the reaction of the wall is also supposed to be uniformly distributed over each element in the section cd .

It is clear that such suppositions must be far from the truth.

In practice, the load P must be hung by some means from the beam, say by a stirrup passing over the top. The whole load is then concentrated at the line of contact of the stirrup with the beam, and it is obviously untrue to say that every

* This article was kindly written by Professor Carus-Wilson and is an abstract of a Paper presented by him to the Physical Society.

elemen
than t
the lo
a certa
each el
parison
produce

It w
certain
that thi
to be a
that wit

But t
zero and

Thus
distribut
 α , and h

Engi
"surface
provided
strains ;

in the cas
ure is th
account t
applied.

It can
tons per in
resting upo

element in the section ab is equally strained. But more than this. It has been assumed that, taking the effect of the load as distributed uniformly over the section ab , and a certain deflection thereby produced, the effect of P on each element of the section ab may be disregarded in comparison with the strains involved in the deflection which P produces.

It will probably be difficult at first to grasp the fact that certain measurable effects have been actually neglected, but that this is so may be seen by supposing the beam in question to be a pine beam, and the stirrup of iron. Experience proves that with a very moderate load the beam will be *indented at a*.

But the theory shows that the longitudinal tension at a is zero and increases to a maximum at d .

Thus, so far from the squeezing effect of the load being distributed uniformly over the section ab , it is concentrated at a , and hence it is impossible to neglect it.

Engineers have always recognized the existence of this "surface-loading" effect in practice, and where possible, have provided a good "bearing" in order to avoid such local strains; but this cannot always be done—as, for instance, in the case of rollers under bridge ends. The theory of flexure is therefore manifestly incomplete if it cannot take into account the actual manner in which the loads are and must be applied.

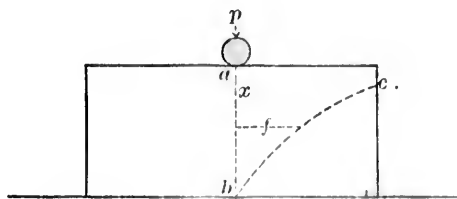

FIG. 266.

It can be shown that the effect of placing a pressure of p tons per inch run, say in the form of a loaded roller, on a beam resting upon a flat surface, as in Fig. 266, to prevent it from

bending, is to compress every element say along ab with an intensity given approximately by the equation

$$f = \frac{2p}{\pi} \left(\frac{1}{x} - \frac{x}{h^2} \right),$$

where f is the pressure at a distance x from a , the point of contact, and $h = ab$. This is the equation to a curve bc which is approximately an hyperbola.

When a beam is bent by the application of external forces, a very close approximation to the true condition may be obtained by superposing this surface-loading effect on that found for bending.

Take the case of a beam supported at the ends and loaded at the centre, and let it be required to find the condition along ab , Fig. 267.

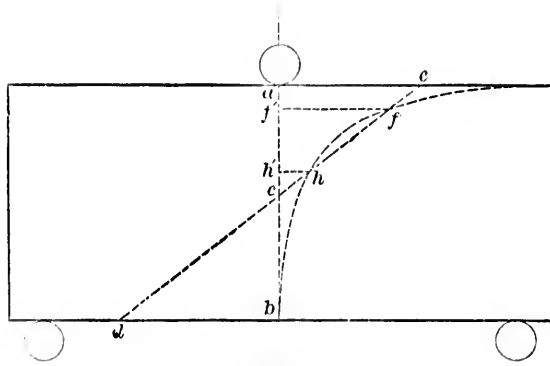

FIG. 267.

The effect of the bending is to produce compression above and tension below the point e , and these effects may be represented by a right line de passing through e .

The surface-loading effect may be represented by an hyperbola giving the compression at any point along ab due to the load. The hyperbola and straight line will intersect in two

point
vertic
the h
elem
sion o
 f' to
horizo
differ
the cu
loading
pass th
tension
This
glass b
under t
 f' . If
clear th
the sam
element
and the
ing the
stretch
"neutra

where y i
 $ab, m = -$

For al
depth, viz
words, for
times the
is stretche

points h and f , which shows that at two points h', f' along ab the vertical squeeze produced by the load is of equal intensity to the horizontal squeeze produced by the bending; hence an element at each of these points is subject to cubical compression only. From a to f' the beam is squeezed vertically, from f' to h' it is squeezed horizontally, and from h' to b it is stretched horizontally. The intensities are given at every point by the difference between the ordinates of the line of bending de and the curve of loading. It will appear that one effect of surface-loading is to make the neutral axis rise up under the load and pass through the point h' , for there is neither compression nor tension at that point.

This can be verified by examining the condition of a bent glass beam by polarized light. The neutral axis is pushed up under the load and there is a black ring passing through the point f' . If the span is diminished and the load kept constant, it is clear that ac will become less, while the curve of loading remains the same, until the line dce ceases to cut the curve; every element along ab will then be subjected to horizontal stretch, and the stretch is greatest at a ; the result obtained by neglecting the surface loading is that only elements from c to b are stretched, the greatest stretch being at b . The position of the "neutral points" is given by the equation

$$\frac{y}{h} = \frac{1}{4} \pm \sqrt{\frac{1}{16} - \frac{1}{m}}$$

where y is the distance from the top edge, h equals the depth ab , $m = \frac{3\pi a}{b} - 4$, and $a =$ one-half of the span.

For all elements in ab to be stretched, the ratio of span to depth, viz., $\frac{2a}{b}$, must be equal to or less than 4.25. In other words, for any beam, and any load, if the span is less than $4\frac{1}{4}$ times the depth, every element in the normal under the load is stretched horizontally.

4. Beam acted upon by a Bending Moment in a Plane which is not a Principal Plane.

Let XOX , YOY be the principal axes of the plane section of the beam.

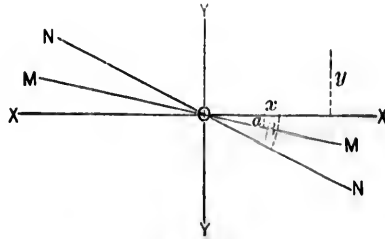

FIG. 268.

Let the axis MOM of the bending moment M make an angle α with OX .

M may be resolved into two components, viz.,

$$M \cos \alpha = X \quad \text{and} \quad M \sin \alpha = Y.$$

These components may be dealt with separately and the results superposed.

Thus, the total stress, f , at any point (x, y)

$$= \text{stress due to } X + \text{stress due to } Y = \frac{Xy}{I_x} + \frac{Yx}{I_y} = f,$$

I_x, I_y being the moments of inertia with respect to the axes XOX, YOY , respectively.

If the point (xy) is on the neutral axis, then

$$\frac{Xy}{I_x} + \frac{Yx}{I_y} = 0,$$

or

$$\tan \beta = \frac{y}{x} = -\frac{YI_x}{XI_y} = -\frac{I_x}{I_y} \tan \alpha,$$

β being the angle between the neutral axis and XOX .

Als
between
 $\theta = \beta$.
5. S
to P bu
are app
spring,
known
linear a
XIII.



FIG. 268.

Conside
action of I

Also see Art. 6, Chap. VIII. In this article θ is the angle between the neutral axis and the axis of the couple, i.e., $\theta = \beta - \alpha$.

5. Springs.—(a) Flat Springs.—If two forces, each equal to P but acting in opposite directions in the same straight line, are applied to the ends of a straight uniform strip of flat steel spring, the spring will assume one of the forms shown below, known as the *elastic curve*. This curve is also the form of the linear arch best suited to withstand a fluid pressure, Chap. XIII.

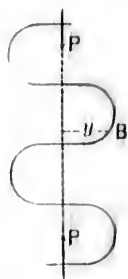

FIG. 265.

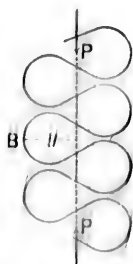

FIG. 270.

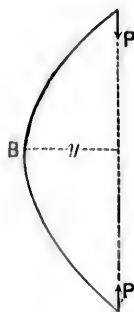

FIG. 271.

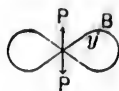

FIG. 272.

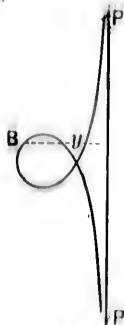

FIG. 273.

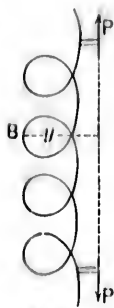

FIG. 274.

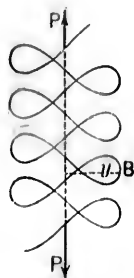

FIG. 275.

Consider a point B of the spring distant y from the line of action of P . Then

$$Py = \text{bending moment at } B = \frac{EI}{R},$$

R being the radius of curvature at B , and I the moment of inertia of the section.

If E and I are both constant,

$$Ry = \text{a constant}$$

is the equation to the elastic curve.

(b) *Spiral Springs* (as, e.g., in a watch).—Let the figure represent a spiral spring fixed at C and to an arbor at A , and subjected at every point of its length to a bending action only.

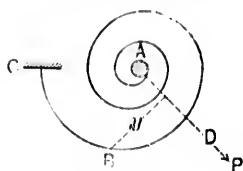

FIG. 276.

Consider the equilibrium of any portion AB of the spring.

The forces at A are equivalent to a couple of moment M , and to a force P acting in some direction AD .

This couple and force must balance the elastic moment at B .

$$\therefore M + Py = EI \times \text{change of curvature at } B,$$

y being the distance of B from the line of action of P , or

$$M + Py = EI \left(\frac{1}{R} - \frac{1}{R_0} \right),$$

R_0 being the radius of curvature at B before winding, and R that after winding.

Let ds be an elementary length of the spring at B .

Then, for the whole spring,

$$\Sigma(M + Py)ds = EI \Sigma \left(\frac{ds}{R} - \frac{ds}{R_0} \right) = EI \Sigma (d\theta - d\theta_0),$$

or $M\Sigma ds + P\Sigma yds = EI \times \text{total change of curvature between } A \text{ and } C$;

$$\therefore Ms + P\bar{y}s = EI(\theta - \theta_0),$$

s being the length of the spring, \bar{y} the distance of its C. of G. from AD , θ the angle through which the spring is wound up, and θ_0 the "unwinding" due to the fixture at C . With a large number of coils the distance between the C. of G. and A may be assumed to be nl and then $\bar{y} = 0$.

Also, if the spring is so secured that there is no change of direction relatively to the barrel,

$$\theta_0 = 0, \text{ and } Ms = EI\theta.$$

Let the winding-up be effected by a couple of moment $Qq = M$, Q being a tangential force at the circumference of a circle of radius q .

The distance through which Q moves (or deflection of Q)

$$= q\theta = \frac{qf}{cE}s, \text{ since } M = \frac{f}{c}I,$$

f being the skin stress, and c the distance of the neutral axis of the spring from the skin.

Thus, if b is the width of a spring of circular or rectangular section, $c = \frac{b}{2}$, and hence

$$\text{the deflection} = \frac{2qf}{bE}s.$$

$$\begin{aligned} \text{The work done} &= \frac{1}{2}Q \times \text{deflection} = \frac{1}{2} \frac{M}{q} q\theta = \frac{M\theta}{2} \\ &= \frac{f^2}{2} \frac{sI}{Ec^2} = \frac{f^2}{2} \frac{sAk^2}{Ec^2} = \frac{f^2 V k^2}{2E c^2}, \end{aligned}$$

k^2 being the square of the radius of gyration, A the sectional area of the spring, and V its volume.

$$\begin{aligned} \text{In case of spring of rectangular section } \frac{k^2}{c^2} &= \frac{1}{3}. \\ \text{" " " " " circular " } \frac{k^2}{c^2} &= \frac{1}{4}. \end{aligned}$$

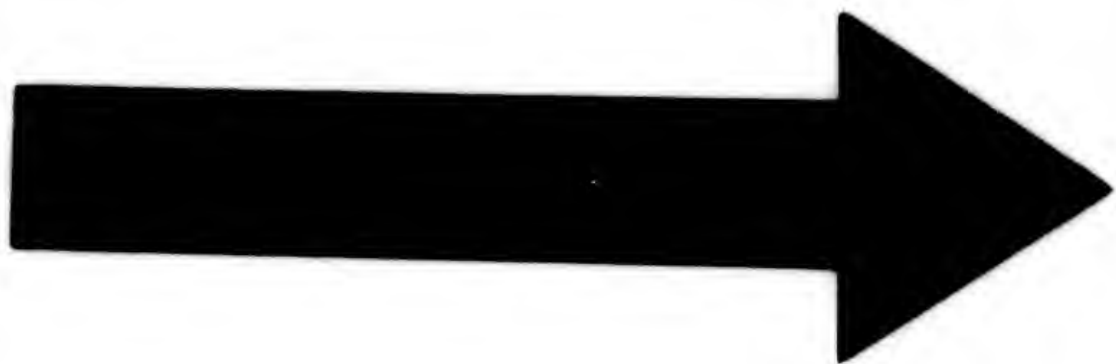

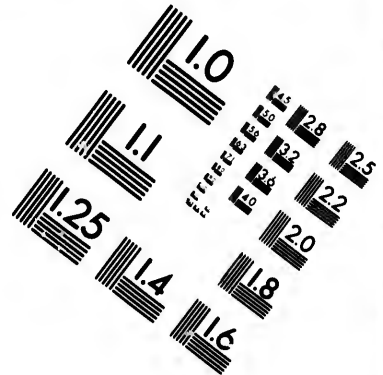
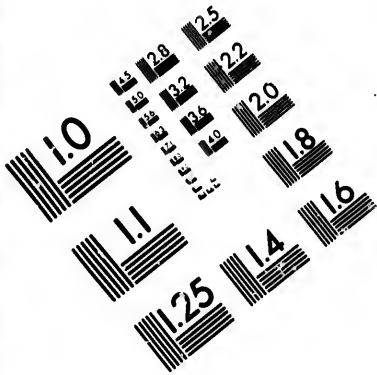

**IMAGE EVALUATION
TEST TARGET (MT-3)**

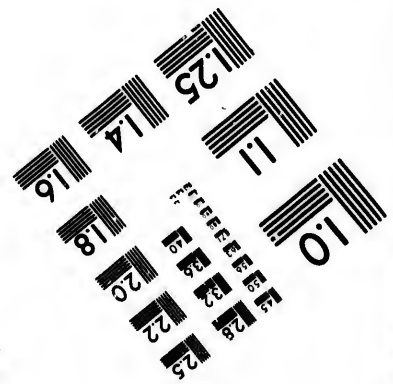
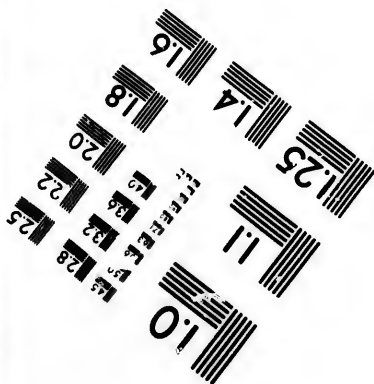
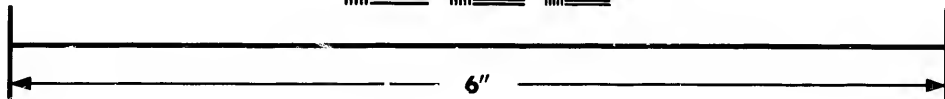
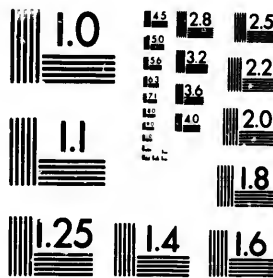

**Photographic
Sciences
Corporation**

23 WEST MAIN STREET
WEBSTER, N.Y. 14580
(716) 872-4503

14
16
18
20
22
25

10

Again, the spiral spring in Fig. 277 is wholly subjected to a *bending* action by means of a *twisting couple* of moment $M = Qq$ in a plane perpendicular to the axis of the spring. Any torsion in the spring itself is now due to the coils not being perfectly flat.

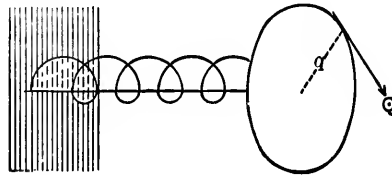

FIG. 277.

Let R_0 = radius of a coil before the couple is applied.
 " R = " " " " after " " " "

$$Qq = M = EI \left(\frac{1}{R} - \frac{1}{R_0} \right) = EI \frac{\theta}{s},$$

θ being the angle of twist; or

$$\frac{Qqs}{EI} = \frac{Ms}{EI} = \frac{s}{R} - \frac{s}{R_0} = (N - N_0)2\pi,$$

N being the number of coils before the couple is applied, and N_0 " " " " " after " " " "

The distance through which Q acts, i.e., the "deflection,"

$$= q\theta = \frac{fqs}{Ec},$$

and the work done

$$= \frac{M\theta}{2} = \frac{fV k^2}{2E c^2},$$

$$= \frac{1}{6} \frac{f^2 V}{E} \text{ for spring of rec.angular section,}$$

$$= \frac{1}{8} \frac{f^2 V}{E} \text{ " " " circular "}$$

6. Beams of Uniform Strength.—A beam having the same maximum unit stress (f) at every section is said to be a beam of uniform strength.

Read Carefully



At
momen
by b .

 c being
the are
Evid

n being
section.
Four
CASE
 $nfb = \frac{1}{p}$

Thus
ordinates
it may b
which cas
EXAM
weight W
At a c
 y

Theor
beam, in
 ACD , the

At any section of a beam $AB (= l)$ denote the bending moment by M , the depth of the beam by y , and its breadth by b . Then

$$\frac{f}{c}I = M = \frac{f}{c}Ak^2,$$

c being the distance of the skin from the neutral axis, and A the area of the section.

Evidently c and k are each proportional to y , and A to by .

$$\therefore fby^2 \propto M,$$

or

$$nfy^2 = M,$$

n being a coefficient whose value depends upon the *form* of section.

Four cases will be considered.

CASE *a*. Assume that the breadth b is constant, and let

$$nfb = \frac{I}{p}. \text{ Then}$$

$$y^2 = pM,$$

or

$$y = \pm \sqrt{pM}.$$

Thus AB may be either the lower edge of the beam, the ordinates of the upper edge being the different values of y , or it may be a line of symmetry with respect to the profile, in which case the ordinates are the different values of $\pm \frac{y}{2}$.

EXAMPLE 1. A cantilever AB loaded at the free end with a weight W_1 .

At a distance x from A ,

$$y^2 = pM = pW_1x.$$

Theoretically, therefore, the beam, in elevation, is the area ACD , the curve CAD being a

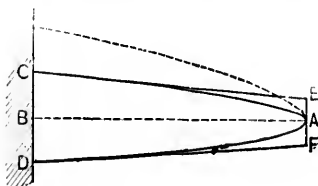

FIG. 278.

parabola with its vertex at A and having a parameter $= \frac{1}{4} \rho W_1$.

$$\text{The max. depth} = 2CB = CD = \sqrt{\rho W_1 l}.$$

The form of this beam is very similar to that adopted for cranks and for the cast-iron beams of engines. In the latter, the material is usually concentrated in the flanges, a rib being reserved along the neutral axis for purposes of connection.

Again, geometrical conditions of transmission require the teeth of wheels to be of approximately uniform strength.

A cantilever of *approximately* uniform strength may be obtained by taking the *tangents* CE, DF as the upper and lower edges of the beam instead of the curves CA, DA . The depth of the beam at A is then $EF = \frac{1}{2}CD = \frac{1}{2} \sqrt{\rho W_1 l}$. Although, *theoretically*, the depth at A is *nil*, practically the beam must have sufficient sectional area at A to bear the shear due to W_1 , and the depth $\frac{1}{2} \sqrt{\rho W_1 l}$ will be found ample for this purpose.

Note.—The dotted lines show the beams of uniform strength, when the lower edge is the horizontal line AB .

EX. 2. A cantilever AB carrying a uniformly distributed load W_2 .

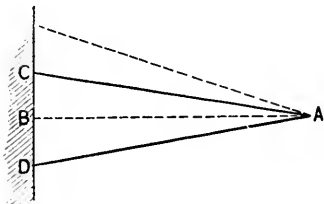

FIG. 279.

At a distance x from A ,

$$y^2 = \rho M = \frac{\rho W_2}{2l} x^3,$$

or

$$y = \pm x \sqrt{\frac{\rho W_2}{2l}}.$$

The beam, in elevation, is therefore the area ACD , AC, AD being two straight lines, and the *maximum* depth being

$$CD = 2BC = l \sqrt{\frac{\rho W_2}{2l}} = \sqrt{\frac{\rho W_2 l}{2}}.$$

The sectional area at A is *nil*, as both the bending moment and shear at that point are zero.

Note.—The dotted lines show the cantilever of uniform strength when AB is the lower edge.

EX. 3. A cantilever AB carrying a weight W_1 at the free end A and also a uniformly distributed load W_2 .

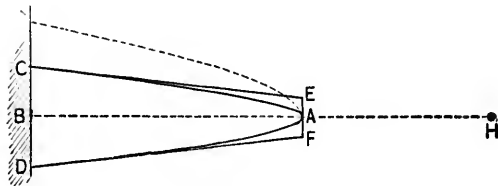

FIG. 280.

At the distance x from A ,

$$y^2 = \rho M = \rho \left(W_1 x + W_2 \frac{x^2}{2} \right).$$

This equation may be written in the form

$$\frac{\left(x + \frac{W_1 l}{W_2} \right)^2}{\frac{W_1^2 l^2}{W_2^2}} - \frac{y^2}{\frac{\rho W_1^2 l}{2 W_2}} = 1.$$

Theoretically, therefore, the beam, in elevation, is the area ACD , the curve CAD being an hyperbola having its centre at H (where $AH = \frac{W_1 l}{W_2}$), and semi-axes equal to

$$\frac{W_1 l}{W_2} \quad \text{and} \quad \sqrt{\frac{\rho W_1^2 l}{2 W_2}}.$$

The *maximum* depth $CD = \sqrt{\rho \left(W_1 l + W_2 \frac{l}{2} \right)} = 2BC$.

A cantilever of approximately uniform strength may be obtained by taking the tangents CE , DF as the upper and lower edges of the beam instead of the curves CA , DA . It may be easily shown that the depth of this beam at A is $\frac{W_1}{2W_1 + W_2}CD$, and this will give sufficient sectional area at A to bear the shear due to W_1 .

Note.—The dotted lines show the cantilever of uniform strength, when the lower edge is the line AB .

Ex. 4. A beam AB supported at A and B , and carrying a load W_1 at the middle point O .

At a distance x from O ,

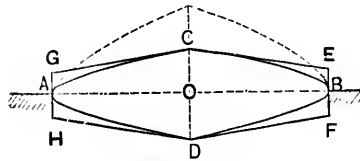

FIG. 281.

$$y^2 = pM = p \frac{W_1}{2} \left(\frac{l}{2} - x \right).$$

Theoretically, therefore, the beam, in elevation, is the area $ACBD$, the curves CAD , CBD being two equal parabolas, having their vertices at A and B , respectively, and having parameters equal to $\frac{1}{2}pW_1$.

The maximum depth $= CD = 2CO = \frac{1}{2}\sqrt{pW_1l}$.

A beam of approximately uniform strength may be obtained by taking the tangents CE , CG as the upper edges instead of the curves CA , CB , and the tangents DF , DH as the lower edges instead of the curves DA , DB .

The depth of the beam at A and B is now $EF = GH = \frac{CD}{2}$, and this depth will give a sectional area at the ends of the beam sufficient to bear the shears at these point, viz., $\frac{W_1}{2}$.

Note.—The dotted lines show the beam of uniform strength when the line AB is the lower edge.

Ex. 5. A beam AB supported at A and B , and carrying a uniformly distributed load W_1 .

At a distance x from the middle point O ,

$$y^2 = \rho M = \frac{\rho W_2 l}{8} \left(1 - \frac{4x^2}{l^2} \right).$$

This equation may be written in the form

$$\frac{x^2}{\frac{l^2}{4}} + \frac{y^2}{\frac{\rho W_2 l}{8}} = 1.$$

Theoretically, therefore, the beam, in elevation, is an ellipse $ACBD$, having its centre at O and axes

$$AB = l \quad \text{and} \quad CD = \sqrt{\frac{\rho W_2 l}{2}}.$$

The maximum depth is of course the axis $CD = 2CO$.

Practically, the beam must have a certain depth at A and B in order to bear the shears due to the reactions at these points, viz., $\frac{W_2}{2}$. If the horizontal tangents at C and at D are substituted for the curves, the volume of the new beam is to the volume of the elliptic beam in the ratio of 4 to π .

Note.—The dotted line shows the beam of uniform strength when its lower edge is the line AB .

EX. 6. A beam AB supported at A and B , and carrying a load W_1 at the middle point O and also a uniformly distributed load W_2 .

At a distance x from O ,

$$y^2 = \rho M = \rho \left\{ \frac{W_1}{2}(l-x) + \frac{W_2 l}{8} \left(1 - \frac{4x^2}{l^2} \right) \right\}.$$

This equation may be written in the form

$$\frac{\left(x + \frac{1}{2} \frac{W_1 l}{W_2} \right)^2}{\frac{1}{4} \frac{l^2}{W_2} (W_1 + W_2)^2} + \frac{y^2}{\frac{\rho l}{8 W_2} (W_1 + W_2)^2} = 1.$$

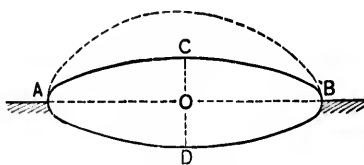
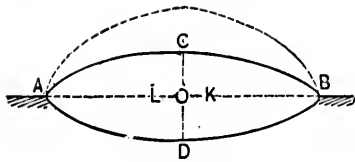

FIG. 282.



Theoretically, therefore, the beam, in elevation, is the area $ACBD$, the curves CAD and CBD being the arcs of ellipses having the centres at the points K and L , respectively, where

$$OK = OL = \frac{W_1 l}{2W_2}$$

The maximum depth $CD = 2OC = p^{\frac{1}{2}} \left\{ \frac{W_1 l}{4} + \frac{W_2 l}{8} \right\}^{\frac{1}{2}}$.

A beam of approximately uniform strength may be obtained by taking as the upper edge the tangents to the curves at C , and as the lower edge the tangents to the curves at D .

It may be easily shown that the depth at the ends A and B is now $CD \frac{W_1 + W_2}{2W_1 + W_2}$, and this depth will make allowance for the shear $\frac{W_1 + W_2}{2}$ at these points.

Note.—The dotted lines show the beam of uniform strength when the lower edge is the line AB .

CASE *b*. Assume that the ratio of the breadth (b) to the depth (y) is constant, i.e., that transverse sections are similar.

$$y \propto b \propto \sqrt[3]{M},$$

or the ordinates of the profile of the beam both in plan and elevation are proportional to the cube roots of the ordinates of the curve of bending moments.

For concentrated loads the bounding curves are evidently cubical parabolas.

CASE *c*. Assume that the depth y is constant. Then

$$b \propto M,$$

so that the ordinates of the beam in plan are directly proportional to the ordinates of the curve of bending moments.

CASE *d*. Assume that the sectional area γb is constant. Then

$$\gamma \propto M,$$



and the
ordina
In
fective
i.e., at
Tim
is no co
beam to
6. F
which t
their le
Cantile
It ha
a beam
that the
withdrew
and conc
severely
of Flang
(or table
webbed o

The w
and contin
The pr
The T
and 289), t
Classif
flanged gir

and the ordinates in elevation are directly proportional to the ordinates of the curve of bending moments.

In this beam, the distribution of the material is very defective, as the breadth b ($= \frac{\text{area}}{y}$) must be infinite when $y = 0$, i.e., at the points at which the bending moment is nil.

Timber beams of uniform strength are uncommon, as there is no economy in their use, the portions removed to bring the beam to the necessary form being of no practical value.

6. Flanged Girders, etc.—Beams subjected to forces, of which the lines of action are at right angles to the direction of their length, are usually termed *Girders*; a *Semi-girder*, or *Cantilever*, is a girder with one end fixed and the other free.

It has been shown that the stress in the different layers of a beam increases with the distance from the neutral surface, so that the most effective distribution of the material is made by withdrawing it from the neighborhood of the neutral surface and concentrating it in those parts which are liable to be more severely strained. This consideration has led to the introduction of *Flanged Girders*, i.e., girders consisting of *one* or *two flanges* (or *tables*), united to *one* or *two webs*, and designated *Single-webbed* or *Double-webbed (Tubular)* accordingly.



FIG. 284.



FIG. 285.



FIG. 286.



FIG. 287.



FIG. 288.



FIG. 289.



FIG. 290.

The web may be open like lattice-work (Fig. 284), or closed and continuous (Fig. 285).

The principal sections adopted for flanged girders are:

The *Tee* (Figs. 286 and 287), the *I* or *Double-tee* (Figs. 288 and 289), the *Tubular* or *Box* (Fig. 290).

Classification of Flanged Girders.—Generally speaking, flanged girders may be divided into two classes, viz.:

1. *Girders with Horizontal Flanges.*—In these the flanges can only convey horizontal stresses, and the shearing force, which is vertical, must be wholly transmitted to the flanges through the medium of the web.

If the web is open, or lattice-work, the flange stresses are transmitted through the lattices.

If the web is continuous, the distribution of stress, arising from the transmission of the shearing force, is indeterminate, and may lie in certain curves; but the stress at every point is resolvable into vertical and horizontal components. Thus, the portion of the web adjoining the flanges bears a part of the horizontal stresses, and aids the flanges to an extent dependent upon its thickness.

With a thin web this aid is so trifling in amount that it may be disregarded without serious error.

II. *Girders with one or both Flanges Curved.*—In these the shearing stress is borne in part by the flanges, so that the web has less duty to perform and requires a proportionately less sectional area.

Equilibrium of Flanged Girders.— AB is a girder in equilibrium under the action of external forces, and has its upper flange compressed and its lower flange extended. Suppose the girder to be divided into two segments by an

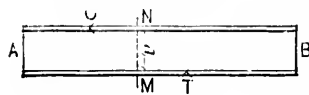

FIG. 291.

imaginary vertical plane MN . Consider the segment AMN . It is kept in equilibrium by the external forces on the left of MN , by the compressive flange stress at N ($= C$), by the tensile flange stress at M ($= T$), and by the vertical and horizontal web stresses along MN . The horizontal web stresses may be neglected if the web is thin, while the vertical web stresses pass through M and N , and consequently have no moments about these points.

Let d be the *effective* depth of the girder, i.e., the distance between the points of application of the resultant flange stresses in the plane MN .

Take moments about M and N successively. Then

$Cd =$ the algebraic sum of the moments about M of

the external forces upon $AMN =$ the bending moment at $MN = M$.

So, $Td = M$; $\therefore Cd = M = Td$, and $C = T$.

Hence, the flange stresses at any vertical section of a girder are equal in magnitude but opposite in kind. The flange stress, whether compressive or tensile, will be denoted by F .

EXAMPLE.—A flanged girder, of which the effective depth is 10 ft., rests upon two supports 80 ft. apart, and carries a uniformly distributed load of 2500 lbs. per lineal foot. Determine the flange stress at 10 ft. from the end, and find the area of the flange at this point, so that the unit stress in the metal may not exceed 10,000 lbs. per square inch.

The vertical reaction at each support

$$= \frac{80 \times 2500}{2} = 100,000 \text{ lbs.}$$

$\therefore F \cdot 10 = M = 100000 \times 10 - 2500 \times 10 \times 5 = 875,000 \text{ ft.-lbs.}$

$$\therefore F = 87,500 \text{ lbs.}$$

The required area = $\frac{87500}{10000} = 8.75 \text{ sq. in.}$

$$\text{Cor. 1. } Fd = M = \frac{E}{R}I = \frac{f_2}{y}I.$$

Cor. 2. At any vertical section of a girder, let a_1, a_2 , be the sectional areas of the lower and upper flanges, respectively;

f_1, f_2 , be the unit stresses in the lower and upper flanges, respectively. Then

$$a_1 f_1 = F = a_2 f_2,$$

and the sectional areas are inversely proportional to the unit stresses.

This assumes that F is uniformly distributed over the areas a_1, a_2 , so that the effective depth is the vertical distance between centres of gravity of these areas. Thus, the flange stresses at the centres of gravity are taken to be equal to the

maximum stresses, and the resistance offered by the web to bending is disregarded. The error due to the former may become of importance, and it may be found advisable to make the effective depth a geometric mean between the depths from outside to outside and from inside to inside of the flanges.

Thus, if these latter depths are h_1 , h_2 , the effective depth $= \sqrt{h_1 h_2}$ (Art. 7).

EXAMPLE 1. At a given vertical section of a flanged girder the sectional area of the top flange is 10 sq. in., and the corresponding unit stress is 8000 lbs. per square inch. Find the sectional area of the lower flange, so that the unit stress in it may not exceed 10,000 lbs. per square inch.

$a_1 \cdot 10000 = P = 10 \cdot 8000$; $\therefore a_1 = 8$ sq. in. and $P = 80,000$ lbs.

EX. 2. A wrought-iron girder weighing w lbs. per lineal ft., of l ft. span and d ft. depth, has horizontal flanges and a uniform cross-section. The weight of the web is equal to the weight of the flanges. Show that if the coefficient of strength is 9000 lbs. per square inch, the limiting value of l is $5400k$ ft., k being the ratio of depth to span.

$$\text{Maximum flange stress} = \frac{wl^2}{8d};$$

$$\text{Area of each flange} = \frac{wl^2}{9000 \cdot 8d} \text{ in.};$$

$$\text{Total sectional area} = \frac{4wl^2}{9000 \cdot 8d} \text{ in.},$$

and

$$\text{total volume of girder in feet} = \frac{4wl^2 \cdot l}{9000 \cdot 8d \cdot 144}$$

Hence,

$$wl = \text{total weight} = \frac{4wl^3 \cdot 480}{9000 \cdot 8d \cdot 144},$$

and

$$l = 5400 \frac{d}{l} = 5400k.$$

Note.—The compressive strength of cast-iron is almost six times as great as the tensile strength, and therefore the area of the tension flange of a girder of this material should be about six times that of the compression flange. Considering, however, the difficulty there is in obtaining sound castings, and also the necessity to provide sufficient lateral strength, it by no means follows, nor is it even probable, that the ratio of ultimate strengths is the best for the working strengths. Some authorities are of the opinion that girders should be designed with a view to their elastic strength, and that therefore the working unit stresses in the case of wrought-iron and steel should be equal, if this will insure sufficient lateral stability, and in the ratio of 2 to 1 or 3 to 1 for cast-iron, which will give sufficient lateral stability and make allowance for defective castings.

The formula $W = C \frac{ad}{l}$ is often employed to determine the strength of a cast- or wrought-iron girder which rests upon two supports l inches apart, d being its depth in inches, and a the net sectional area of the bottom flange in square inches. C is a constant to be determined by experiment. Its average value for *cast-iron* is 24 or 26, according as the girder is cast on its side or with its bottom flange upwards. An average value of C for *wrought-iron* is 80.

Cor. 3. A girder with horizontal flanges, of length l and depth d , rests upon two supports, and is uniformly loaded with a weight w per unit of length.

The bending moment at a vertical plane distant x from the centre is

$$M = \frac{wl}{2} \left(\frac{l}{2} - x \right) - w \left(\frac{l}{2} - x \right) \frac{1}{2} \left(\frac{l}{2} - x \right) = \frac{wl^2}{8} \left(1 - \frac{4x^2}{l^2} \right).$$

Also, $M = Fd = afd$, a being the sectional area of either flange at the plane under consideration, and f the corresponding unit stress.

$$\therefore afd = \frac{wl^2}{8} \left(1 - \frac{4x^2}{l^2} \right).$$

Let A be the flange sectional area at the centre. Then

$$Afd = \frac{\omega l^2}{8}.$$

Hence

$$a = A \left(1 - \frac{4x^2}{l^2} \right),$$

an expression from which the flange sectional area at any point of the girder may be obtained when the area at the centre is known.

Cor. 4. F represents indifferently the sum of the horizontal elastic forces either above or below the neutral axis, and is therefore proportional to A , the sectional area of the girder; d is the distance between the centres of resultant stress and is proportional to D , the depth of the girder.

$$\therefore M \propto AD = CAD,$$

a form frequently adopted for solid rectangular or round girders, but also applicable to other forms.

Remark.—The effective length of a girder may be taken to be the distance from centre to centre of bearings.

The effective depth depends in part upon the character of the web, but in the calculation of flange stresses the following approximate rules are sufficiently accurate for practical purposes:

If the web is continuous and very thin, the effective depth is the full depth of the girder.

If the web is continuous and too thick to be neglected, the effective depth is the distance between the inner surfaces of the flanges.

If the web is open or lattice-work, the effective depth is the vertical distance between the points of attachment of the lattices.

If the flanges are cellular, the effective depth is the distance between the centres of the upper and lower cells.

7.
tion.—
it ma
Le
tre of
Le
and u
each f
Le
Le
Ap
Als

Ag
metal c

If a
Seco
As h

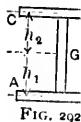

FIG. 292

of the w
Let
flange ce
Let
Appr

7. Examples of Moments of Inertia.—(a) *Double-tee Section.*—First, suppose the web to be so thin that it may be disregarded without sensible error.

Let the neutral axis pass through G , the centre of gravity of the section.

Let a_1, a_2 be the sectional areas of the lower and upper flanges, respectively, and assume that each flange is concentrated at its centre line.

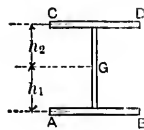

FIG. 292.

Let h_1, h_2 be the distances of these centre lines from G .

Let $h_1 + h_2 = d$.

Approximately, $I = a_1 h_1^2 + a_2 h_2^2$.

Also, $(a_1 + a_2)h_1 = a_2 d$, and $(a_1 + a_2)h_2 = a_1 d$.

$$\therefore I = a_1 \left(\frac{a_2 d}{a_1 + a_2} \right)^2 + a_2 \left(\frac{a_1 d}{a_1 + a_2} \right)^2 = \frac{a_1 a_2 d^2}{a_1 + a_2}.$$

Again, if f_1, f_2 are, respectively, the unit stresses in the metal of the lower and upper flanges,

$$M = \frac{f_1}{h_1} I = f_1 a_1 d, \quad \text{and also} \quad = \frac{f_2}{h_2} I = f_2 a_2 d.$$

If $a_1 = a_2 = a, f_1 = f_2 = f$, suppose, and $M = fad$.

Second. Let the web be too thick to be neglected.

As before, let the neutral axis pass through G , the centre of gravity of the section.

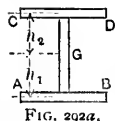

FIG. 292a.

Let a_1, a_2 be the sectional areas of the lower and upper flanges, respectively, and assume that each flange is concentrated at its centre line.

Let a_3, a_4 be the sectional areas of the portions of the web below and above G , respectively.

Let h_1, h_2 be the distances from G of the lower and upper flange centre lines.

Let $h_1 + h_2 = d$.

Approximately,

$$I = a_1 h_1^2 + a_3 \left(\frac{h_1^2}{12} + \frac{h_1^2}{4} \right) + a_2 h_2^2 + a_4 \left(\frac{h_2^2}{12} + \frac{h_2^2}{4} \right) \\ = \left(a_1 + \frac{a_3}{3} \right) h_1^2 + \left(a_2 + \frac{a_4}{3} \right) h_2^2.$$

Also, $(a_1 + \frac{a_3}{2})h_1 = (a_2 + \frac{a_4}{2})h_2$, and this equation, together

with $h_1 + h_2 = d$, will give the values of h_1, h_2 ; hence the value of I may be determined.

As before, $\frac{f_1}{h_1}I = M = \frac{f_2}{h_2}I$.

Let $a_1 = a_2 = A$ and $a_3 = a_4 = \frac{A'}{2}$. Then

$$h_1 = h_2 = \frac{d}{2}, \quad \text{and} \quad I = \left(A + \frac{A'}{6}\right) \frac{d^3}{2}.$$

Hence,

$$M = \frac{2f}{d} \left(A + \frac{A'}{6}\right) \frac{d^3}{2} = f \left(A + \frac{A'}{6}\right) d,$$

f being the unit stress in either flange.

Thus, the web aids the girder to an extent equivalent to the increase which would be derived by adding *one-sixth* of the web area to each flange. If the weight of the material remains constant, M increases with d . At the same time the thickness of the web diminishes, its minimum value being limited by certain practical considerations (Art. 8). Hence it follows that the distribution of material is most effective when it is concentrated as far as possible from the neutral axis (Art. 5).

N.B.—It must be remembered that f_1 and f_2 are not the maximum stresses. If t_1, t_2 are the thicknesses of the lower and upper flanges, respectively, then

$$\text{maximum tension} = f_1 \frac{h_1 + \frac{1}{2}t_1}{h_1},$$

and

$$\text{maximum compression} = f_2 \frac{h_2 + \frac{1}{2}t_2}{h_2}.$$

Ag

which
 f_1, f_2 are
For

a form
cast-iron

If f_1
The
to be c
strength
however
The fibr
effective
they are
with the
to be ga
little, if

EXAM
girder ar
wide; th
is $\frac{1}{2}$ in. th
find the
given sec

$a_1 = 2$

The c
and CD.

Again, take moments about G . Then

$$a_1 h_1 + A' \frac{h_1 - h_2}{2} = a_2 h_2,$$

or

$$a_1 f_1 + A' \frac{f_1 - f_2}{2} = a_2 f_2,$$

which gives a relation between the flange and web areas if f_1, f_2 are known.

For example, take $f_2 = 2\frac{1}{2}f_1$. Then

$$a_1 - \frac{3}{4}A' = \frac{5}{2}a_2,$$

a formula which agrees very closely with modern practice in cast-iron girders.

If $f_1 = f_2, a_1 = a_2$.

The principles of construction require a beam or girder to be designed in such a manner as to be of uniform strength, i.e., equally strained at every point. An exception, however, is usually made in the case of *timber* beams or girders. The fibres of this material are real fibres and offer the most effective resistance in the direction of their length, so that if they are cut, their remaining strength is due only to cohesion with the surrounding material. Besides, there is no economy to be gained by removing a lateral portion, as the waste is of little, if any, practical value.

EXAMPLE. The lower and upper flanges of the section of a girder are 1 in. and $1\frac{1}{2}$ in. thick, respectively, and are each 24 in. wide; the effective depth of the girder is 48 in., and the web is $\frac{1}{2}$ in. thick. Determine the position of the neutral axis; also find the flange unit stresses when the bending moment at the given section is 250 ft.-tons. Using the preceding notation,

$$a_1 = 24 \text{ sq. in.}, \quad a_2 = 36 \text{ sq. in.}, \quad \text{and} \quad a_3 + a_4 = 24 \text{ sq. in.}$$

The centre of gravity of the web is half-way between AB and CD . Thus,

$$24h_1 + 24(h_1 - 24) = 36(48 - h_1),$$

In this value of I , the weakening effect due to the rivet-holes in the tension flange has been disregarded. If it is to be taken into account, let p be the diameter of the rivets.

The centre of gravity of the section is now moved towards the compression flange from its original position through a distance

$$x = \frac{1}{4} \frac{p}{A} (h_1^2 - h_2^2),$$

and the moment of inertia of the net section with respect to the axis through the new C. of G. is

$$I - A'x^2 - \frac{p}{12} (h_1^3 - h_2^3),$$

A' being the *net* area of the section, and I having the value given above.

Fourth. The value of I for a double-tee section may be more accurately determined as follows:

Let the area of the top flange be A_1 , and its depth h_1 .

Let the area of the bottom flange be A_3 , and its depth h_3 .

Let the area of the web flange be A_2 , and its depth h_2 .

Let $A_1 + A_2 + A_3 = A$, and $h_1 + h_2 + h_3 = h$.

Let G be the centre of gravity of the section.

“ G_1 “ “ “ “ top flange.

“ G_2 “ “ “ “ web.

“ G_3 “ “ “ “ bottom of flange.

Let y_1 be the distance of G from the upper edge of the section.

Let y_2 be the distance of G from the lower edge of the section.

Take moments about G_3 . Then

$$\begin{aligned} (A_1 + A_2 + A_3)GG_3 &= A_1 \cdot G_1G_3 + A_2 \cdot G_2G_3 \\ &= A_1 \left(\frac{h_1}{2} + h_2 + \frac{h_3}{2} \right) + A_2 \left(\frac{h_2}{2} + \frac{h_3}{2} \right), \end{aligned}$$

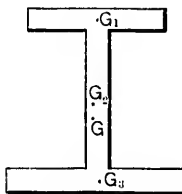

FIG. 294.

or

$$GG_3 = \frac{A_1(h_1 + 2h_2 + h_3) + A_2(h_2 + h_3)}{2A}$$

So,

$$GG_2 = \frac{-A_1(h_1 + h_2) + A_3(h_2 + h_3)}{2A},$$

and

$$GG_1 = \frac{A_2(h_1 + h_2) + A_3(h_1 + 2h_2 + h_3)}{2A}$$

Hence,

$$\begin{aligned} y_2 = GG_3 + \frac{h_3}{2} &= \frac{A_1(h_1 + 2h_2 + h_3) + A_2(h_2 + h_3)}{2A} + \frac{h}{2} - \frac{h_2}{2} - \frac{h_1}{2} \\ &= \frac{h}{2} - \frac{(h_1 + h_2)(A_1 + A_2 + A_3) - A_1(h_1 + 2h_2 + h_3) - A_2(h_2 + h_3)}{2A} \\ &= \frac{h}{2} - \frac{A_3(h_1 + h_2) - A_1(h_2 + h_3) - A_3(h_3 - h_1)}{2A}. \end{aligned}$$

So,

$$y_1 = GG_1 + \frac{h_1}{2} = \text{etc.}$$

Again, I , with respect to G ,

$$\begin{aligned} &= \frac{A_1 h_1^3}{12} + A_1 \cdot G_1 G^2 + \frac{A_2 h_2^3}{12} + A_2 \cdot G_2 G^2 + A_3 \frac{h_3^3}{12} + A_3 \cdot G_3 G^2 \\ &= I_1 + A_1 \cdot G_1 G^2 + A_2 \cdot G_2 G^2 + A_3 \cdot G_3 G^2, \end{aligned}$$

$$I_1 \text{ being equal to } \frac{A_1 h_1^3 + A_2 h_2^3 + A_3 h_3^3}{12}.$$

Hence,

$$\begin{aligned} I &= I_1 + \frac{A_1}{4A^2} \{A_2(h_1 + h_2) + A_3(h_1 + 2h_2 + h_3)\}^2 \\ &\quad + \frac{A_2}{4A^2} \{-A_1(h_1 + h_2) + A_3(h_2 + h_3)\}^2 \\ &\quad + \frac{A_3}{4A^2} \{A_1(h_1 + 2h_2 + h_3) + A_2(h_2 + h_3)\}^2. \end{aligned}$$

= I_1 +

= I_1 +

= I_1 +

= I_1 +

Hence, f

+ \frac{I}{4A} \{A

Cor. 1.

Then

y = —

$$\begin{aligned}
 &= I_1 + \frac{I}{4A^2} \left\{ \begin{aligned} &A_1 A_2^2 (h_1 + h_2)^2 + 2A_1 A_2 A_3 (h_1 + h_2)(h_1 + 2h_2 + h_3) \\ &+ A_1 A_3^2 (h_1 + 2h_2 + h_3)^2 \\ &+ A_2 A_1^2 (h_1 + h_2)^2 - 2A_1 A_2 A_3 (h_1 + h_2)(h_2 + h_3) \\ &+ A_2 A_3^2 (h_2 + h_3)^2 + A_3 A_1^2 (h_1 + 2h_2 + h_3)^2 \\ &+ 2A_1 A_2 A_3 (h_1 + 2h_2 + h_3)(h_2 + h_3) \\ &+ A_3 A_2^2 (h_2 + h_3)^2 \end{aligned} \right\} \\
 &= I_1 + \frac{I}{4A^2} \left\{ \begin{aligned} &A_1 A_2 (h_1 + h_2)^2 (A_1 + A_2 + A_3) \\ &- A_1 A_2 A_3 (h_1 + h_2)^2 \\ &+ A_2 A_3 (h_2 + h_3)^2 (A_1 + A_2 + A_3) - A_1 A_2 A_3 (h_2 + h_3)^2 \\ &- 2A_1 A_2 A_3 (h_1 + h_2)(h_2 + h_3) \\ &+ (A_1 A_2^2 + A_3^2 A_1)(h_1 + 2h_2 + h_3)^2 \\ &+ 2A_1 A_2 A_3 (h_1 + 2h_2 + h_3)(h_1 + h_2 + h_2 + h_3) \end{aligned} \right\} \\
 &= I_1 + \frac{I}{4A^2} \left\{ \begin{aligned} &A_1 A_2 (h_1 + h_2)^2 A + A_2 A_3 (h_2 + h_3)^2 A \\ &- A_1 A_2 A_3 (h_1 + 2h_2 + h_3)^2 \\ &+ (A_1 A_2^2 + A_3^2 A_1)(h_1 + 2h_2 + h_3)^2 \\ &+ 2A_1 A_2 A_3 (h_1 + 2h_2 + h_3)^2 \end{aligned} \right\} \\
 &= I_1 + \frac{I}{4A^2} \left\{ \begin{aligned} &A_1 A_2 (h_1 + h_2)^2 A + A_2 A_3 (h_2 + h_3)^2 A \\ &+ A_1 A_3 (h_1 + 2h_2 + h_3)^2 A \end{aligned} \right\}.
 \end{aligned}$$

Hence, finally,

$$I = \frac{A_1 h_1^2 + A_2 h_2^2 + A_3 h_3^2}{12}$$

$$+ \frac{I}{4A} \{ A_1 A_2 (h_1 + h_2)^2 + A_2 A_3 (h_2 + h_3)^2 + A_1 A_3 (h_1 + 2h_2 + h_3)^2 \}.$$

Cor. 1. If h_1 and h_2 are small compared with h_3 , put

$$h_2 = h' - \frac{h_1 + h_2}{2}.$$

Then

$$y = \frac{A_1 2h' + A_2 \left(h' + \frac{h_3 - h_1}{2} \right)}{2A} + \frac{h_3}{2} = \frac{h' 2A_1 + A_2}{2A}, \text{ nearly,}$$

and

$$I = \frac{A_1 h_1^3 + A_2 \left(h' - \frac{h_1 + h_2}{2} \right)^3 + A_3 h_3^3}{12}$$

$$+ \frac{1}{4A} \left\{ A_1 A_2 \left(h' + \frac{h_1 - h_3}{2} \right)^2 + A_2 A_3 \left(h' + \frac{h_3 - h_1}{2} \right)^2 + A_3 A_1 4h'^2 \right\}$$

$$= \frac{A_2 h'^2}{12} + \frac{1}{4A} \{ A_1 A_2 h'^2 + A_2 A_3 h'^2 + 4A_3 A_1 h'^2 \}$$

$$= h'^2 \left\{ \frac{A_2}{12} + \frac{A_1 A_2 + A_2 A_3 + 4A_3 A_1}{4A} \right\}.$$

Note.—If A_3 is also very small, as in the case of an open web, then

$$y_2 = h' \frac{A_1}{A} \quad \text{and} \quad I = h'^2 \frac{A_2 A_1}{A}, \text{ approximately.}$$

Cor. 2. Let y_a, y_b be the distances of G from the upper and lower edges, respectively; let f_a, f_b be the corresponding maximum working unit stresses.

$$\text{From the preceding corollary, } y_b = y_2 = \frac{y_a + y_b}{2} \frac{2A_1 + A_2}{2A},$$

or

$$\frac{A_1 + A_2 + A_3}{2A_1 + A_2} = \frac{y_a + y_b}{2y_b}.$$

$$\therefore A_3 = A_1 \frac{y_a}{y_b} + A_2 \frac{y_a - y_b}{2y_b} = A_1 \frac{f_a}{f_b} + A_2 \frac{f_a - f_b}{2f_b}.$$

Hence,

$$A_1 + A_2 + A_3 = A_1 + A_2 + A_1 \frac{f_a}{f_b} + A_2 \frac{f_a - f_b}{2f_b}$$

$$= \frac{f_a + f_b}{f_b} \left(A_1 + \frac{A_2}{2} \right) = A,$$

and

$$= \frac{h'^2}{12}$$

$$= \frac{h'^2}{12}$$

Fig.
Let
depth
Let
depth
Let
Let
tion, G
Let
The

and

$$\begin{aligned}
 I &= h^2 \left\{ \frac{A_2}{12} + \frac{A_1 A_2 + A_2 A_2 + 4A_2 A_1}{4A} \right\} \\
 &= h^2 \left\{ \frac{4A_1 A_2 + A_2^2 + 4A_2 A_2 + 12A_2 A_1}{12A} \right\} \\
 &= \frac{h^2}{12} \left\{ \frac{4A_1 A_2 + A_2^2 + 4(A_2 + 3A_1) \left(A_1 \frac{f_a}{f_b} + A_2 \frac{f_a - f_b}{2f_b} \right)}{A} \right\} \\
 &= \frac{h^2}{12} \left\{ \frac{A_2^2 \left(\frac{2f_a - f_b}{f_b} \right) + 2A_1 A_2 \left(\frac{2f_a - f_b}{f_b} \right) + \frac{f_a}{f_b} (6A_1 A_2 + 12A_1^2)}{\frac{f_a + f_b}{2f_b} (2A_1 + A_2)} \right\} \\
 &= \frac{h^2}{6} \frac{A_2 (2f_a - f_b) + 6A_1 f_a}{f_a + f_b} \\
 &= \frac{h}{6} \frac{y_a}{f_a} \{ A_2 (2f_a - f_b) + 6A_1 f_a \}.
 \end{aligned}$$

Fifth. T-section.

Let the area of the flange be A_1 , and its depth h_1 .

Let the area of the web be A_2 , and its depth h_2 .

Let $A_1 + A_2 = A$, and $h_1 + h_2 = h$.

Let G be the centre of gravity of the section, G_1 of the flange, and G_2 of the web.

Let y_1 be the distance of G from foot of the web.

Then

$$\begin{aligned}
 y_1 (A_1 + A_2) &= A_1 \left(\frac{h_1}{2} + h_2 \right) + A_2 \frac{h_2}{2} \\
 &= \frac{(A_1 + A_2)(h_1 + h_2)}{2} + \frac{A_1 h_2 - A_2 h_1}{2},
 \end{aligned}$$

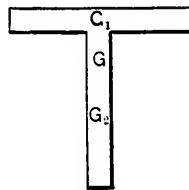

FIG. 295.

and

$$y_1 = \frac{h_1 + h_2}{2} + \frac{A_1 h_2 - A_2 h_1}{2(A_1 + A_2)} = \frac{h}{2} + \frac{A_1 h_2 - A_2 h_1}{2A}$$

Again,

$$G_1 G = \frac{h_1}{2} + h_2 - y_1 = \frac{A_2 h}{2A} \quad \text{and} \quad G_2 G = y_1 - \frac{h_2}{2} = \frac{A_1 h}{2A}$$

Hence I , with respect to a horizontal line through G ,

$$= A_1 \frac{h_1^2}{12} + A_1 \cdot G_1 G^2 + A_2 \frac{h_2^2}{12} + A_2 \cdot G_2 G^2,$$

which reduces to

$$I = \frac{A_1 h_1^2 + A_2 h_2^2}{12} + \frac{A_1 A_2 h^2}{4A}$$

Cor. 1. If h_1 is very small as compared with h_2 , put

$$h_2 = h' - \frac{h_1}{2};$$

then

$$y_1(A_1 + A_2) = A_1 h' + A_2 \left(\frac{h'}{2} - \frac{h_1}{4} \right) = \left(A_1 + \frac{A_2}{2} \right) h', \text{ nearly,}$$

or

$$y_1 = \frac{h' \left(2A_1 + A_2 \right)}{A},$$

and

$$\begin{aligned} I &= \frac{A_1 h_1^2 + A_2 \left(h' - \frac{h_1}{2} \right)^2}{12} + \frac{A_1 A_2 \left(h' + \frac{h_1}{2} \right)^2}{4A} \\ &= \frac{A_2 h'^2}{12} + \frac{A_1 A_2 h'^2}{4A}, \text{ nearly,} \end{aligned}$$

or

$$I = h'^2 \left(\frac{A_2}{12} + \frac{A_1 A_2}{4A} \right).$$

Cor. 2. Let y_a be the distance of the compressed, or upper, side from the neutral axis.

Let
the neu

Let

Fro

$\therefore y_a =$

Hen

=

Note

often use
always b
of inertia

8. T
I-section
Load.

Let y
middle p

Let A
from its

Let A
its middl

Let M
dle point

Let S
point. T

f being t

Let y_b be the distance of the stretched, or lower, side from the neutral axis.

Let f_a be the crushing unit stress, f_b the tensile unit stress.

From the preceding, $y_a = \frac{h' 2A_1 + A_2}{2A_1 + A_2}$; but $h' = y_a + y_b$;

$$\therefore y_a = \frac{y_a + y_b}{2} \frac{2A_1 + A_2}{A_1 + A_2}, \text{ and } A_1 = A_2 \frac{y_a - y_b}{2y_b} = A_2 \frac{f_a - f_b}{2f_b}.$$

Hence, I becomes

$$= \frac{h'^2}{6} A_2 \frac{2f_a - f_b}{f_a + f_b}, \text{ and } \frac{f_a + f_b}{f_a} = \frac{y_a + y_b}{y_a} = \frac{h'}{y_a}.$$

$$\therefore I = \frac{h'}{6} A_2 \frac{y_a}{f_a} (2f_a - f_b).$$

Note.—Although the preceding approximate methods are often useful, they can only be regarded as tentative and should always be checked by an accurate determination of the moment of inertia and of the position of the neutral axis.

8. To design a Girder of Uniform Strength, of an I-section with equal Flange Areas, to carry a Given Load.

Let y be the depth of the girder at a distance x from its middle point.

Let A be the sectional area of each flange at a distance x from its middle point.

Let A' be the sectional area of the web at a distance x from its middle point.

Let M be the bending moment at a distance x from its middle point.

Let S be the shearing force at a distance x from its middle point. Then

$$f \left(A + \frac{A'}{6} \right) y = M,$$

f being the safe unit stress in tension or compression.

Web.—Assume that the web transmits the *whole* of the shearing force. This is not strictly correct if the flange is curved, as the flange then bears a portion of the shearing force. The error, however, is on the safe side.

Theoretically, the web should contain no more material than is absolutely necessary.

Let f_s be the safe unit stress in shear. Then

$$A' = \frac{S}{f_s},$$

and the sectional area is, therefore, independent of the depth.

$$\text{The thickness of the web} = \frac{A'}{y} = \frac{S}{f_s y},$$

but this is often too small to be of any practical use.

Experience indicates that the minimum thickness of a plate which has to stand ordinary wear and tear is about $\frac{1}{4}$ or $\frac{5}{16}$ in., while if subjected to saline influence its thickness should be $\frac{3}{8}$ or $\frac{1}{2}$ in. Thus, the weight of the web rapidly increases with the depth, and the greatest economy will be realized for a certain definite ratio of the depth to the span.

The thickness of the web in a cast-iron girder usually varies from 1 to 2 in.

In the case of riveted girders with plate webs of medium size, all practical requirements are effectively met by specifying that the shearing stress is not to exceed *one-half* of the flange tensile stress, and that stiffeners are to be introduced at intervals not exceeding *twice* the depth of the girder when the thickness of the web is less than *one-eightieth* of the depth. Again, it is a common practical rule to stiffen the web of a plate girder at intervals approximately equal to the depth of the girder, whenever the shearing stress in pounds per square inch exceeds $12000 \div \left(1 + \frac{H^2}{3000}\right)$, H being the ratio of the depth of the web to its thickness.

Flanges.—*First.* Assume that the flanges have the same sectional area from end to end of girder.

If the effect of the web is neglected,

$$y = \frac{M}{fA}$$

and the depth of the beam at any point is proportional to the ordinate of the bending-moment curve at the same point.

For example, let the load be uniformly distributed and of intensity w ; and let l be the span. Then

$$M = \frac{wl^2}{2} \left(\frac{x^2}{4} - x^2 \right),$$

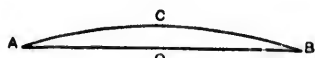

FIG. 296.

and the beam in elevation is the parabola ACB , having its vertex at C and a central depth $CO = \frac{wl^2}{8Af}$. The depths thus determined are a little greater than the depths more correctly given by the equation

$$y = \frac{M}{f \left(A + \frac{A'}{6} \right)}$$

Second. Assume that the depth y of the girder is constant. Then

$$A + \frac{A'}{6} = \frac{M}{fy}$$

and, neglecting the effect of the web, the area of the flange at any point is proportional to the ordinate of the curve of bending moments at the same point.

Let the load be uniformly distributed and of intensity w ; also, let the flange be of the same uniform width b throughout.



FIG. 297

The flange, in elevation, is then the parabola ACB , having its vertex at C and its central thickness $CO = \frac{wl^2}{8fyb}$. Such

beams are usually of wrought-iron or steel, and are built up by means of plates. It is impracticable to cut these plates in such a manner as to make the curved boundary of the flange a true parabola (or any other curve). Hence, the flange is generally constructed as follows:

Draw the curve of bending moments to any given scale. By altering the scale, the ordinates of the same curve will represent the flange thicknesses. Divide the span into segments of suitable lengths.

From A to 1 and B to 7 the thickness of the flange is $1a = 7f$; from 1 to 2 and 7 to 6 the thickness is $2b = 6c$; from 2 to 3 and 6 to 5 the thickness is $3c = 5d$; and from 3 to 5 the thickness is CO .

The more correct value of $A \left(= \frac{M}{fy} - \frac{A'}{6} \right)$ is somewhat less than that now determined, but the error is on the safe side.

Again, at any section,

$$\frac{E}{R} = \frac{2f}{y}, \quad \text{and hence} \quad R \propto y, \quad \text{the depth.}$$

Thus the curvature diminishes as the depth increases, so that a girder with horizontal flanges is superior in point of *stiffness* to one of the parabolic form. The amount of metal in the web of the latter is much less than in that of the former. If great flexibility is required, as in certain dynamometers, the parabolic form is of course the best.

9. Deflection of Girders.—The principles of economy and strength require a girder to be designed in such a manner that every part of it is proportioned to the greatest stress to which it may be subjected. When such a girder is acted upon by external forces, it is uniformly strained throughout, and in bending, the neutral axis must necessarily assume the form of an arc of a circle, provided the limit of elasticity is not exceeded. It might be supposed that the curve of deflection is dependent upon the character of the web, and this is doubtless the case, but experiments indicate that so long as the flange

unit
may
L
the m

assur
Bu

Hence
stant
If

EX
nal for
the for
at O .

Dra
tals BA

The
zontal,
Denote

Let
Sinc
equal to

∴

as D^2 m
Also

dently $\frac{1}{2}$
from the

unit stresses are unaltered in amount, the influence of the web may be disregarded without sensible error.

Let f be the unit stress in the beam at a distance y from the neutral axis; let d be the depth of the beam. Then

$$\frac{f}{y} = \frac{M}{I} = \frac{E}{R} = \text{a constant,}$$

assuming that the neutral axis is an arc of a circle of radius R .

But $y \propto d$, and

$$I = Ak^2 \propto Ad^3.$$

Hence $f \propto y \propto d$; and if the depth is constant, f is also constant and the beam is of uniform strength.

If the area A is constant,

$$d \propto \sqrt{M}.$$

EXAMPLE 1. A cantilever bent under the action of external forces, so that its neutral axis AB assumes the form of an arc of a circle having its centre at O .

Draw the verticals OA , BF , and the horizontals BE , FA .

The vertical deviation of B from the horizontal, viz., BF , is the maximum deflection. Denote it by D .

Let radius of circle = R .

Since the deflection is very small, BE is approximately equal to $AB (= l)$, the length of the cantilever.

$$\therefore l^2 = BE^2 = AE(2R - AE) = 2RD - D^2 = 2RD,$$

as D^2 may be disregarded without much error.

Also, the deflection at any point distant x from A is evidently $\frac{x^2}{2R}$. If f is the stress in the material at a distance y from the neutral axis,

$$\frac{f}{y} = \frac{E}{R} = \frac{2DE}{x^2}, \quad \text{or} \quad f = \frac{2DEy}{x^2}.$$

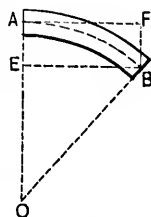

FIG. 298.

Ex. 2. A girder resting upon two supports at A and B is bent under the action of external forces so that its neutral axis ACB assumes the form of an arc of a circle having its centre at O .

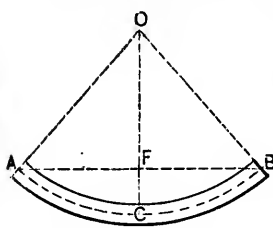

FIG. 299.

Draw the vertical OC , meeting the horizontal AB in F .

CF is the maximum deflection; denote it by D .

Since D is very small, its square may be disregarded and the horizontal AB may be supposed equal to the length ACB ($= l$) of the girder, without much error. Then

$$\frac{l^2}{4} = AF^2 = FC(2R - FC) = 2RD - D^2 = 2RD.$$

Hence,

$$D = \frac{l^2}{8R}$$

Also, since $\frac{f}{y} = \frac{E}{R}$,

$$f = \frac{8DEy}{l^2}.$$

$$R = \frac{l^2}{8D}$$

The deflection at a distance x from $F = D - \frac{x^2}{2R}$.

Ex. 3. A timber beam of 20 ft. span, is 12 in. deep and 6 in. wide: what uniformly distributed load (W) will deflect the beam 1 in., E being 1,200,000 lbs.?

By Ex. 2,

$$1 = D = \frac{(240)^2}{8R}.$$

$$\therefore R = 7200 \text{ in.}$$

Also,

$$\frac{W \cdot 20}{8} \cdot 12 = \frac{E}{R} I = \frac{1200000}{7200} \frac{bd^3}{12} = \frac{1200000}{7200} \cdot \frac{6 \cdot 12^3}{12}.$$

$$\therefore W = 4800 \text{ lbs.}$$

E
length
stretch
(2).

Le
H

Also

Ex.
so that
10,000 a
differenc

Hence

10. Ca
truss, whe

EX. 4. Let s_1, f_1, d_1 , and s_2, f_2, d_2 , respectively, be the length, unit stress, and distance from the neutral axis of the stretched and compressed outside fibres in Examples (1) and (2).

Let $d_1 + d_2 = d =$ the total depth of the girder.

Hence, from similar figures,

$$\frac{s_1}{l} = \frac{R + d_1}{R} \quad \text{and} \quad \frac{s_2}{l} = \frac{R - d_2}{R};$$

$$\therefore \frac{s_1 - s_2}{l} = \frac{d_1 + d_2}{R} = \frac{d}{R}.$$

Also,

$$\frac{f_1}{E} = \frac{s_1 - l}{l} = \frac{d_1}{R} \quad \text{and} \quad \frac{f_2}{E} = \frac{l - s_2}{l} = \frac{d_2}{R}.$$

$$\therefore \frac{f_1 + f_2}{E} = \frac{s_1 - s_2}{l} = \frac{d_1 + d_2}{R} = \frac{d}{R}.$$

EX. 5. A truss of span 120 ft. and 15 ft. deep is strained so that the flange tensile and compressive unit stresses are 10,000 and 8000 lbs., respectively. Find the deflection, and difference of length between the extreme fibres.

$$\frac{10000 + 8000}{30000000} = \frac{s_1 - s_2}{120} = \frac{15}{R}.$$

$$\therefore s_1 - s_2 = .864 \text{ in.}, \quad \text{and} \quad R = 25,000 \text{ ft.}$$

$$\text{Hence also} \quad D = \frac{(120)^2}{8 \times 25000} = .864 \text{ in.}$$

10. **Camber.**—Owing to the play at the joints, a bridge-truss, when first erected, will deflect to a much greater extent

than is indicated by theory, and the material of the truss will receive a permanent set, which, however, will not prove detrimental to the stability of the structure, unless it is increased by subsequent loads.

If the chords were made straight, they would curve downwards, and, although it does not necessarily follow that the strength of the truss would be sensibly impaired, the appearance would not be pleasing.

In practice it is usual to specify that the truss is to have such a *camber*, or upward convexity, that under ordinary loads the grade line will be true and straight.

The camber may be given to the truss by lengthening the upper or shortening the lower chord, and the *difference* of length should be equally divided amongst all the panels.

The lengths of the web members in a cambered truss are not the same as if the chords were horizontal, and must be carefully calculated, otherwise the several parts will not fit accurately together.

To find an approximate value for the camber, etc.:

Let d be the depth of the truss.

Let s_1, s_2 be the lengths of the upper and lower chords, respectively.

Let f_1, f_2 be the unit stresses in the upper and lower chords, respectively.

Let d_1, d_2 be the distances of the neutral axis from the upper and lower chords, respectively.

Let R be the radius of curvature of the neutral axis.

Let l be the span of the truss.

$$\frac{d_1}{R} = \frac{s_1 - l}{l} = \frac{f_1}{E} \quad \text{and} \quad \frac{d_2}{R} = \frac{l - s_2}{l} = \frac{f_2}{E}, \text{ approximately,}$$

the chords being assumed to be circular arcs.

Hence, the excess in length, of the upper over the lower chord,

$$= s_1 - s_2 = \frac{l}{E}(f_1 + f_2) = l \frac{d}{R} = y.$$

Let x_1, x_2 be the cambers of the upper and lower chords, respectively. $R + d_1$ and $R - d_2$ are the radii of the upper and lower chords, respectively.

By similar figures, the horizontal distance between the ends of the upper chord = $\frac{R + d_1}{R}l$, and the horizontal distance between the ends of the lower chord = $\frac{R - d_2}{R}l$.

Hence,

$$\left(\frac{1}{2} \frac{R + d_1}{R} l\right)^2 = x_1 \cdot 2(R + d_1), \text{ approximately,}$$

and

$$\left(\frac{1}{2} \frac{R - d_2}{R} l\right)^2 = x_2 \cdot 2(R - d_2), \text{ approximately.}$$

$$\therefore x_1 = \frac{l^2}{8R} \left(1 + \frac{d_1}{R}\right) \quad \text{and} \quad x_2 = \frac{l^2}{8R} \left(1 - \frac{d_2}{R}\right).$$

Hence, approximately, the camber = $\frac{l^2}{8R} = \frac{ly}{8d}$.

Note.—The deflection of a well-designed and well-built truss is often much less than, and should never exceed, 1 inch per 100 ft. of span under the maximum load.

II. Stiffness.—If D is the maximum deflection of a girder of span l under a load W , then $\frac{W}{D}$, or more usually $\frac{D}{l}$, is a measure of the *stiffness* of the girder.

In practice, the deflection of an iron or a steel girder, under the working load, should lie between $\frac{l}{1200}$ and $\frac{l}{600}$, i.e., it is limited to 1 or 2 in. per 100 ft. of span, and rarely exceeds $\frac{l}{1000}$, or 1.2 in. per 100 ft. of span.

A timber beam should not deflect more than $\frac{l}{360}$, or 1 in. per 30 ft. of span.

Let M_1 be the bending moment at the most deflected point. Then

$$M_1 = \frac{E}{R}I.$$

Also,

$$D \propto \frac{l^3}{R} \propto \frac{M_1 l^3}{EI} = \rho \frac{M_1 l^3}{EI},$$

ρ being a numerical coefficient (in Art. 9, Ex. 1, $\rho = \frac{1}{2}$; in Ex. 2, $\rho = \frac{1}{3}$).

Thus

$$M_1 = \frac{EI(D)}{\rho l \left(\frac{l}{I}\right)},$$

gives the bending moment M_1 , to which the girder of a specified stiffness $\frac{D}{l}$ may be subjected.

Again, if the material is to bear a certain specified unit stress f , the maximum bending moment M_2 , to which the girder may be subjected is given by the equation

$$M_2 = \frac{f}{c}I = \frac{f}{qd}I,$$

q being a numerical coefficient less than unity, depending upon the form of the section.

Ceteris paribus, the ratio of depth to span may be fixed by making the *stiffness* and *strength* of equal importance. Then

$$M_1 = M_2; \text{ and therefore}$$

$$\frac{EI(D)}{\rho l \left(\frac{l}{I}\right)} = \frac{f}{qd}I,$$

or

$$\frac{l}{d} = \left(\frac{D}{l}\right) \frac{qE}{\rho f}.$$

sec
 $\frac{l}{8}$, i
 is co
 I
 20 f
 coeff
 ness
 viz.,

Also,

He

12.
 301 rep

tions A.
 Let t

In practice the proper stiffness of a girder is sometimes secured by requiring the central depth to lie between $\frac{l}{14}$ and $\frac{l}{8}$, its value depending upon the material of which the girder is composed, its sectional form, and the work to be done.

EXAMPLE.—A cast-iron beam of rectangular section and of 20 ft. span carries a uniformly distributed load of 20 tons; the coefficient of working strength is 2 tons per sq. in.; the *stiffness* is .001; E is 8000 tons. Find the dimensions of the beam viz., b the breadth and d the depth.

$$M = \frac{20 \cdot 20}{8} \cdot 12 = \frac{f}{c} I = 2 \frac{bd^3}{6} = \frac{bd^3}{3};$$

$$\therefore bd^3 = 1800.$$

Also,

$$\frac{20 \cdot 20}{8} \cdot 12 = M = \frac{EI(D)}{pl \left(\frac{l}{l}\right)} = \frac{8 \cdot 8000 \cdot bd^3}{12 \cdot 20 \cdot 12} \cdot (.001);$$

$$\therefore bd^3 = 27000.$$

Hence,

$$d = \frac{27000}{1800} = 15 \text{ in. and } b = 8 \text{ in.}$$

12. Distribution of Shearing Stress.—Let Figs. 300 and 301 represent a slice of a beam bounded by two consecutive sec-

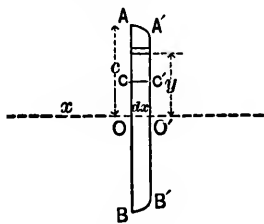

FIG. 300.

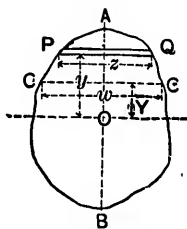

FIG. 301.

tions $AB, A'B'$, transverse to the horizontal neutral axis OO' . Let the abscissæ of these sections with respect to an origin

in the neutral axis be x and $x + dx$, so that the thickness of the slice is dx .

In the limit, since dx is indefinitely small, corresponding linear dimensions in the two sections are the same.

Let I be the moment of inertia of the section AB (or $A'B'$ in the limit) with respect to the neutral axis.

Let c be the distance of A (or A' in the limit) from the neutral axis.

Let f_1, f_2 be the unit stresses at A and A' , respectively.

Consider the portion $ACC'A'$ of the slice, CC' being parallel to and at a distance Y from the neutral axis. Since it is in equilibrium, the algebraic sum of the horizontal forces acting upon it must be nil. These forces are:

The total horizontal force upon ACC ,
 " " " " " $A'C'C'$, and
 " " " shear along the surface CC' .

The horizontal force upon an element PQ of thickness dy and at a distance y from the neutral axis

$$= f_1 \frac{y}{c} z dy,$$

z being the width PQ . Thus the total horizontal force upon ACC

$$= \Sigma \left(\frac{f_1}{c} y z dy \right) = \frac{f_1}{c} \Sigma (y z dy) = \frac{f_1}{c} \int_y^c y z dy = \frac{f_1}{c} A \bar{y},$$

A being the area of ACC , and \bar{y} the distance of the centre of gravity of this area from OO' .

Similarly, the total horizontal force upon $A'C'C'$

$$= \frac{f_2}{c} \int_y^c y z dy = \frac{f_2}{c} A \bar{y}.$$

Hence, $\left(\frac{f_1}{c} - \frac{f_2}{c}\right)A\bar{y}$ = difference of the horizontal forces upon ACC and $A'C'C'$,
 = horizontal shear along CC' ,
 = $qwdx$;

q being the intensity of this shear, and w the width of the section at CC .

Let M and $M - dM$ be the bending moments at the two consecutive sections $AB, A'B'$. Then

$$M = \frac{f_1 I}{c} \quad \text{and} \quad M - dM = \frac{f_2 I}{c},$$

and therefore

$$dM = \left(\frac{f_1}{c} - \frac{f_2}{c}\right)I.$$

Hence,

$$\frac{dM}{I} A\bar{y} = qwdx,$$

or

$$qw = \frac{dM}{dx} \frac{A\bar{y}}{I} = \frac{S}{I} A\bar{y},$$

since $\frac{dM}{dx}$ = shearing force at the section $AB = S$.

EXAMPLE I. *Solid rectangular section of width b .*

$$qb = \frac{S}{b \frac{8c^3}{12}} \frac{b^2 c^2 - Y^2}{2} = \frac{3}{4} \frac{Sb}{bc^2} (c^2 - Y^2),$$

or

$$q = \frac{3}{4} \frac{S}{bc^2} (c^2 - Y^2),$$

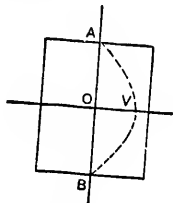

FIG. 102.

and the intensity of the shear at any point of AB may be represented by the horizontal distance of the point from the parabola AVB , having its vertex at V , where $OV = \frac{3}{4} \frac{S}{bc}$.

The *maximum* intensity of shear is at O and its value is

$$q_{max.} = \frac{3}{4} \frac{S}{bc}$$

The value of the average intensity is

$$q_{av.} = \frac{S}{b \cdot 2c}$$

$$\therefore q_{max.} : q_{av.} :: 3 : 2.$$

EX. 2. *A hollow rectangular section; B and $2c$ being the external and B' and $2c'$ the internal width and depth.*

At the neutral axis,

$$q(B - B') = \frac{S}{I} \left\{ \frac{B}{2}(c^2 - c'^2) + \frac{B - B'}{2}(c^2 - Y^2) \right\}.$$

Thus, as in Ex. 1, the intensity of shear is again greatest at the neutral plane, i.e., when $Y = 0$.

EX. 3. *Solid circular section of radius c .*

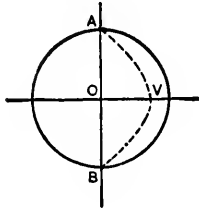

FIG 303

$$\bar{A}y = \int_0^c 2y \sqrt{c^2 - y^2} dy = \frac{2}{3}(c^2 - Y^2)^{\frac{3}{2}}$$

$$w = 2(c^2 - Y^2)^{\frac{1}{2}}, \text{ and } I = \frac{\pi c^4}{4}$$

$$\therefore q = \frac{4S}{3\pi c^3}(c^2 - Y^2),$$

and the intensity of the shear at any point of AB may be represented by the horizontal distance of the point from the parabola AVB , where $OV = \frac{4S}{3\pi c^3}$.

$$\text{Also, } q_{max.} = \frac{4S}{3\pi c^3} \text{ and } q_{av.} = \frac{S}{\pi c^3}.$$

$$\therefore q_{max.} : q_{av.} :: 4 : 3.$$

EX. 4. A double-flanged section, each of the flanges consisting of *five* 8-in. \times $\frac{1}{2}$ -in. plates riveted to a 24-in. \times $\frac{1}{2}$ -in. web by *two* 3-in. \times 3-in. \times $\frac{1}{8}$ -in. angles.

To find the intensity of shear at the surface of contact between the angles and the flange :

$$A\bar{y} = 20 \times 13\frac{1}{4} = 265; \quad w = 6\frac{1}{2} \text{ in.}; \quad I = 8975\frac{1}{4},$$

neglecting the effect of the rivet-holes in the tension flange.

Hence

$$q = S \frac{2120}{466739}.$$

Let $S = 49$ tons. Then $q = .2226$ ton per square inch.

Let the rivets have a pitch of 4 in., then

the total shear on each rivet = $\frac{6\frac{1}{2}}{2} \times 4 \times .2226 = 2.8938$ tons.

Let the coefficient of shearing strength be 4 tons per square inch, and suppose that the surfaces of the angle-irons and of the flange are close together; then

$$\text{area of rivet} = \frac{2.8938}{4} = .7234 \text{ sq. in.,}$$

and its diameter = .96 in.

If the surfaces are not close together, so that the rivet may be subjected to a bending action, then, by Ex. 3, the average intensity of shear in a section = $\frac{4}{3} \cdot 4 = 3$ tons per sq. in., and hence

$$\text{area of rivet} = \frac{2.8938}{3} = .9646 \text{ sq. in.};$$

its diameter is 1.1 in.

13. Beam acted upon by Forces Oblique to its Direction, but lying in a Plane of Symmetry.—In discussing the equilibrium of such a beam the forces may be resolved into components parallel and perpendicular to the beam, and their respective effects superposed.

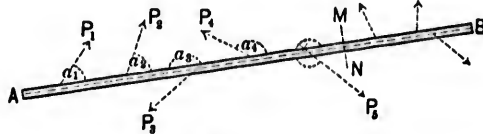

FIG. 304.

Let AB be the beam, P_1, P_2, P_3, \dots the forces, and $\alpha_1, \alpha_2, \alpha_3$ their respective inclinations to the neutral axis.

Divide the beam into any two segments by an imaginary plane MN perpendicular to the beam, and consider the segment AMN .

It is kept in equilibrium by the external forces on the left of MN and by the elastic reaction of the segment BMN upon the segment AMN at the plane MN .

The resultant force along the beam is the algebraic sum of the components in that direction, of P_1, P_2, P_3, \dots ,

$$= P_1 \cos \alpha_1 + P_2 \cos \alpha_2 + \dots = \Sigma(P \cos \alpha).$$

It may be assumed that this force acts along the neutral axis, and is uniformly distributed over the section MN .

Thus, if A is the area of the section, $\frac{\Sigma(P \cos \alpha)}{A}$ is the *intensity* of stress due to this force.

Again, the components of P_1, P_2, P_3, \dots , perpendicular to the beam, are equivalent to a *single force* and a *couple* at MN .

The single force at MN is the *Shearing Force*, is perpendicular to the beam, and is the algebraic sum of $P_1 \sin \alpha_1, P_2 \sin \alpha_2, \dots$,

$$= P_1 \sin \alpha_1 + P_2 \sin \alpha_2 + \dots = \Sigma(P \sin \alpha).$$

This
 $\Sigma(P \sin \alpha)$
A

be of litt
The r
moments

=

P_1, P_2, \dots
applicatio

Now,
forces on
ponents a

and

is the unit
from the n
external fo

Hence,
 MN at a d

$\pm \frac{\Sigma(P \cos \alpha)}{A}$

the signs d

It will
intensities,
to a bendin
of the unit
is sometim
holds true
brickwork
arches, etc.
correspond

This force develops a mean *tangential* unit stress of $\frac{\Sigma(P \sin \alpha)}{A}$ in MN , and deforms the beam, but so slightly as to be of little account.

The moment of the couple is the algebraic sum of the moments with respect to MN of $P_1 \sin \alpha_1, P_2 \sin \alpha_2, \dots$,

$$= P_1 \sin \alpha_1 p_1 + P_2 \sin \alpha_2 p_2 + \dots = \Sigma(Pp \sin \alpha),$$

p_1, p_2, \dots being respectively the distances of the points of application of P_1, P_2, \dots from MN .

Now, $\Sigma(Pp \sin \alpha)$ is the resultant moment of all the external forces on the left of MN , for the resultant moment of the components along the beam is evidently *nil*. Hence,

$$\Sigma(Pp \sin \alpha) = M = \frac{E}{R} I = \frac{f_y}{y} I,$$

and

$$f_y = \frac{y}{I} \Sigma(Pp \sin \alpha),$$

is the unit stress in the material of the beam at a distance y from the neutral axis due to the bending action at MN of the external forces on the segment AMN .

Hence, also, the *total* unit stress in the material in the plane MN at a distance y from the neutral axis is

$$\pm \frac{\Sigma(P \cos \alpha)}{A} \pm f_y = \pm \frac{\Sigma(P \cos \alpha)}{A} \pm \frac{y}{I} \Sigma(Pp \sin \alpha) = f'_y,$$

the signs depending upon the *kind* of stress.

It will be observed that this formula is composed of *two* intensities, the one due to a direct pull or thrust, the other due to a bending action. The latter is proportional to the distance of the unit area under consideration from the neutral axis. It is sometimes assumed that the same law of variation of stress holds true over the real or imaginary joints of masonry and brickwork structures, e.g., in piers, chimney-stacks, walls, arches, etc. In such cases the loci of the centres of pressure correspond to the neutral axis of a beam, and the maximum

and minimum values of the intensity occur at the edges of the joint.

EXAMPLE 1. A horizontal beam of length l , depth d , and sectional area A is supported at the ends, and carries a weight W at its middle point. It is also subjected to the action of a force H acting in the direction of its length.

First. Let the line of action of H coincide with the axis of the beam.

The intensity of the stress in the skin at the centre

$$= \pm \frac{H}{A} \pm \frac{c}{I} M.$$

But $c \propto d$, and $I = Ak^2 \propto Ad^2$.

$$\therefore \frac{I}{c} \propto Ad = \frac{Ad}{n},$$

n being a coefficient depending upon the form of the section.

If the section is a circle, $n = 8$; if a rectangle, $n = 6$. Hence,

$$\text{the skin stress} = \pm \frac{H}{A} \left(1 + \frac{n}{4} \frac{W}{H} \frac{l}{d} \right),$$

$$\text{since } M = \frac{Wl}{4}.$$

$$\text{If the load } W \text{ is uniformly distributed, } M = \frac{Wl^2}{8}.$$

Thus, a very small load on the beam may considerably increase the intensity of stress, and this intensity will be still further increased by the *deflection* of the beam under its load, so that, in order to prevent excessive straining, it is often necessary to introduce more supports than are actually required to make the beam sufficiently *stiff*.

Second. If the line of action of H is at a distance h from the neutral axis, an additional bending moment Hh will be introduced.

Ex.
tributed
against
The
and act
the reac
Let
in B .
at A mu
Let
horizont
The
which m

α being

Consi
tance x f
The c
upon OM
of OM , i.

The c

The c

EX. 2. The inclined beam OA , carrying a uniformly distributed load of w per unit of length, is supported at A and rests against a smooth vertical surface at O .

The resultant weight wl is vertical and acts through the centre C of OA ; the reaction R_1 at O is horizontal.

Let the directions of wl and R_1 meet in B . For equilibrium, the reaction R_2 at A must also pass through B .

Let the vertical through C meet the horizontal through A in D .

The triangle ABD is a triangle of forces for the three forces which meet at B .

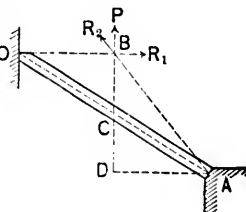

FIG. 305.

$$\therefore \frac{R}{wl} = \frac{AD}{BD} = \frac{AD}{2 \cdot DC} = \frac{1}{2} \cot \alpha,$$

α being the angle OAD . Hence

$$R_1 = \frac{wl}{2} \cot \alpha.$$

Consider a section MN , perpendicular to the beam, at a distance x from O .

The only forces on the left of MN are R_1 and the weight upon OM . This last is wx , and its resultant acts at the centre of OM , i.e., at a distance $\frac{x}{2}$ from MN .

The component of R_1 along the beam

$$= R_1 \cos \alpha = \frac{wl \cos^2 \alpha}{2 \sin \alpha}.$$

The component of R_1 perpendicular to the beam

$$= R_1 \sin \alpha = \frac{wl}{2} \cos \alpha.$$

The component of $w x$ along the beam = $w x \sin \alpha$.

The component of $w x$ perpendicular to the beam = $w x \cos \alpha$.

Hence,

the total compression at $NM = \frac{wl \cos^2 \alpha}{2} \frac{\alpha}{\sin \alpha} + wx \sin \alpha = C_x;$

the shearing force at $MN = \frac{wl}{2} \cos \alpha - wx \cos \alpha = S_x;$

the bending moment at $MN = x \frac{wl}{2} \cos \alpha - \frac{x}{2} wx \cos \alpha = M_x;$

and

$$f_y = \frac{C_x}{A} \pm \frac{y}{I} M_x.$$

These expressions may be interpreted graphically as already described, C_x, S_x being represented by the ordinates of straight lines, and M_x, f_y by the ordinates of parabolas.

f_y , for example, consists of two parts which may be treated independently. Draw OE and AF perpendicular to OA , and respectively equal or proportional to

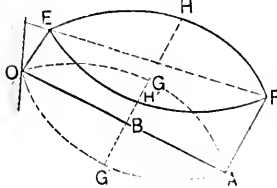

FIG. 306.

$\frac{wl \cos^2 \alpha}{2A \sin \alpha}$ and $\frac{wl \cos^2 \alpha}{2A \sin \alpha} + \frac{wl}{A} \sin \alpha.$

Join EF . The unit stress at any point of the beam due to direct compression is represented by the ordinate (drawn parallel to OE or AF) from that point to EF .

Upon the line GG' drawn through the middle point B perpendicular to OA , take $BG = BG'$, equal or proportional to

$\frac{ywl^2}{I} \frac{\alpha}{8} \cos \alpha.$ According as the stress due to the bending action at any point of the beam is compressive or tensile, it is represented by the ordinate (drawn parallel to OE and AF) from that point to the parabola OGA or $OG'A$: G and G' , respectively, being the vertices, and GG' a common axis.

By s
obtaine
to the v
the bea
surface.
14. S
when the
proportio
Thus,
and lengt

15. T
Girders.—
product o
dimension
Hence,
cubes of th
must vary
(b) The
formula of
l a length.
Now $\frac{d}{l}$ i
tional to a , i
Hence, th
as the square
EXAMPLE
apart is 10 ft.
and depth of

Hence, the
the unit stress
weights in the

By superposing these results, the parabolas EHF , $EH'F$ are obtained, the ordinates of which are respectively proportional to the values of f_y for the compressed and stretched parts of the beam, i.e., for the parts above and below the neutral surface.

14. Similar Girders.—Two girders are said to be *similar* when the linear dimensions of the one bear the same constant proportion to the corresponding linear dimensions of the other.

Thus, if β , β' , δ , δ' , λ , λ' are corresponding breadths, depths, and lengths of two similar girders,

$$\frac{\beta}{\beta'} = \frac{\delta}{\delta'} = \frac{\lambda}{\lambda'} = \text{a constant} = \mu, \text{ suppose.}$$

15. To Deduce the Principal Properties of Similar Girders.—(a) The weight of a girder is proportional to the product of an area and length, i.e., to the cube of a linear dimension.

Hence, *the weights of similar girders vary directly as the cubes of their linear dimensions.* Hence, too, *the unit stresses must vary directly as their linear dimensions.*

(b) The *Breaking Weight* of a girder is calculated from a formula of the form $W = S \frac{ad}{l}$, a being an area, d a depth, and l a length.

Now $\frac{d}{l}$ is constant for similar girders, so that W is proportional to a , i.e., to the square of a linear dimension.

Hence, *the Breaking Weights of similar girders vary directly as the squares of their linear dimensions.*

EXAMPLE.—A girder resting upon two supports 80 ft. apart is 10 ft. deep and weighs 6 tons. Determine the length and depth of a similar girder weighing 48 tons.

$$\left(\frac{\text{length}}{80}\right)^2 = \left(\frac{\text{depth}}{10}\right)^2 = \frac{48}{6} = 8.$$

Hence, the length = 160 ft. and the depth = 20 ft. Also, the unit stresses are in the ratio of 10 to 20, and the breaking weights in the ratio of 10² to 20².

16. To Discuss the Relations between the Corresponding Sectional Areas, Moments of Inertia, Weights, Bending Moments, etc., of two Girders which have the same Sectional Form and are thus related :

The forces upon the one being P_1, P_2, P_3, \dots with abscissæ x_1, x_2, x_3, \dots those upon the other are nP_1, nP_2, nP_3, \dots with abscissæ $\rho x_1, \rho x_2, \rho x_3$.

The spans and corresponding lengths are in the constant ratio ρ .

Corresponding sectional breadths are in the constant ratio q

Corresponding sectional depths are in the constant ratio r .

Let A, A' be corresponding sectional areas;

I, I' " " moments of inertia;

Q, Q' " " weights;

S, S' " " shearing forces;

M, M' " " bending moments;

f, f' " " flange unit stresses;

s, s' " " web unit stresses;

R, R' " " radii of curvature;

Δ, Δ' " " deflections;

W, W' " " breaking weights.

$\therefore (\alpha) A \propto$ product of a breadth and depth ;

$$\therefore A' = Aqr.$$

$(\beta) I \propto$ product of a breadth and the cube of a depth ;

$$\therefore I' = Iqr^3.$$

$(\gamma) Q \propto$ product of a length, breadth, and depth ;

$$\therefore Q' = Qn = Q\rho qr\rho.$$

ρ being the ratio of the specific weights of the materials of the girders.

If the materials are the same,

$$\rho = 1 \quad \text{and} \quad n = \rho qr.$$

Hence, the
those of $A, I,$

(d)

(e)

(c)

(7)

(\theta) $\frac{E}{R} =$

ficients of e

(i) Δ is

(k) W is p

(δ) $S' = Sn = Spqr\rho$, for, from (γ), $u = pqr\rho$.

(ε) M is the product of a force and a length

$$\therefore M' = Mnp = Mp^3qr\rho,$$

$$(ζ) \quad f = \frac{cM}{I} \quad \text{and} \quad f' = \frac{c'M'}{I'};$$

$$\therefore \frac{f'}{f} = \frac{c' M' I}{c M I'} = rnp \frac{1}{qr^3} = \frac{p^3}{r} \rho.$$

$$(η) \quad s = \frac{S}{A} \quad \text{and} \quad s' = \frac{S'}{A'};$$

$$\therefore \frac{s'}{s} = \frac{S' A}{S A'} = \frac{n}{qr} = p\rho.$$

(θ) $\frac{E}{R} = \frac{f}{c}$ and $\frac{E'}{R'} = \frac{f'}{c'}$, E and E' being the coefficients of elasticity of the respective girders;

$$\therefore \frac{R'}{R} = \frac{f' c' E'}{f c E} = \frac{E'}{E} r \frac{r}{p^3 \rho} = \frac{E'}{E} r^2 \frac{1}{p^3 \rho}.$$

(ι) Δ is proportional to $\frac{(\text{a length})^3}{\text{radius of curvature}}$;

$$\therefore \frac{\Delta'}{\Delta} = p^3 \frac{R}{R'} = \frac{E}{E'} \frac{p^3}{r^2} \rho.$$

(κ) W is proportional to $\frac{\text{the product of an area and depth}}{\text{a length}}$;

$$\therefore \frac{W'}{W} = \frac{qr \cdot r}{p} = \frac{qr^2}{p}.$$

Hence, the values of A' , I' , Q' , . . . may be derived from those of A , I , Q , . . . by means of certain constant multipliers.

Cor. 1. If the two girders are *similar* and of the same material,

$$p = q = r = \mu, \quad E = E', \quad \text{and} \quad \rho = 1.$$

Hence,

from (*\gamma*), $Q' = Q\mu^3$, and the weights vary directly as the cubes of the linear dimensions;

“ (*\epsilon*), $M' = M\mu^3$, and the bending moments vary directly as the fourth powers of the linear dimensions;

“ (*\zeta*) and (*\eta*), $\frac{f'}{f} = \mu = \frac{s'}{s}$, and the flange unit stresses vary directly as the web unit stresses;

“ (*\theta*) $\frac{R'}{R} = 1$.

“ (*\iota*), $\frac{\Delta}{\Delta} = \mu^2$, and the deflections vary directly as the squares of the linear dimensions;

“ (*\kappa*) $\frac{W'}{W} = \mu^2$, and the breaking weights vary directly as the squares of the linear dimensions.

Cor. 2. Let the girders be of the same material, of equal length, of equal rectangular sectional areas, and equally loaded.

Let b, b_1 , and d, d_1 , respectively, be the breadths and depths of the girders. Then

$$b_1 = qb \quad \text{and} \quad d_1 = rd.$$

Hence,

$$b_1 d_1 = qrb d.$$

But $b_1 d_1 = b d$; $\therefore qr = 1$. Also, $p = 1$.

Th

If d_1 ,

Hence

17. To
beam is so
importance
must be tal
the beam.
The nec
width of the
the width be
for the elasti
Assume t
are reduced t

Let W_1 be
“ b_1 “

“ B_1 “
“ W_1 “

“ b “
“ B “

Then W

and $\frac{b_1}{b} =$

Thus from ζ ,
$$\frac{f'}{f} = \frac{1}{r} = q;$$

" θ and t ,
$$\frac{R'}{R} = r^2 = \frac{\Delta}{d};$$

" κ ,
$$\frac{W'}{W} = r = \frac{f}{f'}.$$

If $d_1 = b$, then $b_1 = d$, and $r = \frac{b}{d}$.

Hence,
$$\frac{f'}{f} = \frac{d}{b}, \text{ and } \frac{R'}{R} = \left(\frac{b}{d}\right)^2 = \left(\frac{W'}{W}\right)^2.$$

17. To make Allowance for the Weight of a Beam.—A beam is sometimes of such length that its weight becomes of importance as compared with the load it has to carry, and must be taken into account in determining the dimensions of the beam.

The necessary provision may be made by increasing the *width* of the beam designed to carry the external load alone, the width being a dimension of the first order in the expression for the elastic moment.

Assume that the weight of the beam and the external load are reduced to equivalent uniformly distributed loads.

Let W_e be the external load.

" b_e " " breadth of a beam designed to support this load only.

" B_e " " weight of the beam.

" W " " total load, the weight of the beam being taken into account.

" b " " corresponding breadth of the beam.

" B " " weight " " "

Then $W - B = W_e,$

and
$$\frac{b}{b_e} = \frac{B}{B_e} = \frac{W}{W_e} = \frac{W - B}{W_e - B_e} = \frac{W_e}{W_e - B_e}.$$

$$\text{Hence, } b = \frac{W_e b_e}{W_e - B_e}, \quad B = \frac{W_e B_e}{W_e - B_e}, \quad \text{and} \quad W = \frac{W_e^2}{W_e - B_e}.$$

EXAMPLE.—Apply the preceding results to a cast-iron girder of rectangular section resting upon two supports 30 ft. apart. The girder is 12 in. deep and carries a uniformly distributed load of 30,000 lbs.

Take 4 as a factor of safety; b_e is given by

$$\frac{120000}{2} = C \frac{b_e d^2}{l},$$

where $C = 30,000$ lbs., $d = 12$ in., and $l = 360$ in.;

$$\therefore b_e = 5 \text{ in.}$$

Hence,

$$B_e = \frac{5 \times 12}{144} \times 30 \times 450 = 5625 \text{ lbs.};$$

$$W_e - B_e = 30000 - 5625 = 24,375 \text{ lbs.};$$

$$b = \frac{30000 \cdot 5}{24375} = 6\frac{2}{15} \text{ in.};$$

$$B = \frac{30000}{24375} \times 5625 = 6923\frac{1}{3} \text{ lbs.};$$

$$W = W_e + B = 36,923\frac{1}{3} \text{ lbs.}$$

1. A
the coef
ance of
metal, (a
is square
If the
the diam
Ans.

2. A p
working
own weigh
timber ac
ends. Fir
cantilever

3. Is it
spruce plan
ropes at the
per sq. in.
A

4. Comp
two beams
one being
compare the

5. A cast-
16 ft. long, c
coefficient of
P when it is

6. A round
to be of equal
square.

EXAMPLES.

1. An iron bar is bent into the arc of a circle of 500 ft. diameter; the coefficient of elasticity is 30,000,000 lbs. Find the moment of resistance of a section of the bar and the maximum intensity of stress in the metal, (a) when the bar is round and 1 in. in diameter, (b) when the bar is square having a side of 1 inch.

If the metal is not to be strained above 10,000 lbs. per sq. in., find (c) the diameter of the smallest circle into which the bar can be bent.

Ans.—(a) $\frac{2}{3}\pi$ in.-lbs.; 5000 lbs. (b) $833\frac{1}{3}$ in.-lbs.; 5000 lbs. (c) 250 ft.

2. A piece of timber 10 ft. long, 12 in. deep, 8 in. wide, and having a working strength of 1000 lbs. per sq. in., carries a load, including its own weight, of w lbs. per lineal foot. Find the value of w , (a) when the timber acts as a cantilever; (b) when it acts as a beam supported at the ends. Find (c) stress in material 3 in. from neutral axis at fixed end of cantilever and at middle of beam.

Ans.—(a) 320 lbs.; (b) 1280 lbs.; (c) 500 lbs. per sq. in.

3. Is it safe for a man weighing 160 lbs. to stand at the centre of a spruce plank 10 ft. long, 2 in. wide, and 2 in. thick, supported by vertical ropes at the ends? The safe working strength of the timber is 1200 lbs. per sq. in.

Ans. No; the maximum safe weight at the centre is $53\frac{1}{3}$ lbs.

4. Compare the uniformly distributed loads which can be borne by two beams of rectangular section, the several linear dimensions of the one being n times the corresponding dimensions of the other. Also compare the moments of resistance of corresponding sections.

Ans. n^2 ; n^3 .

5. A cast-iron beam of rectangular section, 12 in. deep, 6 in. wide, and 16 ft. long, carries, in addition to its own weight, a single load P ; the coefficient of working strength is 2000 lbs. per sq. in. Find the value of P when it is placed (a) at the middle point; (b) at $2\frac{1}{2}$ ft. from one end.

Ans.—(a) 4200 lbs.; (b) $9577\frac{1}{2}$ lbs.

6. A round and a square beam of equal length and equally loaded are to be of equal strength. Find the ratio of the diameter to the side of the square.

Ans. $\sqrt[3]{56} : \sqrt[3]{33}$.

7. Compare the relative strengths of two beams of the same length and material (*a*) when the sections are *similar* and have areas in the ratio of 1 to 4; (*b*) when one section is a circle and the other a square, a side of the latter being equal to the diameter of the former.

Ans. (*a*) 1 to 8; (*b*) 56 to 33.

8. Compare the strength of a cylindrical beam with the strength of the strongest (*a*) rectangular and (*b*) square beam that can be cut from it.

Ans. (*a*) 112 : 99 $\sqrt{3}$; (*b*) 33 : 14 $\sqrt{2}$.

9. A boiler-plate tube 36 ft. long, 30 in. inside diameter, weighs 4200 lbs. and rests upon supports 33 ft. apart. Find the maximum intensity of stress in the metal. What additional weight may be suspended from the centre, assuming that the stress is nowhere to exceed 8000 lbs. per sq. in.? The tube to be of steel.

Ans. 741 $\frac{1}{8}$ lbs. per sq. in.; 18,854 $\frac{11}{16}$ lbs.

10. Compare the relative strengths of two rectangular beams of equal length, the breadth (*b*) and depth (*d*) of one being the depth (*b*) and breadth (*d*) of the other.

Ans. $d^2 : b^2$.

11. A yellow-pine beam 14 in. wide, 15 in. deep, and resting upon supports 129 in. apart, was just able to bear a weight of 34 tons at the centre. What weight will a beam of the same material, of 45 in. span and 5 in. square, bear?

Ans. $7\frac{3}{8}$ tons.

12. A cast-iron rectangular girder rests upon supports 12 ft. apart and carries a weight of 2000 lbs. at the centre. If the breadth is *one-half* the depth, find the sectional area of the girder so that the intensity of stress may nowhere exceed 4000 lbs. per sq. in.

Ans. 18 sq. in.; if weight of girder is to be taken into account, the depth *d* is given by $d^3 - 1.0125d^2 - 216 = 0$.

13. Find the depth of a wrought-iron girder 6 in. wide which might be substituted for the cast-iron girder in the preceding question, the coefficient of strength for the wrought-iron being 8000 lbs. per sq. in.

Ans. 3 in.; if weight of girder is to be included, the depth *d* is given by $d^3 - 54d - 9 = 0$.

14. An oak beam of circular section and 22 ft. long is strained to the elastic limit (2 tons per sq. in.) by a uniformly distributed load of $2\frac{1}{2}$ tons. Find the diameter of the beam. What load 2 ft. from one end would strain the material to same limit?

Ans. 7 in.; $3\frac{1}{16}$ tons.

15. A uniform beam of weight W_1 crossing a given span can bear a uniformly distributed load W_2 . What load may be placed upon the same beam if it crosses the span in *n* equal lengths supported at the joints by piers whose widths may be disregarded?

Ans. $n^2(W_1 + W_2) - W_1$.

16. A bending 36,000,000

17. Det ing upon s tons at 14 per sq. in. a

18. A wr and carries a so that the s

19. Comp section and scribed in th of the rectang

20. A stres / 12 in. square a and the centra

21. A piece in. deep, was su centre, the corr Find *E* and the What were t beam?

Ans. $E = 55$

22. The effect effective depths 22.25 ft., respecti are respectively c and 461 sq. in. at of the web are 25 tube to be equiva the web compens rivet-holes. Find quarter spans, *E*

16. A flat spiral spring .2 in. wide and .03 in. thick is subjected to a bending moment of 10 in.-lbs. Find its radius of curvature, E being 36,000,000 lbs.
Ans. 1.62 in.

17. Determine the diameter of a solid round wrought-iron beam resting upon supports 60 in. apart and about to give way under a load of 30 tons at 14 in. from one end. Take 5 as a factor of safety and 8960 lbs. per sq. in. as the safe working intensity of stress.
Ans. 5.47 in.; if weight of beam is taken into account, the diameter (d) is given by $2019584 + 938\frac{2}{3}d^2 - 12320d^3 = 0$.

18. A wrought-iron bar $1\frac{1}{2}$ in. wide and 20 ft. long is fixed at one end and carries a load of 500 lbs. at the free end. Find the depth of the bar, so that the stress may nowhere exceed 10,000 lbs. per sq. in.
Ans. 6.928 in.; if weight of bar is included, the depth d is given by $d^2 - 4.8d - 48 = 0$, and $d = 9.73$ in.

19. Compare the moments of resistance to bending of a rectangular section and of the rhomboidal and isosceles sections which can be inscribed in the rectangle, the base of the triangle being the lower edge of the rectangle.
Ans. 4 : 1 : 1 or 4 : 1 : 2.

20. A stress of 1 lb. per sq. in. produces a strain of $\frac{1}{8000000}$ in a beam 12 in. square and 20 ft. between supports. Find the radius of curvature and the central deflection under a load of 2000 lbs. at the middle point.
Ans. 2400 ft.; $\frac{1}{4}$ in.

21. A piece of greenheart 140 in. between supports, 9 in. wide and 8 in. deep, was successively subjected to loads of 4, 8, and 16 tons at the centre, the corresponding deflections being .32 in., .64 in., and 1.28 in. Find E and the total work done in bending the beam.
 What were the corresponding inch-stresses at $\frac{3}{4}$ of the depth of the beam?
Ans. $E = 5582682$ lbs.; 13.44 inch-tons; $\frac{3}{8}$ ton, $\frac{7}{8}$ tons, $1\frac{1}{8}$ tons.

22. The effective length of the Conway tubular bridge is 412 ft.; the effective depths of a tube at the centre and quarter spans are 23.7 ft. and 22.25 ft., respectively; the sectional areas of the top and bottom flanges are respectively 645 sq. in. and 536 sq. in. at the centre and 566 sq. in. and 461 sq. in. at the quarter spans; the corresponding sectional areas of the web are 257 sq. in. and 241 sq. in. Assume the total load upon a tube to be equivalent to 3 tons per lineal foot, and that the continuity of the web compensates for the weakening of the tension flange by the rivet-holes. Find the flange stresses and the deflection at the centre and quarter spans, E being 24,000,000 lbs. What will be the increase in the

central flange stresses under a uniformly distributed live load of $\frac{1}{4}$ ton per lineal foot? (One ton = 2240 lbs.)

$$\text{Ans. At centre } \frac{l}{144} = 176,708; f_t = 4.59 \text{ tons per sq. in.};$$

$$f_c = 3.94 \text{ " " " "}$$

$$\text{Deflection} = 8.56 \text{ in.}$$

$$\text{At quarter span } \frac{l}{144} = 140,278; f_t = 1.367 \text{ " " " "}$$

$$f_c = 1.158 \text{ " " " "}$$

$$\text{Deflection} = 6.72 \text{ in.}$$

The stresses and deflections are increased by the live load in the ratio of 5 to 4.

23. A plate girder of 64 ft. span and 8 ft. deep carries a dead load of 2 tons per lineal foot. At any section the two flanges are of equal area, and their joint area is equal to that of the web. Find the sectional area at the centre of the girder, so that the intensity of stress in the metal may not exceed 3 tons per sq. in. The deflection of the girder is $\frac{3}{8}$ in. at the centre. Find E and the radius of curvature.

$$\text{Ans. } 128 \text{ sq. in.}; 15,360 \text{ ft.}; 25,804,800 \text{ lbs.}$$

24. Taking the coefficient of *direct* elasticity at 15,000 tons, the coefficient of *lateral* elasticity at 60,000 tons, and the limit of elasticity at 10 tons, determine the greatest deviation from the straight line of a wrought-iron girder of breadth b and depth d .

$$\text{Ans. } \frac{b^2}{24000d}$$

25. Find the stress at the skin and also at a point 2 in. from the neutral axis in a piece of 10" x 8" oak, (a) with the 10" side vertical; (b) with the 8" side vertical. The oak rests upon supports 3 ft. apart and carries a load of 4900 lbs. at its middle point. Also compare (c) the strength of the beam with its strength when a *diagonal* is horizontal.

$$\text{Ans.} - (a) 330\frac{3}{4}; 132\frac{3}{16} \text{ lbs. per sq. in.}$$

$$(b) 413\frac{7}{8}; 206\frac{3}{8} \text{ " " " "}$$

$$(c) 4 : \sqrt{41} \text{ or } 5 : \sqrt{41}.$$

26. Find the uniformly distributed load which can be borne by a rolled T-iron beam, 6" x 4" x $\frac{1}{4}$ ", 10 ft. long, fixed at one end and free at the other, the coefficient of strength being 10,000 lbs. per sq. in.

$$\text{Ans. } 438 \text{ lbs.}$$

27. One of the tubes of the Britannia bridge has an effective length of 470 ft., depth of 27 $\frac{1}{2}$ ft., and deflects 12 in. at the centre under a uniformly distributed load of 1587 tons. Find E and the central flange stresses, the sectional areas of the top flange, bottom flange, and web being 648 sq. in., 585 sq. in., and 302 sq. in., respectively.

$$\text{Ans. } E = 12,910,496 \text{ lbs.}; f_t = 5.3 \text{ tons per sq. in.};$$

$$f_c = 4.88 \text{ " " " "}$$

28. flange. a 12 in. What ft.? F point, A

29. A lutely fi per min being 2 material from the

30. T of a wro = $\frac{1}{2}d^2$; t formly dis of stress = stiffness, A

31. Th area is *five* of the sect stress are load so th lbs.

An

32. A d ports carri mensions fe 2 tons and being 8000

An

33. The the ends is material is not depth, E be half the dep

34. Two section of a b

28. Find the moment of resistance to bending, of a steel I-beam, each flange consisting of a pair of 3-in. \times 3 in. \times $\frac{1}{2}$ in. angle-irons, riveted to a 12 in. \times $\frac{3}{4}$ in. web, the coefficient of strength being 5 tons per sq. in. What load will the beam carry at 5 ft. from one end, its span being 20 ft.? Find the central deflection, and also the deflection at the loaded point, E being 15,000 tons.

Ans. 287 $\frac{1}{2}$ in.-tons; 6 $\frac{1}{4}$ tons disregarding weight of beam, or 6 $\frac{1}{8}$ tons if weight of beam is taken into account; deflection at centre = $\frac{1}{8}$ in., at loaded point = $\frac{1}{16}$ in.

29. A shaft $5\frac{1}{2}$ in. deep \times 5 in. wide \times 98 in. long has one end absolutely fixed, while at the other a wheel turns at the rate of 270 revolutions per minute; a weight of 20 lbs. is concentrated in the rim, its C , of G , being 2 $\frac{1}{2}$ ft. from the axis of the shaft. Find the maximum stress in the material of the shaft, and also find the maximum deviation of the shaft from the straight, E being 27,000,000 lbs.

Ans. 4860 lbs. per sq. in.; .31431 in.

30. The square of the radius of gyration of the equal-flanged section of a wrought-iron girder of depth d is $\frac{1}{4}d^2$; the area of the section = $\frac{1}{4}d^2$; the span = 50 ft. In addition to its own weight it carries a uniformly distributed load of $1\frac{1}{8}$ lbs. per lineal foot; the maximum intensity of stress = 10,000 lbs. per sq. in. Find the depth. Also determine the stiffness, E being 25,000,000 lbs.

Ans. 3 $\frac{1}{2}$ in.; $1\frac{2}{5}$.

31. The central section of a cast-iron girder is 10 $\frac{1}{2}$ in. deep; its web area is *five* times the area of the top flange, and the moment of resistance of the section is 360,000 in.-lbs.; the tensile and compressive intensities of stress are 3000 and 7500 lbs. per sq. in., respectively. Find the span and load so that the girder may have a stiffness = .001, E being 17,000,000 lbs.

Ans. $a_1 = 12\frac{8}{7}$ sq. in.; $a_2 = 11\frac{1}{4}$ sq. in.; $a_3 + a_4 = 9\frac{1}{8}$ sq. in.; span = 136 in.; uniformly distributed load = 21176 $\frac{1}{7}$ lbs.

32. A double-flanged cast-iron girder 14 in. deep and 20 ft. between supports carries a uniformly distributed load of 20 tons. Find suitable dimensions for the section, the tensile and compressive inch-stresses being 2 tons and 5 tons, respectively. Also find the stiffness of the beam, E being 8000 tons.

Ans. Let thickness of web = 1 in.; $a_1 = 22\frac{2}{3}$ sq. in.; $a_2 = 4\frac{8}{15}$ sq. in.; stiffness = .001875.

33. The deflection of a uniformly loaded horizontal beam supported at the ends is not to exceed 1 in. in 50 feet of span, and the stress in the material is not to exceed 400 lbs. per sq. in. Find the ratio of span to depth, E being 1,200,000 lbs. per sq. in., and the neutral axis being at half the depth of the beam.

Ans. 20.

34. Two equal weights are placed symmetrically at the points of trisection of a beam of uniform section supported at the ends. These weights

are then removed and other two equal weights are placed at the quarter spans. Find the ratio of the two sets of weights so that the maximum intensity of stress may be the same in each case. Also show that the stiffness of the beam is the same in each case. *Ans.* 3 to 4.

35. A cast-iron beam has a cruciform section with equal ribs 2 in. thick and 4 in. long. If the intensity of longitudinal shear at the neutral axis is 1 ton per sq. in., find the total shear which the section can bear, and also find the moment of resistance, the least coefficient of working tensile and compressive stress being 1 ton per sq. in.

Ans. 59.31 tons; 34.4 tons.

36. If a spiral spring is fastened to the barrel so that there is no change of direction relatively to the barrel, show that the tendency to unwind is directly proportional to the amount of winding up. (Condition of perfect isochronism.)

37. Show that the modulus of rupture of any material is 18 times the load which will break a beam 12 in. long, 1 in. deep, and 1 in. wide when applied at the centre.

38. Find the limiting length of a wrought-iron cylindrical beam 4 in. in diameter, the modulus of rupture being 42,000 lbs. What uniformly distributed load will break a cylindrical beam of the same material 20 ft. long and 4 in. in diameter? *Ans.* 64.3 ft.; 8800 lbs.

39. A red-pine beam 18 ft. long has to support a weight of 10,000 lbs. at the centre. The section is rectangular and the depth is twice the breadth. Find the transverse dimensions, the modulus of rupture being 8500 lbs., and 10 being a factor of safety. (Neglect the weight of the beam.) *Ans.* $b = 9.84$ in.; $d = 19.68$ in.

40. A round oak cantilever 10 ft. long is just broken by a load of 600 lbs. suspended from the free end. Find its diameter, the modulus of rupture being 10,000 lbs. (Neglect the weight of the beam.)

Ans. 4.185 in.

41. Determine the breaking weight at the centre of a cast-iron beam of 6 ft. span and 4 in. square, the coefficient of rupture being 30,000 lbs.

Ans. 26,666 $\frac{1}{2}$ lbs.

42. The flooring of a corn warehouse is supported upon yellow-pine joists 20 ft. in the clear, 8 in. wide, 10 in. deep, and spaced 3 ft. centre to centre. Find the height to which corn weighing 48 $\frac{1}{2}$ lbs. per cu. ft. may be heaped upon the floor, 10 being a factor of safety and 3000 lbs. the coefficient of rupture.

Ans. .68 ft.

43. A yellow-pine beam 14 in. wide, 15 in. deep, and resting upon supports 126 in. apart, broke down under a uniformly distributed load of 60.97 tons. Find the coefficient of rupture.

Ans. 2731.456.

24 in.
7250
4
weig
at th
4
ports
weig
cient
47
woul
coeff
per cu
48.
in. wi
ruptur
49.
end ga
free en
50.
carries
per cu
distrib
(a) neg
Also
stituted
rupture
51. A
Its bott
breaking
being 15
52. A
upon by
Compare
axis.
53. A
whirled a
If the dis
10 ft., find

44. Find the breaking weight at the centre of a Canadian ash beam $2\frac{1}{2}$ in. wide, $3\frac{1}{2}$ in. deep, and of 45 in. span, the coefficient of rupture being 7250. *Ans.* $4934\frac{3}{8}$ lbs.

45. A timber beam 6 in. deep, 3 in. wide, 96 in. between supports, and weighing 50 lbs. per cu. ft., broke down under a weight of 10,000 lbs. at the centre. Find the coefficient of rupture. *Ans.* $891\frac{1}{2}$.

46. A wrought-iron bar 2 in. wide, 4 in. deep, and 144 in. between supports, carries a uniformly distributed load W in addition to its own weight. Find W , 4 being a factor of safety and 50,000 lbs. the coefficient of rupture. *Ans.* $5235\frac{3}{8}$ lbs.

47. Find the length of a beam of Canadian ash 6 in. square which would break under its own weight when supported at the ends. The coefficient of rupture = 7000 lbs., and the weight of the timber = 30 lbs. per cu. ft. *Ans.* 274.9 ft.

48. The teeth of a cast-iron wheel are $3\frac{1}{2}$ in. long, $2\frac{1}{2}$ in. deep, and 7 in. wide. What is the breaking weight of a tooth, the coefficient of rupture being 5000 lbs.? *Ans.* 50,625 lbs.

49. A wrought-iron bar 4 in. deep, $\frac{3}{4}$ in. wide, and rigidly fixed at one end gave way at 32 in. from the load when loaded with 1568 lbs. at the free end. Find the coefficient of rupture. *Ans.* $4181\frac{1}{2}$.

50. A cast-iron beam 12 in. wide rests upon supports 18 ft. apart, and carries a 12-in. brick wall which is $12\frac{1}{2}$ ft. in height and weighs 112 lbs. per cu. ft. Taking 63,000 as the modulus of rupture for a uniformly distributed load and 5 as a factor of safety, find the depth of the beam, (a) neglecting its weight; (b) taking its weight into account.

Also (c) determine the depth of a cedar beam which might be substituted for the cast-iron beam, taking 11,200 lbs. as the modulus of rupture for the cedar. *Ans.* (a) 6 in.; (b) $6\frac{1}{2}$ in.; (c) 14.23 in.

51. A cast-iron girder $27\frac{1}{2}$ in. deep, rests upon supports 26 ft. apart. Its bottom flange has an area of 48 sq. in. and is 3 in. thick. Find the breaking weight at the centre, the ultimate tensile strength of the iron being 15,000 lbs. per sq. in. (Neglect the effect of the web.)

Ans. $253,846\frac{2}{3}$ lbs.

52. A beam of rectangular section, of breadth b and depth d , is acted upon by a couple in a plane inclined at 45° to the axis of the section. Compare the moment of resistance to bending with that about either axis.

$$\text{Ans. } \frac{2\sqrt{2} b^3}{2b^2 + d^2}; \frac{2\sqrt{2} bd}{2b^2 + d^2}$$

53. A 2-in. wrought-iron bar 10 ft. long is held at the ends and is whirled about a parallel axis at the rate of 50 revolutions per minute. If the distance between the axis of the bar and the axis of rotation is 10 ft., find the maximum stress to which the material is subjected.

Ans. 17148.5 lbs. per sq. in.

54. A block of ice 3 in. wide and 4 in. deep has its ends resting upon supports 30 in. apart and carries a uniformly distributed load of 4800 lbs. An increase of pressure to the extent of 1125 lbs. per sq. in. lowers the freezing point 1° F. Assuming that the ordinary theory of flexure holds good, find the temperature of the ice. *Ans.* 30° F.

55. Find the limiting length of a cantilever of uniform transverse section, f being the coefficient of strength, k the ratio of length to depth, and w the specific weight of the material.

Ans. $\frac{288fn}{wk}$, n being a coefficient depending upon the form of the section.

56. If the beam in the preceding question is to be supported at its two ends, what will its limiting length be? *Ans.* $\frac{1152fn}{wk}$.

57. Find the limiting length of a cedar cantilever of rectangular section, k being 40, $w = 36$ lbs. per cu. ft., and $f = 1800$ lbs. per sq. in.

Ans. 60 ft.

58. A steel cantilever 2 in. square has an elastic strength of 15 tons per sq. in. What must its limiting length be so that there may be no set? *Ans.* 23.4 ft.

59. Find the limiting length of a wrought-iron beam of circular section, k being 64 and the elastic strength 8 tons per sq. in. What will this length be if a beam of I-section, having equal flange areas and a web area equal to the joint area of the flanges, is substituted for the circular section? *Ans.* 84 ft.; 224 ft.

60. A rectangular cast-iron beam having its length, depth, and breadth in the ratio of 60 to 4 to 1, rests upon supports at the two ends. Find the dimensions of the beam so that the intensity of stress under its own weight may nowhere exceed 4500 lbs. per sq. in.

Ans. $l = 128$ ft.; $d = 8\frac{8}{5}$ ft.; $b = 2\frac{2}{5}$ ft.

61. A beam supported at the ends can just bear its own weight W together with a single weight $\frac{H}{2}$ at the centre. What load may be placed

at the centre of a beam whose transverse section is similar but m^2 as great, its length being n times as great? If the beam could support only its own weight, what would be the relation between m and n ?

Ans. $W\left(\frac{m^3}{n} - \frac{nm^3}{2}\right)$; $m = \frac{n}{2}$.

62. The flanges of a rolled joist are each 4 in. wide by $\frac{1}{4}$ in. thick; the web is 8 in. deep by $\frac{1}{4}$ inch thick. Find the position of the neutral axis, the maximum intensities of stress per square inch being 10,000 lbs. in tension and 8000 lbs. in compression. *Ans.* $h_1 = 3\frac{5}{8}$; $h_2 = 4\frac{1}{8}$.

side
ing
end
tensi
area
64
lbs. p
at 25
the g
65
carrie
Find
stress
flange
66.
the fo
= 1 to
must b
might

67. :
designe
parabol
fixed en
mately
equal to
tional to
68. D
form str
at the en
wheel's p
elliptical,

69. A
points 1, 6
points, th
form stren
the depth

63. A continuous lattice-girder is supported at four points, each of the side spans being 140 ft. 11 in. in length, 22 ft. 3 in. in depth, and weighing .68 ton per lineal foot. On one occasion an excessive load lifted the end of one of the side spans off the abutment. Find the consequent intensity of stress in the bottom flange at the pier, where its sectional area is 127 sq. in.

Ans. 2.3893 tons per sq. in.

64. A railway girder is 101.2 ft. long, 22.25 ft. deep, and weighs 3764 lbs. per lineal foot. Find the maximum shearing force and flange stresses at 25 ft. from one end when a live load of 2500 lbs. per lineal foot crosses the girder.

Ans. 168,078.3 lbs.; 268,155.5 lbs.

65. A floor with superimposed load weighs 160 lbs. per sq. ft. and is carried by tubular girders 17 ft. c. to c. and 42 ft. between bearings. Find the depth of the girders (neglecting effect of web), the safe inch-stress in the metal being 9000 lbs., and the sectional area of the tension flange at the centre 32 sq. in.

Ans. 24.99 in.

66. Design a timber cantilever of *approximately* uniform strength from the following data: length = 12 ft.; square section; load at free end = 1 ton; coefficient of working strength = $\frac{1}{4}$ ton per sq. in. What must be the dimensions at the fixed and free ends so that the cantilever might carry an additional uniformly distributed load of 2 tons?

Ans. Side = 15.1 in. at fixed end and = 10 in. at free end;
side = 19.1 in. at fixed end and = $\frac{1}{3}$ (19.1 in.) at free end.

67. Show that the curved profile of a cantilever of uniform strength designed to carry a load W at the free end, is theoretically a *cubical* parabola. Also show that by taking the tangents to the profile at the fixed end as the boundaries of the cantilever, a cantilever of *approximately* uniform strength is obtained having a depth at the free end equal to *two-thirds* of the depth at the fixed end (breadth to be proportional to depth).

68. Design a wheel-spoke 33 in. in length to be of *approximately* uniform strength, the intensity of stress being 1000 lbs. per sq. in.; the load at the end of the spoke is a force of 1000 lbs. applied tangentially to the wheel's periphery, and the section of the spoke is to be (a) *circular*, (b) *elliptical*, the ratio of the depth to the breadth being $2\frac{1}{2}$.

Ans.—(a) Depth at hub = 6.982 in., at periphery = 4.634 in.

(b) " " " = 9.435 " " " = 6.29 in.

Breadth " " = 3.774 " " " = 2.516 in.

69. A beam of 17 ft. span is loaded with 7, 7, 11, and 11 tons at points 1, 6, 11, and 15 ft. from one end. Determine the depths at these points, the beam being of uniform breadth and of *approximately* uniform strength; the coefficient of working strength = 2 tons per sq. in., the depth of the section of maximum resistance to bending = 16 in.

$$\text{Ans. } b = \frac{11358}{1088}; d_1^3 = \frac{277 \times 16^3}{1262}; d_2^3 = \frac{1067 \times 16^3}{1262}; d_3^3 = 16^3;$$

$$\text{and } d_4^3 = \frac{670 \times 16^3}{1262}.$$

70. Design a cantilever 10 ft. long, of *approximately* uniform strength, to carry a load of 4000 lbs. at the free end, the coefficient of strength being 2000 lbs. per sq. in., and the section (a) a rectangle of constant breadth and 12 in. deep at the fixed end; (b) a square.

How will the results be modified if it is to carry an additional uniformly distributed load of 4800 lbs.?

Ans.—First. (a) $b = 10$ in., d at free end = 6 in.; (b) side = $\sqrt[3]{1440}$ at fixed end and = $\sqrt[3]{426\frac{2}{3}}$ at free end.

Second. (a) $b = 16$ in., d at free end = 6 in.; (b) side = $\sqrt[3]{2304}$ at fixed end and = $\sqrt[3]{85\frac{1}{8}}$ at free end.

71. Design a cantilever 10 ft. long, of constant breadth, and of *ap-proximately* uniform strength to carry a uniformly distributed load of 5000 lbs. on the half of the length next the free end, the intensity of stress being 2000 lbs. per sq. in., and the section a rectangle 12 in. deep at the fixed end. What must the dimensions be if 1000 lbs. are concentrated at 30 in. from fixed end?

Ans. $b = 9\frac{3}{8}$ in.; d at centre = 6.928 in.; at free end = 0.

$b = 10$ in.; depth = 9.48 in. at $7\frac{1}{2}$ ft. from free end, = 6.708 in. at centre, and = 0 at free end.

72. A gallery 30 ft. long and 10 ft. wide is supported by four 9 in. by 5 in. cantilevers spaced so as to bear equal portions of the superincumbent weight. What load per square foot will the gallery bear, the coefficient of working strength being 700 lbs. per sq. in.? Find the depth of cast-iron cantilevers 3 in. wide which may be substituted for the above, the coefficient of working strength being 2000 lbs. per sq. in. How should the depth vary if the cantilevers are to be of uniform strength?

Ans. 10.5 lbs.; $4d^2 = 189$; variation of depth for cast-iron cantilever is given by $400d^2 = 21x^2$, x being distance from free end.

73. A span of 60 ft. is crossed by a beam hinged at the points of trisection and fixed at the ends; the beam has a constant breadth of 3 in. and is to be of *uniform strength*, the intensity of stress is 3 tons per sq. in. Determine the dimensions of the beam when a load of $\frac{1}{3}$ ton per lineal foot covers (a) the whole span; (b) the centre span.

Ans.—(a) Depth at support = $4\sqrt{10}$ in., at centre = $\sqrt{20}$.

(b) " " " = $\sqrt{80}$ " " " = $\sqrt{20}$.

74. In the following examples determine the position of the neutral axis, the moment of resistance to bending, the resistance to shear, and the ratio of the maximum to the average intensity of shear, the coefficients of strength being $4\frac{1}{2}$ tons per sq. in. for tension and compression and $3\frac{1}{2}$ tons per sq. in. for shear.

(1) A rectangle 2 in. wide and 6 in. deep.

Ans. At centre; 54 in.-tons; 28 tons; 3 to 2.



Also find
ening effect
of the maxim

(II) A circular section 4 in. in diameter.

Ans. At centre; 28.2 in.-tons; 33 tons; 4 to 3.

(III) A regular hexagonal section with a diameter (a) vertical, (b) horizontal, a being a side of the hexagon.

Ans.—(a) At centre; $\frac{45}{32}a^2\sqrt{3}$; $\frac{15}{4}a^2\sqrt{3}$; 7 to 5.

(b) At centre; $\frac{45}{16}a^2$; $\frac{2625\sqrt{3}}{629}a^2$; 1.258.

(IV) A triangular section 6 in. deep, with a base 6 in. wide, the sides being equal. *Ans.* 4 in. from vertex; 40.5 in.-tons; 42 tons; 3 to 2.

(V) A double-tee section composed of a 30-in. \times $\frac{3}{8}$ -in. web and four angle-irons each 5 in. \times $3\frac{1}{2}$ in. \times $\frac{3}{8}$ in.

Ans. At centre; 1424.6 in.-tons; 34.534 tons; 3.1355 to 1.

(VI) A section having a semicircular top flange of 8 in external diameter and 1 in. thick, a web 14 in. deep and 1 in. thick, and a bottom flange 8 in. wide and 1 inch thick.

(VII) A section having a semi-elliptic top flange 2 in. thick, the internal major and minor axes being 8 in. (*horizontally*) and 4 in. (*vertically*), respectively, a bottom flange 8 in. wide and 2 in. thick, and a web 10 in. deep and 2 in. thick.

(VIII) A section having a semi-elliptic top flange 2 in. thick, the external major and minor axes being 10 in. (*horizontally*) and 6 in. (*vertically*), respectively, a trapezoidal web 8 in. deep having a width of 3 in. at the top and 6 in. at the bottom, and a bottom semicircular flange of 10 in. external diameter and 2 in. thick.

(IX) The sections shown by Figs. 307, 308, and 309.

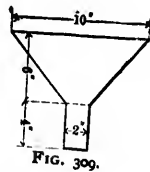
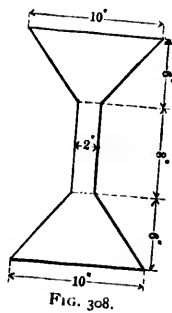
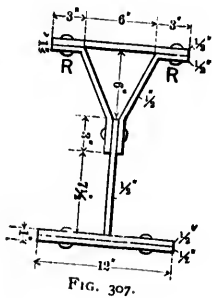

Also find the diameters of the rivets R in Fig. 1, neglecting the weakening effect of the rivet-holes in the bottom flange. What is the ratio of the maximum tensile and compressive stresses in each section?

(X) A trapezoidal section, the top side, bottom side, and depth h (inches) being in the ratio of 1 to 2 to 4.

Ans. $\frac{3}{8}h$ from top side; $\frac{1}{8}h^2$ in.-tons.

(XI) A section in the form of a rhombus of depth $2c$ and with a horizontal diagonal of length $2b$.

Ans. $\frac{1}{2}b^2$; $\frac{5}{8}bc$; 9 to 8.

(XII) An angle-iron 2 in. \times 2 in. \times $\frac{1}{2}$ in.

Ans. Neutral axis divides depth into segments of $\frac{1}{8}$ in. and $\frac{3}{8}$ in.; $\frac{1}{8}$ in.-tons; $\frac{9}{8}$ ton; 1334 to 1369.

(XIII) A hollow circular section of external radius C and internal radius C' .

$$\text{Ans. } \frac{99}{112} \frac{C^4 - C'^4}{C^2}; \frac{33}{4} \frac{C^4 - C'^4}{C^2 + CC' + C'^2}; \frac{4}{3} \frac{C^2 + CC' + C'^2}{C^2 + C'^2}.$$

(XIV) A cruciform section made up of a flat steel bar 10 in. by $\frac{1}{2}$ in. and four steel angles, each 4 in. by 4 in. by $\frac{1}{2}$ in., all riveted together. (Neglect weakening effect of rivet-holes.)

Ans. 76.425 in.-tons; 29.43 tons; 2.208.

75. A girder of 21 ft. span has a section composed of two equal flanges each consisting of two $\frac{3}{2}$ in. \times 5-in. \times $\frac{1}{2}$ -in. angles riveted to a 39-in. \times $\frac{1}{2}$ -in. web; the cover-plates on the flanges are each 12 in. \times $\frac{1}{2}$ in., and the rivets in the covers alternate with those connecting the angles and web; the pitch of the rivets is $3\frac{1}{2}$ in. Find the diameter and also find the maximum flange stresses, (a) disregarding the weakening effect of the rivet-holes in the tension flange; (b) taking this effect into account.

The load upon the girder is a uniformly distributed load of 20,800 lbs. (including weight of girder) and a load of 50,000 lbs. concentrated at each of the points distant $4\frac{1}{2}$ ft. from the middle point of the girder.

Ans. Diam. of rivets = .48 in. if tight, = .54 in. if subject to flexure.

(a) $f_1 = f_2 = 7762$ lbs. per sq. in.

(b) $f_1 = 8248$ lbs. per sq. in., $f_2 = 7847$ lbs. per sq. in.

76. A beam of triangular section, 12 in. deep and with its base horizontal can bear a total shear of 100 tons. If the safe maximum intensity of shear is 4 tons per sq. in., find the width of the base. *Ans.* 64 in.

77. Assuming that the web and flanges of a rolled beam are rectangular in section, determine the ratio of the maximum to the average intensity of shear in a section from the following data: the total depth is $\frac{n}{2}$ times the breadth of each flange, n times the thickness of each flange, and $2n$ times the thickness of the web. Show also that this ratio is $\frac{1}{4}\frac{n^2}{n^2+6}$ or $\frac{1}{4}\frac{n^2}{n^2+6}$ according as the area of the web is equal to the joint area of the two flanges or is equal to the area of each flange. How much of the shearing force is borne by the web? How much by the flange?

$$\text{Ans. ratio} = \frac{3(n^2 + 12n - 12)(n + 6)}{2(n^2 + 18n^2 - 36n + 24)}; 70\%; 85\%.$$

78. In a rolled beam with equal flanges, the area of the web is proportional to the n th power of the depth. Find the most economical distribution of metal between the flanges and web, and the moment of resistance to bending of the section thus designed. Also find the ratio of the average to the maximum intensity of shear.

Ans. Area of each flange : web area :: $2n - 1 : 6$;

$$\text{B. M.} = \frac{1}{2} \frac{n}{n+1} fSy,$$

f being the coefficient of strength, S the total area of section, and y the depth.

Max. intensity of shear : av. intensity :: $(n + 1)(4n + 1) : 6n$.

79. Find the moment of resistance to bending, the resistance to shear, and the ratio of maximum to the average intensity of a shear in the case of a section consisting of two equal flanges, each composed of a pair of 5-in. \times 3½-in. \times ½-in. angle-irons riveted to a 31½-in \times ½-in. web, the 5-in. sides of the angles being horizontal, and 4½ tons per sq. in. being the coefficient of strength.

Ans. 1501.06 in.-tons; 46.21 tons; 3.058.

80. The floor-beam for a single-track bridge is 15 ft. between bearings, and each of its flanges is composed of a pair of 2½-in. \times 2½-in. \times ½-in. angle-irons riveted to a 30-in. \times ½-in. web. The uniformly distributed load (including weight of beam) upon the beam is 4200 lbs., and a weight of 1600 lbs. is concentrated at each of the rail-crossings, 2½ ft. from the centre. Find (a) the maximum flange stress, (b) the ratio of the maximum and average intensities of shear; (c) the stiffness, E being 27,000,000 lbs.

Ans. (a) 1193.7 lbs.; (b) 2.037; (c) .0000663.

$$I = \frac{2451259}{1024}, \text{ neglecting effect of rivet-holes.}$$

81. A beam 36 ft. between bearings is a hollow tube of rectangular section and consists of a 24-in. \times ½-in. top plate, a 24-in \times ½-in. bottom plate, and two side plates each 35 in. \times ½ in. The plates are riveted together at the angles of the interior rectangle by means of four 6-in. \times 4-in. \times ½-in. angle-irons, the 6-in. side being horizontal. Determine—

(a) The intensity of shear at the surface between the angle-irons and the upper and lower plates.

(b) The diameter of the rivets, the pitch being 4 in. and assuming an effective width of 5½ in. in shear per rivet.

(c) The total shearing strength of the section, the safe intensity of shear being 3½ tons per sq. in.

(d) The moment of resistance of the section, the coefficient of strength being 4½ tons per sq. in.

(e) The uniformly distributed load which the beam will safely carry.

Ans.—(a) .11878 tons per sq. in.

(b) .97 in. if rivets are tight, 1.12 in. if liable to flexure.

(c) $109\frac{87}{104}$ tons disregarding effect of riveting, $105\frac{4}{11}$ tons having regard to riveting.

(d) $4085\frac{1}{2}$ in.-tons disregarding effect of riveting, 3830 tons having regard to riveting.

(e) $75\frac{1}{2}$ tons disregarding effect of riveting, 70.92 tons having regard to riveting.

82. A cast-iron channel-beam having a web 12 in. wide and two sides 7 in. deep, the metal being everywhere 1 in. thick, crosses a span of 14 ft. If the tensile intensity of stress is 1 ton per sq. in., what uniformly distributed load will the beam carry (*a*) with the web at the bottom; (*b*) with the web at the top? Find (*c*) the maximum compressive intensity of stress to which the metal is subjected, and (*d*) compare the maximum and average intensities of shear. Also, (*e*) what should be the area of a rectangular section to bear the same total shear?

Ans. $I = 110\frac{1}{2}$; (*a*) $4\frac{1}{2}$ tons; (*b*) $4\frac{1}{2}$ tons.

83. A beam of rectangular section and of a length equal to 20 times the depth is supported at the ends in a horizontal position, and is subjected to a thrust H whose line of action coincides with the axis of the beam. Show that the maximum intensity of stress at the middle point will be doubled by concentrating at that point a weight W equal to *one-thirtieth* of H .

84. The line of action of the thrust in a compression member is at a distance from the axis equal to $\frac{1}{r}$ th of the least transverse dimension. Show that the maximum intensity of stress is doubled if the section is rectangular and $r = 6$, or if the section is circular and $r = 8$.

85. A straight wrought-iron bar is capable of sustaining as a strut a weight w_1 , and as a beam a weight w_2 at the middle point, the deflection being small as compared with the transverse dimensions. If the bar has simultaneously to sustain a weight w as a strut and a weight w' as a beam, the weight being placed at the middle of the span, show that the beam will not break if

$$w + \frac{w_1}{w_2} w' < w_1.$$

86. A metal beam is subjected to the action of a bending moment steadily applied *beyond* the elastic limit. Assuming that the metal acts as if it were perfectly plastic, i.e., so that the stress throughout a transverse section is *uniform*, compare the moment of resistance to bending of a section of the beam with the moment on the assumption that the metal continued to fulfil the ordinary laws of elasticity, (*a*) the section being a rectangle; (*b*) the section being a circle.

87. A lattice-girder of 100 ft. span carries 80 tons uniformly distributed; the girder is 10 ft. deep and the safe working stress is 4 tons per sq. in. If the width of the flange must be 20 in. to carry the load exclusive of the weight of the girder, what must be the width of the flange when the weight of the girder is taken into account?

88. A plate-girder of double-tee section and of 80 ft. span is 8 ft. deep and carries a uniformly distributed load of 80 tons. If the width of the flange must be 12 in. to carry the load exclusive of the weight of the girder, what must the width be when this weight is taken into account?

89. If the plane of bending does not coincide with the plane of symmetry of a beam, show that the neutral axis is parallel to a line joining the centres of two circles into which the beam would be bent by two component couples whose axes are the principal axes of inertia of the section, each couple being supposed to act alone.

90. The flanges of a girder are of equal sectional area, and their joint area is equal to that of the web. What must be the sectional area to resist a bending moment of 300 in.-tons, the effective depth being 10 in. and the limiting inch-stress 4 tons? Ans. $22\frac{1}{2}$ sq. in.

91. The effective length and depth of a cast-iron girder which failed under a load of 18 tons at the centre were 57 in. and $5\frac{1}{2}$ in., respectively; the top flange was 2.33 in. by .31 in., the bottom flange 6.67 in. by .66 in., and the web was .266 in. thick. Assuming that the ordinary theory of flexure held good, what were the maximum intensities of stress in the flanges at the point of rupture?

Ans. $f_t = 12.36$ tons per sq. in.; $f_c = 44.9$ tons per sq. in.

92. A railway bridge is supported upon two main girders each of span 51 ft. 4 in.; at the centre the depth is 6 ft. 6 in., the gross sectional area of the top flange 27 sq. in., and of the bottom flange 28 sq. in. Assuming the efficiency of the tension flange is reduced *one-fifth* by the rivet-holes, find the maximum flange intensities of stress under a uniformly distributed load of 43 tons. Also find the uniformly distributed rolling load which will increase these intensities by two tons.

Ans. .786 ton per sq. in. in compression; .9475 ton per sq. in. in tension; $55\frac{2}{7}$ tons to increase compression; $59\frac{8000}{17248}$ tons to increase tension.

93. A lattice-girder of 80 ft. span and 8 ft. deep is designed to carry a dead load of 60 tons and a live load of 120 tons uniformly distributed; at the centre the net sectional area of the bottom flange is 45 sq. in., and the gross sectional area of the top flange $56\frac{1}{2}$ sq. in. Find the position of the neutral axis and the maximum flange intensities of stress. If the live load travels at 60 miles an hour, what will be the increased pressure due to centrifugal force?

Ans. 3.546 ft. from top; 1120 lbs. per sq. in.; 8920.35 lbs. per sq. in.; $\frac{594000}{EI}$ lbs.

94. Determine the thickness of the metal in a cast-iron beam of 12 ft. span and 8 in. deep which has to carry a uniformly distributed load of 4000 lbs., the section being (a) a hollow square; (b) a circular annulus. The coefficient of working strength = 3000 lbs. per sq. in. Also find the limiting safe span of the beam under its own weight.

Ans. Neglecting weight of beam, (a) .317 in.; (b) .599 in. Taking weight of beam into account, (a) .354 in.; (b) .727 in. Limiting span = 39.53 ft. in (a) and = 32.7 ft. in (b).

95. Determine suitable dimensions for a cast-iron beam 20 in. deep, at a section subjected to a bending moment of 1200 in.-tons; the coefficients of strength per square inch being 2 tons for tension and 8 tons for compression. Take thickness of web = $\frac{1}{8}$ in.

Ans. Sectional area of tension flange = 36 sq. in.; of compression flange = 24 sq. in.

96. The thickness of the web of an equal-flanged I-beam is a certain fraction of the depth. Show that the greatest economy of material is realized when the area of the web is equal to the joint area of the flanges, and that the moment of resistance to bending is $\frac{1}{2}fAd$, f being the coefficient of strength, A the total sectional area, and d the depth.

97. In a double-flanged cast-iron beam the thickness of the web is a certain fraction of the depth, and the maximum tensile and compressive intensities of stress are in the ratio of 2 to 5. Show that the greatest economy of material is realized when the areas of the bottom flange, web, and top flange are in the ratio of 25 to 20 to 4, and that the moment of resistance to bending is $\frac{1}{2}fAd$, where $f = \frac{1}{2}$ maximum tensile intensity of stress.

98. Apply the results in the preceding question to determine the dimensions of a cast-iron beam at a section whose moment of resistance is 800 in.-tons and whose depth is 18 in., taking 2 tons per square inch as the maximum tensile intensity of stress.

Ans. $a_1 = \frac{5}{8}$ sq. in.; $A' = \frac{5}{2}$ sq. in.; $a_2 = \frac{3}{4}$ sq. in.

99. Determine suitable dimensions for a cast-iron girder of 20 ft. span and 24 in. deep, carrying a load of 30,000 lbs. at the centre, the coefficients of working strength in tension and compression being respectively 2000 and 5000 lbs. per square inch.

Ans. $a_1 = 1\frac{1}{8}$ sq. in.; $A' = 2\frac{3}{4}$ sq. in.; $a_2 = \frac{1}{2}$ sq. in.

100. A cast-iron girder of 25 ft. span has a bottom flange of 36 sq. in. sectional area. Find the most economic arrangement of material for the web and top flange which will enable the beam to carry a load of 18,900 lbs. at 10 ft. from one end, the tensile and compressive working strengths being 2000 and 5000 lbs. per sq. in., respectively. Assume that the thickness of the web is a fraction of its depth.

Ans. Depth = $21\frac{1}{4}$ in.; area of web = 28.8 sq. in.; area of top flange = 5.76 sq. in.

101. A double-flanged cast-iron girder has a sectional area of x sq. in.; the web is 1 in. thick and 21 in. deep; the moment of resistance of the section is 100,950 ft.-lbs.; the coefficients of strength are 2100 lbs. per square inch in tension and 5250 lbs. in compression. Find x , the position of the neutral axis, and the areas of the two flanges.

Ans. $a_1 = 29\frac{1}{8}$ sq. in.; $a_2 = 51\frac{1}{8}$ sq. in.

102. Determine the moment of resistance to bending of a section of a beam in which the top flange is composed of *two* 340-mm. \times 12-mm. plates and *one* 340-mm. \times 10-mm. plate, and the bottom flange of *one* 340-mm. \times 10-mm. plate and *one* 340-mm. \times 8-mm. plate, the flanges being riveted to a 1.4-m. \times 7-mm. web plate by means of four 100-mm. \times 100-mm. \times 8-mm. angle-irons. The coefficient of strength = 6 k. per mm.².

103. Compare the moments of resistance to bending of the section in the preceding question and of a section in which *three* 400-mm. \times 15-mm. plates are substituted for the top flange, and *one* 400-mm. \times 15-mm. plate is substituted for the bottom flange.

104. Floor-beams 4.4 m. between bearings and spaced 2.548 m. c. to c. have a section composed of two equal flanges, each consisting of two 85-mm. \times 85-mm. \times 12-mm. angle-irons riveted to a 490-mm. \times 7-mm. web. A weight of 150 k. (due to longitudinals) and a weight of 150 k. (due to rails, etc.), i.e., 300 k. in all, are concentrated at the rail-crossings, and the ties have also to carry a uniformly distributed load of 400 k. due to weight of floor-beam, 4000 k. due to weight of platform, and 4000 k. per square metre of platform due to *proof*-load. Find the moment of resistance to bending and the maximum flange intensities of stress.

Ans. $I = .000438584615$.

105. The section of a beam is in the form of an isosceles triangle with its base horizontal. Show that the moment of resistance to bending of the strongest trapezoidal beam that can be cut from it is very nearly $\frac{1}{24} f b d^2$, b being the width of the base and d the depth of the triangle.

106. Taking f_t, f_c as the tensile and compressive intensities of stress, find the moment of resistance to bending of a section consisting of a 20*t*-in. \times 7*t*-in. top flange, an 80*t*-in. \times 10*t*-in. bottom flange, and a trapezoidal web 4*t* in. thick at the top, 8*t* in. thick at the bottom, and 120*t* in. deep. Also compare the *maximum* and *average* intensities of shear.

107. Each of the flanges of a girder is a 350-mm. by 10-mm. plate and is riveted to a 1.8-m. by 8-mm. web by means of two 100-mm. by 100-mm. by 12-mm. angle-irons. Determine the moment of resistance to bending, the coefficient of strength being 6 k. per square millimetre,

(a) disregarding the weakening effect of riveting; (b) assuming that the flange-plates are riveted to the angles by 20-mm. rivets.

Ans. (a) 108661.04 km.

108. The cross-tie for a single-track bridge is 4.1 m. between bearings, the gauge of the rails being 1.51 m.; each of the flanges is composed of a 148-mm. by 8-mm. plate riveted to a 550-mm. by 8-mm. web by means of two 70-mm. by 70-mm. by 9-mm. angle-irons; a load of 296 k. (weight of rails, etc.) is concentrated at each rail-crossing. What uniformly distributed load will the tie safely bear, the metal's coefficient of strength being 6 k. per square millimetre? The load actually distributed over the tie is 19782 k. Find the maximum intensity of stress.

Ans. 24162 k.; 4.94 k. per sq. mm.

109. Design a longitudinal of .45 m. depth which is to be supported at intervals of 3.3 m. and to carry at its middle point a weight of 7000 k., the coefficient of strength being 5 k. per square millimetre.

Ans. $I = 259.875$, and the I of a section with two equal flanges, each composed of two 70-mm. by 70-mm. by 9-mm. angle-irons riveted to a 450-mm. by 8-mm. web is 259.536.

110. Find the moment of resistance of a section composed of two equal flanges, each consisting of two 600-mm. \times 7-mm. plates riveted to a 1200-mm. \times 8-mm. web plate by means of two 100-mm. \times 100-mm. \times 12-mm. angle-irons; two 70-mm. \times 70-mm. \times 9-mm. angles are also riveted to the lower faces of the flanges, the ends of the horizontal arms being 24 mm. from the outside edges of the flanges; the total depth of the section = 3.228 m., and the interval between the two web plates, which is *open*, is 2 m.; coefficient of strength = 6 k. per mm.².

Ans. $I = .093929232444$ and moment = 349179.3018 km.

111. A longitudinal 2.548 m. between bearings consists of two equal flanges, each composed of two 70-mm. \times 70-mm. \times 9-mm. angle-irons riveted to a 350-mm. \times 7-mm. web plate. Find the flange intensity of stress under a maximum load of 7000 k. at the centre.

Ans. $I = .000139284508$; stress = 5.6 k. per mm.².

112. A cross-tie resting upon supports at the ends and 2.26 m. between bearings is composed of two equal flanges, consisting of two 70-mm. \times 70-mm. \times 9-mm. angle-irons riveted at the top to a 450-mm. \times 7-mm. web plate and at the bottom to a 300-mm. \times 7-mm. web plate, the interval between the web plates, which is open, being 2.55 m.; the tie is designed to carry a uniformly distributed load of 676 k. per lineal metre of its length, and also a load of 11644.8 k. at each of the points distant .375 m. from the bearing. Find the position of the neutral axis and the *maximum* flange stresses.

Ans. 1.516 m. from top flange; $I = .023194564198$; maximum B. M. = 4815.8161 km.; maximum tensile stress = .37 k. per mm.²; maximum compressive stress = .314 k. per mm.².

tra
cen
wh

bear
to c
the t
angle
upon
whee
the c
unifor

115
cross-t
being 7
betwe
consist
due to
is that
wheel l
wheels,
strength

116.
and is m
wide \times 1
distance
ment of r
efficient c

117. T
flanges, ea
riveted to
carries 19,
proof load
etc.) conce
point. As
find the m

N.B.—?

113. Find the maximum concentrated load on a cross-tie for a single track due to a six-wheel locomotive, the wheels being 2.3 m. centre to centre, the ties being 3.2 m. centre to centre, and the weight on each wheel being 7000 k.

Ans. 10937.5 k.

114. The floor-beams for a double-track bridge are 8.3 m. between bearings and are spaced 2.58 m. centre to centre. The distance, centre to centre, between track-rails is 1.5 m., and between inside rails is 2 m.; the tie has equal flanges, each consisting of two 90-mm. x 90-mm. x 9-mm. angle-irons riveted to a 900-mm. x 7-mm. web; the maximum live load upon the tie is that due to a weight of 3000 k. upon each of the six wheels of two locomotives, the wheels being 2.4 m. centre to centre. If the coefficient of working strength is $5\frac{1}{2}$ k. per square millimetre, what uniformly distributed load will the tie carry?

Ans. 3730 k.

115. Determine the safe value of the moment of inertia (I) of a cross-tie for a double-track bridge; the length of the tie between bearings being 7.624 m., its depth .6 m., the gauge of the rails 1.5 m., the distance between inside rails 2 m. The uniformly distributed load upon a tie consists of 850 k. per square metre due to platform, etc., and of 1800 k. due to weight of tie; the ties are 3.584 m. centre to centre; the live load is that due to a weight of 7000 k. upon each of the centre wheels of a six-wheel locomotive and a weight of 6000 k. upon each of the front and rear wheels, the wheels being 2.4 m. centre to centre; the safe coefficient of strength = 6 k. per square millimetre.

116. The upper chord of a Howe truss is 24 in. wide x 12 in. deep and is made up of four 12-in. x 6-in. timbers; the lower chord is 24 in. wide x 16 in. deep and is made up of four 16-in. x 6-in. timbers; the distance between the inner faces of the chords is 24 ft. Find the moment of resistance to bending, taking 800 lbs. per square inch as the coefficient of tensile strength, and neglecting the effect of the web.

Ans. Neutral axis is $137\frac{1}{2}$ in. from bottom face of lower chord; moment = 87441616 in.-lbs.

117. The cross-ties of a single-track bridge consist of two equal flanges, each composed of two 70-mm. x 70 mm. x 9 mm. angle-irons riveted to a 650-mm. x 7-mm. web; the ties are 4.1 m. long, and each carries 19,146 k. (viz., 384 k. for ties, 2762 k. for platform, and 16,000 k. for proof load) uniformly distributed and 635 k. (due to longitudinals, rails, etc.) concentrated at each rail-crossing, i.e., at 755 mm. from the middle point. Assuming that the cross-ties are merely supported at the ends, find the maximum intensity of stress.

Ans. 5.7552 k. per mm.²; $\frac{I}{c} = .0018423$.

N.B.—The fixture of the ends approximately doubles the strength.

118. The longitudinals of the bridge in the last question consist of two pairs of 70-mm. \times 70-mm. \times 9-mm. angle-irons riveted to a 4 m. \times 7 mm. web; the cross-ties are 3.2 m. centre to centre. Determine the maximum intensity of stress due to a load of 7000 k. concentrated on the longitudinal half-way between the cross-ties, assuming that it is an independent girder. What would the stress be if the ties were 3 m. centre to centre?

$$\text{Ans. } \frac{I}{c} = .00095458; 5,866 \text{ k. per mm.}^2; 5,4994 \text{ k. per mm.}^2$$

119. The section for the Estressol bridge cross-ties is the same as that for the Grande Baise (Ex. 117) bridge ties; the load at each rail-crossing is 335 k., and the uniformly distributed load is 18,062 k. Find the maximum intensity of stress in the flanges, assuming that the ties are merely supported at the ends.

$$\text{Ans. } 5.26 \text{ k. per mm.}^2$$

120. In a rolled joist the sum of the two flange areas and the web area is a constant quantity. Find the proportion between them which will give a joist of maximum strength, the thickness of the web being fixed by practical considerations.

$$\text{Ans. Flange area} = \frac{2}{3} \text{ web area.}$$

121. An aqueduct for a span of 20 ft. consists of a cast-iron channel-beam 30 in. wide and 20 in. deep. Find the thickness of the metal so that the water may safely rise to the top of the channel, the safe coefficient of strength being 1 ton per square inch. Find the safe limiting span of the channel under its own weight.

122. A rolled beam with equal flanges and a web whose section is equal to the joint section of the flanges has a span of 24 ft. and carries a weight of 8 tons at the centre. If the stiffness is .001 and if the coefficient of strength per square inch is 5 tons, find the depth of the beam and the web and flange sectional areas. $E = 15,000$ tons.

$$\text{Ans. } 24 \text{ in.}; \text{ area of flange} = 3.66 \text{ sq. in.}; \text{ of web} = 7.33 \text{ sq. in.}$$

123. A wrought-iron beam of I-section, 20 ft. between supports, carries a uniformly distributed load of 4000 lbs. and deflects .1 in.; the effective depth = 8 in.; $E = 30,000,000$ lbs.; web area = joint area of the equal flanges. Find the total sectional area. Also find the width of a rectangular section 8 in. deep which might be substituted for the above.

$$\text{Ans. } I = 288; \text{ area} = 27 \text{ sq. in.}; \text{ width} = 6\frac{1}{2} \text{ in.}$$

124. A cast-iron beam of an inverted T-section has a uniform depth of 20 in. and is 22 ft. between supports; the flange is 12 in. wide and 1.2 in. thick; the web is 1 in. thick; the load upon the beam is 450 lbs. per lineal foot; $E = 17,000,000$ lbs. Find the deflection of the centre, the moment of resistance to bending, the maximum tensile and compressive intensities of stress, and the position of the neutral axis. Why is the flange placed downwards?

$$\text{Ans. } .122 \text{ in.}; 326,700 \text{ in.-lbs.}; 1492 \text{ lbs. and } 3274 \text{ lbs. per sq. in.}; 5.062 \text{ in. from flange surface.}$$

125. Find the sectional area of a wrought-iron beam of T-section which may be substituted for the cast-iron beam in the preceding question, the depth being the same and the coefficients of strength per square inch being 3 tons in compression and 5 tons in tension. Why should the flange be uppermost? What should the total sectional area be if the flange and web are of equal area?

126. A cast-iron girder 139 in. between supports and 10 in. deep had a top flange $2\frac{1}{2}$ in. \times $\frac{7}{8}$ in., a bottom flange 10 in. \times $1\frac{1}{4}$ in., and a web $\frac{3}{4}$ in. thick. The girder failed under loads of $17\frac{1}{2}$ tons placed at the two points distant $3\frac{3}{4}$ ft. from each support. What were the central flange stresses at the moment of rupture? What was the central deflection when the load at each point was $7\frac{1}{2}$ tons? ($E = 18,000,000$ lbs.; weight of girder = 3368 lbs.; ton = 2240 lbs.)

Ans. 182251.9 lbs. = total flange stress; unit flange stresses = 14,580, and 41,657 lbs. per sq. in.; deflection = .35".

127. A cylindrical beam of 2 in. diameter, 60 in. in length, and weighing $\frac{1}{4}$ lb. per cubic inch, deflects $\frac{3}{16}$ in. under a weight of 3000 lbs. at the centre. Find E .

Ans. $E = 21,645,511$ lbs.

CHAPTER VII.

ON THE TRANSVERSE STRENGTH OF BEAMS.—*Continued.*

I. General Equations.—The girder OA of length l carries a load of which the intensity varies *continuously* and is p at a point K distant x from O .

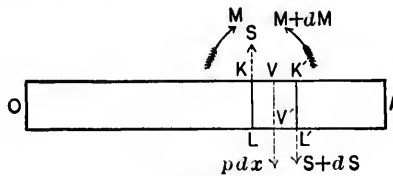

FIG. 310.

Consider the conditions of equilibrium of a slice of the girder bounded by the vertical planes KL , $K'L'$, of which the abscissæ are x , $x + dx$, respectively.

The load between these planes may, without sensible error, be supposed to be uniformly distributed, and its resultant pdx therefore acts along the centre line VV' .

The forces acting upon the slice at the plane KL are equivalent to an *upward* shearing force S , and a *right-handed* couple of which the moment is M , while the forces acting upon the slice at the plane $K'L'$ are equivalent to a *downward* shearing force $S + dS$, and a *left-handed* couple of which the moment is $M + dM$.

Since there is to be equilibrium,

$$S - (S + dS) - pdx = \text{the algebraic sum of the vertical forces} = 0.$$

$$\therefore \frac{dS}{dx} + p = 0. \quad \dots \dots \dots (a)$$

And, $M - (M + dM) + S\frac{dx}{2} + (S + dS)\frac{dx}{2} =$ the algebraic sum of the moments of the forces with respect to V or $V' = 0$.

$$\therefore \frac{dM}{dx} - S = 0. \dots \dots \dots (b)$$

The term $\frac{dS \cdot dx}{2}$ is disregarded, being indefinitely small as compared with the remaining terms.

Equations (a) and (b) are the general equations applicable to girders carrying loads of which the intensity is constant or varies *continuously*. Their integration is easy, and introduces two arbitrary constants which are to be determined in each particular case.

Cor. 1. From equations (a) and (b),

$$\frac{d^2 M}{dx^2} = \frac{dS}{dx} = -p.$$

Let $p = wf(x)$, w being a constant, and $f(x)$ some function of x . Then

$$\frac{dM}{dx} = c_1 - w \int_0^x f(x) dx,$$

and

$$M = c_2 + c_1 x - w \int_0^x \int_0^x f(x) dx^2,$$

c_1 and c_2 being the constants of integration, and 0 and x the limits.

EXAMPLE.—Let the girder rest upon two supports and carry a uniformly distributed load of intensity w . Then

$$\frac{dM}{dx} = c_1 - \int_0^x w_1 dx = c_1 - w_1 x,$$

and

$$M = c_2 + c_1 x - w_1 \frac{x^2}{2}.$$

But M is zero when $x = 0$ and also when $x = l$. Hence

$$c_2 = 0 \quad \text{and} \quad c_1 = \frac{w_1 l}{2}.$$

Therefore,

$$M = \frac{w_1 l}{2} x - \frac{w_1}{2} x^2,$$

and

$$S = \frac{dM}{dx} = \frac{w_1 l}{2} - w_1 x.$$

Cor. 2. The bending moment is a maximum at the point defined by $\frac{dM}{dx} = 0 = S$, i.e., at a point at which the shearing force vanishes.

In the preceding example, the position of the maximum bending moment is given by $S = 0 = \frac{w_1 l}{2} - w_1 x$, or $x = \frac{l}{2}$, and its corresponding value is $\frac{w_1 l}{2} \cdot \frac{l}{2} - \frac{w_1 l^2}{2 \cdot 4} = \frac{w_1 l^2}{8}$.

The shearing force is greatest and equal to $\frac{w_1 l}{2}$ when $x = 0$.

Cor. 3. Suppose that the load, instead of varying continuously, consists of a number of finite weights at isolated points.

By reason of the discontinuity of the loading, the general equations can only be integrated between consecutive points.

Let N_r, N_{r+1} , be any two such points, of abscissæ x_r, x_{r+1} , respectively.

Between these points equations (a) and (b) become

$$\frac{dS}{dx} = 0, \quad \text{and} \quad \frac{dM}{dx} = S.$$

$\therefore S = \text{a constant} = S_r$, suppose, between N_r and N_{r+1} .

Hence, $\frac{dM}{dx} = S_r$, and $M = S_r x + c$, between N_r and N_{r+1} , c being a constant of integration.

Let $M = M_r$ when $x = x_r$. Then

$$c = M_r - S_r x_r, \text{ and } M = S_r(x - x_r) + M_r.$$

Also, if $M = M_{r+1}$ when $x = x_{r+1}$,

$$M_{r+1} = S_r(x_{r+1} - x_r) + M_r.$$

The terminal conditions will give additional equations, by means of which the solution may be completed:

EXAMPLE.—The girder OA , of length l , rests upon two supports at O, A , and carries weights P_1, P_2 , at points B, C ,

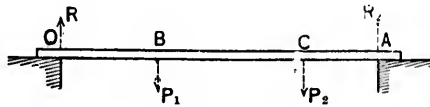

FIG. 312.

dividing the girder into three segments, OB, BC, CA , of which the lengths are r, s, t , respectively.

$$\text{The reaction } R_1 \text{ at } O = \frac{P_1(s+t) + P_2 t}{l}.$$

$$\text{The reaction } R_2 \text{ at } A = \frac{P_1 r + P_2(r+s)}{l}.$$

Between O and B , S is constant $= S_r$ suppose, $= R_1$.

$$\therefore M = S_r x.$$

there being no constant of integration, as $M = 0$ when $x = 0$.

Also, when $x = r$, $M = S_r r$.

Between B and C , S is constant = S_1 suppose, = $R_1 - P_1$.

$$\therefore M = S_1x + c',$$

c' being the constant of integration.

But $M = S_1r$ when $x = r$.

$$\therefore c' = (S_1 - S_2)r, \text{ and } M = S_2x + (S_1 - S_2)r.$$

Also, when $x = r + s$, $M = S_2s + S_1r$.

Between C and A , S is constant = S_2 suppose, = $R_1 - P_1 - P_2$,
and hence

$$M = S_2x + c'',$$

c'' being the constant of integration.

But $M = S_2s + S_1r$ when $x = r + s$.

$$\therefore c'' = S_2s + S_1r - S_2(r + s),$$

and

$$M = S_2x + S_2s + S_1r - S_2(r + s).$$

Hence, at A , $0 = S_2l + S_2s + S_1r$.

Cor. 4. The equation $\frac{dM}{dx} = S$ indicates that the shearing force at a vertical section of a girder is the increment of the bending moment at that section per unit of length, and is an important relation in calculating the number of rivets required for flange and web connections.

2. On the Interpretation of the General Equations.—The bending moment M at any transverse section of a girder may be obtained from the equation $M = \frac{EI}{R}$, R being the

radius of curvature of the neutral axis at the section under consideration.

Let OA , in Figs. 313 and 314, represent a portion of the neutral axis of a bent girder.

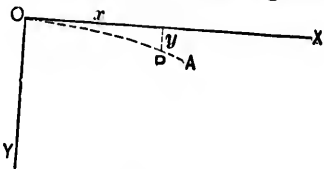

FIG. 313

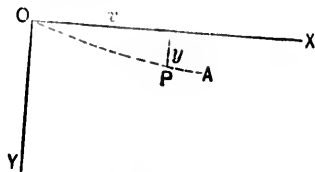

FIG. 314.

Take O as the origin, the horizontal line OX as the axis of x , and the line OY drawn vertically downwards as the axis of y . Let x, y be the co-ordinates of any point P in the neutral axis.

If R is the radius of curvature at P , then

$$\frac{1}{R} = \pm \frac{\frac{d^2y}{dx^2}}{\left\{1 + \left(\frac{dy}{dx}\right)^2\right\}^{\frac{3}{2}}} = \pm \cos \theta \frac{d\theta}{dx};$$

the sign being $+$ or $-$ according as the girder is bent as in Fig. 313 or as in Fig. 314, and θ being the angle between the tangent at P and OX .

Now, $\frac{dy}{dx}$ is the tangent of the angle which the tangent line at P to the neutral axis makes with OX , and the angle is always very small. Thus, $\frac{dy}{dx}$ is also very small, and squares and higher powers of $\frac{dy}{dx}$ may be disregarded without serious error. Hence,

$$\frac{1}{R} = \pm \frac{d^2y}{dx^2}, \text{ approximately,}$$

and the bending-moment equation becomes

$$M = \pm EI \frac{d^2y}{dx^2}.$$

The integration of this equation introduces two arbitrary constants, of which the values are to be determined from given conditions. At the point or points of support, for example, the neutral axis may be horizontal or may slope at a given angle.

Let θ be the slope at P . Since θ is generally very small,

$$\theta = \tan \theta, \text{ approximately,}$$

and hence

$$M = \pm EI \frac{d^2 y}{dx^2} = \pm EI \frac{d\theta}{dx},$$

or

$$\frac{d^2 y}{dx^2} = \frac{d\theta}{dx} = \pm \frac{M}{EI} \dots \dots \dots (A)$$

From this last equation

$$\theta = \pm \frac{1}{EI} \int M dx,$$

and the *change of slope* between any given limits is represented by the corresponding area of the bending moment curve.

Also, since $\frac{dy}{dx} = \theta$, $y = \int \theta dx$,

and the deflection is measured by the area of a curve representing the slope at each point.

Again, by Art. 1,

$$\frac{d^2 M}{dx^2} = \frac{dS}{dx} = -p \dots \dots \dots (B)$$

Comparing eqs. (A) and (B), it will be observed that y , θ , and $\frac{M}{EI}$, i.e., the deflection, slope, and bending moment, are connected with one another in precisely the same manner

as M , S , and p , i.e., the bending moment, shearing force, and load. Thus, the mutual relations between curves drawn to represent the *deflection*, *slope*, and *bending moment* must be the same, *mutatis mutandis*, as those between the curves of bending moment, shearing force, and load.

For example, divide the *effective* bending-moment area into a number of elementary areas by drawing vertical lines at convenient distances apart, and suppose these elementary areas to represent weights. Two reciprocal figures connecting y , θ , and M may now be drawn exactly as described in Chap. I, and it at once follows that—

(a) Any two sides of the funicular polygon, or, in the limit (when the widths of the elementary areas are indefinitely diminished), any two tangents to the funicular or *deflection* curve, meet in a point which is vertically below the centre of gravity of the corresponding *effective* moment area.

(b) The segments $1H$, nH into which the line of weights is divided by drawing OH parallel to the closing line CD , give the slopes ($= \sum Mdx$) at the supports.

N.B.—In the case of a semi-girder, the last side of a polygon is the closing line, and $1n$ gives the total change of slope.

(c) If the polar distance is made equal to EI , the intercept between the closing line and the funicular or *deflection* curve measures the deflection.

3. Examples of the Form assumed by the Neutral Axis of a Loaded Beam.

EXAMPLE I. A semi-girder fixed at one end O so that the neutral axis at that point is horizontal carries a weight W at the other end A . At any point (x, y) of the neutral axis

$$+EI \frac{d^2y}{dx^2} = W(l - x). \quad \dots (A)$$

Integrating,

$$EI \frac{dy}{dx} = W \left(lx - \frac{x^2}{2} \right) + c_1,$$

c_1 being a constant of integration. But the girder is fixed at O , so that the inclination of the neutral

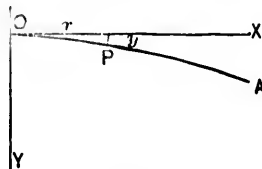

FIG. 315.

axis to the horizon at this point is zero, and thus, when $x = 0$, $\frac{dy}{dx}$ is 0, and therefore $c_1 = 0$.

Hence,

$$EI \frac{dy}{dx} = W \left(Lx - \frac{x^3}{2} \right). \quad \dots \quad (B)$$

Integrating,

$$EIy = W \left(L \frac{x^2}{2} - \frac{x^4}{6} \right) + c_2,$$

c_2 being a constant of integration. But $y = 0$ when $x = 0$, and therefore $c_2 = 0$.

Hence,

$$EIy = W \left(L \frac{x^2}{2} - \frac{x^4}{6} \right). \quad \dots \quad (C)$$

Equation (B) gives the value of $\frac{dy}{dx}$, i.e., the *slope*, at any point of which the abscissa is x .

Equation (C) defines the curve assumed by the neutral axis, and gives the value of y , i.e., the *deflection*, corresponding to any abscissa x .

Let α , be the slope, and d , the deflection at A .

From (B),

$$\tan \alpha = \frac{1}{2} \frac{W L^2}{E I};$$

and from (C),

$$d = \frac{1}{3} \frac{W L^3}{E I}.$$

EX. 2. A semi-girder fixed at one end O carries a uniformly distributed load of intensity w .

At any point $P(x, y)$ of the neutral axis,

$$+ EI \frac{d^2y}{dx^2} = \frac{w}{2}(l-x)^2$$

$$= \frac{w}{2}(l^2 - 2lx + x^2). \quad (A)$$

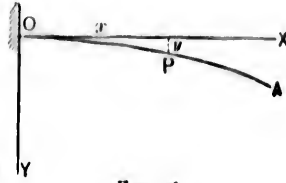

FIG. 316.

Integrating,

$$+ EI \frac{dy}{dx} = \frac{w}{2} \left(l^2x - lx^2 + \frac{x^3}{3} \right) + c_1,$$

c_1 being a constant of integration.

But $\frac{dy}{dx} = 0$ when $x = 0$, and therefore $c_1 = 0$. Hence,

$$EI \frac{dy}{dx} = \frac{w}{2} \left(l^2x - lx^2 + \frac{x^3}{3} \right) \dots \dots \dots (B)$$

Integrating,

$$EIy = \frac{w}{2} \left(l^2 \frac{x^2}{2} - l \frac{x^3}{3} + \frac{x^4}{12} \right) + c_2,$$

c_2 being a constant of integration.

But $y = 0$ when $x = 0$, and therefore $c_2 = 0$. Hence,

$$EIy = \frac{w}{2} \left(l^2 \frac{x^2}{2} - l \frac{x^3}{3} + \frac{x^4}{12} \right) \dots \dots \dots (C)$$

Let α_1 be the slope and d_2 the deflection at A . Hence, from (B),

$$\tan \alpha_1 = \frac{1}{6} \frac{wl^3}{EI};$$

and from (C),

$$d_2 = \frac{1}{8} \frac{wl^4}{EI}.$$

EX. 3. A semi-girder fixed at one end carries a uniformly distributed load of intensity w , and also a single weight W at the free end. This is merely a combination of Examples 1 and 2, and the resulting equations are:

$$EI \frac{d^2y}{dx^2} = W(l-x) + \frac{w}{2}(l-x)^2. \quad \dots \quad (A)$$

$$EI \frac{d^3y}{dx^3} = W \left(lx - \frac{x^2}{2} \right) + w \left(lx - lx^2 + \frac{x^3}{3} \right). \quad \dots \quad (B)$$

$$EIy = W \left(l \frac{x^2}{2} - \frac{x^3}{6} \right) + \frac{w}{2} \left(l \frac{x^3}{2} - l \frac{x^4}{3} + \frac{x^5}{12} \right). \quad \dots \quad (C)$$

Also, if A is the slope and D the deflection at the free end,—from (B),

$$\tan A = \frac{1}{EI} \left(\frac{Wl^2}{2} + \frac{wl^3}{6} \right) = \tan \alpha_1 + \tan \alpha_2;$$

and from (C),

$$D = \frac{1}{EI} \left(\frac{Wl^3}{3} + \frac{wl^4}{8} \right) = d_1 + d_2.$$

Cor.—The slope (α) and deflection (d) of an arbitrarily loaded semi-girder may be determined in the manner described in Art. 2.

Let F be the area of the bending-moment curve. Its centre of gravity is at the same horizontal distance \bar{x} from the vertical through A as the point T in which the tangent at A intersects OX .

$$\therefore \frac{F}{EI} = \alpha = \text{angle } ATX = \frac{d}{\bar{x}}.$$

In Ex. 3, e.g.,

$$F = Wl \frac{l}{2} + \frac{1}{3} \frac{wl^3}{2} l,$$

and

$$F\bar{x} = \frac{Wl^2}{2} \frac{2}{3} l + \frac{wl^3}{6} \frac{3}{4} l = EId.$$

Note.—If the semi-girder in the three preceding examples is only *partially* fixed at *O*, so that the neutral axis, instead of being horizontal at the support, slopes at an angle θ , then

when $x = 0$, $\frac{dy}{dx} = \tan \theta$, and the constant of integration, c_1 , is also $EI \tan \theta$. Thus, the left-hand side of eqs. (B) and (C), respectively, become

$$EI \left(\frac{dy}{dx} - \tan \theta \right) \quad \text{and} \quad EI(y - x \tan \theta).$$

EX. 4. The girder *OA* rests upon two supports at *O*, *A*, and carries a weight *W* at the centre.

The neutral axis is evidently symmetrical with respect to the middle point *C*, and at any point *P* (x, y) between *O* and *C*,

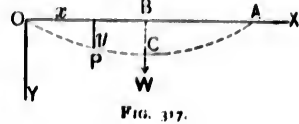

$$-EI \frac{d^2y}{dx^2} = \frac{W}{2}x. \quad \dots \dots \dots (A)$$

Integrating,

$$-EI \frac{dy}{dx} = \frac{W}{4}x^2 + c_1,$$

c_1 being a constant of integration.

But the tangent to the neutral axis at *C* must be horizontal, so that when $x = \frac{l}{2}$, $\frac{dy}{dx} = 0$, and therefore $c_1 = -\frac{Wl^2}{16}$.

Hence,

$$-EI \frac{dy}{dx} = \frac{W}{4}x^2 - \frac{Wl^2}{16}. \quad \dots \dots \dots (B)$$

Integrating,

$$-Efy = \frac{W}{12}x^3 - \frac{Wl^2}{16}x + c_2,$$

c_2 being a constant of integration.

But $y = 0$ when $x = 0$, and therefore $c_1 = 0$. Hence

$$-EIy = \frac{W}{12}x^3 - \frac{Wl^2}{16}x. \dots \dots (C)$$

Cor.—Let α_1 be the slope at O , and d_1 the deflection at the centre. Then,

$$\text{from (B), } \tan \alpha_1 = \frac{1}{16} \frac{Wl^2}{EI}; \text{ and from (C), } d_1 = \frac{1}{48} \frac{Wl^3}{EI}.$$

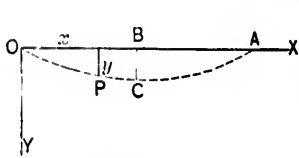

FIG. 318.

Ex. 5. The girder OA rests upon supports at O, A , and carries a uniformly distributed load of intensity w .

At any point $P(x, y)$ of the neutral axis,

$$-EI \frac{d^2y}{dx^2} = \frac{wl}{2}x - \frac{wx^2}{2} \dots \dots (A)$$

Integrating,

$$-EI \frac{dy}{dx} = \frac{wl}{4}x^2 - \frac{wx^3}{6} + c_1,$$

c_1 being a constant of integration.

But $\frac{dy}{dx} = 0$ when $x = \frac{l}{2}$, and therefore $c_1 = -\frac{wl^2}{24}$.

Hence,

$$-EI \frac{dy}{dx} = \frac{wl}{4}x^2 - \frac{wx^3}{6} - \frac{wl^2}{24} \dots \dots (B)$$

Integrating,

$$-EIy = \frac{wl}{12}x^3 - \frac{wx^4}{24} - \frac{wl^2}{24}x + c_2,$$

c_2 being a constant of integration.

But $y = 0$ when $x = 0$, and therefore $c_2 = 0$.

Hence

$$-EIy = \frac{wl}{12}x^3 - \frac{wx^4}{24} - \frac{wl^2}{24}x \dots \dots (C)$$

Let α_2 be the slope at O , and d_2 the deflection at the centre. Then,

$$\text{from (B), } \tan \alpha_2 = \frac{1}{24} \frac{\omega l^3}{EI}; \text{ and from (C), } d_2 = \frac{5}{384} \frac{\omega l^4}{EI}.$$

EX. 6. A girder rests upon two supports and carries a uniformly distributed load of intensity ω , together with a single weight W at the centre. This is merely a combination of Examples 4 and 5, and the resulting equations are:

$$-EI \frac{d^2y}{dx^2} = \frac{W}{2}x + \frac{\omega l}{2}x - \frac{\omega x^2}{2}, \dots \dots \dots \text{(A)}$$

$$-EI \frac{dy}{dx} = \frac{W}{4}x^2 - \frac{W}{16}l^2 + \frac{\omega l}{4}x^2 - \frac{\omega x^3}{6} - \frac{\omega l^3}{24}, \dots \text{(B)}$$

and

$$-EIy = \frac{W}{12}x^3 - \frac{W}{16}l^2x + \frac{\omega l}{12}x^3 - \frac{\omega x^4}{24} - \frac{\omega l^3}{24}x. \text{ (C)}$$

Also, if A is the slope at the origin, and D the central deflection, we have, from (B),

$$\tan A = \frac{1}{EI} \left(\frac{Wl^2}{16} + \frac{\omega l^3}{24} \right) = \tan \alpha_1 + \tan \alpha_2;$$

and from (C),

$$D = \frac{1}{EI} \left(\frac{Wl^3}{48} + \frac{5}{384} \omega l^4 \right) = d_1 + d_2.$$

Cor.—The slope and deflection of an arbitrarily loaded girder resting upon two supports may be determined in the manner described in Art. 2.

Let C be the lowest point of the deflection curve. The tangents at C and O will intersect in a point T which is vertically below the centre of gravity of the bending-moment area corresponding to OC .

Denote this area by F and the horizontal distance of centre

of gravity from OY by \bar{x} . Let α be the angle between OT and CT produced. Then

$$\frac{F}{EI} = \alpha = \frac{d}{\bar{x}},$$

d being the maximum deflection.

In Ex. 6, e.g., the girder being symmetrically loaded,

$$F = \frac{1}{2} \frac{Wl}{4} \frac{l}{2} + \frac{2}{3} \frac{wl^3}{8} \frac{l}{2} \quad \text{and} \quad F\bar{x} = \frac{Wl^3}{16} \frac{2}{3} \frac{l}{2} + \frac{wl^4}{24} \frac{5}{8} \frac{l}{2} = EId.$$

EX. 7. Suppose that the end O of the girder in Ex. 5 is *fixed*. The fixture introduces a *left-handed* couple at O ; let its moment be M_1 .

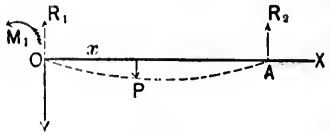

FIG. 319.

Let the reactions at O and A be R_1, R_2 , respectively.

At any point $P(x, y)$ of the

neutral axis,

$$-EI \frac{d^2y}{dx^2} = R_1x - \frac{wx^2}{2} - M_1. \dots \dots (1)$$

But M , i.e., $-EI \frac{d^2y}{dx^2}$, is zero when $x = l$.

$$\therefore 0 = R_1l - \frac{wl^2}{2} - M_1. \dots \dots (2)$$

Integrating eq. (1),

$$-EI \frac{dy}{dx} = R_1 \frac{x^2}{2} - \frac{wx^3}{6} - M_1x. \dots \dots (3)$$

There is no constant of integration, as $\frac{dy}{dx} = 0$ when $x = 0$.

Integrating eq. (3),

$$-EIy = R_1 \frac{x^3}{6} - \frac{wx^4}{24} - M_1 \frac{x^2}{2}. \dots \dots (4)$$

There is no constant of integration, as x and y vanish together.

But y also vanishes when $x = l$, so that

$$0 = R_1 \frac{l^3}{6} - \frac{wl^4}{24} - M_1 l \dots \dots \dots (5)$$

Hence, by eqs. (2) and (5),

$$M_1 = \frac{wl^2}{8}, \quad R_1 = \frac{5}{8}wl, \quad \text{and so} \quad R_2 = \frac{3}{8}wl \dots (6)$$

Thus, the *bending-moment*, *slope*, and *deflection* equations are, respectively,

$$-EI \frac{d^2y}{dx^2} = \frac{5}{8}wlx - \frac{w}{2}x^2 - \frac{wl^2}{8} = M, \dots (7)$$

$$-EI \frac{dy}{dx} = \frac{5}{10}wlx^2 - \frac{w}{6}x^3 - \frac{wl^2}{8}x, \dots (8)$$

$$-EIy = \frac{5}{48}wlx^3 - \frac{w}{24}x^4 - \frac{wl^2}{16}x^2 \dots (9)$$

Cor. 1. The bending moment is *nil* at points given by

$$M = 0 = \frac{5}{8}wlx - \frac{w}{2}x^2 - \frac{wl^2}{8},$$

i.e., when $x = \frac{l}{4}$ or l . Take $OF = \frac{l}{4}$.

Since $\frac{d^2y}{dx^2} = 0$, F is a point of inflexion.

If the girder is cut through at this point, and a hinge introduced sufficiently strong to transmit the shear ($= \frac{3}{8}wl$), the stability of the girder will not be impaired.

Hence, the girder may be considered as made up of two independent portions, viz.:

(a) A cantilever OF of length $\frac{l}{4}$, carrying a uniformly distributed load of intensity w , together with a weight $\frac{3}{8}wl$ at F .

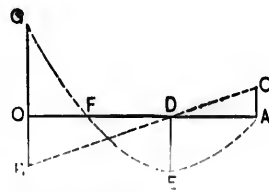

FIG. 320.

The maximum bending moment on OF is at O , and is

$$= \frac{3}{8}wl \frac{l}{4} + \frac{wl}{4} \frac{l}{8} = \frac{wl^2}{8}.$$

(b) A girder FA of length $\frac{3l}{4}$, carrying a uniformly distributed load of intensity w .

The maximum bending moment on FA is at the middle point D , and is $= \frac{w}{8} \left(\frac{3}{4}l \right)^2 = \frac{9wl^2}{128}$.

This result may also be obtained from eq. (7) by putting $\frac{dM}{dx} = 0$. Whence

$$0 = \frac{5}{8}wl - wx, \quad \text{or} \quad x = \frac{5}{8}l,$$

and therefore

$$M_{\max.} = \frac{9}{128}wl^2.$$

The shearing force and bending moment at different points of the girder may be represented graphically as follows:

The shearing force at any point of which the abscissa is x is

$$S = \frac{5}{8}wl - wx.$$

Take OB and AC , respectively equal or proportional to $\frac{5}{8}wl$ and $\frac{3}{8}wl$; join BC . The line BC cuts OA in D , where $OD = \frac{5}{8}l$. The shearing force at any point is represented by the ordinate between that point and the line BC .

The bending moment at the point (x, y) is

$$M = \frac{5}{8}wlx - \frac{w}{2}x^2 - \frac{wl^2}{8}.$$

Take OG , DE , and OF , respectively equal or proportional to $\frac{wl^2}{8}$, $\frac{9}{128}wl^2$, and $\frac{l}{4}$. The bending moment at any point is represented by the ordinate between that point and the parabola passing through G , F , and A , having its vertex at E and its axis vertical.

Cor. 2. The deflection is a maximum when $\frac{dy}{dx} = 0$, i.e., when

$$0 = \frac{5}{16}wlx^2 - \frac{wl}{6}x^3 - \frac{wl^2}{8}x,$$

or at the point given by $x = \frac{l}{16}(15 - \sqrt{33})$.

Substituting this value of x in eq. (9), the corresponding value of y may be obtained.

Ex. 8. If both ends of the girder in Ex. (7) are fixed, the reaction at each support is evidently $\frac{wl}{2}$, and the equation of moments becomes

$$-EI\frac{d^2y}{dx^2} = \frac{wl}{2}x - \frac{wx^2}{2} - M_1, \dots \dots \dots (1)$$

Integrating,

$$-EI\frac{dy}{dx} = \frac{wl}{4}x^2 - \frac{w}{6}x^3 - M_1x, \dots \dots \dots (2)$$

No constant of integration is required, as $\frac{dy}{dx} = 0$ when $x = 0$.

$\frac{dy}{dx}$ is also zero when $x = l$ (also when $x = \frac{l}{2}$).

$$\therefore 0 = \frac{wl^3}{4} - \frac{wl^3}{6} - M_1l,$$

and hence

$$M_1 = \frac{wl^2}{12}, \dots \dots \dots (3)$$

Integrating eq. (2),

$$-EIy = \frac{wl}{12}x^3 - \frac{w}{24}x^4 - \frac{wl^2}{24}x^2, \dots \dots \dots (4)$$

There is no constant of integration, as x and y vanish together.

The central deflection (i.e., when $x = \frac{l}{2}$) = $\frac{1}{384} \frac{wl^4}{EI}$.

If the load, instead of being uniformly distributed, is a weight W concentrated at the centre, then, for *one half* of the girder,

$$-EI \frac{d^2y}{dx^2} = \frac{W}{2}x - M_1. \quad \dots \dots (5)$$

Integrating,

$$-EI \frac{dy}{dx} = \frac{W}{4}x^2 - M_1x. \quad \dots \dots (6)$$

There is no constant of integration, as $\frac{dy}{dx} = 0$ when $x = 0$.

$\frac{dy}{dx}$ is also evidently zero when $x = \frac{l}{2}$, and hence

$$0 = \frac{W}{16}l^2 - M_1 \frac{l}{2}, \quad \text{or} \quad M_1 = \frac{Wl}{8}. \quad \dots \dots (7)$$

Integrating eq. (6),

$$-EIy = \frac{W}{12}x^3 - M_1 \frac{x^2}{2} = \frac{W}{12}x^3 - \frac{Wl}{16}x^2. \quad \dots \dots (8)$$

There is no constant of integration, as x and y vanish together.

$$\text{The central deflection} = \frac{1}{192} \frac{Wl^3}{EI}.$$

4. Supports not in same Horizontal Plane.—In the preceding examples it has been assumed that the ends of the girder are in the same horizontal plane. Suppose that one end, e.g., A , falls below O by an amount y_1 , y_1 being small as compared with l .

The abscissæ of points in the neutral axis are not sensibly changed, but the conditions of integration are altered. Consider Ex. 4.

Between O and C ,

$$-EI \frac{d^2y}{dx^2} = \frac{W}{2}x. \quad \dots \dots (1)$$

Integrating,

$$EI \frac{dy}{dx} = \frac{W}{4}x^3 + c_1, \dots \dots \dots (2)$$

c_1 being a constant of integration.

Integrating again,

$$-EIy = \frac{W}{12}x^3 + c_1x, \dots \dots \dots (3)$$

There is no constant due to the last integration, as x and y vanish together.

Between C and A ,

$$-EI \frac{d^2y}{dx^2} = \frac{W}{2}x - W\left(x - \frac{l}{2}\right) = \frac{W}{2}(l - x), \dots \dots (4)$$

Integrating twice,

$$-EI \frac{dy}{dx} = -\frac{W}{4}(l - x)^2 + c_2, \dots \dots \dots (5)$$

and

$$-EIy = \frac{W}{12}(l - x)^3 + c_2x + c_3, \dots \dots \dots (6)$$

c_2, c_3 being constants of integration.

The tangent at C is no longer horizontal, but makes a definite angle θ with the horizon, so that $\frac{dy}{dx}$ is now $\tan \theta$ when $x = \frac{l}{2}$. Also, the values of $\frac{dy}{dx}$ and y at C , viz., $\tan \theta$ and d , as given by eqs. (2) and (3), must be identical with those given by eqs. (5) and (6), while the value y_1 at A , is given by eq. (6) when $x = l$, is equal to y_1 . Therefore

$$\frac{W}{16}l^2 + c_1 = -EI \tan \theta = -\frac{W}{16}l^2 + c_2,$$

$$\frac{W}{96}l^3 + c_1 \frac{l}{2} = -EId = \frac{W}{96}l^3 + c_2 \frac{l}{2} + c_3,$$

and

$$-EIy_1 = c_2l + c_3$$

Hence,

$$c_1 = -EI\frac{y_1}{l} - \frac{W}{16}l^2, \quad c_2 = -EI\frac{y_1}{l} + \frac{W}{16}l^2, \quad \text{and} \quad c_3 = -\frac{W}{16}l^2,$$

fully defining both halves of the neutral axis

Again, in Ex. 6 it is no longer true that $\frac{dy}{dx} = 0$ when $x = \frac{l}{2}$, but the conditions of integration are $y = 0$ when $x = 0$,

and $y = y_1$ when $x = l$. These, together with $\frac{dy}{dx} = 0$ when $x = 0$, are also the conditions in Ex. 7. Other cases may be similarly treated.

5. To Discuss the Form assumed by the Neutral Axis of a Girder OA which rests upon Supports at O and A, and carries a Weight P at a Point B, distant r from O.

Let OBA be the neutral axis of the deflected girder.



The reactions at O and A are $P\frac{l-r}{l}$ and $P\frac{r}{l}$, respectively.

Let BC, the deflection at C, = d.

FIG. 321.

Let α be the slope of the neutral axis at B.

The portions OB, BA must be treated separately, as the weight at B causes discontinuity in the equation of moments.

First, at any point (x, y) of OB,

$$-EI\frac{d^2y}{dx^2} = P\frac{l-r}{l}x \dots \dots \dots (1)$$

Integrating,

$$-EI\frac{dy}{dx} = P\frac{l-r}{l}\frac{x^2}{2} + c_1$$

c_1 being a constant of integration.

But $\frac{dy}{dx} = \tan \alpha$ when $x = r$, and therefore

$$-EI \tan \alpha = P \frac{l-r}{l} \frac{r^2}{2} + c_1.$$

Hence,

$$-EI \left(\frac{dy}{dx} - \tan \alpha \right) = P \frac{l-r}{l} \left(\frac{x^2}{2} - \frac{r^2}{2} \right). \quad \dots (2)$$

Integrating,

$$-EI(y - x \tan \alpha) = P \frac{l-r}{l} \left(\frac{x^3}{6} - \frac{r^2}{2} x \right). \quad \dots (3)$$

There is no constant of integration, as x and y vanish together.

Also, $y = d$ when $x = r$.

$$\therefore -EI(d - r \tan \alpha) = -P \frac{l-r}{l} \frac{r^2}{3}. \quad \dots (4)$$

In the same manner, if A is taken as the origin, and AB treated as above, equations similar to (1), (2), (3), and (4) will be obtained, and may be at once written down by substituting in these equations $\pi - \alpha$ for α , $P \frac{r}{l}$ for $P \frac{l-r}{l}$, $l-r$ for r , and r for $l-r$.

Thus, the equation corresponding to (4) is

$$-EI\{d - (l-r) \tan(\pi - \alpha)\} = -P \frac{r}{l} \frac{(l-r)^2}{3}. \quad (5)$$

Subtracting (5) from (4),

$$EIl \tan \alpha = \frac{P}{3} r(l-r)(l-2r); \quad \dots (6)$$

and from (4),

$$EId = \frac{P}{3} \frac{r^2(l-r)^2}{l}. \quad \dots (7)$$

Thus, eqs. (2) and (3) become

$$-EI \frac{dy}{dx} = \frac{Pl-r}{2} \frac{x^2}{l} - \frac{Pr}{6l} (l-r)(2l-r), \dots (8)$$

and

$$-EIy = \frac{Pl-r}{6} \frac{x^3}{l} - \frac{Pr}{6l} (l-r)(2l-r)x, \dots (9)$$

the latter being the equation to the portion OB of the neutral axis, and the former giving its slope at any point.

Next, at any point (x, y) of BA ,

$$-EI \frac{d^2y}{dx^2} = P \frac{l-r}{l} x - P(x-r). \dots (10)$$

Integrating,

$$-EI \frac{dy}{dx} = P \frac{l-r}{l} \frac{x^2}{2} - \frac{P}{2} (x-r)^2 + c_1,$$

c_1 being a constant of integration.

But $\frac{dy}{dx} = \tan \alpha$ when $x = r$.

$$\therefore P \frac{l-r}{l} \frac{r^2}{2} + c_1 = -EI \tan \alpha = -\frac{Pr}{3l} (l-r)(l-2r),$$

and

$$c_1 = -\frac{Pl-r}{6} \frac{r}{l} (2l-r).$$

Hence,

$$-EI \frac{dy}{dx} = \frac{Pl-r}{2} \frac{x^2}{l} - \frac{P}{2} (x-r)^2 - \frac{Pr}{6l} (l-r)(2l-r). \quad (11)$$

Integrating,

$$-EIy = \frac{Pl-r}{6} \frac{x^3}{l} - \frac{P}{6} (x-r)^3 - \frac{Pr}{6l} (l-r)(2l-r)x + c_2,$$

c_2 being a constant of integration.

But $y = d$ when $x = r$.

$$\begin{aligned} \therefore \frac{P}{6} \frac{l-r}{l} r^3 - \frac{P}{6} \frac{r}{l} (l-r)(2l-r)r + c, \\ = -EId = -\frac{P}{3} \frac{r^3(l-r)^2}{l}, \end{aligned}$$

and $c = 0$. Hence,

$$-Ely = \frac{P}{6} \frac{l-r}{l} x^3 - \frac{P}{6} (x-r)^3 - \frac{P}{6} \frac{r}{l} (l-r)(2l-r)x, \quad (12)$$

which is the equation to the portion BA of the neutral axis, eq. (11) giving its slope at any point.

In the figure $r < \frac{l}{2}$, and the maximum deflection of the girder will evidently lie between B and A , at a point given by putting $\frac{dy}{dx} = 0$ in eq. (11), which easily reduces to

$$x^2 - 2lx + \frac{2l^2 + r^2}{3} = 0,$$

and therefore

$$x = l - \sqrt{\frac{l^2 - r^2}{3}}$$

is the abscissa of the most deflected point. The corresponding deflection is found by substituting this value of x in eq. (12).

If $r > \frac{l}{2}$, the maximum deflection lies between O and B , at a point determined by putting $\frac{dy}{dx} = 0$ in eq. (8), which then easily reduces to

$$0 = x^2 - \frac{r(2l-r)}{3},$$

from which

$$x = \sqrt{\frac{r(2l-r)}{3}}.$$



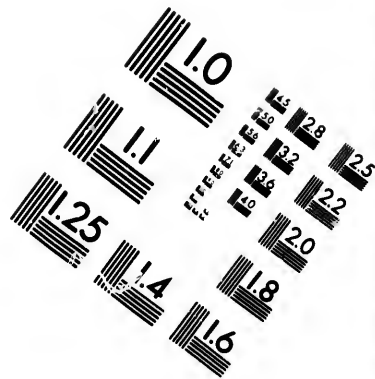
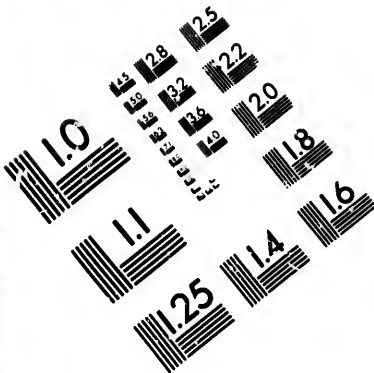

**IMAGE EVALUATION
TEST TARGET (MT-3)**

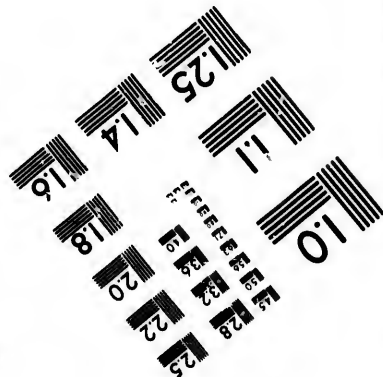
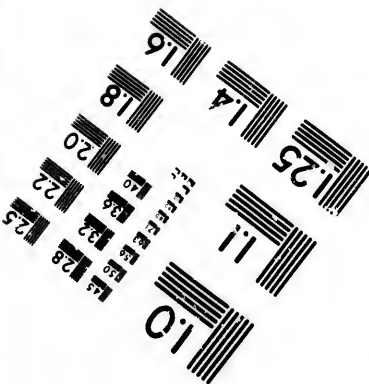
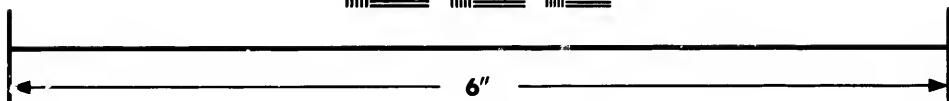
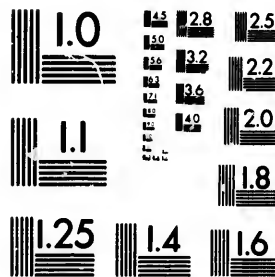

**Photographic
Sciences
Corporation**

23 WEST MAIN STREET
WEBSTER, N.Y. 14580
(716) 872-4503

15
18
22
25
28
32
36
40
45

10
15

Substituting this value of x in eq. (9),

$$\text{the maximum deflection} = \frac{P}{3EI} \frac{l-r}{l} \left(\frac{r(2l-r)}{3} \right)^{\frac{3}{2}}$$

EXAMPLE.— $P = 15,000$ lbs., $l = 100$ ft., $r = 90$ ft.
The distance of most deflected point from O

$$= \sqrt{\frac{90 \times 110}{3}} = 57.44 \text{ ft.},$$

and the maximum deflection

$$= \frac{15000}{3EI} \times \frac{10}{100} \left(\frac{90 \times 110}{3} \right)^{\frac{3}{2}} = \frac{500000}{EI} (33)^{\frac{3}{2}}$$

6. To Discuss the Form of the Neutral Axis of a Girder OA which rests upon Supports at O and A and carries several Weights P_1, P_2, P_3, \dots , at points $1, 2, 3, \dots$, of which the Distances from O are r_1, r_2, r_3, \dots , respectively.

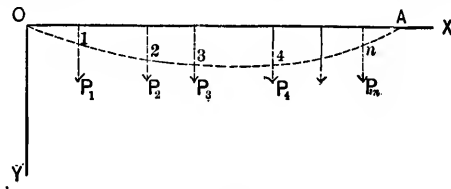

FIG. 322.

It may be assumed that the total effect of all the weights is the sum of the effects of the separate weights, and thus each may be treated independently, as in the preceding article.

Let $\alpha_1, \alpha_2, \alpha_3, \dots$ be the slopes at the points $1, 2, 3, \dots$ of the neutral axis.

Considering P_1 , the equation to $O1$ is

$$-EIy = \frac{P_1 l - r_1}{6} x^3 - \frac{P_1 r_1}{6} (l - r_1)(2l - r_1)x;$$

and to 1A,

$$-EIY = \frac{P_1 l - r_1}{6} x^3 - \frac{P_1}{6} (x - r_1)^3 - \frac{P_1 r_1}{6} (l - r_1)(2l - r_1)x.$$

Considering P_2 , the equation to O2 is

$$-EIY = \frac{P_2 l - r_2}{6} x^3 - \frac{P_2 r_2}{6} (l - r_2)(2l - r_2)x;$$

and to 2A,

$$-EIY = \frac{P_2 l - r_2}{6} x^3 - \frac{P_2}{6} (x - r_2)^3 - \frac{P_2 r_2}{6} (l - r_2)(2l - r_2)x;$$

and so on for P_3, P_4 , etc.

The total deflection Y at any point (x, Y) is the sum of the deflections due to the several loads.

Take, e.g., a point between 3 and 4, and let d_1, d_2, d_3, \dots be the deflections of this point, due to P_1, P_2, P_3, \dots , respectively. Then

$$-EId_1 = \frac{P_1 l - r_1}{6} x^3 - \frac{P_1 r_1}{6} (l - r_1)(2l - r_1)x - \frac{P_1}{6} (x - r_1)^3;$$

$$-EId_2 = \frac{P_2 l - r_2}{6} x^3 - \frac{P_2 r_2}{6} (l - r_2)(2l - r_2)x - \frac{P_2}{6} (x - r_2)^3;$$

$$-EId_3 = \frac{P_3 l - r_3}{6} x^3 - \frac{P_3 r_3}{6} (l - r_3)(2l - r_3)x - \frac{P_3}{6} (x - r_3)^3;$$

$$-EId_4 = \frac{P_4 l - r_4}{6} x^3 - \frac{P_4 r_4}{6} (l - r_4)(2l - r_4)x;$$

and so on. Hence,

$$\begin{aligned} -EIY &= -EI(d_1 + d_2 + \dots) \\ &= \frac{x^3}{6l} \{P_1(l - r_1) + P_2(l - r_2) + P_3(l - r_3) + \dots\} \\ &\quad - \frac{x}{6l} \{P_1 r_1(l - r_1)(2l - r_1) + P_2 r_2(l - r_2)(2l - r_2) + \dots\} \\ &\quad - \frac{1}{6} \{P_1(x - r_1)^3 + P_2(x - r_2)^3 + P_3(x - r_3)^3\}. \dots \quad (A) \end{aligned}$$

Again, the position of the most deflected point is found by making $\frac{dY}{dx} = 0$ in the equation to that portion of the neutral axis between two of the weights in which the said point lies. The result is a quadratic equation, and the value of x derived therefrom may be substituted in eq. (A), which then gives the maximum deflection.

EXAMPLE.—A girder of 100 ft. span supports two weights of 20,000 lbs. and 30,000 lbs. at points distant respectively 20 ft. and 60 ft. from one end.

The most deflected point must evidently lie between the two weights, and the equation to the corresponding portion of the neutral axis is

$$\begin{aligned} -EIV &= \frac{x^3}{600}(20000 \times 80 + 30000 \times 40) - \frac{20000}{6}(x - 20)^3 \\ &- \frac{x}{600}(20000 \times 20 \times 80 \times 180 + 30000 \times 60 \times 40 \times 140) \\ &= \frac{14000}{3}x^3 - \frac{10000}{3}(x - 20)^3 - 26400000x. \end{aligned}$$

Y is a maximum when

$$\frac{dY}{dx} = 0 = 14000x^2 - 10000(x - 20)^2 - 26400000,$$

or

$$x^2 + 100x - 7600 = 0,$$

or

$$x = 50.497 \text{ ft.}$$

Remark.—Instead of assuming $\frac{EI}{R} = \pm EI \frac{d^2y}{dx^2}$, it would be more accurate to take $\frac{EI}{R} = \pm EI \cos \theta \frac{d^2y}{dx^2}$ (Art. 2), and the *first* integration would make the left-hand side of the slope equation $\pm EI \sin \theta$ instead of $\pm EI \tan \theta$.

7. Moment of Inertia variable.—In the preceding examples the moment of inertia I has been assumed to be constant. From the general equations,

$$EI \frac{d^2 y}{dx^2} = \frac{f}{c} I,$$

c being proportional to the depth of the girder at a transverse section distant x from the origin.

Hence, for beams of *uniform strength*, the value of c in terms of x may be substituted in the last equation, which may then be integrated.

Again, let Fig. 323 represent a cantilever of length l , specific weight w , circular profile, and with a parabolic profile, the vertex of the parabola being at A .

Let $2b$ be the depth of the cantilever at the fixed end.

Let the cantilever also carry a uniformly distributed load of intensity p .

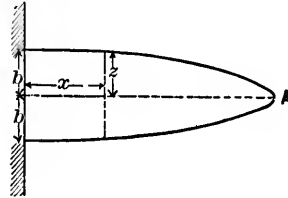

FIG. 323.

Consider a transverse section of radius z at a distance x from the fixed end.

Let x, y be the co-ordinates of the neutral axis at the same section. Then

$$EI \frac{d^2 y}{dx^2} = \frac{w\pi b^2}{6l}(l-x)^2 + \frac{p}{2}(l-x)^2 = E \frac{\pi z^4}{4} \frac{d^2 y}{dx^2}.$$

But $z^2 = \frac{b^2}{l}(l-x)$.

$$\therefore E \frac{\pi b^4}{4l^2}(l-x)^2 \frac{d^2 y}{dx^2} = \frac{w\pi b^2}{6l}(l-x)^2 + \frac{p}{2}(l-x)^2,$$

or

$$\frac{\pi E b^4}{4l^2} \frac{d^2 y}{dx^2} = \frac{w\pi b^2}{6l}(l-x) + \frac{p}{2}.$$

Integrating,

$$\frac{\pi E b^4}{4l^2} \frac{dy}{dx} = \frac{w\pi b^2}{6l} \left(lx - \frac{x^2}{2} \right) + \frac{px}{2} \quad \dots (1)$$

There is no constant of integration, as $\frac{dy}{dx} = 0$ when $x = 0$.

Integrating again,

$$\frac{\pi E b^4}{4 l^2 y} = \frac{w \pi b^2}{6 l} \left(\frac{l x^2}{2} - \frac{x^3}{6} \right) + \frac{p x^2}{4} \dots \dots \dots (2)$$

There is no constant of integration, as x and y vanish together. Thus, equation (1) gives the slope at any point, and equation (2) defines the neutral axis.

The slope at the free end ($x = l$) = $\frac{l^3}{E b^3} \left(\frac{w}{3} + \frac{2p}{\pi b^2} \right)$.

The deflection " " " = $\frac{l^4}{E b^3} \left(\frac{2}{9} w + \frac{p}{\pi b^2} \right)$.

8. Springs Fixed at One End and Loaded at the other with a Weight W .

Data.—Length = l ; breadth = b , and depth = d at fixed support; V = volume of spring; f = maximum coefficient of strength; Δ = maximum deflection.

CASE a. Simple rectangular spring.

By Ex. 1, Art. 3,

$$\Delta = \frac{1}{3} \frac{W l^3}{E I} = \frac{2}{3} \frac{f l^3}{E d}, \dots (1)$$

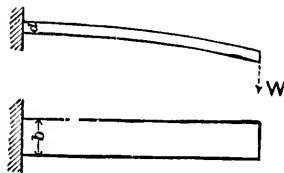

FIG. 324.

since

$$\frac{W l}{I} = \frac{M}{I} = \frac{2f}{d} = \frac{12 W l}{b d^3}.$$

Also,

$$W \Delta = \frac{b d^2 f}{6 l} \cdot \frac{2}{3} \frac{f l^3}{E d} = \frac{1}{9} \frac{f^2 b d l}{E} = \frac{f^2 V}{9 E}.$$

Hence,

$$V = 9 \frac{W \Delta E}{f^2} \dots \dots \dots (2)$$

The work done = $\frac{W \Delta}{2} = \frac{f^2 V}{18 E} \dots \dots \dots (3)$

CASE *b*. Spring of constant depth but triangular in plan.

Let b_x be the breadth at a distance x from the fixed end.

Then

$$\frac{b_x}{b} = \frac{l-x}{l},$$

and I at the same point

$$= \frac{b_x d^3}{12} = \frac{1}{12} \frac{l-x}{l} b d^3.$$

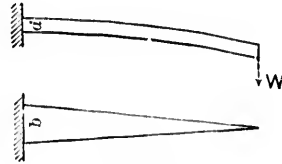

FIG. 325.

$$\therefore \frac{d^2 y}{dx^2} = \frac{W}{EI} (l-x) = \frac{12 W l}{E b d^3}.$$

Integrating twice,

$$\frac{dy}{dx} = \frac{12 W l}{E b d^3} x,$$

and

$$y = \frac{6 W l}{E b d^3} x^2.$$

$$\therefore \Delta = \frac{6 W l^3}{E b d^3} = \frac{f l^3}{E d} \dots \dots \dots (4)$$

Also,

$$W \Delta = \frac{b d^3 f f l^3}{6 l E d} = \frac{f^2 b d l}{6 E} = \frac{f^2 V}{3 E}.$$

Hence,

$$\therefore V = \frac{3 W \Delta E}{f^2} \dots \dots \dots (5)$$

$$\text{The work done} = \frac{W \Delta}{2} = \frac{f^2 V}{6 E} \dots \dots \dots (6)$$

N.B.—The results 1 to 6 are the same if the springs are compound; i.e., if the rectangular spring is composed of n simple rectangular springs laid one above the other, and if the triangular spring is composed of n triangular springs laid one above the other.

CASE *c*. Spring of constant width but parabolic in elevation.

Let d_x be the depth at a distance x from the fixed end.

Then

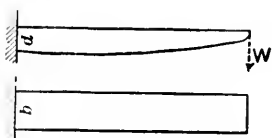

FIG. 326.

$$\left(\frac{d_x}{d}\right)^2 = \frac{l-x}{l},$$

and I at the same point =

$$\frac{bd_x^3}{12} = \frac{bd^3}{12} \left(\frac{l-x}{l}\right)^{\frac{3}{2}}.$$

$$\therefore \frac{d^2y}{dx^2} = \frac{W}{EI}(l-x) = \frac{12W}{E} \frac{l^{\frac{3}{2}}}{bd^3} (l-x)^{-\frac{1}{2}}.$$

Integrating twice,

$$y = \frac{12W}{E} \frac{l^{\frac{3}{2}}}{bd^3} \left\{ \frac{2}{3}(l-x)^{\frac{3}{2}} - 2l^{\frac{1}{2}}(l-x) + \frac{2}{3}l^{\frac{3}{2}} \right\},$$

and hence

$$\Delta = \frac{8W}{E} \frac{l^{\frac{3}{2}}}{bd^3} = \frac{4fl^2}{3Ed} \dots \dots \dots (7)$$

$$\text{Also, } W\Delta = \frac{bd^3f}{6l} \cdot \frac{4fl^2}{3Ed} = \frac{2f^2}{9E} bdl = \frac{1}{3} \frac{f^2}{E} V.$$

$$\therefore V = \frac{3W\Delta E}{f^2}.$$

$$\text{The work done} = \frac{W\Delta}{2} = \frac{1}{6} \frac{f^2 V}{E}.$$

9. Girder Encasté at the Ends.—The girder *BCDEFG* rests upon supports at the ends, is held in position by blocks forced between the ends and the abutments, and carries a uniformly distributed load of intensity w .

It is required to determine the pressure that must be developed between the blocks and the girder so that the straight portion between vertical sections at points O and A of the

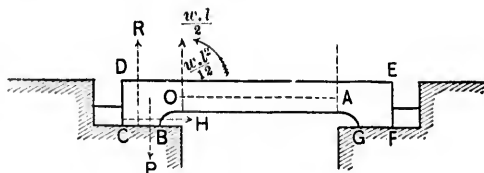

FIG. 327.

neutral axis may be in the same condition as if the girder were *fixed* at these sections.

Let l be the length of OA .

Let R be the reaction at the surface BC , and r its distance from O .

Let H be the reaction between the block and the end CD , and h its distance from O .

Let P be the weight of the segment on the left of the vertical section O , and p its distance from O .

Then for the equilibrium of the segment on the left of the section at O ,

$$R + \frac{wl}{2} - P = 0, \quad \text{and} \quad Rr - Pp - Hh - \frac{wl^2}{12} = 0.$$

$$\therefore R = P - \frac{wl}{2},$$

and

$$H = \frac{\left(P - \frac{wl}{2}\right)r - Pp - \frac{wl^2}{12}}{h} = \text{the required pressure.}$$

Again, take O as the origin, OA as the axis of x , and a vertical through O as the axis of y .

At any point (x, y) of the neutral axis,

$$-EI \frac{d^2y}{dx^2} = \frac{wl}{2}x - \frac{wx^2}{2} - \frac{wl^2}{12}. \quad (\text{See Ex. 8.})$$

10. On the Work done in bending a Beam.—Let

$A'B'C'D'$ be an originally rectangular element of a beam strained under the action of external forces.

Let the surfaces $A'D'$, $B'C'$ meet in O ; O is the centre of curvature of the arc $P'Q'$ of the neutral axis.

Let $OP' = R = OQ'$.

Let the length of the arc $P'Q' = dx$.

Consider any elementary fibre $p'q'$, of length dx' , of sectional area a , and distant y from the neutral axis.

Let t be the stress in $p'q'$.

The work done in stretching $p'q'$

$$= \frac{t}{2}(dx' - dx).$$



FIG. 328.

But $\frac{dx'}{dx} = \frac{p'q'}{P'Q'} = \frac{R+y}{R}$, and $t = Ea \frac{dx' - dx}{dx} = Ea \frac{y}{R}$.

The work done in stretching $p'q' = \frac{1}{2} \frac{E}{R^2} dxay^2$,

and the work done in deforming the prism $A'B'C'D'$

$$= \geq \left(\frac{1}{2} \frac{E}{R^2} dxay^2 \right) = \frac{1}{2} \frac{E}{R^2} dx \Sigma (ay^2) = \frac{1}{2} \frac{EI}{R^2} dx.$$

Hence, the total work between two sections of abscissæ x_1, x_2 ,

$$= \int_{x_1}^{x_2} \frac{1}{2} \frac{EI}{R^2} dx = \frac{EI}{2} \int_{x_1}^{x_2} \frac{dx}{R^2}.$$

But $\frac{1}{R} = \frac{M}{EI}$; therefore the work between the given limits

$$= \frac{EI}{2} \int_{x_1}^{x_2} dx \left(\frac{M}{EI} \right)^2 = \frac{1}{2EI} \int_{x_1}^{x_2} M^2 dx.$$

This expression is necessarily equal to the work of the external forces between the same limits, and is also the semi vis-viva acquired by the beam in changing from its natural state of equilibrium.

Cor.—If the proof load P is concentrated at one point of a beam, and if d is the proof deflection, the *resilience* = $\frac{P}{2}d$.

If a proof load of intensity w is uniformly distributed over the beam, and if y is the deflection at any point, the resilience = $\frac{1}{2} \int wy dx$, the integration extending throughout the whole length of the beam.

The case of the single weight, however, is the most useful in practice.

II. On the Transverse Vibrations of a Beam resting upon Two Supports in the same Horizontal Plane.

It is assumed—

- (a) That the beam is homogeneous and of uniform sectional area.
- (b) That the axis (*neutral*) remains unaltered in length.
- (c) That the vibrations are small.
- (d) That the particles of the beam vibrate in the vertical planes in which they are primarily situated. In reality, these particles have a slight angular motion about the horizontal axis through the centre of gravity of the section, but for the sake of simplicity the effect of this motion is disregarded.

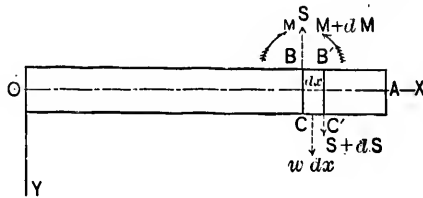

FIG. 329.

Let OA be the beam.

Take O as the origin, the neutral line OA as the axis of x , and the vertical OY as the axis of y .

Consider an element of the beam, bounded by the vertical

planes $BC, B'C'$, of which the abscissæ are x and $x + dx$, respectively.

Let w be the intensity of the load per unit of length; hence $w dx$ is the load upon the given element, and acts vertically through its centre.

Let S be the shearing force at B ; $S + dS$ the shearing force at B' .

Let M be the bending moment at B ; $M + dM$ the bending moment at B' .

Also, the resistance of the element to acceleration $= \frac{w}{g} \frac{d^2 y}{dt^2}$.

Hence, at any time t ,

$$\frac{w}{g} dx \frac{d^2 y}{dt^2} + S - (S + dS) - w dx = 0,$$

or

$$\frac{d^2 y}{dt^2} - \frac{g}{w} \frac{dS}{dx} - g = 0. \dots \dots (1)$$

Again, taking moments about the middle point of BB' or CC' ,

$$M - (M + dM) + S \frac{dx}{2} + (S + dS) \frac{dx}{2} = 0,$$

or

$$\frac{dM}{dx} = S. \dots \dots (2)$$

But $M = -EI \frac{d^2 y}{dx^2}$. Therefore

$$S = -EI \frac{d^3 y}{dx^3}, \quad \text{and} \quad \frac{dS}{dx} = -EI \frac{d^4 y}{dx^4}.$$

Hence, from (1),

$$\frac{d^2 y}{dt^2} + \frac{g}{w} EI \frac{d^4 y}{dx^4} - g = 0. \dots \dots (3)$$

This equation does not admit of a finite integration, but may be integrated in the form of a partial differential equation.

12. Continuous Girders.—When a girder overhangs its bearings, or is supported at more than two points, it assumes a wavy form and is said to be *continuous*. The convex portions are in the same condition as a loaded girder resting upon a single support, the upper layers of the girder being extended and the lower compressed. The concave portions are in the same condition as a loaded girder supported at two points, the upper layers being compressed and the lower extended. At certain points, called *points of contrary flexure*, or *points of inflexion*, the curvature changes sign and the flange stresses are necessarily zero. Hence, apart from other practical considerations, the flanges might be wholly severed at these points without endangering the stability of the girder.

13. The Theorem of Three Moments.—It is required to determine a relation between the *bending moments* at any *three consecutive* points of support of a loaded continuous girder of several spans.

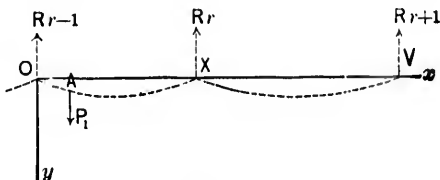

FIG. 330.

Let O, X, V be the $(r-1)$ th, r th, and $(r+1)$ th supports, respectively.

Let $OX = l_r, XV = l_{r+1}$.

CASE A. Let w_r be the load per unit of length on OX , w_{r+1} the load per unit of length on XV .

Let R_{r-1}, R_r, R_{r+1} be the reactions at O, X, V , respectively.

Let M_{r-1}, M_r, M_{r+1} be the bending moments at O, X, V , respectively.

Let α be the angle which the tangent to the girder at X makes with OV .

Consider the segment OX , and refer it to the rectangular axes Ox, Oy .

The equation of moments at any point (x, y) is

$$-EI \frac{d^2y}{dx^2} = R_{r-1}x - w_r \frac{x^2}{2} + M_{r-1} = M. \quad \dots (1)$$

At $X, x = l_r$, and $M = M_r$.

$$\therefore R_{r-1}l_r - w_r \frac{l_r^2}{2} + M_{r-1} = M_r. \quad \dots (2)$$

Similarly, the segment XV gives

$$R_{r+1}l_{r+1} - w_{r+1} \frac{l_{r+1}^2}{2} + M_{r+1} = M_r. \quad \dots (3)$$

Combining (2) and (3),

$$\begin{aligned} R_{r-1}l_r^2 + R_{r+1}l_{r+1}^2 - w_r \frac{l_r^3}{2} - w_{r+1} \frac{l_{r+1}^3}{2} + M_{r-1}l_r + M_{r+1}l_{r+1} \\ = M_r(l_r + l_{r+1}). \quad \dots (4) \end{aligned}$$

Integrating (1),

$$-EI \frac{dy}{dx} = R_{r-1} \frac{x^2}{2} - w_r \frac{x^3}{6} + M_{r-1}x + c, \quad \dots (5)$$

c being a constant of integration.

When $x = l_r$, $\frac{dy}{dx} = \tan \alpha$.

$$\therefore -EI \tan \alpha = R_{r-1} \frac{l_r^2}{2} - w_r \frac{l_r^3}{6} + M_{r-1}l_r + c, \quad \dots (6)$$

Integrating (5),

$$-EIy = R_{r-1} \frac{x^3}{6} - w_r \frac{x^4}{24} + M_{r-1} \frac{x^2}{2} + cx. \quad \dots (7)$$

There is no constant of integration, as x and y vanish together.

Also, $y = 0$ when $x = l_r$.

$$\therefore 0 = R_{r-1} \frac{l_r^3}{6} - w_r \frac{l_r^4}{24} + M_{r-1} \frac{l_r^2}{2} + cl_r,$$

or

$$c = -R_{r-1} \frac{l_r^3}{6} + w_r \frac{l_r^4}{24} - M_{r-1} \frac{l_r^2}{2}. \quad \dots (8)$$

Substituting this value of c in eq. (6),

$$-EI \tan \alpha = R_{r-1} \frac{l_r^2}{3} - w_r \frac{l_r^3}{8} + M_{r-1} \frac{l_r}{2} \dots (9)$$

Similarly, the segment XV gives

$$-EI \tan (\pi - \alpha) = R_{r+1} \frac{l_{r+1}^2}{3} - w_{r+1} \frac{l_{r+1}^3}{8} + M_{r+1} \frac{l_{r+1}}{2} \dots (10)$$

Adding eqs. (9) and (10), transposing, and simplifying, $\rightarrow M_{r+1}$

$$R_{r-1} l_r^2 + R_{r+1} l_{r+1}^2 = \frac{2}{3} w_r l_r^3 + \frac{2}{3} w_{r+1} l_{r+1}^3 - \frac{2}{3} M_{r-1} l_r - \frac{2}{3} M_{r+1} l_{r+1} \dots (11)$$

Finally, combining eqs. (4) and (11),

$$M_{r-1} l_r + 2M_r (l_r + l_{r+1}) + M_{r+1} l_{r+1} = -\frac{1}{2} (w_r l_r^3 + w_{r+1} l_{r+1}^3) \dots (12)$$

If the girder is supported at n points, there are $n - 2$ equations connecting the corresponding bending moments, and two additional equations result from the conditions of support at the ends. For example, if the ends merely rest upon the supports $M_1 = 0$ and $M_n = 0$; if an end is fixed, $\frac{dy}{dx} = 0$ at that point.

The point of maximum bending moment, the points of inflexion, and the point of maximum deflection in any span are found by making $\frac{dM}{dx} = 0$, $M = 0$, and $\frac{dy}{dx} = 0$, respectively.

Thus, for the span OX ,

$$\frac{dM}{dx} = 0 = R_{r-1} - w_r x;$$

$$\therefore x = \frac{R_{r-1}}{w_r}, \text{ and maximum B.M.} = \frac{1}{2} \frac{R_{r-1}^2}{w_r} + M_{r-1};$$

$$M = 0 = R_{r-1} x - w_r \frac{x^2}{2} + M_{r-1},$$

a quadratic giving x ;

$$\frac{dy}{dx} = 0 = R_{r-1} \frac{x^2}{2} - w_r \frac{x^3}{6} + M_{r-1}x + c,$$

a cubic from which x may be found by trial. The maximum deflection is obtained by substituting the value of x in eq. (7); c being given by eq. (8).

CASE B. Let the loads upon OX , XV , respectively, consist of a number of weights P_1, P_2, P_3, \dots , distant p_1, p_2, p_3, \dots from O , and Q_1, Q_2, Q_3, \dots , distant q_1, q_2, q_3, \dots from V . Refer the neutral axis OAX to the rectangular axes Ox, Oy .

It may be assumed that the total effect of all the weights is the algebraic sum of the effects of the weights taken separately.

Consider the effect of P_1 at A .

The equation of moments at any point (x, y) of the neutral axis *between* O and A is

$$-EI \frac{d^2y}{dx^2} = R_{r-1}x + M_{r-1}. \quad \dots \quad (1)$$

Integrating,

$$-EI \frac{dy}{dx} = R_{r-1} \frac{x^2}{2} + M_{r-1}x + c_1, \quad \dots \quad (2)$$

c_1 being a constant of integration.

Integrating again,

$$-EIy = R_{r-1} \frac{x^3}{6} + M_{r-1} \frac{x^2}{2} + c_1x. \quad \dots \quad (3)$$

There is no constant of integration, as x and y vanish together.

The equation of moments at any point (x, y) *between* A and X is

$$-EI \frac{d^2y}{dx^2} = R_{r-1}x - P_1(x - p_1) + M_{r-1}. \quad \dots \quad (4)$$

Integrating,

$$-EI \frac{dy}{dx} = R_{r-1} \frac{x^2}{2} - \frac{P_1}{2}(x - p_1)^2 + M_{r-1}x + c_2. \dots (5)$$

Integrating again,

$$-EIy = R_{r-1} \frac{x^3}{6} - \frac{P_1}{6}(x - p_1)^3 + M_{r-1} \frac{x^2}{2} + c_2x + c_3. (6)$$

Now, at the point *A*, the values of $\frac{dy}{dx}$ and *y*, as given by eqs. (5) and (6), are identical with those given by eqs. (2) and (3); also, in equation (6), *y* = 0 when *x* = *l_r*.

Hence,

$$R_{r-1} \frac{p_1^2}{2} + M_{r-1}p_1 + c_2 = R_{r-1} \frac{p_1^2}{2} + M_{r-1}p_1 + c_2,$$

$$R_{r-1} \frac{p_1^3}{6} + M_{r-1} \frac{p_1^2}{2} + c_2p_1 = R_{r-1} \frac{p_1^3}{6} + M_{r-1} \frac{p_1^2}{2} + c_2p_1 + c_3,$$

and

$$0 = R_{r-1} \frac{l_r^3}{6} - \frac{P_1}{6}(l_r - p_1)^3 + M_{r-1} \frac{l_r^2}{2} + c_2l_r + c_3;$$

so that

$$c_3 = 0,$$

and

$$c_1 = c_2 = -R_{r-1} \frac{l_r^2}{6} + \frac{P_1}{6l_r}(l_r - p_1)^3 - M_{r-1} \frac{l_r}{2}. \dots (7)$$

Let α be the slope at *X*; then, by eqs. (5) and (7),

$$-EI \tan \alpha = R_{r-1} \frac{l_r^2}{3} - \frac{P_1}{6l_r}(l_r - p_1)^3(2l_r + p_1) + M_{r-1} \frac{l_r}{2}. (8)$$

Similarly, the segment *XV* gives

$$-EI \tan (\pi - \alpha) = R_{r+1} \frac{l_{r+1}^2}{3} + M_{r+1} \frac{l_{r+1}^2}{2}. \dots (9)$$

Adding eqs. (8) and (9), and transposing,

$$R_{r-1}l_r^2 + R_{r+1}l_{r+1}^2 = \frac{P}{2l_r}(l_r - p_1)^2(2l_r + p_1) - \frac{3}{2}M_{r-1}l_r - \frac{3}{2}M_{r+1}l_{r+1}. \quad (10)$$

Again, taking moments about X ,

$$R_{r-1}l_r - P_1(l_r - p_1) + M_{r-1} = M_r = R_{r+1}l_{r+1} + M_{r+1}, \quad (11)$$

whence

$$R_{r-1}l_r^2 + R_{r+1}l_{r+1}^2 = M_r(l_r + l_{r+1}) - M_{r-1}l_r - M_{r+1}l_{r+1} + P_1l_r(l_r - p_1), \quad (12)$$

and finally, by eqs. (10) and (12),

$$M_{r-1}l_r + 2M_r(l_r + l_{r+1}) + M_{r+1}l_{r+1} = -P_1\frac{p_1}{l_r}(l_r^2 - p_1^2). \quad (13)$$

The effect of each weight may be discussed in the same manner, and hence the relation between M_{r-1} , M_r , and M_{r+1} may be expressed in the form

$$M_{r-1}l_r + 2M_r(l_r + l_{r+1}) + M_{r+1}l_{r+1} = -\sum \frac{Pp}{l_r}(l_r^2 - p^2) - \sum \frac{Qq}{l_{r+1}}(l_{r+1}^2 - q^2). \quad (14)$$

Cor. 1. The relation between M_{r-1} , M_r , M_{r+1} for a uniformly distributed load may be easily deduced from eq. (14). For example, let a uniformly distributed load of intensity w_r cover a length $2a$ ($< l_r$) of the span OX , and let z be the distance of its centre from O . Then

$$\sum \frac{Pp}{l_r}(l_r^2 - p^2) = \int_{z-a}^{z+a} \frac{w_r dp}{l_r} p(l_r^2 - p^2) = \frac{w_r \cdot 2az}{l_r}(l_r^2 - z^2 - a^2),$$

which reduces to $\frac{w_r l_r^3}{4}$ when $z = a = \frac{l_r}{2}$.

Cor. 2. Considering the r th span and taking moments about the r th support,

$$R_{r-1}l_r - M + M_{r-1} = M_r,$$

M being the moment of the load on the span, and the reaction, or shear,

$$= R_{r-1} = \frac{M}{l_r} + \frac{M_r}{l_r} - \frac{M_{r-1}}{l_r}.$$

Hence, the shear at the $(r-1)$ th support for the r th span
 = the reaction at the same support, supposing the span an independent girder, i.e., cut at its supports,
 + the difference of the forces, or reactions, equivalent to the moments at the supports.

Again, let M_x be the moment of the load on the segment x with respect to the point (x, y) .

Hence, the total moment about (x, y)

$$\begin{aligned} &= R_{r-1}x - M_x + M_{r-1} \\ &= \left(\frac{M}{l_r}x - M_x\right) + \frac{M_{r-1}}{l_r}(l_r - x) + \frac{M_r}{l_r}x \end{aligned}$$

= the moment at the same point supposing the span an independent girder.

+ the reactions equivalent to the moments M_{r-1} , M_r , multiplied respectively by the segments $l_r - x$ and x .

In Fig. 331, OX being the r th span, let OBX be the curve

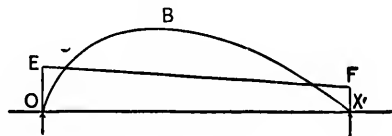

FIG. 331.

of bending moments, supposing OX an independent girder, i.e., cut at O and X . On the same scale as this curve is drawn, take the verticals OE and XF to represent M_{r-1} and M_r , re-

spectively, and join EF . The curve OBX corresponds to the portion $\left(\frac{M}{l_r}x - M_x\right)$ of the above equation, and the line EF to the remainder, i.e., $\frac{M_{r-1}}{l_r}(l_r - x) + \frac{M_r}{l_r}x$. The actual bending moment at any point of OX is represented by the algebraic sum of the ordinates of the curve and line at the same point, which will be the intercept between them, since they represent bending moments of opposite kinds.

Let A be the effective moment area, or the algebraic sum of the areas for the load and for the moments at O and X , and let \bar{x} be the horizontal distance of its centre of gravity from O .

Let A_r be the area for the load, i.e., the area of the curve OBX , and let z_r be the horizontal distance of its centre of gravity from O . Then

$$\begin{aligned} A\bar{x} &= A_r z_r + M_{r-1} \frac{l_r^2}{2} + \frac{1}{3}(M_r - M_{r-1})l_r^2 \\ &= A_r z_r + \frac{1}{6}M_{r-1}l_r^2 + \frac{1}{6}M_r l_r^2. \end{aligned}$$

This result will be referred to in a subsequent article.

14. Applications.—EXAMPLE I. Swing-bridges of two spans revolving about a single support at the pivot pier.

This is a case of a girder of two spans, $OX (= l_1)$, $XV (= l_2)$, resting upon supports at O and V , and continuous over a pier at X .

The bending moments at O and V are both *nil*.
 Let M be the bending moment at X .
 For a uniformly distributed load,

$$2M(l_1 + l_2) = -\frac{1}{2}(w_1 l_1^3 + w_2 l_2^3), \text{ or } M = -\frac{1}{8} \frac{w_1 l_1^3 + w_2 l_2^3}{l_1 + l_2},$$

w_1 being the intensity of the load on OX , w_2 that on XV .

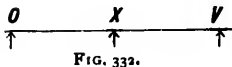

For an *arbitrarily distributed load*,

$$2M(l_1 + l_2) = -Ai - B, \text{ or } M = -\frac{1}{2} \frac{A + B}{l_1 + l_2},$$

where $A = \sum \frac{Pp}{l_1}(l_1^2 - p^2)$ and $B = \sum \frac{Qq}{l_2}(l_2^2 - q^2)$.

Let R_1, R_2, R_3 be the reactions at O, X, V , respectively.

For a *uniformly distributed load*,

$$R_1 = \frac{w_1 l_1}{2} + \frac{M}{l_1} = \frac{3w_1 l_1^2 + 4w_1 l_1^2 l_2 - w_1 l_1^3}{8l_1(l_1 + l_2)},$$

$$R_3 = \frac{w_2 l_2}{2} + \frac{M}{l_2} = \frac{-w_2 l_1^3 + 4w_2 l_1 l_2^2 + 3w_2 l_2^3}{8l_2(l_1 + l_2)}.$$

For an *arbitrarily distributed load*,

$$R_1 = \sum \frac{P(l_1 - p)}{l_1} + \frac{M}{l_1} = \sum \frac{P(l_1 - p)}{l_1} - \frac{1}{2} \frac{A + B}{l_1(l_1 + l_2)},$$

$$R_3 = \sum \frac{Q(l_2 - q)}{l_2} + \frac{M}{l_2} = \sum \frac{Q(l_2 - q)}{l_2} - \frac{1}{2} \frac{A + B}{l_2(l_1 + l_2)}.$$

If $w_1 = 0$, or if P and hence $A = 0$, then R_1 is negative.

So if $w_2 = 0$, or if Q and hence $B = 0$, then R_3 is negative.

Hence, if either of the spans is unloaded, the reaction at the abutment end of the unloaded span is negative and that end is subjected to a *hammering* action. This evil may be obviated:

(a) By loading the spans sufficiently to make R_1 and R_3 zero or positive.

This result is attained for R_1

$$\text{if } 3w_1 l_1^2 + 4w_1 l_1^2 l_2 > w_2 l_2^3, \text{ or if } \sum \frac{P(l_1 - p)}{l_1} > \frac{1}{2} \frac{A + B}{l_1(l_1 + l_2)},$$

and for R_3

$$\text{if } 4w_2 l_1 l_2^2 + 3w_2 l_2^3 > w_1 l_1^3, \text{ or if } \sum \frac{Q(l_2 - q)}{l_2} > \frac{1}{2} \frac{A + B}{l_2(l_1 + l_2)}.$$

(b) By using a latching apparatus to keep the ends from rising.

(c) By employing suitable machinery to exert an upward pressure, at least equal to the corresponding negative reaction upon each end, which is thus wholly prevented from leaving its seat.

Cor. 1. When the load is uniformly distributed, the distance x of the point of inflection in OX from O is given by

$$M = 0 = R_1x - \frac{w_1x^2}{2}, \text{ and therefore } x = \frac{2R_1}{w_1}.$$

Similarly, the distance of the point of inflection in XV from $V = \frac{2R_3}{w_2}$.

If $l_1 = l_2 = l$, then

$$M = -\frac{1}{16}(w_1 + w_2)l^2, \quad R_1 = \frac{7w_1 - w_2}{16}l, \quad R_3 = \frac{-w_2 + 7w_1}{16}l.$$

And if $w_1 = w_2 = w$, then

$$M = -\frac{1}{8}wl^2, \quad R_1 = \frac{3}{8}wl = R_3, \quad R_2 = 2wl - R_1 - R_3 = \frac{1}{4}wl.$$

In the latter case $\frac{2R_1}{w_1} = \frac{3}{4}l = \frac{2R_3}{w_2}$, and thus a hinge may be introduced in each span at a distance from the centre pier equal to one fourth of the span, without impairing the stability of the girder. Hence, also, the continuous girder of two equal spans may be considered as consisting of two independent girders, each of length $\frac{3}{4}l$, resting upon end supports, and of two cantilevers each of length $\frac{l}{4}$.

EX. 2. Swing-bridges with two points of support at the

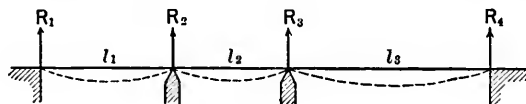

FIG. 333.

pivot pier, as, e.g., when they are carried upon rollers running in a circular path.

This is a case of a continuous girder of three spans.

Let l_1, l_2, l_3 be the lengths of the spaces, w_1, w_2, w_3 the corresponding intensities of the loads, which are assumed to be uniformly distributed.

Let R_1, R_2, R_3, R_4 be the reactions at the supports; M_1, M_2, M_3, M_4 the corresponding bending moments. Then

$$M_1 l_1 + 2M_2(l_1 + l_2) + M_3 l_2 = -\frac{1}{2}(w_1 l_1^2 + w_2 l_2^2); \quad (1)$$

$$M_2 l_2 + 2M_3(l_2 + l_3) + M_4 l_3 = -\frac{1}{2}(w_2 l_2^2 + w_3 l_3^2). \quad (2)$$

Let the ends of the girders rest upon the supports, and assume, as is usually the case in practice, that the centre span is unloaded, i.e., that $w_2 = 0$. Then

$$M_1 = 0 \quad \text{and} \quad M_4 = 0.$$

From (1) and (2),

$$2M_2(l_1 + l_2) + M_3 l_2 = -\frac{1}{2}w_1 l_1^2, \quad \dots \quad (3)$$

and

$$M_2 l_2 + 2M_3(l_2 + l_3) = -\frac{1}{2}w_3 l_3^2. \quad \dots \quad (4)$$

Hence,

$$M_2 = \frac{-2w_1 l_1^2(l_2 + l_3) + w_3 l_3^2 l_2}{4(4l_1 l_2 + 3l_2^2 + 4l_1 l_3 + 4l_2 l_3)}, \quad \dots \quad (5)$$

and

$$M_3 = \frac{w_1 l_1^2 l_2 - 2w_3 l_3^2(l_1 + l_2)}{4(4l_1 l_2 + 3l_2^2 + 4l_1 l_3 + 4l_2 l_3)}. \quad \dots \quad (6)$$

Taking moments about the second support,

$$\begin{aligned} R_1 l_1 &= \frac{w_1 l_1^2}{2} + M_2 \\ &= \frac{w_1(6l_1^3 l_2 + 6l_1^2 l_3 + 6l_1^2 l_2^2 + 8l_1^2 l_2 l_3) + w_3 l_3^2 l_2}{4(4l_1 l_2 + 3l_2^2 + 4l_1 l_3 + 4l_2 l_3)}. \quad (7) \end{aligned}$$

Taking moments about the third support,

$$\begin{aligned} R_3 l_3 &= \frac{w_3 l_3^2}{2} + M_3 \\ &= \frac{w_3(6l_3^3 l_2 + 6l_3^2 l_1 + 6l_3^2 l_2^2 + 8l_3^2 l_2 l_3) + w_1 l_1^2 l_2}{4(4l_1 l_2 + 3l_2^2 + 4l_1 l_3 + 4l_2 l_3)}. \quad (8) \end{aligned}$$

Thus R_1 and R_2 are both *positive* for *all* uniform distributions of load over the side spans, and no hammering action can take place at the ends.

Again, if the span on the left is unloaded, i.e., if $w_1 = 0$, M_1 is *positive* and M_2 *negative*; and if the span on the right is unloaded, i.e., if $w_2 = 0$, M_2 is *negative* and M_1 *positive*.

Thus, at the piers, the flanges of the girder will be subjected to stresses which are alternately tensile and compressive, and must be designed accordingly. The same result is also true for arbitrarily distributed loads.

EX. 3. The weights on five wheels passing over a continuous girder of two spans, each of 50 ft., taken in order, are as follows: 15,000 lbs., 24,000 lbs., 24,000 lbs., 24,000 lbs., 24,000 lbs. The distances of the wheels, centre to centre, taken in the same order, are 90 in., 56 in., 856 in., 56 in. Let it be required to place the wheels in such a position as to give the maximum bending moment at the centre pier.

The pier must evidently lie between the third and fourth wheels.

Let x be the distance, in inches, of the weight of 15,000 lbs. from the nearest abutment. The remaining two weights on the span are respectively $x + 90$ and $x + 146$ in. from the same abutment.

The two weights on the other span are $142 - x$ and $198 - x$ in., respectively, from the nearest abutment.

Hence, by Case B, Art. 13, if M is the bending moment at the centre pier,

$$\begin{aligned} -4M \times 600 &= \frac{15000}{600} x(600^2 - x^2) + \frac{24000}{600} (x + 90) \{600^2 - (x + 90)^2\} \\ &+ \frac{24000}{600} (x + 146) \{600^2 - (x + 146)^2\} \\ &+ \frac{24000}{600} \times (142 - x) \{600^2 - (142 - x)^2\} \\ &+ \frac{24000}{600} \times (198 - x) \{600^2 - (198 - x)^2\}. \end{aligned}$$

Making $\frac{dM}{dx} = 0$ for maximum value of M , and simplifying,

$$15x^2 + 27648x = 2518848,$$

and therefore

$$x = 87.39 \text{ in.} = 7.28 \text{ ft.}$$

Thus, the B. M. at the centre pier is a maximum when the first wheel is 7.28 ft. from the nearest abutment.

The maximum B. M. in inch-pounds is obtained by substituting $x = 87.39$ in. in the above equation.

15. Maximum Bending Moments at the Points of Support of Continuous Girders of n equal Spans.

Let the figure represent a continuous girder of n spans, 1, 2, 3, . . . $n - 1$ being the $n - 1$ intermediate supports.

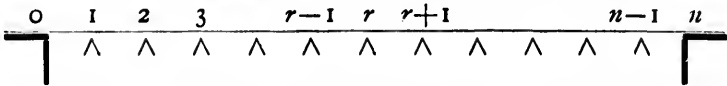

CASE I. Assume all the spans to be of the same length l , and let $w_1, w_2, \dots, w_{n-1}, w_n$ be the intensities of loads uniformly distributed over the 1st, 2d, . . . $(n - 1)$ th and n th spans, respectively.

By the Theorem of Three Moments,

$$4m_1 + m_2 = -\frac{l^2}{4}(w_1 + w_2); \dots \dots (1)$$

$$m_1 + 4m_2 + m_3 = -\frac{l^2}{4}(w_2 + w_3); \dots \dots (2)$$

$$m_2 + 4m_3 + m_4 = -\frac{l^2}{4}(w_3 + w_4); \dots \dots (3)$$

$$m_3 + 4m_4 + m_5 = -\frac{l^2}{4}(w_4 + w_5); \dots \dots (4)$$

$$m_4 + 4m_5 + m_6 = -\frac{l^2}{4}(w_5 + w_6); \dots \dots (5)$$

.

$$m_{n-3} + 4m_{n-2} + m_{n-1} = -\frac{l^2}{4}(w_{n-2} + w_{n-1}); \quad (n-2)$$

$$m_{n-2} + 4m_{n-1} = -\frac{l^2}{4}(w_{n-1} + w_n). \quad (n-1)$$

m_0 and m_n are both zero, as the girder is supposed to be resting upon the abutments at 0 and n .

From these $(n-1)$ equations, the bending moments m_1, m_2, \dots, m_{n-1} may be found in terms of the distributed loads.

Eliminating m_2 from 2 and 3,

$$m_1 - 15m_3 - 4m_4 = -\frac{l^2}{4}\{(w_2 + w_3) - 4(w_3 + w_4)\}. \dots (x_1)$$

Eliminating m_3 from 4 and x_1 ,

$$m_1 + 56m_4 + 15m_5 = -\frac{l^2}{4}\{(w_2 + w_3) - 4(w_3 + w_4) + 15(w_4 + w_5)\}. (x_2)$$

Eliminating m_4 from 5 and x_2 ,

$$\begin{aligned} m_1 - 209m_5 - 56m_6 \\ = -\frac{l^2}{4}\{(w_2 + w_3) - 4(w_3 + w_4) + 15(w_4 + w_5) - 56(w_5 + w_6)\}. (x_3) \end{aligned}$$

Finally, by successively eliminating m_6, m_7, \dots, m_{n-2} ,

$$\begin{aligned} m_1 \pm a_{n-1}m_{n-1} \\ = -\frac{l^2}{4}\{(w_2 + w_3) - 4(w_3 + w_4) + 15(w_4 + w_5) - \dots \\ \pm a_{n-4}(w_{n-3} + w_{n-2}) \mp a_{n-3}(w_{n-2} + w_{n-1}) \pm a_{n-2}(w_{n-1} + w_n)\}, (y) \end{aligned}$$

the upper or lower sign being taken for the terms within the brackets according as n is odd or even, and the coefficients $a_{n-1}, a_{n-2}, a_{n-3}, \dots$ being given by the law,

$$a_{n-1} = 4a_{n-2} - a_{n-3};$$

$$a_{n-2} = 4a_{n-3} - a_{n-4};$$

.

$$a_6 = 4a_4 - a_2 = 209;$$

$$a_4 = 4a_2 - a_1 = 56;$$

$$a_2 = 4a_1 - a_0 = 15;$$

$$a_0 = 4a_{-1} = 4;$$

$$a_{-1} = 1.$$

Commencing with equations $n - 3$ and $n - 2$, and proceeding as before,

$$\begin{aligned} & a_{n-1}m_1 \pm m_{n-1} \\ &= -\frac{l^2}{4} \{ a_{n-2}(w_1 + w_2) - a_{n-3}(w_2 + w_3) + a_{n-4}(w_3 + w_4) - \dots \\ & \quad \pm 15(w_{n-4} + w_{n-3}) \mp 4(w_{n-3} + w_{n-2}) \pm (w_{n-2} + w_{n-1}) \}, \quad (z) \end{aligned}$$

the upper or lower sign being taken for the terms within the brackets according as n is odd or even.

Solving the two equations y and z ,

$$\begin{aligned} m_1(a^2_{n-1} - 1) &= -\frac{l^2}{4} \{ a_{n-1}a_{n-2}w_1 + (a_{n-1}a_{n-2} - a_{n-1}a_{n-3} - 1)w_2 \\ & - (a_{n-1}a_{n-3} - a_{n-1}a_{n-4} - 3)w_3 + \dots \mp (3a_{n-1} + a_{n-4} - a_{n-3})w_{n-2} \\ & \quad \pm (a_{n-1} + a_{n-3} - a_{n-2}w_{n-1} \mp a_{n-2})w_n \}. \end{aligned}$$

and

$$\begin{aligned} \pm m_{n-1}(a^2_{n-1} - 1) &= \\ & -\frac{l^2}{4} \{ -a_{n-2}w_1 + (a_{n-1} + a_{n-3} - a_{n-2})w_2 \\ & - (3a_{n-1} + a_{n-4} - a_{n-3})w_3 \mp (a_{n-1}a_{n-3} - a_{n-1}a_{n-4} - 3)w_{n-2} \\ & \quad \pm (a_{n-1}a_{n-2} - a_{n-1}a_{n-3} - 1)w_{n-1} \pm a_{n-1}a_{n-2}w_n \}. \end{aligned}$$

Hence, since w_1, w_2, \dots, w_n are positive integers, the value of m_n will be *greatest* when $w_1, w_2, w_4, w_6, w_8, \dots$ are greatest and w_3, w_5, w_7, \dots are least; and the value of m_{n-1} will be *greatest* when $w_n, w_{n-1}, w_{n-3}, w_{n-4}, \dots$ are greatest, and $w_{n-2}, w_{n-4}, w_{n-6}, \dots$ are least. In other words, the bending moments at the 1st and $(n - 1)$ th intermediate supports have their maxi-

imum values when the two spans adjacent to the support in question, and then every alternate span, are loaded, and the remaining spans unloaded.

m_2, m_3, \dots, m_{n-2} may now be easily determined.

Thus, by eq. (1),

$$\begin{aligned} m_2 &= -\frac{l^2}{4}(w_1 + w_2) - 4m_1 \\ &= -\frac{l^2}{4} \left\{ (w_1 + w_2) - \frac{4}{a_{n-1}^2 - 1} a_{n-1} a_{n-2} w_1 \right. \\ &\quad \left. + (a_{n-1} a_{n-2} - a_{n-1} a_{n-3} - 1) w_2 - \dots \right\} \\ &= -\frac{l^2}{4(a_{n-1}^2 - 1)} \left\{ (a_{n-1}^2 - 1 - 4a_{n-1} a_{n-2}) w_1 \right. \\ &\quad \left. + (a_{n-1}^2 - 1 - 4a_{n-1} a_{n-2} + 4a_{n-1} a_{n-3} + 4) w_2 + \dots \right\}. \end{aligned}$$

But $a_{n-1} = 4a_{n-2} - a_{n-3}$.

$$\begin{aligned} \therefore m_2 &= -\frac{l^2}{4(a_{n-1}^2 - 1)} \left\{ -(a_{n-1} a_{n-3} + 1) w_1 \right. \\ &\quad \left. + (3a_{n-1} a_{n-3} + 3) w_2 + \dots \right\}, \end{aligned}$$

and is *greatest* when $w_2, w_3, w_4, w_5, \dots$ are greatest and $w_1, w_4, w_6, w_8, \dots$ are least.

Similarly, by eqs. (1) and (2),

$$\begin{aligned} m_3 &= -\frac{l^2}{4}(w_2 + w_3) + \frac{l^2}{4} \cdot 4(w_1 + w_2) + 15m_1 \\ &= -\frac{l^2}{a_{n-1}^2 - 1} \left\{ (a_{n-4} a_{n-1} + 4) w_1 - (3a_{n-1} a_{n-4} + 12) w_2 \right. \\ &\quad \left. + (11a_{n-1} a_{n-4} + 44) w_3 + \dots \right\}, \end{aligned}$$

and is *greatest* when $w_1, w_2, w_3, w_4, w_5, \dots$ are greatest and $w_6, w_7, w_8, w_9, \dots$ are least.

Thus, the general principle may be enunciated, that "in a horizontal continuous girder of n equal spans, with its ends resting upon two abutments, the bending moment at an intermediate support is greatest when the two spans adjacent to such support, and the alternate spans counting in both directions, carry uniformly distributed loads, the remainder of the spans being unloaded."

CASE II. The principle deduced in Case I also holds true when the loads are distributed in any arbitrary manner.

Consider the effect of a weight w in the r th span concentrated at a point distant p from the $(r - 1)$ th support.

By the Theorem of Three Moments,

$$4m_1 + m_2 = 0; \dots \dots \dots (1)$$

$$m_1 + 4m_2 + m_3 = 0; \dots \dots \dots (2)$$

$$m_2 + 4m_3 + m_4 = 0; \dots \dots \dots (3)$$

$\dots \dots \dots$

$$m_{r-2} + 4m_{r-1} + m_r = -w \frac{p}{l} (l^2 - p^2) = -A, \text{ suppose; } (r - 1)$$

$$\begin{aligned} m_{r-1} + 4m_r + m_{r+1} &= -w \frac{l-p}{l} \{l^2 - (l-p)^2\} \\ &= -w \frac{p}{l} (l-p)(2l-p) = -B, \text{ suppose; } (r) \end{aligned}$$

$$m_r + 4m_{r+1} + m_{r+2} = 0; \dots \dots \dots (r + 1)$$

$\dots \dots \dots$

$$m_{n-3} + 4m_{n-2} + m_{n-1} = 0; \dots \dots \dots (n - 2)$$

$$m_{n-1} + 4m_{n-1} = 0 \dots \dots \dots (n - 1)$$

By equations (1), (2), (3), . . . ($r - 2$),

$$m_1 = -\frac{1}{4}m_2 = \frac{1}{15}m_3 = -\frac{1}{56}m_4 = \dots = \mp \frac{1}{a_{n-2}}m_{r-2} = \pm \frac{m_{r-1}}{a_{r-1}}$$

the upper or lower sign being taken according as r is even or odd.

By equations ($n - 1$), ($n - 2$), ($n - 3$), . . . ($r + 1$),

$$\begin{aligned} m_{n-1} &= -\frac{1}{4}m_{n-2} = \frac{1}{15}m_{n-3} = -\frac{1}{56}m_{n-4} = \dots \\ &= \mp \frac{m_{r+2}}{a_{n-r-1}} = \pm \frac{m_{r+1}}{a_{n-r}} = \mp \frac{m_r}{a_{n-r-1}}. \end{aligned}$$

The coefficients a are given by the same law as for the coefficients a in Case I. Thus,

$$m_{r-2} = -\frac{a_{r-2}}{a_{r-1}}m_{r-1} \quad \text{and} \quad m_{r+1} = -\frac{a_{n-r}}{a_{n-r+1}}m_r.$$

Substituting these values of m_{r-2} and m_{r+1} in the ($r - 1$)th and r th equations,

$$m_{r-1}\left(4 - \frac{a_{r-2}}{a_{r-1}}\right) + m_r = -A = m_{r-1}b + m_r$$

and

$$m_{r-1} + m_r\left(4 - \frac{a_{n-r}}{a_{n-r+1}}\right) = -B = m_{r-1} + m_r c,$$

where

$$b = 4 - \frac{a_{r-2}}{a_{r-1}} \quad \text{and} \quad c = 4 - \frac{a_{n-r}}{a_{n-r+1}}.$$

Hence, solving the last two equations,

$$m_{r-1} = -\frac{Ac - B}{bc - 1} \quad \text{and} \quad m_r = -\frac{Bb - A}{bc - 1}.$$

The ratios $\frac{a_{r-2}}{a_{r-1}}$ and $\frac{a_{n-r}}{a_{n-r+1}}$ are each less than unity, and

hence b and c are each < 4 and > 3 .

It may now easily be shown that $Ac - B$ and $Bb - A$ are each positive. Hence, m_{r-1} and m_r are both of the same sign.

The bending moment m_q at any intermediate support on the left of $r - 1$ is given by

$$m_q = + \frac{\alpha_q}{\alpha_{r-1}} m_{r-1} \text{ if } q \text{ and } r \text{ are the one even and the other odd,}$$

or

$$m_q = - \frac{\alpha_q}{\alpha_{r-1}} m_{r-1} \text{ if } q \text{ and } r \text{ are both even or both odd.}$$

Thus the bending moment at the q th support is increased in the former case and diminished in the latter.

If q is on the right of r ,

$$m_q = + \frac{\alpha_{n-q+1}}{\alpha_{n-r+1}} m_r \text{ if } q \text{ and } r \text{ are both even or both odd,}$$

or

$$m_q = - \frac{\alpha_{n-q+1}}{\alpha_{n-r+2}} m_r \text{ if } q \text{ and } r \text{ are the one even and the other odd,}$$

and the bending moment on the q th support is increased in the former case and diminished in the latter.

Thus, the general principle may be enunciated, that, "in a horizontal continuous girder of n equal spans, with its ends resting upon two abutments, the bending moment at an intermediate support is greatest when the two spans adjacent to such support, and the alternate spans counting in both directions, are loaded, the remainder of the spans being unloaded."

CASE III. The same general principle still holds true when the two end spans are of different lengths.

E.g., let the length of the first span be kl , k being a numerical coefficient, and let $2(1 + k) = x$.

Eq. (1) now becomes

$$m_1 x + m_2 = 0.$$

Proceeding as before,

$$\frac{m_1}{b_1} = -\frac{m_2}{b_2} = +\frac{m_3}{b_3} = -\frac{m_4}{b_4} = + \dots,$$

the coefficients b_1, b_2, b_3, \dots being given by the same law as before, viz.,

$$b_1 = 1;$$

$$b_2 = x;$$

$$b_3 = 4b_2 - b_1 = 4x - 1;$$

$$b_4 = 4b_3 - b_2 = 15x - 4;$$

$$b_5 = 4b_4 - b_3 = 56x - 15;$$

.

The two sets of coefficients (a) and (b) are identical when $x = 4$; and when $x > 4$, all the coefficients b except the first ($b_1 = 1$) are numerically increased.

Hence, the same general results will follow.

N.B.—The equations giving m_q are simple and easily applicable in practice. They may be written

$$m_q = \pm \frac{\alpha_q}{\alpha_{r-1}} \frac{B - Ac}{bc - 1} \text{ if } q \text{ is on the left of } r,$$

and

$$m_q = \pm \frac{\alpha_{n-q+1}}{\alpha^{n-r+1}} \frac{A - Bc}{bc - 1} \text{ if } q \text{ is on the right of } r.$$

If there are several weights on the r th span,

$$A = \sum \frac{wp}{l}(l^2 - p^2) \quad \text{and} \quad B = \sum w \frac{p}{l}(l - p)(2l - p).$$

EXAMPLE.—The viaduct over the Osse consists of two end spans, each of 94 ft., and five intermediate spans, each of 126 ft. The platform is carried by two main girders which are con-

tinuous from end to end. The total dead load upon the girders may be taken at one ton (of 2000 lbs.) per lineal foot.

Denote the supports, taken in order, by the letters a, b, c, d, e, f, g, h , and let it be required to find the maximum bending moment at d when the bridge is subjected to an additional proof load of $1\frac{1}{2}$ tons per lineal foot.

The spans ab, cd, de, fg of each girder carry $1\frac{1}{4}$ tons per lineal foot.

The spans bc, ef, gh of each girder carry $\frac{1}{2}$ ton per lineal foot.

Denoting the bending moments at a, b, c, d, e, f, g, h , respectively, by m_1, m_2, \dots, m_8 , the intermediate spans by l , the end spans by kl , and remembering that $m_1 = 0 = m_8$, we have

$$2m_2(k+1) + m_3 = -\frac{l^3}{4}(k \cdot 1\frac{1}{4} + \frac{1}{2});$$

$$m_2 + 4m_3 + m_4 = -\frac{l^3}{4}(\frac{1}{2} + 1\frac{1}{4});$$

$$m_3 + 4m_4 + m_5 = -\frac{l^3}{4}(1\frac{1}{4} + 1\frac{1}{4});$$

$$m_4 + 4m_5 + m_6 = -\frac{l^3}{4}(1\frac{1}{4} + \frac{1}{2});$$

$$m_5 + 4m_6 + m_7 = -\frac{l^3}{4}(\frac{1}{2} + 1\frac{1}{4});$$

$$m_6 + 2m_7(k+1) = -\frac{l^3}{4}(1\frac{1}{4} + k \cdot \frac{1}{2}).$$

But $k = \frac{14}{13} = \frac{1}{4}$, very nearly.

$$\therefore 7m_2 + 2m_3 = -\frac{l^3}{4} \cdot \frac{23}{8}; \dots \dots \dots (1)$$

$$m_2 + 4m_3 + m_4 = -\frac{l^3}{4} \cdot \frac{7}{2}; \dots \dots \dots (2)$$

$$m_2 + 4m_1 + m_0 = -\frac{l^2}{4} \cdot \frac{5}{2}; \quad \dots \quad (3)$$

$$m_3 + 4m_2 + m_1 = -\frac{l^2}{4} \cdot \frac{7}{2}; \quad \dots \quad (4)$$

$$m_4 + 4m_3 + m_2 = -\frac{l^2}{4} \cdot \frac{7}{2}; \quad \dots \quad (5)$$

$$2m_4 + 7m_3 = -\frac{l^2}{4} \cdot \frac{13}{4}. \quad \dots \quad (6)$$

From eqs. (1), (2), (3),

$$97m_4 + 26m_3 = -\frac{l^2}{4} \cdot \frac{347}{8}.$$

From eqs. (4), (5), (6),

$$26m_4 + 97m_3 = -\frac{l^2}{4} \cdot \frac{279}{4}.$$

Hence, m_4 , the maximum required,

$$= -\frac{l^2}{4} \cdot \frac{19151}{8 \times 8733} = -605.5 \text{ ft.-tons.}$$

16. **General Theorem of Three Moments.**—The most general form of theorem of three moments may be deduced as follows:

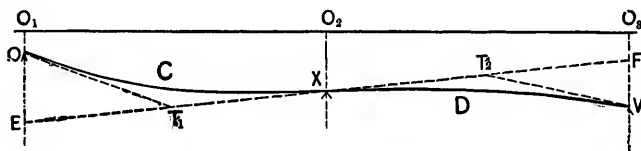

FIG. 334.

Let O , X , V , the $(r-1)$ th, r th, and $(r+1)$ th supports of a continuous girder of several spans, be depressed the vertical distances $a_1 (= O_1O)$, $a_2 (= O_2X)$, and $a_3 (= O_3V)$, respectively, below the proper level $O_1O_2O_3$ of the girder.

d_1, d_2, d_3 are necessarily very small quantities.

Let $OCXDV$ be the deflection curve, and let the tangent at X meet the verticals through O and V in E and F , and the tangents at O and V in T_1 and T_2 .

Let θ_1 be the change of curvature from O to $X (= OT_1E)$.

" θ_2 " " " " " " V to $X (= VT_2V)$.

Let A_1, A_2 be the effective moment areas for the spans OX, XV , respectively.

Let x_1 be the distance (measured horizontally) of the centre of gravity of A_1 from O .

Let x_2 be the distance (measured horizontally) of the centre of gravity of A_2 from F .

Let $O_1E = y_1, O_2F = y_2$.

By Art. 2,

$$y_1 - d_1 = x_1\theta_1 = \frac{A_1x_1}{EI},$$

$$d_2 - y_2 = x_2\theta_2 = -\frac{A_2x_2}{EI}.$$

$$\therefore \frac{y_1}{l_r} + \frac{y_2}{l_{r+1}} - \left(\frac{d_1}{l_r} + \frac{d_2}{l_{r+1}}\right) = \frac{1}{EI} \left(\frac{A_1x_1}{l_r} + \frac{A_2x_2}{l_{r+1}}\right).$$

But

$$\frac{y_1 - d_1}{l_r} = \frac{d_2 - y_2}{l_{r+1}}, \text{ or } \frac{y_1}{l_r} + \frac{y_2}{l_{r+1}} = \frac{d_1}{l_r} + \frac{d_2}{l_{r+1}}.$$

$$\therefore \frac{d_2 - d_1}{l_r} + \frac{d_2 - d_2}{l_{r+1}} = \frac{1}{EI} \left(\frac{A_1x_1}{l_r} + \frac{A_2x_2}{l_{r+1}}\right).$$

Again, by Art. 13, Cor. 2,

$$A_1x_1 = A_r z_r + \frac{1}{8}M_{r-1}l_r^2 + \frac{1}{8}M_r l_r^2$$

and

$$A_2x_2 = A_{r+1}z_{r+1} + \frac{1}{8}M_r l_{r+1}^2 + \frac{1}{8}M_{r+1} l_{r+1}^2,$$

A_r, A_{r+1} being the areas of the bending-moment curves for the spans OX, XV , respectively, on the assumption that they are independent girders, or cut at O, X , and V , and z_r, z_{r+1}

being the horizontal distances of the centres of gravity of these areas from O and V . Hence,

$$\begin{aligned} M_{r-1}l_r + 2M_r(l_r + l_{r+1}) + M_{r+1}l_{r+1} \\ = -6A_r \frac{z_r}{l_r} - 6A_{r+1} \frac{z_{r+1}}{l_{r+1}} + 6EI \left(\frac{d_2 - d_1}{l_r} + \frac{d_3 - d_2}{l_{r+1}} \right). \end{aligned}$$

Note.—If O , X , or V is above O_1O_3 , then d_1 , d_2 , or d_3 is negative.

Cor.—The forms of the Theorem of Three Moments given in Cases A and B, Art. 13, may be immediately deduced from the last equation.

CASE A.

$$d_1 = 0 = d_2 = d_3;$$

$$A_r = \frac{2}{3} \frac{w_r l_r^3}{8} l_r, \quad z_r = \frac{l_r}{2};$$

$$A_{r+1} = \frac{2}{3} \frac{w_{r+1} l_{r+1}^3}{8} l_{r+1}, \quad z_{r+1} = \frac{l_{r+1}}{2}.$$

$$\therefore -6A_r \frac{z_r}{l_r} - 6A_{r+1} \frac{z_{r+1}}{l_{r+1}} = -\frac{1}{4}(w_r l_r^3 + w_{r+1} l_{r+1}^3).$$

CASE B.

$$d_1 = 0 = d_2 = d_3;$$

$$A_r = \frac{1}{2} P \frac{p(l_r - p)}{l_r} l_r, \quad z_r = \frac{l_r + p}{3};$$

$$A_{r+1} = \frac{1}{2} Q \frac{q(l_{r+1} - q)}{l_{r+1}} l_{r+1}, \quad z_{r+1} = \frac{l_{r+1} + q}{3}.$$

$$\therefore -6A_r \frac{z_r}{l_r} - 6A_{r+1} \frac{z_{r+1}}{l_{r+1}} = -\frac{Pp(l_r^2 - p^2)}{l_r} - \frac{Qq(l_{r+1}^2 - q^2)}{l_{r+1}}.$$

17. Advantages and Disadvantages of Continuous Girders.—The advantages claimed for continuous girders are facility of erection, a saving in the flange material, and the removal of a portion of the weight from the centre of a span to

wards the piers. Circumstances, however, may modify these advantages, and even render them completely valueless. The flange stresses are governed by the position of the points of inflexion, which, under a moving load, will fluctuate through a distance dependent upon the number of intermediate supports and upon the nature of the loading. In bridges in which the ratio of the dead load to the live load is small the fluctuation is considerable, so that for a sensible length of the main girders, a passing train will subject local members to stresses which are alternately positive and negative. This necessitates a local increase of material, as each member must be designed to bear a much higher stress than if it were strained in one way only.

Again, the web of a continuous girder, even under a uniformly distributed dead load, is theoretically heavier than if each span were independent, and its weight is still further increased when it has to resist the complex stresses induced by a moving load.

Hence, in such bridges the slight saving, if there be any, cannot be said to counterbalance the extra labor of calculation and workmanship.

In girders subjected to a dead load only, and in bridges in which the ratio of the dead load to the live load is large, the saving becomes more marked, and increases with the number of intermediate supports, being theoretically a maximum when the number is infinite. This maximum economy may be approximated to in practice by making the end spans about four-fifths the intermediate spans.

In the calculations relating to the Theorem of Three Moments, it has been assumed that the quantity EI is constant, while in reality E , even for mild steel, may vary 10 or 15 per cent from a mean value, and I may vary still more. It does not appear, however, that this variation has any appreciable effect if the depth of the girder or truss changes *gradually*, but the effect may become very marked with a *rapid* change of depth, as, e.g., in the case of swing-bridges of the triangular type.

The graphical method of treatment may still be employed by substituting, for the actual curve of moments, a *reduced*

curve, formed by changing the lengths of the ordinates in the ratio of the value of EI at a datum section to EI .

It is often found economical to increase the depth of the girder over the piers, which introduces a local stiffness and moves the points of inflexion farther from the supports. A point of inflexion may be made to travel a short distance by raising or depressing one of the supports.

In order to insure the full advantage of continuity the utmost care and skill are required both in design and workmanship. Allowance has to be made for the excessive expansion and contraction due to changes of temperature, and the piers and abutments must be of the strongest and best description so that there shall be no settlement. Indeed, the difficulties and uncertainties to be dealt with in the construction of continuous girders are of such a serious if not insurmountable character that American engineers have almost entirely discarded their use except for draw-spans.

Much, in fact, is mere guesswork, and it is usual in practice to be guided by experience, which confines the points of inflexion within certain safe limits.

Under these circumstances it may prove desirable to fix the points of inflexion absolutely, and the advantages of doing so are (a) that the calculation of the web stresses becomes easy and definite, instead of being complicated and even indeterminate; (b) that reversed stresses (for which pin-trusses are less adapted than riveted trusses) are almost entirely avoided; (c) that the stresses are not sensibly affected by slight inequalities in the levels of the supports; (d) that the straining due to a change of temperature takes place under more favorable conditions.

The fixing may be thus effected:

(a) A hinge may be introduced at the selected point.

The benefit of doing so is very obvious when circumstances require a wide centre span and two short side spans.

(b) If the web is open, i.e., lattice-work, the point of inflexion in the upper flange may be fixed by cutting the flange at the selected point and lowering one of the supports so as to produce a slight opening between the severed parts. The

position of the point of inflexion in the lower flange is then defined by the condition that the algebraic sum of the horizontal components of the stresses in the diagonals intersected by a line joining the two points of inflexion is zero.

It must be remembered, however, that this *fixing* of the points of inflexion, or the *cutting* of the chords, destroys the property of continuity, and, indeed, is the essential distinction between a continuous girder and a cantilever.

Four methods may be followed in the erection of a continuous girder, viz.:

1. It may be built on the ground and *lifted* into place.
2. It may be built on the ground and rolled endwise over the piers. As the bridge is pushed forward, the forward end acts as a cantilever for the whole length of a span, until the next pier is reached. This method of erection is common in France.
3. It may be built in position on a scaffold.
4. Each span may be erected separately, and continuity produced by securely jointing consecutive ends, having drawn together the upper flanges. A more effective distribution of the material is often made by leaving a little space between the flanges and forming a wedge-shaped joint.

EXAMPLES.

1. Two angle-irons, each 2 in. \times 2 in. \times $\frac{1}{4}$ in., were placed upon supports 12 ft. 9 in. apart, the transverse outside distance between the bars being $9\frac{1}{2}$ in., and were prevented from turning inwards by a thin plate upon the upper faces. The bars were tested under uniformly distributed loads, and each was found to have deflected $2\frac{5}{8}$ in. when the load over the two was 1008 lbs. Find E and the position of the neutral axis.

Ans. $I = 1\frac{9}{4}\frac{3}{4}$; $E = 17,226,139$ lbs.; neutral axis $\frac{1}{2}\frac{3}{8}$ in. from upper face.

2. Both bars in the preceding question failed together when the total load consisted of $10\frac{1}{2}$ cwts. (cwt. = 112 lbs.) uniformly distributed, and 3 cwts. at the centre. Find the maximum stress in the metal.

Ans. Compressive unit stress = 20,323 lbs.;

Tensile unit stress = 39,577 lbs.

3. Show that the moments of resistance of an elliptic section and of the strongest rectangular section that can be cut out of the same are in the ratio of $99\sqrt{3}$ to 112, and that the areas of the sections are in the ratio of 33 to $14\sqrt{2}$.

4. Show that the moments of resistance of an isosceles triangular section and of the strongest rectangular section that can be cut out of the same are in the ratio of 27 to 16, and that the areas of the two sections are in the ratio of 9 to 4.

5. An angle-iron, 3 in. \times 3 in. \times $\frac{9}{8}$ in., was placed upon supports 12 ft. 9 in. apart, and deflected $1\frac{1}{2}$ in. under a load of 8 cwts. uniformly distributed and 2 cwts. at the centre. Find E and the position of the neutral axis.

Ans. $E = 16,079,611$ lbs.; neutral axis $\frac{3}{8}\frac{3}{8}$ in. from upper face.

6. The effective length and central depth of a cast-iron girder resting upon two supports were respectively 11 ft. 7 in. and 10 in.; the bottom flange was 10 in. wide and $1\frac{1}{2}$ in. thick; the top flange was $2\frac{1}{2}$ in. wide and $\frac{7}{8}$ in. thick; the thickness of the web was $\frac{3}{4}$ in. The girder was tested by being loaded at points $3\frac{1}{2}$ ft. from each end, and failed when the load at each point was $17\frac{1}{2}$ tons. What were the total central flange stresses at the moment of rupture?

What was the central deflection when the load at each point was $7\frac{1}{2}$ tons? ($E = 18,000,000$ lbs., and the weight of the girder = 3368 lbs.)

Ans. 164,747.4 lbs.; .368 in.

7. A tubular girder rests upon supports 36 ft. apart. At 6 ft. from one end the flanges are each 27 in. wide and $2\frac{3}{4}$ in. thick, the net area of the tension flange being 60 in., while the web consists of two $\frac{1}{8}$ -in. plates, 36 in. deep and 18 in. apart. Neglecting the effect of the angle-irons uniting the web plates to the flanges, determine the moment of resistance.

The girder has to carry a uniformly distributed dead load of 56 tons, a uniformly distributed live load of 54 tons, and a local load at the given section of 100 tons. What are the corresponding flange stresses per square inch?

How many $\frac{3}{4}$ -in. rivets are required at the given section to unite the angle-irons to the flanges?

Ans. 238.13 \times coeff. of strength; 3,3186 tons; 3,896 tons.

8. A yellow-pine beam, 14 in. wide and 15 in. deep, was placed upon supports 10 ft. 9 in. apart, and deflected $\frac{3}{8}$ in. under a load of 20 tons at the centre. Find E , neglecting the weight of the beam.

Ans. $E = 1,272,112$ lbs.

9. What were the intensities of the normal and tangential stresses at 2 ft. from a support and $2\frac{1}{2}$ in. from neutral plane, upon a plane inclined at 30° to the axis of the beam in the preceding question?

Ans. 132.83 and 218.91 lbs.

10. A beam is supported at the ends and bends under its own weight. Show that the upward force at the centre which will exactly neutralize the bending action is equal to $\frac{3}{8}$ or $\frac{1}{4}$ of the weight of the beam (w), according as the ends are *free* or *fixed*.

Find the neutralizing forces at the quarter spans.

Ans. Ends *free* $\frac{3}{16}w$ at each or $\frac{1}{8}w$ at one of the points of division.

Ends *fixed* $\frac{3}{8}w$ at each or $\frac{3}{4}w$ at one of the points of division.

11. A beam 8 in. wide and weighing 50 lbs. per cubic foot rests upon supports 30 ft. apart. Find its depth so that it may deflect $\frac{1}{4}$ in. under its own weight. ($E = 1,200,000$ lbs.)

Ans. 9.185 in.

12. A rectangular girder of given length (l) and breadth (b) rests upon two supports and carries a weight P at the centre. Find its depth so that the elongation of the lowest fibres may be $\frac{1}{1400}$ of the original length.

Ans. $\sqrt{\frac{2100Pl}{6E}}$

13. A yellow-pine beam, 14 in. wide, 15 in. deep, and weighing 32 lbs. per cubic foot, was placed upon supports 10 ft. 6 in. apart. Under uniformly distributed loads of 59,734 lbs. and of 127,606 lbs. the central

deflections were respectively .18 in. and .29 in. Find the mean value of E .

Also determine the additional weight at the centre which will increase the first deflection by $\frac{1}{5}$ of an inch. *Ans.* 2,552,980 lbs., 24,121 lbs.

14. In the preceding question find for the load of 59,734 lbs. the maximum intensities of thrust, tension, and shear at a point half-way between the neutral axis and the outside skin in a transverse section at one of the points of trisection of the beam. Also find the inclinations of the planes of principal stress at the point.

Ans. 1609.255, 169,562, 119,364 lbs.; $\theta = 3^\circ 48\frac{1}{2}'$.

15. A pitch pine beam, 14 in. wide, 15 in. deep, and weighing 45 lbs. per cubic foot, is placed upon supports 10 ft. 9 in. apart, and carries a load of 20 tons at the centre. Find the deflection and curvature, E being 1,270,000 lbs. What stiffness does this give?

What amount of uniformly distributed load will produce the same deflection? *Ans.* $\frac{3}{17}$; 32 tons.

16. In the preceding question find the maximum intensities of thrust, tension, and shear at points (a) half-way between the neutral axis and the outside skin, (b) at one third of the depth of the beam, in a transverse section at one of the quarter spans. Also find the inclinations of the planes of principal stress at these points.

Ans.—(a) 951.853, 292.969, 329.442 lbs.; $\theta = 9^\circ 34\frac{1}{2}'$.

(b) 658.774, 171.108, 243.833 lbs.; $\theta = 15^\circ 50\frac{1}{2}'$.

17. A piece of greenheart, 142 in. between supports, 9 in. deep, and 5 in. wide, was tested by being loaded at two points, distant 23 in. from the centre, with equal weights. Under weights at each point of 4480 lbs., 11,200 lbs., and 17,920 lbs. the central deflections were .13 in., .37 in., .67 in., respectively. Find the mean coefficient of elasticity. The beam broke under a load of 32,368 lbs. at each point. Find the coefficient of bending strength.

18. A sample cast-iron girder for the Waterloo Corn Warehouses, Liverpool, 20 ft. $7\frac{1}{2}$ in. in length and 21 in. in depth (total) at the centre, was placed upon supports 18 ft. $1\frac{1}{2}$ in. apart, and tested under a uniformly distributed load. The top flange was 5 in. \times $1\frac{1}{2}$ in., the bottom flange was 18 in. \times 2 in., and the web was $1\frac{1}{2}$ in. thick. The girder deflected .15 in., .2 in., .25 in., and .28 in. under loads (including weight of girder) of 63,763 lbs., 88,571 lbs., 107,468 lbs., and 119,746 lbs., respectively, and broke during a sharp frost under a load of 390,282 lbs. Find the mean coefficient of elasticity and the central flange stresses at the moment of rupture.

Ans. $I = 3309.122$; $E = 17,427,327$ lbs.; 20,121 lbs., 47,168 lbs.

19. A steel rectangular girder, 2 in. wide, 4 in. deep, is placed upon

supports 20 ft. apart. If E is 35,000,000 lbs., find the weight which, if placed at the centre, will cause the beam to deflect 1 in.

Ans. 1296 $\frac{2}{7}$ lbs.

20. A timber joist weighing 48 lbs per cubic foot, 2 in. wide \times 12 in. deep \times 14 ft. long, deflected .825 in. under a load of 887 lbs. at the centre. Find E .

Ans. 397,880 lbs.

21. A beam of span l is uniformly loaded. Compare its strength and stiffness (a) when merely resting upon supports at the ends; (b) when fixed at one end and resting upon a support at the other; (c) when fixed at both ends. In case (c) two hinges are introduced at points distant y from the centre; show that the *strength* of the beam is economized to the best effect when $y = \frac{l}{252}$, and that the *stiffness* is a maximum when

$y = \frac{l}{4}$ very nearly.

Ans. Cases (a) and (b). $m_1 : m_2 :: 1 : 1$; $D_1 : D_2 :: 1 : .416$.

Cases (a) and (c). $m_1 : m_3 :: 3 : 2$; $D_1 : D_3 :: 10 : 3$.

Case (c). Max. economy, $m_1 : m_4 :: 2 : 1$;

$D_1 : D_4 :: 5 : 2\sqrt{2}$.

Max. stiffness, $m_1 : m_5 :: 4 : 3$;

$D_1 : D_5 :: 15 : 4$ (approx.).

22. A beam AB of span l , carrying a uniformly distributed load of intensity w , rests upon a support at B and is imperfectly fixed at A , so that the neutral axis at A has a slope of $\frac{1}{48} \frac{wl^2}{EI}$. The end B is lower than A by an amount $\frac{1}{32} \frac{wl^4}{EI}$. Find the reactions. How much must B be lowered so that the whole of the weight may be borne at A ? Find the work done in bending the beam.

Ans. $\frac{21}{32}wl$, $\frac{11}{32}wl$; $\frac{7}{48} \frac{wl^4}{EI}$.

23. A round wrought-iron bar l ft. long and d in. in diameter can just carry its own weight. Find l in terms of d , (a) the allowable deflection being 1 in. per 100 ft. of span, E being 30,000,000 lbs.; (b) the allowable stress being 8960 lbs. per square inch; (c) the stiffness given by (a) and the strength given by (b) being of equal importance.

Ans. (a) $l = \sqrt[3]{250l^2}$; (b) $l = \sqrt{224d}$; (c) $l = \frac{1}{8}d$.

24. A square steel bar l ft. long and having a side of length d in. can just carry its own weight; its stiffness is $\frac{1}{1700}$ and the maximum allowable working stress is 7 tons per square inch. Find l in terms of d , E being 13,000 tons.

Ans. $\frac{l \text{ (in ft.)}}{d \text{ (in in.)}} = \frac{13}{21}$.

25. A uniformly loaded beam with both ends absolutely fixed is hinged at the quarter-spans. Show that the slope is suddenly *doubled* on passing a hinge.

26. A horizontal beam with both ends absolutely fixed is loaded with a weight W at a point dividing the span into two segments a and b . Show that the deflection at the point is $\frac{W}{3EI} \left(\frac{ab}{a+b} \right)^3$, and find the work done in bending the beam.

$$\text{Ans. } \frac{W^2}{6EI} \left(\frac{ab}{a+b} \right)^3.$$

27. Determine the isosceles section of maximum strength which can be cut out of a circular section of given diameter, and compare the strengths of the two sections.

28. A 3-in. \times 3-in. \times $\frac{1}{4}$ -in. angle-iron, with both ends fixed and a clear span of 20 ft., carries a uniformly distributed load of 500 lbs. which causes it to deflect .03909 in. Find E . What single load at the centre will produce the same deflection? Find the work done due to bending in each case.

$$\text{Ans. } E = 20,775,415 \text{ lbs.}; 250 \text{ lbs.}$$

29. A steel plate beam of uniform section and 30 ft. span has both ends fixed and is freely hinged at the points of trisection. Determine the neutral axis (a) for a uniformly distributed load of 6000 lbs.; (b) for a single load of 10,000 lbs. concentrated, *first*, $7\frac{1}{3}$ ft. and, *second*, 15 ft. from a support.

$$\text{Ans. (a) Side span, } y = \frac{100x^2}{EI} \left(100 - 5x + \frac{x^2}{12} \right);$$

$$\text{centre span, } y = \frac{1750000}{3EI} + \frac{25x}{3EI} \left(1000 - 20x^2 + x^3 \right).$$

(b) *First*. Loaded span between support and weight,

$$y = \frac{500}{EI} \left(75x^2 - \frac{10x^3}{3} \right).$$

Loaded span between weight and hinge,

$$y = \frac{1}{EI} \left(281250x - 703125 \right).$$

Unloaded side span horizontal; centre span straight between hinges.

$$\text{Second. Side span, } y = \frac{5000x}{EI} \left(5x - \frac{x^2}{6} \right);$$

$$\text{centre span, } y = \frac{2500x}{EI} \left(25 - \frac{x^2}{3} \right) + \frac{5000000}{3EI}.$$

30. A uniformly loaded beam, with both ends absolutely fixed, is hinged at a point dividing the span into segments a and b . Draw curves of shearing force and bending moment, and compare the strength and stiffness of the beam when the hinge is (a) at the middle point; (b) at a point of trisection; (c) at a quarter-span. Also, determine the slope of the segments of these points.

$$\begin{aligned} \text{Ans. } R_1 &= \frac{w}{8} \frac{5a^4 + 8ab^3 + 3b^4}{a^3 + b^3}; & R_2 &= \frac{w}{8} \frac{3a^4 + 8a^3b + 5b^4}{a^3 + b^3}; \\ M_1 &= \frac{wa}{8} \frac{a^4 + 4ab^3 + 3b^4}{a^3 + b^3}; & M_2 &= \frac{wa}{8} \frac{3a^4 + 4a^3b + b^4}{a^3 + b^3}; \\ M' : M'' : M''' &:: 14 : 14 : 11; & D' : D'' : D''' &:: 6.25 : 3.29 : 2.66. \\ \text{Slopes in (a)} &= \frac{l}{E} \frac{f}{c} \frac{1}{6}; & \text{in (b)} &= \frac{l}{E} \frac{f}{c} \frac{2}{81} \text{ for segment } a, \\ & & & \text{and } = \frac{l}{E} \frac{f}{c} \frac{23}{162} \text{ for segment } b; \\ \text{in (c)} &= \frac{l}{E} \frac{f}{c} \frac{9}{176} \text{ for segment } a, \text{ and} \\ &= \frac{l}{E} \frac{f}{c} \frac{92}{891} \text{ for segment } b. \end{aligned}$$

31. A horizontal beam rests upon two supports and is loaded with a weight W at a point dividing the span into segments a and b . Find the deflection at this point and the work done in bending the beam.

$$\text{Ans. } \frac{W}{3} \frac{a^2b^2}{EI(a+b)}; \frac{W^2}{6EI} \frac{a^2b^2}{a+b} \left(= \frac{W}{2} \times \text{deflection} \right).$$

32. A wrought-iron beam of rectangular section and 20 ft. span is 16 in. deep, 4 in. wide, and is loaded with a proof load at the centre. If the proof strength is 7 tons per square inch, find the proof deflection and the resilience, E being 12,000 tons (1 ton = 2240 lbs.).

$$\text{Ans. } .029 \text{ ft.}; 650 \text{ ft.-lbs.}$$

33. Design a wooden cantilever 12 ft. long, of circular section and uniform strength, to carry a uniformly distributed load of 2 tons, the coefficient of working strength being 1 ton per square inch. Also, find the deflection of the free end.

$$\text{Ans. Taking fixed end as origin and } x \text{ being radius in inches at distance } x \text{ ft. from origin, then } 11x^3 = 14(12 - x)^2.$$

$$\text{Deflection at end} = \frac{2737.9}{E} \text{ in.}$$

34. A girder fixed at both ends carries $(2n + 1)$ weights W concentrated at points dividing the length of the girder into $2n + 2$ equal divisions. Find the total central deflection.

$$\text{Ans. } \frac{n+1}{192} \frac{Wl^3}{EI}.$$

35. A girder 30 m. long has both ends fixed and carries a uniformly distributed load of 5800 k. per lineal metre. Find the deflection and the work of flexure.

$$\text{Ans. } \frac{567675000000}{EI} \text{ km.}$$

36. A steel beam of circular section is to cross a span of 15 ft. and to carry a load of 10 tons at 5 ft. from one end. Find its diameter, the stiffness being such that the ratio of *maximum deflection* to span is .00125. $E = 13,000$ tons.

$$\text{Ans. } 10.3 \text{ in.}$$

37. Determine the dimensions of a beam of rectangular section which might be substituted for the round beam in the preceding question, the stiffness remaining the same and the coefficient of working strength being $7\frac{1}{2}$ tons per square inch.

$$\text{Ans. } bd^2 = 320.$$

38. The flange of a girder consists of a pair of angle-irons and of a plate which extends over the middle portion of the girder for a certain required distance. Show that the greatest economy of material is secured when the length of the plate is $\frac{2}{3}$ of the span and the sectional areas of the plate and angle-irons are as 4 to 5 (the girder being uniformly loaded).

39. The flange of a uniformly loaded girder is to consist of two plates, each of which extends over the middle portion of the girder for a certain required distance, and of a pair of angle-irons. Show that the greatest economy of material is realized when the lengths of the plates and angle-irons are in the ratio of 12 : 18 : 23, and when the areas of the plates are in the ratio of 4 : 5.

What should be the relative lengths of the plates if they are of equal sectional area?

$$\text{Ans. } 1 : \sqrt{2} : \frac{2}{3}(\sqrt{2} + 1).$$

40. An elastic beam rests upon supports at its ends, and a weight placed at a point A produces a certain deflection (d) at a point B . Show that if the weight is transferred to B the same deflection (d) is produced at A .

41. A uniform beam is supported by four equidistant props, of which two are terminal. Show that the two points of inflexion in the middle segment are in the same horizontal plane as the props.

42. Find the slope and deflection at the free end of the following cantilevers when bending under their own weight, l being the length, $2b$ the depth at the fixed end, w the specific weight, and E the coefficient of elasticity:

(a) Of constant thickness t and with profile in the form of a trapezoid with the non-parallel sides equal and of depth $2a$ at the free end.

(b) Of circular section and with profile in the form of an isosceles triangle.

(c) Of constant thickness and with profile in the form of a parabola symmetrical with respect to the axis and having its vertex at the free end.

$$\text{Ans.}-(a) \frac{wl^3}{2Eb^3}; \frac{3wl}{2E(b-a)^3} \left\{ \frac{a^2}{b-a} \log \frac{a}{b} + \frac{b^2 - ab^2 + 8a^2b - 2a^3}{6b^2} \right\},$$

$$(b) \frac{1}{3} \frac{wl^3}{Eb^3}; \frac{1}{6} \frac{wl^4}{b^2E}. \quad (c) \frac{2wl^3}{5Eb^3}; \frac{4wl^4}{15Eb^2}.$$

43. Deduce the slope and deflection at the free end—

(d) When the depth $2a$ in (a) of the preceding question is *nil*, i.e., when the profile is an isosceles triangle.

(e) Due to a uniformly distributed load of intensity p over the cantilever (a). Hence, also, deduce the slope and deflection when the depth $2a$ is *nil*.

(f) Due to a weight W at the free end of (a).

(g) Due to a uniformly distributed load of intensity p upon the cantilever (c).

$$\text{Ans.}-(d) \frac{Wl^3}{2Eb^3}; \frac{Wl^4}{4Eb^2},$$

$$(e) \frac{3}{4} \frac{pl^3}{Et(b-a)^3} \left\{ \log \frac{b}{a} - \frac{(3b-a)(b-a)}{2b^2} \right\};$$

$$\frac{3}{4} \frac{pl^3}{Et(b-a)^3} \left\{ 3a \log \frac{a}{b} + \frac{(2b^2 + 5ab - a^2)(b-a)}{2b^2} \right\} 90^\circ;$$

$$\frac{3}{4} \frac{pl^4}{Et b^3}.$$

$$(f) \frac{3}{4} \frac{Wl^3}{Eat}; \frac{3}{2} \frac{Wl^3}{Et(b-a)^3} \left\{ \log \frac{b}{a} - \frac{3b-a}{2b^2} \right\}.$$

$$(g) \frac{p}{2} \frac{l^3}{Eb^3t}; \frac{3}{10} \frac{pl^4}{Eb^2t}.$$

44. A cantilever of length l , specific weight w , and square in section, a side of the section being $2b$ at the fixed and $2a$ at the free end, bends under its own weight. Find the slope and deflection of the neutral axis at the free end. Hence, also, deduce corresponding results when the cantilever is a regular pyramid.

$$\text{Ans.} \frac{(b+a)wl^3}{4Eb^3}; \frac{(b+2a)wl^4}{8Eb^3}; \frac{wl^3}{4Eb^3}, \frac{wl^4}{8Eb^2}.$$

45. If the section of the cantilever in the preceding question, instead of being square, is a regular figure with *any* number of equal sides, show that the neutral axis is a parabola with its vertex at the point of fixture.

46. The section of a cantilever of length l is an ellipse, the major axis (*vertical*) being twice the minor axis. Find the deflection at the end

under a single weight W , f being the coefficient of working strength and E the coefficient of elasticity.

$$\text{Ans. } \left(\frac{297}{7000} \frac{f^4 l^6}{E^3 W} \right)^{\frac{1}{3}}.$$

47. A cast-iron beam of an inverted T-section rests upon supports 22 ft. apart; the web is 1 in. thick and 20 in. deep; the flange is 1.2 in. thick and 12 in. wide; the beam carries a uniformly distributed load of 99,000 lbs. Find the maximum deflection, E being 17,920,000 lbs.

$$\text{Ans. } .822 \text{ in. } (I = 1668.65).$$

48. Find the maximum deflection of a cast-iron cantilever 2 in. wide \times 3 in. deep \times 120 in. long under its own weight, E being 17,920,000 lbs.

$$\text{Ans. } \frac{1}{8} \text{ in.}$$

49. A girder of *uniform strength*, of length l , breadth b , and depth d rests upon two supports and carries a uniformly distributed load of w lbs. per unit of length, which produces an inch-stress of f lbs. at every point of the material. Show that the central deflection is $\frac{\pi - 2}{2} \frac{f^{\frac{2}{3}}}{E} \left(\frac{b}{3w} \right)^{\frac{1}{3}} l$, when b is constant and d variable. Find the deflection when d is constant and b variable.

$$\text{Ans. } \frac{f l^3}{4 E d}.$$

50. A semi-girder of *uniform strength*, of length l , breadth b , and depth d , carries a weight W at the free end which produces an inch-stress of f lbs. at every point of the material. Prove that the maximum deflection is $\frac{4}{3} \frac{(fl)^{\frac{2}{3}}}{E} \left(\frac{b}{6W} \right)^{\frac{1}{3}}$ when b is constant and d variable, and that it is twice as great as it would be if the section were uniform throughout and equal to that at the support.

What would be the maximum deflection if the semi-girder were subjected to a uniformly distributed load of w lbs. per unit of length?

$$\text{Ans. } \frac{2fl}{E} \sqrt{\frac{bf}{3w}}.$$

51. The neutral axis of a symmetrically loaded girder, whose moment of inertia is constant, assumes the form of an elliptic or circular arc. Show that the bending moment at any point of the deflected girder is inversely proportional to the cube of the vertical distance between the point and the centre of the ellipse or circle.

52. A vertical row of water-tight sheet piling, 12 ft. high, is supported by a series of uprights placed 6 ft. centre to centre and securely fixed at the base. Find the greatest deviation of an upright from the vertical when the water rises to the top of the piling. What will the maximum deviation be when the water is 6 ft. from the top?

$$\text{Ans. } \frac{w b h^3}{30 E I} = \frac{3110400}{E I}; \quad \frac{w c b}{30 E I} (h - c)^3 + \frac{w b c}{24 E I} (h - c)^4 = \frac{218720}{E I}.$$

53. A vertical row of water-tight sheet piling, 30 ft. high, is supported by a series of uprights placed 8 ft. centre to centre and securely fixed at the base, while the upper ends are kept in the vertical by struts sloping at 45° . If the water rises to the top of the piling, find (a) the thrust on a strut; (b) the maximum intensity of stress in an upright; (c) the amount and position of the maximum deviation of an upright from the vertical.

$$\text{Ans. } 45000\sqrt{2} \text{ lbs.; max. B. M.} = \frac{w_0 h^3}{15\sqrt{5}}, \text{ and max. intensity of}$$

$$\text{stress} = \frac{1}{I} \left\{ \frac{w_0 h^2}{10} \pm \frac{c}{I} \frac{8w_0 h^3}{15\sqrt{5}} \right\}; \text{ deflection is a max. when}$$

$$x = \frac{h}{\sqrt{5}} = \frac{30}{\sqrt{5}}, \text{ and its amount} = \frac{w_0 h^5}{EI} \frac{32}{750\sqrt{5}}.$$

54. The piling in the preceding example is strengthened by a second series of struts sloping at 45° from the points of maximum deviation. Find the normal reactions upon an upright and the bending moment at its foot.

What will be the reactions and bending moment if the second row of struts starts from the middle of the uprights?

$$\text{Ans. } .00754w_0 h^2; .137w_0 h^2; .92027w_0 h^2; 1.16w_0 h^2; 1.44w_0 h^2; 1.77w_0 h^2.$$

55. A continuous girder of three spans, the outside spans being equal, is uniformly loaded. What must be the ratio of the lengths of the centre and a side span so that the neutral axis may be horizontal over the intermediate supports?

$$\text{Ans. } \sqrt{3} : \sqrt{2}.$$

56. What should the ratio be if the centre span is hinged (a) at the centre; (b) at the points of trisection? *Ans.*—(a) 1 : 1; (b) 3 : 2 $\sqrt{2}$.

57. Four weights, each of 6 tons, follow each other at fixed distances of 5 ft. over a continuous girder of two spans, each equal to 50 ft. If the second and third supports are 1 in. and $1\frac{1}{2}$ in., respectively, vertically below the first support, find the maximum B. M. at the intermediate support.

$$\text{Ans. } \left(.9855 - \frac{EI}{40000} \right) \text{ ft.-tons.}$$

58. A continuous girder of two equal 50-ft. spans is fixed at one of the end supports. The girder carries a uniformly distributed load of 1000 lbs. per lineal foot. Find the reactions and bending moments at the points of support. How much must the intermediate support be lowered so that it may bear none of the load? How much should the free end be then lowered to bring upon the supports the same loads as at the first?

$$\text{Ans. Reactions} = 23,214\frac{2}{3}, 57,142\frac{6}{7}, 19,642\frac{2}{3} \text{ lbs.;}$$

$$\text{Bending moments} = 178,571\frac{2}{3}, 267,857\frac{1}{3} \text{ ft.-lbs.}$$

59. Four loads, each of 12 tons and spaced 5, 4, and 5 ft. apart, travel in order over a continuous girder of two spans, the one of 30 and the other of 20 ft. Place the wheels so as to throw a maximum B. M. upon the centre support, and find the corresponding reactions.

Draw a diagram of B. M., and find the maximum deflection of each span.

60. The loads upon the wheels of a truck, locomotive, and tender, counting in order from the front, are 7, 7, 10, 10, 10, 8, 8, 8, 8 tons, the intervals being 5, 5, 5, 5, 9, 5, 4, 5 ft. The loads travel over a continuous girder of two 50-ft. spans AB, BC . Place the locomotive, etc., (a) on the span AB so as to give a maximum B. M. at B ; (b) so as to give an absolute maximum B. M. at B .

61. A continuous girder of two spans AB, BC has its two ends A and C fixed to the abutments. The load upon AB is a weight P distant p from A , and that upon BC a weight Q distant q from C . The length of $AB = l_1$, of $BC = l_2$. The bending moments at A, B, C are M_1, M_2, M_3 , respectively. The areas of the bending-moment curves for the spans AB, BC assumed to be independent girders are A_1, A_2 , respectively. Show that

$$M_1 l_1 + M_2(l_1 + l_2) + M_3 l_2 = -2(A_1 + A_2),$$

$$\text{and} \quad M_2(l_1 + l_2) = -2(A_1 p + A_2 q).$$

If $l_1 = l_2 = l$, show that M_2 is a maximum if

$$2l(Pp - Qq) = 3(Pp^2 - Qq^2).$$

62. A continuous girder of two spans AB, BC rests upon supports at A, B . A uniformly distributed load EF travels over the girder. G_1 is the centre of gravity of the portion BE upon AB , and G_2 that of the portion BF upon BC . If the bending moment at B is a maximum, show that

$$\frac{AE \cdot EB}{CF \cdot FB} = \frac{AG_1}{CG_2}.$$

63. An eight-wheel locomotive travels over a continuous girder of two 100-ft. spans; the truck-wheels are 6 ft. centre to centre, the load upon each pair being 8000 lbs.; the driving-wheels are $8\frac{1}{2}$ ft. centre to centre, the load upon each pair being 16,000 lbs.; the distance centre to centre between the front drivers and the nearest truck-wheels is also $8\frac{1}{2}$ ft. Place the locomotive so as to throw a maximum B. M. upon the centre support, and find the corresponding reactions.

64. If an end of a continuous girder of any number of spans is fixed, show that the relation between the moment of fixture (M_1) and the bending moment (M_2) at the consecutive support, is $2M_1 + M_2 = -\frac{wl^2}{4}$, or $2M_1 + M_2 = -\frac{1}{72} \Sigma [Pp(l-p)(2l-p)]$, according as the load upon

the span (l) between the fixed end and the consecutive support is of uniform intensity or consists of a number of weights P_1, P_2, P_3, \dots concentrated at points distant p_1, p_2, p_3, \dots from the fixed end.

65. A continuous girder of two spans AB, BC , carrying a load of uniform intensity, has one end A fixed, and the other end rests upon the support at C . If the bending moments at A and B are equal, show that the spans are in the ratio of $\sqrt{3}$ to $\sqrt{2}$, and find the reactions at the supports, W_1 being the load upon AB , and W_2 that upon BC .

$$\begin{aligned} \text{Ans. At } A \text{ reaction} &= \frac{1}{4} W_1. \\ \text{" } B \text{ " } &= \frac{1}{2} W_1 + \frac{3}{8} W_2. \\ \text{" } C \text{ " } &= \frac{3}{8} W_2. \end{aligned}$$

66. A viaduct over the Garonne at Bordeaux consists of seven spans, viz., two end spans, each of 57.375 m., and five intermediate spans, each of 77.06 m.; the main girders are continuous from end to end, and are each subjected to a dead load of 3050 k. per lineal metre. Determine the absolute maximum bending moment at the third support from one end. Also find the corresponding reactions, the points of inflexion, and the maximum deflection in the first and second spans.

67. A continuous girder consists of two spans, each 50 ft. in length; the effective depth of the girder is 8 ft. If one of the end bearings settles to the extent of 1 in., find the maximum increase in the flange and shearing stress caused thereby, and show by a diagram the change in the distribution of the stresses throughout the girder. (Assume the section of the girder to be uniform, and take $E = 25,000,000$ lbs.)

$$\text{Ans. Increase of maximum B. M.} = \frac{6.25}{16} I \left(\frac{I}{216w} - 1 \right).$$

$$\text{" " shearing force} = \frac{7}{8} I.$$

w being weight per unit of length, and I the moment of inertia.

68. A girder carrying a uniformly distributed load is continuous over four supports, and consists of a centre span (l_2) and two equal side spans (l_1). Find the ratio of l_1 to l_2 , so that the neutral axis at the intermediate supports may be horizontal. Also find the value of the ratio when a hinge is introduced (a) at the middle point of the centre span; (b) at the points of trisection of the centre span; (c) at the middle points of the half lengths of the centre span.

$$\text{Ans. } \frac{l_1^2}{l_2^2} = \frac{2}{3}; \frac{l_1^2}{l_2^2} = \frac{1}{2}; \frac{l_1^2}{l_2^2} = \frac{4}{9}; \frac{l_1^2}{l_2^2} = 3.$$

69. In a certain Howe truss bridge of eight panels, the timber cross-ties are directly supported by the lower chords, and are placed sufficiently close to distribute the load in an approximately uniform manner over the whole length of these chords, thus producing an additional stress due to flexure. Assuming that the chords may be regarded as girders supported at the ends and continuous over seven intermediate

supports coincident with the panel points, and that these panel points are in a truly horizontal line, determine (a) the bending moments and reactions at the panel points; (b) the maximum intermediate bending moments and (c) the points of inflexion, corresponding to a load of w per unit of length, l being the length of a panel.

Ans.—(a) At 1st support; 2d support; 3d support;

$$\text{B. M.} = 0 \quad ; \quad -\frac{41}{388}wl^2; \quad -\frac{39}{388}wl^2;$$

$$\text{Reaction} = R_1 = \frac{13}{388}wl; \quad R_2 = \frac{14}{388}wl; \quad R_3 = \frac{11}{388}wl;$$

At 4th support; 5th support.

$$\text{B. M.} = -\frac{39}{388}wl^2; \quad -\frac{39}{388}wl^2.$$

$$\text{Reaction} = R_4 = \frac{13}{388}wl; \quad R_5 = \frac{11}{388}wl.$$

$$(b) \text{ Maximum intermediate B. M.} = \frac{11704.5}{(388)^2}wl^2 \text{ in 1st span};$$

$$= \frac{5104.5}{(388)^2}wl^2 \text{ in 2d}; \quad = \frac{6600.5}{(388)^2}wl^2 \text{ in 3d};$$

$$= \frac{6208.5}{(388)^2}wl^2 \text{ in 4th.}$$

(c) Points of inflexion in the four spans are given by

$$x = \frac{2R_1}{w} = \frac{306}{388}l; \quad R_1(l+x) + R_2x - \frac{w}{2}(l+x)^2 = 0;$$

$$R_1(2l+x) + R_2(l+x) + R_3x - \frac{w}{2}(2l+x)^2 = 0;$$

$$R_1(3l+x) + R_2(2l+x) + R_3(l+x) + R_4x - \frac{w}{2}(3l+x)^2 = 0.$$

70. A continuous girder of two equal spans is *fixed* at one of the end supports. The girder carries a uniformly distributed load of intensity w . If the length of each span is l , find the reactions and moment of fixture. How much must the intermediate support be lowered so that it may bear none of the load? How much should the free-end support then be lowered to bring upon the supports the same loads as before?

$$\text{Ans.} \quad \frac{11}{28}wl, \quad \frac{16}{14}wl, \quad \frac{13}{28}wl; \quad -\frac{wl^2}{14}; \quad \frac{4}{48} \frac{wl^4}{EI}; \quad \frac{4}{24} \frac{wl^4}{EI}.$$

71. Each of the main girders of the Torksey Bridge is continuous and consists of two equal spans, each 130 ft. long. The girders are double-webbed; the thickness of each web plate is $\frac{1}{2}$ in. at the centre and $\frac{3}{8}$ in. at the abutments and centre pier; the total depth of the girders is 10 ft., and the depth from centre to centre of the flanges is 9 ft. $4\frac{3}{8}$ in. Find (a) the reactions at the supports, and also (b) the points of inflexion, when 200 tons of live load cover *one* span, the total dead load upon each span being 180 tons uniformly distributed. The top flange is

cellular; its *gross* sectional area at the centre of each span is 51 sq. in., and the corresponding *net* sectional area of the bottom flange is 55 sq. in. Determine (c) the flange stresses and (d) the position of the neutral axis. ($I = 372,500$.) Also (e) determine the reactions when, *first*, B and, *second*, C are lowered 1 in. ($E = 16,900$ tons.)

Ans.—(a) 155, 350, 55 tons.

(b) $106\frac{1}{8}$ and $79\frac{3}{8}$ ft. from end support.

(c) 6.7 and 7.3 tons per sq. in. in loaded span; 1.13 and 1.22 tons per sq. in. in unloaded span.

(d) 58.3 in. from centre line of top flange.

$$\left. \begin{aligned} \text{(e) First. } R_1 &= 155 + \frac{1}{4} \frac{EI}{l^3}; R_2 = 350 - \frac{1}{2} \frac{EI}{l^3}; \\ R_3 &= 55 + \frac{1}{4} \frac{EI}{l^3}. \\ \text{Second. } R_1 &= 155 - \frac{1}{8} \frac{EI}{l^3}; R_2 = 350 + \frac{1}{4} \frac{EI}{l^3}; \\ R_3 &= 55 - \frac{1}{8} \frac{EI}{l^3}. \end{aligned} \right\} \begin{array}{l} \text{Where} \\ \frac{EI}{l^3} = \frac{18625}{11232}. \end{array}$$

72. Two tracks, 6 ft. apart, cross the Torksey Bridge, and are supported by single-webbed plate cross-girders 25 ft. long and 14 in. deep. If the whole of the weight upon a pair of drivers, viz., 10 tons, be directly transmitted to one of these cross-girders, draw the corresponding shearing-force and bending-moment diagrams (1) if the ends of the cross-girder are *fixed* to the bottom flanges of the main girders; (2) if they merely rest on the said flanges. Find the *maximum* deflection of the cross-girder and the *work done* in bending it, in each case.

$$\text{Ans. (1) } \left\{ \begin{array}{l} \frac{7988.45}{EI} \text{ at } 13.208 \text{ ft. from one end.} \\ \text{Total work of flexure} = \frac{671616}{EI} \text{ ft.-tons.} \end{array} \right.$$

73. A swing-bridge consists of the tail end AB , and of a span BC , of length 1 ft., the pivot being at B . The ballast-box of weight W extends over a length AD ($= 2c$ ft.), and the weight of the bridge from D to B is w tons per lineal foot. If $DB = x$, if p is the cost per ton of the bridge, and if q is the cost per ton of the ballast, show that the total cost

is a *minimum* when $x + c = \left(\frac{q(l^2 - c^2)}{2p - q} \right)^{\frac{1}{2}}$, and that the corresponding

weight of the ballast is $w \frac{p}{q}(x + c)$.

74. Compare graphically, the shearing forces and bending moments along the span BC of the bridge in the preceding question when the bridge is closed, with their values when the bridge is open. What provision should be made to meet the change in the kind of stress?

75. Each of the main girders of a railway bridge resting upon two end supports and five intermediate supports is fixed at the centre support, is 3 ft. deep throughout, and is designed to carry a uniformly distributed *dead* load of $\frac{1}{4}$ ton and a live load of $\frac{1}{4}$ ton per lineal foot. The end spans are each 51 ft. 8 in. and the intermediate spans each 50 ft. in the clear. Find the reactions at the supports. The girders are single-webbed and double-flanged; the flanges are 12 in. wide and equal in sectional area, the areas for the intermediate spans being 13 sq. in. and 17 sq. in. at the centre and piers respectively. Find the corresponding moments of resistance and flange stresses, the web being $\frac{3}{8}$ in. thick.

Ans. Reaction at 1st and 7th supports = $15\frac{1}{2}$; at 2d and 5th supports = $43\frac{1}{2}$; at 3d and 5th supports = $35\frac{1}{2}$; at 4th support = $38\frac{1}{2}$ tons.

At piers $\frac{I}{c} = 693$ and flange stresses are 3.59 tons per sq. in. at 2d support, 2.45 at 3d, and 2.83 at 4th.

At centre $\frac{I}{c} = 549$ and flange stresses in 1st span = 3.2 tons per sq. in., in 2d = 1.3, and in 3d = 1.78.

76. A continuous beam of four equal spans carries a uniformly distributed load of w intensity per unit of length. The second support is depressed a certain distance d below the horizontal, and the reaction at the 2d support is twice that at the 1st. Show that the reactions at the 1st, 2d, 3d, 4th, and 5th supports are in the ratio of the numbers 15, 30, 36, 34, and 13; find d . With this same value of d find the reactions when one end is fixed.

$$\text{Ans. } d = \frac{1}{48} \frac{wl^4}{EI}.$$

$$R_1 = \frac{15}{100} wl; R_2 = \frac{30}{100} wl; R_3 = \frac{36}{100} wl; \\ R_4 = \frac{34}{100} wl; R_5 = \frac{13}{100} wl.$$

77. A continuous girder of two equal spans (l) is uniformly loaded. Show that the ends will just touch their supports if the centre support is raised $\frac{wl^4}{8EI}$.

78. If d_1, d_2, d_3, d_4 are respectively the deflections of the 1st, 2d, 3d, and 4th panel points in question 69, show that the bending moment at the middle panel point (M_4) is given by

$$-93M_4 = -\frac{6EI}{l^2}(69d_4 - 88d_3 + 24d_2 - 6d_1) + \frac{1}{2}wl^2.$$

79. A girder supported at the ends is 30 ft. in the clear and carries two stationary loads, viz., 7 tons concentrated at 6 ft. and 12 tons at 18 ft. from the left support. Find the position and amount of the maximum deflection, and also the work of flexure. The girder is built up of plates and angle-irons and is 24 in. deep. If the moment of resistance due to the web is neglected, and if the intensity of the longitudinal stress is not to exceed 5 tons per sq. in., what should be the flange sectional area corresponding to the maximum bending moment.

$$\text{Ans. Max. deflection} = \frac{7}{12}x^3 - \frac{1}{3}(x-6)^3 - \frac{480}{EI}x, \text{ where}$$

$$x = 15.34 \text{ ft.}$$

$$\text{Work} = \frac{67161.6}{EI} \text{ ft.-tons.}$$

$$\text{Sect. area} = 10.32 \text{ sq. in.}$$

80. Determine the work of flexure and the necessary flange sectional area at the centre if the girder in the preceding question is subjected to a uniformly distributed load of 40 tons, instead of the isolated loads.

$$\text{Ans. Work} = \frac{540000}{EI} \text{ ft.-tons; sect. area} = 15 \text{ sq. in.}$$

81. (a) The bridge over the Garonne at Langon carries a double track, is about 695 ft. in length, and consists of three spans, AB, BC, CD . The two main girders are continuous and rest upon the abutments at A and D and upon piers at B and C . The effective length of each of the spans AB, CD is 208 ft. 6 in., and of the centre span BC 243 ft. The permanent load upon a main girder is 1277 lbs. per lineal foot, and the proof load is 2688 lbs. per lineal foot. Find the reactions at the supports (1) when the proof load covers the span AB ; (2) when the proof load covers the span BC ; (3) when the proof load covers the spans AB and BC ; (4) when the proof load covers the whole girder.

Draw shearing-force and bending-moment diagrams for each case.

(b) At the piers the web is $\frac{1}{2}$ in. thick and 18 ft. in depth, and each flange is made up of four plates $\frac{1}{2}$ in. thick and 3 ft. wide. Determine the flange stresses for cases (1) and (3).

(c) The angle-irons connecting the flanges with the web at the pier are riveted to the former with $1\frac{1}{2}$ -in. rivets and to the latter with 1-in. rivets. How many of each kind are required in one line per lineal foot on both sides of the pier at B , 8000 lbs. per square inch being safe shearing stress?

(d) The effective height of the pier at B is 41 ft., its mean thickness is $1\frac{1}{4}$ ft. 9 in., its width is 42 ft. 9 in., and it weighs 125 lbs. per cubic foot. If there is no surcharge on the bridge, and if the coefficient of friction between the sliding surfaces at the top of the pier is taken at .15, show that the overturning moment due to the dilatation of the girders is about $\frac{1}{2}$ of the amount of stability of the pier.

(e) Find the *points of inflexion* and also the *maximum deflections* in Case 3.

What practical advantage is derived from the calculation of the deflection?

- Ans.*—(a) Case 1. $R_1 = 398184.8$; $R_2 = 621651.6$;
 $R_3 = 272200.8$; $R_4 = 111230.7$ lbs.;
 $M_2 = -13794181.9$; $M_3 = -4565418.4$ ft.-lbs.
 Case 2. $R_1 = 142200.2 = R_4$ lbs.;
 $R_2 = 605801.8 = R_3$ lbs.;
 $M_2 = -14936321.6$ ft.-lbs. = M_3 .
 Case 3. $R_1 = 306837$; $R_2 = 1039591.3$;
 $R_3 = 639147.8$; $R_4 = 70875.7$ lbs.;
 $M_2 = -22208200.2$; $M_3 = -12979436.7$ ft.-lbs.
 Case 4. $R_1 = 316222.6 = R_4$ lbs.;
 $R_2 = 992227.3 = R_3$ lbs.;
 $M_2 = -2025121.6 = M_3$ ft.-lbs.

- (b) $I = 2130816$; in case 1, $f_2 = 8545.2$ lbs. per sq. in.
 $f_3 = 2828.1$ " " " "
 in case 3, $f_2 = 13757.5$ " " " "
 $f_3 = 8040.5$ " " " "

(Weakening effect of rivet-holes in tension flange is neglected.)

(c) 11 per lineal foot; 11.5 per lineal foot.

(d) Moment of stability = $23833291\frac{1}{8}$ ft.-lbs.;
 overturning moment = 1965323.4 ft.-lbs.;
 ratio = 12.12.

(e) *Points of inflexion*: in AB , 154.7 ft. from A ; in BC ,
 at a distance x from B given by $x^2 - 279.1x + 9045.5$
 = 0; in CD , at 111 ft. from D .

Max. deflections:

In AB , $\frac{1}{EI}(1652\frac{1}{4}x^4 - 51139.5x^3 + 5172004980x)$,

where x is given by $660\frac{3}{8}x^3 - 1586620.9x^2 + 5172004980 = 0$;

In BC , $\frac{1}{EI}(165.2x^4 - 3418.5x^3 + 11104110.5x^2 + 46023583x)$,

where x is given by $x^3 - 393.2x^2 + 33606x + 69645 = 0$.

82. A beam AB of span l carrying a uniformly distributed load of intensity w is fixed at A and merely supported at B . The end B is lowered by an amount $\frac{wl^3}{16EI}$. Find the reactions. How much must B be lowered so that the whole of the weight may be borne at A ?

Ans. $\frac{1}{8}wl$ at A , $\frac{5}{16}wl$ at B ; $\frac{1}{8}\frac{wl^4}{EI}$.

83. Solve the preceding question supposing the fixture at A to be imperfect, the neutral axis making with the horizontal an angle whose tangent is $\frac{1}{48} \frac{wl^3}{EI}$. Ans. $\frac{3}{4}wl, \frac{1}{4}wl; \frac{7}{48} \frac{wl^4}{EI}$.

84. A wrought-iron girder of I-section, 2 ft. deep, with flanges of equal area and having their joint area equal to that of the web, viz., 48 sq. in., carries $\frac{1}{2}$ ton per lineal foot, is 100 ft. long, consists of five equal spans, and is continuous over six supports. Find the reactions when the *third* support is lowered $\frac{1}{2}$ in. How much must this support be lowered so that the reaction may be *nil* at (a) the 1st support; (b) the 3d; (c) the 5th? How much must the support be raised so that the reaction may be *nil* at (d) the 2d; (e) the 4th; and (f) the 6th support? $E = 16,500$ tons.

Ans. $R_1 = 2\frac{3}{8}\frac{wl}{8}; R_2 = 15\frac{5}{8}\frac{wl}{8}; R_3 = 3\frac{6}{8}\frac{wl}{8};$
 $R_4 = 14\frac{3}{8}\frac{wl}{8}; R_5 = 9\frac{1}{8}\frac{wl}{8}; R_6 = 4\frac{1}{8}\frac{wl}{8}$ tons.
 (a) $1\frac{3}{8}$ in.; (b) $\frac{1}{4}\frac{wl}{8}$ in.; (c) $2\frac{1}{4}\frac{wl}{8}$ in.;
 (d) $1\frac{3}{8}\frac{wl}{8}$ in.; (e) $2\frac{3}{8}\frac{wl}{8}$ in.; (f) $6\frac{1}{4}$ in.

85. If the three supports of any two equal consecutive spans of a continuous girder of any number of spans are depressed below the horizontal, show that the relation between the three bending moments at the supports will be unaffected if the depression of the centre support is a mean between the depressions of the other two supports.

86. A girder consists of two spans AB, BC , each of length l , and is continuous over a centre pier B . A uniform load of length $2a (< l)$ and of intensity w travels over AB . Find the reactions at the supports for any given position of the load, and show that the bending moment at the centre pier is a maximum and equal to $\frac{awl}{3\sqrt{3}}\left(1 - \frac{a^2}{l^2}\right)^{\frac{3}{2}}$ when the centre of the load is at a distance $\left(\frac{l^2 - a^2}{3}\right)^{\frac{1}{2}}$ from A .

87. A continuous girder rests upon three supports and consists of two unequal spans $AB (= l_1), BC (= l_2)$. A uniform load of intensity w travels over AB , and at a given instant covers a length $AD (= r)$ of the span. If R_1, R_3 are the reactions at A and C , respectively, show that

$$R_1 l_1^2 + R_3 l_2^2 = wr \left(l_1^2 - \frac{3}{4} r l_1 + \frac{1}{8} \frac{r^3}{l_1} \right).$$

Draw a diagram showing the shearing force in front of the moving load as it crosses the girder.

88. If the live load in the preceding question may cover both spans, show that the shearing force at any point D is a maximum when AD and BC are loaded and BD unloaded.

Illustrate this force *graphically*, taking into account the dead load upon the girder.

89. A continuous-girder bridge has a centre span of 300 ft. and two side spans, each of 200 ft. The dead load upon each of the main girders is 1250 lbs. per lineal foot. In one of the side spans there is also an additional load of 2500 lbs. per lineal foot upon each girder. Find the reactions and points of inflexion. How much must the third support from the loaded end be lowered so that the pressure upon it may be just zero?

Ans. Let W = weight on loaded span = 750,000 lbs.

$$R_1 = \frac{593}{144} W \text{ lbs.}; R_2 = \frac{1877}{144} W \text{ lbs.};$$

$$R_3 = \frac{907}{182} W \text{ lbs.}; R_4 = \frac{177}{182} W \text{ lbs.};$$

$$M_2 = -\frac{375}{182} W \text{ ft.-lbs.}; M_3 = -\frac{49}{48} W \text{ ft.-lbs.}$$

Distance of point of inflexion in loaded span from nearest end support = $162\frac{3}{4}$ ft.

Distance of point of inflexion in unloaded end span from nearest end support = $145\frac{3}{4}$ ft.

Distance of point of inflexion in intermediate span from end support in unloaded span is the value of x in the equation $x^2 - 1\frac{39}{2}x + 4\frac{25}{8} = 0$.

3d support must be lowered a distance = $\frac{56350000}{84} \frac{W}{EI}$.

90. A continuous girder AC consists of two equal spans AB, BC , each of length l , and carries a uniformly distributed load of intensity w_1 upon AB , and of intensity w_2 upon BC . Determine the bending moments at the supports, the maximum intermediate bending moments, and the reactions (a) when both ends of the girder are fixed; (b) when one end A is fixed and the other free.

Ans. Denoting the reactions and bending moments at A, B, C by $R_1, M_1, R_2, M_2, R_3, M_3$, respectively:

$$(a) M_1 = \frac{l^2}{48} (-5w_1 + w_2); M_2 = -\frac{l^2}{24} (w_1 + w_2);$$

$$M_3 = \frac{l^2}{48} (w_1 - 5w_2); M_{max.} \text{ in } AB = \frac{R_1^2}{27w_1} + M_1, \text{ in } BC$$

$$= \frac{R_2^2}{27w_2} + M_2; R_1 = \frac{l}{16} (9w_1 - w_2); R_2 = \frac{l}{2} (w_1 + w_2);$$

$$R_3 = \frac{l}{16} (-w_1 + 9w_2).$$

$$(b) M_1 = -\frac{l^2}{28} (3w_1 - w_2); M_2 = -\frac{l^2}{28} (w_1 + 2w_2);$$

$$M_3 = 0; M_{max.} \text{ in } AB = \frac{R_1^2}{27w_1} + M_1, \text{ in } BC = \frac{R_2^2}{27w_2};$$

$$R_1 = \frac{l}{28} (16w_1 - 3w_2); R_2 = \frac{l}{28} (13w_1 + 19w_2);$$

$$R_3 = \frac{l}{28} (-w_1 + 12w_2).$$

91. In the preceding question, if $w_1 = w_2 = w$, find the points of inflexion and the maximum deflection in each case and for each span.

Ans --(a) Points of inflexion for AB or BC are given by

$$6x^2 - 6xl + l^2 = 0.$$

Max. deflection for AB or BC is given by

$$-EIy = \frac{wx^2}{24}(2lx - x^2 - l^2),$$

in which the value of x is found from

$$2x^2 - 3lx + l^2 = 0.$$

(b) Points of inflexion in AB are given by

$$14x^2 - 13xl + 2l^2 = 0, \text{ and in } BC \text{ by } x = \frac{1}{4}l.$$

Max. deflection for AB is given by

$$-EIy = \frac{wx^2}{168}(13lx - 6l^2 - 7x^2),$$

and

$$28x^2 - 39lx + 12l^2 = 0.$$

Max. deflection for BC is given by

$$-EIy = \frac{wx}{168}(11lx^2 - 7x^3 - 4l^3),$$

and

$$28x^3 - 33x^2 + 4l^3 = 0.$$

92. A continuous girder AC consists of two equal spans AB, BC of 15 m. each. Determine the bending moments at the supports, the maximum intermediate bending moments, and the reactions (a) when the load upon each span is 3000 k. per metre; (b) when the load per metre is 3000 k. upon AB and 1000 k. upon BC . Call M_1, M_2, M_3 the bending moments and R_1, R_2, R_3 the reactions at A, B, C , respectively, and consider three cases, viz., when both ends of the girder are free, when both ends are fixed, and when one end is free and the other fixed.

Ans.—Case I:

(a) $M_1 = 0 = M_3; M_2 = -84375 \text{ km.}; M_{max.} \text{ in } AB \text{ or } BC = 47460.9375 \text{ km.}$

$$R_1 = R_2 = 16875k; R_3 = 56250k.$$

(b) $M_1 = 0 = M_3; M_2 = -56250 \text{ km.}; M_{max.} \text{ in } AB = 58593.75 \text{ km.}, \text{ in } BC = 7031.25 \text{ km.}$

$$R_1 = 18750 \text{ k.}; R_2 = 37500 \text{ k.}; R_3 = 3750 \text{ k.}$$

Case II:

(a) $M_1 = M_2 = M_3 = -56250 \text{ km.}; M_{max.} \text{ in } AB \text{ or } BC = 28125 \text{ km.}$

$$R_1 = \frac{R_3}{2} = R_3 = 22500 \text{ k.}$$

$$(b) M_1 = -65625 \text{ km.}; M_2 = -37500 \text{ km.}; M_3 = -9375 \text{ km.}$$

$$M_{max.} \text{ in } AB = 33398.4375 \text{ km.}, \text{ in } BC = 6445.3125 \text{ km.};$$

$$R_1 = 24375 \text{ k.}; R_2 = 30000 \text{ k.}; R_3 = 5625 \text{ k.}$$

Case III:

$$(a) M_1 = -48214\frac{2}{3} \text{ km.}; M_2 = -72321\frac{2}{3} \text{ km.}; M_3 = 0.$$

$$M_{max.} \text{ in } AB = 24537\frac{1}{3}\frac{2}{3} \text{ km.}, \text{ in } BC = 52088\frac{1}{3}\frac{2}{3} \text{ km.};$$

$$R_1 = 20892\frac{2}{3} \text{ k.}; R_2 = 51428\frac{2}{3} \text{ k.}; R_3 = 17678\frac{2}{3} \text{ k.}$$

$$(b) M_1 = -64285\frac{2}{3} \text{ km.}; M_2 = -40178\frac{2}{3} \text{ km.}; M_3 = 0.$$

$$M_{max.} \text{ in } AB = -32573\frac{1}{3}\frac{2}{3} \text{ km.}, \text{ in } BC = 11623\frac{1}{3}\frac{2}{3} \text{ km.};$$

$$R_1 = 24107\frac{2}{3} \text{ k.}; R_2 = 31071\frac{2}{3} \text{ k.}; R_3 = 4821\frac{2}{3} \text{ k.}$$

93. Show that a uniformly loaded and continuous girder of two equal spans, with both ends fixed, is 2.08 times as stiff as if the ends were free and merely rested on the supports.

94. A single weight travels over the span AB of a girder of two equal spans, AB, BC , continuous over a centre pier B . Show that the reaction at C is a maximum when the distance of the weight from A is $\frac{AB}{\sqrt{3}}$ if the ends A and C rest upon their supports, and when the distance is $\frac{2}{3}AB$ if the two ends are fixed. Find the corresponding bending moments at the central pier.

$$Ans. \frac{Wl}{6\sqrt{3}}; \frac{2}{27} Wl.$$

95. A girder with both ends fixed carries two equal loads W at points dividing the girder into segments a, b, c . Determine the reactions and bending moments at the supports.

$$Ans. R_1 = W \frac{3ab^2 + b^3 + 6abc + 3b^2c + 2c^3 + 6ac^2 + 6bc^2}{(a+b+c)^2};$$

$$R_2 = W \frac{2a^3 + 6a^2b + 3ab^2 + b^3 + 6a^2c + 6abc + 3b^2c}{(a+b+c)^2};$$

$$M_1 = W \frac{2a^2c + 2abc + bc^2 + ab^2}{(a+b+c)^2};$$

$$M_2 = W \frac{2ac^2 + 2abc + a^2b + b^2c}{(a+b+c)^2}.$$

96. A bridge a ft. in the clear is formed of two cantilevers which meet in the centre of the span and are connected by a bolt capable of transmitting a vertical pressure from the one to the other. A weight W is placed at a distance b from one of the abutments. Find the pressure transmitted from one cantilever to the other, and draw the curve of bending moments for the loaded cantilever.

$$Ans. R_1 = W \left(1 - 3\frac{b^2}{a^2} + 2\frac{b^3}{a^3} \right); R_2 = W \left(3\frac{b^2}{a^2} - 2\frac{b^3}{a^3} \right).$$

97. The weights 7, 7, 10, 10, 10, 10, 8, 8, 8, 8 tons, taken in order pass over a continuous girder of two spans, each of 50 ft. and fixed at both ends, the successive intervals being 5, 5, 5, 5, 9, 5, 4, 5 ft. Place the wheels so as to give the maximum bending moment at the centre support, and find its value.

Ans. First wheel 25.8399 ft. from nearest abutment ;
Max. B. M. = 306.62 ft.-tons.

98. The bridge over the Grande Baise consists of two equal spans of 19.8 m.; each of the main girders is continuous and rests upon abutments at the ends. Find the position of the points of inflexion, the bending moment at the centre support, the maximum intermediate bending moment, and the maximum flange stress (*a*) under the dead load of 1700 k. per lineal metre; (*b*) under the same dead load together with an additional proof load of 2000 k. per lineal metre on one span. The depth of the girder = 3.228 m., and $I = .093929232444$.

Ans.—(*a*) 14.85 m. from the abutments; 83308.5 kilogrammetres (km.); 46,861 $\frac{1}{3}$ km.; 1.4315 k. per sq. mm.
(*b*) 16.18 m. from abutment on loaded side; 11,876 m. from abutment on unloaded side; 132313.5 km.; 101991.65625 km.; 2.27356 k. per sq. mm.

99. The Estressol viaduct consists of four spans of 25 m.; the main girders are continuous and their ends rest upon abutments; the dead load upon each girder is 1700 k. per lineal metre. Determine the position of points of inflexion in each span, the reactions and bending moments at the supports when an additional load of 2000 k. per lineal metre crosses (*a*) the 1st span; (*b*) the 1st and 2d spans; (*c*) all the spans.

Also, find the *absolute* maximum bending moments at the intermediate supports.

Ans. Call x_1, x_2, x_3, x_4 the distances of points of inflexion in 1st, 2d, 3d, and 4th spans from the 1st, 2d, 4th, and 5th supports, respectively; R_1, R_2, R_3, R_4, R_5 the reactions; $M_1 (= 0), M_2, M_3, M_4, M_5 (= 0)$ the bending moments.

(*a*) $x_1 = 20.72$ m.;
 x_2 is given by $1700x_2^2 - 424017\frac{6}{7}x_2 + 395089\frac{2}{7} = 0$;
 x_3 by $1700x_3^2 - 47767\frac{6}{7}x_3 + 238839\frac{2}{7} = 0$; $x_1 = 19.38$ m.
 $R_1 = 38348\frac{3}{4}$ k.; $R_2 = 81160\frac{2}{7}$ k.; $R_3 = 34107\frac{1}{4}$ k.;
 $R_4 = 49910\frac{2}{7}$ k.; $R_5 = 16473\frac{3}{4}$ k.
 $M_2 = 197544\frac{2}{7}$ km.; $M_3 = 53571\frac{2}{7}$ km.;
 $M_4 = 4776\frac{1}{4}$ km.

$$(b) \quad x_1 = 19.556 \text{ m.}; \quad 3700x_2^2 - 103000x_2 + 503571\frac{1}{2} = 0;$$

$$1700x_3^2 - 41071\frac{3}{4}x_3 + 205357\frac{1}{2} = 0; \quad x_4 = 20.168 \text{ m.}$$

$$R_1 = 361787 \text{ k.}; \quad R_2 = 107821\frac{3}{4} \text{ k.}; \quad R_3 = 62964\frac{3}{4} \text{ k.};$$

$$R_4 = 45892\frac{1}{2} \text{ k.}; \quad R_5 = 17142\frac{1}{2} \text{ k.}$$

$$M_2 = 258928\frac{1}{2} \text{ km.}; \quad M_3 = 120535\frac{1}{2} \text{ km.};$$

$$M_4 = 102678\frac{1}{2} \text{ km.}$$

$$(c) \quad x_1 = 19.64 \text{ m.}; \quad x_2 \text{ and } x_3 \text{ are given by}$$

$$14x^2 - 375x + 1875 = 0.$$

$$M_2 = M_4 = 247767\frac{1}{2} \text{ km.}; \quad M_3 = 165178\frac{1}{2} \text{ km.}$$

Abs. max. B. M. at 2d support (= max. B. M. at 4th support) occurs when 1st, 2d, and 4th spans are loaded, and = $264508\frac{1}{4}$ km.

Abs. max. B. M. at 3d support occurs when 2d and 3d spans are loaded and = $209821\frac{1}{2}$ km.

100. In the preceding question find the absolute maximum flange unit stress at the piers, I being .093929232444. *Ans.* 4.5 k. per sq. mm.

101. The Osse iron viaduct consists of seven spans, viz., two end spans of 28.8 m. and five intermediate spans of 38 m.; each main girder is continuous and carries a dead load of 125 k. per lineal metre. Find the bending moments at the supports when a proof load of 2250 k. per lineal metre for each girder covers all the spans; and also find the absolute maximum bending moment at the *fourth* support. Is the following section of sufficient strength?—two equal flanges, each composed of a 600-mm. \times 8-mm. plate riveted by means of two 100-mm. \times 100-mm. \times 12-mm. angles to a 600-mm. \times 10-mm. vertical web plate and two 80-mm. \times 80-mm. \times 11-mm. angles riveted to each horizontal plate with the ends of the horizontal arms 15 mm. from the edges of the plates; the whole depth of the section being 4.016 m., and the distance between the web plates, which is open, being 2.8 m. If insufficient, how would you strengthen it?

$$\text{Ans. } M_2 = 416,518 \text{ km.}; \quad M_3 = 452,790 \text{ km.}; \quad M_4 = 443,722 \text{ km.}$$

$$\text{Max. B. M.} = 542,199 \text{ km.} \quad I = .14074440467.$$

$$\therefore \frac{I}{c} = .07009183,$$

$$\text{and max. flange stress} = \frac{cM_4}{I} = 7.73 \text{ k. per sq. mm.}$$

This is much too large. The section may be strengthened by adding two 600-mm. \times 8-mm. plates to each flange. I is thus increased by .0783425536, and the flange unit stress becomes 5 k. per sq. mm.



CHAPTER VIII.

PILLARS.

1. Classification.—The manner in which a material fails under pressure depends not merely upon its *nature* but also upon its *dimensions* and *form*. A short pillar, e.g., a cubical block, will bear a weight that will almost crush it into powder, while a thin plank or a metal coin subjected to enormous compression will be only condensed thereby. In designing struts or posts for bridges and other structures, it must be borne in mind that such members have to resist *buckling* and *bending* in addition to a direct pressure, and that the tendency to buckle or bend increases with the ratio of the length of a pillar to its least transverse dimension.

Hodgkinson, guided by the results of his experiments, divided *all pillars with truly flat and firmly bedded ends* into *three* classes, viz.:

(A) *Short Pillars*, of which the ratio of the length to the diameter is less than 4 or 5; these fail under a direct pressure.

(B) *Medium Pillars*, of which the ratio of the length to the diameter exceeds 5, and is less than 30 if of cast-iron or timber, and less than 60 if of wrought-iron; these fail partly by crushing and partly by flexure.

(C) *Long Pillars*, of which the ratio of the length to the diameter exceeds 30 if of cast-iron or timber, and 60 if of wrought-iron; these fail wholly by flexure.

2. Further Deductions from Hodgkinson's Experiments.—A pillar with both ends rough from the foundry so that a load can be applied only at a few isolated points, and a pillar with a rounded end so that the load can be applied only

along the axis, are each *one-third* of the strength of a pillar of class B, and from *one-third* to *two-thirds* of the strength of a pillar of class C, the pillars being of the same dimensions.

The strength of a pillar with one end flat and the other round is an arithmetical mean between the strengths of two pillars of the same dimensions, the one having both ends flat and the other both ends round.

Disks at the ends of pillars only slightly increase their strength, but facilitate the formation of connections.

An enlargement of the middle section of a pillar sometimes increases its strength in a small degree, as in the case of solid cast-iron pillars with rounded ends which are made stronger by about *one-seventh*; hollow cast-iron pillars are not affected. The strength of a disk-ended pillar is increased by about *one-eighth* or *one-ninth* when the middle diameter is lengthened by 50 per cent., but for slight enlargements the increase is imperceptible.

The strength of hollow cast-iron pillars is not affected by a slight variation in the thickness of the metal, as a thin shell is much harder than a thick one. The excess above or deficiency below the average thickness should not exceed 25 per cent.

3. Form.—According to Hodgkinson, the relative strengths of long cast-iron pillars of equal weight and length may be tabulated as follows:

(a) Pillars with *flat* ends.

The strength of a solid round pillar being 100,	
“ “ “ square “ is 93;	
“ “ “ triangular “ is 110.	

(b) Pillars with round ends, i.e., ends for hinging or pin connections.

The strength of a hollow cylindrical pillar being 100,	
“ “ an H-shaped “ is 74.6;	
“ “ a +-shaped “ is 44.2.	

The strengths of a long solid round pillar with flat ends, and a long hollow cylindrical pillar with round ends, are approximately in the ratio of 2.3 to 1.

The *stiffest* kind of wrought-iron strut is a built tube, the

section consisting of a cell or of cells, which may be circular, rectangular, triangular, or of any convenient form.

In experimenting upon hollow tubes, Hodgkinson found that, other conditions remaining the same, the *circular* was the strongest, and was followed in order of strength by the *square* in *four* compartments \boxplus ; the *rectangle* in *two* compartments, \boxminus ; the *rectangle*, \square ; and the *square*.

The addition of a diaphragm across the middle of the rectangle *doubled* its resistance to crippling.

4. Modes of Failure.—The manner in which the crushing of *short pillars* takes place depends upon the material, and the failure may be due to *splitting*, *bulging*, or *buckling*.

(a) *Splitting* into fragments is characteristic of such crystalline, fibrous, or granular substances as glass, timber, stone, brick, and cast-iron.



FIG. 335.

The compressive strength of these substances is much greater than their tensile strength, and when they fail they do so suddenly.

A hard vitreous material, e.g., glass or vitrified brick, splits into a number of prisms (Fig. 335).

A fibrous material, e.g., timber, and granular materials, e.g., cast-iron and many kinds of stone and brick, shear or slide along planes oblique to the direction of the thrust, and form one or more wedges or pyramids (Figs. 336, 337, 338).



FIG. 336. FIG. 337. FIG. 338.

Sometimes a granular or a crystalline substance will suddenly give way and be reduced to powder.

(b) *Bulging*, i.e., a lateral spreading out, is characteristic of blocks of fibrous materials, e.g., wrought-iron, copper, lead, and timber, and fracture occurs in the form of longitudinal cracks.

All substances, however, even the most crystalline, will bulge slightly before they fail, if they possess some degree of toughness.

(c) *Buckling* is characteristic of fibrous materials, and the resistance of a pillar to buckling is always less than its resistance to direct crushing, and is independent of length.

Thin malleable plates usually fail by the bending, pucker-

ing, wrinkling, or crumpling up of the fibres, and the same phenomena may be observed in the case of timber and of long bars.

Long plate tubes, when compressed longitudinally, first bend and eventually fail by the buckling of a short length on the concave side.

The ultimate resistance to buckling of a well-made and well-shaped tube is about 27,000 lbs. per square inch section of metal, which may be increased to 33,000 or 36,000 lbs. per square inch by dividing the tube into two or more compartments.

A rectangular wrought-iron or steel tube offers the greatest resistance to buckling when the mass of the material is concentrated at the angles, while the sides consist of thin plates or lattice-work sufficiently strong to prevent the bending of the angles.

Timber offers about twice the resistance to crushing when dry that it does when wet, as the presence of moisture diminishes the lateral adhesion of the fibres.

5. Uniform Stress.—Let a short pillar be subjected to a pressure of W lbs. uniformly distributed over its end and acting in the direction of its axis.

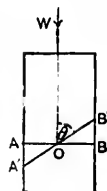

FIG. 339.

Let S be the transverse sectional area of the pillar.

Let $p = \frac{W}{S}$ be the intensity of stress per unit

of area of any transverse section AB .

Let $A'B'$ be any other section of area S' , inclined to the axis at an angle θ . The intensity of stress per unit of area of $A'B' = \frac{W}{S'} = \frac{W}{S} \sin \theta = p \sin \theta$, which may be resolved into a component $p \sin^2 \theta$ normal to $A'B'$, and a component $p \sin \theta \cos \theta$, i.e., $p \frac{\sin 2\theta}{2}$, parallel to $A'B'$. The last

intensity is evidently a maximum when $\theta = 45^\circ$, so that the plane along which the resistance to shearing is least, and therefore along which the fracture of a homogeneous material would tend to take place, makes an angle of 45° with the axis.

None of the materials of construction are truly homogeneous, and in the case of cast-iron the irregularity of the texture and the hardness of the skin cause the angle between the plane of shear and the direction of the thrust to vary from 32° to 42° . Brick chimneys sometimes fail by the shearing of the mortar, the upper portion sliding over an oblique plane.

Hodgkinson's experiments upon blocks of different materials led him to infer that the true crushing strength of a material is obtained when the ratio of length to diameter is at least $1\frac{1}{2}$; for a less ratio the resistance to compression is unduly increased by the friction at the surfaces between which the block is crushed.

6. Uniformly Varying Stress.—The load upon a pillar is rarely, if ever, uniformly distributed, but it is practically sufficient to assume that the pressure in any transverse section varies *uniformly*.

Any variable external force applied normally to a plane surface AA of area S may be graphically represented by a cylinder $AABB$, the end BB being the locus of the extremities of ordinates erected upon AA , each ordinate being proportional to the intensity of pressure at the point on which it is erected.

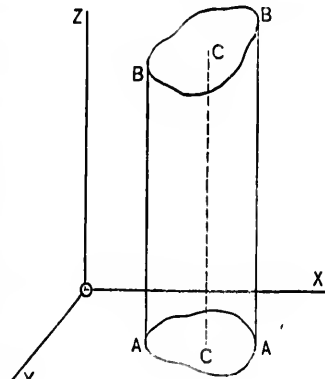

FIG. 340.

Let P be the total force upon AA , and let the line of its resultant intersect AA in C ; C is the *centre of pressure* of AA , and the ordinate CC necessarily passes through the centre of gravity of the cylinder.

Again, the resultant *internal* stress developed in AA is P , and may of course be graphically represented by the same cylinder $AABB$.

Assume that the pressure upon AA varies uniformly; the surface BB is then a plane inclined at a certain angle to AA .

Take O , the centre of figure of AA , as the origin, and AA as the plane of x, y .

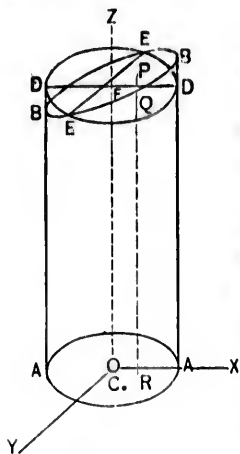

FIG. 34.

Let OY , the axis of y , be parallel to that line EE of the plane BB which is parallel to the plane AA .

Through EE draw a plane DD parallel to AA , and form the cylinder $AADD$.

The two cylinders $AABB$ and $AADD$ are evidently equal in volume, and OF , the average ordinate, represents the mean pressure over AA ; let it be denoted by p_0 .

At any point R of the plane AA , erect the ordinate RQP , intersecting the planes DD, BB , in Q and P , respectively.

Let x, y be the co-ordinates of R .

The pressure at R

$$= p = PR = PQ + QR = PQ + OF = ax + p_0,$$

a being a constant depending upon the variation.

Note.—The sign of x is negative for points on the left of O , and the pressure at a point corresponding to R is $p_0 - ax$.

Let x_0, y_0 be the co-ordinates of the centre of pressure C .

Let ΔS be an elementary area at any point R .

Then $p\Delta S$ is the pressure upon ΔS , and $\Sigma(p\Delta S)$ is the total pressure upon the surface AA , Σ being the symbol of summation.

Hence,

$$x_0 \Sigma(p\Delta S) = \Sigma(px\Delta S), \quad \text{and} \quad y_0 \Sigma(p\Delta S) = \Sigma(py\Delta S).$$

But $p = p_0 + ax$.

$$\therefore x_0 \Sigma\{(p_0 + ax)\Delta S\} = \Sigma\{p_0 x + ax^2\}\Delta S\}$$

and

$$y_0 \Sigma\{(p_0 + ax)\Delta S\} = \Sigma\{p_0 y + axy\}\Delta S\}.$$

Now O is the centre of figure of AA , and therefore $\Sigma(x\Delta S)$ and $\Sigma(y\Delta S)$ are each zero.

Also, $\Sigma(\Delta S) = S$, $\Sigma(x^2\Delta S)$ is the *moment of inertia* (I) of AA with respect to OY , and $\Sigma(xy\Delta S)$ is the *product of inertia* (K) about the axis OZ .

$$\therefore x_0 p_0 S = aI = x_0 P \dots \dots \dots (1)$$

and

$$y_0 p_0 S = aK = y_0 P \dots \dots \dots (2)$$

Cor. 1. In any symmetrical section y_0 is zero, and x_0 is the deviation of the centre of pressure C from the centre of figure O .

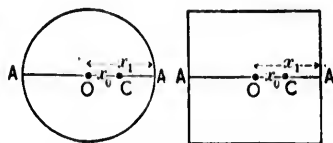

FIG. 342.

Let x_1 be the distance from O of the extreme points A of the section.

The greatest stress in AA is $p_0 + ax_1 = p_1$, suppose.

But $a = \frac{x_0 S p_0}{I}$, by eq. (1).

$$\therefore p_0 + \frac{x_0 x_1 S p_0}{I} = p_1,$$

or

$$\frac{p_0}{p_1} = \frac{I}{I + \frac{x_0 x_1 S}{I}} \dots \dots \dots (3)$$

It is generally advisable, especially in masonry structures, to limit x_0 by the condition that the stress shall be nowhere *negative*, i.e., a tension. Now the minimum stress is $p_0 - ax_1$, so that to fulfil this condition,

$$p_0 > \text{or} = ax_1. \quad \text{But } p_1 = ax_1 + p_0; \quad \therefore p_1 < \text{or} = 2p_0.$$

Hence, by eq. (3),

$$\frac{p_0}{2p_0} < \text{or} = \frac{I}{1 + \frac{x_0 x_1}{I} S},$$

and therefore

$$\frac{x_0 x_1 S}{I} < \text{or} = 1; \quad \text{i.e., } x_0 < \text{or} = \frac{I}{x_1 S}.$$

Cor. 2. The uniformly varying stress is equivalent to a single force P along the axis, and a couple of moment

$$P \times CO = P \sqrt{x_0^2 + y_0^2} = a \sqrt{I^2 + K^2}.$$

Cor. 3. The line CO is said to be *conjugate* to OY .

$$\text{If the angle } COX = \theta, \quad \text{then } \cot \theta = \frac{x_0}{y_0} = \frac{I}{K}.$$

7. Hodgkinson's Formulæ for the Ultimate Strength of Long and Medium Pillars.—When a *long* pillar is subjected to a crushing force it first yields sideways, and eventually breaks in a manner apparently similar to the fracture of a beam under a transverse load. This similarity, however, is modified by the fact that an initial longitudinal compression is induced in the pillar by the superimposed load.

Hodgkinson deduced, experimentally, that the strength of *long solid* round iron and square timber pillars, *with flat and firmly bedded ends*, is given by an expression of the form

$$W = A \frac{d^n}{l^m},$$

W being the breaking weight in tons of 2240 lbs. ;

d " " diameter or side of the pillar in *inches* ;

l " " length of the pillar in *feet* ;

n and m being numerical indices ;

A being a constant varying with the material and with the sectional form of the pillar.

For iron pillars.....	$n = 3.6$ and $m = 1.7$
“ timber pillars.....	$n = 4$ and $m = 2$
“ cast-iron.....	$A = 44.16$
“ wrought-iron.....	$A = 133.75$
“ dry Dantzic oak.....	$A = 10.95$
“ dry red deal.....	$A = 7.81$
“ dry French oak.....	$A = 6.9$

The strength of *long hollow* round cast-iron pillars was found to be given by

$$W = 44.34 \frac{d^{3.6} - d_1^{3.6}}{l^{1.7}},$$

d being the external and d_1 the internal diameter, both in inches.

Thus, the strength of a *hollow* cast-iron pillar is approximately equal to the difference between the strengths of two *solid* cast-iron pillars whose diameters are equal to the external and internal diameters of the hollow pillar.

The strength of *medium* pillars may be obtained by the formula

$$W' = \frac{WfS}{W + \frac{1}{4}fS},$$

W' being the breaking weight in tons of 2240 lbs.;

W “ “ “ “ “ “ “ “ “ “ as derived from the formula for *long* pillars;

f being the ultimate crushing strength in tons per square inch;

S being the sectional area of the pillar in square inches.

Again, if the ends of a cast-iron pillar are rounded, the above formulæ may be still employed to determine its strength, A being 14.9 for a *solid* and 13 for a *hollow* pillar.

8. Gordon's Formula for the Ultimate Strength of a Pillar.—The method discussed in the preceding articles, being practically very inconvenient, is not generally used, and the present article will treat of Professor Gordon's formula, which has a better theoretical basis and is easier of application.



FIG. 343.

The effect of a weight W upon a pillar of length l and sectional area S may be divided into *two* parts:

(a) A *direct thrust*, which produces a uniform compression of intensity $\frac{W}{S} = p_1$.

(b) A *bending moment*, which causes the pillar to yield in the direction of its *least* dimension (h).

Let y be the greatest deviation of the pillar from the vertical.

The bending moment M at the point of maximum stress may be represented by Wy .

Let p_2 be the stress in the extreme layers due to this bending moment.

$$\text{Now} \quad M = \frac{p_2}{c} I = \mu p_2 b h^2,$$

c being the distance of the layer under consideration from the neutral axis, μ a constant depending upon the sectional form, and b the dimension perpendicular to the plane of flexure.

$$\therefore \mu p_2 b h^2 = Wy, \quad \text{and} \quad p_2 \propto \frac{Wy}{b h^2}.$$

$$\text{But } y \propto \frac{l^2}{h}. \quad (\text{Art. 9, Chap. VI.})$$

$$\therefore p_2 \propto \frac{Wl^2}{bh^2} \propto \frac{Wl^2}{Sh^2} \propto p_1 \frac{l^2}{h^2}, \quad \text{and} \quad p_2 = p_1 a \frac{l^2}{h^2},$$

a being some constant to be determined by experiment.

Hence, the *total* stress in the most strained fibre is

$$f = p_1 + p_2 = p_1 \left(1 + a \frac{l^2}{h^2} \right),$$

or

$$\frac{W}{S} = p_1 = \frac{f}{1 + a \frac{l^2}{h^2}},$$

which is Gordon's formula.

Cor—If the weight upon the pillar causes the stress in any transverse section to *vary uniformly*, the *direct thrust* in the

extreme layers is $\frac{W}{S} \left(1 + \frac{x_0 h}{2I} S \right)$ instead of $\frac{W}{S}$, (Cor. 1, Art.

6,) x_0 being the greatest deviation of the line of resultant thrust from the axis of the pillar.

Let k be the *radius of gyration* of the cross-section. Then

$$Sk^2 = I,$$

and the expression for the direct thrust may be written

$$\frac{W}{S} \left(1 + \frac{x_0 h}{2k^2} \right).$$

Hence, Gordon's formula becomes

$$\frac{W}{S} = p_1 = \frac{f}{1 + a \frac{l^2}{h^2} + \frac{x_0 h}{2k^2}}$$

9. Values of a and f .—The following table, giving the values of the constants a and f in Gordon's formula, has been

prepared by taking an average of the best known results, and is applicable to round and square pillars *with square ends*.

	f in lbs. per sq. in.	a
For <i>cast-iron</i> solid rectangular pillars.....	80,000	$1\frac{1}{8}\sigma$
“ “ “ round “	80,000	$1\frac{1}{8}\sigma$
“ “ hollow rectangular “	80,000	$1\frac{1}{8}\sigma$
“ “ “ round “	80,000	$1\frac{1}{8}\sigma$
For <i>wrought-iron</i> solid rectangular pillars.....	36,000	$1\frac{1}{8}\sigma$
“ “ “ round “	36,000	$1\frac{1}{8}\sigma$
“ “ thick hollow round “	36,000	$1\frac{1}{8}\sigma$
For <i>mild-steel</i> solid rectangular pillars.....	67,200	$1\frac{1}{8}\sigma$
“ “ “ round “	67,200	$1\frac{1}{8}\sigma$
“ “ hollow round “	67,200	$1\frac{1}{8}\sigma$
For <i>strong-steel</i> solid rectangular pillars.....	114,000	$1\frac{1}{8}\sigma$
“ “ “ round “	114,000	$1\frac{1}{8}\sigma$
“ “ hollow round “	114,000	$1\frac{1}{8}\sigma$
For <i>pine-timber</i> solid rectangular pillars.....	5,000	$1\frac{1}{8}\sigma$
“ “ “ round “	5,000	$1\frac{1}{8}\sigma$
For <i>dry oak timber</i>	7,200	$1\frac{1}{8}\sigma$

If Gordon's formula is applied to pillars with pin ends, $4a$ takes the place of a ; and if to pillars with one pin end and one square end, $\frac{1}{2}a$ takes the place of a .

10. Graphical Comparison of the Crushing Unit Strength of Solid Round Cast-iron, Wrought-iron, and Mild-steel Pillars.

The crushing unit stress is given by
$$p = \frac{f}{1 + a\frac{l^2}{h^2}}$$

Take the different values of $\frac{l}{h}$ as abscissæ, and the corresponding values of p as ordinates; the resulting curves are shown in Fig. 344.

Hence, the strength of a mild-steel pillar always exceeds that of a wrought-iron pillar but is less than that of a cast-iron pillar when $\frac{l}{h} < 10.7$; a wrought-iron pillar is stronger or weaker than a cast-iron pillar according as $\frac{l}{h} >$ or < 28.5 .

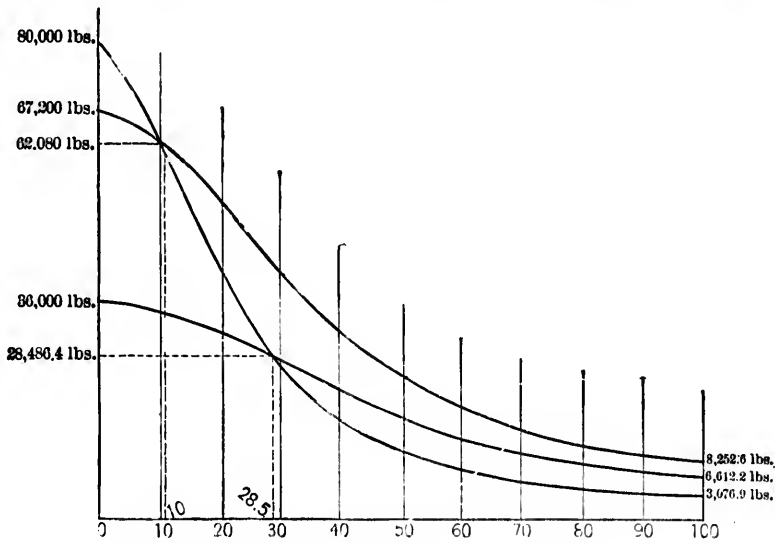

FIG. 344.

II. Application of Gordon's Formula to Pillars of other Sectional Forms.

In any section whatever, the least transverse dimension for calculation (i.e., h) is to be measured in the plane of greatest flexure.

Thus, it may be taken as the *least* diameter of the rectangle circumscribing *tee* (Fig. 345), *channel* (Fig. 346), and *cruciform* (Fig. 347) sections, and as the perpendicular from the angle to the opposite side of a triangle circumscribing *angle* (Fig. 348) sections.



FIG. 345.



FIG. 346.



FIG. 347.



FIG. 348.

From a series of experiments upon wrought-iron pillars of these sections, f was found to be 42,500 lbs., and $a, \frac{1}{900}$.

In cast-iron struts of a cruciform section $f = 80,000$ lbs. and $a = \frac{3}{400}$.

These results are only approximately true, and apply to pillars fixed at both ends.

12. Rankine's Modification of Gordon's Formula.—The factor a in Gordon's formula is by no means constant, and not only varies with the nature of the material, with the length of the pillar, with the condition of its ends, etc., but also with the sectional form of the pillar. The variation due to this latter cause may be eliminated, and the formula rendered somewhat more exact, by introducing the least *radius of gyration* instead of the least transverse dimension.

If k is the least radius of gyration,

$$k^2 = \frac{I}{\text{mass}} = \frac{mbh^3}{nbh} = \frac{m}{n}k^2,$$

m and n being constants which depend upon the sectional form. Thus, Gordon's formula for pillars with square ends may be written

$$\frac{W}{S} = p_1 = \frac{f}{1 + a_1 \frac{l^2}{k^2}}$$

in which a_1 is independent of the sectional form, all variations of the latter being included in k^2 . This modified form of Gordon's formula was first suggested by Rankine.

$4a_1$ is substituted for a_1 , if the pillar has two pin ends, and $\frac{9}{5}a_1$, or $2a_1$, is substituted for a_1 , if the pillar has one pin end and one square end.

Rankine gives

$$\text{for wrought iron, } f = 36000 \text{ lbs., } \frac{1}{a_1} = 36000;$$

$$\text{for cast-iron, } f = 80000 \text{ lbs., } \frac{1}{a_1} = 6400;$$

$$\text{for dry timber, } f = 7200 \text{ lbs., } \frac{1}{a_1} = 3000;$$

In good American practice the safe working unit stress in bridge compression members is determined by the formula

$$\text{Safe working unit stress} = \frac{f'}{1 + x \frac{l^2}{k^2}},$$

f' being 8000 lbs. for wrought-iron and 10,000 lbs. for steel, and $\frac{l}{x}$ being 40,000 for two square ends, 30,000 for one square and one pin end, and 20,000 for two pin ends.

Another formula often employed is,

$$\text{Working stress in lbs. per sq. in.} \times \left(4 + \frac{H}{20}\right) = \frac{f'}{1 + xH^2},$$

H being the ratio of length to least breadth, where, in the case of wrought-iron,

$$f' = 38,500 \text{ lbs. and } \frac{l}{x} = 5820 \text{ for two square ends;}$$

$$f' = 38,500 \text{ " " } \frac{l}{x} = 3000 \text{ " one square and one pin end.}$$

$$f' = 37,800 \text{ " " } \frac{l}{x} = 1900 \text{ " two pin ends.}$$

The *factor of safety*, viz., $4 + \frac{H}{20}$, increases with H , and partially provides for the corresponding decrease in the strength to resist side blows.

EXAMPLES.—According to Rankine the ultimate compressive strength of wrought-iron struts, in pounds per square inch, is

$$\frac{W}{S} = p_1 = \frac{36000}{1 + \frac{1}{36000} \frac{l^2}{k^2}}.$$

If the section is a solid rectangle, $k^2 = \frac{h^2}{12}$, and hence

$$p_1 = \frac{36000}{1 + \frac{1}{3000} \frac{l^2}{h^2}}$$

If the section is a solid circle, $k^2 = \frac{h^2}{16}$, and hence

$$p_1 = \frac{36000}{1 + \frac{1}{2250} \frac{l^2}{h^2}}$$

If the section is a thin annulus, $k^2 = \frac{h^2}{8}$, nearly, and hence

$$p_1 = \frac{36000}{1 + \frac{1}{4500} \frac{l^2}{h^2}}$$

Cor.—If $\frac{l}{k}$ is small, $W = fS$.

If $\frac{l}{k}$ is large, $W = \frac{fSk^2}{a_1 l^2} = \frac{fI}{a_1 l^2}$.

Comparing the last result with eq. (5), Case 4, Art. 16,

$$\frac{1}{a_1} = \frac{4E\pi^2}{f},$$

which gives a theoretical value of a_1 , the actual value being somewhat different.

3. Values of k^2 for Different Sections.

(a) *Solid rectangle*: $k^2 = \frac{I}{S} = \frac{h^2}{12}$, h being the least dimension.

(b) *Hollow rectangle*: $k^2 = \frac{I}{S} = \frac{1}{12} \left(\frac{bh^3 - b'h'^3}{bh - b'h'} \right)$, b , h being the greatest and least outside dimensions, and b' , h' the greatest and least inside dimensions, respectively.

Let t be the thickness of the metal. Then

$$b' = b - 2t \quad \text{and} \quad h' = h - 2t,$$

and hence

$$k^2 = \frac{1}{12} \frac{bh^3 - (b-2t)(h-2t)^3}{bh - (b-2t)(h-2t)} = \frac{h^2}{12} \frac{3b+h}{b+h'}$$

approximately, when t is small compared with h , i.e., for a *thin hollow rectangle*.

For a *square cell*, $k^2 = \frac{h^2}{6}$.

(c) *Solid triangle*: $k^2 = \frac{I}{S} = \frac{h^2}{18}$, h being the height.

(d) *Hollow triangle*: $k^2 = \frac{I}{S} = \frac{1}{18} \frac{bh^3 - b'h'^3}{bh - b'h'}$, b, h being the base and height of the outside triangle, and b', h' the base and height of the inside triangle, respectively. Also, $\frac{b}{b'} = \frac{h}{h'}$.

$$\therefore k^2 = \frac{h^2}{18} \frac{b^4 - b'^4}{b^3 - b'^3} = \frac{h^2}{18} \left(\frac{b^2 + b'^2}{b^2} \right).$$

Hence, for a *thin triangular cell*, $k^2 = \frac{h^2}{9}$.

(e) *Solid cylinder*: $k^2 = \frac{I}{S} = \frac{h^2}{16}$, h being the diameter.

(f) *Hollow cylinder*: $k^2 = \frac{I}{S} = \frac{\pi}{16} (h^4 + h'^4)$, h and h' being the external and internal diameters, respectively.

Hence, for a *thin cylindrical cell*, $k^2 = \frac{h^2}{8}$, approximately.

EXAMPLE.—Gordon's formula for *hollow cylindrical cast-iron pillars* is

$$\frac{W}{S} = p_1 = \frac{f}{1 + \frac{1}{500} \frac{f}{h^2}} = \frac{f}{1 + \frac{1}{4000} \frac{f}{k^2}}.$$

The relation $p_1 = \frac{f}{1 + \frac{1}{4000} \frac{l^2}{k^2}}$ may be assumed to hold for

hollow square struts and also for struts of a *cruciform* section.

EX. 1. For a hollow square having its diagonal equal to the *internal* diameter of the hollow cylinder, i.e., h' ,

$$k^2 = \frac{\left(\frac{h'}{\sqrt{2}}\right)^2}{6} = \frac{h'^2}{12}, \text{ and } p_1 = \frac{f}{1 + \frac{3}{1000} \frac{l^2}{h'^2}}.$$

EX. 2. If the side of the square is equal to the *external* diameter, i.e., h , then

$$k^2 = \frac{h^2}{6}, \text{ and } p_1 = \frac{f}{1 + \frac{3}{2000} \frac{l^2}{h^2}}.$$

(g) *Cruciform section*, the arms being equal:

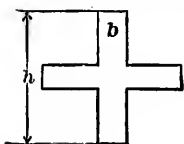

FIG. 349.

$$I = \frac{bh^3}{12} + \frac{hb^3}{12} - \frac{b^4}{12}; \quad S = 2bh - b^2.$$

$$\therefore k^2 = \frac{1}{12} \frac{bh^3 + hb^3 - b^4}{2bh - b^2} = \frac{h^2}{24}, \text{ nearly.}$$

Hence, the formula for a cast-iron pillar of cruciform section may be written

$$\frac{W}{S} = p_1 = \frac{f}{1 + \frac{1}{4000} \frac{l^2}{k^2}} = \frac{f}{1 + \frac{3}{500} \frac{l^2}{h^2}}.$$

(h) *Angle-iron of unequal ribs*, the greater being b and the less h :

$$k^2 = \frac{1}{12} \frac{b^3 h^2}{b^2 + h^2}, \text{ approximately,}$$

Hence, if $b = h$, i.e., if the ribs are equal, $k^2 = \frac{h^2}{24}$.

(i) *Channel-iron*, the dimensions being as in Fig. 350 :

$$I = \frac{bt^3 + 2h^2t}{12} + \frac{2bht^2(h+t)^2}{4(2ht+bt)}$$

$$= k^2 \left\{ \frac{2ht}{12} + \frac{2bht^2}{4(2ht+bt)} \right\}, \text{ nearly.}$$



Also, $S = bt + 2ht$.

$$\therefore k^2 = k^2 \left\{ \frac{2ht}{12(2ht+bt)} + \frac{2bht^2}{4(2ht+bt)^2} \right\}.$$

Let the area of the two flanges = $A = 2ht$, and let the area of the web = $B = bt$. Then

$$k^2 = k^2 \left\{ \frac{A}{12(A+B)} + \frac{AB}{4(A+B)^2} \right\}.$$

(k) *H-iron*, breadth of flanges being b , length of web h , and thickness of metal t :

$$I = 2\frac{b^3t}{12} + \frac{ht^3}{12} = 2\frac{b^2t}{12}, \text{ nearly; } S = 2bt + ht.$$

$$\therefore k^2 = \frac{b^2}{12} \frac{2bt}{2bt+ht} = \frac{b^2}{12} \frac{A}{A+B},$$

A being the area of the flanges, and B the area of the web.

(l) *Circular segment*, of radius r and length $r\theta$:

$$k^2 = r^2 \left\{ \frac{1}{2} + \frac{\sin \theta}{2\theta} - \frac{4 \sin^2 \frac{\theta}{2}}{\theta^2} \right\}.$$

Hence, for a semicircle, since $\theta = \pi$,

$$k^2 = r^2 \left\{ \frac{1}{2} - \frac{4}{\pi^2} \right\} = \frac{r^2}{10}, \text{ nearly.}$$

(m) *Barlow rail*: $k^2 = \frac{r^2}{7}$, nearly.

(n) *Two Barlow rails*, riveted base to base: $k^2 = .393r^2$, nearly.

14. American Iron Columns.—In 1880 Mr. G. Bouscaren read before the American Society of Civil Engineers a paper containing the results of a series of experiments made for the Cincinnati Southern Railroad upon Keystone, square, Phoenix, and American Bridge Co.'s columns.

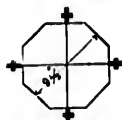

KEYSTONE
FIG. 351.

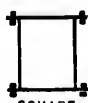

SQUARE
FIG. 352.



PHOENIX
FIG. 353.

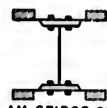

AM. BRIDGE CO.
FIG. 354.

These experiments show, as those of Hodgkinson and others have also shown, that the strength of iron and steel columns is not only dependent on the ratio of length to diameter, and on the form of the cross-section, but also on the proportions of parts, details of design and workmanship, and on the quality of the material of which the columns are constructed.

Further, they seem to lead to the conclusions that Gordon's formula is more correct as modified by Rankine, and that, in the case of columns hinged at both ends, Rankine's formula, with a_1 assumed at double the value it has when the formula is applied to columns with flat ends, is practically correct.

The subjoined table gives the values of the constants a_1 and f as deduced from Bouscaren's experiments by Prof. W. H. Burr.

In 1881 Messrs. Clarke, Reeves & Co. presented to the American Society of Civil Engineers a paper containing the results of experiments upon twenty Phoenix columns, which appeared to show that neither Gordon's nor Rankine's formula expressed the true strength of a column of the Phoenix type. In the discussion that followed the reading of this paper, however, it was demonstrated that, within the range of the experiments, the strength of intermediate lengths and sections of

	<i>f</i> in lbs.	<i>a</i> ₁
For keystone columns with flat ends—swelled.....	36,000	$\frac{1}{18300}$
“ “ “ “ “ “ —straight (open or closed).....	39,500	$\frac{1}{18300}$
“ “ “ “ “ “ —open (swelled straight).....	38,300	$\frac{1}{18300}$
“ “ “ “ “ “ pin ends—swelled.....	38,300	$\frac{1}{18000}$
For square columns with flat ends.....	39,000	$\frac{1}{35000}$
“ “ “ “ “ “ pin ends.....	39,000	$\frac{1}{17000}$
For Phoenix columns with flat ends.....	42,000	$\frac{1}{50000}$
“ “ “ “ “ “ round ends.....	42,000	$\frac{1}{12500}$
“ “ “ “ “ “ pin ends.....	42,000	$\frac{1}{22700}$
For American Bridge Co.'s columns with flat ends.....	36,000	$\frac{1}{40000}$
“ “ “ “ “ “ round ends.....	36,000	$\frac{1}{11500}$
“ “ “ “ “ “ pin ends.....	36,000	$\frac{1}{21800}$

Phoenix columns can be obtained either from Rankine's formula by slightly changing the constants, or from very simple new formulæ.

Mr. W. G. Bouscaren showed that by making $a_1 = \frac{1}{100000}$ and $f = 38000$, the calculated values of $\frac{W}{S}$ agree very nearly with the actual experimental results.

Mr. D. J. Whittemore gave the following (only applicable for lengths varying from 5 to 45 diameters) as expressing the probable ultimate strength of these columns :

$$W \text{ lbs.} = (1200 - H)30 + \frac{525000}{H^2},$$

H being the ratio of length to diameter.

Mr. C. E. Emery stated that the ultimate strength in each case is approximately represented by the formula

$$W \text{ lbs.} = \frac{355063 + 30950H}{H + 6.175},$$

H being the ratio of length to diameter.

Taking the different values of H as abscissæ, and of W as ordinates, this is the equation of an hyperbola. It agrees very accurately with the experimental results from 20 diameters upwards; at 15 diameters the calculated values of W are greater than those given by the experiments; for a less number of diameters the experimental results are the higher, but the variations are slight, and are provided for in the factor of safety.

The following very simple formulæ, due to Prof. W. H. Burr, give results agreeing closely with those obtained in the experiments:

For values of $\frac{l}{k} < 30$, the ultimate strength in pounds per square inch

$$= 64700 - 4600\sqrt{\frac{l}{k}}.$$

For values of $\frac{l}{k}$ between 30 and 140, the ultimate strength in pounds per square inch

$$= 39640 - 46\frac{l}{k},$$

k being the radius of gyration.

15. Long Thin Pillar.—Let ACB be the bent axis of a thin pillar of length l , having two pin ends and carrying a load W at B .

Let d be the greatest deviation of the axis from the vertical. Then

$$Wd = \text{bending moment} = \frac{E}{R}I, \quad \dots (1)$$

$\frac{1}{R}$ being the curvature of the pillar and I the moment of inertia of the most strained transverse section.

FIG. 355. This equation is only true on the assumptions that—

- (1) *initially*, the pillar is perfectly straight;
- (2) *initially*, the line of action of the load coincides with the axis of the pillar;

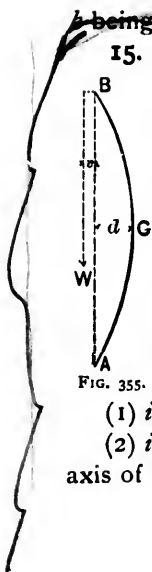

(3) the material of the pillar is homogeneous.

These assumptions cannot be fulfilled in practice, and variations from theoretical accuracy may, perhaps, be provided for by supposing that the line of action of the load is at a small distance x from the axis of the pillar. The bending-moment equation then becomes

$$W(d+x) = \frac{E}{R}I = \frac{f_2 I}{c}, \dots \dots \dots (2)$$

f_2 being the skin stress due to bending at a distance c from the neutral axis.

Again, assuming that the bent axis is in the form of an arc of a circle,

$$\frac{1}{R} = \frac{8d}{l^2} \dots \dots \dots (3)$$

$$\therefore W(d+x) = 8EI \frac{d}{l^2} = \frac{f_2 I}{c}, \dots \dots \dots (4)$$

and consequently

$$d = \frac{Wx}{P-W}, \dots \dots \dots (5)$$

where

$$P = \frac{8EI}{l^2} \dots \dots \dots (6)$$

If the line of action of the load W coincided with the axis of the pillar, then x would be *nil*.

Hence, by eq. (5), so long as the load is less than P , $d = 0$, and the failure of the pillar would be due to direct crushing. If the load is equal to P , d would become *indeterminate*

($= \frac{0}{0}$) and the pillar would remain in a state of neutral equilibrium at any inclination to the vertical.

It is impossible that W should exceed P , as d would then be negative; and therefore a load greater than P would cause the pillar to bend over laterally until it broke.

Thus, $P = \frac{8EI}{l^2}$ must be the *theoretical* maximum compressive strength of the pillar.

Again, let A be the area of the section under consideration ;

“ p be the total intensity of the skin stress at the section ;

“ f be the intensity of the direct stress due to W
 $= \frac{W}{A}$;

“ f_1 be the intensity of the stress due to P
 $= \frac{P}{A}$.

Then

$$p = f \pm f_1 = \frac{W}{A} \pm W(d+x)\frac{c}{I}, \dots (7)$$

the sign of f_1 being *positive* for the compressed side of the pillar and *negative* for the side in tension.

$$\therefore p = \frac{W}{A} \left(1 \pm (d+x)\frac{Ac}{I} \right) = f \left(1 \pm (d+x)\frac{c}{k^2} \right), \dots (8)$$

k being the radius of gyration.

Let h be the least transverse dimension of the section in the plane of flexure. Then

$$c \propto h \quad \text{and} \quad k \text{ also } \propto h$$

$$\therefore \frac{c}{k^2} = \frac{n}{h},$$

n being a coefficient depending upon the *form* of the section. For a rectangle, $n = 6$; for a circle, $n = 8$; also,

$$d+x = \frac{Px}{P-W}.$$

$$\therefore p = f \left(1 \pm \frac{P}{P-W} \frac{nx}{h} \right) = f \left(1 \pm \frac{f_1}{f} \frac{nx}{h} \right). \dots (9)$$

Thus, however small x may be, p continually increases as the difference between f_1 and f diminishes. The pillar will therefore fail for some value of p less than the theoretical maximum. This is in accordance with experience, as it is found that a small load causes a moderate flexure in a long pillar, and that this flexure gradually increases with the load until fracture takes place.

In no case should p exceed the *elastic limit*, as in such case a set would be produced and the deviation x would be increased.

If the tensile strength of the material of the pillar is small, as in the case of cast-iron, failure may arise from the tearing of the stretched layers.

Cor. 1. The above also applies to the case of a pillar with one end fixed and the other free, but the value of P is then $\frac{2EI}{l^2}$.

Cor. 2. According to Euler (see following article), the more correct value of P is $\mu EI \frac{\pi^2}{l^2}$, μ being 1, 2, $\frac{1}{4}$, or 4, according as the pillar has two pin ends, one fixed end and one end guided in the direction of the thrust, one fixed and one free end, or two fixed ends.

$$P \text{ evidently } \propto \frac{EI}{l^2} \propto EA \frac{k^2}{l^2} \propto EA \left(\frac{k}{l}\right)^2.$$

Hence, (a) the strength of a long pillar is proportional to the coefficient of elasticity; (b) the strengths of similar pillars are as the sectional areas.

$$\text{Again, } f_2 \propto \frac{1}{R} \propto d.$$

$$\text{But } Wd = \frac{f_2}{c} I \propto f_2 \propto d.$$

Hence W is approximately constant, and the weight which produces moderate flexure is approximately equal to the breaking weight.

EXAMPLE.—Find the crushing load of a solid mild-steel pillar 3 in. in diameter and 10 ft. long, with two pin ends.

Also find the deviation (x) of the line of action of a load of 20,000 lbs. from the axis of the pillar, so that the maximum intensity of stress may not exceed 10,000 lbs. per square inch.

By Gordon's formula and the table, page 524,

$$\text{the crushing load} = \frac{67200\pi \cdot \frac{9}{4}}{1 + \frac{4}{14400} (1\frac{2}{3}0)^2} = 85292.3 \text{ lbs.}$$

Again, the theoretical maximum compressive strength P

$$= \frac{8EI}{l^2} = \frac{8 \times 28000000}{(120)^2} \frac{\pi(3)^4}{64} = 61875 \text{ lbs.}$$

$$\therefore \frac{P}{P - W} = \frac{f_1}{f_1 - f} = \frac{61875}{41875} = \frac{99}{67}.$$

Hence

$$10000 = \frac{20000}{\frac{2}{3} \cdot \frac{9}{4}} \left(1 + \frac{99}{67} \cdot \frac{8}{3} x \right),$$

or $x = .65 \text{ in.}$

16. Long Columns of Uniform Section. (Euler's Theory.)

CASE I. *Columns with both ends hinged.*

—The column OA of length l is bent under a thrust P and takes the curved form OMA .

Take O as the origin, the vertical through O as the axis of x , and the horizontal through O as the axis of y .

Consider a section at any point M (x, y). If there is equilibrium and if the line of action of P coincides with the axis of the column, the equation of moments at M is

$$-EI \frac{d^2y}{dx^2} = M = Py,$$

or

$$\frac{d^2y}{dx^2} = -\frac{P}{EI}y = -a^2y. \dots \dots (1)$$

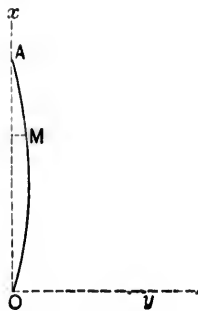

FIG. 356.

Multiplying each side of the equation by $\frac{dy}{dx}$ and integrating,

$$\left(\frac{dy}{dx}\right)^2 = a^2(b^2 - y^2), \dots \dots \dots (2)$$

b being a constant of integration.

$$\therefore \frac{dy}{\sqrt{b^2 - y^2}} = adx.$$

Integrating,

$$\sin^{-1}\left(\frac{y}{b}\right) = ax + c,$$

or

$$y = b \sin(ax + c), \dots \dots \dots (3)$$

c being a constant of integration.

When $x = 0$, y is also 0, and hence $b = 0$ or $c = 0$.

If $b = 0$, y is always 0, and lateral flexure is impossible.

Take $c = 0$. Then

$$y = b \sin ax. \dots \dots \dots (4)$$

Also, when $x = OA = OMA$, nearly, $= l$, $y = 0$.

$$\therefore 0 = b \sin al,$$

or

$$n\pi = al = l \sqrt{\frac{P}{EI}},$$

and hence

$$P = n^2 EI \frac{\pi^2}{l^2}. \dots \dots \dots (5)$$

Now the *least* value of P evidently corresponds to $n = 1$, and hence the *minimum* thrust which will bend the column laterally is

$$P = EI \frac{\pi^2}{l^2}.$$

Cor. 1. If the column is made to pass through N points dividing the vertical OA into $N + 1$ equal divisions, then

$$y = 0 \text{ when } x = \frac{l}{N + 1},$$

and therefore, by eq. (4),

$$0 = b \sin \frac{al}{N + 1},$$

or

$$\frac{al}{N + 1} = n\pi,$$

and hence

$$P = n^2 EI \frac{\pi^2}{l^2} (N + 1)^2.$$

FIG. 357.

As before, the least value of P corresponds to $n = 1$, and

$$P = EI \frac{\pi^2}{l^2} (N + 1)^2$$

is the least force which will bend the column laterally.

Hence, the strength of the column is increased in the ratio of 4, 9, 16, etc., by causing it to pass through points which divide its length into 2, 3, 4, etc., equal parts, respectively.

Cor. 2. The value of b may be approximately determined as follows :

Let ds = length of element at M .

Let θ = inclination to vertical of tangent at M .

Then

$$\text{pressure upon } ds = P \cos \theta = P \frac{dx}{ds},$$

and the

$$\text{compression of } ds = \frac{P \frac{dx}{ds}}{EA} ds = \frac{P}{EA} dx,$$

A being the sectional area of the column.

Hence, the total diminution of the length of the column

$$= \int_0^l \frac{P}{EA} dx = \frac{P}{EA} l.$$

Again, the length of the column

$$\begin{aligned} &= \int_0^l \left(1 + \left(\frac{dy}{dx} \right)^2 \right)^{\frac{1}{2}} dx = \int_0^l (1 + a^2 b^2 \cos^2 ax)^{\frac{1}{2}} dx, \\ &= \int_0^l \left(1 + \frac{a^2 b^2}{2} \cos^2 ax \right) dx, \text{ approximately,} \\ &= l \left(1 + \frac{a^2 b^2}{2} \right). \end{aligned}$$

Hence, if L is the *initial* length of the column, i.e., the length before compression,

$$L - \frac{P}{EA} l = l \left(1 + \frac{a^2 b^2}{2} \right),$$

and consequently

$$b^2 = 2 \frac{EI}{P} \left(\frac{L-l}{l} \right) - 2 \frac{I}{A^2}.$$

CASE 2. *Columns with one end fixed and the other constrained to lie in the same vertical.*

Assume that the lateral deviation is prevented by means of a horizontal force H at the top of a column. Then

$$-EI \frac{d^2 y}{dx^2} = Py - H(l-x). \quad (1)$$

A particular solution of this is

$$0 = Py' - H(l-x).$$

Let $y = y' + u$.

$$\therefore \frac{d^2 y}{dx^2} = \frac{d^2 u}{dx^2},$$

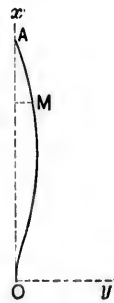

FIG. 358.

and eq. (1) becomes

$$-EI \frac{d^2 u}{dx^2} = Pu,$$

or

$$\frac{d^2 u}{dx^2} = -a^2 u. \quad \dots \dots \dots (2)$$

The solution of the last equation is

$$y - y' = u = b \sin(ax + c), \quad \dots \dots \dots (3)$$

b and c being constants of integration.

$$\therefore y = \frac{H}{P}(l - x) + b \sin(ax + c). \quad \dots \dots \dots (4)$$

But $\frac{dy}{dx} = 0$ when $x = 0$,

and $y = 0$ when $x = 0$ and when $x = l$.

$$\therefore 0 = -\frac{H}{P} + ab \cos c;$$

$$0 = \frac{H}{P} l + b \sin c;$$

$$0 = b \sin(al + c).$$

Hence

$$al + c = 0 \quad \text{and} \quad al = -\tan c = \tan al,$$

and therefore

$$al = 4.493 = l \sqrt{\frac{P}{EI}},$$

which may be written in the form

$$P = 2.045 \pi^2 \frac{EI}{l^2}. \quad \dots \dots \dots (5)$$

It is sufficiently approximate to write

$$P = 2\pi^2 \frac{EI}{l^2} \dots \dots \dots (6)$$

CASE 3. *Columns with one end fixed and the other free.*

A rigid arm *AB* is connected with the free end *A* of a column, and a vertical force *P* applied at *B* bends the column laterally, until its axis assumes the curved form *OMA*.

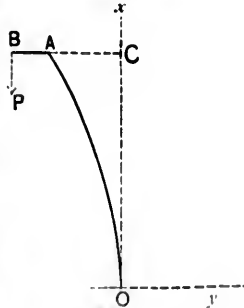

FIG. 359.

Let *AB* = *q*, *AC* = *p*, and let *l* be the length of the column, = *OC*, nearly.

The inclination of *AB* to the horizon is so small that the difference in length between *AB* and its horizontal projection may be disregarded. The moment equation at any point *M* (*x*, *y*) is

$$EI \frac{d^2y}{dx^2} = P(p + q - y).$$

or

$$\frac{d^2y}{dx^2} = a^2(p + q - y) \dots \dots \dots (1)$$

Multiplying each side by $2 \frac{dy}{dx}$ and integrating,

$$\left(\frac{dy}{dx}\right)^2 = a^2\{b + 2(p + q)y - y^2\},$$

b being a constant of integration.

But $\frac{dy}{dx} = 0$ when *y* = 0, and hence *b* = 0.

$$\therefore \left(\frac{dy}{dx}\right)^2 = a^2\{2(p + q)y - y^2\}, \dots \dots \dots (2)$$

or

$$\frac{dy}{\sqrt{2(p + q)y - y^2}} = a dx.$$

Integrating,

$$\cos^{-1} \frac{p+q-y}{p+q} = ax + c,$$

c being a constant of integration, or

$$\frac{p+q-y}{p+q} = \cos(ax + c). \quad \dots (3)$$

But $y = 0$ when $x = 0$, and hence $c = 0$.

$$\therefore \frac{p+q-y}{p+q} = \cos ax. \quad \dots (4)$$

Also, $y = p$ when $x = l$.

$$\therefore \frac{q}{p+q} = \cos al. \quad \dots (5)$$

If q is very small or *nil*, the term $\frac{q}{p+q}$ may be disregarded, and then

$$0 = \cos al.$$

$$\therefore al = n\frac{\pi}{2} = l\sqrt{\frac{P}{EI}}, \quad \dots (6)$$

n being a whole odd number.

The least value of P corresponds to $n = 1$, and the minimum pressure which will cause the column to bend laterally is

$$P = \frac{1}{4}EI\frac{\pi^2}{l^2}. \quad \dots (7)$$

Cor. 1. By eq. (5) the deviation of the top of the column from the vertical is

$$AC = p - q \frac{1 - \cos al}{\cos al}. \quad \dots (8)$$

Cor. 2. Let the force applied at B be oblique and let its vertical and horizontal components be P and H , respectively. The moment equation now becomes

$$EI \frac{d^2y}{dx^2} = P(p + q - y) + H(l - x). \quad \dots \quad (9)$$

A particular solution of this is

$$0 = P(p + q - y') + H(l - x). \quad \dots \quad (10)$$

Let $y = y' + u$.

Substituting in eq. (9),

$$EI \frac{d^2u}{dx^2} = -Pu,$$

or

$$\frac{d^2u}{dx^2} = -a^2u. \quad \dots \quad (11)$$

The solution of this equation is

$$u = b \sin(ax + c) = y - y',$$

b and c being constants of integration.

$$\therefore y = p + q + \frac{H}{P}(l - x) + b \sin(ax + c). \quad \dots \quad (12)$$

When $x = 0$, y and $\frac{dy}{dx}$ are each $= 0$; and when $x = l$, $y = q$.

$$\text{Hence,} \quad 0 = p + q + \frac{H}{P}l + b \sin c;$$

$$0 = -\frac{H}{P} + ab \cos c;$$

$$0 = p + b \sin(al + c);$$



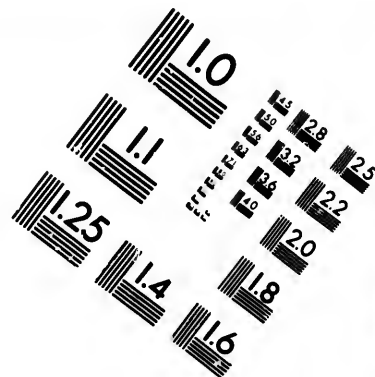
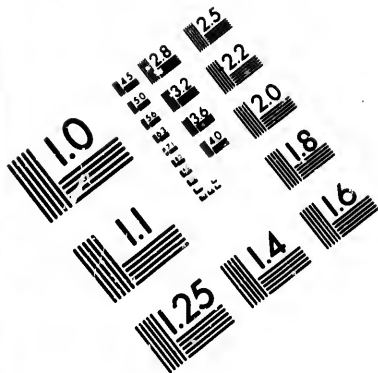

**IMAGE EVALUATION
TEST TARGET (MT-3)**

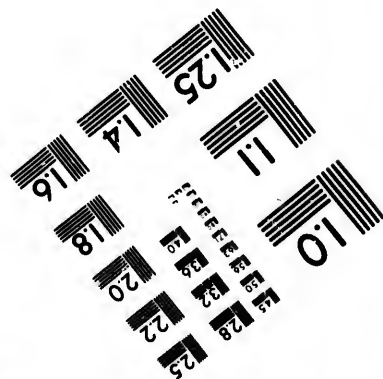
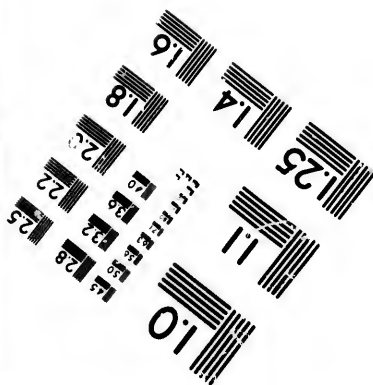
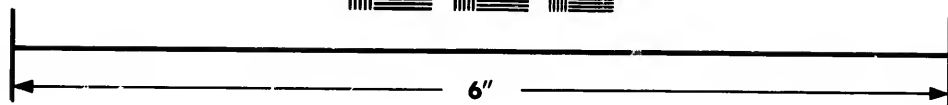
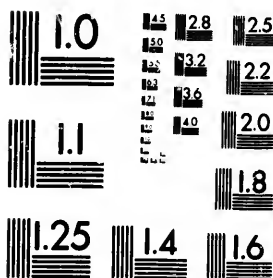

**Photographic
Sciences
Corporation**

23 WEST MAIN STREET
WEBSTER, N.Y. 14580
(716) 872-4503

18 20 22 25
19 28 32 36

10
11

three equations giving b , c , and p , and therefore fully determining y .

CASE 4. *Column with both ends fixed.*

Let μ be the end moment of fixture. Then



Fig. 300.

$$EI \frac{d^2y}{dx^2} = -Py + \mu,$$

or

$$\frac{d^2y}{dx^2} = -a^2y + a^2b = a^2(b - y), \quad \dots (1)$$

where $b = \frac{\mu}{P}$.

Multiplying each side of the equation by $2 \frac{dy}{dx}$ and integrating,

$$\left(\frac{dy}{dx}\right)^2 = a^2(2by - y^2) + d,$$

d being a constant of integration.

But $\frac{dy}{dx} = 0$ when $y = 0$, and hence $d = 0$.

$$\therefore \left(\frac{dy}{dx}\right)^2 = a^2(2by - y^2), \quad \dots (2)$$

or

$$\frac{dy}{\sqrt{2by - y^2}} = adx.$$

Integrating,

$$\cos^{-1} \frac{b - y}{b} = ax + c,$$

or

$$\frac{b - y}{b} = \cos(ax + c), \quad \dots (3)$$

c being a constant of integration.

But $y = 0$ when $x = 0$ and when $x = l$. Hence

$$1 = \cos c \quad \text{and} \quad 1 = \cos (al + c).$$

and therefore $c = 0$ and $al = 2n\pi$,

n being a whole number. Hence,

$$l\sqrt{\frac{P}{EI}} = 2n\pi,$$

or

$$P = n^2 \cdot 4EI \frac{\pi^2}{l^2}. \quad \dots \quad (4)$$

The least value of P corresponds to $n = 1$, and the minimum thrust which will cause the column to bend laterally is

$$P = 4EI \frac{\pi^2}{l^2}. \quad \dots \quad (5)$$

17. Remarks.—From the preceding it appears that the maximum theoretical compressive strength of a column per unit of area may be expressed in the form

$$f = \frac{P}{A} = \lambda E \frac{I}{A} \frac{\pi^2}{l^2} = \lambda E k^2 \frac{\pi^2}{l^2},$$

k being the radius of gyration, and λ a coefficient whose value is 1, 2, $\frac{1}{2}$, or 4, according as the column has *two hinged ends*, *one end fixed and the other guided in the direction of thrust*, *one end fixed and the other free*, or *two fixed ends*.

This formula is easy of application, but Hodgkinson's experiments show that the value of P as derived therefrom is too large. This may be partly due to the assumption that the elasticity of the material is perfect.

The *factors of safety* to be used with this formula vary from 4 to 8 for iron and steel and from 4 to 15 for timber.

The objection to the use of flat bars as compression members has sometimes been overestimated.

Consider, e.g., the case of a flat bar *hinged* at both ends.

Let the coefficient of elasticity of the material be 25,000,000 lbs.

Let the working stress per square inch be 8000 lbs.

The bar will not bend laterally under pressure so long as the unit stress $< Ek^2 \frac{\pi^2}{l^2}$, and

$$8000 < 25000000 \frac{\pi^2 d^2}{12 l^2}, \quad \text{or} \quad \frac{l}{d} < 50.7.$$

Hence, the length of a flat bar in compression seems to be comparatively limited. If, however, both ends are securely *fixed*, the strength is *quadrupled* and the admissible length of bar is *doubled*, while it may be still further increased by fixing the bar at intermediate points as indicated in Corollary 1, page 540. This shows the marked advantage to be gained by riveting together the diagonals of lattice-girders at the points where they cross each other.

The value of $f = \frac{P}{A}$ (Art. 15) must not exceed the elastic limit. It is difficult to define with any degree of accuracy the elastic limit of cast-iron and timber. It is claimed, indeed, that the latter has no elastic limit, properly so called, but that a permanent set is produced by every elastic change of form. It may be assumed, however, that the elasticity of these materials is practically unaffected so long as they are not loaded to more than one half of the *ultimate crushing* load.

Hence, taking

$E = 29,000,000$ lbs.	and	$f = 20,000$ lbs.	for wrought-iron,
$E = 29,000,000$ "	"	$f = 33,600$ "	" soft steel,
$E = 29,000,000$ "	"	$f = 56,000$ "	" hard steel,
$E = 17,000,000$ "	"	$f = 40,000$ "	" cast-iron,
$E = 1,500,000$ "	"	$f = 3,600$ "	" dry timber,

the pillars will not bend laterally unless the ratio of $\frac{l}{d}$ or $\frac{l}{2r}$

(d being the shortest side of a rectangular section and r the radius of a circular section) exceeds the values given in the following table :

Material.	Value of $\frac{l}{d}$.	Value of $\frac{l}{2r}$.	Formula.
Wrought-iron.....	34.5	29.9	} $f = \frac{P}{A} = L k^2 \frac{\pi^2}{l^2}$
Soft steel.....	26.6	24.3	
Hard steel.....	20.3	17.0	
Cast-iron.....	18.7	10.2	
Dry timber.....	18.5	16	
Wrought-iron.....	48.8	42.3	} $f = \frac{P}{A} = 2E k^2 \frac{\pi^2}{l^2}$
Soft steel.....	37.7	34.4	
Hard steel.....	28.8	25.3	
Cast-iron.....	26.4	22.9	
Dry timber.....	26.1	22.7	
Wrought-iron.....	17.2	14.9	} $f = \frac{P}{A} = \frac{1}{2} E k^2 \frac{\pi^2}{l^2}$
Soft steel.....	13.3	12.1	
Hard steel.....	10.1	8.9	
Cast-iron.....	9.3	8.1	
Dry timber.....	9.2	8	
Wrought-iron.....	69	59.9	} $f = \frac{P}{A} = 4E k^2 \frac{\pi^2}{l^2}$
Soft steel.....	53.3	48.7	
Hard steel.....	40.7	35.7	
Cast-iron.....	37.4	32.4	
Dry timber.....	37	32	

Baker has deduced by experiment the following formulæ for the strength of wrought-iron and steel pillars of from 10 to 30 diameters in length and with fixed ends, the tensile strength of the metals ranging from 20 to 60 tons (2240 lbs.) per square inch :

Let t be the tensile strength of the iron or steel, and H the ratio of length to diameter.

Then the ultimate compressive resistance, in pounds per square inch,

- for solid round pillars = $(.4 - .006H)(t + 18)$;
- for thin tubes = $(.44 - .004H)(t + 18)$;
- for tubes with stiffening ribs = $(.44 - .002H)(t + 18)$;
- for girder sections = $(.4 - .004H)(t + 18)$.

18. Weyrauch's Theory of the Resistance to Buckling.

—In order to make allowance for buckling, Weyrauch proposes the two following methods:

METHOD 1. Let F_1 be the necessary sectional area, and b_1 the admissible unit stress for a strut subjected to loads varying from a maximum compression B_1 to a minimum compression B_2 .

Let F' be the necessary sectional area, and b' the admissible unit stress for a strut subjected to loads which vary between a given maximum tension and a given maximum compression, B' being the numerically absolute maximum load, and B'' the maximum load of the opposite kind.

According to Art. 7, Chap. III, if there is no tendency to buckling, and putting $m = \frac{t-u}{u}$, $m' = \frac{u-s}{u}$, and $v' = u \div$ factor of safety,

$$F_1 = \frac{B_1}{b_1} = \frac{B_1}{v' \left(1 + m \frac{B_2}{B_1} \right)} \dots \dots \dots (1)$$

and

$$F' = \frac{B'}{b'} = \frac{B'}{v' \left(1 - m' \frac{B''}{B'} \right)} \dots \dots \dots (2)$$

If there is a tendency to buckling, let l be the length of the strut, F its required sectional area, and T the mean unit stress at the moment of buckling.

Then, according to the theory of long struts,

$$TF \propto \frac{EI}{l^2} = \delta \frac{EI}{l^2}, \dots \dots \dots (3)$$

δ being a coefficient depending upon the method adopted for securing the ends, E the coefficient of elasticity, and I the least moment of inertia of the section.

Also, let t be the statical compressive strength of the material of the strut, and take $t = \mu T$. Then

$$\mu = \frac{t}{T} = \frac{tFl^2}{\delta EI} = \frac{Fl^2}{\delta I}, \dots \dots \dots (4)$$

where $\sigma = \frac{oE}{t}$ (5)

If the strut under a pressure B were not liable to buckling, it would be subjected to a direct thrust only. The required sectional area of the strut would then be $\frac{B}{t}$, and the unit stress for an area F would be $\frac{B}{F}$.

If the strut under the pressure B is liable to buckling, its required sectional area will be $\frac{B}{T}$, since T is the mean unit stress at the moment of buckling. Let x be the unit stress at the moment of buckling, for the area F .

Assuming that the unit stresses in the two cases are in the same ratio as the required sectional areas, then

$$x : \frac{B}{F} :: \frac{B}{T} : \frac{B}{t}$$

$$\therefore x = \frac{B}{F} \frac{t}{T} = \mu \frac{B}{F} \dots \dots \dots (6)$$

The force which, when uniformly distributed over the area F , will produce this stress, is $Fx = \mu B$.

Hence, allowance may be made for buckling by substituting for the *compressive* forces in equations (1) and (2), their values multiplied by μ . Thus, equation (1) becomes

$$F = \frac{\mu B_1}{b_1} = \frac{\mu B_1}{v \left(1 + m_1 \frac{\mu B_2}{\mu B_1} \right)} = \frac{\mu B_1}{v \left(1 + m_1 \frac{B_2}{B_1} \right)} = \mu F_1, \quad (7)$$

and equation (2) becomes

$$F' = \frac{\mu B'}{b_1} = \frac{\mu B'}{v \left(1 - m' \frac{B''}{\mu B'} \right)}, \text{ if } B' \text{ is a compression,} \quad (8)$$

and

$$F = \frac{B'}{b'} = \frac{B'}{v' \left(1 - m' \frac{\mu B''}{B'}\right)}, \text{ if } B'' \text{ is a compression.} \quad (9)$$

If $\mu < 1$, equations (1) and (2) give larger sectional areas than equations (7), (8), and (9), so that the latter are to be applied only when $\mu > 1$.

METHOD II. General formulæ applicable to all values of μ may be obtained by following the same line of reasoning as that adopted in the proof of Gordon's formula. It is there assumed that the total unit stress in the most strained fibre is $p_1 \left(1 + a \frac{l^2}{h^2}\right)$, p_1 being the stress due to direct compression, and $p_1 a \frac{l^2}{h^2}$ that due to the bending action.

So, instead of employing equations (1) and (2) when $\mu < 1$, and equations (7), (8), and (9) when $\mu > 1$, formulæ including all cases may be obtained by substituting for the compressive forces in equations (1) and (2) their values multiplied by $1 + \mu$.

Thus, equation (1) becomes

$$F = \frac{(1 + \mu)B_1}{v' \left(1 + m_1 \frac{B_2}{B_1}\right)} = (1 + \mu)F_1, \quad \dots \dots \dots (10)$$

and equation (2) becomes

$$F = \frac{(1 + \mu)B''}{v' \left(1 - m' \frac{B''}{(1 + \mu)B'}\right)}, \text{ if } B' \text{ is a compression.} \quad (11)$$

or

$$F = \frac{B'}{v' \left(1 - m' \frac{(1 + \mu)B''}{B'}\right)}, \text{ if } B'' \text{ is a compression.} \quad (12)$$

Equations (7), (8), (9), respectively, give larger values of F than the corresponding equations (10), (11), and (12).

Note.—For wrought-iron bars it may be assumed, as in Arts. 5, 6, Chap. III, that $v_1 = v' = 700$ k. per sq. cm., and $m_1 = m' = \frac{1}{2}$.

The value of σ is given by formula (5), but is unreliable, and varies in practice from 10,000 to 36,000 for struts with *fixed* ends.

When the ends are fixed, $\delta = 4\pi^2$, according to theory. Hence,

$$\sigma = 4\pi^2 \frac{E}{l}.$$

Therefore, if $E = 2,000,000$ k. per sq. cm., and $l = 3300$ k. per sq. cm., $\delta = 23,926$, or in round numbers 23,900; 24,000 is the value usually adopted by Weyrauch.

EXAMPLE.—The load upon a wrought-iron column 360 cm. long varies between a compression of 50,000 k. and a compression of 25,000 k. Calculate the sectional area of the column, assuming it to be *first* solid and *second* hollow, allowance being made for buckling.

First. By eq. (1),

$$F_1 = \frac{50000}{700(1 + \frac{1}{2} \times \frac{23926}{250000})} = \frac{400}{7} = \pi r^2,$$

r being the radius of the section.

$$\text{Also, } I = \frac{\pi r^4}{4}.$$

$$\therefore \frac{F_1}{I} = \frac{4}{r^2} = \frac{11}{50}.$$

Hence, by eq. (4),

$$\mu = \frac{360 \times 360}{24000} \times \frac{11}{50} = 1.188.$$

Thus $\mu > 1$, and by eq. (7) the required sectional area is

$$F_1 \times 1.188 = 490 \times 1.188 = 67.9 \text{ sq. cm.}$$

$$\text{Second. } F_1 = 490 = \pi(r_1^2 - r_2^2),$$

r_1 being the external and r_2 the internal radius of the section.

Let $r_1 = 9$ cm. and $r_2 = 7.92$ cm. Then

$$\pi(r_1^2 - r_2^2) = 57.43 \text{ sq. cm.}$$

$$\text{Also, } I = \pi \frac{(r_1^4 - r_2^4)}{4}.$$

$$\therefore \frac{I}{A} = \frac{4}{r_1^2 + r_2^2} = \frac{4}{143.7264}.$$

Hence, by eq. (4),

$$\mu = \frac{360 \times 360}{24000} \times \frac{4}{143.7264} = .15.$$

Thus, in the latter case, since $\mu < 1$, there is no tendency to buckling.

If the area is determined by equation (10), its value becomes $1.15 \times 49.0 = 65$ sq. cm.

19. Flexure of Columns.—In Art. 16 the moment equation has been expressed in the form

$$-EI \frac{d^2y}{dx^2} = M,$$

and this is sufficiently accurate if the deviation of the axis of the strut from the vertical is so small that $\left(\frac{dy}{dx}\right)^2$ may be neglected without sensible error.

The more correct equation is

$$- \frac{EI}{\rho} = M,$$

ρ being the radius of curvature.

Consider, e.g., the strut in Art. 16, Case I. Then

$$-a^2y = -\frac{P}{EI}y = \frac{1}{\rho} = \frac{d\theta}{ds} = \frac{d\theta}{dy} \sin \theta,$$

θ being the inclination of the tangent at M to the axis of x , and ds an element of the bent strut at M .

$$\therefore -a^2 y dy = \sin \theta d\theta.$$

Integrating,

$$\frac{a^2 y^2}{2} = \cos \theta - \cos \theta_0, \quad \dots \dots \dots (1)$$

θ_0 being the value of θ at a strut end.

Let $\sin \frac{\theta_0}{2} = \mu$ and $\sin \frac{\theta}{2} = \mu \sin \phi$. Then

$$\frac{a^2 y^2}{2} = 2\mu^2(1 - \sin^2 \phi),$$

or

$$y = \frac{2\mu}{a} \cos \phi. \quad \dots \dots \dots (2)$$

Let Y be the maximum deviation of the axis of the strut from the vertical, i.e., the value of y when $\theta = 0$ or $\phi = 0$. Then

$$Y = \frac{2\mu}{a} = \frac{2 \sin \frac{\theta_0}{2}}{a}. \quad \dots \dots \dots (3)$$

Again,

$$ds = \rho d\theta = -\frac{1}{a} \frac{d\phi}{\sqrt{1 - \mu^2 \sin^2 \phi}}.$$

Hence, if l be the length of the strut,

$$l = \frac{2}{a} \int_0^{\frac{\pi}{2}} \frac{d\phi}{\sqrt{1 - \mu^2 \sin^2 \phi}} = \frac{2}{a} F_\mu(\phi), \quad \dots \dots (4)$$

$F_\mu(\phi)$ being an elliptic integral of the *first* kind.

Let P' be the *least* thrust which will make the strut bend. As shown in Art. 16,

$$a^2 = \frac{P'}{EI} = \frac{\pi^2}{l^2},$$

and, by eq. (4), the corresponding value of the modulus μ is given by

$$F_{\mu}(\phi) = \frac{\pi}{2} \dots \dots \dots (5)$$

Let the actual thrust on the strut be

$$P = n^2 P'; \dots \dots \dots (6)$$

n^2 being a coefficient $>$ unity.

The corresponding value of the modulus is given by

$$F_{\mu}(\phi) = \frac{l}{2} \sqrt{\frac{P}{EI}} = \frac{l}{2} na = n \frac{\pi}{2} \dots \dots \dots (7)$$

By reference to Legendre's Tables it is found that a large increase in the value of μ , i.e., of $\sin \frac{\theta_0}{2}$ or θ_0 , is necessary in order to produce even a small increase in the value of $F_{\mu}(\phi)$ and therefore of $n \left(= \sqrt{\frac{P}{P'}} \right)$. Hence, as soon as the thrust P exceeds the least thrust which will bend the column, viz., P' , θ_0 rapidly increases.

The total maximum intensity of stress in the skin of the strut at the most deflected point

$$= \frac{P}{A} + \frac{Mz}{I} = \frac{P}{A} + \frac{PYz}{I} = f + \frac{2z}{k} \sin \frac{\theta_0}{2} \sqrt{fE}, \dots (8)$$

z being the distance of the skin from the neutral axis, and f being equal to $\frac{P}{A}$.

The last term of this equation includes the product fE , which is very large, and also the factor $\sin \frac{\theta_0}{2}$, which increases with θ_0 so that the ultimate strength of the material is rapidly approached, and, in fact, rupture usually takes place *before* the column has assumed the position of equilibrium defined by the slope θ_0 at the ends.

If there were no limit to the flexure, the column would take its position of equilibrium only after a number of oscillations about this position, and the maximum stress in the material would be necessarily greater than that given by eq. (8).

Again,

$$dx = ds \cos \theta = -\frac{I}{a} \frac{(1 - 2\mu^2 \sin^2 \phi) d\phi}{\sqrt{1 - \mu^2 \sin^2 \phi}}.$$

Let X be the vertical distance between the strut ends. Then

$$\begin{aligned} X &= \frac{2}{a} \int_0^{\frac{\pi}{2}} \frac{1 - 2\mu^2 \sin^2 \phi}{\sqrt{1 - \mu^2 \sin^2 \phi}} d\phi \\ &= \frac{2}{a} \left\{ \int_0^{\frac{\pi}{2}} 2\sqrt{1 - \mu^2 \sin^2 \phi} d\phi - \int_0^{\frac{\pi}{2}} \frac{d\phi}{\sqrt{1 - \mu^2 \sin^2 \phi}} \right\} \\ &= \frac{2}{a} \{ 2E_\mu(\phi) - F_\mu(\phi) \}; \end{aligned}$$

$E_\mu(\phi)$ being an elliptic integral of the *second* kind.

Hence, the diminution in the length of the strut

$$= L - X = \frac{4}{a} \{ F_\mu(\phi) - E_\mu(\phi) \}.$$

20. Flexure of Columns (Findlay).—In a paper on the flexure of columns read before the Canadian Society of Civil Engineers (Vol. IV, Part I), Findlay expresses the moment equation in the form

$$EI \left(\frac{1}{\rho} - \frac{1}{\rho_0} \right) = M = -EI \left(\frac{d^2 y}{dx^2} - \frac{d^2 y_0}{dx^2} \right), \quad \dots \quad (1)$$

ρ_0 and $\frac{d^2 y_0}{dx^2}$ being the values of ρ and $\frac{d^2 y}{dx^2}$ when $M = 0$.

Hinged Ends.—It is assumed that the line of action of the thrust P is at a distance d from the axis of the strut. Then

$$-EI \left(\frac{d^2 y}{dx^2} - \frac{d^2 y_0}{dx^2} \right) = P(y + d) = \frac{p - f}{z} I, \quad (2)$$

or

$$\frac{d^2 y}{dx^2} - \frac{d^2 y_0}{dx^2} = -a^2(y + d) = -\frac{p - f}{zEI}, \quad (3)$$

where $a^2 = \frac{P}{EI}$, p = total stress at the distance z from the neutral axis, and f = stress due to direct thrust ($= \frac{P}{A}$), so that the stress due to *bending* = $p - f$.

It is also assumed that the form of the axis of the column before it is acted upon by the thrust P , is a *curve of sines* defined by the equation

$$y_0 = \Delta \cos \frac{\pi x}{l}, \quad \dots \dots \dots (4)$$

the origin being half-way between the ends of the strut, and Δ being the maximum *initial* deviation of the axis from the vertical, i.e., the value of y_0 when $x = 0$.

$$\therefore \frac{d^2 y_0}{dx^2} = -\frac{\Delta \pi^2}{l^2} \cos \frac{\pi x}{l},$$

and hence, by eq. (3),

$$\frac{d^2 y}{dx^2} = -a^2(y + d) - \Delta \frac{\pi^2}{l^2} \cos \frac{\pi x}{l}. \quad \dots \dots (5)$$

A solution of this equation is

$$y + d = d \frac{\cos ax}{\cos \frac{a^2 l}{2}} + \Delta \frac{\cos \frac{\pi x}{l}}{1 - \frac{\pi^2}{a^2 l^2}}. \quad \dots \dots (6)$$

Now $\frac{al}{2}$ is always small for such values of f as would constitute a safe working load, and therefore

$$\cos \frac{al}{2} = 1 - \frac{a^2 l^2}{8}, \text{ approximately,}$$

so that eq. (6) becomes

$$y + d = d \cos al \left(1 - \frac{a^2 l^2}{8}\right)^{-1} + \Delta \cos \frac{\pi x}{l} \left(1 - \frac{a^2 l^2}{\pi^2}\right)^{-1},$$

or

$$y + d = d \cos al \left(1 + \frac{a^2 l^2}{8}\right) + \Delta \cos \frac{\pi x}{l} \left(1 + \frac{a^2 l^2}{\pi^2}\right), \text{ approx. (7)}$$

Let Y be the maximum value of y , i.e., the value of y when $x = 0$. Then

$$Y = a^2 l^2 \left(\frac{d}{8} + \frac{\Delta}{\pi^2}\right) + \Delta. \dots \dots (8)$$

Hence, by eq. (3), the total maximum intensity of stress

$$= p = f + a^2 z E (Y + d) = f + f \left(\frac{z}{k}\right)^2 \left\{ c + b \frac{f \left(\frac{l}{k}\right)^2}{E} \right\}, (9)$$

where $b = \frac{1}{z} \left(\frac{d}{8} + \frac{\Delta}{\pi^2}\right)$ and $c = \frac{d + \Delta}{z}$.

Eq. (9) is a quadratic from which f may be found in terms of p . As a first approximation, p may be substituted for f in the last term of the portion within brackets, the error being in the direction of safety.

Fixed Ends.—Let M_1 be the moment of fixture.

Eq. (3) now becomes

$$\frac{d^2 y}{dx^2} - \frac{d^2 y_0}{dx^2} = -a^2 (y + d) - \frac{M_1}{EI} = -a^2 \left(y + d + \frac{M_1}{P}\right). (10)$$

Assuming again that the initial form of the axis is a curve of sines, the solution of the last equation is

$$y + d + \frac{M_1}{P} = \left(d + \frac{M_1}{P}\right) \frac{\cos ax}{\cos \frac{al}{2}} + \Delta \frac{\cos \frac{\pi x}{l}}{1 - \frac{a^2 l^2}{\pi^2}} \quad (11)$$

Initially,

$$y_0 = \Delta \cos \frac{\pi x}{l},$$

and $\frac{dy}{dx}$ is equal to $\frac{dy_0}{dx}$ when $x = \frac{l}{2}$ or $x = -\frac{l}{2}$.

Hence,

$$-\Delta \frac{\pi}{l} = -\left(d + \frac{M_1}{P}\right) a \frac{\sin \frac{al}{2}}{\cos \frac{al}{2}} - \frac{\Delta \frac{\pi}{l}}{1 - \frac{a^2 l^2}{\pi^2}}$$

or

$$d + \frac{M_1}{P} = -\frac{2\Delta}{\pi} - \Delta a^2 l^2 \frac{12 - \pi^2}{6\pi^3} \quad (12)$$

Again, the value of y at the point $x = 0$ is

$$Y = \left(d + \frac{M_1}{P}\right) \frac{a^2 l^2}{8} + \Delta \left(1 + \frac{a^2 l^2}{\pi^2}\right) \quad (13)$$

Also, if p_1, p_2 are the total maximum intensities of stress at the end and at the most deflected point, then

$$\frac{p_1 - f}{sE} = -a^2 \left(d + \frac{M_1}{P}\right) = \text{etc.}, \quad (14)$$

and

$$\frac{p_2 - f}{sE} = -a^2 \left(Y + d + \frac{M_1}{P}\right) = \text{etc.}; \quad (15)$$

two equations from which f may be found as before.

The following conclusions are drawn from the above investigation:

First. The actual strength of a column depends partly upon

known facts as to dimensions, material, etc., and *partly* upon *accidental* circumstances.

Second. Experiments upon the crippling or destruction of columns cannot be expected to give coherent results when applied to the determination of the constants in such an equation as No. (9).

Third. It is a question whether p should be made the *elastic limit* of the material and the working load a definite fraction of the corresponding value of f derived from eq. (9), or whether p should be the allowable skin working stress, and the working stress f be found by means of the same equation. The former seems to be the more logical assumption.

Fourth. It would appear that the strength of hinged columns is likely to be much more variable than the strength of columns with fixed ends, as it depends upon two variable elements d and Δ , while the end fixture eliminates d .

Note.—The Tables on the following page give the numerical values of elliptic integrals of the first and second kind, and are useful in applying the results of Art. 18.

FIRST ELLIPTIC INTEGRAL, $F_{\mu}(\phi)$.

ϕ	$\mu = 0$	$\mu = .1$	$\mu = .2$	$\mu = .3$	$\mu = .4$	$\mu = .5$	$\mu = .6$	$\mu = .7$	$\mu = .8$	$\mu = .9$	$\mu = 1$
0°	0.000	0.000	0.000	0.000	0.000	0.000	0.000	0.000	0.000	0.000	0.000
5°	0.087	0.087	0.087	0.087	0.087	0.087	0.087	0.087	0.087	0.087	0.087
10°	0.175	0.175	0.175	0.175	0.175	0.175	0.175	0.175	0.175	0.175	0.175
15°	0.262	0.262	0.262	0.262	0.262	0.262	0.263	0.263	0.263	0.264	0.265
20°	0.349	0.349	0.349	0.350	0.350	0.351	0.352	0.353	0.354	0.355	0.356
25°	0.436	0.436	0.437	0.438	0.439	0.440	0.441	0.443	0.445	0.448	0.451
30°	0.524	0.524	0.525	0.526	0.527	0.529	0.532	0.536	0.539	0.544	0.549
35°	0.611	0.611	0.612	0.614	0.617	0.620	0.624	0.630	0.636	0.644	0.653
40°	0.698	0.699	0.700	0.703	0.707	0.712	0.718	0.727	0.736	0.748	0.763
45°	0.785	0.786	0.789	0.792	0.798	0.804	0.814	0.826	0.839	0.858	0.881
50°	0.873	0.874	0.877	0.882	0.889	0.898	0.911	0.928	0.947	0.974	1.011
55°	0.960	0.961	0.965	0.972	0.981	0.993	1.010	1.034	1.060	1.099	1.154
60°	1.047	1.049	1.054	1.062	1.074	1.090	1.112	1.142	1.178	1.233	1.317
65°	1.134	1.137	1.143	1.153	1.168	1.187	1.215	1.254	1.302	1.377	1.506
70°	1.222	1.224	1.232	1.244	1.262	1.285	1.320	1.370	1.431	1.534	1.735
75°	1.309	1.312	1.321	1.336	1.357	1.385	1.426	1.488	1.566	1.703	2.028
80°	1.396	1.400	1.410	1.427	1.452	1.485	1.534	1.608	1.705	1.885	2.436
85°	1.484	1.487	1.499	1.519	1.547	1.585	1.643	1.731	1.848	2.077	3.131
90°	1.571	1.575	1.588	1.610	1.643	1.686	1.752	1.854	1.993	2.275	∞

SECOND ELLIPTIC INTEGRAL, $E_{\mu}(\phi)$.

ϕ	$\mu = 0$	$\mu = .1$	$\mu = .2$	$\mu = .3$	$\mu = .4$	$\mu = .5$	$\mu = .6$	$\mu = .7$	$\mu = .8$	$\mu = .9$	$\mu = 1$
0°	0.000	0.000	0.000	0.000	0.000	0.000	0.000	0.000	0.000	0.000	0.000
5°	0.087	0.087	0.087	0.087	0.087	0.087	0.087	0.087	0.087	0.087	0.087
10°	0.175	0.175	0.174	0.174	0.174	0.174	0.174	0.174	0.174	0.174	0.174
15°	0.262	0.262	0.262	0.262	0.261	0.261	0.261	0.260	0.260	0.259	0.259
20°	0.349	0.349	0.349	0.348	0.348	0.347	0.347	0.346	0.345	0.343	0.342
25°	0.436	0.436	0.436	0.435	0.434	0.433	0.431	0.430	0.428	0.425	0.423
30°	0.524	0.523	0.523	0.521	0.520	0.518	0.515	0.512	0.509	0.505	0.500
35°	0.611	0.610	0.609	0.607	0.605	0.602	0.598	0.593	0.588	0.581	0.574
40°	0.698	0.698	0.696	0.693	0.690	0.685	0.679	0.672	0.664	0.654	0.643
45°	0.785	0.785	0.782	0.779	0.773	0.767	0.759	0.748	0.737	0.723	0.707
50°	0.873	0.872	0.869	0.864	0.857	0.848	0.837	0.823	0.808	0.789	0.766
55°	0.960	0.959	0.955	0.948	0.939	0.928	0.914	0.895	0.875	0.850	0.819
60°	1.047	1.046	1.041	1.032	1.021	1.008	0.989	0.965	0.940	0.907	0.866
65°	1.134	1.132	1.126	1.116	1.103	1.086	1.063	1.033	1.001	0.960	0.906
70°	1.222	1.219	1.212	1.200	1.184	1.163	1.135	1.099	1.060	1.008	0.946
75°	1.309	1.306	1.297	1.283	1.264	1.240	1.207	1.163	1.117	1.053	0.966
80°	1.396	1.393	1.383	1.367	1.344	1.316	1.277	1.227	1.172	1.095	0.985
85°	1.484	1.480	1.468	1.450	1.424	1.392	1.347	1.289	1.225	1.135	0.996
90°	1.571	1.566	1.554	1.533	1.504	1.467	1.417	1.351	1.278	1.173	1.000

EXAMPLES.

1. A Phœnix column in four segments, each weighing 17 lbs. per lineal yard, carries a load of 68,000 lbs. What is the compressive unit stress?
Ans. 10,000 lbs. per sq. in.

2. The sectional area of a pillar is 144 sq. in., and the pillar carries a load of 4000 lbs. Find the normal and tangential intensities of stress on a plane inclined at 20° to the axis.
Ans. 3.25 lbs.; 8.93 lbs.

3. A short hollow square column has to support a load of 120,000 lbs., the allowable stress being 15,000 lbs. per square inch. Find the thickness of the metal, an external side of the column being 6 in.
Ans. .36 in.

4. A solid cast-iron pillar 9 ft. in height and 2 in. in diameter supports a load of 55,000 lbs. Find the normal and shearing intensity of stress per square inch in a plane section inclined at 30° to the axis.

If the ends of the pillar are flat and firmly bedded, determine its breaking weight, both by Hodgkinson's and by Gordon's formula.

Ans. 1093½ lbs.; 1894.375 lbs.; 141½ tons by H.; 159 tons by G.

5. A cylindrical pillar 6 in. in diameter supports a load of 400 lbs., of which the centre of gravity is ¾ in. from the axis. Determine the greatest and least intensities of stress upon any transverse section of the pillar.
Ans. 25½⁷⁄₈ lbs.; 2½⁸⁷⁄₈ lbs.

6. Compare the breaking weights of round cast-iron, wrought-iron, and mild-steel pillars with flat and firmly bedded ends, each being 9 ft. in length and 6 in. in diameter.

Ans. 1,250,197 lbs.; 890,109 lbs.; 1,543,572 lbs.

7. A hollow cast-iron pillar with an external diameter of 9 in. is to be substituted for the solid pillar in the preceding question. Determine the thickness of the metal.
Ans. ¾ in.

8. Determine the breaking weight of a solid round pillar with both ends firmly secured, 10 ft. in length and 2 in. in diameter, (1) if of cast-iron; (2) if of wrought-iron; (3) if of steel (mild).

Ans. 25142.8 lbs.; 43516.48 lbs.; 54136 lbs.

9. A hollow cast-iron pillar 12 ft. in height has to support a steady load of 33,000 lbs.; its internal diameter is 5½ in. Find the thickness of the metal, the factor of safety being 6.
Ans. .28 in.

10. A solid wrought-iron pillar is to be substituted for the pillar in the preceding question. Find its diameter.
Ans. 3½ in.

11. What is the breaking weight of a hollow cast-iron pillar 9 ft. in length and 6 in. square, the metal being 1 in. thick?

Ans. 970873.6 lbs.

12. Compare the breaking weight of a solid square pillar of wrought-iron 20 ft. long and 6 in. square with that of a solid rectangular pillar of the same material, the section being 9 in. by 4 in.

Ans. 845,217 lbs.; 589,090 lbs.

13. Compare the breaking weights, as derived from Hodgkinson's and Gordon's formulæ, of a solid round cast-iron pillar 20 ft. in length and 10 in. in diameter, (1) both ends being securely fixed; (2) both ends being imperfectly fixed.

Ans.—(1) 951.4 tons by H.; 1150.05 tons by G.

(2) 414.04 tons by H.; 415 tons by G.

14. Determine by Hodgkinson's formula the diameter of a solid wrought-iron pillar equal in length and strength to that in the preceding question.

Ans. 7.35 in.

15. A solid or hollow pillar of cast-iron, wrought-iron, or mild steel is to be designed to carry a *steady* load of 30,000 lbs. Determine the necessary diameter in each case, 6 being a factor of safety. (The pillar is to be 12 ft. high, and the metal of the hollow pillar is to be $\frac{3}{8}$ in. thick.)

Ans.—*Solid*: 3.42 in.; 3.25 in.; 2.8 in.

Hollow: 4.5 in.; 4.75 in.; 3.5 in.

16. Determine the load in the preceding question that will produce a maximum stress of 9000 lbs. per square inch in the solid steel pillar.

17. A pillar of diameter D supports a given load; if N pillars, each of diameter d , are substituted for this single pillar, show that d must lie

between $\frac{D}{N^{\frac{1}{4}}}$ and $\frac{D}{N^{\frac{1}{2}}}$.

Is it more economical to employ few or many pillars of given height to support a given load?

18. A solid round pillar of mild steel, 16 ft. high, supports a *steady* load of 20,000 lbs. If the factor of safety is 6, what is its diameter?

Ans. 3 in.

19. Find the diameter of each of four pillars of the same material which may be substituted for the single pillar in the preceding question.

Ans. 2.04 in.

20. What is the breaking weight of a cast-iron stanchion of a regular cruciform section and 15 ft. in height, the arms being 24 in. by 1 in.?

Ans. 2,811,215 lbs.

21. Each of the pillars supporting the lowest floor of a refinery is 16.5 ft. high, is of a regular cruciform section, and carries a load of

240,000 lbs.; the total length of an arm is 14 in. Determine its thickness, the factor of safety being 10. *Ans.* 2.598 in.

22. Find the breaking stress per square inch of a 4-in. \times 4-in. solid wrought-iron pillar for lengths of 5, 10, 15, and 20 ft., the two ends being absolutely fixed.

Ans. 33,488 lbs.; 27,692 lbs.; 21,492 lbs.; 16,363 lbs.

23. Find the diameter of a wooden column 20 ft. long, to support a load of 10,000 lbs., 10 being a factor of safety and both ends of the column being absolutely fixed. *Ans.* 8.55 in.

24. The external and internal diameters of a hollow cast-iron column 12 ft. in length are D and $\frac{3}{4}D$, respectively; the load upon the column is 25,000 lbs. If the factor of safety is 4, find D , (a) when both ends of the column are absolutely fixed; (b) when both ends are hinged.

Ans. (a) 4.3 in.; (b) 5.4 in.

25. Determine the breaking weight of an oak pillar 9 ft. high, 11 in. wide, and 5 in. thick. *Ans.* 138,160 lbs.

26. What weight will be safely borne by a pillar of dry oak subject to vibration, 10 ft. high and 6 in. square, 10 being a factor of safety?

Ans. 9969 lbs.

27. The web members of a Warren girder are bars of rectangular section and 10 ft. in length. One of the bars has to carry loads varying between a steady minimum tension of 20.2 tons and a maximum tension of 40.4 tons, and another to carry loads varying between a maximum compression of 8.7 tons and a maximum tension of 14.4 tons. Find the sectional area in each case, allowance being made for buckling in the latter.

28. Determine the sectional area of a double-tee strut which is to carry a load varying between a maximum tension of 80,000 lbs. and a maximum compression of 60,000 lbs. Each flange consists of two 6-in. \times 6-in. \times $\frac{5}{8}$ -in. angle-irons riveted to a 12-in. \times $\frac{5}{8}$ -in. web plate. The length of the strut is to be (a) 6 ft.; (b) 12 ft.

29. A steel strut 10 ft. long consists of two tees back to back, each 4 in. \times 4 in. \times $\frac{1}{2}$ in. Taking $f = 60,000$ lbs., $a_1 = \frac{1}{40,000}$ (page 526), and 6 as a factor of safety, find the working load (a) when the strut has two pin ends; (b) when it has two fixed ends. ($E = 29,000,000$ lbs.)

Also, find the deviation of the axis of the load from the axis of the strut so that the maximum stress in the metal may not exceed 10,000 lbs. per square inch.

Ans.—(a) 25,019 lbs.; (b) 50,019 lbs.

Deviation = .513 in. in (a) and .158 in. in (b).

30. A solid wrought-iron strut 20 ft. high and 4 in. in diameter has one end fixed and the other perfectly free. Find the deviation of the

line of action of a load of 10,000 lbs. from the axis, so that the stress may not exceed 10,000 lbs. per square inch, E being 27,000,000 lbs.

$$\text{Ans. } .88 \text{ in. if } P = \frac{2EI}{l^2}; \quad 1.8 \text{ in. if } P = \frac{1}{4}EI\frac{\pi^2}{l^2}.$$

31. A hollow cast-iron column with two pin ends is 24 ft. high and has a mean diameter of 12 in.; it carries a load of 80,000 lbs. Find the proper thickness of the metal, 10 being a factor of safety. If the deviation of the line of action of the load from the axis is 1 in., find the maximum stress per square inch in the metal, E being 17,000,000 lbs.

$$\text{Ans. } 1.28 \text{ in.}; \quad 2236 \text{ lbs. per sq. in.}$$

32. Find the crushing load of a solid wrought-iron pillar 3 in. in diameter, 10 ft. high, and fixed at both ends. Calculate the deviation which will produce a maximum stress in the metal of 9000 lbs. per square inch under loads of (a) 15,000 lbs.; (b) 30,000 lbs.; E being 29,000,000 lbs.

$$\text{Ans. } 148,775 \text{ lbs. (a) } 1.158 \text{ in.}; \quad (b) .38 \text{ in.}$$

33. Solve the preceding question on the assumption that the column has two pin ends.

$$\text{Ans. } 66,218 \text{ lbs.}; \quad (a) .985 \text{ in.}; \quad (b) .261 \text{ in.}$$

34. A pier consists of N rows of posts equidistant from each other, N being even; d is the distance from centre to centre of the outside rows; W is the gross vertical load upon the pier; H is the greatest horizontal thrust, and acts upon the pier at a height y above the base. Assuming the principle of a uniformly varying stress, the portion of the load borne by the n -th row of posts measured from the centre line is $\frac{W}{N} + \frac{ad}{2} \frac{2n-1}{N-1}$. Find the value of the coefficient a in terms of d , H , y , and N , and determine the best value for d .

35. Prove that the flexural rigidity of a straight beam, of sectional area A , under a thrust P per unit of area, is $EAK^2 \left(1 - \frac{P}{E}\right)$, and that the beam will bend if its length, when unstrained, exceeds

$$\pi \sqrt{\frac{EK^2}{P} + \left(1 - \frac{P}{E}\right)},$$

Ak^2 being the moment of inertia of the section, and E the coefficient of elasticity of the material.

36. Find the safe load on a rolled tee-iron strut 6 in. \times 4 in. \times $\frac{1}{2}$ in., 10 ft. long, fixed at one end, free at the other.

37. In Art. 19, show how equations (3) and (6) will be modified if the line of action of P is distant $\alpha + \beta$ from one end and $\alpha - \beta$ from the other end of the column's axis. Also, if the coefficient of elasticity, E , is variable and equal to $m \pm n \frac{z}{r}$ at a point distant z from the axis, r being

the maximum value of z , and m and n coefficients, show that $y + \frac{n}{m} \frac{k^2}{r}$ must be substituted for y in eq. (3).

38. In one of Christie's experiments an angle-bar 2 in. \times 2 in. \times $\frac{5}{16}$ in., with hinged ends, for which $\frac{l}{k}$ had the value 154, deflected .01 in. for an increase in the load of 3000 lbs. Show that $\frac{d}{\delta} + \frac{A}{\pi^2} = .0048$ in.

39. A long column with pin ends is bent laterally until the angular deviation (θ_0) at the ends is 4° . Find the total maximum intensity of stress, the section of the column being (a) a circle; (b) a square. $E = 29,000,000$ lbs., and the stress due to direct thrust = 1500 lbs. per square inch.

Ans.—(a) 3,515 lbs.; (b) 26,715 lbs.

40. With the same *maximum* stress as in the last question, find the angular deviation at the ends so that the stress due to direct thrust may be 10,000 lbs. per square inch.

Ans.—(a) $1^\circ 5'$; (b) $1^\circ 33'$.

41. Show that the load required to produce an angular deviation of 14° at the two pin ends of a long column is only *one per cent* greater than that which *just produces flexure*.

Whole Chapter

CHAPTER IX.

TORSION.

1. TORSION is the force with which a thread, wire, or prismatic bar tends to recover its original state after having been twisted, and is produced when the external forces which act upon the bar are reducible to two equal and opposite couples (the ends of the bar being free), or to a single couple (one end of the bar being fixed), in planes perpendicular to the axis of the bar. The effect upon the bar is to make any transverse section turn through an angle in its own plane, and to cause originally straight fibres, as *DE*, to assume helicoidal forms, as *FG* or *DC*. This induces longitudinal stresses in the fibres,

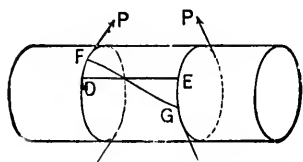

FIG. 360.

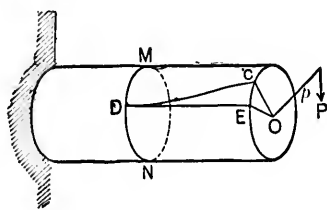

FIG. 361.

and transverse sections become warped. It is found sufficiently accurate, however, in the case of cylindrical and regular polygonal prisms, to assume that a transverse section which is plane before twisting remains plane while being twisted. In order that the bar may not be bent, its axis must coincide with the axis of the twisting couple.

2. Coulomb's Laws.—The angle turned through by one transverse section relatively to another at a unit distance from it, is called the *Angle of Torsion*, and Coulomb deduced from

experiments upon wires, that this angle is *directly* proportional to the moment of the twisting couple, and *inversely* proportional to the fourth power of the diameter.

Thus, if a force P , at the end of a lever of radius p , twists a cylindrical bar of length L and radius R , and if θ is the *circular measure* of the angle of torsion, then

$$\theta \propto Pp, \text{ and also } \propto \frac{1}{R^4},$$

so that $\theta = C \frac{Pp}{R^4}$, C being a constant depending only upon the nature of the material.

Let T be the total angle of torsion, in circular measure, i.e., the angle turned through by one end of the bar relatively to the other. Then

$$\frac{T}{L} = \theta = C \frac{Pp}{R^4}.$$

3. Torsional Strength of Shafts (see Art. 23, Chap. IV).—Consider a portion of the shaft bounded by the planes CE and MN , Fig. 361. It is kept in equilibrium by the couple $(P, -P)$, and by the elastic resistance at the section MN . Hence, this elastic resistance must be equivalent to a couple equal and opposite to $(P, -P)$.

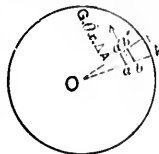

FIG. 362.

Let Fig. 362 be the transverse section at MN , on an enlarged scale, and let $abb'a'$ be any elementary area ($= \Delta A_1$) ($P, -P$) of the surface bounded by the radii OA, OB , and by the concentric arcs aa', bb' .

Let x_1 be the distance of ΔA_1 from O .

It is assumed, and is approximately true, that the resistance of any element $abb'a'$ to torsion is directly proportional to the angle of torsion (θ), to its distance from the axis (x_1), and to its area (ΔA_1), and also that it acts at right angles to the radial line of the element, i.e., to OA or OB .

Thus, the resistance of $abb'a'$ to torsion $= G\theta x_1 \Delta A_1$, G being a constant to be determined by experiment.

The corresponding moment of resistance about the axis $= G\theta x_1^2 \Delta A_1$. Similarly, if x_2, x_3, x_4, \dots are the distances

from the axis of any other elements, $\Delta A_1, \Delta A_2, \Delta A_3, \dots$, respectively, the corresponding moments of resistance are $G\theta x_1^2 \Delta A_1, G\theta x_2^2 \Delta A_2, \dots$. Hence, the *total* moment of resistance of the section

$$\begin{aligned} &= G\theta(x_1^2 \Delta A_1 + x_2^2 \Delta A_2 + \dots), \\ &= G\theta \Sigma(x^2 \Delta A) = G\theta I, \end{aligned}$$

I being the moment of inertia with respect to the axis.

But this moment of resistance (M) is equal and opposite to the moment of the couple ($P, -P$). Hence,

$$M = G\theta I = Pp. \quad \checkmark$$

The twisting moment will of course vary with a variable resistance, and the last equation gives its mean value.

The shaft, however, must be designed (see Cor. 4) for the maximum couple to which it may be subjected, and the moment of this couple ($= M_1$) may be expressed in terms of the mean by the equation

$$M_1 = \mu M, \quad \checkmark$$

μ being a coefficient to be determined in each case. In a series of experiments with different engines, Milton found that μ varied from 1.3 to 2.1, but doubtless the variation is often between still wider limits.

Cor. 1. Let f be the stress at the point farthest from the axis. For a *solid round* shaft, of diameter D ,

$$I = \frac{\pi D^4}{32}, \quad \text{and} \quad f = G\theta \frac{D}{2}.$$

$$\therefore M = Pp = G\theta I = \frac{\pi}{16} f D^3 = .196 f D^3.$$

Let T° be the total torsion in degrees. Then

$$\theta = \frac{1}{L} \frac{\pi T^\circ}{180},$$

and hence

$$f = \frac{G \pi T^\circ D}{L 180 \cdot 2},$$

or

$$\frac{L}{D} = \frac{G \pi}{f 360} T^\circ.$$

Taking the following mean values of G and f :

Material.	G	f
Cast-iron	6,300,000	5,600
Wrought-iron	10,500,000	7,200
Steel	12,000,000	11,200

$\frac{L}{D} = 9.8T^\circ$ for cast iron, $= 12.7T^\circ$ for wrought-iron, $= 9.3T^\circ$ for steel.

Thus, the twist is 1° each 9.8 diameters in length for cast-iron, each 12.7 diameters in length for wrought-iron, and each 9.3 diameters in length for steel. This is often much too large, and in practice the twist is usually limited to $\frac{1}{18}^\circ$ per lineal foot of length. For a *hollow round shaft*, D being the external and D_1 the internal diameter,

$$I = \frac{\pi}{32} (D^4 - D_1^4), \text{ and } f = G\theta \frac{D}{2}.$$

$$\therefore M = P\phi = \frac{\pi}{16} f \frac{D^4 - D_1^4}{D} = .196f \frac{D^4 - D_1^4}{D}.$$

If the thickness (T) of the hollow shaft is small compared with D ,

$$D^4 - D_1^4 = D^4 - (D - 2T)^4 = 8D^3T, \text{ approximately,}$$

and

$$M = P\phi = 1.57D^3Tf.$$

The use of compressed steel admits of shafts being made hollow. For a *solid square* shaft, H being the side of the square,

$$I = \frac{H^4}{6},$$

and f , the stress at the end of a diagonal, = $G\theta \frac{H}{\sqrt{2}}$

$$\begin{aligned} \therefore M = Pp &= \frac{f\sqrt{2} H^3}{H} \frac{H}{6} \\ &= \frac{\sqrt{2}}{6} fH^3 = .236fH^3, \end{aligned}$$

and

$$\theta = \frac{M}{GI} = \frac{6M}{GH^3}$$

In these results it is assumed that $G\theta$ ($= \frac{2f}{D}$ or $= \frac{\sqrt{2}f}{H}$) is constant at different points of the cross-section, which, however, is only true for circular sections.

In non-circular sections the stress is more generally greatest at points in the bounding surface which are nearest to the axis and least at those points which are farthest from the axis. St. Venant, who first called attention to this fact, gave the following, amongst others, as the results of his investigations.

Designating by *unity* the torsional rigidity ($= \frac{M}{\theta}$) of a shaft with circular section, the torsional rigidity of a shaft of equal sectional area is .8863, $.8863 \times \sqrt{\frac{2n}{n^2+1}}$, .7255, or $\sqrt{\frac{b}{a}}$, according as the section is a square, a rectangle with sides in the ratio n to 1, an equilateral triangle, or an ellipse whose major and minor axes are $2a$ and $2b$, respectively.

Cor. 2. The torsional stress per unit of area at a distance x from the axis is $G\theta x$.

Hence, if $\theta = 1$ and $x = 1$, G is the force that will twist a

unit of area at a unit of distance from the axis through an angle unity.

Cauchy found analytically that in an *isotropic* body G is two-fifths of the coefficient of direct elasticity.

Experiments indicate that G is about three-eighths or one-third of the coefficient of direct elasticity.

Cor. 3. For a solid cylinder, $P\theta = \frac{G\pi\theta R^4}{2}$, R being the radius, and therefore $R^4 \propto \frac{P\theta}{G}$. If the shaft is to have a certain *specified stiffness*, i.e., if θ is fixed, $R^4 \propto \frac{P\theta}{G}$, and for a given twisting moment $R^4 \propto \frac{1}{G}$. Now G is nearly the same for wrought-iron and steel, so that there is little if any advantage to be gained by the use of the latter.

After passing the elastic limit, the stress varies much more slowly than as the distance from the axis, and there will be a partial equalization of stress, the apparent torsional strength being increased.

Cor. 4. In any transverse section of a solid cylindrical shaft, the maximum unit stress

$$f = G\theta \frac{D}{2} = \frac{16}{\pi} \frac{M_1}{D^3},$$

M_1 being the moment of the maximum twisting couple.

This relation is true so long as the stress does not exceed the elastic limit, and agrees with the practical rule that the diameter of a cylindrical shaft subjected to torsional forces is proportional to the *cube root* of the twisting couple.

The rule is usually expressed in the form

$$M_1 = KD^3, \text{ so that } K = \frac{f\pi}{16}.$$

Wöhler's experiments show that the value of f depends, to some extent, upon its fluctuation under the variable twist-

ing moment. Ordinarily it should not exceed 7200 lbs. per square inch for wrought-iron, in which case $K = 11000 \times \frac{2}{7} = 1414$.

(Note.—If P_1 is the torsional breaking weight,

$$K = \frac{M_1}{D^3} = \frac{P_1 \rho}{D^3}$$

is the *coefficient of torsional rupture*.)

Cor. 5. Let W be the work transmitted to a shaft of D in diameter, in foot-pounds per minute, N being the corresponding number of revolutions. Then

$$\begin{aligned} 12W = \text{inch-pounds transmitted} &= 2\pi MN = 2\pi \frac{M_1 N}{\mu} \\ &= 2\pi \frac{KD^3}{\mu} N, \end{aligned}$$

since $M = \text{mean twisting moment} = \frac{M_1}{\mu}$. Hence,

$$\mu \frac{W}{N} = \frac{\pi}{6} KD^3.$$

Let HP be the horse-power transmitted per minute. Then $W = 33000 HP$. Also for wrought-iron $K = 11000 \times \frac{2}{7}$.

Hence $\mu \frac{490}{11} \frac{HP}{N} = D^3$, and if $\mu = 1.43$,

$$D = 4 \sqrt[3]{\frac{HP}{N}},$$

a formula agreeing with the best practice in the case of wrought-iron shafts subjected to torsional forces only. Such shafts should, therefore, carry no pulleys.

Cor. 6. The *resilience* of a cylindrical axle is the product of one half of the greatest moment of torsion into the corresponding angle of torsion.

Cor. 7. It often happens in practice that a shaft (or beam) is subjected to a bending as well as to a torsional action.

The combined bending and twisting moments are equivalent (Art. 9, Chap. IV) to the moment

$$M_c = M_b + \sqrt{M_b^2 + M_t^2} = M_t(n + \sqrt{n^2 + 1}),$$

where $M_b = nM_t$, M_b being the bending and M_t the twisting moment at the given section.

Hence, remembering that the maximum twisting moment M_t is equal to μM_c , we have for a wrought-iron shaft,

$$\mu(n + \sqrt{n^2 + 1}) \frac{490}{11} \frac{HP}{N} = D^3.$$

If $n = .36 +$, this becomes

$$D = 4\frac{1}{2} \sqrt[3]{\frac{HP}{N}},$$

a formula agreeing with the best practice in the case of transmission with bending, as, e.g., in the crank-shafts of marine engines.

It often happens that n has a still larger value, as, e.g., in the case of head shafts properly supported against springing. The usual formula is then

$$D = 5 \sqrt[3]{\frac{HP}{N}},$$

corresponding to $n = .72 +$.

4. Distance between Bearings.—The distance between the bearings of a line of shafting is limited by the consideration that the stiffness of the shaft must be such as will enable it to resist excessive bending under its own weight and under any other loads (e.g., pulleys, wheels, etc.) applied to it. For this reason, the ratio of the maximum deviation of the axis of the shaft from the straight to the corresponding distance between bearings should not exceed a certain fraction whose value has been variously estimated by different writers.

Let l be the distance in feet between bearings, d the diameter of the shaft in inches, w the weight of the ma-

terial of the shaft per cubic foot, and let the applied load be equivalent to a load per lineal unit of length m times that of the shaft. Assume a *stiffness* of $\frac{1}{1200}$, and that the axis of the shaft is truly in line at the bearings. The maximum deflection of the shaft is given by the formula (Art. 3, Ex. 8, Chap. VII)

$$\begin{aligned} D &= \frac{1}{384} \frac{(m+1)(\text{weight of shaft})l^3 \cdot 1728}{EI} \\ &= \frac{1}{384} (m+1) \frac{\pi d^3}{4} \frac{1}{144} \omega l \frac{64}{\pi d^4} \frac{l^3 \cdot 1728}{E} \\ \therefore \frac{D}{l} &= \frac{1}{100} = \frac{(m+1)\omega l^3}{2E d^3}, \end{aligned}$$

or

$$l = \sqrt[3]{\frac{Ed^3}{50\omega(m+1)}}.$$

EXAMPLE.—For wrought-iron, $E = 30,000,000$ lbs. and $\omega = 480$ lbs.

$$\therefore l = 12.7 \sqrt[3]{\frac{d^3}{m+1}}.$$

If the applied load, instead of being uniformly distributed, is concentrated at the centre, the maximum deflection

$$= D \text{ in.} = \frac{1}{192} \frac{(m+\frac{1}{2})(\text{weight of shaft})l^3 \cdot 1728}{EI},$$

and hence

$$l = \sqrt[3]{\frac{Ed^3}{100\omega(m+\frac{1}{2})}}.$$

$$\text{EXAMPLE.—For wrought-iron } l = 8.5 \sqrt[3]{\frac{d^3}{m+\frac{1}{2}}}.$$

5. **Efficiency of Shafting.**—Let it require the whole of the driving moment to overcome the friction in the case of a shaft of diameter d and length L . The *efficiency* of a shaft of the same diameter and length $l = 1 - \frac{l}{L}$.

$$\begin{aligned} \text{But } \frac{f\pi d^3}{16} = (P\phi) = \text{moment of friction} &= \mu \frac{w\pi d^2}{4} L \frac{d}{2} \\ &= \frac{\mu w\pi d^3}{8} L, \end{aligned}$$

w being the specific weight of the material of the shaft, and μ the coefficient of friction. Hence,

$$\frac{l}{L} = 2\mu \frac{w}{f},$$

and the efficiency $= 1 - 2\mu \frac{wl}{f}$.

6. **Cylindrical Spiral Spring.**—Let the figure represent a cylindrical spiral spring of length S , supporting a weight W . Consider a section of the spring at any point B .

At this point there is a shear W and a torque Wy , y being the distance of B from the axis of the spring, i.e., the radius of the coil.

The effect of W may generally be neglected as compared with the effect of the moment Wy , and it may be therefore assumed that the spring is under torsion at every point. Let there be n coils. Then

$$S = 2\pi y n, \text{ approx.}$$

Hence,

$$Wy = \frac{f\pi r^3}{2} = \frac{G\theta\pi r^4}{2},$$

r being the radius of the spring.

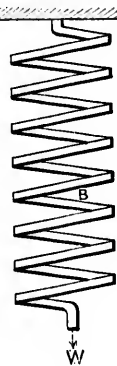

FIG. 353.

The elongation of the spring

$$= S_y \theta = \frac{2Wy^2S}{G\pi r^4} = \frac{S_y f}{Gr} = \frac{2\pi f n y^2}{Gr}.$$

$$\text{The work done} = \frac{Wy}{2} \theta S = \frac{W^2 y^2 S}{G\pi r^4} = \frac{f^2 \pi r^2 S}{4G}.$$

A weight hung at the lower end tends to turn as well as lengthen the spring, and this is due to a slight bending action.

According to Hartnell, $f = 60,000$ lbs. per square inch for $\frac{3}{8}$ -in. steel, $f = 50,000$ lbs. per square inch for $\frac{1}{2}$ -in. steel, and G varies from 13,000,000 lbs. for $\frac{1}{4}$ -in. steel to 11,000,000 lbs. for $\frac{3}{8}$ -in. steel.

Also for wire less than $\frac{3}{8}$ in. in diameter,

$$W = \frac{48000r^3}{y}, \text{ and the deflection} = \frac{Wny^3}{288000r^4}.$$

EXAMPLE.—A wrought-iron shaft in a rolling-mill makes 95 revolutions per minute and transmits 120 H. P., which is supplied from a waterfall by means of a turbine. Determine the diameter of the shaft (1) if the maximum stress in the metal is not to exceed 9000 lbs. per square inch; (2) if the angle of torsion is not to exceed $\frac{1}{18}^\circ$ per lineal foot.

As a matter of fact, the diameter of the shaft is $3\frac{3}{4}$ in. at the bearings and 4 in. in the intermediate lengths. What are the corresponding maximum inch-stresses in the metal?

Let the twisting couple be represented by force P at the end of an arm p . Then

$$P \times 2\pi p \times 95 = 120 \times 33,000 \text{ ft.-lbs.}$$

$$\therefore Pp = \frac{120 \times 33000}{2\pi \times 95} = \frac{126000}{19} \text{ ft.-lbs.} = \frac{126000}{19} \times 12 \text{ in.-lbs.}$$

$$\text{First, } \frac{126000 \times 12}{19} = Pp = \frac{f\pi D^3}{16} = \frac{9000 \times 22}{16 \times 7} D^3;$$

and hence

$$D = 3.56 \text{ in.}$$

$$\text{Second, } \frac{126000}{19} \times 12 = P\rho = \frac{G\theta\pi D^4}{32}.$$

But $\theta = \frac{\pi}{180} \times \frac{1}{13} \times \frac{1}{12}$; take $G = 10,500,000$. Then

$$\frac{126000 \times 12}{19} = \frac{10500000}{32} \times \frac{22}{7} \times \frac{1}{180} \times \frac{1}{13} \times \frac{1}{12} \times \frac{22}{7} D^4.$$

Hence,

$$D^4 = 689.45, \text{ and } D = 5.12 \text{ in.}$$

Third, the maximum stresses in the real shaft at the bearings and in the intermediate lengths are respectively given by

$$\frac{126000}{19} \times 12 = \frac{\text{stress}}{16} \times \frac{22}{7} \times (3\frac{1}{2})^3,$$

and

$$\frac{126000}{19} \times 12 = \frac{\text{stress}}{16} \times \frac{22}{7} \times (4)^3.$$

From the former, the maximum stress = 7682 lbs. per sq. inch.

“ “ latter, “ “ “ “ = 6330 “ “ “ “

EXAMPLES.

1. A steel shaft 4 in. in diameter is subjected to a twisting couple which produces a circumferential stress of 15,000 lbs. What is the stress (shear) at a point 1 in. from the centre of the shaft?

Determine the twisting couple. *Ans.* 7500 lbs.; 188,571 $\frac{2}{3}$ lbs.

2. A weight of 2 $\frac{3}{4}$ tons at the end of a 1-ft. lever twists asunder a steel shaft 1 $\frac{3}{8}$ in. in diameter. Find the breaking weight at the end of a 2-ft. lever, and also the modulus of rupture.

Ans. 1 $\frac{1}{2}$ tons; 23,510 lbs.

3. A couple of N ft.-tons twists asunder a shaft of diameter d . Find the couple which will twist asunder a shaft of the same material and diameter $2d$.

Ans. $8N$.

4. Compare the couples required to twist two shafts of the same material through the same angle, the one shaft being l ft. long and d in. in diameter, the other $2l$ ft. long and $2d$ in. in diameter.

Compare the couples, the diameter of the latter shaft being $\frac{d}{2}$.

Ans. 1 to 8; 32 to 1.

5. A shaft 15 ft. long and 4 $\frac{1}{2}$ in. in diameter is twisted through an angle of 2° under a couple of 2000 ft.-lbs. Find the couple which will twist a shaft of the same material 20 ft. long and 7 $\frac{1}{2}$ in. in diameter through an angle of $2\frac{1}{2}^\circ$.

Ans. 12,288 ft. lbs.

6. A round cast-iron shaft 15 ft. in length is acted upon by a weight of 2000 lbs. applied at the circumference of a wheel on the shaft; the diameter of the wheel is 2 ft. Find the diameter of the shaft so that the total angle of torsion may not exceed 2° .

Ans. 3.76 in.

7. A wrought-iron shaft is subjected to a twisting couple of 12,000 ft.-lbs.; the length of the shaft between the sections at which the power is received and given off is 30 ft.; the total admissible twist is 4° . Find the diameter of the shaft, μ (page 570) being $\frac{3}{8}$, and G 10,000,000 lbs.

Ans. 5.8 in.

8. A wrought-iron shaft 20 ft. long and 5 in. in diameter is twisted through an angle of 2° . Find the maximum stress in the material, G being 10,500,000 ft.-lbs.

Ans. 3819.2 lbs. per sq. in.

9. A crane chain exerts a pull of 6000 lbs. tangentially to the drum upon which it is wrapped. Find the diameter of a wrought-iron axle which will transmit the resulting couple, the effective radius of the drum being $7\frac{1}{2}$ in.; the safe working stress per square inch being 7200 lbs.

Ans. 3.17 in.

10. Find the diameter and the total angle of torsion of a 12-ft. wrought-iron shaft driven by a water-wheel of 20 H. P., making 25 revolutions per minute, G being 10,000,000 lbs., and the working stress 7200 lbs. per square inch.

Ans. 3.29 in.; $3^{\circ}.6$.

11. A turbine makes 114 revolutions per minute, and transmits 92 H. P. through the medium of a shaft 8 ft. 6 in. in length. What must be the diameter of the shaft so that the total angle of torsion may not exceed $\frac{2^{\circ}}{3}$, G being 10,500,000 lbs.?

Ans. 4.7 in.

Determine the side of a square pine shaft that might be substituted for the iron shaft.

12. A steel shaft 20 ft. in length and 3 in. in diameter makes 200 revolutions per minute and transmits 50 H. P. Through what angle is the shaft twisted?

A wrought-iron shaft of the same length is to do the same work at the same speed. Find its diameter so that the stress at the circumference may not exceed $\frac{3}{8}$ of that at the circumference of the steel shaft.

Ans. $2^{\circ}.6$; 3.556 in.

13. A vertical cast-iron axle in the Saltaire works makes 92 revolutions per minute and transmits 300 H. P.; its diameter is 10 in. Find the angle of torsion.

Ans. $.0144^{\circ}$ per lineal foot.

14. In a spinning-mill a cast-iron shaft $8\frac{1}{2}$ in. in diameter makes 27 revolutions per minute; the angle of torsion is not to exceed $\frac{1^{\circ}}{13}$ per lineal foot. Find the work transmitted.

Ans. 62.19 H. P.

15. A square wooden shaft 8 ft. in length is acted upon by a force of 200 lbs., applied at the circumference of an 8 ft. wheel on the shaft. Find the length of the side of the shaft, so that the total torsion may not exceed 2° ($G = 400,000$). What should be the diameter of a round shaft of equal strength and of the same material?

Ans. 4.46 in.; 4.74 in.

16. A shaft transmits a given H. P. at N revolutions per minute without bending. Find the weight of the shaft in pounds per lineal foot.

Ans. $32.9 \left(\frac{\text{H. P.}}{N} \right)^{\frac{3}{2}}$.

17. The working stress in a steel shaft subjected to a twisting couple of 1000 in.-tons is limited to 11,200 lbs. per square inch. Find its diameter; also find the diameter of the steel shaft which will transmit 5000 H. P. at 66 revolutions per minute, μ being $\frac{3}{4}$. *Ans.* 10 in.; 6.88 in.

18. A wrought-iron shaft is twisted by a couple of 10 ft.-tons. Find its diameter (a) if the torsion is not to exceed 1° per lineal foot, (b) if the safe working stress is 7200 lbs. per square inch. $G = 10,000,000$ lbs.

Ans.—(a) 3.7 in.; (b) 5.7 in.

19. A steel shaft 2 in. in diameter makes 100 revolutions per minute and transmits 25 H. P. Find the maximum working stress and the torsion per lineal foot, G being 10,000,000 lbs. Also find the diameter of a shaft of the same material which will transmit 100 H. P. with the same maximum working stress. *Ans.* 10,022 $\frac{8}{11}$ lbs.; $.0574^\circ$; 3.17 in.

20. The crank of a horizontal engine is 3 ft. 6 in. and the connecting-rod 9 ft. long. At half-stroke the pressure in the connecting-rod is 500 lbs. What is the corresponding twisting moment on the crank-shaft?

Ans. 1716 $\frac{1}{2}$ ft.-lbs.

21. If the horizontal pressure upon the piston end of the connecting rod in the previous question is constant, find the maximum twisting moment on the crank-shaft.

Ans. $P \left(\sin \theta + \frac{\sin \theta \cos \theta}{\sqrt{n^2 - \sin^2 \theta}} \right)$, θ being given by

$$n^6 \cos^2 \theta + n^4 (\sin^2 \theta \cos^2 \theta - 1) + n^2 \sin^4 \theta (1 + \sin^2 \theta) - \sin^6 \theta = 0$$

where $n = \frac{1.08}{.7} = 1\frac{3}{4}$.

N.B.—If $\sin^2 \theta$ is neglected as compared with n^2 ,

$$\text{the maximum moment} = P \sin \theta \left(1 + \frac{\cos \theta}{n} \right),$$

θ being very nearly 72° .

22. Show that a hollow shaft is both stiffer and stronger than a solid shaft of the same weight and length.

23. Find the percentage of weight saved by using a hollow instead of a solid shaft.

$$\text{Ans. If of equal stiffness} = \frac{200}{m^2 + 1}.$$

$$\text{If of equal strength} = 100 \left\{ 1 - \sqrt[3]{\frac{m^2(m^2 - 1)}{(m^2 + 1)^2}} \right\},$$

m being the ratio of the external to the internal diameter of hollow shaft.

24. A hollow cast-iron shaft of 12 in. external diameter is twisted by a couple of 27,000 ft.-lbs. Find the proper thickness of the metal so that the stress may not exceed 5000 lbs. per square inch. *Ans.* .619 in.

25. The external diameter of a hollow shaft is p times the internal. Compare its torsional strength with that of a solid shaft of the same material and weight.

$$\text{Ans. } \frac{p \sqrt{p^2 - 1}}{p^2 + 1}.$$

26. If the solid shaft is 10 in. in diameter, and the internal diameter of the hollow shaft is 5 inches, find the external diameter and compare the torsional strengths.

$$\text{Ans. } 5 \sqrt[3]{5} \text{ in.}; \sqrt[3]{5} \text{ to } 3.$$

27. A hollow steel shaft has an external diameter d and an internal diameter $\frac{d}{2}$. Compare its torsional strength with that of (a) a solid steel shaft of diameter d ; (b) a solid wrought-iron shaft of diameter d ; the safe working stresses of steel and iron being 5 tons and $3\frac{1}{2}$ tons respectively.

$$\text{Ans.}-(a) \frac{1}{18}; (b) \frac{1}{15}.$$

28. What twisting moment can be transmitted by a hollow steel shaft of 8 in. internal and 10 in. external diameter, the working stress being 5 tons per square inch?

$$\text{Ans. } 579\frac{1}{2} \text{ in.-tons.}$$

29. If f_1 is the safe torsional working stress of a shaft, and f_2 is the safe working stress when the shaft acts as a beam, show that the torsional resistance of the shaft is to its bending resistance in the ratio of $2f_1$ to f_2 .

30. The wrought-iron screw shaft of a steamship is driven by a pair of cranks set at right angles and 21.7 in. in length; the horizontal pull upon each crank-pin is 176,400 lbs., and the effective length of the shaft is 866 in. Find the diameter of the shaft so that (1) the circumferential stress may not exceed 9000 lbs. per square inch; (2) the angle of torsion may not exceed $\frac{1^\circ}{13}$ per lineal foot; G being 10,000,000 lbs. The actual diameter of the shaft is 14.9 in. What is the actual torsion?

$$\text{Ans.}-(1) 14.53 \text{ in.}; (2) 14.89 \text{ in.}; (3) \text{ total torsion} = 5^\circ.545.$$

31. The ultimate tensile strength of the iron being 60,000 lbs. per square inch, find the actual ultimate strength under unlimited repetitions of stress.

$$\text{Ans. } 59,361 \text{ lbs. (Unwin's formula).}$$

32. What is the torsion in the preceding question when one of the cranks passes a dead point?

33. A steel shaft 300 feet in length makes 200 revolutions per minute and transmits 10 H. P. Determine its diameter so that the greatest stress in the material may be the same as the stress at the circumference of an iron shaft 1 in. in diameter and transmitting 500 ft.-lbs.

$$\text{Ans. } .807 \text{ in. } (= \frac{1}{5} \text{ in.})$$

34. Determine the coefficient of torsional rupture for the shaft in Question 33, 10 being the factor of safety.

35. A wrought-iron shaft in a rolling-mill is 220 feet in length, makes 95 revolutions per minute, and transmits 120 H. P. to the rolls; the main body of the shaft is 4 in. in diameter, and it revolves in gudgeons $3\frac{1}{2}$ in.

in diameter. Find the greatest shear stress in the shaft proper and in the portion of the shaft at the gudgeons. *Ans.* 6330.2 lbs.; 7508 lbs.

36. Power is taken from a shaft by means of a pulley 24 inches in diameter which is keyed on to the shaft at a point dividing the distance between two consecutive supports into segments of 20 and 80 in.; the tangential force at the circumference of the pulley is 5500 lbs. If the shaft is of cast-iron, determine its diameter, taking into account the bending action to which it is subjected. *Ans.* 5.65 in.

37. Show that the resilience of a twisted shaft is proportional to its weight.

$$\text{Ans. Resilience} = \frac{\int^2 \text{Volume}}{m} \frac{1}{4}.$$

38. If a round bar of any material is subjected to a twisting couple, show that its maximum resilience is two-thirds the maximum resilience of the material.

39. Determine the diameter of a wrought-iron shaft for a screw steamer, and the torsion per lineal foot; the indicated H. P. = 1000, the number of revolutions per minute = 150, the length of the shaft from thrust bearing to screw = 75 ft., and the safe working stress = 7200 lbs. per square inch. *Ans.* 6.67 in.; $10^\circ.5$.

40. In a spinning-mill a cast-iron shaft 84 ft. long makes 50 revolutions per minute and transmits 270 H. P. Find its diameter (1) if the stress in the metal is not to exceed 5000 lbs. per square inch; (2) if the angle of torsion per lineal foot is not to exceed $\frac{1^\circ}{13}$.

Also (3) in the first case find the total torsion.

$$\text{Ans. (1) } 7.02 \text{ in.}; (2) 10.23 \text{ in.}; (3) 13^\circ.048.$$

41. A circular shaft is twisted beyond the limit of elasticity. If the equalization of stress is perfect, show that for a given maximum stress the twisting couple is greater than it would be if the elasticity were perfect, in the ratio of 4 to 3.

42. Determine (a) the profile of a shaft of length l which at every point is so proportioned as to be just able to bear the power it has to transmit plus the power required to overcome the friction beyond the point under consideration. Find (b) the efficiency of such a shaft, and (c) the efficiency of a shaft made up of a series of n divisions, each of uniform diameter.

Ans. (a) The radius y of any section distant x from the driving end

is $y = re^{-\frac{x}{3L}}$, r being the radius of the driving end and L the length of a shaft of uniform diameter, such that the whole driving moment is required to overcome its own friction.

$$(b) e^{-\frac{l}{L}}; (c) \left(1 - \frac{l}{nL}\right)^n.$$

43. A steel shaft carries a 5-ft. pulley midway between the supports and makes 6 revolutions per minute. the tangential force on the pulley being 500 lbs. Taking the coefficient of working strength at 11,200 lbs. per square inch, find the diameter of the shaft and the proper distance between the bearings.

44. A steel shaft 4 inches in diameter and weighing 490 lbs. per cubic foot makes 100 revolutions per minute. If the working stress in the metal is 11,200 lbs. per square inch, find the twisting couple and the distance to which the work can be transmitted; the coefficient of friction being .05, and the efficiency of the shaft $\frac{1}{4}$.

Ans. 140,800 in.-lbs.; 8228 $\frac{1}{4}$ ft.

45. If the shaft is of steel, and if the loss due to friction is 20 per cent, find the distance to which work may be transmitted, μ being .05.

Ans. 6582 $\frac{1}{4}$ ft.

46. A wrought-iron shaft 220 ft. between bearings and 4 in. in diameter can safely transmit 120 H. P. at the rate of 95 revolutions per minute. What is the efficiency of the shaft? ($\mu = \frac{1}{5}$) *Ans.* .976.

47. The efficiency of a wrought-iron shaft is $\frac{1}{4}$; the working stress in the metal is 7200 lbs. per square inch; the coefficient of friction is .125. How far can the work be transmitted? *Ans.* 4320 ft.

48. A spring is formed of steel wire; the mean diameter of the coils is 1 inch; the working stress of the wire is 50,000 lbs. per square inch; the elongation under a weight of 19 $\frac{1}{4}$ lbs. is 2 inches; the coefficient of transverse elasticity is 12,000,000 lbs. Find the diameter of the wire and the number of coils.

49. Find the weight of a helical spring which is to bear a safe load of 6 tons with a deflection of 1 inch, G being 12,000,000 lbs., and f 60,000 lbs.

50. Find the time of oscillation of a spring, the normal displacement under a given load being Δ .

Ans. $\pi \sqrt{\frac{\Delta}{g}}$.

51. Find the deflection under the weight W of a conical helical spring (a) of circular section; (b) of rectangular section, the radii of the extreme coils being y_1 and y_2 , and the radial distance from the axis to a point of the spring at an angular distance ϕ from the commencement of the spiral

being given by the relation $\frac{y_2 - R}{y_2 - y_1} = \frac{\phi}{2\pi n}$. (n = number of coils.)

Ans. (a) $\frac{n(y_1 + y_2)(y_1^2 + y_2^2)W}{Gr^4}$ ($= \frac{ny^3 W}{Gr^4}$, if $y_1 = 0$ and $y_2 = y$);

(b) $1.8\pi n(y_1 + y_2)(y_1^2 + y_2^2) \frac{b^2 + h^2}{b^3 h^3} \frac{W}{G}$;

b and h being the sides of the rectangular section.

52. The efficiency of an axle is $\frac{1}{4}$; the working stress in the shaft is 9000 lbs. per square inch; the coefficient of friction is .10. How far may work be transmitted?

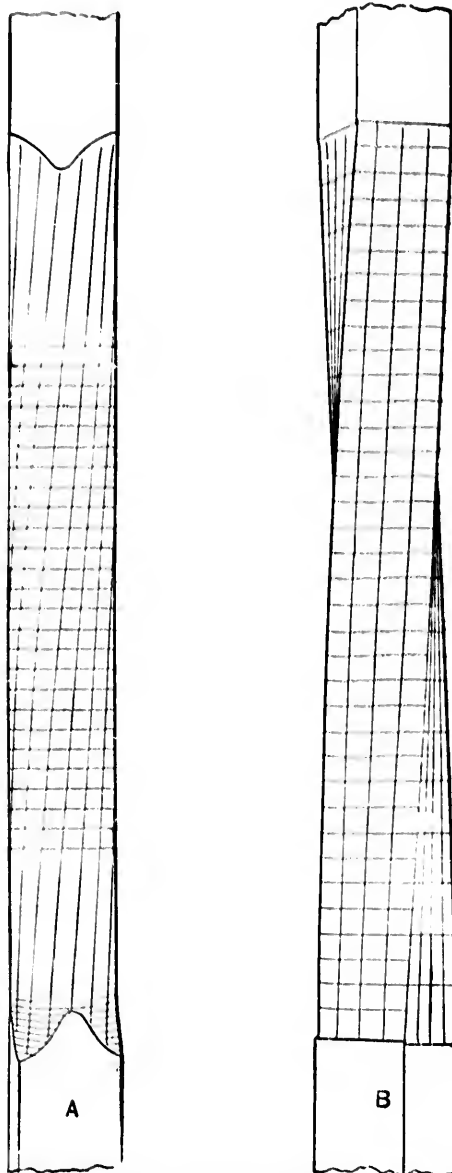
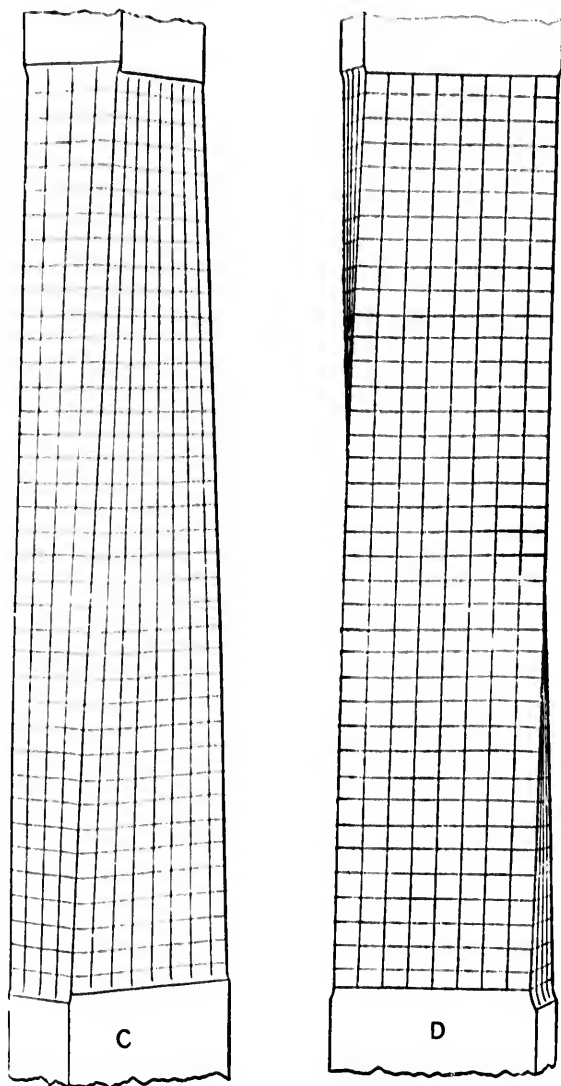

Fig. A shows the distortion produced by twisting a round $\frac{3}{4}$ -in. iron bar.
Fig. B shows the distortion produced by twisting a square $\frac{3}{4}$ -in. iron bar.



The above figures show the distortion produced by twisting a $1\frac{1}{4} \times \frac{3}{4}$ " iron bar.

CHAPTER X.

STRENGTH OF CYLINDRICAL AND SPHERICAL BOILERS.

1. Thin Hollow Cylinders; Boilers; Pipes.

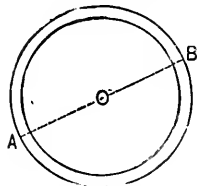

FIG. 364.

Let r be the radius of the cylinder.

Let t be the thickness of the metal.

Let p be the fluid pressure upon each unit of surface.

Let f be the tensile or compressive unit stress, according as p is an internal or external pressure.

Assume (1) that the metal is homogeneous and free from initial strain;

(2) that t is small as compared with r ;

(3) that the pressures are uniformly distributed over the internal and external surfaces;

(4) that the ends are kept perfectly flat and rigid;

(5) that the stress in the metal is *uniformly* distributed over the thickness.

The last assumption is equivalent to supposing that it is the *mean* circumferential stress which is governed by the strength of the metal, while in reality it is the *internal* or maximum circumferential stress which is so governed.

The figure represents a cross-section of the cylinder of thickness unity.

A section made by any diametral plane, as AB , must develop a total resistance of $2tf$, and this must be equal and opposite to the resultant of the fluid pressure upon each half, i.e., to $2pr$. Hence,

$$2tf = 2pr, \text{ or } tf = pr. \dots \dots (1)$$

This formula may be employed to determine the *bursting*, *proof*, or *working pressure* in a cylindrical or approximately cylindrical boiler, provided that f , instead of being the tensile or compressive unit stress, is some suitable coefficient which has been determined by experiment. If η is the efficiency of a riveted joint, the formula

$$\eta f = pr$$

may be employed to determine the working pressure in a cylindrical or approximately cylindrical boiler.

In ordinary practice the values of η and f are given by the following table:

Material.	Joint.	η	f in lbs. per sq. in.
Wrought-iron.....	Single-riveted	.55	8000 to 9000
"	Double-riveted	.7	"
"	Treble-riveted	.8 to .85	"
Steel.....	Single-riveted	.55	12000 to 13000
"	Double-riveted	.7	"
"	Treble-riveted	.8 to .85	"

For cast-iron cylinders the working value of f may be taken at about 2000 lbs. per square inch.

The total pressure upon each of the flat ends of the cylinder

$$= \pi r^2 p.$$

The longitudinal tension in a thin hollow cylinder

$$= \frac{\pi r^2 p}{2\pi r t} = \frac{pr}{2t}, \quad (2)$$

and is one half of the circumferential stress f .

Cor. 1. Let the cylinder be subjected to an external pressure p' as well as to an internal pressure p . Then

$$ft = pr - p'r', \quad \dots \dots \dots (3)$$

r' being the radius of the outside surface of the cylinder. f is a tension or a pressure according as $pr \geq p'r'$.

Generally, $r - r'$ is very small, and the relation (3) may be written

$$ft = r(p - p').$$

2. Thick Hollow Cylinder.—If t is large, the stress is no longer uniformly distributed over the thickness. Suppose that the assumptions (1) and (3) of Art. 1 still hold, also that the cylinder ends are free, and that the annulus forming the section of the cylinder is composed of an infinite number of concentric rings. Under these conditions the straining of the cylinder cannot affect its cylindrical form. Hence, right sections of the cylinder in the unstrained state remain planes after the straining, so that the longitudinal strain at every point must be the same. Two methods will be discussed.

FIRST METHOD.—Let dx be the thickness of one of the rings of radius x , and let dq be the intensity of the circumferential stress.

$pr - p'r' =$ difference between the total pressures from within and without $=$ total circumferential stress $= \int_r^{r'} dq$.

If it be assumed that the thickness ($= r' - r$) remains unchanged under the pressure, then the circumferential extension of each of the concentric rings must be equal to the same constant quantity λ , and therefore

$$dq = Edx \frac{\lambda}{2\pi x},$$

E being the coefficient of elasticity. Hence,

$$pr - p'r' = \frac{E\lambda}{2\pi} \int_r^{r'} \frac{dx}{x} = \frac{E\lambda}{2\pi} \log_e \frac{r'}{r}.$$

Let f be the tensile unit stress. Then $f = E \frac{\lambda}{2\pi t}$ if the elastic limit is not exceeded, and therefore

$$pr - p'r' = fr \log_e \frac{r'}{r},$$

or

$$\frac{r'}{r} = e^{\left(\frac{pr - p'r'}{fr}\right)}.$$

$$\therefore \frac{r'}{r} = 1 + \frac{pr - p'r'}{fr} + \frac{1}{2}\left(\frac{pr - p'r'}{fr}\right)^2, \text{ approx.,} \quad (4)$$

if p is small as compared with f ; and hence,

$$\frac{t}{r} = \frac{r'}{r} - 1 = \frac{pr - p'r'}{fr} + \frac{1}{2}\left(\frac{pr - p'r'}{fr}\right)^2. \quad \dots (5)$$

In most cases which occur in practice p' is so small as compared with p that it may be disregarded.

Hence, making p' zero in equation (5),

$$\frac{t}{r} = \frac{p}{f}\left(1 + \frac{1}{2}\frac{p}{f}\right). \quad \dots (6)$$

Formulae (5) and (6) may be employed even if the elastic limit is exceeded, if f is considered a coefficient of strength to be determined by experience.

Cor.—Rankine, in his Applied Mechanics, obtains by another method,

$$\frac{r'}{r} = \sqrt{\frac{f+p}{f-p+2p'}} = \sqrt{\frac{f+p}{f-p}},$$

if p' be neglected. Hence,

$$\begin{aligned} \frac{r'}{r} &= \left(1 + \frac{p}{f}\right)^{\frac{1}{2}} \left(1 - \frac{p}{f}\right)^{-\frac{1}{2}} \\ &= \left(1 + \frac{1}{2}\frac{p}{f} - \frac{1}{8}\frac{p^2}{f^2}\right) \left(1 + \frac{1}{2}\frac{p}{f} + \frac{3}{8}\frac{p^2}{f^2}\right) \\ &= 1 + \frac{p}{f} + \frac{1}{2}\frac{p^2}{f^2}, \text{ approximately,} \end{aligned}$$

if p is small as compared with f , and therefore

$$\frac{r'}{r} - 1 = \frac{t}{r} = \frac{f}{f} \left(1 + \frac{1}{2} \frac{p}{f} \right),$$

an equation identical with (6).

SECOND METHOD.—Consider a ring bounded by the radii x , $x + dx$, at any point.

Let q be the normal (i.e., radial) intensity of stress.

Let f be the intensity of stress tangential to the ring.

“ s “ “ “ “ “ “ perpendicular to the plane of the ring.

Let α , β , γ be the corresponding strains.

Let E and mE be respectively the coefficients of direct and lateral elasticity.

Then, since E , f , s are principal stresses (Chap. IV),

$$\alpha = \frac{q}{E} - \frac{f+s}{mE}, \quad \beta = \frac{f}{E} - \frac{q+s}{mE}, \quad \gamma = \frac{s}{E} - \frac{f+q}{mE}. \quad (1)$$

But γ is constant. Also, since the ends are free, the total pressure on a transverse section is nil, and hence it might be inferred that s is zero at every point. Adopting this value of s ,

By eq. (1),

$$f + q = \text{a constant} = c. \quad (2)$$

Again,

$$d(qx) = f dx = x dq + q dx. \quad (3)$$

By eqs. (2) and (3),

$$x dq + 2q dx = c dx.$$

$$\therefore d(x^2 q) = c x dx.$$

Integrating,

$$x^2 q = \frac{c x^2}{2} + c', \quad (4)$$

c' being a constant of integration.

When $x = r$, the internal radius, $q = p$.

“ $x = r'$, the external radius, $q = p'$.

Hence, by eq. (4),

$$r^2 p - \frac{cr^2}{2} = c' = r'^2 p' - \frac{cr'^2}{2};$$

and therefore

$$c = 2 \frac{r^2 p - r'^2 p'}{r^2 - r'^2} \quad \text{and} \quad c' = - \frac{(p - p') r^2 r'^2}{r^2 - r'^2}.$$

Hence, by eq. (4),

$$q = \frac{r^2 p - r'^2 p'}{r^2 - r'^2} - \frac{p - p'}{x^2} \frac{r^2 r'^2}{r^2 - r'^2}; \dots (5)$$

and, by eq. (2),

$$f = \frac{r^2 p - r'^2 p'}{r^2 - r'^2} + \frac{p - p'}{x^2} \frac{r^2 r'^2}{r^2 - r'^2} \dots (6)$$

3. Spherical Shells.—Let the data be the same as before. The section made by any diametral plane must develop a total resistance of $2\pi r t f$. Then

$$2\pi r t f = \pi r^2 p,$$

or

$$2t f = p r. \dots (1)$$

Hence, a spherical shell is *twice* as strong as a cylindrical shell of the same diameter and thickness of metal, so that the strongest parts of *egg-ended* boilers are the ends.

Cor. 1. Let the shell be subjected to an external pressure p' as well as to an internal pressure p . Then

$$2\pi \frac{r' + r}{2} t f = \pi r p^2 - \pi r'^2 p'.$$

$$\therefore f(r' + r)t = r^2 p - r'^2 p'. \dots (2)$$

f is a tension or a pressure according as $r^2 p \geq r'^2 p'$.

Generally, $r' - r$ is very small, and the relation (2) may be written

$$f t = \frac{r}{2} (p - p'). \dots (3)$$

Cor. 2. For a thick hollow sphere, Rankine obtains

$$p = 2f \frac{r'^3 - r^3}{r'^3 + 2r^3}, \text{ approximately.} \quad \dots (4)$$

4. Practical Remarks.—A common rule requires that the working pressure in fresh-water boilers should not exceed one-sixth of the bursting pressure, and in the case of marine boilers that it should not exceed one-seventh.

An English Board of Trade rule is that the tensile working stress in the boiler-plate is not to exceed 6000 lbs. per square inch of gross section, and French law fixes this limit at 4250 lbs. per square inch.

The thickness to be given to the wrought-iron plates of a cylindrical boiler is, according to French law,

$$t = .0036nr + .1 \text{ in.};$$

according to Prussian law,

$$t = (e^{.003n} - 1)r + 1 \text{ in.} = .003nr + .1 \text{ in.}, \text{ approximately,}$$

r being the radius in inches, and n the excess of the internal above the external pressure in atmospheres.

The thickness given to cast-iron cylindrical boiler-tubes is, according to French law, five times the thickness of equivalent wrought-iron tubes; according to Prussian law,

$$t = (e^{.01n} - 1)r + \frac{1}{3} \text{ in.} = .01nr + \frac{1}{3} \text{ in.}, \text{ approximately.}$$

Steam-boilers before being used should be subjected to a hydrostatic test varying from $1\frac{1}{2}$ to 3 times the pressure at which they are to be worked.

Fairbairn conducted an extensive series of experiments upon the collapsing strength of riveted plate-iron flues, by enclosing the flues in larger cylinders and subjecting them to hydraulic pressure. From these experiments he deduced the following formula for a *wrought-iron* cylindrical flue or tube:

$$\left. \begin{array}{l} \text{Collapsing pressure} \\ \text{in pounds per square inch of surface} \end{array} \right\} = p = 403150 \frac{t^{2.19}}{tr},$$

t being the thickness and r the radius in inches, and l the length in feet.

This formula cannot be relied upon in extreme cases and when the thickness of the tube is less than $\frac{3}{8}$ in.

Note.—In practice, t' may be generally used instead of $t^{2.19}$. The experiments also showed that the strength of an elliptical tube is almost the same as that of a circular tube of which the radius is the radius of curvature at the ends of the minor axis. Hence, if a and b are the major and minor axes of the ellipse, the above formula becomes

$$p = 403150 \frac{b t'^{2.19}}{a^2 l r}.$$

By riveting angle- or T-irons around a tube, its length is virtually diminished and its strength is therefore increased, as it varies inversely as the length.

The thickness of tubes subjected to external pressure is, according to French law, twice the thickness of tubes subjected to interior pressure, but under otherwise similar conditions; according to Prussian law the thickness of heating pipes is

$$t = .0067d \sqrt[3]{n} + .05 \text{ in., if of sheet-iron,}$$

and

$$t = .01d \sqrt[3]{n} + .07 \text{ in., if of brass.}$$

According to Reuleaux, the thickness (t) of a round flat plate of radius r , subjected to a normal pressure, uniformly distributed and of intensity p , is given by the formula

$$\frac{t}{r} = \sqrt{\frac{p}{f}}, \text{ or } \frac{t}{r} = \sqrt{\frac{2}{3} \frac{p}{f}},$$

according as the plate is merely supported around the rim or is rigidly fixed around the rim, as, e.g., the end plates of a cylindrical boiler; f , as before, is the coefficient of strength. The corresponding deflections of the plate are

$$\frac{5}{6} \left(\frac{r}{t}\right)^4 \frac{p t}{E} \text{ and } \frac{1}{6} \left(\frac{r}{t}\right)^4 \frac{p t}{E}.$$

EXAMPLES.

1. What should be the thickness of the plates of a cylindrical boiler 6 ft. in diameter and worked to a pressure of 50 lbs. per square inch, in order that the working tensile stress may not exceed 1.67 tons per square inch of gross section? *Ans.* .42 in.
2. A cylindrical boiler with hemispherical ends is 4 ft. in diameter and 22 ft. in length. Determine the thickness of the plates for a steam-pressure of 4 atmospheres.
3. What is the collapsing pressure of a flue 10 ft. long, 36 in. in diameter, and composed of $\frac{1}{4}$ -in. plates? Also of a flue 30 ft. long, 48 in. in diameter, and $\frac{1}{8}$ in. thick? *Ans.* 490.84 lbs.; 91.59 lbs.
4. Determine the thickness of a 2-in. locomotive fire-tube to support an external pressure of 5 atmospheres.
5. A copper steam-pipe is 4 in. in diameter and $\frac{1}{4}$ in. thick. Find the working pressure, the safe coefficient of strength for copper being 1000 lbs. per square inch. *Ans.* 125 lbs. per square inch.
6. A 7-ft. boiler of $\frac{1}{8}$ -in. plates was burst at a longitudinal double-riveted joint by a pressure of 310 lbs. per square inch. Find the coefficient of ultimate strength. *Ans.* 29,760 lbs.
7. A 50-in. cylindrical boiler of $\frac{1}{8}$ in. plates is made of wrought-iron whose safe coefficient of strength is 4000 lbs. per square inch. Find the working pressure. *Ans.* 50 lbs. per square inch.
8. A 10-in. cast-iron water-pipe is subjected to a pressure of 250 lbs. per square inch. Find its thickness, the coefficient of working strength being 2000 lbs. per square inch. *Ans.* $1\frac{1}{8}$ in.
9. A steel spherical shell 36 in. in diameter and $\frac{3}{8}$ in. thick is subjected to an internal fluid pressure of 300 lbs. per square inch. Find its coefficient of strength. *Ans.* 7200 lbs.
10. A thin, hollow, spherical, elastic envelope, whose internal radius is R , was subjected to a fluid pressure which caused it to expand gradually until its radius became R_1 . Determine the work done.
11. The plates of a cylindrical boiler 5 ft. in diameter are $\frac{1}{2}$ in. thick. Find to what pressure the boiler may be worked so that the tensile stress in the plates may not exceed $1\frac{1}{2}$ tons per square inch of gross section.

12. Show that the assumption of a uniform distribution of stress in the thickness of a cylindrical or spherical boiler is only admissible when the thickness is very small.

13. A metal cylinder of internal radius r and external radius nr is subjected to an internal pressure of p tons per square inch. Show that the total work done in stretching the cylinder circumferentially is $\frac{6p^2r}{E} \frac{n^2 + 1}{n^2 - 1}$ ft.-tons per square foot of surface, E being the metal's coefficient of elasticity.

14. The cast-iron cylinder of an hydraulic press has an external diameter twice the internal, and is subjected to an internal pressure of p tons per square inch. Find the principal stresses at the outer and inner circumferences. Also, if the pressure is 3 tons per square inch, and if the internal diameter is 10 in., find the work done in stretching the cylinder circumferentially, E being 8000 tons.

Ans. At inner circumference, $q = p$, a thrust, and $f = -\frac{2}{3}p$, a tension.
 At outer circumference, $q = 0$, and $f = -\frac{2}{3}p$, a tension.
 Work = 126 ft.-lbs. per square foot of surface.

15. The chamber of a 27-ton breech-loader has an external diameter of 40 in. and an internal diameter of 14 in. Under a powder pressure of 18 tons per square inch, find the principal stresses at the outer and inner circumferences, and also the work done; E being 13,000 tons.

Ans. At inner, $q = 18$ tons, compression; at outer, $q = 0$.
 At inner, $f = -23\frac{1}{3}$ tons, tension; at outer, $f = -5\frac{1}{3}$ tons, tension.
 Work = $1\frac{1}{2}$ ft.-tons per sq. ft. of surface.

16. What should be the thickness of a 9-in. cylinder (a) which has to withstand a pressure of 8000 lbs. per square inch, the maximum allowable tensile stress being 24,000 lbs. per square inch; (b) which has to withstand a pressure of 6000 lbs. per square inch; the maximum allowable tensile stress being 10,000 lbs. per square inch?

Ans.—(a) 1.86 in.; (b) $4\frac{1}{2}$ in.

17. Show that the radial (α) and hoop (β) strains in thick hollow cylinders and spheres are connected by the relation $\alpha = \frac{d(\beta x)}{dx}$.

18. Prove that the relation in Ex. 17 is satisfied by the values obtained for f and q in the Second Method of Art. 2, Chap. X.

19. A thick hollow sphere of internal radius r and external radius nr is subjected to an internal pressure p and an external pressure p' . Determine the principal stresses at a distance x from the centre.

$$\text{Ans. } q = \frac{p'n^3 - p}{n^3 - 1} + \frac{p - p'}{x^3} \frac{n^2 r^3}{n^3 - 1}; \quad f = \frac{p'n^3 - p}{n^3 - 1} - \frac{p - p'}{2x^3} \frac{n^2 r^3}{n^3 - 1}$$

20. Assuming that the annulus forming the section of a cylindrical boiler is composed of a number of infinitely thin rings, show that the pressure at the circumference of a ring of radius r is $\frac{A}{r^{1+m}}$ per unit of

surface, and that the circumferential stress is $\frac{B}{r} + \frac{A}{mr^{m+1}}$, A and B denoting arbitrary constants, and m being the coefficient of lateral contraction. Find the values of A and B , p_0 and p_1 being respectively the internal and external pressures.

21. Show that in the case of a spherical boiler the pressure and circumferential stress are respectively $\frac{A}{r^{1+m}}$ and $\frac{B}{r^2} + \frac{2A}{(m-1)r^{m-3}}$. Find A and B .

22. Solve Questions 1, 2, 6, 7, 8, 9, and 11 on the supposition that t is not small as compared with r .

23. Taking $f = 4000$ lbs. per square inch and $E = 30,000,000$ lbs., Find the thickness and deflection of the end plates of the boiler in Question 7.

CHAPTER XI.

BRIDGES.

1. Classification.—Bridges may be divided into four general classes, viz.: (A) Bridges with horizontal girders; (B) Cantilever bridges (Art. 15); (C) Suspension bridges (Chap. XII); (D) Arched bridges (Chap. XIII). The present chapter treats of bridges in Classes A and B only.

2. Comparative Advantages of Curved and Horizontal Flanges in Girders for Bridges of Class A.—The depth is sometimes varied for the sake of appearance, and it is also claimed that an economy of material is effected by giving the chord a slope, as, e.g., in the case of the Sault Bridge (Art. 19). Such a truss is intermediate between a truss with horizontal flanges and one of the parabolic form. The curved or parabolic form is not well suited to plate construction, and a diminution in depth lessens the resistance of the girder to distortion. Again, if the bottom flange is curved, the bracing for the lower part of the girder is restricted within narrow limits, and the girder itself must be independent, so that in a bridge of several spans any advantage which might be derivable from continuity is necessarily lost. Generally speaking, the best and most economical form of girder is that in which the depth is uniform throughout, and in which the necessary thickness of flange at any point is obtained by increasing the number of plates.

3. Depth of Girder or Truss (Class A).—The depth usually varies from *one-fifteenth* to *one-seventh* (and even more) of the span. It is generally found advisable to give large girders

an increased depth, and they should, therefore, be designed to have a specified *strength*. If the span is more than *twelve* times the depth, the *deflection* becomes a serious consideration, and the girder should be designed to have a specified *stiffness*. The depth should not be more than about $1\frac{1}{2}$ times the width of the bridge, and is therefore limited to 24 ft. for a single and to 40 ft. for a double-track bridge.

4. Position of Platform.—The platform may be supported either at the top or bottom flanges, or in some intermediate position. In favor of the last it is claimed that the main girders may be braced together below the platform (Fig. 365), while the upper portions serve as parapets or guards, and also that the vibration communicated by a passing train is diminished. The position, however, is not conducive to rigidity, and a large amount of metal is required to form the connections.

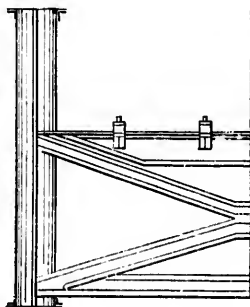

FIG. 365.

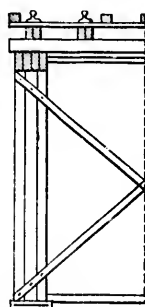

FIG. 366.

The method of supporting the platform on the top flanges (Fig. 366) renders the whole depth of the girder available for bracing, and is best adapted to girders of shallow depth. Heavy cross-girders may be entirely dispensed with in the case of a single-track bridge, and the load most effectively distributed, by laying the rails directly upon the flanges and vertically above the neutral line. Provision may be made for side spaces by employing sufficiently long cross girders, or by means of short cantilevers fixed to the flanges, the advantage of the

former arrangement being that it increases the resistance to lateral flexure, and gives the platform more elasticity.

Figs. 367, 368, 369 show the cross-girders attached to the bottom flanges, and the desirability of this mode of support increases with the depth of the main girders, of which the centres of gravity should be as low as possible. If the cross-girders are suspended by hangers or bolts below the flanges (Fig. 369), the depth, and therefore the resistance to flexure, is increased.

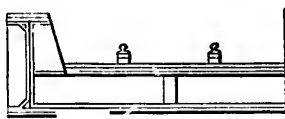

FIG. 367.



FIG. 368.

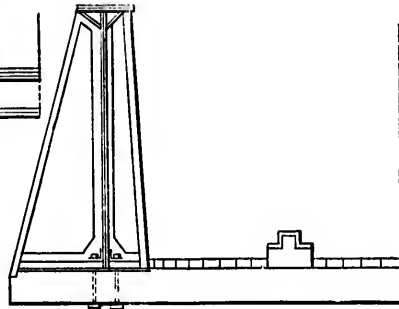

FIG. 369.

In order to stiffen the main girders, braces and verticals, consisting of angle- or tee iron, are introduced and connected with the cross-girders by gusset pieces, etc.; also, for the same purpose, the cross-girders may be prolonged on each side, and the end joined to the top flanges by suitable bars.

When the depth of the main girders is more than about 5 ft., the top flanges should be braced together. But the minimum clear headway over the rails is 16 ft., so that some other method should be adopted for the support of the platform when the depth of the main girders is more than 5 ft. and less than 16 ft.

Assume that the depth of the platform below the flanges is 2 ft., and that the depth of the transverse bracing at the top is 1 ft.; the total limiting depths are 7 ft. and 19 ft., and if 1 to 8 is taken as a mean ratio of the depth to the span, the corresponding limiting spans are 56 ft. and 152 ft.

5. Comparative Advantages of Two, Three, and Four Main Girders.—A bridge is generally constructed with two main girders, but if it is crossed by a double track a third is occasionally added, and sometimes each track is carried by two independent girders.

The employment of four independent girders possesses the one great advantage of facilitating the maintenance of the bridge, as one-half may be closed for repairs without interrupting the traffic. On the other hand, the rails at the approaches must deviate from the main lines in order to enter the bridge, so that the width of the bridge is much increased, and far more material is required in its construction.

Few, if any, reasons can be urged in favor of the introduction of a third intermediate girder, since it presents all the objectionable features of the last system without any corresponding recommendation.

The two-girder system is to be preferred, as the rails, by such an arrangement, may be continued over the bridge without deviation at the approaches, and a large amount of material is economized, even taking into consideration the increased weight of long cross-girders.

6. Bridge Loads.—In order to determine the stresses in the different members of a bridge truss, or main girder, it is necessary to ascertain the amount and character of the load to which the bridge may be subjected. The load is partly *dead*, partly *live*, and depends upon the type of truss, the span, the number of tracks, and a variety of other conditions.

The *dead* load increases with the span, and embraces the weight of the main girders (or trusses), cross-girders, platform, rails, ballast, and accumulations of snow.

As to the live load see Art. 19.

7. Trellis or Lattice Girders.—The ordinary trellis or lattice girder consists of a pair of horizontal chords and two series of diagonals inclined in opposite directions (Fig. 370). The system of trellis is said to be single, double, or treble, according to the number of diagonals met by the same vertical section.

Vertical stiffeners, united to the chords and diagonals, may be introduced at regular intervals.

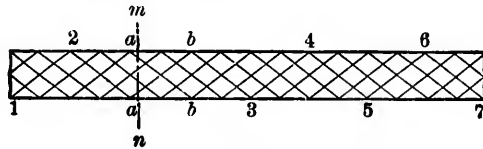

FIG. 370.

Figs. 371, 372, 373, 374 show appropriate sections for the top chord; the bottom chord may be formed of fished and riveted plates, or of links and pins.



FIG. 371.



FIG. 372.



FIG. 373.

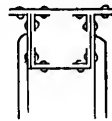

FIG. 374.

The verticals and diagonals may be of an L, T, I, H, \sqcup , or other suitable section, but the diagonals, except in the case of a single system of trellis, are usually flat bars, riveted together at the points of intersection.

An objection to this class of girder is the number of the joints.

The stresses in the diagonals are determined on the assumption that the shearing force at any vertical section is equally distributed between the diagonals met by that section, which is equivalent to the substitution of a *mean* stress for the different stresses in the several bars.

E.g., let w be the permanent load concentrated at each apex in Fig. 370.

Let θ be the inclination of the diagonals to the vertical.

The reaction at $A = 7\frac{1}{2}w$, and the shearing force at the section $MN = 7\frac{1}{2}w - 4w = 3\frac{1}{2}w$.

This shearing force must be transmitted through the diagonals.

Hence, the stress in ab due to the permanent load

$$= \frac{3\frac{1}{2}w}{4} \sec \theta = \frac{7}{8}w \sec \theta.$$

Again, let w' be the *live* load concentrated at an apex.

The greatest shear at mn due to the live load occurs when every apex between a and 7 is loaded.

This shear = corresponding reaction at $1 = \frac{1}{3}w'$, and the stress in ab due to the live load

$$= \frac{1}{3} \times \frac{1}{3}w' \sec \theta = \frac{1}{9}w' \sec \theta.$$

Hence, the total maximum stress in $ab = (\frac{1}{3}w + \frac{1}{9}w') \sec \theta.$

The greatest stress of a kind *opposite* to that due to the dead load is produced in ab when the live load w' is concentrated at every apex between 1 and b .

The shear to be transmitted is then $2\frac{1}{2}w$ due to the dead load, and $-\frac{1}{3}w'$ due to the live load, and the resultant stress in ab

$$= \frac{1}{3}(2\frac{1}{2}w - \frac{1}{3}w') \sec \theta = (\frac{5}{6}w - \frac{1}{9}w') \sec \theta.$$

This stress may be negative, and must be provided for by introducing a counter-brace or by proportioning the bar to bear both the greatest tensile and the greatest compressive stress to which it may be subjected.

The stress in any other bar may be obtained as above.

The chord stresses are greatest when the live load covers the whole of the girder, and may be obtained by the method of moments, or in the manner described in the succeeding articles.

In the above it is assumed that the members of the girder are riveted together. If they are connected by pins, each of the diagonal systems may be treated as being independent.

Thus, the system $1\ 2\ a\ b\ 3\ 4\ 5\ 6\ 7$ transmits to the supports the stresses due to loads at a , 3 , and 5 .

The shear due to the dead load, transmitted through ab ,

$$= \text{reaction at } 1 - \text{load at } a = \frac{3}{2}w - w = \frac{w}{2}.$$

Hence, the stress in ab due to the dead load $= \frac{w}{2} \sec \theta.$

The stress in ab due to the live load is greatest when w' is concentrated at each of the points 3 and 5 ,

The maximum shear due to live load transmitted through ab

$$= \frac{1}{2} w' = \frac{1}{2} w',$$

and the corresponding stress in $ab = \frac{1}{2} w' \sec \theta$.

Hence, the total maximum stress in ab

$$= \left(\frac{w}{2} + \frac{3}{4} w' \right) \sec \theta,$$

as compared with $\left(\frac{1}{2} w + \frac{3}{4} w' \right) \sec \theta$ obtained on the first assumption.

8. Warren Girder.—The Warren girder consists of two horizontal chords and a series of diagonal braces forming a single triangulation, or zigzag, Fig. 375.

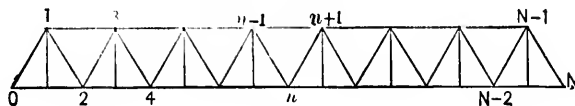

FIG. 375.

The principles which regulate the construction of trellis girders are equally applicable to those of the Warren type.

The cross-girders (floor-beams) are spaced so as to occur at the apex of each triangle.

When the platform is supported at the top chords, the resistance of the structure to lateral flexure may be increased by horizontal bracing between the cross-girders and by diagonal bracing between the main girders.

When the platform is supported on the bottom chords, additional cross-girders may be suspended from the apices in the upper chords, which also have the effect of adding to the rigidity of the main girders.

Let w be the dead load concentrated at an apex or joint.

- " w' " " live " " " " " " "
- " l " " span of the girder.
- " k " " depth " " "
- " s " " length of each diagonal brace.
- " θ " " inclination of each diagonal brace to the vertical.
- " $N + 1$ be the number of joints.

Then

$$\sec \theta = \frac{s}{k}, \quad \tan \theta = \frac{l}{Nk}.$$

Two cases will be considered.

CASE I. *All the joints loaded.*

Chord Stresses.—These stresses are greatest when the live load covers the whole of the girder.

Let S_n be the shearing force at a vertical section between the joints n and $n + 1$.

Let H_n be the horizontal chord stress between the joints $n - 1$ and $n + 1$.

The total load due to both dead and live loads

$$= (w + w')(N - 1).$$

The reaction at each abutment due to this total load

$$= \frac{w + w'}{2}(N - 1).$$

The shearing forces in the different bays are

$$S_0 = \frac{w + w'}{2}(N - 1), \text{ between } 0 \text{ and } 1;$$

$$S_1 = \frac{w + w'}{2}(N - 3), \quad \text{“} \quad 1 \quad \text{“} \quad 2;$$

$$S_2 = \frac{w + w'}{2}(N - 5), \quad \text{“} \quad 2 \quad \text{“} \quad 3;$$

$$S_3 = \frac{w + w'}{2}(N - 7), \quad \text{“} \quad 3 \quad \text{“} \quad 4;$$

and

$$S_n = \frac{w + w'}{2}(N - 2n - 1).$$

The corresponding diagonal stresses are

$$S_0 \sec \theta, \quad S_1 \sec \theta, \quad \dots, \quad S_n \sec \theta.$$

The last stresses multiplied by $\sin \theta$ give the increments of the chord stresses at each joint. Thus,

$$H_1 = \text{tension in } 02 = S_0 \tan \theta \\ = \frac{w + w'}{2} (N - 1) \frac{l}{Nk} = \frac{w + w' l}{2} \frac{N - 1}{k N};$$

$$H_2 = \text{compression in } 13 = S_0 \tan \theta + S_1 \tan \theta \\ = \frac{w + w' l}{2} \frac{N - 1}{k N} + \frac{w + w' l}{2} \frac{N - 3}{k N} \\ = \frac{w + w' l}{2} \frac{2(N - 2)}{k N};$$

$$H_3 = \text{tension in } 24 = H_1 + S_1 \tan \theta + S_2 \tan \theta \\ = \frac{w + w' l}{2} \frac{3(N - 3)}{k N};$$

$$H_4 = \text{compression in } 35 = H_2 + S_2 \tan \theta + S_3 \tan \theta \\ = \frac{w + w' l}{2} \frac{4(N - 4)}{k N};$$

and $H_n =$ horizontal stress in chord, between the joints $n - 1$ and $n + 1 = \frac{w + w' l}{2} \frac{n(N - n)}{k N}$, being a tension for a bay in the bottom chord, and a compression for a bay in the top chord.

Note.—The same results may be obtained by the method of moments; e.g., find the chord stress between the joints $n - 1$ and $n + 1$.

Let a vertical plane divide the girder a little on the right of n .

The portion of the girder on the left of the secant plane is kept in equilibrium by the reaction at the left abutment, the horizontal stresses in the chords, and the stress in the diagonal from n to $n + 1$.

Take moments about the joint n . Then

$$H_n k = \frac{w + w'}{2} (N - 1) n \frac{l}{N} - \{(n - 1)(w + w')\} \frac{nl}{2N}$$

$$= \frac{w + w'}{2} l n \frac{N - n}{N}$$

$\therefore H_n = \text{etc.}$

Diagonal Stresses due to Dead Load.

Let d_n be the stress in the diagonal $n, n + 1$, due to the dead load.

The shearing forces in the different bays due to the dead load are

$$\frac{\tau w}{2} (N - 1), \text{ between } 0 \text{ and } 1; \quad \frac{\tau w}{2} (N - 3), \text{ between } 1 \text{ and } 2;$$

$$\frac{\tau w}{2} (N - 5), \quad " \quad 2 \quad " \quad 4; \quad \frac{\tau w}{2} (N - 7), \quad " \quad 3 \quad " \quad 4;$$

.....

and $\frac{\tau w}{2} (N - 2n - 1)$, between n and $n + 1$.

The corresponding diagonal stresses are :

a compression $\frac{\tau w}{2} (N - 1) \sec \theta = \frac{\tau w}{2} (N - 1) \frac{s}{k} = d_0$ in 01 ;

a tension $\frac{\tau w}{2} (N - 3) \sec \theta = \frac{\tau w}{2} (N - 3) \frac{s}{k} = d_1$ in 12

a compression $\frac{\tau w}{2} (N - 5) \sec \theta = \frac{\tau w}{2} (N - 5) \frac{s}{k} = d_2$ in 23 ;

.....

and the stress in the n th diagonal between n and $n + 1$ is

$$d_n = \frac{\tau w}{2} (N - 2n - 1) \frac{s}{k},$$

being a tension or a compression according as the brace slopes down or up towards the centre.

Diagonal Stresses due to Live Load.—The live load produces the greatest stress in any diagonal ($n, n + 1$), of the *same* kind as that due to the dead load, when it covers the *longer* of the segments into which the diagonal divides the girder. Represent this maximum stress by D_n .

The live load produces the greatest stress in any diagonal ($n, n + 1$), of a kind *opposite* to that due to the dead load, when it covers the *shorter* of the segments into which the diagonal divides the girder. Represent this maximum stress by D'_n .

The shearing force at any section due to the live load, as it crosses the girder, is the reaction at the end of the unloaded segment, and the corresponding diagonal stress is the product of this shearing force by $\sec \theta$, or $\frac{s}{k}$.

The values of the different diagonal stresses are :

D_0 = compression in 0 1 when all the joints are loaded

$$= \frac{s}{k} \frac{w'}{2} \frac{N(N-1)}{N}$$

D_1 = tension in 1 2 when all the joints except one are loaded

$$= \frac{s}{k} \frac{w'}{2} \frac{(N-1)(N-2)}{N}$$

D_2 = compression in 2 3 when all the joints except 1 and 2 are

$$\text{loaded} = \frac{s}{k} \frac{w'}{2} \frac{(N-2)(N-3)}{N}$$

D_3 = tension in 3 4 when all the joints except 1, 2, and 3 are

$$\text{loaded} = \frac{s}{k} \frac{w'}{2} \frac{(N-3)(N-4)}{N}$$

D_n = stress in $n, n + 1$ when all the joints except 1, 2, 3, . . .

$$\text{and } n \text{ are loaded} = \frac{s}{k} \frac{w'}{2} \frac{(N-n)(N-n-1)}{N}$$

D'_0 = stress in 0 1 before the load comes upon the girder = 0.

$$D_1' = \text{compression in } 1\ 2 \text{ when the joint } 1 \text{ is loaded} = \frac{s}{k} \frac{w'}{N} 1.$$

$$D_2' = \text{tension in } 2\ 3 \text{ when the joints } 1 \text{ and } 2 \text{ are loaded} = \frac{s}{k} \frac{w'}{N} 3.$$

$$D_3' = \text{compression in } 3\ 4 \text{ when the joints } 1, 2, \text{ and } 3 \text{ are loaded} \\ = \frac{s}{k} \frac{w'}{N} 6.$$

$$\dots \dots \dots \\ D_n' = \text{stress in } n, n + 1, \text{ when the joints } 1, 2, \dots \text{ and } n \text{ are loaded} \\ = \frac{s}{k} \frac{w'}{N} \frac{n(n+1)}{2}.$$

The total maximum stress in the n th diagonal of the *same* kind as that due to the dead load $= d_n + D_n$.

The resultant stress in the n th diagonal when the load covers the shorter segment $= d_n - D_n'$.

This resultant stress is of the same kind as that due to the dead load so long as $d_n > D_n'$, and need not be considered since $d_n + D_n$ is the maximum stress of that kind.

If $D_n' > d_n$, it is necessary to provide for a stress in the given diagonal of a kind opposite to that due to $d_n + D_n$, and equal in amount to $D_n' - d_n$.

This is effected by counterbracing or by proportioning the bar to bear both the stresses $d_n + D_n$ and $D_n' - d_n$.

CASE II. *Only joints denoted by even numbers loaded.*

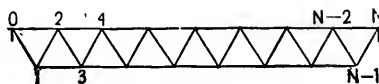

FIG. 376.

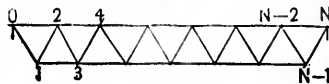

FIG. 377.

Chord Stresses.—The stresses are greatest when the live load covers the whole of the girder.

The total load due to both dead and live loads

$$= (w + w') \frac{(N - 2)}{2}.$$

The reaction at each abutment due to this total load

$$= \frac{w + w'}{4} (N - 2).$$

To find H_1 , take moments about 1. Then

$$H_1 k = \frac{w + w'}{4} (N - 2) \frac{l}{N}.$$

To find H_2 , take moments about 2.

$$H_2 k = \frac{w + w'}{4} (N - 2) 2 \frac{l}{N}.$$

To find H_3 , take moments about 3.

$$H_3 k = \frac{w + w'}{4} (N - 2) 3 \frac{l}{N} - (w + w') \frac{l}{N}.$$

To find H_4 , take moments about 4.

$$H_4 k = \frac{w + w'}{4} (N - 2) 4 \frac{l}{N} - (w + w') 2 \frac{l}{N}.$$

.....

To find H_n , take moments about n , and *first* let n be even.
Then

$$\begin{aligned} H_n k &= \frac{w + w'}{4} (N - 2) n \frac{l}{N} \\ &- (w + w') \frac{l}{N} \{ (n - 2) + (n - 4) + \dots + 6 + 4 + 2 \} \\ &= (w + w') \frac{l}{N} \left\{ \frac{(N - 2)n}{4} - \frac{n(n - 2)}{4} \right\}, \end{aligned}$$

and

$$H_n = \frac{w + w'}{4} \frac{l}{k} \frac{n(N - n)}{N}.$$

Next, let n be odd. Then

$$H_n k = \frac{w + w'}{4} (N - 2) n \frac{l}{N}$$

$$- (w + w') \frac{l}{N} \{ (n - 2) + (n - 4) + \dots + 5 + 3 + 1 \}$$

$$= (w + w') \frac{l}{N} \left\{ \frac{(N - 2)n}{4} - \frac{(n - 1)^2}{4} \right\},$$

and

$$H_n = \frac{w + w'}{4} \frac{l}{k} \frac{(N - 2)n - (n - 1)^2}{N}.$$

Note.—If $\frac{N}{2}$ is even,

$$H_{\frac{N}{2}}, \text{ the stress in the middle bay, } = \frac{w + w'}{16} \frac{l}{k} N.$$

If $\frac{N}{2}$ is odd,

$$H_{\frac{N}{2}}, \text{ the stress in the middle bay, } = \frac{w + w'}{16} \frac{l}{k} \frac{N^2 - 4}{N}.$$

Diagonal Stresses due to the Dead Load.—The shearing forces in the different bays due to the dead load are $\frac{w}{4}(N - 2)$ between 0 and 2, $\frac{w}{4}(N - 6)$ between 2 and 4, $\frac{w}{4}(N - 10)$ between 4 and 6, etc.

The corresponding diagonal stresses are

$$d_0 \text{ in } 01 = \frac{s}{k} \frac{w}{4} (N - 2) = d_1 \text{ in } 12;$$

$$d_2 \text{ in } 23 = \frac{s}{k} \frac{w}{4} (N - 4) = d_3 \text{ in } 34;$$

$$d_4 \text{ in } 45 = \frac{s}{k} \frac{w}{4} (N - 10) = d_5 \text{ in } 56;$$

etc., etc., etc.

Thus the stresses in the diagonals which meet at an unloaded joint are equal in magnitude but opposite in kind.

Diagonal Stresses due to the Live Load.—These are found as in Case I, and

$$D_0 = D_1, \quad D'_0 = D'_1;$$

$$D_2 = D_3, \quad D'_2 = D'_3;$$

$$D_4 = D_5, \quad D'_4 = D'_5.$$

If $\frac{N}{2}$ is odd, there is a single stress at the foot of each of these columns.

The maximum resultant stress due to both dead and live loads is obtained as before.

E.g., the maximum resultant stress in 3 4 when the longer segment is loaded

$$= d_2 + D_2 = d_3 + D_3,$$

and the maximum resultant stress in 3 4 when the shorter segment is loaded

$$= d_2 - D'_2 = D_3 - D'_3.$$

Note.— θ is generally 60° , in which case $s = 2 \frac{l}{N}$.

9. **Howe Truss.**—Fig. 378 is a skeleton diagram of a Howe truss.

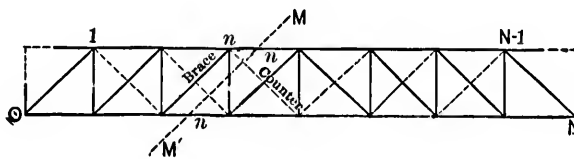

FIG. 378.

The truss may be of timber, of iron, or of timber and iron combined.

The chords of a timber truss usually consist of three or more parallel members, placed a little distance apart so as to allow iron suspenders with screwed ends to pass between them (Figs. 379 and 380).

Each member is made up of a number of lengths scarfed or fished together (Figs. 381 and 382).

The main braces, shown by the full diagonal lines in Fig. 378, are composed of two or more members.

The counter-braces, which are introduced to withstand the effect of a live load, and are shown by the dotted diagonal lines in Fig. 378, are either single or are composed of two or more members. They are set between the main braces, and are bolted to the latter at the points of intersection.

The main braces and counters abut against solid hard-wood or hollow cast-iron angle-blocks (Fig. 380). They are designed to withstand compressive forces only, and are kept in place by tightening up the nuts at the heads of the suspenders.



FIG. 379.

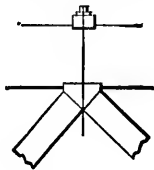

FIG. 378.

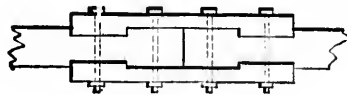

FIG. 381.



FIG. 382.



FIG. 383.



FIG. 384.

The angle-blocks extend over the whole width of the chords; if they are made of iron, they may be strengthened by ribs.

If the bottom chord is of iron, it may be constructed on the same principles as those employed for other iron girders. It often consists of a number of links, set on edge, and connected by pins (Figs. 383 and 384). In such a case the lower angle-blocks should have grooves to receive the bars, so as to prevent lateral flexure.

If the truss is made entirely of iron, the top chord may be formed of lengths of cast-iron provided with suitable flanges by which they can be bolted together. Angle-blocks may also be cast in the same piece with the chord.

To determine the stresses in the different members, the

same data are assumed as for the Warren girder, except that N is now the number of panels.

Chord Stresses.—These stresses are greatest when the live load covers the whole of the girder.

Let H_n be the chord stress in the n th panel.

The total load due to both dead and live loads

$$= (\tau w + \tau w')(N - 1).$$

The reaction at each abutment due to this total load

$$= \frac{\tau w + \tau w'}{2} (N - 1).$$

Let a plane MM' divide the truss as in Fig. 378. The portion of the truss on the left of the secant plane is kept in equilibrium by the load upon that portion, the reaction at the left abutment, the chord stresses in the n th panels, and the tension in the n th suspender.

First, let the load be on the top chord and take moments about the foot of the n th suspender. Then

$$\begin{aligned} H_n k &= \frac{\tau w + \tau w'}{2} (N - 1) n \frac{l}{N} - (\tau w + \tau w') \frac{l}{N} \frac{n(n - 1)}{2} \\ &= \frac{\tau w + \tau w'}{2} l \frac{n(N - n)}{N}, \end{aligned}$$

or

$$H_n = \frac{\tau w + \tau w'}{2} \frac{l}{k} \frac{n(N - n)}{N}.$$

Next, let the load be on the bottom chord and take moments about the head of the n th suspender. Then

$$H_n k = \frac{\tau w + \tau w'}{2} l \frac{n(N - n)}{N}, \text{ as before.}$$

Thus, H_n is the same for corresponding panels, whether the load is on the top or bottom chord.

Diagonal Stresses due to the Dead Load.—Let V_n' be the

shearing force in the n th panel, or the tension on the n th suspender due to the dead load.

First, let the load be on the top chord. Then

$$V_n' = \frac{\tau w}{2}(N-1) - n\tau w = \tau w \left(\frac{N-1}{2} - n \right).$$

Next, let the load be on the bottom chord. Then

$$V_n' = \frac{\tau w}{2}(N-1) - (n-1)\tau w = \tau w \left(\frac{N+1}{2} - n \right).$$

The corresponding diagonal stresses are

$$d_n = \frac{s}{k} \tau w \left(\frac{N-1}{2} - n \right),$$

and

$$d_n = \frac{s}{k} \tau w \left(\frac{N+1}{2} - n \right).$$

Diagonal Stresses due to the Live Load.—Let V_n'' be the shearing force in the n th panel, or tension on the n th suspender, when the live load covers the longer segment.

First, let the load be on the top chord.

The greatest stress in the n th brace, of the same kind as that produced by the dead load, occurs when all the panel points on the right of MM' are loaded. With such load, V_n'' , the shearing force on the left of MM' , = the reaction at o

$$= \frac{\tau w'}{2}(N-n-1) \frac{N-n}{N},$$

and the corresponding diagonal stress, D_n ,

$$= \frac{s}{k} V_n'' = \frac{s}{k} \frac{\tau w'}{2}(N-n-1) \frac{N-n}{N}.$$

Hence, the resultant tension on the n th suspender due to both dead and live loads = $V_n = V_n' + V_n''$

$$= \tau w \left(\frac{N-1}{2} - n \right) + \frac{\tau w'}{2}(N-n-1) \frac{N-n}{N},$$

and the resultant maximum compression on the n th brace due to both dead and live loads

$$= \frac{s}{k} V_n = \frac{s}{k} \left\{ w \left(\frac{N-1}{2} - n \right) + \frac{w'}{2} (N-n-1) \frac{N-n}{N} \right\} = d_n + D_n.$$

The live load tends to produce the greatest stress in the n th counter when it covers the shorter segment up to and including the n th panel point. Even then there will be no stress in the counter unless the effect of the live load exceeds that of the dead load in the $(n+1)$ th brace.

The shearing force on the right of $MM' =$ the reaction at N

$$= \frac{w' n(n+1)}{2} \frac{1}{N}.$$

Hence,

$$D_n', \text{ the corresponding diagonal stress, } = \frac{s}{k} \frac{w' n(n+1)}{2} \frac{1}{N},$$

and the resultant stress in the counter $= D_n' - d_{n+1}$

$$= \frac{s}{k} \left\{ \frac{w' n(n+1)}{2} \frac{1}{N} - w \left(\frac{N-3}{2} - n \right) \right\}.$$

Next, let the load be on the bottom chord. Then

$$V_n'' = \frac{w'}{2} (N-n) \frac{N-n+1}{N},$$

and

$$D_n = \frac{s}{k} \frac{w'}{2} (N-n) \frac{N-n+1}{N}.$$

Hence,

$$V_n = V_n' + V_n'' = w \left(\frac{N+1}{2} - n \right) + \frac{w'}{2} (N-n) \frac{N-n+1}{N},$$

and

$$d_n + D_n = \frac{s}{k} \left\{ w \left(\frac{N+1}{2} - n \right) + \frac{w'}{2} (N-n) \frac{N-n+1}{N} \right\}.$$

Also, the stress in the n th counter is

$$D_n' - d_{n+1} = \frac{s}{k} \left\{ \frac{w' n(n+1)}{2} \frac{1}{N} - w \left(\frac{N-1}{2} - n \right) \right\}.$$

Note.—A common value of θ is 45° , when $\sec \theta = \frac{s}{k} = 1.414$,
and $\tan \theta = \frac{l}{Nk} = 1$.

The end panels and posts, shown by the dotted lines in Fig. 378, may be omitted when the platform is suspended from the lower chords.

10. Single and Double Intersection Trusses.—Fig. 385 represents the simplest form of single-intersection (or

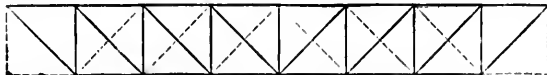

FIG. 385.

Pratt) truss; i.e., a truss in which a diagonal crosses *one* panel only. It may be constructed entirely of iron or steel, or may have the chords and verticals of wood. The verticals are in compression and the diagonals in tension. The angle-blocks are therefore placed above the top and below the bottom chord. Counter-braces, shown by the dotted diagonals, are introduced to withstand the effect of a live load.

If the truss is inverted it becomes one of the Howe type, and the stresses in the several members of both trusses may be found in precisely the same manner.

Fig. 386 represents a double intersection (or Whipple)

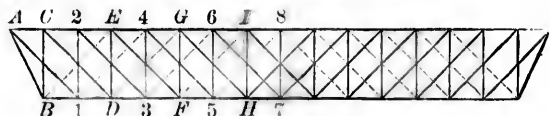

FIG. 386.

truss, i.e., a truss in which a diagonal crosses *two* panels. It may be constructed entirely of iron or steel. It is of the *pin-connected* type, and the two diagonal systems may be treated independently.

Let θ' be the inclination of AB to the vertical.

“ θ “ “ “ “ $A1, CD, \dots$ to the vertical.

Chord Stresses.—These stresses are greatest when the live load covers the whole of the girder.

The reaction at A from the system $ABCD \dots = 4(w + w')$;

“ “ “ A “ “ “ $A123 \dots = \frac{7}{2}(w + w')$;

w, w' being the dead and live loads concentrated at the panel points $C, 2, E, 4, \dots$

The shearing forces in the different bays are :

- $4(w + w')$ in AC , from the system $ABCD \dots$
- $\frac{7}{2}(w + w')$ in AC , " " " $A 1 2 3 \dots$
- $3(w + w')$ in $C2$, " " " $ABCD \dots$
- $\frac{5}{2}(w + w')$ in $2E$, " " " $A 1 2 3 \dots$
- $2(w + w')$ in $E4$, " " " $ABCD \dots$
- $\frac{3}{2}(w + w')$ in $4G$, " " " $A 1 2 3 \dots$
- $1(w + w')$ in $G6$, " " " $ABCD \dots$
- $\frac{1}{2}(w + w')$ in $6I$, " " " $A 1 2 3 \dots$

The corresponding diagonal stresses are :

- $4(w + w') \sec \theta'$ in AB ; $3\frac{1}{2}(w + w') \sec \theta$ in $A 1$;
- $3(w + w') \sec \theta$ in CD ; $2\frac{1}{2}(w + w') \sec \theta$ in 23 ; etc.

Hence, the *top* chord stresses are :

$$C_1 \text{ in } AC = 4(w + w') \tan \theta' + 3\frac{1}{2}(w + w') \tan \theta;$$

$$C_2 \text{ in } C2 = C_1 + 3(w + w') \tan \theta$$

$$= 4(w + w') \tan \theta' + 6\frac{1}{2}(w + w') \tan \theta;$$

$$C_3 \text{ in } 2E = C_2 + 2\frac{1}{2}(w + w') \tan \theta$$

$$= 4(w + w') \tan \theta' + 9(w + w') \tan \theta; \text{ etc.}$$

The *bottom* chord stresses are :

$$T_1 \text{ in } B1 = 4(w + w') \tan \theta';$$

$$T_2 \text{ in } 1D = T_1 + 3\frac{1}{2}(w + w') \tan \theta$$

$$= 4(w + w') \tan \theta' + 3\frac{1}{2}(w + w') \tan \theta = C_1.$$

So, $T_3 = C_2, T_4 = C_3, \text{ etc., etc.}$

Again, the stress in any diagonal $4 5$ of the system $A 1 2 \dots$ due to the dead load $= 1\frac{1}{2}w \sec \theta$.

The live load produces the greatest stress in $4 5$, of the same

kind as that due to the dead load, when it is concentrated at all panel points of the system $A 1 2 3 \dots$ on the right of 4.

The reaction at A is then $\frac{1}{8}w'$, and the corresponding diagonal stress = $\frac{1}{8}w' \sec \theta$.

Hence the maximum resultant stress in 45 = $(\frac{3}{8}w + \frac{1}{8}w')$ sec θ .

The live load tends to produce the greatest stress in any counter 58 when it is concentrated at all the panel points of the system $A 1 2 3 \dots$ on the left of 8.

The reaction at the right abutment is then $\frac{3}{4}w'$, and the corresponding stress in the counter = $\frac{3}{4}w' \sec \theta$. Thus, the resultant stress in the counter = $(\frac{3}{4}w' - \frac{1}{2}w) \sec \theta$, $\frac{1}{2}w \sec \theta$ being the stress in 67 due to the dead load.

Similarly, the stresses in any other diagonal and counter may be found.

The Pratt truss composed entirely of iron and with some of the details of the Whipple truss is sometimes called a Murphy-Whipple truss. The Linville truss is a Whipple truss made of wrought-iron, the verticals being tubular columns.

11. Post and Quadrangular Trusses.—

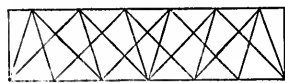

FIG. 387.

The peculiarity of the Post truss (Fig. 387) is that the struts are inclined at an angle of about $22^\circ 30'$ to the vertical, with a view to an economy of material.

The ties cross two panels at an angle of 45° with the vertical.

In the quadrangular truss (Fig. 388) the bottom chord has additional points of support halfway between the panel points.

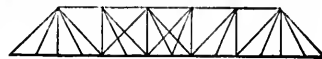

FIG. 388.

The Bollman, Fink, and other bridge-trusses have been referred to in a previous chapter.

12. Bowstring Girder or Truss.—

The bowstring girder in its simplest form is represented by Fig. 389, and is an excellent structure in point of strength and economy.

The top chord is curved, and either springs from shoes (sockets) which are held together by a horizontal tie, or has its ends riveted to those of the tie.

The strongest bow is one composed of iron or steel cylin-

drical tubes, but any suitable section may be adopted, and the inverted trough offers special facilities for the attachment of verticals and diagonals.

The tie is constructed on the same principles as those employed for other iron girders, but in its best form it consists of flat bars set on edge and connected with the shoes by gibs and cotters.

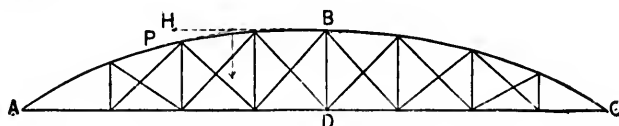

FIG. 389.

The platform is suspended from the bow by means of vertical bars which are usually of an I section, and are set with the greatest breadth transverse, so as to increase the resistance to lateral flexure. In large bridges the webs of verticals and diagonals may be lattice-work.

If the load upon the girder is uniformly distributed and stationary, verticals only are required for its suspension, and the neutral axis of the bow should be a parabola. An irregularly distributed load, such as that due to a passing train, tends to change the shape of the bow, and diagonals are introduced to resist this tendency.

A circular arc is often used instead of a parabola.

To determine the stresses in the different members, assuming that the axis ABC of the top chord is a parabola:

Let w be the dead load per lineal foot.

“ w' “ “ live “ “ “ “

“ l “ “ span of the girder.

“ h “ “ greatest depth BD of the girder.

Chord Stresses.—These stresses are greatest when the live load covers the whole of the girder.

The total load due to both dead and live loads = $(w + w')l$.

The reaction at each abutment due to this total load

$$= \frac{w + w'}{2} l.$$

Let H be the horizontal thrust at the crown.

" T " " " tension in the tie.

Imagine the girder to be cut by a vertical plane a little on the right of BD . The portion ABD is kept in equilibrium by the reaction at A , the weight upon AD , and the forces H and T .

Take moments about B and D . Then

$$Tk = \frac{w + w'}{8} l^2 = Hk,$$

and

$$T = \frac{w + w'}{8} \frac{l^2}{k} = H.$$

Let H' be the thrust along the chord at any point P .

Let x be the horizontal distance of P from B .

The portion PB is kept in equilibrium by the thrust H at B , the thrust H' at P , and the weight $(w + w')x$ between P and B . Hence,

$$H^2 \sec^2 i = H'^2 = H^2 + (w + w')^2 x^2,$$

i being the inclination of the tangent at P to the horizontal, and

$$\text{the thrust at } A = \left(\frac{w + w'}{2} l \right) \left(\frac{l^2}{16k^2} + 1 \right)^{\frac{1}{2}}.$$

Diagonal Stresses due to Live Load.—Assume that the load is concentrated at the panel points, and let it move from A towards C .

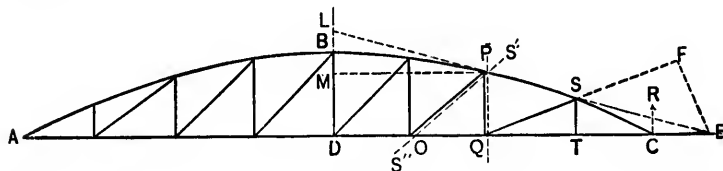

FIG. 390.

If the diagonals slope as in Fig. 390, they are all ties, and the live load produces the greatest stress in any one of them, as QS , when all the panel points from A up to and including Q are loaded.

Let x, y be the horizontal and vertical co-ordinates, respectively, of any point on the parabola with respect to B as origin

The equation of the parabola is

$$y = \frac{4k}{l^2}x^2. \dots \dots \dots (1)$$

Let the tangent at the apex P meet DB produced in L , and DC produced in E .

Draw the horizontal line PM .

From the properties of the parabola, $LM = 2BM$.

Let $PM = x$ and $BM = y$.

From the similar triangles LMP and LDE ,

$$\frac{LM}{MP} = \frac{LD}{DE}, \text{ or } \frac{2y}{x} = \frac{k+y}{x+QE}.$$

$$\therefore QE = x \frac{k-y}{2y} = \frac{l^2 - 4x^2}{8x}.$$

$$\text{Also, } CE = QE - \left(\frac{l}{2} - x\right) = \frac{(l-2x)^2}{8x}.$$

$$\therefore \frac{CE}{QE} = \frac{l-2x}{l+2x}. \dots \dots \dots (2)$$

Draw EF perpendicular to QS produced, and imagine the girder to be cut by a vertical plane a little on the right of PQ .

The portion of the girder between PQ and C is kept in equilibrium by the reaction R at C , the thrust in the bow at P , the tension in the tie at Q , and the stress in the diagonal QS .

Denote the stress by D_n , and let the panel OQ be the n th.

Let θ be the inclination of QS to the horizontal.

Take moments about E . Then

$$D_n EF = R \times CE,$$

or

$$D_n = R \frac{CE}{QE} \operatorname{cosec} \theta. \dots \dots \dots (3)$$

Let N be the total number of panels. Then

$\frac{l}{N}$ is a panel length, and $w' \frac{l}{N}$ is a panel weight.

Also, $x = n \frac{l}{N} - \frac{l}{2}$, and hence

$$\frac{l - 2x}{l + 2x} = \frac{CE}{QE} = \frac{N - n}{n}.$$

R , the reaction at C when the n panel points preceding T are loaded,

$$= \frac{w' l n(n+1)}{2 N^2}.$$

Thus, equation (3) becomes

$$D_n = \frac{w' l (n+1)}{2} \frac{N-n}{N^2} \operatorname{cosec} \theta. \dots (4)$$

Again, by equation (1),

$$k - ST = \frac{4k}{l^2} DT^2 = 4k \left(\frac{n+1}{N} - \frac{1}{2} \right)^2.$$

$$\therefore ST = k \left\{ 1 - 4 \left(\frac{n+1}{N} - \frac{1}{2} \right)^2 \right\} = 4k \frac{(N-n-1)(n+1)}{N^2},$$

and

$$\operatorname{cosec} \theta = \frac{QS}{ST} = \frac{(QT^2 + ST^2)^{\frac{1}{2}}}{ST}.$$

Hence, finally,

$$D_n = \frac{w' l}{8 k} \frac{N-n}{N} \frac{\left[l^2 + \frac{16k^2}{N^2} \left\{ (N-n-1)(n+1) \right\}^2 \right]^{\frac{1}{2}}}{N-n-1}. \quad (5)$$

This formula evidently applies to all the diagonals between D and C .

Similarly, it may be easily shown that the stress in any diagonal between D and A is given by an expression of precisely the same form.

Hence, the value of D_n in equation (5) is general for the whole girder.

A load moving from C towards A requires diagonals inclined in an opposite direction to those shown in Fig. 390.

Stresses in the Verticals due to the Live Load.—Let V_n be the stress in the n th vertical PQ due to the live load. This stress is evidently a compression, and is a maximum when all the panel points from A up to and including O are loaded.

Imagine the girder to be cut by a plane $S'S''$ very near PO , Fig. 390. The portion of the girder between $S'S''$ and C is kept in equilibrium by the reaction R' at C , the thrust in the bow at P , the tension in the tie at O , and the compression V_n in the vertical.

Take moments about E . Then

$$V_n QE = R' \times CE, \quad \text{or} \quad V_n = R' \frac{N-n}{n},$$

and R' , the reaction at C when the $(n-1)$ panel points from A up to and including O are loaded, $= \frac{w'l}{2} \frac{n(n-1)}{N^2}$.

Hence,

$$V_n = \frac{w'l}{2} \frac{(n-1)(N-n)}{N^2}, \dots \dots \dots (6)$$

a general formula for all the verticals.

Let v_n be the tension in the n th vertical due to the dead load. The resultant stress in it when the live load covers AO is $v_n - V_n$, and if negative, this is the maximum compression to which PQ is subjected.

If $v_n - V_n$ is positive, the vertical PQ is never in compression.

The maximum tension in a vertical occurs when the live load covers the whole of the girder and $= w' \frac{l}{N}$ + the tension due to the dead load.

Note.—The same results are obtained when N is odd.

13. Bowstring Girder with Isosceles Bracing.

Diagonal Stresses due to the Dead Load.—Under a dead load the bow is equilibrated and the tie is subjected to a uniform tensile stress equal in amount to the horizontal thrust at the crown. The braces merely serve to transmit the load to the bow and are all ties.

Let T_1, T_2 be the tensile stresses in the two diagonals meeting at any panel point Q . Let θ_1, θ_2 be the inclinations of the diagonals to the horizontal.

Let W be the panel weight suspended from Q .

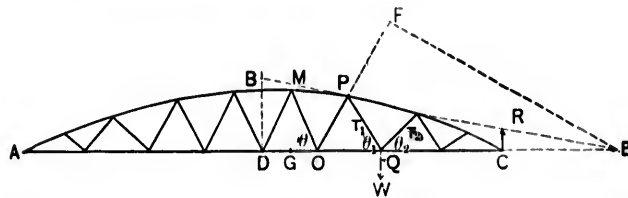

FIG. 391.

The stress in the tie on each side of Q is the same, and therefore T_1, T_2 , and W are necessarily in equilibrium.

Hence,

$$T_1 = W \frac{\cos \theta_2}{\sin (\theta_1 + \theta_2)}, \quad \text{and} \quad T_2 = W \frac{\cos \theta_1}{\sin (\theta_1 + \theta_2)}.$$

Diagonal Stresses due to the Live Load.—Let N be the number of half panels.

The length of a panel = $\frac{2l}{N}$; the weight at a panel point = $w \frac{2l}{N}$.

Let the load move from A towards C . All the braces inclined like OP are ties, and all those inclined like QP are struts.

The live load produces the greatest stress in OP when it covers the girder between A and O .

Denote this stress by D_n ; OG is the n th half-panel.

As before,

$$D_n EF = R \times CE \dots \dots \dots (1)$$

The load upon $AO = nw' \frac{l}{N}$, and hence $R = \frac{w'nl(n+2)}{N \cdot 2N}$.

The ratio of CE to EF is denoted by the same expression as in the preceding article. Thus,

$$D_n = \frac{w' l n + 2 N - n}{8 k n + 1} \frac{N - n}{N} \frac{\left[l^2 + \frac{16k^2}{N^2} \{(N - n - 1)(n + 1)\}^2 \right]^{\frac{1}{2}}}{N - n - 1} \quad (2)$$

The live load produces the greatest stress in OM when it covers the girder up to and including D .

Denote the stress by D'_n ; DG is now the n th half panel.

Let R' be the reaction at C .

As before,

$$D'_n = R' \frac{CE}{OE} \operatorname{cosec} \theta, \dots \dots \dots (3)$$

θ being the angle MOD .

The weight upon $AD = (n - 1)w' \frac{l}{N}$,

and hence

$$R' = \frac{w' l n^2 - 1}{2 N^2}.$$

It may be easily shown, as in the preceding article, that

$$\frac{CE}{OE} = \frac{N - n - 1}{n + 1}, \text{ and } \operatorname{cosec} \theta = N \frac{\left[l^2 + \frac{16k^2}{N^2} \{(N - n)n\}^2 \right]^{\frac{1}{2}}}{4nk(N - n)}.$$

$$\therefore D'_n = \frac{w' l n - 1}{8 k n} \frac{N - n - 1}{N} \frac{\left[l^2 + \frac{16k^2}{N^2} \{(N - n)n\}^2 \right]^{\frac{1}{2}}}{N - n} \quad (4)$$

Hence, when the load moves from A towards C , eq. (2) gives the diagonal stress when n is even, and eq. (4) gives the stress when n is odd.

If the load moves from C towards A , the stresses are reversed in kind, so that the braces have to be designed to act both as struts and ties.

Note.—By inverting Fig. 391, a bowstring girder is obtained with the horizontal chord in compression and the bow in tension.

14. Bowstring Suspension Bridge (*Lenticular Truss*).—

This bridge is a combination of the ordinary and inverted bowstrings. The most important example is that erected at Saltash, Cornwall, which has a clear span of 445 feet. The bow is a wrought-iron tube of an elliptical section stiffened at intervals by diaphragms, and the tie is a pair of chains.

A girder of this class may be made to resist the action of a passing load either by the stiffness of the bow or by diagonal bracing.

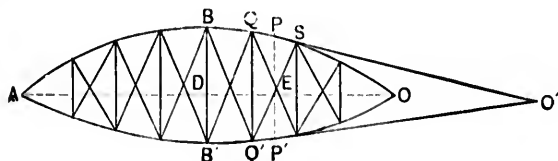

In Fig. 392, let $BD = k$, $B'D = k'$.

Let H be the horizontal thrust at B , and T the horizontal pull at B' , when the live load covers the whole of the girder. Then

$$H = \frac{w + w'}{8} \frac{l^2}{k + k'} = T.$$

First, let $k = k'$. Then

$$H = T = \frac{w + w'}{16} \frac{l^2}{k},$$

which is one half of the corresponding stress in a bowstring girder of span l and depth k .

One half of the total load is supported by the bow and one half is transmitted through the verticals to the tie. Hence,

$$\text{the stress in each vertical} = \frac{l}{N}(w' + w''),$$

w'' being the portion of the dead weight per lineal foot borne by the verticals, and N the number of panels.

The diagonals are strained only under a passing load.

Let PP' be a vertical through E , the point of intersection of any two diagonals in the same panel, and let the load move from A towards O .

By drawing the tangent at P and proceeding as in Art. 13, the expression for the diagonal stress in QS becomes, as before,

$$D_n = \frac{w' l \frac{n(n-1)l - 2x}{N^2}}{2} \frac{l - 2x}{l + 2x} \operatorname{cosec} \theta. \dots (1)$$

Similarly, the stress in the vertical QQ' is

$$V_n = w' \frac{l}{N} + \frac{w' l \frac{n(n-1)l - 2x}{N^2}}{2} \frac{l - 2x}{l + 2x}. \dots (2)$$

Next, let k and k' be unequal.

Let W be the weight of the bow, W' the weight of the tie. Then, under these loads,

$$\frac{W l}{8 k} = H = H' = \frac{W' l}{8 k'}, \text{ or } \frac{W}{W'} = \frac{k}{k'}. \dots (3)$$

The verticals are not strained unless the platform is attached to them along the common chord ADO . In such a case, the weight of the platform is to be included in W' .

The tangents at P and P' evidently meet AO produced in the same point O' , for EO' is independent of k or k' . Hence, the stresses in the verticals and diagonals due to the passing load may be obtained as before.

15. Cantilever Trusses.—A cantilever is a structure supported at one end only, and a bridge of which such a structure forms part may be called a cantilever bridge. Two cantilevers



BRIDGE OVER ST. LAWRENCE AT NIAGARA,
FIG. 393.

may project from the supports so as to meet, or a gap may be left between them which may be bridged by an independent

girder resting upon or hinged to the ends of the cantilevers. The form of the cantilever is subject to considerable variation.

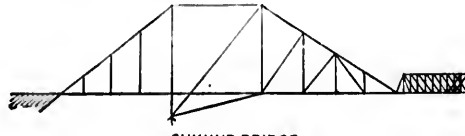

SUKKUR BRIDGE

FIG. 394.

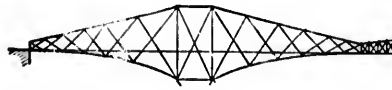

FORTH BRIDGE.

FIG. 395.

Figs. 396 to 401 represent the simplest forms of a cantilever frame. If the member AB has to support a uniformly dis-



FIG. 396.

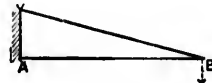

FIG. 397.



FIG. 398.



FIG. 399.



FIG. 400.



FIG. 401.

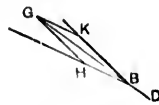

FIG. 402.



FIG. 403.

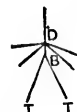

FIG. 404.

tributed load as well as a concentrated load at B , intermediate stays may be introduced as shown by the full or by the dotted

lines in Figs. 398 and 399. Should a live load travel over AB , each stay must be designed to bear with safety the maximum stress to which it may be subjected.

Figs. 400 and 401 show cantilever trusses with parallel chords. If the truss is of the double-intersection type, Fig. 401, the stresses in the members terminating in B become indeterminate. They may be made determinate by introducing a short link BD , Fig. 402. Thus, if, in DB produced, BC be taken to represent the resultant stress along the link, and if the parallelogram HK be completed, BK will represent the stress along BE , and BH that along BF .

This link device has been employed to equalize the pressure on the turn-table TT of a swing-bridge (Fig. 403). An "equalizer" or "rocker-link" BD , Fig. 404, conveys the stresses transmitted through the members of the truss terminating in D to the centre posts BT .

Theoretically, therefore, the pressure over TT will be evenly distributed, whatever the loading may be, if the direction of BD bisects the angle TBT and if friction is neglected.

The joint between the central span and the cantilever requires the most careful consideration and should fulfil the following conditions:

(a) The two cantilevers should be free to expand and contract under changes of temperature.

(b) The central span should have a longitudinal support which will enable it to withstand the effect of the braking of a train or the pressure of a wind blowing longitudinally.

(c) The wind-pressure on the central span should bear equally on the two cantilevers.

(d) The connections at both ends should have sufficient lateral rigidity to check undue lateral vibration. Conditions (a) and (c) would be fulfilled by supporting the central span like an ordinary bridge-truss upon a rocker bolted down at one end and upon a rocker resting on expansion rollers at the other. This, however, would not satisfy condition (b). It is preferable to support the span by means of rollers or links at both ends, and to secure it to one cantilever only on the central line of the bridge with a large vertical pin, adapted to

transmit all the lateral shearing force. A similar pin at the other end, free to move in an elongated hole, or some equivalent arrangement, as, e.g., a sleeve-joint bearing laterally and with rollers in the seat, is a satisfactory method of transmitting the shearing force at that end also. (If there is an end post, it may be made to act like a hinge so as to allow for expansion, etc.) The points of contrary flexure of the whole bridge under wind-pressure are thus fixed, and all uncertainty as to wind-stresses removed.

Where other spans have to be built adjacent to a large cantilever span, it should not be hastily assumed that it is necessarily best to counterbalance the cantilever by a contiguous cantilever in the opposite direction. If it is possible to obtain good foundations and if piers are not expensive, it might be cheaper to build a number of short independent side spans and to secure the cantilever to an independent anchorage. If this is done, care must be taken to give the abutment sufficient stability to take up the unbalanced thrust along the lower boom of the cantilever.

Suppose that the cantilever is anchored back by means of a single back-stay.

Let W = weight necessary to resist the pull of the back-stay :

h = depth of end post of cantilever ;

z = horizontal distance between foot of post and anchorage ;

M = bending moment at abutment = Wz .

If it is now assumed that the sectional areas of the post and back-stay are proportioned to the stresses they have to bear (which is never the case in practice), the quantity of material in these members must be proportional to

$$W \frac{z^2 + h^2}{h} + Wh = W \frac{z^2 + 2h^2}{h} = M \frac{z^2 + 2h^2}{hz},$$

which is a minimum when $z = \sqrt{2}h$.

If a horizontal member is introduced between the feet of

the back-stay and the post, the quantity of material becomes proportional to

$$W \frac{s^2 + h^2}{h} + Wh + W \frac{s^2}{h} = 2M \frac{s^2 + h^2}{sh},$$

which is a minimum when $s = h$, i.e., when the back-stay slopes at an angle of 45° . By making the angle between the back-stay and the horizontal a little less than 45° , a certain amount of material may be saved in the joints of the back-stays and also in the anchors, which more than compensates for the increased weight of the anchors themselves.

(*Note.*—In these calculations it is also assumed that the top chord is horizontal, and that the feet of the post and back stay are in the same horizontal plane. This is rarely the case in practice.)

According to the above the weight of material necessary for the back-stay is *directly* proportional to the bending moment at the abutment and *inversely* proportional to the depth of the cantilever, other things being equal. A double cantilever has, in general, no anchorage of any great importance.

If the span is very great, a cantilever bridge usually requires less material than any other rigid structure of equal strength, even though anchorage may have to be provided. If two large spans are to be built, a double cantilever, requiring no anchorage, may effect a very considerable saving in material, although a double pier, of sufficient width for stability under all conditions of loading, will be necessary.

Again, where false-works are costly or impossible, the property of the cantilever, that it can be made to support itself during erection, gives it an immense advantage. If the design of the cantilever is such that it can be built out rapidly and cheaply, it will often be the most economical frame in the end, even if the total quantity of material is not so small as that required for some other type of bridge. In all engineering work, *quantity of material* is only *one* of the elements of cost, and this should be carefully borne in mind when designing a cantilever bridge, because a want of regard to the method of

erection may easily add to its cost an amount much greater than can be saved by economizing material.

In ordinary bridge-trusses the amount of the web metal is greatest at the ends and least at the centre, while the amount of the chord metal is least at the ends and greatest at the centre. Thus, the assumption of a uniformly distributed dead load for such bridges is, generally speaking, sufficiently accurate for practical purposes. In the case of cantilever bridges, however, the circumstances are entirely different. In these the amount of the metal both in the web and in the chords is greatest at the support and least at the end. For example, the weight of the cantilevers (exclusive of the weight of platform, viz., $\frac{1}{2}$ ton per lineal foot) for the Indus Bridge, per lineal foot, varies from $6\frac{1}{2}$ tons at the supports to 1 ton at the outer ends. Hence, the hypothesis of a uniformly distributed dead load for such structures cannot hold good.

The weight of a cantilever for a given span may be approximately calculated in the following manner:

Determine the stresses in the several members, panel by panel—

- (A) For a load consisting of
- (1) a given unit weight, say 100 tons, at the outer end ;
 - (2) the corresponding dead weight.
- (B) For a load consisting of
- (1) the specified live load ;
 - (2) the corresponding panel dead weight.

Thus, the whole weight of a panel will be the sum of the weights deduced in (A) and (B), and the total weight of the cantilever will be the sum of the several panel weights.

This process evidently gives at the same time the weights of cantilevers of one, two, three, etc., panel lengths, the loads remaining the same.

The panel dead weights referred to in (A) and (B) must, in the first place, be assumed. This can be done with a large degree of accuracy, as the dead weight must necessarily *gradually* increase towards the support, and any error in a particular panel may be easily rectified by subsequent calculations.

Again, the preceding remarks indicate a method of finding the most economical cantilever length in any given case.

Take, e.g., an opening spanned by two equal cantilevers and an intermediate girder. Having selected the type of bridge to be employed for the intermediate span, estimate, either from existing bridges or otherwise, the weights of independent bridges of the same type and of different spans. Sketch a skeleton diagram of the cantilever, extending over one-half of the whole span, and apply to it the processes referred to in (A) and (B).

If L is the length of the cantilever and P that of a panel, the following table, in which the intermediate span increases by two panel lengths at a time, may be prepared :

Length of Intermediate Span.	Half Weight of Intermediate Span.	Weight on End of Cantilever from Intermediate Span.	Length of Cantilever.	Weight of Cantilever for each foot at its end.	Weight of Cantilever due to Load at its end from Intermediate Span.	Weight of Cantilever due to Specified Live Load and its own Weight.	Total Weight of one-half Span.
0			L				
$2P$			$L - 2P$				
$4P$			$L - 4P$				
$6P$			$L - 6P$				
$8P$			$L - 8P$				
etc.			etc.				
1	2	3	4	5	6	7	8

Weight in col. 3 = *one-half* of the weight of the intermediate girder

+ *one-half* of the live load it carries if uniformly distributed. (The proportion will be greater than one-half for arbitrarily distributed loads, and may be easily determined in the usual manner.)

Col. 5 gives the weights obtained as in *A*.

Col. 6 = col. 5 $\times \frac{\text{weight on end of cantilever}}{100}$.

Col. 7 gives the weights obtained as in *B*.

Col. 8 = col. 2 + col. 6 + col. 7.

It is important to bear in mind that an increase in the weight of the central span necessitates a corresponding increase in the

weights of the cantilevers. Hence, in order that the weight of the structure may be a minimum, the best material with the highest practicable working unit stress should be employed for the centre span.

The table must of course be modified to meet the requirements of different sites. Thus, if anchorage is needed, a column may be added for the weights of the back-stays, etc.

16. Curve of Cantilever Boom.—Consider a cantilever with one horizontal boom OA , and let x, y be the co-ordinates of any point P in the other boom, O being the origin of co-ordi-

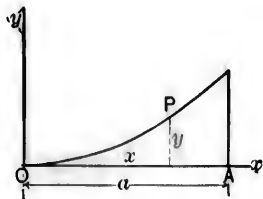

FIG. 405.

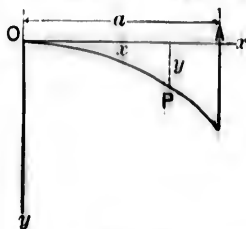

FIG. 406.

ates and A the abutment end of the cantilever.

Let W be the portion of the weight of an independent span supported at O .

Let w be the *intensity* of the load at the vertical section through P .

Assume (1) that there are no diagonal strains, and, hence, that the web consists of vertical members only;

(2) that the stress H in the horizontal boom is constant, and therefore the bending moment at $P = Hy$;

(3) that the *whole* load is transmitted through the vertical members of the web.

Let k be such a factor that kTl is the weight of a member of length l , subjected to a stress T .

(*Note.*—If l is in feet and T in tons, then k for steel is about .0003, allowance being made for loss of section or increase of weight at connections.)

w consists of two parts, viz., a *constant part* p , due to the weight of the platform, wind-bracing, etc., which is assumed to

be uniformly distributed; and a *variable part*, due to the weight of the cantilever, which may be obtained as follows:

Weight of element dx of horizontal boom = $kHdx$.

“ “ web corresponding to dx = $kwydx$.

“ “ element of curved boom corresponding to dx
 = $kH\left(\frac{ds}{dx}\right)^2 dx$.

Hence the variable intensity of weight

$$= kH + kwy + kH\left(\frac{ds}{dx}\right)^2,$$

and

$$w = p + kH + kwy + kH\left(\frac{ds}{dx}\right)^2.$$

Again, if M is the bending moment and S the shearing force at the vertical section through P , then

$$\frac{d^2M}{dx^2} = \frac{dS}{dx} = w = H\frac{d^2y}{dx^2}.$$

$$\begin{aligned} \therefore H\frac{d^2y}{dx^2} &= p + kH + kwy + kH\left(\frac{ds}{dx}\right)^2 \\ &= p + kH + kHy\frac{d^2y}{dx^2} + kH\left\{1 + \left(\frac{dy}{dx}\right)^2\right\} \\ &= p + 2kH + kH\left\{y\frac{d^2y}{dx^2} + \left(\frac{dy}{dx}\right)^2\right\}. \end{aligned}$$

Integrating twice,

$$Hy = A + Bx + (p + 2kH)\frac{x^2}{2} + kH\frac{y^2}{2},$$

A and B being constants of integration.

When $x = 0$, $y = 0$, and $H\frac{dy}{dx} = W$.

Thus, $A = 0$ and $B = W$.

Hence,

$$Hy = Wx + (p + 2kH)\frac{x^2}{2} + kH\frac{y^2}{2}$$

is the equation to the curve of the boom, and represents an ellipse with its major axis vertical, and with the lengths of the two axes in a ratio equal to $\left(\frac{p + 2kH}{kH}\right)^{\frac{1}{2}}$.

The depth of the longest cantilever is determined by the vertical tangent at the end of the minor axis, and corresponds to the value of y given by making $\frac{dx}{dy} = 0$ in the preceding equation, which gives $y = \frac{1}{k}$.

For a given value of H the curve of the boom is independent of the span. Again, for a given length of cantilever with a boom of this elliptic form, a value of H may be found which will make the total weight a minimum, and which will therefore give the most economical depth. Such an investigation, however, can only be of interest to mathematicians, as the hypotheses are far from being even approximately true in practice, and the resulting depth would be obviously too great.

Assumption (1) on page 634 no longer holds when a live load has to be considered. Diagonal bracings must then be introduced, which become heavier as the depth increases, in consequence of their increased length. The diagonal bracings are also largely affected by the length of the panels. If the panels are short, and if a great depth of cantilever, diminishing rapidly away from the abutment, is used, the angles of the diagonal bracing, near the abutment, will be unfavorable to economy. This difficulty may be avoided by adopting a double system of triangulation over the deeper part of the cantilever only, or even a treble system for some distance in a large span. The objections justly urged against multiple systems of triangulation in trusses lose most of their force in large cantilevers. In the first place, the method of erection by building out insures that each diagonal shall take its proper share of the dead load; and in the second place, it should be

remembered that only in large spans could a double system have anything to recommend it, and then only near the abutment where the stresses are greatest: in such cases the moving load only produces a small portion of the entire stress in the web. In practice, a compromise has to be made between different requirements, and the depth must be kept within such limits as will admit of reasonable proportions in other respects, while the diagonal ties or struts may be allowed to vary in inclination, to some extent, from one panel to another.

Again, in fixing the panel length, care must be taken that there is no undue excess of platform weight, as this will produce a corresponding increase in the weight of the cantilever.

An excessive depth of cantilever generally causes an increase in the cost of erection.

Both theory and practice, however, indicate that it will be more advantageous to choose a greater depth for a cantilever than for an ordinary girder bridge.

An ordinary proportion for a large girder bridge would be one-ninth to one seventh of the span, and if for the girder were substituted two cantilevers meeting in the middle of the span, the depth might with advantage be considerably increased beyond this proportion at the abutment, if it be reduced to *nil* where the cantilevers meet. When a central span is introduced, resting upon the ends of the two cantilevers, the concentrated load on the end gives an additional reason for still further increasing the depth at the abutment *proportionally to the length of the cantilever*. The greatest economical depth has probably been reached in the Indus bridge, in which the depth at the abutment = $.54 \times$ length of cantilever. Probably the proportion of one-third of the length of the cantilever would be ample, except where the anchorage causes a considerable part of the whole weight, but each case must be considered on its own merits. The reduction of deflection obtained by increasing the depth is also an appreciable consideration.

If a depth be chosen not widely different from that which makes the quantity of material a minimum, the weight will be only slightly increased, while it is possible that great structural advantages may be gained in other directions. In recommend-

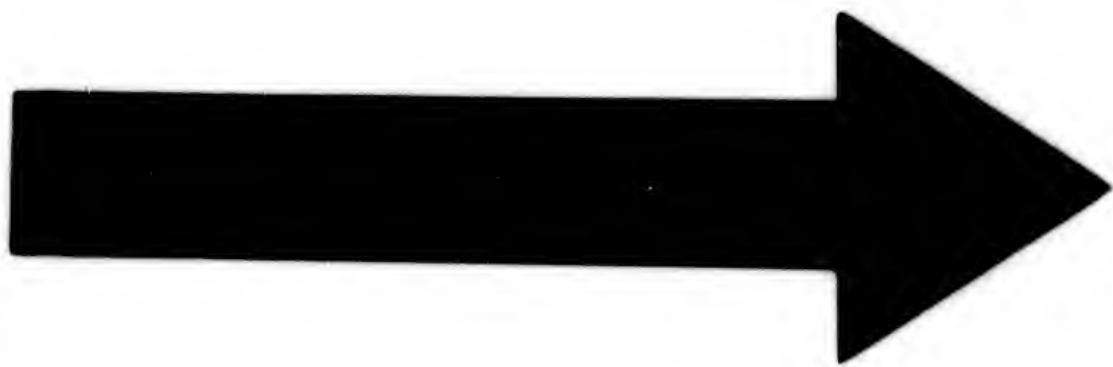

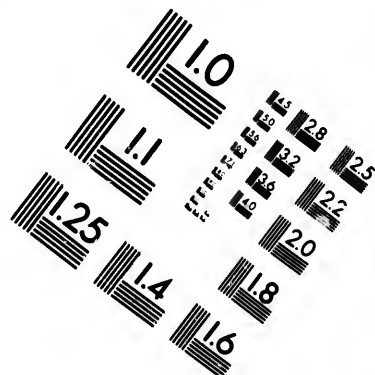
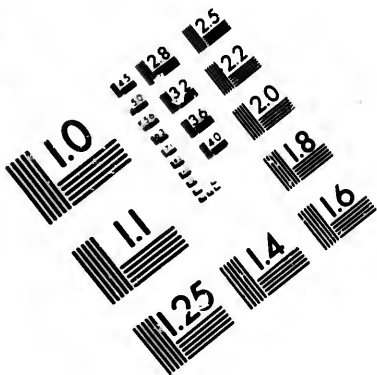

**IMAGE EVALUATION
TEST TARGET (MT-3)**

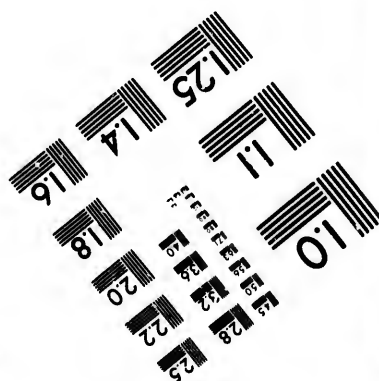
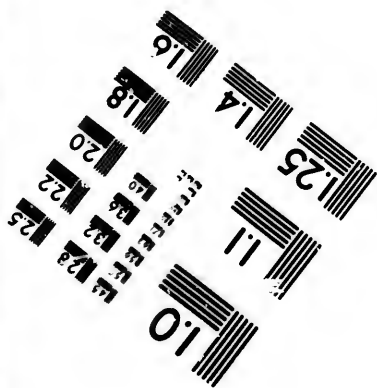
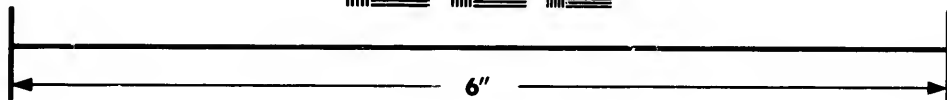
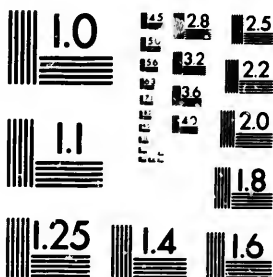

**Photographic
Sciences
Corporation**

23 WEST MAIN STREET
WEBSTER, N.Y. 14580
(716) 872-4503

15 28 25
16 32 22
18 20

10

ing a great depth for a cantilever at its abutment, it is assumed that the depth will be continuously reduced from the abutment outwards. If the load were continuously distributed, it is by no means certain that a cantilever of uniform depth would require more material than one of varying depth, but it has already been pointed out to what extent the weight of the structure itself necessarily varies, and if the concentrated load at the end were separately considered, the economical truss would be a simple triangular frame of very great depth. From economic considerations, it would be well to reduce the depth of the cantilever at the outer end to *nil*, but in many cases it is thought advisable to maintain a depth at this point equal to that at the end of the central span, so that the latter may be built out without false-works, under the same system of erection as is pursued in the case of the cantilever. The post at the ends of the central span and cantilever is sometimes hinged to allow for expansion.

17. Deflection.—A serious objection urged against cantilever bridges is the excessive and irregular deflection to which they are sometimes subject. They usually deflect more than ordinary truss-bridges, and the deflection is proportionately increased under suddenly applied loads. In the endeavor to recover its normal position, the cantilever springs back with increased force and, owing to the small resistance offered by the weight and stiffness at the outer end, there may result, especially in light bridges, a kicking movement. It must, however, be borne in mind that the deflection, of which the importance in connection with iron bridges has always been recognized, is not in itself necessarily an evil, except in so far as it is an *indication* or a *cause* of over-strain.

18. The Statical Deflection, due to a quiescent load, must be distinguished from what might be called the dynamical deflection, i. e., the additional deflection due to a load in motion. The former should not exceed the deflection corresponding to the statical stresses for which the bridge is designed. The amount of the *dynamical* deflection depends both upon the nature of the loads and upon the manner in which they are applied, nor are there sufficient data to determine its value.

even approximately. It certainly largely increases the statical stresses and produces other ill effects of which little is known.

Hitherto, the question as to the deflection of framed structures has received but meagre attention, and formulæ deduced for solid girders have been employed with misleading results. It would seem to be more scientific and correct to treat each member separately and to consider its individual deformation.

19. Rollers.—One end of a bridge usually rests upon nests of turned wrought-iron or steel friction rollers running between planed surfaces. The diameter of a roller should not be less than 2 inches, and the pressure upon it in pounds per lineal inch should not exceed $500\sqrt{d}$ if made of wrought-iron, or $600\sqrt{d}$ if made of steel, d being the diameter in inches.

20. Live Load.—It is a common practice with many engineers to specify the live load for a bridge as consisting of a number of arbitrary concentrated weights which are more or less equivalent to the loads thrown upon the locomotive and car axles.

Figs. 407, 408, and 409 are examples of such practice.

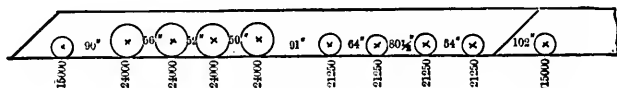

FIG. 407.

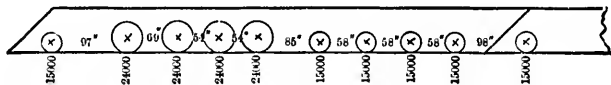

FIG. 408.

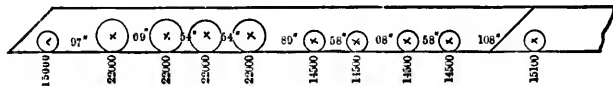

FIG. 409.

With such a live load, the determination of the position of the locomotive and cars which will give a maximum shear and a maximum bending moment at any section is much facilitated by the principles enunciated in Art. 8, Chap. II.

If the chords are parallel, and if S is the maximum shear transmitted through a diagonal inclined at an angle θ to the vertical, the maximum stress in that diagonal $= S \sec \theta$, and the corresponding stress transmitted to a chord through the diagonal

$$= S \sec \theta \sin \theta = S \tan \theta.$$

A modification is necessary when the chords are not parallel. Consider, e.g., a truss with a horizontal bottom chord and a top chord composed of inclined members. Retain the same notation as in the article referred to, and let D_1, D_2 be the stresses corresponding to the *first* and *second* distributions, respectively, in a diagonal met by a vertical section between the r th and $(r+1)$ th weights. Also, let the member of the upper chord cut by the same section be produced to meet the horizontal chord produced in the point C .

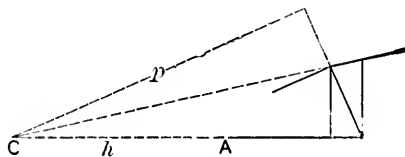

FIG. 41c.

Let $AC = h$, and let p be the perpendicular from C upon the diagonal in question.

Taking moments about C ,

$$D_1 p = R_1 h - w_1(h+l-a_1) - w_2(h+l-a_2) - \dots - w_r(h+l-a_r),$$

and

$$D_2 p = \bar{K}_r h - w_1(h+l-a_1-x) - w_2(h+l-a_2-x) - \dots - w_r(h+l-a_r-x) - w_{r+1}(h+l-a_{r+1}-x) - \dots - w_{r+q}(h+l-a_{r+q}-x).$$

It is assumed, for simplicity, that no weights leave or advance upon the bridge.

$$\therefore D_1 \begin{matrix} > \\ < \end{matrix} D_2.$$

according as

$$R_1 h - w_1(h + l - a_1) - w_2(h + l - a_2) - \dots - w_r(h + l - a_r) \begin{matrix} \succ \\ \equiv \\ \prec \end{matrix}$$

$$R_2 h - w_1(h + l - a_1 - x) - w_2(h + l - a_2 - x) - \dots \\ - w_r(h + l - a_r - x) - w_{r+1}(h + l - a_{r+1} - x) - \dots \\ - w_{r+q}(h + l - a_{r+q} + x),$$

or

$$R_q'(l + h) \begin{matrix} \succ \\ \equiv \\ \prec \end{matrix} x(w_1 + w_2 + \dots + w_r + w_{r+1} + \dots + w_{r+q}) \\ + W_n \frac{x}{l} h,$$

where $R_q'(l + h)$ = algebraic sum of the moments, with respect to C , of the weights transferred,

$$= w_{r+1}(h + l - a_{r+1}) + \dots + w_{r+q}(h + l - a_{r+q})$$

and

$$R_2 - R_1 = \frac{x}{l} W_n.$$

Hence,

$$D_1 \begin{matrix} \succ \\ \equiv \\ \prec \end{matrix} D_2,$$

according as

$$R_q'(l + h) \begin{matrix} \succ \\ \equiv \\ \prec \end{matrix} x(W_r + T) + W_n \frac{x}{l} h.$$

Take, e.g., the truss represented by the accompanying diagram (Sault Ste. Marie Bridge), the live load being that shown by Fig. 407, i.e., the loading from a Standard Consolidation engine with four drivers and one leading wheel.

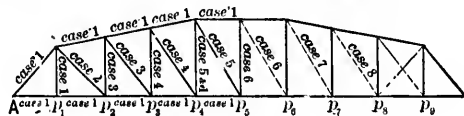

FIG. 411.

Span = 239 ft.

Length of centre verticals = 40 ft.; of end verticals = 27 ft.

Applying the principles referred to in the preceding it is found that the distributions of live load, *concentrated at the panel points*, which will give the maximum stresses in the several members, may be tabulated as below :

Distributions.	End Reaction at A.	Load at p_1 .	Load at p_2 .	Load at p_3 .	Load at p_4 .	Load at p_5 .	Load at p_6 .	Load at p_7 .	Load at p_8 .	Load at p_9 .
Case 1	187990	49500	38700	45925	43750	36225	36000	36000	36000	36000
" 2	162920	11900	49500	38700	45925	43750	36225	36000	36000	36000
" 3	124230		6400	47200	40200	43400	45800	37100	36000	36000
" 4	95020			6400	47200	40200	43400	45800	37100	36000
" 5	69410				6400	47200	40200	43400	45800	37100
" 6	47400					6400	47200	40200	43400	45800
" 7	29100						6400	47200	40200	43400
" 8	15380							6400	47200	40200
Dead weight	121500	27000	27000	27000	27000	27000	27000	27000	27000	27000

N.B.—These numbers are convenient whole numbers within about one-half of one per cent of the calculated results. The panel length is also assumed to be 24 ft.

In Cases 1 and 2 the *third* driver is at a panel point ; in the remaining cases the *second* driver is at a panel point.

The *dead* weight includes the weight of the ironwork and flooring. The panel loads may be easily calculated, either analytically or graphically. For example, let *A, B, C, D* be four consecutive panel points, and let the *third* driver be at *B*.

Panel load at *A*

$$= 7500 \frac{198}{288} + 12000 \left(\frac{108 + 52}{288} \right) = 11823, \text{ say } 11,900 \text{ lbs.}$$

Panel load at *B*

$$= 7500 \frac{90}{288} + 12000 \left(\frac{180 + 236 + 288 + 232}{288} \right) + 10625 \left(\frac{141 + 77}{288} \right) \\ = 49387, \text{ say } 49,500 \text{ lbs.}$$

Panel load at *C*

$$= 12000 \left(\frac{56 + 281}{288} \right) + 10625 \left(\frac{187 + 211 + 284\frac{1}{2} + 220\frac{1}{2}}{288} \right) + 7500 \frac{118\frac{1}{2}}{288} \\ = 38445, \text{ say } 38,700 \text{ lbs.}$$

Or, *graphically*, upon the vertical through B (Fig. 412) take BM to represent 7500 lbs., and join AM . Let the vertical through a , meet AM in b_1 , and the horizontal through AM in c_1 . Then a_1b_1 represents the portion of 7500 lbs. borne at B , and b_1c_1 the portion borne at A .

Also, take BN to represent 12,000 lbs.; join AN, CN . Let the verticals through a_2, a_3, a_4 meet AN, CN in b_2, b_3, b_4 , and the horizontal through N in c_2, c_3, c_4 . Then a_2b_2, a_3b_3, a_4b_4 ,

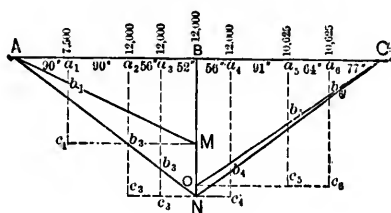

FIG. 412.

represent the portions of each 12,000 lbs. borne at B , while b_2c_2, b_3c_3 represent the portions borne at A , and b_4c_4 the portion borne at C .

Finally, take BO to represent 10,625 lbs., and join CO . Let the verticals through a_5, a_6 meet CO in b_5, b_6 , and the horizontal through O in c_5, c_6 . Then a_5b_5, a_6b_6 are the portions of each 10,625 lbs. borne at B , while b_5c_5, b_6c_6 are the portions borne at C . Thus the total weight at B

$$= a_1b_1 + a_2b_2 + a_3b_3 + BN + a_4b_4 + a_5b_5 + a_6b_6.$$

It is open to grave question whether the extremely nice calculations required by the assumption of arbitrary weight calculations are not unnecessary except for floor systems. The constantly increasing locomotive and car weights and the variety in type of locomotive would seem to render such calculations, based as they are upon *one* particular distribution of load, of no effect.

On the other hand, if it is assumed that the standard live load consists of a uniform load of, say, 3000 lbs. to 3600 lbs. per lineal foot, with a single weight of, say, 25,000 lbs. to 35,000 lbs. for each truss, at the head or at any other specified

point, i.e., rolling on the uniform load, the calculations would be much simplified and the resulting stresses would be at least as approximately accurate.

Let E be the single concentrated load, T the panel train load, and D the panel dead load.

Consider a truss of N panels with a single diagonal system, Fig. 413, and let E be at the r th panel point.

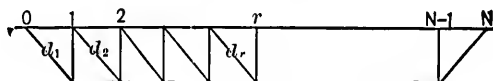

FIG. 413.

The shear immediately in front of E due to E

$$= \frac{E}{N}(N - r);$$

the shear at same point due to T

$$= \frac{T}{N} \frac{(N - r - 1)(N - r)}{2};$$

the shear at same point due to D

$$= \frac{D}{N} \frac{N(N - 2r + 1)}{2}.$$

Diagonal Stresses.—The maximum diagonal stresses may now be easily tabulated as follows:

TABLE I.

Diagonal.	Multiplier $(N - r)$.	Max. Vertical Shear due to E transmitted. $\left(\frac{E}{N}\right)$	Multiplier $\frac{(N - r - 1)(N - r)}{2}$.	Max. Vertical Shear due to T transmitted. $\left(\frac{T}{N}\right)$	Total Maximum Vertical Shear due to Live Load transmitted.	Secant θ .	Max. Diagonal Stress due to Live Load.	Multiplier $\frac{N(N - 2r + 1)}{2}$.	Vertical Shear due to Dead Load transmitted. $\frac{D}{N}$	Diag. Stress due to Dead Load.	Total Max. Diagonal Stress.
d_1	$N - 1$	$(N - 1) \frac{E}{N}$	$\frac{N - 2, N - 1}{2}$	$\frac{N - 2, N - 1}{2} \frac{T}{N}$	$(N - 1) \frac{E}{N}$ $+ \frac{N - 2, N - 1}{2} \frac{T}{N}$			$\frac{N, N - 1}{2}$	$\frac{N, N - 1}{2} \frac{D}{N}$		
1	2	3	4	5	6	7	8	9	10	11	12

Col. 1 designates the several diagonals.

Col. 2 gives the multiplier $N - r$ for different values of r .

Col. 3 gives the maximum vertical shears due to E transmitted through the several diagonals. This shear for any given diagonal is the product of the corresponding multiplier in col. 2 and $\frac{E}{N}$.

Cols. 4 and 5, 9 and 10 give similar quantities for the live and dead loads.

Col. 6 gives the sums of the shears in cols. 3 and 5, i.e., it gives the total maximum vertical shears due to live load.

Col. 8 gives the maximum diagonal stresses due to live load. For any specified diagonal it is the product of the corresponding shear in col. 7 and the secant of the angle between the vertical and the diagonal in question.

Col. 11 in like manner gives the maximum diagonal stress due to dead load.

Col. 12 gives the total maximum diagonal stresses due to both live and dead loads.

Another column might be added giving the sectional areas of the diagonals.

In the above table the diagonal stresses due to the live and dead loads are separately determined, as different coefficients of strength are sometimes specified for the two kinds of load. With a suitable compound coefficient of strength, cols. 6, 8, and 11 may be replaced by a column giving the sums of the corresponding shears in cols. 3, 5, and 10. These sums, multiplied by secant θ , give the maximum diagonal stresses.

Stresses in the Verticals.—The maximum stress in any vertical, say at the r th panel point, is evidently the vertical component of the maximum diagonal stress in the r th panel, i.e., it is the maximum vertical shear in the r th panel.

To be more accurate, this amount should be diminished by the portion of the weight of the lower chord borne at the foot of the vertical in question.

Chord Stresses.—Take the load at each panel point

$$= \frac{E}{N} + T + D.$$

TABLE II. (COMPRESSION CHORD.)

Chord Length.	Multiplier $\frac{N(N - 2r + 1)}{2}$.	Vertical Shear transmitted, $\left(\frac{E}{N} + \frac{T + D}{N}\right)$.	Tan θ .	Stress, transmitted to Chord through Diagonal.	Total Chord Panel Stress.
1	2	3	4	5	6

Col. 1 designates the chord panel length.

Col. 3 gives the several vertical shears transmitted to the chords through the diagonals. They are the product of $\frac{1}{N} \left(\frac{E}{N} + T + D \right)$ and the multipliers in col. 2.

Col. 5 gives the chord stresses due to these shears, i.e., the product of the shears in col. 3 and the corresponding values of $\tan \theta$ in col. 4.

Col. 6 gives the *total* chord stresses in the several panels. In any given panel the total chord stress is equal to the chord stress due to the shear in that panel *plus* the total chord stress in the preceding panel.

Another column for the sectional areas of the several lengths of chord may be added if required, each length being designed as a strut, hinged or fixed at the ends, according to the method of construction.

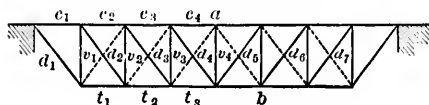

FIG. 413a.

A precisely similar table may be prepared for the tension chord.

EXAMPLE I. An *eight*-panelled deck-truss of 108 ft. span and 18 ft. deep, with a single diagonal system.

Concentrated load E for each truss = 25,000 lbs.

Train load T for each truss = 1600 lbs. per lineal ft.

= 21,600 lbs. per panel.

Bridge (dead) load D for each truss = 800 lbs. per lineal ft.

= 10,800 lbs. per panel.

$$\sec \theta = \frac{5}{4}, \quad \tan \theta = \frac{3}{4}.$$

TABLE OF MAXIMUM DIAGONAL STRESSES. (See TABLE I.)

Diagonal.	$B - r$.	$\frac{25000}{8} = 3125$.	$\frac{17 - r}{2}(8 - r)$.	$\frac{21600}{8} = 2700$.	Total Max. Shear due to Live Load.	Secant θ .	Max. Diag. Stress due to Live Load.	$4(9 - 2r)$.	$\frac{10800}{8} = 1350$.	Diag. Stress due to Dead Load.	Total Max. Diag. Stress.
d_1	7	21875	21	56700	78575	11	98218½	28	37800	47250	145468½
d_2	6	18750	15	40500	59250	12	74062½	20	27000	33750	107812½
d_3	5	15625	10	27000	42625	12	53281½	12	16200	20250	73531½
d_4	4	12500	6	16200	28700	12	35875	-4	5400	6750	42625
d_5	3	9375	3	8100	17475	12	21843½	-4	5400	-6750	15093½
d_6	2	6250	1	2700	8950	12	11187½	-12	16200	-20250	
d_7	1	3125			3125	12	3906½	-20	-27000	-33750	

It will be observed that in the *fifth* panel there is a maximum *positive* shear of 17,475 lbs. and a *negative* shear of 5400 lbs., the former due to the live and the latter to the dead load. The resultant shear of 12,075 lbs., *which is opposite in kind to that due to the dead load*, is provided for by means of the counterbrace *ab*. No counterbraces are theoretically required in the sixth and seventh panels, but they are often introduced in order to stiffen the truss.

TABLE OF MAXIMUM STRESSES IN THE VERTICALS.

$$v_1 = 78,575 + 37,800 = 116,375 \text{ lbs.}$$

$$v_2 = 59,250 + 27,000 = 86,250 \text{ "}$$

$$v_3 = 42,625 + 16,200 = 58,825 \text{ "}$$

$$v_4 = 28,700 + 5,400 = 34,100 \text{ "}$$

Chord Stresses.—Load at each panel point

$$= \frac{E}{8} + T + D = 35,525 \text{ lbs.}$$

TABLE OF MAXIMUM STRESSES IN COMPRESSION CHORD.

Member.	$4(9 - 2r)$.	$\frac{35525}{8} = 4440\frac{5}{8}$.	Tan θ .	Chord Stress due to Shear.	Total Max. Chord Stress.
c_1	28	124337½	½	93253½	93253½
c_2	20	88812½	½	66609½	159862½
c_3	12	53287½	½	39965½	199825½
c_4	4	17762½	½	13321½	213150

TABLE OF MAXIMUM STRESSES IN TENSION CHORD.

Member.	$s(l) - 2r$.	$\frac{35525}{8} = 4440\frac{1}{2}$.	Tan θ .	Chord Stress due to Shear.	Total Max. Chord Stress.
t_1	28	124337 $\frac{1}{2}$	$\frac{1}{2}$	93253 $\frac{1}{2}$	93253 $\frac{1}{2}$
t_2	20	88812 $\frac{1}{2}$	$\frac{1}{2}$	66609 $\frac{1}{2}$	159862 $\frac{1}{2}$
t_3	12	53287 $\frac{1}{2}$	$\frac{1}{2}$	39965 $\frac{1}{2}$	199828 $\frac{1}{2}$

The above figures may be checked by the method of moments.

Note.—If the truss is inverted it becomes one of the Howe type. The stresses are the same in magnitude, but reversed in kind.

Ex. 2. An eight-panel through-bridge of the double-intersection type (Fig. 414), having the same span, depth, and loading as in Ex. 1.

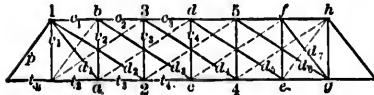

FIG. 414.

The systems 1 2 3 4 . . . and 1 a b c . . . are independent. It is assumed that the load at the foot of the end vertical (g/h) is divided equally between the two systems.

TABLE OF MAXIMUM STRESSES IN END-POSTS AND DIAGONALS.

Member.	Multiplier.	$\frac{25000}{8} = 3125$.	Multiplier.	$\frac{21600}{8} = 2700$.	Total Max. Shear due to Live Load.	Secant θ .	Max. Diag. Stress due to Live Load.	Multiplier.	$\frac{10800}{8} = 1350$.	Diag. Stress due to Dead Load.	Total Max. Diag. Stress.
p	7	21875	21	56700	78575	$1\frac{1}{2}$	68218 $\frac{1}{2}$	28	37800	47250	145468 $\frac{1}{2}$
d_1	6	18750	6 $\frac{1}{2}$	17550	36300	$1\frac{1}{2}$	48375	12	16200	20250	65625
d_2	5	15625	3 $\frac{1}{2}$	9450	25075	$1\frac{1}{2}$	45135	8	10800	19440	64575
d_3	4	12500	2 $\frac{1}{2}$	6750	19250	$1\frac{1}{2}$	34750	4	5400	9720	44370
d_4	3	9375	$\frac{1}{2}$	1350	10725	$1\frac{1}{2}$	19395	0	0	0	19395
d_5	2	6250	$\frac{1}{2}$	1350	7600	$1\frac{1}{2}$	13680	-4	-5400	-9720	3960
d_6	$\frac{1}{2}$	1562 $\frac{1}{2}$	$\frac{1}{2}$		1562 $\frac{1}{2}$	$1\frac{1}{2}$	2812 $\frac{1}{2}$	-8	-10800	-19440	
d_7	$\frac{1}{2}$	1562 $\frac{1}{2}$	$\frac{1}{2}$		1562 $\frac{1}{2}$	$1\frac{1}{2}$	1953 $\frac{1}{2}$	-12	-16200	-20250	

The counterbrace cf is required to take up the resultant shear of $7600 - 5400 = 2200$ lbs., which is opposite in kind to that due to the dead load.

The first line in the table gives the maximum thrust along the end post (p). It is made up of the stresses transmitted

TABLE OF MAXIMUM STRESSES IN DIAGONALS.

Member.	Multiplier.	$\frac{25800}{8} = 3125.$	Multiplier.	$\frac{21600}{8} = 2700.$	Multiplier.	$\frac{10800}{8} = 1350.$	Total Maximum Shear transmitted.	Secant $\theta.$	Maximum Diagonal Stress.
$d_1 = d_2$	7	21875	21	56700	28	37800	116375	1.155	134414
$d_3 = d_4$	6	18750	15	40500	20	27000	86250		99619
$d_5 = d_6$	5	15625	10	27000	12	16200	58825		67943
$d_7 = d_8$	4	12500	6	16200	4	5400	34100		39386
$d_9 = d_{10}$	3	95.5	3	8100	-4	-5400	12075		13947
$d_{11} = d_{12}$	2	6250	1	2700	-12	-16200			
$d_{13} = d_{14}$	1	3125			-20	-27000			

The resultant stresses, $d_9 = d_{10}$, are of an opposite kind to the corresponding stresses due to the dead load. Thus, the diagonals upon which they act must be designed so as to bear both tensile and compressive stresses. The stresses d_1, d_3, d_5, \dots are compressions, and d_2, d_4, d_6, \dots tensions.

TABLE OF MAXIMUM STRESSES IN COMPRESSION CHORD.

Member.	Multiplier.	$\frac{35525}{8} = 4440\frac{1}{2}.$	Shear transmitted.	Tan $\theta.$	Chord Stress.	Total Maximum Chord Stress.	
c_1	28	Through d_1	124337 $\frac{1}{2}$	} 248675	.577	143485 +	143486
	28	" d_2	124337 $\frac{1}{2}$				
c_2	20	" d_3	88812 $\frac{1}{2}$	} 177625	.577	102489 +	245976
	20	" d_4	88812 $\frac{1}{2}$				
c_3	12	" d_5	53287 $\frac{1}{2}$	} 106575	.577	61493 +	307469
	12	" d_6	53287 $\frac{1}{2}$				
c_4	4	" d_7	17762 $\frac{1}{2}$	} 35525	.577	20497 +	327967
	4	" d_8	17762 $\frac{1}{2}$				

TABLE OF MAXIMUM STRESSES IN TENSION CHORD.

Member.	Multiplier.	$\frac{35525}{8} = 4440\frac{1}{2}.$	Shear transmitted.	Tan $\theta.$	Chord Stress.	Total Maximum Chord Stress.	
t_1	28	Through d_1	124337 $\frac{1}{2}$	124337 $\frac{1}{2}$.577	71742 +	71743
t_2	28	" d_2	124337 $\frac{1}{2}$	} 248675	.577	122987 +	194731
	20	" d_3	88812 $\frac{1}{2}$				
t_3	20	" d_4	88812 $\frac{1}{2}$	} 177625	.577	81991 +	276722
	12	" d_5	53287 $\frac{1}{2}$				
t_4	12	" d_6	53287 $\frac{1}{2}$	} 106575	.577	40995 +	317718
	4	" d_7	17762 $\frac{1}{2}$				

21. Wind-pressure.—Numerous experiments to determine the pressure and velocity of the wind have been made by means of feathers, cloud-shadows, anemometers of various kinds, wind-gauges, pendulum, tube, and spring instruments. The results, either through errors of observation, errors of construction, or for other occult reasons, are almost wholly unreliable and give the engineer no accurate information upon which to base his calculations as to the effect of wind upon a structure. Theoretical investigations on the subject are equally unsatisfactory. The formulæ expressing the relations between the speed of the anemometer, the velocity of the wind and its pressure, are of a purely empirical character, and are only applicable to a specific series of recorded observations.

Smeation inferred from Rouse's experiments that the average pressure in pounds per square foot = (velocity in miles per hour)² ÷ 200, or

$$P = \frac{V^2}{200}.$$

According to Dines the formula should be

$$P = \frac{7V^2}{2000}.$$

The Wind-Pressure Commission (Eng.) recommended the formula

$$P = \frac{V^2}{100},$$

as giving with tolerable accuracy the *maximum* pressure.

Stokes considers that the *actual* wind velocities should be about $\frac{2.4}{3} = \frac{4}{5}$ of the values recorded by anemometers, so that a velocity of 64 miles per hour recorded as corresponding to a *maximum* pressure of 40.6 lbs. per square foot (the average of *five* observed pressures) would be reduced to 51.2 miles per hour. The *average* pressure corresponding to 51.2 miles

per hour would be 13.1 lbs. per square foot according to Smeaton's rule and only 9.18 lbs. according to Dines.

Again, certain experiments at Greenwich indicated that the pressure was increased by the stiffness of the copper wire connecting the recording pencil with the pressure plate, and a flexible brass chain was therefore substituted for the wire. Thus modified, a pressure of 29 lbs. per square foot was registered as corresponding to a velocity of 64 miles per hour, whereas with the copper wire a pressure of $49\frac{1}{2}$ lbs. per square foot had been registered with a velocity of only 53 miles per hour.

These facts tend to show that the *actual* pressure is much less than that given by a recording instrument, and that the very high pressures, as, e.g., 80 lbs. per square foot and even more, must be due to gusts or squalls having a purely local effect. This opinion seems to be confirmed by Sir B. Baker's experiments at the Forth Bridge, which also indicate that the pressure per square foot diminishes as the area acted upon increases. No engineering structure could withstand a pressure of 80 lbs. per square foot of surface, and a pressure of 28 lbs. to 32 lbs. would overturn carriages, drive trains from the track, and stop all traffic.

It is, of course, well known that wind-forces sufficiently powerful to uproot huge trees and to demolish the strongest buildings are occasionally developed by whirlwinds, tornadoes, and cyclones, but these must be classed as *acta Dei* and can scarcely be considered by an engineer in his calculations.

Numerous observations as to the effect of wind upon structures in different localities must yet be made before any useful and reliable rules can be enunciated. In the case of existing bridges the elongation of the wind-bracés during a storm can easily be measured within $\frac{1}{1000}$ of an inch. Investigations should be made as to the action of the wind upon surfaces of different forms and upon sheltered surfaces, as, e.g., upon the surfaces behind the windward face in bridge-trusses. Again, it is quite possible, if not probable, that many of the recorded upsets have been due to a *combined* lifting and side action, requiring a much less flank-pressure than would be necessary

if there were no upward force, and hence further light should be obtained on this point.

Under any circumstances, the wind-stresses should be as small as possible, compatible with safety, seeing how largely they influence the sections of the several members, especially in bridges of long span.

22. Empirical Regulations.

Wind-Pressure Commission Rules.—For railway bridges and viaducts assume a maximum pressure of 56 lbs. per square foot upon an area to be estimated as follows :

- A. In *close-girder* bridges or viaducts the area
 = area of windward face of girder
 + area of train surface *above* the top of the same girder.
- B. In *open-girder* bridges or viaducts the area for the *windward* girder
 = area of windward face, *assumed close*, between rails and top of train
 + *calculated* area of windward surface *above* the top of the train
 + *calculated* area of windward surface *below* the rails.

For the leeward girder or girders the area

- = calculated area of surface of *one* girder above the top of the train and below the level of the rails, the pressure being 28, 42, or 56 lbs. per square foot, according as this area $< \frac{2}{3}S$, $> \frac{2}{3}S$ and $< \frac{1}{4}S$, or $> \frac{1}{4}S$, where S is the total area within the outline of the girder. The assumed factor of safety is to be 4.

American Specifications.—(a) The lateral bracing *in the plane of the roadway* is to be designed so as to bear a pressure of 30 lbs. per square foot upon the vertical surface of one truss and upon the surface of a train averaging 12 sq. ft. per lineal foot, i.e., 360 lbs. per lineal foot; this latter is to be regarded as a *live* load. The lateral bracing *in the plane of the other chord* is to be designed so as to bear a pressure of 50 lbs. per square foot upon *twice* the vertical surface of one truss.

(b) The portal, vertical, and horizontal bracing is to be

proportioned for a pressure of 30 lbs. per square foot upon *twice* the vertical surface of one truss and upon the surface of a train averaging 10 sq. ft. per lineal foot, i.e., 300 lbs. per lineal foot, the latter being treated as a *live* load.

(c) Live load in plane of roadway due to wind-pressure
= 300 lbs. per lineal foot.

Fixed load in plane of roadway due to wind-pressure
= 150 lbs. per lineal foot.

Fixed load in plane of other chord due to wind-pressure
= 150 lbs. per lineal foot.

Lateral Bracing.—Consider a truss-bridge with parallel chords and panels of length p . Let A be the area of the vertical surface of one truss.

According to (a), the lateral bracing in the plane of the roadway is subjected to (1) a panel live load of $360p$ lbs. and (2) a panel fixed load of $30A$ lbs., while in the plane of the other chord it is subjected to a panel fixed load of

$$50 \times 2A = 100A \text{ lbs.}$$

Thus, if the figure represent the bracing in the plane of the roadway of a ten-panel truss, and if the wind blow upon the

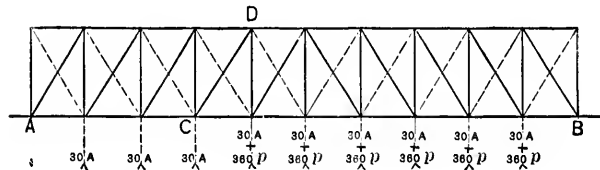

FIG. 416.

side AB , the *maximum* horizontal force for which any diagonal, e.g. CD , is to be designed is

= $45A$ lbs. due to the horizontal force of $30A$ lbs. at each panel point

+ $756p$ lbs. due to the horizontal force of $360p$ lbs. at each panel point between C and B .

The dotted lines show the bracing required when the wind blows on the opposite side.

It is sometimes maintained that the wind-forces in the

plane of the upper chords of a through-bridge or the lower chords of a deck-bridge are transmitted to the floor-bracing through the posts. This can hardly be correct in the case of long posts, as they do not possess sufficient stiffness. It has, however, been pointed out by Mr. W. B. Dawson that, in through-bridges, the cumulative effect of the wind-pressure at the ends of the bridge might produce a serious bending action in the end posts. This action would have to be resisted by additional plating on the end posts below the portals, or by an increase of their sectional area.

Under wind-pressure the floor-beams act as posts; hence, if the wind-bracing is attached to the top or compression flange of a floor-beam, the flange's sectional area must be proportionately increased. If the bracing is attached to the lower or tension flange, the stresses in the latter will be diminished.

23. Chords.—The wind-pressure transmitted through the floor-bracing increases the stresses in the several members, or panel lengths, of the leeward chord, the greatest increments being due to a horizontal force of $(360p + 30A)$ lbs. at each of the panel points in AB . The corresponding chord stresses in the ten-panel truss-bridge referred to above are :

$$C_1 = 0;$$

$$C_2 = 4\frac{1}{2}(360p + 30A) \tan \theta \text{ lbs.};$$

$$C_3 = C_2 + 3\frac{1}{2}(360p + 30A) \tan \theta = 8(360p + 30A) \tan \theta \text{ lbs.};$$

$$C_4 = C_3 + 2\frac{1}{2}(360p + 30A) \tan \theta = 10\frac{1}{2}(360p + 30A) \tan \theta \text{ lbs.};$$

$$C_5 = C_4 + 1\frac{1}{2}(360p + 30A) \tan \theta = 12(360p + 30A) \tan \theta \text{ lbs.}$$

$90^\circ - \theta$ being the angle between a diagonal and a chord.

Again, the wind-pressure tends to capsize a train and throws an additional pressure of $P \frac{y}{G}$ lbs. per lineal foot upon the leeward rail, P being the pressure in pounds per lineal foot on the train surface, y the vertical distance between the line of action of P and the top of the rails, and G the gauge of the rails.

Thus, the total pressure on leeward rail

$$= \left(\frac{w}{2} + P \frac{y}{G} \right) \text{ lbs. per lineal foot,}$$

and the total pressure on windward rail

$$= \left(\frac{w}{2} - P \frac{y}{G} \right) \text{ lbs. per lineal foot,}$$

w being the weight of the train in pounds per lineal foot.

Hence, the total vertical pressure at a panel point of the leeward truss

$$\begin{aligned} &= \left(\frac{w}{2} + P \frac{y}{G} \right) p \frac{S+G}{2S} + \left(\frac{w}{2} - P \frac{y}{G} \right) p \frac{S-G}{2S} \\ &= \frac{w}{2} p + p P \frac{y}{G} \frac{G}{S} = \left(\frac{w}{2} p + p P \frac{y}{S} \right) \text{ lbs.,} \end{aligned}$$

S being the distance between the trusses.

24. Stringers.—Each length of stringer between consecutive floor-beams may be regarded as an independent girder resting upon supports at the ends, and should be designed to bear with safety the *absolute maximum* bending moment to which it may be subjected by the live load. If the beams are not too far apart, the absolute maximum bending moment will be at the centre when a driver is at that point. Again, in the case of the Sault Ste. Marie Bridge, it may be easily shown that the maximum bending moment is produced when the four pairs of drivers are *between* the floor-beams.

Let y = distance of first driver from nearest point of support.

The reaction at this support

$$= \frac{12000}{8}(824 - 4y) = \frac{500}{3}(206 - y).$$

The bending moment is evidently a maximum at the second or third driver, and at the second driver

$$= \frac{500}{3}(206 - y)(56 + y) - 12000 \times 56;$$

at the third driver

$$= \frac{1}{3} \times 2(206 - y)(108 + y) - 12000(52 + 108).$$

In the first case it is an *absolute maximum* when $y = 75''$;

“ “ second “ “ “ “ “ “ “ “ $y = 49''$;

its value in each case being 2,188,166 $\frac{2}{3}$ in.-lbs.

Hence, the bending moment is an absolute maximum and equal to 2,188,166 $\frac{2}{3}$ in.-lbs., at two points distant 75 in. from each point of support.

Also, if I_1 is the moment of inertia of the section of the stringer at these points, c_1 the distance of the neutral axis from the outside skin, and f_1 the coefficient of strength, then

$$\frac{2}{3}(2188166\frac{2}{3}) = f_1 \frac{I_1}{c_1} \text{ for the inner stringer,}$$

and

$$\frac{1}{3}(2188166\frac{2}{3}) = f_1 \frac{I_1}{c_1} \text{ for the outer stringer.}$$

The continuity of the stringers adds considerably to their strength.

25. Maximum Allowable Stress.—Denoting by A and B , respectively, the numerically greatest and least stresses to which a member is to be subjected, the following rules will give results which are in accordance with the best practice :

I. *Members subjected to Tensile Stresses only.*

For *wrought-iron*, maximum stress per square inch

$$= 10000 \text{ lbs.} = 8000 \left(1 + \frac{B}{A} \right) \text{ lbs.} = \left(3.81 + 1.9 \frac{B}{A} \right) \text{ tons.}$$

For *steel*, maximum stress per square inch

$$= 12000 \text{ lbs.} = 10000 \left(1 + \frac{B}{A} \right) \text{ lbs.} = \left(5.08 + 2.54 \frac{B}{A} \right) \text{ tons.}$$

II. Members subjected both to Tensile and Compressive Stresses.

For wrought-iron, maximum stress per square inch

$$= 8000\left(1 - \frac{B}{2A}\right) \text{ lbs.} = \left(3\ 81 - 1.9\frac{B}{A}\right) \text{ tons.}$$

For steel, maximum stress per square inch

$$= 10000\left(1 - \frac{B}{2A}\right) \text{ lbs.} = \left(5.08 - 2.54\frac{B}{A}\right) \text{ tons.}$$

III. Members subjected to Compressive Stresses only.

Denote the ratio of the length (l) to the least radius of gyration (k) by r .

$$\text{The maximum stress per square inch} = \frac{f}{1 + ar^2} \text{ lbs.,}$$

f being 8000 lbs. for wrought-iron and 10,000 lbs. for steel, and $\frac{1}{a}$ being 40,000, 30,000, or 20,000, according as the member has two square (fixed) ends, one square and one pin end, or two pin ends.

Again, the maximum stress per square inch for steel struts

$$\text{with two pin ends} = (10000 - 60r)\left(1 + \frac{B}{A}\right) \text{ lbs.};$$

$$\text{“ “ square ends} = (10000 - 40r)\left(1 + \frac{B}{A}\right) \text{ lbs.};$$

$$\text{“ “ pin ends} = \left(5 - \frac{r}{40}\right)\left(1 + \frac{B}{A}\right) \text{ tons};$$

$$\text{“ “ square ends} = \left(5 - \frac{r}{60}\right)\left(1 + \frac{B}{A}\right) \text{ tons.}$$

In the last two expressions $r < 40$. These expressions may be also employed in the case of alternating stresses, but the factor must then be changed to $\left(1 + \frac{B}{2A}\right)$.

26. Camber.—Owing to the play at the joints, a girder or truss will deflect to a much greater extent than is indicated by theory, and the material will receive a permanent set, which, however, will not prove detrimental to the stability of the structure unless it is increased by subsequent loads. If the chords were initially made straight, they would curve downwards; and although it does not necessarily follow that the strength of the truss would be sensibly impaired, the appearance would not be pleasing.

In practice it is often specified that the girder or truss is to have such a camber or upward convexity that under ordinary loads the grade line will be true and straight; or, again, that a camber shall be given to the span by making the panel lengths of the top chord greater than those of the bottom chord by .125 in. for every 10 ft.

The lengths of the web members in a cambered truss are not the same as if the chords were horizontal, and must be carefully calculated so as to insure that the several parts will fit together.

To find an Approximate Value for the Camber, etc.

Let d be the depth of the truss.

Let s_1, s_2 be the lengths of the upper and lower chords, respectively.

Let f_1, f_2 be the unit stresses in upper and lower chords, respectively.

Let d_1, d_2 be the distances of the neutral axis from the upper and lower chords, respectively.

Let R be the radius of curvature of the neutral axis.

Let l be the span of the truss.

Then

$$\frac{d_1}{R} = \frac{s_1 - l}{l} = \frac{f_1}{E} \quad \text{and} \quad \frac{d_2}{R} = \frac{l - s_2}{l} = \frac{f_2}{E}, \text{ approx.,}$$

the chords being assumed to be circular arcs.

Hence, the excess in length of the upper over the lower chord

$$= s_1 - s_2 = \frac{l}{E}(f_1 + f_2) = l \frac{d}{R}.$$

Let x_1 , x_2 be the cambers of the upper and lower chords, respectively; $R + d_1$ and $R - d_2$ are the radii of the upper and lower chords, respectively.

By similar triangles,

$$\left. \begin{array}{l} \text{the horizontal distance between} \\ \text{the ends of the upper chord} \end{array} \right\} = \frac{R + d_1}{R} l;$$

$$\left. \begin{array}{l} \text{the horizontal distance between} \\ \text{the ends of the lower chord} \end{array} \right\} = \frac{R - d_2}{R} l.$$

Hence,

$$\left(\frac{1}{2} \frac{R + d_1}{R} l \right)^2 = x_1 \cdot 2(R + d_1), \text{ approximately,}$$

and

$$\left(\frac{1}{2} \frac{R - d_2}{R} l \right)^2 = x_2 \cdot 2(R - d_2), \text{ approximately.}$$

$$\therefore x_1 = \frac{l^2}{8R} \left(1 + \frac{d_1}{R} \right) \quad \text{and} \quad x_2 = \frac{l^2}{8R} \left(1 - \frac{d_2}{R} \right).$$

27. Rivet-connection between Flanges and Web.—

The web is generally riveted to angle-irons forming part of the flanges.

The *increment* of the flange stress transmitted through the web from point to point tends to make the angle-irons slide over the flange surfaces.

Denote the increment by F , and let h be the effective depth of the girder or truss.

Then, if S be the shearing force at any point,

$$Fh = \text{the increment of the bending moment per unit of length}$$

$$= \left(\frac{dM}{dx} \right) = S \text{ in the case of a close web,}$$

$$\text{and} \quad Fh = \text{the increment of the bending moment} \\ = (\Delta M) = Sa \text{ in the case of an open web;}$$

a being the distance between the two consecutive apices or panel points within which S lies.

Hence, if N be the number of rivets *per unit* of length for the close web, or the number between the two consecutive apices for the open web,

$$N \frac{\pi d^2}{4} f_s = F = \frac{S}{h} \text{ for the close web,}$$

and

$$= \frac{Sa}{h} \text{ for the open web,}$$

d being the diameter of a rivet, and f_s the safe coefficient of shearing strength.

28. Eye-bars and Pins.—Eye-bars connected with pins have been commonly employed in the construction of suspension cables, the tension chords of ordinary trusses and cantilevers, and the diagonals of web systems. The requisite sectional area is obtained by placing a number of bars side by side on the same pin, and, if necessary, by setting two or more tiers of bars one above another.

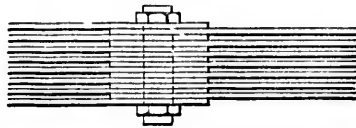

FIG. 417.

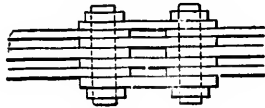

FIG. 418.

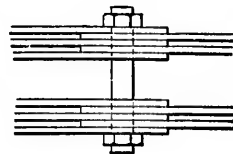

FIG. 419.

The figures represent groups of eye-bars as they often occur in practice.

If two sets of $2n$ bars pull upon the pin in opposite directions, as in Figs. 418 and 419, the bending moment on the pin will be nPp , P being the pull upon each bar, and p the distance between the centre lines of two consecutive bars.

Hence,

$$nPp = \frac{f}{c}I,$$

f being the stress in the material of the pin at a distance c from the neutral axis, and I the moment of inertia.

In general, the bending action upon a pin connecting a number of vertical, horizontal, and inclined bars may be determined as follows:

Consider one-half of the pin only.

Let V , Fig. 420, be the resultant stress in the vertical bars. It is necessarily equal in magnitude but opposite in direction to the vertical component of the resultant of the stresses

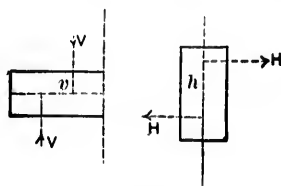

FIG. 420.

in the inclined bars. Let v be the distance between the lines of action of these two resultants. The corresponding bending action upon the pin is that due to a couple of which the moment is Vv .

Let h be the distance between the lines of action of the equal resultants H of the horizontal stresses upon each side of the pin. The corresponding bending action upon the pin is that due to a couple of which the moment is Hh .

Hence, the maximum bending action is that due to a couple of which the moment is the resultant of the two moments Vv and Hh , viz.,

$$\sqrt{(Vv)^2 + (Hh)^2}.$$

Eye-bars.—In England it has been the practice to roll bars having enlarged ends, and to forge the eyes under hydraulic

pressure with suitably shaped dies. In America both hammer-forged and hydraulic-forged eye-bars are made, the latter being called *weldless eye-bars*. Careful mathematical and experimental investigations have been carried out to determine the proper dimensions of the link-head and pin, but owing to the very complex character of the stresses developed in the metal around the eye, an accurate mathematical solution is impossible.

Let d be the width and t the thickness of the *shank* of the eye-bar represented in Fig. 421. Let S be the width of the metal at the sides of the eye, and H the width at the end. Let D be the diameter of the pin.

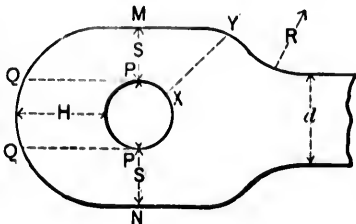

FIG. 421.

The proportions of the *head* are governed by the general condition that each and every part should be at least as strong as the shank.

When the bar is subjected to a tensile stress the pin is tightly embraced, and failure may arise from any one of the following causes :

(a) *The pin may be shorn through.*

Hence, if the pin is in double shear, its sectional area should be at least *one-half* that of the shank.

It may happen that the pin is bent, but that fracture is prevented by the closing up of the pieces between the pin-head and nut ; the efficiency, however, of the connection is destroyed, as the bars are no longer free to turn on the pin.

In practice, D for flat bars varies from $\frac{3}{8}d$ to $\frac{1}{2}d$, but usually lies between $\frac{2}{3}d$ and $\frac{3}{4}d$.

The diameter of the pin for the end of a round bar is generally made equal to $1\frac{1}{4}$ times the diameter of the bar.

The pin should be turned so as to fit the eye accurately, but the best practice allows a difference of from $\frac{1}{8}$ to $\frac{1}{16}$ of an inch in the diameters of the pin and eye.

(b) *The link may tear across MN.*

On account of the perforation of the head, the direct pull on the shank is bent out of the straight and distributed over

the sections S . There is no reason for the assumption that the distribution is uniform, and it is obviously probable that the intensity of stress is greatest in the metal next the hole. Hence, the sectional area of the metal across MN must be at least equal to that of the shank, and in practice is always greater.

S usually varies from $.55d$ to $.625d$.

The sectional area through the sides of the eye in the head of a round bar varies from $1\frac{1}{2}$ times to twice that of the bar.

(c) *The pin may be torn through the head.*

Theoretically, the sectional area of the metal across PQ should be *one-half* that of the shank. The metal in front of the pin, however, may be likened to a uniformly loaded girder with both ends fixed, and is subjected to a bending as well as to a shearing action. Hence, the *minimum* value of H has been fixed at $\frac{3}{4}d$, and if H is made equal to d , both kinds of action will be amply provided for.

(d) *The bearing surface may be insufficient.*

If such be the case, the intensity of the pressure upon the bearing surface is excessive, the eye becomes oval, the metal is upset, and a fracture takes place. Or again, as the hole elongates, the metal in the sections S next the hole will be drawn out, and a crack will commence, extending outwards until fracture is produced.

In practice, adequate bearing surface may be obtained by thickening the head so as to confine the maximum intensity of the pressure within a given limit.

(e) *The head may be torn through the shoulder at XY .*

Hence, XY is made equal to d .

The radius of curvature R of the shoulder varies from $1\frac{1}{2}d$ to $7.6d$.

Note.—The *thickness* of the shank should be $\frac{d}{4}$, or $\frac{2}{7}d$ at least.

The following table gives the eye-bar proportions common in American practice :

Value of <i>d</i> .	Value of <i>D</i> .	Value of <i>S</i> .	
		Weldless Bars.	Hammered Bars.
1.00	.67	1.5	1.33
1.00	.75	1.5	1.33
1.00	1.00	1.5	1.50
1.00	1.25	1.6	1.50
1.00	1.33	1.7	
1.00	1.50	1.85	1.67
1.00	1.75	2.00	1.67
1.00	2.00	2.25	1.75

Also, in weldless bars, $ll = S$; in hammered bars, $ll = d$.

29. Steel Eye-bars.—Hydraulic-forged steel eye-bars are now being largely made. The steel has an ultimate tenacity of from 60,000 to 68,000 lbs. per square inch, an elastic limit of not less than 50 per cent, and an elongation of from 17 to 20 per cent in a length equal to *ten* times the least transverse dimension.

The Phœnix Bridge Co. and the Edge Moor Iron Co. give the following tables of steel eye-bar proportions:

Phœnix Bridge Co.			Edge Moor Iron Co.				
Width of bar <i>d</i> .	Diameter of Pin-hole.	Diameter of Head.	Width of bar <i>d</i> .	Diameter of Pin-hole.	Diameter of Head.	Minimum Thickness of Bar.	Excess of Sectional Area of Head along PP over Section of Bar.
3	2 ⁷ / ₁₆ , 2 ¹ / ₈	7	2	1 ⁷ / ₈	4 ¹ / ₂	1	33%
3	3 ⁷ / ₁₆ , 3 ¹ / ₈	8	2	2 ⁷ / ₈	5 ¹ / ₂	1	33%
4	3 ⁷ / ₁₆	9	2 ¹ / ₂	2 ³ / ₈	5 ⁷ / ₈	1	33%
4	3 ¹ / ₈ , 4 ¹ / ₈ , 4 ⁵ / ₁₆	10	2 ¹ / ₂	3 ³ / ₈	6 ¹ / ₂	1	33%
5	3 ¹ / ₈ , 4 ¹ / ₈ , 5 ¹ / ₈	11	3	2 ¹ / ₂	6 ¹ / ₂	¹ / ₂	33%
5	4 ¹ / ₈ , 5 ¹ / ₈ , 6 ¹ / ₈	12	3	4	8	¹ / ₂	33%
5	5 ¹ / ₈ , 6 ¹ / ₈ , 7 ¹ / ₈	13	4	4 ¹ / ₈	9 ¹ / ₂	¹ / ₂	33%
6	4 ¹ / ₈ , 5 ¹ / ₈ , 6 ¹ / ₈	13	4	5 ¹ / ₈	10 ¹ / ₂	¹ / ₂	33%
6	5 ¹ / ₈ , 6 ¹ / ₈ , 7 ¹ / ₈	14	5	4 ³ / ₈	11 ¹ / ₂	¹ / ₂	37%
6	6 ¹ / ₈ , 7 ¹ / ₈ , 8 ¹ / ₈	15	5	5 ³ / ₈	12 ¹ / ₂	¹ / ₂	37%
7	5 ¹ / ₈ , 6 ¹ / ₈ , 7 ¹ / ₈	15	6	5 ¹ / ₂	13 ¹ / ₂	¹ / ₂	37%
7	6 ¹ / ₈ , 7 ¹ / ₈ , 8 ¹ / ₈	16	6	6 ¹ / ₂	14 ¹ / ₂	¹ / ₂	37%
7	6 ¹ / ₈ , 7 ¹ / ₈ , 8 ¹ / ₈	17	7	5 ³ / ₈	15 ¹ / ₂	¹ / ₂	40%
8	6 ¹ / ₈ , 7 ¹ / ₈ , 8 ¹ / ₈	17	7	7 ¹ / ₈	17	¹ / ₂	40%
8	6 ¹ / ₈ , 7 ¹ / ₈ , 8 ¹ / ₈	18	8	5 ³ / ₈	17	1	40%
8	7 ¹ / ₈ , 8 ¹ / ₈	19	8	6 ¹ / ₂	18	1	40%
8	8 ¹ / ₈ , 9 ¹ / ₈	20					
9	7 ¹ / ₈ , 8 ¹ / ₈	20					
9	8 ¹ / ₈ , 9 ¹ / ₈	21					
10	8 ¹ / ₈	22					
10	8 ¹ / ₈ , 9 ¹ / ₈	23					
10	10, 10 ¹ / ₂	24					

In both the Phœnix and Edge Moor bars the thickness of the head is the same as that of the body of the bar, or does not exceed it by more than ¹/₁₆ in.

30. Rivets.—A *rivet* is an iron or steel *shank*, slightly tapered at one end (the *tail*), and surmounted at the other by a *cup* or *pan-shaped head* (Fig. 422). It is used to join steel or iron plates, bars, etc. For this purpose the rivet is generally heated to a cherry-red, the shank or *spindle* is passed through

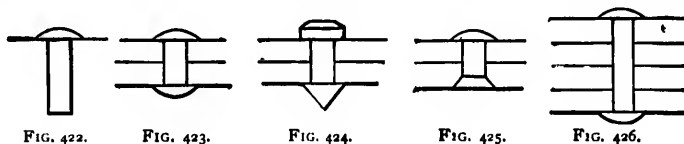

the hole prepared for it, and the tail is made into a *button*, or *point*. The hollow cup-tool gives to the point a nearly hemispherical shape, and forms what is called a *snap-rivet* (Fig. 423). Snap-rivets, partly for the sake of appearance, are commonly used in girder-work, but they are not so tight as *conical-pointed rivets* (*staff-rivets*), which are hammered into shape until almost cold (Fig. 424).

When a smooth surface is required, the rivets are *counter-sunk* (Fig. 425). The counter-sinking is drilled and may extend *through* the plate, or a shoulder may be left at the inner edge.

Cold-riveting is adopted for the small rivets in boiler work and also wherever heating is impracticable, but tightly-driven turned bolts are sometimes substituted for the rivets. In all such cases the material of the rivets or bolts should be of superior quality.

Loose rivets are easily discovered by tapping, and, if very loose, should be at once replaced. It must be borne in mind, however, that expansions and contractions of a complicated character invariably accompany *hot-riveting*, and it cannot be supposed that the rivets will be perfectly tight. Indeed, it is doubtful whether a rivet has any hold in a straight drilled hole, except at the ends.

Riveting is accomplished either by hand or machine, the latter being far the more effective. A machine will squeeze a rivet, at almost any temperature, into a most irregular hole, but the exigencies of practical conditions often prevent its use, except for ordinary work, and its advantages can rarely be obtained

where they would be most appreciated, as, e.g., in the riveting up of connections.

31. Dimensions of Rivets.—The diameter (d) of a rivet in ordinary girder-work varies from $\frac{3}{4}$ in. to 1 inch, and rarely exceeds $1\frac{1}{8}$ in.

The thickness (t) of a plate in ordinary girder-work should never be less than $\frac{1}{2}$ in., and a thickness of $\frac{3}{8}$ in., or even $\frac{5}{16}$ in., is preferable.

Let T be the total thickness through which a rivet passes.

According to Fairbairn,

When $t < \frac{1}{2}$ in., d should be about $2t$.

When $t > \frac{1}{2}$ in., d should be about $1\frac{1}{2}t$.

According to Unwin,

When t varies from $\frac{1}{4}$ in. to 1 in. and passes through two thicknesses of plate, d lies between $\frac{3}{4}t + \frac{5}{16}$ and $\frac{7}{8}t + \frac{3}{8}$.

When the rivets join several plates, $d = \frac{T}{8} + \frac{5}{8}$.

According to French practice,

Diameter of head = $1\frac{2}{3}d$.

Length of rivet from head = $T + 1\frac{2}{3}d$.

According to Rankine,

Length of rivet from head = $T + 2\frac{1}{2}d$.

The rise of the head = $\frac{2}{3}d$.

The diameter of the rivet-hole is made larger than that of the shank by from $\frac{1}{32}$ to $\frac{1}{8}$ in., so as to allow for the expansion of the latter when hot.

There seems to be no objection to the use of long rivets, provided they are properly heated and secured.

32. Strength of Punched and Drilled Plates.—Experiment shows that the tenacity of iron and steel plates is considerably diminished by punching. This deterioration in tenacity seems to be due to a molecular change in a narrow annulus of the metal around the hole. The removal of the annulus largely neutralizes the effect of the punching, and, hence, the holes are sometimes punched $\frac{1}{8}$ in. less in diameter than the rivets and are subsequently rimmed or drilled out to the full size. The original strength may also be almost

entirely restored by annealing, and, generally, in steel work, either this process is adopted or the annulus referred to above is removed.

Punching does not sensibly affect the strength of Landore-Siemens unannealed plates, and only slightly diminishes the strength of thin steel plates, but causes a considerable loss of tenacity in thick steel plates; the loss, however, is less than for iron plates.

The harder the material the greater is the loss of tenacity.

Iron seems to suffer more from punching when the holes are near the edge than when removed to some distance from it, while mild steel suffers less when the hole is one diameter from the edge than when it is so far that there is no bulging at the edge.

The injury caused by punching may be avoided by drilling the holes. In important girder-work and whenever great accuracy of workmanship is required, a uniform pitch may be insured and the full strength of the metal retained by the use of multiple drills. Drilling is a necessity for first-class work when the diameter of the holes is less than the thickness of the plate, and also when several plates are *piled*. It is impossible to punch plates, bars, angles, etc., in spite of all expedients, in such a manner that the holes in any two exactly correspond, and the irregularity becomes intensified in a pile, the passage of the rivet often being completely blocked. A *drift*, or *rimer*, is then driven through the hole by main force, cracking and bending the plates in its passage, and separating them one from another.

The holes may be punched for ordinary work, and in plates of which the thickness is less than the diameter of the rivets. Whenever the metal is of an inferior quality, the holes should be drilled.

33. **Riveted Joints.**—In *lap* joints (Figs. 427 and 430) the plates overlap and are riveted together by one or more rows of rivets which are said to be in *single shear*, as each rivet has to be sheared through one section only.

In *fish* (or *butt*) joints (Figs. 428 and 429) the rivets are in *double shear*, i.e., must be each sheared through two sections.

Thus they are not subjected to the one-sided pull to which rivets in single shear are liable.

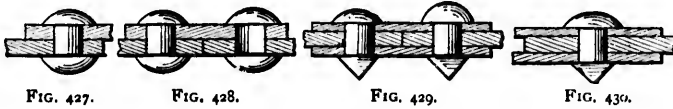

In *fish* joints the ends of the plates meet, and the plates are riveted to a single cover (Fig. 428), or to two covers (Fig. 429), by means of one or more rows of rivets on each side of the joint.

A fish joint is properly termed a *butt* joint when the plates are in compression. The plates should butt evenly against one another, although they seldom do so in practice. Indeed, the mere process of riveting draws the plates slightly apart, leaving a gap which is often concealed by caulking. A much better method is to fill up the space with some such hard substance as cast-zinc, but the best method, if the work will allow of the increased cost, is to form a *jump joint*, i.e., to plane the eyes of the plates carefully, and then bring them into close contact, when a short cover with one or two rows of rivets will suffice to hold them in position.

The riveting is said to be *single*, *double*, *triple*, etc., according as the joint is secured by *one*, *two*, *three*, or more rows of rivets.

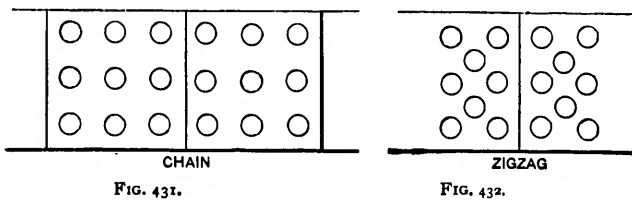

Double, triple, etc., riveting may be *chain* (Fig. 431) or *zigzag* (Fig. 432). In the former case the rivets form straight lines longitudinally and transversely, while in the latter the rivets in each row divide the space between the rivets in adjacent rows. Experiments indicate that chain is somewhat stronger than zigzag riveting.

Figs. 433 to 435 show forms of joint usually adopted for bridge-work. In boiler-work the rivets are necessarily very close together, and if the strength of the solid plate be assumed to be 100, the strength of a single-riveted joint hardly exceeds 50, while double-riveting will only increase it to 60 or 70. Fair-

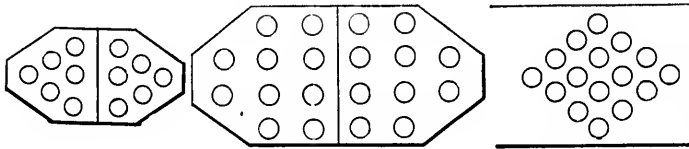

FIG. 433.

FIG. 434.

FIG. 435.

bairn proposed to make the joint and unpunched plate equally strong by increasing the *thickness* of the punched portion of the plate, but this is somewhat difficult in practice.

The stresses developed in a riveted joint are of a most complex character and can hardly be subjected to exact mathematical analysis. For example, the distribution of stress will be necessarily irregular (*a*) if the pull upon the joint is one-sided; (*b*) when local action exists, or the plates stretch, or internal strains are in the metal before punching; (*c*) if there is a lack of symmetry in the arrangement of the rivets, so that one rivet is more severely strained than another; (*d*) when the workmanship is defective.

The joint may fail in any one of the following ways :

- (1) The rivets may shear.
- (2) The rivets may be forced into and crush the plate.
- (3) The rivets may be torn out of the plate.
- (4) The plate may tear in a direction transverse to that of the stress.

The resistance to rupture should be the same in each of the four cases, and always as great as possible.

The shearing and tensile strengths of plate-iron are very nearly equal. Thus, iron with a tenacity of 20 tons per square inch has a shearing strength of 18 to 20 tons per square inch. Rivet-iron is usually somewhat stronger than plate-iron.

Again, the shearing strength of steel per square inch varies

from about 24 tons for steel, with a tenacity of about 30 tons, to about 33 tons for steel, with a tenacity of about 50 tons; an average value for rivet-steel with a tenacity of 30 tons being 24 tons.

Hence, if 4 be a factor of safety, the working coefficients become

For wrought-iron $\left\{ \begin{array}{l} 5 \text{ tons per square inch in shear, and} \\ 5 \text{ " " " " " " tension.} \end{array} \right.$

For steel $\left\{ \begin{array}{l} 6 \text{ tons per square inch in shear, and} \\ 7\frac{1}{2} \text{ " " " " " " tension} \end{array} \right.$

Allowance, however, must be made for irregularity in the distribution of stress and for defective workmanship, and in riveting wrought-iron plates together it is a common practice to make the aggregate section of the rivets at least equal to and sometimes 20 per cent greater than the net section of the plate through the rivet-holes.

Hence, the working coefficients are reduced to

4 or $4\frac{1}{2}$ tons per square inch for wrought-iron,
and
5 or $5\frac{1}{2}$ " " " " " steel,

according to the character of the joint.

There is very little reliable information respecting the indentation of plates by rivets and bolts, and it is most uncertain to what extent the tenacity of the plates is affected by such indentation. Further experiments are required to show the effect of the crushing pressure upon the bearing area (i.e., *the diameter of the rivet multiplied by the thickness of the plate*), although a few indicate that the shearing strength of the rivet diminishes after the intensity of the bearing pressure exceeds a certain maximum limit.

34. Theoretical Deductions.

Let S be the total stress at a riveted joint;

f_1, f_2, f_3, f_4 , be the safe tensile, shearing, compressive,
and bearing unit stresses, respectively;

t be the thickness of a plate, and w its width,

N be the total number of rivets on one side of a joint ;
 n be the total number of rivets in one row ;
 p be the *pitch* of the rivets, i.e., the distance centre to centre ;
 d be the diameter of the rivets ;
 x be the distance between the centre line of the nearest row of rivets and the edge of the plate.

Value of x .—It has been found that the minimum safe value of x is d , and this in most cases gives a sufficient *overlap* ($= 2x$), while $x = \frac{3}{2}d$ is a maximum limit which amply provides for the bending and shearing to which the joint may be subjected. Thus the overlap will vary from $2d$ to $3d$.

x may be supposed to consist of a length x_1 , to resist the shearing action, and a length x_2 to resist the bending action. It is impossible to determine theoretically the exact value of x_2 , as the straining at the joint is very complex, but the metal in front of each rivet (the rivets at the ends of the joint excepted) may be likened to a uniformly loaded beam of length d , depth $x_2 - \frac{d}{2}$, and breadth t , with both ends *fixed*. Its moment of resistance is therefore $\frac{f}{6}t \left(x_2 - \frac{d}{2}\right)^2$, f being the maximum unit stress due to the bending. Also, if P is the load upon the rivet, the *mean* of the bending moments at the end and centre is $\frac{P}{8}d$.

Hence, *approximately*,

$$\frac{P}{8}d = \frac{f}{6}t \left(x_2 - \frac{d}{2}\right)^2, \quad \text{or} \quad P = \frac{4}{3} \frac{ft}{d} \left(x_2 - \frac{d}{2}\right)^2.$$

It will be assumed that the shearing strength of the rivet is equal to the strength of a beam to resist cross-breaking.

Single-riveted lap and single-cover joints (Figs. 427 and 428).

$$\frac{\pi d^2}{4} f_s = (p - d)tf_s = dtf_s; \quad \dots \dots \dots (1)$$

$$2x_1 t f_2 = \frac{\pi d^3}{4} f_2.$$

$$\therefore x_1 = \frac{\pi d^3}{8 t} \dots \dots \dots (2)$$

$$\frac{4}{3} \frac{f t}{d} \left(x_2 - \frac{d}{2}\right)^2 = \frac{\pi d^3}{4} f_2.$$

$$\therefore x_2 = \frac{d}{2} + \frac{1}{4} \sqrt{3 \pi \frac{d^3 f_2}{t f}} \dots \dots \dots (3)$$

As already pointed out, these joints are weakened by the bending action developed, and possibly also by the concentration of the stress towards the inner faces of the plates.

Single-riveted double-cover joints (Fig. 429).

$$2 \frac{\pi d^2}{4} f_2 = (p - d) t f_1 = d t f_4; \dots \dots \dots (4)$$

$$2x_1 t f_2 = 2 \frac{\pi d^3}{4} f_2.$$

$$\therefore x_1 = \frac{\pi d^3}{4 t} \dots \dots \dots (5)$$

$$\frac{4}{3} \frac{f t}{d} \left(x_2 - \frac{d}{2}\right)^2 = \frac{1}{2} \frac{\pi d^3}{4} f_2.$$

$$\therefore x_2 = \frac{d}{2} + \frac{1}{4} \sqrt{\frac{3}{2} \pi \frac{d^3 f_2}{t f}} \dots \dots \dots (6)$$

These joints are much stronger than joints with *single covers*. Also, equation (4) shows that the bearing unit stress in a double-cover joint is twice as great (*theoretically*) as in a single-cover joint (eq. 1), so that rivets of a larger diameter may be employed in the latter than is possible in the former, for corresponding values of $\frac{d}{t}$.

Chain-riveted joints (Fig. 431).

$$f_1(w - nd)t = S = f_2 Ndt; \dots \dots \dots (7)$$

$$S = N \frac{\pi d^2}{4} f_2 \text{ when there is one cover only; } \dots (8)$$

$$S = N \frac{\pi d^2}{2} f_2 \text{ when there are two covers. } \dots (9)$$

This class of joint is employed for the flanges of bridge girders, the plates being piled as in Figs. 436, 437, 438, and n being usually 3, 4, or 5.

In Fig. 437 the plates are grouped so as to *break joint*, and opinions differ as to whether this arrangement is superior to the *full butt* shown in Fig. 438. The advantages of the latter

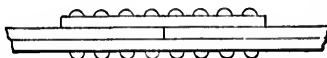

FIG. 436.

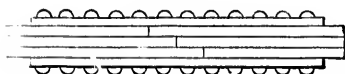

FIG. 437.



FIG. 438.

is that the plates may be cut in uniform lengths, and the flanges built up with a degree of accuracy which cannot be otherwise attained, while the short and awkward pieces accompanying broken joints are dispensed with.

A good practical rule, and one saving much labor and expense, is to make the lengths of the plates, bars, etc., multiples of the pitch, and to design the covers, connections, etc., so as to interfere with the pitch as little as possible.

The distance between two consecutive joints of a group (Fig. 437) is generally made equal to *twice* the pitch.

An excellent plan for lap and single-cover joints is to arrange the rivets as shown in Figs. 431 to 435.

The strength of the plate at the joint is only weakened by *one* rivet-hole, for the plate cannot tear at its weakest section,

i.e., along the central row of rivets (aa), until the rivets between it and the edge are shorn in two.

Let there be m rows of rivets, 1 1, 2 2, 3 3, . . . (Fig. 439).

The total number of rivets is evidently m^2 .

Let $f_1, q_2, q_3, q_4, \dots$ be the unit tensile stresses in the plate along the lines 1 1, 2 2, 3 3, . . ., respectively. Then

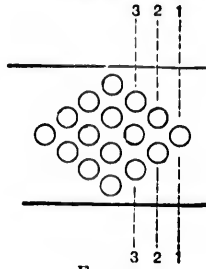

FIG. 439.

$$S = (w - d)tf_1 = \frac{\pi d^2}{4} m^2 f_1, \quad \text{for the line 1 1;}$$

$$= (w - 2d) tq_2 = \frac{\pi d^2}{4} (m^2 - 1) f_2, \quad \text{“ “ 2 2;}$$

$$= (w - 3d) tq_3 = \frac{\pi d^2}{4} (m^2 - 3) f_3, \quad \text{“ “ 3 3;}$$

$$= (w - 4d) tq_4 = \frac{\pi d^2}{4} (m^2 - 6) f_4, \quad \text{“ “ 4 4;}$$

.

$$\therefore S = (w - d)tf_1 = (w - 2d) \frac{m^2}{m^2 - 1} tq_2 = \dots$$

Assume that $f_1 = q_2$. Then $w = (m^2 + 1)d$.

Hence, by substituting this value of w in the first of the above relations, $\frac{d}{t} = \frac{14}{11} \frac{f_1}{f_2}$. Since q_3, q_4, \dots are each less than f_1 , the assumption is justifiable.

35. Covers.—In *tension* joints the strength of the covers must not be less than that of the plates to be united. Hence, a *single* cover should be at least as thick as a single plate; and if there are two covers, each should be at least half as thick.

When two covers are used in a tension pile it often happens that a joint occurs in the top or bottom plate, so that the greater portion of the stress in that plate may have to be

borne by the nearest cover. It is, therefore, considered advisable to make its thickness five-eighths that of the plate.

The number of the joints should be reduced to a minimum, as the introduction of covers adds a large percentage to the dead weight of the pile.

Covers might be wholly dispensed with in *perfect-jump* joints, and a great economy of material effected, if the difficulty of forming such joints and the increased cost did not render them impracticable. Hence, it may be said that covers are required for all *compression* joints, and that they must be as strong as the plates; for, unless the plates butt closely, the whole of the thrust will be transmitted through the covers. In some of the best examples of bridge construction the tension and compression joints are identical.

36. Efficiency of Riveted Joints.*—The efficiency of a riveted joint is the ratio of the maximum stress which can be transmitted to the plates through the joint to the strength of the solid plates.

Denote this maximum efficiency by η .

Let p be the pitch of the rivets;

d " diameter of the rivets;

t " thickness of the plates;

f_s " tenacity of the solid plate;

mf_s " " " riveted plate;

f_r " shearing strength of the rivets;

N " number of rivets in a pitch length;

e " ratio of the strength of a rivet in double shear to its strength in single shear.

Then

$$\begin{aligned} \eta_1 = \text{efficiency as regards the plates} &= \frac{(p-d)tmf_s}{ptf_s} \\ &= \frac{m(p-d)}{p}. \end{aligned} \quad (1)$$

$$\eta_2 = \text{efficiency as regards the rivets} = \frac{eN\frac{\pi}{4}d^2f_r}{ptf_s}. \quad (2)$$

* From an article by Professor Nicolson in the *Engineer*, Oct. 9, 1888.

The efficiency of the joint is, of course, the smaller of these two values; and the joint is one of maximum efficiency when $\eta_1 = \eta_2 = \eta$; that is, when

$$m \frac{p - d}{p} = \frac{eN \frac{\pi}{4} d^2 f_s}{p t f_s}$$

or

$$(p - d) t m f_s = eN \frac{\pi}{4} d^2 f_s. \dots \dots (3)$$

In this expression the quantities $m f_s$, N , and e are constants for any given joint, being of necessity known, or having been fixed beforehand; and the equation thus expresses one condition governing the relations of the three variables p , d , and t to each other. It is obvious, however, that, in order to determine the values of any two of these variables in terms of the third, another relation between them must be postulated. In short, in designing a joint, the value of one of the three ratios $\frac{p}{d}$, $\frac{p}{t}$, and $\frac{d}{t}$ must be fixed.

CASE I. Suppose that the ratio $\frac{p}{d}$ has a certain value. This is very frequently the quantity predetermined; but it is most usually done by fixing the value of η , η very obviously involving $\frac{p}{d}$; in fact $\eta = m \left(1 - \frac{d}{p} \right)$.

Equation (3) may be written

$$p = eN \frac{\pi}{4} \frac{d^2}{t} \frac{f_s}{m f_s} + d,$$

or

$$p = d \left(eN \frac{\pi}{4} \frac{d}{t} \frac{f_s}{m f_s} + 1 \right). \dots \dots (4)$$

If the ratio $\frac{d}{t}$ be denoted by k , then

$$\frac{p}{d} = eN \frac{\pi}{4} k \frac{f_s}{m f_s} + 1. \dots \dots (5)$$

But since $\eta = \frac{m(p-d)}{p}$,

$$\frac{p}{d} = \frac{m}{m-\eta} \dots \dots \dots (6)$$

Therefore, substituting in (5),

$$\frac{\eta}{m-\eta} = eN\frac{\pi}{4}k\frac{f_t}{mf_s}; \dots \dots \dots (7)$$

and, ultimately,

$$k = \frac{4}{eN\pi} \frac{mf_s}{f_t} \frac{\eta}{m-\eta} \dots \dots \dots (8)$$

The process of designing a joint of maximum efficiency for a boiler of given diameter and pressure of steam, when η (or the ratio $\frac{p}{d}$) is fixed, is then as follows: Settle the number of rivets per pitch (i.e., N); the value to be allowed for e (depending on the nature of the shearing stress on the rivets); and the values of m , f_s , and f_t . Then k is known from equation (8).

But t may be found from the relation,

$$\text{pressure} \times \text{diameter} = \eta \times 2tf_t,$$

or

$$t = \frac{\text{pressure} \times \text{diameter}}{2\eta f_t} \dots \dots \dots (9)$$

Hence, since $k = \frac{d}{t}$ is known, d may be found; and since

$$\frac{p}{d} = \frac{m}{m-\eta} \text{ is known, } p \text{ is also fixed.}$$

CASE II. When $\frac{p}{t}$, the ratio of rivet pitch to plate thickness, is given, equation (5) must be otherwise manipulated.

Multiplying it by $\frac{d}{p}$, and substituting for d its value kt , we have

$$1 = \frac{cN\pi}{4} \frac{t}{p} k^2 \frac{f_s}{mf_t} + \frac{t}{p} k. \quad (10)$$

Putting this in the form of a quadratic equation in k ,

$$k^2 + \frac{4}{cN\pi} \frac{mf_t}{f_s} k - \frac{4}{cN\pi} \frac{mf_t}{f_s} \frac{p}{t} = 0. \quad (11)$$

For brevity, substituting A for $\frac{4}{cN\pi}$, T for $\frac{mf_t}{f_s}$, and R for $\frac{p}{t}$, and solving the quadratic,

$$k = -\frac{AT}{2} \pm \frac{1}{2} \sqrt{A^2 T^2 + 4ATR}. \quad (12)$$

The method of designing the joint is, then, as follows:

A , T , and R being known, k may be found by substituting their values in equation (12), the positive sign of the second term being taken.

Now,

$$\eta = m \left(1 - \frac{d}{p} \right) = m \left(1 - \frac{kt}{p} \right) = m \left(1 - \frac{k}{R} \right);$$

and since both k and R are now known, the thickness of plate (t) may be found, as in Case I, by equation (9). The values of the diameter and pitch of rivets follow at once from the known values of k and R .

This method of designing a joint appears to be the most rational of the three. For the greatest pitch for which a joint will remain steam-tight depends mainly on the relation of pitch of rivets to thickness of plates; although it is also affected by the relative size of rivets and of rivet-heads.

CASE III. If $\frac{d}{p}$, or k , be predetermined, the value of η must first be obtained, in order that the plate thickness may

be found by means of equation (9). Now, $\eta = m \frac{p-d}{p}$ may be put into the form

$$p = \frac{md}{m-\eta};$$

and if this value is substituted for p in equation (4),

$$\frac{md}{m-\eta} = \left(\frac{cN\pi}{4} k \frac{f_s}{mf_t} + 1 \right) d.$$

From this is finally deduced

$$\eta = m \frac{cN\pi k f}{cN\pi k f_s + 4mf_t} \dots \dots \dots (13)$$

The plate thickness may now be found by equation (9); the diameter of rivet from $d = kt$, and the pitch from $p = \frac{md}{m-\eta}$. In the above investigations no account has been taken of the effect of the bearing pressure on the rivets or plate.

If f_c be the allowable bearing pressure per projected square inch of rivet surface, the following relation must obtain:

$$(p-d)tmf_t = Ndtf_c \dots \dots \dots (14)$$

This may be written

$$f_c = \frac{(p-d)mf_t}{Nd} \dots \dots \dots (15)$$

Then if f_c be estimated by this equation, and if it should be greater than 43 tons per square inch in a lap joint, or 45 to 50 tons in a butt joint, such joint will fail by the rivets shearing before the full strength of the plate is exerted, as Kennedy's experiments show that with these values of f_c the rivets do not attain their natural ultimate shearing strength (viz., f_t), but fail at shearing stresses much below this.

Again, the maximum allowable ratio of $\frac{d}{t}$ (i.e., k) as the preliminary datum for the design of a joint, may be fixed by using the expression

$$\frac{d}{t} = \frac{f_c}{\frac{\pi}{4} f_s} \dots \dots \dots (16)$$

deduced from the obvious relation—similar to (14)—

$$eN \frac{\pi}{4} d^2 f_s = Nd^2 f_c.$$

(Unwin suggests the relation $d = \frac{1}{8} \sqrt{t}$.)

In designing the joint by any of the methods given above, any value obtained for k greater than that supplied by (16) should be rejected.

Note.—The following Tables of the Weights of Bridges have been prepared from data supplied by the engineers of the bridges in question.

TABLE OF ACTUAL WEIGHTS OF MODERN PLATE-GIRDER BRIDGES.
(From data kindly supplied by Messrs. MACDONALD, WILSON, PETERSON, YEATMAN, and others.)

No. of Spans	Length.	Depth.	No. of Tracks.	Deck, $\frac{1}{2}$ Through, or Through, $\frac{7}{8}$.	Weight in lbs.	Weight per Lineal Foot of Each Track in tons of 2000 lbs.	Engineer, Builder, or Owner.	Remarks.
1	26'		1	D	8212		P. McK. & Y. R. R.) Add to <i>dead load</i> 400 lbs. per foot for ties and rails. { <i>Live load</i> . Two engines. 160,000 lbs. in 108 ft., followed by 2240 lbs. per lineal foot.
1	30'		1	D	10160		P. McK. & Y. R. R.	
1	30'		1	D	10000		Dominion B. Co.	
1	33'		1	D	12800		Edge Moor I. Co.	
1	34' 8"		1	D	15600		D. B. Co.	
1	34' 8"	3' 6"	2	D	16550	.375	Wilson	
1	37' 7 $\frac{1}{2}$ "	3' 6"	2	D			P. McK. & Y. R. R.	<i>Dead load and live load. As for 26' girder.</i>
1	38'		1	D	15153		Edge Moor I. Co.	
1	44' 8"	31' 6"	1	D	23383		D. B. Co.	
1	44' 8"		1	D	25750		P. McK. & Y. R. R.	<i>Dead load and live load. As for 26' girder.</i>
1	54' 2"		1	D	23900		Phoenix I. Co.	
1	56'	5'	2	T	103720		D. B. Co.	
1	59'	5'	1	D	35000		D. B. Co.	
1	59'	5'	1	D	44400		Phoenix I. Co.	
1	60'		2	D	12000	.6	P. McK. & Y. R. R.	<i>Dead load and live load. As for 26' girder.</i>
1	60'		1	H	39448		Wilson	
1	64'	5' 5"	2	D	37000		D. B. Co.	
1	64'	5' 5"	2	D	43800		D. B. Co.	
1	64' 6"	5' 4"	2	D	52530	.54	Wilson	Girders = 799 lbs.; floor system = 203 lbs.
1	67'	5' 4"	2	D		.52		Girders = 755 lbs.; floor system = 293 lbs.
1	68'	5' 4"	2	D		.55		<i>Dead load and live load. As for 26' girder.</i>
1	68'	5' 4"	2	D	46340	.55	P. McK. & Y. R. R.	Girders = 1125 lbs.; floor system = 275 lbs.
1	64' - 69' 4 $\frac{1}{2}$ "	6'	2	D		.525	Wilson	Girders = 935 lbs.; floor system = 275 lbs.
4	to 68' 8 $\frac{1}{2}$ "	5' 9"	2	D		.55		
5	to 68' 10 $\frac{1}{2}$ "	5' 6"	2	D		.55		
1	71' 4 $\frac{1}{2}$ "	5' 6"	2	H		.4		
1	71' 4 $\frac{1}{2}$ "	5' 6"	2	H		.7		
1	82'	6' 6"	2	D	82440		D. B. Co.	<i>Live load. Two 98-ton engines.</i>
1	82'	6' 6"	2	D	110000		D. B. Co.	
1	85'	6' 6"	1	T	118600		D. B. Co.	<i>Live load. Two 98 ton engines.</i>
1	85'	7' 7"	1	D	84100		D. B. Co.	<i>Live load. Two 98-ton engines.</i>
1	86'	7' 7"	1	D	87300		Wilson	
1	87' 6"	7' 7"	1	D		.65		
1	88'	7' 7"	2	D				
1	90'	7' 7"	2	D				

TABLE OF ACTUAL WEIGHTS OF MODERN BRIDGES. 683

TABLE OF ACTUAL WEIGHTS OF MODERN OPEN-TRUSS BRIDGES.
(From data kindly supplied by MESSRS. COOPER, WILSON, MACDONALD, PETERSON, YEATMAN, and others.)







No of Spans	Length C. to C. of Pins.	Depth.	No. of Tracks.	Deck, D, Half Through, H, or Through, T	Weight in lbs.	Wt. per lineal foot of each track, in tons of 2000 lbs.	Engineer, Builder, or Owner.	Remarks.
1	28'		1	D	12000		Alden Moor I. Co.	
1	30'		1	D	11000		Passaic	
1	40' 6"		1	D	11500		Edge Moor I. Co.	
1	47'		1	T	31000		Phoenix I. Co.	
1	49'		1	D	19800		Edge Moor I. Co.	
1	53' 4 1/2"	10' 3"	1	D	36000	.585	Wilson	Single intersection.
1	54'		1	D			Alden	Single intersection.
1	61' 4"	10' 3"	2	D	146000	.59	Wilson	
1	71' 9"	9' 11 1/2"	2	T			Alden	
3	73'	24'	1	D	78,448	.5	C. B. R. R.	
1	77' 6"		1	D				
1	82' 6"	8' 8"	1	D	52800	.54	Edge Moor I. Co.	
3	82' 6"		2	D			Wilson	
1	89' 6" - 91' 6"	10' 3"	2	D		.72	"	Single intersection.
1	90' 1"	17' 7"	2	D		.61	"	Single intersection; 8 panels.
1	94'	17'	2	D		.596	"	
1	10' 04' 0 1/2" {	15'	2	D		.69	"	Single intersection.
1	10' 05' 8 1/2" }	10'	2	H		.76	"	Flooring 1 track = 480 lbs. Iron " = 1525 "
1	109'	11'	1	T	120000		G. T. R. R.	
1	109'		1	T	01000		Phoenix I. Co.	
1	109'		1	T	76000		D. B. Co.	
1	102' 6"	24'	1	D	112855		Passaic	
1	103'		1	T	92000		Phoenix I. Co.	
1	106'		1	D	128000		Wilson	
2	115' 6"	17'	1	D		.54	"	Truss similar to B.
1	116' 10 1/2"	20' 7"	2	T		.65	"	

TABLE OF ACTUAL WEIGHTS OF MODERN OPEN-TRUSS BRIDGES.
(From data kindly supplied by Messrs. COOPER, WILSON, MACDONALD, PETERSON, YEATMAN, and others.)

No. of Spans	Length C. to C. of Pins.	Depth.	No. of Trusses.	Deck, D. or Through.	Weight in lbs. of each Span.	Wt. per linear foot of each Track, in tons of 2000 lbs.	Engineer, Builder, or Owner.	Remarks.
1	125' 21"	15'	2	D	135271	.75	Wilson	Single intersection.
1	125' 10"	24'	1	D	144368	.57	D. B. Co.	Truss similar to B.
1	126' 8"	17'	1	T			P. McK. & V. R.R.	
1	134'	18'	2	D		.76	Wilson	Single intersection.
2	131' 1"		1	T	143000	.76	Passaic	Single intersection; 12 panels.
1	134' 7"	17' 7"	2	D		.59	Wilson	Truss similar to B.
3	136' 9"	17'	2	D				
3	136'							
1	137' 1½"	21'	2	T		8	Wilson	 Half truss.
4	137' 8"	17' 10"	1	D	376600	.8	"	Truss similar to B.
4	147' 6"	17'	2	D	310000	.8	"	Truss similar to B.
1	150'		1	T	327870		Cooper	
1	150'	24'	2	T		.5	Keystone B. Co.	Drawbridge—truss similar to B.
1	151' 4"	17'	2	D	161000		P. McK. & V. R.R.	
1	152'		1	D	180000		Wilson	
1	153'		1	T	221200		Phoenix I. Co.	
1	154' 7"	28'	1	D	267,600	.86	D. B. Co.	Single intersection.
3	154'	20'	1	D			Peterson	Single intersection.
3	156'		2	D	161000		Wilson	
3	156'	25' 4"	1	D	223400	.65	Cooper	Truss similar to B.
3	159' 9"	18' 4"	2	D	260700		Edge Moor I. Co.	
23	157' 2½"	27'	1	T	229458	.82	D. B. Co.	Floor system—1 track = 300 lbs.; iron = 1340 lbs.
1	161' 3"		1	T	208340	.85	Wilson	Single intersection; 10 panels.
1	161' 10"	27'	1	T			Phoenix I. Co.	Floor system—1 track = 380 lbs.; iron = 1200 lbs.
1	162' 9"	25'	2	T			Wilson	Single intersection; 13 panels.
1	163' 2½"		2	T			"	
1	163' 5½"	20' 4"	1	D			"	

TABLE OF ACTUAL WEIGHTS OF MODERN OPEN-TRUSS BRIDGES.

TABLE OF ACTUAL WEIGHTS OF MODERN OPEN-TRUSS BRIDGES.
 (From data kindly supplied by Messrs. COOPER, WILSON, MACDONALD, PETERSON, YEATMAN, and others.)

No. of Spans	Length C. to C. of End Pins.	Depth.	No. of Tracks.	Deck, D, or Through, T.	Weight of each Span.	Wt. per lineal foot of each Track, in tons of 2000 lbs.	Engineer, Builder, or Owner.	Remarks.
3	166'	27'	1	T	440000	.89	Wilson Cooper	 <p>Track and floor ties = 300 lbs.; iron = 1520 lbs. Single intersection; 9 panels. <i>Live load.</i> Two 98-ton engines followed by 3000 lbs. per lineal foot.</p> <p>Double intersection (pin).</p> <p>Truss similar to A; upper chord with 9 divisions. Truss similar to A; upper chord with 12 divisions. Aqueduct bridge for Panama Canal.</p>
1	167' 7"	28	2	T	250000	.91	Wilson	
1	175' 31"	30'	2	T	600600		Wilson	
1	192'	30'	2	T	2510000		D. B. Co.	
1	195' 81"		1	T	3160000		Phoenix I. Co.	
1	197'		1	T	6120000		Lassig Cooper	
2	206'	33'	2	T	4547713		Peterson	
3	214' 6"	33'	2	T	6550000		Cooper	
1	208' 4"	33'	2	T	8250000		Cooper	
1	245' 7"	40'	2	T	4500000		Edge Moor I. Co.	
1	253'		1	T	1006000	1.24	Wilson	
1	250'	26'	1	T	780000	1.4	Cooper	
1	266'	27'	1	T	4100000		Phoenix I. Co.	
1	270'	27'	1	T	3815000		Edge Moor I. Co.	
1	345' 1"	40'	1	T			Phoenix I. Co.	
1	355'		2	T				
1	550'	12 R. R. 2 R. R. ways. 2 P. ways.	1	T				

TABLE OF ACTUAL WEIGHTS OF MODERN OPEN-TRUSS BRIDGES.
(From data kindly supplied by Messrs. COOPER, WILSON, MACDONALD, PETERSON, YEATMAN, and others.)

Bridge.	Length C. to C. of Piers.	No. of Trusses.	Deck or Through.	Weight in lbs.	Remarks.
Kentucky River Bridge.	1 Suspended.....	1	D	435000	<p>35' deep, 24' wide, 10 panels. Depths, 60' and 35'; 31' over towers. Depths, 60' and 25'; 8 panels. Unit stresses. Floor, soft steel = $9000 \left(1 + \frac{\min.}{\max.} \right)$. Trusses, hard steel = $12000 \left(1 + \frac{\min.}{\max.} \right)$. Live load. Two 86-ton engines followed by 3000 lbs. Depths of shore arms at end = 24', at centre = 44'; width = 20'. Depths of river arms at pier = 68', at end = 24'; width = 20'; 8 panels. Depth = 24'; width = 20'; 8 panels. Live load. Two consolidated engines of 171 tons in 108'. Wind-pressure. 450 lbs. per foot of loaded bridge. 250 lbs. per foot of unloaded bridge.</p>
	2 Arms.....	1	D	ca. 415000	
	2 Trestle girders.....	1	D	ca. 513500	
	2 Main towers.....	1	D	ca. 8500	
	Trestle bents.....	vert.		ca. 309000	
	Floor of cantilever system in cluded	in above.		230000	
	2 Anchor towers.....	Base to cap.		ca. 79250	
				ca. 10750	
	2 Shore arms.....		T	ca. *550345	
	2 River arms.....		T	ca. 37966	
Kanawha Bridge.	1 Suspended.....	1	T	ca. 211810	<p>719207 636668 384979 2029032 423945 270799 375734 312580 253443 153292 18065</p>
	Shore arm.....	2	D	719207	
	Cantilever.....	2	D	636668	
	Suspended.....	2	D	384979	
	Connecting.....	2	D	2029032	
	River towers.....	2	D	423945	
	Shore towers.....	2	D	270799	
	E. Viaduct.....	2	D	375734	
	W. ".....	2	D	312580	
	E. ".....	2	D	253443	
Poughkeepsie Bridge.	1 Suspended.....	1	D	153292	<p>18065</p>
	Shore arm.....	2	D	719207	
	Cantilever.....	2	D	636668	
	Suspended.....	2	D	384979	
	Connecting.....	2	D	2029032	
	River towers.....	2	D	423945	
	Shore towers.....	2	D	270799	
	E. Viaduct.....	2	D	375734	
	W. ".....	2	D	312580	
	E. ".....	2	D	253443	
Thames River Bridge.	West approach.....	2	T	342894	<p>259174 162228 178399 32283</p>
	River bridge.....	2	D	342894	
	River bridge (draw).....	2	T	259174	
	River bridge (draw).....	2	T	162228	
	Turn-table, shafting.....	2	T	178399	
				32283	

* Includes back-stays connecting tower with span.

Live load. Two consolidated engines of 171 tons in 103 ft., followed by 3000 lbs. per linear foot.
 Stresses. All tension = $10000 \left(1 + \frac{\min.}{\max.} \right)$.
 Alternate tension of cables is $11000 \left(1 - \frac{\min.}{\max.} \right)$.
 Posts, pin ends = $(10000 - 600) \left(1 + \frac{\min.}{\max.} \right)$.
 Chords (compression) = $(10000 - 400) \left(1 + \frac{\min.}{\max.} \right)$.

TABLE OF ACTUAL WEIGHTS OF MODERN OPEN-TRUSS BRIDGES.
(From data kindly supplied by Messrs. COOPER, WILSON, MACDONALD, PETERSON, YEATMAN, and others.)

TABLE OF ACTUAL WEIGHTS OF MODERN BRIDGES. 687

TABLE OF ACTUAL WEIGHTS OF MODERN OPEN-TRUSS BRIDGES.

(From data kindly supplied by Messrs. COOPER, WILSON, MACDONALD, PETERSON, YEATMAN, and others.)

Location.	No. of Spans.	Length C. to C. of Pins.	Depth.	No. of Tracks.	Deck, D, or Through, T.	Weight in lbs. of Each Span.	Type.	Engineer, Builder, or Owner.
St. Lawrence River, Lachine.....	3	80'		1	D	70527	Plate girder Pin, double intersection " " " Pin, single intersection	Peterson and C. Shaler Smith
	8	240'		1	D	482162		
	2	269'		1	D	706631		
	2	408'		1	D	1343021		
Ottawa River, Vaudreuil...	1	119'		1	D	176314	Lattice, double intersection " " " Plate girder	Peterson
	8	100'		1	D	108478		
	7	74'		1	D	64337		
	2	65'		1	D	53560		
Ottawa River, St. Anne's...	1	324'		1	T	931740	Pin, single intersection Lattice, double intersection " " " Plate girders	Peterson
	3	104'		1	T	176870		
	2	100'		1	D	108478		
	8	66'		1	D	55541		
Sault Ste. Marie.....	1	53'	{ 27' ends 40' centre }	1	D	41158	Plate girder Pin, single intersection Lattice, double intersection	Peterson
	10	238' 7 1/2"			T	465936		
Prince of Wales Bridge, Ottawa River.....	2	104'		1	T	163476	" " " " " " " " " " " "	Peterson
	2	255'		1	D	478388		
	10	160'		1	D	199303		
	1	150'		1	D	174354		
Blair.....	1	135'		1	D	143224	" " " " " "	Morison
	1	330'		1	T	492000 (I.) 288000 (S.)		
Bismarck.....	1	110'		1	D	780000	" " " " " " " " "	Morison
	1	400'		1	T	120000 (I.) 600782 (I.) 348797 (S.) 25777 (C.I.)		
	1	113'		1	D	973356 97515		

TABLE OF LOADS FOR HIGHWAY BRIDGES.

Span in Feet.	City and Suburban Bridges liable to Heavy Traffic.	Bridges in Manu- facturing Districts, Ballasted Road.	Bridges in Country Districts, Unballasted Roads.
100 and under	100 lbs. per sq. ft.	90 lbs. per sq. ft.	70 lbs. per sq. ft.
100 to 200	80 " " "	60 " " "	60 " " "
200 to 300	70 " " "	50 " " "	50 " " "
300 to 400	60 " " "	50 " " "	45 " " "
above 400	50 " " "	50 " " "	45 " " "

ton
etc.

whe
 & be
 Hen
 I
 struc
 foot
 spans
 is equ

An.

2.
 and it
 throw
 car wi
 pressu

3.
 right-a
 Determ
 bay fro
 the gir

An.

EXAMPLES.

1. A bridge of N equal spans crosses a span of L ft.; the weights in tons per lineal foot of the main girders of the platform, permanent way, etc., and of the live load, are w_1 , w_2 , w_3 , respectively. Show that

$$w_1 = \frac{LA}{N - LB},$$

where $A = w_2(pk + r) + w_3(pk + q)$ and $B = pk + r$,

k being the ratio of span to depth, and p, q, r numerical coefficients. Hence also determine the limiting span of a girder.

If X is the cost of a pier and if Y is the cost per ton of the superstructure, find the value of N which will make the total cost per lineal foot a minimum, and prove that this is approximately the case when the spans are so arranged that the cost of one span of the bridge structure is equal to the cost of a pier

Ans. A span $< \frac{1}{pk + r} \frac{Y}{X}$. Cost is a minimum when $N - LB = L\sqrt{\frac{AY}{X}}$.

and the minimum cost of the span $= X\left(1 - \frac{LB}{N}\right) = X$, approx.

2. A car of weight W for a gauge of 4 ft. 8½ in. is 33 ft. long, 6 ft. deep, and its bottom is 2 ft. 6 in. above the rails. Find the additional weight thrown upon the leeward rail when the wind blows upon a side of the car with a pressure of 20 lbs. per square foot. Also find the minimum pressure that will blow the car over. *Ans.* 4625.84 lbs.; .428 W .

3. A lattice-girder 200 ft. long and 20 ft. deep, with two systems of right-angled triangles, carries a dead load of 800 lbs. per lineal foot. Determine the greatest stresses in the diagonals and chords of the fourth bay from one end when a live load of 1200 lbs. per lineal foot passes over the girder.

Ans. If riveted: Diagonal stress = 37,200√2 lbs.;

Chord stress = 450,000 lbs.

If pin-connected: Diagonal stress = 44,800√2 and 29,600√2 lbs.;

Chord stress = 460,000 lbs. in compression
and = 440,000 lbs. in tension.

4. A lattice-girder 80 ft. long and 8 ft. deep carries a uniformly distributed load of 144,000 lbs. Find the flange inch-stresses at the centre, the sectional area of the top flange being $56\frac{1}{2}$ sq. in. gross, and of the bottom flange 45 sq. in. net.

What should be the camber of the girder, and what extra length should be given to the top flange, so that the bottom flange of the loaded girder may be truly horizontal? ($E = 29,000,000$ lbs.)

Ans. 3185.8 lbs.; 4000 lbs.

$$x_1 = .29735 \text{ in.}; x_2 = .2987 \text{ in.}; s_1 - s_2 = \frac{1.024}{8.1925} \text{ ft.}$$

5. A lattice-girder 80 ft. long and 10 ft. deep, with four systems of right-angled triangles, carries a dead load of 1000 lbs. per lineal foot. Determine the greatest stresses in the diagonals met by a vertical plane in the seventh bay from one end when a live load of 2500 lbs. per lineal foot passes over the girder. Design the flanges, which are to consist of plates riveted together.

The lattice-bars are riveted to angle-irons. Find the number of $\frac{7}{8}$ -in. rivets required to connect the angle-irons with the flanges in the first bay, 10,000 lbs. per square inch being the safe shearing strength of the rivets.

Ans. If riveted: Diagonal stress = $10,664\frac{1}{4}\sqrt{2}$ lbs.

If pin-connected: " = $9062\frac{1}{2}\sqrt{2}$; $6250\sqrt{2}$; $15,468\frac{3}{4}\sqrt{2}$;

$$11,875\sqrt{2} \text{ lbs}$$

22 rivets ($21\frac{3}{4}$).

6. The bracing of a lattice-girder consists of a single system of triangles in which one of the sides is a strut and the other a tie inclined to the horizontal at angles of α and β respectively; in order to give the strut sufficient rigidity its section is made k times that indicated by theory, the coefficient k being $>$ unity. Show that the amount of material in the struts and ties is a minimum when

$$\tan \alpha = k \tan \beta.$$

7. A lattice-girder of 40 ft. span, 5 ft. depth, and with horizontal chords has a web composed of two systems of right-angled triangles and is designed to support a dead and a live load, each of $\frac{1}{2}$ ton per lineal foot upon the bottom chord. Determine the maximum stresses in the members of the third bay from one end met by a vertical plane.

Ans. If riveted: Diagonal stress = $1\frac{33}{8}\sqrt{2}$ tons;

Chord stress = $33\frac{3}{8}$ tons.

If pin-connected: Diagonal stress = $\frac{85}{8}\sqrt{2}$ and $\frac{59}{8}\sqrt{2}$ tons;

Chord stress = $32\frac{1}{2}$ tons in tension;

35 tons in compression.

8. A lattice-truss of 100 ft. span and 10 ft. depth has a web composed of four systems of right-angled triangles. The maximum stress in the

diagonal joining the sixth apex in the upper chord to the fourth apex in the lower is 16 tons. Find the dead load, the live load being 1 ton per lineal foot, assuming the truss to be (a) riveted, (b) pin-connected.

Ans. (a) .554 ton; (b) 1.062 tons.

9. A lattice-girder of 40 ft. span has a web composed of two systems of triangles (base = 10 ft.) and is designed to carry a live load of 1600 lbs. per lineal foot and a dead load of 1200 lbs. per lineal foot. Defining the stress-length of a member to be the product of its length into the stress to which it is subjected find the depth of the truss so that its total stress-length may be a minimum. Ans. 18.25 ft.

10. Determine the maximum stresses in the members of a lattice-truss of 40 ft. span and 4 ft. depth, with two systems of triangles (= 8 ft.), (a) when riveted together; (b) when pin-connected. Dead load = $\frac{1}{2}$ ton per lineal foot, live load = $\frac{1}{2}$ ton per lineal foot.

Ans. Bays— 1st; 2d; 3d; 4th; 5th.
 (a) Diags. $6\frac{1}{2}\sqrt{2}$; $5.35\sqrt{2}$; $4.05\sqrt{2}$; $2.85\sqrt{2}$; $1\frac{1}{2}\sqrt{2}$ tons;
 Tens. chd. $6\frac{1}{2}$; $18\frac{1}{2}$; $27\frac{1}{2}$; $33\frac{1}{2}$; $36\frac{1}{2}$ "
 Comp. chd. Same.
 (b) Diags. $\left\{ \begin{matrix} 6\sqrt{2} \& \\ 7.5\sqrt{2} \end{matrix} \right\}$; $\left\{ \begin{matrix} 6\sqrt{2} \& \\ 4.7\sqrt{2} \end{matrix} \right\}$; $\left\{ \begin{matrix} 3.1\sqrt{2} \& \\ 4.7\sqrt{2} \end{matrix} \right\}$; $\left\{ \begin{matrix} 3.4\sqrt{2} \& \\ 2.3\sqrt{2} \end{matrix} \right\}$; $\left\{ \begin{matrix} 1.2\sqrt{2} \& \\ 2.3\sqrt{2} \end{matrix} \right\}$ tons;
 Tens. chd. 6; 18; 27; 33; 36 "
 Comp. chd. $7\frac{1}{2}$; 19 $\frac{1}{2}$; 28 $\frac{1}{2}$; 34 $\frac{1}{2}$; 37 $\frac{1}{2}$ "

11. The platform of a single-track bridge is supported upon the top chords of two Warren girders; each girder is 100 ft. long, and its bracing is formed of ten equilateral triangles (base 10 ft.); the dead weight of the bridge is 900 lbs. per lineal foot.; the greatest total stress in the seventh sloping member from one end when a train crosses the bridge is 41,394.8 lbs. Determine the weight of the live load per lineal foot. Prepare a table showing the greatest stress in each bar and bay when a single load of 15,000 lbs. crosses the girder.

Ans.  2771 $\frac{2}{3}$ lbs. per lin. ft.

FIG. 440.

Stresses in diagonals: $d_1 = d_2 = 4\frac{1}{2}\sqrt{3}$; $d_3 = d_4 = 4\sqrt{3}$;
 $d_5 = d_6 = 3\frac{1}{2}\sqrt{3}$; $d_7 = d_8 = 3\sqrt{3}$;
 $d_9 = d_{10} = 2\frac{1}{2}\sqrt{3}$ tons.
 Stresses in compression chord: $c_1 = 2\frac{1}{2}\sqrt{3}$; $c_2 = 6\sqrt{3}$; $c_3 = 8\frac{2}{3}\sqrt{3}$;
 $c_4 = 10\frac{1}{2}\sqrt{3}$; $c_5 = 11\frac{1}{3}\sqrt{3}$ tons.
 Stresses in tension chord: $t_1 = 4\frac{1}{2}\sqrt{3}$; $t_2 = 8\sqrt{3}$; $t_3 = 10\frac{1}{3}\sqrt{3}$;
 $t_4 = 12\sqrt{3}$ tons.

12. A Warren girder with its bracing formed of nine equilateral triangles (base = 10 ft.) is 90 ft. long, and its dead weight is 500 lbs. per lineal foot. Determine the maximum stresses in each member when a live load of 1350 lbs. per lineal foot, preceded by a concentrated load of 18,000 lbs., crosses the girder, assuming that every joint is loaded. The diagonals and verticals are riveted to angle-irons forming part of the flanges.

How many $\frac{1}{4}$ -in. rivets are required for the connection of the several members meeting at the third apex in the upper chord? (23, 6, and 13.) How many are required in the first bay of each chord to prevent longitudinal slip? (15 in tension chord and 18 in compression chord.)

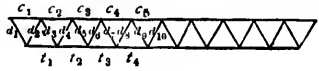
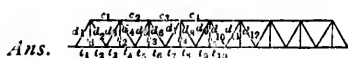

FIG. 441.

$$\text{Tension chord stresses: } t_1 = t_2 = \frac{89250}{\sqrt{3}}; t_3 = t_4 = \frac{217500}{\sqrt{3}};$$

$$t_5 = t_6 = \frac{308750}{\sqrt{3}}; t_7 = t_8 = \frac{363000}{\sqrt{3}};$$

$$t_9 = t_{10} = \frac{380250}{\sqrt{3}} \text{ lbs.}$$

$$\text{Compression chord stresses: } c_1 = \frac{158000}{\sqrt{3}}; c_2 = \frac{267750}{\sqrt{3}}; c_3 = \frac{340500}{\sqrt{3}};$$

$$c_4 = \frac{376250}{\sqrt{3}} \text{ lbs.}$$

$$\text{Stresses in sloping members: } d_1 = \frac{178500}{\sqrt{3}}; d_2 = \frac{159500}{\sqrt{3}}; d_3 = \frac{14250}{\sqrt{3}};$$

$$d_4 = \frac{123750}{\sqrt{3}}; d_5 = \frac{107000}{\sqrt{3}}; d_6 = \frac{91000}{\sqrt{3}};$$

$$d_7 = \frac{75750}{\sqrt{3}}; d_8 = \frac{61250}{\sqrt{3}}; d_9 = \frac{47500}{\sqrt{3}};$$

$$d_{10} = \frac{34500}{\sqrt{3}}; d_{11} = \frac{22250}{\sqrt{3}}; d_{12} = \frac{10750}{\sqrt{3}}$$

lbs. The stresses d_{10} , d_{11} , d_{12} , are max. stresses of an opposite kind to those due to dead load.

Verticals: Max. load on each vertical = 20,500 lbs.

13. If a force of 5000 lbs. strike the bottom chord of the girder in the preceding question at 20 ft. from one end and in a direction inclined at 30° to the horizontal, determine its effect upon the several members.

14. A Warren girder for a single-track railway bridge consists of eight equilateral triangles and has to cross a span of 96 ft.; the platform is on the bottom chord; the loads per lineal foot for which the truss is to be designed are 2250 lbs. due to engine, 1500 lbs. due to train, and 450 lbs. due to bridge. Determine the maximum stresses (both tensile and compressive) in the members met by vertical planes immediately on the right of the second, third, and fourth apices in the compression chord. Also, find how many $\frac{7}{8}$ -in. rivets are required to connect the diagonals met by these planes with the chords and to prevent any tendency to longitudinal slip between the support and the first apex, and between the first and second apices in the tension chord.

15. The accompanying figure represents the half-truss for a bridge of 80 ft. span. Show how to determine the stresses in the several members. Depth at centre = 12 ft.; at $B = 12$ ft.; at $A = 6$ ft.



FIG. 442.

16. A Warren girder composed of eight equilateral triangles has its upper chord in compression and has every joint loaded with a weight of 2 tons, the loads being transmitted to the joints in the lower chord by means of vertical struts. The span = 80 ft. Find the stresses in all the members.

Ans. Bays in compression chord: 1st = $5\sqrt{3}$; 2d = $13\sqrt{3}$;
 3d = $18\frac{1}{2}\sqrt{3}$; 4th = $21\sqrt{3}$ tons.
 Bays in tension chord: 1st = $9\frac{1}{2}\sqrt{3}$; 2d = $16\sqrt{3}$;
 3d = $20\sqrt{3}$; 4th = $21\frac{1}{2}\sqrt{3}$ tons.
 Stresses in verticals: In each vertical = 2 tons.
 Stresses in diagonals: 1st = $10\sqrt{3}$; 2d = $8\frac{2}{3}\sqrt{3}$;
 3d = $7\frac{1}{2}\sqrt{3}$; 4th = $6\sqrt{3}$;
 5th = $4\frac{2}{3}\sqrt{3}$; 6th = $3\frac{1}{2}\sqrt{3}$;
 7th = $2\sqrt{3}$; 8th = $\frac{2}{3}\sqrt{3}$ tons.

17. A Warren girder, with the platform on the lower boom, carries a load of 20 tons at the centre. Find the stress in each member, and also find the weight at each joint of lower boom which will give the same stresses in the centre bays.

There are six bays in the lower chord.

Ans. Stress in each diagonal = $\frac{20}{3}\sqrt{3}$ tons.
 Tens. chord: stress in 1st bay = $\frac{10}{3}\sqrt{3}$; 2d = $10\sqrt{3}$; 3d = $\frac{40}{3}\sqrt{3}$ tons.
 Comp. chord: stress in 1st bay = $\frac{20}{3}\sqrt{3}$; 2d = $\frac{40}{3}\sqrt{3}$; 3d = $20\sqrt{3}$ tons.
 Weight at each joint = $5\frac{1}{3}$ tons.

18. The accompanying truss of 240 ft. span and 30 ft. deep is to be designed for a panel engine load of 24,000 lbs., a panel train load of 18,000 lbs., and a panel bridge load of 12,000 lbs. Determine graphically the maximum stresses in the members met by the vertical MN . Also, draw a stress diagram for the whole truss when it is covered with a uniformly distributed live load of 180,000 lbs.

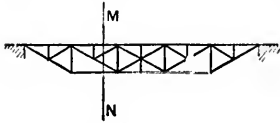

FIG. 443.

19. Loads of $3\frac{3}{4}$, 6, 6, and 6 tons follow each other in order over a ten-panel truss at distances of 8, $5\frac{1}{2}$, $4\frac{1}{2}$, and $4\frac{1}{2}$ ft. apart. Determine the position of the loads which will give the maximum diagonal and chord stresses in the third and fourth panels. Span = 120 ft.

20. Determine the moment of resistance of a floor-beam for the Sault Ste. Marie Bridge from the following data: Floor-beams, 16' 6" long and 23' 10 $\frac{1}{2}$ " apart; the dead weight of the flooring, stringers, etc. = 800 lbs. per lineal foot of floor-beam; the live load as given in Fig. 407, Art. 20, page 639; the load is transmitted to the floor-beam by four lines of stringers so spaced as to throw two-thirds of the load upon the inner pair, which are 3 ft. C. to C.

21. In a truss-bridge the panels are 17 ft. and the floor-beams 13 ft. in length. Loads of 8, 12, 12, 12, 12, 10, 10, 10, and 10 tons follow each other in order over the bridge at the distances of $7\frac{1}{2}$, $4\frac{1}{2}$, $4\frac{1}{2}$, $4\frac{1}{2}$, $7\frac{1}{2}$, $5\frac{1}{2}$, $6\frac{1}{2}$, and $5\frac{1}{2}$ ft. apart. Determine the moment of resistance of the beam, taking the load due to the platform, etc., to be 500 lbs. per lineal foot.

22. If the bridge in the preceding question is of the riveted type with a single diagonal system, and with verticals at the panel points, the number of the panels being ten, find how many 1-in. rivets are required in the third panel from one end to connect the web with the chords, assuming the panel live load to be 30,000 lbs. and the panel dead load to be 10,000 lbs.

23. With the loading given by Fig. 409, Art. 20, page 639, design a floor-beam for a single-track bridge with panels 22 ft. long, the weight of the platform being 450 lbs. per square yard, and of each longitudinal 200 lbs. per lineal yard.

24. Prepare a table giving the stresses of the several members of a double-intersection through-truss of 154 ft. span, 20 ft. depth, and with eleven panels. The panel engine, live, and bridge loads are 56,000, 35,000, and 16,800 lbs., respectively.

25. Prepare a table giving the stresses in the several members of a double-intersection deck-truss of 342 ft. span, 33 ft. depth, and with eighteen panels. (Double-track bridge.) The panel engine, train (or live), and dead loads are 96,000, 54,000, and 36,200 lbs., respectively.

26. Prepare a table giving the stresses in the several members of a

through-truss for a double-track bridge of 342 ft. span, 40 ft. depth, and with nineteen panels. The panel engine, live, and dead loads are 96,000, 53,000, and 43,200 lbs., respectively (double-intersection).

Ans.

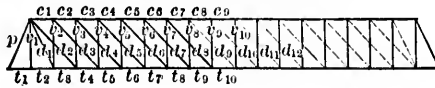

FIG. 444.

Chord Panel.	Mult.	7326	Mult.	5063	Total Shear transmitted to Panel.	Tang.	Panel Stress from Shear.	Total Panel Stress.
$t_1 = t_2$	18	131868	153	774639	906507	.45	407929	407929
t_3	—	3663	80½	407571½	403908½	.45	181758.825	589688
t_4	—	—	72½	—	—	.9	—	—
t_5	—	—	61½	—	—	.9	—	—
t_6	—	—	53½	—	—	.9	—	—
t_7	—	—	42½	—	—	.9	—	—
t_8	—	—	34½	174673½	171010½	.9	153909.45	—
t_9	—	—	23½	—	—	.9	—	—
t_{10}	—	—	15½	—	—	.9	—	—
c_1	18	—	153	—	—	.45	—	916751
c_2	—	—	80½	—	—	.45	—	—
c_3	—	—	72½	—	—	.9	—	—
c_4	—	—	61½	—	—	.9	—	—
c_5	—	—	53½	—	—	.9	—	—
c_6	—	—	42½	—	—	.9	—	—
c_7	—	—	34½	—	—	.9	—	—
c_8	—	—	23½	—	—	.9	—	—
c_9	—	—	15½	—	—	.9	—	—
c_{10}	—	—	8	—	—	.9	—	—
c_{11}	—	—	3½	—	—	.9	—	—

Diag.	Mult	5053	Mult.	2790	Shear due to Live Load.	Mult.	2274	Total Shear.	Secant.	Max. Stress.
d_1	18	—	153	—	—	171	—	—	1.0965	—
d_2	17	—	63½	—	—	80	—	—	1.0905	—
d_3	16	—	56½	—	—	72	—	—	1.345	—
d_4	15	75795	48½	135315	211110	61	138714	349824	1.345	—
d_5	14	70742	42½	189317	189317	53	120522	309839	1.345	—
d_6	13	65689	35½	99045	164734	42	95508	250242	1.345	—
d_7	12	60636	30½	85095	145731	34	77316	223047	1.345	299998
d_8	11	—	24½	—	—	23	—	—	1.345	—
d_9	10	—	20½	—	—	15	—	—	1.345	—
d_{10}	9	—	15½	—	—	4	—	—	1.345	—
d_{11}	8	40424	12½	34875	75299	—	—	—	1.345	890430
d_{12}	7	35371	8½	23715	—	—	—	—	1.345	33593

$v_1 = 139200$ lbs.

$v_2 = 349824$ "

$v_3 = 309839$ "

$v_4 = 260242$ lbs.

$v_5 = 223047$ "

$v_6 = 176240$ "

$v_7 = 141835$ lbs.

$v_8 = 97818$ "

$v_9 = 66203$ "

27. Prepare a table showing the stresses in the several members (including counters) of a ten-panel double-track through railway bridge of 184½ ft. span and 34 ft. depth, the live and dead loads being respectively 2250 lbs. and 1100 lbs. per lineal foot. (Thamesville Bridge.)

28. Determine the minimum stress-length (stress in a member multiplied by its length) for a double-intersection Pratt truss of 154 ft. span and with eleven panels. The panel loads for engine = 44,000 lbs., for train =

27,500 lbs., for bridge = 13,200 lbs.; coefficient of working strength = 8000 lbs. per square inch for both compression and tension.

29. A six-panel single-intersection Pratt truss is uniformly loaded. Assuming the same coefficient of strength both for compression and tension, show that the economy of material will be greatest when the diagonals are inclined at $32^{\circ} 36'$ to the vertical. (Load on upper chords.)

30. A double-intersection truss for a single-track through-bridge of 204 ft. span is 29 ft. deep, 20 ft. wide, and has twelve panels. Find the stresses produced in the members of the leeward truss by a panel wind-pressure of 5000 lbs. acting 8 ft. above base of rails (5-ft. gauge).

Ans. Sloping members : 1st = 27500 sec α ; 2d = 12500 sec α ;
3d = 10000 sec β ; 4th = 7500 sec β ;
5th = 5000 sec α ; 6th = 2500 sec β ;
7th = 0.

Tension chord : 1st panel = 27500 tan α = 2d; 3d = 40000 tan α ;
4th = 40000 tan α + 10000 tan β ;
5th = 40000 tan α + 17500 tan β ;
6th = 40000 tan α + 22500 tan β .

Compression chord : 1st = 40000 tan α + 10000 tan β ;
2d = 40000 tan α + 17500 tan β ;
3d = 40000 tan α + 22500 tan β ;
4th = 40000 tan α + 25000 tan β ;
5th = 40000 tan α + 25000 tan β .

Verticals : 1st = 5000; 2d = 7500; 3d = 5000;
4th = 2500; 5th = 0.

$$\tan \alpha = \frac{1}{4}; \quad \tan \beta = \frac{3}{4}.$$

31. In the preceding question find the maximum stresses in the members of the fourth panel met by a vertical plane; engine panel load = 85,000 lbs., train panel load = 40,800 lbs., bridge panel load = 22,500 lbs.

Ans. Stresses in tension chord = 465,795.11 lbs.; in compression chord = 647,011.2 lbs.; in sloping members = 204,800.66 lbs. and 155597.14 lbs.

32. Each of the two Pratt single-intersection five-panel trusses for a single-track bridge is 55 ft. centre to centre of end pins and 11 ft. 6 in. deep. Timber floor-beams are laid upon the upper chords $2\frac{1}{4}$ ft. centre to centre; the width between the chords = 10 ft. Find the proper scantling of the floor-beams for the loading given in Fig. 407, page 639. Also determine the maximum chord and diagonal stresses in the centre panel due to the same live load.

33. Prepare a table giving the stresses in the several members of a double-intersection deck-truss of 342 ft. span, 40 ft. depth, and with

nineteen panels. (Double-track bridge.) The panel engine, train (or live), and dead loads are 96,000, 53,000, and 43,200 lbs., respectively.

34. Prepare a table giving the stresses in the several members of a deck-truss for a double-track bridge of 342 ft. span, 33 ft. depth, and with eighteen panels. The panel engine, live, and dead loads are 96,000, 54,000, and 36,000 lbs., respectively.

35. The two trusses for a 16 ft. roadway are each 100 ft. in the clear 17 ft. 3 in. deep, and of the type represented in the figure; under a live load of 1120 lbs. per lineal foot the greatest total stress in AB is 35,400 lbs. Determine the permanent load.

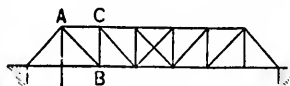

FIG. 445.

The diagonals and verticals are riveted to angle-irons forming part of the flanges. How many $\frac{3}{4}$ -in. rivets are required for the connection of AB and BC at B ? Also, how many are required between A and C to resist the tendency of the angle-irons to slip longitudinally? Working-shear stress = 10,000 lbs. per square inch.

Ans. 708.6 lbs.; 8; 4; 7.

36. The compression chord of a bowstring truss is a circular arc of 80 ft. span and 10 ft. rise; the bracing is of the isosceles type, the bases of the isosceles triangles dividing the tension chord into eight equal lengths. Determine the maximum stresses in the members met by a vertical plane 28 ft. from one end. The live and dead loads are each $\frac{1}{2}$ ton per lineal foot.

37. Design a parabolic bowstring truss of 80 ft. span and 10 ft. rise for a dead load of $\frac{1}{2}$ ton and a live load of 1 ton per lineal foot. The joints between the web and the tension chord are to divide the latter into eight equal divisions.

38. The compression chord of a bowstring truss is a circular arc. The depth of the truss is 14 ft. at the centre and 5 ft. at each end; the span = 100 ft.; the load upon the truss = 840 lbs. per lineal foot. Find the stresses in all the members. Determine also the maximum stresses in the members met by a vertical 25 ft. from one end when a live load of 1000 lbs. per lineal foot crosses the girder. What counter-braces are required?

39. A Pratt truss with sloping end posts has a length of 150 ft. centre to centre, and a height of 30 ft. centre to centre, with panels 15 ft. long; the dead load is 3000 lbs. per lineal foot, and the live load 1200 lbs. Determine the maximum stresses in the end posts, in the third post from one end, in the middle of the bottom chord, and in the members of the third panel met by a vertical plane.

40. Design a cross-tie for a double-track open-web bridge, the ties

being 18 ft. 5 in. centre to centre, and the live load for the floor system being 8000 lbs. per lineal foot.

41. A bowstring roof-truss of 50 ft. span, 15 ft. rise, and five panels is to be designed to resist a wind blowing horizontally with a pressure of 40 lbs. per square foot. The depth of the truss at the centre is 10 ft. Determine, graphically, the stresses in the several members of the truss, assuming that the roof rests on rollers at the windward support.

42. A bowstring truss of 120 ft. span and 15 ft. rise is of the isosceles braced type, the bases of the isosceles triangles dividing the tension chord into twelve equal divisions; the dead and live loads are $\frac{1}{2}$ ton and 1 ton per lineal foot, respectively. Find the maximum stresses in the members met by vertical planes immediately on the right of the second and fourth joints in the tension chord.

43. The figure is a skeleton diagram of the Sault Ste. Marie Bridge (C. P. R.). Span = 239 ft.; there are ten panels, each of 23.9 ft., say 24

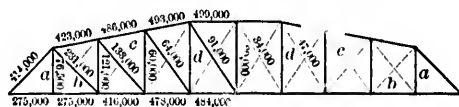

FIG. 446.

ft.; the length of the end verticals = 27 ft., of the centre verticals = 40 ft.; width on truss centres = $17\frac{1}{2}$ ft. The bridge is designed to bear the loading given by Fig. 407, page 639. Show that—

(a) The stresses in every panel length of each chord are greatest when the third driver is at a panel point; and find the value of the several stresses.

(b) The stresses in the verticals a and the diagonals b are greatest when the third driver is at a panel point; and find their values.

(c) The stresses in the remaining members of the truss are greatest when the second driver is at a panel point; and find their values.

(d) The maximum stresses in the verticals d vary from a tension of 64,000 lbs. to a compression of 11,000 lbs.

(e) The stress in the counter-brace e is nil.

Ans. The values of the stresses in the several members are marked on the diagram. They are deduced from the distributions given in the table on page 642, and are correct within a very small percentage.

44. The figure represents a counterbalanced swing-bridge, 16 ft. deep and wholly supported upon the turn-table at A and B ; the dead weight is 650 lbs. per lineal foot of bridge; the counterpoise is hung from C and D . Find its weight, assuming (a) that the whole of it is transmitted to B ; (b) that a portion of it is transmitted to A through

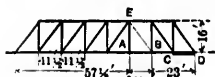

FIG. 447.

a member BE , sufficient to make the reactions at A and B equal. Also, determine the stresses in the several members of the truss.

Ans. Counterpoise in case (a) = 26,162½ lbs.;
in case (b) = 22,186¼ lbs.

Stress transmitted through BE in case (b) = 24,012 lbs.

45. The figure represents a counterbalanced swing-bridge; the dead load upon the bridge is 650 lbs. per lineal foot; the counterpoise is suspended from CD . Find its value, the joint at E being so designed that the whole of the load upon the bridge is always transmitted through the main posts EA, EB , and is evenly distributed between the points of support at A and B .

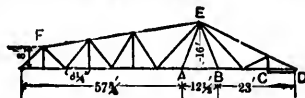

FIG. 445.

Ans. 20,694.3 lbs.

46. Find the stresses in the several members of the truss in the preceding question (a) when the bridge is open; (b) when the bridge is closed and is subjected to a live load of 3000 lbs. per lineal foot. Height of truss at E = 16 ft., at F = 8 ft.

47. Prepare a table giving the stresses in the several members of a single-intersection through-truss of 154 ft. span, 20 ft. depth, and with eleven panels. The panel engine, live, and dead (or bridge) loads are 27,500, 17,600, and 7,470 lbs., respectively.

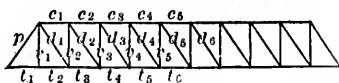

FIG. 449.

27,500, 17,600, and 7,470 lbs., respectively.

Ans.

Diag.	Mult.	2500	Mult.	1600	Sum.	Mult.	770	Sum.	sec.	Total Max. Stress.
p	10	25000	45	72000	97000	55	42350	139350	1.22	170007
d_1	9	22500	36	57600	80100	44	33880	113980	1.22	139059
d_2	8	20000	28	44800	64800	33	25410	90210	1.22	110057
d_3	7	17500	21	33600	51100	22	16940	68040	1.22	83009
d_4	6	15000	15	24000	39000	11	8470	47470	1.22	57014
d_5	5	12500	10	16000	28500	0	0	28500	1.22	34779
d_6	4	10000	6	9600	19600	-11	-8470	11130	1.22	13579

Panel.	Mult.	3270	Mult.	2370	Sum.	tan.	Panel Stress.	Total Panel Stress.
$t_1 = t_2$	10	32700	45	106650	139350	7/10	97545	97545
t_3	-1	-3270	45	106650	103380	"	72366	169911
t_4	-1	-3270	34	80580	77310	"	54117	224028
t_5	-1	-3270	23	54510	51240	"	35868	259896
t_6	-1	-3270	12	28440	25170	"	17619	277515

Panel.	Multi.	3270	Multi.	2370	Sum.	lan.	Total Stress.	Total Max. Stress.
c_1	10	32700	45	107650	242730	10	169911	169911
	1	3270	45	106650				
c_2	1	3270	34	80580	77310	"	54117	224028
c_3	1	3270	23	54510				
c_4	1	2270	12	28440	25170	"	17619	277515
c_5	1	3270	1	2370				
					900		630	276885

$$v_1 = 35,970 \text{ lbs.}; v_2 = 90,210; v_3 = 68,040; v_4 = 47,470; v_5 = 28,500 \text{ lbs.}$$

48. Compare the relative amounts of iron required in the webs of a single- and a double-intersection Pratt deck-truss of 100 ft. span and having eight panels. Panel live load = L , panel dead load = D .

49. The figure represents a pier, square in plan, supporting the ends of two deck-trusses, each 200 ft. long and 30 ft. deep. The height of the pier is 50 ft. and is made up of three panels, the upper and lower being each 17 ft. deep. Ten square feet of bridge surface and ten square feet of train surface per lineal foot are subjected to a wind-pressure of 40 lbs. per square foot. The centre of pressure for the bridge is 68 ft., and for the train 86 ft., above the pier's base. The wind also produces a horizontal pressure of 4000 lbs. at each of the intermediate panel points on the windward side of the pier. Width of pier = 17 ft. at top and 33½ ft. at bottom. The bridge load = 1600 lbs. per lineal foot, live load = 3000 lbs. per lineal foot. Determine—

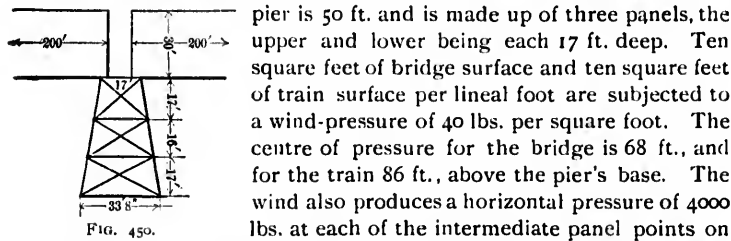

FIG. 450.

(a) The overturning moment (3180 ft.-tons).
 (b) The horizontal force due to the wind at the top of the pier. (61.6 tons.)
 (c) The tension in the vertical anchorage ties at S and T . (Nil.)
 (d) The vertical and horizontal reactions at T . (275 and 65.6 tons.)

Draw a diagram giving the wind-stresses in all the members, and indicate which are in tension and which in compression. Ascertain whether the wind-pressure of 40 lbs. per square foot upon a train of empty cars weighing 900 lbs. per lineal foot will produce a tension anywhere in the inclined posts. What will be the tension in the anchorage ties? (20.75 tons.)

Find the stresses in the traction bracing (1) when a loaded train travelling at 30 miles an hour is braked just as the engine is over the pier and brought to rest in a length of 300 ft.; (2) when a loaded train with the engine over the pier is started by a sudden admission into the cylinders of steam at 100 lbs. per square inch. Stroke of cylinder = 16 in., diameter of drivers = 5 ft.



EsXY

50. The figure represents one half of one of the piers of the Bouble Viaduct. The spans are crossed by two lattice-girders, 14' 9" deep and having a deck platform. The height of the pier is 183' 9" and is made up of eleven panels of equal depth. Width of pier at top = 13' 1½", at bottom = 67' 7". With wind-pressure at 55.3 lbs. per square foot, the total pressure on the girder, train, and pier have been calculated to be 20, 16.2, and 20 tons, acting at points 196.2, 210.3, and 92.85 ft., respectively, above the base. The dead weight upon each half pier is 222½ tons, of which 60 tons is weight of half span, 120 tons the weight of the half pier, and 42½ tons the weight of the train. Assuming that the wind-pressure on the pier is a horizontal force of 2 tons at each panel point on the windward side, and that the weight of the pier may be considered as a weight of 6 tons at each panel point, determine—

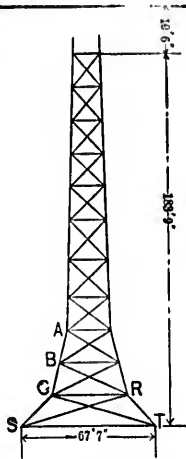

FIG. 451.

- (a) The overturning moment.
- (b) The total horizontal force at the top of the pier due to the wind.
- (c) The tension in each of the vertical anchorage ties at *S* and *T* due to the wind-pressure.
- (d) The vertical and horizontal reactions at *T*.

Show that the greatest compressive stress occurs in the member *RT*, and that it amounts to 422 tons.

Draw a stress diagram giving the stresses in all the members, indicating which are in tension and which in compression. Width of pier at *A* = 20 ft., at *B* = 23½ ft., at *C* = 36½ ft.

What will be the effect of braking the train when running at 30 miles an hour, so as to bring it to rest within a distance of 220 ft.? Width of pier in direction of bridge = 9½ ft. at top and = 20 ft. at bottom.

Ans.—(a) 9188 ft.-tons; (b) 39.9 tons; (c) 24½ tons. (d) Horizontal reaction = 59.9 tons; vertical reaction = 247 tons.

51. The accompanying figure represents a portion of a cantilever truss, the horizontal distances of the points *A*, *B*, *C* from the free end being l_1 , l_2 , l_3 , respectively. The boom *ABC* is inclined at an angle α , and the boom *XYZ* at an angle β , to the horizon. Find the deflections at the end of the cantilever due to (1) an increase $k_1 AB$ in the length of *AB*; (2) an increase $k_2 BY$ in the length of *BY*; (3) a decrease $k_3 XY$ in the length of *XY*; (4) a decrease $k_4 BX$ in the length of *BX*.

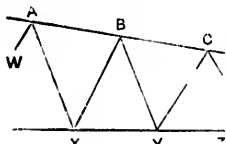

FIG. 452.

Ans.—(1) $\frac{k_1 l_1 AB}{BX \sin \alpha \beta}$

$$(2) k_2 \left\{ \frac{BY \cos \beta}{\sin B Y X} - l_2 (\cot YBC - \cot B Y X) \right\}.$$

$$(3) \frac{k_2 X Y l_2}{BX \sin B X Y}.$$

$$(4) k_1 \left\{ \frac{BX \cos \alpha}{\sin A B X} - l_1 (\cot B X Y - \cot A B X) \right\}.$$

In the preceding question, if $k_1 = k_2 = k_3 = k_4 = k$, and if AW is parallel to BX , and AX to BY , show that the angle between WX and XY after deformation

$$= 2k(\cot ABX + \cot B Y X).$$

Hence also, if the truss is of uniform depth d , show that the "deviation" of the boom per unit of length is constant and equal to $\frac{2k}{d}$.

52. Six bars have to be arranged upon a steel pin; each bar is 1 in. wide and is subjected to a stress of 64,000 lbs. Should the bars be ar-

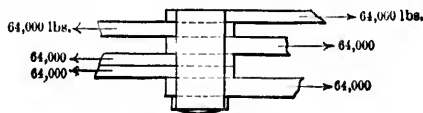

FIG. 453.—Method 1.

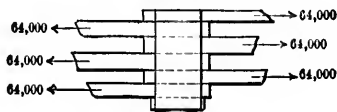

FIG. 454.—Method 2.

ranged according to method 1 or method 2? Why? Determine the diameter of the pin.

53. The accompanying sketch represents one of the pin connections in a certain bridge which was recently overthrown. The two innermost bars are web members inclined to the horizon at an angle whose cosine

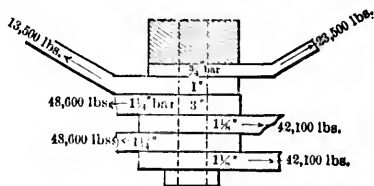

FIG. 455.

is .815. The thickness of the bars and the maximum stresses to which they are severally subjected are shown on the diagram. Is the 3-in. wrought-iron pin sufficiently strong?

CHAPTER XII.

SUSPENSION-BRIDGES.

1. Cables.—The modern suspension-bridge consists of two or more cables from which the platform is suspended by iron or steel rods. The cables pass over lofty supports (piers), and are secured to anchorages upon which they exert a direct pull.

Chain or link cables are the most common in England and Europe, and consist of iron or steel links set on edge and pinned together. Formerly the links were made by welding the heads to a flat bar, but they are now invariably rolled in one piece, and the proportional dimensions of the head, which in the old bridges are very imperfect, have been much improved.

Hoop-iron cables have been used in a few cases, but the practice is now abandoned, on account of the difficulty attending the manufacture of endless hoop-iron.

Wire-rope cables are the most common in America, and form the strongest ties in proportion to their weight. They consist of a number of parallel wire ropes or strands, compactly bound together in a cylindrical bundle by a wire wound round the outside. There are usually *seven* strands, one forming a core round which are placed the remaining six. It was found impossible to employ a seven-strand cable in the construction of the East River Bridge, New York, as the individual strands would have been far too bulky to manipulate. The same objection held against a thirteen-strand cable (thirteen is the next number giving an approximately cylindrical shape), and it was finally decided to make the cable with nineteen strands. Seven of these are pressed together so as to form a centre core, around which are placed the remaining twelve, the whole being continuously wrapped with wire.

In laying up a cable great care is required to distribute the tension uniformly amongst the wires. This may be effected either by giving each wire the same deflection or by using straight wire, i.e., wire which when unrolled upon the floor from a coil remains straight and shows no tendency to spring back. The distribution of stress is practically uniform in untwisted wire ropes. Such ropes are spun from the wires and strands without giving any twist to individual wires.

The back-stay is the portion of the cable extending from an anchorage to the nearest pier.

The elevation of the cables should be sufficient to allow for settling, which chiefly arises from the deflection due to the load and from changes of temperature.

The cables may be protected from atmospheric influence by giving them a thorough coating of paint, oil, or varnish, but wherever they are subject to saline influence, zinc seems to be the only certain safeguard.

2. Anchorage, Anchorage Chains, Saddles.—The anchorage, or abutment, is a heavy mass of masonry or natural rock to which the end of a cable is made fast, and which resists by its dead weight the pull upon the cable.

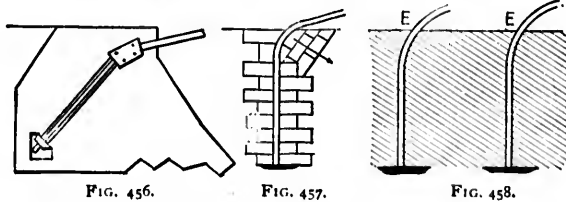

The cable traverses the anchorage as in Figs. 456 to 458, and passes through a strong, heavy cast-iron anchor-plate, and, if made of wire rope, has its end effectively secured by turning it round a dead-eye and splicing it to itself. Much care, however, is required to prevent a wire-rope cable from rusting on account of the great extent of its surface, and it is considered advisable that the wire portion of the cable should always terminate at the entrance to the anchorage and there be attached to a massive chain of bars, which is continued to the anchor-plate or plates and secured by bolts, wedges, or keys.

In order to reduce as much as possible the depth to which it is necessary to sink the anchor-plates, the anchor-chains are frequently curved as in Fig. 458. This gives rise to an oblique force, and the masonry in the part of the abutment subjected to such force should be laid with its beds perpendicular to the line of thrust.

The anchor-chains are made of compound links consisting alternately of an odd and an even number of bars. The friction of the link-heads on the knuckle-plates considerably lessens the stress in a chain, and it is therefore usual to diminish its sectional area gradually from the entrance *E* to the anchor. This is effected in the Niagara Suspension Bridge by varying the section of the bars, and in the East River Bridge by varying both the section and the number of the bars.

The necessity of preserving the anchor-chains from rust is of such importance that many engineers consider it most essential that the passages and channels containing the chains and fastenings should be accessible for periodical examination, painting, and repairs. This is unnecessary if the chains are first chemically cleaned and then embedded in good hydraulic cement, as they will thus be perfectly protected from all atmospheric influence.

The direction of an anchor-chain is changed by means of a saddle or knuckle-plate, which should be capable of sliding to an extent sufficient to allow for the expansion and contraction of the chain. This may be accomplished without the aid of rollers by bedding the saddle upon a four- or five-inch thickness of asphalted felt.

The chain, where it passes over the piers, rests on *saddles*, the object of which is to furnish bearings with easy vertical curves. Either the saddle may be constructed as in Fig. 459, so as to allow the cable to slip over it with comparatively little friction, or the chain may be secured to the saddle, and the saddle supported upon rollers which work over a perfectly true and horizontal bed formed by a saddle-plate fixed to the pier.

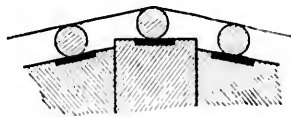

FIG. 459.

3. Suspenders.—The suspenders are the vertical or inclined rods which carry the platform.



FIG. 460.



FIG. 461.

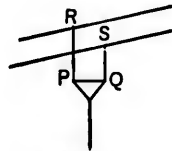

FIG. 462.

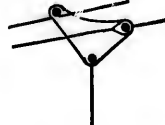

FIG. 463.

In Fig. 460 the suspender rests in the groove of a cast-iron yoke which straddles the cable. Fig. 461 shows the suspender bolted to a wrought-iron or steel ring which embraces the cable. When there are more than two cables in the same vertical plane, various methods are adopted to insure the uniform distribution of the load amongst the set. In Fig. 462, for example, the suspender is fastened to the centre of a small wrought-iron lever PQ , and the ends of the lever are connected with the cables by the equally strained rods PR and QS . In the Chelsea bridge the distribution is made by means of an irregularly shaped plate (Fig. 463), one angle of which is supported by a joint-pin, while a pin also passes through another angle and rests upon one of the chains.

The suspenders carry the ends of the cross-girders (floor-beams), and are spaced from 5 to 20 ft. apart. They should be provided with wrought-iron screw-boxes for purposes of adjustment.

4. Curve of Cable.—CASE A. An arbitrarily loaded flexible cable takes the shape of one of the catenaries, but the *true* catenary is the curve in which a cable of uniform section and material hangs under its own weight only.

Let A be the lowest point of the cable, and take the vertical through A as the axis of y .

Take the horizontal through O as the axis of x , the origin O being chosen so that

$$p \cdot AO = H = mp, \dots \dots \dots (1)$$

p being the weight of a unit of length of the cable, and H the horizontal pull at A .

m or AO is the parameter, or modulus, of the catenary, and OG is the directrix.

Let x, y be the co-ordinates of any point P , the length of the arc AP being s .

Draw the tangent PT and the ordinate PN .

The triangle PNT is evidently a triangle of forces for the portion AP , PN representing the weight of AP (viz., ps), PT

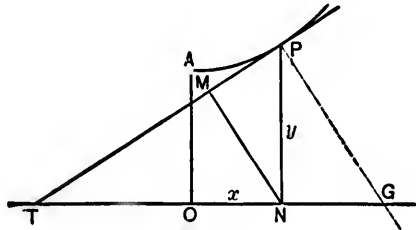

FIG. 464.

the tangential pull T at P , and NT the horizontal pull H at A .

$$\therefore \frac{dy}{dx} = \tan PTN = \frac{PN}{TN} = \frac{ps}{H} = \frac{s}{m}, \quad \dots (2)$$

which gives the differential equation to the catenary.

It may be easily integrated as follows :

$$\frac{ds}{dx} = \sqrt{1 + \left(\frac{dy}{dx}\right)^2} = \sqrt{1 + \frac{s^2}{m^2}} = \frac{1}{m} \sqrt{s^2 + m^2}, \quad (3)$$

or

$$\frac{ds}{\sqrt{s^2 + m^2}} = \frac{dx}{m}.$$

$$\therefore \log (s + \sqrt{s^2 + m^2}) = \frac{x}{m} + c,$$

c being a constant of integration.

When $x = 0$, $s = 0$, and therefore $\log m = c$.

Hence,

$$\log \frac{s + \sqrt{s^2 + m^2}}{m} = \frac{x}{m},$$

or

$$s + \sqrt{s^2 + m^2} = me^{\frac{x}{m}},$$

or

$$s = \frac{m}{2}(e^{\frac{x}{m}} - e^{-\frac{x}{m}}). \quad \dots \dots \dots (4)$$

Again,

$$\frac{dy}{dx} = \frac{s}{m} = \frac{1}{2}(e^{\frac{x}{m}} - e^{-\frac{x}{m}});$$

and hence,

$$y = \frac{m}{2}(e^{\frac{x}{m}} + e^{-\frac{x}{m}}). \quad \dots \dots \dots (5)$$

The constant of integration is zero, since $y = m$ when $x = 0$.

The last equation is the equation to the catenary, while eq. (4) gives the length of the arc AP .

By equations (4) and (5),

$$y^2 = s^2 + m^2. \quad \dots \dots \dots (6)$$

Draw NM perpendicular to PT , and let the angle $PTN = PNM = \theta$. Then

$$PM = PN \sin \theta = y \frac{s}{\sqrt{s^2 + m^2}} = s, \quad \dots \dots (7)$$

and

$$MN = PN \cos \theta = y \frac{m}{\sqrt{s^2 + m^2}} = m, \quad \dots \dots (8)$$

since $\tan \theta = \frac{dy}{dx} = \frac{s}{m}$.

Thus, the triangle PMN possesses the property that the side PM is equal to the length of the arc AP , and the side MN is equal to the modulus m ($= AO$).

The area $APNO$

$$= \int_0^x y dx = \frac{m^2}{2}(e^{\frac{x}{m}} - e^{-\frac{x}{m}}) = ms = 2 \times \text{triangle } PMN.$$

The radius of curvature, ρ , at P

$$= \frac{\left\{ 1 + \left(\frac{dy}{dx} \right)^2 \right\}^{\frac{3}{2}}}{\frac{d^2y}{dx^2}} = \frac{\left(\frac{y}{m} \right)^3}{\frac{y}{m^3}} = \frac{y^3}{m} = PG, \dots (9)$$

PG being perpendicular to PT .

At A , $y = m$, and the radius of curvature is also m . (10)

Again,

$$\frac{T}{ps} = \frac{PT}{NP} = \operatorname{cosec} \theta = \frac{y}{s}.$$

$$\therefore T = py; \dots (11)$$

$$H = pm = p\rho_0; \dots (12)$$

ρ_0 being the radius of curvature at A .

These catenary formulæ are of little if any use in the design and construction of suspension-bridges, as they are based upon the assumption of a purely theoretical load which never occurs in practice, viz., the weight of a chain of uniform section and density.

CASE B. Let the platform be suspended from chains composed of a number of links, and let W be the whole weight be-

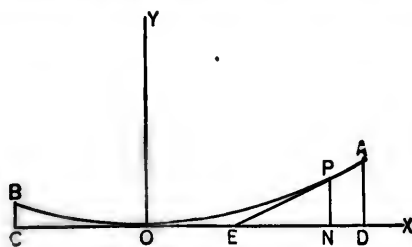

FIG. 465.

tween the lowest point O of the chain and the upper end P of any given link. Let the direction of this link intersect that of the horizontal pull (H) at O in E . Drop the perpendicular PN .

The triangle PNE is evidently a triangle of forces; and if the angle $PEN = \theta$,

$$\tan \theta = \frac{PN}{NE} = \frac{W}{H},$$

and hence

$$\tan \theta \propto W.$$

Thus, by treating each link separately, commencing with the lowest, the exact curve of the chain may be easily traced.

Generally speaking, the distribution of the load may be assumed to be approximately uniform per *horizontal* unit of length, the load being suspended from a number of points along each chain or cable by means of rods. The curve of the cable will then be a parabola.

Let w be the intensity of the load per horizontal unit of length.

Let x, y be the co-ordinates of any point P of the cable with respect to the horizontal OX and the vertical OY as axes of x and y , respectively.

Let θ be the inclination of the tangent at P to the horizontal. The portion OP of the cable is kept in equilibrium by the horizontal pull H at O , by the tangential pull T at P , and by the load wx upon OP , which acts vertically through the middle point E of ON , PN being the ordinate at P .

Hence, the tangent at P must also pass through E , and PEN is a triangle of forces. Hence,

$$\frac{H}{wx} = \frac{\frac{x}{2}}{y}, \quad \text{or} \quad x^2 = \frac{2H}{w}y, \quad \dots \dots \dots (1)$$

the equation to a parabola with its vertex at O , its axis vertical, and its parameter equal to $\frac{2H}{w}$.

Again,

$$\frac{T}{H} = \frac{PE}{EN} = \frac{1}{\cos \theta},$$

and hence

$$T \cos \theta = H = \frac{wx^2}{2y}, \dots \dots \dots (2)$$

and the horizontal pull at every point of the cable is the same as that at the lowest point.

Also,

$$T = \frac{wx^2}{2y} \sec \theta = \frac{wx^2}{2y} \sqrt{1 + \frac{y^2}{x^2}} = wx \sqrt{1 + \frac{x^2}{4y^2}}$$

The radius of curvature at P

$$\begin{aligned} &= \frac{\left(1 + \frac{4y^2}{x^2}\right)^{\frac{3}{2}}}{\frac{2y}{x^2} \left(\frac{w}{H}\right)} = \frac{\left(1 + 2y \frac{w}{H}\right)^{\frac{3}{2}}}{\frac{w}{H}}, \end{aligned}$$

so that the radius at O is

$$\rho_0 = \frac{H}{w},$$

or

$$H = w\rho_0.$$

5. Parameter, etc.—Let h_1, h_2 be the elevations of A and B , respectively, above the horizontal line COD , Fig. 465.

Let $OD = a_1, OC = a_2$, and let $a_1 + a_2 = a = CD$.

By equation (1), Art. 4, Case B,

$$\sqrt{\frac{2H}{w}} = \frac{a_1}{\sqrt{h_1}} = \frac{a_2}{\sqrt{h_2}} = \frac{a_1 + a_2}{\sqrt{h_1} + \sqrt{h_2}} = \frac{a}{\sqrt{h_1} + \sqrt{h_2}}.$$

Denote the parameter by P . Then

$$P = \frac{2H}{w} = \left(\frac{a}{\sqrt{h_1} + \sqrt{h_2}}\right)^2.$$

Also,

$$\tan \theta = \frac{2y}{x} = \frac{wx}{H} = \frac{2x}{P} = 2\sqrt{\frac{y}{P}}.$$

ii h_1, θ_1 be the values of θ at A and B , respectively.

$$\tan \theta_1 = 2\sqrt{\frac{h_1}{P}} \quad \text{and} \quad \tan \theta_2 = 2\sqrt{\frac{h_2}{P}}.$$

Note.—If $h_1 = h_2 = h$,

$$a_1 = a_2 = \frac{a}{2}, \quad P = \frac{a^2}{4h},$$

and hence

$$\tan \theta_1 = \frac{4h}{a} = \tan \theta_2.$$

6. Length of Arc of Cable.—Let $OP = s$, Fig. 465.

Since $\tan \theta = \frac{wx}{H}$,

$$\sec^2 \theta d\theta = \frac{w}{H} dx = \frac{w}{H} ds \cos \theta,$$

or

$$ds = \frac{H}{w} \frac{d\theta}{\cos^3 \theta}$$

Hence,

$$s = \frac{H}{w} \int_0^\theta \frac{d\theta}{\cos^3 \theta} = \frac{H}{2w} \{ \tan \theta \sec \theta + \log_e (\tan \theta + \sec \theta) \}.$$

Again,

$$\tan \theta = \frac{w}{H} x,$$

and

$$\sec \theta = \sqrt{1 + \frac{w^2}{H^2} x^2}.$$

$$\therefore s = \frac{H}{2w} \left\{ \frac{w}{H} x \sqrt{1 + \frac{w^2}{H^2} x^2} + \log_e \left(\frac{w}{H} x + \sqrt{1 + \frac{w^2}{H^2} x^2} \right) \right\}.$$

Note.—An approximate value of the length of the arc may be obtained as follows:

$$ds^2 = dx^2 + dy^2 = dx^2 \left\{ 1 + \left(\frac{dy}{dx} \right)^2 \right\} = dx^2 \left(1 + \frac{w^2 x^2}{H^2} \right).$$

$$\therefore ds = dx \left(1 + \frac{1}{2} \frac{w^2 x^2}{H^2} \right), \text{ approximately.}$$

Integrating between O and P ,

$$s = OP = x + \frac{1}{6} \frac{w^2 x^3}{H^2} = x + \frac{2}{3} \frac{y^2}{x}.$$

7. Weight of Cable.—The ultimate tenacity of iron wire is 90,000 lbs. per square inch, while that of steel rises to 200,000 lbs., and even more. The strength and gauge of cable wire may be insured by specifying that the wire is to have a certain ultimate tenacity and elastic limit, and that a given number of lineal feet of wire is to weigh *one* pound. Each of the wires for the cables of the East River Bridge was to have an ultimate tenacity of 3400 lbs., an elastic limit of 1600 lbs., and 14 lineal feet of the wire were to weigh *one* pound. A very uniform wire, having a coefficient of elasticity of 29,000,000 lbs., has been the result, and the process of *straightening* has raised the ultimate tenacity and elastic limit nearly 8 per cent.

Let W_1 be the weight of a length a , ($= OD$) of a cable of sufficient sectional area to bear safely the horizontal tension H .

Let W_2 be the weight of the length s , ($= OA$) of the cable of a sectional area sufficient to bear safely the tension T , at A .

Let f be the safe inch-stress.

Let q be the specific weight of the cable material.

Then

$$W_1 = \frac{H}{f} a, q$$

and

$$W_2 = \frac{H \sec \theta}{f} s, q.$$

$$\therefore W_2 = W_1 \frac{s_1}{a_1} \sec \theta_1 = \frac{W_1}{a_1} \left(a_1 + \frac{2}{3} \frac{h_1^2}{a_1} \right) \left(1 + \frac{2h_1^2}{a_1^2} + \dots \right),$$

or

$$W_2 = W_1 \left(1 + \frac{8}{3} \frac{h_1^2}{a_1^2} \right), \text{ nearly.}$$

A saving may be effected by proportioning any given section to the pull across that section.

At any point (x, y) the pull = $H \sec \theta$, and the corresponding sectional area = $\frac{H \sec \theta}{f}$. The weight per unit of length = $\frac{H \sec \theta}{f} q$, and the total weight of the length s_1 ($= OA$) is

$$\begin{aligned} W_2 &= \int_0^{s_1} \frac{H \sec \theta}{f} q \frac{ds}{dx} dx = \frac{Hq}{f} \int_0^{s_1} \sec^2 \theta dx \\ &= \frac{Hq}{f} \int_0^{a_1} \left(1 + \frac{2y^2}{x^2} + \dots \right)^2 dx. \end{aligned}$$

But $x^2 = \frac{a_1^2}{h_1} y$.

$$\begin{aligned} \therefore W_2 &= \frac{Hq}{f} \int_0^{a_1} \left(1 + 2 \frac{h_1^2}{a_1^2} x^2 + \dots \right)^2 dx \\ &= \frac{Hq}{f} \left(a_1 + \frac{4}{3} \frac{h_1^2}{a_1} \right), \text{ nearly.} \end{aligned}$$

Hence,

$$W_2 = W_1 \left(1 + \frac{4}{3} \frac{h_1^2}{a_1^2} \right),$$

and also

$$2W_2 = W_1 + W_2.$$

The weight of a cubic inch of steel averages .283 lb.

The weight of a cubic inch of wrought-iron averages .278 lb.

The volume in inches of the cable of weight $W_1 = 12a_1 \frac{H}{f}$.

$$\therefore \frac{W_1}{H} = .283 \text{ lb. or } .278 \text{ lb.,}$$

$$12a_1 f$$

according as the cable is made of steel or iron.

Let the safe inch-stress of steel wire be taken at 33,960 lbs., of the best cable-iron at 14,958 lbs., and of the best chain-links at 9972 lbs. Then

$$W_1 = Ha_1 \times .283 \times \frac{12}{33600} = \frac{Ha_1}{10000} \text{ for steel cables ;}$$

$$W_1 = Ha_1 \times .278 \times \frac{12}{14958} = \frac{Ha_1}{4500} \text{ for iron cables ;}$$

$$W_1 = Ha_1 \times .278 \times \frac{12}{9972} = \frac{Ha_1}{3000} \text{ for link cables.}$$

Note.—About one-eighth may be added to the net weight of a chain-cable for eyes and fastenings.

8. Deflection of a Cable due to an Elementary Change in its Length.

By the corollary of Art. 6 the total length (S) of the cable AOB is

$$S = a_1 + a_2 + \frac{2h_1^2}{3a_1} + \frac{2h_2^2}{3a_2}.$$

Now a_1 and a_2 are constant; $h_1 - h_2$ is also constant, and therefore $dh_1 = dh_2$. Hence,

$$dS = \frac{4}{3} \left(\frac{h_1}{a_1} + \frac{h_2}{a_2} \right) dh.$$

If the alteration in length is due to a change of t° in the temperature,

$$dS = e t S,$$

e being the coefficient of linear expansion and $= \frac{1}{800 \times 180}$ per degree Fahr. for wrought-iron.

In England the effective range of temperature is about 60° Fahr., while in other countries it is usual to provide for a range of from 100° to 150° F.

If the alteration is due to a pull of intensity f per unit of area,

$$dS = \frac{f}{E} S,$$

E being the coefficient of elasticity of the cable material.

If $h_1 = h_2 = h$,

$$a_1 = a_2 = \frac{a}{2}, \quad \text{and} \quad dS = \frac{16h}{3a} dh.$$

9. **Curve of Cable** from which the load is suspended by a series of sloping rods.

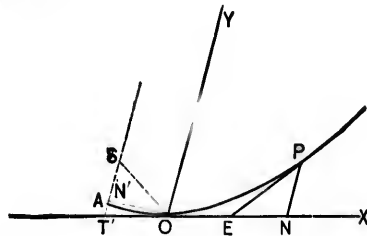

FIG. 466.

Let O be the lowest point of such a cable. Let the tangent at O , and a line through O parallel to the suspenders, be the axes of x and y , respectively.

Let w' be the intensity of the oblique load. Consider a portion OP of the cable, and let the co-ordinates of P with respect to OX , OY be x and y .

Draw the ordinate PN , and let the tangent at P meet ON in E .

As before, PNE is a triangle of forces, and E is the middle point of ON . Then

$$\frac{w'x}{H} = \frac{PN}{NE} = \frac{2y}{x}, \quad \text{or} \quad x^2 = \frac{2H}{w'} y,$$

the equation to a parabola with its axis parallel to OY and its focus at a point S , where $4SO = \frac{2H}{w'}$.

Cor. 1. Let the axis meet the tangent at O in T' , and let its inclination to OX be i .

Let A be the vertex, and ON' a perpendicular to the axis. Then

$$SO = ST' = SA + AT' = SA + AN'.$$

But $4AS \cdot AN' = ON'^2 = N'T'^2 \tan^2 i = 4AN'^2 \tan^2 i$.

$$\therefore AS = AN' \tan^2 i, \text{ and } SO = AS(1 + \cot^2 i) = \frac{AS}{\sin^2 i}.$$

Hence, the parameter = $4AS = 4SO \sin^2 i$.

Cor. 2. Let P be the oblique load upon the cable between O and P .

Let Q be the total thrust upon the platform at E .

" w " " load per horizontal unit of length.

" q " " rate of increase of thrust along platform.

" t " " length of PE .

Then

$$w' = \frac{w}{\sin i}, \text{ and } q = w \cot i;$$

$$H = \frac{w'x^2}{2y} = 2w' \cdot SO = 2AS \frac{w'}{\sin^2 i} = 2AS \frac{w}{\sin^2 i};$$

$$P = H \frac{2t}{x} = \frac{w'tx}{y};$$

$$t^2 = y^2 + \frac{x^2}{4} + xy \cos i.$$

Cor. 3. Let s be the length of OP , and let θ be the inclination of PE to OY . Then

$$\begin{aligned} s &= AP - AO \\ &= \frac{H \sin^2 i}{2w'} \left\{ \tan(90^\circ - \theta) \sec(90^\circ - \theta) \right. \\ &+ \log_e \{ \tan(90^\circ - \theta) + \sec(90^\circ - \theta) \} - \tan(90^\circ - i) \sec(90^\circ - i) \\ &\quad \left. - \log_e \{ \tan(90^\circ - i) + \sec(90^\circ - i) \} \right\} \\ &= \frac{H \sin^2 i}{2w'} \left\{ \cot \theta \operatorname{cosec} \theta - \cot i \operatorname{cosec} i + \log_e \frac{\cot \theta + \operatorname{cosec} \theta}{\cot i + \operatorname{cosec} i} \right\}. \end{aligned}$$

It may be easily shown, as in the Note to Art. 6, that approximately

$$s = x + y \cos i + \frac{2}{3} \frac{y^3 \sin^2 i}{x + y \cos i}.$$

10. Pressure upon Piers, etc.

Let T_1 be the tension in the main cable at A .

" T_2 " " " " " back-stay at A .

" α, β be the inclinations to the horizontal of the tangents at A to the main cable and back-stay, respectively.

The total vertical pressure upon the pier at A

$$= T_1 \sin \alpha + T_2 \sin \beta = P.$$

The total resultant horizontal force at A

$$= T_1 \cos \alpha \sim T_2 \cos \beta = Q.$$

If the cable is secured to a saddle which is free to move horizontally on the top of the pier (Fig. 467),

$Q \leq$ the frictional resistance to the tendency to motion,

$$\text{or } Q \leq \mu_1 P,$$

μ_1 being the corresponding coefficient of friction.

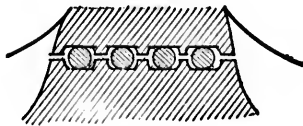

FIG. 467.

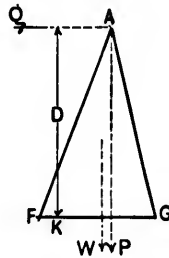

FIG. 468.

Let D , Fig. 468, be the total height of the pier, and let W be its weight.

Let FG be the base of the pier, and K the limiting position of the centre of pressure.

Let p, q be the distance of P and W , respectively, from K .
Then

$$\text{for stability of position } Q \leq \frac{Pp + Wq}{D},$$

and for *stability of friction*, when the pier is of masonry,

$$\frac{Q}{P + W} \leq \text{the coefficient of friction of the masonry.}$$

If μ_1 is sufficiently small to be disregarded, Q is approximately *nil*, and $T_1 \cos \alpha = T_2 \cos \beta = H$. The pressure upon the pier is now wholly vertical and is $= H(\tan \alpha + \tan \beta)$.

When the cable slides over smooth rounded saddles (Fig. 459), the tensions T_1 and T_2 are approximately the same.

Thus,

$$P = T_1(\sin \alpha + \sin \beta) \quad \text{and} \quad Q = T_1(\cos \alpha - \cos \beta).$$

If $\alpha = \beta$, $Q = 0$, and the pressure upon the pier is wholly vertical, its amount being $2T_1 \sin \alpha$.

The piers are made of timber, iron, steel, or masonry, and allow of great scope in architectural design.

The cable should in no case be rigidly attached to the pier, unless the lower end of the latter is free to revolve through a small angle about a horizontal axis.

II. Auxiliary or Stiffening Truss.—The object of a stiffening truss (Fig. 469) is to distribute a passing load over the cable in such a manner that it cannot be distorted. The pull upon each suspender must therefore be the same, and this vir-

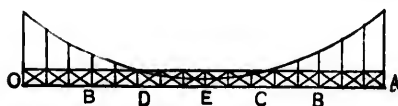

FIG. 469.

tually assumes that the effect of the extensibility of the cable and suspenders upon the figure of the stiffening truss may be disregarded.

The ends O and A must be anchored, or held down by pins, but should be free to move horizontally.

Let there be n suspenders dividing the span into $(n + 1)$ equal segments of length a .

Let P be the total weight transmitted to the cable, and z the distance of its centre of gravity from the vertical through O .

Let T be the pull upon each suspender.

Taking moments about O ,

$$Pz = T(a + 2a + 3a + \dots + na) = Ta \frac{n(n+1)}{2} = T \frac{nl}{2},$$

l being the length of OA .

Also, if t is the intensity of pull per unit of span,

$$tl = nT, \quad \text{and hence} \quad Pz = t \frac{l^2}{2}.$$

Let there be a central suspender of length s . There will, therefore, be $\frac{n-1}{2}$ suspenders on each side of the centre.

The parameter of the parabola = $\frac{l^2}{4h}$.

Hence, the total length of all the suspenders

$$\begin{aligned} &= s + 2 \left\{ \frac{n-1}{2} s + \frac{4h}{l^2} a^2 \left[1^2 + 2^2 + 3^2 + \dots + \left(\frac{n-1}{2} \right)^2 \right] \right\} \\ &= ns + 8h \frac{a^2 n(n^2-1)}{l^2 \cdot 24} = n \left(s + \frac{h}{3} \frac{n-1}{n+1} \right). \end{aligned}$$

If there is no central suspender, i.e., if n is even,

$$\text{the total length} = (n-1) \left(s + \frac{h}{3} \frac{n}{n+1} \right).$$

Denote the total length of suspenders by L . Then

$$\text{the stress-length} = TL = \frac{2z}{nl} PL.$$

Let w be the uniform intensity of the dead load.

CASE I. *The bridge partially loaded.*

Let w' be the maximum uniform intensity of the live load, and let this load advance from A and cover a length AB .

Let $OB = x$, and let R_1, R_2 be the pressures at O and A , respectively.

For equilibrium,

$$R_1 + R_2 + tl - wl - w'(l - x) = 0; \dots (1)$$

$$R_1 l + t \frac{l^2}{2} - w \frac{l^2}{2} - \frac{w'}{2} (l - x)^2 = 0. \dots (2)$$

Also, since the whole of the weight is to be transmitted through the suspenders,

$$tl = wl + w'(l - x). \dots (3)$$

From eqs. (1), (2), and (3),

$$-R_1 = \frac{w'x}{2} (l - x) = R_2, \dots (4)$$

which shows that the reactions at O and A are equal in magnitude but opposite in kind. They are evidently greatest when $x = \frac{l}{2}$, i.e., when the live load covers half the bridge, and the common value is then $\frac{w'l}{8}$.

The *shearing force* at any point between O and B distant x' from O

$$= R_1 + (t - w)x' = w' \frac{l - x}{l} (x' - \frac{x}{2}), \dots (5)$$

which becomes $\frac{w'x}{2} (l - x) = -R_1 = R_2$ when x' equal x .

Thus the shear at the head of the live load is equal in magnitude to the reaction at each end, and is an absolute maximum

when the live load covers half the bridge. The web of the truss must therefore be designed to bear a shear of $\frac{w'l}{8}$ at the centre and ends.

Again, the *bending moment* at any point between O and B distant x' from O

$$= R_1 x' + \frac{l-w}{2} x'^2 = \frac{w'l-x}{2} \frac{x}{l} (x'^2 - x x'), \quad \dots (6)$$

which is greatest when $x' = \frac{x}{2}$, i.e., at the centre of OB , its value then being $-\frac{w'l-x}{8} \frac{x}{l} x^2$. Thus, the bending moment is an *absolute maximum* when $\frac{d}{dx}(lx^2 - x^3) = 0$, i.e., when $x = \frac{2}{3}l$, and its value is then $-\frac{w'l^2}{54}$.

The bending moment at any point between B and A distant x' from O

$$= R_1 x' + \frac{l-w}{2} x'^2 - \frac{w'}{2} (x' - x)^2 = \frac{w'}{2} \frac{x}{l} (x' - x)(l - x'), (7)$$

which is greatest when $\frac{d}{dx}\{(x' - x)(l - x')\} = 0$, i.e., when $x' = \frac{l+x}{2}$, or at the centre of AB , its value then being $\frac{w'}{8} \frac{x}{l} (l - x)^2$. Thus, the bending moment is an *absolute maximum* when $\frac{d}{dx}\{x(l - x)^2\} = 0$, i.e., when $x = \frac{l}{3}$, and its value is then $+\frac{w'l^2}{54}$.

Hence, *the maximum bending moments of the unloaded and loaded divisions of the truss are equal in magnitude but opposite in direction, and occur at the points of trisection (D, C) of OA*

when the live load covers one-third (*AC*) and two-thirds (*AD*) of the bridge, respectively.

Each chord must evidently be designed to resist both tension and compression, and in order to avoid unnecessary nicety of calculation, the section of the truss may be kept uniform throughout the middle half of its length.

CASE II. *A single concentrated load W at any point B of the truss.* *W* now takes the place of the live load of intensity *w*'.

The remainder of the notation and the method of procedure being precisely the same as before, the corresponding equations are

$$R_1 + R_2 + (t - w)l - W = 0. \dots (1')$$

$$R_1 l + \frac{t - w}{2} l^2 - W(l - x) = 0. \dots (2')$$

$$t - w = \frac{W}{l}. \dots (3')$$

$$-R_1 = \frac{W}{l} \left(x - \frac{l}{2} \right) = R_2, \dots (4')$$

which shows that the reactions at *O* and *A* are equal in magnitude but opposite in kind. They are greatest when *x* = 0 and when *x* = *l*, i.e., when *W* is either at *O* or at *A*, and the common value is then $\frac{W}{2}$.

The *shearing force* at any point between *O* and *B* distant *x'* from *O*

$$= R_1 + (t - w)x' = \frac{W}{l} \left(x' - x + \frac{l}{2} \right), \dots (5')$$

which is a maximum when *x'* = *x*, and its value is then $\frac{W}{2}$.

The web must therefore be designed to bear a shear of $\frac{W}{2}$ throughout the whole length of the truss.

Again, the bending moment at any point between O and B distant x' from O

$$= R_1 x' + (t - w) \frac{x'^2}{2} = \frac{W}{l} \left\{ \frac{x'^2}{2} + x' \left(\frac{l}{2} - x \right) \right\}. \quad (6')$$

First, let $x < \frac{l}{2}$. The bending moment is *positive* and is a maximum when $x' = x$, its value then being

$$+ \frac{W}{2l} (lx - x^2).$$

Next, let $x > \frac{l}{2}$. The bending moment is then *negative* and is a maximum when $x' = x - \frac{l}{2}$, its value then being

$$- \frac{W}{2l} \left(x - \frac{l}{2} \right)^2.$$

The bending moment at any point between B and A distant x' from O

$$= R_1 x' + (t - w) \frac{x'^2}{2} - W(x' - x) = \frac{W}{l} (x' - l) \left(\frac{x'}{2} - x \right), \quad (7')$$

which is a maximum when

$$\frac{d}{dx'} \left\{ (x' - l) \left(\frac{x'}{2} - x \right) \right\} = 0,$$

i.e., when $x' = x + \frac{l}{2}$, and its value is then $-\frac{W}{2l} \left(x - \frac{l}{2} \right)^2$.

Note.—The stiffening truss is most effective in its action, but adds considerably to the weight and cost of the whole structure. Provision has to be made both for the extra truss and for the extra material required in the cable to carry this extra load.

Stiffening Truss hinged at the Centre.—Provision may be made for counteracting the straining due to changes of temperature by hinging the truss at the centre *E*.

Let a live load of intensity w' advance from *A*.

First, let the live load cover a length $AB = x \left(> \frac{l}{2} \right)$.

Let R_1, R_2 be the pressures at *O, A*, respectively.

The equations of equilibrium are

$$R_1 + R_2 + (t - w)l - w'x = 0; \dots (1)$$

$$R_1 \frac{l}{2} + (t - w) \frac{l^2}{8} - \frac{w'}{2} \left(x - \frac{l}{2} \right)^2 = 0; \dots (2)$$

$$R_2 \frac{l}{2} + (t - w) \frac{l^2}{8} - \frac{w'}{8} l^2 = 0. \dots (3)$$

Eqs. (2) and (3) being obtained by taking moments about *E*.

Hence,

$$t - w = - \frac{w'}{l^2} (l^2 - 4lx + 2x^2); \dots (4)$$

$$R_1 = \frac{1}{2} \frac{w'}{l} (l^2 - 4lx + 3x^2); \dots (5)$$

$$R_2 = \frac{1}{2} \frac{w'}{l} (l - x)^2. \dots (6)$$

Next, let the live load cover the length $BO \left(< \frac{l}{2} \right)$.

Let $AB = x$ as before, and let R_1', R_2', t' be the new values of R_1, R_2, t , respectively.

The equations of equilibrium are now

$$R_1' + R_2' + (t' - w)l - w'(l - x) = 0; \dots (7)$$

$$R_1' \frac{l}{2} + (t' - w) \frac{l^2}{8} - \frac{w'}{2} x(l - x) = 0; \dots (8)$$

$$R_2' \frac{l}{2} + (t' - w) \frac{l^2}{8} = 0; \dots \dots \dots (9)$$

and hence,

$$t' - w = 2 \frac{w'}{l^2} (l - x)^2 [= -(t - w - w')]; \dots (10)$$

$$R_1' = -\frac{1}{2} \frac{w'}{l} (l^2 - 4lx + 3x^2) (= -R_1); \dots (11)$$

$$R_2' = -\frac{1}{2} \frac{w'}{l} (l - x)^2 (= -R_2). \dots \dots \dots (12)$$

Diagram of Maximum Shearing Force.—The shear at any point distant z from A in the unloaded portion BO when the live load covers AB

$$= R_1 + (t - w)(l - z). \dots \dots \dots (13)$$

$$= -\{R_1' + (t' - w - w')(l - z)\}$$

$$= -\{R_1' + (t' - w)(l - z) - w'(l - z)\}$$

= minus the shear at the same point when AB is unloaded and the live load covers BO .

For a given value of z the maximum shear, positive or negative, at any point of OB , is found by making (see eq. (13))

$$dR_1 + (l - z)d(t - w) = 0,$$

or

$$\frac{w'}{l}(-2l + 3x) - \frac{w'}{l^2}(l - z)(-4l + 4x) = 0,$$

or

$$x = l \frac{4z - 2l}{4z - l}. \dots \dots \dots (14)$$

Hence, by eqs. (4), (5), (13), (14),

$$\text{the maximum shear} = \pm \frac{1}{2} w' x \frac{l-2x}{l-x}, \dots (15)$$

and may be represented by the ordinate (positive or negative) of the curve *mnpq*.

For example, at the points defined by

$$z = l, \quad \frac{3}{4}l, \quad \frac{1}{4}l,$$

the shears are greatest when

$$x = \frac{3}{8}l, \quad \frac{3}{8}l, \quad \frac{1}{8}l,$$

and their values are, respectively,

$$\mp \frac{1}{8} w' l, \quad \mp \frac{3}{8} w' l, \quad 0.$$

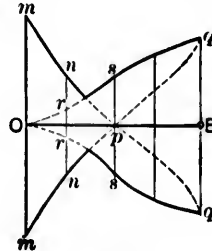

FIG. 470.

Again, the shear at any point distant *z* from *A* in the loaded portion *BE* when the live load covers *AB*

$$= R_1 + (l-w)(l-z) - w'(x-z) \dots (16)$$

$$= R_1 + (l-w-w')(l-z) + w'(l-x)$$

$$= - \{ R_1' + (l'-w)(l-z) - w'(l-x) \}$$

= minus the shear at the same point when *AB* is unloaded and the live load covers *BO*.

Hence, by eqs. (4), (5), (16),

$$\text{the shear} = \mp \frac{1}{2} \frac{w'}{l^2} (l-4z)(l-x)^2, \dots (17)$$

increasing for a given value of *z* with *l-x*, and, therefore, a maximum when *x = z*. Thus,

$$\text{the maximum shear} = \mp \frac{1}{2} \frac{w'}{l^2} (l-4x)(l-x)^2, \dots (18)$$

and occurs immediately in front of the load when it covers *AB*, and immediately behind the load when it covers *BO*. It

may be represented by the ordinate (*positive or negative*) of the curve *orsq*.

For example, at the points defined by

$$z = x = l, \quad \frac{3}{8}l, \quad \frac{4}{8}l, \quad \frac{5}{8}l, \quad \frac{7}{8}l,$$

the maximum shears given by eq. (18) are, respectively,

$$0, \quad \pm \frac{5}{8}w'l, \quad \pm \frac{1}{8}w'l, \quad \pm \frac{3}{8}w'l, \quad \pm \frac{1}{8}w'l.$$

Diagram of Maximum Bending Moment.—The bending moment at any point in *BO* distant *z* from *A* when the live load covers *AB*

$$= R_1(l - z) + (t - w)\frac{(l - z)^2}{2} \dots \dots \dots (19)$$

$$= - \left\{ R_1'(l - z) + (t' - w - w')\frac{(l - z)^2}{2} \right\}$$

$$= - \left\{ R_1'(l - z) + (t' - w)\frac{(l - z)^2}{2} - w'\frac{(l - z)^2}{2} \right\}$$

= *minus* the bending moment at the same point when the live load covers *BO*.

Hence, by eqs. (4), (5), (19), the bending moment

$$= \pm \frac{1}{2} \frac{w'}{l} (l^2 - 4lx + 3x^2)(l - z) \mp \frac{1}{2} \frac{w'}{l^2} (l^2 - 4lx + 2x^2)(l - z)^2.$$

For a given value of *z* this is a maximum and equal to

$$\pm \frac{w' \ zl - zl - 2z}{2 \ (l - 2z)} \quad \text{when} \quad x = \frac{2lz}{l + 2z}.$$

Thus, the maximum bending moment may be represented by the ordinate (*positive or negative*) of a curve.

For example, at the points defined by

$$z = l, \quad \frac{3}{8}l, \quad \frac{4}{8}l, \quad \frac{5}{8}l, \quad \frac{l}{2},$$

the bending moments are greatest when $x =$

$$\frac{1}{8}l, \quad \frac{1}{11}l, \quad \frac{3}{8}l, \quad \frac{5}{11}l, \quad \frac{7}{8}l;$$

their values being, respectively,

$$0, \quad \mp \frac{7}{1408}w'l^2, \quad \mp \frac{3}{100}w'l^2, \quad \mp \frac{6}{884}w'l^2, \quad 0.$$

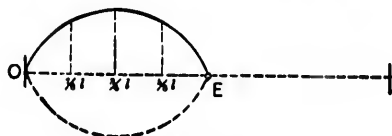

FIG. 471.

The *absolute maximum* bending moment may be found as follows:

For a given value of x the bending moment (see eq. (19)) is a maximum when

$$R_1 + (t - w)(l - z) = 0,$$

or

$$l - z = -\frac{R_1}{t - w}.$$

Hence, the maximum bending moment

$$= \mp \frac{1}{2} \frac{R_1^2}{t - w} = \pm \frac{w'(l^2 - 4lx + 3x^2)}{8(l^2 - 4lx + 2x^2)}.$$

It will be an *absolute maximum* for a value of x found by putting its differential with respect to x equal to *nil*.

This differential easily reduces to

$$3x^2 - 9lx^2 + 6l^2x - l^3 = 0.$$

$x = \frac{3}{8}l$ is an approximate solution of this equation, and the corresponding maximum bending moment = $\frac{6}{428}w'l^2$.

The preceding calculations show that at every point in its length the truss may be subjected to equal maximum shears and equal maximum bending moments of opposite signs.

Again, it may be easily shown, in a similar manner, that

when a single weight W travels over the truss,
the maximum *positive* shear at a distance s from A

$$= \frac{W}{l^2}(2l^2 - 5lz + 4s^2);$$

the maximum *negative* shear

$$\text{either} = \frac{W}{l^2}(l^2 - 5lz + 4s^2)$$

$$\text{or} = \frac{1}{2} \frac{W}{l}(3l - 4s);$$

and the maximum bending moment

$$= \pm \frac{W}{l^2}s(l-s)(l-2s).$$

12. Suspension-bridge Loads.—The heaviest distributed load to which a highway bridge may be subjected is that due to a dense crowd of people, and is fixed by modern French practice at 82 lbs. per square foot. Probably, however, it is unsafe to estimate the load at less than from 100 to 140 lbs. per square foot, while allowance has also to be made for the concentration upon a single wheel of as much as 36,000 lbs., and perhaps more.

A moderate force repeatedly applied will, if the interval between the blows corresponds to the vibration interval of the chain, rapidly produce an excessive oscillation (Chap. III, Cor. 2, Art. 24). Thus, a procession marching in step across a suspension-bridge may strain it far more intensely than a dead load, and will set up a synchronous vibration which may prove absolutely dangerous. For a like reason the wind usually sets up a wave-motion from end to end of a bridge.

The *factor of safety* for the dead load of a suspension-bridge should not be less than $2\frac{1}{2}$ or 3, and for the live load it is advisable to make it 6. With respect to this point it may be remarked that the efficiency of a cable does not depend so much upon its ultimate strength as upon its limit of elasticity,

and s
injur
cable
its li
facto
limit
of su
tion
T
from
for sr
give
passa
tortic
Stead
adopt

The c
great.
anch
the d
the st
vertic
many
mann

(a)

where
attach

(b)

the pi
numb
in the

and so long as the latter is not exceeded the cable remains uninjured. For example, the *breaking weight* of one of the 15-inch cables of the East River Bridge is estimated to be 12,000 tons, its *limit of elasticity* being 8118 tons; so that with $1\frac{1}{2}$ only as a factor of safety, the stress would still fall below the elastic limit and have no injurious effect. The *continual* application of such a load would doubtless ultimately lead to the destruction of the bridge.

The dip of the cable of a suspension-bridge usually varies from $\frac{1}{15}$ to $\frac{1}{12}$ of the span, and is rarely as much as $\frac{1}{10}$, except for small spans. Although a greater ratio of dip to span would give increased economy and an increased limiting span, the passage of a live load would be accompanied by a greater distortion of the chains and a larger oscillatory movement. Steadiness is therefore secured at the cost of economy by adopting a comparatively flat curve for the chains.

13. Modifications of the Simple Suspension-bridge.—

The disadvantages connected with suspension-bridges are very great. The position of the platform is restricted, massive anchorages and piers are generally required, and any change in the distribution of the load produces a sensible deformation in the structure. Owing to the want of rigidity, a considerable vertical and horizontal oscillatory motion may be caused, and many efforts have been made to modify the bridge in such a manner as to neutralize the tendency to oscillation.

(a) The simplest improvement is that shown in Fig. 472, where the point of the cable most liable to deformation is attached to the piers by short straight chains *AB*.

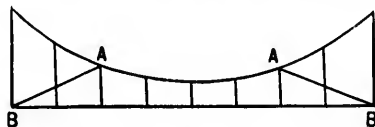
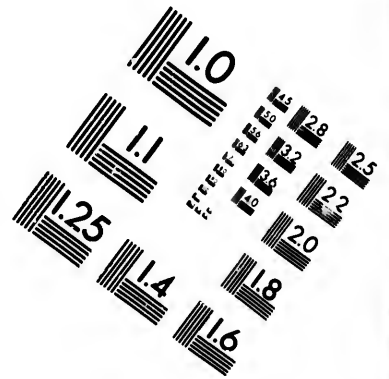
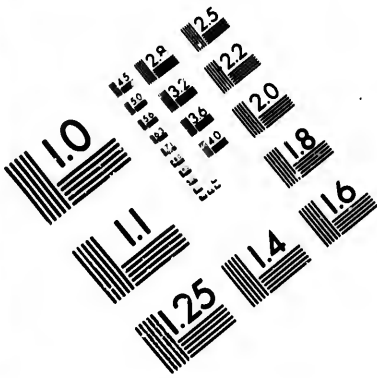

FIG. 472.

(b) A series of inclined stays, or iron ropes, radiating from the pier-saddles, may be made to support the platform at a number of equidistant points (Fig. 473). Such ropes were used in the Niagara Bridge, and still more recently in the East River





**IMAGE EVALUATION
TEST TARGET (MT-3)**

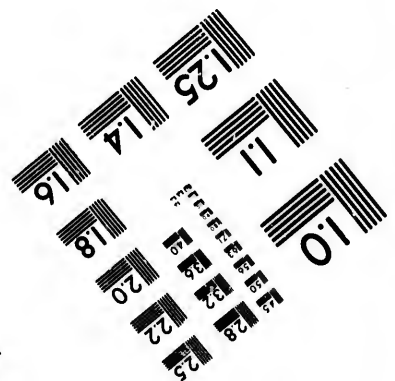
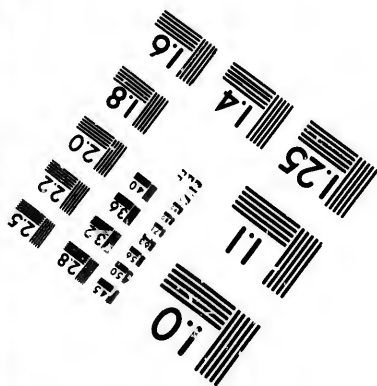
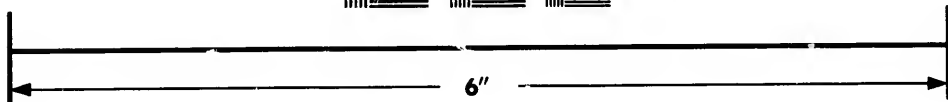
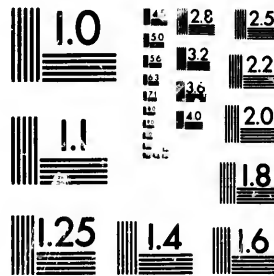

**Photographic
Sciences
Corporation**

23 WEST MAIN STREET
WEBSTER, N.Y. 14580
(716) 872-4503

15 28
16 25
17 22
18 20

19
20
21
22

Bridge. The lower ends of the ropes are generally made fast to the top or bottom chord of the bridge-truss, so that the corresponding chord stress is increased and the neutral axis proportionately displaced. To remedy this, it has been proposed to connect the ropes with a horizontal tie coincident in position with the neutral axis. Again, the cables of the Niagara and



FIG. 473.

East River bridges do not hang in vertical planes, but are inclined inwards, the distance between them being greatest at the piers and least at the centre of the span. This drawing in adds greatly to the lateral stability, which may be still further increased by a series of horizontal ties.

(c) In Fig. 474 two cables in the same vertical plane are diagonally braced together. In principle this method is similar

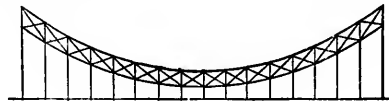

FIG. 474.

to that adopted in the *stiffening truss* (discussed in Art. 11), but is probably less efficient on account of the flexible character of the cables, although a slight economy of material might doubtless be realized. The braces act both as struts and ties, and the stresses to which they are subjected may be easily calculated.

(d) In Fig. 475 a single chain is diagonally braced to the platform. The weight of the bridge must be sufficient to insure

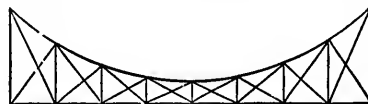

FIG. 475.

that no suspender will be subjected to a thrust, or the efficiency of the arrangement is destroyed. An objection to this as well

as to the preceding method is that the variation in the curvature of the chain under changes of temperature tends to loosen and strain the joints.

The principle has been adopted (Fig. 476) with greater perfection in the construction of a foot-bridge at Frankfort. The



FIG. 476.

girder is cut at the centre, the chain is hinged, and the rigidity is obtained by means of vertical and inclined braces which act both as struts and ties.

(e) In Fig. 477 the girder is supported at several points by



FIG. 477.

straight chains running directly to the pier-saddles, and the chains are kept in place by being hung from a curved chain by vertical rods.

(f) It has been proposed to employ a stiff inverted arched rib of wrought-iron instead of the flexible cable. All straining action may be eliminated by hinging the rib at the centre and piers, and the theory of the stresses developed in this tension rib is precisely similar to that of the arched rib, except that the stresses are reversed in kind.

(g) The platform of every suspension-bridge should be braced horizontally. The floor-beams are sometimes laid on the skew in order that the two ends of a beam may be suspended from points which do not oscillate concordantly, and also to distribute the load over a greater length of cable.

EXAMPLES.

1. The span of a suspension-bridge is 200 ft., the dip of the chains is 80 ft., and the weight of the roadway is 1 ton per foot run. Find the tensions at the middle and ends of each chain. *Ans.* $31\frac{1}{2}$ tons; 58.94 tons.

2. Assuming that a steel rope (or a single wire) will bear a tension of 15 tons per square inch, show that it will safely bear its own weight over a span of about one mile, the dip being one-fourteenth of the span.

Ans. Max. tension = 33,074 lbs.

3. Show that a steel rope of the best quality, with a dip of one-seventh of the span, will not break until the span exceeds 7 miles, the ultimate strength of the rope being 60 tons per square inch. (1 ton = 2240 lbs.)

Ans. Max. tension = 59,545 tons per square inch.

4. The river span of a suspension-bridge is 930 ft. and weighs 5976 tons, of which 1439 tons are borne by stays radiating from the summit of each pier, while the remaining weight is distributed between four 15-in. steel-wire cables, producing in each at the piers a tension of 2064 tons. Find the dip of the cables.

Ans. 63.884 ft.

The estimated maximum traffic upon the river span is 1311 tons uniformly distributed. Determine the increased stress in the cables.

Ans. 596.4 tons.

To what extent might the traffic be safely increased, the limit of elasticity of a cable being 8116 tons, and its breaking stress 12,300 tons?

Ans. To 13,303 tons uniformly distributed.

5. If the span = l , the total uniform load = W , and the dip = $\frac{l}{12}$, show that the maximum tension = $1.58W$, the minimum tension = $1.5W$, the length of the chain = $1.018l$, and find the increase of dip corresponding to an elongation of 1 in. in the chain.

6. A cable weighing p lbs. per lineal foot of length is stretched between supports in the same horizontal line and 20 ft. apart. If the maximum deflection is $\frac{1}{3}$ ft., determine the greatest and least tensions.

Ans. Parameter $m = 100$ ft.; max. tension = $100\frac{1}{3}p$; min. tension = $100p$.

7. A light suspension-bridge carries a foot-path 8 ft. wide over a river 90 ft. wide by means of eight equidistant suspending rods, the dip being 10 ft. Each cable consists of nine straight links. Find their several lengths. If the load upon the platform is 120 lbs. per square foot, and

if *one-sixth* of the load is borne by the piers, find the sectional areas of the several links, allowing 10,000 lbs. per square inch.

Ans. Lengths in ft., 10; 10.049; 10.198; 10.44; 10.77.

Tensions in lbs., 45,000; $4500\sqrt{101}$; $4500\sqrt{104}$; $4500\sqrt{109}$;
 $4500\sqrt{116}$.

Areas in sq. in., 4.5; 4.522; 4.59; 4.698, 4.847.

8. A suspension-bridge of 240 ft. span and 20 ft. dip has 48 suspenders on each side; the dead weight = 3000 lbs. per lineal foot; the live load = 2000 lbs. per lineal foot. Find the maximum pull on a suspender, the maximum bending moment and the maximum shear on the stiffening truss. Also, find the elongation in the chain due to the live load.

Ans. Max. pull = 12,500 lbs.; max. shear = 30,000 lbs.; max. B.M. = 1,066,666 $\frac{2}{3}$ ft.-lbs.; elongation = $89,600,000 \div EA$, A being sectional area of a cable, and E the coefficient of elasticity.

9. A foot-path 8 ft. wide is to be carried over a river 100 ft. wide by two cables of uniform sectional area and having a dip of 10 ft. Assuming the load on the platform to be 112 lbs. per square foot, find the greatest pull on the cables, their sectional area, length, and weight. (Safe stress = 8960 lbs. per square inch; specific weight of cable = 480 lbs. per cubic foot.)

Ans. $H = \frac{5}{\sqrt{29}}T = 56,000$ lbs.; area = 6.73 sq. in.;
 length = $102\frac{1}{2}$ ft.; weight = 2302.65 lbs.

10. Find the depression in the cables in the last question due to an increment of length under a change of 60° F. from the mean temperature. (Coefficient of expansion = $1 \div 144000$.) *Ans.* .0802 ft.

11. Each side of the platform of a suspension-bridge for a span of 100 ft. is carried by nine equidistant suspenders. Design a stiffening truss for a live load of 1000 lbs. per lineal foot, and determine the pull upon the suspenders due to the live load when the load produces (1) an *absolute maximum* shear; (2) an *absolute maximum bending moment*.

Ans. Max. shear = 6250 lbs.; max. B.M. = $92,592\frac{1}{2}$ ft.-lbs.; pull on suspender = (1) $2777\frac{1}{2}$ lbs., (2) = $1851\frac{2}{3}$ lbs. or $3703\frac{1}{2}$ lbs.

12. In a suspension-bridge (recently blown down) each cable was designed to carry a total load of 84 tons (including its own weight). The distance between the piers = 1270 ft.; the deflection of the cable = 91 ft. Find (a) the length of the cable; (b) the pull on the cable at the piers and at the lowest point; (c) the amounts by which these pulls are changed by a variation of 40° F. from the mean temperature; (d) the tension in the back-stays, assuming them to be approximately straight and inclined to the vertical at the angle whose tangent is $\frac{3}{4}$.

Ans.—(a) 1287.4 ft.; (b) $H = \frac{T}{1.04} = 146\frac{1}{4}$ tons; (c) depression due

to change of temp. = .936 ft. and amount of change in $H = \frac{.936}{91.936} H$
 = $1\frac{1}{2}$ tons, in $T = 1.45$ tons; (d) 394.55 tons, neglecting pier friction.

13. The platform of the bridge in the preceding question was hung from the cables by means of 480 suspenders (240 on each side). Find the pull on each suspender and the total length of the suspenders, the lowest point of a cable being 14 ft. above the platform.

Ans. .35 ton; $10,565\frac{1}{4}$ ft.

14. A suspension-bridge has a dip of 10 ft. and a span of 300 ft. Find the increase of dip due to a change of 100° F. from the mean temperature, the coefficient of expansion being .00125 per 180° F.

Ans. 1.17 ft.

Also, find the corresponding flange stress in the stiffening truss, which is $12\frac{1}{2}$ ft. deep, the coefficient of elasticity being 8000 tons.

Ans. 6.24 tons.

15. The ends of a cable are attached to saddles free to move horizontally. If Δa is the horizontal movement of each saddle due to the expansion of the cables in the side spans, and if ΔS is the extension of the chain between the two saddles, show that the increment of the dip (h) is approximately

$$\frac{3}{16} \frac{\alpha}{h} \Delta S + \Delta a \left(\frac{3\alpha}{8h} - \frac{h}{a} \right).$$

16. The platform of a suspension-bridge of 150 ft. span is suspended from the two cables by 88 vertical rods (44 on each side); the dip of the cables is 15 ft.; there are two stiffening trusses; the dead weight is 2240 lbs. per lineal foot, of which *one-half* is divided equally between the two piers. Find the stresses at the middle and ends of the cables when a uniformly distributed load of 73,750 lbs. covers one half of the bridge. Also, find the maximum shears and bending moments to which the stiffening trusses are subjected when a live load of 1050 lbs. per lineal foot crosses the bridge.

Ans. Pull on suspender = $2803\frac{1}{4}$ lbs.; $H = \frac{5}{\sqrt{29}} T = 154,218\frac{3}{4}$ lbs.

Max. shear on each truss at centre and due to 78,750 lbs.
 = $9843\frac{3}{4}$ lbs. = that due to 1050 lbs. per lineal foot.

Max. B. M. due to 78,750 lbs. is at centre of loaded and unloaded halves and = $184,570\frac{5}{8}$ ft.-lbs.

Abs. max. B.M. due to 1050 lbs. per lineal foot is at points of trisection and = 218,750 ft.-lbs.

17. Solve the preceding question when the trusses are hinged at the centre.

Ans. Pull on suspender = $2803\frac{1}{4}$ lbs.; $H = \frac{5}{\sqrt{29}} T = 154,218\frac{1}{4}$ lbs.

Max. shear due to 78,750 lbs. = $9843\frac{3}{4}$ lbs. at centre of span and at end of loaded half of bridge; max. shears due to 1050 lbs. per lineal foot = 13,125, 5906 $\frac{1}{2}$, 4921 $\frac{1}{2}$, 8305 $\frac{8}{15}$, and 9843 $\frac{3}{4}$ lbs. at ends of the half truss and at the points dividing the half span into four equal segments.

Max. B. M. due to 78,750 lbs. is at centre of half truss and = $184,570\frac{5}{16}$ ft.-lbs. Max. B. M. due to 1050 lbs. per lineal foot = 176,180 $\frac{2}{3}$, 221,484 $\frac{2}{3}$, and 153,808 $\frac{1}{3}$ ft.-lbs. at points dividing the half truss into four equal segments.

18. Show that the total extension of a cable of uniform sectional area A under a uniformly distributed load of intensity w is

$$\frac{wl^3}{8EA\delta} \left(1 + \frac{16}{3} \frac{\delta^3}{l^2} \right),$$

l being the span and δ the dip.

19. The dead weight of a suspension-bridge of 1600 ft. span is $\frac{1}{2}$ ton per lineal foot; the dip = $\frac{\text{span}}{13}$. Find the greatest and least pulls upon one of the chains. The ends of the chains are attached to saddles on rollers on the top of piers 50 ft. high, and the back-stays are anchored 50 ft. from the foot of each pier. Find the load upon the piers and the pull upon the anchorage.

Ans. 255 tons; 243 $\frac{3}{4}$ tons; 637 $\frac{1}{2}$ tons; 344.6 tons.

20. A bridge 444 ft. long consists of a central span of 180 ft. and two side spans each of 132 ft.; each side of the platform is suspended by vertical rods from two iron-wire cables; each pair of cables passes over two masonry abutments and two piers, the former being 24 ft. and the latter 39 ft. above the surface of the ground; the lowest point of the cables in each span is 19 ft. above the ground surface; at the abutments the cables are connected with straight wrought-iron chains, by means of which they are attached to anchorages at a horizontal distance of 66 ft. from the foot of each abutment; the dead weight of the bridge is 3500 lbs. per lineal foot, and the bridge is covered with a proof load of 4500 lbs. per lineal foot. Determine—

(a) The stresses in the cables at the points of support and at the lowest points.

(b) The dimensions and weights of the cables (1) if of uniform sec-

tion throughout; (2) if each section is proportioned to the pull across it. (Unit stress = 14,958 lbs. per square inch.)

(c) The alteration in the length of the cables and the corresponding depression of the platform at the centre of each span, due (1) to a change of 60° F. from the mean temperature; (2) to the total load, L being 30,000,000 lbs.

(d) The pressure and bending moment at the foot of pier.

(e) The mass of masonry in the anchorage necessary to resist the tendency to overturning and to horizontal displacement.

Data.—Weight of masonry per cubic foot = 128 lbs.; safe compressive stress per square foot = 12,000 lbs.; coefficient of friction = $\frac{7}{16}$; deviation of centre of pressure in base of pier from centre of figure = $\frac{3}{8}$ x thickness of base.

Ans.—(a) Side span, $T_1 \frac{22}{\sqrt{509}} = H_1 = 387,200$ lbs. = $T_2 \frac{11}{\sqrt{146}}$, T_1 and T_2 being the tensions in a cable at summits of low and high piers, respectively; centre span, $T \frac{9}{\sqrt{97}} = 405,000$ lbs. = H , T being tension at summit of high pier.

(b) Side span: Length = $135\frac{5}{8}$ ft.; sect. area at summit of high pier = 26.54 sq. in.; weight if of uniform section = 11,991 lbs., if proportioned to pull = 11,406 lbs. Centre span: Length = $185\frac{3}{4}$ ft.; sect. area at summit of pier = 29.6 sq. in.; weight if of uniform section = 18,378 lbs., if proportioned to pull = 17,308 lbs.

(c) (1) .0594 ft. for side span and .0775 ft. for centre span;
(2) .0675 " " " " " .0874 " " " "

(d) High pier: Overturning moment = $942,400 \times 39$ ft.-lbs.; bearing area at summit = $118\frac{3}{8}$ sq. ft.; thickness = 8 ft.; uniform width = $14\frac{3}{8}$ ft.; thickness of base = 36.6 ft.; weight of pier = 1,651,270.4 lbs.; total pressure on base = 2,679,270.4 lbs.

(e) Weight to resist upward pull = $29,333\frac{1}{8}$ lbs.; weight to resist horizontal displacement = 509,474 lbs.

21. In the preceding question, if the piers are wrought-iron oscillating columns, and if equilibrium, under an unequally distributed load, is maintained by connecting the heads of the columns with each other and with the abutments by iron-wire stays, determine the proper dimensions of the stays, assuming them approximately straight. Assume that the proof load covers (a) a side span; (b) two side spans; (c) the centre span.

Ans.—(a) Pull on stays in centre span = 840,050 lbs.

(b) " " " " " = double that in (a).

(c) " " " " side span = 948,466 lbs.

22. A floating landing-stage is held in position by a number of 4-in. steel-wire cables anchored to the shore, a shoreward movement being prevented by rigid iron booms, pivoted at the ends and stretching from shore to stage. The difference of level between the shore and stage attachments of the cables is 50 ft., and the horizontal distance between these points is 150 ft. The horizontal pull upon each cable is 1360 lbs. Find the length of the cable, and the tensions at the points of attachment. (Weight of cable = 490 lbs. per cubic foot; form of cable a common catenary.)

Ans. 342.82 ft.; 12,267.2 lbs. and 10,132 lbs.

CHAPTER XIII.

ARCHES AND ARCHED RIBS.

I. AN arch may be constructed of masonry, brickwork, timber, or metal.

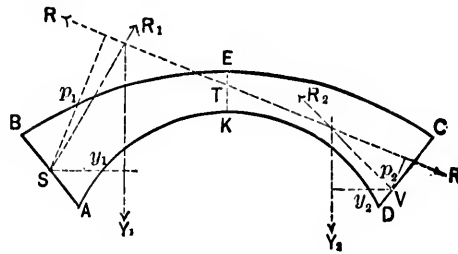

FIG. 478.

In the figure $ABCD$ represents the profile of an arch. The under surface AD is called the *soffit* or *intrados*. The upper surface BC is sometimes improperly called the *extrados*. The highest point K of the soffit is the *crown* or *key* of the arch. The *springings* or *skewbacks* are the surfaces AB, DC from which the arch springs, and the *haunches* are the portions of the arch half-way between the springings and the crown. Upon each of the arch faces stands a *spandril* wall, and the space between these two *external* spandrils may be occupied by a series of *internal* spandrils spaced at definite distances apart, or may be filled up to a certain level with masonry (i.e., *backing*) and above that with ordinary ballast or other rough material (i.e., *filling*).

A *masonry* arch consists of courses of wedge-shaped blocks with the bed-joints perpendicular, or nearly so, to the soffit.

The blocks are called *voussoirs*, and the *voussoirs* at the crown are the *keystones* of the arch.

A *brick arch* is usually built in a number of rings.

Consider the portion of the arch bounded by the vertical plane KE at the key and by the plane AB .

It is kept in equilibrium by the reaction R at KE , the reaction R_1 at AB , and the weight Y_1 of the portion under consideration and its superincumbent load.

Let S and T be the points of application of R_1 and R , respectively.

Let the directions of R_1 and R intersect in a point. The direction of Y_1 must also pass through the same point.

Taking moments about S ,

$$R\rho_1 = Y_1y_1,$$

ρ_1 and y_1 being the perpendicular distances of the directions of R and Y_1 from S , respectively.

Similarly, the portion $KECD$ of the arch gives the equation

$$R\rho_2 = Y_2y_2,$$

Y_2 being the weight to which it is subjected, and ρ_2 , y_2 the perpendicular distances of the directions of R and Y_2 from the point of application V of the reaction at the plane DC .

If the arch and the loading are symmetrical with respect to the plane KE ,

$$Y_1 = Y_2, \quad y_1 = y_2, \quad \text{and therefore } \rho_1 = \rho_2.$$

Hence the direction of R will be horizontal, which might have been inferred by reason of the symmetry.

The magnitudes of the reactions are indeterminate, as the positions of the points of application (S , T , V) are arbitrary, and can only be fixed by a knowledge of the law of the variation of the stress in the material at the bounding planes AB , KE .

2. Equilibrated Polygon and Line of Resistance.—

Suppose an arch divided into a number of elementary portions

$ke', k'e'' \dots$ (e.g., the voussoirs of a masonry arch) by a series of joints $ke, k'e' \dots$

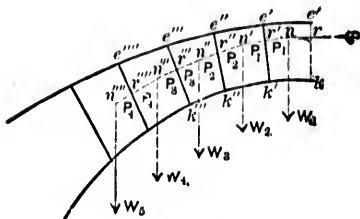

FIG. 479.

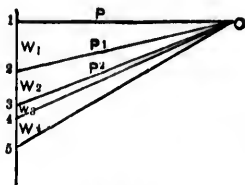

FIG. 480.

Let W_1, W_2, \dots be the loads directly supported by the several portions. These loads generally consist of the weight of a portion (e.g., ke') + the weight of the superincumbent mass + the load upon the overlying roadway; the lines of action of the loads are, therefore, nearly always vertical.

Each elementary portion may be considered as acted upon and kept in equilibrium by *three* forces, viz., the external load and the pressures at the joints. If the pressure and its point of application at any given joint have been determined, the pressures and the corresponding points of application at the other joints may also be found.

For, let 1 2 3 4 . . . be the line of loads, so that 1 2 = W_1 , 2 3 = W_2 , . . .

Assume that the pressure P and its point of application r at any given joint ke are known.

Draw $o1$ to represent P in direction and magnitude.

Then $o2$ evidently represents the resultant of P and W_1 in direction and magnitude, and this resultant must be equal and opposite to the pressure P_1 at the joint $k'e'$.

Hence, a line $n'n$ drawn through n , the intersection of P and W_1 , parallel to $2o$, is the direction of the pressure P_1 , and intersects $k'e'$ in the point of application r' of P_1 .

Again, $o3$ represents the resultant of P_1 and W_2 in direction and magnitude, and this resultant must be equal and opposite to the pressure P_2 at the joint $k'e''$.

The line $n''n'$ drawn through n' , the intersection of P_1 and

E
W
 sec
 or
 cor
P, F
 ular
 ?
 succ
 I
 these
 equil
 T
 ident
 imagi
 action
 follow
 Le
 the jo
 of the
 Re
 arch m
 Let
 overly
 point, a
 unit of
 Also
 weight d
 Ther
 is given

If th
 mined at
 obtained
 substitut
 of the ma

W_2 , parallel to 30 , is the direction of the pressure P_2 and intersects $k'e''$ in the point of application r'' of P_2 .

Proceeding in this manner, a series of points of application or *centres of resistance* r', r'', r''', \dots may be found, the corresponding pressures being represented by $02, 03, 04, \dots$.

The *polygon of pressures* formed by the lines of action of P, P_1, P_2, \dots is termed an *equilibrated polygon*, and is a funicular polygon of the loads upon the several portions.

The polygon formed by joining the points r, r', r'', \dots successively, is called the *line of resistance*.

In the limit, when the joints are supposed indefinitely near, these polygons become curves, the curve in the case of the equilibrated polygon being known as a *linear arch*.

The two curves may, without sensible error, be supposed identical, and they will exactly coincide if the joints (of course imaginary in such a case) are made parallel to the lines of action of the external loads. This may be easily proved as follows:

Let the figure represent a portion of an arch bounded by the joints (imaginary) KE, MN parallel to the lines of action of the external loads, which will be assumed vertical.

Reduce the superincumbent loads to an equivalent mass of arch material.

Let h , e.g., be the depth of material of specific weight w_1 , overlying the arch at any given point, and let Q be the load per unit of area of roadway.

Also, let w be the specific weight of the arch material.

Then x , the equivalent depth, is given by

$$wx = w_1h + Q.$$

If the value of x is determined at different points along the arch, a profile en may be obtained defining a mass $ENne$ of arch material which may be substituted for the superincumbent load. Denote the weight of the mass $MKen$ by W .

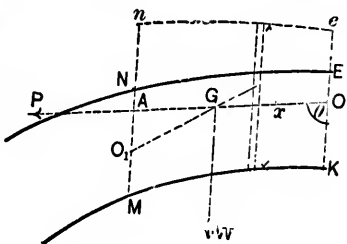

FIG. 401.

Let the pressure P and its point of application O at the joint KE be given.

Take O as the origin, the line OA in the direction of P as the axis of x , and the vertical through O as the axis of y , and let θ be the angle between the two axes.

Let the lines of action of P and W intersect in G . The line of action of their resultant will intersect MN in the centre of resistance O_1 .

Let X, Y be the co-ordinates of O_1 .

Let z be the depth of an elementary slice of thickness dx , parallel to OK at any abscissa x . Its weight = $wzdx \sin \theta$. Then

$$W \cdot OG = \int_0^X wzdx \sin \theta \cdot x = W(X - AG),$$

But $\frac{P}{W} = \frac{AG}{AO_1} = \frac{AG}{Y}$, since the triangle AGO_1 is evidently a triangle of forces for the forces acting upon the mass under consideration.

Also,

$$W = \int_0^X wzdx \cdot \sin \theta.$$

$$\therefore \int_0^X wzxdx \cdot \sin \theta = WX - W \frac{P}{W} Y = X \int_0^X wz \sin \theta dx - PY.$$

This is the equation to the line of resistance.

Taking the differential of this equation,

$$wz'X \sin \theta dX = Xwz' \sin \theta dX + WdX - PdY,$$

z' being the depth corresponding to the abscissa X .

$$\therefore \frac{dY}{dX} = \frac{W}{P} = \frac{AO_1}{AG} = \frac{\sin AGO_1}{\sin AO_1G} = \tan AGO_1, \text{ if } \theta = 90^\circ.$$

Thus the tangents to the curve of pressures and to the curve of centres of pressure at any given point coincide, and the curves must therefore also coincide.

3. Conditions of Equilibrium.—Let the figure represent a portion of an arch of thickness *unity*, between any two bed-joints (*real or imaginary*) *MN*, *PQ*.

Let *W* be its weight together with that of the superincumbent load. Let the direction of the reaction *R'* at the joint *MN* intersect *MN* in *m* and the direction of *W* in *n*. For equilibrium, the reaction *R''* at the joint *PQ* must also pass through *n*. Let its direction intersect *PQ* in *O*. In order that the equilibrium may be stable, three conditions must be fulfilled, viz. :

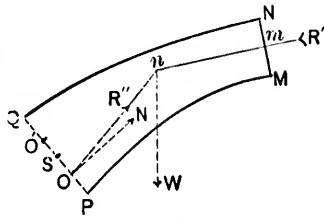

FIG. 482.

First. The point *O* must lie between *P* and *Q*, so that there may be no tendency to turn about the edges *P* and *Q*.

Second. There must be no sliding along *PQ*, and therefore the angle between the direction of *R''* and the normal to *PQ* must not exceed the angle of friction of the material of which the arch is composed.

N.B.—The angle of friction for stone upon stone is about 30° .

Third. The maximum intensity of stress at any point in *PQ* must not exceed the safe resistance of the material.

Further, the stress should not change in *character*, in the case of masonry and brick arches, but should be a compression at every point, as these materials are not suited to withstand tensile forces.

The best position for *O* would be the middle point of *PQ*, as the pressure would then be uniformly distributed over the area *PQ*. It is, however, impracticable to insure such a distribution, and it has been sometimes assumed that the stress varies uniformly,

With this assumption, let *N* be the normal component of *R''*.

Let *f* be the maximum compressive stress, i.e., the stress at the most compressed edge, e.g., *P*.

Let $OS = q \cdot PQ$, *S* being the middle point of *PQ*, and *q* a coefficient whose value is to be determined.

Then if $PO < \frac{PQ}{3}$,

$$N = \frac{2}{3}f \cdot PO = \frac{2}{3}f \cdot PQ(\frac{1}{3} - q);$$

if $PO > \frac{PQ}{3}$,

$$N = \frac{f \cdot PQ}{1 + 6q};$$

and in the limit when $PO = \frac{PQ}{3}$, i.e., when the intensity of stress varies uniformly from f at P to *nil* at Q ,

$$q = \frac{1}{6} \quad \text{and} \quad N = \frac{f \cdot PQ}{2}.$$

(See Art. 16, Chap. IV.)

Similarly, if Q is the most compressed edge, the limiting position of O , the *centre of resistance or pressure*, is at a point O' defined by $QO' = \frac{PQ}{3}$.

Hence, as there should be no tendency on the part of the joints to open at either edge, it is inferred that PO or QO' should be $> \frac{PQ}{3}$, i.e., that the point O should lie within the *middle third* of the joint.

Experience, however, shows that the "middle-third" theory cannot be accepted as a solution of the problem of arch stability, and that its chief use is to indicate the proper dimensions of the abutments. Joint cracks are to be found in more than 90% of the arches actually constructed, and cases may be instanced in which the joints have opened so widely that the whole of the thrust is transmitted through the edges. In Telford's masonry arch over the Severn, of 150 ft. span, Baker discovered that there had been a settlement (15 in.) sufficient to induce a slight *reverse* curvature at the crown of the soffit. Again, the *position* of the centre of pressure at a joint is indeterminate, and it is therefore impossible as well as useless to make any calculations as to the maximum *intensity* of stress due to the pressure at the joint. What seems to

happ
excee
formly
curve
arch a
been
Baker
Let
width
Let
square
An a
surfaces
sures, ca
advance
were pos
compress
ments, h
reliance c
values.
4. Joi
between w

the centre
pressure ma
different val
Let $4xy$
horizontal th
 x is called th
The ang

happen in practice is, that the straining at the joints generally exceeds the limit of elasticity, and that the pressure is uniformly distributed for a certain distance on each side of the curve of pressures. Thus, the proper dimensions of a stable arch are usually determined by empirical rules which have been deduced as the results of experience. For example, Baker makes the following statement:

Let T be the thrust in tons or pounds per lineal foot of width of arch.
Let f be the safe working stress in tons or pounds per square foot.

An arch will be stable if an ideal arch, with its bounding surfaces at a minimum distance of $\frac{1}{2f}T$ from the curve of pressures, can be traced so as to lie within the actual arch. An advance would be made towards a more correct theory if it were possible to introduce into the question, the elasticity and compressibility of the materials of construction. These elements, however, vary between such wide limits that no reliance can be placed upon the stresses derivable from their values.

4. Joint of Rupture.—Let 1 2, 3 4 be the bounding surfaces between which the curve of pressures must lie, and let 4 be

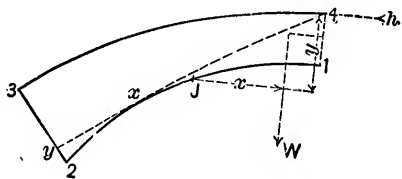

FIG. 483.

the centre of pressure at the crown. A series of curves of pressure may be drawn for the same given load, but with different values of the horizontal thrust H .

Let $4xy$ be that particular curve which for a value H of the horizontal thrust is tangent to the surface 1 2 at x ; the joint at x is called the *joint of rupture*.

The angle which the joint of rupture makes with the

horizontal is about 30° in semicircular and 45° in elliptic arches.

The position of the joint in any given arch may be tentatively found as follows:

Let J be any joint in the surface 1 2.

Let W be the weight upon the arch between J and 1.

Let X be the horizontal distance between J and the centre of gravity of W .

Let Y be the vertical distance between J and 4.

It will also be assumed that the thrust at 4 is horizontal.

If the curve of pressure be now supposed to pass through J , the corresponding value of the horizontal thrust h is given by

$$hY = WX.$$

By means of this equation, values of h may be calculated for a number of joints in the neighborhood of the haunch, and the greatest of these values will be the horizontal thrust H for the joint x . This is evident, as the curve of pressure for a smaller value of h must necessarily fall *below* $4xy$.

When this happens, the joints will tend to open at the lower edge of the joint 1 4 and at the upper edges of the joints at x and at 2 3, so that the arch may sink at the crown and spread, unless the abutments and the lower portions of the arch are massive enough to counteract this tendency.

If the curve of pressure fall *above* $4xy$, an amount of backing sufficient to transmit the thrust to the abutments must be provided. The same result may be attained by a uniform increase in the thickness of the arch ring, or by a gradual increase from the crown to the abutments.

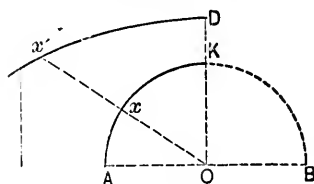

FIG. 484.

For example, the upper surface (extrados) of the ring for an arch with a semicircular soffit AKB , having its centre at O , may be delineated in the following manner:

Let x define the joint of rupture in the soffit; then $Aox = 30^\circ$.

ness
duce
ring,
 x' to
5-
result
recta
Le
tion f
Le
comp
Le
in the
Le
Le
In
toe D ,
to D pl
than th

This
abutmen

which def
ment.

In Ox produced take $xx' = 2 \times KD$, KD being the thickness at the crown.

The arc Dx' of a circle struck from a centre in DO produced may be taken as a part of the upper boundary of the ring, and the remainder may be completed by the tangent at x' to the arc Dx' .

5. Minimum Thickness of Abutment.—Let T be the resultant thrust at the horizontal joint BC of a rectangular abutment $ABCD$.

Let y be the distance of its point of application from B .

Let H and V be the horizontal and vertical components of T .

Let w be the specific weight of the material in the abutment.

Let h be the height AB of the abutment.

Let t be the width AD of the abutment.

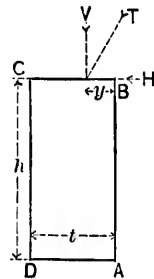

FIG. 485.

In order that there may be no tendency to turn about the toe D , the moment of the weight of the abutment with respect to D plus the moment of V with respect to D must be greater than the moment of H with respect to D . Or,

$$wht \frac{t}{2} + V(t - y) > Hh,$$

or

$$t + \frac{V}{wh} > \sqrt{\frac{2H}{w} + \frac{2V}{wh}y + \frac{V^2}{w^2h^2}}$$

This relation must hold good whatever the height of the abutment may be; and if h is made equal to ∞ ,

$$t > \sqrt{\frac{2H}{w}},$$

which defines a minimum limit for the thickness of the abutment.

6. Empirical Formulæ.—In practice the thickness t at the crown is often found in terms of s , the span, or in terms of ρ , the radius of curvature at the crown, from the formulæ

$$t = c\sqrt{s}, \text{ or } t = \sqrt{c\rho},$$

t , s , and ρ being all in feet, and c being a constant.

According to Dupuit, $t = .36\sqrt{s}$ for a full arch;

$$t = .27\sqrt{s} \text{ for a segmental arch.}$$

According to Rankine, $t = \sqrt{.12\rho}$ for a single arch;

$$t = \sqrt{.17\rho} \text{ for an arch of a series.}$$

7. Examples of Linear Arches, or Curves of Pressure.

(a) *Linear Arch in the Form of a Parabola.*—Suppose that the cable in Art. 4, Chap. XII, Case B, is exactly inverted, and that it is stiffened in such a manner as to resist distortion. Suppose also that the load still remains a uniformly distributed weight of intensity w per horizontal unit of length. A thrust will now be developed at every point of the *inverted* cable equal to the tension at the corresponding point of the original cable. Thus the inverted parabola is a linear arch suitable for a real arch which has to support a load of intensity w per horizontal unit of length.

$$\text{The horizontal thrust at the crown} = H = w\rho,$$

ρ being the radius of curvature at the crown.

(b) *Linear Arch in the Form of a Catenary. Transformed Catenary.*—If the cable in Art. 4, Chap. XII, Case A, is in-

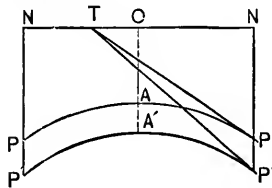

FIG. 486.

verted and stiffened as before, a linear arch is obtained suitable for a real arch which has to support a load distributed in such a manner that the weight upon any portion AP is proportional to the length of AP , and is in fact $= \rho s$. The area $OAPN = ms$.

Thus, a lamina of thickness unity and specific weight w , bounded by the curve AP , the directrix ON , and the verticals AO, PN , weighs wms , and may be taken

to
i.e.,
the
cate
thro
sary
meet
may
U
horiz
gener
Cu
quired
solid v
arch, a
the arc
lamina
The
length.
The
of the l
of the a
Let
formed
Let
in the c
Let
Then

The equa

to represent the load upon the arch if $wms = ps$, i.e., if $wm = p$, i.e., if the weight of m units of the lamina is w .

The horizontal thrust at the crown = $H = wm = w\rho$, the radius of curvature (ρ) at the crown being equal to m .

A disadvantage attached to a linear arch in the form of a catenary lies in the fact that only *one* catenary can pass through *two* given points, while, in practice, it is often necessary that an arch shall pass through *three* points in order to meet the requirements of a given rise and span. This difficulty may be obviated by the use of the *transformed catenary*.

Upon the lamina $PAPNN$ as base, erect a solid, with its horizontal sections all the same, and, for simplicity, with its generating line perpendicular to the base.

Cut this solid by a plane through NN inclined at any required angle to the base. The intersection of the plane and solid will define a transformed catenary $P'A'P'$, or a new linear arch, and the shape of a new lamina $P'A'P'NN$, under which the arch will be balanced. This is evident, as the new arch and lamina are merely parallel projections of the original.

The projections of horizontal lines will remain the same in length.

The projections of vertical lines will be c times the lengths of the lines from which they are projected, c being the secant of the angle made by the cutting plane with the base.

Let x, Y be the co-ordinates of any point P' of the *transformed catenary*.

Let x, y be the co-ordinates of the corresponding point P in the catenary proper.

Let $A'O = M$.

Then

$$\frac{Y}{y} = \frac{P'N}{PN} = c = \frac{A'O}{AO} = \frac{M}{m} \dots \dots (1)$$

The equation to the catenary proper is

$$y = \frac{m}{2} \left(e^{\frac{x}{m}} + e^{-\frac{x}{m}} \right) \dots \dots (2)$$

Substituting in the last equation the value of y given by eq. (1),

$$Y = \frac{M}{2} \left(e^{\frac{x}{m}} + e^{-\frac{x}{m}} \right), \dots \dots \dots (3)$$

which is the equation to the transformed catenary.

With this form of linear arch the depths M over the crown and Y over the springings, for a span $2x$, may be assumed, and the corresponding value of m determined from eq. (3).

It is convenient, in calculating m , to write eq. (3) in the form

$$\frac{x}{m} = \log_e \left\{ \frac{Y}{M} + \sqrt{\frac{Y^2}{M^2} - 1} \right\} \dots \dots \dots (4)$$

The slope i' at P' is given by

$$\tan i' = \frac{dY}{dx} = \frac{M}{2m} \left(e^{\frac{x}{m}} - e^{-\frac{x}{m}} \right) = \frac{Ms}{m^2},$$

s being the length AP of the catenary proper, corresponding to the length $A'P'$ of the transformed catenary.

$$\text{The area } OA'P'N = \int_0^x Y dx = \frac{Mm}{2} \left(e^{\frac{x}{m}} - e^{-\frac{x}{m}} \right) = Ms.$$

The triangle $P'TN$ is a triangle of forces for the portion $A'P'$.

The triangle PTN is a triangle of forces for the portion AP . (The tangents at P and P' must evidently intersect ON in the same point T .)

Let H' be the horizontal thrust at A' , H being that at A .

Let P' be the weight upon $A'P'$, P being that upon AP .

Let R' be the thrust at P' .

Then

$$\frac{P'}{P} = \frac{\text{area } OA'P'N}{\text{area } OAPN} = \frac{Ms}{ms} = \frac{M}{m},$$

and hence

$$P' = \frac{M}{m}P = \frac{M}{m}wms = wMs;$$

$$H' = P' \cot i' = wMs \frac{m^2}{Ms} = wm^2 = H;$$

$$R' = H' \sec i' = wm^2 \sqrt{1 + \frac{M^2 s^2}{m^4}} = w \sqrt{m^4 + M^2 s^2}.$$

The radius of curvature ρ' at the crown = $\frac{m^2}{M}$.

$$\therefore H' = wM\rho' = H = w\rho,$$

and the radius of the "catenary proper" is M times the radius of the transformed catenary.

The term "equilibrated arch" has generally been applied to a linear arch with a horizontal extrados.

(c) *Circular and Elliptic Linear Arches.*—A linear arch which has to support an external normal pressure of uniform intensity should be circular.

Consider an indefinitely small element CD , which may be assumed to be approximately straight.

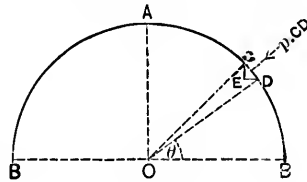

FIG. 487.

Let the direction of the resultant pressure upon CD , viz., $p \cdot CD$, make an angle θ with OB .

Let CE, DE be the vertical and horizontal projections of CD .

The angle $DCE = \theta$.

The horizontal component of $p \cdot CD = p \cdot CD \cos \theta = p \cdot CE$.

This is distributed over the vertical projection CE .

\therefore the horizontal intensity of pressure = $p \cdot CE \div CE = p$.

Similarly, it may be shown that the vertical intensity of pressure = p .

Thus, at any point of the arch,

the horizontal intensity of pressure

$$= \text{vertical intensity} = \text{normal intensity} = p.$$

Again, the total horizontal pressure on one-half of the arch

$$= \Sigma(p \cdot CE) = p\Sigma(CE) = pr = H,$$

and the total vertical pressure on one-half of the arch

$$= \Sigma(p \cdot DE) = p\Sigma(DE) = pr = P.$$

Hence, at any point of the arch the tangential thrust = pr .

Next, upon the semicircle as base, erect a semi-cylinder. Cut the latter by an inclined plane drawn through a line in the

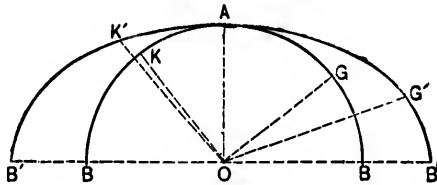

FIG. 488.

plane of the base parallel to OA . The intersection of the cutting plane and the semi-cylinder is the semi-ellipse $B'AB'$, in which the vertical lines are unchanged in length, while the lengths of the horizontal lines are c times the lengths of the corresponding lines in the semicircle, c being the secant of the angle made by the cutting plane with the base. A semi-elliptical arch is thus obtained, and the forces to which it is subjected are parallel projections of the forces acting upon the semicircular arch.

These new forces are in equilibrium (see Corollary).

Let P' = the total vertical pressure upon one-half of the arch ;

H' = the total horizontal pressure upon one-half of the arch ;

$p'_y = \text{vertical intensity of pressure} = \frac{P'}{OB'}$;

$p'_x = \text{horizontal intensity of pressure} = \frac{H'}{OA'}$.

Then

$$P' = P = H = pr; \dots \dots \dots (1)$$

$$p'_y = \frac{P'}{OB'} = \frac{P}{c \cdot OB} = \frac{pr}{cr} = \frac{p}{c}; \dots \dots \dots (2)$$

$$H' = cH = cP = cP'; \dots \dots \dots (3)$$

$$p'_x = \frac{H'}{OA'} = \frac{c \cdot H}{OA} = \frac{cpr}{r} = cp. \dots \dots \dots (4)$$

Hence, by eq. (3),

$$\frac{H'}{P'} = c = \frac{OB'}{OA'}$$

or, the total horizontal and vertical thrusts are in the ratio of the axes to which they are respectively parallel, and, by eqs. (2) and (4),

$$\frac{p'_y}{p'_x} = \frac{1}{c^2} = \frac{OA'^2}{OB'^2}$$

or, the vertical and horizontal intensities of pressure are in the ratio of the *squares* of the axes to which they are respectively parallel.

Any two rectangular axes OG, OK in the circle will project into a pair of conjugate radii OG', OK' in the ellipse.

Let $OG' = r_1, OK' = r_2$;

$Q = \text{total thrust along elliptic arch at } K;$
 $R = \text{ " " " " " " } G.$

Then

$$\frac{H}{Q} = \frac{r}{r_1}, \text{ and } \frac{H}{R} = \frac{r}{r_2}.$$

$$\therefore \frac{Q}{R} = \frac{r_1}{r_2};$$

or, the total thrusts along an elliptic arch at the extremities of a pair of conjugate radii are in the ratio of the radii to which they are respectively parallel.

The preceding results show that an elliptic linear arch is suitable for a load distributed in such a manner that the vertical and horizontal intensities (eqs. (2) and (4)) at any point of the arch are unequal, but are uniform in direction and magnitude.

Corollary.—It can be easily shown that the projected forces acting upon the elliptic arch are in equilibrium.

The equations of equilibrium for the forces acting upon the circular arch may be written

$$d\left(T\frac{dx}{ds}\right) + Xds = 0,$$

$$d\left(T\frac{dy}{ds}\right) + Yds = 0;$$

T being the thrust along the arch at the point xy , and X , Y the forces acting upon the arch parallel to the axes of x and y , respectively.

If T' , X' , Y' be the corresponding projected forces,

$$\frac{T'}{ds'} = \frac{T}{ds}, \quad Xds = cX'ds', \quad Yds = Y'ds'.$$

Hence, the above equations may be written

$$d\left(\frac{T'}{ds'}cdx'\right) + cX'ds' = 0,$$

and

$$d\left(\frac{T'}{ds'}dy'\right) + Y'ds' = 0;$$

or

$$d\left(T'\frac{dx'}{ds'}\right) + X'ds' = 0,$$

and

$$d\left(T'\frac{dy'}{ds'}\right) + Y'ds' = 0.$$

Hence, the forces T' , X' , and Y' are also in equilibrium.

(d) *Hydrostatic Arch.*—Let the figure represent a portion of a linear arch suited to support a load which will induce in it a normal pressure at every point. The pressure being normal has no tangential component, and the thrust (T) along the arch must therefore be everywhere the same.

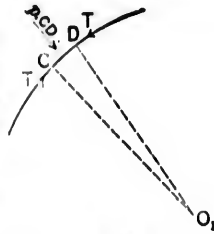

FIG. 48j.

Consider any indefinitely small element CD .

It is kept in equilibrium by the equal thrusts (T) at the extremities C and D , and by the pressure $p \cdot CD$. The intensity of pressure p being assumed uniform for the element CD , the line of action of the pressure $p \cdot CD$ bisects CD at right angles.

Let the normals at C and D meet in O_1 , the centre of curvature.

Take $O_1C = O_1D = \rho$, and the angle $CO_1D = 2\Delta\theta$.

Resolving along the bisector of the angle CO_1D ,

$$2T \sin \Delta\theta = p \cdot CD = p\rho \cdot 2\Delta\theta,$$

or

$$2T\Delta\theta = p\rho \cdot 2\Delta\theta;$$

and hence,

$$T = p\rho = \text{a constant.} \quad \dots (1)$$

Thus, a series of curves may be obtained in which ρ varies *inversely* as p , and the hydrostatic arch is that curve for which the pressure p at any point is directly proportional to the depth of the point below a given horizontal plane.

Denote the depth by y , and let w be the specific weight of the substance to which the pressure p is due. Then

$$p = wy, \dots (2)$$

and

$$T = p\rho = wy\rho = \text{a constant.} \dots (3)$$

The curve may be delineated by means of the equation

$$y\rho = \text{const.} \dots (4)$$

It may be shown, precisely as in Case (c), that the horizontal intensity of pressure (p_x)

$$= \text{the vertical intensity } (p_y) = p. \dots (5)$$

Take as the origin of co-ordinates the point O vertically above the crown of the arch, in the given horizontal plane.

Let the horizontal line through O be the axis of x .

" " vertical " " " " " " " " y .

Any portion AM of the arch is kept in equilibrium by the equal thrusts (T) at A and M , and by the resultant load P upon AM , which must necessarily act in a direction bisecting the angle ANM .

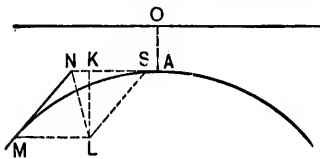

FIG. 490.

Complete the parallelogram AM , and take $SN = NM$ to represent T .

The diagonal NL will therefore represent P .

Let θ be the inclination of the tangent at M to the horizontal.

The vertical load upon $AM =$ vertical component of P

$$= LK = T \sin \theta = p\rho \sin \theta = w y \rho \sin \theta = w y_0 \rho_0 \sin \theta, \dots (6)$$

y_0, ρ_0 being the values of y, ρ , respectively, at A .

The horizontal load upon $AM =$ horizontal component of P

$$\begin{aligned} &= NK = SN - KS = T - T \cos \theta = 2T \left(\sin \frac{\theta}{2} \right)^2 \\ &= 2p\rho \left(\sin \frac{\theta}{2} \right)^2 = 2w y \rho \left(\sin \frac{\theta}{2} \right)^2 = 2w y_0 \rho_0 \left(\sin \frac{\theta}{2} \right)^2. \dots (7) \end{aligned}$$

Again, the vertical load upon AM

$$= \int_0^x p dx = w \int_0^x y dx = w y_0 \rho_0 \sin \theta; \dots (8)$$

the horizontal load upon AM

$$= \int_{y_0}^y p dy = w \int_{y_0}^y y dy = \frac{w}{2} (y^2 - y_0^2) = 2w y_0 \rho_0 \left(\sin \frac{\theta}{2} \right)^2. (9)$$

Equation (8) also shows that the area bounded by the curve AM , the verticals through M and A , and the horizontal through O is equal to $y_0 \rho_0 \sin \theta$, and is therefore proportional to $\sin \theta$. At the points defined by $\theta = 90^\circ$ the tangents to the arch are vertical, and the portion of the arch between these tangents is alone available for supporting a load. The vertical and horizontal loads upon one-half the arch are each equal to $wy_0 \rho_0$.

Corollary.—The relation given in eq. (1) holds true in any arch for elements upon which the pressure is wholly normal.

This has been already proved for the parabola and catenary, in cases (a) and (b).

At the point A' of the elliptic arch,

$$\rho = \frac{OB'^2}{OA'} = \frac{c^2 r^2}{r} = c^2 r.$$

Hence, the horizontal thrust at A'

$$= p_y \rho = \frac{p}{c} \rho = pcr = cH.$$

(e) *Geostatic Arch.*—The *geostatic* is a parallel projection of the *hydrostatic* arch.

The vertical forces and the lengths of vertical lines are unchanged.

The horizontal forces and lengths of horizontal lines are changed in a given ratio c to 1.

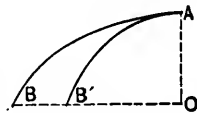

FIG. 491.

Let $B'A$ be the half-geostatic curve derived from the half-hydrostatic curve BA .

The vertical load on AB'

$$= P' = P = \text{thrust along arch at } B'. \quad \dots (1)$$

The horizontal load on AB'

$$= H' = cH = \text{thrust along arch at } A. \quad \dots (2)$$

The new vertical intensity

$$= p'_y = \frac{P'}{OB'} = \frac{P}{c \cdot OB} = \frac{p_y}{c} = \frac{p}{c}. \quad \dots (3)$$

The new horizontal intensity

$$= p'_x = \frac{H'}{OA} = \frac{cH}{OA} = cp_x = cp. \dots (4)$$

Thus, the geostatic arch is suited to support a load so distributed as to produce at any point a pair of conjugate pressures; pressures, in fact, similar to those developed according to the theory of earthwork.

Let R_1, R_2 be the radii of curvature of the geostatic arch at the points A, B' , respectively, and let r_1, r_2 be the radii of curvature at the corresponding points A, B of the hydrostatic arch.

The load is wholly normal at A and B' . Thus,

$$H' = p'_y R_1 = \frac{P}{c} R_1 = cH = cpr_1. \dots (5)$$

$$\therefore R_1 = c^2 r_1. \dots (6)$$

Also,

$$P' = p'_x R_2 = cpR_2 = P = pr_2. \dots (7)$$

$$\therefore cR_2 = r_2. \dots (8)$$

(f) *General Case.*—Let the figure represent any linear arch suited to support a load which is symmetrically distributed with respect to the crown A , and which produces at every point of the arch a pair of conjugate pressures, the one horizontal and the other vertical.

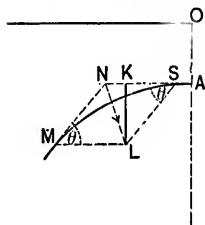

FIG. 499.

distance from A .

Any portion AM of the arch is kept in equilibrium by the horizontal thrust H at A , the tangential thrust T at M , and the resultant load upon AM , which must necessarily act through the point of intersection N of the lines of action of H and T .

Since the load at A is wholly vertical, H is given by

$$H_0 = p_0 \rho_0, \dots (1)$$

p_0 and t
L
Co
result
Th
NL a
loads
De

and

 θ being

 p_y , the
 p_x , the

EXA
zonal e
The

 ω being t

p_v and ρ_0 being, respectively, the vertical intensity of pressure and the radius of curvature at A .

Let $MN = T$, and take $NS = H_0$.

Complete the parallelogram SM ; the diagonal NL is the resultant load upon AM in direction and magnitude.

The vertical (KL) and the horizontal (KN) projections of NL are, therefore, respectively, the *vertical* and *horizontal* loads upon AM .

Denote the vertical load by V , the horizontal by H . Then

$$T \sin \theta = KL = V = \int_0^x p_v dx, \dots \dots \dots (2)$$

and

$$H = KN = SN - SK = H_0 - V \cot \theta, \dots \dots (3)$$

θ being the angle between MN and the horizon.

$$p_v, \text{ the vertical intensity of pressure, } = \frac{dV}{dx}. \dots \dots \dots (4)$$

p_h , the horizontal intensity of pressure

$$= \frac{dH}{dy} = - \frac{d}{dy}(V \cot \theta). \dots \dots \dots (5)$$

EXAMPLE.—A semicircular arch of radius r , with a horizontal extrados at a vertical distance R from the centre.

The angle between the radius to M and the vertical = θ .

$$\therefore x = r \sin \theta, \quad y = R - r \cos \theta. \dots \dots (1)$$

$$dx = r \cos \theta d\theta, \quad dy = r \sin \theta d\theta. \dots \dots (2)$$

$$p_h = wy = w(R - r \cos \theta), \dots \dots \dots (3)$$

w being the specific weight of the load. Hence,

$$\begin{aligned} V &= w \int_0^\theta (R - r \cos \theta) r \cos \theta d\theta \\ &= wr \left(R \sin \theta - \frac{r\theta}{2} - \frac{r \sin 2\theta}{4} \right). \dots \dots (4) \end{aligned}$$

Equations (3) and (4) give H ; for

$$p_0 = w(R - r), \dots \dots \dots (5)$$

and hence

$$H_0 = wr(R - r) \dots \dots \dots (6)$$

p_x , the horizontal intensity of pressure,

$$= - \frac{d}{dy}(V \cot \theta) = w \left(R - \frac{r \theta - \sin \theta \cos \theta}{2 \sin \theta} - r \cos \theta \right). \quad (7)$$

Rankine gives the following method of determining whether a linear arch may be adopted as the intrados of a real arch. At the crown a of a linear arch ab measure on the normal a length ac , so that c may fall within the limits required for stability (e.g., within the middle third).

At c two equal and opposite forces, of the same magnitude as the horizontal thrust H at a , and acting at right angles to ac , may be introduced without altering the equilibrium.

Thus the thrust at a is replaced by an equal thrust at c , and a right-handed couple of moment $H \cdot ac$.

Similarly, the tangential thrust T at any point d of ab may be replaced by an equal and parallel thrust at e , and a couple of moment $T \cdot de$.

The arch will be stable if the length of de , which is normal to ab at d , is fixed by the condition $T \cdot de = H \cdot ac$, and if the line which is the locus of e falls within a certain area (e.g., within the middle third of the arch ring).

8. Arched Ribs in Iron, Steel, or Timber.—In the following articles, the term arched rib is applied to arches constructed of iron, steel, or timber. The coefficients of elasticity are known quantities which are severally found to lie between certain not very wide limits, and their values may be introduced into the calculations with the result of giving to them greater accuracy. There are other considerations, however, involved in the problem of the stability of arched ribs which still render its solution more or less indeterminate.

It has been shown that the curve of pressure, or linear arch.

is a
the r
draw
girde
V
tribu
with
cross
T
subs
direc
chang
separ
9.
of an
axis o
Le

on the
distrib
Re
compo
Sin
betwe
Bu

Let
T is th

is a funicular polygon of the extraneous forces which act upon the real arch. It is, therefore, also the *bending-moment curve*, drawn to a definite scale, for a similarly loaded *horizontal girder* of the same span, whose axis is the springing line.

When the arched rib carries a given symmetrically distributed load, it will be assumed that the linear arch coincides with the axis of the rib, and that the thrust at any normal cross-section is *axial* and *uniformly* distributed.

The total stress at any point is made up of a number of subsidiary stresses, of which the most important are: (1) a direct thrust; (2) a stress due to flexure; (3) a stress due to a change of temperature. Each of these may be investigated separately, and the results superposed.

9. Bending Moment (*M*) and Thrust (*T*) at any Point of an Arched Rib under a Vertical Load.—Let *ABC* be the axis of the rib.

Let *D* and *E* be points on the same vertical line, *E* being

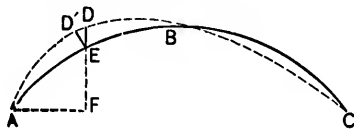

FIG. 493.

on the axis of the rib and *D* on the linear arch for any given distribution of load.

Resolve the reaction at *A* into its vertical and horizontal components, and denote the latter by *H*.

Since all the forces, excepting *H*, are vertical, the difference between the moments at *D* and *E* = *H* . *DE*.

But moment at *D* = 0. Hence,

$$\text{moment at } E = M = H \cdot DE.$$

Let the normal at *E* meet the linear arch in *D'*. Then, if *T* is the thrust along the axis at *E*,

$$T \cos \angle DED' = H = T \frac{D'E}{DE}, \text{ approximately,}$$

or

$$H \cdot DE = T \cdot D'E = M.$$

10. Rib with Hinged Ends; Invariability of Span.—
Let ABC be the axis of a rib supported at the ends on pins or

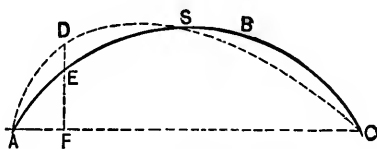

FIG. 494.

on cylindrical bearings. The resultant thrusts at A and C must necessarily pass through the centres of rotation. The vertical components of the thrusts are equal to the corresponding reactions at the ends of a girder of the same span and similarly loaded, and H is given by the last equation in the preceding article when DE has been found.

Let ADC be the linear arch for any arbitrary distribution of the load, and let it intersect the axis of the rib at S . The curvature of the more heavily loaded portion AES will be flattened, while that of the remainder will be sharpened.

The bending moment at any point E of the axis tends to change the inclination of the rib at that point.

Let the vertical through E intersect the linear arch in D and the horizontal through A in F .

Let θ be the inclination of the tangent at E to the horizontal.

Let I be the moment of inertia of the section of the rib at E .

Let ds be an element of the axis at E .

$$\text{Change of inclination at } E = d\theta = \frac{Mds}{EI} = \frac{H \cdot DE \cdot ds}{EI}.$$

If this change of curvature were effected by causing the whole curve on the left of E to turn about E through an angle $d\theta$, the horizontal displacement of A would be

$$EF \cdot d\theta = \frac{H \cdot DE \cdot EF \cdot ds}{EI}.$$

This is evidently equal to the horizontal displacement of E , and the algebraic sum of the horizontal displacements of all points along the axis is

$$\sum \frac{H \cdot DE \cdot EF \cdot ds}{EI} = \int \frac{H \cdot DE \cdot EF \cdot ds}{EI} = 0, \dots (1)$$

since the length AC is assumed to be invariable.

Thus, the actual linear arch must fulfil the condition expressed by eq. (1), which may be written

$$\int \frac{DE \cdot EF \cdot ds}{I} = 0, \dots (2)$$

since H and E are constant.

If the rib is of uniform section, I is also constant, and eq. (2) becomes

$$\int DE \cdot EF \cdot ds = 0. \dots (3)$$

Also, since DE is the difference between DF and EF ,

$$\int (DF - EF) EF \cdot ds = 0 = \int DF \cdot EF \cdot ds - \int EF^2 ds (4)$$

Remark.—Eq. 1 expresses the fact that the span remains invariable when a series of bending moments, $H \cdot DE$, act at points along the rib. These, however, are accompanied by a thrust along the arch, and the axis of the rib varies in length with the variation of thrust.

Let H_0 be the horizontal thrust for that symmetrical loading which makes the linear arch coincide with the axis of the rib.

Let T_0 be the corresponding thrust along the rib at E .

The shortening of the element ds at E of unit section

$$= \frac{T - T_0}{E} ds.$$

EXAMPLE I. Let the axis of a rib of uniform section and hinged at both ends be a semicircle of radius r .

Let a single weight W be placed at a point upon the rib whose horizontal distance from O , the centre of the span, is a .

The "linear arch" (or bending-moment curve) consists of two straight lines DA, DC .

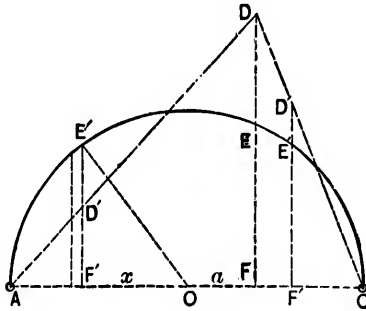

FIG. 495.

Draw any vertical line intersecting the axis, the linear arch, and the springing line AC in E', D', F' , respectively.

Let $OF' = x$, and let dx be the horizontal projection upon AC of the element ds at E' .

Then

$$\frac{ds}{dx} = \text{cosec } E'D'F' = \frac{r}{E'F'}$$

or

$$E'F' ds = r dx \dots \dots \dots (1)$$

Applying condition (4),

$$\int_{-a}^a D'F' r dx + \int_a^r D'F' r dx = \int_{-r}^r E'F' r dx,$$

or

$$\int_{-a}^a D'F' dx + \int_a^r D'F' dx = \int_{-r}^r E'F' dx,$$

or

area of triangle $ADC =$ area of semicircle.

And if z be the vertical distance of D from AC ,

$$zr = \frac{\pi r^2}{2}$$

or

$$z = \frac{\pi r}{2} = \text{one-half of length of rib.} \dots (2)$$

$$\therefore DE = DF - EF = \frac{\pi r}{2} - \sqrt{r^2 - a^2}. \dots (3)$$

Hence, if h be the horizontal thrust on the arch due to W ,

$$h \cdot DE = M = W \frac{r^2 - a^2}{2r}. \dots (4)$$

Similarly, if there are a number of weights W_1, W_2, W_3, \dots upon the rib, and if h_1, h_2, h_3, \dots are the corresponding horizontal thrusts, the total horizontal thrust H will be the sum of these separate thrusts, i.e.,

$$H = h_1 + h_2 + \dots (5)$$

It will be observed that the apices (D_1, D_2, D_3, \dots) of the several linear arches (triangles) lie in a horizontal line at the vertical distance $\frac{\pi r}{2}$ from the springing line.

EX. 2. An arched rib hinged at the ends and loaded with weights W_1, W_2, W_3, \dots

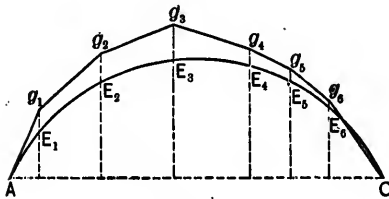

FIG. 496.

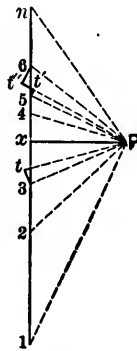

FIG. 497.

Let 1 2 3 4 ... n be the line of loads, W_1 being represented by 1 2, W_2 by 2 3, W_3 by 3 4, etc., and let the segments 1x,

nx , respectively, represent the vertical reactions at A and C . Take the horizontal length xP to represent H , and draw the radial lines P_1, P_2, P_3, \dots .

The equilibrium polygon $Ag_1g_2g_3 \dots$ must be the funicular polygon of the forces with respect to the pole P , and therefore the directions of the resultant thrusts from A to E_1, E_1 to E_2, E_2 to E_3, \dots are respectively parallel to P_1, P_2, P_3, \dots .

The tangential (axial) thrust and shear at any point p of the rib, e.g., between E_1 and E_2 , may be easily found by drawing Pt parallel to the tangent at p , and $3t$ perpendicular to Pt . The direct tangential thrust is evidently represented by Pt , and the normal shear at the same point by $3t$. The latter is borne by the web.

If p is a point at which a weight is concentrated, e.g., E_2 , draw $Pt't''$ parallel to the tangent at E_2 , and $5t', 6t''$ perpendicular to $Pt't''$.

Pt' represents the axial thrust immediately on the left of E_2 , and $5t'$ the corresponding normal shear, while Pt'' represents the axial thrust immediately on the right of E_2 , and $6t''$ the corresponding normal shear.

A vertical line through P can only meet the line of loads at infinity.

Thus, it would require the loads at A and C to be infinitely great in order that the thrusts at these points might be vertical. Practically, no linear arch will even approximately coincide with the axis of a rib rising vertically at the springings, and hence neither a semicircular nor a semi-elliptical axis is to be recommended.

EX. 3. Let the axis of the rib be a circular arc of span $2l$ and radius r , subtending an angle 2α at the centre N .

Let the angles between the radii NE, NE' and the vertical be β and θ , respectively.

The element ds at $E' = r d\theta$.

Also, $E'F' = r(\cos \theta - \cos \alpha)$; $AF' = l - r \sin \theta$;

$$D'F' = \frac{z}{l \pm a}(l - r \sin \theta).$$

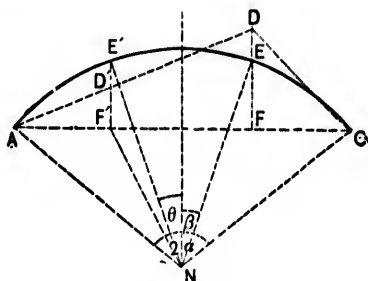

FIG. 498.

Applying condition (4),

$$\int_{-\alpha}^{\alpha} r^2 (\cos \theta - \cos \alpha)^2 r d\theta$$

$$= \int_{-\beta}^{\alpha} \frac{z}{l+a} (l-r \sin \theta) r (\cos \theta - \cos \alpha) r d\theta$$

$$+ \int_{\beta}^{\alpha} \frac{z}{l-a} (l-r \sin \theta) r (\cos \theta - \cos \alpha) r d\theta,$$

which easily reduces to

$$r \left\{ \alpha (\cos 2\alpha + 2) - \frac{3}{2} \sin 2\alpha \right\}$$

$$= \frac{2z}{l^2 - a^2} \left\{ l^2 (\sin \alpha - \alpha \cos \alpha) + \frac{rl}{4} (\cos 2\alpha - \cos 2\beta) \right.$$

$$\left. - rl \cos \alpha (\cos \alpha - \cos \beta) - la (\sin \beta - \beta \cos \alpha) \right\},$$

an equation giving z or DF . Also,

$$DE = DF - EF,$$

and the corresponding horizontal thrust may be found, as before, by the equation

$$h \cdot DE = W \frac{l^2 - a^2}{l}.$$

Note.—If $\alpha^\circ = 90^\circ$,

$$r \frac{\pi}{2} = \frac{2z}{l^2 - a^2} \left(\frac{l^2 - a^2}{2} \right), \quad \text{or } z = \frac{\pi r}{2} \text{ as in Ex. 1.}$$

EX. 4. Let the axis be a parabola of span $2l$ and rise k . (Fig. 498, Ex. 3). From the properties of the parabola,

$$E'F' = k \left(1 - \frac{x^2}{l^2} \right), \quad D'F' = \frac{z(l-x)}{l \pm a},$$

and

$$ds^2 = dx^2 \left(1 + \frac{k^2}{4l^2} x^2 \right),$$

or, approximately,

$$ds = dx \left(1 + \frac{k^2}{2l^2} x^2 \right).$$

Applying condition (4),

$$\begin{aligned} & \int_{-l}^l k^2 \left(1 - \frac{x^2}{l^2} \right)^2 dx \left(1 + \frac{k^2}{2l^2} x^2 \right) \\ &= \int_{-a}^l \frac{z(l-x)}{l+a} k \left(1 - \frac{x^2}{l^2} \right) \left(1 + \frac{k^2}{2l^2} x^2 \right) dx \\ & \quad + \int_a^l \frac{z(l-x)}{l-a} k \left(1 - \frac{x^2}{l^2} \right) \left(1 + \frac{k^2}{2l^2} x^2 \right) dx, \end{aligned}$$

which easily reduces to

$$\begin{aligned} z \left\{ 1 + \frac{1}{6} \frac{l^2 + a^2}{l^2} \left(\frac{2k^2}{l^2} - 1 \right) - \frac{2}{15} \frac{k^2}{l^2} (l^2 + l^2 a^2 + a^4) \right\} \\ = k \left(\frac{16}{15} + \frac{32}{105} \frac{k^2}{l^2} \right), \end{aligned}$$

an equation giving z or DF .

Note.—If the arch is very flat, so that ds may be considered

as approximately equal to dx , the term $2\frac{k^2}{l^2}x^2$ in the above equation may be disregarded, and it may be easily shown that

$$z \left\{ 1 - \frac{1}{6} \frac{l^2 + a^2}{l^2} \right\} = k \frac{16}{15},$$

or

$$z = \frac{32}{5} \frac{kl^2}{5l^2 - a^2}.$$

II. Rib with Ends absolutely Fixed.—Let ABC be the axis of the rib. The fixture of the ends introduces two un-

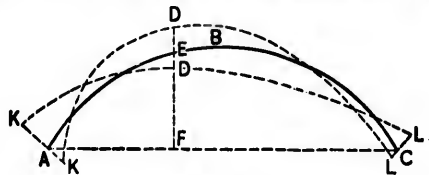

FIG. 499.

known moments at these points, and since H is also unknown, three conditions must be satisfied before the strength of the rib can be calculated.

Represent the linear arch by the dotted lines KL ; the points K, L may fall above or below the points A, C .

Let a vertical line DEF intersect the linear arch in D , the axis of the rib in E , and the horizontal through A in F .

As in Art. 10, change of inclination at E , or $d\theta = \frac{Mds}{EI}$.

But the total change of inclination of the rib between A and C must be nil, as the ends are fixed.

$$\therefore \int \frac{Mds}{EI} = 0 = \int \frac{H \cdot DE \cdot ds}{EI}, \quad \dots (1)$$

which may be written

$$\int \frac{DE}{I} ds = 0, \quad \dots (2)$$

since H and E are constant.

If the section of the rib is uniform, I is constant and eq. (2) becomes

$$\int DE \cdot ds = 0 \quad \dots \dots \dots (3)$$

Again, the total *horizontal* displacement between A and C will be nil if the abutments are immovable. If they yield, the amount of the yielding must be determined in each case, and may be denoted by an expression of the form μH , μ being some coefficient.

As in Art. 10, the total horizontal displacement

$$= \int \frac{H \cdot DE \cdot EF \cdot ds}{EI}$$

$$\therefore \int \frac{H \cdot DE \cdot EF \cdot ds}{EI} = 0 \quad \text{or} \quad = \mu H \quad \dots \dots (4)$$

But H and E are constant.

$$\therefore \int \frac{DE \cdot EF \cdot ds}{I} = 0 \quad \text{or} \quad = \mu E \quad \dots \dots (5)$$

If the section of the rib is uniform, I is also constant, and hence

$$\int DE \cdot EF \cdot ds = 0 \quad \text{or} \quad = \mu EI; \quad \dots \dots (6)$$

and since DE is the difference between DF and EF , this last may be written

$$\int DF \cdot EF \cdot ds \sim \int EF^2 \cdot ds = 0 \quad \text{or} \quad = \mu EI \quad \dots \dots (7)$$

Again, the total *vertical* displacement between A and C must be *nil*.

The vertical displacement of E (see Art. 10)

$$= AF \cdot d\theta = \frac{M \cdot AF \cdot ds}{EI};$$

Hence, the total vertical displacement

$$= \int \frac{H \cdot DE \cdot AF}{EI} ds = 0, \dots \dots \dots (8)$$

which may be written

$$\int \frac{DE \cdot AF}{I} ds = 0, \dots \dots \dots (9)$$

since H and E are constant. If the section of the rib is also constant,

$$\int DE \cdot AF \cdot ds = 0 = \int DF \cdot AF \cdot ds - \int EF \cdot AF \cdot ds. \quad (10)$$

Eqs. (2), (5), and (9) are the three equations of condition. In eq. (9) AF must be measured from same abutment throughout the summation.

The integration extends from A to C .

EXAMPLE 1. Let the axis of the rib be a circular arc of span $2l$, subtending an angle 2α at the centre N .

Let a weight W be concentrated on the rib at a point E

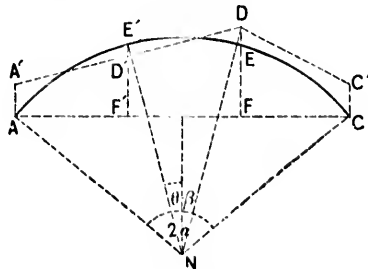

FIG. 500.

whose horizontal distance from the middle point of the span is α .

Let the radius NE make an angle β with the vertical.

The "linear arch" consists of two straight lines DA' , DC' .

Let $AA' = y_1$, $DF = z$, $CC' = y_2$.

Draw any ordinate $E'F'$ intersecting the linear arch in D' .
Let the radius NE' make an angle θ with the vertical.
Then

$$E'F' = r(\cos \theta - \cos \alpha).$$

$$AF' = l - r \sin \theta, \text{ and } D'F' = (l - r \sin \theta) \frac{z - y_1}{l + a} + y_1$$

if F' is on the left of F ;

$$AF' = l + r \sin \theta \text{ and } D'F' = (l - r \sin \theta) \frac{z - y_2}{l - a} + y_2$$

if F' is on the right of F .

Also, $ds = r d\theta$.

Applying condition (2),

$$\begin{aligned} & \int_{-\beta}^{\alpha} \left\{ (l - r \sin \theta) \frac{z - y_1}{l + a} + y_1 \right\} d\theta \\ & \quad + \int_{\beta}^{\alpha} \left\{ (l - r \sin \theta) \frac{z - y_2}{l - a} + y_2 \right\} d\theta \\ & = r \int_{-\alpha}^{\alpha} (\cos \theta - \cos \alpha) d\theta. \quad \dots \quad (1) \end{aligned}$$

Applying condition (5), and assuming $\mu = 0$,

$$\begin{aligned} & \int_{-\beta}^{\alpha} (\cos \theta - \cos \alpha) \left\{ (l - r \sin \theta) \frac{z - y_1}{l + a} + y_1 \right\} d\theta \\ & \quad + \int_{\beta}^{\alpha} (\cos \theta - \cos \alpha) \left\{ (l - r \sin \theta) \frac{z - y_2}{l - a} + y_2 \right\} \\ & = r \int_{-\alpha}^{\alpha} (\cos \theta - \cos \alpha)^2 d\theta. \quad \dots \quad (2) \end{aligned}$$

Applying condition (9),

$$\begin{aligned} & \int_{-\beta}^{\alpha} (l - r \sin \theta) \left\{ (l - r \sin \theta) \frac{z - y_1}{l + r} + y_1 \right\} d\theta \\ & \quad + \int_{\beta}^{\alpha} (l + r \sin \theta) \left\{ (l - r \sin \theta) \frac{z - y_2}{l - r} + y_2 \right\} d\theta \\ & = r \int_{-\beta}^{\alpha} (\cos \theta - \cos \alpha) (l - r \sin \theta) d\theta \\ & \quad + r \int_{\beta}^{\alpha} (\cos \theta - \cos \alpha) (l + r \sin \theta) d\theta. \quad (3) \end{aligned}$$

Equations (1), (2), (3) may be easily integrated, and the resulting equations will give the values of y_1 , z , and y_2 .

The corresponding horizontal thrust, h , may now be obtained from the equation $h \cdot DE = M = h(z - EF)$.

Note.—If the axis is a semicircle, and if W is at the crown,

$$a = 0, \quad \alpha = 90^\circ, \quad \beta = 0,$$

and eqs. (1), (2), (3) reduce to

$$z(\pi - 2) + y_1 + y_2 = 2r;$$

$$2z + y_1 + y_2 = \pi r,$$

$$z(\pi - 2) + y_1 \left(\frac{\pi}{4} - 1 \right) - y_2 \left(\frac{\pi}{4} + 1 \right) = 2r.$$

$$\therefore z = r \frac{\pi - 2}{4 - \pi}, \quad \text{and} \quad y_1 = y_2 = r \frac{4 + 2\pi - \pi^2}{4 - \pi}.$$

Ex. 2. Let the axis be a parabola of span $2l$ and rise k (Fig. 500 in Ex. 1).

As in Ex. 3, Art. 10,

$$E'F' = k \left(1 - \frac{x^2}{l^2} \right); \quad ds' = \left(1 + \frac{2k^2}{l^2} x^2 \right) dx.$$

Also,

$$D'F' = y_1 + (l-x) \frac{z-y_1}{l+a} \text{ on the right of } DF,$$

and

$$= y_2 + (l-x) \frac{z-y_2}{l-a} \text{ on the left of } DF.$$

$$AF' = l \mp x.$$

The equations of condition become

$$\begin{aligned} \int_{-a}^l \left\{ y_1 + (l-x) \frac{z-y_1}{l+a} \right\} \left(1 + 2 \frac{k^2}{l^2} x^2 \right) dx \\ + \int_a^l \left\{ y_2 + (l-x) \frac{z-y_2}{l-a} \right\} \left(1 + 2 \frac{k^2}{l^2} x^2 \right) dx \\ = \int_{-l}^l k \left(1 - \frac{x^2}{l^2} \right) \left(1 + 2 \frac{k^2}{l^2} x^2 \right) dx; \end{aligned}$$

$$\begin{aligned} \int_{-a}^l \left\{ y_1 + (l-x) \frac{z-y_1}{l+a} \right\} k \left(1 - \frac{x^2}{l^2} \right) \left(1 + 2 \frac{k^2}{l^2} x^2 \right) dx \\ + \int_a^l \left\{ y_2 + (l-x) \frac{z-y_2}{l-a} \right\} \left(1 - \frac{x^2}{l^2} \right) k \left(1 + 2 \frac{k^2}{l^2} x^2 \right) dx \\ = \int_{-l}^l k^2 \left(1 - \frac{x^2}{l^2} \right)^2 \left(1 + 2 \frac{k^2}{l^2} x^2 \right) dx; \end{aligned}$$

$$\begin{aligned} \int_{-a}^l \left\{ y_1 + (l-x) \frac{z-y_1}{l+a} \right\} (l-x) \left(1 + 2 \frac{k^2}{l^2} x^2 \right) dx \\ + \int_a^l \left\{ y_2 + (l-x) \frac{z-y_2}{l-a} \right\} (l+x) \left(1 + 2 \frac{k^2}{l^2} x^2 \right) dx \\ = \int_{-a}^l k \left(1 - \frac{x^2}{l^2} \right) (l-x) \left(1 + 2 \frac{k^2}{l^2} x^2 \right) dx \\ + \int_a^l k \left(1 - \frac{x^2}{l^2} \right) (l+x) \left(1 + 2 \frac{k^2}{l^2} x^2 \right) dx. \end{aligned}$$

These equations may be at once integrated, and the resulting equations will give the values of y_1 , y_2 , z .

If the arch is very flat, so that ds may be taken to be approximately the same as dx , it may be easily shown that

$$y_1 = \frac{2kl + 5a}{15} \frac{1}{l+a}, \quad y_2 = \frac{2kl - 5a}{15} \frac{1}{l-a}, \quad \text{and} \quad z = \frac{6}{5}k.$$

12. Effect of a Change of Temperature.—The variation in the span $2l$ of an arch for a change of t° from the mean temperature is approximately $= 2\epsilon tl$, ϵ being the coefficient of expansion.

Hence, if H_t is the horizontal force induced by a change of temperature, the condition that the length AC is invariable is expressed by the equation

$$H_t \int \frac{DE \cdot EF \cdot ds}{EI} \pm 2\epsilon tl = 0.$$

If the rib is of uniform section, I is constant; and since E is also constant, the equation may be written

$$\frac{H_t}{EI} \int DE \cdot EF \cdot ds \pm 2\epsilon tl = 0.$$

EXAMPLE 1. Let the axis AEC of a rib of uniform section

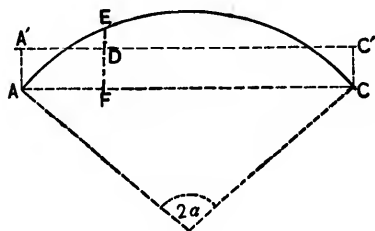

FIG. 501.

be the arc of a circle of radius r subtending an angle 2α at the centre.

First, let the rib be *hinged* at both ends.

It is evident that the straight line AC is the "linear arch."
Then,

$$\int DE \cdot EF \cdot ds = \int EF^2 ds = r^2 \int_{-\alpha}^{\alpha} (\cos \theta - \cos \alpha)^2 d\theta$$

$$= r^2 \left\{ \alpha(2 + \cos 2\alpha) - \frac{2}{3} \sin 2\alpha \right\}.$$

Also, $l = r \sin \alpha$.

$$\therefore \frac{H_t}{EI} \frac{l^3}{\sin^3 \alpha} \left\{ \alpha(2 + \cos 2\alpha) - \frac{2}{3} \sin 2\alpha \right\} \pm 2etl = 0.$$

Note.—If the axis is a semicircle, $\alpha = 90^\circ$, and

$$\frac{H_t}{EI} \frac{\pi l^3}{2} \pm 2etl = 0.$$

Second, let the rib be *fixed* at both ends.

The "linear arch" is now a straight line $A'C'$ at a distance $z (= DF)$ from AC given by the equation

$$\int DE \cdot ds = 0.$$

$$\therefore \int DF \cdot ds = \int EF \cdot ds,$$

or

$$z \int ds = r^2 \int_{-\alpha}^{\alpha} (\cos \theta - \cos \alpha) d\theta,$$

or

$$az = r(\sin \alpha - \alpha \cos \alpha).$$

Also,

$$\int DE \cdot EF \cdot ds = \int (DF \cdot EF \sim EF^2) ds = z \int EF ds \sim \int EF^2 ds$$

$$= 2zr^2(\sin \alpha - \alpha \cos \alpha) \sim r^2 \left\{ \alpha(2 + \cos 2\alpha) - \frac{2}{3} \sin 2\alpha \right\}.$$

$$\therefore \frac{H_t}{EI} \left\{ 2zr^2(\sin \alpha - \alpha \cos \alpha) - r^2 \left\{ \alpha(2 + \cos 2\alpha) - \frac{2}{3} \sin 2\alpha \right\} \right\}$$

$$\pm 2etl = 0,$$

$$\text{and } l = r \sin \alpha.$$

EX. 2. Let the axis AEC of a rib of uniform section be a parabola of span $2l$ and rise k . (See Fig. 501 in Ex. 1.)

First, let the rib be *hinged* at both ends.
The straight line AC is the linear arch. Then

$$\begin{aligned}\int DE \cdot EF \cdot ds &= \int_{-l}^l EF^2 \left(1 + \frac{2k^2}{l^2} x^2\right) dx \\ &= \int_{-l}^l k^2 \left(1 - \frac{x^2}{l^2}\right)^2 \left(1 + \frac{2k^2}{l^2} x^2\right) dx = \frac{16}{15} kl^2 + \frac{32}{105} \frac{k^3}{l};\end{aligned}$$

and hence,

$$\frac{H_l}{EI} kl \left(\frac{16}{15} + \frac{32}{105} \frac{k^2}{l^2} \right) \pm 2\epsilon tl = 0.$$

Second, let the rib be *fixed* at both ends.

The linear arch is the line $A'C'$ at a distance z ($= DF$) from AC given by the equation

$$\int DE \cdot ds = 0 = \int (DF \sim EF) ds,$$

or

$$DF \int ds = \int EF \cdot ds.$$

$$\therefore z \int_{-l}^l \left(1 + \frac{2k^2}{l^2} x^2\right) dx = \int_{-l}^l k \left(1 - \frac{x^2}{l^2}\right) \left(1 + \frac{2k^2}{l^2} x^2\right) dx.$$

$$\therefore 2zl \left(1 + \frac{2}{3} \frac{k^2}{l^2}\right) = 2kl \left(\frac{2}{3} + \frac{4}{15} \frac{k^2}{l^2}\right),$$

or

$$z \left(1 + \frac{2}{3} \frac{k^2}{l^2}\right) = \frac{2}{3} k \left(1 + \frac{2}{5} \frac{k^2}{l^2}\right).$$

Also,

$$\int DE \cdot EF \cdot ds = \int DF \cdot EF \cdot ds \sim \int EF^2 ds$$

$$= z \int EF \cdot ds - \int EF^2 ds = 2klz \left(\frac{2}{3} + \frac{4}{15} \frac{k^2}{l^2}\right) \sim \left(\frac{16}{15} k^2 l + \frac{32}{105} \frac{k^3}{l}\right).$$

Hence,

$$\frac{H_1 4kl}{EI 3} \left\{ z \left(1 + \frac{2k^2}{5l^2} \right) \sim \frac{4k}{5} \left(1 + \frac{2k}{7l^2} \right) \right\} \pm 2\epsilon ll = 0.$$

Remark.—The coefficient of expansion per degree of Fahrenheit is .0000062 and .0000067 for cast- and wrought-iron beams, respectively. Hence, the corresponding total expansion or contraction in a length of 100 ft., for a range of 60° F. from the mean temperature, is .0372 ft. ($= \frac{9}{250}''$) and .0402 ft. ($= \frac{1}{2}''$).

In practice the actual variation of length rarely exceeds *one-half* of these amounts, which is chiefly owing to structural constraint.

13. Deflection of an Arched Rib.

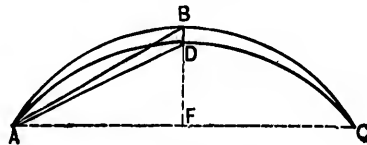

FIG. 502.

Let the abutments be immovable.

Let ABC be the axis of the rib in its normal position.

Let ADC represent the position of the axis when the rib is loaded.

Let BDF be the ordinate at the centre of the span; join AB, AD .

Then

$$DF^2 = AD^2 - AF^2 = AB^2 \left(\frac{\text{arc } AD}{\text{arc } AB} \right)^2 - AF^2.$$

But

$$\frac{\text{arc } AB - \text{arc } AD}{\text{arc } AB} = \frac{f}{E},$$

f being the intensity of stress due to the change in the length of the axis.

$$\therefore DF^2 = AB^2 \left(1 - \frac{f}{E} \right)^2 - AF^2 = BF^2 - AB^2 \left\{ 2 \frac{f}{E} - \left(\frac{f}{E} \right)^2 \right\}.$$

abut
is th
the
conc
plica
L
AA'
upon
T
to a
the r
of C.
T
along

$$\therefore AB^2 \left\{ 2\frac{f}{E} - \left(\frac{f}{E}\right)^2 \right\} = BF^2 - DF^2 = (BF - DF)(BF + DF) \\ = 2BF(BD), \text{ approximately.}$$

$\left(\frac{f}{E}\right)^2$ is also sufficiently small to be disregarded. Hence,

$$BD, \text{ the deflection,} = \frac{AB^2 f}{BF E} = \frac{k^2 + l^2}{k} \frac{f}{E}, \text{ approximately.}$$

14. Elementary Deformation of an Arched Rib.

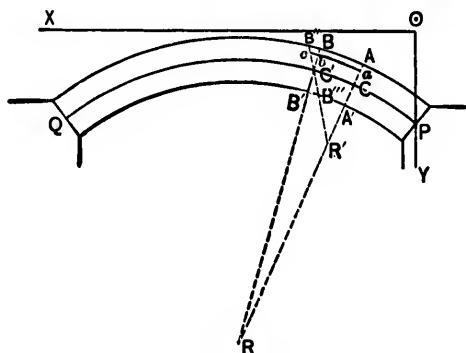

FIG. 503.

The arched rib represented by Fig. 503 springs from two abutments and is under a vertical load. The neutral axis PQ is the locus of the centres of gravity of all the cross-sections of the rib, and may be regarded as a linear arch, to which the conditions governing the equilibrium of the rib are equally applicable.

Let AA' be any cross-section of the rib. The segment $AA'P$ is kept in equilibrium by the external forces which act upon it, and by the molecular action at AA' .

The external forces are reducible to a single force at C and to a couple of which the moment M is the algebraic sum of the moments with respect to C of all the forces on the right of C .

The single force at C may be resolved into a component T along the neutral axis, and a component S in the plane AA' .

The latter has very little effect upon the curvature of the neutral axis, and may be disregarded as compared with M .

Before deformation let the consecutive cross-sections BB' and AA' meet in R ; R is the centre of curvature of the arc CC' of the neutral axis.

After deformation it may be assumed that the plane AA' remains unchanged, but that the plane BB' takes the position $B''B'''$. Let AA' and $B''B'''$ meet in R' ; R' is the centre of curvature of the arc CC' after deformation.

Let abc be any layer at a distance z from C .

Let $CC' = \Delta s$, $CR = R$, $CR' = R'$, and let Δa be the sectional area of the layer abc .

By similar figures,

$$\frac{ac}{\Delta s} = \frac{R' + z}{R'} \quad \text{and} \quad \frac{ab}{\Delta s} = \frac{R + z}{R}.$$

$$\therefore bc = ac - ab = \Delta s \cdot z \left(\frac{1}{R'} - \frac{1}{R} \right).$$

The tensile stress in abc

$$\begin{aligned} &= E \cdot \Delta a \frac{bc}{ab} = E \cdot \Delta a \frac{\Delta s \cdot z}{ab} \left(\frac{1}{R'} - \frac{1}{R} \right) \\ &= E \cdot \Delta a \cdot z \left(\frac{1}{R'} - \frac{1}{R} \right), \text{ very nearly.} \end{aligned}$$

The moment of this stress with respect to C

$$= E \cdot \Delta a \cdot z^2 \left(\frac{1}{R'} - \frac{1}{R} \right).$$

Hence, the moment of resistance at AA'

$$= \int E \cdot \Delta a \cdot z^2 \left(\frac{1}{R'} - \frac{1}{R} \right) = E \left(\frac{1}{R'} - \frac{1}{R} \right) \int \Delta a \cdot z^2,$$

the integral extending over the whole of the section.

$$\therefore M = EI \left(\frac{1}{R'} - \frac{1}{R} \right). \quad \dots \quad (1)$$

Again, the effect of the force T is to lengthen or shorten the element CC' , so that the plane BB' will receive a motion of translation, but the position of R' is practically unaltered.

Corollary 1. Let A be the area of the section AA' .

The total unit stress in the layer abc

$$= p = \frac{T}{A} \pm \frac{Mz}{I}, \dots \dots \dots (2)$$

the sign being *plus* or *minus* according as M acts towards or from the edge of the rib under consideration.

From this expression may be deduced (1) the position of the point at which the intensity of the stress is a maximum for any given distribution of the load; (2) the distribution of the load that makes the intensity an absolute maximum; (3) the value of the intensity.

Cor. 2. Let w be the total intensity of the vertical load per horizontal unit of length.

Let w_1 be the portion of w which produces only a direct compression.

Let H be the horizontal thrust of the arch.

Let P be the total load between the crown and AA' which produces compression.

Refer the rib to the horizontal OX and the vertical OPY as the axes of x and y , respectively.

Let x, y be the co-ordinates of C .

Then

$$P = H \frac{dy}{dx}; \text{ but } dP = w_1 dx.$$

$$\therefore w_1 = H \frac{d^2y}{dx^2}; \dots \dots \dots (3)$$

also,

$$T = H \frac{ds}{dx} \dots \dots \dots (4)$$

15. General Equations.

Let l be the span of the arch.

Let x, y be the co-ordinates of the point C before deformation.

Let x', y' be the co-ordinates of the point C after deformation.

Let θ be the angle between tangent at C and OX before deformation.

Let θ' be the angle between tangent at C and OX after deformation.

Let ds be the length of the element CC' before deformation.

Let ds' be the length of the element CC' after deformation.

Effect of flexure. $\frac{d\theta'}{ds'} = \frac{1}{R'}$ and $\frac{d\theta}{ds} = \frac{1}{R}$

$$\therefore \frac{M}{EI} = \frac{1}{R'} - \frac{1}{R} = \frac{d\theta'}{ds'} - \frac{d\theta}{ds} = \frac{d\theta' - d\theta}{ds}, \text{ very nearly.}$$

Let i be the change of slope at C . Then

$$di = d\theta - d\theta' = \frac{Mds}{EI} = \frac{M ds}{EI} \frac{dx}{dx}$$

$$\therefore i' = \theta - \theta' = i_0 + \int_0^x \frac{M ds}{EI} \frac{dx}{dx}, \dots (5)$$

i_0 being the *change of slope* at P , and a quantity whose value has yet to be determined.

Again, the general equations of equilibrium at the plane AA' are

$$\frac{d^2M}{dx^2} = \frac{dS}{dx} = -(w - w_1) = -\left(w - H \frac{d^2y}{dx^2}\right), \dots (6)$$

for the portion w_1 , Cor. 2, Art. 14, produces compression only and no shear.

$$\therefore S = S_0 - \int_0^x w dx + H \left(\frac{dy}{dx} - \frac{dy_0}{dx_0} \right), \dots (7)$$

S_0 being the still undetermined vertical component of the shear at P , and $\frac{dy_0}{dx_0}$ the slope at P . Also,

$$M = M_0 + S_0 x - \int_0^x \int_0^x w dx^2 + H \left(y - y_0 - x \frac{dy_0}{dx_0} \right), \quad (8)$$

M_0 being the still undetermined bending moment at P .

Equations (5), (6), (7), and (8) contain the *four* undetermined constants H, S_0, M_0, i_0 .

Let $M_1, S_1,$ and i_1 be the values of $M, S,$ and $i,$ respectively, at Q .

Equations of Condition.—In practice the ends of the rib are either *fixed* or *free*.

If they are fixed, $i_0 = 0$; if they are free, $M_0 = 0$. In either case the number of undetermined constants reduces to *three*.

If the abutments are immovable, $x_1 - l = 0$. If the abutments yield, $x_1 - l$ must be found by experiment. Let $x_1 - l = \mu H$, μ being some coefficient. The *first* equation of condition is

$$x_1 - l = 0, \text{ or } x_1 - l = \mu H. \quad \dots \quad (9)$$

Again, Q is immovable in a vertical direction, and the *second* equation of condition is

$$y_1 - y_0 = 0. \quad \dots \quad (10)$$

Again, if the end Q is fixed, $i_1 = 0$; and if free, $M_1 = 0$; and the *third* equation of condition is

$$i_1 = 0, \text{ or } M_1 = 0. \quad \dots \quad (11)$$

Substituting in equations (7) and (8) the values of the three constants as determined by these conditions, the shearing force and bending moment may be found at any section of the rib.

Again,

$$\cos \theta' = \cos (\theta - i) = \cos \theta + i \sin \theta;$$

$$\sin \theta' = \sin (\theta - i) = \sin \theta - i \cos \theta.$$

$$\therefore \frac{dx'}{ds'} = \frac{dx}{ds} + i \frac{dy}{ds} \quad \text{and} \quad \frac{dy'}{ds'} = \frac{dy}{ds} - i \frac{dx}{ds}. \quad (12)$$

Hence, approximately,

$$\frac{d}{ds}(x' - x) = i \frac{dy}{ds} \quad \text{and} \quad \frac{d}{ds}(y' - y) = -i \frac{dx}{ds}.$$

Thus, if X and Y are respectively the horizontal and vertical displacements,

$$\frac{dX}{ds} = i \frac{dy}{ds} \quad \text{and} \quad \frac{dY}{ds} = -i \frac{dx}{ds},$$

or

$$\frac{dX}{dy} = i = -\frac{dY}{dx}. \quad \dots \dots \dots (13)$$

16. Effect of T and of a Change of t° in the Temperature.

$$ds' = ds \left(1 - \frac{T}{EA} \right).$$

Also, if there is a change from the mean of t° in the temperature, the length $ds \left(1 - \frac{T}{EA} \right)$ must be multiplied by $(1 \pm \epsilon t)$, ϵ being the coefficient of linear expansion.

$$\begin{aligned} \therefore ds' &= ds \left(1 - \frac{T}{EA} \right) (1 \pm \epsilon t) \\ &= ds \left(1 - \frac{T}{EA} \pm \epsilon t \right), \quad \text{approximately.} \end{aligned} \quad (14)$$

By equations (12),

$$dx' = (dx + i \cdot dy) \frac{ds'}{ds} = (dx + i \cdot dy) \left(1 - \frac{T}{EA} \pm \epsilon t \right)$$

and

$$dy' = (dy - i \cdot dx) \frac{ds'}{ds} = (dy - i \cdot dx) \left(1 - \frac{T}{EA} \pm \epsilon t \right).$$

$$\therefore dX = d(x' - x) = idy - \left(\frac{T}{EA} \mp \epsilon t \right) dx$$

and

$$dY = d(y' - y) = -idx - \left(\frac{T}{EA} \mp \epsilon t \right) dy, \text{ approximately,}$$

Hence,

$$X = x' - x = \int_0^{x'} i \frac{dy}{dx} dx - \int_0^{x'} \left(\frac{T}{EA} \mp \epsilon t \right) dx \quad (15)$$

and

$$Y = y' - y = - \int_0^{x'} idx - \int_0^{x'} \left(\frac{T}{EA} \mp \epsilon t \right) \frac{dy}{dx} dx. \quad (16)$$

Note.—A nearer approximation than is given by the preceding results may be obtained as follows:

Let $x + dx$, $y + dy$ be the co-ordinates of a point very near C before deformation.

Let $x' + dx'$, $y' + dy'$ be the co-ordinates of a point very near C after deformation.

Then

$$ds^2 = dx^2 + dy^2 \quad \text{and} \quad ds'^2 = dx'^2 + dy'^2.$$

$$\therefore ds'^2 - ds^2 = dx'^2 - dx^2 + dy'^2 - dy^2,$$

or

$$(ds' - ds)(ds' + ds) = (dx' - dx)(dx' + dx) + (dy' - dy)(dy' + dy).$$

$$\therefore (ds' - ds)ds = (dx' - dx)dx + (dy' - dy)dy, \text{ approximately.}$$

$$\therefore dx' - dx = (ds' - ds) \frac{ds}{dx} - (dy' - dy) \frac{dy}{dx}$$

and

$$dy' - dy = (ds' - ds) \frac{ds}{dx} \frac{dx}{dy} - (dx' - dx) \frac{dx}{dy}.$$

Hence, by equations (12) and (14),

$$dx' - dx = i \frac{dy}{dx} dx - \frac{T}{EA} \left(\frac{ds}{dx} \right)^2 dx \pm \epsilon t \left(\frac{ds}{dx} \right)^2 dx$$

and

$$dy' - dy = -idx - \frac{T}{EA} \left(\frac{ds}{dx} \right)^2 \frac{dx}{dy} dx \pm \epsilon t \left(\frac{ds}{dx} \right)^2 \frac{dx}{dy} dx.$$

$$\therefore x' - x = \int_0^x i \frac{dy}{dx} dx - \int_0^x \frac{T}{EA} \left(\frac{ds}{dx} \right)^2 dx \pm \epsilon t \int_0^x \left(\frac{ds}{dx} \right)^2 dx$$

and

$$y' - y = - \int_0^x i dx - \int_0^x \frac{T}{EA} \left(\frac{ds}{dx} \right)^2 \frac{dx}{dy} dx \pm \epsilon t \int_0^x \left(\frac{ds}{dx} \right)^2 \frac{dx}{dy} dx.$$

These equations are to be used instead of equations (15) and (16), the remainder of the calculations being computed precisely as before.

The following problems are, in the main, the same as those given in Art. 180 of Rankine's *Civil Engineering*, 13th edition.

17. Rib of Uniform Stiffness.—Let the *depth* and *sectional form* of the rib be uniform, and let its breadth at each point vary as the *secant* of the inclination of the tangent at the point to the horizontal.

Let A_1, I_1 be the sectional area and moment of inertia at the crown.

Let A, I be the sectional area and moment of inertia at any point C , Fig. 503.

Then

$$A = A_1 \sec \theta = A_1 \frac{ds}{dx} \dots \dots \dots (17)$$

Also, since the moments of inertia of similar figures vary as the breadth and as the cube of the depth, and since the depth in the present case is constant,

$$I = I_1 \sec \theta = I_1 \frac{ds}{dx} \dots \dots \dots (18)$$

Again, $\frac{T}{A} = \frac{H \sec \theta}{A_1 \sec \theta} = \frac{H}{A_1}$, and the intensity of the thrust is constant throughout.

Hence, equations (5), (15), and (16), respectively, become

$$i = i_0 - \frac{1}{EI} \int_0^x M dx; \dots \dots \dots (19)$$

$$x' - x = \int_0^x i \frac{dy}{dx} dx - \frac{H}{EA_1} x \pm \epsilon l x; \dots \dots (20)$$

$$y' - y = - \int_0^x i dx - \left(\frac{H}{EA_1} \mp \epsilon l \right) (y - y_0). \dots (21)$$

Equation (19) shows that the deflection at each point of the rib is the same as that at corresponding points of a straight horizontal beam of a uniform section equal to that of the rib at the crown, and acted upon by the same bending moments.

Ribs of uniform stiffness are not usual in practice, but the formulæ deduced in the present article may be applied without sensible error to flat segmental ribs of uniform section.

18. Parabolic Rib of Uniform Depth and Stiffness, with Rolling Load; the Ends fixed in Direction; the Abutments immovable.

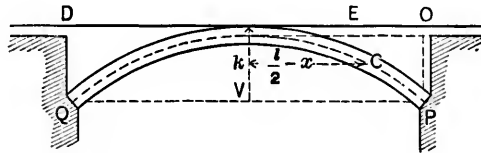

FIG. 504.

Let the axis of x be a tangent to the neutral curve at its summit.

Let k be the rise of the curve.

Let x, y be the co-ordinates at any point C with respect to O .

Then

$$y = \frac{4k}{l^2} \left(\frac{l}{2} - x \right)^2, \dots \dots \dots (22)$$

and

$$\frac{dy}{dx} = -\frac{8k}{l^2} \left(\frac{l}{2} - x \right), \quad \frac{dy_0}{dx_0} = -\frac{4k}{l}, \quad \frac{dy_1}{dx_1} = \frac{4k}{l}, \quad \frac{d^2y}{dx^2} = \frac{8k}{l^2}. \quad (23)$$

Let w be the dead load per horizontal unit of length.

" w' " " live " " " " " " " "

Let the live load cover a length DE , $= rl$, of the span.

Denote by (A) formulæ relating to the unloaded division OE , and by (B) formulæ relating to the loaded division DE .

Equations (7) and (8), respectively, become

$$(A) \quad S = S_0 + \left(\frac{8kH}{l^2} - w\right)x; \quad \dots \dots \dots (24)$$

$$(B) \quad S = S_0 + \left(\frac{8kH}{l^2} - w\right)x - w'\{x - (1-r)l\}. \quad \dots (25)$$

$$(A) \quad M = M_0 + S_0x + \left(\frac{8kH}{l^2} - w\right)\frac{x^2}{2}; \quad \dots \dots \dots (26)$$

$$(B) \quad M = M_0 + S_0x + \left(\frac{8kH}{l^2} - w\right)\frac{x^2}{2} - \frac{w'}{2}\{x - (1-r)l\}^2. \quad (27)$$

Since the ends are fixed,

$$i_0 = 0 = i_1. \quad \dots \dots \dots (28)$$

Hence, by equations (19) and (26),

$$(A) \quad i = -\frac{1}{EI_1} \left\{ M_0x + S_0\frac{x^2}{2} + \left(\frac{8kH}{l^2} - w\right)\frac{x^3}{6} \right\}; \quad \dots (29)$$

and by equations (19) and (27),

$$(B) \quad i = -\frac{1}{EI_1} \left\{ M_0x + S_0\frac{x^2}{2} + \left(\frac{8kH}{l^2} - w\right)\frac{x^3}{6} - \frac{w'}{6}\{x - (1-r)l\}^3 \right\}. \quad (30)$$

When $x = l$, $i = i_1 = 0$, and therefore, by the last equation,

$$0 = M_0 + S_0\frac{l}{2} + \left(\frac{8kH}{l^2} - w\right)\frac{l^3}{6} - \frac{w'}{6}r^3l^3. \quad \dots (31)$$

Again, let $i = \frac{dv}{dx}$. Then

$$\int_0^l i \frac{dy}{dx} dx = \int_0^l \frac{dv}{dx} \frac{dy}{dx} dx = i_1 \frac{dy}{dx} - \int_0^l v \frac{d^2y}{dx^2} dx.$$

But $i_1 = 0$, and $\frac{d^2y}{dx^2} = \frac{8k}{l^2}$.

$$\therefore \int_0^l i \frac{dy}{dx} dx = - \frac{8k}{l^2} \int_0^l v dx = - \frac{8k}{l^2} \int_0^l \int_0^x i dx^2. \quad (32)$$

By the conditions of the problem, $x' - x$ and $y' - y$ are each zero at Q . Hence, equations (20) and (21), respectively, become

$$0 = - \frac{8k}{l^2} \int_0^l \int_0^x i dx^2 - \left(\frac{H}{EA} \mp \epsilon t \right) l; \quad \dots \quad (33)$$

$$0 = - \int_0^l i dx. \quad \dots \dots \dots \quad (34)$$

Substitute in eqs. (33) and (34) the value of i given by eq. (30), and integrate between the limits 0 and l . Then

$$0 = - \frac{8k}{l^2} \frac{1}{EI_1} \left\{ M_0 \frac{l^3}{6} + S_0 \frac{l^3}{24} + \left(\frac{8kH}{l^2} - w \right) \frac{l^5}{120} - w'r^2 \frac{l^5}{120} \right\} - \left(\frac{H}{EA_1} \mp \epsilon t \right) l,$$

and

$$0 = - \frac{1}{EI_1} \left\{ \frac{M_0 l^2}{2} + \frac{S_0 l^2}{6} + \left(\frac{8kH}{l^2} - w \right) \frac{l^4}{24} - w'r^2 \frac{l^4}{24} \right\},$$

which may be written

$$0 = M_0 + S_0 \frac{l}{4} + \left(\frac{8kH}{l^2} - w \right) \frac{l^3}{20} - w'r^2 \frac{l^3}{20} + \frac{3}{4} \left(\frac{H}{EA_1} \mp \epsilon t \right) \frac{EI_1}{k} \quad (35)$$

and

$$0 = M_0 + S_0 \frac{l}{3} + \left(\frac{8kH}{l^2} - w \right) \frac{l^2}{12} - w'r^2 \frac{l^2}{12} \dots \dots \dots (36)$$

Hence, by eqs. (31), (35), (36),

$$S_0 = \frac{wl}{2} + w'l r^2 \left(1 - \frac{r}{2} \right) - \frac{4k}{l} H; \dots \dots \dots (37)$$

$$M_0 = -\frac{wl^2}{12} - \frac{w'l^2 r^2}{3} \left(1 - \frac{3r}{4} \right) + \frac{2}{3} kH; \dots \dots \dots (38)$$

$$H = \frac{l^2 \left\{ \frac{w}{8} + w' \left(\frac{5}{4} r^2 - \frac{15}{8} r + \frac{3}{4} \right) \pm \frac{45}{4} \epsilon l \frac{EI_1}{k} \right\}}{k \left(1 + \frac{45}{4} \frac{I_1}{I_2} \right)} \dots \dots \dots (39)$$

When $x = l$, $M = M_1$, and $S = S_1$.

Hence, by eqs. (25) and (27),

$$S_1 = S_0 + \left(\frac{8kH}{l^2} - w \right) l - w'rl,$$

and

$$M_1 = M_0 + S_0 l + \left(\frac{8kH}{l^2} - w \right) \frac{l^2}{2} - \frac{w'r^2 l^2}{2}.$$

Substituting in these equations the values of S_0 , M_0 , given above, we have

$$S_1 = -\frac{wl}{2} - w'rl \left(1 - r^2 + \frac{r^2}{2} \right) + \frac{4kH}{l}, \dots \dots (40)$$

and

$$M_1 = -\frac{wl^2}{12} - w'l r^2 \left(\frac{1}{2} - \frac{2}{3} r + \frac{r^2}{4} \right) + \frac{2}{3} kH. \dots (41)$$

To find the greatest intensity of stress, etc.—The intensity of the stress due to direct compression = $\frac{T}{A} = \frac{H}{A_1}$.

The intensity of the stress in the outside layers of the rib due to *bending* is the same as that in the outside layers of a horizontal beam of uniform section A_1 , acted upon by the same moments as act on the rib, for the deflections of the beam and rib are equal at every point (eq. (19)). Also, since the rib is fixed at both ends, the bending moment due to that portion of the load which produces flexure is a *maximum* at the loaded end, i.e., at Q . Hence, the maximum intensity of stress (p_1) occurs at Q , and $p_1 = \frac{H}{A_1} \pm M_1 \frac{z_1}{I_1}$, z_1 being the distance of the layers from the neutral axis.

H and M_1 are both functions of r , and therefore p_1 is an absolute maximum when

$$\frac{dp_1}{dr} = 0 = \frac{1}{A} \frac{dH}{dr} \pm \frac{z_1}{I_1} \frac{dM_1}{dr} \dots \dots \dots (42)$$

But

$$\frac{dH}{dr} = \frac{15 w'l^2}{4 k} \frac{r^2(1-r)^2}{1 + \frac{45}{4} \frac{I_1}{A_1 k^2}}, \dots \dots \dots (43)$$

and

$$\frac{dM_1}{dr} = -w'l^2 r(1-r)^2 + \frac{2}{3} k \frac{dH}{dr} \dots \dots \dots (44)$$

Hence, p_1 is an absolute maximum when

$$0 = w'l^2 r(1-r)^2 \left\{ \frac{15}{4} \frac{r \left(\frac{1}{A_1} \pm \frac{2}{3} \frac{kz_1}{I_1} \right)}{k \left(1 + \frac{45}{4} \frac{I_1}{A_1 k^2} \right)} \mp \frac{z_1}{I_1} \right\}.$$

The roots of this equation are

$$\text{and } \left. \begin{aligned} r &= 1 \\ r &= \pm \frac{2}{5} \frac{1 + \frac{45}{4} \frac{I_1}{A_1 k^2}}{\frac{2}{A_1 k^2} \pm 1} \end{aligned} \right\} \dots \dots \dots (45)$$

Th. S. O. K. Henry

$r = 1$ makes $\frac{d^2 p}{dr^2}$ zero, so that the maximum value of p corresponds to one of the remaining roots.

Thus,

$$\text{the max. thrust} = \frac{1}{A_1} \left(H + \frac{A_1 z_1}{I_1} M_1 \right) = p_1' \dots (46)$$

and

$$\text{the max. tension} = \frac{1}{A_1} \left(-H + \frac{A_1 z_1}{I_1} M_1 \right) = p_1'', \quad (47)$$

the values of H and M_1 being found by substituting in eqs. (39) and (41)

$$\left. \begin{aligned} r &= \frac{2}{5} \frac{1 + \frac{45}{4} \frac{I_1}{A_1 k^2}}{1 - \frac{3}{2} \frac{I_1}{A_1 z_1 k}} \\ \text{or} \\ r &= \frac{2}{5} \frac{1 + \frac{45}{4} \frac{I_1}{A_1 k^2}}{1 + \frac{3}{2} \frac{I_1}{A_1 z_1 k}} \end{aligned} \right\} \dots \dots \dots (48)$$

according as the stress is a thrust or a tension.

If eq. (47) gives a *negative* result, there is no tension at any point of the rib.

Note.—The moment of inertia may be expressed in the form

$$I = q z_1^2 A_1,$$

q being a coefficient depending upon the *form* of the section.

Hence,

$$\text{the maximum intensity of stress} = \frac{1}{A_1} \left(\pm H + \frac{M_1}{q z_1} \right) \dots (49)$$

Corollary 1.—If the depth of the rib is small as compared with k , the fraction $\frac{z_1}{k}$ will be a small quantity, and the maximum intensity of stress will approximately correspond to $r = \frac{2}{5}$.

The denominator in eq. (39) may be taken to be k , and it may be easily shown that the values of p_1', p_1'' are

$$p_1' = \frac{1}{A_1} \left\{ \frac{wl^2}{8} \left(\frac{1}{k} + \frac{15z_1}{2k^2} \right) \mp \frac{5\epsilon t EI_1}{4qs_1k} + \frac{54}{3125} \frac{w'l^2}{qs_1} \right\}; \quad (50)$$

$$p_1'' = \frac{1}{A_1} \left\{ \frac{wl^2}{8} \left(-\frac{1}{k} + \frac{15z_1}{2k^2} \right) \mp \frac{5\epsilon t EI_1}{4qs_1k} + \frac{54}{3125} \frac{w'l^2}{qs_1} \right\}. \quad (51)$$

Cor. 2. If the numerator in eqs. (48) is greater than the denominator, then r must be *unity*. Hence, by eq. (39) and putting $b = 1 + \frac{45}{4} \frac{I_1}{A_1 k^2} = 1 + \frac{45}{4} \frac{qs_1^2}{k^2}$,

$$H = \frac{l^2}{8} \frac{w + w'}{bk} \pm \frac{45\epsilon t EI_1}{4bk^2}; \quad \dots \dots \dots (52)$$

and by eqs. (38) and (41),

$$M_1 = M_0 = \frac{l^2}{12} (w + w') \frac{1-b}{b} \pm \frac{15\epsilon t EI_1}{2bk}$$

$$= -\frac{15}{16} l^2 \frac{w + w'}{b} q \frac{z_1^2}{k^2} \pm \frac{5\epsilon t EI_1}{4b} \frac{1}{k}. \quad (53)$$

Thus, p_1', p_1'' can be found by substituting these values of H and M_1 in eqs. (46) and (47).

19. Parabolic Rib of Uniform Stiffness, hinged at the Ends.

Let the rib be similar to that of the preceding article.

Since the ends are hinged, $M_0 = 0 = M_1$, while i is an undetermined constant.

The following equations apply:

(A) $S = S_0 + \left(\frac{8kH}{l^2} - w \right) x; \quad \dots \dots \dots (54)$

(B) $S = S_0 + \left(\frac{8kH}{l^2} - w \right) x - w' \{ x - (1-r)l \}; \quad \dots (55)$

$$(A) \quad M = S_0 x + \left(\frac{8kH}{l^2} - w \right) \frac{x^2}{2}; \dots \dots \dots (56)$$

$$(B) \quad M = S_0 x + \left(\frac{8kH}{l^2} - w \right) \frac{x^2}{2} - \frac{w'}{2} \{ x - (1-r)l \}^2. \quad (57)$$

$$i = i_0 - \frac{1}{EI} \left\{ S_0 \frac{x^2}{2} + \left(\frac{8kH}{l^2} - w \right) \frac{x^3}{6} \right\}; \dots \dots \dots (58)$$

$$i = i_0 - \frac{1}{EI} \left\{ S_0 \frac{x^2}{2} + \left(\frac{8kH}{l^2} - w \right) \frac{x^3}{6} - \frac{w'}{6} \{ x - (1-r)l \}^3 \right\}. \quad (59)$$

Assume that the horizontal and vertical displacements of the loaded end are *nil*.

Substitute in eqs. (20) and (21) the value of *i* given by eq. (59). Integrate and reduce, neglecting the term involving the temperature. Then

$$0 = i_0 - \frac{1}{EI_1} \left\{ S_0 \frac{l^2}{12} + \left(\frac{8kH}{l^2} - w \right) \frac{l^3}{60} - w' l^2 \frac{r^5}{60} \right\} - \frac{H}{4} \frac{1}{EA_1} \frac{l}{k}; \quad (60)$$

$$0 = i - \frac{1}{EI_1} \left\{ S_0 \frac{l^2}{6} + \left(\frac{8kH}{l^2} - w \right) \frac{l^3}{24} - w' l^2 \frac{r^4}{24} \right\}. \dots \dots (61)$$

From (57), since *M*₁ = 0,

$$0 = S_0 + \left(\frac{8kH}{l^2} - w \right) \frac{l}{2} - w' l \frac{r^2}{2}. \dots \dots (62)$$

Equations (60), (61), and (62) are the equations of condition.

Subtract (61) from (60). Then

$$0 = \frac{1}{EI_1} \left\{ S_0 \frac{l^2}{12} + \left(\frac{8kH}{l^2} - w \right) \frac{l^3}{40} - w' l^2 \left(\frac{r^4}{24} - \frac{r^5}{60} \right) \right\} - \frac{H}{4} \frac{1}{EA_1} \frac{l}{k},$$

which may be written

$$0 = S_0 + \left(\frac{8kH}{l^2} - w \right) \frac{3l}{10} - w' l \left(\frac{r^4}{2} - \frac{r^5}{5} \right) - 3H \frac{1}{A_1} \frac{1}{kl}. \quad (63)$$

Subtract (63) from (62). Then

$$0 = \left(\frac{8kH}{l^2} - w\right)\frac{l}{5} - w'l\left(\frac{r^2}{2} - \frac{r^4}{2} + \frac{r^6}{5}\right) + 3H\frac{I_1}{A_1 k l}. \quad (64)$$

Hence,

$$H = \frac{l^3 \left\{ w + \frac{w'}{2}(5r^2 - 5r^4 + 2r^6) \right\}}{8k \left(1 + \frac{15}{8} \frac{I_1}{A_1 k^2} \right)}. \dots (65)$$

Eliminating S_0 between (61) and (62),

$$i_0 = -\frac{1}{EI} \left\{ \left(\frac{8kH}{l^2} - w\right)\frac{l^3}{24} - w'l^3\left(\frac{r^2}{12} - \frac{r^4}{24}\right) \right\}. \quad (66)$$

Also, by (55),

$$S_1 = S_0 + \left(\frac{8kH}{l^2} - w\right)l - w'rl = -P, \text{ suppose.} \quad (67)$$

Eliminating S_0 between (62) and (67),

$$-P = S_1 = \left(\frac{8kH}{l^2} - w\right)\frac{l}{2} - w'l\left(r - \frac{r^3}{2}\right). \dots (68)$$

Eqs. (62), (65), (66), and (68) give the values of H , S_0 , S_1 , and i_0 .

Again, the maximum bending moment M' occurs at a point given by $\frac{dM}{dx} = 0$ in (57), i.e.,

$$0 = S_0 + \left(\frac{8kH}{l^2} - w\right)x - w'\{x - (1-r)l\}. \quad (69)$$

Subtract (69) from (67). Then

$$-P_1 = S_1 = \left(\frac{8kH}{l^2} - w\right)(l-x) - w'(l-x).$$

Hence, the distance from the loaded end of the point at which the bending moment is greatest is

$$l - x = \frac{P}{w + w' - \frac{8kH}{l^2}} \dots \dots \dots (70)$$

Substitute this value of x in (57), and, for convenience, put

$$w + w' - \frac{8kH}{l^2} = m.$$

Then

$$\begin{aligned} M' &= S_0 \left(l - \frac{P}{m} \right) + \frac{w' - m}{2} \left(l - \frac{P}{m} \right)^2 - \frac{w'}{2} \left(-\frac{P}{m} + rl \right)^2 \\ &= l \left(S_0 + \frac{w' - m}{2} l - \frac{w'}{2} r^2 l \right) - \frac{P^2}{m} \left\{ S_0 + (w' - m) l - w' r l \right\} \\ &\quad + \frac{P^2}{m^2} \left(\frac{w' - m}{2} - \frac{w'}{2} \right). \end{aligned}$$

$$\text{But by (62), } 0 = S_0 + \frac{w' - m}{2} l - \frac{w'}{2} r^2 l.$$

$$\therefore M' = l(0) - \frac{P^2}{m} (-P) + \frac{P^2}{m^2} \left(-\frac{m}{2} \right) = \frac{P^2}{2m}.$$

Hence, M' , the maximum bending moment,

$$= \frac{P^2}{2 \left(w + w' - \frac{8kH}{l^2} \right)} \dots \dots \dots (71)$$

As before, the greatest stress (a thrust)

$$= \frac{1}{A_1} \left(H + \frac{A_1 z_1}{I_1} M' \right) = p_1', \dots \dots \dots (72)$$

and the value of r which makes p_1' an absolute maximum is given by $\frac{dp_1'}{dr} = 0$. But by (71), M' involves r^{10} in the numera-

tor and r^3 in the denominator, so that $\frac{dp_1'}{dr} = 0$ will be an equation involving r^4 .

One of its roots is $r = 1$, which generally gives a *minimum* value of p_1' . Dividing by $r - 1$, the equation reduces to one of the *thirteenth* order, but is still far too complex for use. It is found, however, that $r = \frac{1}{2}$ gives a *close approximation* to the *absolute* maximum thrust.

With this value of r , and, for convenience, putting

$$1 + \frac{15}{8} \frac{I_1}{A_1 k^2} = n,$$

By (65),

$$H = \frac{l^2}{8kn} \left(w + \frac{w'}{2} \right). \dots \dots \dots (73)$$

By (62),

$$S_0 = \frac{l}{2} \left\{ \left(w + \frac{w'}{2} \right) \frac{n-1}{n} - \frac{w'}{4} \right\}. \dots \dots \dots (74)$$

By (68),

$$-S_1 = P = \frac{l}{2} \left\{ \left(w + \frac{w'}{2} \right) \frac{n-1}{n} + \frac{w'}{4} \right\}. \dots \dots \dots (75)$$

By (66),

$$\Delta\theta_0 = \frac{l^2}{24EI} \left\{ \left(w + \frac{w'}{2} \right) \frac{n-1}{n} - \frac{w'}{16} \right\}. \dots \dots \dots (76)$$

By (70),

$$l - x = \frac{\frac{l}{2} \left\{ \left(w + \frac{w'}{2} \right) \frac{n-1}{n} + \frac{w'}{4} \right\}}{\left(w + \frac{w'}{2} \right) \frac{n-1}{n} + \frac{w'}{2}} \dots \dots \dots (77)$$

By (71),

$$M' = \frac{\frac{l^2}{8} \left\{ \left(w + \frac{w'}{2} \right) \frac{n-1}{n} + \frac{w'}{4} \right\}^2}{\left(w + \frac{w'}{2} \right) \frac{n-1}{n} + \frac{w'}{2}} \dots \dots \dots (78)$$

Note.—If the rib is merely supported at the ends but not fixed, the *horizontal* displacement of the loaded end may be

represented by μH (Art. 11). Thus the term $-\mu H$ must be added to the right-hand side of eq. (15).

20. Parabolic Rib of Uniform Stiffness, hinged at the Crown and also at the Ends.—In this case $M = 0$ at the crown, which introduces a *fourth* equation of condition.

By (57),

$$0 = S_0 \frac{l}{2} + \left(\frac{8kH}{l^2} - w \right) \frac{l^2}{8} - \frac{w'l^2}{2} \left(-\frac{1}{2} + r \right)^2,$$

which may be written

$$0 = S_0 + \left(\frac{8kH}{l^2} - w \right) \frac{l}{4} - w'l \left(r^2 - r + \frac{1}{4} \right). \quad (79)$$

Eliminating S_0 between (79) and (62),

$$\frac{8kH}{l^2} - w = w'(-2r^2 + 4r - 1).$$

Hence,

$$H = \frac{l^2}{8k} \{ w - w'(2r^2 - 4r + 1) \}. \quad (80)$$

By (79),

$$S_0 = \frac{w'l}{2} (3r^2 - 4r + 1). \quad (81)$$

By (68),

$$P = S_1 = \frac{w'l}{2} (r - 1)^2. \quad (82)$$

By (66),

$$i_0 = \frac{w'l^3}{24EI_1} (1 - 4r + 4r^2 - r^3). \quad (83)$$

By (70) and (82),

$$l - x = \frac{\frac{w'l}{2} (r - 1)^2}{2w'(r - 1)^2} = \frac{l}{4}. \quad (84)$$

By (71),

$$M' = \frac{w'l^2}{16} (r - 1)^2. \quad (85)$$

When $r = \frac{1}{2}$,

$$\left. \begin{aligned} H &= \frac{l^2}{8k} \left(w + \frac{w'}{2} \right), & S_0 &= -\frac{wl}{8}, & P &= -S_1 = \frac{w'l}{8}, \\ i_0 &= -\frac{1}{384} \frac{w'l^3}{EI_1}, & \text{and} & & M' &= \frac{w'l^2}{64}. \end{aligned} \right\} \cdot (86)$$

These results agree with those of (73) to (78), if $n = 1$.
In general, when $n = 1$,

$$w + \frac{w'}{2} (5r^2 - 5r + 2r^3) = w - w'(2r^2 - 4r + 1),$$

by (65) and (80). Hence,

$$2r^3 - 5r^2 + 9r^2 + 8r + 2 = 0 = (2r - 1)(r - 1)^2(r^2 - 2),$$

and the roots are $r = \frac{1}{2}$, $r = 1$, $r = \pm \sqrt{2}$.

Hence, $n = r$ only renders the expressions in (86) identical with the corresponding expressions of the preceding article when $n = \frac{1}{2}$ or 1.

Again, the intensity of thrust is greatest at the outer flange of the loaded and the inner flange of the unloaded half of the rib, and is

$$= \frac{l^2}{8A_1} \left\{ \frac{z_1 w'}{I_1} \frac{1}{8} + \frac{1}{k} \left(w + \frac{w'}{2} \right) \right\}.$$

The intensity of tension is greatest at the inner flange of the loaded and the outer flange of the unloaded half of the rib, and is

$$= \frac{l^2}{8A_1} \left\{ \frac{z_1 w'}{I_1} \frac{1}{8} - \frac{1}{k} \left(w + \frac{w'}{2} \right) \right\}.$$

The *greatest total horizontal thrust* occurs when $r = 1$, and its value is

$$\frac{l^2}{8k} (w + w').$$

21. Maximum Deflection of an Arched Rib.—The deflection must necessarily be a maximum at a point given by $i = 0$. Solve for x and substitute in (16) to find the deflection $y' - y$; the deflection is an *absolute* maximum when $\frac{d}{dr}(y' - y) = 0$. The resulting equation involves r to a high power, and is too intricate to be of use. It has been found by trial, however, that in all ordinary cases the absolute maximum deflection occurs at the middle of the rib, when the live load covers its whole length, i.e., when $x = \frac{l}{2}$, and $r = 1$.

CASE I. *Rib of Art. 18.* For convenience, put $1 + \frac{45}{4} \frac{I_1}{Ak^2} = s$. Then, by (39),

$$H = \frac{l^2}{8k} \frac{w + w'}{s} \pm \frac{15}{8} \frac{\epsilon l EI_1}{s k^2} \dots \dots \dots (87)$$

By (38) and (41),

$$-M_0 = \frac{l^2}{12} (w + w') \frac{s - 1}{s} \mp \frac{5}{4} \frac{\epsilon l EI_1}{s k} = -M_1 \dots (88)$$

By (36) and (38),

$$S_0 = -6 \frac{M_0}{l} \dots \dots \dots (89)$$

By (30), (38), (89),

$$i = -\frac{1}{EI_1} \left(M_0 x - 3M_0 \frac{x^2}{l} + 2M_0 \frac{x^3}{l^2} \right) \dots \dots (90)$$

Hence, the maximum deflection

$$\begin{aligned} &= -\int_{\frac{l}{2}}^{l^0} i dx = -\frac{M_0}{EI} \int_0^x \left(x - 3\frac{x^2}{l} + 2\frac{x^3}{l^2} \right) dx = -\frac{M_0 l^2}{EI 32} \\ &= \frac{l^4}{384} \frac{w + w'}{EI} \frac{s - 1}{s} \mp \frac{5}{128} \frac{\epsilon l l^3}{s k} = d_1, \text{ suppose. } \dots (91) \end{aligned}$$

The central deflection d_2 of a uniform straight horizontal beam of the same span, of the same section as the rib at the crown, and with its ends fixed, is

$$d_2 = \frac{l^3}{384} \frac{w + w'}{EI_1} \dots \dots \dots (92)$$

Hence, neglecting the term involving the temperature,

$$d_1 = \frac{3 - 1}{5} d_2 \dots \dots \dots (93)$$

CASE II. *Rib of Art. 19.*

By (65),

$$H = \frac{l^2}{8k} \frac{w + w'}{n} \dots \dots \dots (94)$$

By (66) and (62),

$$i_0 = \frac{l^3}{24EI_1} (w + w')^{\frac{n-1}{n}} = \frac{S_0 l^n}{12EI} \dots \dots \dots (95)$$

By (30), (94), and (95),

$$i = \frac{S_0}{EI_1} \left(\frac{l^2}{12} - \frac{x^2}{2} + \frac{x^3}{3l} \right) \dots \dots \dots (96)$$

Hence, the maximum deflection

$$= \frac{S_0}{EI_1} \int_0^{\frac{l}{2}} \left(\frac{l^2}{12} - \frac{x^2}{2} + \frac{x^3}{3l} \right) dx = \frac{5}{384} \frac{l^3}{EI} (w + w')^{\frac{n-1}{n}} = d_1' \dots (97)$$

If the ends of the beam in Case I are free, its central deflection

$$= \frac{5}{384} \frac{l^3 (w + w')}{EI} = d_2'$$

$$\therefore d_1' = \frac{n-1}{n} d_2' \dots \dots \dots (98)$$

Thus, the deflection of the arched rib in both cases is less than that of the beam.

22. Arched Rib of Uniform Stiffness fixed at the Ends and connected at the Crown with a Horizontal Distributing Girder.—The load is transmitted to the rib by vertical struts so that the vertical displacements of corresponding points of the rib and girder are the same. The horizontal thrust in the loaded is not necessarily equal to that in the unloaded division of the rib, but the excess of the thrust in the loaded division will be borne by the distributing girder, if the rib and girder are connected in such a manner that the horizontal displacement of each at the crown is the same.

The formulæ of Art. 18 are applicable in the present case with the modification that I_1 is to include the moment of inertia of the girder.

The maximum thrust and tension in the rib are given by equations (64) and (65).

Let z' be the depth of the girder, A' its sectional area.

$$\text{The greatest thrust in the girder} = \frac{H}{A_1 + A'} + \frac{M_1 z'}{2EI_1}. \quad (99)$$

$$\text{The greatest tension in the girder} = \frac{M_1 z'}{2EI_1}. \quad (100)$$

H and M , being given by equations (66) and (67), respectively.

The girder must have its ends so supported as to be capable of transmitting a thrust.

23. Stresses in Spandril Posts and Diagonals.—Fig. 505 represents an arch in which the spandril consists of a series of vertical posts and diagonal braces.

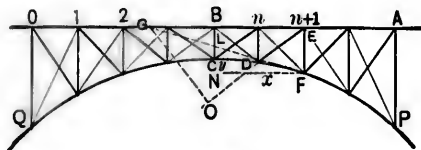

FIG. 505.

Let the axis of the curved rib be a parabola. The arch is then equilibrated under a uniformly distributed load, and the diagonals will be only called into play under a passing load.

Let x, y be the co-ordinates of any point F of the parabola with respect to the vertex C . Then

$$y = \frac{4k}{l^2} x^2.$$

Let the tangent at F meet CB in L , and the horizontal BE in G .

Let $BC = k'$. Then

$$BL = BC - CL = BC - CN = k' - y.$$

Let N be the total number of panels.

Consider any diagonal ED between the n th and $(n + 1)$ th posts.

Let w' be the greatest panel *live* load.

The greatest compression in ED occurs when the passing load is concentrated at the first $n - 1$ panel points.

Imagine a vertical section a little on the left of EF .

The portion of the frame on the right of this section is kept in equilibrium by the reaction R at P , and by the stresses in the three members met by the secant plane.

Taking moments about G ,

$$D \cdot GE \cos \theta = R \cdot AG,$$

D being the stress in DE , and θ the angle DEP .

Now,

$$R = \frac{w' n(n-1)}{2N}.$$

Also,

$$\frac{x + GB}{GB} = \frac{k' + y}{k' - y}; \quad GB = \frac{k'x - xy}{2y};$$

and hence,

$$GE = GB + x = \frac{k'x + xy}{2y}, \quad \text{and} \quad GA = \frac{l}{2} + \frac{k'x - xy}{2y}.$$

Hence,

$$D = \frac{w' n(n-1)ly + k'x - xy}{2N(k'x + xy)} \sec \theta.$$

The stresses in the counter-braces (shown by dotted lines in the figure) may be obtained in the same manner.

The greatest thrust in $EF = w' + w$.

The greatest tension in $EF = D \cos \theta - w$, w being the dead load upon EF .

If the last expression is negative, EF is never in tension.

24. Clerk Maxwell's Method of determining the Resultant Thrusts at the Supports of a Framed Arch.—Let Δs be the change in the length s of any member of the frame under the action of a force P , and let a be the sectional area of the member. Then

$$\pm \frac{P}{Ea}s = \Delta s,$$

the sign depending upon the character of the stress.

Assume that all the members except the one under consideration are perfectly rigid, and let Δl be the alteration in the span l corresponding to Δs . The ratio $\frac{\Delta l}{\Delta s}$ is equal to a constant m , which depends only upon the geometrical form of the frame.

$$\therefore \Delta l = m \cdot \Delta s = \pm mP \frac{s}{Ea}.$$

Again, P may be supposed to consist of two parts, viz., f_1 due to a horizontal force H between the springings, and f_2 due to a vertical force V applied at one springing, while the other is firmly secured to keep the frame from turning.

By the principle of virtual velocities,

$$\frac{f_1}{H} = \frac{\Delta l}{\Delta s} = m.$$

Similarly, $\frac{f_2}{V}$ is equal to some constant n , which depends only upon the *form* of the frame.

$$P = f_1 + f_2 = mH + nV.$$

$$\therefore \Delta l = \pm (m^2H + mnV) \frac{s}{Ea}.$$

Hence, the total change in l for all the members is

$$\Sigma \Delta l = \pm \Sigma \left(m^2 H \frac{s}{Ea} \right) \pm \Sigma \left(mnV \frac{s}{Ea} \right).$$

If the abutments yield, let $\Sigma \Delta l = \mu H$, μ being some coefficient to be determined by experiment. Then

$$H = \frac{\pm \Sigma \left(mnV \frac{s}{Ea} \right)}{\mu \mp \Sigma \left(m^2 \frac{s}{Ea} \right)}. \quad \dots \dots \dots (C)$$

If the abutments are immovable, $\Sigma \Delta l$ is zero, and

$$H = - \frac{\Sigma \left(mnV \frac{s}{Ea} \right)}{\Sigma \left(m^2 \frac{s}{Ea} \right)}. \quad \dots \dots \dots (D)$$

V is the same as the corresponding reaction at the end of a girder of the same span and similarly loaded. The required thrust is the resultant of H and V , and the stress in each member may be computed graphically or by the method of moments. In any particular case proceed as follows:

- (1) Prepare tables of the values of m and n for each member.
- (2) Assume a cross-section for each member, based on a probable assumed value for the resultant of V and H .

(3) Prepare a table of the value of $m^2 \frac{s}{Ea}$ for each member, and form the sum $\Sigma \left(m^2 \frac{s}{Ea} \right)$.

(4) Determine, separately, the horizontal thrust between the springings due to the loads at the different joints. Thus, let v_1, v_2 be the vertical reactions at the right and left supports due to any *one* of these loads. Form the sum $\Sigma \left(mnV \frac{s}{Ea} \right)$, using v_1 for all the members on the right of the load and v_2 for all those on its left. The corresponding thrust may then be

found by eq. (C) or eq. (D), and the *total* thrust H is the sum of the thrusts due to all the weights taken separately.

(5) Repeat the process for each combination of live and dead load so as to find the maximum stresses to which any member may be subjected.

(6) If the assumed cross-sections are not suited to these maximum stresses, make fresh assumptions and repeat the whole calculation.

The same method may be applied to determine the resultant tensions at the supports of a framed suspension-bridge.

Note.—The formulæ for a parabolic rib may be applied without material error to a rib in the form of a segment of a circle. More exact formulæ may be obtained for the latter in a manner precisely similar to that described in Arts. 18–22, but the integrations will be much simplified by using polar coordinates, the centre of the circle being the pole.

by i
arch
and
being
the
the
2
trad
faces
extra
at th
the e
lbs. p
joint
the s
the in

3.
of a c
140 lb
lbs. p
key a
specti
sure.

4.
catena
weigh
Deter

5.
height
lbs. p
and di
crown

6. 1
15 ft. 1
per cu
abutm

EXAMPLES.

1. Assuming that an arch may be divided into elementary portions by imaginary joint planes parallel to the direction of the load upon the arch, find the limiting span of an arch with a horizontal upper surface and a parabolic soffit (latus rectum = 40 ft.), the depth over the crown being 6 ft. and the specific weight of the load 120 lbs. per cubic foot; the thrust at the crown is horizontal (= P) and 4 ft. above the soffit.

2. A masonry arch of 90 ft. span and 30 ft. rise, with a parabolic intrados and a horizontal extrados, springs from abutments with vertical faces and 10 ft. thick, the outside faces being carried up to meet the extrados. The depth of the keystone is 3 ft. The centre of resistance at the springing is the middle of the joint, and at the crown 12 in. below the extrados. The specific weight of the masonry may be taken at 150 lbs. per cubic foot. Determine (*a*) the resultant pressure in the vertical joint at the crown; (*b*) the resultant pressure in the horizontal joint at the springing; (*c*) the maximum stress in the vertical joint aligning with the inside of an abutment.

3. The intrados of an arch of 100 ft. span and 20 ft. rise is the segment of a circle. The arch ring has a uniform thickness of 3 ft. and weighs 140 lbs. per cubic foot; the superincumbent load may be taken at 480 lbs. per lineal foot of the ring. Determine the mutual pressures at the key and springing, their points of application being 2 ft. and $1\frac{1}{2}$ ft., respectively, from the intrados. Also find the curve of the centres of pressure.

4. The soffit of an arch of 30 ft. span and 10 ft. rise is a transformed catenary. The masonry rises 10 ft. over the crown, and the specific weight of the load upon the arch may be taken at 120 lbs. per cubic foot. Determine the direction and amount of the thrust at the springing.

5. A concrete arch has a clear spring of 75 ft. and a rise of $7\frac{1}{2}$ ft.; the height of masonry over crown = 5 ft.; the weight of the concrete = 144 lbs. per cubic foot. Determine the transformed catenary, the amount and direction of the thrust at the springing, and the curvatures at the crown and springing.

Ans. $m = 23.9$; thrust = 91,354 lbs.; slope at springing = $25\frac{1}{2}^\circ$;
radius of curvature = 114.2 ft. at crown and = 248.7 ft. at springing.

6. Determine the transformed catenary for an arch of 60 ft. span and 15 ft. rise, the masonry rising 6 ft. over the crown and weighing 120 lbs. per cubic foot. Also find the amount and direction of the thrust at the abutments.

7. Determine the transformed catenary for an arch of 30 ft. span and $7\frac{1}{2}$ ft. rise, the height of masonry over the crown being 4½ ft. ; weight of the masonry = 125 lbs. per cubic foot. Also find the thrust at the springing and the curvature at the crown and the springing.

8. In a parabolic arch of 50 ft. span and 10 ft. rise, hinged at both ends, a weight of 1 ton is concentrated at a point whose horizontal distance from the crown is 10 ft. Find the total thrust along the axis of the rib on each side of the given point, allowing for a change of 60° from the mean temperature ($\epsilon = .0000694$).

9. A parabolic arched rib of 100 ft. span and 20 ft. rise is fixed at the springings. The uniformly distributed load upon one-half of the arch is 100 tons, and upon the other 200 tons. Find the bending moment and shearing force at 25 ft. from each end.

10. An arched rib with parabolic axis, of 100 ft. span and $12\frac{1}{2}$ ft. rise, is loaded with 1 ton at the centre and 1 ton at 20 ft. from the centre, measured horizontally. Determine the thrusts and shears along the rib at the latter point, and show how they will be affected by a change of 100° F. from the mean ; the coefficient of linear expansion being .00125 for 180° F.

11. A parabolic arched rib hinged at the ends, of 64 ft. span and 16 ft. rise, is loaded with 1 ton at each of the points of division of eight equal horizontal divisions. Find the horizontal thrust on the rib, allowing for a change of 60° F. from the mean temperature. Also find the maximum flange stresses, the rib being of double-tee section and 12 in. deep throughout. (Coefficient of linear expansion per 1° F. = $1 + 144000$.)

12. The axis of an arched rib of 50 ft. span, 10 ft. rise, and hinged at both ends is a parabola. Draw the linear arch when the rib is loaded with two weights each equal to 2 tons concentrated at two points 10 ft. from the centre of the span. If the rib is of double-tee section and 24 in. deep, find the maximum flange stresses.

If the arch is loaded so as to produce a stress of 10,000 lbs. per square inch in the metal, show that the rib will deflect .029 ft., E being 25,000,000 lbs.

13. A steel parabolic arched rib of 50 ft. span and 10 ft. rise is hinged at both ends and loaded at the centre with a weight of 12 tons. Find the horizontal thrust on the rib when the temperature varies 60° F. from the mean, and also find the maximum flange stresses, the rib being of double-tee section and 12 in. deep.

14. A semicircular rib, pivoted at the crown and springings, is loaded uniformly per horizontal unit of length. Determine the position and magnitude of the maximum bending moments, and show that the horizontal thrust on the rib is *one-fourth* of the total load.

15. Draw the linear arch for a semicircular rib of uniform section

unc
hin
wh

Fin
load

spat
spec
the
of th
I
cent

1
ques
when

19
(mea
the c
trate

20
and a
the a
point
flange

21
at bot
40 ft.,
at the

22.
for an
each o
divisio

under a load uniformly distributed per horizontal unit of length (*a*) when hinged at both ends; (*b*) when hinged at both ends and at the centre; (*c*) when fixed at both ends.

16. A semi-elliptic rib (axes $2a$ and $2b$) is pivoted at the springings. Find the position and magnitude of the maximum bending moment, the load being uniformly distributed per horizontal unit of length.

How will the result be affected if the rib is also pivoted at the crown?

17. Draw the equilibrium polygon for a parabolic arch of 100 ft. span and 20 ft. rise when loaded with weights of 3, 2, 4, and 2 tons, respectively, at the end of the third, sixth, eighth, and ninth division from the left support, of ten equal horizontal divisions. (Neglect the weight of the rib.)

If the rib consist of a web and of two flanges $2\frac{1}{2}$ ft. from centre to centre, determine the maximum flange stress.

18. Find the flange stresses at the ends of the rib, in the preceding question, and also at the points at which the weights are concentrated, when both ends are absolutely fixed.

19. A semicircular rib of 28 ft. span carries a weight of $\frac{1}{2}$ ton at 4 ft. (measured horizontally) from the centre. Find the thrust and shear at the centre of the rib and at the point at which the weight is concentrated.

20. The axis of an arched rib hinged at both ends, for a span of 50 ft. and a rise of 10 ft., is a parabola. Draw the equilibrium polygon when the arch is loaded with two equal weights of 2 tons concentrated at two points 10 ft. from the centre of the span. Also determine the maximum flange stress in the rib, which is a double-tee section 2 ft. deep.

21. The load upon a parabolic rib of 50 ft. span and 15 ft. rise, hinged at both ends, consists of weights of 1, 2, and 3 tons at points 15, 25, and 40 ft., respectively, from one end. Find the axial thrusts and the shears at these points.

Ans. Horizontal thrust = 9.6 tons.
 Axial thrusts: above 1 ton = 9.3 tons;
 below 1 " = 9.7 "
 above 3 tons = 8.3 "
 below 3 " = 10.1 "
 Shears: above 1 ton = 3.1 tons;
 below 1 " = 2.2 "
 above 3 tons = 5 "
 below 3 " = 2.6 "

22. Draw the linear arch and determine the maximum flange stresses for an arched rib of 80 ft. span, 16 ft. rise, and loaded with five weights each of 2 tons at the end of the first, second, third, fourth, and fifth division, of eight equal horizontal divisions. The rib is of double-tee

section and 30 in. deep. Also find the shears and the axial thrusts at the fifth point of division.

23. A wrought-iron parabolic rib of 96 ft. span and 16 ft. rise is hinged at the two abutments; it is of a double-tee section uniform throughout, and 24 in. deep from centre to centre of the flanges. Determine the compression at the centre, and also the position and amount of the maximum bending moment (*a*) when a load of 48 tons is concentrated at the centre; (*b*) when a load of 96 tons is uniformly distributed per horizontal unit of length.

Determine the deflection of the rib in each case.

24. Design a parabolic arched rib of 100 ft. span and 20 ft. rise, hinged at both ends and at the middle joint; dead load = 40 tons uniformly distributed per horizontal unit of length, and live load = 1 ton per horizontal foot.

25. Show how the calculations in the preceding question are affected when both ends are absolutely fixed.

26. In the framed arch represented by the figure, the span is 120 ft., the rise 12 ft., the depth of the truss at the crown 5 ft., the fixed load at each top joint 10 tons, and the moving load 10 tons. Determine the maximum stress in each member with any distribution of load. Show that, approximately, the amount of metal required for the arch: the amount required for a bowstring lattice-girder of the same span and 17 ft. deep at the centre: the amount required for a girder of the same span and 12 ft. deep :: 100 : 155 : 175.

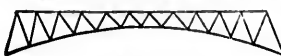

FIG. 506.

27. The steel parabolic ribs for one of the Harlem River bridges has a clear opening of 510 ft., a rise of 90 ft., a depth of 13 ft., and are spaced 14 ft. centre to centre. The dead weight per lineal foot is estimated at 33,000 lbs. and the live load at 8000 lbs.; a variation in temperature of 75° F. from the mean is also to be allowed for. Determine the maximum bending moment (assuming I constant), and the maximum deflection. $E = 26,000,000$ lbs. Show how to deduce the play at the hinges.

28. A cast-iron arch (see figure) whose cross-sections are rectangular and uniformly 3 in. wide, has a straight horizontal extrados, and is hinged at the centre and at the abutments. Calculate the normal intensity of stress at the top and bottom edges D, E of the vertical section, distant 5 ft. from the centre of the span, due to a vertical load of 20 tons concentrated at a point distant 5 ft. 4 in. horizontally from B . Also find the maximum intensity of the shearing stress on the same section, and state the point at which it occurs. ($AB = 21$ ft. 4 in.).

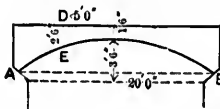

FIG. 507.

MISCELLANEOUS EXAMPLES.

1. A chain of $2m - 1$ equal rods (each of weight W), linked at the ends, is suspended from two points in the same horizontal plane. Prove (a) that the horizontal component of the stress at each joint is constant, (b) that the vertical component at the junction of the n th and $(n + 1)$ th (reckoned from one end) is $W(m - \frac{1}{2} - n)$, and (c) that the tangent of the inclination of the n th rod to the horizon is proportional to $m - n$.

2. Sketch the reciprocal diagram of a frame consisting of four equal rods, placed so as to form a parallelogram with angles of 30° , and braced by two diagonals crossing each other without joint, the rods being pinned at the corners of the figure only. The frame is free from external forces, but in such constraint that the longer diagonal is under a tension of 2 tons.

3. A horizontal girder of length l rests upon end supports and carries N weights, each equal to W . If a is the distance between consecutive weights, place the weights so as to throw a maximum bending moment on the girder. Find this moment.

Ans. If N is even, distance of first weight from support

$$= \frac{l}{2} - \frac{a}{2} \left(N - \frac{3}{2} \right), \text{ and max. B. M.} = \frac{W^2 N}{16} \left\{ \frac{4l^2 + a^2}{l} - 2Na \right\}.$$

If N is odd, distance of first weight from support

$$= \frac{l}{2} - \frac{a}{2} (N - 1), \text{ and max. B. M.} = \frac{W^2 N l}{4} - \frac{W^2 a}{8} (N^2 - 1).$$

4. Two weights P and Q ($Q < P$) are carried by a horizontal girder of length l resting upon supports at the ends, the distance between the weights being a . Place the weights so as to throw a maximum bending moment on the girder and find the value of this moment.

$$\text{Ans. Distance of } P \text{ from support} = \frac{Pl + Q(l - a)}{2(P + Q)}.$$

$$\text{Max. B. M.} = \frac{\{Pl + Q(l - a)\}^2}{4(P + Q)l}.$$

5. A locomotive has two pairs of 6-ft. driving-wheels and 8-ft. coupling-rods 6 in. deep, of wrought-iron, capable of withstanding a working load of 20,000 lbs. per square inch. The cranks are 12 in. in length. Find the speed corresponding to the greatest centrifugal force.

Ans. 90.6 miles per hour.

6. A cast-iron fly-wheel of 36 sq. in. section and 120 in. mean diameter makes 60 revolutions per minute. Find, approximately, the mean energy of rotation. Also find the number of revolutions per minute after losing 800 ft.-lbs. of energy.

Ans. 54,424 ft.-lbs.; 59.

7. A fly-wheel with a rim of uniform axial thickness weighs 1000 lbs., has a 60-in. external and a 48-in. internal diameter, and makes 60 revolutions per minute. The greatest fluctuation of energy is 1000 ft. lbs. Find the variation in speed.

Ans. 9.36 revolutions per minute.

8. A revolving weight W is at a distance r from the axis of rotation, and is to be balanced by two weights each r_1 from the axis, the one being a on the right and the other b on the left of the weight to be balanced. Find the weights.

$$\text{Ans. } W \frac{r}{r_1} \frac{b}{a+b}; \quad W \frac{r}{r_1} \frac{a}{a+b}$$

9. Each piston of a locomotive weighs 300 lbs. What balance weights will completely balance one piston so that there may be no couple and no horizontal force? Stroke = 24 in.; distance C. to C. of cylinders = 42 ins.; radial distance of balance weights = 39 in.; distance between centres of gravity of balance weights = 57 inches.

Ans. 12.15 lbs.; 80.15 lbs.

10. A uniform circular plate weighing 4 lbs. and 1 ft. in diameter is hung in a horizontal plane by three parallel cords from the ceiling, and when set into small torsional oscillation is found to have a period of three seconds. A body weighing 6 lbs. is laid on it, and the period is then found to be five seconds. Find the moment of inertia of the body.

11. A weight of 10 lbs. at the end of a spiral spring stretches it 3 inches. The spring is then stretched an additional 3 inches and suddenly released. Find the time of a complete oscillation.

Ans. .555 sec.

12. The weight of the piston of an indicator and its attached parts is equivalent to .1 lb. on the piston. The pencil moves six times as fast as the piston. The area of the piston is .5 sq. in. Find the period of oscillation with a 100-lb. spring.

Ans. .00586 sec.

13. A weight of 1 ton depresses its supports .01 ft. Neglecting the weight of the supports, find the time of a complete oscillation.

Ans. .1111 sec.

14. A circular disk of cast-iron (s. g. = 7.1) 10 in. in diameter and 1 in. thick acts as a pulley for a cord carrying 10 lbs. on one end and 5 lbs. on the other. Find the angular velocity of rotation of the pulley and the linear velocities of the weights 50 seconds after starting from rest, disregarding the fluctuation of the shaft and its inertia.

Ans. 770; 320 ft. per sec.

15. A member of a truss is subjected to tensile stresses varying from a maximum of 150,000 lbs. to a minimum of 50,000 lbs. Find the proper sectional area of the member, 1st, if of steel, 2d, if of wrought-iron, the factor of safety being 3.

Ans. 7.523 sq. in.; 17.5 sq. in.

16. The diagonal of a truss is subjected to stresses varying from a maximum of 120,000 lbs. in tension to a minimum of 80,000 lbs. in compression. Find the proper sectional area of the diagonal, 1st, if of steel, 2d, if of wrought-iron, 3 being the factor of safety.

Ans. 8 sq. in.; 12.41 sq. in.

17. The fly-wheel of an engine makes 80 revolutions per minute and the reciprocal of the coefficient of fluctuation of the velocity is not to exceed 40. Determine the least moment of energy required, the fluctuation of energy per second being 8000 lbs. If the weight of the wheel is 4000 lbs., find the radius of gyration.

Ans. 4500; 6 ft.

18. If n is the resistance to distortion and k the resistance to dilatation, the elongation under a uniform stress p is $p\left(\frac{1}{3n} + \frac{1}{6k}\right)$ and the lateral contractions are each $p\left(\frac{1}{6n} - \frac{1}{9k}\right)$. Also, find E in terms of k and n .

19. The front face of a wall is plumb, and the rear face, which retains water level with the top of the wall, has a batter. The density of the wall is twice that of the water. If the width of the base is N times the width of the top, find the deviation of the centre of pressure in the base from the middle of the base, and if this deviation is $\frac{1}{8}$ of the thickness of the base, show that the height of the wall is $(N^2 + 1)^{\frac{1}{2}}$ times the width of the top, and find the maximum intensity of pressure in the base.

20. A vertical rectangular retaining-wall of height h has a row of rectangular counterforts. The width of a counterfort is equal to the distance between two consecutive counterforts. Find the thickness of a rectangular wall giving the same moment of stability. If V_1 is the volume of the counterforted wall, V_2 the volume of the equivalent uni-

form wall, and V_3 the difference between the volumes of the portions of the wall with and without counterforts, show that $V_2^2 - V_1^2 = V_3^2$.

21. A vertical rectangular anchor-plate of depth h ft. has its horizontal centre line s ft. below the ground surface, which is horizontal. Find the maximum holding power of the plate per foot of width.

Ans. $\frac{4ws^2h \sin \phi}{\cos^2 \phi}$, ϕ being the angle of repose of the earth and w its specific weight.

22. The front and rear faces of a wall retaining water level with the top have a batter of 1 in 12. The height of the wall is 12 feet. Find the thickness of the wall, (a) if q is .25, (b) if the stress at the base is nowhere to exceed 12,000 lbs. per square foot. Weight of masonry = 125 lbs. per cubic foot.

Ans. (a) 7.078 ft., (b) 5.547 ft.

23. A rope is wound three times round a post, one end being held tight by a force of 10 lbs. Find the pull at the other end which will produce slip. ($\mu = \frac{1}{4}$)

Ans. 1000 lbs.

24. A string of wood blocks embraces the 24-in. pulley of an engine, one end of the string being attached to a load of 112 lbs. and the other to a spring-balance which indicates 12 lbs. when the pulley is making 60 revols. per minute. Find the work given out at the brake and the coefficient of friction between the blocks and pulley.

Ans. 1.143 H. P.; .355.

25. A Froude water-brake has recesses of 6 in. internal and 18 in. external diameter, the axis of the recesses being at 45° to the plane of the disk. The disk makes 80 revols. per minute. The resistance to motion is balanced by 50 lbs. at the end of a 48-in. lever. Find the H. P. developed and the velocity of the water in feet per second in the direction of the recess axis.

Ans. 3.05 H. P.; 11.4 ft.

26. A Reynolds water-brake has recesses of 9 in. internal and 18 in. external diameter. Find the velocity in feet per second with which the water must circulate so as to absorb 15 H. P. at 200 revols. per minute, the axis of the recesses being at 45° to the plane of the disk.

Ans. 7.13 ft.

27. The radii of the pulleys of a differential pulley-block are 6 in. and $5\frac{1}{4}$ in. Find the efficiency when a pull of 200 lbs. in the hauling-chain is required to raise a weight of 1 ton.

28. The coupling-rod of a locomotive is 10 ft. in length, the crank radius is 1 ft. in length, and the driving-wheels are 6 ft. in diameter. What must be the depth of the rod if the stress in it is not to exceed 5 tons per square inch at 70 miles an hour?

Ans. 5.17 in.

29. The horizontal section of a crane-hook is a rectangle 3.5 in. in width, the thickness of the hook being 1.3 inches. The stress in a horizontal section is not to exceed 6 tons per square inch. Find the maximum load which can be raised, the horizontal distance between the centre of the section and the line of action of the load being 2.5 inches.

Ans. 5.614 tons.

30. An iron bar is rectangular in section, its width being 3 in. and its thickness 1 in. The tensile strength of the metal is 50,000 lbs. per square inch. Find the total tensile force which will break the bar, the line of action of the pull being $\frac{3}{8}$ in. distant from the axis of the bar.

Ans. 85,714 $\frac{7}{8}$ lbs.

31. A 2-in. helical spring with 30 coils is made of $\frac{1}{4}$ -in. steel wire. Find the deflection under a load of 1 lb., the coefficient of distortion being 10,000,000 lbs.

Ans. .04915 in.

32. A horizontal beam of weight P rests at the ends in recesses. A weight W suspended from the centre of the beam by a string 3 ft. in length makes 60 revolutions per minute. Find the minimum value of P so that the beam may not rise up out of the recesses.

Ans. $\frac{9W}{323}P$.

33. Determine the dimensions of the strongest section in the form of (a) a rectangle with vertical sides, (b) an isosceles triangle with horizontal base, that can be cut out of an elliptical section having a vertical major axis of length $2p$ and a minor axis of length $2q$.

Ans. (a) depth of rect. = $p\sqrt{3}$; width of rect. = q .

(b) depth of triangle = $\frac{1}{2}p$; base of triangle = $\frac{q}{2}\sqrt{7}$.

34. The area of the compression flange of a cast-iron beam is 17 square inches. The thickness of the web is a certain fraction of the depth. The unit stresses are in the ratio of 2 to 5. Find the areas of web and tension flange which will give a section of maximum strength.

Ans. 12 sq. in.; 3.2 sq. in.

35. In a cast-iron beam the area of the web is *five* times the area of the tension flange, the depth of the beam is 9 in., and the unit stresses are 2 tons per square inch in tension and 4 tons per square inch in compression. The maximum moment of resistance is 162 in.-tons. Find the flange and web areas.

Ans. Area of tension flange = 2 sq. in., of web = 10 sq. in., of compression flange = 9 sq. in.

36. In the preceding example find the length of the beam so that its stiffness might not exceed .001. Also find the net weight on the beam and the work of flexure.

Ans. 8 ft.; 8.72 tons; .0016 in.-tons.

37. A horizontal beam of depth d , breadth b , and length 12 ft. rests upon supports at the ends. A weight W_1 at the centre deflects the beam .1 in. when the side of length b is vertical. An additional weight of 1250 lbs. is required to produce the same deflection when the side of length d is vertical. If $d = 2b$ and if $E = 1,200,000$ lbs., find the sectional area of the beam and the maximum skin stress.

Ans. 72 sq. in.; 277½ lbs. per sq. in.

38. A horizontal girder AB , of length l , and fixed at A and B , carries a load P at a point C . If $AC = a$, find the maximum deflection.

$$\text{Ans. } \frac{2P(l-a)^2a^2}{3EI(3l-2a)^3}$$

39. A horizontal girder AB , of length l , is fixed at A , and rests upon its support at B . It carries a weight P at a point C , and $AC = a$. Find the position of the most deflected point, and show that the bending moment at C is greatest when $a = l \times .634$.

Ans. Distance of most deflected point from point of fixture

$$= l \left(\frac{l-a}{3l-a} \right)^{\frac{1}{3}}$$

40. A horizontal continuous girder of three equal spans, resting upon supports at A, B, C, D , carries a uniformly distributed load. Show that the bending moments at the intermediate supports will be unaffected when the supports B, C, D are depressed below the horizontal, provided that the amounts of the depressions are in the ratios of 1 to 2 to 3.

41. The horizontal girder ABC is fixed at A and rests upon supports at B and C , AB being equal to BC . If the depression of C is n times that of B , and if R_1, R_2, R_3 are the reactions at A, B, C , respectively, show that $R_1(48 - 17n) + R_2(8 - n) = R_3(80 - 23n)$.

42. The horizontal girder ABC is fixed at A and rests upon supports at B and C . If AB is n times BC , show that the bending moments at A and B are in the ratio of $n^3 + 2n^2 - 1$ to $n^3 + 2$.

43. Show that the work done in deflecting, within the elastic limits, a uniform rectangular bar, supported at the ends and loaded in the middle, is equal to the volume of the bar multiplied by $\frac{1}{18} \frac{f^2}{E}$, f being the maximum stress in the bar.

44. The vertical sections of a cantilever ABC , of length l , and fixed at the end BC , are circular. The profile is a cubical parabola with its vertex at A . Show that, under its own weight, the slope at the free end of the neutral axis is seven-tenths of the maximum deflection divided by the length.

45. A continuous girder $ABCD$ is fixed at A , rests upon supports at B, C , and D , and carries a uniformly distributed load. If the reac-

tions at A, B, C, D are equal show that the ratio of the length of CD to AB must be greater than unity and less than $\frac{3}{2}$. Also, if CD is equal to five-fourths of AB show that $AB : BC : CD :: 4 : 7 : 5$.

46. A continuous girder $ABCDE$ of four spans, each of length l , rests upon supports at A, B, C, D , and E , and carries a uniformly distributed load of intensity w . By how much must the supports at B, C , and D be lowered, so that the reactions at the five supports may be equal?

Ans. B and D must be lowered by an amount $\frac{23}{40} \frac{wl^4}{EI}$, and C

by an amount $\frac{4}{5} \frac{wl^4}{EI}$.

47. A horizontal girder AB of length l , and fixed at A and at B , carries two weights P and Q , concentrated at points C and D respectively. If $AC = X$ and $BD = Y$, show that the bending moment at C is greater or less than the bending moment at D according as

$$PX^2(3l - 2X) \gtrless QY^2(3l - 2Y).$$

48. Show that the work done in bending a horizontal beam is the same whether it has two ends fixed, or one end fixed and one resting upon its support, or two ends resting upon supports, if the load intensities in the several cases are in the ratio of $2\sqrt{6}$ to 3 to 2.

49. A continuous girder of three spans, the side spans being equal, carries a uniformly distributed load of intensity w . Find the error in the B. M. at the intermediate support, if an error Δ is made in the length (a) of the centre span, (b) of a side span. If the three spans are each of length l , show that this error is $.09w\Delta l$ in the first case and $.11w\Delta l$ in the second case.

50. A horizontal girder ABC is fixed at A , rests upon supports at B and C , and carries a uniformly distributed load $2W$. If an error Δ is made (1) in AB , (2) in BC , find the consequent errors in the B. Ms. at A and B , and if $AB = BC$, show that these errors are—

$$(1) \frac{43}{196} W\Delta; \frac{12}{196} W\Delta; (2) \frac{18}{196} W\Delta; \frac{36}{196} W\Delta.$$

51. A horizontal girder AC is fixed at A , rests upon the support at C , carries a uniformly distributed load of intensity w , and is hinged at B , dividing the girder into the segments $AB = a$ and $BC = b$. Find (1) the reactions at A and C , (2) the moment of fixture, (3) the deflection at B .

$$\text{Ans. (1) } w\left(a + \frac{b}{2}\right); \quad w\frac{b}{2}; \quad (2) \frac{wa}{2}(a + b); \quad (3) \frac{wa^3}{EI} \left(\frac{a}{8} + \frac{b}{6}\right).$$

52. The horizontal girder ABC is fixed at A , rests upon supports at B and C , and carries weights W_1 and W_2 concentrated at the middle

points of AB and BC , respectively. Find the reactions and the bending moments at A and B . If $AB = BC$ and if $W_2 = 3W_1$, show that the moment of fixture is nil, that the bending moment at B is $-\frac{1}{8}W_1AB$, and that the reactions at A , B , and C are $\frac{1}{8}W_1$, $\frac{1}{4}W_1$, and $\frac{1}{8}W_1$, respectively.

How much must B be lowered so that the reaction at B may be nil? Find the corresponding reactions at A and C . How much must C now be lowered so that the reactions may be the same as before?

$$\text{Ans. } \frac{AB^3}{EI} \left(\frac{25W_1 + 43W_2}{768} \right); \frac{AB}{128} (117W_1 + 47W_2),$$

$$\frac{AB}{128} (11W_1 + 81W_2); 4 \times \text{depression of } B.$$

53. A hollow cast-iron column of 19 in. external and 16 in. internal diameter has rounded ends, is 80 feet in length, and is stayed laterally at intervals of 20 ft. Find the least force which will cause the column to bend.

$$\text{Ans. } 2,182,300 \text{ lbs., } E \text{ being } 16,000,000 \text{ lbs.}$$

54. Find the breaking weight of a wrought-iron column 3 in. in diameter, 160 in. in length, and hinged at both ends.

Also, find the deviation for which the stress in the metal will not exceed 10,000 lbs. per sq. inch when the load upon the column is 40,000 lbs.

$$\text{Ans. } 117,720 \text{ lbs.; } .99 \text{ in.}$$

55. A seven-panel single-intersection truss for a single-track bridge has a length of 105 ft. and a depth of 20 ft., the load being on the lower chord. Find the stresses in the several members (a) when the apex live load is 12 tons, (b) when the live load is produced by concentrated loads of 8, 8, 20, 20, 8, 8, 8, 8, and a uniformly distributed load of 1.5 tons per lineal ft., following each other in order over the bridge at the distances of 5.5, 9, 8, 9.5, 5, 5.5, 5, and 3 ft. apart.

56. The 3-in. plunger for the cast-steel cylinder of an intensifier is connected with a piston which works in a 48-in. cylinder under a pressure equivalent to a 120-ft. head of water. Find the proper thickness of the metal of the intensifier, allowing a maximum stress of 20,000 lbs. per sq. in.

$$\text{Ans. } 2.46 \text{ in.}$$

57. The barrel of a gun consists of two rings A and B , the bore of the gun and the diameters of the inner and outer rings being in the ratio of 1 : 2 : 4. The ring A is shrunk upon B , producing a pressure of 5 tons per sq. in. at the surface of contact. If the firing of the gun pro-

duces an internal pressure of 20 tons per sq. in., find the stresses induced in the gun.

Ans. — $19\frac{1}{2}$ tons, + 11 tons; — 15 tons, — 6 tons.

58. The barrel of a gun is made up of three rings *A*, *B*, *C*, the bore of the gun and the diameters of the three rings being in the ratio of 2 : 4 : 5 : 6. The ring *B* is shrunk upon *A* and the ring *C* upon *B*, the resulting pressures at the surfaces of contact being 4 tons per sq. in. If the firing of the gun produces an internal pressure of 20 tons per sq. in., find the stresses induced in the gun.

59. A rubber tire weighing 2 lbs. per foot is stretched over the circumference of a wheel 3 ft. in diameter, the tangential pull in the rubber being 10 lbs. Find the radial pressure exerted by the tire on the circumference of the wheel, per inch of length, when the wheel is at rest and the speed at which the wheel must revolve to make the tire cease to exert any radial pressure.

60. A countershaft, 10 ft. between bearings, carries two 24-in. pulleys, the one 2 ft. and the other 5 ft. from a bearing. Assuming that the tight is twice the slack tension, determine (*a*) the equivalent twisting moment on the shaft, (*b*) the diameter of the shaft, (*c*) the angle of torsion when one pulley receives and the other transmits 50 H. P. at 80 revolutions per minute, the belts being horizontal and on opposite sides of the shaft.

Ans. (*a*) 3281.25 ft.-lbs. ;

(*b*) 7.13 in., *f* being 10,000 lbs. ;

(*c*) 2.06 minutes, *G* being 12,000,000 lbs.

APPENDIX I.

RECIPROCAL DIAGRAMS OF STRESS.

(CHAPTER I.)

An examination of the Frame and Stress Diagrams, Figs. 4 and 5, page 3, shows—

(1) That if the lines representing external forces on parts of the frame diagram meet in a point, the corresponding lines in the stress diagram will form a closed polygon.

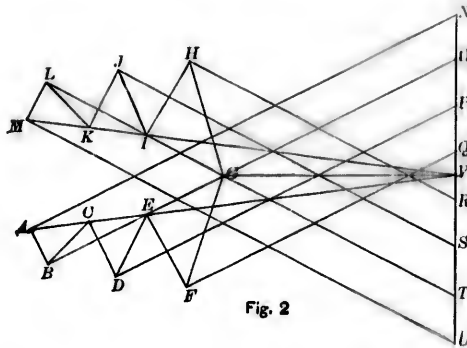
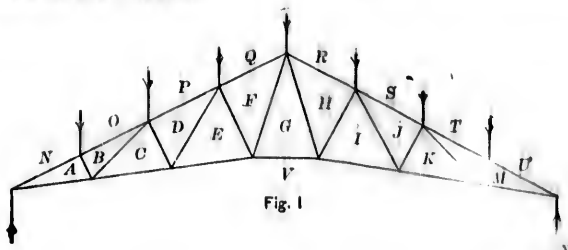

(2) That if the lines representing parts of the frame diagram form a closed polygon, the corresponding lines in the stress diagram will meet in a point.

(3) That if lines meet at a point in the stress diagram the corresponding lines in the frame diagram are contiguous, and form either non-closing or closed polygons.

(4) That of all the stress diagrams which can be drawn for a given frame under given loads, there is only one which satisfies the three re-

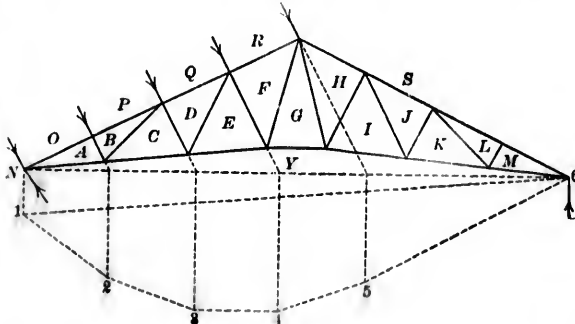

Fig. 3

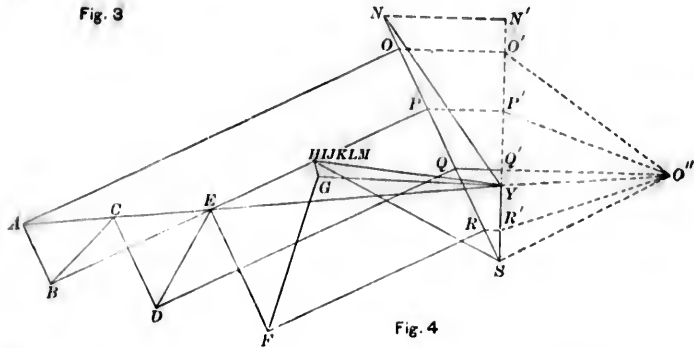

Fig. 4

ciprocal relationships expressed in (1), (2), and (3), and it is called the Reciprocal Diagram of Stress.

As a consequence of these relationships, Bow devised a system of notation which greatly facilitates the construction of the stress diagram.

Lines are drawn to represent the external forces at the joints at which they act. A letter is then assigned to each enclosed area of the frame, and also to each space between the lines of action of the external forces. Thus each line in the frame diagram is defined by the two letters in the two spaces separated by the line in question. The corresponding line in the reciprocal figure is parallel to this line, and is similarly named.

This method is clearly illustrated by the loaded roof frame, Fig. 1, and the reciprocal stress diagram, Fig. 2.

Again, let the frame, Fig. 3, be subjected to inclined loads at the joints. The reactions due to these loads may be found as follows:

Produce the lines of action of the loads to meet the springing line.

Resolve the loads NO , OP , PQ , QR , and RS into their vertical and horizontal components, the former being represented by $N'O'$, $O'P'$, $P'Q'$, $Q'R'$, and $R'S'$.

Take any pole O'' and join it with O' , P' , Q' , R' , S' .

Construct the funicular polygon 1 2 3 4 5 6 and draw $O''Y$ parallel to the closing line 1 6. Then SY and YN are the actual reactions at the

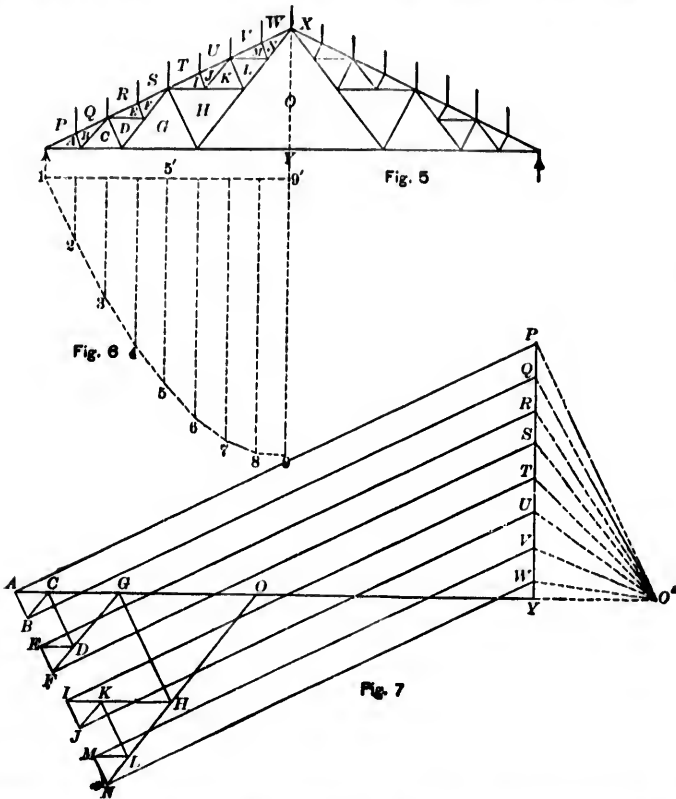

supports, and the reciprocal diagram 4 can be easily constructed, as already described.

In this figure the points H, I, J, K, L , and M coincide, and there can be no stress in HI, IJ, JK, KL , or LM .

In certain trusses the stresses at two or more joints, called lock-joints, are indeterminate, and the reciprocal figure cannot be directly drawn. A further condition is required, and it is sometimes assumed, as in the truss on page 48, that the stresses in two of the members meeting at a lock-joint are equal. A simple and independent method may be illustrated by means of the truss shown in Fig. 5. Taking any pole O' , Fig. 6 is the semi-funicular polygon of the loads on the roof, and the bending moment at any point is measured by the intercept between the closing line $19'$ and the line $1\ 2\ 3\ \dots\ 9$ (Art. 6, Chapter 11).

Let F_1 be the force in OY ;

" x be the vertical distance between OY and the truss apex.

$$\begin{aligned} \text{Then } F_1 \cdot x &= \text{the bending moment at the apex} \\ &= 99' \times O'Y. \end{aligned}$$

Take $O'Y = x$;

$$\text{then } F_1 = 99,$$

and therefore $99'$ is the stress in the member OY .

Let F_2 be the force in GY .

$$\begin{aligned} \text{Then } F_2 \frac{x}{2} &= \text{bending moment at apex of space } G \\ &= 55' \times O'Y \\ &= 55' \times x. \end{aligned}$$

$$\text{Therefore } F_2 = 2 \times 55',$$

and thus the stress in GY is twice the intercept $55'$.

In Fig. 7 take $YO = 99$ and $YG = 2 \times 55'$. The reciprocal diagram can now be easily constructed.

As a final example, take the rational truss, Fig. 8, with two lock-joints. In this truss the rise is about one fifth of the span; the struts FG and ST are normal to the rafters, and about one tenth of the span in length. The members AB and BC, CD and DE, \dots, JK and KL meet on a circular arc drawn through the inner end of the strut FG and through the ends of the rafter.

Let x be the distance between the member MZ and the apex of the truss.

Let the truss be fixed at the left support and rest on rollers at the right support.

Consider the effect of a normal wind-pressure.

At the points of intersection of the springing line with the lines of action of the loads, resolve the loads into vertical and horizontal components, and represent the former by $a'b', b'c', c'd' \dots i'j'$. Take the pole



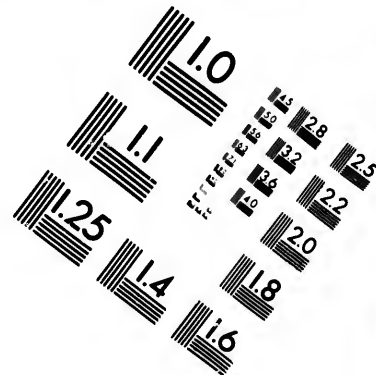
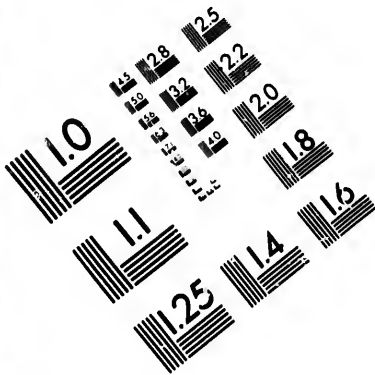

**IMAGE EVALUATION
TEST TARGET (MT-3)**

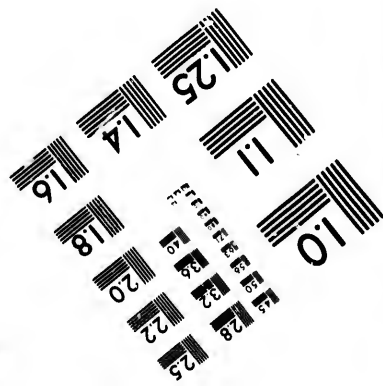
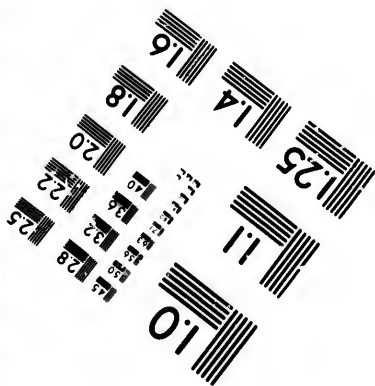
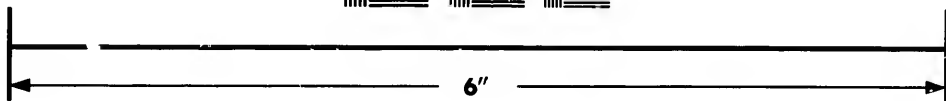
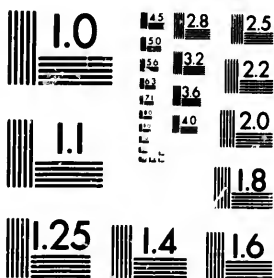

**Photographic
Sciences
Corporation**

23 WEST MAIN STREET
WEBSTER, N.Y. 14580
(716) 872-4503

14 28
16 32 25
18 22
20
18

10

O'' at a distance from the load line $a'j$ equal to the vertical distance between the ridge and MZ . Draw the funicular polygon $1\ 2\ 3\ \dots\ rs$ for the vertical components of the loads and draw $O''Z$ parallel to the closing line $1s$. Then, jZ is the reaction at the right Z support, and is of course

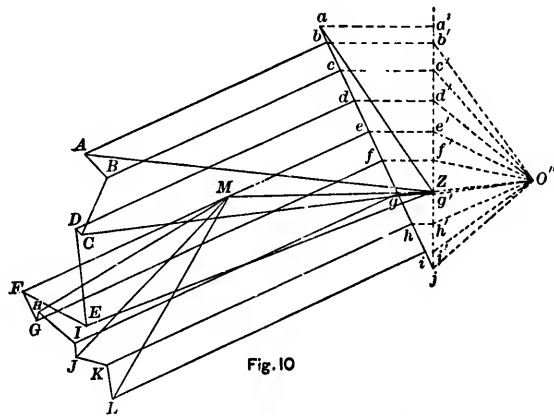
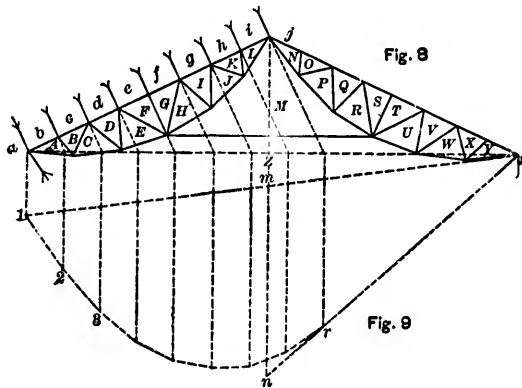

vertical. Hence if the vertical through the truss apex intersects the closing line $1s$ in m and sr produced in n , mn is the total stress in MZ , and thus the position of the point M in Fig. 10 is defined. The diagram can now be completed in the usual manner.

APPENDIX II.

THICK CYLINDERS.

(CHAP. X., ART. 2.)

The radial pressure diminishes from the inner to the outer surface, and may be represented by the ordinate of some curve f or f_1 , in which $r_0 f_0$, $r f$ and $r_1 f_1$ define the intensities of stress p_0 , p , and p_1 , at the

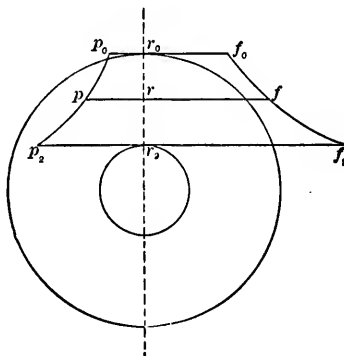

outer surface of radius r_0 , at any radius r and at the inner surface of radius r_1 .

Then,

$2 \times \text{area } r_1 r_0 f_0 f_1 = \text{the total resistance to separation between the two halves of the cylinder} = 2(p_1 r_1 - p_0 r_0)$,

and

$$\text{area } r_1 r_0 f_0 f_1 = p_1 r_1 - p_0 r_0.$$

So,

$$\text{area } r_1 r f f_1 = p_1 r_1 - p r = - \int_{r_1}^r f \cdot dr,$$

the sign being negative as p and f are of opposite sign.

Hence,

$$\frac{d}{dr} (p r) = f \dots \dots \dots (1)$$

Again,

$$p = \frac{p+f}{2} + \frac{p-f}{2} = C_1 + C_2, \dots \dots \dots (2)$$

and

$$f = \frac{p+f}{2} - \frac{p-f}{2} = C_1 - C_2, \dots \dots \dots (3)$$

Thus the pair of stresses p and f may be regarded as consisting of a pair of equal stresses of the same kind and of intensity $C_1 \left(= \frac{p+f}{2} \right)$, and a pair of equal stresses of opposite kind and of intensity $C_2 \left(= \frac{p-f}{2} \right)$.

First. Assume that only the stresses $\pm C_2$ act, and that $C_1 = \frac{p+f}{2} = 0$.

Then
and

$$p = -f,$$

$$\frac{d}{dr}(pr) = f = \frac{d}{dr}(-fr) = -r \frac{df}{dr} - f.$$

Therefore,

$$r \cdot df + 2f \cdot dr = 0 \quad \text{or} \quad fr^2 = a \text{ constant} = a.$$

Hence,

$$C_2 = \frac{p-f}{2} = -f = -\frac{a}{r^2}, \dots \dots \dots (4)$$

Second. Assume that only the stresses C_1 act and that $C_2 = 0 = \frac{p-f}{2}$.

Then
and

$$p = f,$$

$$\frac{d}{dr}(pr) = f = \frac{d}{dr}(fr) = r \frac{df}{dr} + f.$$

Therefore,

$$\frac{df}{dr} = 0,$$

and

$$f = a \text{ constant} = p = C_1, \dots \dots \dots (5)$$

Third. Assume that the two pairs of stresses act together and that their effects are superposed. Then

$$p = C_1 + C_2 = C_1 - \frac{a}{r^2}, \dots \dots \dots (6)$$

and

$$f = C_1 - C_2 = C_1 + \frac{a}{r^2}, \dots \dots \dots (7)$$

But $p = p_0$ when $r = r_0$ and $p = p_1$ when $r = r_1$.
Therefore,

$$p_0 = C_1 - \frac{a}{r_0^2},$$

and

$$p_1 = C_1 - \frac{a}{r_1^2}.$$

Hence,

$$p_0 - p_1 = a \left(\frac{r_0^2 - r_1^2}{r_0^2 r_1^2} \right)$$

or

$$a = \frac{r_0^2 r_1^2}{r_0^2 - r_1^2} (p_0 - p_1), \dots \dots \dots (8)$$

and

$$C_1 = \frac{p_0 r_0^2 - p_1 r_1^2}{r_0^2 - r_1^2}, \dots \dots \dots (9)$$

Also, by Eq. 7,

$$f = C_1 + \frac{a}{r^2} = \frac{p_0 r_0^2 - p_1 r_1^2}{r_0^2 - r_1^2} + \frac{p_0 - p_1}{r^2} \frac{r_0^2 r_1^2}{r_0^2 - r_1^2}, \dots \dots (10)$$

and therefore

$$f_1 = \frac{2p_0 r_0^2 - p_1 (r_1^2 + r_0^2)}{r_0^2 - r_1^2}, \dots \dots \dots (11)$$

and

$$f_0 = \frac{p_0 (r_0^2 + r_1^2) - 2p_1 r_1^2}{r_0^2 - r_1^2}, \dots \dots \dots (12)$$

If $p_0 = 0$,

$$f = \frac{p_1 r_1^2}{r_0^2 - r_1^2} \left(1 + \frac{r_0^2}{r^2} \right), \dots \dots \dots (13)$$

$$f_1 = -p_1 \frac{r_0^2 + r_1^2}{r_0^2 - r_1^2}, \dots \dots \dots (14)$$

$$f_0 = -\frac{2p_1 r_1^2}{r_0^2 - r_1^2}, \dots \dots \dots (15)$$

and

$$\frac{f_1}{f_0} = \frac{r_0^2 + r_1^2}{2r_1^2} > 1, \dots \dots \dots (16)$$

The results (11) and (12) are used in the design of gun-barrels and the results (14) and (15) in the design of the cylinders for hydraulic presses, accumulators, etc. From (14) and (15) the important condition is deduced that if f is the ultimate intensity of stress which the material will bear, then $p \left(= f \cdot \frac{r_0^2 - r_1^2}{r_0^2 + r_1^2} \right)$ is the maximum intensity of pressure to which the cylinder can be subjected (assuming $p_0 = 0$) and is always less than f whatever the thickness of the cylinder may be.

A
A
A
A

A
A

A
A

A
A

A

Ar

Ar
l
Ar
2
Ar
l
Arc
s
Arc
7
Arc

Arc
la
Arc
77
Arc
77
Arc
Aux

Bach
Bak
54
Bal

INDEX.

- Allowance for the weight of a beam, 403.
 Alternating stresses, 152.
 American iron columns, 532.
 Anchorage, 704.
 Angle of repose, 237.
 " " torsion, 563.
 Angular momentum, 177.
 Anti-friction curve, 320.
 " " pivots, 320.
 Arch, 470.
 Arch abutment, maximum thickness of, 649.
 Arch, conditions of equilibrium of, 745.
 " " formulae for thickness of, 750.
 " " linear, 743, 750, 760.
 Arched ribs, 740, 762.
 " " deflection of, 780, 802.
 Arched ribs, effect of change of temperature on, 770, 786.
 Arched ribs, elementary deformation of, 781.
 Arched ribs, general equations of equilibrium of, 784.
 Arched ribs, graphical determination of stresses in, 677.
 Arched rib of uniform stiffness, 788, 789, 795, 800, 804.
 Arched ribs with fixed ends, 771.
 " " with hinged ends, 764.
 Arched ribs with axis in form of circular arc, 769, 773.
 Arched ribs with parabolic axis, 760, 775.
 Arched ribs with semicircular axis, 765, 775.
 Arches, middle-third theory of, 746.
 Auxiliary truss, 719.
 Back-stays, 16, 704.
 Baker's formulae for strength of pillars, 549.
 Balancing, 198.
 Beam acted upon by oblique forces, 396.
 Beam, transverse strength of, 340, 429.
 Beam, transverse vibration of loaded, 461.
 Beams, equilibrium of, 93.
 " " of uniform strength, 358-365.
 Bearing surface, 314, 315.
 Belts, 321.
 " " effect of high speed in, 325.
 " " effective tension of, 324.
 " " slip of, 326.
 " " stiffness of, 327.
 Bending moment, 96, 118, 434.
 Bending moment in plane which is not a principal plane, 354.
 Bending moment, relation between, and shearing stress, 108.
 Level-wheels, 335.
 Boilers, 586.
 Bollman truss, 56, 618.
 Bowstring truss, 61, 618.
 Brace, 1, 25.
 Brakes, 323.
 Breaking-down point, 149.
 Breaking stress, 147.
 " " weights, 348, 399.
 Breaking weights of iron girders, 369, 370.
 Breaking weights, tables of, 212.
 Backwork, 149.
 Bridge, bowstring suspension, 626.
 " " loads, 600.
 " " trusses, 17, 52.
 " " chords of, 625.
 " " depth of, 597.
 Bridge trusses, maximum allowable stress in, 657.
 Bridge trusses, stiffness of, 598.
 " " stringers of, 656.
 Bridges, 597.
 " " position of platform of, 598.
 Buckling of pillars, 513, 515.

- Cable with sloping suspenders, 717.
 Cables, 703.
 " curves of, 706.
 " deflection of, 714.
 " length of arc of, 712.
 " parameter of, 711.
 " weight of, 713.
 Camber, 388, 659.
 Cantilever, 305.
 " curve of boom of, 634.
 " deflection of, 638.
 " depth of, 637.
 " weight of, 632.
 Cast-iron, 147.
 Catenary, 34, 706, 750.
 Cement, 150.
 Centres of gravity, 11.
 Centre of resistance, 1, 743.
 Centrifugal force, 181.
 Centripetal force, 182.
 Clapeyron's theorem, 292.
 Coefficient of cubic elasticity, 255.
 " " elasticity, 141, 143.
 " " fluidity, 162.
 " " hardness, 164.
 " " lateral elasticity, 144.
 " " rigidity, 254, 285.
 " " rupture, 248.
 " " torsional rupture, 574.
 " " transverse elasticity, 285.
 Collar-beams, 25.
 Columns, *see* Pillars, 513, 538.
 " flexure of, 554, 557.
 Compound strain, 236.
 Compression, 141.
 Conjugate stresses, 247.
 Continuous girders, 463.
 Continuous girders, advantages and disadvantages of, 486.
 Continuous girders, maximum bending moment in, 465.
 Coulomb's laws, 568.
 Counterbrace, 60.
 Counter-efficiency, 328.
 Counterforts, 270.
 Covers of riveted joints, 665.
 Cranes, 13.
 " bent, 31.
 " derrick, 16.
 " jib, 13.
 " pit, 15.
 Crank effort, 207.
 Cubic elasticity, 255.
 " strain, 283.
 Dead load, 143, 600.
 Deflection, curve of, 434.
 " of girders, 384-386, 638.
 Deformation, 140, 251, 254.
 Dock walls, 270.
 Dynamometer, Prony's, 327.
 Earth foundations, 258.
 Earthwork, 255.
 " pressure of, 257.
 Earthwork, Rankine's theory applied to retaining walls, 264.
 Efficiency of mechanisms, 335.
 " of riveted joints, 666.
 Elastic curve, 355.
 " moment, 96, 340.
 Elasticity, 140.
 " coefficient of, 141, 143.
 " " " cubic, 255.
 " " " lateral, 144.
 " " " transverse, 285.
 " limit of, 145.
 Ellipse of stress, 241.
 Ellipsoid of stress, 281.
 Empirical rules for wind-pressure, 663.
 Encasté girders, 458.
 Energy, 207.
 " curves of, 207.
 " fluctuation of, 207.
 " kinetic, 167, 169, 170.
 " potential, 167.
 Envelope of moments, 121.
 Equalization of stress, 349.
 Equalizer, 629.
 Equilibrated polygon, 740.
 Equilibrium of beams, 428.
 Equilibrium of beams, general equations of, 428.
 Equilibrium of flanged girders, 366.
 Euler's theory of the strength of pillars, 537.
 Examples, 69-92, 132-139, 216-234, 294-298, 337-339, 407-427, 490-512, 563-567, 580-585, 594-596, 689-702, 734-739, 809-812.
 Expansion of solids, 215.
 Extension of prismatic bar, 289.
 Extrados, 740.
 Eyebars, 661.
 " steel, 665.
 Factor of safety, 150.
 Fatigue, 152.
 Fink truss, 54.
 Flanged girders, 365.
 " " equilibrium of, 366.
 " " stiffness of, 384.
 Flanges, 365, 597.
 " curved, 366.
 " horizontal, 366.
 Flexure of columns, *see* Pillars, 554, 557.
 Flow of solids, 162.

- Fluctuation of stress, 151.
 Fluid pressure, 162.
 Force polygon, 3, 7, 119.
 Foundations, earth, 258.
 " limiting depth of, 258.
 " of walls, 270.
 Fracture, 141.
 Framed arch, stresses in, 804.
 Framed arch, Clerk Maxwell's method
 of determining stresses in a, 806.
 Frames, 1, 2.
 " incomplete, 27, 61.
 Friction, 300.
 " angle of, 237.
 " coefficient of, 300, 313.
 " journal, 310.
 " rolling, 310.
 Funicular curve, 10.
 " polygon, 3, 7, 117, 119.
 Girders, 17.
 Girder of uniform strength, 381.
 Gordon's formulæ for pillars, 522.
 Hinged girders, 127-131.
 Hodgkinson's formulæ for the strength
 of pillars, 513, 517-521.
 Hooke's law, 142.
 Howe truss, 58, 611.
 Impact, 184.
 Impulse, 176.
 Incomplete frames, 27.
 Inertia, 198.
 " moment of, 12, 342.
 " pressure due to, 200.
 Inflection, point of, 453-463.
 Internal stress, 235.
 Isotropic bodies, 283.
 Joint of rupture, 747.
 Keystone, 741.
 Lateral bracing, 654.
 Lattice girder, 600.
 Launhardt's formula, 153.
 Lenticular truss, 626.
 Limit of elasticity, 145.
 Line of loads, 5.
 " " resistance, 273-276, 741, 750.
 " " rupture, 265.
 Linear arch, 743, 753-760.
 Loads, live, 111, 115, 119, 600, 639, 641,
 730.
 Loads, stationary (dead), 118, 600.
 Long pillars, 535.
 Mansard roof, 6.
 Masonry, 149.
 Mechanical advantage, 294.
 Middle third theory of arches, 746.
 Modulus of elasticity, 141.
 " " rupture, 348.
 " " transverse elasticity, 254.
 Moment of forces, 116.
 " " inertia, 12, 342.
 " " " examples of, 371-381.
 Moment of inertia, variable section of,
 455.
 Moment of inflexibility, 96.
 " " resistance, 96.
 Momentum, 176.
 Mortar, 150.
 Neutral axis, 340.
 " " of a loaded beam, 435-454.
 " " surface, 340.
 Oblique resistance, 169.
 Oscillatory motion, 190, 195.
 Panel points, 52.
 Panels, 54.
 Piers, 65.
 Pillars, 513.
 " Euler's formulæ for, 527.
 " failure of, 515.
 " flexure of, 515.
 " formulæ for American, 527-532.
 " Gordon's formulæ for, 522.
 Pillars, Hodgkinson's formulæ for, 517-
 521.
 Pillars, Rankine's formula for, 526.
 Pillars with stress uniformly distributed,
 516.
 Pillars with uniformly varying stress,
 517.
 Pins, 661.
 Piston velocity, curves of, 205.
 Pivots, 316.
 " conical, 319.
 " cylindrical, 316.
 " Schiele's (anti-friction), 320.
 Plasticity, 141.
 Poisson's ratio, 142.
 Pole, 7.
 Polygon of forces, 3, 7.
 " " pressure, 743.
 Pratt truss, 60.
 Primitive strength, 153.
 Principals, 33, 34.
 Prony's dynamometer, 327.
 Proof strain, 171.
 " stress, 171.
 Purchase, 304.
 Purlins, 33, 34.
 Radius of gyration, 174, 528-531.
 Rate of twist, 289.

- Redundant bars, 48.
 Reservoir walls, 271.
 Resilience, 171.
 Retaining walls, 260.
 Retaining walls, conditions of equilibrium of, 260.
 Retaining walls, Rankine's theory applied to, 264.
 Rivet connection between flange and web, 660.
 Riveted joints, 668.
 " " covers of, 675.
 " " design of, 678.
 " " efficiency of, 679.
 " " failure of, 670.
 " " stresses in, 670.
 " " theory of, 671-675.
 Riveting, 666.
 Rivets, 666.
 " dimensions of, 667.
 Rocker-link, 629.
 Rollers, 35, 639.
 Roof trusses, 17.
 " " distribution of loads on, 39.
 " " types of, 33.
 " " weights of, 37.
 Ropes, 321.

 Saddles, 704.
 Schiele's pivots, 320.
 Screws, 306.
 " endless, 309.
 Sections, method of, 62
 Set, 145.
 Shafting, distance between bearings of, 575.
 " efficiency of, 577.
 " internal stress in, 237.
 " stiffness of, 573.
 " torsional strength of, 288-291.
 Shear, 141.
 " maximum, 121, 237.
 Shearing force, 95.
 " " examples of, 97, 108.
 Shearing force and bending moment, relation between, 108.
 Shearing stress, 198.
 " " distribution of, 391.
 Shear-legs, 17.
 Similar girders, 401-404.
 Skew-backs, 34, 740.
 Soffit, 740.
 Spandril, 740.
 Specific weight, 143.
 Spherical shells, 594
 Springings, 740.
 Springs, 355, 456-458.
 " simple rectangular, 456.
 " spiral, 477.
 Springs of constant depth, but triangular in plan, 457.
 Springs of constant width, but parabolic in elevation, 457.
 Statical breaking strength, 153.
 Steel, 148.
 Stiffening truss, 719.
 " " hinged at centre, 725.
 Stiffness, 190, 387, 389.
 Strain, 140, 251.
 Straining cill, 18.
 Stress, 141, 251
 " and strain, relation between, 281.
 " general equations of, 277.
 " principal, 241.
 " " planes of, 237.
 Stresses, conjugate, 248, 250.
 Stress-strain curves, 147-149.
 " " line, 144.
 Strut, 1.
 St. Venant's torsion results, 572.
 Surface loading, 350.
 Suspenders, 706.
 Suspension-bridges, 703.
 " " loads on, 730.
 Suspension-bridges, modifications of, 731.
 Suspension-bridges, pressure upon piers of, 718.
 Swing-bridges, 470-472.

 Tables of breaking weights and coefficients of bending strength of timber, 212, 213.
 Table of coefficients of axle friction, 336.
 Table of coefficients in Gordon's formula, 524.
 Table of coefficients in Rankine's modification of Gordon's formula, 526.
 Tables of diagonal and chord stresses, 644-650.
 Tables of efficiencies, 587.
 " " elliptic integrals, 562.
 " " expansion of solids, 215.
 " " eyebar dimensions, 665.
 " " factors of safety, 214.
 Tables of loads for highway bridges, 687.
 Tables of strengths, elasticities, and weights of iron and steel, 210.
 Table of strengths, elasticities, and weights of various alloys, 211.
 Tables of weights of modern bridges, 682-687.
 Table of weights and crushing strength of rocks, 214
 Table of weights of roof coverings, 67.

- Table of weights of roof frames, 67.
 Tension, 1.
 Theorem of three moments, 463-470.
 Thick hollow cylinder, 588.
 Timber, 149.
 Torsion, 141, 568.
 " St. Venant's results, 572.
 Torsional coefficient of elasticity, 145.
 " resilience, 574.
 Torsional strength of shafts, 288, 289,
 571, 572.
 Transverse strength, 141.
 Transverse vibration of a loaded beam,
 461.
 Trellis girder, 600.
 Tresca's theory of flow of solids, 162.
 Tripods, 17.
 Truss, 2.
 " composite, 31.
 " king-post, 21.
 " queen-post, 25.
 " roof, 32.
 " triangular, 19.
 Trussed beams, 53.
 Twist, 141.

 Unwin's formula, 159.

 Values of k^2 , 174, 528-531.
 Vibration strength, 153.
 Voussoir, 741.

 Warren truss, 57.

 Web thickness, 382.
 Wedge, 303.
 Weights of roof coverings, 67.
 " " " frames, 67.
 Weyrauch's formula, 153.
 Weyrauch's theory of buckling of pillars,
 550.
 Wheel and axle, 329.
 Whipple truss, 618.
 Wind pressure, 38, 67, 629, 651, 653.
 Wind-pressure, American specifications
 of, 652.
 Wind-Pressure Commission rules, 653.
 Wind-pressure, empirical regulations,
 653.
 Wöhler's law, 150.
 Work, 167.
 " effective, 178.
 " external, 168.
 " internal, 168.
 " useful, 178.
 " waste, 178.
 Work done in bending a beam, 460.
 Work done in small deformation of a
 body, 292.
 Work of journal friction, 314.
 Working load, 150.
 " strength, 150.
 " stress, 150.
 Wrought-iron, 148.

 Yield-point, 149.

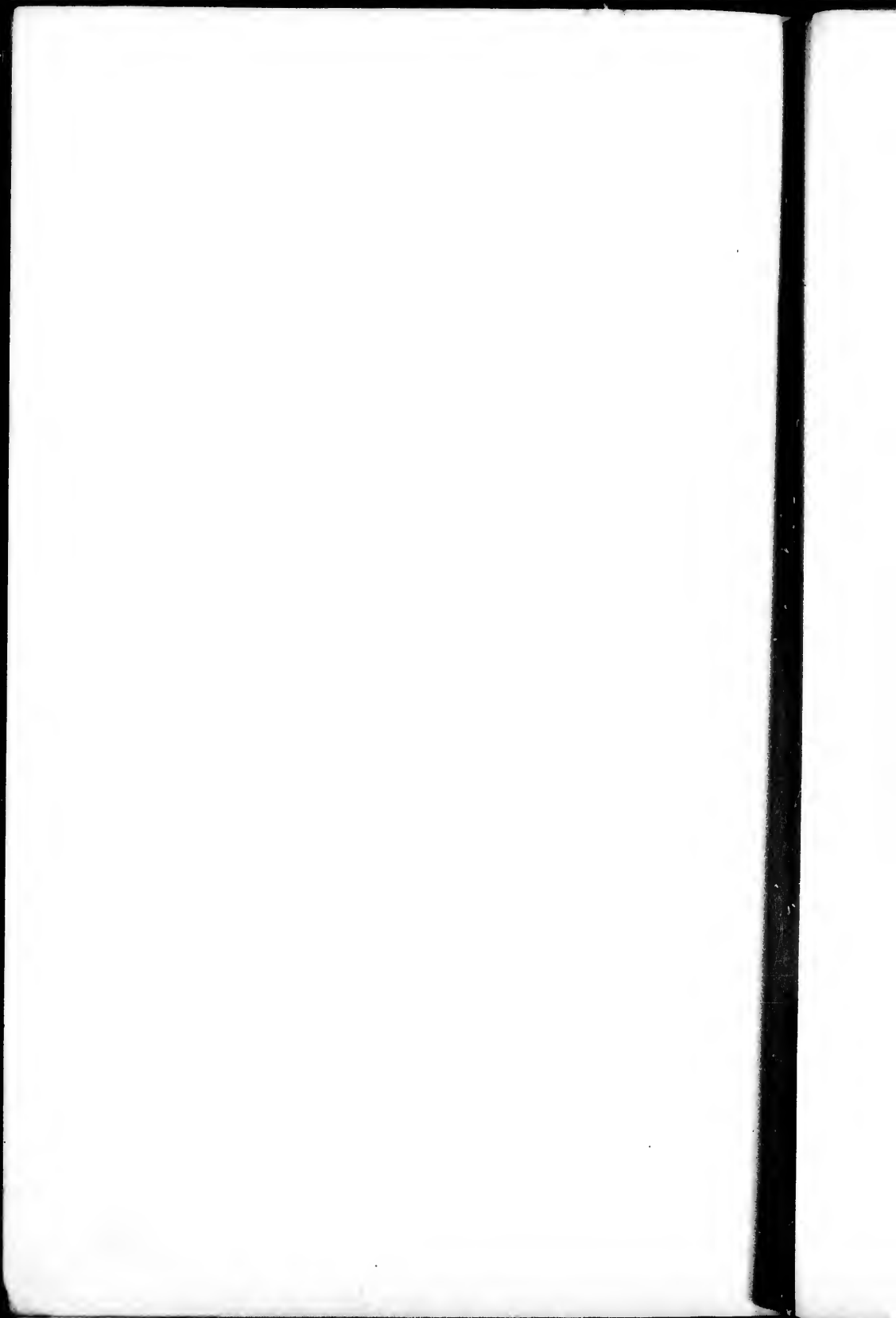

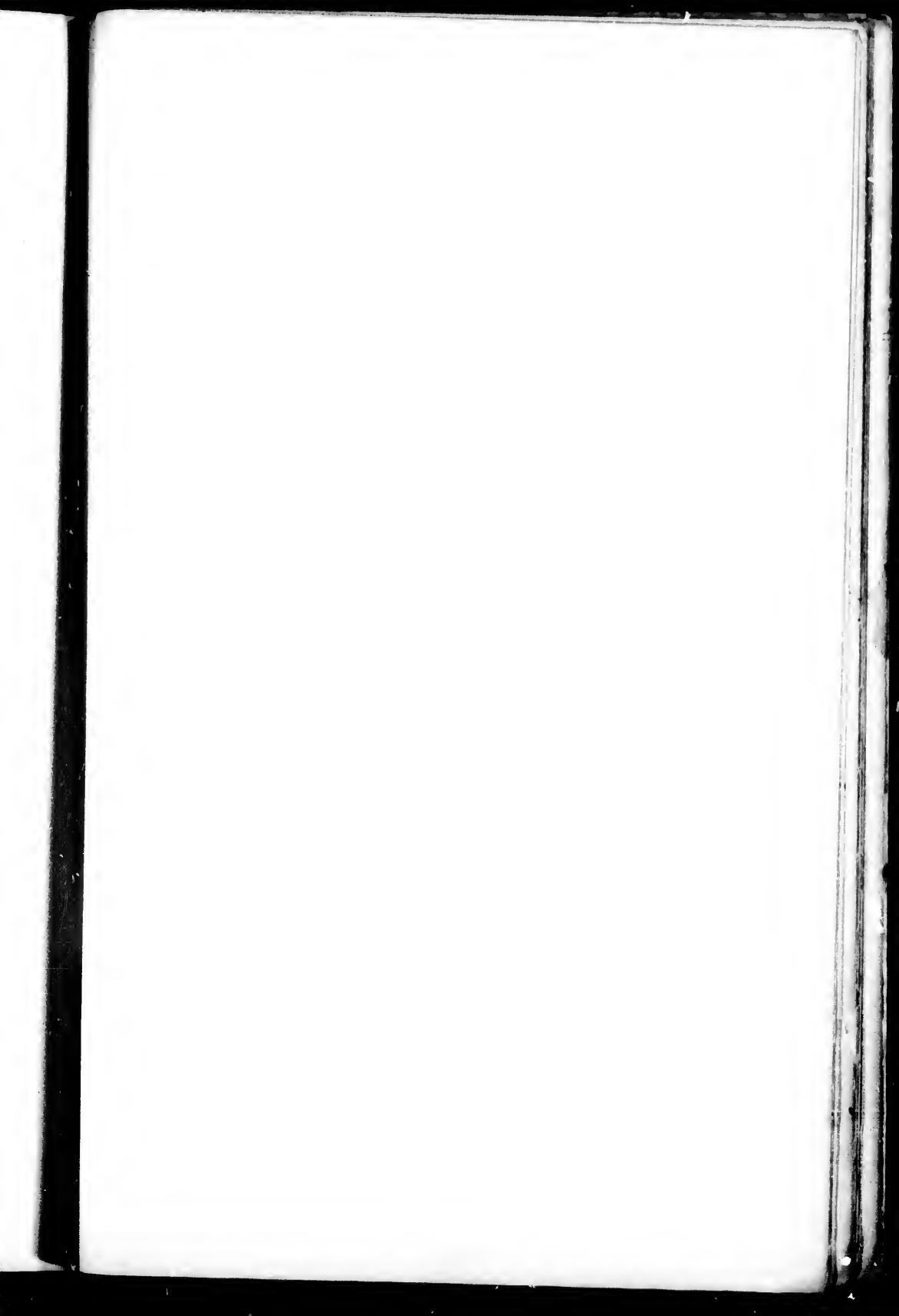

Arm
Dow
Ken
Stoc
Lloy
Louc
Steel
"
Grote

Berg's
Birkm
"

SHORT-TITLE CATALOGUE

OF THE

PUBLICATIONS

OF

JOHN WILEY & SONS,

NEW YORK.

LONDON: CHAPMAN & HALL, LIMITED.

ARRANGED UNDER SUBJECTS.

Descriptive circulars sent on application.

Books marked with an asterisk are sold at *net* prices only.

All books are bound in cloth unless otherwise stated.

AGRICULTURE.

CATTLE FEEDING—DISEASES OF ANIMALS—GARDENING, ETC.

Armsby's Manual of Cattle Feeding.....	12mo,	\$1 75
Downing's Fruit and Fruit Trees.....	8vo,	5 00
Kemp's Landscape Gardening.....	12mo,	2 50
Stockbridge's Rocks and Soils.....	8vo,	2 50
Lloyd's Science of Agriculture.....	8vo,	4 00
Loudon's Gardening for Ladies. (Downing.).....	12mo,	1 50
Steel's Treatise on the Diseases of the Ox.....	8vo,	6 00
“ Treatise on the Diseases of the Dog.....	8vo,	3 50
Grotenfelt's The Principles of Modern Dairy Practice. (Woll.)	12mo,	2 00

ARCHITECTURE.

BUILDING—CARPENTRY—STAIRS, ETC.

Berg's Buildings and Structures of American Railroads....	4to,	7 50
Birkmire's Architectural Iron and Steel.....	8vo,	3 50
“ Skeleton Construction in Buildings.....	8vo,	3 00

Birkmire's Compound Riveted Girders.....8vo,	\$2 00
" American Theatres—Planning and Construction.8vo,	3 00
Carpenter's Heating and Ventilating of Buildings.....8vo,	3 00
Freitag's Architectural Engineering.....8vo,	2 50
Kidder's Architect and Builder's Pocket-book.....Morocco flap,	4 00
Hatfield's American House Carpenter.....8vo,	5 00
" Transverse Strains.....8vo,	5 00
Monckton's Stair Building—Wood, Iron, and Stone.....4to,	4 00
Gerhard's Sanitary House Inspection.....16mo,	1 00
Downing and Wightwick's Hints to Architects.....8vo,	2 00
" Cottages.....8vo,	2 50
Holly's Carpenter and Joiner..	18mo. 75
Worcester's Small Hospitals—Establishment and Maintenance, including Atkinson's Suggestions for Hospital Archi- tecture... ..12mo,	1 25
The World's Columbian Exposition of 1893.....4to,	2 50

ARMY, NAVY, Etc.

MILITARY ENGINEERING—ORDNANCE—PORT CHARGES, ETC.

Cooke's Naval Ordnance	8vo, \$12 50
Metcalf's Ordnance and Gunnery.....	12mo, with Atlas, 5 00
Ingalls's Handbook of Problems in Direct Fire.....	8vo, 4 00
" Ballistic Tables.....	8vo, 1 50
Bucknill's Submarine Mines and Torpedoes.....	8vo, 4 00
Todd and Whall's Practical Seamanship	8vo, 7 50
Mahan's Advanced Guard.....	18mo, 1 50
" Permanent Fortifications. (Mercur.).....	8vo, half morocco, 7 50
Wheeler's Siege Operations.....	8vo, 2 00
Woodhull's Notes on Military Hygiene.....	12mo, morocco, 2 50
Dietz's Soldier's First Aid.....	12mo, morocco, 1 25
Young's Simple Elements of Navigation..	12mo, morocco flaps, 2 50
Reed's Signal Service.....	50
Phelps's Practical Marine Surveying.....	8vo, 2 50
Very's Navies of the World.....	8vo, half morocco, 3 50
Bourne's Screw Propellers.....	4to, 5 00

Hunter's Port Charges.....	.8vo, half morocco,	\$13 00
* Dredge's Modern French Artillery.....	.4to, half morocco,	20 00
" Record of the Transportation Exhibits Building, World's Columbian Exposition of 1893..	.4to, half morocco,	15 00
Mercur's Elements of the Art of War.....	.8vo,	4 00
" Attack of Fortified Places.....	.12mo,	2 00
Chase's Screw Propellers.....	.8vo,	3 00
Winthrop's Abridgment of Military Law.....	.12mo,	2 50
De Brack's Cavalry Outpost Duties. (Carr.)...	.18mo, morocco,	2 00
Cronkhite's Gunnery for Non-com. Officers....	.18mo, morocco,	2 00
Dyer's Light Artillery.....	.12mo,	3 00
Sharpe's Subsisting Armies.....	.18mo,	1 25
" " " 18mo, morocco,	1 50
Powell's Army Officer's Examiner.....	.12mo,	4 00
Hoff's Naval Tactics.....	.8vo,	1 50
Bruff's Ordnance and Gunnery.....	.8vo,	6 00

ASSAYING.

SMELTING—ORE DRESSING—ALLOYS, ETC.

Furman's Practical Assaying.....	.8vo,	3 00
Wilson's Cyanide Processes.....	.12mo,	1 50
Fletcher's Quant. Assaying with the Blowpipe..	.12mo, morocco,	1 50
Ricketts's Assaying and Assay Schemes... ..	.8vo,	3 00
* Mitchell's Practical Assaying. (Crookes.).....	.8vo,	10 00
Thurston's Alloys, Brasses, and Bronzes.....	.8vo,	2 50
Kunhardt's Ore Dressing.....	.8vo,	1 50
O'Driscoll's Treatment of Gold Ores.....	.8vo,	2 00

ASTRONOMY.

PRACTICAL, THEORETICAL, AND DESCRIPTIVE.

Michie and Harlow's Practical Astronomy.....	.8vo,	3 00
White's Theoretical and Descriptive Astronomy.....	.12mo,	2 00
Doolittle's Practical Astronomy.....	.8vo,	4 00
Craig's Azimuth.....	.4to,	3 50
Gore's Elements of Geodesy.....	.8vo,	2 50

BOTANY.

GARDENING FOR LADIES, ETC.

Westermaler's General Botany. (Schneider.).....8vo,	\$2 00
Thomé's Structural Botany.....18mo,	2 25
Baldwin's Orchids of New England.....8vo,	1 50
Loudon's Gardening for Ladies. (Downing.).....12mo,	1 50

BRIDGES, ROOFS, ETC.

CANTILEVER—HIGHWAY—SUSPENSION.

Boller's Highway Bridges.....8vo,	2 00
* " The Thames River Bridge.....4to, paper,	5 00
Burr's Stresses in Bridges.....8vo,	3 50
Merriman & Jacoby's Text-book of Roofs and Bridges. Part I., Stresses.....8vo,	2 50
Merriman & Jacoby's Text-book of Roofs and Bridges. Part II., Graphic Statics.....8vo,	2 50
Merriman & Jacoby's Text-book of Roofs and Bridges. Part III., Bridge Design.....8vo,	5 00
Merriman & Jacoby's Text-book of Roofs and Bridges. Part IV., Continuous, Draw, Cantilever, Suspension, and Arched Bridges.....(<i>In preparation</i>).	
Crehore's Mechanics of the Girder.....8vo,	5 00
Du Bois's Strains in Framed Structures.....4to,	10 00
Greene's Roof Trusses.....8vo,	1 25
" Bridge Trusses.....8vo,	2 50
" Arches in Wood, etc.....8vo,	2 50
Waddell's Iron Highway Bridges.....8vo,	4 00
Wood's Construction of Bridges and Roofs.....8vo,	2 00
Foster's Wooden Trestle Bridges.....4to,	5 00
* Morison's The Memphis Bridge.....Oblong 4to,	10 00
Johnson's Modern Framed Structures.....4to.	10 00

CHEMISTRY.

QUALITATIVE—QUANTITATIVE—ORGANIC—INORGANIC, ETC.

Frensius's Qualitative Chemical Analysis. (Johnson.).....8vo,	4 00
" Quantitative Chemical Analysis. (Allen.).....8vo,	6 00
" " " " (Bolton.).....8vo,	1 50

Warren's Drafting Instruments.....	12mo,	\$1 25
“ Projection Drawing.....	12mo,	1 50
“ Linear Perspective.....	12mo,	1 00
“ Plane Problems.....	12mo,	1 25
“ Primary Geometry.....	12mo,	75
“ Descriptive Geometry.....	2 vols., 8vo,	3 50
“ Problems and Theorems.....	8vo,	2 50
“ Machine Construction.....	2 vols., 8vo,	7 50
“ Stereotomy—Stone Cutting.....	8vo,	2 50
“ Higher Linear Perspective.....	8vo,	3 50
“ Shades and Shadows.....	8vo,	3 00
Whelpley's Letter Engraving.....	12mo,	2 00

ELECTRICITY AND MAGNETISM.

ILLUMINATION—BATTERIES—PHYSICS.

* Dredge's Electric Illuminations....	2 vols., 4to, half morocco,	25 00
“ “ “ Vol. II.....	4to,	7 50
Niaudet's Electric Batteries. (Fishback.).....	12mo,	2 50
Anthony and Brackett's Text-book of Physics.....	8vo,	4 00
Cosmic Law of Thermal Repulsion....	18mo,	75
Thurston's Stationary Steam Engines for Electric Lighting Purposes.....	12mo,	1 50
Michie's Wave Motion Relating to Sound and Light,.....	8vo,	4 00
Barker's Deep-sea Soundings.....	8vo,	2 00
Holman's Precision of Measurements.....	8vo,	2 00
Tillman's Heat.....	8vo,	1 50
Gilbert's De-magnete. (Mottelay.).....	8vo,	2 50
Benjamin's Voltaic Cell.....	8vo,	3 00
Reagan's Steam and Electrical Locomotives.....	12mo	2 00

ENGINEERING.

CIVIL—MECHANICAL—SANITARY, ETC.

* Trautwine's Cross-section.....	Sheet,	25
* “ Civil Engineer's Pocket-book....	12mo, mor. flaps,	5 00
* “ Excavations and Embankments.....	8vo,	2 00
* “ Laying Out Curves.....	12mo, morocco,	2 50
Hudson's Excavation Tables. Vol. II.....	8vo,	1 00

Searles's Field Engineering.....	12mo, morocco flaps,	\$3 00
" Railroad Spiral.....	12mo, morocco flaps,	1 50
Godwin's Railroad Engineer's Field-book.....	12mo, pocket-bk. form,	2 50
Butts's Engineer's Field-book.....	12mo, morocco,	2 50
Gore's Elements of Goodesy.....	8vo,	2 50
Wellington's Location of Railways.....	8vo,	5 00
* Dredge's Penn. Railroad Construction, etc. . .	Folio, half mor.,	20 00
Smith's Cable Tramways.....	4to,	2 50
" Wire Manufacture and Uses.....	4to,	3 00
Mahan's Civil Engineering. (Wood.).....	8vo,	5 00
Wheeler's Civil Engineering.....	8vo,	4 00
Mosely's Mechanical Engineering. (Mahan.).....	8vo,	5 00
Johnson's Theory and Practice of Surveying.....	8vo,	4 00
" Stadia Reduction Diagram..Sheet, 22½ × 28½ inches,		50
* Drinker's Tunnelling.....	4to, half morocco,	25 00
Eissler's Explosives—Nitroglycerine and Dynamite.....	8vo,	4 00
Foster's Wooden Trestle Bridges.....	4to,	5 00
Ruffner's Non-tidal Rivers.....	8vo,	1 25
Greene's Roof Trusses	8vo,	1 25
" Bridge Trusses.....	8vo,	2 50
" Arches in Wood, etc.....	8vo,	2 50
Church's Mechanics of Engineering—Solids and Fluids....	8vo,	6 00
" Notes and Examples in Mechanics.....	8vo,	2 00
Howe's Retaining Walls (New Edition.).....	12mo,	1 25
Wegmann's Construction of Masonry Dams.....	4to,	5 00
Thurston's Materials of Construction.....	8vo,	5 00
Baker's Masonry Construction.....	8vo,	5 00
" Surveying Instruments.....	12mo,	3 00
Warren's Stereotomy—Stone Cutting.....	8vo,	2 50
Nichols's Water Supply (Chemical and Sanitary).....	3vo,	2 50
Mason's " " " " "	8vo,	5 00
Gerhard's Sanitary House Inspection.....	16mo,	1 00
Kirkwood's Lead Pipe for Service Pipe.....	8vo,	1 50
Wolff's Windmill as a Prime Mover.....	8vo,	3 00
Howard's Transition Curve Field-book.....	12mo, morocco flap,	1 50
Crandall's The Transition Curve.....	12mo, morocco,	1 50

Crandall's Earthwork Tables8vo,	\$1 50
Patton's Civil Engineering.....	.8vo,	7 50
" Foundations.....	.8vo,	5 00
Carpenter's Experimental Engineering8vo,	6 00
Webb's Engineering Instruments.....	12mo, morocco,	1 00
Black's U. S. Public Works.....	.4to,	5 00
Merriman and Brook's Handbook for Surveyors....	13mo, mor.,	2 00
Merriman's Retaining Walls and Masonry Dams.....	.8vo,	2 00
" Geodetic Surveying.....	.8vo,	2 00
Kiersted's Sewage Disposal.....	12mo,	1 25
Siebert and Biggin's Modern Stone Cutting and Masonry...	.8vo,	1 50
Kent's Mechanical Engineer's Pocket-book.....	12mo, morocco,	5 00

HYDRAULICS.

WATER-WHEELS—WINDMILLS—SERVICE PIPE—DRAINAGE, ETC.

Weisbach's Hydraulics. (Du Bois).....	.8vo,	5 00
Merriman's Treatise on Hydraulics.....	.8vo,	4 00
Ganguillet & Kutter's Flow of Water. (Hering & Trautwine.).....	.8vo,	4 00
Nichols's Water Supply (Chemical and Sanitary).....	.8vo,	2 50
Wolf's Windmill as a Prime Mover.....	.8vo,	3 00
Ferrel's Treatise on the Winds, Cyclones, and Tornadoes....	.8vo,	4 00
Kirkwood's Lead Pipe for Service Pipe.....	.8vo,	1 50
Ruffner's Improvement for Non-tidal Rivers.....	.8vo,	1 25
Wilson's Irrigation Engineering.....	.8vo,	4 00
Bovey's Treatise on Hydraulics.....	.8vo,	4 00
Wegmann's Water Supply of the City of New York.....	.4to,	10 00
Hazen's Filtration of Public Water Supply.....	.8vo,	2 00
Mason's Water Supply—Chemical and Sanitary.....	.8vo,	5 00
Wood's Theory of Turbines.....	.8vo,	2 50

MANUFACTURES.

ANILINE—BOILERS—EXPLOSIVES—IRON—SUGAR—WATCHES—

WOOLLENS, ETC.

Metcalf's Cost of Manufactures.....	.8vo,	5 00
Metcalf's Steel (Manual for Steel Users).....	12mo,	2 00
Allen's Tables for Iron Analysis.....	.8vo,	3 00

West's American Foundry Practice	12mo,	\$2 50
" Moulder's Text-book	12mo,	2 50
Spencer's Sugar Manufacturer's Handbook	12mo, mor. flap,	2 00
Wiechmann's Sugar Analysis8vo,	2 50
Beaumont's Woollen and Worsted Manufacture	12mo,	1 50
* Reisig's Guide to Piece Dyeing8vo,	25 00
Elssler's Explosives, Nitroglycerine and Dynamite8vo,	4 00
Rehmann's Aniline Colors. (Crookes.)8vo,	2 50
Ford's Boiler Making for Boiler Makers	18mo,	1 00
Thurston's Manual of Steam Boilers8vo,	5 00
Booth's Clock and Watch Maker's Manual	12mo,	2 00
Holly's Saw Filing	18mo,	75
Svedelius's F indbook for Charcoal Burners	12mo,	1 50
The Lathe and Its Uses8vo,	6 00
Woodbury's Fire Protection of Mills8vo,	2 50
Bolland's The Iron Founder	12mo,	2 50
" " " " Supplement	12mo,	2 50
" Encyclopædia of Founding Terms	12mo,	3 00
Bouvier's Handbook on Oil Painting	12mo,	2 00
Steven's House Painting	18mo,	75

MATERIALS OF ENGINEERING.

STRENGTH—ELASTICITY—RESISTANCE, ETC.

Thurston's Materials of Engineering3 vols., .8vo,	8 00
Vol. I., Non-metallic8vo,	2 00
Vol. II., Iron and Steel8vo,	3 50
Vol. III., Alloys, Brasses, and Bronzes8vo,	2 50
Thurston's Materials of Construction8vo,	5 00
Baker's Masonry Construction8vo,	5 00
Lanza's Applied Mechanics8vo,	7 50
" Strength of Wooden Columns8vo, paper,	50
Wood's Resistance of Materials8vo,	2 00
Weyrauch's Strength of Iron and Steel. (Du Bois.)8vo,	1 50
Burr's Elasticity and Resistance of Materials8vo,	5 00
Merriman's Mechanics of Materials8vo,	4 00
Church's Mechanic's of Engineering—Solids and Fluids8vo,	6 00

Beardslee and Kent's Strength of Wrought Iron.....8vo,	\$1 5
Hatfield's Transverse Strains.....8vo,	5 00
Du Bois's Strains in Framed Structures.....4to,	10 00
Merrill's Stones for Building and Decoration.....8vo,	5 00
Bovey's Strength of Materials.....8vo,	7 50
Spalding's Roads and Pavements.....12mo,	2 00
Rockwell's Roads and Pavements in France.....12mo,	1 25
Byrne's Highway Construction.....8vo,	5 00
Patton's Treatise on Foundations.....8vo,	5 00

MATHEMATICS.

CALCULUS—GEOMETRY—TRIGONOMETRY, ETC.

Rice and Johnson's Differential Calculus.....8vo,	3 50
“ Abridgment of Differential Calculus....8vo,	1 50
“ Differential and Integral Calculus,	
2 vols. in 1, 12mo,	2 50
Johnson's Integral Calculus.....12mo,	1 50
“ Curve Tracing.....12mo,	1 00
“ Differential Equations—Ordinary and Partial....8vo,	3 50
“ Least Squares.....12mo,	1 50
Craig's Linear Differential Equations.....8vo,	5 00
Merriman and Woodward's Higher Mathematics.....8vo,	5 00
Bass's Differential Calculus.....12mo,	
Halsted's Synthetic Geometry.....8vo,	1 50
“ Elements of Geometry.....8vo,	1 75
Chapman's Theory of Equations.....12mo,	1 50
Merriman's Method of Least Squares.....8vo,	2 00
Compton's Logarithmic Computations.....12mo,	1 50
Davis's Introduction to the Logic of Algebra.....8vo,	1 50
Warren's Primary Geometry.....12mo,	75
“ Plane Problems.....12mo,	1 25
“ Descriptive Geometry.....2 vols., 8vo,	3 50
“ Problems and Theorems.....8vo,	2 50
“ Higher Linear Perspective.....8vo,	3 50
“ Free-hand Drawing.....12mo,	1 00
“ Drafting Instruments.....12mo,	1 25

Warren's Projection Drawing.....	12mo,	\$1 50
" Linear Perspective.....	12mo,	1 00
" Plane Problems.....	12mo,	1 25
Searles's Elements of Geometry.....	8vo,	1 50
Brigg's Plane Analytical Geometry.....	12mo,	1 00
Wood's Co-ordinate Geometry.....	8vo,	2 00
" Trigonometry.....	12mo,	1 00
Mahan's Descriptive Geometry (Stone Cutting)....	8vo,	1 50
Woolf's Descriptive Geometry.....	Royal 8vo,	3 00
Ludlow's Trigonometry with Tables. (Buss.).....	8vo,	3 00
" Logarithmic and Other Tables. (Buss.).....	8vo,	2 00
Baker's Elliptic Functions.....	8vo,	1 50
Parker's Quadrature of the Circle.....	8vo,	2 50
Totten's Metrology.....	8vo,	2 50
Balhard's Pyramid Problem.....	8vo,	1 50
Barnard's Pyramid Problem.....	8vo,	1 50

MECHANICS—MACHINERY.

TEXT-BOOKS AND PRACTICAL WORKS.

Dann's Elementary Mechanics.....	12mo,	1 50
Wood's " ".....	12mo,	1 25
" " " Supplement and Key.....		1 25
" Analytical Mechanics.....	8vo,	3 00
Michie's Analytical Mechanics.....	8vo,	4 00
Merriman's Mechanics of Materials.....	8vo,	4 00
Church's Mechanics of Engineering....	8vo,	6 00
" Notes and Examples in Mechanics.....	8vo,	2 00
Mosely's Mechanical Engineering. (Mahan.).....	8vo,	5 00
Weisbach's Mechanics of Engineering. Vol. III., Part I., Sec. I. (Klein.).....	8vo,	5 00
Weisbach's Mechanics of Engineering. Vol. III., Part I., Sec. II. (Klein.).....	8vo,	5 00
Weisbach's Hydraulics and Hydraulic Motors. (Du Bois.).....	8vo,	5 00
" Steam Engines. (Du Bois.).....	8vo,	5 00
Lanza's Applied Mechanics.....	8vo,	7 50

Crehore's Mechanics of the Girder.....	.8vo,	\$5 00
MacCord's Kinematics.....	.8vo,	5 00
Thurston's Friction and Lost Work.....	.8vo,	3 00
" The Animal as a Machine.....	.12mo,	1 00
Hall's Car Lubrication.....	.12mo,	1 00
Warren's Machine Construction.....	.2 vols., 8vo,	7 50
Chordal's Letters to Mechanics.....	.12mo,	2 00
The Lathe and Its Uses.....	8vo,	6 00
Cromwell's Toothed Gearing.....	.12mo,	1 50
" Belts and Pulleys.....	.12mo,	1 50
Du Bois's Mechanics. Vol. I., Kinematics.....	.8vo,	3 50
" " Vol. II., Statics.....	.8vo,	4 00
" " Vol. III., Kinetics.....	.8vo,	3 50
Dredge's Trans. Exhibits Building, World Exposition,	4to, half morocco,	15 00
Flather's Dynamometers.....	.12mo,	2 00
" Rope Driving.....	.12mo,	2 00
Richards's Compressed Air.....	.12mo,	1 50
Smith's Press-working of Metals.....	.8vo,	3 00
Holly's Saw Filing.....	.18mo,	75
Fitzgerald's Boston Machinist.....	.18mo,	1 00
Baldwin's Steam Heating for Buildings.....	.12mo,	2 50
Metcalf's Cost of Manufactures.....	.8vo,	5 00
Benjamin's Wrinkles and Recipes.....	.12mo,	2 00
Dungey's Machinery Pattern Making.....	.12mo,	2 00

METALLURGY.

IRON—GOLD—SILVER—ALLOYS, ETC.

Egleston's Metallurgy of Silver.....	8vo,	7 50
" Gold and Mercury.....	.8vo,	7 50
" Weights and Measures, Tables.....	.18mo,	75
" Catalogue of Minerals.....	.8vo,	2 50
O'Driscoll's Treatment of Gold Ores.....	.8vo,	2 00
* Kerl's Metallurgy—Copper and Iron.....	.8vo,	15 00
* " " Steel, Fuel, etc.....	.8vo,	15 00

Thurston's Iron and Steel.....	.8vo,	\$3 50
" Alloys.....	.8vo,	2 50
Trollius's Chemistry of Iron.....	.8vo,	2 00
Kunhardt's Ore Dressing in Europe.....	.8vo,	1 50
Weyrauch's Strength of Iron and Steel. (Du Bois.).....	.8vo,	1 50
Beardslee and Kent's Strength of Wrought Iron.....	.8vo,	1 50
Compton's First Lessons in Metal Working.....	.12mo,	1 50
West's American Foundry Practice.....	.12mo,	2 50
" Moulder's Text-book.....	.12mo,	2 50

MINERALOGY AND MINING.

MINE ACCIDENTS—VENTILATION—ORE DRESSING, ETC.

Dana's Descriptive Mineralogy. (E. S.).....	.8vo, half morocco,	12 50
" Mineralogy and Petrography. (J. D.).....	.12mo,	2 00
" Text-book of Mineralogy. (E. S.).....	.8vo,	3 50
" Minerals and How to Study Them. (E. S.).....	.12mo,	1 50
" American Localities of Minerals.....	.8vo,	1 00
Brush and Dana's Determinative Mineralogy..	.8vo,	3 50
Rosenbusch's Microscopical Physiography of Minerals and Rocks. (Iddings.).....	.8vo,	5 00
Hussak's Rock-forming Minerals. (Smith.).....	.8vo,	2 00
Williams's Lithology.....	.8vo,	3 00
Chester's Catalogue of Minerals.....	.8vo,	1 25
" Dictionary of the Names of Minerals.....	.8vo,	3 00
Egleston's Catalogue of Minerals and Synonyms.....	.8vo,	2 50
Goodyear's Coal Mines of the Western Coast.....	.12mo,	2 50
Kunhardt's Ore Dressing in Europe.....	.8vo,	1 50
Sawyer's Accidents in Mines.....	.8vo,	7 00
Wilson's Mine Ventilation.....	.16mo,	1 25
Boyd's Resources of South Western Virginia.....	.8vo,	3 00
" Map of South Western Virginia.....	Pocket-book form,	2 00
Stockbridge's Rocks and Soils.....	.8vo,	2 50
Eissler's Explosives—Nitroglycerine and Dynamite.....	.8vo,	4 00

*Drinker's Tunnelling, Explosives, Compounds, and Rock Drills.		
	4to, half morocco,	\$25 00
Beard's Ventilation of Mines.....	12mo,	2 50
Ihlseng's Manual of Mining..	8vo,	4 00

STEAM AND ELECTRICAL ENGINES, BOILERS, Etc.

STATIONARY—MARINE—LOCOMOTIVE—GAS ENGINES, ETC.

Welsbach's Steam Engine. (Du Bois.).....	8vo,	5 00
Thurston's Engine and Boiler Trials.....	8vo,	5 00
" Philosophy of the Steam Engine.....	12mo,	75
" Stationary Steam Engines.....	12mo,	1 50
" Boiler Explosion.....	12mo,	1 50
" Steam-boiler Construction and Operation.....	8vo,	
" Reflection on the Motive Power of Heat. (Carnot.)	12mo,	2 00
Thurston's Manual of the Steam Engine. Part I., Structure and Theory.....	8vo,	7 50
Thurston's Manual of the Steam Engine. Part II., Design, Construction, and Operation.....	8vo,	7 50
	2 parts,	12 00
Röntgen's Thermodynamics. (Du Bois.).....	8vo,	5 00
Peabody's Thermodynamics of the Steam Engine.....	8vo,	5 00
" Valve Gears for the Steam-Engine.....	8vo,	2 50
" Tables of Saturated Steam.....	8vo,	1 00
Wood's Thermodynamics, Heat Motors, etc.....	8vo,	4 00
Pupin and Osterberg's Thermodynamics.....	12mo,	1 25
Kneass's Practice and Theory of the Injector.....	8vo,	1 50
Reagan's Steam and Electrical Locomotives.....	12mo,	2 00
Meyer's Modern Locomotive Construction.....	4to,	10 00
Whitham's Steam-engine Design.....	8vo,	6 00
" Constructive Steam Engineering.....	8vo,	10 00
Hemenway's Indicator Practice.....	12mo,	2 00
Pray's Twenty Years with the Indicator.....	Royal 8vo,	2 50
Spangler's Valve Gears.....	8vo,	2 50
*Maw's Marine Engines.....	Folio, half morocco,	18 00
Trowbridge's Stationary Steam Engines.....	4to, boards,	2 50

Ford's Boiler Making for Boiler Makers.....	18mo,	\$1 00
Wilson's Steam Boilers. (Flather.).....	12mo,	2 50
Baldwin's Steam Heating for Buildings.....	12mo,	2 50
Hoadley's Warm-blast Furnace.....	8vo,	1 50
Sinclair's Locomotive Running.....	12mo,	2 00
Clerk's Gas Engine.....	12mo,	4 00

TABLES, WEIGHTS, AND MEASURES.

FOR ENGINEERS, MECHANICS, ACTUARIES—METRIC TABLES, ETC.

Crandall's Railway and Earthwork Tables.....	8vo,	1 50
Johnson's Stadia and Earthwork Tables.....	8vo,	1 25
Bixby's Graphical Computing Tables.....	Sheet,	25
Compton's Logarithms.....	12mo,	1 50
Ludlow's Logarithmic and Other Tables. (Bass.).....	12mo,	2 00
Thurston's Conversion Tables.....	8vo,	1 00
Egleston's Weights and Measures.....	18mo,	75
Totten's Metrology.....	8vo,	2 50
Fisher's Table of Cubic Yards.....	Cardboard,	25
Hudson's Excavation Tables. Vol. II.....	8vo,	1 00

VENTILATION.

STEAM HEATING—HOUSE INSPECTION—MINE VENTILATION.

Beard's Ventilation of Mines.....	12mo,	2 50
Baldwin's Steam Heating.....	12mo,	2 50
Reid's Ventilation of American Dwellings.....	12mo,	1 50
Mott's The Air We Breathe, and Ventilation.....	16mo,	1 00
Gerhard's Sanitary House Inspection.....	Square 16mo,	1 00
Wilson's Mine Ventilation.....	16mo,	1 25
Carpenter's Heating and Ventilating of Buildings.....	8vo,	3 00

MISCELLANEOUS PUBLICATIONS.

Alcott's Gems, Sentiment, Language.....	Gilt edges,	5 00
Bailey's The New Tale of a Tub.....	8vo,	75
Ballard's Solution of the Pyramid Problem.....	8vo,	1 50
Barnard's The Metrological System of the Great Pyramid.....	8vo,	1 50

* Wiley's Yosemite, Alaska, and Yellowstone	4to,	\$3 00
Emmon's Geological Guide-book of the Rocky Mountains . . .	8vo,	1 50
Ferrel's Treatise on the Winds	8vo,	4 00
Perkins's Cornell University	Oblong 4to,	1 50
Ricketts's History of Rensselaer Polytechnic Institute . . .	8vo,	3 00
Mott's The Fallacy of the Present Theory of Sound . . .	Sq. 16mo,	1 00
Rotherham's The New Testament Critically Emphathized.	12mo,	1 50
Totten's An Important Question in Metrology	8vo,	2 50
Whitehouse's Lake Mœris	Paper,	25.

HEBREW AND CHALDEE TEXT-BOOKS.

FOR SCHOOLS AND THEOLOGICAL SEMINARIES.

Gesenius's Hebrew and Chaldee Lexicon to Old Testament. (Tregelles.)	Small 4to, half morocco,	5 00
Green's Grammar of the Hebrew Language (New Edition). . .	8vo,	3 00
“ Elementary Hebrew Grammar	12mo,	1 25
“ Hebrew Chrestomathy	8vo,	2 00
Letteris's Hebrew Bible (Massoretic Notes in English). . .	8vo, arabesque,	2 25
Luzzato's Grammar of the Biblical Chaldaic Language and the Talmud Babli Idioms	12mo,	1 50

MEDICAL.

Bull's Maternal Management in Health and Disease	12mo,	1 00
Mott's Composition, Digestibility, and Nutritive Value of Food. Large mounted chart,		1 25
Steel's Treatise on the Diseases of the Ox	8vo,	6 00
“ Treatise on the Diseases of the Dog	8vo,	3 50
Worcester's Small Hospitals—Establishment and Maintenance, including Atkinson's Suggestions for Hospital Archi- tecture	12mo,	1 25
Hammarsten's Physiological Chemistry. (Mandel.)	8vo,	4 00

