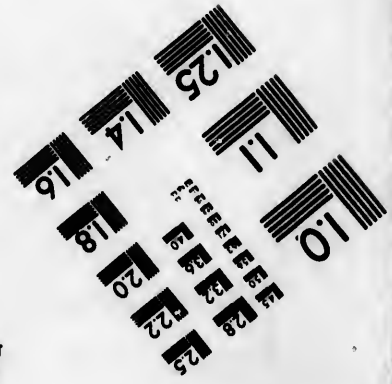
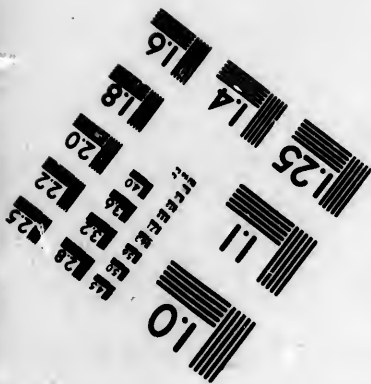
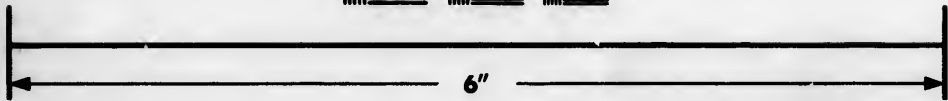
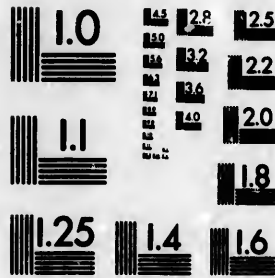

**IMAGE EVALUATION
TEST TARGET (MT-3)**



**Photographic
Sciences
Corporation**

23 WEST MAIN STREET
WEBSTER, N.Y. 14580
(716) 872-4503

**CIHM/ICMH
Microfiche
Series.**

**CIHM/ICMH
Collection de
microfiches.**



Canadian Institute for Historical Microreproductions / Institut canadien de microreproductions historiques

© 1984

Technical and Bibliographic Notes/Notes techniques et bibliographiques

The Institute has attempted to obtain the best original copy available for filming. Features of this copy which may be bibliographically unique, which may alter any of the images in the reproduction, or which may significantly change the usual method of filming, are checked below.

L'institut a microfilmé le meilleur exemplaire qu'il lui a été possible de se procurer. Les détails de cet exemplaire qui sont peut-être uniques du point de vue bibliographique, qui peuvent modifier une image reproduite, ou qui peuvent exiger une modification dans la méthode normale de filmage sont indiqués ci-dessous.

- Coloured covers/
Couverture de couleur
- Covers damaged/
Couverture endommagée
- Covers restored and/or laminated/
Couverture restaurée et/ou pelliculée
- Cover title missing/
Le titre de couverture manque
- Coloured maps/
Cartes géographiques en couleur
- Coloured ink (i.e. other than blue or black)/
Encre de couleur (i.e. autre que bleue ou noire)
- Coloured plates and/or illustrations/
Planches et/ou illustrations en couleur
- Bound with other material/
Relié avec d'autres documents
- Tight binding may cause shadows or distortion along interior margin/
La reliure serrée peut causer de l'ombre ou de la distortion le long de la marge intérieure
- Blank leaves added during restoration may appear within the text. Whenever possible, these have been omitted from filming/
Il se peut que certaines pages blanches ajoutées lors d'une restauration apparaissent dans le texte, mais, lorsque cela était possible, ces pages n'ont pas été filmées.
- Additional comments:/
Commentaires supplémentaires:

- Coloured pages/
Pages de couleur
- Pages damaged/
Pages endommagées
- Pages restored and/or laminated/
Pages restaurées et/ou pelliculées
- Pages discoloured, stained or foxed/
Pages décolorées, tachetées ou piquées
- Pages detached/
Pages détachées
- Showthrough/
Transparence
- Quality of print varies/
Qualité inégale de l'impression
- Includes supplementary material/
Comprend du matériel supplémentaire
- Only edition available/
Seule édition disponible
- Pages wholly or partially obscured by errata slips, tissues, etc., have been refilmed to ensure the best possible image/
Les pages totalement ou partiellement obscurcies par un feuillet d'errata, une pelure, etc., ont été filmées à nouveau de façon à obtenir la meilleure image possible.

Irregular pagination : [2], [i] - cxcli, [1] - 208, 193-208, 209-478, 465-478, [1] - 75 p.

This item is filmed at the reduction ratio checked below/
Ce document est filmé au taux de réduction indiqué ci-dessous.

10X	14X	18X	22X	26X	30X
<input type="checkbox"/>	<input type="checkbox"/>	<input type="checkbox"/>	<input type="checkbox"/>	<input checked="" type="checkbox"/>	<input type="checkbox"/>
12X	16X	20X	24X	28X	32X

The copy filmed here has been reproduced thanks to the generosity of:

National Library of Canada

The images appearing here are the best quality possible considering the condition and legibility of the original copy and in keeping with the filming contract specifications.

Original copies in printed paper covers are filmed beginning with the front cover and ending on the last page with a printed or illustrated impression, or the back cover when appropriate. All other original copies are filmed beginning on the first page with a printed or illustrated impression, and ending on the last page with a printed or illustrated impression.

The last recorded frame on each microfiche shall contain the symbol \rightarrow (meaning "CONTINUED"), or the symbol ∇ (meaning "END"), whichever applies.

Maps, plates, charts, etc., may be filmed at different reduction ratios. Those too large to be entirely included in one exposure are filmed beginning in the upper left hand corner, left to right and top to bottom, as many frames as required. The following diagrams illustrate the method:

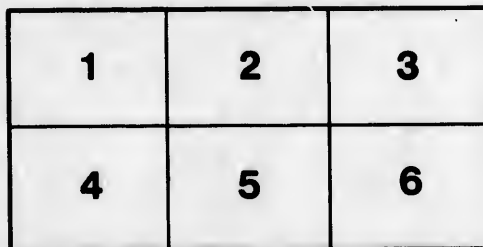
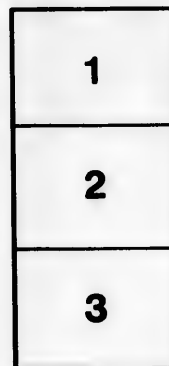
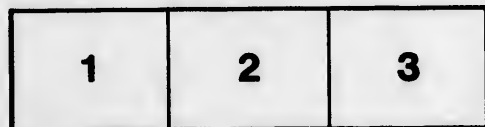

L'exemplaire filmé fut reproduit grâce à la générosité de:

Bibliothèque nationale du Canada

Les images suivantes ont été reproduites avec le plus grand soin, compte tenu de la condition et de la netteté de l'exemplaire filmé, et en conformité avec les conditions du contrat de filmage.

Les exemplaires originaux dont la couverture en papier est imprimée sont filmés en commençant par le premier plat et en terminant soit par la dernière page qui comporte une empreinte d'impression ou d'illustration, soit par le second plat, selon le cas. Tous les autres exemplaires originaux sont filmés en commençant par la première page qui comporte une empreinte d'impression ou d'illustration et en terminant par la dernière page qui comporte une telle empreinte.

Un des symboles suivants apparaîtra sur la dernière image de chaque microfiche, selon le cas: le symbole \rightarrow signifie "A SUIVRE", le symbole ∇ signifie "FIN".

Les cartes, planches, tableaux, etc., peuvent être filmés à des taux de réduction différents. Lorsque le document est trop grand pour être reproduit en un seul cliché, il est filmé à partir de l'angle supérieur gauche, de gauche à droite, et de haut en bas, en prenant le nombre d'images nécessaire. Les diagrammes suivants illustrent la méthode.

ails
du
difler
une
page

rata

elure,
à

- 75 p.

32X



NE NOSTRA, ISTA QUÆ INVENIMUS, DIXERIS:
INSITA SUNT NOBIS OMNIUM ARTIUM SEMINA,
MAGISTERQUE EX OCCULTO DEUS PRODUKIT INGENIA.

HUMANI GENERIS PROGRESSUS,
EX COMMUNI OMNIUM LABORE ORTUS,
UNIUSCUIUSQUE INDUSTRIÆ DEBET ESSE FINIS:
HOC ADIUVANDO,
DEI OPT: MAX: VOLUNTATEM EXSEQUIMUR.

LONDON: PRINTED BY WILLIAM CLOWES AND SONS,
PRINTERS TO THE ROYAL COMMISSION,
STAMFORD STREET AND CHARING CROSS.

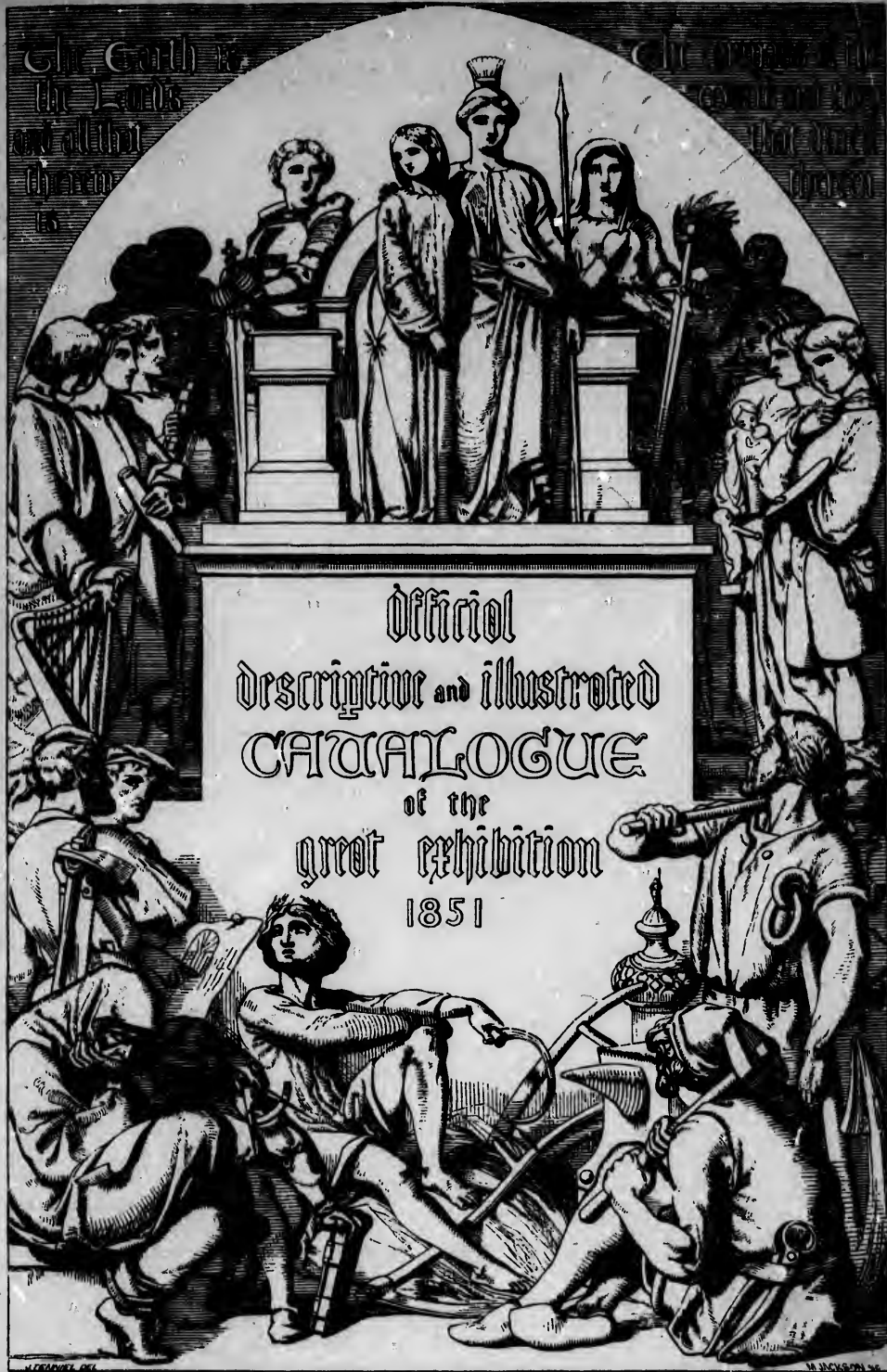

Official
Descriptive and illustrated
CATALOGUE
of the
great exhibition
1851

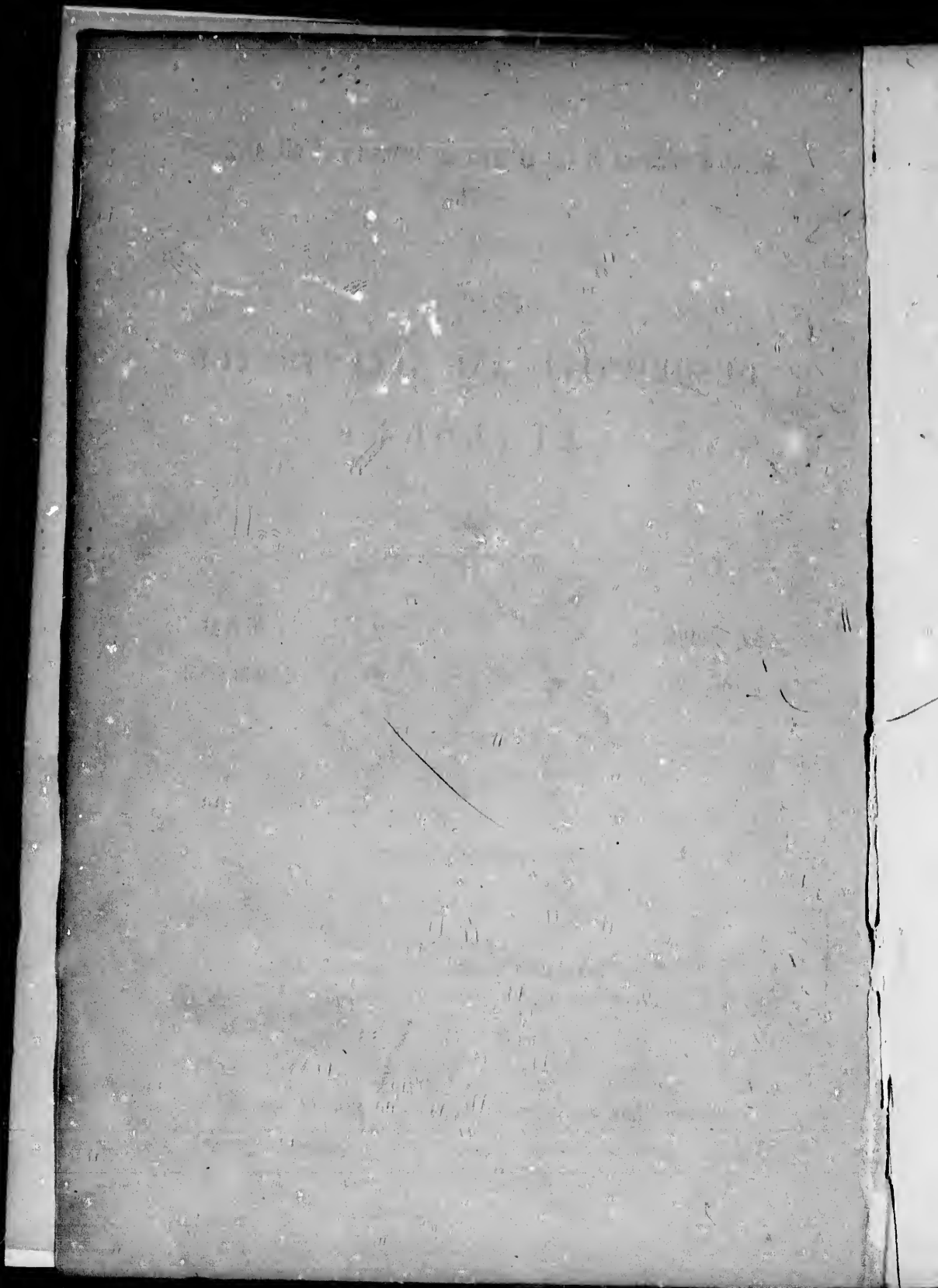

Great Exhibition of the Works of Industry of all Nations,
1851.

OFFICIAL
DESCRIPTIVE AND ILLUSTRATED
CATALOGUE.

By Authority
of the



Royal
Commission.

IN THREE VOLUMES.

VOL. I.

INDEX AND INTRODUCTORY.

SECTION I.—RAW MATERIALS, CLASSES 1 TO 4.

SECTION II.—MACHINERY, CLASSES 5 TO 10.

LONDON:

SPICER BROTHERS, WHOLESALE STATIONERS; W. CLOWES AND SONS, PRINTERS;

CONTRACTORS TO THE ROYAL COMMISSION,

29 NEW BRIDGE STREET, BLACKFRIARS, AND AT THE EXHIBITION BUILDING.

M DCCCL I.

T690

D62

v.1

fol.



SHEWING AT ONE VI



Engraved on Stone by A. P. ...

GEOGRAPHICAL VIEW OF THE GREAT EXHIBITION

SHEWING AT ONE VIEW THE RELATIVE & TERRITORIAL DISTRIBUTION OF THE VARIOUS LOCALITIES FROM WHENCE THE RAW MATERIALS & MANUFACTURES OF THE GREAT EXHIBITION WERE OBTAINED

Compiled and drawn by AUGUSTUS PETERMANN, F.R.G.S. Honor. & Correspond. Member of the Geogr. Soc.

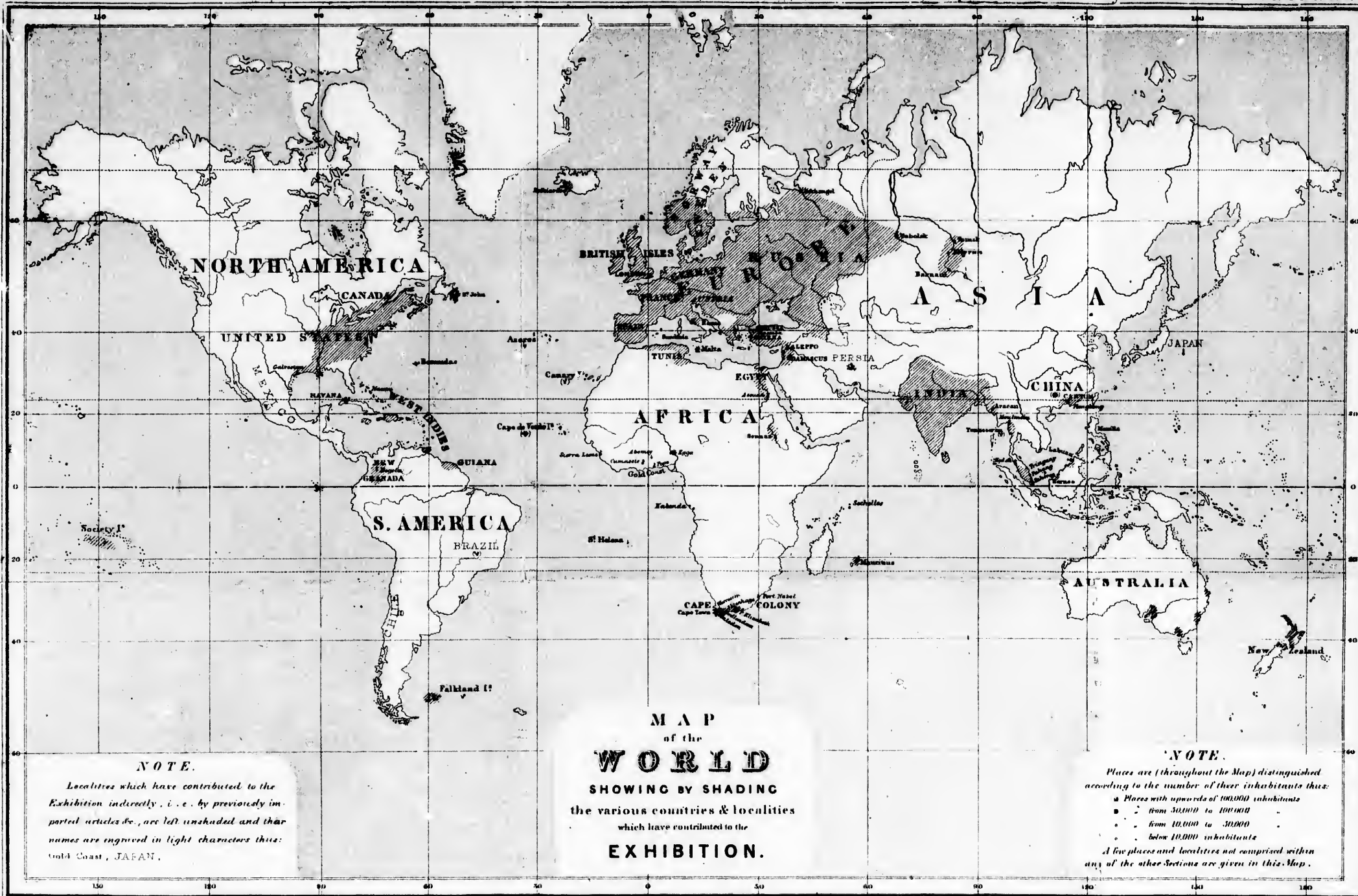

NOTE.
Localities which have contributed to the Exhibition indirectly, i. e. by previously imported articles &c., are left unshaded and their names are engraved in light characters thus: Gold Coast, JAPAN.

MAP
of the
WORLD
SHOWING BY SHADING
the various countries & localities
which have contributed to the
EXHIBITION.

NOTE.
Places are (throughout the Map) distinguished according to the number of their inhabitants thus:
• Places with upwards of 100,000 inhabitants
• from 50,000 to 100,000
• from 10,000 to 50,000
• below 10,000 inhabitants
A few places and localities not comprised within any of the other Sections are given in this Map.

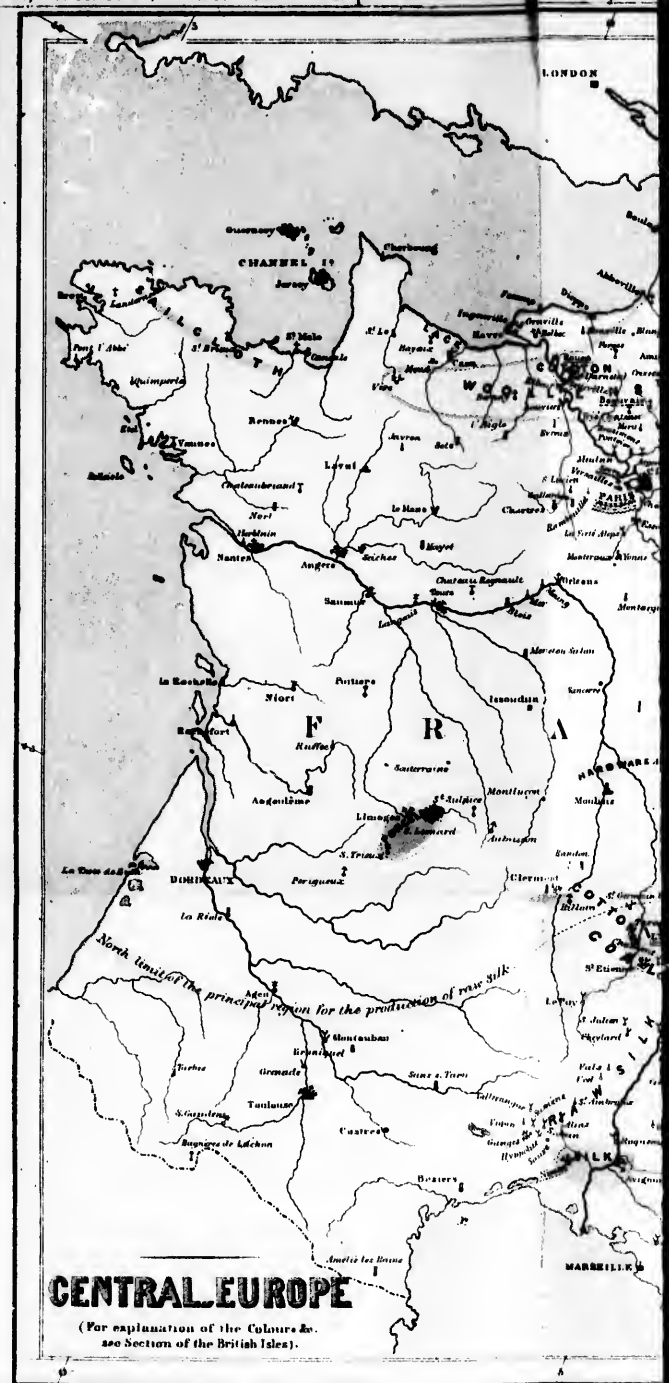

CENTRAL EUROPE
(For explanation of the Colours &c. see Section of the British Isles.)

ENGLISH COLONIES, UNITED STATES &c.



**THE
BRITISH ISLES**

REFERENCE (to the whole Map).
The several Sections of this Map contain the names of the Places which have contributed to the Exhibition all other names being omitted.

THE K H I
ALS & MANUFAC
ber of the Geogr. S



GEOGRAPHY

SHOWING AT ONE VIEW THE RELATIVE & TERRITORIAL DISTRIBUTION



NOTE.

Localities which have contributed to the Exhibition indirectly, i. e. by previously imported articles &c. are left unshaded and their names are engraved in light characters thus: Gold Coast, JAPAN.

MAP
of the
WORLD

SHOWING BY SHADING
the various countries & localities
which have contributed to the
EXHIBITION.

ENGLISH COLONIES, UNITED STATES &c.

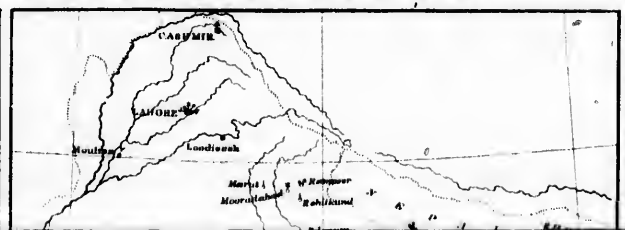

B
The
Place
name

GEOGRAPHICAL VIEW OF THE GREAT EXHIBITION

TERRITORIAL DISTRIBUTION OF THE VARIOUS LOCALITIES FROM WHENCE THE RAW MATERIALS & MANUFACTURES WERE OBTAINED

Compiled and drawn by AUGUSTUS PETERMANN, F.R.G.S., Honor. & Corresponding Member of the Geogr. Soc. Lond.

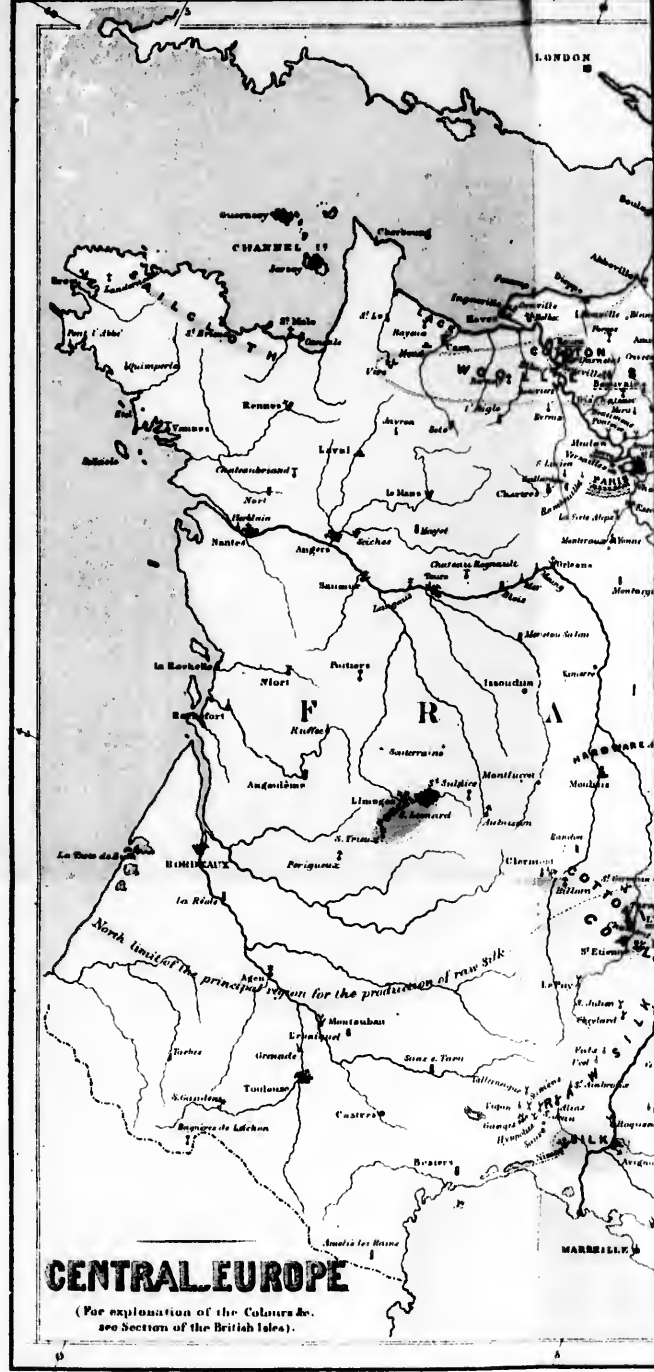
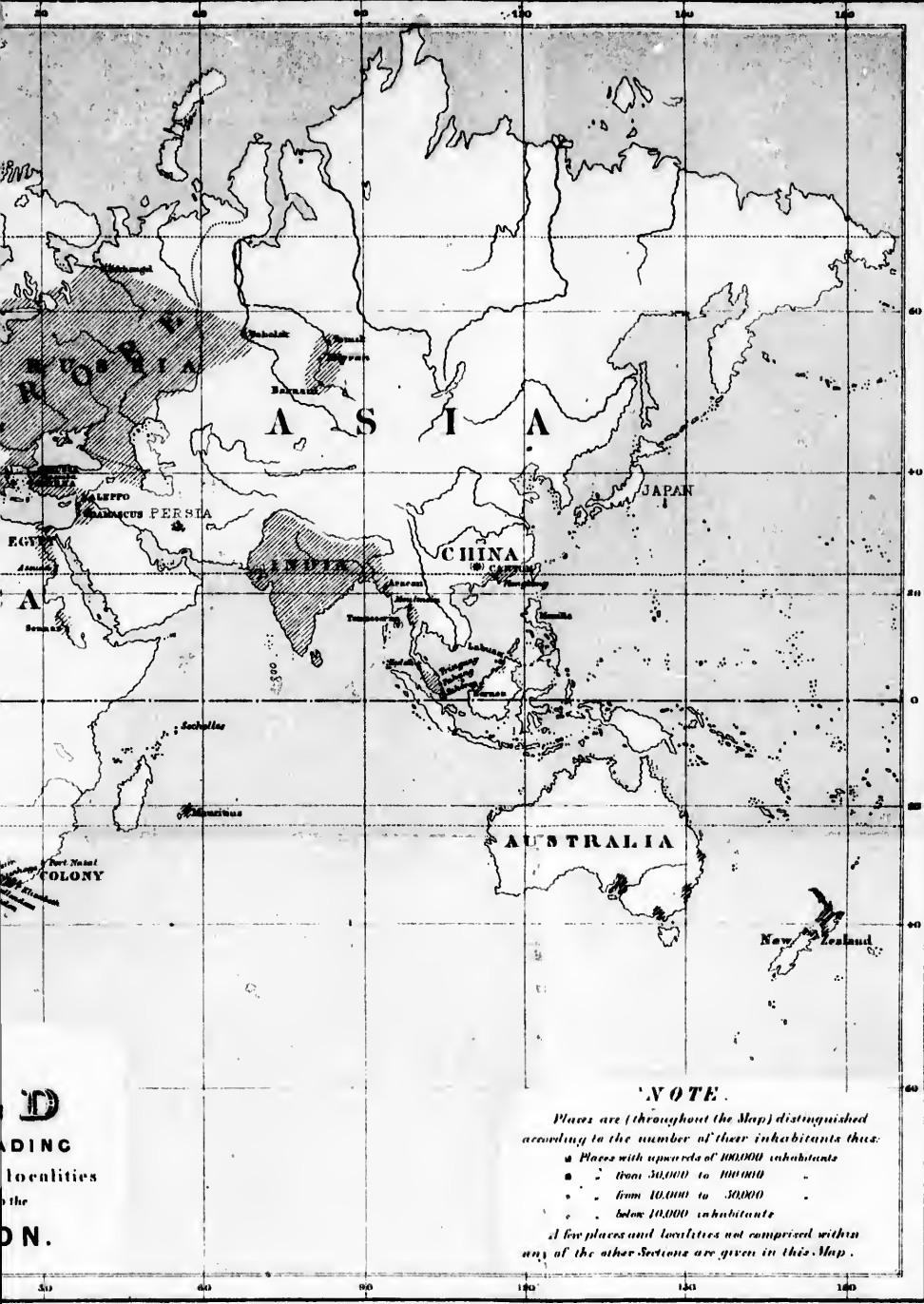

NOTE.
 Places are (throughout the Map) distinguished according to the number of their inhabitants thus:
 ■ Places with upwards of 100,000 inhabitants
 ● " " " 50,000 to 100,000
 ○ " " " 10,000 to 50,000
 * " " " below 10,000 inhabitants
 A few places and localities not comprised within any of the other Sections are given in this Map.

CENTRAL EUROPE
 (For explanation of the Colours &c. see Section of the British Isles.)

D
 ADING
 localities
 the
ON.

THE BRITISH ISLES

REFERENCE (to the whole Map).
 The several Sections of this Map contain the names of the Places which have contributed to the Exhibition, all other names being omitted.



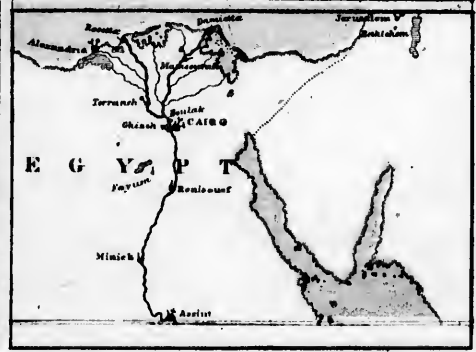
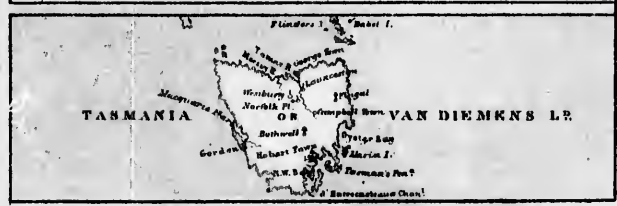
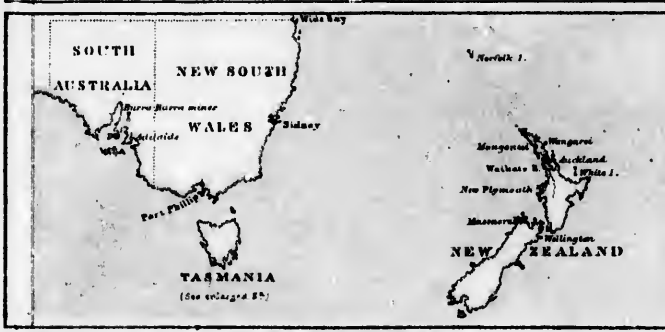

Reprinted on Stone by A. D. Newman, 5, Camden St. (N.) Camden Town

The several Sections of this Map contain the names of the Places which have contributed to the Exhibition, all other names being omitted.

The various kinds of Manufactures supplied by each Place are distinguished by signs (☉).

The chief manufacturing districts are shown by colours and inscribed with bold letters, thus: **COTTON**; secondary districts being less prominently coloured, thus: **CLOTH**.

The names of Places forming the great centres of the Manufactures are underlined, thus: LEADS.

Important Regions of natural products are indicated by sloped letters, thus: **IRON**.

RAW MATERIALS.

☉ Mining and Mineral Products

☉ Animal and Vegetable Products

MANUFACTURES.

☉ Machinery and Instruments

☉ Cotton

☉ Wool

☉ Linen

☉ Silk

☉ Leather

☉ Cutlery and Hardware

☉ Glass

☉ China and Earthenware

☉ Fine Arts

☉ Articles left undistinguished

☉ All kinds of manufactures (in the British Isles only)

☉ Paper

☉ Jewellery

☉ Tapestry, Laces &c



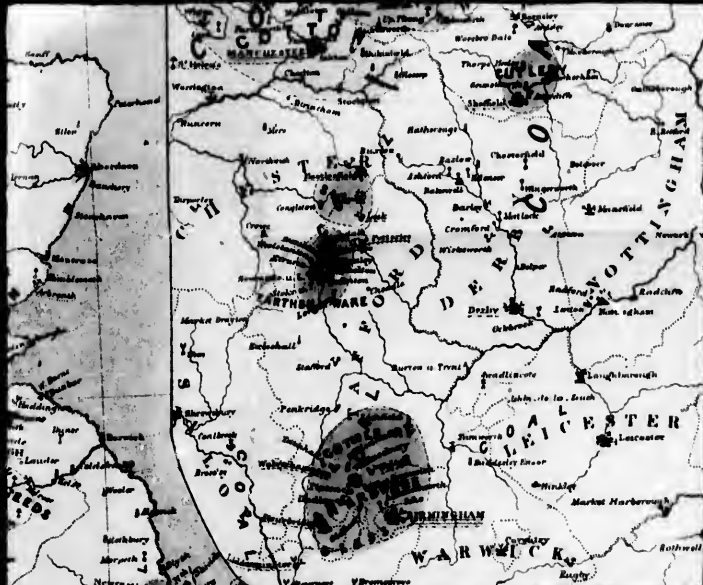

Enlarged Section of the
GREAT MANUFACTURING DISTRICTS
 OF
ENGLAND.



NORTH-EASTERN EUROPE

The shaded part  represents
 the chief Manufacturing districts of
 Russia.





EUROPE

represents
districts of

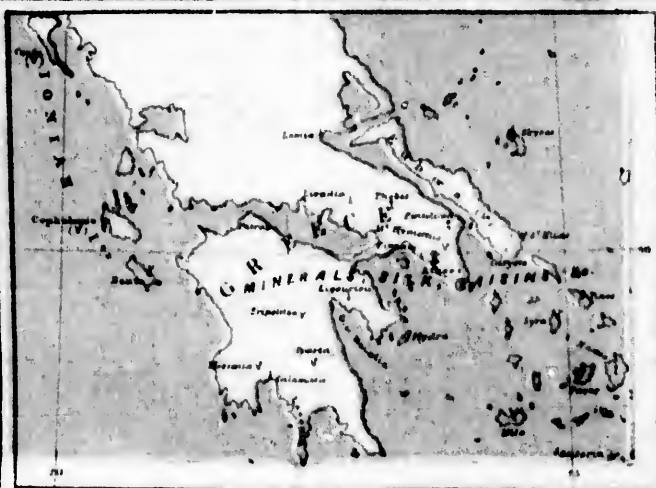



P R E F A C E .

PERHAPS no statement connected with the appearance of this work is calculated to create more surprise than that the greater portion of it was actually in type prior to the first of May. Its condition at that period may be thus described. The manuscript accounts of the articles of a large number of the Exhibitors had been compiled, set up in type, and subsequently condensed, annotated and revised, and required but a little more attention to fit them for publication. In addition, a large proportion of the illustrations were completed and fit for printing. But at that moment, what was the condition of the Exhibition Building itself? Only on the morning of the first of May were tickets affixed to a few articles in a few Classes, and the position of many Exhibitors, even on the British side, was not finally determined. This arose out of the efforts made to obtain a strictly classified arrangement of articles on this side. Many articles placed in the hurry of preparation in the space allotted to one Class were improperly thus placed, and required to be removed to other Classes, and a large number of explanations were found to have been received from Exhibitors who had ultimately not been able to send in their goods in time. Whilst many Classes were arranged rapidly, others remained, owing to peculiar difficulties, in a state of great incompleteness, and incessant alterations of the numbers and position of the Exhibitors were necessary before they could be considered perfect. During this time, which is to be reckoned by weeks rather than days, the number of additional manuscripts received from Exhibitors, who had neglected sending them in until long after the opening of the Exhibition, was immense, and the adjustment of the additional matter thus created was in itself a difficulty not to be easily subdued.

While an amount of order—surprising in its extent, though imperfect in the degree requisite for the publication of a work so costly in its preparation as the present—reigned on the British side of the Building, the state of that devoted to other nations could scarcely be entitled to that term until a month subsequent to the day of opening. Many foreign states had not sent in their catalogues, and the arrangement of their productions was very imperfect.

The peculiar nature of the Catalogue, also, as a work produced by many thousand authors, naturally brought upon it, through the medium of the small Catalogue, the corrections of a large number of those whose manuscripts formed its foundation, in addition to those rendered necessary, in order to obtain some degree of uniformity in the literary composition.

The combination of the elements of disorder thus presented has never before arisen to oppose the publication of any work in this or other times; and its effect upon its preparation is only to be estimated by those who have watched its progress, and are familiar with the complicated arrangements necessarily preceding the production of any printed book containing illustrations. The great extent of the Catalogue rendered the disturbance of any of its parts absolutely fatal to its publication in a reasonable time, and even in a moderate condition of accuracy. In the midst of all these adverse circumstances an attempt was made to publish it as speedily as possible after the opening of the Exhibition; but this attempt was rendered fruitless in consequence of the ceaseless accessions of additional matter, and of the alterations of position in that already set up.

Under these circumstances the Contractors, anxious to produce so extensive a work in as perfect a condition as possible, resolved, at considerable loss to themselves, to delay its appearance until every alteration of importance had been made in the arrangement of the Building and by Exhibitors themselves. In this state it is now published, and is intended to serve as a lasting memorial of the splendid collection of which it professes to be the exponent. When its magnitude is considered, and due regard had to the great difficulties inseparable from the production of an illustrated book of this kind, it must be acknowledged that the period occupied in its publication has been comparatively brief and its preparation rapid.

The due appearance of the smaller Catalogue, on the first of May,—in itself, perhaps, one of the most remarkable instances of rapid typographical execution ever accomplished,—is also an indication of the substantive pre-existence of the present work before that date, since the smaller Catalogue is only a very condensed summary of the present, and was derived from the material forming

the illustrated edition. The difficulties attending the publication, even of that work, may be gathered from the fact, that only three days before it appeared was the order of succession and temporary arrangement of the Exhibitors in the Building determined on; and in that short interval, and before its publication, their arrangement in the Catalogue had much of it to be made.

For an account of the method adopted in the preparation of this Catalogue reference should be made to another page. It is, however, due to those whose valued assistance has added so much to the permanent interest which will attach to this work to state, that there are several portions which could not, by pressure of time, be submitted to the benefit of their revision, and for such, and the general scientific accuracy of the work, the subscriber to this notice must be considered alone accountable. That the following pages are to be considered free from technical and scientific inaccuracies could scarcely be expected; but much care and labour have been expended to give them, as far as possible, this character.

The consideration just named may also render expedient, if not necessary, a simple statement of the part fulfilled by the writer in connection with this work. The production of the general plan of the book, its development, after sanction by the Executive Committee, and literary construction out of the crude material obtained after compilation from the manuscripts of Exhibitors—this material resulting from the official instructions given for the compilation of the Catalogue, and the term compilation including, in this case, merely the rough preparation of Exhibitors' manuscripts for setting up in type, the resulting matter being consequently in a very imperfect state—with the general literary and scientific superintendence and management of the work—these have formed the occupation of the writer in connection with it, and for these he may be held responsible. As the result of the combined labours of the scientific annotators and of the writer, and after having received official sanction and revision on the part of the Executive by the officer appointed, this Catalogue is now put forth. The constant effort of the writer has been to prepare a work of permanent value and enduring interest. May it be shown in the issue that the labour bestowed upon it has not been in vain.

At the period when this work makes its appearance in a complete state, the Exhibition is about to close. The first function of a Descriptive Catalogue can therefore scarcely be fulfilled ere the great spectacle it illustrates will pass away. To those wonders of Art and Industry which man, taught by God, has been by Him enabled to accomplish, it will prove a guide but for a brief period. But its more permanently valuable offices then commence; and it may be reasonably

hoped that, as a record of the most varied and wonderful collection of objects ever beheld, and as a book of reference to the philosopher, merchant, and manufacturer, it will constantly prove both interesting and instructive to the reader.

It is probable that, with the return of the Exhibitors and of the articles to the numerous localities abroad whence they were derived, copies of this Catalogue will be sent, and taken also, and that these pages will be read in many lands long after the Exhibition shall have become matter of history. May they be found, on examination, to contain nothing which is not in harmony with the spirit of the motto on the title-page; and, while descriptive of the successful labours of man, may it not have been forgotten that the glory and praise are due to God alone.

ROBERT ELLIS.

Chelsea, 1851.



Artic
R
H
S

SECT.

1.
2.
3.
4.

SECT.

11.
12 &
13.
14.
16.
17.
18.
19.
20.
21.
22.
23.

GENERAL CONTENTS.

Volume the First.

	Page
List of Illustrations	xi
List of Local Committees (and Secretaries) of the United Kingdom which returned Exhibitors and Subscriptions to the General Fund	xxiv
Table for facilitating reference from the Indexes to the Catalogue	xxvii
Alphabetical and Classified Index of Articles Exhibited	xxxiii
Index of Exhibitors and others, whose Names appear in the Catalogue	cxviii
Historical Introduction, illustrating the Rise of the Exhibition, its Progress and Completion	1
Directory	36
List of Jurors	44
Construction of the Exhibition Building, with the Mechanical Applications employed	49
Scientific Revision and Preparation of the Catalogue	82
Annotators of the Catalogue	88
Classification of Subjects in the Thirty Classes into which the Exhibition is divided	89

UNITED KINGDOM.—CLASSES 1 to 10.

	Page		Page
Articles exhibited by Her Majesty the Queen, His Royal Highness Prince Albert, and His Royal Highness the Prince of Wales in the Four Sections of the Exhibition	111	SECT. II.—MACHINERY:—CLASSES 5 to 10.	
SECT. I.—RAW MATERIALS:—CLASSES 1 to 4.		5. Machines for direct use, including Carriages, Railway and Marine Mechanism	209
Objects outside the Building	113	6. Manufacturing Machines and Tools	262
1. Mining and Mineral Products	119	7. Civil Engineering, Architecture, and Building Contrivances	308
2. Chemical and Pharmaceutical Products	184	8. Naval Architecture, Military Engineering, Guns, Weapons, &c.	333
3. Substances used as Food	200	9. Agricultural and Horticultural Machines and Implements	364
4. Vegetable and Animal Substances used in Manufactures	194*	10. Philosophical, Musical, Horological, and Surgical Instruments	404

Volume the Second.

UNITED KINGDOM.—CLASSES 11 to 30.

	Page		Page
SECT. III.—MANUFACTURES:—CLASSES 11 to 29.		24. Glass	697
11. Cotton	479	25. China, Porcelain, Earthenware, &c.	709
12 & 15. Woollen and Worsted	485	26. Furniture, Upholstery, Paper Hangings, Decorative Ceilings, Papier Maché, and Japanned Goods	729
13. Silk and Velvet	503	27. Manufactures in Mineral Substances, for Building or Decorations.	763
14. Flax and Hemp	509	28. Manufactures from Animal and Vegetable Substances, not being Woven or Felted	777
16. Leather, Saddlery and Harness, Boots and Shoes, Skins, Fur, and Hair	517	29. Miscellaneous Manufactures and Small Wares	789
17. Paper, Printing, and Bookbinding	537	SECT. IV.—FINE ARTS:—CLASS 30.	
18. Woven, Felted, and Laid Fabrics, Dyed and Printed (including Designs).	553	30. Sculpture, Models, and Plastic Art, Mosaics, Enamels, &c.	819
19. Tapestry, Carpets, Floor-Cloths, Lace and Embroidery	559	Miscellaneous objects of interest placed in the Main Avenue of the Building, not classified	847
20. Articles of Clothing for immediate personal or domestic use	575		
21. Cutlery, Edge and Hand Tools	591		
22. General Hardware, including Locks and Grates	595		
23. Works in Precious Metals, Jewellery, &c.	671		

BRITISH COLONIES AND DEPENDENCIES.

	Page		Page
BRITISH POSSESSIONS IN ASIA:—		BRITISH POSSESSIONS IN AMERICA:—continued.	
East Indies	857	Bermudas	971
Ceylon	937	Jamaica	971
BRITISH POSSESSIONS IN EUROPE:—		Barbadoes	971
Channel Islands	939	Trinidad	972
Malta	943	Antigua	975
Gibraltar	947	St. Vincent	975
Ionian Islands	947	Bahamas	975
BRITISH POSSESSIONS IN AFRICA:—		Grenada	976
South Africa	940	Montserrat	970
Western Africa	952	St. Kitt's	976
Gold Coast and Ashantee	955	British Guiana	970
St. Helena	955	Falkland Islands	987
Mauritius	950	BRITISH POSSESSIONS IN AUSTRALASIA:—	
BRITISH POSSESSIONS IN AMERICA:—		Eastern Archipelago	988
Canada	957	New South Wales	988
New Brunswick	909	South Australia	991
Nova Scotia	970	Van Diemen's Land	993
Newfoundland	971	New Zealand	1000

Volume the Third.

FOREIGN STATES.

	Page		Page
Austria	1005	The Netherlands	1142
States of the German Zollverein:—		Belgium	1150
Prussia, Baden, and other States of Northern		France	1168
Germany	1047	Algiers	1250
a. Prussia	1047	Switzerland	1264
b. Grand Duchy of Baden, Southern parts		Papal States	1285
of the West Provinces of Prussia and		Tuscany	1269
Electoral Hesse	1068	Sardinia	1302
c. Prussia and Lithuania	1075	Portugal	1300
d. Prussia, Electoral Hesse, Lippe	1075	Madeira	1319
e. Prussia, Saxon Grand Duchy and Duchies,		Spain	1320
Brunswick, Anhalt, and Thuringian		Sweden and Norway	1348
Principalities	1087	Denmark	1355
Bavaria	1098	Russia	1361
Saxony	1104	Turkey	1385
Wurtemberg	1114	Greece	1400
Frankfort-on-the-Maine	1121	Egypt	1408
Hesse-Darmstadt	1125	Tunia	1412
Luxemburg	1130	China	1418
Nassau	1131	Persia	1420
North Germany:—		Society Islands	1428
Hanover	1133	St. Domingo	1428
Mecklenburg-Strelitz	1134	Brazil	1429
Mecklenburg-Schwerin	1134	Bolivia	1429
Nuremberg	1135	Chili	1429
Oldenburg	1135	New Granada	1430
Hanse Towns:—		Mexico	1430
Hamburg	1136	United States	1451
Lübeck	1140		

LIST OF ILLUSTRATIONS.

Engraved Title-page, drawn by J. TENNIEL, R.A., engraved by Mr. JACKSON.
 Geographical View of the Great Exhibition of 1851, showing at one view the relative and territorial distribution of the various localities from whence the raw materials and manufactures contributed to the Exhibition have been severally supplied. By AUGUSTUS PETERMANN, F.R.G.S.
 Thirty-one Engravings illustrative of the Construction of the Building.
 View of the Interior of the Building from the South Entrance - - - - - page 57
 View of the Exterior of the Building from the North-west Angle - - - - - 67
 Coloured Lithographic Plan of the Building - - - - - 111

Page
 . . . 971
 . . . 971
 . . . 971
 . . . 972
 . . . 975
 . . . 975
 . . . 976
 . . . 976
 . . . 979
 . . . 979
 . . . 987
 . . . 988
 . . . 988
 . . . 991
 . . . 993
 . . . 1000

Page
 . . . 1142
 . . . 1150
 . . . 1108
 . . . 1259
 . . . 1204
 . . . 1285
 . . . 1289
 . . . 1302
 . . . 1306
 . . . 1319
 . . . 1320
 . . . 1348
 . . . 1355
 . . . 1361
 . . . 1385
 . . . 1400
 . . . 1408
 . . . 1412
 . . . 1418
 . . . 1426
 . . . 1428
 . . . 1428
 . . . 1429
 . . . 1429
 . . . 1429
 . . . 1430
 . . . 1430
 . . . 1431

Description of Illustrations.	Name of Exhibitor.	Class.	No.	Page.
Compartments of electro-deposit table-top - - - - -	Her Majesty - - - - -	—	—	111
Table of gold and silver electro-plate - - - - -	Her Majesty - - - - -	—	—	—
Table-top in silver - - - - -	Her Majesty - - - - -	—	—	—
Shield presented by the King of Prussia to H. R. H. the Prince of Wales - - - - -	H. R. H. Prince Albert - - - - -	—	—	112
Portion of a slab for a table - - - - -	H. R. H. Prince Albert - - - - -	—	—	—
Thesus and the Amazons - - - - -	H. R. H. Prince Albert - - - - -	—	—	—
Mineral map of the United Kingdom - - - - -	Hunt, Robert - - - - -	I.	—	156
Coal-fields of Europe, and of the United States and British North America - - - - -	Ansted, D. T., F.R.S. - - - - -	—	—	166
Improved blasting cartridge - - - - -	Rogers, E., F.G.S. - - - - -	—	430	180
Diagram of a section and plan of a shaft - - - - -	Ditto - - - - -	—	—	—
Ground plan, elevation, and sections of furnace, chimneys, &c. - - - - -	Bucoleugh, His Grace the Duke of, - - - - -	—	509	175
Crystals of sulphate of iron - - - - -	Spence, Peter - - - - -	II.	7	188
Nutt's beehives - - - - -	Bentley, John F. - - - - -	III.	4	201
Patent marine trunk engines - - - - -	Penn, J., & Son - - - - -	V.	8	211
Marine oscillating engines - - - - -	Ditto - - - - -	—	—	212
Pendulous high-pressure engine, side and front elevation - - - - -	Joyce, William - - - - -	—	20	213
Patent double cylinder steam-engine - - - - -	McNaught, William - - - - -	—	22	—
Steam pump, front and end elevation - - - - -	Garrett, William Elliot - - - - -	—	35	214
Patent feathering screw propeller, in action and out of gear - - - - -	Maudslay, Sons, & Field - - - - -	—	38	215
Double cylinder marine engines, end and side elevation - - - - -	Ditto - - - - -	—	—	216
Direct acting oscillating cylinder steam-engines, end and side elevation - - - - -	Ditto - - - - -	—	—	—
Double piston-rod engines, for shallow-river navigation, end and side elevation - - - - -	Ditto - - - - -	—	—	—
Marine beam steam-engine, end and side elevation - - - - -	Ditto - - - - -	—	—	217
Annular cylinder marine engines, end and side elevation - - - - -	Ditto - - - - -	—	—	—
Horizontal direct-acting marine engines for screw propulsion, end elevation and plan - - - - -	Ditto - - - - -	—	—	—
Oscillating engine - - - - -	Clayton & Shuttleworth - - - - -	—	39	218
A new method of converting rectilinear into rotatory motion - - - - -	Fitzmaurice, Hon. W. E. - - - - -	—	57	219
Rotatory engine, front elevation and section - - - - -	Morrell, G. - - - - -	—	82	221
Fire annihilator, entire and in section - - - - -	Phillips, William H. - - - - -	—	92	222
Balance valves &c., in section - - - - -	Ersine, Daniel - - - - -	—	100	—
Hollow furnace-bars and fire-bars - - - - -	Frith, T. & J. - - - - -	—	119	224
Model, showing improvements in lubricating - - - - -	Hurry, H. C. - - - - -	—	122	—
Carriage fire-engine - - - - -	Merryweather, M. - - - - -	—	401	226
Cabinet fire-engine - - - - -	Ditto - - - - -	—	—	227
Improved Brigade fire-engine - - - - -	Shand & Mason - - - - -	—	410	—
Patent weighing crane - - - - -	James, J., & Co. - - - - -	—	411	228
Small patent weighing machine - - - - -	Ditto - - - - -	—	—	—
Hydraulic press, employed in raising the Britannia Bridge - - - - -	Bank Quay Foundry Co. - - - - -	—	412	229
The press shown in operation, and end elevation - - - - -	Ditto - - - - -	—	—	—
Patent tubular crane, side and back view - - - - -	Fairbairn, W., & Sons - - - - -	—	417	231
Overshot water-wheel - - - - -	Warner, J., & Sons - - - - -	—	424	233

Description of Illustrations.	Name of Exhibitor.	Class.	No.	Page.
Patent steam travelling crane, end and side elevation	M'Nicholl & Vernon	v.	434	233
Crampton's patent express engine	I. and N. W. Railway Co.	—	513	234
High-pressure fire-engine	Smith, R., & Son	—	449	235
Ornamental fountain	Froeman & Roe	—	402	—
Patent vulcanized India-rubber water-taps	Lambert & Son	—	478a	236
Patent coupling for railway waggons	Thornton, J., & Sons	—	490	—
Hydraulic lifting jack	—	—	—	237
Improved lifting screw-jack	—	—	—	—
Express engine	Crampton, Thomas R.	—	508	—
The "Cornwall" express narrow-gauge engine	—	—	—	238
Locomotive double-boiler tank-engine, side and half-end elevation	Wilson, E. B., & Co.	—	526	239
Improved covered railway waggons, end elevation	Henson, Henry H.	—	532	—
Improved covered railway waggons, side elevation	—	—	—	240
Locomotive tank engine	Kitson, & Co.	—	534	—
Locomotive engine	Hawthorn, R. & W.	—	530	—
Cross section of patent permanent way for railways	Hoby, James W.	—	614	244
Patent traversing machine	Dunn, T.	—	618	—
Patent traversing machine, side elevation and plan	Ormerod, R., & Son	—	624	245
Dunn's patent turn-tables, sections and plan	—	—	—	—
Patent charcoal tire for railway wheels and rails and patent axle	Thorneycroft, G.B., & Co.	—	636	246
Automatic apparatus for mail trains, ground plan	Dicker, John	—	674	248
Elevation of the same	—	—	—	249
Patent turn-table for railways	Greenway, Charles	—	698	250
Triform railway signal	Hoy, Joseph	—	719	251
Machine for ascertaining and recording the weight of goods	Morris, William	—	764	252
Improved lever weighing machine	Nicholl, W., Lewis & Co.	—	770	—
Dial weighing machine	—	—	—	—
Improved engine counter	Richmond, John	—	775	—
Portable weighing machine	Craig, John	—	776	253
Bale weighing machine	—	—	—	—
Elevation of office and railway weigh bridge	Pooley, Henry	—	784	—
Internal construction of weigh bridge	—	—	—	254
Platform weighing machine	—	—	—	—
Improved sociable	—	—	—	—
Patent park phaeton	Booker, E., & Sons	—	809	255
Improved patent wheel, elevation and side view	Cook, Rowley, & Co.	—	816	—
Section of globular nave	Crosskill, Edmund	—	826	256
Low-bodied dog cart	—	—	—	—
The "Ampton" carriage, closed	Fowler & Fry	—	843	—
The same carriage, open, as a barouche	Kesterton, E.	—	894	257
Improved pony carriage	—	—	—	—
Patent "dioropa," or two-headed carriage	Mason, W. Henry	—	910	258
Improved carriage for invalids	Rock & Son	—	956	259
Perspective view, showing Messrs. Hibbert & Platt's cotton machines (lap and carding machine), and Messrs. Hicks and Son's high-pressure steam-engine and driving-gear	Willoughby, Solomon	—	992	260
Perspective view, showing Messrs. Hibbert and Platt's cotton machinery (power-looms, throstles, and mules), and Messrs. Hicks and Son's steam-engine and driving gear	Hibbert & Platt	—	1	263
Patent self-acting mule	—	—	—	—
Carding engine	Macindoe, G. Park	—	24	266
Patent slubbing and roving frame and collars	Mason, J.	vi.	10	269
Modern power loom	—	—	—	—
Old power loom	Harrison, J.	—	18	270
Models of patent sizing and warping machine	—	—	—	—
A large Jacquard loom	Hornby & Kenworthy	—	20	—
Patent spinning frame	Taylor & Son	—	23	272
Improved heald machine	Sutcliffe, R.	—	42	273
Sample of healds	Judkins, C. Fiot	—	52	274
Sewing machine	—	—	—	—
Flax seeding machine	—	—	—	—
Metal disc, for scutching flax	Robinson, Richard	—	54	275
Front elevation of rotatory disc scutching mill	Plummer, Robert	—	74	276
Improved flax-breaking machine, side and front elevation	—	—	—	—
Improved holders, for flax-heckling	—	—	—	—
Double cylinder heckling machine, side elevation	—	—	—	—
Double cylinder heckling machine, end elevation	—	—	—	—
Patent double action Jacquard loom	—	—	—	277
Applegath's printing machine	Barlow, Alfred	—	82	279
Printing machine	Ingram, Herbert	—	122	281
Embossing press	Cowper, Edward, F.R.S.	—	134	282
Improved galley press	Jarrett, Griffith	—	154	284
Plough-cutting machine	Harrild & Sons	—	157	—
Numerical printing machine	—	—	—	—
Patent registering compass	—	—	—	—
	Napier, D., & Son	—	158	285

LIST OF ILLUSTRATIONS.

xlii

No.	Page.	Description of Illustrations.	Name of Exhibitor.	Class.	No.	Page.
434	231	Hydro-electric machine	Watson, Henry	VI.	165	285
513	234	Patent valve, for fluids	Ditto	—	—	286
449	235	Patent riveting machine, side elevation	Falrbairn, W., & Sons	—	200	—
492	—	Plan of the same	Ditto	—	—	287
478	236	Self-acting foot-lathe	Whitworth & Co.	—	201	—
490	—	Self-acting duplex lathe	Ditto	—	—	—
—	237	Self-acting duplex railway wheel turning lathe	Ditto	—	—	288
508	—	Self-acting planing machine	Ditto	—	—	289
—	238	Self-acting universal shaping and planing machine	Ditto	—	—	—
525	239	Self-acting slotting and shaping machine	Ditto	—	—	—
532	—	Self-acting vertical drilling and boring machine	Ditto	—	—	—
—	240	Self-acting radial drilling and boring machine	Ditto	—	—	290
534	—	Punching and shearing machine	Ditto	—	—	—
530	—	Self-acting wheel-cutting and dividing machine	Ditto	—	—	—
614	244	Self-acting bolt head and nut-shaping machine	Ditto	—	—	—
618	—	Patent screwing apparatus	Ditto	—	—	291
624	245	Powerful self-acting planing machine	Sharp, Brothers	—	204	—
—	—	Steam riveting machine	Garforth, W. J., & J.	—	208	292
636	246	Hydraulic press	Hick, B., & Son	—	218	293
674	248	Two-horse oscillating steam-engine	Ditto	—	—	—
—	249	Patent forging machine	Ryder, W.	—	222	294
698	250	Coining-press	Maudslay, Sons, & Field	—	228	—
710	251	Patent mould-making machine, side and front elevation	Stewart, D. Y., & Co.	—	238	296
704	252	Patent tile-machine	Hart, James	—	208	297
770	—	Patent tenoning machine	Furness, William	—	401	298
—	—	Forms for rubbing surfaces	Schlele, C.	—	402	—
775	—	Grinding mill for vegetable substances	Crosskill, William	—	404	299
776	253	Mill for mineral substances	Ditto	—	—	—
—	—	Patent coffee-roasting apparatus	Dakin & Co.	—	408	300
784	—	Steam sugar-cane crushing mill	Robinson and Russell	—	418	—
—	254	Hydraulic seed presses	Blundell, Spence, & Co.	—	420	302
—	—	Mill to grind bark	Huxhams & Brown	—	446	303
809	255	Centrifugal washing and drying machine (for hand power)	Manlove, Allott, & Co.	—	454	304
816	—	Centrifugal washing and drying machine (for steam power)	Ditto	—	—	—
826	256	Machine for roasting coffee	Law, W.	—	460	—
—	—	Patent refrigerator	Lawrence, James	—	604	306
843	—	Patent soda-water machine	Tyler, Hayward, & Co.	—	605	—
894	257	Double soda-water machine	Tylor & Son	—	608	307
—	—	Diving dress and helmet	Siebe, Augustus	VII.	1	309
910	258	Brunel's wrought-iron bridge over the Wye	Finch & Willey	—	9	310
956	259	Improved compasses	Birmingham, Thomas	—	13	—
992	260	Block of union paving	Woods, F. F.	—	42	313
—	—	Straight-grooved blocks, parallel and continuous	Ditto	—	—	314
—	—	Straight-grooved blocks, parallel and discontinuous	Ditto	—	—	—
—	—	Zig-zag grooved planks	Ditto	—	—	—
—	—	Equilateral perforated blocks	Ditto	—	—	—
—	—	Circular perforated blocks	Ditto	—	—	—
—	—	Hexagonal perforated blocks	Ditto	—	—	—
—	—	Smoke removal plan	Devey, George	—	54	315
24	266	Patent effluvia traps	Lowe, Alice, & Co.	—	62	316
10	269	Universal telegraphic lighthouse	Wells, George	—	82	318
18	270	Assimilation of railway gauges	Smith, E.	—	96	319
—	—	Views of the great suspension bridge at Kieff	Vignoles, Charles	—	105	321
20	—	Suspension aqueduct over the Calder	Leather, John W.	—	107	322
23	272	Cast-iron bridge over the Aire	Ditto	—	—	323
42	273	Catadropic apparatus	Wilkins & Letourneau	—	157	326
52	274	Improved revolving apparatus for a light vessel	Ditto	—	—	327
—	—	Patent marine signals	Rettie, Robert	—	159	328
—	—	Wind guard for chimney tops	Green, Isaac	—	186	329
54	275	Porter's patent anchor	Honiball, James	VIII.	95	339
74	276	Registered marine signal lamp	Gilbert, Edward	—	120	340
—	—	Bow, stern, and transverse sections of H. M. S. "Queen"	The Admiralty	—	146	344
—	—	Lightning conductors for ships	Harris, Sir W. Snow	—	150	345
—	—	New propeller for steam vessels	Penrice, Lieut. R. E.	—	173	347
—	—	Duplex rudder and screw propeller	Carpenter, Capt. E. J.	—	194	345
—	—	Ornamented presentation cimeter	Wilkinson & Son	—	200	351
82	279	New officers' infantry helmet	Landon & Morland	—	204	352
122	281	India-rubber air-gun	Shaw, J.	—	254	357
134	282	Patent safety gun	Forayth & Co.	—	256	—
154	284	Waterproof gun	Erskine, James	—	257	—
157	—	Working model of a t. m. stern steam-ship	Sturdee, A. B.	—	337	362
—	—	Model of H. M. steam-ship "Medea"	Hudson, J., jun.	—	338	363
—	—	Two-horse portable steam-engine; end elevation	Stanley, W. Proctor	IX.	1	365
158	285	Registered steam cooking apparatus for farmers	Ditto	—	—	—
—	—	Chaff-engine	Ditto	—	—	—

Description of Illustrations.	Name of Exhibitor.	Class.	No.	Page.
Improved draining plough and windlass	Fowler, John, jun.	IX.	28A	387
Six-horse portable steam-engine	Burrell, Charles	—	37	368
Hurdle-making machine	Ditto	—	—	—
Gorse-cutting and bruising machine	Ditto	—	—	—
Brick, tile, and pipe making machine	Clayton, Henry	—	47	369
Broad-cast sowing machine	Watt, James	—	63	370
Sheep-dipping apparatus	Bigg, Thomas	—	65	371
Improved chaff-engine	Gillett, John	—	78	372
Crushing and grinding mill	Woods, James	—	82	—
Chaff-cutting machine	Cornes, James	—	83	—
Instrument for fumigating plants	Brown, David S.	—	91	373
Temple beehive	Pettit, Wyatt J.	—	92	—
Enamelled stable fittings	Cottam & Hallen	—	109A	375
Locomotive steam-plough	Usher, James	—	123A	376
Union mill for splitting and bruising seeds	Wedlake, Mary, & Co.	—	127	377
Chaff-cutting and oat-bruising machine	Ditto	—	—	—
Four-horse power portable steam-engine	Barrett, Exall & Andrews	—	128	—
Four-horse power thrashing machine	Ditto	—	—	378
Patent horse-gear for the same	Ditto	—	—	—
Iron thrashing machine	Ditto	—	—	379
Cam chaff-cutter	Ditto	—	—	—
Universal crushing mill	Ditto	—	—	—
Iron two-wheel plough	Ditto	—	—	380
Clod-crusher	Crosskill, W.	—	135	381
Norwegian harrow	Ditto	—	—	—
One-horse cart	Ditto	—	—	—
Pair-horse waggon	Ditto	—	—	—
Liquid manure cart	Ditto	—	—	382
Steam-engine, fixible or portable	Ditto	—	—	—
Beating machine	Ditto	—	—	—
Archimedean root-washer	Ditto	—	—	383
Seed-cleaner and separator	Gillam, John	—	138	—
Wrought-iron skim	Hill, E., & Co.	—	140	384
Expanding horse-hoe	Ditto	—	—	—
Wrought-iron gates and posts	Ditto	—	—	385
Wrought-iron hurdles	Ditto	—	—	385
Seeding drill	Garrett & Son	—	142	—
Turnip drill	Ditto	—	—	—
Patent horse-shoe	Ditto	—	—	386
Patent thrashing-machine	Ditto	—	—	—
Portable steam-engine	Ditto	—	—	—
Patent iron harrows	Williams, W.	—	151	388
Patent wrought-iron plough	Ditto	—	—	—
Chaff-engine	Ditto	—	—	—
Drain-pipe and tile-machine	Ditto	—	—	—
Improved Taylor's horse-drag rake	Ditto	—	—	—
Four-horse bolting thrashing-machine	Blyth, R. J.	—	154	389
Agricultural chimney filter drain	Sadler, W. J.	—	156	—
Patent tank cleaner	Deane, Dray, & Deane	—	180	390
Patent water-engine	Ditto	—	—	—
Howard's, J. K., plough	Ditto	—	—	—
Howard's, J. A., plough	Ditto	—	—	—
Patent corn-mill	Ditto	—	—	391
Four-horse portable steam-engine	Turner, E. R.	—	182	—
Steam-boiler feeding apparatus	Ditto	—	—	—
Crushing-mill	Ditto	—	—	392
Broad share and subsoil plough	Bentall, Edward H.	—	217	394
Patent seed-drill	Hornaby, R., & Son	—	230	395
Patent manure-drill	Ditto	—	—	—
Patent drill-machine	Ditto	—	—	—
Six-horse power portable steam-engine	Ditto	—	—	396
Patent corn-dressing machine	Ditto	—	—	—
Patent double-acting turnip-cutter	Key & Mitchell	—	237	396
Patent iron plough	Howard T. & F.	—	240	397
Patent iron harrows	Ditto	—	—	—
Thrashing machine	Holmes & Sons	—	241	397
Manure-sowing machine	Ditto	—	—	—
Six-horse power portable steam-engine	{ Clayton, Shuttleworth, } & Co.	—	242	398
Agricultural mill	Clayton, & Co.	—	242	—
Thrashing machine	Ditto	—	—	—
Ornamental conservatory	Weeks, J., & Co.	—	248A	399
Patent rotary garden pump	Siebe, A.	—	255A	400
Patent chaff-cutter	Smith, J.	—	256	—
Patent grass-cutter	Ferrabee, J., & Sons	—	274	401

LIST OF ILLUSTRATIONS.

xv

No.	Page.	Description of Illustrations.	Name of Exhibitor.	Class.	No.	Page.
28A	367	Cottage, observatory, and other beehives	Neighbour, G., & Son	IX.	290	402
37	368	The "Royal Alfred," and other hives	Milton, John	—	291	—
—	—	Munn's bar and frame beehives	— Ditto —	—	—	403
47	369	Black marble timepiece	Adams, Thomas	X.	14	408
63	370	Imitation oak timepiece	— Ditto —	—	—	409
65	371	Marine chronometer	Delolme, Henry	—	19	—
78	372	The "Polyhorion" or many-hour clock	Tanner, William	—	28	411
82	—	Exeter clock	Britton, Charles	—	96	411
83	—	Improved compensating balance	Pennington, J.	—	53	412
91	373	New calibre for watches	Frodsham, C.	—	57	414
92	—	Plan of an escapement	Hall, G. F.	—	60	415
109A	375	Pendulum with micrometrical adjustment	— Ditto —	—	—	—
123A	376	Astronomical and meteorological clock	— Ditto —	—	—	416
127	377	Exeter clock	Brutton, Charles	—	96	418
—	—	Patent electro-magnetic clock (numerous illustrations)	Shepherd, Charles	—	128	419
—	—	Self-registering magnetometer	Brooke, Charles	—	144	423
128	—	Self-registering barometer	— Ditto —	—	—	424
—	378	Self-registering thermometer	— Ditto —	—	—	425
—	—	Atmospheric recorder	Dollond, George	—	145	426
—	379	Sectional working of the same	— Ditto —	—	—	427
—	—	Lawson's thermometer stand	— Ditto —	—	—	—
—	—	Improved barometer	Dobbie, William	—	166	430
—	380	Gilbert's tooth extractor	Mathews, William	—	181	—
135	381	Artificial hand	Little, Major	—	196	431
—	—	Large organ with modern improvements	Willis, Henry	—	209	432
—	—	Mechanical figure	Dunin, Count	—	210	433
—	382	Terrestrial globe	Newton, W., & Son	—	212	434
—	—	Planetarium	— Ditto —	—	—	—
—	—	Electro-galvanic machine	Horne, & Co.	—	220	—
—	—	Solid eye-piece	Reade, Rev. J. B.	—	254A	436
—	383	Registered helicographs	Penrose, Francis C.	—	318	443
138	—	Typhoidictor or storm-pointer	Lloyd, Lieut.-Col.	—	322	444
140	384	Patent power-engine	Brown, S.	—	335	447
—	—	Patent meter	— Ditto —	—	—	—
—	—	Planometer	Sang, John	—	338	448
—	385	Dial weighing and measuring machine	Siebe, A.	—	358	450
142	385	Table weighing machine	Young & Son	—	386	—
—	—	Magnetic balance	Fox, R. W.	—	377	451
—	386	Steam gauge	Baker, Henry	—	396	452
—	—	Vacuum gauge	— Ditto —	—	—	—
—	—	Registered typograph	Hughes, William	—	401	—
151	388	Fox's magnetic dip and intensity instrument	Wilton, William	—	402	—
—	—	Fox's miners' theodolite	— Ditto —	—	—	453
—	—	An electrophorous	Phillips, John, F.R.S.	—	411	454
—	—	Rain gauge	— Ditto —	—	—	—
—	—	Index mouthpiece	Whishaw, Francis	—	419	—
154	389	Electric telegraph	Alexander, W. R. S. E.	—	426	456
156	—	Electric telegraph instruments for hotels	Reid, William	—	427	—
180	390	Similar instruments for public companies	— Ditto —	—	—	—
—	—	Domestic telegraphs	— Ditto —	—	—	—
—	—	Patent electric telegraph, with and without cover	Henley, W. T.	—	428	457
—	—	Magneto-electric machine	— Ditto —	—	—	—
—	391	Copying electric telegraph	Bakewell, F. C.	—	433	459
182	—	Copper-covered glass apparatus	Edwards, J. B.	—	438	461
—	—	Improved sounding-board for pianoforte	Cudby, C.	—	471	464
—	392	Registered pianoforte	Brimsmead, J.	—	474	465
217	394	Registered cottage pianoforte	Allison, R.	—	480	466
233	395	Twin semi-cottage pianoforte, front and side views	Jones, J. C.	—	481	—
—	—	Elizabethan new patent grand oblique pianoforte	Erard, P. O.	—	496	454
—	—	Violin, after M. Savart's description	Spurgin, Thomas	—	542	470
—	396	Silver flute	Card, William	—	546	471
—	—	Finger-board for enharmonic organ (front view and profile)	Robson, T. J. F.	—	559	472
237	396	Ornamental clock-case	Walker, John	X.	697	472
240	397	An organ, in the Tudor style	Walker, J. W.	—	561	474
—	—	Pedestal planisphere	Mollison, J.	—	585	475
241	397	Invalid couch	Chapman, Alderman	—	601c	478
—	—	Apparatus for applying medicated vapour	Downing, C. T., M.D.	—	634	478
242	398	Lunar globe	Readhouse, C.	—	877	469
—	—	Improved pianoforte	Oetzmann & Plumb	—	683	470
242	—	A salinometer	Mudie, David	—	683A	471
—	—	Dioptric revolving light-house	Chance, Brothers, & Co.	—	742	477
248A	399	Silk trophy	Keith, D., & Co.	XIII.	1	503
255A	400	Banner of silk, grown in England by the late Mrs. Whithy	Houldsworth, J., & Co.	—	64	507
256	—	Racing whip, with emblematic design	Swaine & Adeney	XVI.	92	523
274	401	Patent elastic waist boots	Taylor & Bowley	—	181	528

Description of Illustrations.	Name of Exhibitor.	Class.	No.	Page.
Royal Bible, the top, back, and front as reflected in a mirror	Messrs. Leighton	XVII.	24	539
Commemorative shield of the Great Exhibition	Ditto	—	—	—
Specimen of antique binding	Gould, J.	XXVIII.	143	541
Specimen of antique binding	Westley, Josiah	XVII.	48	—
Envelope folding-machine	Hill, E., & De la Rue, T.	—	76	543
Heraldic table-cloth	Underwood, W.	XVIII.	22	554
State bed	Faudel & Phillips	XIX.	165	566
Axminster carpet for Her Majesty's drawing-room, Windsor Castle	Watson, Bell, and Co.	XIX.	337	572
Crimson satin eider-down quilt, with white satin border	Heal & Son	—	396	574
Patent guard razor	Stewart, C., & Co.	XXI.	21	592
Ornamental wire flower-table	Reynolds, John	XXII.	37	597
Ornamental iron bedstead	Tonkin, James	—	58	599
Patent iron bedstead	Cowley & James	—	62	600
Ornamental cast-iron vase	Handyside, Andrew	—	82	—
Registered conducting leaf-stove	Keene, W.	—	94	602
Interior of the same, showing the conducting leaves	Ditto	—	—	—
Improved Oxford range	Benham & Sons	—	98	602
Pyro-pneumatic stove-grate	Pierce, William	—	107	604
Louis Quatorze drawing room stove-grate	Ditto	—	—	—
Chased or-molu fender	Ditto	—	—	605
Ornamented fire-dogs	Ditto	—	—	—
Fish-carver and fork	Deakin & Co.	—	110	606
Fire-lump stoves (front views and vertical sections)	Deane, Dray, & Deane	—	186	613
Nautilus register-stove	Burton, W. S.	—	247	620
Ridgway & Co.'s cabinet water-closet	Stokes, J. C.	—	252	621
Hydrostatic syphon water-purifier	Bird, A.	—	267	623
Victoria night-light	Ditto	—	—	—
Gold ever-pointed pencil-case, with various combinations	Sheldon, J.	—	292	626
Ornamental gas-bracket	Potts, William	—	323	630
Electro-plated asuffer-tray	Sturges, R. F.	—	341	633
Electro-plated decanter-stand	Ditto	—	—	634
Electro-plated tea-urn	Ditto	—	—	—
Electro-plated tea-kettle and stand	Ditto	—	—	—
Electro-plated cake-basket	Ditto	—	—	—
Electro-plated candlestick	Ditto	—	—	—
Four-post brass bedstead in the renaissance style	Winfield, R. W.	—	373	639
Metallic bedstead	Ditto	—	—	—
Two ornamental coats in brass	Ditto	—	—	—
Gas chandelier with parian figures (style of Francis I.)	Ditto	—	—	—
Bronzed gas chandelier, with ornamental enamel shades	Ditto	—	—	—
Metallic bedstead	Peyton and Harlow	—	371	639
Sherwood range	Wakefield, F.	—	381	640
Dr. Arnott's oblong bronzed corrugated stove	Edwards, F.	—	387	641
Dr. Arnott's circular bronzed corrugated stove	Ditto	—	—	—
Dr. Arnott's chimney valves	Ditto	—	—	—
Enamelled copper bath	Taylor & Son	—	401	642
Ornamental tea-urn	Ditto	—	—	—
Copper coal-scuttle	Ditto	—	—	—
Radiating stove-grate	Gray, J., & Son	—	405	643
Portable cooking stove	Rigby, Peter	—	411	—
Patent dry gas-meter	Shears & Son	—	438A	645
Gas cooking range	Strode, William	—	443	—
Gas broiler	Ditto	—	—	—
Patent diamond table lamp	Clark & Restell	—	446	646
Pearl hanging lamp	Ditto	—	—	—
Patent diamond sideboard or reading-lamp	Ditto	—	—	—
Patent diamond table-lamp	Ditto	—	—	—
Patent star night-light	Ditto	—	—	—
Patent reflector for gas-lights	Ditto	—	—	647
Improved oil lamp, with reservoir below the light	Ditto	—	—	—
Patent distress signal-lamps	Rettie, M., & Sons	—	449	—
Improved ship's hearth	Goodbehere, G. T.	—	481	649
Ornamental bracket	Hale, T., & Co.	—	486	—
Patent vulcanized valve-cocks	Lambert, T.	—	534	652
Economic lamp	Ditto	—	—	653
Registered mangle	Tindall, E. O. D. L.	—	542	—
New elastic pressure mangle	Stutterd, J.	—	545	654
Patent rotatory knife-cleaning machine	Kent, G.	—	553	—
Transverse section of the same	Ditto	—	—	—
Perpendicular section of the same	Ditto	—	—	—
Aerating machine for soda-water	Masters, Thomas	—	634	658
Freezing-machine	Ditto	—	—	—
Rotary knife-cleaner	Ditto	—	—	—
Fountain and park-gates in cast iron	Coalbrook Dale Company	—	641	659
Specimen of ornamental structure in cast-iron	Ditto	—	—	—

No.	Page.	Description of Illustrations.	Name of Exhibitor.	Class.	No.	Page.
24	539	Bronzed flower-pot stand	Coalbrook Dale Company	XXII.	641	660
143	541	Serpent-handled vase and base	Ditto	—	—	—
48	—	Ornamental vase and base	Ditto	—	—	—
76	543	Patent holdfast, and fire-resisting safe	Milner & Son	—	642	661
22	554	Ornamental Gothic lantern	Hulett, David	—	643	662
165	566	Antique bronze candelabrum	Ditto	—	—	—
337	572	Patent Admiralty regulation lights	Miller & Sons	—	645	—
396	574	Steam-vessel with regulation lights	Ditto	—	—	663
21	592	Patent detector lock and key	Chubb & Son	—	646	—
37	597	Gothic lock and key	Ditto	—	—	—
58	599	Patent fireproof safe	Ditto	—	—	—
62	600	"Koh-i-noor" diamond case	Ditto	—	—	—
82	—	Patent penholder	Windle & Blyth	—	688	665
94	602	Patent Collinge hinges	Thrupp, H. J.	—	676	666
98	602	Irish railway signal-post	Boake, J. F.	—	697	668
107	604	Portable domestic vapour-bath	Culverwell, Wm.	—	754	669
—	—	Patent check indicator	Warner, J., & Sons	—	798	—
—	605	Vase in silver, emblematical of the great Exhibition	Elkington, Mason, & Co.	XXIII.	1	672
110	606	Antique vase	Payno & Sons	—	4	673
186	613	Safety chain brooches	Ellis, H., & Son	—	12	674
247	620	Ornamental brooch	Rettie, M., & Sons	—	24	675
252	621	Ornamental plateau	Wilkinson, T., & Co.	—	32	676
267	623	Etruscan tea-urn	Ditto	—	—	—
—	—	Ornamental venison dish	Ditto	—	—	677
292	626	Ornamental candelabrum	Ditto	—	—	—
323	630	Antique candelabrum	Collis, G. R.	—	34	—
341	633	Registered toast-rack	Roberts & Hall	—	40	679
—	634	Electro-plated coffee and tea-pot, cream sower, and sugar-basin	Broadhead & Atkins	—	43	680
—	—	Blue diamond medallion, surrounded by brilliants	Hope, H. T., M.P.	—	73	682
—	—	Equestrian statuette	Phillips, Brothers	—	87	684
—	—	Infantry statuette	Ditto	—	—	—
—	—	Silver-gilt knife and spoon	Adams, G. W.	—	88	685
—	—	Tweeddale testimonial, in silver	Hunt & Roakell	—	97	686
—	—	Ornament in silver, designed for flowers or lights	Ditto	—	—	—
373	639	Bouquet of brilliants	Ditto	—	—	688
—	—	The Hartlepool testimonial	Ditto	—	—	—
—	—	The Montefiore testimonial	Ditto	—	—	—
—	—	The Ellenborough testimonial	Ditto	—	—	—
—	—	The Ellenborough plate	Ditto	—	—	—
—	—	The Ellenborough testimonial	Ditto	—	—	—
871	639	Jewellery, opals, and brilliants	Ditto	—	—	—
381	640	Emperor of Russia's ewer, with fruit-basket and sugar-basket	Garrard & Co.	—	98	688
387	641	Enamelled and silver flagons, vase, and goblet	Angell, George	—	103	690
—	—	Group of articles in silver	Smith, Nicholson, & Co.	—	110	691
—	—	Group, "The Well in the Desert"	Ditto	—	—	—
401	642	Group in silver, "The entry of Queen Elizabeth on horseback into Kenilworth Castle"	Hancock, C. F.	—	112	692
—	—	Ebony inlaid silver table	Ditto	—	—	—
405	643	Spoons and fork (new design)	Attenborough, R.	—	113	—
411	—	Louis Quatorze silver inkstand	Dodd, P. George	—	122	694
438A	645	Cut crystal fountain	Oslar, F., & Co.	XXIV.	20	700
443	—	Specimens of engravings on glass	Green, J. G.	—	32	701
—	—	Anglo-Venetian gilt and frosted glass	Apsley Pellatt & Co.	—	33	702
446	646	Bridal tea-service and tray	Ditto	—	—	—
—	—	Glass furnace.—Ground plan	Ditto	—	33	703
—	—	" Elevation	Ditto	—	—	—
—	—	" Section of elevation	Ditto	—	—	704
—	647	Window composed of national emblems	{ St. Helen's Crown Glass } Company	—	66	706
—	—	One of the windows of the Royal Commission room	{ Royal Patent Decorative } Glass Works	—	83	707
449	—	Ino and the Infant Bacchus	Copeland, W. T.	XXV.	2	711
481	649	Statuette, the Prodigal's Return	Ditto	—	—	—
486	—	Statuette, Rebecca	Ditto	—	—	—
534	652	Porcelain table service	Ridgway, J., & Co.	—	5	714
542	653	Tea and coffee service	Ditto	—	—	—
545	654	Dessert service	Ditto	—	—	—
553	—	Porcelain fountain	Ditto	—	—	717
—	—	Pottery sanitary vessels	Ditto	—	—	—
634	658	Ornamental candlestick	Meigh, C., & Sons	—	10	720
—	—	Portrait vase	Ditto	—	—	—
—	—	Bacchanalian vase	Ditto	—	—	721
—	—	Ornamental vase	Ditto	—	—	—
641	659	Portrait vase	Ditto	—	—	—
—	—	Illuminated Gothic font	Ditto	—	—	—

Description of Illustrations.	Name of Exhibitor.	Class.	No.	Page.
Ornamental clock	Meigh, C., & Sons	XXV.	10	722
Ornamental centre-piece, on pillar, with embossed vine border	Hilditch & Hopwood	—	17	723
Improved ship's furniture	Taylor & Sons	XXVI.	9	730
Carved sideboard of mahogany in the Italian style	Johnstone & Jeanes	—	10	—
Dressing-case, inkstand, and jewel-case	Asprey, C.	—	50	730
Expanding circular dining-table	— Ditto —	—	—	731
Slate top billiard-table	Thurston & Co.	—	17	—
An ornamental carved cabinet in walnut-wood and ebony	Freeman, W. & C.	—	38	732
Ornamental papier maché fire-screen	Spiers & Son	—	70	734
Irish bog-yew occasional table and timepiece	Jones, A. J.	—	78	735
Irish bog-yew teapoy	— Ditto —	—	—	736
Irish bog-yew omnium and statuette	— Ditto —	—	—	—
Irish bog-yew fire-screens	— Ditto —	—	—	737
Irish bog-yew arm-chair	— Ditto —	—	—	—
Irish bog-yew garde-vin, or wine-cooler	— Ditto —	—	—	738
Carved music temple	— Ditto —	—	—	—
Ornamental and inlaid bagatelle table	Mechi, J. J.	—	79	739
Ornamental work-table	— Ditto —	—	—	—
Carved cabinet of walnut wood	Stevens, John	—	124	741
Winged and carved mahogany wardrobe	Greig, E., and Son	—	159	744
Cabinet made for Her Majesty	Holland & Sons	—	161	745
Carved and ornamental sideboard	Trollope, G., & Sons	—	162	—
Circular table, supported by swans	Morant, G. J.	—	164	—
Circular table, supported by storks	— Ditto —	—	—	—
Ornamental candelabrum	Webb, John	—	171	746
Expanding plateau	Johnstone & Jeanes	—	10	—
Carved and engraved jewel-casket and stand	Wertheimer, S.	—	177	747
Hanging mirror and bracket-table	Clark, S. B.	—	179	—
Mirror in carved frame, and carved table	Lecand, S.	—	183	748
An easy chair, in papier maché	Jennens & Betteridge	—	187	—
Papier maché toilet-table and glass	Clay, Henry, and Co.	—	189	749
Geometrical Ottoman couch	Sowerby and Castle	—	192	—
Papier maché chess-table	Clay, Henry, & Co.	—	189	750
Carved sideboard, in walnut-tree wood	Poole and Macgillivray	—	204	—
— Ditto —	Hunter, W., J. R., & E.	—	202	751
Invalid couch (reclining position)	Minter, George	—	211	752
— Ditto (sitting position) —	— Ditto —	—	—	—
Carved oak cabinet	{Harrison's Wood Carving Company}	—	222	753
Patent screw movement for dining-tables	Hawkins, S.	—	237	754
Patent cog-wheel movement for dining-tables	— Ditto —	—	—	—
A sideboard, ornamented with appropriate emblems	Jackson and Graham	—	261	755
Ornamental chimney-piece	Thomas, J.	—	276	756
Commercial writing-desk	Waller, F.	—	285	—
Specimens of paper-hangings	Woollams, W. & Co.	—	309	—
Patent reading-stand	Warren, Thomas	—	288	757
Specimen of paper-hanging	Townsend & Parker	—	318	758
Specimen of block-printed paper-hangings	— Ditto —	—	—	—
Specimen of paper-hanging	Turner, H., & Co.	—	320	—
Looking-glass and console-table	M'Lean, C.	—	386	759
Table intended for President of French Republic	Orsi & Armani	XXVII.	36	766
Group of pedestals, vases, candelabra, &c.	Pearce, William	—	75	768
Serpentine obelisk	Organ, J.	—	85	770
Font and vase in serpentine	— Ditto —	—	—	—
Sculptured baptismal font in Caen stone	Margetts and Eyles	—	91	771
Slate filters and wine cooler	Stirling, Thomas	—	120	773
Prince Albert's model houses	{Society for Improving the Condition of Labouring Classes,	—	124	774
Sections of the hollow bricks of the model structure	—	—	—	775
Chemical pottery wares	Green & Co.	—	125	776
Octagonal alms-basin	Wippell, J., jun.	XXVIII.	10	778
Oriental towers in vegetable ivory	Taylor, Benjamin	—	47	780
Specimens of the vegetable ivory nut	— Ditto —	—	—	—
Halkett's India-rubber cloak-boat	Matthews, Samuel	—	81	782
Mediæval dressing-case	Leuchars, W.	XXIX.	44	791
Ornamental dressing-case	Mechi, J. J.	—	45	792
Or-molu jewel cabinet	Asprey, C.	—	50	—
Patent acolyte	Jones, Rev. W. H.	—	95	795
Shaksperian shield	Limner, Luke	XXX.	35	822
Shaksperian shield	Leighton, John	—	30	—
Book-cover	Wyatt, M. Digby	—	59	—
Patent relievo leather panel	Leake, Fred.	—	63A	823
Specimen of carving in wood	Wallis, T. W.	—	89	825
Group of fruit, flowers, &c., carved out of solid lime-tree	— Ditto —	—	—	—
The Taunton vase	Porry, W.	—	101	826

No.	Page.	Description of Illustrations.	Name of Exhibitor.	Class.	No.	Page.
10	732	The Kenilworth buffet	Cookes & Sons	xxx.	110	827
17	723	Panels and centre compartment of the Kenilworth buffet	Ditto	—	—	—
9	730	Gladiatorial table	Fletcher, J.	—	111	827
10	—	Ornamented Bible	Nisbet & Co.	—	118	828
50	730	Specimen of heraldic decoration, in glass mosaic	Stevens, George Henry	—	158	830
—	731	Brien Boru's harp (model)	Ball, Rob., LL.D.	—	157	830
17	—	Specimen in glass mosaic	Stevens, George H.	—	158	830
38	732	Model of a house, in card-board, built in the Tudor style	Harrison, Wm.	—	180	831
70	734	Group of Mexican figures	Montanari, N.	—	224	833
78	735	Statuette of Osceola	Ditto	—	—	834
—	736	Physiognomical scale	Hopley, Edward	—	298	839
—	737	Bacchanalian vase in serpentine marble	Norchi, E.	—	309	840
—	738	Group in serpentine marble	Ditto	—	—	—
—	739	Small table, from original designs	Wilkinson, Sir G.	—	319	841
—	739	Royal cradle, carved in Turkey boxwood	Rogers, W. G.—The Queen	—	353	842
—	741	Statue of Whittington	Carew, J. E.	—	10	843
124	741	H.R.H. the Prince of Wales as a young shepherd	Thornycroft, T. & Mary	—	34	844
159	744	H.R.H. the Princess Royal as a gleaner	Ditto	—	—	—
161	745	A group.—The Murder of the Innocents	Adams, G. G.	—	37	—
162	—	A group of children and animals	Jones, J. E.	—	40	—
164	—	The Babes in the Wood	Bell, John	—	72	845
—	—	Greek hunter and dog	Yarborough, Lord	—	80	846
—	—	Statue of Shakspeare	Bell, John	—	—	847
171	746	Youth at a Stream	Foley, J. H., A.R.A.	—	—	848
10	—	Group in marble.—Theseus and the Amazons	H.R.H. Prince Albert	—	—	—
177	747	Eldon and Stowell group	Eldon, Earl of	—	—	—
179	—	Model for a statue of Hampden	Foley, J. H., A.R.A.	—	—	—
183	748	Model of a statue of Safer de Quincey, Earl of Winchester, 1215	Westmacott, J. S.	—	—	—
187	—	Great pearl, cat's eye, and handle of Murat's sword	Hope, A. J. B.	—	—	849
189	749	The Fairy Queen (Titania)	Lough, J. G.	—	—	850
192	—	Ariel	Ditto	—	—	—
189	750	The Mourners	Ditto	—	—	—
204	—	The archangel Michael, having subdued Satan	Ditto	—	—	—
202	751	An altar-screen—specimen of machine-carving in wood	Jordan, —	—	—	851
211	752	Model of the docks and town of Liverpool	Liverpool Local Committee	—	—	—
—	—	Puck	Lough, J. G.	—	—	—
222	753	Hereford Cathedral spandril	Potter, T.	—	—	852
237	754	Fountain, suitable for a market-place	Seeley, John	—	—	—
261	755	Acis and Galatea fountain	Thomas, J.	—	—	853
276	756	Statue of Rosamond	Ditto	—	—	—
285	—	Statue of Dante's Beatrice	Hancock, J.	—	—	—
309	—	Equestrian statue of Her Majesty the Queen	Thornycroft, T. & Mary	—	—	—
288	757	Sleeping Child and Dog	Weekes, H.	—	—	—
318	758	—	—	—	—	—

BRITISH COLONIES AND DEPENDENCIES.

No.	Page.	Description of Illustrations.	Name of Exhibitor.	Name of Place.	No.	Page.
320	—	—	—	—	—	—
386	759	—	—	—	—	—
36	766	—	—	—	—	—
75	768	—	—	—	—	—
85	770	—	—	—	—	—
91	771	Battle-axes, deer-skin shield, and other arms	—	India	—	911
120	773	Trophy of Indian arms	—	Ditto	—	912
124	774	Native musical instruments	—	Ditto	—	913
—	775	Ditto ditto	—	Ditto	—	—
—	776	Ditto ditto	—	Ditto	—	—
25	776	Brass, copper, and earthenware vessels, for domestic purposes	—	Ditto	—	919
10	778	Inlaid vessels and works in gold and silver filigree	—	Ditto	—	—
47	780	Specimen of wood-carving	—	Ditto	—	921
81	782	Carved chair, in Bombay blackwood	—	Ditto	—	—
44	791	Indian royal bedstead, with silk velvet covering, and velvet mattress	Baboo Denarain Sing, of Benares	Ditto	—	—
45	792	Specimen of Indian carving	—	Ditto	—	—
50	—	Carved Indian table (ebony)	—	Ditto	—	—
95	795	Sideboard, of native design and carving	—	Ditto	—	—
95	822	Sofa, of native design and execution	—	Ditto	—	—
30	—	Ornamental state umbrella	—	Ditto	—	—
59	—	Royal reception seat (carved ivory)	Her Majesty the Queen	Ditto	—	924
63A	823	Ivory howdah, with elephant trappings complete, in gold and silver	Ditto	Ditto	—	929
89	825	Carved sideboard, representing King John signing Magna Charta	Feuvre, G. C., Le	Channel Islands	20	941
1	826	—	—	—	—	—

Description of Illustrations.	Name of Exhibitor.	Name of Place.	No.	Page.
Maltese stone vase - - - - -	Deceare, P. P. - - -	Malta - - -	27	945
Stone vase - - - - -	Ditto - - -	Ditto - - -	—	—
Jug of Maltese stone - - - - -	Ditto - - -	Ditto - - -	—	946
Stone vase - - - - -	Ditto - - -	Ditto - - -	—	—
Vase, ornamented with satyrs and flowers - - - - -	Testa, S. - - -	Ditto - - -	30	947
Vase, ornamented with eagles - - - - -	Ditto - - -	Ditto - - -	—	—
Walnut centre and pier table - - - - -	Hilton, J. & W. - - -	Canada - - -	123	966
A canoe of bark - - - - -	{ Central Commission, } Montreal - - -	Ditto - - -	171	967
Canadian timber trophy - - - - -	Ditto - - -	Ditto - - -	—	—
Single sleigh - - - - -	M'Lean & Wright - - -	Ditto - - -	178	968
Powerful Canadian fire-engine - - - - -	Perry, G. F. - - -	Ditto - - -	181	—

FOREIGN STATES.

Description of Illustrations.	Name of Exhibitor.	Name of Place.	No.	Page.
Ornamental bronzed street lamp - - - - -	Salm, Prince - - -	Austria - - -	430	1032
Ornamental furniture, made of iron tubes - - - - -	Kitschelt, A. - - -	Ditto - - -	434	—
An ornamental table, cast in zinc, with candlesticks, &c. - - - - -	Ditto - - -	Ditto - - -	—	—
A lady's inlaid toilet table - - - - -	Moschim, P. - - -	Ditto - - -	638	—
Specimens of ornamental glass - - - - -	Hofmann, W. - - -	Ditto - - -	590	1037
A group of ornamental glass vases, &c. - - - - -	{ Hofmann, W., & Meyr's } Nephews - - -	Ditto - - -	{ 590 } { 595 }	—
Specimens of ornamental glass vases, &c. - - - - -	Hofmann, W. - - -	Ditto - - -	590	—
State bed - - - - -	Leistler & Son - - -	Ditto - - -	633	1040
Carved sideboard - - - - -	Ditto - - -	Ditto - - -	—	—
Carved and ornamental sofa and chair - - - - -	Ditto - - -	Ditto - - -	—	—
Carved tables and chair - - - - -	Ditto - - -	Ditto - - -	—	—
Carved and ornamental arm-chairs - - - - -	Ditto - - -	Ditto - - -	—	—
Specimens of carved chairs - - - - -	Ditto - - -	Ditto - - -	—	—
Sofa and table - - - - -	Ditto - - -	Ditto - - -	—	—
Gothic bookcase, in carved oak, presented to Her Majesty, by the Emperor of Austria - - - - -	Ditto - - -	Ditto - - -	—	—
An inlaid table - - - - -	Ditto - - -	Ditto - - -	—	—
Carved bookcase - - - - -	Ditto - - -	Ditto - - -	—	—
Picture-stand - - - - -	Thonet, M. - - -	Ditto - - -	641	—
Sculptured flower-stand - - - - -	Afh, Fried. - - -	Ditto - - -	646	—
Prie-Dieu altar, in Gothic style - - - - -	Polt, Anton - - -	Ditto - - -	650	1041
Vase designed by B. di Bernardis - - - - -	Becker & Kronik - - -	Ditto - - -	643	—
Sculptured marble mantelpieces - - - - -	Bottinelli, G. - - -	Ditto - - -	726	1043
Vacuum boiling apparatus - - - - -	Heckmann, C. - - -	Prussia - - -	52	1051
Ornamented cast-iron fountain - - - - -	Lehmann, A. F. - - -	Ditto - - -	197	1059
Specimens of ornamental glass, with various decorations - - - - -	Schaffgotsch, Count - - -	Ditto - - -	208	—
Specimens of porcelain - - - - -	{ Royal Porcelain Manu- } factory - - -	Ditto - - -	213	1060
Specimens of porcelain - - - - -	Ditto - - -	Ditto - - -	—	—
Vase and epergne in porcelain - - - - -	Ditto - - -	Ditto - - -	—	—
Fountain in terra-cotta - - - - -	March, E. - - -	Ditto - - -	240	1062
Gothic vase and pedestal - - - - -	Ditto - - -	Ditto - - -	—	—
Boy with a swan - - - - -	Geiss, M. - - -	Ditto - - -	267	1064
Athenian vase, with figures - - - - -	Royal Iron Foundry - - -	Ditto - - -	271	1065
Colossal group in zinc and bronze, representing an Amazon attacked by a tiger - - - - -	Kies, Professor - - -	Ditto - - -	279	—
Specimens of earthenware, in various shapes and colours, decorated - - - - -	Villeroy and Boch - - -	Ditto - - -	361	1071
An assortment of jewellery - - - - -	Backes, J. F., & Co. - - -	Ditto - - -	411	1073
Specimens of jewellery of various designs - - - - -	Ditto - - -	Ditto - - -	—	—
Casket in silver, with a coral tree, &c. - - - - -	Weishaupt & Sons - - -	Ditto - - -	412	—
Flower, in brilliants, rubies, &c. - - - - -	Haulick, F. G. - - -	Ditto - - -	413	—
Specimens of various articles of jewellery - - - - -	Backes, J. F., & Co. - - -	Ditto - - -	411	—
Set of chessmen and board, in silver and gold, ornamented with precious stones, &c. - - - - -	Weishaupt, C. M., & Sons - - -	Ditto - - -	412	—
Stove in the form of a knight in armour - - - - -	Baume, D. - - -	Ditto - - -	760	1092
A garden table top, in bronze - - - - -	{ Stolberg Wernigerode, } Le Comte - - -	Ditto - - -	779	1093
Gothic vase - - - - -	Stolberg, Le Comte - - -	Ditto - - -	—	—
Carved ivory goblet, with scriptural device - - - - -	Schulz, L. W. - - -	Ditto - - -	811	1095
Table ornament, emblematical of the civilization of mankind - - - - -	Wagner, J., & Son - - -	Ditto - - -	840	1096

No.	Page.	Description of Illustrations.	Name of Exhibitor.	Name of Place.	No.	Page.
27	945	Carved ivory goblet, with reliefs from the "Lay of the Niebelungen"	Frank, C.	Bavaria	75	1101
—	946	A goblet of ivory, carved with bacchanalian figures and arabesques	Hagen, M.	Ditto	83	1102
30	947	Goblet in plaster of Paris, with subject,—"Loving and living on the Rhine"	Knoll, C.	Ditto	88	—
123	966	Porcelain jug and tankard	{Royal Porcelain Manu- factory, Nymphenburg}	Ditto	64	—
171	967	Colossal lion	Miller, F.	Ditto	90	—
—	—	Colossal group of lions	Ditto	Ditto	—	—
—	—	King and Queen of the Bohemians	Ditto	Ditto	—	—
178	968	Printing-machine	Reichenbach, C.	Ditto	102	1103
181	—	A bell of bronze	Gruhl, F.	Saxony	37	1106
—	—	A large vase in porcelain, with a smaller one, from Berlin	Royal Porcelain Manufac- tory, Dresden	Ditto	174	1112
—	—	Chemical apparatus	Wolf, F. A.	Wurttemberg	13	1116
—	—	Ornamental bird-cage and flower-stand	Rau & Co.	Ditto	72	1118
—	—	Groups of stuffed animals,—Bowl-positing and stag-hunt	Plouquet, H.	Ditto	107	1120
—	—	Porcelain stove	Hoffman & Son	Frankfort	16	1123
—	—	Alabaster crystal fountain	Tacchis & Co.	Ditto	21	—
430	1032	An ivory cup and porcelain vase	Heyl, C. W.	Hesse Darmstadt	75	1129
434	—	Hull of a barque, side view	Bufe & Son	Hamburg	9	1136
—	—	Stag-horn furniture	Rampendahl, H. F. C.	Ditto	60	1138
636	—	Writing bureau, inlaid with harthorn and ivory work	Ditto	Ditto	70	1139
590	1037	Ornamental sideboard of rosewood	Adikee, J. D.	Ditto	67	—
—	—	Sugar-cane mill	Vlissingen & Co.	The Netherlands	75	1146
590	—	Two large candelabra and flower-vase in cut crystal	Regout, P.	Ditto	99	1148
595	—	Ornamental marble mantelpiece	Leclercq, A.	Belgium	425	1164
590	—	A sculptured group in oak	Geerts, M. C.	Ditto	450	1165
633	1040	Specimen of wood carving	Ditto	Ditto	—	—
—	—	Plaster statue—Cain	Jehotte, L.	Ditto	463	—
—	—	Carved oak cabinet	Berndert, A.	Ditto	439	1165
—	—	Marble statuettes—The Happy Child, and Unhappy Child	Simonis, M.	Ditto	464	1166
—	—	Colossal equestrian statue in plaster—Godfrey de Bouillon	Ditto	Ditto	—	—
—	—	Plaster group—The Lion in Love	Geefs, G.	Ditto	466	—
—	—	Machine for counting, numbering, and labelling	Baranowski, J. J.	France and Algiers	15	1171
—	—	Ready-reckoning machine	Ditto	Ditto	—	1172
641	—	Status of Eve and her children	De Bay, M.	Ditto	45	1173
646	—	Segnier's mint-balance	Deleuill, L. J.	Ditto	160	1179
650	1041	Delicate balance	Ditto	Ditto	—	1180
643	—	Electric-light regulator	Ditto	Ditto	—	—
726	1043	Microscope and regulator combined	Ditto	Ditto	—	—
52	1051	Church organ, Gothic style	Ducroquet, P. A.	Ditto	173	1182
197	1059	Colossal group in plaster: Archangel Michael conqueror of Satan	Duseigneur, J. B.	Ditto	187	1183
208	—	An improved double turbine	Fromont & Son	Ditto	220	1184
213	1060	Double turbine, sectional elevation	Fromont & Son	Ditto	220	1185
—	—	Ditto, sectional elevation of working arrangement	Ditto	Ditto	—	1186
—	—	Stained window-glass	Lafaye, P.	Ditto	284	1190
—	—	Tiara and brooches of brilliants and pearls belonging to the Queen of Spain	Lemonnier, —	Ditto	304	1191
240	1062	Bouquets of brilliants and jewels, belonging to the Queen of Spain	Ditto	Ditto	—	—
267	1064	Ornamental sword and dagger	Marrel Brothers	Ditto	331	1193
271	1065	Specimen of ornamental binding and crucifix	Marrel Brothers	Ditto	—	—
279	—	Cellini cup	Marrel Brothers	Ditto	—	—
361	1071	Vase in oxidized silver, representing the battle of the Amazons	Marrell Brothers	Ditto	—	—
411	1073	Machine for performing arithmetical calculations	Thomas, C. X.	Ditto	390	1196
—	—	Tubular bricks	Borie Brothers	Ditto	417	1198
412	—	Grand carved pianoforte	Erard, P.	Ditto	497	1201
413	—	A four-wheeled carriage, called "Town Berlin"	Dunaine, J. A.	Ditto	490	1202
411	—	An ornamental fan	Duvelleroy, P.	Ditto	495	1203
412	—	Group, in plaster, of the child, the dog, and serpent	Lechesne, A. J. B.	Ditto	573	1205
—	—	Ditto	Ditto	Ditto	—	—
60	1092	Ornamental metallic bedsteads	Leonard, M. C.	Ditto	589	1206
79	1093	Six illustrations of lamps	Neuburger, A.	Ditto	662	1210
—	—	Moderator lamp	Truc, C.	Ditto	703	1212
—	—	Paper-mill, with Messrs. Varrall, Middleton, and Elwell's continuous paper machines	{Varrall, Middleton, & Elwell}	Ditto	717	1214
11	1095	An improved portable weighing apparatus	Beranger & Co.	Ditto	761	1216
40	1096	New steelyard	Ditto	Ditto	—	1217

Description of Illustrations.	Name of Exhibitor.	Name of Place.	No.	Page.
A novel apparatus for weighing	Beranger & Co.	France and Algiers	761	1217
Pattern of a shawl	Hartweck, E.	Ditto	867	1221
Punches for cutting out gloves	Jouvin, M. X.	Ditto	893	1222
Carved ivory cabinet	Matifat, C. S.	Ditto	923	1224
Silver vase, with figures	Ditto	Ditto	—	—
Specimens of fenders and fire implements	Pieron, L.	Ditto	957	1225
Oil-colour painting of flowers and fruits	Saint Jean, M.	Ditto	996	1227
Bronze iron fountain, with figures of tritons	Andre, J. P. V.	Ditto	1053	1229
Indicators for steam-boilers	Bourdon, E.	Ditto	1108	1231
Ornamental nautpiece, with mirror	Luce, P. N.	Ditto	1132	1240
Table and vase in Sèvres porcelain	{Sèvres National Manu- factory}	Ditto	1369	1241
Sèvres porcelain vases, various designs	Ditto	Ditto	—	—
Sèvres china vases	Ditto	Ditto	—	—
Group of Sèvres china articles	Ditto	Ditto	—	—
Two vases of Sèvres china	Ditto	Ditto	—	—
Letter-weight and rose-water dish, by Wagner	Rudolphi, M.	Ditto	1485	1246
Apparatus for aerated waters	Savaresse, P.	Ditto	1477	1247
Carved ivory goblet	Lautz, M.	Ditto	295	1250
Bronze vase	Vittoz, —	Ditto	—	—
Group of articles and statuettes in bronze	Vittoz, —	Ditto	1530	1250
Chased cup and salver, by Le Brun	Durand, J.	Ditto	1508	1253
Table centre-piece, accompanied with four crystal cups, &c.	Durand, F.	Ditto	1595	—
Vase in silver, with ornaments in relief	Durand, J.	Ditto	1596	—
A theodolite	Froment, G.	Ditto	1609	1254
Toilet-table, the property of the Duchess of Parma	Froment, Maurice	Ditto	1720	1258
Silver chased ornament	Ditto	Ditto	—	—
Swords presented to Generals Cavaignac and Chan- garnier, and a hunting-knife	Ditto	Ditto	—	—
Carved ivory tankard	Ditto	Ditto	—	—
An ivory statue—Leda and Swan	Ditto	Ditto	—	—
Carved bookcase	Krieger & Co.	Ditto	1741	1259
Diagram representing an Artesian boring	Laue, F.	Switzerland	85	1270
Patent iron plough	Gain, J.	Ditto	72	1271
Gold watch, enamelled and jewelled	Mercier, S.	Ditto	96	1273
Embossed drinking cup	Fries, H.	Ditto	221	1280
Lady's mechanical caccitroire	Wetli, M. L.	Ditto	237	1281
Watches, ornamented and enamelled	Fatek & Co.	Ditto	274	1284
Circular inlaid table-top	Moglia, Cavaliere L.	Rome	20	1286
Marble statue of Glycera	Wyatt, R. J., the late	Ditto	16	—
Cameo, "Jupiter overcoming the Titans"	Manley, General	Ditto	32A	1287
Organ with coatra-basso amisons	Ducci Brothers	Tuscanly	58	1295
Stove in terra cotta	Cantagalli, L.	Ditto	71	1297
Carved casket	Barbetti, A.	Ditto	74	—
Inlaid table-top	Ragnini, E.	Ditto	86	—
Ditto	Ditto	Ditto	109	1299
Alabaster vase, Etrurian style	Cheric & Sons	Ditto	112	—
An inlaid table-top	Buoninsegni Brothers	Ditto	—	—
An inlaid slab for a table	Della Valle Brothers	Ditto	114	—
Ditto	Ditto	Ditto	114	1300
Flowers and stand of cast bronze	Papl, C.	Portugal	116	—
Carved ivory statue—Prometheus chained	Vieira, M. J.	Ditto	1234	1318
Tabernacle, silver gilt, inlaid with precious stones	Moratilla, D. F.	Spain	261	1345
Specimen of decorated and inlaid arms	Zuluage, A.	Ditto	264A	1346
An enamelled and gilt dagger and case, and serpent- form sword	Royal Ordnance, Toledo	Ditto	266	1346
An ornamental dagger and case, and stirrups	Ditto	Ditto	266	—
Straight sword, of extraordinary temper and flex- ibility, with a metallic scabbard in the form of a serpent	Ysasi, D. M. de	Ditto	267	—
Inlaid secretaire	Medina, D. M.	Ditto	270	—
Harp-guitar and stand	Gallegos, D. J.	Ditto	272	—
Octagonal table of inlaid wood	Perez, —	Ditto	271A	—
Statue of a shepherd, by M. Molin	Hillman, A.	Sweden & Norway	31	1351
Specimen of carving in wood by the peasantry	Thesen, J. P.	Ditto	44	1352
Specimen of carving in wood by the peasantry	Ditto	Ditto	—	—
Lady's writing-table and chair	Hausen, M.	Denmark	25	1357
Statue of Cupid	Bissen, H. W.	Ditto	38	1358
Ivory jewel-casket	Klingrey, C. G.	Ditto	34	—
Basso-relievo	Jerichau, J. A.	Ditto	39	1359
Hunter and panther	Prichau, M. J.	Ditto	39	—
Model of a patent electro-magnetic engine	Hjorth, Soren	Ditto	47	1360
Inlaid jewel cabinet	{Imperial Polishing Ma- nufactory}	Russia	298	1376

No.	Page.	Description of Illustrations.	Name of Exhibitor.	Name of Place.	No.	Page.
761	1217	Specimen of wood mosaic	Miller, George	Russia	299	1376
867	1321	Specimen of wood mosaic	Ditto	Ditto	—	—
893	1222	Inlaid cabinet	Gams	Ditto	297	—
923	1224	Candelabrum and jasper vase	Krumbigel	Ditto	287	—
957	1225	Great vase in porcelain and jasper vase	{Imperial China Manu- factory	Ditto	318	—
996	1227	Porcelain table top	Ditto	Ditto	—	—
1053	1229	Great vase in porcelain	Ditto	Ditto	—	—
1108	1231	Table in mosaic	{Imperial Polishing Ma- nufactory	Ditto	298	—
1132	1240	Fireplace in malachite and or-molu	Demidoff, Messrs.	Ditto	323	1377
1369	1241	Large vases of malachite	Ditto	Ditto	—	—
—	—	Ornamental time-piece, in malachite	Ditto	Ditto	—	—
—	—	Large vase in malachite	Ditto	Ditto	—	—
—	—	Chair and table, part of a suite of furniture in mala- chite	Ditto	Ditto	—	—
1465	1246	Jewellery, brilliants and rubies	Bolin & Ian	Ditto	322	—
1477	1247	Vase in malachite	Demidoff, Messrs.	Ditto	323	—
295	1250	Figures in silver and malachite	Ditto	Ditto	—	1379
1530	1250	Square bordered vase of grey violet jasper	{Imperial Polishing Ma- nufactory of Kolyvan.	Ditto	327	1380
1508	1253	Model of Warwick vase, in beaten copper	Heke, D.	Ditto	329	1381
1595	—	Model of doors	Tolstoy, Count	Ditto	328	—
1596	—	Four medallions, commemorative of the wars of 1812-14	Ditto	Ditto	—	—
1609	1254	Droshki, for one person	Jakoleff Brothers	Ditto	344	1382
1720	1258	Figures of Russian peasantry in silver	Sazikoff, Ignace	Ditto	366	1383
—	—	Clock and stand, design representing the ascent of the first balloon	Chopin, —	Ditto	365	—
—	—	Large candelabrum, in or-molu	Ditto	Ditto	—	—
—	—	Bronze candelabrum, with twelve solar lamps	Shtange & Verfel	Ditto	370	1384
—	—	Goblet, vase, and bell, of gold and silver	Sazikoff, Ignace	Ditto	366	—
—	—	Specimens of articles of gold and silver plate	Ditto	Ditto	—	—
1741	1259	Candelabrum and two groups, in silver	Ditto	Ditto	—	—
65	1270	Tiara, brooches, &c., of brilliants	Kaemmerer & Zeftigen	Ditto	376	—
72	1271	Articles in gold and silver plate	Sazikoff, Ignace	Ditto	366	—
96	1273	Silver ornament, the pine tree	Ditto	Ditto	—	—
221	1280	Vase and flagons, in gold and silver plate	Ditto	Ditto	—	—
237	1281	Ornamented hookahs	Ditto	Ditto	—	—
274	1284	Ornamented hookahs	Ditto	Ditto	—	—
20	1286	Falcor dress, embroidered in gold	Saris & Rengosa	Turkey & Egypt	—	1399
16	—	Cross, carved in wood	Triandaphylos, Rev. A.	Greece	50	1406
32A	1287	Cross, carved in wood (obverse)	Ditto	Ditto	59	1407
58	1295	Specimen of wood carving, after the old Byzantine style	Ditto	Ditto	—	—
71	1297	Water jugs and bottles of Konch earth	The Egyptian Government	Egypt	347	1411
74	—	Ornamented and embroidered Tunisian saddle	The Bey of Tunis	Tunis	43	1414
86	—	Domestic implements of Tunis	Ditto	Ditto	51	1415
109	1299	A carved and inlaid door	Ditto	Ditto	59	—
112	—	Specimens of Tunisian jewellery	Ditto	Ditto	83	1417
—	—	Arab tent, weapons, implements, &c.	Ditto	Ditto	82	—
114	—	Carved Chinese table	Bowman, W.	China	24	1424
114	1300	Chandelier	Cornelius & Co.	United States	46	1436
116	—	Patent centripetal spring chair	American Chair Company	Ditto	85	1438
1234	1318	Dunn's patent caloric engine	Erricsson, J.	Ditto	146	1445
261	1345	Model of the floating church at Philadelphia	Dennington, C. L.	Ditto	356	1457
264A	1346	A light carriage, called the "Gazelle"	Watson, G. W.	Ditto	361	1458
266	1348	Cabinet of Maryland products	Maryland Committee	Ditto	371	1459
—	—	India-rubber life-boat	Goodyear, C.	Ditto	378	1460
266	—	India-rubber pontoon	Ditto	Ditto	—	—
—	—	Air-warming and ventilating furnace	Chilson, Richardson, & Co.	Ditto	417	1462
267	—	—	—	—	—	—
270	—	—	—	—	—	—
272	—	—	—	—	—	—
271A	—	—	—	—	—	—
31	1351	—	—	—	—	—
44	1352	—	—	—	—	—
—	—	—	—	—	—	—
25	1357	—	—	—	—	—
38	1358	—	—	—	—	—
34	—	—	—	—	—	—
39	1359	—	—	—	—	—
39	—	—	—	—	—	—
47	1360	—	—	—	—	—
298	1376	—	—	—	—	—

A List of the LOCAL COMMITTEES and NAMES of SECRETARIES of the UNITED KINGDOM, which returned Exhibitors and Subscriptions to the General Fund up to the period of the opening of the Exhibition.

[Corrected to 29th September, 1851.]

Places.	Amount paid to Exhibitors.	Secretary of Committee.	Amount paid to Commission.	Places.	Amount paid to Exhibitors.	Secretary of Committee.	Amount paid to Commission.
			£. s. d.				£. s. d.
METROPOLIS.							
City of London		Cattley, Rev. S. R.	24353 17 9	Brentwood	1	Branfoot, J. H., M.D.	0 11 0
Do. Ladies		Wire, D. W.	500 0 0	Bridgenorth		Jones, William	21 1 0
Westminster		Drew, Geo. Henry	6031 2 10	Bridgwater	5	Smith, Rich., jun.	21 10 0
Do. Ladies		Bridport	2	Colfox, Thomas	50 0 0
Society of Arts	1082 7 10	Brighton	25	Clarke, Somers	150 0 0
Brentford		Clark, George	55 19 5	Bristol	52	Wilksou, John	650 0 0
Chelsea		Rudge, Rev. Edw.	100 0 0	Bromsgrove	2	Maund, Benjamin	
Chiswick		Wylde, W. H.	78 3 7	Buckingham	3	Nelson, G.	20 0 0
Finchbury		James, Edward W.	205 4 0	Burnley	1	Heelis, John	
		Hopwood, C. H.		Burton-on-Trent	1	Richardson, John	113 3 0
Greenwich		Nicholls, John W.	180 0 0	Bury St. Edmunds	8	Holmes, J. H.	20 0 0
	2697	Glaishier, James		Bury (Lancashire)	2	Norris, W. H.	66 11 6
		Roberts, Alfred J.	38 1 4	Buxton	2	Bright, Selim	6 15 11
Hammersmith		Paxon, William	25 0 0				
Kensington		Morris, John	299 13 0	Camborne	1	Bickford, T. S.	37 5 6
Marylebone		Greenwell, W. E.	500 0 0	Budge, J. H.		Budge, J. H.	
Poplar		Baln, W. P.	65 8 6	Cambridge Unvers.		Dabington, C., M.A.	132 2 0
		Coleman, Edward		Cambridge Town	8	Gotobed, H.	176 0 0
South London		Taylor, Robert	619 2 6			Harris, H. H.	
		Gibson, William		Canterbury	3	Aris, John	
Southwark		Sturmy, Herbert	340 8 0	Cardiff	8	Bird, Hugh	96 0 0
Tower Hamlets		Humphreys, John	155 12 2	Carlisle	10	Nanson, John	200 0 0
Woolwich		Graham, Geo. H.	200 0 0	Chatham		Limbirt, B. T.	62 14 10
				Cheadle	3	Cattlow, John	
Aberdeen	43	Reid, W. L.	190 0 0	Cheltenham	9	Gwinnett, W. H.	100 0 0
Abingdon	5	Bartlett, A. D.	9 2 6	Chelmsford	8	Meggy, George	83 14 0
Alloa	7	Wingate, John	41 16 0			Chancellor, Frank	
Arbroath	5	Macdonald, John	15 0 0	Cheshunt	3	Chaplin, J. B.	8 0 0
Ashborne		Bamford, John	1 11 0	Chester	10	Maddock, J. F.	62 10 0
Ashburton	4	Leaman, T. L. Hunt	7 0 0	Chesterfield	8	Roberts, John	
Ashford	2	Whitfield, W.		Chichester	6	Mason, W. H.	98 2 2
Ashton-under-Lyne	3	Gartside, Henry		Chippenham	3	Wharry, James	20 0 0
						Alexander, Thomas	
Bakewell	7	Barker, James		Cockermouth	3	Benson, Robert	11 3 0
Banbury	12	Austin, G. B.	45 14 0	Coggeshall	3	Clemance, J. A.	21 0 0
Barnard Castle	2	Monkhouse, J. C.	11 11 0	Colchester	13	Hayward, Robert	60 0 0
Barnsley	16	Newman, Edward	132 0 0	Colne	2	Hartley, H. W.	20 0 0
Barnstaple	3	Cotton, Richard W.	30 15 0	Congleton		Latham, John	24 18 0
		Millar, John May		Cork	22	Feath, G. C.	50 0 0
Basingstoke	2	Shebbeare, J. C.	126 14 0	Coventry	24	Skidmore, F. A.	112 0 0
Bath	45	Tunstall, Jas., M.D.	200 0 0	Crayford (Kent)	13 2 0
		Akerman, William		Crewkerne	17	Pearce, Joseph	10 0 0
Batley (Yorkshire)	10	Jubb, Samuel	133 11 6	Cricklade	1	Lovell, James	
Bedford	10	Fulley, Henry, jun.	115 13 2	Cupar		Duncan, W.	18 10 0
Belfast	53	MacAdam, J., jun.	300 0 0				
Belper		Ingle, Thomas	60 0 0	Dalkeith	1	Mitchell, Alex.	6 3 6
Berwick-on-Tweed	2	Weatherhead, R. B.	22 2 0	Darlington	9	Humble, Stephen	50 0 0
Beverley	4	Crust, Thomas	93 3 6	Deal	2	Reaks, Thomas	5 17 0
Bideford	9	Carter, Charles	10 0 0	Derby	37	Stevens, Henry J.	250 0 0
Billericay		Tardrew, Henry	0 15 0	Devizes	6	Every, Fred. S.	
Bingley (Yorkshire)	2	Passavant, P., jun.	152 10 0	Devonport	5	Waylen, George	13 4 6
Birmingham	230	Marshall, W. P.	500 0 0			Norman, Alfred	40 0 0
Bishops Stortford	1	Glasscock, John L.		Doncaster	3	Mason, T. B.	123 13 0
		Simpson, Thomas		Dorchester	3	Stone, J.	14 14 0
Blackburn	8	Clark, W. J. D.	650 0 0	Dorking	83 18 6
Bodmin		Bray, R.	35 18 0	Dover	6	Bass, T. B.	70 0 0
Bolton (Lancashire)	12	French, Gilbert J.	664 11 4			Stilwell, J.	
Boston	6	Bontoft, James A.	26 10 5	Driffield, Great	1	Conyers, E. D.	35 0 0
Bradford (Wilts.)	4	Merrick, W.	31 2 6	Dublin	197	Porter, W. H.	
Bradford (Yorksh.)	57	Tee, Samuel L.	1100 0 0			Fry, William	
		Taylor, George		Dundley	6	Blackwell, John	246 0 0
Braintree		Cannington, A.	8 7 8	Dumbarton		Mitchell, R. G.	80 0 0
Brampton		Graham, John, M.D.	13 3 5	Dumfries, Burgh	140 0 0
Brecon	70 4 0	Dunbar	1	Shed, James	11 9 8

LOCAL COMMITTEES OF THE UNITED KINGDOM.

OM, which returned
to Exhibition.

Committee	Amount paid to Commission.
...	£. s. d.
...	6 11 0
...	21 1 0
...	24 16 0
...	50 0 0
...	150 0 0
...	650 0 0
...	20 0 0
...	113 3 0
...	30 0 0
...	68 11 6
...	6 15 11
...	37 5 6
...	132 2 0
...	170 0 0
...	96 0 0
...	200 0 0
...	62 14 10
...	100 0 0
...	83 14 0
...	8 0 0
...	62 10 0
...	08 2 2
...	20 0 0
...	11 3 0
...	21 0 0
...	60 0 0
...	20 0 0
...	24 18 0
...	50 0 0
...	112 0 0
...	13 2 0
...	10 0 0
...	18 10 0
...	6 3 6
...	50 0 0
...	5 17 0
...	250 0 0
...	13 4 6
...	40 0 0
...	123 13 0
...	14 14 0
...	83 18 6
...	70 0 0
...	35 0 0
...	246 0 0
...	80 0 0
...	140 0 0
...	11 9 8

Places.	Number of Exhibitors	Secretary of Committee.	Amount paid to Commission.	Places.	Number of Exhibitors	Secretary of Committee.	Amount paid to Commission.
			£. s. d.				£. s. d.
Dundee	3	Millne, George	100 0 0	Iale of Wight	2	Eldridge, James	50 8 4
Dunfermline	8	Monro, W. C.	193 1 0	Newport	1	Hearn, J. H.	85 0 0
Dunmow	1	Kilgour, Alexander	10 0 0	Ryde	2	Eldridge, T. W.	25 0 0
Dunstable	2	Morris, F. J.	11 6 9	Cowes	2	Manning, J. O.	60 15 6
Durham	3	Osborn, Joseph	150 0 0	Ventnor	1	Burt, John	5 8 9
Edinburgh	137	Forster, J. H.	300 0 0	Jedburgh	1	Laing, —	13 6 7
Egham	6	Tod, James	83 17 0	Jersey	10	Hilson, George, jun.	250 0 0
Elgin	6	Duff, Patrick	21 14 4	Keighley (Yorksh.)	2	Le Quenne, Chas.	Evans, George E.
Exeter	29	Brutton, Charles	00 0 0	Kendall	7	Spencer, George E.	105 2 8
Exmouth	1	Adams, H. C.	17 15 0	Keswick	2	Hudson, T. D.	Gandy, Gerard
Falkirk	6	Gentleman, Patrick	3 5 1	Kidderminster	17	Hall, Joseph	110 10 0
Falmouth & Penryn	23	Rundell, W. W.	30 0 0	Kilmarnock	7	Hallen, Thomas	226 7 6
Farnham	5	Nicholls, Benj.	21 0 0	King's Lynn	5	Wilson, James	44 10 0
Farrington	1	Crowder, G.	2 16 9	Kirkcaldy	12	Brow, Alexander	56 0 0
Fleetwood	1	Knapp, —	3 8 10	Knaresborough	12	Sang, William	68 10 3
Folkestone	1	Stewart, J.	38 6 0	Lancaster	5	Powell, S., jun.	19 4 6
Frome	2	Brockman, R. T.	31 14 0	Launceston	1	Olliver, J. S.	Dunn, W.
Galashiels	12	Walters, Geo., jun.	60 0 0	Leamington	2	Gurney, Charles	17 3 0
Glasgow	126	Haldane, Robert	2400 0 0	Leeds	134	Hambury, John B.	33 2 4
Glastonbury	8	Johnson, William	30 0 0	Leek	10	Wilson, Thomas	1600 0 0
Glossop	1	Liddell, Andrew	25 0 0	Leicester	38	Kitson, James	Cawood, Martin
Gloucester	10	Strang, J., LL.D.	21 16 0	Leicester	38	Stone, S.	21 5 0
Godalming	4	Clark, J.	23 1 6	Leicester	38	Wheeler, S. H.	150 0 0
Gosport	1	Ball, John	41 13 4	Lewes	6	Lower, M. A.	100 0 0
Grantham	4	Fryer, K. H.	59 8 0	Lichfield	4	Lomax, T. G.	22 15 6
Gravesend	5	King, William	17 16 0	Limerick	12	Boyes, John	56 12 0
Great Grimsby	9	Wilkinson, Josiah	77 8 0	Lincoln	3	Mason, R.	10 0 0
Greenock	14	Ekin, Thomas	100 0 0	Liskeard	63	Jago, James	500 0 0
Guernsey	14	Sharland, George	271 10 6	Liverpool	9	Grantham, John	128 9 3
Guildford	1	Daubeny, N. H.	87 0 0	Llanely	2	Thomas, John	28 5 3
Haddington	31	Hill, Ninian, M.D.	14 17 0	Louth (Lincoln)	1	Ingoldby, C.	150 0 0
Halifax	31	Macnaughtan, P.	608 10 3	Luton	6	Higginbotham, S.	49 12 8
Hartlepool	1	Clugas, Thomas	35 0 0	Macclesfield	1	Smith, James	74 4 6
Harwich	20	Le Lievre, Peter	80 0 0	Maidenhead	21	Moncton, John	13 0 7
Hastings	6	Haydon, S.	19 10 0	Maldstone	191	Chubb, R.	4000 0 0
Hawick	2	Routhead, D.	21 0 0	Malmesbury	2	Fleming, Hugh	62 3 1
Helston	1	Carter, Richard	72 8 8	Manchester	7	Cavaler, William	3 0 0
Hemel Hempstead	11	Crosley, Frank	33 9 2	Margate	1	Leighton, Robert	15 4 6
Henley	8	Brown, William	19 5 8	Market Weighton	7	Williams, Sir E., Bt.	8 9 9
Hereford	8	Belk, Thomas	131 5 5	Marlborough	1	Ward, W. Lakin	20 11 0
Hertford	1	Chapman, Edward	8 0 0	Marlow (Great)	2	Newnes, Rev. Mr.	10 3 2
Hitchin	1	Rock, James, jun.	12 11 8	Matlock	1	Phillip, J. L.	305 14 4
Hong Kong	1	Wilson, James	850 0 0	Melksham	2	Erskine, James	45 0 0
Honiton	1	Hill, Frederick	19 5 8	Melrose	2	Wolrige, John C.	Fallows, William
Horncastle	70	Stallon, Samuel	131 5 5	Merthyr Tydvil	7	Gilkes, Edgar	50 18 0
Huddersfield	27	Cooper, Samuel	8 0 0	Middlesboro'	2	Fallowes, William	Myers, G. C.
Hull	1	Johnson, Richard	12 11 8	Montrose	2	Burnaby, F. F. A.	32 0 0
Huntingdon	1	Longmore, P.	850 0 0	Newark	7	Roake, J. W.	50 0 0
Ifracombe	22	Goodwin, Samuel	227 12 6	Newbury	9	Tomkinson, W.	32 14 0
Ipswich	13	Devenish, Samuel	50 2 6	Newcastle (Stafford)	8	Watson, Joseph	448 16 0
Ile of Man, Douglas	13	Weir, George	7 4 8	Newcastle-on-Tyne	76	Burnett, Thomas	Wintle, James
		Greenwood, Fred.	200 0 0	Newnham (Glo'ster)	1	Latch, Thomas	79 19 3
		Shaw, Joseph	42 11 8	Newport (Monm.)	10	Bull, W. B.	60 0 0
		Laycock, J. C.		Newport Pagnell	1	Jefferson, W. T.	5 6 0
		Jacobs, Bethel		Northallerton	2	Rands, G., jun.	55 0 0
		Frost, Horaca		Northampton	16	Leman, R.	400 0 0
				Norwich	35	Willett, Henry	

Place.	Number of Committees.	Secretary of Committee.	Amount paid to Commission.	Place.	Number of Committees.	Secretary of Committee.	Amount paid to Commission.
			£. s. d.				£. s. d.
Nottingham	60	Enfield, William . Rawson, George Butler, Rev. W. J.	200 0 0	Stirling	10	Boyd, A. Morrison, P. G.	83 14 1
Oldham (Hants)		Seymour, J. O.	18 10 6	Stockport	4	Vaughan, John	400 0 0
Oldham		Radcliffe, Henry	75 0 0	Stockton	11	Crosby, John	70 0 0
Oswestry	5		22 10 0	Stonhouse (Plymouth)	1	Laing, Joseph	15 0 0
Oxford	27	Walker, Rev. R., M.A. Spiers, R. J. Plowman, Joseph	150 0 0	Stourbridge	17	Rodd, Richard	15 0 0
Palsley	31	Martin and Hodge	126 8 6	Stroud	13	Mann, J. P.	50 0 0
Pateley Bridge		Vivian, Henry A.	12 0 0	Sunderland	17	Gibson, G. W.	92 16 0
Penzance	4	Pearce, Richard	40 0 0	Swansea	19	Freston, W. A.	150 0 0
Perth	19	Reid, Archibald	40 0 0	Swindon		Candlish, John	105 0 0
Peterborough	1	Ruddle, James	18 17 5	Tamworth	2	Snowball, William	8 0 0
Plymouth	8	Waite, Robert	110 12 0	Taunton	13	Francis, G. G.	41 18 6
Pocklington		Arthur, Oswald C. Hornby, T.	4 11 6	Tavistock	3	Thompson, J.	55 2 6
Pools	7	Welch, M. K.	30 0 0	Tewkesbury		White, Esias	30 12 7
Portland			19 0 6	Torrington		Luxton, R.	20 18 0
Portsmouth	9	Deacon, Henry	328 12 8	Totnes	3	Vosper, A. S. M. Thomas, Joshua	17 12 10
Preston	4	Howard, John Cartwright, S.	256 12 7	Tring		Seaman, Henry	2 15 0
Ramegate	4	Burgess, George	30 0 0	Truro	25	Faithful, Henry	41 3 6
Reading	17	Lovejoy, George	70 0 0	Trowbridge		Simmons, G. N.	30 0 0
Redruth	12	Peters, John L.	38 9 0	Tunbridge Wells	3	Bladon, Thomas	279 5 6
Reigate	9	Martin, Peter	15 0 0	Uttoxeter		Witham, James	39 10 6
Retford (East)	3	Phillips, William	84 6 6	Wakefield	12	Newman, John W.	24 0 0
Richmond (Yorksh.)	3	Cooke, Leonard	15 0 0	Walsall	10	Jessop, Laveton	22 0 0
Ripon	4	Nicholson, R. W.	1 0 8	Waltham Abbey	3	Filliter, Freeland	150 0 0
Rochester		Pral, R.	18 13 10	Wareham	10	Fike, J.	60 0 0
Romey (Hants)	1	Daman, W.	40 0 0	Warrington	7	Marsh, John F.	150 0 0
Rotherham	8	Barras, John	16 18 2	Warwick	7	Tibbitts, James	70 0 0
Rugby	6	Highton, Rev. H.	22 14 6	Waterford	3	Nevis, Hugh N.	38 15 8
Runcorn	1	Simpson, John	20 6 0	Wellington (Salop)	1	Benson, J.	5 0 0
Rye	1	Dawes, E. N.	70 19 0	Wellington (Somers)	2	White, Fred.	46 16 8
Saffron Walden	5	Spurgen, Thomas	29 0 0	Wells	1	Davies, Robert	106 10 0
Salisbury	2	Lee, L. Charles	18 16 0	Wentworth		Dillon, Rev. E.	160 0 0
Scarborough	5	Moody, J. J. P.	24 0 0	Wexford	12	Cramp, W. H.	90 0 0
Salby	3	Lowther, George	4 0 0	Whitby	17	Belcher, Henry	300 0 0
Selkirk	2	Standerer, Thos. Rodger, Peter	21 10 0	Whitehaven	6	Armistead, R.	15 0 0
Settle	4	Robinson, W.	500 0 0	Wigan	4	Acton, Thomas	30 0 0
Sheerness	4	Keddel, J. T.	282 0 0	Winchester	2	Bailey, Charles	300 0 0
Sheffield	158	Plimsole, Samuel	7 2 0	Windsor	6	Voules, C. S.	15 0 0
Shrewsbury	13	Pidgeon, Henry	38 15 0	Wirksworth	2	Whittaker, James	02 13 6
Sidmouth		Radford, George	369 2 2	Wisbeach	10	Walford, S., jun.	200 0 0
Slough		Deacon, C. E.	5 18 0	Witham	3	Walker, Thomas	6 0 0
Southampton	13	Lewis, Richard	13 18 6	Wolverhampton	35	Allen, J. G.	206 4 2
Southport		Pearse, James	20 0 0	Wolverton	1	Webb, Edward	6 11 5
South Molton		Riccard, R. M.	80 0 0	Worcester	20	Purchas, Samuel	30 0 0
South Shields	8	Elliott, Robinson	240 15 6	Workington	5	Armstrong, George	30 0 0
Spalding	8	Stevenson, Alex. Watkinson, Henry	20 0 0	Worthing	5	Tribe, W. F.	26 10 0
Stafford	3	Turnock, James	10 15 0	Wotton-under-Edge	2	Foxwell, W. Gulse	307 18 7
Staffordshire Pot-teries	40	Battam, Thomas	10 15 0	Yarmouth, Great	10	Palmer, C. J.	66 3 3
Stamford	7	French, William	50 0 0	Yeovil	10	Batten, John, jun.	103 6 3
St. Albans	7	Langley, Ald.	15 0 9	York	15	Munby, Joseph	67,208 3 10
St. Austell	17	Drew, J. H.	11 10 6	Sundry Subscriptions not included elsewhere			
St. Neots	1	Wilkinson, J.		Total	6146		

TABLE FOR FACILITATING REFERENCE FROM THE INDEXES TO THE CATALOGUE,
Shewing the CLASS, COLONY, or FOREIGN COUNTRY, and EXHIBITORS' NUMBER, on each page.

UNITED KINGDOM.—CLASSES Nos. 1 to 30.

	Amount paid to Commission.
	£. s. d.
	83 14 1
P. G.	400 0 0
John	70 0 0
ph	
ard	15 0 0
W.	50 0 0
A. A.	92 16 0
John	150 0 0
William	105 0 0
G.	8 0 0
J.	41 18 6
s.	55 2 0
	80 12 7
S. M.	
ahua	20 18 0
	1 9 0
ry	17 12 10
enry	2 15 0
N.	
	41 3 6
omas	30 0 0
ames	279 5 6
ohn W.	39 10 0
ston	24 0 0
eland	32 0 0
F.	150 0 0
nes	80 0 0
h N.	
	70 0 0
rt	
	38 15 8
	5 0 0
E.	
I.	46 16 8
ry	
	106 10 0
ns	160 0 0
les	90 0 0
	300 0 0
ames	15 0 0
	92 13 6
uo.	
mas	200 0 0
	8 0 0
d	200 4 2
uel	
George	6 11 5
	30 0 0
Guise	26 10 0
	30 7 0
un.	66 3 3
h	103 6 3
	307 18 7
	67,208 3 10

No. of CLASS.	Exhibitors' Numbers.	Page.	No. of CLASS.	Exhibitors' Numbers.	Page.	No. of CLASS.	Exhibitors' Numbers.	Page.	
OUTSIDE THE BUILDING. (Vol. I.)	1 to 5	113	CLASS III. - (Vol. I.)	1 to 4	200	CLASS V. - contd.	922 to 956	259	
	6 - 19	114		5 - 13	201		958 - 992	260	
	20 - 37	115		14 - 31	202		993 - 1000	261	
	38 - 53	116		32 - 48	203				
	54 - 71	117		49 - 70	204				
	75 - 104	118		71 - 91	205		CLASS VI. - (Vol. I.)	1	263
				92 - 115	206			2 - 10	268
CLASS I. - (Vol. I.)	1 - 8	120	CLASS IV. - (Vol. I.)	1 - 6	195*		14 - 24	270	
	9 - 11	121		7 - 24	196*		25 - 39	271	
	12 - 24	122		25 - 43	197*		30 - 44	273	
	25 - 29	123		44 - 49	198*		45 - 54	274	
	30 - 36	124		51 - 64	199*		55 - 74	275	
	37 - 47	125		65 - 77	200*			277	
	48 - 55	126		78 - 103	201*		78 - 92	279	
	56 - 61	127		104 - 105	202*		94 - 122	280	
	62 - 68	128		106 - 114	203*		124 - 134	282	
	69 - 78	129		115 - 128	204*		135 - 151	283	
	79 - 91	130		128A - 135	205*		152 - 157	284	
	92 - 101	131		136	206*		158 - 165	285	
	102 - 109	132		137 - 139	207*		166 - 200	286	
110 - 128A	133				201	287			
129 - 131	134				202 - 206	291			
131A - 137	135				207 - 218	292			
					219 - 220	293			
					221 - 228	294			
					230 - 308	295			
					310 - 400	297			
					401 - 404	298			
					405 - 408	299			
					410 - 424	301			
					426 - 441	302			
					442 - 454	303			
					455 - 460	304			
					462 - 604	305			
					605 - 606	306			
					608 - 631	307			
					CLASS VII. (Vol. I.)	1 - 6	309		
						7 - 13	310		
						14 - 26	311		
						29 - 31	312		
						32 - 42	313		
						43 - 52	314		
						53 - 56	315		
						57 - 70	316		
						71 - 82	317		
						84 - 96	318		
						97 - 99	319		
						100	320		
						101 - 107	321		
						109 - 114	323		
						115 - 134	324		
						137 - 148	325		
						150 - 157	326		
						158 - 175	328		
						176 - 192	329		
						193 - 205	330		
						206 - 334	331		
						CLASS VIII. (Vol. I.)	1 - 15	334	
							16 - 34	335	
							35 - 59	336	
							60 - 71	337	
							72 - 92	338	
							93 - 110	339	
							111 - 127	340	
							128	341	
							129 - 136	342	
							136 - 143	343	
							144 - 149	344	
							150	345	
							151 - 161	346	

TABLE FOR FACILITATING REFERENCE

No. of Class.	Exhibitors' Numbers.	Page.	No. of Class.	Exhibitors' Numbers.	Page.	No. of Class.	Exhibitors' Numbers.	Page.	
CLASS VIII.—cont.	162 to 173	347	CLASS X.—cont.	317 to 320	443	CLASS XIV.—cont.	54 to 67	513	
	174 - 188	348		322	444		68 - 73	514	
	189 - 194	349		323 - 335	446		74 - 81	515	
	195 - 200	350		336 - 340	448		92 - 96	516	
	201 - 211	352		341 - 357	449				
	212 - 224	353		358 - 376	450		CLASS XVI. - (Vol. II.)	1 - 19	518
	225 - 238	354		377 - 398	451			20 - 46	519
	238A - 245	355		399 - 402	452			47 - 60	520
	246 - 252	356		403 - 406	453			61 - 78	521
	253 - 257	357		407 - 419	454			79 - 92	522
	258 - 284	358		420 - 426	455			93 - 114	523
	285 - 302	359		427	456			115 - 151	524
	303 - 317	360		428	457			152 - 181	525
	317A - 335	361		429 - 430	458			182 - 207	526
	336 - 337	362		432 - 433	459			208 - 248	527
	CLASS IX. - (Vol. I.)	338 - 353		363	434 - 437		460	249 - 283	528
		1 - 13		365	438 - 440		461	284 - 301	529
		15 - 28A		366	441 - 453		462	301A	530
		28B - 37		367	454 - 459		463	302 - 327	534
		38 - 41A		368	460 - 474		464	328 - 332	535
42 - 49		369	475 - 480	465	CLASS XVII. - (Vol. II.)	1 - 22	538		
50 - 63		370	481 - 486	466		23 - 25	539		
65 - 78		371	487 - 503	467		26 - 41	540		
80 - 86		372	504 - 520	468		42 - 48	541		
87 - 93		373	522 - 531	469		49 - 76	542		
94 - 108		374	532 - 546	470		77 - 94	544		
109 - 123		375	547 - 556	471		96 - 123	545		
123A - 127		376	557 - 559	472		124 - 142	546		
128		377	560 - 573	473		143 - 154	547		
129 - 135		380	574 - 577	474		155 - 171	548		
136 - 140		383	578 - 596	475	172 - 175	549			
141 - 142		385	597 - 619	476	176 - 194	550			
143 - 150		387	620 - 631	477	195 - 200	551			
151		388	631A - 634	478	201 - 210	552			
152 - 180		389	635 - 655	465*	CLASS XVIII. - (Vol. II.)	1 - 26	554		
181 - 182	391	656 - 664	466*	27 - 38		555			
183 - 193	392	664A - 672A	467*	39 - 56A		556			
195 - 215A	393	673 - 677	468*	57 - 74		557			
216 - 230	394	677A - 682	469*	76 - 94		558			
232 - 233	395	683 - 684A	470*	CLASS XIX. - (Vol. II.)		1 - 3	559		
234 - 239	396	685 - 688	471*		4 - 28	560			
240 - 241	397	689 - 700	472*		29 - 56	561			
242 - 246	398	702 - 711	473*		57 - 74	562			
248 - 255A	399	712 - 730	474*		75 - 97	563			
256 - 266	400	732 - 741	475*		100 - 135	564			
267 - 290	401	743	477*	136 - 165	565				
CLASS X. - (Vol. I.)	291	402	CLASS XI. - (Vol. II.)	1 - 14	480	166 - 192	566		
	1 - 4	406		15 - 44	481	192A - 217	567		
	6 - 9	407		46 - 60	482	218 - 249	568		
	10 - 16	408	CLASSES XII, XV. (Vol. II.)	61 - 65	483	250 - 271	569		
	17 - 19	409		1 - 15	486	272 - 309	570		
	20 - 31	410		16 - 47	487	310 - 336	571		
	32 - 40	411		48 - 80	488	337 - 371	572		
	41 - 53	412		81 - 109	489	372 - 390	573		
	54 - 55	413		110 - 129	490	391 - 403	574		
	56 - 57	414		130 - 139	491	CLASS XX. - (Vol. II.)	1 - 2	575	
	60	415		140 - 146	492		3 - 8	576	
	62 - 67	416		147 - 165	493		9 - 16	577	
	68 - 87	417		165A - 178	494		16A - 35	578	
	90 - 113	418	179 - 201	495	36 - 46		579		
	115 - 128	419	202 - 222	496	46A - 61		580		
	129 - 144	422	223 - 247	497	62 - 80		581		
	145	426	248 - 266	498	81 - 91		582		
	146 - 161	429	267 - 281	499	92 - 111		583		
	162 - 188	430	282 - 304	500	112 - 128		584		
	CLASS XII. - (Vol. I.)	189 - 202	431	305 - 469	501	128A - 146	585		
204 - 210		433	470 - 501	502	147 - 168	586			
212 - 220		434	CLASS XIII. (Vol. II.)	1 - 3	503	168A - 188	587		
223 - 254		435		5 - 24	504	189 - 205	588		
254A - 263		436		25 - 43	505	206 - 217	589		
264 - 270		437	CLASS XIV. (Vol. II.)	44 - 64	506	CLASS XXI. - (Vol. II.)	1 - 4	591	
271 - 285		438		65 - 80	507		5 - 24	592	
286 - 290		439		1 - 18	510		25 - 39	593	
291A - 296		440	19 - 36	511	40 - 49	594			
297		441	37 - 53	512					
298 - 303	442								

FROM THE INDEXES TO THE CATALOGUE.

Exhibitors' Numbers.	Page.	No. of Class.	Exhibitors' Numbers.	Page.	No. of Class.	Exhibitors' Numbers.	Page.	No. of Class.	Exhibitors' Numbers.	Page.
54 to 67	513	CLASS XXII. - (Vol. II.)	110-30	596	CLASS XXIII. - (Vol. II.)	1	671	CLASS XXVI. - <i>continued.</i>	346 to 401	759
68 - 73	514		31 - 45	597		2 to 11	673		402 - 528	760
74 - 91	515		46 - 60A	598		12 - 14	674		539 - 534	761
92 - 96	516		62 - 64	599		15 - 25	675		535 - 536	762
1 - 19	518		65 - 84	600		26 - 32	676			
20 - 46	519		85 - 94	601		33 - 34	677	CLASS XXVII. - (Vol. II.)	1 - 17	764
47 - 60	520		95 - 98	602		35 - 37	678	18 - 33	765	
61 - 78	521		99 - 106	603		38 - 42	679	35 - 45	766	
79 - 92	522		106A - 107	604		43 - 51	680	46 - 63	767	
93 - 114	523		108 - 110	605		52 - 65	681	65 - 75	768	
115 - 151	524		110A - 115	606		66 - 79	682	76 - 85	769	
152 - 181	525		116 - 127	607		80 - 86	683	86 - 89	770	
182 - 207	526		128 - 138	608		87 - 88	684	90 - 97	771	
208 - 248	527		139 - 149	609		89 - 94	685	98 - 112	772	
249 - 283	528		150 - 158	610		95 - 97	686	113 - 121	773	
284 - 301	529		159 - 170	611		98	688	122 - 124	774	
302 - 327	530		171 - 182	612		99	689	125 - 127	775	
328 - 332	535		183 - 186	613		100 - 105	690	128 - 144	776	
1 - 22	538		187 - 193	614		106 - 111	691			
23 - 25	539	194 - 204	615	112 - 113	692	CLASS XXVIII. - (Vol. II.)	3 - 21	778		
26 - 41	540	204A - 211	616	115 - 119	693	22 - 51	779			
42 - 48	541	212 - 223	617	120 - 131	694	52 - 76	781			
49 - 76	542	224 - 235	618	140	695	77 - 85	782			
77 - 94	544	236 - 241	619			86 - 104	783			
96 - 123	545	242 - 249	620	CLASS XXIV. - (Vol. II.)	1 - 12	106 - 128	784			
124 - 142	546	250 - 255	621	13 - 19	699	131 - 160	785			
143 - 154	547	256 - 263	622	20 - 22	700	161 - 188	786			
155 - 171	548	264 - 270	623	23 - 33	701	191 - 200	787			
172 - 175	549	271 - 282	624	34 - 40	704					
176 - 194	550	283 - 286	625	41 - 63	705	CLASS XXIX. - (Vol. II.)	1 - 3	789		
195 - 200	551	287 - 292	626	64 - 78	706	4 - 32	790			
201 - 210	552	293 - 300	627	79 - 100	707	33 - 50	791			
1 - 26	554	301 - 309	628			51 - 68	793			
27 - 38	555	310 - 316	629	CLASS XXV. - (Vol. II.)	1	69 - 95	794			
39 - 56A	556	317 - 323	630	2	709	96 - 115	795			
57 - 74	557	324 - 330	631	3 - 5	711	116 - 140	796			
76 - 94	558	331 - 336	632	5A - 6	714	141 - 155	797			
1 - 3	559	337 - 241	633	7 - 9	717	156 - 170	798			
4 - 28	560	342 - 345	634	10	720	171 - 196	799			
29 - 56	561	346 - 349	635	11 - 14	722	197 - 226	800			
57 - 74	562	350 - 354	636	15 - 20	723	228 - 267	801			
75 - 97	563	355 - 360	637	21 - 26	724	270	802			
100 - 135	564	361 - 370	638	27 - 38	725	273 - 290	815			
136 - 165	565	371 - 373	639	39 - 46	726	291 - 305	816			
166 - 192	566	374 - 384	640	47 - 53	727	305A - 320	817			
192A - 217	567	386 - 389	641	54 - 60	728					
218 - 249	568	390 - 401	642			CLASS XXX. - (Vol. II.)	1 - 3	820		
250 - 271	569	402 - 411	643			5 - 23	821			
272 - 309	570	412 - 438	644	CLASS XXVI. - (Vol. II.)	1 - 10	25 - 48	822			
310 - 336	571	438A - 443	645	11 - 23	730	49 - 65	823			
337 - 371	572	444 - 446	646	24 - 48	732	66 - 76	824			
372 - 390	573	447 - 451	647	49 - 67	733	77 - 89	825			
391 - 403	574	452 - 481	648	69 - 76	734	90 - 109	826			
1 - 2	575	482 - 486	649	77 - 78	735	110 - 111	827			
3 - 8	576	487 - 495	650	79 - 85	739	111A - 123	828			
9 - 16	577	496 - 523	651	87 - 110	740	124 - 147	829			
16A - 35	578	524 - 534	652	111 - 124	741	148 - 166	830			
36 - 46	579	535 - 545	653	125 - 132	742	167 - 189	831			
46A - 61	580	546 - 553	654	133 - 143	743	190 - 215	832			
62 - 80	581	554 - 560	655	144 - 159	744	216 - 224	833			
81 - 91	582	563 - 592	656	160 - 164	745	225 - 232	834			
92 - 111	583	594 - 611	657	165 - 177	746	232A - 241	835			
112 - 128	584	612 - 637	658	178 - 180	747	242 - 250	836			
128A - 146	585	638 - 641	659	181 - 187	748	251 - 268	837			
147 - 168	586	642 - 643	661	188 - 192	749	269 - 288	838			
168A - 188	587	644 - 645	662	193 - 198	750	289 - 300	839			
189 - 205	588	646	663	199 - 211	751	301 - 315	840			
206 - 217	589	647 - 658	664	211A - 215	752	316 - 355	841			
1 - 4	591	659 - 672	665	217 - 237	753	336 - 360	842			
5 - 24	592	673 - 688	666	238 - 255	754	361 - 364	843			
25 - 39	593	690 - 696	667	256 - 275	755					
40 - 49	594	697 - 705	668	276 - 287	756	SCULPTURE (Vol. II.)	1 - 16	843		
		754 - 798	669	288 - 313	757	17 - 49	844			
		799 - 810	670	314 - 345	758	50 - 73	845			
						74 - 86	846			

ALPHABETICAL LIST OF COLONIES AND FOREIGN STATES.

NAME OF PLACE.	Exhibitors' Numbers.	Page.	NAME OF PLACE.	Exhibitors' Numbers.	Page.	NAME OF PLACE.	Exhibitors' Numbers.	Page.
ALGERIA - - - (Vol. III.)	1 to 10 11 - 18 19 - 45 46 - 66 67 - 73	1259 1260 1261 1262 1263	<i>Bermudas</i> - - - (Vol. II.)	- - -	971	FRANCE—continued.	136 to 160 161 - 176 177 - 182 183 - 210 211 - 220 220A - 235 236 - 252 253 - 272 273 - 294 295 - 308 309 - 326 327 - 348 349 - 374 375 - 384 385 - 391 394 - 411 412 - 422 424 - 444 445 - 478 479 - 504 505 - 518 519 - 551 552 - 581 582 - 600 601 - 626 627 - 642 643 - 664 665 - 688 689 - 707 708 - 726 727 - 742 744 - 761 762 - 777 778 - 798 799 - 821 822 - 849 850 - 880 881 - 893 894 - 915 916 - 933 934 - 964 965 - 995 996 - 1022 1023 - 1047 1048 - 1079 1080 - 1106 1107 - 1114 1115 - 1143 1144 - 1172 1173 - 1194 1195 - 1214 1215 - 1239 1241 - 1268 1269 - 1295 1296 - 1328 1329 - 1349 1350 - 1369 1370 - 1389 1390 - 1413 1414 - 1434 1435 - 1462 1463 - 1476 1477 - 1485 1486 - 1514 1515 - 1525 1526 - 1548 1549 - 1568 1569 - 1586 1587 - 1606 1607 - 1619 1620 - 1644 1645 - 1670 1671 - 1703 1704 - 1724 1725 - 1741	1178 1181 1182 1183 1184 1187 1188 1189 1190 1191 1192 1193 1194 1195 1196 1197 1198 1199 1200 1201 1203 1204 1205 1206 1207 1208 1209 1211 1212 1213 1215 1216 1217 1218 1219 1220 1221 1222 1223 1224 1225 1226 1227 1228 1229 1230 1231 1232 1233 1234 1235 1236 1237 1238 1239 1240 1241 1242 1243 1244 1245 1246 1249 1250 1251 1252 1253 1254 1255 1256 1257 1258 1259
<i>Antigua</i> - - - (Vol. II.)	- - -	975	BOLIVIA - - - (Vol. III.)	- - -	1429			
AUSTRIA - - - (Vol. III.)	1 - 4 5 - 19 20 - 38 39 - 58 59 - 72 73 - 80 81 - 98 99 - 122 122A - 140 141 - 167 168 - 182 183 - 199 200 - 232 233 - 265 266 - 286 287 - 297 298 - 322 324 - 340 341 - 361 362 - - 363 - 375 376 - 399 400 - 408 409 - 434 435 - 443 444 - 483 484 - 517 518 - 557 558 - 587 588 - 601 602 - 619 620 - 633 634 - 647 648 - 666 667 - 696 696A - 726 728 - 748	1006 1007 1008 1009 1010 1011 1012 1013 1014 1015 1016 1017 1018 1019 1020 1021 1022 1023 1024 1025 1028 1029 1030 1031 1032 1033 1034 1035 1036 1037 1038 1039 1040 1041 1042 1043 1044	<i>Brazil</i> - - - (Vol. III.)	- - -	1429			
			<i>British Guiana</i> - - (Vol. II.)	1 to 11 12 - 24 25 - 45 46 - 59A 60 - 77 78 - 86A 87 - 98A 99 - 113A 116 - 119 120 - 148B 149 - 164A	977 978 979 980 981 982 983 984 985 986 987			
			<i>Canada</i> - - - (Vol. II.)	1 2 - 18A 19 - 54 55 - 80 81 82 - 121 123 - 147 148 - 178 179 - 341 346 - 355	958 961 962 963 964 965 966 967 968 969			
			<i>Ceylon</i> - - - (Vol. II.)	- - -	937			
			<i>Channel Islands</i> - (Vol. II.)	1 2 - 6 7 - 22 23 - 33 34 - 49	939 940 941 942 943			
			CHILE - - - (Vol. III.)	- - -	1429			
			CHINA - - - (Vol. III.)	1 - 2 3 4 - 6 7 - 10 11 - 16 17 - 18 19 - 32 33 - 38	1418 1419 1420 1421 1422 1423 1424 1425			
<i>Bahamas</i> - - - (Vol. II.)	- - -	975	DENMARK - - - (Vol. III.)	1 - 4 5 - 20 21 - 33 34 - 38 39 - 47 48 - 53	1355 1356 1357 1358 1359 1360			
<i>Barbadoes</i> - - - (Vol. II.)	- - -	971	<i>Eastern Archipelago</i> - (Vol. II.)	- - -	988			
BAVARIA - - - (Vol. III.)	1 - 7 8 - 29 30 - 59 60 - 78 79 - 97 98 - 102	1098 1099 1100 1101 1102 1103	EGYPT - - - (Vol. III.)	1 - 18 19 - 183 184 - 336 337 - 391	1408 1409 1410 1411			
BELGIUM - - - (Vol. III.)	1 - 6 7 - 24 25 - 38 39 - 78 79 - 114 115 - 139 140 - 167 168 - 206 207 - 242 243 - 279 280 - 311 312 - 342 343 - 373 374 - 407 408 - 440 441 - 463 464 - 498 499 - 512	1150 1151 1152 1153 1154 1155 1156 1157 1158 1159 1160 1161 1162 1163 1164 1165 1166 1167	<i>Falkland Islands</i> - (Vol. II.)	- - -	987			
			FRANCE - - - (Vol. III.)	1 - 7 8 - 15 16 - 33 34 - 53 54 - 69 70 - 94 95 - 114 115 - 135	1169 1170 1172 1173 1174 1175 1176 1177			

FROM THE INDEXES TO THE CATALOGUE.

xxx1

Exhibitors' Numbers.	Page.	NAME OF PLACE.	Exhibitors' Numbers.	Page.	NAME OF PLACE.	Exhibitors' Numbers.	Page.				
136 to 160	1178	FRANKFORT - - - (Vol. III.)	1 to 8	1121	MECKLENBURG-SCHWERIN - - (Vol. III.)	1134	PRUSSIA—continued.				
161 - 176	1181		9 - 24	1122		202 to 210		1059			
177 - 182	1182		25 - 33	1124		211 - 227		1060			
183 - 210	1183		GREECE - - - (Vol. III.)	1 - 3		1400		228 - 249	1061		
211 - 220	1184			4 - 7		1401		250 - 267	1063		
220A - 235	1187			8 - 15		1402		268 - 272	1064		
236 - 252	1188			16 - 23		1403		273 - 284	1065		
253 - 272	1189			24 - 39		1404		285 - 305	1066		
273 - 294	1190			40 - 50		1405		306 - 310	1067		
295 - 308	1191			51 - 57		1406		311 - 319	1068		
309 - 326	1192			58 - 62		1407		320 - 331	1069		
327 - 348	1193			HANOVER - - - (Vol. III.)		- - -		976	332 - 356	1070	
349 - 374	1194					1 - 9		1136	357 - 380	1071	
375 - 384	1195					10 - 45		1137	381 - 403	1072	
385 - 391	1196					46 - 64		1138	404 - 415	1073	
394 - 411	1197	65 - 98			1139	416 - 432	1074				
412 - 422	1198	99 - 123			1140	433 - 451	1075				
424 - 444	1199	HANOVER - - - (Vol. III.)			- - -	1133	452 - 458	1076			
445 - 478	1200		1 - 5		1125	459 - 468	1077				
479 - 504	1201		6 - 13		1126	469 - 485	1078				
505 - 518	1203		14 - 32		1127	486 - 509	1079				
519 - 551	1204		33 - 59		1128	510 - 534	1080				
552 - 581	1205		60 - 86		1129	535 - 556	1081				
582 - 600	1206		HANOVER - - - (Vol. III.)		I.	860	557 - 580	1082			
601 - 626	1207				II.	869	581 - 598	1083			
627 - 642	1208				III.	870	599 - 622	1084			
643 - 664	1209			IV.	876	623 - 642	1085				
665 - 688	1211			V.	907	643 - 662	1086				
689 - 707	1212			VI.	908	663 - 682	1087				
708 - 726	1213			VII. VIII.	909	683 - 694	1088				
727 - 742	1215			IX.	912	695 - 712	1089				
744 - 761	1216			X.	913	713 - 735	1090				
762 - 777	1217	XI. to XIII.		914	736 - 759	1091					
778 - 798	1218	XIV. XV.		915	760 - 768	1092					
799 - 821	1219	XVI.		916	769 - 780	1093					
822 - 849	1220	XVII. to XX.		917	781 - 809	1094					
850 - 880	1221	XXI.		918	810 - 839	1095					
881 - 893	1222	XXII. XXIII.		919	840 - 867	1096					
894 - 915	1223	XXIV. to	921	868 - 897	1097						
916 - 933	1224	XXVII.	HESSE DARMSTADT (Vol. III.)	1 - 4	1362						
934 - 964	1225	XXVIII.		5 - 6	1363						
965 - 995	1226	XXIX.		7 - 9	1364						
996 - 1022	1227	XXX.		10 - 14	1365						
1023 - 1047	1228	XXXI.		15 - 21	1366						
1048 - 1079	1229	XXXII.		22 - 43	1367						
1080 - 1106	1230	XXXIII.		44 - 72	1368						
1107 - 1114	1231	XXXIV. to		73 - 106	1369						
1115 - 1143	1232	XXXVII.		107 - 141	1370						
1144 - 1172	1233	XXXVIII.		142 - 162	1371						
1173 - 1194	1234	XXXIX.		163 - 187	1372						
1195 - 1214	1235	XXXX.		188 - 225	1373						
1215 - 1239	1236	IONIAN ISLANDS - - - (Vol. II.)		1 - 2	947	226 - 256	1374				
1241 - 1268	1237			3 - 6	948	257 - 286	1375				
1269 - 1295	1238			JAMAICA - - - (Vol. II.)	- - -	971	287 - 320	1376			
1296 - 1328	1239		1 - 4		1140	321 - 323	1377				
1329 - 1349	1240		5 - 11		1141	324 - 327	1378				
1350 - 1369	1241		LÜBECK - - - (Vol. III.)		- - -	1130	328 - 334	1381			
1370 - 1389	1242				1 - 4	1140	335 - 349	1382			
1390 - 1413	1243				5 - 11	1141	350 - 365	1383			
1414 - 1434	1244				LUXEMBOURG - - - (Vol. III.)	- - -	1130	366 - 376	1384		
1435 - 1462	1245					1 - 2	1047	SARDINIA - - - (Vol. III.)	1 - 11	1302	
1463 - 1476	1245					3 - 18	1048		12 - 38	1303	
1477 - 1485	1247					19 - 35	1049		39 - 68	1304	
1486 - 1514	1246					36 - 57	1050		69 - 97	1305	
1515 - 1525	1249					58 - 76	1052		SAXONY - - - (Vol. III.)	1 - 5	1104
1526 - 1548	1250					77 - 89	1053			6 - 23	1105
1549 - 1568	1251	90 - 114				1054	24 - 45			1106	
1569 - 1586	1252	115 - 136				1055	46 - 64			1107	
1587 - 1606	1253	137 - 153		1058		65 - 89	1108				
1607 - 1619	1254	154 - 180		1057		90 - 112	1109				
1620 - 1644	1255	181 - 201		1058		113 - 140	1110				
1645 - 1670	1256	MAURITIUS - - - (Vol. II.)	- - -	956		141 - 165	1111				
1671 - 1703	1257		1 - 2	1047		166 - 179	1112				
1704 - 1724	1258		3 - 18	1048		180 - 188	1113				
1725 - 1741	1259		19 - 35	1049	MECKLENBURG-STRELITZ (Vol. III.)	- - -	1134				
			36 - 57	1050		1 - 8	1142				
			58 - 76	1052		9 - 29	1143				
			77 - 89	1053		30 - 48	1144				
			90 - 114	1054		49 - 70	1145				
			115 - 136	1055		71 - 81	1146				
			137 - 153	1058		82 - 89	1147				
			154 - 180	1057		90 - 105	1148				
			181 - 201	1058		106 - 114	1149				
						1 - 8	1142				
						9 - 29	1143				
						30 - 48	1144				
				49 - 70		1145					
				71 - 81		1146					
				82 - 89		1147					
				90 - 105	1148						
				106 - 114	1149						
				1 - 27	969						
				28 - 29	970						
				- - -	971						
				1 - 13	989						
				15 - 25	990						
				- - -	971						
				1 - 3	1000						
				4 - 24	1001						
				25 - 40	1002						
				- - -	970						
				- - -	1135						
				- - -	1135						
				1 - 14	1285						
				15 - 24	1286						
				25 - 48	1287						
				49 - 57	1288						
				1 - 4	1426						
				5 - 10	1427						
				1 - 3	1306						
				4 - 28	1307						
				29 - 82	1308						
				83 - 136	1309						
				137 - 273	1310						
				274 - 358	1311						
				359 - 445A	1312						
				446 - 551	1313						
				552 - 637	1314						
				638 - 855	1315						
				856 - 1022	1316						
				1022A-1126	1317						
				1126A-1299	1318						
				1 - 2	1047						
				3 - 18	1048						
				19 - 35	1049						
				36 - 57	1050						
				58 - 76	1052						
				77 - 89	1053						
				90 - 114	1054						
				115 - 136	1055						
				137 - 153	1058						
				154 - 180	1057						
				181 - 201	1058						

* In India the articles are distinguished by the numbers of the Catalogue only.

TABLE FOR FACILITATING REFERENCE, &c.

NAME OF PLACE.	Exhibitors' Numbers.	Page.	NAME OF PLACE.	Exhibitors' Numbers.	Page.	NAME OF PLACE.	Exhibitors' Numbers.	Page.
SOCIETY ISLANDS (Vol. II.)	- -	1438	SWEDEN AND NORWAY— <i>contd.</i>	32 to 45 46 - 79 80 - 117	1352 1353 1354	UNITED STATES— <i>continued.</i>	55 to 73 74 - 90 91 - 101 102 - 115 116 - 140 141 - 146 147 - 156 157 - 166 167 - 176 177 - 201 202 - 225 227 - 243 244 - 277 278 - 308 309 - 325 326 - 344 345 - 356 357 - 361 362 - 365 366 - 374 375 - 381 382 - 417 418 - 440 441 - 469 470 - 483 494 - 504 505 - 529 530 - 548 549 - 580 582 - 599	1437 1438 1439 1440 1441 1442 1446 1447 1448 1449 1450 1451 1452 1453 1454 1455 1456 1457 1458 1459 1460 1461 1462 1463 1464 1465 1466 1467 1468 1469
South Africa (Vol. II.)	1 to 8 10 - 45 46 - 47 48 - 60	499 950 951 952	SWITZERLAND (Vol. III.)	1 - 6 7 - 15 16 - 23 24 - 36 37 - 52 53 - 68 69 - 78 79 - 95 96 - 112 113 - 135 136 - 152 153 - 156 157 - 179 180 - 191 192 - 208 209 - 224 225 - 241 242 - 257 258 - 277	1265 1266 1267 1268 1269 1270 1271 1272 1273 1274 1275 1276 1277 1278 1279 1280 1281 1282 1283	Trinidad (Vol. II.)	- -	972
South Australia (Vol. II.)	- -	991	TUNIS (Vol. II.)	1 - 9 10 - 40 41 - 49 50 - 79 80 - 189	1412 1413 1414 1415 1416	Van Diemen's Land (Vol. II.)	1 - 9 10 - 65 66 - 130 131 - 186 187 - 226 227 - 289 290 - 330 331 - 348 349 - 350	992 993 994 995 996 997 998 999 1000
SPAIN (Vol. III.)	1 - 6 7 8 - 11 12 13 - 15 16 - 17 18 - 20 21 - 30 31 - 45 46 - 54 55 - 79 80 - 98 99 - 115 116 - 127 128 - 148 149 - 157 158 - 176 177 - 186 187 - 193 194 - 215 216 - 228 229 - 249 249 ^B - 263 264 - 275 ^A 276 - 300	1322 1323 1325 1326 1327 1328 1329 1330 1331 1332 1333 1334 1335 1336 1337 1338 1339 1340 1341 1342 1343 1344 1345 1346 1347	TURKEY (Vol. III.)	- -	1385	WURTEMBERG (Vol. III.)	1 - 11 12 - 33 34 - 64 65 - 78 79 - 105 106 - 110	1114 1115 1117 1118 1119 1120
ST. DOMINGO (Vol. III.)	- -	1428	TUSCANY (Vol. III.)	1 - 7 8 - 16 17 - 19 20 - 30 31 - 57 58 - 61 62 - 71 72 - 89 90 - 109 110 - 114 115 - 121 122 - 123	1290 1291 1292 1293 1294 1295 1296 1297 1298 1299 1300 1301	UNITED STATES (Vol. III.)	1 - 17 18 - 37 38 - 49 50 - 54	1433 1434 1435 1436
St. Helena (Vol. II.)	- -	955	WESTERN AFRICA (Vol. II.)	1 - 5 5 ^A 5 ^B - 19 20 - 24	952 953 954 955	Western Africa (Vol. II.)	1 - 5 5 ^A 5 ^B - 19 20 - 24	952 953 954 955
St. Kitts (Vol. II.)	- -	976						
St. Vincent (Vol. II.)	- -	975						
SWEDEN AND NORWAY. (Vol. III.)	1 2 - 7 8 - 24 25 - 31	1348 1349 1350 1351						

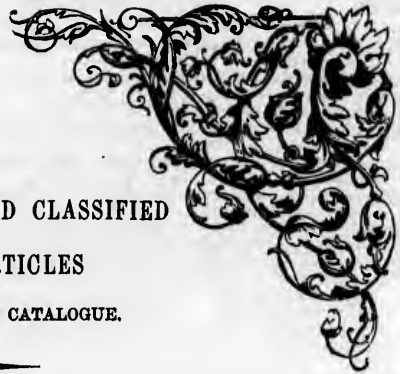
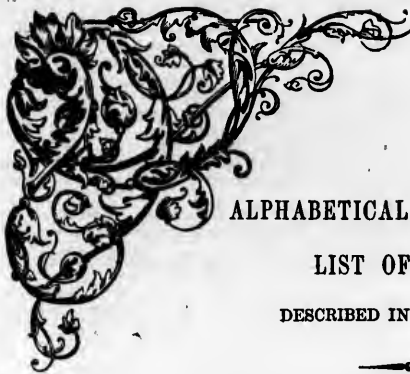

ALPHABETICAL AND CLASSIFIED

LIST OF ARTICLES

DESCRIBED IN THE CATALOGUE.

Memorandum.—Persons consulting this Index will find that the articles contained therein are arranged according to a principle by which the whole of a series of the same species are grouped together as far as practicable. *Es. gr.*; Under "Magnesia" will be found "Magnesia, Bi-carbonate of," "Magnesia, Sulphate of," and so on. Under "Railways" will be found "Railway Axles," "Railway Bars," &c. &c. The references following each Article distinguish—1. The Class in the United Kingdom, the Colony, or Foreign Country in which the same will be found, and Name of Exhibitor; and 2. The Number in the Catalogue borne by the entry to which the same is prefixed.]

ABSYNTHIUM—Sardinia, Saluce, 10.
 ACCIDENT DETECTOR—v. Angus, 716.
 ACCORDIONS—Austria, Reinisch, 163. Steinkellner, 164.
 Zollerlein (1), Wagner and Co., 701. (3), Zimmerman, 24.
 ACCORDION-STAND—x. Faulkner, 530.
 ACCOUNT BOOKS—XVII. Cowan & Sons, 101. Harris & Galabin, 373. Knight, 86. Rock & Co., 108. Roy-ston & Brown, 205. Waterlow & Sons, 46.
 China, Copland. France, Gaymaril and Gerault, 518.
 United States, Herrick, 502. M'Adams, 482. Sibell & Mott, 339. See also *Ledgers*.
 ACCOUTREMENTS, MILITARY—See *Military Accoutrements*.
 ACCUMULATOR—v. Armstrong, 44.
 ACETIC ACID—Austria, Wagenmann & Co., 19.
 ACOLYTE (Patent Safety Candle-Cap)—XXIX. Jones, 95.
 ACONITE AND ITS PREPARATIONS—II. Hopkins & Williams, 41. Morson & Son, 106. India, 11.
 Spain, Tabala, 129.
 ACORN—Spain, 93, 115.
 ÆOLIAN—Zollerlein (1), Baltzer, 82.
 ÆOLIAN PITCHPIPES—x. Greaves, 503.
 ÆOLIAN VIOLIN MUTE—x. Greaves, 503.
 ÆOLOPHON—x. Storer, 529.
 AERATING MACHINES—See *Soda-Water Machines*. *Vases*, *Syphon* (for Aerated Waters).
 AERIAL CURRENTS REGULATOR—XXII. Edwards, 241.
 AERIAL MACHINES (Models)—x. Brown, 713. Graham, 233. Plummer, 716. Sadd, 301—See also *Balloons*, &c.
 AERIAL TINTING—XXX. (Fine Art Court) Concanen, 2.
 AGATES—I. Dyer, 10. Gelling, 139. Tolan, 22. XXIII. Morel & Co., 117. Canada, Logan, 1.
 India, 1.
 Zollerlein (1), Eiffer & Co., 891. Görlitz, 890. Keller & Co., 888. Wild & Robinson, 889.
 AGAVE FIBRE—Barbadoes. Trinidad, Lord Harris.
 AGON, THE GAME OF—XXIX. Peacock, 193.
 AGRA MARBLE (inlaid)—XXVII. Stewart, 33.
 AGRICULTURAL IMPLEMENTS—IX. 1 to 279. XXI. Wal-dron & Sons, 17. XXII. Butterley, 240. Hutton, 166. Keep & Watkin, 76. Slagg, 158. Waldron & Sons, 17, 185.
 Austria, Horsky, 123. Magui, 126. Prince Lohkowitz's Agricultural Implement Manufactory, 124. Riesi-Stallburg, Baron, 125.
 Belgium, Claes, 163. Delatanehe, 510. D'Omalus, 171. Romedenne, 165. Scheidweiler, 164. Train, 167.
 Canada, Glassford, 89. Skinner & M'Culloch, 88, 90.
 Ceylon, Denmark, Andersen, 15. Egypt, 169-174.
 France, Batailler, 412. Bodin, 426. Jerome, Brothers, 549. Lebert, 569. Mittelette, 1661. Moysen, 467. Schneider & Legrand, 1001. Vachon & Co., 705.

India, VI. IX.
 Netherlands, Cazaux, 89. Heeslink, 66. Jenken, 74.
 Portugal, 632. Switzerland, Chollet, 70.
 United States, Allen & Co., 97. Emory & Co., 148. Gates, 423. Gating, 162. Hussey, 65. McCormick, 73. Smith, 86. Wells, 107.
 Western Africa, Jamieson, 22.
 Zollerlein (1), Sprengel & Co., 67. Stolle, 65.
 (6), Heese-Darmstadt Board of Agriculture, 13.
 See also *Barley Aveler*. *Carts and Waggons*. *Chaff-cutting Machines*. *Churns*. *Cultivator*. *Drill Grubbers*. *Drill Ploughs*. *Drills*. *Fanning-mill*. *Farm Buildings*. *Grass-cutting, &c.*, *Machine*. *Grass and Hay-cutting Machines*. *Grubbers*. *Harrow*. *Hay-making Machines*. *Hay and Straw-cutting Machines*. *Liquid Manure Machines*. *Mowing and Reaping Machines*. *Oil-cake Mill*. *Ploughs*. *Scarifiers*. *Scythes*. *Seed-dibbling, &c.*, *Machines*. *Shearing Machines*. *Steam-Engines*, *Agricultural*. *Subsoil Pulverizers*. *Thrashing Machines*. *Turnip-cutting Machines*. *Uley Cultivators*. *Winnowing Machines*.
 AGRICULTURAL MODELS—Austria, Carniolian Agricultural Society, 127.
 United States, Bryant, 171. Mix and Gardinier, 96.
 AIR CONDUCTOR—VII. Cochrane, 158.
 AIR GUNS. See *Guns*, &c.
 AIR PONTOONS—United States, Armstrong, 219.
 AIR PUMPS AND ENGINES—v. Parsey, 591. x. Bryan, 408. Heywood, 404. Newman, 674. Orchard, 161. Varley, 257. Yeates, 332.
 Denmark, Nissen, 20. France, Breton, Brothers, 1113.
 AIR-TIGHT BED CHAIR—XXVIII. Hancock, 83.
 AIR-TIGHT BOTTLES—v. Stocker, 422.
 AIR-TIGHT JAR—XXII. Hampden, 612.
 AIR-TIGHT TAPS—XXIV. Shephard, 8.
 AIRE CAST-IRON BRIDGE (Model)—VII. Leather, 107 (Main Avenue, West).
 AIRISH MOW (for the preservation of corn in rainy seasons)—IX. Jones, 52.
 ALABASTER (Stalactite or Stalagmite) AND ALABASTER ARTICLES—Cundy, page 848. I. Monteiro, 150. Whittaker, 53. XXVII. Hall, J. & T., 37, 38. Egypt, 1-5.
 Greece, Greek Government, 49. India, 1.
 Tuscan, Y. Chemici & Sons, 109. De Lardere, 24. Fontana, 122.
 Zollerlein (1), Finsch, 211.
 ALABASTER FOUNTAIN—Zollerlein (5), Tacchis & Co., 21.
 ALABASTER PAINTINGS—Switzerland, Schöck, 251.
 ALABASTER TAZZA.—Rome, Tommaso della Moda, 19 (Main Avenue, East).

Exhibitors' Numbers.	Page.
55 to 73	1437
74 - 90	1438
91 - 101	1439
102 - 115	1440
116 - 140	1441
141 - 146	1442
147 - 156	1446
157 - 166	1447
167 - 176	1448
177 - 201	1449
202 - 225	1450
227 - 243	1451
244 - 277	1452
278 - 308	1453
309 - 325	1454
326 - 344	1455
345 - 356	1456
357 - 361	1457
362 - 365	1458
366 - 374	1459
375 - 381	1460
382 - 417	1461
418 - 440	1462
441 - 469	1463
470 - 483	1464
494 - 504	1465
505 - 529	1466
530 - 548	1467
549 - 580	1468
582 - 599	1469
1 - 9	992
10 - 65	993
66 - 130	994
131 - 186	995
187 - 226	996
227 - 289	997
290 - 330	998
331 - 348	999
349 - 350	1000
1 - 11	1114
12 - 33	1115
34 - 64	1117
65 - 78	1118
79 - 105	1119
106 - 110	1120
1 - 5	952
5A	953
5B - 19	954
20 - 24	955

- ALARM GUNS**—VIII. Carron, 251. Naylor, 199. See also *Alarm Guns*.
- ALARM BEDSTEADS**—X. Jones, 656. XXII. Savage, 56.
- ALARM BELLS**—XXII. Lea, 665.
- Belgium*, Van Hecke, 480.
- ALARM GUNS**—IX. Gillett, 78. Warren, 237. See also *Alarm Guns*.
- ALARUMS** (for Clocks, &c.)—X. Baker, 396. XXIII. Martin, Baskett, & Martin, 2. France, Pierret, 330.
- ALARUMS** (for Houses, &c.)—VIII. Carte, 29. X. Darnell, 363. XXII. Cooke, 579.
- ALBERT**, H.B.H. PRINCE, Equestrian Statue of, Wyatt; page 853. Electrotypic Bust of, Elkington & Co., page 848. Portrait of, in Sèvres China, Main Avenue, East, 97. Bust of, in stucco, I. Vieille Montagne Mining Company, 437. Portrait of, woven in silk, XIII. Cross, 32. Statuette of, in silver, XXIII. Zimmerman, 80. Portrait of, on jewel-case, XXX. (Fine Art Court) 352. Design for monument to, Bennett, 268.
- ALBERT STREET**, Mile End, New Town, Model of dwellings of Artizans at, VII. Metropolitan Association for Improving the Dwellings of the Industrious Classes, 172.
- ALBUMEN**—Austria, Engelmann, 22.
- ALBUMEN OF BLOOD**—France, Boyer & Co., 71.
- ALBUMEN FROM EGGS**—France, Aleou, 1538.
- ALBUMS**—Belgium, Parent, 278.
- France, Godefroy, 1722. Pilout, 681.
- Switzerland, Spalinger, 253.
- Zollverein* (1), Gehardt, 248. Leisegang, 149. Beisser, 748. Schoening, 154. (2), Bieschoff & Co., 98.
- ALCOHOL**—France, Lefebv & Brothers, 579. Maire & Co., 317. Portugal, 518.
- ALHAMBRA**, THE (Piece of the Wall of)—Spain, Yaasi, 284.
- ALIMENTARY PRESERVES**—France, Appert, 751. Carnet-Saumiere, 791. Chatelein & Basset, 797. Chevet, 121. Clot, 456. Cuvillier, 469. Du Liscolt & Son, 1328. Dupas, 1204. Durand, 1598. Feyeux, 209. Gillet, 521. Gremailly, 246. Groult, 530. Guibery, Deslandelle, & Co., 1263. Houssard, 1826. Levrault, 59. Maquin, 1337. Maason, 1348. Noye, 1372. Peneau, 950. Philippe & Canaud, 956. Rodet & Son, 992. Rouchier & Son, 994. Seyeux, 1486. Sigaut, 1487. Thorel, 1041. Vidal, 727.
- Canada, Brunsten & Co., 17.
- Lubeck, Carstena, 2. Netherlands, Janssen, 19.
- Russia, Eloff, 80. Tunis, 89, 90, 154, 157, 158.
- Zollverein* (1), Farthmann, 18. Weill, 20. See also *Amazones, Preserved*.
- ALKALI**—St. Helena, Agricultural Society, 2.
- ALKALI SALT**—II. Ward & Co., 54.
- ALKALOID BERBERINE**—II. Howards & Kent, 11.
- ALLOYS**—I. Jordan, 487. Stirling, 428.
- ALMANACKS**—VII. Holland, 132. XVII. Hume, 166.
- ALMOND OIL**—IV. Brotherton & Co., 23.
- Portugal, 487-489.
- ALOE** (manufactured specimens of)—Gibraltar.
- ALOE-FIBRE STUFFING** (for Furniture)—Belgium, Hausens-Hap, 257.
- ALOE AND ITS PREPARATIONS**—II. Lamplough, 71. Smith, T. & H., 94. Ceylon.
- ALOPS THREAD CLOAK**—Algeria, Bernardon, 8.
- ALPACA FABRICS**—XII. & XV. Bliss, 270. Craven & Harrop, 153. Dalby, 152. Fifth & Sons, 37. Milligan & Son, 140. Salt, 139. Schwann & Co., 141. Senior, 476. Walker & Sons, 87.
- Belgium, Decock, 221.
- ALPINE PLANTS**—*Zollverein* (1), Heckel, 430.
- ALTAR FURNITURE**—XXVI. French, 110. Ponsanby, 190. Pratt, 196. See also *Ecclesiastical Furniture*.
- ALTAR-PIECES** (Painting, Sculpture, &c.)—XXVI. Carter, 185. Thomas, 277.
- ALTAR SCREEN, CHAIRS, &c.**—Jordan, page 851.
- ALTO-RELIEFS**—France, Kirstein, 281.
- ALUM AND ITS PREPARATIONS**—II. Copper, 118. Hurlet & Campsie Alum Company, 13. Moberley, 17 (Main Avenue, West). Pattinson, 18 (Main Avenue, West). Spence, 7. Wilson, 6 (Main Avenue, West).
- Austria, Hochbeyer, 14. Miesbach, 1. Egypt, 371.
- France, Bouxwiller Mines Joint Stock Co., 376.
- India, I. Rome, Pellegrini, 27. Snelker, 3.
- Russia, Itohegolaff, 336. Schlippe, 27.
- Spain, Mauraudy, 40. Turkey.
- Tuscany, 5. Volterra Salt Manufactory, 2.
- United States, Davidson, 561.
- Van Diemen's Land, Bichenow, 294.
- Zollverein* (1), Bleibtreu, 313. Harkort, 876. Prussian Chemical Manufactory, 683. Schwesmal Alum Works, 463.
- AMADOU**—*Zollverein* (1), Becker, Sapp, & Co., 471.
- AMAZON**, THE (Group in sino)—*Zollverein* (1), Kiss, 279 (Main Avenue, East).
- AMAZONE, OR ESSENCE OF MEAT**—III. Warriner & Soyer, 21. Russia, Schetverikoff, 187.
- AMBER**—XXIX. Fletcher, 244.
- Zollverein* (1), Hoffmann, C. W., 439. Hoffmann, G. F., 440. Manheimer, 438. Roy, 441. Tessler, C. L., 41. Tessler, D. F., 40.
- AMBER, OIL OF**—II. Godfrey & Cooke, 92.
- ANDER ORNAMENTS**—Turkey.
- Zollverein* (1), Jantsen, 205. Winterfeld, 204.
- AMBER, SALT OF**—Godfrey & Cooke, 92.
- AMBERGRIS**—II. Godfrey and Cooke, 92.
- AMBULANCE, MEDICO-CHIRURGICAL**—X. Veitch, 6.
- AMMONIA**—II. Godfrey & Cooke, 92. XXII. Holliday, 448. Moberley, 17.
- AMMONIA, BENZOATE OF**—II. Hopkins & Williams, 41.
- AMMONIA, CARBONATE OF**—XXII. Holliday, 448.
- AMMONIA, HYDROCHLORATE OF**—India, II.
- AMMONIA, MURIATE OF**—II. Brown & Co., 7c. XXII. Holliday, 448.
- AMMONIA, SULPHATE OF**—II. Brown & Co., 7c. Wilson, 6. XXII. Holliday, 448. France, Digeon, 1590.
- ANATOMICAL FIGURES AND MODELS**—X. Gordon, 639. Highley, 727. Simpson, 624. Towne, 625.
- France, Aurour, 13. Carreau & Chailion, 792. Mantois, 602. *Zollverein* (2), Fleichman, 71.
- ANCHORS**—Western End, North Enclosure (Outside), Rodger, 55. Longridge & Co., 57. Brown, Lenox, & Co., 58. VIII. Allen, 992. Bowen, 325. Brown, Lenox, & Co., 61. Ezall, 3. Hely, 14. Honiball, 95. Inglefield, 99. Longridge & Co., 333. Rodger, 338. Smale, 94. Wood & Co., 102. XXII. Wood, Brothers, 75. See also *Cables, Chain-cables*.
- ANCHORS, MACHINES FOR RAISING**—VIII. Robinson, 100. See also *Captains*.
- ANCIENT WRITINGS** (fac-similes of)—XVII. Harrison, 202.
- ANEMOMETERS**—Adcock, 364. X. Gowland, 27.
- Belgium, De Hennault, 183.
- Zollverein* (1), Kruger, 67.
- ANGLE-METER**—X. Cox, 347.
- ANGOLA CLOTH**—XII. & XV. Harris & Fison, 145. Midgley, Brothers, 99. Scott & Wright, 1.
- ANHYDROUS STEAM-ENGINE**—V. Haycraft, 151.
- ANIMAL BLEAK**—Belgium, Seghers, 110. Verstraeter, 108.
- ANNUNCIATOR, JACKSON'S**—United States, Brooks, 222.
- ANTIMONY AND ANTIMONY ORE**—I. Hallett, 481. Liekeard Committee, 513. II. Howards & Kent, 11.
- Austria, Geisberger, 11. Ssolteny, 12. Szegö, 10.
- India, I. Portugal, Perseveranca, 14.
- Spain, The Inspector of Mines at Saragossa, 11.
- Tuscany, Mejean, 15. Western Africa, Jamieson, 22.
- Zollverein* (1), Masgesprung Works, 682.
- ANTI-SARGASSIAN CONSERVATIVE PAINT**—II. Peacock, 73.
- ANTWERP** (Plan of)—Belgium, Valerius-Jouan, 452.
- ANVILS**—XXII. Armitage, M. & H., 150. Sandersou, 220. Stirk, 74. Warden, 368.
- APERITIVE FOUNTAIN**—IX. Read, 89.
- APIARIES**. See *Beehives*.
- APPAREL**. See *Wearing Apparel*.
- APPENZEL MOUNTAINS** (Model in relief)—Switzerland, Schoell, 252.
- APPOFF'S SELF-REGULATING FRICTION BREAK**—V. Botten, 429.
- AQUATIC VELOCIMETER**—United States, St. John, 534.
- ARAB TENTS**—Tunis, 82.
- ARABESQUE DECORATION**—XXVI. M'Lachlan, 337. Smith, 341. Spain, Contreras, 283.

- Co., 376.
ider, 3.
- 7, 2.
- rt, 876. Prussian
Alum Works,
& Co., 471.
ein (1), Kiss, 279
- III. Warriner &
87.
- Hoffmann, G. F.,
Tessler, C. L.,
92.
- feld, 204.
2.
k. Veitch, 6.
XIII. Holliday, 448.
- & Williams, 41.
Holliday, 448.
z, II.
& Co., 7c. XXII.
- & Co., 7c. Wilson,
Digeon, 1590.
-x. Gordon, 639.
owns, 625.
hailou, 792, Man-
man, 71.
e (Outside), Rodger,
Lenox, & Co., 58.
Browne, Lenox, &
oniball, 95. Ingie,
33. Rodger, 336.
II. Wood, Brothers,
27.
- III. Robinson, 100.
- XVII. Harrison, 202.
eland, 27.
- ia & Fison, 145.
right, 1.
raft, 151.
D. Verstraeter, 108.
es, Brooks, 222.
Hallett, 481. Lis-
ds & Kent, 11.
2. Szegö, 10.
4.
gossa, 11.
ca, Jamieson, 22.
682.
INT—II. Peacock,
e Jouat, 452.
D. Sandersou, 226.
- ef)—Switzerland,
BREAK—v. Bot-
St. John, 534.
hlan, 337. Smith,
- ARBELA, BATTLE OF (copper embossed tableau)—*Austria*,
Scentpeetrij, 729.
- ABRUTUS-WOOD ORNAMENTS—XXIII. Connell, 16.
- ARCHIL—*See Orchil*.
- ARCHIMEDEAN AGRICULTURAL MACHINE—IX. Murphy,
388.
- ARCHIMEDEAN SCREWS (for raising fluids, &c.)—v. Beere,
467. *Belgium*, Van Burkhoven, 502.
- ARCHITECTURAL MODELS, &c.—XXVI. Bielsfeld, 157. Jack-
son & Sons, 5. Jones & Co., 380. Norwood, 314.
Pugin, 529. XXVII. Keene, 10. Stevens & Sons, 24.
XXX. (Fine Art Court) Clarke, 342A. Coulton, 342.
Day, 161A. Gorrings, 164. Herwitz, 347. Nicholl,
272. Potter, page 832. Smith, 211, 213. Talbot, 349.
- Austria*, Montanari, 738. *Belgium*, Joostens, 457.
British Guiana, Barkly, 81. *Ceylon*,
France, Flacheron-Hayard, 836. Traversa, 1044.
India, XXX. Oldenburgh, Casseboh, 1.
Trinidad, Lord Harris. *Sorzano*,
Tuscany, Ducci, 82. Mazatti, 115.
United States, Basham, 315. *Peru*, ania Railroad
Company, 327.
Zolloverein (1), Boesche, Kruse. *See also*
Church Architecture. Canvas Windows. House Deco-
tions. Mouldings.
- ARGENTIFEROUS GALENA. *See Lead, Sulphuret of.*
- AROILLA KNOBS—*United States*, Dean, Amos, & Co., 101.
- AROL—*South Africa*, De Villiers, 2.
- ARM-HOLDER FOR GUNS—*Tunis*, 58.
- ARM-PAD (for Tailors)—XXVIII. Collings, 120.
- ARMATURES—x. Jouis, 440.
- ARMING PRESS (for Bookbinders)—vi. Sherwin, Cope, &
Co., 104.
- ARMINUS, Prince of the CHERUSKERS, Statue of—Zoll-
verein (1), Cauer, 431 (Main Avenue, East).
- ARNORIAL BEARINGS (Designs of)—XXVI. Clarke, 127.
See also Heraldic Engraving.
- ARNOUR—*India*, VIII.
- ARMY CLOTHING—Zollverein (1), Mentzel, 94. *See also*
Military Accoutrements. Regimental Trousers.
- AROMATIC VINEGAR—*France*, Brunier, Lenormand, & Co.,
75.
- ARROWROOT—III. Brown & Polson, 123. Miller, 127.
St. Etienne, 138.
Bermudas, Gray. *British Guiana*, Garnett, 31 & 32.
Ceylon, China, East India Company. *India*, III.
Jersey and Guernsey, Martin, 26. *Montserrat*,
Trinidad, Lord Harris.
Van Diemen's Land, Denison, Sir W. T. 25.
Western Africa, Trotter, 5. Weston 1.
- ARROWS—*See Bows and Arrows.*
- ARSENIC AND ARSENICAL COMPOUNDS—I. Garland, 489.
Jenkins, 502. Pattinson & Cain, 497. II. Jenkins, 453.
Austria, Voltzrauer, 13. *China*, *France*, Briere, 438.
India, II. Zollverein (1), Guettler, 6.
- ARSENIC, INSTRUMENT FOR TESTING—x. Morton, 285.
- ARTESIAN WELL BORING APPARATUS—vi. Beart, 301.
- ARTIFICIAL FLOWERS—*See Flowers, Artificial. Flowers*,
Was.
- ARTIFICIAL FUEL. *See Fuel, Artificial. Steam Fuel.*
- ARTISTS' TOOLS, MATERIALS, &c.—I. Winsor & Newton, 28.
XVII. Bowden, 63. XXVI. Boddella, 193. XXX.
(Fine Art Court) Harvey, 31. Hopley, 296. Rowney
& Co., 3. Wolff & Son, 129.
France, Fontaine, 205. Lehond, 1301. *See also Brushes*,
Artists'. Canvas for Painting. Colours, Artists'.
Crayons. Drawing Instruments. Lay Figures.
Zollverein (1), Karcher, 877.
- ASBESTUS—*Canada*, Logan, 1.
- ASHLAR STONE—I. Thorns, 475.
- ASPHALTE—Eastern end (outside). I. Seyssel Asphalte Co.,
229. *Canada*, Logan, 1.
France, Dufour, 485. Henning, 1.
New Brunswick, Gould. *Portugal*, Goulard, 25. Sub-
serta, 23. *Rome*, Pasquali, 2.
Spain, Inspector of the Soria Mines, 28.
- ASPHALTE ROOFING FELT—VII. Croggon & Co., 110.
- ASSAY BALANCES—x. De Grave & Co., 333.
- ASSAYING MATERIALS AND PROCESS—I. Mathison, 479.
Pattinson, 480.
- ASTRONOMICAL INSTRUMENTS—x. Bateman, 157. Brake,
354. Elliott & Sons, 390. Reade, 254A (Main Ave-
nue, West). *Rom*, 254 (Main Avenue, West).
France, Vedy, 719.
Zollverein (1), Tiedt, 78, (2), Ertel, Frangott, & Sons, 25.
See also Astroramas. Chronoglobium. Clocks, Astro-
nomical. Clocks, Geographical. Eclipse Indicators.
Lunarians. Periphans. Planispheres. Sextants.
Telescopes. Uranium.
- ASTORAMAS—x. Matthews, 193.
- ATLASES—XVII. Wyld, 175.
- ATMOSPHERES—XXII. Edwards, 241.
- ATMOSPHERIC PROPELLER—v. Eccleshall, 132.
- ATMOSPHERIC RECORDER (for registering changes in the
atmosphere)—x. Dollond, 145.
- AUTOCHRONOGRAPHS—x. Thomson, 80.
- AUTOGRAPHIC PRESSES—vi. Watlow & Sons, 161.
- AUTOPHON—x. Dawson, 554.
- AUTUMNAL LEAVES—*United States*, De Bonneville, 210.
Maxwell, 384. Olmsted, 359. Williams, 243.
- AVIARY—XXX. (Fine Art Court) Zuccani, 348.
- AXES—*See Tools, Carpenters', &c.*
- AXLES AND WHEELS—v. Beecroft, Butler, & Co., 646.
Collinge & Co., 817. Drabble & Co., 842. Gibson,
848. Greenway, 698. Raworth, 913. Squire & Co.,
706. Thornton & Sons, 490. XXII. Eykyn & Milliclap,
309. Hutton, 166. Lucas & Son, 204A. Williams,
280.
Denmark, Smed, 29. *France*, Rastouin, 1727.
Netherlands, Soeders, 81.
United States, Billings and Ambrose, 34. Hyde, 582.
See also Railway Axles.
- AZIMUTH COMPASSES—*See Compasses, Azimuth.*
- AZURE AND MINERAL BLUES—*Belgium*, Wouvermans, 35.
- BABY JUMPER—XXIX. Rogers & Co., 100.
- BACKRAMON BOARDS—XVII. Woodman, 42. *India*, XXIX.
- BADGES, &c., OF KNIGHTHOOD—VIII. Firmin & Sons, 211.
xx. Firmin and Sons, 161.
- BAEL TREE WINE—II. Fould, 108.
- BAGATELLE BOARD—XXVI. Wilson & Sons, 293.
- BAGPIPES—*New South Wales*, Clutch, 5.
- BAIZE—*Netherlands*, Vreede & Co., 33.
Spain, Moreno, Brothers, 253D.
Zollverein (3), Lehmann, 107.
- BAKED CLAY ORNAMENTS—*France*, Garnaud, 233.
- BALLASTING VESSELS (method of)—VIII. Shuidham, 172.
Pugh, 353.
- BALL-COCKS AND TAPS—XXII. Common, 630. Murray,
793. *See also Valves, Cisterns.*
- BALLOONS AND PARACHUTES—VII. Brown, 202. x. Bell,
715. Luntley, 237. Mason, 714. *See also Aerial*
Machines.
- BALLOT BOX—*France*, Baranowski, 15.
- BALSAMS—II. The London Druggists, 117. *Turkey*.
- BAMBOOS—*Labuan, &c.*, Hammond & Co., 2.
- BANDAGES. *See Trusses, Bandages, &c.*
- BANK CHEQUE PAPER—II. Niszen & Parker, 36. XVII.
Saunders, 36.
- BANK NOTES, COPIES OF—XVII. Caffry, 167. *Sweden*,
Broling, 114.
- BANK-NOTE NUMBERING MACHINE—vi. Waterlow &
Sons, 164.
- BANK-NOTE PAPERS—XVII. Saunders, 36.
- BANK-NOTE PRINTING-MACHINE—vi. Schlesinger & Co.,
168.
- BANNISTERS. *See Stair Balustrades.*
- BARGES (Models)—VIII. Holl & Co., 166. Searle & Sons,
169 (Main Avenue, West).
- BARILLA—*See Potash.*
- BARILLA PLANT—*Spain*, 45.
- BARIUM, CHLORIDE OF—II. Robertson, 81.
- BARK, ARTICLES MADE OF—*Canada*, Campbell, 176. *Central*
Commission, 171. *Rochelean*, 175.
St. Vincent, Bullock. *Sweden*, Bjorckman, 103. *Turkey*.
- BARK CLOTH—*India*, XIV. *Labuan, &c.*, Woolley, 3.
- BARK SOLUTION—*Van Diemen's Land*, Button, 22.
- BARKS—II. The London Druggists, 117. xv. Gillman, 44.
British Guiana, Outridge, 62. Stutchbury, 59-61, 63,
65, 66.

- South Africa*, Timalwiter, 27.
New Zealand, McVay, 5. *Russia*, N.N., 88.
St. Vincent, Bullock. *Trinidad*, Lord Harris.
Van Diemen's Land, Button, 23. Denlau, Sir W. T., 71, 72, 74-76. Milligan, 39. Hees, 314. See also *Oak Bark*. *Tunners Bark-grinding Mill*. *Willow Bark*.
- BARLEY**—See *Corn*.
BARLEY AVELER—IX. Holmes & Sons, 241.
BARLEY AWNER—IX. Raisomes & May, 124.
BARLEY CHUMPER—IX. Guldin, 45A.
BARLEY HUMMELLERS—IX. Barrett, Esall, & Andrews, 128. Cooch, 43A, 53. McCartney & Drummond, 246.
BAROMETERS—IX. Brown, 91. X. Abraham, 140. Baker, 396. Brooke, 144. Brown, 676. Burall, 673. Casello & Co., 157A. Chadburn, Brothers, 259. Dixey, 271. Dobbie, 166. Gray & Keen, 138. Griffiths, 331. Grimoldi, 159. Harris & Son, 149. Moyle, 710. Negretti & Zambra, 160A. Newman, 674. Orchard, 161. Pace, 117. Phillips, 411. Pizala, 163. Ross, 187. Somalvicco & Co., 681A. Tremlett, 163. Yeates, 332.
BAROMETERS, ANEROID—X. Moreau, 326. Rush, 137.
BAROMETER CLOCKS—See *Clocks, Barometer*.
BARREL ORGANS—See *Organs, &c.*
BARRELS—See *Casks*.
BARRICADE MORTAR—V. Rock, 952.
BARRICADE—*British Guiana*, Manget, 121.
BARTES—J. Potter, 87. *Canada*, Logau, 1.
BARYTES, CARBONATE OF—I. Beamish, 112. Co'ns, 63. Cumming, 157. Pennock, 218.
BARYTES, NITRATE OF—*Portugal*, Serzedello & Co., 61. *Sardinia*, Albain, Brothers, 7.
BARYTES, SULPHATE OF—I. Riddell, Sir J. M., 53. Robertson, 81. *Zollverein* (8), Nassau Government Engineers of Mines, 1.
BASKETS AND BASKET WORK—XX. Capper & Son, 45. XXVI. Greverie, 255. XXVIII. Adamson, 156. Bode, 103. Cannings, 159. Dunlop, 155. Franks, 128. Indigent Blind School, 100. King, 41. Potts, 104. Smith, 172. Toplis & Sons, 154. Williams, 102. XXIX. Warrell, 32.
Algeria, Saad Ben Barba, 63.
British Guiana, Dennis, 140. Outridge, 148A-163. *Ceylon*.
Egypt, 255, 257, 277, 344, 346, 353, 357-360.
France, Debray, 139. *India*, XXVIII. XXIX. Lubeck, Breyer, 10.
Mauritius, Balkfield & Co., 6. Grey, Countess, 1. Reader, 7. Royal Society of Natural History of Mauritius, 4. *Netherlands*, Landkroon, 67.
New Zealand, 38. St. John's College, 7.
St. Vincent, Bullock.
Trinidad, Lord Harris. *United States*, Mellichamp, 177A. *Van Diemen's Land*, Symonds, 246-253, 274-278. *Western Africa*, Beecham, 12. Hutton, J. F., 21. Hutton & Sons, 6. Jamieson, 22. Townsend, 11. Trotter, 5. Weston, 1.
Zollverein (1), Koerner, 246. (6), Gick, 57.
BAS-RELIEFS—XXX. (Fine Art Court) Caldwell, 33. Edwards, 67. Leighton, 59. Russel, 206. XXX. (Sculpture Court) Adams, 48. Farmer, 31. Gibson, 64. Kirk, 46. Miller, 38, 49, 66-69. Thornycroft, 65. *Austria*, Szentpeterij, 729. *China*.
Denmark, Jerichan, 39. *France*, Huber, 876. *Greece*, Vitalis, 60, 61. *Russia*, Varhovzoff, 368. *Switzerland*, Schneider, 102.
Tuscany, Barbetti, 77. *Zollverein* (5), Von Kress, 32.
BASSOONS—X. Warril, 527. *France*, Buffet, 442. *Zollverein* (4), Helwert, 24. (8), Heckel, 8.
BATH ABBEY CHURCH (Model)—XXX. (Fine Art Court) Hoare, 168.
BATH FREESTONE (Articles in)—XXVII. Newman, 60. Vaughan, 20.
BATH-HEATER (Gas)—XXII. Warriner, 248.
BATHS—XXII. Azulay, 597. Benham & Sons, 98. Bray, 500. Culverwell, 754. Dale, 500. Gilbert, 494. Gillespie & Son, 493. Hardwicks, 496. Loseby, 796. Macbell, 639. Mather, 504. Moggridge, 495. Moss, 498. Shoollred & Co., 66. Tylor & Son, 401. Walton & Co., 69. Wilson, 490. XXV. Finch, 39. XXVIII. Winterborn, 168.
France, Charbonnier, 115.
BATHING-MACHINE (for Ladies)—VIII. Holbrook, 9.
BATS—See *Cricchet Bats*.
BEADED ARTICLES—XXIX. Schrader, 319.
BEADS (Various)—*India*, 1. *Western Africa*, Jamieson, 22.
BEAM AND CUTTING MACHINE—*France*, Chaleyey, 111.
BEAMS AND SCALES—See *Weights and Measures*.
BEAN-MILLS—IX. De Porquet, 202. Grant & Co., 267. Samuelson, 193.
BEANS AND PEAS—III. Croughton, 92. Fordham, 94. Raynbird, 73. Strange, 83.
Canada, Boa, 39. Brien, 44. Fisher, 43. Fournier, 45. Jones, 41. Limoges, 40. La Mere, 42.
New Brunswick, Hutchison, 25. Porter, 27. Searle, 21. Wyse, 22.
Portugal, Boa, 378. Cesar, 373. Caryac, 307. Henriques, 364. Proenca, 371. Silva, 370.
Spain, Gil, 25.
BEAN-SOWING MACHINE—IX. Ponton, 104.
BEARERS FOR BEAMS (in BUILDING)—VII. Perkes & Co., 162.
BEAVER CLOTH—XII. & XV. Hague & Co., 25. Wheeler, 271. *Belgium*, Pirenes & Duesberg, 199.
BEERINE SULPHATE OF—II. Macfarlan & Co., 107. See also *Alkaloid Beberine*.
BED-FEATHERS, DOWN, &c.—IV. Blyth & Co., 60. Dundee Local Committee, 63. Heal & Sons, 59. Nightingale, 57. XXVI. Board, 240. Gilbert & Co., 129A. *Russia*, Lajahn, 145. See also *Eider Down*. *Flocks (for Bedding)*.
BED-FURNITURE—XII. & XV. Schofield, 125. See also *Bedsteads and Furniture*.
BED-JOINTS—XXII. Burrows, 676.
BED-QUILTS—XI. Barlow, 35. Myerscough & Co., 39. Spencer & Son, 52. XIX. Fryer, 237. Richmond Lunatic Asylum, 249. Risdon, 276. Roberts, 365. XX. Standon, 213. XXVI. Board, 240. *France*, Debbedl & Co., 1173. *Turkey*. *United States*, Colman, 71. Spalding, 313. See also *Eider-Down Quilts*.
BED-SACKING—XIV. Dundee Local Committee, 63. Morrison & Hurn, 49. Wall, E. & T., 70.
BED-SACKING, METALLIC—XXII. Chambers, 807.
BEDS, EQUIPOISE—VII. Brown, Sir S., 334.
BEDS, MECHANICAL—*France*, Kissel, 554.
BEDS, PORTABLE—XXVI. Pratt, 403. *United States*, Browne & Co., 334.
BEDSTEADS, ALARUM—X. Jones, 656. XXII. Savage, 56.
BEDSTEADS AND FURNITURE—XIX. Faudel & Phillips, 165. XXII. Jelfcoat, 755. XXVI. Cawley, 225. Dowbiggin & Co., 404. Durley & Co., 169. Fox, 168. Mummery, 292. Rogers & Dear, 264. Smees & Son, 174. Wakeling & Sons, 194.
Canada, Morris, 114. *France*, Maillard, 1338. *India*, XXVI. *United States*, Batjeman, 552. Dunton, 195. See also *Rheo-clines*. *Soft Bedsteads*.
BEDSTEADS, METALLIC—XXII. Cuttarn, 59. Cowley & James, 62. Hill & Co., 65. Johnson, 67. Mapplebeck & Lowe, 370. Perkes & Co., 64. Peyton & Harlow, 371. Smith, 57. Tonkin, 58. Tylor & Pace, 63. Winfield, 373. XXVI. Cuning, 165A. Lyon, 30. Robinson, 263.
France, Dupont, 180. Gandillat & Co., 230. Laude, 847. Leonard, 569. *Sardinia*, Granini, 55.
Spain, Miguel, 260. Sanchez Pescador & Miguel, 259.
BEDSTEADS, PORTABLE—XXII. Blair, 409.
BEDSTEADS FOR SHIPS—XXVI. Bro'ns, 140. See also *Soft Bed*.
BED-TICK STUFFS—XIV. Canter, 36. Carter, Brothers, 36. Fletcher, 36. Hattersley & Co., 36. Hakeworth & Carnley, 36. Jackson & Mathewman, 36. Lockhart & Sons, 57. Pigott & Newton, 36. Wemyss, 58. *Belgium*, Felhouen-Caucke, 481.
BED-WARMER—XXII. Farrar, 527.
BEEHIVES—IX. Briggs, 103. Golding, 45. Hayes, 208A. Jones, 207. Keens, 103. Marriott, 243. Milton, 291. Neighbour & Son, 290. Pettit, 92. Phillips, 72A. Ponder, 146. Rowbottom, 262A. Sholl, 120. Wood, 90. XXVIII. Ramsey, 12.

Brook, 9.

Chalcyer, 111.
Deacons.
Grant & Co., 267.

Fordham, 94.

43. Fournier,
ere, 42.
er, 27. Searle, 21.

arvac, 367. Hen-
370.

4.
VII. Perkes & Co.,

Co., 25. Wheeler,
199,
& Co., 107. See

lyth & Co., 60.
eal & Sons, 59.
Gilbert & Co.,
also *Eider Down*.

1, 123. See also

ough & Co., 39.
237. Richmond
76. Roberts, 365.

27.
ug, 313. See also

mittee, 63. Mor-
70,
ber, 807.
34.
4.

XXII. Savage, 56.
andel & Phillips,
awley, 225. Dow-
169. Fox, 168.

34. Smees & Son,

rd, 1338.
ao, 552. Dunton,
Bedsteads.

59. Cowley &
on, 67. Mapple-
Payton & Har-
Taylor & Pace, 63.
65A. Lyon, 30.

Co., 230. Laude,
nsini, 55.
& Miguel, 259.
9.

140. See also

ter, Brothers, 34.
6. Haxworth &
an, 36. Lockhart
Wemyss, 58.

5. Hayes, 208A.
43. Milton, 291.
& Phillips, 72A.
oll, 120. Wood,

*France, De Beauvoys, 47. Paix de Beauvoys, 941.
United States, Sholl, 538.
Zollverein (1), Bruckiachi, 66. See also Bees (Instru-
ment for securing Swarms).*
BEEHIVE VENTILATOR—IX. Instance, 100.
BEER—II. Truman & Hanbury, 91.
*Turkey. Zollverein (1), Christloul, 15.
BEER ENGINES*—V. Stocker S. & G., 422. XXII. Warner
& Sons, 798.
BEER AND SPIRIT PRESERVERS—XXII. Green & Co., 532.
BEES (at work in Glass Hives)—IX. Milton, 291.
BEES (Instrument for securing Swarms)—IX. Nunn, J. P.
& E. B., 218. See also *Beehives*.
BEES' WAX—Canada, Parisault, 129.
*South Africa, Lindenberg, 45. Ceylon. China.
France, Langier, 1640. India, IV.
Portugal, Bretes, 622. Carvalho, 623, 624. De Fialho,
618, 619.
Van Diemen's Land, Milligan, 273. Rout, 293.*
BETHOVEN, LOUIS VON, STATUE OF (Brouse)—Zollverein
(1), Blasser, 310.
BETLES—II. The London Druggists, 117.
BEE-ROOT RASPING MACHINE—IX. White, 181.
BEE-ROOT SUGAR—XXIX. Wright, 250.
*Austria, Lohkowitz, Prince, 58. Lurisch-Moennich,
Count, 59. Neuwall's Manufactory, 56. Richter &
Co., 57. Robert & Co., 55. Tiernacs Manufactory, 60.
France, Dubreulle & Co., 480. Serret, Hamoir, & Co.,
1465.
Russia, Koukell Jasmopolsky, 335. Sangouibko, Prin-
cess, 78.
Zollverein (1), Behm, 685. Brumme & Co., 687.
Hennigs & Wiese, 691. Von Sanden, 14.
BELGIUM, STATISTICS OF—Belgium, Lesigne, 279.*
BELLS, CATTLE—Austria, Blumauer, 474. Tomasschitz,
475. Switzerland, Schoepfer, 218.
BELLS, CHURCH, &c.—Main Avenue, West (from Montreal).
I. Stirling, 428 (Main Avenue, East). v. Drury,
738. x. Broadbent, 122. XXII. Hodges, 519. Mears,
C. & G., 684 (Main Avenue, West). Murphy, 683
(Main Avenue, West). Taylor & Sons, 682 (South
Transsept). Warner & Sons, 798 (North Transsept).
Canada, Molson, 164.
France, Bollee, 1093. Hildebrand, 540.
Netherlands, Petit & Fritsen, 78.
Zollverein (3), Gruhl, 37 (Main Avenue, East). See also
Hand-bells.
BELLS, ELECTRIC—x. Brett, J. & J. W., 429.
BELLS, MUSICAL CLOCK—XXII. Hale, T. & Co., 486.
BELLS, MUSICAL HAND—x. Drury, 606. XXII. Warner &
Sons, 798.
BELL-HANGING AND FURNITURE—XXII. Bryden & Sons,
44. France, Petithomme, 954. See also *Bell-Ropes*.
BELL-METAL—I. Stirling, 428. India, I.
BELL-ROCK LIGHTHOUSE (Model of)—VII. Commissioners
of Northern Lighthouses, 99.
BELL-ROPE—XXVIII. Woodhead, 191.
Portugal, 1165-1157. Zollverein (1), Zeisig, 225.
BELL-ROPE (Church)—XIV. Day, 55.
BELL TELEGRAPH—United States, Howland, 486.
BELLOWS—XVI. Allio, 35. XXII. Allday, 253. Linley
& Sons, 41. Onions, 249. Taylor, 251. See also *Blast
Fans*.
BELTS, SURGICAL—x. Lawrence & Co., 722.
BENTINCK, LORD G. (Design for Monument to)—XXX.
(Fine Art Court) Mines, 184.
BENZOIC ACID—II. Fowler, 55. India, II.
BERLIN ROYAL ARSENAL (Model)—Zollverein (1), Seeling,
291.
BERLIN WOOL WORK—XII. & XV. Quizow & Co., 178.
XIX. Barnard, 94. Bloomfield, 187. Burton, 118.
Butcher, 256. Evenlen, 162. Gardner, 174. Hayter,
198. Heyn, 178. Kiddell, 221. Kingsbury, 225.
Macdonald, 242. Osborn, 260. Russell, 285. Sib-
thorpe, 299. Smith, 304. Sturmy, 90. Ssaffell, 398.
Tarin, 340. Taylor, 312. Whitwell & Co., 345.
Williams, Lady, 349. Wilson, 350. xx. Miles, 89.
XXVI. Azulay, 64.
BERLIN WOOL AND WORSTED YARNS—XII. & XV. Burgess
& Co., 243.

*Austria, Vöslau Worsted Yarn Spinning Co., 198.
BERRY WAX*—South Africa, Lindenberg, 45.
BIBLES—XXVII. British & Foreign Bible Society, 201.
*Belgium, Briard, 277.
Netherlands, Eusehede & Sons, 109.
United States, Starr, 98.
Zollverein (1), Badeker, 832. Graf, 746.*
BILLIARD CLOTHS—XII. & XV. Fenton, 60. Falling, 213.
*Billiard Cloths—France, Jeannin, 1275.
BILLIARD TABLES*—XXVI. Burroughes & Watts, 4. Ha-
mus, 152. Thurston & Co., 17. Austria, Kulll, 632.
*France, Boudardet, 1106. Forton, Duponçeau & Co.,
1228. Fouqueau, 1930. Saurau, 367.*
BINDING—See *Bookbinding*.
BINNACLES, SHIPS—VIII. Browning, 103. Helmsley, 106.
Jenkins, 111. MacDonald, 329. Taylor, 105. See
also *Compasses, Mariners'*.
BIRD-CAVES—XXII. Fox, 35. Kain, 45. Vere, 31.
XXVIII. Whitaker, 137. XXIX. Hall, 242. Quin, 230.
*Hamburg, Buss, 111. Helms, 51. Lehmann, 47.
Richter, 50. Schultz, 48. Zollverein (1), Gaertner, 193.
See also *Aviary*.*
BIRDS' NESTS (Edible, &c.)—India, IV.
BIRDS, STUFFED—Van Diemen's Land, Bouvey, 281.
Ince, 349.
Western Africa, Sutherland, Duchess of, 16.
BISCUIT-MAKING MACHINE—VI. Barrett & Co., 410.
BISCUITS (Ship and other)—III. St. Etienne, 138. XXIX.
Holand, 104.
*Canada, Pitts, 135. Robb, 126. Stewart, 134.
Van Diemen's Land, Brock, 54, 55. Milligan, 53.
Portugal, Violette, 1528. Portugal, Wheelhouse, 529*
BISMUTH—II. Howards & Kent, 11.
BISMUTH, OXIDE—II. Godfrey & Cooke, 92.
BITS AND BRIDLES—See *Saddlery and Harness*.
BITUMEN, MOSAIC—Zollverein (4), Seeger, 78.
BITUMINOUS SHALE—I. Bituminous Shale Company, 221.
**BITUMINOUS SUBSTANCES, Apparatus for generating heat
from**—VII. English Patent Camphine Company, 133.
BLACK LEAD—I. Nicholson, 504A. II. Blundell & Co., 48.
*Canada, Harwood, 167.
Spain, Malaga Mines, Inspector of, 19.
Van Diemen's Land, Walker, 105.*
BLACK LEAD PENCILS—I. Banks & Co., 69. Reeves &
Sons, 66. Wolff & Sons, 68. XXIX. Borch & Son,
69. Morell, 248. XXX. (Fine Art Court) Reeves &
Sons, 7.
*Zollverein (2), Birkmann, 79. Faber, 81. Rehbach, 82.
See also *Pencils*.*
BLACK LEAD PENCILS (Materials for)—I. Adair, 67.
Brockedon, 65. Brookman & Langdon, 64.
BLACKING AND HOOT VARNISH—II. Mason & Son, 22.
IV. Coovey, 70. XVI. Carr, 322. Everett & Co., 39.
XXIX. Alecock & Co., 272. Cockerill, 281.
*France, Hebert, 869. Sardinia, Bourgoin, 75.
United States, Baker, 401. Steere, 290. Turner, 425.
Van Diemen's Land, Ward, 186.*
BLANKETS—XII. & XV. Burnley & Sons, 490. Clay &
Sons, 138. Crabtree, 55. Early, E., 269. Early, J.,
& Co., 268. Fox & Co., 7. Firth & Sons, 37. Hagues
& Co., 25. Neill & Sons, 263. Nicolls, 261. Robin-
son, 54. Schwann, 115. Thornton & Co., 32.
*Algeria, Algiers, Delegate of, 58. Haractas, Tribe, 56.
St Alimed-el-Hachemi, 48.
Austria, Mateschuko, 201. Maurer, 200.
Canada, Gamble, 139. Paterson, G., 115. Patterson,
J., 146. South Africa, Thalwitzer, 27.
France, Albinet, 400. Buffault & Truchon, 1120. Guy-
on, 1264. Guyotin-Lorsignol, 253. Pepin-Vieillard,
1675.
Netherlands, Hoogeboom & Son, 37. Scheltema, 38.
Wyk, Brothers, & Co., 35. Zaalberg & Son, 34.
Zuurdeeg & Son, 34.
Nova Scotia, Nova Scotia Central Committee, 2.
Portugal, 715. Corsino, 899. Lafaurie & Co., 810-813.
Tunis, 1-3, 7-9, 11, 80. Tuscany, Franceschini, 62.
United States, Parker, Wilder, & Co., 407.
Zollverein (1), Haan & Sons, 366.
BLANKETS, COTTON—Belgium, De Behault du Carmois,
191. Malta, Villo, Fratelli, 5.*

- BLANKETS, HORSE**—See *Horse Clothing*.
BLAST FANS FOR FURNACES, &c.—L. Kennedy, 304. See also *Bellevue*.
BLAST FURNACES—I. James, 413A. Watney, 276. *United States*, Baron, Brothers, 370. Perkins, 341.
BLASTING CARTRIDGES—I. Copeland, 520.
BLEACHING POWDER—H. Kane, 53.
BLEEDING, INSTRUMENTS FOR—X. Ross, 666. See also *Cupping Instruments*.
BLINDS & SHUTTERS—I. Grey, 506. Rowe, 492.
BLIND, APPLICATUS FOR TEACHING THE—X. Hughes, 410. Tolpitt, 382. XVII. Edinburgh Blind School, 170. Gall, 171. Hughes, 20. Society for Teaching the Blind (Regent's Park), 198. Stidolph, 19. Watts, 164. France, Foucault, 220. Laas d'Agne, 1238, 1635. *United States*, Eisenbrandt, 480. Howe, 439. Starr, 88. Thompson, 26. Zollverein (3), Barthell, 5. (2), Fehr & Eisering, 54. See also *Ink for the Blind*.
BLIND, MANUFACTURES BY THE (Various)—XVIII. Glasgow Blind Asylum, 56A. *United States*, New York Blind Institute, 112. See also *Baskets and Basket-work*. *Netted Work*.
BLIND, NEEDLE-THREADER FOR THE—XXIX. Adams, 33.
BLIND-ROLLERS—See *Window-Blind Rollers*.
BLOCKS FOR BUILDING—VII. Asser, 5.
BLOCKS, SHIPS—VIII. Betteley, 63. Brown, Lenox & Co., 61. Chapman, 121. Estiales & Co., 125. Ferguson, C. A. & T., 184. Canada, Clarke, 163. *Hamburgh*, Friedrichsen, 8.
BLOOD JUICE—*Van Diemen's Land*, Denison, Sir W. T., 287.
BLOTTING ROLLER—VII. Nunn, 187.
BLOWING MACHINES—V. Lloyd, 300. France, Enfer, 830.
BLOWPIPES—X. Braham, 289. Ibbetson, 459.
BLUE DIAMONDS—XXIII. Hope, 73.
BLUE LIAS—See *Limestones*.
BLUES (for Dyeing, &c.)—See *Azure and Mineral Blues*. *Cobalt Blue*. *Indian Blue*. *Indigo*. *Pastel*. *Ultramarine*.
BLUES (for Laundresses)—IV. Coovey, 70.
BOAT-PLUGS—V. Stevens, 136.
BOAT PROPELLERS—V. Ferguson, 78. Reed, 91.
BOAT REELS, SHEETS, &c.—VIII. Beadon, 90. Johnson, 328.
BOATS, GUTTA PERCHA—VIII. Hubbard, 180.
BOATS, SHIPS', RIVER, &c.—VIII. Bayley, 352. Biffen, 179. Jarrett, 319. Leftwich, 27. Mouteagle, Lord, 317. Noulton & Co., 178. Searle & Sons, 169. Wentzell, 167. *Bermudas*. *Canada*, Central Commission, 171. *Ceylon*. *China*, Haedmon. *India*, VIII. *Eastern Archipelago*, &c.—Hammond & Co., 2. *Netherlands*, Vollenhoven, 93. *New Brunswick*—Grey, the Dowager Lady, 1. *Turkey*. *United States*, Capers, 174. Francis, 533. Goddard, 537. *Van Diemen's Land*—Milligan, 279. See also *Canoes*. *Fishing-boats*. *Life-boats*. *Punts*. *Yawls*. *Wild-fowl shooting*, &c.
BOATS, SHIPS' (Method of launching)—VIII. Baird, 74. Etrick, 327.
BOBBIN LADDER (for Vessels)—VII. Hopkinson, 104.
BOBBIN MACHINE—France, Vigouroux, 728.
BOBBIN-MAKING MACHINES—VI. McNaught, W., 25.
BOBBIN-NET-LACE MACHINERY—VI. Birkin, 94. Sewell, 92.
BOBBINS (Cotton, &c.)—VI. Mather, 18. XXIX. Brown & Son, 237.
BODKINS—VI. Morrall, 240.
BOG—See *Peat*.
BOG-WOOD FURNITURE, CARVING, &c.—XIX. Irish Work Society, 77. XXVI. Bell, 212. Jones, 78. XXIX. Austin, 36. XXX. (Fine Art Court) Jones, 70. Kehoe, 90.
BOILERS, COPPER—V. 129. France, Gervais, 520.
BOILERS, STEAM—V. Carrett, 35. Erskine, 100. Fossick & Hackworth, 10. Galloway, W. & J., 124. VII. Croggon & Co., 110. Sampson, 137. IX. Blackhall, 33. XXII. Kerslake, 92. Prideaux, 239. *United States*, Stevens & Co., 475.
BOILER CLEANER—V. Scott, 151.
BOILER EXPLOSIONS (Safety apparatus in case of)—France, Galy Cazalot, 1239.
BOILER-FELT (for preventing radiation of heat)—VII. Croggon & Co., 110.
BOILER-PLATES, FUSIBLE—V. Whitney, 69.
BOILER PUMPS—V. Broughton, 447.
BOLT AND NUT-MAKING MACHINES—VI. Shanks, 210. Williams, 234.
BOLT RIFLE, AUSTRIA, 113.
BOLTING APPARATUS—France, Hennecart, 1206.
BOLTS FOR GATES, &c.—VII. Wilson, 168. XXII. Damber & Son, 681. France, Dervaux Lefebvre, 143.
BOMBAZINES—XIII. Pugh, 2.
BONE BLACK—France, Tordeux, 809.
BONE CARVING—Zollverein (1), Bergmann, 268.
BONE DUST—I. Ramsay, 44.
BONES, HUMAN (Specimen of)—*Nova Scotia*, Central Committee, 2.
BONNETS, BEAVER, FELT, &c.—XX. Pearson, 126A. *Austria*, Muck, 354.
BONNETS, HIGHLAND—XX. Darling, 131.
BONNETS, STRAW—XX. Allan, 13. Bethel, Ware & Co., 76. Cooper, J. J. & G., 172A. Elliott, 172. Field & Sons, 10. Muir & Co., 173, 215. Spurden & Co., 14. Vyse & Sons, 11. Welch & Sons, 12. Woodhouse & Co., 13. *Russia*, Lot, 272. *Switzerland*, Isler & Otto, 213. *Tuscany*, Nannucci, 67. Vyse & Sons, 66. *Zollverein* (1), D'Heureuse, 244. See also *Straw Plait*, &c.
BONNETS (Various)—XX. Ashton, 171. Corah & Sons, 208. Gwatkin, 87. Harri & Sons, 198. Laurence, 138. Long, 16A. Price & Harvey, 9. Ruttens, 147A. *United States*, Milward & Son, 93. *Zollverein* (3), Stoelzel & Son, 66. See also *Feather Bonnets*.
BONNET TOPS AND CROWNS—XX. Johnston, J. & G., 143.
BOOKBINDERS' PRESSES—VI. Whittaker, 140.
BOOKBINDERS' TOOLS—VI. Sherwin, Cope, & Co., 104. XXII. Briggs, 145. *Hamburgh*, Berend, 145. *United States*, Thompson, 224.
BOOKBINDING—XVII. Barrett & Co, 196. Batten, 59. Bone & Son, 92. Budden, 97. Churton, 67. Clark, 134. Clark & Davidson, 135. Clarke, 68. Cleaver, 297. Cocks & Co, 123. Cundall & Adley, 106. De la Rue & C., 76. Evans, S. Gould, 143. Leighton, J. & J., 24. Leighton, J. & R., 158. Lewis, 163. Macnair, 117. Macomie & Co, 20. Neil, 91. Orr & Co, 109. Rains, 162. Remnant & Co, 5. Riviere, 89. Sapsford, 35. Stirling, 118. Tarrant, 43. Westley, J. 48. Westleys & Co, 111. Wodderspoon, 159. Wright, 139. xxx. (Fine Art Court), Corns, 36. Leake, 63A. Wilson, 55. *Austria*, Strauny, 377. *France*, Dauthuille, 1171. Houdaille, 1270. Lebrun 906. Lortic, 1651. Simier, 693. Weber, 739. *Hamburgh*, Mielot, 114. *India*, xvii. *Malta*, Fenech, 6. *Netherlands*, Reeger, 112. *Sweden*, Beck, 104. *United States*, Bradley & Co, 473. Brady, D'Avignon, & Lester, 142. Gassett, 420. Hobart & Robins, 399. Lippincott, Grambo, & Co., 57. Putnam, 122. Walker & Co., 123. *Van Diemen's Land*—Royal Society of Van Diemen's Land, 345.
BOOKBINDING in Silver, (ancient mode of)—XXIII. Skidmore & Son, 129.
BOOKBINDING MACHINE—*United States*, Starr, 88.
BOOKBINDING (Materials for)—XVII. Atkinson, 56. Bingley, 61. Clements, 71. Cussons & Co., 69. Newbery, J. & R., 148. xviii. Wilson, 17. xxvi. Newbery, J. & R., 313. *Russia*, Dolgorouky, Prince, 356.
BOOKMAKING—*United States*, Winship, 354.
BOOKS—XVII. Religious Tract Society, 154. *Belgium*, Briard, 277. *Egypt*, 248, 374. *France*, Bailliere, 406. Bauce, 446. Bouchard-Husard, 775. Desrosiers, 817. Firmin-Didot, Brothers, 212. Garach, 232. Gaume & Co., 843. Gide & Baudry, 236. Gruel, 857. Maitre, 318. Niedree, 665. Pagnere, 940. Plon, Brothers, 1395. Rame, 1418. Renouard, Jules and Co., 352. Schoenenberger, 371. Texier, 1034. *Hamburgh*, Müller, 22.

ase of)—France,

of heat)—VII.

59.

i. Shanks, 210.

, 1206.

S. XXII. Bamber

re, 143.

an, 268.

Scotia, Centra

an, 126a.

Ware, & Co., 76.

2. Field & Sons,

& Co., 14. Vyse

Woodhouse & Co.,

eler & Otto, 213.

66.

Straw Plat, &c.

orah & Sons, 209.

Laurence, 198.

tens, 147a.

See also Feather

on, J. & G., 143.

o.

e, & Co., 104.

Batten, 59. Bone

7. Clark, 134.

p. Cleaver, 207.

100. De la Rue

ghton, J. & J., 24.

Macnair, 117.

Co. 109. Rains,

D. Sapsford, 55.

J. 48. Westleys

ght, 139. xxx.

3A. Wilson, 55.

1270. Lebrun

eber, 739.

112.

dy, D'Avignon,

& Robius, 399.

m, 122. Walker

Van Diemen's

)—XXIII. Skid-

arr, 88.

son, 56. Bing-

n, 69. Newbery,

xvi. Newbery,

ince, 356.

ohari-Husard,

Brothers, 212.

ide & Baudry,

Niedree, 665.

Rame, 1418.

enberger, 371.

Netherlands, Zweenaarit, 111.
 New South Wales, Callaghan, 4. Mitchell, 5.
 Portugal, Monteiro, 1252. Rome, Dees, 50.
 Sardinia, Chirio & Mina, 69.
 United States, Besch, 692. Lipplcott, Grambo, & Co., 57.
 Putnam, 123. Roy, 373. Stanton Blind Institute, 270.
 Van Diemen's Land, Dowling, 331-333. Milligan, 197.
 Rolwegan, 196. Royal Society of Van Diemen's Land,
 345.
 Zollverein (1), Baderer, 832. Schoening, 154. Vieweg
 & Son, 822. Vogel, 671. (3). Brockhaus, 178. See
 also *Bibles. Typographical Works.*
BOOKS, ILLUSTRATED AND ILLUMINATED—XXVII. Macken's,
 94. Parker, 120. Pickering, 140. Wiseman, 103.
 Wright, 139. Belgium, Muquardt, 473.
 France, Barlat, 1067. Langlois & Leclercq, 289. Mame
 & Co., 321. Rome, Dees, 50.
 United States, Brady, 380.
 Zollverein (1), Graf, 746. (5). Schmerber, 36. Wester-
 man, 749.
BOOK-CASES—XXVI. Doveston, 122. Jackson and Graham,
 261. Wills & Bartlett, 160. Austria, Leitler, 633.
 India, xxvi. Zollverein (1), Splun and Menke, 638.
BOOK-CASES AND MOUNTINGS—XXII. Biddle, 297.
BOOK TITLES (Illuminated)—VI. Nelson, 120.
BOOK TRAYS (Carved)—XXVI. Barrie, 104.
BOOT BLOCKING MACHINE—VI. Mansell, 502.
BOOT AND SHOE LASTS—XVI. Bowler, 236. Garner, 312.
 Lewin, 165. Scott, 228. XXVIII. Wheatley, 109. xxix.
 Brien, 257. Belgium, Stainler, 428.
 Canada, Wardle, 104.
 Van Diemen's Land, Milligan, 181. See also *Boat Trees.*
BOOT AND SHOE MACHINE—VI. Wait, 504.
BOOTS AND SHOES—XVII. Allen & Son, 149. Allin, 327.
 Athensium Boot and Shoe Warehouse (Norwich), 137.
 Atloff, 131. Barker, 118. Barraclough, 148. Baxter,
 156. Bearn & Jeffs, 168. Beckett, 220. Berrall &
 Son, 115. Bird, 189. Bossard, 294. Bridges, 219.
 Brochie, 200. Burgess, 155. Butterworth & Co., 210.
 Clapham, 9. Clark, 154. Clarke, 191. Cowling, 142.
 Creak, 141. Cremer & Co., 198. Crow, 196. Currie,
 215. Desmond, 171. Dodge, 160. Dodson, 182a.
 Doe, 145. Duwie, 180 (Main Avenue, West). Essex,
 326. Faulkner, 216. Geary, 235. Gilbert & Co.,
 179 (Main Avenue, West). Godfrey & Hancock,
 168. Goodeve, 176. Gordon, 212. Graham, 122.
 Groom, 121. Grundy, 227. Gundry, 173. Guppy,
 177. Hall & Co., 164. Hall, J. S., 163. Hall, R., 182.
 Hartley, 166. Heath, 195. Hefford & Eacer, 150.
 Henson, 133. Hickson & Sons, 192 (Main Avenue,
 West). Hoby, 202. Hodges, 184. Hook, 114. Hubert,
 194. Hudson, 151. Hutchings, 124. Langdale, 222.
 Line & Co., 120. Lloyd, 117. McDougall, 331.
 M'Dowall, 170. McGibbon, 147. March, 174.
 Marsden, 318. Marshall, 241. Mather, 139. Med-
 win & Co., 162. Mitchell, 213. Moore, 119. Nelson,
 324. Newcome, 323. Newman, 146. Norman, 201.
 Parker, J., 242. Parker & Sons, 116. Pattison,
 186. Peal, 197. Peplow, 137. Pettitt & Son,
 134a. Phipps, 319. Pollett, 210. Hamabottom,
 127. Ridley, 204. Robarts, 128. Robert, 224.
 Robotham, 199. Salter, 209. Saunders, 135. Schal-
 ler, 203. Smith, 237. Stanley, 208. Tallowman, 70.
 Taylor & Bowley, 181 (Main Avenue, West). Thomas
 & Son, 211. Thompson, 130. Walker, 206. Wallace,
 132. Walsh, 207. Wildsmith, 190. Wilahin, 205.
 Winter, 178. Wright, 152. xx. Atloff, 32. Hall, 4.
 Longdon & Sons, 166. Norman, 167. Ridley, 165.
 Smith, 119. xxviii. Hall, 184. Jones, 122.
 Austria, Christl, 327. Frank, 328. Friedl, 323. Helia,
 331. Hermandstadt Shoemakers' Association, 330.
 Kunerth, 333. Langder, 329.
 Belgium, Cabu-Fevrier, 263. Vandenbos Poelman, 274.
 Vanderost, 427. Van Troostenbergh, 264.
 Canada, Barbeau, 110. Dangersfeld, 111. Montreal
 Central Commission, 112. Ondragahout, 172.
 China, Hewett & Co. Lindsay. Denmark, Petersen, 11.
 Egypt, 261-265.
 France, Bredif, Brothers, 73. Bridard, 1115. Crucifix,
 133. Desclamps, 1185. Dufosse, 1201. Dufosse, sen.,

1200. Guillot, 534. Jacobs & Dupuis, 666. Lefebvre,
 578. Masses, 1347. Meier, 1352. Poirier, 1398.
 Rapp, 974. Thierry, 391. Vauvit-Eate, 725.
 Hamburg, Hensel, 40. Kinol, 30. Magdallinski, 38.
 Sahlburg, 36. Schooht, 37. India, xxix.
 Jersey and Guernsey, Manual, 48.
 Netherlands, Rouyackers & Son, 52.
 Nova Scotia, Nova Scotia Central Committee, 2.
 Russia, Barslaghan, 312. Miller, 234. Nijl-Nov-
 gorod Peasants, 314. Pupinoff, 310. Shouvaloff &
 Son, 241. Starikoff, 313. Sardinia, Gullia, 52.
 Sweden, Stubecke, 112.
 Switzerland, Dietiker, 211. Tunis, 12, 87. Turkey.
 United States, Addington, 471. Breed & Co., 411.
 Church & Chittenden, 362. Foggy & Burlbank, 410.
 Frisbie, 136. Hayward Rubber Co., 294. Jeffers, 118.
 New Brunswick India Rubber Company, 560. Ro-
 binson & Co., 429.
 Van Diemen's Land, Flegg, 271. Sly, 329. Wanl, 183.
 Western Africa, Jamieson, 22.
 Zollverein (1), Adolph, 172. Andresen, 177. Buchner,
 735. Gottschalk, 753. Langenthal, 740. Mohr, 185a.
 Muller, 183. Pfeiffer, 184. Schmetzeidorf, 399. Wie-
 gand, 745. (2). Frank, 53. (9). Schumacher & Son, 47.
 Werner, 48. (7). Wemmer, 7. See also *Woods' Loas.*
BOOT-TREES—XVI. Cant, 169. Garner, 230, 312. Lomas
 & Eves, 125.
 Belgium, Stalnier, 428. United States, Upheld, 470.
 See also *Boot and Shoe Lasts.*
BORAX—II. Howards & Kent, 11. India, II.
**BORING MACHINES AND TOOLS (for mining and other
 purposes)—I.** Gowans, 132.
 Netherlands, Soudermeyer, 72. Switzerland, Lue, 65.
BOTANICAL GARDENS, ROBERT'S PARK (Model)—VII.
 Turner, 7.
BOTANICAL SPECIMENS—Loddiges & Sons, page 851.
 II. Kent, 90. III. Lawson & Son, 105. IV. King, 2.
 Rock, 3. Tilley, 5a. X. Ward, 664 (North Triquet).
 China, Bernacastle. Nova Scotia, Central Committee, 2.
 Spain, 117. Zollverein (1), Heckel, 430.
BOTTLES, GLASS—XXIV. Aire & Calder Bottle Co., 6.
 XXVII. Westwood and Moore, 113.
 France, Audelle & Co., 1540. De Puilly & Co., 1396.
 Deviolaine, Brothers, 1167. Leroy Soyer, 1320. Van
 Leempoel, De Colnet, & Co., 714.
 Hamburg, Wright, 57. Zollverein (1), Wagner, 414.
BOTTLES (for Antimony)—Egypt, 275.
BOTTLING AND CORKING APPARATUS—VI. Masterman, J.
 & T., 621. Tylor & Son, 606. VIII. Hely, 13. xxvi.
 Kendall, 246.
 France, Montebello, 651. Jersey and Guernsey, Harris, 28.
BOWLS, PAIR OF—XXIX. Massey, 190.
 Bows and Arrows—xxix. Beane, 130. Buchanan, 175.
 Hore, 151. Jacobs, 183. Muir, 150.
 British Guiana, Annot, 142, 145a.
 South Africa, Thalwitzer, 27. India, XIII.
 Switzerland, Kapp, 66.
 Western Africa, M'William. Trotter, 5.
BOXES (for Lace, &c.)—XX. Oliver, 88.
BRACELETS (Designs for)—XXX. (Fine Art Court) Fatten,
 12. See also *Jewellery.*
BRACKETS—XXVIII. Rogers 179. xxx. (Fine Art Court)
 Wright, 98.
BRANCH-PIPES, FLEXIBLE—Canada, Ferguson, 164.
BRANDY—Zollverein (6), Sichel, 84.
BRASS FOUNDRY AND OTHER WARE (various)—XXII.
 Hale & Co., 486. Hands, 263. Harcourt W. & J.
 257. Haywood & Son, 647. Home, 275. Kimberley,
 362. Lea, W. & J. 665. Malins & Son, 261. Marian,
 363. Osmond, 658. Simcox & Co. 321. Tonks &
 Son, 361. Whitfield, 356. Winfield, 373. Woods,
 33. Woolridge, 347. xxvi. Bibling, 11.
 Austria, Haller, 462.
 Belgium, Chaudoir, 377. De Rosee, 365.
 France, Carle, 1132. Poulat, 965. Thoumin, 696.
 India, xxii. Sweden, Dahlbom, 71. Djurson, 70. Turkey.
 Zollverein (1), Kissing & Möllmann, 647. See also
Lacquered Ware.
BRASS LETTERING ON GLASS—XXIX. Fletcher, 240. See
 also *Metallic Letters.*

BRASS, PERFORATED—XXII. Walker, 29.
BRASS SOLDIER—XXII. Bolton, 351.
BREAD-CUTTING MACHINES—XXII. Green, 570.
Switzerland, Boelstler, 60. *Zollverein* (4), Boelstler, 110.
BREAD-MAKING MACHINE—VII. Pratt, 115.
France, Mouchot, 1667.
BREAD PLATTERS—XXVIII. Smith J., 22.
BREAKWATERS (Models)—VII. Hooper, 106. Hurwood, 31. Remington, G. W. & J. 70. Rettie, 159. Smith, 165. Taylor, 215.
India, VII. See also *Goodwin Sands*. *Plymouth Breakwater*.
BREWERY (Model of)—VI. Tizard, 630.
BRICKS—I. Fisher, 119. King, 115. Hoake, 60. XXII. King, 407. XXV. Bowers, 13. XXVII. Ambrose, 128. Bewick, 106. Fortham & Son, 118. Haddon & Co., 114. Laurie, 100. Lovelace, Earl of, 87. Luft, 111. Rufford, 89. Sealy, 130. Workman, 119.
Austria, Miesbach, 610. *Canada*, Logan, 1.
India, 1. *Portugal*, 275-291. *Tunis*, 108.
Zollverein (1), Milch, 9. See also *Fire Bricks*. *Floating Bricks*.
BRICKS, GLAZED—XXV. Finch, 38.
BRICKS, HOLLOW—IX. Grimaley, 136. Roberts, 226. XXV. Ridgway & Co., 5. XXVII. Betts, 22.
BRICK EARTH—I. Fisher, 119. King, 115.
BRICK AND TILE MACHINES—V. Grotorez, 415. VI. Beart, 301. Bradley & Co., 310. Hart, 308. IX. Grimaley, 136. Jones, 133. Whitehead, 259.
Belgium, Kessels, 127. *United States*, Adams, 570. Cochran, 141. See also *Drain Tile and Pipe Machines*.
BRICK WINDOW FRAMES—XXVII. Key, 126.
BRIDGE GIRDERS (Model)—VII. Todd, 52.
BRIDGES, FOOT (Models)—VII. Williams, 109.
BRIDGES, PORTABLE—VII. Lowe, 33.
Belgium, De Pauw, 485.
BRIDGES, RAILWAY, &c. (Models)—Salter, page 851. VII. Byie, 35. Freeman 177. Leather, 107. McKirdy, 4. Perkes & Co., 162. Rennie, 98. Sadler, 61. IX. Sawney, 31. Spurgin, 76.
Belgium, Van Eschelen, 137. *Canada*, Lewis, 244.
India, VII. *New South Wales*, Shields, 18.
Netherlands, Conrad, 90.
United States, New York Iron Bridge Company, 147, 511 (Main Avenue, East).
Van Diemen's Land, Blackburn & Thomson, 343. Thomson, 344. See also *Suspension Bridges*. *Timber Viaduct*.
BRIEN BOROIHME'S HARP (Model of)—XXX. (Fine Art Court) Ball, 157.
BRIGHTON CHAIN PIER (Model)—VII. Brown, Sir S., 334.
BRISTLES—*Belgium*, Hausens-Hap, 237. Somse-Mahy, 265. *India*, IV.
Russia, Erchoff, 339. Koriakin & Moujikoff, 134. Semenov & Faleyeff, Brothers, 135. Zolotoreff, 136.
Zollverein (1), Fosse, 813. Hucks, 697.
BRITANNIA BRIDGE (Model)—VII. Clark, 106 (Main Avenue, West).
BRITANNIA METAL GOODS—XXIII. Broadhead & Atkins, 43. Dixon & Sons, 35. Owen & Leveck, 41.
BRITISH METROPOLITAN NECROPOLIS (Model)—XXX. (Fine Art Court) Willson, 304.
BROCADES—XI. Owtram & Co., 62. XII. & XV. Blakeley, 285. Kay & Co., 186. Grosvenor, 52. XIII. Duthoit, 12.
Austria, Gianni, 237. Kostner, 264. Lemann & Son, 265. *India*, XV.
Russia, Kolokolnikoff, 203. Sapognikoff, 372. Sitoff, Brothers, 202, 323. *Tuscany*, Riva & Maffei, 63.
BROCADES FOR CURTAINS, &c.—XIII. Stillwell & Son, 7. XXVI. Grace, 530.
BROMELIA FIBRE—*Trinidad*, Lord Harris.
BROUZE COLOURS AND POWDERS—*Zollverein* (2), Benda, 1, 9. Birkner & Hartman, 2. Brandeis, 3. Fuchs & Sons, 4. Haenle, 47. Lepper, 6. Meier, 3a. Rau, 13. Stober, 16. Stoebers & Son, 7, 16.
BROUZE FRAMES—*France*, Carre, 445.
BROUZE MEDALS—*Sardinia*, Cavigioli, 87.
BROUZE WARES—*China*, Reeves.

France, Delacour, 1682. Fetu, 1601. Henry, 1622. Levy, Brothers, 895. Roblin, 1447. Villameusa, 1707.
Zollverein (4), Erhardt & Sons, 63.
BROUZE—Wray, page 853. Cwalbrook Dale Company, XII. 641. XXX. (Fine Art Court) Gardis, 261. Hatfield, 135. Hawkins, 132. Peachey, 320. Richardson, 133.
Austria, Berg, 679. Gasser, 703.
Belgium, Hichant, 498. Jacquet, 461. Lecherf, 479.
China, Haring, Brothers. Hawett & Co. Lindsay.
France, Barbadienne & Co., 1709, 1723. Bonnamex, 64. Boulonnois, 433. Boyer, 70. Brocot, 441. Bulgner, 1124. Cain, 1129. Cardier, 460. De Braux-D'Anglure, 779. Eck & Durand, 1211. Fratin, 1235. Gillot, 849. Grignon, 1617. Laursau, 293. Lerolles, Brothers, 1318. Lombard, 913. Mattifat, 923. Mene, 650. Miroy, Brothers, 646. Moriset, 931. Pallard, 1713. Pradier, 1407. Saye, 1601. Susse, Brothers, 1023. Vittois, 1530. Weygaud, 740.
Hanover, Bernstorff & Eichweile, 8.
Netherlands, Lurasco, Brothers, 100.
Russia, Krumhigel, 287. *Spain*, Nauri, 281.
Sweden, Bergstrom, 68.
Tuscany, Castoli, 106. Dupre, 105.
Zollverein (1), Bernhard Adinger, 309. Blasser, 310. Einaledel, 762. Jadderjohn, 294. Fischer, 296. Fleischmann, 763. Franz, 293. Fribel, 289 (Main Avenue, East). Frub, 298. Kaldie, 285 (Main Avenue, East). Kessler, 299 (Main Avenue, East). Kiss, 279 (Main Avenue, East). Konarszewski, 300. Moeller, 292. Müller, 90, 287 (Main Avenue, East). Wild & Robinson, 889. (2). Grenantb, Brothers, 93. Miller, 90.
BROOCH-FASTENERS AND PROTECTORS—XXIII. Gowan, 69. Restall, 63. Tucker, 10. Wisdill, 65.
BROOCHES (Highland)—XX. Macdougall, 83.
BROOMS—See *Brushes and Brooms*.
BROWN COLOUR (from the Smut of Corn)—II. Farrott, 46.
BRUSHES, ARTISTS' AND PAINTERS'—XXVIII. Child, 61. Friunehy, 181. Naah, 68. Rigby, 68. Smith, 55a.
Austria, Lang, 310. *France*, Pieté, 959. Presbourg, 689.
BRUSHES, PLATE, &c.—XXVIII. Dow, 29. Jackson, 21.
BRUSHES, SHOE, &c.—XXVIII. Hastings, 3.
BRUSHES, TOILET—XVI. Burgess, 244. XXVIII. Baker, 84. Child, 61. Coate & Co., 51. Gosnell & Co., 55. Hamilton, 177. Hawkins, 200. Hawley, J. & T., 161. Low & Co., 30. Ross & Sons, 64. Titterton, 53. Truefitt, 65.
Austria, Pattak, 350. Ritter, 696.
Belgium, Loncke-Haeze, 430.
France, Laurenot, 1296. Paillette, 1377.
United States, Clinton, 190.
Zollverein (4), Klein, 80. (5), Ehr, 25.
BRUSHES AND BROOMS (Various, including Clothes and other Brushes, Floor and other Brooms)—XXII. Aston, 367. XXVIII. Cook, 34. Hinde, 196. Slape, 67.
Austria, Pattak, 350.
Belgium, Loncke-Haeze, 430. Somse, J., 268. Somse-Mahy, 265.
Canada, Brainerd, 83. Nelson, & Co. 84. Wheeler, 167.
France, Dafour, 174. Fauquier-Lemaitre, 502. Laurenot, 1296. Paillette, 1377.
Netherlands, Dirks, 29. *Sardinia*, Fino, 77. Montu & Co., 78. *Sweden*, Carlsson, 110.
United States, Barnard, 17. Clinton, 190. Eaton, 28. Henry, 508. Moore, 149. Rowe, 326. Sanderson, 504a. Taply, Brothers, 520. Tew, 320e. Warner & Co., 431. *Van Diemen's Land*, Rout, 173.
Zollverein (1), Engeler & Son, 242. (4), Klein, 80. (5), Ehr, 25. See also *Bristles*. *Brushes, Artists' and Painters'*. *Brushes, Toilet*. *Feather Brooms*.
BUCKINGHAM PALACE, MODEL OF A FIRE-PLACE IN—VII. Quincey, 146.
BUCKLES—*France*, Mathieu, 617.
BUCKSKINS—*Austria*, Brunn Trade Union, 213. Steffens, 232.
Zollverein (1), Merkelbach & Son, 351. Muller, 352. Offermann, 350. Oßrffers & Ax, 667. Sauerbier, 353. Scheibler, 354. (3), Bernard, 121. Hueffer, 111. Kirsten, 113. Lehmann, 107. Mueller &

1. Henry, 1622.
 Villemouze, 1707.

2. Dale Company,
 Gardie, 261. Hat-
 320. Richardson,

3. Lecher, 479.
 Lintsey.

4. Bonnamiez,
 Brocot, 441.
 ordier, 460. De
 and, 1211. Fratin,
 7. Laureau, 293.
 13. Mattifat, 923.
 6. Morisot, 931.
 eye, 1691. Susse,
 eygaud, 740.

1. 281.

9. Blaeser, 310.
 1. Fiesler, 296.
 Fribel, 289 (Main
 Alide, 285 (Main
 Avenue, East).
 Konarszewski, 300.
 in Avenue, East).
 uth, Brothers, 95.

—XXIII. Gowland,
 cedili, 65,
 63.

—II. Parrott, 46.
 XXVIII. Child, 61.
 568. Smith, 554.
 9. Presbourg, 689.
 3. Jackson, 21.

3. XXVIII. Baker,
 Gosnell & Co.,
 Hawley, J. & T.,
 64. Titterton,

77.

25.
 ing Clothes and
 no)—XXII. Aston,
 6. Slape, 67.

J., 268. Somse-

4. Wheeler, 167.
 nitre, 502. Lau-

o, 77. Montu &

100. Eaton, 28.
 326. Sanderson,
 207. Warner &
 t, 173.

(4). Klein, 80.
 Brushes, Artists'
 uth Brooms.

IRE-PLACE IN—

, 213. Steffens,

. Muller, 352.
 67. Sauerbier,
 121. Hueffer,
 7. Mueller &

Co., 115. Spengler, 117. Zschille & Co., 119.
 (7). Godeshaus, Brothers, 1.

BUOYER—VIII. Shaw, 254. x. McNeill, 512.

BUHL WORK—XXVI. Hoadella, 103. Earle, 130. See
 also *Marquetrie*.

BUILDING MATERIALS—I. 152, 154. Hill, 200. Liskeard
 Committee, 167. St. Austell Committee, 166.

BUNIONS, APPARATUS FOR THE CURE OF—x. Lenagan, 728.

BURNED/TIMBER, CANVAS, &c.—IV. Buruel, Sir
 W., 7.

BURNHAM LANTHORN (Model)—XXIX. Fletcher, 244.

BURNISHING STONES (for Plate, &c.)—XXIX. Chamber-
 lain, 231. France, Degardin, 1174.

BUTS, THE LATE MARQUIS OF, Statue of, Thomas, page 653.

BUTTER—EGYPT, 63.
 France, Dinant & Huet, 1100. Ondin, 1376.
 Westera Africa, M'William, Weston, 1. See also *Churns*.

BUTTER PRINTS AND BOARDS—IX. Jolly, 69.

BUTTER TUBS—IX. Jolly, 60. Egypt, 361.

BUTTON FASTENINGS—XXIII. Harding & Co., 74.

BUTTONS, HORN—XXII. Iugram, 304. Wells, 290. XXIX.
 Wright, 250.
 Austria, Kratschmann, 607.
 Zollverein (1), Teischke, 258. Weecher & Straumann, 634

BUTTONS, LEATHER—XVI. Hadden, 313. Judge, 41.

BUTTONS, METAL (Military, Naval, &c.)—VIII. Firmin
 & Sons, 211. Jenners & Co., 201. xx. Firmin &
 Sons, 161. Woodhouse, 180. XXII. Chatwin &
 Sons, 286. Elliott & Sons, 302. Hammonds & Co.,
 282. Hartman & Co., 284. Knowles, 299. Pigott
 & Co., 281. Smith & Co., 295. Twigg, G. & W., 279.
 Russia, Buch, 289. Switzerland, Scheitlin, 217.
 Zollverein (1), Caron, 555. Greef & Son, 653. Hosterey,
 648. Riisel, 639. Turk, 636.

BUTTON, METAL, MACHINERY—VI. Jaquin, 68. See also
Dies.

BUTTONS, MOTHER OF PEARL, &c.—XX. Harding, 211.
 XXII. Banks, 287. Erliband, 364. Smith, Kemp, &
 Co., 295. Wheeler, 799.
 Austria, Arter, 665. Metner, 698.
 Zollverein (1), Tritschke, 258.

BUTTONS, SCREW—France, Redelix, 1424.

BUTTONS, SELF-ADJUSTING—XXII. Lee, 693.

BUTTONS, SILK, STUFF, &c.—XIII. Stubbs, 43. Weston
 & Son, 46.
 France, Dabaret-Tampe, 152. Martin, 613. Morieux,
 1562. Turkey.
 Zollverein (1), Greeff, Bredt, & Co., 590. Grelich &
 Greiff, 537. Langenbeck & Martini, 676. Trapp-
 mann & Spita, 564. Weyerbusch, 570.

Zollverein (3), Hillmann, 160. Muehlenderlein, 157.
 Oehrig & Schmidt, 154. Uhlrig's Widow & Junker,
 155. (6). Schmidt, 58.

BUTTONS, WIRE—XXIX. Fisher, 220.

CABBAGE OIL—Belgium, Debbant, 92.

CABIN FURNITURE (Ship's)—VIII. King, 19. XXVI. Tay-
 lor & Sons, 9. See also *Tables for Ship's Cabins*.

CABINETS & CABINET WORK—XXIII. Sheffield School of
 Design, 39. XXVI. Arrowmith, H. & A., 385. Bamp-
 ton, 125. Bellealy, 145. Cheek, 46. Doveston, 122.
 English, 57. Footthorp & Co., 132. Halstead &
 Wellings, 131. Hanson & Sons, 197. Harrison's
 Wood Carving Co., 232. Hayball, 344. Herbert,
 67. Howard & Son, 238. King, 113. Medical, 80.
 Smece & Son, 174. Tamer, 65. Toms & Luscumb,
 178. XXVIII. Hayden, 132. XXIX. Burch & Son,
 309. Hine, 47. Hodge, 313. XXX. (Fine Art Court)
 Freeman, 100. Ingram, 321.

Algeria, Cailliez, 13. Converso, 21.
 Austria, Klauer, 642. Belgium, Demanet, 402.
 South Africa, Woodman, 26.
 Ceylon, Kitchen. China.
 France, Jeauselme, 1276. Laurent, 564. Tahan, 1556.
 Hamburg, Aspern, 88. Mehne, 81.
 Luback, Roepert, 11. New South Wales, Burchett, 3.
 Russia, Gamba, 297. Sardinia, Griva, 65. Martinotti, 62.
 Switzerland, Vogel, 226. Wettli, 237.
 Tuscany, Barbetti, 74.
 United States, State of Maryland, 371.

Van Diemen's Land, Hamilton, 8.
 Zollverein (1), Bauer, 223. Hamann, 224. Drenseke,
 245. Hagen, 770. Hilgers, 659. Pallenberg, 421.
 Richt, 229. Schievelbein, 237. (2). Barth, Brothers,
 67. Fortner, 69.

CABLES, SHIPS—VII. Brown, Sir S., 334. Belgium, Goens,
 237. See also *Chain Cables*.

CAFFEINE—II. Spencer, 31.

CAOER—See *Aviary. Bird-Cages*.

CAIRNGORM STONES—I. Jamieson, 26. XXIII. Weighton
 & Son, 22.

CARE-BREAKING MACHINES (for Cattle and Manure)—IX.
 Hornsby & Son, 213. Stanley, 1.

CALABASSES—British Guiana, Outridge, 148n-153. West-
 erna Africa, Jamieson, 5b.
 Trinidad, Lord Harris.
 Westera Africa, Jamieson, 5a, 22. M'William, Trot-
 ter, 5.

CALAMINE—India, 1.
 Zollverein (1), Hagen, 322. Malapane Royal Prussian
 Iron Works, 2.

CALCAREOUS GRIT—Van Diemen's Land, Denison, Sir
 W. T., 272.

CALCINED STRAW—IV. Crowcher, 3A.

CALCULATING MACHINES—X. Werthelmer, 387.
 France, Clair, 1151. Delabanne, 1581. Hamann,
 861. Marce, Jayet, & Co., 621. Thomas, 390.
 Russia, Staffel, 148. Switzerland, Schilt, 69.

CALDER SUSPENSION AQUEDUCT (Model)—VII. Leather,
 107 (Main Avenue, West).

CALICOES—XI. Glover & Dunn, 59.
 Belgium, De Baet, 189. Deceweime, 293. Idiers, 287.
 Verhulst & Co., 289. Voornman, 294.
 France, Denis, 161. Gros-Odier-Roman & Co., 218.
 Hartmann & Sons, 256. Japius & Son, 274. Ours-
 camp Society, 379.
 Portugal, Scotch Linen Trade, 701-704.
 Russia, Babeneck, 173. *Sarabula*, Amney & Pont, 54.
 Switzerland, Greuter & Reter, Brothers, 123. Hermann,
 194. Sulzer, 187.
 United States, Globe Print Company, 31. Paige & Co.,
 436.
 Zollverein (1), Bockmühl, Schieper, & Hecker, 606.
 Dammberg & Son, 710. Ehrenberg & Richter, 750.
 Hagen Turkey Red Dyeing Company, 502. Lupp &
 Son, 605. Nauen, Loewe, & Co., 93. Rolfs &
 Co., 345. Westhoff, Brothers, 599. (3). Becker &
 Schrap, 84.

CALICO FOR BOOKBINDING. See *Bookbinding, Materials*
 for.

CALICO, &c., PRINTING (Illustrations and Specimens of)—
 II. Johnson, 60. XVIII. Andrews & Co., 5. Ashworth,
 87. Bayley & Craven, 34. Benecke & Co., 42.
 Black & Co., 51. Bramley, 84. Burd & Sons, 26,
 Collins, 86. Dalgleish & Co., 27. Ewing & Co.,
 67. Hargreaves & Co., 38. Hoyle & Sons, 36.
 McCulloch, 64. Mercer, 48. Nelson & Co., 29.
 Potter & Co., 30. Sale, 39. Sallis & Co., 41.
 Simpson & Co., 47. Strines Printing Company, 28.
 Swanick & Co., 35. Waterhouse, 72.
 France, Feltrappe, 1600. India, XVIII. See also *Colours*
 (for *Calico-Printing*, &c.). *Printed Fabrics (Designs*
 for).

CALICO PRINTING MACHINERY—VI. Dalton, 4. Mather,
 16. XXVIII. Clayton, 96.

CALIFORNIAN GOLD, Specimens of—r. Marriott, 530
 (Main Avenue, East).

CALIGRAPHY (Specimens of)—XVII. Caffry, 167. Gard-
 ner, 199. Wilson, 178.
 Austria, Greiner, 374A. Schutz, 375.
 Denmark, Schöler, 37. France, Berliner, 52.
 United States, Dunlop, 483. Stanton, 367.
 Zollverein (1), Heinrige, 857.

CALOTYPE APPARATUS—X. Bingham, 302. Horne & Co.,
 220.

CALOTYPE PROCESS (Illustrations of)—x. Colla, R. & L.,
 303. Field & Son, 250. Henneman & Co., 297.
 Owen, 670. xxx. (Fine Art Court) Buckle, 301
 (Main Avenue, West). Harmer, 298. Hill, 300.
 Jersey and Guernsey, Collie, 22.

CANALOSE (Picture-frame made of)—*Mexico*, the Mexican Commissioners.

CAMBRICS—*xi*. Mair & Co., 59. *xii*. & *xv*. Salomons & Sons, 365. *xiv*. Bell & Co., 6. Holden & Co., 1. Richardson & Co., 21. Sadler, 30.

Austria, Leitenberger, 186, 187.

Belgium, Dnmmer, 233. *Egypt*, 179, 185.

France, Boniface & Sons, 32. Godard & Bontemps, 240. Guynet & Becquet, 254. Legrand, 1313. Mestivier & Hamoir, 636.

Russia, Charlovetz, 374. Prokhoroff, Brothers, 349.

Switzerland, Raschle & Co., 168.

Zollverein (1), Westermann & Sons, 544. (3), Glaeser, 63.

CAMBRIDGE ASSIZE COURTS (Model)—*vii*. Salter, 220 (Main Avenue, West).

CAMELS' HAIR—*Russia*, Bashkirs Tribe, 133, 200.

Tunisia, 190. *Turkey*.

CAMELS' HAIR CLOTH—*Russia*, Dourassoff, 197. Noguis Tartars, 196. *Turkey*.

CAMEOS AND CAMEO EMBOSING—*xxiii*. Paravagna & Casella, 84. *xxv*. Wedgwood & Sons, 6. *xxix*. Thompson, 209. *xxx*. (Fine Art Court) Brett, 52. Nichols, 251. Whiting, 123. Wood, 209.

Belgium, Julin, 383. *China*.

Denmark, Petersen, 35. Conradsen, 36.

France, DAfrique, 1575. *Netherlands*, Dionisy, 106. Rome, Deas, 49. Manley, Gen., 32A. Savalini, 24.

CAMERA OBSCURA (Photographic and other)—*x*. Abraham & Co., 263. Ross, 254 (Main Avenue, West). Varley & Son, 257. Willats, T. & R., 265.

France, Mayer, Brothers, 623.

United States, Harrison, 223.

CAMOMILE FLOWERS—*iii*. Carleton, 3.

CAMPHINE—*xxii*. Salt and Lloyd, 343.

CAMPHINE LAMPS—*Zollverein* (6), Reis & Co., 49.

CAMPOR AND ITS PREPARATIONS—*ii*. Howards & Kent, 11. Murray, Sir J., 87.

China. *France*, Conrad, 1156.

CAMWOOD DYE—*Western Africa*, M^oWilliam.

CANAL BOAT WEIGHING MACHINE—*v*. Pooley, 784.

CANAL LIFT, or HYDRO-PNEUMATIC ELEVATOR—*v*. Leadbetter, 650. *vii*. Watt, 20.

CANDELABRA—*xxiii*. Hunt & Roskell, 97 (Main Avenue, West). Mayer, 14. Smith, Nicholson and Co., 110. *xxiv*. Pellatt & Co., 33. *xxvi*. Nuteley, 258. Wills & Bartlett, 160. *xxx*. (Fine Art Court) Romoli, 351. Stevens, 158.

Austria, Hollenbach, 581. Salm, Prince, 430 (Main Avenue, East). *China*.

France, Marchand, 607. Susse, Brothers, 1023.

Hamburg, Schultz, 112. *India*, *xxvi*.

Russia, Chopin, 365. Krumbigel, 257. Sazikoff, 366.

Shtange and *Vesfel*, 370.

Sweden, Bergstrom, 68.

CANDELABRUM (Design for)—*Austria*, Bougiovanni, 741.

CANDLE CAP—*xxix*. Jones, 95.

CANDLE MOULD FRAME—*vi*. Bierumpfel, 506.

CANDLES, BITUMEN—*i*. Gowars, 132.

CANDLES, MINERAL—*xxix*. Mitchell, 94.

CANDLES, WAX, TALLOW, COMPOSITE, STEARINE, &c.—*ii*. Humfrey, 78. *iv*. Barclay & Son, 24. Freeman, 25. Price's Patent Co., 83. *xxvi*. Tucker & Co., 536. *xxix*. Brien, 90. Dixon, 91. Hale, 99. Morrell, 92.

Austria, Cackelius, 45. Hermannstadt Stearine Candle Company, 42. Pfitzer & Beckers, 41. Vienna Stearine Candle (Apollo Candle) Company, 39. Stearine Candle (Milly Candle) Company, 40.

Belgium, Delstanche, 433. Quannone, 431. Vancampenhout, 436. *Canada*, Matthewson & Son, 329.

China, East India Company. *Denmark*, Holmblad, 27. *Egypt*, 200.

France, Delacretaz & Co., 158. De Milly, 644. Donnad & Co., 478. Dumortier & Co., 1593. Jaillon & Co., 273. Masse, 1346. *Netherlands*, Brandon, 70. *Nova Scotia*, Central Committee, 2. *Portugal*, Carvalho, 1212.

Russia, Afian, 308. Manufacturing Company, 363. Matisen & Co., 303. Nilson & Junker, 308. Pitansier, 307. Sapelkin, 300.

Sardinia, Guiso, 23. Ross & Co., 6.

Spain, Bert, 245, 246.

Sweden and Norway, Hierta & Michaelson, 99. Johanson, 17, 98. Lamm, 18.

United States, Emory, 18. Macy & Sons, 306. *Van Diemen's Land*, Murray, 40.

Zollverein (1), Motard, 262. (4), Reuss, 99. *See also* *Spermaceti*. *Stearine*.

CANDLESTICKS—*xxii*. Blews & Sons, 349. *Sweden*, Moltenberg, 66.

CANE-TOP CUTTER—*ix*. Ransomes & May, 124.

CANNEL COAL—*See Coal, Anthracite*.

CANNON (Models, &c.)—*viii*. Ferguson, 184. Fitzmanrice, 283. Gardner, 280. Haughter, 295. Lillywhite, 273. Mauro, 282. Tylden, 275. *x*. Webster, 671A. *xxii*. Daniell, 607. Hird & Co., 85.

Belgium, Duntrewe, 149. Royal Cannon Foundry, 142.

Canada, Bartram, 162.

France, Delvigne, 473. *India*, *viii*.

Spain, Onate Ordnance Office, 282 (Main Avenue, East). Seville Cannon Foundry, 263 (Main Avenue, East).

Sweden, Baron Valrenhorst, 52. Bergquist, 80.

Zollverein (1), Krupp, 677.

CANNON LOCKS—*iv*. Evans, 9A.

Portugal, Bobone, 643, 644.

CANOTS—*New Brunswick*, Grey, the Dowager Lady, 1. *United States*, Capers, 174. *See also Boats, Ships, &c*

CANTERBURY PILGRIMS (Carving in Oak)—*xxviii*. Halliday, 157.

CANTHARIDES—*ii*. Burt, 85. *Turkey*.

CANTHARIDINE—*ii*. Burt, 85. Smith, T. & H. 94.

CANVAS—*viii*. Margary, 87. *xiv*. Anderson, 86. Bridport Local Committee, 73. Dundee Local Committee, 63. Fraser, 79. Hayward & Sons, 44. Jameson & Co., 60. Plummer, 78. Ramsey & Co., 85.

Belgium, Kums, 469.

India, *xi*. *xiv*. *Netherlands*, Theunissen, 39.

Portugal, 670. Janquetia Manufactory, 656, 666. Torres Novas Company, 658-660.

Spain, Manufactory of Isabel II., 193.

Switzerland, Heinger, 124.

Zollverein (6), Bingman, 85. *See also Sail-cloth*.

CANVAS FOR EMBROIDERY—*xix*. Hall, 185.

Zollverein (1), Meungen, 581.

CANVAS FOR PAINTING—*xxx*. (Fine Art Court) Robertson & Co., 6.

Belgium, Van Nuffel and Coveliers, 225.

France, Haro, 866.

Zollverein (2), Schutzmänn, 40. (3), Eimenkel, 165.

CAOUTCHOUC, AND MANUFACTURES THEREOF—*i*. Turner, 223. *iv*. Granville & Co., 116. *viii*. Hodges, 269. *ix*. Hurgess & Key, 237. *xx*. Jobert, 40. *xxii*. Sparks, 430. *xxviii*. Bunn & Co., 77. Hancock, 83. Hodges, 72. Horsey, 188. Mackintosh & Co., 76. Mathews, 81. Nickels & Co., 78. Sanders, 73.

British Guiana, Ontridge, 47 & 48.

France, Briquet and Perrier, 1116. Ducourtioix, 1199. Grossmann & Wagner, 856. Huet, 270. Leblond, 197. Rabourdin, 1416. Vie, 726.

India, *iv*. *Eastern Archipelago*, Hammond & Co., 2.

Netherlands, Rooyackers & Son, 52.

Russia, Lerkhe, 311. *Switzerland*, Piecer, 233.

United States, Day, 308. Goodyear, 378. Goodyear Rubber Co., 295. Hayward Rubber Co., 294. Moulton, 534. Ross, 584.

Zollverein (1), Hoeltring & Hoeffken, 662. Rompler, 781. *See also Gutta Percha. Waterproof Fabrics*.

CAPE TOWN (Model of)—*Cape of Good Hope*, Ford, 30.

CAPERS—*Portugal*, 452.

CAPS, MEN'S—*See Hats and Caps*.

CAPS (Travelling)—*xx*. Braund, 86. Haley, 124.

CAP PEARS (Leather)—*xx*. Garrard, R. & J. 61.

CAPSCICUMS—*British Guiana*, Shier, 21-24. Stutchbury, 25. *Portugal*, 445. *Spain*, Manso, 133.

CAPSTANS, SHIPS—*viii*. Salter, 116.

France, Barbotin & Legoff, 1083.

CAPSULES FOR BOTTLES—*xxvi*. Kendal, 246.

France, Dupre, 495.

CAPSULES OF COPAIBA—*Portugal*, Norberto, 517.

Sardinia, Scola, 16.

CAPSULES, MEDICINAL—Lehuby, 302.

son, 99. Johans-
Sons, 306.
Reuss, 99. See also
349. Sweden, Mol-
May, 124.
on, 184. Fitzmau-
ghter, 295. Lilly-
275. x. Webster,
& Co., 85.
non Foundry, 142.
Main Avenue, East).
in Avenue, East).
ergquist, 80.
owager Lady, J.
Boats, Ships, &g
hak)—xxviii. Hal
T. & H. 94.
Anderson, 86.
undee Local Com-
Sons, 44. Jarne-
msey & Co., 85.
issen, 39.
actory, 655, 656.
3.
Sail-cloth.
185.
Court) Robert-
25.
Einenkel, 165.
PROOF—r. Turner,
Hodges, 269. ix.
0. xxii. Sparks,
ock, 83. Hodges,
p. 76. Mathews,
8.
ucourtion, 1199.
0. Leblond, 197.
mond & Co., 2.
ee, 233.
375. Goodyear
Co., 294. Moul-
662. Rompler,
eproof Fabrics.
ops, Fourd, 30.
ley, 124.
J. 61.
4. Stutchbury,
133.
46.
o, 517.

CARDBOARD CUTTING AND PRINTING MACHINE—VI.
Church and Goddard, 133.
CARDBOARD MODELS (Architectural, &c.)—Salter, page
831. Wyatt & Brandon, page 854. xxx. (Fine Art
Court) Spiers & Son, 361. Swain, 176.
CARDING—Portugal, Loureiro, 647.
CARDING COMBS (Cast Steel)—France, Raguene, 1417.
CARDING ENGINES—VI. Manon, 46. Parr, Curtis, &
Madeley, 6.
CARDS (for Cotton and Wool Carding)—VI. Rigge & Co.,
63. Belgium, Fetu & Co., 120.
France, Cuppin, 128. Scrive, Brothers, 1005. Whitaker
& Co., 741. United States, Bryant, 184.
Zollverein (1), Uhlhorn, 475.
CARDS (Paper)—Belgium, Glenisson & Vangenechten,
286.
France, Bondon, 63. Breacte, 36. Mroude, Brothers, 645.
CARD-CUTTING MACHINES—VI. Crabtree, 3.
Fra, Papavoine & Chate, 339.
CARDWARE—United States, Washburn & Co., 421.
CARNINE—II. Godfrey & Cooke, 92. Marshall, 68.
Austria, Pets, 28.
Russia, Tchuplatoff, 315. Voloskoff, A., 317. Volos-
koff, M., 316.
CARPENTERS' TOOLS—See Tools (Carpenters', &c.).
CARPET—xii. & xv. Schwann, 115. Wilson & Son,
468. xix. Bright & Co., 115, 401. Brinton & Sons,
110. Brown & Co., 114. Cardinal & Co., 321.
Cole & Son, 132. Crossley & Sons, 142. Dove &
Co., 155. Dowbiggen & Co., 156. George, 175.
Gilbert, 176. Gregory & Co., 182. Halling & Co.,
212. Harris & Co., 192. Henderson & Co., 200.
Henderson & Widnell, 201. Hindley & Sons, 206.
Holmes, 208. Humphries, 210. Jackson & Graham,
390. Kiteley, 226. Lapworth, 232. McFarlane,
Brothers, 243. Monkhouse & Son, 251. Morant, J.,
291. Morton & Sons, 252. Newcomb & Jones, 257.
Newton & Co., 258. Sewell, Evans, & Co., 268.
Sheridan, 294. Shirer, 296. Simcox, 302. Templeton
& Co., 315. Turbeville & Co., 318. Watson,
Bell & Co., 337. Waugh & Son, 339. White, Son &
Co., 345. Whitwell & Co., 345. Woodward, 354.
Woodward & Co., 355. Wright & Co., 358. xxvi.
Crace, 530. Jackson & Graham, 261A. Morant, 164.
Algeria, Delegate of Algiers, 58. Haractas Tribe,
56. Si Ahmet-el-Hachem, 48.
Austria, Dierzers, Heirs of, 244. Fusinata, 300.
Belgium, Freitag, 342. Royal Carpet Manufactory, 297.
Verdure, 206. Weinknecht, 259.
Canada, Barber, 140. Gamble, 139.
Denmark, Warming, 7. Egypt, 249.
France, Braquenie & Co., 435. Flaisier, Brothers, 204.
Gobelins Manufactory, 1366. Laroque & Jaquemot,
901. Lecun & Co., 1305. Queru & Co., 1415. Salland-
roue de Lamornaix, 1468. Hamburg, Appel, 119.
India, xix.
Netherlands, Alphon, 41. Henkeusfeldt, 42. Kroonen-
burg, 43. Nova Scotia, Central Committee, 2.
Persia, Copeland. Watson, Bell & Co.
Portugal, Daupias & Co., 895-898.
Russia, Baba-Iman-Verdi-Ogli, 264. Korbaly-Khooda-
Aghali-Ogli, 263.
Switzerland, Hermann, 194. Zuppinger, 209.
Tunis, 19, 20. Turkey.
United States, Lawrence & Co., 409.
Zollverein (1), Beckh, Brothers, 174. Dinglinger, 175.
Grossmann, 752. Lipke, 165. Osion, 150. Parey,
169. (3), Beck & Heynig, 148, 149. (5), Vaconius,
15. See also *Druggets. Felt Carpeting.*
CARPETS (Worked by hand)—xix. Barclay, 389. Cham-
bers, 126. Coveney, Mrs., 139. Ladies of Great
Britain, 379. xx. Macdugall, 83. Austria, Thomp-
son, 747.
Russia, Shechtel, 357.
CARPETS (Designs for)—xix. George, 381. Lawson, 235A,
325. Waugh & Son, 339. xxx. (Fine Art Court)
Lawson, 357. Somerset House School of Design, 10.
France, Chebeaux, 1146. Grandbarbe, 244.
CARPET CLEANING (Process of)—xxvi. Arrowsmith,
H. & A., 385.

CARPET LOOM (at work)—xix. Jackson & Graham, 390
(North Transcript).
CARPET SHUTTLES—xxix. Quin, 230.
CARPET STRAINER—xxvi. Woodman, 73.
CARRIAGES (Various, including Models)—v. Anderson,
801. Andrews, J. 803. Andrews, R. 802. Bascombe,
804. Bishop, 805. Black & Co., 806. Booker &
Sons, 809. Bowler, 756. Briggs & Co., 811. Brown,
Marshall & Co., 812. Brown, Owen & Co., 813.
Browne, 814. Cable, 808. Chand & Munro, 819.
Coates & Blizard, 815. Cook, Rowley & Co., 816.
Corben & Sons, 818. Cousina & Son, 820. Croall
& Co., 824. Crosskill, 826. Davies, 828. Duffield
& Co., 844. Fowler & Fry, 843. Fuller, G. & T.,
845. Greville, 856. Hadley, 860. Hallmarke &
Co., 862. Harvey, 946. Hill & Stone, 970. Holmes
& Co., 872. Hooper, 874. Horne, 880. Hutton &
Son, 884. Kent, 892. Keesterton, 894. Kinder &
Wheeler, 895. Kings, 896. Masou, 910. Middleton,
W. & C., 914-916. Mitchell, 918. Mulliner, F., 922.
Mulliner, H. 924. Newham, 926. Nurse & Co., 932.
Oford, 934. Peters & Sons, 938. Quan & Sons,
940. Rigby & Lee, 947. Robinson & Co., 950.
Rock & Son, 956. Sauuders, 958. Shank, 962. Silk
& Brown, 965. Swain, 976. Thomson, 978. Thorn,
W. & F., 979. Thrupp, 982. Tibury, 984. Vezev,
R. & E., 988. Walker & Gilder, 989. Ward, 990.
Wyburn, Meller, & Turner, 996.
Austria, Knierim, 107. Laurenzi, 108.
Belgium, Deman, 116. Jones, Brothers, 118. Van
Aken, 121. Van Aken & Son, 122.
Canada, Laurin, 180. McLean & Wright, 178.
O'Meara, M., 179. Ceylon.
France, Arnoux, 1542. Belvalette, Brothers, 50. De-
longueuil, 1555. Dumaine, 490. Dupasquier, 1205.
Hayot, 258. Moussard, 657.
Hamburg, Croissant & Lautenstein, 7. India, v.
Russia, Babouff, 343. Jakoleff, Brothers, 344. Tou-
liakoff, Brothers, 346. Sardinia, Bertinetti, 61.
Sweden, Wegelin, 53.
United States, Artman, 174A. Gould & Co., 98. Rid-
dle, 466. Watson, 53, 361. Wood & Tomlinson, 396.
Zollverein (1), Friedrich, 49. Mengelbier, 340. (6).
Dick & Kirschten, 17. See also *Omnibuses. Railway
Carriages. Wheels, Carriage, &c.*
CARRIAGES, HAND—xxviii. Hodges, 72. See also *In-
valid Wheel Chairs.*
CARRIAGE AXLES—See *Axles & Axletrees. Railway Axles.*
CARRIAGE FITTINGS (Metal)—xxii. Holded, 348. See
also *Coach Ironmongery.*
CARRIAGE JACKS—v. Fuljames, 993.
CARRIAGE RETARDER—v. Shuff, 971.
CARRIAGE RUGS—xvi. Essex, 326. Robinson, 7. xxviii.
Armstrong, 43.
CARRIAGE SPRINGS—v. Rock, J. jun. 952.
Sweden, Wegelin, 53.
CARRIAGE TIME-PIECES—xxiii. Ellis & Son, 12.
CARRIAGE UPHOLSTERY (Lace Trimmings, &c.)—v.
Durt & Son, 849. Harding & Co., 864. Huttly, 882.
Paternoster, 936. xii. & xv. Fry & Co., 267. Lupton
& Co., 33. xiii. Keith & Co., 1. xix. Onion, 56.
Zollverein (1), Schaeff, 118.
CARRIAGE WHEELS. See *Wheels, Carriage.*
CARTHAME OIL—Egypt, 53.
CARTONPIERRE (Works in)—xxvi. Jackson & Sons, 5.
xxx. (Fine Art Court) Brown, 264.
France, Cruchet, 810. Lecheane, Brothers, 574.
Zollverein (1), Grupius, 226. (2), Mayer, 70.
CARTRIDGE CASES—xxii. Tarian, 544.
CARTRIDGES—VIII. Cavers & Lane, 286 A. Eley, W. &
C., 225. Joyce & Co., 277.
CARTS AND WAGGONS (for Agricultural and other Pur-
poses)—v. Brotherhood, 502. Crosskill, 826. ix.
Ball, 132. Barker, 230. Barrett, Exall & Andrews,
128. Baddon, Capt., 208A. Braby & Sons, 24. Bubby,
15. Chard & Munro, 235. Crosskill, 133. Crowley
& Sons, 96. Digges La Touche, 263. Forbes, 269A.
Fowler & Fry, 28A. Glover, 121. Harding, 13.
Harveys & Tait, 16. Kingwell, 29A. Law, 94.
Maynard & Son, 122. Race, 44. Ransomes & May,

124. Robertson, 26. Smith & Son, 234. Squires, 144. Swan, 80. XXIX. Spratt, 121. *India*, ix.
- CARVERS' TOOLS**—XXI. Addis, J. B., 23. Addis, S. J., 11. Mathieson, 32. Howarth, 181.
- Zollverein** (4), Boelsterli & Co., 55. Weber, 84.
- CARVING MACHINE**—Jordan, page 831. *Belgium*, Wynants, 472.
- CARVINGS, IVORY**—See *Ivory Carving*.
- CARVINGS, STONE**—See *Stone Carving*.
- CARVINGS, WOOD**—See *Wood Carvings*.
- CASH BOXES**—*Austria*, Beil, 438. Wagner, 437.
- CASHMERES** (including Cashmere Wool)—XII. & xv. Albert, H. R. H. Prince, 500 (Main Avenue, West). Cowgill, Jessop & Co., 122. Learoyd, 89. Mason & Co., 303. Schofield, A., 474. Schofield, J., 125. Thornton & Co., 32.
- Austria*, Posselt, 223. Schmitt, 238. Schoell, 226. Seidel, 228.
- France*, Hietry & Son, 356. Croen, 809. Fean-Bechard, 198. Randoing, 973. Thierry-Mieg, 1506. *India*, xv. *Portugal*, 805.
- Russia*, Goutchkoff, 189. Matvieff, 367. Prokhoroff, Brothers, 349. Tchurloff, 188. Volner, 190.
- United States*, Vasselboro Manufacturing Comp., 324.
- Zollverein** (1), Boehme, 362. Bruegmann & Co., 363. Hilger, Brothers, 874. Grafe & Neviardt, 591. Zambona, 339.
- CASHMERES, WATERPROOF**—XXVIII. Tallerman, 70.
- CASKS**—VI. Barlow, 613. Laurence, 604. Wild, 8. XXVIII. Mac Gregor, 146. XXIX. Brindley, 210. Warner, 9. *Belgium*, Van Loy, 508.
- France*, Herviot, 1708. See also *Vats*.
- CASK-TILTING FRAME**—IX. Heddon, 208 b.
- CASKETS**—XXVI. Du Cane, 535. XXVIII. Tate, 162. *Tuscany*, Marchetti, 121. See also *Jewel Cases*.
- CASSAVA JUICE**—*British Guiana*, Bee, 29. Stulchbury, 28, 30.
- CASSAVA-SIFTER**—*British Guiana*, Bee, 134.
- CASSAVA-SQUEEZER**—*British Guiana*, Shier, 133.
- CASSIA**—*Egypt*, 19.
- CASSIMERES OR KERSEYMERES**—XII. & xv. Brook & Son, 487. Brown & Forster, 9. Peters, 220. Schofield, 474. Shepherd, W. B. & G., 485. Walker & Sons, 79.
- Austria*, Steffens, 232.
- France*, Machet-Marote, 596. Nazet, 660.
- United States*, Lawrence, Stone & Co., 464. Skinner & Co., 450.
- Zollverein** (1), Elbers, 348. Menerath, 356. Pauli & Buchholz, 368.
- CASSIMERS**—*Switzerland*, Ernst, 149.
- Zollverein** (3), Buettiger, 108. Burkhardt, 109. Collel, 110. Hueffer, 111. Kaufmann & Son, 114. Kirsten, 113. Matthes, 118.
- CASTING POTS (FOR BRASS, GOLD, SILVER, &c.)**—I. Antey, 118.
- CASTOR OIL**—*Egypt*, 24, 71. *Russia*, Mikirticheff, 73. *Sardinia*, Girardi, 5.
- CASTOREINE**—II. Lamplough, 71.
- CASTORS (for Furniture)**—V. Greenway, 698.
- France*, Roux & Co., 995. See also *Brass Foundry*.
- CATAMARANS**—See *Life-Boats*.
- CATAWBA WINE**—*United States*, Buchanan, 12. Cornear, 13. Duhme, 15. Longwoith, 199. Schumanns, 204. Yeatman, 11.
- CATCH-KEY LOCK**—VII. Cochrane, 158.
- CATECHU**—*Zollverein* (1), Krimmellbein & Bredt, 457.
- CATENARY WATER-WHEEL (Model)**—V. Wight, 480.
- CATTLE MEDICINES**—See *Veterinary Medicines*.
- CATTLE SLAUGHTERING INSTRUMENT**—X. Titterton, 727A.
- CATTLE-WEIGHING GAUGES**—X. Tree & Co., 324.
- CEILING DECORATIONS**—XXVI. Bay J. Bielefeld, 25. Croughton, 21. Herrievu, 20. Jackson & Sons, 19. School of Design, 23, 24. Thomas, 22. Bay M. Calli & Cotti, 24. Jackson & Graham, 23. Jackson & Sons, 22. Trollope & Son, 21. Bay P. Jones & Co. (late Robson & Jones), 15. Litbrow & Purdie, 1. *Austria*, Montanari, 738.
- CEILING LATHS**—*Belgium*, Lioen, 138.
- CEMENT (Poloos' Chinese, &c.)**—II. Mason, 77. XXII. Nixey, 640.
- CEMENT, ROMAN, PORTLAND, &c.** (with illustrations of their application)—Western end, South Enclosure (Outside), Greaves, 7. Robins & Co., 5. Towler, 27. White & Sons, 10. I. Dyer, 131b. Fahie, 30. Greaves, 99. MacAnaspie, P. & J., 131A. Monkland Iron & Steel Company, 426. Piper, T. & W., 130A. Randall, 275. Sweetman, 40. Thorne, 475. White & Sons, 130, 130A. II. Nixey, 112. XXVII. Francis & Sons, 47. Griffiths & Strong, 67. Robins & Co., 103. Stevens & Sons, 24. XXX. (Fine Art Court) Pulham, 216.
- France*, Regny & Co., 1427. *New Zealand*, Smith, 19.
- Zollverein** (1), Eisner & Co., 4. See also *Chalk Cement*.
- Dolomite*. *Gypsum*. *Hydraulic Cement*.
- CENOTAPH (of Granite)**—*France*, Poillen, Brothers, 962.
- CENSERS**—*China*, Sichert & Co. See also *Ecclesiastical Furniture*.
- CENTRIPETAL PUNCH AND GAUGE**—X. Park, 337.
- CHACOS AND HELMETS (Military)**—XX. Buckmaster & Co., 1. *Canada*, Allu, 81. Morris, 334.
- CHAFF-CUTTING MACHINES**—IX. Alcock, 27. Barret & Co., 128. Bland, 205. Cornes, 83. Cottam & Hallen, 109A. Crosskill, 135. Deane & Co., 180. Domax, 275. Ferrabee & Sons, 274. Garrett & Sons, 142. Gillett, 78. Gray & Sons, 150. Lomax, 275. Marychurch, 93. Richmond & Chandler, 137. Samuelson, 185. Smith, A., 256. Smith & Son, 234. Smith, W., 276. Stanley, I. Wedlake & Co., 127. Williams, 157.
- Austria*, Pammer, 445. *Belgium*, Delstanebe, 510.
- Zollverein** (1), Stolle, 65. See also *Hay and Straw Cutting Machines*.
- CHAIN CABLES**—I. Beecroft, Butler, & Co., 415. VII. Brown, Lenox & Co., 61. Brown, Sir S., 334. Parkes, 108. VIII. Hawks, Crawshaw & Co., 86. Wood & Co., 102. XXII. Wood, Brothers, 75.
- CHAIN CABLE WELDING MACHINE**—*Jersey and Guernsey*, Sarchet, 32.
- CHAINS**—VII. Hawks, Crawshaw & Co., 86. *Austria*, Kurg, 465.
- France*, Dervaux Lefebvre, 145. *India*, i.
- CHAINS FOR PRTS**—VIII. Brown, Lenox & Co., 61. Parkes, 108. XXII. Edge, 51.
- CHAINS, WOOD**—XXVIII. McClintock, 20.
- CHAIRS**—XIX. Tension, 313. XXVI. Aspiuwall & Son, 213. Billamore, 230. Dawes, 135. Earp, 13. England, 7. 528. Evans, 224. Herbert, 67. Hindley & Co., 266. Jackson & Graham, 201. Jordans, 384. Lambert, 35. Meakin, 148. Scholey, Misses, 142. Spurrier, 76. Tomasini, 176. XXVIII. Criper, 101.
- Belgium*, Colfs, 417. Dosing, 429. Judo, 420.
- Canada*, Allau, 121. Dunn, 119. Hilton, 123. Redhead, 120. Reed & Co., 115 a.
- South Africa*, Alderley, 57.
- France*, Balny, 1066. Descartes, 815. Durand, 1207. Faure, 1219. Jeanselme, 1276. Verge, 722. Pinsonnet, 1392.
- Hamburg*, Kruger, 80. Geeller, 68. Heymann, 78.
- India*, XXVI. *Sardinia*, Cugliero, 67. Canepa, 74.
- Tuscany*, Bonaluti & Sons, 81. Falcini, Brothers, 84.
- United States*, American Chair Company, 85. Augustus, 515. Commiford & Co., 129, 495. Elias, 515. Ragan, 590. Tupp, 383.
- Zollverein** (1), Becker, 232. Walker & Son, 782. See also *Rocking Chairs*.
- CHAIRS, APPENDAGE TO (to hold Gloves, &c.)**—XXVI. Allan, 87.
- CHAIRS, CARVED**—XXVI. Brittan, 220. Budge, 219. Carmichael, 114. Collinson, 90. Curran & Sons, 215. Findley, 146. Gillow & Co., 186. Hunter, W. J. R. & E. 202. Le Mercier, 181. Martin, 406. Hutchinson, 22. Shacklock, 29.
- CHAIRS, INVALID**—V. Thunfall & Williams, 1000. Ward, 997. XXVI. North, 259. Ward, 279.
- Portugal*, Royal Military Arsenal, 1119. See also *Chairs, Spinal Curvature. Invalid Beds, Chairs, &c. Invalid Wheel Chairs*.
- CHAIRS, PORTABLE**—XXVI. Lovegrove, 23.
- CHAIRS, RECLINING**—XXVI. Hancock, 239. *United States*, Ragan, 193.

with illustrations of
South Enclosure (Out-
do., 5. Towler, 27.
131b. Fahie, 30.
131a. Monkland
per, T. & W., 130a.
borne, 475. White
12. xxvii. Francis
67. Robins & Co.,
k. (Fine Art Court)

Zealand, Smith, 19.
also Chalk Cement.
Cement.

len, Brothers, 962.
also Eccelesiastical

Park, 337.

xx. Buckmaster &
Cris, 334.

ock, 27. Barret &
83. Cottam &
Deane & Co., 160.

74. Garrett & Sons,
150. Lomax, 275.
& Chandler, 137.

Smith & Son, 234.
edlake & Co., 127.

Delstaene, 510.
no Hay and Straw

& Co., 415. vii.
Sir S., 334. Parkes,
86. Wood & Co.,

ersey and Guernsey,

86.

dia, i.

& Co., 61. Parkes,

20.

Aspinwall & Son,
p. Earp, 13. Eng-
rt, 67. Hindley &
261. Jordans, 384.
holey, Misses, 142.

viii. Cripser, 101.
do, 420.

Hilton, 123. Red-

5. Durand, 1207.

Verge, 722. Piu-

Heymann, 78.

7. Canepa, 74.

ni, Brothers, 84.

ny, 85. Angustus,
Elias, 515. Ragan,

& Son, 782. See

ves, &c.)—xxvi.

0. Budge, 219.

Curran & Sons,
86. Hunter, W. J.
artin, 406. Hut-

ms, 1000. Ward,
9.

. See also Chairs,
Chairs, &c. In-

23.
39.

CHAIRS, RUSTIC—North Transept. xxvi. Cooper, 291.
Earp, 13. Grigg, 401. Hudson, 34. Mollay, 81.

CHAIRS, SPINAL CURVATURE—x. Seltzer, 726.

CHAIRS, SUSPENSORY—xxvi. Brown, J. M. & T., 15.

CHALK—i. 39. Turkey.

CHALK CEMENT—Zollverein (4), Leube, Brothers, 5.

CHAMONIS HUNTING (Relief Model)—Switzerland, Meze-
ner, 247.

CHAMPAGNE BOTTLES—xxiv. Wood, 16.

CHAMPAGNE CAPSULES—xxvi. Kendall, 246.

CHAMPAGNE CLARIFIERS—France, Cannaux & Sons, 1130.

CHANDELIERS (Metal, Glass, &c.)—xxii. Bailey & Sons,
605. Faraday & Son, 444. Hale, T. & Co., 486.
Hill, 355. Hughes, 471. Hulett, 643. Leaver, 583.
Lloyd & Summerfield, 700A. Lockerby & Stephenson,
439. Martin & Gray, 332. Messenger & Sons, 340.
Potts, 323. Sedgwick & Taylor, 644. Winfield, 373.

xxiv. Pellatt & Co., 33. xxviii. King, 41.

Austria, Briese, 550. Salm, Prince, 430 (Main Avenue,
East).

France, Carrier-Rouge, 1135.

Sweden, Bergstrom, 68.

Zollverein (1), Hermann, 435.

CHARACTOGRAPH—x. Chaiburn, Brothers, 259.

CHARCOAL—I. Azulay, 24. Cahill, 222. Rogers, 240.

Denmark, Owen, 44.

France, Lapeyriere, 1710. Popelin-Ducarre, 1404.

Violette, 1528. Mecklenburg-Schwerin, Meyer, 6.

Netherlands, Smits, 20.

Portugal, Pinto Basto, 629, 630.

Russia, Demidoff, 21, 120.

Spain, The Director of S. Pedro De Araya Factory, 12.

Trinidad, Warner, 9. Zollverein (1), Waechter, 434.

CHARCOAL FILTERS—France, Ducommun, 482.

CHARLOTTE, PRINCESS, THE LATE (Velvet Carpet made for
the Marriage of)—x. Sincox, 302. Electrotype
Plaster Statue of—Belgium, Michiels, 385.

CHARTS (Undescribed)—Hamburg, Gerbera, 21.

CHARTS (to assist memory, &c.)—xvii. Bell, 203.
Strangeways, 204. United States, Ringgold, 598.
Willard, 536.

CHAR-VOLANT (Carriage drawn by Kites)—x. Gilbert, 234.

CHAPELAINES—xxi. Durham, 46. xxiii. Thornhill, 49.
Durham, 58.

CHEESE PRESSES—ix. Carson, 110. Harkes, 23.
Rudenhurst, W. & J., 61. Stokes, 255.

CHEMICAL BALANCES FOR ANALYSIS—x. Dover, 344.
Marriott, 341. Oertling, 334. Sweden, Bergstrom, 85.

CHEMICAL DRAWINGS—xxx. (Fine Art Court) Hamer,
118.

CHEMICAL MATCHES—Sardinia, Albani, Brothers, 7.

CHEMICAL AND PHILOSOPHICAL APPARATUS—x. Coffey
& Smith, 454. Griffin & Co., 457. Knight & Sons,
453. Statham, 456. xxv. Minton, 1.

Austria, Batka, 135. Jerak, 134.

France, Bonnet, 1096. Briet, 439. Grosse, Brothers,
529. Fouche, 216. Laperdriel, 307. Machily, 915.
Ozouf, 670. Quennessen, 1683.

Tuscany, Nardi, Brothers, 70.

Zollverein (1), Arnoldi, 778. Gressler, 854. Hoffmann
& Eberhardt, 88. (5), Albert, 23. Lühme, 83.
March, 240. Seel, 483.

CHEMICAL PREPARATIONS (Various)—i. Longmaid, 441.
Smith, 499. ii. Bullock, 34. Button, 3 Davenport,
111. Davy, Mackinrold & Co., 62. Fox
& Barrington, 44. May & Baker, 14. Squire, 93.
Watts, 103. xxix. Fisher & Co., 22.

Austria, Braun, 21. Wagenmann & Co., 19.

Belgium, Cappellemans, 37. Société de Floreff, 38.

France, Bataille, 42. Bobee & Lemire, 1092. Coignet
& Son, 1153. Cowmerie & Co., 462. De Cavillon,
109. Digeon, 1590. Drouin & Brossier, 169.
Grandvaul, 1255. Kuhlmann, Brothers, 555. Lalande
& Chevallier, 1288. Patoux, Drion & Co., 674.
Poizat & Co., 1399. Pomnier, 1400.

India, ii. Jersey and Guernsey, Arnold, 33.

Nova Scotia, Central Committee, 2.

Russia, Hirschmann & Co., 26.

Sardinia, Bonjean, 12. Calloud, 11.

Spain, Santo, 242.

United States, Penfield & Camp, 296. Power &
Weightman, 262. Wetherill, Brothers, 43.

Zollverein (1), Kunheim, 13. Marquart, 327. Mat-
thes & Weber, 464. Pauli, 328. Prussian Chemical
Manufactory, 683. Schuer & Kobering, 543. Schwem-
sal Alum Works, 463. Stohmann & Wustefeld,
460. Wessenfeld & Co., 461. (5), Zimmer, 3.
(6), Oehler, 8.

CHEPSTOW RAILWAY BRIDGE (Model)—vii. Finch &
Willey, 9 (Main Avenue, West).

CHERRY-STONE, CARVED. Tuscany, Romoli, 120.

CHESS BOARDS AND MEN—xxv. Wedgwood & Sons, 6.
xxvi. Nunn & Sons, 165. xxviii. Fentum, 48. xxx.
(Fine Art Court)—Lang, 240.

Austria, Wien, 578. Belgium, Branden, 511.

Bermudas, Jackson, 2. China, Copland, India, xxvi.
New South Wales, Burchett, 3.

Zollverein (1), Scharf, 776. Schrader, 777. Weishaupt
and Sons, 412. (3) Jahn, 34.

CHESS TABLES—xi. Lincoln & Bennett, 57. xxiii. Eady
109. xxvi. Jennens & Bettridge, 187. Nunn &
Sons, 165. Rose, 28. Webb, 171. xxvii. Vokins,
30. Whishaw, 61. Wilson, 11. Woodruff, 77.

CHEST EXPANDERS (Elastic)—x. Binyon, 610. xxix.
Clive, 54.

CHEST PROTECTORS—x. Cook & Williams, 685.

CHICORY—iii. Saunders & Gatchill, 144.
France, Lervilles, 591. Netherlands, Heuvelodp, 16.
Russia, Sorokin, 69.

Zollverein (1), Bleibken, 686. Salomon & Co. 692.
(6), Zahn & Volbrecht, 12. See also Pastel.

CHICORY-CUTTER—ix. Ransomes and May, 124.

CHIFFONNIERS—xxvi. Clay & Co., 189. Gillow & Co.
186. Hindley & Co. 266. Newton, 97. Spurrier,
76. Trapnell & Son, 312a.

Canada, Reed & Makins, 115a. India, xxvi.

CHILDREB LINES—xix. Smith, Anderson & Co., 82.

CHIMNEY FILTER-DRAIN—ix. Sailer, 156.

CHIMNEY GUARDS—vii. Bramhall, 129.

CHIMNEY PIECES (Stone, Metal, &c.)—Brine & Sharp,
page 847. xxii. Coalbrook Dale Co., 641.
Glenton & Chapman, 238. Pierce, 107. Johnson & Co.,
106. Robertson & Co., 802. xxvi. Moxon, 252.
Thomas, 276. Wurme & Lunaden, 19. xxvii. Bovey,
4. Brendon, 3. Coates, 19. Frewer, 5. Lomax, 81.
London Marble and Stone Working Co., 17. Mirror
Marble Co., 18. xxix. Stilling, 315.

Austria, Benzoni, 725. Bottinelli, 726. Motelli, 728.

Belgium, Du Bois & Co., 360. Leclercq, 424.

France, Aubanel, 1055. Desanges, 114X. Dupuis, 184.
Lebrun, 572. Luce, 1332. Maras, 608. Seguin, 692.

Zollverein (1), Egells, 200. Porzelt & Harperath,
317.

CHIMNEY PIECES (Machine for Constructing)—vii.
Vaughan, 139.

CHIMNEY POTS—vii. Oliver, 65. xxiii. Cowper, 23.
Green, 42.

Jersey and Guernsey—White, 12. See also Wind
Guards.

CHIMNEY SCREENS—Hamburg, Albrecht, 59.

Switzerland, Hallmeyer-Appenzeller, 246.

CHIMNEY-SWEEPING MACHINES—vii. Dorr, 57. Every,
120. Neale, 121. Taylor, 194. Teagler, 217. xxii.
Bentley, 606. xxix. Barrett & Son, 308.

Zollverein (3), Rickborn, 14.

CHIMNEY VENTILATING APPARATUS—vii. Beeston, 191.
Friarson, 203. Hearder, 205. Hill, 68. Oliver, 65.
Stafford, 189. xxii. Hart & Sons, 636.

CHIMNEYS, TOWERS, &c. (Machine for Constructing)—vii.
Bain, 34.

CHINA—See Earthenware and China. Porcelain Ware.
Pottery.

CHINA (Designs for)—xviii. Heaviside, 91.

CHINA, IMITATION—xxvi. Gushlow, 37.

CHINA CLAY—Belgium, Gaiffier, 14. Tombelle, 12. See
also Pottery Clay.

CHINA GRASS—iv. Hives & Atkinson, 45. Marshall &
Co., 58. Wright & Co., 42.

CHINA GRASS FABRICS—xiv. Wilford & Sons, 42.

CHINIDINE—Zollverein (5), Zimmer, 3.

- CHINTZES**—XII. & XV. Littler, 282. XVIII. Hindley & Sons, 15. M'Alpin & Co., 14. Mansbuel, 88. Nelson & Co., 29. Swainson, 21. XXVI. Grace, 530. *India*, xi.
- Russia*, Carevsk Chintz Manufactory, 178. Lutch, 179. Mayer & Zindell, 177. Prokhoroff, Brothers, 349. *Switzerland*, Hurlimann, 125.
- CHIRAGON, THE, OR HAND-GUIDE FOR BLIND OR TREMULOUS WRITERS**—XVII. Stidolph, 19.
- CHISELS.** See *Tools (Carpenters', &c.)*.
- CHITTLE**—*Mexico*.
- CHLORINE**—IV. Piesse, 129.
- CHLOROFORM**—II. Duncan & Co., 104. Squire, 93. *Zollverein* (1), Marquart, 327. Prussian Chemical Manufactory, 683.
- CHOCOLATE**—III. F. & Son, 31. Gentile, 109. Lebaigue, 29. Monteiro, 34. Moore, 139. Paris Chocolate Company, 30. St. Etienne, 138. White, 32. *France*, Choquant, 1149. De Sandoval & Co., 365. Feyeux, 209. Louit, Brothers, & Co., 316. Menier & Co., 925. Perron, 343. Turpin, 1046. Watrelot Delespaul, 733. *Netherlands*, Deyl Leendert & Son, 10. *Spain*, Inesca, 178. *Switzerland*, Suchard, 2. *Zollverein* (1), Gros, 17. Wittekop & Co., 695. (3). Jordan & Timmens, 6. See also *Cocoa*.
- CHOCOLATE APPARATUS**—VI. Gatti and Bolla, 450.
- CHOPPING MACHINES**—XXII. Price, 397. *France*, Mareschal, 330. See also *Lump Sugar Chopping-Machines. Sausage-Choppers*.
- CHOPSTICKS**—*China*, Berncastle.
- CHOREOGRAPHICAL APPARATUS**—*Zollverein* (6), Baron Klein, 80.
- CHRISTIAN MEMORIALS, &c. (Models)**—XXVII. Laurie 101.
- CHROMATYPE PICTURES** (Mr. R. Hunt's)—X. Henneman & Malone, 297.
- CHROME**—*India*, I. Sveden and Norway, Hoe, 8.
- CHROMIC ACID**—II. Hopkins and Williams, 41.
- CHROMO-LITHOGRAPHY (Specimens of)**—XXVI. Richardson, 207B. XXX. (Fine Art Court), Day and Son, 80. Dicksee, 271. Hanhart, M. & N., 64. Ward & Co., 43. *Russia*, Dregger, 362. *United States*, Duval, 52.
- CHRONOLOGIUM AND PLANETARIUM**—*Austria*, Zibermayr, 132.
- CHRONOGRAPHERS**—*France*, Rieussec, 1685.
- CHRONOMETERS, MARINE**—X. Aubert and Klaffenberger, 52A. Barraud and Lund, 34. Bennett, 1. Brockbank and Atkins, 40. Connell, 11. Delolme, 19. Dent, 55. Frodsham, 57. Hutton, 7. Jackson, W. H. & S., 32. Lowry, 10. Olorenshaw & Co., 3. Pennington, 53. Philcox, 22. Veyeres and Repingon, 91. *France*, Huard, Brothers, 266. Lefebvre, 577. Redier, 1425. *Zollverein* (1), Richard, 342. Tiede, 78.
- CHRONOMETERS (Pocket and other)**—X. Barraud & Lund, 34. Gowlund, 27. Holl, 13. Hutton, 7. Lowry, 10. Parkinson & Frodsham, 35. Walker, 697. XXIII. Hunt & Roskell, 97. Lester & Sons, 27. Martin & Co., 2. Phillips, Brothers, 87. *Austria*, Marenzeller, 166. *Denmark*, Jurgensens, 17. *France*, Leroy & Son, 1186. Detouche & Houdin, 1359. Laumain, 292. Lefebvre, 577. Monet, 1664. Vissiere, 733. *Sweden*, Kulberg, 116. *Switzerland*, Andermars, 22. Brandt, 10. Courvoisier, 34. Favre, 23. Goly-Lereche, 92. Grandjean, 8. Lecoultre, 25. Mercier, 96. Aterinod, Brothers, 15. Patek, 99. Retor, 101.
- CHRONOMETERS, RAILWAY**—X. Wishaw, 419.
- CHUCKS (for Lathes).** See *Lathes*.
- CHURCH ARCHITECTURE**—V. Swain, 976. XXX. (Fine Art Court) Johnston, 19.
- CHURCH WINDOWS (Designs for, &c.)**—XXX. (Fine Art Court) Stocker, 270. *Belgium*, Pluys, 491. *France*, Thibaud-Dallet, 1501. See also *Painted Windows. Stained-Glass Windows*.
- CHURNS**—V. Whitelaw, 68. VIII. Williams, 332. IX.
- Amos, 66A. Burgess & Key, 237. Deum & Co. 180. Digges La Touche, 263. Drummond, 88. Jolly, 69. Robinson & Son, 139A. Samuelson 185. Smith & Co., 266. Tytherleigh, 212. Wilkinson, 220. *Belgium*, Duchene, 166. *Canada*, Weese, 85. *France*, Lavoisy, 1299. *United States*, Dalphin, 493. Tillaghast, 27. *Van Diemen's Land*, Jennings, 236.
- CIDER**—*Canada*, Penner, 132.
- CIDER PRESSES**—IX. Harke, 23. White, 181. XXII. Garton & Co., 493.
- CIGARETTES**—*Russia*, Protassoff, 334. *Spain*, Fernandez, 127B. The Central Factory of Tobacco, Philippine Islands, 248.
- CIGAR-HOLDERS**—*Austria*, Alba, 664. Astrath, 666. Beisiegel, 667. Floge, 670. Friedrich, 671. Grunhut, A., 672. Grunhut, J., 673. Grunhut, W., 674. Litschke, 678. Nagl, 680. Pfeigner, 682. Sievers, 683.
- CIGAR-MAKING MACHINE**—VI. Adorno, 448.
- CIGARILLAS**—III. Buckland & Toppliss, 48.
- CIGARS**—III. Benson, 39. Cohen & Orr, 49. Goodes, G. & S., 50. Jonas, Brothers, 42. Jones & Co., 43. Sales & Co., 47. *Algeria*, Andre, 1. Oxela & Aqni, 40. *South Africa*, Moss, 36. *India*, III. *Portugal*, Royal Tobacco & Snuff Company, 1196-1209. Gomez, 126A. Gonzalez, 126B. Manilla Factory, 248. Partagas & Co., 251. *Russia*, Protassoff, 334. *Spain*, Gomez Alvaric, 126A. Gonzalez Carvajal, 126B. The Central Factory of Tobacco, Philippine Islands, 248. *Zollverein* (1), Carstanjen, 468. Rocholl, 467. See also *Cigarettes. Cigarillas. Tobacco*.
- CINOLITE**—*Greece*, The Greek Government, 16.
- CINCIONIE**—II. Morson & Son, 106.
- CINCIONIE**—II. Howards & Kent, 11.
- CINDER-SIFTERS**—XXII. Bishop, 591. Kent, 553.
- CINNABAR**—I. Forbes, 522. *India*, II. *Zollverein* (1), Du Bois, 7. Lucas, 8.
- CINNAMON**—*Ceylon*, Parlett & Co. *India*, III.
- CIRCUS MODELS**—*Spain*, Mata Aguilera, 289.
- CISTERNS, ENAMELLED**—XXII. Kendrick & Sons, 360A.
- CISTERNS, SELF-CLEANING**—VII. Lowe, 145.
- CITRIC ACID**—II. Copner, 118. Howards & Kent, 11. Huskisson, J. W. & H., 86. *Sardinia*, Acquarone, 84.
- CLARIFIED FATS**—IV. Ewen, 30.
- CLARIONETS**—Koenig & Pask, 504. *Austria*, Hell, 152. *Belgium*, Mahillon, 175. *Canada*, M'Pherson, 183. *France*, Boët, 442. Breton, 1555. *Switzerland*, Felchlin, 80. *Zollverein* (1), Lampferhoff, 485. (2). Boehm, 23. (3). Herold, 19. Schuster, 23. (6). Klein, 23. Seidel, 26. (8). Heckel, 8.
- CLAY**, (undescribed) I. 39, 96. Fahie, 30. Nicholson, 504A. Ross, 51. III. Strange, 83. XXVII. Ambrose, 128. Sealy, 130. *British Guiana*, Bee, 5. *India*, I. *Turkey*. See also *Pipe Clay. Pottery Clay*.
- CLAY (Articles in)**—Panormo, page 850. XXVII. Brannan, 131. Sioger & Co., 98. XXX. (Fine Art Court) Christie, 188. *India*, xxx. *Netherlands*, Martin, 61. See also *Baked Clay Ornaments*.
- CLAY PIPES**—*France*, Dumeril & Co., 176. Fiolet, 211.
- CLAY-SCREENING MACHINE (for making bricks, pipes, &c.)**—IX. Harken, 23.
- CLAYSTONE**—I. Rock, 50.
- CLINOMETERS (for showing list and trim of ships)**—VIII. Berthon, 104.
- CLOCKS, ASTRONOMICAL**—X. Dent, 55. Frodsham, 57. Hall, 60. Parkinson & Frodsham, 35. Payne & Co., 73. *Denmark*, Funch, 16. *France*, Gannery, 516. *Netherlands*, Hohwu, 86. Kaiser, 84. *Switzerland*, Dubois, 9. *Zollverein* (1), Thiede, 78.
- CLOCKS, BAROMETRIC**—X. Bryson & Sons, 154, 665.
- CLOCKS, CENTRIFUGAL**—X. Gerard, 109.
- CLOCKS, ELECTRIC AND ELECTRO-MAGNETIC**—X. Bain, 434. Gowlund, 27. Shepherd, 128. (and South Transit). Webster, 17. *Hamburgh*, Bröcking, 11. *United States*, Bond & Son, 463.

337. Deane & Co.
 J. Drummond, 88'
 139A. Samuelson
 Merleigh, 212. Wil-
 oisy, 1299.
 nghast, 27.
 White, 181. XXII.
 ntral Factory of To-
 54. Astrath, 666.
 edrich, 671. Grun-
 Grunhut, W., 674.
 er, 682. Sievers, 683.
 o, 448.
 o, 48.
 Orr, 49. Goodes,
 42. Jones & Co.,
 40.
 i.
 ff Company, 1196-
 251.
 azles Curvajal, 126n.
 Philippine Islands, 248.
 chol, 467. See also
 nment, 16.
 .
 Kent, 553.
 II.
 India, III.
 era, 289.
 ck & Sons, 360A.
 we, 145.
 wards & Kent, 11.
 linia, Acuarone, 84.
 Austria, Hell, 152.
 M'Pherson, 183.
 (2), Boehm, 23.
 (6), Klein, 23.
 0. Nicholson, 504A.
 VII. Ambrose, 128.
 Turkey. See also
 850. XXVII. Bran-
 x. (Fine Art Court)
 ed Clay Ornaments.
 176. Fiolet, 211.
 g bricks, pipes, &c.)
 im of ships)—VIII.
 5. Frodsham, 57.
 35. Payne & Co.,
 e, Gannery, 516.
 84.
 in (1), Thiede, 78.
 n, 154, 665.
 9.
 ONETIC—x. Bain,
 128, (and South
 rgh, Bröcking, 11.

CLOCKS, GEOGRAPHICAL—x. Radford, 119. Stoker, 204.
Austria, Ratszenhofer, 167. *France*, Pierret, 350.
CLOCKS, HYDRAULIC—See *Hydraulic Clock*.
CLOCKS, MARINE—x. Gerardi, 109.
CLOCKS, MUSICAL—x. Churchill, 99. Marchand, 71.
Zollverein (1), Spiegelhalter, 879.
CLOCKS, POLYHORION—x. Tanner, 28.
CLOCKS, TELL-TALE—x. Newington, 20. Smith & Sons,
 129. *France*, Arera, 752. See also *Alarums (for
 Clocks, &c.)*.
CLOCKS, TIMEPIECES, &c.—x. 105. Adams, 14. Allis,
 87. Bell, 679. Bennett, G. W., 49. Bennett, J.,
 1. Bricall, 95A. Broadbent, 122. Brutton, 96.
 Cole, 31. Dell, Brothers, 100. Edwards, J., 104.
 Edwards, J. T., 103. Elisha, 39. Frodsham, 57.
 Gerard, 109. Gowland, 27. Harvey, 47. Howell,
 James & Co., 16. Hutton, 7. Jackson, W. H. & S.,
 32. Kaiser, 66. Lamb, 42. Lovejoy, 158. McDowall,
 68. Mapple, 69. Moore & Sun, 33. Pace, 117.
 Parkinson & Frodsham, 35. Payne & Co., 73. Rix,
 74. Robinson, 37. Smith & Son, 129. Taffinler, 54.
 Taylor, 127A. Thorneilowe, 43. Trotman, 698.
 Walker, 697. Walter, 41. Webster, 17. Yates, 9.
 Young, 131. XXII. Clark & Retell, 446. XXIII.
 Walker, 93.
Austria, Anderwalt, 170A. Kralik, 169. Schubert,
 168. Zelisko, 170.
France, Arera, 752. Bally, 408. Chavin, 450. Gillot,
 849. Gourdin, 525. Leon - Clement & Bourgeois,
 306. Lerolles, Brothers, 1318. Leroux, 309. Leroy
 & Son, 1186. Mallat, 1340. Matifat, 923. Moser,
 653. Pescheloche-Vavin, 344. Potonie, 964, 1401.
 Redier, 1425. Reyder & Colin, 984. Susse, Brothers,
 1023. Wagner, 736. Weygand, 740.
Hamburg, Nieberg, 10.
Jersey and Guernsey, Felham, 8.
Netherlands, Eder, 88. *Russia*, Chopin, 365.
Sweden, Linderoth, 86.
Switzerland, Ferret, 18. Vuilleumier, 12.
United States, Holloway, 114. Rogers & Co. 532.
 Sperry, 345.
Zollverein (1), Baltzer, 82. Guerin, 68. Seemann, 75.
 (4), Haller, 16. Holch, 18. Stoss, 19.
CLOCKS, TIMEPIECES, &c. (Designs for)—XXX. (Fine
 Art Court) Thomas, 236. See also *Clock Cases*.
CLOCKS, TRAVELLING—*Austria*, Liszt, 165.
France, Bailly-Comte & Son, 407. Bechof, 48. Leroy
 & Son, 1186. Moser, 653.
Switzerland, Borel, 19. Girard, 30. Leuba, 91.
Zollverein (1), Thiemeke, 72.
CLOCKS, TURRET—x. Bell, 679. Bennett, 1. Blaylock, 92.
 Dent, 55 (Main Avenue, West). Roberts, 130. Smith
 & Sons, 129. *Jersey & Guernsey*, White, 12.
CLOCK CASES—x. Drury, 56. XVII. Macomie & Co., 27.
 See also *Clocks, Timepieces, &c. (Designs for)*.
CLOCK DIALS—*France*, Dorey, 479. See also *Dial Illumi-
 nating Apparatus*.
CLOCK AND WATCH WORKS—*France*, Hnari, Brothers,
 266. Japy, Brothers, 275. Marti, 611.
CLOCK-WINDERS—x. Maple, 69.
CLOD CRUSHERS—IX. Bennett, 75. Cambridge, 238.
 Crosskill, 135. Gibson, 129. Pearce, 77. Starkey, 43.
CLODS—XVI. Caron, 325.
CLOTH PAPERS (for pressing & finishing Woollen Cloth)—
 XVII. Hamer, 84.
CLOTHS—See *Woollen Fabrics*.
CLOTHS (systems for cutting out)—XX. Griffin, 117. See
 also *Tailors' Measuring Apparatus*.
CLOUGH'S SELF-ACTING—VII. Oates, 10.
CLOVER & TREFOIL SEND, ENGINE FOR DRAWING—IX.
 Maynard, 109.
CLUMBER HOUSE (Model)—XXX. (Fine Art Court) Bai-
 nbridge, 163.
CLYSTER IRRIGATOR—*France*, Biber, 62.
COACHES—See *Carriages*.
COACH IRONMONGERY—v. Gibson, 849. XXII. Ward &
 Payne, 196. Warden, 368. See also *Carriage Fittings
 (Metal)*.
COACHSMITHS' TOOLS—*New South Wales*, Devitt & Moore,
 10.

COAL—Western End, South Enclosure (Outside), Abercarn
 Coal Company, 49. Bagnall & Genson, 53. Barrow, 41.
 Bymbo Company, 47. Cameron's Coalbrook Steam
 Coal Company, 39. Davis, 43. Fitzwilliam, Earl,
 48. Gilmour & Co., 50. Haines & Sons, 40. Ince
 Hall Coal Company, 38. Neath Abbey Coal Com-
 pany, 44. Oakeley, 34. Price, T. P. & D., 45. Round,
 36. i. Abercarn & Gwythen Collieries Company, 430.
 Atkinson, 261. Barrow, 255. Butler, 247. Butterley
 & Co., 400. Cadell, 217. Clarke, Executors of, 266.
 Cowper, 61. Day & Twibell, 262. Ebbw Vale
 Company, 412. Fornley Company, 406. Field,
 Coopers & Fauds, 263. Frith & Co., 264. Ince
 Hall Coal & Cannel Company, 268. Llangenech
 Coal Company, 259. Mitchell, 270. Monkland Iron
 & Steel Company, 426. Moore, 208. Nixon & Co.
 267. O'Byrne, 218. Pease, 122. Rock, 50. Rogers,
 241. Russell, 271. Turner, 223. Wylam's Patent
 Fuel Company, 252. XXII. Bowring Iron Company,
 83. Hird & Co., 85. *Barbadoes*.
Belgium, Bouhier Charbonnage, 29. Chatelneau Four-
 neaux et Charbonnages, 27. Couillet Fourneaux et
 Mines, 120. Delcourt, 30. Dianet, 31. Petit & Co.,
 13. Pire et Violetto Charbonnages, 34. Pont de
 Loup Charbonnages, 28. D'Oignie Coal-mines, 32.
 Romeae, 506. Suermond, 505.
France, Berard & Co. 51. *India*, i.
Labuan, &c., Woolley, 3. *New Brunswick*, Gould, 3.
New South Wales, Australian Agricultural Com-
 pany, 19.
New Zealand, 38, 39. Connell, 10. Greenwood, 9.
 Waikato Coal Committee, 22.
Nova Scotia, Central Committee, 2.
Portugal, Lacerda, 19.
Spain, Asturias Mines, Inspector of, 15. De Araya's
 Factory, 12. Palen Mines, Inspector of, 27. Pedroso
 Iron Company, 24. *Trinidad*, Lord Harris, 28.
Turkey, *Tuscany*, Caillon, Maillon & Co., 19.
United States, Dermold, 66.
Van Diemen's Land, Douglas River Company.
Zollverein (1), Haniel, 455. Saelzer & Nenack United
 Coal-mines, 450. (8), Nassau Government Engineers
 of Mines.
COAL, ANTHRACITE (Cannel or Stone Coal)—Western End,
 South Enclosure (Outside), Buckingham, 35. Jumea
 & Aubrey, 37. Jones, Sells, & Co. 42. Neath Abbey
 Coal Company, 44. i. Bagot, 244. Bideford An-
 thracite Micing Company, 242. Buckingham, 254.
 Butler, 247. Fahie, 30. Ince Hall Company, 268.
 Jones, Sells & Co., 258. Morgan & Sons, 272. Ram-
 say, 269. Russell & Son, 249. Wandesforde, 111.
 Watney, 276. Western Gas Light Company, 260.
 XXVII. Cowan & Co., 112. *Portugal*, Oporto Co., 17.
 See also *Furnaces for Burning Anthracite Coal*.
COAL, ANTHRACITE, ARTICLES IN—XXVII. Albert, H.R.H.
 Prince, 140. Ramsay, 90.
United States, Patterson, 478. Peale, 74.
COAL, ARTIFICIAL—Western End, South Enclosure (Out-
 side), Buckingham, 35.
COAL-DROP (for loading ships)—v. Durham, Earl, 999.
COAL-MINES (Models)—i. Cawley, 403. Hunter, 219.
 Wales, 431. vi. Bradley & Co. 310.
COAL-MINE MACHINERY—i. Baugh & Co., 401. Mills,
 418. Powell, 253. Sutcliffe, 413. Wood, 432.
 vi. Waring, 305. See also *Chains for Pits*.
COAL-MINE TOOLS—i. Abercarn & Gwythen Collieries
 Company, 430.
COAL-MINE VENTILATION (Models and Plans)—i. Brun-
 ton, 404. vii. Martin, 25. x. Weight, 450.
COAL PLANTS, DIAGRAM OF A GROUP OF, i. Ansted,
 Prof., 241.
COAL-SCALES (for ships)—XXII. Stanley, 238.
COAL-SCUTTLES, VASES, &c.—VII. Quincey, 146. XXII.
 Ferrucombe, 160A. Shoobert & Co. 66. Soutter,
 354. Walton & Co., 69. XXVI. Rogers & Dear, 264.
COAT (made from the fleece in 13½ hours)—xx. Newbury
 Local Committee, 166. See also *Wearing Apparel*.
COBALT-BLUE—*Canada*, Logan, i. *France*, Peyroult, 1676.
Zollverein (1), Graf, 592. (3), Schneeberg Royal Saxon
 Cobalt and Nickel Works, 9.

- COBALT ORES**—I. Barrois, 511. Blee, 512.
Spain, Granada Mines, Inspector of, 16.
Sweden and Norway, Tunaberg Cobalt Works, 9.
Zollverein (1), Graf, 592.
- COBWEB CLOTHS**—XII. & XV. Behrens, 180. Clapham, 158. Dalby, 152. Eckroyd & Son, 130A. Horsfall & Co., 174. Pease & Co., 184. Peel & Co., 164. Rand & Sons, 173. Rogers, 142. Schwann & Co., 141.
COCHINEAL—IV. Jewsbury & Co., 66. Sattler, 76.
Algeria, Hardy, 28.
Madeira, Read, 1.
Spain, 138. Aleaide, 151. Beronguer, 192A. Cruz, 149, 201. Meron, 150.
- COCKS OR TAPS**—V. Little, 476. VI. Cox, 608. Langlands, 336. XXII. Barlow, 462. Davis, 536. Hall, 172. Lambert, 534. Masters, 634. XXIV. Shephard, 8. Wood & Perkes, 7. *Belgium, Peres, 375. See also Air-tight Taps. Ball Cocks and Taps. Hermetic Taps. Spirit Taps. Valves, Cistern.*
- COCKS FOR KITCHEN BOILERS**—VII. Holland, 132. XXII. Holland, 602.
- COCKS FOR STEAM BOILERS**—V. Little, 476. Siebe, 440. VII. Bain, 34. XXII. Lambert, 534.
- COCOA**—III. Benham, 38. Fry & Son, 31. Grut, 36. Shinton, 33. White, 32.
New Granada, 1. Grut, 2. Trinidad, Lord Harris. See also Chocolate.
- COCOA, EXTRACT OF**—III. Budd, 37.
COCOA-FAT—Trinidad, Lord Harris.
- COCOA-NUTS**—Ceylon.
Mauritius, Royal Society of Natural History, 4.
- COCOA-NUT FIBRE** (including Matting and other Articles made therefrom)—IV. Barsham, 56. XIV. Morrison & Hurn, 49. Yeates, 56. XXVIII. Bevington & Morris, 38. Bristol Mill School, 30. Trelour, 39. Wildley & Co., 40.
- COCOA-NUT OIL**—*Mauritius, Mellon, 6. Royal Society of Natural History, Mauritius, 4.*
Trinidad, Lord Harris.
- COCOA-NUT SHELLS, CARVED**—India, XXVIII.
- COD-LIVER OINTMENT**—II. Dickson & Co. 79.
- COD AND SKATE LIVER OIL**—II. Bell, 116. Dickson & Co., 79. Lawrence, 56. Linklater, 82. Owen, 83. Robertson, 81.
Newfoundland, Stabb.
Nova Scotia, Central Committee, 2.
Portugal, Norberto, 599. United States, Simes, 60.
- COFFEE**—III. Moore, 139. Snowden, 28.
British Guiana—Bee, 17 & 18. Kennedy, 16A & 16B. Neischer, 16. Ceylon, France, Tourneur, 1509.
St. Helena, Magnus, 3. Massana, 1.
Eastern Archipelago, Hammond & Co., 2.
Portugal, 446-451. Society Islands, Queen Pomare, 5.
Trinidad, Lord Harris.
Van Diemen's Land, Denison, Sir W. T.
Western Africa, Weston, 1.
- COFFEE, ESSENCE OF**—Lane, 35.
- COFFEE EXTRACTOR, Zollverein (2), Jacob, 78.**
- COFFEE FILTERERS**—XXII. Luysel, 498. Sears, 620.
- COFFEE LEAVES (PREPARED)**—III. Gardner, 142.
- COFFEE MILLS**—VI. Fieldhouse & Co., 443. Muir, 206. Egypt, 153.
- COFFEE POTS**—XXII. Lane, 794. Shoalbred & Co. 66. Warner & Son, 798. Zollverein (1), Leick, 436.
- COFFEE, REFINING POWDER FOR**—XXIX. Wood, 285.
- COFFEE ROASTING APPARATUS**—V. Dakin & Co., 408. Law, 469. XXII. Collier & Co., 100. Keith, 601. Orpwood, 532.
France, Vandenbroucke, 711.
- COFFEE WORKS AND APPARATUS, (Model)**—Ceylon, Clerihew.
- COFFER-DAM**—VII. Teasdel, 44.
- COFFIN, AIR-EXHAUSTED**—United States, Tuckerman, 229.
- COFFIN FURNITURE**—XXII. Cooksey, 320. Hickmann & Clive, 271.
- COFFINS, SLATE**—XXVII. Ekins, 13.
- COGNAC OIL**—Zollverein (3), Busch, 2.
- COG-WHEELS FOR MACHINERY**—Zollverein (7), Metz & Co., 6.
- COINAGE (designs for)**—Canada, Duncan, 351.
- COINING PRESSES**—VI. Maublay & Co., 228. India, v. Zollverein (1), Uhlhorn, 476.
- COINS**—x. Hamilton, 733.
Switzerland, Schuchmann, 264. See also Medals, Coins, &c. United States, Miles, 489.
- COIR FIBRE (and articles made thereof)**—Ceylon. India, xiv. United States, Mills, 489.
- COKE**—I. Butler, 247. Cury, W. & W., jun., 265. Farnley & Co., 406. Pease, 122. Ramsay, 260.
Spain, Palen Mines, Inspector of, 27.
Trinidad, Lord Harris, 10-14.
United States, Detmold, 66.
Zollverein (1), Stinnes, 448. (8), Rosler, 4.
- COLD CREAM**—II. Jouni, 108.
- COLLIERIES (Models)**—See Coal Mines.
- COLOGNE (Designs for a Bridge over the Rhine at)**—VII. Mouram, 178. Russell, 78.
- COLOQUINTO**—Egypt, 22.
- COLOUR EXTRACTOR APPARATUS**—VI. Bourra, 610.
- COLOUR PRINTING**—XXX. (Fine Art Court) Baxter, 115. Cundall and Adley, 112. Dicks, 68. Kronheim, 40. See also Chromo-Lithography.
- COLOURED GLASS**—See Stained Glass.
- COLOURS (for Calico Printing, &c.)**—II. Dentith & Co., 8. xxv. Emery, 57.
- COLOURS (for China and Pottery)**—II. Dentith & Co., 8.
- COLOURS, COMBINATION OF (Device)**—XXX. (Fine Art Court) Oliver, 16.
- COLOURS (for Painting, &c.)**—II. Hell & Co., 66. Hurdell & Co., 48. Elian & Co., 58. Hamfray, 78. IV. Burch, 77. Smiths, 65.
Austria, Bigaglia, 34. Kinsleberger & Co., 27. Kutzer & Loher, 24. Setzer, 23.
Belgium, Ougrée Charbonnages et Fournaux, 40.
Ceylon.
China, France, Lange, 1291. Viard, 1521.
Netherlands, Diederichs Brothers, 6. Duura & Versteven, 5.
Sardinia, Ba, 19. Spain, Zabala, 240.
Tuscany, Muscati, 26. Ridolfi, 25.
Zollverein (1), Diesel & Co., 824, 882. Heyl & Co., 44. Schwarzensfels Electrical Manufactory, 465. (2), Sattler, 14. (4), Abt, 7. Siegle, 6.
- COMB-CUTTING MACHINE**—VI. Staighl & Sons, 455.
Belgium, Van Mierlo, 133.
- COMB-MAKERS' WARE, Sweden, Schuldhuis, 105.**
- COMBS, METALLIC**—XXII. Deakin, 157. Marshall, 197. *Belgium, Houthave, 130.*
- COMBS, TORTOISESHELL, IVORY, &c.**—XXII. Armstrong, 580. XXVIII. Crummeck, 18. Gonnell & Co., 55. Stevenson, J. & J., 152. China, Hewett & Co.
Austria, Hermannstadt Trades Union, 696A.
France, Fauvello Delabere, 202. Massus, 615. Noel, 666. Poinsignon, 1397. Trancart, 393.
Hamburg, Umlauff, 85. India, XXIX.
Van Diemen's Land, Anderson, 198.
Western Africa, Jamieson, 22.
- COMMERCIAL AND BANKING TABLES**—United States, Bartlett, 30.
- COMMONS**—XXVII. Dowbiggin & Co., 404. Pratt, 196.
- COMPASSES, AZIMUTH**—x. Cameron, 356. Crichton, 452. Elliott & Sons, 320. *Denmark, Weibach, 21.*
- COMPASSES, DRAWING**—VII. Birmingham, 13. x. Barton, 708. Lawrence, 115. Penrose, 318.
Belgium, Gerard, 182. De Hennault, 183. Lambert, 185.
Sweden and Norway, Littman, 15. Viberg, 14.
- COMPASSES, MARINERS**—VI. Napier & Son, 158. VII. Brown, Sir S., 334. VIII. Souby, 110. West, 109. x. 692. Dent, 55. Hughes, 691. XXII. Howarth, 181. China, Lindsay. *Denmark, Weibach, 21.*
United States, St. John, 95. See also Binnacles, Ships'.
- COMPASSES, PRISMATIC**—x. Green, 446. Yeates, 332.
- COMPASSES, SOLAR**—United States, Burt, 187.
- COMPOSING FRAMES**—France, Claye, 798.
- COMPOSING MACHINE**—Denmark, Sorensen, 13.
- COMPOSITORS' PAGE-MARKER**—Belgium, Mackintosh, 471.
- COMPRESSED AIR, APPLICATION OF, TO PREVENT VESSELS SINKING**—VII. Wait, 20.

Co., 228. *India*, v.See also *Medals*,
489.
—*Ceylon*.489.
& W., jun., 265.
Ramsay, 269.
17.

Losler, 4.

en.
the Rhine at)—VII.Bourra, 610.
Court) Baxter, 115.
68. Krouheim, 40.

Dentith & Co., 8.

Dentith & Co., 8.
)—XXX. (Fine Art.& Co., 66. Hun-
Humphrey, 78. IV.

Berger & Co., 27.

Fourmaux, 40.

ard, 1521.

6. Duura & Ver-

240.

882. Heyl & Co.,
manufactory, 465. (2),
6.

& Sons, 455.

theia, 105

157. Marshall, 197.

—XXII. Armstrong,
Gomell & Co., 55.
Hewitt & Co.

on, 696A.

Lassus, 915. Noel,
4, 393.
IX.

—United States,

404. Pratt, 196.

56. Crichton, 452.

Veilbach, 21.

an, 13. x. Barton,

18.

183. Lambert, 185.

Viberg, 14.

& Son, 158. VII.

7, 110. West, 109.

XII. Howarth, 181.

h, 21.

See also *Binnacles*,

6. Yates, 332.

4, 187.

98.

en, 13.

im, Mackintosh,

PREVENT VESSELS

COMPRESSED AIR, MOTIVE POWER BY—V. Fell, 438.

CONCENTRATED MILK—France, De Lignac, 922. Ou-
din & Co., 1375. See also *Lactine*. Milk, Es-
sence of.CONCRETE—X. Case, 545. Chidley, 544. Wheat-
stone & Co., 526.*Austria*, Reinsch, 163. Steinkellner, 164.

CONCRETE—I. Smith, 177. White & Sons, 130.

CONFECTIONERS' MOULDS—XXII. Biggs, 453. XXIX. Leale
& Albrecht, 108. Denmark, Meyer, 43.CONFECTIONERS' ORNAMENTS—XXIX. Farrell, 129. Hem-
mie, 167. Wilken, 110. See also *Wedding-Cake*
Ornaments.CONFECTIONERY—XXIX. Hegg, 109. Graham, Lemon, &
Co., 103. Gunter, 112. Huntley & Palmer, 107.
Lucas, 110. Schouling, 114. Watrick, Brothers, 115.
Wotherspoon & Co., 106.*Canada*, Fletcher, 136.*France*, Aucler, 1059. Durand & Co., 1206. Oudard

& Co., 1374. Jersey and Guernsey, Pope, 43.

Spain, Martinez, 179.*Zollverein* (1), Baur, Brothers, 87. Goll, Brothers,

88. Roth, 89. Trøglen, 91.

CONFLAGRATION, MODEL OF A—V. Selve, 452.

CONCRETE MATCHES—See *Lucifer Matches*.CONIFER SUPPORTER (FOR CYPRESSES, ARBOR-VITÆ, &
—IX. Seward, 51.CONSERVATORIES—See *Greenhouses*.COOKING APPARATUS—IX. Gill & Ward, 62. Hodges &
Sons, 116. Thompson, 248n. XXII. Andrews, 379.Aigall, J. & W., 404. Bentley, 606. Brown & Red-
path, 477. Callam, 479. Cornell, 245. Edwards,

241. Evans & Co., 103. Flavel, 38. Frost, 393.

Garton & Jarvis, 463. Goldard, 380. Keed, 378.

Kepp & Co., 499. Longden & Co., 105. Mapple-
beck & Lowe, 370. Ricketts, 433. Seares, 620.

Tozer, 390. Wakefield, 381.

Austria, Albrecht, Archduke, 431. Bartelmus, Brothers,

& Bernhardt, 432. Pleischl, 433.

France, Andreoletti, W. C., 10. See also *Gas-Cooking*,*Apparatus*. *Steam-Cooking Apparatus*.

COOKING APPARATUS (FOR SHIPS)—XXII. Goodbehere,

481. Wallace & Son, 413.

COOKING STOVES—XXII. Rigby, 411. Wakefield, 381.

Canada, Cheney, 151.

COOKING UTENSILS—IV. Dufaville, 125. XXII. Bray,

310. Kent, 396. Simonite, 270.

Belgium, De Rose, Baron, 365.*France*, Boucher & Co., 776. Budy, 783.*Hamburg*, Thiel, 123. *India*, XXII.*Russia*, Imperial Mining Works (Poland), 288.*Western Africa*, Trotter, 5.*Zollverein* (3), Lattermann & Sons, 27.

COOLING APPARATUS—XXII. Masters, 634. See also

Freezing Machines.COOPERS' TOOLS—*Canada*, Shaw, 149.

COOPERS' ARTICLES—XXVII. Springfield, 138.

Canada, Bailey, 86. Dodd, 87. See also *Cusha*.*Churns*.COPAL VARNISH—*Belgium*, Reuvsen, 100.

COPING—VII. Beadon, 51.

COPPER—I. Berger, 439, 518 (Main Avenue, West). Gra-
ham, 517. Low, 489. Royal Dublin Society of Ire-
land, 508. Swansea Committee, 473.*Austria*, Upper Hungarian Mining Association, 3.*Vienna Imperial Mines*, 2.*Canada*, Montreal Mining Company, 10. *China*.*Netherlands*, Bosch, 82. *New South Wales*, Mitchell,

5.

New Zealand, Taylor, 11.*Russia*, Perm Imperial Copper Works, 6. Bogoslovsky

Copper Works, 1. Pashkoff, 23, 24.

Spain, Asturias Mines, Inspector of, 5. Ibarra, 20.*Rio Tinto Mines*, Director of, 8. Fernandez, 25.*Sweden and Norway*, Rorass Copper Works, 37.*Tunis*, 33, 34. *Turkey*, Tuscany, Hall, Brothers, 12.*United States*, Feuchtwanger, 469.*Zollverein* (1), Mansfeld Combined Mining Works,

850.

COPPER, ACETATE OF—France, Maire & Co., 317.

COPPER, CARBONATE OF—*South Australia*, Graham & Co.,

3.

COPPER DECORATIONS, STAMPED—France, Marinix &
Legrand, 332.COPPER MINING, SMELTING, &c., MACHINERY AND
TOOLS—I. Bankart & Sons, 429. Duchy of Corn-
wall, 452. Richards, 441A. Taylor, 434, 450.

COPPER ORES—I. Barratt, 511. Bennett & Co., 450.

Berger, 439. Breualbaine, Marquis of, 7, 442.

Collett, 458. Devon Great Council Copper Mining

Company, 453. Dublin Royal Society, 515. Fahie,

30. Lean, 415. Mining Company for Ireland, 507.

Murchison, 521A. Muschamp, 514. Puckey, 446.

Redruth Local Committee, 413. Secombe, 454.

Swansea Committee, 473. Taylor, 434. Tennant,

516. Thorne, 475. Welborne, 470.

Algeria, Mousaie Mines, 18.*Belgium*, De Rasse, 33.*Canada*, Montreal Mining Company, 10. *India*, 1.*New Zealand*, Lewis, 13. *Murcison*, 2. Reeve, 12.*Russia*, Bogoslovsk Copper Works, 1.*St. Domingo*, Schomburgk, Sir R.*South Australia*, South Australian Company, 1. Barossa

Range Mining Company, 2. Joseph, 10.

Spain, Almeria Mines, Inspector of, 13. Rio Tinto

Mines, Director of, 8. Santander Mines, Inspector

of, 9. Saragusa Mines, Inspector of, 11.

Tuscany, Volterra Salt Manufactory, 2.*United States*, Ward, 408.*Zollverein* (8), Nassau Government Engineers of

Mines, 1.

COPPER ORES, STATISTICS OF SALES—I. Polkinghorne,

460.

COPPER OXIDE—*South Australia*, Graham & Hallett, 3.COPPER, PROCESSES FOR OBTAINING—*Zollverein* (1),

Mansfeld Combined Mining Works, 850.

COPPER-PLATE ENGRAVING (SPECIMEN OF)—*Sardinia*,

Mantua, 53.

COPPER-PLATE PRESSES—VI. Greig, D. & J., 114.

COPPER-PLATE PRINTING—XXX. (Fine Art Court)

Whiting, 123.

Austria, Raitich, 29. *France*, Beard, 759.

COPPER PLATES (FOR ENGRAVING)—XXII. Hughes &

Kimber, 609. Pinder & Sons, 574. See also *Engra-**ving Plates*.

COPPER, &c., SALTS OF—II. Tennants & Co., 7.

COPPER, SULPHATE OF—I. Tennants & Co., 71. II.

Copner, 118. Hatmel & Ellis, 10 (Main Avenue,

West). Pontifex & Wood, 1.

France, Digeon, 1590. *India*, II.*Portugal*, Hirsch, 68. Leal, 66, 67.*Sardinia*, Selopis, Brothers, 4.COPPER, SULPHURET OF—*South Australia*, Barossa Range

Mining Company, 2.

Spain, Granada Mines, Inspector of, 16.

COPPER TUBES—France, Grault & Co., 531.

COPPER VASES—*Russia*, Demidoff, 324.

COPPER WARES—XXII. Terry & Son, 691A. Tylor &

Sons, 401. *Gold Coast and Ashantee*, Forster &

Smith, 1.

Turkey, Western Africa, Jameson, 22.*Zollverein* (4), Wagner, 61.

COPPERAS, CRYSTALS OF—II. Buckley, Trustees of the

late, 4.

COPPERAS (OR GREEN VITRIOL)—II. Dick & Co., 7D.

Hall, 40. Lindsay, 16.

COPYING MACHINES AND PRESSES—V. Dunn, 618. VI.

Mordan & Co., 205. Muir, 206. Pope & Co., 148.

Waterlow & Sons, 164. VII. Plowman, 121. Welch,

156. Wedgewood, 475. XXII. Baker, 19. Pierce,

18. Price, 397. Ruthven, 20.

Canada, Perry, 157. *France*, 'oirier, 963.COQUILLO OIL—*Mexico*.CORALS—See *Underchiefs*, *Silk*.

CORAL AND CORAL ORNAMENTS—XXIII. Paravagna &

Casella, 84. *Algeria*, La Calle Fisheries, 41.*Cape of Good Hope*, Maitland Mines, 1. *Turkey*.*Tuscany*, Raffaelli & Son, 69.CORDAGE—See *Hopes*, *Cordage*, &c.

CORK (RAW AND MANUFACTURED)—IV. French, 127. Peet,

132. XVII. Lloyd, 25. XXVIII. Haas, 124. Esdale & Margrave, 125. French & Butler, 126.
- Algeria*, Wood and Forest Commission, 47.
- France*, Duprat & Co., 492. *Portugal*, 514.
- Spain*, Gerona, 189. Guinart, 188.
- CORK, ARTICLES EXECUTED IN—Zollverein (1)**, Gerhardt, 539.
- CORK CARVINGS—XXX.** (Fine Art Court) Bury, 23. O'Byrn, 257. *Oldenburgh*, Cassebohn, 1.
- CORK HATS—XXVIII.** Clarkson, 197.
- CORKS, MECHANICAL—France**, Journal, 553.
- CORCSCREWS—VIII.** Richards & Co., 240. XXI. Bradford, H. & Co., 3. XXII. Haynes, 584. Jones & Sons, 277. Unwin, 178.
- CORN (including Grain of all Kinds)—III.** Albert, H. R. H. Prince, 107. Asprey, 93. Hexley, Lord, 100. Cahill, 90A. Cousins, 88. Croughon, 92. Fordham, 94. Fox, 90. Gibbs & Co., 104. Gibson, 102. Ilingsworth, 115. Irwin, 99. Jones, 106. Jison, 95. Keene, 98. Kendall, 75. Levy, 120. McKillican, 114. Maund, 79. Milne, 85. Payne, 82. Raynbird, H. L., 74. Raynbird, R. H., 73. Sadler, 103A. Sheppard, 70. Stevens, 91. Sutton & Sons, 112. Taylor & Son, 77. Turro Local Committee, 71. Walker, 83. Wait, 110. Webb, 72. Wellman, 78. Wrench, J., & Sons, 80.
- Algeria*, Chullart, 17. Dupre de St. Maur, 23. Jeantot, 29. Lepelletier, 33. Marchal, 36.
- Austria*, Carniolan Agricultural Society, 70.
- Belgium*, Behey, 76. Collie, 61. Coosemans, 56. Delbaere, 66. De Mulder, 57. De Mathelieu, 58. D'Hollanders, 51. D'Huart de Villemont, 48. Herinck, 43. Legras, 47. Merckx, 496. Mertens, Baron, 55. Minien, 54. Peemans, 50. Peers, 75. Perdicus, 53. Stobbelaers, 60. Vanleu Elst, 45. Vanleu Porre, 44. Van Opheun, 49. Verheyden, 46. Vyvens, 59. Willems, 77.
- British Guiana*, Netscher, 8-11.
- Canada*, Allan, 28. Boa, 46. Desjardins, 30, 47. Drummond, 32. Graham, 34. Laurent, 31. Logan, 27, 57. Muir, 37. Provincial Agricultural Association, 33, 35. Shaw, 56. Tittenore, 30. Watts, 38. Weewe, 20.
- South Africa*, Barn, 46. Rutherford, 23. Volstedt, 6. *Ceylon*.
- Denmark*, Benzon, 45. Puggaard & Co., 1. Voight, 46.
- Egypt*, 52, 68, 70, 73, 84, 85, 87-91, 101.
- France*, Baziu, 1073. Cresjel-Deusse, 465. Mabire, 1334.
- India*, III. *Jersey and Guernsey*, Le Couteur, 2.
- Malta*, Pulis, 4. *Montserrat*, *Netherlands*, Vis, 7.
- New Brunswick*, Blackville, 14. Brophy, 19. Chalmers, 29. Gouldfellow, 28. McDermot, 18. Wyse, 15, 17, 22.
- New South Wales*, Hallett, H. C. & M., 5. Moses, 4.
- New Zealand*, 38. Low and Motion, 24.
- Nova Scotia*, Central Committee, 2.
- Portugal*, 297-329, 331-391.
- Russia*, Bagnier, 39. Bistram, 46. Bolrinsky, Count, 56.
- Caucasus*, Agricultural Society of, 38. Cossacks of the Azoff Sea, 37. Dokhtouff, 36. Ershoff, 60. Gooriel, Prince, 61. Hirshmann, 34, 114. Horticulture, School of, 41. Karkhoff, 45. Kbalil-Beek-Saphieff, 57. Klepatsky, 33. Koucheleff, Count, 32. Loshikareff, 33. Matvieff, 40. Morozoff, 38. Oounkovsky, 54. Pavloff, 333. Pousanoff, 59. Ratshinsky, 49. Rekke, 48. Ropp, Baron, 47. Safonoff, 55. Selivanoff, 52. Shabelsky, 42. Treskoff, 43. Vielhorsky, Count, 44. Vladimirsky, 50. Zilfoogar Beck & Iskander Beck Oglis, 51.
- South Australia*, Heath & Burrow, 9.
- Spain*, 56, 59, 60, 63, 72, 79, 82, 86, 87, 91, 92, 96, 130. Badillo, 57. Barrientos, 83. Becerri, 71. Benito, 78. Casado, 85. Castellon, Corporation of, 76. Cea, 64. Colon, 74. De Cordoba, 69. Enriquez, 73. Gil, 95. Gioaves, 70. Guzman, 53. Macorra, 65. Medina del Campo, Pedosa, & Gomezzarro, 66. Monfort, 88. Nunn, 62. Penafiel, 77. Piedrola, 84. Pinan, 61. Portilla, 291, 291. Salido, 75. Ternero, 68. Torres, 67. *Trinidad*, Lord Harris.
- Tunis*, 60-67, 69-72, 102-105. *Turkey*.
- Tuseany*, Brocchi, 27. Paolelli, 20. Pastorelli, 35. Sloane, 28.
- United States*, Bell, 103. Dix, 139. Heath, 6. Hecker & Brother, 114. Horry, 320E. Hotchkiss, 342. Jewett, 499. Kirtland, 84. Lathrop, 299. Newton, 337. New York State Agricultural Society, 83. Remsburg, 317. Ohio State Board of Agriculture, 24. Thompson, 238.
- Van Diemen's Land*, Brown & Co., 45, 46. Denison, Sir W. T., 26, 28, 35, 38. Harper, 185. Lipscombe, 42. McPherson & Francis, 350. McNaughten, 41, 43. Marshall, 36, 37. Patterson, 48. Tooth, 47. Walker, 44, 49.
- Zollverein (1)*, Lissa Corporation of Millers, 35. (2), Krich, 19. Hammerschmidt, 18. (6), Hesse Darmstadt Board of Agriculture, 13. See also *Flour*.
- CORN-DRYING MACHINE—IX.** Vivian, 227.
- CORN AND GRAIN CLEANING AND DRESSING MACHINES—VI.** Hicks & Son, 218. IX. Brown & Archbold, 250. Caborn, 200. Garrett & Sons, 142. Grounwell, 148. Holmes & Sons, 241. Hornsly & Son, 233. Robinson, 126. Rowley, 87. Royce, 58. Smith, 276. Spiller & Taylor, 64, 64A. White, 181.
- Belgium*, Dancena, 507. Delstanche, 510.
- CORN AND GRAIN GRINDING AND CRUSHING MILLS—VI.** Fairhair & Co., 421. Huxhams & Brown, 446. IX. Barrott, Exall & And, 128. Bendell, 32. Clayton & Shuttleworth, 2. Crosskill, 133. Deane, Dray & Deane, 150. Gillett, 78. Garrett & Sons, 142. Hart, 72. Hayes, 117. Ransomes & May, 124. Richmond & Chandler, 137. Samuelson, 185. Smith, 256. Smith & Co., 266. Turner, 182. Wedlake & Co., 127. White, 181. Woola, 82.
- France*, Mauzaize, 924. Messer, Mill & Co., 635. See also *Grinding and Crushing Mills*. *Millstones*.
- CORN-LIFT—V.** Armstrong, 44.
- CORN MILLS—VI.** Corcoran & Co., 410. Fairbairn, 403. Westrup, 442. Ix. Howard, J. & F., 240.
- CORN AND SEED METERS—IX.** Gingell, 25c. XXVIII. MacGregor, 146.
- CORN STACKS AND STACK LEVELS—IX.** Johnson, 70.
- CORN WHIRLS AND DUSTERS—Canada**, Brainerd, 82. Nelson & Butters, 84.
- CORNELIAN ENGRAVING—XXX.** (Fine Art Court) Gifford, 250.
- CORNET-A-PISTONS—X.** Gishorne, 507. Jordan, 523. Macfarlane, 673. Oates, 520. Pace & Sons, 517.
- Canada*, M'Pherson, 183.
- France*, Besson, 421. Gaubot, 844.
- Zollverein (3)*, Glier & Son, 20. (6), Mueller, 24.
- CORNWALL MINING MAP—I.** Hunt, 524.
- CORNWALL AND SWANSEA—STATISTICS OF SALES OF COPPER—I.** Polkinghorne, 460.
- CORRUGATED GALVANIZED IRON—I.** 216.
- CORSETS.** See *Stays and Corsets*.
- CORUNDUM-STONE—II.** Ellan, Jones & Co., 58.
- COTTAGES, LABOURERS', &c. (Models)—V.** Greatorex, 415. VII. Holmes, 176. IX. Elliott, 41. Grimsley, 136. XXVII. Albert, H. R. H. Prince (at the Cavalry Barracks, opposite the Exhibition). Allen, 68. Griffiths & Strong, 67. Society for improving the condition of the labouring classes, 124. xxx. (Fine Art Court) Bardwell, 175. Bond, 28. Evans, 202. Sillett, 26.
- COTTON FABRICS (Various)—XI.** Allen, 65. Cross, 41. Glover & Dunn, 50. Horrocks, Miller & Co., 60. King, R. & W., 23. Owttram & Co., 62. Paterson & Co., 11. Sudworth, 42. Thackeray & Sons, 27. Walker, 46. XII. & XV. Behrens, 180. Dalby, 152. Firth & Sons, 37. Pearson, 239. Wilson, 138. XIV. Walton & Co., 38. XX. Carver & Gilbert, 38.
- Algeria*, Cox & Co., 68. Delegate of Algiers, 58.
- Austria*, Ebinger, 181. Friedrich, 182. Lang, 185. Leitenberger, K., 186. Leitenberger, F., 187. Osberger's Succesor, 189. Wolfrum, 301.
- Belgium*, Canlyn, 190. De Cuyper, 192. Petit Noel, Lerouge, & Co., 246-250. Saffre, 483. Schelstraete, 251. Servaes, 295. Servais, 291. Vanderberghe, 252.
- Ceylon*. *China*, Hewitt & Co. *Lindsay*.

- Pastorelli, 35.
139. Heath, 6.
20c. Hotchkiss,
Lathrop, 299.
Agricultural Society,
e Board of Agri-
- 45, 46. Denison,
185. Lipscombe,
McNaughten, 41,
48. Touth, 47.
- Millers, 35. (2),
(6). Hesse Darm-
e also Flour.
227.
-ING MACHINES—
a & Archbold, 250.
2. Groussell, 148.
8on, 233. Robin-
58. Smith, 276.
uite, 181.
e, 510.
- SHINO MILLS—VI.
& Brown, 446. IX.
Bendell, 32. Clay-
kirkill, 135. Deane,
Garrett & Sons,
osmes & May, 124.
uelson, 185. Smith,
r, 182. Wedlake &
32.
Son & Co., 635.
Mills. Millstones.
10. Fairbairn, 403.
& F., 240.
agell, 23c. XXVIII.
- x. Jenkinson, 70.
ada, Braiuerd, 82.
- ine Art Court) Gif-
Jordan, 523. Mac-
& Sons, 517.
-), Mueller, 24.
21.
S OF SALES OF CO-
216.
& Co., 58.
s)—v. Greatorex,
liott, 41. Grimmsley,
nce (at the Cavalry
ion). Allen, 68.
y for improving the
s, 124. xxx. (Fine
, 23. Evans, 202.
- en, 65. Cross, 41.
Miller & Co., 60.
Co., 62. Paterson
ckeray & Sons, 27.
rens, 180. Dalby,
, 239. Wilson, 135.
arver & Gilbert, 98.
of Algiers, 58.
, 182. Lang, 185.
rger, F., 187. Oss-
n, 301.
, 192. Petit Noel,
, 483. Scholstraete,
Vanderbergh, 252.
ulday.
- Denmark*, Wulff & Sons, 5.
Egypt, 173, 178, 180, 182, 183, 184, 186, 187, 207.
France, Blech, Steinbach, & Mants, 29. Bouchard,
1103. Delamoriniere & Co., 1583. Dahar-Deles-
paul, 148. Duranton, 494. Hartman & Sons, 256.
Ourcamp Society, 379. Patria, 1380. Scamps,
1479. Schlumberger & Co. 1481. Schwartz & Hu-
guenin, 1003. Soins & Son, 381.
Gold Coast and Ashantee, Forster & Smith, 1.
India, xi.
Malta, Bonavia, 3. Pulis, 4. Schembri, 3. Villa,
Fratelli, 5.
Portugal, Harboza, 682, 683. Da Luz, 775, 776.
Daufrias & Co., 856-865. Lisbon Weaving Co., 684-
700. Pinto & Co., 770-774, 777-786.
Russia, Molkehanoff, 373. Popoff, 174.
Sweden and Norway, 26.
Switzerland, Anderegg, 111. Bovet & Co., 35. Brei-
tenstein, 117. Hunsiker & Co., 166. Lauterberg,
129. Rikkl, 133. Vaucher & Co., 36. Zeller, 144.
Tunis, 10. *Turkey*. *Tuscany*, Padreddi, 60.
United States, Amoskeag Manufacturing Co., 2. Char-
leston Factory, 175A. Delano, 545. Fox & Polhe-
mus, 352. Graniteville Factory, 175. Kimball, 457.
Lonsdale Co., 35. Sayle, Merriam, & Brewer, 406.
Western Africa, 24. Forster & Smith, 2. Hutton,
J. F., 21. Hutton & Sons, 6. King, 7. McWilliam,
Bothey, 4. Townsend, 11. Weston, 1.
Zollverein (1), Bodemer & Co., 820. Cramer, 610.
Crown, Brothers, 609. Dahlheim, 814. Funke, 587.
Lambert & May, 579. Neuhaus, 577. Seipermann
& Mohlau, 676. Stephan & Co., 159. Voelkel &
Co., 91. Vogel & Carner, 711. (2). Lienhart, 43.
(1), Beck, 65. Becker & Schrans, 84. Boehler &
Soy, 56. Hetzer & Son, 64. Heyning & Co., 57.
(1), Kolb & Schule, 28. Zaia, 45. (5), Meyer &
Schwartz, 8. See also *Mixed Fabrics*.
- COTTON GINS—India**, vi.
United States, Bates, Hyde, & Co., 440. See also *Calic-
oes*. *Cambrics*. *Chintzes*. *Cotton-opening, &c. Machi-
nes*. *Damasks* (Cotton, &c.). *Doeshkins* (Cotton).
Dyed Cotton Velvets. *Dyed Cotton Yarns and Cloth*.
Ginghams.
- COTTON MACHINERY—v. Squire & Co., 706. vi. Crichton**,
36. Hibbert, Platt & Sons, 1. Higgins & Sons, 14.
Leach, 7. Ryler, 222. Sutcliffe, 42. *India*, vi. See
also *Hobbins* (Cotton, &c.). *Carding Engines*. *Reoving*
Frames. *Spindles*. *Spinning Wheels and Machinery*.
Warping Machinery.
- COTTON MANUFACTURE, ILLUSTRATIONS OF—xi. Bailly**,
53. Glover & Dunn, 50.
- COTTON OPENING AND CLEANSING MACHINES—vi. Calvert**,
27. Crichton & Co., 36. Hibbert, Platt & Sons, 1.
See also *Cotton Gins*.
- COTTON PLANT, WILD, Canada**, Ashton, 355.
COTTON, RAW—iv. Royle, 107. xi. Brook & Brothers,
24.
Algeria, Benes, 6. Cluffart, 17. Dupre de St. Maur,
23. Grima, 26. Haloch, 27. Morin, 39. Pelissier,
42. Reverchon, 44.
Barbadoes.
British Guiana, Bee, 74, 75, 76. Blair, 71, 72. Netscher,
73. Ridgway, 163. Ross, 76A, 76B.
South Africa, Bazley, 30b. Botanic Garden, 10.
Manuel, 11. *Ceylon*.
China, Shuangbae, H. M.'s Consul at.
Egypt, 106, 134, 151.
India, iv. *Malta*, Pulis, 4. Schembri, 3.
New South Wales, Ludgdon & Co., 4.
Portugal, 539, 540. Nogueira, 538.
Russia, Abdourza-Maran-Ogli, 94. Djidjivadze, Prince,
95. *St. Helena*, Agricultural Society, 2.
Society Islands, Queen Pomare.
Spain, Villars, 162. *Trinidad*, Lord Harris. *Turkey*.
United States, Almy, Patterson, & Co., 454. Bagby,
329. Bond, 37. Hampton, 173b. Holmes, 516.
Jones, J. R., 172A. Jones, J. V., 172. Lak, 330.
M'Leod, 172b. Merrivether, 164. Mitchell, 179.
Morgan, 288. Nailor, 178. Pope, 32. Seabrook,
172F, 320D. Truesdale & Co., 494.
- Western Africa*, Trotter, 5. Weston, 1.
COTTON SEED—iii. Burn, 18. Western Africa, Weston, 1.
COTTON YARN—ii. Duncan, 76.
COTTON YARN, TWIST, &c.—xi. Dixon & Sons, 19.
Greenhalgh & Sons, 28. Houldsworth & Co. 64.
Oswall, Stevenson & Co., 10. Waters & Co., 43.
xii. & xv. Black & Wingate, 204.
Austria, Chieschich, 171. Diersiers, 176A. Grillmayer,
172. Grohmann, 178. Hirschell & Minerbi, 173.
Lensen, 173A. Perger, 174. Pordenone Cotton Mill
and Dyeing Establishment, 175. Richter, 176. *Briti-
sh Guiana*, Hies, 137.
France, Cox & Co., 392. Hofer & Co., 875. Motte,
Bussat & Co., 651. Piquot, 389. Vantruyen &
Mallet, 715.
Switzerland, Billeter, 147. Blum, 114. Buchler &
Sons, 120. Clair, 121. Imhoof, 126. Leumann, Broth-
ers, 130. Rietor, 132. Schmid, 133. Schwarz,
137. Springer, 138. Winkler, 142. *Turkey*.
Zollverein (1), Brinck, 607. Hugs Turkey Ired Dye-
ing Company, 602. Neuhoff, 603. Sartoens & Co.,
611. Schoeller, 608. Wiedemann & Co., 488.
Wolf, 600. (3). Bodemer, 40. Heymsun 39. Pansa
& Hauechill, 42. Strans, 33. Otto, 47.
- COURT COSTUME—xx. Phillpotts, 18. xxx. (Fine Art**
Court) Mitchell, 12, 13, 35b.
- COURT PLUMES—See Feathers, Plumes, &c.**
- COUSORRODEUR—France**, Magnin, 1654.
- COW BELLS—See Bells, Cattle.**
- COW HAIR—XXIX. Wright, 250.**
- CRADLES, COTS, &c.—xx. Capper & Son, 45. xxii. Reid**,
543. xxvi. Dixce, 16. Jenuens & Heltridge, 187.
xxviii. Tarbutt, 185. xxx. (Fine Art Court) Her
Majesty the Queen, 353.
- CRANES—v. Allan, 711. Fairbairn & Sons, 417. Fox**,
Henderson, & Co., 404. James & Co., 411. McCnicoll
& Vernon, 434. Slight, 765. Stothert, Rayno, & Pitt,
403. Warren, 558. vii. Bremner, 95. Spurgin,
76. ix. Deane, Dray, & Deane, 180. Slight, 42.
Netherlands, Enthoven, 76. See also *Fireplace Crane*.
Hydraulic Crane. *Steam Cranes*.
- CRANKS FOR STEAM-ENGINES, &c.—v. Judge, 130.**
Squire & Co. 706.
- CRAPE—xii. & xv. Bottomley, 181. xiii. Courtauld &**
Co., 34. Grout & Co., 36. Pulling, 53.
Egypt, 215, 318.
France, Brunet & Co., 1120. Montessuy & Clomer,
1360. Theveot, Raffin & Roux, 1500. *Turkey*.
Zollverein (1), Funke, 587.
- CRAYON BOARDS, COLOURED—xvii. Turnbull, J. L. & J.**
45.
- CRAYON PAINTING—xxx. (Fine Art Court) Kearney, 5.**
CRAYONS—Zollverein (2), Rehbach, 82.
- CREAM OF TARTAR—Austria**, Welter, 18.
- Sardinia*, Castagneto, 76. *Spain*, Bescanans, 239.
- CREOSOTE—ii. Morsou & Son, 106.**
Zollverein (5), Broenner, 1. (6), Oehler, 8.
- CRIBBAGE-BOARD—xxx. (Fine Art Court) Wilson, 200.**
- CRICKET BATS, &c.—xxix. Caldecourt, 199. Clapshaw**,
186. Clements, 189. Dark, M., & Sons, 197. Dark,
R., 198. Duke & Son, 191. Lillywhite & Sons, 196.
Medway, 195. Page, K. & W., 194.
- CROCHET NEEDLES—xxii. Hurdy, 140.**
- CROCHET WORK—xix. Constable, 134. Copeland, 136.**
Cross, 141. Danby, C. & T., 71. Fandel & Phillips,
165. Fryer, 237. Irish Work Society, 77. Lock-
wood, 240. Padwick, 251. Pearse, 266. Riego de la
Branchardiere, 17. Sutton, 308. Waterhouse, E. &
M., 336. Woolcock, 356. Wratiaslaw, 357.
- Ionian Islands*, Mavrotanni, 2. *Madeira*, Read, 1.
Zollverein (6), Mutschel, Winzenried & Co., 28.
- CROSBY HALL, BISHOPSCLATE—xxx. (Fine Art Court) Seal**,
218.
- CROWN GLASS—xxiv. Chance & Co., 22. Hartley & Co.,**
100 (Main Avenue, East).
- CRUCIBLES—i. Rucl, 435. xxv. Juleff, J. & J., 30.**
Michell, 29A. *Belgium*, Puisseant, 356.
France, Deyeux, 476. *United States*, Atwood, 426.
- CRUMD CLOTHS AND STAIR CARPETING—xiv. Beveridge**,
20.

CRYSTALLOGRAPHY (Models illustrative of).—I. Leeson, 8. **CRYSTALS**—I. Devonshire, Duke of, 14, 531. Mitchell, 9. Tennant, 14. XXIII. Emanuel, 119. XXIV. Richardson, W. H. B. & J., 14. *France*, Bertrand, 1549. Lambert, 1638. See also *Rock Crystals*.

CUDDEAR—II. Marshall, 68. IV. Smith & Son, 68.

CULINARY UTENSILS.—See *Cooking Utensils*.

CULTIVATOR, SELF-ADJUSTING—IX. Bendall, 32. See also *Uley Cultivators*.

CUPPING INSTRUMENTS—X. Pratt, 635. *Switzerland*, Lunod, 106.

CURD-MILL—IX. Stokes, 255.

CURLING STONES—I. Cassels, 26. Kay, 27.

CURRANT-DRESSING MACHINE—VI. Weatherley, 441.

CURRIERS' TOOLS—XXII. Briggs, 145.

CURRY-COMBS—*Austria*, Koller, 466. *United States*, Gardner, 304.

CURRY-POWDER, CHUTNEY, &c.—III. Payne & Son, 22.

CURTAIN RODS—*France*, Dupes & Co., 1594. See also *Brass Foundry, &c.*

CURTAINS—*Austria*, Volkman, 190. *France*, Castel, 83. Daudville, 156. *Hamburgh*, Heiser, 25. Muckenheim & Alpers, 27. Verheim, 28. *Zollverein* (4), Van Zwerger & Co., 52.

CUSHIONS, NEEDLE WORK, &c.—XIX. Jones, 219. Kiddle, 384. XXVI. Blott, 18. *Western Africa*, Beecham, 12. Forbes, 8. Hutton, 21. King, 7.

CUSTARD POWDER—III. Edwards, 134.

CUTLERY—I. Solly & Co., 410. x. Philp & Whicker, 641. Weston, 640. XXI. Beach, 48. Blofeld & Co., 4. Bradford, R. & W., 3. Bradford, S., 26. Colgan & Son, 25. Deane & Co., 6. Durham, 46. Gradwell, 40. Hilliard & Co., 33. Loy, 15. Mathews, 181. Mechi, 12. Morton, J. & G., 7. Mosely & Son, 13. Offord, 28. Sharpe, J. & R., 10. Thornhill, 2. Yeates, 19. XXII. Algor, 118. Barge, 144. Bashaw, 143. Blake & Parkin, 193. Brookes & Son, 110A. Burrows, 222. Clayton, 142. Elin & Co., 120. Ellis, 156. Eyre & Co., 203. F. zue, 226A. Hargreaves & Co., 116. Hincliffe, 224. Holt, 130. Hut, 166. Ibbotson & Co., 191. Jones, 136. Ledger, 155. Leon, 225. Makin, 112. Mappin & Brothers, 139. Marsh & Co., 162. Marshall, 197. Mottram & Hawkins, 691. Newbould & Baildon, 133A. Nicholson, 137. Nowill & Sons, 149. Oliver, 121. Parkin & Marshall, 119. Roulgers & Sons, 690 (Main Avenue, West). Saynor & Sons, 198. Sellers, 147. Turner & Co., 117. Unwin & Rogers, 159. Unwin, W., 178. Whittles & Froggart, 693. Willoughby, 173. Wilson & Son, 195. Winks & Son, 134. Wostenholm, 125. XXIII. Higgins, 115. *Austria*, Alsterberger, 503. Bauer, 504. Bley, 505. Breshnauer, 506. Bubenitsch, 507. Daucher, 508. Derubetger, 509. Dietz, 510. Doppler, 511. Forster, 512. Freukner, 513. Fröhlich, C., 514. Fröhlich, J., 515. Grunwald, 516. Haindl, 517. Helm, 512. Hofer, 519. Kalbaumark, 520. Kerbler, 521. Kraunwetter, 522. Lichtl, 523. Lieder, 521. Löschenkohli, C., 525. Löschenkohli, J., 526. Maderböck, 527. Miller, 528. Mitter, J., 530. Mitter, J. sen., 529. Moser, A., 531, 532. Moser, C., 533. Moser, F., 534. Moser, G., 535. Moser, J., 536, 537. Osterberger, 538. Peesl, 544. Pfusterschmidt, 546. Pichler, 539. 513. Pillas, 541. Pilsa, C., 540. Pilsa, G., 542. Pilsa, M., 543. Rapp, 547. Reidler, J., 550. Reidler, L., 551. Resl, J., 548. Resl, M., 549. Rödel, 552. Rupprecht, 553. Salzwimmer, 554. Schindler, 555. Schwinghammer, 556. Stierhofer, 557. Stierl, 558. Stuckhart, 559. Voith, 560. Wacter, 561. Weichselbamer, J., 562. Weichselbamer, M., 563. Teyfelmeyer, 564.

Belgium, Mounoyer, 352.

South Africa, Moravian Missionary Station at Genaden a, 44. *Ceylon*.

France, Chariere, 1145. Guerre, 858. Lanne, 1641. Picault, 848. Renollet & Son, 982. Roissard, 1450. Tahourdeau, 1496.

India, I. XXI. *Jersey and Guernsey*, Carmalt, 18.

Ionian Islands, Ward, 6.

Nova Scotia, Acadian Iron Mining Association, 1. Archibald, 2. *Russia*, Iakvlev, 286.

Sweden and Norway, Heljestränd, 11. Lundqvist, 11. Oesterberg, 11. Stille, 12A. Svalling, 11. *Turkey*.

United States, Lawrence, 617. Pooley, 225.

Western Africa, Jamieson, 22.

Zollverein (1), Hoecker, 631. Cüppel, 628. Hasenclever & Sons, 631. Henkels, 187. Hilgers & Sons, 631. Hoeller, 637. Linder, 629. Luokhaus & Co., 631. Post, J. D. 615. Post & Sons, 616. Schmolz & Co., 673. Scholz, 680. Schwarte, 640. Thomas, 671. (3). Krumbholz & Trinka, 30. Levy, 31. (4). Dittmar, Brothers, 57.

CYANIDE POWDER—*Zollverein* (1), Krimmelbein & Bredt, 457.

CYANOTYPE AND CHRYSTOTYPE PICTURES (Sir J. Herschel's)—X. Heneman & Malone, 297.

CYCLOPS STEEL WORKS, SHEFFIELD, (Model of)—XXII. Johnson, Cammell, & Co., 109.

CUTTING MACHINE—VI. Harriid & Son, 157.

CYPRESS TREE—*China*, Standish & Noble.

DAAGERS—*France*, Vilpelle, 1523. *Russia*, Hazalay, 164. Oate-Selim-Molla-Nouri-Ogli, 165. *Spain*, Toledo Royal Ordnance, 266. *Turkey*. *Western Africa*, Hutton & Sons, G. McWilliam. *Zollverein* (1), Schu, 8, 880.

DAGUERRETYPE APPARATUS—X. Beauford, 406. Claudet, 296. Field & Son, 250. Horne & Co., 220. *France*, Mayer, Brothers, 623. *Zollverein* (1), Schneider, 203. (5). Albert, 7. See also *Calotype Apparatus. Camera Obscura*.

DAGUERRETYPE (OR PHOTOGRAPHIC) PICTURES—X. Beard, 292. Bingham, 302. Claudet, 296. Griffiths and Le Beau, 404. Kilburn, 294. Mayall, 231. Paine, 295. Rippingham, 304. Tyre, Brothers, 290. XXX. (Fine Art Court) Graddock, 227. Laroche, 232. Voigtlander & Co., 254. *Austria*, Vogel, 739, 740. *France*, Bayard, 414. Gouin, 211. Le Gray, 585. Maucomble, 620. Plagniol, 1679. Sabatier, 1467. Saugrin, 690. Thiery, 1038. *Hamburgh*, Kolmke, 103. *United States*, Brady, 137. Brainard, 509. Evans, 105. Fontain & Porter, 550. Gavit, 125. Harrison, 223. Lawrence, 151. Mayall, 491. Mead & Brothers, 109. Pratt & Co., 264. Root, J. H. Whipple, 451. Whitehurst, J., 525. Whitehurst, 42. H. 377. *Zollverein* (4), Von Minutoli, 191. See also *Calotype Process. Chromatype Pictures. Cyanotype and Chrystotype Pictures*.

DAIRY UTENSILS—*India*, VI. See also *Butter Prints and Boards. Butter Tubs. Cheese Presses. Churns. Curd Mills. Milk Pails. Milk Strainers*.

DAM FOR RIVER OPERATIONS (Model)—VII. Green, 17.

DAMASK LOOMS—VI. Henning, 43.

DAMASKS (Cotton, and Cotton and Woollen)—*Switzerland*, Blumer & Jenny, 116. *Zollverein* (2), Braun, 39. (3). Heynig & Co. 57. Hessel & Co. 86. Lohse, 85. Roehrig & Albrecht, 87. Seyffert & Breyer, 86.

DAMASKS (Linen)—XIV. Brown & Sons, 17. Canter, 36. Capper & Son, 95. Carter, Brothers, 36. Curry & Co., 24. Coulson, 92. Crawford & Lindsays, 13. Devas & Co., 34. Fletcher, 36. Hattersley & Co., 36. Haxworth & Camley, 36. Houghton, 50. Hunt & Son, 28. Jackson and Matthewman, 36. Kinnia, 26. Pegler, 43. Pigott & Newton, 36. Richardson & Co. 7. *Austria*, Von Harrach, 285. Simonetta, 291. *Belgium*, Dujardin, 217. *France*, Grassut & Co., 326, 1257. *Netherlands*, Galle, 47. Geffen, 46. Ven, 44. Voort, 45. *Zollverein* (1), Mueller, 541. Urban, 724. Westermann & Sons, 544. Wiedenmann, 669. (2). Trendels & Son, 41. (3). Beyer & Co., 51. Lieske & Haebler, 52. Proels & Sons, 54. Wanstig & Sons, 53. (4). Faber, 33. (6). Lohm, 29. Starth, 30.

- Association, 1.
Lundqvist, 11.
25.
628. Hasou-
Hilgers & Sons,
Luokhaus & Co.,
Schmolz & Co.,
Thomas, 671.
31. (4), Dittmar,
mamelbau & Bredt,
(Sir J. Herschel's)
Model of) -XXII.
137.
Molla-Nouri-Oglli,
266. Turkey.
McWilliam.
ford, 406. Claudet,
Co., 226.
Albert, 7. See also
scura.
(c) PICTURES—X.
ndet, 296. Griffiths
4. Mayall, 291.
Tyre, Brothiers, 299.
227. Laroche, 252.
Vogel, 739, 740.
l. Le Gray, 585.
P. Sabatier, 1467.
599. Evans, 105.
25. Harrison, 223.
nd & Brothers, 109.
ipple, 451. White-
377.
See also *Calotype*
Cyano-type and
Butter Prints and
Presses. Churns.
Strainers.
—VII. Green, 17.
Woollen)—Switzer-
g & Co. 57. Hessel
& Albrecht, 87.
e, 17. Canter, 36.
hers, 36. Curry &
d & Lindsay, 13.
Hattersley & Co.,
ughton, 50. Hunt
man, 36. Kimis,
n, 36. Richardson
etta, 291.
Ven, 44. Voort,
724. Westermann
(2), Treindels & Son,
ke & Hasbier, 52.
us, 53. (4), Faber,
- DAMASKS (Silk, Satin, and Velvet)—XII. & XV. Hoadley & Pridie, 128. Shepard & Perfect, 131. XIII. Boyd, 13. Campbell & Co., 31. Grosvener, 52. Sewell & Co. 19. Stillwell & Son, 7. Swan and Edgar, 11. Wright, 54. Austria, Gianl, 257. China, Lindsay, Shea. France, Adolphe, 1. Lapeyre, 1292. Portugal, Jorge, 963-967. Russia, Kouhrashev, 353. Matviéff, 367. Sardinia, Chichisola & Co., 39. Spain, Orduna, 214. Sweden, Almgren, 80. Folcker & Son, 89. Zollorein (1), Lucius & Co., 729. Wiegand, 734. (3), Behr & Schubert, 60. Hoessel & Co. 86. Lohes, 85. Roehrig & Albrecht, 87. Seyffert & Breyer, 88. Thiemer & Toeper, 90.
- DAMASKS (Worsted and Woollen)—XII. & XV. Akroyd & Son, 130. Brown, 129. Craven & Harrop, 153. Hoadley & Pridie, 128. Holdsworth & Co., 166. Mo Croa, 135. Ripley & Son, 148. Shepard & Perfect, 131. Ward, 134. Russia, Favar, 195.
- DAMP (Composition for preserving against) — Belgium, Coldiers, 41.
- DAMP DETECTORS—X. Green, 446.
- DAMP WALLS, FELT FOR—VII. Croggon & Co., 110.
- DATE DIALS (for Counting-houses)—XXII. Shoobred & Co., 66.
- DATES—Egypt, 27-36, 54, 60, 132, 133, 167. Tunisia, 78, 79, 112, 134.
- DECANTERS—XXIV. Davis & Co., 15. Gatchell, 12. Jones & Sons, 11. Molincaux & Co., 13. XXV. Sharpus & Cullum, 41. See also *Glass Ware*.
- DECIMAL SCALES—Portugal, Pinto Basto, 631.
- DECOCTIONS AND INFUSIONS—II. Austin, 114. Bass, 95.
- DECORATIONS (Undescribed)—XXVI. Bonnar & Carfrae, 108. Cameron, 93. Goodson, 201. Spain, Yraboro, 275. See also *House Decorations*.
- DENTAL INSTRUMENTS—X. Finzi, 602. Goddard, 636. Harnett, 684. Harrington, 721. Jack, 678. Wood, 643. United States, Chevalier, 120. See also *Electric Galvanic Apparatus*.
- DENTIST'S CHAIR—X. Matthews, 181.
- DENTISTRY (Articles of, including Artificial Teeth.)—X. Ash & Sons, 578. Dinsdale, 718. Finzi, 602. Glrimes, 574. Harnett, 684. Harrington, 721. Horne, 575. Laurie, 576. Miles, 601. Morrison, 189. Nolan, 558. Parks, 413A. Perkins, 581. Ransom, 584. Robinson, 582. Rose, 719. Sinclair & Hockley, 329. Truman, 720. Waite, 441. Watt, 717. XXIII. Mortimer, 57. Austria, Eider Von Wurth, 52. Canada, Dickinson, 193. Rahu, 19A. Jersey and Guernsey, De le Coude, 7A. Spain, Leon, 274. Switzerland, Schneider, 102. United States, Alcock, 220. Ambler & Avery, 214, 291. Avery, 76. Barlow, 350. Brown, 216. Browne, 419. Buckingham, 63. Hawes, 153. Hitchcock, 518. Hu ter, 9. Jones, White, & McCurdy, 33. Philadelphia, 558. Reynolds, 61. Wardle, 47. Zollorein (1), Kunst, 70.
- DEODORIZING CHAMBERS—IX. Rogers, 183.
- DEPURATOR—France, Risler & Son, 1438.
- DERBYSHIRE SPAR—I. Potter & Co., 87.
- DERRICK CRANES—V. Fox, Henderson & Co., 404.
- DESIGNS (Undescribed)—XVIII. Gann, 94. Hunt, 90. Sandway, 93.
- DESKS—See *Writing Desks*.
- DEVRANCE'S PATENT METAL—V. Squire & Co. 706.
- DEXTRINE—Austria, Eugelman, 22.
- DIAGRAPHS AND PANTOGRAPHS—France, Gavard, 235.
- DIAL ILLUMINATING APPARATUS—X. Blaylock, 92.
- DIAL PLATES (Barometer)—X. Rupp, 137.
- DIALS, SUN—X. Evans, 106. Green, 16. Lawrence, 115. Mauritius, Balkeld & Co. 5. Natural History Society, 4. Netherlands, Uhlman, 85.
- DIALS, SUN (Portable)—X. Parkes & Son, 671.
- DIAMOND BALANCES—X. De Grave & Co., 333.
- DIAMONDS—XXIII. "Koh-i-Noor," Her Majesty the Queen, 140 (Main Avenue, East). Hope, 73. India, (Durra-i-Noor, or Sea of Light), XXIII. See also *Precious Stones*.
- DIAPERS—XIV. Beveridge, 29. Carter, 36. Carter, Bro-
- thers, 36. Clibborn & Co., 20. Fletcher, 36. Hattersley & Co., 33. Haxworth & Carnley, 36. Hibbert, 39. Jackson and Matthewman, 36. Pigott & Newton, 36. Netherlands, Gessen, 48. Zollorein (1), Dierig, 92. (3). Brandstetter, 55.
- DIAPHRAGM—Zollorein, (4) Kinselbach, 26.
- DIBBLING MACHINES—See *Seed-Dibbling, &c., Machines*.
- DIES (Medal, Button, &c.)—XVII. Pinches & Co., 33. XXII. Lingard, 261. Nash, 310. XXX. (Fine Art Court) Soumes, 330. Sardinia, Lendy, 60. See also *Button, Metal, Machinery*.
- DIGGING MACHINE (Model)—IX. Parsons, 112.
- DIMITY—XI. Cook, 38. Martin & Son, 37. Zollorein (1), Neuhaus, 577.
- DINANT CAKE—Belgium, Clavereau, 60.
- DINTING VALE VIADUCT (Model)—VII. Jee, 222 (Main Avenue, West). Sauter, page 831.
- DIPLEIDOSCOPE—X. Dent, 55.
- DIRECTION-LABELS—XVI. Evans & Son, 18.
- DISINFECTING FLUIDS—IV. Burnet, Sir W., 7. See also *Deodorizing Chambers*.
- DISINFECTING POWDER—II. Collins, 109.
- DISSOLVING VIEWS—X. Horne & Co., 220.
- DISTANCES (Instruments for ascertaining and measuring)—X. Hridges, 339. Elliott & Sons, 320.
- DISTILLER OR RECTIFIER'S RECORDING CLOSE SAFE—VI. Dawson, 612.
- DISTILLED WATERS—XXIX. Taylor & Co., 5.
- DISTILLING APPARATUS—France, Andreoleit, 10. Leinster, 1716. Mecklenburg-Schwerin, Stolzenberg, 1.
- DISTRIBUTOR—VI. Lawrence, 604.
- DIURNAL REFLECTORS—France, Troupeau, 1703.
- DIVIDING MACHINE—X. Best, 330.
- DIVING APPARATUS—V. Deane, 420. VII. Heinks, 53. Siele, 1.
- DIVING BELLS—VIII. Bell, 14.
- DOCK-GATE CAISSONS—VIII. Ditchburn, 30.
- DOESKINS (Woollen)—XII. & XV. Brook & Son, 487. Cooper, D. & J., 42. Scott & Wright, 1. Wheeler, 271. Austria, Biedermann & Co., 206. Binder, 207. Gaez Cloth Manufacturing Company, 209. 11lek, 216. Namiet Cloth Manufacturing Company, 220. Fossell, 223. Schnell, 226. New South Wales, Rayner, A. & G., 22. Russia, Moss & Co. 192. United States, Withered & Co., 529.
- DOG-KENNELS—XXVIII. Toplis & Sons, 154.
- DOLFOR CHURCH (Model)—V. I. Newham, 170.
- DOLLS—Zollorein (2), Neubronner, 97.
- DOLOMITE (for Cement)—I. Sweetman, 40. Canada, Logan, 1. Wilson, 2.
- DOMESTIC IMPLEMENTS—Tunis, 51, 52. See also *Cooking Utensils*.
- DOORS (Models)—VI. Williams, 234. VII. Beadon, 51. Smith, 119A. XXII. Greenfield, 676A. XXVII. Emery, 141.
- DOORS, SWING—XXII. McClure, 568.
- DOOR FASTENINGS—X. Elisha, 39. XXII. Greenfield, 676A. Knight, 587. British Guiana, Steele, 154, 155B. France, Credine, 134. Rebert, 975. Jersey and Guernsey, White, 12.
- DOOR FURNITURE (Porcelain)—XXV. Meyer, T. J. & J. 9.
- DOOR MATS—See *Mats. Matting*.
- DOOR PLATES, KNOBS, &c.—XXVIII. Smith, 22. XXIX. Lucas, 277. France, Corderant, 1157. Trelon, Weldon & Weil, 700.
- DOOR SLIDES (for excluding draughts)—VII. Wilson, 113, 158. VIII. Beadon, 90. XXIV. Gidney, 556.
- DOOR SPRINGS—XXII. Hampden, 612. Savage, 56.
- DOUBLING MACHINE (for lace thread)—VI. Gardner & Bazley, 87.
- DOWN—Russia, Ladighin, 283. Pophoff, 144. See also *Bed Feathers, Down, &c. Eider-down*.
- DRAQS AND OTHER APPARATUS FOR SAVING LIFE FROM DROWNING—VIII. Cleare, 311. Royal Humane Society, 15. IX. Whitfield, 68. See also *Ice-Boats*.
- DRAIN-TILE AND PIPE MACHINES—IX. Brodie, 68. Clayton, 47. Cottam & Hallen, 109A. Dean, 4.

Scrapp, 228. Whitehead, 239. Williams, 151. xxii. Pridoux, 240. See also *Brick and Tile Machines*.

DRAIN-TILES AND PIPES—Western End, North Enclosure, (Outside), Doulton & Co. 64. Ferguson, Miller, & Co., 66. Francis & Sons, 71. I. Cooper, 120A. Fahle, 30, 120. Methven & Sons, 126. Pease, 122. ix. Emiskillen, Earl of, 232. Grimsley, 130.
France, Thibault Boileve, 1502.

DRAIN TRAPS—See *Sewer Traps*.

DRAINING MACHINE (Model)—ix. Gregory, 17 A.

DRAINING TOOLS—ix. Cottam & Hallen, 100A. Saunders, 269a. x. Cox, 347. Denton, 317. xxii. Skelton, 220. See also *Land Presser*.

DRAINING APPARATUS (Silk machinery)—vi. Davenport, 40.

DRAUGHT BOARDS—See *Cheese Boards*.

DRAWBRIDGE, PORTABLE (Model)—vii. Lavancky, 84.

DRAWING BOARDS—xvii. Turibol, J. L. & J., 43.

DRAWING BOOKS—xxx. (Fine Art Court) Brown, 34.

DRAWING INSTRUMENTS—x. Dobson, 323. Elliott & Sons, 320.
Russia, Imperial Horsk Works, 169.
Sweden and Norway, Littman, 15. Viberg, 14.
Zollverein (1), Nietzschmann & Vaccani, 700.

DRAWING MODELS—xxx. (Fine Art Court) Green & Fahley, 8. Sharp, 20.

DRAWING REGULATOR—United States, Hayden, 386.

DRAWING, ROVING, AND SPINNING FRAMES—vi. Higgins & Sons, 14. Parr & Co., 6. See also *Roving Frames, Spinning Wheels and Machines*.

DRAWINGS (Various)—vi. Bennett, 215. vii. Martin, 25. x. Peterman, 711. xvii. Anderson, 200. xxx. (Fine Art Court) Place, 267.
Falkland Islands, Whittington.
Labuan, &c., Grey, the Countess, 1.
New South Wales, M'Arthur, 13. See also *Chemical Drawings, Pen and Ink Drawings, Rice-Paper Drawings*.

DRESS FASTENERS (Steel)—xxii. Aston, 283.

DRESSING-CASES—x. Smith & Son, 31. xvi. Brindley, 21. Hardy, 131. Nowill & Sons, 140. xxii. Fearicombe, 169A. xxiii. Stocken, 81, 200. xxvi. Page, 229. xxix. Best, 37. Edwards, 89. Mechi, 45. Strudwick, 42. *France*, Ancoe, 1052.
Zollverein (1), Schreiber, 783.

DRESSING-CASE FITTINGS—xxii. Brookes, 171.

DRESSING MACHINES—ix. De Porquet, 202. See also *Corn Cleaning and Dressing Machines*.

DRIED FRUITS—See *Fruits (Dried and Preserved)*.

DRILL GRINDERS—ix. Gray & Sons, 150. Wilkie & Co., 21.

DRILL PLOUGHS (for Green Crops)—ix. France, 73. See also *Drills*.

DRILLING MACHINES (for Iron-work)—vi. Hick & Son, 218. Parr & Co., 6. Whitworth & Co., 201. Williams, 234.

DRILLS—ix. Crosskill, 135. Garrett & Sons, 142. Grounell, 148. Horvay & Son, 233. See also *Drill Ploughs, Seed-Dibbling, &c., Machines*.

DRIPE-STONE—Van Diemen's Land, Denison, Sir W. T., 80.

DRIVING BELTS (for Machinery)—xvi. Lupton, 3. xxviii. Curtia, Brothers, 194.

DRIVING-WHEEL (for Railway Engines)—v. Warren, 1001.

DROWNING PERSONS, APPARATUS FOR THE RECOVERY OF—viii. Cleare, 311. See also *Drugs, Ice-Boats, Life Belts and Boats, Life-Boats, Rafts, &c.*

DRUGGETS—Austria, Tartler, 262.
France, Boyer, Lacour, Brothers, & Co., 35.

DRUGS (undescribed)—ii. The London Druggists, 117.
Turkey.
United States, Hackell, Merrit & Buel, 340.
Zollverein (1), 120A. See also *Chemical Preparations, Medical Herbs and Drugs*.

DRUMS—x. Ward, 527. *Hamburg*, De Role, 16. *India*, x. *Western Africa*, Hutton & Sons, 6. Townsend, 11.
Zollverein (2), Knoeke, 100. (4), Rexr, 25.

DRY DOCK (Model)—vii. Giles, 71.

DRYING OIL—ii. Blundell & Co., 48.

DUELING PISTOLS—See *Guns, &c.*

DUMP LEVELS—See *Levels, Surveyors', &c.*

DUNDER TRIUMPHAL ARCH (Model)—xxx. (Fine Art Court) Rocheat, 232.

DURHAM, EARL OF, MONUMENT TO (Model)—vii. Grosu, 3.

DURRIA-I-NOOR, or Sea of Light (a Diamond)—*India*, xxiii.

DYED COTTON VELVETS—xviii. Andrews & Co., 43. Cussons & Co., 55. Stirling & Sons, 56.

DYED COTTON YARN AND CLOTH—vi. Lowthian & Parker, 22. xviii. Cairns, 49A. Greenwood & Co., 46. Steiner & Co., 37.
Gold Coast and Ashantee, Forster & Smith, 1.

DYED FEATHERS—xvi. Adcock & Co. 323 A (Main Avenue, West).

DYED FURS—xvi. Bevington & Morris, 332.

DYED GOODS (Various)—xii. & xv. Armitage & Co., 146. Holdsworth, 163A. Holroyd & Co. 163. Ripley & Son, 148. Schofield & Co., 3. Smith, 163. xviii. Johnson, 20.

DYED HAIR—xviii. Hitch, 59. xxviii. Ross & Sons, 64.

DYED LEATHER—iv. Smith & Son, 68.

DYED SILK & SATIN—xi. Dally & Co., 64. xviii. Jourdan, 61. Lelievre, 60. Reynolds & Son, 63.
Russia, Hadji-bahi-Kelbalay-Osseln-Ogli, 53, 142.

DYED WOOL AND WOOLEN CLOTH—xii. & xv. Bateson & Co., 39. Pawson & Co., 40. xviii. Chabot, 62. Hitch, 59.

DYED WORSTED—iv. Robinson & Co., 72. xviii. Walshaw & Sons, 58.

DYING AND SCOURING (Specimens of)—*France*, Griffin, 1258.

DYING STUFFS—i. Jenkins, 502. ii. Kurts & Schmersahl, 9. Dentith & Co., 8. Lee, 69. Lindsay, 16. Tennants & Co., 7. iv. Hurch, 77. xx. Macdougall, 83. Harris, S. & H., 117.
Belgium, Vloebergo, 36. *Ceylon*.
China, East India Company.
France, Bataille, 42. Michel, 640. Mottet, 932. Steiner, 383. *India*, iv.
Netherlands, Smits, 20. *New Zealand*, Collinson, 3. *Russia*, 89.
Spain, Giabert, 137. Huelva, 130. Saragossa Agricultural Board, 148. *Turkey*.
Zollverein (1), Gruene, 43. Weis, 684. See also *Cochineal, Colour Extractor Apparatus*.

DYNAMOGRAPHIS—Austria, Vienna Polytechnic Institute, 130.
France, Clair, 1151. Tailfer & Co., 386, 1026.

DYNAMOSTATER—*Netherlands*, Casaux, 89.

DYNAMOMETERS—ix. Bentall, 217. See also *Electro-Dynamometers*.

EAR TRUMPETS—x. Rein, 629.

EARLY-CALLING MACHINE—x. Smith, 359. See also *Alarm Bells, Alarms (for Clocks, &c.)*.

EARTH-BORER—*Netherlands*, Sondermeyer, 72. See also *Boring Machines, &c.*

EARTHENWARE AND CHINA—xxv. Allen, 40. Anderson & Bettany, 16. Bowers, 13. Bramell, 43. Brown, T. & M. L., 45. Chamberlain & Co., 44. Clementson, 8. Coke & Edge, 21. Copeland, 2. Daniel, A. B. & R. P., 23. Deakin, 18. Dudson, 50. Edwards & Sons, 37. Fell & Co., 28. Finch, 38. Glover & Colclough, 25. Green, 50. Hilditch & Hopwood, 17. Juleff, J. & J., 30. Kennedy, 4. Keys & Mountford, 14. Lockett, 55. Lowe, 30. Mason, 3. Meigh & Sons, 10. Meyer, T. J. & J., 9. Miles, 32. Minton & Co., 1. Pratt & Co., 22. Sharp & Co., 36. Sharpus & Cullum, 41. Simpson, 33. Till & Son, 20. xxvii. Porter, 66.
Austria, Hardmuth, 621. Minitzek, 624. *Ceylon*.
China, Baring, Brothers. Braine. Hewett & Co. Reeves. Sichert & Co.
Denmark, Polmager, 24. *Egypt*, 345, 347.
France, Allmand, 1051. Aviseau, 1543. Barre-Russin, 20. Boyer, 1554. De Boissson, 427. Goras & Perier, 1233. Lecoq & Rieder, 1304. Mayer & Co., 1656. Morel, Brothers, 1734. Nast, 659. Poutyat,

687. Provancher, 970. Riechel & Co., 956. Rnaud, 1463. *Sèvres National Manufactory*, 1369.
- Hamburgh, Haasa, 58. India, xxv. Malta, Decesare, 27. Netherlands, Draalams, 68.*
- Portugal, Pinto, Haato & Co., 1110, 1111.*
- Russia, St. Petersburg Imperial China Manufactory, 318. Spain, Yaal, 51. Tientsin, 130-148. Turkey, Tawany, Ginori, Marquis, 72.*
- Van Diemen's Land, Tilds, 234.*
- Western Africa, Jamieson, 22. McWilliam.*
- Zollverein (1), Altmann, 215. Cotta & Boehme, 815. Frankenberg, 210. Jannarsch, 821. Mattschas, 217. Paetsch & Hintze, 218. Strahl, 206. (3), Adler, 175. Saxon Royal Manufactory, 174. (4), Uechtritz & Faint, 03. See also Porcelain Ware. Pottery. Clay. Stone Ware.*
- EARTHENWARE CORNICERS—xxv. Bowes, 13.**
- EARTHENWARE GLAZING, COMPOSITION FOR—xxv. Whalley, 27.**
- EARTHUS—See Soils and Earths.**
- EAST POOL (COPPER) MINE (Sectional Model of)—1. Richmond, 441A.**
- EAU-DE-COLOGNE—xxix. Farina, 21.**
- Zollverein (1), Farina, 426, 858. Herstatt & Co. 427. Martin, 425. Spendler & Co., 424. Zoull, 558.*
- EAU-DE-COLOGNE (British)—xxix. Stevenson, 25.**
- EAU-DE-COLOGNE FOUNTAINS—Austria, Farina, 748.**
- EVEN-GUTTERS—vii. Beulton, 51.**
- ERWV VALE IRON-WORKS (Maps and Models illustrative of)—1. Erhw Vale Company, 412.**
- ERONY—See Timber. Woods.**
- ECCENTRIC TUMBLER—v. Hecroft, Butler, & Co., 646.**
- ECCLESIASTICAL FURNITURE, DECORATIONS, &c.—xxvi. French, 110. Hardman & Co., 532. Poinsonly, 191. Pratt, 196. Pugin, 329. Wynne & Lumsden, 10. xxviii. Wippel, 10.**
- Austria, Krickl, 253. Pfeningberger, 359.*
- Belgium, Dussart, 407. Van Halle, 303. India, xxii.*
- See also Altar Furniture. Lecterns. Pulpits.*
- ECLIPSE INDICATORS—x. Murdoch, 202.**
- ECONOMIC GEOLOGY (Specimens of)—United States, Ohio State Board of Agriculture, 21.**
- EFFLUVIA TRAPS—v. Jackson, 682. vii. Lowe & Co., 62. xxii. Duley, 89. See also Sewer Traps.**
- EGG-BEATER—xxii. Lockin, 692. xxv. Lockin, 52.**
- EGG-ROLLER—viii. Huskip, 227.**
- EGG-SHELL CARVINGS, &c.—xxix. Bessent, 293. xxx. (Fine Art Court) Jacot, 210.**
- KIDEN DOWX—iv. Heal & Sons, 59.**
- Anasia, Semenoff & Faleyell, Brothers, 217. See also Down.*
- EIDER-DOWN QUILTS—iv. Heal & Sons, 59. Nightingale and Co., 57. xix. Heal & Son, 396.**
- ELDER PITH (Models in)—xxx. (Fine Art Court) Clifford, 222. Cossens, 25. Limeuse, 179.**
- ELDON AND STOWELL GROUP—Eldon, Earl of, page 848.**
- ELECTRIC CLOCKS—See Clocks, Electric.**
- ELECTRIC COPYING TELEGRAPH—x. Bakewell, 433.**
- ELECTRIC GALVANIC APPARATUS (for use in Dental Surgery)—x. Waite, 441.**
- ELECTRIC LOCOMOTIVES—France, Brton, Brothers, 1113.**
- ELECTRIC PRINTING TELEGRAPHS—x. Brett, J. & J. W., 429. United States, Smead, 237.**
- ELECTRIC TELEGRAPHS & APPARATUS—x. Alexander, 426. Allan, 201. Bain, 434. Beatt, 422. British Electric Telegraph Company, 432. Dering, 436. French, 435. Henley, 428. McNair & Co., 421. Mapple, 126. Reid, 427. Walker, 430. Wishaw, 419. xxii. Tipper & Carr, 550. xxiv. Aire & Calder Battle Company, 6.**
- Hawover, Lohdelink, 4. United States, Dodge, 560.*
- Zollverein (1), Siemens & Halske, 252A, 3. O.A. (3). Stohrer, 15.*
- ELECTRIC TELEGRAPHS (Comic)—x. Smith, 424.**
- ELECTRICAL MACHINES AND APPARATUS—x. Harrison, 464. France, Duchenne, 171. See also Galvano-Electric Machines. Thermo-Electric Battery.**
- ELECTRICAL MACHINES, GUTTA PERCIA.—x. Westmoreland, 444.**
- ELECTRO-DYNAMOMETERS (for measuring Galvanic Currents)—Zollverein (3), Leyser, 16.**
- ELECTRO-GILDING (Specimens of)—xxii. Cartwright & Hiron, 250. Prime & Son, 342. Sturges, 341. Winton & Sons, 268. xxiii. Broadhead & Atkins, 43. Elkington, Mason & Co., 1. (Main Avenue, West), Elkington, 92, 93, 94. Gough, 33. Harrison, 37. Hawkesworth & Co., 35. Morley, 67. Roberts & Hall, 40. Robinson, 91. Sharp, 120. Smith & Co., 119. Wilkinson & Co., 32.**
- France, Thouret, 1712.*
- Zollverein (1), Mühring, 275.*
- ELECTRO-MAGNETIC ALARUM—x. Nichols, 414.**
- ELECTRO-MAGNETIC ENGINE—v. Stanton, 601. x. Creswell, 417. Harley, 85. Harrison, C. W. & J. A. 420. Watkins & Hill, 659. Denmark, Hjorth, 47.**
- ELECTRO-MAGNETIC MACHINES AND APPARATUS—x. Dunn, 689A. Henley, 428. Joule, 440. Sinous, 663.**
- Nova Scotia, Archibald, 2.*
- Zollverein (3), Zweibrücken Mechanical School, 32.*
- ELECTRO-PLATING AND GILDING APPARATUS—vi. Lyons, 293.**
- ELECTROPHORUS—x. Phillips, 411.**
- ELECTRO-STEREOTYPE PLATE (for Printing)—xvii. Muir, 174.**
- ELECTROTYPES (including Specimens of Electrotyping)—x. Hamilton, 733, 742. Newbury, 460. Palmer, 451. xvii. Barrett & Co., 196. Figgins, V. & J., 124. xxx. (Fine Art Court) Ibbetson, 323. Pring, 256. Westwood, 292.**
- Zollverein (1), Süssman, 305. Winkelmann, 282. (3), Huettner, 187.*
- ELEPHANTS' TEETH AND TUSKS—South Africa, Buchanan & Law, 53. Bush, 60. Deane and Johnson, 1. Egypt, 115.**
- India, iv. Eastern Archipelago, Hammond & Co., 2. Western Africa, Hutton & Sons, 6.*
- ELEPHANT TRAPPINGS—India, xvi.**
- ELIZABETH, QUEEN (Statue of)—xxiii. Morel & Co., 117.**
- ELICTOGRAPHI (Wilson's)—xxii. Hird & Co., 85.**
- ELSTER, &c., VIADUCTS (Models)—Zollverein (3), Dresden Royal Direction of Railways, 26.**
- EMBOSSED ARTICLES—France, Desjardins-Lieaux, 1588.**
- Netherlands, Grebe, 102.*
- EMBOSSED IRONS—xxii. Lee, 693A.**
- EMBOSSED PRESSES—vi. Collett, 155. Harris, 151. Jarrett, 154. Muir, 206. United States, Dick, 79.**
- EMBROIDERY AND EMBROIDERED GOODS (Silk, Muslin, &c.)—xi. Muir & Company, 59. xii. & xv. Baird, 290. Balfour, 181. Brown & Foster, 9. Burgess & Co., 243. Clark, 169. Forbes & Hutchinson, 291. Salomons & Sons, 305. Smith & Whyte, 459. Tetley, 172. Whitehill & Co., 257. xiii. Houldsworth & Co., 64. Mason, 35. xiv. Brown, 2. Dufferin's, Lord, School, Belfast, 3. Henning, 16. Pelling, 4. Rogers & Co., 32. xix. Blackburn, 103. Brooks, 113. Brown & Co., 57. Brown, S. R. & T. 58. Cangart School of Clarity, 227. Dalrymple, 377. Daniel and Cossins, 115. Davidson, 148. Dill, 152. Evans, 161. Foster & Co., 306. Harris, Brothers, 193. Hatch, 202. Howell & Co., 5. Irish Work Society, 77. Jackson, 84. Jones, 139. King, 224. Lambert, 229. Lanchenick, 200. Mallalieu, 214. Meg, 51. Meltou, 250. Moore, Mrs., 47A. Mowlund, 228. O'Donnell, 53. Oliver, 250. Palmer, B., 262. Palmer, R., 400. Purcell, 88. Rogers, 111. Rooome, 253. Sisters of Mercy, 213A. Stirling, 86. Sutherland, 309. Tawton, 391. Washbourne, 335. West, 374. Wheeler, 238. Whitney, 347. xx. Moore, 47. Oddy, 121. Wheeler & Ablett, 22. xxvi. Scholey, Misses, 142.**
- Algeria, Baruch Tolatano, 59.*
- Austria, Benkowitz, 389. Bossi, 366. Laporta, 357. Memi, Heira of, 383. Rolz, 384.*
- Belgium, Belloni-Auce, 319. Berenbarts & Co. 334. Darteville and Mounroy, 320. Dujardin, 317. Jacquemin, 459. Paternastre, 331. Roy, 301. Sweveghem, Embroidery Workshop of, 323. Vander Kelen, 313. Weil-Meyer & Co. 336.*
- Canada, De Montene, 163. Dunn, 119. Henderson, 174. Henderson, H., 145.*
- China, Baring, Brothers, Hewett & Co. Lindsay, Rawson,*

- Egypt*, 220, 283, 285-287, 319, 322, 323, 331.
France, Audiat, 1515. Berr & Co., 54. Bietry & Son, 336. Conchomal & Co., 1160. Delaroché-Daigremont, 267. Dabbel, Pellerin & Co., 1173. Felix, 503. Guyenet & Bequet, 254. Hooper, Carroz, & Salourier, 1625. Hubert, 268. Quern & Co., 1415. Seib, 1009.
Hamburgh, Gerson, 32. Rey, 30. Schele, 31.
India, xv, xix.
Ionian Islands, Mavroiani, 2. Seaton, Lord, 5.
Jersey and Guernsey, McDonald, 29.
Lubeck, Spiegel & Co. S. Stolle, 9.
Malta, Azzopardi, 20. Dimech, 21. Enriquez, 9. Grech, 17. Lagrestiz, 18. Nanti, 8.
Mecklenburg-Schwerin, Yerber, 10.
Netherlands, Otto, 55. *Persia*, Arman.
Russia, Hadji-Aga-Baba, 289. Oaste, 194.
Sardinia, Crocco, Brothers, 50. Stefani, 86. Tessala, 49.
Spain, 235, 238. Gilard, 237. Hammond & Co., 230.
Sweden and Norway, Almgen, 30. Hamrén, 28. Horn, 29. Lingren, 96.
Switzerland, Alder & Meyer, 109. Alther, 110. Baenziger, 188. Depierre, Brothers, 189. Ehrenzeller, 191. Eugster, Brothers, 190. Fisch, Brothers, 192. Holderegger, 195. Koellreutter, 196. Pauly, 199. Schoch, Schiess & Son, 202. Staeheli-Wild, 208. Sutter, 203. Tanner, B., 204. Tanner, J. U., 205. Tanner & Koller, 206. Walthurger & Langenegger, 207. Zuelmer & Schiess, 143. *Turkey*.
United States, Borgnis, 487. Getsinger, 320. Haight, 385. *Van Diemen's Land*, Burgess, 109, 110.
Western Africa, M'William.
Zollereïn (1), Grossmann, 752. Koenig, 163. Parey, 169. Pintus, 135. Schiess, 160. Sommerfeld, 173. Stieff & Harras, 161. Weissfog, 720. (2), Graetzsch, 51. Mayer, 52. Praetsch, 51. (3), Boehler & Son, 56. Foerster, 68. Hietel, 168b. Koester & Uhlmann, 70. Krause & Co., 58. Mammen & Co., 59. Meinhold & Stoffgen, 61. Schmidt & Co., 60. Schnorr & Steinhäuser, 62. Schreiber, 71. Schumber, 156. Stoelzel & Son, 66. Teubner, 150a. (4), Neuhurger & Sons, 49. Van Zwerger, Duffner & Weiss, 52. (6), Kern, 45. Dulcius, 72. See also *Berlin Wool Work*. *Crochet Work*. *Knitted Work*. *Needle Work*. *Netted Work*.
EMBROIDERY (Gold and Silver)—xii. & xv. Bottomley, 181. Forbes and Hutchinson, 291. xix. Abraham, 76. Harrett & Cunney, 76. Dirl, 152. Hanson, 188. Harrison, 85. Jaicowaki, 48. Lambert & Brown, 83. Newton & Co., 258. Rodgers & Son, 280. xx. Solomon, 85. Walsh & Co., 109. xxiii. Hancock, 112. xxviii. Rousseau, 116.
Algeria, Judas Moha, 30.
Austria, Bauhofer, 388. *Belgium*, Paternoster, 331.
China, Thoms. *Egypt*, 218, 220, 221, 313-317, 329, 330.
France, Vaugeois & Truchy, 718.
India, xv, xix. *Ionian Islands*, Seaton, Lord.
Persia, Arman. Thompson.
Russia, Popinoff, 310. Shikhonin, 275, 276.
Spain, Gilart, 237. *Tunis*, 41, 42, 83, 93, 94.
Turkey, *Tuscany*, Parlanti, 101.
Zollereïn (1), Alberti, 751. Kausche, 794. Sommerfeld, 173. (2), Brentano, Pellouz & Co., 36.
EMBROIDERY PATTERNS AND DESIGNS—xxx. (Fine Art Court) Belfast Government School of Design, 338.
Zollereïn (1), Gluer, 176. Grunthal, 166. Neie, 168. Rudloff Brothers, 170. Seiffert & Co., 162. Todt, 171.
EMERALD, CRYSTAL—(the property of the Duke of Devonshire) I. Tennant, 14.
EMERALDS—See *Precious Stones*.
EMERY—II. Ellum & Co., 58.
France, Roujon, 358. *Greece*, 20.
EMERY CLOTH—xxix. Barsham & Co., 213. Rogers, H. & H., 215.
EMERY GRINDERS—*France*, Dabus, 481.
EMIGRANT'S HOUSE (Model)—vii. Whytock, 156.
EMIGRANTS' KITCHENS—xxii. Rigby, 411.
ENAMELS AND ENAMEL PAINTING—xxiii. Buss, 79. Edwards, 78. xxx. (Fine Art Court) Bell, 219. Bone, 238. Chesters, 246. Doe, 253. Essex, 211. Etherington, 234. Haslem, 237.
China, Shea. Siehart & Co.
France, Bandouin, 44. Boquet, 1098. Sèvres National Manufacture, 1389. Sturm, 384.
Switzerland, Bantte, 236. Chenevard, 210. Dufaux, 249. Hess, 241. Lombard, 245.
United States, Savery, 55.
Zollereïn (1), Juenger, 400. (3), Walther, 177.
ENAMELLED GLASS—xxiv. Baillie, 61.
ENAMELLED MANGERS, &c.—xxii. Hood, 1.
ENAMELLED SLATE—xxx. (Fine Art Court) Bingley, 226.
ENAMELLED WARE (Various)—x. Barling, 90. xxii. Clark, 657. Hampden, 612. Hood, 1. Kenrick & Sons, 360a.
ENCAUSTIC PAINTINGS—xxvi. Foster, 33.
Austria, Buggatti-Valseichi, 616.
Tuscany, Ridolfi, 25.
ENCAUSTIC TILES—I. Quillam and Creer, 151. xxv. Mintou & Co. I. xxvii. Allen, 68.
ENGINE COUNTER (applicable also to Turnstiles and Bridges)—v. Richmond, 775.
ENGINE TURNING, on Glass—xxiv. Long, 86.
ENGINEERING INVENTIONS (Undescribed)—vii. Williams, 109.
ENGLAND (Models of portions of)—Main Avenue, West, Carrington, 90.
ENGRAVED RAZOR & KNIFE HANDLES—xxii. Mappins, 180.
ENGRAVERS' TOOLS—xxii. Howarth, 181. Sellers, 147. T aylor, 129.
France, Cliequot, 1563. Reynard, 978.
ENGRAVING, BRASS FOUNDRY—xxii. Haywood & Son, 647.
ENGRAVING & CARVING MACHINES—*France*, Barrere, 40.
ENGRAVING AND CHASING ON METAL (Fac-similes of)—xxx. (Fine Art Court) Skinner, 362.
ENGRAVING BY CLOCKWORK—xxx. (Fine Art Court) Bishop, 278.
ENGRAVING FOR EARTHENWARE PATTERNS—xxv. Serjeant & Pepper, 19. Sherwin, 51.
ENGRAVING ON GLASS—xxiv. Danby, 88.
Belgium, Deville-Thiry, 445.
ENGRAVING ON MARBLE—xxvii. Bird, 83. xxx. (Fine Art Court) Rayner, 47.
ENGRAVING BY MACHINERY (Specimens of)—xxx. (Fine Art Court) Chabot, 239. Luntley & Co., 214.
ENGRAVING ON PEWTER—xvii. Coeks, R. & Co., 123.
ENGRAVING-PLATES—xxii. Hughes & Kimber, 609. Pinder & Sons, 574. xxx. (Fine Art Court) Sellers, 295.
 See also *Steel Plates for Engravers*.
ENGRAVINGS—xvii. Manchin & Morel, 128. Royston & Brown, 205. *Austria*, Arneti, 368. Dinkler, 735.
France, Blaise, 1089. Chardon & Son, 116. Gaspard, 1610. Hulst, 882. Perot, 051. Petitcolin, 953.
Sardinia, Scotto, 91.
Zollereïn (3), Jahn, 183. (6), Felsing, 73. See also *Copper-Plate Engraving*. *Line Engravings*. *Lithographic Drawing*. *Engraving, &c.* *Wood Engraving*.
ENGRAVINGS, FAC-SIMILES OF (Process for producing)—xxx. (Fine Art Court) Russell, 230.
ENGRAVINGS AND WRITINGS (Restoration of, after being damaged)—ii. Clifford, 26.
ENVELOPES—xvii. Dudman, 137. Ralph, 142. Spiers & Son, 208. *Belgium*, Turdifi, 281.
Zollereïn (1), Maennel, 828. Ruhl & Son, 597.
ENVELOPE CASES—xxvi. Stocken, 200. *India*, xxix.
ENVELOPE-MAKING MACHINES—vi. Redmond, 128. Waterlow & Sons, 164. xvii. De la Rue & Co., 76.
EPITHEMS FOR MEDICAL & SURGICAL PURPOSES—iv. Markwick, 114.
EPSON SALTS—See *Magnesia Sulphate of*.
ESCRITOIRES—xxvi. Levien, 203. See also *Writing Desks*.
ESSENCES, CULINARY—xxix. Galbraith, 17.
ESSENCES (Various and undescribed)—*France*, Cullas, 801. Hughes and Son, 881. *Tunis*, 83. See also *Perfumes*.
ESSENTIAL OILS—*Portugal*, Seal, 497-500.
ETCHINGS—*Belgium*, Mignee, 440.
ETCHING-GROUPS—COPPER ROLLERS (Method of applying)—vi. Foster, 202.
EUCESIS (for Shaving without Soap)—xxix. Lloyd, 6.
EXCAVATOR FOR RAILWAYS OR CANALS (Model)—vi. Runsom & May, 146.
EXCELSIOR SOAP—*United States*, St. John, 510.

- EXHIBITION OF 1851 (Carving in Commemoration of)—*Belgium*, Vandermeersch, 458. Model of the Building, xxiv. Cogan, 26.
- EXTRACTS—II. Trix, 125.
- EYES, ARTIFICIAL—X. Fuller, 592. Grossmith, 565. Halford, 604. Whitehouse, 280. *Austria*, Schwefel, 608. *Netherlands*, Hess, 108. *United States*, Gray, 302.
- FALKLAND, LORD, STATUE OF (Model)—Bell, page 847.
- FANCY STUFFS—*Austria*, Furst, 296. *Portugal*, Carneiro, 937, 938, 946, 947. Martins, 939. Pimentel, 935. *Zollverein* (3), Thumer & Toeper, 90.
- FANCY WARES AND WORK—XIII. Penfold, 59. xvii. Trouheim & Co., 181. *Austria*, Habentich, 376. Johns & Thiele, 379. Renel, 378. *Canada*, Campbell, 176. Henderson, 174. Rocheleau, 175. *China*, Copland, Rawson. *France*, Basely, 411. Claveronadier, 453. Colletta-Lefebvre, 458. Cornillon, 95. Mercier, 1354. Moulard, 655. *India*, xxix. *Malta*, Falson, 25. *Russia*, Flerovsky, 320. Loukutin & Son, 319. *Turkey*. *Western Africa*, Jamieson, 22. McWilliam. Townsend, 13. *Zollverein* (1), Gehhardt, 248. Koppe, 143. Krebs, 260. Mossner, 251. Schmerbauch, 264. Schreiber, 783. Sommer, 390. (3). Feistel & Son, 171. Rockhausen, 172. Vogel, 89. Ziegler & Haussmann, 92. (4). Kieser & Co., 81. Schmidt, 83. Weeber & Co., 86. Wittich, Kimmel, & Co., (2). (5). Gouda, 26. Koehler, 27. Wollfarth, 28. (6). Moench & Co., 66.
- FANNING MILL—*United States*, Grant, 82.
- FAN PAINTINGS—*Spain*, Mitjana, 287. Pasual y Abad, 286.
- FANS—*British Guiana*, Holmes, 130-132. *Canada*, Henderson, 174. Rocheleau, 175. *Ceylon*. *China*, Braine. Hewett & Co. *Egypt*, 349. *France*, Doucet & Petit, 149. Duvellerry, 435. Felix, 199. *India*, xxix. *Spain*, Mitjana, 287. *Trinidad*, Lord Harris. *Western Africa*, Jamieson, 22.
- FARDER—*Egypt*, 10.
- FARINA—III. Miller, 127. Stenhouse, 154.
- FARM BUILDINGS (Models)—IX. Blain, 205. Elliott, 41. Morewood & Rogers, 152A. Tebhutt, 190. Thornton, 211. Tyson, 215A. Wilmot, 170. xxix. Mechi, 45. xxx. (Fine Art Court) Baxter, 334. Bulman, 228A. Chancellor, 331.
- FARM MACHINE-HOUSE AND MACHINERY (Model)—IX. Barrett, Exall, & Andrews, 128.
- FARNING IMPLEMENTS—*See Agricultural Implements*.
- FAT-BOILING FURNACE—VI. Gilbertson, 508.
- FAT-CUTTING MACHINE—IX. Smith & Son, 234.
- FEATHER BONNETS—XXIX. Harding, 166.
- FEATHER BROOMS—*France*, Henoc, 261.
- FEATHER FLOWERS—*See Flowers, Artificial*.
- FEATHERS, PLUMES, &c.—XVI. Alcock & Co., 323A (Main Avenue, West). xx. Poore, 169. Tollet, 154. xxvi. Gilbert & Co., 130. xxix. Foster & Co., 74. Sturgeon, 53. Sugden & Co., 62. *South Africa*, Rutherford, 23. Schmieterloew, 42. *France*, L'Huillier, 1325. Loude, 1329. *India*, iv. xvi. *Netherlands*, Hase, 31. *Turkey*. *United States*, Pratt, 162. *Van Diemen's Land*, Gunn, 153. *See also Bed Feathers, Ostrich Feathers*.
- FEATHER TISSUES—*France*, Badin, 1063.
- FEET, ARTIFICIAL—*France*, De Beaufort, 46.
- FELSPAR—I. 31. Fahie, 30.
- FELT—VII. Croggon & Co., 110. McNeill & Co., 142. xxii. Pope, 566. xxix. Eadale, 278. Pope, 76. *Algeria*, Algiers, Delegate of, 58. *Austria*, Bayer, 351. Muck, 354. *France*, Budin-Signez, 78. Lambert & Son, 1289. *Russia*, Bardoffsky, 265. *Turkey*. *Thaciny*, Chui, Brothera, 65. *Zollverein* (3), Muehle, 167.
- FELT CARPETING—XIX. Victoria Felt Carpet Company, 327. *Turkey*.
- FENCING IMPLEMENTS—VIII. Cox, 208. xxii. Kuper, 32.
- FENUGRU—*Egypt*, 46.
- FERNS, GLASS CASES FOR—X. Ward, 664 (North Transept).
- FERULE FOR GENERATORS—*France*, Hurltel & Co., 894.
- FIELD DRAINS (Model)—IX. Thornton, 211. *See also Drain Tiles and Pipes*.
- FIGURE-HEADS (Ships)—VIII. Brooker, 181. xxx. (Fine Art Court) Hall, 317.
- FILE-CUTTING MACHINE—*Russia*, Mentchinsky, 131.
- FILES AND RASPS—XXII. Brooksbank, 163. Carr & Riley, 108. Cocker & Son, 115. Johnson, Cammill & Co., 109A. Jowitt & Co., 187A. Kirk & Warren, 161. Marriott & Atkinson, 160. Pinder & Sons, 574. Sheffield Journeyman File-makers, 138. *Algeria*, Ain Morka Mines Co., 19. *Austria*, Beyer, 495. Fischer, 501A. Lechner, 496. Nusbaumner, 497. Preitler, 498. Richel, 499. Sonnliether, 500. Unzeitig, 501. Vater, 502. *Denmark*, Naylor, 22. *France*, Alcan & Locelli, 4. Froely, 218. Proutat & Co., 969. Taborin, 1024. Talalot & Co., 1027. *India*, I. *Spain*, Ibarra, 256A. *Sweden and Norway*, Haglund, 11. Oelberg & Co., 11. Rudberg, 11. Thunberg, 11. *Zollverein* (1), Bleckmann, 623. Huth, Fried, & Co., 632. Lohmann, 630. Mamesmann, 617. Pickhardt, 618. Reinalagen, 622. Schmidt, 646.
- FILIGREE-WORK (Silver and Gilt, &c.)—XXII. Allen, 293. xxiii. Loenartark, 62. *France*, Roucou, 1689. *India*, xxiii. *Ionian Islands*, Mavroiamni, 2. Woodford, Lady, 1. *Malta*, Critien, 24. Falson, 25. Portelli, 23. *Sardinia*, Bennati, 59. Loleo, 58. *Sweden*, Folcker, 67. *Turkey*. *Zollverein* (1), Loewenorn, 437.
- FILTERCOCKS—VIII. Beadon, 90.
- FILTERS—Western End, South Enclosure (Outside), Struthers, 16. I. Stirling, 209. v. Fell, 438. Slack, 423. vi. Beart, 301. vii. Askew, 48. Forster, 26 (Main Avenue, West). xxii. Dawbee & Dumbleton, 499. Green & Co., 532. Murray, 793. Wenham Lake Ice Company, 600. xxv. Lipscombe & Co., 54. xxvii. Hunt, 109. Lipscombe, 49. xxix. Fletcher, 244. Stirling, 315. Warner, 9. *France*, Bernard, 420. Noel, 936. *Van Diemen's Land*, Denison Sir W. T., 80. *See also Charcoal Filters*.
- FILTERING PUMP—V. Cheavin, 448.
- FINGER BASINS—*See Glass*.
- FINGER PLATES—XXII. Hart & Sons, 636. *See also Brass Foundry, &c*.
- FIR-CONES & FIR-NUTS—*Tuscany*, Ridolfi, Marquis, 30.
- FIRE ALARM—X. Mapple, 126.
- FIRE ANNILATOR—V. Phillips, 92. x. Wear, 386.
- FIRE-ARMS—*See Guns, &c*.
- FIRE-BARS, HOLLOW—V. Firth, T. & J., 119.
- FIRE-BOXES (for Locomotive and other Furnaces)—XXII. Frith, 96A.
- FIRE-BRICKS—I. Pease, 122. Russell, 271. Seacombe, 454. *Belgium*, Smal Werpin, 398. *Russia*, Barnavulsk Imperial Works, 4. Kousinsk Iron Works, 9. *Portugal*, Bastos, 279. *Spain*, Aluencia Co., 53. Lugo Mines, Inspector of, 18. *See also Fire-Clay Goods*.
- FIRE-CLAY—I. King & Co., 91. Monkland Iron and Steel Company, 426. Moore, 408. Nicolls, 89. Pease, 122. Phillips, 101. *Belgium*, Boncher, 390. Pastor-Bertrand & Co., 395. Temsounet and Dartet, 394. *Zollverein* (1), Vou Mulmann, 319. (2), Wagner & Co., 99.
- FIRE-CLAY GOODS—Western End, North Enclosure (Outside), Ferguson, Miller & Co., 66. Ramsay, 70. xxvii. Cowan & Co., 112. Ferguson, Miller, & Co. 93. Graingemouth Coal Company, 99. Potter, 115. Ramsay, 110. Rufford, 89. Sprot, M. & T. 98. *See also Fire-Bricks*.
- FIRE-ENGINES—V. Baddeley, 409. Berriedale, Lord, 465.

- Fire Annihilator Co., 92A. Fletcher, 444. Merryweather, 401. Reall, 90. Shand & Mason, 410 (South Trasept). Smith & Son, 449. Warner & Sons, 424. Van Geary, 2. ix. Crump, 160. Siebe, 255A.
- Canada*, Perry, 181.
- Denmark*, Dirksen, 40. *France*, Flaud, 507.
- Hamburgh*, Reynold, 6.
- United States*, Cincinnati Fire Company, 206. See also *Garden Eng'g*: see *Hose for Fire-Engines*.
- FIRE-ESCAPES**—v. Merryweather, 401. vii. Bayliss, 131. Daniel, 182. Dunn, 204. Ell, 94. Houke, 80. Jackson, 201. Jackson & Clay, 75. Haulty, 184. Hopkinson, 104. Madge, 190. Nicholson, 40. Oliver, 65. Stucky, 193. Theobald, 147. Tipler, 92. Tuckey, 101. Welby, 148. Welster, 185. viii. Bowen, 325. Brown, 169A. Dutton, 326. Purser, 28. Walters, 34. x. Webster, 671A. xiv. Morrison & Hurn, 49. xxii. 308. Hampden, 612. Nixey, 640. xxvi. Dixce, 16. xxviii. Baker, 84. Winterborn, 168.
- Belgium*, Jouvne, 123.
- United States*, Baron, 353.
- FIRE-EXTINGUISHERS**—v. Macbay, 586. vii. Bain, 197. Bergin, 183. Rettie, 159. xxviii. Winterborn, 168. See also *Fire-Ammunition*. *Hydrant, or Fire Cock*.
- FIRE-EXTINGUISHERS** (for Ships)—xxii. Riddle, 637. *New South Wales*, Bland, 17.
- FIRE-IRONS**—See *Hardware*.
- FIREMEN'S HELMETS, TOOLS, &c.**—v. Merryweather, 401.
- FIREPLACE CRANE** (for Farm Kitchen)—ix. Harveys & Tait, 16.
- FIRE-PLUGS**—v. Sumption, 445.
- FIREPROOF DOOR**—vii. Boydell, 55.
- FIREPROOF FLOORING OR ROOFING**—vii. Fox & Barrett, 166.
- FIREPROOF SAFES**—xxii. Baker, 509. Barnwell & Son, 678. Clubb & Sons, 646. Leather, 596. Milner & Son, 642. Tann & Sons, 507. Whitfield, 356. Williams, 280. *Netherlands*, Giesbers, 62.
- United States*, Herring, 124.
- Zollverein* (1), Sommermeyer & Co., 802. See also *Safes (Wrought-Iron)*.
- FIRE-PUMPS**—v. Shand & Mason, 410.
- FIRE REVIVERS**—i. Parsons, 232.
- FIRE-SCREENS**—xxii. Gregory, 99. xxvi. Warrack, 102. Wetherell, 236. *Austria*, Becker, 643.
- Netherlands*, Zeegers, 96.
- FISU-HOOKS**—xxii. Bartlett & Sons, 329. Hemming, 331. James, 317.
- FISHING BOATS**—viii. Simmonds, 124. xxix. Falmouth & Penryn Local Committee, 185.
- FISHING NETS, TACKLE, &c.**—iv. Trent, 41. v. Day & Millward, 772. viii. Pearce, 340. xiii. Mason, 35. xiv. Bridport Local Committee, 73. Falmouth Committee, 57A. Tull, 69. xxii. Alecock, 367A. xxix. Ainge & Aldred, 180. Alfred, 179. Allies 157. Anderson, 224. Baim, 160. Bazin, 178. Bernard, 177. Davidson, G. & W., 158. Farlow, C., 176. Farlow, J. K., 181. Flynn, 156. Gould, 31, 171. Harner, 168. Haywood, 38. Jones, 182. Kelly & Son, 159. Lambert, 138. Lascelles, 123. Linton, 142. Little & Co., 174. M'Nair, 162. Morley, 165. Nicholas, 154. Parkins, 152. Northumberland Patent Twine, Rope, & Net Company, 155. Pearce, 173, 311. Pulman, 163. Rattery & Thompson, 206. Richards, 118. Rowell, 153. Utomson & Peters, 172.
- British Guiana*, Stutchbury, 138, 139. *Ceylon*.
- France*, Bertrand & Co., 59.
- Jersey and Guernsey*, Dorey, 37.
- New Zealand*, 39. Moore, 37.
- Nova Scotia*, Central Committee, 2.
- St. Kitts*, St. Vincent, Bullock.
- FLAGS, ENSIGNS, &c.**—viii. Edgington, 302. Hawkes & Co., 212. xiii. Houldsworth & Co., 61. xiv. Morrison & Hurn, 49. xix. Flower, 164. Sheilten, 293. xxx. (Fine Art Court) Whitte, 340.
- Belgium*, Melotte, 302. *Hamburgh*, Meinke, 120.
- Zollverein* (3), Hietel, 168b.
- FLAGSTONES**—See *Paving-stones*.
- FLANNEL**—xi. Mair, Son, & Co., 59. xii. & xv. Bamford,
237. Clay & Sons, 136. Hoath & Whiting, 44. Kelsall & Barlemore, 486. Leach & Sons, 5. Lloydt & Co., 254. Middlebrook, 74. Nicholls, 261. Sampson, 215. Schofield & Co., 3, 125. Smith & Sons, 235. Swaindale, 283. Tweedale & Sons, 4. Wilks, 6. xviii. Mair & Co., 63A. xx. Peart & Dusseter, 5.
- Austria*, Hermannstadt Clothmakers' Association, 214.
- Belgium*, De Heesle, 203. Janssens, 193.
- France*, Boyer & Lacour Brothers, 35. Chatelain & Foron, 86.
- Netherlands*, Vreede & Co., 33.
- United States*, Johnson, Sewall & Co., 441.
- Zollverein* (1), Damsch & Muensers, 715. Dietrich & Son, 807. Merton, 502. Scheibler, 354. (3), Glatfey & Neubarth, 105. Lehmann, 107. (1), Schill & Wagner, 30.
- FLASKS (Drinking)**—xxii. Dixon & Sons, 797.
- Western Africa*, Jamieson, 22.
- FLATTING-ROLL**—*Netherlands*, Nerin, Bogel, & Co., 80.
- FLAX**—ii. Picciotto, 33. iv. Adams, 49. Cator, Nelson, & Co., 46. Chausson, 105. Donlan, 43. Gillman, 44. Hives & Atkinson, 45. Mason, 54. Picciotto, 53. Royal Belfast Flax Improvement Society, 106. Sectional Committee on Vegetable Kingdom, 40. Trent, 41. xii. & xv. Quitzow, Schlesinger, & Co., 178. xiv. Bridport Local Committee, 73. Jameson & Co., 60. Sadler & Co., 18.
- Austria*, Hermannstadt Rojenmakers' Association, 277. Patrak, 289. Schöuberg Linen Yarn Spinning-mill, 95A. Ullersdorf Flax-Raiting Establishment, 96.
- Belgium*, De Boe, 98. Degraeve, 60. Desmedt & Co., 104. Ghent Liniere Company, 230. Haese, 115. Lavolette, 26. Leclercq, 28. Roels & Co., 83. Van Aekere, 215. Van Bognert, 107. Van Hoey, 106. Van Weill, 114. Verbeek, 113. Vercurysse, 213.
- Canada*, Bastien, 70.
- China*, Linslay. Rawson. *Egypt*, 105, 107, 108.
- France*, Dumortier, 177. Jonbert, Houdaire, & Co., 552. Lailier, 539. Rouxel, 302. *India*, iv.
- Netherlands*, Swaab, 50.
- New Zealand*, 38, 39. Caradus, 25. Collinson, 3. King, 26. Robertson, 4. Smith, 19. Tyrrel, 1. Tyrrel, J., 28. Whytlaw & Son, 34.
- Portugal*, 533, 534, 533.
- Russia*, n. n. 103, 106, 107. Alexandrovsk Imperial Manufactory, 19. Ardamatsky, Brothers, 99. Ardamatsky, K. & T. 97. Baharikin, 96. Hirschmann, 34, 114. Jarovitch, 31, 101. Melnikoff, 111. Mikroshtetnoi, 110. Vanukoff, 113. Zakharoff, 168.
- Spain*, 91, 155, 153. Heras, 161. Pisan, 159. Valgoma, 98.
- Sweden and Norway*, 21. *Turkey*.
- United States*, Dix, 139. Ferguson, 574.
- Vin Diemen's Land*, Dixon, 19. Lipscombe, 174.
- Zollverein* (1), Bruegger, 559. Elmendorf, 470. Freiherr Von Luetwitz, 42. Hurnig, 722. Koenigs & Buecklers, 552. Mevissen, 557. Ollerliessen, 551. Ruffin, 34. (3), Gaetzschmann, 3. Sommer, 1. Watteyne, 2. See also *Hemp. Tow*.
- FLAX COATS, WATERPROOF**—vi. Brown, 56.
- FLAX MANUFACTURES (Various)**—iv. Gillman, 44. vi. Brown, 56.
- Belgium*, Ameye-Berte, 209. See also *Linen Fabrics (various)*. *Stail-Cloth. Sheetting*.
- FLAX SEED**—*Canada*, Desjardins, 58.
- New Zealand*, Smith, 19.
- FLAX STRAW**—vi. Robinson, 54.
- FLAX YARNS**—xii. & xv. Quitzow, Schlesinger & Co., 178. xiv. Frazer, 79. Jameson & Co., 60.
- China*, Rawson. *France*, Landerwan Linen Co., 1019.
- Zollverein* (1), Elmendorf, 470. Heepen Spinning School, 546. (3) Sommer, 1.
- FLAX TOOLS AND MACHINERY**—vi. Higgins & Sons, 14. Lawson & Sons, 75. Nimmo & Son, 37. Plummer, 74. Robinson, 54. Taylor, E. 72. Taylor, J. 51. ix. McPherson, 258. xxii. Worrall & Co., 161.
- Belgium*, Lanthiere, 486.
- France*, Malo, Dickson & Co., 320. Harding-Cocker, 864.
- Zollverein* (4), Schoettle, 12.

a & Whiting, 44.
 & Sons, 5. Lloyd
 Schull, 261. Samp-
 5. Smith & Sons,
 & Sons, 4. Wilks,
 & Pear & Dosseter, 5.
 Association, 214.
 193.
 35. Chatelain &
 441.
 715. Dietrich &
 354. (3). Glasfey
 7. (4). Schill &
 is, 797.
 ogel, & Co., 80.
 19. Cator, Nelson,
 lan, 43. Gillman,
 on, 54. Picciotto,
 ment Society, 106.
 le Kingdom, 40.
 Schlesinger, & Co.,
 ittee, 73. Jameson
 Association, 277.
 am Spinning-mill,
 blishment, 96.
 . Deamedt & Co.,
 230. Haese, 115.
 ls & Co., 83. Van
 Van Hoey, 106.
 vercury, 213.
 05, 107, 108.
 onnaire, & Co., 552.
 s, IV.
 25. Collinson, 3.
 Tyrrel, 1. Tyrrel,
 androvsk Imperial
 others, 99. Ardu-
 96. Hirshmann,
 nikoff, 111. Milo-
 Zakharoff, 108.
 Pinan, 159. Val-
 574.
 scombe, 174.
 orff, 470. Freiherr
 enigs & Buecklers,
 551. Ruffin, 34.
 Watteyne, 2. See
 56.
 fillman, 44. vi.
 so *Linen Fabrics*
 singer & Co., 178.
 linen Co., 1019.
 Deepen Spinning
 gins & Sons, 14.
 37. Plummer,
 Taylor, J. 51.
 & Co., 161.
 Harding-Cocker,

FLOWERS, ARTIFICIAL—XIX. Dralbee, 72. Vischi, 47.
 XXIX. Arthur, 58. Blackmore, 125. Fisher, 80.
 Foster & Co., 74. Gatti, A. & G. 73. Hool, 87.
 Jackson, 59. Maguire, 71. Perry, 60. Randolph,
 66. Riddiford, 69. Slanghan, 64. Sugden & Co.,
 62. xxx. (Fine Art Court) Fouts, 208A.
 Austria, Buerger, 700. Schlater, 701.
 Brazil, Adamson, 1. Major, 4.
 France, Breteau, 1112. Chagot, 1139. Constantin,
 94. Florimond, 1224. Funstenhoff, 492A. Gaudet
 Du Fresnoe, 842. Grandjean, 243. Lacombe, 557.
 Mallet & Bailly, 1740. Perrot, Petit & Co., 952.
 Iloyer, 1462. Tilman, 698.
 Hamburg, Olshardsen, 90. India, xvi.
 Jamaica, Nash. Malta, Gerada & Daughters, 32.
 Madeira, Read, 1.
 Portugal, Marques, 1299. Ruball, 1152, 1153. Rus-
 sell, 1298.
 Sweden and Norway, Furstenhoff, 27.
 Zollverein (4), Lindauer, 101. Viehhaeuser, 103.
 FLOWERS, DRIED—XXIX. Walker, 319.
 FLOWERS, GELATINE—France, Pitoux, 960.
 FLOWERS, ORNAMENTAL—XXX. (Fine Art Court) Hesse,
 259.
 FLOWERS CUT IN VEGETABLES—IV. Pursey, 4. XXIX.
 Pursey, 67.
 FLOWERS, WAX (including Wax Fruit and Vegetables)
 —XXIX. Chistolme, 78. Dorvell, 77. Down, 56.
 Ewart, 75. Fielder, 86. Galton, 93. Harrison,
 304. Hoakings, 72. Jones, 82. Mintorn & Co., 70.
 Skill, 84. Stanton, 88. Strickland, 63. Temple, 61.
 xxx. (Fine Art Court) Lumsden, 125. Makepeace,
 185. Peake, 144.
 Bahamas, Barnet. Barbados, F. ell, 2. Reade, 1.
 France, Parisien, 945.
 Jersey and Guernsey, Stafford, 49. Mexico.
 Zollverein (1), Schmidt, 831. (4), Riess, 90. (6).
 Birnwill, 71. (8), Beesten, 12. See also *Wax for*
Modeling Flowers.
 FLUID CAMPHOR AND MAGNESIA—II. Murray, Sir J. 87.
 FLUOR SPAR (Articles in)—XXVII. Bright, 80. Hall,
 J. & T., 37, 38. Vallance, 40.
 FLUTES—x. Card, 546. Potter, 538. Rudall, Rose &
 Co., 536. Siccama, 635. Ward, 527.
 Denmark, Selboe, 31.
 France, Breton, 1555. Buffet, 442. Clare Godefroy,
 454. Tulon, 398. India, x.
 Switzerland, Felchlin, 80. United States, Pfaff, 526.
 Zollverein (1), Lampferhoff, 495. (2), Bachm, 23. (3).
 Gher, 21. (6), Seidel, 26.
 FLY PRESSES (For Cutting Steel)—VI. Mansel, 502.
 FLY PRESSES (For Embossing). See *Embossing Presses*.
 FOG OR ALARM SIGNALS—VIII. Robertson, 18. Scouller,
 113. United States, Wilder, 388.
 FOLIO FRAME—XXX. (Fine Art Court) Vokins, J. & W.
 46.
 FOLDING DOORS, BOLT FOR—XXII. Knight, 557.
 FOLETT, SIR WILLIAM, STATUE OF—Main Avenue,
 West, Behnes, 57.
 FONTS—Peyman, page 850. XXVII. Bovey, 4. Margotts
 & Eyles, 91. xxx. (Fine Art Court) Castle, 314.
 FONTS (Designs for)—XXX. (Fine Art Court) Driver, 269.
 Mahing, 154.
 FOOTBALLS—XXIX. Gilbert, 187.
 FOOT GAUGES—x. Hay, 376.
 FORCE PUMPS—See *Pumps, Lift and Force*.
 FORGES—Ceylon.
 FORGES, PORTABLE—v. Napier, 301. ix. Deane, Dray &
 Co., 180. XXII. Allday, 253. Linley & Sons, 41.
 Onions, 249.
 FORGES, PORTABLE (Steam)—vi. Campbell, 216.
 FORGING MACHINE—vi. Ryder, 222.
 FORTIFICATION (Models and Plans)—VIII. Fergusson,
 276. Staines, 268.
 FOSSILS (including FOSSIL WOOD)—Western End, South
 Enclosure, (Outside), Crutwell & Co., 52. i. 1, 52.
 Hewick, 423. Paine, 36. Powell, 202. Randall, 275.
 Tennant, 14. Webb, 12.
 Antigua, Grey, The Countess, 1. India, i.
 Nova Scotia, Central Committee, 2.

- Tuscany, Santi*, 20.
Van Diemen's Land, McLachlan.
FOUNTAINS—Eastern End (Outside), Legler, 103. Seeley, page 852. Thomas, page 853. v. Roe, 462 (North Transept). vii. Forster, 26. James, 19 (Main Avenue, West). viii. Trotman, 153. x. Lipscombe & Co., 703. xxii. Coalbrook Dale Co., 641, (and North Transept, 48). Farrar, 627. Handyside, 82. Stewart, 46. xxiv. Binns, 54. Ouler, F. & C., 20 (Traosept). xxv. Lipscombe & Co., 54. xxvii. Lipscombe & Co., 49.
Austria, Farina, 748.
France, André, 1053 (Main Avenue, East). Lechesne, Brothers, 574.
Switzerland, Leemann, 258.
Zollverein (1), March, 240 (Main Avenue, East).
FOUNTAINS, PORTABLE—v. Lipscombe, 679. xxv. 61.
FOWLING-PIECES—See *Guns, Pistols, &c.*
FRACTURES, APPARATUS FOR—x. Blackwell, 734. Gowing, 736. Salt & Son, 628. Thomson, 590.
FRAUD PREVENTOR (for indicating the number of People entering Vehicles, &c.)—v. Olliffe, 771.
FREDERIC WILLIAM III. OF PRUSSIA (Cast of part of the Pedestal of the Monument of)—*Zollverein* (1), Drake, 273 (Main Avenue, East).
FREE-LABOUR PRODUCE, and the Produce of Cuba, Brazil, &c. (Undescribed)—III. Wheeler, 27A.
FREESTONE—Western End, South Enclosure (Outside), Dove, 23. i. 173. Cumming, 195. Haigh, 173. Price, 184. Williams, 191.
Nova Scotia, Central Committee, 2. See also *Bath Freestone*.
FRENCH HORNS—x. Colcott, 547.
FRESCO PAINTING—xxx. (Fine Art Court) Mills, 329. West, 326.
FRESNEL'S DIOPTRIC APPARATUS—vii. Commissioners of Northern Lighthouses, 99. xxiv. Chance & Co., 60.
FRESNEL'S UNDLATING FLAIN (Model of)—*Zollverein* (1), Engel, 274.
FRETWORK—xxviii. Taylor, C. & A., 113.
FRETWORK CUTTINGS—xxviii. Faulding, 91.
FRIEZES (Irish and other)—xii. & xv. Allen, 259. Daly, 264. Dillon, 258. Ellis & Co., 70. Macdona, 260. Murphy, 262. Neill & Sons, 263. Nicolls, 261. Willans, Brothers, & Co., 257.
FRILL MACHINE—*Zollverein* (1), Doerffel, 54.
FRINGE, MACHINE FOR TWISTING—xii. & xv. Sampson, 215.
FRINGES, BRAID, &c.—xi. Waters & Co., 43. xiii. Allen & Holmes, 50. xix. Arthur, 69. Burch, 75. Evans & Co., 74. Foot & Sons, 68. Vokes, 329. xxix. Standing & Brother, 239. Westhead & Co., 275.
Denmark, Holzapfel, 41. *Egypt*, 211, 214, 221, 223. *Turkey*.
Zollverein (3), Bach & Son, 158. Haenel, Brothers, 153. Helweg, 159.
FRUITS (Dried and Preserved)—II. The London Duggists, 117. III. Batty & Feast, 116. Clemens, 56. Copland, Barnes & Co., 11. Faulkner, R. & C., 54. Fortnum, Mason & Co., 55. Webb, 72.
Barbadoes.
British Guiana, Duggin, 26. Purton, 15, 15b.
South Africa, Bayley, 5. Clarence, 54. Volsteedt, 35. *China, Hewett* & Co.
France, Aubert & Noel, 403. Maille & Segond, 1339. Oulard & Boucherot, 1374. Rousseau, 360.
Greece, Inglesias, 7. London, G. Perotis, 8.
Ionian Islands, Mavrolianni, 2.
Portugal, 401, 439.
Russia, Nikitin, 68. *Sardinia, Romanengo*, 82. *Spain*, 81, 82, 92. *Alvargonzales*, 177. *Albenr*, 100. *Arambarri*, 101, 103. *Cordova Agricultural Board*, 99. *Enriquez*, 106. *Malaga Agricultural Board*, 94. *Montfort*, 88. *Olmo*, 107.
Tunis, 76, 84. *Turkey*.
United States, Lounderback, 7. Stephens, 392.
Van Diemen's Land, Dixon, 20. Smith, 238-241.
Zollverein (1), Haberland, 689. (4), Brenning, 8. Ficker, 10. Schmidt, 9. See also *Dates*.
FRUIT STONES, CARVED (with a Penknife)—*Zollverein* (Octagon Room), Coburg-Guths, Count Ernst of, 836.
FRUIT, WAX—See *Flowers, Wax*.
FUEL, ARTIFICIAL (or Patent)—I. Azulay, 224. Bankart & Sons, 429. Bideford Anthracite Mining Company, 242. Evans, 227. Great Peat-working Company of Ireland, 231. Lyon & Co., 226. Parsons, 232. Patent Fuel Company, 230. *France, Moreau*, 326. See also *Steam Fuel*.
FULLER'S EARTH—I. Cawley, 47. Gawkröger & Hynam, 48. *South Africa, Calif*, 55. *Spain, Malaga Mines, Inspector of*, 19. *Turkey, Zollverein* (8), Nassau Government Engineers of Mines, 1.
FULLING-MILL (Model)—*United States, Read*, 212.
FUMIGATING APPARATUS (for Plants)—vii. Boulanger 198. ix. Brown, 91. xxii. English, 572.
FUMIGATING PASTILES—xxix. Tidmarsh, 111.
FUMIGATORS (for Vapour Baths)—vii. Boulanger, 198.
FUNERAL CARRIAGE—v. Shillibeer, 964.
FUNERAL PALL (Design for)—xix. M'Carten, 246.
FUNNEL (for Marine Boilers)—v. Taplin, 5.
FUNNEL PIPE (Valved)—*Belgium, Lund*, 476.
FUNNELS (Bottle)—xxii. Marsden, 531.
FURNACE BARS—v. Firth, 119. ix. Weeks & Co., 248A. *Austria, Wurm*, 137.
FURNACE BELLOWS. See *Bellows, Blast Fans for Furnaces*.
FURNACES, BLAST. See *Blast Furnaces*.
FURNACES FOR BURNING ANTHRACITE COAL—I. Watney, 276. v. Williams, 63.
FURNACES FOR ROILING FAT—vi. Gilbertson, 508.
FURNACES, SMOKE-CONSUMING—v. Clay, 68. xxii. Maplebeck & Lowe, 370. Pope, 566.
FURNACES (for Steam Engines)—v. Newcombe, 205.
FURNITURE (Various)—xvii. Isaac, 165. xxvi. 60. Banting, W. & T., 166. Crace, 530. Eyles, 50. Foot-horape & Co., 132. Greig & Son, 159. Grubb, 25. Herbert, 67. Hindley & Co., 266. Holland & Sons, 161. Isaacs & Campbell, 241. Jackson & Graham, 261. Johnson & Jeanes, 10. Miles, 115. Morant, 164. Pratt, 196. Ramuz, 152. Snell & Co. 170. Spurrier, 76. Toms & Luscombe, 178. Trollope & Sons, 162. Wilkinson, W. & C., 184. Wills & Bartlett, 160. xxviii. Thorne & Co., 86. xxix. Austin, 217. xxx. (Fine Art Court) Coukes & Sons, 110.
Austria, Lechner, 634. *Leister* & Son, 633. *Mentasti*, 635. *Moschini*, 636. *Falhuber*, 637. *Rosani*, F. G., 639. *Rosani*, P., 640. *Thonet*, 641.
Belgium, Barthelemi, 429. *Bruno*, 411. *Delevoeye*, 421. *De Raedt*, 418. *Hoghtael*, 422. *Jehio*, 410. *Judo*, 420. *Marin*, 414. *Massarido*, 415. *Misson*, A., 413. *Misson*, E. & L., 412. *Route*, 419.
Canada, Central Commission, 301. *Hilton*, J. & W., 123. *Reed* & Co., 115A.
China, Astell & Co. *Baring, Brothers*. *Bowman*. *Braine*. *Hewett* & Co. *Rowson*, C. *Rowson*, T. S. *Shea*. *Denmark, Hasen*, 25. *Nielsen*, 26.
France, Balny, 1066. *Beaufils*, 1074. *Bellange*, 1077. *Berliner*, 52. *Cardonnier* & Co., 1159. *Cremer*, 1573. *Daubet* & *Dumaret*, 1579. *Descartes*, 815. *Dulud*, 1202. *Durand*, 1207. *Duval*, 474. *Faure*, 1219. *Florange*, 1223. *Fourdiniois*, 1231. *Grade*, 1254. *Jansselme*, 889. 1276. *Jolly-Leclerc*, 890. *Krieger* & Co., 1283. *Lechesne, Brothers*, 574. *Lefebvre, Son* & Co. 907. *Lombard*, 913. *Mercier*, 927. *Protot*, 1410. *Ringuet-Leprince*, 1437. *Rivart* & *Audrieux*, 1439. *Van Valthoven*, 1516.
Hamburgh, Adikes, 67. *Bruening*, 63. *Engels*, 65. *Faulwasser*, 71. *Hagen*, 64. *Heymann*, 78. *Koll*, 82. *Kopke*, 77. *Loose*, C. L., 74. *Loose*, J. R., 75. *Rampendahl*, 70. *Sengle*, 65. *Thiele*, 109. *Werner* & *Pigheim*, 79. *India*, xxvi.
Jersey and Guernsey, Stead, 21. *Le Feuvre*, 20
Madeira, Read, 1.
New Zealand, Lucas & Co., 40.
Portugal, Fletcher, 1116-1119. *Capello*, 64. *Griya*, 65. *Descalzi*, 72. *Speich*, 71.
Spain, Medina, 270. *Tuscany, Barbelti*, 74, 80.

Count Ernest of
 224. Bankart
 Mining Company,
 working Company
 226. Parsons, 232.
 Moreau, 326.

Gawkroger &
 55.
 19. Turkey.
 Engineers of
 Read, 212.
 VII. Boulanger
 572.
 111.
 Boulanger, 198.
 64.
 Carten, 246.
 5.
 476.
 1.
 Weeks & Co., 248A.

Glass Fans for Fur-
 naces.

COAL—I. Watney,
 508.
 Gilbertson, 508.
 19. Map-
 5.
 Newcombe, 205.
 65. XVI. 60. Bant-
 Eyles, 50. Foot-
 Son, 159. Grubb,
 o., 266. Holland &
 241. Jackson &
 10. Miles, 115.
 152. Snell &
 & Luscombe, 178.
 son, W. & C., 184.
 Thorne & Co., 86.
 Art Court) Cooke
 & Son, 633. Men-
 eber, 637. Rosani,
 641.
 o., 411. Delevoye,
 el, 422. Jehio, 410.
 ardo, 415. Misson,
 Ronle, 419.
 Hilton, J. & W.,
 18.
 Brothers. Bowman,
 C. Rowson, T. S.
 Olsen, 26.
 4. Bellange, 1077.
 o., 1159. Cremer,
 9. Descartes, 815.
 Duval, 474. Faure,
 nois, 1231. Grude,
 Jolly-Leclerc, 890.
 re, Brothers, 574.
 ard, 913. Mercier,
 eprince, 1437. Ri-
 thoven, 1516.
 63. Engels, 65.
 eymann, 78. Koll,
 Loose, J. R., 75.
 hiele, 109. Werner
 Faivre, 20
 ello, 64. Griva, 65.
 etti, 74, 80.

Sweden, Bohman, 57. Dumrath, 60. Edberg, 61.
 Malmqvist, 59. Sjöblom, 63. Stenstrom, 58.
 Van Diemen's Land, Brown, 14. Pierson, 9.
 Zollverein (1), Fleischmann, 763. Hoffmeister & Co.,
 773. Kramer, 610. Knettner, 236. (4), Wirth, 70.
*See also Beds, Bedsteads, Bedsteads, Metallic, Cabi-
 nets, &c. Chairs, Chairs, Carved, Chiffonnières,
 Cradles, Cots, &c. Curtains, Escritaires, Iron Fur-
 niture, Sofas, Tables.*
 FURNITURE (Designs for)—France, Zepelius & Fuchs, 1738.
 FURNITURE ORNAMENTS—France, Lemaire, 1315.
 FURNITURE STUFFS—XI. Crocker, J. & A., 61. XII. & XV.
 Reynolds, 266. XIII. Houldsworth & Co., 64. XVIII.
 Nelson & Co., 29. XXVI. Crace, 530. Turner & Co.,
 320. Turkey. Sweden, Meyerson, 90.
 Zollverein (1), Danneberg & Son, 710. *See also Tissues
 for Furniture, Window Curtains.*
 FURS AND SKINS (Main Avenue, West)—Nicholay & Son,
 Hudson's Bay Company, and others (XVI. 301).
 XVII. Bevington & Morris, 332. Booth, 112. Clap-
 ham, 9. Clarke & Sons, 307. Dick, 311. Drake,
 306. Ellis, 305. Hudson's Bay Company, 301.
 Inc., 309. Lutge & Co., 328. Lutge & Parsons,
 130. Meyer, S. & M., 304. Nicholay & Son, 301A.
 Robinson, 7. Sanson, 303. Smith & Sons, 310A.
 Winsor & Son, 14.
 Austria, Geyer, 346. Hermannstadt Associated Furriers,
 347. Belgium, Weink recht, 239.
 Canada, Henderson, 107.
 South Africa, Blackburn, 18. Bridges, 21. Cluppini
 & Co., 22. Hanbury, E., 20. Hanbury, E. J., 28.
 India, IV. XVI.
 Nova Scotia, Central Committee, 2.
 Russia, Abass-Bak, 244. Ablool Mahomet-Ogli, 243.
 Ali-Mehmet, 246. Ekaterinoslaw, Peasants of, 230.
 Mahomet-Ogli, 245. Nijni Novgorod, Merchants, &c.
 225. Spain, Delgado, 231.
 Sweden, Forsell, 109. Gulda, 108.
 Switzerland, Meyer & Ammann, 176. Tunisia, 92.
 Turkey. United States, Mawson, Brothers, 87. Tricker,
 577.
 Van Diemen's Land, Barnard, 143. Denison, Sir W. T.,
 176. Rout, 187.
 Zollverein (1), Koenig, 139. Langner, 833. Pintus,
 135. Schuitze, 884. (b), Dumrich, 79.
 FURTC—Trinidad, Lord Hari's.
 FUZES FOR BLASTING, &c.—I. Bickford, Smith, & Davey,
 424. Brunton, 519. XXIX. Bell, 101.
 Zollverein (3), Schmidt & Co., 11.

GAITERS (Cloth and Leather)—XX. Smith & Gibbs, 71.
 Wheeler & Ahlett, 22.
 GALENA—See Lead, Sulphuret of.
 GALIC ACID—II. Macfarlan & Co., 107. Morson &
 Sun, 106. Smith, T. & H. 94.
 Sardinia, Girod & Co., 8.
 Zollverein (1), Schwabebeck Royal Chemical Manufac-
 tory, 683.
 GALLOONS, &c.—XIII. Booth and Pyke, 63.
 Russia, Albertzoom, 284.
 GALVANIC BATTERIES AND MACHINES—X. Meinig, 437.
 Gore, 690. Horne & Co., 220. Ritterbandt, 730.
 France, Lemolt, 303. *See also Walking Sticks, Electro-
 Galvanic.*
 GALVANIZED IRON—XXII. Tupper & Carr, 550.
 France Paris, 1379. *See also Wire Netting, Galvanized.*
 GALVANIZED IRON, CORRUGATED—I. 216.
 GALVANIZED TINNED IRON—I. Morewood & Rogers, 436.
 IX. Morewood & Rogers, 152A. XXII. Morewood &
 Rogers, 610.
 GALVANO-ARSENICAL APPARATUS—X. Morton, 678.
 GALVANO-ELECTRIC MACHINES—X. Chadburn, 259.
 GALVANOGRAPHY (Specimens of)—Zollverein (2), Hauf-
 staengl, 85.
 GALVANOMETER—X. Gogerty, 407. Horne & Co., 220.
 Loot, 696.
 GALVANO-PLASTIC ARTICLES—France, Lefevre, 1648.
 Zollverein (3). Buethner, 187A.
 GALVANO-TYPIC PLATES—Switzerland, Stoetzier & Co.,
 234.

GAMBOGE—India, II.
 GAMBRoons—Austria, Witschell & Reinsich, 293.
 GAME REGISTERS—VIII. Needham, W. & J. 218.
 GARDENS, &c. (Models and Plans of)—XXX. (Fine Art
 Court) M'Hardy, 325.
 Belgium, Roscell, 449. Vanhulle, 453.
 GARDEN ENGINES, &c.—V. Merryweather, 401. Shaid &
 Mason, 410. Warner & Son, 424. IX. Crump, 160.
 Jones, 123b. Reast, 89. Siebe, 255A. Weir, 123.
 XXII. Taylor & Son, 401.
 GARDEN KNIVES—Austria, Bubenitsch, 507. Dernberger,
 509.
 GARDEN LABELS (Enamelled and Metallic)—IX. Smith,
 219. Restell, 208.
 GARDEN LIGHT OR SKYLIGHT—VII. Nixon, 174. IX.
 Nixon, 161.
 GARDEN POTS AND STANDS (Clay and Earthenware)—
 Western end, North Enclosure, (Outside), Phillips, 63.
 IX. Roberts, 226. XXV. Kay, 31. Wedgwood &
 Sons, 6. Wood, 34. XXVI. Martin, 254. *See also
 Garden Seats (Earthenware).*
 GARDEN ROCKING-HORSE—XXIX. Lucas, 127.
 GARDEN SEATS (Earthenware, Oak, &c.)—IX. Hoines,
 90A. XXII. Coalbrook Dale Company, 64! (Main
 Avenue, West). XXV. Meyer, T. J. & J., 9. Dimmock,
 12. XXVI. Alexander, 99. XXVII. Blackburn, 21.
See also Chairs, Rustic.
 GARDEN TOOLS—See Horticultural Implements.
 GAS APPARATUS—VII. Allen, 122. Booth, 134. Thomp-
 son, 112. Young, 171. XXII. Leslie, 101. Love, 382.
 France, Pauwels, 342.
 GAS COOKING AND WARMING APPARATUS—VII. Lamb,
 206. XXII. Edwards, 241. Grant, 431. Hedley,
 577. Hulett, 613. Love, 382. Tozer, 389. Warri-
 ner, 248.
 GAS FITTINGS (including Burners, &c.)—VII. Allen, 122.
 XXII. Biddell, 438. Cowley & James, 62. Debauffer,
 445. Grant, 431. Hallane & Rae, 432. Messen-
 gers & Sons, 340. Sarsou, 470. Whitehouse & Co.,
 667. Wilkes, 266. XXIV. Vizeletly & Branston, 29.
 Austria, Salm, Prince, 430.
 France, Dumas, 486. Pauwels, 1382. Parisot, 1673.
 GAS-METERS—I. Glover, 438. V. Squire & Co., 706.
 VII. West & Gregson, 21. XXII. Bolt & Allen, 422.
 Botten, 426. Cochran, 434. Edge, 441. Hulett,
 643. Paddon & Ford, 424. Roper, 437. Ryan,
 436. Shears & Sons, 438. France, Pauwels, 1382.
 GAS, PORTABLE—Spain, Golferichs, 247.
 GAS RETORTS (Iron Clay)—XXVII. Cowan & Co., 112.
 Hickman, 107. Potter, 115. Ramsey, 110.
 GAS-SOOT CONSUMER—V. Judge, 130.
 GASEOUS AND AERIAL CURRENTS REGULATOR—XXII.
 Edwards, 241.
 GASEOUS WATERS APPARATUS—See Soda-Water Ma-
 chines.
 GASSINO-MACHINE—(For singeing loose fibre from lace,
 &c.)—VI. Burton & Eames, 96.
 GATES FOR PARKS, RAILWAY CROSSINGS, &c.—VII. Ad-
 cock, 192. IX. Hill & Co., 140. Uphill, 277. XXII.
 Coalbrook Dale Company, 641 (North Transept), 49.
 Cullinge & Co., 573. Cottam & Hallen, 698 (South
 Transept). King, 5. United States, Woolman, 138.
 GAUFFERING-MACHINES—XXII. Hughes, 581.
 GAUFRE IRON DOOR—Sardinia, Ropolo, 54.
 GAUGES—VIII. Somalivico & Co., 681A.
 France, Vassa De St. Ouen, 716. *See also Cattle-
 weighing Gauges. Centripetal Punch and Gauge.
 Foot Gauges. Pressure Gauges. Rain Gauge.
 Square-cutting Gauge. Steam-Boiler Water Gauge.
 Steam and Vacuum Gauges. Tide Gauges. Timber
 Gauges.*
 GAUNTLETS (Military)—XVI. Geary, 235.
 GAUZES—XIII. Brocklehurst & Sons, 38. Penfold, 59.
 China, Hewett & Co.
 France, Grolleau & Deville, 1618. Vatin & Co., 1704.
 Russia, Rochefort, 176, 191, 199, 208.
 Switzerland, Forster, 193. Turkey. *See also Lace,
 Muslins, Ribbons.*
 GELATINE—III. Glass, 141. IV. Dufaville, 125. Mul-
 ler, 125A. Nimmo & Co., 122. Swinborne & Co., 119.

- France, Coignet & Son, 1153. Bouasse, Lebel & Co., 774, 1102. Castelle, 107. D'Enfert, Brothers, 496. Grenet, 247. Herve, Br. lora, 1624. Humbert & Co., 1272. Leclercq, 1302. Riess, 355. Royer, 1461. Netherlands, Oemen, 8. Portugal, Norberto, 625, 626. Switzerland, Lendenmann, 56.
- FLATINE SOUP**—XXIX. Wright, 250.
- GEM PAINTING ON GLASS**—XXVI. Lunde, 128.
- GEOGRAPHY, INDICATOR FOR TEACHING**—X. Malloch, 208.
- GEOLOGICAL SPECIMENS**—I. Highley, 98.
- Canada, Logan, 1. France, Eloffe, 1597. Jersey and Guernsey, White, 1. New Zealand, Collinson, 3. Smith, 14. Taylor, 11. Russia, Koussinsk Iron Works, 9. Perm Imperial Copper Works, 6. Poland Imperial Mining Works, 15. Satkinsk Iron Works, 17. South Australia, Joseph, 7. See also *Minerals*, &c. Spain, Keene, 300.
- GEOMETRICAL INSTRUMENTS**—X. Matthias, 395. Yates, 373. Austria, Rocchetti, 136. See also *Mathematical Instruments*.
- GEOMETRICAL MODELS**—Zollverein (6), Schroeder, 77.
- GEOMETRICAL STAIRCASES**—VII. Banks, 55. XXX. (Fine Art Court) Seager, 13.
- GEORGE I. OF BOHEMIA**, Statue of—Zollverein (2), Müller, 90.
- GEORGE TOWN AND DEMERARA**, Diagrams showing the Temperature at—*British Guiana*, 157, 157A.
- GERMAN SILVER WARE**—Austria, Poiger, 461. *Macklenburg-Schwerin*, Meyne, 5. Zollverein (1), Nottebohm & Co., 635. (8), Isabella Hutte Smelting Works, 3.
- GILDING** (Illustrations of)—XXVI. Baxter, 380. Vinn, 278. XXX. (Fine Art Court) Vinn, 205. Watson, 130. Austria, Behr, 645. Polt, 650. France, Mazarin, 626. Zollverein (2), Bonge, 222. (4), Heller, 77. Mansis, 391. Maier, 227.
- GILDING, WASHABLE**—XXVI. Fuise, 369.
- GINGERBREAD NUTS**—XXIX. Hubbard, 113.
- GINGHAMS**—XI. Anderson, D. & J., 16. Anderson, J. & A., 7. Nixon & Sons, 19. Fyfe & Son, 18. Henry & Sons, 15. Lethem & Co., 9. Lowthian & Parker, 22. McBride & Co., 6. McGibbon, 20. O'Connell, 31. Paterson & Co., 11. Pearson & Co., 21. Pullar & Sons, 4. Walker, J. R. & R., 3. India, XI. Switzerland, Anderegg, 111. Boesch & Sons, 115. Hunziker & Co., 166. Mettler & Son, 197. Raschle & Co., 168. United States, Uppham, Appleton & Co., 403. Zollverein (2), Jaeken & Luehdorf, 56.
- GIRANDOLE** (Antique)—XXVI. Pousonby, 199.
- GIRDERS, BRIDGE**—VII. Todd, 52.
- GIRDERS FOR ROOFS**—Russia, Votinsk Imperial Iron Works, 156.
- GLASS CHIMNEY-PIECES**—XXIV. Forrest & Bromley, 42.
- GLASS-CUTTING** (Illustrations of)—XXIV. Ohlson, 10. Perry & Co., 36.
- GLASS DECORATIONS**—XXIV. Barnes, 49.
- GLASS ENGRAVING**—Belgium, Deville-Thiry, 445.
- GLASS FOUNTAINS**—XXIV. Hinos, 34. Osler, F. & C., 20 (Trausept). XXVII. Lipscombe & Co., 49.
- GLASS-HOUSE** (Models of), MELTING-POTS AND TOOLS—1. King & Co., 91. Squires & Sons, 117. XXIV. Hartley & Co., 100 (Main Avenue, East). Sinclair, 50. XXVII. Harper & Moore, 119.
- GLASS LETTERS**—XXIV. Shove & Co., 24.
- GLASS-MAKERS' SAND**—See *Sand* (for Glass-making).
- GLASS ORNAMENTS**—*Gold Coast and Ashantee*, Forster & Smith, 1.
- GLASS PANNELING**—XXIV. Ballantine & Allan, 78. XXVI. Davies, 129. Ihrwota, 335.
- GLASS PERFORATED** (for Ventilation, &c.)—XXIV. Lockhead, 23. Swinburne, 4. See also *Ventilators, Window*.
- GLASS PIPES, TUBING, &c.**—I. May & Co. 18. X. Edwards, 438. XXIV. Cuthlups & Co., 47. Powell & Sons, 31. Shephard, S. Swinburne, 4.
- GLASS SASH BARS, &c.**—XXII. Jones, 230.
- GLASS SHADE-CUTTING MACHINE**—VI. Claudet & Houghton, 306.
- GLASS SILVERING** (Processes, & Articles in)—XXIV. Kidd 3. Swinburne, 4. Varnish, 27.
- GLASS TILES**—Zollverein (1), Rohrig, 768.
- GLASS VERANDAIS** (Portable, for Flowers)—XXIV. Cogan, 26.
- GLASS WARE** (Various)—XXII. Edwards, 345. XXIII. Lambert & Rawlings, 102. Martin & Co., 2. XXIV. Bacchus & Sons, 19. Binns, 34. Chauce & Co., 22. Claudet & Houghton, 25. Cuthlups & Co., 47. Cogan, 26. Coune, 28. Davis & Co., 15. Gatchell, 12. Green, 32. Hancock & Co., 46. Harris & Son, 21. Hettley & Co., 2. Jones & Sons, 11. Lloyd & Summerfield, 18. Molineaux & Co., 13. Naylor, 30. Osler, F. & C., 20. Pellatt & Co., 33. Perry & Co., 36. Pettit, 55. Powell & Sons, 31. Richardson, W. & J., 14. Sanderson & Son, 9. Shephard, S. Varnish, 27. Visctely & Branton, 29. Webb, 17. Wood, 16. XXV. Brown, T. & M. L., 15. Copeland, 2. XXVI. Braun & Co., 172. XXX. (Fine Art Court) Donalds & Co., 41. Austria, Buquoy, 584. Czermak, 585. Franke, 602. Großmann, 586. Harrach, 587. Hegenbarth, 588. Helmich, 589. Hofman, 590. Hottinger, 589A. Janke, Brothers, 591. Kittl's Heirn, 592. König, 596. Kuchinka, 593. Lütz & Gerstner, 594. Meyr's Nephews, 595. Pelikan, 597. Pfeiffer & Co. 606. Spietschka, 609. Vivat, 598. Zahn, 599. Belgium, Brudier, 386. Capellemans, 37, 387. Dierckx, 391. Frison, 392. Zoude & Co., 368. France, Chartier, 85. De Poilly & Co. 1396. Jouhaenaud & Dubois, 1630. Lacarriere, 1284. Maes Ponselgoue-Rusand, 1405. *Gold Coast and Ashantee*, Forster & Smith, 1. *Hamburg*, Bohm, 97. India, XXIV. Netherlands, Regout, 99. Portugal, Alfonso, 1023-1043. Russia, Ralivsky, 293. Turkey. United States, Chapman, 68. Zollverein (1), Couta & Boehme, 915. Finsch, 211. Goebel, 808. Hutschenreuther & Sons, 805. Metzger & Lühme, 212. Schaffgotsch, Couit, 208. Solms, Couit, 210. Von Minutoli, 191. (2), Reinsch, 63. (3), Tuetich & Co., 21. Vogelsel & Sons, 22. See also *Bottles, Glass. Decanters. Flint Glass. Optical Glasses. Picture Frames, Glass. Window Glass*.
- GLASS, WINDOW**—See *Crown Glass. Flint Glass. Painted Glass. Painted Windows. Plate Glass. Sheet Glass. Stained Glass. Stained Glass Windows. Window Glass*.
- GLAUBERITE**—Spain, Burgos Mines, Inspector of, 35.
- GLAZIERS' DIAMOND**—VI. Radcliffe, 328. *Hamburg*, Hildebrand, 2.
- GLAZING FOR GREENHOUSES**—XXVII. Kent, 122.
- GLOBES**—X. Adorno, 218. Bentley, 213. Edkins & Son, 207. Fletcher, 200. Johnston, W. & A. K., 198. Newton & Son, 212. Richards, 188. Stoker, 204. XVII. Wyll, 175. Austria, Riedl, 131. Zibermayr, 132. Belgium, Browne, 490. France, Gosselin, 249. Zollverein (1), Kummer, 194. (2), Klingler, 29.
- GLOVE BOXES**—Zollverein (1), Blankestein, 842.
- GLOVE CLASPS**—France, Lepine, 910.
- GLOVE-MAKING MACHINES AND TOOLS**—France, Brun, 37. Jewell, 893. Jewin & Doyon, 1279.
- GLOVES, CLOTH, THREAD, SILK, &c.**—XX. Biggs & Sons, 205. Dent & Co., 78. Firkins J. & C., 163. Foster & Co., 2. Fowdes, Brothers, 82. Galloway & Harris, 93. Harris & Sons, 198. Longdon & Sons, 168. Macdougall, 83. Morley, I. & R., 101. Musson, R. & J., 97. Pitman, 187. Redgrave, 164. Saxton, 90. Ward & Co., 195. Wheeler & Ablett, 22. Wood, 137. France, Dussol, 150. Heyler, 539. Lauret, Brothers, 803. Tallhouis, Verdier & Co., 1023. Malta, Azoparoli, 20. Russia, Lafont, 270, 277. Sweden, Isot, 197. Turkey. *Van Diemen's Land*, Queen's Orphan Schools, 138.

Claudet & Hough-
es in)—xxiv. Kidd

768.
ers)—xxiv. Cogan,

ards, 345. xxiii.
in & Co., 2. xxiv.
Chance & Co., 22.
hupes & Co., 47.
Co., 15. Gatchell,
46. Harris & Sun,
sons, 11. Lloyd &
Co., 13. Naylor, 30.
33. Perry & Co.,
l. Richardson, W.
ephard, 8. Varnish,
bb, 17. Wood, 16.
opoland, 2. xxvi.
Art Court) Donalds

585. Franke, 602.
Hegenbarth, 588.
Hofinger, 580A.
eics, 592. König,
rstner, 594. Meyr's
eiffier & Co. 606.
ahn, 599.
3, 37, 387. Dierckx,
368.
Co. 1396. Jouhan-
riere, 1284. Maes

Smith, 1.

Alfonso, 1023-1043.

815. Finsch, 211.
Sons, 805. Metzger
ount, 208. Solms,
(2), Reinsch, 63.
saang & Sons, 22.
ers. Flint Glass.
e, Glass. Window

ers. Flint Glass.
ers. Plate Glass.
Stained Glass Win-
nspector of, 35.
28.

ent, 122.
3. Edkins & Son,
W. & A. K., 198.
88. Stoker, 204.

elin, 249.
(2), Klingler, 29.
stein, 842.

—France, Brun,
n, 1279.
x. Higgs & Sons,
C. 163. Foster &
alloway & Harris,
& Sons, 168. Mac-
r. Musson, R. &
64. Saxton, 90.
ellett, 22. Wood,

Lauret, Brothers,
25.
t, 270, 277.

Schools, 138.

Zollverein (3), United Merchant Manufacturers, 72-83.
(6), Merschel, Winzenfried & Co., 28.
GLOVES, CLOTH FOR—xii. & xv. Allen, 225. Hooper
& Co., 210. Norton, 126.
GLOVES, FLESH—x. Lawrence & Co., 722.
GLOVES, LEATHER—xx. Corry, J. & J. 100. Dicks,
184. Firkins, J. & C. 163. Foster & Co. 2. Money,
189. Whitby, 186. Wingrave & Sons, 16.
Austria, Jaquemar, 333. Prague Glovers' Association,
336. Belgium, Hegle, 348.
Denmark, Mattat & Sons, 10. Thomsen, 9.
France, Brun, 37. Chossou & Co. 1150. Houbigant,
1627. Jouvin & Doyon, 1279. Leccocq Preville, 1303.
Tambour-Lafroyen, 388. Texier, 1033.
Netherlands, Kaiser, 51.
Portugal, Baron, 1154.
Russia, Beimo-Niveta, 273.
Spain, Vilardet & Callejas, 256.
Sweden, Isoz, 107.
Zollverein (1), Lehmann, 138. Plessner, 179. Schnei-
der, 185. Wahlen & Schmidt, 401. Wolter, 180.
(7), Luxembourg Ganterio Française, 4. See also
Skins (for Gloves).
GLUE—iv. Abbott & Wright, 121. Groves, 131. Muller,
125A. Nimmo & Co. 122. Swinborne & Co. 119.
Tucker, 124. Watt & Son, 120.
Belgium, Bilet, 93. Briers, 99. Hansotte-Delloye, 94.
Johart, 89.
Canada, McFarlane, 124.
Denmark, Halmblad, 27.
France, Cugnet & Son, 1153. Estivant, Brothers, 1214.
Herve, Brothers, 1621. Lubeck, Belreus, 3.
Netherlands, Oemen, 8. Roosegarder, 21.
Portugal, Da Fonseca, 627. Pixotto, 626.
Van Diemen's Land, Button, 21. Hart, 162.
Zollverein (1), Feigenspahn, 688. Loosen, 336. Lo-
renz, 37. See also Marine Glue.
GLUTEN—iii. Jones & Co., 128. St. Etienne, 138.
France—Vezun, Brothers, 1520.
GNEISS—I. Riddell, Sir J. M., Bart., 55.
GOATS' HAIR—Russia, Alramoff, 131. Cossack Women,
193. Tunis, 181.
GOATS-HAIR SHAWLS—Russia, Bondarevsky, Prascovia,
Olga, &c. 358. A Cossack's Wife, 232.
GOBEITANGE STONES—Belgium, Becuaret, 439.
GODFREY OF BOUILLON (Equestrian Statue of)—Belgium,
Simonia, 464 (Main Avenue, East).
GOLD AND GOLD-ORE—I. Brucciani, 486. Marriott, 530
(Main Avenue, East).
Canada, Chaudiere Mining Co. 12. Logan, 1.
Chili, Schneider & Co. 1. India, 1.
New South Wales, Hallett & Sons, 5.
Russia, Demidoff, 21, 120. Turkey.
United States, Hobson, 277. Walbridge, 186.
Western Africa, Swanzy, 23.
GOLD-BEATERS' SKIN—iv. Puckridge, 108. x. Puckridge,
609. Marshall, 104.
Van Diemen's Land, Hood, 166.
GOLDBEATING MACHINES—France, Bottier, 1101.
United States, Vine & Ashmead, 196.
GOLD-LEAF (including SILVER-LEAF)—I. Bennet, 498.
Pinn & Co. 478. xxiii. Marshall, 101.
France, Favrel, 1220. Turkey.
United States, Abbey & Son, 54. Asmead & Harlburt,
535. Van Diemen's Land, Hood, 165.
GOLD MANUFACTURE (PROCESSES OF)—xxiiii. Emanuel, 119.
GOLD ORE, Specimens of, from California—I. Marriott,
530 (Main Avenue, East).
GOLD ORES (Machines for Washing)—Russia, Demidoff,
133.
GOLD PENS—vi. Mordan & Co. 205. Wiley & Co. 325.
xxiii. Mosley & Co. 107. Nicoll, 21.
United States, Reed, 484. Stimpson, 461.
GOLD PLATES (Engraved)—Switzerland, Grandjean, 46.
Kündert, 45.
GOLD PLATING—France, Ilmrier, 76.
GOLD-REVIVING FLUID—France, Rosset, 1452.
GOLD SAND—Spain, The Inspector of the Granada Mines,
16.
GOLD AND SILVER LACE—xix. Harding & Co., 189.

Belgium, Noel, 332.

France, Guillemot, Brothers, 251. Puzin, 1414.

Russia, Startchikoff, 321.

Zollverein (2), Troeltsch & Hauselmann, 59. (0), Anselm,
59.

GOLD AND SILVER STUFFS—Netherlands, Travagliino, 48.
Portugal, Carvalho, 909-917. Lima, 605. Russia,
Sapognikoff, 372. Turkey, Zollverein (1), Kröning, 851.
GOLD AND SILVER WARE—xxii. Bell, 232. Guest, J. &
W. 524. Wiley & Co. 325. xxiii. Abbott, 66.
Adams, 88. Angell, G. 103. Angell, J. 111. Attenbu-
rough, 113. Barling, 85. Bennett, 18. Broadhead
& Atkins, 43. Collis, 34. Connell, 16. Dixon & Sons,
38. Dodd, 122. Donne & Sons, 127. Eaton, 52.
Ellis & Son, 12. Emanuel, 119. Forrest, 108. For-
ster, 77. Garrard, R. & S. 98. Gass, S. H. & D.
83. Greenwell, 7. Hancock, 112. Harvey & Co.,
92. Hawkesworth, Eyre, & Co. 35. Higgins, 115.
Hilliard & Thomason, 29. Hunt & Rusckell, 97.
Keith, 121. Lambert and Rawlings, 102. Lester &
Sons, 27. Lias & Son, 126. Loewenstark, 62. Mar-
rian, 31. Marshall & Sons, 23. Martin, Baskett &
Co., 2. Mason, 128. Mayer, 14. Mills, 56. Morel
& Co. 117. Mosley & Co. 107. Padley, Parkin,
& Co. 42. Payne & Sons, 4. Phillips, Brothers,
87. Reid & Sons, 3. Sharp, 120. Skidmore & Son,
129. Smily, 94. Smith, Nicholson, & Co. 110.
Spurrer, 28. Thompson, 25. Wertheimer, 130. Wild-
down & Veale, 100. Wilkinson & Co. 44. Wood-
bridge, 53. xxvi. Hardman & Co. 532. xxx. (Fine
Art Court) Donalds, W. J. & C. 41.

Algeria, Algiers, Delegate of, 58.

Austria, Baecher, 575A. Friedrich, 720A. Ratzersdorfer,
577.

Belgium, Verberck, 470. Canada, Savage, 340.

Ceylon, Grey, the Countess. China, Walkinshaw.

Egypt, 369, 373, 378-380, 382, 383-387.

France, Christoffe & Co. 1562. Durand, 1595. Fray,
512. Froment, 1720. Gueyton, 1619. Marrel, Bro-
thers, 331. Odior, 1671.

Gold Coast & Ashantee, Forster & Smith, 1.

Hamburg, Brahmfeld & Gutrup, 54. India, xxiii.

Ionian Islands, Seaton, Lord, 5. Woodford, Lady, 1.

Malta, Cretien, 24. Falson, 25.

Netherlands, Grebe, 102. Kempen, 101. Lucardie, 103.

Portugal, De Franca, 1022c. Rodrigues, 1022A.

Russia, 274, 291. Koshloff, 369. Varhovzoff, 368.

Sardinia, Montefiori, 57.

Sweden and Norway, Folcker, 67. Palmgren, 40. 68.

Tostrop, 46.

Switzerland, Dubois, 43. Dutertre, 219. Fries, 221

Golay, 220. Tunis, 83. Turkey

United States, Bateman, 587. Brown, 134. Simpson,

565. Wright, 589.

Zollverein (1), Jacobi, 787. Schneider, 203. Strahl,

206. Wagner & Son, 840. Weishaupt & Sons, 412.

(2), Grenanth, Brothers, 95. Zeiler, 93. (3), Strube

& Son, 33. (4), Groener, 66.

GOLD, SILVER, AND COLOURED TISSUES—xxvi. Newbery,

J. & R. 313.

GOLF BALLS—xxix. Gourlay, 192.

GOLOSIES—xxviii. Hall, 190. Denmark, Petersen, 11.

United States, New Brunswick India Rubber Co., 560.

GONGS—China, Hewett & Co. Turkey.

GONTO-METER—Zollverein (4), Kinzelbach, 26.

GOODHALL, DR., STATUE OF—Weekes, page 853.

GOODWIN SANDS (Model of Breakwater and Lighthouse for),

—vii. King, 160.

GORINGBY BELLS, invention to prevent—xxix. Mitchell, 274.

GORSE CUTTING AND BRUISING MACHINES—I. Bennett,

75. Burrell, 37. Wedlake & Co., 127. White, 181.

GOTHIC DOOR—xxx. (Fine Art Court) Emery, 345.

GOTHIC WINDOW (Undescribed)—Zollverein (4), Staib &

Wasserut, 69.

GRAIN—See Corn.

GRAINING AND FLATTING (Specimens of)—ii. Fawcett,

29. iv. Enderson, 16. xxvi. Arthur, 303. See

also Wood, *Painting on*.

GRANITE—Western End, North Enclosure (Outside),

Hosken, 75. i. 193. Bredalbane, Marquis of, 7.

- Clark, 190. Cumming, 195. Falmouth & Penryn Local Committee, 163. Freeman, W. & J., 160. Jamieson, 25. Maxwell, 134. Riddell, Sir J. M., 55. Ross, 51. Rossmore, Lord, 142. Sim, 137. Sparks, 154. Canada, Logan, 1. Wilson, 2.
- France, Colin, 1564.
- Jersey and Guernsey, Clugas, 25.
- Portugal, Bonnet, 89, 103-105.
- Sweden and Norway, Kullgrin, 118 (Eastern End, Outside). Turkey.
- Van Diemen's Land, Milligan, 256, 257.
- GRANITE COLUMNS, OBELISKS, &c.—Western End, South Enclosure (Outside), Freeman, W. & J., 14. Western End, North Enclosure (Outside), Cheesevring Granite Co., 54. Hosken, 75. Eastern End, Kullgrin, 100. XXVII. McDonald & Leslie, 74. Pearce, 75. Wright, 43.
- GRANITE (Small Articles in)—I. Hutchison, 101. Jamieson, 25. XXIII. Ellis & Son, 12.
- GRASSES—III. Gibbs & Co., 104.
- Turkey. New Zealand, Moore, 37.
- GRASSES, BRITISH, TREATISE ON—XVII. Binns & Goodwin, 14.
- GRASS CLOTH—China, Hewett & Co. Lindsay. Rawson. Gold Coast and Ashantee, Forster & Smith, 1. Western Africa, Forster & Smith, 2. Hutton, J. F., 21. Hutton & Sons, 6. Straith, 18.
- GRASS FIBRE—British Guiana, De Burton, 80, 81. Duggin, 79.
- GRASS AND HAY CUTTING MACHINES—IX. Shanks & Son, 67. Ferrabee & Sons, 274.
- GRATES—XXII. 111. Coalbrook Dale Co., 641. Featham & Co., 686. Deane, A., 392. Gorton, 374. Gray & Son, 405. Hoole & Co., 140. Leslie, 101. Nicholson, 87. Robertson & Co., 802. Stewart & Smith, 102. See also Kitchen Ranges. Stoves.
- GRATTAN, HENRY, THE LATE (Statue of)—XXVII. Montague, Lord, 72.
- GRAVY DISHES—XXII. Gray, 615.
- GREASE—IV. Rose, 27.
- GREAT BRITAIN, STEAM SHIP, Means used for raising (Model)—VII. Bremner, 95.
- GREEK SLAVE, THE (Statue by H. Powers)—United States, Grant, 522 (Main Avenue, East).
- GREEK THEATRE (Model of)—Zollverein (I), Stetter, 304.
- GREENHOUSES, CONSERVATORIES, &c.—Western End, North Enclosure (Outside), Dench, 61. Kent, 62. IX. Toby & Son, 210. Weeks & Co., 248A. (North Transept.) XXII. Coalbrook Dale Company, 641. (Main Avenue, West.) Gidney, 556. XXX. (Fine Art Court) Frewer, 219. See also Glazing for Greenhouses.
- GREENHOUSES, PORTABLE—X. Ward, 664. United States, MacVeenev, 305.
- GREEN PEAS—Russia, Khokholkoff & Co. 63. Mlagkoff, 62.
- GREEN STONE—I. Graham, 517. Sparks, 154. New Zealand, Moore, 37. Van Diemen's Land, Milligan, 342.
- GREEN VITROL—See Copperas.
- GRENADES—Russia, Imperial Nijne Issetsk Iron Works, 159.
- GREY, EARL, THE LATE, Monument to (Model)—VII. Green, 3.
- GRINDING AND CRUSHING MILLS (for Minerals, Grain, Seeds, Drugs, &c.)—VI. Crosskill, 404. Hall, 472. Savage, 455. IX. Crosskill, 135. XXII. Whitmee & Chapman, 242. See also Corn and Grain Grinding and Crushing Mills. Hydraulic Seed-Presses. Tanners' Bark-grinding Mill.
- GRINDING MACHINES—France, Hermann, 873. Huck, 541.
- GRINDSTONES—Western End, South Enclosure (Outside), Belford & Co. 24. Dove, 23. Haywood, 22. I. Meinig, 81. IX. Deane, Dray & Co., 180. India, XXIX. New Brunswick. Portugal, 295, 296. United States, Lombard & Hall, 428. See also Hones. Millstones. Whetstones.
- GRIST-MILLS—See Corn and Grain, &c. Mills.
- GRITSTONE—I. Devonshire, Duke of, and Capt. Eddy, 496.
- GROATS (Prepared)—III. Styles, 157.
- GROOVING MACHINE—United States, Woodbury, 443.
- GRUBBERS (or Cultivators)—IX. Cowan, 121n. Digges La Touche, 263. Drummond & Sons, 49. France, 73.
- GUALDA DYE—Spain, Gisbert, 137.
- GUANO—I. Gill, 38.
- South Africa—De Pass, 50. Searight, 37.
- United States, Dix, 139.
- Van Diemen's Land, Milligan, 255.
- GUERIDON, A.—France, Comolera Madame, 1741.
- GUIPURE—Belgium, Establishment of St. Joseph, 322.
- GUITARS—X. Church, 514. Dobrowolski, 524. Panormo, 525.
- Austria, Bittner, 144. France, Husson & Co. 865.
- India, x.
- Zollverein (1), Rhumann, 90. (3), Glier & Son, 20. Klemm, 18.
- GUITARRA HARPA—Spain, Gallegos, 272.
- GUM-PASTE FIGURES—XXX. (Fine Art Court). Wood, 174.
- GUMS—II. Jennings, 99. London Druggists, 117. Picciotto, 33. III. Colman, 117. Tucker, 121. IV. Coovey, 70. Gillman, 44. Halliday & Co., 73. Rea, 116.
- Austria, Engelmann, 22.
- British Guiana, Duggin, 49. Outridge, 51.
- Ceylon, Pieria. Egypt, 20, 120, 121. France, Augan, 12.
- India, IV. Eastern Archipelago, &c., Hammond & Co. 2.
- New Zealand, Brown, 16. Portugal, 458.
- Sardinia, Saluce, 10. Trinidad, Lord Harris. Turkey. Van Diemen's Land, Milligan, 81, 254. Milligan & Hall, 288. Quinn, 94. Smith, 296.
- Western Africa, Weston, 1.
- GUN BARRELS—VIII. Goddard, 235. Hart, 245. Robinson, 214. Wilkinson & Son, 200.
- Belgium, Amand, 369. Moncheur, 366.
- Russia, Ismael-Abdool-Rugtiel-Ogli, 160.
- Zollverein (1), Anschutz, 698.
- GUN CARRIAGES—VIII. Ferguson, 84. Ferguson, C. A. & T., 184. Mumford, 144. Munro, 292.
- Russia, Poland Mining Works, 147, 155. Votkinsk Imperial Iron Works, 156.
- GUN ELEVATOR—Bealton, 90.
- GUN FURNITURE—VIII. Beattie, 216.
- GUN IMPLEMENTS—VIII. Baylis & Son, 251A.
- GUN LOCKS—VIII. Baker, 263. Rippingille, 258.
- Belgium, Ledent, 148. Tunis, 83.
- GUN METAL—I. Stirling, 428.
- GUNPOWDER—II. Tulloch, 21. Tunis, 91.
- GUNS, ENLAYING AND ENGRAVING ON—VIII. Shorman, 266.
- GUNS, PISTOLS, &c., (including Rifles, Muskets, Blunderbusses, &c.)—VII. Leattie, 216. Beckwith, 220. Bentley & Son, 221. Boss, 219. Brazier, J. & R., 206. Brookes & Son, 246. Bull, 239. Cherrett, 297. Cooper & Co., 241. Davidson, 238. Davis, 253. Deane & Co., 223. Deane, G. & J., 223A. Egg, 232. Erskine, 257. Fairman, 233. Fletcher, 255. Forsyth & Co., 256. Gibbs, 215. Goddard, 235. Golden & Son, 264. Golding, 228. Grainger, 275. Greener, 59. Hart, 245. Haswell, 259. Hosking, 252. King, 281. Lang, 226. Manton & Son, 217. Moore & Grey, 209. Mortimer, 267. Needham, 260. Needham, W. & J., 218. Osborne, 234. Parker & Co., 221. Parsons, 270. Potts, 207. Powell & Son, 249. Reilly, 237. Richards & Co., 240. Rigby, W. & J., 236. Shaw, 254. Squires, 287. Townsend, 243. Trulock & Son, 222. Watkins & Hill, 238A. Webster, 265. Yeomans & Son, 231. x. Webster, 671A. Winton, 250. Witton & Co., 203. Woodfield, 229. Woodward, 230. XXII. Oliver, 121. Ashfield, 78, 260. Boyd, 77, 259.
- Austria, Kehlner's Nephew, 116. Kirner, 121. Lebeda, 114. Meyer & Co., 112. Micheloni, 119. Nowak, 115. Perger, 111. Schamal, 118. Schoenhuber, 113.
- Belgium, Ancion & Co., 143. Bermiolu & Brothers, 150. Dehonse, 153. Dautrewe, 149. Falise & Rapmann, 154. Henrard, 140. Jansen, 139. Lardinois, 151. Lepage, 145. Malherbe, 147. Montigny & Fusnot, 155. Plumdur, 146. Renkin, 503. Renkin, Brothers, 141. Thonet, 144. Tintot, 152. Tourey, 155.
- Canada, Ashfield, 161. Boyd, 160. Ceylon. Denmark, Jessen, 14.
- France, Berger, 418. Beringer, 1546. Bernard, 1547. Bertoulet, 58. Caron, 1133. Cusson, Pouchier, & Rossignol, 468. Deviane, 166. Duclos, 1712. Flo-

bert, 215. Fontenau, 509. Gasthine-Renette, 1611. Gauvain, 1612. Goddet, 1251. Houllier, 1628. Jacquemart, Brothers, 272. Lagrage, 1724. Lafrancoeur, 1308. Mathieu, 618. Morel, Brothers, 1734. Moutier le Page, 1364. Peigne, 947. Prelat, 1681. Ronchard-Slaue, 1461.

Hanover, Tanner, 3. *India*, VIII.

Jersey and Guernsey, Joulaud, 19.

Lubeck, Fischer, 5.

Mecklenburg-Schwerin, Schmidt, 2. *Persia*, Major.

Portugal, Royal Military Arsenal, 635-640.

Russia, Shah-Wedi-Ogli, 166.

Spain, Aretio, 269. Garate, 270A. Ibarzabal, 268. Placencia Royal Ordnance, 265. Zuluaga, 261A.

Sweden and Norway, Hagstrom, 79. Hook's Iron Works, 78. Kongaberf Manufactory, 40.

Switzerland, Destras, 71. Fischer, 265. Jeannet, 5. Peter, 67. Saurberg, 68. Yamod, 69. *Turkey*.

United States, Allen, 236. Anthony, 585. Colt, 331. Palmer, 347. Pecare & Smith, 307. Robbins & Lawrence, 328.

Zollverein (1), Blancke, 801. Brecht, 699. Gehrman, 60. Gleichauf, 857. Grzybowski, 63. Hanau, 700. Kehl, 64. König & Sons, 701. Lüdlich, 61. Pistor, 451. Pokorny, 79. Sauerberg, 702. Sauer & Son, 479. Schaller, 478. Schilling, 855. Spangeberg, Sauer, & Sturm, 477. Teutenberg, 678. Weiland, 388. (2), Hehllein, 20. Huckenreuter, 21. (3), Thuerigen, 32. (4), Oberuldor Royal Gun Manufactory, 15. (5), Weber & Schultheis, 6. (6), Dickore, 18. See also Cartridges. *Percussion Caps*. *Shot & Bullets*. *Stanchion Guns*. *Steam Gun*. *War-Engine*. *Wild Fowl Shooting*. *Guns*, &c., for.

GUN-SHOT DISTANCE MEASURER—Switzerland, Zeigler, 108.

GUN-STOCKS—Van Diemen's Land, Robinson, 90.

GUN WADDINGS—VIII. Fairman, 233. Joyce & Co., 277. Symington, 286. Walker & Co., 284. Walker, R., 242. XII. & XV. Wilkinson, 51. XVII. Hamer, 84.

GUTTA PERCHA, AND ARTICLES MADE THEREOF—VI. Gutta Percha Company, 424. x. Wislaw, 419. XIX. O'Donnell, 53. xx. Helps, 168A. XXII. Tasker, 221. Thompson, 808. XXVI. Gutta Percha Company, 21. Thurn & Co., 1. XXVIII. Bunn & Co., 77. Gutta Percha Company, 65. Hancock, 90. Walker, 87. XXIX. Ihff, 253. Moorson, 253. *Austria*, Dinzel, 348. *Canada*, Wheeler, 353. *India*, iv.

Eastern Archipelago, Hammond & Co., 2. *Turkey*. See also *Boats*, *Gutta Percha*. *Electrical Machines*, *Gutta Percha*.

GUTTA PERCHA HORSE-SHOEING—XXVIII. Hewens, 195.

GYMNASTIC APPARATUS—x. Chaplin, 570.

GYPSUM—Western End, South Enclosure (Outside), Raysdale 4. 1. 131c. Blyth & Jacobs, 131.

Canada, Logan, 1. *Labuan*, &c., Hammond & Co., 2. *Trinidad*, Lord Harris. *Tunis*, 50, 166, 169-171.

GYPSUM (Articles in)—XXVII. Hall, J. & T., 37, 38. *Tunis*, 13. *Turkey*. *Zollverein* (1), Noe, 418.

HACKLES—See *Flax Tools and Machinery*.

HAEMATITE—I. Ainsworth, 422. Dickenson, 407. Drew, 449. Ulverston Mining Company, 420.

Trinidad, Lord Harris, 24.

HAIR (Artificial)—XVI. Laycock & Sons, 330. XXVIII. Ross & Sons, 64. Truefitt, 65. XXIX. Rimmel, 3.

Hamburgh, Pepper, 18. *Tunis*, 182. *Turkey*.

United States, Wisdom, Russel, & Whitman, 205.

Zollverein (3), Goetae, 169. See also *Dyed Hair*. *Wigs*.

HAIR-BRUSHES—See *Brushes*, *Toilet*.

HAIR-CLOTH—XVI. Laycock & Sons, 330. Webb, 243.

HAIR, COW—XXIX. Wright, 250.

HAIR-DRESSERS' FIGURES—France, Allix, 6.

HAIR DYES—IV. Barker & Co., 62. XVI. Leathart, 317. XXVIII. Truefitt, 62. *Russia*, Belitchoff, 330.

HAIR FANCY-WORK AND ORNAMENTS—XXIII. Bakewell, 70. Cleal, 59. Forrer, 99. Gass, S. H. & D., 83. Hanssen & Co., 124. Hermann, 90. Lee, 71. Townley, 125. Wall, 5. XXVIII. Green, 60. School for the Indigent Blind, 100. XXIX. Adair, 307. XXX. (Fine Art Court) Gray, 293.

Austria, Franke, 602. *Denmark*, Lange, 42. *France*, Lemoine & Co., 909. *Hamburgh*, Gompertz, 33. *Madeira*, Read, 1.

Netherlands, Lesfere, 107.

United States, Bourgard, 309. Phalon, 390.

Zollverein (1), Seel, 637.

HAIR-POWDER—III. Jones & Co., 128.

Austria, Ritter, 696.

HAIR SIEVES—Tunis, 137.

HAIR SPRINGS—Switzerland, Lutz, 94.

HAIR, VEGETABLE—Algeria, Averseug & Co., 3.

HAIR-WORKING MACHINE—VI. Thompson, 603.

HALTERS (Horses)—XIV. Wall, E. & T., 70.

HAMMOCKS—British *Guyana*, Barkly, 125, 128, 129. Rose, 136. Stutchbury, 126, 127.

HAMPDEN, STATUE OF (Model)—Page 848.

HAND-BELLS—v. Warner & Sons, 424.

HANDKERCHIEFS (Cambric, Cotton, and others)—XI. Thompson & Son, 15. XII. & XV. Black & Wingate, 204. Webber & Hair, 277. XIV. Dufferin's, Lord, School, Belfast, 3. Richardson, J. & T., & Co., 21. XVIII. Mair & Co., 13.

China, Baring, Brothers. *Egypt*, 319, 322, 323, 328, 331. *France*, Lazare & Lacroix, 905.

Ionian Isles, Fitzroy, Lord C., 4.

Portugal D. Lusa, 756-760. Mutter, Weyhe, & Co., 748-755. *Yusai*, Rabeneck, 173.

Switzerland, Wenziger, 112. Greater & Rister, Brothers, 123. Langziker & Co., 166. Mueller, 160. Schiesser, 134. *Turkey*.

Zollverein (1), Banck, 793. Funke, 587. Kirstein, 120. Prentzel, 120. (4), Kohlor, 46.

HANDKERCHIEFS (Silk)—XI. Mair, Son, & Co., 59. XVIII. Baker & Co., 2. Foster & Co., 16. Kerr & Co., 54. Keymer, J., 12. Walford, 19. Welch & Co., 7. Wilkinson, 8. XIX. Bennock & Co., 394.

Algeria, Castelain, 15.

Austria, Laportz, 387. Liebig, 241. Mayer, Brothers, 266. Rohz, 384. Siebert, 271. Spanraft, 273.

Belgium, Verreyt, 290. *China*, Hewett & Co.

France, Chambon, 112. Depouilly, 1586. Lazare & Lacroix, 905. Menres & Candin, 1357. Nourry, Brothers, & Meynard, 1670. Paul, 676.

Greece, Nuns of St. Constantine, 54.

Hamburgh, Hahr & Co., 122. Lule, 23.

Ionian Islands, Mavrianni, 2. Seaton, Lord, 5.

Portugal, Carneiro, 960-982. Martin, 957.

Russia, Jraf-Ogli, 207. *Sardinia*, Amney & Pont, 34.

Switzerland, Baenziger, Kolb, & Co., 156. Schmid, Brothers, 269. Tanner, 205. Wally, Brothers, 141.

Tunis, 10. **United States**, Pierce, 248A. Updegraff, 540.

Zollverein (1), Simons, 514.

HANDKERCHIEFS (Designs for)—France, Preinsler, 1409.

HAND-LOOM FABRICS (Cotton, Wool, Silk)—France, Tricot, Brothers, 396.

HAND-MILLS (for grinding Flour)—VI. Adams, S. & C., 429. *Egypt*, 155. *France*, Bouchon, 431.

HAND-MULE COTTON MACHINERY—VI. Mason, 10.

HAND-POWER MACHINE—v. Guhn, 754.

HANDLEY, H. (M.P.), TESTIMONIAL TO THE MEMORY OF (Model)—XXX. (Fine Art Court) Mabey, 141.

HANDS, ARTIFICIAL—x. Bursill, 673A. Little, 190.

HARBOUR OF REFUGE ON THE EAST COAST OF IRELAND (Model)—VII. Bruff, 49.

HARDWARE (various)—XXII. Bailey & Sons, 805. Blews & Sons, 340. Burton, 247. Carpenter & Tildesley, 655. Chambers, 607. Ferncombe, 160A. Featham & Co., 646. Glenton & Chapman, 238. Gorton, 374. Gray & Son, 262. Hale & Co., 486. Hardy, 146. Harper & Sons, 96. Harrison, 555. Holgate, 450. Hoole & Co., 140. Mappins, 180. Mapplebeck & Lowe, 370. Moore & Co., 274. Moreton & Langley, 669. Morton, 104. Newbold & Owen, 133. Pender & Sons, 574. Price, 307. Robertson, Carr & Co., 802. Rowley, 278. Shenstone & Mills, 273. Shoobred & Co. 66. Smaunite, 270. Steer & Webster, 124. Strick, 666. Tavin, 514. Taylor, 359. Terry & Son, 631A. Turner & Co., 174. Walton, 701. Wright, 177. XXIX. Mitchell, 138. Without, 266.

Austria, Hauser, 482.

- France*, Bricard & Gauthier, 437. *Oculaux & Co.*, 129. *Dervaux-Lefebvre*, 145. *Goldenberg & Co.*, 851. 1737. *Jacquemart Brothers*, 272. *Lauray*, 568. *Morel Brothers*, 1731. *Pierou*, 957.
- Hamburgh*, *Classen*, 110. *Fliersheim*, 52. *Meyer*, 55. *Schmitze & Schenmany*, 49. *India*, xxii.
- Nova Scotia*, *Archibald*, 2. *Russia*, *Jakvloff*, 286. *Zollverein* (1), *Basse & Fischer*, 664. *Boecker*, 633. *Christian*, 624. *Funke & Hueck*, 632. *Hasenclever & Sons*, 631. *Hilgers & Sons*, 631. *Huth, Fried & Co.*, 632. *Lucas & Co.*, 650. *Luckhaus & Co.*, 631. *Mogler*, 765. *Schmidt*, 651. (3), *Hoffman*, 56. (4), *Deffner*, 71. See also *Ironmongery*. *Iron Wares*. *Japanned Wares*.
- HARMONIUMS**—x. *Wheatstone & Co.*, 526. *Belgium*, *Verhasselt*, 179. *Zollverein* (3), *Zimmermann*, 24. *France*, *Debain*, 1172. *Tremaux*, 304.
- HARNESS, &c.**—See *Saddlery and Harness*.
- HARPOON GUN AND APPARATUS**—VIII. *Murray*, 438. See also *Wale-Guns*.
- HARPCONS**—XXII. *Thomas*, 358.
- HARPS**—x. *Bray*, 531. *Jones*, 532. *Ventura*, 18. *France*, *Domey*, 477. *Erard*, 407.
- HARROWS**—IX. *Barker*, 230. *Barrett*, *Exall & Andrews*, 128. *Campbell*, 17. *Carson*, 110. *Coleman*, 216. *Comins*, 143. *Crosskill*, 135. *Digges La Touche*, 263. *Garrett & Sons*, 142. *Grant & Co.*, 207. *Williams*, 151. *India*.
- Zollverein* (1), *Kuenemund*, 795. *Sprengel & Co.*, 67.
- HASSOCKS**—XIX. *Hope*, 209.
- HAT-BANDS, &c.**—XIII. *Bothe & Pyke*, 63. *Wilson*, 56.
- HAT-MAKING (Materials for)**—XIII. *Walters & Son*, 9. *Wilson & Co.*, 16. xx. *Dietrich*, 56. *Simmonds & Wadman*, 105.
- HAT MANUFACTURE (Illustrations of)**—VI. *Gaines, Sanders, & Nichol*, 57, 58. xv. *Christy & Co.*, 35. *Stainburn & Baugh*, 58.
- HATS AND CAPS**—VIII. *Allen & Co.*, 202. xi. *Lincoln & Bennett*, 57. xx. *Ashton & Tyler*, 53. *Ashton & Sons*, 52. *Barber*, 57. *Harford*, 170. *Beeson*, 162A. *Berni & Mellard*, 103. *Bethel, Ware & Co.*, 76. *Braun*, 64A. *Braund*, 66. *Carrington, S. & T.*, 126. *Clemes & Sons*, 156. *Dando, Sons & Co.*, 50. *Darling*, 131. *Davies*, 216. *Dietrich*, 56. *Elliott & Cooper*, 172. *Eveleigh & Son*, 104. *Felix & Co.*, 51A. *Gaines, Sanders, & Nichol*, 57, 58. *Giarrard, R. & J.*, 61. *Gregory, Cabitt & Co.*, 8. *Johnson & Co.*, 48. *Laughland*, 144. *Lees*, 127A. *Long*, 16A. *Mason*, 157. *Melton*, 54. *Middlebrook*, 123. *Mollady & Sons*, 125. *Ritchie*, 145. *Smith & Co.*, 55. *Thompson & Co.*, 192. *Tress & Co.*, 102. *White*, 51. *Zox*, 59. xxviii. *Clarkson*, 197.
- Algeria*, *Algiers*, *Delegate*, of 58.
- Austria*, *Hubsch*, 352. *Kriese*, 353. *Muck*, 351. *Srba*, 355.
- Belgium*, *Auchiaux*, 344. *Jacquot*, 347. *Lievain*, 351. *Van Nieuwenburg, Brothers*, 343. *Brazil*, *Morway*, 8. *South Africa*, *Deane & Johnson*, 19.
- France*, *Badin*, 1063. *Baton & Son*, 1069. *Chenard, Brothers*, 87. *Coupin*, 1162. *Donat & Co.*, 1193. *Duchene*, 1198. *Ernooux*, 498. *Lambert & Son*, 1289. *Lejeune*, 1314.
- Hamburgh*, *Caken*, 34. *Colin*, 42. *Curjar*, 35. *Hanover*, *Wagner*, 7. *India*, xv. xxviii.
- New Zealand*, *St. John's College*, 7.
- Portugal*, *Borges*, 973-977. *Kirsh*, 985, 986. *Roxo*, 978-984. *Russia*, *Fitzner*, 271.
- Spain*, *Belmonte*, 256. *Sweden*, *Ericsson & Co.*, 106.
- Switzerland*, *Jeanmeret*, 38.
- Tunis*, 10. *Turkey*.
- United States*, *Gutin*, 232. *Leary & Co.*, 130. *Oakford*, 45. *Western Africa*, *Mason*, 9.
- Zollverein* (1), *Freystadt, Brothers*, 173. *Israel*, 754. *Leimkueller*, 398. *Roesser*, 397. *Rups*, 613. *Schmidt & Sons*, 756. *Seldis*, 181. *Vassel & Co.*, 186. (0), *Schuchard*, 19. See also *Plushes (for Hats, &c.)*.
- HATS, STRAW, &c.**—xx. *Cooper*, I. J. & G., 172A. *Elliott*, 172. *Austria*, *Faller*, *Fritscheller & Co.*, 656. *British Guiana*, *Barkly*, 76. *Canada*, *Commissioners*, 349. *Malta*, *Villa*, *Fratelli*, 5.
- Spain*, *Settier*, 272A.
- New South Wales*, *Webster*, 23.
- Van Diemen's Land*, *Symonds*, 274-278.
- Western Africa*, *Beecham*, 12. *Hutton & Sons*, G. *McWilliam*. *Zollverein* (1), *Faller & Co.*, 419.
- HAUTROUS**—See *Oboe*.
- HAY**—*Belgium*, *Vanden Abeele*, 52.
- HAY CART (Mole)**—XXIX. *Spratt*, 121.
- HAYMAKING MACHINES**—IX. *Barrett*, *Esall & Andrews*, 128. *Grant & Co.*, 207. *Smith & Co.*, 234. *Wedlake & Co.*, 127.
- HAY AND STRAW CUTTING MACHINES**—IX. *Hollenhurst*, W. & J., 61. *Smith, A. & W. & Co.*, 266. See also *Chaff-cutting Machines*.
- HAY-RACKS (for Sheep)**—IX. *Uppill*, 277.
- HAY-RAKES (Horse)**. See *Rakes, Horse*.
- HAY-SAFFRON**—II. *Keating*, 102.
- HEALD-MAKING MACHINES**—VI. *Judkins*, 52.
- HEARTH AND OTHER RUGS**—XVI. *Clapham*, 9. *Clark, C. & J.*, 48. *Dick*, 311. *Poland & Co.*, 362. *Robinson*, 7. *Hood & Co.*, 49. xix. *Beavis*, 393. *Batton*, 106. *Bruton and Sons*, 110. *Estace, R. & J.*, 160. *Fortune*, 168. *Lawson*, 235A, 325. *McFarlane, Brothers*, 243. xxviii. *School for the Indigent Blind*, 100. See also *Carpets*. *Carriage Rugs*.
- HEARTH RUGS (Designs for)**—XIX. *Hanson*, 188.
- HEATING APPARATUS**—*France*, *Pignot*, 1391. See also *Atmospres*. *Gas Cooking and Warming Apparatus*. *Hot-water Apparatus*.
- HEDGES (Models)**—IX. *Junison*, 70.
- HEIDELBERG CASTLE (Model)**—*Oldenburg*, *Cassebohm*, 1.
- HELIOGRAPHIC PRINTS**—*France*, *Blanquart*, 1551.
- HELMETS**—See *Military Accoutrements*.
- HEMMING-MACHINES**—*France*, *Senechal*, 373.
- HEMP (including manufactures thereof)**—XIV. *Bridport Local Committee*, 73. *Jameson & Co.*, 60. xxviii. *Bevington & Morris*, 38. *Treloar*, 39. *Woodhead*, 191.
- Austria*, *Bimbaum*, 95. *Hermannshalt Ropemakers' Association*, 277. *Jager*, 278. *Parsch, Brothers*, 279.
- Bahamas*, *Thompson*.
- Belgium*, *Gilta*, 105. *Van Bogaert, Brothers*, 107. *Van Riet*, 103. *Verhelst*, 102. *Canada*, *Grice*, 71.
- South Africa*, *Watermeyer*, 17.
- China*. *Egypt*, 152.
- France*, *Joubert-Bonnaire & Co.*, 552. *Laine-Laroche & Ma.*, 286. *Leclere, Brothers*, 576.
- India*, &c.
- Portugal*, *Palmella*, *Duke of*, 530-532.
- Rome*, *Centre Chamber of Commerce*, 9. *Minghetti*, 10.
- Russia*, *Filemonoff*, 103. *Krasheueroff*, 100. *Milnikoff-Gloushokoff*, 212. *Milnikoff-Gloushokoff, M.*, 211. *Milnikoff-Gloushokoff, P.*, 213. *Volkhonsky, Prince*, 109.
- Spain*, 154, 155, 157, 158. *Calderon*, 152. *Castellon Corporation*, 153, 194. *Diez de Ribera*, 172. *Ripalda*, *Count*, 163.
- Turkey*. *United States*, *Dix*, 139. *White*, 397. *Western Africa*, *Trotter*, 5.
- Zollverein* (1), *Burbach, Brothers*, 799. *Doebel*, 547. *Hauch*, 792. *Kiaker*, 553. *Krieg*, 886. *Verein*, 790. (2), *Braun*, 39. See also *Flax*. *Oakum*. *Rope and Cordage*. *String and Twine*. *Tow*.
- HEMP-DRESSING MACHINES**—*United States*, *Williams*, 14.
- HEMP PALM**—*China*, *East India Company*.
- HENBANE, EXTRACT OF**—II. *Tustinn*, 97.
- HERALDIC ENGRAVING**—XXIII. *Matthews*, 95. See also *Armorial Bearings*.
- HERNANIUM**—*United States*, *Chase*, 99.
- HERBS AND ROOTS**—II. *McCulloch*, 96.
- HEREFORD CATHEDRAL (Lectern for)**—*Main Avenue*, *West*, *Potter*, 63.
- HERMETIC TAPS**—*France*, *Frinault*, 1609.
- HIDES**—See *Leather and Hides*.
- HIDE-ROLLING MACHINE**—V. *Newcombe*, 205.
- HIGHLAND DRESSES AND ORNAMENTS**—XX. *Macdougall*, 83. xxiii. *Marshall & Sons*, 23. *Meyer & Mortimer*, 47.
- HIGHLAND GAMES (Model)**—XXX. (*Fine Art Court*) *Auderson*, 159.

8. Dutton & Sons, G. & Co., 419.

Small & Andrews, Co., 234. Wedlake

IX. Rodenhurst, Co., 266. See also

7. See also

52. Clark, C. Co., 302. Robinson, Co., 393. Bottom, Co., 160. M'Farlane, the Indigent Blind, Co., 188. See also

1391. See also

Apparatus.

burg, Casseholm, 1. quart, 1551.

il, 373.

of)—xiv. Bridport & Co., 60. xxviii.

ar, 39. Woodhead,

stant Rope-makers' arscl, Brothers, 279.

et, 170. Van Riet, Price, 71.

Laine-Laroche &

2. Minghetti, 10. neroff, 190. Milni-Gloukhoff, M., 214. folkonsky, Prince,

on, 152. Castellon Ribera, 172. Rip-

White, 307.

799. Doebel, 517. 886. Verein, 790. Dakum. Rope and

ates, Williams, 14. ary.

ews, 95. See also

— Main Avenue,

03.

e, 205.

—xx. Macdonnell, Meyer & Morrison,

ne Art Court) An-

HINAL, OR INDIAN VARE—*Society Islands*, Queen Pomare, 4.

HINGERS (VARIOUS)—xxii. Barnard & Bishop, 34. Collings & Co., 573. Gerlach, 632. Gollop, 651. Haslam, 421. Thripp, 676. Whitley, 656.

HOES—ix. Dufour & Co., 124a. Spurgin, 250. Warren, 257.

HOES, HORSE—ix. Barker, 230. Bentall, 217. Bushy, 15. Comins, 143. Crosskill, 135. Crowley & Sons, 96. Garrett & Sons, 142. Gray & Sons, 150. Harkes, 23. Samuelson, 185. Smith, 270. Wedlake & Co., 127.

HOES, TURNIP—ix. Grounell, 148.

HOISTING-MACHINES—v. Greatorex, 415.

HOLY-WATER VESSELS—See *Ecclesiastical Furniture*.

HOMOPATHIC MEDICINE CASES—xvi. Allen, 30.

HONE-STONES and HONES—I. Ross, 51. Scrampton, 82. Solomon, 81. Thorne, 475.

Belgium, Guillaume, 1. Lamberty, 3. Offergeld, 4. Otte, 2. *India*, 1. *Trinidad*, Lord Harris, 30.

Van Diemen's Land, Milligan, 79.

HONEY and HONEYCOMB—iii. Bentley, 4. Doubleclay, 2. Dutton, 6. Fortnum, Mason, & Co., 55. Kitchener, 5. Lighton, 1. Weatherley, 27.

Austria, Carniolian Agricultural Society, 70.

British Guiana, Bee, 124. *Canada*, Lynam, 131.

Spain, Labat, 165. *Portugal*, 593-598.

Sardinia, Guiso, 21.

Spain, Abad, 181. *Belgium*, 185, 189 A. Centenera, 184. Colmeiro, 182. Escudero, 183. Huelva, 189c. Labat, 165. Molina, 180.

Tunis, 155, 163. *Turkey*, *Van Diemen's Land*, Fenton, 330. Rout, 291. See also *Beeswax*.

HONEY (Apparatus for obtaining)—iii. Kitchener, 5. See also *Beehives*.

HONEYCOMBS, ARTIFICIAL—*France*, Damainville, 153.

HONNA-LEAVES—*Tunis*, 56.

HOOKAHS—*India*, xxv. xxviii.

HOOPS and RINGS—xxii. Hardin & Hiffie, 284. Woods, 33. *France*, Hue, 269.

HOPS—I. Paine, 36. iii. Ashburnham, 60. Attfield, 61. Golding, 63. Masters, 65. Paine, 62. Richardson & Sons, 59.

Austria, Schoefel, 99. Von Wallis, 93.

Belgium, Degryse, 63. De Quidt, 64. Lava, 500. Van Meris, 65.

Canada, Penner, 65. Smith, 64. *New Zealand*, 39.

Van Diemen's Land, Smith, 78.

Zollverein (6), Stein & Schroeder, 81.

HOP-BAGGING MACHINES—ix. Elliott, 144a. Plenty, J. & E., 272. Wheeler, 216a. Woodbourne, 76.

HOP FUNGUS—iii. Plumley, 64.

HOP SEPARATING MACHINES—xxii. Collins, 88.

HOP TALLIES—x. Richardson, 264.

HORN (Articles in)—*Turkey*, *Zollverein* (8), Montag, 11. See also *Horn Carvings*.

HORN CARVINGS—*Switzerland*, Ueltschi, 256.

HORN PAINTINGS—*Hamburg*, Cornelis, 101.

HORN, STAINED (to imitate tortoiseshell)—xviii. Hitch, 59.

HORNBLEND—i. Liskeard Committee, 513.

HORNS (Animal)—*Canada*, Thompson, 99.

South Africa, Bridges, 21. Hanbury, 28. Meerer, 16. Watson, 58. *Ceylon*, *Egypt*, 113, 114, 117-119, 124, 125. *India*, iv. *Turkey*, *United States*, Goddard, 537.

HORNS (Musical Instruments)—See *Trumpets and Horns*.

HORSE-BONES, RAILWAY—ix. Lydes, 141.

HORSE & CATTLE MEDICINES—See *Veterinary Medicines*.

HORSE-CLOTHING—xii. & xv. Gandy, 216. Hagues & Co., 25. Whitworth & Son, 56. Wilson, J. & W., 245. xiv. Morrison & Horn, 49.

Austria, Maurer, 200. *Canada*, Gamble, 139.

HORSE-HAIR—iv. Blyth, Hamilton, & Blyth, 60.

Belgium, Haivsens-Hap, 257. *Kistemeckers*, 270. *Somerset*, 265.

Hamburg, Meyer, 105. *Netherlands*, Catz & Co., 30.

Russia, Bezoukhnikoff-Sokoloff, 248. Ivanoff, 259. Kondriakoff-Jadensky, 340.

Switzerland, Hurier & Dubois, 231. Roth, 53.

Van Diemen's Land, Roat, 212.

Zollverein (1), Fudicker, 596.

HORSEHAIR CLOTHES-LINER—xiv. Wall, E. & T., 70.

HORSEHAIR LACE—*Switzerland*, Sulzberger & Akermann, 294.

HORSEHAIR TEXTURES—xiv. Wall, E. & T., 70.

Belgium, Kistemeckers, 270.

France, Delacour, 472.

Zollverein (1), Mengen, 581.

HORSE-POWER MACHINES (Undescribed)—*France*, Pouyer, 967.

United States, Eddy & Co., 523.

HORSE-SHOES—v. Holmes & Co., 872. xxii. Chopping & Co., 11. Cook, 16. Fogarty, 13. Guy, 4. Hillman, 15. Holmes, 12. Miles, 9. Plumley, 17. Stevens, 7. Whitehead, 10. Woodin, 8.

Zollverein (2), Gradman, 55.

HORSE-SHOES (Temporary)—x. MacMahon, 601d.

HORSE-SHOING, GUTTA PERCHA—xxviii. Hewens, 195.

HORSE-SHOING TOOLS—ix. Barrett, Exall, & Andrews, 128.

HORN-BLANK CLOAK—*Russia*, Khirghis, 278.

HORN-BRETT, INSTRUMENT FOR OPERATING ON—x. Horn, 645, 736.

HORSE-WHEEL—v. Warner & Sons, 424.

HORTICULTURAL IMPLEMENTS—ix. Bates, 186. Ebbs, 56a. Sanders, 269b. Smith, 222. Winton, 259a.

xxii. Brookes & Son, 110a. Eyre & Co., 203.

Maraden & Co., 169. Skellons, 220. Sorby & Sons, 204. Thomas, 358. Thornhill, 1.

Austria, Lobkowitz, Prince, 454.

Belgium, Le Ducte, 161. *France*, Arnheiter, 733.

India, ix. *Switzerland*, Chollet, 70.

Tuscany, Mareri, 66a.

United States, Allen & Co., 97.

Zollverein (1), Scheller & Weber, 663. See also *Agricultural Implements*.

Flower-Stands, *Garden Engines*, *Garden Pots and Stands*, *Scythes*.

HOSE FOR FIRE-ENGINES—v. Merryweather, 401. Shand & Mason, 410. ix. Burgess & Key, 237.

HOSIERY—xii. & xv. Burgess & Co., 243. Dicksons & Laings, 234. Garvie & Dias, 227. Reid & Son, 481.

Standen & Co., 281. xix. Hollins, 30. Irish Work Society, 77. xx. Allan & Sully, 100. Angrave, Brothers, 202. Baines, 200. Barnes, T. & G., 27. Beale & Latchmore, 204. Biddle, 207. Biggs & Sons, 205.

Billon & Hames, 201. Braishaw, 39. Brie & Co., 24. Cartwright & Warners, 196. Carver & Gilbert, 98. Corah & Sons, 208. Farrage, 176. Foster, Porter, & Co., 2. Fry, 193. Furley, 94. Glenny, 37. Hadden & Sons, 134. Holland & Co., 194.

Hollins, 96. Homan & Co., 17. Hudson, 199. Hurst & Sons, 99. Johnston, 128a. Kaye & Co., 146. Laing, 133. Lart & Son, 81. Morley, I. & R., 101. Muir & Co., 146. Neville & Co., 7, 20. Paterson, 19.

129. Peart & Dosseter, 5. Pope & Plante, 6. Roy, 136. Sandland & Craze, 38. Shaw, 91. Taylor, 3. Taylor & Beales, 197. Thompson & Co., 192. Thresher & Glenny, 79. Thurman & Co., 92. Ward & Sons, 203. Ward, Strut, & Co., 195. Weatherhead, 33. Welch & Co., 212. Wheeler, 206. Wheeler & Ablett, 22. Whitehead & Son, 139. Willner, 44a. Wilson & Son, 183.

Austria, Budinsky, 393.

France, Cuchois & Colin, 124. Esprit & Noye, 409. Lauret, Brothers, 903. Milon, 930. Trotte, 701.

New South Wales, Morrison, 25.

Portugal, Jorge, 968. Loureiro, 727. Parreira, 1169, 1170.

Russia, Narimoff, 193.

South Australia, Webster, 3.

Switzerland, Bally & Co., 210. Frey, 212. *Turkey*, *United States*, Brown, 110. Peck, 248.

Van Diemen's Land, Queen's Orphan Schools, 138-141.

Zollverein (1), Kohlstadt, 400. Krockner & Son, 755. Schopper, C. F., 758. Schopper, F., 757. Wehenderfer, Brothers, 759. Zimmermann & Son, 718. (3).



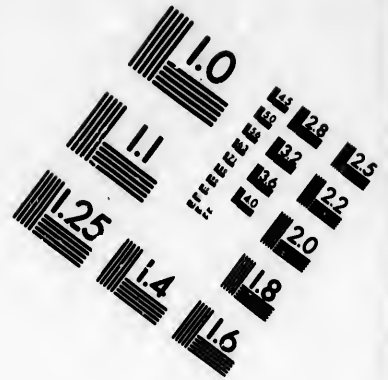
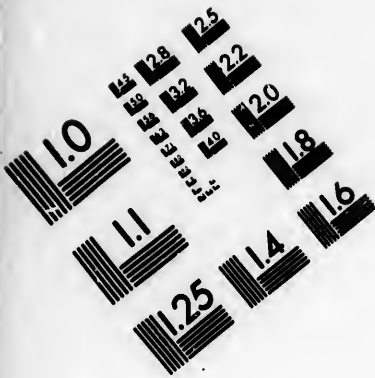

**IMAGE EVALUATION
TEST TARGET (MT-3)**

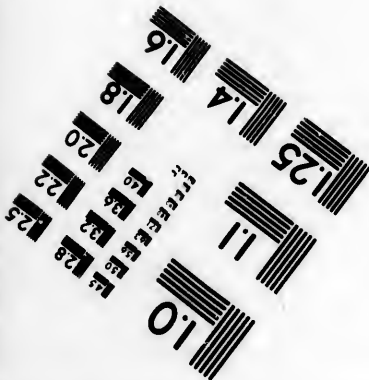
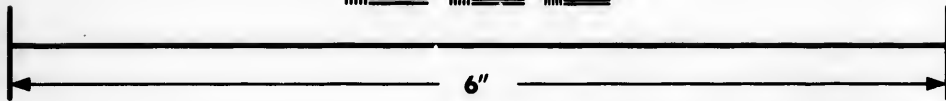
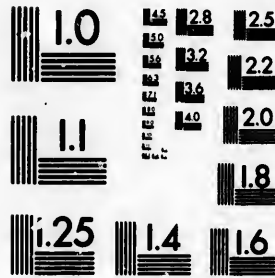

**Photographic
Sciences
Corporation**

23 WEST MAIN STREET
WEBSTER, N.Y. 14580
(716) 872-4503

15 28 25
16 32 22
18 20

10
11
12
13
14
15
16
17
18
19
20
21
22
23
24
25
26
27
28
29
30
31
32
33
34
35
36
37
38
39
40
41
42
43
44
45
46
47
48
49
50
51
52
53
54
55
56
57
58
59
60
61
62
63
64
65
66
67
68
69
70
71
72
73
74
75
76
77
78
79
80
81
82
83
84
85
86
87
88
89
90
91
92
93
94
95
96
97
98
99
100

- United Merchant Manufacturers, 72-83. (4), Hils, Haas, & Co., 53. Rehm, 54.
- HOSIERY LOOMS—France, Berthelot, 422.
- HOSIERY YARNS—XI. Hollins & Co., 1, 36. XII. & XV. Fox, Brothers, & Co., 7.
- HOSPITAL (Model of)—XXX. (Fine Art Court), Merrett, 172.
- HOT-AIR APPARATUS—V. Green, 53. *United States*, Perkins, 472.
- HOT-AIR OVENS—*United States*, Rodriguez, 485.
- HOT-WATER APPARATUS—V. Hill, 94. IX. Pannell, 204. Weeks & Co., 248A. XXII. Dale, 501. Garton & Jarvis, 483. Toser, 390. XXIX. Frost, 34. *United States*, Perkins, 541.
- HOUSES (Models of)—I. George, 213. VII. McLachlan, 181. Metropolitan Association for Improving the Dwellings of the Industrious Classes, 172. XXIX. Lascelles, 123. XXX. (Fine Art Court) Harrison, 180. Pearce, 32. *British Guiana*, Barkley, 135. Colling, 162. *India*, VII. See also *Cottages, Labourers*.
- HOUSE DECORATIONS (Designs for)—XVIII. Glover, 92. XXVI. Horne, 32. Moxon, 252. Turner & Co., 320. XXX. (Fine Art Court), Papworth, W. & J. W., 22A.
- HOWDAHs—State Howdahs and Palanquins presented to Her Majesty. *India*, and page 847.
- HOWITZERS—See *Cannon, &c.*
- HUDDERSFIELD VADUCT (Model)—VII. Roebuck, 30.
- HUMAN AND ANIMAL BLOOD—France, Brocchieri, 74. See also *Albumen of Blood*.
- HUMMELLING-MACHINES—IX. Garrett & Sons, 142. See also *Barley-Hummellers*.
- HUNTING KNIVES—See *Cutlery*.
- HUNTING AND SHOOTING BAGS AND NETS—Zollverein (1), Zeschke, 259.
- HURDLE OR GATE-MAKING MACHINES—IX. Burrell, 37.
- HYACINTH GLASSES AND SUPPORTS—XXII. Tye, 314.
- HYDRANT, OR FIRE-COCK—XXII. Guest & Chrimes, 524. *United States*, Bartholomew, 335.
- HYDRAULIC BATTERY—X. Brett, 422.
- HYDRAULIC CEMENT—Western End, South Enclosure (Outside), Towler, 27. *Canada*, Logan, 1. *Netherlands*, Maas, 4. *Portugal*, 116.
- HYDRAULIC CLOCK—France, Tiffereau, 1042.
- HYDRAULIC CRANE—V. Armstrong, 44. Scott, 98.
- HYDRAULIC ENGINES—V. Shalders, 402. Shaw, 113.
- HYDRAULIC FOOT-WARMER—France, Viguier, 729.
- HYDRAULIC LAMP—X. Taylor, 672.
- HYDRAULIC LOCOMOTIVE—V. Erskine, 100.
- HYDRAULIC MACHINES—V. Armstrong, 44. Scott, 98. France, De Caligny, 101. Fontaine, 1227. Leclerc, 299. Moisson, 1358. *Jersey and Guernsey*, Seignuel, 3.
- HYDRAULIC PRESSES—V. Bank Quay Foundry Company, 412. Greatorex, 415. Jackson, 682.
- HYDRAULIC RAM—V. Easton & Amor, 408. Roe, 462. *United States*, Gatchel, 468.
- HYDRAULIC VALVES AND SEATS—V. Carnell & Hosking, 201.
- HYDROCHLORIC ACID—*Sardinia*, Selopis, Brothers, 4.
- HYDRO-ELECTRIC MACHINES—VI. Watson, 163. *Sweden*, Bergstrom, 85. *Zollverein* (2), Ozann, 87.
- HYDRO EXTRACTOR—France, Bezaull & Co., 425.
- HYDROGRAPHIC ENORAVINGS—France, Collin, 126.
- HYDROGRAPHIC INSTRUMENTS—France, Keller, 280.
- HYDROMETERS—X. Acland, 368. Baker, 396. Durham, 668. Griffin & Co., 457. Nunn, 371. France, Arreza, 752. *United States*, Bakins, 256. *Zollverein* (4), Kinzelback, 26. See also *Spirit Meters, Water Meters*.
- HYDROMETERS (Scales for making)—X. Acland, 368.
- HYDRO-PNEUMATIC APPARATUS—X. Statham, 456.
- HYDRO-PNEUMATIC ELEVATORS—VII. Watt, 20.
- HYDRO-PNEUMATIC ENGINE—V. Jenkins, 86.
- HYDRO-PNEUMATIC LIFT FOR CANAL LOCKS—V. Led-bitter, 650. VII. Watt, 20.
- HYDRO-PNEUMATIC SHIP LIFT—VII. Watt, 20.
- HYDROSTATIC BALANCES, &c.—X. De Grave, Short, & Faumer, 333.
- HYDROSTATIC PRESSES & APPARATUS—V. Burgess, 471. Firth, 472. VI. Cottam & Hallen, 221. VIII. Gale, 79.
- HYGROMETERS—X. Negretti & Zambra, 160A. Newman, 674.
- HYMN FOR ALL NATIONS—(in thirty languages) XVII. Brettell, 169.
- ICE-BOATS (FOR SAVING LIFE FROM DROWNING)—VIII. Royal Humane Society, 15.
- ICE-BOX—XXII. Keith, 601.
- ICE-CREAM FREEZER—*United States*, Fryer, 372.
- ICE-MAKING MACHINES—France, Fumet, 513. *United States*, Asher, 355, 372.
- ICE-PLANE—XXII. Keith, 601.
- ICE SAFES—Keith, 601. Wenham Lake Ice Company, 600.
- ILLUMINATED DESIGNS, MISALS, &c.—XVII. Hood, 157. XXX. (Fine Art Court) Beeson, 111A. *China*, Boileau. France, De Bastard, 1717.
- ILLUSTRATED BOOKS—See *Books, Illustrated*.
- IMPULSORIA—V. Crestadora, 557.
- INCENSE—*Trinidad*, Lord Harris.
- INCLINES, mode of assisting Carriages up and down—V. Snowden, 588.
- INCUBATION (Models of)—X. Dinsdale, 718.
- INDIA PAPER (Substitute for)—XXX. (Fine Art Court) Leith, 114.
- INDIA-RUBBER MANUFACTURES—See *Caoutchouc*.
- INDIAN BLUE—II. Estcourt, 64.
- INDIAN CURIOSITIES, &c.—Her Majesty the Queen, page 547. *British Guiana*, Barkly, 135. Colling, 162. *Canada*, Indians of Lorette, 177. *India*, XXX. *Nova Scotia*, Central Committee, 2. *United States*, Davis, 563.
- INDIAN INK—*China*, Copland, Reeves, J. Reeves, J. R. *Zollverein* (1), Diesel & Co., 892.
- INDICATING LEVELS (Engineers')—X. Blyth, 367. Cameron, 356.
- INDIGO—II. Marshall, 68. III. Colman, 117. IV. Coovey, 70. *Austria*, Fials, 25. *China*, East India Company. *Egypt*, 79. *India*, IV. *Tunis*, 15-17. *Western Africa*, Beecham, 12. *Zollverein* (1), Krimmelbein & Bredt, 457.
- INFUSION APPARATUS—II. Squire, 93.
- INFUSIONS, MEDICINAL. See *Decoctions and Infusions*.
- INHABER EINES, Patent and other Fabrics—XXVIII. Forster, 178.
- INKS—XVII. Galbraith, 179. Hawthorne, 7. Lines & Co., 168. Loveloy, 170. Peckerd, 110. Stokes, 80. Todd, 119. XXIX. Edle & Co., 18. Galbraith, 17. *Austria*, Halla & Co., 54. *France*, Larenaudiere, 1294. *Hanover*, Hostmann, 2. *India*, XXIX. *Sardinia*, Bo, 19. *Tunis*, 81. *United States*, Maynard & Noyes, 445. *Zollverein* (2), Sammet, 50.
- INK FOR THE BLIND—XVII. Edinburgh School for the Blind, 170.
- INK-BOTTLES—XVII. Isaac, 165.
- INK-LITHOGRAPHY (Specimens of)—XXX. (Fine Art Court) Leighton, 69.
- INK, MARKING—II. Ponting, 25. XVII. Swann, 155.
- INK-POWDER—XVII. Todd, 119.
- INK, PRINTERS'—XVII. Parsons & Co., 31.
- INKSTANDS—VI. Murdan & Co., 205. Cole, 31. XXII. Edwards, 345. XXIII. Cartwright & Hiron, 30. Mayer, 14. Mortimer, 13. XXIV. Wood & Perkes, 7. XXVI. England, 528. Howell & Co., 190A. North, 257. LXXVII. Rowlands, 63. XXVIII. Mallandain & Co., 108. XXIX. Strudwick, 42. *Turkey*. *Ionian Islands*, Ward, 6.
- INLAID FLOORING—XXVI. Cowell & Co., 526. *Austria*, Leistler, 663. *Russia*, Miller, 299. See also *Parqueterie Flooring*.
- INLAID WOODS (Imitation of)—XXVI. Davis, 329. Fonnereau, 40. XXX. (Fine Art Court) Bonnar & Carfrae, 314.
- INLAID WORK—XXVIII. Peters & Son, 131. XXX. (Fine Art Court) Carrick 93. Millbank, 99. Sutton, 105. *Ceylon*, Kitchin.

v. Burgess, 471.
 l. VIII. Gale, 79.
 160A. Newman,
 (languages) XVII.
 (CROWNING)—VIII.
 372.
 513.
 ce Company, 600.
 -XVII. Hood, 157.
 11A.
 1717.
 trated.
 up and down—v.
 1718.
 (Fine Art Court)
 outhouche.
 y the Queen, page
 . Colling, 162.
 ommittee, 2.
 J. Reeves, J. R.
 Blyth, 367. Ca-
 117. iv. Coovey,
 dia Company.
 457.
 s and Infusions.
 ce—XXVIII. For-
 7. Lines & Co.,
 Stokes, 80. Todd,
 ith, 17.
 School for the
 (Fine Art Court)
 Swann, 155.
 31.
 e, 31. XXII. Ed-
 iron, 30. Mayer,
 Perkes, 7. XXVI.
 0A. North, 257.
 andain & Co., 108
 526,
 299. See also
 Davis, 329. Fon-
 bouinar & Carfrae,
 31. xxx. (Fine
). Sutton, 105.

- Hamburgh*, Faulwasser, 71. *Loose*, C. L., 74. *Loose*, J. R., 75. *Rampendahl*, 70. *Werner & Pighlein*, 79. *Sardinia*, Bertinetti, 61. *Capello*, 64. *Spain*, Medina, 270. *Peres*, 271A. *Sweden*, Dumrath, 60. *Tuscany*, Mazzetti, 90. *Polli*, 85. *Van Diemen's Land*, M'Naughten, 192. *Zollverein* (1), Praetorius, 853. See also *Buhl Work*. *Mosaic Work*.
- INSECTS, COLLECTIONS OF**—*New Zealand*, Moore, 37. *Van Diemen's Land*, Cox, 280. *Zollverein* (4), Noerdlinger, 11.
- INSECTS, FUMIGATING APPARATUS FOR KILLING**—VII. *Boulauger*, 198. IX. *Brown*, 91. XXII. *English*, 572. See also *Vermin Destroyer*.
- INSTRUCTION TABLES**—*Jersey and Guernsey*, Messervy, 11. *White*, 12.
- INSTRUMENTAL PERFORMERS** (Instruments for giving strength, &c., to the fingers of)—X. *Andrews*, 551. *Edwards & Son*, 616.
- INTAGLIOS**—XXX. (Fine Art Court) *Butters*, 290. *Warner*, 275. *Wilson*, 315.
- INTAGLIOS**, (Mode of taking Impressions from)—XVII. *Hyde & Co.*, 21.
- INVALID BED CARRIAGES**—v. *Willoughby*, 992. XXVI. *Ridge*, 8.
- INVALID BEDS, CHAIRS, &c.**—X. *Chapman & Alderman*, 601c. *Gray*, 724. *Greenhow*, 630. *Lee*, 614. *Weiss & Son*, 631. XXII. *Jeffcoat*, 755. *Savage*, 56. *Tippen*, 412. XXVI. *Gilbert & Co.*, 130. *Minter*, 211. *Townshend*, 2A. See also *Chairs*, *Invalid*.
- INVALID WHEEL CHAIRS**—v. *Dawson*, 830. *Heath*, 868. *Jordan*, 888. *Newham*, 928. *Ward*, 997.
- IODINE**—II. *Bullock & Co.*, 37. *Howards & Kent*, 11. *Huskisson*, J. W. & H., 86. *Ward*, 89. *Ward & Co.*, 54. *Watt*, 32. *France*, Cournerie & Co., 462. *Zollverein* (1), Prussian Chemical Manufactory, 683.
- IFECACUANHA**—II. *Lamplough*, 71.
- IRIDIUM**—I. *Johnson & Mathey*, 477.
- IRISH GOLD AND SILVER**—X. *Donegan*, 52.
- IRISH JEWELLERY**—XXII. *Waterhouse*, G. & S., 20. *West & Son*, 15. XXIII. *Bennett*, 18. *CConnell*, 16. *Mosley*, 17. XXVIII. *Griffith*, 192.
- IRON** (Various)—I. *Butterley Iron Co.*, 400. *Crittwell & Co.*, 402. *Solly & Co.*, 410. II. *Howards & Kent*, 11. v. *Coalbrook Dale Company*, 641. XXII. *Johnson & Co.*, 109. *Solly*, 258. *Whitehouse & Co.*, 667. *Austria*, Schwarzenburg, Prince, 417. *Thurn, Count*, 419. *Topper*, 411. *Canada*, Ferrier, 5. *France*, Festugiere & Co., 1721. *Gallicher & Co.*, 229. *Masat*, 920. *Nova Scotia*, Acadian Iron Mining Association, 1. *Archibald*, 2. *Russia*, Perm Imperial Copper Works, 6. *Votkinak Iron Works*, 13. *Sardinia*, Grange, 1. *Spain*, Cerain, 1. *Giro*, 23. *Pedro De Araya's Factory*, Director of, 12. *Tunis*, 31, 33, 34. *Turkey*. *United States*, Adirondac Manufacturing Co., 344. *Darling*, 191. *Farrington*, 238. *Zollverein* (2), Gienanth, Brothers, 95.
- IRON ARBUMENTS AND TENSION ROPE ON PIERS**—VII. *Morrell*, 59.
- IRON, BAR**—I. *Bird & Co.*, 411. v. *Coalbrook Dale Company*, 641. *Eastwood & Frost*, 672. VII. *Royal Scottish Society of Arts*, 29. XXII. *Fisher & Bramall*, 206. *Perry*, 61. *Austria*, Andrassy, Count, 415. *Bouquoy*, Count, 414. *Lindheim*, 422. *Zois*, 405. *France*, Lapeyriere, 1710. *India*, 1. *Sweden and Norway*, Flood, 7. *Lagerhjelm*, 1. *Treschow*, 36. *Zollverein* (8), Lassen, 2.
- IRON, BLOOM OF**—XXII. *Bateman*, 84. *India*, 1. *Sweden and Norway*, Lagerhjelm, 1.
- IRON, CAST**—I. *Stirling*, 428. *Austria*, Vienna Dept of the Imperial Iron Mines and Iron Works, 408. *Belgium*, Pommeruel Furneaux, 6. *France*, Morel, Brothers, 1866. *Moul Brothers*, 1734. *Russia*, Kamensk Iron Works, 8. *Satkin Iron Works*, 17. *Spain*, Pedrosa Iron Company, 24. *Tuscany*, Follonica Royal Foundry, 73. *Zollverein* (1), Vorster, 446. (6), *Lossen*, 2. See also *Iron Castings*.
- IRON, CAST, TESTING-MACHINE**—VI. *Stewart & Co.*, 238.
- IRON CASTINGS**—I. *Wingerworth Iron Company*, 416. v. *Coalbrook Dale Company*, 641. VII. *Clark*, 8. XXII. *Bramah & Co.*, 653. *Coalbrook Dale Company*, 641 (Main Avenue, West). *Gidney*, 558. *Handyside*, 82 (Main Avenue, West, 85). XXX. (Fine Art Court) *Baily & Sons*, 308. *Sherwood Iron Works*, 138. *Austria*, Fischer, 421. *Kitschelt*, 434. *Salm, Prince*, 430 (Main Avenue, East). *Belgium*, De Latour, 333. *Moncheur*, 366. *France*, Andre, 1653. *Muehl-Wahl & Co.*, 934. *New Zealand*, Bourne, 35. *Nova Scotia*, Central Committee, 2. *Zollverein* (1), Berlin Royal Prussian Iron Foundry, 271 (Main Avenue, East). *Drake*, 273 (Main Avenue, East). *Jacobi*, 833. *Malapane Royal Prussian Iron Works*, 2. *Schlegelmilch*, 643.
- IRON, CHEMICAL PREPARATIONS OF**—II. *Huskisson*, J. W. & H., 86.
- IRON, CHROMATE OF**—*India*, 1. *Sweden and Norway*, Garman, 38.
- IRON, FAOOTTED**—XXII. *Warden*, 368.
- IRON FLOORING**—*United States*, Lawrence, 516.
- IRON-FOUNDING** (Instrument for illuminating moulds in), x. *Jordan*, 285.
- IRON FURNITURE**—*France*, Gandillot & Co., 230. *Trouchon*, 1512.
- IRON JOISTS AND RAFTERS** (New method of joining to wood, &c.)—VII. *Boydell*, 56.
- IRON LIFTING-CRABS**—IX. *Barrett*, *Exall*, & *Andrews*, 128.
- IRON OCHRE**—*Canada*, Dulberger, 21. *La Barre*, 17. *Caron*, 19. *Hall*, 18. *Kelly*, 22. *Logan*, 1. *Seer*, 16. *Turkey*.
- IRON ORES**—*Western End*, South Enclouure ("Outside"), *Round*, 136. I. *Ainsworth*, 422. *Atkinson*, 261. *Blackwell*, 427. *Cumming*, 195. *Drew*, 449. *Falmouth & Penryn Local Committee*, 163. *Harrison & Co.*, 405. *Montague*, 421. *Moore*, 408. *Ross*, 51. *Russell*, 271. *Schneider*, 409. *Sweetman*, 40. *Taylor*, 448. *Thomas*, 419. *Thorne*, 473. *Ulverston Mining Company*, 420. *Welborne*, J. W., 470. *Wellborne*, W. 447. *Wingerworth Iron Company*, 416. XXII. *Bowling Iron Company*, 83. *Perry*, 61. *Algeria*, Beauregard, 4. *egger*, Count, 401, 402. *Austria*, Rauscher & Co., 403. *Belgium*, Benoit, 369. *De Hanseh*, 23. *Perard & Mineur*, 18. *Canada*, Dickson, 3. *Ferrier*, 5. *Lancaster*, 6. *Logan*, 1. *Marcotte*, 8. *Morin*, 9. *Proulx*, 7. *Wilson*, 2. *South Africa*, Greig, 56. *Maitland Mines*, 1. *Greece*, 17. *India*, 1. *New Brunswick*, *Hutchison*, 10. *New Zealand*, *Purchas*, 23. *Nova Scotia*, Central Committee, 2. *Russia*, Alexandrovsk Imperial Cannon Foundry, 2. *Spain*, Almeria Mines, Inspector of, 13. *Amor*, 22. *Sweden and Norway*, Grekasar Blast Furnace, 3. *Hellefors Iron Works*, 4. *Lovenskiold*, 35. *Motala Works*, 6. *Norberg & Sather*, 102. *Osterby Iron Works*, 6. *Rettig*, 2. *Uddeholm's Co.* 117. *Trinidad*, *Lord Harris*. *Turkey*. *Tuscany*, Volterra Salt Manufactory, 2. *United States*, *Anderson & Co.* 281. *Cocke*, 271. *James & Chapman*, 181. *Lee*, 332. *Missouri Iron Mountain Company*, 163. *Patteson*, 278. *Rousseau*, 314. *Sims*, 267. *Swedish Iron Manufacturing Company*, 320c. *Van Diemen's Land*, *Little*, 310. *Milligan*, 263, 266, 267, 306. *Zollverein* (1), *Bennighaus*, 679. *Dresler*, 449. *Ham-block*, 454. (8), *Nassau Government Engineers of Mines*, 1.
- IRON, OXIDE OF**—*United States*, *Barton*, 228.
- IRON, PIG**—I. *Ainsworth*, 422. *Bird & Co.*, 411. *Montague*, 421. *Schneider*, 409. *Wingerworth Iron Company*, 416. XXII. *Fisher & Bramall*, 206. *Hind & Co.* 85. *Perry*, 61. *Austria*, Fischer, 420. *Kossuch*, 406. *Pillersee Imperial*

- Smelting Works, 407. Radmeister Community, 400. Zeis, 403. *Belgium*, Behr, 20. Cockeril, 119.
- Canada*, Marmorà Iron Company, 4. *India*, 1.
- Russia*, Koushivinsk Iron Works, 5. Verkhne-Tourinsk Iron Works, 12. *Sweden and Norway*, Lagerhjelm, 1.
- United States*, Detmold, 66. Hopkins, 192. Morris, Jones, & Co., 44.
- Zollverein (1), Lohe Steel-works, 324. Lohmann, 630. Maesgesprung Works, 682. (8), Lassen, 2.
- IRON, PHOSPHATE OF—II. Greenish, 124. *Canada*, Lancaster, 6.
- IRON, ROLLED—V. Eastwool & Frost, 672. Mersey Iron Company, 645.
- IRON-ROLLING MACHINES—VII. Dobson, 114.
- Zollverein (1), Kipp, 649.
- IRON ROOFING—VII. Allen, 151. Turner, 7. XXII. Tupper & Carr, 540.
- IRON SAFES—Zollverein (1), Arubheim, 189. Kolesch, 196. See also *Fire-proof Safes*.
- IRON, SALTS OF—II. Hemingway, 24.
- IRON-SAND—*New Zealand*, Collinson, 3. Smith, 14. *Van Diemen's Land*, Abbot, 290.
- IRON, SHEET AND PLATE—I. Phillips, Smith, & Co., 500. XXII. Perry, 61.
- Belgium*, Delloye, 376. Orban & Son, 372. Remacle, Perard, & Son, 371. *Canada*, Cheney, 153.
- Russia*, Khamouitsky Iron Works, 20. Nijne-Issetak Works, 16. Nijne-Tourinsk Iron Works, 10. Vsevolosky, 330A.
- United States*, Morrell, Stewart, & Co., 202.
- IRON SHIPS AND VESSELS (Contrivance for construction of)—VII. Sadler, 61.
- IRON STAMPINGS—XXII. Griffiths, 254.
- IRON, SULPHATE OF—I. Samuel, 489A. II. Bankart, 49. Buckley, 4. Wilson, 6.
- Austria*, Hochberger, 14. *China*.
- France*, Bouxwiller Mines Company, 376. Dupre, 183.
- Portugal*, Algoza, 63. Hirsch, 64. Leal, 65.
- Sardinia*, Selopia, Brothers, 4.
- IRON WARES (generally)—I. Biddulph, 417. Wingerworth Iron Company, 416. XXI. Nicholson, 87. XXII. Clark & Co., 657.
- France*, Camion-Pierron, 790. Ducal, 824. Karcher & Westerman, 1632. Martin, 614. *India*, XXII.
- Portugal*, Bacheval, 1015-1020. *Spain*, Zuluaga, 264.
- Sweden and Norway*, Bolinder, 56. Hallenius & Co., 11. Motala Works, 6. Spangberg & Co. 11.
- United States*, Perkins, 541.
- Zollverein (1), Assmann, 406. Einsiedel, 762. Kising & Mollmann, 647. Lehmann, 197. Schlegelmilch, 643. (6), Seebass, 50.
- IRON WARES, GLAZED—XXII. Smallman & Co., 2.
- IRON WIRE (Coppered)—XXII. Cornforth, 322.
- IRON-WIRE NETTING—See *Wire Netting*, &c.
- IRON-WIRE ROPE—See *Wire Rope*.
- IRON, WROUGHT (including articles made thereof)—I. Wingerworth Iron Company, 416. VII. Nasmyth, 169. XXII. Hardman & Co., 700. Hird & Co., 85. XXX. (Fine Art Court) Crook, 57.
- Austria*, Furstenburg, Prince, 412.
- Belgium*, Chimay, Fruceof, 370. Couillet Mines et Charbonages, 120. *India*, 1.
- Russia*, Satskiusk Iron Works, 17. Verkhne-Barantchiusk Iron Works, 11.
- Zollverein (1), Gleiwitz Royal Prussian Smelting Works and Iron Foundry, 1.
- IRON, WROUGHT, TABLE OF WEIGHTS OF—V. Richardson, 648.
- IRONMONGERY (Various)—XXII. Cope & Collinson, 255. White, 200.
- France*, Cugnot, 90. Daudey, Maillard, Lucq & Co., 491. Jacquemart, Brothers, 272. Jarry, Brothers, 275. Morel, Brothers, 1666. See also *Hardware*.
- IRONSTONE—I. Bewick, 423. Brodie, 54. Butterley Iron Co., 400. Ebbw Vale Co., 412. Farley Co., 406. Monkland Iron and Steel Co., 426. Page, 425. XXII. Fisher & Bramall, 206. Hird & Co., 85.
- Austria*, Von Christaljuigg's Mining Co., 401.
- Van Diemen's Land*, Milligan, 264.
- Western Africa*, Weston, 1.
- Zollverein (1), Benninghaus, 679.
- IRONSTONE MINES (at Dowlais, South Wales), Section of— I. Dickinson, 414.
- IRRIGATING MACHINES—IX. Burcham, 25b. Wier, 123. Bentley, 606. *Belgium*, Debaune, 131.
- ISINGLASS—IV. Dawson & Morris, 118. Simpson & Co., 117. Swinborne & Co., 119.
- British Guiana*, Morison and Knox, 123.
- France*, Faussemaigne, 1599. *India*, IV.
- Eastern Archipelago*, Hammond & Co., 2.
- Russia*, Marimanoff, 81. Vsevolodowitch, 338. *Turkey*.
- ITALIAN PASTE—*Portugal*, 520, 527.
- Sardinia*, Guelf, 94.
- IVORY—IV. Fauntleroy & Sons, 135. *Belgium*, Seghers, 110. *South Africa*, Deane & Johnson, 19. *Ceylon*.
- Turkey*. See also *Elephant's Teeth and Tusks*. *Vegetable Ivory*.
- IVORY (British)—XXVIII. Brown, 49. XXX. (Fine Art Court) Gear, 245.
- IVORY BLACK (for Printers, &c.)—XVII. Cahn, 65.
- Zollverein (6), Michel & Morell, 16.
- IVORY CARVING AND TURNING—IV. Straight, 100. Tebbitt, 111. VI. Holtzapffel & Co., 232. XXVIII. Hamphill, 158. Johnson, 15. Maudier, 28. Smith, 93. William, 163. XXIX. Straight & Sons, 252. XXX. (Fine Art Court) Cheverton, 194. Jordan, 208. Lucas, 306. Solomons, 69. Stirling, 186. Tobin, 171.
- Austria*, Dreher, 668. Kettler, 668A. *Ceylon*.
- China*, Baring, Brothers. Hammond & Co. Hewett & Co. Rawson, Sichert & Co. Denmark, Klingsey, 34.
- France*, Lautz, 295. Teller, 389. Wolf, 744.
- Hamburg*, Meyer, 68. Rampendahl, 98. Zuber, 107. *India*, XXVIII. *Persia*, Thompson.
- Portugal*, Malarinho, 1236. Vieira, 1234, 1235.
- Sweden*, Danckwart, 48.
- Tuscany*, Bigotti, 78. *United States*, Fenn, 111.
- Western Africa*, Trotter, 3.
- Zollverein (1), Fischer, 281. Schulz, J., 580. Schulz, L. W., 811. Schulz, W., 881. (2), Frank, 75. Hagen, 38. Lang, 77. (3), Kietz, 185A. (4), Stoll, 85. (6), Friedrich, 74. Heyl, 75. (8), Geismar & Co., 13. See also *Turning in Wood*, &c.
- IVORY-CUTTING MACHINE—VI. Straight & Sons, 455.
- IVORY, PAINTINGS ON—XXX. (Fine Art Court) Newton, Sir W., 250.
- IVORY, STATUETTES IN IMITATION OF—XXX. (Fine Art Court) Franchi, 190.
- IVORY VENEER—*United States*, Pratt & Co., 567.
- JACONETS—*Austria*, Leitenberger, E., 186. Leitenberger, F., 187. *Belgium*, Verholst & Co., 243.
- Switzerland*, Storzeneeger-Nef, 139. Zellweger, 145.
- JACQUARD LOOMS AND MACHINERY—VI. Barlow, 82. De Fontaine Moreau, 30. M'Kenzie, 39. Taylor & Son, 23. XI. Walmsley, 51. XII. & XV. Atkinson & Co., 256 (Main Avenue, West).
- Austria*, Gamba, Hairs, of, 109.
- France*, Acklin, 399. Matin, 323.
- Russia*, Alexandrowsk Imperial Manufactory, 149.
- Zollverein (1), Bonardel, Brothers, 53. Winter, 56.
- JALAP-ROOT—XI. Keating, 102.
- JAMES'S, ST. CHURCH, LOUTH (Model)—XXX. (Fine Art Court) Ashton, 152.
- JAPANNED SLATE—XXVI. Steedman, 346.
- JAPANNED WARES—XXII. Fearnscombe, 100A. Perry, 60A. Terry & Son, 691A. XXVI. Eloure, 188. Scroxtou, 271. *British Guiana*, Hopkinson, 159.
- China*, Hewett & Co. Denmark, Meyer, 6.
- France*, Delignon, 1180. *Sardinia*, Baico, 79.
- Zollverein (1), Meyer & Wried, 764. Stohwasser & C., 199. (4), Rau & Co., 72. See also *Lacquered Wares*.
- JARDINIER—Pugin, North Transept.
- JARS—*Egypt*, 342.
- JASPER—I. Courtown, Lord, 143. *India*, I. *Turkey*.
- JASPER VASES—*Russia*, Ekuterinborg Imperial Polishing Manufactory, 326. Kolyvan Imperial Polishing Manufactory, 327.
- JAW-LEVER (for administering Medicine to Cattle)—X. MacMahon, 601D.
- JELLY MOULDS—See *Confectioners' Moulds*.

- (e), Section of—
 5a. Wier, 123.
 l. Simpson & Co.,
 1.
 2.
 338. Turkey.
 um, Seghers, 110.
 Ceylon.
Cushs, Vegetable
 XXX. (Fine Art
 abn, 65.
 ight, 109. Tebbitt,
 XVIII. Hemphill,
 th, 95. William,
 XXX. (Fine Art
 98. Lucas, 306.
 171.
 Ceylon.
 Co. Howett
 rk, Klingey, 34.
 16, 744.
 98. Zuber, 107.
 34, 1235.
 ann, 111.
 ., 580. Schulz,
 Frank, 75. Ha-
 (4), Stoll, 85.
 Geimar & Co.,
 & Sons, 455.
 (Court) Newton,
 XXX. (Fine Art
 Co., 567.
 . Leitenberger,
 243.
 Zellweyer, 145.
 vi. Barlow, 82.
 39. Taylor &
 xv. Atkinson &
 actory, 149.
 Wiuter, 56.
 XXX. (Fine Art
 DA. Perry, 60A.
 58. Scofield,
 . 6.
 co, 79.
 shwasser & C.,
 equered Wares.
 Turkey.
 erial Polishing
 rial Polishing
 to Cattle)—X.
- JENNER, DR. (Model for a Statue of—Marshall, page 850.
 JERSEY, Model representing Her Majesty landing at, in
 1846—*Jersey and Guernsey*, Saunders, 23.
 JET AND JET ORNAMENTS—I. Slater & Wright, 11. VIII.
 Slater & Wright, 312. XXIII. Greenbury, 8. XXIX.
 Fletcher, 244.
 Spain, 33. *Van Diemen's Land*, Milligan, 324.
 JEWEL-BOXES—VI. Mordan & Co., 205. XXIII. H. M.
 The Queen, 140. XXVI. Footorape & Co., 132.
 Levien, 203.
 Zollevrein (1), Kullrich, 58. Wallack, 767.
 JEWEL-ENGRAVERS' MODELS—France, Perot, 1385.
 JEWELLERY—XXII. Balleny, 299. Goude & Boland,
 294. Guest, J. & W., 324. Parker & Acott, 298.
 Sheldon, 292. Walters & Stone, 296. XXIII. Bake-
 well, 70. Campbell, 76. Ellis & Sun, 12. Forrer, 99.
 Gass, S. H. & D., 83. Harding, 11. Hilliard & Thom-
 ason, 29. Hunt & Roakel, 97. Lester & Sons, 27.
 Martin & Co., 2. Mayer, 14. Mott, 116. Nash, 86.
 Phillips, Brothers, 87. Rittie & Sons, 24. Row-
 lands, C. & W., 118. Stone & Son, 123. Wather-
 ston & Brogden, 105. Wheeler, G. & M., 01. Wolff,
 68. Zimmerman, G. & S., 80.
 Austria, Grohmann, 576. Spietechko, 609.
 Belgium, Hubert, 482. Prins, 382.
 Canada, Leggat, 341.
 France, Bouillette, Hyvelin & Co., 1107. Bruneau, 1119.
 Dafrigue, 1575. Foyelle, 197. Felix, 199. Henne-
 quin, 1623. Henri, 871. Houdaille, 1270. Latellin
 & Payen, 1643. Lemonnier, 304. Montignac, 480.
 Ochs, 668. Payen, 1674. Pichard, 1388. Plichon,
 684. Rouvenat, 1460. Rudolphi, 1465. Savard,
 1476.
 Gold Coast and Ashantee, Ferster & Smith, 1.
 India, XXIII.
 Ionian Islands, Seaton, Lord, 5. Woodford, Lady, 1.
 Malta, Cretioe, 24. Falsoe, 25.
 Netherlands, Romain, 104. Sauerbier, 114.
 Portugal, Mamede, 1022. Sousa, 1021.
 Russia, Aga-Melik-Mahomet, 290.
 Spain, Moratilla, 261. Tunis, 83. Turkey, Tuscany, 18.
 Western Africa, Jamieson, 22. Townsend, 11.
 Zollevrein (1), Backes & Co., 411. Devaranne & Son,
 280. Hauck, 413. Hoeller, 637. Keller & Co., 888.
 Schwartz, 292. Steinhauer & Bier, 410. Teslar, 41.
 (5), Goldschmidt, 20. (6), Schroyer, 51. See also
*Bracelets, Coral, &c. Gold and Silver Ware. Irish
 Jewellery. Jet and Jet Ornaments. Precious Stones.*
 JEWS' HARPS—Austria, Grabner, 469. Schwarz, C., 470.
 Schwarz, F., jun., 472. Schwarz, F., sen., 471.
 Schwarz, I., 473.
 JOHN & ST. CHURCH, PADDINGTON (Model)—XXX. (Fine
 Art Court) Fowler, 142.
 JOHNSTOWN CASTLE, WEXFORD (Model)—XXX. (Fine Art
 Court) Morgan, 215.
 JOINERS' TOOLS—See *Tools (Carpenters', &c.)*.
 JOINERY AND CABINET-MAKING MACHINES—VI. Gilbert,
 447.
 JORDAN'S MACHINE CARVING (Specimens of)—page 851.
 JUJUPE FRUIT—II. Pound, 108.
 JUJUPE WOOD—Tunis, 35.
 JUTE—XIV. Dagnal & Co., 89. Dundee Local Commit-
 tee, 63. Jameson & Co., 60. India, IV. XIV.
- KALEIDOSCOPES—X. Saunders & Son, 205.
 KALMUCK FABRICS—Zollevrein (1), Lambert & Son, 004.
 KAOLIN EARTH—India, I.
 KARMAN—British Guiana, Bonyun, 50.
 KEELSONS, WROUGHT-IRON (for wood-built Ships)—VIII.
 Pilkington, 176.
 KELP, and its products—II. Bullock & Co., 37. Ward,
 89. Watt, 32.
 KERNES (Red Dye)—Greece, Petropoulos, 5.
 KERSEYMERS—See *Cassimeres*.
 KETTLES—See *Tea Kettles*.
 KEYS—See *Locks, &c.*
 KIEFF SUSPENSION BRIDGE, RUSSIA (Model)—VII.
 Vignoles, 106 (Main Avenue, West).
 KITCHEN RANGES, &c.—XXII. Benham & Sons, 98.
 Bentley, 606. Coalbrook Dale Company, 641.
 Crook, 244. Deane & Co., 186. Ellis, 86. Halstead
 & Sons, 93. Kennard & Co., 804. Sherwin, 243.
 Steele, W. & P., 60. Tindal, 542. Wakefield, 381.
 Wordsworth, 360. Sweden, Bolinder, 56. See also
Grates. Stoves.
 KITCHEN RANGES, PORCELAIN (Adapted to a gas fire)—
 XXII. Edwards, 241. Strode, 443.
 KITES, See *Char-Volant*.
 KNEADING MACHINES—France, Boland, 428. See also
Breadmaking Machines.
 KNEEJOINT EXTENSOR—X. Eaglaunt, 567.
 KNIFE-CLEANING MACHINES—XXII. Cunningham, 626.
 Kent, 553. Masters, 634. Price, 397.
 KNIGHTHOOD, BADGES OF. See *Badges, &c., of Knight-
 hood*.
 KNITTED WORK (various)—XI. Ratcliff, 34. XII. & XV.
 Standen & Co., 281. XIX. A blind person, 214.
 Baynes, 97. Bernard, 372. Burton, 117. Caulfield,
 125. Conarding, 146. Cunliffe, 144. Dawson, 149.
 Hollowell, Mrs., 270. Hardy, 147. Holloway, 207.
 Kettlewell, 223. Lerwick Local Committee, 213.
 Newcastle-upon-Tyne Blind Asylum, 284. Richmond
 Lunatic Asylum, 240. Sewall & Co., 288. Thwaites,
 317. Turner, 322. XX. Beaufort, 156A. Farrange, 176.
 Hathaway, 160. Laughland, 144. Linklater, 174.
 Mackenzie, 142. McCrae, 218. Roy, 136. Shreeve,
 46A. Webb, 138. Westminster, Marchioness of, 217.
 XXVIII. Indigent Blind School, 100.
 Austria, Schreier, 390A. France, Foulquie & Co., 1603.
 Jersey and Guernsey, Bertraus, 41. Bruhier, 13. De
 Faye, 14. Dunlevie, 3A. Guernsey Cottagers, 38.
 Marie, 16. Vibert, 15.
 Malta, Conservatorio di San Giuseppe, 22.
 Van Diemen's Land, Queen's Orphan Schools, 139-142.
 Western Africa, McWilliam.
 Zollevrein (4), Robeck, 50.
 KNITTING MACHINES—VI. Whitworth & Co., 201.
 United States, Eastman, 338.
 KNITTING-PINS—Morral, 246.
 KNIVES AND FORKS—See *Cutlery*.
 KNOX'S JOHN HOUSE, EDINBURGH (Model)—XXX. (Fine
 Art Court) Weir, 151.
 "KOH-I-NOOR" (Diamond)—XXIII. Her Majesty the
 Queen, 140 (Main Avenue, East).
 KOUSO (a Drug)—II. Krating, 102.
 KREOSOTE—See *Cresote*.
- LABEL-PRINTING MACHINE—VI. Marriott, 116.
 LABOUR MACHINE (for Frimons)—v. Dotten, 429.
 LABRADORITE—Canada, Clausen, 13.
 LAC-DYE—II. Marshall, 68. IV. Jewesbury & Co., 66
 Ren, 116. India, IV.
- LACE—XIX. Adams & Sons, 21. Ayers, 388. Ball & Co.,
 19. Biddle, I. Birkie, 20. Cardwell, C. T., 122.
 Clark, 18. Clarke, Eliza, 129. Clarke, Esther, 130.
 Crick, 140. Digges, 234. Fisher & Robinson, 2.
 Forrest & Sons, 45. Frewin, 170. Gard, 16. Gill,
 386. Goull, J. & F., 14. Greasley & Co., 34.
 Groucock & Co., 3. Herbert & Co., 29. Heymann
 & Alexander, 25. Hill, 203. Hollins, 30. Howell,
 James, & Co., 5. Hurs, 211. Irish Work Society,
 77. Johnson, G. & C., 216, 316. Kettlewell, 223.
 Nightley, 123. Ladies' Industrial Society, 213.
 Lambert & Burt, 4. Laugher & Couzens, 10.
 Lee, 241. Lester, 236. Macarthur & Co., 00.
 McFarlane & Porter, 63. Mackellar & Hampson, 231.
 Maclean, 248. MacQuarie, Fisher, & Co., 65.
 Mallet & Barton, 29. Moore, 31. Nerneck, Sœurs, 8.
 Patent Utrecht Company, 265. Phillips, 272. Price,
 373. Pullan, 12. Reckless & Hicking, 32. Rose,
 50. Sim, 301. Stergmann & Co., 41. Tawel, 13.
 Tizard, Brothers, 274. Treadwin, 55. Uphill, 323.
 Uring, 15. Viccars, 235. Vickers, 33. Vincent, 328.
 Weedon, F., 6. Weedon, F. P., 11. Whitlock &
 Billiard, 27. XX. Capper & Co., 45. Hollins, 96.
 Austria, Grohmann, 382. Meinel, Heirs of, 383. Schlick,
 355.
 Belgium, Atelier de Notre Dame, Brussels, 304.
 Beck & Son, 324. Belloni-Ancr, 319. Bernaert &
 De Cuyper, 326. Bousson De Vlieghter, 328.

- Darteville & Mounoury, 329. Delehaye, 305. Deblauwe-Peel, 325. Dfrennes, 316. Duhajon-Brunfaut & Co., 314. Everaert, 321. Haeck, 341. Hammelrath, 337. Heuschou & Co., 310. Joseph, St., Establishment of, 322. Lemaleur & Co., 300. Naeltjeas, 308. Pasteyns, 484. Plettinck, 340. Reallier, 309. Robyt, 311. Soenen, 338. Stocquart, Brothers, 307. Tollenaers, 330. Van Haelen, 299. Van Halle, 303. Van Liel, 333. Van Loo, 339. Van Straelen, 327. Vanderhaegen, 312. Vandermissen, 314. Washer, 318.
- Ceylon*, Denmark, Wulff & Sons, 5.
- France*, Aubry, Brothers, 1844. Chaverondier, 453. Collet, 93. Delcambre, 1884. Docagne, 1718. Dopter, 1194. Julien, 279. Lefebvre, 1846. Mallet Brothers, 699. Randon, 1884. Robert-Faure, 1442. Seguin, 1008. Van Eckout & Co., 713. Videcoq & Simon, 1706. Violar, 731. *India*, xv. xix.
- Madeira*, Read, 1.
- Malta*, Camilleri, E. 14. Camilleri, F. 16. Casha, 12. Dimech, 21. Gozo, 11. Gravagna, 7. Naudi, 8. Politto, 13. Schembri, 10. Vella Paolo & Co. 15.
- Portugal*, 1255-1293.
- Russia*, Rochefort, 176, 191, 199, 208.
- Sardinia*, Bayno, 48. Tessada, 49.
- Spain*, Fister, 221, 222. Margarit & Ena, 223.
- Switzerland*, Besou, 40. Perret, 39, 271.
- Van Diemen's Land*, Sharland, 321.
- Zollverein* (3), Doerffel & Sons, 69. Foerster, 68. Haemel, 152. Koester & Uhlmann, 70. Priem, 67. Schreiber, 71. Stoelzel & Son, 66.
- LACE (Designs for)—xix. Smith, 158.
- Belgium*, Polak, 298. Violar, 320.
- France*, Mereaux, 631. Toussaint, 464.
- LACE-DRESSING FRAME—vi. Hudson & Bottom, 88.
- LACE IMITATION—xiv. Adams, 12. xix. Rolph, 282.
- Belgium*, Atelier de Notre Dame, 304. Van Haelen, 299.
- LACE MANUFACTURE, Paintings illustrating—vi. Fussell, 95.
- LACE PAPERS—xxix. (Fine Art Court) Moseman, 204.
- France*, Devrange, 1168.
- LACE TRIMMINGS—xix. Cardwell, C. & T., 122. Kightley, 123. *Spain*, Mir, Brothers, 276.
- LACE-WEAVING MACHINE—France, Foucher, 837.
- LACQUERED WARE—Belgium, Giron, 408.
- China*, Baring, Brothers, Hewett & Co. Rawson. Shea. *India*, xxviii. Sweden, Dahlbom, 71. Hultman, 81. *Turkey*. See also *Japanned Wares*.
- LACTINE (Artificial Milk)—iii. Piesse, 129. See also *Concentrated Milk*.
- LADDERS—vii. Ell, 94. Spurgin, 76. ix. Starkey, 43. *Belgium*, Lambert, 185. See also *Library Ladders*.
- LADIES' DRESSES (New Material for, undescribed)—xix. Newcomb & Jones, 257.
- LAILOGOME—Austria, Engelmann, 22.
- LAKE—ii. Godfrey & Cooke, 92.
- LAMPBLACK—Zollverein (6), Michel & Morell, 16. Oehler, 8.
- LAMP-BURNERS—France, Grison, 1260. *Zollverein*, (3) Hoffmann, 36.
- LAMP-OIL—See *Oils*.
- LAMP REFLECTORS, GLASS—xxiv. Tarin, 51.
- LAMP-SCREENS—Austria, Oppenheimer, 701A.
- LAMP-GLASSES—xxiii. Bright, 458.
- LAMPS, CARRIAGE—xxii. Black, 464. Dugard, W. & H. 350. Hawkins, 474. Hetherington & Co., 351. Lowe, J. & H., 340, 803. Messenger & Sons, 340. Miller & Sons, 645. See also *Railway Carriage Lamps*.
- LAMPS, ELECTRIC TABLE—x. Allman, 458.
- LAMPS AND LANTERNS, SHIPS—viii. Macdonald, 329. xxii. Blews & Sons, 349. Brown & Redpath, 477.
- LAMPS, MARINE SIGNAL—xxii. Gilbert, 120. Rettie & Sons, 449.
- LAMPS, RAILWAY CARRIAGE—xxii. Holden, 348. Saunders, 455. Smiths & Co., 452. Squire, 451.
- LAMPS, SAFETY, OR DAVY—I. Wales, 431. x. Newman, 674. xxii. Baker & Co., 319. xxix. Purdon, 30. *Belgium*, Eloin, 11. Museler, 24. *France*, Chuard, 123.
- LAMPS AND LANTERNS (Various)—vii. Quincey, 146.
- Rettle, 159. x. Newcomb, 672A. Boake, 697. Bright, 458. xxiii. Childs, 469. Clark & Restell, 446. Deane & Co., 186. Evans & Co. 103. Hodges & Sons, 487. Lambert, 534. Lloyd & Summerfield, 700A. Miller & Sons, 643. Naylor, 638. Nibbs, 472. Palmer & Co., 447. Salt & Lloyd, 343. Strode, 443. Warner & Sons, 798. Young, 442. xxiv. Webb, 17. xxx. (Fine Art Court) Cuff, 312. *Egypt*, 340. *France*, Bourgogne, 1553. Delignon, 1180. Duval & Paris, 151. Gagneau, Brothers, 277. Hadrot, 255. Lefebvre & Co. 580. Neuburger, 662. Truc, 703. *India*, xxii. *Ionian Islands*, Ward, 6. *Sweden*, Djurson, 70. *United States*, Cornelius & Co. 46.
- Western Africa*, Forbes, 8.
- Zollverein* (1), Piegler, 765. Pokorny, 79. Stobwasser & Co. 195. Stulgen & Kleeman, 766. Zobel, 190. (5). Tacchis & Co., 21. See also *Camphine Lamps*. *Gas Lamps*. *Singing Lamps*.
- LAMPS, ORNAMENTS FOR—xxii. Hill, 355.
- LANA FRUIT AND DYE—British *Guiana*, Kock, 55A, 55B.
- LAND-MEASURING CHAINS—xxii. Gortie, 41.
- LAND-PRESSER FOR FEN LAND—ix. Chenery, 56.
- LANDSCAPE (Model of)—xxx. (Fine Art Court) Critch, 146.
- LANTERN OF DEMOSTHENES, ATHENS (Model)—xxviii. Minns, 99.
- LANTERNS. See *Lamps and Lanterns*.
- LANTERNS, DIOPTRIC—vii. Northern Lighthouse Commissioners, 99. x. Abraham & Co. 263.
- LANTERNS, HOROLOGICAL—x. Cole, 31.
- LANTERNS, MAGIC—See *Phantasmagoria*.
- LANTERNS, TRINOPTIC—x. Abraham & Co. 263.
- LANTERNS, WEATHER—xxii. Nibbs, 472.
- LANTARD PLATES FOR SHIPS—viii. Rigmaiden, 291.
- LAPIS LAZULI, ARTICLES IN—xxiii. Morel & Co., 117. *Rome*, Jones, 48.
- LAPPING MACHINE—United States, Campbell, 553.
- LARD—xxix. MacKean, 28. *Belgium*, Touche, 434.
- LARD OIL—xxix. MacKean, 28.
- United States*, Emory, 18. Frank, 19. Holbrook & Stanley, 208. Mears, 562. Shearman, 672. Whipple, 579.
- LASTS, SHOE, &c.—See *Boot and Shoe Lasts*.
- LATCHES, DOOR—See *Locks*, &c.
- LATHES (Slide, Screw-cutting, and other) AND TOOLS CONNECTED THEREWITH—vi. Church, 244. Dalgety, 226. Kades & Son, 224. Holtzapffel & Co. 232. Mason, 10. Muir, 206. Parr, Curtis & Madeley, 6. 213. Sandford & Co., 223. Sharp, Brothers, 204. Shepherd & Co., 220. Smith & Co., 230. Victory, 67. Whitworth & Co., 201. Williams, 234. xxi. Buck, 18. Mathieson, 52. Howarth, 18. xxviii. Peel, 175. *Hamburg*, Kohn, 17. *Switzerland*, Erbrau, 4. *Zollverein* (1), Hamann, 58.
- LAUNDRY, DOMESTIC (in one machine)—xxii. Nunn, 703.
- LAUNDRY IRONS, APPARATUS FOR HEATING—xxii. Jeffcoat, 755.
- LAVENDER, OIL OF—xxix. Short, 129.
- LAW, CLERICAL, AND CIVIC GOWNS—xx. Price, 69.
- LAWN—xiv. Malcolm, 22.
- France*, Bleriot & Lemaitre, 30. Boniface & Sons, 32. Goulard & Bontemps, 240. Legrand, 1313. Mestivier & Hamoir, 636.
- LAWRENCE, SIR THOMAS, BRONZE BUST OF—xxx. (Fine Art Court) Peachey, 320.
- LAY FIGURES—x. De Dunin, 210. *Austria*, Borini, 734.
- LEAD, ACETATE OF—ii. Melnicrythen Chemical Co., 2. *France*, Maire & Co. 317.
- LEAD, CARBONATE OF—I. Dyer, 62. Wallace & Cooper, 510. Walton, 85. ii. Russell & Robertson, 59. *India*, ii. *Portugal*, Narzivellia, 71. *Spain*, Zamora Mines (Inspector of), 20.
- LEAD, CHROMATE OF—ii. Russell & Robertson, 59. *Portugal*, Leal, 73.
- LEAD AND LEAD MANUFACTURES (Generally)—i. Bucleuch, Duke of, 509. Royal Society of Ireland (Dublin), 503. Sopwith, 484. Truro Local Committee, 467. ii. Huskisson, J. W. & H., 86. xxii. Hudson, 616. *Belgium*, Blyberg Mines et Fonderies, 22. Vedrin Societe, 17. *Spain*, Almeria Mines, Inspector of, 13. Asturias

ake, 697. Bright,
& Restall, 446.
Hodges & Sons,
Immerfeld, 700A.
Nibbs, 472. Fal-
3. Strode, 443.
2. xxiv. Webb,
12. Egypt, 340.
1180. Duval &
7. Hadrot, 255.
2. Truc, 703.
1. Sweden, Djur-
Co. 46.
79. Stobwasser
666. Zobel, 190.
Camphine Lamps.
1555.
Kock, 55A, 55B,
41.
nery, 55.
Cour) Cribb, 146.
(Model)—xxviii.
ghthouse Commis-
Co. 263.
maiden, 291.
orel & Co., 117.
ppbell, 553.
Touche, 434.
Holbrook & Stan-
2. Whipple, 579.
Lasts.
er) AND TOOLS
h, 244. Dalgety,
ffel & Co., 232.
is & Madeley, 6.
p, Brothers, 204.
230. Victory, 67.
34. XXI. Bock,
xxviii. Peel, 175.
brau, 4.
xxii. Nunn, 703.
ING—xxii. Jeff-
—xx. Price, 68.
face & Sons, 32.
1313. Meastvier
BUST OF—xxx.
a, Borrini, 734.
emical Co., 2.
allace & Cooper,
bertson, 59.
ertson, 59.
rally)—I. Buc-
ety of Ireland
ro Local Com-
II., 86. xxii.
22. Vedrin
13. Asturias

Mines, Inspector of, 15. Livares Mines, Director of,
5. Lugo Mines, Inspector of, 18. Zamora Mines, In-
spector of, 20. *Tunis*, 28-30, 32, 45. *Turkey.*
Tuscany, Metallurgic Society, 14. Vegni, 13. Volterra
Salt Manufactory, 2.
Zollverein (1), Brasseur & Co. 314. Bredt & Co. 315.
Cusack, 825. Eschweiler Mines et Fonderies, 318.
Harkort, 878. Lamblon, Ulrich & Co. 451. Maeg-
desprung Works, 682.
LEAD-MINE MACHINERY—I. Buccleuch, Duke of, 509.
LEAD, NITRATE OF—II. Hamel & Ellis, 10.
Portugal, Sereselello & Co., 72.
Zollverein (1), Kunheim, 13.
LEAD ORES (including Silver-Lead Ores)—I. Arkansas
Mining Co., 523. Bird, 457A. Breadalbane, Marquis
of, 7. Byers, 494. Coates, 492A. Davies & Taylor,
523. Erskine, 532. Fahie, 30. Harrison, 491. Mining
Co. for Ireland, 507. Murchison, 521. O'Maherty,
521. Pattinson & Cain, 497. Rowe, 492. Royal
Society of Ireland (Dublin), 508. Sopwith, 484.
Thorne, 475. Walton, 25.
Canada, Logan, 1.
South Africa, Maitland Mines, 1.
France, Cavelan & Co. 1131. *India*, I. *Portugal*, 1295.
Spain, Linares Lead-mining Association, 14.
Sweden and Norway, Guldsmedhyttan Mines, 16.
United States, Urbici, 239.
Zollverein (1), Meinerzhagen & Krenser, 316. (8), Nassau
Government Engineers of Mines, 1.
LEAD, OXIDIZED—*Zollverein* (1), Brasseur and Co., 314.
LEAD PENCILS—See *Black-Lead Pencils.*
**LEAD, &c. PIPES, JOINT FOR CONNECTING WITHOUT
SOLDERING**—xxii. Jennings, 810.
LEAD, RED DICHROMATE OF—II. Russell & Robertson, 59.
LEAD, SHEET AND PIPE—I. Byers, 494. Royal Society
of Ireland (Dublin), 508. Morewood & Rogers, 436.
Austria, Eggar, 435.
LEAD, SPUN—*France*, Poulet, 1680.
LEAD, SOAP OF—II. Melinerythan Chemical Co., 2.
Russia, Sauin, 28.
Zollverein (1), Augustin, 526. Kunheim, 13.
LEAD, SULPHURET OF (OF GALENA)—I. Cumming, 493.
Riddell, Sir J. M., 55.
Belgium, Blyberg Mines, 22. Vedrin, Société de, 17.
India, I. *New South Wales*, Mitchell, 5.
Portugal, Nazareth, 13.
Spain, Linares Mines, Director of, 5. Tarragona and
Gerona Mines, Inspectors of, 2.
Van Diemen's Land, De Little, 309. Milligan, 311.
LEAD, WHITE OXI-CHLORIDE OF—II. Bell 12. Blan-
dell, Spence & Co., 48.
LEAF METALS—*Zollverein* (2), Gerstedorffer, 10. Kùb-
ler, 11. Lepper, 6. Lins, 5. See also *Gold Leaf.*
LEATHER AND HIDES—xvi. Bevington & Sons, 1.
Bossard, 294. Bouchier, Mortimer & Co., 293. Buse,
4. Curry, J. & J., 314. Cousins & Greatrix, 283.
Deed, 10. Dixon & Whiting, 290. East & Son,
34. Evans & Son, 18. Garry, 26. George, C., 32.
George, J., 289. Glover, J. & T. 19. Heintze, 29.
Hemsworth & Lindsey, 20. Hogarty Brothers, 13.
Holmes, 16. Jackson, 288. Kelsey, 266. Lambert & Son,
63. Lalwyche & George, 53. Nicholls, 5. Oastler
& Palmer, 286. Pullman, 285. Randall & Dicks,
284. Read, 47. Rheam, 15. Southey & Co., 51.
Squire, 2. Stokill, 17. Tombs, 297. Wilson &
Co., 11. Wood, W. & S., 25. xx. Whitley, 186.
Austria, Emhauser, 344. Hermannstadt Leather-cut-
ters' Association, 345. Messner, 321. Pollak, 322.
Portcheat, 337. Seykara, 321. Suesz, 325. Wolfe, 326.
Belgium, Dauchau de Bare, 262. Boone, 468. Bouvy,
266. Deweweirne, 293. Dubois, 469. Dusaecholt,
272. Fasbenter, 260. Hessault & Brother, 273.
Houdin & Lambert, 253. Jorez & Son, 306. Lom-
bare, 261. Massou, 267. Moothy, 117. Taillet, 254.
Tiberghien, 493. Van Alleyennes, 271. Weber, 258.
Brazil, De Mornay, 3.
Canada, Allos, 94. McLean & Co., 95. Murray, 96.
Teongathasea, 97. Tett, 109. Tourangean, 98.
South Africa, Bridges, 21. Cluappini & Co., 22. Mossos,
41. Schmieterloew, 42. *Ceylon.*

Denmark, Topp, 3.
Egypt, 127, 232-242, 247, 268-271.
France, Barraude, 758. Hayvet, Brothers, & Co., 415.
Berthiot, 57. Erlson, 781. Brun, 37. Budin, 77.
Carriere, Brothers, 106. Corniquel, 461. Coulbois,
1589. Courtrees-Duchessay, 808. Courtois, 808,
1571. David, 812. Deadde, 813. Delisle & Co.,
1181. Despreaux, 164. Desaux-Lacour, 167. Du-
buis & Son, 170. Dolud, 1262. Dumont, 488. Du-
port, 182. Dnrand, 1208. Emmerich & Goeger,
1212. Estivant, Brothers, 1214. Felix, 508. Fleux
& Co., 210. Fortier-Beaulieu, 510. Gauthier, 1244.
Giraud, Brothers, 850. Goube-Pberacie, 852. Guerlin,
1261. Guillot, 534. Herrenschmidt, 539. Houette
& Co. 1271. Jouvin, 893. Jouvin & Doyon, 1279.
Laroque & Jaquemot, 901. Landrum, Brothers, 1639.
Laydier, 206. Legal, 595. Leven & Son, 1923. Lo-
lagnier, 1330. Maniguet, 1341. Manson, 917.
Massemin, 1345. Merlant, 634. Nysset & Co., 1873.
Paillart, Brothers, 348. Pelteran, 677, 949. Prin &
Son, 1411. Reulow, 1434. Robant, 928. Rouget,
Son & Co. 1456. Simon, 1697. Souoin-Corbet, 1698.
Suser, 1022. Trouve-Catviel & Co., 702. Ventujol
& Chassaing, 1384. Vincent, 1527.
Gold Coast and Ashantee, Forster & Smith, 1.
Greece, Calotas, 55. *Hamburg*, Wamoy, 19.
Hanover, Friedrich, 10. *India*, xv, xvi.
Lubeck, Beckmann, 4. Behrens, 3. Brunnag, 7.
Netherlands, Buyteweg, 23. Kok, 23. Rosegarde, 21.
New South Wales, Watson & Co., 16. *New Zealand*, 39.
McVay 5.
Nova Scotia, Central Committee, 2.
Portugal, 1124-1124a. Barreto, 1123a. Bello, 1123b,
1126. Bratts, 1125a-1125c. Brettes, 1122a. Da
Silva, 1123c. Fialho, 1122, 1123, 1125. Fragata,
1126a. Monteiro, 1123a.
Russia, Abass-Bak, 244. Bakhrustrin & Sons, 240.
Boudelin, 238. Dolgroucky, Prince, 366. Gribanoff,
237. Jolovitain, 236. Kotelnif, 239. Koussoff & Sons,
224. Litke, 226. May, 227. Oserov, 228. Podso-
soff, 229. Satourmin, 233. Shouvaloff & Son, 231.
Skvorzoff, 232, 235.
Sardinia, Durio, Brothers, 46.
Spain, Roig, 249a. Vignaux, 249A.
Switzerland, Gissiger, 171. Hauser, 172. Imhof &
Sons, 173. Kappeler, 174. Mercier, 175. Meyer &
Ammann, 176. Mueller & Co., 177. Raichlen, 178.
Ressegneire, 179. Raymond, jun., 170. Schalach, 180.
Spengler, 181. *Tunis*, 12, 21, 35, 83, 92. *Turkey.*
United States, Crawford, 51. Gamble & Brothers, 165.
Van Diemen's Land, Button, 135. Reeves, 11. Regan,
184. Rout, 187.
Western Africa—Jamieson, 22. Trotter, 5.
Zollverein (1), Adolph, 172. Bardfeld, 188. Berres,
385. Buschmann, 386. Encke, 736. Federer, Bro-
thers, 381. Grammersbach, Brothers, 860. Gruts-
macher & Sons, 142. Harkort, 874. Heintze & Freuden-
berg, 382. Kramer & Baldamus, 737. Leudersdoff,
387. Lietzmann, 182. Mecklinghaus & Wix, 672.
Obercouz, 383. Ranniger & Sons, 741. Scheibe, 742.
Selenka, 800. Weber, 384. (2), Eacherich, 48. Mayer,
46. (3), Kunze, 5. (4), Bantlin, 37. Eckhardt, 38.
(5), Roth, 9. Roth & Sons, 10. Rupp & Bechstein,
11. (6), Doerr & Reinhard, 33. Hellmann, 34. Heyl,
32. Ihm, Buehm & Pfaltz, 31. Mayer, 35. Mayer,
Michel & Deninger, 36. Minoprio & Huhwiesner, 37.
(7), Ganterier, Français, 4. See also *Buckskins. Dyed
Leather.*
LEATHER ARTICLES (Various)—xix. O'Donnell, 53. xxvi.
Burton, 77. xxx. (Fine Art Court) Esquilant, 103.
Austria, Einhauser, 344. Hermannstadt Leather-cutters'
Association, 345. *Gold Coast and Ashantee.*
India, xvi. *Jersey and Guernsey*, Ellis, 44.
Portugal, Royal Military Arsenal, 1126.
Van Diemen's Land, Davies, 178, 179. Denison, Sir W.
T., 188. Sharland, 175.
Western Africa, Trotter & Sons, 6. Jamieson, 22.
M'William, Hutton, 5.
Zollverein (1), Scheibe, 719. Scholler & Weber, 663.
Schulz, 593. Stab, 228. (4), Reichhold, 39. Schenck

- & Co. 40. (8), Bery, Brothers, 60. Klein, 64. Lust-
trunghaus, 63. Naeiny, 67. Seeling & Becker, 69.
LEATHER CLOTHING—XVI. Vincent, 153.
LEATHER CLOTHS—XII. & XV. Lockwood & Kelghley, 104.
LEATHER, DYED—IV. Smith & Son, 68.
LEATHER-MAKING MACHINERY—X. Newcomb, 672A.
LEATHERS, STAINED (in Imitation of Wood)—XVII. Evans,
8.
LEATHER TAPESTRY HANGINGS—XXX. (Fine Art Court)
Leake, 63A.
LEAVES (Impressions of)—XXIX. Stirling, 57.
LECTERNS FOR CHURCHES—Potter, page 52. XXVIII. Lee,
33.
LEDGERS—XVII. Thomas & Sons, 44. Williams, 53.
France, Netaudeau, 661.
United States, M'Adams, 482. See also *Account Books*.
LEECHEE, MECHANICAL—X. Kidston & Co., 648. Mouil-
liard, 95. *Russia*, Rosinsky, 342.
LEEDS INDUSTRIAL TRAINING SCHOOL—(Model) XXX.
(Fine Art Court) Cotton, 177.
LEG REST—X. Woodhouse, 731. Woodman, 281.
LEGS, ARTIFICIAL—X. Bosingham, 723. Brunton, 596.
Evans, 274A. Fuller, 592. Grossmith, 565. Heath,
351. Masters, 569. Robinson, 617. Swithenbank,
571. See also *Wooden Legs*.
LEILOCOME—*Russia*, Schlippe, 27.
LEMONADE—XXIX. Gower, 102.
LEMONS, ESSENCE OF—*Spain*, Canales, 242A.
LENSES—X. Brabant, 259. Callaghan, 268. Chadburn,
Brothers, 299. Sharp, 308. Hyams, 278.
LENTILS—III. Guilleter, 103. *Egypt*, 96, 98.
LETTER-BOXES (for Street-Doors)—XXII. Bradnack, 675.
Green, 570.
LETTER-CLIPS—XVII. Schlesinger & Co., 38. Wedge-
wood, 47.
LETTER-COPYING PRESSES. See *Copying-Machines*.
LETTER ENGRAVING—*Switzerland*, Patton, 44.
LETTERPRESS PRINTING—See *Printing*.
LETTUCE-OIL—*Egypt*, 53.
LEVELS, SURVEYORS', &c.—IX. Rickman, 278. Weir, 123
x. Chadburn, Brothers, 259. Elliott & Sons, 320.
Watkins & Hill, 659.
Austria, Vienna Polytechnic Institute, 130.
Belgium, De Hennault, 183. *Netherlands*, Becker, 83.
Sweden and Norway, Littman, 15.
Zollverein (1), Lüttig, 81. (6), Huch, 22. See also
Dumpy Levels. *Draining Levels*. *Indicating Levels*.
Road Levels. *Spirit Levels*.
LEVER-BRIDGE CHURCH, BOLTON (Model)—VII. Willock
& Co., 223 (Main Avenue, West), page 853.
LEVER-WHEEL PLATES (Carriage)—V. Saunders, 358.
LIBRARY LADDERS—*Netherlands*, Hortix, Brothers, 97.
LIBUSSA, QUEEN OF THE BOHEMIANS (Statue of)—*Zoll-
verein* (2), Müller, 90.
LICHEN AND ITS PRODUCTS—II. Wood & Bedford, 47.
LIFE-BELTS, BUOYS, &c.—VII. Ayckbourn, 23. Carte,
29. Clayton, 1. Hely, 13. Hitt, 296. Holbrook,
9. Laurie, 195. Lavars, 31. Lee, 10. Light, 5.
Reekes, 6. Taylor, 197. Vickers, 8. xx. Bain, 70.
Caulcher, 112. Zox, 59. XXII. Reekes, 400. XXVIII.
Walker, 87. XXIX. Cox, 68.
LIFE-BOATS, RAFTS, &c.—Western End, [North Enclosure
(Outside), Bateman, 59 (Eastern End). v. Angus, 716
VII. Bremner, 95. Martin, 25. Rettie 159. VIII.
Acheson, 47. Allan, 51. Anderson, J., 187. An-
derson, R., 190. Ayckbourn, 23. Bateman, 335.
Beardon, 90. Bell, 14, 157. Berthon, 104. Bonney,
49. Bremner, 83. Clark, 91. Clarkson, 2. Corryton,
82. Croid, 304. Druery, 322. Dyne, 60. Erskine, 45.
Fawcett, 62. Foster, J. & T. 168. Gale, H. 79
Gale, O. H. 323. Harland, 324. Hatt, 16. Haug-
hter, 295. Hawks, 136A. Hawkeworth, 53. Hely, 13.
Holson, 50. Holbrook, 9. Husband, 151. Laurie,
195. Light, 5. Mainly, 22. Mason, 81. Milburn,
138. National Institution for Preservation of Life from
Shipwreck, 309. Northumberland Life-boat Committee,
136. Plenty, J. & E. P. 137. Reed, 54. Reid, 54A.
Rhind, 290. Richardson, 46. Robinson, 100. Slater &
Wright, 312. Sparke, 17. Sparrow, 313. Spencer,
11. Swallow, 308. Taylor, 197, 215. Tredwen, 55.
Truscott, 259. Wentzell, 167. White, T. J. & R., 36A.
Wilson, 299. XXVIII. Godfrey, 183.
Jersey and Guernsey, Draks, 45. Goodridge, 39. Grellier,
7. See also *Shipwreck Apparatus*.
LIFE PRESERVERS—*India*, XXVIII.
LIFE PROTECTOR—VII. Jeffrey, 14.
LIFT-PUMPS. See *Pumps, Lift and Force*.
LIFTING-CRABS—IX. Barrett, Ezall & Andrews, 128.
LIFTING JACKS—V. Bayman, 485. Galloway, W. & J. 124.
Gladstone & Co., 468. Halsey, 486. Thornton & Sons,
490. See also *Screw Lifting Jacks*. *Traversing Jacks*.
LIGHTHOUSES AND LIGHTHOUSE APPARATUS (Models,
&c.)—VII. Gandell, 35. Maplin, 164. Northern Light-
houses Commissioners, 99. Stevenson, 100. Wells, 62.
Wilkins, 167 (Main Avenue, West). VII. Brown, Sir S.,
334. XXIV. Chance & Co., 22 (and Main Avenue,
West, 60).
France, Saget, 364, 1468.
Jersey and Guernsey, Chevalier, 6.
LIGHTNING CONDUCTORS—XXII. Kuper, 32.
United States, Spratt, 5.
LIGHTNING CONDUCTORS (for Shipping)—VIII. Harris,
Sir W. S., 150.
LIGNITE—*India*, I. *New Zealand*, Hargreaves, 8.
Portugal, Roque, 18, 19. *Trinidad*, Lord Harris, 27.
Zollverein (6), Sa'hhausen Salt & Lignite Works, 3.
LIMBS, ARTIFICIAL—X. Atkinson, 605.
Belgium, Champagne, 187. See also *Arms, Artificial*.
Eyes, Artificial. *Hands, Artificial*. *Legs, Artificial*.
Noses, Artificial. *Wooden Legs*.
LIME—I. Dann, 56. Greaves, 210. *France*, Agombani, 2.
Regny & Co., 1427.
Portugal, Machado, 54-56. *Spain*, Prats, 45.
Tunis, 38, 91. *Western Africa*, Trutter, 5.
LIME, ACETATE OF—*France*, Maire & Co., 317.
LIME, CARBONATE OF—I. Walton, 55.
LIME, CHLORIDE OF—*Austria*, Wagenmann & Co., 19.
Portugal, Hirsch & Co., 77.
Zollverein (1), Wesenfeld & Co., 461.
LIME, PHOSPHATE OF—*Canada*, Wilson, 2.
Western Africa, M'William.
LIME, SULPHATE OF—II. Austin, 114. *Spain*, Cuesta, 49A.
LIME, SUPERPHOSPHATE OF—I. Ramsay, 44. II. Austin,
114.
LIMES—*British Guiana*, Netscher, 18.
LIMESTONE—Western End, South Enclosure (Outside),
Greaves, T., Raynes & Co. 25. Towler, 27. I. 6,
156. Bell, 189. Cumming, 157. Fahie, 30. Leu-
talgne, 5. Moore, 405. Smith, 177. Sparks, 154.
Sweetman, 40. Taylor, 201. Walton, 85.
Canada, Logan, 1. *India*, 1.
New Zealand, Brown, 18. Purchas, 23.
Portugal, Bonnet, 107.
Russia, Alexandrovsk Imperial Caumon Foundry, 2. Bar-
navulsk Imperial Works, 4. Kameinsk Iron Works, 8.
Tunis, 168. *Turkey*.
United States, Penniman, 249.
Van Diemen's Land, Bichens, 326, 327. Denison, Sir
W. T., 270. Milligan, 260-262, 325.
LINE ENGRAVINGS—See *Engravings*.
LINEN FABRICS (Various)—XII. & xv. Allen, 259.
Baumann & Wunth, 206. Bird, 223. Leadbetter &
Co., 205. XIV. Anderson, 86. Bennett & Adams,
11. Canter, 36. Capper & Son, 95. Carson, 14.
Carter, Brothers, 36. Dundee Local Committee, 63.
Emshall, 40. Fletcher, 36. Hattersley & Co. 36.
Haxworth & Carnley, 36. Henning, 16. Jackson &
Matthewson, 36. Jeffrey, 59. Kirk & Sons, 10.
Leadbetter & Co., 9. Leeming, 41. M'Murray & Co.,
25. Malcolm, 22. Pegler, 43. Pigott & Newton,
36. Pinkerton, J. & R., 16. Richardson & Co., 23.
Richardson, Sons, & Owden, 7. Sailer, 30, 91. Sailer
& Co., 18. Walton & Co., 38. Wilford & Sons, 42.
Wilks, 31.
Austria, Haupt, 286. Hielton, 275. Milan Benevolent
Society's Establishment, 263. Peldrian's Heirs, 288.
Siegl & Co., 290. Vouwiller & Co., 292. Witschell
& Co., 293.
Belgium, Ameye-Berte, 200. Bernard, Saint, House of
Correction, 226. Bongaerts, 229. Cattaux, 215.

- T. J. & R., 36A.
 39. Grallier,
 32.
 —VIII. Harris,
 8.
 Harris, 27.
 Works, 3.
 Artificial.
 Artificial.
 Agombard, 2.
 43.
 5.
 317.
 & Co., 19.
 2.
 Cueta, 49A.
 II. Austin,
 (Outside),
 27. I. 6.
 Leu-
 Sparks, 134.
 85.
 2. Bar-
 Iron Works, 8.
 Denison, Sir
 Allen, 250.
 Leadbetter &
 nett & Adams,
 Carson, 14.
 Committee, 63.
 & Co. 36.
 6. Jackson &
 & Sons, 10.
 Murray & Co.,
 & Newton,
 & Co., 33.
 30, 91. Sailer
 & Sons, 42.
 Benevolent
 Heirs, 288.
 2. Witschell
 House of
 ataux, 245.
- Decock, 221. Deroubaix, 230. Des Medt, 232. Dob-
 belaire, 208. Donner, 233. Hartog, Brothers, 224.
 Moerman, 231. Parmentier, 222. Servalis, 201. Thi-
 ban-Accou, 220. Thilan, 292. Van Ackere, 215.
 Van Oost, 219. Vercurysse, 213.
 Canada, Fortier, 141. China, Hewitt & Co. Rawson.
 Egypt, 228, 300-309, 311, 312, 338.
 France, Boniface & Sons, 32. Doucet & Duclero, 147.
 Mestivier & Hamoir, 636. Scrive, Brothers & Danser,
 1006. Hanover, Schultze, 6.
 Madeira, Real, 1.
 Portugal, Barboza, 682. Torres Novas Company, 661-
 663, 667-669, 673, 677.
 Russia, Dumbrowitch, 355. Julenius, 221. Konovlain, 220.
 Spain, Castellon Corporation, 194. Isabel II., Manu-
 factory of, 193.
 Sweden and Norway, 23.
 Switzerland, Haag & Sons, 164. Hunsiker & Co., 166.
 Roethlisberger & Sons, 169. Tuntis, 10, 18.
 Turkey. United States, Mills & Co., 444.
 Zollverein (1), Bolenius & Nolte, 562. Brockmann,
 539. Bruenger, 559. Delius, 560. Delius & Sons,
 518. Gaute & Sons, 553. Heideick, 555. Klöpfer,
 480. Kramsta & Sons, 128. Koenig, Wilhelm,
 & Sons, 556. Landwehrmann, Brothers, 550. Rimann
 & Geisler, 124. Schnell & Sons, 558. Schraidt &
 Co., 732. Seyler, 121. Tachorn & Birge, 130.
 Velbagen, 540. Websky & Son, 122. Wessel, 542.
 Westermann, 543. Westermann & Sons, 544. (4).
 Laup, 34. Seemann, 36. See also *Cambria*. *Da-
 masks (Linen)*. *Diapers*. *Flax*. *Ginghams*. *Hemp*.
Linen Sheetings. *Linen Twists*. *Linen Yarn*. *Table*
Cloths (Linen, &c.).
 LINEN PRESSES—XXII. Thudall, 542.
 Zollverein (1), Kuttner, 256.
 LINEN SHEETING—XIV. Crawford & Lindsays, 13. Curt
 & Co., 88. Nicol & Co., 87. Sailer & Co., 18.
 Portugal, 672-674, 676, 678. Torres Novas Co., 666.
 LINEN AND SILK (mixed fabrics)—XIV. Beveridge, 29.
 Hunt & Son, 23. See also *Mixed Fabrics*.
 LINEN TWISTS—France, Soius & Son, 381.
 Portugal, 654.
 LINEN-WASHING MACHINES—See *Washing, Drying, and*
Ironing Machines.
 LINEN YARNS—Austria, Feldrian's Helrs, 288. Petrak, J.
 289.
 France, Duranton, 494. Hanover, Schultze, 6.
 Zollverein (1), Bolenius & Nolte, 562. (4). Urach Ma-
 nufactory of Linen Yarn, 35.
 LINENS, WOOLEN CLOTHS, &c. (ORNAMENTS FOR DECO-
 RATING)—XVII. Mansell, 27.
 LINES, CLOTHES—See *Horse-hair Clothes*—lines. *Ropes*,
Cordage, &c.
 LINING AND RELIEF COPYING-MACHINE (Specimens)—
 Zollverein (1), Wagner, 155.
 LINSSEED PRESSES—VI. Blundel & Co., 420. XVI. Ben-
 son, 12.
 LINSSEED AND LINSSEED-OIL AND CAKE—III. McGarry &
 Sons, 132. Peterson, 66. IV. Penney, 64. Spur, 58.
 Austria, Steimböck, 183.
 Belgium, Vanlastraeten, 84. Vercauteren, 82. Ver-
 curysse, Brothers, 91.
 Hamburg, Petersen, 5. India, IV. Lubeck, Platzman, 1.
 Netherlands, Oermen, 8. Calvi, 22.
 Sardinia, Girardi, Brothers, 5. Spain, 170.
 United States, Lee & Co., 530.
 Zollverein, Waechter, 434. See also *Cake-breaking*
Machines. *Rape-seed and Rape-seed Oil, &c.*
 LINSLEY-WOLSEY FABRICS—XII & XV. Byers & Son, 232.
 Clay & Sons, 136. Garvie & Dias, 227. Green, 92.
 Locke, 15. Mills, 253. Phillips, 222. Roberts, 460.
 Renwick, T. & A., 233.
 LINT—II. Oyler, 113.
 LINT-MACHINE—VI. Searle, 65.
 LION, BAVARIAN—Zollverein (1), Müller, 90 (Main
 Avenue, East).
 LIQUEURS—XXIX. Taylor & Co., 5. Turkey.
 LIQUID-MANURE MACHINES—VIII. Truscott, 259. IX.
 Reeves, T. R. & J. 108. See also *Pumps, Liquid*
Manure.
 LIQUID METRE—V. Keith, 468. Tebay, 436. XXII. Keith,
 601.
 LIQUIDS, APPARATUS FOR COOLING OR WARMING—XXII.
 Hewitt, 395. See also *Ice-Machines*.
 LIQUORICE—Egypt, 50. Greece, Congos, 57.
 Spain, Saragosa, Academy of Medicine and Surgery,
 128A.
 LITHARGE—I. Byers, 494. India, II.
 LITHOGRAPHIC DRAWING, ENGRAVING, AND PRINTING
 (Specimens of)—XXVI. Richardson, 207. XXX. (Fine
 Art Court) Cox, 248. Duellin, 58. Graf, 76. Hull-
 mandel & Walton, 71. Martin & Hood, 85. Stan-
 didge & Co., 37. Underwood, 77.
 Austria, Bermann, 370. Neumann, 373. Raub, 369.
 Belgium, Avanzo, 446. Daveluy, 448.
 Canada, Meyer, 190.
 France, Cousin, 1572. Dupont, 181. Engelmann &
 Graf, 192. Gillot, 522. Guesau, 859. Kuppelin,
 894. Schmitts, 370. Tudof, 397.
 Hamburg, Kahler, 117. New Zealand, Moore, 37.
 Portugal, 1238-1251. Lopes, 1254.
 United States, Brady & Co., 142. Browning, 557. D'Avig-
 non, 132. Pease, 230. Pratt, 102. Sowrell, 448.
 Zollverein (1), Winkelman & Sons, 306. See also
Chromo-Lithography.
 LITHOGRAPHIC MUSIC PRINTING—XXX. (Fine Art Court)
 Chappell & Co., 66.
 LITHOGRAPHIC PRESSES—VI. Greig, D. & J. 114. Mo
 Clure & Co., 160. Straker, 142. Underwood, 103.
 France, Brisset, 440. Lacroix & Son, 253.
 Switzerland, Ledoux, 58.
 LITHOGRAPHIC STONES—Western end, South Enclosure
 (outside), Raynes & Co., 25. I. Brodie, 54.
 Canada, Logan, 1.
 France, Chapot & Pelon, 448. Marx & Co., 1732.
 Marx & Co., 1343.
 Greece, The Greek Government, 24. India, I.
 Portugal, Dejante, 110-115. See also *Limestone*.
 LITHOPONY (Specimens of)—France, Du Tremblay, 395.
 LITHOTYPES—Canada, Matthews, C., 188.
 LIVERPOOL BATHS AND WASH-HOUSES (Drawing)—V.
 Pooley, 734.
 LIVERPOOL DOCKS, &c. (Model)—Liverpool Local Com-
 mittee, page 851.
 LIVERPOOL, SPECIMENS OF IMPORTS INTO (Undescribed)
 —XXIX. Liverpool Local Committee, 270.
 LLAMA CLOTH—See *Merinoes*.
 LOCKMAKING (Illustrations of the art of)—XXII. Aubin,
 663.
 LOCKS, &c. (Various)—XXII. Barnwell & Son, 678. Barron
 & Son, 695. Bigford, 650. Boobyer, 680. Bramal
 & Co., 633. Bryden & Sons, 44. Carpenter & Til-
 derley, 655. Cartwright, 661. Chubb & Sons, 646.
 Clark & Rastell, 446. Cotterill, 307. Downs, 675.
 Fenham & Co., 686. Foss, De La, 800. Foster, 650.
 Gerish, 652. Gibbons, 654. Harley, 660. Haywood
 & Son, 647. Horton, 674. Huffer, 649. Lewis, 673.
 Lingard, 264. Longfield, 503. Marr, 510. Mayo &
 Bates, 648. Mitchell, 672. Parker, 639. Pearce, 671.
 Taylor, 622. Tucker, 668A. Walters, B. & P., 670.
 Windle & Blythe, 668. Wisson, 679. Wolverton,
 276. Yates, 664. Egypt, 168.
 France, Cugnot, 99. Fayet-Baron, 1221. Granger,
 1734. Grangoir, 1256. Hue, 269. Pabluu, 946.
 Portugal, 652. Sardinia, Barbis, 56. Spain, Callejo, 257.
 Sweden and Norway, Hallenius & Co., 11. Hedlund,
 11. Lundberg, 11. Ulander, 11.
 Tuscany, Cioni, 104.
 United States, Adams & Co. 462. Arrowsmith, 138.
 Day & Newell, 298. Hanley, 375. Knight, 576.
 McGregor & Lee, 20. Tuckerman, 333.
 Western Africa, Miller, 10.
 Zollverein (1), Bleckmann, 623. Post, 615. Schmidt, 651.
 (5). Raab, 18. See also *Door-fasteners*.
 LOCKS, WOODEN—British Guiana, Steele, 154, 154n.
 LOCKSMITHS' TOOLS—Zollverein (1), Asbeck & Co., 645.
 LOCOMOTIVE AXLE AND CONNECTING ROD—V. Squire &
 Co., 706.
 LOCOMOTIVE-ENGINE DRIVING WHEELS—V. Warren,
 558, 1001.

- LOCOMOTIVE ENGINES, RAILWAY (including Models)**—
 v. Adams, 510. Crampton, 508. Dodds & Son, 64. Elliott, 702. Engliani, 509. Erskine, 100. Fairbairn, 522, 732. Fossick & Hackworth, 10. Great Western Railway Company, 506. Harvey, 692. Hawthorn, R. & W., 536. Hemmingway, 574. Hinitz, 714. Kilsou, Thompson & Co., 534. Lambert & Son, 479. Lester, 700. London and North-Western Railway Company, 512, 513. Stanton, 661. Wilson, C., 697. Wilson & Co. 526. vii. Reucynski, 27. xxii. Johnson, Cammill & Co., 109. *Belgium*, Cockerill, 119. Marcinelle et Couillet, Société Anonyme, 120. *Canada*, Rodler, 346. *France*, Call & Co., 1557. *Netherlands*, Maitland, 92. *Tuscany*, Pelosi, 56. *United States*, Pinkus, 504.
- LOCOMOTIVE ENGINE SAFETY APPARATUS**—*France*, Le-thuillier-Pinel, 312.
- LOCOMOTIVE MACHINERY (for Inclines from or to Wharfs)**—
 v. Barber-Beaumont, 752.
- LOCOMOTIVE REGULATOR, SPINDLE JOINT FOR**—vi. Schiele, 402.
- LOCOMOTIVE STEAM-CARRIAGE FOR COMMON ROADS**—
 v. Bevan, 105.
- LOCOMOTIVE STRAP**—*France*, Blanchet, Brothers, 768.
- LOGS, SHIPS**—viii. Berthon, 104. *Jersey and Guernsey*—Allend, 27.
- LOGWOOD**—*Trinidad*, Lord Harris.
- LONDON (Model of)**, with designs for Railways in the Streets—v. Macbray, 586.
- LONDON BRIDGE (Model)**—vii. Townley, 39.
- LONGCLOTHS**—*See Cotton Fabrics*.
- LONGITUDE (Instrument to find the)**—x. Macdonald, 357.
- LOOKING-GLASSES, MIRRORS, &c.** (including Chimney and Pier Glasses)—xxvi. British Plate Glass Company, 408 (Main Avenue, West). Chapman, 191. Crawford, 96. Donne, 198. Gardner, 231. Herring & Sons, 205. McCullum & Hodson, 136. McLean, 396 (Main Avenue, West). Ponsobny, 199. Rogers, 195. Squire, 273. Whitcombe, 211A. *Austria*, Ahele, 582. Ratsersderfer, 677. Viehofen, Mirror Manufactory, 583. *China*, Hewitt & Co. *France*, Berlios & Co. 53. Chamouillet, 1142. Ledreney, 1307. Luce, 1332. Paillard, 671. *Hamburgh*, Huebner & Pohle, 61. Korlan, 62. Rampendahl, 60. *Russia*, Ameloung & Son, 296. *Tuscany*, Serafini, 123. *Zollverein* (1), Fleischmann, 763. Heinrich, 771. (2), Hechinger, 60. Heilbronn, 61. (6), Buettner, 53.
- LOOKING-GLASS FRAMES**—xxvi. Bielefeld, 157. xxviii. Thorn & Co., 56. *France*, Hardouin, 865. *Jersey and Guernsey*, Ellis, 41. *Sardinia*, Martinotti, 93.
- LOOMS (including Models)**—vi. Brown, 56. Cross, 64. Hensing, 43. Smith, 22. xix. Jackson & Graham, 390 (North Transept). *Belgium*, Jouvne, 123. *Ceylon*. *France*, Jacquin, 546. Mercier & Co. 632. *India*, vi. *Western Africa*, Forbes, 8. *See also Hand Looms. Jacquard Looms. Power Looms. Silk Looms. Stocking Looms.*
- LORD MAYOR'S STATE BARGE (Model)**—viii. Searle & Sons, 169 (Main Avenue, West).
- LORD MAYOR'S STATE COACH (Model)**—xxx. (Fine Art Court) Jibb, 14.
- LOZENGES**—xxix. Lucas, Brothers, 316.
- LOZENGES, DIGESTIVE**—*Austria*, Prince Lobkowitz's Mines, 53.
- LUBRICATORS**—v. Haaketh, 206. Hurry, 122.
- LUCIFER-MATCH BOXES**—*France*, Lefrançois, 301, 582.
- LUCIFER MATCHES**—xxix. Bell & Black, 243. *Austria*, De Majo, 50. Furth, 46. Hoffmann, 49. Pollak, 47. Preschel, 48. *Zollverein* (4), Kuhn, 102. Sutorius, 100.
- LUDLOW CASTLE (Model)**—xxx. (Fine Art Court), Gill, 145.
- LUMP-SUGAR CHOPPING-MACHINES**—xxii. Symes, 23.
- LUNARIANS**—x. Faxon, 191. Perigal, 693.
- LUSTRES**—*Hanover*, Bernstorff & Eichwede, 8. *Zollverein* (5), Junge & Walther, 17.
- LUXOR OBELISK (Model)**—*Zollverein* (1), Sussmann, 305.
- MACARONI, VERMICELLI, &c.**—iii. Gantile, 168. Levy, 120. *Portugal*, 519, 528. *Sardinia*, De Barbieri, 63. Guelfi, 94. Valdettaro, 81. **MACE (with Samples of the Meal)**—iii. M'Cullum, 133. *India*, iii. *Labuan, &c.*, Hammond & Co., 2.
- MACHINE CARDS**—*United States*, Earle & Co., 456.
- MACHINE MOULDINGS**—*United States*, Chatais, 337. Fay & Co., 203. Roddie, 571.
- MACREADY TESTIMONIAL**—xxiii. Smith, Nicholson & Co., 110.
- MADDER AND Madder ROOT**—*Algeria*, Dupre de St. Maur, 23. Montigny, 38. Piglin, 49. *France*, Avignon Chamber of Commerce, 1049. Sengonwald, 1010. *Greece*, Malandrinus, 3. Philippos, 4. *India*, iv. *Mecklenburg-Strelitz*, Scharenberg, 3. *Russia*, Bahaleff, 86. Kerim Raghim Oglı, 87. *Spain*, 86, 135, 141, 142. Marcus, 147. Mateus, 140, 144. Semovilla, 113. *Turany*, Pastorelli, 35. *Zollverein* (1), Weiss, 684.
- MAGIC LANTERN**. *See Phantasmagoria*.
- MAGNA CHARTA**, on vellum, ornamented with alights—xxx. Partridge, 333.
- MAGNESIA**—ii. Howards & Kent, 11. *Austria*, Prince of Lobkowitz's Mines, 53. *India*, i. *United States*, Hubbard, 49.
- MAGNESIA, BICARBONATE OF**—ii. Murray, Sir J., 87.
- MAGNESIA, CARBONATE OF**—ii. Murray, Sir J., 87. *Greece*, Greek Government, 21. *India*, i. *Sardinia*, Rossi & Schiapparelli, 6.
- MAGNESIA, CITRATE OF**—ii. King, 84.
- MAGNESIA LOZENGES**—*Austria*, Lobkowitz, Prince of, 53.
- MAGNESIA, SULPHATE OF**—ii. Copner, 118. Moberley, 17. *France*, Malapert, 319. *Jersey and Guernsey*, Gould, 34. *Van Diemen's Land*, Smith, 295.
- MAGNESIAN MINERALS AND CHEMICALS**—ii. Dinneford & Co., 51. *Canada*, Logan, 1.
- MAGNETIC DIP AND INTENSITY INSTRUMENTS**—x. Brooke, 144. Wilton, 402.
- MAGNETIC IRON AND IRON ORE**—*India*, i. *Russia*, Goroblagodatsk Imperial Iron Works, 7.
- MAGNETIC TOYS**—*Zollverein* (2), Isamayer, 26.
- MAGNETIZED BALANCES**—x. Fox, 377.
- MAGNETO-ELECTRIC MACHINES**—*See Electro-Magnetic Machines*.
- MAGNETOMETERS (Self-Registering)**—x. Brooke, 144.
- MAGNETS**—x. Chadburn, Brothers, 259. Hearder, 439. Henley, 428. Rundell, 435A. xxii. Stubbs, 36. xxii. Shaw and Son, 216. *Netherlands*, Logeman, 87. *See also Compasses, Mariners'.*
- MAHOAGANY**—iv. Fauntleroy & Sons, 135 (Main Avenue, West). Gillow & Co., 15. *St. Domingo*, Schomburgk, Sir R.
- MALACHITE**—i. Hall, T. & J., 146. *Russia*, Bogolouck Copper Works, 1. Perm Imperial Copper Works, 6. *South Australia*, Graham and Hallett, 3. *Zollverein* (1), Weishaupt & Sons, 412.
- MALT**—iii. Wright, 107. *New Zealand*, Hooper & Co., 39.
- MALT, CRYSTALLIZED**—iii. Poole, 146.
- MALT-DRYING MACHINES**—vi. Corcoran and Co., 416. ix. Abbott, 55.
- MANCHESTER, PLAN OF THE TOWN**—xxx. (Fine Art Court) Adahed, 328. Illustration of Sewering, Paving, &c. at—vii. Naylor, 81.
- MANDOLINES**—*Switzerland*, Metert & Co., 97.
- MANDRILLS**—vi. Hick & Son, 218.
- MANGANESE AND MANGANESE ORE**—i. Fahie, 30. Sweetman, 40. Williams & Sons, 505. ii. Kane, 53. *Canada*, Logan, 1. *France*, Cavelan & Co., 1131. *Hamburgh*, Meyer, 1. *India*, i. *New Zealand*, McLeod 30. McRae, 8. *Van Diemen's Land*, Milligan, 268. *Zollverein* (1), Biegel, 311. Harkort, 874. (6), Briel & Co., 4. Rosenberg & Co., 2. (6), Nassau Government Engineers of Mines, 1.
- MANOLES**—ix. Wilkinson, 220. xxii. Baker & Co., 547. Daunnatt, 43. Moreton, 554. Strutterd, 545. Tindall, 542. Wilkinson, 540.
- MAN-HELP FOR PAINTING SHIPS, &c.**—vii. Williams, 126.

- MAN, ISLE OF, LIFE BOATS—VIII. Fawcett, 62.
- MARCOCA—*Portugal*, Bataha, 541, 542.
- MANNA—*Van Diemen's Land*, Bouney, 280.
- MANNITE—II. Piccolini, 33.
- MANNITE, CRYSTALLIZED—II. Smith, T. & H. 94.
- MANNITERS—*France*, Galy Casalat, 1239.
- MANTEL-PIECES.—*See Chimney-pieces.*
- MANUFACTORY (Model of)—XXX. (Fine Art Court) Norton, 346.
- MANUFACTURES (Various Designs for)—XXX. (Fine Art Court) Wyatt, 30. Graves, 322. Harvey, 119.
- France*, De Lisle, 1455. Galimard, 223. Jaret, 888. Meynier, 639. Ragot, 971. Rouget de Lisle, 1455.
- MANURE MACHINE—*Netherlands*, Stam, 73.
- MANURES—I. Blyth & Jacobs, 131. Evans, 227. Gill, 38. Harris, 42. Ipswich Museum Committee, 35. Lance, 37. Neubitt, 40. Ramsay, A. 44. Ramsay, G. II., 269. Teschemacher, 41. II. Moberley, 17. IX. Blackhall, 33. Daniell, 265.
- Belgium*, Bortier, 95. *Denmark*, Owen, 44.
- France*, Fouche le Pellatier, 1229. Rancher, 1422.
- Zollverein* (1), Waechter, 434. *See also Guano.*
- MANUSCRIPTS (of the 15th century)—*France*, Lundy, 914.
- MAPS (Various)—I. Knipe, 529. X. Adorno, 218. Clupham, 712. Denton, 317. Sanderson, 160. XVII. Candy, 66. Cruchley, 74. Hughes, 4. National Society, 211. Orr & Co., 109. Ruff & Co., 103. Sanderson, 37. Tapprell & Innes, 191. Whitehead, 192. XXX. (Fine Art Court) Wishaw, 232A.
- Austria*, Curri, 364. Military Geographical Institute, 363. Kaysar, 368A. Müller, 372. Raffelsperger, 365. *Belgium*, Vandermaelen, 437. *Egypt*, 126.
- France*, Bauerkeller & Co., 1072. Cosquin, 804. Maillon, 1653.
- New South Wales*, Mitchell, 5.
- New Zealand*, Moore, 37.
- Nova Scotia*, Central Committee, 2.
- United States*, Bidwell, 477. Culton, 310. Cowperthwaite & Co., 360. Disturnell, 215. Lawience, 521. Sherman & Smith, 143. Siebert, 595.
- Zollverein* (1), Heymann, 290. Schopp, Simon, & Co., 303. Stulle, Dr., 895. Trautwein, 158. (3), Royal Saxon Military Plan Office, 184. (6), Junghaus & Venator, 6. *See also Atlases. Globes.*
- MAPS, ORDNANCE—I. Tennant, 159. VIII. Ordnance Survey Departments, 123.
- MAPS IN RELIEF—XXX. (Fine Art Court) Staveley, 263.
- France*, Gass D'Agnein, 1238, 1635.
- Switzerland*, Schneider, 42. *Zollverein* (1), Dickert, 432.
- MARBLES (Specimens of)—Western End, South Enclosure (Outside), Franklin, 28. I. 155. Bell, 189. Clark, 190. Cumming, 195. Fahle, 30. Galling, 139. Hall, J. & T., 146. Howard, 29. Lentaigne, 138. Manderson, 148. Quillam & Creer, 151. Taylor, 201. Whittaker, 53. XXVII. Frankliu, 73. Porter, 66. Puiham, 108. XXX. (Fine Art Court) Conte, 140.
- Belgium*, Fallon Pirn, 10. *Canada*, Logan, 1.
- France*, Caffort, 444. Coliu, 1561. Derville & Co., 162. Seguin, 1693.
- Greece*, 23-39, 43-45, 47, 49. Cleanthes, 40-42. Hy-mettus Monastery, Prior of, 48. *India*, I.
- Portugal*, 120-231.
- Spain*, 30, 32. Almeria Mines, Inspector of, 13. Asturias Mines, Inspector of, 15. Cordova, Mining Inspector of, Spain, 29. Granada Mines, Inspector of, 16. Madrid Royal Library, 31. Santosy Diaz, 34. *United States*, McKensie, 569. Pierce, 248A.
- Van Diemen's Land*, Denison, Sir W. T., 337. Strutt, 232.
- Zollverein* (1), Laverdure, 845. Meyern-Hohenberg, 892. Rüdeland Ducal Foundry Inspector, 780. (8), Diez Marble Manufactory, 5. *See also Parbeck Marble.*
- MARBLE COLUMNS, SLABS, AND OTHER WORKS—I. Champ-ernowne, 158, page 848. Colles, 140. Franklin, 144. XXVI. Hunter, W. J. R. & E., 202. XXVII. Bird, 83. Cumming, 64. Hall, J. & T., 37, 38. Huban, 58. Lomas, 81. London Marble & Stone Company, 17. Monteagle, Lort, 72. Oldfield & Co., 76. Royal Dublin Society, 71. Rumley, 59. Stuart, 55. Turner,
82. Vallance, 40. XXX. (Fine Art Court) Simmons, 126.
- Belgium*, Desmasset de Bieme, Viset., 16. Guislain 423. Leclercq, 425. *South Africa*, Walls, 60.
- France*, Simon, 1016. *India*, I. XXVII.
- Portugal*, Bounet, 258. De Figueiredo, 248, 249, 252-257. DeJant, 232-247, 250, 251, 256-274. Thomas, Count, 1223. *Rome*, 37. *Tunisi*, 95.
- Tuscany*, Fontina, 122. Guidotti, 92. Maffei, Of. Nobili, 91. Royal Technological Institute, 95.
- Zollverein* (1), Cantian, 235 (Main Avenue, East). De- vaise, 837. Meyern, 892.
- MARBLE, APPLICATION OF, TO MINIATURE PAINTING— XXX. (Fine Art Court) Carrick, 242.
- MARBLE, ARTIFICIAL—XXVI. Taylor & Sons, 9. XXVII. Ransom & Parsons, 97. *Austria*, Behr, 646.
- Sardinia*, Spanius & Co., 86.
- Spain*, The Apolytomene Company, 55A.
- MARBLE, IMITATION (Various)—XXVI. Arthur, 303. Cumber, 307. Hanbury, 41. Hopkins, 234. Pur- kias & Son, 315. Sewell, C. & F., 340. Smith, C., 341. Smith, G. F., 141. Southall & Co., 342. XXVII. Bradley, 35. Buckley, 44. Ilse, C. & C., 28. Kershaw, I. Moore, 25. Nicol & Allen, 69. Oliver, 41. Read, 32. Wilson, 14. XXX. (Fine Art Court), Williams, 82.
- France*, Bisiaux, 767. Evrot, 190. Letillou, 1322.
- MARBLE PAINTING ON GLASS—XXIV. Davies, G., 37. Davies, I., 38. Kiddle, 39. XXVI. Holland & Sons, 62A, 407. Lee, 43, 402. M'Lachlan, 337. Wallace, 2. XXX. (Fine Art Court) Lee, 341.
- MARBLE PASTES FOR MOSAICS—XXVII. Skiuner & What- ley, 121.
- MARBLE, PREPARED (to resist Grease, &c.)—XXVII. Page 26.
- MARBLE AND STONE WORKING MACHINERY, &c.—IX. Rudd, 157.
- MARINE ENGINES. *See Steam-Engines, Marine.*
- MARINE GLUE—VIII. Jeffery & Co., 188.
- MARINE PLANTS—IV. Holt, 128.
- MARINE PRODUCTIONS—*Bermudas*, Jackson, 2.
- MARKING INK—*See Ink, Marking.*
- MARL. *Turkey. United States*, Braxton, 269.
- MARQUEES—*See Tents and Marquees.*
- MARQUETERIE—XXVI. Bailes, 203. Headella, 193. Bruns- wick, 180. Gallow & Co., 186A. Watson, 175. Wood, 105.
- MARQUETERIE, IMITATION—*France*, Pichot, 349.
- MARY'S, ST., CHURCH, WHITECHAPEL (Model)—XXX. (Fine Art Court) Evans, 202.
- MASKS—*Austria*, Serafini, Palatini, & Co., 702.
- MASONIC JEWELS—XXIII. Leostark, 62.
- MASONS' TOOLS—I. Mitchell, 461.
- MAST CLAMPS—VIII. Beadon, 90.
- MASTING-SHEARS—VIII. Hughes, 313.
- MASTS (Ships)—VIII. Burgess, 123. Dempster, 174. Ferguson, C. A. & T., 184. Shulldham, 172. *Bermudas.*
- MATCHES—II. Dixon, Son, & Co., 126.
- MATCH-BOXES—*See Lucifer-Match Boxes.*
- MATHEMATICAL INSTRUMENTS—X. Aiorio, 218. Ashe, 194. Braham, 289. Cameron, 356. Gerard, 109. Graham, 355. Haggard, 328. Hardy, 348. Miller, 361. Parkes & Son, 671. Penrose, 318. Rooke, J. & A., 340. Ross, 342. Williams, 352. Yates, 378. XXX. (Fine Art Court), Rowney & Co., 3.
- Belgium*, Groetaerea, 156.
- France*, Buron, 443. Desbordes, 1587. Guidicelli & Delabarre, 1614. Lemsaigne, 1728. Molteni & Siegler, 649. *Jersey and Guernsey*, Le Moyne, 5.
- Switzerland*, Gisi, 85. Homel-Esser, 81. Kern, 88.
- United States*, Fisher, 263.
- Zollverein* (1), Lüttig, 81. (2), Riefler, 34. *See also Geometrical Instruments.*
- MATHEMATICAL TELEGRAPH—*United States*, Fuller, 490.
- MATICO (Drug)—II. Keating, 102.
- MAT MACHINE (for wiping Shoes)—XXX. (Fine Art Court) Deacuck, 72.
- MATS—XIV. Dagnall & Co., 89. Wall, E. & T., 70. XVI. Robinson, 7. XXVIII. Armstrong, 43. Bevington & Morris, 38. Canley, 103. *India*, XXVIII.

- Netherlands*, Cray, 23. *Portugal*, Ferrira, 1114. *Souza*, 1112.
- Russia*, Ivanoff, 267. *Levashoff*, 266. *Schultz*, 268.
- Society Islands*, Queen Pomare, 1. *Tunis*, 178-180, 181.
- Western Africa*, Forester & Smith, 2. Trotter, 5. Weston, 1.
- MAPLE SUGAR**—*Canada*, Bales, 67. Fisher, 69. Montreal Commission, 69. Parker, 68.
- Nova Scotia*, Central Committee, 2.
- United States*, Barnes, 246. Dean, 243. Dix, 139.
- MATTING**—xxviii. Robinson & Co. 42.
- Algeria*, Beal Saous Tribe, 67. *Ceylon*, China, Hewett & Co. *Egypt*, 128.
- New Zealand*, Collinson, J. Moore, 37.
- Portugal*, Ferraire, 1112-1115. See also *Cocoa-nut Fibre*, &c.
- MATRESSES**—iv. Nightingale & Co. 57. xii. & xv. Gisl, 208. xxvi. Bacon, 218. Johnston & Co., 73. *United States*, Kittendege, 253.
- MATTRESS COVERS**—Belgium, Felhoen-Cuicks, 481.
- MEASURES**. See *Corn or Seed Meters*. *Weights & Measures*.
- MEASURING APPARATUS** (for Tailors)—x. Thompson, 303. xx. Cattansch, 135A. Jones, 149. Robinson, 149A. Smart, 133. *United States*, Oliver, 593.
- MEASURING MACHINES**—vi. Whitworth & Co. 201. *Tuscany*, Gunnella, 57.
- MEAT-CUTTER**—*United States*, Perry, 72. See also *Sausage Choppers*.
- MEAT, ESSENCE OF**—iii. Warriner & Soyer, 21.
- MEAT PRESERVER**—xxii. Hockin, 502.
- MEAT SCREEN**—xxii. Andrewer, 379.
- MEATS, PRESERVED**—See *Provisions, Preserved*.
- MECHANICAL DRAWINGS FROM SCULPTURE**—*France*, Lhoest, 912.
- MECHANICAL FIGURES**—*France*, Mallat, 1340. See also *Lay Figures*. *Milliners' Dolls*.
- MECHANICAL INVENTIONS** (Undescribed) Specimens of—*United States*, Godwin, 217.
- MECHANICAL PICTURES**—xxvi. Grigg, 401.
- MECHANICAL PURCHASES**—xxviii. Hodges, 72.
- MECHANICAL SYLLABICATOR**—xvii. Benner, 60.
- MECONIC ACID**—ii. Morson & Son, 100.
- MEDALLIONS**—xxiii. Hilt, 106.
- Austria*, Petrowitz, 730.
- Rome*, 30. *Russia*, Count Tolstoy, 328.
- Tuscany*, Ghinai, 117.
- MEDALS**—viii. National Institution for the Preservation of Life from Shipwreck, 309. xxii. Allen & Moore, 300. Otley, 306. Pigott & Co. 231. xxx. (Fine Art Court) Adams, 281. Woodhouse, 289A. Wyon, l. C. 286. Wyon, W. 284.
- Austria*, Fraener, 732. Zappharelli, 733.
- Belgium*, Hart, 441. Jehotte, 447. Wiener, 442.
- Canada*, Wheeler, 353.
- Denmark*, Conradsen, 36. Petersen, 35.
- Russia*, Tolstoy, Count, 328.
- United States*, Gevelot, 189.
- Zollverein* (1), Fischer, 281. Pfeuffer, 286. See also *Coins*.
- MEDALS, COINS, &c.**, FAC-SIMILES OF—xxviii. Peel, 175.
- MEDICAL CLOTH** (backed with India Rubber)—xii. & xv. Wilkinson, 51.
- MEDICAL HERBS & DRUGS** (Various)—ii. The London Druggists, 117. *Austria*, Batka, 100.
- British Guiana*, Duggin, 70.
- Canada*, Fletcher, 127. Macculloch, 72.
- South Africa*, Jeppe, 4. Scheuble & Co. 48. Thawitzer, 3.
- Spain*, 118, 119, 120, 122, 123, 125. Bartolome, 126. Durango y Trigo, 127. Palencia, 121. Pardo y Bartolini, 116. Saragossa Academy of Medicine & Surgery, 128A.
- Tunis*, 136. See also *Chemicals, Drugs*.
- MEDICAL WALKING-STAFF** (containing Instruments, Medicine, &c.)—x. Gray, 101A.
- MEDICATED BANDS** (for the Cure of Rheumatism)—x. Coles, 660. *Austria*, Bachrich, 45A.
- MEDICINE CHESTS**—xxix. Lucas, 49.
- MEDICO-CHIRURGICAL AMBULANCE**—x. Veitch, 6.
- MEDICO-GALVANIC APPARATUS**—x. Hearder, 439.
- MEDIAEVAL OBJECTS** (Undescribed)—*Zollverein* (3), Schwarber, 30. See also *Eccelesiastical Furniture*.
- MEERSCHAUM**—*Greece*, 23. *Turkey*.
- MEERSCHAUM PIPES**—xxiii. Iudewick, 56. xxix. Barling & Sons, 305.
- Austria*, Allis, 664. Belsiegel, 667. Grunhut, A. 672. Grunhut, J. 673. Grunhut, W. 674. Zeltler, 687.
- Spain*, 42A. *Zollverein* (1), Ziegler, Brothers, 784.
- MELODIUM ORGAN**—*France*, Alexandre & Son, 1719.
- MELOPHONES**—*France*, Pellerin, 1363.
- MELTING & DISTILLING** (New Mode of)—xxii. Desfries, 482.
- MERCURY**—i. Forbes, 522. ii. Howards & Kent, 11.
- MERCURY, BINOXIDE OF**—ii. Hopkins & Williams, 41.
- MERCURY, BISULPHURET OF**—*Portugal*, Sersedello & Co. 80.
- MERCURY, CHEMICAL PREPARATIONS OF**—ii. Huskisson, J. W. & H. 86. *Austria*, Brusche, 20.
- MERCURY, OXIDE OF**—*Portugal*, Seal, 78.
- MERINO FABRICS** (Various)—xi. Henry & Sons, 13. xii. & xv. Brewin & Wheatstone, 242. Clough, 151. Craven & Son, 149. Day & Son, 113. Hudson & Bouffiel, 21. Masou & Co. 303. Rogers, 497. Schofield, A., 474. Schwann, Keil, & Co. 141.
- Belgium*, Wood, 492.
- France*, Bahuet, 17. Barbeaux Leueyer, 19. Bouches-Pothier, 34. Caillet, 82. Dauphinot-Perard, 471. David-Labbes & Co. 138. Fournival & Co. 221. Galliani, 989. Gussou-Maillie, 223. Gigot & Boisotau, 221. Girot de l'Ain, 1249. Lamort, 806. Lemaitre, 1316. Lesieur & Son, 1321. Levart, Brothers, 1324. Lucas, Brothers, 1331. Maquet, 604. Maquet-Hermel, 603. Mareille, 605. Oudin-Cormy, 669. Petit-Clement, 679. Ragot-Mayens, 972. Rambouillet National Sheepfold, 1080. Requillart, Russell, & Choqueviel, 1435. Robert-Boiteau, 31. Robert-Guerin, 1411. Robert-Mathieu, 1443. Rousselet & Barunnet, 1459. Sautret & Son, 1473. Vaucher-Picard, 710. Veisistere, 720. *Russia*, Volner, 190.
- Switzerland*, Mueller, Plessis, & Co. 151. Ziegler, 140.
- Zollverein* (1), Rothachill, 29. See also *Cashmere*. *Cobourg Cloths*. *Orleans Cloths*. *Paramatta Cloths*.
- MERINO WOOL**—iv. Dorrien, 81. *Russia*, n. n., 125.
- Zollverein* (1), Kùpfer, 29. Oberburggraf Von Brunneck, 45.
- METAL** (Anti-friction)—xxii. Bolt & Allen, 422.
- METAL ARTICLES** (Various)—xvii. Condy & Aldrey, 106. xxii. Allen & Moore, 300. See also *Hardware*.
- METAL BLINDS**—xxvi. Burt, 390.
- METAL CASTINGS** (Undescribed)—xxii. Stocker, 414.
- METAL & FLOCK COMBINED**—xxvi. Williams & Co., 321.
- METAL GAUDES**—x. Hayward, E. L. & W., 298.
- METAL MODEL**—i. Ibbetson, 486A.
- METAL, PERFORATED**—xxii. Tylor & Pace, 63. See also *Blinds, Perforated*.
- METALS AND THEIR ALLOYS** (Various)—i. Jordan, 487.
- METALS, MALLEABILITY OF** (Illustrations of)—xxiii. Marshall, 104.
- METALS** (Rolled)—xxii. Everitt & Son, 352.
- METALLIC CLAY, ARTICLES IN**—xxvii. Haywood, H. & l. 127.
- METALLIC CLOTHS & GAUZES**—*France*, Rouwag & Son, 1688.
- Switzerland*, Graeser & Schweizer, 216.
- METALLIC COLOURING, NEW MODE OF**—xxx. (Fine Art Court) Guild, 247.
- METALLIC CORD**—xxix. Ritchie, 250. See also *Wire Rope*.
- METALLIC LAVA PAVEMENT**—xxvii. Orsi & Armani, 36.
- METALLIC LETTERS** (for fixing on Glass)—xx. Woodhouse, 180. xxx. (Fine Art Court) Humphreys, 231A. See also *Brass Lettering*.
- METALLIC PASTE OR CEMENT** (for preventing Damp in Walls)—v. Cheavin, 448.
- METALLIC POCKETBOOKS**—xvii. Clark & Davidson, 135. Penny, 32.
- METALLIC ROOFING**. See *Iron Roofing*.
- METALLIC SHIELD**—x. Jones, 652.
- METALLIC SPONGES**—*France*, Chenot, 119.
- METROGRAPH**—x. Hardy, 348.
- METRONOMES**—x. Greaves, 303. Scholefield, 148. See also *Norma Viriana*.

Zollverein (5),
 ical Furniture.
 k, 58. XXIX. Bar.
 Grunhut, A. 672.
 74. Zeitler, 697.
 Brothers, 784.
 re & Son, 1719.
 (f)—XXII. Dufries,
 a & Kent, 11.
 & Williams, 41.
 Suredello & Co. 89.
 of—II. Huskisson,
 10.
 8.
 & Sons, 13. XII.
 12. Clough, 151.
 113. Hudson &
 33. Rogers, 497.
 & Co. 141.
 r, 19. Bouches-Po-
 erard, 471. Davil-
 Co. 221. Gallaud,
 & Bolsotau, 221.
 3. Lemaitre, 1316.
 hera, 1324. Lucas,
 aquet-Hermel, 603.
 9. Petit-Clement,
 mbouillet National
 ell, & Clucquesel,
 bert-Guerin, 1411.
 & Barounet, 1459.
 re, 710. Veisiere,
 151. Ziegler, 146.
 See also Cashmeres.
 Paramatta Cloths.
 sia, n.n., 123.
 graf Von Brunneck,
 llen, 422.
 ndy & Aitday, 106.
 no Hardware.
 r. Stocker, 414.
 Williams & Co., 321
 W., 298.
 ace, 63. See also
 —I. Jordan, 487.
 tions of)—XXIII.
 352.
 Haywood, H. & R.
 e, Roswag & Son,
 —XXX. (Fine Art
 e also Wire Rope.
 rei & Armani, 36.
 as)—XX. Wood-
 Humphreys, 231A.
 venting Damp in
 & Davidson, 135.
 9.
 efield, 148. See

METROPOLITAN CATTLE AND CARCASS MARKET, ABAT-
 TOIR, &c. (Model)—VII. Dunhill, 90.
 MICROGRAPHIC INSTRUMENTS—France, Nacet, 1370.
 MICROMETER—Zollverein (1), Nobert, 77.
 MICROSCOPE, Illustrations of the Uses of the—X. Leonard,
 306.
 MICROSCOPES—X. Abraham & Co. 243. Chadburn,
 Brothers, 259. Jackson, E. & W. 258. Ladd, 291A.
 Pillscher, 269. Ross, 254 (Main Avenue, West).
 Stadbit, 677A. Sweden & Norway, Littman, 15.
 United States, Hassert, 16.
 Zollverein (1), Ausfeld, 704. (2), Moss & Sons, 30.
 MICROSCOPES, ACHROMATIC, &c.—X. Fluid & Son, 250.
 King, 287. Pillscher, 269. Pritchard, 248. Smith
 & Beck, 263.
 MICROSCOPES, OXY-HYDROGEN—X. Horse & Co., 220.
 Ibbetson, 450.
 MICROSCOPE TABLES—X. Smith & Beck, 253.
 MICROSCOPIC OBJECTS—X. Hettl, 249. Hudson, 256.
 Poulton, 252. Stark, 284. Toppling, 667.
 France, Bourgogne, 434.
 MICROSCOPIC OBJECTS, CABINET FOR—X. Smith & Beck,
 253.
 MILDEW—Egypt, 21.
 MILDEW OIL—Egypt, 39.
 MILMETER—X. Webster, 671A.
 MILITARY ACCOUTREMENTS—VIII. Berington, 213.
 Hawkes & Co., 212. Landon & Co., 201. xvii.
 Geary, 235. xix. Hanson, 188. xx. Buckmaster, 1.
 Lyons, 67. Middlebrooke, 123.
 Canada, Morris, 334. India, viii.
 Netherlands, Heynberger, 102A.
 Sardinia, Gaudoll, 95.
 Zollverein (1), Meitzel, 94. (6), Maury, 21. See also
 Chacos & Helms. Regimental Troopers. Sworils.
 MILITARY ACCOUTREMENTS (Brass Mountings for)—VIII.
 Firmin & Sons, 211. xx. Woodhouse, 160.
 MILITARY CLOAK COAT (Desigu fur)—VIII. Powell, 210.
 MILITARY PLANS, MODELS, &c.—VIII. Moulin, 272.
 Belgium, Neyt, 167. New Zealand, Balneavis.
 MILK, CONSOLIDATED OR SOLIDIFIED—III. Fadeuilhs,
 140. Belgium, Fontaine, 67.
 France, Martin de Lignac, 922. See also Concentrated
 Milk. Lactine.
 MILK, ESSENCE OF—III. Moore, 139.
 MILK PAILS, TUBS, &c.—IX. Jolly, 69. XXII. Walton &
 Co. 69. Switzerland, Faessler, 229.
 MILK STRAINER—IX. Jolly, 69.
 MILLBOARDS—XVII. Spicer, Brothers, 42. See also Card-
 board.
 MILLINERS' DOLLS—France, Danjard, 136.
 MILLINERY. See Bonnets, Straw. Bonnets (various).
 Wearing Apparel.
 MILLS (Undescribed)—France, Mousillac, 933.
 United States, Ross, 213.
 MILLS, CORN-CRUSHING AND GRINDING. See Corn-
 grinding, &c. Mills.
 MILLSTONE DRESSING MACHINE—V. Parsons, 642.
 MILLSTONES—I. Coreoran & Co. 416. Sparks, 151. VI.
 Hughes & Sons, 459. Huxhams & Brown, 446.
 Toms & Co. 457.
 Belgium, Morimout, 9. St. Hubert, 8.
 Canada, Logan, 1.
 France, Gaillard, 226. Gueuvin-Buchon & Co. 532.
 Montcharmant, 650. Petit, Son, & Co. 345. Riby,
 985. Roger, 1448. Thell, 1033. Thibault Boileave,
 1502. Touaillon, 1508. Greece, 18. Tunisia, 167.
 Zollverein (1), Landau, 321. Michels, 871.
 MILLSTONES, APPARATUS FOR SUPPLYING AIR TO THE
 SURFACE OF—VI. Hurwood, 414.
 MILTON, ROYAL TERRACE PIER AT (Model of)—VII.
 Rollman, 12.
 MINE SHAFT MACHINERY (for ascending & descending)
 —I. Blew, 459. White & Grant, 471. v. Begg, 407.
 Fourdrinier, 406. Belgium, Vander Hecht, 475.
 MINERAL BLUE. See Azure.
 MINERALS AND MINERAL ORES (Various and Undescribed)
 —I. 32, 34. Bymbo Co., 274. Burr, T. W. & G. 495.
 Clive, 277. Deering, 121. Howard, 29. Ipswich
 Museum Committee, 35. Lance, 37. Mitchell, 45.

Randall, 275. Rowlandson, 490. Smith, 499. Sup-
 with, and a Committee of Mining Agents, 493. Tal-
 ling, 33. Taylor, 474. Tennant, 14. Wallace &
 Cuyper, 610. xxvii. 29.
 Algeria, Algiers Mines Commission, 45. Bonn Mines
 Commission, 46.
 Austria, Baska, 9. Christligng's, Count von, Mining
 Company, 404. Egger, Count, 401, 402. Hochber-
 ger, 14. Kengyel, 8. Kochmeister, 8. Kossuth,
 406. Pillersse & Zennbach Smelting Works, 407.
 Rudmeister Community, 400. Raucher & Co. 403.
 Sapy, 5. Saunrak, 4. Upper Hungarian Mining
 Association, 3. Vienna Imperial Mines, 2, 408.
 Zumberg Mine, 7. Zola, 405.
 Canada, Logan, 1. Wilson, 2.
 Ceylon. Falkland Islands, Whittington.
 France, Basin, 758. India, 1.
 Madeira, Real, 1.
 New Brunswick, Fraser, 9. McCully, 11.
 New South Wales, Dudgeon & Co., 11. New Zealand, 38.
 Portugal, 1-17, 20-27, 58-60, 82-102, 106-109, 119.
 Russia, 22. Alexandrovsk Imperial Cannon Foundry, 2.
 Barnaulsk Imperial Works, 4. Boguslovsk Copper
 Works, 20. Kamensk Iron Works, 8.
 Sardinia, Grange, 1.
 South Australia, Graham & Co., 3. Joseph, 7. South
 Australian Company, 1.
 Spain, 3. Almeria Mines, Inspector of, 13. Asturias
 Mines, Inspector of, 15. Barcelona Mines, Inspector
 of, 2. Corsica, 1. Granada Mines, Inspector of, 16.
 Gulpuzcos Mines, Inspector of, 4. La Mancha Mines,
 Inspector of, 6. Leon Mines, Inspector of, 17. Linares
 Lead Mining Association, 14. Linares Mines, Direc-
 tor of, 5. Lugo Mines, Sub-Inspector of, 18. Ma-
 laga Mines, Inspector of, 19. Marte Mining Com-
 pany, 10. Murcia Mines, Inspector of, 7. Pedro
 De Araya's Factory, 12. Rio Tinto Mines, Director of,
 8. Santander Mines, Inspector of, 9. Saragossa Mines,
 Inspector of, 11. Zamora Mines, Inspector of, 20.
 Sweden and Norway, Flood, 7. Grekasar Blast Fur-
 nace, 3. Hellefors's Iron Works, 4. Legerhohn, 1.
 Osterby Iron Works, 5. Rettig, 2.
 Trinidad, Lord Harris, 26. Tunisia, 25.
 Tuscan, Volterra Salt Manufactory, 2.
 United States, Cooke, 271. Collyer, 289. Faber, 279.
 Faker, 280. Feutchwanger, 469. Maupin, 265.
 New Jersey Mining Company, 168. Tuury, 169.
 Zollverein (1), Bigel, 311. Bischof and Rhodus, 312.
 Bissner & Co., 314. Bredt & Co., 315. Couack,
 825. Druher, 449. Echweller Mines at Fonderiev,
 318. Felthaus, 666. Hagen, 322. Hamblock, 454.
 Koningshuette, Royal Works at, 3. Ulrich & Co.,
 451. Malapara Prussian Iron Works, 2. Meiner-
 shagen & Kreuser, 316. (9). Nassau Government
 Engineers of Mines, 1. See also Copper Ores. Iron
 Ores. Zinc Ore.
 MINERAL OILS—II. Young, 7.
 Trinidad, Lord Harris, 16-14.
 Zollverein (1), Wisemann & Co., 331.
 MINERAL PAINTS—I. Thorne, 475. II. Blundell, Spence
 & Co., 48. Coulson, Jukes, & Co., 72.
 Nova Scotia, Central Committee, 2.
 United States, Mott, 81.
 MINERAL WASHING CASES—See Ore Washing Cases.
 MINERAL WATERS (natural and artificial)—I. Ellis, 13.
 II. Godson, 50. Schilling & Sutton, 52. Struve & Co.,
 52A.
 Canada, Mand, 324.
 Sardinia, Domenget, 06.
 Tunisia, 152, 153. See also Soda Water. Soda Water
 Machines.
 MINIATURE FRAMES—France, Carre, 445. Martens, 610.
 MINIATURE PAINTING—XXX. (Fine Art Court) Tennent,
 273. France, De Bastard, 1717.
 Zollverein (4), Holder, 106.
 MINING MACHINERY AND IMPLEMENTS—I. Hosking, 472.
 VI. Wasley, 412. India, vi. See also Boring Ma-
 chines and Tools. Chains for Pits. Coal-mine Ma-
 chinery. Fuzes for Blasting. Lead-mine Machinery.
 Parachute for Mines. Pumps. Mining.

MINING VENTILATING APPARATUS—VII. Rettle, 159.
Belgium, Couillet Mines, 120. *France*, Mehu, 627.
MINT, ESSENCE OF—*Egypt*, 111.
MIRRORS. See *Looking-glasses*.
MISCELLANEOUS ARTICLES (Undescribed)—XXVIII. Canning, 186.
MISSALS, ROMAN—*Belgium*, Hanig, 235. *Wesmael-Legros*, 282.
MIXED FABRICS (Cotton, Silk, Wool, &c.)—XII. & XV. *Bottomley & Sons*, 165. *Claburn & Son*, 284. *Clapham*, 157. *Day & Son*, 113. *Drummond*, 150. *Ecroyd & Son*, 130. *Ellis*, 70. *Foster & Son*, 143. *Fowler & Co.*, 309. *Gregory, Brothers*, 182. *Jebb & Sons*, 82. *Jowett & Co.*, 144. *Mason & Co.*, 303. *Milligan & Son*, 140. *Peace & Co.*, 91. *Pease, Heaton & Co.*, 60. *Pugh*, 306. *Sayce & Co.*, 307. *Schofield, Brown & Co.*, 3. *Thornton & Co.*, 32. *Trenel & Co.*, 147. *Welch & Co.*, 304. *Willey, Nephew & Co.*, 310. *Woodhouse*, 71. XIV. *Beveridge*, 29. XVIII. *Andrews, Sons & Gee*, 5. *Bannerman & Sons*, 33. *Crocker J. & A.*, 11. *Inglis & Wakefield*, 4. *Kesselmeier & Co.*, 44. *Ramsay & Co.*, 32. *Samuels & Co.*, 31. *Thomson, Brothers*, 25. *Wundercroft & Co.*, 45. XIX. *Ladies' Industrial Society*, 213. XX. *Macdougall*, 83.
Austria, *Furst*, 296. *Kroitzsch*, 297. *Tial*, 307. *Westhauser*, 305.
France, *Boute*, 33. *Mollet-Warme, Brothers*, 648. *Velin, Brothers*, 721. *Vigouroux*, 728. *India*, XV.
Switzerland, *Borel, Boyer & Co.*, 37. *Mueller, Pluess & Co.*, 151. *Naef*, 131. *Turkey*.
Zollverein (1), *Bauer & Furbringer*, 725. *Bodemer*, 726. *Boeddinghaus & Co.*, 572. *Cohn & Hermann*, 104. *Cohn & Co.*, 137. *Diergardt*, 509. *Kauffmann*, 123. *Lorentz*, 588. *Neuhauss*, 577. *Pferdmenges, Brothers*, 574. *Pferdmenges & Kleinjung*, 573. *Pfirffers & Ax*, 667. *Pintus*, 133. *Rorinann & Merkel*, 580. *Scheibler*, 314. *Sisumann & Wiesenthal*, 132. *Zollmann & Steigerthal*, 566. (2), *Steinhäuser*, 44. *Trendels & Son*, 41. (3), *Dietrich & Straff*, 103. *Graefe & Son*, 102. *Lehmann*, 107. *Richter*, 104. *Trinks*, 98. See also *Linen & Silk mixed Fabrics*.
MOHAIR, MOHAIR CLOTH, &c.—XII. & XV. *Baughan, Brothers*, 183. *Gill & Bishop*, 77. *Haggas & Sons*, 155. *Huth & Fischer*, 123. *Lambert*, 30. *Milligan & Son*, 140. *Salt*, 139. *Smith & Son*, 29. *Stowell & Sugden*, 496. *Townend, Brothers*, 162. *Walker & Co.*, 23. *Walker & Sons*, 87. *Wheeler*, 271. XIII. *Browett, W. & H.*, 80. *Turkey*.
Zollverein (3), *Haelen, Brothers*, 153.
MOHAIR MANUFACTURES, ILLUSTRATIONS OF—XII. & XV. *Milligan & Son*, 140.
MOLASSES—British Guiana, *Shier*, 27.
MOLASSES, &c., CENTRIFUGAL APPARATUS FOR—VI. *Napier & Son*, 158. *Hutch & Finzee*, 405.
MOLASSES SPIRIT—*France*, *Francois-Gregoire*, 511. *Gregoire*, 1730.
MOLESKIN MANUFACTURE, ILLUSTRATIONS OF—XI. *Barnes*, 40. See also *Cotton Manufactures*.
MONUMENT TO H.R.H. PRINCE ALBERT, DESIGN FOR—XXX. *Bennett*, 268.
MONUMENT, GOTHIC—*Mather*, page 530. *Purdy*, page 852.
MONUMENT OF LONDON (Model)—XXX. (*Fine Art Court*) *Smith*, 167.
MONUMENTAL BRASSES, &c.—*Archer*, page 847. *Gould*, page 849. *Ross*, page 852. *Waller & Co.*, page 853.
MOON, MAPS AND MODELS OF THE—X. *Blunt*, 372. *Nasmyth*, 688. *Readhouse*, 677.
MOORING CHAINS—VIII. *Parke*, 109. See also *Chain Cables*. *Screw Moorings*.
MOQUETTE—*France*, *Requillart, Roussel & Chocqueul*, 1433.
MORAVIAN SETTLEMENTS, LABRADOR (Models of Dwellings, &c., at)—XXIX. *Millaud*, 289.
MOREENS—XII. & XV. *Craven & Harrop*, 153. *Salt*, 139.
MORPHIA—II. *Macfarlan & Co.*, 107. *Morson & Son*, 106. *India*, II.
MORTISING AND BORING MACHINE—*United States*, *Otis*, 23.
MOSAIC WORK—XXVII. *Bright*, 80. *Tomlinson*, 79. XXX. (*Fine Art Court*) *Crichton*, 229. *Wyatt*, 30.

Austria, *Bigaglia*, 600. *Gröger*, 631. *Speluzzi*, 638A.
Belgium, *Couvert & Lucas*, 404. *De Keyn, Brothers*, 406. *Leclerc*, 425.
France, *Bossi*, 773. *Chretien*, 1561. *Laurent-François*, 1297. *Marcelin*, 606. *Theret*, 1499.
Portugal, *Bunnet*, 258.
Rome, 23, 32c, 36, 39. *Barberi*, 15. *Boschetti*, 17. *Moglia*, 20, 21. *Pater's St.*, *Royal Manufactory*, 21. *Rinaldi (Main Avenue, East)*, *Rochigiani*, 22.
Russia, *Peterhoff Imperial Polishing Manufactory*, 298.
Spain, *Jimenez*, 285.
Tuscany, *Bianchini*, 113. *Buonnisegni, Brothers*, 112. *Della Valle, Brothers*, 114. *Romoli*, 118, 119.
Zollverein (1), *Kielman & Von Minutoli*, 847. *March*, 240. *Moosbrugger & Kobbie*, 428. *Praetorius*, 853. *Schievelbein*, 237. *Trebbe*, 33. *Wiegandt*, 415. (7), *Boch*, 5. See also *Mosaic Pastes for Mosaic Pavement, Mosaic*.
MOSAIC CLOTH WORK—XII. & XV. *Braysham*, 463.
MOSAIC, IMITATION—XXX. (*Fine Art Court*) *Albert, His Royal Highness Prince*, 350.
Rome, *Marchesi & Co.*, 13.
MOSES—II. *The London Druggists*, 117. IV. *Holt*, 128. *Rock*, 5. *New Zealand*, 139.
United States, *Davidson*, 561. *Miller*, 559. See also *Lichens*.
MOTHER-OF-PEARL—XXII. *Banks*, 287.
MOTHER-OF-PEARL ARTICLES—XXII. *Brishand*, 364. *Austria*, *Schwarz*, 681.
China, *Copland*. *Hewett & Co.*, *Shea*.
Egypt, 272, 273. *Hamburg*, *Eckert*, 84. *Turkey*. See also *Buttons, Mother of Pearl*.
MOTION, NEW METHOD OF TRANSMITTING—X. *Good*, 146.
MOTIVE POWER (Model of convertible Wind, Water, or Steam power)—V. *Fit*, 118.
MOULDINGS (Picture-Framc, Ceiling, Cornice, &c.)—XXVI. *Bielefeld*, 157. *Vigers*, 362. *White & Parby*, 6. *Woolams & Co.*, 210. XXVIII. *Blisard*, 127.
France, *Archambault*, 401. *Vincent*, 1525.
MOULDING MACHINE—VI. *Furness*, 401.
MOULDING TOOLS—XXVIII. *Blizard*, 127. *Canada*, *Wallace*, 147.
MOUNTS, &c., FOR DRAWINGS, &c.—XIII. *Burke*, 57. XVII. *Kirby*, 23. XXVI. *Burke*, 361.
MOUTH-BAG FOR HORSES—IX. *Low*, 264.
MOWING AND REAPING MACHINES—IX. *Bates*, 190. *Beckford & Gosling*, 60. *Blakie*, 89A. *Fairless*, 155. *Garrett & Sons*, 142. *Mackay*, 81. *Trotter*, 145.
France, *Brother Eustate*, 193.
United States, *McCormick*, 73.
MULES (Cotton, &c., Spinning)—VI. *Mason*, 46. *Parr*, *Curtis*, & *Madeley*, 6. *Higgins & Sons*, 14.
MULTUM IN UNO (turning Loo, Hagatelle, &c. Table)—XXVI. *Jennens & Hettridge*, 187 (Main Avenue, West).
MUNDICS—See *Pyrites*.
MUNJEET (Dye)—XI. *Sandeman*, 2.
MURIATIC ACID—*Denmark*, *Owen*, 44.
Zollverein (1), *Mathes & Weber*, 464.
MUSHROOM SPAWN—III. *Grace*, 58A.
MUSIC—XVII. *Baxter*, 209. *Brettell*, 169. *Cocks, R. & Co.*, 123. *Fromefield School*, 172. *Wealey*, 160.
Austria, *Mechetti*, 371. *Muller*, 372.
France, *Brandus & Co.*, 1111. *Roussel*, 361. *Tautenstein & Cordel*, 1029.
Hamburg, *Schuberth & Co.*, 102.
Nova Scotia, *Central Committee*, 2.
Zollverein (1), *Körner*, 747.
MUSIC, DIAGRAMS FOR TEACHING—X. *Oakey*, 675. See also *Transparent Music*.
MUSIC ENGRAVING, PLATES FOR—*France*, *Dumery*, 487.
MUSIC (New System of)—XVII. *Davis*, 153.
MUSIC PRINTING—XVII. *Armstrong*, 77. *Novello*, 127. *Sinclair & Co.*, 92. XXX. (*Fine Art Court*) *Julien & Co.*, 63. *Hamburg*, *Schultze*, 46.
MUSIC-STANDES—X. *Besant*, 369. XXVI. *Evans*, 224. *McCullum & Hodson*, 136. *Riddett*, 49.
MUSICAL BELLS—X. *Drury*, 506. XXII. *Warner & Sons*, 798.
MUSICAL BOXES—*Austria*, *Hzebitcheck*, 162.
Switzerland, *Du Commun Girod*, 77. *Gay & Louprin*, 33. *Jaccard, Brothers*, 27. *Jaques & Son*, 33. *Le-*

- Speluzzi, 638A.
 yn, Brothers, 406.
- Laurent-François,
 99.
- Boschetti, 17.
 Manufactory, 21.
 Bigiani, 22.
 Manufactory, 298.
- ni, Brothers, 112.
 i, 118, 119.
 oli, 847. March,
 Prætorius, 853.
 egandri, 415. (7).
 r Mosaic. Pave-
 sham, 463.
 Court) Albert, His
- . iv. Holt, 128.
 559. See also
- risband, 364.
- a.
 34. Turkey. See
- no—x. Good, 146.
 Wind, Water, or
- rice, &c.)—XXVI.
 ard & Parby, 6.
 date, 127.
 525.
- Burke, 57. XVII.
- ates, 190. Beck-
 Fairless, 155.
 Trotter, 145.
- son, 46. Parr,
 us, 14.
 e, &c. Table)—
 Avenue, West).
99. Cocks, II.,
 Wesley, 169.
- l, 361. Tanten-
- akey, 675. See
- Dumery, 487.
 53.
- Novello, 127.
 Court) Julien
- . Evans, 224,
 49.
 ner & Sons, 798.
 62.
 Gay & Lamprin,
 & Son, 33. Le-
- coultre, Brothers, 90. Leconltre & Son, 32. Metert
 & Langlorf, 97. Faillard, 26.
- MUSICAL COMPOSING STICK—France, Beacher, 60.
- MUSICAL GAME—x. Prince, 522.
- MUSICAL INSTRUMENTS (Various)—x. Anelli, 511. Kœnig
 & Pask, 504. Kohler, 510.
 Austria, Hell, 152. Iluther, 149. Kiendl, 148. Pelitti,
 161. Riedl's Widow, 153. Rott, A. H., 158. Rott,
 J., 159. Stehle, 154. Stöhr, 160. Theiaz, 152A.
 Uhlmann, 155. Ziegler, 156.
 Belgium, Mahillon, 175. Canada, McPherson, 183.
 China, Hewett & Co.
 France, Beson, 424. Courtois, 463, 1163. Debanl,
 1172. Derazey, 814. Gaubot, 844. Labbays, 556.
 Roth, 993. Savaresse, 997. Sax & Co., 1726.
 Triebert, 1510. Villeroi, 1522. Vuillaume, 735.
 India, x. Malta, Tuncu, 1. Turkey. Tuscany, Fon-
 tina, A., 122.
 Western Africa, M^WWilliam. Matson, 9.
 Zollverein (1) Sommen, 893. (3). Herold, 19. Klemm,
 18. Schuster, L. 22. Schuster, M., 23. (6). Klein, 23.
 See also Accordions, Bassoons, Clarionets, Cornet-a-
 Pistons, Drums, Flutes, Guitars, Harmonicas, Har-
 moniums, Harps, Oboes, Ophecleides, Organs, Piano-
 fortes, Trombones, Trumpets and Horns, Violins,
 Violoncellos.
- MUSICAL INSTRUMENT STRINGS—Austria, Callegari, 150.
 Indri, 151. Belgium, Lacroix, 482.
 France, Bernardel, 421. Combes, 459. Savaresse, 997.
 Zollverein (1), Reichel, Brothers, 442.
- MUSK, ARTIFICIAL—II. Godfrey & Cooke, 92.
- MUSK ROOT—II. Savary & Moore, 115
- MUSKETS—See Guns, &c.
- MUSLIMS—XI. Anderson, J. & A., 7. Auld & Co., 5.
 Cook, W. W. & J., 38. Crocker, J. & A., 61.
 Davidson, W. & J., 17. Finlayson & Co., 8.
 Henry & Sons, 13. Johnson & Nephew, 55. Le-
 thern, Blyth & Lethern, 9. Mair & Co., 59.
 Outram & Co., 62. Rogers, Lowett, Holyland & Co.,
 58. Symington & Co., 14. Young & Co., 12. XIII.
 Grout & Co., 36. XIV. Holden & Co., 1. XVIII.
 Devas & Co., 6.
 Austria, Leitenberger, E., 186. Leitenberger, F., 187.
 France, Berr & Co., 54. Dollfus, Mieg & Co., 1191.
 Frouville & Rolland, 200. Hartmann & Sons, 256.
 Jourdain, 1631. Matagrin, Stolts & Co., 618.
 India, XI.
 Russia, Charlovetz, 374. Rochefort, 176, 191, 199,
 208.
 Switzerland, Baenziger, 112. Fehr, 123. Forster, 193.
 Imhoof, Brunner & Cu., 127. Nef, 193. Schlaepper,
 135. Schlaepper, Schliatter & Co., 201. Vouweller,
 140. Turkey. See also Gussing-Machines. Lawns.
- MUSLINS (Designs for)—XVIII. Cudman, 74. Percival,
 73. Roberts, 81. Whittaker, 76.
- MUSLINS, SEWED—XIX. Brown, 64. Cannaught Schools,
 Glasgow, 61. Macdonald, D. & J. & Co., 66.
 McFarlane & Porter, 63. Park & Thomson, 59.
 Robertson & Sons, 62.
- MUSLIN TRIMMINGS—XII. & XV. Salomons & Sons, 305.
- MUSTARD—III. Colman, 117. Dewar, 119. McGarry
 & Sons, 132.
 France, Grey, 527. Louit, Brothers, & Co., 316.
 Spain, Cordova Agricultural Bural, 99.
 United States, M^Alister & Tannehill, 362. McCulloch,
 70.
- MUSTARD SEED—Cape of Good Hope, Jeype, 4.
 Egypt, 51. Portugal, Fonte Hue, Viscount, 518.
- MYLITA AUSTRALIS—Van Diemen's Land, Dunn, 190.
 Lowes, 191.
- MYRRH—II. Lamplough, 71.
- MYRRHINE AIDS TO THE DIGESTIVE ORGANS—II. Lea,
 105.
- NAILS—XXII. Bartrum & Co., 25. Cornforth, 322. Keep &
 Watkins, 76. Manly, 313. Reynolds, 315.
 Austria, Egger, Count, 402. Ernst, 457. Falent, 458.
 Sanderl, 459. Vingert, 460. Weidl, 461.
 Belgium, Couillet Mines & Charbonages, 120. De
 Bayay, 361. Fauconier, 380. Drion, 353. Lefebvre
- & Co., 354. Limelette, 381. Macquinary, Brothers and
 Nephew, 378. Mallet, 407. Sevrin, 367. Steron, 358.
 Canada, Holland & Dunn, 152.
 France, Morel, Brothers, 1666. Sirot, 1017.
 Nova Scotia, Archibald, 2. Russia, Zeitler, 343.
 Sweden and Norway, Godgard Forges, 13.
 United States, Field, 455. Morris, Jones, & Co., 44.
 Swedish Iron Manufacturing Company, 320c.
 Zollverein (3), Wolf, 29.
- NAIL-MAKING MACHINE, France, Frey, 1607.
- NANKEENS—XI. Major & Gill, 49. China, Hewett & Co.
 Malta, Dimech, 21.
- NAPHTHA—Turkey. Zollverein (6), Oehler, 8.
- NAPHTHA, APPARATUS FOR PRODUCING—XXII. Pope, 566.
- NAPHTHALINE—II. Evans, 5. Spencer, 31. Wilson, 6.
- NAPOLION, STATUES, &c., of—France, Seguin, 1693.
 Russia, Imperial Alexandrovsk Cannon Foundry, 285.
- NATIONAL GALLERY, DESIGN FOR—XXX. Bury, 349.
- NATRON—Egypt, 11, 16, 17.
- NAUTICAL APPARATUS (Various)—VIII. Wood, 102. See
 also Binnacles. Ships' Compasses. Mariners' Logs.
 Ships' Rudders. Ships' Sounding-Leads.
- NAUTICAL MODELS—I. Vieille Montagne Mining Company,
 437. VII. Morton S. & H., 24. - VIII. Admiralty,
 145, 146 (North Transept). Aldebert, 152. Allan,
 85. Auzlay, 39. Bailey, 64. Baillic, 70. Bilbe &
 Co., 141. Brown, Sir S., 334. Browne, 158. Cole-
 grave, 142. Deans, 40. Downs, 133. Ellis, 129.
 Enderby, 162. Grantham, 93. Gray, 160. Green,
 131. Hall, 73. Harvey, 150. Hedley, 307. Hen-
 derson, 306. Hodgson, 316. Horn, 161. Howe, 132.
 Inglefield, 99. Laing, 315. Lampart, 134. Lap-
 thorne, 170. MacLaren, 139. Moore, 35. Penrice,
 173. Rose, 164. Royal Thames Yacht Club, 294.
 Russell, 127. Simms, 33. Smith, II., 165, 279.
 Smith, T. W., 305. Stevenson, 304. Tovell, 37. Turn-
 bull, E. 154. Torriball, R. 153. Weld, 186. White,
 J., 30. White, T., jun., 52. White, T. J. & R., 36A.
 Wigram, Monev & Sons, 58. xxx. (Fine Art Court)
 Brooker, 109. Brazil, Cox, 2. China, Haemond,
 Hamburg, Hufe & Son, 9. India, VIII.
 Labuan, &c., Hammond & Co., 2.
 United States, Boole, 312. Darton, 449. Griffith, 226.
 Pook, 446. See also Boats. Figure-Heads (Ships).
 Fishing-Boats. Steam-Vessels.
- NAVAL ARCHITECTURE (Diagrams, &c., illustrative of)—
 VIII. Allan, 85. Brown, 334. Hall, 73. White,
 52. Scamp, 298. Sloggett, 32. Smith, 125.
 United States, Griffith, 226.
- NAWAB NAZIM OF BENGAL, Articles presented to Her
 Majesty by—India.
- NEPTANDRIA RADIAEI, OR GREEN-HEART BARK—II.
 Howards & Kent, 11.
- NEEDLE-MAKING MACHINERY—VI. Morrall, 240.
- NEEDLES—VI. Morrall, 240. XXII. Bartlett & Sons, 329,
 Bunton & Son, 330. Chambers, 297. Cucker & Sons,
 115, 234. Goodman, 335. James, 295, 317. Morrall,
 333. Worrall & Co., 164. XXIX. Kirby, Beard &
 Co., 96. Austria, Struz, 477.
 Barbadoes, France, Tachy & Co., 1497.
 Zollverein (1), Beissel & Son, 407. Schleicher, 405.
- NEEDLEWORK—XIX. Bates, 375. Brayshaw, 362. Davies,
 49. Fandel & Phillips, 165. Harttree, K. & G., 195.
 Hayes, 330. Hellesouer, 199. Hill & Co., 204.
 Lee, 255. M'Dermid, 247. Phillips, 271. Pickthorn,
 273. Read & Humphreys, 275. Robinson, 278.
 Shakell, M., F., & E., 289. Tennison, 313. Ward,
 334. xx. Smith, 29. Standish, 106. Standou, 213.
 Belgium, Plettingck, 340. Van Looy, 339.
 China, Rawson.
 France, Billicock, 26. Helbrouner, 260.
 Hamburg, Appel, 119. Hartog, 115. Severin, 118.
 Persia, Thomson. Sweden and Norway, Alner, 42.
 Switzerland, Baenziger, 188. Schiess, 200.
 United States, Getzinger, 320. Golding, 320A. Leask,
 108. See also Embroidery (Silk, Muslin, &c.). Tatting.
- NETTED WORK—XIX. Wilson, 112. XXVIII. Schol for
 the Indigent Blind, 109. France, Blancher, 27.
 Western Africa, Trotter, 5.
- NETTING (for Fruit-Trees, &c.)—IX. Farlow, 221. Hall,

158. xiv. Morrison & Hurn, 49. xix. Hall, 185. xxviii. Woodhead, 191.

NETTING-MACHINES—*United States*, M'Mullen, 64.

NEWCASTLE AND NORTH SHIELDS RAILWAY, MODEL OF ARCH ON THE—vii. Green, 3.

NEWCASTLE-UPON-TYNE CENTRAL RAILWAY STATION, ROOF (Model)—vii. Dubsou, 114.

NEWCASTLE-UPON-TYNE COUNTY COURTS, &c. (Models)—xxx. (Fine Art Court) Grainger, 165.

NEWCASTLE-UPON-TYNE HIGH LEVEL BRIDGE (Drawings)—vii. Green, 3. Hawks, Crawshaw, & Co., 86.

NEWSPAPERS (published in New York)—*United States*, Beach, Brothers, 544. Dawson, 543.

NEW YORK (Views of)—*United States*, Bachman, 391.

NEW ZEALAND, VIEWS, &c. OF—*New Zealand*, Moore, 37.

NIAGARA, FALLS OF (Model)—*United States*, Catlin, 531; page 847.

NIBELUNGENLIED HEROES (Statues)—*Austria*, Salm, Prince, 430.

NICHOLAS, ST., CHURCH, HAMBURG (Model)—vii. Scott, 22 (Main Avenue, West).

NICKEL—*Spain*, Lugo Mines, Sub-Inspector of, 18. Malaga Mines, Inspector of, 19.

Zollverein (8), Isabellen Hutte Smelting Works, 3.

NICKEL ORE—i. Goothalo & Reeves, 476.

Spain, Lugo Mines, Sub-Inspector of, 18.

NIGHT DIALS—vii. Trotman, 155.

NIGHT LIGHTS—xxii. Bird, 267.

NINEVEH MARBLES (Models of)—xxx. (Fine Art Court) Layard, 78.

NIPPLE-SHIELDS—x. Jones, 652.

NITRE—*Portugal*, Seradello & Co., 42.

Spain, Elias, 39. Paulo y Bartolini, 44.

NITRIC ACID—*Sardinia*, Selopis, Brothers, 4. *India*, ii.

NITRIC ACID, CRYSTALS OF—ii. Pontifex & Wood, 1.

NOCTOGRAPHS (for the Blind)—xvii. Wedgwood, 47.

France, Couteux, 805.

NORB VIADUCT, KILKENNY (Model)—vii. Moorsom, 178.

NORMA VIRIUM, OR MUSICAL ACCENTUATORS—x. Simpson, 532. See also *Metronomes*.

NORTHUMBERLAND AND DURHAM COAL-FIELDS (Maps and Plans illustrative of)—i. Coal-Trade of Northumberland and Durham, 273.

NOSES, ARTIFICIAL—x. Fuller, 592. Whitehouse, 280.

NOYEAU, CRYSTALLIZED—*Sardinia*, Saluce, 10.

NUTGALLS—xvii. Hawthorne, 7. *India*, iv.

NUT-OIL—*Spain*, 166.

NUTS (Various)—*British Guiana*, Duggin, 20.

Portugal, 392-400.

Spain, 97, 110. Labat, 104. Malaga Board of Agriculture, 94. Reus Board of Trade, 109. Tarragona Board of Agriculture, 114. Valgoma, 98. *Trinidad*, Lord Harris, *Tunis*, 107, 108.

Turkey. *Western Africa*, Jamieson, 22.

OAK-BARK—*Belgium*, Stabbe & Bacye, 97. See also *Barks*.

OARUM—*Russia*, Ardanatsky, Brothers, 99. Kazalett, 102. Sabinin, 116.

OARS FOR BOATS—viii. Pearson, 65.

New South Wales, Bogue, 2. *Turkey*.

United States, Page, 92.

OAT-FLOUR—iii. Smith, 161. *Russia*, Davidoff, 332.

OATMEAL AND WHEATMEAL—iii. McCann, 153. Buck & Son, 162.

Canada, Richer, 55. Squair, 51. Trenholm, 54. *United States*, Clark, 234.

ORBOES (or Hautboys)—*Denmark*, Selboe, 31.

France, Buffet, 442. *Zollverein (2)*, Boehm, 23.

OCRES (Yellow and other)—i. Gore, 128A. Jenkins & Beer, 92. Sweetman, 40. *Canada*, Logan, 1.

France, Gautier, 1245. *India*, i.

Nova Scotia, Central Committee, 2.

Trinidad, Lord Harris, 17-20, 31.

Van Diemen's Land, Denison, Sir W. T., 335, 336. Milligan, 265.

ODOMETER (for measuring distances)—x. Payne & Co., 73.

ODORIFEROUS LIGHTERS (for igniting Tapers, Lamps, &c.)—xxix. Sandell, 97.

OFFICE INDEX AND TABLE MEMENTO—x. Dyer, 379.

OIL FOR PAINTING—ii. Blondell & Co., 48.

Belgium, Vanlestraeten, 84.

OIL-CAKE MILLS, CRUSHERS, &c.—ix. Barrett, Exall, & Andrews, 128. Bennet, 75. Halstead & Sons, 106. Maynard, 109. Nicholson, 50. Ransomes & May, 124. Sammlson, 185. Weillake & Co., 127.

United States, Bullock, 145. See also *Linseed-Presses*.

OILCLOTH—xiv. Grimshawe & Wilkinson, 92. xviii. Clarke, 23.

Austria, Pfeunberger, 359.

Belgium, Jorez & Sun, 306. Van Nuffel & Covelliers, 225.

Canada, Laflamme, 116, 122. *France*, Le Cromier, 1305.

United States, Albro & Hoyt, 183. Woodcock, 135.

Zollverein (1), Burchardt & Scus, 163. Lehmann, 167. (3), Goehring & Boehme, 164. Quast, 162. Roeller & Huste, 161. Teubner & Co., 163.

Zollverein (5), Ihm, 46. See also *Floor Cloth*.

OIL-COLOUR PRINTING—See *Colour Printing*.

OIL-PAINTING ON VELVET—xxx. (Fine Art Court) Yeo, 260.

OIL-PRESSES—See *Linseed-Presses*.

OIL-TESTING MACHINES—v. Whytehead, 101. vi. Muir, 206.

OILS, EXPRESSED AND ESSENTIAL—ii. London Druggists, 117. iv. Barker & Co., 62.

Ceylon, Parlett & Co. Pieris. See also *Lavender, Oil of, Peppermint, Oil of*.

OILS, MEDICINAL—*India*, ii. iv. See also *Castor Oil*.

OILS, PROCESSES OF EXTRACTING, FROM THE REFUSE SOAPSDUFS OF WOOLLENS, &c.—iv. Bauweis, 26.

OILS (Various)—ii. Breary, 80. iv. Freeman, 25. Hillas, 28. Miller & Sons, 29. xxix. Langdale, 55.

Algeria, Carlet, 22.

Belgium, Claude, 85. Rohyus, 487. Vandestraeten, 84. *British Guiana*, Stutchbury, 52, 53.

South Africa, Clarence, 4. Jeppe, 4. Kunhardt & Co., 14. Schmieterloew, 12. *Ceylon*.

China, East India Company. *Denmark*, Owen, 44.

Egypt, 39, 53, 57, 102, 129-131, 390.

France, Geminy, 1613. Jolly, 276. Moreau, 325. De Ruolz, 1466. *India*, iv. *New South Wales*, Gilbe, 24. Leam, 20.

New Zealand, Smith, 29. *Sardinia*, Girardi, Brothers, 5. *South Australia*, Webster, 3. *Trinidad*, Lord Harris. *Tunis*, 187, 188. *Turkey*.

Van Diemen's Land, Brown & Co., 283, 285. Gunn & Milligan, 282. Loves, 286. Hart, 163, 164.

Western Africa, Hutton & Sons, 6.

Zollverein (1), Romer, 337. Schramm, 806. See also *Olive Oil*.

OLEIC ACID—*Belgium*, Vancampenhout & Co., 436.

OLEINE (For Waxes and Fine Machinery)—ii. Breary, 80. Godfrey & Cooke, 92. *Belgium*, Bisse, 87.

OLIVE-TAR (Earthen)—*Portugal*, 1098 (Main Avenue, East).

OLIVE OIL—iv. Brotherton & Co., 23.

Algeria, Borle, 9. Corret, 22. Maffre, 35. Mercurin, 37. *Ionian Islands*, Mavroiaoui, 3.

New South Wales, Hallett & Sons, 5. *Portugal*, 460-486.

Sardinia, Mesnia, 31. Simone Mauci, 15.

Spain, 164, 165, 171. Diez de Rihera, 172. Fernandez, 169. Montesinos, 167. Sobradiel, Count of, 174. Valencia Board of Agriculture, 173. Zayas, 168. *Turkey*.

Tuscany, Orsetti, 31. Pacini, 33. Ruschi, Brothers, 32. Saracini, 34.

OLIVES—*Algeria*, Julien, 31. *Egypt*, 57, 58. *Portugal*, 440-444.

Spain, Carabe, 112. Cordova Agricultural Board, 99. Lesaca, 113. Marquez, 108. Zambrano, 111.

Tunis, 68, 156, 159-161.

OMNIBUSES (including Models)—v. Cook & Co., 816. Kinross & Co., 898. Lewis, 902. Menzies, 912. Parsons, 807. Rock & Gower, 954. Wheatley, 810.

OMNIBUS PASSENGER REGISTER—x. Webster, 671A.

OMNIBUS VENTILATOR—v. Stevens, 130.

OPERA GLASSES—x. Dixey, 271. Elliott & Sons, 320. Piltacher, 269. Solomon, 286. Whitehouse, 280.

France, Plagniol, 1679. Prudent, 1412.

OPHICLEIDES—x. Jordan, 523.

Belgium, Mahillon, 175.

- 48.
- Barrett, Exall,
stead & Sons, 106.
Barnes & May,
Co., 127.
Linsed-Presses.
son, 52. XVIII.
- 1 & Coveliers, 225.
Le Crosnier, 1305.
Woodcock, 135.
Lehmann, 167.
Maat, 162. Roeller
3.
- oor Cloth.
Printing.
ne Art Court) Yeo,
- ad, 101. VI. Muir,
- London Druggists,
also Lavender, Oil
- also Castor Oil.
FROM THE REFUSE
IV. Bauwens, 26.
reeman, 25. Hillas,
angdale, 55.
7. Vandestraeten,
52, 53.
e, 4. Kunhardt &
ylon.
ark, Owen, 44.
D.
- Moreau, 325. De
h Wales, Gibbs, 24.
- Girardi, Brothers, 5.
dad, Lord Harris.
- 283, 285. Gunn &
t, 163, 164.
- nm, 806. See also
- dt & Co., 436.
ery)—II. Breurey,
nm, Biase, 87.
8 (Main Avenue,
- re, 35. Mercurin,
Portugal, 460-486.
u, 15.
y, 172. Fernandez,
unt of, 174. Valen-
yas, 168. Turkey.
tsuchi, Brothers, 32.
- 57, 58.
- ultural Board, 99.
brano, 111.
- ook & Co., 816.
2. Menzies, 912.
Wheatley, 810.
Welster, 671A.
36.
t & Sons, 320.
Whitehouse, 280.
12.
- France, Beason, 424. Courtois, 1163. Gaubot, 844.
Zollverein (2), Pfaff, 35.
- OPIMUM—II. Howards & Kent, 11. Lamplough, 71.
Algeria, Frederic, 25. Hanly, 23. Egypt, 23.
France, Aubergier, 754. India, II., III.
- OPTIC SQUARE—X. Yeates, 332.
- OPTICAL INSTRUMENTS (Various)—X. Heath, 351. Gard-
ner, 365. Goddard, 274. Hyams, 278. Jorlan, 285.
XXIV. Chance & Co., 22. Powell & Sons, 31.
France, Bernard, 702. Beyerle, 765. Biron, 443.
Chevalier, 1729. Dillensager & Patry, 168. Duboscq-
Soleil, 1197. Jamin, 549. Lebrun, 298, 571.
Molteni & Siegler, 649. Schiertz, 999.
Russia, Piek, 170. Spain, Oppelt, 271.
Switzerland, Daguot, 75. Jaccard, 104.
Zollverein (1), Busch, 89. (2), Eisenmenger, 24. Merz
& Sons, 30. See also Lenses. Opera Glasses. Specta-
cles. Telescope Glasses. Telescopes.
- ORANGE-WINE—Sardinia, Garissini, 9.
- ORCHIL—II. Marshall, 68. IV. Smith & Son, 68.
Austria, Heinken, 26. France, Mottet, 932.
Zollverein (1), Krimmelbein & Co., 457.
- ORCHILLA-WEED—II. Hatmel & Ellis, 10.
Cape of Good Hope, Watermeyer, 51.
New Zealand, Smith, 19. Portugal, 505-509.
- ORDERS OF KNIGHTHOOD (in Enamel and Silver)—VIII.
Firmin & Sons, 211. XX. Firmin & Sons, 161.
- ORDNANCE. See Cannon.
- ORDNANCE SURVEY INSTRUMENTS—X. Hall, 4.
- ORE WASHING-CASES AND MACHINES—I. Hunt, 482.
VI. Bruntton, 304. Hunt, 207. Russia, Demidoff, 153.
- ORGAN-PIPES, &c.—X. Roome, 548.
Van Diemen's Land, Valentine, 182.
- ORGANS (Church, Cabinet, and other)—X. Bishop, 553.
Bysson, 735. Brutton, 96. Forster & Andrews, 562.
Gray & Davison, 555. Hill & Co., 556. Hollitch,
557. Robson, 559. Walker, 561. Willis, 209.
France, Alexandre & Son, 1719. Ducroquet, 173
(Main Avenue, East). Fourneaux, 1605. Herz, 1268.
Jaulin, 1274. Martin, 1711. Muller, 1363.
Tuscany, Ducei, 58.
Zollverein (1), Körner, 747. Schultze, 707.
- ORGANS, BARREL (for Travelling)—France, Husson, 885.
Muller, 1365.
- ORGANZINE—France, Dumaine, 175. Dyedier, 1580.
Farjon, 1217. Jourdain, 1631. Menet, 1657. Mourgue
& Bousquet, 1363. Verdet & Co. 1510.
Russia, Rebhoff, 143.
Sardinia, Imperatori, Brothers, 38.
- ORLEANS CLOTH—XII. & XV. Eckroyd & Son, 130A. Green
& Sons, 65. Haggas & Son, 155. Kershaw, S. & II.
161. Milner & Co. 168. Shuttleworth, 156. Simon,
Siltler & Co. 163. Wall, Cockshot & Wall, 159.
Belgium, Decock, 221.
Zollverein (1), Friedheim & Sons, 109.
- OR-MOLU ARTICLES—XXIII. Warriner, 60. XXIV. Green,
32. XXVI. Toms & Luscombe, 178. Wertheimer, 177.
United States, Hooper & Co. 459.
- OR-MOLU, IMITATION OF—XXIII. Rawlings, 54. XXVI.
Fullis, 364. Lithgow & Purdie, 106. Newnham, 365.
XXX. (Fine Art Court) Vinn, 205.
- ORNAMENTAL WORK (Undescribed)—XIII. Greenhields,
58.
- ORNAMENTS FOR INTERIOR DECORATIONS—XXVI. Tilling,
111.
- ORNITHOLOGICAL SPECIMENS—VIII. Hubbard, 160. IX.
Milton, 291. XXIX. Bartlett, 291. Dennis, 161.
Gardner, 223. Gordon, 302. Hancock, 320. Lead-
beater, 221. Spencer, 222. Walford, 207. Williams,
219. Withers, 292. XXX. (Fine Art Court) 27.
Belgium, Brenta, 435.
British Guiana, Ridgway, 160, 161.
- ORRERIES—X. Facy, 195. Newton & Son, 212. Plant,
215. Jersey and Guernsey, Le Fenvre, 10.
- ORTHORACHIDIC INSTRUMENTS (for Deformity of the Spine)
—X. Caplin, 570, 570A.
- ORTHOCHORD—Denmark, Moller, 32.
- ORTHOPEDEAL APPARATUS, &c.—France, Pillant & Co.,
351. Spain, Cort y Marti, 273.
- OSSETIAN CLOTH—Russia, Cacki Shivilly, 183.
- OSTEOTOM (Surgical Instrument)—X. Hess, 648.
Switzerland, Wermuth, 107.
- OSTRACIDE (or Oyster-opener)—X. Brown & Son, 627.
- OSTRICH EGGS—South Africa, Trutor, 8.
Egypt, 270.
- OSTRICH FEATHERS—XXIX. Foster & Co. 74.
South Africa, Rutherford, 23. Tunisia, 92.
Turkey.
- OSTRICH SKINS—Tunisia, 186.
- OTTO OF ROSES—II. Bell, 116. India, IV. Tunisia, 83.
- OTTOMANS—XXVI. Aggio, 83. Everest, 27. Sandeman,
173. Sowerby & Castle, 192. XXIX. Aggio, 312.
- OUSE RIVER RAILWAY BRIDGE (at Selby)—VII. Walker
& Burgess, 224 (Main Avenue, West).
- OVENS—XXII. Powell, 372. Shave, 90.
China, Reeves. France, Lespinasse, 311.
United States, Perkins, 541. Zollverein (1), Kaesen,
408.
- OVENS, GAS—XXII. Edwards, 241. Warriner, 248.
- OVENS, PORTABLE—Powell, 95.
- OXALIC ACID—Schlippe, 27.
Portugal, Hirsch & Co. 503.
- OXFORD, MARTYRS' MEMORIAL AT—XXX. (Fine Art
Court) Day, 161A. Spiers & Son, 361.
- OXYDIZED SILVER, TABLE OF—Main Avenue, East, Wag-
ner, 1200.
- OYSTER SHELLS—South Africa, Calp, 55.
- PACKING-MACHINE—VI. Marriot, 116.
- PADDING AND WADDING—XII. & XV. Wilkinson, 51.
PADDLE-WHEELS, BOXES, &c. (including Molels)—V.
Flynn, 123. Jones, 156. Pym, 160. Terrett, 126.
Wilding, 60. VII. Askew, 48. Spurgin, 76. Wilson,
97. VIII. Flynn, 183. Long, 173. Mathews, 119.
Mumford, 144. Poole, 77. Pym, 321. X. Adcock,
364.
- PADDLE-WHEELS, INSTRUMENT FOR FEATHERING THE
FLOAT OF—V. Smith, 141.
- PADDLE-WHEELS, INSTRUMENT FOR REGISTERING SPEED
OF—XXII. McKenzie, 418.
- PAGING AND NUMBERING MACHINE—VI. Schlesinger &
Co. 168.
- PAINTS—IV. Bruce, 74. Rose, 27.
British Guiana, Ontridge, 55c.
France, De Ruola, 1466. Zuber & Co. 1536.
Netherlands, Bleekrode, 1. See also Colours.
- PAINT, FIRE-PROOF—United States, Blake, 233. Houston,
554.
- PAINT-MILLS—United States, Harris, 512.
- PAINTED GLASS—XXIV. Chance & Co. 60. Davies, G., 37.
Davies, W., 38. Gibbs, 75.
- PAINTED WINDOWS—XXIV. Bland, 80. Chance & Co.,
60. Claudet & Houghton, 25. Gault, 68. Gibson,
72. Toms, 71. XXVI. Hartman & Co., 532.
Austria, Bertini, 737 (Main Avenue, East).
France, Lason, 565. Laurent, Gsell, & Co. 294. Mare-
chal & Guyonni, 329. Hamburgh, Bostelmann, 99.
Zollverein: Kellner, 86.
- PAINTING C—ASS—XXIV. Jackson, E. & W. H. 77.
Kiddle, Newsham, 79. Powell & Son, 31. Price,
43. XXVI. M'Lachlan, 337. XXX. (Fine Art Court)
Pike, 336. Austria, Geyling, 736.
China, Hewett & Co. Siehart & Co.
France, Lafaye, 284. Thevenot, 1036.
Hamburgh, Rösing, 100.
Zollverein (1), Burckhardt, Brothers, 810. Zebger, 308.
(4) Wetzel, 109. See also Painted Windows.
- PAINTING ON MARBLE—XXVI. Horsfall, 56.
- PAINTING ON TILES—XXVII. Dupper, 51.
- PAINTING, ENCAUSTIC—See Encaustic Paintings.
- PAINTING, HOUSE-DECORATIVE—XXVI. Calvert, 82. Hol-
land, 407.
- PAINTING IN IMITATION OF MARBLE—See Marble, Imita-
tion.
- PAINTING IN IMITATION OF WOOD—XXVI. Carson, 109.
Coomber, 307. Davis, 143. Gathwaite, 48. Holland,
407. Sewell, C. & F., 340. Smith, 141. XXVII.
Kershaw, 1.
- PAINTING, NEW STYLE OF—XXX. (Fine Art Court) King,
113.

- PAINTINGS (Oil and other)**—vi. Fussell, 95. xx. Newbury Local Committee, 166. xxx. (Fine Art Court) Miller, 1.
China, Baring, Brothers, Hewett & Co. Reeves.
France, Bowrgery, 778. Marese, 1355. *India*, xxx.
Eastern Archipelago, Hammond & Co. 2. *Roma*, 40-47.
United States, Jeffrey, 150.
Zollverein (1), Jacob, 786. Stockmann & Co. 788. See also *Miniature Paintings*.
- PAINTINGS PRODUCED BY CHEMICAL ACTION**—*Zollverein* (1), Rings, 302.
- PALANQUINS**—State and other Palanquins presented to Her Majesty. *India*, v.
- PALLADIUM**—i. Johnson & Matthey, 477.
- PALM FRUIT, &c.**—*Egypt*, 38.
Western Africa, Hutton & Sons, 6. Trotter, 5.
- PALM-HOUSE, KEW (Model)**—vii. Turner, 7.
- PALM OIL**—iv. Price's Patent Co. 83. Rose, 27. xxix. MacKean, 28.
Portugal, 496A.
Western Africa, Hutton & Sons, 6. Weston, 1.
- PALMATINE CANDLES**—*Austria*, Pfitner & Beckers, 41.
- PALMETTO PLAIT**—*Bermudas*, —.
- PANELS AND PANEL DECORATIONS**—xviii. Gauthorp, 70. xix. Greenwood, 181. xxvi. D'Almaine, 301. Hinchliff & Co. 310. Pickering, 347. Turner & Co. 320. xxx. (Fine Art Court) Cook, 9. See also *Glass Panelling*.
- PANOPTIC POLYRAMA**—xxix. Bouchet, 124.
- PANORAMAS**—*France*, Janlin, 1274.
- PANTOGRAPH**—*France*, Gavard, 235.
- PAPER**—xvii. Cowan & Sons, 101. De la Rue & Co. 76. Dubbs & Co. 79. Hastings & Mellor, 85. Johnson, 42A. Mansell, 27. Spicer, Brothers, 42. Spiers & Son, 208. Venables, Wilson, & Tyler, 149. Waterlow & Sons, 46. xxx. (Fine Art Court) Burke, 42.
Algeria, Algiers, Delegate of, 58. Fletchey, 24.
Austria, Eggerth, 361. Smith & Meynier, 360.
Belgium, Glenisson & Vangenechten, 286.
China, Copland. *Denmark*, Drewsen & Sons, 4.
France, Angrand, 7. Blanchet, Brothers, & Kleber, 1090. Bondon, 63. Breton, Brothers, & Co. 436. Callaux Belienoriel De Tinan & Co. 788. Delicourt, 1715. De Sarlay, 1484. Doumerc, 822. Dufour, 483. Guenou, 1714. Germain-Simier, 1246. Gratiot, 854. Gueno, 250. Houzeau, 878. Lacroix, Brothers, 1636. Lapeyre, Kob, & Co. 1642. Lefevre, 1311. Marion, 609. Manban & Vincent, 377, 619. Mayer, 624. Meillet & Pichot, 629. Muntgolfier, 324. Obry & Co. 334. Odent, 938. Reichmann, 1429. Souche Paper-mills Company, 377, 619. Zuber & Co. 1536.
India, xvii. *Netherlands*, Gel & Sons, 61.
Portugal, De Tojal, Count, 987A-989. *Rome*, Miliani, 12.
Russia, Aristarkhoff, 359. Fetter & Rahn, 262. Selenikoff, 261. *Spain*, Romany y Miró, 250.
Switzerland, Steinlin, 183. Thurneisen, 182.
Tuscany, Cini, Brothers, 68.
United States, Belvidere Manufacturing Company, 282.
Zollverein (1), Ehart, Brothers, 145. Engelhard & Karth, 417. Fechner, 266. Hoesch & Son, 392. Karcher, 391. Koch, 329. Maniac, 249. Piette, 394. Ruhl & Son, 597. Schaeffler, Otto, & Co. 153. Schnell, 393. Selenka, 800. (2), Dessaur, 68. Haenle, 47. (3), Fischer, 108. (4), Rauch Brothers, 44. Schaeuffelen, 41. Veiel & Co. 45. (6), Freund, 38. Weber, 43. West, Brothers, 44. See also *India Paper*. *Perforated and Lace Papers*. *Rice Paper*. *Stationery*.
- PAPER-CLOTH**—xvii. Brettnall, 164. *China*, Shea.
- PAPER-CUTTING AND FOLDING MACHINES**—vi. Black, 138. Titcombe, 108. Wilson, 112. See also *Envelope-making Machines*.
- PAPER-HANGINGS (Various)**—xii. & xv. Cropper, 249. Martin, 249. xviii. Carter, 65. Law, W. & E., 10. xxvi. Archer, 265. Arthur, 303. Ascroft, 304. Barrett, 305. Clarke & Co., 62. Cotterill, Brothers, 149. Crace, 530. Fletcher, E. 84. Fletcher, R. 151. Gaunt & Son, 88. Goddard, 303. Haselden, 95. Helbrunner, 123. Heywood & Co., 71. Hinchliff & Co., 310. Horne, 32. Jeffrey & Co., 326. Law & Sons, 89. Marden, 527. Newbery, J. & R. 313. Polter, C. H. & E. 74. Richardson, 207. Scott & Co., 300. Simpson, 270. Townsend & Co., 318. Turner & Co., 320. Williams & Co., 321. Woollams and Co., 210, 309. Woollams J. & Co., 322.
Austria, Sporlein & Zimmermann, 651.
Belgium, Deviss, 401. Lefevre, 403. Picard-Masy, 405.
China, Hewett & Co.
France, Cerceuil, 793. Couder, 1566. Daudrieu, 155. Williams, 742.
Hanover, Herting, 9. *Russia*, Felter & Ran, 262. Vargounin, Brothers, 260, 302.
United States, Hart, Montgomery & Co., 260. Howell & Brothers, 48. *Sweden*, Arundal, 111.
Zollverein (1), Arnold, 835. (7), Lamort, 2.
- PAPER-MAKING MACHINERY**—vi. Brewer, C. & W., 144. Brewer, J. 132. Cowan & Sons, 166. Fourdrinier, 100. Lightfoot, 162. Sullivan, 156. Watson, 165. xxii. Makin, 112.
France, Bauchet-Verliude, 413. Varrall, Middleton & Elwell, 717. *Zollverein* (1), Wuttig, 151.
- PAPER-RULING MACHINE**—vi. Shaw, 110.
- PAPER-SHADES-MAKING MACHINE**—vi. Taylor, 136.
- PAPER WEIGHTS (Marble)**—*Van Diemen's Land*, Boyd, 233.
- PAPIER-MACHÉ WARE**—xxii. Bray, 500. Walton, 701. xxv. Davies, 129. Gushlow, 37A. Jackson & Sons, 5. Jennens & Bettridge, 187. Spiers & Son, 70. Welch, 150.
Austria, Hecker and Kronick, 643. Hoffrichter, 644.
France, Trouve, 1513. *Persia*, Abbot.
Sweden, Johnson, 64.
Zollverein (1), Below, 233. Herford Prison Directors, 721. Hupfer & Wallerman, 774. Sommer, 390. (2), Adt, Brothers, 56. Fleisch, 72. (4), Rau & Co., 72. (3), Kindermann, 170.
- PAPIER-MACHÉ (Designs for)**—xviii. Heaviside, 91.
- PAPYROGRAPHY**—vi. Taylor, 136. xxviii. Barber, 116. Burgess, 119. School for the Indigent Blind, 100. xxix. Daniel, 170. Herbert, 301. Prideaux, 303. xxx. (Fine Art Court) Hine, 201. Uwin, 22.
Jersey and *Guernsey*, Saunders, 23. Simon, 24.
Rome, Livizzano, 14.
Sweden and *Norway*, De Liewen, 32.
- PARACHUTES FOR MINES**—*Belgium*, Vander Hecht, 475. See also *Balloons and Parachutes*.
- PARAFFINE**—ii. Young, 7.
- PARAMATTA CLOTHS**—xii. & xv. Craven & Harrop, 153. Fowler, Campin & Co., 309. Middleton & Ainsworth, 312. Peel & Co., 164. *Belgium*, Decock, 221.
- PARASOLS**. See *Umbrellas and Parasols*.
- PARCHMENT**—iv. Groves, 131. xvi. Evans & Son, 18. Lever, J. & J. 24. Tomlin, 22. xvii. Saunders, 36. *Belgium*, Bemand, 478. *France*, Berthault, 56. *Netherlands*, Honig, B. C. & F. 59. Honig & Son, 60. *Van Diemen's Land*, Button, 172.
Zollverein (1), Sondermann, 743.
- PARIAN ARTICLES IN**—xxv. Boote, T. & R. 11. Hughes, 60. Meigh & Sons, 10. Meyer, T. J. & J., 9. Mintou & Co. 1. Rose & Co., 47. Simpson, 33. xxvii. Keene, 1, 27. xxx. (Fine Art Court) Boote, T. & R. 139.
- PARIS WHITE**—i. Walker, 120.
- PARK GATES**—xxii. Coalbrook Dale Co. 641. (North Transept, 49). Cottam & Hallen, 698 (South Transept).
- PARK GATES, DESIGNS FOR**—xxii. Phillips, 6.
- PARQUETERIE FLOORING**—*Austria*, Leinster & Son, 633. *France*, Laurent-François, 1297.
Zollverein (1), Beyer & Heintze, 761. Elsholz, 230. (2), Hartmann, 73. See also *Inlaid Flooring*.
- PARTHENON, Athens (Model of the Portico)**—xxx. (Fine Art Court) Day, 161A.
- PARTITIONS OF ROOMS (Model of Partition, to rise from, and sink into the Floor)**—vii. Hurst, 66.
- PASTEBOARD**—*Algeria*, Flecheby, 24. *Belgium*, Dussart, 407. Henry, 283.
France, Beguin, 23. Deuzy, 165. Piques, 1393.
Zollverein (1), Biefang, 661. (4), Kaemmerer, 42. Schaeuffelen, 41. See also *Cartonpierre*. *Miliboard*.
- PASTEBOARD WORK**—*France*, Bertou, 1084. Cerf & Nazara, 84.
- PASTEL, OR IMITATION WOOD (made from the Chicory Plant)**—iv. Saunders & Gatsball, 71.

- d & Co., 318.
 321. Woulams
 o., 322.
- eard-Mas., 405.
- Daudrieu, 155.
- Ran, 262. Var-
- o., 260. Howell
 111.
- ort, 2.
- er, C. & W., 144.
66. Foudrinier,
6. Watson, 165.
- all, Middleton &
 g. 151.
- Taylor, 136.
- en's Land, Boyd,
0. Walton, 701.
- Jackson & Sons, 5.
70. Welch, 150.
6. Richter, 644.
- Prison Directors,
 ommer, 390. (2),
), Rau & Co., 72.
- eavieside, 91.
- VII. Barber, 116.
- igent Blind, 100.
- Pridesaux, 303.
- Unwin, 22.
- Simon, 24.
- nder Hecht, 475.
- ven & Harrop, 153.
- leton & Ainsworth,
 Decock, 221.
- s.
- Evans & Son, 18.
- VII. Saunders, 36.
- haul, 56.
- Hoing & Son, 60.
- & R. H. Hughes,
 J. & J., 9. Minton
 oco, 33. XXVII.
 ert) Boote, T. &
- Co. 641. (North
 (South Transsept)
 lips, 6.
- ater & Son, 633.
- l. Elsholz, 230.
- Flooring.
- co)—XXX. (Fine
- ion, to rise from,
 66.
- Belgium, Dussart,
- ques, 1393.
- Kaemmerer, 42.
- erre. Millboard.
1084. Cerf &
- from the Chicory
- PASTILES—XXIX. Tidmarsh, 111.
- PATCHOULY, Essence of—III. Piesse, 129.
- PATCHWORK—XII. & XV. Barnes, 219. XIX. Chaplin,
 367. Penley, 392.
- PATHOLOGICAL ILLUSTRATIONS—X. Paxton, 742.
- PATTERN CARDS—XII. & XV. Nicholson, 170A.
- PATTERNS (Tartan and other) Machine for Inventing—XII.
 & XV. Stewart, 298.
- PAUL'S, ST., CATHEDRAL (Model)—XXX. (Fine Art Court)
 Scollick, 178. Wilby, 162. (Model of Ball and
 Cross)—XXX. (Fine Art Court), Kepp & Co., 15.
- PAVEMENT, Specimens of—(Western End, South Enclosure),
 Sinclair, Brown, Rusby & Co. Franklin. (Eastern
 End), Sessel Asphalte Company. (South or Transsept
 Entrance), Festiniog. VII. Hadley, 91.
- PAVEMENT, MOSAIC, ENCAUSTIC, &c.—XXX. (Fine Art
 Court), Wyatt, 30.
- PAVEMENT, ORNAMENTAL—XXX. (Fine Art Court) Pap-
 worth & Co., 22A.
- PAVING-STONES—Western End, South Enclosure, (Out-
 side), 17. Brown & Co., 29. Carnegie, 20. Falmouth
 and Penryn Local Committee, 30. Franklin, 28. Mor-
 phet, 16. Sharp, 18. Sinclair, 13. I. Carnegie, 198.
 Dublin Royal Society, 207. Johnstone, 175. Long,
 199. Sinclair, 206. VII. Woods, 42.
- Austria*, Cristofoli, 38.
- Belgium*, Soetens, 424. Zannar & Co., 136. *Tuscany*,
 Giovannini, 99. See also *Metallic-Lava Pavement*.
- PAVING-MACHINE (for Vessels)—United States, Baker, 1.
- PEARLS—Hope, page 849. I. Cowie & Rae, 16. Jamieson,
 25. *Ceylon*.
- PEARLS, IMITATION—France, Estique & Delamare, 1213.
 Truchy, 1045. Vales, 707.
- PEARLASH—India, 1.
- PEARL GLASS ARTICLES—XXVI. Lane, 128.
- PEAS—See *Beans and Peas*. *Green Peas*.
- PEAS, ARTIFICIAL—XXIX. Gatti, A. & G., 73A.
- PEA-SUPPORTER—IX. Stent, 18.
- PEAT AND ITS PRODUCTS—I. Bagot, 244. Cahill, 222.
 Cubbold, 228. Evans, 237. Fitzgerald, Rev. 233.
 Great Peat-working Company of Ireland, 231. Moore,
 408. Oxland, 225. Rees, 227. Rogers, 240. IV.
 Classon, 22.
- Canada*, Boutillier, 26.
- Zollverein* (1), Von Mulmann, 319. See also *Bog-Wood
 Furniture, &c.*
- PEBBLES—I. Falmouth & Penryn Local Committee, 88.
 IV. Rock, 5.
- PEDOMETER—X. Payne & Co., 73.
- PEDOMOTIVE OR SELF-PROPELLING CARRIAGE—V.
 Dawson, 830.
- PEEL, SIR ROBERT, The late (Electro Bust of)—Elking-
 ton & Co. (Bronze Bust of), xxx. (Fine Art Court)
 Gardie, 261. (Statuettes of), I. Vieille Montagne
 Mining Company, 437. xxx. (Fine Art Court)
 Ross, 191.
- PEEL TESTIMONIAL DESIGNS FOR (Models, &c.)—XXX.
 (Fine Art Court) Wilson, 327.
- PEGS (to hold Papers, &c.)—XXVIII. Begent, 110.
- PEGS, SHOE—See *Shoe Pegs*.
- PEMETTORO (Machine for carrying heavy Burdens)—
Tuscany, Turchini, 55.
- PEN AND INK DRAWINGS—Portugal, Da Silva, 1296,
 1297. Godinho, 1253.
- PENCILS—Austria, Hardmuth, 381.
 France, Gilbert & Co. 238, 847. See also *Black-Lead
 Pencils*.
- PENCILS (Ever-pointed)—I. Brockedon, 65. II. Stevens, 74.
 XXII. Hague, 226A.
- PENDULUM, NEW MODE OF SUSPENDING (Model)—X. Vul-
 liamy, 700.
- PENDULUM REGULATOR—France, Moriceau & Cayeux, 328.
- PENHOLDERS—XXII. Bidle, 273. Mitchell, J. 339.
 Mitchell W. 328.
- PENMANSHIP (Specimens of)—XVII. Caffry, 167. Gardner,
 199. Wilson, 178. xxx. (Fine Art Court), Salt-
 marsh, 343A. *Austria*, Greiner, 374A. Schutz, 375.
 France, Berliner, 52.
- United States, Dunlop, 483. Stanton, 367.
- PENS, GLASS—XXIV. Cogan, 26. *United States*, Parrh, 588.
- PENS, METALLIC—II. Stevens, 74. VIII. Walker, 242.
 XXII. Gillott, 324. Hincks & Co., 326. Kell, A. &
 Co., 327. Knight & Foster, 689, 694. Mitchell,
 J., 339. Mitchell, W., 328. Myers & Son, 338.
 Perry & Co., 687. Windle & Blyth, 668.
 France, Blanz, Poure & Co. 28. See also *Gold Pens*.
Steel Pens, Machine for making.
- PEPPER—II. London Druggista, 117. *Barbadoes*.
India, iii. *Eastern Archipelago*, Hammond & Co., 2.
Portugal, 445A. *Trinidad*, Lord Harris.
Tunis, 101, 149. *Turkey*.
Van Diemen's Land, Denison, Sir W. T., 27.
Western Africa, Jamieson, 22. *Weston*, I. See also *Matico*.
- PEPPER-GRINDING MILLS—VI. Fieldhouse & Co., 443.
- PEPPERMINT, CRYSTALLIZED—Sardinia, Saluce, 10.
- PEPPERMINT, OIL OF—XXIX. Short, 129.
- United States, Hotchkiss, 156.
- PERCOLATOR—XXIV. Freeman, 46.
- PERCUSSION CAPS—VIII. Fairman, 233. Joyce & Co., 277.
 Walker, R., 242. Walker, S. & Co., 284.
Austria, Sellier & Bellott, 122.
 France, Givélet & Lemaire, 519.
Zollverein (1), Dreyse & Colchenbusch, 638.
- PERCUSSION-CAP MACHINERY—Netherlands, Goossens,
 77.
- PERFORATED BLINDS, ZINC—I. Jack, 437A.
- PERFORATED AND LACE PAPERS—XXX. (Fine Art Court)
 Mossman, 204. France, Devrange, 1188.
- PERFORATED PLATES (for marking Linen)—XVII. White-
 man, 51.
- PERFUMES AND PERFUMERY—IV. Barker & Co., 62.
 XXVIII. Gosnell & Co., 55. Ross & Sons, 64. XXIX.
 Ede & Co., 18. Faiera, 26. Fisher & Co., 22. Gal-
 brath, 17. Grossmith, 13. Hendrie, 10. Kendall
 & Co., 25. Low & Co., 30. Payne, 29. Rimmel, 3.
 Rowland & Sons, 1. Wharry, 27.
- Algeria*, Mercurin, 37. Simouet, 51. *Ceylon*, —.
Egypt, 135-137.
- France, Bertou, 1084. Bleuze, 1091. Gelle & Co., 845.
 Landon & Co., 1290. Leisner, 908. Mero, 1356.
 Oger, 939. Thollou, 1701. *Tunis*, 83.
- United States, Basin, 36. Haul, 40.
- Zollverein* (1), Kendall, 422. Lipp, 658. See also *Dis-
 tilled Waters*. *Eau de Cologne*. *Roses*, *Otto of*.
- PERIPHANS (for the Study of Astronomy)—X. Baker, 354.
 Cox, 347.
- PERSIAN POWDER (for destroying Insects)—Russia, N. X.
 146.
- PERSPECTIVE, ILLUSTRATIONS OF—XXX. (Fine Art Court)
 Herdman, 343A.
- PERSPECTIVE-DRAWING MACHINE—X. Anderson, 403.
- PERSPECTIVE RULES—Austria, Vienna Polytechnic In-
 stitute, 130.
- PERUVIAN BARK, ALKALOIDS FROM—Zollverein (6), Koch,
 7.
- PESTACHIO POWDER—III. Piesse, 129.
- PETER, ST., STATUE OF (in canopied Niche)—XXVII.
 Lane and Lewis, 53.
- PETRIFICATIONS (& PETRIFIED WOOD)—I. Horne, 17.
 XXVI. Clarke, 179. *Egypt*, 6. *India*, I.
 United States, Davidson, 561.
St. Domingo, Schumburgk, Sir R.
- PETROLEUM—India, I. *Trinidad*, Lord Harris, 2, 10-14.
- FEWER ARTICLES—V. Stocker, S. & G., 422. XXII. Watts
 & Harton, 557.
 France, Robert & Co., 1440. *India*, I.
 Austria, Hirsche, 436.
- PHAETON-HOOD LIFTER—VIII. Beadon, 90.
- PHANTASMAGORIA—X. Carpenter & Westley, 270. Or-
 chard, 161. *United States*, Langenbeim, 62.
- PHARMACEUTICAL APPARATUS—France, Leperdier, 307.
Zollverein (1), Arnoldi, 778. See, 483. See also *Chem-
 ical and Philosophical Apparatus*. *Surgical Ap-
 paratus*.
- PHARMACEUTICAL PRODUCTS—II. 1 to 123. See *Chemical
 Preparations*.
- PHENASTICCOPE—Zollverein (5), Albert, 23.
- PHILOSOPHICAL INSTRUMENTS—France, Collott, Brothers,
 1155. Delvil, 160. Grosse, Brothers, 529. Lant, 567.
Switzerland, Favre, 11. *United States*, Erricson, 146.

- See also *Astronomical Instruments*. *Barometers*. *Chemical and Philosophical Apparatus*. *Magnetic Dip, &c.*, *Instruments*. *Magnets*. *Mathematical Instruments*. *Microscopes*. *Thermometers*.
- PHONETIC SHORT-HAND PRINTING**—XVII. Pitman, 197.
- PHONICON**—*Austria*, Cervený, 157.
- PHONOGRAPHIC AND PHONOTYPIC ALPHABETS**—XVII. Pitman, 197.
- PHOSPHORUS**—*France*, Cuignet & Son, 1153.
- Spain*, Coucha, 49. *Zollverein* (1), Pauli, 328.
- PHOTOGRAPHIC SELF-REGISTERING MAGNETIC AND METEOROLOGICAL APPARATUS**—X. Brooke, 144.
- Zollverein* (5), Strauch, 33.
- PHOTOGRAPHS AND PHOTOGRAPHIC APPARATUS**. See also *Daguerreotyp Apparatus*. *Daguerreotype* (or *Photographic*) *Pictures*.
- PHOTOMETERS**—X. Edge, 702. XXII. Edge, 441.
- PHRENOLOGICAL BUSTS** (in Miniature)—XXX. (Fine Art Court) Bally, 173.
- PHYSICAL INSTRUMENTS**—*Zollverein* (1), Breithaupt & Sons, 670. See also *Philosophical Instruments*. *Surgical Instruments*.
- PIANOFORTES** (including Models)—X. Addison, 487. Aggio, 468. Akerman, 490. Allison, 480, 483. Bainsmead, 474. Broadwood & Sons, 518 (Main Avenue, West). Cadby, 471. Collard & Collard, 168 (Main Avenue, West). Deacock, 473. Dimoline, 489. Ennever & Steedman, 479. Greiner, 468. Harrison, 464A. Harwar, 493A. Holderness, 482. Hopkinson, J. & J., 500. Hund & Son, 486. Hunt, 477A. Jenkins & Son, 484. Jones, 481. Kirkman & Son, 467. Mathews, 550. Metzler, 475. Moore & Co., 476. Mott, 498. Oetmann & Plumb, 683. Peachey, 502. Rolfe & Sons, 472. Smyth & Roberts, 491. Southwell, 469. Stadart & Son, 470. Tootal and Brown, 706. Towus & Packer, 494. Woolley, 493. Wornum, 499. XXVI. Crace, 530. Jennens & Bettridge, 187 (Main Avenue, West).
- Austria*, Deutschmann, 141D. Hoxa, 141E. Pottje, 141A. Schneider, 140 Seuffert, 141B. Vlaaky, 141.
- Belgium*, Aerts, 186. Berden, 174. Deffaux, 188. Jastrzebski, 176. Sternberg, 180. Vogelsangs, 181.
- Canada*, Herbert, 18A.
- Denmark*, Hornung, 30.
- France*, Ancher, 404. Bord, 1099. Cropet, 131. Deban, 1172. Detir & Co., 475. Domeuy, 477. Erard, 497. Franche, 1234. Harleng, 335. Herz, 1268. Kleinjager, 1633. Mercier, 633. Montal, 1665. Paye, 943. Roller & Blanchet, 1687. Scholtus, 1482. Songetto, 1699, 1731. Zeiger, 747.
- Hamburg*, Baumgarten & Hains, 12. Rumms, 14. Schürder, 13. Lubeck, Lunau, 6.
- Netherlands*, Cuijpers, 95.
- Nova Scotia*, Central Committee, 2.
- Russia*, Lichtental, 172.
- Sweden*, Rosenwall, 62.
- Switzerland*, Frey, 82. Hueni & Hubert, 87. Kuetzing, 89. Sprechar & Baer, 103.
- United States*, Chickering, 458. Gilbert & Co., 435. Hems, 438. Meyer, 49. Nums & Clark, 374. Pirson, 90.
- Zollverein* (1), Adam, 487. Bessalie, 71. Gerhard, 487. Guricke, 73. Heilmeyer, 486. Klems, 595. Scheel, 668. Westermann & Co., 80. Zeitter & Winkelman, 709. (3). Breitkopf & Haertel, 25. (4). Dieudonne & Bladel, 20. Doerner, 21. Lipp, 22. Schiedmayer & Sons, 23. (6). Kuehust, 20. Schotts & Sons, 25.
- PIANOFORTE CASE BEDSTEAD**—XXVI. Mummery, 292.
- PIANOFORTE FRAMES, STRINGS, &c.**—X. Erard, 496. Newcomb, 672A. Turnbull, 500A.
- Austria*, Wilhelm, 142. *France*, Fortin-Boutellier, 484.
- PIANOFORTE AND HARMONIUM**—X. Luff & Son, 477.
- PIANOFORTE-MAKERS' TOOLS**—XXI. Mathieson, 32.
- PIANO-VIOLINO**—*United States*, Hale, 533.
- PICKLES AND PRESERVES**—III. Batty & Feast, 116. Payne & Son, 22.
- Van Diemen's Land*, Haines, 298-303.
- PICTURE FRAMES**—IV. Samuels, 21A. XIX. Burton, 117. XXIV. Beningfield, 45. XXVI. Alexander, 99. Hurton, 77. Gillow, & Co., 186. Grundy, 121. Hanson & Sons, 197. Hay, J. & J., 100. Hold, 83. Mcxmi, 252. Nicoll, 182. Num, 228. Ponsanby, 199. Richardson, C. J., 207. Squire, 273. Thomas, 275. Wallace, 2. Whitcombe, 211A. Jones, 7. XXIX. Rankin & Lear, 302. XXX. (Fine Art Court) Kehoe, 90. Ross & Thomson, 299.
- Austria*, Kübel, 645A. Pauller, 649.
- France*, Bouguillard, 777. Clerget, 799. Lemerrier, 587. Leecy, 592. Lombard, 913. Saintin, 691. Servais, 1012. *Hamburg*, Korlaw, 53. *Mexico*. *Madeira*, Head, 1. *Rome*, 40-47.
- Van Diemen's Land*, Hood, 126, 127, 129. Marriott, 128. *Zollverein* (1), Gebuhr, 848. Kersten, 243. (4). Lettemeyer, 75. Vetter and Erno, 74. (6). Wenderlein, 55. See also *Miniature Frames*.
- PICTURE MODELS**—XXX. (Fine Art Court) Barritt, 339.
- PICTURE PRINTING**—See *Printing in Colours*.
- PICTURE-SUPPORTING MOULDINGS**—XXII. Potts, 323.
- PICTURES AND TRANSPARENCIES** (Undescribed)—*France*, Poget, 1677. *Zollverein* (1), TrumpeImann, 789.
- PIER-GLASSES**. See *Looking-Glasses*.
- PIERS FOR BRIDGES, &c.** (Model)—VII. Morrell, 59. Sankey, 32.
- PILL-MAKING MACHINES**—*France*, Viel, 1047. *Zollverein* (1), Pokorny, 79.
- PILLOWS, SPRING**—XXVI. Board, 240.
- PINCHBECK RINGS**—*Austria*, Kranowither, 463.
- PINS**—XXII. Edelsten & Williams, 336. Goodman, 335. XXIX. Chambers, 297. James, 295. Kirby, Beard, & Co., 96.
- Austria*, Struss, 477. *France*, Vantillard & Co., 1517. *Malta*, Falso, 25. *Zollverein* (1), Reinecker and Co., 404.
- PIN-STICKING MACHINE**—VI. Iles, 61.
- PINE-NEEDLE WOOL** (for Wadding)—*Zollverein* (1), Fahian, 95.
- PINE-TREE FUNGUS**—*Canada*, Macculloch, 186.
- PIPE-CLAY**—I. 127A. Pike, W. & J., 102. Whiteway & Co., 90. *India*, I. *Turkey*.
- PIPE FITTINGS AND JOINTS**—VII. Martin, 25. XXII. Mitchell, 611.
- PIPES, CAST-IRON, MOULD-MAKING MACHINE FOR**—VI. Stewart & Co. 238.
- PIPES FOR DRAINAGE, GAS, AND WATER**—VI. Stewart & Co. 233. IX. Craig & Co. 262A. Mapplebeck & Low, 131. X. Wishaw, 419. XXII. Hodges, 519. Kenrick & Sons, 360A.
- Canada*, Ferguson, 164. See also *Tubes & Tubing*.
- PIPES, DRAINING, MACHINES FOR MAKING**—IX. Clayton, 47. *United States*, Leroy, 586. See also *Brick and Tile Machines*.
- PIPES, GLASS**. See *Glass Pipes, Tubing, &c.*
- PIPES FOR SMOKING**. See *Meerschaums*. *Smoking Pipes*. *Tobacco Pipes*.
- PIPES FOR WARMING BUILDINGS BY HOT WATER**—IX. Weeks & Co. 248A.
- PIQUES** (Printed)—*Austria*, Liebisch, 188. Winter, 180.
- PISTOLS**. See *Guns, &c.*
- PISTONS FOR MUSICAL INSTRUMENTS**—*France*, Courtois, 130.
- PISTONS FOR STEAM ENGINES**—V. Thornton & Son, 490. x. Gillett, 79D.
- PIT-CHAINS**—VIII. Brown, Lenox & Co. 61. Parkes, 108. XXII. Edge, 51.
- PIT-FRAMES**—XXII. Edge, 51. See also *Mine-Shaft Apparatus*.
- PITCH**—*Portugal*, 459.
- Trinidad*, Lord Harris, 1, 3-8. *Turkey*.
- PITH MODELS**—XXX. (Fine Art Court) Clifford, 222. Cossens, 25. Limeuse, 179.
- PLAIDS, OF ALL KINDS**—XII. & XV. Brunton & Co. 230. Clapperton, T. & G. 193. Clay & Sons, 136. Cross, 202. Dalrymple, 240. Dicksons & Laings, 234. Dixon, A. & T. 187. Gibson, 132. Halley, 479. Johnston, 274. Lees, R. & G. 192. Morgan & Co. 299. Reid & Son, 481. Hewick, T. & A. 233. Robertson, J. & J. 301. Sanders, R. & A. 196. Schwann, F. 115. Schwann, Kell & Co. 141. Sims & Co. 195. Sinclair, 467. Tolson & Sons, 116. Watson, J. & A. 477. Willans & Co. 257. xx. Wigham & Co. 85.

- Mexon, 252.
199. Richard-
275. Wallace,
ix. Rankin &
ehos, 90. Ross
9. Lemerrier,
Saintin, 691.
Mexico.
- Marriott, 128.
43. (4), Lette-
Wanderlein, 55.
- Barritt, 339.
Potts, 323.
France,
manu, 789.
- Morrell, 50.
463.
Goodman, 335.
Kirby, Beard,
& Co., 1517.
- verlein (1), Fa-
186.
Whiteway &
tin, 25. xxii.
HINE FOR—VI.
VI. Stewart &
plebeck & Low,
319. Kenrick
& Tubing.
IX. Clayton,
also Brick and
c.
Smoking Pipes.
- T WATER—IX.
Wiuter, 180.
rance, Courtois,
n & Son, 490.
61. Parkes,
ine-Shaft Ap-
Clifford, 222.
on & Co. 239.
6. Cross, 202.
234. Dixon,
70. Johnston,
& Co. 299.
3. Robertson,
6. Schwann,
Sime & Co.
16. Watson,
ham & Co. 85.
- PLANES—xxi. Ibbotson, 27. King & Co. 5.
Canada, Wallace, 147. See also *Planing Machines*.
PLANETARIUM—Switzerland, Masset, 95.
United States, Barlow, 69.
PLANIMETERS (for calculating Area of Plane Figures)—
x. Sang, 338. Switzerland, Goldschmid, 84.
Zollverein (1), Ausfeld, 704.
PLANING-MACHINES—vi. Furness, 401. Shanks, 210.
Sharp, Brothers, 204. Thomson, 430. Whitworth &
Co. 201.
France, Sautreuil, 1474.
Zollverein (1), Moser & Co. 861.
PLANING-MACHINES (for Metals)—vi. Parr & Co. 6, 213.
PLANING-MACHINES, STEAM ENGINES FOR—v. Erskine,
100.
PLANISPHERES—x. Mollison, 585.
PLANTAGENET GUARD RAZORS—xxi. Stewart & Co. 21.
PLANTAIN FIBRE—British Guiana, Davison, 77. Netscher,
78. India, iv. xiv.
Gold Coast & Ashantee. Spain, Vinas, 160.
PLANTAIN FRUIT—iii. Colquhoun, 13.
PLANTAIN MEAL—British Guiana, Netscher, 8-11.
Davison, 12. Garnett, 13, 14.
PLANTING-LINE (Garden)—ix. Padwick, 215.
PLANTS, CLOSED CASES FOR THE GROWTH OF—x. Ward,
664 (North Transept).
PLANTS, SPECIMENS OF—North Transept, Lodiges & Sons.
ii. Kent, 90. x. Ward, 664 (North Transept).
Canada, Ashton, 335.
Spain, 117. South Australia, Hallett & Sons, 5.
Trinidad, Lord Harris. Turkey. See also *Botanical
Specimens*.
PLANT-WATERING MACHINE—ix. Kennedy, 208c.
PLASTER CASTS, STATUES, MODELS, &c. (Various)—
Bell, page 847. Forrest, page 849. Leitch, page
851. Panormo, page 850. Sibson, page 852. xxx.
(Fine Art Court) Brodie, 159. Burns & Palmer, 21.
Colley, 121. Fox, 29a. Gushlow, 223. Harmer, 56.
Peppercorn, 356. Richardson, 133. Smith, 211.
Smith, F. S. 170. xxx. (Sculpture Court) Gallagher,
43. Hughes, 3. Kirk, 25. Lawlor, 22. Summers, 32.
Belgium, Follet, 426. Geefs, 451.
Denmark, Jerichau, 39 (Main Avenue, East).
France, Du Seigneur, 187. Etex, 1215. Imlin, 543.
Simon, 1015. Hamburg, Engelhard, 96.
Rome, Trentanove 31. Tuscany, Papi, 116.
United States, Chickering, 555.
Zollverein (1), Cauer, 431. Drake, 273. Eichler, 272.
Franz, 283. Harrel & Lauchhammer, 852. Kalide,
285. Krausz, 879. Sondermann, 288. (2), Foltz,
94. Hurlbig, 84. Knoll, 88. (3), Rietschel, 185.
PLASTER OF PARIS—I. Blyth & Jacobs, 131. White &
Sons, 130. See also *Cement, Roman, &c.*
PLASTER STONE—Egypt, 7.
PLASTERS (Membrane)—x. Puckridge, 609.
PLASTIC CASTS (in imitation of metal)—xxviii. Tate, 162.
PLASTIC EARTH—Belgium, De Ferrare, 15.
PLASTIC WORK (Tableau of Rural Fête at Castle Florence),
—Zollverein (1), Sonnenberg Association of Manufac-
turers, 804.
PLATE-GLASS—xxiv. Chance & Co. 22 (Main Avenue,
West). Harley and Co. 100 (Main Avenue, East).
Swindon, 4 (North Transept). xxvi. Thames Plate-
Glass Works, 399 (Main Avenue, West).
Zollverein (1), Röhling, 768. Willmanns, 209.
PLATE-GLASS GRINDING AND POLISHING TABLE—vi.
Bessemer, 400.
PLATE, GOLD AND SILVER. See *Gold & Silver Ware*.
PLATE-WARMER—xxii. Roper & Son, 399.
PLATED-WARE—xxii. Clayton, 142. Hardy, 131. Sobey,
685. xxiii. Bradbury & Son, 36. Cartwright &
Hiron, 30. Creswick, T. J. & N. 45. Dixon &
Sons, 38. Gray, 101. Owen & Levick, 44. Spurrier,
28. xxiv. Pinkerton, 5.
Russia, Petz, 292. Switzerland, Bantard, 235.
Zollverein (1), Wolf & Erlshof, 556. (4), Bruckmann
& Sons, 65. Rau & Co. 72.
PLATILES ROYALES—Zollverein (1), Alberti Brothers,
231.
PLATINUM—I. Johnson & Matthey, 477.
- PLAYING CARDS—xvii. Whitaker, 49. xxx. (Fine Art
Court) Baetens, 212.
Austria, Steiger, 374. Belgium, Daveluy, 448.
Denmark, Holmblad, 27.
France, Blaquiere, 1532. Hulot, 882.
Sweden, Huerlin, 113.
Zollverein (5), Wuest, 14. (6), Frommann, 39. Reuter,
40. Schnapper, 42.
PLAYING CARDS, MINIATURE—xxx. (Fine Art Court)
Baetens, 212.
PLOUGHS—ix. Abbot, 55. Alcock, 27. Alexander, 198.
Armitage & Co. 38a. Ball, 132. Barker, 230. Bar-
rett & Co. 128. Bentall, 217. Busby, 15. Clark,
99. Comins, 143. Cottam & Hallen, 109a. Cross-
kill, 135. Drummond & Sons, 49. Dufour & Co.
124a. Fenwick De Forquet, 202. Garrett & Sons, 142.
Grant & Co. 267. Gray & Sons, 159. Halstead &
Sons, 100. Harkes, 23. Hayward, 114. Heneman
& Co. 149. Howard, J. F., 240. Jordan, 91a.
Law, 94. Laycock, 131. Low, 264. Lowcock, 28.
Ponton, 104. Ransomes & May, 121. Ritchie, W.
& J., 224. Samuelson, 185. Sellar & Son, 83.
Sewell & Co. 107. Slight, 42. Smith, 256. Squires,
144. Sturt, 268. Warren, 257. Wedlake & Co., 127.
Williams, 151. Willoughby D'Ereshy, Lord, 195.
Wilkie & Co. 21. xxix. Wautless, 266.
Austria, Prince Lobkowitz' Agricultural Implement
Manufactory, 124.
Belgium, Berckmans, 170. Delstanehe, 510. Denis, 169.
D'Onsiaux, 171. Dufour, 159. Odeur, 169. Ro-
medenne, 165. Van Macle, 168. Verbiest, 162.
Canada, Fleck, 92. Hulbert, 91. Egypt, 173.
France, Andre & Comte De Brono-Bronski, 1054. Basin,
416. Badin, 426. Bonnet, 1095. Lebert, 569.
Pardoux, 341. Seguy, 372. Talbot, Brothers, 1028.
India, ix.
Netherlands, Jenken, 74. Switzerland, Gisin, 72.
United States, Allen & Co. 97. Hall & Spear, 255.
Frouy & Mears, 404, 413. Rogers, 258. Starbuck,
91. Thompson, 26.
Zollverein (6), Hesse-Darmstadt Board of Agriculture,
13. See also *Drill-Plouchs, Dynamotater*.
PLOUGHS, DRAINING—ix. Ferguson, 214. Fowler, 28a.
PLOUGHS, STEAM—ix. Usher, 123a. Willoughby D'Ereshy,
Lord, 195.
PLOWING, &c., MACHINE—xxvi. Lyon, 30.
PLUG FOR SHIPS' BOATS—viii. Parker, 67. Robinson, 68a.
Thompson, 66.
PLUMBAGO—South Africa, Calif, 55. India, i.
New Brunswick, Gould, 3.
United States, Clingman, 358. Richards, 357.
Zollverein (2), Kapeller, 28.
PLUMBAGO CRUCIBLES—Belgium, Coste, 397.
PLUM-PUDDING STONES (for Crucibles, &c.)—Belgium,
Marchiu Communal Commission, 396.
PLUSHES (for Hats, &c.)—xii. & xv. Baughen, Brothers, 183.
xiii. Booth & Pyke, 63. Evans, 60. xx. Ashton &
Sons, 32. Taylor & Co., 127. Austria, Schipper, 269.
France, Barth, Massing & Plichon, 21. Brisson, Bro-
thers, 1117. Courte, 1164. Couturier & Renault, 98.
Donat & Co. 1193. Martin & Casimir, 612. Massing,
Brothers, 333. Thibert & Adam, 1037.
Russia, Lortef, 204. Sardinia, Guillot & Co. 41.
United States, Dumont, 287.
Zollverein (1), Andrae, 360. Bachoven & Volls-
chitz, 830. Kauffmann, 117. Lehmann, 136. Meyer,
Max, & Co. 133. Oehme, 116. Scheibler & Co. 534.
(2), Knorr, 38. Simon, 37.
PLYMOUTH BREAKWATER AND LIGHTHOUSE (Model)—
vii. Stuart, 28 (Main Avenue, West).
POCKET KNIVES—See *Cutlery*.
Pois Chiche—Egypt, 43, 95, 97.
PNEUMATIC INSTRUMENTS—x. Ladd, 291a. Taylor, 466.
PNEUMATIC GOVERNOR (Lariviere's Patent)—v. Tuck,
200.
POCKET-BOOKS—xvii. Schlesinger & Co. 38. Widnall
& Co. Ionian Islands, Seaton, Lord, 5.
Zollverein (1), Sommer, 878. (6), Haas & Co., 62.
POCKET PROTECTOR—xx. Shinton, 75.
POLISTIES (Harness, &c.)—xxviii. Harris, S. & H., 117

- United States, M'Lennan, 252. See also Blacking and Boot Varnish.*
- POLISHING POWDERS**—I. Flather & Haden, 80.
- POLYCHROMATIC DECORATIONS** (Designs for)—XXX. (Fine Art Court) Pullian, 265.
- POMEGRANATES**—Tunis, 135.
- PONTOONS**—*United States*, Armstrong, 219.
- POPPLINS**—XI. Lowthian & Parker, 22. XII. & XV. Atkinson & Co. 256. Bolingbroke, C. & F., 311. Claburns & Son, 294. Fry & Co. 267. Hinde, E. & F. 313. Jones, 261. Middleton & Ainsworth, 312. Pim & Co. 255. Reynolds, 266. Townsend, 175. XIII. Carter & Co. 30. Gregson & Brien, 14. XIX. Irish Work Society, 77. *Russia*, Gutchhoff, 189.
- PORCELAIN FRIZES**—XXVII. Minton, H. & Co. 86.
- PORCELAIN LETTERS**—XXV. Earnshaw & Greaves, 24. Lee, 48.
- PORCELAIN PAINTINGS**—*France*, Nurgat, 1504A. Simonet, 375.
Tuscany, Fontina, 122.
Zollverein (1), Schade, 680. (2), Schmidt, 92. (3), Bucker, 176.
- PORCELAIN PAPER**—*France*, Bandon, 63.
- PORCELAIN WARE**—X. Edwards, 438. XXV. Alcock & Co. 7. Bell & Co. 26. Brown, T. & M. L., 45. Clementson, 8. Copeland, 2. Dimmock, 12. Finch, 38. Grainger, 46. Keys & Mountford, 14. Minton & Co. 1. Pindar & Co. 15. Ridgway & Co. 5. Rose & Co. 47. Wedgwood & Sons, 6. XXVI. Gillow & Co. 186. Minton & Co. 531. XXVII. Rufford, 89. *Austria*, Bagatti, 616. Fischer, C. 617. Fischer, M., 618. Haas, 619. Haidinger, Brothers, 620. Hubner, 622. Kriegel & Co. 623. Nowotny, 625. Portheim, 626. Quast, 627. Vienna Imperial Porcelain Manufactory, 615. Zsacha, 628.
Belgium, Cappellemans & Daboust, 393. De Fuisseaux, 400. *China*, Lindsay. Monteiro, Reeves.
Denmark, Copenhagen Royal Porcelain Manufactory, 33. *Egypt*, 391.
France, Bapierrosses, 409. Bettignies, 1086. Boquet, 1098. Boudon, 432. Colville, 802. De Serionne, Loin & Co. 1483. Fouiques, 1692. Gille, 848. Honore, 877. Jacob Petit, 1629. Jacobber, 271. Jolly, 277. Lachasagne, 1288. Latoche, 1287. Laurent, 563. Peyroulx, 1676. Piedagnel, 1390. Valin, 708.
Portugal, Pinto Basto & Co. 1047-1104.
Zollverein (1), Berlin Royal Prussian Porcelain Manufactory, 213. Conta & Buelme, 815. Goebel, 808. Henneberg & Co. 772. Loeffl, 192. Tielsch & Co. 219. Ungerer, 241. (2), Kymphenburg Royal Porcelain Manufactory, 64.
- PORCELAIN WARE, RAW MATERIALS USED IN THE MANUFACTURE OF**—XXV. Minton & Co. 1.
China, Kiaing-tih-t Ching's Porcelain Works.
France, Demuelle, 1183.
- PORCELAIN WARE** (Semi, or Chemical)—XXV. Grainger, 46.
- PORPHYRY**—Wallis, page 853. I. Barry & Barry, 178. Breadbane, Marquis of, 7. Cumming, 195. Gelling, 139. Falmouth & Penryn Local Committee, 163. Hicks, 164. Jenkins & Stick, 170. Meredith, 141. Nicholls, 162. Rodd, 189. Whitley, 165. *Greece*, 46.
Sweden, Elfdahls Works, 47.
- POBROGRAPHES**—*France*, Recy, 1423.
- PORTE-MONNAIES**—*Zollverein* (1), Sommer, 818. (2), Bischoff & Co. 98.
- PORTFOLIOS**—XVI. James, 40. XVII. Hood, 157. XXVI. McCullum & Hodson, 135.
Zollverein (2), Bischoff & Co. 98. (6) Klein, Reisser, & Co., 86.
- PORTFOLIO BRACKETS AND STANDS**—XVII. Rickman, 194. XXVI. Hindley & Co. 266.
- PORTLAND CEMENT**—*See Cement, Roman, &c.*
- PORTMANTAUS**—*See Trunks, &c.*
- PORTLAND VASE, COPIES, &c. OF THE**—XXV. Boote, T. & R., 11. XXX. (Fine Art Court) Copland, 136. Hulmer, 231.
- POSTAGE-STAMP EXPEDIENT**—XVII. Gill, 12.
- POSTAGE-STAMPS**—*France*, Meillet & Pichot, 629.
- POTASH** (POTASS, POTASSIUM, or BARILLA)—II. Bullock & Co., 37. Howards & Kent, 11.
France, Antheims, 1541. *India*, 1.
Sardinia, Seloipa, 4. *Spain*, 37, 42, 45. *Turkey*, *Tuscany*, Ilston, 42A.
Vin Diemen's Land, Denison, Sir W. T., 334.
- POTASH, ACETATE OF**—*Portugal*, 75.
- POTASH, BICHRONATE OF**—II. Dentith, 8 (Main Avenue, West). *India*, 1.
Sweden and Norway, Leeren Manufactory, 39.
- POTASH, CHLORIDE OF**—II. Watt, 32.
France, Cournerie & Co., 462.
- POTASH, CHROMATE OF**—*India*, 1.
- POTASH, CYANATE OF**—*Zollverein* (1), Kunhelm, 13.
- POTASH, FERRO-CYANIDE OF**—II. Bramwell & Co., 27. *Austria*, Braun, 21.
- POTASH, HYDRO-IODINIC**—*Zollverein* (4), Bone & Son, 2.
- POTASH, IODINE OF**—*France*, Curral, 1136. Cournerie & Co., 462. *Jersey and Guernsey*, Arnold, 33.
- POTASH, MURIATE OF**—II. Warl, J., 89. Ward, Smith, & Co. 54. *Austria*, Wagenmann & Co., 19.
- POTASH, NITRATE OF**—II. Mills, 23. *India*, 1. *Spain*, Paulo y Bartolini, 44.
- POTASH, PRUSSIAN OF**—II. Bramwell & Co., 27. Hurlet & Campsie Alum Company, 13.
France, Coignet & Son, 1153.
Russia, Brughlin, 29. Schlipps, 27.
Zollverein (1), Coelius, 12. Guthell & Co., 439. Krimmelbein & Bredt, 457. Pauli, 328. Prussian Chemical Manufactory, 683.
- POTASH, SULPHATE OF**—II. Warl, 89. Ward, Smith, & Co., 54. Watt, 32. *France*, Cournerie & Co., 462.
- POTASH, TARTAR OF**—*Portugal*, Ferreira, 33, 34. Garland & Co., 39. Leal, 32. Serretello & Co., 38.
- POTATO-FLOUR**—III. St. Etienne, 135.
Belgium, Blyckaert, 78. Doquir & Parys, 68. Van Buren, 74.
France, Lebleis, 570. Le Paisant, 590.
Netherlands, Schoneveld & Westerbaan, 13. Visser & Co., 15. *Russia*, Abasheff, 331.
Zollverein (1), Eipenscheleid, 330. Farthmann, 16. Wahl, 332. Weerth, 333. Welcker, 331.
- POTATO-GERM EXTRACTOR**—IX. Stewart & Co., 213.
- POTATO-ROASTER**—XXII. Loyell, 488.
- POTATOES** (Preserved)—*Canada*, Brimaden & Shipton, 128. *Russia*, Abasheff, 331.
- POTATOES, PREPARATIONS FROM**—*Sweden*, Lundgren, 100.
- POTATO-STARCH**—*Canada*, Brimaden & Shipton, 128. *Russia*, Yurkhehman, 72.
Zollverein (1), Lubrig Manufactory, 094. Paetsch, 18. Uechtritz, 21. (6), Hofmann, 14.
- POTTERS' FLINT AND COLOUR-MILL**—VI. Fourdrinier, 100.
- POTTERY** (Various)—I. Buller, 128. Methven & Sons, 126. Hoake, 60. XXVII. Rowers & Co., 104.
Gold Coast and Ashantee, Forster & Smith, 1.
India, XXV. *Switzerland*, Ziegler-Pellis, 260.
Western Africa, Jamieson, 22.
Zollverein (1), Villeroy & Hoch, 361. *See also Earthenware and China. Porcelain-ware. Pottery-clay. Stone-ware.*
- POTTERY-CLAY**—I. Browne, 109. Burnett, 108. Ennikillen, Earl of, 116. Fahie, 129. Fayle & Co., 100. Grimley, 105. Holgson, Sir G., 123. Jenkins & Courtney, 93. Martyn, 107. Michell, 110. Minton & Co., 97. North Devon Pottery Company, 127. Phillips, 101. Phippard, 113. Pike, W. & J. 102. Pease, 122. Thruscutt, 94. Truscott, 104. Wandesforde, Hon. C., 111. West of England China, Stone, & Clay Company, 103. Wheeler & Co., 108. White-way & Co., 90. Whitley, 95. *Egypt*, 12. *Turkey*, *Zollverein* (6), Leicher, 6. Nassau Government Engineers of Mines, 1.
- POTTERY KILNS**—XXV. Ridgway, 625.
- POTTERY PRINTING**—XXV. Putta, 49.
- POTTERY PRINTING-PRESSES**—VI. Fourdrinier, 100.
- POTTERY TISSUE-PAPER**—VI. Fourdrinier, 100. XVII. Lamb, 147.
- POULTRY-TROUGHS**—IX. Wislaw, 59.
- POWDER-BARREL**—VIII. Slater, 78.
- POWDER AND SHOT FLASKS**—VIII. Inskip, 227. XXII.

- Dixon & Sons, 797. France, Roche, 769. India, VIII. See also *Shot Bells, Fouches, &c.*
- POWDER-MACHINES FOR MARITIME PURPOSES**—VIII. Bearfoot, 274.
- POWER-ENGINE METERS**—X. Brown, 335.
- POWER-LOOMS (Including Models)**—VI. Bullough, 12. Chalmers, 32. Crichton, 35. Elliott & Hayes, 50. Harrison, 18. Hilbert, Platt, & Sons, 1. Mason, 10. Milligan, 38. Parker & Co., 77. Reed, 85. France, Dorcy, 823. Fromage, 219. United States, Lowell Machine-shop, 447.
- PRECIOUS STONES**—Hope, page, 849. 1. Balleras, Bonitto, & Paris, 4. Macdonald, 20. Majendie, 28. XXII. Goode & Boland, 294. XXIII. Garrari, R. & S., 95. Hunt & Roskell, 97. Morel & Co., 117. Phillips, Brothers, 87. Thistlethwayte, 24. Austria, Lohkowitz, Prince of, 10. Schönborn, Count of, 15. Ceylon. France, Lemonnier, 304. New Brunswick, India, I. XXIII. New Granada, 1. Balleras, 3. Bonitto, 5. Paris, 4. Turkey. United States, Fautschwanger, 469. Van Diemen's Land, Kemp, 320. Milligan, 310-319. Zollverein (1), Rumann, 10. Weishaupt & Sons, 412. William, 207. (4), Falst & Steinhäuser, 64. See also *Diamonds, Emeralds, Pearls.*
- PRECIOUS STONES, IMITATION**—XXIII. Henrys & Co., 131. Austria, Hligaglia, 600. Blaschka & Sons, 601. Pazelt, 603. Pfeiffer, 604. Sander, 607. France, Henri, 871. Savary & Mosbach, 368. Switzerland, Maszy, 222. Veret, 223. Zollverein (1), Weber, 325. (0), Wagner, 52.
- PRECISE CLIMBING APPARATUS**—VIII. Hubbard, 180.
- PREPARATIONS FROM THE TORPEDO**—*Tuscany*, Prof. Callamia, 60a.
- PRESERVED FRUITS**—See *Fruits, dried and preserved.*
- PRESERVED FLOWERS**—IV. Stevens, 3.
- PRESERVED PITCHER-PLANTS**—IV. Cook, 2A.
- PRESERVED PROVISIONS. See *Provisions, Preserved.***
- PRESS (Undescribed)**—France, Meurant, Brothers, & Willemain, 1659.
- PRESS-PAPERS**—XVII. Hamer, 84. Hastings & Mellor, 85.
- PRESSURE GAUGE**—V. Bursill, 753.
- PRESTON HALL (Model)**—XXX. (Fine Art Court) Thomas, 235 A.
- PRINCE ALBERT'S MIRROR**—VIII. Beadon, 90.
- PRINTED FABRICS (Cambries, Muslin, Linnen, Silk, &c.)**—XIV. Devou & Co., 34. Tee & Son, 37. XVIII. Bradwell & Adams, 40. Gourlie & Sons, 52. XIX. Bright & Co., 115. Burch, 115. India, XVIII. Portugal, Miranda & Co., 728-747. United States, Reed, Chadwick, & Dexter, 400. See also *Calico Printing.*
- PRINTED FABRICS (Designs for)**—XVIII. Bridges, 79. Cadman, 74. Fletcher, 69. Green, 70A. Hobbs, 83. Jarvie, 82. Kay, 68. Smith, 89. Waterson, 67. XIX. Harvey, 197. Austria, Hartmann, 742. France, Barbe, 1068. Chatelet, 118. Didier, 820. Gattiker, 841. Henry, 1267. Laroche, 291. Naze, Son, & Co., 625. Picard, 347. Queru & Co., 1415. Trouillier, 466. Walwein, 737.
- PRINTERS' COUNTING-MACHINES**—X. Greaves, 503.
- PRINTERS' FRAMES**—XVII. Gallard, 11.
- PRINTERS' INK**—Zollverein (3), Hartegen, 7. Jagodzinsky, 8. (5), Baldenecker, 12. (6), Petri, 41.
- PRINTERS' PAGE MARKERS**—Belgium, Mackintosh, 471.
- PRINTERS' ROLLERS**—Switzerland, Lendenmann, 232.
- PRINTING, ANASTATIC**—XXX. (Fine Art Court) Cowell, 38.
- PRINTING APPARATUS**—VI. Cooke, 118. See also *Composing Frames, Composing Machine.*
- PRINTING CASES**—XXIX. Napier, 262.
- PRINTING, CHINESE**—Zollverein (1), Beyerhaus, 144.
- PRINTING, COLOURS FOR**—XVII. Caslon & Co., 78.
- PRINTING IN COLOURS**—XVII. Fisher, 10. Hodson, 166. XXX. (Fine Art Court) Baxter, 115. Cundall & Addey, 112. Dicks, 68. Jones, 54. Kronheim, 40. Melton, 297.
- PRINTING, DECORATIVE**—XXX. (Fine Art Court) Humphreys, 50.
- PRINTING, LETTER-PRESS (Specimens of)**—XVII. Bagster & Sons, 87. Bradbury & Evans, 130. De la Rue & Co., 76. Evans, 113. Leighton, J. & J., 21. Owen, 180. Silverlock, 40. XXX. (Fine Art Court) Harris, 244. Myers, 117.
- Austria**, Vienna Imperial Court and Government Printing-Office, 302. Canada, Bureau & Marcotti, 192. France, Battenberg, 1070. Chardon & Son, 110. Fry & Riggs, 1237. Gauthier, 234. Gouvan, 250. Meyer, 637. National Printing-Office, Paris, 544. Silbermann, 374. India, XVII. Netherlands, Noordendorp, 110. United States, Walker & Co., 123. Whiting, 556. Zollverein (1), Dacker, 148. Engel, 885. Liepmann, 147. Moester & Kühn, 156. Wagner, 155. (3), Hirschfeld, 160. Melhold & Sons, 181. (5), Bauer & Krebs, 13. See also *Type, Typography.*
- PRINTING-MACHINES**—VI. Cowper, 134. Hopkinson & Cope, 162. Jugam, 122. Napier & Son, 158. Nelson, 120. Sherwin & Co., 104. Ullmer, 121. Waterlow & Sons, 164. China, Astell & Co. Zollverein (2), Reichenbach, 102. See also *Label Printing-Machines.*
- PRINTING ON METALLIC SURFACES**—XVII. Arliss & Tucker, 55. XXII. Abate, 265.
- PRINTING, MUSIC**—See *Music Printing.*
- PRINTING, ORNAMENTAL**—XVII. Gill, 160. Ramsay, 187. XXX. (Fine Art Court) Wilson, 44. Canada, Starke & Co., 191.
- PRINTING, PHONETIC SHORT-HAND**—XVII. Pitman, 197.
- PRINTING PRESSES AND MACHINES**—V. Ransmore & May, 640. VI. Clymer & Dixon, 124. Cobb, 150. Cowlaids & Lovejoy, 01. Harrild & Son, 157. See also *Type.*
- PRINTING ON TINFOIL**—XVII. Arliss and Tucker, 55.
- PRINTING TYPOGRAPH FOR THE BLIND**—X. Hughes, 401.
- PRINTING TYPE**—See *Type.*
- PRINTING, WOOD-CUT**—XVII. Bradbury & Evans, 130. Folkard, 112.
- PRINTS (Undescribed)**—XXX. (Fine Art Court) Apple, 274. France, Simon, 1014. Zollverein (1), Engel, 389.
- PRISMATIC COLOURS IN GLASS (Specimens of)**—X. Richardson, 264.
- PROPELLING APPARATUS (Undescribed)**—VIII. Corryton, 82. XXII. Marsden, 513.
- PROVING PRESSES**—V. Fox, Henderson, & Co., 404.
- PROVISIONS, PRESERVED**—III. Brocchieri, 6. Copland, Barnes, & Co., 1. (a), 16. 12. Leonard, J. & T. P., 20. Linklater, 24. Moses, H. E. & M., 101. Ritchie & McCall, 15. Smith, 14. Underwood, 23. Whitney, 26. IV. Dufaville, 220. Canada, Nicolson, 326. South Africa, Martini, 40. Schlusler, 39. Hamburg, Schuauz, 104. New Brunswick, Fraser, 24. New South Wales, Bogue, 2. Briens, 2A. Daugar, 7. Dudgeon & Co. 11. Nova Scotia, Central Committee, 2. Russia, Vsevolodowitch, 338. Spain, 139B. Conti, 139A. Switzerland, Baup, 52. Turkey. United States, Borden, 524. Duffield, 363, 363A. Hough, 507. Smith & Co., 519. Usher, 379. Wadsworth & Sheldon, 348. Van Diemen's Land, Adcock, 6. Lipscombe, 297. See also *Alimentary Preserves, Amalone.*
- PRUSSIAN BLUE**—II. Heade, 3A. France, Souchon, 1491.
- PULLEYS, ANTI-FRICTION**—VII. Coles, 11.
- PULP-STRAINER (for Paper-making)**—See *Paper-making Machinery.*
- PULPITS**—XXVI. Cooper, 235. Moulin, 163. XXVIII. Cooper, 151.
- PULPITS WITH HEARING APPARATUS FOR THE DEAF**—X. Heeps, 615.
- PULPITS, PORTABLE**—XXVI. Melville, 3.
- PUMICE-STONE**—Austria, Harlithuth, 35. Schabas, 36. Bermudas. New Zealand, Meurant, 15.
- PUMP (Model in Glass)**—XXIV. Skidmore, 52.
- PUMP FOR SUPPLYING BOILERS**—V. Broughton, 447.
- PUMPS, AIR**—See *Air-Pumps.*
- PUMPS, BOAT**—VIII. O'Conner, 189.
- PUMPS, CENTRIFUGAL**—United States, Gwynne, 140.
- PUMPS, DRAINING**—V. Apple, 420. Bessemer, 421.

- PUMPS, FORCE, SUBSTITUTE FOR**—x. Plant, 215.
PUMPS, LIFT AND FORCE—v. Stocker, S. & G., 422. Warner & Sons, 424. Williams, 128.
Belgium, Jouvne, 123.
- PUMPS, LIQUID MANURE**—ix. Cottam & Hallen, 109A. Crump, 160. Weir, 123.
- PUMPS, MEDICAL**—x. Nunn, 371. Einals, 127.
- PUMPS, MINING**—i. Arthur, 462. Eddy, 463.
- PUMPS, SHIPS**—v. Bessemer, 421. Gossage, 414. viii. Macdonald, 329. Robinson, 190. Williams, 332.
- PUMPS (Various, including Models)**—v. Clunes, 475. Daly, 400. Downton, 474. Read, 90. Selfe, 432. Shalders, 402. Smith, R. & Son, 449. Warner & Sons, 424. Whitelaw, 68. vi. Pontifex & Wood, 602. viii. Dutton, 326. ix. Thompson, 248b. Burgess & Key, 237. Doane, Dray, & Doane, 180. Fairless, 155. Key & Mitchell, 237. x. Einals, 127. Well-way, 465. xvi. Thomas & Son, 211. xxii. Hodges, 519. *Belgium, Jouvne, 123. Keatmont, 309. China, Lindsay. Denmark, Lund, 12. France, Nilus, 935. Jersey and Guernsey, White, 12. United States, Baker, 257. Zollverein (1), Warden & Co. 51. See also Archimedean Screw. Steam Pumps.*
- PUMP VALVES**—i. Hoaking, 466.
- PUNCHING-MACHINES**—vi. Whitworth & Co. 201. viii. Etrick, 337.
- PUNTS (for wild fowl shooting)**—viii. Ansell, 185.
- PURBECK MARBLE (with articles therein)**—Main Avenue, West, Mather, 61. i. Freeman, W. & J., 160. Sparks, 154. Voss, 135.
- PURCHASE BLOCKS**—United States, Sutton, 430.
- PURSE-MAKING MACHINE**—France, Lanerville, 287.
- PURTY-STONE ORNAMENTS**—France, Heiligenthal & Co. 259.
- PUZZLES**—xxvi. Asulay, 64.
- PUZOLANA**—Greece, 22.
- PYRITES**—i. Jenkins, 502. ii. Hall, 40. *Belgium, Société de Vedin, 17. India, i. Sardinia, Selopia, Brothers, 4.*
- PYRITES, IRASS**—Algeria, Briqueler & Co. 11.
- PYRITES, COPPER**—i. Grylls, S., & Redruth Committee, 444. *Russia, Boguslovsk Copper Works, 1. Turkey.*
- PYRITES, IRON**—i. Llakeard Committee, 513. ii. Spence, 7. Wilson, 6. *Turkey.*
- PYRITES, SULPHUR**—ii. Kane, 33.
- PYRO-GALLIC AND PYRO-MECONIC ACIDS**—ii. Marson, T. & Son, 106.
- PYROGRAPHY (Specimens of)**—xxx. (Fine Art Court) Calvert, 97. Marshall, 358. Mills, 96. Mitchell, 87. *Belgium, Duchastel, 443.*
- PYROLIGNEOUS ACID**—France, Batnille, 42.
- PYROLIGNEOUS ACID MANUFACTURE APPARATUS**—vi. Halliday, 617.
- PYROMETERS**—Austria, Wurm, 137. *United States, Erricson, 146.*
- QUADRANTS**—See Sextants, Quadrants, &c.
- QUADRANT-STAND**—vii. Renczynski, 27.
- QUADRIGA (Model of)**—xxx. (Fine Art Court) Wyatt, 183.
- QUARTZ**—i. Cook, 19. Falmouth & Penryn Local Committee, 88, 163. Oldfield, 21. Sweetman, 40. Braidley, 23A. *Ceylon, Allbrecht, Greenhill & Co. France, Bertaud, 1549. Spain, Barcelona Mines, Inspector of, 2. Turkey. Tuscany, Frediani, 16. United States, Brown, 283.*
- QUARTZ-CRUSHER**—United States, Wright, 185.
- QUARTZ CRYSTAL**—i. Duke of Devonshire, 331 (Main Avenue, East).
- QUASSIA**—British Guiana, Arrindell, 69.
- QUEEN, HER MAJESTY THE**—Equestrian Statue of Her Majesty by Thornycroft, page, 853.—Equestrian Statues of Her Majesty and H.R.H. Prince Albert, by Wyatt, page 853.—Portraits on S^{cs}res China of Her Majesty, by Ducluzau, and of H.R.H. Prince Albert, by Bazenget, after Winterhalter, Main Avenue East, 96, 97.—Statue of Her Majesty, in Zinc, by the Vieille Montagne Mining Co., i. 437 (Main Avenue, East).—Busts of the Queen and Prince Albert, in Zinc, i. Vieille Montagne Mining Co., 437.—Portrait of Her Majesty, woven in silk, xiii. Cross, 32.—Portrait of Her Majesty in Embroidery, xix. Lambert, 229.—Domestic Groups of Her Majesty and the Prince of Wales, in Ormolu and Bronze, by Bell, xxii. Messenger & Sons, 340.—Silver Statuettes of Her Majesty and H.R.H. Prince Albert, xxiii. Zimmerman, 80.—Bronze Bust of Her Majesty, after Chantrey, xxx. (Fine Art Court) Hatfield, 135.—Oval Medallion of Her Majesty, produced by a single line of equal thickness, xxx. (Fine Art Court) Bishop, 278.—Jewel-case, designed by Gruner, with portraits of Her Majesty, H.R.H. Prince Albert, and the Prince of Wales, after Thorburn, xxiii. 140 (Main Avenue, West).—Cradle carved in Turkey Boxwood, by Rogers, 353.—Wax Figure of Her Majesty, Holding, 217.—Wax Figure of Her Majesty and H.R.H. Prince Albert, Trundle, 73.—Portrait of Her Majesty in Needlework, Sweden and Norway, Alner, 42.—Full-length Portrait of Her Majesty, in enamel, after Clason, Switzerland, Dufaax, 249.
- QUERCUS-CERRIS, EXTRACT**—Zollverein (2), Boerer & Porcellius, 8.
- QUICKSILVER**—France, Violette, 1528. *Spain, Almeria Mines, Inspector of, 13. Tuscany, 0-11. Volterra Salt Manufactory, 2.*
- QUILTS**—iv. Morrell, 58. xxvi. Gilbert & Co. 130. *Ceylon. Oldenburgh, Bramlage, 2. Russia, Rahsevitch, 350.*
- QUILTS**—See Bed Quilts. *Elder-Down Quilts.*
- QUILTINOS**—Zollverein (4), Weigle, 29. See also Waist-coatings.
- QUINCE (Beugal)**—ii. Pound, 108.
- QUININE**—ii. Howards & Kent, 11. Spencer, 31. *Sardinia, Dufour, 13.*
- QUININE, SULPHATE OF**—Tuscany, Corriti, 22. *Zollverein (4), Jolst, 4.*
- RADEZKY, FIELD-MARSHAL COUNT (Statue of)**—Austria, Prince Salin, 430 (Main Avenue, East).
- RAILWAYS (Models, &c.)**—v. Dunn, 998. Perry, 562. viii. Brown, Sir S., 334. *Netherlands, Chabot, 91.*
- RAILWAY ACCIDENTS, PLANS FOR PREVENTING.** See *Railway Collisions Prevention.*
- RAILWAY, ATMOSPHERIC (Models)**—v. Cunningham & Carter, 654. Harlow & Young, 655. Jackson, 703.
- RAILWAY AXLES**—i. Beecroft, Butler, & Co. 415. v. Beecroft, Butler, & Co. 646. Patent bhatt & Axletree Co. 543. Thornycroft & Co. 630. *Zollverein (1), Piepenstock & Co. 472.*
- RAILWAY-AXLE BOXES**—v. Adams, 510. Parsons, 642. *Worsdell & Co. 637.*
- RAILWAY-AXLE FORGES**—v. Worsdell & Co. 637.
- RAILWAY BARS**—v. Cwm Avon Iron Co. 645. Derwent Iron Co. 647. Dudds & Son, 64. Ebbw Vale Co. 638.
- RAILWAY BREAKS**—v. Botten, 429. Davies, 628. Dillon, 560. Gray, 694. Handley, 600. Jones, 656. Knox, 514. McNaught, 22, 686. Piziaz, 539. Stoy, 705. Walker, 693. vi. Chalmers, 32. *France, Laigne, 1637. Jersey and Guernsey, Berland, 4. United States, Cochran, 481.*
- RAILWAY BRIDGES (Models)**—See *Bridges, Railway, &c.*
- RAILWAY BUFFERS**—v. De Bergue, 552. Clarkson, 568. Fossick & Hackworth, 10. vii. Nicholson, 40. xxii. Brown, 235.
- RAILWAY CARRIAGES (including Models & Plans)**—v. Adams, 510. Chabot, 684. Cripps, 576. Green, 704. Hadlem, 541. Lester, 700. Macbay, 586. McConnel, 539. Mellioh, 708. Tennant, 564. Williams, 530. vii. Coles, 11. Geary, 2. Nicholson, 40. Sankey, 32. Smith, 96. viii. Brown, Sir S., 334. *Zollverein (1), Reiffert, 886.*
- RAILWAY CARRIAGE CUSHIONS**—France, Voruz, 1533.

ne, by the Vieille Avenue, East).—
 Albert, in Zinc, 1.
 —Portrait of Her
 s, 32.—Portrait
 x. Lambert, 249,
 and the Prince of
 Bell, XXII. Mos-
 es of Her Majesty
 Zimmerman, 80.
 r Chantrey, XXX.
 val Medallion of
 ne of equal thick-
 s.—Jewel-case, de-
 Majesty, H. H. H.
 es, after Thorburn,
 —Cradle carved in
 —Wax Figure of
 k Figure of Her
 Trundle, 73.—
 work, Sweden and
 portrait of Her Ma-
 zeland, Dufaux,
 (2), Boerer & Por-
 ctory, 2.
 & Co. 130.
 Quills.
 See also Waist-
 onces, 31.
 idli, 22.
 ne of)—Austria,
 st).
 998. Perry, 562.
 da, Claasen, 91.
 EVENTING. See
 Cunningham &
 553. Jackson,
 Co. 415. v. Bee-
 shaft & Axletree
 Parsons, 642.
 Co. 637.
 . 645. Derwent
 Ebbw Vale Co.
 ies, 828. Dillon,
 nes, 556. Knox,
 559. Stoy, 705.
 nsey, Berland, 4.
 idyes, Railway,
 Clarkson, 568.
 Nicholson, 40.
 & Plans)—v.
 576. Green,
 Machay, 589.
 aut, 564. Wil-
 2. Nicholson,
 . Brown, Sir S.
 Voruz, 1533.

RAILWAY CARRIAGE LAMPS. See *Lamps, Railway Carriage*.
RAILWAY CARRIAGE SPRINGS—v. Adams, 510. Gibson, 848. Spencer & Son, 553. XXII. Johnson, Cammill, & Co., 109.
RAILWAY CASH-BOXES—XXII. Sparks, 430.
RAILWAY CHAIRS—v. Baines, 643. Samuel, 616.
RAILWAY COLLISIONS PREVENTION, &c. (Plans for)—v. Cheshire, 601. Gompertz, 632. Mitchell, 919. x. Mapple, 126.
RAILWAY COUPLINGS—v. Jones, 656. Murray, 566. Thornton & Son, 490. Warren, 558.
RAILWAY CROSSINGS, GATES FOR—v. Young & Co. 600 (Western End, North Kilmorie, Outside, 60).
RAILWAY CURVES, INSTRUMENT FOR SETTING OUT—v. Sanderson, 570.
RAILWAYS, FARM—IX. Crosskill, 135.
RAILWAY GAUGES (Models)—VII. Smith, 96.
RAILWAY GREASE—France, Moreau, 1361.
RAILWAY GUARDS' TIME-PIECES—x. Bennett, 1. Fairer, 36. Tobias & Co. 78.
RAILWAY INCLINES, Mode of assisting Carriages up and down—v. Snowden, 588.
RAILWAY LOCOMOTIVE ENGINES. See *Locomotive Engines, Railway*.
RAILWAYS, APPARATUS FOR TRANSFERRING MAIL BAGS ON—v. Dickier, 674.
RAILWAY PERMANENT WAYS (Models, &c.)—v. Barlow, W. H. 602. Barlow, P. W. 601. Crittwell & Co. 659. Culitt, 628. Great Western Railway Company, 501. Hoby, 614. Samuel, 616.
RAILWAY, PORTABLE (Model)—IX. Steevens, 38.
RAILWAY RAILS—v. Greaves, 615. Richardson, 651. Austria, Lindheim, 422. *New South Wales*, Shields, 18. Russia, Poland Imperial Mining Works, 15.
RAILWAY SIDING STOP—v. Becker, 503.
RAILWAY SIGNAL-LAMPS—VII. Rettie, 159. VIII. Pearce, 330. XXII. Roake, 697. Ilulgate, 450. Messenger & Sons, 340. Riddle, 637. Smith & Co. 452.
RAILWAY SIGNALS—v. Brotherhood, 502. Conley, 561. Copling, 608. Cowper, 699. De Fontaine, 610. Hattersley, 701. Hoy, 710. Lockyer, 562. Long, 662. Pearce, 709. Shaw & Co. 728. Stevens, 572. Stevens & Son, 609. Tidmarsh, 707. Watson, 712. VII. Jeffrey, 14. VIII. Pearce, 330. x. Allen, 413. XXII. Clark & Restell, 446.
RAILWAY SLEEPERS—v. Barlow, 601. Greaves, 615. Lucy, 556. Ransomes & May, 640. Belgium, Marchal, 362.
RAILWAY SNOW-SWEEPING ENGINE—v. Faure, 726.
RAILWAY SWITCHES & CROSSINGS—v. Baines, 643. Kennard, 641. Parsons, 642. Sharp & Co. 728. *United States*, Cochran, 297. Tyler, 597.
RAILWAY TICKETS-DATING MACHINE—VI. Church & Goldard, 135.
RAILWAY TRAINS (Models)—v. Jones, 650.
RAILWAY TRAINS, APPARATUS FOR SHIPPING & UN-SHIPPING—VII. Houch, 73.
RAILWAY TRAVERSING APPARATUS—v. Great Western Railway Company, 501. Dunn, 618. Ormerod & Son, 624.
RAILWAYS, TRENAILS & WEDGES FOR—v. Ransomes & May, 640.
RAILWAY TRUCKS—v. Ashbury, 731. See also *Springs, Railway Truck*.
RAILWAY TURN-TABLES—v. Allan, 711. Greenway, 698. Leadbetter, 630. Ormerod & Son, 624. Ransomes & May, 640.
RAILWAY TURN-TABLES, Model of Railway dispensing with—v. Dunn, 998.
RAILWAY WAGGONS—v. Henson, 532.
RAILWAY WATER-CHANES—v. Ransomes & May, 640.
RAILWAY WHEELS—v. Banks & Chambers, 666. Beccroft, Butler, & Co. 646. Haddan, 541. Mansell, 715. Sandford, Owen, & Watton, 554. Wharton, 713. VII. Irish Engineering Company, 150. *United States*, Shaltuck, 609.
RAILWAY WHEELS, INVENTION TO PREVENT VIBRATION OF—v. Lipcombe, 670.
RAILWAY WHEEL-TIRES & TIRE-BARS—I. Beccroft, But-

ter, & Co. 415. v. Beccroft, Butler, & Co., 646. Thorneycroft, 636. Warren, 1001. Wordsell & Co. 637.
RAILWAY WHISTLES—v. Fourness, 581. Roberts, 550. Tabur, 641.
RAILWAY WRAPPERS—XII. & XV. Gaudy, 246. Wilson, J. & W., 245.
RAIN-GAUGES—x. Baker, 396. Newman, 674. Phillips, 411.
RAISING-MACHINE—XXII. Jackson, 311.
RAISING—Spain, Casado, 193. Tunisia, 107, 109.
RAKES, HORSE, &c.—IX. Grant & Co. 267. Holmes & Sons, 241. Howard, I. & F. 240. De Porquet, 202. Smith & Son, 234.
RAMRODS—VIII. Brider, 261. See also *Lugs, &c.*
RAMSGATE HOVELLERS, MODEL OF GUNNER USED BY—VIII. Twyman, 149.
RAPSEED & RAPE-SEED OIL & CAKE—III. McGarry & Sons, 132. IV. Brotherton & Co. 23. Austria, Malviuk, 192. Netherlands, Dehaan, 9. See also *Linseed & Linseed-Oil, &c.*
RASPBERRY VINEGAR—Canada, Fletcher, 127.
RATCHET-HOISTING MACHINE (Model)—United States, Holmes, 531.
RATTANS—Lubnan, &c., Hammond & Co. 2. Netherlands, Hoop & Co. 24.
RAZORS—XXI. Bradford, R. & W., 3. Stewart & Co. 21. Tuzacks, 22. Wood, 8. XXII. Butcher, W. & S. 192. Elliott, 151. Feuney, 114. Gilbert, Brothers, 123. Hawcroft & Sons, 135. Maria, 132. Webster, 154. Winks & Son, 134. Austria, Bley, 505. Bresilmair, 506. Rösler, 552. Rupprecht, 553. Wachter, 561. China, Herculite. India, 1. Mecklenburg-Schwerin, Bahrt, 9. Sweden & Norway, Stille, 120. Switzerland, Burkhardt, 270. Lecoutre, 215, 262. Lecoutre, Brothers, 214. Hoeller, 637. Zollverein (4), Dittmar, Brothers, 57.
RAZOR-GUARDS—x. Heather & Blackwell, 653. XXI. Stewart & Co. 21.
RAZOR-STROPS—x. Saunders & Son, 205. XX. Barnes, T. & G., 27. XXI. Cowvan, B. & S. 9. Saunders, G., 34. Stewart & Co., 21. XXVIII. Dewnap, 199. XXIX. Sacker, 214. Gibraltar, Clarng, 1. Sweden and Norway, Burkhardt, 270.
READING STANDS AND TABLES—XXVI. North, 259. Riddett, 49. Warren, 258.
READY-MADE LINEN—XX. Brie & Co., 21. Ford, 36. Hemming, 23. Human & Co., 17. Lennox, 147. Marshall, 25. Miniffe, 151. Neville & Co., 20. Nicoll, 34. Paterson, 19. Porter, 30. Reid, 23. Scott, 141. Smith, 29. Wheeler & Aibett, 22. White, 159. *United States*, Forrest, 539.
REAPING-MACHINES—See *Mowing and Reaping Machines*.
RECEPTION SEAT, WITH CANOPY, &c. Presented to Her Majesty by the Nawab Nazim of Bengal—India.
RECIPROCATING ENGINES (Invention for converting into a uniform force the fluctuating force derived from reciprocating Engines) Models—v. Constable, 70.
RECLINIA, THE (for Astronomical purposes)—x. Roper, 197.
RECORD OFFICE (Model of)—XXX. (Fine Art Court), Dighton, 160.
RECTILINEAR MOTION (Machine for converting into Curvilinear Motion)—Belgium, Demanet, 178.
RED LEAD—Austria, Herbert, 32. Zollverein (1), Ohle, 62.
REEDS (for Weaving)—VI. De Burque, 45. Gatenby & Pass, 60.
REFRACTOR—Zollverein (2), Merg & Sons, 30.
REFRIGERATORS—VI. Askew, 611. Coffey, 615. Hulls, 618. Lawrence, 604. x. Darvell, 359.
REGENT'S PARK BOTANICAL GARDENS (Model)—VII. Turner, 7.
REGIMENTAL AXE—Portugal, Buhona, 616.
REGIMENTAL APPOINTMENTS—See *Military Accoutrements*.
REGIMENTAL TROUSERS, INVENTION FOR PRODUCING A RED STRIPE ON—XX. Grosjean, 60.

- REGULATING SCREW FOR CARRIAGES**—France, Rastouls, 1421.
- RESIN**—II. Hayes & Co., 78. The London Druggists, 117. Ceylon, Florin. India, iv. Russia, Rudert, 84. Spain, Flores, Calderon & Co., 241. Turkey. Van Diemen's Land, Milligan, 292. See also Gums.
- RESPIRATOR SMOKING PIPES**—XXV. Lettch & Hammond, 59.
- RETICULES**—XVI. Brindly, 21. XXVI. Foothorpe & Co., 132.
- RETORTS**—See Crucibles. Gas-Retorts.
- REVERSIBLE CLOTH** (Hulshrd on both sides)—XII. & XV. Hargrave & Massey, 28. Shaw, Son, & Co., 110. Wrightley, J. & T. C., 117.
- REVOLVERS**—See Guns, &c.
- RHEOCYLINDERS** (or Spring Bedsteads)—XXVI. Cottam, 221.
- RHEUMATIC FITCH-PLASTER**—Zollverein (4), Faulhaber & Leube, 43.
- RHEUMATISM, MEDICATED BANDS FOR THE CURE OF**—x. Coles, 660.
- RHODIUM**—I. Johnson & Matthey, 477.
- RHODODENDRON WOOD**—Russia, Cootals (Government of), 118.
- RHUSARB**—II. Lamplough, 71. Tustian & Usher, 98.
- RIBBONS** (Silk, Gause, &c.)—XIII. Allen & Holmes, 50. Berry, Brothers, 75. Bray & Co., 67. Bridgett & Co., 49. Brocklehurst & Sons, 38. Caldecott, R. & R., 68. Cope & Co., 70. Cornell & Co., 22. Coventry Ribbons Committee, 72. Cox, 66. Hart, 76. Howell & Co., 27. Lewis & Allenby, 16. M'Ray, 78. Marshall & Snelgrove, 33. Rattiff, J. & C., 73. Redmayne & Co., 1A. Robinson, 77. Sharp & Co., 68. Sturdy & Turner, 79. XIX. Beunock & Co., 394. Austria, Messut, A., 246. Moering, 217. Pfeningberger, 248. France, Balay, 1064. Barrallon & Brossard, 16. Buisson, 1125. Collard & Conte, 1154. Couchoud, 1161. De Hajeclair, 18. Duanel & Mauseur, 1195. Dutton, 1209. Gerimon, Son, 242. Larcher, Faure, & Co., 1293. Michelin, 641. Molyv Le-ouef, 1359. Robert-Faure, 1442. Schneider & Legrand, 1002. Tuveo & Co., 704. Vignat, Brothers, 1524. India, XIII. Russia, Lotteff, 204. Spain, Sena, 274A. Switzerland, Ribbon Manufacturers, 152. Tunis, 10. Turkey. Zollverein (1), Andreas, 379. Bruck & Sons, 535. Grote, 538. Heydeweller & Sons, 521. Hoeninghaus & Sons, 519. Lingenbrink & Vennemann, 526. Menghuis, Brothers, 530. Pass, 377. Schelbler & Co., 534. Siebel, 513. Zollverein (3), Eisenstuck & Co., 151.
- RIBBONS** (Designs for)—France, Braud, 72.
- RICE**—Algeria, Hardy, 28. British Guiana, Duggin, 7. Netscher, 6. Ceylon. Enry, 4, 40-43, 73, 83, 86. France, Forj, 505. India, III. Labuan, &c., Hammond & Co., 2. Mauritius, Reader, 7. Natural History Society, 4. Sardinia, Blondel, Gaston, & Co., 18. Palestrini, Brothers, 17. Spain, 72. Martinez y Perez, 89. Trinidad, Lord Harris, Turkey. United States, Heriot, 172c. Merriweather, 164. Ward, 172d.
- RICE, MACHINE FOR PEELING**—Belgium, Houyet, 125.
- RICE PAPER**—China, C. pland.
- RICE-PAPER DRAWINGS**—China, Copland. Hammond & Co.
- RICHARD CRUR-DE-LEON** (Statues of)—Western End (Outside) Marochetti, Hamburg, Englehard, 93.
- RICK CLOTHS**—XIV. Morrison & Hurn, 49. XXIX. Fisher, 25. See also Tarpaullins.
- RICK VENTILATOR**—IX. Gillett, 78.
- RIFLE MALLETS** (for hot climates)—VIII. Brijer, 262.
- RIFLES**—See Guns, &c.
- RIVETING-MACHINES**—VI. Fairbairne & Sons, 200. Garforth, W. J. & J., 208.
- ROAD LEVELS** (for Agricultural purposes)—X. Richman, 681.
- ROAD-MEASURING AND MAPPING MACHINE**—X. Adcock, 353.
- ROAD-WATERING MACHINES**—V. Geary, 846. IX. Coode, 164A.
- ROASTING APPARATUS**—VII. Remington, 175. See also Cooking Apparatus.
- ROCKHILL SALTS**—II. Pontifex & Wood, 1.
- ROCK CRYSTALS** (including Articles therein)—I. Carter, 3. XXVI. Webb, 171. Ceylon. Spain, Zamora Mlaca, Inspector of, 30. Zollverein (3), Kuegler, 186.
- ROCK URCHILLA**—Portugal, Batalha, 509A.
- ROCK SALT**—I. Thompson, 72. Worthington, 57. Russia, Obroutcheff, 348. St. Helena, Agricultural Society, 2. Turkey. ROCK STONE—Gibraltar I. (from Arctic regions) Snow, 86.
- ROCKET APPARATUS**—VIII. Cortis, 177.
- ROCKING BOAT**—XXIX. Porter, 144.
- ROCKING CHAIRS**—XXVI. Cunnig, 165A.
- ROCKING HORSES**—XXIX. Dear, 126.
- ROLLED IRON PLATES** (used in Marine Engines, &c.)—V. Detwent Iron Company, 647.
- ROLLER BLINDS**—See Window Blinds.
- ROLLER-MILL**—IX. Stanley, 1.
- ROLLERS** (for Land). See Clod Crushers. Garden Rollers.
- ROLLING-MACHINES**—See Iron-rolling Machines.
- ROMAN CEMENT**—See Cement, Roman, &c.
- ROMAN MISALS**—Belgium, Hancicq, 285. Wesmael Legros, 282.
- ROOD SCREENS**—XXVI. Ringham, 42.
- ROOFING** (for Houses, &c.)—v. Tensaut, 664. VII. McClelland, 116. Newnham, 170. Willet, 11. Canada, Hall, 18. See also Glass Tiles. Iron Roofing. Slates for Roofs. Tiles for Roofing. Timber Roof.
- ROOTS OF AGRICULTURAL PLANTS**—III. M'Arthur, 111.
- ROPES, CONDAE, &c.**—I. Huggie, Brothers, 300. IV. Trunt, 41. VIII. Robertson, 16. XIV. Gordon G. & A. 82. Gourcock Rope-work Company, 72. Hall & Co., 61. Hawks, 54. Holloway, 74. Huddart, Sir J. & Co., 68. Morrison & Hurn, 49. Smith, 65. Super, 64. Spyyce & Coopers, 62. Tull, 69. XXVIII. Woodhead, 191. Bahamas, Balnes & Co. British Guiana, Stutchbury, 70, 126, 127. Canada, Dixon, 170. Henderson, 168. Henderson, H., 291. Ceylon. Egypt, 258, 259, 354-356, 382. France, Bernard, Richoux, & Genest, 61. Joly, 891. Leclere, Brothers, 576. Leduc, 1645. Louis-Blais, Son, Letellier, & Co., 315. India, IV. XIV. Netherlands, Beestingh & Co., 27. Cats, 54. Hoogen, 26. Lafebre, 28. New South Wales, Mitchell, 5. Russia, Cazalett, 223. Spain, 157. Martines, 156. Switzerland, Beugger, 113. Braendling, Brothers, 119. Trinidad, Lord Harris. Turkey. Tuscan, Ferrigini, 100. United States, Evans, 474. Van Diemen's Land, Rout, 154-158. Western Africa, M'William. Trotter, 5. Zollverein (1), Felten & Guilleaume, 380. See also Bell-Ropes. String and Twine. Wire Rope.
- ROPE** (for Paper-making)—XVII. Lamb, 147.
- ROPE-MAKING MACHINE**—VI. Crawhall, 78.
- ROPE-MANOEUVRING APPARATUS** (for Ships)—France, Harbotin & Legoff, 1083.
- ROSES, CONFECTION OF**—II. Tustian, 97.
- ROSES, OTTO OF**—See Otto of Roses.
- ROSE ENGINE LATHE**—Hamburg, Kohn, 17.
- ROSE KNOIVE AND TRACING MACHINE**—VI. Mordan & Co., 205.
- ROBIN**—See Resin.
- ROTATORY MACHINERY** (Machine for giving motion to)—IX. Nicholls, 20.
- ROVING FRAMES**—VI. Higgins & Sons, 14. Mason, 10. Parr & Co., 6. See also Drawing, Roving, &c. Frames.
- ROVING AND SPINNING IRONSTONE PORCELAIN GUIDES**—VI. Watkins, W. & T., 66.

—X. Rickman,
 —X. Adcock,
 846. IX. Coode,
 175. See also
 1.
 —I. Carter, 3.
 509a.
 ington, 57.
 Turkey.
 (regions) Snow, 85.
 5a.
 Engines, &c.)—V.
 s. Garden Rollers.
 Machines.
 &c.
 285. Westmael Le-
 nnant, 564. VII.
 Willet, 11.
 s. Iron Roofing.
 g. Timber Roof.
 i. M'Arthur, 111.
 Brothers, 300. IV.
 XIV. Gordon G. &
 pany, 72. Hall &
 74. Huddart, Sir
 49. Smith, 65.
 Tull, 69. XXVIII.
 127.
 Henderson, H.,
 61. Joly, 891.
 645. Louis-Blais,
 IV. XIV.
 Cats, 54. Hoogen,
 Martines, 156.
 ing, Brothers, 119.
 es, Evans, 474.
 5.
 e, 380. See also
 Vire Rope.
 147.
 178.
 Ships)—France,
 7.
 17.
 E—VI. Mordaa &
 iving motion to)—
 14. Mason, 10.
 ing, Roving, &c.
 CRAIN GUIDES—

ROWLOCKS (Boats)—VIII. Beadon, 90.
 ROYAL KITCHEN (Models)—XXX (Fine Art Court)
 Smith, 167. Title, 189.
 RUDDER FASTENINGS—VIII. Young & Co., 52.
 RUDDERS (Ships)—VIII. Carpenter, 194. Hall, 156.
 XXIII. Hampden, 612. Portugal, Bicalho, 1294. See
 also Screw-propelling Rudder, Steering-Wheels and
 Apparatus, Tillers, Ships'.
 RUGS—XVI. Bevington & Morris, 332. Eises, 326. Ince,
 309. Luge & Co., 328. XIX. Beauvis, 385. Bot-
 tom, 106. Burton, 110. Burton, 117. Cox, 220.
 Crosley & Sons, 142. Mustace, R. & J., 160. For-
 tune, 188. Harris, 192. Hill, 203. Jackson & Gra-
 ham, 300 (North Transvaal). Lawson, 325. Parlow &
 C., 263. Pickthorpe, 273. Sheridan, 294. Simcox,
 302. Templeton & Co., 310. XXVI. Jackson &
 Graham, 261. XXVIII. Canley, 103.
 Austria, Kamner, 199. Matchoko, 201. Maurer, 200.
 Persia, Abbot. Portugal, Daufrias & Co., 699-904.
 Russia, Mahmet-vell-Ogll, 249. Turkey.
 Zollverein (1), Dinglinger, 175. See also Carriage
 Rugs, Hearth and other Rugs.
 RULES, MEASURES, &c.—X. Best, 330. Elliott & Sons, 320.
 Tree & Co., 324. XVII. Schlesinger & Co., 38.
 Austria, Bogenwiger, 689. Buchberger, 690. Tober, 691.
 Egypt, 144.
 RULING-MACHINES—See Paper-ruling Machines.
 RUN—Egypt, 389.
 RUNJETT SIMON'S DIAMOND—XXIII. Her Majesty the
 Queen, 140 (Main Avenue, East).
 RUB—Portugal, 536, 537.
 RUSSIA, EMPEROR OF (Equestrian Statue, Bronze)—
 Zollverein (1), Blasser, 310.
 RUSSIAN DUCK—See Linen Fabrics.
 RUST-PREVENTIVE COMPOSITION—XXII. Jones & Co.,
 136, 801.
 RUTLAND, DUKE OF, Status of.—Davis, page 848.
 RYE FLOUR—Russia, Davidoff, 332.
 RYE GRASS—XIV. Nicol & Co., 87.
 SABIOR—Spain, Sempers, 41.
 SACCHAROMETERS—Austria, Brandels, 133.
 SACKS AND SACKING—XIV. Beale Brown, T., 77. Dun-
 dee Local Committee, 63. Garland, 84. Grimshaw &
 Wilkinson, 62. Morrison & Horn, 49. Nicol &
 Co. 57. Ramsey & Co. 85. Ceylon.
 Western Africa, Becham, 12. Trotter, 5. See also
 Bed Sacking.
 SACK-HOLDER—IX. Cooch, 83.
 SACRED HARMONIC SOCIETY, EXETER HALL (Model of the
 Orchestra)—VII. Sacred Harmonic Society, 38 (Main
 Avenue, West).
 SADDLERY AND HARNESS—V. Duffield & Co. 544.
 Holmes & Co. 872. IX. Key and Mitchell, 237. XII.
 & XV. Gandy, 246. XVI. Asford, W. & G. 64. Ban-
 ton, C. 56. Bell, 93. Blackwell, S. & R. 75. Blowers,
 272. Blythe, 96. Bower, 328. Bowmar, 87. Brace, 56.
 Brown & Son, 65. Bywater, 94. Calster, 77. Casavan,
 101. Charge, 277. Clark, 75. Clarkson, 102. Colegrave,
 97. Coleman, 68. Cooper, 60. Cowan, 273. Cox, S.
 55. Cox, T. 273. Cuff, 96. Dax, 278. Ducie,
 Karl, 267. Earnshaw, 107. Garnet, 69. Green, 85.
 Hawkins, 58. Hicks, 81. Hudson, 60. Hughes, 106.
 Kirkby, 111. Langdon, 89. Lennan, 61. Mackie
 & Son, 104. Maiben, 46. Marlow, 54. Middle-
 more, 67. Moriarty, 95. Musselwhite, 71. Oakley,
 270. Passmore, 79. Pearl, 100. Peel, 66. Penny,
 91. Pim 59. Pollock, 279. Ramsey, 74. Rutland,
 99. Saunders, 271. Shipley, 82. Skinner, 83. Stoker,
 103. Swaine & Adeny, 92. Taylor, 269. Thomas,
 76. Tisdale, 88. Vick, 70. Weir, 72. White, 86.
 Wilson & Son, 98. XXII. Dugard, W. & H. 350.
 Flather, 167. Hale, 563. Marples, 218. Ward &
 Payne, 196.
 Algeria, Boulanger, 10. Si-El-Bey Ben-Bou-Ras, 50
 Austria, Gellinek, 338. Loffer, 339. Weinberger, 280.
 Zapf, 340.
 Belgium, Gillay, 379. Ladoubee, 256. Lambert, 373.
 Van Molla, 255. Vanstraelen, 269. Brazil, Mor-
 nay, 3.

Canada, Bell, 103. Holwell, 101. McGillan & Sull-
 van, 165. Morris, 113. Stewart, 533a. Stewart, W.
 134.
 Egypt, 227-231, 251, 267, 365, 370, 372, 373.
 France, Bancard, 24. Liogard, 1651. Frat & Lambin,
 688. Barro, 1471.
 Hamburg, Cahen, 34. Kruger, 30. India, XVI.
 Jersey and Guernsey, Le Boir, 36. Searle, 17.
 Netherlands, Lafber, 63.
 Portugal, Piquelrado, 1121. Rome, Bianchini, 11.
 Russia, Agadjan, 251. Arutin, 252. Babouoff, 345.
 Casim-Onesim-Cool-Ogll, 249. Dada, 260. Gam-
 bartzomoff, 287. Hassan-Oste-Nefai-Ogll, 253.
 Iran-Cool-Hadji-Cogranan-Ogll, 254. Jukolek, Bro-
 thers, 344. Petit, 268. Raphi-Nuba-Ogll, 265.
 Roustan, 256. Spain, Basches, 258a.
 Tunis, 36, 42, 43, 53, 93. Turkey.
 Tuscan, Corn, 103.
 United States, Adams, 476. Baker, 498. Jennings &
 Claghorn, 276. Lacey & Phillips, 41. Lloyd, 78.
 Miles, 266, 444. Searle, 486. Trotman, 207.
 Van Diemen's Land, Wiseman, 133.
 Western Africa, Brown, 3.
 Zollverein (1), Lange, 730. Mueller, 201. Reinecke,
 594. (2), Grisea, 45. (3), Hausman, 173m. Papp-
 rit, 173. See also Curry Combs.
 SADDLE RUGS, Linen—XIV. Tee & Son, 37.
 SADDLERS' IRONMONKEY—XXII. Lowe, J. & H., 346.
 SAFES (Wrought-Iron)—XXII. Longfield, 603.
 Netherlands, Pflger, 62a. See also Fire-proof Safes.
 Strong Boxes and Safes.
 SAFETY BOLT—France, Boeringer & Co., 770.
 SAFETY BOXES (for collecting money)—XXII. Fisher, 508.
 SAFETY COT—VII. Williams, 129.
 SAFETY DOORS—XXII. Rileley & Elser, 621.
 SAFETY FOCKERS—XX. Gronjean, 60. Hurley, 73.
 SAFETY LAMPS—See Lamps (Safety or Davy).
 SAFFLOWER—IV. Long & Reynolds, 75.
 Russia, Kvaiviloff, 50.
 SAFFLOWER CARMINE—Zollverein (1), Krimmelbein &
 Brodt, 467.
 SAFFLOWER EXTRACT—Zollverein (1), Jaeger, 469.
 SAFFRON—II. Spurgin, 38.
 Algeria, De Lutsow, 34. Montigny, 38.
 China, Egypt, 100.
 France, Chailouss, Lepage, & Pochon, 1568.
 Russia, Ayzarov, 91. Spain, 92. Cabello, 139.
 Tunis, 14.
 SAGO—III. St. Etienne, 138. Ceylon. India, III.
 Eastern Archipelago, Hammond & Co., 2.
 SAILCLOTH—IV. Donlan, 43. XIV. Bremser, 74a. Dixon
 & Longstaff, 75. Duncan & Co., 80. Gourcock Rope-
 work Company, 72. Huffer, 71. Huddart, Sir J. &
 Co. 68. M'cowman & Co. 96. Moore, 67. Poole,
 J. & C. 46. Renny & Co., 81. Row, 45. Salmond, 83.
 Austria, Butschek & Grass, 281. Chiaccio, 282.
 Belgium, Amey-Berte, 209. Boitevis-Geeerick, 238.
 Haegens, 228. Van Overloop, 236. Wilford, 211.
 Egypt, 229, 250.
 France, Landernan Linen Joint-Stock Company, 1019.
 Mack, O. Dickson & Co., 320. Hanover, Hausen, 5.
 Malta, Bouayla, 2.
 Russia, Belbin, 217. Bistrom, 215. Brughin, 216.
 Zotoff, Brothers, 218.
 Spain, Cartagena Royal Arsenal, 191. Castella, 190.
 Esculero and Azara, 192.
 Zollverein (1), Kiker, 553. See also Canvas.
 SAILS FOR SHIPS (Models, &c.)—VIII. Addison & Co., 192.
 Geordeson, 42. Trail, 191.
 SAILS FOR OPEN BOATS, TREATISE ON—VIII. Orr, 75.
 SAIL-HOOKS—XXII. Boulton & Son, 330.
 ST. MICHAEL AND THE DRAGON (Colossal Group in
 Plaster)—France, Du Seigneur, 187 (Main Avenue,
 East).
 SAL-AMMONIAC—II. Hills, 23.
 Zollverein (1), Paull, 328. (6), Oehler, 8.
 SALE ORNAMENTS—China, Reeves.
 SALINE ARBES—British Guiana, De Patron, 29a.
 SALINE PRODUCTS—France, Prat & Agard, 1682.
 SALINOMETER—X. Mudie, 683a.

- SALT**—I. Hill, 58. Longmaid, 441. II. Bell, 116. Cheshire, 30. III. Noak, W. & J. 118.
- Algeria*, Bedel, 5.
- Austria*, Gallicia Imperial Salt Works, 17. *India*, 1.
- Portugal*, Correa De Samora, 43, 44-48. St. Ube's Salt Works, 45.
- Russia*, Barnavulak Imperial Works, 4.
- St. Helena*, Agricultural Society of St. Helena.
- Spain*, Anana Salt Works, Sô. Maisterra, 43.
- Tunis*, 165. *Tuscany*, Volterra Salt Manufactory, 2.
- Van Diemen's Land*, Strahan, 17.
- Zollverein* (1), Artern Royal Salt Works, 681. Duerrenberg Royal Saltery, 856. Prussian Chemical Manufactory, 683. Prussian Salt Works, 445. Schoenebeck Royal Salt Works, 834. (6). Salzhause Salt & Lignite Works, 3. Theodorshalle Salt Works, 5.
- SALT, CHEMICAL PREPARATIONS OF**—*Zollverein* (1), Prussian Chemical Manufactory, 683.
- SALT WATER DISTILLATION**—*France*, Leroux-Mainguet, 447. See also *Sea-Water Regenerators*.
- SALTPETRE**—II. Richardson, Brothers, & Co. 19.
- Egypt*, 13. *India*, I. & II. *Tunis*, 46. *Turkey*.
- SANDALS**—*Western Africa*, Jamieson, 22.
- SANDS FOR CASTINGS**—I. Collinson, 75. Moore, 409. Wanslesfurde, 111. Wilson, Sir T. M., 49.
- SANDS FOR GLASS-MAKING**—I. 127A. Claxton, 73. Lee, 125. Morrison, 77. Phippard, 113. Smedley, 124. Squire, J. & W. 74.
- United States*, Gray & Co., 405.
- SANDS (Various)**—I. Fahie, 30. Falmouth & Penryn Local Committee, 88, 163. Howard, 29. Long, 78. Nicholson, 504A. Relf, 70. Rock, 50. Rouse & Whitley, 79. Sweetman, 40. Whittaker, 53. II. Austin, 114.
- British Guiana*, Bee, 5. Duggin, 3 & 4. Pollard, 1 & 2. *Trinidad*, Lord Harris, 23.
- SANDSTONE**—I. Bewick, 423. Freeman, 172. Jennings, 194. Sparks, 154. Walsh (Executors of), 183. Taylor, 201. *Canada*, Boudoin & Lebers, 15. Ferrier, 5. Logan I. *New Zealand*, 39.
- Trinidad*, Lord Harris, 16, 21, 22.
- Zollverein* (1), Koenig, 323.
- SANDSTONE CARVING**—XXX. (Fine Art Court) Montefiore, Sir M. B., 161.
- SARDINES**—*Algeria*, Verrier, 57.
- France*, Caillô & Prin, 100. Camus, 789.
- SARSAPARILLA AND ITS PREPARATIONS**—II. Bell, 116. Hattersley, 110. Keating, 102.
- Portugal*, 516.
- Spain*, Academy of Medicine & Surgery, 128A. Alvarez, 118. *Trinidad*, Lord Harris.
- United States*, Andrews, 540. Howe, 497.
- SARSENET**—XIII. Clark, 20. *Sardinia*, Amney & Pont, 34.
- SASHES AND SASH-FRAMES**—See *Windows, &c.*
- SASH-FASTENERS**—See *Window Fastenings*.
- SASH-LINES**—XIV. Wall, E. & T., 70. XXII. Kuper, 32. XXVI. Austin, 391.
- SASH AND ROOF BAR-CUTTING MACHINES**—V. Coalbrook Dale Company, 641. VI. Birch, 406.
- SATINS**—XIII. Campbell & Co., 31. Carter & Co., 30. Robinson, J. & R. & Co., 5. Robinson, J. & W. & Co. 24.
- Austria*, Blaha & Rosenberger, 251. Mayer, Brothers, 266.
- Belgium*, D'Hot, 206. *China*, Baring, Brothers, Lindsay.
- France*, Bacot & Son, 1062. Barralou & Brosard, 16. Bonnet & Co., 1097. Bonchard, 1103. Gimdre, 1247. Heckel & Co., 870. Joly, 892. Kunzer, 893. Pin-Bayard, 682. Randolow, 973.
- Portugal*, Barboza, 959. Carmiers, 926. Joirge, 928-932. Pimentel, 927. *Russia*, Zalaglin, 209.
- Sardinia*, Chichizola & Co., 39. Molinari, 43.
- Switzerland*, Bischoff, 157. *Turkey*.
- Zollverein* (1), Hermes & Wolliers, 520. Jacobs & Bering, 524. Kaibe', 525. Kraubhaus & Kanertz, 527. Kuper & Steinhauer, 528. Peltzer, 518. Schildknecht, 131. (3). Behr & Schubert, 50. Kaufmann & Co., 114. Shraer, 120. Zechling & Co. 119. See also *Silk Fabrics*.
- SATIN-DE-LAINE**—*Belgium*, Pirene & Dueberg, 199. Piron, 200.
- Zollverein* (1), Siegfried & Waldthausen, 862.
- SATINETTE**—XIII. Le Mare & Sons, 21.
- Canada*, M'Kay & Co. 144.
- SATINWOOD**—See *Woods*.
- SAUCES**—XXVI. Blot, 18. XXIX. Cocks, E., 286. Cocks & Co., 317. Easterling, 282. Harvey, 169. Nicholls, 164. Payne, 29. See also *Piches and Preserves*.
- SAUSAGE CHOPPERS**—VI. Perry, 501.
- SAWING (Specimens of)**—XXVIII. Sandy & Powell, 112. Turnbull, 98.
- SAWING-BENCH (Models, &c.)**—VI. Barker, 417.
- SAWING-MACHINES**—VI. Barker, 417. Prosser & Hadley, 456.
- United States*, Tuckerman, 117. Wright, 77.
- SAW-MILLS MACHINERY**—*United States*, Hotchkiss, 94.
- SAWS (Various)**—XXI. Buck, 18. Hill, 47. Weatherly, 1. XXII. Atkin & Son, 365. Carr & Riley, 108. Cocker & Son, 115. Hall, 172. Ibbotson, R., 209. Ibbotson & Co. 191. Peace, 233. Slack & Co. 208. Spear & Jackson, 113. Tasker, 205. Taylor, Brothers, 211. Turner & Co. 117.
- Austria*, Brunner, 574. *Hamburgh*, Hunten, 44. *India*, I. *Zollverein* (1), Bleckmann, 623. Brand, 620. Felde, 625. Post, 615. Schöni, 402. Ullrich, 403.
- SAWS, MACHINE FOR SETTING THE TEETH OF**—VI. Vaughan, 242.
- SAXE CONOURG GOTHIA; Tableau representing Fête held at Castle Florence**—*Zollverein* (1), 804.
- SCAFFOLDING FOR BUILDING PURPOSES (Model of)**—VII. Nicholson, 40.
- SCAGLIOLA**—See *Marble, Artificial*.
- SCAGLIOLA (Works in)**—XXVII. Dolan, 45. *Tuscany*, Romoli, 118, 119.
- SCALES AND WEIGHTS**—See *Weights and Measures*.
- SCARFS**—See *Shawls*.
- SCARIFIERS (for Agricultural Purposes)**—IX. Beart, 34. Carsou, 110. Coleman, 216. Hill & Co., 140. Hainsomes & May, 124. Smith & Son, 234. Thompson, 105. Wedlake & Co., 127.
- SCENT-BOTTLES**—VIII. King, 281.
- SCENT FOUNTAINS**—XXIX. Riminel, 3.
- Austria*, Farina, 748.
- SCENTED WATERS**—*Tunis*, 53-57. See also *Perfumes and Perfumery*.
- SCHOOLS, MODELS FOR THE USE OF**—XVII. National Society for the Education of the Poor, 211. XXIX. Cowper, 245.
- SCHOOL DESKS**—*United States*, Shattuck, 412.
- SCHOOL STATIONERY**—XVII. Heywood, 83. Shean, 177. Tait, 185. XXIX. Dutton & Co., 287.
- New South Wales*, Mitchell, 5. See also *Instruction Tables*.
- SCIENTIFIC INSTRUMENTS**—*France*, Froment, 1609.
- Zollverein* (1), Lüttig, 81. See also *Chemical and Philosophical Apparatus. Mathematical Instruments. Philosophical Instruments*.
- SCISSORS**—XXI. Beach, 48. XXII. Cousins & Sons, 165. Gibbins & Sons, 194. Higginbotham, G. & W., 188. Newbold & Owen, 133. Unwin, 178. Whiteley, 126. Wilkinson, T. & G., 175.
- Austria*, Kaltenmark, 520. Mitter, 530. Rosler, 552. Stier, 558. *Nova Scotia*, Archibald, 2.
- Portugal*, Da Silva Cerqueira, 634. *Tunis*, 137.
- Turkey*, *United States*, Heinich, 168.
- Zollverein* (1), Berg, Brothers, 873. Bleckmann, 623. Gerresheim & Neef, 872. Plumacher, 618. Post & Sons, 616. Woeste & Co., 654. See also *Cutlery. Shears*.
- SCOTCH ARTICLES, in wood (painted, &c.)**—XXVIII. M'Rae & Co. 106. XXIX. Smith, W. & A., 205, 280.
- SCOTT'S, SIR WALTER, MONUMENT, EDINBURGH (Model)**—x. Evans, 106.
- SCOURING-POWDERS**—IV. Classon, 22. See also *Bleaching-Powders*.
- SCRAP-BOOKS**—XVII. Cross, 58. Rock & Co., 108.
- SCRAPER (Shoe)**—XXII. Avere, 303.
- SCREENS (of various kinds)**—XIX. Greene, 180. Stirling, 86. XXVI. Arthur, 303. Bigfeld, 534. Gore, 144. Hall, 63. Innes, E. & S., 91. Rose, 28. Sewell, 340. Turley, 138. XXX. (Fine Art Court) Earle, 49. *China*, Copland, Hewett & Co. Sichart & Co. Twining. *Hamburgh*, Albrecht, 59.
- Switzerland*, Hallmeyer-Appenzeller, 246.
- SCREENING-MACHINE**—IX. Smith, 4A.

SCREW AND BED WRENCHES—See *Wrenches*.
 SCREW FRICTION CLUTCH—V. Ashby, 202.
 SCREW JACK LOADING-MACHINE—France, Mars, 919.
 SCREW LIFTING-JACKS—V. Collinge & Co., 492. VI. Williams, 234. See also *Lifting Jacks*.
 SCREW MOORINGS—V. Wilson & Co., 526.
 SCREWS, PERFORATED FLEXIBLE (For hanging Pictures)—XXVI. Barker, 147.
 SCREW PROPELLERS (Models, &c.)—V. Hodgson, 143. Keasley, 140. Maudslay, Sons, & Field, 38. Powell, 2. Smith, 3. VIII. Admiralty, 145. Carpenter, 194. Inglefield, 99. *New South Wales*, Mitchell, 5. See also *Ship Propellers*.
 SCREW PROPELLING RUDDER—VIII. Lyons, 86.
 SCREWS AND NUTS—VI. Schiele, 402. XXII. Hall, 172. Hawkins, 318. Hemi & Bradley, 316. Patent Pointed Screw Company, 649. Russia, Zeiler, 343. *Zollverein* (1), Altenloh, Brinka, & Co., 642. Mannesmann, 617. Ullenberg & Schintzler, 355. (3), Recksteiner, 28.
 SCREW STEAM-VESSELS (Models, &c.)—VIII. Buckland, 308. Campbell, 147. Mason, 81. Rankine, 351.
 SCREW STOCKS, TAPS, &c.—VI. Muir, 206. Whitworth & Co., 201.
 SCREW WINCH (for Ships' Rigging, &c.)—VIII. Chapman, 121.
 SCREWING-MACHINES—VI. Glasgow, 219. Whitworth & Co., 201.
 SCULPTURE—Adams, page 847. Bailey, page 847. Behnes, page 847. Brucciani, page 847. Davis, page 848. Earle, page 848. Eldon, Earl of, page 848. Elkington & Co., page 848. Engel, page 848. Foley, page 848. Hancock, page 849. Hollins, page 849. Legrew, page 851. Lough, page 850. McCarthy, page 851. Macdowell, page 850. Marshall, page 850. Miller, page 850. Milnes, page 850. Peyman, page 850. Physic, page 850. Stephens, page 853. Thomas, page 853. Walton, page 853. Weekes, page 853. Woodington, page 853. Wyatt, page 854.
 I. Gowans, 132.
 XXVI. Minter & Co., 155.
 XXVII. Plow, 34.
 XXX. (Fine Art Court) Abbot, 53. Barker, 131. Batsford, 262. Beauclerc, 156. Burnard, 302. Cox, 283. Davis, 65. Evans, 202. Franchi, 100. Gardie, 261. Kaulbach, 316. Norchi, 309. Pajera, 17. Pidgley, 225. Watkins, 187. Worrall, 196. Wright, 203.
 XXX. (Sculpture Court) 28, 55, 85. Adams, 37, 62. Beauclerc, 51, 63. Belnes, 54, 77. Bell, 24, 71, 72. Brown, 1. Campbell, 23. Carew, 9, 10, 11, 53. Durrant, 5, 78. Durham, 75, 76. Earle, 16, 21, 82. Farrell, J., 52. Farrell, T. 18. Foley, 4, 19, 70. Francia, 33. Franks, 60. Hogan, 14. Jennings, 81. Jennings, B., 6. Jones, 40, 45, 84. Kirk, 2. Legrew, 8. McDowell, 30. McDowell, 61. Manning, 57. Marshall, 15. Miller, 50. Miller, F. M., 17. Miuro, 41. Neilson, 35. Papworth, 27. Physick, 47, 69. Ritchie, 29. Sharpe, 20, 26. Smith, 44, 83. Stephens, 36. Taylor, 42. Theed, 13, 59, 79. Thomas, J., 12. Thomas, J. E., 7. Thripp, 56, 58. Thripp, E., 39. Wyon, 86. Yarborough, Earl of, 60.
Austria, Cacciatori, 706. Cesari, 731. Cocchi, 707. Croft, 708. Dal Negro, 719. Emanuelli, 709. Fracaro, 710 (Main Avenue, East). Galli, 711. Gandolfi, 712 (Main Avenue, East). Kaehszmann, 704. Magni, 714. Manfredini, 715. Marchesi, 716. Max, 705. Micotti, 717. Monti, 746 (Main Avenue, East). Motelli, 718, 728. Pierotti, 720 (Main Avenue, East). Puttinati, 721. Sangiorgio, 722. Somagni, 723. Strazza, 713.
Belgium, De Cuyper, 455 (Main Avenue, East). Fraikin, 465 (Main Avenue, East). Geefs, 466, 466A (Main Avenue, East). Jaquet, 463 (Main Avenue, East). Jehotte, 463 (Main Avenue, East). Marchand, 460. Simouis, 464 (Main Avenue, East). Tuerlinckx, 458 (Main Avenue, East). Van Linden, 512.
Denmark, Bissen, 38 (Main Avenue, East). Jerichau, 39 (Main Avenue, East).

France, Dagand, 811. De Bay, 45 (Main Avenue, East). Du Seigneur, 187 (Main Avenue, East). Etex, 1215 (Main Avenue, East). Famin, 833. Farochon, 834. Lache-Lemaire, 586 (Main Avenue, East). Lequesne, (Main Avenue, East). Michel, 1660. Pradier, 1407. Ramus, 1419. Seguin, 1693. Susse, Brothers, 1023. *Hamburg*, Kleft, 94. Schiller, 95.
Netherlands, Veranel, 105.
Rome, Cassin, 328. (Groups by Benoni) Leyland, 16 (Main Avenue, East). Gott, 28. Macdonald, 18. Rinaldi, 20 (Main Avenue, East).
Sardinia, Frumento, 92. *Spain*, Bicnaine, 293.
Sweden and Norway, Hillmann, 31.
Tuscany, Dupre, 105. Freccia, 110. Giovannini, 97. Nencini, 108. Villa, 107.
United States, Grant, 522. Powers, 522, 548 (Main Avenue, East). Remers, 254. Stephenson, P., 467 (Main Avenue, East). Stephenson, R., 548 (Main Avenue, East).
Zollverein (1), Bianconi, 295. Bonge, 222. Cauer, 431 (Main Avenue, East). Dietrich, 297. Drake, 273 (Main Avenue, East). Egloffstein, Count, 597. Kalide, 285. Wessely, 849. Wolff, 307. (2), Helbig, 87. Leeb, 89. Miller, 90. (3), Rietachel, 185. (4), Van Hofer, 105 (Main Avenue, East). Wagner, 108. (5), Kress, 32. Vanni, 31. See also *Alto-Relievs*.
Bas-Reliefs. *Bronzes*. *Plaster Casts*.
 SCULPTURE ENGRAVING (Specimens)—XXX. (Fine Art Court) Chabot, 239.
 SCULPTURE BY MECHANICAL PROCESSES—XXVIII. Shaw, 164. *France*, Barbadienne & Co., 1709.
 SCUTLES (SHIPS)—VII. Hurwood, 31. VIII. Gregory, 69. Hopwood & Co., 68. XXIV. Lockhead, 23.
 SCYTHES—IX. Fussel & Co., 197A. Boyd, 199. XXI. Tomlin & Co., 38. XXII. Eyrse & Co., 203. Garfit & Son, 219. Hutton & Newton, 215. Keep & Watkin, 76. Slagg, 158. Stauniford, 214. Waldron & Sons, 185. Wood, Brothers, 75.
Austria, Dietrich, Baron, 439. Gatt, 440. Graber, 441. Grauss, 442. Hierzenberger, 443. Offner, Brothers, 444. Pammer, 445. Penz, J., 446. Penz, T., 447. Weinmeister, G., 448. Weinmeister, J., 449. Zeitlinger, J., 450. Zeitlinger, J. A., 451. Zimmermann, 452. *France*, Talabot & Co., 1027.
Russia, Imperial Artistic Works, 167.
United States, Hitchcock, 376. North Wayne Scythe Company, 323.
Zollverein, Post, 615. (4) Hauelsen & Son, 58.
 SCYTHES, IRON AND STEEL WELDED FOR—XXII. Hutton, 166.
 SCYTHE-STONES—IX. Seal, 262.
 SEA WALLS, Apparatus for building, in deep water (Model)—VII. Bremner, 95.
 SEA-WATER REGENERATOR—V. Fell, 438. See also *Salt-Water Distillation*.
 SEA-WEED, WITH ITS PREPARATIONS—II. Bullock & Co., 37. Watt, 32. XVII. Ackerman & Co., 1.
 SEALING-WAX—IV. Morrell, 58. Rea, 116. XVII. Cooke & Sons, 73. Hyde & Co., 21. Waterston, 93.
Belgium, Zegelaer, 280. *India*, XVII. *Portugal*, Lassa, 1151. *Zollverein* (2), Kohn, 49.
 SEA-SNAILS—Ceylon.
 SEALS AND DIES—XXII. Biddle, 297. XXX. (Fine Art Court) Kitchener, 289. Rundell, 279. *India*, XXIX. SEALS, IMPRESSIONS FROM—XXX. (Fine Art Court) Longman, 288. Wyon, 287.
 SEED DRIBBLING AND SOWING MACHINES—IX. Dufour & Co., 124A. Eaton, 22. Guest, 3. Haywood, 14. Hensman & Co., 149. Holmes & Sons, 241. Hunter, W. & J., 119. Johnson, 257A. Lampitt, 130. Marshall, 35. Newberry, 57. Nicholls, 20. Padwick, 215. Ransomes & May, 124. Revis, 21A. Sheriff, 74. Watt, 63. West, 246. Windsor, 25.
France, Crespel-Deliasse, 465. See also *Drill-Grubbers*. *Drill Ploughs for Green Crops*. *Drills*.
 SEED PRESSES—See *Grinding and Crushing Mills*.
 SEEDS (Agricultural, Horticultural, and other)—II. The London Druggists, 117. III. Gibbs & Co., 104. Illingworth, 115. McKillican, 114. *Barbades*. *British Guiana*, Duggin, 54, 56, 57, 64, 119. Ifughe,

- 74A, 74B. Mauget, 69, 121. Netscher, 19. Shier, 55, 58, 67, 122. Stutchbury, 63, 65, 66.
Canada, Fisher, 59. McGinn, 61. Jeffries, 62. Shepherd, 63. Uhardeau, 60.
Egypt, 51, 67, 72, 74, 76, 78, 81, 109, 110, 122, 123.
Malta, Palla, 4. *New Brunswick*, Searle, 26.
Russia, Felkersam, Baron, 82. Mikitticheff, 73. Trescoff, 74. *Trinidad*, Lorril Harris. *Tunis*, 106, 110.
Turkey. *United States*, Bell, 103.
Zollverein (1), Verein, 790. (6), Appel, 15.
- SEEDS** (Mode of preparing for sowing)—IX. Keene, 193.
SELBY RAILWAY BRIDGE (Model)—VII. Walker & Burgess, 224 (Main Avenue, West).
SELF-CALCULATOR—X. Sang, 338.
SELF-INKING PRESS—VI. Ullmer, 121.
SELF-MOTIVE MECHANISM—France, Bourdaloue, 67.
SENNA—*Egypt*, 25. *India*, 11.
SERPUCHAL MONUMENTS—Main Avenue, West, Cumby, 60. XXVII. Baker, 54. Brown, 52. See also *Tombs*.
SERAPHINES—X. Snell, 528.
SEROE—XII. & XV. Clarke, 432. Craven & Harrop, 153. Fox, Brothers, & Co. 7. XIII. Brocklehurst & Sons, 39. Davidson & Co., 47.
SERPENTIDES—X. Jordan, 523.
SERPENTINE STONE—Western End, South Enclosure (Outside), Organ, 1. Penzance Serpentine Company, 26. *Canada*, Logan, 1. Wilson, 2. *France*, Colin, 1564. *India*, 1. *Portugal*, Bonnet, 119. *Spain*, Granada Mines, Inspector of, 16. Malaga Mines, Inspector of, 19. *Turkey*.
SERPENTINE STONE ARTICLES—XXVII. Organ, 85.
SERVING MALLETS—*United States*, Batty, 351.
SETONS, COTTON FOR—X. Morlin, 678A.
SEVRES CHINA, Portraits of Her Majesty and H.R.H. Prince Albert on, after Portraits by Winterhalter—Main Avenue, East, 96, 97.
SEWAGE OF LONDON, MODEL FOR REMOVING—V. Stohert, 403A.
SEWAGE OF TOWNS, Application of, to Agricultural Purposes—VII. Martin, 25. Various inventions in connexion with—VII. Legras, 93.
SEWER TRAPS—V. Jackson, 682. VII. Lowe & Co. 62. Martin, 25. Pratt, 16. Wilson & Woodfin, 195. XXII. Duley, 89. Thompson, 705. See also *Effluvia Traps*.
SEWING COTTON—XI. Clark, 32. Evans & Co., 33. Haythorn, 25. Harris, 29. Marsland & Co. 63. Raworth & Co. 30. XXIX. Danbarn, 228.
SEWING-MACHINES—VI. Barlow, 41. Judkins, 52. Mather, 16. *France*, Maguin, 1654. *United States*, Bacon, 465. Blodget, 551. Morey, 573. See also *Hemming Machines*.
SEWING AND OTHER THREAD—XIV. Bridport Local Committee, 73. Finlayson & Co., 48. Harris & Sons, 76. Holdsworth & Co., 53. Tittley & Co., 51.
Austria, Hiellen, Sons of the late Elias, 275. Tauber, 276.
Belgium, Berthelot & Boute, 216. Cattaux, Brothers, 244. Cooreman, 212. Cumont, 235. Debraubandere, 218. Demeuleaere, 223. Klikaert, 234. Gheut Liniere Company, 230. Idiers, 287. Pyn & Van Pelt, 210. Scheppers, 497.
France, Cherot & Co., 88. Dautremet & Co., 137. Delage-Montignac, 141. Fauquet Lemaitre, 201. Franc & Son, and Martelin, 1213. Langevin & Co., 898. Legrand, 1313. Pesel & Menuet, 678. Polliart & Carpentier, 686. Roger, Brothers, & Co., 1449. Schwartz, Trapp, & Co., 1004. Scrive, Brothers, 1007. Verstraete, Brothers, 723. *Malta*, Palla, 4.
Oldenburg, Sharnhorst, 3.
Portugal, 1167. Da Cmeta Romão, 1168. De Ficalho, Marquis, 535. Lisbon Weaving Company, 725, 726. Loureiro, 716-720.
Spain, Alcala & Son, 213. Ferrer & Co., 206. Martinez, 158. Monfort, 208.
Sweden and Norway, 22. Johnsdotter, 33.
Switzerland, Kunz, 128. Miescher & Co., 167.
Tunis, 87. *Turkey*. *Western Africa*, Trotter, 5.
Zollverein (1), Felten & Guilleaume, 350. Mevissen, 557. (3), Mattoch, 43. Trinius & Sons, 45.
- SEXTANTS, QUADRANTS, &c.**—VIII. Soulby, 110. x. Barrett, 349. Crichton, 432. Dixey, 271. Heath, 331. Somalvico & Co., 681A. Taylor, 350. Watkins & Hill, 659.
- SHADE** (Undescribed)—XXVI. Hopkins & Son, 154.
SHAKESPEARE, UNFINISHED STATUE OF—Bell, page 847. Bust of, XXX. (Fine Art Court), Wilbred, 291.
SHAKESPEARE'S HOUSE (Model of)—XXX. (Fine Art Court) Powell, 148.
SHAKESPEARE JUBILEE—XXX. (Fine Art Court) Aldred, 235.
SHALE (or Schist)—I. Bituminous Shale Company, 221. Cowper, 61. II. Spence, 7.
SHAWL-BOXES—XXVIII. Rousseau, 116.
SHAWL CLOAKS—XX. Holmes & Co., 84.
SHAWL DRESSES (Wool and Cotton)—XII. & XV. Rainey, Knuck, & Co., 198.
SHAWLS (Various Fabrics)—Jackson, I. XII. and XV. Abercrombie & Yuill, 292. Albert, H.R.H. Prince, 600 (Main Avenue, West). Archibald, J. & R., 461. Archibald & Sons, 465. Barber & Co. 19. Baumann & Wanch, 206. Blakely, 285. Brunton & Co. 230. Brunton & Nesbit, 462. Burgess, 289. Campbell & Co. 201. Clabburn & Son, 284. Clark & Co. 293. Cross, 202. Dick & Sons, 293. Forbes & Hutchinson, 291. Fyfe & Co. 197. Gibson & Co. 464. Holmes & Co., 280. Holms, Brothers, 288. Jackson & Banks, 278. Kay & Co. 186. Keith & Co., 279. Kerr, 300. Kerr & Scott, 275. Lawson & Co., 294. Lewis & Allenby, 276. Littler, 282. Morgan & Co. 299. Norton, 126. Oddy, 121. Paton, J. & D., 466. Robertson, J. & J., 301. Rowat, R. T. & J., 302. Roxburgh, J. & A., 296. Sampson, 115. Schwann, 115. Smith & Sons, 235. Swaisland, 283. Towler, Campin & Co. 286. Watson, J. & A., 477. Webber & Hairs, 277. Whitehill & Co. 287. Wilson, 133. Wingate, Sou & Co. 200. XIII. Smith, 51. XVIII. McNair & Brand, 50. Monteith & Co., 49, 53. XIX. Ball & Co., 19. Patent Utrecht Company, 265. Shuldam, 298. xx. Haywood, 148. Holmes & Co. 84. Macdougall, 83. Oddy, 121.
Algeria, Algiers, Delegate of, 56.
Austria, Berger, 309. Bossi, 239, 356. Brotzmann, 310. Haydler, 311. Kubo & Son, 312. Laporta, 387. Martinek, 313. Mogel, 314. Ramede, 300. Reinhold, 315. Ries, 316. Schindl, 318. Schmitt (Heirs of) & Co. 238. Spanraft, 273. Wenzel, 319. Zjicisel & Blumel, 320.
Belgium, Dietsen, 288. Paquet, 335. Stocquart, Brothers, 307. *China*, Hewitt & Co.
France, Aubry, Brothers, 1544. Berrus, Brothers, 55. Bertrand, Gayet & Dumontal, 1085. Bietry & Son, 356. Bouffis, Michel, Souvraz & Co. 1094. Chambellau & Co. 1140. Chinard, 89. Choqueuel, F., 1148. Choqueuel, L., 90. Damiron & Co. 1167. Delamoriniere, Gouin & Michelet, 1583. Denelrouse, Glavy & Co. 1182. Duché, 1592. Fourquemin & Guilet, 1604. Gausson & Co. 1241, 1243. Godefroy, 1252. Grillet & Co. 1259. Herbert & Son, 1621. Lion, Brubers & Co. 1327. Pin-Bayard, 682. Reppey, 983. Reyner, Cousins, 353, 1435. Roche & Dime, 990. Thevenet, Raffin & Roux, 1500. Trocon, 1511. Zadig, 1535.
Greece, John, 58. *Hamburgh*, Windmüller, 29.
India, XII. xv.
Ionian Islands, FitzRoy, Lord C., 4. Seaton, Lord, 5.
Nova Scotia, Central Committee, 2.
Portugal, Cruz, 756. Da Silva, 955. Daupias, 866-881. Lafaurie & Co., 814-839. Lisbon Company, 707-712. Moreira, 956. Pereira, 713, 714.
Russia, Bondarevsky, &c. 358. A Cossack's Wife, 282. Lafont, 270, 277. Meelin, A. & V., 281. Prokhoroff, Brothers, 349. Rochefort, 176, 191, 199, 208.
Switzerland, Anderregg, 111. Baenziger, 112. Cuendet, 159. Mettler & Son, 197. Mueller, 160. Tanner & Koller, 206. *Tunis*, 7, 9, 10, 80. *Turkey*. *United States*, Lawrence, Stone, & Co. 464. Roy, 578. *Van Diemen's Land*, Queen's Orphan Schools, 142. *Western Africa*, Faddy, 20.
Zollverein (1), Bauch, F. T., 728. Banchi, J. F., 793. Bockmuehl, 586. Colu & Co. 137. Engelmann &

71. Heath, 351.
50. Watkins &
- Son, 154.
—Bell, page 847.
bred, 291.
(Fine Art Court)
t Court) Aldred,
e Company, 221.
- . & xv. Rainey,
I. and xv. Aber-
L.H. Prince, 500
J. & R., 461.
o. 19. Baumann
Brunton & Co.
ess, 289, Camp-
, 284. Clark &
ous, 295. Forbes
197. Gibson &
Holms, Brothers,
ay & Co. 186.
err & Scott, 275.
by, 276. Littler,
on, 126. Odly,
son, J. & J., 301.
h, J. & A., 296.
ith & Sons, 235.
Co. 286. Watson,
Whitehill & Co.
o. 200. XII.
d, 50. Monteith
Patent Utrecht
Haywood, 148.
Oddy, 121.
- Brotzman, 310.
Laporta, 387.
ede, 300. Rein-
Schmitt (Heirs
ize), 319. Zjzisel
- Stocquart, Bro-
us, Brothers, 55.
Bietry & Son,
o. 1094. Cham-
Chocqueel, F.,
ron & Co. 1167.
1883. Denel-
92. Fourquemin
11, 1243. Gode-
bert & Son, 1621.
ayard, 682. Re-
1435. Roche &
ux, 1500. Troc-
- iller, 29.
eaton, Lord, 5.
aupias, 866-881.
mpany, 707-712.
ack's Wife, 282.
281. Prokhoroff,
99, 208.
, 112. Cuendet,
160. Tanner &
urkey.
164. Roy, 578.
chools, 142.
- anch, J. F., 793.
Engelmann &
- Son, 571. Haarhaus, 567. Kein, 578. Luehdorff &
Co. 584. Marx & Weigert, 113. Meikel, 396. Meyer
& Engelmann, 582. Opienhoff & Hartung, 134.
Pluecker, 568. Rurmann & Meckel, 580. Schilt-
knecht, 131. Simons, 514. Weigert & Co. 115.
(2), Gelhart, Brothers, 42. Steinhaeuser, 44. (3),
Facillides & Co. 95. Koester & Uhlmann, 70. Sey-
ferth & Co. 106. Stoezel & Son, 66.
SHAWLS (Designs for)—XVIII. Hudson, 66.
France, Carnet, 165. Hartweck, 867. Herault, 872.
Mathieu, 1331.
SHEARING-MACHINES—VI. Whitworth & Co. 201. IX.
Taylor, 139. Belgium, Troupin, 128.
France, Schneider & Legrand, 1001.
Zollverein (1), Thomas, 57.
SHEARS (various)—XXI. Tomlin & Co. 38. XXII. Hunter,
228. Jowett, 170. Linley, 211. Maclean, 168.
Matkin, 210. Shearer, 127. Steer & Wchster, 124.
Wilkinson & Son, 122. Wilkinson, T. & G., 175.
United States, Heinzych, 168.
Zollverein (1), Blackmann, 623. See also Scissors.
SHEATHING METAL AND SHIPS' FASTENINGS—VIII.
Muntz, 101. XII. & xv. Wilkinson, 51.
SHEEP-CRIB—IX. Eaton, 22.
SHEEP-DIPPING APPARATUS—IX. Bigg, 65. Rome, 152.
SHEEP-WASHING APPARATUS—IX. Fyfe, 41A.
SHEET GLASS—XXIV. Hartley & Co., 100. See also
Plate Glass.
SHEETING—See Linen Sheeting.
SHEETS FOR COTTON CARDING—Switzerland, Schelling,
62.
SHEFFIELD WARE—See Plated Ware.
SHELL MARL—Canada, Boston, 25. De Lesderniers, 24.
Kelly, 22. Yeomens, 23.
SHELLS & SHELL-WORK—Bahamas, Gregory, Governor.
Greig, Nicolle.
China, Thoms. France, Hostin, 265. India, XXVIII.
Jersey and Guernsey, Dobree, 30. Hutchinson, 31.
Valpy, 40. Eastern Archipelago, Hammond & Co. 2.
Mauritius, Balkfield & Co. 5.
Rome, Deas, 49. Sardinia, Rondelli, 90.
Van Diemen's Land, Milligan, 194.
SHELL PROPELLER—United States, Treese, 169.
SHIELD, Presented by the King of Prussia to the Prince of
Wales—Main Avenue, East, H.R.H. Prince Albert,
98. Casts taken from the Shield, Zollverein (1), Krause,
278.
SHIPPING, MODELS OF—See Nautical Models.
SHIP-PROPELLERS—VII. Brown, Sir S., 334. Corryton,
82. Kincaid, 89. IX. Starkey, 43. See also Screw
Propellers.
SHIPS' CABIN TABLES—VIII. King, 19. Ladd, 80.
Austria, Reitch, 633.
SHIPS' CABIN WINDOW APPARATUS—XXII. Gray, 518.
SHIPS' DECK, Section of—VIII. Mason, 81.
SHIPS (Apparatus for preventing Ships from Logging)—VIII.
Spenceley, 117.
SHIPS' CABIN FURNITURE—XXVI. Taylor & Son, 9.
SHIPS' CARGOES, MACHINE FOR DISCHARGING—V. Nevill,
450.
SHIP FASTENINGS—VIII. Husband, 151.
SHIPS' LANTERNS. See Lamps and Lanterns, &c.
SHIPS' PUMPS—See Pumps, Ships'.
SHIP SCREWS—VII. Peile & Co., 77.
SHIP-SCRUBBERS—VIII. Murray, 38.
SHIP'S STOVE—XXII. Harvey, 410.
SHIP SHEATHING, FELT—VII. Croggon & Co., 110.
SHIP TRENAILS—V. Radnumes & May, 640.
SHIP VENTILATORS—United States, Emerson, 433.
SHIPS' YARDS—Jersey and Guernsey, Marquard, 42.
SHIPWRECK, APPARATUS FOR SAVING LIFE IN CASE OF—
VII. Bain, 197. VIII. Carte, 29. Greener, 59. Holtum,
20. Jerningham, 21. Mariners' Friend Society, 310.
Olford, 25. Olford & Braibeer, 26. Parsey, 88.
Jersey and Guernsey, Chevalier, 6. See also Life-Belts.
Life-Boats.
SHIPWRIGHTS' TOOLS—See Tools, Shipwrights'.
SHIRTINGS—XI. Cross, 41. Horrockses, Miller & Co., 60.
Pearson & Co., 21.
SHIRTS—See Ready-made Linen.
- SHOEMAKERS' AWLS AND OTHER TOOLS—XXII. Baker,
559. Timmins & Sons, 312.
Austria, Bachner, 565. Buchberger, 479. Derfler, 480.
Diltzch, 481. Grossaver, A., 567. Grossaver, F., 568.
Kettenhuber, 483. Kohn, 484. Molterer, C., 486,
487. Molterer, G., 488. Molterer, M., 490. Molterer,
V., 491. Northian, 492.
SHOEMAKERS' TRIMMINGS, Sweden, Hanel, 93.
SHOE-MAKING MACHINE—France, Dumerey, 487.
SHOE-PEGS—XXVIII. Jones, 122.
United States, Bretts, 211. Thayer, 422.
SHOES. See Boots and Shoes.
SHOE-SOCKS—XVI. Clark, C. & J. 48.
SHOE-STUFFS—Zollverein (1), Kretschmann, 738. Macht,
730.
SHOE-TIPS AND HEELS—Austria, Mitterberger, 467.
SHOP BLINDS, ROTATORY—XXVI. Lucas, 397. See also
Shutters, Iron Safes.
SHOP FITTINGS—Austria, Batka, 629.
SHOP FRONTS (Models)—VII. Hurris, 74. McLean, 72.
XXX. (Fine Art Court) Beesham, 332.
SHOP LETTERS—XXIX. Miers, 85. XXX. (Fine Art Court)
Thompson, 343. See also Brass Lettering on Glass.
Glass Letters. Metallic Letters. Porcelain Letters.
Wooden Letters.
SHOP-SHUTTER SHOE—XXII. Jennings, 810.
SHOT BELTS, POUCHES, &c.—XVI. Jones, 30. Middle-
more, 67.
Western Africa, Hutton & Sons, 6. See also Powder &
Shot Flasks.
SHOT AND BULLETS—I. Royal Dublin Society of Ireland,
508. Austria, Diez, 122A.
Portugal, Da Silva, 991-1014.
Russia, Barantchik Imperial Iron Works, 158. Koush-
vinsk Imperial Cast-Iron Works, 157.
SHOT TOWER (Model)—VII. Shield, 79.
SHOVELS, RAILWAY—V. Thornton & Sons, 490.
SHOWER-BATHS—See Baths.
SHUMAC—IV. Kitchin, 126A.
SHUTTERS (for Shops & Private Houses)—VII. Askew, 48.
Holland, 132.
France, Hoen, 264.
SHUTTERS, IRON SAFETY—VII. Bunnett & Co. 152. Horn,
87. Quincey, 146.
SIDE-ARMS—France, Coulaux & Co. 129.
SIDEBOARDS—XXIII. Sheffield School of Design, 39. XXVI.
Bland, 112. Caldecott, Messers., 206. Gillow & Co.,
156. Hindley & Co., 266. Hoyle, 345. Hunter,
W. J. R. & E., 202. Jackson & Graham, 261. Le-
vien, 203. Palmer, 59. Poole & Macgillivray, 204.
Rivett & Sons, 153. Ross, 107. See also Furniture.
SIEVES—VI. Saddington, S. & W., 609. Egypt, 156-161.
Tunis, 86, 87. Trinidad, Lord Harrie.
Van Diemen's Land, Symonds, 243-245.
Western Africa, Trotter, 5.
SIEVE-BOTTOMS—Austria, Benedig, 356. Globotsching,
357. Locker, 358.
SIEVE-HOOPS—France, Peyron, 955, 1387.
SIFTING-MACHINE, ARCHIMEDEAN—IX. Service, 122A.
SIGN-BOARDS—France, Remoud, 977.
SIGNALS (Undescribed)—VII. Rettie, 159. See also
Lamps, Marine Signal.
SIGNALS, FOG. See Fog Signals.
SIGNALS, HAND—XXII. Squire, 451.
SIGNALS, MARINE—VIII. Dempster, 174.
SIGNALS, RAILWAY—See Railway Signals.
SIGNALS, STEAM-BOAT—V. Tidmarsh, 707.
SILK, RAW—IV. Dodge, 32. Duxat & Co., 35. Durant,
31. Jaquemot, 37. XIII. Hadwen & Sons, 42. XIX.
Simpson, 67.
Austria, Canossa, 86. Ouerim, 84. Parc, 85. Ron-
cietti, 82. Rossi, 88. Scheibler & Co., 80. Steiner
& Sons, 87. Verza, Brothers, 87A.
British Guiana, 76A. China, Hammond & Co.
France, Chambou, 113. Champagnet-Sargens, 114. La-
pierre & Son, 561.
India, IV. XIII. Ionian Islands, Seaton, Lord.
Jersey and Guernsey, Martin, 26. Malta, Pulis, 4.
Madeira, Read, 1. Mauritius, Dupont, 2. Netherlands,
Enthoven, 49. Portugal, Garcia, 611.

- South Australia*, Murray, 6. Grey, Earl, 7. *Sweden*, Haga Plantation, 95. *Turkey*, Western Africa, Trotter, 5.
- SILK DOWN**—XXVI. Herring, 379.
- SILK FABRICS (Various)**—IV. Hands & Leavesley, 34. Howe & Co. 30. XII. & XV. Belrens, 180. Dalby, 152. Macfarlane, 297. Shuttleworth, & Co., 489. Whitehill & Co., 257. XIII. Adashead & Co., 39. Boyd, 13. Brucklehuret & Sons, 38. Brooks, 26. Browett, W. & H., 80. Burke, 57. Clarke, 20. Critchley & Co. 40. Cross, 32. Davidson & Co. 47. Dear, 37. Graham & Sons, 17. Grout & Co. 36. Hadwen & Sons, 42. Harrop & Co. 62. Hill & Co. 25. Howell & Co. 27. Keith & Co., 1 (and Main Avenue, Wcat). Lewis & Allenby, 16. Marshall & Snelgrove, 33. Pugh, 2. Robinson J. & R. & Co. 5. Robinson, J. & W. & Co. 24. Sanderson & Reid, 3. Seamer, 15. Sewell & Co. 19. Super, 29. Stone & Kemp, 18. Swan & Edgar, 11. Towler, Campin & Co. 236. Vanuer & Son, 4, 28. Wardle Co., 41. Weston & Son, 46. Winkworth & Procters, 65. XVIII. Evans & Co. 1. Jourdain, 61. Le Lievre, 60. Reynolds & Son, 63. Swan & Edgar, 9. XIX. Bennock & Co. 394. Mackellar & Hampson, 231. Perry, 268. XX. Carver & Gilbeir, 98. Rawlings, 189.
- Algeria*, Delegate of Algiers, 58. Casteiran, 15. Chuffant, 17. Hardy, 28. Moriu, 39.
- Austria*, Backhausen, C. & J. 249. Bader, Brothers, 250. Bugatti, 252. Dorleuthner, 253. Flemmich, 254. Fries & Zeppezauner, 255. Gianni, 257. Gratz Silk-worm-Breeding Association, 73. Gruber & Euzinger, 258. Haas & Sons, 259. Hell, 260. Herzig & Son, 261. Herzog, 76. Kofler, Hermann & Co., 76A. Hornbostel & Co., 262. Lorenz, 75. Mattiuzzi, 77. Mestrosi, 267. Pappafava, 79. Pavi, 85. Querini, G. 84. Radulovita, Brothers, 74. Reichert, 268. Roncietti, 82. Rossi, 88. Salzer, 245. Scheibler & Co. 80. Schlopper, 270. Scola, 72. Secchi, 81. Senigaglia & Carminati, 78. Sigmund, 272. Steiner & Sons, 87. Verza, Brothers, 87A.
- Belgium*, Decouinck, 112. De Mevina, 86. Depotter, 111. Metdepenningen, 207. Olivier & Co. 201.
- China*, Astell & Co. Copland, Hewett & Co. Lindsay.
- Egypt*, 198-201, 203, 205-210, 295, 296-298, 300, 305, 325, 339, 384.
- France*, Affourit, 749. Alcan, 1050. Alcan & Limey, 5. Arduin & Chancel, S. Ayne, Brothers, 755. Barral, 410. Barrallon & Brossard, 16. Barres, Brothers, 41. Barthelats, 757. Beauvais, 1076. Bellon & Co. 1079. Benonville, 760. Bert, 63. Bertrand, 764. Bertrand, Gayet & Dumontat, 1085. Bianchi & Duseigneur, 1087. Bunual & Co. 429. Boumet & Co. 1097. Bonneton, 771. Boudon, 1105. Bourdin, 1730. Bouvard & Lancon, 1110. Bronski, 782. Brunet, Lecomte, Guichard & Co. 1120. Buisson, Robert, & Co. 784. Cabrit & Roux, 81. Carriere, 1136. Causse & Garion, 1137. Chambon, 113, 793A. Champagne & Rougier, 1143. Champpanhet, 114. Champoiseau, 794. Champouet, 793B. Chartron & Sons, 796. Couderc & Soncarret, 96. Darras, 470. Darvieu, Val-mald & Co. 1169. Delarbat, 1175, 1176. Deleuze, 1178. Despreaux, 164. Dumaine, 175. Dussol, 150. Duval, 189. Deydier, 1590. Eymien & Son, 831. Fabregue-Nourry, Barriouin & Co. 832. Farjon, 1217. Galimard, E. 515. Galimard, F. 839A. Gibelin & Son, 846. Gindre, 1247. Girodon, 1250. Grolleau & Deville, 1618. Guinon, 1263. Herme, 537. Jame, Bianchi & Duseigneur, 1273. Lavernie & Mathieu, 1298. Lapeyre, 1292. Lemira & Son, 1649. Lyons Agricultural Society, 1537. Lyons Chamber of Commerce, 1141, 1565. Mathévon & Bouvard, 1349. Me-jean, 1333. Meuet, 1657. Molines, 647, 930A. Montessey & Chomer, 1360. Mourgue & Bonquet, 1363. Nogarede, 937. Pature-Lupin, Seytoux, Seibler & Co. 1351. Pousson, 1403. Pottin, Rambaut & Co. 1402. Pradier, 1406. Regard, Brothers, 1426. Reidon, 1430. Repiquet & Silvent, 1432. Reynier, 1433. Ruas & Co. 1464. Sambuc, 1470. Schlumberger, Gaspard, & Co. 1000. Teissier du Cros, 1031.
- Thomas, Brothers, 1040. Valansot, 1514. Verdet & Co. 1510. Vincent, 1526.
- Gold Coast and Ashantes*, Forster & Smith, 1.
- Greece*, Constantinachi, 53. Pantaxopoulis, 51. Pit-houllis, 52. Ralli, 50. St. Constantine, the Nuns of, 54. India, IV., XIII., XVIII.
- Netherlands*, Eyndhoven, 49. Rooyen, 58.
- Persia*, Thompson.
- Portugal*, 856-859, 940-945, 948-950, 1171. Carneiro, 958. Garcea, 611-615. Jorge, 963. Palmella, Duke of, 604-610. Pimentel, 964. Ramos, 954.
- Rome*, Berrette, 6. Filanda-Bracci al Fano, 7. Morti, 5.
- Russia*, Hadji Babi-Kelbalay-Oossein-Ogli, 53, 142. Jraf-Ogli, 207. Juditsky, 137. Kherson Peasant Women, 211. Kondrasheff, 353. Lapteff, 371. Poliakov & Zamiatin, 205. Rayko, 140. Rebhoff, 139, 143. Rier, 138. Vikoulin, 141. Zalaghin, 209.
- Sardinia*, Bravo, 24. Casassa & Sons, 27. Chichizola & Co. 39. Defferari, Brothers, 44. Fermento, 27. Galimberto, 29. Jaquet & Co. 26. Rignon & Co. 30. Sinigaglia, Brothers, 25. Soley, 40. Vertu, Brothers, 28.
- Spain*, 196, 203. Alcalá & Son, 213. Almanza, 200. Amigo y Saury, 217. Calderon, 220. Castillo, 218. Cruz, 201. Dotres, Gaspar & Co. 215. The Baron of Finestral, 195. Garcia, 205. Genet, 212. Gonzalez, 198. Margarit, 204. Monfort, 208. Montfort, 202. Orduna, 214. P'ryals, 197. Rey & Co., 207. Reynoso, 211. Roig, 216. Talavera Guilds' Manufacturing Co., 219. Treuor, 210. Valencia Board of Agriculture, 209.
- Sweden and Norway*, Casparsson & Schmitt, 24. Meyer-son, 24.
- Switzerland*, Alioth, 154. Boelger, 158. Custer & Schachtler, 148. Fogliardi, 54. Goetz, 155. Lane, 55. Muller, 155. Romain, 155. Rybner & Sons, 161. Schmid, Brothers, 269. Sulzer, 186. Von der Muehl, Brothers, 162. Wegner, 155. Zurich Silk-Stuffs Manufacturers, 153. Tunisia, 10. Turkey, Tuscany, Casuccini, 50. Davitti, 40. Della Ripa, 38. Franceschini, 43. Lambruschini, 36. Lepori, 47. Mordini, 45. Pannilini, 42. Petrucci, 40. Pieri, 41. Poidebard, 39. Ravagli, 48. Rimediotti, 44. Savi, 51. Scotti, Brothers, 37. Zavagli, 49.
- United States*, Ryle, 336. *Western Africa*, Trotter, 5.
- Zollverein* (1), Bovenascher, 536. Dvyn, Hipp & Co., 510. Funke, Boeddinghaus & Co., 572. Gabain, 119. Greef, 533. Hermes & Wolfers, 520. Holdick, 598. Jacobs & Bering, 524. Kaible, 525. Kerkanf, 512. Kizawsky, 39. Lucius & Co., 729. Lumm & Ruetten, 531. Meer & Co., 529. Neuhaus, H. T. 522. Neuhans, L. 577. Peltzer, 518. Rappard & Co., 516, 517. Schmidt & Co., 589. Schroers, 515. Simons, 514. Stork, 511. Weyerbusch, 570. (3), Behr & Schubert, 50. Roehling & Co., 50n. (6), Weintraut, 76. See also *Brocades*. *Damasks* (Silk, &c.). *Dyed Silk Gauzes*. *Mixed Fabrics*. *Organzine*. *Poplins*. *Ribbons*. *Sarsenets*. *Satins*. *Waistcoatings*.
- SILK GRASS**—XIV. Dagnall & Co. 89.
- SILK LOOMS & MACHINERY**—VI. Davenport, 80. Frost, 84. Smith, 22. *Austria*, Scheibler, 80.
- France*, Harding-Cocker, 864. Muzard, 1366. Roek, 1446. Souheyraud, 1490. *Russia*, Graff, 150.
- Zollverein* (1), Diepers, 472. Schrödter, 484.
- SILK SPINNING, NETTING, &c.**—XIII. Alop & Co. 48. Bridgett & Co. 49. Brucklehuret & Sons, 38. Brough & Co. 44. Brownett, W. & H. 80. Davidson & Co. 47. Hammersley & Bentley, 43. XIX. Simpson, 67. Surr & Co. 80.
- SILK SPINNING**—*France*, De Tillancourt, 697.
- SILK, THROWS**—XI. Walsh & Windley, 26.
- SILK TROPHY**—XIII. Keith & Co. 1 (Main Avenue, West).
- SILK WASTE**—XIII. Holdforth & Son, 61. Hadwen & Sons, 42. XIX. Cox, Miss A., 220.
- SILK-WORM GUT**—Spain, 199.
- SILK-WORMS**—*Austria*, Grass, 83. Hoepfner, 128. *Turkey*, SILK-WORM SPINNING APPARATUS (Models)—*Austria*, Hoepfner, 128. *Zollverein* (1), Bolzani, 38.
- SILVER**—II. Howards & Kent, 11.

514. Verdet & Co., 1. Montreal Mining Company, 10. *Chili*, 2 (Main Avenue, East). *China*, Lindsay.
- Spain*, Almeria Mines, Inspector of the, 13. *Sweden and Norway*, Kongsberg Silver Works, 34. *Turkey*. *Zollverein* (1), Eachweiler Mines, 318.
- SILVER EMBOSSED CHASING—XXX. (Fine Art Court) Brenner, 238.
- SILVER LACK—See *Gold and Silver Lack*.
- SILVER LEAD-ORES—See *Lead Ores*.
- SILVER LEAF—See *Gold and Silver Leaf*.
- SILVER ORE—*Canada*, Badgley, 11. *China*, Lindsay. *Russia*, Barnaulsk Imperial Works, 4. *Spain*, 3. *Sweden and Norway*, Guldsmelshytan Mines, 16. *Zollverein* (1), Cosack, 825. Lambson & Co. 451.
- SILVER PLATE—See *Gold and Silver Ware*.
- SILVER PROCESSES FOR OBTAINING—*Zollverein* (1), Mansfeld Combined Mining Works, 850.
- SINGING HORSES WITH GAS (Instrument for)—IX. Crump, 160.
- SINGING LAMPS—XXII. Deakin, 157.
- SIZE—II. Davies, 70.
- SIZING OR DRESSING MACHINE—VI. Hornby & Kenworthy, 20.
- SKATES—XXI. Loy, 14. XXII. Brown & Sons, 182. Flather, 167. Marsden & Co. 169. Wright, 177. XXIX. Puddon, 39.
- Sweden*, Nystrand, 82.
- SKATES, SUMMER—XXII. Bradnack, 275.
- SKERRYVORE LIGHTHOUSE (Model)—VII. The Commissioners of Northern Lighthouses, 99.
- SKINS (for Furs, &c.)—See *Furs and Skins*.
- SKINS FOR GLOVES—*Austria*, Boulogne, 334.
- SKINS AND HIDES—See *Leather and Hides*.
- SKIPPING-ROPE—XIV. Soper, 64.
- SKYLIGHTS—VII. Maxwell, 102. Nixon, 174.
- SLAG—*Spain*, Cerain, 1.
- SLATE—Western End, South Enclosure, (Outside), Old Delabole Slate Company, 8. Stirling, 9. Welsh Slate Company, 12. 1. 205. Bredalbane, Marquis of, 211. Dawbarn & Co. 208. Delabole Slate Company, 214. Freeman, W. & J., 160. Greaves, 210. Limerick Local Committee, 212. Taylor, 201. Williams, 215.
- SLATE, ENAMELLED—XXVII. Hall, 42. Magnus, 46.
- SLATE MANUFACTURES—Western End, South Enclosure (Outside), Old Delabole Slate Company, 8. Struthers, 16. I. Stirling, 209. v. Slack, 423. X. Wishaw, 419. XXVI. Steelman, 348. XXVII. Blackburn, 21. Stirling, 120.
- SLATE PAINTING—XXX. (Fine Art Court) Borrowes, 11.
- SLATE PAVEMENT—South, or Transept Entrance, Festiniog, North Wales.
- SLATE-PENCILS—*Belgium*, Collette-Doucet, 5. *United States*, Cain, 247.
- SLATES (for Roofs, &c.)—*Belgium*, Collette-Doucet, 5. *Canada*, Hall, 18. Logan, 1. Quigley, 20. *France*, Lariviere Angers Slate Works, 290. Rimogne Slate Works Company, 378, 694. *Sardinia*, Pimello, 3. Zolesi, 2. *Trinidad*, Lord Harris. *United States*, Sims, 274, 275. *Zollverein* (3), Nassau Government Engineers of Mines, 1.
- SLATES, METALLIC—*Zollverein* (4), Rometsch, 73.
- SLIDGES—*Russia*, Babounoff, 345. Jakoleff, Brothers, 344. *Sweden*, Norman, 54.
- SLEIGHS—*Canada*, Lawrin, 180. McLean & Wright, 178. O'Meara, 179.
- SLIDE TAPS (for Fire-engines)—v. Fletcher, 444.
- SLIDE VALVES (for Steam-Engines)—v. Atherton, 1. Houghton, 7. Wheeler, 305.
- SLIDING RULE OF INVOLUTION—Rooker J. and A. 340.
- SLOTTING-MACHINES—VI. Sharp, Brothers, 204. Whitworth & Co., 201.
- SLUBBING AND ROVING FRAMES—VI. Mason, 10. Parr & Co., 6.
- SMALT—*Zollverein* (1), Horstmann & Co., 462.
- SMELLING-BOTTLES—*France*, Maillot, 597. See also *Scent-Bottles*.
- SMELLING SALTS—II. Hills, 23.
- SMELTING FURNACE (Model)—I. Fressez, 464. *Ceylon*. SMITH'S HEARTH OR FORGE (Portable)—VI. Hick & Sun, 218.
- SMITH'S IMPLEMENTS—XXII. Keep & Watkin, 70. Wood; Brothers, 75.
- SMOKE-CONDENSERS—VII. Cochraue, 158.
- SMOKE-CONSUMING FURNACES (Jukes' Patent)—v. Surmon & Co., 65.
- SMOKE CONSUMPTION (Apparatus for effecting)—VII. Deyey, 54.
- SMOKE-DAMPER—v. Craig, 770.
- SMOKE-JACKS—XXII. Benham & Sons, 98. Crook, 244.
- SMOKING-PIPES—XXV. Leitch and Hammond, 59. *Canada*, Henderson, 187. *Gold Coast and Ashantee*, Forster & Smith, 1. *Persia*, Hudson. *Turkey*. *Western Africa*, Beecham, 12. McWilliam. *Zollverein* (1), Lux, Brothers, 769. See also *Hookahs*. *Meerschaim Pipes*. *Tobacco Pipes*, &c.
- SMOKY CHIMNEYS, APPARATUS FOR CURING—VII. Bramhall, 129. Gristall, 58. *France*, Foudet, 503.
- SMOOTHING-TREE (for Kid Leather)—*Zollverein* (1), Weber, 744.
- SMUT-MACHINES—VI. Coombe & Co., 444. Millington, B. & E., 462. Rankin, R. & J., 466.
- SNOW-SHOVELS—*Canada*, Montreal Central Commission, 301.
- SNUFF—III. Lundy Foot & Co., 44. Richardson, Brothers, 52. Taylor, 45.
- Austria*, Vienna Imperial Tobacco Manufacturers, 69. *Belgium*, Brovelli, 72. Plaideau, 71. *Canada*, Levey, 130. *Portugal*, Royal Tobacco and Snuff Company, 1172-1195. *Russia*, Protasoff, 331. Spigiazoff, 76. *Tunis*, 81, 88. *Zollverein* (1), Carstensen, 468. (5) Minoprio & Co., 4. (6) Bernard, Brothers, 9.
- SNUFF AND TOBACCO BOXES—I. Jamieson, 25. XXIII. Baird, 26. McGregor, 40. XXVIII. Garrett, 141. XXIX. Stevens & Sons, 35. *Austria*, Hoffrichter, 644. *China*, Shea. *France*, Mercier, 1658. *India*, XXVIII. *Van Diemen's Land*, Milligan, 201-203. *Zollverein* (1), Schulz, 860. (2), Pleisch, 72. (4) Abele & Co. 76. (8), Frank, 61.
- SOAPS (Common, Scented, &c.)—XXVIII. Goenell & Co., 55. Williams & Son, 4. XXX. Carrick, 16. Cleaver, 20. Cowan & Sons, 19. Dixon, 91. Gibbs, D. & W., 305A. Going, 87A, 201. Grossmith, 13. Hendrie, 10. Kendall & Co., 25. Knight, 8. Low & Co., 30. Mackean, 28. Payne, 29. Pears, A. & F., 24. Taylor & Co. 5. Williams & Son, 4. Yardley & Statham, 2.
- Algeria*, Arnaud, 2. *Austria*, Chiozza & Son, 43. Hermannstadt Stearine Candle Company, 42. Melzer, 44. Richter, 44 A. *Belgium*, Touche, 434. *Canada*, Matthewson & Son, 329. *South Africa*, Smithers, 38. *Ceylon*. *Denmark*, Owen, 44. *France*, Allard & Claye, 750. Arnason, 402. Bleuze, 1091. Jaillon, Moitier & Co., 273. Million, 929. Moreau, 1361. Piver, 1678. Roulet, Gilly, & Champouiniere, 359. *Hamburgh*, Douglas & Son, 92. *India*, XXIX. *Netherlands*, Perselaert & Son, 71. *New South Wales*, Hallett & Sons, 5. *New Zealand*, Smith, 6. *Nova Scotia*, Central Committee. *Portugal*, Royal Soap Contractors, 1158-1164. *Russia*, Bescke, 303. Nilson & Junker, 308. Stier, 364. *Sardinia*, Albani, Brothers, 7. Rossi & Schiappavelli, 0. *Spain*, 275 A. Bert, 245, 246. Giro, 244. Leon y Rico, 243. *Tunis*, 172-176, 180. *Turkey*. *Tuscany*, Conti & Son, 23. *United States*, Bazin, 36. Clawson, 503. Hanel, 40. Hyde, 67. Lord, Lynch & Co., 366. Moore, 361. St. John, 510. Taylor, 292. *Van Diemen's Land*, Cleburne, 144. *Western Africa*, Hutton & Sons, 6. *Zollverein* (1), Delmel, 254. Palis, 263. Sarr, 253. Wunder, 250.

- SOAP-BERRIES (*Sapindus*)—II. Pound, 108.
British Guiana, Ross, 120.
- SOAP-CUTTING MACHINE—VI. Muir, 206.
- SOAP, SOFT—Knight, 8. McKean, 38.
- SOAP-STONE—*Canada*, Logan, 1. *Greece*, 15.
Switzerland, Pedolin, 49.
United States, Cocks, 271. M'Henry, 501. Maryland Soap-Stone Company, 180.
- SODA—II. Huskisson, 86.
Cape of Good Hope, Seppé, 4. *Egypt*, 367.
India, 1. *Turkey*.
- SODA, ACETATE OF—*France*, Maire & Co., 317.
- SODA, ANHYDROUS SULPHATE OF—*Belgium*, Société de Fléffe, 38.
- SODA, BICARBONATE OF—II. Pattinson, 18. Stevenson, 20.
- SODA, CARBONATE OF—II. Bower, 42. Cook, 15. Watt, 32.
South Africa, Seppé, 49. *India*, 1. II.
Portugal, Hirsch, Brothers, 51. Serszedello & Co. 60.
Spain, Canary Islands, 33.
Zollverein (1), Matthes & Weber, 464.
- SODA, PREPARATIONS FROM—*Zollverein* (1), Wesenfeld & Co., 461.
- SODA SOAP—*Sardinia*, Albain, Brothers, 7.
- SODA, STANNATE OF—*Austria*, Braun, 21.
Zollverein (1), Krammelbein & Brüd., 457.
- SODA, SULPHATE OF—II. Bullock & Co. 37. Kane, 53.
France, Melapert, 319. *India*, II.
Spain, Angula, 38. Burgos Mines, Inspector of, 35.
Zollverein (1), Matthes & Weber, 464.
- SODA, TINATE OF—*Zollverein* (1), Kunheim, 13.
- SODA-WATER—XXIX. Thwaites, A. & R. & Co. 105. See also *Vases*, *Syphon* (for *Aerated Waters*).
- SODA-WATER MACHINES—VI. Cooper and Bursill, 624.
Cox, 608. Tyler & Co., 605. Tyler & Son, 606.
XXII. Masters, 634. *France*, Savareuse, 1477.
- SODIUM, ACETATE OF—*Austria*, Wagenmann & Co. 19.
- SOFA BED (to prevent sea-sickness)—VIII. Brown, 169A.
- SOFA BEDSTEADS—XXVI. Bursill, 7A. Ramuz, 152. Verriuer, 217.
- SOFAS—XXVI. Bursill, 7. Gillow & Co., 186. Jackson, 242.
Canada, Reed & Co., 115A.
- SOILS AND EARTHS (Specimens)—I. 43. Lance, 37.
Roake, 60. Rogers, 70. *Egypt*, 9, 12, 18.
Portugal, Marapez, 116. Telim, 117.
Rome, Bianconcini, 1.
Spain, Almeria Mines, Inspector of, 13.
Trinidad, Lord Harris, 33-35. *Tunis*, 24. *Tuscany*, 3.
See also *Brick Earth*. *Clay*. *Pottery Clay*.
- SOLIDIFIED MILK—See *Concentrated Milk*.
- SOLITE OBELISKS—XXVII. Beld, 57.
- SOUNDING INSTRUMENTS—*Belgium*, Van Hecke, 480.
France, Lecoentre, 300. Mulot & Son, 638.
- SOUTH SHIELDS COBLES (Models)—VIII. Alau, 85.
- SOUTH WALES RAILWAY IRON BRIDGE (Model)—VII. Finch & Willey, 9.
- SOUTHWATER CHURCH, SUSSEX (Mod. of)—XXX. (Fine Art Court) Carruthers, 305.
- SOEWING MACHINES. See *Seed-Dibbling and Sowing Machines*.
- SPEDES—See *Digging Machine*. *Horticultural Implements*.
- SPAIN, HER MAJESTY THE QUEEN OF; Articles of jewellery belonging to—*France*, Lemonnier, 304.
- SPAIN, THE KING OF, Iron bust of—*Spain*, Trubia, Royal Ordnance, 280.
- SPANNERS—X. Park, 337.
- SPECTACLES, READING-GLASSES, &c.—X. Bayley, 273.
Braham, 289. Braithwaite, 283. Callaghan, 268.
Coadburn, Brothers, 259. Clark, 276. Dixey, 271.
Rowley, 290. Solomon, 286. Weaver, 279. Whitehouse, 280. Yeates, 332. XXII. Balleny, 299.
Belgium, Latinie, 184.
France, Berger-Walter, 25. Henri, 282. Plagniol, 1679 Poulot, 956.
Zollverein (1), Busch, 89. (2), Eisenmenger, 24.
- SPECTACLE-FRAMES—*Zollverein* (4), Lenz, 67.
- SPEED INDICATOR (for Steam-engines or Machines)—V. Yates, 777.
- SPELL-MACHINE—VI. Smith, 59.
- SPELT—*Belgium*, De Heunheuse, 62.
- SPELTER—I. Grey, 506.
- SPERMACEITI AND SPERMACEITI CANDLES—IV. Miller & Sons, 29 (Main Avenue, West). XXIX. Oglesby & Co., 139. *Sweden and Norway*, Lamm, 18.
United States, Macy & Sons, 306.
- SPERMACEITI OIL—See *Oils* (various).
- SPHERO-ANNULAR CONDENSER (for Microscopes)—X. Shadbolt, 677A.
- SPICES—II. London Druggists, 117. III. London Spice Trade, 53. *Barbadoes*. *Grenada*, Gross, 1.
India, XII. *Labuan*, &c., Hammond & Co., 2.
Mauritius, Natural History Society, 4. Reader, 7.
Trinidad, Lord Harris, 2. *Western Africa*, Weston, 1.
- SPIKE-MACHINE—*United States*, Morey, 589.
- SPINAL CURVATURE CHAIRS—X. Seltzer, 726.
- SPINAL CURVATURE, SUPPORT FOR—X. Wood, 737. See also *Orthorachidic Instruments*.
- SPINDLES (For Cotton and Silk Spinning)—VI. Booth & Co., 2. Lewis & Sons, 209. Preston, 5. Ryder, 222. XXII. Lucas & Son, 204A. *Portugal*, 1222.
- SPINNING-WHEELS AND MACHINERY—VI. Higgins & Sons, 14. Leach, 7. Macindoe, 24. Parr & Co., 6. *Belgium*, Société du Phenix, 134. Guudeau, 135.
Vanderlin, 126. *France*, Stamini & Co., 1021.
Gold Coast and Ashantes, Forster & Smith, 1.
Hamburgh, Boys, 113. *India*, v.
Mecklenburg-Sirelitz, Gundlach, 4. *Sweden*, Ehrenberg, 65. See also *Mules* (*Cotton*, &c. *Spinning*). *Throistles* for *Spinning*.
- SPIRIT-CASES—XXII. Young, 442.
- SPIRIT-LEVELS—V. Judge, 130. X. Dobbs, 316. Liddell, 362. XXII. Bloomer & Phillips, 176. Morrison & Parker, 177.
- SPIRIT-METERS—X. Brown, 335. Towns, 327. XXII. McCullum, 523. See also *Hydrometers*.
- SPIRIT-TAPS—V. Stocker, S. & G., 422.
- SPIROMETERS—X. Ewart, 729.
- SPONGES—XXVIII. Harris, S. & H., 117.
Bahamas, Barnes & Co. *Greeney*, Paulides, 12.
Tunis, 73-75, 150, 151. *Turkey*.
Zollverein (1), Winkler, 31. (3), Thieme-Wiltmarkter & Puschel, 4.
- SPONGIO-FILINE—IV. Markwick, 114.
- SPORTING IMPLEMENTS—*Austria*, Cussel, 478.
France, Boche, 769. See also *Gunpowder*. *Guns*, *Pistols*, &c. *Shot-Belts*, &c.
- SPOONS—See *Gold and Silver Ware*. *Plated Ware*.
- SPRING-BED—*United States*, Day, 575.
- SPRING BRACES—X. Grossmith, 565.
- SPRING PROPELLER—V. Clarke & Williams, 965.
- SPRING SEATS—*United States*, American Chair Company, 85.
- SPRING WINDOWS (requiring no lines)—*Sweden and Norway*, Rosenkilde, 45.
- SPRINGS (Carriage, Cart, &c.)—V. Gibson, 848. Marriot & Atkinson, 160. *India*, 1.
- SPRINGS FOR DOORS—XXII. Aldridge, 687.
- SPRINGS, LOCOMOTIVE-ENGINE—XXII. Turton & Sons, 190.
- SPRINGS, MATTRESS—XXII. Wakefield, 337.
- SPRINGS, RAILWAY-TRUCK—XXII. Marsh & Co., 162.
- SPUR WHEELS—V. Jackson, 692.
- SPURS—XVI. Maxwell & Co., 52. Thomas & Son, 211.
Belgium, Gillay, 379. *Western Africa*, Jamieson, 22.
- SQUARE-CUTTING GAUGE—XXII. Robertson, 565.
- SQUARE FOR MEASURING—X. Purvis, 325.
- STACK-COVERING (Various)—XXIX. Fisher, 225.
- STAFF OF HONOUR (African)—*W. Africa*, McWilliam.
- STAINED GLASS—XXIV. Ballie, 61. Ballantine & Allan, 78. Holland & Son, 63. Swinburne, 4. Tubey, 81. XXVI. Lee, 43, 402. *Austria*, Bigaglia, 600.
Belgium, Junet, 389. *France*, Gerente, 517. Maes, 656.
United States, Gibson, 346. Hanington, 311.
Zollverein (6), Schiffmann, 76.
- STAINED GLASS, SUBSTITUTE FOR—XXVIII. Bushell, 182.
- STAINED-GLASS WINDOWS—XXIV. Bankart & Sons, 87.
Bury, 64. Castle-street Glass-Works, 83. Forrest & Bromley, 42. Hall, 41. Mayer, 76. XXX. (Fine Art Court) Wyatt, 30.
Belgium, Capromier, 438. *France*, Leclerc, 575.
- STAINED-GLASS WINDOWS (Designs for)—XXII. King, 5.

- iv. Miller & Ogleby & Co., 8.
- (Microscopes)—x. London Spice Co., 2. Reader, 7. Africa, Weston, 1. 589. 726. Wood, 737. See
- vi. Booth & Ryder, 222. 1222.
- vi. Higgins & Parr & Co., 6. Goudeau, 135. Co., 121. Smith, 1.
- Sweden, Ehren- &c. (Spinning).
316. Liddell, 176. Morrison & 327. xxii. 176.
- 12.
- Wiltmarkter
478. Guns, Plated Ware.
965. Chair Company, Sweden and Nor- 848. Mariot 87. Turton & Sons, 337. sh & Co., 162.
- mas & Son, 211. z, Jamieson, 22. son, 565. 25. 225. z, McWilliam, allantine & Allan, e, 4. Tubey, 81. glia, 600. s, 517. Maes, 656. ton, 311.
- viii. Bushell, 182. kart & Sons, 87. k., 83. Forrest &c. xxx. (Fine Art) eclerc, 575. —xxii. King, 5.
- STAINED WOODS—II. Hawthorne, 39. Naylor, 35. iv. Stowe, 10. xxvi. Palmer, 53.
- STAINS FOR WOOD—II. Coppock, 65. Hawthorne, 39. Stevens, 74.
- STAIR BALUSTRADES—XVI. Marlow, 54. xxii. Longlen & Co., 105. France, Iron, 504.
- STAIRCASE RAILINGS, FERN (Design for)—XXII. Cottam & Hallen, 698
- STAIRCASES, FARTHENWARE—XXV. Ridgway & Co., 5.
- STAIRCASES, SPIRAL—Zollverein (6), Schroeter, 77.
- STAIR RODS—United States, Hiler, 218.
- STALACTITE (OR STALAGMITE). See *Alabaster*.
- STAMPING-PRESS—XVII. Pinches & Co., 33.
- STANCHION-GUNS (For Wild-duck Shooting)—VIII. Ansell, 185.
- STANNATES—II. Young, 7.
- STARCH—II. Jennings, 99. III. Berger, 130. Brown & Pelson, 123. Colman, J. & J., 117. St. Etienne, 138. Jones & Co., 128. Miller, D. & W., 127. Reckitt & Son, 125. Shand & Muckart, 126. Tucker, E., 122. Tucker, R. G., 121. Wotherpoon, 124. iv. Conney, 70.
- Belgium, Bocken & Co., 73. Vangeeteruyen, 489.
- British Guiana, Garnett, 31. 2. Shier, 33-35.
- Canada, Prendergast, 123.
- France, Belleville, Brothers, 1078. Ruez, 363. Steinbach, 392. Netherlands, Bocken, 11. Prins, 12.
- Portugal, 453. Holbeche, 454.
- Russia, Roteman, J. Verdan & Co., 30. Volkonsky, Prince, 70. St. Domingo, Schomburgk, Sir R.
- Spain, Mirat, 128. Trinidad, Lord Harris.
- United States, Colegate & Co., 301. Oswego Starch Factory, 104. Van Diemen's Land, Murray, 18.
- Zollverein (1), Barre & Kuster, 327. Haller, 690. Kruse, 19. Lubing Manufacturing, 694. Schramm, Brothers, 466. (6), Hofmann, 14. See also *Potato Starch*.
- STARCH GUNS—III. St. Etienne, 138.
- STATE BARGE, THE LORD MAYOR'S (Model)—VIII. Searle & Sons, 169 (Main Avenue, West).
- STATE BEDS—XXVI. Strymgeur, 101.
- STATE COACH, THE LORD MAYOR'S (Model)—XXX. (Fine Art Court), Jibb, 14.
- STATIONERY—XVII. Cowan & Sons, 101. De la Rue & Co., 76. Hastings & Mellor, 83. Mansell, 27. Ralph, 42. Smith, K., 100. Smith, J., 41. Spicer, Brothers, 42. Waterlow & Sons, 46. xxx. (Fine Art Court) Burke, 42. France, Vincent & Tisserant, 730.
- India, xvii. Zollverein (1), Glanz, 146. Kuhn & Sons, 152. See also *Account-books. Albums. Bookbinding. Books. Envelopes. Lace Papers. Ledgers. Paper. Parchment. Sealing-Wax*.
- STATIONERY, FANCY—XIII. Burke, 57. xvii. Ackerman & Co., 1. Austin, 151. Bancks, Brothers, 96. Burke, 152. Byam, 144. Denn & Son, 18. Dahls & Co., 79. Hampson, 153. Hilder, 17. Kronheim & Co., 181. Meek, 190. Spiers & Son, 208. Wiltes, 102. xxvii. Dixon, 190. xxviii. Rousseau, 116. xxix. Stocken, 43.
- France, Vallant, 1515. Vanderdorpel & Son, 712.
- Malta, Fenech, 19. Russia, Aristarkhoff, 359.
- STATUARY—See *Sculpture*.
- STAYS AND CORSETS—XX. Caplin, 32A. Devy, 44. Galloway, 120. Geary, 49. Hodgson, 155. Hurst & Reynolds, 162. Jonbert, 40. M'Clintock & Co., 152. Paper, 41. Pope & Plante, 6. Roberts, 40A. Shreeve, 46A. Smith, 119. Sykes, 43. Thomas, W. & Brothers, 46. Tinsley & Co., 122.
- Belgium, Berger, 349. Van Beneden, 345, 346.
- France, Allix, 6. Caillaux, 80. Clemencon, 1152. Dumoulin, 178. Fontaine, 1226. Grangoir, 1616. July, 892. Jusselin, 551. Mace, 1335. Meurisse, 924. Richez, 1436. Robert-Werly & Co., 1444. Soules, 1402. Suchell, 1790.
- STAYS FOR WEAVERS—Zollverein (1), Erdelen, 474.
- STEAM BOILERS—See *Boilers, Steam*.
- STEAM BOILER COCKS—See *Cocks for Steam Boilers*.
- STEAM-BOILER FEEDER—x. Siebe, 358.
- STEAM-BOILER FURNACES—v. Green, 53. x. Newcomb, 672A. xxii. Edwards, 241.
- STEAM-BOILER SAFETY APPARATUS—France, Lethuillier-Pinel, 312.
- STEAM-BOILER WATER-GAUGES—v. Goodfellow, 778. Howe, 779.
- STEAM-CHEST AND VALVE—VIII. Macdonald, 320.
- STEAM-COOKING APPARATUS (for Agricultural purposes)—IX. Stanley, 1.
- STEAM CRANES (Models)—I. Gowans, 132. v. M'Nicoll & Vernon, 434.
- STEAM DISTILLING APPARATUS—Zollverein (1), Wolff, 13.
- STEAM-ENGINE CRANKS—v. Judge, 130. Squire & Co., 706.
- STEAM-ENGINE FITTINGS—v. Lambert & Son, 478. Thomson & Sons, 490.
- STEAM-ENGINE INDICATORS—v. Whitehead, 101.
- STEAM-ENGINES, VARIOUS (including Models)—I. Vincent, 465. Wilding, 60. v. Armstrong, 44. Becker, 106. Bickle, 131. Bunnett & Co., 48. Butterley & Co., 34. Clayton, Shuttleworth, & Co., 39. Colegrave, 162. Collings & Co., 49. Constable, 70. Cradlock, 76. Crosskill, 25. Davies, J. & G., 16. Deane, 158. Ebbw Vale Company, 67. Kilwards, 12. Evans & Son, 37. Fairbairn & Sons, 26. FitzMaurice, 57. Gadil & Bird, 208. Carrett, 35. Hawthorn & Co., 11. Haycraft, 151. Hick & Son, 13. Hodge & Bailey, 29. Joyce, 20. Leigh, 61. Lambert & Son, 478. Linton, 116. Lloyd, 45. Lynch & Inglis, 24. McNaught, 22. Maudslay, Sons & Field, 38. Morrell, 52. Nasmyth, 41. Paterson, 148. Perry, 112. Pope & Son, 40. Potts, 102. Ransomes & May, 35. Redmond, 68. Samuel, 616. Sharp, 104. Siemens, 46, 203. Simpson & Shipton, 14. Squire & Co., 706. Tuck, 200. Watkins & Hill, 56. vi. Crosskill, 404. Foudrinier, 100. Hick & Son, 218. Shank, 110. Williams, 234. vii. Remington, G. W. & J., 70. Renczynski, 27. ix. Tuxford & Sons, 271. x. Bettle, 679A. Gogery, 407. xxii. Stuart & Smith, 102. Austria, Miles, 106. Schmidt, 105.
- Belgium, Cuckerill, 119. Sardinia, Benoit, 33.
- France, Bourdon, 1108. Flaud, 507. Gal Casalot, 1239. Pierrat, 938. Stolta & Son, 1494.
- Nova Scotia, Archibald, 2.
- United States, Higginbotham, 231.
- STEAM-ENGINES, AGRICULTURAL—IX. Barrett, Ezall & Andrews, 128. Caborn, 200. Burrell, 37. Buttin, 115. Clayton, Shuttleworth, & Co., 242. Hemming, 134. Heusman & Son, 149. Hornish & Son, 233. Ransomes & May, 124. Roe & Hanson, 84. Stanley, 1. Turner, 182.
- STEAM-ENGINES, MARINE (including Models)—v. Atherton, 1. Day, 133. Doukin & Co., 42. Elder, 152. Hodges, 103. Maudslay, Sons, & Field, 38. Penn & Son, 8. Renie, G. & Sir J., 52. Richards, 138. Stothert, Slaughter & Co., 4. Watt & Co., 6. Webster, 108. vii. Remington, G. W. & J., 70, 175. Canada, Garth, 158. See also *Sub-marine Condenser*.
- STEAM-ENGINES, RAILWAY (Locomotive)—See *Locomotive Engines, Railway*.
- STEAM FUEL—XXVII. Stirling, 120.
- STEAM-GENERATOR—IX. Gill & Ward, 62.
- STEAM GUN—United States, Perkins, 541.
- STEAM-HAMMER—VI. Nasmyth, 236.
- STEAM-INDICATORS—x. Oxley, 689. Somalvico & Co., 681A.
- STEAM-PRODUCING APPARATUS—Mecklenburg-Strelitz, Benecke, 1.
- STEAM-PUMPS—v. Carrett, 35. Macintosh, 28. Zollverein (1), Wurlen & Co., 51. See also *Pumps for supplying Boilers*.
- STEAM TRAVELLING CRANE—v. M'Nicoll & Vernon, 434.
- STEAM TRIGGER (Model)—VI. Radcliffe, 328.
- STEAM-TUGS—VIII. Brook, 42. Brookes, 143. Petley, 58. Robson, 57.
- STEAM AND VACUUM GAUGES—v. Lees, 204. Watkins & Hill, 56. x. Baker, 396. Cameron, 356. Chadburn, 239. Somalvico & Co., 681A. xxii. Davis, 643.
- STEAM-GAUGE WHISTLE—Denmark, Lundie, 12. See also *Railway Whistles*.
- STEAM-VESSELS (Models, &c.)—VII. Royal Scottish So-

- ciety of Arts, 29. VIII. Clarke, 135. Ditchburn, 30. Gibson, 41. Hudson, 303. Macnab, 130. Mare & Co. 149. Miller & Co. 163. Robinson & Russell, 193. Rook, 320. Rutven, 171. Sturdee, 337. White, T. J. & R., 36A. See also *Paddle-Wheels. Screw Propellers. Screw Steam-Vessels.*
- STEAM-VESSELS** (application of Whistle to)—v. Tabor, 691.
- STEARIC ACID**—France, Donneaud & Co. 478.
- STEARINE**—II. Bell, 116. IV. Field, J. C. & J., 130. XXIX. Ogley & Co., 139.
- Austria*, Hermannstadt Stearine Candle Company, 42. Stearine Candle (Apollo Candle) Company, 39. Stearine Candle (Milly Candle) Company, 40.
- Belgium*, Quanonie, 431.
- Russia*, Manufacturing Company, 363. Matisen & Co. 305.
- Sweden and Norway*, Johansson, 1798. See also *Candles (Wax, Tallow, &c.).*
- STEATITE**—I. Sweetman, 40. *India*, I. *Turkey*.
- STEEL MANUFACTURE** (Illustrations of)—XXII. Jowitt & Battie, 187A. Naylor, Vickers, & Co. 199. Turton & Sons, 190.
- STEEL AND STEEL WARES**—I. Schneider, 409. Solly & Co., 410. Wingerworth Iron Company, 416. VIII. Greener, 59. XXI. Stubs, 39. XXII. Cocker & Son, 115. Earl & Co., 207. Hale, 563. Heesley & Sons, 305. Hutton, 166. Johnson & Co., 109 A. James & Co., 801. Jowitt & Co., 187A. Makin, 112. Marriott & Atkinson, 160. Marsh, Brothers, & Co., 162. Naylor, Vickers, & Co., 199. Oxley, W. & Co., 806. Solly, 258. Worrall & Co., 164.
- Algeria*, Ain Morka Mines Company, 19. Boum Mines and Iron Works Company, 20.
- Austria*, Egger, 402, 400, 410. Fischer, A., 420. Fischer, B., 421. Gurk, Iron Works of the Chapter of, 416. Pfeiler, 418. Pillersee and Zeinlach Imperial Smelting Works, 407. Schwarzenberg, Prince, 417. Thurn, 419. Vienna Depot of the Imperial Iron Mines and Iron Works, 408. Zois, 405.
- Belgium*, Delloye, 376. Falloise, 384. St. Leonard Company, 374. *Ceylon*.
- France*, Baudry, 1071. Chauvin, 449. Daniel, 1163. Huet, 880. Voizat, 1531. *India*, I.
- Nova Scotia*, Acaadian Iron Mining Association, I. Archibald, 2.
- Russia*, Artinsk Imperial Works, 3. Jakovleff, 25. Perm Imperial Copper Works, 6. Tomsk Imperial Works, 18. Zlatoust Fire-arm Manufactory, 14.
- Spain*, Carreras, 252. Leonesa Asturian Company, 21.
- Sweden and Norway*, Eskilstuna, 12. Kockum, 75. Wardelell, 74.
- Switzerland*, Fischer, 47. Mathey & Son, 41.
- United States*, Adirondac Manufacturing Company, 344.
- Zollverein* (1), Ante, 627. Asbeck & Co., 645. Boeing, Roehr, & Lesky, 453. Devaranne & Son, 280. Eske Royal Mines, 326. Erbschloe & Sons, 614. Harkort & Son, 406. Huth, Fried, & Co., 632. Krupp, 649. Lehrkind, Falkeuroth, & Co., 447. Loh Steelworks, 324. Lohmann, 630. Mannemann, 617. (2), Grenanath, Brothers, 95.
- STEEL-CUTTERS**—*Sweden and Norway*, Halleberg, 11.
- STEEL PENS**—See *Pens, Metallic.*
- STEEL PENS, MACHINE FOR MAKING**—XXII. Hinks & Co., 326.
- STEEL PLATES FOR ENGRAVERS**—XXII. Hughes & Kimber, 609. Spear & Jackson, 113.
- STEEL PLATES (Process of Tinting)**—XXX. (Fine Art Court) Hayward, 337.
- STEELS (Butchers')**—XXI. Barker, 37.
- STEELS FOR STRIKING LIGHTS**—*Austria*, Ring, 468.
- STEERING WHEELS AND APPARATUS**—VIII. Allison, 115. Fayrer & Co., 112. Hughes, 318. Long, 71. Robinson, 100. Wood & Co., 102. XXX. Grissell, 335. See also *Rudders. Screw Propelling Rudder.*
- STEREOCHROMIC PICTURES**—*Zollverein* (2), Muhr, 91.
- STEREOSCOPIES**—*Zollverein* (3), Allen, 23.
- STEREOTYPE PLATES**—XVII. Knight & Hawkes, 107. Manchin & Morell, 128.
- STEREOTYPING (Specimens of)**—France, Curmer, 135. *United States*, Star, 194.
- STETHOSCOPIES**—X. Delume, 19.
- STETHOSCOPIES**—X. Leared, 620. Matthews, 181.
- STICKS**—See *Whips, &c.*
- STILLS**—Western End, North Enclosure (Outside), Singer & Co., 65. *Ceylon*.
- STOCKING FRAMES**—VI. Carver, T. & T. G., 80. XXX. (Fine Art Court), Lees, 105.
- STOCKINGS**—See *Hosiery.*
- STOCKINGS, ELASTIC**—See *Surgical Bandages, &c.*
- STONE (Specimens of)**—Western End, South Enclosure (Outside), Brown & Co., 29. Franklin, 28. Freeman, W. & J., 14. Raynes & Co., 25. Sinclair, 13. Towler, 27. I. 106. Abercorn & Gwythen Collieries Company, 430. Clark, 190. Clugas, 168. Damon, 149. Driver, 203. Falmouth & Penryn Local Committee, 163. Freatau, 133. Gillaume, 153. Gowans, 132. Grissell, 185. Howard, 29. Kirk & Parry, 179. Lindley, 187. Long, 147. Luard, Beetham, & Co., 176. Powell, F., 197. Powell, W. J., 202. Ross, 51. Rutherford, 182. St. Austell Local Committee, 470. Seymour, 192. Snowden, 171. Sparks, 154. Stanhope Limestone Quarries, 204. Staple, 181. Stocks, 188. Townsend, 186. Walsh, Executors of, 183.
- Egypt*, 14, 15. *India*, I.
- Ionian Islands*, Lord Seaton, 5.
- Malta*, Darmanin & Sons, 26.
- New South Wales*, Hallett & Sons, 5.
- New Zealand*, Greenwood, 17. *Trinidad*, Lord Harris.
- Tuscany*, Royal Technological Institute, 1.
- Zollverein* (4), Zeller, 1. See also *Ashlar Stone. Bath Freestone. Flint Stone. Freestone. Granite. Limestone. Marble. Paving Stones. Quartz. Serpentine Stone.*
- STONE, ARTIFICIAL (including Works therein)**—Western End, South Enclosure (Outside), Board, 2. Furse, 19. Seeley, 11. Teagle, R. & W., 3. XXVII. Bowen, 94. Pitham, 103.
- Austria*, Cristofoli, 38. Rohlik, 37.
- France*, Debay, 45. Virehart, Brothers, 732. See also *Marble, Artificial. Scagliola (Works in).*
- STONE-BORING APPARATUS**—VI. Bear, 301.
- STONE CARVING**—I. King, 136. XXX. (Fine Art Court) Foster, 203. *China*, Thoms.
- Malta*, Dimch, 28. Soler, 29. Testa, F., 33. Testa, S. 30. *Turkey*.
- STONE, COLOURED (by Infiltration)**—X. Phillips, 411.
- STONE SAWING, DRESSING, PLANING, &c., MACHINES**—VI. Hunter, 312. Randlell and Saunders, 324.
- United States*, Eastman, 3. Murey, 460. Foot, 180. Freeman, W. & J., 160.
- STONE TOMBS, &c.**—XXVII. Hartley, 12.
- STONE-WARE GENERALLY**—Western End, North Enclosure (Outside), Doulton & Co., 64. Ferguson & Co., 69. Garnkirk Co., 69. Grangemouth Coal Company, 68. Green & Co., 67. Singer & Co., 65. XXV. Bell & Co., 26. Bourne, 35. XXVII. Betts, 22. Doulton & Co., 23. Ferguson & Co., 63. Green & Co., 125. Westwood & Moore, 113.
- Austria*, Nowotny, 625.
- Cape of Good Hope*, Bridges, 21. *France*, Mansard, 1342.
- Portugal*, Pinto, Lasto, & Co., 1109.
- Sweden and Norway*, Iljula Quarry, 43. *Turkey*.
- Tuscany*, Imperial Hard Stone Works, 111.
- Zollverein* (1), Actien, 214. Villeroy & Boch, 361.
- STOPPERS TO BOTTLES**—XXIV. Ayre and Calder Bottle Company, 6.
- STOVE FURNITURE**—*Canada*, Cheny, 159.
- STOVE ORNAMENTS**—XXII. Smith, 269.
- STOVE POLISH**—*United States*, Seabury, 121.
- STOVES**—VII. Rettie, 159. XXII. Alderton & Shrewsbury, 403. Bailey & Sons, 805 (Main Avenue, West). Hurton, 247. Coalbrook Dale Company, 641. Collins, 88. Court, 359. Crook, 244. Deane, A. 392. Deane & Co., 186. Downson, 476. Duley, 89. Edwards, D. O., 241. Edwards, F., 387. Evans & Co., 103. Feetham & Co., 276 (Main Avenue, West). Gidney, 556. Gray, J. & Son, 465. Harvey, 440. Haywood, 97. Huxham & Brown, 406. Huxley &

133.

181.

Outside), Singer

89. xxx. (Fine

ges, &c.

South Enclosure

B. Freeman, W.

C. Towler, 27.

Company, 450.

D. Driver, 203.

E. 163. Freston,

G. Grissell, 185.

H. Ludley, 187.

I. 178. Powell,

J. 1. Rutherford,

K. 170. Seymour,

L. Slope Limestone

M. 88. Townsend,

ad, Lord Harris.

1.

ar Stone. Bath

Granite. Lime-

stone. Serpentine

erein)—Western

1, 2. Furse, 19.

vii. Bowen, 94.

732. See also

30).

101.

(Fine Art Court)

33. Testa, S. 30.

Phillips, 411.

MACHINES—

ers, 324.

30. Foot, 180.

North Enclosure

son & Co., 60.

Company, 68.

xxv. Bell &

22. Doulton &

n & Co., 125.

Mansard, 1342.

Turkey.

Boch, 361.

Calder Bottle

21.

& Shrewsbury,

Avenue, West),

ny, 641. Col-

Deane, A. 392.

Duley, 89. Ed-

Evans & Co.,

Avenue, West),

Harvey, 440.

06. Huxley &

Heriot, 236. Jeakes, 237 (Main Avenue, West). Johnson & Co., 108 (Main Avenue, West). Keene, 94. McSherry, 408. Maund, 792. Nettleton & Son, 368. Nicholson, 87. Norman, 391. Peterson, 383. Pierce, 107. Pope & Son, 243. Price, 397. Redgate, 410. Searle, 450. 443. Yates & Co., 384. xxvi. Lyon, 30.

Austria, Metternich, Prince, 413.

Belgium, Mathys, 359. Point & Son, 474.

Canada, Cheney, 156.

China, Baring, Brothers. *Denmark*, Laine, 12.

France, Delignon, 1180. Durand, 186. Ferouelle & Holland, 200. Lecocq, 1644.

Hamburg, Beluhauer, 121.

Mechlenburg-Strelitz, Benecke, 1. Lange, 2.

Netherlands, Graamans, 65. Martin, 63.

Tuscany, Cantagalli, 71.

United States, Burch, 513. Chilson, Richardson, & Co., 417. Learned & Thatcher, 100. Pond & Co., 414, 434.

Zollverein (1), Balm, 760. Schmidt, 644. Stolberg-Wernigrode, Earl of, 770. (5). Hoffman & Son, 16. (7). Metz & Co., 8. See also *Grates*. *Kitchen Ranges*.

STOVES, GAS—ix. Smith, 192. xxii. Anzley, 597. Desfris, 482. Edwards, 241. Sharp, 91. Toser, 350.

STOVES, LAMP—xxii. Deane & Co., 186.

STOVES, THERMOMETER—xxii. Warren, 402.

STOWELL, LORD—See *Eldon and Stowell Group*.

STRASBURG CATHEDRAL (Model)—*Switzerland*, Wytenbach, 257.

STRAW CHAIRS—*Zollverein* (0), Reinhard, 54.

STRAW-CUTTERS—*United States*, Whiteman, 240. See also *Chaff-cutting Machines*.

STRAW-PLAIT, &c., FOR BONNETS—xx. Cooper, J. J. & G. 172A. Elliott, 172. Gregory, Cubitt, & Co., 8. Mat., 182. Muir & Co., 173, 215. Wexford

Peasants, 181. xxviii. Rendall, 144. Still, 145.

Austria, Taundler, 657.

Madeira, Read, 1.

Switzerland, Abt, Brothers, & Co. 227. Clares, 228. Hartmann & Co., 230. *Tuscany*, Pastorelli, 35.

Zollverein (4), Haas, 79. See also *Bonnets*, *Straw*.

STRAW-SHAKES—ix. Robinson, 126.

STRAW TABLE—*Belgium*, Bertani, 477.

STRAW WORK—xix. Sewell, Evans & Co., 238. xx. Cooper, J. J. & G., 172A. Elliott, 172.

Malta, Bultigieg, 31. *Mauritius*, Bulkfield & Co., 5.

Switzerland, Sulzberger & Ackermann, 234.

Tunis, 178-180. *Zollverein* (2), Weppler, 96.

STRAWBERRIES, EARTHENWARE SUPPORT FOR—ix. Smith, 222.

STREET BARRICADE—vii. Rock, 143.

STREET-CLEANING MACHINES (Models)—vii. Nicholson, 40. Towling, 39.

STREET ENGINE—v. Fire Annihilator Co. 92A.

STREET WATERING-CARTS (Models)—v. Geary, 846. ix. Coode, 154A.

STRICHNINE—ii. Morson & Son, 106.

STRING AND TWINE—xiv. Bridport Local Committee, 73. Haywood & Sons, 44. Moore, 67. Morrison & Hurn, 49. Nicol & Co., 87. Smith, 65. Tull, 69. Withey & Smith, 47. xxviii. Farrar & Son, 16.

Canada, Sponser, 169. *New Zealand*, Caradua, 25.

Zollverein (1), Blankenburg, 561. Engel, 125. Heinig & Sons, 812. Hoersick, 554. Schwemann & Sons, 545. See also *Ropes*, *Cordage*, &c.

STRING AND TWINE BOXES—xxi. Yeates, 19. xxx. (Fine Art Court) Christie, 137.

STRING AND TWINE REELS—vi. Slate, 69. xxix. Slate, 226.

STRINGS FOR MUSICAL INSTRUMENTS—See *Musical Instrument Strings*.

STRONG BOXES AND SAFES—*Belgium*, Delaroche, 364. Goh, 357. Mathys, 359. *France*, Verstaen, 1705. See also *Fire-proof Safes*.

STRONTIA, CARBONATE OF—i. Riddell, Sir J. M. 55.

France, Digeon, 1590.

STRONTIA, NITRATE OF—*France*, Digeon, 1590.

Portugal, Serzelello & Co., 62.

STRONTIA, SULPHATE OF—*France*, Digeon, 1590

STUCCO CASTS—*Sardinia*, Parinl, 91.

Zollverein (1), Kramer, 416.

STUFFS (Worsted, &c.)—xii. & xv. Hirst & Green, 404.

Bahamas, Haines & Co.

Belgium, Cateaux, 245. Gilsen & Bossut, 241. Lemaire, Decamps & Peissart, 240. Lienart Chiffaux, 242.

France, Heux, 1058. Bertecle, Chesnon & Co., 1082.

Cheou, e. 1559. Jubel Demaroes, 278. Koecklin, Brothers, 1034. Naset, 660. Sauvage & Co., 1472.

Telluril, 1030. Terrier & Co., 1032.

Zollverein (1), Broesel, 727. Kramer, 610. Morand & Co., 731. Neitzer & Brabant, 583. Schweitzer & Heller, 733. Schmits & Hulthaus, 585. Trnost, 601. Weissflug, 720. Weber, 716. (3). Behr & Schubert, 50. Glauchau Weavers School, 100. Graefe & Son, 102. Hecker & Taact, 96. Koehler & Schellich, 93. Rochling & Co., 508. Trinks, 98. Vogel, 89. (4). Kolb and Schule, 28.

STUFFED BIRDS AND ANIMALS—xxix. Beevor, 204. Dunhar, 234. Hancock, 320 (North Transept). Harbor, 203. Walford, 212.

Canada, Perry, 354.

Nova Scotia, Central Committee, 2.

Sardinia, Cumba, 83. *Turkey*.

United States, Hurst, 80. Moyston, 25.

Western Africa, Faddy, 19.

Zollverein (1), Graff, 803. Leeven, 423. Ringelamm, 253. (4). Plouquet, 107. See also *Ornithological Specimens*.

STYLOGRAPHY (Specimen of)—*Denmark*, Schüler, 37.

SUBCLAVIAN SECTOR (for measuring the body)—xx. Smart, 135.

SUB-MARINE BOATS—viii. Bell, 14.

SUB-MARINE CONDENSER—*France*, Hoche, 991.

SUB-MARINE CONSTRUCTION, MACHINES AND APPARATUS FOR—vii. Bismar, 95, 164. Gardiner, 50.

SUB-MARINE PROPELLERS—v. Ecclesall, 132. viii. Brown, Sir S., 334. See also *Screw Propellers*. *Ship Propellers*.

SUBSOIL PULVERISERS—ix. Barrett, Exall, and Andrews, 128. Cornish, 143. Gray & Sons, 150.

SUCCINE ACID—*Austria*, Broecher, 20.

SUCCORY—*Zollverein* (1), Teichman, 693.

SUEZ, ISTHMIUS OF, SHIP CANAL THROUGH (Model)—vii. Clark, 18.

SUGAR—iii. Perkins, 149. Wheeler, 27A. xxix. Oxland, R. & J., 98. *Austria*, Real, 61.

Belgium, Claus & Carron, 81. *Barbadoes*.

British Guiana, Anderson & Co., 36. Jones, 37 & 38. Laing, 40. Shier, 41-44. Stutchbury, 39, 45 & 46.

Ceylon, *Egypt*, 44, 45, 47, 48, 103, 391.

France, Jeanti, Prevost, Perrault, & Co., 1277. Numa, Graf, & Co., 687. Ronsean, Brothers, 1457.

Hamburg, Reising, 3. Wagener, 4. *India*, iii.

Eastern Archipelago, Hammond & Co., 2. *Mauritius*, Webb, 3.

Portugal, Pinto, Bastos, & Co., 455-477.

Russia, Arrhmann & Co., 79.

Spain, Ariela, 292. Arrieta, 295. Knriques, 176.

Zulueta, 179A.

Sweden, Seyboldt & Co., 101.

Trinidad, Lord Harris. *Turkey*.

United States, New York State Agricultural Society, 83. White, 397. See also *Beetroot Sugar*. *Maple Sugar*.

SUGAR HATENS (satin-wood)—xxvi. North, 257.

SUGAR, BEETROOT—See *Beetroot Sugar*.

SUGAR-CANDY—*Denmark*, Tutein, 28. *Egypt*, 66.

SUGAR-CANES—*Egypt*, 104. *Turkey*.

SUGAR OF LEAD—ii. Melinrythan Chemical Company, 2. *Russia*, Sainu, 28.

Zollverein (1), Augustin, 826. Kunheim, 13.

SUGAR-OF-MILK CRYSTALS—ii. Hopwood, 100.

SUGAR-MILLS, MACHINERY, &c.—v. Squire & Co., 706.

vi. Collinge & Co., 432. Graham, West & Co., 445.

Pontifex & Wood, 602. Robinson & Russell, 418.

Sharp, 440. Squire & Co., 449. ix. Rameses & May, 124. Smith & Co., 266. xxii. Hirt & Co., 85.

Belgium, Van Goethem, 124. *France*, Nilus, 1371.

- Hamburgh*, Thiel, 123. *Netherlands*, Van Vlielingen & Co. 75. See also *Vacuum Pans*.
- SULPHUR**—I. Highly, 23. II. Hatmel & Ellis, 10. *Egypt*, 8. *Greece*, 19. *India*, 1. *New Zealand*, Smith, 14. *Rome*, Raineri, 20. *Sardinia*, Selopis, Brothas, 4. *Spain*, 42a, 45. Durando y Trigo, 46. Yust & Co., 47. *Turkey*, *Tuscany*, 4. Volterra Salt Manufactory, 2. *Zollverein* (1), Harkort, 876.
- SULPHUR ORE**—I. Williams & Sons, 505.
- SULPHURATOR AND FUMIGATOR FOR HOPS, &c.**—IX. Alsop, 23A. Epps, 101.
- SULPHURIC ACID**—Denmark, Owen, 44. *Portugal*, Hirsch, 29. *Sardinia*, Albain, Brothers, 7. *Selopis*, Brothers, 4. *Sweden*, Hierta & Michaelson, 99.
- SULPHURIC-ACID CLAY**—*Zollverein* (1), Schwemmal Alum Works, 463.
- SULPHURING APPARATUS**—VI. Thom, 71.
- SUMACH WOOD**—*Russia*, 93.
- SUMACK**—*Portugal*, 511-513. Monteiro, 510. *Spain*, 146.
- SUN PICTURES (on Paper)**—See *Cylotype Process*.
- SUN SHADES**—XXVI. Dawes, 135.
- SURGICAL BANDAGES, STOCKINGS, &c.**—X. England, 367. Longdon & Tubberer, 572. *France*, Flamet, 213. See also *Medicated Bands*. *Truces*. *Bandages, &c.*
- SURGICAL INSTRUMENTS AND APPARATUS**—IX. Read, 89. x. Amot, 619. Bigg & Son, 576. Blackwell, 459. 734. Bottomley, 657. Brown & Son, 627. Chadburn, Brothers, 259. Coxeter, 682. Ellis, 631B. Evans & Co., 643A. Eward, 647. Ferguson & Sons, 631. Gowing, 286, 645, 736. James, 577. Jordan, 285. L'Estrange, 597. List, 175. Machell, 654. Marshall & Co. 686. Matthews, 181. Moore, 66A. Philp & Whicker, 641. Reid, 583. Ross, 601x. Salt & Son, 628. Simpson, 642. Sparks & Co., 591. Weedon, 640. Weiss & Son, 631A. Whitbely, 607. Wood, 737. Woodhouse, 731. XXII. Nelson, 220. Scidmore & Co., 183. Sellers, 147. Whittles & Froggart, 213, 693.
- Austria*, Teufmeyer, 564. *Belgium*, Noggerath, 401. *Denmark*, Lauggaard, 18. *Nyrop*, 19.
- France*, Biondetti, 766. Barsary, 1100. Calbirol, 786. Chariere, 1145. Darbo, 1577. Hamm & Co. 862. Luer, 1333. Mathieu, 618. Pujade, 1413. Roissard, 1450. Thier, 1565. Valerius, 706.
- Nova Scotia*, Archibald, 2. *Russia*, Roach, 341.
- Sardinia*, Masera, 97. *Spain*, Pareren, 249.
- United States*, Benjamin, 152, 251. Fitch, 479. Palmer, 39. Thompson, 26. Yeager & Ord, 58.
- Zollverein* (1), Baunscheidt, 344. Goldschmidt, 85. Luppold, 84. Mies, 341. (2), Jordan, 27. See also *Dentists' Instruments*. *Fractures*, *Apparatus for Medical Walking Staff*. *Orthopedical Apparatus*. *Osteotom*. *Thoracitone*.
- SURVEYING INSTRUMENTS**—X. Crichton, 452. Davis, 70. Gerard, 100. William, 343. See also *Land-measuring Chains*. *Levels*, *Surveyors'*. *Road-measuring and Mapping Machine*. *Theodolites*.
- SURVEYORS' PLANS**—XVII. Wason (M.P.), 188.
- SUSPENDED ANIMATION (Apparatus for restoring)**—X. Small, 651.
- SUSPENSION-BRIDGE LINKS**—V. Howard, Ravenhill, & Co. 413. Patent Shaft and Axletree Company, 543.
- SUSPENSION BRIDGES (Models, &c.)**—V. Watts, 750. VII. Bell, 63. Clive, 41. Grout, 47. Hammond, 15. Renczynski, 27. Royal Scottish Society of Arts, 29. Russell, 78. Smith, 165.
- United States*, New York Iron Bridge Company, 511. See also *Kieff Suspension Bridge*.
- SUSPENSION TUNNEL (Model)**—VII. Smith, 165.
- SWAK**—Tunis, 137, 138.
- SWANSDOWN**—XI. Barnes, 40.
- SWANSKINS**—XII. & XV. Nicolls, 251. *Zollverein* (3), Lehmann, 107.
- SWIMMING-BELTS**—See *Life Belts and Buoyas*.
- SWIMMING-GLOVES**—VIII. Cooper, 334A.
- SWIVEL-BRIDGE ELEVATOR, &c.**—V. Leadbetter, 650.
- SWORDS**—VIII. Firmin & Sons, 211. Mole, 248. Reeves, Greaves & Co. 244. Wilkinson & Son, 200. XX. Firmin & Sons, 161.
- Austria*, Mitter, 529. Riedler, 110.
- China*, Berncastle. *Egypt*, 224, 252.
- France*, Delacour, 1592. *India*, I. VIII.
- Nova Scotia*, Archibald, 2.
- Russia*, Khamoff, 162. Ooste-Catchley-Ooste-All-Beck-Ogill, 163. Zlatoust Imperial Manufactory of Arms, 161.
- Spain*, Toledo Royal Ordinance, 266. Ysasi, 267. Zuluagn, 264A. *Sweden and Norway*, Ahlbeck, 73. Zetterberg, 10.
- Turkey*, *Tuscany*, Mariotti, 68A.
- Western Africa*, Ackland, Sir T. D., 17. Hutton & Sons, 6. Jamieson, 5m.
- Zollverein* (1), Hoeller, 637. Schmolz & Co. 673. Schnitser & Kirschbaum, 460. (4), Kuhl, 14. See also *Daggers*.
- SYDEROLITE WARE**—*Austria*, Bahr & Mareech, 612. Schiller & Gerbing, 614.
- SYMMETROMETER (for cutting Coats)**—XX. Jones, 149. See also *Measuring Apparatus*.
- SYMPHONIAN**—X. Wheatstone & Co. 520.
- SYMPHONOMETER**—X. Negretti & Zambra, 160A.
- SYRINOES, ROTATORY**—XXII. Siebe, 435.
- SYRUPS**—II. Greenish, 124. *Turkey*.
- TAAFFE'S PATENT SLATING**—VII. Russell, 78.
- TABINETS**—XII. & XV. Allen, 259. Jones, 265. Pim, Brothers, & Co., 255.
- TABLE CLOTHS, &c. (Linen, &c.)**—XI. Walmesley, 51. XIV. Andrews, 5. *Austria*, Mäthle, 287. Simon, ta, 291. *Belgium*, Hausens Hsp, 257. *Canada*, Bean, 137, 142. *France*, Daudre, 1170. *Hamburgh*, Arndt & Berend, 24. *Mecklenburg-Schwerin*, Gerber, 3. *Russia*, Dombrowitch, 355. Von Mengden, 222. *Sweden*, Stenberg, 94. *Switzerland*, Beck and Sons, 163. Fankhanser, Brothers, 163. Miescher & Sons, 163. Schmid, Brothers, 163. *Zollverein* (1), Eickholt, 549. See also *Damasks*, *Linen*. *Diapers*.
- TABLE COVERS (Silk, Cotton, Worsted, &c.)**—XI. McBride & Co., 6. XII. & XV. Baughen, Brothers, 183. McCrea, 135. Ward, 134. XIV. Birrell, 27. Dewar, Son, and Sons, 35. XVIII. Underwood, 22. Welch, 18. Yates & Taylor, 24. XIX. Cook, 135. Dewar, Son, & Sons, 150. Johnstone, 218. Stokes, 307. Victoria Felt Carpet Company, 327. White, Son, & Co., 343. Wood, H. & T., 352. *Austria*, Liebig, 241. Pfenniberger, 359. Prochaska, 244A. Wurrat, 302. *Canada*, Bean, 137. Henderson, 145. Lafamme, 116, 122. *Hamburgh*, Dissmar & Harloff, 25. *Persia*, Bidwell. Thompson. *Portugal*, Thomar, 1233. *United States*, Nicholson, 549. *Zollverein* (1), Karscheltz, 157. (3), Glasfey & Neubarth, 105. Schubert, 156. Seyffert & Breyer, 88. Thuemer & Toeper, 90.
- TABLE KNIVES**. See *Cutlery*.
- TABLE ORNAMENTS (Composition)**—XXIX. Keogh, 119.
- TABLES (CONSOLE)**—XXVI. Holland & Sons, 161. Le-cand, 183. McLean, 386 (Main Avenue, West). *Portugal*, Caetano, 1224. *Sardinia*, Da Fieno, 73. Descalzi, 72.
- TABLES (INLaid, PAPER MACHÉ, &c.)**—XXIII. Elkington & Co., I. Hancock, 112. XXVI. Abbott, 45. Clark, 179. Dawes, 135. Edwards, 247. Gillow & Co., 186. Grundy, 121. Harding & Son, 209. Herring & Sons, 205. Jordans, 384. Ker, 103. Lee, 133. Lithgow and Purdie, 106. Miles, 256. Price, 312. XXVI. Dixon, 190. Holbeard & Wellings, 131. Jenuens & Bettridge, 187 (Main Avenue, West). Lane, 128. McCullum & Hodson, 136. Mechi, 79. XXVII. Plows, 50. Woodruffe, 77. *Austria*, Becker & Kronick, 643. Mentasti, 635. *Belgium*, Branden, 511. Bruno, 411. Demauct, 402. *Ceylon*, Kitchin. *France*, Grade, 1254.

- Hamburgh, Bey, 73. Faulwasser, 71. Köhler, 72. Loose, 74. Müller, 76. Plambeck, 69. Werner & Pflügel, 79. *India*, xxvi. *Rome*, Dies, 34, 35. *Sardinia*, Blasso, Brothers, 69. Clando, 68. Magul, 70. Perelli, 66. *Spain*, Perez, 271A. *Switzerland*, Vogel, 226.
- Tuscany*, Corridi, 89. Martinetti, 88. *Van Diemen's Land*, Hamilton, 8. Lipsecomb, 308. *Zollverein* (1), Helmburger, 881. Puff, 775.
- TABLES (MARBLE, STONE, &c.)—xxvii. Champ-
pernowke, 6. Humble, 9. Lambert, 70. Moon, 56.
Pearson, 65. Plows, 50. Thornhill, 48. Tomliu-
son, 79. Woodley, 39. *Canada*, Hammond, 118.
Cape of Good Hope, 58. *Rome*, 38.
Tuscany, Guido De Conti, 93. Guidotti, 92. Nanni,
94. Panciatici, 96. Royal Technological Insti-
tute, 98.
Zollverein (1), Cantian, 235 (Main Avenue, East).
Devisse, 837. Stolberg Wernigfode, Earl of, 779.
- TABLES (METAL)—ix. Samuelson, 185.
- TABLES FOR MODELLERS, &c.—xxx. (Fine Art Court),
Palmer, 197.
- TABLES, RUSTIC—xxvi. Drew, 116. Warner, 72.
Bates, 44.
- TABLES FOR SHIPS' CABINS—viii. King, 19. Ladd, 80.
Austria, Hetch, 638.
- TABLES (Various)—ix. Starkey, 43. xxvi. Aspinwall
& Son, 213. Auldjo, Mrs., 405. Caldecott, 206.
Calder, 55. Chaplin, 214. Cresser, 289. Dawes, 135.
Dinham, 92. Eloure, 188. Fisher, 36. Foothorpe &
Co., 132. Gardner, 231. Geake, 31. Gillow & Co.
156. Greverie, 255. Harrold, 117. Hawkins, 237.
Herbert, 67. Herring & Sons, 205. Hockendon, 69.
Jennens & Bettridge, 187 (Main Avenue, West). Jones,
287. Marchant, 253. Morant, 164. Newton, 97.
Palmer, 59. Richardson, 207. Simpson, 267. Star-
key, 26. Turley, 138. Turnell, 317. White &
Parlby, 8. Whyte, 43. Wilson & Sons, 293. Wood,
118. xxix. Down, 56. xxx. (Fine Art Court)
Fletcher, 111. Wilkinson, Sir G., 139.
Austria, Colombo, 630. *Belgium*, Dorin, 429.
British Guiana, Bee, 158.
Canada, Hilton, J. & W., 123. Ramsay & McArthur,
117. Read & Meakin, 115A. *Ceylon*, Kitchin.
France, Balny, 1066. Grade, 1254.
Hamburgh, Köhler, 72. *New Zealand*, Lucas, 40.
Russia, Schoenfeldt, 375.
Sardinia, Capello, 64. *Switzerland*, Finekk, 224.
United States, Doe, Hazelton & Co., 418. South Caro-
lina Railroad Company, 177.
Van Diemen's Land, Brown, 16, 16. Champion, 12.
Denison, Sir W. T., 149-151. Lumsden, 145, 146.
Zollverein (1), Sommerfeld & Hubner, 238.
- TABLE-TOPS (Marble, &c.)—xxiv. Jones, 44. Mathieson,
120. xxvi. Mousley, 123. Wells & Co., 392.
xxx. (Fine Art Court) Earle, 49.
British Guiana, Bee, 82, 83. *Malta*, Darmanin & Sons,
26. *New Zealand*, 38.
Tuscany, Maggiorelli, Brothers, 87. Polli, 85. Ragnini,
86. *Van Diemen's Land*, Brown, 15.
Zollverein (1), Cantian, 235.
- TABLETS (Glass, &c.)—xxiv. Aire & Calder Bottle Co. 8.
xxx. (Fine Art Court) Herwitz, 347.
Western Africa, Jamieson, 22.
- TAFFETAS—xiii. Redmayne & Co. 1A. xix. Ball & Co. 19.
Egypt, 301, 326, 334-335.
Russia, Ayrapet, 201. Iraf-Ogli, 207. Tedjoom-Beck-
Melik-Shah-Nazroff, 206.
Sardinia, Soley, 40.
Switzerland, Von Der Muehl, Brothers, 162. *Turkey*.
- TAILORS' ARM-PAD—xxviii. Collings, 120.
- TAILORS' MEASURING &c. APPARATUS—x. Thompson,
363. xx. Cattanach, 135A. Griffin, 117. Jones, 149.
Robinson, 149A. Smart, 135.
- TAILORS' TRIMMING—France, Laurent, 902. Leu-
nenschloss, 313.
Zollverein (3), Muehlenderlein, 157. Oehmig & Schmidt,
154. Uhlig's Widow & Junka, 155.
- TALBOTYPE PROCESS—See *Calotype Apparatus*. *Calotype*
Process.
- TALC—v. Riddell, 6. *India*, 1.
United States, Ruggles, 46.
- TALLOW—Belgium, Futeux, 131.
New South Wales, Moses & Co. 13.
South Africa, 38.
Tunis, 185. *Turkey*, *United States*, Dominick, 2.
Van Diemen's Land, Watchorn, 14.
Zollverein (1), Palis, 263. See also *Stearine* and *Engle-*
table.
- TALLOW OIL—Zollverein (1), Palis, 263.
- TAMARINDS—Egypt, 64.
- TANKS—xxii. Burney & Bellamy, 633. See also *Cis-*
terna.
- TANNERS' BARK-GRINDING MILL—vi. Huxhams & Brown,
446.
- TANNIC ACID—ii. Macfarlan & Co. 107. Morson & Son,
106.
- TANNING MATERIALS—ii. Hopkin & Williams, 41. iv.
Curtis, Brothers & Co. 126. Kitchin, 126A. xvi.
Bouchier, Mortimer, & Co. 293.
Canada, Allou, 100. *India*, iv.
New Zealand, McVay, 5.
Trinidad, Lord Harris. *Tunis*, 137. See also *Barks*.
Leather-making Tools, &c. *Oak Bark*.
- TANNING MATERIALS (Instrument for Testing)—x. Evans,
670A.
- TAPER & LACES—Zollverein (1), Wuefing & Windrath, 565.
- TAPESTRY—xii. & xv. Underwood, 501. xix. Batters,
96. Benbow, 100. Bridges, 108. Bright & Co. 401.
Brinton & Sons, 110. Chapman, 128. Harnsworth,
181. Hindhaugh, 205. Hull Patent Camphine Co.,
264. Lees & Co., 79. Pardoe, Hoomans, & Co., 263.
Trollope, 320. xxvi. Craze, 530.
France, Beauvais, National Manufacture of, 1367.
Braguenie & Co. 435. Carquillat, Caidy & Co. 1134.
Gentiloo, 1241. Gobelins, National Manufacture
of, 1366. Lyons Chamber of Commerce, 1141. Sal-
landrouze de Lamornaix, 1469. *India*, xviii.
Jersey and *Guernsey*, Le Feuvre, 11A.
Persia, Edle & Son.
Russia, Imperial Alexandrovsk Mannfactory, 210, 219.
Zollverein (1), Flammersheim, 395. Weygold, 429. (3).
Beck, 149.
- TAPESTRY (Designs for)—xix. Underwood, 403.
Zollverein (4), Tanner, 51.
- TAPIOCA—iii. Etienne, 138. *Grenada*, Grose, 1. *India*, iii.
Portugal, Bataha, 543.
- TAPS—See *Cocks* or *Taps*.
- TARAXACUM, JUICE OF—ii. Bell, 116.
- TARBOUCHES OF TOBACCO—Egypt, 302-304.
- TARGET, MARINE—viii. Browning, 103.
- TARPAULIN—vi. Brown, 56. xiv. Anderson, 86. Beale
Brown, 77. Bridport Local Committee, 73. Can-
ter, 36. Carter, Brothers, 36. Edgington, 90. Fletch-
er, 36. Hattersley & Co. 36. Huxworth & Carnley,
36. Jackson & Matthewman, 36. Pigott & Newton,
36. Salmond, 83. See also *Canvas*. *Rickcloths*.
- TARTANS (Woolen & other)—xi. Anderson, J. & A. 7.
xii. & xv. Archibald & Sons, 465. Ballantyne & Son,
194. Forbes & Hatchison, 291. Gibson & Co. 464.
Gill, 190. Gilmour & Co. 203. Laird & Thomson,
199. Locke, 15. McBride & Co. 6. Paton, J. & D.
466. Willans & Co. 257. Wilson & Son, 468. See
also *Plaids*.
- TARTARIC ACID—Howards & Kent, 11. Huskisson, J. W.
& H. 86. Pontifex & Wood, 1.
Austria, Brosche, 20. Wagenmann & Co. 10.
Portugal, Serzedello & Co. 504.
- TATTING—xix. Ellis, 159.
- TAZZA (of Iron, Alabaster, &c.)—France, Matifat, 923
(Main Avenue, East).
Rome, Mola, 19. (Main Avenue, East).
- TEA—iii. Assam Tea Co. 143.
China, Reeves. Hammond & Co. Ripley. *India*, iii.
TEA CANNIES—xxii. Fearncombe 160A. xxvi. Newton,
C. North, 257. xxviii. Bevan, 171. Day, 169.
- TEA CHESTS—xxix. Mechi, 45.
- TEA-DEALERS' AND GROCERS' SHOW-GOODS (for deco-
rating Shops)—xxvi. Seroxton, 271.
- TEA EQUIPAGE (Travelling)—xxix. Leuchars, 44.

- TEA KETTLES (Patent & other)—VII. Williams, 128. IX. Hodges & Sons, 116. XXII. Durham, 614. Fearncombe, 160A. Hodges & Sons, 487. Pyrke & Sons, 465. Soutter, 354. Torr, 289. Walton & Co., 69. Canada, Savage, 340. See also *Hardware*.
- TEA-LEAVES (Untwisted)—China, Hammond & Co.
- TEA UENS—XXII. Hampden, 612. Pyrke & Sons, 465. Soutter, 354. Tylor & Sons, 401. Warner & Sons, 798.
- Denmark, Wulff, 23.
- TEETH, ANIMALS' (Various)—*Eastern Archipelago*, Hammond & Co., 2. *South Africa*, Thomson, 15. *Van Diemen's Land*, Moses & Co., 228.
- TEETH, ARTIFICIAL—See *Dentistry*.
- TEETH, NATURAL (Specimens of)—X. Harriet, 684. *United States*, Evans, 558.
- TELEGRAPH, MARINE (Drawing of a System of Sea Signals)—VIII. Dempster, 174.
- TELEGRAPH REGISTERS—*United States*, Rogers, 127.
- TELEGRAPHIC BELTS—Zollverein (1), Siemens & Halske, 252A.
- TELEGRAPHIC LIGHTHOUSE—VII. Wells, 82.
- TELEGRAPHS, CHEMICAL—Zollverein (1), Siemens & Halske, 252A.
- TELEGRAPHS, DOMESTIC—X. Burdett, 425.
- TELEGRAPHS, ELECTRIC—See *Electric Telegraphs*.
- TELEGRAPHION OR SPEAKING TELEGRAPH—X. Whlahaw, 419.
- TELESCOPES—X. Boyle, 392. Callaghan, 268. Chadburn, Brothers, 259. Crichton, 452. Dixey, 271. Elliott & Sons, 320. Harris & Son, 149. Marratt, 409. Hein, 629. Richardson, 264. Ross, 254 (Main Avenue, West). Salmon, 266. Varley & Son, 257. Wray, 309. Zollverein (4), Kinkellbach, 26. See also *Astronomical instruments*.
- TELESCOPE GLASSES—X. Harris & Son, 149. Reade, 254A.
- TELESCOPE STANDS—X. Crichton, 267. Renczynski, 661.
- TEMPER PROGNOSTICATOR—X. Merryweather, 151.
- TEMPLE CHURCH (Model)—XXX. (Fine Art Court) Day, 161.
- TEMPLES, MODELS OF—XXX. (Fine Art Court) Fulton, 169. India, xxx.
- TENNIS RACQUETS—XXIX. Jeffries, 184.
- TENTS AND MARQUEES—Eastern End (Outside), Jubulpore School of Industry, (India, VIII.) VIII. Duthoit, 301. Richardson, 285. XIV. Morrison & Hurn, 49. Tunisia, 82.
- TERRA COTTA (Specimens of, Articles in, &c.)—Willock, page 853. 1. Bank Park Pyropolite Works, 86. XXV. Bell & Co. 26. Dimmock, 12. Marsh, 58. Meigh & Sons, 10. Minton & Co. 1. Pratt & Co. 22. XXVII. Bell & Co. 96. Betts, 22. Blanchard, 92. Doulton & Co. 23. Fernley Iron Works, 102. Minton & Co. 86. Pulham, 108. Willock, 8. XXX. (Fine Art Court) Pulham, 216. Saugiovanni, 83.
- France, Devers, 818. Fox, 1232. Graillon, 853. Holstein, 876.
- Spain, Gutierrez de Leon, 281A. Pena, 282.
- Zollverein (4), Staib & Wasseroff, 69.
- TERRALITE WARE—Austria, Hoffzky, 613.
- TERRO-METALLIC ARTICLES—XXVII. Jones, 105. Peake, 123.
- TESSELLATED WORK—I. Mcredith, 141.
- TETRAGONS PORROGRAPHES—France, Reay, 142.
- THAMES TUNNEL (Model)—VII. Donkin & Co. 46.
- TREATISE, HER MAJESTY'S, Model of the Interior of—Deighton, page 818.
- THEODOLITES—VI. Muir, 206. X. Crichton, 452. Elliott & Son, 320. Marratt, 409. Watkins & Hill, 650. Wilton, 402. Yates, 332.
- Austria, Vienna Polytechnic Institute, 130. Canada, Joseph, 182.
- THERMO-ELECTRIC BATTERY—Zollverein (1), Svess, 482.
- THERMOMETERS—X. Acland, 368. Baker, 396. Bennett, 1. Brooke, 144. Cameron, 356. Casello & Co. 157A. Dixey, 271. Durham, 668. Green, 416. Harris & Son, 149. Jones, 141. Negretti & Zambra, 160A. Newman, 674. Phillips, 411.
- Zollverein (5), Albert, 23.
- TRIMBLES (Ventilated)—XXII. Marsden, 531.
- TRIETHERS—Portugal, Holbeche, 544.
- THORACITONE (Medical Instrument)—X. Barker, 649.
- THRASHING-MACHINES—V. Dodds & Son, 64. IX. Blyth, 154. Carpenter, 30. Clayton & Shuttleworth, 242. Crosskill, 135. Davis, 46. Garrett & Sons, 142. Gray & Sons, 150. Heenan & Son, 149. Holmes and Sons, 241. Hornby & Son, 233. M'Cartney & Drummond, 248. Ransomes & May, 124. Rudd, 157. Sargent, 29. Smith, 256.
- THREAD COUNTER, OR LINEN PROVER—X. Willats, T. & H. 265.
- THREAD AND COTTON, SEWING. See *Sewing Thread*.
- THREAD AND PAPER (British Vegetable Fibre for the Manufacture of)—IV. Robertson, 61.
- THREADS, SHOEMAKERS' AND SADDLERS'—XIV. Ullathornes and Longstaff, 66.
- THREADWORK—Portugal, 1165, 1166. See also *Needlework*.
- THRONE, AFRICAN CHIEF'S—Western Africa, Hutton & Sons, 6.
- THROTTLES FOR SPINNING—VI. Booth & Co. 2. Sharp, Brothers, 15.
- TICKET-PRINTING, &C. MACHINES—VI. Church & Goddard, 135. Schlesinger & Co. 168.
- France, Baranowski, 15. See also *Railway-ticket Dating-machine*.
- TICRINO (for Bedding, &c.)—Belgium, Derouhaix, 239. Marynen Vues, 227. Verriest, 214.
- France, Sanson, 366. Verrie, Brothers & Danser, 1006. Tallandier, 387.
- Netherlands, Theunissen, 39.
- Portugal, Scotch Linen Trade, 705, 706. Torres Novas Co. 668.
- Zollverein (1), Schraidt & Co. 732. Stiller & Son, 127.
- TIDAL INDICATOR—X. Hyles, 190.
- TIDAL STAIRCASE—VII. Russell, 78.
- TIDE GAUGES—X. Hewitson, 152.
- TILES, ENCAUSTIC—I. Quillam & Creer, 151. XXV. Minton & Co. 1. XXVII. Allen, 68.
- TILES FOR ROOFING, &C. (Various)—I. Roake, 60. IX. Enniskillen, Earl of, 232. Grimsley, 136. XXVI. Minton, 531. XXVII. Griffiths & Strong, 67. Key, 126. Brown, 117. Jones, 105. Lovelace, Earl of, 87. Luft, 111. Minton & Co. 86. Scaley, 130. Austria, Miesbach, 610.
- France, Ameller, 405. Fox, 1232. Roger, 1448. Thibault Bollewe, 1502.
- Spain, Gonzalez y Yalls, 55. Tegr & Co. 54. See also *Drain-Tiles and Pipes*.
- TILE, &C. MACHINES—IX. Cottam & Hallen, 109A. Dean, 4. See also *Brick & Tile Machines. Drain-Tile and Pipe Machines*.
- TILL (to prevent Fraud)—XXII. Nixey, 640.
- TILLAGE-MACHINE AND IRRIGATOR—IX. Hurcham, 239B.
- TILLERS, SHIPS'—VIII. Denham, 72. Robertson, 18. See also *Rudders. Steering-apparatus for Ships*.
- TIMBER (Specimens of)—Main Avenue, West, IV. Grigor & Co. 1.
- Canada, Davis, 78. Henson, 79. Montreal Commission, 80. Parisault, F., 77. Parisault, J., 76. Reed & Meakins, 75. India, IV. *New Brunswick. New South Wales*, Bogue, 2. Francis, 5. *Turkey. Van Diemen's Land*, Demison, Sir W. T., 1-5, 73-77, 338-340. Euston & Milligan, 105, 106. Hood, 111-120. Hull, 208, 217-220. Watson, 346.
- Western Africa, Weston, 1. See also *Woods*.
- TIMBER GAUGE, &C. (for measuring standing Timber)—X. Adenck, 364. Davidson, 385.
- TIMBER-LIFTING APPARATUS—VIII. Etrick, 327.
- TIMBER ROOF (Model)—VII. Giles, 71.
- TIMBER-SEASONING APPARATUS—VI. Hart, 468. Ransomes & May, 146. Squire, 467. XXVI. Squire, 273. See also *Burntized Timber. Wood, Seasoned*.
- TIMBER VIADUCT (Design for)—VII. Rose, 180.

& Zamora, 160A.
 531.
 Barker, 640.
 n, 64. ix. Blyth,
 ttleworth, 342.
 t & Sons, 142.
 n, 149. Holmes
 293. M'Cartney
 ay, 124. Rudd,
 —x. Willats, T.
 ewing Thread.
 le Fibre for the
 EN'S—xiv. Ulla-
 See also Needle-
 Africa, Hutton &
 & Co. 2. Sharp,
 Church & God-
 ny-ticket Dating-
 Deroubaix, 239.
 & Danser, 1006.
 06. Torres Novas
 Stillier & Son,
 151. xxv. Min-
 Roake, 60. ix.
 ley, 136. xxvi.
 Strong, 67. Key,
 oveance, Earl of
 Sealey, 130.
 oger, 1448. Thi-
 Co. 54. See also
 len, 109A. Dean,
 Drain-Tile and
 640.
 Dorcham, 259n.
 bertson, 18. See
 or Ships.
 West, iv. Grigor
 Montreal Com-
 arisant, J., 76.
 ew Brunswick.
 5. Turkey.
 T., 1-5, 73-77,
 Hood, 111-120.
 oods.
 ling Timber)—
 ck, 327.
 rt, 468. Ran-
 xxvi. Squire,
 Wood, Sea-
 e, 180.

TIMEPICKERS. See *Clocks and Timepieces*.
TIMEPIECE STANDS—x. Gradt, 46.
TIN—i. Hird & Co. 411. Welborne, 455. xxii, Perry,
 61. Terry & Son, 691.
Austria, Vienna Imperial Mines, 2.
France, Robert & Co. 1440.
Russia, Perm Imperial Copper Works, 6.
Spain, Lugo Mines, Sub-Inspector of the, 18.
United States, Prosser, 594, 595.
 Zollerlein (1), Lewy, Brothers, 198.
TIN, MURIATE OF—*Russia*, Schlippe, 27.
TIN ORE—i. Bolltho, 440. Colo, 504. Diamond, 457.
 Phillips, Smith, & Co. 500. St. Austell Local Com-
 mittee, 469. Secombe, 454. Welborne, 455, 470.
India, 1. See also *Wolfram*.
TINCTURES—ii. Greenish, 124.
TINFOLI—*France*, Jandin, 887. Robert & Co. 1440.
TINFLE MANUFACTURERS—i. Hiddulph, 417.
TINFLE-WORKERS TOOLS—xxii. Jackson, 311.
TIN-POWDER—Zollerlein (1), Krimmelbein and Bredt,
 457.
TIN-SMELTING MACHINERY—i. Bolltho, 440.
TIN-STONE—i. Headwin, 456.
TIN-WARE—i. Truro Local Committee, 468. Welborne,
 455. xxii. Griffiths, 254. Perry, 61. Terry &
 Son, 691A. Walton & Co., 69.
Austria, Hirsche, 436. *France*, Delignon, 1180.
Western Africa, Jamieson, 22.
 Zollerlein (1), Lewy, Brothers, 198. Zobel, 195.
TIN-WARE (Method of Ornamenting)—xxii. Aubin, 683.
TINNED SHEET-IRON—xxii. Cornforth, 323.
Austria, Kieist, 424. Privileged Association of Manu-
 facturers, 423. Zollerlein (1), Assman, 406.
TINSEL ORNAMENTS—*France*, Noel, 1669.
TINTEAN ARNEY (Models of)—xxx. (Fine Art Court),
 Lewis, 143. Morgan, 266.
TIP TREE-HALL FARMERY, KELVEDON (Model)—xxx.
 (Fine Art Court) Mechi, 220.
TIRE BARS—v. Dodds & Son, 64.
TISSUE PAPER—*China*, Copland.
 Zollerlein (1), Hoesch & Son, 392. See also *Pottery*
Tissue Paper.
TISSUES (for Furniture, &c.)—*France*, Dauchel, 154.
 Hess, 263. Mourceau, 1663.
Tuscany, Catanzaro, 64. Manetti, Brothers, 61.
TOBACCO—iii. Benson, 39. Bremner & Till, 41. Cohen
 & Orr, 49. Hyman, 46. Jonas, Brothers, 42. Lambert
 & Butler, 40. Richardson, Brothers, 52. Taylor, 45.
Algeria, Andre, 1. Dupre de St. Maur, 23. Morin,
 39. Oxeda & Aqul, 40. Reverchon, 44.
Belgium, Billiard, 70. Brovello, 72. Lahousse, 80.
 Flaideau, 71. Verschave, 79. *Canada*, Levey, 73.
Ceylon. *Egypt*, 37.
Greece, Athanas'ou, 9. Cacoulidis, 11. Lapas, 10.
India, 111.
Netherlands, Linden, 60. *Persia*, Hudson. Thompson.
Russia, Dovidinsky, 77. Eydaroff, 75.
South Africa, Moss, 36.
Spain, Manila, Society of, 250A.
Trinidad, Lord Harris. *Tunis*, 49, 88. *Turkey*,
United States, Cooke & Sons, 318. De Ford & Co. 528.
 Dill & Muchahay, 273. Grant, 284. Hardgrove, 268.
 Luuilaud, 389. Monahan & Beers, 349. Mooklar &
 Childs, 8. Owens, 319. Oyler & Anderson, 305.
 Robinson, 265. Stewart & Co. 393. Stratton, 182.
 Warwick & Otey, 325. Whitlock, 369.
Van Diemen's Land, Denison, Sir W. T. 24.
 Zollerlein (1), Carstanjen, 468. (6), Mueller, 11. See
 also *Cigars*. *Snuff*.
TOBACCO BOXES—See *Snuff & Tobacco Boxes*.
TOBACCO PIPES, BOWLS, TUBES, &c.—i. 127A. xxii.
 Mitchell, 611. xxv. Leitch & Hammond, 59. South-
 or & Co., 29. Yerbury, 208.
Ar tria, Biodek, 660. Einstaller, 669. Floge, 670.
 Hartmann, 675. Infanger, 676. Lang, 661. Litschke,
 678. Partsch, 611, 662. Petschacher, 68°. Tren-
 ner, 663. Wojtech, 686.
Egypt, 278, 279, 363, 364. *Hamburgh*, Wöbke, 39.
Sardinia, Struss, 80. *Tunis*, 162.
 Zollerlein (1), Ziegler, Brothers, 784. (2), Held, 65.
 (3), Muhlenbach & Thewahl, 10. Windgender, Bro-
 thers, 9. See also *Smoking Pipes*.
TOILET BOX—xxix. Johns, 61.
TOILINETS—Zollerlein (4), Hecht & Arnold, 27. Weigle,
 29.
TOMBAC—*Egypt*, 26.
TOMBS (Designs for)—xxx. (Fine Art Court) Truefit,
 75. Webber, 110. See also *Sepulchral Monuments*,
Stone Tombs.
TONNAGE IN SHIPS (Plan for Measurement of)—viii.
 Watson, 76.
TONQUIN BRAN—*British Guiana*, Stutchbury, 118, 118A.
Trinidad, Lord Harris.
TOOLS (Carpenters' & other Edge Tools)—i. Selly &
 Co., 410. vi. Maillou, 407. xxi. Hannah, 31.
 Mathieson & Co., 35. xxii. Armitage, M. & H.,
 180. Atkin & Son, 365. Higgin & Sons, 312.
 Bloomer & Phillips, 176. Briggs, 145. Brookes &
 Son, 110A. Brown & Sons, 182. Butcher, W. & S.,
 192. Chambers, 807. Coker & Son, 115. Cütler,
 217. Jowett, 170. Marjules, 128. Marsden & Co.
 169. Morrison & Parker, 179. Spear & Jackson,
 113. Sorby & Sons, 204. Warburton, 187. Ward &
 Payne, 196. *Algeria*, Soutal, 52.
Austria, Feldbauer, 453. Hanser, 482. K' ant,
 569. Metz, 485. Reindo, 493. Schmidhauer, 455.
 Seiler, 570. Weiss & Son, 572. Weisbach, 571.
 Wertheim, 573.
Canada, Ladd, 181A. Leavitt, 150. Scott, 148. Shaw,
 149. Wallace, 147.
France, Goldenberg & Co. 1737. *Hamburgh*, Ritter,
 43.
India, vi. xxi. *Nova Scotia*, Archibald, 2.
Russia, Skaliki, 347.
Sweden, Skalhberg, 84.
United States, Simmons & Co. 119.
 Zollerlein (1), Arns, 626, 627. Braunschweig, 621.
 Christian, 624. Huth, Fiedl, & Co. 632. Post, 618.
 Urschloe & Sons, 614. See also *Saws*.
TOOLS, SUETWEIGHTS—*Canada*, Montreal Commission,
 80.
TOOLS (Various)—xxi. Baker, 20. Belcher, 42. Carr &
 Riley, 108. Hill, 47. Macpherson, 36. Moseley &
 Son, 13. xxii. Blake & Parkin, 193. Flatner, 16.
France, Dandoy, Goldenberg & Co., 851, 1737. Lem-
 seigne, 1728. Maillard, Lucq, & Co. 491.
Russia, Ekaterinburg Engine Factory, 168.
Switzerland, Keigel, 3.
United States, Bliss & Co. 415. Brown & Wells, 259.
Van Diemen's Land, Milligan, 180.
 Zollerlein (1), Brand, 620. Braunschweig, 621. Felde,
 625. Hasandever & Sons, 631. Hilgers & Sons, 631.
 Luchhaus & Co. 631. Post, 618. (4), Goebel, 68.
TOOTH FORCEPS—See *Dental Instruments*.
TOOTH-PICKERS—*Portugal*, 543-551.
TOOTH POWDER—*Switzerland*, Gimper, 272. Soutter, 51.
United States, Cummings, 452. See also *Perfumery*.
TOOTH-POWDER BOX—xvi. Allen, 36.
TOPOGRAPHICAL PAINTING—xxx. (Fine Art Court)
 Caplin, 221.
TORMALINE—*Tuscany*, Annunciat, 17.
TORNOROGRAPHY (Specimens of)—xxx. (Fine Art Court)
 Martin, 282.
TORTOISESHELL & TORTOISESHELL ARTICLES—*Ceylon*,
Eastern Archipelago, Hammond & Co., 2. *France*,
 Philip, 680.
Trinidad, Lord Harris.
TOURNIQUETS (RAILWAY)—x. Brown & Son, 627.
TOW—iv. Trent, 41. *Rome*, Biancoucini, 4.
Russia, Alexandrovsk Imperial Manufactory, 19.
 Ardamatsky, 98. Bukhareff, 104. Zempsoff, 115.
 Zollerlein (1), Hornig, 722. See also *Flax*. *Hemp*.
Ropes, *Cordage*, &c. *String & Twine*.
TOW-BAIS—xiv. Lockhart & Sons, 57.
TOW-BOAT—*France*, Lebel, 1300.
TOW-SHEETING—xiv. Carr & Co. 88.
TOW-VITRIF—xiv. Salmond, 83.
TOW-YARN—xiv. Gordon, G. & A. 82.
TOWELLING—xi. Christy, 44. McBride & Co. 6. xiv.
 Canter, 36. Capper & Son, 95. Carter, Brothers, 36.

- Fletcher, 36. Hattersley & Co., 36. Haxworth & Carnley, 36. Jackson & Matthewman, 36. Pigott & Newton, 36. Row, 45.
- Austria, Harrach, 235. *Sardinia*, Borzone, 45.
- TOWER OF LONDON, after the Destruction of the Armoury (Model)—VIII. Hall, 271.
- TOYS (Various)—XXIX. Bursill, 216. Montanari, 122. Spurin, 126. Trebeck, 200.
- Austria, Hallers, 652. Kietabl, 653. Muller, 654. Pirger, 655. *China*, Hewett & Co.
- Hamburgh, Lowenthal & Co. 91. *India*, XXVIII.
- Zollverein (1), Bahn, 256. Gerlach, 252. Kummer, 817. Scheller & Weber, 663. Soehle, 265. (2), Eichner, 80. Issmayer, 26. Lang, 77. (3), De Buensu, 35. (4), Blumhardt, 94. Buhner, 59. Dieterich, 96. Knosp & Bache, 27. Rock & Grauer, 98. Rominger, 95. Wittich, Kimmel & Co. 82. (5), Albert, 23.
- TRACING-MACHINE—X. Stephenson, 674A.
- TRAFALGAR, BATTLE OF (Model)—VIII. Constable, 140.
- TRAM-ROADS (New Mode of Paving Streets, &c., by Trams)—VII. Geary, 2.
- TRAME—Austria, Cluavilla, 71.
- TRANEEN GRASS, PLAITED—XX. Pensants of Wexford, 181.
- TRANSIT INSTRUMENTS—See *Astronomical Instruments*.
- TRANSPARENCIES—Zollverein (1), Trimpelmann, 789.
- TRANSPARENT CLOTH—France, Husson, 542.
- TRANSPARENT MUSIC (used in Teaching)—X. Groome, 549.
- TRANSPARENT SHADES—Zollverein (1), Schmidt, 809.
- TRANSPARENT SILK—XIX. Caley, J. W. & F. 119.
- TRANSPARENT WRITING—Netherlands, Foon, 113.
- TRANSPLANTING MACHINES—IX. Bates, 186. See also *Tree-Remover*.
- TRAPS, PIGEON-SHOOTING—XXII. Robertson, 565.
- TRAPS FOR RABBITS—XXII. Gray, 571.
- TRAPS, RAT—XXII. Robertson, 565.
- TRAPS FOR STREET DRAINS—See *Sewer Traps*.
- TRAVANCORE'S, RAJAH OF, STATE PALANQUIN (Model)—India, v.
- TRAVELLERS' STAFFS—XXVIII. Hodges, 72.
- TRAVELLING BELTS—Egypt, 299.
- TRAVELLING CASES—XVI. Byam, 23. Harrows, 43. Smith & Son, 31. XVII. Byam, 144.
- TRAVELLING POUCHES—Austria, Bubenick, 120.
- TRAVELLING JACKS—V. England, 484.
- TRAYS—Egypt, 350-352.
- TREE-GUARD—IX. Uphill, 277.
- TREE REMOVER (for Transplanting large Shrubs & Trees)—IX. Seaward, 51.
- TREE SUPPORTERS—IX. Restell, 208.
- TREES—Spain, Castellon Agricultural Board, 132.
- TRIGONOMETRICAL INSTRUMENTS—X. Gerani, 109.
- TRIGONOMETRICAL MACHINES FOR MARKING OUT CLOTHING—X. Thompson, 363.
- TRIMMING CARDING MACHINES—VI. Steane, 70.
- TRIMMINGS, GIMP, &c.—XIII. Browett, W. & H. 80. XIX. Kightley, 123. Franc, Julien, 1280.
- TRINKETS. See *Gold & Silver Wares. Jewellery. Precious Stones*.
- TRINITY COLLEGE, CAMBRIDGE (Model)—XXX. (Fine Art Court), Brooker, 109.
- TRIPDS—XXVI. Jones, 287.
- TRITURATING STRAINERS—XXII. Kent, 553.
- TRITURATORS—VI. Mackenzie, 314.
- TROENE—Egypt, 65.
- TROMBONES—Belgium, Mahillon, 175. France, Courtois, 463. 1163. Ganbot, 844.
- TROWER STUFFS (Undescribed)—Belgium, Lemaire-Deschamps & Pliasant, 240. Lienart-Chauffaux, 242. Petit Noel & others, 246-250.
- TRUMPETS & HORNS—X. Oates, 520. Austria, Hell, 15a. Belgium, Mahillon, 175. France, Courtois, 463. 1163. Gaubot, 844. India, x. Sweden, Ahlberg, 72. Switzerland, Huebscher, 86. Zollverein (2), Pfaff, 35. (3), Glier, G. 21. Glier & Son, 20. Herold, 19. Klemm, 18. Schuster, L. 22. Schuster, M. 23. See also *Cornet-a-Pistons*.
- TRUNKS, PORTMANTEAUS, &c.—VIII. Etrick, 327. XVI. Finnigan, 29. James, 40. Jimison, 28. Kane, 62. Last, J., 33. Last, S., 38. Lenny, 27. Meller, 73. Motte, 37. Weir, 72. xx. Thomas & Brothers, 46. XXVI. Pratt, 403. XXIX. Purdon, 39.
- Austria, Groshopp, 343.
- Canada, Dean, 102. Irwin, 196.
- Spain, Morella Corporation, 232.
- United States, Hickey & Tull, 58. Hill, 364. Mattson, 50. *Van Diemen's Land*, Rout, 152.
- Zollverein (1), Scheller & Weber, 663.
- TRUSSES, BANDAOS, &c.—X. Atkinson, 605. Blackwell, 734. Bourgeaud, 566. Bunney, 606. Coles, 560. England, 567. Ellis, 631B. Huxley, 598. Lindsey, 613. Longdon & Tubberer, 572. Miles, 568. Newson, 675. Offord, 680. Salmon, Ody & Co., 594. Salt & Son, 628. Spratt, 612. Smith, 573. Tod, 589. White, 587, 687. Wood, 737. xxii. Hilliard & Co., 34. XXII. Wright, 177.
- France, Burat, Brothers, 79. Charbonnier, 115. Spain, Jaren, 249.
- TUBES AND TUBING (Metal)—XXII. Bolton, 353. Everitt & Son, 352. Lloyd, 357. Mapplebeck & Co., 370. Massey & Co. 416. Winfield, 373.
- TUBES, WHISPERS—X. Rein, 629.
- TUBULAR BRIDGES (Drawings, &c., of)—VII. Bain, 34. Sankey, 32.
- TUNBRIDGE WARE—XXIX. Hollamby, 41. Russell, 40.
- TUNING FORKS—X. Greaves, 503.
- TURBINE (Model of a)—France, Fromont, 220.
- TURF OR PEAT—See *Peat*.
- TURMERIC—II. Marshall, 68.
- British Guiana, Stutchbury, 28. 30. Ceylon, China, Trinidad, Lord Harris.
- TURNING LATHES AND TOOLS—See *Lathes*.
- TURNING, PATTERNS FOR—Hamburgh, Jantzen, 83.
- TURNING IN WOOD, &c. (Specimens of)—VI. Holtzapffel & Co., 232. XXVI. Fleet, 24. XXVIII. Hemphill, 153. Johnson, 15. Mifford, 167. Austria, Kraft, 677. Canada, Bailey, 293. Dodd, 294. Parkes, Brothers, 186. Switzerland, Meystre, 225. Turkey, United States, Everett, 427. *Van Diemen's Land*, Brown, 199. Milligan, 200-206, 227.
- Zollverein (2), Baader, 74. See also *Ivory Carving and Turning*.
- TURNIP-CUTTING MACHINES—IX. Burgess & Key, 237. Carson, 110. Crosskill, 135. De Porquet, 202. Digges La Touche, 263. Hay, 259c. Holmes & Sons, 241. Key & Mitchell, 237. Marychurch, 93. Palmer, 48A. Phillips & Co., 252. Samuelson, 185. Smith, 256. Wedlake & Co., 127. Canada, Montreal Central Commission, 93.
- TURNIP DIBBLERS—IX. Digges La Touche, 263.
- TURNIP PLANTS, PREPARATION FOR PRESERVING—II. Sturges, 88.
- TURNIP-SOWING MACHINE—IX. Wilson, 249.
- TURNIPS—III. Sutton & Sons, 112.
- TURPENTINE—France, Flemyr, 214. Russia, Lisinsk Forest Institution, 83. Spain, Flores, Calderon & Co., 241. United States, Jamison, 173.
- TUSKS, ELEPHANTS'—See *Elephants' Teeth and Tusks*.
- TWEEDS (for Trussing, &c.)—XII. & xv. Allen, 259. Ballantyne & Son, 194. Bliss, 270. Bowman & Son, 231. Brown & Co., 469. Byers & Son, 232. Clapperton, T. & G., 193. Cochrane, J. & W., 188. Crombie & Co., 228. Dalrymple, 240. Dixon, R. & T., 187. Gilmour & Co., 203. Hartley & Son, 61. Inghis & Brown, 191. Lambert, 30. Locke, 15. Macedonia, 260. Morton, 160. Roberts & Co., 480. Sanderson & Sibbald, 189. Sime & Co., 195. Watson, J. & A., 477. *Van Diemen's Land*, Denison, Sir W. T. 136.
- TWINE—See *String, &c*.
- TWINE CANVAS—XIV. Moore, 67.
- TWIST—XIII. Also, Robins & Co., 48. Portugal, Rio Vizello Co., 723. Russia, Rabeneck, 173A. Zollverein (1), Lueddorff & Co., 584. (3), Hoeffler, 41.

327. xvii.
 28. Kane, 62.
 27. Meller, 73.
 & Brothers, 46.
 99.
 364. Mattson,
 2.
 605. Blackwell.
 606. Coles, 660.
 598. Lindsey,
 2. Miles, 568.
 n, Ody & Co., 594.
 h, 573. Tod, 589.
 r. Hilliard & Co.,
 onnier, 115.
 ton, 353. Everitt
 beck & Co., 370.
)—vii. Bain, 34.
 11. Russell, 40.
 nt, 220.
 Ceylon.
 thes.
 Jantzen, 83.
 —vi. Holtzapffel
 iii. Hemphill, 158.
 ria, Kraftl, 677.
 Parke, Brothers,
 Miligan, 200-206,
 Ivory Carving and
 gress & Key, 237.
 de Porquet, 202.
 Holmes & Sons,
 Marychurch, 93.
 Samuelson, 185.
 n, 93.
 che, 263.
 PRESERVING—ii.
 249.
 th and Tusks.
 xv. Allen, 259.
 Bowman & Son,
 n. 232. Clapper-
 n. 188. Crombie
 on, R. & T., 187.
 n, 61. Inglis &
 15. Macdona,
 480. Sanderson
 Watson, J. & A.,
 Sir W. T. 138.

TYNMOUTH CASTLE (Model)—xxx. (Fine Art Court)
 Morgan, 266.
TYPE (Specimens of)—xvii. Besley & Co. 195. Fair-
 hairn, 9. Ferguson, Brothers, 90. Figgins, V. & J.,
 124. Knight & Hawkes, 107. Miller & Richard,
 150. Reed & Pardon, 184. Stephenson & Co., 182.
 Watts, 164.
Austria, Battagia, 366. Haase, 367. Government
 Printing Office (Vienna), 362.
Canada, Herbert, 18a. Palgrave, 189.
France, Laboulaye, 895. Legrand, 584.
Netherlands, Enschede & Sons, 79.
Russia, Revillon, 361.
United States, Hobart & Robins, 399. Stanton Blind
 Institute, 270. Tobit, 395.
Zollverein (1), Beyrhaus, 144. Decker, 148. Haenel,
 284. (3), Schelter, 182. (5), Dresler, 24.
TYPE, CALLIGRAPHIC—xvii. Caslon & Co., 78.
TYPE FOUNDERS' IMPLEMENTS—xvii. Besley & Co., 195.
Sardinia, Farina, 47.
TYPE-FOUNDING, &c., MACHINES—vi. Harding & Co. 102.
Zollverein (1), Leonhardt, 55. (3), Brockhaus, 13.
 Hoffman, 12.
TYPE MOULDS—xvii. Figgins, V. & J., 124.
Portugal, Das Neves, 648-651.
TYPE, MUSIC—xvii. King, T. & J. H., 22.
TYPEDEFLECTOR—x. Lloyd, Col., 322.
TYPOGRAPHICAL ENGRAVING (Drawings for)—France,
 Cabasson, 785.
TYPOGRAPHICAL ORNAMENTS—xvii. Besley & Co., 195.
TYPOGRAPHICAL WORKS—Belgium, Casterman & Son,
 275. Hayez, 276. Leaigne, 279.
Zollverein (3), Barth, 179. (6), Zabern, 78. See also
Books.
TYPOGRAPHY (Specimens of)—See Printing, Letter-press.
ULEY CULTIVATORS—ix. Barrett, Exall & Andrews, 128.
 Grant & Co., 267.
ULTRAMARINE—ii. Dauplain, Gorton & Co., 63. Picciotto,
 33. Kurtz & Schmersahl, 9.
Austria, Kutzer & Lehrer, 24. Setzer, 23.
France, Bonze & Brothers, 772. Chapus & Richter,
 795. Courtail, 807. Guimet, 1620. *India*, i.
Zollverein (1), Curtius, 458. (2), Gadenhan, 12.
 Leverkusen, 875. Schrnock & Uhlich, 15. Wolf &
 Co., 17. (3), Saxon China Manufactory, 10. (4),
 Breuninger & Son, 3. (6), Buechner, 1. (8), Rochr, 7.
UMBER—i. Sweetman, 40.
UMBRELLAS AND PARASOLS—xix. Boss, 146. Evans &
 Co., 148. Foster & Co., 149. Hargrave, Harrison
 & Co., 147. Holland, 131. Jacobs, 183. Lewis &
 Allenby, 141. Morland & Son, 306. Rutter, J. &
 W. 137. Sangster, W. & J., 136. Slark, 135. Stears,
 132. Waddington & Sons, 134. Wilson & Matheson,
 133.
Austria, Herdt, 694. Rademacher, 695.
Belgium, Robert, 432. *Ceylon*.
China, Hewett & Co.
France, Cazal, 108. Charageat, 1144. Connerot, 1567.
India, xxix. *Portugal*, 1127-1150. *Tunis*, 37, 87.
UMBRELLA AND PARASOL STRICES—Austria, Tiffe, 692.
 Weiss, 892a. Zandra, 693. *Zollverein* (1), 257.
UNDERCLIFF, ISLE OF WIGHT (Model of)—Ibbetson,
 page 551.
UNION SUSPENSION BRIDGE ACROSS THE TWEED (Draw-
ing of)—viii. Brown, Sir S., 334.
UPHOLSTERY—See Furniture.
UPTON-LOVEL BRIDGE (Model)—vii. Chapman, 45.
URANIUM—i. Johnson & Matthey, 477.
VACCINATION DRAWINGS—x. Badcock, 732.
VACUUM GAUGES (for Steam Engines)—See Steam and
Vacuum Gauges.
VACUUM PANS, &c.—Russia, Heke, 152.
Zollverein (1), Heckmann, 52. Siegert, 74.
VALERIANIC ACID AND VALERIANATES—ii. Barnes, 45.
VALONIA—Greece, Sophianos, 2. Zaphviakis, 1.
VALVES—vi. Watson, 163. xxii. Jennings, 810.
VAPOUR, APPARATUS FOR APPLYING—x. Downing, 634.
VAPOUR BATHS—See Baths.

VARNISH, LEATHER—See Blacking & Boot Varnish.
VARNISHED CLOTH—France, Langlade, 1650a.
VARNISHES (Various)—i. Blundell, Spence, & Co., 48.
 Hayes & Co., 75. Naylor, 35. Tennant, 101. iv.
 Barker & Co., 62. Bruce, 74. English's Patent Cam-
 phine Company, Hall, 61. Manning, 63. Rea, 116.
 Rose, 27. Penney, 64. *Belgium*, Wouwermans, 35.
China.
France, Dida, 1189. Le Fevre, 1647. Leon, 305. Le-
 tillois, 1322. Pommier, 1400. Renard, 1431. Soehnee,
 Brothers, 380. Viard, 1521.
Tuscany, Querci, 21.
Zollverein (1), Gammersbach, Brothers, 860. (8), Ja-
 godzinsky, 8.
VASES (Gold, Enamelled, &c.)—xxiii. Goodwin, 64. Sey-
 mour, E. & J. 72. Watherston & Brogden, 105.
 xxvi. Latham & Dighton, 251. Nicoll, 182. Seibe,
 11. xxix. Harding & Standfast, 81. Spurrier, 76.
Bahamas, Grant. *Ceylon*.
VASES (Marble, Terra Cotta, Iron, Bronze, &c.)—North
 Transept, Minton, 50. Main Avenue, West, Tho-
 mas, 68. Main Avenue, East, Wallis. xxii. Han-
 dyside, 62. xxv. Battam, 53. Minton & Co., 1.
 xxvi. Greverie, 255. xxvii. Bright, 80. Ferguson
 & Co. 93. Jepson, 132. Redfern, 78. Woodruffe,
 77. xxx. (Fine Art Court) Daymond, 192. Pulham,
 216.
Austria, Gotti, 724.
France, De Brax D'Anglure, 779 (Main Avenue, East).
Malta, Decesare, 27. Dimch, 28.
Rome, Norchi, 51. Trenta Uno, 52a.
Sweden and Norway, Hjula Quarry, 43.
Zollverein (1), Cantian, 235 (Main Avenue, East). Roys,
 Prussian Iron Foundry, Berlin, 271 (Main Avenue
 East). (2), Royal Porcelain Manufactory, 64.
Mauritius, Balkfield & Co. *Russia*, Sazikoff, 366.
VASES, SYPHON (for AERATED WATERS)—xxvii. Mayr
 & Co., 7.
VATS, ENGLISH OAK (Models)—xxix. Hurrell, 46.
VAULT LIGHT—xxii. Barlow, 462.
VEGETABLE FIBRES (of a Silky Nature)—Zollverein (1),
 Holtzstamm, 48.
VEGETABLE GAS APPARATUS—vii. Booth, 134.
VEGETABLE GUMS—iv. Coovey, 70.
VEGETABLE IVORY (including articles in)—iv. Fauntleroy
 & Sons, 135. xxviii. Taylor, 47.
VEGETABLE MEAL—France, Begou, Brothers, 49.
VEGETABLE OILS AND MANURES—iii. Peterson, 66. See
 also *Cabbage Oil. Linseed and Linseed Oil and*
Cake. Rapeseed Oil.
VEGETABLE PRODUCTS OF SCOTLAND (Undescribed)—iii.
 Lawson & Son, 105.
VEGETABLE TALLOW—iv. Price's Patent Company, 83.
VEGETABLE WAX—ii. Jennings, 99.
China. *St. Domingo*, Schomburgk, Sir R.
VEGETABLES, WAX. See Flowers, Wax.
VEGETO-ANIMAL FOOD—iii. Gentile, 108. St. Etienne,
 138.
VELLUM—xvi. Lever, J. & J. 24.
VELLUM (Design on)—xxx. (Fine Art Court) De Lara,
 243.
VELOCIMETER, AQUATIC—United States, St. John, 542.
VELOCIPEDS—v. Sawyer, 960. Watts, 991. Wilson,
 995. *United States*, Rodgers, 496.
VELVETS—xii. & xv. Baughen & Brothers, 183. Bennett
 & Co. 185. Lockwood & Keighley, 104. xiii.
 Brocklehurst & Sons, 38. Brooks, 26. Burke, 57.
 Campbell & Co. 31. Casey & Philips, 23. Graham
 & Sons, 17. Harrop & Co. 62. Hill & Co. 25. Le
 Mare & Sons, 21. Robinson, J. & R. & Co. 5. Robin-
 son, J. & T. 6. Robinson, J. & W. & Co. 24. Seamer,
 15. Stone & Kemp, 18. Swan & Edgar, 11. xviii.
 Law, W. & E., 10. Swau & Edgar, 9. xix. Ball &
 Co. 19.
Austria, B্লাh & Rosenberger, 251. Fröhlich & Sons,
 177. Grohmann, 178. Haas & Sons, 243. Lange &
 Sons, 179.
France, Balleidier, 1065. Barth, Massing, & Plichon,
 21. Brosse & Co. 1118. Fontaine, 1225. Girard &
 Co. 1248. Motte, Bossut, & Co., 654.

- India*, XIII. *Netherlands*, Warnar, 32.
Portugal, Martins, 919. Moureira, 918. Pimentel, 923-925.
Russia, Lorteff, 204. Panteloeff, 175. Solovieff, 354.
Sardinia—Chichizola & Co. 39. Defferrari, Brothers, 44. Guillot & Co. 42. Molinari, 43.
Spain, Orduna, 214.
Switzerland, Silk Stuff Manufacturers, 153. *Turkey*, Zollerlein (1), Andreae, 360, 379. Fudickar, 596. Gerlich & Greiff, 537. Lehmann, 136. Lingenbrink & Vennemann, 526. Marx & Weigert, 113. Menggen, 581. Menghius, Brothers, 530. Margenroth & Krugmann, 532. Peltzer, 518. Rappard & Goesmann, 517. Scheibler & Co. 534. Schroers, 515. Weigert & Co. 115. (3), Batz, 150.
- VELVETS, PRINTED**—XII. & XV. Swaisland, 283.
VELVETEEN—*Russia*, Rabeneck, 173.
VENEERING (New Method of)—XXVIII. Meadows, 165.
VENEERING (Specimens of)—IV. Scott & Co. 19.
Algeria, Cabanillas, 12. *Belgium*, Siron, 138. *Canada*, Montreal Commission, 81. *France*, Bernard, 1081. Volkert, 1532. *Hamburg*, Rall & Baltheimer, 108. *New Zealand*—Lucas & Co., 40. *Sardinia*, Bertinetti, 61. *United States*, Parmenter, 244. *Van Diemen's Land*—Freeman, 210-216. Peck, 224-226. Quinn, 95. *Zollerlein* (6), Andre, Brothers, 56.
- VENETIAN BLINDS**—VII. Geary, 2. Quincey, 146. XXIV. Mash, 54. XXVI. Avery & Dangar, 309.
VENETIAN STUCCO—XXVII. Orsi & Armani, 36.
VENTILATING APPARATUS—VI. Greig, D. & J. 114. VII. Inglis, 199. XXII. Edwards, 387. *Belgium*, Debaune, 131. Van Hecke, 480. See also *Chimney Ventilating Apparatus*. *Coal-mine Ventilation*. *Glass*, *Perforated*.
VENTILATING CURTAIN-PUMP—VII. Hill, O. & J., 124.
VENTILATORS—XXII. Bobbhyer, 680. Hayward, Brothers, 582. Price, 397. XXIV. Moore, 53.
VENTILATORS FOR MINES. See *Mining Ventilating Apparatus*.
VENTILATORS, WINDOW—VII. Naylor, 64. XXII. Moore, 595. See also *Glass*, *Perforated*.
VERATRIC ACID—II. Morson & Son, 106.
VERD ANTIQUE, IRISH—I. Talbotde Malahide, Lord, 145.
VERMICELLI—See *Macaroni*.
VERMIN DESTROYER—*Austria*, Dolleschal, 51. *United States*, Lyon, 221. See also *Insects*, *Fumigating Apparatus for Killing*.
VETERINARY INSTRUMENTS. See *Horses' Teeth*, *Instrument for extracting*. *Jaw Lever*.
VETERINARY MEDICINES—*France*, Miramont, 1358A. *Netherlands*, Jorritsma, 18.
VICES—VI. Mason, 46. XXII. Armitage, M. & II., 150. Stirk, 74. Warden, 368. Wright, 366. *Austria*, Teuffmayer, 494. *Belgium*, Mertens, 132. *Sweden and Norway*, Bjork, 11.
VICTORIA TOWER, KINGSTOWN (Model)—XXX. (Fine Art Court) Russell, 327.
VICUNA CLOTH—XII. & XV. Bennett, J. & A. 95. Clay, 124. Hargreave & Nusseys, 28.
VIGNETTES—*France*, Doublet & Huchet, 821.
VINEGAR—III. Hills & Underwood, 7. XXIX. Mitchell, 94. *Austria*, Wagenmann & Co. 19. *Canada*, Gillespie & Co. 133. *Ceylon*, *France*, Courtin, 1570. Gregoire, 1739. Maire & Co. 317. Rigault, 1686. *Russia*, Schlippe, 27. *Zollerlein* (1), Jahnasch, 836.
VINEGAR APPARATUS, PLANT, &c.—VI. Hill, Evans, & Co. 619. XXIX. Mitchell, 94.
VIOLIN, CLAVIC ATTACHMENT TO—X. Brooks, 705.
VIOLINS—X. 289. Beloe, 709. Betts, 519. Dearlove, 707. Forster, 509. Guinness, 541. Purdy & Fendt, 537. Spurgin, 542. *Austria*, Bittner, 144. Cerveny, 157. Enrico, 147. Herzlieb, 146. *Belgium*, Darche, 177. *Canada*, Higgins, 185. *France*, Bernardel, 421. Husson & Bathod, 885. Jacquot, 547. *Russia*, Rudert, 171.
- Sardinia*, Rocca, 32. *Switzerland*, Pupinat, 100. *United States*, Gemunder, 442. *Western Africa*, Hutton & Sons, 6. *Zollerlein* (2), Baader, 22. Neuner & Hornsteiner, 33. (3), Glier and Son, 20. Kienn, 18.
- VIOLIN AND OTHER STRINGS**—X. Dodd, 505. *Austria*, Callegari, 150. Indri, 151. *Belgium*, Bernardel, 421. Combes, 473. Savarese, 997. *Zollerlein* (1), Reichel, Brothers, 442.
- VIOLIN AND VIOLONCELLO BOWS**—X. Dodd, 543. *France*, Simon & Henry, 1489. Vuillaume, 735. *Zollerlein* (2), Neuner & Hornsteiner, 33. (3), Klein, 18.
- VIOLONCELLOS**—X. Hesps, 510. Gisborne, 507. *Austria*, Bittner, 144. Herzlieb, 146. Kosselt, 145. *Belgium*, Darche, 177. Mahillon, 175. *France*, Bernardel, 421. Jacquot, 547. *Hamburg*, Cellier & Son, 15. *Switzerland*, Pupinat, 100. *Zollerlein* (2), Baader, 22. Neuner & Hornsteiner (3), Klom, 18.
- VISITING CARDS, DESIGNS FOR**—XXX. (Fine Art Court) Barclay, 286.
- VITRIOL**. See *Copperas*. *Muriatic Acid*.
VITRUM MARMORIATUM (for Table-tops)—XXIV. Ford, 40.
- VOLCANIC SKORIES**—*Portugal*, 118.
"VOLTA-SUMITO," TURN-OVER DESK AND STAND—X. Tudsbury, 704.
- VOTE RECORDERS** (Models of)—X. Chamberlain, 399.
VOTING TELEGRAPHS—*United States*, Smith, 556.
VULCAN SPRING, FOR CLOSING DOORS—VII. Mackenzie, 125.
- WADDINGS**—*France*, Candlot, 102. See also *Gun Wadding*.
WAFERS—IV. Morrell, 58. XVII. Waterston, 93. *Austria*, Berger, 380.
- WAGGONS**. See *Carts and Waggon*s.
WAISTCOATS, EMBROIDERED—XII. & XV. Allen, 259. Forbes & Hutchison, 291. Macdonia, 260. Whitehill & Co., 287. Xiv. Tee & Son, 37. XIX. Clowes, 150. Gabriel, 70. XX. M'Gee & Co., 118. *Zollerlein* (1), Dieckmann, 612. Steff & Hartas, 161.
- WAISTCOATINGS** (Silk, Woollen, and other)—XI. Barlow, Goodly & Jones, 35. Johnson, 43. Spencer & Son, 52. XII. & XV. Brown & Forster, 9. Goodwin, 11. Helme, 207. Murley, W. & C., 10. Schlofeld, 125. Schwann, 115. Taylor & Son, 111. Tolson & Sons, 116. XIII. Robinson, J. & R. & Co. 5. Vanner, J. & Son, 4. Washington & Davies, 8. XIV. Cory & Co. 24. Tee & Son, 37. *Austria*, Beinert, 303. Bruler's Widow, 295. Echinger, Brothers, 304. Kraal, 305. Mayer, Brothers, 266. Mestrozzi, 267. Rockstroh, 306. Wogtech, 274. *France*, Croco, 609. Debnely, 140. Vigoroux, 728. Viviry & Co., 1529. *India*, xv. *Portugal*, Daupins and Co., 853-859. Pimentel, 951-953. *Russia*, Lorteff, 204. *Sardinia*, Crocco, Brothers, 50. *Zollerlein* (1), Bockmuhl, 586. Boeddinghaus and Co., 572. Grave & Neviand, 591. Heymann, 575. Neuhaus, 577. Rurmann & Meckel, 580. Schulte, 675. Tack & Pelizans, 674. Welber & Metzger, 569. (3), Krause, 147.
- WALES (PRINCE OF) AND ROYAL CHILDREN, Statues of**—XXX. (Sculpture Court) Thomeycroft, T. & M., 34. Portrait of the Prince of Wales in hair, XXIII. Haussen & Co., 124. Chair in honour of the Prince of Wales, XXVI. Le Mercier, 181.
- WALES', PRINCE OF, SHIELD**—Main Avenue, East, II. R.H. Prince Albert, 98. Casts from the Shield, *Zollerlein*, (1), Krause, 278.
- WALKING-STICKS AND CANES**—VIII. Pearce, 330. XVI. Atkinson & Eldrid, 80. Case, 315. Martin, 81. XXIX. Carpenter, 143. Clurie, 14. Dean, 128. Jacobs, 183. Meyers, 140. Preston, 145. *Austria*, Ludwig, 679. Hartmann, 675. Pfeiffer, 681. Tantz, 685. *British Guiana*, Bee, 156. Duggin, 146-148A. *China*, Carpenter.

- upinnat, 100.
 & Hornsteiner, 33.
 8.
 4, 505.
 9. Savarasse, 997.
 1.
 Dodd, 543.
 Guillaume, 735.
 steiner, 33. (3),
 507.
 Kosselt, 145.
 7.
 er & Hornsteiner
 (Fine Art Court)
 id.
 ps)—XXIV. Ford,
 AND STAND—X.
 emberlain, 399.
 Smith, 556.
 —VII. Mackenzie,
 also *Gun Wadding*.
 rston, 93.
 xv. Allen, 259.
 260. Whitehill
 ix. Clowes, 150.
 E.
 ff & Harrass, 161.
 er)—XI. Barlow,
 Spencer & Son,
 9. Goodwin, 11.
 Schofield, 125.
 Tolson & Sons,
 5. Vanner, J. &
 xiv. Cory & Co.
 295. Echinger,
 r, Brothers, 266.
 gtech, 274.
 Vigoroux, 728.
 659. Pimentel,
 rein (1), Bock-
 572. Grave &
 huns, 577. Rut-
 Pack & Pelizaeus,
 Krause, 147.
 EN. Statues of—
 st, T. & M., 34.
 in hair, XXIII.
 ur of the Prince
 ue, Rast. H.R.H.
 ield, Zollverein,
 urce, 330. XXV.
 artin, 81. XXVI.
 128. Jacobs,
 Pfeiffer, 681.
 5-148A.
 France, Bugre, 1123.
 Hamburg, Harter and Huben, 87.
 South Africa, Bridges, 21. Haubury, 28. Groenkloof
 Missionary Station, 43.
 Trinidad, Lord Harris.
 Tuscany, Tonti, 101. United States, Peckham, 320b.
 Van Diemen's Land, Denison, Sir W. T. 304. Marriott,
 307. Screen, 305.
 Zollverein, (1), Lusk, 140. Schulz, 593. (4), Heidinger,
 92. (6), Frank, 61. See also *Medical Walking Staff*.
 WALKING-STICK BOTTLE, WITH WINE GLASS—XVI.
 Martin, 81.
 WALKING-STICK STOOL, &c.—XXII. Lestwood, 578.
 WALKING-STICKS, ELECTRO-GALVANIC—X. Winter, 423.
 WALLS—Egypt, 244-246.
 WALNUT-OIL—Sardinia, Girardi, Brothers, 5.
 WAR-ENGINE (for Discharging Ball-Cartridges) — VIII.
 M'Gettrick, 288.
 WARDROBES—See *Furniture*.
 WARDROBES, TRAVELLING—XXVI. Pratt, 403.
 WARLIK'S PATENT FUEL—I. Patent Fuel Company, 230.
 WARBUNN AND OTHER PLACES (Models of, in Composi-
 tion)—Zollverein (1), Lidel, 276.
 WARMING APPARATUS—VI. Plimsoll, 631. XXII. Nunn,
 703. France, Foudet, 508.
 See also *Atmopyres. Gas Cooking and Warming Appa-
 ratus. Hot-Air Apparatus. Hot-Water Apparatus*.
 WARPING-MACHINES—VI. Ball & Co., 90. Dickens, 62.
 Jerdan, 29.
 WARWICK VASE (Copies of)—XXX. (Fine Art Court)
 Norchi, 309. *Italia*, Heke, 329.
 Zollverein (1), Royal Prussian Iron Foundry, Berlin,
 271 (Main Avenue, East).
 WASH-HAND BASINS—XXII. Haldane & Rae, 432.
 WASH-STANDS—XXII. Fearncombe, 160A. XXVI. Cattle,
 20. Riddle, 14.
 WASHING, DRYING, IRONING, &c., MACHINES FOR—VI.
 Manlove & Co., 454. Marsden, 317. XXII. Adams,
 538. Fryer, 546. Macalpine, 548. Nunn, 703.
 Pearson, 541. Price, 535. Price, V., 397. Reid, 543.
 Tasker, 539. France, Charles & Co., 117.
 WATCH AND CHRONOMETER WORKS, &c.—X. Brookes, 25.
 Bryson & Sons, 665. Chevalier, 23. Dell, Brothers,
 100. Hart & Co. 113. MacDonal, 67. Philcox, 22.
 Roskell, 123. Tobias & Co. 78.
 France, Clemen-Bourgeois, 455. Montandon, Brothers,
 601.
 Switzerland, Banelier, 6. Darier, 76. Lecoultré &
 Goley, 263. Paquet-Fazy, 105.
 Zollverein (4), Bacher, 17.—See also *Clock and Watch
 Works*.
 WATCH DIALS—X. Hinton, 62.
 WATCH GLASSES—XXIV. Ross & Co. 1.
 France, Burgun, Waller, & Co. 39.
 WATCHES—X. Adams & Sons, 2. Aubert & Klaffenberger,
 52A. Bell, 679. Bolton, 94. Copland, 46A.
 Cousens & Whiteside, 86. Cragg, 8. Davis, 30.
 Delolme, 19. Dent, 55. Donegan, 52. Elisha, 39.
 Froisham, 57. Fuller, 592. Funnell, 26. Gibbs, 21.
 Gowland, 27. Hutton, 7. Jackson, W. H. & S., 32.
 Jones, 64; 338 Strand, 699. Loseby, 12. Marchand,
 71. Parkinson & Rudsham, 35. Pettit & Co. 81.
 Roberts, 130. Rotherham & Sons, 124. Tanner, 28.
 Tobias & Co. 78. Vieyeres & Refrincon, 91. Walker,
 697. Watkins, 85A. Yates, 9. XXIII. Harvey & Co. 92.
 Hunt & Roskell, 97. Martin & Co. 2. Phillips, Broth-
 ers, 87.
 France, Boyer, 69. Fraigneau, 1606. Lefebvre, 577.
 Leon-Clement & Bourgeois, 306. Paget, 337. Pesche-
 loche-Yavin, 344. Rieussac, 1685.
 Switzerland, Aubert, 73. Audemars, 22. Baron &
 Uhlman, 74. Bock, 31. Bovet, 13. Dely, 16.
 Ellroth, 78. Eward, 29. Fatio, 79. Figuet Brothers,
 266. Goley, 220. Grosclaude, 24. Imod, Brothers,
 7. Kopp, 17. Kramer, 268. Mercier, 96. Mermoud,
 Brothers, 15. Meylan-Golay, 98. Moser, 20. Perrut
 & Son, 21. Piquet, Brothers, 273. Rauss & Coloub,
 14. Taillard, Brothers, 267. Vaucher, 28.
 United States, Jacot & Courvoisier, 381.
 Zollverein (1), Dorer, 343. (3), Lange, 17. (4), Bacher,

- 17.—See also *Chronometers, Marine; Chronometers,
 Pochet; Chronometers, Railway*.
 WATCHES (Models of)—X. Bryson & Sons, 154.
 WATCHMAKERS' TOOLS & MACHINERY—X. MacDonal, 67.
 Sardinia, Benoit, 33.
 Sweden, Lidberg, 76.
 Switzerland, Darier, 61. Pagan, 64. Stutzer, 63.
 WATCH-MAKING, JEWELLERY, &c., DESIGNS FOR—Swit-
 zerland, Dubois, 43.
 WATER-CARTS—V. Geary, 846. VII. Geary, 2. IX.
 Coode, 151A.
 WATER-CLOSETS—VIII. Macdonald, 329. XXII. Aberly,
 529. Chambers & Robbins, 533. Downton, 530.
 Green & C., 532. Guest & Chrimes, 524. Haldane
 & Rae, 432. Hansou, 702. Jennings, 810. Lambert,
 534. Stokes, 252. Warner & Sons, 798. Wiss, 523.
 France, Gaignier, 252.
 WATER-CLOSETS (Service-box applicable to)—XXII. Rosin-
 dale, 516.
 WATER COLOURS—XXX. (Fine Art Court) Robertson &
 Co. 6. Sweden, Hasselgren, 97. Switzerland, Gwin-
 ner, 50. See also *Colours, Artists', &c*.
 WATERING HOADS AND STREETS (Machines for) — VIII.
 Tyscutt, 289. IX. Read, 89. See also *Street Water-
 ing-Cart*.
 WATER-JETS—France, Plasse, 1394.
 WATERMARKS IN PAPER (Improvements in)—XVII. Saun-
 ders, 36, 160.
 WATER-METERS—V. Billinton, 468. X. Brown, 335. See
 also *Hydrometers*.
 WATER-MILL (Model)—Netherlands, Wal, 94.
 WATER-POWER FOR GRINDING CORN (Improvements in)
 —IX. Paxton, 125. See also *Water-Wheels*.
 WATERPROOF FABRICS (Various)—VI. Brown, 56. IX.
 Bell & Co, 197. XII. & XV. Martin, 249. Stanton &
 Son, 224. XIV. Morrison & Hurn, 49. XXVIII. Waus-
 borough, 75. France, Gilbert, 237. Moreau, 1361.
 See also *Caoutchouc*.
 WATERPROOF COATING PAINTING—France, Paradis De
 Rouz & Co. 340.
 WATERPROOF PAPER—XVII. Martin, 29.
 WATERPROOFING COMPOSITION—XVI. Hodges, 184.
 Switzerland, Lauterberg, 48.
 WATER PURIFIERS—XXII. Bird, 267. See also *Filters*.
 WATER, SUPPLY OF, TO TOWNS (Models) — V. Turner,
 428. XXII. Turner, 520.
 WATER TANKS (Models)—VII. India.
 WATER-VASE—United States, Salt & Mear, 203.
 WATER WHEELS (Models)—V. Devon Great Consol Copper
 Mining Company, 418. Erskine, 100. Ferguson, 78.
 Stevens, 136. Warner & Sons, 424. Wight, 480. IX.
 Smith & Co., 266. X. Alcock, 364. India, VII.
 United States, Griffin, 144.
 WAVERTREE CHURCH (Model)—XXX. (Fine Art Court)
 Loscelles, 18.
 WAX—Austria, Renli, 101. Egypt, 116.
 Netherlands, Visser, 17.
 Portugal, Bretes, 620, 622. Carvalho, 617. De Ficalho,
 Marquis, 618, 619, 621.
 Russia, N. N. 85. Spain, Colmenero, 162. Tunis, 183.
 Turkey. See also *Bees' Wax. Vegetable Wax*.
 WAX BASKETS—Zollverein (1), Krumteich, 261.
 WAX BLOSSOM OF FRUIT—Madeira, Ferraz, 2.
 WAX, FOR ETCHING—XXX. (Fine Art Court) Cock,
 147.
 WAX FIGURES—XXX. (Fine Art Court) Allin, 199. Hold-
 ing, 217. Montanari, 224. Sonies, 277.
 Austria, Schlatter, 701.
 Malta, Darmarin & Sons, 26. Politto, 34. Mexico.
 See also *Hairdressers' Figures*.
 WAX FLOWERS—See *Flowers, Wax*.
 WAX, FOR MODELLING FLOWERS—XXIX. Lemare, 79.
 WAX MODELS—XXX. (Fine Art Court) Bursill, 60.
 France, Chomereau, 122. Barbadoes, Elwell,
 WAX PAINTINGS—France, Vivet, 734.
 WAX PORTRAITS—XXX. (Fine Art Court) Morrison, 276.
 Rouw, 294.
 WEAPONS (small-arms and other)—Austria, Preis, 117.
 Reidler, 110.
 British Guiana, Arnott, 142-144, 145A. Duggin, 141.

Ceylon. New Zealand. Moore, 37. Turkey. Western Africa, Acland, Sir T. D., 17. Hutton & Sons, 6. Jamieson, 22. McWilliam. See also Guns, Pistols, &c. Swords.

WEAVING APPAREL (Various)—XI. Cross & Co. 47. XII. & XV. Albert, H. R. H. Prince, 500 (Main Avenue, West). Blakely, 235. Clarke, 432. Fyfe & Co., 197. Knox, 197A. Mason & Co., 301. Rainey & Co., 198. Smith & Whyte, 459. Taylor & Son, 111. Webber & Hairs, 277. XIII. Cross, 32. XIV. Beale Brown, 77. XIX. Patent Utrecht Co., 265. XX. Beale & Latchmore, 204. Birt, 153. Cahau, 74. Caplin, 32A. Capper & Son, 45. Capper & Waters, 21. Clowes, 150. Cody, 64. Cutler, 69. Dingley, W. & S., 115. Doudney, 113. Firkins & Co., 163. Fry, 116. Gates, 72. Goulding, 110. Harris & Tomkins, 111. Hill, 107. Holmes & Co., 84. Hurley, 73. Kearse, 175. Kelly & Co., 178. Kisch, 65. Laurence, 158. Lee, 110A. Lewis & Son, 114. M'Rae, 128. Martiu, E. & E. H., 42. Nairn, 179. Neville & Co. 7. Powell, 26. Redgrave, 164. Robert, 130. Solomon, 86. Stewart, 177A. Thompson & Son, 62. Vincent, 177. Wagner, 31. Walker & Babb, 63. Walsh & Co., 109. Watts, 108. Wheeler & Ablett, 22. XXII. Hardman & Co., 700. XXVI. Hardman & Co. 332. XXVIII. Cording, 82.

Algeria, Ben Zekri, 7. Beni Abbas Tribe, 53. Bernardon, 8. Bou Taleb Tribe, 54. Caid Ben Zekie des Seignas, 61. Cherif Ben Mimoun, 60. Drides Tribe, 55. Mohamed Ben Achir, 62. Si Ali Bel Lamouchi, 65. Si Amou Ben Onatuf, 64.

Austria, Bruder's Widow, 295. Budinsky, 393. Hermannstadt Trade Union, 398. Jenny & Schindler, 183. Klamer, 184. Krach, Brothers, 391. Malatinsky, 394. Nessel, 395A. Neubert, 399. Oestreicher, 396. Rigo & Kraetschmar, 395. Schramm, 397. Seitter, 399. Singer, 392. Volkmann, 190.

Belgium, Weil, Meyer, & Co., 336.

Canada, Adams, 331. Bell, 173. Henderson, 107, 332. Herbert, 18A.

China, Bowring. Daniel. Hewitt & Co.

Denmark, Fjeldrad, 8.

Egypt, 192-194, 197, 281-283, 285-294, 320-324, 327, 328, 332, 333, 336.

France, Brie & Jeoffrin, 780. Cherif Ben Mimoun, 1560. Cochois & Colin, 124. Cocu, 125. Damet, 1578. Depouilly, 1586. Donat, 1192. Doncet & Duclerc, 147. Haraud, 863. Hayem, 1285. Martel, Geoffrey & Valensot, 921. Meyroers & Son, 639. Milton, 930. Mohamed Ben Salah, 1663. Mohammed Ben Achir, 1662. Molyv Lesonet, 1359. Moreau & Co., 652. Opigez & Chazelle, 336. Parvuit & Co., 673. Reynier, Cousins, 1435. Si Ali Ben Lamouchi, 1695. Si Amou Ben Onatuf, 1694. Si Hamidi, 1696. Tailbouis, 385. Valtat & Rouille, 709.

Greece, Saris & Hengos, 56.

Hamburgh, Kupp & Kroll, 41.

India, xv. xx. *Ionian Islands*, Lady Woodford, 1.

Jersey and Guernsey, Dobree, 35.

Malta, Dimeck, 21. Feneck, 6.

Nova Scotia, Central Committee.

Persia, Araman. Thompson.

Russia, Kerhalay-Hoossein-Ogli, 279. N. N. 280. Prokhoroff, Brothers, 349.

Sardinia, Furno, 51. Gandolfi, 95.

Society Islands, Queen Pomare, 2.

South Africa, Deane & Johnson, 19. Moag, 29. Schmieterloew, 12.

Spain, 235. Carborell, 290. Fister, 222. Lucena Corporation, 231A.

Sweden, Forsell, 109. Gulda, 108.

Switzerland, Bruderer, 118. Hunselmann, 165.

Tunis, 1-12, 22, 23, 41-44, 47, 48, 94. *Turkey*.

United States, Haight, 385. Jennings & Co., 118. Leask, 108. Hallings, 398. Shepherd, 10. Simmons, 303. Thornton, 227.

Van Diemen's Land, M'Kenzie, 167, 170. Slieglitz, 168. Tooth, 169, 171.

Western Africa, Forbes, 8. Hutton & Sons, 6. M'William. Rothery, 4. Townsland, 11. Trotter, 5. Zollverein (1), Boeddinghaus & Co., 572. Levin &

Sons, 114. Neviandt & Pfeleider, 523. Zeitz, 841. (2), Gebhart, Brothers, 42. (3), Luther, 187. See also *Bonnets. Boots and Shoes. Gloves. Gaiters. Hats and Caps. Ready-made Linen. Shawls. Stays and Corsets. Waistcoats.*

WEAVERS' HEADLES—United States, Senne, 75.

WEAVING CARDS—Spain, Aleman, 254. Den, 253.

WEAVING COMBS—France, Bavarot & Son, 800. Durand & Bal, 829. Henry, 536.

Spain, Carreras y Alberich, 252. *Tuscany*, Cuyere, 59.

WEAVING MACHINES—See *Hand-Looms. Looms. Power-Looms.*

WEAVING, SPECIMENS OF (Various)—XI. Walmesley, 51. XII. & XV. Rogers, 472. *Zollverein* (6), Klein, 63. Rust, 68.

WEAVING AND SPINNING INSTRUMENTS (Undescribed)—Gold Coast and Ashantee, Forster & Smith, 1.

WEBBING, ELASTIC—XX. Hall, 4.

WEBS AND WEBBING—XII. & XV. Bliss, 270. Bridport Local Committee, 73. Early, 269. Gaudy, 246. XVI. Taylor, 269. XX. Thomas & Brothers, 46.

Ceylon.

WEBSTER, DANIEL, PLASTER CAST OF—United States, Chickering, 555.

WEDDING-CAKE ORNAMENTS—XXIX. Vine, 116.

WEDDING CARS—XXIX. Gunter, 112. Moore & Murphy, 332.

WEDGES—VIII. Bennett, 293.

WEED-DESTROYING MACHINES—IX. Fleming, 253. Grant & Co., 267.

Belgium, Delstanehe, 510. *India*, IX.

WEeping CYPRUS (WITH SPECIMENS OF THE WOOD)—Eastern End (Outside), Standish & Noble, 100.

WEFT (Undescribed)—Portugal, Rio Vezello Company, 721, 722, 724.

WEIGH-BRIDGES—IX. James & Co., 86.

WEIGHING MACHINES—V. Catell, 766. Craig, 776. Davidson & Co., 774. Day & Millward, 772. Donbavand, 782. James & Co. 411. Medhurst, 780.

Morris, 764. Nicholl & Co., 770. Pooley, 784. IX. Grant & Co., 267. James & Co., 86. Mapplebeck & Lowe, 131. Maynard, 109. Smith, A. & W. & Co., 266. X. Macpherson, 684A. Webster, 671A. Young & Son, 366. XXII. Marriott, 793.

WEIGHTS AND MEASURES (including Scales, Beams, &c.)—I. Cudell, 256. Nicholl & Co., 770. X. De Grave, Short & Fanner, 333. Siehe, 358. Tree & Co., 324. XXII. Elliott, 151. Tyler & Son, 401. Warner & Sons, 798. *Austria*, Pfeleider, 476. Schmidt, 105.

Belgium, Saere, 304. *Canada*, Ladd, 151A. *Egypt*, 162, 163, 165.

France, Beranger & Co., 761. Conservatoire des Arts et Metiers, 1568. Parant, 944.

Gold Coast and Ashantee, Forster & Smith, 1. *India*, v. *Netherlands*, Becker, 83.

Russia, Vesoffchikoff, 173. *Tunis*, 37. *United States*, Bachs, 393A. Insler, 161.

Western Africa, Beecham, 12. Hattou & Sons, 6. *Zollverein* (1), Baumann, 76. Broemel, 705. Oertling, 87. Reinmann, 86. See also *Decimal Scales. Diamond Balances.*

WELD—Spain, Martinez, 145.

WELL-BLOCK—Tunis, 86, 164.

WELL-BORING APPARATUS—VI. Beart, 301. Speller, 330.

WELLESLEY, MARQUIS OF, (Statue of)—Weekes, page 833.

WELLINGTON, DUKE OF (Busts and Statues of)—Milnes, page 850. Elkington & Co., page 848. XXIII. Widdowson & Veale, 100. Ritchie, 193.

WESLEY, JOHN, Bust of—XXV. Hughes, 60. Statue of, XXX. (Sculpture Court) Manning, 73.

WESTMINSTER, DESIGNS FOR A BRIDGE AT—VII. Hunt & Gandell, 37. Rovere, 163. Russell, 78.

WESTMINSTER, DESIGN FOR IMPROVEMENTS—XXX. (Fine Art Court) Barwell, 175.

WHALE, JAW-BONE OF—Van Diemen's Land, Moses, 207 (Main Avenue, West).

WHALEBONE—IV. Horau, 103. Westall & Co., 104. *United States*, Goldard, 537.

Van Diemen's Land, Moses, 237.

323. Zeitz, 841.
 author, 187. See
Gloves. Gaiters.
Shafts. Stays
 75.
 Deu, 253.
 800. Durand
 Cuyere, 59.
 Looms. Power-
 Walmsley, 51.
 (Undescribed)—
 Smith, 1.
 270. Bridport
 Gandy, 246.
 Brothers, 46.
 —United States,
 116.
 Moore & Murphy,
 253. Grant
 OF THE WOOD)—
 Noble, 100.
 Vezello Company,
 776.
 772. Dumba-
 Medhurst, 780.
 Pooley, 784.
 56. Mapplebeck
 Smith, A. & W. &
 671A. Young
 Beams, &c.)
 x. De Grave,
 Tree & Co., 324.
 Warner & Sons,
 105.
 151A.
 atoire des Arts et
 Smith, 1.
 61.
 & Sons, 6.
 705. Oertling,
 Scales. Diamond
 301. Speller, 330.
 —Weekes, page
 (ies of)—Milnes,
 S. XXIII. Wid-
 00. Statue of,
 AT—VII. Hunt
 sell, 78.
 NTS—XXX. (Fine
 Land, Moses, 207
 & Co., 104.

WHALE-FISHING IMPLEMENTS—XXII. Boulton & Son,
 330.
 WHALE-GUN—VIII. Bealson, 90. See also *Harpoon-Guns.*
 WHALE-OIL—See *Oils (various).*
 WHEAT—See *Corn.*
 WHEAT-DRESSING MACHINES—See *Corn & Grain Dress-
 ing Machines.*
 WHEAT (Remedy for the Smut in)—II. Sturges, 58.
 WHEAT-STRAW PAPER, &c.—IV. Wright & Co., 42.
 WHEEL BANDS, GUT—V. Potter, 639.
 WHEELBARROWS—VII. Ell, 94. IX. Ellis, 29. Windus,
 36.
 WHEEL-CHAIRS—See *Invalid Wheel-Chairs.*
 WHEEL-CUTTING AND DIVIDING-ENGINE—VI. Lewis &
 Sons, 209.
 WHEELER'S PATENT CONDENSERS—VI. Hulls, 618.
 WHEEL-FRAME—Russia, Imperial Coach-making Estab-
 lishment, 154.
 WHEELS, CARRIAGE, CART, AND OTHER (Models, &c.)—
 v. Brown, Marshall, & Co., 812. Crosskill, 526.
 Gompertz, 652. Grisdale, 858. Jackson, 682. Lee,
 507. Shilton, 966. IX. Crosskill, 11. X. Broadbent,
 122.
 Sweden, Bernhardt, 87.
 Van Diemen's Land, Fraser, 10.
 WHEELS FOR GUN-CARRIAGES—V. Smith, 972.
 WHEELS, METAL—V. Eastwood & Frost, 672. XXII.
 Lucas & Son, 204A.
 WHEELS, NOISELESS (VULCANIZED INDIA-RUBBER)—V.
 Marks, 908. Tilbury, 984. XXVI. Ward, 279.
 WHEATSTONES—I. Scrampton, 82. IX. Seal, 262.
 Belgium, Collette Doucet, 5. Dupuyrie, 494. Lam-
 berry, Brothers, 25. Canada, Logau, 1.
 Turkey.
 Zollverein (4), Schmaecher, 93. Wagner, 104. See
 also *Grindstones; Hones.*
 WHIPCORDS—XIV. Wall, E. & T., 70.
 WHIPS—XVI. Atkinson & Eldrid, 80. Callow & Son,
 308. Case, 315. Maitin, 81. XXIX. Callow & Son,
 83. Stark, 135.
 Austria, Griess, 341. Manschön, 342.
 Canada, Threlkeld, 166.
 India, XVII. Netherlands, Post & Wendt, 55.
 South Africa, Bridges, 21. Hanbury, 28. Groenkloof
 Missionary Station, 43.
 United States, Rowe, 326. Marshall, 159, 160. Wis-
 man, 130-132.
 Zollverein (1), Becherer, 141. Wirth, 819.
 WHIPSTONES—XXIX. Barnes, J. & W., 15.
 WHITBY ABBEY, RUINS (Model of)—XXX. (Fine Art
 Court) Robinson, 120.
 WHITE ISLAND (Model in Sulphur)—New Zealand, Ligar,
 27.
 WHITE-LEAD AND WHITE-LEAD ORE—I. 59. Dyer, 62.
 Potter & Co., 87. Whittaker, 53.
 Austria, Bigaglia, 34. Diez, 33. Egger & Co., 31.
 Herbert, 30. Belgium, Brassens, 42. Dehhaull, 39.
 France, Bouze & Brothers, 772. Maire & Co., 317.
 Poelman, 961.
 Netherlands, Poortman & Visser, 2. Stratinigh & Co.,
 3. Sardinia, Profumo, 14.
 United States, Wetherill, Brothers, 43.
 Zollverein (1), Bischop & Rhodins, 312. Patent Manu-
 factory, 5. Walthausen, 320.
 WHYTOCK'S PATENT VELVET (Portière made of)—XIX.
 Henderson & Widnell, 201.
 WICKER TABLE-MATS—Austria, Kumpf, 658. Wunsche,
 659.
 WICKER-WORK. See *Baskets & Basket-Work.*
 WICKS FOR STEARINE CANDLES—France, Nicod & Son,
 663.
 WIGS—XVI. Beck, 247. Bouchet, 246. Brown, 300.
 Browne, 245. Burgess, 244. Carles, 251. Coussé,
 259. Douglas, 257. Gates, 183. Hewlett, 238.
 Isidore & Brandt, 253. Madden & Black, 256.
 Mantel, 321. Missa, 260. O'Leary, 265. Pigot,
 261. Prevost, 250. Rolley, 262. Rossi, 248. Tyzack
 264. Winter, 249. Worn, 255. XXVIII. Trueblitt,
 62. France, Croisat, 1574. Thilberge, 695.
 Netherlands, Coucke, 57.

United States, Bourgard, 309. Clirehugh, 133. Gilbert,
 42. Phalon, 310. See also *Hair, Artificial.*
 WILD-FOWL DECOY (Model)—XXIX. Down, 267.
 WILD-FOWL SHOOTING, GUNS, PUMPS, &c., FOR—VIII.
 Hawker, 205. Wilkinson & Son, 200. See also
Stanchion Guns.
 WILLOW-BARK—France, Leroux, 308.
 WILLOW-STRAW—Austria, Tamassia, 97.
 WILTON CHURCH (Model)—VII. Wyatt & Brandon, 220
 (Main Avenue, West).
 WINE FOR CLIMBING PRECIPICES (Model)—VIII. Hub-
 bard, 150.
 WINCHESTER, EARL OF, A. D. 1215 (Model)—XXX.
 (Sculpture Court) Westmacott, 74.
 WIND-DIALS—X. Bennett, 1. Sweden, Adm. Knuger, 55.
 WIND-GUARDS FOR CHIMNEY-TOPS—VII. Green, 116.
 Grisdale, 58. XXII. Edwards, 357. Jersey and
 Guernsey, Dupre, 9.
 WINDING AND CLEANING ENGINE—VII. Davenport, 80.
 WINDING-MACHINES (Cotton)—VI. Mansland & Co., 47.
 Paterson, 28. France, Risler & Son, 1438.
 WIND INSTRUMENTS. See *Cornet-a-Pistons. Ophicleides.*
Trumpets & Horns, &c. &c.
 WINDLASS PURCHASE—VIII. Brown, Lemux & Co., 303.
 Glastone, 182. Wood & Co., 102. XXII. Wood,
 Brothers, 75.
 WINDLASSES, SHIPS'—VIII. Betteley, 63, 97. Brown,
 Lenox, & Co., 61. Cuttew, 98. Hastings, 114.
 Sulby, 110.
 WINDMILLS (Models, &c.)—V. Terret, 126. Vallance,
 127.
 WINDOW-BLIND ROLLERS, PULLEYS, &c.—XXII. Bryden &
 Sons, 45. Jenkinson, 594. Long & Co., 290A.
 WINDOW-BLINDS (SPRING-ROLLER)—XXII. Azulay, 597.
 XXVI. Kohelt & Sons, 316.
 WINDOW-BLINDS, TRANSPARENT AND PAINTED—XXVI.
 Harris, 395. Heasman, 52. Norl, 400. Wells, 232.
 France, Bach-Perey, 1061. Hoen, 201. Morgant, 1726.
 Hamburg, Boekel, 116.
 Zollverein (1), Bengen, 234. Wamp & Schroeder, 239.
 See also *Metal Blinds. Perforated Blinds, Zinc.*
Venetian Blinds.
 WINDOW-BLINDS, WIRE—VII. Walker, 119.
 WINDOW-CLEANER—VII. Ness, 123.
 WINDOW-CURTAINS—XI. Bradbury, Greatorex, & Beale,
 56. XIX. Templeton & Co. 315. XX. Shaw, 91.
 Zollverein (1), Eichelberg, 660.
 WINDOW FASTENINGS—VII. Mackie, 126. XXII. Boulter,
 677. Foun, De La, 800. Pierce, 118.
 France, Credrie, 134.
 WINDOW GLASS—Belgium, Bennert & Bivort, 390. Frison,
 392.
 France, Patoux, Drion, & Co., 674. Renard & Son, 181.
 Robichon, Brothers, & Co., 1445.
 Hamburg, Hildebrand, 56.
 Portugal, Pinto, Basto & Co., 1044-1046.
 Russia, Kokhanoff, 285. Moussin, 294.
 Switzerland, Dague, 75. Zollverein (2), Hoff, 62.
 See also *Crown-Glass. Flint-Glass. Painted Glass.*
*Painted Windows. Plate-Glass. Sheet-Glass. Stained-
 Glass. Stained-Glass Windows.*
 WINDOW-GLASS, COLOURED—XXIV. Clance & Co., 22.
 Hartley & Co., 100.
 WINDOW-GLASS, ORNAMENTED BY MACHINERY—XXIV.
 James, 85.
 WINDOW-SHUTTERS—See *Shutters (for Shops, &c.)*
 WINDOWS, WINDOW-SASHES, &c. (Models, &c.)—VII. An-
 derson, 144. Bates, 09. Botley, 43. Bunnett & Co.,
 152. Farrell, 140. Harper, 141. Herring, 60. Hill,
 68. Hurwood, 31. Mackrory, 173. Maxwell, 192.
 Newnham, 170. Roberts, 127. Theohald, 147.
 Tutton, 118. XXII. Barrow, 4A. Jones, 230. XXIV.
 Castle-street Glass Works, 83. St. Helen's Plate
 and Sheet-glass Works, 66. XXVI. King, 61. XXVIII.
 Gouffrey, 183. Jersey and Guernsey, Dupre, 9. See also
Brick Window Frames. Church Windows. Painted
Windows. Sash Lines. Spring Windows. Stained-Glass
Windows.
 WINE-CASKS, VATS, &c.—XXX. (Fine Art Court) Wood
 48.

- France, Lesourd-Delisle, 593.
 Portugal, Rangel, 1120.
- WINE-FINING WHISK—XXVI. Kendall, 246.
- WINE JAR, KARTHEN (from Tuboco in La Mancha).
 Spain, Ysasi, 51 (Main Avenue, East).
- WINE-MACHINES (Used in the Management of Wines and other Liquors)—XXII. Farrow, 500.
- WINE-PRESSES—VI. Barlow, 613.
 France, La Forestier, 1709.
- WINES—China, Lindsay, Turkey.
 Zollverein (1), Deinhart & Jordan, 869. Geyger & Co., 870. (6) Dael, 82. Metternich, 83.
- WINNOWER-MACHINES—IX. Cooch, 53. Cottam & Hallen, 109A. Marychurch, 93. Nicholson, 50. Ralston, 254. Sawney, 31. Sheriff, 74. Smith, J., 256. Smith, W. 270. Welllake & Co. 127. Windsor, 25. Belgium, Delstanehe, 510.
- WIRE—1. Morewood & Rogers, 436. XXII. Bateman, 81. Bolton, 353. Cornforth, 322. Everitt & Son, 852. Horsfall, 334. Wakefield, 337.
 Austria, Eberstaller & Schindler, 427. Egger, 425. Hueber, 428. Scheil, 429.
 France, Estivant, Brothers, 1214. Palmer, 042.
 India, XXII.
 Nova Scotia, Acaadian Iron Mining Association, 1. Archibald, 2. Nuremberg, Fuchs.
 Russia, Zeitler, 343.
 Sweden, Ekman, 83.
 Switzerland, Nenhaus & Blösch, 1.
 United States, Trenton Iron Co. 167.
 Zollverein (1), Kising & Möllman, 647. Ohle, 62. Reinecker & Co., 404. Schleicher, 405. (2) Ammon, 11A. Fuchs, 11B. Grenanth, Brothers, 95. Kaltenacker, 54A. Kuhn, 57. (4) Rexer, 62. Stohrer, 60.
- WIRE BRIDGES FOR PARKS, &c.—VII. Groat, 47.
- WIRE CARTRIDGES—VIII. Eley, W. & C., 225. Joyce & Co., 277.
- WIRE CLOTH—XXII. Greening & Sons, 39.
 Canada, Rice, 150A.
 Spain, Sastacha, 255. See also *Metallic Cloth. Wire, Wove and Twist*.
- WIRE-DRAWING BENCHES—VI. Johnson & Co., 212.
- WIRE FENCES—XXII. Gidney, 536.
- WIRE FENCES, SCREW FOR STRAINING—X. Richardson, 264.
- WIRE GAUZE—XXII. Baker & Co., 319.
 France, Gaillard, 225. Lang, 288.
 Zollverein (4), Rexer, 62. See also *Wire, Wove and Twist*.
- WIRE NETTING—XXII. Fox, 35. Gorrie, 40.
- WIRE NETTING, GALVANIZED—XXII. Barnard & Bishop, 31.
- WIRE ROPE—XXII. Kuper, 32. Newall, 36. Wilkins & Co., 30.
 Austria, Fischer & Wurm, 426. Wurm, 137.
 Zollverein (1), Felten & Guillaume, 380 (Main Avenue, East). See also *Metallic Cord*.
- WIRE ROPE, GALVANIZED—XXII. Wilkins & Co., 30.
- WIRE TACKS—Austria, Dubsy, 456.
- WIRE-WORK (various articles, in)—IX. Green, 66. XXII. Cornforth, 322. Fox, 35. Reynolds, 37. Richardson, 26. XXX. Hull, 324. Zollverein (5), Zimmermann, 19.
- WIRE, WOVE AND TWIST—VI. Coombe, B. & Co., 444. Corcoran & Co., 416. XXII. Coombes, 27. Nicklen & Sneath, 332. See also *Wire-Cloth. Wire Gauze*.
- WITNEY DUFFELS (Wool Dyed)—XII. & XV. Swaine, J. & E., & Co., 41.
- WOAD—IV. Saunders & Gatchell, 71.
 Zollverein (1), Giessler, 696.
- WOLFRAM—I. Jenkins, 502. Oxland, 485.
- WOODS (Specimens of)—II. London Druggists, 117. IV. Breadalbane, Marquis of, 134. Clason, 22. Cross, 136. Dillon, Viscount, 138. Evans, G. A. Fawcett & Sons, 135. Fitch, 8. Gilman, 44. Harrison, R. & J., 6. Holtzapfel & Co., 14. Lang, 47. Murray, Sir W., 137. Oliver 39. Saunders, 9. XXII. Onions, 249.
 Algeria, Wood and Forest Commission, 47. Bahamas. British Guiana, Bee, 102C, 103, 103A, 105B, 105C, 116—117A, 156. Buchanan, 86, 86A, 90, 90A, 93, 95A, 96, 96A. Duggin, 90B, 99—102A. Fauset, 93, 94. Ontridge, 84, 84A, 85, 85B, 85C, 87, 87A, 88, 86A, 89, 89A, 91, 91A, 92, 92A, 97, 97A, 97B, 98, 98A, 104, 105A, 106—115A, 117A—117E. Pontifex, 102B. Stutchbury, 85A, 117B—117F.
- Canada, Central Commission, 80, 81. Davis, 78. Egau, 74. Parisault, 76, 77. Reed & Meakin, 75.
 Ceylon. Eautern Archipelago, & Woolley, 3B.
 Egypt, 112, 138—140, 388.
 France, Baudou, 43. Boucherie, 1104. St. Ubery, 1405.
 Ionian Islands, Lord Seaton, 5.
 Mauritius, Mellou, 6.
 Mexico. New Brunswick, Mackie, 7. McKillop, 7A. McRae, 4, 8. Shields, 18.
 New South Wales, Bidwell, 1. Dudgeon & Co., 11.
 New Zealand, 38. Johnson, 21. Lucas & Co., 40.
 Nova Scotia, Central Committee, 2.
 Portugal, 515, 508, 581—591. Batalha, 509. De Ficalho, Marquis, 552. De Loulé, Marquis, 553—579. Vaz, 580.
 Rome, Bianconcini, 4.
 Russia, Kauffmann, 117. x.x. 89. Tiflis, Government of, 119. St. Domingo, Schumburgk, Sir R.
 South Africa, Bush, 60. Dumbleton, 47. Moravian Missionary Station, Genadendal, 44. Woodman, 26.
 Spain, Madrid Cabinet Botanical Garden, 186. Manilla Economical Society, 187.
 Trinidad, Lord Harris. Tunis, 96—100. Turkey. United States, Bell, 176. De Saussure, 176A. Pell, 115. Thompson, 241.
 Van Diemen's Land, Akers, 328. Brownrigg, 107, 108. Denison, Sir W. T., 56—70, 121—123, 229, 269. Fowler, 82—89. Freeman. 210—216. Hadden, 103, 104. McLachlan, 348. M'Naughten, 96, 102, 200. Milligan, 221, 223, 313, 341. Quinn, 05. Smith, 189. Whitesides, 91—93.
- Western Africa, Hutton & Sons, 6.
 Zollverein (1), Hilgers, 659. Mess & Co., 247. (4). Noerdlinger, 11. See also *Mahogany. Timber*.
- WOOD CARVINGS—Eastern end, outside, Standish & Noble, 1. Main Avenue, West, Boulton & Swales, 63. XXVI. Hayball, 344. Harrison's Wood Carving Company, 222. Hoyle, 345. Myers, 533. Seibe, 11. Thomas, 275. XXVIII. Crespin, 36. Howton, 160. Moore, 176. Sandy & Powell, 112. Wallis, 8. Winterborn, 168. Wolstenholme, 173. XXX. (Fine Art Court) Atken & Allen, 310. Austin, 313. Biss, 307. Bond, 311. Cook, 104. De Groot, 92. Field, 360. French, 62. Gordon, 81. Harvey, 86. Hellyer & Son, 61. Liechfield, 330. Longley, 93. Nisbet & Co., 116. Perry, 101. Pullen, 84. Ringham, 88. Rogers, 74. 353. Stalon, 108. Tweltdige, 102. Walker, 102. Wallis, 89. Webber & Bartlett, 153.
- Belgium, Geerts, 450 (Main Avenue, East). Menge, 409 (Main Avenue, East). Vanhool, 454 (Main Avenue, East). Wynants, 472. Ceylon.
 China, Hewett & Co. Shea. Sichert & Co.
 France, Cruchet, 810. Dumont-Petrelle, 826. Faure, 1218. Knecht, 282. Lehard, 1326. Lescheane, 573. Pinsouet, 1392. Yon, 745.
 Hamburg, Bartels, 106. India, xxx.
 Mecklenburg-Schwerin, Bear, 8.
 New Brunswick, Gibbs & Co. 2.
 Oldenburg, Cassebul, 1. Persia, Abbot.
 Portugal, Caetano, 1223—1231. Naval Arsenal, 1225—1227. Vieira, 1232.
 Sardinia, Busio, 65. Capello, 64.
 South Africa, 59.
 Sweden and Norway, Ahlborn, 50. Thesen, 44.
 Switzerland, Baumann, 239. Fluekk, 239. Jann, 255. Kehri, Brothers, 242. Kessler, 243. Klarer, 244. Michel, 248. Schild, 250. Wettli, 237. Tunis, 59.
 Tuscany, Barbetti, 76. Lombardi, 75. Marchetti, 79. Pasqui, 83. Western Africa, Trotter, 5.
 Zollverein (1), Alberty, 270. Bouge, 222. Daehn, 269. Graykowski, 444. Heylbreicht, 443. Jaunda, 894. (2), Lang, 77.
- WOOD ENGRAVING AND PRINTING—XVII. Manchin & Morel, 128. XXX. (Fine Art Court) Cundal & Adley, 112. Belgium, Jamar, 444. China, Thums.
 France, Cabonneau, 104. Dujardin, 825.
 Zollverein (1), Kiliau, 603. Osten, 150.

88A, 89, 89A, 91,
104, 105A, 106—
Stutchbury, 85A,
Davis, 78. Egau,
skins, 75.
y, 33.
St. Ubery, 1495.
McKillop, 7A.
on & Co., 11,
as & Co., 40.
509. De Ficalho,
3-579. Vaz, 580.
iffia, Government
Sir R.
Moravian
Woodman, 26.
en, 186. Manila
Turkey.
ure, 176A. Pell,
ownrigg, 107, 108,
229, 209. Fow-
alden, 103, 104.
3, 102, 209. Mil-
95. Smith, 189.
& Co., 247. (4),
y, Timber.
Standish & Noble,
& Swales, 63.
Wood Carving Com-
533. Seibe, 11.
8. Howton, 166.
Wallis, 8. Winter-
(Fine Art Court)
Biss, 307. Bond,
1, 360. French, 62.
& Son, 61. Liech-
Co., 116. Perry,
Rogers, 74. 353.
ker, 102. Wallis,
ast). Menge, 400
4 (Main Avenue,
& Co.
elle, 826. Faure,
Leschesne, 573
Arsenal, 1225-
esen, 44.
238. Jann, 255.
3. Klarer, 244.
237. Tans, 59.
Marchetti, 79.
5.
222. Daehns,
sch, 443. Jauda,
VII. Manchin &
Cundal & Adley,
Thoms.
225.
25.
0.

WOOD, IMITATION—XXVI. Holland & Sons, 62A.
United States, Newman, 402.
WOOD IMPREGNATED WITH BLOCK TIN—I. Dowdham,
501.
WOOD AND INDIAN-RUBBER JOININGS—VIII. Foster, 7.
WOOD MATRICES (Casts from, for the use of Silk, Cotton,
and other Printers)—XVII. Barker, 189.
WOOD, MOSAIC—XXVI. Nye, 54. *Spain*, Jimines, 285.
WOOD MOULDINGS—Zollverein (1), Nees, 420.
WOOD FOR MUSICAL INSTRUMENTS—*Switzerland*, Stern,
57. *Zollverein* (2), Henseth, 76.
WOOD ORNAMENTS (for Furniture, &c.)—*Belgium*, De
Joughe, 416.
WOOD, PAINTING ON—*Switzerland*, Wirtz, 259. See also
Graining and Flatting.
WOOD, SEASONED (Specimens)—II. Peacock, 73. IV.
Bethell, 21. Newton, 20. Payne's Patent Company,
130. See also *Burnettized Timber. Timber-Seasoning
Apparatus*.
WOODS, STAINED—II. Hawthorne, 39. Naylor, 35. IV.
Stowe, 10. XXVI. Palmer, 33. See also *Stains for
Wood*.
WOOD TISSUE—*France*, Christophe, 91.
WOOD TYPES—XVII. Fairbairn, 9.
WOOD WARE (Fancy & other)—XVII. Clark & Davidson,
135. XVIII. Shepherd, 111. XXIX. Smith, 280.
India, XXVIII.
WOODEN LEOS—*Switzerland*, Lempard-Janpeau, 93.
WOODEN LETTERS—XXX. (Fine Art Court) Thompson,
343.
WOODEN SHOES—*Belgium*, De Ketelaere, 350. Poussele,
495.
France, Bathier, 22. Frament, 208.
WOOL (of various kinds)—IV. Cahill, 91A. Darrien, 81.
Good & Co., 95. Henderson, 80. Irving, 94. Lippert,
97. Manings, 86. Millner, 85. Moore, 78. Preller,
91. Kebab, 84. Sants & Co., 88. Sectional Com-
mittee on Animal Kingdom, 85A. Smithsonian, 101A.
XII. & xv. Bruntton & Co., 230. Burgess & Co., 243.
Cheesborough, 179. Cheetham, C. G. & W., 45.
Fox & Co., 272. Pease & Co., 184. Salt, 139.
Sykes & Ogden, 118. Thomas, 493. xx. Laugh-
land, 144. XXIX. Quin, 230.
Algeria, Canton, 14. Haractas Trille, 56. Si Amar
Smin, 49.
Austria, Figdor & Sons, 90. Honyard Von Kethley,
89. Larisch Moennich, 92. Panna & Alexia, 94.
Rotsch & Reichel, 98. Von Mittrowsky, 91. Von
Wallis, 93.
Belgium, Le Chevalier Loenens, 100. Petit Noel, Leronge,
& Co., 246-250. Schepers, 497.
South Africa, Breda, 32. Dumbleton, 47. Reitz & Co., 31.
Denmark, Kolbjornsen, 2.
France, Bernoville, 1548. Billiet & Haot, 1550. Bra-
neaux & Son, 38. Cauvet, 1138. Delattre & Son, 142.
Desplanque, 816. Dollfus, Mieg & Co., 1191. Gaillet-
Baronnet, 839. Girod de l'Ain, 1249. Graux, 245.
Guerot, 533. Hartmann & Co., 257. Lautein & Co.,
566. Laporte & Son, 900. Laroque & Jaquemot, 901.
Latache de Neuville, 562. Lefevre, 1312. Malin-
gie, 322. Manjuet, 1341. Pature-Lupin, Seydoux,
Seibler, & Co., 1381. Richer, 354. Rivaud, 987.
Sentis & Son, 1011. Sourd, 1493. Terrasson de Mont-
jeau, 1498. Warmont, 1048.
Madaira, Read, 1.
New South Wales, Armitage, 1. Learmouth, 8, 10.
McArthur, 13. Motley, 9.
New Zealand, Tyrel, 1, 28.
Portugal, Coriça, 600. Daufrias & Co., 856-863,
855-889. De Ficalho, Marquis, 601-603.
Russia, Gamaley, 123. Gigo, 130. Gorigoretz Farm,
121. Konoviltzin, 337. N. N. 128. Narielkan,
127. Philibert, 124. Shah, 126. Vassal, 122. Youz-
bash, 129.
Sardinia, Brun, Brothers, 21. Mesina, 31. Nuoro Divi-
sional Committee, 36. Prever, 20.
Spain, 226, 229. Barrasa, 228. Hernandez, 230. Montero,
225. Muncio, 224. Tudela Economical Society,
227.
Sweden and Norway, 20. *Tunis*, 5, 9, 11, 39, 40. *Turkey*,

Tuscany, Collacchioni, 52. *Tuscany*, Grand Duke of,
53, 54.
United States, Blakeslee, 131. Brown, 4. Browne, 102A.
Ewing, 188. Hurdley, 583. Kimber, 500. Parker &
Brown, 235. Perkins & Brown, 201. Peters, 106.
Sibley, 197.
Van Diemen's Land, Grant, 346. Kermodie, 235. Oak-
den, 161. Reeves, 322. Richardam & Co., 346.
Smith, 222.
Zollverein (1), Eckardstein, 32. Flockenhaus & Co.,
335. Frankenfelde, Royal Administration of, 27.
Lehmann, 47. Lilbert, 24. Nordmann, 30. Ober-
burggraf Von Brunick, 45, 46. Peill & Co., 360. Sau-
ken, 433. Solweim, Count of, 33. Thier, 21. Von
Lipki, 25. Von Luetwita, 42. Treptow Royal Remun-
ding Depot, 22. Weimarson, 797. (3). Schuetze, 189.
WOOL, ARTIFICIAL—*Belgium*, Van der Schrieck, 101.
WOOL-COMBING MACHINES—VI. Donisthorpe, 40.
France, Desplanque, 816. Harding-Coker, 864.
WOOL-COMBING, TOOLS FOR—VI. Binus, 55. XXII. Wur-
rall & Co., 164.
WOOL SHRETS (for Packing Wool)—XXIX. Earnshaw, 261.
WOOLEN COUNTERPANES—*Canada*, Beau, 137. Dixon,
138.
WOOLEN FABRICS (various)—XII. & xv. Aked & Sons,
137. Allen & Banks, 226. Armitage, Brothers, 101.
Barber & Co., 19. Barber & Son, 105. Barnicot &
Hirst, 105. Barraclough & Son, 133. Beardsell & Co.
109. Beardell & Son, 120. Beaumont, 72. Bennett,
J. & A., 95. Binus, 31. Bramley Woollen Cloth
Company, 64. Brett, Brothers, & Co., 20. Brook, J.
& Son, 487. Brook & Sons, 86. Brown & Forster, 9.
Brown J. & H. & Co., 469. Bull & Wilson, 12. Carr,
T. & W., 273. Cheetham, C. G. & W., 45. Chick,
221. Clark, J. & J. 13. Clay, 124. Comper, D. &
J., 42. Cormack, 68. Crosland, W. & H., 97.
Davies & Sons, 214. Dicksons & Laings, 234. East
& Co., 2. Erocroy & Son, 130A. Edmunds & Edmund,
218. Ellis & Co., 70. Eyles & Son, 27. Fox & Co.,
272. Godfrey, 308. Gutt & Sons, 47. Gray, 67.
Hagues & Co., 25. Haigh & Sons, 296. Haley, A. &
C. 59. Harris & Fison, 145. Hastings, Brothers, 100.
Hayley & Sons, 58. Henry & Co., 38. Hibble-
thwaite & Lister, 96. Hinchliff, J. & G., 119. Hinch-
liffe & Son, 93. Holmes & Sons, 107. Hooper &
Co., 210. Horsfall & Co., 174. Hudson & Bouffard,
21. Hutwell & Son, 85. Hughes, 251. Huth &
Fischer, 123. Ireland & Co., 247. Irwin, 26. Jelb &
Sons, 82. Kenyon, J. & J., 94. Lambert, 30. Lewis,
238. Lockwood & Keighley, 104. M'Crea, 135. Mal-
linson & Sons, 108. Marling & Co., 209. Mills, 253.
Oldfield & Co. 127. Overbury, 216. Paterson, 213. Par-
tridge, 212. Pearson, 239. Phillips & Co., 217.
Playne & Co., 211. Powell, 8. Ripley & Son, 148.
Roberts, 171. Salter & Co., 250. Saville, 46. Schu-
field, A., 474. Schuffield, J., 125. Schwamm, 115. Shaw,
J. W. & H., 98. Shaw, P., 90. Shaw, Son, & Co.,
110. Sheard & Sons, 81. Sheppard, W. B. & G., 18.
Slater, 22. Smith & Co., 14. Smith & Son, 29. Smith,
W., 80. Smitson, 48. Snell, 24. Stancomb & Son,
16. Stancomb, W. & J., 17. Starkey, J. & A., 121.
Stead & Co., 57. Stow, Brothers, 35. Swain &
Co., 41. Sykes, D., & Co., 75. Sykes & Sons, 34.
Taylor, 68. Thornton & Co., 32. Vickerman & Beau-
mont, 102. Walker & Sons, 87. Webster, A., 84.
Webster, D., 63. Webster, T., 62. Wheeler, 271.
Wilkinson, W. & E., 52. Willott & Co., 114. Wilson,
D., 83. Wilson, J., 138. Wilson & Son, 252. Win-
gate & Co., 200. Wrigley, J. & T. C., 117. Wrigley
& Sons, 101. Yewdall & Son, 78. York & Sheep-
shanks, 49. xx. Cross & Co., 115A.
Algeria, Algiers, Delegate of, 58.
Austria, Auspitz, 204. Bauer & Co., 205. Biedermann
& Co., 206. Binder, 207. Blaschka & Co., 204.
Bracht, 240. Brunn Trade Union, 212. Fial, 307.
Furler, 209. Gacs Cloth Manufacturing Company,
209. Ginzler, 210. Guertler, 211. Haitig, 212. Her-
mannstadt Cloth-makers' Association, 214. Honauer,
215. Illek, 216. Kammer, 199. Kruitsoch, 297.
Liebig, 298. Miess, 217. Moro, Brothers, 218.

- Mueller, 219. Namiest Cloth Manufacturing Company, 220. Neuhauser, Seigmund, & Co., 229. Offermann, 221. Popper, Brothers, 222. Posselt, 223, 223a. Schmieger, A., 193. Schlegler, J., 224. Schmitt, 225. Schoell, 226. Schoeller, Brothers, 227. Seidel, 228. Seigmund, 230. Stepanek, F., 231. Steffens, P., 232. Strakosch & Son, 233. Thomas, 196. Thum, 197. Trenkler & Son, 234. Technerner, 235. Ullrich, 236. Vonwiller & Co., 237. Wochovsky, 203. Wolfrum, 301.
- Belgium**, Biolley, 193. Dubois, 196. Janssens, 193. Leonard, 198. Olivier & Co., 201. Simonis, 194. Sirtaine, 197. Snoeck, 202. Vanderstraeten, 203.
- Canada**, Bean, 137. McKay & Co., 144. Paterson, G., 115. Paterson, J., 146. Willert, 143.
- Egypt**, 188, 189, 366.
- France**, Bisson, 1988. Bouchard, 1103. Chatelain & Foron, 86. Chemeviere, 120. Courty, Brothers, & Bares, 97. David, Brothers, & Co., 157. Delamontiere & Co., 1583. Deleque & Co., 143. Delusse, Brothers, 144. Fean-Bechard, 198. Fortel, Larbre, & Co., 206. Fortin-Boutellier, 1109. Fournival, Son, Altmayer, & Co., 221. Gaudchaux-Picard, 222. Guiffet-Salle, 524. Guinonprez & Co., 533. Gros-Odier-Roman & Co., 248. Guilbert & Wateau, 860. Guion, 1263. Hartmann & Sons, 236. Hindenlang, 1269. Kunzer, 883. Laporte & Son, 900. Lefebvre Ducatteau, Brothers, 1300. Lenormand, 388. Mache-Marote, 596. Malstre, Brothers, 598. Milon, 642. Naset, 660. Paret, 1378. Patriau, 1380. Pin-Rayard, 652. Poitevin & Son, 685. Roussel-Dazin, 1458. Schlumberger & Co., 1000, 1481. Schwartz & Huguenin, 1903. Signoret Rochas, 1013. Si Hamida, 1696. *India*, xii.
- Eastern Archipelago**, Grey, The Countess, 1.
- Netherlands**, Heuvellou, 16. Knoopmans, 40. Vreede & Co., 33. **New Zealand**, St. John's College, 7.
- Nova Scotia**, Central Committee, 2.
- Portugal**, 806-808. Correa & Co., 798-803. Lafaurie & Co., 814-840. Larchers & Co., 787-797. Mello, 804. Valerio, 798.
- Russia**, Arsenoff, 182. Beilano Peasant Women, 350. Fiedler, 331. Isaieff, 184. Stumpf, 181. Tcharit-Oblool-Ogli, 186. Varen, 312. Zakhert, 185. Zauhoff & Stepounin, 180. **Sardinia**, Rey, Brothers, 35.
- Society Islands**, Queen Pomare, 3.
- Spain**, Cruz De Arcas, 253c. Mendez, 253a. Santa Maria de Nlewa, Alcalde of, 233. Sastre, 253a. Truela y Campo, 253e.
- Sweden and Norway**, Bergewall, 19. Landmark, 19. Malmgren, 19. Söderberg & Arsenius, 19.
- Switzerland**, Hug-Ith, 185. Kelly, 150. Kunz, 128.
- Tunisi**, 77. **Turkey**.
- United States**, Cook, 242. Lawrence & Co., 409. Macy, Stanton, & Co., 368.
- Western Africa**, Acland, Lady, 14. Beecham, 12. Hutton & Sons, 6. McWilliam, Trotter, 5.
- Zollverein** (1), Anthoni, 378. Beck, 494. Behrend & Schmidt, 98. Bolten, Wilhelm, & Son, 490. Bornmann, 112. Bothcher & Engel, 865. Braun, Brothers, 491. Bruhm & Nagler, 816. Christoffel, 347. Cohn & Hermann, 104. Delius, 866. Feaux & Riesel, 364. Feller & Son, 107. Feulgen, Brothers, 507. Forster, 220. Forshmann & Hoffmann, 508. Geissler, 100. Gevers & Schmidt, 50. Graff, 803. Haan & Sons, 366. Haas & Sons, 337. Haberland, 99. Harrass, 798. Heseloff & Co., 713. Hendrichs, 367. Hey, 26. Hilger, Brothers, 498. Hoffmann, 110. Homberg & Scheibler, 339. Hueck, 499. Hoffmann, Brothers, 500. Itzigsohn, 97. Jansen, 349. Jobamy-Abhoe, 493. Kayser, 370. Kesselkaul, 371. Kleinschmit & Co., 372. Knops, Brothers, 373. Lucius & Co., 729. Lutze, Brothers, 103. Mucht, 730. Martens, 568. Mentzel, 94. Mertins, 867. Mull, 501. Müller, 723. Peill & Co., 369. Pelbermann & Co., 497. Ruffer & Son, 101. Scheder & Co., 102. Scheibler & Sons, 864. Scheidt, 505. Scheidt, Gebruder, & Co., 504. Schlieff, Brothers, 108. Schnabel, Brothers, 503. Schowiller, J. P., 365. Schoeller & Sons, 374. Schuermann & Schübler, 406. Sternickel & Guelcher, 376. Tescheymacher & Kattenbuech, 492. Thywissen, Brothers, 375. Traugott & Co., 111. Visser, 358. Wagner & Son, 348. Walther, Hemig, & Co., 714. Weyerhuesch, 570. Wieser, Brothers, 405. Zamboni, 359. Ziegler, 36. Zirkenbach, 791. Zschille, J. C. & K., 844.
- (3), Bernhard, 121. Boettiger, 108. Buchwald, 133. Burkhart, 109. Caspari, 132. Collet, 110. Fiedler, 128. Glafey & Neubarth, 105. Graefs & Son, 102. Grossman, Brothers, 125. Grossmann, 124. Gruener, 101. Helling & Co., 112. Herrmann, 139. Herrmann & Son, 122. Hoesel & Co., 86. Hoeffler, 111. Jaehnig, 134. Junghans, 131. Kauffmann, 114. Kirsten, 113. Koblich, 123. Lehmann, 107. Meissner, E. 136. Meissner, F. A., 130. Meissner, F. T. 129. Meissner, M., 137. Meissner, T. 126. Muerblitz, 127. Maeller & Co., 115. Oehler, Brothers, 116. Petzoldt, 141. Pressprich, Ernst, & Son, 135. Reichel, 140. Schrorer, 120. Seyferth & Co., 106. Singer, 145. Spengler, 117. Unger, 140. Weickert, 166. Wolf, C. A. 142. Wolf, J. G., 143. Wolf, 144. Ziegler & Hausmann, 92. Zschille, Brothers, 138.
- (4), Finckh, 31. Kohler, 46. Schill & Wagner, 30. Schunleber, 32. (6), Arzi, 27.
- See also *Deniz*. *Blankets*. *Cassimeres*. *Damashes (Worsted and Woollen)*. *Doeshins (Woollen)*. *Dyed Wool and Woollen Cloth*. *Felt*. *Fannel*. *Friezes*. *Plaids*. *Reversible Cloth*. *Turtans*. *Tweeds*. *Waist-coatings*.
- WOOLLEN NETTING**—xii. & xv. Slater, 170.
- WOOLLEN RUOS**, &c.—xvi. Clapham, 9. Deed, 10. Hartly, 6. Hill, 8. Robinson, 7. xix. Harrison, 194.
- Jersey and Guernsey**, Randall, 46.
- WOOLLEN YARNS**—iv. Brendalbane, Marquis of, 95a. xii. & xv. Bruntton, & Co., 230. Burgess & Co., 243. Fox & Co., 272. Marriott & Son, 473. Henwick, T. & A., 233. Sharp, 177. Simon & Co., 163. Thomas, 493. Townsend, 175. Williams & Co., 257.
- Austria**, Keller, 191. Leidenfrost, 192. Schmieger, 193. Suxhler, 194. Tetzner, 193. Thum, 197.
- France**, Billiet & Hoot, 1359. Hartmann & Co., 257. Lachapelle & Levarlet, 1285. Lorthiois-Desplanque, 314. Lucas, Brothers, 1331. Pradine & Co., 1408.
- Russia**, Mues & Co., 192.
- Sardinia**, Messina, 31.
- Van Diemen's Land**, Denison, Sir W. T., 137.
- Zollverein** (1), Clarenbach & Son, 506. Cockerill, 105. Feller & Son, 107. Hugenbruch, 712. Ullenberg & Schintaler, 355. Wald & Son, 98. (3), Schmidt & Sons, 49. Solbrig, 47. Wolf, 48.
- WOOLLEN MACHINERY**—vi. Hunt, 49. Leach, 7. Sandeman, 44. xvii. Hamer, 54. xxii. Carr & Riley, 168.
- France**, Dorey, 823. Harding Cocker, 864.
- United States**, Read, 212.
- WORK-BOXES**—xxvi. Davis, 129. Welch, 150. xxviii. Horne, 160. xxix. Mechi, 45. xxx. (Fine Art Court) Newham, 106. *China*, Hammond & Co.
- France**, Avulot, 11.
- South Africa**, Groenkloof Missionary Station, 43.
- WORK-BOX FITTINGS**—xxii. Brookes, 171.
- WORKING CLASSES, DWELLINGS FOR (Models)**—See *Cottages, Labourers', &c.*
- WORSTED FABRICS**—xii. & xv. Akroyd & Son, 130. Bird, 223. Dalby, 152. Eckroyd & Son, 130a. Fowler & Co., 309. George, W. T. & Co., 50. Huggas & Son, 155. Holdsworth & Co., 166. Pease & Co., 184. Hand & Son, 173. Shepard & Perfect, 131. School of Industry for the Blind, 30. Sugden, Brothers, 167. Towler, Campin & Co., 309. Wilson, 138. xx. Hadlen & Son, 134.
- Zollverein** (3), Guenther & Simon, 94. Schiffner & Zimmermann, 97. Strauss & Leuschner, 99. Winkler & Son, 91. See also *Merino Fabrics*. *Mixed Fabrics*. *Stuffs (Worsted, &c.)*. *Turtans*.
- WORSTED MACHINERY**—vi. Berry & Sons, 48.
- India**, 1.
- WORSTED MANUFACTURE (Illustrations of)**—xii. & xv. Peace & Co., 184.

376. Tescheyn, Brothers, 375.
Wagner & Son, Veyernsch, 570.
Ziegler, 36.
C., 844.
Buchwald, 133.
1, 110. Fielder, Cafe & Son, 102.
124. Gruener, 39. Herrmann & J. Jasling, 134.
rsten, 113. Kob- 136. Meissner, eissner, M., 137.
Mueller & Co., 141. Press- 140. Schroer, 5. Spengler, 117.
A. 142. Wolf, Hausmann, 92.
& Wagner, 30.
neres. *Damask Woolen*. Dyed Lannel. Friezes. Tweeds. Waist- 170.
9. Deed, 10.
XIX. Harrison,
Marquis of, 95A.
gess & Co., 243.
73. Renwick, T.
163. Thomas, 192. Schmieger, Thum, 197.
ann & Co., 257.
Jois-Desplausque, e & Co., 1408.
137.
506. Cockerill,
712. Ullenberg
(3). Schmidt
each, 7. Sande-
Carr & Riley,
664.
150. XXVIII.
(Fine Art Court)
Co.
ation, 43.
1.
dels)—See Cot-
Son, 130. Bird,
130A. Fowler
50. Haggas &
Pease & Co., 184.
ct, 131. Schul
th, Brothers, 167.
138. xx. Hal-
4. Schiffner &
er, 99. Winkler
Mixed Fabrics.
48.
f)—XII. & xv.
- WORSTED SPINNING** (Illustrations of)—*Zollverein* (3), Leipzig Society of Worsted Spinners, 44.
WORSTED YARNS—XII. & xv. Brewin & Whetstone, 242. Eckroyd & Son, 130A. Poppleton, 214. Tuwanni, Brothers, 162. Wall & Co., 159. Whitmore & Co., 241. xx. Cartwright & Wamers, 196.
Austria, Dierzer's Heitz, 169A. Schmieger, 193. Worsted Yarn Spinning Company, 198.
Belgium, Khoffray & Co., 204.
Zollverein (1), Bergmann, 106, 106. Weiss & Co., 717. (3) Petalold & Eh., 20. Trinius & Sons, 45. (4) Schonleber, 32. See also *Dyed Worsted*.
WORT HEATING AND COOLING MACHINES—VI. Thompson, Younger, & Co., 623. See also *Refrigerators*.
WRENCHES, SCREW AND OTHER—V. Thornton & Sons, 490. VIII. Williams, 332. IX. Ferrabee & Sons, 274. Lawrence, 115.
WRITING CABINET—XXVI. Sapwith, T. & J., 316.
WRITING CASES—X. Smith & Son, 31. *Egypt*, 348.
Sweden, Hasselgren, 97.
Zollverein (1), Sommer, 878.
WRITING DESKS—XXVI. Pouthorpe & Co. 132. Stophor, 66. Strugnell, 343. Thompson & Worthy, 134. XXVIII. Baker, 84. Strugnell, 174. Waller, 121. XXIX. Asprey, 50. Dalton, 48. Mechi, 45. Turrill, 52. xxx. (Fine Art Court) Newham, 100.
Ceylon, France, Gocht, 1615.
New South Wales, Burchet, 3.
Portugal, Portugal, King of, 1237.
WRITING AND TRACING CLOTH—XVII. Smith, 41.
WROUGHT IRON—See *Iron, Wrought*.
- XYLOPYROGRAPHY** (or Charred Wood Engraving)—XXX. (Fine Art Court) Calvert, 97. Marshall, 353. Mills, 96. Mitchell, 87. *Belgium*, Duchastel, 443.
- YARD MEASURES**—X. Elliott & Sons, 320.
YARN TARRING MACHINE—VI. Plenty, J. & E., 53.
YARN WASHING MACHINE—XXII. Robertson, 565.
YARNS (Various)—XII. & xv. Burgess & Co., 243. Eckroyd & Son, 130A. Sugden, 167. Whitley, 176. Williams & Co., 257. XIV. Schwann, 50A.
France, Crouelle, 132. *Turkey*.
Zollverein (1), Lueddoff & Co., 584. See also *Cotton Yarn*. *Flax Yarn*. *Hemp Yarn*. *Linen Yarn*. *Woolen Yarn*. *Worsted Yarn*.
- YASMAS**—*Switzerland*, Geilinger, Brothers, 251.
YAWLS (non-capizable)—*France*, Lahure, 285.
YEAST, DRIED POWDERED—*Zollverein* (1), Friedenthal, 846.
YELLOW BERRIES (FOR DYEING)—*Russia*, 92.
YORK MINSTER (Models)—XXX. (Fine Art Court) Dickenson, 181. Middleton, 166.
- ZAFFRE**—*Zollverein* (1), Horstmann & Co., 462.
ZINC AND ZINC CASTINGS AND MANUFACTURES—I. Morewood & Rogers, 436. Vieille Montagne Mining Company, 437. II. Howards & Kent, 11. Huskisson, J. W. & H., 86. XXII. Lawrence & Co. 54. Treggott, II. & W., 55. XXVI. Vinuell, 260.
Belgium, Corphalie, Société de, 21. Dethier, 19. Nouvelle Montagne, Société de, 7. Vauclercamer, 355.
Egypt, 368.
France, De Braux D'Anglure, 779 (Main Avenue, East). Deydier, 819. Lefevre, 581. Paillard, 671. Sorel, 1020. Vieille Montagne Company, 1018.
Netherlands, Bleekrode, 1. Schütz, 98 (Main Avenue, East).
Spain, Granada Mines, Inspector of, 16.
Zollverein (1), Bischof & Rhodius, 312. Bredt & Co. 315. Devaranne & Son, 280. Geiss, 267. Hagen, 322. Harkort, 874. Hösch & Sons, 563. Kies, 279 (Main Avenue, East). Lambinton & Co. 451. Malapane Iron Works, 451. Renner, 59. Hochatz, 452. Huffer & Co., 11. (3). Zimmermann, 19.
- ZINC CEMENT**—II. Spence, 7.
ZINC CERUSE OF—*France*, Mantois, 918.
ZINC ENGRAVING—XXX. (Fine Art Court) Calvert, 228. Green, 233.
ZINC ORE—I. Davey, 503. XXII. Lawrence & Co., 54. *Belgium*, Corphalie, Société de, 21. Vieille Montagne Mines et Foudries, 26. *Canada*, Logan, 1. *United States*, New Jersey Mining Company, 166 (Main Avenue, East).
Zollverein (1), Eschweiler Mines et Foudries, 318. (8). Nassau Government Engineers of Mines, 1.
ZINC, OXIDE OF (with colours made therefrom)—II. Brown, 57. Scott, 61.
ZINC, PERFORATED—I. Jack, 437A.
ZINC, SULPHATE OF—*Portugal*, Serzedello & Co., 69.
ZINC, SULPHURET OF—I. Riddell, Sir J. M., 55.
ZITHERS—*Austria*, Huther, 149. Kiendl, 148.



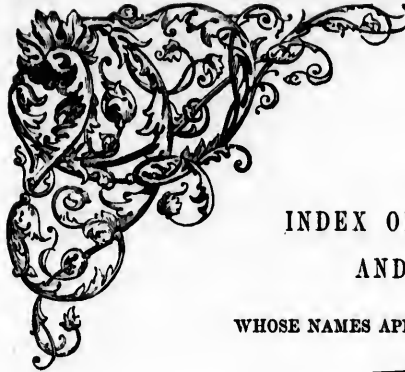

INDEX OF EXHIBITORS AND OTHERS

WHOSE NAMES APPEAR IN THE CATALOGUE.

Memorandum.—This Index includes the name of every Person, and Public or other Company, mentioned in the Catalogue, whether as Contributor, Manufacturer, Patentee, Agent, or in any way connected with Articles in the Exhibition. The references following each name distinguish—1. Class in the United Kingdom, the Colony, or Foreign Country in which the same will be found; and 2. The number in the Catalogue borne by the entry to which the name is prefixed.

- | | | |
|---|---|---|
| <p>ALBERT, H.R.H. PRINCE.—Page 112
 Abad, M.—Spain, 181
 Abasheff, N.—Russia, 331
 Abass-Isak.—Russia, 244
 Abate, F.—xxx. 265
 Abbey & Son.—United States, 51
 Abbott, F.—Persia, ..
 Abbott, G.—xxxiii. 66; xxx. (Fine Art Court), 53
 Abbott, J.—xxvi. 45; Van Diemen's Land, 290
 Abbott, T. T.—United States, 596
 Abbott, W.—ix. 55
 Abbott & Wright.—iv. 121
 Abdool-Mahomet-Ogli.—Russia, 243
 Abdourza-Maram-Ogli.—Russia, 94
 Abele and Co.—Zollverein (4), 76
 Abele, F.—Austria, 582
 Abell, W.—vi. 80
 Abercarn Coal Co.—Western end, South enclosure (Outside), 40
 Abercarn & Gwythen Collieries Co., (Newport).—i. 430
 Abercrombie & Yuill.—xii. & xv. 292
 Aberry, J.—xxii. 529
 Ablett, see Wheeler & Ablett
 Abraham, A. & Co.—x. 263
 Abraham, G. A.—xix. 76
 Abraham, J. A.—x. 140
 Abramoff, J.—Russia, 131
 Abt, Brothers.—Switzerland, 227
 Abt, W.—Zollverein (4), 7
 Acadian Iron Mining Association.—Nova Scotia
 Ach, Dubois & Co.—Belgium, 360
 Acheson, J.—viii. 47
 Ackere, J. C., Van.—Belgium, 215
 Ackerman & Co.—xvii. 1
 Ackland, W.—x. 369
 Acklin.—France, 399
 Acland, Lady.—Western Africa, 14
 Acland, Sir T. D., Bart., M.P.—Western Africa, 17
 Acott, see Parker & Acott
 Acquarone, J. B.—Sardinia, 84
 Actien, Verein.—Zollverein (1), 214
 Adair, B.—xxix. 307
 Adair, R.—i. 67
 Adam, see Thibet & Adam
 Adam, A.—Western end, South enclosure (Outside), 18</p> | <p>Adam, G.—Zollv. (1), 487
 Adams, iv. 49; see Bradwell & Adams. Deane, Adams, & Deane
 Adams, G.—xxx. (Fine Art Court), 281
 Adams, G. G.—xxx. (Sculpture Court), 37. 48. 62.—Page 817; see also Howell, James, & Co.
 Adams, G. W.—xxiii. 88
 Adams, H.—United States, 476
 Adams, J.—xxiii. 538
 Adams, Jane.—xiv. 12
 Adams, N.—United States, 570.
 Adams, R.—ix. 28
 Adams, S.—xxix. 33
 Adams, S. & C.—vi. 429
 Adams & Sons.—x. 2; xix. 21
 Adams, T.—x. 14
 Adams, W. B.—v. 510
 Adams, W. & Co.—United States, 462
 Adams, W. H. F.—Canada, 331
 Adamson, O. G.—Brazil, 1
 Adamson, R.—xxx. (Fine Art Court), 300; xxviii. 196.
 Adcock & Co.—xvi. 323A (Main Avenue West)
 Adcock, J.—x. 353, 364
 Adcock, T., jun.—vii. 192
 Adcock, Mrs. W.—Van Diemen's Land, 6
 Alderley, C. B., M.P.—South Africa, 57
 Aldley, see Cundall and Aldley
 Addington, W. H.—United States, 471
 Addis, J. B. Jun.—xxi. 23
 Addis, S. J.—xxi. 11
 Addison & Gilbert.—viii. 192
 Addison, R.—x. 487
 Adikes, J. D.—Hamburgh, 67
 Adirondac Manufacturing Company.—United States, 344
 Adler, C.—Zollverein (3), 175
 Admiralty (Somerset House)—viii. 145, 146 (North Transept)
 Adolphe, C.—France, 1.
 Adolphi, C. F. W.—Zollv., (1), 172
 Adorno, J. N.—vi. 448; x. 218
 Adshead, J.—xxx. (Fine Art Cr.), 328
 Adshead, W. & Co.—xiii. 39
 Ait, Brothers.—Zollverein (2), 66
 Aeris, F. G.—Belgium, 180
 Affourtit, G. L.—France, 749</p> | <p>Afti, F.—Austria, 616
 Aga Melik Mahomet Hadji Ussoof Ogli.—Russia, 290
 Agadjan, D.—Russia, 251
 Agard, F., see Prat A. & F. Agard
 Aggio, G. H.—x. 498; xxvi. 83; xxix. 312
 Agombar, P.—France, 2
 Ahlbeck, G. C.—Sweden, 73
 Ahlberg, O.—Sweden, 72
 Ahlborn, C.—Sweden, 50
 Aiken.—v. 812
 Ain Morka Mines Co.—Algeria, 19
 Ainge & Aldred.—xxix. 180
 Ainslie, see Harrison, Ainslie, & Co.
 Ainsworth, J.—Middleton and Ainsworth
 Ainsworth, G. H.—viii. 136
 Ainsworth, T.—i. 422
 Aire & Calder Bottle Co.—xxiv. 6
 Aitken & Allen.—xxx. (Fine Art Court), 310
 Aked & Sons.—xii. & xv. 137
 Aken, C. B. Van.—Belgium, 121
 Aken, P. Van, & Son.—Belgium, 122
 Akerman, W. H. H.—x. 490
 Akermann, see Sulzburger & Akermann
 Akers, Lieut.—Van Diemen's Land, 328
 Akroyd & Son.—xii. & xv. 130
 Akenoff, J.—Russia, 182
 Alabama, Governor of the State of.—United States, 269
 Alba, S.—Austria, 664
 Albaccet.—Spain, 56
 Albani, Brothers.—Sardinia, 7
 Albar, J.—Spain, 100
 Alber, J. V., jun.—Zollverein (5), 23
 Albert, J. W.—Zollverein (5), 7
 Alberti Brothers.—Prussia, 231
 Alberti, Fr.—Zollverein (1), 751
 Alberty, J.—Zollverein (1), 270
 Albertzoom, S.—Russia, 284
 Albinet.—France, 400
 Albrecht, see Leale & Albrecht. Roehrig & Albrecht
 Albrecht, A.—Hamburgh, 59
 Albrecht, Archduke.—Austria, 431
 Albright, A.—ii. 126
 Albro & Hoyt.—United States, 183
 Albuquerque, A. S. d'.—Portugal, 353
 Albuquerque, J. D', e Mello.—Portugal 478, 479</p> |
|---|---|---|



v, whether as Contr-
 following each name
 d. 2. The number in
 6
 Hadji Ussoof Ogli.
 251
 A. & F. Agard
 488; XXVI. 83;
 ce, 2
 len, 73
 7, 72
 50
 .—Algeria, 19
 XIX. 180
 Anulie, & Co.
 ton and Ainsworth
 136
 2
 Co.—XXIV. 6
 XXX. (Fine Art
 & xv. 137
 Belgium, 121
 .—Belgium, 122
 —x. 490
 rger & Akermann
 iemen's Land, 328
 & xv. 130
 182
 of the State of.—
 64
 ardinia, 7
 0
 Zollverein (5), 23
 rein (3), 7
 ssia, 231
 ein (1), 751
 u (1), 270
 a, 284
 Albrecht. Roel-
 argh, 59
 —Austria, 431
 ed States, 183
 .—Portugal, 353
 Mello.—Portugal

Alcala, D. M. G.—Spain, 151
 Alcala & Son.—Spain, 213
 Alcan.—France, 1050
 Alcan & Limes.—France, 5
 Alcan & Loatell.—France, 4
 Alcock, J.—United States, 220
 Alcock, S. XXII. 367A
 Alcock, S. & Co.—xxv. 7
 Alcock, S. B. & Co.—XXIX. 272
 Alcock, T.—IX. 27
 Aldebert, see Hullmarke, Aldebert, &c.
 Aldebert, I.—VIII. 152
 Alder & Meyer.—Switzerland, 109
 Alderman, J., see Chapman, T. & Alderman, J.
 Alderton & Shrobury.—XXII. 403
 Aldred, see Alings & Aldred
 Aldred, S.—XXX. (Fine Art Court) 235
 Aldridge, J. M.—XXII. 688.
 Aleman, P.—Spain, 254
 Aleu, H.—France, 1538
 Alexander, see Heyman & Alexander
 Alexander, E.—IX. 198.
 Alexander, J. T.—XXVI. 99
 Alexander, W.—x. 426
 Alexandre & Son.—France, 1719
 Alexis, J., see Panna, N. & Alexis, J.
 Alfonso, M. J.—Portugal, 1023-1043
 Alfred, W. H.—XXIX. 179
 Alfau.—Russia, 306
 Algiers, Delegate of.—Algeria, 58
 Algiers Mines, Commission of.—Algeria, 45
 Algor, J.—XXII. 118
 Ali, Mehemet.—Russia, 246
 Alioth, T. S. & Co.—Switzerland, 151
 Allard & Claye.—France, 750
 Allan, see Dallantine & Allan.
 Allan, A.—v. 711
 Allan, D.—XXVI. 87
 Allan, J.—XX. 13; Canada, 28
 Allan, J. sen.—VIII. 122
 Allan, J. H.—VIII. 61, 85
 Allan, T.—x. 201
 Allan, W.—Canada, 121
 Allcroft, see Dent, Allcroft, & Co.
 Allday, W.—XXII. 253
 Allen.—XXIX. 196; see also Aitken & Allen. Bott & Allen. Jeffrey, Allen, & Co. Nicol & Allen. Oldfield, Allen, & Co.
 Allen, A. B. & Co.—United States, 97
 Allen & Banks.—XII. & xv. 236
 Allen & Co.—VIII. 202
 Allen, C. B.—XXVII. 68; xxx. (Fine Art Court), 79
 Allen, E. E.—x. 413
 Allen, F. G.—XXII. 293
 Allen, G.—xii. & xv., 225
 Allen, G. P.—United States, 236
 Allen & Holmes.—XIII. 50.
 Allen, J.—VIII. 292; Canada, 35
 Allen, J. M.—xvi. 36; xxv. 40
 Allen & Moore.—XXII. 300
 Allen, R.—xi. 65; xii. & xv. 259
 Allen & Solly.—xx. 100
 Allen & Son.—xvi. 149
 Allen, T.—VII. 151
 Allenby, see Lewis & Allenby
 Almond, Emanuel.—Jersey & Guernsey, 27
 Allies, see Cruttwell, Allies, & Co.
 Allies, F.—XXIX. 157
 Allin, J.—XXX. (Fine Art Court), 199
 Allin, W.—xvi. 35
 Allin, W. S.—xvi. 327
 Alliot, see Maulore, Alliot, & Seyrig
 Allis, J. H.—x. 87
 Allison, E. W.—VIII. 115
 Allison, R.—x. 480, 483

Allix, A. J.—France, 6
 Allman, F.—x. 459
 Allou, J.—Canada, 100
 Allou, J.—Canada, 94
 Allouard, sen.—France, 1051
 Almanza, D.—Spain, 209
 Almeida, J. V. d.—Portugal, 318
 Almeida, Silva, & Co.—Portugal, 473.
 477, 480
 Almeria, Inspector of the Mines of the district of.—Spain, 13
 Almgren, K. A.—Sweden and Norway, 30, 89
 Almy, Patterson, & Co.—United States, 454
 Alner, Anna.—Sweden and Norway, 42
 Alpers, see Muckenheim & Alpers.
 Alphen, G. Van.—Netherlands, 41
 Alsop, D.—IX. 25A
 Alsop, Robius, and Co.—XIII. 48
 Alsterberger, J.—Austria, 503
 Altenhauer, Brink, & Co., Zoll. (1), 612
 Alteyines, S. L., Van.—Belgium, 271
 Althor, J. C.—Switzerland, 110
 Altmann, J. G.—Zollverein (1), 215
 Altmayer, see Fournival, Son, Altmayer & Co.
 Alvarez, Calleja, D. S.—Spain, 118, 166
 Alvarozales, D. R.—Spain, 177
 Alves, E. J. da.—Portugal, 407
 Amann, J.—Belgium, 368
 Amann & Egli, Switzerland, 153
 Amann, J.—Switzerland, 153
 Ambler & Avery.—United States, 214, 291
 Ambrose, see Billings and Ambrose.
 Ambrose, J.—XXVII. 128
 Ameloung & Son.—Russia, 295
 American Chair Co.—United States, 55
 Amezte Berte, R.—Belgium, 209
 Amigo y Saury, R.—Spain, 217.
 Amman, see Meyer and Amman
 Ammanniati, Capt. G.—Tuscany, 17
 Ammon, J. P.—Zoll. (2), 11A
 Amor, J.—Spain, 22, 121
 Amos, see Dean, Amos, & Co. Easton & Amos
 Amos, J.—IX. 66A
 Amoskeag Manufacturing Company.—United States, 2
 Amstell, P.—Zollv. (1), 543; (3) 52
 Amster.—Zollverein (1), 772
 Amuller, E. F.—France, 405
 Anana Salt Works, Alava.—Spain, 36
 Ancliaux, J.—Belgium, 344
 Ancion & Co.—Belgium, 143
 Andelle, G. & Co.—France, 1540
 Andereg, T.—Switzerland, 111
 Andersen, P.—Denmark, 15
 Anderson.—Van Diemen's Land, 198.
 See also Oyler & Anderson. Smith, Anderson, & Co.
 Anderson & Bettany.—xxv. 16
 Anderson, C.—xiv. 56
 Anderson, D.—xvii. 200
 Anderson, D. & J.—xi. 16
 Anderson, G.—VII. 144
 Anderson, G. & Co.—British Guiana, 36
 Anderson, J.—v. 801; VIII. 187; x. 403; see also Anderson, D. & J.
 Anderson, J. & A.—xi. 7.
 Anderson, J. R. & Co.—United States, 281
 Anderson, R.—VIII. 190; XXIX. 224
 Anderson & S. ms.—Zollv. (1), 897
 Anderson, T.—VIII. 130
 Anderson, W.—XXX. (Fine Art Court), 189
 Anderwalt, Pasquale.—Austria, 170A
 Andrassy, Count G.—Austria, 415

Anhe.—Main Avenue East; Algeria, 1; Zollverein (1), 788
 Andre, Brothers.—Zollverein (6), 56
 Andre, J. & Major Count de Z. Bronco-
 Ironski.—France, 1054
 Andre, J. P.—France, 1053
 Andree, C.—Zollverein (1), 360, 379
 Andreoletti, W. C.—France, 10
 Andresen, P.—Zollverein (1), 177
 Andrews, H. P.—XXII. 370
 Andrews, see Harrett, Exall & Andrews. Forster & Andrews
 Andrews, H. Q.—United States, 540
 Andrews, J.—v. 803
 Andrews, M.—xiv. 5
 Andrews, R.—v. 802; x. 551
 Andrews, Sons, & Gee, XVIII. 5
 Andrews, W. & Co.—XVIII. 43
 Andrieux, see Hivart & Andrieux
 Anelli, J.—x. 511
 Angeli, G.—XXIII. 103
 Angell, J. C.—XXIII. 111
 Angermaland.—Sweden & Norway, 21, 22, 23
 Angraull.—France, 7
 Angrave Brothers.—xx. 202
 Angulo, I.—Spain, 38
 Angus, F. J.—v. 710
 Animal Kingdom, Sectional Committee on.—iv. 53A
 Anichy & Pont.—Sardinia, 34
 Anichez, R.—Zollverein (1), 693
 Ansell, C.—VIII. 185
 Anselm, F. C.—Zollverein (6), 50
 Ansted, Professor, D. T.—I. 241
 Anstey, S.—I. 119
 Ante, A.—Zollverein (1), 627
 Antheit, Societe Corpallie D.—Belgium, 21
 Anthelme.—France, 1541
 Anthoni, H. A.—Zollverein (1), 378
 Anthony, C. J.—IX. 237; United States, 585
 Anund Nath Roy, Rajah.—India, XXVI.
 Apolytomen Co., Madrid.—Spain, 35A
 Appel, C.—Zollverein (6), 15
 Appel, J. C.—Hamburg, 119
 Appel, R.—xxx. (Fine Art Court), 274
 Appert.—France, 751
 Applegath, —vi. 122
 Applegath, A.—XVIII. 12
 Appleton, see Upham, Appleton, & Co.
 Appold, J. G.—v. 420
 Aqui, see Oxeila & Aqui
 Araman, H.—Persia
 Aranturri, G.—Spain, 101
 Aranturri, G. A.—Spain, 103
 Archambault.—France, 401
 Archbold, see Brown & Archbold
 Archer, F. T.—XXVI. 265
 Archer, J. S.—XXIII. 110
 Archer, J. W.—Page 847.
 Archibald, C. D.—Nova Scotia, 2
 Archibald, J. R.—xii. & xv. 461
 Archibald & Sons.—xii. & xv. 465
 Arlamatsky, Brothers.—Russia, 99
 Arlamatsky, J.—Russia, 98
 Arlamatsky, J. & T.—Russia, 97
 Ardini & Chancel.—France, 8
 Atera, N. G.—France, 732
 Aretio, C.—Spain, 269
 Argall, J. & W.—XXII. 404
 Argall, W., see Argall, J. & W.
 Aristarkoff.—Russia, 359
 Arkansas Mining Company.—I. 52
 Arliss & Tucker.—xvii. 55
 Arukoonu, see Marimato & Arukoonu
 Armangand, France, 14
 Armani, see Orsi & Armani

Armitage, Brothers.—xii. & xv. 103;
New South Wales, 1
Armitage, G. & Co.—ix. 38A; xii. &
xv. 146
Armitage, M. & H.—xxiii. 150.
Armistead, H.—xxiii. 97
Armstrong, see Hopwood & Armstrong
Armstrong, J.—xviii. 77; xxviii. 43
Armstrong, J. Jun.—xxii. 580
Armstrong, S. T.—United States, 210
Armstrong, W. G.—v. 44
Arnaut, D.—Algeria, 2
Arnaut, H.—France, 402
Arnaut & Berend.—Hamburgh, 24
Arneth, J.—Austria, 368
Arnheim, S. J.—Zollverein (1), 189
Arnheiter.—France, 753
Arnold, see Hecht & Arnold
Arnold, A.—Jersey & Guernsey, 33
Arnold, C. H.—Zollverein (1), 835
Arnold, S. W.—xxv. 7
Arnold, E. P.—Zollverein (1), 778
Arnott, Dr.—x. 994, 612, 619; xxii.
357, 636
Arnott, R.—British Guiana, 142—143A
Arnoux, C.—France, 1542
Arns, A.—Zollverein (1), 626
Arntin, Tabanoff.—Russia, 252
Aronald's Manufactory, Sweden, 111
Arosenius, see Solerberg & Arosenius
Arault.—France, 9
Arer, J.—Austria, 262
Arrieda.—Spain, 693
Arrieta.—Spain, 295
Arrindell, Mrs.—British Guiana, 69
Arrowsmith, A., see Arrowsmith, H. & A.
Arrowsmith, G. A.—United States, 138
Arrowsmith, H. & A.—xxvi. 355
Artem, Royal Salt Works at.—Zoll-
verein (1), 681
Arthur, see Holmes, Herbert, & Arthur
Arthur, Ann.—xix. 69
Arthur & Eley.—xxix. 185
Arthur & Frazer.—xii. & xv. 466.
Arthur, J.—i. 462
Arthur, Mary, S.—xxix. 58
Arthur, O. C.—xxvii. 4
Arthur, T.—xxvi. 303
Artman, J.—United States, 174A
Arzi, P. L.—Zollverein (6), 27
Asbeck, C. & Co.—Zollverein (1), 645
Ascroft, T.—xxvi. 304
Ash & Sons.—x. 578
Ashburnham, Dowager Lady.—iii. 60
Ashbury.—v. 739
Ashby, J.—v. 202
Ashby, W.—vi. 470
Ashie, Lieut. E. D.—x. 194
Asher, W. A.—x. 194
Asher, A.—United States, 355
Ashfield, J.—Canada, 161
Ashford, G., see Ashford W. & G
Ashford, W. & J.—xvi. 64
Ashmead, see Vine & Ashmead
Ashmead & Tyler, J. T.—xx. 53
Ashmead & Harlburt.—United States,
535
Ashton, see Nicholls & Ashton.
Ashton, A.—xx. 171
Ashton, J. P.—Canada, 355
Ashton & Sons.—xx. 52
Ashton, W.—xxx. (Fine Art Court),
152
Ashworth, S. A.—xviii. 87
Askew, C.—vi. 611; vii. 48
Aspdin, see Robins, Aspdin, & Cux
Aspern, W. M. V.—Hamburgh, 88
Aspinall, J.—v. 57
Aspinwall & Son.—xxvi. 213
Asprey, C.—xxix. 50

Asprey, J.—iii. 93
Assam Company.—iii. 143
Asser, L.—vii. 5
Assmann, J.—Zollverein (1), 468
Atell & Co.—China
Atton, J.—xxii. 301, 367
Atton, W.—xxii. 263
Astrath, C.—Austria, 666.
Asturias (Oviedo), Inspector of the
Mines of the District of.—Spain, 15
Athamasiou, D.—Greece, 9.
Athensum Boot & Shoe Warehouse,
(Norwich).—xvi. 137
Athers, Lieut.—Van Diemen's Land,
528
Atherton, C.—v. 1
Atkin & Son.—xxii. 365
Atkins, see Broadhead & Atkins. Brock-
bank & Atkins
Atkinson, see Hives & Atkinson. Mar-
riott & Atkinson
Atkinson, B. F.—x. 603
Atkinson & Eldrid.—xvi. 80
Atkinson, J.—i. 261
Atkinson, R. & Co.—xii. & xv. 256
Atkinson, W.—xvii. 56
Atloff, J. G.—xvi. 131; xx. 32
Attenborough, R.—xxiii. 113
Attfield, C.—iii. 61
Atwood, G. B.—United States, 426
Aubanel.—France, 1055
Aubergier, P. H.—France, 751
Aubert & Klaffenberger.—x. 52A
Aubert, L. A.—Switzerland, 73
Aubert & Noel.—France, 403
Aubeux.—France, 1658
Aubin, C.—xxii. 663
Aubin, F., see Aubin, H. & F.
Aubin, H. & F.—xxii. 603
Aubrey, see James & Aubrey
Aubry, Brothers.—France, 1544
Aucher.—France, 404
Auckland & Waikato Coal Company.
—New Zealand, 10
Aueler, P., see Aueler, W. & P.
Aueler, W. & P.—France, 1050
Aucoc.—France, 1032
Audemars, L.—Switzerland, 22
Audiat, F.—France, 1545
Audot, J.—France, 11
Augan, M.—France, 12
Augustin, H. F. L.—Zollverein (1), 826
Augustus, E.—United States, 515
Auld, Barrie, & Mathieson.—xi. 5
Auldjo, Mrs. Richardson.—xxvi. 405
Auleuzia Compy, Madrid.—Spain, 53
Ausfeld, H.—Zollverein (1), 704
Auspitz, L.—Austria, 204
Austell, St., Local Committee.—i. 166,
469
Austin, G.—xxix. 36
Austin, J.—xxvi. 391
Austin, J. B.—ii. 114
Austin, W.—xvii. 151; xxix. 217;
xxx. (Fine Art Court), 313
Australian Agricultural Company, New
S. Wales, 19
Anzoux, Dr. L.—France, 13
Avanza, D.—Belgium, 446
Avern, E.—xxii. 303
Averseng & Co.—Algeria, 3
Avery.—x. 631A, see also Ambler &
Avery
Avery & Dangar.—xxvi. 389
Avery, O.—United States, 76
Avignon, Chamber of Commerce of.—
France, 1049
Avignon, Dr. F. D.—United States,
132; see also Brady, D'Avignon &
Lester

Avissau, C.—France, 1543
Ax, see Pfiffers & Ax
Ayekboom, F.—viii. 23
Ayers, W.—xix. 398
Ayne, Brothers.—France, 755
Ayrapet, T.—Russia, 201
Ayton, J.—vi. 428
Ayzaoff, S.—Russia, 91
Azevelo, J. R. de.—Portugal, 310
Azoff Sea, Cossacks of the.—Russia, 37
Azulay, B.—i. 224; viii. 39; xxii.
597; xxvi. 64
Azzopardi, J. M.—Malta, 20
Bader, I.—Zollverein (2), 74
Bader, J. A. & Co.—Zollverein (2), 22
Bader, J. A.—Switzerland, 235
Baba-Imam-Verdi-Oghl.—Russia, 264.
Babaieff, A.—Russia, 86
Babarikin, M.—Russia, 96
Babst, see Walker & Babst
Baber, see Smith & Baber
Babitt.—v. 706
Ba'jounoff, B.—Russia, 345
Bacelus & Sons.—xxiv. 19.
Bach.—Zollverein (1), 717
Bach, G. F. & Son.—Zollv. (3), 158
Bach, P.—France, 1061
Bache, Professor, A. D.—United States,
305
Bacheley, T.—Portugal, 1015-1020
Bachler, A.—Zollverein (1), 10
Bachman, J.—United States, 391
Bachner, F.—Austria, 505
Bachoven & Vollschwitz.—Zollverein
(1), 830
Bachrich, J., Austria—45A
Bacse, see Knapp & Bacse
Bacses, J. F. & Co.—Zollv. (1), 411
Backhausen, C. & J.—Austria, 249
Backhausen, J., see Backhausen, C. & J.
Bacon, see Sewell, Evans, & C.
Bacon, S. F.—United States, 465
Bacon, W.—xxvi. 218
Bacut, P. & Son.—France, 1002
Bacze, see Stulbe & Bacze
Baddock, J.—x. 732
Badderey, J. H.—xxv. 13
Baddeley, W.—v. 409
Baedeker, J.—Zollverein (1), 832
Baeder, Brothers.—Austria, 250
Badgley, J. F.—Canada, 11
Badillo, J. M.—Spain, 57
Badin, J. C. F.—France, 1063
Badouin, A. P.—France, 41
Baedner, A. B.—Austria, 575
Baebes, A.—Spain, 258A
Baenziger & Co.—Switzerland, 112
Baenziger, J.—Switzerland, 168
Baenziger, Kulp, & Co.—Switzerland,
156
Baer, see Sprecher & Baer
Baetens, Miss.—xxx. (Fine Art Court),
212
Baffeo, J. L. F.—Sardinia, 70
Bagatti, V.—Austria, 616
Bagby, Gov. A. P.—United States, 329
Bagnall & Jesson.—Western end, South
Enclosure (Outside), 53
Bagot, C.—i. 244
Bagshaw, W.—xxii. 143
Bagster & Sons.—xvii. 87
Bagner.—Russia, 39
Bahn, A. E.—Zollverein (1), 256
Bahr, H. & Co.—Hamburgh, 122
Bahr & Marsch.—Austria, 612
Bahrt, H.—Mecklenburg-Schwerin, 9
Bahuet, A.—France, 17
Baildon, see Newbould & Baildon

1843
23
ce, 755
201
91
Portugal, 310
the.—Russia, 37
VIII. 39; XXII.
alta, 20
u (2), 74
Zollverein (2), 23
echnid, 235
II.—Russia, 264.
86
ia, 96
labi
aber
a, 345
iv. 19.
, 747
Zollv. (3), 158
01
).—United States,
al, 1015-1020
in (1), 10
States, 391
, 565
witz.—Zollverein
—45a
Bucke
—Zollv. (1), 411
—Austria, 219
ckhausen, C. & J.
yas, &c.
States, 465
8
auce, 1062
Bucye
z. 13
9
in (1), 832
ria, 259
da, 11
b, 57
ce, 1063
ce, 41
ria, 575
58a
erland, 112
land, 188
Co.—Switzerland,
uer
(Fine Art Court),
inia, 79
United States, 329
estern end, South
, 53
43
t. 87
in (1), 256
burgh, 122
ria, 612
rg-Schwerin, 9
7
& Baikdon
Bales, H.—XXVI. 208
Bailly, B.—VIII. 64
Bailley, E. H.—XXIII. 97
Bailley, J.—Canada, 86
Baillie, B.—VIII. 70
Baillie, E.—XXIV. 91
Bailliere, J. B.—France, 406
Baillly, see Mallet & Bailly
Baillly, Comte, & Son.—France, 407
Baillly, E. H.—Page 847
Bailey, J.—VIII. 332
Bailey & Sons.—XXII. 805, (Main Avenue, West); XXX. (Fine Art Court), 308
Bain, A.—X. 434
Bain, C.—VII. 34
Bain, W.—VII. 197; XX. 70
Bainbridge, J.—XXX. (Fine Art Court), 163
Baines & Co.—Bahamas
Baines, J.—XX. 200
Baines, T.—Cape of Good Hope, 67
Baines, W.—V. 643
Baird, J.—XII. & XV. 290
Baird, J. R.—VIII. 74
Baird, W.—XXIII. 26
Bajalatre, E. De.—France, 18
Bakefem, T. T. & Sons.—Switzerland, 152
Baker, see May & Baker
Baker, A.—United States, 257
Baker, C.—XXII. 509; XXVIII. 81
Baker & Co.—XXI. 319, 517
Baker, E. B.—XXII. 19
Baker, H.—X. 391
Baker, J. B.—United States, 498
Baker, R.—X. 351
Baker, H. C.—XXVII. 54
Baker, S.—United States, 1
Baker, S. & Co.—Mauritius
Baker, T. K.—VIII. 203
Baker, Tuckers, & Co.—XVIII. 2
Baker, W.—XXI. 20; XXII. 559
Baker, W. R.—United States, 401
Bakewell, F.—X. 433
Bakewell, W.—XXIII. 70
Bakhrumshin & Sons.—Russia, 240
Balanca, J. & Sons.—XVIII. 9
Balay, J.—France, 1064
Baldamus, see Kramer & Baldamus
Baldenecker, T. B. jun.—Zollv. (5) 12
Balca, J.—Canada, 67
Balfour, J.—XIV. 35
Balkfield & Co.—Mauritius, 5
Ball, Dumichiffe & Co.—VI. 90; XIX. 19
Ball, R.—XXX. (Fine Art Court), 157
Ball, W.—IX. 132
Ball, W. Y. & Co.—XX. 80
Ballantine & Allan.—XXIV. 78
Ballantyne & Son.—XII. & XV. 194
Balleicher, F.—France, 1665
Ballenly, J.—XXII. 299
Balleras, G. E.—I. 4; New Granada, 3
Ballheimer, see Pralle & Ballheimer.
Balling, J. N.—Austria, 133
Bally & Co.—Switzerland, 210
Bally, P.—France, 408
Bally, W.—XXX. (Fine Art Court), 173
Balneavis, Lieut. H. C.—New Zealand, 20
Balny, J. P. jun.—France, 1065
Balthoven, P. Van.—France, 1516
Baltzer, A.—Zollverein (1), 82
Bamler & Son.—XXII. 681
Bamberger, L.—Bavaria, 102
Bamford, J.—XII. & XV. 237
Bampton, J. A.—XXVI. 125
Bance, jun.—France, 410
Bance, Brothers.—XVII. 96

Handeller, P. Y.—Switzerland, 6
Banim, M.—XXIX. 160
Bank Park Pyropolis Works.—I. 86
Bank Quay Foundry Company (Warrington).—V. 412
Bankart.—XXII. 343
Bankart, F.—II. 49
Bankart & Sons.—I. 429. XXIV. 87
Banks, see Allen & Banks; Jameson & Banks
Banks & Barry.—X. 561
Banks & Chambers.—V. 666
Banks, E.—XXII. 257
Banks, L.—VII. 65
Banks, Son, & Co.—I. 69
Banerman & Sons.—XVIII. 33
Banting, T., see Banting, W. & T.
Banting, W. & T.—XXVI. 166
Bantlin, C. D.—Zollverein (4), 37
Banton, E.—XVI. 56
Baptrocasse, J. F.—France, 409
Barantuhluk, Imperial Iron Works of.—Russia, 158
Baranowski, J. J.—France, 15
Barbatiemue & Co.—France, 1709
Barbat.—France, 1067
Barbs, C.—France, 1068
Barbeau, J.—Canada, 110
Barbeaux Lecuyer, L. J.—France, 19
Barbedienne, J., & Co.—France, 1723
Barber, see Pith, Barber, & Co.; Jordan & Barber
Barber-Beaumont, G. D.—V. 752
Barber, C. A.—XXVIII. 118
Barber, Howe, & Mead.—XII. & XV. 19
Barber, James, & Co.—China,
Barber, Messrs.—Canada, 140
Barber, S.—XX. 57
Barber & Sons.—XII. & XV. 106
Barbieri.—Rome, 15
Barbetti, A.—Tuscany, 74, 80
Barbetti, R.—Tuscany, 76, 77
Barbie, J.—Sardinia, 56
Barbieri, De.—Sardinia, 93
Barbotin & Legoff.—France, 1033
Barboza, Jose.—Portugal, 683, 949, 950
Barbrinsky, Count A.—Russia, 56
Barcelona, Inspector of Mines of the District of.—Spain, 2
Barclay, G.—XXX. (Fine Art Court) 285
Barclay, J.—VII. 117
Barclay, Miss P. S.—XXX. (Fine Art Court) 285
Barclay & Son.—IV. 24
Barclotfsky, T.—Russia, 265
Bardwell, W.—XXX. (Fine Art Cr.) 175
Barez, see Courtey, Brothers, & Barez
Barfield, C.—Zollverein, (1), 188
Barford, F.—XX. 170
Barge, H.—XXII. 144
Baring, Brothers.—China
Baring, Thos., M.P.—Austria, 746
Barker, C. M.—VI. 417
Barker & Co.—IV. 62
Barker, G.—XXVI. 147
Barker, J.—IX. 230; XVII. 189
Barker, Dr. J.—X. 649
Barker, H.—XXI. 37
Barker, T. J.—XXX. (Fine Art Court) 131
Barker, W. G.—XVI. 188
Barkly, Mrs.—British Guiana, 125, 128, 129, 135
Barling, J.—X. 90; XXIII. 85
Barling & Sons.—XXIX. 305
Barlow.—V. 640
Barlow, A.—VI. 82
Barlow, C.—VI. 41
Barlow, E.—United States, 350
Barlow, Gooddy, & Jones.—XI. 35

Barl w, H. B.—VI. 613
Barlow & Heald.—V. 640
Barlow, J.—XXII. 461
Barlow, P. W.—V. 601
Barlow, T. H.—United States, 69
Barlow, W. H.—V. 602
Barn, T. A.—South Africa, 46
Barnaulsk Imperial Works.—Russia, 4
Barnard & Bishop.—XXII. 34
Barnard, E.—XIX. 94
Barnard, J.—United States, 17; Van Diemen's Land, 143
Barnes, see Greenwood & Barnes.
Barnes & Co., Bahamas.
Barnes, E.—XII. & XV. 219.
Barnes, G. see Barnes, T. & G.
Barnes, J. H.—II. 45
Barnes, J. W.—XXIX. 15.
Barnes, R. V.—IX. 95
Barnes, T.—XI. 10.
Barnes, T. & G.—XX. 27
Barnes, W.—XXIV. 49. United States, 246 see also Barnes, J. & W.
Barnett, Mrs. Edward.—Bahamas
Barnicutt, see Beach & Barnicutt
Barnicot & Hirst.—XII. & XV. 105
Barnouin & Co. see Fabregue-Nourry, Barnouin, & Co.
Barnwell & Son.—XXII. 678
Baron, Brothers.—United States, 353, 370
Baron, F.—Portugal, 1154
Baron & Uhlman.—Switzerland, 74
Baromet, see Rousset & Baromet
Barossa Range Mining Co.—South Australia, 2
Barraclough, S.—XVI. 148
Barraclough, W. & Son.—XII. & XV. 153
Barra, C.—France, 410
Barraillon & Brossard.—France, 16
Barraude, J. B.—France, 756
Barraza, M.—Spain, 228
Barraud & Lund.—X. 34
Barre, D. G. La—Canada, 17
Barre & Kuester.—Zollverein (1), 827
Barre, B.—France, 40
Barre-Russin.—France, 20
Barres Brothers.—France, 41
Barreto, F. T.—Portugal, 1123a
Barrett & Co.—VI. 410
Barrett, see Fox & Barrett
Barrett, Capt.—I. 511
Barrett & Conroy.—XIX. 70.
Barrett, Exall, & Andrews.—VI. 410; IX. 128
Barrett, J.—XXVI. 805
Barrett, R. M.—X. 349
Barrett & Son.—XXIX. 308
Barrie, J.—XXVI. 104
Barricotes, F.—Spain, 83
Barrington, see Fox & Barrington
Barritt & Co.—XVII. 196
Barritt, J. L.—XXX. (Fine Art Court) 339
Barrou.—XXII. 622
Barron & Son.—XXII. 695
Barrow.—XXII. 4
Barrow, R.—Western end, South enclosure (Outside), 41; I. 235
Barrowman, J.—IX. 49
Barry, see Banks & Barry
Barry & Barry.—I. 178
Barry, C.—XXVII. 27, 92
Barshaghan.—Russia, 312
Barsham, J.—IV. 564
Barsham, Son, & Co.—XXIX. 213
Bartelmus, Brothers, & Bernhartl.—Austria, 432
Bartels, J. C. M.—Hamburgh, 106
Barth, Brothers.—Zollverein (2), 67

- Barth, J. A.—Zollverein (3), 179
 Barth, Masing, & Plichon.—France, 21
 Barthel, J. C.—Zollverein (5), 5
 Barthelats, L.—France, 757
 Bartholomew, F. H.—United States, 335
 Bartlett, W. & Sons.—XXII. 329
 Bartlemore, see Kelsall & Bartlemore
 Bartlett, see Webber & Bartlett; W. L. and Bartlett
 Bartlett, A. D.—XXIX. 291
 Bartlett, R. M.—United States, 30
 Bartley—xvi. 97.
 Bartolome, M.—Spain, 126
 Barton, see Mallett & Barton
 Barton, C. D.—United States, 223
 Barton, H. W.—x. 703
 Bartram, A.—Canada, 162
 Bartrum & Pretzman.—XXII. 25
 Baruch Toledoano.—Algeria, 59
 Barwell & Co.—XXII. 556
 Barwis, W. H. B.—Western end, South enclosure (Outside), 12
 Bary, T. de, & Bischoff.—Switzerland, 152
 Basely.—France, 411
 Basham, F.—United States, 315
 Bashkins, tribe of the.—Russia, 133, 200
 Basin, A.—France, 758
 Baskcomb, G. H.—v. 804
 Baskett, see Martin, Baskett, & Martin
 Bass, J.—II. 95
 Blass, J. H.—XXVIII. 124
 Bast, C. de.—Belgium, 189
 Basse and Fischer.—Zollverein (1), 664
 Basset, see Chatelain & Basset
 Bastard, A. de.—France, 1717
 Bastien, M.—Canada, 70
 Bastos, F. Pinto, & Co.—Portugal, 9. 279. 290. 455-457. 551. 629. 631. 1044. 1109
 Bataille, V.—France, 42
 Batailler, A. P. E.—France, 412
 Batalha, F. R.—Portugal, 401A. 495A. 496A. 505. 509. 541-513, 538.
 Batatho, see Miranda, Batatho, & Co.
 Bateman.—Western end, North enclosure (Outside), 59
 Bateman, D. & Sons.—XXII. 84
 Bateman, J.—VII. 333
 Bateman, Dr. J.—x. 187
 Bateman, J. & A. Moore—XXII. 524
 Bateman, James.—XXII. 84
 Bateman, Mrs.—United States, 587
 Bates, see Mayo & Bates
 Bates, F.—IX. 186
 Bates, Hyde, & Co.—United States, 440
 Bates, Jemima.—XIX. 375
 Bates, T.—VII. 69
 Bates, T. H.—XXVI. 44
 Bateson & Co.—XII. & xv. 39
 Bathier, V.—France, 22
 Batjeman, H. C.—United States, 552
 Baska, Wenzel.—Austria, D. 100. 135. 629
 Batley, see Hodge & Batley
 Baton, W. & Son.—France, 1069
 Batsford, J.—xxx. (Fine Art Court), 262
 Batt, R. & Sons.—xx. 116A
 Battam, T.—xxv. 53
 Battaglia, G.—Austria, 366
 Batten, A.—I. 19
 Batten, D.—XVII. 59
 Battenberg, G.—France, 1070
 Batters, Martha.—xix. 96
 Battie, see Jovitt & Battie
 Batty & Feast.—III. 116
 Batty, T.—United States, 351
 Batz, P.—Zollverein (3), 150
 Bauch.—Netherlands, 98
 Bauch, F. T.—Zollverein (1), 728, 793
 Bauchau De Bare, A.—Belgium, 262
 Bauchet-Verlinde.—France, 413
 Baudon.—France, 43
 Baudry, see Gils & Baudry
 Baudry, A. T.—France, 1071
 Baner & Fuerbringer.—Zollv. (1), 725
 Baner, G.—Zollverein (2), 78
 Bauer, J.—Austria, 504
 Bauer & Krebs.—Zollverein (5), 13
 Bauer, R.—Zollverein (1), 223
 Bauer, Theodor, & Co.—Austria, 205
 Bauerkeller.—Zollverein (6), 6
 Bauerkeller & Co.—France, 1072
 Baugh, see Stainburn & Baugh
 Baugh—Deeley, & Co.—I. 401
 Baughen, Brothers.—XII. & xv. 183
 Baughen, T., see Baughen, R. & T.
 Baufhofer, F.—Austria, 389
 Baum, E.—Zollverein (1), 760
 Baumann, A.—Switzerland, 239
 Baumann, Louise.—Zollverein (1), 224
 Baumann & Streueli.—Switzerland, 153
 Baumann, T.—Zollverein (1), 76
 Baumann & Wunsch.—XII. & xv. 206
 Baumgarten & Hains.—Hamburg, 12
 Baunscheidt, C.—Zollverein, 344
 Baup, H.—Switzerland, 52
 Baur, Brothers.—Zollverein (4), 87
 Haute, T. F.—Switzerland, 236
 Bauwens, L. F.—IV. 26
 Bavay, P. De.—Belgium, 361
 Baxter.—XVII. 172
 Baxter, G.—xxx. (Fine Art Court), 115
 Baxter, J.—xxx. (Fine Art Court), 334
 Baxter, R.—xvi. 156; xxvi. 380
 Bay, J. De.—France, 45; Main Avenue East, 573
 Bayard, H.—France, 414
 Bayer, J. G.—Austria, 351
 Bayley and Craven.—XVIII. 31
 Bayley, J.—VII. 352
 Bayley, J. B.—South Africa, 5
 Bayley, R.—x. 273
 Bayley, W.—XXIII. 75.
 Baylis & Son.—VIII. 251A
 Bayliss, T.—VII. 131
 Blyman, H.—v. 485
 Baynes, R. Agnes.—XIX. 97
 Bayno, J.—Sardinia, 48
 Bayvet, Brothers, & Co.—France, 415
 Bazalay, M.—Russia, 164
 Bazanget, A.—Main Avenue East, 97
 Bazin, sen.—France, 1073
 Bazin, A.—France, 416
 Bazin, G.—XXIX. 178
 Bazin, Xavier.—United States, 36
 Bazley, see Gardner & Bazley
 Bazley, T.—XI. 53; South Africa, 30b
 Beach, Brothers.—United States, 544
 Beach, W.—XXI. 48; United States, 592
 Beach & Barnicot—XIX. 222
 Beacock, see Smith, Reacoel, & Tannett
 Beadon, G., Capt. R.N.—VIII. 90; ix. 208a
 Beadon, W.—VII. 51
 Beale Brown, T.—XIV. 77
 Beale & Latchmore—xx. 204
 Beale, Rev. J. B.—II. 3
 Beales, see Taylor & Beales
 Beall, see Bradbury, Greatorex, & Beall
 Beamish.—I. 112
 Bean, S. E. T.—Canada, 142
 Bean, S. Hatley.—Canada, 137
 Beaney, T.—XXIX. 130
 Bear, H.—Mecklenburg-Schwerin, 8
 Beard, see Kirby, Beard, & Co.
 Beard, J.—United States, 759
 Beard, R.—x. 292
 Beards, S.—Canada, 03, 98
 Beardsell, C. & Sons.—XII. & xv. 120
 Beardsell, I. & Co.—XII. & xv. 109
 Bearfoot, R.—VIII. 274
 Bearn & Joffa.—xvi. 118
 Beart.—XXVI. 282; see also Roberts & Beart
 Beart, R.—vi. 301; ix. 34
 Beattie, J.—VIII. 216
 Beattie, W.—XXIII. 110
 Beau, Le, see Griffiths & Le Beau
 Beauclere, Capt. G.—xxx. (Fine Art Court), 156; xxx. (Sculpture Cit.), 51, 63
 Beaufile.—France, 1074
 Beauford, R.—x. 406
 Beaufort, Miss.—xx. 156A
 Beaufort, De.—France, 46
 Beaumont, see Vickerman & Beaumont
 Beaumont, G. D. Barber.—v. 752
 Beaumont, W.—XII. & xv. 72
 Beauregard.—Algeria, 4
 Beauvais, C.—France, 1076
 Beauvais, National Manufacture of.—France, 1367
 Beauvoys, Ch. De.—France, 46
 Beavis, J.—XIX. 395
 Becerril, A.—Spain, 71
 Beclerier, J.—Zollverein (1), 141
 Becht, juu.—France, 48
 Bechtstein, see Rupp & Bechtstein
 Beck, see Smith and Beck
 Beck & Co.—Spain, 134
 Beck, F.—Sweden, 104
 Beck, G. F.—Zollverein (3), 65
 Beck, Heury.—Zollverein (3), 149
 Beck & Heynig.—Zollverein (3), 148
 Beck, R.—xvi. 247
 Beck & Son.—Belgium, 324
 Beck & Sons.—Switzerland, 163
 Becker, see Seeling & Becker
 Becker, C.—Netherlands, 83
 Becker, F. C.—Zollverein (1), 232
 Becker & Kroniek.—Austria, 643
 Becker, Sapp, & Co.—Zollv. (1), 471
 Becker & Schraap.—Zollverein (3), 84
 Beckers, G. E.—v. 503.
 Beckett, E. G.—v. 106
 Beckett, G.—xvi. 220
 Beckford, T. & Gosling, W.—ix. 60
 Beckli, Brothers.—Zollverein (1), 174
 Beckmann, J. J. C.—Lubeck, 4
 Beckwith, H.—VIII. 220
 Beccuet, see Guynet & Beccuet
 Bedel.—Algeria, 5
 Bedford, see Wood & Bedford
 Bedford, Bouison, Drake, & Co.—Western end, South enclosure (Outside), 24
 Bedford, F.—xxx. (Fine Art Court) 80
 Bedford, J.—vi. 426
 Bedfordington.—XXII. 370
 Bellano, Peasant Women of.—Russia, 350
 Bee, B.—VIII. 324
 Bee, J. F.—British Guiana, 5, 17, 18, 29, 74-76, 82, 83, 102c, 103, 103a, 103b, 105a, 110-117A, 124, 134, 156, 158
 Beecham.—xxx. (Fine Art Court) 332
 Beecham, Rev. Dr.—Western Africa, 12
 Beeching, J.—VIII. 136
 Beechly, Rev. St. V.—x. 263
 Beek, J. C. Van der.—Zollverein (1), 494
 Beekmans, J.—Belgium, 170
 Beecroft, Butler, & Co.—I. 415; v. 640
 Beekham, see Luard, Beekham, & Co.
 Beekingh, N. Van, & Co.—Netherlands, 27
 Beek, B. Van.—Netherlands, 80
 Beer, see Jenkins & Beer

& xv. 109

also Roberts &

14

Le Beau
x. (Fine Art
Sculpture Crt.),h & Beaumont
-v. 732
v. 7276
nufacture of.—

ce, 46

(1), 141

echstein

k

(3), 65

(3), 149

rein (3), 148

324

nd, 163

cker

83

n (1), 232

ria, 643

ilv. (1), 471

verein (3), 84

W.—ix. 60

rein (1), 174

eck, 4

ecquet

ford

e & Co.—West-

re (Outside),

rt Court) 80

of.—Russia,

a, 5, 17, 18,

103, 103A,

24, 134, 156.

Court 332

ern Africa, 12

53

illverein (1),

170

415; v. 640

ham, & Co.

Netherlands,

is, 80

Beere, G.—v. 467
 Beernaert, A.—Belgium, 439
 Beernaerth & De Cuyper, H.—Belgium,
 326
 Beers, see Monahan & Beers
 Beeson, J.—xxx. (Fine Art Court) 111A
 Beesten, J. Van.—Zollverein (8), 12
 Beeston, J.—vii. 191
 Beaton, J. S.—xx. 162A.
 Beavor, J.—xxix. 204
 Becht, T. J.—xxviii. 110
 Begg, W. G.—v. 407; xxix. 109
 Begon, Brothers.—France, 49
 Begsteiger, M.—Austria, 689
 Beguin, A.—France, 23
 Behault, Du Carmois de.—Belgium,
 191
 Behydt—Belgium, 76
 Behn, F.—Zollverein (1), 685
 Behnes—xxx. (Sculpture Court), 54.
 77. Page 847
 Behr, C.—Austria, 645
 Behr, F. L.—Belgium, 20
 Behr & Schubert.—Zollv. (3), 50
 Behrend & Schmitt.—Zollverein (1), 98
 Behrens, J.—xii. & xv. 180
 Behrens, J. C.—Lubeck, 3
 Behnhauer, C.—Hamburg, 121
 Beir, N. le.—Jersey and Guernsey, 36
 Beiser, W.—Zollv. (1) 748
 Beisiegel, P.—Austria, 667
 Beissel & Son.—Zollverein (1), 407
 Beitz, F.—Austria, 438
 Belcher, I.—xxi. 42
 Belfast Royal Flax Improvement So-
 ciety.—iv. 106
 Belfast School of Design.—xx. 118;
 xxx. (Fine Art Court) 338
 Belbin, P.—Russia, 217
 Béliise-Callaud, Nouel, Detinan, & Co.
 see Callaud, & Co.
 Bellichi, M.—Russia, 350
 Bell, see Watson, Bell, & Co.
 Bell & Black.—xxix. 243
 Bell, C.—xvi. 53
 Bell & Co.—ii. 66; xxv. 26
 Bell, D.—xxvi. 212
 Bell, E. B.—United States, 176
 Bell, F. & Co.—ix. 197
 Bell, H.—viii. 14, 157; x. 715
 Bell, J. L.—ii. 12
 Bell, J.—i. 189; ii. 116; xxvii. 57
 Bell, J. & Co.—xxvii. 96
 Bell, John.—xxii. 232. 340. 641;
 xxx. (Sculpture Court), 24, 71, 72.
 Page 847
 Bell, Major.—xvii. 203
 Bell, P. W.—Canada, 103, 173
 Bell, R.—xxix. 101
 Bell, T.—x. 679; xv. 63; United
 States, 103
 Bell, T. & Co.—xiv. 6
 Bell, W.—vii. 63
 Bell, W. C.—xxx. (Fine Art Crt.), 249
 Bell, W. P.—Canada, 280
 Bellamy, see Burney & Bellamy
 Bellange, A. L.—France, 1077
 Bellebay, W.—xxvi. 145
 Belleville, Brothers.—France, 1078
 Bellhouse, E. T. & Co.—v. 416
 Bellioni-Ance, L.—Belgium, 319
 Bello, J. G.—Portugal, 1123b. 1128.
 Bellon, J. & Co.—France, 1070
 Bellot, see Sellier & Bellot
 Belmonte, Count de.—Portugal, 386—
 389
 Belmonte, R.—Spain, 256
 Beloe, W. L.—x. 709
 Below, F.—Zollverein (1), 233
 Belvallette, Brothers.—France, 50

Belvidere Manufacturing Co. (Rich-
 mond)—United States, 282
 Bemard, R.—Belgium, 478
 Ben Zekri.—Algeria, 7
 Beniagzil, Viscount de.—Portugal, 307.
 324. 328. 339. 366. 376. 377. 402
 Benbow, Mrs.—xix. 100
 Bencraft, S.—France, 24
 Benda, George.—Zollverein (2), 1. 9
 Bendall, J.—ix. 32
 Benecke, W.—Mecklenburg-Strelitz, 1
 Benecke, W. & Co.—xviii. 42
 Beneden, Van.—Belgium, 345, 346
 Benedig, J.—Austria, 356
 Benes, Miss M.—Algeria, 6
 Bengen, D.—Zollverein (1), 234
 Benham & Sons.—xxii. 98
 Benham, W. A.—iii. 38
 Beni Abbes, Tribe of the.—Algeria, 53
 Beni Snous, Tribe of the.—Algeria, 67
 Benningfield, W.—xxiv. 45
 Benito, M.—Spain, 78
 Benjamin, J. R.—United States, 152, 251
 Benjamin & Moses.—New South Wales
 Benjumea, J. M.—Spain, 185. 189A
 Benkowitz, Marie.—Austria, 389
 Bennati, J.—Sardinia, 59
 Benner, Dr. W.—xvii. 60
 Benner & Bivort.—Belgium, 390
 Bennett, see Lincoln and Bennett
 Bennett, A. see Bennett, J. & A.
 Bennett & Adams.—xiv. 11
 Bennett, Carr, & Co.—i. 450
 Bennett & Co.—xii. & xv. 185
 Bennett, E.—viii. 293; xxx. 268
 Bennett, G. W.—x. 49
 Bennett, H.—ix. 75
 Bennet, J.—vi. 215; x. 1
 Bennett, J. & A.—xii. & xv. 05
 Bennett, T.—i. 498; xxiii. 18
 Bennighaus, J. C.—Zollv. (1), 679
 Beuno-Niveta.—Russia, 273
 Bennoch, Twentyman, & Rigg.—xix.
 394
 Benoit, A.—Sardinia, 33
 Benoit, F.—Belgium, 369
 Benouville, M.—France, 760
 Benson, C.—xvi. 12
 Benson, W.—iii. 39; Spain, 251
 Bentall, E. H.—ix. 217
 Bentinck, Col. H.—xix. 400
 Bentley—viii. 264; see also Hammers-
 ley & Bentley
 Bentley, J.—x. 213
 Bentley, J. F.—iii. 4
 Bentley & Son.—viii. 221
 Bentley, W. H.—xxii. 606
 Benzon.—Denmark, 45
 Benzon, G.—Austria, 725
 Benzon, Gio. Maria.—Rome, 16
 Beranger, J. & Co.—France, 761
 Berard & Co.—France, 51
 Berckmans, J.—Belgium, 170
 Berden, F. & Co.—Belgium, 174
 Berend, see Arndt & Berend
 Berend, W.—Hamburg, 45
 Berenguer, J. B.—Spain, 192A
 Berenharts, A. & Co.—Belgium, 334
 Berg, Brothers.—Zollv. (1), 873
 Berg, F.—Austria, 579
 Berge, Brothers.—Zollverein (6), 60
 Berger, see Burgun, Waller, & Co.
 Berger, C. H.—Austria, 389
 Berger, F.—i. 439 (Main Avenue,
 West); France, 418
 Berger, J.—i. 518; Austria, 309
 Berger, Madame.—Belgium, 349
 Berger, S. & Co.—iii. 130.
 Berger, Walter.—France 23. 1072
 Bergewall, F.—Sweden & Norway, 19

Bergin, M. O.—vii. 183
 Bergmann & Co.—Zollverein (1), 106
 Bergmann, L.—Zollverein (1), 268
 Bergmann, W.—Zollverein (1), 207
 Bergquist.—Sweden, 60
 Bergstrom, J. W.—Sweden, 68. 77. 85
 Berge, C. de.—v. 552; vi. 45
 Bérichon, M. Eug.—Mauritius
 Beringer, B.—France, 1546.
 Berington, J.—viii. 213
 Berland, J.—Jersey & Guernsey, 4
 Berlin, L. R. & Lode.—Zollv. (1), 342
 Berlin Royal Prussian Iron Foundry.—
 Zollv. (1), 271. (Main Avenue East)
 Berliner, A.—France, 52
 Berlioz & Co.—France, 53
 Bermann, J.—Austria, 370
 Bermingham, T.—vii. 13
 Bernadon, H. A.—Algiers
 Bernaert & De Cuyper, H.—Belgium,
 326
 Bernard.—France, 420
 Bernard, Brothers.—Zollverein (6), 9
 Bernard, D. F.—France, 762.
 Bernard, J.—xxix. 177
 Bernard, J. B.—France, 1081.
 Bernard, Hon. Jane G.—ix. 372
 Bernari, Jules, see Oury, Jules Bernard,
 & Co.
 Benari, L.—France, 1547.
 Bernard, St., Board of Direction of the
 House of Correction at—Belgium, 226
 Bernaride, senior.—France, 421
 Bernardia.—Austria, 480
 Bernardis, Bernardo de.—Austria, 141n.
 430 (Main Avenue, East); 633, 643,
 646
 Bernacoste, Dr.—China
 Bernhard, Afinger, J.—Zollv. (1), 309
 Bernhard, von Sanden.—Zollv. (1), 14
 Bernhard, W.—Zollverein (3), 121
 Bernhardt, see Bartelmann, Brothers, & Co.
 Bernhardt, G.—Sweden, 87
 Berni & Melliard.—xx. 103
 Bernimolin, N. & Brothers.—Belgium,
 150
 Bernoville, Larsonnier, & Chenest.—
 France, 1548
 Bernstorff & Eichwede.—Hanover, 8
 Berr & Co.—France, 54
 Berrall, W. and Son.—xvi. 115
 Berres, M.—Zollverein (1), 385.
 Berretta, Daniele.—Rome, 6
 Berrie, see Auld, Berrie, & Mathieson
 Berriedale, Lord.—v. 405
 Berrus, Brothers.—France, 55
 Berry, B. & Sons.—vi. 48
 Berry, Brothers.—xiii. 75
 Bert.—France, 763
 Bert, J.—Spain, 246
 Bert, J. J.—Spain, 245.
 Bertani, A.—Belgium, 477
 Bertaud, jun.—France, 1549
 Bertheche, Chesnon, & Co.—France,
 1082
 Berthault.—France, 56
 Berthelot, N.—France, 422
 Berthelot & Bonte.—Belgium, 216
 Berthiot.—France, 57
 Berthon, Rev. E. L.—viii. 104
 Berthoven, Van.—Belgium, 502
 Bertinetti, P.—Sardinia, 61
 Bertini, G.—Austria, 737 (Main Avenue,
 East)
 Bertounet.—France, 58
 Bertou, H.—France, 1084
 Bertram, J.—viii. 136
 Bertrams, Mrs.—Jersey and Guernsey, 41
 Bertrand, A.—France, 764
 Bertrand, F. & Co.—France, 59

Bertrand, Gayet, & Dumoutat.—France, 1085
 Bertrand, Provancher.—France, 970
 Besant.—x. 369.
 Bescansa, F.—Spain, 230
 Beschler, R. F.—France, 60
 Beske.—Russia, 303
 Besley, R. & Co.—xvii. 195
 Besnard, Richoux, & Genest.—France, 61
 Bessalie, H. P.—Zollverein (1), 71
 Bessarabia, School of Horticulture.—Russia, 41
 Bessemer, H.—v. 421 ; vi. 400
 Bessent, Maria.—xxix. 293
 Besson, A. D.—Switzerland, 40
 Besson, G. A.—France, 424
 Best, Messrs.—Van Diemen's Land, 345
 Best, T.—x. 330 ; xxix. 37
 Beswick, J.—iii. 100
 Beswick, R.—xxvii. 106
 Bethel, Ware, & Co.—xx. 76
 Bethel, J.—iv. 21
 Bettany, see Anderson & Bettany
 Betteley.—viii. 97
 Betteley, J.—viii. 63
 Betteley, J. & Co.—viii. 97
 Bettignies, M.—France, 1086
 Bettle, P.—x. 679A
 Bettridge, see Jennings & Bettridge
 Betts, A.—x. 519
 Betts, E. L.—xxvii. 22
 Bugger, J.—Switzerland, 113
 Bevan, C.—xxviii. 171
 Bevan, H.—v. 105
 Beveridge, E.—xiv. 29
 Bevington & Morris.—xvi. 332 (Main Avenue West, 301) ; xxviii. 38
 Bevington & Sons.—xvi. 1
 Bewick, J.—i. 423
 Bexley, Lord.—iii. 100
 Bey, H.—Hamburg, 73
 Beyer, A.—Austria, 495
 Beyer & Co.—Zollverein (3), 51
 Beyer & Heins.—Zollverein (1), 761
 Beyerhans, A.—Zollverein (1), 144
 Beyerle, G.—France, 765
 Bezault, J. & Co.—France, 425
 Bezroukavnikoff-Sokoloff, A.—Russia, 248
 Bianchi, J. & Duseigneur.—France, 1037—1273
 Bianchini, G.—Tuscany, 113
 Bianchini, Luigi.—Rome, 11
 Biancoini, F.—Zollverein (1), 205
 Biancoincini, Count.—Rome, 4
 Biancoincini, Count Biagio.—Rome, 1
 Biber, L.—France, 62
 Bicalho, the Manufacturers of.—Portugal, 1294
 Bicheno, J. E.—Van Diemen's Land, 294. 326. 327
 Bickford, Smith, & Davey.—i. 424
 Bickle, W.—v. 131
 Biddell.—ix. 124
 Biddell, G. A.—xxii. 438
 Biddle, D.—xix. 1
 Biddle, J.—xx. 207 ; xxii. 297
 Biddulph, J.—i. 417 ; v. 645
 Bideford Anthracite Mining Co.—i. 242
 Biden, F. see Biden, J. & F.
 Biden, J. & F.—xxiii. 51
 Bidwell, J.—Persia, 7
 Bidwell, J. G.—New South Wales, 1A
 Bidwell, Rev. W. H.—United States, 477
 Biedermann, M. L. & Co.—Austria, 206
 Biefang, C.—Zollverein (1), 661
 Biegel, J.—Zollverein (1), 311
 Bielefeld, C. F.—xxvi. 157 (Main Avenue West) ; xxvi. Bay I. 25
 Biennaime, A.—Spain, 293

Bienert, D. & Son.—Austria, 143
 Bienert, F.—Austria, 303
 Bier, see Steinhauer & Bier
 Bier, Brothers.—Zollv. (1), 673
 Biertumpfel, H.—vi. 506
 Biffen, W.—viii. 170
 Bigfield, Caroline.—xxvi. 534
 Bigaglia, Lorenzo, see Bigaglia, P.
 Bigaglia, P. (late Lorenzo Bigaglia)—Austria, 600
 Bigaglia, Pietro.—Austria 34
 Bigford, H.—xxii. 650
 Bigg, H. & Son.—x. 676
 Bigg, T.—ix. 65
 Biggin & Sons.—xxii. 212
 Biggs, S.—xxii. 453
 Biggs & Sons.—xx. 205
 Bigotti, L.—Tuscan, 78
 Bihet, H.—Belgium, 93
 Bilbe & Co.—viii. 141
 Billamore, Mrs.—xxvi. 230
 Billecoq, A.—France, 20
 Billeter, Z.—Switzerland, 147
 Billiard, see Whitlock & Billiard
 Billiard, L.—Belgium, 70
 Billiet & Huot.—France, 1550
 Billings & Ambrose.—United States, 34
 Billinton, W.—v. 468
 Billson & Hames.—xx. 201
 Binder, Traugott.—Austria, 207
 Biingham, H. J.—x. 302
 Bingley, H.—xxx. (Fine Art Cr.) 226.
 Bingley, M.—xvii. 61
 Bingham & Co.—Zollverein (6), 85
 Binks, B.—xii. & xv. 31
 Binns & Goodwin.—xvii. 14
 Binus, R. W.—xxiv. 34
 Binus, W.—vi. 55.
 Binsmead, J.—x. 474
 Binyon, A.—x. 610
 Biotley, F.—Belgium, 195
 Biondek, M.—Austria, 660
 Biondetti, H.—France, 766
 Birch, J.—vi. 406
 Bird, see Gadd & Bird
 Bird, A.—xxii. 267
 Bird, Alfred.—xxii. 600
 Bird & Co.—i. 411
 Bird, E.—xxvii. 83
 Bird, J.—i. 457A
 Bird, R.—xii. & xv. 223
 Bird, W.—xvi. 189
 Birk.—Zollverein (1), 191
 Birker & Hartman.—Zollverein (2), 2
 Birkin, R.—vi. 94 ; xix. 20
 Birkmann, M.—Zollverein (2), 79
 Birnbaum, J.—Austria, 95
 Birnstell, J.—Zollverein (6), 71
 Birrell, D.—xiv. 27
 Birt, H.—xx. 153
 Bischof.—Zollverein (1), 682
 Bischoff, see Bary, T. de, & Bischoff
 Bischoff, C. A. & Co.—Zollverein (2) 98
 Bischoff, C. J.—Switzerland, 157
 Bischoff, Brothers.—Switzerland, 152
 Bischoff, Siber, Switzerland, 152.
 Bischof & Rhodius.—Zollv. (1), 312
 Bishop, see Barnard & Bishop; Gill & Bishop
 Bishop, J.—v. 805 ; xxx. (Fine Art Court), 278
 Bishop, J. C.—x. 553
 Bishopp, Rev. J.—xxii. 591
 Bisiaux.—France, 767
 Bias, J.—xxx. (Fine Art Court), 307
 Biase, L. E.—Belgium, 87
 Bissen.—Denmark, 38 (Main Avenue, East)
 Bisso, Brothers.—Sardinia, 60
 Bisson, J. jun.—France, 1058

Bistrom, Baron.—Russia, 46
 Bistrom, Madame.—Russia, 215
 Bittner, D.—Austria, 144
 Bittner, F.—Austria, 699
 Bituminous Shale Co.—i. 221
 Bitum & Co.—iii. 8
 Björk, C. L.—Sweden & Norway, 11
 Bjorkman, J. L.—Sweden, 103
 Black, see Bell & Black
 Black, H.—xxii. 464
 Black, Dr.—x. 453
 Black, H. & Co.—v. 806
 Black, J.—vi. 138
 Black, J. & Co.—xviii. 51
 Black & Wingate.—xii. & xv. 204
 Blackburn, Ann Maria.—xix. 103
 Blackburn, B.—xxvii. 21
 Blackburn, J.—South Africa, 18
 Blackburn & Thomson.—Van Diemen's Land, 343
 Blackett, Walter.—xxx. (Fine Art Court), 55
 Blackhall, J.—ix. 33
 Blackmore, Brothers.—xix. 325, 337
 Blackmore, Mary.—xxix. 125
 Blackmore, W.—vi. 428
 Blackville.—New Brunswick, 12
 Blackwell, R. see Blackwell, S. & H.
 Blackwell, S. H.—i. 427
 Blackwell, S. & R.—xvi. 78
 Blackwell, W.—x. 653, 734
 Blackwood & Co.—xvii. 105A
 Bladel, see Dieudonne & Bladel
 Blaeser, G.—Zollverein (1), 310
 Blagg, see Cooper & Blagg
 Blaha & Rosenberger.—Austria, 251
 Blain, see Corry, Blain, & Co.
 Baikie, J.—ix. 89A
 Blair, D.—British Guiana, 71, 72
 Blair, J.—xxii. 400 ; viii. 303
 Blair, R.—viii. 136
 Blais, see Louis, Blais, & Co.
 Blaize, H.—France, 1089
 Blake, see Stephenson & Blake
 Blake & Parkin.—xxii. 193
 Blake, W.—United States, 233
 Blakely, E. T.—xii. & xv. 285
 Blakeslee, J.—United States, 131
 Blanchard, M. H.—xxvii. 92
 Blanchet, see Roller & Blanchet
 Blanchet, Brothers.—France, 768
 Blanchet, Brothers, & Kleber.—France, 1090
 Blancher, J. B.—France, 27
 Blauck, E.—Zollverein (1), 801
 Bland, Dr.—New South Wales, 17
 Bland, J. G.—ix. 205
 Bland, M.—xxvi. 112
 Bland, S. K.—xxiv. 80
 Blank, E. & H.—Zollv. (1), 656 ; (3), 70.
 Blank, H., see Blank, E. & H.
 Blankenburg, F. S.—Zollverein (1), 561
 Blauenstein.—Zollverein (1) 842
 Blanquart, E.—France, 1551
 Blanz, Poure, & Co.—France, 28
 Blaquiere, J. M.—France, 1552
 Blasicka & Co.—Austria, 294
 Blasicka & Sons.—Austria, 601
 Blaylock, J.—x. 92
 Blech, Steinhilch, & Mantz.—France, 29
 Bleckmann, J. E.—Zollverein (1), 623
 Blee, H.—i. 459. 512
 Bleekrade, Prof. S.—Netherlands, 1
 Bleibtreu, L.—Zollverein (1), 313
 Bleibtreu, L. O.—Zollverein (1) 686
 Merlot & Lemaître.—France, 30
 Bleuze, H.—France, 1091
 Blews & Sons.—xxii. 349
 Bley, J.—Austria, 605
 Blind Asylum (Glasgow).—xviii. 56A

- Blind, Society for teaching the, (Regent's Park).—xvii. 198
 Bliss, R. & Co.—United States, 415
 Bliss, W.—xii. & xv. 270
 Blizard, see Coates & Blizard
 Blizard, J.—xxviii. 127
 Blodget, S. C.—United States, 551
 Blofeld, J. H.—St. Helena, 4
 Blofeld, T. G. & Co.—xxi. 4
 Blofeld, T. J.—ii. 77
 Bloncel, Gaston, & Co.—Sardinia, 17
 Bloomer & Philipps.—xxii. 176
 Bloomfield, Miss.—xix. 187
 Blösch, see Neuhaus & Blösch
 Blott, Esther.—xxvi. 18
 Blowers, W. R.—xvi. 272
 Blum, T. G.—Switzerland, 114
 Blumauer, W.—Austria, 474
 Blumel, C., see Zjciisel, J., & Co.
 Blamel, J., see Zjciisel, J., & Co.
 Blumer & Lemny.—Switzerland, 116
 Blumhardt, H.—Zollverein (4), 94
 Blundell, Spence, & Co.—ii. 48; vi. 420
 Blunt, H.—x. 372
 Blyberg, Compagnie des Mines et Fonderies de (Liège).—Belgium, 22
 Blyckaert, G.—Belgium, 78
 Blyth, see Lethem, Blyth, & Co.; Wüindle & Blyth
 Blyth & Jacobs.—i. 131
 Blyth, Hamilton, & Blyth.—iv. 60
 Blyth, R.—x. 367
 Blyth, R. J.—ix. 154
 Blythe, R.—xvi. 90
 Bo, A.—Sardinia, 19
 Boa, Viscount de, Portugal.—327. 378. 518
 Boa, W.—Canada, 39. 46
 Boadella, J.—xxvi. 193
 Boake, J. F.—xxii. 697
 Board.—Western End, South Enclosure (Outside), 2
 Board, C.—xxvi. 240
 Bobee & Lemire.—France, 1092
 Boboune, D. J. d'Azevedo.—Portugal, 641. 646
 Boch, see Villeroy & Boch
 Boch, J. F.—Zollverein (7), 5
 Boche, M.—France, 769
 Bock, H.—Switzerland, 31
 Bocken, C.—Netherlands, 11
 Bocken, Hubert, & Co.—Belgium, 73
 Bockmühl, P. E.—Zollverein (1), 586
 Beckmühl, Schieper, & Hecker.—Zollverein (1), f66
 Bode, H.—xxviii. 103
 Bodemer & Co.—Zollverein (1) 820
 Bodemer, G.—Zollverein (3), 40
 Bodemer, J. jun.—Zollverein (1), 726
 Bodin, J.—France, 426
 Bodley.—vii. 43
 Bode, D. De.—Belgium, 98
 Boecker, H., see Boecker, R. & H.
 Boecker, R. & H.—Zollverein (1), 633
 Boeddinghaus & Co.—Zoll. (1), 572
 Boehler, F. L. & Son.—Zoll. (3), 56
 Boehm.—x. 536; see also Ihm, Boehm, & Pfaltz
 Boehm, T.—Zollverein (2), 23
 Boehme, see Conta & Boehme
 Boehme, C. L.—Zollverein (1), 362
 Boeing, Roehr, & Lefsky.—Zoll. (1), 453
 Böckel, A.—Hamburg, 116
 Boelger, M.—Switzerland, 158
 Boelster, J.—Switzerland, 60
 Boelster, T.—Zollverein (4) 110
 Boelsterli, C., & Co.—Zoll. (4), 55
 Boeringer & Co.—France, 770
 Boesch & Sons.—Switzerland, 115
 Boesche, C. J.—Zollverein (1), 785
 Boettiger, H. G.—Zollverein (3), 108
 Bogaert, J. B. Van.—Belgium, 107
 Bogel, see Nering, Bogel, & Co.
 Bogoslovsky Imperial Copper Works.—Russia, 1
 Bogue, A.—New South Wales, 2
 Bohm, Aug.—Hamburg, 97
 Boileau, E.—xvii. 78
 Bohman, E. J.—Sweden, 57
 Boileau, Lieut.-Col., A. H. E.—China
 Boillieu R.—France, 31
 Bois, A. Du & Co.—Belgium, 360
 Boisotau, see Gigot & Boisotau
 Boissimon, C. de.—France, 427
 Boland, A.—France, 428
 Boland, see Gootle & Boland
 Boland, P.—xxix. 104
 Bolenius & Nolte.—Zollverein (1), 562
 Bolla, see Gatti & Bolla
 Bollee, E.—France, 1083
 Bollin, C.—Russia, 322
 Bolinder, J. & C.—Sweden, 56
 Bolingbroke, C. & F.—xii. & xv. 311
 Bolitto, E.—i. 440
 Bolter, C.—xix. 184
 Bolm, C.—Zollverein (1), 769
 Bolten, Wilhelm, & Son.—Zollverein (1), 490
 Bolton, Capt.—St. Helena, 2
 Bolton, T.—x. 94; xxii. 353
 Bolzani, A. M.—Zollverein (1) 38
 Bompiani, Roberto.—Rome, 23
 Bonaiuti, C. & Sons.—Tuscany, 81
 Bonardel, Brothers.—Zollverein (1), 53
 Bonasse, Label, & Co.—France, 774
 Bonavia, C.—Malta, 2
 Boncourt, see Durand, Boncourt, & Co.
 Bond, C.—xxx. (Fine Art Court), 28
 Bond, S.—United States, 37
 Bond, W. & Son.—United States, 463
 Bondarevsky, Prascovia, Ogla, & Co.—Russia, 558
 Bouteilin, A.—Russia, 238
 Boudon, L.—France, 63
 Bone, H. P.—xxx. (Fine Art Court), 238
 Bone & Son.—xvii. 62
 Bonet, see Vaccosin, Bonet, & Co.
 Bonfils, Michel, Souvraz, & Co.—France, 1094
 Bongaerts, F. A.—Belgium, 229
 Bonge, A. L.—Zollverein (1), 223
 Bongiovanni, B.—Austria, 741
 Boniface & Sons.—France, 32
 Bonito, Sir T.—New Granada, 5
 Bonitto, J.—i. 4
 Bonjean & Co.—France, 1082
 Bonjean, J.—Sardinia, 12
 Bonn Mines & Iron Works.—Algeria, xx. 46
 Bonmal, V. & Co.—France, 429
 Bonmar & Carfrae.—xxvi. 108. xxx. (Fine Art Court), 344
 Bonmassieu.—France, 61
 Bonnet, jun.—France, 1096
 Bonnet, C.—Portugal, i. 22. 58. 89. 107. 119. 258. 381. 1223
 Bonnet & Co.—France, 1097
 Bonnet, J. B.—France, 1095
 Bonneton.—France, 771
 Boneville, M. De.—United States, 210
 Bonney.—Van Diemen's Land, 281. 289
 Bonney, W. W.—viii. 49
 Bonson, see Bedford, Bonson, & Co.
 Bonte, see Berthelot & Bonte
 Bonte, L.—France, 33
 Bontemps, see Godard & Bontemps.
 Bontems.—France, 430
 Bontems, C.—Switzerland, 184
 Bonvenschen, H. & Co.—Zoll. (1), 536
 Bonyun, G. R.—British Guiana, 50
 Bona & Son.—Zollverein (4), 2
 Bonanigo.—xxx. (Fine Art Court) 82
 Bonaz & Brothers.—France, 772
 Boobyer, J. H.—xxii. 680
 Bonker, E. & Sons.—v. 809
 Boote, L. H.—United States, 312
 Boone, J. A.—Belgium, 488
 Boote, R., see Boots, T. & R.
 Boote, T. & R.—xxv. 11; xxx. (Fine Art Court), 139
 Booth, see Brown, Rusby, & Booth
 Booth & Co.—vi. 2
 Booth, G. H.—vii. 134
 Booth, J. P.—xvi. 112
 Booth & Pike.—xiii. 83
 Boquet, Marie Virginie.—France, 1098
 Bord.—France, 1099
 Borda, J.—Algeria, 9
 Borden, G.—United States, 524
 Boreham, S.—xxiii. 92
 Borel, H. J.—Switzerland, 19
 Borel, Boyer, & Co.—Switzerland, 37
 Böier & Porzelius.—Zollverein (2), 8
 Borges, Suttere Antonio.—Portugal, 973-977
 Borgia, Miss M. A.—United States, 487
 Bormann, F. A.—Zollverein (1), 112
 Borrás, see Sugden, Borrás, & Co.
 Borrini, L.—Austria, 734
 Borrows, Mary L.—xxx. (Fine Art Court), 11
 Borsary.—France, 1100
 Bortier, P.—Belgium, 95
 Borzone, J.—Sardinia, 45
 Bosch, C. G.—Netherlands, 62
 Bosch, P. Van den.—viii. 136
 Boschetti, Benedetto.—Rome, 17
 Bosio, A.—Sardinia, 85
 Bosquet, see Mourgue & Bosquet.
 Boss, I. A.—xxix. 146
 Boss, T.—viii. 219
 Bossard, J.—xvi. 294
 Bossi, J.—Austria, 239, 386
 Bossi, J. B.—France, 773
 Bossipham, B.—x. 723
 Bossut, see Gilson & Bossut.
 Bossut, see Motte, Bossut, & Co.
 Booteels Geerneck, J.—Belgium, 238
 Bostelmann, A.—Hamburg, 95
 Boston, Mr. Sheriff.—Canada, 29
 Botanic Garden.—South Africa, 10
 Bötcher & Engel.—Zollverein (1), 865
 Bott & Allen.—xxii. 422
 Botten, C.—v. 429. xxii. 426
 Bottier, L. N.—France, 1101
 Bottinelli, G.—Austria, 726
 Bottinelli & Gandolfi.—Austria, 727
 Bottom, see Hudson & Bottom.
 Bottom, J.—xix. 106
 Bottomley, G.—x. 657
 Bottomley, J.—xii. & xv. 181
 Bottomley & Sons.—xii. & xv. 165
 Bou Taleb (tribe of the).—Algeria, 54
 Bouvasse, V. L. & Co.—France, 1102
 Boubier, Compagnie du Charbonnage de.—Belgium, 29
 Bouch, T.—vii. 73
 Bouchard, F.—France, 1103
 Bouchard-Houzard, W.—France, 775
 Boucher, E. & Co.—France, 776
 Boucher, T.—Belgium, 399
 Boucherie, J. A.—France, 1104
 Boucheron, see Oudard, L. & Bouchard
 Bouchet, A.—xxix. 124
 Bouchet, C.—xvi. 246
 Bouchez-Potier.—France, 34
 Bouchon, L. A.—France, 431
 Bondel.—France, 508
 Boudoin and Lebre.—Canada, 15

Boudon, L.—France, 1105
 Boudon de St. Amand.—France, 432
 Boudouris, B.—Greece, 21
 Bouffet, jun.—France, 442
 Boulardet, C. P.—France, 1106
 Bouillette, Hyvelin, & Co.—France, 1107
 Boulanger, Pierre Honore.—Algeria, 10
 Boulanger, T. C.—vii. 198
 Boulgon, P.—Austria, 334
 Boulonnois.—France, 433
 Boulter, B.—xxii. 677
 Boulton & Son.—xxii. 330
 Boulton & Swales.—Page 652
 Bouquillard.—France, 777
 Bouquet, Comt.—Austria, 414
 Bourdaloue.—France, 67
 Bourdin, C.—France, 1730
 Bourdon, E.—France, 1108
 Bourgard, C.—United States, 309
 Bourgeard, P.—x. 566
 Bourgeois, see Leun-Clement & Bourgeois
 Bourgers, Mrs.—France, 778
 Bourgonne, A.—France, 1533
 Bourgonne, J.—France, 434
 Bourgois, B.—Sardinia, 75
 Bourne, see Pinder, Bourne, & Hope
 Bourne, K.—x. 636
 Bourne, J.—xxv. 35
 Bourne, W.—New Zealand, 35
 Bourra, L. A.—vi. 610
 Bousfield, see Finlayson, Bousfield, & Co.
 Hudson and Bousfield
 Bousson, Mrs. Vleigbeer de.—Belgium, 328
 Boutchier, Mortimer, and Co.—xvi. 293
 Boutilier, Dr.—Canada, 26
 Bouvard & Lancon.—France, 1110.
 Bouvy, A.—Belgium, 266
 Bouxwiller Mines Joint-Stock Company.—France, 376.
 Bovenschen & Co.—Zollverein (1), 536
 Bovet & Co.—Switzerland, 35
 Bovet, F.—Switzerland, 13
 Bovey, J.—xxvii. 3, 4
 Bowden, G.—xvii. 63
 Bowell, J.—xxix. 153
 Bowen, A. F.—viii. 325
 Bowen, J.—xxvii. 94
 Bower, J.—ii. 42.
 Bower, M. xvi. 329
 Bowers, Challinor, & Wooliscroft.—xxvii. 164
 Bowers, G. F.—xxv. 13
 Bowler, J.—v. 756; xvi. 236
 Bowley, see Taylor & Bowley
 Bowling Iron Company.—xxii. 83
 Bowmen & Son.—xii. & xv. 231
 Bowman, William.—China.
 Bowmar, C. B.—xvi. 87
 Bowring, Edgar A.—China
 Hoyce, Dr.—xvii. 123
 Boyd, C.—i. 462A; see also Hunt, J.
 Boyd, F. J.—Canada, 160
 Boyd, I.—xiii. 13
 Boyd, J.—Van Diemen's Land, 233
 Boyd, J. E.—ix. 199
 Boydell, J.—v. 660; vii. 56
 Hoye, C. T.—Hamburgh, 113
 Boyer.—France, 70, 1534; see also Borel, Boyer, & Co.
 Boyer, sen.—France, 35
 Boyer & Co.—France, 71
 Boyer, P. J.—France, 69
 Boyle.—x. 392, see Turbeville, Smith, & Co.; Williams, Coopers, & Co.
 Boyle, R.—v. 1002
 Boyle, W.—xxx. (Fine Art Court), 141
 Brabant, see Neitzer & Brabant
 Braby & Son.—ix. 24

Brace, H.—xvi. 58
 Bracht, F. W.—Austria, 240
 Bradbee, G. W.—xix. 72
 Bradbeer, S., see Offord & Bradbeer
 Bradbury & Evans, xvii. 136
 Bradbury, Greatorex, & Beall.—xi. 56; xviii. 64A
 Bradbury & Son.—xxiii. 36
 Bradford, R. & W.—xxi. 3
 Bradford, S.—xxi. 26
 Bradford, W. see Bradford, R. & W.
 Bradley, see Heim & Brailley
 Bradley, B. & Co.—United States, 473
 Bradley, J.—xxvii. 35
 Bradley, R. & Co.—vi. 310
 Bradnack, I. R.—xxii. 575
 Bradshaw, G.—xx. 39
 Bradwell & Adams, xviii. 40
 Brady, M. B.—United States, 137
 Brady, W. N.—United States, 380
 Brady, D'Avignon, & Lester.—United States, 142
 Brandlin, Brothers.—Switzerland, 119
 Braham, J.—x. 289
 Brahmfeld & Gutrup.—Hamburgh, 54
 Braidley, Mrs.—i. 23A
 Brain, see Saxby & Brain
 Braine, C. T.—China
 Brahnard, C. H.—United States, 509
 Brainerd, O. M.—Canada, 83
 Brainerd, O. N.—Canada, 82
 Braithwaite, S.—x. 283
 Brake, R.—x. 354
 Bramah.—xxii. 622
 Bramah & Co.—xxii. 653
 Bramall, see Fisher & Bramall
 Brameld, J. W.—xxv. 43
 Bramhall, T.—vii. 129
 Bramlage, A.—Oldenburgh, 2
 Bramley.—xviii. 84
 Bramley Woollen Cloth Company.—xii. & xv. 64.
 Bramwell, T. & Co.—ii. 27
 Brand, see M'Nair & Brand
 Brandl, P. W.—Zollverein (1), 620
 Brandeis, I. jun.—Zollverein (2), 3
 Brandeis, R. W.—Austria, 133
 Branden, J. A. Van den.—Belgium, 511
 Brandon, see Wyatt & Brandon
 Brandon, N. D.—Netherlands, 70
 Brandtetter, F.—Zollverein (3), 55
 Brandt, see Isidore & Brandt
 Brandt, F. E.—Switzerland, 10
 Braudos & Co.—France, 1111
 Braunam, T.—xxvii. 131
 Branscombe, S.—xvi. 298
 Branston, see Vizetelly & Branston
 Braquenie & Co.—France, 435
 Brasseur & Co.—Zollverein (1), 314
 Brasseur, E.—Belgium, 42
 Braun.—Zollverein (2), 39
 Braumüller, W.—Austria, 368
 Braun, Brothers.—Zollverein (1), 491
 Braun, C.—France, 72
 Braun & Co.—xxvi. 172
 Braun, G. J.—Austria, 21
 Braun, H.—xxiv. 46
 Braun, L.—xx. 54A
 Braund, J.—xx. 66
 Braunschweig, T.—Zollverein (1), 621
 Braux-d'Anglure, De.—France, 779
 Bravo, M.—Sardinia, 24
 Braxton, C.—United States, 269
 Bray, C.—xxii. 500
 Bray, C. & Co.—xiii. 67
 Bray, J.—x. 531
 Braysham, G.—xii. & xv. 463
 Brayshaw, J.—xix. 382
 Brazier, J. & R.—viii. 206
 Brazier, R. see Brazier, J. & R.

Breaute, E.—France, 36
 Breadalbane, Marquis of.—i. 7, 211, 442; iv. 95A. 134
 Breary, W. A.—ii. 80
 Brecht, A.—Zollverein (1), 699
 Breda, D. J. Van.—South Africa, 32
 Bredif, Brothers.—France, 73
 Bredt, see Greeff, Bredt, & Co.; Kremmelhein & Bredt
 Bredt & Co.—Zollverein (1), 315
 Breeu, N. A. & Co.—United States, 411
 Breitenstein, J. & Co.—Switzerland, 117
 Breithaupt, F. W. & Sons.—Zollverein (1), 670
 Breitkopp & Haertell.—Zollv. (3), 25
 Bremmer, J.—viii. 83, 136; xiv. 74A; xxx. (Fine Art Court), 258
 Bremier, J. D. & A.—vii. 95
 Bremmer & Till.—iii. 41
 Brendon, W. S.—xxvii. 3
 Breuta, D.—Belgium, 435
 Brentano, Pellouz, & Co.—Zollv. (2), 36
 Brehlmaier, J.—Austria, 506
 Breteau, C. A.—France, 112
 Bretes, M. F.—Portugal, 620, 622, 1122A, 1125A
 Brettnall, T. D.—xvii. 64
 Breton.—France, 1555
 Breton, Brothers, & Co.—France, 436, 1113
 Brett, A.—x. 422
 Brett, Brothers, & Co.—xii. & xv. 20
 Brett, G.—xxx. (Fine Art Court), 52
 Brett, J. & J. W.—x. 429
 Brett, J. W. see Brett J. & J. W.
 Brett & Little.—x. 422, 696
 Brett, S. G.—United States, 211
 Brett, T. W. B.—x. 429
 Brettell, T.—xvii. 169
 Brettes, M. F.—Portugal, 393
 Breuning, F.—Zollverein (4), 8
 Breuninger & Son.—Zollverein (4), 3
 Brevia, Brothers, Messrs.—Austria, 60
 Brewer, see Sayle, Merriam, & Brewer
 Brewer, C. & W.—vi. 144
 Brewer, Jane.—vi. 132
 Brewer, W. see Brewer, C. & W.
 Brewin & Whetstone.—xii. & xv. 242
 Breyer, see Seyfert & Breyer
 Breyer, G. W.—Lubeck, 10
 Briard, J. H.—Belgium, 277
 Briard & Gauthier.—France, 437
 Brichaut.—Belgium, 498
 Bridard, J.—France, 1115
 Brider, G.—viii. 262
 Brider, J.—viii. 261
 Bridges.—xviii. 79
 Bridges, C.—South Africa, 21
 Bridges, C. H.—xvi. 219
 Bridges, G.—x. 339
 Bridges, W.—xix. 108
 Bridgett, T. & Co.—xiii. 49
 Bridport Local Committee.—xiv. 73
 Brie, J. & Co.—xx. 24
 Brie & Jeoffrin.—France, 780
 Briers, J.—New South Wales, 2A
 Briel, W. & Co.—Zollverein (5), 4
 Brien, see Gregson and Brien
 Brien, C.—xxix. 90
 Brien, J.—Canada, 44
 Briere, A.—France, 438
 Briers, J. sen.—Belgium, 99
 Briet, J. C.—France, 439
 Brigg.—v. 636
 Briggs, G. & Co.—v. 811
 Briggs, S.—xxii. 145
 Briggs, T.—ix. 103
 Bright, see G. Ibbis, Bright, & Co.
 Bright & Co.—xix. 401
 Bright, J. & Co.—xix. 115

of.—i. 7. 211.

(1), 699
th Africa, 32
e, 73
& Co.; Krem-

(1), 315
ited States, 411
witzerland, 117
na.—Zollverein

Zollv. (3), 25
36; xiv. 74A;
, 258
vii. 95

3
Zollv. (2), 36
506
112
gal, 620. 622.

34
—France, 436.

xii. & xv. 20
Art Court), 52
29
& J. W.
696
ates, 211
9

l, 393
in (4), 8
lverein (4), 3
—Austria, 80
am, & Brewer
144

C. & W.
xii. & xv. 242
Breyer
, 10
277
rance, 437
8
5

ca, 21
9

l. 49
ee.—xiv. 73

780
Wales, 2A
erein (6), 4
Brien

99

& Co.

15

Bright, R.—xxii. 458
Bright, S.—xxvii. 80
Brilles.—xxii. 655
Brimley & Sons.—xii. & xv. 490
Brinck, J. W.—Zollverein (1), 607
Brindley, J.—xxix. 210
Brindley, T.—xvi. 21
Brine, Brothers, & T. Sharp.—Page 847
Brinks, see Altenloh, Brinks, & Co.
Brinsley, see Critchley, Brinsley, & Co.
Brinsmead, J.—x. 474
Brinton & Sons.—xix. 110
Briqueleer & Co.—Algeria, 11
Briquet & Perrier.—France, 1116
Brishand, H.—xxii. 364
Briscall, J.—x. 65 A
Brison, P. sen.—France, 781
Brison, R.—xxx. 257
Brisset, E.—France, 440
Brison, Brothers.—France, 1117
Bristol School of Industry for the Blind.—xxviii. 30
British Electric Telegraph Co.—x. 432
British & Foreign Bible Soc.—xvii. 201
British Plate Glass Co.—xxvi. 408 (Main Avenue, West)
Briton and Sons.—xix. 296
Brittan, W.—xxvi. 220
Britten, J.—xxii. 698
Brixhe, M. E.—Belgium, 21
Broadbent, J.—x. 122
Broadhead & Atkins.—xxiii. 43
Broadwood & Sons.—x. 518 (Main Avenue, West)
Brocchi, C. F.—Tuscany, 27
Brocchiere, P.—iii. 16
Brocchieri, P.—France, 74
Brock.—Van Diemen's Land, 54, 55
Brockbank & Atkins, x. 40
Brockedon, W.—i. 65
Brockhaus, F. A.—Zollv. (3), 13. 178
Bröcking, W.—Hamburg, 11
Brocklehurst & Sons, xiii. 38
Brocklesby & Wessels.—Zollv. (1), 830
Brockman, F.—Zollverein (1), 539
Brocot, A.—France, 441
Brodie, see Muirs, Connell, & Brodie
Brodie, P. B.—i. 54
Brodie, W.—ix. 98; xviii. 56A; xxx. (Fine Art Court) 159
Brodtier, C.—Belgium, 366
Broemel, A.—Zollverein (1), 705
Broemer, F. I.—Zollverein (5), 1
Broesel, E.—Zollverein (1), 727
Brogden, see Watherstone & Brogden
Brohier, H.—Jersey and Guernsey, 13
Broitzsch, M.—Austria, 297
Broling, J.—Sweden, 115
Bromley, G.—viii. 136; see also Forrest & Bromley
Bronski, Major Count de Brono.—France, 782; see also Andre, J. & Co.
Brook, J. & Brothers.—xi. 24
Brook, J. and Son.—xii. & xv. 487
Bronke, C.—x. 144
Brooke, Gov. Sir Jas.—Labuan, & c. 1
Brooke & Sons.—xii. & xv. 86
Brooker, G.—xxx. (Fine Art Court) 109
Brooker, J.—viii. 181
Brookes, H.—viii. 143
Brookes, J.—x. 25; xxii. 171
Brookes & Son.—viii. 216
Brookes, Wm. & Sons.—xxii. 110A
Brooklyn Flint Glass Comp.—United States, 113
Brookman & Langdon.—i. 64
Brooks, E.—xix. 113
Brooks, G. jun.—x. 705
Brooks, H. & T.—x. 479

Brooke, T.—xiii. 26; see also Brooks, H. & T.
Brooks, W. T.—United States, 222
Brooksbank, A.—xxii. 163
Brophy, P.—New Brunswick, 19
Broche, F. X.—Austria, 20
Brose, W.—Austria, 580
Broseley, M.—i. 275
Brossard, see Barrallon & Brossard
Brosse & Co.—France, 1118
Brossier, see Drouin & Brossier
Brothie, R.—xvi. 200
Brotherhood, R.—v. 502
Brotherton & Co.—iv. 23
Brotmann, A.—Austria, 310
Brough, J. & J. & Co.—xiii. 44
Brough, J. see Brough, J. & J. & Co.
Broughton, H. H.—v. 447
Brovellio, J. B. & Co.—Belgium, 72
Browett, H., see Browett, W. & H.
Browett, W. & H.—xiii. 80
Brown.—xxii. 370; United States, 283; see also Inglis & Brown; Lambert, Brown, & Patrick; Parker & Brown; Perkins & Brown; Royston & Brown; Schofield, Brown, & c.; Silk & Brown; Tootall & Brown
Brown, A.—xvi. 300; xxx. (Sculpture Court), 1
Brown, Alfred.—xxiii. 97. 105
Brown & Archbold.—ix. 250
Brown, Captain S.—vii. 10
Brown & Co.—ii. 7c; Van Diemen's Land, 45-46. 283-285
Brown, D. S.—ix. 91; x. 676A
Brown, F.—ii. 57
Brown, Fielding.—Van Diemen's Land, 199
Brown & Forster.—xii. & xv. 9
Brown, G.—xxx. (Fine Art Court) 264
Brown, G. S.—United States, 110
Brown, H.—xix. 64; xxviii. 49; see also Brown, J. & H. & Co.
Brown, J.—vii. 202; viii. 169A; x. 713; xxii. 235; xxvi. 140; xxx. (Fine Art Court), 34
Brown, J. & H. & Co.—xii. & xv. 469
Brown, John.—Van Diemen's Land, 14, 15, 16
Brown, J. M. & T.—xxvi. 15
Brown, J. P.—Western Africa, 3
Brown, J. R. & W.—xiv. 2
Brown, L.—United States, 134
Brown, Lenox, & Co.—Western end, North Enclosure (Outside), 58; viii. 61
Brown, M. L., see Brown, T. & M. L.
Brown, M'Laren, & Co.—xix. 114
Brown, Marshall, & Co.—v. 812
Brown, Owen, & Co.—v. 813
Brown, P. A.—United States, 4
Brown & Polson.—iii. 123
Brown, R.—xxvii. 52, 117
Brown & Redpath.—xxii. 477
Brown, Rusby, & Booth.—Western end, South Enclosure (Outside), 29; Western end, North Enclosure (Outside)
Brown S.—x. 335; United States, 216
Brown, Capt. Sir S.—vii. 334; see also Brown, Lenox, & Co.
Brown, S. R. & T.—xix. 58
Brown & Son.—x. 627; xiv. 97; xvi. 65; xxix. 237
Brown & Sons.—xiv. 17; xxii. 182
Brown, T.—Van Diemen's Land, 345; see also Brown, J. M. & T.; Brown, S. R. & T.
Brown, T. & M. L.—xxv. 45
Brown, W.—xii. & xv. 129; New

Zealand, 16, 18; see also Brown, J. R. & W.
Brown & Wells.—United States, 259
Browne, see Coode, Browne, & Co.; Wright, Tootall, & Browne
Browne, C. A.—United States, 419
Browne, F.—xvi. 245
Browne, J. H.—viii. 136
Browne, H.—Belgium, 490
Browne & Lambert.—United States, 334
Browne, P. A.—United States, 102A
Browne, W.—i. 109; v. 814
Browne, W. C.—viii. 158
Browne, Sharpe, & Co.—xix. 57
Browne, T. B.—vi. 56
Browning, S. J.—viii. 103
Browning, W.—United States, 557
Brownrigg.—Van Diemen's Land, 107, 108
Bruciani, D.—Page 847; i. 486
Bruce, G.—iv. 74
Bruck.—Zollverein (1), 747
Bruck, H. von & Sons.—Zoll. (1), 535
Bruckisch, W.—Zollverein (1), 66
Bruckmann & Sons.—Zollverein (4), 65
Bruder's Widow, Rudolph.—Austria, 295
Bruderer, J.—Switzerland, 118
Brumbeck, Von O.—Zoll. (1), 45, 46
Brueger, A.—Zollverein (1), 559
Brueing, C. D.—Hamburg, 63
Bruff, P.—vii. 49
Bruegmann & Co.—Zollverein (1), 363
Brugisser & Co.—Switzerland, 227
Brulm & Naegler.—Zollverein (1), 816
Brumme, A. F. W. & Co.—Zollverein (1), 687
Brun, A.—France, 37
Brun, Brothers.—Sardinia, 21
Bruneau, L. A.—France, 1110
Bruneaux & Son.—France, 38
Brunel, I. K.—vii. 9 (Main Avenue, West)
Brunet, Lecomte, Guichard, & Co.—France, 1120
Brunier.—France, 76
Brunier, Lenormand, & Co.—France, 75
Bruniquel Iron Works.—France, 1710
Brünn Trade Union.—Austria, 213
Brunner, see Imhoof, Brunner, & Co.
Brunner, A.—Austria, 574
Brunner, H.—Switzerland, 153
Bruno, H.—Belgium, 411
Brunsdon & Shipton.—Canada, 128
Brunswick, Ducal Foundry Inspection.—Zollverein (1), 780
Brunswick Iron Works (Wednesbury).—v. 543
Brunswick, M.—xxvi. 180
Brunwig, G. H.—Lubeck, 7
Brimton, J.—x. 596
Brunton & Nesbit.—xii. & xv. 462
Brunton, W.—i. 404. 519
Brunton, W., jun.—vi. 304
Brunton, W. J. & Co.—xii. & xv. 230
Brunbacher & Bleuler.—Switzerland, 153
Brusghin, A.—Russia, 20
Brussels, Atelier de Notre Dame.—Belgium, 301
Bruthwaite, H.—Barbadoes, 2
Bruthwaite, Mrs. H.—Barbadoes, 2
Britten, C.—x. 96
Brizghim, A.—Russia, 216
Bryan, Rev. J.—x. 408
Bryant, W.—United States, 171. 184
Bryceson, H.—x. 735
Bryden & Sons.—xxii. 45

Beyrbo Coal Company (Wrexham).—
Western end, South Enclosure (Out-
side), 47; i. 274
Bryson & Sons.—x. 154. 665
Bubenitsek, J.—Austria, 120. 507
Buceleugh, Duke of.—i. 309
Bucerill, A.—Spain, 71
Buch.—Russia, 289
Buchanan, A.—Brit. Guiana, 86, 86A,
90, 90A, 95-96A
Buchanan, J.—xxx. 175
Buchanan & Law.—South Africa, 53
Buchanan, R.—United States, 12
Buchberger, F.—Austria, 690
Buchberger, J.—Austria, 479
Buchholz, see Pauli & Buchholz
Buchler, E.—Zollverein (3), 93
Buchner, A.—Zollverein (1), 735
Buchwald, R.—Zollverein (3), 133
Buck, J.—xxi. 18
Buck & Son.—iii. 162
Bucker, H.—Zollverein (3), 176
Buckingham, J.—Western end, South
Enclosure (Outside), 35; i. 254;
x. 673A
Buckingham, T. L.—United States, 63
Buckland, J.—viii. 308
Buckland & Toplis.—iii. 48
Buckle, S.—xxx. (Fine Art Court),
301 (Main Avenue, West)
Buckley, G.—xxvii. 44
Buckley, Trustees of the late.—ii. 4
Buckmaster, W. & Co.—xx. 1
Budd, J. T.—iii. 37
Budden, E.—xvii. 97
Budge, J.—xxvi. 219
Budin.—France, 77
Budin, Signes.—France, 78
Budinsky, A.—Austria, 303
Budy, J. P. A.—France, 783
Buechner, W.—Zollverein (6), 1
Buecklers, see Koenigs & Buecklers
Buehler & Sons.—Switzerland, 120
Buel, see Haskell, Merrit, and Buel
Bueman, R.—Zollverein (3), 35
Buerger, J.—Austria, 700
Buettner, G.—Zollverein (3), 187A
Buettner, P.—Zollverein (6), 53
Bufe, T. C. & Son.—Hamburgh, 9
Buffault and Truchon.—France, 1122
Buffet, jnn.—France, 442
Buge, A.—Franc., 1123
Buholzer, see Hurter & Buholzer
Bühner, F.—Zollverein (4), 59
Buignier, G. S. F.—France, 1124
Buisson, sen.—France, 1125
Buisson, E. Robert & Co.—France, 784
Bujatti, F.—Austria, 252
Bukhareff.—Russia, 104
Bullfour, J.—xiv. 35
Bull, J.—viii. 239
Bull & Wilson.—xii. & xv. 12
Buller, T. W.—i. 128
Bullock, E. & Co.—ii. 37
Bullock, G.—St. Vincent
Bullock, J.—see Bullock, S. W. & J.
Bullock, J. G.—xxx. (Fine Art Court),
199
Bullock, J. L.—ii. 34
Bullock, S. W. & J.—United States,
145
Bullough, J.—vi. 21
Bulman, J.—xxx. (Fine Art Court),
228a
Bunee, Miss Van.—Belgium, 74
Burn, Lockington & Co.—xxviii. 77
Bunnett, J. & Co.—v. 48; vii. 132
Bunney, C.—x. 606
Buouinsegni, Brothers.—Tuscany, 112
Buquoy, Count.—Austria, 584

Burat, Brothers.—France, 79
Burlach, Brothers.—Zoll. (1), 700
Burbank, see Foyg & Burbank
Burch.—xix. 401
Burch, C. & Son.—xxix. 69, 309
Burch, J.—xix. 115
Burch, S. D.—United States, 513A
Burch, W.—iv. 77
Burcham, C.—ix. 250a
Burchamit & Sons.—Zollverein (1), 164
Burchett, J. R.—New South Wales, 3
Burckhard, T. C. & Sons.—Switzerland,
152
Burckhardt Brothers.—Zollv. (1), 810
Burckhardt, D.—Switzerland, 152
Burl & Sons.—xviii. 26
Burdett, J.—x. 425
Bureau & Marcotte.—Canada, 192
Burg, Chevalier A. De.—Austria, 130
Bürgeosee, Tachorn.—Zollverein (1), 130
Burger, M. L.—Zollverein (1), 148
Burgess, see Walker & Burgess
Burgess, A. & Co.—xii. & xv. 243
Burgess, C.—xii. & xv. 259
Burgess, D.—v. 471
Burgess, E.—xxiii. 2
Burgess, F.—viii. 123
Burgess, G.—xvi. 155
Burgess, J.—xxviii. 110
Burgess & Key.—ix. 237
Burgess, Mrs.—Van Diemen's Land,
109, 110
Burgess, R.—xvi. 241
Burgin, R.—xix. 75
Burgi, J. J.—Switzerland, 153
Burgos, Inspector of Mines of the Dis-
trict of.—Spain, 35
Burgun, Walter, Berger & Co.—France,
39
Burke.—xxx. (Fine Art Court), 42
Burke, J. H.—xxvi. 361
Burke, T. H.—xiii. 57; xvii. 152
Burke, W. H.—iv. 115
Burkhard and Naegeli.—Switzerland,
153
Burkhardt, J.—Switzerland, 270
Burkhardt, H. T.—Zollverein (3), 109
Burkhoven, Van.—Belgium, 502
Burn, R.—iii. 68
Burnard, N.—xxx. (Fine Art Court),
302
Burnay—Portugal, 493. 496
Burnett, N.—i. 106
Burnett, Sir W.—iv. 7
Burney & Bellamy.—xxii. 633
Burnley & Sons.—xii. & xv. 490
Burns & Palmer.—xxx. (Fine Art Co.)
21
Buron.—France, 443
Burr, G. see Burr, T. W. & G.
Burr, T. W. & G.—i. 495
Burrell, C.—ix. 37
Burronges & Watts.—xxvi. 4
Burrongs, J.—Zollverein (3), 92
Burrows, see Heath & Burrows
Burrows, Mary L.—xxx. 11
Burrows, S.—xxii. 222
Burrows, T.—xxii. 576
Bursill.—xxvi. 7; see also Cooper &
Bursill
Bursill, E. & Chra.—xxix. 216
Bursill, G. H.—v. 753; x. 673A,
xxvi. 7
Bursill, G. H. & H.—xxx. (Fine Art
Court), 60
Bursill, H. see Bursill, G. H. & H.
Burt, H.—xxvi. 390
Burt, H. P.—vi. 468
Burt, S. J.—ii. 85
Burt, T. & Sons

Burt, W. A.—United States, 187
Burton & Barnes.—vi. 96
Burtou, H.—xxix. 117
Burton, J. De.—British Guiana, 70
Burton, M.—xix. 117
Burton, Matilda Sarah.—xix. 118
Burton, Miss.—xxvii. 77
Burton, W. S.—xxii. 247
Bury, see Lambert & Bury
Bury, R. xxx. (Fine Art Court).—23
Bury St. Edmunds.—vi. 140
Bury, Talbot.—xxx. 349
Bury, T. T.—xxiv. 64
Busbacher & Zufriedenheit.—Zollverein
(1), 315
Busby, W.—ix. 15
Busch, E.—Zollverein (1), 89
Busch, P. A.—Zollverein (5), 2
Buschmann, J. W.—Zollverein (1), 386
Busch, N.—xvi. 4
Busch, C. J.—South Africa, 60
Buschell, G.—xxviii. 182
Buss, H.—xxiii. 79
Buss, W. H.—Hamburgh, 111
Butcher, Misses.—xix. 256
Butcher, S. see Butcher, W. & S.
Butcher, W. & S.—xxii. 192
Buthod, see Hussen & Buthod
Butler, see Reercraft, Butler, & Co.
French & Butler; Lambert & Butler
Butler, J. see Naah, E.
Butler, J. L.—i. 247
Butlin, W.—ix. 115
Butschek & Graff.—Austria, 281
Butteley.—viii. 97
Butterley Iron Co.—i. 400; v. 34
Butterley, R.—xxii. 240.
Butters, see Nelson & Butters
Butters, L.—xxx. (Fine Art Co.), 290
Butterworth.—United States, 333
Butterworth & Co.—xvi. 240
Buttigieg, M.—Malta, 31
Button, C.—ii. 3
Button, T.—Van Diemen's Land, 21 to
23. 135. 172
Buxtorf & Bischoff.—Switzerland, 152
Byteweg, N.—Netherlands, 22
Byam, Eliza.—xvi. 23; xvii. 144
Byers, J.—i. 494
Byers and Son.—xii. & xv. 232
Byne, R. H.—vii. 36
Byrn, O.—xxx. (Fine Art Court), 257
Bywater, W. M.—v. 427; xvi. 94

Cabanes & Rambie.—France, 1126
Cabanic Patent Co.—xxvii. 142
Cabanillas, Widow.—Algeria, 12
Cabanon, G. A.—France, 785
Cabello, D. E.—Spain, 139
Cable, G.—v. 598
Calorn, J.—ix. 200
Calvrit, J. M.—France, 756
Calvrit & Roux.—France, 81
Cahu-Fevrier, F.—Belgium, 263
Cacciatari, B.—Austria, 706
Cacki-Shvilly.—Russia, 183
Cacopolis, J.—Greece, 11
Cadby, C.—x. 471
Cadell, H.—i. 217; v. 766
Cadman.—xviii. 74
Caesar, J.—Portugal, 373
Caetano, T.—Portugal, 1224. 1228-
1231
Caffort, J.—France, 444
Caffry, J.—xxvii. 167.
Cahan, E.—xx. 74
Cahen, T. J.—Hamburgh, 34
Cahill, M.—i. 222; iii. 90A; iv. 91A
Cahlman, Consul S.—Zoll. (1), 699

- Cahn, D.—xviii. 65
 Cahn, S. & Co.—Zollverein (1), 593
 Caid Ben Zekie Des Seignas (the wife of)—Algeria, 61
 Cail & Co.—France, 1557
 Cail, Derusie, see Vlissingen, Van, & Co.
 Caillaux, Madame A.—France, 80
 Caillet, Franqueville.—France, 82
 Cailles, A. L. J.—Algeria, 13
 Caillo, jun., & Prin.—France, 100
 Caillou, Maillan, & Formigli.—Tuscany, 19
 Cain, see Pattinson & Cain
 Cain, J.—France, 1129; United States, 247
 Cairns, J.—xviii. 49A
 Cairns, J., jun.—i. 63
 Caistor, A. B.—xvi. 77
 Callama, Prof.—Tuscany, 69A
 Calcutta Lapidaries.—India, 1
 Caldecott, Messrs.—i. 206
 Caldecourt " " " "—i. 199
 Calder B. Co., see E. & Calder Bottle Co.
 Calder, J.—xxvi. 55
 Calderon, see Flores, Calderon, & Co.
 Calderon, J. M.—Spain, 152
 Calderon, J. M.—Spain, 220
 Caldicott, R. & R.—xiii. 68
 Caldwell, G.—xxx. (Fine Art Cr.), 33
 Caley, F. G., see Caley, J. W. & F. G.
 Caley, J. W. & F. G.—xix. 119
 Calif, J.—South Africa, 55
 Calheiros, J. L.—Portugal, 460
 Caligny, Do.—France, 101
 Callaghan, Attorney-General.—New South Wales, 4
 Callaghan, W.—x. 268
 Callum, T.—xiii. 479
 Calland-Béliste, Nouel, Detinan & Co.—France, 788
 Calicut, J.—x. 547
 Calle, La, Fisheries of.—Algeria, 41
 Callegari, A.—Austria, 150
 Callejas, see Villardel & Callejas
 Callejo, J.—Spain, 257
 Calli & Gotti.—xxvi. Bay M. 24.
 Calloud, F.—Sardinia, 11
 Callow & Son.—xvi. 308; xxix. 83
 Calotas, P.—Greece, 55
 Calvert, F. A.—vi. 27
 Calvert, G.—xxvi. 82
 Calvert, W.—xxx. (Fine Art Cr.), 228
 Calvert, Rev. W.—xxx. (Fine Art Cr.), 97
 Calvi, J.—Sardinia, 22
 Cambridge, W.—ix. 238
 Cameron, J. B.—Bahamas
 Cameron, G.—xxvi. 93.
 Cameron, P.—x. 356
 Cameron's Coalbrook Steam Coal, and Swansea and Lough Railway Co.—Western end, South Enclosure (Outside), 39.
 Camilleri, E.—Malta, 14
 Camilleri, Fortinata.—Malta, 16
 Cammill, see Johnson, Cammill, & Co.
 Camp, see Penifield and Camp
 Campbell.—viii. 147; see also Isaacs & Campbell.
 Campbell, A.—xxiii. 76
 Campbell, A. F.—viii. 147; ix. 17
 Campbell & Co.—xii. & xv. 201
 Campbell, G.—vi. 246
 Campbell, G. H.—xxx. (Fine Art Cr.), 220
 Campbell, Harrison, & Lloyd.—xiii. 31
 Campbell, Major.—Canada, 176
 Campbell, S.—United States, 533
 Campbell, T.—xxx. (Sculpture Court), 23
 Camphine Co., English's Patent, iv. 61; vii. 133; xix. 264
 Campin, see Fowler, Campin, & Co.
 Campos, M. & Brothers—Portugal, 805
 Camus, M.—France, 789
 Canada West, Provincial Agricultural Association.—Canada, 33, 35
 Canales, J.—Spain, 242A
 Canaud, see Philippe & Canaud
 Canavani, A.—xvi. 101
 Candin, see Meures & Candin
 Candlot.—France, 102.
 Candy, M., see Carquillat, Miss M., Candy & Co.
 Candy, T. H.—xvii. 66
 Canepa, J. B.—Sardinia, 74
 Canfin, N.—Belgium, 190
 Caniff, T., see Caniff, F. & T.
 Canneaux & Sons—France, 1130
 Canning, Mary Jane.—xxviii. 186
 Cannon-Pie " " "—France, 790
 Canossa, M. velona de Eleonora.—Austria, 86
 Cant, G. W.—xvi. 169
 Cantagalli, L.—Tuscany, 71
 Canter, J.—xiv. 36
 Cantian, C.—Zollverein (1), 235. (Main Avenue, East)
 Canton.—Algeria, 14
 Cape of Goud Hope Agricultural Society.—South Africa, 31-39
 Capellemans, J. B.—Belgium, 397
 Capello, G.—Sardinia, 64
 Capera, C. B.—United States, 174
 Caplin, J. F.—x. 570
 Caplin, J. H. I.—xxx. (Fine Art Cr.), 221
 Caplin, Madame R. A.—x. 570A
 Cappellemans, J. B. & Co.—Belgium, 37
 Cappellemans, J. H., & Daboust.—Belgium, 393
 Capper & Son.—xiv. 95; xx. 45
 Capper & Waters.—xx. 21
 Capronnier, J. B.—Belgium, 438
 Carabe, M.—Spain, 112
 Caradua, J.—New Zealand, 25
 Carbonneau, J. B. C.—France, 104
 Carboneau, J. B.—France, 104
 Carborell, M.—Spain, 290
 Card, W.—x. 546
 Cardinal & Co.—xix. 321
 Cardwell, C. & T.—xix. 122
 Carew, J. E.—xxx. (Sculpture Court), 23
 Carfitt, T. & Son.—xxii. 219
 Carfrae, see Bonnar and Carfrae
 Carinthia Iron-works of the Chapter of Gurk St. Magdalena.—Austria, 416
 Carl, see Tielsch, Carl, & Co.
 Carle, A. F.—France, 1132
 Carles, H. R.—xvi. 231
 Carletui, E.—iii. 3
 Carlson, C. A.—Sweden, 110
 Carmalt, J.—Jersey and Guernsey, 18
 Carmichael, J.—xxvi. 114
 Carminati, see Senigaglia & Carminati
 Carnegie, W. F.—Western end, South Enclosure (Outside), 20; i. 198.
 Carneiro, D. F.—Portugal, 926. 937, 938, 943-948, 960-962
 Carnell & Hosking.—v. 201
 Carnet, X.—France, 105
 Carnet-Saussier.—France, 791
 Carnet, see Haxworth and Carnley
 Caron, see Claus & Caron
 Caron, A.—France, 1133
 Caron, J. M. & Co.—Zollverein (1), 653
 Caron, E.—Canada, 19
 Carpenter, Captain.—viii. 194
 Carpenter & Co.—xxii. 655
 Carpenter, J.—xxix. 143
 Carpenter, T. S.—China
 Carpenter & Tildesley.—xxii. 655
 Carpoiter, W.—ix. 30
 Carpenter & Westley.—x. 270
 Carpoiter, see Poillart & Carpoiter
 Carquillat, Miss M. Candy & Co.—France, 1134
 Carr, see Bennett, Carr, & Co.; Roberts-son, Carr, & Steel; Tupper & Carr Carr, J., & Riley.—xxii. 108
 Carr, T. & W.—xii. & xv. 273
 Carr, W.—xvi. 322, see Carr, T. & W.
 Carre, L.—France, 445
 Carreras, Y. Alberich.—Spain, 252
 Carrett, W. E.—v. 35
 Carriek, C.—xxx. (Fine Art Court), 53
 Carriek, J.—xxix. 16
 Carriek, T.—xxx. (Fine Art Court), 242
 Carrier-Houge—France, 1135
 Carriere, Brothers—France, 106
 Carriere, F.—France, 1136
 Carrington, C. A.—Main Avenue West, 90
 Carrington, S. & T.—xx. 126
 Carron, W.—viii. 251; xvi. 325
 Carros, see Hooper, Carros, and Sallouner.
 Carruthers, W.—xxx. (Fine Art Court), 305
 Carson.—xxii. 592; see also Ross, O'Connell, & Carson
 Carson, H.—ix. 110
 Carson, R.—xiv. 14
 Carson, W.—xxvi. 109
 Carstajen, A. F. jun.—Zollv. (1), 468
 Carstena, D. H.—Lubeck, 2
 Castagna, Royal Arsenal.—Spain, 191
 Carte.—x. 536
 Carte, A. G.—viii. 29
 Carteaux & Chaillou.—France, 792
 Carter.—xviii. 65; see Cunningham & Carter
 Carter, Brothers.—xiv. 36
 Carter, J.—Western end, South Enclosure (Outside), 8; i. 3
 Carter, M.—xxvi. 185
 Carter, Vayasseur & Rix.—xiii. 30
 Cartier, see Mercier & Cartier
 Cartisser, Joseph.—xxiv. 83
 Cartisser, Puissein.—xxiv. 83
 Cartwright, D.—xxii. 661
 Cartwright & Hiron.—xxii. 250; xxiii. 30
 Cartwright & Warners.—xx. 196
 Carvalho, G. R.—Portugal, 909-917. 919.
 Carvalho, M. L. de.—Portugal, 617, 624. 1212-1221
 Carvae, A. F.—Portugal, 359. 367
 Carver & Gilbert.—xx. 98
 Carver, T. & T. G.—vi. 89
 Casado, J. P.—Spain, 85
 Casado, J.—Spain, 105
 Case, G.—xvi. 315
 Case, G.—x. 545
 Casella, see Paravagna & Casella
 Casella, L. P. & Co.—x. 157A, 676A
 Caselli.—viii. 184
 Casey and Phillips.—xiii. 23
 Casia, C.—Malta, 12
 Casissa & Sons.—Sardinia, 27
 Caston & Co.—xvii. 78
 Caspari, J. F.—Zollverein (3), 132
 Casparson & Schmidt.—Sweden and Norway, 24. 91
 Carvalho, G. R.—Portugal, 909-917. 919
 Casebohm, T. H.—Oldenburgh, 1
 Casel, J.—Austria, 478

- Casels, A.—I. 26
 Casim-Ousseïn-Cooli-Ogli. — Russia, 249
 Cassin, H.—Rome, 32a.
 Castagneto, E.—Sardinia, 76
 Casteiran.—Algeria, 15
 Castel, E.—France, 83
 Castelle, H.—France, 107
 Castellini, Raffaele.—Iome, 23
 Castellon, Agricultural Board of.—Spain, 132
 Castellon, Corporation of.—Spain, 76. 153, 194
 Castell, J.—Spain, 190
 Casterman, J. & Son.—Belgium, 275
 Castle, see Sowerby & Castle
 Castle, J.—xxx. (Fine Art Court), 314
 Castle-Street Glass Works.—xxiv. 83
 Castrucini, C. F.—Tuscany, 50
 Catanzaro, M.—Tuscany, 54
 Catharino, M.—Portugal, 1278
 Catlin, G.—United States, 531.—Page 847
 Castillo, M.—Spain, 218
 Catlin, H. W.—United States, 250
 Cator, Nelson & Co.—iv. 46
 Cattanauch, C.—xx. 135a
 Catteaux, Brothers.—Belgium, 244
 Catteaux, G.—Belgium, 245
 Cattle, J.—xxvi. 20
 Cats, J. B. Van.—Netherlands, 54
 Cats, P. S. & Co.—Netherlands, 30
 Catez, Brothers.—Zollverein (1), 431. (Main Avenue East)
 Caulcher, J. D.—xx. 112
 Caulfield, W. B.—xix. 125
 Cause, D. A.—xvi. 250
 Cause & Garion.—France, 1137
 Cauvet, C.—France, 1138
 Cavaillon, De.—France, 109
 Cavelan & Co.—France, 1131
 Cavers & Lane.—viii. 286a
 Caviglioli, C.—Sardinia, 87
 Cawley, J.—I. 47; xxvi. 225; xxviii. 193
 Cawley, P.—I. 403
 Cayeux, see Moriceau & Cayeux
 Cayley, Sir G.—x. 673a
 Cazal.—France, 108
 Cazalet, A.—Russia, 223
 Cazaux, J.—Netherlands, 59
 Cea, P. A.—Spain, 64
 Cellier, F. & Son.—Hamburg, 15
 Centenera, E.—Spain, 184
 Cento Chamber of Commerce.—Rome, 9
 Cerain, J. B.—Spain, 1
 Cerceuil, L. F.—France, 793
 Cerf & Naxara.—France, 84
 Cerqueira, M. J. da Silva.—Portugal, 634
 Cerri, C.—Austria, 361
 Ceru, C.—Tuscany, 103
 Ceruti, E.—Austria, 147
 Cervený, W. F.—Austria, 157
 Cesari, D.—Austria, 731
 Chabot, C.—v. 684; xxx. (Fine Art Court), 239
 Chabot, P. J.—xviii. 62
 Chadburn, Brothers.—x. 259
 Chadwick, see Reed, Chadwick, & Co.
 Chagot, sen.—France, 1139
 Chailloux, Lepage, & Pochon.—France, 1538
 Chaleyser, J.—France, 111
 Challinor, see Bowers, Challinor, & Wooliscroft
 Chalmers, D.—vi. 32
 Chalmers, J.—New Brunswick, 29
 Chambellan & Co.—France, 1140
 Chamberlain.—xxx. (Fine Art Court), 74
 Chamberlain & Co.—xxv. 44; xxvi. 50
 Chamberlain, T.—xxix. 231
 Chamberlain, W., jun.—x. 399
 Chambers, see Bank & Chambers
 Chambers, Elizabeth R.—xix. 120
 Chambers, R.—xxix. 297
 Chambers & Robbins.—xxii. 533
 Chambers, W.—xxii. 807
 Chambou, C. A.—France, 113, 793a
 Chambori, F.—France, 112
 Chamouillet.—France, 1142
 Champagne, D.—Belgium, 187
 Champagne & Rougier.—France, 1143
 Champainhet-Sargeas, M. M. J.—France, 114
 Champernowne, H.—I, 158.—Page 848. xxvii. 6.
 Champion.—Van Diemen's Land, 12; see also Moses, Champion, & Co.
 Champoiseau, N.—France, 794
 Champouet, J.—France, 793a
 Chance, Brothers & Co.—x. 742; xxiv. 22
 Chancel, see Arduin & Chancel
 Chancellor, F.—xxx. (Fine Art Court), 331
 Chandler, see Richmond & Chandler
 Chandler, T.—ix. 108
 Chantry, Sir F. (the late).—xxiii. 97; xxx. (Fine Art Court), 135
 Chapel.—Algeria, 16
 Chapin, W. G.—United States, 31
 Chaplin, C.—xix. 367
 Chaplin, T.—xxvi. 214
 Chapman.—viii. 121; see also Glenton & Chapman; Hilliard & Chapman; James & Chapman; Whittee & Chapman
 Chapman, Elizabeth Annie.—xix. 128
 Chapman, J.—vii. 45; xxvi. 191
 Chapman, J. L.—United States, 63
 Chapman, T. & J. Alderman.—x. 601c
 Chapman & Whitaker.—xii. & xv. 163
 Chapon, Madame E.—Mauritius, 5
 Chapomiere, see Roulet, Gilly, & Co.
 Chapot & Pelon.—France, 448
 Chappell & Co.—xxx. (Fine Art Court), 66
 Chapuis & Richter.—France, 795
 Charageat, E.—France, 1144
 Charbonnier.—France, 115
 Chard & Munro.—v. 819; ix. 235
 Chardon & Son.—France, 116
 Charge, R.—xvi. 277
 Charles & Co.—France, 117
 Charleston Factory.—United States, 175a
 Charlovetz.—Russia, 374.
 Charlwood & Curminia.—United States, 97
 Charrière.—France, 1145
 Charrière & Deleuil.—France, 171
 Charny.—Gibraltar, 1
 Charny, P.—France, 85
 Chartreuse Société des Charbonnages Pire et Violetto.—Belgium, 34
 Chartron & Sons.—France, 796
 Chase, Mary W.—United States, 99
 Chassang see Ventujol & Chassang
 Chatain, H.—United States, 337
 Chatel.—France, 118; see also Papa-voine & Chatel
 Chatelain & Basset.—France, 797
 Chatelain & Foron.—France, 66
 Chatelneau, Société des Hautes Four-neaux Usines e Charbonnages De.—Belgium, 27
 Chutwin, H.—xxviii. 14
 Chatwin & Sons.—xxii. 286
 Chamlière Mining Company.—Canada, 12
 Chaudoir, C. & H.—Belgium, 377
 Chauvin, G.—France, 449
 Chauverondier, H.—France, 453
 Chavin.—France, 450
 Chazelle, see Opjacs & Chazelle
 Cheavin, S.—v. 418
 Chebanx, J.—France, 1146
 Cheek, W.—xxvi. 48
 Cheesborough, W.—xii. & xv. 179.
 Cheesewring Granite Co.—Western end, North Enclosure (Outside), 54
 Cheetham, G. C. & W.—xii. & xv. 45
 Cheetham, W., see Cheetham, G. C. & W.
 Chevard, Brothers.—France, 87
 Chenary, S.—ix. 56
 Chémet, see Bernoville, Larsonnier, & C.
 Chenevard, L.—Switzerland, 240
 Cheney, G. H.—Canada, 151. 155, 156, 150
 Cheueneviers, D.—France, 120
 Cheueneviers, T.—France, 1559
 Chenot, A.—France, 119
 Cherif, G. & Sons.—Tuscany, 109
 Cherif Ben Mimoun.—Algeria, 60; France, 1560.
 Cherot & Co.—France, 68
 Cherrert, D.—viii. 297
 Chesire, J. jun.—xi. 30
 Chesium, see Betsche, Chesium & Co.
 Chessire, E.—v. 691
 Chesters, S.—xxx. (Fine Art Co.), 246
 Chevalier, B.—x. 23
 Chevalier, C.—France, 1729
 Chevalier, J.—Jersey and Guernsey, 6
 Chevalier, J. D.—United States, 120
 Chevallier, see Lalande & Chevallier
 Cheverton, B.—xxx. (Fine Art Court), 194
 Chevot, J.—France, 121
 Chiachic, M.—Austria, 171. 282
 Chichisola, J. & Co.—Sardinia, 39
 Chick, R.—xii. & xv. 221
 Chickering, J.—United States, 458, 555.
 Child, R.—x. 544
 Child, W. H.—xxviii. 61
 Childs, see Mooklar & Childs
 Childs, J.—xxii. 459
 Chilson, Richardson, & Co.—United States, 417
 Chimay, Prince de.—Belgium, 370
 Chisard, jun.—France, 80
 Chiozza, C. A. & Son.—Austria, 43
 Chirio & Mina.—Sardinia, 89
 Chisholme, Emma.—xxix. 78
 Chittenden, see Church & Chittenden
 Chitty, E.—iii. 159
 Chucquel, L.—France, 90
 Chullet, S.—Switzerland, 70
 Chomer, see Montessery & Chomer
 Chomereau.—France, 122
 Chopin, F.—Russia, 365
 Chopping & Maund.—xxii. 11
 Choquet, C.—France, 1149
 Chosson & Co.—France, 1150
 Chretien, M. T.—France, 1561
 Chrimcs, see Guest and Chrimcs
 Christ, see Frey, Thurneisen, & Christ
 Christalning's, Count Von, Mining Co.—Austria, 404
 Christian, E.—xxvi. 10
 Christian, T.—Zollverein (1), 624
 Christiani, C. H.—Zollverein (1), 15
 Christie, A.—xxx. (Fine Art Court), 137
 Christie, J.—xxx. (Fine Art Court), 188

286
pany.—Canada,
Belgium, 377
449
nce, 453
Chazelle
1146
t. & xv 179.
—Western ent,
side), 54
—xii. & xv. 45
etham, G. C. &
ance, 87
Larsonnier, & c.
land, 240
adu, 151. 155,
ce, 120
se, 1559
19
Tuscany, 109
—Algeria, 60;
58
0
Chesnon & Co.
e Art Co.), 246
1729
and Guernsey, 6
ed States, 120
& Chevallier
Fine Art Court),
1
171. 282
Sardinia, 30
221
States, 458, 555.
61
Childs
& Co.—United
Belgium, 370
59
—Austria, 43
nia, 89
ix. 78
& Chittenden
90
d. 70.
& Chomer
22
5
xii. 11
1149
1150
1561
Chrimies
isen, & Christ
on, Mining Co.
n (1), 624
erein (1), 15
e Art Court),
e Art Court),

Christi, J.—Austria, 327
Christoffel, L.—Zollverein (1), 317
Christoffe & Co.—France, 1562.
Christophe, L. A.—France 91
Christy & Co.—xx. 35. 66
Christy & Sons.—xi. 44
Chrystall.—xxvi. 222
Chuard.—France, 123
Clubb & Son.—xxii. 646
Chuffart.—Algeria, 17
Church, G.—x. 514
Church, J.—vi. 214.
Church & Chittenden.—United States,
382
Church & Goddard.—vi. 135
Churchill, G.—x. 99
Churton, E.—xvii. 67
Chwalla, Ant. C.—Austria 71
Cini, Brothers.—Tuscany, 65, 68
Cioni, G.—Tuscany, 104
Clausen, P. C.—Netherland, 91
Claburn & Son.—xii. & xv. 284
Claes, P.—Belgium, 163
Claghorn, see Jennings & Claghorn
Clair, P.—France, 1151
Clais, C. S. Von.—Switzerland, 121
Clapham, John.—xii. & xv. 157; xvii.
9
Clapham, J. K.—x. 712
Clapham, W.—xii. & xv. 158
Clapperton, T. & G.—xii. & xv. 103
Claphaw, M.—xxix. 186
Claraz, A.—Switzerland, 228
Clare, Godfrey, sen.—France, 454
Clarenbach & Sons.—Zollverein (1),
506
Clarence, R.—South Africa, 13, 54
Clark, see Nunn and Clark
Clark, B.—xvi. 154
Clark, C.—vii. 15
Clark, C., see Clark, T. & C. & Co.
Clark, C. C.—xxii. 517
Clark, C. & J.—xvii. 48
Clark, D. G.—v. 425
Clark & Davidson.—xvii. 135
Clark, M.—vii. 106
Clark, F.—x. 276
Clark, G. D.—v. 425; vii. 8
Clark, G. H.—i. 190
Clark, J.—viii. 91; ix. 99; xii. &
xv. 169; xix. 78; Canada, 80; see
also Clark, C. & J.
Clark, J. A.—viii. 135.
Clark, J. & J.—xii. & xv. 13
Clark, J., jun. & Co.—xii. & xv. 293
Clark, R.—United States, 234
Clark, R., & Restell.—xxii. 446
Clark, S. B.—xxvi. 179
Clark & Co.—xxii. 637.
Clark, W.—xvi. 75; xvii. 134
Clarke.—xxvi. 42
Clarke & Co.—xxvi. 62
Clarke, E.—xviii. 23
Clarke, Eliza.—xix. 129
Clarke, Esther.—xix. 130
Clarke, K. W.—xvi. 191
Clarke, G. R.—xxii. 3
Clarke, J.—xiii. 20; xvii. 68; xix.
18; xxvi. 127; Canada, 165
Clarke, J. P.—xi. 32
Clarke, Phidas.—vii. 38 (Main Ave-
nue West)
Clarke, R. C. (Executors of).—i. 266
Clarke, R. & Sons.—xvi. 307; (Main
Avenue West 301)
Clarke, T.—xii. & xv. 432
Clarke, T. C.—xxx. (Fine Art Court),
342A
Clarke & Williams.—v. 965
Clarkson, J. C.—xvi. 102

Clarkson, T. C.—v. 569; viii. 2;
xxviii. 197
Clarkson & Co.
Clarrie, W. R.—xxix. 14
Classen, F. F.—Hamburgh, 110
Clason, J.—iv. 22
Claude, L.—Belgium, 85
Claudet, A. F. J.—x. 296
Claudet & Houghton.—v. 306; xxiv.
25, 74
Claudio, J.—Sardinia, 68
Claus & Caron.—Belgium, 81
Clausen, Chevalier.—Canada, 13.
Clausen, P.—iv. 105; vi. 86
Clavereau, Brothers, J.—Belgium, 09
Clawson, H. N.—United States, 503
Claxton, J.—i. 73
Clay, see Jackson & Clay
Clay & Co.—xxvi. 189
Clay, J.—iii. 17; v. 88.
Clay, J. T.—xii. & xv. 124
Clay & Sons.—xii. & xv. 136
Claye, see Allard & Claye
Claye, J.—France, 798
Clayton, H.—xxviii. 96
Clayton, G.—xxii. 142
Clayton, H.—ix. 47; Van Diemen's
Land, 50
Clayton, R.—viii. 1
Clayton, Shuttleworth, & Co.—v. 39;
ix. 212
Cleal, W.—xxiii. 59
Cleanthes, S.—Greece, 40—42
Cleare, C.—viii. 311
Cleaver, F. S.—xxix. 20
Cleave, W. J.—xvii. 207
Cleburne, R.—Van Diemen's Land,
144
Clemengon, Malmae.—France, 1152
Clemens, J.—iii. 56
Clement-Bourgeois, L.—France, 455
Clements, J.—xvii. 71; xxix. 189
Clementson, J.—xxv. 8
Clemes & Son.—xx. 156
Clerget, C. E.—France, 799
Clesinger.—France, 1709
Clesinger, T.—France, 410
Clibborn, Hill, & Co.—xiv. 20
Cliequot.—France, 1563
Clifford, G.—ii. 26
Clifford, W.—xxx. (Fine Art Court),
222
Clinch, J.—New South Wales, 5
Clingman, T. L.—United States, 358
Clinton.—x. 538
Clinton, E.—United States, 190
Clirehugh, V.—United States, 133
Clive, see Hickman & Clive
Clive, J. H.—vii. 41; xxix. 54
Clive, J. W.—i. 277
Clnet, C.—France, 456
Close, Misses.—New Brunswick
Clough, H.—xii. & xv. 151
Clowes, F.—xx. 150
Cluappini, A. & Co.—South Africa, 22
Clugas, T., jun.—Jersey and Guern-
sey, 25
Clunes, T.—v. 475
Clutton, H.—xxvi. 19
Clymer & Dixon.—vi. 124
Coalbrook Dale Co.—v. 641; xxii.
641 (Main Avenue West)
Coalbrook Dale China Manufactory.—
xxv. 23
Coate, J., & Co.—xxviii. 51
Coates & Blizard.—v. 615
Coates, E. J.—xxvii. 19
Coates, W.—i. 492A
Coatlupnes & Co.—xxiv. 47
Cobb, T.—vi. 150

Cobbald, E.—i. 228
Cobourg-Gotha, Count Ernest of.—
Zollv. (Octagon Room), 836
Cocchi, L.—Austria, 707
Cocchia, E. E.—Zollverein (1), 12
Cochois & Collin.—France, 124
Cochequel, see Hequillart, Roussel, & Co.
Cochequel, F.—France, 1148
Coehran, J. W.—United States, 141.
207. 480
Cochrane, A.—vii. 158
Cochrane & Co.—vii. 26
Cochrane, J.—xxii. 434
Cochrane, J. & W.—xii. & xv. 188
Cochrane, W., see Cochrane, J. & W.
Cock, H.—xxx. (Fine Art Court), 147
Cocke, Gen. J. H.—United States, 271
Cocker, S. & Son.—xxii. 115
Cocker & Sons.—xxii. 234
Cockerill, J.—Belgium, 119
Cockerill, R.—xxx. 251
Cockerill, W.—Zollverein (1), 105
Cocks, C., see Cocks, J. & C.
Cocks, E.—xxix. 266
Cocks, J. & C.—xxix. 317
Cocks, R. & Co.—xvii. 123
Cockshot, see Wall, Cockshot, & Wall
Cocu, A.—France, 125
Cody, Nicholas.—New Zealand
Cody, J.—xx. 64
Coffey, J. A., and J. Smith.—x. 454
Coffey, T.—vi. 615
Cogan, R.—xxiv. 26
Cohen, B.—Austria, 746
Cohen & Orr.—iii. 49
Cohn, J. H.—Zollverein (1), 603
Cohn, L. H.—Hamburgh, 42
Cohn, Brothers, & Herman, Brothers.—
Zollverein (1), 104
Cohn, Phillip, & Co.—Zollverein (1),
137
Coignot & Son.—France, 1153
Coimira, the Nuns of.—Portugal, 417
Coit-Bavant, & Son.—France, 800
Colclough, see Glover & Colclough
Colderts, Van Roy.—Belgium, 41
Cole, E. J.—i. 504
Cole & Son.—xix. 132
Cole, T.—x. 31
Colegate, W. & Co.—United States, 301
Colegrave, F. E.—v. 162; viii. 142;
xvi. 97
Coleman.—United States, 374
Coleman, Mrs. C.—United States, 71
Coleman, R.—ix. 216
Coleman, T. G.—xvi. 68
Coles, W.—vii. 11; x. 600
Colfs, J. T.—Belgium, 417
Colgan & Son.—xxi. 25
Colin, see Cochois & Colin
Colin, J. R.—France, 1564.
Collocchioni, G.—Tuscany, 52
Collard & Collard.—x. 168
Collars, J. B.—viii. 309A
Collas, M. A. C.—France, 801
Colle.—Belgium, 61
Collet, F.—Zollverein (3), 110
Collembusch, see Dreyse & Collembusch
Colles, A.—i. 140
Colles, F. C.—France, 93
Collet, C.—vi. 155
Collet, W. R.—i. 458
Colletta-Lefebvre.—France, 458
Collette, Doucet.—Belgium, 5
Colley, G.—xxx. (Fine Art Court), 121
Collard & Comte.—France, 1154
Collie, W.—Jersey and Guernsey, 22
Collier, Son, & Snowdon.—xxii. 100
Collin, C. E.—France, 126
Colling, J.—British Guiana, 162

- Callinge.—v. 848.
 Collinge, C. & Co.—v. 49, 482, 817; vi. 432; xxii. 573
 Collings, J.—xxviii. 120
 Collins, C. W.—x. 459
 Collins, F.—xviii. 86
 Collins, J.—xxii. 88
 Collins & Rose.—xi. 133
 Collins, H. N.—ii. 109
 Collinson, see Cope & Collinson
 Collinson, G.—i. 75
 Collinson, G. C.—xxvi. 90
 Collinson, Rev. J.—New Zealand, 3
 Collis.—France, 1709
 Collis, G. R.—xxiii. 34
 Collison, see Prince, Collison, & Co.
 Collot, Brothers.—France, 1155
 Colla, L., see Colla, R. & L.
 Colla, R. & L.—x. 303
 Collyer, Gov. H. W.—United States, 289
 Colman, J. & J.—iii. 117
 Colmenero, F. & J.—Spain, 182
 Colnet, De, see Leempol, Van, De Colnet & Co.
 Colom, D. Juan.—Spain, 74
 Colomb, see Rauss & Colomb
 Colombo, G.—Austria, 630
 Colquhoun, J. N., Lt.-Col.—iii. 13.
 Colt, S.—United States, 321
 Colton, J. W.—United States, 310
 Colville, M. & Mills.—France, 802
 Comba, F.—Sardinia, 83
 Combes.—France, 459
 Comins, J.—ix. 143
 Commeford & Redgate.—United States, 129, 495
 Common, J.—xxii. 630
 Comolera, Mavime.—France, 1741.
 Comte, see Colliard & Comte
 Con, Van der Maeren & Co.—xxiv. 20
 Concanen, E.—xxx. (Fine Art Court), 2
 Concha, A.—Spain, 49
 Conde, M. De la.—Jersey and Guernsey, 7
 Coverling, Mrs. Ida Von.—xix. 146
 Cougou, G.—Greece, 57
 Counaught Schools.—xix. 61
 Conne, A.—xxiv. 28
 Cornell, see Muira, Cornell, & Brodie
 Cornell, D.—xxiii. 16
 Cornell, W.—x. 11; New Zealand, 10
 Cornerot, M.—France, 1567
 Courad, F. U.—Netherlands, 90
 Conrad, W.—France, 1156
 Conradsen, N.—Denmark, 36
 Constable.—ix. 109
 Constable, H.—viii. 140
 Constable, Hannah.—xix. 134
 Constable, W.—v. 70
 Constantin, Messrs.—France, 94
 Constantine, St. Nuns of.—Greece, 54
 Constantinople, Central Committee of.—Turkey,
 Constantinolachi.—Greece, 53
 Coota & Boehme.—Zollverein (1), 815
 Coute.—xxx. (Fine Art Court), 140
 Conti, Guido de.—Tuscany, 93
 Conti & Son.—Tuscany, 23
 Conti, V.—Spain, 139A
 Contreras, R.—Spain, 283
 Couverso.—Algeria, 21
 Cooch, J.—ix. 53
 Coode, Browne, & Co.—South Australia
 Coode, G.—ix. 154A
 Cook, see Hague, Cook, & Wormal
 Cook, A.—i. 19
 Cook, G.—xxx. (Fine Art Court), 104
 Cook, J.—xxviii. 34; United States, 242; see also Cook, W. W. & J.
 Cook, J. E.—xxx. (Fine Art Court), 9
 Cook, Rowley, & Co.—v. 816
 Cook, T.—xxii. 579
 Cook, T. A.—ii. 15
 Cook, W.—xix. 135; xxii. 16
 Cook, W. W. & J.—xi. 38
 Cook & Williams.—x. 685
 Cooke, see Gouffrey & Cooke.
 Cooke, E. W.—iv. 2A; x. 664A
 Cooke, H.—vi. 118
 Cooke & Sons.—xvii. 73
 Cooke, W. & Sons.—United States, 318
 Cookes & Sons.—xxx. (Fine Art Cr.) 110
 Cooksey, H. R.—xxii. 320
 Cooley, J.—v. 561
 Coomber, J.—xxvi. 307
 Coombes, B. & Co.—xxii. 27; vi. 444
 Cooney, C.—iv. 70
 Cooper & Blagg.—Zollverein (3), 90
 Cooper & Bursill.—vi. 624
 Cooper, D. & J.—xii. & xv. 42
 Cooper, E. G.—viii. 334A
 Cooper, G.—xxii. 223; xxvi. 291; see also Cooper, J. J. & G.
 Cooper, J., see Cooper, D. & J.
 Cooper, J. J. & G.—xx. 172A
 Cooper, J. M.—xxviii. 151
 Cooper, J. R. & Co.—viii. 241
 Cooper, M.—xvi. 50
 Cooper & Maclean.—viii. 72
 Cooper, S.—i. 129A
 Cooper, M. M.—xxvi. 235
 Coopers, see Field, Coopers, & Faulds; Snyvee & Coopers; Williams, Coopers, Hoyle, & Co.
 Cooreman, A. J.—Belgium, 212
 Coosemans, M.—Belgium, 56
 Coostals, Government of.—Russia, 118
 Cope, see Hopkinson & Cope; Snerwin, Cope, & Co.
 Cope & Collinson.—xxii. 255; xxvi. 122
 Cope, Hammetton, & Co.—xiii. 70
 Copeland, Ald. M. P.—Persia, 6; see also Copeland, W. T.
 Copeland, Fanny.—xix. 136
 Copeland, G. A.—i. 520
 Copeland, W. T.—xxv. 2; xxvi. 186A
 Copenhagen Royal Porcelain Manufactory.—Denmark, 33
 Copestake, see Groucock, Copestake & Moore
 Copland, Barnes, & Co.—iii. 11
 Copland, C. M. A.—x. 46A; xxx. (Fine Art Court), 136; China
 Copling, J. jun.—v. 668
 Copney, W.—ii. 118
 Coppel, A.—Zollverein (1), 628
 Coppi, see Hall, Brothers, Sloane & Coppi
 Coppin, L. jun.—France 128
 Coppock, J.—ii. 65
 Corali & Sons.—xx. 208
 Corben & Sons.—v. 818
 Corboda.—Spain, 29
 Corcoran, B. & Co.—vi. 416
 Cordel, see Tautenstein & Cordell
 Corderant, A.—France, 1157
 Cordier, C.—France, 460
 Cord'ng, J. C.—xxviii. 82
 Cordoumier & Co.—France, 1159
 Cordova, Agricultural Board of.—Spain, 99
 Cordova, Mining Inspector of.—Spain, 29
 Cork & Edge.—xxv. 21
 Cornéa, V. G.—Portugal, 600
 Corneau & Son.—United States, 13
 Corneiro, B. F.—Portugal, 946
 Cornelius, & Co.—United States, 46
 Cornelius & Kaulbach.—Zollverein (1), 148
 Cornell, Lyell, & Webster.—xiii. 1A, 22
 Cornell, T.—xxii. 246
 Cornes.—ix. 205
 Cornes, J.—ix. 83
 Corney, see Barrett & Corney
 Cornforth, J.—xxii. 322
 Cornides, L.—Hamburgh, 101
 Cornillon, J. H.—France, 95
 Corniquel, C.—France, 461
 Cornu, W.—xxx. (Fine Art Court), 36.
 Cornwall, Duchy of.—i. 452
 Correa, B. de S.—Portugal, 43
 Correa, V. G.—Portugal, 600
 Corridi, G.—Tuscany, 22
 Corridi, P.—Tuscany, 89
 Curry, Blain, & Co.—xiv. 24
 Curry, J. & J.—xvi. 314; xx. 100
 Curreyton, J.—viii. 82
 Curuso, J. da F.—Portugal, 809
 Curt y Marti, P.—Spain, 273
 Corte.—viii. 177
 Coruna, Inspector of Mines.—Spain, 18
 Cury, W. & W. jun.—i. 265
 Cosack, J.—Zollverein (1), 825
 Cosens, see Laugher & Cosens
 Cosquin, J.—France, 804
 Cosack women, Orenbourg.—Russia, 132, 198
 Cosack's Wife, A.—Russia, 282
 Cosens, E. J.—xxx. (Fine Art Court), 25
 Cosins, see Daniel and Cosins
 Cosley & Sons.—xix. 142
 Costa, R. da.—Portugal, 343
 Costain, T.—viii. 136
 Coste, F.—Belgium, 397
 Costoli, Prof. A.—Tuscany, 106
 Cottam, E.—xxii. 69
 Cottam & Hallen.—vi. 221; ix. 109A; xxii. 698 (South Transept)
 Cotterell, Brothers.—xxvi. 149
 Cullerill, E.—xxii. 307
 Cottle, J. E.—viii. 98
 Cotti, see Calli and Cotti
 Cottingham, N. J.—Main Avenue West, 63
 Cotton, D.—xxx. 177
 Couchonnel & Co.—France, 1160
 Couchoud, St. E.—France, 1161
 Coucke, C.—Netherlands, 57
 Coulter, A.—France, 1566
 Couderc & Soucaret, jun.—France, 96
 Coulaux, sen. & Co.—France, 129
 Coulbois.—France, 1560
 Coulson, J. & Co.—xiv. 92
 Coulson, Jakes, & Co.—ii. 72
 Coulson, W.—xiv. 93
 Coulton, J. D.—xxx. (Fine Art Court), 342
 Coupin, J.—France, 1162
 Cournerie & Co.—France, 462
 Court, J.—xxii. 389
 Courtauld, S. & Co.—xiii. 34
 Courte, P.—France, 1164
 Courtepe-Duchessauy.—France, 806
 Courtney, Brothers, and Bares.—France, 97
 Courtil.—France, 807
 Courtin, R.—France, 1570
 Courtney, see Jenkins and Courtney
 Courtois, A.—France, 1163
 Courtois, A. sen.—France, 131, 463
 Courtois, E.—France, 808, 1571
 Courtown, Lord.—i. 143
 Courvoisier, see Jacot & Courvoisier
 Courvoisier, F.—Switzerland, 34
 Cousens, S.—iii. 88
 Cousens & Whiteside.—x. 86
 Cousin.—France, 1572
 Cousins & Son.—v. 820; xxii. 163

er.—XIII. 1A. 22
 Corney
 gh, 101
 ce, 95
 461
 Art Court), 36.
 L. 452
 gical, 43
 al, 600
 22
 89
 iv. 24
 14; xx. 190
 gical, 809
 in, 273
 Mines—Spain, 18
 L. 265
 (1), 825
 Cosens
 04
 bourg.—Russia,
 ussia, 282
 Fine Art Court),
 Cousins
 142
 , 343
 17
 any, 106
 221; ix. 109A;
 ansept)
 VI. 149
 ti
 Avenue West,
 nce, 1160
 ce, 1161
 la, 57
 66
 n.—France, 96
 France, 129
 92
 II. 72
 Fine Art Court),
 62
 ce, 462
 III. 34
 51
 France, 806
 Barez.—France,
 70
 and Courtney
 163
 ce, 130, 463
 08, 1571
 Courvoisier
 land, 34
 x. 86
 ; xxii. 163

Couteaux, A. J.—France, 805
 Coute, D. V.—139A
 Couteur, Col. John Le—Jersey & Guernsey, 3
 Couturier & Renault.—France, 98
 Couvert & Lucas.—Belgium, 404
 Couveliers, see Nuffel, Van, & Couveliers
 Coveney, Mrs.—xix. 139
 Coventry Ribbons' Committee.—xiii. 72
 Cowan, A. & Sons.—vi. 166; xvii. 101
 Cowan, H.—ix. 124a
 Cowan, L.—xvi. 273
 Cowan & Sons.—xxix. 19
 Cowell, S. H.—xxx. (Fine Art Co.), 38
 Cowell & Thomas.—xxvi. 326
 Cowen & Co.—xxvii. 112
 Cowgill, Jessop, & Co.—xii. & xv. 122
 Cowie & Rae.—i. 16
 Cowley & James.—xxii. 62
 Cowling, J.—xvi. 142
 Cowper, see Murray & Cowper
 Cowper, Prof. E.—vi. 134
 Cowper, R. A.—v. 699; xxix. 245
 Cowper, J.—i. 61
 Cowper, T., see Wallace, W.
 Cowperthwaite & Co.—United States, 360
 Cowslade & Lovejoy.—vi. 91
 Cowvan, B. & S.—xxi. 9
 Cowvan, S., see Cowvan, B. & S.
 Cox.—Brazil, i; see also Robins, Asquith, & Cox
 Cox, Miss A.—xix. 220
 Cox, E., & Co.—Algeria, 68
 Cox, F.—Van Diemen's Land, 280
 Cox, G.—x. 347
 Cox, G. J.—xxx. (Fine Art Co.), 248
 Cox, H.—xxx. (Fine Art Court), 263
 Cox, J.—xxix. 68
 Cox, N. F.—viii. 208
 Cox, R. S., & Co.—xiii. 66
 Cox, S.—xvi. 55
 Cox, T.—xvi. 275
 Cox, W.—vi. 608
 Coxeter, J.—x. 682
 Coxhead, see Fordat, Coxhead, & Co.
 Coxens & Greatrex.—xvi. 283
 Crabtree, T.—vi. 3
 Crabtree, W.—xii. & xv. 55
 Crace, J. G.—xiii. 97; xxvi. 530
 Craddock, T.—v. 76; xxx. (Fine Art Court), 227
 Cragg, J.—x. 8
 Craig.—x. 259
 Craig, J.—v. 776
 Craig, J., & Co.—ix. 262A
 Cramer, L. & Co.—Zollverein, (1) 610
 Crampton, T. R.—v. 598
 Craue, see Sandland & Craue; also Wright, Crump, & Craue
 Crane, J.—xxvi. 210
 Crap, H. J. L.—Netherlands, 25
 Craven, see Bayley & Craven
 Craven & Harrop.—xii. & xv. 153
 Craven & Son.—xii. & xv. 149
 Crawford, H. M.—United States, 51
 Crawford, J.—xxvi. 96
 Crawford & Lintsaux.—xiv. 13
 Crawhall, J.—vi. 78
 Crawshaw, see Hawks, Crawshaw, & Co.
 Creuk, J.—xvi. 141
 Creaser, Mrs.—xxvi. 289
 Credrus, F.—France, 134
 Creer, see Quilliam & Creer
 Cremer & Co.—xvi. 198
 Cremer, J.—France, 1573
 Crespel-Dellisse.—France, 465
 Crespin, E.—xxviii. 36
 Cresson, Elliott.—United States, 327
 Cresswell, J.—x. 417

Crestadoro, A.—v. 557
 Creswick, N., see Creswick, T. J. & N.
 Creswick, T. J. & N.—xxiii. 45
 Crew, J. J.—xxiii. 83
 Cribb, T. J.—xxx. (Fine Art Court), 146
 Crichton & Co.—vi. 36
 Crichton, D.—vi. 35
 Crichton, G.—xxx. (Fine Art Court), 229
 Crichton, J.—x. 452
 Crick, Ellen.—xix. 140
 Crickitt, R. E.—x. 267
 Crisler, R.—xxviii. 101
 Crippa, W. N.—v. 576
 Cristofoli, A.—Austria, 38
 Critchley, Brinsley, & Co.—xiii. 40
 Critien, E.—Malta, 24
 Croall, W., jun., & Co.—v. 824
 Crocco, Brothers.—Sardinia, 50
 Crocker, A., see Crocker, J. & A.
 Crocker, J. & A.—xi. 61; xviii. 11
 Croco, F.—France, 809
 Croff, G.—Austria, 708
 Croguon & Co.—vii. 110
 Croid, R.—viii. 304
 Crolsat, J.—France, 1574
 Croissant & Lauenstein.—Hamburg, 7
 Cromack, J. J.—xii. & xv. 68
 Crombie, J. & Co.—xii. & xv. 228
 Crook, F.—xxx. (Fine Art Court), 57
 Crook, W.—xxii. 244
 Crookes, C.—North Transept, 49; xxii. 641 (Main Avenue, West)
 Croon, Brothers.—Zollverein (1), 609
 Crompt.—France, 131
 Crozier, M. L. Le.—France, 1305
 Cross, C.—vi. 64; xiii. 32
 Cross, C. & Co.—xi. 47; xx. 115A
 Cross, G.—xvii. 88
 Cross, J.—xi. 41
 Cross, Mary.—xix. 141
 Cross, S.—iv. 136
 Cross, W.—xii. & xv. 202
 Crosskill, E.—v. 826; ix. 11
 Crossland, W.—v. 25; vi. 404; ix. 135
 Crossland, H., see Crossland, W. & H.
 Crossland, W. & H.—xii. & xv. 97
 Crossley & Sons.—xix. 142
 Crouch.—South Africa, 58A
 Croughton, H.—xxvi. Bay I. 21
 Croughton, W. P.—iii. 92
 Croutelle.—France, 132
 Crow, T.—xvi. 196
 Crowcher, C. jun.—iv. 3A
 Crowley & Sons.—ix. 96
 Crowquill, Alfred.—xxv. 7
 Cruchley, G. F.—xvii. 74
 Cruchet, V.—France, 810
 Crucifix, E.—France, 133
 Crüger, see Droin, Crüger & Co.
 Crummack, E.—xxviii. 18
 Crump, see also Wright, Crump, & Co.
 Crump, T.—ix. 160
 Crutwell, Allies & Co.—Western end, South Enclosure (Outside), 52; i. 402
 Crutwell & Co.—v. 659
 Cruz, Arcas, D.—Spain, 253c
 Cruz, F. J. da—Portugal, 756, 776
 Cruz, J. de la—Spain, 149, 201
 Cruz, S. de la—Spain, 196
 Cubitt, see Gregory, Cubitt, & Co.
 Cubitt, J.—v. 628
 Cuendét, Adeline.—Switzerland, 159
 Cuesta, A. De la—Spain, 49A
 Cuff, R.—xvi. 96
 Cuff, R. P.—xxx. 312
 Gugaj, J. P.—Spain, 247
 Gugliero, R.—Sardinia, 67
 Cugnot, A.—France, 99

Culpera, J. F.—Netherlands, 95
 Cullum, see Sharpes & Cullum
 Culverwell, W.—xxii. 734
 Cumming, J. G.—i. 151, 493
 Cumming, Rev. J. G.—i. 157, 195; xxvii. 64
 Cummings, see M'Lean & Cummings
 Cummings, J. A.—United States, 452
 Cummins, see Charwood & Cummins
 Cumont, D.—Belgium, 236
 Cumvall & Adley.—xvii. 106; xxviii. 13; xxx. (Fine Art Court), 112
 Cundy, S.—Page 848
 Cunliffe, Sarah Ann.—xix. 144
 Cunniff, W.—xxvi. 165
 Cunningham, A. R.—xviii. 626
 Cunningham & Carter.—v. 654
 Cummings, Jas.—xxviii. 159
 Curjar, T.—Hamburg, 35
 Curmer, A.—France, 135
 Curr & Co.—xiv. 88
 Curran & Sons.—xxvi. 215
 Currie, J.—xvi. 215
 Currier, see Pritt, Tanner, & Co.
 Curtis, jun.—Algeria, 22
 Curtis, see Parr, Curtis and Madeley
 Curtis, Brothers & Co.—iv. 126; xxviii. 194
 Curtis, J.—Zollverein (1), 458
 Cusson, Pouchet, & Roussignol.—France, 468
 Cassons & Co.—xvi. 34; xvii. 69; xviii. 55
 Custer & Schachtler.—Switzerland, 148
 Cutch, Rao of.—India, viii.; xxx.
 Cuthbertson, see Scott & Cuthbertson
 Cutler, J.—xxii. 217
 Cutler, W.—xx. 69
 Cuvillier, H., sen.—France, 469
 Cuyere, Mrs.—Tuscany, 59
 Cuyper, De.—Belgium, 455 (Main Avenue East)
 Cuyper, De L.—Belgium, 455 (Main Avenue East)
 Cuyper, H. De, see Bernaert & Cuyper, H. De
 Cuyper, J. F. De.—Belgium, 192
 Cuyper, H. De, see Beervoert, & Co.
 Cym Avon Iron Co.—v. 645
 Czekelius, C.—Austria, 45
 Czermak, P.—Austria, 585
 Dabaret-Tampe.—France, 152
 Daboust, see Cappelmeans, J. B. and Daboust
 Dada, B.—Russia, 250
 Daels, A.—Zollverein (1), 269
 Daël, G.—Zollverein (6), 82
 Daflamme, M. A.—Canada, 113
 Daffrique, F.—France, 1575
 Dagand.—France, 511
 Dagnall & Co.—xiv. 89
 Dagnet, T.—Switzerland, 75
 Dahlbom, P. A.—Sweden, (1) 814
 Dahlheim, J.—Zollverein (7), 814
 Daily and Co.—xi. 64
 Dakin & Co.—vi. 408
 Dalby, J.—xii. & xv. 152
 Dale, H.—xxii. 501
 Dalgety, A.—vi. 226
 Dalgleish, Falconer, & Co.—xviii. 27
 D'Almeida, W. F.—xxvi. 301
 Dalphin, J. E.—United States, 493
 Dalrymple, Mary E.—xix. 377
 Dalrymple, W.—xii. & xv. 240
 Dalton, J.—vi. 4
 Dalton, T.—xxix. 48
 Daly, J.—v. 400; xii. & xv. 264.

Damaiville.—France, 153
 Damaun, W.—xxvii. 3, 4
 Damirot, & Co.—France, 1167
 Danson, T.—I. 149
 Damsch & Mueners Sons.—Zollverein (1), 715
 Danby, C. & T.—xix. 71.
 Danby, J.—xxiv. 88.
 Danby, T., see Danby, C. & T.
 Danckwart, Lieut.—Sweden, 48
 Dando, see Harding, Dando, & Co.
 Dando, Sons, & Co.—xx. 50
 Dando, Maillard, Lucq, & Co.—France, 491
 Dangar, see Avery & Dangar
 Dangar, R. C.—New South Wales, 7
 Dargerfield—Canada, 111
 Daniel, jun.—France, 1168
 Daniel & Cousins.—xix. 145
 Daniel, J.—China
 Daniel, T.—xxix. 170
 Daniell, A. B. & R. P.—xxv. 23
 Daniell, J. C.—ix. 265; xxii. 607
 Daniell, M. P., see Daniell, A. B. & R. P.
 Daniell, W.—vii. 182
 Daniells.—xii. & xv. 12.
 Danjard, L. F.—France, 138
 Dano, T.—i. 56.
 Danuati, J.—xxii. 43
 Danneau.—Belgium, 607.
 Danneberg & Son.—Zollverein (1) 710
 Danser, J., see Scrive, Hra. & J. Danser
 Darblay, jun.—France, 1576
 Darbro, F.—France, 1577
 Darche, C. F.—Belgium, 177
 Darier, H.—Switzerland, 61, 76
 Dark, Matilda, & Sons.—xxix. 197
 Dark, R.—xxix. 198
 Darling, G.—xx. 131
 Darling, W.—United States, 191
 Darmain, J., & Sons.—Malta, 20
 Darnell, J.—x. 383
 Darnet.—France, 1878
 Darras, P.—France, 470
 Dart & Son.—v. 849
 Dartet, see Temoumet, Dartet, & Co.
 Darteville & Monoury.—Belgium, 329
 Darton, W.—United States, 449
 Darvell, W. J.—x. 389
 Darvieu, sen, Valmald & Co.—France, 1169
 Daubarn.—xxix. 228
 Daubert and Dumaret.—France, 1579
 Dauchel, jun.—France, 154
 Daucher, S.—Austria, 508
 Daudre, A.—France, 1170
 Daulrieu.—France, 155
 Daudrille, A.—France, 156
 Dauphinot-Perard.—France, 471
 Daupiax & Co.—Portugal, 851-904
 Dauphin, Gorton, & Co.—ii. 63
 Dauthuille, A. T.—France, 1171
 Dautremer & Co.—France, 137
 Dautrême, see Parnuit, V. Dautrême, Sons & Co.
 Daveluy, D.—Belgium, 448
 Davenport, J. L.—vi. 80
 Davenport, J. T.—ii. 111
 Davey, see Bickford, Smith & Davey
 Davey, S.—i. 503
 David, Brothers, & Co.—France, 157
 David, C.—France, 812
 David, Lalbez, & Co.—France, 138
 Davidoff, B.—Russia, 332
 Davidson, see Clark & Davidson
 Davidson, A.—x. 385
 Davidson, C. H.—viii. 298
 Davidson, Capt. D.—viii. 238
 Davidson, G. & W.—xxix. 158
 Davidson, J., see Davidson, W. & J.

Davidson, J. & Co.—v. 774; xiii. 47
 Davidson, J. D.—United States, 561
 Davidson, Lieut.—xix. 148
 Davidson, W., x. 108; see Davidson, G. & W.
 Davidson, W. S. J. & Co.—xi. 17
 Davies, Archdeacon.—Van Diemen's Land, 178, 179
 Davies, D.—v. 828
 Davies, G.—xxiv. 37; see also Davies, J. & G.
 Davies, G. C.—xxvi. 129
 Davies, J.—ii. 70
 Davies, J. & G.—v. 16
 Davies, Mrs.—xix. 49
 Davies, R.—xx. 216
 Davies & Sons.—xii. & xv. 214
 Davies & Taylor.—i. 523
 Davies, W.—xxiv. 38
 Davis, see Moses, Son & Davis; also Schofield, Brown, & Co.
 Davis, C.—xxii. 522; xxvi. 329
 Davis, D.—Western end, South Enclosure (Outside), 43
 Davis, E.—Page 818
 Davis, G.—xxvi. 143
 Davis, Greathead, & Green.—xxiv. 15
 Davis, H. A., see Davis, W.
 Davis, J.—viii. 253; x. 70, 331; xvii. 183; Canada, 78
 Davis, J. H.—xxii. 536, 643
 Davis, J. D.—United States, 563
 Davis, R.—viii. 271.
 Davis, T.—ix. 40
 Davis, W.—x. 30; xxx. (Fine Art Court), 65
 Davison, see Gray and Davison
 Davias, see Washington & Davias
 Davison, W.—British Guiana, 12, 77
 Davitti, L.—Tucumay, 40
 Davy.—ix. 237
 Davy, Rev. C. R.—vi. 234
 Davy, Mackmurdo, & Co.—ii. 62
 Daw, see Witton, Daw, & Co.
 Dawharn & Co.—i. 208
 Dawbes & Dumbleton.—xxii. 499
 Dawes, B.—xxvi. 135
 Dawson, see Hird, Dawson, & Hardy
 Dawson, C.—x. 534
 Dawson, Deborah.—xix. 140
 Dawson, F. W.—v. 830
 Dawson, G.—United States, 543
 Dawson, J.—vi. 612
 Dawson & Morris.—xv. 118
 Dax, R.—xvi. 278
 Day.—xxvi. 280; xxx. (Fine Art Court), 30
 Day, H. H.—United States, 308
 Day, H. J.—v. 133
 Day, J.—xiv. 55; United States, 575
 Day, T. & W.—New South Wales, 2
 Day & Millward.—v. 772
 Day, Miss.—xxviii. 169
 Day & Newell.—United States, 298
 Day, R.—xxx. (Fine Art Court), 161a
 Day & Son.—xii. & xv. 113; xxx. (Fine Art Court), 80
 Day & Twibell.—i. 202
 Day, W., see Day, J. & W.
 Daymond, J.—xxx. (Fine Art Co.), 192
 Deacock, E.—xxx. (Fine Art Co.) 72
 Deacock, T.—x. 473
 Deadle.—France, 813
 Deakin, E.—xxv. 18
 Deakin, G.—xxii. 157
 Deakin, G. & Co.—xxii. 110
 Dean.—Canada, 111
 Dean, Amos & Co.—United States, 101
 Dean, I.—United States, 245
 Dean, R.—Canada, 102

Dean & Son.—xvii. 18
 Deau, T.—ix. 4.
 Deane, A.—xxii. 392
 Deane, Adams & Deane.—viii. 223
 Deane, C. A.—v. 158
 Deane, Dray, & Deane.—ix. 180; xxi. 6; xxii. 180
 Deane, G. & J.—viii. 223a
 Deane, J.—v. 426, & see Deane, G. & J.
 Deane & Johnson.—South Africa, 19
 Deans, W.—viii. 40
 Dear, see Rogers & Dear
 Dear, A.—xiii. 37
 Dear, J. C.—xxix. 128
 Dearlove, M. W.—x. 707
 Deas, see Garvie & Deas
 Deas, G.—Home, 49
 Debaun, A. C.—France, 1172
 Debauffer, H.—xxii. 445
 Debaune, U.—Belgium, 131
 Deblaut, Brothers.—Belgium, 39
 Deblaut, De la Croix.—Belgium, 92
 Debel, Pellerin & Co.—France, 1173
 Deblauwe-Peel, Jean.—Belgium, 325
 Debrabantere, P. F.—Belgium, 218
 Debray, C.—France, 139
 Debulny, F.—France, 140
 Deby, A. & Co.—Belgium, 37
 Deccare, P. P.—Malta, 27
 Decker, R. L.—Zollverein (1), 148
 Decock, W.—Belgium, 221
 Deconinck, A.—Belgium, 112
 Deel, J. S.—xvi. 10
 Deering, J.—i. 121
 Deffaux, J. B.—Belgium, 188
 Defferrari, Brothers.—Sardinia, 44
 Deffner, see Zwenger, Van, Deffner, & Weiss
 Deffner, C.—Zollverein (4), 71
 Defreine, Sophie.—Belgium, 310
 Defries, N.—xxii. 482
 Degardin, V. A. M.—France, 1174
 Degraeve, D.—Belgium, 90
 Degryse, L.—Belgium, 63
 Dehmel, H.—Zollv. (1), 254
 Dehoune, L.—Belgium, 153
 Deighton.—Main Avenue West, 58a
 Deimhard & Jordan.—Zollv. (1), 869
 Deitrich, Baron J., Von.—Austria, 430
 Delante.—Portugal, 110, 111, 115, 232-247, 250, 251, 263, 264, 266, 267
 Delabarre, see Guidicelli & Delabarre
 Delabaune, C.—France, 1581
 De la Bond, Count.—xxx. 311
 Delabole Slate Company.—Western end, South Enclosure (Outside), 8; i. 214
 Delacour, H. P.—France, 472
 Delacour, L. F.—France, 1582
 Delacour, Peigne.—France, 370
 Delcretas & Fourcade.—France, 158
 De la Foss, J. P.—xxii. 800
 Delage-Montignac, F.—France, 141
 Delahaye, A.—Belgium, 305
 Delamare, see Estique & Delamare
 De la Morinière, Gouin, & Michellet.—France, 1583
 Delano, Capt. J. C.—United States, 545
 Delarbre.—France, 1175
 Delarbre, V.—France, 1176
 Delacroche, F. T.—Belgium, 364
 Delacroche-Daignemont.—France, 267
 De la Rue & Co.—xvii. 76, 177
 Delattre & Son.—France, 142
 Delhaere, Madame.—Belgium, 66
 Delcambre, A.—France, 1584
 Delcourt, A.—Belgium, 30
 Deleigne & Co.—France, 143
 Deleuil, see Charrière & Deleuil
 Deleuil, L. J.—France, 160

- Deleuze, A.—France, 1178
 Delevigne.—Belgium, 297
 Deleroye, F. D.—Belgium, 421
 Delosse, Brothers.—France, 144
 Delgado, D.—Spain, 231
 Delgado, J. J. R.—Portugal, 300
 Delicourt, E.—France, 1715
 Deliege, J., see Fetu, A., & J. Deliege
 Belignon, V.—France, 1180
 Delisle & Co.—France, 1181
 Delius, C.—Zollv. (1), 806
 Delius, E. A. & Sons.—Zollv. (1), 548
 Delius, J. D.—Zollverein (1), 560
 Delkshamp, F. W.—Zollv. (3), 29
 Dell, Brothers.—x. 100
 Delolme, H.—x. 19
 Delongueil, H.—France, 1565
 Delloye, M. C.—Belgium, 378
 Delstanche, L. see Delstanche, R. & L.
 Delstanche, R. & Leroy.—Belgium, 433
 Delstanche, P.—Belgium, 510
 Delvigue, G.—France, 473
 Dely, M.—Switzerland, 16
 Deman, T.—Belgium, 116
 Demanet, C.—Belgium, 402
 Demanet, Colonel.—Belgium, 178
 Dementiencro, E.—Belgium, 223
 Demidoff, Messrs.—Russia, 21, 120,
 153, 324
 Demontreuil.—xxx. 360
 Dempster, M.—VIII. 174
 Demythensers.—Belgium, 246-250
 Dench.—Western Knd, North Enclouure,
 (Outside), 61
 Demelroue, E. Bois, Glavy & Co.—
 France, 1182
 Denham, Captain.—VIII. 72
 Deninger, see Mayer, Michel, & Co.
 Denis, A.—France, 161
 Denis, J. B.—Belgium, 160
 Denison, Sir W. T.—Van Diemen's
 Land, 1-3, 24-35, 38, 66-77, 80,
 121-125, 136, 137, 140-151, 176,
 188, 217-220, 229, 269, 270, 272,
 287, 304, 312, 331-340
 Dennington, C. L.—United States, 336
 Dennis G.—British Guiana, 140
 Dennis, Rev. J. B. P.—XXIX. 161
 Dennys, see Swainson & Dennys
 Dent, Alcroft & Co.—xx. 78
 Dent, E. J.—x. 53, 68 (Main Avenue
 West)
 Dent, L.—China
 Denter, see Reed, Chadwick & Denter
 Dentith, W.—II. 8 (Main Avenue West)
 Denton, J. B.—x. 317
 Deumelle, A. D.—France, 1183
 Deo Narain Sing.—India, xxvi.
 Depierre, Brothers.—Switzerland, 189
 Depotter, A.—Belgium, 111
 Depouilly, C.—France, 1536
 Derazey.—France, 814
 Derfer, J.—Austria, 480
 Dering, G. E.—x. 436
 Deruberger, F.—Austria, 509
 Deroubaix, H.—Belgium, 230
 Dervaux-Lefebvre.—France, 145; see
 also Dubreulle, & Co.
 Derville & Co.—France, 162
 Derwent Iron Company.—v. 647
 Desanges, A.—France, 1184
 Desarbodes.—France, 1587
 Descalzi, J.—Sardinia, 72
 Descartes, J.—France, 815
 Deschamps, N.—France, 1189
 Desjardins, B.—Canada, 58
 Desjardins, P.—Canada, 30, 47
 Desjardins-Lieux.—France, 1585
 Deslandelles, see Guillery, Deslandelles,
 & Co.
 Desmanet de Biesme, Viscount C.—
 Belgium, 16
 Desmet & Co.—Belgium, 104
 Desmet, Madame.—Belgium, 323
 Desmond, M.—xvi. 171
 Desplasque, Jun.—France, 816
 Despointaines, Maison, Leroy, & Son.—
 France, 1186
 Despreaux, A. A.—France, 164
 Desrosiers, A.—France, 517
 Dessauer.—Austria, 371
 Dessauer, A.—Zollverein (2), 68
 Destras, L.—Switzerland, 71
 Detape.—France, 1710
 Dethier, A.—Belgium, 19
 Detige, see Lemaire, C., Detige, & Co.
 Detir & Co. (Piano Workmen Society).—
 France, 475
 Detmold, C. E.—United States, 66
 Detouche & Houdin.—France, 15, 9
 Deu, G.—Spain, 253
 Deutschmann, J.—Austria, 141D
 Deuzy, P.—France, 165
 Devaframe & Son.—Zollverein (1), 260
 Devns, Minchener, & Routledge.—
 xiv. 34; xviii. 6
 Devaux & Co.—France, 340
 Devers, J.—France, 818
 Devoy, G.—vii. 54
 Deville, see Grolleau & Deville
 Deville-Thiry H.—Belgium, 483
 Deviolaine, Brothers.—France, 1187
 Devis, E.—Belgium, 401
 Devisme.—France, 166
 Devise, N.—Zollv. (1), 837
 Devitt & Moore.—New South Wales, 10
 Devon Great Consolidated Copper
 Mining Co. (Tavistock).—i. 453;
 v. 418
 Devon North Pottery Company.—i.
 127
 Devonshire, Duke of.—i. 14, 496, 531;
 (Main Avenue East); Austria, 740
 Devrange, B. Jun.—France, 1185.
 Devy, Elias.—xx. 44
 Dewar, Son, & Sons.—xiv. 35; xix.
 150
 Dewar, T.—III. 119
 Dewdney, J.—xvii. 143
 Deweweirne, J. J.—Belgium, 293
 Dewrance.—v. 706
 Downap, J.—xxviii. 109
 Doyler, Mdme.—France, 819
 Deyeux.—France, 476
 Deyl, Van der, Leendert & Son.—
 Netherlands, 10
 Desaux-Lacour.—France, 167
 Diamond, J.—i. 457
 Dianet, S. G.—Belgium, 31
 Dick, A.—xvi. 311
 Dick, D.—United States, 79
 Dick, D. & Co.—II. 7D
 Dick & Kirschten.—Zollverein (6), 17
 Dick and Sons.—xii. & xv. 295
 Dickenson and Falkou, xxii. 422
 Dickenson, J.—xxx. (Fine Art Court)
 181
 Dicker, J.—v. 674
 Dickert, T.—Zollverein (1), 432
 Dickes, W.—xxx. (Fine Art Court)
 68
 Dickins, T.—vi. 62
 Dickinson, C. M.—Canada, 163
 Dickinson, J.—i. 414.
 Dickinson, T. F.—i. 407
 Dickore, A.—Zollverein (6), 18
 Dicks, W.—xx. 184
 Dicksee, J. R.—xxx. (Fine Art Court)
 271
 Dickson, see Malo, Dickson, & Co.
 Dickson, Mr. Sheriff A.—Canada, 3
 Dickson, G. & Co.—ii. 79.
 Dickson and Lalings.—xii. & xv.
 234
 Dila, A.—France, 1189
 Diller, F.—France, 820
 Dilit, Brothers.—France, 812.
 Dieckmann, W. & C.—Zollverein (1),
 612
 Dieckerichs, Brothers.—Netherlands, 6
 Diepers, J. H.—Zollverein (1), 472
 Dierckx, F.—Belgium, 391
 Diergardt, F.—Zollverein (1), 569
 Dierig, C.—Zollverein (1), 93
 Dierzers, J., heirs of.—Austria, 176A.
 196A, 244
 Dies.—Rome, 34, 35, 60
 Diesel & Co.—Zollverein (1), 824, 882
 Dietsen, J. H.—Belgium, 288
 Dieterich, C. F.—Zollverein (4), 66
 Dietiker, J.—Switzerland, 211
 Dietrich, Baron.—Austria, 439
 Dietrich, F.—Zollverein (1), 207
 Dietrich, F. A.—xx. 66.
 Dietrich & Son.—Zollverein (1), 807
 Dietrich & Straff.—Zollverein (3), 103
 Dietrich & Co.—France, 146
 Dietel, M.—Austria, 810
 Dieuloune & Bladel.—Zollv. (4), 20
 Dies, Marble Manufactory at.—Zoll-
 verein (5), 6
 Dies, K.—Austria, 33, 122A
 Dies de Ribera, A.—Spain, 172
 Diegen.—France, 1690
 Digges, Miss La Touche.—xix. 234
 Digges, Rev. T. La Touche.—ix. 263
 Dighton, see Latham & Dighton
 Dighton, T.—xxvi. 276; xxx. (Fine
 Art Court), 142, 235A
 Dighton, T. D.—xxx. 160.—Page 848
 Dill & Mulcahey.—United States, 273
 Dillenseger & Patry.—France, 168
 Dillon, J.—v. 560
 Dillon, L.—xii. & xv. 258
 Dillou, Viscount.—iv. 138
 Diltach, J.—Austria, 481
 Dimech, F.—Malta, 28
 Dimech, Mrs.—Malta, 21
 Dimmoor, T.—xxv. 12
 Dimoline.—xxvi. 187
 Dimoline, A.—x. 489
 Dinant & Huetre.—France, 1190
 Dingley, S., see Dingley, W. & S.
 Dingley, W. & S.—xx. 115
 Dingsler, A. F.—Zollverein (1), 176
 Dinham, Annie.—xxvi. 92
 Dinkler, C.—Austria, 735
 Dinesford & Co.—ii. 51
 Dinestale, C.—x. 718
 Dital, F.—Austria, 348
 Dionisij, J. M.—Netherlands, 100
 Dirk, see Voorst, Van, Dirk, & Son
 Dirks, H. J.—Netherlands, 29
 Dirksen, G.—Denmark, 40
 Dismar & Harloff.—Hamburgh, 25
 Diturnell, J.—United States, 215
 Ditchburn, T. J.—xiii. 30
 Diti, Madame.—VIII. 152
 Dittmar, Brothers.—Zollverein (4), 57
 Dix, see Randall and Dix
 Dix, E. R.—United States, 139
 Dixce, T.—xxvi. 16
 Dixer, C. W.—x. 271
 Dixon, F.—Canada, 94
 Dixon, G.—xxix. 91
 Dixon, J.—xxvi. 190; Van Diemen's
 Land, 19, 20
 Dixon, J. & Sons.—xxii. 797; xxiii.
 38
 Dixon & Longstaff.—xiv. 75

- Dixon, P. & Sons.—xi. 19
 Dixon, R. & T.—xii. & xv. 187
 Dixon, Son, & Co.—ii. 125
 Dixon, T.—Canada, 138, 170, see also Dixon, R. & T.
 Dixon & Whiting.—xvi. 290
 Djidjvatze, Prince Niko.—Russia, 95
 Djurson, C.—Sweden, 70
 Dobbelaers, H.—Belgium, 208
 Dobbie, W.—x. 166
 Dobbs, G.—x. 346
 Dobbs, Kidd, & Co.—xvii. 79
 Dobree, D.—Jersey & Guernsey, 35
 Dobres, Harriett.—Jersey & Guernsey, 30
 Dobrowolaki, B. W.—x. 524
 Dubson, J.—vii. 114; x. 323
 Duogane, S.—France, 1718
 Doequir, P. J. & J. Parys—Belgium, 68
 Doete, H. Le—Belgium, 161
 Dodd, E.—x. 505
 Dodd, J.—x. 543
 Dodd, P. G.—xxiii. 122
 Dodd, R. S.—Canada, 87
 Dodds & Son.—v. 64
 Dodge, Catherine.—iv. 32
 Dodge, N. S.—United States, 566
 Dodge, W.—xvi. 169
 Dodshaux, Brothers.—Zollverein (7), 1
 Dodson, J.—xvi. 182a
 Doe, E.—xxx. (Fine Art Court), 25
 Doe, Hazleton & Co.—United States, 418
 Doe, W.—xvi. 145
 Doedel, H. J.—Zollverein (1), 547
 Doerffel, C. G. & Sons.—Zollverein (3), 69
 Doerffel, T.—Zollverein (1), 54
 Doerner, F.—Zollverein (4), 21
 Doerr & Reinhardt.—Zollverein (6), 33
 Dokhtouroff.—Russia, 36
 Dolan, D.—xxvii. 45
 Dolbeau, see Lapère & Dolbeau
 Dolgarouck, Prince.—Russia, 356
 Dolleschal, J.—Austria, 51
 Dollfus, Mieg, & Co.—France, 1191
 Dollund, G.—x. 145.
 Dombrowitch, C.—Russia, 355
 Domenget.—Sardinia, 96
 Domeuy, L. J.—France, 476
 Doninick, G.—United States, 21
 Dummer, T.—Belgium, 234
 Don, Brothers, G. E.—xiv. 63
 Don, W. & J., & Co.—xiv. 63
 Donalds.—xxiii. 103
 Donalds, C. see Donalds, W. J. & C.
 Donalds, W. J. & C.—xxx. (Fine Art Court), 41
 Donat, A.—France, 1192
 Donat & Co.—France, 1193
 Donbavand, W.—v. 782
 Doncaster, D.—xxii. 184
 Donegan, J.—x. 52
 Doniethorpe, G. E.—vi. 40
 Dunkin, B. & Co.—v. 42; vi. 130; vii. 46
 Donlan, M. J. J.—iv. 43
 Dome, G.—xxiv. 4
 Done, G. J.—xxvi. 198
 Donns & Sons.—xxiii. 127
 Donneaud & Co.—France, 478
 Danohue, J.—Western end, South Enclosure (Outside), 2
 Danzel and Maussier.—France, 1195
 Doodinsky.—Russia, 77
 Doppler, A.—Austria, 611
 Dopter, J. V. M.—France, 1194.
 Dorer, M.—Zollverein (1), 343
 Dorey, D.—Jersey & Guernsey, 37
 Dorey, J.—France, 479.
 Dorey, J. F.—France, 823
 Dorfeuthner, L.—Austria, 253
 Dorr, W.—vii. 57
 Dorrien, C.—iv. 81
 Dorvell, Elizabeth.—xxix. 77
 Douin, B. J.—Belgium, 429
 Dousetor, see Pearl & Dousetor
 Dotres, Gaspar, & Co.—Spain, 215
 Doubleday, H.—iii. 2
 Doublet & Huchet.—France, 821
 Doucet & Duclerc, A.—France, 147
 Doucet & Petit.—France, 149
 Doudney, E.—xx. 113
 Douglas, J. S. & Son.—Hamburgh, 92
 Douglas, R.—xvi. 257
 Douglas River Coal Co.—Van Diemen's Land, 13
 Doulton & Co.—Western end, North Enclosure (Outside), 64; xxvii. 24
 Doulton & Watts.—North Transept, 43a; xxvii. 95
 Doumerc, E.—France, 822
 Doussouff.—Russia, 197
 Douthrew, F. J.—Belgium, 149
 Dove, C. W. & Co.—xix. 155
 Duve, D.—Western end, South Enclosure (Outside), 23
 Dover, J.—x. 344
 Doveston, G.—xxvi. 122
 Dow, A.—xxviii. 29
 Dowbiggin & Co.—xix. 156; xxvi. 404
 Dower, J.—xvii. 37
 Dowie, J.—xvi. 180; (Main Avenue West)
 Dowling, H.—Van Diemen's Land, 331-333
 Down, J.—xxix. 56
 Down, S.—xxix. 267
 Downing, Dr. C. T.—x. 634
 Downing, G. & J. H.—xix. 157
 Downing, J. H., see Downing, G. & Co.
 Downman, H. H.—i. 501
 Downs, Andrew.—Nova Scotia
 Downs, H.—viii. 133
 Downs, W.—xxii. 675
 Downton, J.—v. 474; xxii. 530
 Dowse.—xvii. 41
 Dowse, Henrietta.—xxx. (Fine Art Court), 230A
 Dowson, see Young, Dowson, & Co.
 Dowson, J. E.—xxii. 476
 Doxat & Co.—iv. 35
 Doyon, see Jouvin & Doyon
 Draaisma, D.—Netherlands, 68
 Drabble & Co.—v. 842
 Drake, see Bedford, Bonson, & Co.
 Drake, P.—Jersey and Guernsey, 45
 Drake, Professor F.—Zollverein (1), 273; (Main Avenue East)
 Drake, R.—xvi. 306
 Draper.—v. 997
 Draper, W.—xxvi. 320
 Dray, see Deane, Dray, and Deane
 Dregger, F.—Russia, 362
 Dreher, A.—Austria, 668
 Dresden Royal Saxon Military Pian Office.—Zollverein (3), 184
 Drexler, F.—Zollverein (5), 24
 Drexler, J. H., sen.—Zollverein (1), 449
 Drensike, W.—Zollverein (1), 245
 Drew, D.—xxvi. 116
 Drew, J.—i. 449
 Drew, T.—xxx. 352
 Drewson and Sons.—Denmark, 4
 Dreyse & Coltenbusch.—Zollverein (1), 638
 Drides, Tribe of the.—Algeria, 55
 Driom, E.—Belgium, 353
 Driver, C. H.—xxx. (Fine Art Court), 269
 Driver, J.—x. 102.
 Driver, W.—i. 203
 Dronwich Patent Salt Works.—ii. 116
 Dronin, Crüger, & Co.—Zollverein (1), 357
 Drouin & Brossier.—France, 169
 Druery, J.—viii. 322
 Druggists' Company.—ii. 117
 Druitt, R.—x. 612.
 Drummoul, see M'Cartney & Drummoul.
 Drummond, J.—xii. & xv. 150; Canada, 32
 Drummond, P. R.—ix. 88
 Drummond & Sons.—ix. 49
 Drury, F.—v. 758
 Drury, J.—x. 56
 Drury, J. F.—x. 506
 Duban-Delepaul.—France, 149
 Dubar, G.—Canada, 21
 Dubler & Sons.—Switzerland, 227
 Dublin, Royal Society of.—i. 207, 508, 513; vii. 141; xxvii. 71
 Dubois, see Jouhame & Dubois
 Dubois, A.—Switzerland, 43
 Dubois, A. & Co.—Belgium, 360
 Dubois, C., see Dubois, G. & Co.
 Dubois, F. W.—Switzerland, 9
 Dubois, G.—Belgium, 469.
 Dubois, G. & Co.—Belgium, 196
 Dubois and Son.—France, 170
 Duboscq-Soleil.—France, 1197
 Dubreulle, Dervaux, Lefebvre, & De Fitte—France, 480
 Dubsky, Count.—Austria, 456
 Dubus.—France, 481
 Du Cane, A.—xxvi. 535
 Ducci, A.—Tuscany, 82
 Ducci, A. & M.—i. 501
 Ducci, M., see Ducci A. & M.
 Ducci, S. J.—France, 824
 Duchastel, Comte.—Belgium, 443
 Duchie, sen. & Co.—France, 1592.
 Duchene, sen.—France, 1198.
 Duchene, J. J.—Belgium, 166.
 Ducheme, Dr.—France, 171.
 Ducheme.—France, 172
 Ducie, Barl.—xvi. 267.
 Duclerc, A., see Doucet & Duclerc
 Duclou, J.—France, 1712
 Ducluseau, A.—Main Avenue East, 96
 Ducummun.—France, 482
 Du Commun Girod, F. W.—France, 77
 Ducourtoux, C. L.—France, 1199
 Ducroquet, P. A.—France, 173 (Main Avenue East)
 Dudgeon & Co.—New South Wales, 11
 Duldgeon, Patrick.—China
 Dudman, J.—xvii. 137
 Dudson, J.—xxv. 56
 Duellin, M.—xxx. (Fine Art Court), 59
 Duerrenberg, Royal Saltery at.—Zollv. (1), 856
 Duesberg, see Pirenne & Duesberg
 Dufaux, L.—Switzerland, 249
 Dufaux, O.—Switzerland, 249
 Dufaville, W.—iv. 125
 Dufferin's, Lord, School, Belfast.—xiv. 3
 Duffield, C.—United States, 363
 Duffield, J. E. & Co.—v. 844
 Dufosse.—France, 1201.
 Dufosse, sen.—France, 1200
 Dufour.—Belgium, 159; see also Sar-rao, H. & Dufour
 Dufour, jun.—France, 174
 Dufour & Co.—ix. 124A

- 353
Fine Art Court),
- Works.—ii. 110
Zollverein (1),
- France, 169
- ii. 117
- rtney & Drum-
- i. & xv. 150;
- c. 88
- ix. 49
- ance, 148
- 21
- erland, 227
- of.—i. 207, 508.
- ii. 71
- & Dubois
- ud, 43
- gium, 360
- G. & Co.
- erland, 9
- 469.
- gium, 196
- ce, 170
- ce, 1197
- Lefebvre, & De
- tria, 456
- 35
- 2
- any, 58
- A. & M.
- 824
- gium, 443
- ance, 1592.
- 1198.
- am, 166.
- 171.
- 2
- & Duclerc
- 12
- Avenue East, 90
- 482
- W.—France, 77
- ance, 1199
- nce, 173 (Main
- South Wales, 11
- ua
- Art Court). 59
- ery at.—Zollv.
- Dnesberg
- i. 249.
- d, 249
- ool, Belfast. —
- ates, 363
- 7, 844
- 200
- see also Sur-
- 74
- Dufour, J. B.—France, 485
- Dufour, L.—France, 483; Sardinia, 13
- Dufreiz, Albert.—France, 193
- Dugard, H. see Dugard, W. & H.
- Dugard, W. & H.—xxii. 350
- Dugoin, T. B.—British Guiana, 3, 4,
7, 20, 26, 49, 51, 56, 57, 61, 80, 81,
90n, 99-102a, 119, 141, 146-148a.
- Dohajour-Bronfaut & Co.—Belgium,
314
- Duhme, H.—United States, 15
- Dojardin.—Belgium, 246-250
- Dojardin, C.—Belgium, 217
- Dojardin, L.—Belgium, 317; France, 825
- Duke & Son.—xxix. 191
- Dulcius, C.—Zollverein (6), 72
- Duley, J.—xxii. 89
- Dulgen Brothers.—Zollverein (1), 641
- Dulud.—France, 1202
- Dumaine, J. A.—France, 490
- Dumaine, X.—France, 175
- Dumaret, see Daubert & Dumaret
- Dumas, A.—France, 486
- Dumbleton, see Dawbee & Dumbleton
- Dumbleton, H.—South Africa, 47
- Dumery.—France, 487
- Dumeril, Sons, & Co.—France, 176
- Dummich, P.—Zollverein (6), 79
- Dumont, F. L. H.—France, 468
- Dumont, J. S.—United States, 287
- Dumont-Petrelle.—France, 826
- Dumontat, see Bertrand, Gayet, &c.
- Dumortier & Co.—France, 1593
- Dumortier, L.—France, 177
- Dumoulin, S.—France, 178
- Dumrath, H.—Sweden, 60
- Dunbar, D.—New South Wales, 6
- Dunbar, D. & Sons.—viii. 315
- Dunbar, W.—xxix. 234
- Duncan, see Sinclair, Duncan & Son
- Duncan, D. & Co.—xiv. 80
- Duncan, Floekhart, & Co.—ii. 104
- Duncan, J.—Canada, 351
- Duncan, W. L.—ii. 76
- Duncum, see Foster, Son, & Duncum
- Dundee Local Committee.—xiv. 63
- Dunhill, T.—vii. 90
- Dunin, Mx. K. de.—x. 210
- Dunlevie, Mrs.—Jersey & Guernsey, 3
- Dunlop, J.—xxviii. 155
- Dunlop and Serles.—Mexico
- Dunlop, W. A.—United States, 483
- Dunn.—v. 624; Van Diemen's Land,
190; see also Holland & Dunn
- Dunn, J.—v. 998
- Dunn, M.—vii. 204
- Dunn, T.—v. 618; x. 689A
- Dunn, W.—Canada, 119
- Dunnicliff, see Ball, Dunnicliffe & Co.
- Dunt, see Hancock, Rixon, & Dunt
- Dunton, J. H.—United States, 195
- Dupas, E.—France, 1204
- Dupasquier, J. P.—France, 1205
- Dupes & Co.—France, 1594
- Dupierry, C. jun.—Belgium, 494
- Duponcean, see Forton, Duponcean, &
Co.
- Dupont, A.—France, 180
- Dupont, Evana.—Mauritius, 2
- Dupont, P.—France, 181
- Duport, V.—France, 182
- Duppa.—xxvii. 51
- Duprat & Co.—France, 492
- Dupre, Prof. A.—Tuscany, 105
- Dupre, A. G.—France, 493
- Dupre, J. F.—France, 183
- Dupre de St. Maur.—Algeria, 23
- Dupre, W. H.—Jersey and Guernsey, 9
- Dupuis, J.—France, 184
- Duquesne, see Serret, Hamoir, & Co.
- Durand.—France, 186; see also Eck
& Durand
- Durand & Bal.—France, 829
- Durand, Boncourt, & Pitard.—France,
1206
- Durand, E. P.—France, 1207
- Durand, F.—France, 1595
- Durand, G.—France, 1208
- Durand, J.—France, 1596
- Durango y Trigo, J.—Spain, 46, 127
- Durant, R. jun.—iv. 31
- Durant, Susan.—xxx. (Sculpt. Ct.) 5, 78
- Duranton, J. B.—France, 494
- Durham, Earl of.—v. 999
- Durham, J. B.—xxi. 46; xxiii. 58;
xxx. (Sculpture Court), 75, 76
- Durham, J. B.—x. 668.
- Durham, T. D.—xxii. 614
- Durio, Brothers.—Sardinia, 46
- Durley & Co.—xxvi. 169
- Dusauchoit, E.—Belgium, 272.
- Duseigneur, see Bianchi, J., & Duseig-
neur
- Dussert, J.—Belgium, 407
- Dussol.—France, 150
- Dutertré, A.—Switzerland, 219
- Duthoit, J.—xiii. 12.
- Duthoit & Co.—viii. 301
- Dutron, jun.—France, 1209
- Dutton & Co.—xxix. 287
- Dutton, R. W.—iii. 6.
- Dutton, S.—viii. 326.
- Dura, Van, & Versteeven.—Nether-
lands, 5
- Duval.—France, 474
- Duval, A.—France, 189
- Duval, M.—France, 1210
- Duval, P. S.—United States, 52
- Duval & Paris.—France, 151
- Duvelloyer, P.—France, 495
- Duyn, Hipp & Co.—Zollverein (1), 510
- Dyedier, C. P.—France, 1580
- Dyer, C. K.—i. 131B
- Dyer, H.—x. 379
- Dyer, W.—i. 10
- Dyer, W. B.—i. 62
- Dyne, W.—viii. 60
- Fades & Son.—vi. 224
- Eady, H. J.—xxiii. 109.
- Bagland, T.—x. 567
- Eakins, S.—United States, 256
- Eames, see Burton & Eames
- Earl, Smith, & Co.—xxii. 207
- Earle, J. H.—xxx. 40
- Earle, T.—Page 848; xxx. (Sculpture
Court), 16, 21, 82
- Earle, T. K. & Co.—United States, 456
- Early, E.—xii. & xv. 269
- Early, J. & Co.—xii. & xv. 268
- Earnshaw.—x. 11
- Earnshaw & Greaves.—xxv. 24
- Earnshaw, H.—xvi. 107
- Earnshaw, R. J.—xxix. 261
- Earp, E.—xxvi. 13
- Eason, A.—xiv. 63
- East India Company.—China; India
- East, Landon & Holland.—xii. & xv. 2
- East & Son.—xvi. 34
- Easterling, J.—xxix. 282
- Eastern Archipelago Co.—Labuan, &c.
- Eastman R.—United States, 3
- Eastman, W. P.—United States, 338
- Easton & Amos.—v. 408
- Eastwood & Frost.—v. 672
- Eastwood, G.—xxi. 49
- Eaton, C. L.—United States, 28
- Eaton, F.—xxiii. 52
- Eaton, J. ix. 22
- Ebart, Brothers.—Zollverein (1), 145
- Ebba, B.—ix. 56A
- Ebbw Vale Co. Abergaveuny.—i. 412;
v. 67, 638
- Eberhardt, see Hoffman & Eberhardt
- Eberstaller & Schludler.—Austria, 427
- Eccleshall, T.—v. 132
- Eckinger, Brothers.—Austria, 304
- Eck & Durand.—France, 1211
- Eckardstein, Baron A.—Zollverein (1),
32
- Eckert, J. C. H.—Hamburg, 64
- Eckhardt, F. M.—Zollverein (4), 38
- Ecklin, see Goets & Ecklin
- Economical Society (Amicos del Pais),
Blayaz Islands.—Spain, 234
- Ecroyd, W. & Son.—xii. & xv. 130A
- Edberg, C. K.—Sweden, 61
- Eddy, Capt.—i. 496
- Eddy & Co.—United States, 509, 523
- Eddy, J.—i. 463
- Ede & Co.—xxix. 18
- Ede, F. & Son.—Persia, 4
- Edelesten & Williams.—xxii. 336
- Eder, S. T.—Netherlands, 88
- Edey, see Arthur & Edey
- Edgar, see Swan & Edgar
- Edge, see Cork & Edge
- Edge, J.—xxii. 51
- Edge, T.—x. 702; xxii. 441
- Edgington, B.—viii. 302
- Edgington, T. F.—xiv. 90
- Edinburgh School for the Blind.—xvii
170
- Edkins & Son.—x. 207
- Eller Von Wurth, W.—Austria, 52
- Edmond, J.—viii. 136
- Edmonds, see Remnant, Edmonds, &c.
- Edmonds & Edmonds.—xii. & xv. 218
- Edser, see Ridley & Edser
- Edwards, D. O.—xxii. 241
- Edwards, E.—xxii. 345
- Edwards, F.—xxii. 387
- Edwards, H.—iii. 134
- Edwards, J.—x. 104; xiv. 73; xxx.
(Fine Art Court), 67
- Edwards, R. J.—x. 516
- Edwards, J. & Sons.—xxv. 37
- Edwards, J. B.—x. 438
- Edwards, J. T.—x. 103
- Edwards, R.—xxiii. 78
- Edwards, S.—xxvi. 247
- Edwards, T.—v. 12; xxiii. 94
- Edwards, T. J.—xxix. 69
- Beckhout, Van, see Heusschen, Van
Beckhout & Co.
- Beckhout, Van, & Co.—France, 713
- Egan, J.—Canada, 74
- Egella, F. A.—Zollverein (1), 200
- Egg, D.—viii. 345
- Egg, H.—viii. 232
- Egger, Count Ferdinand Von.—Austria,
409, 410, 425
- Egger, Count G. Von.—Austria, 31,
401, 402
- Egger, J. B.—Austria, 435
- Eggerth, J.—Austria, 361
- Egluffstein, Count.—Zollverein (1), 897
- Egyptian Government.—Egypt, 1-391
- Ehinger, A.—Austria, 181
- Ehr, N.—Zollverein (5), 25
- Ehrenberg, J. F.—Sweden, 65
- Ehrenberg & Richter.—Zollverein (1),
730
- Ehrenperger & Co.—Zollverein (3),
192
- Ehrenzeller, F.—Switzerland, 191
- Eichleberg, H. D. & Co.—Zollverein
(1), 660
- Eichler, G.—Zollverein (1), 272

Michner, G. L.—Zollverein (2), 80
 Richwede, see Bernstorff & Richwede
 Rickholt, A.—Zollverein (1), 549
 Rifer & Co.—Zollverein (1), 891
 Rimen.—Turkey
 Riuenkel, J. C. C.—Zollverein (3), 165
 Rinhauser, J.—Austria, 344
 Rinsiedel, Count G.—Zollverein (1), 762
 Rinsiedelschen.—Main Avenue, East
 Rinsle, E.—x. 127
 Ripenschleid, L.—Zollverein (1), 330
 Eisenbrandt, C. H.—United States, 481
 Risenmenger, G.—Zollverein (2), 24
 Risenring, see Fehr & Risenring
 Risenruck & Co.—Zollverein (3), 151
 Ejoft, J.—Russia, 80
 Rkaterinburg Imperial Polishing Manufactory.—Russia, 326
 Rkaterinsoff, Peasantsof.—Russia, 230
 Rkina, G.—xxvii, 13
 Ekman, G.—Sweden, 83
 Kibers, J. H.—Zollverein (1), 348
 Eklor, D.—v. 152
 Eldon, Earl of.—Page 848
 Eldrid, see Atkinson and Eldrid
 Electric Telegraph.—x. page 941.
 Mlemenhorst, Brothers.—Zollverein (1), 708
 Flex, A.—France, 1215
 Eley, C., see Eley, W. & C.
 Eley, W. & C.—viii. 225
 Kiffialds Porphyry Works.—Sweden, 47
 Elfröth, D. H.—Switzerland, 78
 Eliaert, C.—Belgium, 234
 Elias, A.—United States, 515
 Elias, M.—Spain, 39
 Eliasson.—Sweden, 93
 Elinhauser, J.—Austria, 344
 Eliaba, C.—x. 39
 Elkington & Co.—Page 848
 Elkington, H.—xxiii. 1
 Elkington, Mason, & Co.—xxiii. 1.
 Ell, G.—vii. 94
 Ellam, Jones & Co.—ii. 58
 Elliot, T. & Co.—xxii. 120
 Elliott.—vii. 13
 Elliott, G.—ix. 144.
 Elliott & Hays.—vi. 50
 Elliott, J.—ix. 41; xxii. 151
 Elliott & Sons.—x. 320, 322; xxii. 302
 Elliott, T.—v. 702
 Elliott, W.—xx. 172
 Ellis, F. A.—viii. 129
 Ellis, F. & J.—x. 209
 Ellis, G.—xvi. 305
 Ellis, H.—xvii. 141.
 Ellis, J.—x. 631a; xxii. 156; see also Ellis, F. & J.
 Ellis, J. W. & Co.—xii. & xv. 70
 Ellis, Miss.—Jersey and Guernsey, 44
 Ellis, R.—i. 13; see also Hahnel & Ellis.
 Ellis & Son, xxiii. 12
 Ellis, Sophie A.—xix. 159
 Ellis, W.—xxii. 86
 Ellis.—ix. 29
 Elmendorf, E. F.—Zollverein (1), 470
 Eloffse.—France, 1597.
 Eloin, F.—Belgium, 11
 Eloure, W. W.—xxvi. 188
 Elsholtz, F.—Zollverein (1), 230
 Elaser, Von Gronow & Co.—Zollverein (1), 4
 Elwell, see Varrall, Middleton, & Elwell
 Elwell, H.—Barbadoes, 2
 Emanuel, M.—xxiii. 119
 Emanuel, G.—Austria, 709
 Emerson, F.—United States, 433
 Emery, F.—xxv. 57

Emery, J.—i. 532; xxxvii. 141
 Emmerich, J. B. & Goerger, M. jun.—France, 1212
 Emory & Co.—United States, 148
 Emory, T.—United States, 18
 Ena, G.—Zollverein (1), 583
 Enshall, G.—xiv. 40.
 Ena, see Margarit & Ena
 Encke, F.—Zollverein (1), 736
 Enderby, S.—viii. 162
 Enderson, H. J.—iv. 16
 Enfer.—France, 830
 Enfert, D', Brothers.—France, 496
 Engel, see Boscher & Engel
 Engel, E., jun.—Zollverein (1), 125
 Engel, F.—Zollverein (1), 274
 Engel, J.—Page 848; xxx. (Fine Art Court), 74
 Engel, P.—Zollverein (1), 885
 Engel, P. H.—Zollverein (1), 389
 Engeler & Son.—Zollverein (1), 242
 Engelhard & Karth.—Zollverein (1), 417
 Engelhard, F.—Hamburg, 93
 Engelhard, W.—Hamburg, 96
 Engelmann & Graf.—France, 192
 Engelmann, S.—Austria, 22
 Engelmann & Son.—Zollverein (1), 571
 Engels, H. W. M.—Hamburg, 65
 England, G.—v. 484, 509
 England, G. W.—xxvi. 528
 English.—xxii. 343
 English, E. F.—xxvi. 57
 English, J.—xxii. 572
 English's Patent Camphine Co.—iv. 61; vii. 133
 Ennever & Steelman.—x. 479
 Enniskillen, Earl of.—i. 116; ix. 232
 Enrico, C.—Austria, 147
 Enriquez, J.—Spain, 73, 106
 Enriquez, J. N.—Spain, 176
 Enriquez, Maria.—Malta, 9
 Enschede & Sons.—Netherlands, 79, 109
 Ensor, T.—xx. 185
 Enstoller, G.—Austria, 669
 Enthoven, C. L.—Netherlands, 76
 Enthoven, Van, A. J.—Netherlands, 49
 Enthoven & Son.—Netherlands, 1
 Enzinger, see Gruber & Enzinger
 Eoke, Royal Mines at.—Zollverein (1), 326
 Epps, W. J.—ix. 101
 Erard, P.—France, 497
 Erard, P. O.—x. 496
 Erbrau, J.—Switzerland, 4
 Erbschloe & Sons.—Zollverein (1), 614
 Erbsloh, see Wolf & Erbsloh
 Erchoff, A.—Russia, 339
 Erdelen, C.—Zollverein (1), 474
 Erhardt & Sons.—Zollverein (4), 63
 Erich, C. A.—Zollverein (2), 19
 Ericsson, A. & Co.—Sweden, 106
 Ericsson, J.—United States, 116
 Erivan, Agricultural Society of the Caucasus.—Russia, 58
 Erno, see Vetter & Erno
 Ernoux, C. H.—France, 498
 Ernst, see Hetzer, Ernst & Son; Presspich, Ernst, & Son
 Ernst, F.—Switzerland, 149
 Ernst, P.—Austria, 457
 Erret, see Petzold & Erret
 Ershoff.—Russia, 60
 Erskine, D.—v. 100; viii. 45
 Erskine, J.—i. 532; viii. 257
 Ertel, Traugott & Sons.—Zollv. (2), 25
 Escher, S.—Switzerland, 153
 Escherich, T.—Zollverein (2), 48
 Eschweiler, D., Société des Mines et Fonderies.—Zollverein (1), 318

Escudero, C.—Spain, 183
 Escudero and Alama.—Spain, 192
 Esdails, J.—xxix. 278
 Esdailes & Margrave.—viii. 126
 xxviii. 125
 Esprit & Noye.—France, 499
 Esquillant, E.—xxx. (Fine Art Court), 103
 Eschen, N. G. Van.—Belgium, 137
 Essex, J.—xvi. 326
 Essex, W.—xxx. (Fine Art Court) 241
 Esatcourt, S.—ii. 64
 Estivaux & Delamare.—France, 1213
 Estivant, Brothers.—France, 1214
 Estrange, F. L.—x. 597
 Etex.—France, 1215 (Main Avenue East)
 Etherington, H.—xxx. (Fine Art Court) 234
 Etienne, Madame D. St.—iii. 138
 Etlick, A.—viii. 327
 Euhosa, Bishop of.—Greece, 14
 Engster, Brothers.—Switzerland, 190
 Eustace, J., see Eustace, R. & J.
 Eustace, R. & J.—xix. 160
 Eustace, Friar.—France, 193
 Euston & Milligan.—Van Diemen's Land, 105, 106
 Evans, see Braubury & Evans; Galden & Evans; Hill, Evans & Co.; Sewell, Evans & Co.; Voigtlander, Evans & Co.
 Evans & Co.—x. 643a; xi. 33
 Evans, D., & Co.—xviii. 1
 Evans, Dr.—United States, 358
 Evans, E.—xvii. 113
 Evans, F.—xxvi. 224
 Evans, F. J.—ii. 5
 Evans, G.—i. 227
 Evans, H.—United States, 474
 Evans, J.—xxx. (Fine Art Court), 202
 Evans, J. S.—xvii. 8
 Evans, O. B.—United States, 105
 Evans, R. & Co.—xix. 74
 Evans, S.—x. 670a; xiii. 60
 Evans, S. A.—xix. 161
 Evans & Son.—v. 37; xvi. 18
 Evans, Son, & Co.—xxii. 103
 Evans, T. & Co.—xxix. 148
 Evans, W.—iv. 9a; x. 274a
 Evans, W. F.—x. 106
 Evard, E. P.—Switzerland, 29
 Eveleigh & Son.—xx. 104
 Eviden, Eliza Anne.—xix. 162
 Everaert, Mises.—Belgium, 321
 Everest, J.—xxvi. 27
 Everett, A.—United States, 427
 Everett & Co.—xvi. 39
 Everett & Son.—xxii. 352
 Every, S. F.—vii. 120
 Eyraud, J.—x. 647
 Eyrot, C. N.—France, 190
 Ewald, L.—Zollverein (6), 6
 Ewart.—x. 324
 Ewart, G.—x. 729
 Ewart, Henrietta.—xxix. 75
 Ewen, J.—iv. 30
 Ewens, J. B. & Co.—xiv. 73
 Ewing, J. H.—United States, 188
 Ewing, Orr, & Co.—xviii. 57
 Exall, see Barrett, Exall, & Andrews
 Exall, W.—viii. 3
 Kyalroff, M.—Russia, 73
 Eyrkyn & Millichap.—xxii. 309
 Eyles, see Margatta, T. K., & Eyles
 Eyles, H.—xxvi. 50; xxvii. 91
 Eymien & Son.—France, 831
 Eynthoven, A. J. Van.—Netherlands, 19
 Eyre, see Hawksworth, Eyre, & Co.

- 183
Spain, 192
ve.—VIII. 126
ce, 499
(Fine Art Court),
Belgium, 137
(Fine Art Court)
France, 1213
France, 1214
7
(Main Avenue
(Fine Art Court)
St.—III. 138
reece, 14
witzerland, 190
e, R. & J.
e, 193
—Van Diemen's
Evans; Gault-
Evans & Co.;
o.; Voigtlander
; xi. 33
II. 1
ates, 558
ates, 474
Art Court), 202
States, 105
74
II. 60
xvi. 18
II. 103
1. 148
274A
and, 29
04
xix. 162
ium, 321
tes, 427
52
90
6), 6
75
v. 73
ates, 188
II. 57
& Andrews
II. 309
, & Eyles
VII. 91
531
Netherlands, 9
yre, & Co.
- Byre, Ward, & Co.—XXII. 203
Eyre, W. & Son.—XII. & xv. 27
Ezcaray, Manufacturing Company of
the Guilds at.—Spain, 219
- Faber, A. W.—Zollverein (2), 81
Faber, C.—Zollverein (4), 33
Faber, W.—United States, 279
Falian, C. G.—Zollverein (1), 95
Faabe, B. A.—Switzerland, 11
Fabrège, Noury, Son, Barnouin, & Co.
—France, 832
Facer.—XVI. 150
Facilides & Co.—Zollverein (3), 95
Facy, R.—x. 195
Fadderjahn, B.—Zollverein (1), 294
Faddy, Mrs. Col.—Western Africa, 20
Faddy, Col. P.—Western Africa, 10
Faduilhe, V. B.—III. 140
Faessler, J. A.—Switzerland, 229
Fahie, J. K.—i. 30, 129
Faiers, J.—XXIX. 26
Fairbairn & Co.—vi. 421
Fairbairn, R.—xvii. 9
Fairbairn, W. & Sons.—v. 26; 417,
522, 732; vi. 200, 403
Fairer, J.—x. 36
Fairless, F.—ix. 155
Fairly, E.—VIII. 339
Fairman, J.—VIII. 233
Faist, see Uechtritz & Faist
Faist & Steinhaeuser.—Zollv. (4), 54
Faker, W.—United States, 280
Falcini, Brothers.—Tuscany, 84
Falent, M.—Austria, 458
Falisse & Rapmann.—Belgium, 154
Falkenroth, see Lehrkina, Falkenroth,
& Co.
Falkingbridge, W.—VIII. 133
Falkou, see Dickenson & Falkou
Faller, Tritscheller, & Co.—Austria, 656
Zollverein (1), 419
Falloise, J.—Belgium, 384
Fallon Pirn, J. B.—Belgium, 10
Falmouth Local Committee.—i. 88
Falmouth & Penryn Local Committee.
—Western Engl., South Enclosure (Out-
side), 30, 163; xv. 57A; XXIX. 185
Falson, S.—Malta, 25
Famin, T. A.—France, 833
Fancourt, Catherine.—xix. 378
Fano, The Filanla-Bracci Al.—Rome, 7
Faraday, see Smee & Faraday
Faraday & Sons.—XXII. 444
Farina, A.—Sardinia, 47
Farina, J. M.—XXIX. 21; Austria, 748;
Zollverein (1), 426, 858
Farjon, H.—France, 1217
Farlow, C.—XXIX. 176
Farlow, J. K.—ix. 221; XXIX. 181
Farmer, P.—xxx. (Sculpture Crt.) 31
Farmer, T.—xxx. (Sculpture Crt.) 73
Farnley Coal Co.—i. 406
Faroehon, E.—France, 834
Farquharson, J.—x. 655
Farrage, Miss.—xx. 176
Farrar & Son.—xxviii. 16
Farrar, W.—XXII. 627
Farrel, A.—France, 1220
Farrell, I. J.—VII. 140; xxx. (Sculp-
ture Court), 52
Farrell, R. H.—XXIX. 120
Farrell, T.—xxx. (Sculpture Court) 18
Farren, M.—xxx. (Fine Art Crt.) 12
Farrington, A. C.—United States, 286
Farrow, Count de.—Portugal, 469, 470
Farrow, C.—XXII. 560
Farrow, G.—VIII. 136
Farthmann.—Zollverein (1), 16
- Fasbender, H. J.—Belgium, 260
Fatio, J. A.—Switzerland, 79
Faucouner, Madame.—Belgium, 380
Fauel and Phillips.—XIX. 165
Faukhauer, Brothers.—Switzerland, 163
Faulding, J.—XXII. 502; xxviii. 91
Faulds, see Field, Coopers, & Faulds
Faulhaber & Leube.—Zollverein (4), 43
Faulkner, C. see Faulkner, R. & C.
Faulkner, E.—x. 530
Faulkner, C.—xvi. 216
Faulkner, R. & C.—III. 54
Faulwasser, C. K.—Hamburgh, 71
Fauntleroy, R. & Sons.—iv. 135 (Main
Avenue West)
Fauquet-Lemaître.—France, 201
Fauquier-Lemaître, F.—France, 502
Faure, see Larcher, Faure, & Co.
Faure, M.—France, 1218, 1219
Faure, T.—v. 720.
Fauset, T.—British Guiana, 93, 94
Faussemagne, J. M.—France, 1599
Fauvel-Delebarre.—France, 202
Favar, C.—Russia, 195
Favre, A. E.—Switzerland, 10
Favre, B. A.—Switzerland, 11
Favre, H. A.—Switzerland, 23
Fawcett, B.—II. 29
Fawcett, F.—VIII. 62
Favens, G.—VIII. 137
Fay & Co.—United States, 293
Faye, T. De—Jersey & Guernsey, 14
Fayet-Baron.—France, 1221
Fayle & Co.—i. 100
Fayulle, L. T.—France, 197
Fayrer & Robinson.—VIII. 112
Featcombe, H.—XXII. 160A
Feast, see Batty & Feast
Featham, Miller, & Sayer.—XXII. 686
Feau-Bechart, V. A.—France, 198
Feaux & Riedel.—Zollverein (1), 364
Fechner, F.—Zollverein (1), 266
Federer, Brothers.—Zollverein (1), 381
Feer, F. & Co.—Switzerland, 192
Feetham & Co.—XXII. 276A (Main
Avenue West)
Fehr & Eisenring.—Zollverein (2), 54
Fehr, J. C.—Switzerland, 122
Feigenpan, A.—Zollverein (1), 698
Feistel & Son.—Zollverein (3), 171
Felchlin, C.—Switzerland, 80
Feldhauser, P.—Austria, 453
Felde, R.—Zollverein (1), 025
Felo, T. & Co.—xxv. 28
Felloen-Coucke, Madame.—Belgium,
481
Felix, A.—France, 109
Felix & Co.—xx. 51A
Felix, J.—France, 503
Fellersham, Baron.—Russia, 82
Fell & Co.—i. 106; xxv. 28
Fell, R.—v. 438
Feller & Son.—Zollverein (1), 107
Felling Chemical Works (Gateshead).—
II. 18.
Felaing, H.—Zollverein (6), 73
Felten & Guillaume.—Zollv. (1), 380
Fetter & Rahn.—Russia, 262
Feltham, R. D.—Jersey & Guernsey, 8
Felthaus.—Zollverein (1), 666
Feltrappe, Brothers.—France, 1600
Fendt, see Purdy & Fendt
Fenech, Antonia.—Malta, 19
Fenech, V.—Malta, 6
Fenu, J.—United States, 111
Fenny, F.—XXII. 114
Fenton.—XXII. 422; see also Sadler,
Fenton, & Co.
Fenton, Mrs.—Van Diemen's Land, 330
Fenton, W.—XII. & xv. 69
- Fenton, M.—XXVIII. 48
Ferguson, Brothers.—XVII. 90
Ferguson, C. A. & T.—VIII. 84, 184;
XXII. 55
Ferguson, D.—v. 78—United States, 574
Ferguson, J.—ix. 214
Ferguson, Miller, & Co.—Western end,
North Enclosure (Outside), 66;
XXVII. 93
Ferguson & Sons.—x. 631
Ferguson, T. see Ferguson, C. A. & T.
Ferguson, W.—Canada, 164
Fergusson, J.—VIII. 276
Ferle, W.—Austria, 284
Fermento, L. A.—Sardinia, 37
Fernandez, D. F.—Spain, 127A
Fernandez de Corloba, D. M. M.—
Spain, 69
Fernandez, M.—Spain, 169
Fernandez, V.—Spain, 25
Fernandez Vitoras, J. M.—Spain, 90
Ferenczi.—Austria, 430 (Main Avenue
East)
Fernkera.—Austria, 430
Fernley Iron Works.—XXVII. 102.
Feron.—France, 86
Feron, J. F.—France, 504
Feroelle & Rolland.—France, 200
Ferrabee & Sons.—ix. 274
Ferrare, F. de.—Belgium, 15
Ferraz & Sisters.—Madeira, 2.
Ferreira, A. J.—Portugal, 32-36
Ferreira, G. B.—Portugal, 1114, 1115
Ferreira, M. B. jun.—Portugal, 510
Ferrer & Co.—Spain, 206
Ferrer, Hon. J.—Canada, 5
Ferrigini, G.—Tuscany, 100
Fery, A.—France, 505
Festugiere, E. J. & Co.—France, 1721
Fetu, A. & J. Deliege.—Belgium, 129
Fetu, J.—France, 1601
Feulgen, Brothers.—Zollverein (1), 507
Feuchtwanger, Dr. L.—United States,
469
Feuvre, G. C. Le.—Jersey & Guernsey, 20
Feuvre, Mrs. F. Le.—Jersey & Guern-
sey, 11
Feuvre, P. Le.—Jersey & Guernsey, 10
Fevre, Le.—France, 1647
Feyeu.—France, 209
Fial, J.—Austria, 307
Fiala, W.—Austria, 25
Fialho, D. da Cunha.—Portugal, 1'22,
1123
Ficalho, Marquis de.—Portugal, 299,
301, 317, 335, 347, 356, 357, 375,
382, 400, 440, 481, 482, 535, 552,
596, 602, 603, 619, 621
Ficker, C.—Zollverein (4), 10
Ficker, see Maudslay, Sons, & Field;
Parker, Field, & Sons
Field, A.—United States, 455
Field, Coopers, and Faulds.—i. 263
Field, E.—xxi. 16
Field, G.—xxx. 360
Field, J. see Field, J. C. & J.
Field, J. C. & J.—iv. 130
Field & Son.—x. 250
Field & Sons.—xx. 10
Fielder, A. D. G.—Zollverein (3), 128
Fielder, A. G.—Russia, 351
Fielder, W. E.—XXIX. 86
Fieldhouse, G. & Co.—vi. 443
Fieno, J. B. da.—Sardinia, 73
Fierz, R.—Switzerland, 153
Fieux, sen. Sui, & Co.—France, 210
Figdor, I. & Sons.—Austria, 90
Figgus, V. & J.—XVII. 124
Figueiredo, J. J. de.—Portugal, 218,
249, 252, 257, 1121

- Fiquet, Brothers.—Switzerland, 266
 Filemonoff.—Russia, 103
 Fillemore, G.—Canada, 42
 Finch, H.—United States, 300
 Finch, J.—xxv. 38
 Finch & Willey.—vii. 9; 150
 Finch, J. G.—Zollverein (4), 31
 Findlay, see Kaye, Findlay, & Co.
 Findley, C. V.—xxvi. 146
 Finistrat, Baron de.—Spain, 195
 Finlay, John.—xxii. 140
 Finlayson, Bousfield, & Co.—xiv. 48
 Finlayson, F. & Co.—xxi. 8
 Finnagan, J.—xvi. 29
 Fino, J.—Sardinia, 77
 Finsch, M.—Zollverein (1), 191. 211
 Finzel, see Rotch & Finzel
 Finzi, S. K.—x. 602
 Fiolet, Louis.—France, 211
 Fire Annihilator Co.—v. 92A
 Firkins, J. & Co.—xx. 163
 Firmin Didot, Brothers.—France, 212
 Firmin & Sons.—viii. 211; xx. 161
 Firth, see Thornton, Firth, & Co.
 Firth, T.—v. 472; xxii. 96A; xxx. (Fine Art Court), 263
 Firth, T. & J.—v. 119
 Firth, Barber, & Co.—i. 264
 Firth & Sons.—xii. & xv. 37
 Fisch Brothers.—Switzerland, 192
 Fischer.—Zollverein (1), 747; see also Basse & Fischer; Huth & Fischer
 Fischer, A.—Austria, 420.
 Fischer, B.—Austria, 421
 Fischer, Brothers.—France, 506
 Fischer, C.—Austria, 617
 Fischer, C. A.—Lubeck, 5.
 Fischer, C. F. A.—Zollverein (3), 168
 Fischer, C. H.—Zollverein (1), 296
 Fischer, E.—Switzerland, 265
 Fischer, F.—India, iv.
 Fischer, G.—Austria, 501A
 Fischer, G. F.—India, i.
 Fischer, J. C.—Switzerland, 47
 Fischer, K.—Zollverein (1), 281
 Fischer, M.—Austria, 618
 Fischer and Wurm.—Austria, 426
 Fishbourne, Captain.—viii. 127
 Fisher, see MacQuarie, Fisher, & Co.
 Fisher, A.—Canada, 69
 Fisher & Bramall.—xxii. 206
 Fisher, E.—xxix. 225
 Fisher, F.—i. 110
 Fisher, J.—xxix. 60, 220; Canada, 43. 59
 Fisher, J. H.—xvii. 10
 Fisher, J. N.—xxii. 508
 Fisher, J. W.—xxvi. 37
 Fisher & Robinson.—xix. 2
 Fisher, T.—United States, 263
 Fisher, T. W. & Co.—xxix. 22
 Fister, J.—Spain, 221, 222
 Fitch, F. C.—iii. 160; iv. 8
 Fitch, Dr. S. S.—United States, 479
 Fiter, J.—Spain, 221, 222
 Fitt, W.—v. 118
 Fitte, De, see Dubreulle, & Co.
 Fitts, A.—Canada, 135
 Fitzgerald, Rev. R.—i. 233
 FitzMaurice, Hon. W. E.—v. 57; viii. 283.
 Fitzner, C.—Russia, 271
 Fitzroy, Lord C.—Ionian Islands, 4
 Fitzwilliam, Earl.—Western end, South Enclosure (Outside), 48
 Fiume Privileged Steam Flour-mill.—Austria, 63
 Fiuzi, S. L.—x. 602
 Fjeldrad.—Denmark, 8
 Flacherou-Hayard.—France, 836
 Flaisier, Brothers.—France, 204
 Flamet.—France, 213
 Flammerheim, W.—Zollv. (1), 395
 Flather, D.—xxii. 167
 Flather & Haden.—i. 80
 Flaud, H. P.—France, 507
 Flaussen, Dr.—Zollverein (1), 704
 Flavell, S.—xxii. 38
 Flechey, J. B.—Algeria, 24
 Fleck, A.—Canada, 92
 Fleet, J.—xxvi. 24
 Flegg, R. C.—Van Diemen's Land, 271
 Fleisch, N.—Zollverein (2), 72
 Fleischman, C. W.—Zollverein (2), 71
 Fleischmann, A.—xxix. 126; Zollverein (1), 763
 Fleming, G.—ix. 253
 Fleming, S.—Canada, 153. 350
 Flemmich, A.—Austria, 254
 Flemry, J. F.—France, 214
 Flerovsky, M.—Russia, 320
 Fletcher, see Parsons, Fletcher, & Co.
 Fletcher, A.—xiv. 8
 Fletcher, E.—xxvi. 84
 Fletcher, H.—xxix. 240
 Fletcher, H. T.—xiv. 36
 Fletcher, J.—xviii. 69; xxx. (Fine Art Court), 111; Canada, 127. 136
 Fletcher, P.—x. 200
 Fletcher, R.—xxvi. 151. 207
 Fletcher, T.—v. 444; viii. 255
 Fletcher, W.—xxix. 244
 Flobert.—France, 215
 Flockenhaus & Co.—Zollv. (1), 335
 Flockhart, see Duncan, Flockhart, & Co.
 Flossheim, J. M.—Hamburg, 62
 Flogs, G.—Austria, 670
 Flood, J.—Sweden and Norway, 7
 Floodman, see Good, Floodman, & Co.
 Florance.—France, 1223
 Floreffe, Société de.—Belgium, 38
 Flores, Calderon, & Co.—Spain, 241
 Florimond.—France, 1224
 Flower, Ann.—ix. 164
 Fluëck, Elizabeth.—Switzerland, 238
 Fluëck, J.—Switzerland, 224
 Flynn, W.—xxix. 156
 Flynn, W. P.—v. 125; viii. 183
 Foerster, F.—Zollverein (3), 68
 Foese, G.—Zollverein (1), 813
 Fogarty, J.—xxii. 13
 Fogg & Burbank.—United States, 410
 Fogliardi, G. B.—Switzerland, 54
 Folcker, G. F.—Sweden, 67
 Folcker, J. P. & Son.—Sweden, 68
 Foley, J. H.—Page 818. xxx. (Sculpture Court) 4. 19. 70
 Folkard, W. J.—xvii. 112
 Follet, G.—xxvi. 364
 Follet, Narcisse.—Belgium, 426
 Follonica, Royal Foundry at—Tuscany, 73
 Foltz, L.—Zollverein (2), 94
 Fouseca Vaz, A. P. da.—Portugal, 394-399. 406. 411. 580
 Fouseca, J. L. F. da.—Portugal, 627
 Fonnereau, Kate G.—xxvi. 40
 Fountain & Porter.—United States, 550
 Fontaine, F.—France, 1225, 1226
 Fontaine, G.—Belgium, 67
 Fontaine Moreau, De.—v. 610; vi. 30; x. 326
 Fontaine, P. L.—France, 1227
 Fontana, Mrs.—France, 205
 Fonte Boa, Viscount de.—Portugal, 305. 327. 378. 441. 518
 Fontenau, F.—France, 509
 Fontinn, A.—Tuscany, 122
 Foon, Dr. H.—Netherlands, 113
 Ford, R.—South Africa, 30
 Foot, J.—i. 180
 Foot & Sons.—xix. 68
 Foots, Mrs.—xxx. 208A (Fine Art Cr.)
 Footthorpe, Showell, & Shenton.—xxvi. 132
 Forbes, Dr.—i. 522
 Forbes, F. G.—Western Africa, 8. 15
 Forbes & Hutchison.—xii. & xv. 291
 Forbes, R. B.—ix. 269A
 Forri, see also Padlon & Ford
 Ford, C. D. de, & Co.—United States, 528
 Ford, D.—xxiv. 40
 Ford, R.—xx. 36
 Fordati, Coxhead, & Co.—France, 1464. 1490
 Fordham & Son.—xxvii. 118
 Fordham, T.—iii. 94
 Forestier, Le.—France, 1709
 Formigli, see Caillon, & Co.
 Formo, J.—Sardinia, 51
 Forrer, A.—xxiii. 69
 Forrer, Biedeman, G.—Switzerland, 153
 Forrest, A. H.—Page 849
 Forrest & Bromley.—xxiv. 42
 Forrest, R.—United States, 539
 Forrest & Sons.—xix. 45
 Forrest, W.—xxiii. 108
 Forsell, D.—Sweden, 109
 Forster.—xxviii. 178, see also Brown & Forster
 Forster & Andrews.—x. 562
 Forster, E.—xxiii. 77
 Förster, F.—Zollverein (1), 220
 Forster, J.—Main Avenue West, 26; vii. 28; viii. 7
 Forster, J. B.—Switzerland, 193
 Forster, J. & T.—viii. 168
 Forster, L.—Austria, 512
 Forster, Simon A.—x. 509
 Forster & Smith.—Gold Coast and Ashantee, 1; Western Africa, 2
 Forster, J. & T.
 Forstmann & Hufmann.—Zoll.(1), 508
 Forstny & Co.—viii. 256
 Fortel, Larbre, & Co.—France, 206
 Fortier, M.—Canada, 141
 Fortier-Beaulieu.—France, 510
 Fortin, see Roux & Fortin
 Fortin-Boullier.—France, 484. 1109
 Fortner, F. X.—Zollverein (2), 69
 Fortnum, Mason, & Co.—iii. 55
 Forton, Duponceau, & Co.—France, 1228
 Fortuna, Eliza.—xix. 168
 Fortzano, see Ruffoni, Vincenzo, & Fortzano
 Fossick & Hackworth.—v. 10
 Foster, see Knight & Foster
 Foster, E. R.—xxx. (Fine Art Cr.), 503
 Foster, G.—xxvi. 33
 Foster, Porter, & Co.—xviii. 16; xx. 2; xxix. 149
 Foster, R.—xxii. 650A
 Foster, Rothy, & Co.—xix. 306
 Foster & Son.—xii. & xv. 113
 Foster, Son, & Duncum.—xxix. 74
 Foster, T.—vi. 202
 Foucault, P.—France, 220
 Fouché, L.—France, 216
 Fouché le Pelletier, E. E. F.—France, 1229
 Foucher.—France, 837
 Foulis, Dr.—xvii. 170
 Fouques, H.—France, 1602
 Fouquier, Mlle. & Co.—France, 1603
 Fougneau, L.—France, 1230
 Fourcade, see Delacretaz & Fourcade
 Fourdinois, A. G.—France, 1231

(Fine Art Cr.)
menton.—xxvi.Africa, 8. 15
II. & xv. 291Ford
—United States,

—France, 1464.

. 118

709

—Switzerland,

iv. 42

, 539

see also Brown

562

), 220

ie West, 26;

nd, 193

68

2

99

d Coast and

Africa, 2

& T.

—Zoll.(1), 503

France, 206

e, 510

, 484. 1109

(2), 69

III. 55

Co.—France,

enzo, & For-

10

Art Cr.), 503

III. 16; xx.

. 306

113

xxix. 74

F.—France,

2

ance, 1603

4

Fourcade

1231

Faurdriner, E. N.—v. 406
 Faurdriner, G. H.—vi. 100
 Fournes, W.—v. 581
 Fournex.—France, 1605
 Fournier, see Vacossin, Bonet, &c.
 Fournier, C.—Canada, 45
 Fournival, Son, Altmayer, & Co.—
 France, 221
 Fourquemin & Godet.—France, 1604
 Fouz, J. P. De la—xxii. 800
 Fowler.—Van Diemen's Land, 82-89
 Fowler, C.—xxx. (Fine Art Court), 142
 Fowler & Fry.—v. 843; ix. 28a
 Fowler, J.—ii. 53; ix. 28a
 Fownes, Brothers.—xx. 82
 Fox.—x. 402
 Fox & Barrett.—vii. 166
 Fox & Barrington.—ii. 44
 Fox, Brothers, & Co.—xii. xi. & xv. 7
 Fox, C.—xxx. (Fine Art Court), 29
 Fox & Co.—xiii. & xv. 272
 Fox, E.—xxx. 29a
 Fox, Hendersson, & Co.—Western end,
 North Enclosure (Outside), 55; v.
 404; viii. 336
 Fox, J. F.—France, 1232
 Fox, J. F.—iii. 90
 Fox & Polhemus.—United States, 352
 Fox, H. W.—x. 377
 Fox, T.—xxv. 168
 Fox, T. H.—xxii. 35
 Fraccaroli, I.—Austria, 710 (Main
 Avenue East)
 Frener, G. B.—Austria, 732
 Fragata, C. A.—Portugal 1126a
 Fraignieu, A.—France, 1606
 Fraikin, C. A.—Belgium, 465 (Main
 Avenue East)
 Franc, A. & Son, & Martelin.—France,
 1233
 Franco, A. de.—Portugal, 1022b,
 1022c
 France, A.—ix. 73
 Franceschini, F.—Tuscany, 62
 Franceschini, G.—Tuscany, 43
 Franche, C.—France, 1234
 Frauchi, G. J.—xxx. (Fine Art Court),
 190
 Francis, J.—viii. 136; xxx. (Sculpture
 Court), 33; United States, 533
 Francis & Sons.—Western end, North
 Enclosure (Outside), 71; xxvii. 47
 Francis, see Macpherson & Francis
 Franck, C.—Zollverein (2), 75
 Francois-Greguire.—France, 511
 Frank, F.—United States, 19
 Frank, J.—Austria, 328; Zoll. (?), 53
 Frank J. G.—Zollverein (6), 61
 Franke, J.—Austria, 602
 Frankenber, Count L.—Zollv.(1), 216
 Frankensfelde, Royal Administration of.
 —Zollverein (1), 27
 Franklin.—Western end, North Enclo-
 sure (Outside); see also Robson,
 Levey, &c.
 Franklin, J. D.—xix. 169
 Franklin, Joseph.—v. 784
 Franklin, P. L.—Western end, South
 Enclosure (Outside), 28; i. 144;
 xxvii. 73
 Franklinaki, J. A.—v. 816
 Franks, C.—xxviii. 128
 Franks, J.—xxx. (Sculpture Court), 60
 Franz, see Lange, Franz, & Sons
 Franz, J.—Zollverein (1), 283, 293
 Franzny, A.—Austria, 614
 Fraser, A.—Van Diemen's Land, 10
 Fraser, D.—xiv. 79
 Fraser, W. J.—New Brunswick, 9, 24
 Fratini.—France, 135

Frauenknecht, O.—Austria, 606
 Fray, M.—France, 512
 Frazer, see Arthur & Frazer
 Frearson, J.—xxii. 288
 Freccia, P.—Tuscany, 110
 Frederic, J. B.—Algeria, 25
 Frederickken, J. F.—Cape of Good
 Hope, 30a, 58
 Freliani, C.—Tuscany, 16
 Fredric, Col. C.—Belgium, 142
 Freeman.—iv. 25; xxiv. 48
 Freeman, C.—see Freeman, W. & C.
 Freeman, D.—xxiii. 51
 Freeman, E. & J.—xxiv. 28
 Freeman, Rev. E.—Van Diemen's Land,
 210-216
 Freeman, J.—vii. 177; see Freeman,
 W. & J.
 Freeman & Roe.—v. 462
 Freeman, S.—i. 172
 Freeman, W. & C.—xxvi. 38
 Freeman, W. & J.—Western end, South
 Enclosure (Outside), 14; i. 160
 Friedenthal, C.—Zollverein (1), 846
 Friedrich & Son.—Zoll. (3), 72-83
 French, B.—iv. 127
 French & Butler.—xxviii. 126
 French, C.—xxx. (Fine Art Court), 62
 French, G. J.—xxvi. 110
 French, J. & Sons—xxiii. 89
 French, W. H.—x. 435
 Frenholm, E.—Canada, 52
 Fresnel, M.—vii. 99
 Freston, W.—i. 133
 Fretigny, L.—Belgium, 342
 Freudenburg, see Heintze & Freudenburg
 Freukner, A.—Austria, 513
 Freund, E. A.—Zollverein (6), 38
 Frewen, Elizabeth.—xix. 170
 Frewer, J.—xxvii. 5
 Frewer, J. R.—xxx. (Fine Art Court) 219
 Frey, A. J. G.—Switzerland, 82
 Frey & Son.—France, 1607
 Frey, T., see Frey, T. F. & T.
 Frey, T. F. & T.—Switzerland, 152, 212
 Frey, Thurneisen, & Christ.—Switzer-
 land, 152
 Freystadt, Brothers.—Zoll. (1), 178
 Freyvogel & Hensler.—Switzer. 152
 Friarson, M.—vii. 203
 Friebl, L.—Zollverein (1), 289. (Main
 Avenue East.)
 Friedheim & Sons.—Zollverein (1), 109
 Friedl, L.—Austria.—332
 Friedrich, A.—Austria, 182
 Friedrich, C.—Zollverein (1), 49
 Friedrich, J. H. Zollverein (6), 74
 Friedrich, J.—Austria, 671; 729a
 Friedrich, J. P.—Hanover, 10
 Friedrich & Son.—Zoll. (3), 72-83
 Friedrichsen, K. A.—Hamburg, 8
 Frieul.—Zollverein (1), 747
 Fries, H.—Switzerland, 221
 Fries & Zeppezauer.—Austria, 255
 Friault.—France, 1608
 Frimby, F. R.—xxviii. 181
 Friry & Rega.—France, 1237
 Fritchie, M. J.—United States, 136
 Frison, J.—Belgium, 392
 Fritscheller, see Faller, Fritscheller, & Co.
 Fritsen, see Petit & Fritsen
 Frodsham, see Parkinson & Frodsham
 Frodsham, C.—x. 57
 Froely, A.—France, 218
 Froggart, see Whittles & Froggart
 Fröhlich, C.—Austria, 614
 Fröhlich, J.—Austria, 515
 Fröhlich, G., & Sons.—Austria, 177
 Fromage, L.—France, 129
 Frome Field School.—xvii. 172

Froment, Clovis.—France, 208
 Froment.—France, 1720
 Froment, G.—France, 1606
 Frommann, M.—Zollverein (6), 39
 Fromont.—France, 220
 Frost, see Eastwood & Frost
 Frost, H.—xxii. 393; xxix. 34.
 Frost, J.—vi. 84
 Frost, Noakes, and Vincent.—v. 476
 Frueh, G.—Zollverein (1), 298
 Frumento, J. B.—Sardinia, 92
 Fry, see Fowler & Fry
 Fry, J.—xx. 193
 Fry, J. L.—xx. 116
 Fry & Son.—iii. 31
 Fry, W. & Co.—xii. & xv. 267
 Fryer, F.—United States, 372
 Fryer, Miss N.—xix. 237
 Fryer, R.—xxii. 516
 Fuchs, H. M.—Zollverein (2), 11a
 Fuchs, M.—Nuremberg.
 Fuchs & Son.—Zollverein (2), 4
 Fudickar, H.—Zollverein (1), 598
 Fuisscaux, N. de.—Belgium, 400
 Fuller, G. & T.—v. 546
 Fuller, J.—x. 592
 Fuller, J. E.—United States, 490
 Fuller, T., see Fuller, G. & T.
 Fulljames & Co.—v. 993
 Fulton, H.—xxx. (Fine Art Court) 169
 Fumet, C. F.—France, 513
 Funch, A.—Denmark, 16
 Funke & Boeddinghaus & Co. Zoll-
 verein (1), 572
 Funke & Huck.—Zollverein (1) 652
 Funke, R.—Zollverein (1), 387
 Funnell, E.—x. 26
 Furlinger, see Baur & Furlinger
 Furler, Franz.—Austria, 208
 Furler, J.—xx. 04
 Furness, W.—vi. 401
 Furse, C. & S.—xxvi. 369
 Furse, S., see Furse, C. & S.
 Furse, T. W.—Western end, South en-
 closure (Outside), 19
 Furst, J.—Austria, 296
 Furstenberg, Prince.—Austria, 412
 Furstenhoff, Emma.—France, 452;
 Sweden and Norway—27
 Furth, H.—Austria, 46
 Fusinata, Maria.—Austria, 390
 Fusnot, see Montigny & Fusnot
 Fussell, F. R.—vi. 95
 Fussell, Son, & Co.—ix. 197a
 Fitcher, R.—Portugal, 1116
 Fyer & Robinson.—viii. 112
 Fyfe, A. & Co.—xii. & xv. 197
 Fyfe, H. & Son.—xi. 18
 Fyfe, W. W.—ix. 41a
 G. M., Mrs.—Spain, 238
 Gaas D'Aguien, V.—France, 1238
 Gabain, G.—Zollverein (1), 119
 Gabelberger.—Zollverein (3), 182
 Gabriel, J. W.—xix. 70
 Gadd & Birl.—v. 208
 Gademan, H.—Zollverein (2), 12
 Gaidlen & Evans.—British Guiana, 26
 Gaertner, A.—Zollverein (1), 193
 Gace Cloth Manufacturing Co.—Austria,
 209
 Gaetschmann, W.—Zollverein (3), 3
 Gagein, see Onigex & Chaele
 Gagneau, Brothers.—France, 227
 Gaffier, Baron E. de.—Belgium, 14
 Gaillard.—France, 225
 Gaillard, sen.—France, 226
 Gaillet-Baromet.—France, 839
 Gaines, Sanders, & Nicol.—vi. 57, 58

Galabin, *see* Harris & Galabin
 Galbraith, W. J. T.—XVII. 179; XXIX. 17
 Gale, G. H.—VIII. 136. 323
 Gale, J. & R.—VIII. 79. 136
 Gale, R., *see* Gale, J. & R.
 Galimard, E.—France, 515
 Galimard, F.—France, 839A
 Galimard, N. A.—France, 228
 Galimberti, C.—Sardinia, 29
 Gall, J.—X. 687A; XVII. 170, 171
 Gall, M.—XVII. 171.
 Gallagher, J.—XXX. (Sculpture Court) 43
 Galland, R.—France, 959
 Gallard, W.—XVII. 120
 Gallaway, T.—XX. 120
 Galle, P. H.—Netherlands, 47
 Gallegos, J.—Spain, 272
 Galli, A.—Austria, 711
 Gallicher & Co.—France, 229
 Galloway, J., *see* Galloway, W. & J.
 Galloway & Sons.—XX. 93
 Galloway, W. & J.—v. 124
 Galton, Mary Ann.—XXIX. 93
 Galy Cazalot.—France, 1239
 Gamaley, T.—Russia, 123
 Gamba, P., the Heir of.—Austria, 109
 Gambartzomoff, Artem.—Russia, 237
 Gamble, G. F.—XXIX. 45
 Gamble, J. H.—III. 12
 Gamble, Brothers.—United States, 165
 Gamble, W.—Canada, 139
 Gambs.—Russia, 297
 Gammersbach, Brothers.—Zollv. (1), 860
 Gaucourt, Mdlles.—Mauritius, 5
 Gandell, *see* Hunt and Gandell
 Gandell, E. F.—VII. 35
 Gandillot & Co.—France, 230
 Gandolfi.—Sardinia, 95; *see* also Bottinelli & Gandolfi
 Gandolfi, D.—Austria, 712 (Main Avenue East)
 Gandy, G.—XII. & XV. 246
 Gann, Louisa.—XVIII. 94; XXX. 12A
 Gannery, V.—France, 516
 Ganer, J.—Austria, 256
 Gante & Sons.—Zollverein (1), 563
 Ganter, F.—Zollverein (7), 4
 Gantillon, C. E.—France, 1241
 Garville, W.—Canada, 95. 114
 Garach, J.—France, 232
 Garate, M. de.—Spain, 270A
 Garcia, J.—France, 205
 Garcia, J. C.—Portugal, 611
 Gard, W. S.—XIX. 16
 Garde.—Portugal, 1155
 Gardie, L.—XXX. (Fine Art Court) 261
 Gardiner, M.—XXI. 556.
 Gardiner, *see* Mix and Gardinier
 Gardiner & Hazley.—VI. 87
 Gardner & Co.—X. 365
 Garduer, H.—VII. 50.
 Gardner, J.—XXIX. 223
 Gardner, J., M. D.—III. 142
 Gardner, J. H.—XXVI. 231
 Gardner, J. N.—United States, 304
 Gardner, M. A.—XIX. 174
 Gardner, W. H.—XVII. 199
 Gardner, W. T.—VII. 280
 Garforth, J., *see* Garforth, W. J. & J.
 Garforth, W. J. & J.—VI. 209
 Garion, *see* Causse & Garion
 Garland & Co.—Portugal, 39-41
 Garland, T.—I. 488
 Gaaland, W.—XIV. 84
 Garman, H. C.—Sweden & Norway, 38
 Garman, jun.—France, 233
 Garner, D.—XVI. 230. 312
 Garnett, H. T.—British Guiana, 13, 14. 31, 32

Garnett, W.—XVI. 69
 Garnikik Co.—Western end, North Enclosure (Outside), 69
 Garrard, J., *see* Garrard, R. & J.
 Garrard, R. & J.—XX. 61
 Garrard, R. & S.—XXIII. 98; Austria 729
 Garrard, S., *see* Garrard, R. & S.
 Garrett, G.—XXVIII. 141
 Garrett & Sons.—IX. 142
 Garrisini, P.—Sardinia, 9
 Garry.—XVI. 20
 Garth, C.—Canada, 158
 Garthwaite, W.—XXVI. 48
 Garton & Jarvis.—XXII. 53
 Garvie & Deas.—XII. & XV. 227
 Gaspar, *see* Dotres, Gaspar, & Co.
 Gaspard, G. A.—France, 1610
 Gass, D. *see* Gass, S. H. & D.
 Gass, S. H. & D.—XXIII. 53
 Gasser, J.—Austria, 703
 Gassett, H.—United States, 420
 Gastinne-Renette.—France, 1611
 Gaston, *see* Blouel, Gaston, & Co.
 Gatchel, J. L.—United States, 468
 Gatchell, G.—XXIV. 12
 Gatchill, *see* Saunders & Gatchill
 Gatenby & Pass.—VI. 60
 Gates, Laura Charlotte.—XX. 72
 Gates, T. F.—XVI. 183
 Gates, W.—United States, 423
 Gating, R. J.—United States, 162
 Gatt, A.—Austria, 440
 Gatti, A. & G.—XXIX. 73
 Gatti & Bolla.—VI. 450
 Gatti, G. *see* Gatti, A & G.
 Gattiker, G.—France, 841
 Gaubot, sen.—France, 844
 Gaudchaux-Picard, Sons.—France, 222
 Gaudet du Fresno.—France, 842
 Gaume & Co.—France, 843
 Gaunt & Son.—XXVI. 88
 Gaunt, T.—XXIV. 08
 Gausson & Co.—France, 1242
 Gausson, jun.—France, 1343
 Gauthier, *see* Bricard & Gauthier
 Gauthier, jun.—France, 234
 Gauthier, J.—France, 1244
 Gauthorp.—XVIII. 70
 Gautier, B.—France, 1215
 Gautier, J.—France, 1244
 Gauvain, J.—France, 1612
 Gavard, A.—France, 235
 Gavit, D. E.—United States, 125
 Gawkröger & Hynn.—I. 48
 Gay & Luquin.—Switzerland, 83
 Gayet, *see* Bertrand, Gayet, & Dumontat
 Gaynard & Gerault.—France, 518
 Gayraud, *see* Vechte, Gayraud, & Yon
 Gaze.—X. 196
 Gaze, T.—VIII. 136
 Geake, T.—XXVI. 31
 Gear, J. W.—XXX. (Fine Art Court), 245
 Geary, N.—XVI. 235; XX. 49
 Geary, S.—v. 816; VII. 2
 Gabauhr, C. J.—Zollv. (2), 848
 Gebhardt, C. A.—Zollverein (1), 248
 Gebhardt, Ruttman, & Co.—Zollverein (1), 585; Zollverein (3), 90
 Gebhart, Brothers.—Zollverein (2), 42
 Gebruder, *see* Scheidt, Gebruder, & Co.
see, *see* Andrews, H. & Sons, & Co.
 Geefs, G.—Belgium, 466; (Main Avenue East)
 Geefs, J.—Belgium, 451; (Main Avenue East)
 Geels, S.—Belgium, 451, 466A
 Geertz, C.—Belgium, 450
 Geffen, J. H. Van.—Netherlands, 46

Gehrenbeck, *see* Nacke & Gehrenbeck
 Gehrmann, T.—Zollverein (1), 60
 Geiger, Professor.—Austria, 372
 Geilinger, Brothers.—Switzerland, 261
 Geimar, L. & Co.—Zollverein (8), 13
 Geise.—Zollverein (1), 267. 279
 Geissberger, F.—Austria, 11
 Geissler, C. S.—Zollverein (1), 100
 Geismann & Co.—Switzerland, 227
 Gelder, Van, & Sons.—Netherlands, 61
 Gelle, sen.—France, 845
 Gellinek, J.—Austria, 338
 Gelling, F. L.—I. 139
 Geminy.—France, 1613
 Gemmner, G.—United States, 442
 Genatendal Missionary Station.—South Africa, 44
 Genest, *see* Bernard, Richoux, & Genest
 Genin, J. N.—United States, 232
 Genoa, Duke of.—Sardinia, 64
 Genoux, F.—France, 1714
 Gentile, J. P.—III. 108
 Gephagan, W. M.—XIII. 14
 Geological Survey of the United Kingdom.—I. 159
 Georgeon, J.—VIII. 42
 George, *see* Lutwyche & George
 George, C.—XVI. 32; XIX. 175
 George, J.—I. 213; XVI. 289
 George, J. B.—XIX. 381
 George, T. W. & Co., XII. & XV. 50
 George's, St., Fields, School for the Indigent Blind.—XXVII. 100
 Gerard, A., and daughters.—X. 109
 Gerard, A. J.—Belgium, 182
 Gerstendoeffler, J. & Kubler, jun.—Zollverein (2), 10
 Gerault, A.—Malta, 32
 Gerault, *see* Gaynard & Gerault
 Gerler, C. H. A.—Mecklenburg-Schwerin, 3
 Gerber, E.—Hamburg, 21
 Gerente, France, 517
 Gerhard, A.—Zollverein (1), 487
 Gerhardt, A.—Zollv. (1), 839.
 Germain, Son, France, 242
 Gerieb, F. W.—XXII. 652
 Gerlach, C. F.—Zollverein (1), 252.
 Gerlich & Grieff.—Zollverein (1), 537
 German, A. A. & Co.—France, 81
 Germain-Simier M.—France, 1246
 Gerresheim & Neef.—Zollv. (1), 872
 Gerson, H.—Hamburg, 32
 Gerstendoeffler, J. & Kubler, jun.—Zollverein (2), 10
 Gerstner, *see* Lötz & Gerstner
 Gervais.—France, 520
 Geseller, H.—Hamburg, 68
 Gessner, A.—Switzerland, 153
 Gesson-Mazille.—France, 223
 Gettinger, M. H.—United States, 320
 Gevelot.—United States, 189
 Gevelot and Lemaire.—France, 519
 Gevers & Schmidt.—Zollverein (1), 50
 Geyer, J.—Austria, 348
 Geyger, A. & Co.—Zollverein (1), 870
 Geyting, C.—Austria, 736
 Ghent Liniere Comp.—Belgium, 230
 Ghent Société du Phœnix.—Belgium, 134
 Ghrimes, S.—X. 574
 Gian, J.—Austria, 257
 Gibbons, J., jun.—XXII. 654
 Gibbons & Sons.—XXII. 194
 Gibbs, Bright, & Co.—New Brunswick, 2
 Gibbs & Co.—III. 104
 Gibbs, Col.—New South Wales, 24
 Gibbs, D. & W.—XXIX. 305A
 Gibbs, G.—VIII. 215

& Gehrenbeck
 rein (1), 60
 austria, 372
 Switzerland, 261
 Zollverein (8), 13
 267, 279
 rein, 11
 (1), 100
 witzerland, 227
 —Netherlands, 61
 445
 338
)
 13
 d States, 442
 y Station.—South
 ichoux, & Genest
 States, 232
 dinia, 64
 1714
 18
 III, 14
 he United King-
 2
 & George
 XIX, 175
 VI, 289
 51
 XII. & xv. 50
 School for the In-
 III, 100
 ters.—x. 109
 m, 182
 Kubler, jun.—
 2
 & Gerault
 —Mecklenburg-
 ght, 21
 in (1), 487
 (1), 839.
 242
 52
 rein (1), 252.
 lverein (1), 537
 —France, 81
 —France, 1246
 Zollv. (1), 872
 , 32
 Kubler, jun.—
 ratner
 gh, 68
 nd, 153
 e, 223
 ed States, 320
 e, 189
 France, 519
 llverein (1), 50
 rein (1), 870
 36
 —Belgium, 230
 mix.—Belgium,
 654
 194
 —New Bruns-
 Wales, 24
 305A

Gibbs, H.—x. 21
 Gibbs, I. A.—xxiv. 75
 Gibelin & Son.—France, 846
 Gibson, A.—VIII. 41
 Gibson, C.—III. 102.—xx. 132
 Gibson & Co.—VI. 19; XVII. 101
 Gibson, John.—xxiv. 72; xxx. (Sculp-
 ture Court), 64
 Gibson, M.—IX. 129
 Gibson, T.—v. 848
 Gibson, W.—United States, 468
 Gibson, W. & Co.—XII. & xv. 464
 Gick, J. G.—Zollverein (8), 37
 Gide & Bandy.—France, 230
 Gidney, J. W.—XXII. 556
 Gienanth, Brothers.—Zollv. (2), 95
 Giesbers, T. M.—Netherlands, 62
 Giesler, see Rimann & Giesler
 Giesler, N. H.—Zollverein (1), 696
 Gifford, J.—xxx. (Fine Art Court),
 280
 Gigolo, S.—Russia, 130
 Gigot & Boisson.—France, 224
 Gil, V.—Spain, 95
 Gilart, R. D.—Spain, 237
 Gilbert, A.—United States, 432
 Gilbert, Brothers.—XXII. 123
 Gilbert, C.—xvi. 179; (Main Avenue
 West); see also Addison & Gilbert;
 Carver & Gilbert
 Gilbert, C. J.—France, 237
 Gilbert & Co.—xvi. 179; (Main
 Avenue West); xxvi. 130—
 France, 238, 847; United States, 436
 Gilbert, E.—VIII. 129
 Gilbert, G. M.—x. 234
 Gilbert, H.—IX. 53
 Gilbert, J.—vi. 447; XIX. 176
 Gilbert, S.—XXII. 494
 Gilbert, W.—XXIX. 187
 Gilbertson, J.—vi. 508
 Gilder, see Walkers & Gilder
 Giles, A.—VII. 71
 Gill & Bishop.—XII. & xv. 77
 Gill, G.—xxx. (Fine Art Court), 145
 Gill, H.—XVII. 160
 Gill, R.—XII. & xv. 190
 Gill, T. D.—XVII. 12
 Gill, V.—Spain, 95
 Gill & Ward.—IX. 62
 Gill, W. E.—I. 38
 Gill, W. L.—XIX. 386
 Gillam, J.—IX. 138
 Gille, J. M.—France, 848
 Gillespie & Co.—Canada, 133
 Gillespie & Son.—XXII. 493
 Gillet, A.—France, 521
 Gillett, J.—IX. 78
 Gillett, W. S.—x. 79
 Gillman, E.—IV. 44
 Gillot.—France, 522
 Gillot, F.—France, 849
 Gillott, J.—XXII. 324
 Gillow & Co.—IV. 15; xxvi. 186
 Gilly, see Roulet, Gilly & Chapomière
 Gilmour, A. & Co.—Western end, South
 Enclosure (Outside), 50
 Gilmour, W. & Co.—XII. & xv. 203
 Gilson & Bosaut.—Belgium, 241
 Gilta, J. L.—Belgium, 105
 Giltay, J. J.—Belgium, 379
 Gimper, G.—Switzerland, 272
 Giner, J.—Spain, 212
 Gingell, W. J.—IX. 25c
 Ginoiri, Marquis L.—Tuscany, 72
 Ginores, J.—Spain, 70
 Ginzl, R. C.—Austria, 210
 Giovanni, San.—xxv. 7
 Giovannini, Pasqual.—Tuscany, 1. 97.
 99

Girard, Nephew & Co.—France, 1248
 Girard, P.—Switzerland, 30
 Girardi, Brothers.—Sardinia, 5
 Girard, Brothers.—France, 850
 Gim, J.—Spain, 23. 244
 Girod, M. & Co.—Sardinia, 8
 Giroud de L'Ain, Le General.—France,
 1249
 Giroud, A.—France, 1250
 Giron, Madame.—Belgium, 408
 Gisbert, J.—Spain, 137
 Giaborne, J.—x. 507
 Gisi, F.—Switzerland, 85
 Gisin, J.—Switzerland, 72
 Gissiger, V.—Switzerland, 171
 Giudicelli & Delabarre.—France, 1614
 Giuseppe, San, Conservatorio of.—
 Malta, 22
 Giusti, P.—Tuscany, 117
 Gladstone, J. jun. & Co.—v. 488; VIII.
 182
 Glaeser, F.—Zollverein (3), 63
 Glaeser, J. S. jun.—Zollv. (3), 72-83
 Glafey & Neubarth.—Zollv. (3), 105
 Glandore Mining Co, Wicklow.—I.
 505
 Glanz, P.—Zollverein (1), 146
 Glasgow, J.—VI. 219
 Glass, G. M.—III. 141
 Glassford.—Canada, 80; see also,
 Scott & Glassford
 Glauchau Weavers' School.—(Saxony)
 Zollverein (3), 100
 Glavy, see Deneirouse, E. Bois, Glavy,
 and Co.
 Gleichauf, B.—Zollverein (1), 887
 Gleiwitz Royal Prussian Smelting-works
 and Iron Foundry.—Zollv. (1), 1
 Glenison & Vangenechten.—Belg. 286
 Glennay, see Thresher & Glennay
 Glennay, C.—xx. 37
 Glenton & Chapman.—XXII. 238
 Glier, F. & Son.—Zollverein (3), 20
 Glier, G.—Zollverein (3), 21
 Globe Print Company (Massachusetts).
 —United States, 31
 Globotschnig, A.—Austria, 357
 Glover & Colclough.—xxv. 25
 Glover & Dunn.—XI. 50
 Glover, J. & T.—XVI. 19
 Glover, M.—XVIII. 92
 Glover, T.—I. 438; see also Gluwer,
 J. & T.
 Glover, W.—IX. 121
 Gluer, L.—Zollverein (1), 170
 Gub, J.—Belgium, 357
 Gobelins, National Manufacture of.—
 France, 1368
 Gocht, F.—France, 1615
 Godard & Bontemps.—France, 240
 Goddard, see Church & Goddard
 Goddard, Brothers.—United States, 35
 Goddard, H.—XXII. 380
 Goddard, J.—xxvi. 303
 Goddard, J. T.—x. 274
 Goddard, L.—x. 636; United States, 531.
 537
 Goddard, S. A.—VIII. 235
 Goddet, A.—France, 1251
 Godfrey.—France, 1722
 Godfrey, L.—France, 1252
 Godfrey, P. A.—XII. & xv. 308
 Godfrey & Cooke.—II. 92
 Godfrey & Hancock.—xvi. 168
 Godfrey, W.—xxviii. 183
 Godin, J. L. & Son.—Belgium, 264
 Godinho, M. N.—Portugal, 1253
 Godschaux, Brothers.—Zoll. (7), 1
 Godson, S. H.—II. 50
 Goebel, F. D.—Zollverein (1), 608

Goebel, G.—Zollverein (4), 56
 Goehring & Boehmer.—Zollv. (3), 164
 Goens, L.—Belgium, 237
 Goerger, M. jun. see Emmerich and
 Goerger, M. jun.
 Goets, F.—Switzerland, 155
 Goethem, V. Van.—Belgium, 124
 Goetz & Ecklin.—Switzerland, 152
 Goetze, H.—Zollverein (3), 169
 Goffinet-Salle, J. B.—France, 524
 Gogerty, R.—x. 407
 Going, J.—XXIX. 201
 Going, J. & Co.—XXIX. 87a
 Golay, see Lecaultre & Golay
 Golay, L.—Switzerland, 220
 Golay-Lereche, A.—Switzerland, 92
 Golden & Son.—VIII. 264
 Goldenberg, G. & Co.—France, 851.
 1737
 Golding, E.—IX. 45a.
 Golding, M. C.—United States, 320a
 Golding, Mrs.—United States, 320a
 Golding, R.—III. 63; IX. 45
 Golding, W.—VII. 228
 Goldner.—III. 15
 Goldschmidt, J.—Switzerland, 84
 Goldschmidt, M., jun.—Zollverein (5),
 20
 Goldschmidt, S.—Zollverein (1), 85
 Gollerichs & Cugat.—Spain, 247
 Goll, Brothers.—Zollverein (4), 88
 Gollon, J.—XXII. 651
 Golovanoff.—Russia, 64
 Gomez, J. L.—Portugal, 403. 418-420
 Gomez Alveric, B.—Spain, 1:6a.
 Gompertz, B.—Hamburg, 33
 Gompertz, I.—v. 652
 Gonin, see Delamorfinière, Gonin, &c.
 Gonella, Prof. T.—Tuscany, 57
 Gonzalez, P.—Austria, 713
 Gonzalez, Carvajal, M.—Spain, 126a
 Gonzalez, S.—Spain, 198.
 Gonzalez Valls, R.—Spain, 55
 Good, Floodman, and Co.—IV. 95
 Good, S. A.—x. 146
 Goodheere, G. T.—XXII. 481
 Goode & Boland.—XXII. 294
 Goodes, G. & S.—III. 50
 Goodes, S., see Goodes, G. & S.
 Goodve, G.—XVI. 176.
 Goodfellow, A.—New Brunswick, 28
 Goodfellow, J.—v. 779
 Goodgard Forges.—Sweden & Norway, 13
 Goodhale & Reeves.—I. 476
 Goodison.—xxvi. 201
 Goodman, G.—XXII. 355
 Goodridge, J., jun.—Jersey and Guern-
 sey, 39
 Goodwin, see Binus & Goodwin
 Goodwin, C.—XXIII. 64
 Goodwin, J.—XII. & xv. 11
 Goodwin, T.—United States, 217
 Goodyear, C.—United States, 378
 Goodyear Rubber Co.—United States,
 295
 Goolab Singh, Maha Rajah.—India, xv.
 xxvi.
 Gouriell, Prince Lieven.—Russia, 61
 Goussens, G.—Netherlands, 77
 Gordon, A., see Gordon, G. & A.
 Gordon, C.—XXIX. 202
 Gordon, E.—XVI. 212
 Gordon, G. & A.—xiv. 82
 Gordon, J.—x. 639; xx. (Fine Art
 Court), 81
 Gore, C. W.—I. 128a
 Gore, G.—x. 690a; xxvi. 144
 Gorigoretzk Farm.—Russia, 121
 Görlitz, L.—Zollverein (1), 890.
 Gorrie, T.—XXII. 40

- Gorrings, W.—xxx. (Fine Art Court), 164
 Gossas & Perier.—France, 1253
 Gorton, *see* Dauplain, Gorton, & Co.
 Gorton, G.—xxx. 374
 Gosemann, *see* Rappard & Goseman
 Gosling, W., *see* Beckford, T., & Gosling, W.
 Gosnell & Co.—xxviii. 55
 Goes, H.—vi. 206
 Gossage, J.—v. 414
 Gosselin, A.—France, 249
 Gott, M.—Rome, 28
 Gott & Sons.—xii. & xv. 47
 Gottl, B.—Austria, 724
 Gottschalk, J. A.—Zollverein (1), 753
 Gottschalk & Schöbeler.—Zollverein (1), 730, 758; Zollverein (3), 88, 163
 Goube-Pheraie.—France, 652
 Gouda, P. F.—Zollverein (5), 26
 Goudeau, C.—Belgium, 135
 Gough, W.—xxiii. 33
 Gouin, A.—France, 241
 Goulard—Portugal, 20, 23
 Gould.—Page 849
 Gould, A.—xxix. 31, 171
 Gould, F., *see* Guilli, J. & F.
 Gould, J.—xxviii. 143; xxx. (Fine Art Court), 247
 Gouli, J. & Co.—United States, 98
 Goult, J. & F.—xix. 14
 Gault, N.—New Brunswick, 3; Nova Scotia
 Gould, T.—Jersey and Guernsey, 34
 Goulding, J.—xx. 110
 Gourdin.—France, 525
 Gourlau, I.—xxix. 192
 Gourlie & Son.—xviii. 52
 Gourock Ropework Co.—xiv. 72
 Gous, B.—Zollverein (1), 720
 Goutchkoff, E. & J.—Russia, 189
 Goutchkoff, J., *see* Goutchkoff, E. & J.
 Gowans, J.—i. 132
 Gower, *see* Rock & Gower
 Gower, T.—xxix. 102
 Gowing, J. W.—x. 736
 Gowing, T. W.—x. 645
 Gowingland, J.—x. 27
 Gowlum, T.—xxiii. 69
 Gozo, Salvo Del.—Malta, 11
 Graber, J.—Austria, 441
 Grabner, F.—Austria, 469
 Grace, D.—iii. 56A
 Grade, L.—France, 1254
 Gradmann, A.—Zollverein (2), 55
 Gradmans, H. C.—Netherlands, 65
 Gradwell, G.—xxi. 40
 Graefe, J. F. & Son.—Zollverein (3), 102
 Graeser & Schweizer.—Switzerland, 216
 Graetzer & Hermann.—France, 54, 199, 296; Zollverein (1), 589
 Graetzsch, —Zollverein (2), 51
 Graf, C.—xxx. (Fine Art Court), 76
 Graf, H.—Zollverein (1), 746
 Graf & Neviardt.—Zollverein (1), 591
 Graff, *see* Butschete & Graff, 281
 Graff, H.—Russia, 150
 Graff, P.—Zollverein (1), 592
 Graff, W.—Zollverein (1), 803
 Graham.—Canada, 23; *see also* Jackson & Graham
 Graham, G.—x. 233
 Graham, J.—i. 517; x. 356; xvi. 122; Canada, 34
 Graham & Hallett.—South Australia, 3
 Graham, Lemon, & Co.—xxix. 103
 Graham & Sons.—xiii. 17
 Graham, West, & Co.—vi. 445
 Grailon, P. A.—France, 853
 Gralnger, G. & Co.—xxv. 46
 Grainger, J.—viii. 278
 Grainger, R.—xxx. (Fine Art Court), 165
 Grambs, *see* Lippincott & Co.
 Granada, Inspector of Mines of.—Spain, 16
 Grandcharbe.—France, 244
 Grandjean, H.—Switzerland, 8
 Grandjean, Madame O.—France, 243
 Grandjean, P. H.—Switzerland, 46
 Grandval, J. B.—France, 1255
 Grauer, *see* Rock & Grauer
 Grauge, F.—Sardinia, 1
 Grangemouth Coal Company, Sunterland.—Western end, North Enclasure (Outside), 68; xxvii. 99
 Granger, J. M. F. L.—France, 1734
 Graugoir, E.—France, 1616.
 Graugoir, J. M.—France, 1256
 Graniteville Factory (South Carolina).—United States, 175
 Grant, *see* White & Grant
 Grant, A. T. & Co.—United States 85
 Grant, C.—xxiii. 93, 110; xxx. (Fine Art Court) 190
 Grant, D.—xxii. 431
 Grant, J.—United States, 5; Van Diemen's Land, 347
 Grant, J. C.—ix. 267
 Grant, J. H.—United States, 284
 Grant, Miss.—Bahamas
 Grant, P.—x. 46
 Grant, W.—viii. 136
 Grantham, J.—viii. 93
 Grantham, W.—xxix. 39
 Grantoff, B. A. & Co.—Austria, 122
 Granville & Co.—iv. 115
 Grauzini, J.—Sardinia, 55
 Grassi, Dr. G.—Austria, 83
 Grassot & Co.—France, 526, 1257
 Gratiot, A.—France, 854
 Gratz Silkworm Breeding Association.—Austria, 73
 Graus, J.—Austria, 442
 Graux, J. L.—France, 157, 245
 Gravagna, Maria.—Malta, 7
 Grave & Neviardt.—Zollv. (1), 591
 Grave, De, Slurt, & Faumer.—x. 333
 Graves, D.—xxx. (Fine Art Court), 322
 Gravit, Capt.—xvi. 16
 Gray.—Bermudas; *see also* Martin & Gray
 Gray, A. *see* Gray, J. & A.
 Gray & Davison.—x. 555
 Gray, Kliza Maria.—xxx. (Fine Art Court), 293
 Gray, G.—v. 694
 Gray, G. Le.—France, 585
 Gray, J.—viii. 160; xxii. 571, 615; xxiii. 101
 Gray, Dr. J.—x. 104A; United States, 302
 Gray, J. & Son.—xxii. 405
 Gray & Keen.—x. 138
 Gray, P.—x. 724
 Gray, S.—xii. & xv. 67
 Gray & Son.—xxii. 262
 Gray & Sons.—ix. 150
 Gray, T. & Co.—United States, 405
 Gray, T. H.—xxii. 513
 Grayson, *see* Slack, Sellers, & Grayson
 Greasley & Hopcroft.—xix. 34
 Great Peat Working Co. of Ireland.—i. 231
 Great Western Railway Co.—v. 501, 566
 Greathead, *see* Davis, Greathead, & Co.
 Greatorex, *see* Bradbury, Greatorex, & Co.
 Greatorex, D.—v. 415
 Greatorex, *see* Cozens & Greatrex
 Greaves, *see* Earnshaw & Greaves;
 Reeva, Greaves & Co.
 Greaves, E.—x. 503
 Greaves, H.—v. 615
 Greaves, J. W.—i. 210
 Greaves, R.—Western end, South Enclasure (Outside), 7; i. 99
 Grebe, J. G.—Netherlands, 102
 Grech, Giuseppe.—Malta, 17
 Greef, F. W.—Zollverein (1), 533
 Greeff, Bredt, & Co.—Zollverein (1), 590
 Greeff & Son, J. P.—Zollverein (1), 653
 Greek Government.—Greece, 15—20, 22—24, 26—39, 43, 44, 46, 47, 49
 Green.—xxviii. 60; *see* Davis, Greathead, & Green; Hirt & Green
 Green, A.—xxii. 42
 Green, H.—vii. 3
 Green, C.—xxii. 570
 Green & Co.—xxii. 532
 Green, E.—v. 63
 Green & Fahey.—xxx. (Fine Art Court), 8
 Green, H.—xviii. 70A
 Green, I.—vii. 186
 Green, J.—vii. 17; xii. & xv. 92; xxv. 50; xxx. (Fine Art Court), 233
 Green, J. G.—xxiv. 32
 Green, R.—viii. 131; xvi. 85
 Green, S.—x. 446; xxii. 632
 Green, S. & Co.—Western end, North Enclasure (Outside), 67; xxvii. 123
 Green & Sons.—xii. & xv. 65
 Green, T.—ix. 66
 Green, W.—v. 704
 Greenbury, J.—xxiii. 7
 Greene, R.—xix. 160
 Greener, W.—viii. 59; 136
 Greenfield, J.—xxiii. 676A
 Greenhalgh & Sons.—xi. 28
 Greenhow, T. M.—x. 630
 Greening & Sons.—xxii. 39
 Greenish, T.—ii. 124
 Greenshield, W.—xiii. 58
 Greenway, C.—v. 698
 Greenwell, J.—xxiii. 6
 Greenwood, Annie Christians.—xix. 161
 Greenwood & Barnes.—xviii. 46
 Greenwood, W.—New Zealand, 9, 17
 Grogan, J. E.—xxx. (Fine Art Court), 21
 Gregoire, F.—France, 1739
 Gregory, A.—viii. 69
 Gregory, Brothers.—xii. & xv. 182
 Gregory, Cubitt, & Co.—xx. 8
 Gregory, Governor.—Bahamas
 Gregory, R.—ix. 17A
 Gregory, T.—xxii. 99
 Gregory, Thomsons, & Co.—xix. 182
 Gregson & Hien.—xiii. 14
 Greig, D. & J.—vi. 114
 Greig, G. & Co.—South Africa, 56
 Greig, J., *see* Greig, D. & J.
 Greig, Misses.—Bahamas
 Greig & Son.—xxvi. 159
 Greiner, G. F.—x. 468
 Greiner, M.—Austria, 374A
 Greikaar, Blast Furnace of.—Sweden & Norway, 3
 Grollier, J.—Jersey & Guernsey, 7
 Gremailly, sen.—France, 246
 Grenier, L. F.—France, 247
 Gressler, E.—Zollverein (1) 854
 Greuter & Rieter, Brothers.—Switz. 123
 Greverie, A. S.—xxvi. 255
 Greville, J.—v. 856
 Grey, *see* Moore & Grey
 Grey, the Countess.—Antigua, 1; Ceylon; Eastern Archipelago, 1; Mauritius, 1
 Grey, Earl.—South Australia, 7

aw & Greaves,
Co.

10

end, South Enclon-
r. 99

lands, 102

Malta, 17

rein (1), 533

Zollverein (1), 590

Zollverein (1), 653

—Greece, 15-20.

41, 46, 47, 49

see Davis, Great-
street & Green

32

xxx. (Fine Art
A

xii. & xv. 92;
Fine Art Crit.) 233

32

xvi. 85

xii. 532

estern end, North
, 67; xxvii. 125
& xv. 65

7

9; 136

676A

xi. 28

630

ii. 39

ii. 58

6

etians.—xix. 151

—xviii. 46

Zealand, 9, 17

Fine Art Co.), 21

1739

r. & xv. 182

—xx. 8

Salamas

Co.—xix. 182

i. 14

4

h Africa, 56

& J.

aa

59

374A

ce of.—Sweden

Guernsey, 7

e, 246

247

(1) 854

ers.—Switz. 123

255

antigua, 1; Cey-
lago, 1; Mau-
Australia, 7

Grey, the Dowager Lady.—New Brun-
swick, 1

Grey, J.—i. 506

Grey, M.—France, 527

Gribanoff, P.—Russia, 237

Grice, F.—Canada, 71

Grieff, see Gerlich & Grieff

Griess, F.—Austria, 341

Griess, L.—Zollverein (2), 45

Griffin, B.—xx. 117

Griffin, D.—United States, 144

Griffin, J. J. & Co.—x. 457

Griffin & Ward, see Ward (late Griffin
& Ward)

Griffith, J.—x. 331

Griffith, J. W.—United States, 226

Griffiths, W.—xxviii. 192

Griffiths & Le Beau.—x. 404

Griffiths & Strong.—xxvii. 67

Griffiths, T. F.—xxii. 254

Griffon, Brothers, &c.—France, 1258.

Grigg, J.—xxvi. 401

Grignon, M.—France, 1617

Grigor, J. & Co.—iv. 1

Griller, J.—Austria 374

Grillet, sen. & Co.—France, 1259

Grillmayer, J.—Austria, 172

Grima, F.—Algeria, 26

Grimoldi, H.—x. 159

Grignonprez & Co.—France, 855

Grimshawe & Wilkinson.—xiv. 52

Grimshay, H.—i. 105

Grimsey, T.—ix. 136

Griodale, J. E.—v. 858; vii. 58

Grisson.—France, 1260

Grissell, H. & M. D.—xxx. 335

Grissell, T.—i. 185

Grist, M.—xix. & xv. 208

Griva, M.—Sardinia, 65

Groebler, A.—Zollverein (4), 66

Groenkloof Missionary Station.—South
Africa, 43

Groetaers, Capt. J. B.—Belgium, 156

Gröger, F.—Austria, 631

Grolmann, A.—Austria, 382

Grolmann, C.—Austria, 178

Grolmann, H.—Austria, 576

Grolmann, J.—Austria, 586

Grollean & Deville.—France, 1618

Gronow, Vm, see Elsner & Co.

Groom, J. & R.—xvi. 121

Groom, R., see Groom, J. & R.

Groome, J.—x. 549

Groot, C. De.—xxx. (Fine Art Court),
92

Gropius, P.—Zollverein, 226

Gros-Odier, Roman, & Co.—France,
248

Grosclaude, C. H.—Switzerland, 24

Grose, H.—Grenada

Groskopf, G.—Austria, 343

Grosjean, F.—xx. 60

Gross, D. J.—Zollverein (1), 17

Grossauer, A.—Austria, 567

Grossauer, F.—Austria, 568

Grosse Brothers.—France, 529

Grossmann Brothers.—Zoll. (3), 125

Grossmann, C. G.—Zollverein (3), 124

Grossman & Wagner.—France, 856

Grossmann, Agnes.—Zollverein (1), 752

Grossmith, J.—xxix. 13

Grossmith, W. R.—x. 565

Grosvenor, W.—xiii. 52

Grote, H. G.—Zollverein (1), 538

Groucock, Copestake, Moore, & Co.—
xix. 3

Grout, jun.—France, 530

Grout & Co.—France, 531

Gronssell, W.—ix. 148

Grout, A.—vii. 47

Grout, J. & Co.—xiii. 36

Graves, N.—iv. 131

Grubb, F. C.—xxvi. 25

Grober & Kuzinger, Brothers.—Austria,
258

Gruel.—France, 857

Grueue, W., jun.—Zollverein (1), 43

Grueuer, F. W.—Zollverein (3), 101

Grugeon, A.—xxviii. 97

Gruhl, F.—Zollverein (3), 37; (Main
Avenue, East)

Grund.—Zoll. (1) 338

Grundy, J. C.—xxvi. 121

Grundy, T.—xvi. 227

Gruener, L.—xix. 156; xxii. 310;
xxiii. 140, (Main Avenue West);
xxvii. 140, 141; xxx. (Fine Art
Court), 350

Grunhut, W. & Co.—Austria, 672

Grunhut, J., jun.—Austria, 673

Grunhut, A. sen.—Austria, 674

Grunthal, —Zollverein (1), 166

Grunwald, J.—Austria, 516

Grut, B.—iii. 36; New Granada, 2

Grutzmacher & Sons.—Zollverein (1),
142

Grylls, S.—i. 444

Grzybowaki, H.—Zollverein (1), 63

Grzybowaki, Rev.—Zollverein (1), 444

Gudalajura.—Spain, 3

Gubba, H.—Zollverein (1), 435

Guebni, M.—France, 1

Guelcher, see Sternickel & Guelcher

Guelff—Sardinia, 94

Goemal.—France, 1589

Guenther & Simon.—Zollverein (3),
94

Guercino.—Rome, 23

Guertin, H.—France, 1261

Guertin, P.—Zollverein (1), 68

Guernsey Cottagers.—Jersey and Guern-
sey, 38

Guerot, A.—France, 533

Guerre, sen.—France, 858

Guertler, J.—Austria, 211

Guessu.—France, 250. 859

Guest, J.—ix. 3

Guest, J. & W.—xxii. 524A

Guest, W. see Guest, J. & W.

Guest & Chrimes.—xxii. 524

Guettler, W.—Zollverein (1), 6

Guevrin-Bonchon & Co.—France, 532

Gueyton—France, 1619

Guichard, see Brunet, &c.

Guidotti, G.—Tuscany, 92

Guidre, L.—France, 1247

Guilhery, Deslandelles, & Co.—France,
1262

Guilbert & Wateau.—France, 860

Guillaume, G.—i. 153

Guillaume, J. A.—Belgium, 1

Guillaume & Son.—France, 1618

Guillaume, see Felten & Guillaume

Guillemot, Brothers.—France, 251

Guillerez, A. F.—iii. 103

Guillot, J. & Co.—Sardinia, 41, 42

Guillot, J. J. A.—France, 534

Guinaet, J. B.—France, 1620

Guinart, J.—Spain, 158

Guinier, T.—France, 252

Guinness, R.—x. 541

Guinor, N. P.—France, 1263

Guipuzcoa, Inspector of the Mines of
the district of.—Spain, 4

Guialain, C.—Belgium, 123

Guiso, M.—Sardinia, 23

Gulda, J.—Sweden.

Gulidsmedhyttan Mines.—Sweden and
Norway, 16

Gullia, J. B.—Sardinia, 52

Gumllach, C.—Mecklenburg-Strelitz, 4

Gundry, J. & Co.—xiv. 73

Gundry, W.—xvi. 173

Gunn, J.—v. 754

Gunn, W.—Van Diemen's Land, 153.
282

Gunter, see Luckhaus & Gunter

Gunter, R.—xxix. 112

Guppy, J. W.—vii. 177

Guricks, B.—Zollverein (1), 73

Gurr, C.—viii. 136

Gushlow, G.—xxx. (Fine Art Ct.) 223

Gushlow, T.—xxvi. 37A

Gutierrez de Leon, R.—Spain, 281A

Guthel & Co.—Zollverein (1) 459

Gusta Percha Co.—vi. 424; xxvi. 21;
xxviii. 85

Guy, S.—xxii. 4

Guyonem, A. sen.—France, 1018

Guyon & Bequet.—France, 254

Guyon, see Marchal & Guyon

Guyon, E.—France, 1264

Guyot, see Laurenaudiere

Guyotin-Lorignol.—France, 253

Guzman, H.—Spain, 58

Gwatkin, Eliza, see Gwatkin, Emily

Gwatkin, Emily & Eliza.—xx. 87

Gwinmer, J.—Switzerland, 50

Gwynne & Hay.—i. 231

Gwynne, J. S.—United States, 140

Gwythen Collieries, see Abercrom and
Gwythen Collieries Co.

Gyal, F.—Switzerland, 85

Haug & Son.—Switzerland, 164

Haan, A. de.—Netherlands, 9

Haan, C. & Sons.—Zollverein (1), 366

Haarhaus, J. C. & Sons.—Zoll. (1), 567

Haas & Co.—Zoll. (6), 62

Haas & Sons, Zoll. (1), 357

Haas, A.—Austria, 619

Haas, F. P.—Zollverein (4), 79

Haas, P. & Sons.—Austria, 243. 259

Haase, G. & Sons.—Austria, 367

Habenicht, A.—Austria, 376

Haberland, G. A.—Zollverein (1), 99

Haberland, W.—Zollverein (1), 689

Hackworth, see Fossick & Hackworth

Haddon, J. C.—v. 541

Hadden, Capt.—Van Diemen's Land,
103, 104

Hadden & Sons.—xx. 134

Haddon, J. C.—xxvii. 114

Haden, see Flather & Haden

Hadjji Aga Baba.—Russia, 265

Hadjji Babu Kelbalay Ousseini Oglu.—
Russia, 53

Hadley, C.—vii. 91

Hadley, see Prosser and Hadley

Hadley, J.—v. 860

Hadley, R.—xvi. 320

Haidro, jun.—France, 255

Hadwen & Sons.—xiii. 42

Haebler, see Lieske & Haebler

Haect, I. T.—Belgium, 341

Haegens, C.—Belgium, 228

Haelen, Madame Van.—Belgium, 299

Haemond, W.—China

Haenel, Brothers.—Zollverein (3), 153

Haenel, F.—Zoll. (1), 284; (3), 152

Haenel, J.—Zoll. (1), 852

Haenle, L.—Zollverein (2), 47

Haertel, H. C.—Zollverein (3), 72-83

Haese, B.—Belgium, 115

Haga Silkworm Plantation.—Sweden,
95

Hagen, A. Von.—Zollverein (1), 770

Hagen, F.—Zollverein (1), 322

Hagen, M.—Zollverein (2), 83

Hagen, T. F.—Hamburg, 64
 Hagen Turkey-red Dyeing Company.—
 Zollverein (1), 602
 Hagenbusch, C. G.—Zollverein (1), 712
 Haggard, W.—x. 328
 Haggas & Son.—xii. & xv. 155
 Haghe, L.—xxx. (Fine Art Court), 80
 Haglund, E.—Sweden & Norway, 11
 Hagstrom.—Sweden, 79
 Hague, S.—xxii. 226
 Hagues, Cook, & Wormald.—xii. &
 xv. 25
 Haidinger, Brothers.—Austria, 620
 Haigh, J.—i. 174
 Haigh & Sons.—xii. & xv. 236
 Haight, Mrs. E.—United States, 385
 Haindl, A.—Austria, 517
 Haines, G.—xxvi. 114
 Haines, J.—Van Diemen's L. 298-303
 Haines & Sons.—Western end, South
 Enclosure (Outside), 40
 Hains, see Baumgarthen & Hains
 Hairless, T.—ix. 155
 Hairs, see Webber & Hairs
 Halbeard & Wellings, xxvi. 131
 Halbig, J.—Zollverein (2), 84
 Haldane & Roe.—xxii. 432
 Hale, J.—xxii. 563
 Hale, J. P.—United States, 533
 Hale, T. & Co.—xxii. 486
 Hale, W. S.—xxix. 99
 Haley.—v. 486
 Haley, A. & C.—xii. & xv. 59
 Haley, C., see Haley, A. & C.
 Haley, J. & Son.—xii. & xv. 58
 Haley, W.—xx. 124
 Halfern, Von, see Kleinschmit, &c.
 Halford, H.—x. 604
 Hall, see also Lombard & Hall; Roberts
 & Hall
 Hall, A.—ix. 158; xix. 185
 Hall, Brother, Sloane, & Coppi.—Tus-
 cany, 12
 Hall & Co.—xvi. 164
 Hall, G. F.—x. 60
 Hall, H. W.—viii. 349
 Hall, J.—ii. 40; viii. 156; xxix.
 242; Canada, 18
 Hall, J. & Co.—xiv. 61
 Hall, J. S.—xvi. 163; xx. 4; xxviii.
 184
 Hall, J. & T.—i. 146; xxvii. 37, 38
 Hall, J. W.—xxiv. 41
 Hall, Lieut.-Col.—viii. 271; x. 4
 Hall, Messrs.—viii. 136
 Hall, R.—xvii. 182; xxx. (Fine Art
 Court), 317
 Hall & Son.—xxiv. 70
 Hall & Spear.—United States, 255
 Hall, T.—iii. 131; xxvi. 63; see also
 Hall, J. & T.
 Hall, T. H.—xxii. 172
 Halt, Thomas, & Co.—New S. Wales
 Hall, W.—vi. 472; xxvii. 42
 Hall, W. E.—viii. 73
 Halla & Co.—Austria, 54
 Hallam, see Worrall, Hallam, & Co.
 Halle, J. Van.—Belgium, 303
 Halleberg, L. J.—Sweden & Norway, 11
 Hallen, see Cottam and Hallen
 Hallenius & Co.—Sweden & Norway, 11
 Haller, A.—Austria, 462
 Haller, F.—Zollverein (4), 16
 Haller, J. C.—Zollverein (1), 690
 Hallers, J.—Austria, 652
 Hallett, see Graham & Hallett
 Hallett, G.—i. 481
 Hallett, R. & Sons.—New South Wales, 5
 Halliday, A. P.—vi. 617
 Halliday, W.—xxviii. 157

Halliday and Co.—iv. 73
 Halling, Pearse and Stone, xix. 212
 Hallmarke, Aldebert, & Hallmarke.—
 v. 862
 Hallmeyer-Appenzeller.—Switzerland,
 246
 Hallowell, Mrs.—xix. 270
 Hally, G.—xii. & xv. 470
 Haloche.—Algeria, 37
 Halae, see Schofield, Brown, &c.
 Halske, see Siemens & Halske
 Halstead & Sons.—ix. 106; xxii. 93
 Hamann, A.—Zollverein (1), 58
 Hamann, E. F.—France, 861
 Hambloch, J.—Zollverein (1), 464
 Hamburger, Rogers, & Co.—xix. 188
 Hamer, A.—xvii. 84
 Hamer, M. J.—xxx. (Fine Art Court),
 118
 Harnes, see Billson & Harnes
 Hamilton.—Van Diemen's Land, 7, 8;
 see also Blyth, Hamilton, and Blyth
 Hamilton, C. F.—xxviii. 177
 Hamilton, G. & P.—iii. 8A
 Hamilton, H. G.—x. 733
 Hamilton, Miss.—xii. & xv. 259
 Hamm & Co.—France, 862
 Hammelrath, P. II.—Belgium, 337
 Hammerschmidt, K.—Zollv. (2), 18
 Hammersley & Bentlaw.—xiii. 45
 Hammersley, J. A.—xviii. 71
 Hammersley, W., & Co.—xiii. 48
 Hammerton, see Cope, Hammerton,
 & Co.
 Hammond, see Leitch & Hammond
 Hammond, N. P., & Co.—Spain, 236
 Hammond, R.—Canada, 118
 Hammond, R. C.—vii. 15
 Hammond, Turner, & Sons.—xxii. 282
 Hammond, W. P., & Co.—China,
 Eastern Archipelago, 2
 Hamoir, see Mestiviers & Hamoir;
 Serret, Hamoir, & Co.
 Hampden, J.—xxii. 612
 Hampson, see Mackellar & Hampson
 Hampson, B.—xvii. 153
 Hampton, W.—United States, 172b
 Hamren, Sophie—Sweden & Norway, 29
 Hamsworth, Martha—xix. 161
 Hanau, W.—Zollverein (1), 700
 Hanbury, see Truman & Hanbury
 Hanbury, E.—South Africa, 20
 Hanbury, E. J.—South Africa, 28
 Hanbury, Louisa Emily—xxvi. 41
 Hancock, see Godfrey & Hancock
 Hancock, C.—xxviii. 90
 Hancock, C. F.—xxiii. 112
 Hancock, J. A.—Page 849; xxix. 320
 Hancock, J. L.—xxviii. 83
 Hancock, N.—xxvi. 239
 Hancock, Rixon, & Dunt—xxiv. 46A
 Handley, W.—v. 690
 Hands, J.—xxii. 263
 Hands & Leavesley—iv. 34
 Handyside, A.—Main Avenue, West,
 85; xxii. 82
 Hanel, C. E.—Sweden, 92
 Hanesl, De.—Belgium, 23
 Hanfstaengl, J.—Zollverein (2), 85
 Hanhart, M. & N.—xxx. (Fine Art
 Court) 64
 Hanhart, N.—see Hanhart, M. & N.
 Hanicq, P. J.—Belgium, 285
 Haniel, F.—Zollverein (1), 455
 Hanley, J.—United States, 375
 Hanon-Valcke, vi. 457
 Hannab, A.—xxi. 31
 Hannay, Major.—India, 1
 Hannington, W.—United States, 311
 Hansa—Hamburg 58

Hanselmann, see Troeltsch & Hansel-
 mann
 Hanselmann, J.—Switzerland, 165
 Hansen, C. B.—Denmark, 25
 Hansen, J. G.—Hanover, 5
 Hansen & De Koening—xxiii. 124
 Hanser, J.—Austria, 492
 Henser-Kisen, &c.—Hamburg, 123
 Hanson, see Iloe & Hanson
 Hanson, C.—xix. 188
 Hanson, G.—xxii. 702
 Hanson, J.—xxii. 616
 Hanson & Sons.—xxvi. 197
 Hansotte Delloye, H. G.—Belgium, 94
 Hanssen-Hap.—Belgium, 257
 Haractas, Tribe of the.—Algeria, 50
 Harand, E.—France, 863
 Harbor, T.—xxix. 293
 Harcourt, J., see Harcourt, W. & J.
 Harcourt, W. & J.—xxii. 257
 Hardegen, G.—Zollverein (3), 7
 Hardegen—France, 335
 Hardgrove, T. & S.—United States, 268
 Harding-Cocker.—France, 864
 Harding, Dando, & Co.—xxiii. 74
 Harding, E.—ix. 13
 Harding, J.—xxiii. 11; see also Hard-
 Ing, J. & J. viii. 136
 Harding, J. P.—xxix. 166
 Harding, Pullen, & Johnson.—vi. 102
 Harding & Son.—xxvi. 209
 Harding & Stanfast.—xxix. 81
 Harding, T.—xx. 211
 Harding, W. & Co.—v. 864
 Harding, Lord.—Page 847
 Hardman & Hiffe.—xxii. 284
 Hardman, J. & Co.—xxii. 700; xxvi.
 532
 Harduin.—France, 865
 Hardtmuth, C. see Hardtmuth, L. & C.
 Hardtmuth, L. & C.—Austria, 35. 381.
 621
 Hardwen & Sons.—xiii. 42
 Hardwick, W.—xxii. 496
 Hardy.—Algeria, 28; see also Hird,
 Dawson, &c.
 Hardy, Miss F. C.—xix. 147
 Hardy, G.—x. 85
 Hardy, J.—x. 348
 Hardy, R. E.—xxii. 131
 Hardy, T.—viii. 315; xxii. 146
 Hare, J. & Co.—xix. 190
 Harford, G.—xiv. 71
 Hargrave, Harrison, & Co.—xxix. 147
 Hargrave & Nussey.—xii. & xv. 28
 Hargreaves, Brothers, & Co.—xviii. 9. 38
 Hargreaves, J.—New Zealand, 8
 Hargreaves, W. & Co.—xxii. 116
 Harkes, D.—ix. 23
 Harkort, C.—Zollv. (1), 876
 Harkort & Son.—Zollverein (1), 456
 Harland, E.—viii. 324
 Harley, G.—xxii. 660
 Harloff, see Dismar & Harloff
 Harlon, W. H. & Co.—India, xiv.
 Harlow, see Peyton & Harlow
 Harlow & Young.—v. 655
 Harmer, H. R.—xxix. 168; xxx. (Fine
 Art Court), 298
 Harmer, J. jun.—xxx. (Fine Art Court),
 50
 Harmon, A.—United States, 158.
 Harnsworth, Martha.—xix. 191
 Harnett, J.—x. 684
 Harnett, W.—x. 633
 Haro, E. F.—France, 860
 Harper.—Van Diemen's Land, 185
 Harper & Moore.—xxvii. 119
 Harper & Sons.—xxii. 96
 Harper, T.—vii. 141

itch & Hansel-
 erland, 165
 ark, 25
 er, 5
 —XXIII. 124
 32
 umbergh, 123
 onson
 2
 .t. 197
 —Belgium, 94
 am, 257
 —Algeria, 66
 363
 16
 166
 olomon.—vi. 102
 i. 209
 —XXIX. 81
 v. 864
 e 847
 XII. 284
 XXII. 700; XXVI.
 65
 rdtmuth, L. & C.
 —Austria, 35. 381.
 IL. 42
 . 496
 see also Hird,
 IX. 147
 31
 XII. 146
 90
 Co.—XXIX. 147
 —XII. & XV. 28
 Co.—XVIII. 9. 38
 Zealand, 8
 —XXII. 116
), 876
 rein (1), 456
 Harloff
 India, XIV.
 Harlow
 555
 168; XXX. (Fine
 Fine Art Court),
 ates, 158.
 XIX. 191
 36
 Land, 185
 II. 119
 36

Harperath, see Porzelt & Harperath
 Harrach, Count F. K. Von.—Austria,
 285, 587
 Harras, P.—Zollverein (1), 798
 Harrild & Sons.—vi. 157
 Harrington, G. F.—x. 721
 Harris.—United States, 512
 Harris, Brothers.—XIX. 193
 Harris, C.—vi. 151
 Harris & Flson.—XII. & XV. 145
 Harris, G. & Co.—XIX. 192
 Harris & Galabiu.—XVII. 173
 Harris, H. see Harris, S. & H.
 Harris, H. G.—XXVI. 395
 Harris, J.—I. 42; XXX. (Fine Art Court),
 244
 Harris, J. C.—VII. 74
 Harris, Lord.—Trinidad
 Harris, P. G.—Jersey & Guernsey, 28
 Harris, R. & Son.—XXIV. 21
 Harris, S. & H.—XXVIII. 117
 Harris & Son.—x. 149
 Harris & Sons.—XIV. 76; XX. 198
 Harris & Tomkins.—XCI. 111
 Harris, W.—Page 851
 Harris, W. S.—XI. 29
 Harris, Sir W. S.—VIII. 150
 Harrison, see Campbell, Harrison, &c.;
 Hargrave, Harrison, & Co.
 Harrison, A. P.—XVII. 202
 Harrison, Anselie, & Co.—I. 405
 Harrison, C. C.—United States, 223
 Harrison, C. W. & J. J.—X. 420
 Harrison, J.—I. 491; VI. 18; X. 404,
 464A; XIX. 194; XXIII. 37
 Harrison, J. J. see Harrison, C. W. & J. J.
 Harrison, J. P.—XXX. (Fine Art Court),
 303
 Harrison, Margaret.—XXIX. 304
 Harrison, R. & J.—IV. 6
 Harrison, T.—XIX. 85
 Harrison, W.—XXII. 565; XXX. 180
 Harrison's Wood Carving Co.—XXVI.
 222
 Harrold, T.—XXVI. 117
 Harrop, see Craven & Harrop
 Harrop, Taylor, & Pearson.—XIII. 62
 Harrows, G.—XVI. 43
 Hart, see Walker & Hart
 Hart, C.—IX. 72
 Hart, G.—XIX. 81
 Hart, H.—VIII. 245
 Hart, J.—VI. 303; XIII. 76; Cape of
 Good Hope, 57
 Hart, L. J.—Belgium, 441
 Hart, Montgomery, & Co.—United States,
 260
 Hart & Sons.—XXII. 636
 Hart, W. & Co.—x. 113
 Hürtel, H. C.—Zollverein (3), 72. 83
 Harter & Huben.—Hamburg, 87
 Hartig, J.—Austria, 212
 Hartley, Elizabeth.—XVI. 6
 Hartley, J.—XVI. 166
 Hartley, J. & Co.—XXII. 700; XXIV.
 100; South-East corner (United
 States department)
 Hartley & Son.—XII. & XV. 61
 Hartley, T. H.—XXVII. 12
 Hartman, see .ner & Hartman
 Hartmann & Co.—France, 257
 Hartmann, L.—Austria, 675. 742
 Hartmann, L. & Co.—Switzerland, 230
 Hartmann & Sons.—France, 256
 Hartmann, J. J.—Zollverein (2), 73
 Hartog, Brothers.—Belgium, 224
 Hartog, C. H.—Hamburg, 115
 Harton, see Watts & Harton
 Hartree, E. & G.—XIX. 195
 Hartree, G. see Hartree, E. & G.

Hartung, see Opaschhoff & Hartung
 Hartweck, E.—France, 807
 Harvey, A.—XXX. (Fine Art Court),
 86
 Harvey & Co.—XXIII. 92; see also Price
 & Harvey
 Harvey, D.—v. 692; VIII. 159
 Harvey, F.—XXX. (Fine Art Court), 31
 Harvey G.—XXII. 440
 Harvey H.—XXIX. 187
 Harvey, J.—v. 948
 Harvey, J. K.—XIX. 197; XXX. (Fine
 Art Court) 19
 Harvey & Knight.—XIX. 106
 Harvey, T. & Son.—VIII. 136
 Harvey & Tait.—IX. 16
 Harvey, W.—x. 47
 Harwar, J.—x. 493A
 Harwood, Hon.—Canada, 14
 Hase, J. H.—Netherlands, 31
 Haselden.—XXVI. 93
 Haseloff & Co.—Zollverein (1), 713
 Hasenclever & Sons.—Zollv. (1), 631
 Haskell, Merrit, & Buel.—United States,
 340
 Hasketh.—v. 205
 Haslam, W.—XXII. 421
 Haslem, J.—XXIII. 97; XXX. (Fine Art
 Court), 237
 Haslen, T.—XXIII. 72
 Hass & Co.—Zollverein (6), 62
 Hass & Sons.—Zollverein (1), 357
 Hassan-Ooste-Nefali-Ogdi.—Russia, 253
 Hasse, E.—XXX. (Fine Art Court), 259
 Hastings, Brothers.—XII. & XV. 100
 Hastings, J.—VIII. 114
 Hastings & Mellor.—XVII. 85
 Hastings, S.—XXVIII. 3
 Haswell, R.—VIII. 259
 Hatch, Caroline.—XIX. 202
 Hatfield, J. A.—XXX. (Fine Art Court),
 135
 Hathaway, Mrs.—XX. 160
 Hatmel & Ellie.—II. 10 (Main Ave-
 nue, West)
 Hatt, C.—VIII. 16, 136
 Hattersley, Parkinson, & Co.—XIV. 36
 Hattersley, W.—II. 110; v. 701
 Hauch, A.—Zollverein (1), 792
 Haucien & Son.—Zollverein (4), 58
 Hanel, J.—United States, 4
 Haulter, V.—VIII. 295
 Haulick, F.—Zollverein (1), 413
 Haupt, L.—Austria, 286
 Hauschild, see Pains & Hauschild
 Hauser, J.—Austria, 482
 Hauser, J. de J.—Switzerland, 172
 Hausman, see Ziegler & Hausman
 Hausmann, L.—Zollverein (3), 173A
 Havenner, T. H. & Brothers.—United
 States, 322
 Hawcroft & Sons.—XXII. 135
 Hawes, G. E.—United States, 153
 Hawke, E. H.—I. 526; XIV. 54
 Hawker, Col. P.—VIII. 205, 234
 Hawkes & Co.—VIII. 212
 Hawkins, see Mottram & Hawkins
 Hawkins, B. W.—XXII. 641; XXX.
 (Fine Art Court), 132
 Hawkins, Capt.—India, VIII.
 Hawkins, G.—XXX. (Fine Art Court),
 80
 Hawkins, J.—XVI. 57; XXII. 318. 474
 Hawkins, S.—XXVI. 237.
 Hawkins, T.—XXVIII. 200
 Hawks, Crawshaw, & Co.—VII. 86
 Hawks, W. R.—VIII. 136A.
 Hawkaworth, A.—VIII. 53
 Hawksworth, Eyre, & Co.—XXIII. 35
 Hawley, J. & T.—XXVIII. 161.

Hawley, T.—see Hawley J. & T.
 Hawranek, C.—Austria, 63
 Hawthorn & Co.—v. 11
 Hawthorn, H. & W.—v. 558
 Hawthorn, W. see Hawthorn H. & W.
 Hawthorne, J.—II. 39; XVII. 7
 Hazworth & Canley.—XIV. 36
 Hay, see Gwynne & Hay
 Hay, J.—IX. 259c
 Hay, J., Right Hon. Lord.—VIII.
 136
 Hay, J. & J.—XXVI. 100
 Hay, W.—x. 376
 Hayball, A.—XXVI. 344
 Haycraft, W. T.—v. 151
 Hayday, James.—XVII. 106
 Hayden, J.—XXVIII. 132
 Hayden, W.—United States, 386
 Hayder, S.—Austria, 311
 Hayem, sen.—France, 1265
 Hayes, Miss E. J.—XIX. 330
 Hayes, J.—IX. 117
 Hayes, M.—IX. 208A
 Hayes, P. & Co.—II. 75
 Hayes, M.—Belgium, 270
 Haynes, J.—XXII. 584
 Hayot, Jules Joseph.—France, 258
 Hayter, F. S.—XIX. 198
 Hayter, Sir G.—XXIII. 97
 Haythorn, J. W.—XI. 25
 Hayward, Brothers.—x. 299; XXII. 582
 Hayward, G.—IX. 114
 Hayward, R. J.—XXX. (Fine Art
 Court), 337
 Hayward Rubber Co.—United States,
 294
 Hayward & Sons.—XIV. 44; see also
 Hayward, C. L. & W.
 Hayward, see Yates, Haywood, & Co.
 Haywood, H. & R.—XXVII. 127
 Haywood, J.—Western end, South en-
 closure (outside), 22; XXII. 97
 Haywood, M.—XXIX. 38
 Haywood, Mary.—XX. 148
 Haywood, R. see Haywood, H. & R.
 Haywood & Son.—XXII. 647
 Haywood, W. see Haywood, E. L.
 & W.
 Hazart, H.—United States, 16
 Hazelton, see Doe, Hazelton, & Co.
 Heal & Son.—IV. 59; XIX. 396
 Heald, see Harlow & Heald
 Heald, B.—XIX. 269
 Heald, H.—XIX. 295
 Healy, J.—XII. & XV. 259
 Heaphy.—New Zealand, 27
 Heaps, J. K.—x. 510
 Hearder, J. H.—VII. 205
 Hearder, J. N.—x. 439
 Heasman, W.—XXVI. 52
 Heath, G.—x. 351; United States, 6
 Heath, J.—v. 868
 Heath, S. H.—XVI. 195
 Heath & Burrow.—South Australia, 9
 Heaton, see Pease & Heaton
 Heaviside, J.—XVIII. 91
 Hebblethwaite & Lister.—XII. & XV. 96
 Hebert, L. A.—France, 869
 Hebert & Son.—France, 1621
 Hebrides, School in the.—XX. 191
 Hechinger, H.—Zollverein (2), 60
 Hecht & Arnold.—Zollverein (4), 27
 Hecke, Der A. T. Van.—Belgium, 480
 Hecker, sen. & Co.—France, 370
 Hecker, C. F.—Zollverein (1), 430
 Hecker, T. A.—Zollverein (5), 8
 Hecker, see Buckmühl, Schejner, &c.
 Hecker Brothers.—United States, 114
 Hecker & Tasch.—Zollverein (3), 96
 Heckmann, C.—Zollverein (1) 52

Hedglund, G.—xxiv. 69
 Hedinger C.—Zollverein (4), 92
 Hedley, G.—viii. 307; xxii. 377
 Hedlund, J.—Sweden & Norway, 11
 Heel, Van, see Vliessen, Van, Van
 Heel, & Co.
 Heeley & Sons.—xxii. 305
 Heepen, Spinning School.—Zollverein
 (1), 546
 Heeps, J. H.—x. 615
 Hefford & Facer.—xvi. 150
 Heigenbath, A.—Austria, 388
 Heige, C.—Belgium, 318
 Heilnick, L. A.—Zollverein (1), 555
 Heilweiller & Sons.—Zoll. (1), 521
 Heilbroun, L.—Zollverein (2), 61
 Heilgenthal & Co.—France, 259
 Heimbürger.—Zollverein (1), 853
 Heine, G. T.—Hamburgh, 51
 Heining, J. G. & Sons.—Zollverein (1),
 812
 Heinger, J.—Switzerland, 124
 Heintzsch, H.—United States, 168
 Heinke, C. E.—vii. 53
 Heinein, C. V.—Zollverein (2), 20
 Heirich, Zollverein (1), 771
 Heirigs, J. Zollverein (1), 857
 Heintze, see Meyer & Heintze
 Heintze, L.—xvi. 299
 Heintze & Freudenburg.—xvi. 299;
 Zollverein (1), 382
 Heintzman, A.—Zollverein (1), 252.
 373, 654, 820; Zollverein (3), 67.
 72-83, 104
 Heinsen, Brothers.—Austria, 26
 Heiratmann.—Zollverein (1), 617
 Heischmann, A.—Zollverein (1), 763
 Heiser, F. L.—Hamburgh, 26
 Heiteneier, T.—Zollverein (1), 486
 Heke, D.—Russia, 152, 329
 Hellig, J.—Zollverein (2), 87
 Helbrunner, G.—France, 269
 Helbrunner, R.—xix. 199
 Held, K.—Zollverein (2), 65
 Helena, St. Agricultural Society.—St.
 Helena, 2
 Helen's, St. Plate and Sheet Glass
 Works.—xxiv. 66
 Helia, J.—Austria, 331
 Heljestrand, C. V.—Sweden & Norway,
 11
 Hell, F.—Austria, 152
 Hell, G.—Austria, 260
 Hellefors Iron Works.—Sweden & Nor-
 way, 4
 Heller, see Schweitzer & Heller
 Heller, C.—Zollverein (1), 77
 Helling, O. & Co.—Zollverein (3), 112
 Hellmann, J.—Zollverein (6), 34
 Hellyer & Son.—xxx. (Fine Art Ct.) 61
 Helma, A.—Austria, 518
 Helme, W.—xii. & xv. 207
 Helmich, F. A.—Austria, 559
 Helms, Miss.—xx. 168A
 Helweg, Hans.—Zollverein (3), 159
 Helwert, J.—Zollverein (4), 24
 Hely, A. A.—viii. 13; xxii. 604
 Helys, N. J.—xxviii. 195
 Hemmingway, A. W.—ii. 24
 Hemming, E.—xx. 28
 Hemming, G.—v. 134
 Hemming, H.—xxii. 331
 Hemmingway, A.—v. 574
 Hemphill, W. D.—xxviii. 158
 Hemsley, T.—viii. 106
 Hensworth & Linley.—xvi. 20
 Henderson.—v. 765; ix. 42; Canada,
 168, 187; see also Fox, Henderson,
 & Co.
 Henderson & Co.—xix. 200

Henderson, H.—Canada, 143
 Henderson, J.—viii. 306; Canada, 107
 Henderson, R.—iv. 80
 Henderson, T.—Canada, 174
 Henderson & Withell.—xix. 201
 Hendley, H.—United States, 683
 Hendrichs, F.—Zollverein (1), 367
 Hendrie, R.—xxix. 10
 Hendry, J.—vii. 184
 Henkeis, J. A.—Zollverein (1), 167
 Henley, W. T.—x. 428
 Henr & Hradley.—xxii. 316
 Henmault, De.—Belgium, 183
 Henneberg, F. E. & Co.—Zoll. (1),
 772
 Hennecart, J. F.—France, 1266
 Hennehan & Malone.—x. 297
 Hennequin.—France, 1623
 Hennig, see Walther, Hennig, & Co.
 Hennige & Wiese.—Zollverein (1), 691
 Henning.—Hanover, 1
 Henning, J.—vi. 43; xiv. 16
 Henne.—France, 261
 Henard, M.—Belgium, 140
 Henri, J.—France, 262
 Henri, P.—France, 871
 Henriques, A.—Portugal, 364
 Henry, see Simon & Henry
 Henry, A. & S. & Co.—xii. & xv. 38
 Henry, C.—France, 536
 Henry & Co.—xxii. 532
 Henry, F.—France, 1622
 Henry, H. F.—France, 1267
 Henry, P.—Belgium, 283
 Henry, S.—United States, 508; see
 also Henry, A. & S. & Co.
 Henry & Sons.—xi. 13
 Henrys & Co.—x. 508; xxiii. 131
 Hensel, C. J.—Hamburgh, 40
 Henseth, J.—Zollverein (2), 76
 Henslow, Rev. J.—see Ipawich Museum
 Committee
 Hensman & Son.—ix. 149
 Henson, H. H.—v. 532
 Henson, J.—Canada, 79
 Henson, W. G.—xvi. 133
 Henton, J.—ix. 191
 Herapath.—x. 289
 Herna, P. de las.—Spain, 161
 Herant.—France, 872
 Herbert, see Holmes, Herbert, & Arthur
 Herbert & Co.—xix. 28
 Herbert, Mrs.—xxix. 301
 Herbert, F. P.—Austria, 30
 Herbert, J.—Austria, 32
 Herbert, J. W.—Canada, 18A
 Herbert, Right Hon. S.—Page 854
 Herbert, W.—xxvi. 67
 Herdman, W. G.—xxx. 343A
 Herdt, J. B.—Austria, 694
 Herford Prison (Westphalia), Director
 of.—Zollverein (1), 721
 Herinck, F.—Belgium, 43
 Heriot, see Huxley & Heriot; Huxley,
 Heriot, & Co.
 Heriot, E. T.—United States, 172c.
 Hermann, see Graetzer & Hermann;
 Hoffer, Hermann, & Co.
 Hermann, A.—xxiii. 90
 Hermann, C.—Zollverein (1), 435
 Hermann, F.—Switzerland, 194
 Hermann, F. G. & Son.—Zoll. (3), 122
 Hermann, G.—France, 873
 Hermann, J. W.—Zollverein (3), 139
 Hermannstadt Associated Furriers.—
 Austria, 347
 Hermannstadt Cloth-makers' Associa-
 tion.—Austria, 214
 Hermannstadt Leather-cutters' Associa-
 tion.—Austria, 345

Hermannstadt Rope-makers' Association.
 —Austria, 277
 Hermannstadt Shoemakers' Association.
 —Austria, 330
 Hermannstadt Stearine Candle Com-
 pany.—Austria, 42
 Hermannstadt Trade Union.—Austria,
 277; 3, 4; 600A
 Herme.—France, 537
 Hermes, Brothers, & Wolfers.—Zollv.
 (1), 520
 Hernandez, J.—Spain, 230
 Herold, C. G.—Zollverein (3), 19
 Herrenschmidt, G. F.—France, 538
 Herrick, J. K.—United States, 303
 Herring, C.—vii. 60; xxvi. 379
 Herring, S. C.—United States, 124
 Herring & Sons.—xxvi. 205
 Herriol, L.—France, 1708
 Herstatt & Co.—Zollverein (1), 427
 Hetting, C.—Hanover, 9
 Hertz.—1. 24
 Herve, Brothers.—France, 1624
 Herwin, A.—xxvi. Hay 1. 20
 Herz, H.—France, 1268
 Herzig, J. & Son.—Austria, 261
 Herzlich, F.—Austria, 146
 Herzog, E.—Austria, 76
 Hess, J. A. de.—Belgium, 203
 Hesnault & Brother.—Belgium, 273
 Hess, G.—France, 263
 Hess, L.—Switzerland, 241
 Hess, H.—x. 648
 Hess, T. A.—Netherlands, 108
 Hesse-Darmstadt, Board of Agriculture
 of.—Zollverein (6) 13
 Hesselink, W. F.—Netherlands, 66
 Hetherington, T. & Co.—xxii. 351
 Hetley, J. H. & Co.—xxiv. 2
 Hett, A.—x. 249
 Hetzer, Ernst, & Son.—Zollv. (3), 64
 Heukensfeldt, I.—Netherlands, 42
 Heunhuse, De.—Belgium, 62
 Heurouse, C. D.—Zollverein (1), 214
 Heurteloup, Baron.—x. 606
 Heuschen, Van, Eeckhoudt, & Co.—
 Belgium, 310
 Heuveloop, H.—Netherlands, 16
 Hewett & Co.—China.
 Hewitt, D. C.—x. 560
 Hewitson, see Kitson, Thompson, &c.
 Hewitson, J.—x. 152
 Hewitt, H. B.—xxii. 395
 Hewlett, A.—xvi. 233
 Heworth Chemical Works (Newcastle-
 upon-Tyne)—ii. 27
 Hews, G.—United States, 438
 Hey.—Zollverein (1), 26
 Heydenreich.—Zollverein (1), 443
 Heyl, C.—Zollverein (6), 32
 Heyl, C. W.—Zollverein (6), 75
 Heyl, J. F. & Co.—Zollverein (1), 44
 Heyler, Mary.—France, 539
 Heymann, C.—Zollverein (1), 290, 575
 Heymann, G. F.—Zollverein (3), 39
 Heymann, J. D.—Hamburgh, 75
 Heymann & Alexander.—xix. 25
 Heyn, Emma.—xix. 178
 Heynig, see Beck and Heynig.
 Heynig, J. G. & Co.—Zollv. (3), 57
 Heynsbergen, W. J. Van.—Netherlands,
 102A
 Heya, see Elliott and Heya
 Heywood, Higginbottoms, Smith, & Co.
 —xxvi. 71
 Heywood, J.—xvii. 83
 Heywood, W.—x. 404A
 Hibbert, Platt, & Sons.—vi. 1
 Hibbert, T.—xiv. 39
 Hick, B. & Son.—v. 13; vi. 1, 218

akers' Association.
 kees' Association.
 e Candle Com-
 Union.—Austria,
 Wolfers.—Zollv.
 230
 rein (3), 10
 —France, 538
 d States, 502
 xxvi. 379
 d States, 124
 l. 205
 708
 rein (1), 427
 9
 ace, 1624
 ay i. 20
 8
 rein, 261
 146
 6
 gium, 203
 Belgium, 273
 241
 ands, 108
 d of Agriculture
 13
 erlands, 60
 —. xxii. 351
 —xxiv. 2
 —Zollv. (3), 64
 erlands, 42
 em, 62
 lverein (1), 214
 t. 666
 choudt, & Co.—
 rlands, 16
 Thompson, &c.
 395
 orks (Newcastle-
 es, 438
 26
 ein (1), 443
 6), 32
 ein (6), 75
 llverein (1), 44
 e, 539
 rein (1), 200, 575
 lverein (3), 39
 burgh, 78
 r.—xix. 25
 78
 Heynig.
 Zollv. (3), 57
 —. Netherlands,
 eys
 ns, Smith, & Co.
 —vi. 1
 ; vi. 1, 218

Hickey & Tull.—United States, 98
 Hickling, see Reckless & Hickling
 Hickman & Clive.—xxii. 371
 Hickman, H. & Co.—xxvii. 107
 Hicks, G.—United States, 559
 Hicks, H.—xvi. 84
 Hicks, T.—i. 164
 Hickson & Sons.—xvi. 192 (Main
 Avenue, West)
 Hidden, T.—xvi. 313
 Hider, Elizabeth.—xvii. 17
 Hiellen (sons of the late Elias).—
 Austria, 275
 Hierta & Michaelson.—Sweden, 99
 Hlarsenberger, G.—Austria, 443
 Hietel, J. A.—Zollverein (3), 168n
 Higginbotham, G. & W.—xxii. 188
 Higginbotham, L. C.—United States, 231
 Higginbotham, W., see Higginbotham,
 G. & W.
 Higginbottoms, see Heywood, &c.
 Higgins, F.—xxiii. 115
 Higgins, P. H.—Canada, 185
 Higgins & Sons.—vi. 14
 Higginson, Governor.—Antigua,
 Highley, S.—x. 727
 Highley, S. jun.—i. 23, 98
 Highton.—x. 432
 Hildebrand, A.—France, 540
 Hildebrand, C. G.—Hamburg, 2
 Hildebrand, C. L.—Hamburg, 36
 Hilditch & Hopwood.—xxv. 17
 Hilier, S.—United States, 218
 Hilger, Brothers.—Zoll. (1), 498, 574
 Hilgers, C.—Zollverein (1), 659
 Hilgers & Sons.—Zollverein (1), 631
 Hill, see Clifton, Hill, & Co.; Shep-
 herd, Hill, &c.; Watkins & Hill
 Hill, B.—xix. 203
 Hill, C. J. & Son.—United States, 157
 Hill & Co.—xix. 204
 Hill, D. O.—xxx. (Fine Art Court), 390
 Hill, E. & Co.—ix. 140; xxii. 65
 Hill, E. & W. De la Rue.—xvii. 76
 Hill, Evans, & Co.—vi. 619
 Hill, G.—xvi. 8
 Hill, J.—xxii. 355
 Hill, J. & Co.—xiii. 25
 Hill, J. V.—i. 58, 200; xxi. 47; United
 States, 364; see also Hill, O. & J.
 Hill, L. M.—xx. 107
 Hill, O. & J.—vii. 124
 Hill, S.—vii. 68
 Hill & Stone.—v. 970
 Hill, W.—v. 94
 Hill, W. & Co. x. 556.
 Hiltas, F.—iv. 28
 Hilliard & Chapman.—xxi. 33
 Hilliard & Thomson.—xxiii. 29
 Hillier, G.—xxx. 354
 Hillman, A.—Sweden and Norway, 31
 Hillman, F.—Zollverein (3), 160
 Hillman, J.—xxii. 16
 Hills, F. C.—ii. 23
 Hills & Underwood.—iii. 7
 Hillyer, V.—United States, 343
 Hils, Haas, & Co.—Zollverein (4), 53
 Hilton, J. & W.—Canada, 123
 Hilton, John.—x. 625
 Hilton, W. see Hilton, J. & W.
 Hinchcliffe, J.—xxii. 224
 Hinchliff & Co.—xxvi. 310
 Hinchliff, G. see Hinchliff, J. & G.
 Hinchliff, J. & G.—xii. & xv. 119
 Hinchliffe & Son.—xii. & xv. 93
 Hincks, Wells, & Co.—xxii. 326
 Hinde, E. & F.—xii. & xv. 313
 Hinde, F. see Hinde, E. & F.
 Hinde, J. G.—xxviii. 196
 Hindenlang.—France, 1269

Hindhaugh, Mary.—xix. 205
 Hindley & Sons.—xviii. 16; xix. 206;
 xxvi. 266
 Hine, E.—xxx. (Fine Art Court), 201
 Hine, J.—xxix. 47
 Hinitz, J.—v. 714
 Hinks, H.—viii. 136
 Hinton, C.—x. 62
 Hintze, see Paetoch & Hintze.
 Hipp, see Duyn, Hipp, & Co.
 Hird, Dawson, & Hardy.—xxii. 85
 Hiron, see Cartwright & Hiron.
 Hirsch & Brother.—Portugal, 28, 52,
 64, 68, 77, 503, 985
 Hirsche, F.—Austria, 436
 Hirschel & Mierbi.—Austria, 173
 Hirschfeld, J. B.—Zollverein (3), 160
 Hirschhorn, see Ullman, Hirschhorn, &
 Co.
 Hirschendorff, see Hirschman, Hirsch-
 dorff, &c.
 Hirschman.—Russia, 34-114
 Hirschmann, Hirschendorff, & Ravitch.—
 Russia, 79
 Hirschmann & Kijevski.—Russia, 26
 Hirst, see Barnicot & Hirst
 Hiteh, M.—xviii. 59
 Hitchcock, Dr. D. K.—United States,
 518
 Hitchcock, W. L.—United States, 376
 Hitt, T.—viii. 296
 Hives & Atkinson.—iv. 45
 Hjorth, S.—Denmark, 47
 Hjula Quarry.—Sweden and Norway,
 43
 Hoadley, G.—xxiv. 82
 Hoadley & Priddy.—xii. & xv. 128
 Hoare, M.—xxx. (Fine Art Court), 168
 Hoban, M.—xxvii. 58
 Hobart & Robins.—United States, 300
 Hobbs, W.—xviii. 83
 Holson, F.—United States, 277
 Hoby, G.—xvi. 202
 Hoby, J. W.—v. 614
 Hoebnerger, J.—Austria, 14
 Hockendon, J.—xxvi. 60
 Hockin, C.—xxii. 592
 Hockley, see Sinclair & Hockley
 Holdick, W.—Zollverein (1), 598
 Hodge & Batley.—v. 29
 Hodges, W.—xxix. 318
 Hodges, B. J.—v. 103
 Hodges, R. E.—viii. 269; xxviii. 72
 Hodges & Sons.—ix. 116; xxii. 467
 Hodges, T.—xvi. 184; xxii. 319
 Hodgson & Halsey.—vi. 38
 Hodgson, M.—viii. 316
 Hodgson, R.—v. 143
 Hodgson, T. jun.—xx. 155
 Holson, see McCallum & Holson
 Holson, Sir G., Bart.—i. 123
 Holson, J.—viii. 50, 136
 Holson, J. S.—xvii. 166
 Høe, H.—Sweden & Norway, 8
 Hoefler, C. F.—Zollverein (3), 41
 Hoefken, see Hoeltring & Hoefken
 Hoehn & Baumann.—Switzerland, 153
 Hoehn & Stuetli.—Switzerland, 153
 Hoeller, A. & E.—Zollverein (1), 637
 Hoeller, E. see Hoeller, A. & E.
 Hoeltring & Hoefken.—Zoll. (1), 662
 Hoer, J. B.—France, 264
 Hoeninghaus & Sons.—Zoll. (1), 519
 Hoepfner, J.—Austria, 128
 Hoerrens, H. I.—Zollverein (1), 554
 Hoesch & Son.—Zollverein (1), 392
 Hoesel, R.—Zollverein (3), 86
 Hoey, S. P. Van.—Belgium, 106
 Hofer, H. & Co.—France, 875
 Hofer, L. Von.—Zollverein (4), 105

Hofer, P.—Austria, 519
 Hofer, Von.—Zollverein (1), 105
 Hoffman, C.—Zollverein (3), 12
 Hoffman, Emanuel.—Switzerland, 152
 Hoffman, G. J.—Zollverein (1), 449
 Hoffmann, C. W.—Zollverein (1), 439
 Hoffmann, E.—Zollverein (1), 110
 Hoffmann & Eberhardt.—Zoll. (1), 88
 Hoffmann, F.—Zollverein (3), 36
 Hoffmann, F. A. & Co.—Zoll. (3), 153
 Hoffmann, C. & G.—Austria, 49
 Hoffmann, G. W.—Zollverein (6), 14
 Hoffmann & Son.—Zollverein (5), 16
 Hoffmeister, T. & Co.—Zoll. (1), 773
 Hofmann, W.—Austria, 599
 Hofrichter, C.—Austria, 644
 Hogan, J.—xxx. (Sculpture Court), 14
 Hogarty, Brothers.—xvi. 13
 Hohwiener, see Minopier, &
 Co.
 Hohwu, A.—Netherlands, 86
 K. de Jhr, M. M.—Portugal, 454, 544
 Holbeck, J. & Co.—xxiii. 112
 Holbrook, J. N.—viii. 9
 Holbrook & Stanley.—United States,
 298
 Holch, W.—Zollverein (4), 18
 Holli, A.—xxvi. 59
 Hollen, H. A.—xxii. 348
 Hollen, J. C.—xiv. 1
 Holler, T. M.—Zollverein (4), 106
 Holderegger, C.—Switzerland, 105
 Holderness, C.—x. 482
 Hollich, G. M. II.—x. 537
 Holding, Mrs. Sybella.—xxx. (Fine Art
 Court), 217
 Holdsworth & Son.—xiii. 61
 Holdsworth & Co.—xii. & xv. 166;
 xiv. 53
 Holdsworth, J.—xii. & xv. 165A
 Holgate, J.—xxii. 450
 Hoff, F. H.—x. 13
 Holl, J. & Co.—viii. 166
 Hollamby, H.—xxix. 41
 Holland, see East, Lantion, &c.
 Holland, C.—Austria, 600; Zollverein
 (1), 528, 716, 731, 781; (3), 23, 69,
 128, 166
 Holland & Dunn.—Canada, 152
 Holland, H.—xxix. 131
 Holland & Son.—xxiv. 63
 Holland & Sons.—xxvi. 161
 Holland, T.—vii. 132; xxii. 002
 Holland, T. & Co.—xx. 194
 Holland, W.—xxvi. 407
 Holland, W. & Sons.—xxvi. 62A
 Hollanders, D.—Belgium, 51
 Hollenbach, A.—Austria, 141b
 Hollenbach, D.—Austria, 581
 Holliday, H.—xxii. 448
 Hollins, P.—Page 849
 Hollins, S.—xix. 30; xx. 06
 Hollins, W. & Co.—xi. 36
 Holloway & Co.—United States, 514
 Holloway, Phoebe.—xix. 207
 Holloway, T. J.—xiv. 74
 Holm.—vi. 162
 Holmblad, L. P.—Denmark, 27
 Holmer, S.—xxx. (Fine Art Court), 231
 Holmes, see Allen & Holmes
 Holmes, C.—xxii. 130
 Holmes, Captain.—xxii. 12
 Holmes & Co.—xii. & xv. 260
 Holme, G. L.—United States, 316
 Holmes, Herbert & Arthur.—v. 872
 Holmes, J.—vii. 176 ix. 90A; xix.
 208
 Holmes, J. & Co.—xx. 84
 Holmes, J. E.—United States, 331
 Holmes & Sons.—ix. 241; xii. & xv.
 107

- Holmes, T.—xvi. 16
 Holmes, W. H.—British Guiana, 130-132
 Holms, Brothers.—xii. & xv. 258
 Holroyd & Co.—xiii. & xv. 153
 Holste, Mr.—Austria, 143
 Holstein, J. P.—France, 876
 Holt, E.—iv. 128
 Holt, J.—xxiii. 106
 Holthaus, see Schmits & Holthaus
 Holium, W.—viii. 20
 Holtzapffel & Co.—iv. 14; vi. 232
 Holtzstamm, F.—Zollverein (1), 48
 Holwell.—Canada, 101
 Holyland, see Rogers, Lowry, & Co.
 Holzapfel, C.—Denmark, 41
 Homan & Co.—xx. 17
 Homburg & Scheibler.—Zollv. (1), 339
 Homer, F. L.—United States, 504A
 Hommel-Esser, F.—Switzerland, 81
 Honaer, F.—Austria, 215
 Honegger, H.—Switzerland, 153
 Honiball, J.—viii. 95
 Honig, B. C. & F.—Netherlands, 59
 Honig, F. see Honig, H. C. & F.
 Honig & Son.—Netherlands, 60
 Honore, E.—France, 877
 Hont, J. D.—Belgium, 206
 Hood, see Martin & Hood
 Hood, J. H.—xvii. 157
 Hood, R. V.—Van Diemen's Land, 111-120. 126. 127. 129. 165, 166. 345
 Hood, S.—xxii. 1
 Hoogboom, J. J. & Son.—Netherlands, 37
 Hoogen, T. Van der.—Netherlands, 26
 Hoogstoel, L. F.—Belgium, 422
 Hook, J.—xvi. 114
 Hook's Iron Works.—Sweden, 78
 Hooke, T.—vii. 80
 Hool, Mary.—xxix. 87
 Hoole, Hobson, & Hoole.—xxii. 140
 Hoornans, see Parodie & Hoornans
 Hoop, J. Van der, & Co.—Netherlands, 24
 Hooper & Co.—New Zealand, 39
 Hooper, C. & Co.—xii. & xv. 210
 Hooper, F. see Hooper, S. & F.
 Hooper, G.—v. 874
 Hooper, G. Carroz, & Solourier.—France, 1625
 Hooper, H. N. & Co.—United States, 459
 Hooper, W. jun.—v. 196
 Hooper, W. H.—vii. & Hopcraft
 Hopcraft, see Greasleyroe, & Hope
 Hope, see Pinder, Bourne, & Hope
 Hope, A. J. B. Esq., M.P.—Page 849
 Hope, G. C.—xix. 209
 Hope, H. T. (M.P.)—xxiii. 73 (Main Avenue, East)
 Hopkins, H.—xxvi. 234
 Hopkins, J. M.—United States, 192
 Hopkins, R. P.—xxvi. 139
 Hopkins & Son.—xxvi. 154
 Hopkins & Williams.—ii. 31
 Hopkinson & Cope.—v. 2
 Hopkinson, J. sen.—vii. 164
 Hopkinson, J. & J.—x. 500
 Hopkinson, Jonathan.—British Guiana, 159
 Hopley, E.—xxx. (Fine Art Court), 296
 Hopwood, see Hilditch & Hopwood
 Hopwood & Armstrong.—viii. 68
 Hopwood, H.—ii. 100
 Horan, H.—iv. 103
 Hore, W.—xxix. 151
 Horn, A.—vii. 67
 Horn, H.—viii. 161
 Horn, Mrs.—Sweden & Norway, 29
 Hornan & Co. late Rodgers & Son.—xx. 17
 Hornbostel, C. G. & Co.—Austria, 262
 Hornby and Kenworthy.—vi. 20
 Horne.—i. 17; xxii. 255
 Horne, J.—x. 575
 Horne, R.—xxvi. 32
 Horne, T.—xxii. 275
 Horne, Thornthwaite, & Wood.—x. 220
 Horne, W. v. 550; xxviii. 160
 Horner, G.—xxx. 364
 Hornig, C. E.—Zollverein (1), 722
 Hornsby & Son.—ix. 233
 Hornung, C. C.—Denmark, 30
 Horrix, M. & W.—Netherlands, 97
 Horrix, W. see Horrix, M. & W.
 Horrockses, Miller, & Co.—xi. 320
 Harry, W. B. C.—United States, 602E
 Horsey, J.—xxviii. 188
 Horsfall, J.—xxii. 334
 Horsfall, J. G. & Co.—xii. & xv. 174
 Horsfall, Mrs.—xxvi. 56
 Horsky, F.—Austria, 123
 Horsteiner, see Neuner & Horsteiner
 Horstman, J.—Zollverein (1), 691
 Horstmann & Co.—Zollverein (1), 462
 Horticultural Society of London.—China.
 Horton, A.—xxii. 674
 Hüsch & Sons.—Zollverein (1), 863
 Hosken, R.—Western end (Outside), 75; i. 466. 472; xxix. 185
 Hosking, R.—i. 466, 472
 Hosking, R.—v. 201
 Hoskings, Ann.—xxix. 72
 Hoskins, J.—viii. 452
 Hötsterey, G.—Zollverein (1), 648
 Hostin.—France, 265
 Hostmann, C.—Hanover, 2
 Hotchkiss, G.—United States, 94
 Hotchkiss, H. G. & L. B.—United States, 156
 Hotchkiss, L. B. see Hotchkiss, H. G. & L. B.
 Hotchkiss & Prescott.—United States, 154
 Hotchkiss, W.—United States, 342
 Hotham & Whiting.—xii. & xv. 44
 Hottinger, A.—Austria, 589A
 Houbigant, C.—France, 1627
 Houdaille, F. N.—France, 1270
 Houdin, see Detonche & Houdin
 Houdin & Lambert.—Belgium, 253
 Houette, A. & Co.—France, 1271
 Hough, see Schoonley and Hough
 Hough, R. M.—United States, 507
 Houghton, see Clandet & Houghton
 Houghton, Sarah.—xiv. 50
 Houldsworth, J. & Co.—xiii. 64
 Houldsworth, T. & Co.—xi. 54. 59
 Houlgate, see Puckering & Houlgate
 Houllier, B.—France, 1628
 Hounsell, J.—xiv. 73
 Hounsell, W. & Co.—xiv. 73
 Housard, E. F.—France, 1626
 Houston, J. D.—United States, 554
 Houten, W. Van.—viii. 136
 Houthave, S.—Belgium, 130
 Houyet, A.—Belgium, 125
 Houzeau, E.—France, 878
 Howard, F. see Howard I. & F.
 Howard, Frank.—xxiii. 97
 Howard, T. & F.—ix. 233
 Howard & Kent.—ii. 11
 Howard, Ravenhill & Co.—v. 413
 Howard & Son.—xxvi. 233
 Howard, T.—i. 29
 Howarth, J.—xxii. 181
 Howe.—viii. 132
 Howe, D. W.—United States, 407
 Howe, G.—v. 779
 Howe, J. & Co.—iv. 36
 Howe, J. G.—xxiv. 67
 Howe, S. G.—United States, 439
 Howell & Brothers.—United States, 48
 Howell, James, & Co.—x. 16; xiii. 27; xix. 5; xxvi. 190A
 Howland, C.—United States, 456
 Howse, see Barber, Howse, & Co.
 Howton, G. W.—xxviii. 166
 Hoxa, F.—Austria, 141c
 Hoy, J.—v. 710
 Hoyle & Sons.—xviii. 36
 Hoyles, H.—xxvi. 345
 Hoyt, see Albro & Hoyt
 Huard, Brothers.—France, 266
 Huard de Villenont, D.—Belgium, 48
 Hubbard, see Sewell, Evans, & Co.
 Hubbard, C.—viii. 180
 Hubbard, H. B.—xxix. 113
 Huben, see Harter & Huben
 Huber, C. E.—France, 879
 Huber & Co.—France, 333
 Huber, Franz.—Austria, 633
 Huber, Hordorf.—Switzerland, 153
 Hubert, see Boken, Hubert, & Co.; Hoeni & Hubert
 Hubert, A.—Belgium, 482
 Hubert, C.—xvi. 194
 Hubert, Josephine.—France, 268
 Hubert, E. de St.—Belgium, 8
 Hubner, see Summerfeld & Hubner
 Hubner, J.—Austria, 622
 Hübsch, J.—Austria, 352
 Huch, H. C.—Zollverein (1), 22
 Huchet, see Doublet & Huchet
 Huck.—France, 541
 Hucks, C.—Zollverein (1), 697
 Huddart, Sir J. & Co.—xiv. 68
 Hudson & Bousfield.—xii. & xv. 21
 Hudson, A.—xvi. 151
 Hudson & Bottom.—vi. 88
 Hudson, C.—xviii. 66
 Hudson, F. T.—x. 256
 Hudson, J.—viii. 338; xx. 199; xxvi. 34, Persia
 Hudson, S.—xvi. 60
 Hudson's Bay Company.—xvi. 301A
 Hudsonwell & Son.—xii. & xv. 85
 Hue, J. B.—France, 269
 Huebener & Pöhle.—Hamburg, 61
 Hueber, F.—Austria, 428
 Huebscher, C.—Switzerland, 86
 Hueck, see Funke & Hueck
 Hueck, A. see Hueck, D. & A.
 Hueck, D. & A.—Zollverein (1), 499
 Hueffer, H.—Zollverein (3), 111
 Hueni & Hobert.—Switzerland, 87
 Huerlimann, J.—Switzerland, 125
 Huerlin.—Sweden, 113
 Huet, J.—France, 880
 Huet, Made.—France, 270
 Huetite, see Dinant & Huetite
 Huffer, J.—xxii. 649A
 Hufmann, Brothers.—Zollv. (1) 500
 Hufnagle, C.—India, iv.
 Hufzky, Vincenz.—Austria, 613
 Huggt, J. jun.—United States, 209
 Huggt, Brothers.—i. 300
 Hughes.—vi. 459; x. 691
 Hughes, E.—xvii. 4
 Hughes, G. A.—xvii. 20
 Hughes, H.—xxii. 581
 Hughes, J.—viii. 318
 Hughes, J. G.—xxii. 461
 Hughes & Kimber.—xxii. 609

- Hughes P.—British Guiana, 74A 74a
 Hughes, R.—xii. & xv. 251; xvi. 106; xxii. 609
 Hughes & Sons.—vi. 459
 Hughes, T.—xxx. (Sculpture cov.), 3
 Hughes, T., jun.—xxv. 60
 Hughes, W.—x. 401; xii. & xv. 472. 473
 Hug-lik.—Switzerland, 185
 Huguenin, see Schwartz & Huguenin
 Hugues, J. J. & Son.—France, 881
 Huillier, E. L.—France, 1325
 Hulbert, S.—Canada, 91
 Hulet, D.—xx.ii. 643
 Hull, D.—xxx. 324
 Hull, Hugh.—Van Diemen's Land, 208, 288
 Hull Local Committee.—xxxix. 290
 Hull Patent Camphine Co.—xix. 264
 Hull, Theodosia.—xxvi. 63
 Hullmandel & Walden.—xxx. (Fine Art Court), 71
 Hulls, J.—vi. 618
 Hulot, A.—France, 882
 Hultman, J. A.—Sweden, 81
 Humane Society, Royal.—viii. 15
 Humbert & Co.—France, 1272
 Humble, W.—xxvii. 9
 Hume, Rev. W. E.—xvii. 186
 Humphrey, C.—ii. 78
 Humphrey, see Simpson, Humphrey, & Co. Taylor, Humphrey, & Co.
 Humphrey, H. Noel.—xvii. 139
 Humphreys, see Read & Humphreys
 Humphreys, J.—xxx. (Fine Art Court), 231A
 Humphreys, N. H.—xxx. (Fine Art Court) 30
 Humphries, T.—xix. 210
 Hund, F. & Son.—x. 466
 Hungarian, Upper, Mining Association, (Schmölnitz).—Austria, 3
 Hunt, C.—xxvii. 109
 Hunt, E.—vi. 49
 Hunt & Gandell.—vii. 37
 Hunt, J.—i. 482; vi. 422
 Hunt, J. (per Boyd, C.)—vi. 207
 Hunt, J. C.—xviii. 90
 Hunt, R.—x. 477A
 Hunt, Robert.—i. 524; x. 297
 Hunt & Rusnell (late Storr & Mortimer).—xxiii. 97 (Main Avenue, West)
 Hunt & Son.—xiv. 28
 Hünter, J. A. F.—Hamburgh, 44
 Hunter, Dr.—India, xxv.
 Hunter, E.—xxii. 228; see also Hunter W. J. R. & E.
 Hunter, J.—vi. 312; see also Hunter, W. & J.
 Hunter, L.—i. 219
 Hunter, W. & J.—ix. 119
 Hunter, W. J. R. & E.—xxvi. 202
 Hunter, W. M.—United States, 9
 Huntley & Palmer.—xxix. 107
 Hunyadi Van Ketheley, Count J. II.—Austria, 89
 Hunziker & Co.—Switzerland, 166
 Huot, see Billiet & Huot
 Hupfer & Wolfemann.—Zollv. (1), 774
 Hurlet & Campsie Alum Co.—ii. 13
 Hurley, D.—xx. 73
 Hurllmann, J.—Switzerland, 119
 Hurn, see Morrison & Hurn
 Hurrell, W.—xxix. 46
 Hurry, H. C.—v. 122
 Hurst, A.—i. 44.
 Hurst, G.—vii. 66; xix. 211
 Hurst, J. A.—United States, 80
 Hurst & Reynolds.—xx. 162
 Hurst & Sons.—xx. 99
 Hurst, W.—xxii. 102
 Hurtell, M.—Society Islands
 Hurter & Bubolzer.—Switzerland, 231
 Hurltel & Co.—France, 884
 Hurwitz, B.—xxx. 347
 Hurwood, G.—vi. 414; vii. 31
 Husband, J.—viii. 151
 Husband, T. J.—United States, 49
 Huschenreuther, F. A. & Sons.—Zollverein (1), 805
 Huskisson, H. see Huskisson, J. W. & H.
 Huskisson, J. W. & H.—ii. 86
 Hussey, O.—United States, 65
 Husson & Bathod.—France, 885
 Husson, F. C.—France, 542
 Huste, see Hoeller & Huste
 Hutchings, J.—xvi. 124
 Hutchinson, E.—xxvi. 22
 Hutchinson, E. jun.—xxvi. 22
 Hutchinson, Elizabeth.—Jersey & Guernsey, 31
 Hutchison, J.—i. 161
 Hutchison, see Forbes & Hutchison
 Hutchison, R.—New Brunswick, 10. 25
 Hutchison, T.—xii. & xv. 298
 Huth, F. & Co.—Zollv. (1), 578. 632
 Huth & Fischer.—xii. & xv. 123
 Huthier, M.—Austria, 149
 Huttly, F.—v. 882
 Hutton, J.—x. 7; xxii. 166
 Hutton, J. F.—Western Africa, 21
 Hutton & Newton.—xxii. 215
 Hutton & Sons.—v. 884
 Hutton, W. B. & Son.—W. Africa, 6
 Huxham & Brown.—vi. 446; xxii. 406
 Huxley, E.—x. 598
 Huxley, Heriot, & Co.—xxii. 236
 Hyams, H.—x. 278
 Hyams, M.—iii. 46
 Hyde, see Bates, Hyde, & Co.
 Hyde & Co.—xvii. 21
 Hyde, F.—United States, 67
 Hyde, J. J.—United States, 582
 Hymettus, Prior of the Monastery of.—Greece, 48
 Hynam, see Gawkröger & Hynam
 Hyvelin, see Bouillette, Hyvelin, & Co.
 Iakoleff, Brothers.—Russia, 344
 Ibarra J.—Spain, 256A
 Ibarra, J. M.—Spain, 26
 Ibarzabal, G.—Spain, 268
 Ibbatson, Brothers.—France, 1710
 Ibbatson, Capt. L. L. B.—Page 851. i. 486A; x. 459; xxx. (Fine Art Court), 323
 Ibbatson.—xxi. 27
 Ibbatson, Brothers, & Co.—xxii. 191
 Ibbatson, R.—xxii. 239
 Ibrahim Pasha.—Egypt, 391
 Ildiers, A. J.—Belgium, 287
 Ihm, F.—Zollverein (6), 46
 Ihm, Boehm, & Pfaltz.—Zollverein (6), 31
 Iles, C.—vi. 61; xxvii. 28
 Iliff, W. T.—xxix. 253
 Iliffe, see Hardman & Iliffe
 Illek, F.—Austria, 216
 Illegworth, A.—iii. 115
 Imhof & Sons.—Switzerland, 173
 Imhoof, B.—Switzerland, 126
 Imhoof, Brunner.—Switzerland, 127
 Imlin, F.—France, 343
 Imperatori, J. H. Brothers.—Sardinia, 39
 Imperial Salt Works, Galicia.—Austria, 17
 Imrie, P.—xxvi. 98
 Ince Hall Coal and Cannel Co., Wigan.—Western end, South enclosure (Outside), 38; i. 268
 Ince, J.—xvi. 309
 Ince, W. H.—Van Diemen's Land, 349
 Inderwick, J.—xxiii. 56
 Indian Iron & Steel Co.—India, i.
 Indore, Resident at.—India, xv.
 Indri, A.—Austria, 151
 Infanger, M.—Austria, 676
 Infeld, Chevalier Von.—Austria, 124
 Inglesfield, E. A.—viii. 99
 Inglessis, N.—Greece, 7
 Inglis, see Lynch & Inglis
 Inglis, A.—vii. 199
 Inglis & Brown.—xii. & xv. 191
 Inglis & Wakefield.—xviii. 4
 Ingram, H.—vi. 122
 Ingram, J. W.—xxx. 321
 Ingram, T. W.—xxii. 304
 Innes, Elizabeth & Susanna.—xxvi. 91.
 See also Tapperel & Innes
 Innes, Susanna, see Innes, Elizabeth & Susanna
 Inskip, H.—viii. 227
 Inslee, J. A.—United States, 161
 Inspectors of Works.—Portugal, 113. 563—570
 Ipswich Museum Committee, (by Rev. J. Henslow).—i. 35
 Ireland, J. & Co.—xii. & xv. 217
 Ireland Mining Co.—Dublin, i. 507
 Irish Engineering Co.—vii. 150
 Irish Work Society.—xix. 77
 Iron Bridge Company, New York.—United States, 147
 Irving, G. V.—iv. 94
 Irwin, E.—xii. & xv. 26
 Irwin, Elizabeth.—iii. 99
 Irwin, J.—Canada, 196
 Irza-Cooli-Hadji-Cagaram-Ggii.—Russia, 234
 Isaac, J. R.—xvii. 165
 Isaac & Campbell.—xxvi. 241
 Isabel II., Manufactory of.—Spain, 193
 Isabellen Hütte Smelting Works.—Zollverein (8), 3
 Isaiëff, P.—Russia, 184
 Isern, J.—Spain, 117
 Isidore & Brandt.—xvi. 252
 Iskander-Beck-Ogli, see Zilfulgen-Beck, & Co.—Switzerland, 227
 Isler, J. jun.—Switzerland, 227
 Isler, J. & Son.—Switzerland, 227
 Isler & Otto.—Switzerland, 213
 Ismael-Abdool-Rughil-Ogli.—Russia, 160
 Isou, J. P.—Sweden, 107
 Israel, C.—Zollverein (1), 754
 Issmayer, I. M.—Zollverein (2), 26
 Issuare, R.—ix. 100
 Itzehogloff.—Russia, 136
 Itzigsohn, M.—Zollverein (1), 97
 Innod Brothers.—Switzerland, 7
 Ivanoff.—Russia, 267
 Ivanoff, P.—Russia, 259
 Jaccard, Brothers.—Switzerland, 27
 Jaccard, L.—Switzerland, 104
 Jack, C.—i. 437A
 Jack, W.—x. 678
 Jackson, see Spenser & Jackson
 Jackson, C.—xix. 84
 Jackson & Clay.—vii. 75
 Jackson, Elizabeth.—xxix. 59
 Jackson, E. & W.—x. 258
 Jackson, E. & W. II.—xxiv. 77
 Jackson, G.—xxvi. 212

- Jackson & Graham.—xix. 390; (North Transp); xxvi. 261; Bay M. 23
 Jackson, H.—vii. 201
 Jackson, H. H.—Bermudas
 Jackson, J.—v. 703; xi. 1
 Jackson & Matthewman, xiv. 30
 Jackson, P. H.—v. 682
 Jackson, R. B.—xvi. 258
 Jackson, S. see Jackson, W. H. & S.
 Jackson & Sone.—xxvi. 5. Bay M. 22. 1. 19
 Jackson, T.—xxviii. 21
 Jackson, W.—xxii. 311; see also Jackson, E. & W.
 Jackson, W. H. see Jackson, E. & W. II.; Jackson, W. H. & S.
 Jackson, W. H. & S.—x. 32
 Jacob, H.—Zollverein (1), 786
 Jacob, J.—Zollverein (2), 78
 Jacob, P.—France, 1629
 Jacobber.—France, 271
 Jacobs, see Blyth & Jacobs; Truesdale, Jacobs, & Co.
 Jacobs & Bering.—Zollverein (1), 524
 Jacobs & Dupuis.—France, 836
 Jacobs, G.—xxix. 183
 Jacoby, F. A.—Zollverein (1), 787
 Jacot, H. L.—xxx. (Fine Art Court), 210
 Jacot & Courvoisier.—United States, 351
 Jacquain, G.—Belgium, 459
 Jacquemar Brothers.—France, 272
 Jaquet, H. & Co.—Sardinia, 26
 Jaquet, R.—France, 545
 Jacquin, J. J.—France, 546
 Jaquot.—France, 547
 Jaquot, F.—Belgium, 347
 Jaeger, G.—Zollverein (1), 469
 Juen.—Spain, 82
 Jaehuij, W.—Zollverein (3), 134
 Jaffray, J. R.—Austria, 722
 Jager, F. I.—Austria, 278
 Jaget, see Maurel, Jaget, & Co.
 Jagodzinsky, A.—Zollverein (3), 8
 Jahn, A.—Zollverein (3), 34
 Jahn, F. H.—Zollverein (3), 163
 Jallou, Monier, & Co.—France, 273
 Jakoleff, Madame Catherine.—Russia, 25, 286
 Jalovitzin, J.—Russia, 236
 Jamar, A.—Belgium, 444
 James, see Cowley and James; Howell, James, & Co.; Wait, James, & Co.
 James & Aubrey.—Western end, South enclosure (Outside), 37
 James & Chapman.—United States, 181
 James, H.—xix. 215
 James, J.—i. 413a; vii. 19 (Main Avenue, West); xvi. 40; xxii. 317; xxix. 295
 James, J. & Co.—v. 411; ix. 86
 James, J. H.—x. 577
 James, Jabez.—vii. 106 (Main Avenue, West)
 James, W. H.—xxiv. 85
 Jameson & Banks.—xii. & xv. 278
 Jameson & Co.—xiv. 60
 Jamieson, see Paterson, Jamieson, & Co.
 Jamieson, G.—i. 25
 Jamieson, J.—Western Africa, 5n
 Jamieson, H.—Western Africa, 22
 Junin.—France, 548
 Jamison, V. D. V.—United States, 173
 Jancowski.—xvi. 50
 Jancowski, W.—xix. 48
 Janila, J. Zollverein (1) 894
 Janke, Brothers.—Austria, 591
 Jannasch, H.—Zollverein (1), 821
 Jantusch, O.—Zollverein (1), 836
 Janqueria, Manufactory of.—Portugal, 655, 656, 657
 Jansen, A.—Belgium, 139
 Jansen, J. W.—Zollverein (1), 349
 Jansse & Luehdorf.—Zollverein (2), 56
 Janssen, N. H. A.—Netherlands, 19
 Janssens, D.—Belgium, 193
 Jantzen, G. E.—Zollverein (1), 205
 Jantzen, J. C. F.—Hamburgh, 83
 Japuis & Son.—France, 274
 Japy, Brothers.—France, 275
 Jaquemar, F.—Austria, 335
 Jaquet, see Loroque, & Co.
 Jaquemot, J. M.—iv. 37
 Jaques & Son.—Switzerland, 33
 Jaquet, J.—Belgium, 461 (Main Avenue, East)
 Jaquet, jun.—Belgium, 462
 Jaquin, C.—vi. 68
 Jaren, J. A.—Spain, 249
 Jarret, G.—vi. 154
 Jarret, W.—viii. 319
 Jarrow Chemical Works (South Shields).—ii. 20
 Jarvica.—xviii. 82
 Jarvis, see Garton & Jarvis
 Jastrzabski, F.—Belgium, 176
 Jaulin, A.—France, 887
 Jaulin, J.—France, 1274
 Jaun, T.—Switzerland, 255
 Javet, C.—France, 888
 Jeakes, W.—xxii. 237
 Jean, Franc.—Switzerland, 152
 Jeanes, see Johnstone & Jeanes
 Jeanneret, Brothers.—Switzerland, 38
 Jeannet, F.—Switzerland, 5
 Jeannin.—France, 1275
 Jeanselme.—France, 1276
 Jeanselme, J. P. F.—France, 880
 Jeantet.—Algeria, 29
 Jeanti, Prevost, Perraud, & Co.—France, 1277
 Jee, A. S.—vii. 222. 755. (Main Avenue, West)
 Jeffcoat, F. L.—xxii. 755
 Jeffers, W. H.—United States, 116
 Jeffery, R.—vii. 14
 Jeffery, Walsh, & Co.—viii. 188
 Jeffrey, A.—United States, 150
 Jeffrey, Allen, & Co.—xxvi. 326
 Jeffrey, R.—xiv. 59
 Jeffries, I.—xxix. 184
 Jeffries, J.—Canada, 62
 Jeffs, see Bearn & Jeffs
 Jehin, H. J.—Belgium, 410
 Jehotte, C.—Belgium, 447
 Jehotte, L.—Belgium, 463 (Main Avenue, East)
 Jenken, W.—Netherlands, 71
 Jenkins & Beer.—i. 92
 Jenkins & Courtney.—i. 93
 Jenkins, G.—v. 88
 Jenkins, J.—viii. 111
 Jenkins & Stick.—i. 170
 Jenkins, W. H.—i. 502; ii. 43
 Jenkins, W. & Son.—x. 484
 Jenkinson, J.—xxii. 594
 Jenmens & Bettridge.—xxii. 371; xxvi. 187 (Main Avenue, West)
 Jenmens & Co.—viii. 201
 Jennings, B.—i. 104; xxx. (Sculpture Court) 6. 81
 Jennings & Claghorn.—United States, 276
 Jennings & Co.—United States, 118
 Jennings, G.—xxii. 810
 Jennings, H. C.—ii. 99
 Jennings, J. D.—Van Diemen's Land, 236
 Jemison, J.—ix. 70
 Jenny, see Blumer & Jenny
 Jenny & Schindler.—Austria, 183
 Jens, see Wulff, Jens, & Sons
 Jeppe, H.—South Africa, 4
 Jeppon, W.—xxvii. 132
 Jerak, F.—Austria, 134
 Jerichau, J. A.—Denmark, 39 (Main Avenue, East)
 Jerningham, Commander.—viii. 21
 Jerome, Brothers.—France, 549
 Jessen, N. S.—Denmark, 14
 Jesson, see Bagnall & Jesson
 Jessop.—v. 64; see also Cowgill, Jessop, & Co.
 Jeto, C. A.—Canada, 109
 Jewett, S. W.—United States, 499
 Jewsbury & Co.—iv. 66
 Jimenez, M.—Spain, 285
 Jimison, C.—xvi. 28
 Jibb, J.—xxx. (Fine Art Court), 14
 Jimenez, M.—Spain, 285
 Jobart, A.—Belgium, 89
 Johnson & Co.—xxvi. 106
 Jobst, F.—Zollverein (4), 4
 Jodhpore, H. H. the Rajah of.—India, x.
 Johanny-Abhoe, A. W.—Zoll. (1), 493
 Johansson, J.—Sweden and Norway, 17. 98
 John, A.—Greece, 59
 John, J. R. St.—United States, 95. 510. 542
 John's, St. College.—New Zealand, 7
 John & Thiele.—Austria, 379
 Johns, G. E.—xxix. 51
 Johnslotter, Christina M.—Sweden & Norway, 33
 Johnson, see Deane & Johnson; Harding, Pullen, & Johnson; Swanwick & Johnson
 Johnson, A.—Sweden, 64
 Johnson, Cammell, & Co.—xxii. 109
 Johnson & Co.—xx. 48
 Johnson, E.—xxii. 67; xxvi. 243
 Johnson, G. & Co.—xix. 316
 Johnson, H. T.—viii. 328
 Johnson, J.—xi. 48; xii. & xv. 112
 New Zealand, 21
 Johnson, J. H.—ii. 60
 Johnson & Matthey.—i. 477
 Johnson, P.—xxviii. 15
 Johnson, R., & Brother.—vi. 212
 Johnson, H. J.—xviii. 20
 Johnson, H., & Nephew.—xi. 55
 Johnson, Sewall, & Co.—United States, 441
 Johnson, T.—ix. 257a
 Johnston.—x. 419
 Johnston, A. K., see Johnston, W. & A. K.
 Johnston & Co.—xxvi. 75
 Johnston, G., see Johnston, J. & G.
 Johnston, G. J.—xxx. (Fine Art Co.), 19
 Johnston, J.—xii. & xv. 274; xx. 128a.
 Johnston, J. & G.—xx. 143
 Johnston, W. & A. K.—x. 198
 Johnstone, G.—i. 175
 Johnstone, J.—xix. 218
 Johnstone & Jeanes.—xxvi. 10
 Johnstone, W.—i. 124a
 Jolly, F.—France, 276
 Jolly, J.—ix. 69
 Jolly-Leclerc.—France, 890
 Joly.—France, 277
 Joly, J. M., sen.—France, 891
 Joly, Mmes.—France, 892
 Jonas Brothers.—iii. 42
 Jones.—xxii. 121; see also Barlow, Goadly, & Jones; Ellum, Jones, & Co.; Morris, Jones, & Co.

- Jones, A. J.—xxvi. 78; xxx. (Fine Art Court), 70
 Jones, B.—x. 533
 Jones, Brothers.—Belgium, 118
 Jones, C. E.—ix. 269
 Jones & Co.—iii. 43; xxvi. 336; Bay P. 15
 Jones, D.—xviii. 73; Canada, 41
 Jones, E.—ix. 52, 133; xii. & xv. 250, 265; xxvi. 215
 Jones, Dr. E.—x. 127
 Jones, G.—iii. 106
 Jones, Isabella B.—xxix. 82
 Jones, J.—xx. 149; xxii. 136, 230; xxviii. 122; xxix. 182; British Guiana, 37, 38
 Jones, J., & Co.—xxii. 801
 Jones, John—x. 61
 Jones, J. C.—x. 481
 Jones, J. E.—xxx. (Sculpture Court), 40, 45, 81
 Jones, J. jun.—viii. 136
 Jones, J. R.—United States, 172A
 Jones, J. V.—United States, 172
 Jones, L. V.—xix. 138
 Jones, Mary.—xix. 219
 Jones, Owen.—xvii. 139; xxx. (Fine Art Court), 54
 Jones, O. & Co.—iii. 128
 Jones, P.—ix. 123B; x. 652
 Jones, R. & Sons.—xxii. 277
 Jones, Sells, & Co.—Western end, South Enclosure (Outside), 42; r. 258
 Jones, Simonson, & Co.—Zollverein (1), 787
 Jones & Sons.—xxiv. 11
 Jones, T.—viii. 344; x. 656
 Jones, T. M.—v. 656
 Jones, W.—v. 156; xxvi. 287; xxvii. 105; Rome, 48
 Jones, W. D.—xvi. 30
 Jones, Rev. W. H.—xxix. 95
 Jones, White, & McCordy.—United States, 33
 Jones, W. & S.—x. 141
 Jones, Z.—xxiv. 44
 Jonet, D.—Belgium, 389
 Jonghaus & Venator—Zollverein (6), 6
 Jonghe, A. De.—Belgium, 416
 Joostens, G. J.—Belgium, 457
 Jordan.—Page 851; see also Deinhart & Jordan
 Jordan & Barber.—Austria, 68
 Jordan, C.—i. 487; x. 285; xxx. (Fine Art Court), 208
 Jordan, J.—x. 523
 Jordan, J. F.—Zollverein (2), 27
 Jordan, T.—ix. 91A
 Jordan & Timaeus.—Zollverein (3), 6
 Jordan, W.—vi. 29
 Jordan, W. H.—v. 888
 Jordans.—xxvi. 384
 Jorez, L. jun.—Belgium, 306
 Jorge, M. J.—Portugal, 920, 928-931, 933, 963, 965, 968-972
 Joritsma, A.—Netherlands, 18
 Joseph, J. A.—South Australia, 10
 Joseph, J. G.—Canada, 182
 Joshua, D.—Zollverein (3), 72-83, 89
 Josselin, A. J.—France, 551
 Joubert, Bonnaire, & Co.—France, 552
 Joubert, J. G.—South Africa, 52
 Joubert, Caroline—xx. 40
 Joudpore, Rajaji of.—India, xxvii.
 Jouhannaud & Dubois.—France, 1630
 Joohand, P.—Jersey & Guernsey, 19
 Joule, J. P.—x. 440
 Jourdain, W. D.—xviii. 61
 Journet, V., see Maubait & Journet, V.
 Jourdain, X.—France, 1631
 Journal, J.—France, 553
 Jouvin & Doyon.—France, 1279
 Jouvin, Wilow.—France, 893
 Jouvne, L. H. F.—Belgium, 123
 Jowett, J.—xxii. 179.
 Jowitt & Battie.—xxii. 187A
 Jowitz, T., & Co.—xii. and xv. 144
 Joyce, F., & Co.—viii. 277
 Joyce, W.—v. 20
 Joysson.—xvii. 42
 Joysson, W.—xvii. 42A
 Joyzel.—xxii. 612
 Jraf-Ogli.—Russia, 207
 Jubb & Sons.—xii. & xv. 82
 Juhlpore School of Industry.—Eastern end (outside), 104.—India, viii.
 Judas Moha.—Algeria, 30
 Judge, C.—xvi. 41
 Judge, T.—v. 130
 Juditsky.—Russia, 137
 Judkins, C. F.—vi. 52
 Judo, J. B.—Belgium, 420
 Juenger, J. (Wilow).—Zoll. (1), 409
 Jukes, see Coulson, Jukes, & Co.
 Juhl, F. J. & J.—xxv. 30
 Julenius, Anna.—Russia, 221
 Julien, Marguerite.—France, 279
 Julin, N.—Belgium, 383
 Jullien.—Algeria, 31; France, 1280
 Jullien & Co.—xxx. (Fine Art Court), 63
 Junge & Walther.—Zollverein (5), 17
 Jungmans, I. G.—Zollverein (3), 131
 Junker, see Nilson and Junker; Uuhig's widow & Junker
 Junod, T.—Switzerland, 106
 Jubel-Desmares, J.—France. 278
 Jurgenseus, Sons.—Denmark, 17
 Jury, see Sharp, Oulell, & Jury
 Jason, W.—iii. 95
 Kaegi-Fiurz, J.—Switzerland, 153
 Kaehzmann, J.—Austria, 701
 Kaenmerer, C.—Zollverein (4), 42
 Kaeser, J.—Zollverein (1), 408
 Kahler, A.—Hamburgh, 117
 Kaihel, J.—Zollverein (1), 525
 Kain, J. F.—xxviii. 45
 Kaiser, A.—Netherlands, 84
 Kaiser, C. C. F.—Netherlands.—51
 Kaiser, J.—x. 66
 Kalide, T.—Zollverein (1), 285
 Kallenecker, J.—Zollverein, 54A
 Kalltemack, P.—Austria, 520
 Kämmer, G. W.—Austria, 199
 Kane, G.—xvi. 62
 Kane, W. J.—ii. 53
 Kowitz & Sons, M. L.—Austria, 697
 Kappeler F.—174
 Kappeler, L. & Son.—Zollverein (2), 28
 Kapp, C. H.—Switzerland, 66
 Karcher, F.—Zollverein (1), 391, 877
 Karcher & Westermann.—France, 1632
 Karnovitch.—Russia, 31, 101
 Karscheltz, S. N.—Zollverein (1), 157
 Karth, see Engelhard & Karth
 Kase.—ix. 237
 Kattenbusch, see Tescheymacher & Kattenbusch
 Kauertz, see Krahnus & Kauertz
 Kautmann, H.—Zollverein (1), 117
 Kauffmann, M.—Zollverein (1), 123
 Kauffmann, A.—Russia, 117
 Kauffmann, C. H. & Son.—Zollverein (3), 114
 Kaulbach, see Cornelius & Kaulbach
 Kaulbach, E.—xxx. 316
 Kausche, G.—Zollverein (1), 794
 Kawau Company.—New Zealand
 Kay, H.—xviii. 68
 Kay, J.—x. 27
 Kay, Richardson & Wroe.—xii. and xv. 180
 Kay, T.—xxv. 31
 Kaye, Findlay, & Co.—xx. 140
 Kayser, A.—Zollverein (1), 370
 Kayser, J.—Austria, 368A
 Kearney, W. H.—xxx. (Fine Art Ct.), 5
 Kenise, T.—xx. 175
 Kearsley, W. H.—v. 140
 Keating, T.—ii. 102; Belvia
 Keddell, J. S.—xix. 221
 Keed, G. F.—xxii. 378
 Keen.—xxx. (Fine Art Court), 158; see also Gray & Keen
 Keene, R. W.—xxvii. 27
 Keene, W.—iii. 98; ix. 193; xxii. 94; Spain, 300
 Keep & Watkin.—xxii. 76.
 Keht, J. C.—Zollverein (1), 64
 Kehlners, A. C.—Austria, 116
 Kehne, J.—xxx. 90
 Kehrl, Brothers.—Switzerland, 242
 Keigel, F. A.—Switzerland, 3
 Keighley, see Lockwood & Keighley
 Keith, D. & Co.—xiii. 1 (Main Avenue, West)
 Keith, G.—v. 466; xxii. 601
 Keith, J.—xxiii. 121
 Keith, Shoobridge, & Co.—xii. and xv. 279
 Kekulé, C.—Zollverein (1), 5.
 Kell, see Schwann & Co.
 Kell, A. & Co.—xxii. 327
 Keller.—France, 280
 Keller & Co.—Zollverein (1), 688
 Keller, J.—Austria, 191
 Kellermann, F.—Zollverein (5), 19; Zollverein (6), 62
 Kellner, S.—Zollverein (2), 86
 Kelly, J. & Co.—xx. 178
 Kelly, J. J.—Switzerland, 150
 Kelly, R. W.—Canada, 22
 Kelly & Son.—xxix. 159
 Kelsall & Bartlemore.—xii. & xv. 466
 Kelsey, J. T.—xvi. 266
 Kimmel & Co., see Willich, A. Kimmel, & Co.
 Kemp, see Smith, Kemp, & Wright; Stone & Kemp
 Kemp, G.—Van Diemen's Land, 320
 Kemp, T.—Zollverein (1), 727
 Kempen, J. M. Van.—Netherlands, 101
 Kendall, C. H.—xxvi. 246
 Kendall & Co.—xxxix. 25
 Kendall, H.—Zollverein (1), 422
 Kendall, J.—iii. 14, 75, 92; Zollverein (1), 791, 763, 773, 815, (2), 98
 Kendall, II.—Zollverein (1), 422
 Kengel, J.—Austria, 8
 Kennard, R. W.—v. 644; xxii. 804
 Kennedy, Dr.—ix. 208c
 Kennedy, Dr. E.—x. 725
 Kennedy, J.—British Guiana, 16A, 16B
 Kennedy, M.—v. 304
 Kennedy, W. S.—xxv. 4
 Kenrick & Sons.—xxii. 360A
 Kent.—xvi. 101, see also Howard & Kent
 Kent, A.—Western End, North Enclosure (Outside), 62; xxvii. 122
 Kent, G.—xxii. 533
 Kent, J.—xxii. 396
 Kent, J. H.—ii. 90
 Kent, II.—v. 892
 Kenworthy, see Hornby & Kenworthy
 Kenyon, J. & J.—xii. & xv. 91
 Keogh, II.—xxix. 119

- Kepp & Co.—XXII. 489; xxx. (Fine Art Court), 15
 Ker, W.—XXVI. 103
 Kerbalay-Hooseda-Ogli.—Russia, 279
 Kerbelay-Khooada-Aghali-Ogli.—Russia, 263
 Kerbler, J.—Austria, 621
 Keremerle, M.—United States, 527
 Kerim-Raglim-Ogli.—Russia, 87
 Kerke, A.—Russia, 48
 Kerkhoff, Van der, & Kreitz.—Zollverein (1), 512
 Kermode, R. Q.—Van Diemen's Land, 235
 Kern, H.—Zollverein (6), 45
 Kern, J.—Switzerland, 88
 Kerr & McMillan.—XVIII. 54
 Kerr, R.—XII. & xv. 300
 Kerr and Scott.—XII. & xv. 275
 Kershaw, H. see Kershaw, S. and H.
 Kershaw, S. & H.—XII. & xv. 161
 Kershaw, T.—XXVII. 1
 Kerslake, T.—XXII. 92
 Kersten, A.—Zollverein (1), 243
 Kesseler, C.—Zollverein (1), 299 (Main Avenue, East)
 Kesselkaul, J. H.—Zollverein (1), 371
 Kesselmeyer & Mellowdew.—XVIII. 44
 Kessels, H.—Belgium, 127
 Kessler, N.—Switzerland, 243
 Kestermont, J. B.—Belgium, 509
 Kentemoet, J. B.—Belgium, 509
 Kesterton, E.—v. 894
 Ketelaere, De.—Belgium, 350
 Kettelhuber, J.—Austria, 483
 Kettel, E.—Austria, 668A
 Kettlewell, Mary.—XIX. 223
 Key, see Burgess and Key
 Key, E. S.—XXVII. 126
 Key & Mitchell.—IX. 237
 Keymer, J.—XVIII. 12
 Keyn, De, Brothers.—Belgium, 406
 Keys & Mountford.—XXV. 14
 Khalil-Beek-Saphieff.—Russia, 57
 Khamoff, M.—Russia, 162
 Khamonnitsky, Iron Works of.—Russia, 20
 Kharkoff, N. N.—Russia, 45
 Kherson, Peasant Women.—Russia, 211
 Khirghis.—Russia, 278
 Khokhulkoff & Gregorieff.—Russia, 63
 Kiaing Tih' Chin, Great Porcelain Works of.—China,
 Kidd, see Dobbs, Kidd, & Co.
 Kidd, W.—XXIV. 3
 Kidd & Podger.—III. 150
 Kiddler, C. F.—United States, 492
 Kiddle, H. E.—XXIV. 39
 Kiddle, J.—XIX. 384
 Kidston, W. & Co.—x. 616
 Kiel, Misses Van.—Belgium, 333
 Kielman.—Zollverein (1), 847
 Kiendl, A.—Austria, 148
 Kieser & Co.—Zollverein (4), 81
 Kietaihl, F.—Austria, 653
 Kietz, T.—Zollverein (3), 185A
 Kightley, J.—XIX. 123
 Kijeovski, see Hirschmann and Kijeovski
 Kilburn, W. E.—x. 291
 Kilian, H.—Zollverein (1), 665
 Killrogan Parochial School.—XIX. 372
 Kimbal, D.—United States, 457
 Kimber, see Hughes & Kimber
 Kimber, A. M. & Co.—United States, 500
 Kimberley, J.—XXII. 362
 Kimmermann, E. G.—Zollverein (5), 19
 Kincaid-Lennox, F. M.—xx. 147
 Kincaid, T.—VIII. 89
 Kinder & Wheeler.—v. 895
 Kiendermann, A.—Zollverein (3), 170
 King.—XXIII. 94
 King, C.—XXII. 5; XXVI. 61
 King & Co.—I. 91
 King, Emma.—IV. 2
 King, G.—I. 115
 King, J.—II. 13; XXVIII. 41
 King, J. H. see King, T. and J. H.
 King, Miss.—XIX. 224; New Zealand, 26
 King, P. H. F.—VIII. 10
 King & Pe. ch.—XXI. 5
 King R. & W.—XI. 23; Western Africa, 7
 King, S.—XXII. 407
 King, T.—I. 136
 King, T. D.—x. 287
 King, T. J.—VII. 281
 King, T. & J. H.—XVII. 22
 King, T. R.—XXX. (Fine Art Court), 113
 King, W.—VII. 160; see also King, R. and W.
 King, W. A., XXVI. 113
 King, W. W.—II. 84
 Kings, W.—v. 896
 Kingsbury, Louisa.—XIX. 225; XXVI. 124
 Kingswell, F.—IX. 25B
 Kinnear, see Johnson, T.
 Kinuis, W.—XIV. 26
 Kinul, A.—Hamburg, 39
 Kinross, W. & Co.—v. 898
 Kinzelbach, T.—Zollverein (4), 26
 Kinzleberger & Co.—Austria, 27
 Kirby, Beard & Co.—XXIX. 96
 Kirby, J.—XVII. 23
 Kirby, W.—XVI. 111
 Kirk, Henry.—Austria, 729
 Kirk, J.—XXX. (Sculpture Court), 46
 Kirk, J. M.—XII. & xv. 163
 Kirk, J. R.—XXX. (Sculpture Court), 2
 Kirk & Sons.—XIV. 10
 Kirk & Parry.—I. 179
 Kirk, W. B.—XXX. (Sculpture Court), 25
 Kirk & Warren.—XXII. 161
 Kirkman & Son.—x. 467
 Kirkwood, W.—XXII. 524
 Kirner, J.—Austria, 121
 Kirschlamm, see Schentzler & Kirschlamm
 Kirschten, see Dick & Kirschten
 Kirsh, J. N.—Portugal, 985—987
 Kirstein, C.—Zollverein (1), 120, 120A
 Kirstein, F.—France, 281
 Kirsten, C. W.—Zollverein (3), 113
 Kirtland, B. B.—United States, 84
 Kitoh, S. A.—xx. 65
 Kiaker, W.—Zollverein (1), 553
 Kiss, Prof. A.—Zollverein (1), 279; (Main Avenue, East)
 Kissel, J.—France, 554
 Kissling & Möllmann.—Zoll. (1), 647
 Kiatamaeckers, H.—Belgium, 270
 Kiszewski.—Zollverein (1), 39
 Kitcheiner, T.—XXX. (Fine Art Court), 289
 Kitcheiner, W. C.—III. 5
 Kitclau, J.—IV. 126A; Ceylon
 Kiteley, J.—XIX. 226
 Kitshelt, A.—Austria, 434
 Kitson, Thompson, & Hewitson.—v. 534
 Kitteridge, F. O.—United States, 253
 Kittl's Heirs, Aut.—Austria, 592
 Klaffenberger, see Aubert & Klaffenberger
 Klamer, J.—Austria, 184
 Klanner, F.—Austria, 642
 Klarer, J. A.—Switzerland, 244
 Klaus, R.—Switzerland, 153
 Kleber, see Blanchet, Brothers, & Kleber
 Kleeman, see Sturgen and Kleeman
 Kleff, Brothers.—Hamburg, 94
 Klein, Baron.—Zollverein (6), 80
 Klein, C.—Zollverein (6), 23
 Klein, F.—Zollverein (1), 595
 Klein, F. G.—Zollverein (4), 80
 Klein, J. G. sen.—Zollverein (6), 64
 Klein, P.—Zollverein (6), 63
 Klein, Reisser, & Co.—Zoll. (6), 86
 Klein-Schater, S. C. F.—Zoll. (1), 578
 Kleinjapper, J. F.—France, 1633
 Kleinjung, see Pferdenges & Kleinjung.
 Kleinschmidt & Von Halfern.—Zollverein (1), 372
 Kleist, Baron Von.—Austria, 424
 Klement, F.—Austria, 569
 Kleinm, G. & A.—Zollverein (3), 18
 Klems, J. B.—Zollverein (1), 595
 Klepatsky.—Russia, 35
 Klingner, C. A.—Zollverein (2), 29
 Klingsey, C. G.—Denmark, 34
 Klöpffer, H.—Zollverein (1), 489
 Knecht, Emile.—France, 282
 Kneeland, H.—United States, 146
 Knerim, F.—Austria, 107
 Knight, see Harvey & Knight
 Knight & Foster.—XXII. 694
 Knight, G. & Sons.—x. 433; XXI. 24
 Knight & Hawkes.—XVII. 107
 Knight, J.—XXIX. 8
 Knight, J. Y.—XVII. 86
 Knight, T. & Co.—XVIII. 42
 Knight, T. W.—XXII. 587
 Knight, W.—IX. 22; United States, 576
 Knill, J.—Austria, 632
 Knipe, J. A.—I. 529
 Knocke, A.—Zollverein (2), 100
 Knoll, Brothers.—Austria, 724
 Knoll, C.—Zollverein (?), 88
 Knops, Brothers.—Zollverein (1), 373
 Knorr, F.—Zollverein (2), 38
 Knosp & Backe.—Zollverein (4), 97
 Knowles, see Nelson, Knowles, & Co.
 Knowles, II.—XXII. 289
 Knox, see Morison & Knox; Rainey, Knox, & Co.
 Knox, A. L.—XII. & xv. 197A
 Knox, G.—v. 514
 Knuepfer & Steinhauser.—Zoll. (1), 528
 Knuttner, A.—Zollverein (1), 236
 Kolbe, see Mousbrugger & Kolbe
 Kolbelt & Sons.—XXVI. 896
 Kolbick, H. M.—Zollverein (3), 123
 Koch, C. A.—Zollverein (?), 329
 Koch, F.—Zollverein (6), 7
 Kochmeister, F.—Austria, 5
 Kock, H. A.—British Guiana, 53A, v. 55B, 59A
 Kockum.—Sweden, 75
 Koecklin & Sons.—Switzerland, 152
 Koecklin, Brothers.—France, 1634
 Koehler & Schledich.—Zollverein (3), 93
 Koellreutter, F.—Switzerland, 196
 Koenigs & Buecklers.—Zollverein (1), 552
 Koenig, C. A.—Zollverein (1), 163
 Koenig, G.—Zollverein (1), 323
 Koenig, L.—Zollverein (1), 139
 Koenig & Pusk.—x. 504
 Koenig, F. P.—Austria, 596
 Koerner, M.—Zollverein (1), 246
 Koester & Uhlmann.—Zollverein (3), 70
 Kohler, Hermann, & Co.—Austria, 76A
 Koehler, J.—Zollverein (5), 27
 Kohl, G. H.—Zollverein (1), 14

nd, 244
133
thera, & Kleber
d Kleeman
burgh, 94
n (6), 80
, 23
, 595
(4), 80
erein (6), 64
, 63
Zoll. (6), 86
—Zoll. (1), 578
ce, 1633
ges & Klein-
lfern.—Zoll-
ria, 424
69
erein (3), 18
(1), 595
ein (2), 29
ark, 34
(1), 489
, 282
ates, 146
7
ight
694
453; XXI. 24
. 107
42
7
ited States, 576
(2), 100
, 724
, 88
erein (1), 373
, 38
erein (4), 97
wles, & Co.
nox; Rainey,
197A
Zoll. (1), 528
(1), 236
Kobbe
(3), 123
(1), 329
7
5
Guiana, 55A,
Hamd, 152
ce, 1634
ollverein (3),
nd, 196
ollverein (1),
(1), 163
, 323
, 139
6
, 246
erein (3), 70
Austria, 76A
, 27
, 14

Kohler, F.—Zollverein (4), 46
Kohler, J.—VIII. 254; x. 540; Ham-
burgh, 72
Kohlstadt, L.—Zollverein (1), 400
Kuhn, M. A.—Hamburgh, 17
Kohn, M. T.—Zollverein (2), 40
Kohuke, F. J.—Hamburgh, 103
Kohmstamm, H.—Zollverein (3), 68
Kohring, see Schuer, Dr. & Kohring
Kok, A. P.—Netherlands, 23
Koklanoff.—Russia, 205
Kolb & Schule.—Zollverein (4), 28
Kolbel, B.—Austria, 645A
Kollbjørnsen, K.—Denmark, 2
Kolesch, H.—Zollverein (1), 156
Koll, J. N.—Hamburgh, 82
Kollr, see Tamer & Koller
Koller, F.—Austria, 466
Kolm, J.—Austria, 484
Kolokolnikoff.—Russia, 203
Kolp, see Baenzegi, Kolp, & Co.
Kolyvan, Imperial Polishing Manufac-
tory at.—Russia, 327
Konarzewski, A.—Zollverein (1), 300
Kondrasheff.—Russia, 353
Kondriaffzell-Jadenskiy, B.—Russia,
346
Kongsberf, Manufactory of Arms.—
Sweden and Norway, 40
König, C. G. & Sons.—Zollverein (1),
701
König, F. P.—Austria, 596
Köing, G.—Austria, 262
Koning, de, see Hansen & de Koning
Koningshuette, Royal Works at.—
Zollverein (1), 3
Konovnitzin, Count J.—Russia, 377
Konovnitzin, Countess.—Russia, 220
Koopmans, K.—Netherlands, 40
Kopke, C. J. L.—Hamburgh, 77
Kopp, H. F. J.—Switzerland, 17
Kopp & Kroll.—Hamburgh, 41
Koppe, A.—Zollverein (1), 143
Koppelin, E.—France, 894
Koriakin & Mougikoff (Peasants).—
Russia, 131
Korian, G.—Hamburgh, 53, 62
Körner, G. W.—Zollverein (1), 747
Koslikoff, M.—Russia, 369
Kosselt, J.—Austria, 145
Kossuch, J.—Austria, 406
Kostner, A.—Austria, 264
Kotelloff, P.—Russia, 239
Kotcheleff, Count.—Russia, 32
Kongsberg Silver Works.—Sweden &
Norway, 34
Koukell, Jasiupolsky, J.—Russia, 335
Koushivinsk Imperial Cast Iron Works,
—Russia, 5; 157
Koussoff, J. & Sons.—Russia, 224
Krach, Brothers.—Austria, 391
Kraetschmar, see Rigo & Kraetschmar
Krauf, G. J.—Austria, 677
Krauß & Kauertz.—Zollverein (1),
527
Kral, A.—Austria, 365
Kralik, S.—Austria, 169
Kramer, A.—Switzerland, 268
Kramer & Baldamus.—Zollverein (1),
737
Kramer, C. A.—Zollverein (1), 416
Kramer, G., see Kramer, L. & G.
Kramer, L. & G.—Zollverein (1), 610
Kransta & Sons.—Zollverein (1), 128
Kraunwetter, J.—Austria, 522
Krauner, J.—Austria, 633
Kranowther, J.—Austria, 463
Kraschenekoff.—Russia, 100
Kratschmann, M.—Austria, 697
Kraubauss & Kauertz.—Zoll. (1), 527

Krause, C. G., & Co.—Zollverein (3), 58
Krause, F. V.—Zollverein (3), 147
Krause, M.—Zollverein (1), 278
Krausz.—Zoll. (1) 379
Krebs, W.—Zollverein (1), 260
Kreiger & Co.—France, 1283
Kreith, see Kerkzoff, Van der, & Kreith
Kreso, G. L. Von.—Zollverein (5), 32
Kress, G. L.—Zollverein (5), 32
Kretschmann, H. W. E.—Zollverein (1),
738
Kreuger, Adme.—Sweden, 55
Kreuser, see Meinerzigen & Kreuser
Krichuber.—Austria, 371
Krickl, E.—Austria, 263
Krieg, J., Zollverein (1), 896
Kriegel & Co.—Austria, 623
Krimmelbein & Biedt.—Zollverein (1),
457
Krise, C.—Austria, 353
Krucker & Son.—Zollverein (1), 755
Kruenig, F. W., & Sons.—Zollverein
(1), 556
Krohn, Brothers.—Zollverein (1), 178
Kraitsch, M.—Austria, 297
Kroll, see Kopp & Krull
Kronheim & Co.—xvii. 181
Kronheim, J. M.—xxx. (Fine Art
Court), 40
Kronheim, M.—Zollverein (1), 284
Kronick, see Becker & Kronick
Krönig, Dr.—Zoll. (1) 850
Kroonenburg, W. F.—Netherlands, 43
Krueger, A.—Hamburgh, 20; Zollverein
(1), 69
Kruger, G. H.—Hamburgh, 80
Krugmann, see Morgenroth & Krug-
mann
Krumholz & Trinks.—Zollverein (3),
30
Krumbigel.—Russia, 287
Krumteich, L.—Zollverein (1), 261
Krupp, F.—Zollverein (1), 649, 677
Kruse, A. T.—Zollverein (1), 19
Kruse, C. B.—Zollverein (1), 277
Kubler, G.—Zollverein (2), 11
Kubo, J., & Son.—Austria, 312
Kuchenreuter, T. A.—Zollverein (2), 21
Kuhinka, F.—Austria, 593
Kuegler, H.—Zollverein (3), 186
Kuehust, G.—Zollverein (6), 20
Kuehnemund, J. G.—Zollverein (1),
795
Kuetner, C. A., Zollverein (1), 236
Kuetzing, C.—Switzerland, 89
Kohler, J. H.—Hamburgh, 72
Kuhlmann, Brothers.—France, 555
Kühmstedt.—Zollverein (1), 747
Kuhn, see Moeser & Kuhn
Kuhn, C.—Zollverein (2), 57
Kuhn, J.—Zollverein (4), 102
Kuhn & Sons.—Zollverein (1), 152
Kulberg, V.—Sweden, 116
Kullgrin, C. A.—Sweden and Norway,
118 (Eastern End, Outside, 100)
Kullrich, F.—Zollverein (2), 58
Kummer, K. W.—Zollverein (1), 194
Kummer, W. L.—Zollverein (1), 817
Kumpf, J.—Austria, 658
Kuns, E.—Belgium, 468
Kunert, F.—Switzerland, 45
Kunert, A.—Austria, 333
Kunhardt & Co.—South Africa, 14
Kunheim, L. A. H.—Zollverein (1), 13
Kunst, J. A.—Zollverein (1), 70
Kunz, H.—Switzerland, 128
Kunze, C. F.—Zollverein (3), 120
Kunze, F.—Zollverein (3), 5
Kunzer, J.—France, 346, 563
Kuper, W.—xxii. 52

Küpfer.—Zollverein (1), 29
Küpfer & Steinhauser.—Zoll. (1), 528
Kursteiner, see Schlapfner, Schlatter, &c.
Kurtz & Sebnersahl.—II. 9
Kurz, C.—Austria, 465
Kuster, see Barre & Kuster
Kutzer & Lehr.—Austria, 24
Kvaviloff, P.—Russia, 90
Labat, M.—Spain, 104
Labbaye.—France, 556
Laboulaye, C. & Co.—France, 895
Labouring Classes, Society for improv-
ing the condition of the.—xxviii. 124
Lacarrière, A.—France, 1284
Lacerda, R. V. de S.—Portugal, 19
Lacey & Phillips.—United States, 41
Lachapelle & Levarlet.—France, 1285
Lachassagne, A.—France, 1286
Lacombe, L.—France, 557
Lacour, Brothers.—France, 35
Lacroix.—Belgium, 499
Lacroix, Brothers.—France, 1636
Lacroix & Son.—France, 283
Lacy, H. C.—v. 556
Ladd, C. P.—viii. 80; Canada, 151A
Ladd, W.—x. 291A
Lade, E.—Hamburgh, 23
Ladies of Great Britain.—xix. 379
Ladies' Industrial Society.—xix. 213
Ladighin, Madame.—Russia, 283
Ladoubee, L.—Belgium, 256
Lafaurie, P. A.—Portugal, 810-850
Lafaye, P.—France, 284
Lafébre, A.—Netherlands, 28, 53
Lafamme, M. A.—Canada, 116, 122
Lafout, P.—Russia, 270-277
Lagerhjelm, P.—Sweden and Norway, 1
Lagrestiz, Elena Nuzzo.—Malta, 18
Lagrezze.—France, 1724
Lahoche, P. I.—France, 1287
Lahousse, A.—Belgium, 80
Lahure.—France, 285
Laibach Carniolian Agricultural So-
ciety.—Austria, 70, 127
Laignel, R. V.—France, 1637
Lailier, E. H.—France, 559
Laine-Laroche & Max.—France, 266
Laing.—xiv. 63
Laing, J.—viii. 315; xx. 133; xxx.
(Fine Art Court) 240; British Gui-
ana, 40
Laings, see Dicksons & Laings
Laird & Thomson.—xii. & xv. 199
Lak, D.—United States, 330
Lalonde & Chevallier, late Mallet.—
France, 1288
La Mancha, Inspector of mines of the
district of.—Spain, 6
Lamb, J.—vii. 265; x. 42; xvii. 147
Lambert, see Browne and Lambert;
Houdin & Lambert
Lambert, A. C.—xxvii. 70
Lambert, Brown, & Patrick.—xix. 83
Lambert and Bury.—xix. 4
Lambert & Butler.—iii. 40
Lambert, Eleanor.—xxix. 188
Lambert, Elizabeth.—xix. 229
Lambert, G.—Belgium, 185
Lambert, J.—xii. & xv. 30
Lambert & Hawlings.—xxiii. 102
Lambert, S.—xxvi. 35; France, 1638
Lambert & Son.—v. 478; xvi. 63;
France, 1289
Lambert, T.—xxii. 534
Lamberts & May.—Zollverein (1), 579
Lamberts & Son.—Zollverein (1), 604
Lamberty, Brothers.—Belgium, 25
Lamberty, C.—Belgium 3.

- Lambinon, Ulrich & Co.—Zollverein (1), 451
 Lambruschini, R.—Tuscany, 36
 Lamere, Madame.—Canada, 42
 Lamm, S. L.—Sweden and Norway, 19
 Lamort, G.—France, 896
 Lamort, J.—Zollverein (7), 2
 Lampferhoff, A., see Lampferhoff, F.
 Lampferhoff, J. & A.—Zollverein (1), 485
 Lampitt, C.—ix. 130
 Lamplough, H.—ii. 71
 Lamport, C.—viii. 184
 Lampson, C. M.—xvi. 301. (Main Avenue, West.)
 Lamson, F.—x. 728
 Lancaster.—viii. 346; Canada, 6
 Lance, E. J.—i. 37
 Lauenbeck, Jane.—xix. 230
 Lancon, see Bonvard & Lancon
 Landau, S.—Zollverein (1), 321
 Landert, L.—Austria, 459
 Landernau Joint Stock Linen Company.—France, 1019
 Landgraf, C.—Zollverein (3), 72-83
 Landgraf, Gotfried.—Zollverein (3), 72-83
 Landkron, J.—Netherlands, 67
 Landmark, T.—Sweden & Norway, 19
 Landon, see Kast, Landon, & Co.
 Landon & Co.—France, 1289, 1250
 Landon & Morland.—vii. 201
 Landrin, Brothers.—France, 1639
 Landwermann, Brothers.—Zollverein (1), 550
 Lane, see Cavers and Lane
 Lane and Lewis.—xxvii. 53
 Lane, T.—xxvi. 128
 Lane, W. R.—iii. 35; xxii. 794
 Laneegger, see Waldburger & Lanenegger
 Lavenille, V.—France, 287
 Lang, A. F.—Zollverein (4), 34
 Lang, F.—Austria, 349, 661
 Lang, G.—Zollverein (2), 77
 Lang, J.—viii. 226; Austria, 185
 Lang, L.—France, 288
 Langdals, Ann & Helen.—xvi. 222
 Langdale, D.—i. 220
 Langdale, E. F.—xxix. 53
 Langdale, H.—xvi. 23
 Langdon, see Brookman & Langdon
 Langdon & Sons.—xx. 168
 Langdon, W.—xvi. 91
 Langdon, W. jun.—xvi. 89
 Langdorf, see Metert & Langdorf
 Lange, A.—Zollverein (3), 17
 Lange, C.—Mecklenburg-Strelitz, 2
 Lange, Desmoulin.—France, 1291
 Lange, F.—Zollverein (1), 739
 Lange, Franz, & Sons.—Austria, 179
 Lange, H.—Denmark, 42
 Langenbeck & Martini.—Zollverein (1), 576
 Langenheim, W. F.—United States, 62
 Langner, J.—Austria, 329
 Langenthal, G.—Zollverein (1), 740
 Langevin & Co.—France, 898
 Langgaard, J. P.—Denmark, 18
 Langlade.—France, 1650a.
 Langlands, J.—x. 336
 Langley, see Morton & Langley
 Langlois & Leclercq.—France, 299
 Langner, H.—Zollverein (1), 833
 Lame, E.—France, 1641
 Lantein & Co.—France, 566
 Lantheere, F. & Co.—Belgium, 486
 Lapas, D.—Greece, 10
 Laperriere.—France, 1710
 Lapiere & Son.—France, 561
 Lapeyre (Uncle) & Dolbean.—France, 1202
 Lapeyre, Koh, & Co.—France, 1642
 Laporta, H. F.—Austria, 387
 Laporte, V. & Son.—France, 900
 Lapshin.—Russia, 145
 Lapeff, N.—Russia, 371
 Laphors, J.—viii. 170
 Lapworth, A.—xix. 232
 Lara, D. de.—xxx. (Fine Art Court), 243
 Larche, see Fortel, Larche, & Co.
 Larcher, Faure, & Co.—France, 1293
 Larcher, Juao.—Portugal, 467, 468
 Larchers & Co.—Portugal, 787-797
 Lardere, Comit F. de.—Tuscany, 24
 Lardinis, N. C.—Belgium, 151
 Larisch-Moennich, Comit H.—Austria, 59, 92
 Lariviere, C.—France, 290
 Laroche, E.—France, 291
 Laroche, M.—xxx. (Fine Art Court), 252
 Laroque, Son, Brothers, and Jaquemet.—France, 901
 Larsonnier, see Hemoville, & Co.
 Larstig, M.—Austria, 62
 Lart & Son.—xx. 81
 Lasaca, J. J.—Spain, 113
 Lascelles, E.—xxx. (Fine Art Ct.), 18
 Lascelles, J. W.—xxix. 123
 Lassa, M. R.—Portugal, 1151
 Lasson, A.—France, 565
 Last, J.—xvi. 33
 Last, S.—xvi. 38
 Lata.—Portugal, 1151
 Latache de Neuville, P. A.—France, 562
 Latchmare, see Beale, C. & Latchmore
 Latellin & Puyen.—France, 1643
 Latham & Dighton.—xxvi. 251
 Lathrop, J.—United States, 299
 Lathie, A.—Belgium, 184
 Latour, A. de.—Belgium, 363
 Lattermann & Sons.—Zollverein (3), 27
 Lauchhammer.—Zollverein (1) 852
 Laudacher.—Austria, 164a
 Lauda, A.—France, 897
 Laue, Eliza.—Switzerland, 55
 Laue, F.—Switzerland, 65
 Laugier & Cosens.—xix. 10
 Laughland, J.—xx. 141
 Laugier.—France, 1610
 Laumain, C.—France, 292
 Laur, J. A.—France, 567
 Laurean, L.—France, 293
 Laureaudiere, late Guyot.—France, 1294
 Laurence, Elizabeth.—xx. 158
 Laurencot, E.—France, 1296
 Laurent, D.—Canada, 31
 Laurent, F.—France, 564, 1297
 Laurent-François.—France, 1297
 Laurent, J. B.—France, 902
 Laurent, Pauline.—France, 563
 Laurent-Gsell & Co.—France, 294
 Laurentz, L.—Austria, 108
 Lauret, Brothers.—France, 903
 Laurie, R. W.—viii. 195
 Laurie, S.—x. 576
 Laurie, W.—xxvii. 101
 Laurin, J. J.—Canada, 180
 Laury, G. A.—France, 568
 Lautenstein, see Croissan & Lautenstein
 Lauterburg, F.—Switzerland, 48
 Lauterburg, J. & Co.—Switzerland, 129
 Lauts, L.—France, 295
 Lava, De K.—Belgium, 500
 Lavanchy, J. B.—vii. 84
 Lavars, J.—viii. 31
 Laverdure.—Zollverein (1) 845
 Laverrihe & Mathieu dit Verger.—France, 1298
 Laviollette, De Moor.—Belgium, 96
 Lavoiay, A. D.—France, 1290
 Law & Sons.—xxvi. 59
 Law, see Buchanan & Law.
 Law, E., see Law, W. & E.
 Law, R.—ix. 94
 Law, W.—vi. 460
 Law, W. & E.—xviii. 10
 Lawden, see Tipping & Lawden
 Lawlor.—xxx. (Sculpture Court), 22
 Lawrence, see Robbins & Lawrence
 Lawrence, A., see Lawrence, A. & A. & Co.
 Lawrence, Hon. A.—United States, 521
 Lawrence, A. & A. & Co.—United States, 453
 Lawrence & Co.—x. 722
 Lawrence, I.—x. 115
 Lawrence, J., see Lawrence, T. B. & J.
 Lawrence, J., sen.—vi. 604
 Lawrence, M. M.—United States, 151
 Lawrence, Stone, & Co.—United States, 494
 Lawrence, Col. T. B.—United States, 516, 517
 Lawrence, T. B. & J.—xxii. 54
 Lawrence, W.—ii. 56
 Lawson.—North Transept, 390
 Lawson, A.—xiv. 63
 Lawson, H.—x. 194
 Lawson, J.—xix. 325; xxx. 337
 Lawson, J. & Co.—xii. & xv. 294
 Lawson, P. & Son.—iii. 195
 Lawson & Sons.—vi. 75
 Laxton, H.—xxii. 106a
 Laya & Co.—Algeria, 32
 Layard, Caroline M.—xxx. (Fine Art Court), 78
 Laycock, J.—ix. 134
 Laycock & Sons.—xvi. 330
 Laydet, sen., & Co.—France, 296
 Lazure, V. sen., & Lacroix.—France, 905
 Lea, A.—ii. 105
 Lea, J., see Lea, W. & J.
 Lea, W. & J.—xxii. 665
 Leach, H. J., see Leach, M. S. & H. J.
 Leach, M. S. & H. J.—United States, 155
 Leach & Sons.—xii. & xv. 5
 Leach, T.—vi. 7.
 Leadbeater, J.—xxii. 506; xxix. 221
 Leadbetter & Co.—xiv. 63
 Leadbetter, J. & Co.—xii. & xv. 205; xiv. 9
 Leadbetter, J. G.—v. 650
 Leake, F.—xxx. (Fine Art Court), 63a
 Leal, F. M. C.—Portugal, 31, 32, 65-67, 73, 74, 78, 79, 497, 515
 Leale & Albrecht.—xxix. 108
 Leau, J.—i. 443
 Lear, Ellen, see Rankin, Emily, & Co.
 Leard, A.—x. 620
 Learmouth, T.—New South Wales, 8, 12
 Leard & Reynolds.—United States, 35
 Learned & Thatcher.—United States, 100
 Leary, E.—xii. & xv. 89
 Leaward, T.—xxii. 578
 Leary & Co.—United States, 130
 Leask, Mrs. J.—United States, 103
 Leathart, T.—xvi. 317
 Leather, J. W.—vii. 107. (Main Avenue, West)
 Leaver, J.—xxii. 583
 Leavesley, see Hands & Leavesley

u (1) 845
u dit Verger.—
Belgium, 96
ce, 1299
59
Law.
& E.
10
& Lawlen
ture Court), 22
& Lawrence
rence, A. & A. &
United States, 521
& Co.—United
22
rence, T. B. & J.
e, 604
United States, 151
—United States,
—United States,
—xxii. 54
ept, 390
xxx. 357
i. & xv. 204
ii. 195
5
32
—xxx. (Fine Art
i. 330
France, 296
acroix.—France,
J.
55
, M. S. & H. J.
United States, 155
xv. 5
06; xxix. 221
63
—xii. & xv.
50
Art Court), 63A
al, 31, 32, 65—
7, 513
x. 108
Emily, &c.
th Wales, 8, 12
—United States,
—United States,
59
8
ates, 130
States, 108
07 (Main Ave—
Learesley

Leavitt, G.—Canada, 150
Lebaigue.—iii. 29
Lebeda, A. V.—Austria, 114
Lebel, L.—France, 1300
Lebert, L.—France, 569
Leblanc, E.—x. 658A
Leblanc, A.—France, 297
Lefebvre, H.—France, 570
Leblond, J. D.—France, 1301
Lebere, see Boudoin & Lebere
Lebrun, A.—France, 298, 571
Lebrun, J. A. jun.—France, 572
Lebrun, L. J.—France, 900
Lecland, S.—xxvi. 183
Leclercq.—Belgium, 479
Leclercq.—France, 573 (Main Avenue,
East)
Leclercq, Brothers.—France, 574
Lechner, F.—Austria, 631
Lechner, M.—Austria, 496
Leclere, Brothers.—France, 576
Leclere, H.—France, 299
Leclerc, J.—France, 575
Leclercq, A.—Belgium, 425
Leclercq, J. P.—Belgium, 88
Leclercq, N.—France, 1302
Leclery, see Langlois and Leclery
Leclercq, H.—France, 1614
Leclercq-Preville.—France, 1303
Lecoentre.—France, 300
Lecomte, see Bruner, &c.
Leocq & Reider.—France, 1304
Lecloutre, A.—Switzerland, 25
Lecloutre, Brothers.—Switzerland, 90
214
Lecloutre, G.—Switzerland, 262
Lecloutre & Goulay.—Switzerland, 263
Lecloutre, J.—Switzerland, 215
Lecloutre, D., & Son.—Switzerland, 32
Leclun & Co.—France, 1306
Leddiard & Co.—xviii. 38
Ledent, M.—Belgium, 148
Ledger, C.—xxii. 155
Ledoux, A.—Switzerland, 58
Ledreney, C.—France, 1307
Ledue, C.—France, 1645
Lee, see McGregor & Lee; Rigby & Lee
Lee, B.—xxiii. 71
Lee, C.—ii. 69
Lee, F.—xxviii. 35
Lee, G.—viii. 136; xxii. 693
Lee, G. L.—xxvi. 402.
Lee, J.—v. 507; x. 614; xix. 241;
xx. 110A; xxv. 48
Lee, Dr. J.—i. 125
Lee, J. & Co.—United States, 530
Lee, J. G.—xxx. (Fine Art Court), 311
Lee, L.—xxvi. 133
Lee, R.—xxix. 185
Lee, T.—viii. 10
Lee, W.—United States, 332
Leeb, J.—Zollverein (2), 89
Leech, H.—United States, 159
Leeman, Z.—Switzerland, 257, 258
Leemig, J.—xiv. 41
Leempool, Van, de Colnet & Co.—
France, 714
Leemert, see Deyl, Van der, &c.
Leeren Manufactory.—Sweden and Nor-
way, 39
Lees, A.—xx. 127A
Lees, G., see Lees, R. & G.
Lees, J.—xxx. (Fine Art Court), 195
Lees, R. & Co.—xix. 79
Lees, R. & G.—xii. & xv. 192
Lees, T.—v. 204.
Leeson, Dr. H. B.—i. 8
Lefancheux.—France, 1308
Lefebvre, see Dubreuil, &c.
Lefebvre, L. J. jun.—Netherlands, 107

Lefebvre, A.—France, 1646
Lefebvre, J. B.—France, 578
Lefebvre, A.—Belgium, 401
Lefebvre, A. P., France, 577.
Lefebvre, Brothers.—France, 579
Lefebvre, Son, & Co.—France, 907
Lefebvre, T. & Co.—France, 580
Lefebvre, V. & Co.—Belgium, 354
Lefevre.—France, 581, 1311, 1648
Lefevre, E.—France, 1312
Lefevre, Ducatteau, Brothers.—France,
1309
Lefrançois.—France, 301, 582
Lefsky, see Boeing, Roehr, & Lefsky.
Lefwich, W. H.—viii. 27
Legal, R.—France, 583
Leggatt.—v. 640
Leggatt, H.—Canada, 341
Legler.—Eastern end (outside) 103.
Legloff, see Barholin & Legloff.
Legrand, see Marsaux & Legrand;
Schneider, Brothers, & Legrand
Legrand, D.—France, 1313
Legrand, M.—France, 584
Legras, A.—Belgium, 47
Legras, L. N.—vii. 93
Legrew, J.—Page 851; xxx. (Sculpture
Court), 8
Lehmann, A. F.—Zollverein (1), 107
Lehmann, C. G.—Zollverein (3), 107
Lehmann, D. J.—Zollverein (1), 136
Lehmann, H.—Zollverein (1), 138
Lehmann, J. A.—Hamburgh, 49
Lehmann, M.—Zollverein (1), 167
Lehmann, R.—Zollverein (1), 47
Lehrer, see Kutzer and Lehrer
Lehrkuhl, Falkenroth, & Co.—Zoll-
verein (1), 447
Lehrmann, J. J. A.—Hamburgh, 47
Lehuby.—France, 302
Leicher, A.—Zollverein (8), 6
Leichtfrost, E.—Austria, 192
Leitchild, H. S.—Page 851
Leigh, E.—v. 61.
Leighton.—xxx. (Fine Art Court), 112
Leighton, J.—xxx. (Fine Art Court), 59
Leighton, J. & J.—xvii. 24
Leighton, Jane & R.—xvii. 158
Leighton, R., see Leighton, Jane, & R.
Leimkueller.—Zollverein (1), 398
Leinster, G. L.—France, 1716
Leipzig, Society of Worsted Spinners at.—
Zollverein (3), 44
Leisegang, W.—Zollverein (1), 149
Leistler, C. & Son.—Austria, 633
Leitner, G. L.—France, 908
Leitch & Hammond.—xxv. 59
Leitenberger, E.—Austria, 186
Leitenberger, F.—Austria, 187
Leith, S.—xxx. (Fine Art Court), 114
Lejeune, E.—France, 1314
Lellan, P.—xxix. 185
Lemaître, C., Detige & Co.—Belgium,
300
Lemaire.—France, 1315; see also
Gevelat & Lemaire
Lemaire-Descamps & Plissart.—Bel-
gium, 240
Lemaire, H.—France, 586. (Main
Avenue, East).
Lemaire, P. H.—France, 586
Lemaître, see Bleriot & Lemaître
Lemaitre, B.—France, 1316
Lemann, J., & Son.—Austria, 265
Lemare, Jane Clara.—xxix. 79
Lemerier, R. J.—France, 557
Lemire, see Bohee & Lemire
Lemire & Son.—France, 1649
Lemolt, A. E.—France, 303
Lemou, see Graham, Lemou, & Co.

Lemoumier.—France, 304
Lemoumier & Co.—France, 909
Lemseigne, L.—France, 1728
Lendenmann, J. C.—Switzerland, 232
Lendenmann, T. C.—Switzerland, 56
Lendy, N.—Sardinia, 60
Lemna, W.—xvii. 61
Lemou, R.—xviii. 77
Lemox, F. M. K.—xx. 147
Lenny, J. T.—xvi. 27
Lenormand, see Brunier, Lenormand,
& Co.
Lenormand, A.—France, 588
Lenox, see Brown, Lenox, & Co.
Lennsen, J.—Austria, 173A
Lentaigne, J.—i. 5, 138
Lentz, C.—Zollverein (4), 67
Leon.—France, 365
Leon, A.—xxii. 220
Leon District, Inspector of Mines of.—
Spain, 17
Leon, J.—Spain, 274
Leon-Clement & Bourgeois.—France,
306
Leoy, L.—New South Wales
Leon y Rico, E. de.—Spain, 243
Leonard, C.—France, 9
Leonard, D.—Belgium, 198
Leonard, J. & T. P.—iii. 20
Leonard, S. W.—x. 306
Leonard, Str., Company of (Liège).—
Belgium, 374
Leonard, T. P., see Leonard, J. & T. P.
Leonessa Asturian Co.—Spain, 21
Leonhardt, J. E.—Zollverein (1), 55
Lepage.—Belgium, 145; see also
Chailoux, Lepage, & Pochon
Lepel'etier.—Algeria, 33
Lepel'etier.—France, 307
Lepine, F. D.—France, 910
Lepori, T.—Tuscany, 47
Lepyer, G.—Zollverein (2), 6
Lequestre, E. E. L.—Main Avenue, East
Lerkhe.—Russia, 311
Lerolles, Brothers.—France, 1318
Leroux.—Belgium, 246-250
Leroux.—France, 303, 309
Leroux-Maignin.—France, 447
Leroy & Co.—United States, 586
Leroy & Son.—France, 1186.
Leroy Soyer.—France, 1320
Lervilles, J.—France, 591
Lerwick Local Committee.—xx. 213A
Lesaca, J. J.—Spain, 113
Leschene, A. J. B.—France, 573
Lesdernieres, P. T. C. de.—Canada, 24
Lesecq, H.—France, 592
Lesigne, T.—Belgium, 279
Leslie.—xxii. 87; see also McDonald
& Leslie
Leslie, J.—xxii. 101
Lesourd-Delisle, A.—France, 593
Lespinasse.—France, 311
Lesseux & Son.—France, 1321
Lester, see Brady, D'Avignon, & Lester
Lester, T.—v. 700; xix. 236
Letaurel, J. H.—Jersey & Guernsey, 47
Lettellier, see Louis, Blais, &c.
Lethem, Hlyth, & Lethem.—xi. 9
Lethuillier-Pinel.—France, 312
Lettourneur, J.—vii. Main Avenue,
West, 157
Lettmeyer, T.—Zollverein (4), 75
Lettilliois, F. L. G.—France, 1322
Leuba, H.—Switzerland, 91
Leube, Brothers.—Zollverein (4), 5
Leuchars, W.—xxix. 44
Lenderdorff, A. C.—Zollverein (1), 387
Lennmann, Brothers.—Switzerland, 130
Leimenschloss, M.—France, 313

Lenschner, *see* Stauss & Lenschner
 Levarlet, *see* Laclapelle & Levarlet
 Levashoff, —Russia, 266
 Leven, F.—Zollverein (1), 423
 Leven & Son.—France, 1323
 Lever, J. & J.—xvi. 24
 Leverkus, C.—Zollverein (1), 875
 Levert, Brothers.—France, 1324
 Levey, J.—Canada, 73. 130
 Levick, *see* Owen & Levick
 Levien, J. M.—xxvi. 203
 Levin & Sons.—Zollverein (1), 114
 Levraud, P. J.—France, 594
 Levy, *see* Robson, Levy, & Co.
 Levy, Brothers.—France, 595
 Levy, H.—Zollverein (3), 31
 Levy, W.—iii. 120
 Lewin, H. G.—xvi. 165
 Lewis, *see* Lane & Lewis
 Lewis & Allenby.—xii. & xv. 276; xiii. 16; xxix. 141
 Lewis, Miss.—xxix. 98
 Lewis, Mrs. C.—xvii. 163
 Lewis, C. B.—v. 902
 Lewis, D.—xxx. (Fine Art Court), 143
 Lewis, G.—xxii. 673
 Lewis, R.—Canada, 244
 Lewis & Son.—xx. 114
 Lewis & Sons.—vi. 209
 Lewis, T.—New Zealand, 13
 Lewis, W.—xii. & xv. 238
 Lewy, Brothers.—Zollverein (1), 198
 Ley, F.—xix. 255
 Leyland, Capt.—Main Avenue, East, 103; Rome, 16
 Leyser, M. L.—Zollverein (3), 16
 Lhoest, C. V.—France, 912
 Lias & Son.—xxiii. 126
 Lichtenal, M.—Russia, 172
 Lichtl, J.—Austria, 523
 Lidberg, A. G.—Sweden, 76
 Liddell, J. J.—x. 362
 Liddiard & Co.—xviii. 43
 Liebig, F.—Austria, 241
 Liebig, J.—Austria, 298
 Liebisch, J.—Austria, 188
 Liechfield.—xxx. (Fine Art Court), 330
 Lieck, A.—Zollverein (1), 436
 Liel, C. I.—Zollverein (1), 276
 Lieder, F.—Austria, 524
 Liegard, H.—France, 1651
 Liege, Royal Cannon Foundry.—Belgium, 142
 Lienard, M. J.—France, 1326
 Lienart-Chaffaux, Madame.—Belgium, 242
 Lienhardt, F.—Zollverein (2), 43
 Liepmann, J.—Zollverein (1), 147
 Lieske & Haebler.—Zollverein (3), 52
 Lietzmann, J. C. H.—Zollverein (1), 182
 Lievain, L.—Belgium, 351
 Lievigliani.—Tuscany, 6
 Lievre, H. Le.—xviii. 60
 Liewen, Madlle, de.—Sweden & Norway, 32
 Ligar, C.—New Zealand, 27
 Light, E.—viii. 5
 Lightfoot, T. M.—vi. 152
 Lightly & Simon.—Trinidad, Mexico.
 Lighton, J.—iii. 1
 Lignac, Martin de.—France, 922
 Likhacheff, P.—Russia, 325
 Lillywhite, J.—viii. 273
 Lillywhite & Sons.—xxix. 106
 Lima, J. M. da.—Portugal, 905
 Limelette, F.—Belgium, 381
 Limerick Local Committee.—i. 212
 Limes, *see* Alcan & Limes
 Limeuse, Charlotte.—xxx. (Fine Art Court), 179

Limoges, D.—Canada, 40
 Linares, the Director of the Mines of.—Spain, 5
 Linares Lead Mining Association.—Spain, 14
 Linmer, L.—xvii. 24, 47, 158; xxx. (Fine Art Court), 35, 211
 Lincoln & Hemmett.—xi. 57
 Lindauer, Miss E. L.—Zoll. (4), 101
 Linden, P. Van.—Belgium, 512
 Linden, A., Van der.—Netherlands, 60
 Lindenbergh, J.—South Africa, 45
 Linder, *see* Wax & Linder
 Linder, B.—Zollverein (1), 629
 Linder, R.—Switzerland, 152
 Linderoth.—Sweden, 80
 Lindgren, C.—Sweden, 96
 Lindheim, H. D.—Austria, 422
 Lindley, C.—i. 187
 Lindsay & Co.—viii. 134
 Lindsay, G.—ii. 16
 Lindsay, H. H.—China
 Lindsay, J.—xvii. 200
 Lindsays, *see* Crawford & Lindsays
 Lindsey, M.—x. 613
 Lindt, *see* Meyer & Lindt
 Line, J., *see* Line, W. & J.
 Line, W. & J.—xvi. 120
 Lines & Co.—xvii. 168
 Lingard, G.—xxii. 264
 Lingenshink & Vennemann, Zollverein (1), 526
 Lingham, T.—Canada, 49
 Linares, Count de.—Portugal, 483, 484
 Linioges, D.—Canada, 46
 Linklater, J.—xx. 174
 Linklater, J.—ii. 82; iii. 24
 Linley, *see* Hensworth & Linley
 Linley, G. A. F.—xxii. 231
 Linley & Sons.—xxii. 41
 Linton, J.—v. 116
 Linton, W.—xxix. 142
 Lintz, J. L.—Zollverein (2), 5
 Lion, Brothers, & Co.—France, 1327
 Lipke, W.—Zollverein (1), 165
 Lipp, R. R.—Zollverein (4), 22
 Lipp, Friedrich von.—Zollverein (1), 658
 Lippe, Count.—Zollverein (1), 316
 Lippert, D.—iv. 97
 Lippincott, Grambo, & Co.—United States.—57
 Lippmann, Julius.—Austria, 46
 Lipscombe & Co.—x. 703
 Lipscombe, F.—v. 670; xxv. 61; Van Diemen's Land, 42, 174, 297, 308
 Lipscombe, J. & Co.—xxv. 54; xxvii. 49
 Lipski, Von.—Zollverein (1), 25
 Lisabou Company.—Portugal, 707-712
 Lisbon Weaving Company.—Portugal, 684-712. 715. 723
 Liscoet, Du, Sou & Co.—France, 1328
 Lisinsk Forest Institution.—Russia, 83
 Liskeard Committee.—i. 167, 513
 Lissa, Corporation of Millers at.—Zollverein (1), 35
 List, G. B.—x. 175
 Lister, *see* Hebblethwaite & Lister
 Lister & Sons, xxiii. 27
 Liszt, A.—Austria, 165
 Litchfield, J.—xxx. (Fine Art Ct.) 330
 Lithgow & Purdie.—xxvi. 105; Bay, P. i.
 Litke, J.—Russia, 226
 Litschke, C.—Austria, 678
 Little & Co.—xxix. 174
 Little, R. De.—Van Diemen's Land, 309, 310
 Little, Major R. J.—v. 476; x. 196
 Littlehales, P.—x. 333

Littler, Mary Ann.—xii. & xv. 282
 Littman, E.—Sweden and Norway, 15
 Liverpool Local Committee.—Page 85; xxix. 270
 Livisiana, Avo Ercole.—Rome, 14
 Llanguenech Coal Company.—i. 259
 Lloyd, *see* Campbell, Harrison, & Co.; Salt & Lloyd
 Lloyd, A.—xxix. 6
 Lloyd, E.—v. 45
 Lloyd, G.—v. 300
 Lloyd, G. B.—xxii. 357
 Lloyd, Lieut.-Col. J. A.—x. 322
 Lloyd, J. P.—xvi. 117
 Lloyd, L. J.—United States, 78
 Lloyd, R.—xvii. 25
 Lloyd & Summerfield.—xxii. 700A - xxiv. 18
 Lloyd, W. & Co.—xii. & xv. 254
 Lokowitz, Prince Ferdinand Von.—Austria, 16, 53, 58, 124, 454
 Lochart Manufacturing.—Zoll. (1), 694
 Locatelli, *see* Alcan & Locatelli
 Lochhead, J.—xxiv. 23
 Locke, J.—xii. & xv. 15
 Lockert, D'Antonio.—Austria, 358
 Lockery & Stephenson.—xxii. 439
 Lockett, G.—xxv. 55
 Lockhart & Sons.—xiv. 57
 Lockington, *see* Bun, Lockington, & Co.
 Lockwood, Georgia.—xix. 240
 Lockwood & Keighley.—xii. & xv. 104
 Lockyer, J. H.—v. 582
 Lodde.—France, 1329
 Lodiges, J. & Sons.—Page 851
 Loeff, S.—Zollverein (1), 192
 Loewe, *see* Nauen, & Co.
 Loewenson, M.—Zollverein (1), 437
 Loewenstark, A. D.—xxiii. 62
 Löffler, F.—Austria, 339
 Logan, J.—Canada, 27, 57
 Logan, W. E.—Canada, 1
 Logeman, W. M.—Netherlands, 87
 Lohdesluk, W. A.—Hanover, 4
 Loh Steelworks.—Zollverein (1), 324
 Lohmann, F.—Zollverein (1), 630
 Lohm.—Zollverein (6), 29
 Lolise, F.—Zollverein (3), 85
 Loins, *see* Serinnee De Loins, & Co.
 Lokteff, J.—Russia, 204
 Lolagnier.—France, 1330
 Lolo, J.—Sardinia, 58
 Lomas, J.—xxvii. 81
 Lomas & Eves.—xvi. 125
 Lomas, W. R.—ix. 275
 Lombaer, J. B.—Belgium, 261
 Lombard.—France, 913
 Lombard, A. C.—Switzerland, 245
 Lombard & Hall.—United States, 428
 Lombardi, A.—Tuscany, 75
 Lombard-Jampeau, C. A.—Switzerland, 93
 Loncke-Haeze, C. L.—Belgium, 430
 London Art Union.—xxx. (Sculpture Court) 85
 London, D. H.—United States, 393
 London Druggists.—ii. 117
 London Marble and Stone Working Company.—xxvii. 17
 London & North-Western Railway Company.—v. 512, 513
 London Spice Trade.—iii. 53
 Loundos, A.—Greece, 6
 Long, C.—xxiv. 86
 Long, C. A.—v. 662
 Long, G.—xx. 16A
 Long, J.—i. 78, 123A; iv. 47; *see* also Long, J. & J. & Co.
 Long, J. & J. & Co.—viii. 71; xxii. 290A

- Long, J. P.—VIII. 175
 Long & Reynolds.—IV. 75
 Long, W.—I. 199
 Longden & Co.—XXII. 105
 Longdon & Sons.—XX. 168
 Longdon & Tubher.—XX. 572
 Longfield, W.—XXII. 503
 Longley, W. H.—XXX. (Fine Art Court) 95
 Longmaid, W.—I. 441
 Longman, J. & R.—XXX. (Fine Art Court) 238
 Longridge & Co.—Western end, North enclosure (Outside), 57; VIII. 333
 Longstaff, see Dixon & Longstaff, Ullathornes & Longstaff
 Longworth, N.—United States, 199
 Lonkutin & Son.—Russia, 319
 Lonsdale Co.—Rhode Island, United States, 35
 Loo, F., see Loo, E. J. & F. Van Lou, E. J. & F. Van.—Belgium, 339
 Loose, C. L.—Hamburg, 74
 Loose, J. R.—Hamburg, 75
 Loosen, J. G.—Zollverein (1), 336
 Loot.—x. 696
 Lopes, T. J.—Portugal, 1254
 Lord, Lynch, & Co.—United States, 366
 Loreutz, F.—Zollverein (1), 589
 Lorenz, Alois.—Austria, 75
 Lorenz, G.—Zollverein (1), 37
 Lorette, Indians of.—Canada, 177
 Loring, G.—United States, 424
 Lorkin, J.—XXII. 692; xxv. 52
 Lorse, E.—Zollverein (3), 85
 Lorthois-Desplanque.—France, 314
 Lortie, P. M.—France, 1652
 Löschenkohl, C.—Austria, 525
 Löschenkohl, J.—Austria, 526
 Loseby, E. T.—x. 12; xxii. 796
 Loshikareff.—Russia, 35
 Lossen, M.—Zollverein (8), 2
 Loft, G.—Russia, 272
 Lötz & Gerstner.—Austria, 594
 Louderback, M. J.—United States, 7
 Lough, J. G.—Page 850
 Louis, Blais, Letellier, & Co.—France, 315
 Louit, Brothers, & Co.—France, 316
 Loulé, Marquis de.—Portugal 401b, 578
 Loureiro, A. J.—Portugal, 647
 Loureiro, A. G.—Portugal, 716-720. 727
 Love, J.—XXII. 332
 Lovegrove, H. jun.—xxvi. 23
 Lovejoy, G.—x. 158; xvii. 176; see also Cowstade & Lovejoy
 Lovelace, Earl of.—xxvii. 87
 Lovenskiöld.—Sweden & Norway, 35
 Loveridge, see Shoalbred, &c.
 Low, A.—ix. 264
 Low & Co.—XXIX. 30
 Low, J.—I. 489
 Low & Motion.—New Zealand, 24
 Lowcock, H.—ix. 28
 Lowe, see Mapplebeck & Lowe
 Lowe, A. & Co.—vii. 62
 Lowe, G. G.—vii. 145
 Lowe, H., see Lowc, J. & H.
 Lowe, J. & H.—XXII. 346.
 Lowe, T.—xxv. 39
 Lowe, W.—vii. 33
 Lowell Machine Shop.—United States, 447
 Lowenthal & Co.—Hamburg, 91
 Lowes, T. Y.—Van Diemen's Land, 191. 286
 Lowry, see Rogers, Lowry, &c.
 Lowry, J. W.—I. 18A.
- Lowry, S.—x. 10
 Lowthian & Parker.—xi. 22
 Loy, F. Van.—Belgium, 508
 Loy, W.—xxi. 14
 Loy, W. T. jun.—xxi. 15
 Loyel, E.—xxii. 488
 Luard, Beetham, & Co.—I. 176
 Lubbert, E.—Zollverein (1), 24
 Lucardie, J. M.—Netherlands, 103
 Lucas, Brothers.—XXIX. 316; France, 1331
 Lucas, F.—XXIX. 49
 Lucas, F. W. & C.—Zollverein (1), 650
 Lucas, G.—XXIX. 110. 277
 Lucas, H.—XXIX. 127
 Lucas, M.—Zollverein (1), 8
 Lucas, P. jun.—xxvi. 397
 Lucas, R. C.—xxx. (Fine Art Court), 306
 Lucas, R. & Co.—New Zealand, 40
 Lucas & Son.—XXII. 204A
 Luce, P. N.—France, 1332
 Lucena, the Corporation of.—Spain, 231A
 Lucius, J. C. & Co.—Zollverein (1), 729
 Luckhaus & Gunther.—Zoll. (1), 631
 Luckman, see Woodhouse & Luckman
 Luce, see Dandoy, Maillart, & Co.
 Lüdens.—Zollverein (1), 682
 Ludlam, —United States, 389
 Ludwig, F.—Austria, 679
 Luedlich, W.—Zollverein (1), 61
 Luehdorf, see Jansen and Luehdorf
 Luehdorff, J. & Co.—Zoll. (1), 584
 Luer, A.—France, 1333
 Luettringhaus.—Zollverein (6), 65
 Luetwitz, Freiherr Von.—Zoll. (1) 42
 Luff, J.—xxvii. 111
 Luff & Son.—x. 477
 Lugo, Breausa, & Corunna, Inspectors of Mines of.—Spain, 18
 Lühme, J. F. & Co., see Metser, U. & J. F. Lühme
 Lumm & Ruettlen.—Zollverein (1), 531
 Lumsden.—Van Diemen's Land, 145, 146; see also Wynne & Lumsden
 Lumsden, Miss I.—xxx. (Fine Art Court), 125
 Lunau, B. H.—Lubeck, 6
 Lund.—xii. & xv. 163; Belgium, 476; see also Barraud & Lund
 Lund, W.—France, 15
 Lundberg, R.—Sweden & Norway, 11
 Lunde, P. F.—Denmark, 12
 Lundgren, P. W.—Sweden, 100
 Lundqvist, A.—Sweden & Norway, 11
 Lundy, J. A. V.—France, 914
 LundyFoot & Co.—III. 44
 Luntley, J.—x. 237
 Luntley, J. & Co.—xxx. 214
 Lupp & Son.—Zollverein (1), 605
 Luppold.—Zollverein (1), 84
 Lupton, see Raynes, Lupton, & Co.
 Lupton, J.—xvi. 3
 Lupton, W. & Co.—xii. & xv. 33
 Lurasco, Brothers.—Netherlands, 100
 Luscombe, see Toms & Luscombe
 Lusk, A.—Zollverein (1), 140
 Luspria, see Gay & Luspria
 Lussy & Co.—Switzerland, 153
 Lutch, J.—Russia, 179
 Lutge & Parsons.—xvi. 310. 328
 Luther, G.—Zollverein (3), 187
 Luttig, C.—Zollverein (1), 81
 Lutwyche & George.—xvi. 53
 Lutz.—Switzerland, 94
 Lutz, Brothers.—Zollverein (1), 103
 Lutzou, de.—Algeria, 34
 Lux, Brothers.—Zollverein (1), 796
 Luz, F. J. da.—Portugal, 756-769. 775, 776
- Lydes.—ix. 141
 Lyell, see Cornell, Lyell, &c.
 Lyngton & Co.—xi. 151
 Lyman, H.—Canada, 135
 Lynch, see Lord, Lynch, & Co.
 Lynch & Inglis.—v. 24
 Lyon & Co.—I. 226
 Lyon, E.—United States, 221
 Lyon, W.—xxvi. 30
 Lyons, Agricultural Society.—France, 1537
 Lyons, Chamber of Commerce.—France, 1141. 1565
 Lyons, G.—viii. 86. 136
 Lyons, J.—xx. 67
 Lyons, M.—vi. 203
- Maas, H.—Netherlands, 4
 Mabey, J.—xxx. (Fine Art Court), 141
 Mahire.—France, 1334
 Mabrun, P.—France, 653.
 M'Adams, J. & W.—United States, 482
 M'Adams, W., see M'Adams, J. & W.
 M'Alister & Tamehill.—United States, 382
 McAlpin, Stend, & Co.—xviii. 14.
 Macalpine, W.—xxii. 548
 MacAnaspie, P. & J.—I. 131A
 McArthur, see Ramsay & McArthur
 Macarthur, D. & Co.—xix. 60
 Macarthur, Lieut.-Col. E.—New South Wales, 13
 Macbay, W.—v. 586
 M'Bride & Co.—xi. 6
 McCall, see Ritchie & McCall
 McCallum.—xviii. 64.
 McCallum & Hodson.—xxvi. 136
 McCann, J.—III. 153
 M'Carten, H.—xix. 246
 M'Carthy.—xxiii. 112
 M'Carthy, H.—Page 851
 M'Cartney & Drummond.—ix. 248
 M'Cay, T.—xiv. 19
 M'Clelland, D.—viii. 116
 McClintock, G.—xxvii. 20
 M'Clintock, J. & Co.—xx. 152
 McClure & Co.—vi. 160
 M'Clure, J.—xxii. 568
 McConnell, I. E.—v. 539
 M'Cormick, C. H.—United States, 73
 M'Cra.—xx. 218
 McCracken, J. & R.—Austria, 590
 McCracken, R., see McCracken, J. & R.
 M'Cra, H. C.—xii. & xv. 135
 McCulloch, see Glassford, Skinner, &c.
 McCulloch, C.—II. 96
 McCulloch, Dr. J.—Canada, 72
 McCulloch, S. D.—United States, 70
 McCullum, J.—xxii. 523
 McCullum, M.—III. 133
 McCully, C.—New Brunswick, 11
 M'Curdy, see Jones, White, &c.
 MacDaniel, O.—United States, 166
 M'Darmid, Miss.—xix. 217
 McDermott, F.—New Brunswick, 18
 Macdonna, G.—xii. & xv. 260
 M'Donald, A.—xxvii. 66; Rome, 30
 Macdonald, Dr.—x. 357
 Macdonald, Major C.—I. 20
 Macdonald, D. & J. & Co.—xix. 66
 Macdonald, J.—viii. 329; see also Macdonald, D. & J. & Co.
 Macdonald, L.—Rome, 18
 McDonald & Leslie.—xxvii. 74
 Macdonald, Margareta.—xix. 242
 MacDonalid, Sophia.—Jersey & Guernsey, 29
 McDunnell.—xxx. (Sculpture Court), 30

- MacDonal, E. J.—x. 67
 Macdougall, D.—xvi. 331; xx. 83
 MacDowall, C.—x. 68
 McDowall, W.—xvi. 170
 MacDowell, P.—Page 850; xxx. (Sculpture Court), 61
 Mace, J. M.—France, 1335
 Macedo, J. J. da.—Portugal, 465
 Macfarlan, J. F. & Co.—ii. 107
 MacFarlane, A.—Canada, 124
 MacFarlane, Brothers.—xix. 243.
 MacFarlane, G.—x. 673
 MacFarlane & Foster.—xix. 63
 Macfarlane, Son & Co.—xii. & xv. 297
 McGarry & Sons.—iii. 132
 McGee, J. G. & Co.—xx. 118
 McGerrick, F.—viii. 288
 McGibbon, E.—xi. 20
 McGibbon, J.—xvi. 147
 McGillan & Sullivan.—Canada, 105
 McGinn, T.—Canada, 61
 McGivan & Sullivan.—Canada, 106
 MacGregor, J. W.—xxviii. 146
 McGregor & Lee.—United States, 20
 McGregor, M.—xxiii. 46
 Machado, F. A.—Portugal, 54
 McHardy.—xxx. (Fine Art Court), 325
 Machell, T.—x. 654; xxii. 639
 M'Henry, J.—United States, 501
 Machet-Marote.—France, 596
 Machly.—France, 915
 Machon, J.—xxii. 168
 Macho, H. W.—Zollverein (1), 730
 Macindoe, G. P.—vi. 24.
 McKay & Co.—Canada, 144
 Mackay, W. H.—ix. 81
 McKay, W. L.—Newfoundland
 MacKeau, W.—xxix. 28
 Mackie, A.—New Brunswick, 7
 Macheller & Hampson.—xix. 231
 Macintosh, J.—v. 28
 McKensie, J.—United States, 569
 Mackenzie, D.—vi. 39
 Mackenzie, A.—xxii. 418
 Mackenzie, J. S.—vi. 314; vii. 125
 McKenzie, Mrs.—Van Diemen's Land, 167, 170
 MacKenzie, W.—xvii. 54
 Mackenzie, W. R.—xx. 112
 Mackie & Son.—xvi. 104
 Mackie, W.—vi. 126
 McKillean.—iii. 114
 McKillop, New Brunswick, 5
 Mackintosh & Co.—xxviii. 76; India, iv.
 Mackintosh, T.—Belgium, 471
 McKirdy, J. G.—vii. 4
 Mackinosh & Co.—Davy, Macmurdo, & Co.
 Mackrory, F.—vii. 173
 M'Lachlan, J.—vii. 181; xxvi. 337; Van Diemen's Land, 348
 MacLardy, L.—vi. 209
 McLaren, W.—viii. 139
 Macle, Van.—Belgium, 168
 McLean.—vii. 72; xxvi. 386; (Main Avenue, West); Nova Scotia; see also Cooper & Maclean
 McLean & Cummings.—Canada, 95
 Maclean, Jane.—xix. 248
 McLean & Wright.—Canada, 178
 McLenan, E.—United States, 252
 McLeod, R.—New Zealand, 30. 36
 M'Leud, W. W.—United States, 172x
 McLeannan, J. & Co.—xiv. 96
 MacLise.—xxiii. 83
 MacMahon, C.—x. 601b
 McMillan, see Keer & McMillan
 McMullen, J.—United States, 64
 M'Murray, T. & Co.—xiv. 25
 Macnab, J.—viii. 139
 McNaughten—Van Diemen's Land, 96. 102
 M'Nair.—xxix. 162
 McNair, A. & Co.—x. 421
 M'Nair & Brand.—xviii. 50
 Macnar, W.—xvii. 117
 McNaught.—v. 101
 McNaught, W.—v. 22. 680; vi. 23
 M'Naughten.—Van Diemen's Land, 52. 96-102. 192-194. 209
 M'Naughten, A.—Van Diemen's Land, 41. 43
 McNeill, F. & Co.—vii. 142
 McNeill, J.—x. 512
 McNicholl & Verman.—v. 434
 Macomle & Co.—xvii. 25
 Macorra, F.—Spain, 65
 MacPherson, D.—x. 684a
 Macpherson, C. & H.—xxi. 36
 Macpherson & Francis.—Van Diemen's Land, 350
 Macpherson, H., see Macpherson, C.
 McPherson, J. & Sons.—Canada, 183
 McPherson, P.—ix. 258
 McQuacie, Fisher, & Co.—xix. 65
 Macquinay, Brothers, & Nephews.—Belgium, 373
 Macquoid.—xxvi. 161
 McRae, J.—viii. 341; xiii. 78
 McRae, J. & Co.—xxviii. 106
 McRae, J. J.—xx. 128
 McRae, W.—New Brunswick, 4. 6. 8.
 McSherry, M.—xxii. 408
 McVay, J.—New Zealand, 5
 McWeeny, M.—United States, 365
 McWilliam, Dr. J. O.—Western Africa, 5a
 Macy, J. & Sons.—United States, 306
 Macy, Stauton, & Co.—United States 368
 Maddon & Black.—xvi. 256
 Madeira, F. A.—Portugal, 1265
 Madeley, see Parr, Curtis, & Co.
 Maderboeck, M.—Austria, 527
 Madrid, Agronomical Cabinet of the Botanical Garden of.—Spain, 156
 Madrid, Royal Library.—Spain, 31
 Maele, Van.—Belgium, 168
 Maennel, F.—Zollverein (1), 828
 Maeren Vandlen, see Con Vandlen Maeren & Co.—Maes, France, 656
 Maffei, see Riva & Maffei
 Maffei, C. J.—Tuscany, 95
 Maffre, E. F.—Algeria, 35
 Magdaliniski, J.—Hamburgh, 38
 Magdesprung, Iron Works at.—Zollverein (1), 682
 Magee, W. J.—xiv. 7
 Maggiorelli, Brothers.—Tuscany, 67
 Magne, F.—Belgium, 440
 Magni, F.—Sardinia, 70
 Magni, G.—Austria, 126
 Magni, P.—Austria, 714
 Maguin, J. M.—France, 1654
 Maguin, J. V.—France, 1337
 Magnus.—x. 419
 Magnus, G. E.—xxvii. 46
 Magnus, Samuel.—St. Helena, 3
 Maguire, W. J.—xxix. 71
 Maha Rajah Goolab Singh.—India, xv. xxvi.
 Maha Rajah Rao Scindiah.—India, xv. xvi.
 Mahan, F.—United States, 568
 Maher, Louisa.—xx. 182
 Mahillon, C.—Belgium, 175
 Mahmet-Veli-Ogli.—Russia, 242
 Mahomet-Ogli.—Russia, 245
 Maiben, C.—xvi. 46
 Maidlow, J.—vi. 407
 Maillard, F.—France, 1338
 Maille & Segond.—France, 1339
 Maillot, E.—France, 597
 Mair.—xxii. 236
 Mair & Co.—France, 317
 Mair, Son, & Co.—xi. 591; xviii. 12. 63a
 Maisterra.—Spain, 43
 Maître, Brothers.—France, 598
 Mainland Mines.—South Africa, 1
 Mainland, R. T.—Netherlands, 92
 Maître, A.—France, 318
 Majendie, Ashurst.—i. 28
 Major, S. De.—Austria, 50
 Major & Gill.—xi. 49
 Major, C. T.—Brazil, 4; Persia
 Makepeace, Eliza.—xxx. (Fine Art Court), 165
 Makin, W.—xxii. 112
 Malaga, Agricultural Board of.—Spain, 91
 Malaga, Inspector of Mines of.—Spain, 19
 Malakatesi, J.—Greece, 25
 Malandrinus, A.—Greece, 3
 Malapane Iron Works.—Zollv. (1), 2
 Malapert.—France, 319
 Malatintzky, E.—Austria, 394
 Malcom, J.—xiv. 22
 Malherbe, L.—Belgium, 147
 Maling.—xxx. (Fine Arts Court), 154
 Maling & Small.—xxv. 42
 Malinge.—France, 322
 Malins & Son.—xxii. 261
 Mallien, Brothers.—xix. 244
 Mallien, W.—xxix. 289
 Mallandain & Co.—xxviii. 108
 Mallot, J. B.—France, 1340
 Millet, see Lalande & Chevalier; Vantroyen & Mallet
 Millet, Brothers.—France, 599
 Millet, E. C.—Belgium, 467
 Mallet & Co.—France, 1655. 1740
 Mallet, R.—i. 243
 Mallet & Barton.—xix. 29
 Mallinson & Sons.—xii. & xv. 108
 Malloch, P.—x. 208
 Malmgren, C. T.—Sweden & Norway, 19
 Malmqvist, A.—Sweden, 59
 Malo, Dickson, & Co.—France, 320
 Maltos, T. P. de.—Portugal, 533, 594
 Malvieux, C. J.—Austria, 102
 Mame & Co.—France, 321
 Mamede, B. G.—Portugal, 102
 Mammen, F. A. & Co.—Zollv. (3), 59
 Manby, G. W.—viii. 22
 Manchin & Morel.—xvii. 128
 Manco, le Chevalier Simone.—Sardinia, 15
 Manderson, W.—i. 148
 Manetti, Brothers.—Tuscany, 61
 Manfredini, G.—Austria, 715
 Manget, Mrs.—British Guiana, 68. 121
 Maniguet, N.—France, 1341
 Manilla, Economical Society of.—Spain, 187, 234, 235, 275a
 Manilla, Society of.—Spain, 250
 Mannin.—Russia, 65
 Mannings.—iv. 86
 Manley, General.—Rome, 32a
 Manlove, Alliot, & Seyrig.—vi. 405, 454
 Manly, J. jun.—xxii. 313
 Mann, A.—Canada, 324
 Mannesmann, A.—Zollv. (1), 617
 Mannheimier, W.—Zollverein (1), 438
 Manning, J.—iv. 63
 Manning, S.—xxx. (Sculpture Court), 57, 73

vi. 407
 France, 1338
 and.—France, 1339
 France, 597
 236
 France, 317
 Co.—xi. 59; xviii. 13
 bain, 43
 ers.—France, 598
 es.—South Africa, 1
 F.—Netherlands, 92
 France, 318
 burst.—i. 28
 Austria, 50
 —xi. 49
 —Brazil, 4; Persia
 Eliza.—xxx. (Fine Art
 xvii. 112
 Cultural Board of.—Spain,
 ctor of Mines of.—Spain,
 —Greece, 25
 A.—Greece, 3
 Works.—Zollv. (1), 2
 France, 319
 E.—Austria, 394
 xiv. 22
 —Belgium, 147
 (Fine Arts Court), 154
 ll.—xxv. 42
 France, 322
 —xxii. 261
 thers.—xix. 244
 —xxix. 289
 Co.—xxviii. 108
 —France, 1340
 ande & Chevalier; Van-
 illet
 rs.—France, 599
 —Belgium, 467
 —France, 1655. 1740
 243
 on.—xix. 29
 ons.—xii. & xv. 108
 t. 208
 —Sweden & Norway, 19
 —Sweden, 59
 & Co.—France, 320
 e.—Portugal, 533, 591
 —Austria, 102
 France, 321
 —Portugal, 1022
 & Co.—Zollv. (3), 59
 —viii. 22
 el.—xvii. 126
 alier Simone.—Sardinia,
 —i. 148
 —Tuscany, 61
 —Austria, 715
 British Guiana, 68. 121
 France, 1341
 ical Society of.—Spain,
 of.—Spain, 250
 65
 6
 l.—Rome, 32A
 s; & Seyrig.—vi. 405,
 xxii. 313
 ada, 324
 —Zollv. (1), 617
 —Zollverein (1), 438
 63
 xx. (Sculpture Court),

Mannings, G.—iv. 86
 Mansard.—France, 1312
 Mansbendel.—xviii. 88
 Manschön, M. F.—Austria, 342
 Mansell, D.—xii. & xv. 248
 Mansell, J.—xvii. 27
 Mansell, R. C.—v. 715
 Mansell, T.—vi. 502
 Mansfeld, the Combined Mining Works
 at.—Zollverein (1), 850
 Mansis, H.—Zollverein (1), 301
 Manso, R.—Spain, 133
 Manson, E.—France, 917
 Mansaut, L.—Sardinia, 53
 Mantel, W.—xvi. 321
 Mantois, Mme.—France, 918
 Mantou & Son.—viii. 217
 Mantz, see Blech, Steinhach, &c.
 Manuel, C.—South Africa, 11
 Manuel, H. S.—Jersey & Guernsey, 48
 Manufactory of Patent White Lead.—
 Zollverein (1), 5
 Maplin.—vii. 164
 Mappin & Brothers.—xxii. 139
 Mappings, J.—xxii. 180
 Mapple, D. D.—x. 69
 Mapple, H.—x. 126
 Mapplebeck & Lowe.—ix. 131; xxii.
 370
 Maquet, A.—France, 604
 Maquet-Hermel.—France, 603
 Marcelin.—France, 606
 Marcelle, S.—France, 605
 March, E.—Zollverein (1), 240 (Main
 Avenue, East)
 Marchal.—Algeria, 36
 Marchal, D.—Belgium, 362
 Marchand, E.—Belgium, 480
 Marchand, J. B.—France, 607
 Marchand, L.—x. 71
 Marchant, M.—xxvi. 320
 Marchant, W.—xxvi. 253
 Marchesi, G. B.—Austria, 139
 Marchesi, L.—Austria, 716
 Marchesi & Ossoli.—Rome, 13
 Marchetti, L.—Tuscany, 79. 121
 Marchiu, Communal Commission of.—
 Belgium, 306
 Marcinielle et Couillet, Societé An-
 onyme, De.—Belgium, 120
 Marcos, J.—Spain, 147
 Marcotte, F.—Canada, 8
 Marcuard, C. R.—viii. 343
 Mare, C. J. & Co.—viii. 149
 Mare, Le, & Sons.—xiii. 21
 Marechal & Guynon.—France, 329
 Marenzeller, L.—Austria, 166
 Maresch, see Bahr & Maresch
 Mareschal, J.—France, 330
 Marga, E.—France, 608
 Margarit & Eua.—Spain, 223
 Margarit, J.—Spain, 204
 Margary.—viii. 87
 Margetts, T. K. & Eyles.—xxvii. 91
 Margrave, see Esdailles & Margrave
 Marguerit, J.—Spain, 204
 Maria, J.—Portugal, 1279
 Marie, Louise.—Austria, 747
 Marie, M.—Jersey & Guernsey, 16
 Marimanoff & Armakoona.—Rus. lu, 81
 Marin, J. E.—Belgium, 414
 Mariner's Friend Society.—viii. 310
 Marion, A.—France, 609
 Mariotti, S.—Tuscany, 68A
 Marks, J. L.—v. 008
 Markwick, M.—iv. 114
 Marling, S. S. & Co.—xii. & xv. 209
 Marlow, J.—xvi. 54
 Marmora Iron Co.—Canada, 4
 Marne, A. & Co.—France, 1732

Marochetti, Baron.—Western extremity
 (Outside), 76; North Trausept, 30;
 Main Avenue, West, 92; xxiii. 112;
 xxv. 1
 Marples, R.—xxii. 128
 Marples, W.—xxii. 218
 Marquard, P.—Jersey & Guernsey, 42
 Marquard, Dr. L. C.—Zollv. (1) 327
 Marques, C. J.—Portugal, 1399
 Marques, J.—Spain, 108.
 Marr, W.—xxii. 510
 Marratt, J. S.—x. 409
 Marrel, Brothers.—France, 331
 Marrel.—Tuscany, 66A
 Marriage, E.—iii. 152
 Marrian, F.—xxiii. 31
 Marrian, J. P.—xxii. 363
 Marriott, Archdeacon.—Van Diemen's
 Land, 128. 307
 Marriott & Atkinson.—xxii. 160
 Marriott, Mrs. F.—i. 530; (Main
 Avenue, East)
 Marriott, J.—ix. 243
 Marriott, M.—x. 341
 Marriott, W.—vi. 116; xxii. 795
 Mars.—France, 919
 Marsaux & Legrand.—France, 332
 Marsden, B.—vi. 317
 Marsden, Brothers, & Silverwood.—
 109
 Marsden, C.—xvi. 316; xxii. 531;
 xxvi. 527
 Marsh.—xxvi. 67
 Marsh, F.—xvi. 174
 Marsh, J.—xxv. 58
 Marsh, Brothers, & Co.—xxii. 162
 Marsh, Mrs.—xix. 72
 Marsh, W.—xxvi. 31
 Marshall.—Van Diemen's Land, 150,
 160; see also Brown, Marshall, &
 Co.; Parking & Marshall
 Marshall, C.—xvi. 241
 Marshall & Co.—iv. 55; x. 686; xiv.
 26
 Marshall, E. S.—xxiii. 104
 Marshall, G.—Van Diemen's Land, 36,
 37
 Marshall, J.—ii. 68
 Marshall, Lieut. R.—xxx. 358
 Marshall, S.—xxii. 107
 Marshall & Snelgrove.—xiii. 33
 Marshall & Sons.—xxiii. 23
 Marshall, W.—Page 850; xx. 25;
 xxx. (Sculpture Court), 15
 Marshall, Lieut. Col. W.—ix. 35
 Marsland & Co.—vi. 47; xi. 63
 Marte Mining Co.—Zamora, Spain, 10
 Martel, Geoffray, & Valenot.—France,
 921
 Martelin, see Franc, A. & Son, &c.
 Martens, F.—France, 610
 Marti, S.—France, 601
 Martin, see Pawaon, Son, & Martin
 Martin, Baskett, & Martin.—xxiii. 2
 Martin, C. A.—France, 613
 Martin & Casimir.—France, 612
 Martin, E. C.—Netherlands, 63
 Martin, E. & E.—xx. 42
 Martin & Gray.—xxii. 332A
 Martin & Hood.—xxx. (Fine Art
 Court), 85
 Martin, J.—vii. 25; xii. & xv. 249;
 xvii. 29; xxvi. 406
 Martin, L. P. A.—France, 1711
 Martin, M. C.—Zollverein (1), 425
 Martin, O. & Viry, Brothers.—France,
 614
 Martin, Peter.—Jersey & Guernsey, 26
 Martin, R. J.—Portugal, 957
 Martin, S.—xxii. 132

Martin & Son.—xi. 37
 Martin, T.—xxx. (Fine Art Co.), 282
 Martin, W.—xxvi. 254; South Africa,
 40; France, 323
 Martin, W. H.—xvi. 81
 Martinek, J.—Austria, 313
 Martinetti, F.—Tuscany, 88
 Martinez, D. J.—Spain, 145
 Martinez, P.—Spain, 156
 Martinez, S.—Spain, 179
 Martinez y Perez, V.—Spain, 80
 Martini, see Langenbeck & Martini
 Martinotti, J.—Sardinia, 62, 63
 Martins, R. J.—Portugal, 930-942,
 957-959
 Martyu, E.—i. 107
 Marx & Co.—France, 1343
 Marx & Weigert.—Zollverein (1), 113
 Marychurch, J.—ix. 93
 Maryland, Committee of State of.—
 United States, 371
 Maryland Soap-stone Company (Balti-
 more)—United States, 169
 Marynen Vues.—Belgium, 227
 Masera.—Sardinia, 97
 Mash, J.—xxiv. 54
 Mason, see Elkington, Mason, & Co.;
 Fortnum, Mason, & Co.; Shand &
 Mason
 Mason, Mrs. B.—ii. 77
 Mason, C.—xxx. 3.
 Mason, E.—viii. 81; x. 714
 Mason, G.—iv. 54; xiii. 35
 Mason, J.—vi. 10, 46
 Mason, J.—xxiii. 128
 Mason & Son.—ii. 22
 Mason, W.—xx. 157
 Masout, W. & Co., xii. & xv. 303
 Masou, W. H.—v. 910
 Masrat.—France, 920
 Massaris, S.—St. Helena, 1
 Massardo, Madame J.—Belgium, 415
 Masse, W. Tribouillet & Co.—France,
 1346
 Masemin, C. L.—France, 1345
 Maset, L.—Switzerland, 95
 Massey.—France, 1347
 Massey & Co.—xxx. (Fine Art Court),
 140A
 Massey, W. & Co.—xxii. 416
 Massey, W. A.—xxix. 190
 Massing, see Barth, Massing, &c.
 Massing, Brothers.—France, 333
 Masson, C.—Belgium, 267.
 Masson, E.—France, 1345
 Masson, V.—France, 628
 Massue, L. J.—France, 615
 Massey, J. F.—Switzerland, 222
 Masterman, J. & T.—vi. 621
 Masterman, T., see Masterman, J. & T.
 Masters.—India, xi.
 Masters, A.—iii. 63
 Masters, M.—x. 569, 733
 Masters, T.—xxii. 631
 Mata Aguilera, J. de.—Spain, 289
 Matagrin, Stoltz, & Co.—France, 616
 Mateuz, A.—Spain, 140. 141
 Mathelieu, De.—Belgium, 58
 Mather, A. A.—Page 850
 Mather, J.—xvi. 139; xxii. 504
 Mather, C.—see Mather, W. & C.
 Mather, W. & C.—vi. 16
 Matherton & Bouvard.—France, 1349
 Matheson, see Wilson & Matheson
 Mathes & Weber.—Zollverein (1), 464
 Mathews, Mary.—x. 193
 Mathews, T.—viii. 110
 Mathews, W.—x. 550
 Mathy & Son.—Switzerland, 41
 Mathias, L. A.—France, 1330



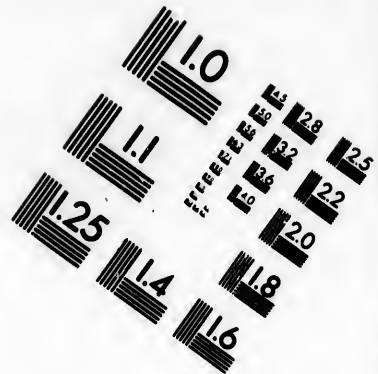
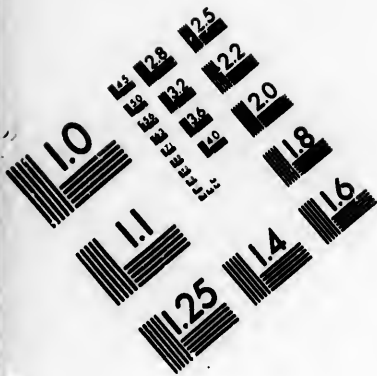

**IMAGE EVALUATION
TEST TARGET (MT-3)**

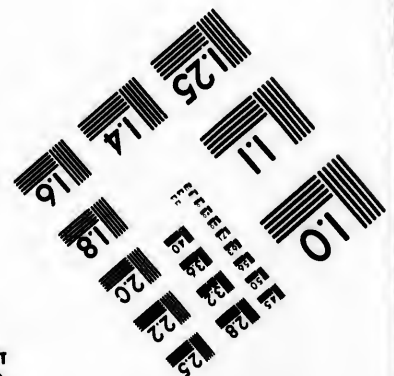
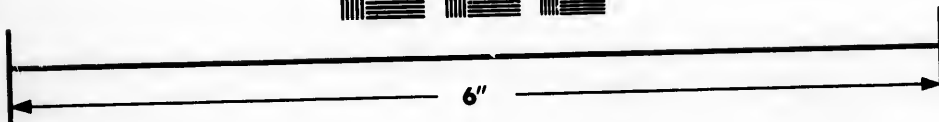
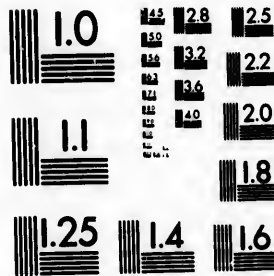

**Photographic
Sciences
Corporation**

23 WEST MAIN STREET
WEBSTER, N.Y. 14580
(716) 872-4503

1.8
2.0
2.2
2.5
2.8
3.2
3.6

4.0
4.5
5.0
5.6
6.3
7.1
8.0
9.0
10.0

Mathie, J.—Austria, 287
 Mathieson, see Auld, Berrie, & Co.
 Mathieson, A.—XXI. 32
 Mathieson, Lady.—xx. 191
 Mathieson, R. R.—xxvi. 120
 Mathieson, T. A. & Co.—xxi. 35
 Mathieu, E.—France, 1351
 Mathieu, L.—France, 618
 Mathieu, N. Danloy.—France, 617
 Mathieu, dit Verger, see Laverne, & Co.
 Mathison, G. F.—I. 479
 Mathys, J.—Belgium, 359
 Matifat, C. S.—France, 923 (Main Avenue, East)
 Matisen, A. & Co.—Rusia, 305
 Matkin, T.—XXII. 210
 Matschuko, N.—Austria, 201
 Matson, Captain.—Western Africa, 9
 Mattat & Sons.—Denmark, 10
 Matthes, C., jun.—Zollverein (3), 118
 Matthewman, see Jackson and Matthewman
 Matthews, C.—Canada, 188
 Matthews, E.—XXIII. 95
 Matthews, G.—Canada, 152
 Matthews, S.—XXVIII. 81
 Matthews, W.—x. 181
 Matthewson & Son.—Canada, 329
 Matthey, see Johnson & Matthey
 Matthias, J. H.—x. 395
 Mattiuzzi, G. B.—Austria, 77
 Mattoch, C. G.—Zollverein (3), 43
 Mattoe, J. B. da.—Portugal, 593
 Mattschas, J. G. H.—Zollverein (1), 217
 Mattau, T. W.—United States, 50
 Matveieff, —Russia, 40
 Matvieff, P.—Russia, 367
 Mauban, —France, 377
 Mauban & V. Jouraet.—France, 619
 Maucamble, —France, 620
 Maudo, De.—Portugal, 465, 466
 Maudalay, Sons, & Field.—v. 38; vi. 228
 Mauget, Mrs.—British Guiana, 68
 Maulaz, J., see Maulaz, L. J. & Co.
 Maulaz, L. J. & Co.—Belgium, 29
 Maunt, see Chopping & Maunt
 Maund, B.—III. 79
 Maund, E.—XXII. 792
 Maundler, J.—XXVIII. 28
 Maupin, S.—United States, 285
 Maudraud, D. A. J.—Spain, 40
 Maurel, Jaget & Co.—France, 621
 Maurer, V.—Austria, 200
 Mauritius Royal Society of Natural History.—Mauritius, 4
 Maury, J. C.—Zollverein (6), 21
 Mautois, Madame.—France, 602
 Mauzaise, J. N.—France, 924
 Mavroianini.—Ionian Islands, 3
 Mavroianini, Madame.—Ionian Islands, 2
 Mawson, Brothers.—United States, 87
 Max, see Laine-Laroche & Max; Meyr, Max, & Co.
 Max, E.—Austria, 705
 Maxwell & Co.—xvi. 52
 Maxwell, J.—vii. 102
 Maxwell, Miss.—United States, 384
 Maxwell, W.—i. 134
 May, see Lambert & May; Ransomes and May
 May & Baker.—II. 14
 May, R.—Russia, 227
 Mayall, J. E.—x. 291; United States, 491
 Mayer, Brothers.—Austria, 266; France, 623, 1656
 Mayer, Familie.—Zollverein (2), 52
 Mayer, G.—XXIV. 76

Mayer, J.—XXIII. 14; see also, Mayer, T. J. & J.
 Mayer, Madame J.—France, 624
 Mayer, J. G.—Austria, 346
 Mayer, J.—Zollverein (2), 46
 Mayer, Michel, & Deninger.—Zollverein (6), 36
 Mayer, Paul.—Zollverein (6), 35
 Mayer, J.—Zollverein (2), 70
 Mayer, T. J. & J.—xxv. 9
 Mayer & Zindell.—Russia, 177
 Maynard & Noyes.—United States, 445
 Maynard, R.—IX. 109
 Maynard & Son.—IX. 122
 Mayo & Bates.—XXII. 648
 Mayo & Co.—i. 18; xxvii. 7
 Mayoress, the Lady.—XIX. 379
 Mazarin, J. G.—France, 626.
 Mazetti, A.—Tuscany, 90, 115
 Mead.—v. 706; see also Barber, Howse, & Mead
 Meade, Brothers.—United States, 109
 Meadows, J.—XXVIII. 165
 Meagher, J.—New Zealand, 7
 Meakin, J. F.—XXVI. 148
 Meakins, see Reed & Meakins
 Mear, see Salt & Mear
 Mears, see Prouty & Mears
 Mears, C. & G.—XXII. 684 (Main Avenue, West)
 Mears, G.—United States, 562; see also Mears, C. & G.
 Mechetti (late Carlo Mechetti)—Austria, 371
 Mechi, J. J.—XXI. 12; xxvi. 79; xxxix. 45; xxx. (Fine Art Co.), 220
 Mecklinghaus & Wex.—Zollverein (1), 672
 Metcalf, F.—xxvi. 80
 Methurst, T.—v. 780
 Medina, M.—Spain, 270
 Medina del Campo, Pedrosa, & Gomeznarro.—Spain, 66
 Medway, J.—XXIX. 195
 Medwin & Co.—xvi. 162
 Mer, Cornelia.—xix. 51
 Meek, G.—XVII. 190
 Meer & Co.—Zollverein (1), 529
 Messer, F.—South Africa, 16
 Mehne, P.—Hamburgh, 81
 Mehu, J. M. F.—France, 627
 Meier, F.—France, 1352
 Meier, J. C.—Zollverein (2), 3 B
 Meigh & Sons.—xxv. 10
 Meilert.—Zollverein (1), 177
 Meillet & Pichot.—France, 629
 Meinert, Brothers.—Zollv. (3), 72-83
 Meinerzhagen & Kreuser, Brothers.—Zollverein (1), 316
 Meinhold & Sons.—Zollverein (3), 181
 Meinhold & Stoffregiu.—Zollverein (3), 61
 Meinig, C.—I. 84
 Meinig, C. L. A.—x. 437
 Meinke, W. C.—Hamburgh, 120
 Meinh, A., Heirs.—Austria, 383
 Meindraud, C., jun.—Zollverein (6), 70
 Meissen China Manufactory, Saxony.—Zollverein (3), 10, 174
 Meissner, E.—Zollverein (3), 136
 Meissner, F. A.—Zollverein (3), 130
 Meissner, F. T.—Zollverein (3), 129
 Meissner, M.—Zollverein (3), 137
 Meissner, T.—Zollverein (3), 126
 Meixel, A.—Zollverein (1), 396
 Mejean, A.—France, 1353
 Mejean, G.—Tuscany, 15
 Melincrythan Chemical Co.—II. 2
 Meller, see Wyburn, Meller, & Turner.

Meller, C. C.—xvi. 73
 Mellard, see Berni & Mellard
 Mellichamp, Mary H.—United States, 177
 Melling, R. jun.—v. 708
 Mello, see Albuquerque, J. D' e Mello
 Mello & Brothers.—Portugal, 804, 805
 Mellon, M.—Mauritius, 6
 Mellor, see Hastings & Mellor
 Mellote, E.—Belgium, 302
 Mellowdew, see Kesselmeier & Mellowdew
 Melnikoff.—Russia, 111
 Melnikoff-Glaushkoff, M.—Russia, 214
 Melnikoff-Glaushkoff, P.—Russia, 212, 213
 Melton, —xxx. (Fine Art Court), 297
 Melton, Eliza.—XIX. 250
 Melton, H.—xx. 54
 Melville, J.—xxvi. 3
 Melzer, D.—Austria, 44
 Melzer, G.—Austria, 648
 Mendelssohn.—Zollverein (1), 747
 Mendels, R. P.—Portugal, 410
 Mendez, J. J.—Spain, 253n
 Mene, P. J.—France, 630
 Menet, J.—France, 1657
 Meneses, see Cosheiros, J. L. de
 Mengten, M. Von.—Russia, 222
 Menge, A. G.—Belgium, 409
 Mengelbier, J.—Zollverein (1), 340
 Mengon, C.—Zollverein (1), 581
 Menghius, Brothers.—Zollverein (1), 530
 Menier & Co.—France, 925
 Menke, see Spion & Menke
 Mennet, see Pesel & Mennet
 Mentasti, B.—Austria, 635
 Mentchinsky, A.—Russia, 151
 Mentzel.—Zollverein (1), 94
 Menzerath, J.—Zollverein (1), 356
 Menzies, A.—v. 912
 Meraux, J. H.—France, 631
 Mercer, J.—XVIII. 38, 48
 Mercier, —France, 927, 1354
 Mercier, A. & Co.—France, 632
 Mercier, C. V.—France, 1658
 Mercier, J. J.—Switzerland, 175
 Mercier, S.—France, 633; Switzerland, 96
 Mercier, Sarah S. A. Le.—xxvi. 181
 Merckx, M.—Belgium, 496
 Mercurin, H. J.—Algeria, 37
 Mere, Madame La.—Canada, 42
 Meredith, see Poland, Son, & Co.
 Meredith, J. H.—i. 141
 Meresse, M. A.—France, 1355
 Merkelbach & Son.—Zollverein (1), 351
 Merlaut, L. T.—France, 634
 Merlin, A. & V.—Russia, 281
 Merliu, V., see Merlin A. & V.
 Mermod, Brothers.—Switzerland, 15
 Mero, D.—France, 1356
 Meron, E.—Spain, 150
 Merrett, H. S.—xxxix. 45; xxx. (Fine Art Court), 172, 220
 Merriam, see Sayle, & Co.
 Merria, Madame Van.—Belgium, 65
 Merritt, see Haskell, & Co.
 Merryweather, J. B.—United States, 164
 Merryweather, G.—x. 151
 Merryweather, M.—v. 401
 Mersey Iron Co.—v. 649
 Merten, J. F.—Zollverein (1), 502
 Mertens, Baron.—Belgium, 53
 Mertens, C.—Belgium, 132
 Mertens, H. J.—Zollverein (1), 867
 Mertens, P.—Zollverein (1), 868
 Mers & Sons.—Zollverein (2), 30 & 31

Melliard
—United States,
08
e, J. D' e Mello
ortugal, 804, 805
s, 6
Mellor
s, 302
meyer & Mellow-
11
M.—Russ'a, 214
P.—Russia, 212.
Art Court), 297
280
44
648
rein (1), 747
ugal, 410
s, 253n
630
657
s, J. L. de
Russia, 222
um, 409
rein (1), 340
ein (1), 581
—Zollverein (1),
nce, 925
Menke
Mennet
s, 635
ussia, 151
o (1), 94
verein (1), 356
nce, 631
8, 48
27, 1354
France, 632
nce, 1658
erland, 175
633; Switzerland,
Le.—xxvi. 181
m, 496
geria, 37
—Canada, 42
Son, &c.
41
nce, 1355
—Zollverein (1),
nce, 634
ussia, 281
n A. & V.
Switzerland, 15
350
x, 45; xxx. (Fine
20
c.
—Belgium, 65
c.
—United States, 164
s. 151
s, 401
649
erein (1), 502
gium, 55
m, 132
verein (1), 867
ein (1), 668
erein (2), 30 & 31

Mesina, S.—Sardinia, 31
Mesnier & Cartier.—France, 635
Mess & Co.—Zollverein (1), 468, 487
Mesa, L. & Co.—Zollverein (1), 247
Messat, A.—Austria, 246
Messenger & Sons.—xxx. 340
Messervy, G.—Jersey and Guernsey, 11
Messner, F.—Austria, 321
Mestiviers & Hamoir.—France, 636
Mestrosi, P.—Austria, 247
Metdepenningen, G.—Belgium, 207
Metert & Langdorf.—Switzerland, 97
Metesans, Z.—Spain, 140
Methven & Sons.—I. 126
Metropolitan Association for Improving
the Dwellings of the Industrious
Classes.—vii. 172
Metternich, C. A. de.—Zollv. (6), 83
Metternich, Prince.—Austria, 413
Mettler & Son.—Switzerland, 197
Metz, A. & Co.—Zollverein (7), 6
Metz, G.—Austria, 485
Metzer, U., & J. F. Luhme.—Zollve-
rein (1), 83, 212
Metzler, G.—x. 475
Metzner, W.—Austria, 698
Meunier, Brothers, & Willemijn.—
France, 1659
Meurant, E.—New Zealand, 15
Meures & Caudin.—France, 1357
Meurisse.—France, 928
Mevisson, G.—Zollverein (1), 557
Mevius, C. de.—Belgium, 86
Mexican Commissioner.—Mexico
Meyer.—Hamburg, 105; see also Al-
der and Meyer
Meyer, A. D.—Denmark, 43
Meyer & Amman.—Switzerland, 176
Meyer, Brothers.—Switzerland, 153, 227
Meyer, C.—United States, 59
Meyer & Co.—Austria, 112; Switzer-
land, 153
Meyer, D.—Hamburg, 55
Meyer, E.—France, 637
Meyer & Englemann.—Zollverein (1),
582
Meyer, H.—Canada, 190
Meyer, H. C., jun.—Hamburg, 86
Meyer, J. E.—Denmark, 6
Meyer & Lindt.—Zollverein (6), 10
Meyer, M., see Meyer, S. & M.
Meyer, Max, & Co.—Zollverein (1), 133
Meyer & Mortimer.—xxxii. 47
Meyer, S. & M.—xvi. 304 (Main
Avenue, West)
Meyer & Schwartz.—Zollverein (5), 8
Meyer, T. W.—Hamburg, 1
Meyer, W.—Mecklenburg-Schwerin, 6
Meyer & Wried.—Zollverein (1), 764
Meyers, H. L.—Zollverein (1), 892
Meyers, A. & P. J., & Co.—Zollverein
(1), 768
Meyers, B.—xxx. 140
Meyers, P. J., see Meyers, A. & P. J.
Meyerson, L.—Sweden & Norway, 25, 90
Meyerstein, W.—Zollverein (1), 757;
Zollverein (3), 72-83, 87, 95
Meylan-Gulay, H.—Switzerland, 98
Meyne, J.—Mecklenburg-Schwerin, 5
Meynier.—France, 638; see also Smith
& Meynier
Meyr, Adolf & Leonorbain.—Austria,
595
Meyruis & Son.—France, 639
Meystre, E.—Switzerland, 225
Mezener, J.—Switzerland, 247
Miagkoff.—Russia, 62
Michel, A.—France, 640
Michel, Bonfil, Michel, Souvraz, & Co.
Michel, G.—Switzerland, 248

Michel & Morell.—Zollverein (6), 16
Michal, P.—France, 1660
Michele, see Delanoriniere, &c.
Michelin, T.—France, 641
Michell, F.—I. 461
Michell, J. xxv. 29A
Michell, Sarah.—I. 110
Michelson, G.—Austria, 119
Michels, F. X.—Zollverein (1), 871
Michels, J.—Belgium, 385
Micolci, C. L.—Hamburg, 114
Micotti, J.—Austria, 717
Middlebrook, J.—xii. & xv. 74
Middlebrook, T.—xx. 123
Middlemore, W.—xvi. 67
Middleton, see Varrall, Middleton, &c.
Middleton & Ainsworth.—xii. & xv. 312
Middleton, C., see Middleton, W. & C.
Middleton, J.—xxx. (Fine Art Ct.), 166
Middleton, W. & C.—v. 914-916
Midgley, Brothers.—xii. & xv. 99
Midworth, W.—xxx. (Fine Art Court),
308
Mienerts, J.—Austria, 212
Mierlo, A. Van.—Belgium, 133
Miers, W. J.—xxix. 85
Mierstein, W.—Austria, 592
Mies, J.—Zollverein (1), 341
Miesbach, A.—Austria, 1, 610
Miescher & Co.—Switzerland, 167
Miescher & Sons.—Switzerland, 163
Miss, G.—Austria, 217
Miguel, J. de.—Spain, 260
Miguel, T.—Spain, 259
Milan Benevolent Society's Establish-
ment.—Austria, 283
Milburn, G.—viii. 136, 138
Milch, A.—Zollverein (1), 9
Miles, E.—x. 601
Miles, G. Z.—United States, 444
Miles, H.—xxvi. 256
Miles, J.—x. 568; Zollv. (1), 341
Miles, P.—United States, 489
Miles, S.—xx. 89.
Miles, W.—xxii. 9
Milesi, A.—Austria, 106
Milford, J.—xix. 193
Milkoroschetchnoi, K.—Russia, 110
Millbank, D.—xxx. (Fine Art Ct.), 99
Miller.—xxxii. 112; see also Featham,
&c.; Ferguson, Miller, & Co.; Hor-
rockes, Miller, & Co.; Mitchell,
Miller, &c.
Miller, D. & W.—iii. 127
Miller, F. M.—Page 850; xxx. (Sculp-
ure Court), 17, 38, 49, 50, 66-68
Miller, F.—Zollverein (2), 90
Miller, G. jun.—Russia, 299
Miller, J. jun.—x. 361
Miller, J. E.—United States, 559
Miller, L. jun.—Russia, 234
Miller, R.—Austria, 528
Miller, Ravenhill, & Co.—viii. 163
Miller & Richard.—xvii. 150
Miller & Sons.—Main Avenue, West,
29; xxii. 645
Miller, T.—xxx. (Fine Art Court), 1;
Western Africa, 10
Miller, T. J.—iv. 29
Millian, jun.—France, 929
Milliani, P.—Rome, 12
Millichap, see Ekyu & Millichap
Milligan, see Euston & Milligan
Milligan, A. M.—Van Diemen's Land,
53, 282
Milligan, J.—Van Diemen's Land, 39,
79, 81, 180, 181, 194, 197, 200-206,
221, 223, 227, 230, 231, 254-268,
273, 279, 288, 292, 306, 311, 313,
315-319, 324, 325, 341, 342

Milligan, J. & Hull, H.—Van Diemen's
Land, 288
Milligan & Son.—xii. & xv. 140
Milligan, W.—vi. 38
Millington, B. & E.—vi. 462
Millington, E. see Millington, B. & E.
Miller, R.—iv. 65
Milner & Co.—xii. & xv. 168
Mills, see Shenstone & Mills
Mills, Eliza.—xxx. (Fine Art Court),
329
Mills, Elizabeth.—xii. & xv. 253
Mills, Isabella.—xxx. (Fine Art Court),
95
Mills, J.—xxv. 32
Mills, M.—xxxii. 55
Mills, R.—I. 418
Mills, T.—xxvi. 115
Mills, W. F. jun.—Persia
Millward, see Day & Millward
Milly, De.—France, 644
Milne, W.—iii. 85
Milner, J. & Co.—xii. & xv. 168
Milner & Son.—xxxii. 642
Milnes, T.—Page 850; xxx. (Fine
Art Court), 184
Milon, M.—France, 642
Milon, T. D. sen.—France, 930
Milton, J.—ix. 291.
Millward, J. & Son.—United States,
93
Mina, see Chirio & Mina
Minchner, see Devas, Minchner, &
Routledge.
Miner.—x. 402
Mineur, see Perard & Mineur
Minghetti, Marco.—Rome, 10
Miniffe, C.—x. 151
Minitzek, Count S. von.—Austria, 624
Minna, J.—xxviii. 99
Minoprio & Co.—Zollverein (5), 4
Minoprio & Hohwiemer.—Zollv. (6), 37
Minten, A.—Belgium, 54
Minter and Co.—xxvi. 155
Minter, G.—xxvi. 211
Minton, H. & Co.—North Transept,
50; i. 97; xxv. 1; xxvi. 531;
xxvii. 86
Mintorn, Eliz., see Mintorn, J. H. H.
Mintorn, J. H. H., Eliz., & Rebecca.—
xxx. 70
Mintorn, Rebecca, see Mintorn, J. H. H.
Minutoli, A. Von.—Zollverein (1), 191,
845, 847
Mir, Brothers.—Spain, 276
Miramout.—France, 1358A
Miranda, Batato, & Co.—Portugal,
728-747
Mirat, G.—Spain, 128
Miroud, Brothers.—France, 645
Miry, Brothers.—France, 646
Mirror Marble Company (Castle-street,
Southward).—xxvii. 18
Misou, A.—Belgium, 413
Misou, Emile & Louis.—Belgium, 412
Misou, Louis, see Misou, Emile, &c.
Missouri Iron Mountain Co.—United
States, 163
Mitchell, F.—xvi. 213
Mitchell, Rev. G.—v. 918
Mitchell, G. A.—xxx. 94
Mitchell, G. D.—United States, 179
Mitchell, J.—xxii. 339, 611, 672;
xxv. 29A; xxix. 138
Mitchell, J. T.—xxx. (Fine Art Court),
87
Mitchell, Miller, and Ogilvie.—xii. &
xv. 466
Mitchell, Mrs. S. A.—xxx. (Fine Art
Court), 124

- Mitchell, Sir T. L.—New South Wales, 21
 Mitchell, W.—XXII. 328
 Mitchell, Rev. W.—i. 9, 270; v. 919; XXIX. 274
 Mitchell, W. B.—i. 45
 Mitford, B.—XXVII. 167
 Mitjana, R.—Spain, 287
 Mittelelle, V.—France. 1661
 Mitter, J.—Austria, 53
 Mitter, J., sen.—Austria, 529
 Mitterberger, J.—Austria, 467
 Mittrowsky, Count A. Von—Austria, 91
 Mix & Gardinier.—United States, 96
 Moag, W.—South Africa, 19
 Moberley, W.—ii. 17 (Main Avenue, West)
 Mock, J. W.—Canada, 333
 Moda, Tommaso Della.—Rome, 19 (Main Avenue, East)
 Moes & Co.—Russia, 192
 Moeller.—Zollverein (1), 289 (Main Avenue, East)
 Moeller, C.—Zollverein (1), 292
 Moench, J., & Co.—Zollverein (6), 66
 Moerbitz, C. G. E.—Zollverein (3), 127
 Moering, C.—Austria, 247
 Moerman, V. L.—Belgium, 231.
 Mœrschel, Winzenried, & Co.—Zollverein (6), 28
 Moeser & Kühn.—Zollverein (1), 156
 Mogel, N.—Austria, 314
 Mogford, —XXVI. 181
 Moggridge, M.—XXII. 495
 Moglia, Domenico.—Rome, 21
 Moglia, Cavaliere Luigi.—Rome, 20
 Mohamed Ben Achir.—Algeria, 62; France, 1663
 Mohammed Ben Salah.—France, 1663
 Mohr, W.—Zollverein (1), 186A
 Möhring, F. L.—Zollverein (1), 275
 Moïnier, see Jaillon, Moïnier, & Co.
 Moir McD.—ix. 180
 Moïson, F.—France, 1358
 Mole, R.—viii. 248
 Molin.—Sweden & Norway, 31
 Molina, A.—Spain, 180
 Molinari, A.—Sardinia, 43
 Molinaux, Webb, & Co.—XXIV. 13
 Molines, L.—France, 647. 930A
 Molkhanoff.—Russia, 373
 Moll, C.—Zollverein (1), 501
 Mollady & Sons.—xx. 125
 Molle, E. Van.—Belgium, 255
 Mollouberg, G.—Sweden, 66
 Müller, C. H. A.—Hamburgh, 22
 Müller, H. P.—Denmark, 32
 Moller & Welke.—Portugal, 748
 Mollet-Warne, Brothers.—France, 648
 Mollison, J.—x. 585
 Möllmann, see Kising & Möllman
 Molloy.—XXVI. 81
 Molson, G. E.—Canada, 154
 Molteni & Siegler.—France, 649
 Molterer, C.—Austria, 486, 487
 Molterer, G.—Austria, 488
 Molterer, M.—Austria, 490
 Molterer, V.—Austria, 491.
 Molyn Lesouef.—France, 1359
 Monahan & Beers.—United States, 349
 Moncheur, F. & A.—Belgium, 366
 Monet.—France, 1664
 Money, see Wigram, Money, & Sons
 Money, Elizabeth.—xx. 189
 Monfort, F.—Spain, 88, 208
 Moniac, E.—Zollverein (1), 249
 Monjikko, see Kiriakin & Monjikko
 Monkhouse & Son.—ix. 251
 Monkland Iron & Steel Co., Glasgow —i. 426
 Monnoyer, P. J.—Belgium, 352
 Montag, L.—Zollv. (8), 11
 Montague, A.—i. 421
 Montal, C.—France, 1665
 Montanari, A.—XXIX. 122; Austria, 738
 Montanari, N.—xxx. (Fine Art Court), 224
 Montandon, Brothers.—France, 601
 Montcharmont.—France, 650
 Monteagle, Lord.—viii. 317; XXVII. 72
 Montebello.—France, 651
 Montefiore, Sir M., Bart.—xxx. (Fine Art Court), 160
 Montefiori, C.—Sardinia, 57
 Monteiro, L. A.—i. 150; iii. 34; China
 Monteiro, M. B., jun.—Portugal, 510, 1123A
 Monteiro, T. P.—Portugal, 1238, 1252
 Monteith, H., & Co.—XVIII. 49
 Monteith, J., & Co.—XVIII. 53
 Monténac, Madame De—Canada, 163
 Montero, S.—Spain, 225
 Montesinos, C. J.—Spain, 167
 Montesny & Chomer.—France, 1360
 Montfort, F.—Spain, 202
 Montgolfier.—France, 324
 Montgomery.—v. 22, 553; see also Hart, Montgomery, & Co.
 Montny, A.—Belgium, 117
 Monti, R.—Austria, 746
 Montignac.—France, 489
 Montigny.—Algeria, 38
 Montigny & Fuanot.—Belgium, 158
 Montioni.—Tuscany, 5
 Montreal Commission.—Canada, 66, 80, 81, 93, 112, 171, 301
 Montreal Mining Co.—Canada, 10
 Moutn, J., & Co.—Sardinia, 78
 Moody, E.—ix. 110
 Mooklar & Childs.—United States, 8
 Moon, G.—XXVII. 56
 Moor, Major W.—x. 66A
 Moore, see Allen & Moore; Devitt & Moore; Groucock, &c.; Harper & Moore; Savory & Moore; Westwood & Moore.
 Moore, A.—XXVII. 25; see also Date-man, J., & A. Moore
 Moore & Co.—x. 476; XXII. 274
 Moore, D. D. T.—United States, 149
 Moore, E. D.—iii. 139
 Moore, G.—xvi. 119
 Moore & Grey.—viii. 209
 Moore, G. W.—XXVIII. 176
 Moore, J.—iv. 78; XXII. 595; XXIV. 53
 Moore, Dr. J.—i. 408
 Moore & Murphy.—XXIX. 332
 Moore, Mrs.—xix. 47A
 Moore, F. G.—New Zealand, 37
 Moore & Sons.—x. 33
 Moore, S. W.—xix. 31
 Moore, W.—United States, 564
 Moore, W. F.—viii. 35; xiv. 67
 Moorsom, Capt.—vii. 178
 Moorsom, Miss E.—XXIX. 253
 Moosbrugger & Kobbe.—Zollverein (1), 428
 Morand & Co.—Zollverein (1), 731
 Morant, G. J.—xix. 291; XXVI. 164
 Moratilla, F.—Spain, 261
 Muravian Missionary Station.—Cape of Good Hope, 44
 Mordan, S.—i. 65
 Mordan, S., & Co.—vi. 205
 Mordini, C. G.—Tuscany, 45
 Moreau, A.—France, 378
 Moreau, A. U.—France, 1361
 Moreau & Co.—France, 652
 Moreau, F.—France, 326
 Moreau, U.—France, 325
 Moreira, M. C.—Portugal, 918, 956, 1169
 Morel, Brothers.—France, 1666; see also Mauchin & Morel
 Morel, J. V. & Co.—XXIII. 117; XXVI. 171
 Morell, see Michel & Morell
 Morell, H.—XXIX. 248
 Morella, The Corporation of.—Spain, —232
 Moreno, Brothers.—Spain, 253d
 Moreton, J.—XXII. 554
 Moreton & Langley.—XXII. 669
 Morewood & Rogers.—i. 436; ix. 152A; XXII. 610
 Morey, C.—United States, 460, 573, 580
 Murgau, E.—xxx. (Fine Art Court), 265
 Morgan, H. K. G.—xxx. (Fine Art Court), 215
 Morgan, J. & Co.—xii. & xv. 299
 Morgan, J. S.—United States, 288
 Morgan & Sons.—i. 272
 Morgant, E.—France, 1726
 Morgenroth & Krugmann.—Zollverein (1), 532
 Mori, J.—xiv. 63
 Moriarty, D.—xvi. 95
 Moriceau & Cayeux.—France, 328
 Morimont, J. B.—Belgium, 9
 Morin.—Algeria, 39
 Morin, Capt.—Canada, 9
 Morisou, D.—xxx. (Fine Art Court), 276
 Morison & Knox.—British Guiana, 123
 Morisot.—France, 931
 Morland, see Landon & Morland
 Morland, J. & Son.—XXIX. 306
 Morley, I. & R.—xx. 101
 Morley, J.—XXIX. 165
 Morley, R., see Morley, I. & R.
 Morley, T.—XXIII. 67
 Mornay, E. De.—Brazil, 3
 Mornieux, F.—France, 1362
 Moro, Brothers.—Austria, 218
 Morozoff.—Russia, 38
 Morphet, J.—Western end, South enclosure (Outside), 6
 Morral, A.—vi. 240; XXII. 333
 Morrell, G.—v. 82; vii. 59
 Morrell, H.—iv. 56
 Morrell, J.—XXIX. 92
 Morrell, Stewart, & Co.—United States, 292
 Morris, see Bevington & Morris; Dawson & Morris
 Morris, J.—Canada, 114
 Morris, John.—St. Kitts
 Morris, Jones, & Co.—United States, 44
 Morris, R.—Canada, 113, 334
 Morris, W.—v. 764
 Morrison, G.—i. 77
 Morrison, J. D.—x. 189
 Morrison, Mrs.—New South Wales, 25
 Morrison & Hurn.—xiv. 49
 Morrison & Parker.—XXII. 179
 Morrison & Son.—ix. 48
 Morse.—x. 432
 Morson, T. & Son.—ii. 106
 Mort, Signor.—Rome, 5
 Mortimer, see Boutchier, Mortimer, & Co.; Hunt & Roskell; Meyer & Mortimer
 Mortimer, T. E.—VIII. 267
 Mortimer, W.—XXIII. 13
 Mortimer, W. H.—XXIII. 57
 Morton, D.—xii. & xv. 160
 Morton, J.—XXII. 104
 Morton, J. & G.—xxi. 7
 Morton, Prof.—x. 678A

- 1, 918, 956.
666; see also
117; xxvi.
all
of.—Spain,
253d
t. 669
16; ix. 152A;
460, 573, 580
Art Court),
x. (Fine Art
ates, 298
6
—Zollverein
ance, 328
m, 9
e Art Court),
Guiana, 123
orland
x. 306
1
& R.
3
362
218
nd, South en-
xii. 333
59
United States,
Morris; Daw-
ited States, 44
334
th Wales, 25
49
l. 179
6
Mortimer, &
l; Meyer &
67
57
60
- Morton, S. & H.—vii. 24
Morton & Sons.—xix. 252
Mosbach, see Savary & Mosbach
Moschlin, P.—Austria, 636
Moscow, Casarevsk Chintz Manufactory.—
Russia, 178
Moscow Manufacturing Co.—Russia,
353
Moseley & Son.—xxi. 13
Moser.—France, 653
Moser, A.—Austria, 531, 532
Moser, A. & Co.—Zollverein (1), 861
Moser, C.—Austria, 533
Moser, F., jun.—Switzerland, 20
Moser, F.—Austria, 534
Moser, G.—Austria, 535
Moser, J.—Austria, 536, 537
Moses, see Benjamin & Moses
Moses, Champion, & Co.—Van Die-
men's Land, 228
Moses, H. E. & M.—iii. 101; New
South Wales, 4
Moses, M., see Moses H. E. & M.
Moses, S.—Van Diemen's Land, 207,
237
Moses, Son, & Davis.—New South
Wales, 16
Moseley & Co.—xxiii. 107
Mosley, J.—xxiii. 17
Moss Hall Coal Co.—Wigan, i. 247
Moss, N.—South Africa, 36
Moss, R.—xxii. 498
Mossman, W.—xxx. (Fine Art Court),
204
Mossner, A.—Zollverein (1), 251
Mosso, T.—South Africa, 41
Motala, Iron and Engine Works.—
Sweden & Norway, 6
Motard, A.—Zollverein (1), 262
Motelli, G.—Austria, 728
Motelli, M.—Austria, 718
Motion, see Low & Motion.
Motley, T.—New South Wales, 9
Mott, see Sibell & Mutt
Mott, C. A.—United States, 81
Mott, I. H. R.—x. 498
Mott, W.—xxiii. 116
Motte, A.—xvi. 37
Motte, Bossut, & Co.—France, 654
Mottet, Weyhe, & Co.—Portugal,
748-755
Mottet, C.—France, 932
Motttram & Hawkins.—xxii. 691
Moucheur, F. A.—Belgium, 366
Mouchot.—France, 1667
Mouilliard, P. F. V.—x. 95
Moulard, Mdlle.—France, 655
Moulin.—xxvi. 163
Moulin, C.—viii. 272
Moulton, S. C.—United States, 534
Mounoury, see Dartevelle, &c.
Mountford, see Keys & Mountford
Moureau, —France, 1668
Mourgue & Bouquet.—France, 1363
Moutley, C. E.—xxvi. 123
Moussard, —France, 657
Moussillac, —France, 933
Moussin, P.—Russia, 294
Moutier le Page.—France, 1364
Mouzaie Mines, Commission of.—Al-
geria, 13
Mowland, Charlotte G.—xix. 228
Moxon, C.—xxvi. 252, 276
Moyle, S.—x. 710
Moyné, H. Le—Jersey & Guernsey, 5
Moyson.—France, 467
Moyston, W. A.—United States, 25
Muck, J.—Austria, 354
Muckart, see Shand & Muckart
Muckenheim & Alpers.—Hamburg, 27
- Mudge, J.—vii. 190
Mudie, J.—x. 683A
Muehl, Von der, Brothers.—Switzerland,
162
Muehl, Wahl, & Co.—France, 934
Muehle, A.—Zollverein (3), 167
Muehlenderlein, C. F.—Zoll. (8), 157
Mueller, A. L.—Austria, 219
Mueller, C. A.—Zollverein (6), 24
Mueller & Co.—Switzerland, 177; Zoll-
verein (3), 115
Mueller, J. F.—Zollverein (1), 201
Mueller, J. G.—Zollverein (1), 541
Mueller, J. P.—Zollverein (6), 10
Mueller, Pluess, & Co.—Switzerland,
151
Mueller, T. B. & Co.—Switzerland, 160
Muelman, A. Von.—Zollverein (1), 319
Muenzers, see Damsch & Muenzers
Mullenbach & Thewald.—Zoll. (8), 10
Mubr, J.—Zollverein (2), 91
Muir, A.—Canada, 37
Muir, G.—Malta, 29
Muir, P.—xxix. 150
Muir, R.—xvii. 174
Muir, W.—vi. 206
Muir, Connell, & Brodie.—xx. 173.
216
Mularioho, M.—Portugal, 1236
Mulcahey, see Dill & Mulcahey
Mulder, De.—Belgium, 57
Müller.—Zollverein (1), 287; (2), 90;
(Main Avenue, East)
Müller, A.—Zollverein (1), 148
Müller, A. F.—Zollverein (1), 723
Müller, C. A.—Austria, 654
Müller, D.—Persia
Müller, F.—iv. 125A; Zollv. (1), 227;
Switzerland, 165
Müller, H. F.—Austria, 372
Müller, J. Van.—Denmark, 32
Müller, M. W.—Zollverein (1), 352
Müller, T. A.—France, 1365
Müller, T. L.—Zollverein (1), 123
Müller, W. O.—Hamburg, 76
Mulliner, F.—v. 922
Mulliner, H.—v. 924
Muloet & Son.—France, 658
Munford, W. T.—viii. 144
Mummery, F. H.—xxvi. 292
Municipio, V.—Spain, 224
Munro, see Chard & Munro
Munro, A.—xxx. (Sculpture Court), 41
Munro, J., jun.—viii. 282
Munz, G. F. (M.P.)—viii. 101
Muquardt, C.—Belgium, 473
Murchisou, J. H.—i. 521A; New Zea-
land, 2
Murcia, Inspector of Mines of the dis-
trict of—Spain, 7
Murdoel, J.—x. 202
Murley, W. & C.—xii. & xv. 10
Murphy, D. J.—ix. 38b; see also Moore
& Murphy
Murphy, J.—xxii. 683 (Main Avenue,
West)
Murphy, Margaret.—xii. & xv. 262
Murray & Cowper.—xxvii. 66
Murray, H.—Canada, 98
Murray, J.—vii. 4
Murray, Mrs.—South Australia, 6
Murray, Sir J., M.D.—ii. 87
Murray, W.—l. 426; v. 566; viii. 38;
xxii. 793; Van Diemen's Land, 18, 40
Murray, Sir W. Bart.—iv. 137
Muschamp, W.—i. 514
Müseler, B. L.—Belgium, 24
Museum of Royal Academy.—Portugal,
136-231
Mussa, M.—xvi. 260
- Mussini, Professor.—Tuscany, 26
Musulwhite, T.—xvi. 71
Musson, J., see Musson, R. & J.
Musson, R. & J.—xx. 97
Mutrot, see Proutat, &c.
Muzard, L.—France, 1366
Myers.—xxvi. 533; xxx. (Fine Art
Court), 117
Myers & Co.—Western End, South
Enclosure (Outside), 35
Myers & Son.—xxii. 338
Myerscough, Steel, & Co.—xi. 39
- Nachet.—France, 1370
Nacke & Gehrenbeck.—Zollverein (3),
72-83
Naef, M.—Switzerland, 131
Naef & Schwarzenbach.—Switzerland,
153
Naeltjens, J.—Belgium, 308
Naenny, H.—Zollverein (6), 67
Nagi, L.—Austria, 680
Nagler, see Bruhm & Nagler
Nagpore, Resident at.—India, xi.
Nailor, J.—United States, 178
Nairn, M.—xix. 253
Nairne, T. G.—xx. 179
Nameche, see Temsonet, G. &c.
Namiest Cloth Manufacturing Com-
pany.—Austria, 220
Nanni, L.—Tuscany, 94
Nannucci.—Tuscany, 67
Napier, J.—xxix. 262
Napier, J. R.—v. 301
Napier & Son.—vi. 158
Naples, the late Queen of.—Austria,
747
Nardi, Brothers.—Tuscany, 70
Narimoff, O.—Russia, 193
Narishkin, L. K.—Russia, 127
Narivellia, M.—Portugal, 71
Nasareth, A. J. D.—Portugal, 13
Nash.—xxii. 612
Nash, E. (late J. Butler).—xxiii. 88
Nash, Mrs.—Jamaica
Nash, R.—xxii. 310
Nash, T., jun.—xxviii. 68
Nasmyth, G.—vii. 169
Nasmyth, J.—v. 41; vi. 236; x. 688
Nassau Government Engineers of Mines.
—Zollverein, (8), 1
Nast, H. J.—France, 659
National Society for the Education of
the Poor.—vii. 211
Naudi, Rosina—Malta, 8
Nauen, Loewe, & Co.—Zoll. (1), 93
Nauri, J. B.—Spain, 281
Nawe, François.—x. 592
Nazara, see Cerrf & Nazara
Naylor, I.—xiii. 199
Naylor, J.—xxii. 638
Naylor, J. H.—xix. 173
Naylor, J. W.—Denmark, 22
Naylor, M.—vii. 81
Naylor, Vickers, and Co.—xxii. 199
Naylor, W.—ii. 35; xxiv. 30
Naylor, W.—vii. 64
Naze, Son, and Co.—France, 625
Naset, B.—France, 660
Neal & Tonks.—xxii. 285
Neale, W. J.—vii. 121
Neath Abbey Coal Company.—Western
end, South enclosure (Outside), 44
Needham, H.—viii. 260
Needham, J., see Needham, W. & J.
Needham, W. & J.—viii. 218
Neef, see Gerresheim & Neef
Nees, A. F.—Zollverein (1), 420
Nef, J. J.—Switzerland, 198

- Neft, M. N.—Zollverein (2), 62
 Negretti & Zambra.—x. 160A
 Negro, P. Dal.—Austria, 719
 Neie, F. W.—Zollverein (1), 163
 Neighbour & Son.—ix. 290
 Neil, R.—xvii. 91
 Neill, Catherine, and Sons.—xii. & xv. 263
 Neish, J.—xiv. 63
 Neitsner & Brabant.—Zollverein (1), 583
 Nelis, J.—i. 15
 Nelson & Butters.—Canada, 84
 Nelson, G.—Page 848; xxx. (Sculpture Court), 35
 Nelson, J.—xvi. 324; xxii. 229
 Nelson, Knowles & Co.—xviii. 29
 Nelson, Messrs.—xxii. 102
 Nelson, T. jun.—vii. 120
 Nencini, Prof. L.—Tuscany, 109
 Neraudeau, J. A.—France, 661
 Nering, Bogel, & Co.—Netherlands, 80
 Nerinck, Sisters.—xix. 8
 Nesbit, see Brunton and Nesbit
 Nesbitt, J. C.—i. 46
 Ness, Mary.—vii. 123
 Nessel, C.—Austria, 395A
 Netscher, A. D. van der Gon.—British Guiana, 6. 8-11. 16. 19. 27. 73. 78
 Nettleton & Son.—xxii. 388
 Netto, M.—Zollverein (1), 148
 Neuack, see Saelger & Neuack
 Neubarth, see Glafey & Neubarth
 Neuber, Friedrich.—Zoll. (3), 72-83
 Neubert, C. G.—Austria, 299
 Neubronner, G.—Zollv. (2) 97
 Neuberger.—France, 662
 Neuberger & Sons.—Zollverein (4), 49
 Neuhaenser, Siegmund, & Co.—Austria, 229
 Neuhaus & Blösch.—Switzerland, 1
 Neuhaus, H. J.—Zollverein (1), 522
 Neuhaus, L.—Zollverein (1), 577
 Neuhoff, J. H.—Zollverein (1), 603
 Neumann, Brothers.—Switzerland, 153
 Neumann, T. L.—Austria, 373
 Neuner & Hornsteiner.—Zoll. (2), 33
 Neuwall, Chevaliers de.—Austria, 56
 Nevell & Co.—xx. 7
 Neves, A. J. das.—Portugal, 648-651
 Neviandt, see Grave & Neviandt
 Neviandt & Pfeleider.—Zoll. (1), 523
 Nevill & Co.—xx. 20
 Nevill, J. P.—v. 450
 Nevill, Major.—xvi. 301A
 New Brunswick India-rubber Co.—United States, 560
 New Jersey Exploring & Mining Company.—United States, 166
 New York Agricultural Soc.—United States, 83
 New York Atlantic Dock Mills.—United States, 126
 New York Blind Institute.—United States, 112
 New York City Bank.—United States, 339
 New York Iron Bridge Company.—United States, 511
 Newall, R. S. & Co.—xxii. 36
 Newberry, F.—x. 460
 Newberry, W.—ix. 57
 Newbery, J. & R.—xvii. 148; xxvi. 313
 Newbery, R., see Newbery, J. & R.
 Newbold & Owen.—xxii. 133
 Newbould & Baildon.—xxii. 133A
 Newbury Local Committee.—xx. 166
 Newcomb, T.—v. 205; x. 672A
 Newcomb & Jones.—xix. 257
 Newcombe, F.—v. 205
 Newcome, J.—xvi. 323
 Newell, see Day and Newell
 Newham, J.—v. 926
 Newham, R.—xxx. 100
 Newington, S.—x. 20
 Newington, Dr. S.—ix. 121A
 Newman, G.—xvi. 146
 Newman, H. J.—United States, 402
 Newman, J.—x. 297. 674
 Neumann, W. H.—xxvii. 60
 Newnham, B.—v. 928; xxvi. 365
 Newnham, T. G.—vii. 170
 Newsham, S. J.—xxiv. 79
 Newsom, H.—x. 675
 Newton, see Hutton & Newton; Winsor & Newton; Pigott & Newton
 Newton, C. H.—iv. 20
 Newton, I.—United States, 387
 Newton, Jones, and Willis.—xix. 258
 Newton & Son.—x. 212
 Newton, W.—xxvi. 97
 Newton, Sir W. J.—xxx. (Fine Art Court) 250
 Neyt, A.—Belgium, 157
 Nibbs, J. S.—xxii. 472
 Nicholas, Martha.—xxix. 154
 Nicholay & Son.—xvi. 301A (Main Avenue, West)
 Nicholl & Co.—v. 770
 Nicholl, S. J.—xxx. (Fine Art Court), 272
 Nicholls, H.—xvi. 5
 Nicholls, J.—i. 89. 162
 Nicholls, R. H.—ix. 20
 Nicholls, W.—x. 414; xxix. 164
 Nicholls & Ashton.—Belgium, 318
 Nichols, Mary Ann.—xxx. (Fine Art Court) 231
 Nicholson, see Smith, Nicholson, & Co.
 Nicholson, A.—United States, 549
 Nicholson, Siret.—i. 504A
 Nicholson, G. jun.—vii. 40
 Nicholson, J.—xii. & xv. 170A
 Nicholson, R.—Canada, 326
 Nicholson, V.—xxiii. 38
 Nicholson, W.—xxii. 137
 Nicholson, W. N.—ix. 50; xxii. 87
 Nickels, C. & Co.—xxviii. 78
 Nicklin & Sneath.—xxii. 332
 Nicod, V. & Son.—France, 663
 Nicol, see Gaimés, Sanders, & Nicol
 Nicol, A. & Co.—xiv. 87
 Nicol & Allen.—xxvii. 69
 Nicolas, P.—France, 664
 Nicoll, B.—xx. 34
 Nicoll, T.—xxvi. 182
 Nicoll, W.—xxiii. 21
 Nicolls, Miss.—Bahamas
 Nicolls A.—xii. & xv. 261
 Nicolson, R.—Canada, 326
 Nieberg, J. L.—Hamburgh, 10
 Niedree, J. E.—France, 665
 Nielsen, N.—Denmark, 26
 Nietzschemann & Vaccani.—Zollverein (1), 706
 Nieuwenborg, Brothers.—Belgium, 343
 Nieva, the Alcalde of Santa Maria de.—Spain, 233
 Nightingale, C., see Nightingale, W. & C.
 Nightingale, W. & C.—iv. 57
 Nijue-Tourinck, Imperial Iron Works of.—Russia, 10
 Nijui Novgorod, Merchants, & Co. of.—Russia, 225. 314
 Nikitin.—Russia, 68
 Nililus.—France, 1371
 Nilson & Junker.—Russia, 308
 Nilus, jun.—France, 935
 Nimmo & Son.—vi. 37
 Nimmo, T. & Co.—iv. 122
 Nisbet, J. & Co.—xxx. (Fine Art Court), 116
 Nissen, J.—Denmark, 20
 Nissen & Parker.—ii. 36
 Nixey, W. G.—ii. 112; xxii. 640
 Nixon, J. & Co.—i. 267
 Nixon, T.—vii. 174; ix. 161
 N. N.—Russia, 85. 88. 89. 105-107. 125. 128. 146. 274. 280. 291
 Noak, J. see Noak, W. & J.
 Noak, W. & J.—iii. 118
 Noakes, see Frost, Nonkes, & Vincent
 Nobert, F. A.—Zollverein (1), 77
 Nobili, C.—Tuscany, 91
 Noble, see Standish & Noble
 Noe, O.—Zollverein (1), 418
 Noel.—France, 666. 1669; see also Aubert & Noel
 Noel, F.—Belgium, 322; France, 936
 Noel, H. W.—xxvi. 400
 Noerdlinger, Professor.—Zoll. (4), 11
 Nogaiak Tartars.—Russia, 195
 Nogaredo, J. L.—France, 937
 Noggerath, Dr.—Belgium, 501
 Nogueira, A. de S4.—Portugal, 401. 438
 Noirsain, J.—xxii. 491
 Nolan, W. H.—x. 538
 Nolte, see Boletius, & Co.
 Noordendorp, P. H.—Netherlands, 110
 Noose.—Zollverein (1), 310A
 Norberg & Sather's Iron Mines.—Sweden, 102
 Norberto, P. F.—Portugal, 517. 599. 625. 626
 Norehi, A.—xxx. (Fine Art Court) 309
 Rome, 51
 Nordmann, G. L.—Zollverein (1), 30
 Norgate, see Williams & Norgate
 Norman.—Sweden, 59
 Norman, G.—xxii. 391
 Norman, S. W.—xvi. 201; xx. 167
 North, C.—xxvi. 259
 North, D.—xxvi. 257
 Northern Lighthouses, Commissioners of.—vii. 99
 Northern, W.—x. 419
 Northumberland Life Boat Committee.—viii. 136
 Northumberland Patent Rope Company.—xxxix. 155
 Northumberland & Durham Coal Trade.—i. 273
 Norton, J.—xii. & xv. 126; xxx. 340
 Norwood, C.—xxvi. 314
 Nothhaft, F.—Austria, 492
 Nottebohm & Co.—Zollverein (1), 635
 Noulton & Wylde.—viii. 178
 Nourry, Brothers, & Maynard, Cousins.—France, 1670
 Nouvelle Montagne (Société de la), Verviers.—Belgium, 7
 Nova Scotia Central Committee.—Nova Scotia
 Novello, J. A.—xvii. 127
 Nowak, F.—Austria, 115
 Nowill, J. & Sons.—xxii. 149
 Nowotny, A.—Austria, 66. 625
 Noye, see Keprit & Noye
 Noye, F.—France, 1372
 Noyes, see Maynard & Noyes
 Nox & Diggelmann.—Switzerland, 163
 Nuffel, Van, & Coveliera.—Belgium, 225
 Numa-Grar & Co.—France, 667
 Nunes, J. P.—Portugal, 1237
 Nunn, A.—vii. 187; ix. 92A; xxii. 703
 Nunn, E. B. see Nunn, J. P. & E. B.
 Nunn, J.—xxvi. 228

(Fine Art
 XXII. 640
 161
 89, 105-107.
 0. 291
 J.
 & Vincent
 n (1), 77
 ble
 418
 39; see also
 France, 938
 Zoll. (4), 11
 196
 937
 801
 Portugal, 401.
 etherlands, 110
 110A
 Mines.—Swe-
 tal, 517. 599.
 Art Court) 309
 verein (1), 30
 Norgate
 1; xx. 187
 mmissioners of.
 at Committee.
 ope Company.
 m Coal Trade.
 26; xxx. 346
 92
 verein (1), 635
 178
 ard, Cousins.
 sieté de la),
 nities.—Nova
 149
 625
 yes
 tzerland, 153
 s.—Belgium,
 667
 237
 92A; xxii.
 P. & E. B.

Nunn, J. P. & E. B.—ix. 218
 Nunn, R. M.—x. 371
 Nunn & Sons.—xxvi. 165
 Nunn & Clark.—United States, 374
 Nuno, D.—Spain, 62
 Nuoro, the Divisional Committee of.—
 Sardinia, 36
 Nurgat, Made.—France, 1504A
 Nurse & Co.—v. 932
 Nusbaum, L.—Austria, 497
 Nusseys, see Hargreave & Nusseys
 Nutchey, J.—xxvi. 238
 Nye, E.—xxvi. 54
 Nyrop, C.—Denmark, 19
 Nysset & Co.—France, 1373
 Nystrand.—Sweden, 82
 Oakden, P.—Van Diemen's Land, 161
 —164
 Oakeley, E.—Western end, South en-
 closure (Outside), 34
 Oakley, H.—x. 675A
 Oakford, C.—United States, 45
 Oakley, T.—xvii. 270
 Oastler & Palmer.—xvi. 286
 Oates, J. P.—x. 520
 Oates, W.—vii. 10
 Obercons, H.—Zollverein (1), 353
 Oberdorf, Royal Gun Manufactory.—
 Zollverein (4), 15
 Obroutcheff—Russia, 348
 Obry, Jules Bernard, & Co.—France,
 334
 O'Byrne, W. C.—i. 248
 Ochs.—France, 668
 O'Connor, J.—xi. 31
 O'Conner, H.—viii. 189; see also Ross,
 & Co.
 O'Connor, see Ross, O'Connor, & Carson
 O'Connor, A., see O'Connor, M. & A.
 O'Connor, M. & A.—xxiv. 65
 Oddy, S.—xx. 121
 Odell, see Sharp, Odell, & Jury
 Odent, X., Sons, & Co.—France, 938
 Odeux, J. M.—Belgium, 169
 Odiot.—France, 1617
 O'Donnell, Mary.—xix. 53
 Ody, see Salmon, Ody, & Co.
 Oehberg & Co.—Sweden & Norway, 11
 Oehler, Brothers.—Zollverein (3), 116
 Oehler, C.—Zollverein (6), 8
 Oehme, C. W.—Zollverein (1), 116
 Oehmg & Schmidt.—Zoll. (3), 154
 Oelbermann, D. Sons, & Co.—Zoll-
 verein (1), 497
 Oertling, A.—Zollverein (1), 87
 Oertling, L.—x. 334
 Oesterberg, C. G.—Sweden & Norway, 11
 Oestreichler, D.—Austria, 396
 Oetsmann & Plumb.—x. 683.
 Offergeld, F. J.—Belgium, 4
 Offermann, F. W.—Zollverein (1), 350
 Offermano, J. H.—Austria, 221
 Offlabertie, H.—i. 521
 Offner, J. W.—Austria, 444
 Offord, D.—viii. 25; x. 680; xxi. 28
 Offord, D. & Bradbeer.—viii. 26
 Offord, R.—v. 934
 Oglten, see Sykes & Oglten.
 Oger, J. L. M.—France, 939
 Ogleby & Co.—xxix. 139
 Ogilvie, see Mitchell, Miller, & Co.
 O'Halloran, see Parlett, O'Halloran, & Co.
 Ohio Board of Agriculture.—United
 States, 24
 Ohle, E. F.—Zollverein (1), 62
 Ohlson, J.—xxiv. 10
 Oignie, Charbonnage d', Coal Mines.—
 Belgium, 32

Oldfield, Allan, & Co.—xii. & xv. 127
 Oldfield & Co.—xxvii. 76
 Oldfield, Rev.—i. 21
 Oldriul, J.—Austria, 106A
 O'Leary, J.—xvi. 265
 Oliver, F.—United States, 593
 Oliver, J.—xxvii. 41
 Oliver, B. S.—xx. 88
 Oliver, G. T.—xxx. (Fine Art Court),
 16
 Oliver, O.—vii. 65
 Oliver, T.—United States, 341
 Oliver, W.—iv. 39; xxii. 121
 Olivier & Co.—Belgium, 261
 Ollerdiseu, P.—Zollverein (1), 551
 Olliffe, C. H.—v. 771
 Olmo, J.—Spain, 107
 Olmsted, Mrs. J.—United States, 359
 Olonetz, Imperial Alexandrovsk Cannon
 Foundry at—Russia, 285
 Oloroushaw, J. & Co.—x. 3
 Olsharden, F.—Hamburg, 90
 Oliver, Lydia.—xix. 259
 Omaliu, G. D.—Belgium, 171
 O'Meara, M.—Canada, 179
 Omer, Kibury.—Turkey
 Onate; Royal Ordnance Office.—Spain,
 262 (Main Avenue, East)
 Ondagahout, P.—Canada, 172
 Onion, E.—xix. 56
 Onions, J. C.—xxii. 249
 Oomen, A. M.—Netherlands, 8
 Oossein-Ogilt.—Russia, 142
 Oost, P. Van.—Belgium, 219
 Ooste, A.—Russia, 194
 Ooste-Catchey-Ooste-Ali-Beck-Ogilt.—
 Russia, 163
 Ooste-Selim-Molla-Noori-Ogilt.—Russia,
 165
 Opendhoff & Hartung.—Zoll. (1), 134
 Ophen, Van.—Belgium, 49
 Opigea & Chazella (late Gagein)—
 France, 336
 Oporto Coal Mining Co.—Portugal, 17
 Oppelt, E.—Spain, 271
 Oppenheim, H. & Co.—Zollverein (1),
 728; (3), 99
 Oppenheimer, Caroline.—Austria, 701A
 Orban, J. M. & Son.—Belgium, 372
 Orchard, J.—x. 161
 Ordnance Survey of the United King-
 dom.—i. 159; viii. 128; x. 4
 Orduna, V.—Spain, 214
 Orense, Mining Inspector of.—Spain, 18
 Organ, J.—Western end, South en-
 closure (Outside), 1; xxvii. 85
 Ormerod, R. & Son.—v. 624
 Orpwood, G.—xxii. 552
 Orr, see Cohen & Orr; Ewing, Orr, &
 Co.
 Orr, M.—viii. 75
 Orr, W. S. & Co.—xvii. 109
 Orsetti, C. T.—Tuscany, 31
 Orsi & Armani.—xxvii. 36
 Ortega y Soler, F.—Spain, 193
 Orton, R.—viii. 136
 Osborn, Matilda.—xix. 200
 Osborne.—xx. 121
 Osborne, C.—viii. 234
 Oster, F. & C.—xxiv. 20 (Main
 Avenue and Transsept)
 Osmond, G.—xxii. 658
 Osberger's, P. successor.—Austria, 189
 Ossoli, see Marchesi & Ossoli
 Osten, L. V. D.—Zollverein (1), 150
 Osterberger, L.—Austria, 538
 Osterby Iron Works.—Sweden and
 Norway, 6
 Oswald, M. & Co.—Switzerland, 152
 Oswald, Stevenson, & Co.—xi. 10 & 45

Oswego Starch Factory.—United States,
 104
 Otis, B. H.—United States, 23
 Otte, J.—Belgium, 2
 Otley, T.—xxii. 306
 Otto, see Isler & Otto; Schaefer, Otto, &
 Scheibe
 Otto, F. H.—Netherlands, 56
 Otto, H.—Zollverein (4), 47
 Ondard, L. Son, & Boucherot—France,
 1374
 Oudin, C. A. F.—France, 1376
 Oudin & Co.—France, 1375
 Oudin-Cormy.—France, 669
 Ouerim, G.—Austria, 84
 Ougrée.—Société des Charbonnages et
 Hauts Fournaux, D.—Belgium, 40
 Ounkovsky.—Russia, 54
 Ourcamp Society.—France, 379
 Outridge, J.—British Guiana, 20A. 47.
 48. 51. 55c. 62. 64-85. 85c. 85c. 87
 89A. 91-92A. 97-98A. 104. 105A.
 106.-115A. 117D-117E. 148B.-153
 Overbeck.—xxiii. 129
 Overbury, J.—xii. & xv. 216
 Overloop, J. C. van.—Belgium, 236
 Overman.—Belgium, 297
 Owden, see Richardson, Sons, & Co.
 Owen, see Brown, Owen, & Co.; New-
 bold & Owen; Sandford & Owen;
 Sandford, Owen, & Watson
 Owen, C.—ii. 83
 Owen, H.—x. 670; xvii. 180
 Owen, J.—Denmark, 47
 Owen & Levick.—xxiii. 41
 Owens, J.—United States, 319
 Owtram & Co.—xi. 62
 Oxeda & Agui.—Algeria, 40
 Oxland, J. & R.—ii. 120
 Oxley, W.—x. 689
 Oxley, W. & Co.—xxii. 806
 Oyler, S.—ii. 113
 Oyler & Anderson.—United States, 305
 Ozann, Dr. G.—Zollverein (2), 87
 Ozerov, T. Russia.—228
 Ozouf, H.—France, 670
 Paardeberg, J. S. C.—South Africa, 7
 Pace, see Tylor & Pace
 Pace, J.—x. 117
 Pace & Sons.—x. 517
 Pacini, D.—Tuscany, 33
 Packer, see Packer & Towns
 Paddon & Ford.—xxii. 424
 Padley, Parkin, & Staunforth.—xxiii. 42
 Padreddi, F.—Tuscany, 60
 Padwick, Anne.—xix. 261
 Padwick, W. F.—ix. 215
 Paetch, G. T.—Zollverein (1), 18
 Paetch & Hintze.—Zollverein (1), 218
 Pagan, F.—Switzerland, 64
 Page, E.—United States, 92
 Page, Eleanor & W.—xxix. 194
 Page, H. C.—xxvii. 26
 Page, H. M.—xxvii. 229
 Page, J. R.—i. 425
 Page, J. A.—France, 337
 Pagnerre.—France, 940
 Paige, J. W. & Co.—United States, 436
 637
 Paillard, A., see Paillard, E. & A.
 Paillard, A. V.—France, 1713
 Paillard, E.—France, 671
 Paillard Brothers.—Switzerland, 26
 Paillard, J. M.—France, 672
 Paillard, Brothers.—France, 338
 Paillote, P.—France, 1377
 Paine, J. M.—i. 36; iii. 62
 Paine, W.—x. 295

Palasant, L. de.—France, 590
 Pals, Beauvoys C. De.—France, 341
 Pajk, G.—Austria, 127
 Palastini, *see* Serafino, Palastini & Co.
 Palencia, Inspector of Mines of the district of.—Spain, 27
 Palenola, M. R.—Spain, 12
 Palmneber, V.—Austria, 637
 Palla, A.—Zollverein, (1), 263
 Pallenberg, H.—Zollverein, (1), 421
 Palling, W.—XII. & xv. 213
 Palmella, Duke de.—Portugal, 114. 530-534. 604-610
 Palmer, *see* Burns and Palmer; Huntley and Palmer; Oastler and Palmer
 Palmer & Co.—XXII. 447
 Palmer, F. B.—United States, 39
 Palmer, G.—VIII. 136
 Palmer, H.—XXVI. 59
 Palmer, Helen.—XIX. 262
 Palmer, J. L.—France, 942
 Palmer, Mackillop, & Co.—China
 Palmer, Miss.—XXVI. 322
 Palmer, R.—IX. 48A; XIX. 400; XXVI. 53
 Palmer, W.—XXX. (Fine Art Ct.), 197
 Palmer, W. R.—United States, 347
 Palmer, W. V.—x. 451
 Palmgren, P. F.—Sweden, 49, 68
 Palgrave, J. T.—Canada, 189
 Pamer, S.—Austria, 445
 Panciafichi, Marquis.—Tuscany, 96
 Panna, N. & J. Alexis.—Austria, 94
 Pannell, J.—IX. 204
 Pannilini, C. A. G.—Tuscany, 42
 Panormo, C.—Page 850
 Panormo, L.—x. 525
 Pansa & Hauschild.—Zollverein (3), 42
 Pantazapoulos, A.—Greece, 51
 Panteleeff, M.—Russia, 175
 Paoletti, F.—Tuscany, 29
 Paolo, *see* Vella, Paolo, & Co.
 Papavoine & Chatel.—France, 339
 Pape, J. H.—France, 943
 Papeira, J. P.—XXX. (Fine Art Ct.), 17
 Papi, C.—Tuscany, 116
 Pappafava.—Austria, 79
 Papperitz, J. F.—Zollverein (3), 173
 Papworth, E. G.—XXX. (Sculpture Court), 27
 Papworth, J. W.—XIX. 379
 Papworth, W. & J. W.—XXX. (Fine Art Court), 22A
 Paquet, Marie.—Belgium, 335
 Paquet-Fazy, Mde.—Switzerland, 105
 Paradis, De Ruolz, & Co.—France, 340
 Paravagna & Casella.—XXIII. 84
 Pardo y Bartolini, M.—Spain, 116
 Pardoe, Hoomans, & Pardoe.—XIX. 263
 Pardon, *see* Reed & Pardon
 Pardoux.—France, 341
 Pare, Gera Di.—Austria, 85
 Parent.—France, 944
 Parent, T. J. F.—Belgium, 278
 Paret, M.—France, 1378
 Parey, C. F. W.—Zollverein (1), 169
 Parfrey, G.—v. 972
 Paris, G.—Austria, 85
 Parini, J.—Sardinia, 91
 Paris, *see* Duval & Paris
 Paris, C. E.—France, 1379
 Paris Chocolate Co.—III. 30
 Paris Conservatoire des Arts et Metiers.—France, 1568
 Paris, E.—I. 4; New Granada, 4
 Paris, National Printing-office.—France, 544
 Parisault, F.—Canada, 77
 Parisault, J.—Canada, 76, 129
 Pariah, R. jun.—United States, 568

Parisot, F.—France, 1673
 Park, S. H.—x. 337
 Park and Thompson.—XIX. 59
 Parker, *see* Lowthian & Parker; Morrison & Parker; Nissen & Parker; Townsend, Parker, & Co.
 Parker, & Acott.—XXII. 298
 Parker & Brown.—United States, 235
 Parker, C.—VIII. 67; *see also* Parker, C. E. & C.
 Parker, C. E. & C.—VI. 77
 Parker, Field, & Sons.—VIII. 224
 Parker, J.—XVI. 242; Canada, 68
 Parker, J. H.—XVII. 120
 Parker, Rev. Dr.—China
 Parker & Sons.—XVI. 118
 Parker, Wilder, & Co.—United States, 513
 Parkes, Brothers.—Canada, 186
 Parkes, H. P.—VIII. 108
 Parkes, H. W.—XXII. 859
 Parkes, J. & Son, x. 671
 Parkin, *see* Blake & Parkin; Padley, Parkin, & Stamford, & Co.
 Parkin & Marshall.—XXII. 119
 Parkins, T.—XXIX. 152
 Parkinson, *see* Hattersley, Parkinson, & Co.
 Parkinson & Frodsham.—x. 35
 Parks.—x. 579
 Parks, S. H.—x. 337
 Parks, W. J.—x. 413A
 Parianti, E.—Tuscany, 101
 Pariby, *see* White & Pariby
 Parlett, O'Halloran, & Co.—Ceylon
 Parmenter, E.—United States, 244
 Parmentier, P.—Belgium, 222
 Parmit, V. Dautresme, Sons, & Co.—France, 673
 Paroissien, A.—France, 945
 Parr, Curtis, & Madeley.—VI. 6. 213
 Parreira, M.—Portugal, 1169, 1170
 Parrot, W.—II. 46
 Parry, *see* Kirk & Parry
 Parich, Brothers.—Austria. 279
 Parsey, A.—v. 591
 Parsey, W.—VIII. 88
 Parsons, v. 807, *see* Ransom & Parsons
 Parsons, Fletcher, & Co.—XVII. 31
 Parsons, J.—IX. 112
 Parsons, John.—I. 232
 Parsons, P. M.—v. 642
 Parsons, W.—VIII. 270
 Partagas & Co.—Spain, 251
 Partridge, N.—XII. and xv. 212
 Partridge, W.—XXX. (Fine Art Court), 333
 Partsch, A. jun.—Austria. 611. 662
 Parys, J. *see* Doequir, P. J., & Co.
 Pascual y Abad, A.—Spain, 286
 Pashkoff, A.—Russia, 23
 Pashkoff, M.—Russia, 24
 Pask, *see* Koenig & Pask
 Pasquali, D. R.—Rome, 2
 Pasquet, Du, *see* Vaucier, & Co.
 Pasqui, R.—Tuscany, 83
 Pass, *see* Gatenby & Pass
 Pass, A. De.—South Africa, 50
 Pass, C. G.—Zollverein (1), 377
 Passamonte, S.—Rome, 32A
 Passmore, W.—xvi. 79
 Pasteyns, P.—Belgium, 484
 Pastor-Bertrand & Co.—Belgium, 395
 Pastorelli, D.—Tuscany, 35
 Patek, P. & Co.—Switzerland, 99, 274
 Paternoster, T.—v. 936
 Paternostro, J.—Belgium, 331
 Paterson, G.—Canada, 115
 Paterson, J.—XX. 19, 129
 Paterson, Jamieson, & Co.—XI. 11

Paterson, T.—v. 148
 Paterson, T. L.—VI. 28
 Paton, D. *see* Paton, J. & D.
 Paton, J. & D.—XII. & xv. 466
 Patouze, Drilon, & Co.—France, 674
 Patricin, C.—France, 1380
 Patrick, *see* Lambert, Brown, & Co.
 Patron, J. de.—29A
 Pattak G.—Austria, 350
 Patterson, D.—United States, 478; Van Diemen's Land, 48; *see also* Almy, Patterson, & Co.
 Patterson, J.—Canada, 146
 Patterson, W.—VIII. 136
 Patterson, R. S.—United States, 278
 Pattinson & Cain.—I. 497
 Pattinson, H. L.—I. 480
 Pattinson, W. W.—II. 18 (Main Avenue, West)
 Pattison, E.—XVI. 186
 Patton, J.—Switzerland, 44
 Pature-Lupin, Seydoux, Seibler, & Co.—France, 1381
 Paulban.—France, 946
 Paul-Ulysee.—France, 678
 Pauli & Buchbois.—Zollverein (1), 368
 Pauller, J. & Son.—Austria, 649
 Pauloy, y M. Bartolini.—Spain, 44
 Pauly, A., *see* Pauly, G. & A.
 Pauly, G. & A.—Switzerland, 199
 Pauly, O.—Zollverein (1), 328
 Pawe, De.—Belgium, 485
 Pawels, A.—France, 342, 1382
 Pavlides, E.—Greece, 12
 Pavloff, N.—Russia, 333
 Pawson, Son, & Martin.—XII. & xv. 40
 Paxon, W.—x. 191
 Paxton, J.—IX. 125; x. 742
 Payen, A. R.—France, 1674
 Payne.—XXVI. 383; *see also* Rock, & Co.; Ward & Payne.
 Payne, G.—XXIX. 29
 Payne, H.—III. 82
 Payne & Son.—III. 22
 Payne & Sons.—XXIII. 4
 Payne, W. & Co.—x. 73
 Payne's Patent Timber Preserving Company.—IV. 139
 Pezelt, A.—Austria, 603
 Pezce, A. & Co.—XII. & xv. 91; xx. 128
 Pezce, H.—XXII. 233A
 Pezce, J.—XXII. 233
 Peach, *see* King & Peach
 Peachey, Emma.—XXVI. 238
 Peachey, G.—x. 502
 Peachey, J. jun.—XXX. (Fine Art Court) 320
 Peacock, A.—XXIX. 193
 Peacock, G.—II. 73
 Peake, C. C.—XXX. (Fine Art Court), 144
 Peake, T.—XXVII. 123
 Peal, N.—XVI. 197
 Peale, C. W.—United States, 74
 Pearce, E. E.—XXX. (Fine Art Court), 32
 Pearce, T. B.—v. 709; VIII. 330; XIX. 173. 311
 Pearce, W.—IX. 77; XXII. 671; XXVII. 75
 Pearl, J.—XVI. 100
 Peare, A. & F.—XXIX. 24
 Pears, F., *see* Pears, A. & F.
 Pearese, *see* Halling, Pearese, & Stone
 Pearese, Clara.—XIX. 266
 Pearson.—XVII. 29; XXII. 541; Van Diemen's Land, 109; *see also* Harrop, Taylor, and Pearson.
 Pearson & Co.—XI. 21

- Pearson, J.—XII. & XV. 239; XX. 126A
 Pearson, J. W.—VIII. 65
 Pearson, W. P.—XXVII. 65
 Peart & Doucet.—XX. 5
 Peasants, Female, of Westford, XX. 181
 Pease, H. & Co.—XII. & XV. 184
 Pease, Heaton, & Co.—XII. & XV. 60
 Pease, J.—I. 122
 Pease, R. H.—United States, 230
 Peat.—Brazil, 3
 Peat-working Company of Ireland.—I. 231
 Pecare & Smith.—United States, 307
 Peck, Mrs. C. P.—United States, 248
 Peck, G.—Van Diemen's Land, 224-226
 Peckerd, J. P.—XVII. 110
 Peckham, J.—United States, 320A
 Pedolin, F.—Switzerland, 49
 Pedro, S. de Araya, the Director of the
 Factory of.—Spain, 12
 Pedrosa Iron Co., Sevilla.—Spain, 24
 Peel, A. R.—XVII. 66
 Peel, J.—XXVIII. 175
 Peel, W. & Co.—XII. & XV. 164
 Peemans, Mad. H.—Belgium, 50
 Peers, Le Chevalier E.—Belgium, 75
 Peet, T.—IV. 132
 Pegler, C.—XIV. 43
 Peigne, V. J.—France, 947
 Peite, J. J. & Co.—VII. 77
 Pell & Co.—Zollverein (1), 369
 Peiros, W.—XXII. 18
 Peixoto, J. C.—Portugal, 628
 Peidrian's Heirs.—Austria, 288
 Pelikan, J.—Austria, 597
 Pelitti, G.—Austria, 181
 Pelissar, see Tack, W. & Co.
 Pell, R. J.—United States, 115
 Pellatt & Co.—XXIV. 33
 Pellegrini, S.—Rome, 27
 Pellerin, C. A.—France, 1383
 Peller, Brothers.—France, 948
 Pelling, C.—XIV. 4
 Pellissier.—Algeria, 42
 Pelusi, E.—Tuscany, 56
 Pelterau, A.—France, 677
 Pelterau, F. Jun.—France, 949
 Peltzer, W.—Zollverein (1), 518
 Pemberton, see Simeox, &c.
 Pena, A.—Spain, 282
 Penañal, E.—Spain, 77
 Pendleton Alum Works, Manchester.—
 II. 7
 Peneau, J.—France, 950
 Peneipe, Council of.—Portugal, 1281
 Penfield & Camp.—United States, 296
 Penfold, O.—XIII. 59
 Penley, E. A.—XIX. 392
 Penn & Son, v. 8
 Penner, J.—Canada, 65. 132
 Penney, H.—IV. 64
 Penniman, U. H.—United States, 249
 Pennington, J.—X. 53
 Pennock & Co.—I. 218
 Pennsylvania Railroad Company.—
 United States, 327
 Penny, H.—XVII. 32
 Penny, J.—XVI. 91
 Peurice, Lieut. R. E.—VIII. 173
 Peurose, F. C.—X. 318
 Penryn Local Committee, see Falmouth
 and Penryn Local Committee
 Pentelcon, Prior of the Monastery.—
 Greece, 45
 Pens, J.—Austria, 446
 Pens, T.—Austria, 447
 Penzance Serpentine Co.—Western end,
 South enclosure (Outside) 26
 Pepin-Vielard.—France, 1675
 Peplow, W.—XVI. 157
 Pepper, see Sergeant and Pepper
 Pepper, Otto.—Hamburg, 18
 Peppercorn.—XXX. 356
 Perard, see Remacle, J. &c.
 Perard & Mineur.—Belgium, 18
 Percival, J.—XVIII. 73
 Percy.—XXIII. 94
 Perdeux, J.—Belgium, 63
 Pérdé, J. F.—Belgium, 375
 Perelli, A.—Sardinia, 66
 Perelli, Mines of.—Tuscany, 4
 Peres & Co.—Spain, 271A
 Perfect, see Shepard and Perfect
 Perger, J.—Austria, 111. 174
 Perier, see Gorsas & Perier
 Pereira, J. da S.—Portugal, 713
 Perigal, H. Jun.—X. 693
 Perisault, J.—Canada, 322
 Perkes & Co.—XXII. 64
 Perkes, see Wood & Perkes
 Perkes, S. & Co.—VII. 162
 Perkins, A. M.—United States, 532. 541
 Perkin & Brown.—United States, 201
 Perkins, H.—III. 149
 Perkins, S. M.—United States, 472
 Parkins, W.—X. 681
 Perm, Imperial Bogoslovak Copper
 Works of.—Russia, 6. 20
 Perm, Imperial Ekaterinburg Engine
 Factory.—Russia, 168
 Perm, Imperial Gorohlagodatsk Iron
 Works at.—Russia 7
 Perm, Imperial Kamenak Iron Works at.
 —Russia 8
 Perm, Imperial Kousinsk Iron Works
 at.—Russia, 9
 Perm, Imperial Nijne-Issetak Works at.
 —Russia, 16
 Perot, G. G.—France, 1385
 Perot, G. J. sen.—France, 951
 Perotia, G.—Greece, 8
 Perret, A.—Switzerland, 18
 Perret, C.—Switzerland, 271
 Perret, Charlotte.—Switzerland, 39
 Perret & Son.—Switzerland, 21
 Perron.—France, 343
 Perrot, Petit, & Co.—France, 952
 Perry & Co.—XXII. 687; XXIV. 36
 Perry, E.—XXII. 60A
 Perry, Rev. E.—XIX. 268
 Perry, G. J.—Canada, 181
 Perry, H.—V. 112
 Perry, H. J.—V. 362; VI. 501
 Perry, J.—XXIX. 60; Canada, 157;
 United States, 72
 Perry, Mrs.—XIX. 268
 Perry & Son.—XXII. 691A
 Perry, W.—XXX. (Fine Art Court)
 101
 Perselaert & Son.—Netherlands, 71
 Perseveranca, C.—Portugal, 14
 Pescheloche-Vivin.—France, 344
 Pesel & Meimet.—France, 578
 Pessl, G.—Austria, 544
 Pester, A.—Zollverein (3), 72-83.
 Peter, J.—Switzerland, 67
 Peterhoff Imperial Polishing Manufac-
 tory.—Russia, 298
 Peterman, A.—X. 711
 Peters, see Ustonsen & Peters
 Peters, D.—XII. & XV. 220
 Peters & Son.—XXVIII. 131
 Peters & Sons.—V. 958
 Peters, T. C.—United States, 106
 Petersburg, St., Imperial Alexandrovsk
 Manu.—Russia, 19. 149. 210. 219.
 Petersburg, St., Imperial China Manu.—
 —Russia, 318
 Petersburg, St., Imperial Coach Making
 Establishment.—Russia, 154
 Petersburg, St., Imperial Jorok Works.
 —Russia, 169
 Petersen, J.—Hamburg, 5
 Petersen, P.—Denmark, 35
 Petersen, P. L.—Denmark, 11
 Peterson, T.—III. 66. XXII. 383.
 Petit, see Doucet & Petit
 Petit, A.—Russia, 258
 Petit, Clement.—France, 679
 Petit & Co. see Perrot, Petit, & Co.
 Petit, F. & Co.—Belgium, 13
 Petit & Fritsen.—Netherlands, 78
 Petit Noel, Leronge, & Co.—Belgium,
 246-250
 Petit, sen, & Co.—France, 345
 Petitcollin, J.—France, 953
 Petithomme, L. A.—France, 954
 Petley, T.—VIII. 58
 Petrak, J.—Austria, 289
 Petri, J.—Zollverein (6), 41
 Petrina, Professor.—Austria, 135
 Petropoulos, C.—Greece, 5
 Petrotida, D.—Austria, 730
 Petrucci, C. C.—Tuscany, 40
 Petschacher, A.—Austria, 688
 Pettit, R. Lewis.—XXIV. 55
 Pettit, W. J.—IX. 92
 Pettitt & Son.—XVI. 134
 Petz, C.—Russia, 292
 Petz, W.—Austria, 28
 Petzoldt & Ehret.—Zollverein (3), 46
 Petzoldt, F.—Zollverein (3), 141
 Peugey, F.—XXVII. 92
 Peyman, H. P.—Page 850
 Peyron, S.—France, 953. 1387
 Peyroux, H.—France, 1678
 Peyton & Harlow.—XXII. 371
 Pfaff, G.—United States, 528
 Pfaff, M.—Zollverein (2), 35
 Pfalts, see Ihm, Boehm, & Pfalts
 Pfeiffer, A. F.—Austria, 604
 Pfeiffer, C.—Zollverein (1), 184
 Pfeiffer, J.—Austria, 418
 Pfeiffer, J., & Co.—Austria, 606
 Pfeiffer, L.—Austria, 681
 Pfeningberger, J.—Austria, 248. 359
 Pfdmenges, see Widemann, &c.
 Pfdmenges, Brothers.—Zollverein (1)
 574
 Pfdmenges & Kleinjung.—Zollverein
 (1), 678
 Pfeuffer, C.—Zollverein (1), 286
 Pfeuffers & Ax.—Zollverein (1), 667
 Pfizner & Beckers.—Austria, 41
 Pfeiderer, see Neviandt, &c.
 Pfeiderer, J.—Austria, 476
 Pfgner, F. A.—Austria, 682
 Pfgsterschmidt, J.—Austria, 548
 Phalou, E.—United States, 390
 Pharland, Mrs.—Van Diemen's Land,
 177
 Philadelphia.—United States, 558
 Philcox, G.—X. 22
 Philibert, F., see Philibert, L. & F.
 Philibert, L. & F.—Russia, 124
 Philip.—France, 680; see also Wheeler,
 Philip, & Co.
 Philip, J.—Page 848
 Philippe & Canaud.—France, 956
 Philippine Islands, The Central Fac-
 tory of Tobacco.—Spain, 248
 Philippos, G.—Greece, 4
 Phillips, see Bloomer & Phillips; Casey
 & Phillips; Faudell & Phillips;
 Lacey & Phillips
 Phillips, Brothers.—XXIII. 67
 Phillips, C.—Western end, North En-
 closure (Outside), 63
 Phillips, C., & Co.—IX. 252

Phillips, Emily.—XIX. 271
 Phillips, G.—IX. 72A
 Phillips, H.—XXII. 291
 Phillips, J.—X. 411; XII. & XV. 222
 Phillips, J. B.—XXII. 6
 Phillips, Rebecca.—XIX. 272
 Phillips, Smith & Co.—I. 500
 Phillips, Smith & Phillips.—XII. & XV. 217
 Phillips & Son.—Zollverein (1), 412
 Phillips, W.—I. 101
 Phillips, W. H.—v. 92
 Phillpotts, Mary Anne.—XX. 18
 Philp & Whicker.—X. 641
 Philppard, T.—I. 113
 Philippe, Dr.—VIII. 127
 Philippe, W. D.—XVI. 319
 Phcenix Manufacturing Co., Massachusetts.—United States, 426
 Physlok, E. G.—XXX. (Sculpture Court) 69
 Physick, E. J.—Page 850; XXX. (Sculpture Court), 47
 Pian, Castagnolo.—Tuscany, 10
 Pianello, D.—Sardinia, 3
 Picard, E.—France, 347
 Picardi-Massy, E.—Belgium, 405
 Picault, G. F.—France, 348
 Picciotto, M. H.—II. 33; IV. 53
 Pichard, A. F.—France, 1388
 Pichler, J.—Austria, 339, 345
 Pichot, see Meillat and Pichot
 Pichot, A.—France, 349
 Pick, J.—Russia, 170
 Pickering, E. T.—XXX. (Fine Art Court), 254
 Pickering, J.—XXVI. 347
 Pickering, W.—XVII. 140
 Piekhardt, G.—Zollverein (1), 619
 Pickthorn, Kether.—XIX. 273
 Picquot, K. France, 1389
 Pidgley, F. J.—XXX. (Fine Art Court), 225
 Piece, Louis.—Switzerland, 233
 Piedagnel, Mlle.—France, 1390
 Piedrola, M.—Spain, 84
 Piegler, G.—Zollverein (1), 765
 Piepenstock & Co.—Zollverein (1), 473
 Pierce, Mrs. J. S.—United States, 248A
 Pierce, W.—XXII. 107
 Pieri, Count G.—Tuscany, 41
 Pieris, T. A.—Ceylon
 Pierotti, G.—Austria, 720, (Main Avenue, East)
 Pierret.—France, 350
 Pierret, J. B.—France, 958
 Pierson.—France, 957; Van Diemen's Land, 9
 Piesse, S.—III. 129
 Piette, L.—Zollverein (1), 394
 Piggott, see Thurman, Piggott, & Co.
 Pighlein, see Werner & Pighlein
 Piglia.—Algeria, 43
 Pigott & Co.—XXII. 281
 Pigott, J.—XVI. 261
 Pigott & Newton.—XIV. 36
 Pike, see Booth & Pike
 Pike, J., see Pike, W. & J.
 Pike, T. J.—XXX. (Fine Art Court), 336
 Pike, W. & J.—I. 102
 Pilger, L.—Netherlands, 52A
 Pilkington, J.—VIII. 176
 Pillaat & Co.—France, 351
 Pillarsee & Zenbach, Imperial Smelting Works.—Austria, 407
 Pillscher, M.—X. 269
 Pillas, F.—Austria, 541
 Pilout.—France, 681
 Pillas, C.—Austria, 540

Pilas, G.—Austria, 542
 Pilas, M.—Austria, 543
 Pim, Brothers, & Co.—XII. & XV. 255
 Pim, J. E.—XVI. 59
 Pimentel, J. M.—Portugal, 920-925. 927. 935. 951, 952. 964
 Pimm, H. & Co.—I. 478
 Pinmont.—France, 1391
 Pinan, J.—Spain, 81, 159
 Pin-Bayard.—France, 682
 Pluches & Co.—XVII. 33
 Pinder, Bourne, & Hope.—XXV. 16
 Pinder, W. & Sons.—XXII. 574
 Pinkerton, J.—XXIV. 5
 Pinkerton, J. & R.—XIV. 15
 Pinkerton, R., see Pinkerton, J. & R.
 Pinkus, H.—United States, 594
 Pinnell, T. D.—XXVI. 260
 Pinner, K. M.—Zollverein (3), 179
 Pinsonnet, A. L.—France, 1392
 Pinto & Co.—Portugal, 770-774. 777-786
 Pinto, F. X.—Portugal, 1280
 Pinto, J. B.—Portugal, 471, 472
 Pinto Peres & Co.—II. 121
 Pinto e Sousa.—Portugal, 1021
 Pintus, H. jun.—Zollverein (1), 135
 Piper, T. F.—XX. 41
 Piper, T. & W.—I. 130A
 Piper, W.—see Piper, T. & W.
 Piques.—France, 1393
 Piquet, Brothers.—Switzerland, 273
 Fire-et-Violetto Charbonnages.—Belgium, 34
 Pirene & Duesberg.—Belgium, 199
 Piron, T.—Belgium, 200
 Pirsson, J.—United States, 90
 Pistor, G. & W.—Zollverein (1), 481
 Pitansier.—Russia, 307
 Pitard, see Durand, Boucourt, & Pitard
 Pitet, sen.—France, 959
 Pithoullis, N.—France, 52
 Pitman, I.—XVII. 197
 Pitman, J.—XX. 187
 Pitoux, V.—France, 960
 Pitt, see Stothert, Rayno, & Co.
 Piuto, Ferreira, & Sons.—Portugal, 279-293
 Piver, A.—France, 1678
 Pizala, F. A.—X. 162
 Piazzi, W.—v. 559
 Place, G. G.—XXX. (Fine Art Court), 267
 Placentia, Royal Ordnance.—Spain, 265
 Plagniol.—France, 1679
 Plaideau, J. P.—Belgium, 71
 Plambeck, C. F. H.—Hamburg, 69
 Plant, see Pope & Plant
 Plant, F.—X. 215
 Plasse.—France, 1394
 Platt.—XXIV. 17; see also Hibbert, Platt, & Sons
 Platman, Conrad.—Lubeck, 1
 Playne, C., see Playne, P. P. & C.
 Playne, P. P. & C.—XII. & XV. 211
 Pleischl, A.—Austria, 433
 Plenty, E., see Plenty, J. & R.
 Plenty, J. & E.—VI. 53; VIII. 137; IX. 272
 Plenty & Pallew.—VIII. 136; IX. 272
 Plessner, S.—Zollverein (1), 179
 Plettinck, Madame.—Belgium, 340
 Plichon, see Barth, Massing, & Co.
 Plichon, V.—France, 684
 Plimoll, S.—VI. 631; XXII. 185
 Pliassart, see Lemaire-Descamps, & Co.
 Plomdeur, N.—Belgium, 146
 Plomley, F.—III. 64
 Plomley, W.—XXII. 17

Plon, Brothers.—France, 1395
 Plouquet, H.—Zollverein (4), 107
 Plowman, J.—XVII. 121
 Plows, W.—XXVII. 34, 50
 Pluecker, M.—Zollverein (1), 568
 Pluess, see Mueller, Pluess, & Co.
 Plümacher, W.—Zollverein (1), 616
 Plumb, see Oetmann, & Co.
 Plummer, H. L.—X. 78
 Plummer, H.—VI. 74; XIV. 78
 Pluys, J. F.—Belgium, 491
 Pochou, see Chailloux, Lepage, & Co.
 Podgry, see Khid & Podger
 Podossow, P. & Sons.—Russia, 229
 Poehle.—Zollverein (1), 191
 Poelman, J.—France, 961
 Pogot.—France, 1677
 Pohle, see Husebener & Pohle
 Poidebard, N.—Tuscany, 39
 Polger, F.—Austria, 464
 Pollart & Carpenter.—France, 686
 Poilleu, Brothers.—France, 962
 Polly, De, & Co.—France, 1396
 Polignou.—France, 1397
 Point & Son.—Belgium, 474
 Polint Screw, Patent, Co.—XXII. 649
 Polier, L.—France, 963
 Polirar, P.—France, 1398
 Poizat, Uncle, & Co.—France, 1399
 Poltevin & Son.—France, 685
 Pokorny, J. A.—Zollverein (1), 79
 Polak, Mlle. F.—Belgium, 298
 Poland, Imperial Mining Works In.—Russia, 15, 155, 258
 Poland, Son, & Meredith.—XVI. 302
 Polhemus, see Fox & Polhemus
 Poliakoff & Zamiatin.—Russia, 205
 Polito, the Canonico.—Malta, 13, 34
 Polkinghorne, W.—I. 460
 Pollak, J. J. & Sons.—Austria, 322
 Pollak, A. M.—Austria, 47
 Pollard, see Sales, Pollard, & Co.
 Pollard, T. M.—British Guiana, 1 & 2
 Pollett, T.—XVI. 210
 Pulli, F.—Tuscany, 85
 Pollock, J.—XVI. 279
 Polson, see Brown & Polson
 Polt, A.—Austria, 650
 Polycarpo, A.—Portugal, 632, 633
 Pomare, Queen.—Society Islands, 1-4
 Pommerel Société Anonyme des Hauts Fourneaux de.—Belgium, 6
 Pommier, P.—France, 1400
 Pond, M. & Co.—United States, 414, 434
 Ponder, W. R.—IX. 146
 Pouseele, E.—Belgium, 495
 Ponsou.—France, 1403
 Ponsouby, T.—XXVI. 199
 Pont, see Amney & Pont.
 Pont de Loup, Compagnie des Charbonnages, de.—Belgium, 28
 Pontifex, G.—British Guiana, 102A
 Pontifex & Wood.—II. 1; VI. 602
 Ponting, T. C.—II. 25.
 Ponton, G.—IX. 104
 Pook, S. M.—United States, 446
 Pool, C., see Pool, J. & C.
 Pool, J. & C.—XIV. 46
 Poole, J. jun.—VIII. 77
 Poole & Macgillivray.—XXVI. 204
 Poole, Sarah R.—III. 146
 Pooley, H. v. 784.
 Pooley, S. J.—United States, 225
 Poore, J. B.—XX. 169
 Poortman & Visser.—Netherlands, 2
 Pope, C., see Pope, T. & C.
 Pope, J.—United States, 32
 Pope, Mrs.—Jersey & Guernsey, 43.
 Pope & Plant.—XX. 6

395
 (4), 107
 (1), 588
 & Co.
 (1), 618
 7. 78
 1
 age, & Co.
 220
 11
 19
 1999
 964
 1390
 74
 -XXII. 649
 1999
 985
 (1), 79
 298
 Works In.—
 -XVI. 302
 1999
 205
 13. 34
 322
 & Co.
 1 & 2
 32, 633
 1-4
 6
 States, 414.
 28
 102a
 VI. 602
 446
 VI. 204
 225
 lands, 2
 sey, 43.

Pupe & Son.—v. 40; XXII. 243
 Pupe, T. & Co.—vi. 148
 Pupe, W.—XXII. 566; XXIX. 76
 Popelin-Ducarre.—France, 1404
 Popinoff, Sophia.—Russia, 310
 Popoff, A.—Russia, 144
 Popoff, T. & Sons.—Russia, 174
 Popper, Brothers.—Austria, 322
 Poppleton, R.—XII. & xv. 244
 Pordone Cotton Mill and Dyeing
 Establishment.—Austria, 175
 Porquet, Fenwick, de.—IX. 202
 Portelli, A.—Malta, 23
 Porter, see Foster, Porter, & Co.;
 M'Farlane & Porter
 Porter, J.—New Brunswick, 27
 Porter, T.—xx. 30
 Porter, W.—XXIX. 144
 Porter, W. H.—XXVII. 66
 Porthelm, A. P. & Son.—Austria, 626
 Porullia.—Spain, 291, 294.
 Portscheat.—Austria, 337
 Portugal, the King of.—Portugal, 1237
 Portugal Naval Arsenal.—Portugal,
 1225-1227
 Portugal Royal Marine Arsenal, 582.
 1126c
 Portugal Royal Military Arsenal.—
 Portugal, 635
 Portugal Royal Tobacco and Snuff
 Company.—Portugal,
 Porselt, see Börer & Porseltius
 Porselt & Harperath.—Zollverein (1),
 317
 Posselt, A.—Austria, 223A
 Posselt, A. jun.—Austria, 223
 Post, J. D.—Zollverein (1), 615
 Post & Sons.—Zollverein (1), 616
 Post & Wendt.—Netherlands, 55
 Potier, W.—v. 639
 Potmager, H.—Denmark 24
 Potouie.—France, 964
 Potouie, L.—France, 1401
 Potter, A.—XXVII. 115
 Potter, C. H. & E.—XXVI. 74
 Potter & Co.—i. 87
 Potter, E. see Potter, C. H. & E.
 Potter, E. & Co.—XVIII. 30
 Potter, H.—x. 538
 Potter, L.—IX. 49
 Potter, T.—Page 852
 Pottje, J.—Austria, 141a
 Potton, Rambaut & Co.—France, 1402
 Potts, D.—XVIII. 104
 Potts, J.—v. 102
 Potts, T. H.—VIII. 207
 Potts, W.—XXII. 323
 Potts, W. W.—XXV. 49
 Poulat, A.—France, 965
 Poulet, J. F.—France, 1660
 Poullot.—France, 966
 Poulton, C.—x. 252
 Pound, M.—II. 108
 Pourcher, see Cusson, & Co.
 Pousanoff.—Russia, 59
 Pousielgue-Rusand.—France, 1405
 Pouyat, J.—France, 687
 Poyer.—France, 967
 Powell, see also Sandy & Powell
 Powell, E. J.—v. 2
 Powell, F.—i. 197
 Powell, J.—XXII. 372; XXX. (Fine Art
 Court), 148
 Powell, R.—VIII. 210
 Powell, S.—XII. & xv. 8; XX. 26
 Powell & Son.—VIII. 249
 Powell & Sons.—XXIV. 31; 62
 Powell, T.—i. 253
 Powell, W.—XXII. 95.

Powell, W. J.—i. 2. 202
 Power & Weightman.—United States,
 302
 Powers, Hiram.—United States, 522;
 (Main Avenue, East), 548
 Pradier, J.—France, 1406, 1407
 Pradine & Co.—France, 1408
 Praetech, M.—Zoll. (2), 51
 Pratorius, L.—Zollverein (1), 853
 Prague Glovers' Assoc.—Austria, 396
 Pralle & Ballheimer.—Hamburg, 108
 Prat, A. & F. Agard.—France, 1662
 Prats, F.—Spain, 48
 Pratt & Co.—United States, 567
 Pratt, F. & R. & Co.—xxv. 22
 Pratt, H.—VII. 115; XXVI. 403
 Pratt, J.—x. 635
 Pratt, Major.—VII. 16
 Pratt, R. see Pratt F. & R. & Co.
 Pratt, S.—XXVI. 196
 Pratt, W. A. & Co.—United States, 264
 Pratt, Z.—United States, 102
 Prax & Lambin.—France, 688
 Preinaler, T. F. V.—France, 1409
 Preira, J. S.—Portugal, 713, 714
 Preis, A.—Austria, 117
 Preiswerck, D. & Co.—Switzerland, 152
 Preiswerck, Lui.—Switzerland, 152
 Preitler, M.—Austria, 498
 Prelat.—France, 1681
 Preller, C. A.—IV. 91
 Prendergast, J.—Canada, 125
 Prentzel, J. C.—Zollverein (1), 129
 Presbourg, P.—France, 689
 Prescott, see Hotchkiss & Prescott
 Prescott, S. H.—Canada, 87
 Pressel, F.—Austria, 48
 Pressprich, Ernst, & Son.—Zollverein
 (3), 135
 Preston, F.—VI. 5
 Preston, R.—XXIX. 145
 Pretot, L. H. E.—France, 1410
 Pretymmer, see Bartrum & Pretymmer
 Preyer, J. J.—Sardinia, 20
 Prevost, see Jeanti, & Co.
 Prevost, M.—XVI. 250
 Price.—XXII. 333
 Price & Harvey.—XX. 9
 Price, D.; see Price, T. P. & D.
 Price, J.—i. 184; XXIV. 43; XXVI. 312
 Price, T. P. & D.—Western end, South
 enclosure (outside), 45
 Price, V.—XXII. 397
 Price, W.—XX. 68
 Price's Patent Candle Co.—IV. 83
 Pridaux, Miss.—XXIX. 303
 Pridaux, T. S.—XXII. 239
 Pridie, see Hoadley & Pridie
 Priem, Emily.—Zollverein (3), 67
 Prime & Son.—XXII. 342
 Priu, see Caillo, jun. & Prin
 Prin, sen.—France, 1411
 Prince, Abelinde.—x. 522
 Prince, Cullison, & Co.—South Africa,
 34
 Pring, Dr. J. H.—XXX. (Fine Art
 Court), 256
 Prins, C. C.—Netherlands, 12
 Prins, L. & J. B.—Belgium, 382
 Prior, Rev. H. E.—XIX. 373
 Pritchard, A.—x. 248
 Prochaaka, W.—Austria, 244A
 Procter, see Winkworth & Procter.
 Proenca, T. T.—Portugal, 371, 462
 Proelas & Sons.—Zollverein (3), 54
 Profumo, J.—Sardinia, 14
 Prokhoroff, Brothers.—Russia, 349
 Prokuch, A.—Austria, 129
 Prosser & Hadley.—VI. 456
 Prosser, T.—United States, 594, 595

Protassoff, A.—Russia, 334
 Prouis, J.—Canada, 7
 Proutat, Mutrot & Thomeret.—France,
 969
 Prouty & Meare.—United States, 413
 Provincial Agricultural Association.—
 Canada, 33. 35
 Prudent, L.—France, 1412
 Prussia, King of.—Zollverein (1), 270.
 285 (Main Avenue, East)
 Prussian Royal Iron Foundry.—Zoll-
 verein (1), 271 (Main Avenue, East)
 Prussian Royal Porcelain Manufactory.
 —Zollverein (1), 213
 Prussian Royal Salt Works.—Zollve-
 rein (1), 445
 Pucher, J.—Austria, 740
 Puckbridge, F. L.—x. 609
 Puckring & Houlgate.—v. 826
 Puckey, J.—i. 446
 Puckriug, F.—IV. 108
 Puschel, see Thieme-Widmarkter, & Co.
 Puff, W.—Zollverein (1), 775
 Pugaard, H. & Co.—Denmark, 1
 Pugh, D.—India, XXV.
 Pugh, E.—VIII. 333
 Pugh, J. W.—XII. & xv. 306; XIII. 2
 Pugin, A. W.—XIX. 246; XXII. 700;
 XXVI. 186A. 529 (North Transept)
 Puisseant, F.—Belgium, 356
 Pujade, J.—France, 1413
 Pujals, F.—Spain, 187
 Pulham, J.—XXVII. 108; XXX. (Fine
 Art Court), 216
 Pulla, G.—Malta, 4
 Pullan, Mathia.—XIX. 12
 Pullan, R. P.—XXX. (Fine Art Court),
 265
 Pullar & Sons.—XI. 4
 Pullien, see Harding, Pullien, & Co.
 Pullen, R.—XXX. (Fine Art Court), 84
 Pulling, J.—XIII. 53
 Pullman, J., see Pullman, R. W. & J.
 Pullman, R. W. & J.—XVI. 285
 Pulman, G. P. R.—XXIX. 163
 Pulfiser, J. S.—United States, 261
 Pulvermacher, T. L.—x. 437
 Pupunant, F. H.—Switzerland, 100
 Purcell, France.—XIX. 88
 Puchea, Rev. A.—New Zealand, 23
 Purdie, see Lithgow & Purdie
 Purdon, T.—XXIX. 39
 Purdy & Fendt.—x. 537
 Purser, J. B.—Austria, 655
 Purkiss & Son.—XXVI. 315
 Purser, J.—VIII. 28
 Pursey, W. H.—IV. 4; XXIX. 67
 Purvis, J.—x. 325
 Putnan, W. & Co.—China
 Putnam, G. P.—United States, 122
 Potron, J. De.—British Guiana, 15-
 15a. 29A
 Puttinati, A.—Austria, 721
 Puxley, W.—XXVI. 39
 Putin.—France, 1414
 Pym, J.—v. 160; VIII. 321
 Pymore Company.—XIV. 73
 Pyn & Van Pelt.—Belgium, 210
 Pyne, J. B.—XXVI. 121
 Pysson.—XXX. (Fine Art Court), 244
 Pyrke & Sons.—XXII. 465

QUEEN, HER MAJESTY THE.—Pages
 111, 112. 847
 Quai & Sons.—v. 940
 Quanonne, C. & J.—Belgium, 431
 Quast, F.—Zollverein (3), 162
 Quast, J.—Austria, 629

Quebec Commissioners.—Canada, 339
 Queen's Orphan Schools.—Van Diemen's Land, 138-142
 Querel, G.—Tuscany, 21
 Quers, A. & Co.—France, 1415
 Quidt, Madame De.—Belgium, 64
 Quigley, M.—Canada, 20
 Quilliam & Greer.—x. 151
 Queensborough Copper Works (late of Sheppey).—ii. 40
 Quennessen.—France, 1683
 Querin, G.—Austria, 84
 Quin, J.—xxix. 230
 Quincey, H.—vii. 146
 Quinn.—Van Diemen's Land, 94, 95
 Quitsov, Schlesinger, and Co.—xii. & xv. 178

 Raab, G. A. B.—Zollverein (5), 18
 Rabeneck, L.—Russia, 173A
 Rabourdin.—France, 1416
 Rabovitch.—Russia, 360
 Race, E.—ix. 44
 Rachas, C.—Zollverein (1), 452
 Radcliffe, A.—vi. 328
 Rademacher, C.—Austria, 695
 Radford, J.—x. 119
 Radster Community.—Austria, 400
 Radulovita, Brothra.—Austria, 74
 Rae, see Cowie & Rae; Haldane & Rae
 Raedt, J. G. de.—Belgium, 418
 Raempler, J. L.—Zollverein (1), 745
 Raffaele, Mount.—Austria, 746
 Raffelsperger, F.—Austria, 363
 Raffin, see Thvenet, Raffin, & Co.
 Ragan, W.—United States, 193, 590
 Ragner, A. & G.—New South Wales
 Ragnini, E.—Tuscany, 86
 Ragot, J. F.—France, 971
 Ragot-Mayens.—France, 972
 Raguenet, H.—France, 1417
 Rahn, C.—Canada, 19A
 Raichlen, L.—Switzerland, 178
 Raineri, Bianca, Couns.—Rome, 26
 Rainey, Knox, & Co.—xii. & xv. 198
 Raina, T.—xvii. 162
 Ralisch.—Zollverein (1), 788
 Ralivsky, Madame.—Russia, 293
 Ralli, L.—Greece, 50
 Rallings, Mrs. W.—United States, 399
 Ralph, F. W.—xvii. 142
 Ralston, W.—ix. 254
 Rambaut, see Potton, Rambaut, & Co.
 Rambie, see Cabanes & Rambie
 Rambouillet, National Sheepfold of.—France, 1080
 Rame, B.—France, 1418
 Rameder, J.—Austria, 300
 Ramos.—Portugal, 954
 Rampendahl, H. F.—Hamburgh, 98
 Rampendahl, H. F. C.—Hamburgh, 60, 70
 Ramsay, R.—xvii. 187
 Ramsay, G. H.—Western end, North enclosure (Outside), 70; i. 44. 269; xxvii. 90, 110
 Ramsay & M'Arthur.—Canada, 117.
 Ramsay & Smart.—xiv. 65
 Ramsbottom, E.—xvii. 127
 Ramsden, see Thornton, Firth, & Co.
 Ramsey, C. & Co.—xviii. 32
 Ramsey, J.—xxviii. 12
 Ramsey, W.—xvi. 74
 Ramus, J. M.—France, 1419
 Ramus, A.—xxvi. 152
 Ran, see Felter & Ran
 Ranaldi, R.—Rome, 29
 Rand & Sons.—xii. & xv. 173
 Randall & Dix.—xvi. 284

Randall, J.—i. 275
 Randall & Saunders.—vi. 324; ix. 136
 Randall, Miss.—Jersey & Guernsey, 46
 Randolng, J.—France, 973
 Randolph, Wilhelmina.—xxix. 66
 Randou, L.—France, 1684
 Rangel, A. P.—Portugal, 1120
 Rankin, Emily, & Ellen Lear.—xxix. 302
 Rankin, R. & J.—vi. 466
 Rankine, A.—viii. 351
 Ranniger & Sons.—Zollverein (1), 741
 Ransom & Parsons.—xxvii. 97
 Ransom, R.—x. 584
 Ransomes & May.—v. 30; 640; vi. 146; ix. 124.
 Ranuzzi, Count Angelo.—Rome, 8
 Rao Scindiah, Maha Rajah.—India, xv. xvi.
 Raphi-Nuba-Ogil.—Russia, 255
 Rapmann, see Falisee & Rapmann
 Rapp, C. F.—France, 974
 Rappi, M.—Austria, 547
 Rappard and Co.—Zollverein (1), 518
 Rappard & Gosemann.—Zollv. (1), 517
 Raschle & Co.—Switzerland, 168
 Raase, A. de.—Belgium, 33
 Rastouin, V.—France, 1421, 1727
 Raswag, A. & Son.—France, 1688
 Ratcliff, Mrs.—xi. 34
 Ratliff, J. & C.—xiii. 73
 Ratchinsky.—Russia, 49
 Rattery & Thompson.—xxix. 208
 Rattich, J. B.—Austria, 29
 Ratsenhofer, J. F.—Austria, 167
 Ratsersdorfer, H.—Austria, 577
 Rau & Co.—Zollverein (4), 72
 Rau, J.—Zollverein (2), 13
 Rauch, Brothers.—Zollverein (4), 44
 Rauch, Professor.—Page 653
 Raucher, L. jun.—France, 1422
 Rauscher's Co. Ironworks.—Austria, 403
 Rauss & Colomb.—Switzerland, 14
 Rauh, J.—Austria, 369
 Ravenhill, see Howard & Ravenhill; Miller, Ravenhill, & Co.
 Ravagli, P.—Tuscany, 48
 Ravitch, see Hirschmann, Hershendorff, & Co.
 Rawlings, see Lambert & Rawlings
 Rawlings, J.—xxiii. 54
 Rawlings, J. B.—xx. 168
 Raworth & Co.—xi. 30
 Raworth, B. P.—v. 913
 Rawson, C.—China
 Rawson, Mrs.—China
 Rawson, T. S.—China
 Rayko, N.—Russia, 140
 Raymond & Schuyler.—United States, 128
 Raynbird, H.—iii. 74
 Raynbird, R.—iii. 73
 Rayner, A. & G.—New South Wales, 22
 Rayner, Mrs.—xxx. (Fine Art Court), 47
 Raynes, Lupton, & Co.—Western end, South enclosure (Outside), 25; i. 197A
 Rayno, see Stothert, Rayno, & Co.
 Raysdale W.—Western end, South enclosure (Outside), 4
 Razumovsky & Reitach.—Austria, 68A
 Rea, E.—iv. 116
 Read.—ix. 42
 Read, C. A.—United States, 212
 Read & Humphreys.—xix. 275
 Read, J.—Madeira.
 Read, J. B.—xvi. 47
 Read, R.—ix. 59
 Read, S. K.—v. 90

Read, W.—xxvii. 32
 Reade, A.—Barbadoes, 1
 Reade, Rev. J. B.—ii. 5A; (Main Avenue, West), x. 234A
 Reader, J. S.—Mauritius, 7
 Readhouse, Charlotte.—x. 677
 Readwin, T. A.—i. 458
 Reali, G. (late Antonio Reali).—Austria, 61, 101
 Reallier, Miss.—Belgium, 309
 Robert, C.—France, 975
 Robow, J. G.—iv. 84
 Robsch, J. J.—Zollverein, ii. 82
 Robuff.—Russia, 143
 Robuff, A.—Russia, 139
 Rochetiner, J. B.—Zollverein (3), 28
 Reckitt & Son.—iii. 125
 Reckless & Hickling.—xix. 32
 Reedy, C. M. H.—France, 1423
 Redelix, C. H.—France, 976
 Redelin, H.—France, 1424
 Redfern, G.—xxvii. 72
 Redgate, see Commeford & Redgate
 Redgrave, J.—xxi. 410
 Redgrave, J.—xx. 164
 Redhead, T.—Canada, 120
 Redier, A.—France, 1427
 Redman, J. B.—vii. 12
 Redmayne & Co.—xiii. 1A
 Redmond, A. F.—v. 66; vi. 128
 Redpath, see Brown & Redpath
 Redpath Local Committee.—i. 443, 444
 Red.—xvi. 101
 Reed, Chadwick, & Dexter.—United States, 400
 Reed, J.—viii. 54
 Reed, J. H.—v. 91
 Reed, J. & Son.—United States, 484
 Reed, J. W.—xxix. 211
 Reed & Meakin.—Canada, 75, 115A
 Reed & Pardon.—xvii. 184
 Reed, T. S.—vi. 85
 Reches, J.—xxii. 400
 Reches, T.—viii. 6
 Rees.—i. 429; xviii. 85; Van Diemen's Land, 314
 Rees, Mary—xviii. 65
 Rees, R.—i. 227
 Reesing, H. B.—Hamburgh, 3
 Reeve, J.—New Zealand, 12
 Reeves.—Van Diemen's Land.—322, 323, 345; see also Goodhale & Reeves
 Reeves, Greaves, & Co.—viii. 244
 Reeves J.—China; see also Reeves, T. R. & J.
 Reeves, J. G.—Van Diemen's Land, 11
 Reeves, J. R.—China
 Reeves & Sons.—i. 66; xxx. (Fine Art Court), 7
 Reeves, T. R. & J.—ix. 108
 Reffaeli, P. & Son.—Tuscany, 69
 Regan.—Van Diemen's Land, 184
 Regard, Brothers.—France, 1426
 Regeer, H. J.—Netherlands, 112
 Reguier, Mr.—Belgium, 374
 Regny, L. & Co.—France, 1427
 Regout, P.—Netherlands, 99
 Reibach, J. J.—Zollverein (2), 82
 Rehm, F. F.—Zollverein (4), 54
 Reichel, Brothers.—Zollverein (1), 442
 Reichel, C. F.—Zollverein (3), 149
 Reichel, J.—Austria, 499
 Reichelbach, C.—Zollverein (2), 102
 Reichert, F.—Austria, 268
 Reichhold, G.—Zollverein (4), 39
 Reichmann, A.—France, 1429
 Reil, Capt.—viii. 350
 Reid, J.—viii. 54A; xxii. 543
 Reid, R.—x. 583
 Reid & Son.—xii. & xv. 481

- Reid & Sons.—XXIII. 3
 Reid, W.—x. 427; xx. 23
 Reider, see Lecocq & Rahter
 Reidon, K.—France, 1430
 Reiffert, T. C.—Zollverein (1), 686
 Reilly, E. M.—viii. 237
 Reimann, L.—Zollverein (1), 80
 Rein, C.—x. 629
 Reindl, J.—Austria, 493
 Reinecker & Co.—Zollverein (1), 404
 Reineke, C.—Zollverein (1), 694
 Reinhard, see Doerr & Reinhard
 Reinhard, J. M.—Zollverein (6), 54
 Reinhardt, G.—Canada, 10. 320
 Reinhold, W.—Austria, 315
 Reinsch, see Witschell & Reinsch
 Reinsch, J.—Austria, 163
 Reinoso, M.—Spain, 211
 Reinsch, A.—Zollverein (2), 63
 Reinschagen, G.—Zollverein (1), 622
 Reis, G. & Co.—Zollverein (6), 49
 Reiz, J. J. doe—Portugal, 1127
 Reits, Rieda, & Co.—South Africa.—
 ix. 31
 Reif, S.—i. 76
 Religious Tract Society.—vii. 164
 Remacle, J. & Perard & Son.—Belgium,
 371
 Remers, P.—United States, 254
 Remington, Anne.—vii. 175; xxii.
 398
 Remington, G. W. & J.—vii. 70.
 Remington, J. see Remington, G. W.
 & J.
 Remmie, Misses.—xxix. 167
 Remnant, Edmonds, & Remnant.—
 xvii. 6
 Remond, N.—France, 977
 Remsburg, J.—United States, 317
 Renard.—France, 978
 Renard, L.—France, 1431
 Renard & Son.—France, 979
 Renault, see Costurier & Renault
 Renczynski, Capt. G. A.—vii. 27; x.
 661
 Rendall & Coombs.—xiv. 73
 Rendall, J.—ix. 36; xxviii. 144
 Repel, A.—Austria, 378
 Rengos, see Saris & Rengos
 Reukin, sen.—Belgium, 503
 Renkin, Brothers.—Belgium, 141
 Renner, S. B. jun.—Zollverein (1), 69
 Rennie, G.—v. 62; vii. 98
 Rennie, G. B. jun.—vii. 98
 Rennie, Sir J.—v. 62
 Renny, Sons, & Co.—xiv. 81
 Renodier & Son.—France, 982
 Renouard, Jules, & Co.—France, 352
 Renwick, T. & A.—xii. & xv. 233
 Repeyre, S.—France, 983
 Repington, see Vieyres & Repington
 Repiquet & Silvent.—France, 1432
 Requillart, Roussel, & Chocqueel.—
 France, 1433
 Reseguisre, C.—Switzerland, 179
 Resal, J.—Austria, 648
 Resal, M.—Austria, 549
 Restell, see Clark, R. & Restell
 Restell, H.—ix. 208; xxiii. 63
 Rettie, H.—vii. 159
 Rettie & Sons.—xxii. 449; xxiii. 24
 Rettig, C. A.—Sweden & Norway, 2
 Retor, F.—Switzerland, 101
 Reulou, A. J.—France, 1434
 Reus, the Board of Trade of.—Spain, 109
 Reusen, P. T.—Belgium, 100
 Reuss, Brothers.—Zollverein (4), 99
 Reuter, S.—Austria, 206
 Reuter, W.—Zollverein (6), 40
 Reverchon, H.—Algeria, 44
 Revillon.—Russia, 361
 Revis, T.—ix. 214
 Rezer, C.—Zollverein (4), 25
 Rexer, F.—Zollverein (4), 62
 Rey, Brothers.—Sardinia, 35
 Rey & Co.—Spain, 207
 Rey, G. E.—Hamburg, 30
 Reydor, Brothers, & Collin.—France,
 984
 Raymond, jun.—Switzerland, 170
 Reynier, Cousins.—France, 353. 1435
 Reynolds, A. & G.—Hamburg, 6
 Reynolds, G. see Reynold, A. & G.
 Reynolds.—xxx. (Fine Art Court) 237;
 see also Hurst & Reynolds; Learned
 & Reynolds; Long & Reynolds
 Reynolds, J.—xxii. 37. 316; xxvi.
 262
 Reynolds, R. J.—United States, 61
 Reynolds & Son.—xviii. 63
 Reynolds, W.—xii. & xv. 260
 R. F.—viii. 136
 Rheam, E.—xvi. 16
 Rhind, W. G.—viii. 290
 Rhodius, see Bischof & Rodius
 Rhone, E.—v. 97
 Rihy, P.—France, 985
 Rice, W. H.—Canada, 1504
 Richard, see Miller & Richard
 Richard, L.—Zollverein (1), 342
 Richards, Alfred.—i. 441a
 Richards, B. W.—United States, 357
 Richards, N.—x. 168
 Richards, R.—xxix. 118
 Richards, T.—v. 136
 Richards, Westley, & Son.—viii. 240
 Richardson, —see also Chilson, Richard-
 son, & Co.; Kay, Richardson, & Co.
 Richardson, Brothers.—iii. 62
 Richardson, Brothers, & Co.—ii. 19;
 Van Diemen's Land
 Richardson, C. J.—xxvi. 207
 Richardson & Co.—xiv. 23
 Richardson, E.—xxx. (Fine Art Court),
 133
 Richardson, H. T.—viii. 46.
 Richardson, J. & T. & Co.—xiv. 21
 Richardson, R.—v. 651; viii. 285;
 xxii. 26
 Richardson & Sons.—iii. 69
 Richardson, Sons, & Owden.—xiv. 7
 Richardson, T., see Richardson, J. & T.
 & Co.
 Richardson, T. W.—x. 264
 Richardson, W. H. B. & J.—xxiv. 14
 Richer, A.—Canada, 55
 Richer, F.—France, 354
 Richer, Madame.—France, 1436
 Richmond & Chandler.—ix. 137
 Richmond, J.—v. 775
 Richmond Lunatic Asylum.—xix. 249
 Richoux, see Besnard, Richoux, & Co.
 Richt, G.—Zollverein (1), 229
 Richter, see Chapus & Richter
 Richter, A.—Austria, 44a
 Richter & Co.—Austria, 37
 Richter, F.—Austria, 176
 Richter, H. L.—Zollverein (3), 104
 Richter, J. M. S.—Hamburg, 50
 Richter, Linder.—Switzerland, 152
 Rickards, C.—viii. 342
 Rickborn, C. H.—Zollverein (3), 14
 Rickets, C.—xxii. 433
 Rickman, W. C.—ix. 278; x. 681;
 xvii. 194
 Ricroch, C. & Co.—France, 986
 Riddell, Sir J. M. Bart.—i. 55
 Riddell, T.—vii. 6
 Riddett, G.—xxvi. 49
 Riddiford, Jane.—xxix. 65
 Riddle, E.—United States, 466
 Riddle, T.—xxvi. 14
 Riddle, W.—xxii. 637
 Rider.—xvii. 21
 Rider, E.—United States, 511
 Ridge, B.—xxvi. 8
 Ridgway, A. F.—British Guiana, 160.
 161. 163. 164a
 Ridgway & Co.—xxii. 262
 Ridgway, J. & Co.—xxv. 5
 Ridgway, W.—xxv. 5a
 Riedler, F.—Austria, 110
 Riedley & Edser.—xxii. 621
 Riedley, J.—xvi. 204; xx. 165
 Riedolf, Marguie C.—Tuscany, 30
 Riedolf, Professor M.—Tuscany, 25
 Rieda, see Riets, Rieda, & Co.
 Riedl, Von.—Austria, 131
 Riedl, J. F., Widow.—Austria, 163
 Riedler, J.—Austria, 550
 Riedler, L.—Austria, 551
 Rieffer, C.—Zollverein (2), 34
 R'ego de la Branchardiere, Eleonor.—
 xix. 17
 Riepe, E.—Zollverein (1), 447
 Rier.—Russia, 138
 Rier, B.—British Guiana, 137
 Rissi-Stallburg, Baron W. F. von.—
 Austria, 125
 Riese, F. H.—Zollverein (1), 90
 Riese, M.—France, 355
 Riet, Pierre Jean Von.—Belgium, 103
 Rieter, T. J. & Co.—Switzerland,
 132
 Rietzy & Son.—France, 356
 Rietsch, F. G.—Austria, 638
 Rietschel.—Zollverein (3), 32
 Rietschel, Ernst.—Zollverein (3), 186
 Rioussac, N.—France, 1683
 Rifter, W.—Hamburg, 43
 Riga, see Firly & Riga
 Rigault.—France, 1686
 Rigby, E. R.—xxviii. 58
 Rigby J., see Rigby, W. & J.
 Rigby & Lee.—v. 647
 Rigby, P.—xxii. 411
 Rigby, W. & J.—viii. 236
 Rigg, see Bennoch, Twentyman, & Co.
 Rigge & Co.—vi. 63
 Rigmalden, Lieut. J.—viii. 291
 Rignon, F. & Co.—Sardinia, 30
 Rigo & Kraetschmar.—Austria, 395
 Rikli, A. F.—Switzerland, 133
 Riley, E.—ii. 123; see also Carr, J. &
 Riley
 Rimann, E.—Zollverein (1) 10
 Rimann & Giesler.—Zollverein (1) 124
 Rimediotti, Signora A.—Tuscany, 44
 Rimmel, E.—xxix. 3
 Rimogne Slate Works Company.—
 France, 378. 694
 Rinaldi, R.—Main Avenue, East,
 Rome, 29
 Ring, J.—Austria, 468
 Ringelmann.—Zollverein (1) 253
 Ringeridge Nickel Works (Norway).—
 i. 476
 Ringgald, C.—United States, 598
 Ringham, H.—xxvi. 42; xxx. (Fine
 Art Court), 88
 Ringuet-Leprince.—France, 1437
 Rio Tinto Mines (Seville), Director of.—
 Spain, 8
 Rio Vizello Co.—Portugal, 721-724
 Ripa, L. D. Della.—Tuscany, 38
 Ripalda, Count.—Spain, 163
 Ripley, P. W.—China
 Rippley & Son.—xii. & xv. 148
 Rippingham, W.—x. 304
 Rippinghille, E.—viii. 258

- Riston, J.—xix. 278
 Risler & Son.—France, 1438
 Rias, J.—Austria, 316
 Rister, Brothers, *see* Greuter & Rister
 Ristori, M.—Tuscany, 42A
 Ritchie, A. H.—i. 132
 Ritchie, J.—xxix. 259; xxx. (Fine Art Court), 193; xxx. (Sculpture Court), 20; *see* also Ritchie, W. & J.
 Ritchie & McCall.—iii. 15.
 Ritchie, P.—xx. 145
 Ritchie W. & J.—ix. 224
 Ritter, N.—Austria, 696
 Ritter, W.—Hamburgh, 43
 Ritterhandt, L. A.—x. 730
 Ritzel, Wilow.—Zollverein (1), 639
 Riva & Maffei.—Tuscany, 63
 Rivart & Andrieux.—France, 1439
 Rivaud, G.—France, 987
 Rivett & Sons.—xxvi. 153
 Riviere, R.—xvii. 89
 Rix, *see* Carter, Vavasseur, & Rix; Collins & Rix
 Rix, I.—x. 74
 Nixon, *see* Hancock, Rixon, & Dunt
 Roake, J. W.—i. 60
 Roat, W.—Van Diemen's Land, 242
 Robant, L.—France, 988
 Roberts, G.—xvi. 128
 Robb, J.—Canada, 126
 Robbins, *see* Chambers & Robbins
 Robins & Lawrence.—United States, 328
 Robeck, C.—Zollverein (4), 50
 Robert, A.—xvi. 224; France, 357
 Robert, A. & Co.—France, 1440. 1735
 Robert & Co.—Austria, 55; *see* also Buisson, E. Robert, & Co.
 Robert, P. J. jun.—Belgium, 432
 Robert-Faure, C.—France, 1442
 Robert-Guerin.—France, 1441
 Robert-Mathieu.—France, 1443
 Robert-Werly & Co.—France, 1444
 Roberts, *see* Smyth & Roberts
 Roberts, E. B.—xx. 77
 Roberts, B. E.—vii. 127
 Roberts & Beart.—xxvii. 22
 Roberts, G.—xxx. 40A.
 Roberts, H.—xii. & xv. 171; xxvii. 141.
 Roberts & Hall.—xxiii. 40
 Roberts, J.—ix. 226
 Roberts, J. E.—v. 550
 Roberts, Mrs.—xix. 365
 Roberts, R.—x. 130; xii. & xv. 460
 Roberts, T.—xviii. 81
 Roberts, W. & Co.—xii. & xv. 480
 Roberts, W. H.—ii. 10
 Robertson, Carr, & Steol.—xxii. 802
 Robertson & Co.—xxx. (Fine Art Court), 6
 Robertson, G.—ix. 26
 Robertson, H.—iv. 51; xxii. 565
 Robertson, J.—viii. 18; New Zealand, 4
 Robertson, J. & J.—xii. & xv. 301
 Robertson & Son.—xix. 62
 Robertson, W.—ii. 81
 Robertson, W. J.—iii. 161
 Robey, W.—xvi. 262
 Robichon, Brothers, & Co.—France, 1445
 Robin, L.—France, 1447
 Robins, *see* Alsop, Robins, & Co.; Hobart & Robins
 Robins, Aspdin, & Cox.—Western end, South enclosure (Outside), 5; xxvii. 103
 Robinson.—Van Diemen's L., 90; *see* also Fisher & Robinson; Fayer & Robinson Wild & Robinson
 Robinson, A.—viii. 136. 214
 Robinson, C.—xxvi. 263
 Robinson, C. & Co.—United States, 429
 Robinson & Co.—v. 950; xxviii. 42
 Robinson, D.—viii. 136
 Robinson, F. K.—xxx. (Fine Art Cr.), 120
 Robinson, Isaac.—i. 493
 Robinson, I. & R. & Co.—xiii. 5
 Robinson, J.—viii. 100; x. 582; xvi. 7; xx. 149A
 Robinson, J. & Co.—iv. 72
 Robinson, J. & T.—xiii. 6
 Robinson, J. & W. & Co.—xiii. 24
 Robinson, Miss.—xix. 278
 Robinson, P.—x. 37; United States, 265
 Robinson, R.—vi. 54; x. 617; *see* also Robinson, I. & R. & Co.
 Robinson & Russell.—vi. 418; viii. 127. 193
 Robinson & Son.—ix. 139A
 Robinson, T.—xii. & xv. 54; xiii. 77; *see* also Robinson, J. & T.
 Robinson, W.—ix. 126; xxiii. 96; *see* also Robinson, J. & W. & Co.
 Robinson, W. F. Lieut.—viii. 68A
 Robinson, W. W.—viii. 136
 Robotham, S.—xvi. 199
 Robson—*see* Hoole, Robson, & Hoole
 Robson, J.—viii. 57
 Robson & Jones (late), *see* Jones & Co.
 Robson, Levy, & Franklin.—xxx. (Fine Art Court), 112
 Rutson, T. J. F.—x. 559
 Robyns, P.—Belgium, 487
 Robyt, L.—Belgium, 311
 Rocca, J.—Sardinia, 32
 Rocchetti, P.—Austria, 136
 Rocchigiani, Antonio.—Rome, 39
 Rochats, C.—Zollverein (1), 652
 Roche & Dime.—France, 990
 Rothead, J. T.—xxx. (Fine Art Cr.), 232
 Rochefort, J.—Russia, 176. 191. 199. 208
 Rocheleau, Helen.—Canada, 175
 Rocher, M.—France, 991
 Rochlitz, E.—Hamburgh, 49
 Rocholl, T.—Zollverein (1), 467
 Rock.—xxii. 655
 Rock, Brothers, & Payns.—xvii. 108
 Rock & Gowar.—v. 954
 Rock & Graner.—Zollverein (4), 98
 Rock, J. jun.—i. 50; v. 952; vii. 143
 Rock, Mary.—iv. 5
 Rock & Son.—v. 956
 Rocke, W.—xxii. 256
 Rockhausen, W.—Zollverein (3), 172
 Rockstroh, H.—Austria, 306
 Rodd, T. H.—i. 169
 Roddis, T. R.—United States, 571
 Roile, F. de.—Hamburgh, 16
 Rodel & Son.—France, 992
 Rodenhurst, J., *see* Rodenhurst, W. & J.
 Rodenhurst, W. & J.—ix. 61
 Rodger, Lieut. W.—Western end, North enclosure (Outside), 55; viii. 336
 Rodgers, H. S.—United States, 496
 Rodgers & Son.—xix. 280; *see* also Hornan & Co.
 Rodgers & Sons.—xxii. 690. (Main Avenue, West)
 Rodier, P.—Canada, 346
 Rodrigues, J. F.—Portugal, 990. 1222A
 Rodriguez, B.—United States, 485
 Rodriguez, Palencia, M.—Spain, 124
 Roe & Freeman.—v. 402; ix. 84
 Roebuck, J. J.—vii. 30
 Roeck, L.—France, 1446
 Roehling & Co.—Zollverein (3), 50A
 Roehr, F.—Zollverein (8), 7
 Roehrig & Albrecht.—Zollverein (3), 87
 Roeller & Husta.—Zollverein (3), 161
 Roels & Co.—Belgium, 83
 Roemer, C.—Zollverein (1), 337
 Roepfer, F.—Lubeck, 11
 Roessler, C. H.—Zollverein (1), 397
 Roetschberger & Sons.—Switzerland, 189
 Roger, Brothers, & Co.—France, 1449
 Roger Jun.—France, 1448
 Rogers.—xix. 111; xxx. (Fine Art Court), 116; *see* also Hamburger, Rogers, & Co.; Morewood & Rogers; Unwin & Rogers
 Rogers, C. B.—United States, 258
 Rogers & Co.—xxix. 100; United States, 523
 Rogers & Dear.—xxvi. 264
 Rogers, E. P. S. & O.—xix. 204
 Rogers, G.—xii. & xv. 142
 Rogers, H., *see* Rogers, R. & H.
 Rogers, J.—United States, 127
 Rogers, J. W.—i. 240; ix. 183
 Rogers, Lowry, Holyland, & Co.—xi. 58
 Rogers, M.—xxviii. 179
 Rogers, R. & H.—xxix. 215
 Rogers, S. S.—i. 70
 Rogers, W. G.—xxvi. 195; xxx. (Fine Art Court), 74. 353
 Rogers, W. H.—xvi. 91
 Rogers & Wroe.—xiv. 32
 Rohlik, L.—Austria, 37
 Röhricg, C.—Zollverein (1), 768
 Roig, J.—Spain, 216
 Roig, S.—Spain, 249B
 Roissard, J. M.—France, 1450
 Rojof, J. L.—France, 359
 Rolfe, W. & Sons.—x. 479
 Rolfs & Co.—Zollverein (1), 345
 Rolland, *see* Ferouelle & Rolland
 Roller & Blanchet.—France, 1687
 Rolis & Son.—xix. 281
 Rolph, J.—xix. 289
 Rolt, P.—xxvii. 92
 Rolwegan—Van Diemen's Land, 196. 345
 Rölls, S.—Austria, 384
 Romain, jun.—Switzerland, 155
 Romain, D.—Netherlands, 104
 Roman, *see* Gros-Oudier, Roman, & Co.
 Romanengo, G.—Sardinia, 82
 Romanes & Paterson.—xii. & xv. 466
 Romanin & Co., *see* Callegari, A.
 Romany y Miró, A.—Spain, 259
 Romão, M. J. da Costa.—Portugal, 1168
 Rome, R. M.—ix. 152
 Rome, Royal Manufactory at St. Peter's.—Rome, 23
 Romedenne, A.—Belgium, 165
 Rometsch, C.—Zollverein (4), 73
 Rominger, J.—Zollverein (4), 96
 Romoli, L.—xxx. (Fine Art Court), 351; Tuscany, 118-120
 Römpler, J. J.—Zollverein (1), 781
 Romée, F.—Belgium, 506
 Ronchard-Siauve.—France, 1451
 Ronchetti, P. A.—Austria, 82
 Rondelli, F.—Sardinia, 90
 Ronze, De, *see* Verhulst, &c.
 Roock, L.—Russia, 311
 Rood, G. & Co.—xvi. 49
 Roock, G. H.—viii. 320
 Rooker, A., *see* Rooker, J. & A.
 Rooker, J. & A.—x. 340
 Roome, Ann Empringham.—xix. 283
 Roome, T. F.—x. 548
 Roosegarle, G. J.—Netherlands, 21
 Roostan, C.—Russia, 256
 Root, M. A.—United States, 42

- Rooyckers & Son.—Netherlands, 52
 Rooyen, H. Van.—Netherlands, 58
 Roper, J.—xxii. 437
 Roper & Son.—xxii. 399
 Roper, W.—x. 197
 Ropolo, P.—Sardinia, 54
 Ropp, Baron.—Russia, 47
 Roque, J. J.—Portugal, 18. 300
 Roraa Copper Works.—Sweden & Norway, 37
 Rosani, Brothers.—Austria, 639
 Rose, see Rudall, Rose, & Co.
 Rose, Elizabeth.—xix. 50.; xxvi. 28
 Rose, J. & Co.—xxxv. 47
 Rose, J. E.—x. 719
 Rose, J. T.—viii. 180; viii. 164
 Rose, Miss.—British Guiana, 136
 Rose, W. A.—iv. 27
 Rose, Baron A. De.—Belgium, 365
 Rosenberg & Co.—Zollverein (6), 2
 Rosenberger, see Blaha & Rosenberger
 Rosenkilde, C. S.—Sweden & Norway, 45
 Rosenthal, P.—Sweden, 62
 Rosindale, C.—xxii. 516
 Rösing, F. W.—Hamburg, 100
 Rosinsky.—Russia, 342
 Roskell, J.—x. 123
 Rösler, J.—Austria, 552
 Ross.—Main Avenue, West, 301
 Ross, A.—x. 254. 666
 Ross, G.—British Guiana, 120; United States, 584
 Ross, A. H.—x. 157
 Ross, C.—United States, 213
 Ross, D.—xxvi. 107
 Ross, E. C.—British Guiana, 76A, 76B
 Ross, H.—xxx. 191
 Ross, Hon. Mrs.—Page 852
 Ross, O'Connor, & Carson.—xxiv. 1
 Ross & Sons.—xxviii. 64
 Ross, T.—i. 51
 Ross & Thomson.—xxx. (Fine Art Court) 299
 Ross, W.—x. 342
 Rosseels, E.—Belgium, 449
 Rosselet, C. P.—France, 1452
 Rossi, G. M.—Austria, 88
 Rossi, L.—xvi. 248
 Rossi & Schiapparelli.—Sardinia, 6
 Rossignol, see Cusson, Pourcher, & Co.
 Rossler, F. Von.—Zollverein (8), 4
 Rossmore, Lord.—i. 142
 Rossmore Mills.—xii. & xv. 264
 Rotch & Finzel.—vi. 405
 Roterman, C.—Russia, 71
 Roth, C. W.—Zollverein (5), 9
 Roth, J.—Switzerland, 53
 Roth, J. C.—France, 993
 Roth & Sons.—Zollverein (5), 10
 Roth, W. jun.—Zollverein (4), 89
 Rotherham & Sons.—x. 124
 Rothery, Miss.—Western Africa, 4
 Rothschild.—Zollverein (1), 452
 Rothschild, Baron S. Von.—Zollverein (1), 28
 Rotsch & Reichel.—Austria, 98
 Rott, A. H.—Austria, 158
 Rott, J.—Austria, 159
 Rouchier, F., & Son.—France, 994
 Roucou, J.—France, 1689
 Ronget de Lisle, T. A.—France, 1455
 Ronget, Son, & Co.—France 1456
 Roughton, R.—v. 7
 Rougier, see Champagne & Rougier
 Rouille, see Valtat & Rouille.
 Roule, A. F.—Belgium, 419
 Roulet, Gilly, & Chaponiere.—France, 359
 Round, D. G.—Western end, South enclosure (Outside), 36
 Rouse, Captain.—i. 79
 Roussanoff.—Russia, 66
 Rousseau, A.—xxviii. 116
 Rousseau, A. J.—United States, 314
 Rousseau, Brothers.—France, 1457
 Rousseau, L.—France, 360
 Roussel, see Requillart, Roussel, & Co.
 Roussel, C.—France, 361
 Roussel, Réquillart, & Chocouel.—France, 1738
 Roussel-Dazin.—France, 1458
 Rousselle & Baromet.—France, 1459
 Rout, W.—Van Diemen's Land, 152. 154-158. 173. 187. 291. 293
 Routledge, see Devas, Mincheur, & Rouvenat, L.—France, 1460
 Rouve, P.—xxx. (Fine Art Court) 294
 Roux, see Cabrit & Roux; Thevenet, Raffin, & Roux
 Roux, F. M.—France, 1690
 Roux & Furtin.—France, 995
 Rouzel, F.—France, 362
 Rovere, F. P.—vii. 163
 Row, J.—xiv. 45
 Rowat, J., see Howat, R. T. & J.
 Rowat, R. T. & J.—xii. & xv. 301
 Rowbottom, J.—ix. 262n
 Rowe, J. M., see Rowe, M. & J. M.
 Rowe, M. & J. M.—United States, 326
 Rowe, R.—i. 492
 Rowell, J.—xxix. 153.
 Rowland and Son.—xxix. 1
 Rowlands & Son.—xxiii. 118
 Rowlands, I.—xxvii. 63
 Rowlands, W., see Rowlands, C. & W.
 Rowlandson, T.—i. 490
 Rowley.—xxii. 278; see also Cook, Rowley, & Co.
 Rowley, J.—x. 290
 Rowley, J. J.—ix. 87
 Rowney & Co.—xxx. (Fine Art Court) 3
 Rowney, F. W.—xxx. (Fine Art Court) 3
 Roxburgh, A., see Roxburgh, J. & A.
 Roxburgh, J. & A.—xii. & xv. 696
 Roy, C. F.—Belgium, 301
 Roy, Jessie.—xx. 136; United States, 578
 Roy, W. L.—United States, 373
 Roy, W. Von.—Zollverein (1), 441
 Royal Cannon Foundry.—Belgium, 142
 Royal Mines (Lobe).—Zoll.—(1); 326
 Royal Ordnance Office.—Spain, 262 (Main Avenue, East)
 Royal Patent Decorative Glass Works.—xxiv. 83
 Royal Porcelain Manufactory (Nymphenburg)—Zollverein (2) 64
 Royal Prussian Iron Foundry (Berlin).—Zollverein (1), 271 (Main Avenue, East)
 Royce, G.—ix. 58
 Royer, J. C. A.—France, 1461
 Royer, L.—Netherlands, 100
 Royer, P. E.—France, 1462
 Royle, Dr. J. F.—iv. 107; India, ii.
 Royston & Brown.—xvii. 34. 295
 Rozario, M. do.—Portugal, 1277
 Ruas & Co.—France, 1464
 Ruand, J. B.—France, 1463
 Ruball, V.—Portugal, 1152
 Rübeland Ducal Foundry Inspectors.—Zollverein (1), 780
 Rubenitsch, J.—Austria, 507
 Rubery, J.—xxvi. 7
 Rudall, Rose, & Co.—x. 536
 Rudberg, C. G.—Sweden & Norway, 11
 Rudd, T.—ix. 157
 Rudert, H.—Russia, 84. 171
 Rudloff, Brothers.—Zollverein (1), 170
 Rudolphi.—France, 1465
 Rue, De la, & Co.—xvii. 76
 Ruel, W. H.—i. 435
 Ruetten, see Lumm & Ruetten
 Ruez, L.—France, 363
 Ruff & Co.—xvii. 193
 Ruffer & Co.—Zollverein (1), 11
 Ruffer & Son.—Zollverein (1), 101
 Raffoni, Vincenzo, & Forzano.—xxx. (Fine Art Court) 220
 Rufford, F. T.—xxv. 38; xxvii. 89
 Rüfin, A.—Zollverein (1), 34
 Ruggles, G. H.—United States, 416
 Rühl & Son.—Zollverein (1), 597
 Ruhmann, A.—Zollverein (1), 90
 Rumley.—xxvii. 59
 Rumms, H.—Hamburg, 14
 Rundell, W. W.—x. 438A; xxx. (Fine Art Court), 279
 Runge, Dr.—Zollverein (1), 302
 Ruolz.—France, 1466; see also Paradiz, De Ruolz, and Co.
 Rupp & Bechtstein.—Zollverein (5), 11
 Rupprecht, S.—Austria, 653
 Rupp, L.—Zollverein (1), 613
 Rurmann & Meckel.—Zollv. (1), 580
 Ruschi, Brothers.—Tuscany, 32
 Rusli, G.—x. 137
 Russell, see Widom, Russell, & Co.
 Russell, G.—xxx. (Fine Art Crt.), 206
 Russell, Vicente.—Portugal, 1152
 Russell, see Robinson & Russell
 Russell, H. H.—vii. 78; xxx. (Fine Art Court), 271
 Russell, J.—i. 271
 Russell, R.—xxix. 40
 Russell & Robertson.—ii. 59
 Russell, S.—xxx. (Fine Art Crt.), 230
 Russell, Sarah Ann.—xix. 285
 Russell & Son.—i. 249
 Russell, T. S.—viii. 127
 Russell, V.—Portugal, 1295
 Rust, F.—Zollverein (6), 68
 Rutherford, A. H.—South Africa, 23
 Rutherford.—x. 160A
 Rutherford, J.—i. 182
 Ruthven, J.—xxii. 171
 Ruthven, M. W.—viii. 171
 Rutland, W.—xvi. 99
 Rutochi & Co.—Switzerland, 153
 Rutenus, Helene.—xx. 147A
 Rutter.—xxii. 643
 Rutter, J. & W.—xxix. 137
 Ruddy, see Foster, Ruddy, & Co.
 Ryan, J.—xxii. 436
 Ryder, W.—vi. 222
 Ryfel & Co.—Switzerland, 153
 Ryhiner, C.—Switzerland, 152
 Ryhiner & Sons.—Switzerland, 161
 Ryle, J.—United States, 336
 Ryles, M.—x. 199
 Rzebitschek, F.—Austria, 162
 Saad Ben Bartha.—Algeria, 63
 Sabatier, H.—France, 1467
 Sabinin.—Russia, 116
 Sachs, T.—Zollverein (1), 411
 Sachse, W. F.—Zollverein (1), 226
 Sacker, F. C.—xxxix. 214
 Sacke, E.—Belgium, 504
 Sacred Harmonic Society.—Main Avenue, West; vii. 38
 Said, W.—x. 301
 Saddington, S. & W.—vi. 609
 Sadler.—xiv. 30. 72
 Sadler, Fentou, & Co.—xiv. 18
 Sadler, J.—iv. 76
 Sadler, J. H.—vii. 61
 Sadler, S.—xiv. 30. 91
 Sadler, W. J.—iii. 103A; ix. 166

- Saelzer & Neuack, United Coal Mines, (Essex).—Zollverein (1), 430
 Saffre, Madame.—Belgium, 483
 Safonoff.—Russia, 55
 Saget, W.—France, 364. 1468
 Sagra, Ramon de la.—Spain, 157. 166
 Sahlberg, C. F. G.—Hamburg, 36
 Sailer, J.—Austria, 570
 Saintin, A.—France, 691
 Salamanca Mines, Inspector of.—Spain, 20
 Sale, J. N.—XVIII. 39
 Sales, Pollard, & Co.—III. 47
 Salido, A.—Spain, 75
 Salis, Schwab, & Co.—XVIII. 41
 Sallandrouse de Lamornaix.—France, 1469
 Salm, Prince.—Austria, 430
 Salmon, Ody, & Co.—x. 594
 Salmon, W. J.—x. 266
 Salmon, W.—xv. 83
 Salomon.—France, 298
 Salomon, J. A. & Co.—Zoll (1), 692
 Salomous & Sons.—xii. & xv. 305
 Salouvier, see Hooper, G., Carroy, & Co.
 Salt & Lloyl.—xiii. 343
 Salt, M. & Son.—x. 628
 Salt & Mear.—United States, 203
 Salt, T.—xii. & xv. 139
 Salt Works, St. Ubes.—Portugal, 45
 Salter.—vii. 107. (Main Avenue, West.)
 Salter, G.—xvi. 209
 Salter, J.—viii. 116
 Salter, S.—vii. 220, Page 851. 854
 Salter, S. & Co.—xii. & xv. 250
 Saltmarsh, G.—xxx. 345
 Saluce, M.—Sardinia, 10
 Salzer, C.—Austria, 245
 Salzhauseu Salt & Lignite Works.—Zollv. (6), 3
 Salzwimmer, P.—Austria, 554
 Sambuc, P.—France, 1470
 Sammet, T.—Zollverein (2), 50
 Samora, Baron de.—Portugal, 43, 44. 48
 Sampson, P.—xvi. 303
 Sampson, T.—vii. 137; xii. & xv. 215
 Samson, see Temsonnet, G. & Co.
 Samuel, J.—v. 616
 Samuel, Miss.—I. 489A
 Samuels, D.—iv. 21A
 Samuels, J. & Co.—XVIII. 31
 Samuelson, B.—ix. 185
 Sanches Pescador and Miguel, T.—Spain, 269
 Sandell, E.—xxix. 97
 Sandeman, G.—xxvi. 173
 Sandeman, H.—vi. 44; xi. 2; xviii. 92
 Sanders.—xxii. 653; see also Gaimes, Sanders, & Co.; Spurden, Woolley, & Co.
 Sanders, J.—xxviii. 73
 Sanders, S.—ix. 269B
 Sanderson, A.—United States, 506
 Sanderson, C.—v. 570
 Sanderson, G.—x. 160
 Sanderson, H. & A. & Co.—xii. & xv. 196
 Sanderson & Reid.—xiii. 3.
 Sanderson & Sibbald.—xii. & xv. 189
 Sanderson & Son.—xxiv. 9
 Sanderson, T. J.—xxii. 226
 Sandford, Owen, & Watson.—v. 554; vi. 223
 Sandlane & Crane.—xx. 38
 Sandoval, De, & Co.—France, 365
 Sands, W. & Co.—iv. 88
 Sandway.—xviii. 93
 Sandy & Powell.—xxviii. 112
 Sang, F.—xxvi. 233
 Sang, J.—x. 338
 Sangiorgio, A.—Austria, 722
 Sangiovanni, B.—xxx. (Fine Art Crt.) 83
 Sangouehko, Princess Mary.—Russia, 78
 Sangster, J., see Sangster, W. & J.
 Sangster, W. & J.—xxix. 136
 Sanin.—Russia, 28
 Sankey, W. H. V.—vii. 32
 Sanson, E.—France, 366
 Santa Maria de Nieva, Alcalde of.—Spain, 233
 Santander, the Inspector of Mines of.—Spain, 9
 Sauti, Dr. C.—Tuscany, 20
 Santo, Dr. D. A. C.—Spain, 242
 Santos y, Diaz J.—Spain, 34
 Sapellin, V.—Russia, 309
 Sapognikoff.—Russia, 372
 Sapujnikoff, Brothers.—Russia, 67
 Sapp, see Becker, Sapp, & Co.
 Sapsford, S.—xvii. 35
 Sapy, A.—Austria, 6
 Saracini, C. A.—Tuscany, 34
 Saragossa, Academy of Medicine & Surgery.—Spain, 128A
 Saragossa, Agricultural Board of.—Spain, 148
 Saragossa, the Inspector of Mines of.—Spain, 11
 Sarasin, J. F.—Switzerland, 152
 Sarasin & Co.—Switzerland, 152
 Sarchet, J.—Jersey and Guernsey, 32
 Sarder, P.—Austria, 607
 Sardinia, King of.—Sardinia, 64
 Sargent, C.—ix. 29
 Sarin & Rengos.—Greece, 56
 Sarrac, H., & Dufour.—France, 1471
 Sarre, H. jun.—Zollverein (1), 235
 Sarson, T. F.—xxii. 470
 Sartorius, A. & Co.—Zollverein (1), 611
 Bastachs, J.—Spain, 255
 Sastre, C.—Spain, 253A
 Sather, see Norberg & Sather
 Satourin, M.—Russia, 233
 Sattler, W.—Zollverein (2), 14
 Saur, see Spangenberg, Sauer, & Co.
 Sauer & Son.—Zollverein (1), 479
 Sauerbier, J. A.—Zollverein (1), 353
 Sauerbier, J. C.—Netherlands, 114
 Sauerbrey, L.—Zollverein (1), 702
 Sauerbrey, V.—Switzerland, 68
 Saugrin.—France, 690
 Sauken, A. Von.—Zollverein (1), 433
 Saulini, T.—Rome, 24
 Saulshauseu Salt Works (Hesse).—Zollverein (6), 3
 Saunders, see Randall & Saunders
 Saunders, C.—v. 958; xvi. 135
 Saunders, F. W.—xvi. 271
 Saunders, G.—xxi. 34; Jersey and Guernsey, 23
 Saunders & Gatchill.—iii. 144; iv. 71
 Saunders & Son.—x. 205
 Saunders, T. H.—xvii. 36
 Saunders, W. J.—xxii. 455
 Saunders, W. W.—iv. 9
 Sanderson, C.—xvii. 37
 Sauraux, J. V.—France, 367
 Sausure, J. B. De.—United States, 176A
 Sautret, jun.—France, 1473
 Sautreuil, jun.—France, 1474
 Sauvage, R. & Co.—France, 1472
 Savage, A.—vi. 458
 Savage, G. & Son.—Canada, 340
 Savage, R. W.—xxii. 56
 Savalini, Thomas.—Rome, 24
 Savard.—France, 1476
 Savarese, jun.—France, 998
 Savarese, H.—France, 997
 Savarese, P.—France, 1477
 Savary and Mosbach.—France, 368
 Savery, P. B.—United States, 55
 Savi, Professor P.—Tuscany, 51
 Saville, J.—xii. & xv. 46
 Savory & Moore.—ii. 115
 Sawney, W.—ix. 31
 Sawyer, W.—v. 960
 Sax, A. & Co.—France, 1726
 Saxby & Brain.—viii. 136
 Saxton, A.—vi. 17
 Saxony, Royal Direction of Railways (Dresden).—Zollverein (3), 26
 Saxton, A.—xx. 90
 Sayce, J. & Co.—xii. & xv. 307
 Saye, P. G.—France, 1691
 Sayer, see Featham, Miller, & Sayer
 Sayle, Merriam, & Brewer.—United States, 404
 Saynor & Sons.—xxii. 198
 Sazikoff, P.—Russia, 366
 Scaling, W.—xxviii. 9
 Scamp, W.—viii. 298
 Scamps, P.—France, 1479
 Scarfe, G.—Jersey and Guernsey, 17
 Schalaus, J.—Austria, 36
 Schachtler, see Custer & Schachtler
 Schaale, E.—Zollverein (1), 680
 Schaeck, Madame.—Switzerland, 251
 Schaefer, Otto, & Scheibe.—Zoll. (1), 153
 Schaeffnellen, G.—Zollverein (4), 41
 Schaeff, R.—Zollverein (1), 118
 Schaffgotsch, Count of.—Zoll. (1), 208
 Schalch, A.—Switzerland, 180
 Schalis, see Dunlop & Schalis
 Schaller, C.—Zollverein (1), 478
 Schaller, J.—xvi. 203
 Schamal, F.—Austria, 118
 Scharenberg, A.—Mecklenburg Strelitz, 3
 Scharf, C.—Zollverein (1), 776
 Schattenman, Mr.—France, 376
 Scheder, J. & Co.—Zollverein (1), 102
 Schedi, C.—Austria, 429
 Scheel, C.—Zollverein (1), 668
 Scheibe, see Schaffer, Otto, & Co.
 Scheibe, G.—Zollverein (1), 719
 Scheibe, H. L.—Zollverein (1), 742
 Scheibler, see Homberg & Scheibler
 Scheibler, F. J.—Zollverein (1), 354
 Scheibler & Co.—Austria, 80; Zollverein (1), 534
 Scheibler & Son.—Zollverein (1), 864
 Scheidt, Brothers, & Co.—Zollv. (1), 504
 Scheidt, J. W.—Zollverein (1), 565
 Scheidweiler, M.—Belgium, 164
 Scheite, C.—vi. 402
 Scheipser, see Honckmühl, & Co.
 Scheit, J. W.—Zollverein (1), 503
 Scheitlin, D. see Scheitlin, H. & D.
 Scheitlin, H. & D.—Switzerland, 217
 Schelle, J. G.—Hamburg, 31
 Scheller, Weber, & Wittich.—Zollverein (1), 663
 Schelling & Co.—Switzerland, 62
 Scheltraete, L.—Belgium, 251
 Scheltema, J. & J.—Netherlands, 38
 Schelter, G.—Zollverein (3), 182
 Schlemamy, see Schulte & Schemany
 Schembri, A.—Malta, 10
 Schembri, G.—Malta, 3
 Schenck & Co.—Zollverein (4), 40
 Schendel, P. Van.—Belgium, 173
 Scheppers, F.—Belgium, 497
 Scheuble, J. H. & Co.—South Africa, 48
 Schiapparelli, see Rossi & Schiapparelli
 Schiedmayer & Sons.—Zoll. (4), 23
 Schiertz, J. G.—France, 999
 Schiess, see Schoch, Schiess, & Co.; Zaelmer & Schiess
 Schiess, E.—Switzerland, 200
 Schiess, G.—Switzerland, 131
 Schiesselbein, J. F. E.—Zoll. (1), 237
 Schiffmann, L.—Zollverein (6), 76

Schiffner & Zimmermann.—Zollverein (3), 97
 Schild, J.—Switzerland, 250
 Schildknecht, C. F.—Zollverein (1), 131
 Schill & Wagner.—Zollverein (4), 30
 Schiller & Gerbing.—Austria, 614
 Schiller, J.—Hamburg, 95
 Schilling, J.—Zollverein (1), 148
 Schilling, V. C.—Zollverein (1), 855
 Schilling & Sutton.—I. 52
 Schilt, V.—Switzerland, 59
 Schindl, A.—Austria, 318
 Schindler, see Eberstaller & Schindler; Jenny & Schindler
 Schindler, S.—Austria, 555
 Schindler & Kirschbaum.—Zollverein (1), 480
 Schipper, C.—Austria, 269
 Schlaepfer, J.—Switzerland, 135
 Schlaepfer, Schlatter, & Kursteiner.—Switzerland, 201
 Schlatter, H.—Austria, 701
 Schlatter, see Schlaepfer, Schlatter, & Co.
 Schledlich, see Köhler & Schledlich
 Schlegelmilch, C.—Zollverein (1), 643
 Schleichner, C.—Zollverein (1), 405
 Schlesinger, see Quitzw, & Co.
 Schlesinger & Co.—VI. 168; XVII. 38
 Schless, H.—Zollverein (1), 160
 Schlick, F.—Austria, 385
 Schlieff, T.—Zollverein (1), 108
 Schlippe, C.—Russia, 27
 Schloss, Widow, & Brother.—France, 1480
 Schlumberger, jun., & Co.—France, 1481
 Schlumberger, Gaspari, & Co.—France, 1000
 Schlusler, H.—South Africa, 39
 Schmanz, C., sen.—France, 370
 Schnerbauch, H.—Zollverein (1), 264
 Schnerber, S.—Zollv. (5), 30
 Schmersahl, see Kurtz & Schmersahl
 Schnid & Abegg.—Switzerland, 153
 Schmid, Brothers.—Switzerland, 163, 269
 Schmid, H.—Switzerland, 136
 Schmid, H. D.—Austria, 105
 Schmidleher, J.—Austria, 455
 Schmidt, see Behren & Schmidt; Casparson & Schmidt; Gevers & Schmidt; Wahlen & Schmidt
 Schmidt, C.—Zollverein (1), 644; (2), 92
 Schmidt, C. H.—Zollverein (1), 809
 Schmidt & Co.—Zollverein (1), 589; Zollverein (3), 11
 Schmidt, E.—Zollverein (6), 58
 Schmidt, F.—Zollverein (1), 83
 Schmidt, G. F. & Co.—Zollverein (3), 60
 Schmidt, H., see Schmidt, C. & H.
 Schmidt, J.—Mecklenburg-Schwerin, 2
 Schmidt, J. C.—Zollverein (1), 631
 Schmidt, J. D.—Zollverein (1), 651
 Schmidt, J. G., jun., & Sons.—Zollverein (3), 49
 Schmidt, P. L.—Zollverein (1), 646
 Schmidt & Sons.—Zollverein (1), 756
 Schmidt, W.—Zollverein (4), 9
 Schmieger, A.—Austria, 193
 Schmiegler, J.—Austria, 224
 Schmieterloew, C.—South Africa, 42
 Schmitt, C.—Zollverein (1), 644
 Schmits & Holthaus.—Zollverein (1), 855
 Schmitt, F.—Austria, 225
 Schmitt, S. M. (Heirs of), & Co.—Austria, 238

Schmoelder, see Widemaun, Pferdmeneger, & Co.
 Schmolz, W. & Co.—Zollverein (1), 673
 Schmuck, Souchay, & Co.—Zollverein (1), 729
 Schnabel, Brothers.—Zollverein (1), 503
 Schnapper, H. L.—Zollverein (6), 42
 Schmutz, W.—Hamburg, 104
 Schmeberg Cobalt and Nickel Works (Saxony)—Zollverein (3), 9
 Schneider, A. see Schneider, E. & A. & Co.
 Schneider, Brothers, & Legrand.—France, 1002
 Schneider, E. & A. & Legrand.—France, 1001
 Schneider, F.—Switzerland, 102; Zollverein (1), 185, 203
 Schneider, H. W.—I. 409
 Schneider, J.—Austria, 140
 Schneidu & Co.—Chili
 Schneiter, J. D.—Switzerland, 42
 Schmelle & Sons.—Zollverein (1), 558
 Schmitzer.—xxx. (Fins Art Court), 161
 Schmitzler & Kirschbaum.—Zollverein (1), 480
 Schmitzler, see Ullenberg & Schmitzler
 Schnorr & Steinhauser.—Zollverein (3), 62
 Schuch, Schiess & Co.—Switzerland, 202
 Schuofel, J.—Austria, 99
 Schuefer.—Zollverein (1), 737
 Schuell, A.—Austria, 226
 Schuell, C. A.—Switzerland, 252
 Schoeller, A. & F.—Zollverein (1), 608
 Schoeller, Brothers.—Austria, 227
 Schoeller, J. P.—Zollverein (1), 365.
 Schoeller & Sons.—Zollverein (1), 374
 Schonebeck Chemical Manufactory.—Zollverein (1), 681
 Schönebeck Salt Works.—Zollverein (1), 834.
 Schoenberger.—France, 371
 Schoenfeldt.—Russia, 375
 Schoenhuber, J.—Austria, 113.
 Schoening, H.—Zollverein (1), 154
 Schoettle, G. J.—Zollverein (4), 12
 Schoefeld, A.—xii. & xv. 474
 Schoefeld, Brown, Davis, and Halse.—xii. & xv. 3
 Schoefeld, J.—xii. & xv. 125
 Schoefeld, D.—x. 148
 Schöler, P. C.—Denmark, 37
 Scholey, Misses.—xxvi. 142
 Scholl, J.—x. 666
 Scholtus.—France, 1482
 Schomburgk, Sir R.—St. Domingo
 Schön, P.—Zollverein (1), 402
 Schönberg Privileged Linen Yarn Spinning Mill.—Austria, 95A
 Schönborn, E.—Austria 15
 Schoneveld & Westerbaan.—Netherlands, 13
 Schönhofer.—Zollverein (1), 785
 Schönhofer, Sebald.—Switzerland, 258
 Schönleber, A.—Zollverein (4), 32
 Schooley & Hough.—United States, 200
 School of Charity, Ireland.—xix. 227
 School for Indigent Blind.—xxviii. 100
 Schooling, H.—xxix. 114
 Schoot, J. N. C.—Hamburg, 37
 Schopfer, S.—Switzerland, 218
 Schopper, F.—Zollverein (1), 757
 Schopper, H.—Zollverein (1), 758
 Schopper, M. A.—Austria, 270
 Schörder, C. H.—Hamburg, 13
 Schotta, B. & Sons.—Zollverein (6), 25
 Schrader, C.—Zollverein (1), 777
 Schraidt & Co.—Zollverein (1), 732

Schramm, Brothers.—Zollverein (1), 466
 Schramm J. L. F.—Zollverein (1), 806
 Schramm, S.—Austria, 397
 Schrader, Miss H.—xxix. 319
 Schrage, see Becker & Schrage
 Schrauber, B.—Zollverein (6), 51
 Schreiber, F. A.—Zollverein (3), 71
 Schreiber, J. C. G.—Zollverein (1), 793
 Schreier, Susanna.—Austria, 300A
 Schrieck, Van Der, Brothers.—Belgium, 101
 Schröder, see Schuermann & Schröder
 Schrödter, E.—Zollverein (1), 484
 Schroeder.—I. 437; see also Gottschalk & Schroeder; Wamp & Schroeder
 Schroeder, J.—Zollverein (6), 77
 Schraer, F. H.—Zollverein (3), 120
 Schroers, G. & H.—Zollverein (1), 515
 Schroers, H., see Schroers, G. & H.
 Schropp, Simon & Co.—Zollverein (1), 303
 Schruck & Uhlisch.—Zollverein (2), 15
 Schuberth & Co.—Hamburg, 102
 Schubert, see Belir & Schubert
 Schubert, A.—Austria, 168
 Schubert, Mrs.—Zollverein (3), 156
 Schuchard, H.—Zollverein (6), 19
 Schuchmann, W.—Switzerland, 264
 Schueler, Dr. G.—Zollverein (1)
 Schuell, L.—Zollverein (1), 393
 Schuer, Dr. & Kohring.—Zollverein (1), 843
 Schuermann & Schröder.—Zollverein (1), 496
 Schuette.—Zollverein (3), 188
 Schuetzendorf, H. J.—Zollverein (1), 399
 Schuldheis, A. E.—Sweden, 105
 Schule, see Kolb & Schule
 Schulte, J. H.—Zollverein (1), 675
 Schulte & Schenmann.—Hamburg, 49
 Schultheis, see Weber & Schultheis
 Schultz.—Russia, 268
 Schultz, F. J.—Hamburg, 48
 Schultz, G. S.—Hamburg, 112
 Schultze, D.—Hanover, 6
 Schmitze, F.—Hamburg, 46
 Schultze, J. & F.—Zollverein (1), 707
 Schulz, C.—Zollverein (1), 593
 Schulz, J.—Zollverein (1), 850
 Schulz, L. W.—Zollverein (1), 811
 Schulz, W.—Zollverein (1), 881
 Schumacher.—Zollverein (4), 93
 Schumacher, J. & Sons.—Zollv. (6), 47
 Schumann, C. A.—United States, 204
 Schuster.—Zollverein (1), 712
 Schuster, L.—Zollverein (3), 22
 Schuster, M., jun.—Zollverein (3), 23
 Schutz, F.—Austria, 375
 Schutz, L. W.—Netherlands, 98
 Schütze, A.—Zollverein (1), 884
 Schutzmann, A.—Zollverein (2), 40
 Schuyler, see Raymond & Schuyler
 Schwabe, see Sals, Schwabe, & Co.
 Schwann, F.—xiii. & xv. 115; xiv. 50A
 Schwann, Kell, & Co.—xii. & xv. 141
 Schwanthaler.—Zollverein (1), 90, 285; (Main Avenue, East)
 Schwarte, J. D.—Zollverein (1), 640
 Schwartz, C.—Zollverein (1), 202
 Schwartz & Huguenin.—France, 1003
 Schwartz, Trapp, & Co.—France, 1004, 1005
 Schwartz, see Meyer & Schwartz
 Schwarz, C.—Austria, 470
 Schwarz, F. jun.—Austria, 472
 Schwarz, F. sen.—Austria, 471
 Schwarz, H.—Switzerland, 137

- Schwarz, I.—Austria, 473
 Schwarz, J.—Austria, 684
 Schwarz, Dr.—Zollverein (3), 179
 Schwarzenbach, J. J.—Switzerland, 153
 Schwarzenbach Brothers.—Switzerland, 153
 Schwarzenberg, Prince.—Austria, 417
 Schwarzenfels Electoral Colour Manufactory.—Zollverein (1), 465
 Schwabemeyer, C.—Zollverein (1), 181
 Schwofel, A.—Austria, 608
 Schweitzer & Heller.—Zollv. (1), 733
 Schweizer, see Graesser & Schweizer
 Schwemanu & Sosa.—Zollv. (1), 545
 Schwemal Royal Alum Works.—Zollverein (1), 463
 Schwerber, S.—Zollverein (5), 30
 Schwerin, Count of.—Zollverein (1), 33
 Schwinghammer, S. T.—Austria, 556
 Scola, A.—Austria, 72
 Sonta, B.—Sardinia, 16
 Soellfick, H. C.—xxx. (Fine Art Court), 178
 Scotch Linen Trade.—Portugal, 701-706
 Scott, Brothers.—Tuscany, 37
 Scott.—xxii. 612; see also Keer & Scott
 Scott, Cutbertson & Co.—xxvi. 300
 Scott, E., & Co.—xv. 19
 Scott, G.—v. 154
 Scott, G. G.—Page 848; vii. 221. (Main Avenue, West) xxvi. 235
 Scott & Glasford.—Canada, 148
 Scott, L.—ii. 61
 Scott, M.—v. 98
 Scott, P.—xx. 141
 Scott, S. T.—xvi. 228
 Scott & Wright.—xii. & xv. 1
 Scottish Royal Society of Arts.—vii. 29
 Scouller, J.—viii. 113
 Scragg, T.—ix. 228
 Scrampton.—i. 82
 Screen, T.—Van Diemen's Land, 305
 Scrive, Brothers.—France, 1005, 1007
 Scrive, Brothers, & J. Danser.—France, 1006
 Scroxtou, J. H.—xxvi. 271
 Scrymgeour, H.—xxvi. 101
 Scuffler, E.—Austria, 141a
 Southless Brothers.—Switzerland, 153
 Seabrook, W.—United States, 320d
 Seabury, J. & J. L.—United States, 121
 Seabury, J. L., see Seabury, J. & J. L.
 Seager, W.—xxx. (Fine Art Court), 13
 Seal, J.—xxx. (Fine Art Court), 218
 Seal, F. M. C.—Portugal, 497, 515
 Seal, S.—ix. 262
 Sealy, J.—xxvii. 130
 Seamer, T.—xiii. 15
 Searight, J.—South Africa, 37
 Searle, C.—xxii. 480
 Searles, G.—United States, 488
 Searle, H.—vi. 65
 Searle, M.—New Brunswick, 21, 26.
 Searle & Sons.—viii. 169 (Main Avenue, West)
 Sears, M. W.—viii. 348
 Sears, H.—xxii. 620
 Seaton, Lord.—Ionian Islands, 5
 Seaward, W.—ix. 51
 Secchi, F.—Austria, 81
 Seccombe, S.—i. 454
 Seigwick & Taylor.—xxii. 644
 Seilag, G.—Zollverein (3), 72-83
 Seebass, A. R.—Zollverein (6), 50
 Seeger, E.—Zollverein (4), 78
 Seeger, J. A.—Zollverein (1), 713
 Seel, G.—Zollverein (1), 637
 Seel, H., jun.—Zollverein (1), 483
 Seely, J.—Western-end, South enclosure (outside), 11; page 852
 Seeling & Becker.—Zollverein (6), 69
 Seeling, G. W.—Zollverein (1), 291
 Seemann, C. & H.—Zollverein (4), 36
 Seemann, G.—Zollverein (1), 75
 Seeman, H., see Seeman, C. & H.
 Seer, L. M.—Canada, 16
 Seghers, B.—Belgium, 110
 Segond, see Maille & Segond
 Seguin.—France, 692, 1893
 Seguin, J.—France, 1008
 Seguy.—France, 372
 Seib, J. A.—France, 1009
 Seibe, A.—xxvi. 11
 Seibrer, see Pature-Lupin, & Co.
 Seil Omer.—Turkey
 Seidel, C. & C.—Austria, 228
 Seidel, J.—Zollverein (6), 26
 Saiffert & Co.—Zollverein (1), 162
 Seigneur, J. B. Du.—France, 187; (Main Avenue, East)
 Seignour, H. J.—Jersey & Guernsey, 3
 Seipermann & Mohlau.—Zollv (1), 676
 Seitter, A.—Austria, 399
 Selboe, J. C.—Denmark, 31
 Seldia, E.—Zollverein (1), 181
 Selenka, J.—Zollverein (1), 800
 Selve, H.—v. 452
 Selivanoff.—Russia, 52
 Sellar & Son.—ix. 85
 Sellers, see Slack, Sellers, & Co.
 Sellers, J.—xxii. 147; xxx. (Fine Art Court), 295
 Sellier & Bellot.—Austria, 122
 Sells, see Jones, Sells, & Co.
 Seloia, Brothers.—Sardinia, 4
 Seltzer, Sophia.—x. 726
 Semenov & Faleyeff, Brothers.—Russia, 135, 247
 Semmens, J.—viii. 136
 Semon, Siltzer, & Co.—xii. & xv. 163
 Semovilla, R.—Spain, 143
 Semper.—Zollverein (3), 174
 Sempere, F. de.—Spain, 41
 Sena Sorni de F.—Spain, 274a
 Senechal.—France, 373
 Sengenwald.—France, 1010
 Sengle, J. G.—Hamburgh, 66
 Senigaglia & Carmiuati.—Austria, 78
 Senn & Suter.—Switzerland, 152
 Sennoff, J.—United States, 75
 Sentis, Son, & Co.—France, 1011
 Seppe, H.—South Africa, 49
 Serafino, B.—Tuscany, 123
 Serafino, Palatini, & Co.—Austria, 702
 Serionne, De, Loim, & Co.—France, 1483
 Serjeant & Pepper.—xxv. 19
 Serley, C. G. De.—France, 1484
 Serret, Hamoir, Duquesne, & Co.—France, 1485
 Servaes, M. F.—Belgium, 295
 Servais, J. B.—Belgium, 291; France, 1012
 Service, W.—ix. 122a
 Sersedello & Co.—Portugal, 37, 38, 42, 50, 61, 69, 70, 72, 75, 76, 80, 81, 504
 Settler, B.—Spain, 272a
 Setzer, J.—Austria, 23
 Seuffert, E.—Austria, 141b
 Severin, E.—Hamburgh, 118; Belgium, 367
 Severn, H. A.—viii. 186
 Sevier.—xix. 115
 Seville Royal Cannon Foundry.—Spain, 263 (Main Avenue, East)
 Sévin, C.—France, 1739
 Sèvres, Manufactory of Porcelain and Stained Glass at.—France, 1369
 Sewall, see Johnson, Sewall, & Co.
 Sewell, C. & F.—xxvi. 340
 Sewell & Co.—ix. 107
 Sewell, Evans, Hubbard, and Bacon.—xxii. 19; xix. 288
 Sewell, F., see Sewell, C. & F.
 Sewell, T. R.—vi. 92
 Seybel, see Wagenmann, Seybel, & Co.
 Seybold, G.—Sweden, 101
 Seydoux, see Pature-Lupin, & Co.
 Seyoux.—France, 1486
 Seyferth, J. & Co.—Zollverein (3), 106
 Seyfarth, Dr.—Zollverein (3), 174
 Seyffert & Breyer.—Zollverein (3), 88
 Seykora, J.—Austria, 324
 Seyker, G.—Zollverein (1), 121
 Seymour, K. & J.—xxiii. 72
 Seymour, J., see Seymour, E. & J.
 Seymour, Z.—i. 192
 Seyrig, see Manlove, Alliot, & Co.
 Seyssel Asphalte Co.—Eastern end; i. 229
 Shabelaky.—Russia, 42
 Shacklock, G.—xxvi. 29
 Shadbolt, G.—x. 677a
 Shaft & Axletree Co.—v. 543
 Shah, A.—Russia, 126
 Shah-Wedi-Ogli.—Russia, 166
 Shakkell, Maria, Fanny, & Edw.—xix. 289
 Shalders, W. jun.—v. 402
 Shand & Mason (late Tilley & Co.)—v. 410 (South Trausep)
 Shand & Muckart.—iii. 126
 Shanghae, H.M. Consul at.—China
 Shanks, A.—vi. 210
 Shanks, R. H.—v. 962
 Shanks & Son.—ix. 67
 Sharland, Mrs.—Van Diemen's Land, 177
 Sharland, W.—Van Diemen's Land.—175
 Sharland, W. S.—Van Diemen's Land.—321
 Sharnhorst, C.—Oldenburgh, 3
 Sharp, see Ward, Street, & Co.
 Sharp, Brothers.—vi. 15, 204
 Sharp, D. W.—xii. & xv. 177
 Sharp, G.—xxx. (Fine Art Court), 20
 Sharp, J.—xxii. 91; xxix. 218
 Sharp, Odell, & Jury.—xiii. 69
 Sharp, S.—Western end, South enclosure (outside), 18; vi. 410; x. 309
 Sharp, T.—xix. 1; xxiii. 120; xxx. (Sculpture Court) 20, 26; see also Brine, Brothers, & T. Sharp
 Sharp, W. D.—v. 104
 Sharpe, B.—viii. 136
 Sharpe, see Browne, Sharp, & Co.
 Sharpe, Brothers, & Co.—xxv. 36
 Sharpe, E.—vii. 223 (Main Avenue, West)
 Sharpe, H. & D.—Zollverein (1), 872
 Sharpe, J. & R.—xxi. 10
 Sharpe, R., see Sharpe, J. & R.
 Sharpus & Cullum.—xxv. 41
 Shattuck, W. F.—United States, 509
 Shattuck, W. G.—United States, 412
 Shave, W. J.—xxii. 90; xxii. 628
 Shaw, A.—Canada, 56
 Shaw, B. L.—v. 113
 Shaw, C.—xxviii. 164
 Shaw, H.—viii. 14; see also Shaw J. W. and H.
 Shaw, J.—viii. 254; xx. 91
 Shaw, J. & Co.—v. 728
 Shaw, J. W. & H.—xii. & xv. 98
 Shaw, P.—xii. & xv. 90
 Shaw, S.—Canada, 149
 Shaw & Son.—xxii. 216

40
and Bacon.—
& F.
Seybel, & Co.
101
in, &c.
ollverein (3),
n (3), 174
erein (3), 88
1), 121
r. 72
r, K. & J.
tiott, &c.
asteru enil; i.
9
543
ia, 166
& Edw.—xix.
02
lley & Co.)—
n)
126
at.—China
Diemen's Land,
emen's Land.—
Diemen's Land.
burgh, 3
&c.
5. 204
v. 177
rt Court), 20
xix. 218
xiii. 69
South enclosure
0; x. 303
xiii. 120; xxx.
0. 26; see also
Sharp
p, & Co.
—xxv. 36
(Main Avenue,
erein (1), 872
0
i. & R.
xv. 41
ed States, 509
ed States, 412
; xxii. 628
e also Shaw J.
x. 91
& xv. 98
0

Shaw, Son, & Co.—xii. & xv. 110
Shaw, W.—vi. 110
Shea, Capt.—China
Sheau, W. J.—xvii. 177
Sheard & Sons.—xii. & xv. 81
Shearer, J.—xxii. 127
Shearman, E. S.—United States, 572
Shears & Sons.—xxii. 438A
Shechtel, F.—Russia, 367
Sheddon, H.—xix. 293
Sheepshanks, see York & Sheepshanks
Sheffield Gas Company.—xxii. 448
Sheffield Journeymen File-makers.—
xxii. 138
Sheffield School of Design, xxiii. 39;
xxvi. 344, 345
Shkhonin.—Russia, 276
Shkhonin, A.—Russia, 275
Sheldon, see Wadsworth & Sheldon
Sheldon, J.—xxii. 292
Shembri, Antouia.—Malta, 10
Shenton, see Foothorpe, Showell, &c.
Shenstone & Mills.—xxii. 273
Shepard & Perfect.—xii. & xv. 131
Shepard, J.—xxiv. 8
Shepherd, C.—x. 128 (South Transept)
Shepherd, G.—Canada, 63
Shepherd, Hill, & Spink.—vi. 220
Shepherd, R. A. J.—United States, 10
Sheppard, A.—iii. 70
Sheppard, F.—xxviii. 111
Sheppard, G., see Sheppard, W. B.,
& G.
Sheppard, W. B. and G.—xii. & xv.
18
Sheridan, P.—xix. 294
Sheriff, T.—ix. 74
Sheringham.—xxii. 582
Sherman & Smith.—United States, 143
Sherrin, G.—New South Wales
Sberwin, H.—xxv. 51
Sherwin, J.—xxii. 243
Sherwin, Cope & Co.—vi. 104
Sherwood Iron Works.—xxx. (Fine
Art Court) 138
Shield, J.—vii. 79
Shields, F. W. (C.E.)—New South
Wales, 18
Shier, D.—British Guiana, 21-24, 33-35,
41-44, 55, 58, 67, 122, 133,
Shillbeer, G.—v. 964
Shilton, T.—v. 966
Shinton, R.—iii. 23; xx. 75
Shiple, J. G.—xvi. 82
Shipton, see Brunslau & Shipton
Shipwreck, National Institution for the
preservation of life from.—viii. 309
Shirer, A.—xix. 296
Sholl, J.—ix. 120; United States, 533
Shoolridge, see Keith, Shoolbridge, & Co
Shoolbred, Loveridge, & Shoolbred.—
xxii. 66; xxvi. 282
Shore, T.—vi. 438
Shorman, J.—viii. 266
Short, see Grave, De, Short, &c.
Short, J.—xxix. 129
Shovaloff & Son.—Russia, 231, 241
Shuve, G.—xxiv. 24
Snowell, see Foothorpe, Showell, &c.
Shreeve, Mrs.—xx. 46A
Shrewsbury, see Alderton & Shrewsbury
Shrance & Vezfel.—Russia, 370
Shuff, W.—v. 971
Shuldian, Harriett.—xix. 298
Shuldham, M.—viii. 172
Shuttleworth, see Clayton, Shuttleworth,
& Co.
Shuttleworth, W. & Co.—xii. & xv.
156
Si Ahmed El Hachemi.—Algeria, 49

Si Ali Ben Lamouchi.—Algeria, 65;
France, 1695
Si Amar Smin.—Algeria, 49
Si Amon Ben Ouaf, A. F. (or Si Ham-
mon Bel Onataf).—Algeria, 64;
France, 1694
Si-El-Bey Ben-Bou-Ras.—Algeria, 60
Si El Medani.—Algeria, 66
Si Han :la.—France, 1696
Sibbald, see Sanderson & Sibbald
Sibell & Mott.—United States, 339
Sibley, S.—United States, 197
Sibson, H.—Page 852
Sibthorpe, Fanny Louisa.—xix. 299
Siccama, A.—x. 535
Sichart & Co.—China
Sichel, M.—Zollverein (6), 84
Siebe, A.—v. 440; vii. 1; ix. 255a;
x. 358; xxii. 435; xxvi. 11
Siebel, C. W. & Brinck.—Zollverein
(1), 513
Siebert, F.—Austria, 271
Siebert, S.—United States, 505
Siegert, C.—Zollverein (1), 74
Siegfried & Walddhausen.—Zollverein
(1), 862
Siegl, J. & Co.—Austria, 290
Siegler, H.—Zollverein (4), 6
Siegsmund, see Neuhäuser, Siegmund,
& Co.
Siegsmund, W.—Austria, 230
Siemens, C. W.—v. 46, 203
Siemens & Hulseke.—Zollverein (1),
310A
Siepermann & Moehlau.—Zollverein
(1), 676
Sieron, L.—Belgium, 358
Sievert, E.—Austria, 683
Sigaut.—France, 1487
Sigmund, I.—Austria, 272
Signoret Rochas, P.—France, 1013
Silbermann, G.—France, 374
Silk & Brown.—v. 968
Sillet, J.—xxx. (Fine Art Court), 26
Siltzer, see Semou, Siltzer, & Co.
Silva, see Almeida, Silva, & Co.
Silva, A. S. P. da.—Portugal, 1297,
1298
Silva, C. J. F. da.—Portugal, 1123c
Silva, H. J. da.—Brasil, 4
Silva, J. J. da.—Portugal, 955, 966,
967
Silva, J. P. da.—Portugal, 370
Silva, M. da.—Portugal, 991-1014
Silva Alves R. J. da.—Portugal, 407
Silva Junior, A. da.—Portugal, 319
Silveira, J. P. da.—Portugal, 349
Silvent, see Repiquet & Silvent
Silverlock, H.—vi. 158, 162; xvii. 40.
Silverwood, see Marsden, Brothers, &c.
Sim, C. J.—xix. 301
Sim, W.—i. 137
Simeox, G. P.—xix. 302
Simeox, Pemberton, & Sons.—xxii. 321
Sime, J. & Co.—xii. & xv. 195
Simes, S.—United States, 60
Simier, J.—France, 693
Simmens, J.—viii. 124
Simmonds & Woodman.—xx. 105
Simmons & Co.—United States, 119
Simmons, G. N.—i. 463
Simmons, J.—xxx. (Fine Art Court),
126
Simmons, Mrs. W.—United States, 303
Simms, W.—x. 741 (Main Avenue,
West); see also Troughton and
Simms
Simon, see Guenther & Simon; Lightly
& Simon; Schrupp, Simon, & Co.;
Videcoq & Simon

Simon, E.—France, 1014
Simon, H.—Zollverein (2), 37
Simon & Henry.—France, 1459
Simon, J.—France, 1016
Simon, Miss.—Jersey & Guernsey, 24
Simon, P.—France, 1015
Simon, S.—France, 1697
Simonet, Virginia.—France, 375
Simonetta, P.—Austria, 291
Simonis, E.—Belgium, 464 (Main Ave-
nue, East)
Simonis, J.—Belgium, 194
Sinouite, J.—xxii. 270
Simons, J. (heirs of).—Zollverein (1),
614
Simons, W.—viii. 33
Simons, W. V.—v. 96; x. 663
Simouson, see Jones, Simouson, &c.
Simunson, J. & Co.—Zollverein (3),
154
Simounet, P.—Algeria, 51
Simpon, Prof.—United States, 565
Simpon, Eastler.—xx. 111
Simpon, G.—x. 624; xxvi. 267
Simpon, H.—x. 642
Simpon, Hannah.—xx. 111
Simpon, Humphrey, & Vickers.—iv.
117
Simpon, J.—xxv. 33
Simpon, J. & Co.—Canada, 48
Simpon, M.—ix. 67
Simpon, Messrs.—India, v.
Simpon & Skipton.—v. 14
Simpon, T.—x. 532
Simpon, T. B.—Canada, 90, 277
Simpon, W. B.—xix. 379; xxvi. 270
Simpon & Young.—xviii. 47
Sims, E. H.—United States, 274, 275
Sims, E. W.—United States, 267
Sinclair, C.—xvii. 50
Sinclair, D.—xiii. 136
Sinclair, Duncan, & Son.—xvii. 92
Sinclair & Huckle, x. 329
Sinclair, J.—Western end, South en-
closure (outside), 13; i. 206
Sinclair, J. jun.—xii. & xv. 467
Singer, C. F.—Zollverein (3), 145
Singer & Co.—Western end, North en-
closure (outside), 65; xxvii. 88
Singer, J.—Austria, 392
Sinigaglia, Brothers.—Sardinia, 25
Sioen, J.—Belgium, 138
Sirof.—France, 1017
Sirtaue, F.—Belgium, 197
Sisters of Mercy.—xix, 213A
Sitoff, Brothers.—Russia, 202, 323
Sjohorn, C. G.—Sweden, 63
Skalkin.—Russia, 347
Skeltous, R., see Skeltous, S. & R.
Skeltous, S. & R.—xxii. 250
Skidmore, T. R.—xxiv. 52
Skidmore & Co.—xxii. 183
Skidmore & Son.—xxiii. 129
Skill, Rebecca.—xix. 84
Skinner.—xxx. (Fine Art Court) 362
Skinner, A.—xvi. 83
Skinner, F., & Co.—United States, 450
Skinner & M'Culloch.—Canada, 88, 90
Skinner & Whalley.—xxvii. 121
Skipton, see Simpon & Skipton
Skvorzuff.—Russia, 232, 235
Slack, J.—v. 423
Slack, Sellers, & Grayson.—xxii. 208
Slagg, H. W.—xxii. 168
Slape, G.—xxviii. 67
Slark, W.—xxix. 135
Slate, J.—vi. 69; xxii. 386
Slater, E.—xii. & xv. 22
Slater, H.—xii. & xv. 170
Slater, J.—xxix. 226

- Slater, W.—VIII. 78
 Slater & Wright.—I. 11; VIII. 136. 312
 Slaughter, Elizabeth.—XXIX. 64
 Slaughter, see Stobert, Slaughter, & Co.
 Sleggits, Mrs.—Van Diemen's Land, 163
 Slight, J.—v. 765; IX. 42
 Sloane, see Hall, Brothers, & Co.
 Sloane, F.—Tuscany, 28
 Slock, E.—xi. 6
 Sloggett, R.—VIII. 32
 Sluter.—Zollverein (1), 270
 Sly, J.—Van Diemen's Land, 329
 Snaal-Werpin, A.—Belgium, 398
 Smaale, W.—VIII. 94
 Small, see Maling & Small
 Small, T.—x. 651
 Small, T. O.—xxv. 42
 Smallman, Smith, & Co.—XXII. 2
 Smart, see Ramsey and Smart
 Smart, R.—xx. 135
 Smead, C.—United States, 237
 Smeel, S.—Denmark, 29
 Smedley, T.—I. 124
 Smedt, B. De.—Belgium, 232
 Smees & Faraday.—x. 464
 Smees & Son.—xxvi. 174
 Smeeton & Son.—xiv. 63
 Smichow (near Prague) Steam Flour Mill.—Austria, 64
 Smily, W. R.—XXIII. 94
 Smith.—XII. & xv. 163; xvii. 33; XXII. 368; see also Bickford, Smith, & Co.; Earl, Smith, & Co.; Forster & Smith; Heywood, & Co.; Pecare & Smith; Phillips, Smith, & Co.; Phillips, Smith, & Phillips; Sherman & Smith; Smallman, Smith, & Co.; Stuart & Smith; Turbeville, & Co.; Ward, Smith, & Co.; Withey & Smith
 Smith, A.—XXVIII. 55A; Canada, 33; see also Smith, W. & A.
 Smith, A. K.—IX. 4A
 Smith, Anderson, & Co.—XIX. 82
 Smith, A. & W., & Co.—IX. 266
 Smith, B.—VII. 96; XXIII. 110; Canada, 64
 Smith & Baber.—XIX. 371
 Smith, Beacock, & Tannett.—VI. 230
 Smith & Beck.—x. 253
 Smith, B. T. & C.—IV. 65
 Smith, C.—I. 190A; xxvi. 341
 Smith, Capt., R.N.—XXX. 318
 Smith, Charlotte.—xx. 119
 Smith & Co.—IX. 234; XXII. 452
 Smith, C. R.—XXX. (Sculpture Court), 44. 83
 Smith, C. T.—Van Diemen's Land, 78, 189
 Smith, Constable, & Co.—Spain, 236
 Smith, D., see Smith, H. & D.
 Smith, E.—XVII. 100
 Smith, F. H.—United States, 566
 Smith, F. P.—v. 3
 Smith, F. S.—XXX. (Fine Art Court), 170
 Smith, G.—v. 141; IX. 219
 Smith, G. A.—XXVIII. 95
 Smith, George, & Co.—xx. 55
 Smith, G. F.—XXVI. 141
 Smith & Gibbs.—xx. 71
 Smith, G. R.—x. 424
 Smith, H.—VIII. 165. 279; IX. 102; see also Smith, T. & H.
 Smith, H. A.—XXX. (Fine Art Court) 211
 Smith, H. & D.—United States, 22
 Smith, H. E.—XXX. (Fine Art Court), 31A
 Smith, J.—III. 161; VI. 59; VII. 119A IX. 256; XIV. 65; XVI. 237; XVII. 41; XVIII. 89; XXVIII. 22; see also Coffey, J. A., and J. Smith
 Smith, J. & Sons.—XII. & xv. 235
 Smith, J. A.—New Zealand, 6. 14. 19. 29
 Smith, J. B. & Co.—XII. & xv. 14
 Smith, J. E.—xx. 29
 Smith, J. M. & Co.—United States, 519
 Smith, J. W.—VI. 73
 Smith, Kemp, & Wright.—XXII. 295
 Smith, L.—United States, 86
 Smith, Lieut., R.N.—Van Diemen's Land, 238-240, 295, 296
 Smith, M.—III. 14; VI. 22
 Smith, M. C. T.—Van Diemen's Land, 189
 Smith, Maria L.—XIX. 158
 Smith, Mary.—XIII. 51
 Smith, Mary A. P.—XXX. (Fine Art Court), 213
 Smith & Meynier.—Austria, 360
 Smith, Nicholson, & Co.—XXIII. 110
 Smith, O.—XXVIII. 95
 Smith, O. H.—v. 972
 Smith, P.—Van Diemen's Land, 222
 Smith, R.—I. 499
 Smith, Mrs. R.—XIX. 394
 Smith, R. & Son.—v. 449.
 Smith, S.—VIII. 125; x. 573
 Smith, Smallman, F.—XXX. (Fine Art Court), 170
 Smith & Son.—IV. 68; XII. & xv. 29; XVI. 31
 Smith & Sons.—x. 129; XVI. 310A (Main Avenue, West)
 Smith, T.—I. 177; IX. 222; XXII. 57; XXVIII. 172
 Smith, T., jun.—XXX. (Fine Art Court), 167
 Smith, T. & H.—II. 94.
 Smith, T. H.—XXII. 269
 Smith, T. & W.—VIII. 305
 Smith, W.—IX. 270; x. 339; XII. & xv. 80; see also Smith, A. & W. & Co.; Smith, T. & W.
 Smith, W. & A.—XXIX. 280
 Smith, W. H.—VII. 165
 Smith & Whyte.—XII. & xv. 459.
 Smithers, J.—South Africa, 38
 Smithson, T.—IV. 101A
 Smithson, T.—XII. & xv. 48
 Smits, P.—Netherlands, 20
 Smyth.—XIX. 77
 Smyth & Roberts.—x. 491
 Sneath, see Nicklin & Sneath.
 Sneider, Pellegrini.—Rome, 3
 Snelgrove, see Marshall & Snelgrove
 Snell & Co.—xxvi. 170
 Snell, J.—XII. & xv. 24
 Snell, R.—x. 528
 Snoeck, C. J.—Belgium, 202
 Snow, W. P.—I. 85
 Snowden, R.—III. 28
 Snowden, see Collier, Son, & Snowden
 Snowden, W. F.—v. 588
 Soap Contractors, Royal.—Portugal, 1158-1164
 Soares, V. C. V.—Portugal, 360. 368. 390. 391
 Sobey, W. R.—XXII. 685
 Sbradiel, Count of.—Spain, 174
 Söderberg & Arosenius.—Sweden and Norway, 19
 Soeders, G.—Netherlands, 81
 Soelke, G.—Zollverein (1), 265
 Soelnee, Brothers.—France, 350
 Soenen, F.—Belgium, 338
 Soenens, Le Chevalier.—Belgium, 109
 Soetens, C.—Belgium, 424
 Soins & Son.—France, 381
 Sozenikoff.—Russia, 261
 Soler, J.—Malta, 29
 Soley, B.—Sardinia, 40
 Soller & Co.—Switzerland, 152
 Solbrig, C. F.—Zollverein (3), 47
 Solbrig, Franz.—Zollverein (3), 72-83
 Solly, see Allen & Solly.
 Solly & Co.—I. 410
 Solly, J.—XXII. 258
 Solms, Count.—Zollverein (1), 210
 Solomon, J.—x. 286
 Solomon, S.—xx. 86
 Solomon, T.—I. 81
 Solomons, A.—XXX. (Fine Art Co.), 69
 Solovieff, J.—Russia, 354
 Somajni, F.—Austria, 723
 Somalvico & Co.—x. 681A
 Somers, Karl.—I. 77
 Somerset House School of Design.—XXVI. 309; Bay I. 23, 24; XXX. (Fine Art Court) 10
 Sommer, C.—Zollverein (3), 1
 Sommer, C. F.—Zollverein (1), 818
 Sommer, F.—Zollverein (1), 878. 893
 Sommer, J.—Zollverein (1), 390
 Sommerfeld, H.—Zollverein (1), 173
 Sommerfeld & Hubner.—Zollverein (1), 238
 Sommermeier & Co.—Zollverein (1), 502
 Souze, J., jun.—Belgium, 268
 Souze-Mahy, H.—Belgium, 265.
 Soudermann.—Zollverein (1), 288
 Soudermann, W.—Zollverein (1), 743
 Soudermeyer, J. K.—Netherlands, 72
 Soudeurberg, Association of Manufacturers at—Zollverein (1), 804
 Sonnelechner, A.—Austria, 500
 Soper, II.—XIII. 29
 Soper, R. S.—xv. 64
 Sophianos, A.—Greece, 2
 Sopwith, J., see Sopwith, T. & J.
 Sopwith, T.—I. 483, 484
 Sopwith, T. & J.—xxvi. 316
 Sorby, R., & Sons.—XXII. 204
 Sorel.—France, 1020
 Sørensen, C.—Denmark, 13
 Soria, Inspector of Mines of.—Spain, 28
 Sorokin, Catherine.—Russia, 69
 Sorzano, Manuel.—Trinidad
 Soten, J.—Canada, 355
 Sotio.—Sardinia, 91
 Soual.—Algeria, 52
 Soubeyrand, L.—France, 1490
 Soucaert, see Couderc & Soucaert
 Souchay, see Schmuck, Souclay, & Co.
 Souche Paper Mills Co.—France, 377
 Souchon, J. M.—France, 1491
 Soucin, Corbet.—France, 1698
 Souffeto.—France, 1699. 1731
 Soulbj, J.—VIII. 110
 Soten.—United States, 342
 Soules, Mme. Hyppolite.—France, 1492
 Sounes, J.—XXX. (Fine Art Ct.), 277
 Sounes, W.—XXX. 359
 Sourd, A.—France, 1493
 Sousa, see Pinto e Sousa
 Souter, W.—XXII. 354
 South Australian Co.—South Australia, 1
 South Carolina Railroad Co.—United States, 170B
 Southall & Co.—xxvi. 342
 Southall, W.—x. 469
 Southey & Co.—xvi. 51
 Southorn, W. & Co.—xxv. 29
 Soutter, G.—Switzerland, 51

- Souvras, *see* Bonfla, Michel & Co.
 Souza, J. B. de.—Portugal, 1112, 1113
 Sowden, M.—I. 171
 Sowerby, *see* Williams & Sowerby
 Sowerby & Castle.—XXVI. 192
 Suwrel, A.—United States, 448
 Soxhlet, R. *see* Soxhlet, H. F. & E.
 Soxhlet, H. F. & E.—Austria, 194
 Soyer, A. *see* Warriner, G. & Co.
 Spalding, J.—x. 561
 Spalinger, J.—Switzerland, 253
 Spangberg & Co.—Sweden and Norway, 11
 Spangenberg, Sauer, & Sturm.—Zollverein (1), 477
 Spanna, J. & Co.—Sardinia, 88
 Spaurath, F. X.—Austria, 273
 Sparks, W.—VIII. 17, 136
 Sparks, J.—XXII. 430
 Sparks J. & Co.—x. 591
 Sparks, W.—I. 154
 Sparrow C.—XXIII. 2
 Sparrow, R.—VIII. 313
 Spaulding, J.—United States, 313
 Spear, *see* Hall & Spear
 Spear & Jackson.—XXII. 113
 Speleli, P.—Sardinia, 71
 Speller, W.—VI. 330
 Spelluzai—Austria, 638A
 Spence, *see* Blundell, Spence, & Co.
 Spence, P.—II. 7
 Spenceley, J.—VIII. 117
 Spencer, E.—VIII. 11
 Spencer, J. A.—II. 31
 Spencer, J. & Son.—XI. 52
 Spencer & Son.—v. 555
 Spencer, T.—v. 555A; XXIX. 222
 Spendeck, P. & Co.—Zollv. (1) 424
 Spengler, C.—Zollverein (3), 117
 Sperry, H.—United States, 345
 Spicer, Brothers.—XVII. 42
 Spiegel, W. A. C. & Co.—Lubeck, 8
 Spiegelhalter & Co.—Zollv. (1), 870
 Spiess & Son.—XVII. 203; XXVI. 70; XXX. (Sculpture Court) 361
 Spietschka, V.—Austria, 609
 Spietzloff.—Russia, 76
 Spiller J.—VI. 436
 Spink, *see* Shepherd, Hill, & Spink
 Spinn & Menke.—Zollverein (1), 838
 Spitalfields School of Design.—XIII. 37
 Spitalfields Patent Utrecht Co.—XIX. 265
 Splengler, H.—Switzerland, 181
 Spoerlin & Zimmermann.—Austria, 651
 Spohr.—Austria, 371
 Spooner, A.—Canada, 163
 Spratt, I.—XXIX. 121.
 Spratt, J.—United States, 5.
 Spratt, W. H.—x. 612
 Sprecher & Baer.—Switzerland, 103
 Sprengel, Dr. C. & Co.—Zollv. (1) 67
 Springer, J. J.—Switzerland, 138
 Springfield, W.—XXVIII. 138
 Sprot, M. & T.—Western end, North enclosure (outside), 69; XXVII. 98
 Spur, G.—III. 58
 Spurden, Woolley, Saunders, & Co.—xx. 14
 Spurgin, J.—VII. 70; IX. 259
 Spurgin, T.—II. 38; x. 542
 Spური, E. C.—XXIX. 126
 Spurrier.—XXIII. 28
 Spurier, C.—XXVI. 76
 Spyvee & Coopers.—XIV. 62
 Squair, R.—Canada, 51
 Squire, C.—VI. 467; XXVI. 273
 Squire, J. & Co.—v. 706.
 Squire, J. & W.—I. 74.
 Squite, P.—II. 93.
 Squire, R.—XXII. 451
 Squire & Co.—vi. 449
 Squire, T.—xvi. 2.
 Squire, W., *see* Squire, J. & W.
 Squires & Sons.—I. 117
 Squires, W.—VIII. 287; IX. 144
 Srba, A.—Austria, 355
 Stab, C. G. sen.—Zollverein, (1), 228
 Stabb, Ewen.—Newfoundland, 1
 Stadion, Count.—Austria, 123
 Staeheli-Wild, C.—Switzerland, 208
 Staehelin, B. di B.—Switzerland, 152
 Staehelin, *see* Waldner & Staehelin
 Staffel, I. A.—Russia, 148
 Stafford, Mrs. B. A.—Jersey & Guernsey, 49
 Stafford, D.—VII. 189
 Stafford, J. R.—United States, 29
 Stahlberg.—Sweden, 84
 Staigt & Sons.—vi. 455; XXIX. 252
 Staigt, T.—IV. 109
 Stainburn & Baugh.—xx. 58
 Staines, E.—VIII. 268
 Stainier, S.—Belgium, 428
 Stalon, J.—XXX. (Fine Art Court) 108
 Stam, F.—Netherlands, 73
 Stamin & Co.—France, 1021
 Stampfer, Professor—Austria, 130
 Stancomb, J., jun., *see* Stancomb, W. & J., junrs.
 Stancomb & Son.—XII. & xv. 16
 Stancomb, W. & J., junrs.—XXI. & xv. 17
 Standen & Co.—XII. & xv. 221
 Staudidge, Harriett, & Co.—XXX. (Fine Art Court), 37
 Staudiah, Anne.—xx. 106
 Standish & Noble—Eastern End, 101; China
 Standon, Ann.—xx. 213
 Standing, J. & Brother.—XXIX. 239
 Stanhope Limestone Quarries.—I. 204
 Stanforth, *see* Padley, Parkin, & Co.
 Stanforth, T.—XXII. 214
 Stanley, *see* Holbrook & Stanley
 Stanley, C.—xvi. 208; XXII. 551
 Stanley, W. P.—IX. 1
 Stanton, *see* Macy, Stanton & Co.
 Stanton, D.—United States, 367
 Stanton Institute for the Blind (Virginia).—United States, 270
 Stanton, Mary.—XXIX. 83
 Stanton, R.—v. 661
 Stanton & Son.—XII. & xv. 224
 Stapfer, Hugi, & Co.—Switzerland, 153
 Stapfer-Kolla.—Switzerland, 153
 Stapfer, Sons.—Switzerland, 153
 Staple, T.—I. 181
 Star, E.—United States, 194
 Starluck, N. B., United States, 91
 Starikoff.—Russia, 313
 Stark, R. M.—x. 284
 Starke & Co.—Canada, 191
 Starke, M.—Austria, 130
 Starkey, A. *see* Starkey, J. & A.
 Starkey, J. & A.—XII. & xv. 121
 Starkey, T.—IX. 43; XXVI. 26
 Starling, Mary Anne.—XIX. 86
 Starr, C.—United States, 68, 89
 Startchikoff, N.—Russia, 321
 Statham, *see* Yardley & Statham
 Statham, W. E.—x. 456
 Staub, Brothers.—Switzerland, 15
 Staudinger, A.—Austria, 640
 Staus & Leuschner.—Zollverein (3), 99
 Staveley, T. K., late R. E.—xxx. 263
 Stead, *see* McAlpine, Stead & Co.
 Stead, W.—Jersey & Guernsey, 21
 Seal, W. & Co.—XII. & xv. 57
 Steane, J. B.—VI. 70
 Stears, S.—XXIX. 132
 Stelbing, J. R.—x. 175
 Stelman, C.—XXVI. 316
 Steelman, *see* Kneuer & Steelman
 Steelman & Co.—XXX. 363
 Steermann & Co.—XIX. 41
 Steel, *see* Myerscough, Steel & Co.; Robertson, Carr & Steel
 Steele, A.—Mauritius, 4
 Steele, M.—British Guiana, 154, 155n
 Steele, P. *see* Steele, W. & P.
 Steele, W. & P.—XXII. 60
 Steer & Webster.—XXII. 124
 Steers, E.—United States, 290
 Steevens, W. D.—IX. 38
 Stevens, J.—XXVI. 124
 Steinhilber, W.—Sardinia, 86
 Steffens, P.—Austria, 232
 Stehle, J.—Austria, 154
 Steiger, G.—Austria, 374
 Steigerhall, *see* Zollmann & Steigerhall
 Stein & Schroeder.—Zollverein (5), 81
 Steinbach, *see* Blech, Steinlach, & Mantz
 Steinbach, J. J.—France, 362
 Steinböck, A.—Austria, 103
 Steiner, C.—France, 383
 Steiner, G. & Sons.—Austria, 87
 Steiner, T. & Co.—XVIII. 37
 Steinhauer & Bier.—Zollverein (1), 410
 Steinhauer, *see* Faust & Steinhauer; Kupfer & Steinhauer; Schnorr & Steinhauer.
 Steinhauer, H.—Zollverein (2), 44
 Steinhilber, Dr.—Austria, 135.
 Steinkellner, C.—Austria, 164
 Steinlin, F.—Switzerland, 183
 Stenborg, G.—Sweden, 91
 Stenhouse, A.—III. 154
 Stenstrom, P. A.—Sweden, 53
 Stent, W.—IX. 18
 Stenphar, A. & Co.—Zollverein (1), 159
 Stephanek, F.—Austria, 231
 Stephens, E. B.—Page 853; xxx. (Sculpture Court) 36
 Stephens, H.—II. 74; United States, 392
 Stephens, J. P. & Co.—XIV. 73
 Stephenson, *see* Lockerby & Stephenson
 Stephenson, Blake, & Co.—XVII. 182
 Stephenson, P.—United States, 467 (Main Avenue, East)
 Stephenson, R.—VII. 106; (Main Avenue, West), x. 674a; United States, 548
 Stepounin, A. *see* Zouhoof, D. & A.
 Stepounin.
 Stern, A.—Switzerland, 57
 Stenberger, L.—Belgium, 180
 Sternickel & Guelcher.—Zollv. (1), 376
 Stetter, C. G.—Zollverein, (1), 304
 Stevens & Co.—United States, 473
 Stevens, G. H.—XXX. (Fine Art Ct.), 158
 Stevens, H. R.—XXII. 7
 Stevens, J.—v. 572; XXVIII. 198
 Stevens, J. L.—v. 136
 Stevens, R.—III. 91
 Stevens & Son.—v. 600
 Stevens & Sons.—XXVII. 24
 Stevens, W.—IV. 3
 Stevenson, *see* Oswald, Stevenson, & Co.
 Stevenson, Alan.—VII. 99
 Stevenson, D.—XXIX. 23
 Stevenson, J. C.—II. 122
 Stevenson, J. & J.—XXVIII. 152
 Stevenson, Robert, (the late) VII. 99
 Stevenson, T.—VII. 99, 100; VIII. 304
 Stevenson, W.—II. 20
 Stewart.—Canada, 333A; *see* also Murrell, Stewart, & Co.
 Stewart, C.—v. 512; XXII. 46

- Stewart, C. & Co.—IX. 213; XXI. 21
 Stewart & Co.—United States, 393
 Stewart, D. Y. & Co.—VI. 233
 Stewart, Jane.—XX. 177A
 Stewart, R.—XII. & XV. 208
 Stewart, W.—XXVII. 33; Canada, 134
 Stiaany, W.—Austria, 377
 Stick, see Jenkins & Stick
 Stidolph.—XVII. 19
 Stief & Harrass—Zollverein (1), 161
 Stierhofer, A.—Austria, 557
 Stierl, J. jun.—Austria, 558
 Still, C. S.—XXVIII. 145
 Stille, A.—Sweden and Norway, 12A
 Stillér & Son.—Zollverein (1), 127
 Stillwell & Son.—XIII. 7
 Stimpson G. jun.—United States, 461
 Stilmus, H. A.—Zollverein (1), 448
 Stirk, J.—XXII. 74
 Stirling, C. M.—XXIX. 57
 Stirling, Elizabeth.—XXX. (Fine Art Court), 186
 Stirling, J. jun.—Western end, South enclosure (outside), 9
 Stirling, Mary Ann.—XIX. 26
 Stirling, Morris J. D.—I. 428; (Main Avenue, East)
 Stirling & Sons.—XVIII. 56
 Stirling, T. jun.—I. 209
 Stirling, T. sen.—XXVII. 120; XXIX. 315
 Stirling, W.—XVII. 118
 Stivens & Sons.—XXIX. 35
 Stublaers.—Belgium, 60
 Stobers, T. T.—Zollverein (2), 16
 Stobwasser & Co.—Zollverein (1), 199
 Stocken, C.—XXIII. 81; XXVI. 200; XXIX. 43
 Stocker.—XXII. 14
 Stocker, G. see Stocker, S. & G.
 Stocker, N. B.—XXX. (Fine Art Court), 270
 Stocker, S. & G.—V. 422
 Stockill, W.—XVI. 17
 Stockman, W. & Co.—Zollv. (1), 788
 Stocks, M.—I. 188
 Stodart & Son.—X. 470
 Stoebér, J. J.—Zollverein (2), 16
 Stoebér & Sons.—Zollverein (2), 7
 Stoehrer, K.—Zollverein (3), 15
 Stoelzel, G. F. & Son.—Zollverein (3), 66
 Stoetner, C. F. & Co.—Switzerland, 254
 Stoffregin, see Meinhold & Stoffregin
 Stollman & Wustenfeld.—Zollverein (1), 460
 Stöhr, F.—Austria, 160
 Stohrer, T. F.—Zollverein (4), 60
 Stoker, J.—X. 204; XVI. 103
 Stokes, J. C.—XXII. 252
 Stokes, H.—XVII. 80
 Stokes, S.—XIX. 307
 Stokes, W.—IX. 255
 Stolberg-Wernigerod.—Zollverein (1), 779
 Stoll, C.—Zollverein (4), 85
 Stolle, C.—Lubeck, 9
 Stollz, Dr. K.—Zollverein (1), 65. 895
 Stöltz, see Matagrin, Stultz, & Co.
 Stoltze.—France, 1494
 Stolsenberg, J.—Mecklenburg-Schwerin, 1
 Stone, see Haling, Pearse, Stone & Hill & Stone; Lawrence, Stone & Co.; Walters & Stone
 Stone, J. & Co.—Austria, 80
 Stone & Kemp.—XIII. 18; XVIII. 9
 Stone & Son.—XXIII. 123
 Stopher, T.—XXVI. 66
 Stoquart, Brothers.—Belgium, 307
 Storer, J.—X. 529
 Storey, W.—VI. 206
 Stark, P.—Zollverein (1), 511
 Starr & Mortimer, see Hunt & Roskell
 Stave, V.—Zollverein (4), 19
 Stobert, H.—V. 403A
 Sutherland, Rayno, & Pitt.—V. 403
 Stobert, Slaughter, & Co.—V. 4
 Stothmann & Wustenfeld.—Zollverein (1), 460
 Stotzer, F.—Switzerland, 63
 Stow, Brothers.—XII. & XV. 35
 Stowe, H.—IV. 10
 Stowell & Sugden.—XII. & XV. 496
 Stoy, H.—V. 705
 Strachey, Lieut.—India, IV.
 Straelen, Malame Van.—Belgium, 327
 Straff, see Dietrich & Straff
 Stralhan, R.—Van Diemen's Land, 17
 Strahl, O.—Zollverein (1), 206
 Straight, T.—IV. 109
 Straith, Major H.—Western Africa, 18
 Straker, S.—VI. 142
 Strakosch, S. & Son.—Austria, 233
 Strange, W.—III. 83
 Strangways, J.—XVII. 204
 Straumann, see Wescher & Straumann
 Stratingh & Co.—Netherlands, 3
 Stratton, W. J.—United States, 182
 Strauch, F.—Zollverein (5), 33
 Strauss.—Austria, 371
 Strauss, E. W.—Zollverein (3), 38
 Strauss, J.—Sardinia, 60
 Street, see Ward, Street, & Co.
 Strazza, G.—Austria, 713
 Strickland, Maria.—XXIX. 63
 Strickland, Mrs.—XXVI. 238
 Strines Printing Co. the (Manchester),—XVIII. 28
 Strode, W.—XXII. 443
 Strong, see Griffiths & Strong
 Strongtharm, see Longman, late Strongtharm
 Strube & Son.—Zollverein (3), 33
 Strudwick, T.—XXIX. 42
 Struëckelberger, see Sulgar & Struëckelberger.
 Strugnell, H.—XXVI. 343; XXVIII. 174
 Strunz, J. Widow.—Austria, 477
 Struth, V., sen.—Zollverein (6), 30
 Struthers, W. S.—Western end, South enclosure (outside), 16
 Strutt.—XIX. 336; XXII. 668
 Strutt, W.—Van Diemen's Land, 232
 Struve & Co.—II. 52A
 Stuart, J.—IX. 268
 Stuart & Smith.—XXII. 102
 Stuart, W.—VII. 28 (Main Avenue, West); XXVII. 55
 Stubbs & Bacye.—Belgium, 97
 Stubbs, P.—XIII. 43
 Stubecks, M.—Sweden, 112
 Stubgen & Kleemann.—Zollv. (1), 776
 Stube, P.—XXI. 39.
 Stuckey, W.—VII. 193
 Stuckhart, J.—Austria, 559
 Stumpf.—Russia, 181
 Stunzi and Sons.—Switzerland, 153
 Sturdee, A. B.—VIII. 337.
 Sturdy and Turner.—XIII. 79
 Sturge, J. E.—II. 119.
 Sturgeon, Harriett.—XXIX. 53
 Sturges, J.—II. 88.
 Sturges, R. F.—XXII. 341
 Sturm, see Spanger, Sauer, & Co.
 Sturm, P. H.—France, 384
 Sturmy, Maria.—XIX. 90.
 Sturrock, J.—X. 724
 Sturzenegger-Nef, L.—Switzerland, 139
 Stutchbury, J. S.—British Guiana, 23.
 28. 30. 39. 45. 46. 52. 53. 59-61.
 63. 65. 66. 70. 85A. 117a-117c, 118, 118A. 126. 127. 138. 139.
 Stutterd, J.—XXII. 545
 Styles, T.—III. 157
 Suabarra, Marquis de—Portugal, 23
 Suchard, F.—Switzerland, 2
 Suchel, J. D.—France, 1700
 Sudworth, J.—XI. 42
 Suermond Brothers.—Belgium, 505
 Sues, A. H.—Austria, 325
 Sues, W.—Zollverein (1), 482
 Sugden, Burras, and Co.—XXIX. 62
 Sugden, J. and Brothers.—XII. & XV. 167
 Sugler, see Stowell & Sugden.
 Sulgar & Stueckelberger.—Switzerland, 152
 Sullivan, see McGivan & Sullivan
 Sullivan, T.—VI. 156
 Sulzberger & Ackermann.—Switzerland, 234
 Sulzer, G.—Switzerland, 186
 Sulzer, H.—Switzerland, 187
 Summerfeld, see Lloyd & Summerfeld
 Summerley.—XXIII. 110
 Summers, C.—XXX. (Sculpture Ct.), 32
 Sumpton, J.—V. 445
 Suremann & Co.—Switzerland, 153
 Surmon and Co.—V. 65
 Surr & Son.—XIX. 80
 Susee, H.—France, 1022
 Susee, Brothers.—France, 1023
 Sussmann, L.—Zollverein (1), 305
 Sussmann & Wiesenthal.—Zollverein (1) 132
 Sutcliffe, J.—XXVI. 137
 Sutcliffe, J. C.—I. 413
 Sutcliffe, R.—VI. 42
 Suter, see Seun, H. A. & Suter
 Sutherland, Duchess of.—XXVI. 164; Western Africa, 10
 Sutherland J.—South Africa, 30A
 Sutherland, Janet.—XIX. 309
 Sutorius, C. F.—Zollverein (4), 100
 Sutter, J. J.—Switzerland, 203
 Sutton, see Schilling & Sutton
 Sutton, Eliza.—XIX. 308.
 Sutton, H.—XXX. (Fine Art Court), 105
 Sutton, J. & Sons.—III. 112
 Sutton, J. A.—United States, 430
 Svalling, F.—Sweden and Norway, 11
 Swaab, S. L.—Netherlands, 50
 Swain, T.—V. 976; XXX. (Fine Art Court), 176
 Swaine & Adeney.—XVI. 92
 Swaine, E., see Swaine, J. & Co.
 Swaine, J. & K. & Co.—XII. & XV. 41
 Swainson & Denny.—XVIII. 21
 Swaisland, C.—XII. & XV. 283
 Swales, see Haulton & Swales
 Swallow, J. C.—VIII. 308
 Swan & Edgar.—XIII. 11; XVIII. 9
 Swan, R. F.—IX. 80
 Swan, T. F.—XVII. 155
 Swansea Committee.—I. 473
 Swanwick & Johnson.—XVIII. 35
 Swansy, A.—Western Africa, 23
 Sweden, the King of.—Sweden, 51
 Swedish Iron Manufacturing Co.—United States, 320c
 Sweetman, J.—I. 40
 Sweveghem, Embroidery workshop of.—Belgium, 323
 Swinborne, G. see Swinborne T. C. & G. & Co.
 Swinborne, T. C. & G. & Co.—IV. 119
 Swinburne, R. W.—XXIV. 4

- ish Guiana, 25.
52, 53, 59-61.
17a-117c, 118,
139.
- Portugal, 23
nd, 2
1700
- elgium, 505
325
(1), 482
-XXIX. 82
-XII. & xv.
- ugden.
rger. — Switzer-
& Sullivan
—Switzerland,
1, 186
1, 187
& Summerfield
0
ulpture Ct.), 32
erland, 153
2
e, 1023
iu (1), 305
— Zollverein
7
& Suter
f.—XXVI. 164;
frica, 39A
k. 309
rein (4), 100
nd, 203
Stutton
8.
ne Art Court),
112
States, 430
nd Norway, 11
uis, 50
XX. (Fine Art
r 92
J. & Co.
-XII. & xv. 41
VIII. 21
v. 283
swales,
08
11; XVIII. 9
473
XVIII. 35
frica, 23
Sweden, 51
cturing Co.—
orkshop of.—
ome T. C. & G.
& Co.—IV. 119
v. 4
- Swinburne, R. W. & Co.—XXIV. 84
Swissbank, J.—x. 371
Swiss Manufacturers of Silk Ribbons.—
Switzerland, 192
Sybilla.—Rome, 48
Sykes, Lieut. Col.—India, xxvi.
Sykes, D. & Co.—XII. & xv. 75
Sykes and Ogden.—XII. & xv. 116
Sykes, Mary E.—xx. 43
Sykes & Brothers—vi. 3
Sykes & Son.—XII. & xv. 34
Sylvester.—XXII. 102
Symes, W.—XXII. 23.
Symington, R. B. & Co.—xi. 14
Symington, W.—VIII. 286
Symonds, K.—Van Diemen's Land,
243-253, 274-278
Szeffold, S.—xix. 308
Segó, S.—Austria, 10
Szentpetyri, J.—Austria, 729
Soellnas, C.—Austria, 13
Saumrak, J. F.—Austria, 4
- Tabor, J. A.—v. 681
Taborin, P. F.—France, 1024
Tabourdeau, P.—France, 1496
Tachis, P. A., & Co.—Zollverein (5),
21
Tachy, A., & Co.—France, 1497
Tack, W., & Peliascus.—Zollverein (1),
674
Tafinder.—x. 54
Tahau, A.—France, 1556
Tailbois, E.—France, 385
Tailbois, Verdier, & Co.—France, 1025
Taily, C. V.—Canada, 30
Taily, V. P.—Canada, 50
Tailfer, J. B.—France, 1026
Teiffler, J. B., & Co.—France, 386
Tallautier, L. H.—France, 387
Tallard, E. A., Brothers.—Switzerland,
267
Talliet, V.—Belgium, 254
Tait, see Harveys & Tait
Tait, W. J.—xvii. 185
Talatol, L. & Co.—France, 1027
Talavera & Escaray, Manufacturing
Co. of the Guilde—Spain, 219
Talbot, B.—xxx. 349
Talbot, Brothers.—France, 1028
Talbot de Malahide, Lord.—I. 145
Tallerman, Rebecca & Son.—xxviii. 70
Talling.—I. 33
Tamasia, L.—Austria, 97
Tambour-Ledoyen.—France, 388
Tamm, Baron.—Sweden & Norway, 6
Tandler, S.—Austria, 657
Tann & Sons.—XXII. 597
Tannehill, see M'Alister & Tannehill.
Tanner, B.—Switzerland, 204
Tanner, C. D.—Hanover, 3
Tanner, J. U.—Switzerland, 205
Tanner & Koller.—Switzerland, 206
Tanner, T.—Zollverein (4), 51
Tanner, W.—x. 28; xxvi. 65
Tannett, see Smith, Beacock, & Co.
Tapiin, R.—v. 5
Tapping, Brothers.—United States, 520
Tapperell & Innes.—XVII. 191
Tarbut, W.—xxviii. 185
Tardif, E.—Belgium, 281
Tarin, M. L. A.—xix. 310; xxii. 544;
xxiv. 51
Tarragona, Board of Agriculture.—
Spain, 114
Tarragona Mines, Inspector of.—Spain, 2
Tarrant, A.—xvii. 43
Tartler, M.—Austria, 202
Tasch, see Hecker & Tasch
- Tasler, H.—XXII. 205
Tasler, J.—XXII. 221
Tasler, W.—XXII. 579
Tate.—xvii. 110
Tate, F.—xxviii. 162
Tatham, see Titley, Tatham, & Co.
Taubner, F.—Austria, 276
Tautenstein & Cordel.—France, 1029
Tauts, A.—Austria, 683
Tawell, S.—xix. 13
Tawton, Mary.—xix. 391
Taylor, E.—xix. 242
Taylor, see Davies & Taylor; Harrop,
Taylor, & Pearson; Sedgwick &
Taylor; Yates & Taylor
Taylor, A., see Taylor, C. & A.
Taylor, B.—xxviii. 47
Taylor & Beales.—xx. 197
Taylor & Bowley.—xvi. 181; (Main
Avenue, West)
Taylor, Brothers.—XXII. 211
Taylor, C. & A.—xxviii. 113
Taylor & Co.—xx. 127
Taylor, D.—xix. 254
Taylor, E.—vi. 72
Taylor, F.—viii. 197; xxx. (Sculpture
Court), 42
Taylor, G.—ix. 139; x. 127A
Taylor, G. R.—x. 740
Taylor, H.—vii. 194; xxii. 129
Taylor, Humphrey, & Co.—xxix. 5
Taylor, H. P., & W. C.—United
States, 292.
Taylor, J.—I. 201. 448; vi. 51; x.
350; xii. & xv. 68; xxii. 622. 662;
India, vi.; New Zealand, 11
Taylor, Janet.—VIII. 105
Taylor, John.—I. 474
Taylor, J. W.—vii. 215
Taylor, R.—I. 434, 451
Taylor, S.—xxii. 251
Taylor & Son.—III. 77; vi. 23; xii. &
xv. 111; xxii. 682 (North Tran-
sept); xxvi. 9
Taylor, J. & Sons.—XXII. 682 (South
Transept)
Taylor & Sons.—XII. & xv. 163
Taylor, T.—x. 466. 672; xvi. 269, 318
Taylor, T. E.—New Zealand, 33
Taylor, T. G.—xii. 45
Taylor, W.—vi. 136. 214; xxii. 359
Taylor, W. C. see Taylor, H. P. & W. C.
Taylor, W. G.—xx. 3
Tcharti-Obdool-Ogih.—Russia, 186
Tchertchy of Beirut.—Turkey
Tchervikoff.—Russia, 187
Tchmiloff.—Russia, 188
Tchupiatoff, T.—Russia, 315
Teagle, R. & W.—Western end, South
enclosure (Outside), 3; vii. 217
Teagle, W. see Teagle, R. & W.
Teasdel, W.—vii. 44; viii. 136
Tebay, J.—v. 436
Tebbutt, W.—iv. 111
Tebbutt, C. P.—ix. 196
Technological Institute—Tuscany, 1. 98
Tedjoom-Beck-Melik-Shah-Nazaroff.—
Russia, 206
Tee & Son.—xiv. 37
Teget & Co.—Spain, 54
Teichman, C.—Zollverein (1), 693
Teil, Messrs.—India, xvi.
Teillard, C. M.—France, 1030
Teissier Du Cros.—France, 1031
Tellier.—France, 389
Temple, Emily.—XXIX. 61
Templeton, J. & Co.—xix. 315
Templetrine Industrial School.—xx.
177A
Temsounet, G., & Dartet.—Belgium, 394
- Tennant, J.—I. 14. 159. 516; xxvii.
37, 38
Tennant, M. B.—II. 101; v. 564
Tennants, C. & Co.—I. 71; II. 7
Tennent, Mrs. R. N.—xxx. (Fine Art
Court), 278
Tennison, Mrs. M. A.—xix. 313
Teongathasas, P.—Canada, 97
Ternero, J.—Spain, 61
Terrason de Moutleau, J. A.—France,
1498
Terrett, R.—v. 126
Terrier, J. & Co.—Franco, 1032
Torrin, J. E. & Co.—Belgium, 246-
250
Terry, R. & Son.—xxii. 691A
Teschemacher, E. F.—I. 41
Teschemacher & Kattenbusch.—Zoll-
verein (1), 492
Tessada, F.—Sardinia, 49
Tessler, C. L.—Zollverein (1), 41
Tessler, D. F.—Zollverein (1), 40
Tetta, F.—Malta, 33
Tetta, S.—Malta, 30
Tetty, Mrs.—xii. & xv. 172
Tetu, C. A.—Canada, 169
Tettard, G.—Austria, 195
Teubner, G.—Zollverein (3), 150A
Teubner & Co.—Zollverein (3), 163
Teufmayer, C.—Austria, 494
Teufmeyer, J.—Austria, 564
Teutenberg, L.—Zollverein (1), 678
Tew, H. S.—United States, 3207
Texier, T. jun.—France, 1033
Texier, V.—France, 1034
Thackeray, J. & Son.—Belgium, 318.
Thackeray, J. & Sons.—xi. 27
Thaer, A. P.—Zollverein (1), 23
Thalwitzer, M.—South Africa, 3. 27
Thames Plate-Glass Works.—xxvi. 399.
(Main Avenue, West)
Thames Royal Yacht Club.—VIII.
294
Thatcher, see Learned & Thatcher
Thayer, E. B.—United States, 422
Theod. W.—xxx. (Sculpture Court),
13, 69. 79
Theil, J.—France, 1035
Theiss, S.—Austria, 152A
Théodat.—vii. 13
Theobald, J.—vii. 147
Theodor, see Bauer, Theodor, & Co.
Theor'orehalle, Salt Works at.—Zoll-
verein (3), 5
Thesen, J. P.—Sweden & Norway, 44
Theret, J.—France, 1499
Theunissen, J.—Netherlands, 39
Theremet, Rafflu, & Roux.—France,
1500
Thevenot, Etienne.—France, 1036
Thewald, see Muelenbach & Thewald
Thiban-Accou.—Belgium, 220
Thibau, S.—Belgium, 292
Thibaud-Dallet, Emile.—France, 1501
Thibault Boileve, H.—France, 1502
Thibert & Adam.—France, 1037
Thibierge.—France, 695
Thiele, see John & Thiele
Thiele, jun.—Hamburg, 109
Thieme-Widmarkter and Puschel.—
Zollverein (3), 4
Thiemke, A. F.—Zollverein (1), 72
Thier.—France, 1505
Thierry, C. A.—France, 391
Thierry, J.—France, 1038
Thierry, Mieg.—France, 1506
Thinks, see Krumbholz & Thinks
Thiathetwayte, H. F.—I. 24
Thoenen, G.—Zollverein (4), 91
Thollou.—France, 1701

- Thom, J.—vi. 71.
 Thomas, Count—Portugal, 1251
 Thomas, *see* Cowell & Thomas
 Thomas, Brothers—France, 1040
 Thomas, C.—xvi. 76; Zollv. (1), 671
 Thomas, C. X.—France, 390
 Thomas, E.—vi. 206
 Thomas, H.—Zollverein (1), 57
 Thomas, J.—xxvi. 276; xxvii. 22; xxx. (Sculpture Court), 12
 Thomas, John.—Page 853; xxii. 237; xxvi. 252, 276; xxx. (Fine Art Court), 235A
 Thomas, J. E.—Page 853; xxx. (Sculpture Court), 7
 Thomas, J. T.—i. 419
 Thomas, L.—Austria, 196
 Thomas, R.—xxii. 358; xxvi. Bay 1. 22
 Thomas & Son.—xvi. 211
 Thomas & Son.—xvii. 44
 Thomas, W.—xii. & xv. 493; xxvi. 275
 Thomas, W. & Brothers.—xx. 46
 Thomason, *see* Hilliard & Thomason
 Thomeret, *see* Proutat, Mitrot, &c.
 Thompson—*see* Kitson, Thompson, &c.; Ratteray & Thompson
 Thompson, F.—xxii. 809
 Thompson, F., Jun.—vii. 112
 Thompson, F. H.—xxiii. 25
 Thompson, G.—ix. 105
 Thompson, H.—xxix. 209
 Thompson, H. A.—ix. 248n
 Thompson, J.—i. 72; viii. 136; x. 363
 Thompson, J. & Co.—xx. 192
 Thompson, J. B.—Persia, 3
 Thompson, J. T.—Bahamas
 Thompson, Miss.—Austria, 747
 Thompson, R.—United States, 26
 Thompson, S.—xvi. 139
 Thompson & Son.—xx. 62
 Thompson, S. L.—United States, 238
 Thompson, T.—viii. 66; Canada, 99
 Thompson, J. B.—Persia
 Thompson, T. H.—xxii. 705
 Thompson, T. J.—xxx. (Fine Art Court), 343
 Thompson, T. Perronet, M.P.—x. 525. 559
 Thompson, W.—vi. 503
 Thompson, W. M.—United States, 224
 Thompson & Worthy.—xxvi. 134
 Thompson, Rev. Z.—United States, 241
 Thoms, P. P.—China
 Thomson, M.—Denmark, 9
 Thomson, *see* Blackburn & Thomson; Laird & Thomson; Ross & Thomson
 Thomson, A.—x. 80
 Thomson, Brothers, & Son.—xviii. 25
 Thomson, G.—v. 974; South Africa, 15
 Thomson, H.—x. 590
 Thomson, *see* Gregory, Thomson, & Co.
 Thomson, J.—xxx. (Fine Art Court), 236; Van Diemen's Land, 344
 Thomson, J. & Son.—xi. 15
 Thomson, R. W.—v. 908
 Thomson, W.—vi. 430; xii. & xv. 229
 Thomson, Wood, & Co.—xxiv. 26
 Thomson, Younger, & Co.—vi. 623
 Thonet, J.—Belgium, 144
 Thonet, M.—Austria, 641
 Thoniet, L.—Belgium, 373
 Thorel, H.—France, 1041
 Thorn & Co.—xxvi. 1; xxviii. 86
 Thorn, F., *see* Thori, W. & F.
 Thorn, W. & F.—v. 979
 Thorne, W.—i, 475
 Thorneloe, C.—x. 43
 Thornycroft, G. B. & Co.—v. 636
 Thornycroft, Mrs.—xxv. 2
 Thornhill, J.—xxvii. 48
 Thornhill, W.—xxi. 2; xxiii. 49
 Thornthwaite.—*see* Horne, Thornthwaite, &c.
 Thornton.—v. 490
 Thornton, D.—ix. 211
 Thornton, Firth, & Ramsden.—xii. & xv. 32
 Thornton, Frances.—United States, 227
 Thornton & Sons.—v. 490
 Thornycroft, Mary, *see* Thornycroft, T. & Mary
 Thornycroft, T. & Mary.—xxx. (Sculpture Court), 34, 63; page 553
 Thoumlin, A.—France, 696
 Thouret, F. A.—France, 1702
 Threadwin, C. E.—xix. 55
 Threlkeld.—Canada, 168
 Thresher & Glenny.—xx. 79
 Threlcutt, C.—i. 94
 Throgmorton, Sir J.—xx. 166
 Throthem & Co.—xvii. 181
 Thrupp, C. J.—v. 982
 Thrupp, F.—xxx. (Sculpture Court), 39, 56, 58
 Thrupp, H. J.—xxii. 676
 Thümler & Toepfer.—Zollv. (3), 90
 Thueigen, F. T.—Zollverein (3), 32
 Thum, A.—Austria, 197
 Thun, Count F.—Austria, 67
 Tunberg, C.—Sweden & Norway, 11
 Turman, Piggott, & Co.—xx. 92
 Thurnschela, Count G. Von.—Austria, 419
 Thurneisen.—Switzerland, 182
 Thurston & Co.—xxvi. 17
 Thwaites, A. & R. & Co.—xxx. 105
 Thwaites, Mary.—xix. 317
 Thwaites, R., *see* Thwaites, A. & R. & Co.
 Thywissen Brothers.—Zollv. (1), 375
 Tial, J.—Austria, 307
 Tibbs.—Van Diemen's Land, 234
 Tiberghien, L. J.—Belgium, 491
 Tidcombe, G.—vi. 108
 Tidmarsh, R.—v. 707; xxix. 111
 Tiede, F.—Zollverein (1), 78
 Tielsch, Carl & Co.—Zollv. (1), 219
 Tiffe, A.—Austria, 692
 Tiffereau, T.—France, 1042
 Tifia, Government of.—Russia, 119
 Tilbury, J.—v. 984
 Tildesley—*see* Carpenter & Tildesley
 Till, *see* Bremner & Till
 Till & Son.—xxv. 20
 Tillaucourt, E. De.—France, 697
 Tilley & Co., *see* Shand & Mason
 Tilley, Lieut.—iv. 5a
 Tilling, E.—xxvi. 111
 Tillinghast, J. B.—United States, 27
 Tillman.—France, 698
 Timaeus, *see* Jorlan & Timaeus
 Timnius & Sons.—xxii. 312
 Tinsall, E. O. D. L.—xxii. 512
 Tintot, M.—Belgium, 152
 Tinsley, J., & Co.—xx. 122
 Tipler, T. W.—vii. 92
 Tippu, J.—xxii. 412
 Tipping & Lawden.—viii. 247
 Tisdale, E.—xvi. 88
 Tisserant, *see* Vincent & Tisserant
 Tite, W.—xxx. (Fine Art Court), 182
 Tittle, Tatham, & Walker.—xiv. 51
 Tittermore, G.—Canada, 36
 Titterton.—x. 727A
 Tiverton, G.—xxviii. 53
 Tizard, W. L.—vi. 630
 Tlumaac, Beetroot Sugar Manufactory.—Austria, 600
 Tolber, J.—Austria, 691
 Tobey, J. D.—xxiv. 81
 Tobias & Co.—x. 78
 Tobin.—xxx. (Fine Art Court), 171
 Tobit, J. H.—United States, 394
 Toby & Son.—ix. 210
 Tod, D.—x. 589
 Todd, C.—vii. 62
 Todd, J.—xvii. 119
 Todt, A.—Zollverein, (1), 171
 Toeper, *see* Thusermer & Toeper
 Tojal, Count de.—Portugal, 987A-989
 Tolan W.—i. 22
 Toledo, Royal Ordnance.—Spain, 266
 Tollenaers, Theresa.—Belgium, 330
 Tolle, G.—xx. 151
 Tolpitt, W. B.—x. 382
 Tolson & Sons.—xii. & xv. 116
 Tolstoy, Count.—Russia, 328
 Tomaculitz, J.—Austria, 475
 Tomalin, D.—xxvi. 176
 Tommasia, L.—Austria, 97
 Tombelle, L. B.—Belgium, 12
 Tombs, E.—xix. 297
 Tomkins, *see* Harris & Tomkins
 Tomlin & Co.—xxi. 38
 Tomlin, W.—xvi. 22
 Tomlinson, *see* Wood & Tomlinson
 Tomlinson, J.—xxvii. 79
 Tompson, L.—xxvii. 100
 Toms & Lacombe.—xxvi. 178
 Toms, G. H. & Co.—vi. 457; France, 1448
 Toms, J.—xxiv. 71
 Tomak, Imperial Works.—Russia, 18
 Tonge, Miss E.—xxvi. 128
 Tonkin, J.—xxii. 58
 Tonks, *see* Neal & Tonks
 Tonks & Son.—xxii. 361
 Tomna, J.—Malta, 1
 Tonti, L.—Tuscany, 102
 Tootal & Browne.—Page 853; x. 706
 Tooth, E.—Van Diemen's Land, 47, 169, 171
 Toplia, *see* Buckland & Toplia
 Toplis & Sons.—xxviii. 154
 Toyp, A. L.—Denmark, 3
 Toypier, A.—Austria, 411
 Topping, C. M.—x. 667
 Tordeux.—France, 609
 Torge, M. J.—Portugal, 953
 Torres, M. M.—Spain, 67
 Torres Novas Spinning Co.—Portugal, 658-682
 Trostrup.—Sweden & Norway, 41, 46
 Touaillon, C.—France, 1508
 Touche, G. E.—Belgium, 434
 Touliakoff, Brothers.—Russia, 346
 Touza, F.—France, 1943
 Tourangeau, P.—Canada, 98
 Tourey, H.—Belgium, 155
 Tourey, Professor.—United States, 160
 Tournai Savonnerie, Royal Carpet Manufactory.—Belgium, 297
 Tonmeir.—France, 1509
 Toussaint, E. N.—France, 464
 Tovell, G. R.—viii. 37
 Tower of London.—viii. 271
 Towler, Campin, & Co.—xii. & xv. 286, 309
 Towler, E.—Western end, South enclosure (Outside), 27
 Towne, J.—x. 625
 Townsend, Brothers.—xii. & xv. 162
 Townsend, S.—xii. & xv. 175
 Townley, R.—xxiii. 125
 Townley, W.—vii. 39

- Towns & Packer.—x. 494.
 Towns, W.—x. 327.
 Townsend, G.—Western Africa, 11, 13
 Townsend, J.—VIII. 243
 Townsend, Parker, & Townsend.—XXVI.
 518
 Townsend, R.—i. 186
 Townsend, J. E.—XXVI. 2A
 Toser, T.—XXII. 390
 Trail, A.—VIII. 191
 Train, B.—Belgium, 167
 Traucart, A. A.—France, 398
 Traugott, see Krtel, Traugott, & Sons
 Traupell & Son.—XXVI. 312A
 Trapp, see Schwartz, Trapp, & Co.
 Trappmann & Spitz.—Zollv. (1), 564
 Traugott, Mende, & Sons.—Zollverein
 (1), 111
 Trautwein, T.—Zollverein (1), 158
 Travagliu, J. A.—Netherlands, 48
 Travancore, Rajah of.—India, iv.
 Travers, P. L.—France, 1044
 Treadwin, C. E.—xix. 55
 Trebeck, T. F.—xxix. 290
 Tredwin, R.—VIII. 55. 136
 Tree & Co.—x. 324
 Treese, T.—United States, 169
 Treggon, H. & W.—xxii. 55
 Treggon, W., see Treggon, H. & W.
 Tregina, R.—xxix. 185
 Treibmann, C. H.—Zollverein (3), 159.
 170
 Treloar, T.—xxviii. 39
 Treloar, Weldon, & Weil.—France, 700
 Tremaux, P.—France, 394
 Tremblay, A. du.—France, 395
 Tremel, A. & Co.—xii. & xv. 147
 Tremlett, R.—x. 163
 Trencard, T. J.—133A.
 Trendels & Son.—Zollverein (2), 41
 Trenholm, E.—Canada, 54
 Trenkler, A. & Sons.—Austria, 234
 Trenner, J.—Austria, 663
 Trenor, T.—Spain, 210
 Trent, E. W.—iv. 41
 Trentanove, A.—xxx. (Fine Art Court),
 351; Rome, 31, 52
 Trenton Iron Company.—United States.
 167
 Treptow Royal Remounting Depot
 (Pomerania)—Zollverein (1), 22
 Treschow.—Sweden & Norway, 36
 Treseoff, Heira of.—Russia, 74
 Trezize, T.—i. 464
 Treskof.—Russia, 43
 Tress & Co.—xx. 102
 Treveschick.—v. 513
 Triandaphyllos.—Greece, 59
 Tricot, Brothers.—France, 396
 Tricker, G.—United States, 577
 Triebert, F.—France, 1510
 Trigena, R.—VIII. 396
 Trinius & Sons.—Zollverein (3), 45
 Trinks, E.—Zollverein (3), 98
 Tritscheller, see Fallier & Tritscheller
 Trix, T.—ii. 125
 Troccon, A.—France, 1511
 Troeglen, G.—Zollverein (4), 91
 Troeltsch & Hanselmann.—Zollverein
 (2), 59
 Trollope, Rose.—xix. 320
 Trollope & Sons.—xxvi. 162; Bay, M.
 21
 Tronchon, N.—France, 1512
 Troost, F., see Troost, C. & F.
 Troostenberghe, Van.—Belgium, 264
 Trost, C. & F.—Zollverein (1), 601
 Trotman, J.—United States, 207
 Trotman, S.—VII. 153; x. 698; xxx.
 (Fine Art Court), 255
 Trotte, H.—France, 701
 Trotter, Capt. H. D.—Western Africa, 5
 Trotter, W.—ix. 145
 Troughton & Simms.—x. 74 (Main
 Avenue, West)
 Trouiller, J.—France, 466
 Troupeau, C. M.—France, 1703
 Trouppin, J. H. & J. P. Verriere.—Bel-
 gium, 128
 Trouve, A.—France, 1513
 Trouve-Cutivel, & Co.—France, 702
 Trobia, Royal Ordnance.—Spain, 280
 Truc.—France, 703
 Truchy, see Vaugeois & Truchy
 Truchy, K.—France, 1045
 Truesba y Campo.—Spain, 253a
 Trueftt, G.—xxx. (Fine Art Court), 75
 Trueftt, H. P.—xxviii. 62
 Trueftt, W.—xxviii. 65
 Truesdale, Jacobs, & Co.—United
 States, 494
 Trulock & Son.—VIII. 222
 Truman, E.—x. 720
 Truman, Hanbury, & Bunton.—ii. 91
 Trumpelmann, A.—Zollverein (1), 789
 Trundle, Mrs.—xxx. 73
 Truro Local Committee.—i. 467, 468;
 iii. 71
 Truscott, C.—i. 104
 Truscott, J.—VIII. 289
 Truter, H. A. O.—South Africa, 8
 Tschornner, J., jun.—Austria, 235
 Tschorn & Murgel.—Zollverein (1), 130
 Tsitsimbiakos, A.—Greece, 13
 Tubberer, see Longdon & Tubberer
 Tuck, J. H.—v. 200
 Tucker, E.—iv. 124; see Arlis &
 Tucker
 Tucker, E.—III. 122
 Tucker, F. & Co.—xxii. 700; xxvi.
 536
 Tucker, J. T.—xxiii. 10
 Tucker, R. G.—III. 121
 Tucker, T.—xix. 1
 Tucker, T. & Co.—xiv. 73
 Tucker, W. H.—xxii. 668A.
 Tuckerman, E. G.—United States, 117,
 229, 333
 Tuckers, see Baker, Tuckers, & Co.
 Tuckey, R.—VII. 101
 Tulela, Economical Society of.—Spain,
 227
 Tudot.—France, 397
 Tulsbury, R.—x. 704
 Tuerlinckx, J.—Rome, 456 (Main Ave-
 nue, East)
 Tull, see Hickey & Tull
 Tull, S.—xiv. 69
 Tullock, A.—ii. 21
 Tullock, J.—xxvii. 17
 Tulon.—France, 398
 Tunaberg Cobalt Works.—Sweden &
 Norway, 9
 Tunis, His Highness Musahir Pacha, Bey
 of.—Tunis
 Tunstall & Williams.—v. 1000
 Tuph, J.—United States, 383
 Tupling, J.—III. 20
 Tupper, M. F.—xvii. 169
 Tupper & Carr.—xxii. 550
 Turbeville, Smith, Boyle, & Co.—xx.
 318
 Turchini, L.—Tuscany, 55
 Turk, Widow.—Zollverein (1), 636
 Turley, R.—xxvi. 138
 Turnbull, E.—VIII. 154
 Turnbull, J., see Turnbull, J. L. & J.
 Turnbull, J. L. & J.—xvii. 45
 Turnbull, R.—VIII. 153
 Turnbull, T.—xxviii. 98
 Turnbull, W.—x. 500A
 Turnbull, J.—xxvi. 317
 Turner.—xii. & xv. 163; see also Han-
 mond, Turner, & Sons; Sturdy &
 Turner; Wyburn, Maller, & Turner
 Turner, Agnes.—xix. 322
 Turner & Co.—xxvi. 320
 Turner, K.—Western end, North side
 (Outside), 54
 Turner, R. R.—ix. 182
 Turner, E. W. K.—v. 428; xxii. 520
 Turner, G.—VIII. 136
 Turner, H. & W.—xxii. 174
 Turner, J.—xxvii. 82
 Turner, R.—VII. 7
 Turner, S.—i. 223
 Turner, T.—United States, 425
 Turner, T. & Co.—xxii. 117
 Turner, F., see Turner, H. & W.
 Turpin, F. A.—France, 1046
 Turritt, J.—xxix. 62
 Turton & Sons.—xxiii. 190
 Tuscany, Grand Duke of.—Tuscany,
 53, 54, 95, 111
 Tuscany Metallurgic Society.—Tus-
 cany, 14
 Tuscany Royal Manufactory.—Tus-
 cany, 111
 Tustian, J.—II. 97
 Tustian & Usher.—II. 98
 Tuttle, P.—Denmark, 28
 Tutton, J.—VII. 118
 Tuvee & Co.—France, 704
 Tuxford & Sons.—ix. 271
 Tweedale & Sons.—xii. & xv. 4
 Tweedale, Marquis of.—ix. 42
 Tweedale, N.—New South Wales
 Tweltdige, —xxx. (Fine Art Ct.), 102
 Twentyman, see Bemloch, Twentyman,
 & Co.
 Twibell, see Day & Twibell
 Twigg, G. & W.—xxii. 279
 Twigg, W., see Twigg, G. & W.
 Twining, —China
 Twyman, H.—VIII. 148
 Tye, G. P.—xxii. 314
 Tylden, Captain.—VIII. 275
 Tyler, see Venables, Wilson, & Co.
 Tyler, H. & Co.—vi. 605
 Tyler, J. E.—United States, 591
 Tyler, J. T., see Aslmade & Tyler
 Tyler, P. B.—United States, 597
 Tyler & Pace.—xxii. 63
 Tylor & Son.—vi. 606; xxii. 401
 Tyree, Brothers.—x. 299
 Tyrrel, Prof. J.—New Zealand, 1, 28
 Tyson, J.—ix. 215A
 Tytherleigh, W.—ix. 212
 Tyzack, W. V.—xvi. 264
 Tyzacks, J.—xxi. 22
 Tzitschke, J. T.—Zollverein (1), 238
 Ubardean, S.—Canada, 60
 Ubery, Str.—France, 1495
 Ubrici, R. W.—United States, 239
 Uddeholm's Co.—Sweden, 117
 Uechtrita & Faust.—Zollverein (4), 68
 Uechtrita, L.—Zollverein (1), 21
 Ueltschi, J.—Switzerland, 256
 Uhlhorn, C. & G.—Zollverein (1), 475
 Uhlhorn, H.—Zollverein (1), 476
 Uhlrig's Widow & Junker.—Zoll. (3),
 155
 Uhlman, see Baron & Uhlman
 Uhlman, K. W.—Netherlands, 85
 Uhlmann, see Koefter & Uhlmann
 Uhlmann, J.—Austria, 155
 Ullander, F.—Sweden & Norway, 11
 Ullahornes & Longstaffe.—xiv. 66

- Ullenberg & Schnitzler.—Zoll. (1), 355
 Ullersdorf Patent Flax Hailing Estab-
 lishment.—Austria, 96
 Ullmann, Hirschhorn, & Co.—Zoll. (3),
 60, 159
 Ullmer, R. & W.—vi. 121
 Ulrich, J.—Zollverein (1), 403
 Ulrich, A. Jun.—Austria, 336
 Ulvershon Mining Company.—i. 420
 Umlauf, Aug.—Hamburg, 85
 Underwood, see Hills & Underwood
 Underwood, G. H.—iii. 23
 Underwood, T.—vi. 103; xxx. (Fine
 Art Crt.) 77
 Underwood, W.—xii. & xv. 501;
 xviii. 22; xix. 403
 Unger, C. G.—Zollverein (3), 146
 Unger, C.—Zollverein, i. 241
 Unwin & Rogers.—xxii. 159
 Unwin, W.—xxii. 178
 Unwin, W. H.—xxx. (Fine Art Crt.), 22
 Unzeitig, F.—Austria, 501
 Unzelmann.—Zollverein (1), 148
 Uplegraff, Dr. J.—United States, 516
 Uphill, E.—ix. 277
 Upham, Appleton, & Co.—United States,
 403
 Uphill, Mary Ann.—xix. 323
 Uppfield, W.—United States, 470
 Urach, Linen Yarn, Manufactory of.—
 (Wurtemberg). Zollverein (4), 35
 Urban, A.—Zollverein (1), 724
 Uriling, G. F.—xix. 15
 Urimann, see Köster & Urimann
 Usher, see Tustan & Usher
 Usher, J.—ix. 123A
 Usher, R.—United States, 379
 Utsonou & Peters.—xxix. 172
 Utrecht Co., Patent.—ix. 265
 Uwins, T.—xxx. (Fine Art Court) 87

 Vaccani, see Nietzsche & Vaccani
 Vachon, Son, & Co.—France, 703
 Vaconius, J. J.—Zollverein (5), 15
 Vacosain, Bunet, & Fournier.—France,
 1082
 Valant, P. T.—1515
 Valdancot.—France, 1514
 Valletaro, J.—Sardinia, 81
 Valencia, Board of Agriculture.—Spain,
 173, 209
 Valensot, see Martel, Geoffray, & Co.
 Valentine, Dr.—Van Diemen's Land,
 182
 Valerio, G. C. & Brothers—Portugal,
 798-804
 Valerius, B.—Belgium, 172
 Valerius, P.—France, 706
 Valerius-Jouan, C.—Belgium, 452
 Vales, C.—France, 707
 Valgoma, F. A.—Spain, 99
 Valin, J.—France, 703
 Vallance, J.—xxvii. 40
 Vallance, P.—v. 127
 Valle, Della, Brothers.—Tuscany, 114
 Valmald, see Darvien, Valmald, & Co.
 Valtat & Emille.—France, 709
 Valpy, Mrs.—Jersey & Guernsey, 40
 Vancampenhoudt, C. & Co.—Belgium,
 436
 Van Diemen's Land Royal Society,
 Council of the.—Van Diemen's Land,
 345
 Vanden, Abele.—Belgium, 52
 Vanden Elst, F.—Belgium, 45
 Vandenbos-Poelman.—Belgium, 274
 Vanden Porre, J.—Belgium, 44
 Vandenbergh, J.—Belgium, 252
 Vandenbroucke, E.—France, 711
 Vanderdorpel & Son.—France, 712
 Vanderhaegen, Van Overloop.—Bel-
 gium, 312
 Vanderhechte.—Belgium, 475
 Vanderoamer, J.—Belgium, 355
 Vanderkelen, B.—Belgium, 313
 Vandermaelen, P.—Belgium, 437
 Vandermoesche, C.—Belgium, 468
 Vanderoost, M.—Belgium, 427
 Vandermissem, P.—Belgium, 315
 Vanderstraeten, A. & C.—Belgium, 205
 Vanderstraeten, F.—Belgium, 84
 Vandervin, F.—Belgium, 126
 Vangenechten, see Glendon & Co.
 Vangesteruyen, C.—Belgium, 459
 Vanhool, J. F.—Belgium, 454
 Vanhulle, H. J.—Belgium, 453
 Vanlucot, T.—Russia, 112, 113
 Vanner & Son.—xiii. 28
 Vanni, A.—Zollverein (5), 31
 Vannod, J.—Switzerland, 69
 Vanstraelen, J.—Belgium, 269
 Vantillart & Co.—France, 1517
 Vantroyen & Mallet.—France, 715
 Varen, A.—Russia, 352
 Vargomlin, Brothers.—Russia, 260, 302
 Varhovzoff, T.—Russia, 309
 Varley & Son.—x. 257
 Varnisi, E. & Co.—xxiv. 27
 Varrall, Middleton, & Elwell.—France,
 717
 Vasquez, V.—Spain, 133
 Vassel.—Russia, 122
 Vasse de St. Ouen.—France, 716
 Vassel & Co.—Zollverein (1), 186
 Vasselboro Manufacturing Company.—
 (Maine), United States, 324
 Vater, F.—Austria, 302
 Vatini, Jun. & Co.—France, 1704
 Vaucher, C.—Switzerland, 28
 Vaucher, Du Pasquier & Co.—Switzer-
 land, 36
 Vaucher-Picard.—France, 710
 Vangeols & Truchy.—France, 716
 Vaughan, G.—vi. 242
 Vaughan, G. H.—xxii. 619
 Vaughan, J.—xxvii. 20
 Vaughan, W.—vii. 139
 Vavasseur, see Carter, Vavasseur, & Co.
 Vas, A. P. F.—Portugal, 550
 Vasquez, J.—Spain, 133a
 Veale, see Willdowson & Veale
 Veichte, A.—xxiii. 97
 Veichte, Gaynard & Yon.—France, 745
 Vedrin, Société de (Namur)—Belgium,
 17
 Vedy, F.—France, 719
 Veevera, Mrs.—xix. 324
 Vegetable Kingdom, Sectional Com-
 mittee on.—iv. 40
 Vegni, Professor A.—Tuscany, 13
 Veiel & Co.—Zollverein (4), 45
 Veismiere, A.—France, 720
 Veitch, J.—x. 6
 Vellhagen, W. R.—Zollverein (1), 510
 Vellin, Brothers.—France, 721
 Vella, Paola, & Co.—Malta, 15
 Ven, P. C. Van der.—Netherlands, 44
 Venables, Wilson, & Tyler.—xvii.
 149
 Venator, see Longhaus & Venator
 Vennemann, see Lingerhank, & Co.
 Venner, J.—Canada, 327
 Ventujol & Chassang.—France, 1384
 Ventura, A. B.—x. 18
 Verbeeck, P. F.—Belgium, 113
 Verberck, H.—Belgium, 470
 Verbiest, E.—Belgium, 162
 Vercauteren, J. L.—Belgium, 82
 Vercruyse, Brothers.—Belgium, 91
 Vercruyse, F.—Belgium, 213
 Verden & Co.—Russia, 30
 Verdet & Co.—France, 1519
 Verlier, see Tallhoux, Verlier, & Co.
 Verdurs, B. C.—Belgium, 206
 Vere, H. H.—xxx. 31
 Veroin, Landwirtschaftlicher.—Zoll-
 verein (1), 790
 Verri, J.—Switzerland, 223
 Verge, A. sen.—France, 722
 Verhasselt, D'Oultrolepot, F.—Bel-
 gium, 179
 Verheilm, J.—Hamburg, 28
 Verhelst, F.—Belgium, 103
 Verheyden, E.—Belgium, 46
 Verhulst, C. & Co.—Belgium, 269
 Verhulst, De Konige, & Co.—Belgium,
 243
 Verkhne Barantchinsk, Imperial Iron
 Works of.—Russia, 11
 Verkhne Tourinsk, Imperial Iron Works
 of.—Russia, 12
 Vernon, see McNioball & Vernon
 Verinum, see Want & Verinum
 Verreyt, J.—Belgium, 290
 Verrier, F.—Algeria, 57
 Verriest, P.—Belgium, 214
 Verriinder, J.—xxvi. 217
 Verschaeve, L.—Belgium, 79
 Veronel, J. S.—Netherlands, 105
 Verstaen, L. N.—France, 1705
 Versteven, see Daura, Van, & Ver-
 steven
 Verstrate, Brothers.—France, 723
 Verstraten, E.—Belgium, 108
 Vertu, Brothers.—Sardinia, 28
 Veruiera, J. P. see Trouplin, J. H. & Co.
 Veruiera, Establishment of St. Joseph.—
 Belgium, 322
 Verza, Brothers (late Carlo Verza).—
 Austria, 87A
 Verza, Carlo, see Verza, Brothers
 Vesochitchikoff, M.—Russia, 173
 Vetter & Krno.—Zollverein (4), 74
 Vesey, E. see Vesey, H. & E.
 Vesey, R. & E.—v. 988
 Vesfel, see Stitange & Vesfel
 Vernon, Brothers.—France, 1520
 Viard, L.—France, 1521
 Viault-Eata.—France, 725
 Viberg, A. P.—Sweden & Norway, 14
 Viberi, S.—Jersey & Guernsey, 15
 Viccars, R.—xix. 235
 Vick, R.—xvi. 70, 267
 Vickersman & Beaumont.—xii. & xv.
 102
 Vickers, see Naylor, Vickers, & Co.;
 Simpson, Humphrey, & Co.
 Vickers, W.—xix. 33
 Vickers, W. R.—viii. 8
 Victoria Asylum for the Blind (New
 castle-upon-Tyne).—xix. 284
 Victoria Felt Carpet Co.—xix. 327
 Victory, J.—vi. 67
 Videcq & Simon.—France, 1706
 Vidal, R.—France, 727
 Vidie.—v. 160
 Vie, J.—France, 726
 Viehhauser, G.—Zollverein, 4, 103
 Viehofen Mirror Manufactory.—Aus-
 tria, 583
 Vieille Montagne Zinc Mining Co.,
 Liege.—i. 437 (Main Avenue, East);
 Belgium, 26; France, 1018
 Vieira, H. T.—Portugal, 1232
 Vieira, M. I.—Portugal, 1234, 1235
 Viel.—France, 1047
 Vielhoraky, Count M.—Russia, 44
 Vienna Depot of the Imperial Iron
 Mines and Iron Works.—Austria, 2,
 408

- Vienna Imperial Military Geographical Institute.—Austria, 363
 Vienna Imperial Polytechnic Institute Mechanical Department.—Austria, 130
 Vienna Imperial Porcelain Manufactory.—Austria, 615
 Vienna Imperial Printing Office.—Austria, 303
 Vienna Imperial Tobacco Manufactory.—Austria, 69
 Vienna Privileged Steam Flour Mill Company.—Austria, 62
 Vienna Stearine Candle Co. (Apollo Candle).—Austria, 39
 Vienna Stearine Candle Co. (Milly Candle).—Austria, 40
 Vieweg & Son.—Zollverein (1), 822
 Vioyres & Repeignon.—x. 91
 Vigers, E. jun.—xxvi. 382
 Vignat, Brothers.—France, 1524
 Vignaux, L. J.—Spain, 249A
 Vignoles, C.—vii. 105 (Main Avenue, West)
 Vigourens, S.—France, 728
 Viguier, B.—France, 729
 Vikoulin.—Russia, 141
 Vilardet & Callejas.—Spain, 258
 Villa, Fratelli.—Malta, 6
 Villa, J.—Tuscany, 107
 Villardel & Callejas.—Spain, 259
 Villars, J. B.—Spain, 162
 Villensena.—France, 1707
 Villeroi.—France, 1522
 Villeroy & Boel.—Zollverein (1), 361
 Villiers, P. J. De.—South Africa, 2
 Vilpelle, T.—France, 1523
 Vinas, A.—Spain, 160
 Vincent, *see* Frost, Noakes, & Co.
 Vincent, H. France, 1525
 Vincent, J.—France, 1526, 1527
 Vincent R.—xvi. 153; xx. 177
 Vincent, S.—xix. 328
 Vincent, T.—i. 465
 Vincent & Tisserant.—France, 730
 Vine & Ashmead.—United States, 196
 Vine, H.—xxx. (Fine Art Court), 249
 Vine, R.—xxix. 116
 Vingert, A.—Austria, 460
 Vlnu, T.—xxx. (Fine Art Court), 265
 Violard, G.—Belgium, 320; France, 731
 Violette, J. H. M.—France, 1528
 Virebent, Brothers.—France, 732
 Viry Brothers, *see* Martin, O. & Viry
 Vis, A.—Netherlands, 7
 Vischi, A. M. J.—xix. 47
 Visser, *see* Poortman & Visser
 Visser, E. E.—Netherlands, 17
 Visser & Co.—Netherlands, 15
 Visseur, P.—Zollverein (1), 358
 Visiere.—France, 733
 Vitalis, G.—Greece, 61
 Vitalis, L.—Greece, 60
 Vitros.—France, 1530
 Viullaume, J. B.—France, 735
 Vivat, B.—Austria, 598
 Vivet, E. T.—France, 734
 Vivian.—ix. 227
 Vivier & Co.—France, 1529
 Viçella Mills.—Portugal, 721
 Viçetelly & Branson.—xxiv. 29
 Vizianagum, Rajah of.—India, xxvi.
 Vladimirov.—Russia, 50
 Vlasky, J.—Austria, 141
 Vlisagen, Van, Van Heel, & Derosne Cail & Co.—Netherlands, 75
 Vloebergs.—Belgium, 36
 Voelck, J. G., & Co.—Zollv. (1), 91
 Vogel, A.—Switzerland, 226
 Vogel, C. F.—Austria, 739
 Vogel & Carner.—Zollverein (1), 711
 Vogel, F. W.—Zollverein (1), 671
 Vogel, M.—Zollverein (1), 148
 Vogel, M. A.—Zollverein (1), 148
 Vogel, W.—Zollverein (1), 89
 Vogelsang, J. & Sons.—Zollv. (5), 32
 Vogelsang, F. J.—Belgium, 181
 Vogt, M.—Zollverein (1), 148
 Voigt.—Denmark, 46
 Voigtlander, Erbes, & Co.—xxx. (Fine Art Court), 254
 Voith, A.—Austria, 560
 Voizat, E.—France, 1531
 Vokes, F.—xix. 329
 Vokins, C.—xxvii. 30
 Vokins, J. & W.—xxx. (Fine Art Court), 46
 Vokins, W., *see* Vokins, J. & W.
 Volbrecht, *see* Zahn & Volbrecht
 Volderauer, G.—Austria, 13
 Volkert.—France, 1532
 Volkonsky, Prince.—Russia, 109
 Volkman, J.—Austria, 190
 Volkonsky, Prince M.—Russia, 53A
 Volkonsky, Prince V.—Russia, 70
 Vollenhoven, C. J., Van.—Netherlands, 93
 Vollschwitz, *see* Daeloven & Vollschwitz
 Volner.—Russia, 160
 Voloskoff, A.—Russia, 317
 Voloskoff, J.—Russia, 316
 Volsteert, J. P.—South Africa, 6. 35
 Volterra Royal Salt Manufactory.—Tuscany, 2
 Vonwiller & Co.—Austria, 237. 292
 Vonwiller, U. de G.—Switzerland, 140
 Voort, Van, Dirk, & Son.—Netherlands, 14
 Voort, H., Van der.—Netherlands, 45
 Voortman, A.—Belgium, 294
 Vorster, C. D.—Zollverein (1), 446
 Vorua, J. S., sen.—France, 1533
 Voelan Worsted Yarn Spinning Company.—Austria, 198
 Voss, J.—i. 135
 Volkink, Imperial Iron-works of, (Viatska).—Russia, 13. 156
 Vreede & Co.—Netherlands, 33
 Vsevolodovitch, N.—Russia, 338
 Vsevolusky.—Russia, 330A
 Vuilleumier, R. de la.—Switzerland, 12
 Vuillamy, B. L.—x. 700
 Vyse & Sons.—xx. 11; Tuscany, 66
 Vyvens, E.—Belgium, 59
- WALDE, H. R. H. THE PRINCE OF.—Page 112
 Wächter, L.—Austria, 561
 Waddington & Sons.—xxix. 1. 4
 Wadsworth & Sheldon.—United States, 343
 Waechter, J.—Zollverein (1), 434
 Waentig, D. & Sons.—Zollv. (3), 53
 Wagenet, J. C. L.—Hamburg, 4
 Wagenmann, Seybel, & Co.—Austria, 19
 Wagner.—xxiii. 108; France, 736; *see* also Schill & Wagner
 Wagner, A.—Zollverein (1), 414
 Wagner, C.—Zollverein (4), 61
 Wagner, C. A.—Hanover, 7
 Wagner & Co.—Zollverein (1), 708; (2) 99
 Wagner & Son.—Zollverein (1), 316
 Wagner, F.—Austria, 437; Zollverein (4), 104
 Wagner, J. G. jun.—Zollv. (1), 156
 Wagner, J.—Zollverein (6), 52
 Wagner, J. & Son.—Zollverein (1), 840
 Wagner, Louisa & Marian.—xx. 31
 Wagner, Marian; *see* Wagner, Louisa
 Wagner, T.—Zollverein (4), 108
 Wahl, F.—Zollverein (1), 333
 Waillen & Schmidt.—Zollv. (1), 401
 Wahrendorf, M. Von, Baron, 52
 Waikato Coal Committee.—N. Zealand, 22
 Waller, W.—xxiv. 73
 Wall, J.—vi. 504
 Waite, G.—x. 441
 Wake, T. & Son.—viii. 136
 Wakefield, *see* Inglis & Wakefield
 Wakefield, F.—xxi. 381
 Wakefield, J. T.—xxii. 337
 Wakeling & Sons.—xxvi. 104
 Wal, K. B. Van der.—Netherlands, 94
 Walbrides, H.—United States, 186
 Walby, J.—vii. 148
 Wald & Son.—Zollverein (1), 96
 Waldburger & Langenegger.—Switzerland, 207
 Waldner & Stachelin.—Switzerland, 152
 Waldron, W. & Sons.—xxi. 17
 Waldhausen, Ed., *see* Siegfried & Waldhausen
 Waldhausen, O. W.—Zollv. (1), 320
 Walden, J.—Sweden and Norway, 11
 Wailes, J.—i. 431
 Walferman, *see* Huper & Walferman
 Walford, C., sen.—xxix. 207
 Walford, J.—xxix. 212
 Walford, H.—xviii. 19
 Walker.—France, 391; *see* also Titley, Tatham, & Co.; Wilson, Walker, & Co.
 Walker, A.—Van Diemen's Land, 195
 Walker Alkali Company (Newcastle-upon-Tyne).—ii. 15
 Walker, Babb, & Co.—xx. 63
 Walker & Burgess.—vii. 28; 224 (Main Avenue, West)
 Walker, C. V.—x. 430
 Walker, E.—vii. 119; xvi. 206; xxii. 29; xxx. (Fine Art Court), 60
 Walker, Edward, & Co.—United States, 123
 Walker, J.—x. 607; xxix. 318; xxx. (Fine Art Court) 102; Van Diemen's Land, 44. 49. 51
 Walker, J. & Co.—xii. & xv. 23
 Walker, J. & R.—xi. 3
 Walker, J. W.—x. 561
 Walker, R.—i. 120; viii. 242; *see* also Walker, J. & R.
 Walker, Sarah, & Co.—viii. 284
 Walker & Son.—xii. & xv. 79. 87
 Walker, T.—xxviii. 87
 Walker, W.—iii. 86; v. 693; xi. 46
 Walkers, G. J. & Gilder.—v. 989
 Walkinshaw, W.—China
 Wall, Cockshot, & Wall.—xii. & xv. 159
 Wall, E. & T.—xiv. 70
 Wall, T.—xxiii. 5; *see* also Wall, E. & T.
 Wallace, A.—Canada, 147
 Wallace, Elizabeth.—xxvi. 2
 Wallace, J. & Co.—xi. 59
 Wallace & Son.—xxii. 413
 Wallace, T.—xvi. 132
 Wallace, W. & Cowper, T.—i. 510
 Wallack, A.—Zollverein (1), 767
 Waller, *see* Burgun, Waller, Berger, & Co.
 Waller & Co.—Page 853
 Waller, F.—xxvi. 285

- Wallis, Capt. R.N.—Page 853
 Wallis, Count O. Von.—Austria, 93
 Wallis, S.—xxviii. 8
 Wallis, T. W.—xxx. (Fine Art Cr.), 89
 Walmsley, H.—xi. 51
 Walsh, *see* Jeffery, Walsh, & Co.
 Walsh & Co.—xx. 109
 Walsh, J., Executors of.—i. 183
 Walsh, W.—xvi. 207
 Walsh & Windley.—xi. 26
 Walshaw, J. & Sons.—xviii. 58
 Walter, F.—x. 41
 Walter, Hennig, & Co.—Zollv. (1), 714
 Walter & Son.—Zollverein (1), 782
 Walters, B. & P.—xxii. 670
 Walters, H.—viii. 34
 Walters, J. & Co.—xxii. 148
 Walters & Son.—xx. 54
 Walters & Sons.—xiii. 9
 Walters & Stone.—xxii. 296
 Waltham Abbey Mills.—ii. 21
 Walther, *see* Junge & Walther
 Walther, G.—Zollverein (3), 177
 Walton, *see* Hullmandel & Walt.n
 Walton, F.—xxii. 701
 Walton & Co.—xiv. 38; xxii. 69
 Walton, T.—xvii. 206
 Walton, W.—Page 851
 Walty, Brothers.—Switzerland, 141
 Walwein.—France, 737
 Wamosy, D.—Hamburgh, 19
 Wamp & Schroeder.—Zollv. (1), 239
 Wandersforde, Hon. C.—i. 111
 Wantless, T.—xxix. 266
 Wanloch Lead Mines (Dumfriesshire).
 —i. 25
 Wann, T. W.—xxvii. 84
 Wansborough, J.—xxviii. 75
 Want & Vermum.—v. 37
 Warburton, C.—xii. 187
 Ward.—viii. 340; xxvii. 23; *see also*
 Eyre, Ward, & Co.; Gill & Ward
 Ward (late Griffin & Ward).—xxvi.
 279
 Ward, Anne.—xix. 334
 Ward, C.—x. 527; Van Diemen's Land.
 —183. 186
 Ward, Sir H.—Ionian Islands, 6
 Ward, J.—ii. 89; v. 990. 997
 Ward, J. J.—United States, 172D
 Ward, J. W.—xii. & xv. 134; *see also*
 Ward, W. & J. W.
 Ward, M. & Co.—xxx. (Fine Art
 Court), 43
 Ward, N. B.—x. 661 (North Tran-
 sept)
 Ward & Payne.—xxii. 196
 Ward, Smith, & Co.—ii. 54
 Ward & Sons.—xx. 203
 Ward, Street, Sharp, & Ward.—xx. 195
 Ward, W. & J. W.—United States, 408
 Warden, A. J.—xiv. 63
 Warden, J. jun.—xxii. 368
 Wardle, H. T. & Co.—xiii. 41
 Wardle, M.—Canada, 104
 Wardle, S.—United States, 47
 Wardle, T.—*see* Wardle, H. T. & Co.
 Ware, *see* Bethel, Ware, & Co.
 Wareham Bituminous Shale Co.—i. 221
 Waring, C. H.—vi. 305
 Warlich's Patent Fuel Co.—i. 239
 Warlinek.—Austria, 116
 Warming, E.—Denmark, 7
 Warnout, V. E.—France, 1045
 Warnar, Willinek.—Netherlands, 32
 Warner, Capt.—viii. 317A
 Warner, H.—Trinidad
 Warner, J. & Sons.—v. 424; xxii. 798
 Warner, M. R.—xxvi. 72
 Warner, R. & Co.—United States, 431
 Warner, W.—xxix. 9; xxx. (Fine Art
 Court) 275
 Warners, *see* Cartwright & Warners
 Warowdell, L. J.—Sweden, 74. 114
 Warrack, Harriet.—xxvi. 102
 Warrell, J.—xxix. 32
 Warren, *see* Kirk & Warren
 Warren, G.—xxii. 402
 Warren, J.—ix. 257; xvii. 123
 Warren, P.—v. 558
 Warren, T.—xxvi. 288
 Warrick, Brothers.—xxix. 115
 Warriner, G.—xxii. 248
 Warriner, G. & A. Soyer.—iii. 21
 Warriner, W.—xxiii. 60
 Warwick & Otey.—United States, 325
 Washburn, Ann.—xix. 335
 Washburn, J. & Co.—United States, 421
 Washer, F. sen.—Belgium, 318
 Washington, Capt., R.N.—viii. 136
 Washington & Davies.—xiii. 8
 Wasley, J.—vi. 412
 Watson, R. (M.P.).—xvii. 188
 Wasserott, Staib.—Zoll. (4), 69
 Watchorn, W.—Van Diemen's Land,
 147
 Wateau, *see* Guilbert & Wateau
 Waterhouse, Emma & Maria, A.—xix.
 336
 Waterhouse, G. & S.—xxiii. 20
 Waterho, *see* J.—xviii. 72
 Waterhouse, Maria A. *see* Waterhouse,
 Emma, & c.
 Waterhouse, S., *see* Waterhouse, G. & S.
 Waterlow & Sons.—vi. 164; xvii. 46
 Watermeyer, C.—South Africa, 17. 51
 Waters, *see* Capper & Waters
 Waters, C. *see* Waters J. & C.
 Waters, J. & Co.—xi. 43
 Waterston, J. A.—xviii. 67
 Waterston, G.—xvii. 93
 Watherston & Brogden.—xxiii. 105
 Watkin, *see* Keep & Watkin
 Watkins, A.—x. 86A
 Watkins, Rev. C. F.—i. 28A
 Watkins, H.—xxx. (Fine Art Cr.), 187
 Watkins & Hill.—v. 56; viii. 238A;
 x. 659
 Watkins, T. *see* Watkins, W. & T.
 Watkins, W. & T.—vi. 66
 Watney, A.—i. 278
 Watrelot-Delespaul.—France, 738
 Watson, *see* Sandford, Owen, & c.
 Watson, A. *see* Watson, J. & A.
 Watson, Hell, & Co.—xix. 337, Persia
 Watson & Co.—xix. 337
 Watson, E. F.—xxx. (Fine Art Court),
 130
 Watson, G.—xxvi. 175.
 Watson, G. W.—United States, 53. 361
 Watson, H.—vi. 165; South Africa, 58
 Watson, J. & A.—xii. & xv. 477
 Watson, John.—Van Diemen's Land, 316
 Watson, M. L. (the late).—Page 818;
 xxx. (Sculpture Court), 60
 Watson, T.—v. 712; viii. 76; xx. 111
 Watson, W.—xvii. 210
 Watson, Young, & Co.—New South
 Wales, 16
 Watt, *see* Doulton & Watt
 Watt, G.—iii. 110
 Watt, G. T.—x. 717
 Watt, J.—ix. 63
 Watt, James, & Co.—v. 6
 Watt & Son.—iv. 120
 Watt, W.—ii. 32; vii. 20
 Watteyne, J.—Zollverein (3), 2
 Watts, *see* Whiteaway, Watts, & Co.;
 Burroughes & Watts
 Watts, C.—v. 991
 Watts & Harton.—xxii. 557
 Watts, J.—ii. 103
 Watts, R. M.—Canada, 38
 Watts, T.—v. 750
 Watts, W.—xx. 108
 Watts, W. M.—xvii. 164
 Waugh & Son.—xix. 339
 Wauw, T. W.—xxvii. 141
 Wautelet, J.—Belgium, 32
 Wayne North Scythe Company.—United
 States, 323
 Weaver, H.—x. 279
 Weare, R.—x. 386
 Weatherhead, H.—xx. 33
 Weatherly, H.—iii. 27; vi. 441
 Weatherly, *see* Wilkins & Weatherly
 Weatherly, E.—xxi. 1
 Webb, *see* Molincaux, Webb, & Co.
 Webb, Charles J.—Manritina, 3
 Webb, E.—xvi. 243; xvii. 172A
 Webb, J.—xxvi. 171
 Webb, J. & C.—i. 533
 Webb, Mr.—ii. 72
 Webb, R.—iii. 72
 Webb & Son.—xix. 150
 Webb, T.—xxiv. 17
 Webb, Captain T.—xx. 138
 Webb, W.—xvii. 156
 Webber & Bartlett.—xxx. (Fine Art
 Court), 153
 Webber & Hairs.—xii. & xv. 277
 Webber, J.—xxx. (Fine Art Cr.). 149
 Webendorffer, C. H. & Sons.—Zollvere-
 in (3), 72-83
 Webenörfer, Brothers.—Zollv. (1), 759
 Weber, *see* Matthes & Weber; Scheller
 & Weber.
 Weber, C.—Zollverein (1), 325. 744
 Weber, C. F.—Zollverein (4), 84
 Weber, E.—Zollverein (1), 716
 Weber, G.—Belgium, 238
 Weber, G. D.—Austria, 18
 Weber, G. & Co.—Zollverein (4), 86
 Weber, J.—France, 739
 Weber, J. B.—Zollverein (6), 43
 Weber & Metzges.—Zollverein (1), 569
 Weber & Schmiltheis.—Zollverein (5), 3
 Weber, W.—Zollverein (1), 384
 Websky & Son.—Zollverein (1), 122
 Webster, *see* Cornell, Lyell, & c.; Steer
 & Webster
 Webster, A.—xii. & xv. 84
 Webster, B.—v. 108
 Webster, Capt.—New South Wales
 Webster, D.—xii. & xv. 63
 Webster, G.—xx. 154
 Webster, R. jun.—x. 17
 Webster, T.—xii. & xv. 62
 Webster, W. H.—vii. 185; x. 671A;
 viii. 265
 Wedgwood, Josiah, & Sons.—xxv. 6.
 51; xxix. 208
 Wedgwood, R.—xvii. 47
 Wedlake, Mary, & Co.—ix. 127
 Wednesbury Slat & Axletree Co.—v.
 543
 Weelton, F.—xix. 6
 Weelton, F. P.—xix. 11
 Weelton, T.—x. 640
 Weekes, H.—Page 853
 Weeks, J. & Co.—ix. 248A (North
 Transsept)
 Weese, W. F.—Canada, 28. 85
 Wegelin, J.—Sweden, 53
 Wegner, T. R.—Switzerland, 155
 Wehrle & Steuert.—Zollverein (1), 879A
 Weichselhammer, J.—Austria, 562
 Weichselhammer, M.—Austria, 563
 Weickert, J. D.—Zollverein (3), 166
 Weill, M.—Austria, 461

Weigert, *see* Marx & Weigert
 Weigert & Co.—Zollverein (1), 115
 Weight, S.—x. 430
 Weightman, *see* Power & Weightman
 Weighton & Son.—xxiii. 22
 Weigle, J. J.—Zollverein (4), 29
 Weil, *see* Trelon, Weldon, &c.
 Weiland.—Zollverein (1), 383
 Weillbach, I. J.—Denmark, 21
 Weill, C.—Zollverein (1), 20
 Weimar's Son.—Zollverein (1), 797
 Weinberger, G.—Austria, 280
 Weinknecht, T.—Belgium, 259
 Weinmeister, C.—Austria, 448
 Weinmeister, J.—Austria, 449
 Weintraut, C. jun.—Zoll. (6), 70
 Weir, E.—ix. 123
 Weir, J.—xvi. 72; xxx. (Fine Art Court), 151
 Weise, W. F.—Canada, 37
 Weishaup, C. M. & Sons.—Zollverein (1), 412
 Weiss, *see* Zwergler, Van, Deffner, &c.
 Weiss, jun. & Co.—Zollverein (1), 717
 Weiss, J. & Son.—Austria, 572
 Weiss, J.—Austria, 692A
 Weiss, J. H.—Zollverein (1), 684
 Weiss & Son.—x. 631A
 Weistlog, E. F.—Zollverein (1), 720
 Welborne, J. W.—i. 470
 Welborne, W.—i. 455
 Welch, Margatson, & Co.—xii. & xv. 304; xviii. 7; xx. 212
 Welch & Sons.—xx. 12
 Welch, T.—xviii. 18; xxvi. 150
 Welch, A. C.—Zollverein (1), 331
 Weld, J.—viii. 186
 Weldon, *see* Trelon, Weldon, &c.
 Wellborne, W.—i. 447, 455
 Wellings, *see* Halbeard & Wellings
 Wells, *see* Brown & Wells; Hinks, Wells, & Co.
 Wells & Co.—xxvi. 392; South Africa, 59
 Wells, E.—xxvi. 232
 Wells, G.—vii. 82
 Wells, J. T.—xxii. 290
 Wells, L.—United States, 107
 Well, W. B.—xix. 311
 Wellman, J.—iii. 78
 Wellway, J. S.—x. 465
 Welsh Slate Company.—Western entl. South enclosure (Outside), 12
 Welzibach, K.—Austria, 571
 Wemmer, F.—Zollverein (7), 3
 Wemyss, R.—xiv. 58
 Wemyss, Rear-Admiral.—xxvii. 141
 Wendentein, J. H.—Zollverein (6), 55
 Wendt, *see* Post & Wendt
 Wenham Lake Ice Company.—xxii. 600
 Wenzel, C.—Austria, 319
 Wentzell, A.—viii. 167
 Weppler, C. L.—Zollverein (2), 96
 Wermuth, J.—Switzerland, 107
 Werner, M.—Zollverein (6), 48
 Werner & Pighlein.—Hamburgh, 79
 Werth, A. & Co.—Zollverein (1), 333
 Wertheim, F.—Austria, 573
 Wertheimer, D. J.—x. 387
 Wertheimer, S.—xxiii. 130; xxvi. 177
 Wescher, Brothers, & Strassmann.—Zollverein (1), 634
 Wesenfeld & Co.—Zollverein (1), 461
 Wesley, S. S.—xvii. 169
 Weismal Legros.—Belgium, 282
 Wessel, F. W.—Zollverein (1), 542
 Wessels, *see* Brucklesby & Wessels
 West, Alice.—xxx. (Fine Art Cr.), 326
 West, Brothers.—Zollverein (6), 44

West, C. Mary.—xix. 374
 West, Commander.—viii. 109; *see* also Graham, West, & Co.
 West of England China, Stone, & Clay Company (St. Austell).—i. 103
 West & Gregson.—vii. 21
 West & Son.—xxiii. 15
 West, W.—ix. 246
 Westall & Co.—iv. 104
 Westerbaan, *see* Schoneveld & Westerb.
 Westergöthland, Peasants of.—Sweden & Norway, 26
 Westermann, *see* Karcher & Westermann
 Westermann, A. H. & Co.—Zollverein (1), 543
 Westermann, A. H. C. & Sons, Zollverein (1), 514
 Westermann & Co.—Zoll. (1), 80
 Westermann, G.—Zollverein (1), 749
 Westermann & Sons.—Zollverein (1), 544
 Western Fire Company (Cincinnati).—United States, 208
 Western Gaslight Co.—i. 260
 West Ham Gutta Percha Company.—xxviii. 90
 Westhauster, J.—Austria, 308
 Westhead & Co.—xxix. 275
 Westhoff, Brothers.—Zoll. (1), 599
 Westley, *see* Carpenter & Westley; Richards, Westley, & Son
 Westley, J.—xvii. 48
 Westleys & Co.—xvii. 111
 Westmacot, J.—xxx. (Sculp. Cr.), 74
 Westminster, Marchioness of.—xx. 212
 Westmoreland, G.—x. 444
 Weston & Son.—xiii. 46
 Weston, Warwick.—Western Africa, 1
 Westrup, W.—vi. 442
 Westwood, J. (the late).—xxx. (Fine Art Court) 292
 Westwood, J. O.—xxx. (Fine Art Court), 292
 Westwood & Moore.—xxvii. 113
 Weszly—Zollverein (1), 849
 Wethered & Brothers.—United States, 529
 Wetherell, F. S.—xxvi. 236
 Wetherill, Brothers.—United States, 43
 Wetti, M. L.—Switzerland, 237
 Wetzel, C. J.—Zollverein (4), 109
 Wee & Lindner.—Zoll. (3), 72-83
 Wexford, Peasants.—xx. 181
 Weyerbusch, C. & Co.—Zollverein (1), 570
 Weygand, A.—France, 740
 Weygold, A.—Zollverein (1), 429
 Weyhe, *see* Motter, Weyhe, & Co.
 Whaitte, H. C. xxx.—(Fine Art Court), 340
 Whalley, *see* Skinner & Whalley.
 Whalley, T.—xxv. 27
 Wharry, J.—xxix. 217
 Wharton, W.—v. 73
 Wheatley, J.—v. 810
 Wheatley, W.—xxviii. 109
 Wheatstone & Co.—x. 526
 Wheeler.—vi. 618; *see* Kinder & Wheeler
 Wheeler & Ablett.—xx. 22
 Wheeler, C.—xxii. 799
 Wheeler, E.—v. 305; ix. 216A
 Wheeler, F.—iii. 27A
 Wheeler, G. & M.—xxiii. 91
 Wheeler, Philip & Co.—i. 108
 Wheeler, T.—iii. 27A; Canada, 167, 353
 Wheeler, T. & Co.—xx. 206
 Wheeler, W. S.—xii. & xv. 271
 Wheelhouse, A.—Portugal, 529

Wheler, Mrs.—xix. 238
 Whetham & Sons.—xiv. 73
 Whetstone, *see* Brewin & Whetstone.
 Whettam, J.—viii. 136
 Whibley, E.—x. 607
 Whicker, *see* Philp & Whicker
 Whipple, J. A.—United States, 451, 579
 Whislaw, F.—ix. 59; x. 418; xvi. 81; xxvi. 264; xxvii. 61; xxx. (Fine Art Court), 232A
 Whitaker, *see* Chapman & Whitaker
 Whitaker, H. W.—xxviii. 137
 Whitaker, R.—vi. 140; xvii. 49
 Whitaker, Son, & Co.—France, 741
 Whitbread, J.—xvii. 192
 Whitley, E.—xx. 186
 Whitcombe, A.—xxvi. 211A
 White.—viii. 162; x. 687; *see* Jones, White, &c.
 White, E.—xx. 159
 White, G.—Jersey & Guernsey, 12
 White, G. B.—iii. 32
 White & Grant.—i. 471
 White, H. C.—Jersey & Guernsey, 1
 White, J.—viii. 36; ix. 181; x. 587; *see* White, T. & J.
 White, J. C.—xvi. 86
 White, M.—United States, 397
 White & Parly.—xxvi. 6
 White, R., *see* White, T. J. & R.
 White, Son, & Co.—xix. 343
 White & Sons.—Western end. South enclosure (Outside), 10; i. 136, 130A; xxvii. 144
 White, T. jun.—viii. 52; xxii. 200
 White, T. J.—viii. 136
 White, T. J. & R.—viii. 36A
 White, W.—xx. 51
 Whitehead.—xi. 40
 Whitehead, J.—ix. 239; xxii. 10
 Whitehead, J. H.—vi. 46
 Whitehead & Son.—xx. 139
 Whitehill, M., & Co.—xii. & xv. 287
 Whitehouse, C. & Co.—xxii. 667
 Whitehouse, N.—x. 280
 Whitehurst, J.—United States, 525
 Whitehurst, J. H.—United States, 377
 Whitelaw, J.—v. 58
 Whiteley, Elizabeth.—xxii. 126
 Whiteley & Sons.—xvii. 98
 Whiteley, Rev. J.—New Zealand, 32
 Whitman, E. jun.—United States, 240
 Whitman, F. J.—xvii. 51
 Whiteside, *see* Cousins & Whiteside.
 Whitesides.—Van Diemen's Land, 91-93
 Whiteway, Watts, & Co.—i. 90
 Whitfield, J. A.—ix. 68
 Whitfield, S.—xxii. 356
 Whitham.—v. 113
 Whiting, *see* Dixon & Whiting; Hotham & Whiting.
 Whiting, C.—xxx. (Fine Art Cr.) 123; United States, 556
 Whitley, J.—xii. & xv. 176; xxii. 656
 Whitley, N.—i. 79. 95. 165
 Whitlock, B. M.—United States, 369
 Whitlock & Billiald.—xix. 27
 Whitman, *see* Widom, Russel, &c.
 Whitmarsh.—United States, 334
 Whitmee & Chapman.—xxii. 242
 Whitmore & Co.—xii. & xv. 241
 Whitney, E.—xix. 347
 Whitney, J.—iii. 26; v. 69.
 Whittaker, J.—i. 53; xviii. 76
 Whittaker, J., & Sons.—vi. 1
 Whittaker, R.—vi. 140
 Whittington.—xxx. (Sculpture Cr.) 10
 Whittington, G. T.—Falkland Islands, 1

Whittles & Froggart.—XXII. 213
 Whitwell, J., & Co.—XIX. 345
 Whitworth, J., & Co.—VI. 201
 Whitworth, J. & Son.—XII & XV. 50
 Whyte, see Smith & Whyte
 Whyte, W.—XXVI. 43
 Whytehead, W. K.—v. 101
 Whytlay & Son.—New Zealand, 34
 Whytack.—XIX. 263
 Whytock, A.—VII. 156
 Wickham.—XXIX. 196
 Widdowson & Veale.—XXIII. 100
 Widmer-au-Kreutz.—Switzerland, 153
 Widmer-Huni.—Switzerland, 153
 Widnall, G. F.—XVII. 52
 Widnell see Henderson & Widnell
 Wiedemann, Ferdinenges, & Sehmolder.
 —Zollverein (1), 488
 Wielenmann, J.—Zollverein (1), 609
 Wiegand, E.—Zollverein (1), 734
 Wiegand, F.—Zollverein (1), 745
 Wiegandt, J.—Zollverein (1), 415
 Wiell, Van.—Belgium, 114
 Wien, L.—Austria, 578
 Wiener, J.—Belgium, 442
 Wiese, see Hennige & Wiese
 Wiese, Brothers.—Zollverein (1), 455
 Wiesenthal, see Susmann & Wiesenthal
 Wiesmann, A. & Co.—Zollverein (1),
 334
 Wigdor, M.—Zollverein (1), 257
 Wigham & Co.—XX. 85
 Wight, J.—v. 480.
 Wigram, Money, & Sons.—VIII. 56
 Willand, J.—XXX. (Fine Art Court),
 291
 Willy, T.—XXX. (Fine Art Cr.), 162
 Wild.—v. 640; vi. 8
 Wild, W.—VI. 8
 Wild & Robinson.—Zollverein (1), 859
 Wilder, see Parker, Wilder, & Co.
 Wilder, A. A.—United States, 398
 Wildes, W.—XVII. 102
 Wildley & Co.—XXVIII. 40
 Wilding, W. H.—v. 60
 Wildsmith, M.—XXII. 190
 Wiley & Co.—XXII. 325
 Wilford, W.—Belgium, 211
 Wilford & Sons.—xiv. 42
 Wilhelm, see Bolten, Wilhelm, & Son
 Wilhelm, A.—Austria, 142
 Wilken, A.—XXIX. 110
 Wilkes, J.—XXII. 266
 Wilkie, J. & Co.—IX. 21
 Wilkins, W. C.—VII. 157 (Main Avenue,
 West)
 Wilkins & Weatherly.—XXII. 80
 Wilkinson.—XXII. 540; see Grimshaw
 & Wilkinson
 Wilkinson & Co.—XXII. 32
 Wilkinson, Sir G.—XXX. (Fine Art
 Court), 319
 Wilkinson, H. & Co.—XXIII. 44
 Wilkinson, J.—XII & XV. 51
 Wilkinson & Son.—VIII. 200; XII. 122
 Wilkinson, T.—IX. 220
 Wilkinson, T. & G.—XXII. 175
 Wilkinson, W.—XVIII. 8
 Wilkinson, W. & Co.—XXVI. 184
 Wilkinson, W. & E.—XII & XV. 52
 Wilke.—XIX. 336
 Wilks, J.—XII & XV. 6; XIV. 31
 Will, Meyer, & Co.—Belgium, 336
 Willans, Brothers, & Co.—XII & XV. 257
 Willard, E.—United States, 536
 Willats, T. & R.—x. 265
 Willcock, E. P.—XXVII. 8
 Willemain.—France, 1659; see also
 Meurant, Brothers, &c.
 Willems.—Belgium, 77

Willet, E., Nephew, & Co.—XII & XV.
 310
 Willett, C.—Canada, 69
 Willett, F.—VII. 111
 Willett, Messrs.—Canada, 143
 Willey, see Finch & Willey
 William, B. H.—x. 343
 William, Evan.—v. 67
 William, H.—XXVIII. 163
 Williams.—XXII. 612; see Clarke &
 Williams; also, Cook & Williams;
 Edelsten & Williams; Hopkins &
 Williams
 Williams, C.—VII. 169
 Williams, C. C.—v. 530
 Williams, Coopers, Hoyle, & Co.—XXVI.
 321
 Williams, D.—I. 215; v. 63
 Williams, F., see Williams, T. & F.
 Williams, G. T.—United States, 389
 Williams, Lady Griffies.—XIX. 349
 Williams, H.—France, 742
 Williams, J.—vi. 234; XVII. 53; XXVIII.
 102; XXX. (Fine Art Court), 82
 Williams, L.—VII. 128
 Williams, Mary.—United States, 243
 Williams, N. L.—United States, 14
 Williamson.—IX. 48
 Williams & Son.—XXIX. 4
 Williams & Sons.—I. 505
 Williams, T.—VIII. 332; XXII. 280
 Williams, T. M.—XXIX. 219
 Williams, W.—I. 101; VIII. 314; IX.
 151; x. 352
 Williams & Norgate.—Zollv. (1), 272
 Willis, H.—x. 209
 Willison, R.—v. 128
 Willmanns, C. W.—Zollverein (1), 209
 Willmers.—Austria, 371
 Willock, B. F. & Co.—VII. 223; (Main
 Avenue, West) XXVII. 8. Page 853
 Willock, J.—Canada, 108
 Willott, W. & Co.—XII & XV. 114
 Willoughby d'Kresby, Lord.—IX. 195
 Willoughby, S.—v. 992
 Willoughby, T.—XXII. 173
 Wills & Bartlett.—XXVI. 160
 Wills, W. J.—XXX. (Fine Art Court),
 364
 Willson, J.—XXX. (Fine Art Court) 315
 Willson, T.—XXX. (Fine Art Court),
 304
 Wilmot, E. W.—IX. 170
 Wilshin, S. B.—XVI. 205
 Wilson.—XIII. 56; XVIII. 17; XXII. 85;
 see also Bull & Wilson; Venables,
 Wilson, &c.
 Wilson, A.—XXX. (Fine Art Court), 55
 Wilson, Anne.—XIX. 350
 Wilson, C.—v. 007
 Wilson, Charlotte.—XIX. 112
 Wilson, Charlotte E.—XXX. (Fine Art
 Court), 363
 Wilson & Co.—XIII. 10.
 Wilson, D.—XII & XV. 83
 Wilson, E. B. & Co.—v. 526
 Wilson, G.—vi. 112; XXX. (Fine Art
 Court), 200
 Wilson, H.—XXX. (Fine Art Court), 44
 Wilson, J.—II. 6 (Main Avenue West);
 v. 595; VIII. 299; IX. 249; XII & XV.
 138; XIII. 56; XXVII. 11; XXX. 315
 Wilson, Dr. J.—Canada, 2
 Wilson, J. & Sons.—Zollverein (3), 51
 Wilson, J. J. & W.—XII & XV. 245
 Wilson, M.—VII. 97
 Wilson & Matheson.—XXIX. 133
 Wilson, R.—XVII. 178
 Wilson, R. & W.—XXII. 400
 Wilson, S.—XXVII. 11

Wilson & Son.—XII & XV. 468; XVI.
 98; XX. 183; XXII. 195
 Wilson & Sons.—XXVI. 293
 Wilson, Sir T. Marjony.—I. 49
 Wilson, T. H.—VII. 113. 185
 Wilson, W.—VII. 97; see also Wilson,
 R. & W.; Wilson, W. & Son
 Wilson, W. & Son, XII & XV. 252
 Wilson, Walker, & Co.—XVI. 11
 Wilson & Woodfin.—VII. 195
 Wilton, W.—x. 402
 Winder, R.—IX. 190
 Windle & Blythe.—XXII. 608
 Windley, see Walsh & Windley
 Windmüller, A.—Hamburg, 29
 Windrath, see Wuelting and Windrath
 Windsor, J.—IX. 25
 Windus, T.—IX. 36
 Winfield, R. W.—XXII. 373.
 Wingate, see Black & Wingate
 Wingate, Son, & Co.—XII & XV. 200
 Wiugener, Brothers.—Zollverein (5), 9
 Wingerworth Iron Co. (Chesterfield).
 —I. 416
 Wingrave & Sons.—XX. 16
 Winkelman, see Zeitler & Winkelman
 Winkelman & Sons.—Zollv. (1), 306
 Winkelmann, J.—Zollverein (1), 282
 Winkler, F.—Zollverein (1), 31
 Winkler & Son.—Zollverein (3), 91
 Winkler, T. C.—Switzerland, 142
 Winknecht, T.—Belgium, 259
 Winks & Sons.—XXII. 134
 Winkworth.—XVIII. 9
 Winkworth & Co.—XIII. 19
 Winkworth & Proctor.—XIII. 65; XVIII. 9
 Winkip, A. H.—United States, 354
 Winsor & Newton.—II. 28
 Winsor & Son.—XVI. 14
 Winter, C.—XVI. 178
 Winter, F.—Zollverein (1), 50
 Winter, J.—x. 423; Austria, 160,
 242
 Winter, T. B.—VI. 134
 Winter, W.—XVI. 249
 Winterborn, J.—XXVIII. 168
 Winterfeld, J. A.—Zollverein (1), 204
 Winterhalter, F.—Main Avenue, East,
 96. 97; XXIII. 97; XXX. (Fine Art
 Court), 237
 Winton, H.—VIII. 250; IX. 259A
 Winton & Sons.—XXII. 268
 Winzenriehl, see Marschel, &c.
 Wippel, J. jun.—XXVIII. 10
 Winkler, T.—Zollverein (1), 786
 Wirth, F. E.—Zollverein (1), 819
 Wirth, T. F.—Zollverein (4), 70
 Wirtz, J.—Switzerland, 259
 Wirs & Co.—Switzerland, 153
 Wisdom, Russel, & Whitman.—United
 States, 205
 Wise, Dr.—India, vi.
 Wiedell, G. V.—XXIII. 65
 Wiseman.—Van Diemen's Land, 130—
 134
 Wiseman, A. & Co.—Zollverein (1), 331
 Wiseman, H. R.—XVII. 103
 Wis, R.—XXII. 525
 Wisson, R.—XXII. 679
 Withers, J. H.—XXIII. 61
 Withers, W.—XXIX. 292; XXX. (Fine
 Art Court), 27
 Withey & Smith.—xiv. 47
 Witschl & Rehnisch.—Austria, 293
 Wittekop & Co.—Zollverein (1), 605
 Wittich, A. Kemmel, & Co.—Zoll-
 verein (4), 82
 Witton, Daw, & Co.—VIII. 203
 Wix, see Mecklinghaus & Wix
 W. M. & H. F.—VIII. 136

- & xv. 468; xv. 195
 t. 298
 —I. 49
 13. 185
 see also Wilson,
 W. & Son
 t. xv. 252
 —I. 11
 VII. 195
- II. 668
 Wintley
 aburgh, 29
 g and Windrath
- t. 373.
 Wingate
 XII. & xv. 200
 Zollverein (8), 9
 (Chesterfield).
- 16
 & Winkelman
 Zoll. (1), 306
 verein (1), 282
 in (1), 31
 verein (3), 91
 rland, 142
 m, 259
 134
- t. 19
 XIII. 65; XVIII. 9
 t. States, 354
 28
- (1), 56
 Austria, 160,
- t. 168
 verein (1), 204
 Avenue, East,
 XXX. (Fine Art
- ix. 259A
 08
 l, &c.
 t. 10
 (1), 786
 (1), 819
 (1), 70
 259
 l, 153
 rman.—United
- 55
 's Land, 130-
- verein (1), 334
 103
- ; xxx. (Fine
- 7
 etria, 293
 in (1), 695
 & Co.—Zoll-
- I. 203
 Wix
- Wöhke, H.—Hamburgh, 89
 Wolderspoon, J.—xvii. 159
 Wögelin, D.—Switzerland, 242
 Woeste, G. & Co.—Zollverein (1), 654
 Wöhler & Co.—Switzerland, 227
 Wohlfahrt, J. E.—Zollverein (5), 28
 Wojtech, F.—Austria, 274
 Wojtech, J.—Austria, 686
 Wolf.—France, 744
 Wolf, C. A.—Zollverein (3), 142
 Wolf, C. H.—Zollverein (3), 48
 Wolf, J. G.—Zollverein (3), 143
 Wolf, T. H.—Zollverein (3), 29
 Wolff, F.—Austria, 326
 Wolff, Albert.—Zollverein (1), 300, 307
 Wolff, E. & Sons.—I. 68; xxx. (Fine Art Court), 129
 Wolff & Ebelöh.—Zollverein (1), 656
 Wolff, F. A.—Zollverein (4), 13
 Wolff, J. F.—Zollverein (1), 600
 Wolff, F.—Zollverein (3), 144
 Wolfers, see Hermes, Brothers, &c.
 Wolfrum, C.—Austria, 301
 Wöllerauf, Privileged Association of Manufacturers.—Austria, 423
 Wolff & Co.—Zollverein (2), 17
 Wolff, L. J.—xxxiii. 68
 Wolstenholme, J.—xxviii. 173
 Wolter, G. C.—Zollverein (1), 160
 Wolverson, E.—xxii. 276
 Wood.—xvii. 198; see also Horne, Thorothwaite, &c.; Pontifex & Wood, Thomson, Wood & Co.
 Wood & Bedford.—II. 47
 Wood, Brothers.—xxii. 75
 Wood, C.—xxx. (Fine Art Court) 174
 Wood, C. H.—xxx. (Fine Art Cr.), 209
 Wood & Co.—viii. 102.
 Wood & Forest, Commission of.—Algeria, 47
 Wood, G.—ix. 90; xxv. 34
 Wood, H. & T.—xix. 352
 Wood, H. L.—i. 432
 Wood, J.—xxi. 8; xxvi. 105, 118; xxx. (Fine Art Court), 48
 Wood, Janet.—xx. 137
 Wood, J. W.—x. 737
 Wood, P. H.—xxix. 285
 Wood & Perkes.—xxiv. 7
 Wood, S., see Wood, W. & S.
 Wood, T.—xxiv. 16; see also Wood, H. & T.
 Wood & Tomlinson.—United States, 396
 Wood, W.—Belgium, 492
 Wood, W. R.—x. 643
 Wood, W. & S.—xvi. 25
 Woodbourne, J.—ix. 76
 Woodbridge, T.—xxiii. 53
 Woodbury, J. P.—United States, 443
 Woodcock, F.—United States, 135
 Woodcroft, J. & Co.—xviii. 45
 Woodfin, see Wilson & Woodfin
 Woodford, Lady.—Ionian Islands, 1
 Woodhead, J.—xxviii. 191
 Woodhouse.—x. 731; xx. 180
 Woodhouse, J.—xii. & xv. 71
 Woodhouse & Luckman.—xx. 15
 Woodhouse, W.—xxx. (Fine Art Cr.), 289A
 Woodin, D.—xxii. 8
 Woodington.—xxiii. 92, 119
 Woodington, W. F.—Page 833
 Woodley, J.—xxiii. 63; xxvii. 39
 Woodman, see Simmonds & Woodman
 Woodman, H. G.—xxvi. 73
 Woodman, J. C.—South Africa, 26
 Woodman, J. T.—x. 281
 Woodman, W.—xvi. 42
 Woodruff, Thomas.—xxvii. 77; xxx. (Fine Art Court), 350
- Woods, F. F.—vii. 42
 Woods, J.—ix. 82
 Woods, W.—xxii. 33
 Woodward, B.—xxvii. 21
 Woodward, B. H.—xix. 354
 Woodward, H. & Co.—xix. 355
 Woodward, J.—viii. 230
 Woolcock, Catherine.—xix. 356
 Wooldridge, J.—xvii. 347
 Woolley, see Spurden, &c.
 Woolley, T.—x. 493
 Woolley, W.—Eastern Archipelago, 3
 Wolf & Son.—xxx. (Fine Art Court), 129
 Woolfield, T.—viii. 229
 Woolismit, see Bowers, Challinor, &c.
 Woollass, J. & Co.—xxvi. 322
 Woollass, W. & Co.—xxvi. 210, 309
 Woolman, E.—United States, 198
 Wordsworth, J.—xxii. 360
 Worke, H.—Hamburgh, 89
 Workman, J.—xxvii. 116
 Worledge.—xviii. 43A
 Wormald, see Hagues, Cook, &c.
 Worn, R.—xvi. 255
 Wornell.—xxvii. 99
 Wornum, R.—x. 499
 Worrall, C.—xxx. (Fine Art Court) 196
 Worrall, Hallam & Co.—xxii. 164
 Worsdell, G. & Co.—v. 637
 Worster.—xxiii. 94
 Worthington, W.—i. 57
 Worthy, see Thompson & Worthy
 Wostenholm, G.—xxii. 125
 Wotherspoon, J. & Co.—xxix. 106
 Wotherspoon, R.—iii. 124
 Wouversmanns, jun.—Belgium, 35
 Wratislaw, Matilda Emily.—xix. 337
 Wray, W.—x. 309
 Wrench & Sons.—iii. 80
 Wried, see Meyer & Wried
 Wright, see Abbott & Wright; M'Lean & Wright; Scott & Wright; Slater & Wright; Smith, Kemp, & Wright
 Wright, C.—xxx. (Fine Art Court), 203
 Wright, C. J.—United States, 589
 Wright, Crump, & Crane.—xix. 358
 Wright, F.—xxx. (Fine Art Court) 98
 Wright, G. W.—United States, 185
 Wright, H.—iii. 107A; xxix. 250
 Wright, J.—Page 853; xvii. 139; xxii. 177; xxvii. 43
 Wright, J. G.—Hamburgh, 57
 Wright, L. W. & Co.—iv. 42
 Wright, P.—xxii. 366
 Wright, P. & R.—xiii. 54
 Wright, R.—xvi. 152; see also Wright, P. & R.
 Wright W.—x. 121
 Wright, W. B. & Co.—United States, 77
 Wrigley, J. & T. C.—xii. & xv. 117
 Wrigley & Sons.—xii. & xv. 101
 Wrigley, T. C., see Wrigley, J. & T. C.
 Wroe, see Kay, Richardson, & Wroe; Rogers & Wroe
 Wrochowsky, J. R.—Austria, 203
 Wuelfing & Windrath.—Zoll. (1), 565
 Wuest, Brothers.—Zoll. (6), 44
 Wuest, C. L.—Zollverein (5), 14
 Wulf.—Denmark, 23
 Wulff, G. H. & J. F.—China
 Wulff, G. H. & J. F. see Wulff, G. H. &c.
 Wulff, Jens, & Sons.—Denmark, 5
 Wunder, L.—Zollverein (1), 250
 Wunsch, see Baumann & Wunsch
 Wunche, A.—Austria, 659
 Wirnden, C. A. Von, & Co.—Zollverein (1), 51
 Wurm, see Fischer & Wurm
- Wurm, F. X.—Austria, 137
 Wurst, J. M.—Austria, 302
 Wurtemberg, the late Queen of—Austria, 747
 Würlth, W. E. Von.—Austria, 52
 Wustenfeld, see Stohmann & Wustenfeld
 Wuttig, G. L.—Zollverein (1), 151
 Wyatt & Brandon.—vii. 220; Page 854
 Wyatt, J.—Page 853; xxx. (Fine Art Court), 183
 Wyatt, M. C.—Page 853 & 854
 Wyatt, M. Digby.—xxx. (Fine Art Court), 30, 80
 Wyatt, Richard J. (the late).—Main Avenue, East, 103
 Wyburn, Meller, & Turner.—v. 996
 Wyk, Van, Brothers, & Co.—Netherlands, 36
 Wyllam's Patent Fuel Company.—i. 252
 Wyld, see Naillon and Wyld
 Wyld, J.—xvii. 175
 Wynants, C.—Belgium, 472
 Wyne & Lumsden.—xxvi. 19
 Wyon, B.—xxx. (Fine Art Cr.), 287
 Wyon, E. W.—xxx. (Sculp. Court), 86
 Wyon, L. C.—xxx. (Fine Art Cr.), 286
 Wyon, W.—xxx. (Fine Art Cr.), 284
 Wyse, J.—New Bruuawick, 15, 17, 20, 22
 Wyttenbach, T.—Switzerland, 257
- Xavier, A. M.—Portugal, 312
 Xhoffray, C. & Co.—Belgium, 204
- Yarborough, Earl of.—xxx. (Sculpture Court), 60
 Yardley & Statham.—xxx. 2
 Yashari-Hosein—Turkey
 Yates.—xxv. 24
 Yates, Emma Jane.—x. 378
 Yates, H.—xxii. 684
 Yates, Haywood, & Co.—xxii. 381
 Yates, T.—x. 9
 Yates & Taylor.—xviii. 24
 Yates, W.—v. 777
 Yeager & Ord.—United States, 56
 Yeates, F. G.—xxi. 19
 Yeates, G.—x. 332
 Yeates, H.—xiv. 56
 Yeatman, T. H.—United States, 11
 Yerber, C.—Mecklenburg-Schwerin, 10
 Yerby, D. D.—xxx. (Fine Art Cr.), 260
 Yeomans & Son.—viii. 231
 Yeomans, A.—Canada, 23
 Yerbury, J.—xxix. 208
 Yewdall & Son.—xii. & xv. 78
 You, see Veclte, Gayrand, &c.
 You, Mme.—France, 745
 York & Sheepshauks.—xii. & xv. 49
 Young, C. & Co.—Western end, North side (Outside), 60; see also Harlow & Young; Simpson & Young; Watson, Young, & Co.
 Young, C. & Co.—v. 600
 Young, J.—ii. 7B; vii. 171; x. 131
 Young, J. H. & Co.—xi. 12
 Young & Son.—x. 361
 Young, W.—xxii. 442
 Young, Dowson, & Co.—viii. 92
 Younge, H.—xxii. 161
 Younger, see Thompson, Younger, & Co.
 Youzbah, K.—Russia, 129
 Yrabraun, G.—Spain, 275
 Yaasi, D. M. de.—Spain, 51, 267, 284
 Yuill, see Abercrombie & Yuill
 Yurgheson.—Russia, 72
 Yust & Co.—Spain, 47

- Zaalberg, J. C., & Son.—Netherlands, 34
 Zabala, P. V.—Spain, 129, 240
 Zaben, T.—Zollverein (5), 78
 Zadig, J. B.—France, 1535
 Zaehner & Schiess.—Switzerland, 143
 Zahn, J., son.—Austria, 599
 Zahn & Volbrecht.—Zollverein (6), 12
 Zais, W.—Zollverein (4), 48
 Zakharoff, S.—Russia, 108
 Zakhert, W.—Russia, 185
 Zaloghlu.—Russia, 209
 Zaman & Co.—Belgium, 136
 Zambona, G., see Zambona, J. & G.
 Zambona, J. & G.—Zollverein (1), 350
 Zambra, see Negretti & Zambra.—x.
 160A
 Zambrano, J.—Spain, 111
 Zamiatin, see Poliakov & Zamiatin
 Zamora, Inspector of Mines of the district of.—Spain, 20
 Zandra, J.—Austria, 693
 Zanoli, C. A.—Zollverein (1), 859
 Zapf, J.—Austria, 340
 Zaphirakis, Z.—Greece, 1
 Zapparelli, G.—Austria, 733
 Zasche, J.—Austria, 628
 Zastarebski, F.—Belgium, 176
 Zavagli, P.—Tuscany, 49
 Zayas, J.—Spain, 168
 Zebger, F. W.—Zollverein (1), 308
 Zeebgra, F.—Netherlands, 96
 Zegelae, E.—Belgium, 280
 Zeiger, A.—France, 747
 Zeigler, H.—Switzerland, 103
 Zeiler, F.—Zollverein (2), 93
 Zeisel, J. & Blumel, J. & Co.—Austria, 320
 Zeisig, H.—Zollverein (1), 225
 Zeitler, J.—Austria, 687
 Zeitler, M.—Russia, 343
 Zeitlinger, J.—Austria, 450
 Zeitlinger, J. A.—Austria, 451
 Zeltler & Winkelmann.—Zollverein (1), 709
 Zeita, J. F.—Zollverein, 841
 Zelisko, A.—Austria, 170
 Zeller, F.—Zollverein (4), 1
 Zeller, H.—Switzerland, 144
 Zeller & Co.—Switzerland, 153
 Zeller & Sons.—Switzerland, 153
 Zellweger, S.—Switzerland, 145
 Zemberg Mine, Dobschau (Hungary).—Austria, 7
 Zemakoff.—Russia, 115
 Zepperzauer, see Fries & Zepperzauer
 Zeschke, L.—Zollverein (1), 259
 Zetterberg, C.—Sweden & Norway, 10
 Zibermayr, M.—Austria, 132
 Ziegler, Brothers.—Zollverein (1), 784
 Ziegler & Haussmann.—Zollverein (3), 92
 Ziegler, H.—Switzerland, 108
 Ziegler, J.—Austria, 156
 Ziegler, Baron T.—Zollverein (1), 36
 Ziegler, T. & Co.—Switzerland, 146
 Ziegler-Pellis, J.—Switzerland, 260
 Zilfoogar-Beck & Iskanda-Beck-Ogli.—Russia, 51
 Zimmer, Dr.—Zollverein (5), 3
 Zimmerman, G. & S.—xxiii. 80
 Zimmermann, S., see Zimmerman, G. & S.
 Zimmerman & Son.—Zollverein (1), 718
 Zimmermann, see Schiffler & Zimmermann; Spoerli & Zimmermann.
 Zimmermann's, B., Heira.—Austria, 452
 Zimmermann, C.—Zollverein (3), 24
 Zimmermann, E. G.—Zollverein (5), 19
 Zindell, see Mayer & Zindell
 Zipelius, G., & Fuchs.—France, 1738
 Zirkenbach.—Zollverein (1), 791
 Zjicisel, J., & Blumel, J. & C.—Austria, 320
 Zlatoust, Imperial Artinsk Works.—Russia, 8, 167
 Zlatoust, Imperial Manufactory of Fire-arms of.—Russia, 14, 161
 Zlatoust, Imperial Salkinak Iron Works.—Russia, 17
 Zobel, J.—Zollverein (1), 195
 Zobel, W.—Zollverein (1), 190
 Zois, Widow Carl, Ironworks.—Austria, 405
 Zolesi, S.—Sardinia, 2
 Zollmann & Steigerhall.—Zollverein (1), 566
 Zolotoff, J.—Russia, 136
 Zoloff, Brothers.—Russia, 218
 Zouboff, D., & A. Stepounin.—Russia, 180
 Zoude & Co.—Belgium, 388
 Zox, L.—xx. 59
 Zschille, Brothers.—Zollverein (3), 138
 Zschille, F. & Co.—Zollverein (3), 119
 Zschille, J. C. & K.—Zollv. (1), 844
 Zuber, J.—Hamburgh, 107
 Zuber, J. & Co.—France, 1536
 Zuccani, H.—xxx. 348
 Zufriedenheit, see Busbacher, & Co.
 Zuloaga, E.—Spain, 264
 Zuluaga, E.—Spain, 264A
 Zulueta, J.—Spain, 179A
 Zuppinger, T.—Switzerland, 209
 Zuppinger & Son.—Switzerland, 153
 Zurrer, J. Switzerland, 153
 Zuurdeeg, J. & Son.—Netherlands, 35
 Zwessaardt, A.—Netherlands, 111
 Zweibrücken Mechanical School (Bavaria).—Zollverein (2), 32
 Zweger, Van, Desfrier and Weiss.—Zollverein (4), 52
 Zwickl, J.—Austria, 138



. & C.—Aus-
insk Works,—
anufactory of
14, 161
alkinsk Iron
, 195
, 190
works.—Aus-
.— Zollverein
36
, 218
min.—Russia,
398
verein (3), 138
verein (3), 119
lv. (1), 844
07
1536
her, &c.
A
and, 209
zerland, 153
33
etherlands, 35
ands, 111
School (Ba-
, 32
and Weiss.—

INTRODUCTION.

THE activity of the present day chiefly develops itself in commercial industry, and it is in accordance with the spirit of the age that the nations of the world have now collected together their choicest productions. It may be said without presumption, that an event like this Exhibition could not have taken place at any earlier period, and perhaps not among any other people than ourselves. The friendly confidence reposed by other nations in our institutions; the perfect security for property; the commercial freedom, and the facility of transport, which England pre-eminently possesses, may all be brought forward as causes which have operated in establishing the Exhibition in London. Great Britain offers a hospitable invitation to all the nations of the world, to collect and display the choicest fruits of their industry in her Capital; and the invitation is freely accepted by every civilized people, because the interest both of the guest and host is felt to be reciprocal.

But the consideration of the wide moral agencies which have contributed to produce the present Exhibition must be postponed, and we proceed at once to trace the course of the more direct influences which have led to its establishment.

Fairs, which are one sort of exhibitions of works of industry, have been established for centuries, in every part of the United Kingdom; but exhibitions resembling the present institution, in which the race is for excellence, and direct commerce is not the primary object, have taken place only during the last century, and have been originated by individuals, or societies, independently of any Government assistance. As early as the years 1756-7 the Society of Arts of London offered prizes for specimens of manufactures, tapestry, carpets, porcelain, &c., and exhibited the works which were offered in competition. About the same period, the Royal Academy, as a private society, patronized by the Sovereign, more in a personal capacity than as representing the head of the Legislature, had organized its exhibitions of painting, sculpture, and engraving.

The first exhibition of industrial productions in France, recognised as a national institution, occurred in 1798, a second took place in 1801, a third in 1802, and a fourth in 1806. But it was not until the year 1819, that the expositions of French industry have taken place systematically; and it is only since that time that the influence of them has been markedly felt in Europe.

During the last thirty years, in each of the metropolitan cities of the United Kingdom, and the most important manufacturing towns, one or more exhibitions of machinery and manufactures have been held; and it may be recorded that,

Local Exhibitions
in United King-
dom.

as early as 1829, the Royal Dublin Society had founded an exhibition of works of art, science, and manufacture, to be held triennially, to which, however, Irish productions only were admitted until the year 1850. But the local exhibition of Birmingham, held in the autumn of the year 1849—originating with individuals, self-supporting in its management, and comprehensive in the scope of the objects exhibited—may be said to have most nearly resembled the Exhibition of the present year. All similar exhibitions, in fact, have been essentially of a private and local character, none of them receiving any kind of Government or national sanction, if we except the exhibition of manufactures applicable to the decoration of the Houses of Parliament, which was instituted by the Fine Arts Commissioners.

To follow the links of the chain which have connected the present Exhibition with the national sympathies and support, we must revert to the French exposition in 1844. The great success of that exposition caused several representations to be made to members of the Cabinet, of the benefit which a similar exhibition would be likely to confer on the industry of the United Kingdom, and some efforts were made to obtain the assistance of the Government, but with no apparent results. No hopes whatever were held out that the Government would undertake any pecuniary liabilities in promoting such an exhibition. It may be mentioned that, even so late as the year 1848, a proposal to establish a self-supporting exhibition of British industry, to be controlled by a Royal Commission, was submitted to HIS ROYAL HIGHNESS the PRINCE ALBERT, and by him laid before the Government; still the Government hesitated to take up the subject, and it became quite evident to those parties who were most desirous of witnessing the establishment of a national exhibition, that if such an event should ever take place, it would have to be carried out independently of any Government assistance.

It is a marking feature in all the institutions and great works of our country, that they are the consequences of popular wishes. It is not until wants become national, and that combined action becomes essential to success, that the people seek the aid of the Government. The great constitutional freedom which this country enjoys, may be ascribed in some measure to the reluctance which the Government always shows to act on behalf of the people in any case where it is possible they can act for themselves. A great part of the success which has attended the institution of this Exhibition, may be attributed to its independence of the Government; and it may be the boast of our countrymen that the Exhibition was originated, conducted, and completed independently of any Government aid whatever, except its sanction. Assistance has only been sought from the Government when it was indispensable, as in correspondence with foreign countries, the provision of a site for the building, the organization of police, &c.; and wherever such assistance, when granted, would have entailed expense, the cost of it has been defrayed from the funds of the Exhibition.

Exhibitions of the
Society of Arts.

Step by step, the subject of a national exhibition, and the means of realizing it, became connected with the Society of Arts. In June, 1845, a committee of members of that Society was formed to carry out an exhibition of national industry, and funds were subscribed by the individuals forming the committee to meet the preliminary expenses. An inquiry was set on foot to ascertain the disposition of manufacturers to support the exhibition, but the attempt failed and was abandoned. In 1847 the Council of the Society substituted action for theory, and, in the midst of discouragement, established a limited exhibition of manufactures, professedly as the beginning of a series.

The success of this exhibition determined the Council to persevere, and to hold similar exhibitions annually. Accordingly in the next year the experiment was repeated with such greatly increased success, that the Council felt warranted in announcing their intention of holding annual exhibitions, as a means of establishing a quinquennial Exhibition of British Industry, to be held in 1851. Having proceeded thus far, the Council sought to connect the Schools of Design, located in the centres of manufacturing industry, with the proposed exhibitions, and obtained the promised co-operation of the Board of Trade, through the President, Mr. LABOUCHERE; moreover, with a view to prepare a suitable building, they secured the promise of a site from the Earl of CARLISLE, then Chief Commissioner of Woods and Forests, who offered either the central area of Somerset House, or some other Government ground. In the year 1849 the exhibition, still more successful than any preceding, consisted chiefly of works in the precious metals, some of which were graciously contributed by HER MAJESTY. To aid in carrying out their intention of holding a National Exhibition in the year 1851, the Council of the Society caused a report on the French Exposition, held in 1849, to be made for them and printed. A petition was also presented by the Council to the House of Commons, praying that they might have the use of some public building for the exhibition of 1851, which was referred to the Select Committee on the School of Design.

HIS ROYAL HIGHNESS THE PRINCE ALBERT, as President of the Society, had of course been fully informed, from time to time, of all these proceedings, which had received His Royal Highness's sanction and approval; but immediately after the termination of the session of 1849, the Prince took the subject under his own personal superintendence. He proceeded to settle the general principles on which the proposed exhibition for 1851 should be conducted, and to consider the mode in which it should be carried out.

Enlarged by
Prince Albert.

His Royal Highness has himself fully expressed the views which prompted him to take the lead in carrying out the Exhibition, and on the occasion of the banquet to promote the Exhibition, given by Mr. FARNCOMB, the Lord Mayor of London, to the municipal authorities of the United Kingdom, His Royal Highness declared these views in the following terms:—

His Royal Highness's views.

It must, indeed, be most gratifying to me, to find that a suggestion which I had thrown out, as appearing to me of importance at this time, should have met with such universal concurrence and approbation; for this has proved to me that the view I took of the peculiar character and requirements of our age was in accordance with the feelings and opinions of the country. Gentlemen, I conceive it to be the duty of every educated person closely to watch and study the time in which he lives; and, as far as in him lies, to add his humble mite of individual exertion to further the accomplishment of what he believes Providence to have ordained. Nobody, however, who has paid any attention to the particular features of our present era, will doubt for a moment that we are living at a period of most wonderful transition, which tends rapidly to the accomplishment of that great end to which, indeed, all history points—the realization of the unity of mankind. Not a unity which breaks down the limits, and levels the peculiar characteristics of the different nations of the earth, but rather a unity the result and product of those very national varieties and antagonistic qualities. The distances which separated the different nations and parts of the globe are gradually vanishing before the achievements of modern invention, and we can traverse them with incredible ease; the languages of all nations are known, and their acquirements placed within the reach of everybody; thought is communicated with the rapidity and even by the power of lightning. On the other hand, the great principle of division of labour, which may

be called the moving power of civilization, is being extended to all branches of science, industry, and art. Whilst formerly the greatest mental energies strove at universal knowledge, and that knowledge was confined to the few, now they are directed to specialties, and in these again even to the minutest points; but the knowledge acquired becomes at once the property of the community at large. Whilst formerly discovery was wrapt in secrecy, the publicity of the present day causes that no sooner is a discovery or invention made, than it is already improved upon and surpassed by competing efforts; the products of all quarters of the globe are placed at our disposal, and we have only to choose which is the best and cheapest for our purposes, and the powers of production are intrusted to the stimulus of competition and capital. So man is approaching a more complete fulfilment of that great and sacred mission which he has to perform in this world. His reason being created after the image of God, he has to use it to discover the laws by which the Almighty governs his creation, and, by making these laws his standard of action, to conquer Nature to his use—himself a divine instrument. Science discovers these laws of power, motion, and transformation: industry applies them to the raw matter, which the earth yields us in abundance, but which becomes valuable only by knowledge: art teaches us the immutable laws of beauty and symmetry, and gives to our productions forms in accordance with them. Gentlemen,—THE EXHIBITION of 1851 is to give us a true test and a living picture of the point of development at which the whole of mankind has arrived in this great task, and a new starting point from which all nations will be able to direct their further exertions. I confidently hope the first impression which the view of this vast collection will produce upon the spectator will be that of deep thankfulness to the Almighty for the blessings which He has bestowed upon us already here below; and the second, the conviction that they can only be realized in proportion to the help which we are prepared to render to each other—therefore, only by peace, love, and ready assistance, not only between individuals, but between the nations of the earth.

Meeting at Buckingham Palace.

On the 29th June, 1849, the general outlines of the Exhibition were discussed by His Royal Highness; and from that day to the present time, accurate accounts of all proceedings have been kept, and the greater part of them printed and published. The minutes of a meeting of several members of the Society of Arts, held at Buckingham Palace on the 30th June, set forth as follows:—

His Royal Highness communicated his views regarding the formation of a Great Collection of Works of Industry and Art in London in 1851, for the purposes of exhibition, and of competition and encouragement.

His Royal Highness considered that such Collection and Exhibition should consist of the following divisions:—

- Raw Materials.
- Machinery and Mechanical Inventions.
- Manufactures.
- Sculpture and Plastic Art generally.

It was a matter of consideration whether such divisions should be made subjects of simultaneous exhibition, or be taken separately. It was ultimately settled that, on the first occasion at least, they should be simultaneous.

Various sites were suggested as most suitable for the building; which it was settled must be, on the first occasion at least, a temporary one. The Government had offered the area of Somerset House; or if that were unfit, a more suitable site on the property of the Crown. His Royal Highness pointed out the vacant ground in Hyde Park on the south side, parallel with, and between, the Kensington drive and the ride commonly called Rotten Row, as affording advantages which few other places might be found to possess. Application for this site could be made to the Crown.

It was a question whether this Exhibition should be exclusively limited to British

industry. It was considered that, whilst it appears an error to fix any limitation to the productions of machinery, science, and taste, which are of no country, but belong, as a whole, to the civilized world, particular advantage to British industry might be derived from placing it in fair competition with that of other nations.

It was further settled that, by offering very large premiums in any, sufficient inducement would be held out to the various manufacturers to produce works which, although they might not form a manufacture profitable in the general market, would, by the effort necessary for their accomplishment, permanently raise the powers of production, and improve the character of the manufacture itself.

It was settled that the best mode of carrying out the execution of these plans would be by means of a Royal Commission, of which His Royal Highness would be at the head. His Royal Highness proposed that inasmuch as the home trade of the country will be encouraged, as many questions regarding the introduction of foreign productions may arise,—in so far also as the Crown property may be affected, and Colonial products imported,—the Secretaries of State, the Chief Commissioner of Woods, and the President of the Board of Trade, should be ex-officio members of this Commission; and for the execution of its details some of the parties present, who are also members or officers of the Society of Arts, and who have been most active in originating and preparing for the execution of this plan, should be suggested as members, and that the various interests of the community also should be fully represented therein.

It was settled that a draft of the proposed Commission, grounded on precedents of other Royal Commissions, be prepared, and that information regarding the most expeditious and direct mode of doing this be procured, and privately submitted to Her Majesty's Government, in order that no time be lost in preparation for the collection when the authority of the Government shall have been obtained.

It was settled that a subscription for donations on a large scale, to carry this object into effect, would have to be organized immediately. It was suggested that the Society for Encouragement of Arts under its charter possessed machinery and an organization which might be useful, both in receiving and holding the money, and in assisting the working out of the Exposition.—(*Minutes of the Meeting on the 30th of June, 1849, at Buckingham Palace.*)

The minutes of a second meeting held on the 14th July, at Osborne, are as follows:—

His Royal Highness stated that he had recently communicated his views regarding the formation of a great collection of works of industry and art in London in 1851, for the purpose of exhibition, and of competition and encouragement, to some of the leading statesmen, and amongst them to Sir ROBERT PEEL.

His Royal Highness judged, as the result of these communications, that the importance of the subject was fully appreciated, but that its great magnitude would necessarily require some time for maturing the plans essential to secure its complete success.

His Royal Highness communicated that he had also requested Mr. LABOUCHERE, as President of the Board of Trade, to give his consideration to this subject. Mr. LABOUCHERE was now at Osborne, and His Royal Highness expressed his desire that he should be present at this meeting. Mr. LABOUCHERE was accordingly invited to be present.

His Royal Highness gave it as his opinion that it was most important that the co-operation of the Government and sanction of the Crown should be obtained for the undertaking; but that it ought to be matter for serious consideration how that co-operation and sanction could be most expediently given.

Mr. LABOUCHERE stated that the whole subject would have the very best consideration he could give it; and on behalf of the Ministry, he could promise an early decision as to the manner in which they could best give their co-operation.

He suggested that if, instead of a Royal Commission being formed, to include some of

the chief members of Her Majesty's Government, those same Ministers were to be elected members of a Managing Committee of the Society of Arts, this object might perhaps be as well accomplished.

It was explained to Mr. LABOUCHERE that the exertions of the Society of Arts would be given to the undertaking, to the utmost extent to which they could be useful; but that these functions would necessarily be of an executive and financial nature, rather than of a judicial and legislative character.

It was further urged by the three members of the Society, that one of the requisite conditions for the acquirement of public confidence was, that the body to be appointed for the exercise of those functions should have a sufficiently elevated position in the eyes of the public, and should be removed sufficiently high above the interests, and remote from the liability of being influenced by the feelings of competitors, to place beyond all possibility any accusation of partiality or undue influence; and that no less elevated tribunal than one appointed by the Crown, and presided over by His Royal Highness, could have that standing and weight in the country, and give that guarantee for impartiality that would command the utmost exertions of all the most eminent manufacturers at home, and particularly abroad: moreover, that the most decided mark of national sanction must be given to this undertaking, in order to give it the confidence, not only of all classes of our own countrymen, but also of foreigners accustomed to the expositions of their own countries, which are conducted and supported exclusively by their Governments.

It was also stated that, under such a sanction, and with such plans as now proposed, responsible parties would, it was believed and could be proved, be found ready to place at the disposal of the Commission sufficient funds to cover all preliminary expenses and the risks incidental to so great an undertaking.

Mr. LABOUCHERE expressed his sense of the great national importance of the proposal, and wished such further communication on the subject as might enable him fully to understand it, to be able better to consider the matter with his colleagues in the Cabinet.

Plan of
operations.

At the same time a general outline of a plan of operations was submitted:—

I. A ROYAL COMMISSION.—For promoting Arts, Manufactures, and Industry, by means of a great Collection of Works of Art and Industry of All Nations, to be formed in London, and exhibited in 1851. President, HIS ROYAL HIGHNESS PRINCE ALBERT.

1. The duties and powers of the Commission to extend to the determination of the nature of the prizes, and the selection of the subjects for which they are to be offered.
2. The definition of the nature of the Exhibition, and the best manner of conducting all its proceedings.
3. The determination of the method of deciding the prizes, and the responsibility of the decision.

II. THE SOCIETY OF ARTS.—To organize the means of raising funds to be placed at the disposal of the Commission for Prizes, and to collect the funds and contributions to provide a building and defray the necessary expenses to cover the risks of the collection and exhibition; and to provide for the permanent establishment of these Quinquennial Exhibitions.

The prizes proposed to be submitted for the consideration of the Commission to be medals, with money prizes so large as to overcome the scruples and prejudices even of the largest and richest manufacturers, and ensure the greatest amount of exertion. It was proposed that the first prize should be £5,000, and that one, at least of £1,000, should be given in each of the four sections. Medals conferred by the Queen would very much enhance the value of the prizes.

Mr. LABOUCHERE finally stated that the whole matter should be carefully considered; but that there was no use in bringing it before the Cabinet at the moment of a closing session—that the Cabinet would now disperse, and not meet again till the autumn. The

interval from now to October or November might be most usefully employed by the Society in collecting more detailed evidence as to the readiness of the great manufacturing and commercial interests to subscribe to and support the undertaking, and he promised to employ that interval in further informing himself, and endeavouring to ascertain the general feeling of the country on the subject.—(*Minutes of the Meeting on the 14th of July 1849, at Osborne.*)

On the 31st July, 1849, His Royal Highness addressed a letter to the Home Secretary, in order to bring the subject officially to the notice of Her Majesty's Government. The Prince's letter to the Home Secretary.

SIR,

Osborne, July 31, 1849.

THE Society of Arts having during several years formed exhibitions of works of national industry, which have been very successful, believe that they have thereby acquired sufficient experience, and have sufficiently prepared the public mind, to venture upon the execution of a plan they have long cherished—to invite a Quinquennial Exhibition in London of the Industry of All Nations.

They think that the only condition wanting to ensure the success of such an undertaking, would be the sanction of the Crown, given in a conspicuous manner; and they are of opinion that no more efficacious mode could be adopted than the issue of a Royal Commission to inquire into, and report upon, the practicability of the scheme, and the best mode of executing it.

I have therefore been asked, as President of the Society, to bring this matter officially before you, and to beg that Her Majesty's Government will give this subject their best consideration.

The Exhibition was proposed to be invited for 1851, and the magnitude of the necessary preliminary arrangements renders it highly desirable that the decision which the Government may have come to should be ascertained within the space of a few months.

I have, &c.,

The Right Honourable
Sir George Grey, Bart., G.C.B.,
&c. &c. &c.

(Signed) ALBERT.

SIR,

Whitehall, August 1st, 1849. Answer.

I HAVE had the honour to receive your Royal Highness's letter of the 31st July, suggesting the issue of a Royal Commission to inquire into, and report upon, the practicability of a scheme which has been formed by the Society of Arts for a Quinquennial Exhibition in London of the Industry of all Nations.

I shall not fail, in obedience to your Royal Highness's command, to take an early opportunity of bringing this important subject under the consideration of Her Majesty's Government, and I am confident that it will receive their careful and deliberate attention.

I have, &c.,

To His Royal Highness Prince Albert, K.G.

(Signed) G. GREY.

(Minutes of the Meeting on the 3rd of September, 1849, at Balmoral.)

In this stage of the proceeding it became necessary to place the accomplishment of the undertaking, as far as possible, beyond a doubt. Having acquired experience, in 1845, of the difficulties to be encountered, the Council of the Society of Arts felt that the proposal must not be brought a second time before the public as an hypothesis, but that the only means of succeeding was to prove that they had both the will and the power to carry out the Exhibition. The Society had no funds of its own available for the advances necessary to be made. The outlay for a Pecuniary arrangements to insure execution of the proposal.

building upon the scale then thought of, and for preliminary expenses, was estimated at the least at £70,000.

After much fruitless negotiation with several builders and contractors, an agreement was made between the Society of Arts and the Messrs. MUNDAY, by which the latter undertook to deposit £20,000 as a prize fund, to erect a suitable building, to find offices, to advance the money requisite for all preliminary expenses, and to take the whole risk of loss on certain conditions. It was proposed that the receipts arising from the Exhibition should be dealt with as follows:—The £20,000 prize fund, the cost of the building, and five per cent. on all advances, were to be repaid in the first instance: the residue was then to be divided into three equal parts; one part was to be paid at once to the Society of Arts as a fund for future exhibitions; out of the other two parts all other incidental costs, such as those of general management, preliminary expenses, &c., were to be paid; and the residue, if any, was to be the remuneration of the contractors, for their outlay, trouble, and risk. Subsequently the contractors agreed that instead of this division they would be content to receive such part of the surplus, if any, as, after payment of all expenses, might be awarded by arbitration. This contract was made on 23rd August, 1849, but the deeds were not signed until the 7th November following.

For the purpose of carrying the contract into execution on behalf of the Society, the Council nominated an Executive Committee of four members, who were afterwards appointed the Executive in the Royal Commission, and the contractors their own nominee. In thus making the contract with private parties for the execution of what, in fact, would become a national object, if the proposal should be entertained by the public, every care was taken to anticipate the public wishes, and to provide for the public interests. It was foreseen that if the public identified itself with the Exhibition, they would certainly prefer not to be indebted to private enterprise and capital for carrying it out. A provision was made with the contractors to meet this probability, by which it was agreed, that if the Treasury were willing to take the place of the contractors, and pay the liabilities incurred, the Society of Arts should have the power of determining the contract before the 1st February, 1850. In the event of an exercise of this power the compensation to be paid to the Messrs. MUNDAY for their outlay and the risk was to be settled by arbitration.

The Society of Arts having thus secured the performance of the pecuniary part of the undertaking, the next step taken was to ascertain the readiness of the public to promote the Exhibition. It has been shown that the proof of this readiness would materially influence Her Majesty's Government in consenting to the proposal to issue a Royal Commission to superintend the Exhibition. The Prince ALBERT, as President of the Society of Arts, therefore commissioned several members of the Society, in the autumn of 1849, to proceed to the "manufacturing districts of the country, in order to collect the opinions of the leading manufacturers, and further evidence with reference to a Great Exhibition of the Industry of all Nations to be held in London in the year 1851, in order that His Royal Highness might bring the results before Her Majesty's Government." Commissioners were appointed, visits made, and reports of the results submitted to the Prince, from which it appeared that 65 places, comprehending the most important cities and towns of the United Kingdom, had been visited. Public meetings had been held, and local committees of assistance formed in them.

Visits to the
manufacturing
districts.

It further appeared that nearly 5000 influential persons had registered themselves as promoters of the proposed Exhibition.

Upon the presentation of these reports to Her Majesty's Government, the Queen was pleased to issue the following Commission, which was published in the London Gazette of 3rd January, 1850:—

Royal Commission appointed.

VICTORIA, R.

VICTORIA, by the grace of God, of the United Kingdom of Great Britain and Ireland, Queen, Defender of the Faith: To Our most dearly-beloved Consort His Royal Highness FRANCIS ALBERT AUGUSTUS CHARLES EMANUEL, Duke of SAXONY, Prince of SAXE-COBURG AND GOTHA, Knight of Our Most Noble Order of the Garter, and Field-Marshal in Our army;—Our right trusty and right entirely well-beloved cousin and Councillor WALTER FRANCIS Duke of BUCCLEUCH AND QUEENSBERRY, Knight of Our Most Noble Order of the Garter; Our right trusty and right well-beloved cousin WILLIAM Earl of ROSSE, Knight of Our Most Illustrious Order of St. Patrick; Our right trusty and right well-beloved cousins and Councillors, GRANVILLE GEORGE Earl GRANVILLE, and FRANCIS Earl of ELLESMERE; Our right trusty and well-beloved Councillor EDWARD GEOFFREY Lord STANLEY; Our right trusty and well-beloved Councillors, JOHN RUSSELL (commonly called Lord JOHN RUSSELL), Sir ROBERT PEEL, Baronet, HENRY LABOUCHERE, and WILLIAM EWART GLADSTONE; Our trusty and well-beloved Sir ARCHIBALD GALLOWAY, Knight Commander of Our Most Honourable Order of the Bath, and Major-General in Our Army in the East Indies, Chairman of the Court of Directors of the East India Company,* or the Chairman of the Court of Directors of the East India Company for the time being; Sir RICHARD WESTMACOTT, Knight; Sir CHARLES LYELL, Knight, President of the Geological Society of London, or the President of the Geological Society of London for the time being;† THOMAS BARING, Esquire; CHARLES BARRY, Esquire; THOMAS BAZLEY, Esquire; RICHARD CODDEN, Esquire; WILLIAM CURTIS, Esquire, President of the Institution of Civil Engineers, or the President of the Institution of Civil Engineers for the time being; CHARLES LOCK EASTLAKE, Esquire;‡ THOMAS FIELD GIBSON, Esquire; JOHN GOTT, Esquire; SAMUEL JONES LOYD, Esquire;§ PHILIP PUSEY, Esquire; and WILLIAM THOMPSON, Esquire, greeting:

WHEREAS the Society for the Promotion of Arts, Manufactures, and Commerce, incorporated by Our Royal Charter, of which Our most dearly-beloved Consort the Prince ALBERT is President, have of late years instituted Annual Exhibitions of the Works of British Art and Industry, and have proposed to establish an enlarged Exhibition of the Works of Industry of all Nations, to be holden in London in the year 1851, at which Prizes and Medals, to the value of at least Twenty Thousand Pounds Sterling, shall be awarded to the Exhibitors of the most meritorious works then brought forward; and have invested in the Names of Our right trusty and entirely beloved cousin SPENCER JOSHUA ALWYNE Marquess of Northampton; Our right trusty and right well-beloved cousin and Councillor GEORGE WILLIAM FREDERICK Earl of CLARENDON, Knight of Our Most Noble Order of the Garter; Our trusty and well-beloved Sir JOHN PETER BOILEAU, Baronet, and JAMES COURTHOPE PEACHE, Esquire, the sum of Twenty Thousand Pounds, to be awarded in Prizes and Medals as aforesaid: and have appointed our trusty and well-beloved ARTHUR KETT BARCLAY, Esquire, WILLIAM COTTON, Esquire, Sir JOHN WILLIAM LUBBOCK, Baronet, SAMUEL MORTON PETO, Esquire, and Baron LIONEL DE ROTHSCHILD, to be the

* At his death in 1850, he was succeeded by JOHN SHEPHERD, Esq.

† Succeeded by WILLIAM HOPKINS, Esquire, M.A., Cambridge, though Sir C. LYELL still remains a Commissioner by election under the Royal Charter afterwards granted.

‡ Now Sir C. L. EASTLAKE, President of the Royal Academy.

§ New Baron OVERSTONE.

Treasurers for all Receipts arising from donations, subscriptions, or any other source on behalf of or towards the said Exhibition; Our trusty and well-beloved PETER LE NEVE FOSTER, JOSEPH PAYNE, and THOMAS WINKWORTH, Esquires, to be the Treasurers for payment of all Executive Expenses; and Our trusty and well-beloved HENRY COLE, CHARLES WENTWORTH DILKE, the younger, GEORGE DREW, FRANCIS FULLER, and ROBERT STEPHENSON, Esquires, with our trusty and well-beloved MATTHEW DIGBY WYATT, Esquire, as their Secretary, to be an Executive Committee for carrying the said Exhibition into effect, under the directions of Our most dearly beloved Consort:

AND whereas the said Society for the Promotion of Arts, Manufactures, and Commerce, have represented unto Us, that in carrying out the objects proposed by the said Exhibition, many questions may arise regarding the introduction of productions into Our kingdom from Our Colonies, and from Foreign Countries; also regarding the site for the said Exhibition; and the best mode of conducting the said Exhibition; likewise regarding the determination of the nature of the Prizes, and the means of securing the most impartial distribution of them; and have also besought Us that We would be graciously pleased to give Our sanction to this undertaking, in order that it may have the confidence, not only of all classes of Our subjects, but of the subjects of Foreign Countries:

NOW KNOW YOU THAT WE, considering the premises, and earnestly desiring to promote the proposed Exhibition, which is calculated to be of great benefit to Arts, Agriculture, Manufactures, and Commerce, and reposing great trust and confidence in your fidelity, discretion, and integrity, have authorized and appointed, and by these presents do authorize and appoint you, Our most dearly beloved Consort FRANCIS ALBERT EMANUEL Duke of SAXONY, Prince of SAXE-COBOURG AND GOTHA, you WALTER FRANCIS DUKE OF BUCCLEUCH AND QUEENSBERRY; WILLIAM Earl of ROSSE; GRANVILLE GEORGE Earl GRANVILLE; FRANCIS Earl of ELLESMERE; EDWARD GEOFFREY Lord STANLEY; JOHN RUSSELL (commonly called Lord JOHN RUSSELL), Sir ROBERT PEEL, HENRY LABOUCHERE, WILLIAM EWART GLADSTONE, Sir ARCHIBALD GALLOWAY, or the Chairman of the Court of Directors of the East India Company for the time being, Sir RICHARD WESTMACOTT, Sir CHARLES LYELL, or the President of the Geological Society for the time being, THOMAS BARING, CHARLES BARRY, THOMAS BAZLEY, RICHARD COBDEN, WILLIAM CUBITT, or the President of the Institution of Civil Engineers for the time being, CHARLES LOCK EASTLAKE, THOMAS FIELD GIBSON, JOHN GOTT, SAMUEL JONES LOYD, PHILIP PUSEY, and WILLIAM THOMPSON, to make full and diligent inquiry,—into the best mode by which the productions of Our Colonies and of Foreign Countries may be introduced into Our kingdom;—as respects the most suitable site for the said Exhibition,—the general conduct of the said Exhibition;—and also into the best mode of determining the nature of the Prizes, and of securing the most impartial distribution of them:

AND to the end that Our Royal Will and Pleasure in the said inquiry may be duly prosecuted, and with expedition, WE FURTHER, BY THESE PRESENTS, WILL AND COMMAND, and do hereby give full power and authority to you, or any three or more of you, to nominate and appoint such several persons of ability as you may think fit to be Local Commissioners, in such parts of Our kingdom and in Foreign parts as you may think fit, to aid you in the premises; which said Local Commissioners, or any of them, shall and may be removed by you, or any three or more of you, from time to time, at your will and pleasure, full power and authority being hereby given to you, or any three or more of you, to appoint others in their places respectively.

AND FURTHERMORE, We do, by these Presents, give and grant to you, or any three or more of you, full power and authority to call before you, or any three or more of you, all such persons as you shall judge necessary, by whom you may be the better informed of the truth of the premises, and to inquire of the premises, and every part thereof, by all other lawful ways and means whatsoever.

AND OUR FURTHER WILL AND PLEASURE IS, That for the purpose of aiding you in the execution of these premises, We hereby appoint Our trusty and well-beloved JOHN SCOTT

RUSSELL and STAFFORD HENRY NORTHCOTE,* Esquires, to be joint Secretaries to this Our Commission.

AND for carrying into effect what you shall direct to be done in respect of the said Exhibition, We hereby appoint the said HENRY COLE, CHARLES WENTWORTH DILKE the younger, GEORGE DREW, FRANCIS FULLER, and ROBERT STEPHENSON, to be the Executive Committee in the premises, and MATTHEW DIGBY WYATT to be the Secretary of the said Executive Committee.

AND OUR FURTHER WILL AND PLEASURE IS, That you, or any three or more of you, when and so often as need or occasion shall require, so long as this Our Commission shall continue in force, do report to Us in writing, under your hands and seals respectively, all and every of the several proceedings of yourselves had by virtue of these presents, together with such other matters, if any, as may be deserving of Our Royal consideration touching or concerning the premises.

AND LASTLY, WE DO BY THESE PRESENTS ORDAIN, That this Our Commission shall continue in full force and virtue, and that you Our said Commissioners, or any three or more of you, shall and may, from time to time, and at any place or places, proceed in the execution thereof, and of every matter and thing therein contained, although the same be not continued from time to time by adjournment.

Given at Our Court at St. James's, the 3rd day of January,
in the 13th year of Our reign.

By Her Majesty's Command,
G. GREY.

The foresight of the Society of Arts, which had provided a mode by which the contract might be determined in conformity with the public wishes, was fully justified by the event. So far as the public manifested its opinion it appeared to be its wish that the undertaking should be carried out as a national work. Accordingly at the first meeting of the Commissioners, held on 11th January, 1850, the propriety of confirming the contract was discussed, and they resolved to avail themselves of the powers which the Council of the Society of Arts had reserved. The first act of the Commissioners was the publication of the following announcement:—

Determination of
the Contract with
the Society of
Arts.

The Royal Commissioners have felt it their duty, at this their first meeting, to take into their immediate consideration the propriety of confirming the Contract which has been entered into with Messrs. MUNDAY.

They are perfectly satisfied that the contract was framed with the sole desire on the part of the Society of Arts of promoting the objects of the Commission,—that in agreeing to it at a time when the success of the scheme was necessarily still doubtful, the Messrs. MUNDAY evinced a most liberal spirit,—that it has hitherto afforded the means of defraying all the preliminary expenses,—and that its conditions are strictly reasonable, and even favourable to the public.

After hearing, however, the statements made by individual members of the Commission,—after communicating with the Executive Committee,—and after a full consideration of the whole subject,—the Commissioners have come to the conclusion that it will be more consonant with the public feeling, and therefore more conducive to the objects for which the Commission has been appointed, to exercise the power reserved, and at once and absolutely to terminate the contract with the Messrs. MUNDAY.

This determination necessarily throws the whole burden of the Exhibition upon voluntary contributions. The experiment is of a national character, and the Commissioners feel that it ought to rest for its support upon national sympathies, and upon such liberal contributions as those sympathies may dictate.

* Now Sir STAFFORD H. NORTHCOTE, Bart.

The amount of the funds which the public may place at the disposal of the Commissioners must determine the extent of accommodation which can be provided for the Exhibitors, and the terms on which admission can be given to the articles to be exhibited, and upon which also the public can be admitted to inspect them.

The Commissioners wish it to be understood that they are invested with unrestricted power over the application of the funds; that it is their intention to invite competition in respect of all branches of expenditure to which competition can advantageously be applied; and that they will proceed, without delay, to establish regulations for insuring an effectual control over the expenditure, and a satisfactory audit of the accounts.

The Commissioners feel, that in thus abandoning a contract which, regarded in a pecuniary point of view alone, is undoubtedly advantageous to the public, and resting the success of the proposed experiment entirely upon public sympathy, they have adopted a course in harmony with the general feelings of the community.

It now rests with the public to determine, by the amount of their contributions, the character of the proposed Exhibition, and the extent of benefit to industry in all its branches which will result from it.

It is desirable that subscriptions for this great purpose be immediately commenced throughout the United Kingdom, and the result ascertained with the least possible delay.

In the mean time the Commissioners will be actively engaged in preparing the various measures, upon which it will be their duty to come to a final decision as soon as they are enabled definitely to ascertain the extent of the pecuniary means which will be placed at their disposal.

It is desirable, before giving any account of the proceedings under the Commission, to notice those changes which necessarily supervened upon the determination of the contract. The Commission itself set forth that the functions of the Commissioners were those of inquiry and general direction, whilst all the pecuniary responsibilities, and the performance of all the executive duties, were to be carried out by and in the name of the Society of Arts; but when the contract was cancelled, although the Commission itself was not altered, the practical result was to place on the Commissioners individually and personally the whole responsibility of the undertaking, both pecuniary and executive. Under these circumstances the Executive Committee felt it to be their duty to tender their resignations (*Min. iv., p. 3*), which they did in the following terms:—

The members of the Executive Committee submit that the dissolution by the Royal Commission of the contract, which they had been appointed for the purpose of carrying out, has changed the nature of their functions, and even superseded many of them. They are of opinion, therefore, that it is desirable that the Royal Commission should be left as free to select the best organization for carrying their intentions into effect, as if the Executive Committee had never been appointed. They feel that they should not be acting in accordance with their sincere wishes of witnessing the perfect success of the Exhibition, if they did not come forward to express their entire readiness at once to place their position in the hands of HIS ROYAL HIGHNESS THE PRINCE ALBERT, and the Royal Commissioners.

These resignations were not accepted, and some time elapsed before the executive arrangements were conclusively modified to meet the altered circumstances of the case. It had been the original intention of the Society of Arts in forming the contract, that in the event of its being determined, the liabilities of the contractors should be simply transferred to the Government, and that the original relations between the Commissioners and the Society of Arts should have remained; but this intention does not seem to have been made sufficiently clear by the deed, and it was not urged by the Society of Arts. The deed of

contract simply provided that the Treasury should have power to undertake the liabilities and relieve the Society of Arts from them. This the Treasury did, but in doing so, at the same time took a guarantee from the Commissioners themselves, and thus the whole responsibilities rested with them. The answer of the Treasury to the Commissioners was that—

Mutual liabilities
of the Treasury
and the Com-
missioners.

My lords have no intention of rendering themselves liable to the payment of any sum on this account; but as it seems that a request from them, that the contract should be determined, is necessary in order to enable the Commissioners to carry out their own intentions, they have no objection to taking the formal step of making the request suggested by the Commissioners to the Council of the Society of Arts, on receiving from the Commissioners an undertaking that the money will be forthcoming when required by Messrs. MUNDAY in conformity with the stipulations of the contract.

The Commissioners accordingly undertook that the money should be forthcoming when required (*Min.* iii., p. 7). The Society of Arts gave the requisite notices to the Messrs. MUNDAY, and in due time all the outlay which they had made, amounting to about £23,000, with the interest which had accrued, was repaid to them.

The pecuniary liabilities having thus devolved wholly on the Commissioners, it became natural that they should desire to appoint a chief executive officer of their own nomination. HER MAJESTY was advised to issue supplemental commissions, appointing Mr. ROBERT STEPHENSON, M.P., a commissioner, upon his resignation as Chairman of the Executive Committee, and Lieutenant-Colonel W. REID, R.E., Chairman of the Executive Committee in his place. These appointments were made by the advice of the Government, Mr. LABOUCHERE stating, "that the subject of the executive arrangements had been under their consideration, and that they had proposed to recommend to HER MAJESTY to appoint Colonel REID to be Chairman of the Executive Committee" (*Min.* v., p. 1). The contractors themselves, as well as their nominee, thereupon ceased to attend the meetings of the Executive Committee.

The earliest step which the Commissioners took after the determination of the contract was to appeal to the country for subscriptions to carry out the Exhibition. They announced that they had undertaken the absolute control over the expenditure of all money that might come into the hands of their Treasurers, and had made arrangements for auditing accounts, and ensuring the strictest economy. It was pointed out that the scale upon which this important undertaking would be conducted must depend entirely on the amount of pecuniary support which it should receive from the public. The Commissioners appealed with confidence to all classes of the community, to enable them to make such liberal arrangements as would ensure the success of the undertaking in a manner worthy of the character and position of this country, and of the invitation which had been given to the other nations of the world to compete with us in a spirit of generous and friendly emulation. It was announced that the amount of the funds which the public might place at the disposal of the Commissioners must determine the extent of accommodation which could be provided for the Exhibition; and that should any surplus remain, after giving every facility to the exhibitors, and increasing the privileges of the public as spectators, Her Majesty's Commissioners intended to apply the same to purposes strictly in connection with the ends of the Exhibition, or for the establishment of similar exhibitions for the future.

Public Subscrip-
tions and financial
management.

All subscriptions were considered to be absolute and definite; they were paid

to the Treasurers of Local Committees, and by them transferred to the general fund at the Bank of England, in the names of the Treasurers named in the Royal Commission. An Appendix to this introduction shows that the *gross* amount of subscriptions reported as having been received has amounted to £75,000. Of this above £64,000 has been paid to the Commissioners, the balance having been reserved by the Local Committees to meet their expenses of collection, printing, &c. The general financial position of the undertaking at the opening of the Exhibition was as follows:—

<i>Receipts.</i>	Revised to Sept. 11.	<i>Expenditure and Liabilities.</i>	Revised to Sept. 11.
Subscriptions paid to April 22	£64,344	Building	£79,800
For privilege to print the Catalogues	3,200	Extra Galleries, Counters, and their fittings, estimated at	35,000
For privilege to sell Refreshments	5,500	By Prize Fund	20,000
By Season Tickets to April 29	40,000	Management, including Printing and all incidental Expenses incurred up to April	20,943
Admissions of the Public	274,521	Management since, including award to Messrs. Munday and part payment to Police	35,000
Royalty on sale of 1s. Catalogue			
			124,452
			20,000
			20,943
			35,000

Subject to the approval of the Commissioners the direct control over this expenditure has been exercised by a Finance Committee, consisting of Lord GRANVILLE (Chairman), Lord OVERSTONE, Mr. LABOUCHERE, Mr. GLADSTONE, Sir ALEXANDER SPEARMAN, Mr. T. F. GIBSON, Mr. T. BARING, Mr. COBDEN, and Mr. PETO. Mr. EDGAR A. BOWRING has acted as Secretary to the Committee, and Assistant Commissary-General CARPENTER, as the financial officer, has administered the actual expenditure of the Commission.

The preceding statement of account shows that, even at the present time, a considerable liability has been incurred by the Commissioners. At the period when it became necessary to make positive arrangements for the erection of the building, the actual receipts were only £35,000: personal responsibility legally attached to His Royal Highness the President, and to every member of the Royal Commission, in respect of every pecuniary engagement. A remedy for this somewhat anomalous position was obtained by means of a charter of incorporation, and the formation of a guarantee fund. The first relieved the Commissioners of all personal responsibility, and the second insured both the completion of the undertaking, and the House of Commons from the liability of being required to make any grant of the national funds towards it.

Charter of Incorporation.

Letters Patent, dated July, 1850, were issued, incorporating the Commissioners, under the title of "The Commissioners for the Exhibition of 1851," and the charter was accepted 15th August, 1850 (*Min.* xxviii. p. 1). A guarantee fund of £230,000 was formed by a limited number of persons, including most of the Commissioners, and other friends of the Exhibition, one of whom opened the list with a subscription of £50,000: upon the security of this fund the Bank of England consented to make such advances of money as might be wanted from time to time.

General principles of the Exhibition.

The fundamental principles upon which it was proposed the Exhibition should be formed had been discussed and settled before the Commission was issued, and are recited in the Commission itself. With the requisite limitations and conditions, these principles were confirmed by the Commissioners, and formally announced in the month of February, 1850, so that there was a full year for preparations. It was declared that the productions of all nations would be

admitted, and classified lists of objects were prepared by Committees of eminent persons in each department (whose names are given in an Appendix), and published to show the nature of the contributions which exhibitors were invited to send in the four departments of RAW MATERIALS and PRODUCE, MACHINERY, MANUFACTURES, and FINE ARTS. The regulations by which certain articles were excluded were as follows:—

Nothing is suitable for the Exhibition, except such results of human industry as are capable of being preserved without injury during many months.

All spirits, wines, and fermented liquors, unless derived from unusual sources, are inadmissible, except in special cases, and under special restrictions; and when oils, spirits, &c., are exhibited, to prevent accidents, they must be shown in well-secured glass vessels.

All highly-inflammable articles, such as gunpowder, detonating powder, lucifer matches, &c., and all live stock, and articles perishable within the duration of the Exhibition, are inadmissible, unless specially excepted.

In respect of the fourth section of the Exhibition, SCULPTURE, MODELS, and the PLASTIC ART, the following were the limitations:—

Objects formed in any kind of material, if they exhibit such a degree of taste and skill as to come under the denomination of *Fine Art*, may be admitted into this section.

The specimens exhibited shall be works of living artists, or works of artists deceased within three years before the 1st of January, 1850.

Oil paintings and water-colour paintings, frescoes, drawings, and engravings, are not to be admitted, except as illustrations or examples of materials and processes; and portrait busts are not to be admitted.

No single artist will be allowed to exhibit more than three works.

It was also announced that the 1st day of May, 1851, was fixed for opening the Exhibition, and the engagement has been kept: that Her Majesty had been graciously pleased to grant a site for the Exhibition on the south side of Hyde Park, lying between the Kensington Drive and the Ride commonly called Rotten Row, and that exhibitors would be required to deliver their objects, at their own charge and risk, at the building, which would be provided to them free from rent.

Opening fixed for
May 1, 1851.

After much examination and inquiry, the Commissioners resolved that prices were not to be affixed to the articles exhibited, although the articles might be marked as shown for economy of production, and the price stated in an invoice to be sent to the Commissioners for the information of the Juries.

It was clear that two very different systems of management would necessarily have to be adopted towards Foreign countries and the United Kingdom, arising out of the different relations of guest and host. Although it was proposed that the expenses of the building and management should be defrayed by voluntary subscriptions, scrupulous care was taken on every occasion to discourage the receipt of any subscription from any foreigner, resident at home or abroad. Over the admission of British articles, the Commissioners reserved to themselves full powers of control; but as respects Foreign articles, the power of admitting them was confided absolutely to an authority of the country which sent them.

Admission of
Foreign articles.

In order to give Foreign countries the utmost time for their preparations, and long before the size or character of the building had been determined, the Commissioners resolved to divide a certain large amount of exhibiting space among all Foreign countries, amounting in the whole to above 210,000 superficial

the general
the Royal
amount of
1,000. Of
having been
printing,
ng of the

	Revised to Sept. 11.
0	
0	124,452
0	20,000
3	20,943
	35,000

over this
g of Lord
LADSTONE,
r. COBDEN,
Committee,
officer, has

time, a
the period
tion of the
ity legally
ber of the
dy for this
orporation,
mmissioners
ion of the
required to

mmissioners,
" and the
tee fund of
f the Com-
list with a
f England
he to time.
ion should
as issued,
ations and
d formally
ll year for
would be

feet, or rather more than the entire space which France occupied for its two expositions of 1844 and 1849. It was estimated that this amount would be about half the size of the building, which was considered to be a fair proportion.

Space offered to
Foreign countries

The amount of space which was offered to each Foreign country, and placed at its absolute disposal, was as follows:—

	Net superficial Feet allotted.		Net superficial Feet allotted.
Arabia	500	Italy—	
Belgium	15,000	Naples	2,500
Bolivia	100	Rome	1,000
Brazil	1,000	Sardinia	1,500
Buenos Ayres	500	Tuscany	3,750
Central America	300	Mexico	1,000
Chili	500	Monte Video	100
China	2,500	Morocco	500
Denmark	2,500	New Granada	500
Egypt	1,500	Norway and Sweden	2,500
Equator	100	Persia	500
France	50,000	Peru	500
Germany—		Portugal	1,000
Austria	21,750	Russia	7,500
Northern Germany—		Spain	2,500
States of the Stuerverein	2,250	Switzerland	4,000
The Two Mecklenbergs	1,250	Tunis	500
Hanse Towns	1,500	Turkey	5,000
Zollverein	30,000	United States	40,000
Greece	1,000	Venezuela	400
Holland	5,000	Western Africa	500
		Total	213,000

Subsequently these amounts were increased in several instances. France, for example, obtained upwards of 65,000 superficial feet of exhibiting space, instead of only 50,000 feet.

Accompanying the allotment of space sent to each Foreign country and colony, the following instructions were transmitted:—

No articles of foreign manufacture, to whomsoever they may belong, or wheresoever they may be, can be admitted for exhibition, *unless they come with the sanction of the central authority of the country of which they are the produce.* All articles forwarded by such central authority will then be admitted, provided they do not require a greater aggregate amount of space than that assigned to the productions of the country from which they come; and, provided also, that they do not violate the general conditions and limitations. It will rest with the central authority in each country to decide upon the merits of the several articles presented for exhibition, and to take care that those which are sent are such as fairly represent the industry of their fellow countrymen.

Her Majesty's Commissioners will consider that to be the central authority in each case which is stated to be so by the Government of its country. Having once been put in communication with a central authority in any country, they must decline, absolutely and entirely, any communication with private and unauthorized individuals; and should any such be addressed to them, they can only refer it to the central body. This decision is essentially necessary, in order to prevent confusion.

The Commissioners do not insist upon articles being in all cases actually forwarded by the central authority, though they consider that this would generally be the most satisfactory

arrangement; but it is indispensable that the sanction of such authority should in all cases be expressly given, and that it be held responsible for the fitness of such articles for exhibition, and for not authorizing the exhibition of a greater quantity than can be accommodated in the space assigned to the productions of the country in question.

In case the central authority in any country should be of opinion that the space allotted to the productions of that country is greater than it will require, the Commissioners have to request that this opinion may be communicated to them, as it is obvious that it would not appear well if a large vacant space should be left in the department assigned to any country.

A definite quantity of space was in like manner offered to each of the British Colonies in the following proportions, and subject to the same rules for admission: And British Colonies.

	Net superficial Feet allotted.		Net superficial Feet allotted.
Australian Colonies—		Nova Scotia and Cape Breton	1,000
New South Wales	2,000	Prince Edward's Island	250
New Zealand	500	St. Helena	50
South Australia	350	Sierra Leone	150
Van Diemen's Land	600	West India Colonies—	
West Australia	350	Antigua	375
Bermudas	50	Bahamas	100
Canada	4,000	Barbadoes	750
Cape of Good Hope and Natal	750	British Guiana	100
Cape Coast Castle and Dependencies	100	Dominica	125
Ceylon	1,500	Granada	250
Falkland Islands	25	Jamaica	1,500
Gambia	100	Montserrat	50
Gibraltar	100	Nevis	100
Hong Kong	Nil.	St. Christopher's	250
Hudson's Bay Co.'s Territories	1,000	St. Lucia	250
India, including Singapore	30,000	St. Vincent	250
Ionian Islands	1,000	Tobago	100
Labuan	250	Tortola and Virgin Islands	50
Malta	1,000	Trinidad	750
Mauritius	750		
New Brunswick	750	Total	51,025
Newfoundland	500		

It was intimated that colonial and foreign productions would be admitted for the purposes of exhibition without payment of duty. The building of the Exhibition has been considered as a bonded warehouse, and the Commissioners of Customs have afforded the utmost facilities consistently with that obedience to Customs' laws, which was imperative.

Those who have had experience only of the continental systems of exhibitions, which are managed and paid for wholly by their Governments, find it difficult to understand the self-supporting and self-acting principle of the present Exhibition, which has hitherto depended wholly upon the voluntary subscriptions of the British people: the heavy liabilities which still hang over the undertaking rest wholly upon individuals in their private capacity, and not upon the Government. The British people, as well poor and working men, as the richer classes, have had the undivided responsibility, not only of conducting the first experiment of an Exhibition of their own works on a national scale, but of collecting funds to pay all the expenses of an Exhibition of the Works of all Nations. Our National Exchequer has not been charged with any portion of the expenses, but the con-

tributions of the most remote towns have been received and applied, even in payment of the military and police assistance which the Government has permitted to be employed on the occasion. So completely spontaneous has been the organization for the Exhibition, that not even the several municipal councils throughout the country were employed, but an independent organization was created for the express purpose wherever a locality was disposed to form its own Local Committee. Without the assistance of the Local Committees of the United Kingdom, no Exhibition of the Works of Industry of all Nations could ever have been accomplished.

Local Committees of the United Kingdom.

About 65 Local Committees had been formed before the issue of the Royal Commission, with the assistance of the Members of the Society of Arts, who had been nominated by the President to visit different parts of the kingdom. To extend this organization over the whole kingdom, into Local Committees, was one of the first acts of the Royal Commission. A circular was issued to the Mayors of all towns within the United Kingdom, having a municipal constitution (*Min. i.*, p. 1), announcing the issue of the Royal Commission, and requesting, if no Local Committee had been formed, that the mayor would communicate with the principal inhabitants for the purpose of ascertaining whether, in their opinion, the circumstances of the town rendered it advisable to appoint a Local Committee. The functions of these Local Committees have chiefly consisted in the recommendation of Local Commissioners to represent the interests of their localities—in encouraging the production of suitable objects for exhibition—in affording information in the locality relative to the Exhibition—in the collection of subscriptions—and in facilitating the means of visiting the Exhibition.

The Commissioners intimated that it was their wish to limit, as far as possible, the necessity for the exercise of the powers of rejection and selection of objects intended for exhibition, and for that purpose to call to their assistance the local knowledge and discretion of the several Local Committees. They recommended that the Local Committees should enter into personal communication with those persons resident within their district, who were likely to be exhibitors; and that they should ascertain the character and number of the objects which it would be their wish to send to the Exhibition. For the purpose of communicating with the Local Committees, the Commissioners appointed Dr. LYON PLAYFAIR, and Lieut.-Colonel LLOYD, Surveyor-General of the Mauritius, Special Commissioners.

Demand for space by British exhibitors.

It was not required that exhibitors should of necessity be subscribers to the fund. All persons desirous of contributing articles to the Exhibition of 1851, were invited to give notice of such intention, and transmit a general description of the nature of each article, and the space which would be required for the exhibition of it, to the Secretary of the nearest Local Committee, and the Local Committee was requested to digest the returns so made to them, and transmit them to the Commission before the 31st Oct., 1850. It was not necessary in the first instance either to exhibit to the Local Committee specimens of the articles to be sent, or to give a minute specification of them. But it was decided that it was necessary for intending exhibitors to obtain the certificate of the nearest Local Committee, of its approval of the articles sent for exhibition, before they could be received by the Commissioners in the building. Upwards of 330 Local Committees were formed in the three parts of the United Kingdom and the Channel Isles. A list of those which have transmitted subscriptions to the fund, or sent articles to the Exhibition, will be found in the Appendix.

The 31st October was appointed the last day when the Local Committees were required to transmit to the Executive Committee the demands for space which intending exhibitors had made through them.

It then appeared that the whole of the demands for horizontal (floor and counter) space in the building which the Local Committees of the United Kingdom returned, exceeded 417,000 superficial feet of exhibiting space, being in excess of the amount of available space for the United Kingdom by about 210,000 superficial feet. The amount of vertical or wall space demanded was only 200,000 superficial feet. The number of persons who proposed to exhibit was upwards of 8,200.

Upon the receipt of these data the Commissioners proceeded to adjust the proportions of floor or counter space which it appeared desirable that the four sections of the Exhibition should occupy in the Building. Upon averages, furnished by the whole of the United Kingdom, and obtained by dividing the total amount of space apportioned to each section by the number of exhibitors in that section, the Commissioners, as a general rule, allotted to each Local Committee an amount of space in each section, in proportion to the number of exhibitors which had been returned by each Committee. The Commissioners left the allotment of space to each exhibitor absolutely to the discretion of each Local Committee. They desired that each Local Committee, in allotting space to the individual exhibitors, should, as far as possible, maintain the proportions of the four sections allotted to it, so that in the ultimate arrangement of the whole Exhibition, the space which each section might occupy, should agree as closely as was possible with the spaces fixed by the Commissioners. It was suggested that only those articles which did honour to our industrial skill as a nation should be admitted, and that the industry of the district should be represented with perfect fairness, so as to do the fullest credit to its industrial position.

The Commissioners then proceeded to cause copies of each individual application for space to be transmitted to the respective Local Committees for revision and correction where necessary, which, when returned by the Committees, were considered as the vouchers for the admission of the articles, and as tantamount to *their unqualified approbation of the articles*. In no case could a Local Committee increase the amount of the total space allotted to it by the Commissioners. The Commissioners appointed the 10th December, as the last day on which vouchers were to be received, but it was not until the 10th January, and even much later in some cases, that the Executive Committee obtained the whole of them, by which their labours were considerably increased, and the arrangements delayed.

If any productions had been rejected by any Local Committee, and the proprietor of them desired to appeal against the decision, it was competent for him to address the Commissioners through the Local Committee, who forwarded the appeal, with their own observations, and the Commissioners, upon consideration of the circumstances, confirmed or negatived the decision. The appeals, however, were few.

With the view of providing against the exhibition of duplicate articles of manufacture, the Commissioners, in cases where duplicates might have been admitted by *different* Local Committees, intimated that they would call upon the exhibitors of such duplicates to produce a certificate from the actual makers, stating which of the exhibitors had arranged with the maker to be proprietor of the absolute and exclusive right of sale and distribution of such article, and the preference of admission would be given to that exhibitor who was the sole pro-

prietor. The Commissioners were not called upon to exercise this power in a single instance.

Metropolis.

Although several Local Committees were formed in the Metropolis, the functions of rejection and selection of articles were performed by a united action of all the several Committees. Each Committee nominated Commissioners to represent a particular department of the Exhibition, who met together to consider the merits of the individual claims for space referred to them.

Such was the course of action by which the articles of British exhibitors were admitted to the Exhibition, and subjected to a preliminary judgment. Imperfect as it necessarily was, the general effect of it was satisfactory, and kept out of the Exhibition many unsuitable articles. Practically the system worked well, and there is no doubt that the Exhibition, as a whole, is a fair representation of the present state of British industry. An examination of the list of exhibitors shows that very few names indeed of artists or manufacturers of eminence are absent. It is probable, however, that there are fewer novelties in mechanical inventions than there would otherwise have been, had the Legislature provided against piracy of them at an earlier period than April, 1851.

The Building.

It is now time to speak of the origin of the Building, and of its general features, so far as they have influenced the system which has been adopted in classifying and arranging the articles in it. An account of its scientific construction will be found in another part of this volume.

As early as January, 1850, the Commission named a Committee "for all matters relating to the Building," consisting of—

The Duke of BUCCLEUCH.	Mr. STEPHENSON.
The Earl of ELLESMERE.	Mr. COCKERELL, R.A.
Mr. BARRY, R.A.	Mr. BRUNEL.
Mr. CUBITT, Pres. Inst. C.E.	Mr. DONALDSON.

Mr. CUBITT was elected Chairman of this Committee, and from the earliest period to the opening of the Exhibition, has given daily and unremitting attention to the subject, at great personal sacrifice of his valuable time. On the 21st of February, 1850, the Building Committee reported favourably on the fitness of the present site in Hyde Park, which had been suggested in the early stages of the undertaking, and for the use of which it had been already announced that HER MAJESTY'S permission had been obtained. The Committee ventured at once to recommend that upwards of 16 acres should be covered in; a bold step at that time (21st February), when no data whatever of the space likely to be filled had been received (*Min.* vii., p. 5). It was their opinion that it was desirable to obtain suggestions, by public competition, as to the general arrangements of the ground plan of the Building, and public invitations were accordingly issued. They also reported that when a plan for the general arrangement should have been obtained and approved, they would invite, by a second public notice, designs accompanied by tenders, from the builders and manufacturers of the United Kingdom, for the construction of the Building, in the form, and according to the general arrangement, which should be fixed upon. In answer to the invitation to send in plans, upwards of 245 designs and specifications were submitted. Of these 38 were contributed by foreigners: France sending 27; Belgium 2; Holland 3; Hanover 1; Naples 1; Switzerland 2; Rhein Prussia 1; Hamburg 1; 128 by residents in London and its environs; 51 by residents in provincial towns of England; 6 by

residents in Scotland; 3 by residents in Ireland; and 7 were anonymous. All these plans were publicly exhibited during a month, from the 10th of June, at the Institution of Civil Engineers, Great George Street, Westminster. The Building Committee reported on the merits of them, selecting two lists of the competitors. They considered the one "entitled to favourable and honourable mention," and the second "entitled to further higher honorary distinction." But they accompanied their report with the important announcement, that in their opinion there was no "single plan so accordant with the peculiar objects in view, either in the principle or detail of its arrangement, as to warrant them in recommending it for adoption" (*Min.* xvii., p. 6). The Committee, therefore, submitted a plan of ^{First plan.} their own, and assisted by Mr. DIGBY WYATT, Mr. CHARLES HEARD WILD, and Mr. OWEN JONES, they prepared extensive working drawings, which were lithographed. They issued invitations for tenders to execute works in accordance with them, requesting from competitors, in addition, such suggestions and modifications, accompanied with estimates of cost, as might possibly become the means of effecting a considerable reduction upon the general expense. In the actual instructions they stipulated that tenders, in which changes were proposed, would be only entertained provided they were "accompanied by working drawings and specifications, and fully priced bills of quantities."

The Building Committee published in detail the reasons, both of economy and taste, which had induced them to prepare plans for a structure of brick, the principal feature of which was a dome two hundred feet in diameter. Public opinion did not coincide in the propriety of such a building on such a site, and the residents in the neighbourhood raised especial objections. The subject was brought before both Houses of Parliament; and in the House of Commons, on the 4th July, 1850, two divisions took place on the question, whether the proposed site should be used at all for any building for the Exhibition. In the one division, the numbers in favour of the site were 166 to 47, and in the second 166 to 46. The Commissioners published, at considerable length, a statement of the reasons which had induced them to prefer the site, and there can be no doubt that the force of this document mainly influenced the large majority in both divisions.

Whilst the plan of the Building Committee was under discussion, Mr. PAXTON ^{Mr. Paxton's proposal.} was led, by the hostility which it had incurred, to submit a plan for a structure chiefly of glass and iron, on principles similar to those which had been adopted and successfully tried by him at Chatsworth. Messrs. FOX, HENDERSON, and Co., tendered for the erection of the Building Committee's plan, and, strictly in accordance with the conditions of tender, they also submitted estimates for the construction of the building suggested by Mr. PAXTON, and adapted in form to the official ground plan. An engraving of Mr. PAXTON's original design was published in the *Illustrated London News*, 6th July, 1850, which, when compared with the building that has been actually erected, will show what changes were subsequently made. The Commissioners having fully investigated the subject, finally adopted, on the 26th July, Messrs. FOX, HENDERSON, & Co.'s tender to construct Mr. PAXTON's building, as then proposed, for the sum of £79,800. Considerable modifications, additions, and improvements in the architectural details were subsequently made, which have raised the proposed original cost of the building. As soon as the decision was made, fresh working drawings had to be prepared, and every means taken for expediting the works. These were carried on under the superintendence of Mr. CUBITT, assisted by Mr. D. WYATT, Mr. O. JONES, and Mr. C. WILD.

The formal deed of contract was not signed until the 31st October, although the first iron column was fixed as early as the 26th September, 1850, the contractors having thereby incurred, in their preparations, a liability of £50,000 without any positive contract; in fact, great reciprocal confidence was manifested by the contracting parties. Whatever objections were entertained originally against the use of the site, gradually disappeared during the progress of the present building, and have become changed into positive approval and admiration, of the building itself and assent to the particular location of it. It should, however, be stated that a deed of covenant, to remove the building and give up the site within seven months after the close of the Exhibition, namely before the 1st June, 1852, has been entered into between HER MAJESTY and the Commissioners. The deed was sealed on the 14th November, 1850.

At a very early period the Commissioners resolved that the whole space of any building should be equally divided, and that one-half should be offered to Foreign countries, and the other reserved to Great Britain and her colonies. And almost simultaneously with this decision, before the plans of any building were settled, offers were made to foreign countries, assuring them more than 210,000 superficial feet of net exhibiting space. But after the ground plan had been settled, and a calculation had been made of the amount of space unavailable for exhibition that was absorbed by the transept, the avenues, the courts and offices, &c., it became evident that the remaining space, after deducting what had been assured to foreigners, was considerably less than the proportion due to Great Britain and her colonies, and much below the demands and wants of British exhibitors. It was at first suggested that an additional structure should be erected to accommodate the agricultural implements, outside the building, but it was found that reasons both of economy and of management greatly preponderated in favour of building an additional gallery, which was accordingly done.

Classification and
arrangement of
articles.

In order to settle the positive arrangement of articles in the building, it became necessary to prepare a more precise system of classification than that furnished by the classified list of admissible objects which the Commissioners had first issued. The various systems which had been tried in the French Expositions proved that any system based upon an abstract philosophical theory was unsuitable, and particularly so to the present Exhibition. It was also desirable that the system of classification should be made conducive to the readiest mode of consulting the vast collection, both by the general visitor and by the juries, who would have to consider the merits of the whole. Dr. PLAYFAIR, to whom the Commissioners had confided the superintendence of the juries, suggested that whilst preserving the original quadrupartite divisions of the Exhibition into Raw Produce and Materials, Machinery, Manufactures, and Fine Arts, those subdivisions which had been determined by commercial experience, should be adopted as far as practicable, as the basis of the Classification. Eminent men of science, and manufacturers in all branches, were invited to assist in determining each one the boundaries of his own special class of productions; and it was resolved, for the purposes of the jury, to adopt thirty broad divisions, and to induce as far as practicable the application of this classification to all articles—both British and Foreign; always, however, bearing in mind the fundamental rule, that the productions of an exhibitor would not be separated, except in very extreme cases. Accordingly, with few exceptions, all articles have been divided into the following thirty classes.

To save repetition, the numbers of the jurors which have been since assigned to each class are here given.

SECTION I. Raw Materials and Produce,—illustrative of the natural productions on which human industry is employed.

	No. of Jurors.		No. of Jurors.
1. Mining and Quarrying, Metallurgy, and Mineral Products	8	3. Substances used as food	6
2. Chemical and Pharmaceutical processes and products generally	8	4. Vegetable and Animal Substances used in manufactures, implements, or for ornament	8

SECTION II. Machinery for Agricultural, Manufacturing, Engineering, and other purposes and Mechanical Inventions,—illustrative of the agents which human ingenuity brings to bear upon the products of nature.

	No. of Jurors		No. of Jurors.
5. Machines for direct use, including carriages, Railway and Naval Mechanism	12	9. Agricultural and Horticultural Machines and Implements (exceptional).	
6. Manufacturing Machines and Tools	12	10. Philosophical Instruments and Miscellaneous Contrivances, including processes depending upon their use, Musical, Horological, Aconatical and Surgical Instruments	12
7. Mechanical, Civil Engineering, Architectural, and Building Contrivances	8		
8. Naval Architecture, Military Engineering and Structure, Ordnance, Armour and Accoutrements.	8		

SECTION III. Manufactures,—illustrative of the result produced by the operation of human industry upon natural produce.

Designs for Manufactures are admitted in the same section with the class of articles for which they are proposed.

	No of Jurors.		No. of Jurors.
11. Cotton	10	23. Works in precious Metals, Jewellery, and all articles of luxury not included in the other classes	8
12. Woolen and Worsted	12	24. Glass	8
13. Silk and Velvet	10	25. Ceramic Manufacture, China, Porcelain, Earthenware, &c.	8
14. Manufactures from Flax and Hemp	10	26. Decoration Furniture and Upholstery, Paper Hangings, Papier Maché, and Japanned Goods	12
15. Mixed Fabrics, including Shawls	12	27. Manufactures in Mineral Substances, used for building or decorations, as in Marble, Slate, Porphyries, Coments, Artificial Stones, &c.	6
16. Leather, including Saddlery and Harness, Skins, Fur, and Hair	10	28. Manufactures from Animal and Vegetable Substances, not being woven, felted, or laid	6
17. Paper, Printing, and Bookbinding	8	29. Miscellaneous Manufactures and Small Wares	10
18. Woven, spun, felted, and laid Fabrics, when shown for Printing and Dyeing	10		
19. Tapestry, including Carpets and Floor Cloths, Lace and Embroidery, fancy and industrial Works	10		
20. Articles of Clothing for immediate, personal, or domestic use	8		
21. Cutlery, Edge Tools and Hand Tools, and Surgical Instruments	6		
22. General Hardware	12		

SECTION IV.

30. Fine Arts, Sculpture, Models, and the Plastic Arts generally, Mosaics, Enamels, &c.—illustrative of the taste and skill displayed in such applications of human industry 12

It had been originally contemplated by the Commissioners, that the arrangement of the whole Exhibition should be, not merely on the basis of the four sections, but that each similar article should be placed in juxtaposition without reference to its nationality, or local origin. To effect this, in so vast an Exhibition and within the short period of two months allowed for the arrangement, it was absolutely necessary to know, before the arrival of the articles, the approximate amount of space each would be likely to occupy—so that each on its arrival might be placed as nearly as possible in its appointed spot. But the event proved that this information, particularly in the case of Foreign countries, was unattainable.

A request was made that each Foreign country should inform the Commis-

Geographical arrangement for Foreign and Colonial articles.

sioners, on or before the 1st of September, what space would be likely to be occupied respectively by its raw materials, its machinery, its manufactures, and fine arts; but only Austria, Belgium, Zollverein, and North Germany complied with this request, and furnished the information in sufficient detail. The great distance of other countries rendered the transmission of the information impossible, and practically it was not known what articles many very important countries would send, until they actually arrived. No choice remained but to adopt a geographical arrangement; and it was not until so late a period as the month of December that the Commissioners were enabled to decide the principles upon which the articles should be arranged in the Building. Circumstances connected with the form of the Building itself, the absence of the necessary information from Foreign countries, the great pressure for time, and above all the vital importance of punctually opening the Exhibition on the first of May, induced the division of the ground floor of the Building into two parts—the one being awarded to Foreign countries, and the other to the British colonies and the United Kingdom.

Allotment of space and position in the building.

The productions of the United Kingdom and the British colonies are generally grouped *westward* of the central transept. The productions of each foreign country are placed together *eastward* of the transept—except machinery in motion, which, on account of the motive power being at the *north-west end* of the building, is placed in that part of the building. The productions of each country are classified nation by nation, and as far as practicable into the thirty classes already mentioned. The position of each country is determined in the building by its own latitude. As a general rule, machinery is placed at the *north* side, and raw materials and produce brought to the *south* side of the building. The intermediate parts are occupied by manufactures and fine arts. There is hardly any choice in respect of *light*, which is nearly the same in all parts of the building. The *south* side, as well as the roof of the building both in the *north* and *south* sides, is covered with canvas. The sides of the upper and the gallery tier on the *north* are not so covered. As a general rule applicable both to foreign countries and the United Kingdom, space was allotted on the following data:—on the ground floor, each area of 24 feet by 24 feet containing 576 feet superficial, was accounted as yielding exhibiting area of 384 feet, it being considered that 192 feet would be a sufficient allowance for passages. The width of these was determined by experiments in the building and by experience of those in the British Museum, in the Soho Bazaar, &c. In the gallery, half of each area was deducted for passages, and the other half, or 288 feet, assigned as exhibiting space. If the exhibitor wished to have more passage-room, then he was obliged to obtain it by deducting it from his exhibiting space: and every exhibitor, desiring to attend himself, or by his representative, during the Exhibition, had to deduct the sitting or standing space for such attendant from the superficial floor or counter-space allotted to him.

System of passages.

A glance at the plan shows the adoption of a simple system of main passages. There is a central avenue 72 feet wide running from east to west, which is partially used to display both works of art and remarkable specimens of manufacture, and likewise to afford sitting room; parallel to this on each of the north and south sides are two uninterrupted passages 8 feet wide, one extending the length of the building and the other taking the circuit of the walls on each side. Besides the transept there are six main passages 8 feet wide, running from *north* to *south*. These were established as passages which must not be infringed upon:

portions of the building being then assigned to Foreign countries and to groups of exhibitors, a considerable latitude was permitted to them in arranging the other passages; at the same time, as the erection of the second gallery brought the whole building into a system of courts, spaces in the form of courts were allotted to Foreign countries, home districts, and classes of objects, and every one was encouraged to preserve them as much as possible. Thus on the British side, at the north there are the several machinery courts—the carriage court—the mineral court—the paper court—the miscellaneous court—the East India court; whilst at the south, there are three courts respectively for printed fabrics, for flax and woollen, and mixed fabrics:—furniture has its court, so have the manufactures of Birmingham and Sheffield—agricultural implements have an extensive court, and there are courts for mediæval furniture, for sculpture, for Canada and colonies, and the East Indies; on the east or Foreign side, almost every country has one or more courts,—France having eight, Austria six, &c.

Spaces of the requisite dimensions having been set apart to receive the productions of the Colonies and each Foreign country, the charge of these departments, as well as the arrangement of the productions, was handed over to each commissioner or agent representing such Colonies or Foreign country.

On account of the vast magnitude of the building, of the shortness of time available for arrangement after the completion of the building, which as the event proved was hardly a week before the opening, and of the delay in sending the goods, it was foreseen by the Executive Committee that it would be necessary to arrange the Foreign productions geographically and the whole of the British Exhibition, not by means of the articles themselves, but of descriptions of them, and to map out the whole space before the articles themselves arrived. Not a few of these descriptions were in the first instance most vague; the exhibitor desiring to reveal as little as possible of the specific character of his articles. Many exhibitors demanded space for “fabrics,” without specifying whether they were even woven or plastic. Others returned “woven fabrics,” leaving it doubtful whether they were made of cotton, wool, or flax; each forming a separate class. The demands for space, merely for “inventions” and “machines,” were numerous. Hence, there have crept in some errors in arrangement which would have been avoided had the description been more precise. Another source of difficulty has been the miscalculations of the amount of space which exhibitors really wanted. So frequently was the meaning of the term “superficial” and “square” feet misunderstood; so often were the expressions “horizontal” and “vertical” space disregarded or confounded, that in planning the arrangement of the Exhibition the difficulties of the Executive Committee have been great, and mistakes inevitable. One instance will afford a sufficient illustration. An important manufacturing town demanded 9,000 feet of wall or vertical space for the exhibition of its shawls, but when the demand came to be investigated, it was found to mean a demand for 900 feet of frontage on the wall, 10 feet high, and 3 feet deep—practically a demand for 27,000 superficial feet—to be arranged in such a way as would occupy half the length of the whole Exhibition! This demand of 27,000, was eventually compressed within 1,800 superficial feet of horizontal space, and submitted to, it must be admitted, with good-natured forbearance. Indeed, it may be said, that whilst almost every exhibitor desired some kind of special arrangement, convenient to himself, but inconvenient to every body else, almost every one submitted to a

Arrangement of
British articles.

curtailment of space, and a constraint on his wishes, with a patience that greatly lightened the labours of the Executive Committee. In fact, owing to these circumstances, inevitable in such a work, without precedent or experience, and to the very late period at which some demands for space were made, it was only possible to make an approximate guess at the space which each of the classes of goods of the United Kingdom would occupy, and to leave a considerable margin for adjustments.

It should be borne in mind that every Foreign country was able to regulate the character of the arrangement by the articles themselves. The whole of its articles were first collected, and then the arrangement settled. Every Foreign country, in this respect, stood in the same position as an individual British exhibitor; but on the British side, the general arrangement, and almost the position of each of the 7,000 exhibitors, were necessarily fixed before the articles were brought into the building. An elaborate classified list of subjects included in each of the 30 classes was prepared, and recommended as a basis of arrangement to exhibitors, though, from the causes already stated, the systematic classification could not be carried out in so complete a manner as was desired.

At the British side, every exhibitor had entire control over his own allotment, the Commissioners, from an early period, having decided that each exhibitor was at liberty to arrange such articles in his own way, so far as was compatible with the convenience of other exhibitors and of the public. When the exhibitor's wishes involved expense, the exhibitor defrayed it himself. Glass cases, frames, and stands of peculiar construction, and similar contrivances for the display or protection of the goods exhibited, were provided by the person requiring them at his own cost. Persons who wished to exhibit machines, or trains of machinery in motion, were permitted to do so. The Commissioners found steam not exceeding 30 lbs. per inch gratuitously to the exhibitors, and conveyed it in clothed pipes to such parts of the building as required steam power. Arrangements were made to supply water at a high pressure gratuitously to exhibitors, who had the privilege of adapting it to the working of their machinery, &c. And the Chelsea Water-works contracted to supply 300,000 gallons of water per day, at the rate of £50 per month.

Catalogues.

It was decided that two Official Catalogues should be prepared and published by the authority of the Commission; the one of a large size, containing full notices of everything that the exhibitor desired to state, and the other an abridgment containing the names of the exhibitors only, with a very general summary of the articles they exhibited. The right of printing and publishing these was offered for competition. The contractors were at liberty to fix the price of the large Catalogue. The smaller Catalogue was to be sold at 1s., and the contractors were bound to pay 2d. for every copy sold to the funds. Several parties tendered. The offer of Messrs. SPICER BROTHERS, and Messrs. CLOWES and SONS, as the highest, was accepted; the amount of their offer being £3,200. It was also provided (*Min.* xxix., p. 1), that should the number sold exceed 500,000 of the small edition, and 5,000 of the large, then the contractors should give a further sum for all sold over and above those numbers. The contract was sealed 6th January, 1851.

Insurance from
fire.

The insurance of goods from fire, or other kinds of accidents, and the responsibility for all losses, devolved upon the exhibitors. The Metropolitan Fire

Brigade took charge of the safety of the Building from fire. With the permission of the Secretary of State for the Home Department, the responsibility for the whole of the police arrangements was placed upon Mr. MAYNE, the Chief Commissioner of Police. The Commissioners expressed their willingness to pay the sum of £5,043 19s. 4d., in consideration of the Commissioners of Police providing the force necessary to be employed outside the Exhibition Building (*viz.*, at the various entrances and approaches within Hyde Park), for the period of six months, from 1st March to 1st September, stipulating, however, that should it appear that the additional force which it was contemplated to provide was greater than was actually required, a proportionate reduction was to be made. The Commissioners left the question of the police force necessary for the interior watching of the building, and of the amount of expense in connection with it, in the hands of Her Majesty's Government, "in the full assurance that the utmost economy will be observed that is compatible with the satisfactory execution of that duty" (*Min.* xxxiii., p. 2).

The Commissioners considered that it would conduce to the convenience of visitors to permit light and moderate refreshments to be obtained and consumed in *certain prescribed parts* of the building but that it would be inconsistent with the nature of the Exhibition to allow the building to assume the character of an hotel, tavern, or dining-rooms. In the Central Area are sold ices, pastry, sandwiches, patties, fruits, tea, coffee, chocolate, cocoa, lemonade, seltzer and soda water; whilst in the Eastern and Western Areas are sold bread, butter and cheese, tea, coffee, chocolate, cocoa, ginger beer, spruce beer, and similar drinks, together with the other articles sold in the Central Area. No refreshments are to be taken out of the Areas. No wines, spirits, beer, or intoxicating drinks are permitted to be sold to the visitors. The privilege of supplying refreshments on these terms was put up to competition, and the tender of Messrs. SCHWEPPE, wherein they offered a sum of £5,500 for the privilege, was accepted. Waiting rooms and conveniences have likewise been provided at a moderate charge at each of the refreshment areas.

With the view of affording information in respect of lodgings for the working classes which might be required in London, a register was opened, in which the names and addresses of persons disposed to provide accommodation for artisans from the country whilst visiting the Exhibition were entered. In doing this, the Commissioners intimated that they did not propose to charge themselves in any respect with the management, but simply to afford information. It was thought most expedient that the public should be led to make its own arrangements; and the object which the Commissioners had in view was simply to call public attention to the subject. Various kinds of organizations have arisen to meet any demands which may arise. The superintendence of this subject was intrusted to Colonel REID and Mr. ALEXANDER REDGRAVE.

The principal railways agreed to afford some increased public accommodation during the Exhibition. Each Railway Company, both in the carriage of goods and passengers, and in the conveyance and delivery of articles intended for the Exhibition, allowed a deduction of one-half of the railway charge to exhibitors, subject to certain conditions. In order to encourage the early formation of "Subscription Clubs" in the country, to enable the labouring classes to travel to London and back during the Exhibition, the Railway Companies undertook to convey all persons so subscribing to local clubs at a single railway fare for both

journeys, up and down, which should in no case exceed the existing fare by Parliamentary trains for the journey in one direction, with some abatement for longer distances, subject to the following conditions, which they published in September, 1850 :—

That in respect of journeys to London, the first 100 miles shall always be charged as 100 miles, and where the distance shall exceed 100 miles, an allowance in the fare be made on the following scale :—

For the first excess 100 miles, 1-5th, or 20 per cent. be allowed.

For the second excess 100 miles, 3-10ths, or 30 per cent. be allowed.

For the third excess 100 miles, 2-5ths, or 40 per cent. be allowed.

For the fourth excess 100 miles, $\frac{1}{2}$ or 50 per cent. be allowed.

Thus for instance :—

A distance of 150 miles will be paid for as 140 miles.

„ 200 „ „ 180 „

„ 300 „ „ 250 „

„ 400 „ „ 310 „

„ 500 „ „ 360 „

and in like proportion between the respective distances.

Regulations
respecting the
admission of
visitors.

The consideration of the admission of Visitors was, in the first instance, referred to a Committee, and upon the recommendations of their Report, the Commissioners published decisions, in which they stated that their attention had been principally directed to the following points :—

1st. The necessity of making such arrangements as shall secure the convenience of the public visiting the Exhibition, whether for study and instruction, or for the more general purposes of curiosity and amusement. 2nd. The due protection and security of the property deposited in the building. 3rd. The effective control over the number of visitors, while the servants and officers intrusted with the maintenance of order and regularity in the building are comparatively inexperienced in their duties. 4th. The necessity of maintaining the self-supporting character of the Exhibition, and of defraying the liabilities incurred. 5th. The desire of the Commissioners to render the Exhibition accessible to all persons at the lowest possible charge, and with the least delay which a due regard to the preceding considerations will admit.

Having these objects in view, Her Majesty's Commissioners have determined to adopt the following regulations :—

The Exhibition will be open every day (Sundays excepted).

The hours of admission and other details will be announced at a subsequent period.

The charges for admission will be as follows :—

Season tickets for a gentleman . . . £ 3 3 0

Season tickets for a lady . . . 2 2 0

These tickets are not transferable; but they will entitle the owner to admission on all occasions on which the Exhibition is open to the public.

The Commissioners reserve to themselves the power of raising the price of the season tickets when the first issue is exhausted, should circumstances render it advisable. On the first day of exhibition season tickets only will be available; and no money will be received at the doors of entrance on that day.

On the second and third days the price of admission on

entrance will be (each day) . . . £ 1 0 0

On the fourth day of exhibition . . . 0 5 0

To be reduced on the twenty-second day to . . . 0 1 0

From the twenty-second day the prices of admission will be as follows :—

On Mondays, Tuesdays, Wednesdays, and Thursdays in each week	1s. 0d.
On Fridays	2s. 6d.
On Saturdays	5s. 0d.

No change will be given at the doors. This regulation is necessary to prevent the inconvenience and confusion which would arise from interruption or delay at the entrances. Should experience in the progress of the Exhibition render any alteration in these arrangements necessary, the Commissioners reserve to themselves the power of making such modifications as may appear desirable, of which due and timely notice, however, will be given to the public. At the first opening of the Exhibition, the hours of admission were fixed from 10 A.M. till 6 P.M.

Upon the question how far, and in what instances, any parties should be furnished with free admissions, the Committee reported,—

That it is very desirable that that privilege should be restricted to as few cases as possible, and feeling the importance of carrying out to the greatest practicable extent a regulation of this nature, they would submit whether it might not be expedient that the Commissioners should place themselves in the same position as the public in general with regard to the admission to the Exhibition. The members of the Executive Committee have expressed their wish to subject themselves to the same conditions as the Royal Commissioners in this respect.

The following are the cases in which the Committee would recommend that an exception to the general rule should be made, and free admissions granted :—

1st. Persons in the employment of, and provided with tickets issued by the Executive Committee, such as the heads of sectional departments, the clerks, the watchers, the cleaners, the Police, the Sappers and Miners. 2nd. Servants of Foreign Commissioners and of exhibitors admitted under the provisions of the 14th published decision of the Commissioners for the purpose of watching the goods sent by their employers, or explaining them to visitors; such servants being provided with tickets issued by the Executive Committee under strict regulations to be hereafter laid down. 3. The press, both metropolitan and provincial; the tickets in both cases admitting the editor or his representative. 4th. The juries, on the production of tickets that have been issued and registered by the Executive Committee, on certain days to be hereafter fixed by the Executive Committee.

And the power of carrying these rules into effect was given to the Executive Committee.

The inauguration of the Exhibition took place on 1st May, in accordance with the arrangements laid down in the accompanying document, which was published by the Commissioners :—

Her Majesty having signified her royal pleasure that arrangements should be made to enable Her Majesty to gratify a wish very generally expressed on the part of the public, to be present at a ceremony by which Her Majesty should open the Exhibition of the Works of Industry of all Nations, on the 1st of May, Her Majesty's Commissioners hereby give notice that the programme of this ceremony, and the regulations under which the holders of season tickets will be admitted, are as follow :—

Exhibitors' attendants who have been sanctioned by the Executive Committee will be admitted between the hours of 8 and 9 o'clock, at doors specified on their cards, and will immediately take their places by the counters or objects exhibited by their employers.

Holders of season tickets will be admitted at all doors on the east, south, and west of the building, between the hours of 9 and half-past 11 o'clock, and will be allowed to take their places, subject to police regulations, in the lower part of the building, and in the galleries, except the parts railed off in the nave and transept.

A platform will be raised to the north of the centre of the transept, on which a chair of state will be placed.

Her Majesty's Commissioners will assemble at half-past 11 o'clock in the transept, opposite the platform, together with their Executive Committee and the Foreign Acting Commissioners, in full dress or in plain evening dress.

His Grace the Archbishop of Canterbury, Her Majesty's Ministers, the great Officers of State, and the Foreign Ambassadors and Ministers, will take their places on the platform to the right and left of the chair of state, in full dress, also at half-past 11 o'clock.

Her Majesty, proceeding in State, with the royal family, foreign guests, &c., and her and their suites from Buckingham Palace up Constitution Hill, and down Rotten Row, will enter the Exhibition building by the north entrance precisely at 12 o'clock. She will ascend the platform and take her seat in the chair of state.

On Her Majesty's arrival a choir will sing "God Save the Queen."

On the Queen taking her seat His Royal Highness Prince Albert will join the Royal Commissioners, and when the music has ceased proceed at their head to the platform, and read to Her Majesty a short report of the proceedings of the Commission up to that time, which he will then deliver to Her Majesty, together with the catalogue of the articles exhibited. Her Majesty will return a gracious answer, handed to her by the Secretary of State; after which His Royal Highness Prince Albert will take his place again by the side of Her Majesty.

His Grace the Archbishop of Canterbury will then say a prayer, invoking God's blessing upon the undertaking, followed by a short anthem sung by the choir.

A Royal procession will then be formed, preceded by the Commissioners, which will turn to the right, move to the west end of the nave by its north side, return to the east end of the nave by its south side, including the south end of the transept, and come back to the centre along the north side of the nave; thus enabling all those present, who will be expected to keep the places which have been assigned to them, to see Her Majesty and the procession.

During the procession the organs appointed will play marches, taking the music up at the Queen's approach.

On Her Majesty's return to the platform the Queen will declare "the Exhibition opened;" which will be announced to the public by a flourish of trumpets and the firing of a Royal Salute on the north of the Serpentine; whereupon the barriers, which had kept the nave clear, will be thrown open, and the public will be allowed to circulate.

Her Majesty will then return to Buckingham Palace by the route by which she came.

All the doors, which will have been closed at half-past eleven o'clock, will, upon Her Majesty's departure, be opened again.

Principles on
which the prizes
were awarded.

In announcing the PRIZES, the Commissioners laid down certain general principles for the guidance of the Juries, which they published as follows:—

In the department of RAW MATERIALS AND PRODUCE, for instance, prizes will be awarded upon a consideration of the value and importance of the article, and the superior excellence of the particular specimens exhibited; and in the case of prepared materials, coming under this head of the Exhibition, the Juries will take into account the novelty and importance of the prepared product, and the superior skill and ingenuity manifested in the process of preparation.

In the department of MACHINERY, the prizes will be given with reference to novelty in the invention, superiority in the execution, increased efficiency, or increased economy, in the

use of the article exhibited. The importance, in a social or other point of view, of the purposes to which the article is to be applied, will also be taken into consideration, as will also the amount of the difficulties overcome in bringing the invention to perfection.

In the department of MANUFACTURES, those articles will be rewarded which fulfil in the highest degree the conditions specified in the sectional list, viz.:—Increased usefulness, such as permanency in dyes, improved forms and arrangements in articles of utility, &c. Superior quality, or superior skill in workmanship. New use of known materials. Use of new materials. New combinations of materials, as in metals and pottery. Beauty of design in form, or colour, or both, with reference to utility. Cheapness, relatively to excellence of production.

In the department of SCULPTURE, MODELS, and the PLASTIC ART, the rewards will have reference to the beauty and originality of the specimens exhibited, to improvements in the processes of production, to the application of art to manufactures, and, in the case of models, to the interest attaching to the subject they represent.

These general inducements are sufficient to show that it is the wish of the Commissioners, as far as possible, to reward all articles in any department of the Exhibition, which may appear to competent judges to possess any decided superiority, of whatever nature that superiority may be. It is the intention of the Commissioners to reward excellence in whatever form it is presented, and not to give inducements to the distinctions of a merely individual competition. Although the Commissioners have determined on having three medals of different sizes and designs, they do not propose to instruct the Juries to award them as first, second, and third in degree for the same class of subjects. They do not wish to trammel the Juries by any precise limitation; but they consider that the Juries will rather view the three kinds of medals as a means of appreciating and distinguishing the respective characters of the subjects to be rewarded, and not of making distinctive marks in the same class of articles exhibited. They fully recognise that excellence in production is not only to be looked for in high-priced goods, in which much cost of labour and skill has been employed, but they encourage the exhibition of low-priced fabrics, when combining quality with lowness of price, or with novelty of production. They can readily conceive that Juries will be justified in giving the same class medal to the cheapest calico prints made for the Brazilian or South American market, as they would to the finest piece of *Mousseline de Soie* or *Mousseline de Laine*, if each possessed excellence of its own kind.

All persons, whether being designers or inventors, the manufacturers or the proprietors of articles, will be allowed to exhibit; but they must state the character in which they do so. They may also state the names of all or any of the parties who have aided in the production. In awarding the prizes, however, it will be for the Juries to consider, in each individual case, how far the various elements of merit should be recognised, and to decide whether the prize should be handed to the exhibitor, or to one or more of those who have aided in the production.

Lastly, the Commissioners, in announcing their intention of giving medal prizes, do not propose altogether to exclude pecuniary grants, either as prizes for successful competition, or as awards under special circumstances, accompanying, and in addition to the honorary distinction of the medal. There may be cases in which, on account of the condition of life of the successful competitor (as for instance, in the case of workmen) the grant of a sum of money may be the most appropriate reward of superior excellence; and there may be other cases of a special and exceptional nature, in which, from a consideration of the expense incurred in the preparation or transmission of a particular article entitled to a prize, combined with a due regard to the condition and pecuniary circumstances of the party exhibiting, a special grant may with propriety be added to the honorary distinction. The Commissioners are not prepared, for the present, at least, to establish any regulations on these heads. They consider it probable that a wide discretion must be left to the Juries, to be hereafter appointed, in respect to the award of money prizes, or the grant of money in aid of

honorary distinctions; it being understood that such discretion is to be exercised under the superintendence and control of the Commission.

Articles marked "Not for Competition" cannot be admitted.

Medals obtained
by competition.

The Commissioners decided to select bronze for the material in which the medals should be executed, considering that metal to be the better calculated than any other, for the development of superior skill and ingenuity in the medallist art, and at the same time the most likely to constitute a lasting memorial of the Exhibition. There are three bronze medals, of different sizes and designs, which were obtained by public competition. Three prizes of 100*l.* each, were awarded for the three designs of the reverses, which appeared the most meritorious, to the following artists:

M. HIPPOLYTE BONNARDEL, Paris.

Mr. LEONARD C. WYON, London.

Mr. G. G. ADAMS, London.

Three prizes of 50*l.* each were also given for the three best designs not accepted, as follows:

Mr. JOHN HANCOCK, London.

Mons. L. WIENER, Brussels.

Mr. GAYRARD, Paris.

(*Min.* xxii., p. 2).

One hundred and twenty-nine models were received, and were exhibited in the rooms of the Society of Arts. The obverses of the medals are heads of HER MAJESTY the QUEEN, and HIS ROYAL HIGHNESS THE PRINCE ALBERT, executed by W. WYON, R. A., the medallist of the Mint, after the type of the Syraeusan medals.

The inscriptions.

The Committee appointed (consisting of the Hon. W. E. GLADSTONE, the Lord LYTTTELTON, the Hon. T. B. MACAULAY, and the Rev. H. G. LIDDELL, Head Master of Westminster School) to suggest inscriptions for the Prize Medals, recommended, for the medal to be executed after design No. 1, the following line, very slightly altered, from MANILIUS (*Astronomicum*, v. 737):—

"Est etiam in magno quedam respublica mundo."

For the medal from design No. 2, the following line from the first book of the *Metamorphoses* of OVID (v. 25):—

"Dissociata locis concordi pace ligavit."

For the medal from design No. 3, the following line from CLAUDIAN (*Eidyll.*, vii. 20):—

"Artificis tacite quod meruere manus."

Constitution of
the juries.

Under the general conditions by which the juries were constituted, it was provided that there should be one jury to each of the 30 classes into which the Exhibition had been divided. The number of jurors in each jury was determined by the amount of articles exhibited in each class, and the greater or less diversity of the subjects included in it, but no abstract idea of the relative importance of the classes was involved in the numbers attached to them. The list of the 30 classes has already been given (*see* p. 23), with the number of jurors appointed to each class. In addition to the juries there described, it was found necessary to appoint three sub-juries; one subordinate to Class V., for carriages, and two subordinate to Class X., viz., for musical and for surgical instruments. The

increased number of jurors for these three sub-juries was 22, of whom half were foreigners.

To facilitate the working, especially with reference to the foreign jurors, the 30 classes were collected into six groups:—

Classes 1, 2, 3, 4, forming the group of Raw Materials.

Classes 5, 6, 7, 8, 9, 10, forming the group of Machinery.

Classes 11, 12, 13, 14, 15, 16, 17, 18, 19, 20, forming the group of Textile Fabrics.

Classes 21, 22, 23, 24, 25, forming the group of Metallic, Vitreous, and Ceramic Manufactures.

Classes 26, 27, 28, 29, forming the group of Miscellaneous Manufactures.

The thirtieth class forming the group of Fine Arts.

A classified list of subjects under the province of each jury was prepared, and formed the limitation to each class, being the same as that upon which the arrangement of articles in the building had been made.

The constitution of the juries was thus regulated:—The jury in general consisted of an equal number of British subjects and of Foreigners. If Foreign Commissioners did not send a sufficient number of Foreigners to represent one-half of the jurors in each class, the deficient numbers might be completed by the appointment of British subjects, or be made up by the persons named by the Foreign Commissioners in London. Country as well as metropolitan districts were represented on the jury. Each jury was presided over by a chairman nominated by the Commissioners, and he was aided by a deputy chairman elected by the jury. Juries were able to appoint one of their own body as a reporter. The chairmen of the thirty juries were associated as a body, and called the "Council of Chairmen." In the absence of a chairman, the deputy-chairman took his seat at the Council. The Council of Chairmen was constituted, as far as practicable, of British subjects and Foreigners in equal numbers. The first and chief duties of the Council of Chairmen were to frame the rules for the guidance of the juries. The Council had to determine the conditions under which the 1st, 2nd, and 3rd class medals respectively were to be awarded, and to define the general principles to which it would be advisable to conform in the awards in the several departments of the Exhibition. It was the wish of the Commission that medals should be awarded to articles possessing decided superiority of whatever nature that superiority might be, and not with reference to a merely individual competition. The Juries were reminded that "the three classes of medals are intended to distinguish the respective characters of subjects, and not as first, second, and third in degree for the same class of subjects." It was the function of the Council of Chairmen to see that the awards of the individual juries were in accordance with the rules before they were considered final. The propriety of pecuniary grants to individual exhibitors as considered by the Commissioners only on the recommendation of the several juries, sanctioned by the Council of Chairmen.

The mode of appointing the English jurors was as follows:—Those towns which exhibited to a considerable extent in any of the classes were invited to send a list of names of persons who would efficiently represent the knowledge of those classes as jurors. It was necessary to state according to the classified jury list, the subdivisions of the class with which the person recommended was specially acquainted; and all nominations were made in classes, and not in the aggregate.

Appointment of
English jurors,

D

As it was necessary to reduce the lists to the standard number for each jury, the Commission charged itself with this duty. Those persons who had been recommended as jurors, but who from the small numbers of the jury were not placed on it, might, on the application of a jury, be called in on special occasions to give aid, under the title of associates, but without a vote.

and Foreign
Jurors.

The nomination of the foreign jurors was conducted on a somewhat different principle. The Foreign Commissioners submitted, that a fuller representation of the foreigners of all nations in the body which it was proposed to constitute for the purpose of confirming the award of individual juries would be secured, by referring the awards for confirmation to a general meeting of the juries of *allied* subjects, according to the groupings already spoken of. And the Commissioners assented to this modification. The selection of jurors for each foreign country was of course left to that country; persons of skilled knowledge being chosen to represent those classes of objects in which the country was a considerable exhibitor. It was recommended that in cases where the Central Commission was too remote to obtain the nomination of the jurors in sufficient time, the Foreign Commissioners should put themselves into communication with the diplomatic representatives of their respective countries in London. The number of jurors allotted to each foreign country by the Commissioners, upon the suggestion of the Foreign Commissioners, was as follows:—Austria, 15; Zollverein, comprehending Bavaria, Prussia, Saxony, Wurtemberg, &c., 19; Belgium, 11; North Germany, comprehending Bremen, Hamburg, and Hanover, 3; Denmark, 1; France, 32; Greece, 1; Holland, 2; Portugal, 2; Russia, 6; Italy, comprehending Sardinia and Tuscany, 6; Spain, 3; Sweden and Norway, 1; Switzerland, 4; Turkey, 3; United States, 21; Egypt, 2.

If exhibitors accepted the office of jurors, they ceased to be competitors for prizes in the class to which they were appointed, and these could not be awarded either to them individually, or to the firms in which they might be partners. Juries were at liberty to take evidence when a majority of the jury deemed it advisable, and to name the persons to be consulted. Jurors of another class might also be called in aid by a jury, when a knowledge involved in that class was required. Juries were empowered to act in matters of detail by sub-committees, but no award could be made except by the majority of the jury. Before a jury could finally make its awards, it was necessary they should have been submitted to a meeting of the juries of allied subjects, as indicated in the groups. These meetings of allied juries had power to confirm the award of the juries, and to investigate any disputed decisions. Before, however, the awards were published, it was requisite they should have been submitted to a Council, consisting of the chairmen of the juries, in order to secure uniformity of action, and a compliance with the regulations originally laid down by that body. The awards of a jury, when reported by the Council of Chairmen as being made in conformity to the rules, were final. The juries were aided in the general transaction of the business by a person named by the Royal Commissioners, who himself, or by a deputy approved of by the Commission, was present at their deliberations, for the purpose of explaining the rules of the Commission. This nominee of the Commission, who was Dr. LYON PLAYFAIR, did not have a vote in any of the juries, or at all interfere in the adjudication of awards.

The Exhibition is open to tell its own tale, and is now submitted to the judgment of the world. Conclusion.

All that has been done has been the work of a short and anxious period of sixteen months. During that time, Her Majesty's Commissioners have assembled together upwards of forty times, to discuss and determine all principles. When the Commissioners were not sitting, every important detail of action was considered by His Royal Highness, the President, and by Lord GRANVILLE, as Chairman of the Finance Committee. From time to time, as their services have been required, the most distinguished persons in art and science have met in Committees, liberally to afford their assistance to the Commissioners. These gentlemen, to whom the Exhibition is thus indebted, are named elsewhere; and it may be permitted to append a list of the staff, materially strengthened by officers of the Royal Engineers, both of Her Majesty's and the Honourable East India Company's service, which has carried the work into execution, and also to acknowledge the effective aid of the Sappers and Miners who have been permitted by the Master General of the Ordnance to bring their military discipline and business knowledge to aid in the arrangements of the Exhibition.

The work is done, and the collection made of the productions of 15,000 exhibitors, working with the ability God hath given them. To these we may say with St. Paul,—“In lowliness of mind let each esteem others better than themselves.” And to spectators we may reiterate the hope expressed by the PRINCE, that “the first impression which the view of this vast collection will produce will be that of deep thankfulness to the Almighty for the blessings which he has bestowed upon us already here below; and the second, the conviction that they can be only realized in proportion to the help which we are prepared to render to each other—therefore, only by peace, love, and ready assistance, not only between individuals, but between the nations of the earth.”

HENRY COLE.

*Exhibition, Hyde Park,
30th April, 1851.*

DIRECTORY.

HER MAJESTY'S COMMISSIONERS.

President, His Royal Highness PRINCE ALBERT, K.G., F.R.S.

His Grace the Duke of Buccleuch, K.G., F.R.S.	CHARLES BARRY, Esq., R.A., F.R.S.
Rt. Hon. the Earl of Rosse, K.P., Pr. of R.S.	THOMAS JAZLEY, Esq.
Rt. Hon. the Earl of Ellesmere, F.S.A.	RICHARD CODDEN, Esq., M.P.
Rt. Hon. the Earl GRANVILLE.	W. CUBITT, Esq., F.R.S., P. of Inst. Civ. Eng.
Rt. Hon. Lord STANLEY.	THOMAS FIELD GIBSON, Esq.
Rt. Hon. Lord OVERSTONE.	JOHN GOTT, Esq.
Rt. Hon. Lord JOHN RUSSELL, M.P., F.R.S.	Professor HOPKINS, President of the Geological Society.
Rt. Hon. HENRY LABOUCHERE, M.P.	PHILIP PUSEY, Esq., M.P., F.R.S.
Rt. Hon. W. E. GLADSTONE, M.P.	JOHN SHEPHERD, Esq., Chairman of the Hon. East India Company.
SIR RICHARD WESTMACOTT, R.A.	ROBERT STEPHENSON, Esq., M.P., F.R.S.
SIR CHARLES LYELL, F.R.S.	Alderman THOMPSON, M.P.
SIR CHARLES LOCK EASTLAKE, P.R.A., F.R.S.	
THOMAS BARING, Esq., M.P.	

J. SCOTT RUSSELL, Esq., F.R.S.	} Secretaries.
SIR STAFFORD HENRY NORTHCOTE, Bart.	
EDGAR A. BOWRING (<i>Acting Secretary</i>).	

EXECUTIVE COMMITTEE.

Lt.-Col. REID, R.E., C.B., F.R.S. (<i>Chairman</i> .)	FRANCIS FULLER, Esq.
HENRY COLE, Esq.	GEORGE DREW, Esq.
CHARLES WENTWORTH DILKE, Esq.	MATTHEW DIOBY WYATT, Esq. (<i>Secretary</i> .)

SPECIAL COMMISSIONERS TO COMMUNICATE WITH LOCAL COMMITTEES.

DR. LYON PLAYFAIR, F.R.S.	Lt.-Col. J. A. LLOYD, F.R.S.
---------------------------	------------------------------

FINANCE COMMITTEE.

Rt. Hon. Earl GRANVILLE.	R. CODDEN, Esq., M.P.
Rt. Hon. Lord OVERSTONE.	T. F. GIBSON, Esq., M.P.
Rt. Hon. H. LABOUCHERE, M.P.	Sir A. Y. SPEARMAN, Bart.
Rt. Hon. W. E. GLADSTONE, M.P.	S. M. PETO, Esq., M.P.
T. BARING, Esq., M.P.	

COMMITTEE APPOINTED FOR ALL MATTERS RELATING TO THE BUILDING.

His Grace the Duke of Buccleuch, K.G., F.R.S.	ROBERT STEPHENSON, Esq., M.P., F.R.S.
Rt. Hon. the Earl of Ellesmere, F.S.A.	C. R. COCKERELL, Esq., R.A.
CHARLES BARRY, Esq., R.A., F.R.S.	I. K. BRUNEL, Esq., F.R.S.
WILLIAM CUBITT, Esq., F.R.S., Pr. of I.C.E.	THOMAS L. DONALDSON, Esq., M.I.B.A.

MEDAL COMMITTEE.

Rt. Hon. Lord COLBORNE.	Mons. PASSAVANT.
W. DYCE, Esq., R.A.	Dr. WAAGEN.
J. GIBSON, Esq., R.A.	M. EUGENE LAMY.
C. NEWTON, Esq.	

INSCRIPTION COMMITTEE.

Rt. Hon. W. E. GLADSTONE, M.P.	The Rev. H. G. LIDDELL.
The Lord LYTTELTON.	The Rev. the Dean of St. Paul's.
Rt. Hon. T. B. MACAULAY.	

COMMITTEE APPOINTED FOR COMMUNICATING WITH THE LOCAL COMMITTEES OF THE METROPOLIS.

Rt. Hon. Earl GRANVILLE (<i>Chairman</i>).	EDWARD CAROWELL, Esq., M.P., F.S.A.
Most Noble the Marquis of SALISBURY, K.G.	JOSEPH LOCKE, Esq., M.P., F.R.S.
Rt. Hon. Viscount CANNING.	W. COTTON, Esq.
Rt. Hon. Lord ASHDURTON.	THOMAS GIBSON, Esq.
Rt. Hon. the LORD MAYOR OF LONDON.	Dr. ARNOTT, F.R.S.
Sir JOHN BOILEAU, Bart., F.R.S.	JOSHUA FIELD, Esq.
FRANCIS SMEDLEY, Esq., High Bailiff of WESTMINSTER.	CHARLES MANDY, Esq., F.O.S.

MEMBERS OF COMMITTEES OF SECTIONS.

SECTION I.—RAW MATERIALS AND PRODUCE.

(a.) MINERAL KINGDOM.

Sir CHARLES LYELL, F.R.S., Pr. of G.S.
 Sir HENRY T. DE LA BECHE, C.B., F.R.S.
 Sir RODERICK MURCHISON, F.R.S.
 Dr. LYON PLAYFAIR, F.R.S.
 RICHARD PHILIPS, Esq., F.R.S.

Professor LINDLEY, D.C.L., F.R.S.
 Professor FARADAY, D.C.L., F.R.S.
 Professor SOLLY, F.R.S.
 HUMPHREY BRANDRETH, Esq.
 W. FISHER HODDS, Esq.

(c.) ANIMAL KINGDOM.

(b.) VEGETABLE KINGDOM.

PHILIP PUSEY, Esq., M.P., F.R.S.
 Sir WILLIAM HOOKER, LL.D., F.R.S.
 Professor ROYLE, M.D., F.R.S.

Rt. Hon. Lord STANLEY.
 Professor OWEN, F.R.S.
 Professor E. FORBES, F.R.S.
 Professor BRADY, F.R.S.
 Professor HOFMANN, F.R.S.

SECTION II.—MACHINERY.

Rt. Hon. the Earl of ROSSE, K.P., Pr. of R.S.
 Sir JOHN RENNIE, F.R.S.
 Sir JOHN HERSCHEL, Bart., F.R.S.
 WILLIAM CUDITT, Esq., F.R.S., Pr. of I.C.E.
 ROBERT STEPHENSON, Esq., M.P., F.R.S.
 The ASTRONOMER ROYAL, F.R.S.
 PHILIP PUSEY, Esq., M.P., F.R.S.

Professor WALKER, F.R.S.
 Professor WULFEN, F.R.S.
 I. K. BRUNNEN, Esq., F.R.S.
 Sir BALDWIN WALKER, K.C.B.
 The PRESIDENT of the College of Surgeons.
 Sir GEORGE SMART.

(a) AGRICULTURAL IMPLEMENTS.

Hon. DUDLEY PELHAM, M.P. (Deceased.)
 Col. B. CHALLONER.
 ANTHONY HAMOND, Esq.
 W. MILES, Esq., M.P.
 JOSEPH LOCKE, Esq., M.P., F.R.S.

PHILIP PUSEY, Esq., M.P., F.R.S.
 BRANDRETH GIBBS, Esq.
 H. S. THOMPSON, Esq.
 J. V. SHELLEY, Esq.

SECTION III.—MANUFACTURES.

Rt. Hon. W. E. GLADSTONE, M.P.
 Alderman THOMPSON, M.P.
 RICHARD COBDEN, Esq., M.P.
 THOMAS FIELD GIBSON, Esq.
 THOMAS BAZLEY, Esq.
 JOHN GOTT, Esq.
 HERBERT MINTON, Esq.
 ARSLEY PELLATT, Esq.
 R. REDGRAVE, Esq., R.A.
 J. R. HERBERT, Esq., R.A.
 H. J. TOWNSEND, Esq.
 J. JOBSON SMITH, Esq.

J. H. MARSHALL, Esq., M.P.
 J. H. VIVIAN, Esq., M.P.
 Professor GRAHAM, F.R.S.
 Professor WOODCROFT.
 Professor COWPER.
 JOHN HARDMAN, Esq.
 H. T. HOPE, Esq., M.P.
 Sir JOHN GUEST, M.P., F.R.S.
 PASCOE GRENFELL, Esq., M.P.
 J. D. MORRIS STIRLING, Esq., F.R.S.E.
 Sir JOHN BOILEAU, Bart., F.R.S.

SECTION IV.—SCULPTURE, MODELS, AND THE PLASTIC ART.

Rt. Hon. the Earl of ABERDEEN, K.T., F.R.S., Pr. S.A.
 Rt. Hon. Viscount CANNING.
 Rt. Hon. Lord ASHDURTON.
 Sir RICHARD WESTMACOTT, R.A.
 Sir CHARLES LOCK EASTLAKE, P.R.A., F.R.S.
 CHARLES BARRY, Esq., R.A., F.R.S.

CHARLES BARING WALL, Esq., M.P., F.R.S.
 Wm. WYON, Esq., R.A.
 EDWARD HODGES BAILY, Esq., R.A., F.R.S.
 D. MACLISE, Esq., R.A.
 THOMAS UWINS, Esq., R.A.

LIST OF COMMISSIONERS, &c. APPOINTED ABROAD TO PROMOTE THE EXHIBITION OF 1851 IN LONDON.

FRANCE.

La Commission générale, instituée par arrêtés des 28 Février et 11 Mars 1850, s'est, dans sa séance du 16 Mars, divisée en 6 Commissions spéciales, dont voici les attributions et la composition :*

1° Commission des Affaires administratives et de la Correspondance.

M. CHARLES DUPIN, de l'Académie des Sciences, Président de la Commission Générale.
M. DE LESSEPS, Directeur des Consuls et des Affaires Commerciales au Ministère des Affaires Étrangères.
M. DE LAVENAY, Secrétaire-Général du Ministère de l'Agriculture et du Commerce.
M. MONNY DE MORNAY, Chef de la division de l'Agriculture.
M. FLEURY, Chef de la division du Commerce Extérieur.
M. DELAMBRE, Chef de la division du Commerce Intérieur.
M. CHEMIN-DUPONTES, Chef du Bureau des Faits-Commerciaux, Secrétaire de la Commission Générale.

2° Commission des Arts Agricoles.

M. HERICART DE THURY, de l'Académie des Sciences.
M. TOURET, Vice Président du Jury Central.
M. PAYEN, de l'Académie des Sciences.
M. ARMAND SEGUIER, de l'Académie des Sciences.
M. DE KERGORLAY, Membre de la Société Nationale et Centrale d'Agriculture.
M. MONNY DE MORNAY.

3° Commission des Arts Mécaniques et de Précision.

M. PUILLET, de l'Académie des Sciences.
M. ARMAND SEGUIER, de l'Académie des Sciences.
M. MORIN, de l'Académie des Sciences.
M. COMBES, de l'Académie des Sciences.
M. MICHEL CHEVALIER, Ingénieur en Chef des Mines.
M. LE CHATELIER, Ingénieur des Mines.

4° Commission des Arts Chimiques et Métallurgiques.

M. BALARD, de l'Académie des Sciences.
M. HERICART DU THURY.

Président.—M. DE BROUCKERE, Bourgmestre de la Ville de Bruxelles, Membre de la Chambre des Représentants, Président du Jury l'Exposition Industrielle de 1847.

Membres.—M. BELLEFROID, Chef de la Division de l'Agriculture au Département de l'Intérieur.
M. BENOÎT FADER, Délégué de la Chambre de Commerce de Namur.

M. CAPITAINE, Fabricant à Liège, délégué de la Chambre de Commerce de cette Ville.

M. CLAES (Paul) DE LEMUECO, Agronome.

M. KINDT, Inspecteur pour les Affaires Industrielles, au Département de l'Intérieur.

M. KUMS, Fabricant à Anvers, délégué par la Chambre de Commerce de cette Ville.

M. MANILIS, Membre de la Chambre des Représentants, délégué par la Chambre de Commerce de Gand.

M. OVERMAN, Fabricant à Tournay, délégué par la Chambre de Commerce de cette Ville.

M. PAYEN.
M. MICHEL CHEVALIER.
M. EBELMEN, Directeur de la Manufacture Nationale de Sèvres.
M. LE CHATELIER.

5° Commission des Tissus.

M. MIMEREL, Président de la Commission des Tissus au Jury Central.
M. LEGENTIL, Président de la Chambre de Commerce de Paris.
M. BARRET, Membre du Jury Central de l'Industrie Nationale.
M. SALLANDROUZE DE LAMORNAIX, Membre du Jury Central.
M. DE LAVENAY.

6° Commission des Beaux-Arts et Arts divers.

M. FONTAINE, de l'Académie des Beaux Arts.
M. LEON DE LABORDE, de l'Académie des Beaux Arts.
M. ARMAND SEGUIER.
M. EBELMEN.
M. DE LAVENAY.
M. DELAMBRE.

Dans une deuxième séance qui a eu lieu le 20 courant, ont été élus Présidents des diverses Commissions:—

I. Commission Administrative	} M. CHARLES DUPIN.
II. Commission des Arts Agricoles	
III. Commission des Arts Mécaniques et de Précision	} M. COMBES.
IV. Commission des Arts Chimiques et Métallurgiques	} M. HERICART DE THURY.
V. Commission des Tissus	} M. LEGENTIL.
VI. Commission des Beaux Arts et Arts divers	} M. FONTAINE.

Tous les renseignements destinés à la Commission doivent être adressés au Ministère de l'Agriculture et du Commerce.

BELGIUM.

M. PARTOES, Directeur du Commerce Extérieur et des Consuls au Département des Affaires Étrangères.

M. QUOILIN, Secrétaire Général au Département des Finances.

M. ROMBERO, Chef de la Division de l'Industrie au Département de l'Intérieur.

M. SIMONIS, (Armand), Président de la Chambre de Commerce de Verviers.

M. SPITAELS, (Ferdinand), Membre du Sénat, délégué par la Chambre de Commerce de Charleroy.

M. VAN HOOFF, Fabricant à Saint-Nicolas, délégué par la Chambre de Commerce de cette Ville.

M. VERCRUYSE-BRUNEEL, (H.), Fabricant à Courtray, délégué de la Chambre de cette Ville.

M. VERRUYT, Fabricant à Bruxelles, délégué par la Chambre de Commerce de cette Ville.

* Voir le Moniteur du 21 Mars 1850.

NETHERLANDS.

President—M. JONKHUR D. R. GIVERS DEYNOOT, Directeur de la Société pour l'Encouragement de l'Industrie à Haarlem, demeurant à Rotterdam.

Membres—M. le Docteur G. SIMONS, Directeur de l'Académie Royale à Delft.
M. D. C. BUCHLEN, Membre de l'Institut Royal des Pays-Bas, Vice-Président de l'Académie Royale des Beaux Arts à Amsterdam.

AUSTRIA.—A Commission formed, consisting of the following Members:—

Präsident—Herr ANDREAS RITTER v. BAUMGARTNER, k. k. geheimer Rath, Sections-Chef im Ministerium der Finanzen, Vice-Präsident der k. k. Akademie der Wissenschaften in Wien, &c.

Präsidentens-Stellvertreter—Herr MICHAEL RITTER v. SPÖRLIN, Fabriksinhaber, Mitglied der Wiener Handelskammer.

Vertreter der Ministerien—Herr Dr. KARL HOCK, Ministerialrath im Ministerium des Handels.

Herr Dr. MORIZ RITTER v. BESTENECK, Sectionsrath im Ministerium der Finanzen.

Herr JOSEPH KUDERNATSCHEK, Sectionsrath im Ministerium des Bergbaues und der Landescultur.

Schriftführer—Herr HEINRICH HENKING, Ministerial-Secretär. Commissions-Mitglieder für Nieder-Oesterreich.

Herr THEODOR HORNPOSTEL, Fabriksinhaber, Präsident der Wiener Handelskammer und des Nieder-Oesterreichischen Gewerbs-Vereines.

Herr CARL RÖSNER, Professor der Baukunst und provisorischer Präsident der k. k. Akademie der Künste in Wien.

Herr CARL RITTER v. KLEYLE, Sections-Chef und Ministerialrath im Ministerium für Landescultur.

Herr ADAM RITTER v. BURG, k. k. Regierungsrath, Director des Polytechnischen Institutes und Vice-Präsident des Nieder-Oesterreichischen Gewerbs-Vereines.

Herr PAUL SPRENGER, Sectionsrath der General-Baudirection.

Herr A. STEINHEIL, Sectionsrath im Ministerium des Handels.

Herr JACOB REGENHART, Kaufmann und Fabriksinhaber,

Herr JOHANN MAYER, Großhändler und Fabriksinhaber,

Herr LUDWIG DAMBÖCK, Fabriksinhaber,

Herr JOSEPH ZEISEL, Fabriksinhaber,

Herr LUDWIG HARDTMUTH, Fabriksinhaber,

Herr GUSTAV HÖFKEN, Sectionsrath im Ministerium des Handels.

Herr FRANZ FRUHHERR VON LEITNER, k. k. Regierungsrath und Fabriks-Director.

Herr ALOIS AUER, k. k. Regierungsrath und Director der Staatsdruckerei.

Herr ANTON SCHÜTTE, Professor der Chemie, Mitglied der Akademie der Wissenschaften in Wien.

Herr LUDWIG VON BREVILLIERS, Fabriksinhaber.

Herr GEORG ENDRIS, Großhandlungs-Diviseur.

Herr THEODOR GULCHERN, Fabriksinhaber.

Herr CARL LEISTLER, Tischlermeister.

Herr MATTHIAS E. MAYER von ROSTHORN, Gewerke.

Herr HEINRICH D. SCHMIDT, Fabriksinhaber.

Herr OTTO SCHUMANN, Kaufmann.

Herr Dr. WILHELM SCHWARZ, Secretär der Wiener Handelskammer.

Herr EMIL SEYDEL, Fabriksgesellschafter.

Herr JOHANN B. STREICHER, Claviermacher.

Herr ERNST WEIDINGER, Fabriks-Director.

Commissions-Mitglieder für Böhmen.

Herr FRANZ GRAF VON HARRACH, Fabriksinhaber und Präsident des böhm. Gewerb-Vereins,

Herr CARL BALLING, Professor der Chemie & Vice-Präsident des böhm. Gewerb-Vereins,

Herr JOHANN B. RIEDEL, Kaufmann & Vorsteher des Handelstandes,

Herr Dr. CARL KREUTZBERG, Fabriksinhaber,

Herr B. VON PARTHEIM, Fabriksinhaber.

Herr FRANZ RICHTER, Fabriksinhaber.

Herr JOHANN LIEBET, Fabriksinhaber und Präsident des Gewerb-Vereins,

Herr WILHELM SIGMUND, Fabriksinhaber.

Herr CARL FISCHER, Fabriksinhaber in Pirkellammer.

Herr EDUARD LEITENBERGER, Fabriksinhaber in Reichstadt.

Herr A. D. MAYER, Fabriksinhaber in Winterberg.

Herr M. MAYER, Bergwerks-Director in Neujochimethal.

Herr JOH. REINHOLD, Fabriksinhaber in Warnsdorf.

Commissions-Mitglieder für Mähren und Schlessen.

Herr HEGO FURST VON SALM-REIFFERSCHIED-KRAUTHHEIM, Fabriksinhaber und Präsident der Mährischen-Schlessischen Landwirthschaftsgesellschaft.

Herr LEOPOLD HAUPT, Fabriksinhaber.

Herr FLORENTIN ROBERT, Fabriksinhaber in Selowitz.

Herr PHILIPP SCHOLLER, Fabriksinhaber in Brünn.

Herr HEINRICH ZURHELLE, Fabriks-Director in Namiet.

Commissions-Mitglieder für Galizien die Bukowina und das Gebiet von Krakau.

Herr ALFRED GRAF V. POTOCKY, k. k. geh. Rath und Fabriksinhaber.

Herr JOSEPH RUSZGGER, k. k. Gubernialrath und Bergwerks-Director in Wieliczka.

Herr CARL HAUNNER, Großhändler in Brody.

Herr VINGENZ KIRCHMAYER, Großhändler, in Krakau.

Herr FLOMAN SEIGER, Großhändler, in Lemberg.

Commissions-Mitglieder für Ungarn, Croaticn, Slavonien, Siebenbürgen die Wojwodina, das Temescher Banat und die Militärgränze.

Herr GHAZ JOH. BARKOTZY, Grundbesitzer,

Herr AUGUST L. KRAUSE, k. k. Cameralrath und Fabriken-Inspcctor,

Herr CHRIST. J. MALVIEUX, Großhändler,

Herr SAMUEL V. JOEB, Güter-Director,

in Prag.

in Reichenberg.

Mitglieder der Wiener Handelskammer.

in Pesth.

AUSTRIA—continued.

- Herr JOSEPH RITTER v. FERRO, k. k. Sectionsrath und Ministerial-Commissär, in Nagy-Banya.
- Herr CARL WALDBURG, Kaufmann, in Kronstadt.
- Herr CARL MEYNIER, Fabriksinhaber, in Fiume.
- Herr AUTON TSCHOFF, Groszhändler, in Carlsbad.
- Commissions-Mitglieder für Steiermark, Kärnthen, Krain, Triest, Görz, Istrien, und Dalmatien.*
- Herr Doctor FRANZ HLUDECK, Professor und Secretär der Steiermärkischen Landwirthschafts-Gesellschaft, in Gratz.
- Herr Dr. CARL PEINTINGER, Bergwerks-Director, in Vordernberg.
- Herr PETER TUNNER, Vorsteher der montanistischen Lehranstalt, in Vordernberg.
- Herr THOMAS RITTER v. MORO, Fabriksinhaber, in Klagenfurt.
- Herr J. SCHELIESZNIGG, Bergwerks-Inspector, in Klagenfurt.
- Herr HEINRICH COSTA, Oberamts-Director, in Laibach.
- Herr WILLIAM MOLINE, Fabriks-Director, in Laibach.
- Herr KALIMAN RITTER v. MINERHI, Groszhändler und Fabriksinhaber, in Triest.
- Herr CARL REGENSDORFF, Groszhandlungs-Dirigent, in Triest.
- Commissions-Mitglieder für das Lombardisch-Venetianische Königreich.*
- Herr GRAFF ARCHINTI, Fabriksinhaber, in Mailand.
- Herr ERNST v. MYLIUS, Groszhandlungs-Gesellschafter, in Mailand.
- Herr ALBERT KELLER, Fabriksinhaber, in Mailand.
- Herr JOSEPH ANT. REALI, Fabriksinhaber, in Venedig.
- Herr PETER BIGAGLIA, Fabriksinhaber, in Venedig.
- Herr FERDINAND ZUCHELLI, Kaufmann, in Venedig.
- Commissions-Mitglieder für Tirol und Vorarlberg.*
- Herr CASPAR LITTI, Fabriks-Director, in Innsbruck.
- Herr JOSEPH MAYER, Kaufmann, in Innsbruck.
- Herr MELCHIOR JENNY, Fabriksinhaber, in Vorarlberg.
- Herr JOHAN KENNEDY, Fabriksinhaber, in Vorarlberg.
- Herr ANTON RHOMBERG, in Vorarlberg.
- Herr JOS. BETTINI, Fabriksinhaber, in Roveredo.
- Herr JOHANN PUTZER, Groszhändler in Botzen.
- Commissions-Mitglied für Ober-Oesterreich und Salzburg.*
- Herr JOHANN RITTER v. DIERZER, Fabriksinhaber in Linz und Vorsteher der Delegation des Nieder-Oesterreichischen Gewerb-Vereines.
- Herr Dr. L. KOMPASZ, Delegirte des Nied. Oesterr. Gewerb-Vereines in Steyer.
- Herr MATH. LECHNER, in Steyer.
- Herr CARL MITTERBACHER, Fabriksinhaber, in Salzburg.

PRUSSIA.—A Commission formed, consisting of the following Members:—

- Geheimen Ober-Finanzrath von VIERAHN.
- Geheimen Regierungsrath DELBRUCK.
- Director des Königlichen Gewerbe-Instituts, Dr. DRUCKENMULLER.
- Professor Dr. SCHUDARTH.
- Fabriken Kommissionsrath WEDDING.
- Fabriken Kommissionsrath BUX.
- Geheimen Kommerzienrath CARL.
- Geheimen Kommerzienrath BAUDOIN.
- Herr F. ZIMMERMANN.
- Herr WEIGERL.
- Herr OERTLING.
- Herr Dr. LUDESDORF.
- Herr BIDTEL.

BAVARIA.—The Polytechnic Society of Munich.

SAXONY.—M. le Dr. WEINLIG, Conseiller intime au Ministère de l'Intérieur.

HAMBURGH.—The Society for the Promotion of Arts and the Useful Professions.

Dr. W. A. KRAMER (*Secretary*).

BREMEN.—Dr. HENRY GRONING.

LUBECK.—The Trades Committee of the Patriotic Society.

WURTEMBERG.—Herr SAUTTER, President of the Central Society for Industry and Trade.

GRAND DUCHY OF HESSE DARMSTADT.

Privy Councillor ECKHARDT, President of the Trades' Union of the Grand Duchy of Hesse.

NASSAU.—The Chamber of Commerce of Nassau, through its President the Assessor ODERNHEIMER of Wiesbaden.

HANOVER.—Art-Union of Hanover.

SWITZERLAND.—A Commission formed, consisting of the following Members:—

- Dr. SCHNEIDER, of Berne (*President*).
- M. BOLLEY, Professor, of Aarau.
- M. COLLADON, Professor, of Geneva.
- Major COURVOISIER, Neuchatel.
- M. JENNI, Manufacturer, of Glaris.
- M. SARASIN, of Basle.
- M. SULZBERGER, Manufacturer, of St. Gall.
- M. ZIEGLER PELLIS, of Winterthur.

RUSSIA.

Two Commissions formed, one at St. Petersburg and the other at Odessa. The Royal Commissioners to communicate with them through the Agent of the Imperial Finance Department (M. KAMENSKY), who resides in London.

SWEDEN.—M. D. C. DE SKOQMAN, *Président du Collège du Commerce.*

NORWAY.

M. LANGBERG, Professor of Natural Philosophy.	Captain VERGELAND, of the Artillery.
Colonel GARBEN, of the Engineers.	M. SCHINNER, Architect.
M. YARBELL, Mechanician.	M. VERGMAN, Ornamental Painter.

Who together form the direction of the Society of Arts at Christiania.

DENMARK.—A Commission formed.

TUSCANY.—A Commission formed, consisting of the following Members:—

<i>President.</i> —The Chevalier BALDASSERONI, Minister of Finance and Commerce.	The Marquis RIDOLPHI, Deputy of the Academy of the Georgofili.
Sir G. B. HAMILTON, H.B.M. Minister Plenipotentiary at the Court of Tuscany. (Since dead.)	Mr. HORACE HALL, Deputy of the Chamber of Commerce of Florence.
Signor CORRIDI, Director of the Technical Institute of Florence.	Count F. DE LARDENEL, Deputy of the Chamber of Commerce of Leghorn.
The Chevalier BROCCINI, Ex-Director of ditto.	The Marquis MAZZAROSA, Deputy of the Chamber of Commerce of Lucca.

NAPLES.—A Commission formed, composed of Members of the Reale Istituto d'Incoraggiamento.

SARDINIA.—A Commission formed, including the Hon. RALPH ABERCROMBY, H.B.M.'s Minister Plenipotentiary at the Court of Sardinia.

SPAIN.—A Commission formed, consisting of the following Members:—

<i>Commissioners.</i>		
EL ALMIRANTE DUQUE DE VERAGUA (<i>President</i>).	Don BUENAVENTURA CARLOS ARIDAN.	
Don SALUSTIANO DE OLOZAGA.	Don MANUEL GARCIA BAVRANALLANA.	
Don ANTONIO RAMON ZARCO DEL VALLE.	Don CIPRIANO SEGUNDO MONTESINO.	
Don JUAN ALVAREZ Y MENDIZABAL.		
Don ALEJANDRO OLIVAN.	<i>Committee.</i>	
Don JOSE CAVEDA.	Don SALUSTIANO DE OLOZAGA (<i>President</i>).	
Don CHRISTOPAL BORDIN.	Don JUAN ALVAREZ Y MENDIZABAL.	
Don JOAQUIN ALFONSO.	Don ANTONIO RAMON ZARCO DEL VALLE.	
Don ANTONIO GUILLERMO MORENO.	Don MANUEL GARCIA BAVRANALLANA.	
Don JUAN MANUEL CALDERON.	Don CIPRIANO SEGUNDO MONTESINO (<i>Secretary</i>).	

TURKEY.—A Commission formed, consisting of the following Members:—

<i>President.</i>		<i>Members.</i>	
ISMAEL PACHA, Minister of Commerce.		NEJEEB EFFENDI.	
		HAJJI BEKIR AGA.	
<i>Vice-Presidents.</i>		YUSUF HAJJAR.	
SALIK BEY, Assistant of the Minister of Commerce.		SEID MUSTAPHA EFFENDI.	
SAID BEY, Secretary to the President.		HAJJI HASHIM ZADEH EMIN EFFENDI.	
M. LAFONTAINE, Secretary to correspond with England.		BALMOOMJI ZADEN SALIK EFFENDI.	
		GORGHI ALESIOGLON.	
		YACOOB VARTORES.	
		ELIA HAVA.	

GREECE.—A Commission formed, consisting of the following Members:—

M. LUCAS RALLI, <i>President</i> .	Professor LANDERER.
M. SIMOS.	M. C. G. DOUBROUTTI.
M. C. N. DOSSIOS.	M. G. P. SCUZÉS.
M. le Capitaine G. TOMBAZIS.	M. DOMNANDO.
M. L. CAFTANGIOGLU.	M. S. A. SPILIOGARIS, <i>Secretary</i> .

PERSIA.—The MELLIK-OOT-TOOJJAB, Chief of the Merchants.

CHILE.—The following Gentlemen have been appointed to correspond with the Commission in London:—

Don PEDRO NOLASCO MENA, Chairman of the Society of Agriculture and Beneficence.
 Don IGNACIO DOMEYKO, Professor of Chemistry.
 Don JULIO JARRIEZ, Director of the School of Arts and Trades.

PERU.

The Minister of the Home Department (*President*). | Don NICOLAS PIEROLA.
Don LUIS FONCECA. | Don NICOLAS RODRIGO.

VENEZUELA.

A Commission formed. The Royal Commissioners to communicate through Mr. MILLIGAN, Consul-General for the Government of Venezuela.

UNITED STATES.

The National Institute, in conformity with the wish of the Government, have appointed the following Gentlemen to form a Central Committee to correspond with the different Societies and Local Committees throughout the United States.

HON. MILLARD FILLMORE, President of the United States, Chancellor of the Regents of the Smithsonian Institution.	Hon. W. W. SEATON, Member of the National Institute, Mayor of Washington.
Colonel PETER FORCE, President of the National Institute.	Hon. JEFFERSON DAVIS, United States' Senate, Member of the Board of Regents of the Smithsonian Institution.
Hon. JAS. A. PEARCE, United States' Senate, Member of the Board of Regents of the Smithsonian Institution.	Lieutenant MATTHEW F. MAURY, United States' Navy, Vice-President of the National Institute, and Superintendent of the National Observatory.
Hon. LEVI WOODBURY, Member of the National Institute, Associate Justice of the Supreme Court of the United States.	CHARLES F. STANSBURY, Esq., Recording Secretary of the National Institute.
Commodore LEWIS WARRINGTON, United States' Navy, Member of the National Institute, Chief of the Bureau of Ordnance and Hydrography.	J. JAMES GREENOUGH, Esq., Member of the National Institute.
Professor JOSEPH HENRY, Vice-President of the National Institute and Secretary of the Smithsonian Institution.	Colonel J. J. ABERT, Member of the National Institute, Chief of the Topographical Bureau.
Professor WALTER R. JOHNSON, Corresponding Secretary of the National Institute.	General JOS. G. TOTTEM, Vice-President of the National Institute, Chief Engineer United States' Army.
Professor ALEXANDER D. BACHE, Member of the National Institute, Member of the Board of Regents of the Smithsonian Institution, and Superintendent of the Coast Survey.	THOMAS EWYBANK, Esq., Commissioner of Patents.
Commander CHARLES WILKES, United States' Navy, Member of the National Institute, late Commander United States' Exploring Expedition.	WILLIAM EASBY, Esq., Treasurer of the National Institute.
	Dr. LEONARD D. GALE, Member of the National Institute, Examiner of Patents.
	J. C. G. KENNEDY, Esq., Member of the National Institute, Superintendent of Census.
	EZRA C. SEAMAN, Esq., Member of the National Institute.
	Professor WALTER R. JOHNSON (<i>Secretary</i>).

FOREIGN ACTING COMMISSIONERS.

AMERICA, UNITED STATES OF . . .	{ EDWARD RIDDLE. N. S. DODGE, Secretary.	NETHERLANDS . . .	G. GOOSSENS.
AUSTRIA . . .	{ CHEVALIER DE BURG. CHARLES BUSCHKE.	PORTUGAL . . .	F. J. VANZELER.
BAVARIA . . .	Professor DR. SCHAFHAULT.	ROME . . .	Sr. CARLO TREBBI.
BELGIUM . . .	CHARLES CUYLITS.	RUSSIA . . .	GABRIEL DE KAMENSKY.
BRUNSWICK . . .	Professor VARENTRAPP.	SARDINIA . . .	Chevalier LENCISA.
DENMARK . . .	REGNAR WESTENHOLZ.	SAXONY . . .	Dr. W. SEYFFARTH, LL.D.
DUCHY OF NASSAU	{ HERR ASSESSOR ODERNHEIMER.	SPAIN . . .	{ Don ALFONSO. Don RAMON DE LA SAGRA. Don M. DE YSASI.
EGYPT . . .	Capt. ABDUL HAMED.	SWEDEN & NORWAY	CHARLES TOTTIE.
ELECTORATE OF HESSE CASSEL . . .	{ HERR ASSESSOR SCHREIDER.	SWITZERLAND . . .	{ Dr. BOLLEY. Professor COLLADON.
FRANCE . . .	{ SALLANDROUZE DE LANGONNAIX.	TUNIS . . .	Sig. HAMDA ELMKADDEN.
FRANKFORT . . .	M. P. ELLISSEN.	TURKEY . . .	EDWARD ZOHRAH.
GRAND DUCHY OF HESSE . . .	M. RÖSSLER.	TUSCANY . . .	Professor P. CORRIDI.
GRECE . . .	M. RALLI.	WURTEMBERG . . .	{ Dr. STEINDEIS. CHARLES BRAND. M. SCHIEDMAYER.
HAMBURGH . . .	M. NOBACK.	ZOLLVEREIN . . .	M. VON VIEBAHN.
HANOVER . . .	M. STAHLSCHEIDT.		

ACTING COMMISSIONERS AND ACTING AGENTS FOR COLONIES.

EAST INDIES, INDIAN ARCHIPELAGO, &c.—Dr. ROYLE, Mr. DOWNING.
 CEYLON.—Mr. JOHN CAPPER, 4 Sussex Place, Canonbury, Islington.
 JERSEY AND GUERNSEY.—Captain CHILDERS, Mr. CLUGAS.
 MALTA.—Mr. GINGELL, 66 Cornhill.
 CAPE OF GOOD HOPE AND NATAL.—Mr. HARRISON WATSON.
 CANADA.—Sir RANDOLPH ROUTH, Mr. PETER MCGILL, Mr. J. H. DREW, Mr. T. HOUGHTON.
 NOVA SCOTIA.—Mr. C. D. ARCHIBALD, 15 Portland Place.
 BARBADOES.—Mr. READE.
 BRITISH GUIANA (DEMERARA, &c.)—Mr. RIDGWAY, 42 Leicester Square.
 BAHAMAS.—Mr. DANIELL, 18 Wigmore Street, Cavendish Square.
 TRINIDAD.—Messrs. LIGHTLY and SIMON, 123 Fenchurch Street.
 SOUTH AUSTRALIA.—Messrs. HALLETT and Co.
 WESTERN AUSTRALIA.—Mr. BARNARD.
 NEW SOUTH WALES.—Mr. BARNARD.
 NEW ZEALAND.—Mr. MOORE, 30 Arundel Street, Strand.
 VAN DIEMEN'S LAND.—Mr. MCLACHLAN, 17 St. Helen's Place.

DEPARTMENTS OF THE EXHIBITION DURING THE ARRANGEMENTS.

The Acting Members of the Executive Committee—Lieut.-Colonel REID, R.E., and Mr. C. W. DILKE (Control of Building and General Superintendence); Mr. H. COLE (Space and Arrangement of Articles).
Jurys—Professor PLAYFAIR and Lieutenant WARD, R.E.
Preparation of Plans, and Superintendence of Building Arrangements—Mr. M. D. WYATT, Clerk of Works—Mr. EARLE.
Architectural Matters, and Decoration of Building—Mr. OWEN JONES.
Engineering Superintendence—Mr. C. H. WILD.
Corresponding Secretary—Mr. F. DUNCOMBE.
Registrar of Letters—Mr. WADE.
Post Office Department—Mr. OSMOND JONES.
Finance—F. S. CARPENTER, A.C.G.
Clerks to Royal Commission—Mr. H. R. LACK and Mr. G. T. WRIGHT.
Superintendents of British Side of Building—Captain COLLINSON, R.E., and Lieutenant CROSSMAN, R.E.
Superintendent of Foreign Side of Building—Captain OWEN, R.E. *Assistants*—Lieutenant E. F. DUCANE, R.E., and Mr. HARMAN. *Secretary*—Mr. WYLDE.
Receiver of Goods, British—Mr. BELSHAW.
Receiver of Goods, Foreign—Captain RAFTER.

Space and Admission of Articles—Captain OWEN, R.E., and Lieutenant CROSSMAN, R.E.
British Colonies—Dr. LINDLEY, Lieutenant TYLER, R.E., and Lieutenant BROWNLOW, Hon. E.I.C.E.
Indian Collection—Dr. ROYLE and Professor SOLLY.
Chinese and Persian Collections—Lieut.-Colonel LLOYD and Lieutenant TYLER, R.E.
Registration of Designs—Captain L. BOSCAWEN IBBETSON.
Arrangements for Working Classes—Mr. A. REDGRAVE.
Catalogue—Superintendent on Part of the Commission—Lieut.-Colonel LLOYD. *Contractors*—Messrs. SPIER and CLOWES. *Scientific Editor*—Mr. R. ELLIS. *Compiler*—Mr. G. W. YAPP.
Police—Superintendent for Commissioner of Police—Mr. PEARCE.
Customs—Mr. ROLLS and Mr. FAIRMAN.
Royal Sappers and Miners—5th Company, Captain OWEN, R.E. 22nd Company, Captain GIBB, R.E.; Acting-Adjutant, Lieutenant STOPFORD, R.E.
Admission of, and information to, Exhibitors—Captain GIBB, R.E., Lieutenant TYLER, R.E., and Lieutenant GORDON, R.E.
Fire Arrangements—Captain GIBB, R.E.

SUPERINTENDENTS OF CLASSES ON BRITISH SIDE.

CLASS I. Professor ANSTED, Mr. R. HUNT, and Dr. WATSON.
 II. Dr. LYON PLAYFAIR, Mr. A. PHILLIPS, and Lieutenant WARD, R.E.
 III. } Dr. LINDLEY, Dr. ROYLE, and Mr. MATCHWICK.
 IV. }
 V. Mr. HENSMAN and Mr. BIDDLE.
 VI. Mr. HENSMAN and Lieutenant CRASTER, E.I.C.E.
 VII. Mr. HENSMAN and Lieutenant WALKER, R.E.
 VIII. Captain WESTMACOTT, R.E., and Commander E. A. INGLEFIELD, R.N.
 IX. Mr. BRANDRETH GIBBS and Ensign SOADY, E.I.C.E.
 X. Lieut.-Colonel LLOYD and Lieutenant TREVOR, E.I.C.E.
 XI. } Mr. GEORGE WALLIS and Mr. W. HAWKINS.
 XII. }
 XIII. } Mr. WALLIS.
 XIV. }

CLASS XV. Mr. WALLIS and Mr. HAWKINS.
 XVI. Mr. DODD.
 XVII. Mr. OWEN JONES.
 XVIII. Mr. WALLIS.
 XIX. Mr. LOWE.
 XX. Mr. WALLIS and Mr. W. HAWKINS.
 XXI. } Mr. R. A. THOMPSON.
 XXII. }
 XXIII. Mr. LOWE.
 XXIV. } Lieutenant PASLEY, R.E.
 XXV. }
 XXVI. Mr. C. T. THOMPSON.
 XXVII. Professor ANSTED.
 XXVIII. Mr. C. T. THOMPSON.
 XXIX. Mr. DODD.
 XXX. Mr. OWEN JONES.

DEPARTMENTS SINCE THE OPENING OF THE EXHIBITION.

Acting Members of Executive Committee—Lieut.-Colonel REID, R.E., Mr. DILKE, and Mr. COLE.
Juries—Professor PLAYFAIR, and Lieutenant WARD, R.E., Secretary.
Building—Mr. DIGBY WYATT. *Clerk of Works*—Mr. HAITE.
Correspondence—Mr. DUNCOMBE. *Registrar*—Mr. WADE.
Post Office—Mr. OSMOND JONES.
Finance—Mr. CARPENTER.
General Superintendent—Captain OWEN, R.E., Assistants Lieutenant TYLER, R.E., and Mr. BELSHAW.
District Superintendents—1. Mr. CONNELL; 2. Mr. THOMPSON; 3. Mr. DODD; 4. Mr. G. PERRY; 5. Mr. G. T. BIDDELL; 6. Mr. B. W. HAWKINS; 7. Lieutenant C. PASLEY, R.E.; 8. Mr. G. H. LOWE; 9. Mr. R. G. WYLDE; 10. Mr. HARMAN. *East Indies*, Mr. DOWNING.

Admission to Exhibitors, &c.—Lieutenant TYLER, R.E.
Refreshment Rooms—Captain IBBETSON.
Superintendent of Doorkeepers—Mr. MURRAY.
Customs—Mr. ROLLS and Mr. FAIRMAN.
Police—*Superintendent for the Commissioner of Police*—Mr. PEARCE.
Fire Arrangements—Captain GIBB, R.E.
Royal Sappers and Miners—5th Company, Captain OWEN, R.E. 22nd Company, Captain GIBB, R.E.; Acting-Adjutant, Lieutenant STOFFORD, R.E.
Catalogue—*superintendent on part of the Commission*—Lieut.-Colonel LLOYD. *Contractors*—Messrs. SPICER and CLOWES. *Scientific Editor*—Mr. R. ELLIS. *Compiler*—Mr. G. W. YAPP.

LIST OF JURORS.

Dr. LYON PLAYFAIR, F.R.S., Special Commissioner in Charge of the Department of Juries.

DEPUTIES.

For Group A. . . Raw Materials, JOHN WILSON, F.R.S.E., late Principal of Royal Agricultural College.
 For Group B. . . Machinery, Col. LLOYD, F.R.S., Special Commissioner.
 For Group C. . . Textile Manufactures, Mr. GEORGE WALLIS.
 For Group D. . . Metallic and Fibrous Manufactures, Captain BOSCAWEN IBBETSON, F.R.S.
 For Group E. and F. Miscellaneous Manufactures and Fine Arts, Sir STAFFORD NORTHCOTE, Bart., Secretary to the Royal Commission.

SECRETARY.

Lieutenant WARD, R.E., Secretary to the Department of Juries. Major BOYD, Interpreter.

COUNCIL OF CHAIRMEN.

- | | |
|--|--|
| <p>A.—RAW MATERIALS.</p> <p>CLASS</p> <p>I. Sir HENRY DE LA BECHE, C.B., F.R.S.
 II. A. DUMAS, Member of Institute, &c.
 III. EDWARD LODE, of St. Petersburg.
 IV. Professor OWEN, F.R.S.</p> <p>B.—MACHINERY.</p> <p>V. Rev. E. MOSELEY, M.A., F.R.S.
 VA. EARL JERSEY.
 VI. Gen. PONCELET, Member of the Institute.
 VII. I. K. BRUNEL, F.R.S.
 VIII. Baron CHARLES DUPIN, Member of Institute.
 IX. PHILIP PUSEY, M.P., F.R.S.
 X. Sir DAVID BREWSTER, F.R.S.
 XA. Sir H. BISHOP.
 XB. E. B. DENISON.
 XC. J. H. GREEN, F.R.S.</p> <p>C.—TEXTILE FABRICS.</p> <p>XI. Sir JAMES ANDERSON.
 XII. Professor HERRMAN.
 XIII. G. T. KEMP.
 XIV. Count VON HARRACK, of Bohemia.</p> | <p>CLASS</p> <p>XV. Herr Von HOEGAERDEN, of Brussels.
 XVI. Hon. Col. ANSON.
 XVII. M. M. VAN DE WEYER, Ambassador to the King of the Belgians.
 XVIII. HENRY TUCKER.
 XIX. Professor BOLLEY, of Switzerland.
 XX. WILLIAM FELKIN, of Nottingham.</p> <p>D.—METALLIC, VITREOUS, AND CERAMIC MANUFACTURES.</p> <p>XXI. Lord WHARFCLIFFE.
 XXII. Hon. HORACE GREELEY, of New York.
 XXIII. Duc DE LUYNES, Member of the Institute.
 XXIV. Lord DE MAULEY.</p> <p>E.—MISCELLANEOUS MANUFACTURES.</p> <p>XXV. Duke of ARGYLL.
 XXVI. Professor ROESSNER, of Vienna.
 XXVII. Signor BENEDETTO PISTRUCCI.
 XXVIII. Señor Don JOAQUIN ALFONSO.
 XXIX. Viscount CANNING.</p> <p>F.—FINE ARTS.</p> <p>XXX. Herr VON VIEBAHN, of Berlin.</p> |
|--|--|

LIST OF JURORS.

45

I. MINING, QUARRYING, METALLURGICAL OPERATIONS, AND MINERAL PRODUCTS.

Sir H. DE LA BECHE, C.B., F.R.S. (Chairman).	W. LOGAN, F.G.S.
M. DUFRENOY (Deputy Chairman and Reporter)— <i>France.</i>	M. F. SCHRIEBER, <i>Zollverein.</i>
M. FARADAY, F.R.S.	RICHARD TAYLOR, F.G.S.
M. C. J. M. GERNAERT— <i>Belgium.</i>	Professor TUNNER, <i>Austria.</i>

II. CHEMICAL AND PHARMACEUTICAL PROCESSES AND PRODUCTS GENERALLY.

JACOB BELL, M.P.	GEORGE GOSELETH— <i>Austria.</i>
M. DUMAS (Chairman)— <i>France.</i>	JOHN MERCER, F.C.S.
T. GRAHAM, F.R.S. (Deputy Chairman and Reporter).	H. L. PATTINSON, F.C.S.
M. D. GALEANI.	M. VARRETRAPP— <i>Zollverein.</i>

III. SUBSTANCES USED AS FOOD.

Sir J. P. BOILEAU, Bart., F.R.S. (Deputy Chairman).	Dr. LINDLEY, F.R.S.
JOSEPH D. HOOKER, M.D., R.N., F.R.S. (Reporter).	Mr. E. LODE (Chairman)— <i>Russia.</i>
Comte HERRE DE KERGOLEY— <i>France.</i>	Hon. A. Smith— <i>United States.</i>

IV. VEGETABLE AND ANIMAL SUBSTANCES CHIEFLY USED IN MANUFACTURES, AS IMPLEMENTS, OR FOR ORNAMENT.

Judge DUNCAN— <i>United States.</i>	M. RAMON DE LA SAGRA— <i>Spain.</i>
Professor RICHARD OWEN, F.R.S. (Chairman).	Professor SOLLY, F.R.S.
M. PAYEN (Deputy Chairman)— <i>France.</i>	N. WALLICH, M.D., F.R.S.
Dr. ROYLE, F.R.S.	M. WEYHE— <i>Zollverein.</i>

V. MACHINES FOR DIRECT USE, INCLUDING CARRIAGES AND RAILWAY AND NAVAL MECHANISM.

Chevallier de BURG— <i>Austria.</i>	H. MAUDSLAY.
M. L. CAPPALLETTO— <i>Austria.</i>	ROBERT MCCARTHY— <i>United States.</i>
Professor ENGERTH— <i>Austria.</i>	Colonel MORN (Deputy Chairman)— <i>France.</i>
W. FAIRBAIRN.	Rev. H. MOSELEY, M.A., F.R.S. (Chairman and Reporter).
JOHN FAREY.	ROBERT NAPIER.
JOHN HICK.	C. DE ROSSIUS-ORDAN— <i>Belgium.</i>

Va. Sub-Jury for Carriages.

M. ARNOUX— <i>France.</i>	Earl JERSEY (Chairman).
J. HOLLAND (Deputy Chairman and Reporter).	O. MCDANIEL— <i>United States.</i>
T. HUTTON.	M. PONCELET— <i>Belgium.</i>

VI. MANUFACTURING MACHINES AND TOOLS.

M. ALOIS DE CRISTOFORIS— <i>Austria.</i>	General PONCELET (Chairman & Reporter)— <i>France.</i>
Professor CORRADI— <i>Tuscany.</i>	GEORGE RENNIE, F.R.S. (Deputy).
BENJAMIN FOTHERGILL.	T. R. SEWELL.
CHARLES GASCOIGNE MACLEA.	S. WEDDER— <i>United States.</i>
JOHN PENN.	Professor WEDDING— <i>Zollverein.</i>
GUILHERME KOPKE.	Professor R. WILLIS, F.R.S. (Deputy Chairman and Reporter).

VII. CIVIL ENGINEERING, ARCHITECTURAL AND BUILDING CONTRIVANCES.

Dr. NEIL ARNOTT, F.R.S.	J. M. RENDEL, F.R.S.
I. K. BRUNEL, F.R.S. (Chairman and Reporter).	Count ROSEN— <i>Sweden and Norway.</i>
M. COMBES (Deputy Chairman)— <i>France.</i>	Dr. J. V. C. SMITH— <i>United States.</i>
M. CONRAD— <i>Holland.</i>	WILLIAM TITE, F.R.S.

VIII. NAVAL ARCHITECTURE AND MILITARY ENGINEERING; ORDNANCE, ARMOUR, AND ACCOUTREMENTS.

Major-Gen. Sir J. BURGOYNE, K.C.B. (Dep. Chnir.)	Major MICHEELS— <i>France.</i>
Lieut.-Col. COLQUHOUN.	Sir BALDWIN WALKER, K.C.B.
Baron DUPIN (Chairman and Reporter)— <i>France.</i>	A. WHITNEY— <i>United States.</i>
M. Ch. LESOINNE— <i>Belgium.</i>	— WATTS.

IX. AGRICULTURAL AND HORTICULTURAL MACHINES AND IMPLEMENTS.

Col. CHALLONER.	W. MILES, M.P.
B. T. BRANDRETH GIBBS.	M. MOLL— <i>France.</i>
A. HAMMOND.	Baron MERTENS D'OSTINS— <i>Belgium.</i>
M. B. HOLWEG— <i>Zollverein.</i>	P. PUSEY, M.P., F.R.S. (Chairman and Reporter).
B. P. JOHNSON— <i>United States.</i>	Professor RAU— <i>Zollverein.</i>
JOSEPH LOCKE, M.P., F.R.S.	J. V. SHELLEY.
C. M. LAMPSON— <i>United States.</i>	H. S. THOMPSON.
Professor HLUBECK— <i>Austria.</i>	

LIST OF JURORS.

X. PHILOSOPHICAL INSTRUMENTS AND PROCESSES DEPENDING UPON THEIR USE; MUSICAL, HOROLOGICAL, AND SURGICAL INSTRUMENTS.

Sir D. BREWSTER, F.R.S. (Chairman and Reporter). Professor COLLADON— <i>Switzerland</i> . E. B. DENISON. J. GLAISHER, F.R.S. Sir JOHN HERSCHEL, Bart, F.R.S. Professor HETSCH— <i>Denmark</i> .	E. R. LESLIE, R.A.— <i>United States</i> . M. MATHIEU— <i>France</i> . W. H. MILLER, F.R.S. RICHARD POTTER, A.M. Professor Dr. SCHUDARTH. Baron SEGUIER— <i>France</i> .
--	---

Sub-Jury A. for Musical Instruments.

W. STERNDAL BENNET. M. BERLIOZ— <i>France</i> . Sir H. R. BISHOP (Chairman and Reporter). Dr. J. ROBERT BLACK— <i>United States</i> . Chevalier NEUKOMM.	CIPRIANI POTTER. Dr. SCHAFFHAUTL— <i>Zollverein</i> . Sir G. SMART. M. SIGISMUND THALBERG (Deputy Chairman)— <i>Austria</i> . Dr. WYLDE.
--	--

B. Sub-Committee and Associate Jurors for Horology.

Professor COLLADON— <i>Switzerland</i> . E. B. DENISON (Chairman and Reporter).	E. J. LAWRENCE. Baron SEGUIER (Deputy Chairman)— <i>France</i> .
--	---

Sub-Jury C. for Surgical Instruments.

Dr. CHADBOURNE— <i>United States</i> . J. H. GREEN, F.R.S. (Chairman and Reporter). JAMES PHILP.	Dr. ROUX— <i>France</i> . Dr. LALLEMAND— <i>France</i> . W. LAWRENCE, F.R.S.
--	--

XI. COTTON.

Sir J. ANDERSON, Lord Provost of Glasgow (Chair). THOMAS ASHTON (Reporter). M. C. BUSCHER— <i>Austria</i> . Col. R. E. COXE— <i>United States</i> . M. PHILIP ELLISEN (Deputy Chairman)— <i>Zollverein</i> .	W. GRAY, Mayor of Bolton. GEORGE JACKSON. M. KIRCHHOFFER— <i>Switzerland</i> . M. MIMEREL— <i>France</i> . J. ASPINAL TURNER.
--	---

XII. WOOLLEN AND WORSTED.

SAMUEL ADDINGTON (Reporter). HENRY BRETT. M. C. C. CARL— <i>Zollverein</i> . JOHN COOPER, J.P. HENRY FORBES, J. P. (Deputy Chairman). Dr. VON HERMANN (Chairman)— <i>Zollverein</i> .	GEORGE LAWTON. THOMAS MARLING. M. RANDONING— <i>France</i> . M. SAMOILOFF— <i>Russia</i> . M. P. SCHOLLER— <i>Austria</i> . M. ARM. SIMONIS— <i>Belgium</i> .
--	--

XIII. SILK AND VELVET.

SAMUEL COURTAULD. Lt.-Col. DANIELLS— <i>Turkey</i> . M. ARLES DUFOUR (Deputy Chairman)— <i>France</i> . THOMAS JEFFCOAT. GEORGE TAWKE KEMP (Chairman).	M. MAHLER— <i>Zurich</i> . M. ANTONIO RADICE— <i>Austria</i> . M. J. VERTU— <i>Sardinia</i> . CHARLES WARWICK. THOMAS WINKWORTH (Reporter).
--	---

XIV. MANUFACTURES FROM FLAX AND HEMP.

WILLIAM CHARLEY (Joint Reporter). Count VAN HARRACK (Chairman)— <i>Austria</i> . M. GRENIER LEFEVRE (Joint Reporter)— <i>Belgium</i> . M. LEGENTIL— <i>France</i> . JOHN McMASTER.	JOHN MOIR. M. CARL NODACK— <i>N. Germany</i> . M. SCHERER— <i>Russia</i> . CHARLES TEE (Deputy Chairman). JOHN WILKINSON, J.P.
--	--

XV. MIXED FABRICS, INCLUDING SHAWLS, BUT EXCLUSIVE OF WORSTED GOODS (CLASS XII).

W. CLADBURN. M. GAUSSEN, <i>France</i> . Herr VAN HOEGAERDEN (Chairman)— <i>Belgium</i> . N. KINGSBURY— <i>United States</i> . JOHN R. LAVANCHY (Deputy Chairman). JOHN MORGAN.	WILLIAM PRINSEP (Reporter). TITUS SALT, J. P. FREDERICK SCHWANN— <i>United States</i> . JOHN H. SWIFT— <i>United States</i> . Sir GARDINER WILKINSON— <i>Turkey</i> .
--	---

XVI. LEATHER, INCLUDING SADDLERY AND HARNESS, SKINS, FURS, FEATHERS, AND HAIR.

Hon. Col. GEORGE ANSON (Chairman).
 J. B. BEVINGTON.
 J. S. CUNNINGHAM—United States.
 M. FAULER—France.
 JOHN FOSTER.

J. W. NEWMAN.
 J. A. NICHOLAY (Reporter).
 M. NOTTBECK (Deputy Chairman)—Russia.
 M. ROESSLER—Zollverein.
 EDWARD ZOHRAH—Turkey.

XVII. PAPER AND STATIONERY, PRINTING AND BOOKBINDING.

M. A. FIRMIN DIDOT—France.
 THOMAS DE LA RUE (Deputy Chairman).
 Viscount MAHON, F.R.S.
 Dr. SEYFFARTH, LL.D.—Zollverein.

H. STEVENS—United States.
 C. VENABLES.
 C. WHITTINGHAM (Reporter).
 M. VAN DER WEYER (Chairman)—Belgium.

XVIII. WOVEN, SPUN, FELTED, AND LAID FABRICS, WHEN SHOWN AS SPECIMENS OF PRINTING OR DYEING.

J. M. BEEDE—United States.
 M. CHEVREUL—France.
 JOHN HARGREAVES.
 ALEXANDER HARVEY.
 EDMUND POTTER (Reporter).

M. PAHUD—Switzerland.
 M. PERSOZ (Deputy Chairman)—France.
 C. SWAISLAND.
 W. SCHWARZ—Austria.
 HENRY TUCKER (Chairman).

XIX. TAPESTRY, INCLUDING CARPETS AND FLOOR-CLOTHS, LACE AND EMBROIDERY, FANCY AND INDUSTRIAL WORKS.

Dr. BOLLEY (Chairman)—Switzerland.
 D. BIDDLE.
 RICHARD BIRKIN (Reporter).
 M. FALK—Zollverein.
 M. FESSLER—Switzerland.

PETER GRAHAM (Deputy Chairman).
 M. LAIMEL—France.
 ROBERT LINDSAY.
 THOMAS SIMCOX LEA, J.P.
 M. WASHER—Belgium.

XX. ARTICLES OF CLOTHING FOR IMMEDIATE, PERSONAL, OR DOMESTIC USE.

T. BROWN.
 M. BERNOVILLE—France.
 T. CHRISTY (Reporter).
 ELLIOTT CRESSON—United States.

WILLIAM FELKIN, Mayor of Nottingham (Chairman).
 M. HULSSE—Zollverein.
 E. SMITH.
 M. PHILLIP WALTNER (Deputy Chairman)—Switzerland.

XXI. CUTLERY AND EDGE TOOLS.

JOSEPH B. DURHAM (Deputy Chairman).
 M. C. KARMARSH—Zollverein.
 M. NUBAR BEY—Turkey.

Mr. Alderman PEACE.
 M. LE PLAY—France.
 Lord WHARNOcliffe (Chairman and Reporter).

XXII. IRON AND GENERAL HARDWARE.

ARTHUR ADAMS.
 M. AUER—Austria.
 W. BIRD (Deputy Chairman).
 W. DYCE, R.A. (Reporter).
 M. GOLDENBERG—France.
 Hon. H. GREELEY (Chairman)—United States.

Don MANUEL HEREDIA—Spain.
 E. STIRLING HOWARD.
 GEORGE SHAW.
 M. FERD. SPITAELS—Belgium.
 Dr. F. STEINBEIS—Zollverein.
 HENRY VAN WART.

XXIII. WORKING IN PRECIOUS METALS, AND IN THEIR IMITATION, JEWELLERY, AND ALL ARTICLES OF VIRTU AND LUXURY, NOT INCLUDED IN THE OTHER CLASSES.

Don MANUEL GARCIA—Spain.
 JAMES GARRARD.
 JOHN GRAY.
 M. GRUNER—Zollverein.
 HENRY HOPE, M.P. (Deputy Chairman).

SALLANDROUZE DE LAMORNAIX—France.
 Earl of LOVELAGE—Turkey.
 DUC DE LUYNES (Chairman and Reporter)—France.
 WESTLEY RICHARDS.
 ROBERT YOUNGE.

XXIV. GLASS.

E. H. BALDOCK, M.P. (Deputy Chairman).
 R. L. CHANCE.
 L. C. DUNCAN—United States.
 M. JULES FRISON—Belgium.

Lord DE MAULEY, F.R.S. (Chairman and Reporter).
 ROBERT OBDARD.
 M. PELIGOT—France.
 Dr. SCHEELER—Zollverein.

XXV. CERAMIC MANUFACTURE, CHINA, PORCELAIN, EARTHENWARE, &c.

Duke of ARGYLL (Chairman and Reporter).
 M. EDELMAN—*France*.
 M. GABRIEL KAMENSKY—*Russia*.
 W. MORTLOCK.
 M. F. ODERHEIMER—*Zollverein*.

CHARLES BARING WALL, Esq., M.P., F.R.S. (Deputy Chairman).
 JOHN A. WISE.
 AUGUSTO PINTO—*Portugal*.

XXVI. DECORATION FURNITURE AND UPHOLSTERY, INCLUDING PAPER HANGINGS, PAPIER MACHÉ, AND JAPANNED GOODS.

Lord ASHDUNTON (Deputy Chairman).
 JOHN LEWIS AUBERT.
 N. CHARLES DE BEYNE—*Russia*.
 M. COPPENS—*Belgium*.
 J. G. CRACE.
 M. CHARLES GROCCO—*Sardinia*.

JOHN JACKSON.
 M. W. MEYER—*North Germany*.
 M. RONDOT—*France*.
 Professor ROESNER (Chairman and Reporter)—*Austria*.
 EDWARD SNELL.
 JOHN WEBB.

XXVII. MANUFACTURES IN MINERAL SUBSTANCES, USED FOR BUILDING OR DECORATION, AS IN MARBLE, SLATE, PORPHYRIES, CEMENTS, ARTIFICIAL STONES, &c.

Professor ANSTED, F.R.S. (Reporter).
 M. BERNARDO DE BERNARDIS—*Austria*.
 GEORGE GODWIN, F.R.S.
 Sir CHAS. LEMON, Bart., F.R.S., M.P.

M. BENEDETTO PISTRUCCI (Chairman)—*Italy*.
 M. EMMANUEL PSYCHA—*Greece*.
 Lord SUDELEY (Deputy Chairman).
 Viscount HERICART DE THURY—*France*.

XXVIII. MANUFACTURES FROM ANIMAL AND VEGETABLE SUBSTANCES, NOT BEING WOVEN OR FELTED, OR INCLUDED IN OTHER SECTIONS.

Rev. GORHAM D. ABBOT—*United States*.
 Don JOAQUIN ALFONSO (Chairman)—*Spain*.
 M. BALARD—*France*.
 J. E. GRAY, F.R.S., P.B.S. (Deputy Chairman).

Dr. E. LANKESTER, F.R.S. (Reporter).
 T. J. MILLER.
 G. PETERSON—*Russia*.
 T. A. WISE, M.D., Hon. E.I.C.S.

XXIX. MISCELLANEOUS MANUFACTURES AND SMALL WARES.

Viscount CANNING (Chairman).
 ARTHUR HENFREY, F.L.S.
 Professor HOFFMAN—*Zollverein*.
 WARREN DE LA RUE, F.R.S., F.C.S. (Reporter).

JOHN JOSEPH MECHI.
 M. OTTO SCHUMANN—*Austria*.
 Mr. W. K. SMITH—*United States*.
 M. WOLOWSKI (Deputy Chairman)—*France*.

XXX. SCULPTURE, MODELS, AND PLASTIC ART.

C. R. COCKERELL, R.A.
 Lord COLBORNE (Deputy Chairman).
 J. GIBSON, R.A.
 Lord HOLLAND—*Tuscany*.
 Count DE LABORDE—*France*.
 C. NEWTON.
 A. PANIZZI (Reporter)—*Tuscany*.

A. W. PUGIN.
 M. QUETELET—*Belgium*.
 RICHARD REDGRAVE, R.A.
 M. SEURMONDT—*Holland*.
 M. G. VON VIEBACH (Chairman)—*Zollverein*.
 Dr. C. WAAGEN—*Zollverein*.
 W. WYON, R.A.

THE
CONSTRUCTION OF THE BUILDING.

HAD circumstances determined that the present industrial position of England should have been represented by the building alone, while other nations should have been allowed to indicate the scope of their resources by a display of choice specimens of all the varied branches of productions to which their efforts had of late years been directed, it is singular to remark how few elements, essential to her commercial success, would have been lost sight of. The courage of her citizens would have been manifested in the vastness of the scheme, their energy, determination, and strength, in the surprising rapidity with which every operation had been carried on.

The present industrial position of England indicated by the building, as well as the leading characteristics of her citizens,

both personal

The happy condition of the liberty of the subject would have been attested by the circumstance of its having been in the power of the people alone to will the existence of so vast a structure; while the fact that the whole expenses had been provided for without in any way trenching on the national resources, would have evidenced at once the wealth and the spirit of enterprise common to every class of society.

and social.

That it should have been possible in any country to have so speedily collected such a vast quantity of materials, without previously sounding the note of preparation, would have furnished strong evidence of the abundance of its native resources, and conveyed some faint idea of the extent of the stores of raw material kept ever ready to supply the exigencies of sudden demand. That that raw material should have been moulded into forms so various, so complex, and so original, in so short a time, would argue that such a result could alone have been effected by the natives of a country in which a knowledge of the principles and practice of mechanics and machinery had been long deeply studied and widely diffused. The facility with which the machinery employed must have been brought to bear upon the masses of raw material supplied, would have evidenced a power to produce, and to elaborate matter into manufacture, of the very highest order; while the grace with which the charm of decoration has been superadded, to so utilitarian a structure, would have served to show, that mindful as the English habitually are, of the practical and economical, they are by no means indifferent to the beautiful in the Fine Arts.

Evidence given by the building of extent of national resources in the production of raw Material,

Machinery,

Manufactures,

and objects of Fine Arts.

Whoever had been enabled to trace through every stage the progress of the Exhibition Building, from the first order given by the contractor, to the issue of the final directions for its opening, would have had an opportunity of realising the perfection to which the practice of connecting commercial co-operation in supply,

Organization of labour, and co-operation in supply, developed by

great engineering works.

and mutual reliance in money and time bargains, with the methodical organization of labour, has been carried in England at the present time. It is by means of the experience acquired in the conduct of the vast engineering works which have of late years occupied the attention, and commanded the labours of some of her most intelligent citizens, that this country has been enabled to reduce to a perfect system this power of subordinating the supply of materials, and of eliciting, in similar works, that precise description of labour from every individual, for which his natural characteristics or education may have specially qualified him.

Combination and division of labour necessary to carry out such works.

The firm through whose exertions the building has been erected, in itself presents an excellent model of the commercial constitution necessary to produce such great works with rapidity. While of its heads, one is remarkable for high scientific attainments, another possesses singular commercial aptitude, together with a minute knowledge of the working details of his business. Others again, bring to the common stock of intelligence a precise knowledge of legal and monetary transactions, together with experience acquired in many years' connection with speculations of great magnitude. The principal superintendents and foremen set in operation by this intellectual motive power, are each adapted to the particular duties they may be called upon to perform, and act precisely as the various portions of a well-devised machine, being at the same time maintained in as perfect control. Through these agents the labour of the artisan, skilled in his own department, profoundly ignorant in others, is brought into useful operation; and thus thousands are combined to realise the will of one directing mind. But for the perfect system of discipline, which frequent practice in directing the labours of masses of workmen has now made general throughout England, it would have been impossible to have fashioned, in so short a time, so novel and so vast a structure as this Temple of Peace, the gates of which may, we trust, be thrown open to the world at large, for many years to come.

Division of the subject into—
I. The building as it stands.
II. Its creation.

How far the Exhibition Building conveys a true idea of English constructive power, can only be ascertained by a minute examination of its anatomy; and we shall therefore proceed to sketch in some detail its actual nature and appearance, and the successive steps by which it has grown into its present condition.

The site in Hyde Park.

The site for the building is the one originally proposed for it by H.R.H. PRINCE ALBERT at the first private meeting, held on the subject of the Exhibition, at Buckingham Palace, on the 30th June, 1849. It consists of a rectangular strip of ground in Hyde Park, situated between the Queen's Drive and Rotten Row, and contains about 26 acres; being approximately 2,300 feet in length, by 500 feet in breadth. Its principal frontage extends from east to west. Several lofty elms stretch across the centre of its length, and a few smaller trees are scattered over its area. These trees have for the most part been retained, and to it the finest of them we are indebted for the existence of the beautiful transept roof; since, had they not presented difficulties to the construction of a roof of lower pitch, it is more than probable that the noble vault which now spans them would have been scarcely ventured on. The ground, although apparently level, actually falls, not less than 1 in 250 from west to east. From the popularity of the spot, the ease with which it can be approached, the opportunities for obtaining beautiful views of the building from every direction, and the facility with which it has been drained, and supplied with gas and water, it is scarcely possible that a site could have been found more admirably adapted for such a purpose, than the one upon which the building now stands.

The principal entrance to the Exhibition is situated in the centre of the south side, opposite to the Prince of Wales's Gate, one of the main entrances to Hyde Park. From this gate a good view of the southern façade of the transept (shown in fig. No. 1) is obtained. Passing through a vestibule, 72 feet by 48, the

The Building—
its principal
entrance!

Fig. 1.

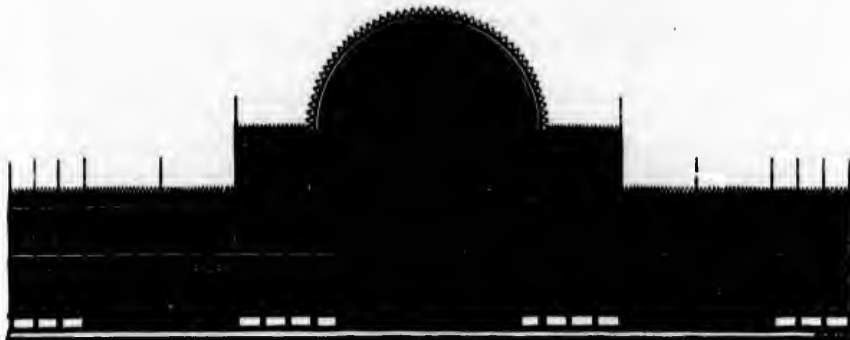

visitor finds admittance to the main building, and stands beneath the roof of the great feature of the whole, the transept. Above his head, at a height of 68 feet from the ground, springs a semi-cylindrical vault, 72 feet in diameter, which extends for a length of 408 feet from south to north. On each side of the space so covered, runs an aisle 24 feet wide. The "coup d'œil" afforded by the transept is represented in Plate I.

The "coup d'œil"
on entering!

Fig. 2.

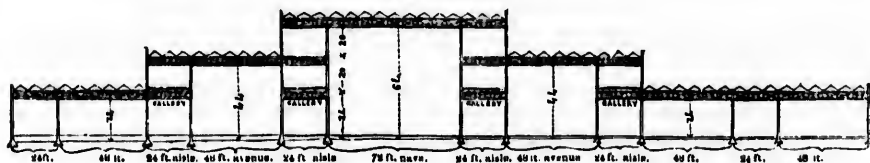

Advancing about halfway along the transept, the visitor will find himself as nearly as possible in the centre of the building; and from this point his eye may range eastward and westward along its vast nave, for a distance of upwards of 900 feet in each direction; the total length of the building being not less than 1848 feet. By reference to the ground plan given at page 1, and to fig. 2, a clearer idea may be formed of the manner in which the vast area, that thus opens itself to the view, has been distributed, than could be conveyed by many pages of description. The nave is a grand avenue 64 feet high and 72 feet wide, crossing the transept at right angles. On each side of it extend aisles 24 feet in width, and above them, at a height of 24 feet from the ground, are carried galleries, surrounding the whole of the nave and the transept; so that a complete circuit of communication is carried throughout the whole structure at that level.

its central point

its extent,

Beyond these first aisles, and parallel with them, at a distance of 48 feet, are second aisles of similar width, and similarly covered for their whole width with galleries on the same level as those over the first aisles. In order that the

and divisions on
plan.

public may pass freely from one line of galleries to the other, bridges, at frequent intervals, span the 48 feet avenues, and at the same time divide them into courts, each of which has been so arranged as to present an "ensemble" to the eye of the spectator looking down upon it from the galleries. The width of 48 feet which we have described as thus subdivided, and the second aisles, are roofed over at a height of 44 feet from the ground. The remaining portion of the building in width consists of one story only, 24 feet high; in which, of course, there are no galleries. Ten double staircases, 8 feet wide, give access to these galleries.

Its lightness of proportion,

The airy lightness of the whole structure, and its immense dimensions, are the features which will no doubt first excite the wonder, and perhaps the timidity of the visitor; but when he learns how rigidly the strength of every portion has been investigated, with what care the connection of every part has been made, and that the whole of that which appears to him so complicated, is but the repetition of a few simple elements, he will throw aside alarm, and rest upon the consciousness that those most competent to investigate questions of force to overturn, and strength to resist, have spared no pains to assure themselves of the perfection of the parts, and the consequent stability of the whole.

General nature of materials.

The lightness of the proportions will at once assure the spectator of the nature of the material which forms the main supports of the building. While the vertical supports consist entirely of cast-iron, the horizontal connections and girders are constructed of both wrought and cast iron. Of wrought-iron it has been estimated that no less than 550 tons have been used, and of cast-iron 3,500 tons. The whole of the roof, above the highest tier of iron frame-work, consists of wood and glass, and the external enclosures and face-work are constructed almost entirely of the same materials. It is estimated that 896,000 superficial feet of glass, weighing 400 tons, have been employed; whilst the quantity of wood used, including the whole of the flooring, has been no less than 600,000 cubic feet.

Quantities of wrought iron;

Cast iron;

Glass;
Wood.

The plan divided into squares of 24 feet.

In designing the building, care has been taken so to arrange that the position of every column shall occur at the points of intersection of lines, 24 feet apart, crossing one another at right angles, while in roofing and flooring the squares, into which the whole plan has been thus allotted, have been subdivided into others of 8 feet. This arrangement accounts for the beautiful regularity of the lines of the columns, &c., when viewed diagonally.

Necessity of realizing the detail of one 24-foot bay, in order thereby to judge of the whole area.

In order to afford some idea of the extent of mechanical difficulties involved in the erection of such a building, and to furnish, as it were, a scale by which to estimate the nature of the work, we shall proceed, before entering upon the subject of its general extent and arrangement, to describe the mode of construction of one of the 24-foot bays or compartments, taken at random from the side aisle adjoining the main avenue.

The description of a 24-foot bay commenced.

The exact situation of the four columns enclosing the space referred to having first been determined, holes were dug to such a depth as to lay bare the gravel; which extends, with scarcely a fault, over the whole surface of the site, at an average depth of between 2 and 4 feet. The size of the holes dug out for the foundations, and the quantity of concrete thrown into those holes in order to form a secure foundation for the superstructure, was determined by the estimated weight of that superstructure; and it was so arranged that, allowing for every possible contingency, under no circumstances should a pressure greater than $2\frac{1}{2}$ tons per foot superficial be brought to bear upon the foundation.

The foundations.

On the surface of fine mortar, with which the concrete was covered, was placed a casting, which has been technically called a *base-plate*. This casting is represented in fig. 3. The lower part consists of a horizontal plate, having attached to it a vertical tube, corresponding in form with the column which it serves to carry. The connection of the plate with this tube is strengthened by shoulders. The length of the whole of the base-plates being set north and south, in those through which roof-water is conducted, two sockets, issuing from the lower part of the tube, extend for some distance on each side in an opposite, or eastern and western direction. Into these sockets cast-iron pipes 6 inches in diameter are inserted, serving as drains to convey away the water; which, passing through the columns above, and through the hollow tubes of the base-plates, escapes into the pipes referred to, and finds its way to capacious drains situated in the centre, and at the extreme east-end of the building, which, in their turn, convey the water to the main sewer in the Kensington-road. At the upper portion of the tube of the base-plate, four projections with holes in them, are cast. At the foot of the column, which is of similar form to the base-plate, are similar projections, with corresponding holes. The upper face of the tube, and the under face of the column, being planed perfectly flat and true, the holes cast in the projections of the one exactly fit those cast to correspond with them in the other. Bolts having been then dropped through the holes in both are secured by nuts; and thus the column is attached to the base-plate, almost as rigidly as if the two had issued from one mould. As a proof of the singular accuracy with which the whole of these base-plates have been set upon their foundations, it may be mentioned that in every instance, the holes in the upper face or bearing surface of the base-plate, have precisely corresponded with those cast in the under face of the columns, at the exact height at which it had been pre-arranged that they should be fixed; and the two (columns and base-plates) have been united without involving the necessity of inserting any packing between them. Pieces of canvas only, cut to the exact form of the bearing surfaces, and dipped in white lead, have been interposed, with a view to insure the joints remaining perfectly secure and water-tight. The tops of the base-plates rise 3½ inches above the ground-floor.

The columns are 8 inches in diameter, and those on the ground-floor are 18 feet 5½ inches high. The plan or horizontal section of these columns, which was the suggestion of Mr. BARRY, is well adapted for its purpose, mechanically as well as artistically; for while it presents a pleasing variation from the ordinary circular form, the different flat bands upon it afford surfaces well suited for the con-

Fig. 3.

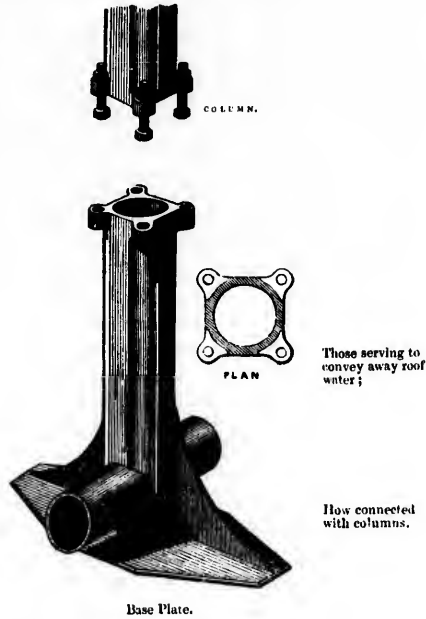

The base plates generally:

Those serving to convey away roof water;

How connected with columns.

The columns:

nection and attachment of the necessary girders, which serve at once to support the galleries and roof, and to tie the various compartments of the building into one vast network. The columns are made hollow, in order to convey the water from the roof of the building; and the thickness of the metal of which they are composed varies, according to the weight each column is intended to support, from $\frac{3}{8}$ of an inch to $1\frac{1}{2}$ inch. The square faces already mentioned add, however, considerably to the sectional area of the metal, upon the amount of which the strength of the column in a great measure depends.

Their strength ;

The extraordinary strength to resist compression in the direction of its length, which the cylindrical form conveys to any material, was illustrated by Professor COWPER, in a lecture delivered by him in the building to the members of the Society of Arts. In a series of experiments with a common quill, and even with a straw, Professor COWPER demonstrated the great force required to crush such slight objects, and, arguing from their comparative scale, illustrated satisfactorily the great strength of the columns in the building.

Their attachment to connecting-pieces.

Beneath the capital, which surrounds the upper part of the column, are concealed projections similar to those at the bottom of the column. These projections serve to attach to the columns what have been technically designated as connecting-pieces. The peculiar office of the connecting-pieces is to afford, by a small and consequently easily modified casting, the means of securely retaining, and connecting in all directions, the various girders throughout the building.

The connecting-pieces ;

The attachment to them of girders

In fig. 4, we have endeavoured to exhibit the peculiar formation of those portions of the connecting-pieces, which serve to effect the end desired. The projections, or, as they are technically termed, "snugs," are cast upon the upper and lower portions of the connecting-pieces, and act partly as brackets and partly as hooks, clutching over, supporting, and retaining, projections cast upon the ends of the standards of the girders. In order to retain the girders in a vertical position, and to prevent any lateral movement, the bottom face of that portion of the girder which rests upon the corresponding projection of the connecting-piece, is formed with what is called a tenon, which drops into a mortice-hole (A, fig. 4), cast in the face of the projection of the connecting-piece with which it comes in contact. The top face of the portion of the girder, over which the hook cast upon

Fig. 4.

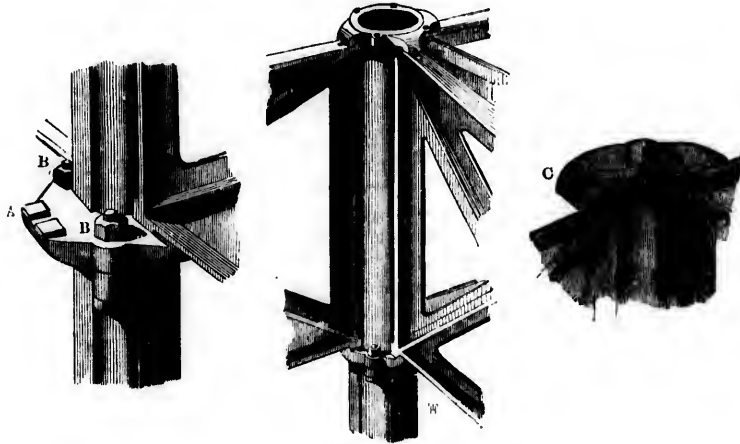

the upper portion of the connecting-piece extends, has a groove sunk upon its surface; a groove corresponding to it in width is also sunk upon the projection of the connecting-piece (C, fig. 4), and a small piece of iron is introduced between the two. This iron acts as a key or dowel, and prevents the two surfaces sliding upon one another.

On the upper and lower part of the connecting-piece, between these projections which serve to retain the girders in their places, are cast holes, corresponding with those at the top of the lower columns, and at the bottom of the upper columns; through which bolts being inserted, nuts (BB, fig. 4), fastened to those bolts, secure the columns and connecting-pieces together. A similar arrangement would enable any number of columns and connecting-pieces to be attached to one another, so as to make up one long length.

In order to make sure that the shaft thus composed of alternate columns and connecting-pieces, should be capable of maintaining itself in a perfectly vertical position, it was necessary that the whole of the surfaces of contact should be wrought perfectly true and flat. Every column and every connecting piece had, therefore, to be placed in a lathe; and the bed or surface at each end faced to a perfectly true plane. When the number of these columns, base-plates, and connecting-pieces is taken into consideration, it may be easily imagined that the labour entailed by this apparently simple necessity could scarcely have been performed in any workshops but those provided with extraordinary facilities and resources.

In the connecting pieces of the 24-feet bay we are now describing, projections are cast upon three sides, so that girders may be attached in three directions; and thus extend in every direction except that towards the nave, and the 48-feet avenue or court on the other side.

The girders, which are attached, as above described, to the connecting pieces, serve to support the gallery floor. As, in the construction of this floor, it had been determined to bring the accumulation of pressure on the girders, upon points at 8 feet intervals, it became necessary, in arranging the form of the girders, to concentrate strength at those points. The vertical lines of the girder have, therefore, been arranged to occur at intervals of 8 feet, connecting the top and bottom tables; on the good proportion of which, to the load to be supported, and to one another, the main strength of the whole depends. Diagonal lines connect the junction of these standards with the top and bottom tables, and the principal parts of the girder present the form shown in Fig. 5.

The girders are 3 feet deep, and the sectional area of the top table, (A, fig. 5,) which is of the T form, equals 5.31 inches, and that of the bottom, (B, fig. 5,) which is of a similar shape, but inverted, equals 7.64 inches. The areas of

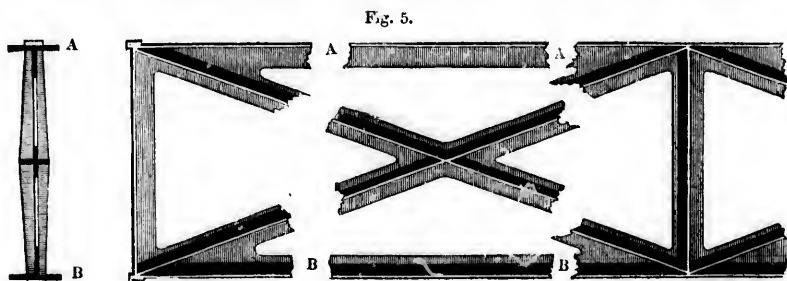

the diagonal struts or standards, and ties, average 3.50 inches. The breaking-weight of the girders is calculated, and has been proved by various experiments, to amount to not less than 30 tons. Every one of the gallery-girders which has been used has been proved upon the ground to a strain of 15 tons; and, in exceptional cases, where it has appeared reasonable to expect that an accumulation of weight would have to be borne, their dimensions of thickness have been increased, and the amount of proof has amounted to no less than 22½ tons.

Their sufficiency

A few simple figures will clearly exhibit the sufficiency of these girders to support the loads that are likely to be brought upon them. A bay of gallery-floor, measuring 24 feet by 24 feet, contains 576 square feet; and it has been found by experiment, that it is impossible to load any surface with men to an amount equal to one hundred-weight per foot superficial. Assuming, then, 576 cwts., or say 30 tons, to be by any possibility accumulated upon such a bay of gallery-floor, the load will be distributed over four girders, any two of which have been found to be fully competent to support the load.

to support a
"dead weight,"

and a moving
load.
How tried:—

In thus estimating the sufficiency of the girders, the load they might possibly be called on to support has been considered only as what is called "dead weight," or load to which no momentum of any kind had been imparted. In order, then, to test them under the action of a moving weight as well, a series of experiments was instituted. A perfect bay of gallery, 24 feet square, was constructed, with connecting pieces, girders, flooring, &c., complete. Its surface was first crowded with the contractors' workmen, as tight as they could be packed. The men were then set to walk over it, run over it, and, finally, to jump upon it with all their force.

By workmen;

By soldiers
marching

In order further to observe the effects which would be produced by a load to which a uniform, instead of an irregular motion, had been conveyed, a number of soldiers of the corps of Royal Sappers and Miners were ordered to march over it, to run over it, and, finally, to mark time upon it in the most trying manner. The result of these experiments developed the correctness of the theory upon which the dimensions of the girders had been based, since not the slightest damage was done to the bay of gallery; and the fact was fully evidenced, that the quality of elasticity or springiness in the floor served to protect the girders from the effect of sudden shocks, and prevented the danger of the communication to them of the accumulating momentum, generated by the possible isochronous movements of a crowd.

By rolling round-
shot "in situ";

Emboldened by the satisfactory result of these experiments, a yet more conclusive series was instituted. An apparatus was contrived by Mr. FIELD, the late President of the Institution of Civil Engineers, by means of which it was possible to draw, at a quick walking pace, over the whole of the galleries on which the public would have to tread, a number of 68-pounder shot, collected together so as to produce a uniform load of 100 lbs. per foot superficial. No damage whatever was produced by these rude tests, and they may be considered to have conclusively set at rest any doubts as to the sufficiency, in point of strength, of the gallery-floor, or of the girders which support it.

Who made by.

The whole of these girders are of cast-iron, and, together with the columns and similar castings, have been made in Staffordshire, at the foundries of the contractors, at the London Works, Sinethwick, near Birmingham; at those of Messrs. A. and B. COCHRANE, of the Woodside Iron Works, Dudley; and at those of Messrs. JOYSON'S, of Holly Hall, near the same town.

breaking-
periments,
which has
; and, in
cumulation
e been in-
s.

girders to
of gallery-
has been
men to an
ing, then,
uch a bay
o of which

at possibly
ed "dead
rted. In
a series of
, was con-
ts surface
be packed.
p upon it

a load to
number of
h over it,
manner.
eory upon
slightest
ced, that
e girders
unication
ochronous

more con-
EFTS, the
ch it was
leries on
collected
cial. No
onsidered
point of

columns
the con-
f Messrs.
those of



The floor, which is supported by these girders, consists of cross-beams, ⁸⁰ under-trussed with iron rods, shoes, and struts, as to distribute the whole weight that may be brought upon the floor pretty equally upon the eight points at which the ends of the beams rest upon the girders. Joists, stretching from the iron girders to the beams, and from one of the beams to the other, form the supports for a floor which is not more than $1\frac{1}{4}$ inch thick, but is at once amply strengthened, and rendered impervious to the passage of dust, by the insertion, in a groove cut in the edge of each floor-board, of iron-hooping, forming a tongue. A railing, designed by Mr. OWEN JONES, surmounted by a mahogany handrail, adds at once to the utility and the beauty of the gallery.

⁸⁰ The gallery floor resting on the girders.

The columns which rise at the gallery level are 16 feet $7\frac{1}{4}$ inches long, and are surmounted by connecting pieces, similar in all respects to those occurring beneath. To these connecting pieces are attached, transversely in one direction and longitudinally in two, cast-iron girders of similar form and scantling to those we have described; their office being to maintain perfectly true and rigid, the vertical shafts which carry the eye upward in one unbroken line from the ground to the roof which they serve to support.

The columns between galleries and roof.

As the strength of an iron column practically depends upon its length being limited, far more than upon its substance, the value of dividing the whole length of the shafts reaching from the gallery to the roof into two parts by these connecting-pieces, and thus reducing the length of the columns one-half, must be readily appreciated.

Strengthened by division into

First tier.

Above the second tier of girders rise columns of the same length as those last mentioned, and on them again are placed connecting pieces, to which the girders supporting the roof are attached. These girders correspond with those supporting the galleries, and exactly resemble those forming the tier immediately beneath them, in every respect except their thicknesses. The whole of the girders on the upper tier have been proved in the building to a strain of nine tons.

Second tier.

By extending the area of our observations, we shall be enabled to include all the varieties of trusses employed to support the flat roofing over the whole extent of the building. It may be well, therefore, to consider that our original limitation to 24 feet square has been enlarged by the addition of a space of 72 feet by 24 feet, being a compartment of the roof over the nave; and of an area of the same *width* by 48 feet, being a portion of the roof over the avenue which extends from east to west, beyond the aisle on each side of the nave.

Varieties of roof trusses.

As we have stated that the latter of these portions of the building (the 48-foot avenue) rises to a height of two stories only from the ground, it will be manifest that its roof-trusses must be attached at the level of the girders which serve to stiffen the main shafts of the nave, namely, at a height of 44 feet from the ground. These 48-foot roof-trusses are attached to connecting pieces in a similar mode to that already described for the girders, with the exception that their vertical position is maintained by bolts passing through their standards and through the column, instead of by the system of keys as in the 24-foot girders.

The 48-ft. trusses;

In fig. 6 a representation is given of the principal parts of one of these trusses, which, it will be seen, is constructed for the most part of wrought iron; the few portions which are of cast iron acting only under compression. These trusses follow the general principle of division into 8-foot compartments; and, consequently, the cast-iron struts or standards ($\Delta \Delta \Delta \Delta$, fig. 6) occur in positions corresponding with those in the gallery-girders already described.

Their details of construction.



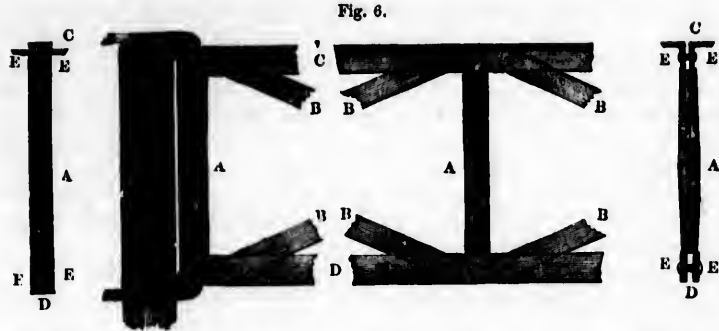

Diagonals of similar width on face (B B B B B, fig. 6) connect them, and, consequently, an uniform lattice-like effect is obtained. The top table of these trusses (C C C, fig. 6) consists of two pieces of angle-iron, set at the distance of an inch apart, their total sectional area equalling 3 inches. The bottom table (D D D, fig. 6) consists of two bars of wrought-iron set at a similar distance apart, and increasing in sectional area up to 3.38 inches, as they approach the centre of the bearing. Between the angle-irons at the top and the bars at the bottom of the truss, are passed the ends of the cast-iron standards and those of the diagonal ties; the sectional area of the principal of the latter equalling 2.75 inches. Rivets, (E E E, fig. 6,) passing through the angle-irons and bars, the standards, and the ties, connect the whole into one truss, which acts upon the principle of a rigid top table under compression, and a suspension-truss beneath; so pressing up the standards or struts as to raise the centre of the upper table to a camber of 4 inches, one of the objects of which is to provide a sufficient fall for the roof-water. One of these 48 feet trusses, complete, weighs about 13 cwt., and when, under proof, having been loaded with a dead weight of 10 tons, deflected 3 inches, perfectly recovering its elasticity upon the removal of the weight.

The 72-ft. trusses; The clear width of the nave being 72 feet, it was of course imperative to construct a third description of truss, the depth of which should not exceed that of the connecting pieces generally throughout the building, namely, 3 feet, and yet sufficiently strong to support the larger weight of roof due to the increased area of roofing it was called upon to support. The construction of this larger truss, as shown in fig. 7, corresponds in every essential particular with that of the 48-foot truss already described, with the difference that the scantling of the angle-irons and bars is necessarily much increased, and that the total length of 72 feet is divided into *nine* 8 feet lengths instead of *six*. The weight of one of these trusses complete is about 35 cwts.; the sectional area of the two angle-irons (A A, fig. 7) being 5.71 inches; that of the two bottom bars, at their maximum, 6.75 inches; and that of the principal diagonal ties 3.38 inches. When loaded under proof, with a dead weight of 16 tons, it deflected 6½ inches, and entirely recovered its elasticity on the weight being removed.

The extra strong 72-foot trusses; their details of construction.

A repetition of one or other of these varieties of trusses suffices to support any portion of the flat roof of the building; but in order to carry the great extra weight thrown by the transept roof upon the last 72-foot trusses of the nave, where it intersects the transept, it was found necessary to employ trusses of double depth, extra lattice-work, and much increased scantling. The construction

Fig. 7.

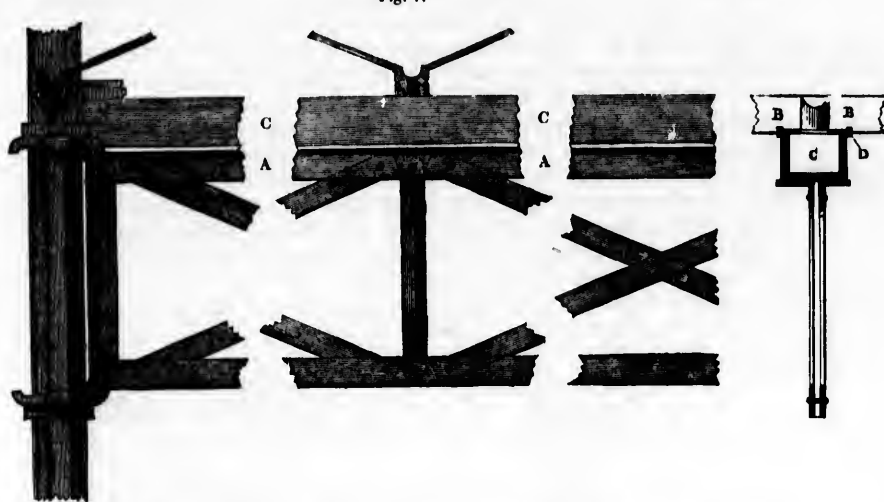

of these trusses is shown in fig. 8. In order to give additional support to them, four extra columns have been attached to those situated at the intersection of the nave and transept.

Fig. 8.

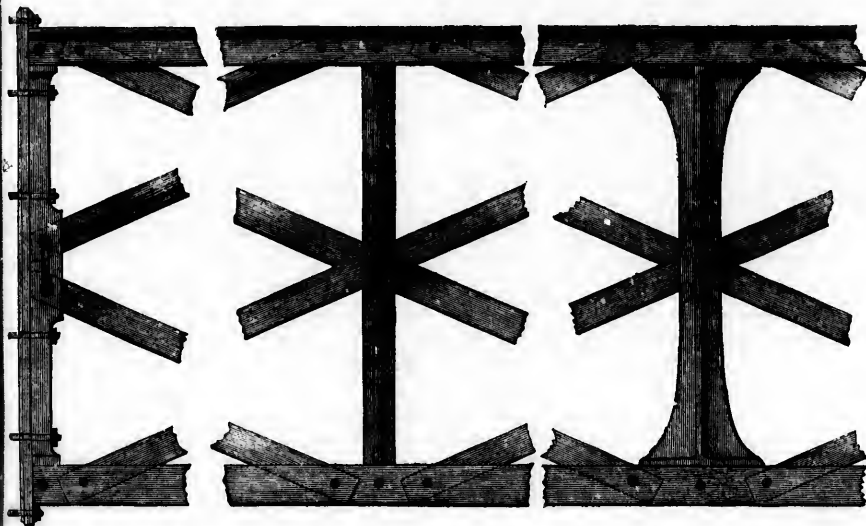

The direction of the 72-foot trusses of the roof of the nave being of course transverse to its length, and the trusses occurring at intervals of 24 feet, it became necessary, in order to perfectly steady them, that timbers (shown in section and elevation at BB, fig. 7) should be thrown across from one to the other, in

The roof trusses, how connected longitudinally.

the direction of from east to west. These timbers are introduced at intervals of eight feet, being placed directly over the vertical standards of the roof trusses.

Box-gutters running transversely over trusses.

Between the top of the truss and the end of these timbers is placed a box (shown in section and elevation at C C C, fig. 7), running along the whole length, and attached to the upper flange of the truss, forming a gutter of considerable capacity, for the purpose of carrying the water away from the roofs to the hollow columns, through which it ultimately descends to the drains.

Connected longitudinally by Paxton gutters, &c.

The peculiar form of the timbers, spanning from truss to truss, and the offices they are called upon to perform, together with the fact that no less than 20 miles of them are required for the construction of the roofing, render them worthy of a detailed description. They are now known as the *Paxton gutters*. The form of their section is clearly shown in fig. 9.

Figs. 9, 10, 11, 12.

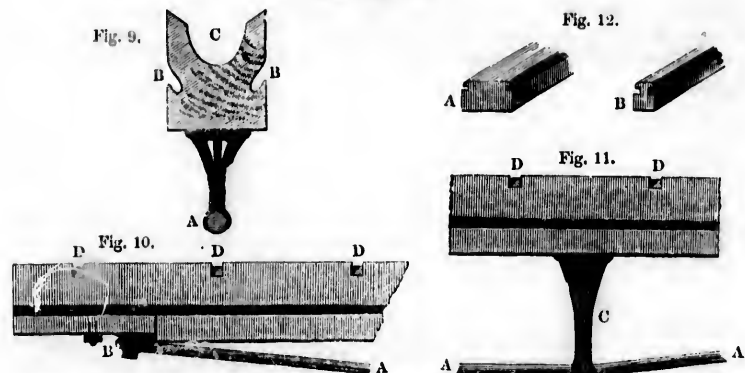

The Paxton gutters;

Their details of construction;

Their trussing;

They consist of pieces of timber 24 feet in length, five inches wide by six inches deep. On the upper surface, a semicircular groove (C, fig. 9), $1\frac{1}{4}$ inch radius, is cut, in order to receive the external water from the roofs. On each of the two vertical sides of the timbers an oblique groove (B B, fig. 9) is cut, in order to receive the condensed water, which, trickling down the inner surface of the glass, finds its way to these small channels, and is carried along them to their ends, where oblique cuts connect them with the box-gutters.

As the length of 24 feet would be too great for the gutter to carry itself without bending, or, as it is technically termed, "sagging," the alternative presented itself of either very much increasing the scantling, or contriving some system of trussing. The former was rejected on account of its heaviness and unsightly appearance; it was therefore determined that a rod of iron (shown at A A A A, figs. 9, 10, and 11) should be passed beneath the Paxton gutter, should be secured to its two ends by cast-iron shoes (B, fig. 10), and should press up, at eight feet intervals in its length, two cast-iron standards (C, fig. 11), so as to effect a camber or rise in its whole length of $2\frac{1}{2}$ inches. So trussed, the gutter is capable of supporting no less a weight than $1\frac{1}{2}$ tons. A semicircular cut is given through the depth of the gutter at both ends, so that when two are placed end to end, the water may flow down to the box-gutters through a circular cavity. Twenty-seven notches are marked by a template, and cut on each side of the upper edge; a few of these are shown at D D D, figs. 10 and 11. The Paxton

gutter, thus complete, is attached to a flanged iron plate, bolted on to the edges of the box-gutters, so that the parallel lines of gutter may form a continuous tie from the eastern or western ends of the Building to the transept, and so that, should the wood shrink in length, it may not pull apart and distort the sides of the box-gutters.

Three of the notches referred to as being cut on each side of the gutters, are larger than the others, and on them bars of wood, 2 inches by 1½ inch, grooved for glass on both sides, are notched down. These bars (shown at A, fig. 12) form principal rafters, and, being set at a pitch of 2½ to 1, are fixed to a ridge 3 inches by 3 inches, grooved for glass on both sides. The angle at which these are fixed being the one which Mr. PAXTON, in numerous experiments, has found to be best adapted to the construction of similar roofs.

Their connection with the roofing

One of the principal reasons which led to the adoption of eight feet and not more, as the pitch of these gutters from centre to centre, was, that the distance from ridge to gutter-edge might be covered with the largest sized glass that could be conveniently manufactured in one length, and that by that means the unsightly appearance, and frequently leaky connection, of joined glass, might be avoided.

Reasons for being their pitch of 4 feet

The method of construction of a single bay of this system of roofing is shown in fig. 13, and from it the reader may be enabled to follow the description we are about to give of the construction of a length of roofing.

A 24-foot bay of roofing

Fig. 13.

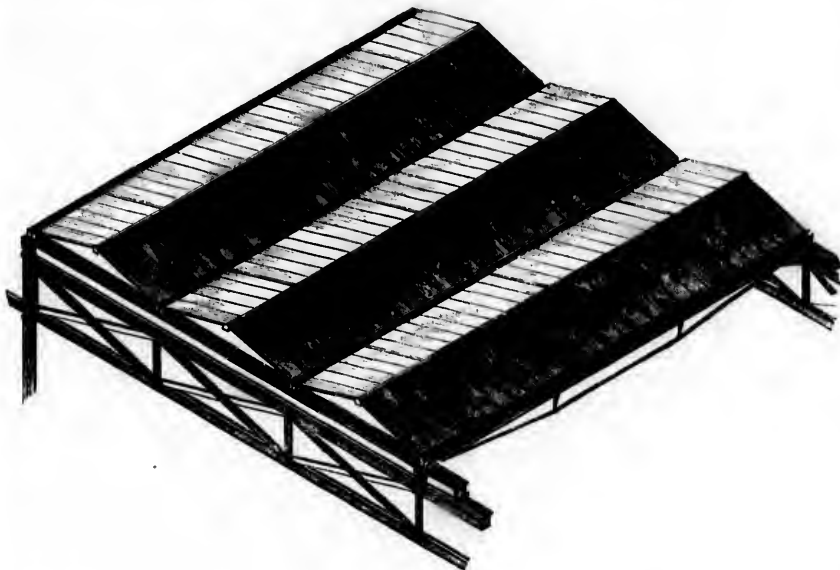

The gutters, principal rafters or main sash-bars, and ridge being fixed in place, the long edge of a sheet of glass, 4 feet 1 inch, by 10 inches, is inserted into the groove of the principal rafter, and a sash-bar (shown in section at B, fig. 12), 1 inch by 1½ inch, also double grooved, is then put on to the other

How constructed.

at intervals of
roof trusses.
s placed a box
e whole length,
of considerable
s to the hollow

and the offices
less than 20
render them
Paxton gutters.

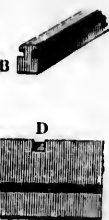

A

e by six inches
inch radius, is
ch of the two
ut, in order to
e of the glass,
to their ends,

to carry itself
ternative pre-
ntriving some
heaviness and
ron (shown at
gutter, should
d press up, at
11), so as to
l, the gutter
ircular cut is
wo are placed
ircular cavity.
n side of the
The Paxton



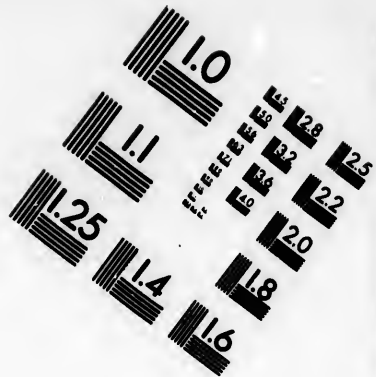
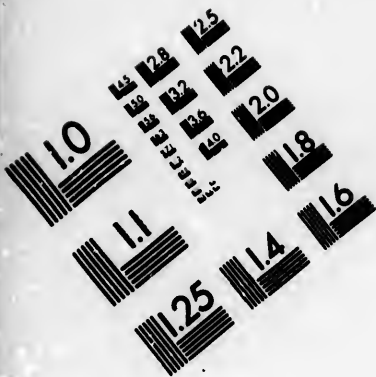

**IMAGE EVALUATION
TEST TARGET (MT-3)**

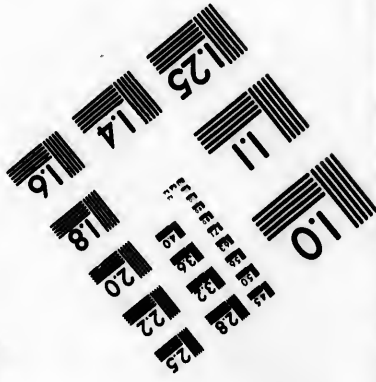
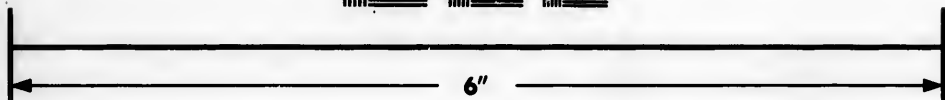
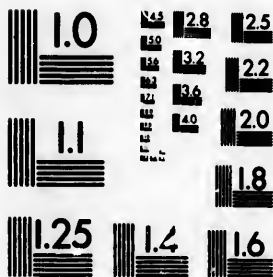

**Photographic
Sciences
Corporation**

23 WEST MAIN STREET
WEBSTER, N.Y. 14580
(716) 872-4503

1.8
2.0
2.2
2.5
2.8
3.2
3.6
4.0

5.0
5.6
6.3
7.1
8.0
9.0
10

long edge of the glass. The sash bar is then brought down and secured at the top to the ridge, and at the bottom to the edge of the gutter; the lower edge of the glass bedding on putty about three-quarters of an inch wide. A slight blow to the lower end brings the upper edge of the glass home into the groove in the ridge. The glass being then pressed down, the putty is made good in the grooves externally, and by the repetition of this simple operation, the essentials of this system of roofing are constructed.

Lightness one of the advantages of Mr. Paxton's roofing.

One among the many advantages of Mr. PAXTON's roofing is its extreme lightness. In the instance of that of the Exhibition Building, the whole of the roofing (the weight of the trusses that support it being of course deducted), weighs only 3½ lbs. per foot superficial upon the average.

The canvas covering, how attached.

In order to mitigate the intensity of the light, and at the same time to assist in keeping the building cool, a canvas covering has been provided, extending over the entire area of the flat roof. The canvas is attached to the ridges, and allowed to hang down between them in a festoon. As one width of canvas is insufficient to reach from ridge to ridge, two are sewn together, the seam occurring in the centre, immediately over the Paxton gutter. The rain descending falls on the canvas, and clings to it by capillary attraction, creeping down until it arrives at the seam, where it passes through the canvas, and falls into the Paxton gutter; thus the danger of the passage of water which might take place through broken panes or imperfect putty-joints, is obviated, and the chances of leakage are consequently materially diminished.

Its uses.

The flooring.

In order to trace continuously the course of the vertical supports from the ground to the roof, we have not interrupted our description by detailing the nature of the flooring; but as that is one of Mr. PAXTON's ingenious contrivances, it would not be right to allow it to pass unnoticed. In a paper, read by Mr. PAXTON at the Society of Arts, on the 13th of November, 1850, that gentleman narrated the experiments which led to the origination of the present design, and stated that he had tried many methods, in order to find out the most suitable floors for the pathways of horticultural structures. After enumerating the objections to the use of stone and close boarding, he mentioned, that "he had ultimately been led to the adoption of trelliced wooden pathways, "with spaces between each board, through which, on sweeping, the dust at once "disappears, and falls into the vacuity below." He thus describes his application of these experiments to the Exhibition Building:—

as described by Mr. Paxton.

"Whilst the accomplishment of this point" (the speedy removal of dust) "was most important in plant-houses, I consider it doubly so with respect to the "Industrial Building, where there will be such an accumulation of articles of "delicate workmanship. Before sweeping the floors of the Great Building, the "whole will be sprinkled with water from a movable hand-engine, which will be "immediately followed by a sweeping-machine, consisting of many brooms, fixed "to an apparatus on light wheels, and drawn by a shaft. By this means a large "portion of ground will be passed over in a very short space of time." The boards for the floor are 1½ inch thick, laid half an inch apart, upon joists 7 inches by 2½ inches, which rest upon large timbers or sleepers, 13 inches by 3½ inches, at intervals of 8 feet apart. Through the interstices left between the boards the dust passes, and the merits of this system of flooring are thus summed up by Mr. PAXTON:—"It is very economical, dry, clean, pleasant to walk upon, admits "of the dust falling through the spaces, and even when it requires to be

"thoroughly washed, the water at once disappears between the openings, and the boards become almost immediately fit for visitors."

Conclusion of notice of general construction of one 24-foot bay.

Having now endeavoured to furnish the reader with sufficient detail of a small portion of the building, to enable him to use it as a scale, whereby to estimate the quantity of labour represented by a structure of the general dimensions we are about to enumerate, it may be stated that the total area of the ground floor is 772,784 square feet, and that of the galleries 217,100 square feet. The galleries extend nearly a mile in length. The total cubic contents of the building are about 33,000,000 feet; there are nearly 2,300 cast-iron girders, and 358 wrought-iron trusses for supporting the galleries and roof, 30 miles of gutters for carrying water to the columns, 202 miles of sash bars, and 900,000 superficial feet of glass. The width of the nave is, within 10 feet, double that of St. Paul's Cathedral, whilst its length is more than four times as great.

General dimensions and quantities.

With a general knowledge of the construction of the nave, we may imagine the visitor, returning to the transept, better qualified to enter into the mechanical details, and the amount of difficulties presented to his notice, by that great feature of the building. The arrangement of the vertical shafts, galleries, &c., is similar to that of the nave; the main points of difference commencing at the level of the flat roof. It will be remembered that the spaces to be covered at a height of 64 feet from the ground, are, firstly, a main avenue, 408 feet long by 72 feet wide; and secondly, two aisles, each 408 feet long by 24 feet wide. It was determined that a semi-cylindrical vault should span the larger of these areas, and for that purpose semicircular ribs (see Plate I.) extend from side to side, their ends being inserted into the hollow columns, whilst they are steadied by the insertion between, and at right angles to them, of stout timbers, 9 feet 2 inches from one another, acting as purlins.

The transept.

its roof.

The structure of the ribs is shown in fig. 14. To quote from a paper descriptive of the building, read at the Institution of Civil Engineers, on the 14th of January, 1851, "they are made in three thicknesses of timber, cut into segments, "9 feet 6 inches long, of a circle of 74 feet extreme diameter, the centre thickness "being 4 inches by 13½ inches, and the outer, or flitches, breaking joint with the "centre, being 2 inches by 13½ inches. The flitches are nailed to the centre "thickness, and ¼ths inch bolts, about 4 feet apart, on the segment, traverse and "bind together the three thicknesses. On the extrados, or outer circumference of the wooden arch thus formed, two planks serving as a gutter board "11 inches by 1 inch, and a bar of iron 2 inches by ¼ths inch, are bent to the "curve; and on the intrados, or inner circumference, a piece of timber, 7 inches "by 2 inches, moulded to correspond with the form of the columns, and a bar of "iron, 3½ inches by ¼ths inch, are also bent to the curve. Bolts, at intervals "of 2 feet from centre to centre, passed through the depth of the rib, unite these "additions to each other, and to the main rib, which, thus increased in scantling, "measures, complete, 1 foot 6 inches by 8 inches." In order to perfectly connect these ribs, so that any force exerted, by wind or other causes, tending to the displacement of any one of them, may be distributed over the whole mass, iron rods have been set diagonally, forming a complete reticulation over the whole inner surface of the roof. The main ribs are fixed spanning the transept, at intervals of 24 feet from centre to centre. Each of these 24 feet widths is divided into three parts, and at 8 feet from one another, and from the main ribs, minor ribs are introduced. Between them again, but being semicircles of larger

Construction of the ribs of the transept roof.

Description quoted from "Transactions of Institution of Civil Engineers."

The transept roof, how constructed.

diameter, are fixed small ribs of wood, which being connected with the main and minor ribs by means of sash bars, become available as ridges. The space between

Fig. 14.

Transsept Ribs.

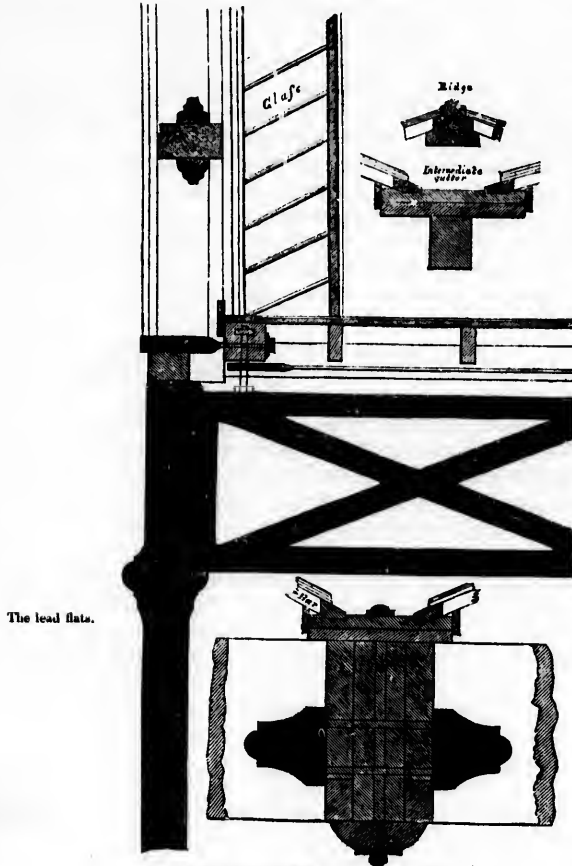

Section of Transsept Rib, and springing of ditto.

them and the ribs is glazed and finished on the same system as that adopted in the flat roof of the building, the sash bars being set at an oblique angle, or "herring-bone" fashion, in order to assist the conduction of the water, and prevent its lodging against the lower putty bed of each pane of glass over which it trickles.

Along the summit of this semi-cylindrical vault runs, from north to south, a narrow lead path, in order to afford access to the apex of the roof, and to provide a means of lowering down workmen to repair any damage that may possibly happen to it. As the quantity of water discharged from this vault must necessarily be considerable, it was deemed advisable that the 24-feet aisles on each side of it should be covered with lead flats, instead of the ordinary glass roofing. These lead flats presented also the further advantage of being so completely connected, as to form solid abutments, steadying the feet of the ribs. In order to convey any pressure in the way of thrust, that the ribs might exert, to those points best capable of resisting

strain, horizontal trusses of wrought-iron were constructed beneath the lead flats, consisting of bars capable of being keyed up at any time from the lead flats, and thus any tendency to movement, on the part of any of the ribs, would be immediately transferred either to the extreme north and south ends, where their feet are securely tied together by the cast-iron girders which cross the transept at those points; or to the angles where the transept intersects the nave, and where the whole force of the *vis inertiae* of the nave roof would serve as abutment.

The general effect produced by this semi-cylindrical roof covering the large elms beneath, is shown in Plate I.

The external enclosures or walls, as seen from within, on the two upper

The external enclosure.

stories, consist of glass in wooden sash frames, inserted between columns 8 feet from centre to centre, and louvre frames for ventilation, surmounting the sash frames. On the ground story, boarding takes the place of the glass; and the height being 24 feet instead of 20 feet, an additional tier of ventilators is inserted. The columns at 24 feet apart being of iron, the intermediate ones, dividing that width into 8 feet compartments, are of wood.

As no less than 1,500 sash frames have been used, they may justify a few The sash-frames. words of description. To quote again from the Transactions of the Institution of Civil Engineers, we learn that "the sash frames are 2½ inches thick, with seven bars in their width; the bars being 2¼ inches deep, double grooved for glass. Wrought-iron bolts, ¾ inch diameter, pass completely through the sash bars and sash frames, at the points where they are attached to the columns; and thus a chain tie is kept up all round the building, in order to prevent displacement of the sashes either bodily or in portions, by the pressure of the wind. To further guard against the same action, timber bridges, 3½ inches by 1½ inch in the centre, are fixed across the middle of the length of the sash; and at the internal angles, where the wind will exert its greatest force, iron rods, half an inch in diameter, are fastened from column to column, pressing against the wooden bridge, and converting it into a continuous strut, bearing up against any force applied to the exterior of the sash. In order to glaze the sashes, the glass is slipped down between the bars, and provision is made for mending, by causing one groove to be cut deeper than the other, so that the glass may be slipped in from one side, and puttied into its exact place. A similar provision is made for mending the roof glass."

As whatever lateral force the wind may exert upon the building will be The action of wind on them, and on the building. principally received by these sashes, it may not be inappropriate, in considering them, to advert briefly to the general question of the action of wind upon the building.

On the 15th of January, 1851, a meeting was held at the Society of Arts, at which Mr. Fox, one of the contractors for the building attended, to afford the members of that Society an opportunity of asking any questions as to the general points of stability and durability, on which they might desire information. One of the questions proposed was, "What would be the effects of the wind How described by Mr. Fox. on such an extensive surface as the building presented, and what means were taken to counteract them?" and as Mr. Fox's reply embraced with remarkable clearness the principal facts connected with the argument, we shall give it at length. Mr. Fox replied "that the building rested on 1,060 columns on the ground floor, and the most likely direction for the wind to have any injurious effect on the building, must of course be in the direction of its greatest width, which was 1,800 feet as compared with 400 in the opposite direction. These columns rested on cast-iron plates based upon concrete; and there was no possibility of their rocking about without the base-plates being broken. Above these plates were sleepers, that carry the floor. They were 13 inches in depth, and fitted accurately up against the two sides of the column, and running transversely from one side of the building to the other; so that it would be very difficult to conceive that one of these columns could be possibly upset until it was actually broken in two. And again, at the top the columns are united together by cast-iron girders 3 feet deep, and four columns are framed together, very much as they would frame a table. Now to break the column,

“ they must exert a force equal to that of twice the transverse strength of the column. According to the experiments it was found that six tons was the bearing weight, and 12 tons the breaking weight of the columns in the centre. Now, 1,060 columns multiplied by six tons, the bearing weight, was equal to 6,360 tons; so that it would be necessary to exert a force equal to 6,360 tons, at a height of 24 feet from the ground, before they would be able to blow down the building, and he was now treating of the building independently of its bracings. The greatest force of wind ever known had been computed at 22 lbs. to the superficial foot. Taking 28 lbs. as the force, and assuming that they could have a gust of wind which would strike the whole side of the building from top to bottom at the same moment, the total force which could be brought against it would be from 1,400 to 1,500 tons. Now, they had got power to resist it of 6,360 tons, not taking into account the bracings and the other constructions and offices which were within the building, and which must of course add to its strength. The building had been tested in the late gale, when Colonel REID ascertained that the force of the wind was 19½ lbs., and it did no harm whatever; and that was at a time when the roof was not on, and the building was quite exposed.”

The ventilators.

The ventilators, to which allusion has been made, and which are shown in fig. 15, fulfil an important office in the building, acting as the organs of respiration to the whole body. The total surface of ventilation is nearly 50,000 superficial feet, and the whole has been so arranged, that, by the application of one man's strength, at about 90 different points, the whole may be opened, closed, or set and secured at any desired angle, simultaneously. The ventilators themselves consist of galvanized iron blades of an S form, 6½ inches wide, fixed on

Fig. 15.

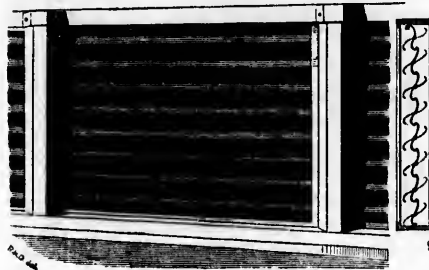

pivots at 6 inches from centre to centre. Of these there are eight in the wooden frame inserted between the columns and the sill on the ground floor, and six in those which surmount the sash-frames on the two upper stories. The section of the blade is of a novel form, and is calculated, when open, to afford the minimum interruption to the passage of the air, compatible with being weather-tight at all times. To each blade, in the centre of its length, are attached small iron brackets furnished with eyes, through which pins are inserted; which pins are secured in a species of wooden rack. These racks are connected with cranks attached to iron rods, to which a movement of torsion is conveyed by screws and powerful levers. A moderate exertion of the strength of one man applied to one of these levers, suffices to regulate, with facility, no less than 600 feet superficial of ventilation.

The decoration.

Hitherto the building has been considered only in a structural point of view. The vivacity of any impression it may convey to the casual visitor will, however, probably depend more strongly on the system of decoration which it has received from Mr. OWEN JONES than on any of the constructional details we have been describing. That gentleman, whose studies in Egypt and in the East generally,

th of the
is was the
he centre.
is equal to
360 tons,
low down
ntly of its
t at 22 lbs.
that they
building
e brought
power to
other con-
a must of
ale, when
nd it did
a, and the

shown in
respiration
The total
is nearly
t, and the
arranged,
on of one
about 90
hole may
set and
ed angle,
e venti-
ist of gal-
of an S
fixed on
e wooden
x in those
the blade
erruption
mes. To
furnished
a species
ron rods,
vers. A
e levers,
tilation.
of view.
however,
received
ave been
generally,



[Fig. 16, p. 67.

VIEW OF THE EXTERIOR OF THE BUILDING FROM THE NORTH-WEST ANGLE.

in
en
the
fir
to
M
the
blu
so
col
of
Br
lig
po
gi
be
th
fo
an
co

vi
m
di
at
ex
w
th

no
ju
pl

ho
75
po
st
qu

ra
er
F
th
h
ti
p
fa
b
g

in Spain, and in other countries of Europe, had qualified him for the task, was enabled at an early stage in the progress of the building, to foresee the effect of the combination in perspective of its various lines. Serious apprehensions were at first entertained as to the propriety of the application of colour, usually devoted to the decoration of extended surfaces, to what were asserted to be lines only. Mr. JONES was, however, enabled to estimate how far the merging in distance of those lines would give them the appearance of surfaces, and the three tints of blue, red, and yellow have been distributed by him over the columns and girders, so that as the surfaces blended in perspective, each column has allied itself in colour with its fellow column, each vertical face of girder with the vertical faces of its fellow girders, and each soffit, or underside, with its fellow soffites. Breadth and distinctness were given to the enunciation of each colour. The light of the sky appearing through the interstices of the roof, the principal portions of which have been tinted of a delicate blue, unites with the colour, giving it at once air and brilliancy. The effect of this mode of treatment has been to add considerably to the apparent elevation of the building. By varying the colours of the vertical and of the horizontal lines, and retaining each uniformly, the eye is enabled to detect, at even the greatest distance, the direction and position of every part of the construction, and thus the otherwise endless confusion of the complexity of lines, is reduced to order and simplicity.

Although a provision for the gratification of the intellectual tastes of the visitor has been the main object in the formation of the Exhibition Building, ministering to his more ordinary appetites has not been lost sight of. Commodious refreshment rooms, with the accompaniments usually connected with them at large railway stations, have been provided around the trees at the northern extremity of the transept, and adjoining open courts towards the eastern and western extremities of the buildings, where the presence of the trees dictated their location.

The official business connected with the conduct of the Exhibition rendered necessary the employment of a large staff of clerks, &c., for whom, and for the juries, &c., a considerable extent of accommodation has been provided in offices placed on each side of the southern entrance.

We have supposed our visitor to enter on the south side; admittance may, however, be also gained at the eastern and western ends, where similar vestibules, 72 feet by 48 feet, afford accommodation for turnstiles, check-takers, &c. Disposed at nearly equal distances from one another, on the four sides of the structure, are 15 exits, by passing through either of which the building may be quitted.

In issuing from its precincts the visitor will pass through the gates of an iron railing designed by Mr. OWEN JONES. Retreating to some distance, he will be enabled to take in a general impression of the whole building, as shown in fig. 16. From the north-west angle the most picturesque view is to be obtained, and from that position may be best appreciated the grand effect produced by Mr. PAXTON'S happy idea of raising the semi-cylindrical vault of the transept roof, above the tiers of terraces which extend on either side of it. For much of the grace of proportion and beauty of form, which from this point of view the visitor cannot fail to notice, the building is indebted to Mr. BARRY. Upon the form and distribution of the arches and filling-in frames, as well as of the columns, the suggestions of that gentleman exercised a happy influence.

The details of an 8-foot bay of elevation.

In fig. 17 we have given a view of a bay of the building, 8 feet in width ; and from that and the other illustrations a tolerably correct idea may be formed of the nature of its external construction.

The spaces enclosed at eastern and western ends.

At the east and west ends considerable spaces have been enclosed, for the purpose of affording accommodation for large objects, the weight or dimensions of which precluded their admittance into the building.

The boiler-house.

At about 155 feet from the north-west angle, a structure, 96 feet by 24 feet, has been erected for the purpose of containing the boilers for generating steam, to be supplied to give motion to the

Fig. 17.

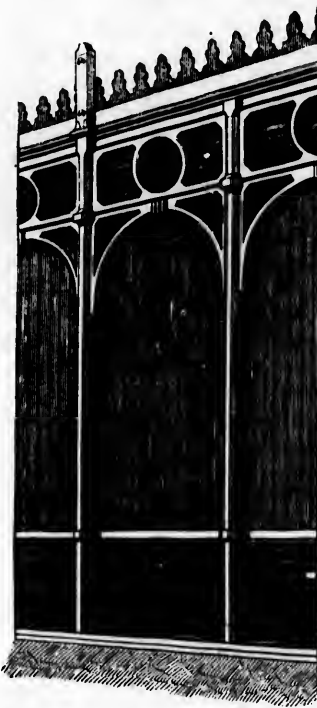

The water supply.

Conclusion of Part I. of subjects—"The building as it stands."

Commencement of Part II.—"Its creation."

Arrangements subsequently to acceptance of tender.

various machines requiring to be exhibited in operation. The external appearance of this building precisely corresponds with that of a portion of the main edifice of similar dimensions. It contains five boilers, equal to 150-horse power, and a large tank, serving as a balance-head to the water-supply. This supply consists of a 6-inch main, entirely surrounding the building ; upon it, at intervals of about 240 feet, are placed fire-cocks ; and at different points in its circuit 16 4-inch branch-pipes enter the building, and lead so far into the interior, that fire-cocks placed upon their ends are so situated that circles of 120 feet radius drawn from each of them would intersect one another. The mains running on the north and south sides of the building are connected across the transept by a 5-inch main, from which, near the centre of the building, pipes diverge, leading east and west, for the supply of the various fountains placed upon the central line of the nave.

Having endeavoured to convey some general idea of the nature of the building as it at present stands, it may be desirable to trace the successive steps by which it has grown into the form it now assumes.

When it is remembered that the tender for its construction was not accepted by the Royal Commissioners until the 26th of July, 1850, that possession of the site was only obtained on the 30th of the same month, and that the first column was fixed on the 26th of September, it will be manifest that into the intervening period must have been crowded arrangements, which, under ordinary circumstances, would have required at least double that period for their completion. Details of construction had to be settled, elaborate calculations as to the strength and proportions of the several constituent parts to be made, machines for economising labour to be devised, contracts for the supply of materials to be entered into, and thousands of hands set actually to work. How unintermitting since that period the labour must have been is testified by the fact, that the opening of the Exhibition takes place on the 1st of May, the day originally appointed.

On the ground being given up to the contractors, the first work undertaken was the construction of a hoarding to inclose the whole area of the site. This hoarding was formed by the insertion into the ground, in pairs, of the timbers ultimately to be used as joists. Between each pair of uprights were slipped the ends of boards, ultimately to be used as floor-boards; and these were secured by attaching together the two ends of the joists extending above them. Thus the expense of the hire of waste boarding was avoided; the timber composing the hoarding was completely uninjured; and the celerity with which the whole area was surrounded was truly remarkable.

Hoarding commenced on site being given up to contractors.

The task of setting out the plan of the building was intrusted to Mr. BROUNGER; and the extreme accuracy with which the situation of every column was fixed, and the adjustment of every level was performed, reflects credit upon that gentleman.

The setting out.

In order that the measurement of 24 feet, upon which the accuracy of the whole plan depended, might be indicated with extreme precision, poles of thoroughly-seasoned pine were fitted with gun-metal cheeks, or small projecting plates, the ends of the poles extending a few inches beyond the cheeks. The measurements were taken by laying one pole on the other, so that the inner edges of the gun-metal cheeks, set at precisely 24 feet from one another, might be brought into contact. Thus the danger of any error, arising from the ends of the poles becoming damaged in use, was avoided. Stakes having been driven into the ground to indicate approximately the position of the columns, their precise centres were ascertained by the use of the theodolite, and marked by driving a nail into each stake at the exact point. When it became necessary to remove these stakes, in order to dig out holes for the concrete foundations, an ingenious method was resorted to, for at any time identifying the position occupied by the nail which had been removed. To effect this a right-angled triangle was framed in deal, at the two ends of which saw-cuts were made. Previous to the removal of the stake, the apex of the triangle was set to the nail indicating the situation of the centre of the column. Two other stakes were then driven beneath the saw-cuts, and two nails driven in at the ends of the saw-cuts. The wooden triangle being then removed, the centre stake was withdrawn, the hole made, and the concrete thrown in. The height of the surface of the mortar, varying with almost every column, was regulated by pegs driven to the correct level under the direction of Mr. BROUNGER. Another triangle of a somewhat similar character to, and having saw-cuts in the same position as, the one already described, having two of its angles adjusted to the two stakes remaining in the ground, determined the exact position in which the base-plates had to be fixed.

How proceeded with.

As every casting was delivered on the ground, it received a careful examination, and an immediate coat of paint. The girders, upon the perfect soundness of which the stability of the galleries and roof mainly depended, were subjected to a rigorous test, in a machine arranged for the purpose by Mr. CHARLES HEARD WILD. One of Mr. HENDERSON'S patent cranes was so placed, that, on a waggon containing girders being brought beneath its range, a girder was lifted from the waggon, and deposited upon a weighing apparatus. An account having been taken of its weight, the girder was again lifted by the crane, and carried forward to an extremely strong frame, the two ends of which corresponded in form and dimensions to the connecting pieces with their projections. The girder being securely confined in these clutches, a force was exerted upon it at the two points upon which the weight of the floors and roofing would have to be carried, that is

Castings examined and girders proved how.

to say, immediately over its vertical lines. The force thus communicated was applied by two pistons, forced upwards by a modification of BRAMAN's hydraulic press; the principle of which, it will be remembered, depends upon the power gained by forcing water (by means of a small piston) into a strong cylinder in which a larger piston works; the power being increased in the proportion borne by the area of the piston to be raised to the area of the small piston. A registering apparatus affixed to the pipe leading from the force-pump to the testing-machine, afforded the means of adjusting the pressure exercised by the hydraulic press. A careful observation of this apparatus conveyed the assurance, that every girder, according to its ultimate destination, was proved to a strain of either 9, 15, or 22 tons. After testing, the girder was released from its confinement, again raised by the crane, and stacked in a convenient place ready for removal. So admirably were the various arrangements made for conducting these operations, that it was possible for a girder to be lifted from its waggon, weighed, secured in the testing-machine, proved, released, again raised, and finally deposited, in less than four minutes.

The columns and girders, how raised,

In order to elevate the columns to their places, what is known in technical language as a pair of shear-legs was employed. This simple apparatus consists of two poles lashed together at their heads, and maintained in a steady position by ropes extending, from the apex of the triangle formed by the base-line of the ground, and the inclination of the poles, to one another, to stakes driven into the ground at a considerable distance. From the apex of the triangle a series of ropes passing over pulleys were suspended perpendicularly; and, by means of this "fall," the majority of the columns, girders, and other heavy portions of the construction, were elevated to their places. The operation of raising girders is shown in the

Fig. 18.



steadied.

view, fig. 18, but on so small a scale as to convey only an imperfect idea of its detail. Modifications of the simple apparatus described sufficed to hoist almost every part of the necessary iron-work. A connecting-piece was attached to each column previous to its elevation; and so soon as two columns with their connecting-pieces were fixed, a girder was run up, slipped between the projections of the connecting-pieces, and secured in its place. An opposite pair of columns having been similarly elevated, another girder was attached to them; and thus two sides of a square were formed, and maintained in a vertical posi-

tion by poles acting as supports to them. Two other girders being then hoisted, and slipped between the connecting-pieces on the remaining two sides of the square, a perfect table was constructed. The "shores" or supports were then removed, together with the shear-legs, and the whole apparatus was at liberty, for the purpose of recommencing a similar operation in an adjoining 24-foot bay.

When a sufficient number of these bays had been completed, starting from the intersection of the nave and transept, to warrant the addition, the hoisting of the columns for the first floor was commenced; more lofty shear-legs being of course employed. The extension of the ground-floor structure proceeding, as that of the first floor was carried on, a base was in turn afforded for the columns of the third tier; and thus the iron frame work of the whole building rose from the ground, firm and secure, without involving the necessity of any scaffolding whatever.

While these operations of actual structure were being carried on, under the immediate superintendence of Mr. JOHN COCHRANE, the work of preparation was yet more vigorously pushed. The manufacture of the Paxton gutters, and the application of machinery to their formation, is so interesting, as to warrant a somewhat lengthened notice.

In the year 1837, when Mr. PAXTON commenced the construction of the Chatsworth conservatory, in which similar gutters were employed, machinery had not been brought to bear upon their construction. By the use of a contrivance, the details of which were arranged by Mr. COWPER, a gentleman in the employment of Messrs. FOX and HENDERSON, a total length of upwards of 2,000 feet per day has been turned out, for many successive days. The pieces of timber destined to form the gutters are sawn into lengths of 24 feet, 6 inches deep, and 5 inches thick. Three of these pieces are fixed on the frame of a planing-machine, and by it are worked true and square. In figures 19, 20, 21, and 22 are given representations of the details of the gutter-making machine, erected at Messrs. FOX and HENDERSON'S workshops, near the Thames, at Chelsea.

Fig. 19 is a side view of a block of cast-iron, to which steel cutters (AAAA) are attached by bolts and nuts (BBBB). Four blocks, of similar construction, are fixed to four spindles, and by the action of drums on the same spindles, set in motion by bands moved by a steam-engine of 20-horse power, the blocks are made to revolve with extreme rapidity. Any piece of timber exposed to the action of these cutters, must obviously be scooped out into the form of the outline of the cutters attached to each block. By modifying the form of the cutters almost any variety of section can be given to the timbers brought into contact with them. In the present case, the four sections A, B, C, and D (fig. 21), represent the successive action of the four sets of cutters lettered to correspond with them (on fig. 20), by means of which the larger cavity for the rain water, and the two smaller channels for the condensed water, are formed. The part removed by each set of cutters is shown by the hatched lines.

Fig. 22 represents a plan of the machine, looking down from above upon the gutters, the gutter being removed in order to show the action of the cutters more clearly.

The operation may be explained as follows:—The piece of timber, properly squared, is placed upon the roller marked E, it is then pushed on until it comes

The second and third stories commenced without scaffolding—how

The preparation of the other work

The gutter-making machine

Fig. 19.



Its mode of operation

in contact with the roller marked F, the projecting points on which so far seize it as to propel it forward to meet the rapidly revolving set of cutters marked A. Passing onwards to B, it is subjected to a second action. By C a third operation is performed, and in passing through D, a perfect form is given to the piece of timber. Thus, while, the end beyond D presents the perfect section of a

Fig. 20.

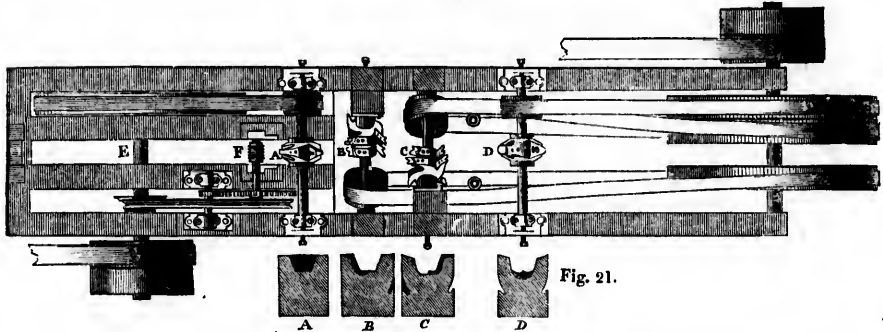
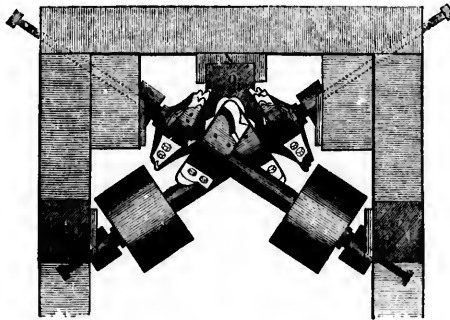

Fig. 21.

finished gutter, the other end, which has not yet passed the set of cutters at A, remains in its original square form. In fig. 22, a vertical section is given, exhi-

Fig. 22.



biting the precise angle at which the cast-iron blocks are made to revolve, and the cutters to clear away the timber before them. O shows the section of the gutter acted on by the cutters, N the holdfast by which the gutter is kept in its place during the operation. By the use of this machine three feet of gutter can be made per minute, and, working night and day at this rate, the whole quantity required was completed in two months.

The Paxton gutters—how completed for use on the ground.

The Paxton gutters, thus prepared, were delivered on the ground, and after having been carefully examined, and the defective ones removed, they were conveyed to other machines (*vide* fig. 23), fixed upon the ground, by means of which they were finished ready for use. A large circular saw, the spindle of which could be raised or depressed by the action of a lever, had fixed in the centre of one of its sides two gouges, adapted to produce, by rapid revolution, a semicircular groove. A frame, the exact length of the gutters, was fixed at right angles to the

plane of this saw. In the centre of this frame a species of chair was constructed, capable of turning round, and a shoe was fixed at the extremity of the frame farthest from the saw. The end of a gutter about 24 feet long was thrust into this shoe, and its middle supported by the chair already mentioned. The end nearest to the saw was then pressed down, and secured by an iron strap. Thus retained in position, it was necessarily bent to precisely that camber arranged to be ultimately given to it by suspension-rods and struts. The circular saw, revolving rapidly, was then made to descend until its edge came in contact with the end of the gutter, which it cut to the precise length required, and at exactly the right angle. The axis of the circular saw was then still further lowered down, until the gouges fixed on its side cut their way through the gutter, making a semicircular groove through its depth. One end being thus scooped out, the gutter was released from its position, turned round, and secured in a contrary direction in the shoe at the opposite extremity of the supporting frame. The other end of the gutter, thus presented in its turn to the saw, was then subjected to a similar process, after which it was removed, perfectly ready for the attachment of its iron bowstring.

A machine of somewhat similar construction (though much simpler) to that by which the Paxton gutters were made, brought the ridges to their proper form.

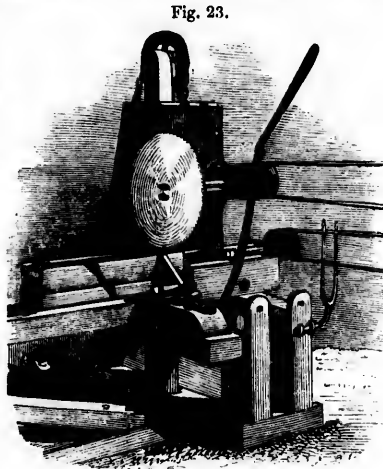

Fig. 23.

The ridges.

In the course of numerous experiments which Mr. PAXTON had commenced as early as the year 1828, the great necessity for providing some machine by which a quantity of sash-bars might be speedily and economically cut, was forcibly impressed upon his mind. In the paper we have already quoted, Mr. PAXTON thus describes the origin of machines of this description:—"In 1837 the foundations of the great conservatory (at Chatsworth) were commenced; and in constructing so great a building, it was found desirable to contrive some means for abridging the great amount of manual labour that would be required in making the immense number of sash-bars requisite for the purpose. Accordingly, I visited all the great workshops of London, Manchester, and Birmingham, to see if anything had been invented that would afford the facilities I required. The only apparatus met with was a grooving-machine, which I had at once connected with a steam-engine at Chatsworth, and which was subsequently so improved as to make the sash-bar complete. For this apparatus the Society of Arts, in April, 1841, awarded me a medal, and this machine is the type from which all the sash-bar machines found in use throughout the country to the present time are taken. As the conservatory was erected under my own immediate superintendence, I am able to speak accurately as to the advantages of the machine. It has, in regard to that building alone, saved in expenses 1,400*l*. The length of each of the bars of the conservatory is 48 inches, only one inch shorter than those

The sash-bars, Mr. Paxton's improvements in the manufacture of, generally.

“ of the Exhibition Building. The machine was first used in its present form in August, 1838, and its original cost, including table, wheels, and everything complete, was 20*l*. The motive power is from a steam-engine employed on the premises for other purposes, and any well-seasoned timber may be used. The attendants required are only a man and a boy, and the expense of the power required for it when in use is comparatively trifling. The sash-bars may be made of any form, by changing the character of the saws. There is one particular feature in working the machine, namely, that the bars are presented to the saws below the centre of motion, instead of above it, as is usual; and to the sides of the saw which are *ascending* from the table, instead of those which are *descending*. These arrangements were necessary to suit the arrangement of the teeth to the grain of the wood; for when the bars were presented to the saws in the usual way, the wood was crushed, instead of being cut and cleaned. It is essential that the machine should revolve 1,200 times in a minute to finish the work in a proper manner.”

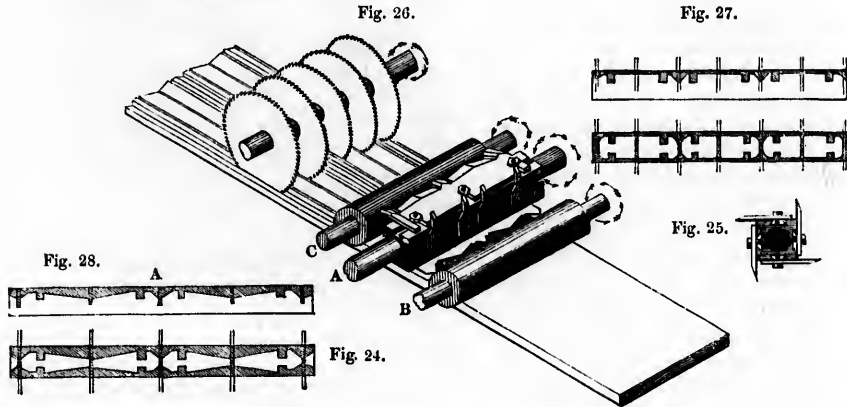

Sash-bar machine used for the building.

We shall now proceed to describe the modification of this machine, which is due to the inventive powers of Mr. BIRCH, of the Phoenix saw mills, near Cumberland-market, Regent's Park, with whom a contract was entered into by Messrs. FOX and HENDERSON for the supply of all the sash-bars for the roof, the upright bars for the vertical lights, and the ridges. Two of the principal points of difference between Mr. BIRCH's machine and that described by Mr. PAXTON are, that revolving cutters are substituted for saws, thus obviating difficulties incident to the grain of the wood; and that, by the addition of a second set of cutters, a plank passed between them is operated upon on its upper and under surfaces at the same time. In fig. 25 is shown a cast-iron block (somewhat similar to those previously described in connection with the gutter-cutting machine), to which are attached a variety of cutters. The rapid revolutions of the spindle (A fig. 26) operate upon the planks submitted to the action of the cutters, in the manner shown in fig. 28. So soon as the plank, presented by the feed-roller, has been operated upon by the rapid revolution of these miniature adzes, it is carried on by the roller C, and is subjected to the action of circular saws of varying diameters, the lesser of which cut just sufficiently deep to form the groove for the

glass, while the larger pass completely through the plank, and divide it into four finished sash-bars. In figs. 24 and 28 is represented the mode in which the sash-bars for the vertical lights are made, the hatched lines indicating the parts removed; and in fig. 27, the way is shown in which the sash-bars for the roof have been cut. Modifications in the cutters affixed to the spindle A, fig. 26, produce the variation in form.

As delivered at the building, the sash-bars were cut approximately only to their length, and in order that it might not be necessary to execute any carpentering operation on the roof, it was requisite that they should be adjusted on the ground, ready for fixing. An arrangement of circular saws, set at the angles requisite to cut the ends of the sash-bars to accord with the pitch at which they would have to be presented for attachment to the ridges, served at once to cut a large number passed between them to a perfectly uniform length, and to form the necessary rebate for notching down upon the gutter edges.

To ensure the gimlet-holes necessary for nailing down the sash-bars being made with perfect regularity, a row of five gouges were set in motion by a band from an adjacent steam-engine, passing over a series of drums. The sash-bars, placed at a proper angle to them, were moved along by boys, in the manner shown in fig. 29, and presented to the points of the gouges, by the rapid revolution of which the necessary nail-holes were pierced.

Fig. 29.

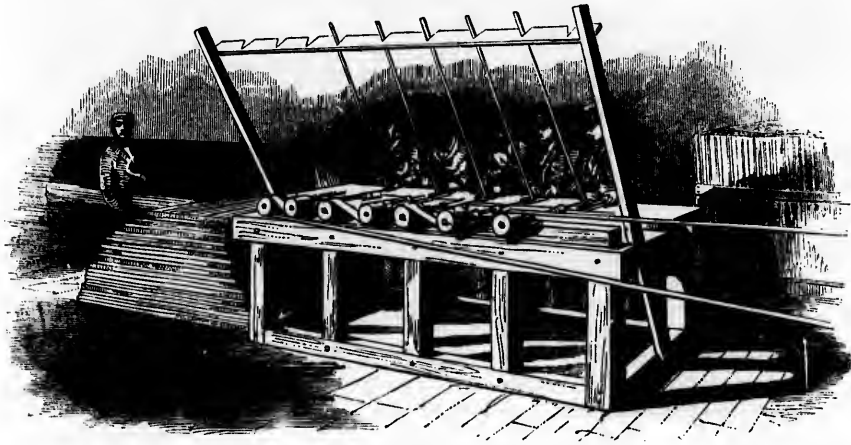

It yet remained to paint these sash-bars, and even for that purpose the ingenuity of Messrs. FOX and HENDERSON provided mechanical assistance. A number of brushes were arranged in a frame, at right angles to one another, in such a manner that their bristles would just admit of the passage between them of a sash-bar. In a trough filled with colour a number of sash-bars were immersed, and one of them being lifted from it, loaded with colour, and presented to an aperture at one end of the series of brushes, it was passed through them to a corresponding aperture at the other end; by which process the whole of the superfluous paint was removed, and the sash-bar drawn out as neatly painted as it could have been by the workman's hand. This machine is represented in use in fig. 30.

The machine for painting the sash-bars.

Morticing machine employed.

To facilitate the putting together of the sash-frames and sash-bars, considerable use was made of a machine for making mortices and tenons, patented by Messrs. FURNESS & Co., of Liverpool.

The making of the glass.

While these various machines were busily operating in the preparation of the necessary framework to receive the glass, Messrs. CHANCE BROTHERS & Co., of Smethwick, near Birmingham, to whom the contract for its supply had been committed, were not less actively employed. The large size of the sheets required (4 feet 1 inch by 10 inches), and the extraordinarily short time within which the

Fig. 30.

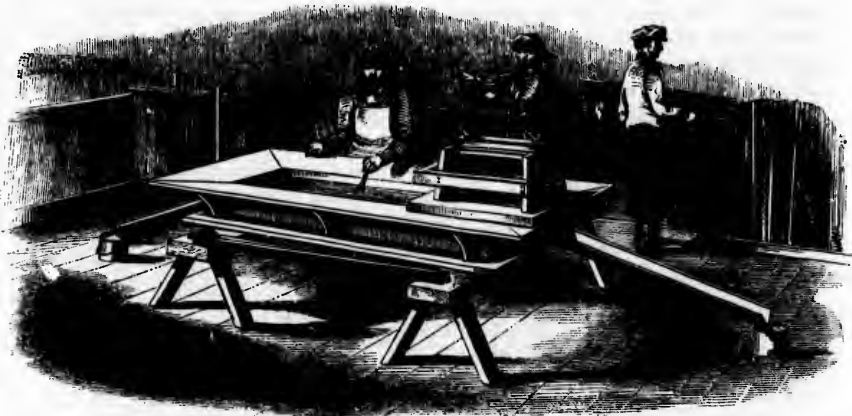

immense quantity necessary had to be supplied, demanded the employment of numerous additional hands, and workmen had to be sought for from abroad to assist in the completion of the order within the requisite time. The mode of manufacturing the description of glass employed is a great improvement on the old system of crown-glass making; as by it the variation of the substance occasioned by the thickness of the glass, as it approaches the bull's-eye, is completely avoided. In the manufacture of sheet glass, the workman, having taken up a lump of glass on the end of his pipe, alternately blows, swings his ball of glass to and fro, and rolls it upon a metal table until it assumes the form of a long cylinder; the ends being then taken off, and the cylinder cut in the direction of its length, the sheet of glass falls down, is flattened to a perfectly true face, and is then trimmed off and finished.

Progress made in framing roof trusses;

by means of drilling, punching, and cutting machines;

During the preparation of the materials necessary to commence the construction of the Paxton roofing, active progress had been made in the framing of the wrought-iron trusses requisite to span the central 72-foot nave, and the 48-foot avenues on each side of it. A steam-engine of 6-horse power gave motion to drilling, punching, and cutting machines, represented in figs. 31 and 32. By means of these, the necessary pieces of bar-iron were adjusted to their requisite lengths. The holes for riveting having been marked upon them with templates, were punched out, and any larger perforations necessary for extra-sized rivets, drilled. The various parts, thus prepared for combination, were then arranged upon platforms, and the holes in the various portions being made to correspond,

the operation of rivetting was gone through. A row of temporary forges was constructed by the side of the platforms, and the red-hot rivets taken from them were passed through the holes, and hammered by the workmen into their requisite forms. By rivetting up.

While these active preparations for the construction of the roofing were in progress, the daily supplies of castings of every description were of the most abundant nature; no less than 316 girders having been cast and supplied in one week. As fast as the columns came upon the ground, they were taken to their places and immediately fixed. Up to the 20th of September 77 columns had been supplied. The rate of delivery of columns, &c.

Figs. 31 and 32.

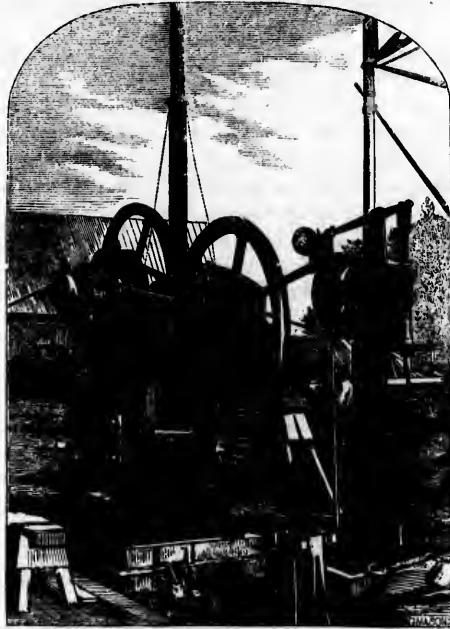

By the week ending the 25th of October, the average number fixed per week amounted to nearly 200, and that rate of supply was continued for several subsequent weeks.

The attention of the contractors was next directed to the formation of the transept ribs. The choicest timber was selected for that purpose, and under the careful superintendance of Mr. FOWLER, their form was set out upon a platform erected for the purpose, and the timbers for the first rib laid down. When the rib thus commenced was completed, it was made to serve as a template for the construction of a second; and thus one was fitted upon the others, until the pile had accumulated to four. Three of these having been then laid down in other places, the remainder were constructed upon them in a similar manner. The formation of the transept ribs.

As the preparations for putting together the main structure advanced, it was requisite to form the necessary wooden columns, sashes, matched and beaded The progress of carpenters' and joiners' work generally.

boarding, louvre frames, &c., for the external enclosures. The vertical sashbars, cut at the Phoenix saw-mills, were delivered by Mr. BIRCH in large quantities. Sash-frames, also cut at the same mills, were supplied, and these were fitted together by the contractor's carpenters, whose time and labour in forming mortices and tenons was much economised by the employment of the machine before alluded to, patented by Messrs. FURNESS & Co.

As supplies of the smaller castings necessary to complete the various portions of the structure poured in, the work of erection and putting together proceeded with wonderful rapidity. The progressive increase in the number of hands employed affords a tolerable indication of the increasing intensity of the work:—

The increasing intensity of the work evidenced by—

The number of hands employed.

1850.	In the week ending Sept. 6,	39 men were employed.
	„	Oct. 4, 419 „
	„	Nov. 1, 1,476 „
	„	Dec. 6, 2,260 „
1851.	„	Jan. 3, 2,112 „

and from that time, until within a month of the opening of the Exhibition, the average number has rarely fallen below 2,000.

Raising of the 72 and 48-foot trusses;

The task of raising to their places the 48 and 72-foot trusses, was accomplished with great facility in the following manner:—A single mast was maintained in a vertical position by ropes, similar to those described as steadying the shear-legs used for hoisting the girders. From the summit of this mast descended other ropes, with blocks and pulleys, for the purpose of gaining power in lifting. What is called a leading or guide-block, having been attached to the bottom of the mast, a rope passing through it was connected with a yoke drawn by a horse. The mast having been placed close alongside the line in which the roof-trusses had to be fixed, and one end of a rope secured to the truss, the draught of the horse caused the truss to ascend to the necessary height, being steadied in its ascent by other ropes secured to its two ends.

Facilities for the above.

When the truss thus hoisted was fixed in its resting place, the mast was moved along a plank by means of crow-bars, being maintained in a perpendicular position by the alternate slackening and tightening of the cords extending from its head to stakes driven into the ground. Having thus been moved 24 feet, it was ready for the operation of a second hoisting. Two of these great masts, fixed on each side of the transept, were used daily, and in one day as many as seven of the great 72-foot trusses have been raised to their proper position and secured, the apparatus for elevating them having travelled in a vertical position no less than 168 feet.

The beginning of December the time of the climax of activity.

Towards the beginning of December the climax of activity was arrived at, and the most trying operation in the whole construction of the building commenced, namely, the hoisting of the main ribs for the great transept roof. The easiest and at the same time the most secure method of proceeding, with respect to the conduct of this operation, had for some time occupied the attention of the contractors. An ingenious suggestion, made to them by Mr. WILBEE, one of their foremen, was at once adopted, and, with certain modifications, it was promptly carried out.

Framing together of the transept ribs preparatory to raising.

The floor for the lead flat was already completed, so that an admirable stage was prepared upon which to make the necessary arrangements. The ends of the column into which it was designed to drop the ends of the ribs, rose about four feet above

the level of the lead flat, and on the tops of those columns timbers were laid, forming landing stages or tram-ways, to receive the ribs when hoisted. It was of course necessary to raise the ribs sufficiently high above the lead flat to enable their ends to descend upon the tram-ways. To effect this it was determined that two ribs should be placed on end, at a distance of 24 feet from each other, and framed together with purlins and diagonal ties, exactly as they would have to be framed in their finished state. Two complete sets of additional temporary ties were further introduced, to provide for the strain to which the ribs would necessarily be exposed from their altered position in the act of hoisting. The feet of the ribs were securely attached to stout pieces of timber, to afford the means of safely attaching the cords by which they were to be raised. Thus framed together, the ribs were moved on rollers to the centre of the square formed by the intersection of the nave and transept.

On the extra strong trusses which have been described as spanning the nave at this point, two pairs of shear-legs were fixed at 24 feet from one another, and secured by ropes connecting them with distant portions of the building. These hoisting shears consisted of two legs on each side of the transept, each leg being formed of three stout scaffold poles lashed together at the top, and footed on planks laid across the lead flat. The heads of these shear-legs inclining slightly forwards, had connected with them blocks and pulleys from which descended ropes, attached to the four ends of the two ribs. The hoisting ropes connected with the sets of pulleys passed down from the shears to leading blocks, attached to the four columns at the angles of the intersection of the nave and transept. From these guide blocks they were led off diagonally to four powerful crabs, so arranged that the gangs of men employed at each were placed opposite the end of the rib acted upon by the crab they worked; and thus the foreman of each gang was enabled so to regulate the exertions of his men as to make them correspond with those of the remaining gangs, and to maintain the two ends on each side in a perfectly horizontal plane.

As the diameter of the semicircular ribs exceeded the width of the transept by their own thickness, it became necessary, in order that they might pass between the trusses, to commence by raising two of their ends to a considerable height from the ground; and to maintain their diameter at the same angle of inclination until they were hoisted above the columns into which they had to drop. On raising them to a height of about 65 feet from the ground, the highest ends were drawn in a horizontal direction, so as to hang over a portion of the lead flats, and thus room was left to allow the other ends to be lifted to a corresponding height on the opposite side. The ribs were shifted slightly in a horizontal direction until the ends came over the columns, they were then lowered down upon rollers placed upon the tram-ways above mentioned, and by means of these rollers the ribs were moved along to the furthest end of the transept. The place in the centre of the building occupied by the ribs thus hoisted was immediately taken by another pair, which were similarly connected, raised, and moved to within 24 feet of the first pair.

When the whole of the ribs were thus elevated to their places, the spaces between them were filled up with the necessary intermediate ribs and connections; and thus the whole roof was framed together complete.

The raising of the main ribs commenced on the 4th of December, and the whole sixteen were fixed in one week. It occupied about an hour to raise a pair

Provisions for raising.

Raising.

When raised, how fitted together.

Time occupied in raising.

and number of men required.

of ribs from the ground to the level of the lead flat, but the previous preparations involved a much longer space of time. Eleven men worked at each crab, and about 16 were employed on the lead flat, to guide the ribs in their ascent, and see to the safe condition of the shear-legs and tackle. Considering the anxious nature of this performance, it must be regarded as a most gratifying circumstance, that the whole operation was accomplished without any untoward occurrence.

Glazing the transept roof.

No sooner had the skeleton of the transept-roof been completed, than the work of glazing commenced. For a considerable portion of the height of the curve, ladders and temporary scaffolds enabled the workmen to proceed with their labours; but in order to complete the upper part an ingenious box was constructed, moving on wheels in the line of the gutters. This box was lowered down from the lead-flat at the summit to any portion of the roof.

Glazing the nave roof.

The glazing of the nave roof presented formidable difficulties, from the great extent of work to be got through in so short a space of time. The ingenuity of the contractors was, however, brought to bear upon the subject, and provisions were made by them for the simultaneous glazing of large areas, entirely independent of variations of weather. 76 machines were constructed, each capable of accommodating two glaziers; these machines consisted of a stage of deal about 8 feet square, with an opening in its centre sufficiently large to admit of boxes of glass, and supplies of sash-bars, putty, &c., being hoisted through it. The stage rested on four small wheels, travelling in the Paxton gutters, and spanned a width consisting of one ridge and two sloping sides. In bad weather the workmen were covered by an awning of canvas, stretched over hoops for their protection.

Construction of glazing-machines;

How used.

In working, the men sat at the end of the platform next to whatever work had been last done; from which they pushed the stage backward sufficiently far to allow them to insert a pane of glass, and as soon as that was completed they moved again far enough to allow of the insertion of another. In this manner each stage travelled uninterruptedly from the transept to the east and west ends of the building. The dexterity acquired by the men in working the machines was very remarkable. By means of them 80 men in one week put in upwards of 18,000 panes of glass, being not less than 62,600 feet superficial. The greatest number of panes inserted by a man in one day was 108, being 367 feet 6 inches of glazing. A somewhat similar machine has been constructed for the purpose of effecting any repairs that may be necessary in the finished roof, with the difference that its wheels travel upon the ridges instead of in the gutters, and that of course there is no aperture for the purpose of hoisting.

Quantity of work done.

Rapid supply of small castings.

Taking into account the innumerable quantity of small castings requisite, and the extreme rapidity with which they had to be supplied, their quality and cleanliness is truly remarkable; and the fact of their having all issued from one foundry, that of the contractors at Smethwick, proves the great facility with which work of that nature can be executed in England.

Celerity with which the painting of the nave roof was executed.

Among the later operations connected with the completion of the work, the most remarkable for the celerity with which it was conducted, was the ornamental painting of the nave roof. Iron straps, attached to the trusses, supported a number of scaffold poles, on which a perfect cloud of boards was laid, and as many as between 400 and 500 painters, by these means, worked their way, with extreme rapidity, from one end of the building to the other.

The magnitude of this great building elevated into serious undertakings matters which, under ordinary circumstances, are accounted little more than trifles. Hence machinery was applied to the formation of the entire length of hand-rail required for the galleries. In fig. 33 is represented a set of cutters (A fig. 33), by exposure to the rapid revolution of which, roughly-shaped strips of mahogany were instantaneously converted into smooth and cleanly rounded hand-rails (B fig. 33). A little sand-paper and French-polish sufficed to bring them to their present excellent condition.

The application of machinery to make the gallery hand-rails.

Fig. 33.



In summing up the description of any great engineering undertaking, it is too often a painful task to have to record the loss of life so frequently involved. Considering the difficulties of construction, the necessary perils to which the workmen were exposed, and their habitual imprudence, arising, partly, from real indifference to danger, and partly from bravado, it has been a source of congratulation that, in the performance of this contract, but very few accidents have occurred, and those, with two or three exceptions, of a slight nature.

Paucity of accidents.

Having now brought to a close our description of the building as it exists, and of the processes by which its existence has been developed, it remains only to reiterate our conviction that the courage, energy, and strength represented by its construction should be regarded by every Englishman with emotions conducive to some yet higher manifestation of national capability; and at the same time to express a hope that the products of British industry (of which the building is but the shrine), may display, in a yet higher degree and in a yet more tangible and varied form, the sources of COMMERCIAL POWER, so many indications of which it has been our happy privilege to trace in the edifice itself.

Conclusion.

M. DIGBY WYATT.

SCIENTIFIC REVISION AND PREPARATION OF
THE CATALOGUE.

Peculiar circumstances of production of Catalogue

The circumstances under which this work is published appear to call for some observations upon the method of its production. From the fact that it is without a precedent in the annals of literature, it follows that its preparation and publication have been attended with peculiar, because unforeseen, difficulties. All those obstacles in the way of its completion which would necessarily develop themselves from the remarkable manner in which its contents have been created, and from the want of a guiding experience in the publication of works of this nature, have been contended with in its progress to a perfect state. The following may be considered as an outline of the manner in which the materials for the construction of this volume were collected, and of the system adopted to reduce them to a definite form, and as far as possible to a certain degree of consistency of expression and of harmony of proportion.

Exhibitors the authors.

It is not the least remarkable fact in connection with the Great Exhibition, that the Catalogue may be really regarded as the production of many thousands of authors,—represented by exhibitors themselves. By a decision of the Executive Committee, every exhibitor was required, prior to the reception of his articles at the Building, to have filled up a certain printed form, containing a description of his productions in the English language, accompanied with such general observations as might be suggested by the peculiar character of the things described and intended for exhibition. These forms, which were to be to the Catalogue what the MS. of an author is to his proposed work, were framed with care, and were accompanied with instructions for filling them up, which suggested those points on which interesting or important information might be supplied, together with the descriptive account. There were four varieties, each appropriated to one of the four great sections of Raw Materials, Machinery, Manufactures, and Fine Arts. The essential characters of these forms were similar in each section, but the instructions for filling them up differed necessarily with the peculiar differences suggested by each section. The subjoined form represents that used in sending in descriptions of machinery, and is a type of those used in the other sections:—

Catalogue form.

List of Articles of MACHINERY to be exhibited by

_____ Exhibitor's Surname. _____ Christian Name.
 _____ Country. _____ Address, stating nearest Post Town.
 _____ Capacity in which the Exhibitor appears, whether as *Producer, Importer, Manufacturer, Designer, Inventor, or Proprietor.*

No. of Articles.	DESCRIPTIONS.

In order to facilitate their classification on being returned by exhibitors, the forms in the four different sections were printed in black, blue, red, and yellow, the latter applying to sculpture and fine art, the former to raw materials, and the intermediate ones respectively to machinery and manufactures. Every exhibitor was required to send in one of these forms, accompanied with a duplicate in every respect similar to it, and in so doing was supplied with a "receipt for catalogue forms," which was a guarantee for the reception of his goods into the Building. A very large number of these forms were printed and supplied to Local Committees, and to all exhibitors who applied for them. The instructions for filling them up were as follows:—

Classification of the forms.

RULES FOR COMPILING THE CATALOGUE.

The Executive Committee are desirous of impressing upon Exhibitors that the formation of the Catalogue which, however great may be its bulk, must necessarily be compiled and printed in a very short time, will be much facilitated, if Exhibitors will have the kindness to follow the rules hereinafter prescribed when they furnish the descriptions of the Articles as they wish them to appear in the Catalogue.

1. Every Exhibitor should write the description of every Article or series of Articles he exhibits, on paper of the same size as the present page (namely, about 13 inches by 8 inches). The paper must be written on *one side only*. There should be a margin of one inch at the left side of the page.

Rules for compiling forms for Catalogues.

2. Should the description extend beyond a single page, each separate page must be marked with the Exhibitor's name, and numbered consecutively, both at the head and foot.

3. To prevent errors in compilation and misprinting, it is desirable the handwriting should be *very clear*, especial care being taken with all names and technical terms.

4. It is indispensable that each Exhibitor should furnish the following particulars, and in the exact order prescribed:—

- I. Exhibitor's surname Christian name.
- II. Country Address, stating the nearest Post Town.
- III. Capacity in which the Exhibitor appears, whether as Producer, Importer, Manufacturer, Designer, Inventor, or Proprietor.
- IV. The name and description of every Article of importance or class of Articles exhibited; each Article or Class beginning a separate paragraph, *e. g.*—
 - a Specimens of dyed Cottons, &c.
 - b Specimens of dyed Silks, &c.

5. It is necessary that the descriptions of the Articles should set forth, as far as may be practicable, the following particulars:—

As respects Articles to be exhibited

In SECTION 1. RAW MATERIALS and PROCESSES, the descriptions should specify—

- a The commercial name in English, French, and German.
- b The scientific name.
- c The place where obtained; the name of the mines and period they have been worked, should be given with minerals.
- d The place where exported.
- e The uses.
- f The consumption.
- g The superior excellence of the particular Specimens.
- h In the case of processes, such as dyes, or prepared materials, such as mixed metals; it should be stated whether the Article is patented or not. The novelty and importance of the prepared product, and the superior skill and ingenuity manifested in the process of preparation should also be very briefly pointed out.
- i Where price is an element for consideration, the price at which the importer or producer can sell the Article.
- j Any particular features which the Exhibitor desires to be noticed by the Jury.

In SECTION 2. MACHINERY, the descriptions should specify—

Raw Materials and Machinery.

- a The uses.
- b The novelty, if any, in the invention.
- c Superiority of execution.
- d Increased efficiency or economy.
- e The importance of the Article in a social or other point of view.
- f The place where produced.
- g Whether the Article is patented or not.
- h Where price is an element for consideration, the price at which the producer can sell the Article.
- i Any particular features which the Exhibitor desires to be noticed by the Jury.

In SECTION 3. MANUFACTURES, the descriptions should specify—

Manufactures.

- a The uses.
- b The novelty.
- c Superiority of execution.
- d Improved forms or arrangements.
- e Increased efficiency or economy.
- f New use of known Materials.
- g Use of new Materials.
- h New combinations of Materials.
- i Importance of the Article in a social or other point of view.

- f The place or places where manufactured.
 g Whether the Manufacture is patented; whether the design is registered.
 h Where price is an element for consideration, the price at which the importer or manufacturer can sell the Article.
 i Any particular features which the Exhibitor desires to be noticed by the Jury.

- b The uses.
 c The novelty in design or treatment.
 d Superiority of execution.
 e New use of known Materials.
 f Use of new materials.
 g New combination of Materials.
 h Improvements in processes of production.
 i The place where the Article was made.
 j If the Article is repeated in quantities for trade, the price at which it is sold by the Producer should be stated.
 k Any particular features which the Exhibitor desires should be noticed by the Jury.

Fine Arts.

IN SECTION 4. FINE ARTS, MODELS, SCULPTURE, and PLASTIC ART, the descriptions should specify—

- a The name of the Artist or Designer, if the same should not be the Exhibitor.

6. Exhibitors are required to make their descriptions brief, and to confine them as much as possible to facts.

7. Two COPIES, in the English Language, of the Exhibitor's descriptions, both being precisely alike, must be furnished before the Articles can be permitted to enter the Building. If an Exhibitor's Articles are sent in several packages, the list should indicate the contents of each separate package.

Illustrations.

8. Her Majesty's Commissioners have consented to allow Illustrations of Articles exhibited to be inserted in the large Catalogue, after approval by the Executive Committee. Exhibitors desirous to avail themselves of this privilege must communicate their intention of providing the Illustrations, and state their character, whether Engraving on Wood, on Steel, or Lithography. Communications are to be addressed to the Executive Committee, at the Building for the Exhibition, Hyde Park, London, marked on the outside, "CATALOGUE."

9. Exhibitors who may desire that their names and the descriptions of their productions should appear in any French and German Editions of the Catalogue which may be authorized, are requested to furnish at the same time with the two *English* Copies, a French and German translation of the descriptions, made out in all respects as before prescribed.

Attention paid to Rules.

That a careful attention to these instructions would have developed a vast amount of most valuable and interesting knowledge, can scarcely be questioned; and that in a considerable proportion of cases such has been the result, will appear on examination of the contents of this volume. That such a degree of attention was not universal is only what was to have been expected, both in consequence of the pressure of time under which many exhibitors laboured, and also from the fact that a large proportion, occupied in exclusively industrial pursuits, were unused to literary composition. The forms, with their duplicates, on being filled up, were transmitted to the Executive Committee; the duplicate being retained by the Executive, the other copy was placed in the compilers' hands.

First stage of preparation for printing.

The first step in preparing these forms for the press was their arrangement into classes corresponding to the thirty divisions decided upon by the Executive. The number and variety of objects embraced by the returned forms rendered this a tedious and difficult task. On its being effected, the forms remained to be examined, and put into such a state as to satisfy the requirements of the printer. They were consequently read, and as far as possible thrown into that state of connection of parts, and removal of superfluous material, which might enable them to be set up in a convenient form in type.

Scientific revision and correction.

Although much had been by these means effected in the preparation of the material of the catalogues, the most important part of the labour involved, prior to its assuming its present form, remained to be accomplished. The scientific and technical inaccuracies of a large proportion of the returned forms, together with their literary reconstruction rendered in a large proportion of cases absolutely necessary, demanded attentive revision and correction. Several considerations rendered this extremely difficult. Among these were the shortness of the period absolutely allotted for the completion of the work, the impossibility of verifying the descriptions given with the objects of which they treated, and the immense variety of subjects comprehended by the Exhibition itself, and necessarily described

in these forms in a manner in many instances more or less imperfect. The occasion called for a large amount of peculiar knowledge—of knowledge not to be gained by study, but taught by industrial experience, in addition to that higher knowledge, the teaching of natural and experimental philosophy. To meet these requirements the following plans were devised, and carried into operation. A number of scientific gentlemen gave their consent to undertake the revision and correction of proofs of the returned forms in their peculiar departments, with a view to remove from them those errors which might present themselves, and to supply what might appear requisite to give prominence to their really important features. In addition to this it appeared advisable, as critical observations were necessarily inadmissible, to relieve the tedium of mere description, and to assist in pointing out the leading features of interest in the objects described, or in direct relation with them, by appending, as the subjects of the proofs suggested, such brief annotations as might appear best calculated to effect these objects.

As a certain degree of harmony of procedure was considered absolutely necessary, in order to give a consistent character to such corrections and annotations, supplied as they would be from a variety of sources, a few suggestions of certain general principles were adopted, and as far as possible acted upon. It is not necessary to reproduce the whole of these suggestions in their original form; but since it is important that exhibitors should be informed of the principles which, to a great extent, guided and determined the corrections and annotations which are found in this work, they are here subjoined. Attention is particularly directed to suggestion 5, under the head annotations, by which it will be perceived that the character of critical notices has been strictly excluded from the annotations appended to the descriptions in this work.

1. *Corrections.* These will be chiefly of the following kind:—

1. To correct in a general way any obvious typographical inaccuracies.
2. To correct with care all technical and scientific errors in names, places, and things.
3. Occasionally, if time permit, to recast badly composed sentences or expressions.
4. To delete redundancies and self-laudatory terms, or expressions that could in any way be so construed, or critical and extraneous statements.

2. *Annotations.* Many of the proofs will undoubtedly suggest interesting elucidatory notes.

As it is desirable that the same notes should not be repeated, the information which, under other circumstances, or in a volume of a different kind, it would be well to present in a mass, may be conveniently subdivided, and a portion appended to the most appropriate proofs on the subject to which it refers. Thus, for a vegetable or animal product, a line or two as to its history might be attached to one proof, a note upon the natural order or tribe yielding it to another, the uses to a third, the commercial importance, &c., to a fourth, &c. In the selection of proofs for annotation, those of course will be preferred which are in themselves the most interesting and suggestive. It is considered desirable that these notes should as far as possible partake of the following characters:—

1. To be as short, clear, and definite as possible.
2. To have reference, as far as may be, if the article cannot be seen—
 - a. To the article as described by the Exhibitor.
 - b. To its uses, history, consumption, production, &c. (See Memorandum for the instruction of Exhibitors in preparing the descriptions as contained in forms for the Catalogue.)
3. To be of the following average length—
 - a. *Articles of primary importance*, as, for example, "cotton," "iron," "steam-engine," and such like, eight or ten lines.
 - b. *Articles of secondary importance*, four and three lines.
4. The same annotations not to be repeated or appended to more than one proof.

5. OBSERVATIONS OF A CRITICAL CHARACTER, IN EITHER SENSE OF THAT TERM, ARE INADMISSIBLE.

So soon as the work actually commenced, a mechanical difficulty of no common proportions presented itself. On the distribution of proofs for the purpose of annotation and correction, they were necessarily cut up into separate portions,

which had destinations as far distant as Germany and remote parts of the United Kingdom, whither they were despatched for the purpose of ensuring their scientific and technical accuracy. Many thousand proofs were thus scattered in various directions, yet all were required to be gathered together again, and arranged precisely in the same form and order as that assumed prior to their dispersion. Some of these proofs were not more than three inches long, and not broader than a narrow ribbon, containing only two or three lines; the difficulty of determining and immediately affixing the proper place of such a minute strip in a work of such magnitude as the present, seemed to be great. A simple method of ascertaining not merely the place in the catalogue, but its entire history, its destination, annotator, and return was, however, contrived, and the history of every proof has thus been accurately recorded. The information thus obtained, was so accurate and precise, that on the temporary delay of very small proofs, their original destination was instantly discovered, together with the date of transmission, and the name of the annotator to whom they had been sent. Much punctuality characterized the return of the dismembered portions of this large volume. Had not such been the case, the original plan of scientific and technical revision could not have been persisted in. As a general rule, it was considered advisable to limit annotations to an average of eight or ten lines in length; but in certain instances, where peculiar technical, local, or scientific information has been available, this rule has been to a very considerable extent departed from.

Record of history
of proofs.

Technological
mistranslations.

The language of the arts among various nations has always been regarded as of extreme difficulty in translation. A considerable portion of this work is necessarily written in this language, and it is therefore to be expected that, notwithstanding the precautions employed, errors of description may occur in those parts of it which describe the productions of foreign exhibitors. It is requested that these may be pointed out. In a number of instances technical terms have been explained by notes. As far as it was possible foreign weights and measures have been converted into English.

Mottoes selected
by Prince Albert.

The mottoes on the title-pages of this work were selected and placed by HIS ROYAL HIGHNESS PRINCE ALBERT.

Catalogue valu-
able as illustra-
tive of the sci-
ence of trades.

There is a peculiar feature in this Catalogue to which attention requires to be directed. This is the fact, that it embodies to a large extent the science of commerce. An attempt has been made here to convert the changing and inaccurate conventional terms of trade into the precise and enduring expressions of science. In classes 1 to 4 of the Exhibition, are contained specimens of a vast proportion of the raw materials upon which human industry daily operates throughout the world. In the majority of the descriptions of the articles exhibited in these four classes, will be found the commercial names of the materials, together with their scientific equivalents. As an instance, may be mentioned the woods employed for furniture, which are enumerated, with their commercial names, their Latin names, their native habitats, and the uses to which they are applicable. In the present edition of this work, prepared as it has necessarily been under highly unfavourable circumstances as to accuracy and correction, this attempt may not be as successful as in future editions; but such arrangements are made in order to obtain this important and valuable result, as will render future editions of this Catalogue permanently valuable in this respect, not only to the naturalist, but also to commercial men. That this feature of the Catalogue will not be without

its fruit in the promotion of the objects of industry, may be expected from the knowledge of the fact, that hitherto, in consequence of the absence of such information in a collected form, the greatest difficulties have been experienced by commercial men in their endeavours to introduce into trade any new material of industrial importance, or to obtain adequate supplies of materials already known, but known under a variety of changing, local, and unintelligible terms. In the seventeenth century, ROBERT BOYLE perceived the important results likely to arise from the "naturalist's insight into trades." It may be hoped that such results will now not fail of their accomplishment.

The smaller Catalogue is an abstract of the present work. It was prepared by condensing the revised and corrected slips forming the Illustrated Catalogue. For economy of space it was necessary to confine the descriptions in that work to an average length of three or four lines.

On the first announcement of a Descriptive Catalogue, erroneous ideas as to its size prevailed, to so large an extent as to lead to the fear that a sufficiency of type of the kind required could scarcely be obtained within the necessary time. Statements appeared which gave birth to the opinion that such a work could not be contained in less than ten volumes of eight hundred pages each; and for a considerable time it appeared probable that more than three such volumes would be required to complete this record of universal industry. It was soon rendered apparent that the estimates thus formed were incorrect. The articles contributed by a number of exhibitors—as in textile manufactures—were of a kind which did not admit of descriptions at length; and the returned forms of such articles were generally received written in the customary abbreviated language of commerce. In cases of another kind, where descriptions of greater length were not only admissible but desirable, economy of space has been obtained by the adoption of a condensed style. The Descriptive Catalogue has thus been reduced, notwithstanding the addition of annotations, to a convenient size.

That a work produced under the circumstances in which this Catalogue appears should contain inaccuracies, can less be cause of surprise than would its complete accuracy. One of the greatest obstacles to its correctness has been the incessant necessity for alterations of place and insertions of fresh material. In its preparation, however, an attempt has been made to communicate to it a value enduring beyond that of the occasion of its production. The vast and wonderful accumulation of the products of human industry, of which it professes to be the exponent, is gathered only for a time. The intention of this Great Collection accomplished and its objects realized, the industrial store must be again scattered among the nations contributing to the gathering. But this record of the history of the Great Exhibition must endure beyond the duration of the Exhibition itself. May it remain to indicate to other times the successful accomplishment of the greatest conception of our own, and the favour of the Divine Providence effecting that result.

ROBERT ELLIS.

ANNOTATORS OF THE CATALOGUE.

Professor OWEN, F.R.S.	JAMES GLAISHER, F.R.S.
Baron JUSTUS LIEBIG, F.R.S.	J. E. GRAY, F.R.S.
Professor LINDLEY, F.R.S.	ROBERT HUNT, Keeper of Mining Records.
Professor FORBES ROYLE, F.R.S.	ROBERT ELLIS, F.L.S.
Professor BELL, F.R.S., Sec. R.S.	SAMUEL CLEGG, Jun., F.G.S.
Professor E. FORBES, F.R.S.	W. DE LA RUE, F.R.S.
Professor ANSTED, F.R.S.	J. SPURGIN, M.D.
Professor HOSKING.	JOHN WILSON, F.R.S.E.
Professor A. DE MORGAN, M.A.	HENRY DIDDIN.
PHILIP PUSEY, M.P., F.R.S.	W. C. AITKEN.
Rev. J. BARLOW, F.R.S.	H. MAUDSLAY, C.E.
Rev. J. BOOTH, F.R.S.	ROBERT HENDRIE, Jun.
Capt. L. L. BOSCAWEN IBBETSON, F.R.S.	J. A. NICHOLAY.

Official Revision and Sanction for Publication by Lieut.-Colonel J. A. LLOYD, F.R.S.
 Scientific Revision and Preparation by ROBERT ELLIS, F.L.S.
 Historical Introduction by HENRY COLE.
 Construction of the Building by M. DIGBY WYATT, C.E., F.R.I.B.A.
 Classification of Subjects in the Thirty Classes into which the Exhibition is divided
 by Dr. LYON PLAYFAIR, F.R.S.
 Compilation and Preparation of the Abridged Catalogue by G. W. YAPP.

Technical information and assistance have also been rendered by Mr. G. TAYLOR, Mr. T. BATTAM, Professor WALLACE, M.A., Mr. C. TOMLINSON, Mr. JOHN GRAHAM, Mr. E. H. DENISON, and other Gentlemen. Much valuable information and assistance have also been kindly furnished by the Royal Commissioners for several of the Foreign States exhibiting. Their contributions have been inserted partly in the form of notes, and occasionally in that of a short introduction.

CLASSIFICATION OF SUBJECTS IN THE THIRTY CLASSES INTO WHICH
THE EXHIBITION IS DIVIDED.

CLASS.

RAW MATERIALS.

- I. Mining, Quarrying, Metallurgical Operations, and Mineral Products.
- II. Chemical and Pharmaceutical Processes and Products generally.
- III. Substances used for Food.
- IV. Vegetable and Animal Substances, chiefly used in Manufactures, as Implements, or for Ornament.

MACHINERY.

- V. Machines for direct use, including Carriages and Railway and Naval Mechanism.
- VI. Manufacturing Machines and Tools.
- VII. Civil Engineering, Architectural, and Building Contrivances.
- VIII. Naval Architecture and Military Engineering; Ordnance, Armour, and Accoutrements.
- IX. Agricultural and Horticultural Machines and Implements.
- X. Philosophical Instruments and Processes depending upon their use; Musical, Horological, and Surgical Instruments.

MANUFACTURES.

- XI. Cotton.
- XII. Woollen and Worsted.
- XIII. Silk and Velvet.
- XIV. Manufactures from Flax and Hemp.
- XV. Mixed Fabrics, including Shawls, but exclusive of Worsted Goods (Class XII.).
- XVI. Leather, including Saddlery and Harness, Skins, Fur, Feathers, and Hair.
- XVII. Paper and Stationery, Printing and Bookbinding.
- XVIII. Woven, Spun, Felted, and laid Fabrics, when shown as specimens of Printing or Dyeing.
- XIX. Tapestry, including Carpets and Floor-cloths, Lace and Embroidery, Fancy and Industrial Works.
- XX. Articles of Clothing for immediate personal or domestic use.
- XXI. Cutlery and Edge Tools.
- XXII. Iron and General Hardware.
- XXIII. Working in precious Metals, and in their imitation, Jewellery, and all articles of Virtu and Luxury, not included in all other Classes.
- XXIV. Glass.
- XXV. Ceramic Manufactures, China, Porcelain, Earthenware, &c.
- XXVI. Decoration Furniture and Upholstery, including Paper-hangings, Papier Maché, and Japanned Goods.
- XXVII. Manufactures in Mineral Substances, used for building or decoration, as in Marble, Slate, Porphyries, Cements, Artificial Stones, &c.
- XXVIII. Manufactures from Animal and Vegetable Substances, not being Woven or Felted, or included in other Sections.
- XXIX. Miscellaneous Manufactures and Small Wares.

FINE ARTS.

- XXX. Sculpture, Models, and Plastic Art.

I. Mining, Quarrying, Metallurgical Operations, and Mineral Products.

- A. MINING AND QUARRYING OPERATIONS.**
1. Quarries and open workings.
 2. Streaming; washing alluvial deposits.
 3. Mines worked on the lode.
 - a. Sinking of shafts.
 - b. Cutting adits.
 - c. Driving levels.
 4. Mines worked on the bed.
 - a. Sinking shafts.
 - b. Driving levels.
 - c. Cutting stalls or headings.
 5. Salt deposits.
 6. Ventilation; Safety Lamps, and other modes of Lighting.
 7. Methods of raising Mon, Ore, and Water.
 - a. Raising Ore.
 - b. Lowering and raising Miners.
 - c. Draining.
- B. GEOLOGICAL MAPS, PLANS, AND SECTIONS.**
- C. ORES AND METALLURGICAL OPERATIONS.**
1. Ores and the Methods of dressing and rendering Ores merchantable.
 - a. Ores of the more common Metals, as of Iron, Copper, Zinc, Tin, Lead.
 - b. Native Metals, as Gold, Silver, Copper, &c.
 - c. Ores used for various purposes, without reduction, as Peroxide of Manganese, &c.
 2. Methods of roasting, smelting, or otherwise reducing Ores.
 - a. The common Metals, as Iron, Copper, Zinc, Tin, Lead.
 - b. The Metals more generally used in combination, as Antimony, Arsenic, Bismuth, Cadmium, Cobalt, Nickel, &c.
 3. Methods of preparing for use the nobler Metals, as Gold, Silver, Mercury, Palladium, Platinum, &c.
 4. Adaptation of Metals to special purposes.
 - a. Metals in various Chemical states, as Iron in the condition of Cast and Malleable Iron, Steel, &c.
 - b. Metals in their progress to finished Manufactures, as Figs and Ingots, Sheets, Bars, Wires, &c.
 5. Alloys, and methods of rendering more generally useful Metals and their alloys—
 - a. Statuary, Bronze, Gun, Bell, and Speculum Metals.
 - b. Brass, and alloys used as a substitute for it.
 - c. White alloys, as Britannia Metal, German Silver, Pewter, &c.
 - d. Type, Sheathing Metals, and other alloys.
- D. NON-METALLIC MINERAL PRODUCTS.**
1. Minerals used as Fuel—
 - a. All kinds of Coal and derived products.
 - b. Lignite and Peat
 - c. Bituminous bodies and "native" Naphtha.
 2. Massive Minerals used in construction.
 - a. For purposes of construction generally—Siliceous or Calcareous Free Stones and Flags. Granites, porphyritic and basaltic Rocks. Slates.
 - b. For purposes of Ornament, Decoration, and the Fine Arts—Marbles. Alabaster, Spar, &c. Serpentine and other hard rocks susceptible of high polish.
 - c. Cements and Artificial Stones—Calcareous and Hydraulic Cements. Puzzuolanas, Trass, &c. Gypsum for plaster. Artificial Stones.
 3. Minerals used in the manufacture of Pottery and Glass—Sands, Limestones, &c., for Glass-making. Various Clays and feldspathic Minerals, as those used for Bricks, Tiles, and various kinds of Pottery and Porcelain. Siliceous, Calcareous, and other Minerals, used in Plastic Arts.
 4. Minerals used for personal Ornaments, or for Mechanical and Scientific purposes.
 - a. Gems and Precious Stones.

- b. Models of Minerals and Crystals, &c.
 - c. Collections of Minerals for scientific or educational use.
5. Minerals used in various Arts and Manufactures.
 - a. Simple bodies or compounds containing the Alkalis or Alkaline Earths—Those used principally for culinary purposes or for Medicine, as Salt, Mineral Waters, &c. Those used in various manufactures, as Sulphur, Borax, &c.
 - b. Earthy and semi-crystalline Minerals. Minerals used for grinding and polishing, as Grindstones, Honestones, Emery, &c. Lithographic Stones, Drawing Chalks, and Slate Pencils. Graphite. Earthy and other Minerals used as pigments, or for staining, dyeing, and colouring. Various Minerals used in Manufactures; as Alum Schist, Fuller's Earth, French Chalk, Casting Sands, &c.
 6. Soils and Mineral Manures.

II. Chemical and Pharmaceutical Processes and Products generally.

- A. CHEMICAL SUBSTANCES USED IN MANUFACTURE.**
1. From the Mineral Kingdom.
 - a. Non-metallic substances. Those used principally in their elementary state, as Sulphur, Phosphorus, &c. Acids, as Sulphuric, Muratic, Nitric, Boracic, &c. Miscellaneous Manufactures, as Sulphuret of Carbon, Chloride of Sulphur, &c.
 - b. Alkalis, Earths, and their compounds. Alkalies and their Alkaline Salts, as Soda, Potash, Ammonia, and the Carbonates, &c. Neutral Salts of the Alkalies, as Sulphate, Nitrate of Soda, Saltpetre, Borax, &c. Earths and their compounds, as Lime, Magnesia, Barytes, Strontia, Alumina, &c.
 - c. The compounds of Metals proper, as Salts of Iron, Copper, Lead, &c.
 - d. Mixed Chemical Manufactures, as Prussiate of Potash, &c.
 2. From the Organic Kingdom, and not included in Sections III. and IV.
 3. Manufactured Pigments, Dyes, and miscellaneous Chemical Manufactures. (See also Section IV.)
 - a. Pigments employed in House Decoration, and for colouring Woods.
 - b. Pigments used for Textile Fabrics.
 - c. Pigments used for Paper Hangings, and for felted and laid Fabrics generally.
 - d. Artists' Colours.
 - e. Miscellaneous Chemical Manufactures.
- B. RARER CHEMICAL SUBSTANCES, MANUFACTURED CHIEFLY FOR THE USE OF THE SCIENTIFIC CHEMIST.**
1. From Substances of the Mineral Kingdom.
 2. " " Vegetable " "
 3. " " Animal " "
- C. CHEMICAL SUBSTANCES USED IN MEDICINE AND IN PHARMACY.**
1. From the Mineral Kingdom.
 - a. Non-metallic substances and their compounds.
 - b. Alkalis, Earths, and their compounds.
 - c. Metallic Preparations.
 2. From the Vegetable Kingdom, when shown for Pharmaceutical purposes. (See also Sections III. and IV.)
 - a. Vegetable Infusions, Decoctions, and Solutions, clear or saccharine.
 - b. Tinctures.
 - c. Extracts and Impassated Juices.
 - d. Resins, Gum Resins, and Oleo Resins and Balsams.
 - e. Aloes, &c.
 - f. Gums as Acacia, Tragacanth, &c.
 - g. Essential Oils, Capeput, Savine, Turpentine, &c.
 - h. Fixed Oils, as Castor, Croton, Almond, Olive, &c.
 - i. Vegetable parts, as leaves of Digitalis, Hemlock, roots of Jalap, Ipecacuanha, &c.
 - j. Barks as imported, Cluchona, Cascarella, Cusparin, &c.

- A. Vegeto-Alkalics, their Salts and other Crystalline principles of medicinal substances.
- L. Vegetable Acids.
- M. Miscellaneous Compounds.
- 3. From the Animal Kingdom.
 - a. Cod-liver and other Animal Oils for internal or external application.
 - b. Unguents of Spermaceti, Lard, Oil, and combinations of them.
 - c. Antispasmodics, as Musk, Castoreum, Civet, Ambergris, &c.
 - d. Phosphorus, Ammonia, and their products.
 - e. Irritants, as Cantharides.
 - f. Antacids, as Crabs'-eyes, Calcareous concretions of the Craw-fish, Cattle-bone, &c.

III. Substances used as Food.
VEGETABLE KINGDOM.

- A. AGRICULTURAL PRODUCE—CEREALS, PULSES, OIL, SEEDS, ETC.
 - 1. Common European Cereals.
 - 2. Cereals more rarely cultivated in Europe.
 - 3. Millet and other small Grains used as food.
 - 4. Pulses and Cattle Food.
 - 5. Grasses, Fodder Plants, and Agricultural Roots.
 - 6. The Flours or preparations of the above classes.
 - 7. Oil Seeds and their Cakes.
 - 8. Hops and other aromatic plants used for like purposes.
- B. DRIED FRUIT AND SEEDS.
 - 1. Raisins, Currants, Figs, Plums, Cherries, Apricots, &c.
 - 2. Dates, Tamarinds, Dried Bananas, &c.
 - 3. Almonds, Chestnuts, Walnuts, &c.
 - 4. Cocoa-nuts, &c.
- C. SUBSTANCES USED IN THE PREPARATION OF DRINKS.
 - 1. Real Teas of all kinds.
 - 2. Substitute for Teas, as Paraguay, Arabian, Benecoolin, &c.
 - 3. Coffee of all kinds, and Cocoa Seeds and Nibs.
 - 4. Various substances, as Chicory Roots, Amande de Terre, Guarana Bread, &c.
- D. INTOXICATING DRUGS, FERMENTED LIQUORS, AND DISTILLED SPIRITS FROM UNUSUAL SOURCES.
 - 1. Fermented Liquors and Spirits from unusual sources.
 - 2. Tobacco.
 - 3. Opium.
 - 4. Hemp, and other Intoxicating Drugs.
- E. SPICES AND CONDIMENTS.
 - 1. Cinnamon, Cæcia, and their substitutes.
 - 2. Nutmegs and Mace; Cloves and Cassia Buds.
 - 3. Peppers, Capsicum, Mustard, Vanilla, Pimento, Cardamums, &c.
 - 4. Ginger, Turmeric, &c.
- F. STARCH SERIES.
 - 1. Starches of all kinds prepared from Wheat, Rice, Potatoes, Maize, &c.
 - 2. Arrowroots of all kinds, Tous les Mois.
 - 3. Sagoe from the Palms, Cassava, Tapioca, &c.
 - 4. Lichens of all kinds.
 - 5. Other Starchy Substances, as Portland Sagoe from *Arum Maculatum*, and from various like plants.
- G. SUGAR SERIES.
 - 1. Sugars from the Cane and Beet.
 - Maple and Palms.
 - Birch, Poplar, Oak, and Ash.
 - 2. Liquorice, Sarcocoll, &c.

ANIMAL KINGDOM.

- II. ANIMAL FOOD AND PREPARATIONS OF FOOD AS INDUSTRIAL PRODUCTS.
 - 1. Specimens of preserved Meats.
 - 2. Portable Soups, and concentrated nutriment as consolidated Milk, &c.
 - 3. Caviare, Trepan, &c.
 - 4. Articles of Eastern commerce, as Shark Fins, Nest of the Java Swallow, &c.
 - 5. Honey and its preparations.
 - 6. Blood and its preparations.
 - 7. Industrial Products, as Gluc, Gelatine, Isinglass, Gluten, &c.

IV. Vegetable and Animal Substances, chiefly used in Manufactures, as Implements, or for Ornaments.

VEGETABLE.

- A. GUM AND RESIN SERIES.
 - 1. Gums of all kinds of natural occurrence—Gums made artificially, as British Gum. Mucilaginous Seeds, Barks, Pods, and Seaweeds.
 - 2. Resins—Resins and Balsams of all kinds. Gum Resins. Gum Elastic and Gutta Pehra. Distilled Resins and Varnishes.
- B. OIL SERIES.
 - 1. Volatile Oils, including Camphor.
 - 2. Drying Fat Oils.
 - 3. Non-drying Fat Oils.
 - 4. Solid Oils.
 - 5. Wax.
 - 6. Distilled Fat Oils.
- C. ACIDS, AS ACETIC, CITRIC, TARTARIC, OXALIC, &c.
- D. DYES AND COLOURS.
 - 1. Indigos.
 - 2. Madders.
 - 3. Lichens and their preparations.
 - 4. Dyeing Barks, as Acaclia, Quercitron, Mangrove, &c.
 - 5. Woods, as Logwood, Brazil wood, Peach wood, Fustica, &c.
 - 6. Flowers and Berries, as Persian Berries, Safflower, Saffron.
 - 7. Miscellaneous, as Turmeric, &c.
- E. TANNING SUBSTANCES.
 - 1. Pods, Berries, Seeds, and Fruits of various kinds, as *Algaroob*, *Acacia*, Nib-nib and Divi-divi Pods, &c.
 - 2. Barks of various kinds, as Barks of the Babool, Brazilian *Acaclia*, Muriel, Bucida, Gordoula.
 - 3. Galls, and similar Tanning Materials.
 - 4. Catechu, Kino, Gambeer, &c.
- F. FIBROUS SUBSTANCES, INCLUDING MATERIALS FOR CORDAGE AND CLOTHING.
 - 1. Cottons of all kinds.
 - 2. Hemp and Flax; Manilla Hemp and New Zealand Flax.
 - 3. China Grass, Nettle Fibre, Plantain, and Pine Apple Fibre.
 - 4. Sunn, Jute, and other tropical substitutes for Hemp, Flax.
 - 5. Coir, or Cocoa-Nut Fibre, Gomuti, &c.
 - 6. Rushes and Miscellaneous Substances.
- G. CELLULAR SUBSTANCES.
 - 1. Corks of all kinds.
 - 2. Woods and Roots used for Corks, as the *Ochroma lagopus* and *Anona palustris*.
 - 3. Rice-paper of China.
 - 4. Birch Bark, Pottery Bark, Citrus Rind, &c.
 - 5. Substances used as Amadou.
- II. TIMBER AND FANCY WOODS USED FOR CONSTRUCTION AND ORNAMENT, AND PREPARED BY DYEING.
 - 1. Suited chiefly for purposes of construction, or for the Navy.
 - 2. Suited chiefly for Ornamental Work.
 - 3. Prepared Woods, as by Kyan's, Payne's, Bethell's, and Boncherie's processes.
- I. MISCELLANEOUS SUBSTANCES.
 - 1. Substances used as Soap, as Quillia Bark, Soap Berries (*Sapindus saponaria*), Soap Roots (*Saponaria officinalis*, &c.).
 - 2. Perfumes, as Pucha Pat, Vetiver, Spikenard, Tonka beans, &c.
 - 3. Substances used mechanically, as Tenzels, Dutch Rushes, &c.
 - 4. Seeds and fruits used for Ornamental purposes, as Ganitrus Beads, the Ivory Nut, the Doom Palm, Coquilla Nuts, Bottle Gourds, &c.

ANIMAL.

- J. FOR TEXTILE FABRICS AND CLOTHING.
 - 1. Wool, Hair, Bristles, Whalebones.
 - 2. Silk from the Silk-worm *Bombyx Mori*, and from other species in India, e. g. *Bombycilla Cynthia* and *Atacus Paphia*.
 - 3. Feather, Down, Fur, Skins.
 - 4. Miscellaneous.

K. FOR DOMESTIC OR ORNAMENTAL PURPOSES, OR FOR THE MANUFACTURE OF IMPLEMENTS.

1. Bone, Horn, Hoofs, Ivory, Tortoiseshell, Shagreen, Quills.
2. Pearls, Seed Pearl, Mother-of-pearl, Coral, and Shells generally.
3. Oils, Tallow, Spermaceti, Wax, Lard.
4. Miscellaneous, as Sponge, Goldbeater's-skin, Catgut, Silkworm-gut, Bladders, &c.

L. AS AGENTS IN THE MANUFACTURE OF VARIOUS ARTICLES.

1. Glue, Isinglass, Gelatine, Bone-black, Ivory-black, Animal Charcoal.

M. FOR THE PRODUCTION OF CHEMICAL SUBSTANCES.

1. Blood, Bones, Horns, &c., for the production of Phosphorus, the Prussiates, the Superphosphates, &c.

N. FOR PIGMENTS AND DYES.

1. Cochineal and Carmine.
2. Dyes from the Gall of the Aphides.
3. Gall-stone, pigment from Ox-gall.
4. Indian dyes from the Coccus, the various kinds of Lacs.
5. Miscellaneous, as Sepia, Enca d'Orient, &c.

MACHINERY.**V. Machines for direct use, including Carriages and Railway and Naval Mechanism.****A. STEAM ENGINES AND BOILERS, WATER AND WIND MILLS, AND VARIOUS OTHER PRIME MOVERS.**

1. Boilers.
2. Land Engines.
3. Marine Engines.
4. Windmills.
5. Water-wheels and Tourbines.
6. Water-pressure Engines, as Richenback's and Armstrong's.
7. Vacuum Power Engines.
8. Electro-Magnetic Engines, &c.
9. Miscellaneous.

B. SEPARATE PARTS OF MACHINES, SPECIMENS OF WORKMANSHIP. (See also WATER AND GAS WORKS in VII.)

1. As heavy Castings or Forgings in the rough; Castings or Forgings, plain, intricate, or beautiful, in the Rough.
2. Specimens of Turning in Metals.
3. Specimens in filing and finished Work in Metals, such as Surfaces, Irregular Figures, &c.
4. Valves, Cocks, Pistons, Governors, &c.

C. PNEUMATIC MACHINES.

1. Air Pumps.
2. Blowing Fans.
3. Blast Engines for Furnaces, &c.
4. Miscellaneous.

D. HYDRAULIC MACHINES, CRANES, ETC., PILE DRIVERS, ETC. (See also VII.)

1. Hydraulic Machines—Pumps and Fire Engines. Water Rams. Hydraulic Presses, &c. Water-meters, &c.
2. Cranes—Any sort of Crane motion and contrivances, Jacks of all sorts. (For Windlasses, Capstans, and Blocks, see VIII. E.)
3. Piling Engines. —(See also VII. A.) By hand power, or steam. Pile Sawing Machines. Pile Extractors, &c.

E. LOCOMOTIVES AND RAILWAY CARRIAGES, &c.

1. Railway Locomotives.
2. Common Road Locomotives.
3. Railway Carriages, Trucks, and Waggon.
4. Railway Velocipedes, &c. &c., of all sorts.
5. Atmospheric Railway Apparatus.
6. Carriage Breaks.
7. Buffers, Couplings, &c.

F. RAILWAY MACHINERY AND PERMANENT WAY.

1. Permanent Way complete.
2. Sleepers.
3. Rails, &c.

4. Rails.
5. Switches.
6. Turntables.
7. Station Arrangements.
8. Signals.
9. Miscellaneous.

G. WEIGHING, MEASURING, AND REGISTERING MACHINES FOR COMMERCIAL AND NOT FOR PHILOSOPHICAL PURPOSES.

1. Commercial Weighing Instruments.
2. Instruments of Measure.
3. Registering Instruments, Gauges, Indicators, and Tell-tales.

V. a. Carriages generally—not including those connected with Rail or Tram Roads.**A. FOR TOWN USE.**

- | | |
|------------------|--------------------|
| Dress Vis-à-Vis. | Landaulet. |
| Dress Coach. | Step-piece Landau. |
| Dress Chariot. | Barouche. |
| Landau. | Sociable. |

B. TRAVELLING CARRIAGES.

- | | |
|------------------------|-------------------|
| Coach. | Britska. |
| Driving Coach. | Droltska. |
| Chariot. | Fourgon. |
| Britska Chariot. | Invalid Carriage. |
| Dormeuse Post Chariot. | Sledges, &c. |
| Post Chariot. | |

C. FOR GENERAL USE.

- | | |
|--------------------|---------------------|
| Basterna. | Curricie. |
| Brougham. | Cabriolet. |
| Double Brougham. | Headed Chaise. |
| Clarence. | Tilbury. |
| Picentum. | Starhope. |
| Carsole. | Dennett. |
| Domestic. | Glg. |
| Driving Phaeton. | Irish Car. |
| Mail Phaeton. | Dog Cart. |
| Cabriolet Phaeton. | Pony Chaise. |
| Park Phaeton. | Invalid Bath Chair. |
| Pony Phaeton. | Velocipedes. |

D. PUBLIC CARRIAGES.

- | | |
|------------------|---------------|
| Mail Coach. | Hansom's Cab. |
| Stage Coach. | Street Cab. |
| Omnibus. | Fly. |
| Hackney Coach. | Hearse. |
| Hackney Chariot. | Caravan. |
| Glass Coach. | |

E. CARTS AND WAGGONS OF ALL KINDS, NOT BEING AGRICULTURAL.**VI. Manufacturing Machines and Tools, or Systems of Machinery, Tools, and Implements employed for the undermentioned purposes.****A. MANUFACTURES OF ALL SPUN, WOVEN, FELTED, OR LAID FABRICS.**

1. Machinery for the complete formation from the Raw Material of all Fabrics of Cotton, Wool, Flax, Hemp Silk, Caoutchouc, Gutta Percha, Hair.
2. Paper-making and Staining.
3. Printing and Bookbinding.

B. MANUFACTURES OF METALS.

1. The manufacture of Metals from the Ore into Bars, Rods, Wire, Sheets, and other general forms; also casting and polishing of Metal, &c.
2. The cutting and working of Metals by Machine Tools, such as Lathes; Machines for Planing, Drilling, Boring, Slotting, Sawing, Stamping, Shearing, Riveting, Punching.
3. Machines and Tools used by the Makers of Gold, Silver, and Plated Goods.
4. Machines and Tools used by the Makers of Cutlery, Nails, Screws, Pins, Needles, Buttons, and metal Pens, &c.
5. Machines and Tools used by Locksmiths, Diesinkers, &c.

C. MANUFACTURES OF MINERAL SUBSTANCES AND MINING MACHINERY. (See also SECTION I.)

1. Machines and Tools for the preparation and working of all kinds of Glass, Stone, Granite, Alabaster, Slate, Clay, &c.
2. Machines and Tools used in the preparation and working of Gems, &c.

D. MANUFACTURES OF VEGETABLE SUBSTANCES.

1. Machines and Tools for the preparation and working of all kinds of Wood.
2. Mills and other machinery for Grinding, Crushing, or Preparing Vegetable Products.

E. MANUFACTURE OF ANIMAL SUBSTANCES.

Machinery and Tools for working in Horn, Bone, Ivory, Leather, &c.

F. MACHINERY AND APPARATUS FOR BREWING, DISTILLING, AND MANUFACTURING CHEMISTRY.

VII. Civil Engineering, Architectural, and Building Contrivances.

A. FOUNDATIONS AND BUILDING CONTRIVANCES CONNECTED WITH HYDRAULIC WORKS.

1. Application of the Screw Pile for the Foundations of Piers, Jetties, &c., Beacons, and Ships' Moorings.
2. Pneumatic Piling, Machinery illustrative of the mode of sinking and guiding the Cylinders, also Contrivances for overcoming difficulties where obstructions are offered to their sinking.
3. Cofferdams on soft and rock bottoms, and Apparatus connected with them.
4. Foundations of Lighthouses exposed to the violent action of the sea.
5. Diving-bells, Helmets, and Apparatus connected with them.
6. Boring Tools, and Contrivances for ascertaining the stratification on Sites of Intended Structures.

B. SCAFFOLDING AND CENTERINGS.

1. Scaffolding for the erection of Brick Chimney Shafts, Columns of Masonry, Towers, and Spires.
2. Portable Scaffoldings, Ladders, and Fire Escapes.
3. Scaffolding for the erection of Monolithic Blocks, as Obelisks, &c., and for the hoisting of great Weights.
4. Fixed and Turning Scaffolding for the repairs, &c., of Domes, &c., internally and externally.
5. Scaffolding and Contrivances for the erection of large Girder Bridges (as Britannia Bridge).
6. Centerings for Arched Bridges, Domes, and Vaults.
7. Centerings for Tunnels, Shields, and Contrivances for facilitating their excavation.

C. BRIDGES, TUNNELS, AND ENGINEERING CONTRIVANCES FOR CROSSING RIVERS, RAVINES, &c.

1. Timber Bridges.
2. Cast-iron Bridges.
3. Wrought-iron Bridges (Girder or Lattice).
4. Turning or Swing Bridges.
5. Lifting or Bascule Bridges.
6. Draw and Rolling Bridges.
7. Suspension Bridges.
8. Temporary Bridges. (See also VIII. M.)
9. Floating Bridges, as across the Hamoaze, and to receive Railway Trains, as across the Humber.
10. Examples of Brick and Stone Bridges.

D. DOCK, HARBOUR, RIVER, AND CANAL WORKS.

1. Docks and Slips for the building and repair of Ships.
2. Mercantile Docks, and Arrangements connected therewith, for the loading and unloading of Ships.
3. Sea and Canal Locks, Gates and Entrances, Stop-gates, Sluices, &c.
4. Marine Railway Slips and Hydraulic Docks.
5. Harbours of Refuge.
6. Breakwaters, Piers, Jetties, Wharfs, and Landing-piers.
7. Groynes, Sea-defences, &c.
8. Perpendicular Lifts for Canals, and other Engineering Contrivances instead of Locks.

9. Dredging-machines, Hedgehogs, and other Machines employed in Harbour Works, for removing Shoals, &c.

E. LIGHTHOUSES AND BEACONS.

F. ROOFS, BUILDINGS, AND CONTRIVANCES FOR COVERING LARGE AREAS.

1. Examples of Timber and Iron Trusses.
2. Roofs for Markets, Railway Stations, &c.
3. Roofs for Theatres.
4. Fire-proof Buildings, arranged so as to be applicable to the economical methods of construction.
5. Coverings for Roofs.

G. WATER-WORKS, AND THE ENGINEERING CONTRIVANCES CONNECTED WITH THE OBTAINING, STORING, AND DISTRIBUTION OF WATER IN TOWNS.

1. Well-sinking and Boring, and the Apparatus connected therewith.
2. Storing, Filtering, and Distributing Reservoirs, and the Contrivances connected with them.
3. Contrivances for maintaining and producing efficient Heads, and the Apparatus connected with Street Mains.
4. Services, and Apparatus connected with Domestic Water Supply. (See also V., B.)

H. GAS-WORKS, AND CONTRIVANCES CONNECTED WITH THE ECONOMICAL PRODUCTION OF ARTIFICIAL LIGHT.

1. Retorts and Distillatory Apparatus.
2. Condensing, Separating, and Purifying Apparatus.
3. Governors and Station Meters.
4. Gauges, Valves, and contrivances connected with the Mains for the Distribution of Gas. (See also XXII.)

I. SEWERAGE, CLEANSING, PAVING, AND THE CONTRIVANCES CONNECTED WITH THE SANITARY CONDITION OF TOWNS.

1. Forms of Sewers, their Entrances and Junctions.
2. Contrivances for Cleansing, Flushing, and Ventilating Sewers.
3. Contrivances for removing and distributing Sewage.
4. Traps, and other means of preventing emanations. (See also XXII.)
5. House Drains, and the Internal Sanitary arrangements of Houses. (See also XXII.)
6. Pavements.

J. WARMING AND VENTILATING DOMESTIC RESIDENCES, AND THE CONTRIVANCES CONNECTED THEREWITH.

1. Arrangements for Warming, as with Hot Air, Water, Steam, &c.
2. Contrivances for preventing Smoke, and Chimney-sweeping Machines.
3. Contrivances for Ventilation on a large Scale.

K. MISCELLANEOUS.

VIII. Naval Architecture, Military Engineering; Ordnance, Armour, and Accountments.

A. ILLUSTRATIONS BY MODELS OF SHIPBUILDING FOR PURPOSES OF COMMERCE.

1. Ships.
2. Barks.
3. Brigs and Brigantines.
4. Snags and Ketches.
5. Schooners.
6. Sloops and Cutters.
7. Luggers, Barges, &c.

B. ILLUSTRATIONS BY MODELS OF SHIPBUILDING FOR PURPOSES OF WAR.

1. Ships of the Line.
2. Frigates.
3. Sloops, Corvettes, and Brigs.
4. Cutters, Brigantines, Ketches, Schooners, Barges, &c.
5. Bomb or Mortar Vessels, Fire-ships, Gun-boats, &c.

C. ILLUSTRATIONS BY MODELS OF SHIPBUILDING FOR THE APPLICATION OF STEAM OR OTHER POWERS.

1. Great War Steamers.
2. Steam-vessels of large burden for long Passages.
3. Steam-vessels for inland, liver, or Lake Navigation.
4. Sailing-vessels fitted for the temporary appliance of Steam or Human Power.
5. Miscellaneous.

D. VESSELS USED FOR AMUSEMENT, AND SMALL VESSELS GENERALLY.

1. Sailing Yachts of all kinds.
2. River Yachts, and Pleasure Boats of a smaller class.
3. Rowing Boats of all kinds.
4. Fishing Boats and Vessels.
5. Life Boats and Paddle-box Boats.

E. RIGGING, ANCHORS, WINDLASSES, CAPTAINS, SHEATHING, AND ARTICLES CONNECTED WITH PRACTICAL SEAMANSHIP AND THE SAVING OF LIFE FROM SHIPWRECK.**F. INFANTRY ARMY-CLOTHING AND ACCOUTREMENTS.****G. CAVALRY ARMY-CLOTHING AND ACCOUTREMENTS.****H. CAMP EQUIPAGE, SUCH AS MARQUEES, TENTS, &c.****I. NAVAL GUNNERY, AND WEAPONS OF ATTACK AND DEFENCE MORE ESPECIALLY ADAPTED TO NAVAL PURPOSES.****J. ARTILLERY EQUIPMENTS, BOTH IN GARRISON AND THE FIELD, MACHINES FOR MOUNTING AND DISMOUNTING ORDNANCE.**

1. Garrison Equipments.
2. Field Equipments.
3. Machinery for Mounting and Dismounting and transporting Ordnance, Carriages, &c.

K. ORDNANCE AND PROJECTILES.

1. Guns.
2. Howitzers.
3. Mortars.
4. Shots, Shells, and other Projectiles.

L. SMALL ARMS.

1. Rifles.
2. Muskets.
3. Carbines.
4. Pistols.
5. Lances.
6. Swords.
7. Bayonets.
8. Cartridges.

M. MILITARY ENGINEERING, FIELD EQUIPMENTS, METHODS OF PASSING RIVERS AND OTHER OBSTACLES, THE ATTACK AND DEFENCE OF FORTRESSES, AND FIELD FORTIFICATION.

1. Field Engineer Equipments.
2. Military Bridges, pontoons, Rafts, Boats, &c.
3. Field Fortification and Materials used in the attack and defence of Fortresses.
4. Permanent Fortification.

IX. Agricultural and Horticultural Implements.**A. IMPLEMENTS FOR TILLAGE.**

1. Ploughs, including Subsoil Ploughs and Pulverisers.
2. Harrows.
3. Sacrifiers, Cultivators, and Grubbers.
4. Clod Crushers and Norwegian Harrows.
5. Rollers.
6. Digging and Trenching Machines.

B. DRILLING, SOWING, MANURING, AND HOING MACHINES.

1. Pressers.
2. Drills.
3. Dibblers.
4. Horse Hoes.
5. Broadcast Sowing Machines.
6. Contrivances connected with the distribution of Manure.

C. HARVESTING MACHINES.

1. Machines for cutting Corn or Grass.
2. Tedding Machines for Hay.
3. Rakes for Hay, Corn, Stubble, &c.

D. BARN MACHINERY.

1. Steam Engines, and Water-power Machines.
2. Horse Works.
3. Thrashing Machines.
4. Straw Shakers.
5. Winnowing, Corn Cleaning, and Barley Hummelling.
6. Crushing and Splitting Mills.
7. Flour and Meal Mills.
8. Chaff Cutters.
9. Corn Weighing and Meters.
10. Horse Brainers and Cutters.
11. Chicory Cutters.
12. Cider Presses.

E. FIELD, FOLD, AND YARD MACHINERY.

1. Turnip-cutters.
2. Root Grating and Squeezing Machines.
3. Potato-washers.
4. Steaming Apparatus.
5. Feeding Apparatus.
6. Weighing Machines for Cattle, &c. (See G.V.)
7. Watering Engines, for Fire or Garden Purposes. (See D.V.)
8. Contrivances connected with the Stack-yard and Storing.
9. Contrivances for Fencing, Folding, &c.
10. Fittings for Stables, Cow-houses, &c.

F. AGRICULTURAL CARRIAGES, HARNESS, AND GEAR.

1. Waggons, Carts, &c.
2. Brakes.
3. Separate parts, as Wheels, Axles, &c.
4. Harness and Gear.

G. DRAINAGE IMPLEMENTS.

1. Machines for making Pipes, Tiles, and Bricks.
2. Implements for Draining, and Tools.
3. Tiles, Pipes, and other Materials used in Draining.
4. Scoop Wheels and other Machines used in Draining or Lifting Water.
5. Machines and Contrivances for Irrigating Lands.
6. Sluices, Draw Gates, &c.

H. DAIRY IMPLEMENTS.

1. Churns.
2. Cheese-presses.
3. Miscellaneous Contrivances used in the Dairy.

I. MISCELLANEOUS IMPLEMENTS USED IN AGRICULTURE.

1. Rick Ventilator.
2. Ladders.
3. Pitch and Tar Melters.
4. Sheep-dipping Apparatus.
5. Farm Railway.
6. Models of Farm Buildings.
7. Alarm Gun for Protecting Crops.
8. Beehives.
9. Instruments for Cattle, Probangs, &c.
10. Tree Remover.
11. Various Miscellaneous Articles.

J. GARDEN ENGINES AND TOOLS.**X. Philosophical Instruments, and Processes depending upon their use: Musical, Horological, and Surgical Instruments.****A. INSTRUMENTS FOR THE MEASUREMENT OF SPACE.**

1. In fixed observatories, as Transits, Transit Circles, great Quadrants, Mural Circles, Zenith Sectors, Altimeters, Equatorials, Collimators, &c.
2. For Nautical Astronomy and Observations, as Sextants, Reflecting and Repeating Circles, Dip Sectors, &c.
3. Astronomical and Topographical Illustrations, as Globes, Orreries, Planetariums, Maps, Charts, &c.
4. Optical Instruments, as great Refracting and Reflecting Telescopes, with their appurtenances, equatorial motions, &c.
5. Apparatus subordinate to Graduated Instruments, as divided Object Glasses and Heliometers, Eyepieces, Micrometers, Micrometer Microscopes, &c.
6. Survey Instruments.
 - a. Topographical, as Base Apparatus, Theodolites, Repeating Circles, Geodetic Signals, Levelling Apparatus, Miners' and Prismatic Compasses, Pocket Sextants, Perambulators, Pedometers.
 - b. Hydrographical, as Sounding Machines, Patent Logs, Current Meters, Siltometers.

A. INSTRUMENTS TO MEASURE THE EFFECTS OF MECHANICAL AND PHYSICAL FORCES.

1. Mechanical, as Dynamometers, Tachymeters.
2. Mass (Weighing Instruments), as Weighing Machines, Scales, Chemical and Assay Balances.
3. Density, as Areometers and other Instruments to determine Specific Gravity, Invariable Pendulums, Atwood's Machine.
4. To measure other Physical Effects, including Meteorological Instruments, as Barometers, Hydrometers, Eudiometers, Thermometers, Pyrometers, Electrometers, Rheometers, Magnetometers, &c.

C. INSTRUMENTS TO ILLUSTRATE THE LAWS OF MECHANICAL AND PHYSICAL SCIENCE.

1. "Kinematics,"—Instruments to exhibit and describe Motions and their Combinations, as Compasses, Pentagraphs, Instruments for describing Elliptical and other Figures, &c.
2. Mechanics, or Instruments to illustrate the Laws of Static and Dynamic Forces.
 - a. Stereo-Mechanics, as for illustrating Mechanical Powers, accelerated and retarded Motion, Equilibrium and Parallelogram of Forces, Levers, Cathometers, Centripetal and Centrifugal Forces, Elasticity, &c.
 - b. Hydro-Mechanics, as Instruments to illustrate the Motion and Impinging Force of Waves, &c.
 - c. Pneumo-Mechanics, as Apparatus connected with the Air-Pump, &c.
3. Instruments to illustrate the Laws of Corpuscular Forces, as Whitworth's Planes, Endosmometers, &c.
4. Instruments to illustrate the Laws of Sound.
5. " " " " Light.
6. " " " " Heat.
7. " " " " Electricity, including Voltaic and Thermo-Electricity, Magnetism, Electro-Magnetism, Magnotic Electricity, Dia-Magnetism, &c.

D. APPLICATION OF MECHANICAL AND PHYSICAL SCIENCE TO USEFUL PURPOSES, NOT INCLUDED IN ANY OF THE PRECEDING OR SUBSEQUENT SECTIONS.

1. Mechanics.
 - a. Stereo-Mechanics (when not included in Sections b. Hydro-Mechanics) describing their more extended uses.
 - c. Pneumo-Mechanics, as Air Pumps, Rarefying and Condensing, Diving Bells, Air Balloons, &c.
2. Sound (not including Musical Instruments).
 - a. Instruments to assist Hearing.
 - b. Alarums, Bells.
 - c. Models of Acoustical Buildings, &c.
3. Light—Instruments to assist Vision, as smaller Telescopes, Opera Glasses, Spectacles, Microscopes, Lenses, Mirrors, Signals, Visual Telegraphs, Light-houses, Optical Illusions, Gas and Solar Microscopes, Camera, Photography, Polarization of Light, &c.
4. Heat—Apparatus for producing Heat, for Freezing, Thermostats, Burning Lenses, and Mirrors, &c.
5. Magnetism and Electricity—Mariner's Compasses, Electric and Electro-Magnetic Telegraphs, Electric Light, applications of Electro-Magnetism as a Motive Power, Therapeutic applications of Electricity, Electrotyping Apparatus and Specimens, &c.

E. CHEMICAL AND PHARMACEUTICAL APPARATUS.

F. MISCELLANEOUS.

X. a. Musical Instruments, &c.

A. WIND INSTRUMENTS.

- | | |
|--|--|
| <ol style="list-style-type: none"> 1. Wood—Flutes (also in Metal, &c.) Flageolets. Oboes. Clarinets. Bassoons. Serpents. | <ol style="list-style-type: none"> 2. Metal—French Horns. Trumpets. Bugle Horns. Cornets à Pistons. Cornopeans. Trombones. Ophicleides. |
|--|--|

B. STRINGED INSTRUMENTS.

- | | |
|--|---|
| <p>Harps.</p> <p>Guitars.</p> <p>Violas.</p> | <p>Violas.</p> <p>Violoncellos.</p> <p>Double Basses.</p> |
|--|---|

C. KEYPED INSTRUMENTS WITH FIXED TONES.

- | | |
|---|---|
| <p>Organs.</p> <p>Pianofortes.</p> <p>Seraphines.</p> | <p>Harmoniums.</p> <p>Concertinas.</p> <p>Accordions.</p> |
|---|---|

D. INSTRUMENTS OF PERCUSSION.

- | | |
|--|---|
| <ol style="list-style-type: none"> 1. Drums—Bass Drums. Kettle Drums. Side Drums. Tambourines. | <ol style="list-style-type: none"> 2. Cymbals—Triangles. |
|--|---|

E. AUTOMATIC INSTRUMENTS.

- Mechanical Organs.
Musical Boxes, &c.

F. MISCELLANEOUS ARTICLES IN CONNECTION WITH MUSICAL INSTRUMENTS.

- Tuning Forks, Tuning Hammers, Pitch Pipes, &c.
Wire Strings, Catgut Strings, &c.

G. MUSICAL DIAGRAMS.

X. b. Ho.logy.

A. GREAT CLOCKS FOR CHURCHES, CASTLES, STABLES, AND PUBLIC BUILDINGS IN GENERAL.

1. With 3 and 4 wheel Trains.
2. With Remontolres and with various Escapements.
3. To strike the Hours, and the Hours and Quarters.
4. The various Compensation Pendulums in use.
5. The various modes of making the Work to carry the Hands, and communicating the motion from the Clock to the Hands.
6. Electric or Magneto-electric Clocks.

B. ASTRONOMICAL CLOCKS.

1. The various Escapements employed.
2. The various Compensation Pendulums used.
3. Equation Clocks.
4. Clocks, commonly called Journeyman Clocks, for Observatories.

C. CLOCKS APPLIED IN REGISTRATION.

1. To register the Barometer daily for twelve months, or other periods.
2. To register Tides and Winds.
3. To register the punctual attendance of Watchmen and others.

D. CLOCKS SHOWING DIFFERENT PHENOMENA.

1. Cycle of the Sun and Moon, Eclipses, Moon's Age, Equation of Time, the Golden Number, Tides, &c.

E. CLOCKS FOR THE COMMON PURPOSES OF LIFE.

1. Weight Clocks.
2. Spring Clocks with Pendulums.
3. Balance Clocks of various descriptions.

F. CLOCKS AND TIME-PIECES IN DECORATED CASES, COMMONLY CALLED ORNAMENTAL CLOCKS, FOR DRAWING-ROOMS, LIBRARIES, &c.

1. In Metal Cases, Gilt and Lacquered.
2. In Buhl Cases.
3. In Wood Cases.
4. In China Cases.

G. SUNDBRIES APPLICABLE TO CLOCKS.

1. The various modes by which Clocks are kept going while being wound.
2. The various Escapements employed in Clocks of different descriptions.
3. Various portions of Mechanism forming parts of, or applicable to, Clocks.

II. MARINE CHRONOMETERS.

1. Eight-day.
2. Two-day.
3. Thirty-hour.
4. The various descriptions of Compensation Balances applied to Chronometers.
5. The various descriptions of Pendulum Springs applied to Chronometers.
6. Pocket Chronometers.

I. POCKET WATCHES OF VARIOUS DESCRIPTIONS.

1. For measuring Minute Portions of Time and registering Observations.
2. With Compensation Balances.
3. " Duplex Escapement.
4. " Horizontal escapement.
5. " Lever Escapement upon different constructions.
6. " the old original Vertical Escapement.
7. Repetitors upon different constructions to strike the Hours and Quarters.
8. The same to strike the Hours, Quarters, and Half-quarters.
9. The same to strike the Hours, Quarters, and Minutes.
10. Clock-watches to strike the Hours and Quarters in a similar manner to Clocks.

11. Clock-watches, and, in addition, Repeaters.
 12. Watches with Alarums.
 13. Watches known by the denomination of Ladies' Watches, with the Cases decorated in various ways.
 14. Various portions of Mechanism forming parts of Watches.
- J. WATCHES FOR DIFFERENT MARKETS—**
1. As for Turkey, with three Cases and Turkish Dials.
 2. For China, with peculiar Cases and Dials.
 3. For India and South America.
 4. For Home Country districts.
- K. MISCELLANEOUS.**

X. c. Surgical Instruments.

A. FOR OPERATIONS ON THE EYE.

Special Instruments for—

1. Operation on the Eyelids.
2. Fistula Lachrymalis.
3. Strabismus.
4. Artificial Pupil.
5. Cataract.
 - By Depression.
 - By Extraction.
 - a. Including Elevators in Silver and Ivory, Fine Bistouries, Trocars, Canulas, Styles, Sounds, various Needles, &c.
 - b. Cataract Knives, Hooks, Capsular Forceps, &c.

B. OPERATION ON THE EAR.

Special Instruments for—

1. Exploration of the Aural and Eustachian Passages.
 - a. Sounds, Catheters, Speculums, &c.
2. The Conveyance of Air or Liquid into the Tympanic Cavity.
 - b. Pneumatic and other Syringes in Metal, Glass, Caoutchouc, &c.
3. The Removal of Foreign Bodies from the Meatus.
 - a. Levers, Branch Forceps, &c.
4. Perforation of, and other Operations on, the Membrana Tympani.
5. The Conduction of Sound.
 - a. Including all kinds of Acoustic Instruments and Contrivances, Ear Cornets, Speaking Trumpets, &c.

C. OPERATIONS ON THE NOSE—NASAL FOSSÆ AND ANTRUM.

Special Instruments for—

1. The Removal of Polypi.
 - a. Various Forceps, Porte-ligatures, Serre-nerfs, &c.
2. The Removal of Extraneous Substances.
3. The Arrest of Hæmorrhage from the Posterior Nares.
 - a. Including all Contrivances for "Tamponnement."
4. Exploration and Injection of the Maxillary Sinus.
 - a. Including Jourdain's Sounds, Catheters, &c.
5. Perforation and Injection of the Antrum.
 - a. Including Liston's Drills, Antrum Syringes, Plugs, &c.

D. OPERATIONS OF THE MOUTH AND PHARYNX.

Special Instruments for—

1. Hare Lip.
2. Operations on the Teeth (Dental Instruments).
3. Myotomy and Ligature of the Tongue.
4. Cleft Palate and other Operations on the Roof of the Mouth (Staphyloraphic Instruments).
 - a. Including Obturators, Cleft and Notched Needles, Palate Holders, Porte-Sutures, &c.
5. Excision of the Uvula and Tonsils.
6. Cauterisation and other Operations on the Pharynx.
 - a. Tonsillar Guillotines, Pharyngotomes, &c.
7. Salivary Fistula.
 - b. Parotidian Canulas, Leadon Threads, &c.

E. OPERATIONS ON THE THORAX AND RESPIRATORY ORGANS.

Instruments for—

1. Tracheotomy and Laryngotomy.
 - a. Including Marshall Hall's Tracheotome, Sampson's Springs and Tubes, &c.

2. The Removal of Foreign Bodies from the Larynx, Trachea, and Bronchi.
3. Paracentesis Thoracis (Empyema).
4. Various Purposes.
 - a. Including Inhalers for the administration of Chloroform, Ether, and other Medicinal vapours. b. Instruments used to restore Suspended Animation. c. Respirators in all Materials.
5. Physical Examination of the Chest.
 - a. Instruments for Auscultation, Percussion, and Admeasurement of the Chest; Stethoscopes and Pleximeters in all materials; Spirometers and Stethometers, as suggested by Quain and Sibson, &c.

F. OPERATIONS ON THE ABDOMINAL WALLS AND ALIMENTARY CANAL.

Special Instruments for—

1. Stricture and other morbid states of the Oesophagus, the removal of Foreign Bodies, &c.
 - a. Including Oesophagus Bougies and Probes in elastic gum and other materials, Oesophagotomes, Gullet-forceps, &c.
2. The Introduction and withdrawal of Fluids from the Stomach; the removal of Poison, &c.
 - a. The Stomach Pump and its appendages, Enema Syringes, &c.
3. The formation and maintenance of artificial Anus.
 - a. Enterotomes, Porte-Sutures, &c., by Dupuytren, Blandin, and others.
4. Prolapsus Ani.
 - a. All kinds of Rectum-Plugs, in metal, elastic gum, &c.
5. Fistula, Fissures, and Vegetations in Ano.
 - a. Fistula Knives, Directors, &c.
 - b. Porte-ligatures (on Luke's and Sampson's plan).
6. Hernia.
 - a. Cutting Instruments for its radical cure.
 - b. Trusses and all artificial means of support.
7. Paracentesis Abdominis.
8. Physical examination of the Rectum.
 - a. Various Speculums (by Hilton and others).

G. OPERATIONS ON THE GENITO-URINARY SYSTEM IN THE MALE.

Instruments for—

1. Lithotomy.
 - a. Including Lithotomes, Gorgels, Staffs, Forceps, Scoops, &c.
2. Lithotripsy.
 - a. Lithotrites, which disintegrate the Stone by Perforation.
 - Ditto ditto by Concentric Pressure.
 - Ditto ditto by Percussion.
 - b. Syringes and other Instruments to inject and explore the Bladder.
 - c. Dilators, Sliding-scoops, and Apparatus to remove Calculi impacted in the Urethra; Instruments for Lithectasy, &c.
3. Urinary Fistula.
 - a. Including all Urethroplastic Instruments, Urethrotomes, &c., for Recto-Urethral, Perineal, and Recto-Vesical Fistulae.
4. Stricture, Prostatic and Vesical Disease, and retention of Urine.
 - a. Every variety of Catheter, Bougie, Sound, Porte-Cautique, and Urinal; Curved Trocars for Puncture of the Bladder above the Pubes, through the Rectum, &c.
5. Phymosis.
 - a. Apparatus employed by Jews. b. By the Profession.
6. Hydrocele.
7. Varicocele.
 - a. Including Instruments for obliteration of the Spermatic Veins (Hicords'), as well as those for simple support; Suspensory and other Bandages; Scrotal Rings, &c.

H. OPERATIONS ON THE GENITO-URINARY SYSTEM IN THE FEMALE.

Instruments for—

1. Exploration.
 - a. Including Speculums in all Materials, Sounds, Dilators, &c.
2. Operations on the Uterus, Vagina, and Cervix Uteri.

- a. Hysterotomes and Instruments for Para-centesis Uteri (Lisfranc's and Simpson's), Uterine Sissors and dressing Forceps (curved and straight), Porte-Cautiques, &c.
- 3. Pollus Uteri.
 - a. Vulcella and other Forceps, Porte-ligatures, Serre-nœuds, &c.
- 4. Prolapsus and Procidencia Uteri.
 - a. Including Pessaries, Bandages, and artificial support of all kinds.
- 5. Vesico-Vaginal Fistula and Recto-Vaginal Fistula.
 - a. Hancock's new Instruments, Urinary Receptacles, &c.
- 6. Obstetrical Purposes.
 - a. Including all Midwifery Instruments, and Contrivances to remedy Lacerated Perineum.

I. OPERATIONS ON THE EXTREMITIES.

Special Instruments for—

- 1. Amputations.
 - a. Army (portable) and Hospital Cases, &c.
- 2. The Adjustment of Fractures.
 - a. Including Splints, Inclined Planes, Pads, Slings, and Bandages, in all Materials.
- 3. The Reduction of Dislocations.
 - a. Pulleys, Rings, Staples, &c.

K. OPERATIONS ON THE OSSEOUS SYSTEM.

Special Instruments for—

- 1. Trepanning.
- 2. Resection and Exarticulation.
- 3. The Extraction of Sequestra, &c.

L. OPERATIONS ON THE VASCULAR SYSTEM.

Instruments for—

- 1. Venæsection.
 - a. Cupping Instruments, Lancets, Leech tubes, &c.
- 2. The Control of Hæmorrhage.
 - a. Tourniquets, Compressors, Torsion Forceps, &c.
- 3. Transfusion.
- 4. Aneurism.
 - By Ligature:—a. Aneurism Needles, Porte-ligatures, Sampson's Speculum, &c.
 - By Compression:—b. New Instruments, by Wyld, Bellingham, and others.
- 5. Nævus.
 - a. Needles, Porte-aiguilles, &c. (Liston's and Brodie's).
- 6. Varices.
 - a. Including Elastic Bandages, Stockings, An-clets, &c.

M. AUTOPLASTIC AND ORTHOPÆDIC OPERATIONS.

Special Instruments for—

- 1. The various Taliæcotic Processes.
 - a. Rhinoplasty.
 - b. Chitoplasty, &c.
- 2. Tenotomy and Myotomy.
 - a. Including long-bladed Knives for the subcutaneous division of Muscles and Tendons, &c.
- 3. Mechanical Compensation of Lost Parts.
 - a. Artificial Eyes, Noses, Ears, Chins, Palates, Teeth, Hands, Arms, Legs, &c.
- 4. Orthopædic Processes.
 - a. Including all Orthopædic Apparatus, Back and Leg Boards and Irons, Stays, Belts, Supports, Suspenders, Boots, Shoes for the cure of Bunions (Lanngan's).

N. DRESSING INSTRUMENTS.

- a. Surgeons' Pocket Cases and their usual contents; Spring Bistouries, Tenaculums, Scalpels, Scissors, Forceps, Spatule, Probes and Directors, Needles, Ligature-Silks, &c.

O. MISCELLANEOUS PHILOSOPHICAL APPARATUS APPLIED TO THE INVESTIGATION AND TREATMENT OF DISEASE.

- a. Microscopes, Engiscopes, and Lenses; Urinometers and Thermometers; Volta-electric Apparatus; various illuminating Speculums; Instruments in India Rubber for the application of Intense Cold; Hooper's Water Cushions for the reception of fluids of any temperature; Spongio-piline, Patent Lint, Plaisters, Collodion, Nipple Shields, Breast-pumps, &c.

P. SURGICAL TABLES, BED MATTRASSES, CHAIRS, CRADLES, RESTS, &c.

Q. POST MORTEM AND DISSECTING INSTRUMENTS, AND INSTRUMENTS FOR PRESERVATION.

R. INSTRUMENTS APPLIED TO VETERINARY PURPOSES.

MANUFACTURES.

XI. Cotton.

A. COTTON YARN AND THREAD.

- 1. Grey Twist in Hanks and Bobbins, from No. 20 to 600.
 - White and Bleached Yarn.
 - Dyed Yarn, assorted Colours.
 - " Turkey-red and Pink.
- 2. Cotton Thread.—
 - Two-fold Lacc; 2, 3, 4, 6, and 9-cord sowings.
 - Two-fold Lisc; knittings.
 - Crochet Cottons.
 - Wire Thread.
- 3. Crape Yarn.—
 - Bleached.
 - Coloured.

B. CALICOES.

- Sheetings (Grey and Bleached)—
 - ¾ and ¾ Super.
- Shirtings (Grey and Bleached).
 - Domestics.
- Madapollams—
 - ¾ and ¾, and 40-inch Printers'.
- Long-cloths (Plain and Twilled)—
 - Imitation Irish.

C. CORDS AND BEAVERTEENS.

- 1. ¾ ell and ¾ Cords.
 - Genoa.
 - Beaverteens.
- 2. Drabbetts.
 - Twillets.
 - Fancy Drills.
 - Grey Twills.
 - Swansdowns.
 - Jeans.
 - Ticks.
- 3. Velvets and Velveteens.

D. MUSLINS, &c.

- 1. Cambric and Jaconnet—
 - Mulls and Books.
 - Bishop and Victoria Lawns, &c.
 - Jaconnet, Organdies, Lenos, and Fancy Checks for Printing (Grey and Bleached).
- 2. Figured Muslins—
 - Lappets, Lenos, and Nettr White and Dyed.
 - Jacquard-made Goods.
 - Lappets, Japan Spots and Honeycombs.
 - " Striped and Corded.
 - " Allover and Diagonal Spider.
 - " Bengal Scarf Spot, assorted.
 - Harness, assorted.
 - " Garments.
 - Window Curtains.
 - " Spot.
 - Book Jaconnet and Dacca Lappets.
 - Lenos, Plain.
 - " Figured.
 - Small Stripe and Check Dorians.
 - Mexican Lappets, Coloured and White.
 - Turkey Gauze, White and Dyed.
- 3. Shawls, Handkerchiefs, and Dresses—
 - Imitation Cambric Handkerchiefs, Plain and Embroidered.
 - Lappet Shawls.
 - Book Muslin Dresses, Checks.
 - Tapes and Corals.
 - Book Handkerchiefs.
 - Specimens of Madapollams.
 - Bleached Goods of various Finishes.
 - " Cambric Finish.
 - " Jaconnet Finish.
 - " Book Muslins, Hard, Elastic, and London Finish.
 - " richly Ornamented.

E. DIMITIES, &c.

1. Furniture Dimities, Plain and Figured—
Hair, Cord, and India, Plain and Figured.
Quilting.
Sateen and Twilled Jean.
2. Marseilles and Summer Quilts—
Counterpanes (White and Coloured).
Toliet Covers (Plain and Coloured).
Anti-Macassars.
Grey Sheets.
Window Hollands.
Cotton Diapers and Damasks.

F. COLOURED WOVEN COTTON.

1. Handkerchiefs for the Pocket, Head, Neck, and
Shoulders—
Imitation Madras and Pulicat.
" Java and Manila
Fancy White Grounds, Checks.
Imitation Manila Pine-Apple Cloth.
" White Cambric.
" Figured Borders.
Cravats, assorted colours.
2. Gingham.
Common Light Grounds, assorted, Plain.
Dark Grounds, assorted, Plain.
Earlston Gingham.
Power-loom Serackers and Checks.
Turkey-red grounds.
Blue and Black heavy Checks.
Muslin Ground, Stripes and Checks.
Furniture, Stripes and Checks.
Coloured Diapers.
Crossover Stripes.
Jean Stripes.
Derries.
Hungarians.
Umbrella Gingham.
3. Dresses, Scarfs, &c.
Java Bugie, and Manila Sarongs.
" Chudles and Scarfs.
4. Zebras—
Blue and White Striped Dresses.
Orange-pine " "
Blue-pine. " "
Robe de Chambre.

G. OILED CALICOES OR CAMBRICS FOR PACKING.**XII. Woolen and Worsted.****A. BROAD CLOTHS.**

1. Single Milled, 52 to 63 inches wide.
Wool-dyed Woaded Colours—
Blue.
Black.
Medleys.
Oxford and other Mixtures.
N.B. The term "Medleys" includes all
Wool-dyed Colours, excepting
Blue and Black.
Wool-dyed, common colour, unwoaded.
Black.
Medleys.
Oxford and other Mixtures.
Drab.
Piece-dyed, Woaded Colours—
Black.
Blue.
Fancy Colours.
Piece-dyed, unwoaded.
Black.
Scarlet.
Gentian.
Other Fancy Colours.

A. BROAD CLOTHS—

2. Double Milled, 52 to 57 inches wide.
Subdivided same as No. 1.
3. Medium-Cloths, 54 to 63 inches wide.
Subdivided same as No. 1.
4. Ladies'-Cloths, 54 to 63 inches wide.
Subdivided same as No. 1.
5. Venetians, 54 to 58 inches wide.
Subdivided same as No. 1.
6. Army-cloth, 52 to 54 inches wide.
Subdivided same as No. 1.

7. Beavers.

Subdivided same as No. 1.

8. Pilots.

Subdivided same as No. 1.

9. Mohair, 54 to 58 inches wide.

Subdivided same as No. 1.

10. Cloakings, 54 to 58 inches wide.

Subdivided same as No. 1.

11. Tweeds—

Single milled.

Double milled.

Trebble milled.

12. China Stripe Cloth, list, piece dyed, and other Cloths,

60 inches wide.

13. India Cloths, piece dyed, 60 inches wide.**14. Billiard Cloths, piece dyed, 72 to 81 inches wide.****15. Elastic Glove Cloth, 64 to 70 inches wide.**

Subdivided same as No. 1.

16. Union Cloths, Cotton Warps, piece dyed, 52 to 54

inches wide.

17. Double Colours, piece dyed, 54 to 63 inches wide.**B. NARROW CLOTHS.****1. Cassimere double milled, 27 to 29 inches wide.**

Subdivided same as Broad Cloths, No. 1.

2. Cassimere, single milled, 27 to 29 inches wide.

Subdivided same as No. 1.

3. Doe-Skins, treble milled, 27 to 29 inches wide.

Subdivided same as No. 1.

4. Doe-Skins, double milled, 27 to 29 inches wide.

Subdivided same as No. 1.

5. Doe-Skins, single milled, 27 to 29 inches wide.

Subdivided same as No. 1.

6. Cashmerettes, 27 to 29 inches wide.

All Colours.

7. Tweeds, Wool dyed, 27 to 29 inches wide.

Double milled.

Single milled.

8. Fancy Trowserings.**C. FLANNEL.****1. Saxony Flannel.**

White.

Coloured.

2. Various Flannels.

Lancashire.

Real Welsh.

Imitation Welsh.

Bath Coating.

D. BLANKETS.**1. Cloth Blankets.****2. Superfine Blankets.****3. Medium Blankets.****4. Ordinary Blankets.****E. WOOLLEN CLOAKING.****1. Plain.****2. Mixtures.****3. Fancy.****F. SERGES.**

Long Ella, White and Coloured.

G. TARTANS.**1. Plain.****2. Fancy.****II. WORSTED STUFF GOODS.****1. Fabrics composed entirely of Wool.**

Merinos.

Shalloons, Sars, Serges, and Plainbacks.

Calimancoes, Plain and Figured.

Lastings, Princettas, Serges de Berry.

Coatings.

De Laines.

Alepins.

Durants and Bantings.

Moreens.

Bismasks.

Damask Aprons, Damask Table Covers, &c.

Russels.

Camlets.

2. Fabrics composed of Wool and Cotton.

Colbourg and Paramatta Cloths.

Union Double Twills.

Plain Orleans Cloths, Single and Double Warps.

Plain Muslin de Laines, Barèges, &c.

Shawl Cloths.

- Union Costings.
- " Lastings, Princettas, and Serges de Berry.
- Stockinets.
- Fancy Lastings.
- " Worsted and Cotton Goods.
- Figured Cobourgs, Orleans, &c.
- Aprons, plain and figured.
- Linings, plain and figured.
- Union Damasks.
- " Damask Table Covers, &c.
- 3. Fabrics composed of Wool and Silk.
- Silk-warp Cobourgs and Orleans.
- " Double Twills.
- " Costings.
- " Russels.
- Silk-warp Lastings.
- Silk-warp Damasks.
- 4. Fancy Goods composed of Wool, Silk, and Cotton.
- 5. Fabrics composed of Alpaca and Mohair mixed with Cotton or Silk.
- Plain Alpaca Lustres.
- " Mixtures.
- Twilled Alpaca Mixtures.
- Plain Mohair Lustres.
- Silk-warp Alpaca Lustres.
- Alpaca and Mohair Linings.
- " Mohair, and Silk Fancy Goods.
- " Umbrella and Parasol Cloth.

I. WOOLLEN, WORSTED, ALPACA, AND MOHAIR YARNS.

XIII. *Silk and Velvet.*

- A. SILK YARNS.
- 1. Spun Silks.
- 2. Thrown Silks.
- 3. Sewing Silks.
- B. PLAIN SILKS.
- 1. Gros, Saranets, Persians, Satinets, Armures, and other plain Silks.
- 2. Satins, black or coloured.
- 3. Armoines, Barattes, and Serges.
- 4. Serges and Lutestrings, for Parasols and Umbrellas.
- 5. Brussels, Ducape, Satin, and other plain Cravats for Men's wear.
- 6. Satin twilled and other plain Handkerchiefs for Ladies' wear.
- 7. Bandanas, Corahs, and other Cloth for Printing.
- 8. Spun Silk Handkerchiefs (for printing.)
- C. FANCY SILKS.
- 1. Shot, striped, checked, watered (molré), shaded, clouded (chiné), or striped with satin.
- 2. Floret, Damask, Tobine, Brocade, and other Figure' Silks.
- 3. Figured Vestings, Cravats, and Scarfs.
- 4. Figured Handkerchiefs, Scarfs, Aprons, and Vells, for Ladies' wear.
- 5. Parasol and Umbrella Silks figured, or with figured borders.
- 6. Furniture Damasks and Brocades.
- 7. Gold and Silver Tissues, figured and plain.
- 8. Figured Pocket Handkerchiefs for Gentlemen's wear.
- D. VELVETS.
- 1. Plain Velvets, black and coloured.
- 2. Plain Terry.
- 3. Figured and Embossed Velvets.
- 4. Plush (Ladies', &c.)
- 5. Hat Plush.
- E. GAUZE AND CRAPE.
- 1. Lisse, Arcophane, and other Gauzes.
- 2. Plain and coloured Crape.
- 3. Figured Gauze (Blonde, &c.).
- 4. Fancy Gauze or Crape Handkerchiefs.
- F. PLAIN RIBBONS.
- 1. Saranet and Lutestring Ribbon.
- 2. Satin Ribbons.
- 3. Gauze Ribbons.
- 4. Velvet Bands or Bindings.
- G. FANCY RIBBONS.
- 1. Shot, striped, checked, shaded, clouded (chiné), or striped with satin.
- 2. Figured or Brocaded.
- 3. Gauze or Crape, with brocaded or cut figures.
- 4. Embossed Fatin.
- 5. Figured or checked Velvet.

XIV. *Manufactures from Flax and Hemp.*

- A. FLAX FINNS.
- 1. Steeped, scutched Flax Fibre, both systems.
- 2. Unsteeped Flax Fibre from dried straw.
- 3. Hackled Flax from both systems, and Hackled Tow.
- 4. Tow from both systems, and from the unsteeped process.
- 5. Tow in the forms to mix with Wool.
- 6. Flax, Hemp, &c., prepared as a substitute for Cotton and Silk.
- B. LINEN YARN AND THREAD.
- 1. Linen Yarn, Thread, &c.: English, Scotch, and Irish (Tow and Linen Yarn, 1/4 to 400 lea).
- 2. Hand-Spun Thread as used for some fine Cambrics, &c. (240 to 800 lea).
- 3. Dyed Yarns and Threads of various colours.
- 4. Dyed Yarns and Threads to resemble Lustre of Silk.
- 5. Flax-Cotton, Flax-Fibre, Flax-Wool, and Flax-silk Yarns.
- 6. Flax Thread from unsteeped Fibre.
- C. PLAIN LINENS OF ALL WIDTHS, BLEACHED, UNBLEACHED, AND DYED.
- 1. Canvas—English, Scotch, Irish, French, Dutch, and Russian.
- 2. Heavy Linens—As Crash, Huckabacks, Glass Cloths, and Sheetings; Yorkshire, Newark, Scotch, Drogheda, Courtra, Ghent, Russia. Tubing for Irrigation, and Banding for Machinery.
- 3. Irish Manufacture—Brown, Black, and coloured Linens.
- 4. Platillas, Cress, Britannias, German ditto ditto.
- 5. Irish Linens and Sheetings—Courtra, Ghent, Bleckfeld, Prussian.
- D. DAMASKS, DIAPERS, DRILLS, AND OTHER TWILLED LINENS: BLEACHED, UNBLEACHED, OR DYED.
- 1. Damasks and Diapers—English, Scotch, Irish, Saxon.
- 2. Drills—English, Scotch, Irish, French, Saxon, Russian.
- 3. Linen Velveteens, Linen Velvets, and Linen Cords.
- E. CAMBRICS, CAMBRIC AND LINEN HANDEKCHIEFS, PLAIN, BORDERED, EMBROIDERED, PLAIN PRINTED OR DYED; PRINTED LINENS, LAWNS, CAMBRICS, BLEACHED, UNBLEACHED, OR DYED.
- 1. Irish.
- 2. French.
- 3. Irish, Scotch, and Swiss Embroidering (in Cambric).
- F. CORDAGE OF ALL KINDS.
- Ropes, Lines, Twines, Nets, &c.

XV. *Mixed Fabrics, including Shawls; but exclusive of Worsted Goods. (Class XII.)*

- A. MIXED WOVEN FABRICS.
- 1. Cotton Warp, plain, watered, or figured.
- Shot with Wool or Worsted. For Dresses, Damasks, Aprons, Shoe and Boot Cloths, Linings, Cravats, Vestings, Ponchos, Pantaloons, Shawls, Scarfs, Costings, Tweeds, Quiltings, Plaids, &c.
- " Mohair.
- " Linen.
- " Silk.
- " Silk and Worsted.
- " Silk and Cotton.
- " China Grass.
- 2. Spun Silk Warp, plain, watered, or figured.
- Shot with Wool or Worsted.
- " Mohair.
- " Linen.
- " Net Silk.
- " Silk and Worsted.
- " All Cotton.
- 3. Silk Warps, plain, watered, figured, or embossed.
- Shot with Cotton.
- " Wool or Worsted.
- " Mohair.
- " Linen.
- " Cotton and Silk.
- " Cotton & Worsted graduated.

4. Linen Warps, plain, watered, or figured.
Shot with Wool or Worsted.
- " Mohair.
- " Cotton and Silk.
- " Silk.
5. Cotton and Silk Warps, plain, watered, or figured.
Shot with Cotton.
- " Mohair.
- " Silk.
- " Worsted.
- " China Grass.

For Dresses, Articles of Furniture, Shawls, &c.

B. SHAWLS.

1. Woven Shawls.
Chenille, all Silk or Silk and Cotton.
Cashmere from the East.
Imitation Cashmeres, that is, Harness or Jacquard Wove Shawls.
Plain Silk and Satin.
Figured Silk and Satin.
Crape, plain and embroidered.
Gauze, plain and figured.
Lace, plain and figured.
Shetland or knitted Woolen.
Barège, all Wool and Silk and Wool.
Grenadine and other thin texture, in Silk and Silk and Wool.
Embroidered Lace, Silk, and Cashmere.
Woolen, plain, tartan, and fancy.
2. Printed Shawls.
Barège.
Silk, including Silk, Grenadine, and other thin mixtures.
Cashmere.
Chiné, or Shawls printed on the warp before they are woven.

XVI. Leather, including Saddlery and Harness, Skins, Fur, Feathers, and Hair.

A. LEATHER.

1. Rough tanned Leather—
Tanned Butts.
 " Crop-hides.
 " Offal, *i. e.* Shoulders and Bellies.
 " Horse Butts.
 " Dressing-hides.
 " Horse-hides.
 " Kips.
 " Calf-skins.
 " Seal-skins.
 " Hog-skins.
 " Bazils.
 " Varieties.
2. Curried Leather—
Curried Calf-skin, Russet (*i. e.* Natural Colour).
 " " Waxed (*i. e.* Black).
 " " Butts, Russett.
 " " Butts, Waxed.
 " Kips, Russett.
 " Kips, Waxed.
 " Cordovan, Waxed.
 " Cordovan, Grain.
 " Shoe-hides.
 " Seal-skins.
 " Dog-skins.
 " Goat-skins.
 " Boot-legs.
 " Boot-fronts.
 " Varieties.
 " Saddlers' Hides.
 " Rein-hides.
 " Collar-hides.
 " Chaise-hides.
 " Pouch and Scabbard Hides.
 " Powder Hides.
 " Bellows Hides.
 " Pipe Backs.
 " Bag Hides.
 " Pig-skins.
 " Hog-skins.
 " Russia Leather.

3. Enamelled Leather—

- Black Enamelled Horse-hides.
 " Cow-hides.
 " Calf-skins.
 " Seal-skins.
 " Goat-skins.
 " Roans.
 " Skivers.
- Coloured Enamelled Calf-skins.
 " Sheep-skins.
- Black Japanned Horse-hides.
 " Cow-hides.
 " Calf-skins.
 " Sheep-skins.
- Coloured Japanned Skins various.

4. Dyed Leather—

- Dyed Morocco, *i. e.* (Goat-skins) for Furniture and Coach Purposes.
- " Roan, *i. e.* (Sheep-skins) for Furniture and Coach purposes.
- " Morocco, for Shoe purposes.
- " Roan ditto.
- " Roan ditto.
- " Morocco for Bookbinding and Pocketbooks, &c.
- " Roan for Bookbinding and Pocketbooks, &c.
- " Skiver ditto ditto.
- " Calf ditto ditto.
- Striped Seal-skin for Shoe-binding, &c.
 " Cape Sheep-skins "
 " Sheep " "
 " Goat " "
 " Horse-hide " "

5. Oil Leather—

- Buck-skins, finished natural colour.
- " Doe " "
- " Calf " "
- " Lambs " "
- " Sheep " "
- " Ox and Cow Hides " "
- Buck-skins, dyed or coloured.
- " Doe " "
- " Calf " "
- " Lamb " "
- " Sheep " "

6. White or Alum Leather—

- Alumed Horse-hides.
 " Calf-skins.
 " Sheep-skins strained white.
 " Lamb-skins
 " Lamb-skins coloured.
 " Kid-skins for Gloves, White Dyed.
 " " "
 " Lamb-skins "
 " Sheep-skins "
 " Kid-skins for Shoes.
 " Calf-skins "
 " Sheep-skins "
 " Varieties.

Gaijer Leather.

7. Sheep and Skin Rugs—

- Sheep and Lamb, Brown Rugs.
 " Coloured.
 " White.
 " Sheep Rugs for Cavalry Saddles.
 " Angola Goat, Coloured.
 " White.
 " Various Wild Animal Skins for Rugs.

8. Parchment and Vellum.

- Sheep-skin Parchment for Deeds.
 " " Bookbinding, White.
 " " Coloured.
- Vellum for Bookbinding, White.
 " Coloured.
 " " Painting.
 " " Tambourines.
 " " Drum-heads.
 " " Gunpowder-sieves.

B. SADDLERY AND HARNESS.

1. Harness; Carriage, Gig, Cart.
2. Saddlery.
3. Whips.

C. MISCELLANEOUS.

1. Leather Manufactures, such as Bellows, &c.
2. Braaces, Webbing-belts, &c.

D. SKINS AND FUR.

1. Sable and Martin—
 - Russian or Siberian Sable
 - Hudson's Bay Martin or Sable, next in repute and value
 - The North American or Canadian Baum or Wood Martin, a native of the Forests of Germany, &c.
 - Stone Martin, living in rocks, old ruined castles, buildings, &c.
 - English Martin
 - Dyed Sable and Martin
2. Otter—
 - Nootka Sound, or Sea Otter
 - Hudson's Bay and North American Otter
 - European Otter
 - Pull-dyed Otter
3. Fox—
 - Hudson's Bay and North American Black and Silver Fox
 - Blue Fox
 - White Fox
 - Red Fox
 - Cross Fox
 - Grey Fox
 - Kitt Fox
 - European Red Fox
4. Bear—
 - Black Bear of Hudson's Bay and North America
 - Brown, or Isabella
 - Grey "
 - European Grey and Black Bear
 - Polar or White Bear
5. Beaver—
 - Beaver from Hudson's Bay and North America
 - Manufactured
 - Dyed ditto
6. Swan.
 - Swan Skin
 - Swansdown Skin
 - Swan Feathers
 - Swan Quills
7. Goose.
 - Goose Skin
 - Goose Down.
8. Mink.
 - North American and Hudson's Bay Mink; as used for Muffs, Tippets, Cuffs, &c.
9. Buffalo, for Sleigh Coverings, Open Carriages, and for Railway purposes.
10. Hudson's Bay and North American Skins.
 - Lynx
 - Lynxcat
 - Dyed Lynx
 - Raccoon
 - Wolf
 - Fisher
 - Wolverin
11. Ermine or Weasel tribe.
 - Ermine
 - Weasel
 - Polecat or Fitch
 - Russian Fitch
 - Dyed Fitch
 - Kolinsk and Dyed Kolinsk
 - Kolrosk and Dyed Kolrosk
12. Seal.
 - South Georgia, Shetland, and Falkland Isles
 - Lemar's Island and Capot
 - The Plucked and Manufactured Seal
 - Seal when dyed
 - The Greenland and Newfoundland Hair Seals
 - The Labrador Spotted and Silver Seal
 - The same in its dyed state
13. Musquash, or large North American Rat, for Ladies' wear, as for Muffs, Boas, &c.
 - Hainster
 - Opossum
 - Perewiazka

14. Hare and Rabbit.
 - White Hair from Russia and the Polar Regions
 - European or Grey Hare
 - Hudson's Bay and North American Rabbit
 - English Rabbit
 - Flemish Rabbit
 - Silver Grey Rabbit
 - White Polish Rabbit
 - Black and Blue Rabbit
 - Australian Rabbit
 - Dyed Rabbit
15. Lamb, &c.
 - Grey Russian Crimea Lamb
 - Black Astrachan Lamb
 - Persian Grey Lamb
 - Persian Black Lamb
 - Hungarian Lamb
 - Spanish Lamb
 - English Lamb
16. Squirrel.
 - Black Russian
 - Blue Siberian
 - Kazan Siberian
 - American Squirrel
 - English Squirrel
 - Indian Striped Squirrel
 - Flying Squirrel
 - Dyed Squirrel
17. Chinchilla.
 - African Chinchilla
 - Buenos Ayres Chinchilla
 - Lima or bastard Chinchilla
18. Cat.
 - Dutch Cat or Jennet
 - European Cat
 - Wild Cat
 - African Cat
19. Grebe
- Eider Duck
- Penguin
20. Tartar Foal
- Angora Goat
- Dyed Goat
21. Skins from the Tropics.
 - Lion
 - Royal Tiger
 - Cape Tiger
 - Leopard
 - Panther
 - Zebra
 - Antelope
 - Black Monkey
 - Antenter
22. Miscellaneous—Moose Deer.
 - Deer
 - Roebuck
 - Badger; the hair of the European badger, as used for shaving-brushes, &c.
 - Mole, as made into articles of Ladies' apparel

E. FEATHERS.

1. Ostrich.
 - Aleppo
 - Magador
 - Alexandria
 - Senegal
 - Cape
 - Algoa Bay
 - Dyed
2. Marabouts.
 - Marabout Stork
 - Adjutant
 - Paddy or Rice Bird
 - White
 - Grey
 - Dyed
3. Rhea.
 - Long Flossy
 - Short Flossy
 - Brown

Furniture and Furniture and

Pocketbooks, Pocketbooks, &c. ditto. ditto. &c.

White. Coloured.

wa, &c.

Muffs, Tippets, Linings, Cuffs, &c.

For general purposes of Dress.

For Ladies' wear, and for Muffs, Tippets, Cuffs, Linings, Trimmings, &c.

As made into various articles of Ladies' Dress.

For Coat Linings, Sleigh Coverings, Travelling Bags, &c.

For Ladies' use.

Various purposes.

Mounted for Ornamental purposes and for Furniture.

The Feathers known by the Plumassiers as "Vulture's," and used for Ladies' wear, made up into fanciful forms, and for military purposes, in America; the common sorts made into dusting-brooms.

4. Osprey. } The Feathers of the small Egrett, as used for Ladies only. Those of the large Osprey for Ladies, and the Small Egrett. } Feathers of the back, as used for Military Plumes for the Hussar Regiments.
5. Emu } The Feathers varying in shades, as used in their natural colour for Ladies' Bonnets, and dyed darker colours and black.
6. Birds of Paradise. } The Birds, as worn by persons of rank in the East, also by Ladies in Europe and America, arranged as a Bird.
- The Large Emerald }
 The Small Emerald }
 The King Bird }
7. Heron. } The Feathers of the head and breast of the *Andrea cinerea*, as used for Ladies, and by Knights at their installation. Those from the back of the *Plotus anhingus*, as used in England by Ladies, and in the Eastern Countries by Princes and persons of Rank.
- The Heron }
 The White-bellied }
 Darter }
8. Ibis. } The Feathers of their natural scarlet colour, as made into Wreaths for the Head.
- Swan } For Ladies' Bonnets and Military Plumes.
- Turkey } The Down of these Birds as used for Ladies' Plumes and Trimmings.
- Cock } The Feathers of the neck, back, and tail made into Plumes for Ladies' and Children's Hats and Military Plumes.
- Peacocks } For Plumes and Screens.
- Argus Pheasant } The Feathers marked with eyes, as used, the small for Plumes, the large for Tiaras for the head.
- Common Pheasant } Made into Trimming.
- Eagle. } The Feathers forming the wing of this Bird as used for the Highland Bonnet.
9. Miscellaneous } The Feathers of the Jay, Duck, Grebe, and Tucan, as also several Birds from the Tropics, in their applications to Ladies' dresses.
- F. HAIR.
1. Hair as a substitute for Human Hair, as Wigs, Curls, Fronts, &c.
 2. Ornaments in Hair, as Plumes, Bracelets, Guards, &c. (See also XXIII. C.)
 3. Hair Cloth for the purposes of Furniture.
 4. Hair for miscellaneous purposes, as for stuffing Furniture.

XVII. Paper and Stationery, Printing; and Book-binding.

- A. PAPER IN THE RAW STATE AS IT LEAVES THE MILL.
1. Brown Paper and Packing Papers.
 2. Millboards and Glazed Boards for pressing.
 3. Printing Papers.
 4. Drawing Papers.
 5. Writing Papers.
 6. Tissue Papers, white and tinted.
 7. Papers tinted in the Pulp.
 8. Tracing Papers, made so in the Pulp.
 9. Papers ornamented in the Water-mark.
 10. Cartridge Paper.
- B. ARTICLES OF STATIONERY.
1. Envelopes, plain and ornamental.
 2. Embossed and Lacc Papers.
 3. Printed Fancy Papers and Surface-coloured Papers, Printed and Embossed Ornaments.

4. Wedding Stationery (Cards, Papers, and Envelopes).
5. Mourning Stationery (Cards, Papers, and Envelopes).
6. Specimens of Ornamenting, Glazing, and Packetting Writing Papers.
7. Sealing-wax and Wafers.
8. Pens.
9. Small Wares for Stationery.
10. Tracing Paper, made transparent by Varnishes.
11. Inks of all kinds.

C. PASTEBOARDS, CARDS, &c.

1. Playing Cards.
2. Message Cards, plain and ornamental.
3. Drawing Boards.
4. Mounting Board, plain and ornamental.
5. Pasteboard and Cardboard.

D. PAPER AND SCALEBOARD BOXES, CARTONS (CARTONNERIE).

All kinds of Boxes and Cases made of Pasteboard and Paper (not being Papier-maché), plain or ornamented.

E. PRINTING (NOT INCLUDING FINE ART PRINTING).

1. Type-printing generally.
2. Printing Inks and Varnishes.

F. BOOKBINDING, &c.

1. Binding in Cloth.
2. " Yellum.
3. " Leather.
4. " Velvet.
5. " Wood, Papier-maché, or Metal.
6. Albums, Scrap-books, Portfolios, Music-books, Manuscript-books, Memorandum-books.
7. Ledgers and Account-books.
8. Blotting-cases, Desks, Cabinets, Pocket-books, Card-cases, Note-cases, &c.
9. Porte-monnaie, and other Articles of a similar nature.

XVIII. Woven, Spun, Felted, and Laid Fabrics, when shown as specimens of Printing or Dyeing.

A. PRINTING OR DYEING OF WOOLLENS, OR ANY MOUSSELINE DE SOIE, DE LAINE, OR ALPACA MIXTURE.

1. Mousseline de Laine, de Soie, &c.—
 Made of all Wool.
 " Cotton and Wool.
Cashmere—
 Made of all Wood.
 " Cotton and Wool.
Barège—
 Made of Silk and Wool.
 " Cotton and Wool.
 " all Wool.
 " Cotton, Silk, and Wool.
Balzarine, plain and figured—
 Made of Cotton and Wool.
 " Silk and Wool.
 " Cotton, Silk, and Wool.
2. Printed or Dyed Cotton or Silk Warps, afterwards woven, known as Châné.
3. Printed Woollen Table-covers.
 " Japanned.
4. Printed and Dyed Silks—
 India Corahs in the Grey.
 " dyed.
 " printed in England.
 India Bandanas (tied and dyed in India).
 " Cloppahs (printed in India).
 British Corahs in the Grey.
 " dyed.
 " printed.
 British Twills in the Grey.
 " dyed.
 " printed.
 British Spun Silks, printed.
 British Cambrics, printed.
 " dyed.
 British Spun Silk Dresses, dyed.
 " " printed.
 British Corah Dresses, printed.
 India Corah Dresses, printed.
 Printed China Crape Shawls.

B. PRINTED CALICOES, CAMBRICS, MUSLINS, VELVET, AND VELVETEENS—

1. Cottons printed by Machinery.
 - " by Block only.
 - " partly by Block and Machinery.
- Turkey-red, printed or dyed. Mules.
- Muslins " printed by Machinery.
 - " by Block only.
 - " partly by Block and Machinery.
- Prints and Furniture by Machine only.
 - " by Block only.
 - " partly Block and Machine.
2. Handkerchiefs for the pocket, head, neck, and shoulders.
 - Single Colours, blue ground, &c.
 - Assorted Colours, fast and loose.
 - Turkey-red, Bandanas printed.
 - " discharged.
 - " Chintz pattern.
 - Printed Border Handkerchiefs.
 - Imitation Cambric.
 - " Fancy Muslin.
 - Imitation Java batticked Handkerchiefs.
 - Printed Aprons.
3. Printed Shawls and Dresses.
 - Shawls, assorted Colours . . . {part with fringe,
 - " Turkey-red, or purple { part without.
 - Java Sarongs batticked.
 - " Turkey-red.
 - Java Slendrons, Turkey-red, and batticked.
 - Malay Chindey or Imitation.
 - Bombay Patolis.
 - Siam Shawls.
 - Scarfs.
 - Dresses.

B. DYED COTTON GOODS.

- Cambrics and Madapolones, assorted Colours.
- " Turkey-red.
- Imitation blue Morris and Basstas.
- Long Cloths of all kinds.
- Mull and Book Muslin of all kinds.
- Cotton Drills (blue).
- Velvet.
- Velveteens.

D. DYED LINEN GOODS.

- Printed Linens.
- Cambric Handkerchiefs.
- Lawn Shirt Fronts.
- Lawn Handkerchiefs.

E. DYEING OR PRINTING OF LEATHER, HAIR, FUR, ETC.

XIX. Tapestry, including Carpets and Floor-cloths, Lace, Embroidery, Fancy and Industrial Work.

A. TAPESTRY.

1. Carpets of all kinds in which the Pattern is produced by Weaving or by the Hand, in the manner of Tapestry proper, including Hall Carpets, Rugs, Stair, &c.
 - a. Axminster Carpets, Flax or Jute, Chain, Woollen, or Worsted Pile, worked by hand.
 - b. Table and Chair Covers, &c., worked in the same way.
 - c. Patent Axminster Carpets, manufactured at Glasgow, made firstly as a woven Fringe, and that adapted afterwards to a thick Flax surface.
 - d. Patent Tapestry Carpet, Pattern printed in warp, any number of Colours used; Table-covers and Curtains, made in same way.
 - e. Patent Tapestry Rugs, Velvet Pile Surface, with a thick west shoot of Cotton, Flax, or other material.
 - f. Brussels and Velvet Pile Carpet.
 - g. Tapestry Brussels Carpets, called Moquette, of a fine quality.
 - h. Kidderminster and Venetian Carpet.
 - i. Patent Mosaic Tapestry and Rugs, where the cut Wool is fixed to a ground by caoutchouc, &c.
 - j. Printed Felt Carpet, Plain and Printed Druggets, Printed and Embossed Cloth for Table-covers and Curtains.

- A. Patent Printed Carpets with Terry Pile Surface; the same Moquette for Curtains or Furniture.
- l. Cloth Embroidered by Machinery for Table-covers or Curtains.
2. Matting of Hemp, Cocoa-nut Fibre, Straw, Reeds, and Grasses, for Floor and Walls.
3. Oil-cloth for Floor or Table, whether painted or printed.
4. Waver or Embroidery, Crochet and Net Work.
5. Counterpanes and Quilts for Bed-covers; Quilting and Dimity for Bed-room Hanging.
6. Ornamental Tapestry of Silk, Wool, Linen, Mohair, Cotton, or of these Materials mingled together, or with Metal Wires, whether woven in the Loom or of any kind of Needlework, but of Patterns having so much artistic excellence as to entitle them to be exhibited in Section XXX. as Works of fine Art.

B. LACE.

1. Pillow Lace, the article or fabric being wholly made by hand (known as Valenciennes, Mechlin, Honiton, Buckingham); or guipure made by the Crochet Needle; and Silk Lace, called "Blonde" when white, and Chantilly, Puy, Grammont, and Black Buckinghamshire when black.
2. Lace, the ground being Machine-wrought, the Ornamentation made on the Pillow and afterwards applied to the Ground (known as Brussels, Honiton, or appliqué Lace.)
3. Machine-made Nets and Quillings, wholly Plain, whether Warp or Bobbin (known as Bobbin Net, Tulles, Blondes, Cambrats, Mechlins, Malines, Brussels, Alençon, &c.).
4. Lace, the Ground being wholly made by Machine; partly Ornamented by Machine and partly by Hand, or wholly Ornamented by Hand, whether Tamboured, Needle-Embroidered, or Darned.
5. Lace actually Wrought and Ornamented by Machinery; comprising Trimming Laces of every description, Veils, Falls, Scarfs, Shawls, Lappets, Curtains, &c.

C. SEWED AND TAMBOURED MUSLINS.

- Ladies' Collars, Cuffs, &c.
- Children's Robes.
- Handkerchiefs.
- Trimmings and Insertions.
- Vest Pieces.
- Shirt Fronts.
- Mantles.
- Dresses.
- Curtains, &c.

D. EMBROIDERY.

1. Gold and Silver and Glass.
2. Silk, as Shawls, Dresses, Mantles, Table Covers, and Curtains, &c.
3. Berlin Wool, Chair Covers and Fancy Articles for the Drawing-room.
4. Embroidery by Machinery.

E. FRINGES, &c.

1. Fringes, Tassels, Gymps, &c., suitable as Trimmings for Upholstery.
2. Ditto for Dresses and other fine Work.

F. FANCY AND INDUSTRIAL WORKS.

1. Berlin Wool Work.
2. Needlework.
3. Miscellaneous Industrial Works.

XX. Articles of Clothing for Immediate Personal or Domestic Use.

A. HATS, CAPS, AND BONNETS.

1. Hats, made of Silk, Beaver, or other materials, for Men.
2. Caps, for Men.
3. Bonnets of Straw, Silk, or other material.
 - a. British Chip Bonnet made from the Poplar.
 - b. Willow Bonnet.
 - c. Brazilian Grass Hats.
 - d. Tuscan and Leghorn Plaiting and Bonnets.
 - e. Straw Plait Bonnets.
 - f. Straw Trimmings and Bonnets.
 - g. Horse-hair Trimmings and Bonnets.
 - h. Silk and other Bonnets made by Milliners.

- B. HOSEERY.**
1. Cotton.
 2. Woollen.
 3. Linen.
 4. Silk.
- C. GLOVES.**
1. Made of Leather or Skins.
 2. Made of any other materials.
- D. BOOTS, SHOES, AND LASTS.**
1. Made of Leather.
 2. Made of other materials.
- E. UNDER CLOTHING.**
1. For Ladies.
 2. For Gentlemen.
- F. UPPER CLOTHING.**
1. For Ladies, including all kinds of Millinery.
 2. For Gentlemen, including all kinds of Tailor's-work.

XXI. *Cutlery and Edge-tools.*

- A. CUTLEBY, SUCH AS KNIVES AND FORKS, PEN AND POCKET KNIVES, RAZORS, SCISSORS, AND SHEARS.**
1. Knives and Forks—
Table, Dessert, Carving.
Dessert or Fruit, with plated and silver blades.
Cake and Melon Carvers, " "
Fish Knives and Forks, " "
 2. Spring Knives—
Pen and Pocket Knives of every description.
Hunting and Sportsmen's Knives.
 3. Knives of all other descriptions—
Paper Knives of all kinds.
Desk or Office Knives.
Pencil Knives.
Knives for Hunting and Self-defence, as Couteaux-de-Chasse, Bowie Knives, &c.
Knives for Kitchen and Domestic Purposes, as Cooks', Oyster, Onion, Bread and Butter, and Cheese Knives.
Knives used in various Trades, as Butchers', Shoemakers', Glaziers', Gardeners', &c.
 4. Scissors and Shears—
Ladies' Work and Cutting-out Scissors of every description.
Nail, Button-hole, Barbers', and Trimming Scissors.
Shears used in various Trades, as Tailors', Brush-makers', &c.
Garden and Sheep Shears.
 5. Razors of all kinds.
 6. Miscellaneous—
Corkscrews, Button-hooks, Boot-hooks, Nail-nippers, Nail-files, Tweezers, &c.
- B. FILES AND OTHER SMALL EDGE TOOLS, NOT INCLUDED IN MANUFACTURING TOOLS IN SECTION VI.**
1. Files and Edge-tools used by Engineers, Smiths, or other Metal Workers.
 2. " for purposes of Building, by Masons, Bricklayers, and Plasterers.
 3. " for fine Metal and other work, as for Cloak and Watch makers, Jewellers, Japanners, Engravers, and Modellers.
 4. " for Wood-work, as for Carpenters, Joiners, Cabinet-makers, Coopers, &c.
 5. " for Leather or Skins, as for Saddlers, Curriers, Shoemakers, and Bookbinders.
 6. Drawing, Artists', and Engraving Instruments.
 7. Files and Edge-tools for other purposes than those specified.

XXII. *Iron and General Hardware.*

- A. BRASS MANUFACTURE.**
1. Cabinet and general Brass Foundry, consisting of Hinges, Fastenings, Escutcheons, Bell-pulls, Brass-foundry used in Ships, Knockers, Door-springs, Castors, &c.
 2. Plumbers' Brass Foundry, Cocks, Valves, Pumps, Water-closets, &c.
 3. Stamped Brass Foundry, Cornices, Curtain-bands, Finger-plates, &c.

4. Gas-fittings, Brackets, Chandeliers, Pillars, Gas Burners, and Consumers' Meters, &c.
5. Tubing, plain and ornamental.
6. Metallic Bedsteads, Brass and Iron.
7. Chandeliers, Lamps, and Candelabra, for Oil, Candles, or Cumpline, and Lamp Chains.
8. Railway and Carriage Brass Foundry, and Signal Lamps and Lanterns.
9. Bronze Figures, Busts, and Chimney Ornaments.
10. Bells, House, Church, Ship, Table, &c., and Alarms.
11. Candlesticks, Table and Bedroom.
12. Monumental Brasses and Ecclesiastical Brass-work.
13. Copper and Steel Plates for Engravers.
14. Miscellaneous.

B. COPPER, ZINC, TIN, PEWTER, AND GENERAL BRASSERY.

1. Kettles, Coalscuttles, Coppers, Saucepans, Steamers, Plate-warmers, &c.
2. Bronzed Tea and Coffee Urns, Kettles, &c.
3. Tubing—Copper, Tin, Lead, &c.
4. Pewter, German Silver, and Britannia-metal Teapots, Basins, Dishes, Spoons, Ladies, Inkstands, &c.
5. Coffin Furniture—Plates, Escutcheons, &c.
6. Zinc Articles generally.

C. IRON MANUFACTURE. (See also I. and V.)

1. Stoves, Grates, Fenders and Fire Irons, Kitchen Ranges, Cooking Apparatus, Smoke-jacks.
2. Warming Apparatus, for Halls and Rooms, Ships, &c., either by Water, Coal, Coke, Wood, Charcoal, or Gas.
3. Shower, Vapour, Air, and Warm-water Baths.
4. Ventilators—Metallic and others.
5. Pipes and Gutters, &c.
6. Locks and Hinges.
7. General Ironmongery.
8. Ice Machines.
9. Knife-cleaning Machines.
10. Letter-copying Machines and Presses.
11. Saddlers' Ironmongery.
12. Hollow Ware, cast and wrought, tinned and enamelled.
13. Spades, Shovels, Pickaxes, Hoes, Rakes, Garden-rollers, &c. (See also S. IX.)
14. Nails, cut, cast, and wrought, in Iron, Copper, and other Metals.
15. Screws and Railway Bolts, &c.
16. Iron Safes, Cash-boxes, fire-proof and otherwise.
17. Horse-shoes.
18. Gates, Railings, Hurdles, and Stable Fittings.
19. Mangles, Washing Machines, &c.

D. STEEL MANUFACTURE.

1. Tools and heavy Steel Toys, Hammers, Vices, &c.
2. Steel Ornaments, and light fancy Steel Toys, Brooches, Buckles, &c.
3. Steel Pens and Metallic Pens.
4. Needles, Fish-hooks, and Fishing Tackle.

E. BUTTONS, ETC.

1. Buttons—Metallic, Florentine, Pearl, Bone, &c.
2. Metal Boxes, Watch Boxes, &c.

F. WIRE WORK, &c.

1. Wire Gauze, for Window Blinds, Fencing, Pheasantry, Birdcages, &c.
2. Wire—Iron, Brass, Steel, and Copper.
3. Pins—white and black.
4. Hooks and Eyes.
5. Metallic Wire Baskets.
6. Wire Rope.

XXIII. *Working in Precious Metals and in their imitations; Jewellery, and all Articles of Virtu and Luxury not included in the other Classes.*

A. COMMUNION SERVICES.

As Altar-dishes, Flagons, Chalice, Patens, Plates, &c.

B. ARTICLES OF GOLD AND SILVER PLATE, FOR DECORATIVE PURPOSES AND PRESENTATION PIECES.

1. Racing Prizes, Testimonials, allegorical, historical, and emblematic Groups and Compositions, Shields, Centre Pieces, Vases, Tazzas, Ewers, Salvers, Candelabra, &c.
2. The same Articles made in hammered or repoussé metal.

C. SMALLER ARTICLES FOR MORE GENERAL DOMESTIC USE.

1. For the Dinner Table; as Smaller Candelabra with branches, Candlesticks, Centre Pieces, Soup and Sauce Tureens, Covered Dishes, Smaller Mounted Dishes, Flat Dishes, Flower-stands and Epergnes, Dessert Services, Table and Dessert Knives, Spoons, and Forks, Salvers, Bread and Cake Baskets, Claret Jugs, Wine Coasters, Cruet Frames, Mustard Pots, Salts, &c.
2. Breakfast and Tea-table Service; as Tea and Coffee Urns and Kettles, Tea and Coffee Pots and Stands, Sugar Basins, Milk and Cream Jugs, Ewers and Basins, Toast Racks, &c.
3. Dressing and Library Table and Travelling Utensils; as Inkstands and Writing Appendages, Dressing Cases and Instruments, &c.
4. Miscellaneous; as Watch and Clock Cases, Toys, Pencil Cases, Seals and Keys, Filigree Baskets and Ornaments.

D. ELECTRO-PLATED GOODS OF ALL DESCRIPTIONS, COMPREHENDING ALL THAT CAN BE EXECUTED IN SILVER AND OTHER METALS.

E. SHEFFIELD AND OTHER PLATED GOODS.

Centre and Side covered Dishes and Warmers, Soup Tureens, Cruet Frames, Liqueur Frames, Pickle ditto, Candlesticks and Branches, Candelabra, Bread and Cake Baskets, Snuffers and Trays, Tea and Coffee Services, Teatrays, Hand Waiters, Claret Jugs, Decanter Stands, Sugar Stands, Flower Stands, Nut Crackers, Grape Scissors, Mustard Pots, &c.

F. GILT AND ON-MOLT WORK.

1. Gilt by the Electro process.
2. Gilt by amalgamation, or "Water Gilding."
3. Imitation Jewellery and Toys.

G. JEWELLERY.

1. Works exhibiting the Precious Stones and Pearls, as Diamonds, Rubies, Sapphires, Emeralds, Opals, Turquoise; and the manner of setting them in Crowns, Coronets, Stars, Orders, Tiaras, Head Ornaments, Bouquets, Necklaces, Bracelets and Armlets, Presentation Snuff Boxes, Brooches, Ear Pendants, Medallions, Studs, and Buttons.
2. Ornaments similar to those of the former class, in which are exhibited the setting of the inferior Stones, Amethysts, Topazes, Carbuncles, Aquamarines, Jacinths, Crysoptases, Carnielians, Onyxes, whether plain or set, Cameos or Intaglios, Engraved Shells, &c. &c.
3. Ornaments made of Gold, whether plain or enamelled; as Bracelets, Brooches, Necklaces, Earrings, Pins, Waist-Buckles, Chains, Buckles, Studs, Châtelaines, &c. &c. &c.
4. Jewellery by imitations of Precious and other Stones.
5. Ornaments worked in Ivory, Jet, Horn, Hair, and other materials, of which the Precious Stones or Metals do not form the principal feature.

H. ORNAMENTS AND TOYS WORKED IN IRON, STEEL, AND OTHER METALS WHICH ARE NEITHER PRECIOUS METALS NOR IMITATIONS OF THEM, AS CHATELAINES OF STEEL, CHAINS OF STEEL, SWORD-HILTS, CUT STEEL SHOE AND KNEE BUCKLES, BERLIN IRON ORNAMENTS, CHAINS, NECKLACES, BRACELETS, ETC.

I. ENAMELLING AND DAMASCENE WORK.

1. Enamelling of subjects on Gold and Precious Metals. (Except when shown in the Section of FINE ARTS.)
2. Damascene Work, or insertion of one Metal in another, not included in the above-named Classes, as forming a minor ingredient in some more important species of Manufactures.

J. ARTICLES OF USE OR CURIOSITY NOT INCLUDED IN THE PREVIOUS ENUMERATION.

XXIV. Glass.

A. WINDOW GLASS, INCLUDING SHEET GLASS, CROWN GLASS, AND COLOURED SHEET GLASS.

1. Crown.
2. Sheet.
3. Blown Plate Glass, silvered and unsilvered.
4. Coloured Sheet, Pot Metal, or flashed.
5. Glass Ventilators.
6. Glass Shades, round, oval, and square.

B. PAINTED AND OTHER KINDS OF ORNAMENTED WINDOW GLASS.

1. Enamelled, Embossed, Etched, painted white, or coloured Window Glass.
2. Painted and Leaded Windows.

C. CAST PLATE GLASS.

1. Rough Plate.
2. Ground and polished, silvered and unsilvered.
3. Pressed Plate.
4. Rolled Plate, white and coloured.

D. BOTTLE-GLASS.

1. Ordinary Bottle-glass, including Moulded Bottles.
2. Medicinal Bottle-glass, including Phials, &c., blown and moulded, of all kinds and shapes.
3. White Bottle-glass, Blown, Pressed, and Moulded Bottles.
4. Water-pipes and Tubing.

E. GLASS FOR CHEMICAL AND PHILOSOPHICAL APPARATUS.

1. Glass for Matras, Retorts, and other kinds of Chemical and Philosophical Apparatus.
2. Water-pipes and Tubing.

F. FLINT GLASS OR CRYSTAL, WITH OR WITHOUT LEAD, WHITE, COLOURED, AND ORNAMENTED FOR TABLE VASES, ETC.

1. Blown.
2. Moulded and Pressed.
3. Cut and Engraved.
4. Reticulated and spun with a variety of colours, incrustated, flashed, enamelled of all colours, opalescent, imitation of Alabaster, gilt, platinised, silvered, &c.
5. Glass Mosaic, Millefiori, Aventurine, and Venetian Glass Weights, &c.
6. Beads, imitation Pearls, &c.
7. Chandellers, Candlesticks, and all Glass Apparatus for Lamps, Candlesticks, Girandoles, Wall Brackets, with or without drops, &c.

G. OPTICAL GLASS, FLINT AND CROWN.

1. Rough Discs of Flint and Crown, to make Lenses for Telescopes, Microscopes, Daguerreotype and Calotype Apparatus, &c.
2. Flint and Crown, blown or cast in plates for the Optician.
3. Thin Glass for Microscopes.
4. Refractive Apparatus, Prismatic Lenses for Lighthouses. (See also Class J.)

XXV. Ceramic Manufactures.—Porcelain, Earthenware, &c.

A. PORCELAIN, HARD.

1. Chinese.
2. Japanese.
3. Continental, as Berlin, Meissen, &c.

B. STATUARY PORCELAIN.

1. Statuary.
2. Parian.
3. Caïra.

C. TENDER PORCELAIN.

1. English Porcelain, soft or tender.
2. French, with Silicious body.

D. STONEWARE, GLAZED AND UNGLAZED.

1. Ironstone, or Stone China, glazed.
2. White Stone body, unglazed.
3. Coloured body, Jasper. "
4. " Egyptian black, unglazed.
5. " Red, "
6. " Crane, "
7. " Drab, "
8. Brownware, with salt glaze. (The Lambeth, Chertfield, and Beauvais manufactures are included in this class.)
9. Chemical utensils. (These are made both in Stoneware and Hard Porcelain.)

E. EARTHENWARE.

1. White body for Printing, Painting, or Enamelling in different Colours.
2. Common Cream-colour.
3. Green glazed ware.
4. Rockingham "

5. Deft ware.
 6. Majolica ware.
 7. Mocha and Dipped ware.
 8. Common Lead glazed ditto, for utensils.
 9. Coloured body, Turquoise.
 10. " Drab.
 11. " Olive.
 12. " Buff.
 13. " Cottage brown.
- F. TERRA COTTA.**
1. Vases and Garden-pots.
 2. Ornaments for Architecture.
 3. Encaustic or Inlaid Tiles.
 4. Tessere of various colours, compressed from powdered clay.
 5. Superior Plain Tiles for Pavements, ditto ditto.
 6. " Bricks, ditto, ditto.
 7. " Roofing Tiles, ditto, ditto.
 8. Chimney Pipes.
 9. Common Bricks.
 10. " Roofing Tiles, &c.
- G. ORNAMENTED OR DECORATED.**
1. Ornamented on *Bisque*—
Painted by hand.
Printed and transferred in various colours.
 2. Ornamented on *the glaze*.
Painted by hand.
Printed by the press.
Printed by hand.
Gold Lustre.
Silver "
Steel "
Enamelling in various colours.
Gliding.
- II. PRODUCTIONS FOR ARCHITECTURAL PURPOSES.**
- XXVI. Decoration Furniture and Upholstery, including Paper-hangings, Papier-maché, and Japanned Goods.**
- A. DECORATION GENERALLY, INCLUDING ECCLESIASTICAL DECORATION.**
1. Ecclesiastical Decoration generally.
 2. Ornamental coloured Decoration, as executed by hand.
 3. Imitations of Woods, Marbles, &c., ditto.
 4. Relief Decoration, mechanically produced.
- B. FURNITURE AND UPHOLSTERY.**
1. Cabinet Work, plain.
 2. Cabinet Work, carved or ornamental.
 3. Marquetrie, Inlaid Work, in Woods, &c.
 4. Buhl or Metallic Inlaid Work.
 5. Chairs, Sofas, and Beds, and general Upholstery.
- C. PAPER-HANGINGS.**
1. Damask Patterns.
 2. Flower Patterns.
 3. Flock and Metal Papers.
 4. Decorative Paper-hangings by Block-work.
 5. " " " " by any other Process.
 6. Machine-printed Paper-hangings.
- D. PAPIER-MACHE, JAPANED GOODS, PEARL, AND TORTOISE-SHELL WORK.**
1. Papier-maché, japanned, inlaid, and decorated.
 2. Papier-maché (not japanned), produced in ornamental forms for decoration.
 3. Japanned Goods in Iron, &c.
 4. Pearl and Tortoiseshell Work.
- XXVI. Manufactures in Mineral Substances used for Building or Decoration, as in Marble, Slate, Porphyries, Cements, Artificial Stones, &c.**
- A. MANUFACTURES IN COMMON STONES.**
1. For Building, and constructions not strictly decorative.
 2. For Decorative purposes.
- B. MANUFACTURES IN SLATE.**
1. For Construction.
 2. For Decoration.
- C. MANUFACTURES IN CEMENT AND ARTIFICIAL STONE.**

D. MANUFACTURES IN MARBLES, GRANITES, PORPHYRIES, ALABASTER, SPAR, ETC., FOR USEFUL OR ORNAMENTAL PURPOSES.

1. For Construction and external Decoration.
2. For internal Decoration (not Furniture), as Chimney-pieces, &c.
3. For articles of Furniture, as Tables, &c.
4. For purposes of mere Ornament.

E. INLAID WORK IN STONE, MARBLE, AND OTHER MINERAL SUBSTANCES.

F. ORNAMENTAL WORK IN PLASTER, COMPOSITION, SCAGGIOLA, IMITATION MARBLE, ETC.

G. COMBINATIONS OF IRON AND OTHER METALS WITH GLASS AND OTHER SUBSTANCES FOR VARIOUS USEFUL PURPOSES.

1. For Architectural purposes.
2. For Miscellaneous purposes.

XXVIII. Manufactures from Animal and Vegetable Substances, not being Woven, Felted, or included in other Sections.

A. MANUFACTURES FROM CAOUTCHOUC.

1. Impermeable Articles.
 - Boots.
 - Holdsworth's Life Preservers.
 - Captain Smith's Hydrostatic Beds. "
 - Air
 - Water Cushions.
 - Air
 - Gas Bags. "
 - Printers' Blankets.
 - Cloaks, Capes, Coats, Paletots, &c.
 - Boots and Shoes.
 - Over Shoes, or Goggles.
 - Fishing Boots.
 - Deck
 - Ship Sheets.
 - Belows.
 - Air-pump Valves for Steam Engines.
 - Sponge Baths and Bags.
 - Prepared Water and Air proof Textures of every description.
2. Elastic Articles.
 - Railway and other Carriage Springs.
 - Buffers.
 - Valve Canves.
 - Knee Caps.
 - Surgical Bottles.
 - Pump Buckets and Valves.
 - Bands and Rings for Letters and Packages.
 - Writing Tablets.
 - Trouser Straps.
 - Gussets for Boots.
 - Vest Backs.
 - Washers for Flange and Socket Joints.
 - Driving Bands for Machinery.
 - Railway Felt.
 - Wheel Tires.
 - E. Smith's Torsion Springs for Window-blinds and Shades.
 - Door Springs.
 - Dr. Bell's Sewer and Sink Valves.
 - Hodge's Projectile and Lifting Straps.
 - Air-pump Valves.
 - Elastic Webbing.
 - Cricketer Gloves and Bails.
 - Stoppers for Decanters, Bottles, Jars, and other vessels.
3. Articles in Caoutchouc—Moulded, Embossed, Coloured, and Printed.
 - Bas-reliefs.
 - Bags.
 - Maps, printed on Caoutchouc.
 - Sheets, in Colour.
 - Embossed and Printed Ornaments.
 - Garters, Bracelets, &c., Embossed, Coloured, or Printed.
 - Bottles, Embossed and in Colours.
 - Embossed Sheets for Seats and other Purposes.
 - Vulcanized Articles combined with Metal—such as Decanter Stoppers, Inkstands, Cocks and Taps for Fluids, Hinges, Locks and Bolts, Wheel Tires, Plugs for Cisterns, Linings of Vessels, &c.

B. MANUFACTURES FROM GUTTA PERCHA.

1. For Waterproofing Purposes.
2. For Agricultural Uses, as Tubing for Manure, &c.
3. For Maritime Purposes, as Speaking Trumpets, Life Buoys, Life Boats, Cords, Tiller Ropes, &c.
4. Decorative Uses, as Ornamental Mouldings, Brackets, Medallions, Picture Frames, &c.
5. Surgical, Electrical, and Chemical Uses, as Dissolved Gutta Percha for Wounds, Stethoscopes, Splints, Ear Trumpets, &c., Carboys, Funnels, Acid Vessels, &c., Covering of Telegraph Wire, Insulating Stools, &c.
6. Domestic and Miscellaneous Uses, as Soles for Shoes, Linings of Cisterns, Conveyance of Water and Gas, Hearing Apparatus, &c.

C. MANUFACTURES FROM IVORY, TORTOISESHELL, SHELLS, BONE, HORN, BRISTLES, AND VEGETABLE IVORY.

D. GENERAL MANUFACTURES FROM WOOD (not being Furniture).

1. Turnery.
2. Carving, &c.
3. Coopers' Work of all kinds.
4. Basket and Wicker work.
5. Miscellaneous Wood work.

E. MANUFACTURES FROM STRAW, GRASS, AND OTHER SIMILAR MATERIALS.

F. MISCELLANEOUS MANUFACTURES FROM ANIMAL AND VEGETABLE SUBSTANCES.

XXIX. Miscellaneous Manufactures and Small Wares.

A. PERFUMERY AND SOAP.

B. ARTICLES FOR PERSONAL USE, AS WRITING DESKS, DRESSING CASES, WORKBOXES, WHEN NOT EXHIBITED IN CONNECTION WITH PRECIOUS METALS (XXIII.), AND TRAVELLING GEAR GENERALLY.

C. ARTIFICIAL FLOWERS.

D. CANDLES, AND OTHER MEANS OF GIVING LIGHT.

E. CONFECTIONERY OF ALL KINDS.

F. BEADS AND TOYS, WHEN NOT OF HARDWARE, FANS, ETC.

G. UMBRELLAS, PARASOLS, WALKING-STICKS, ETC.

H. FISHING TACKLE OF ALL KINDS, ARCHERY.

I. GAMES OF ALL KINDS.

J. TAXIDERMY.

K. OTHER MISCELLANEOUS MANUFACTURES.

FINE ARTS

(So far as they come within the limitations of the Exhibition).

XXX. Sculpture, Models, and Plastic Art.

A. SCULPTURE AS A FINE ART.

1. In Metals simple, as Gold, Silver, Copper, Iron, Zinc, Lead, &c.
2. In Metals compound, as Bronze, Electrum, &c.
3. In Minerals simple, as Marble, Stone, Gems, Clay, &c.
4. In elaborate Mineral Materials, as Glass, Porcelain, &c.
5. In Woods and other Vegetable Substances.
6. In Animal Substances, as Ivory, Bone, Shells, Shell Cameos.

B. WORKS IN DIE-SINKING, INTAGLIO.

1. Coins, Medals, and Models of a Medallion character in any material.
2. Impressions struck from Dies for ornamental purposes.
3. Gems, either in Cameo or in Intaglio, Shell Cameos.
4. Seals, &c.

C. ARCHITECTURAL DECORATIONS.

1. Integral, in Relief, Colour, &c.
2. Adventitious, as Stained Glass, Tapestry, &c.

D. MOSAICS AND INLAID WORKS.

1. In Stone.
2. In Tiles.
3. In Vitrified Materials.
4. In Wood.
5. In Metal.

E. ENAMELS.

1. On Metals.
2. On China.
3. On Glass.

F. MATERIALS AND PROCESSES APPLICABLE TO THE FINE ARTS GENERALLY, INCLUDING FINE ART PRINTING, PRINTING IN COLOUR, ETC. ETC.

1. Encaustic Painting and Fresco.
2. Ornamental Printing, Chromo-typography, Gold-Illuminated Typography, Typography combined or uncombined with Embossing.
3. Lithography, Black, Chromo-lithography, Gold-Illuminated Lithography, Lithography combined or uncombined with Embossing.
4. Zincography or other modes of Printing.

G. MODELS.

1. In Architecture.
2. Topography.
3. Anatomy.

LYON PLAYFAIR.

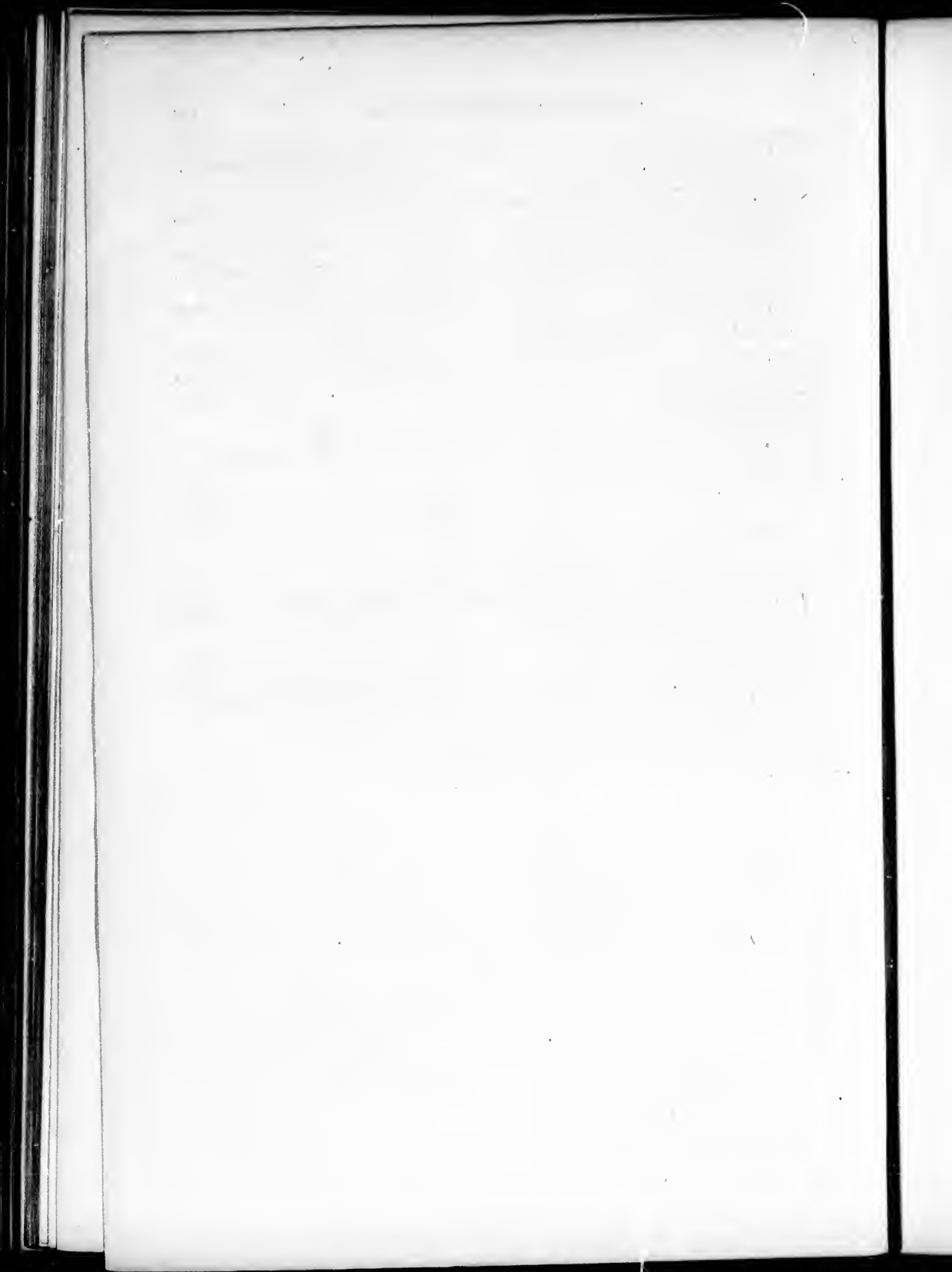

OFFICIAL
Descriptive and Illustrated Catalogue.

~~~~~  
UNITED KINGDOM.

CLASSES I. to XXX.

x

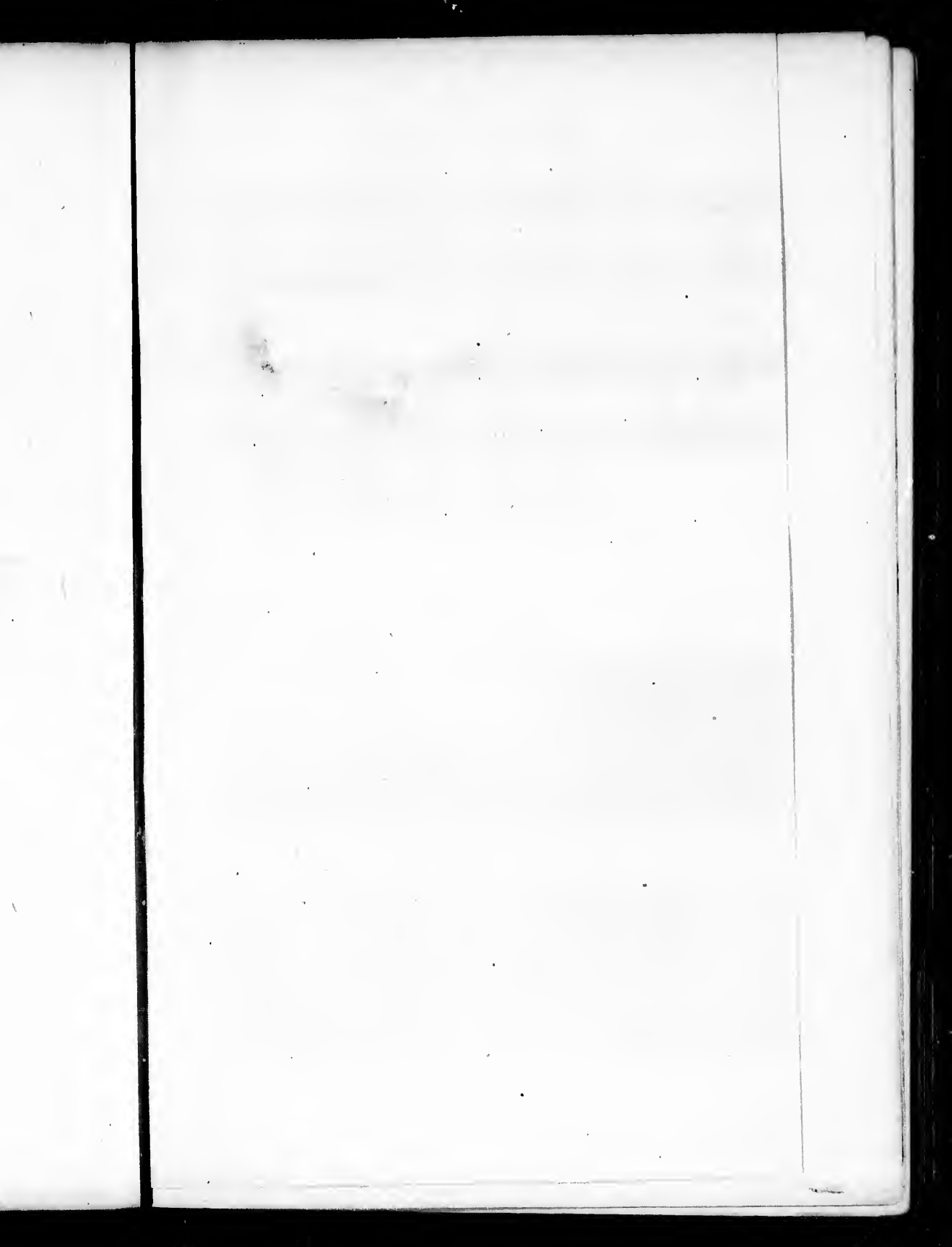

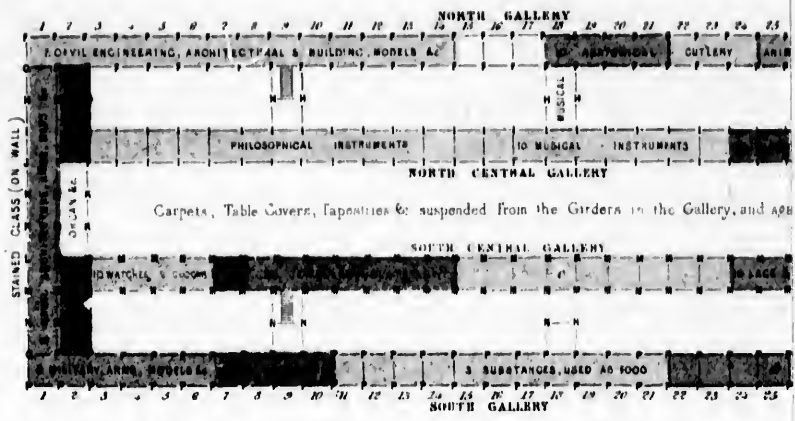

b. Black Diamond                      c. M. Hope's Blue Diamond.                      d. State Bad in

[The Building is divided into areas (spaces of 24 feet square, between 4 columns) which are marked on the plan by letters at each corner of the square and by numbers along the sides of the Building; these letters and numbers are marked on every column in the Building in white characters at about 7 feet from the ground.]

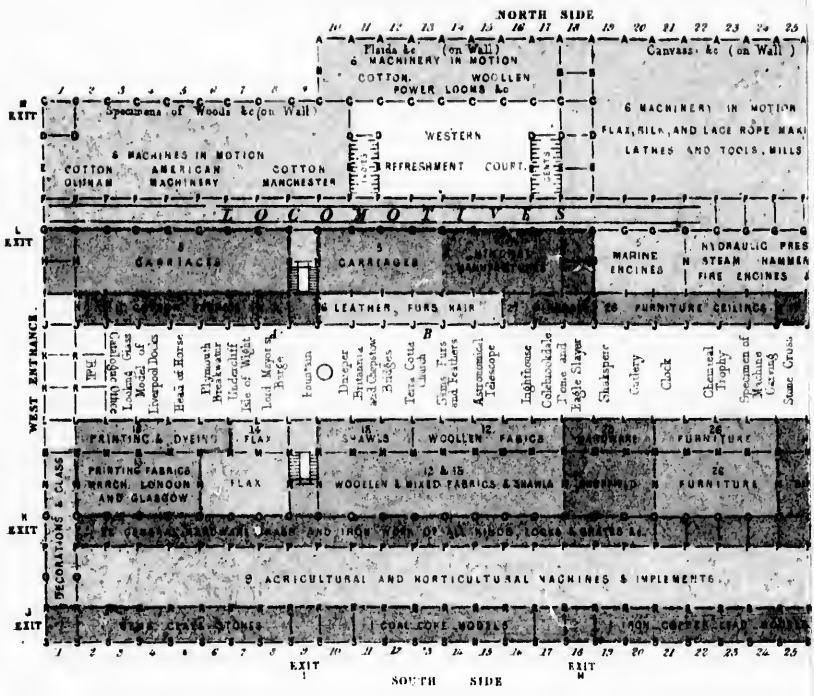

A. Machine for Weaving Structures                      B. Her Majesty's Jewel Case

Against the South wall West of Transept, are several examples of cements (with dates) and together with specimens of woods and ivory, and painted



23 24 25  
FLWY ANIR



lery, and app

FACE



23 24 25

State had in

numbers  
column

23 24 25  
(on Wall)

MOTION  
ROPE MAKING  
TOOLS, MILLS



AUG PRESS  
HAMMER  
ENGINES

LINDS

Specimen of  
Machine  
Carving  
Stone Cross



24 25

case

cements (d painted

PLAN OF THE BUILDING

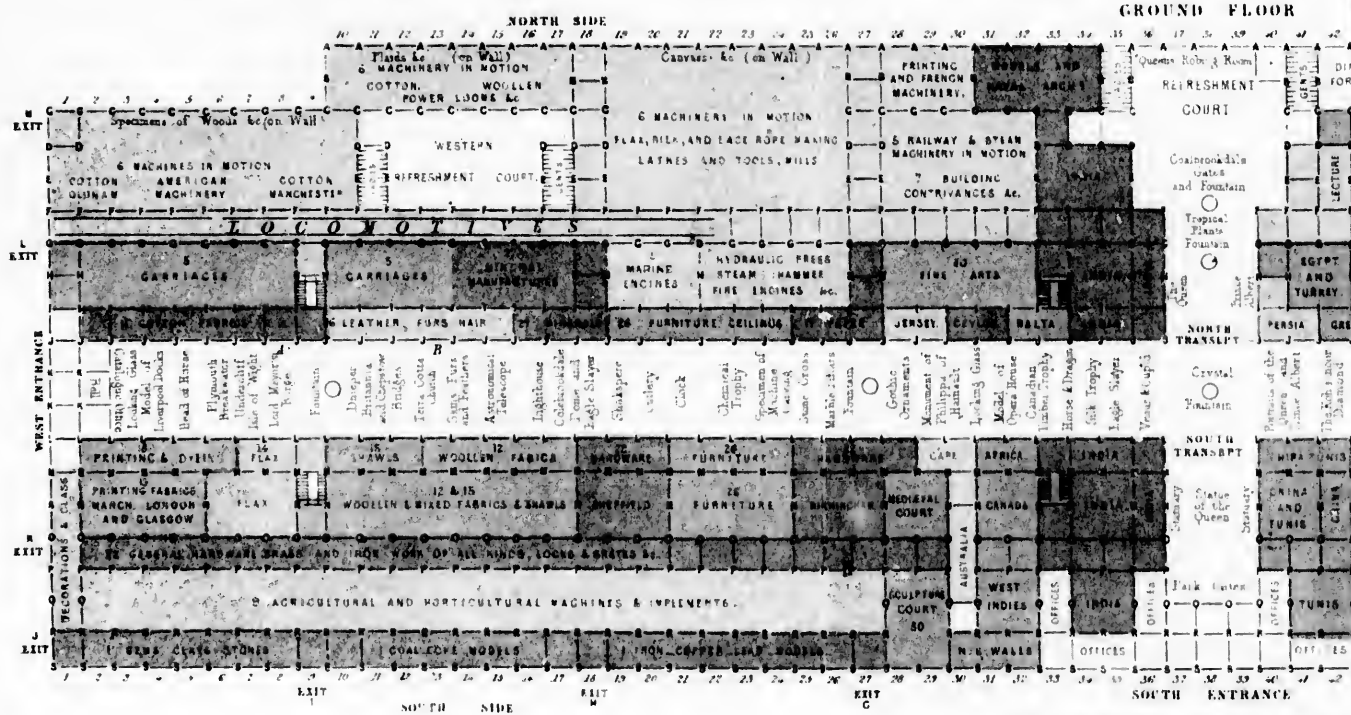
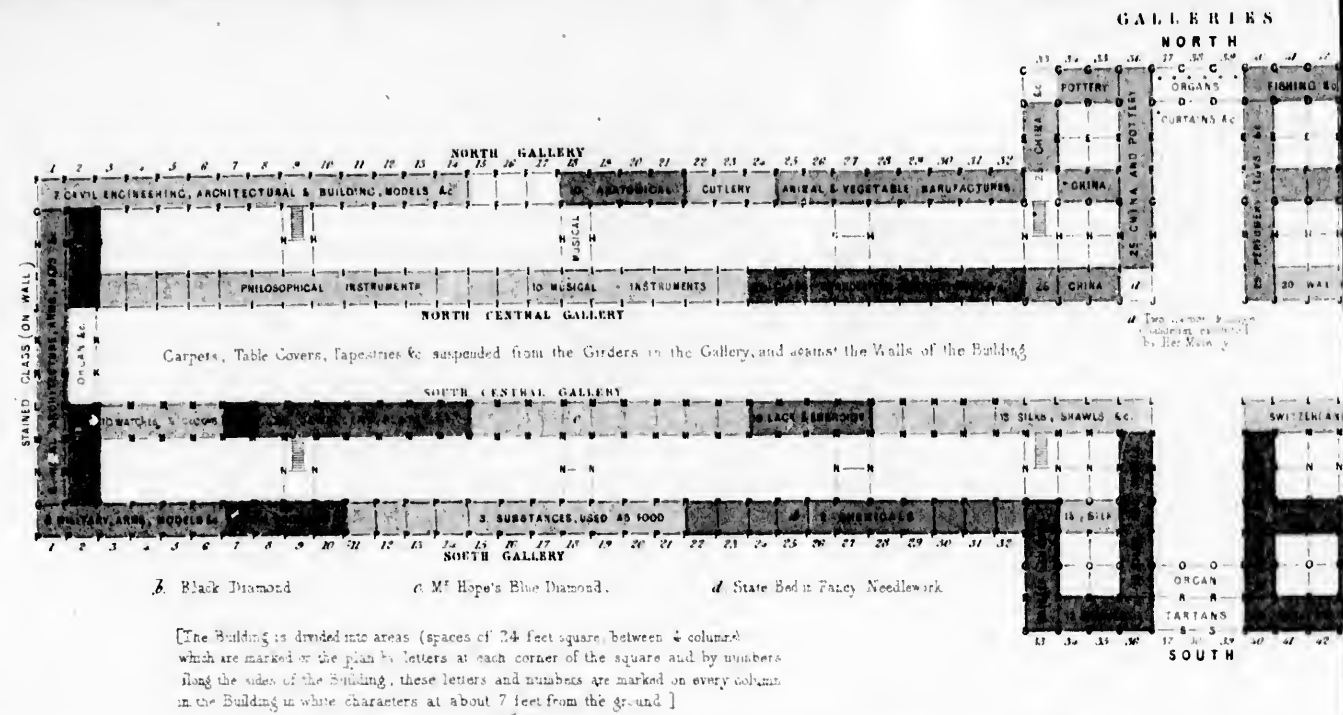

A Machine for Weaving... B Her Majesty's Jewels Case

Admission to the West of Transport, see several samples of cements (Emcaustic and Roman) and of wall paper, together with specimens of woods and ivory, and painted imitations of wood and stone

# OF THE BUILDING.

## GALLERIES

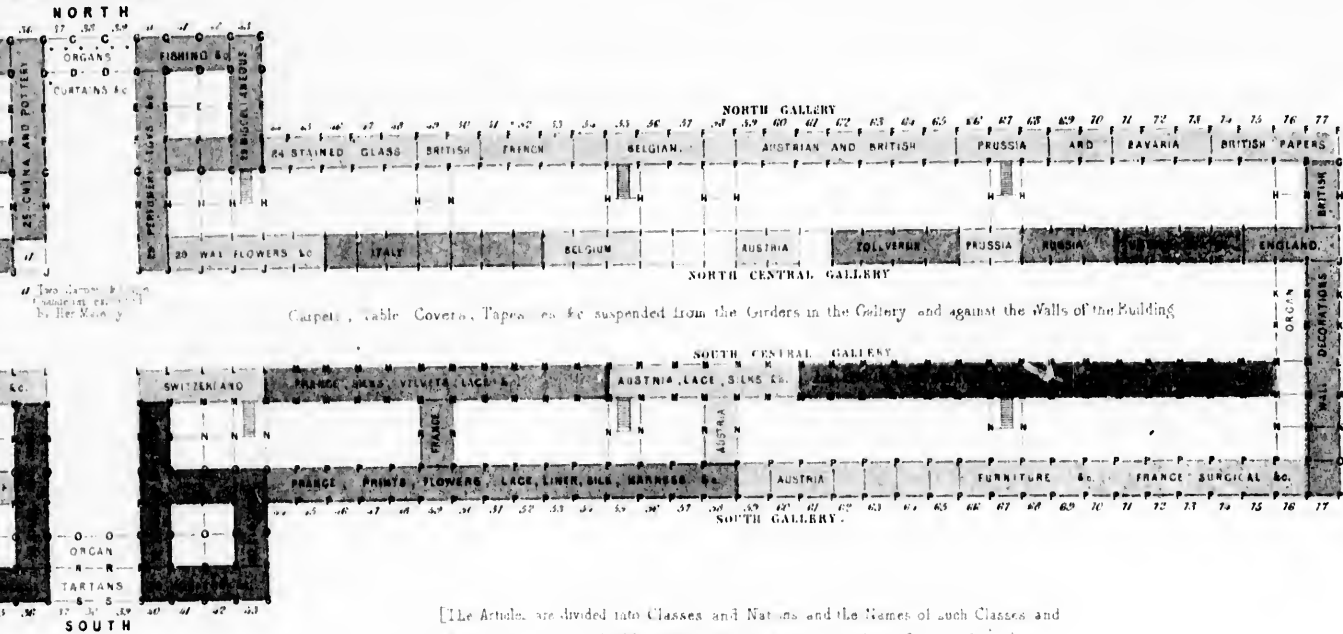

Carpet, Table Covers, Tapes, &c. suspended from the Girders in the Gallery and against the Walls of the Building

[The Articles are divided into Classes and Nations and the Names of such Classes and Nations are given on the Plan, and marked upon the Girders of the Building]

## GROUND FLOOR

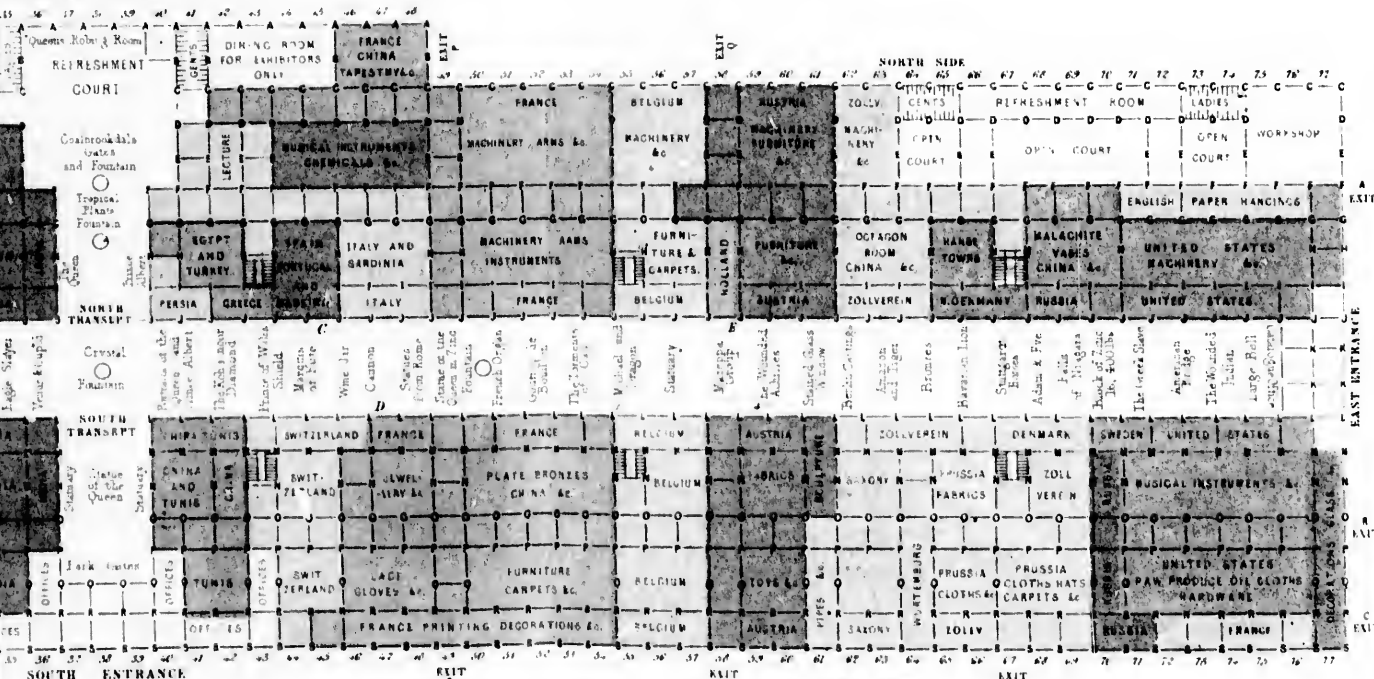

Scale 100 Feet

C Toledo Swords &c. D Queen of Spain's Jewels E M<sup>r</sup> Noye's Jewels

Against the South wall, East of Transsept, are arranged examples of silver and rolled articles, sheets of metal, and examples of metal manufactures



TABLE OF GOLD AND SILVER ELECTROPLATE, EXHIBITED BY HER MAJESTY.

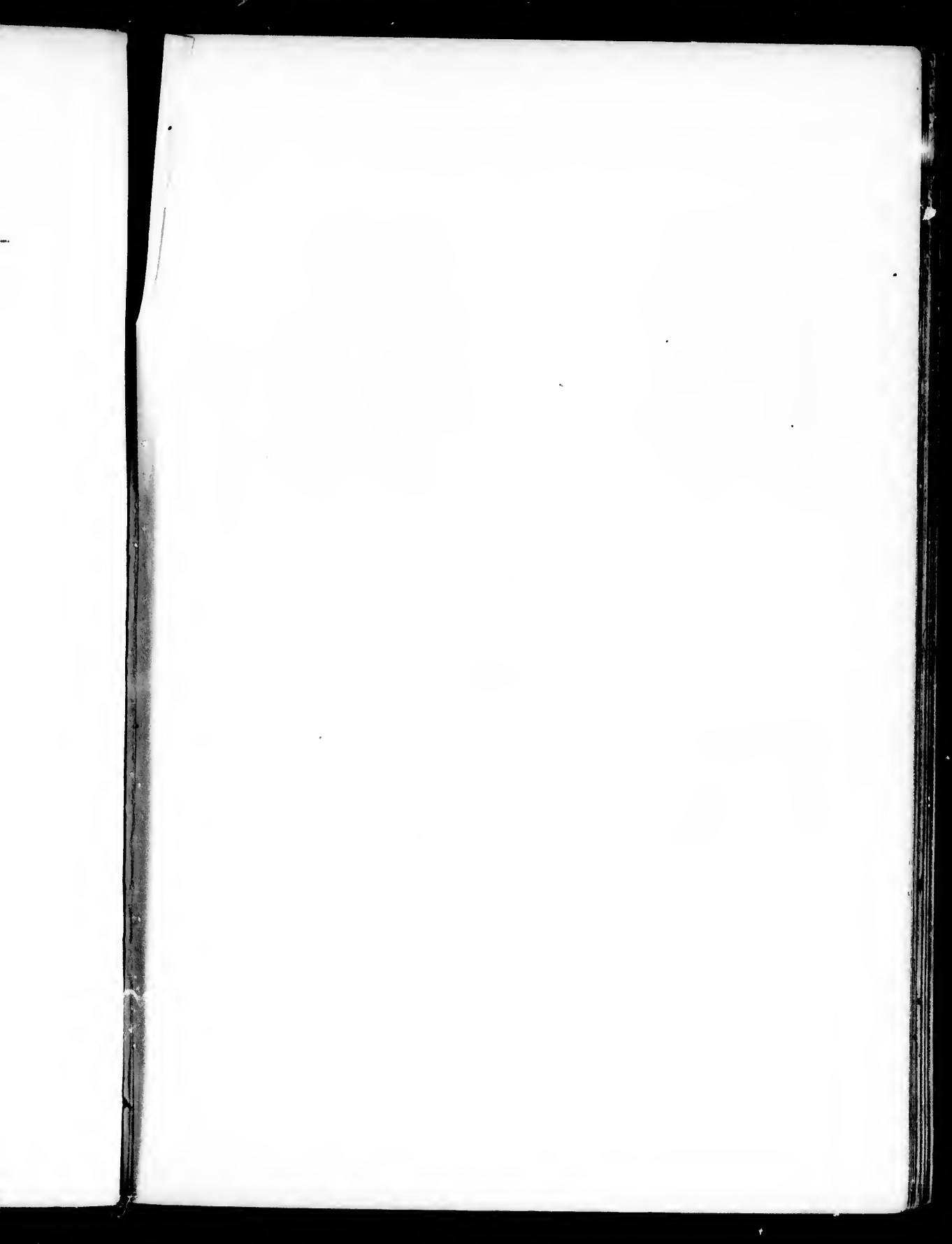

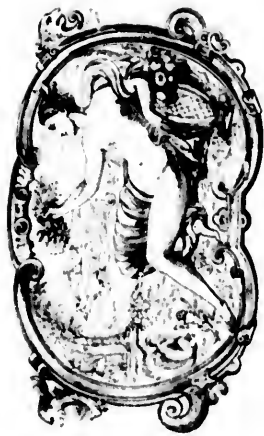

EARTH.



WATER.



TEMPERANCE.



AIR.

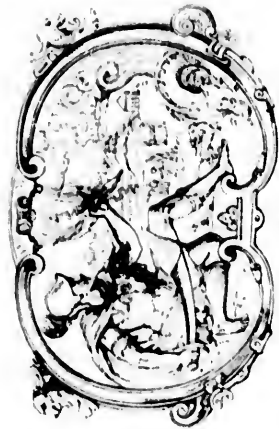

FIRE.





APP.

COMPARTMENTS OF ELECTRODEPOSIT TABLE FOR  
EXHIBITING THE VARIETY OF METALS EXHIBITED BY MESSRS. LEECH AND CO.

FIG. 1.





116. TABLE TOP, IN SILVER, AFTER THE ANTIQUE. PRODUCED BY THE ELECTROTYPE PROCESS. EXECUTED BY MESSRS. ELKINGTON. EXHIBITED BY HER MAJESTY THE QUEEN.



ARTICLES EXHIBITED BY HER MAJESTY THE QUEEN,  
H. R. H. THE PRINCE OF WELLS, AND H. R. H. THE PRINCE OF WALES,  
IN THE FOUR SECTIONS OF THE EXHIBITION.

HER MAJESTY THE QUEEN.

MAIN AVENUE, EAST.

96 Portrait of Her Majesty on Sèvres china, size of life, half length, by A. Duchizeau, after a portrait by F. Winterhalter. Painted in 1846.

97 Portrait of H.R.H. Prince Albert, on Sèvres china, size of life, half length, painted by A. Bezanget, after a portrait by F. Winterhalter. These portraits are exhibited jointly by Her Majesty and H.R.H. Prince Albert.

The Great Diamond of Runjeet Singh, called "Koh-i-Noor," or Mountain of Light.

Jewel-case in the cinque-cento style, designed by L. Gruner, Esq., and executed at the manufactory of Mr. Henry Elkington, at Birmingham. The material is bronze, gilt and silvered by electro-type process; upon this case are portraits, on china, of Her Majesty, H.R.H. Prince Albert, and H.R.H. the Prince of Wales, copied from miniatures by R. Thorburn, Esq., A.R.A. The small medallions, representing profiles of their R.H.'s the Prince and Princesses, were modelled from life by Leonard Wyon, Esq.

CLASS 23.—CENTRAL SOUTH GALLERY.

1 Table of gold and silver electro-plate manufactured by Messrs. Elkington. The top of the table is an electro-type reproduction of a plate of fine workmanship, obtained and copied for Mr. H. Elkington under the direction of the Chevalier de Schlick. The eight subjects in bas-relief represent Minerva, Astrologia, Geometria, Arithmetica, Musica, Rhetorica. The centre figure represents Temperance surrounded by the four elements. At the bottom of this plate is an inscription pointing to the artist. The table is designed by George Stanton, a young artist in the employ of Mr. H. Elkington, and a student in the Birmingham School of Design.

CLASS 30.—FINE ART COURT.

353 A cradle, carved in Turkey boxwood by W. G. Rogers, and designed by his son, symbolising the union of the Royal House of England with that of Saxe Coburg and Gotha. One end exhibits in the centre the armorial bearings of Her Majesty the Queen, surrounded by masses of foliage, natural flowers and birds; on the rocker, beneath, is seen the head of "Nox," represented as a beautiful sleeping female, crowned with a garland of poppies, supported upon bats' wings, and surrounded by the seven planets.

The other end, or the back of the head of the cradle, is devoted to the arms of H.R.H. Prince Albert; the shield

occupies the centre, and round it, among the arabesque foliage, the six crests of the Prince are scattered, with the motto "Treu und fast." Below, on the rocker, is discovered a head of "Somnus" with closed eyes, and over the chin a wimple, which, on each side, terminates in poppies.

In the interior of the head of the cradle, guardian angels are introduced; and above, the royal crown is found embedded in foliage. The friezes, forming the most important part of the sides of the body of the cradle, are composed of roses, poppies, conventional foliage, butterflies, and birds, while beneath them rise a variety of pinks, studied from nature. The edges and the insides of the rockers are enriched with the insignia of royalty and emblems of repose.

CLASS 24.—CENTRAL NORTH GALLERY, I. 27.

20 A pair of richly cut crystal glass candelabra, 8 feet high, carrying 15 lights each. The shaft composed of prisms upwards of 3 feet in length. Designed and manufactured by F. and C. Osler, of Birmingham, and 44 Oxford Street, London.

CLASS 19.—CENTRAL NORTH GALLERY, I. 30.

156 Axminster carpet, designed by L. Gruner, Esq., and manufactured at Glasgow, for Mr. Dowbiggen.

379 A Berlin wool carpet executed by one hundred and fifty ladies of Great Britain. The dimensions of this carpet are thirty feet in length, and twenty in breadth. The carpet has been produced in the following manner:—The pattern, originally designed and painted by the artist, has been subdivided into detached squares, which have been worked by different ladies, and on their completion the squares have been reunited, so as to complete the design. In the pattern, which consists partly of geometrical, and partly of floral forms, heraldic emblems are also introduced. The initials of the executants are ornamentally arranged, so as to form the external border. The whole design is connected by wreaths or bands of leaves and foliage, the centre group representing the store from whence they have been distributed.

The carpet has been produced under the management of a Committee. The design by Mr. J. W. Papworth; the patterns were painted and the work executed under the superintendence of Mr. W. B. Simpson.

CLASS 19.—SOUTH GALLERY, P. 15 to 17.

Axminster carpet, designed by L. Gruner, Esq., and manufactured by Messrs. Blackmore Brothers, at Wilton, for Messrs. Watson, Bell, & Co.

## ON THE "BAHAMAS" COUNTER.

Specimens of Abyssinian saddlery. Two mules' saddles complete. Two brass ornaments suspended on the necks of mules. One large coloured wicker basket. A small one. Two horse saddles, one with bridle, the other without; brass ornaments for the face and neck of the horse.

Two Abyssinian sheepskins, as worn by the natives over their clothes. Each of these is the skin of one sheep, the wool carefully dressed and extremely white. The baskets are good specimens of plaiting, and very flexible. The saddles of a very primitive construction, much resembling the old Morisco pattern, still retained in many districts in the South of Spain; and contrasting singularly with the elaborate and ornamental character of the head-gear, neck ornaments, &c., exhibited with them.

## ON THE "SOUTH AUSTRALIAN" SIDE.

Abyssinian shield of buffalo hide, with silver ornaments, and strip of lion's mane suspended from the boss. Diameter about 2 feet and a half.

Two Abyssinian silver coronets of superior design. One of these, to which a sort of metallic fringe is attached, displays a strong resemblance to the sort of diadem figured in Bruce's Travels. The forms of these coronets are by no means deficient in elegance and simplicity.

Two Abyssinian silver-gilt bracelets, apparently of some antiquity, and very much chased.

Two fine cotton cloths worn by Abyssinians of distinction.

Two Abyssinian double-edged sabres, the handles being made of rhinoceros' horn. The peculiar curve of the blade adapts the inside edge for the purpose of forage and grain-cutting. Two Abyssinian lances.

## HIS ROYAL HIGHNESS PRINCE ALBERT.

## SOUTH TRANSIT.

15 Group in marble, "Theseus and Amazona," executed at Home by Joseph Engel, Esq., from Hungary, pupil of the Royal Academy.

## CLASS 3.

170 Three samples of grain grown on the royal farms at Windsor, consisting of wheat, oats, and beans, one bushel of each.

## CLASS 4.

139 Wool, the production of Cashmere goats kept by His Royal Highness at Windsor. It is imported with a portion of strong white hairs, which it is requisite to have picked out by hand prior to attempting to manufacture the finer portions. These strong hairs are afterwards useful in making coarse woollen cloth.

Examples of these kinds of manufacture from this wool are exhibited in the Central Avenue.

## CLASS 27.

140 A block of Parrot coal from West Wemyss colliery, Kirkcaldy, Fifeshire, partly polished.

141 Garden seat, designed by L. Gruner, Esq., and executed in Fifeshire by Thomas Williams Waun, of Parrot or gravel coal, from the estate of Rear-Admiral Wemyss.

## CLASS 30.

350 Two slabs for tables, designed by L. Gruner, Esq., in the cinque-cento style, executed by Mr. Thomas Woodruff at Bakewell, in Derbyshire stones, in imitation of the Florentine mosaic.

351 Candelabrum in the cinque-cento style, designed by L. Gruner, Esq., modelled by Ant. Trentanovo, and executed in scagliola in imitation of giallo antico, by L. Romoli.

## HIS ROYAL HIGHNESS PRINCE ALBERT, ON BEHALF OF HIS ROYAL HIGHNESS THE PRINCE OF WALES.

98 Shield presented by His Majesty the King of Prussia to His Royal Highness the Prince of Wales, in commemoration of the baptism of the infant Prince, for whom His Majesty acted as sponsor.

The pictorial embellishments of the shield, the general plan for which was given by the king himself, were designed by Doctor Peter Von Cornelius, and the architectural ornaments by Counsellor Stüler. The execution of the remaining portions—the goldenmiths' work, enamel, &c., were performed by M. G. Hossauer; the modelling by M. A. Fischer; the chasing by M. H. Mertens; and the lapidary work by M. Calandrelli.

In the centre of the shield is a head of Our Saviour. The middle compartment, surrounded by a double line of ornamental work, is divided by a cross into four smaller compartments, which contain emblematic representations of the two Sacraments, Baptism and the Lord's Supper, with their Old Testament types, the opening of the fountain in the rock by Moses, and the fall of manna. At the extremities of the arms of the cross are represented the Evangelists, noting down what they have seen and heard in the Gospels, which are to communicate to all futurity the plan of man's salvation, and prove inexhaustible sources of divine revelation and doctrine.

On the extreme points of the arabesques that rise above the Evangelists, are represented the Christian virtues of Faith, Hope, and Charity, and of Christian Righteousness. Around the entire centre stand in a

circle the twelve Apostles. Peter is seen under Faith represented in the arabesque; on the right and left of him are Philip and Andrew; under Hope is James; on either side are Bartholomew and Simon; John is placed beneath the figure of Charity; on either side are James the younger and Thomas; under Righteousness is Paul; on the right and left are Matthew and Judas Thaddeus, going forth into the world to teach and to baptize, and to propagate the kingdom of the Redeemer.

The relieve, which runs round the edge of the shield, represents the betrayal, the redeeming atonement of Christ, and his resurrection. Another portion represents Our Lord's triumphant entry into Jerusalem; a third portion the descent of the Holy Ghost, the preaching of the gospel, and the formation of the church. The fourth and principal compartment contains an allegorical representation of the birth of the Prince of Wales, and of the visit of the King of Prussia, accompanied by Baron Humboldt, General von Natumer, and the Count von Stolberg, and welcomed by H. R. H. Prince Albert and the Duke of Wellington; a Knight of St. George being represented on the beach standing upon a dragon.

The shield has been denominated the Buckler of Faith. The inscription on the shield runs thus:—

FRIDERICUS GULIELMUS REX BORUSSORUM  
ALBERTO EDUARDO, PRINCIPI WALLIE,  
IN MEMORIAM DIEI BAPT. XXV JAN. A. MDCCCXLII.

ZOLLNEREN, OCTAGON ROOM, No. 536.

COUNT ERNEST OF COBURG-GOTHA.

Fruit stones of various sizes, carved with a penknife.

LAN<sup>T</sup> SIDE.

with silver orna-  
suspended from the  
half.  
superior design. One  
fringe is attached,  
the sort of dialem  
ns of these coronets  
and simplicity.  
lets, apparently of  
d.  
inians of distinction,  
s, the handles being  
ular curve of the  
urpose of forage and  
s.

at Wemyss colliery,

Gruner, Esq., and  
ms Waun, of Parrot  
-Admiral Wemyss.

by L. Gruner, Esq.,  
Mr. Thomas Wood-  
in imitation of the

to style, designed  
Trentanove, and  
giallo antico, by

OF WALES.

seen under Faith  
right and left of  
Hope is James;  
Simon; John is  
on either side are  
ler Righteousness  
tthew and Judas  
to teach and to  
of the Redeemer.  
ige of the shield.  
g stonement of  
ortion represents  
rusalem; a third  
the preaching of  
reh. The fourth  
allegorical repre-  
Wales, and of the  
l by Baron Hum-  
ant von Stolberg,  
and the Duke of  
sing represented

Buckler of Faith.

USSOREM

ALLE,

. MDCCLXII.











142. GROUP IN MARBLE, THESEUS AND THE AMAZONS, EXECUTED AT ROME BY JOSEPH ENGEL, ESQ.  
EXHIBITED BY H. R. H. PRINCE ALBERT.

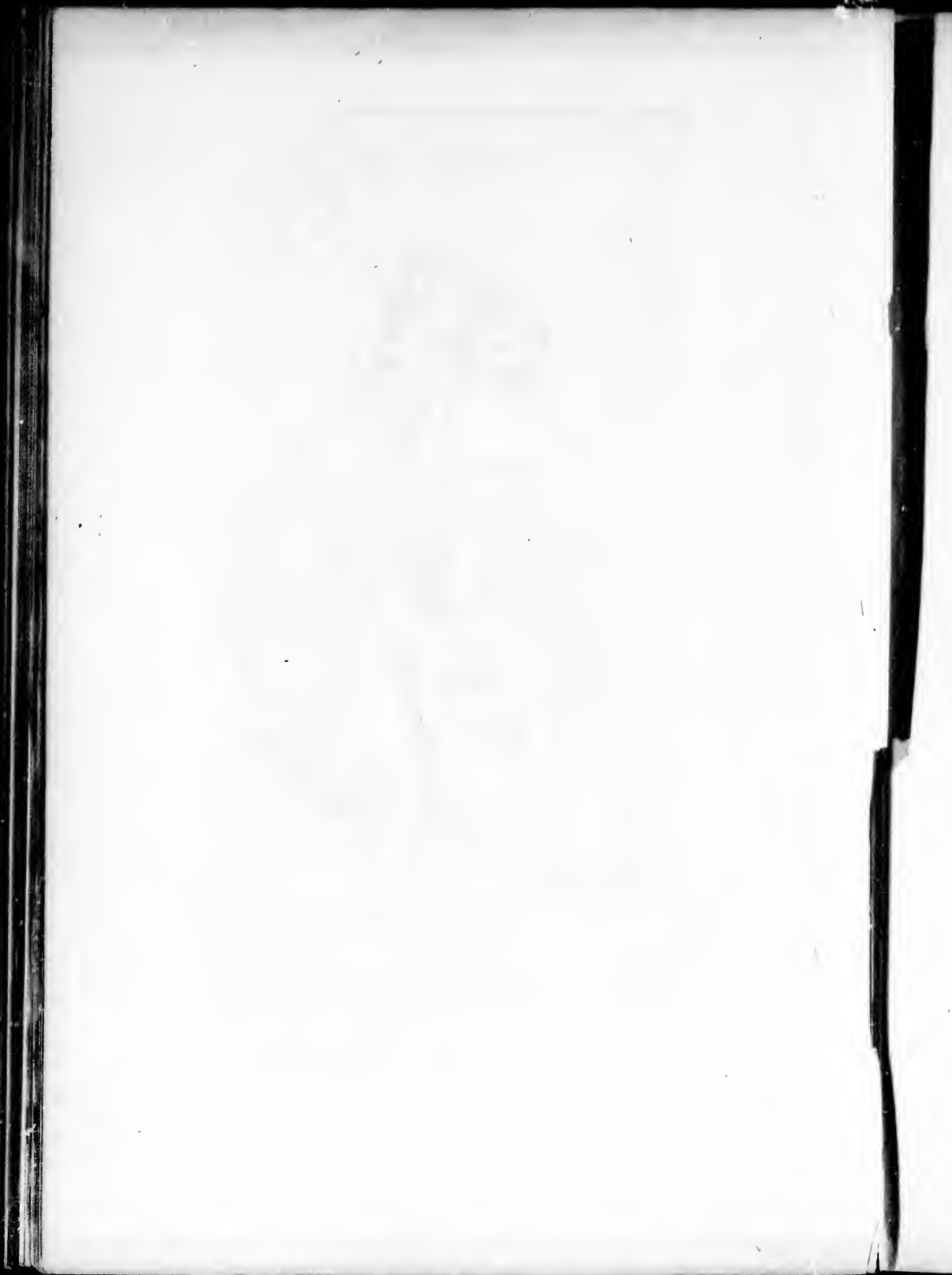



169.

PORTION OF A SLAB FOR A TABLE, DESIGNED BY L. GRUNER, ESQ.  
EXECUTED IN DERBYSHIRE STONE BY MR. THOS. WOODRUFF.  
EXHIBITED BY H. R. H. PRINCE ALBERT.







1861.  
**BEAM OF HOLLOW BRICKS AND  
 PORTLAND CEMENT,**  
*Erected at the*  
**EXHIBITION BUILDING, HYDE PARK,**  
 BY  
**JOHN BAZLEY WHITE & SONS,  
 MILLBANK STREET, WESTMINSTER.**

ELEVATION.

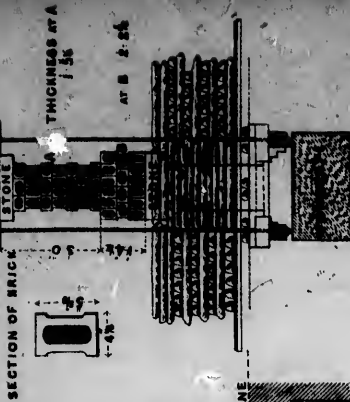
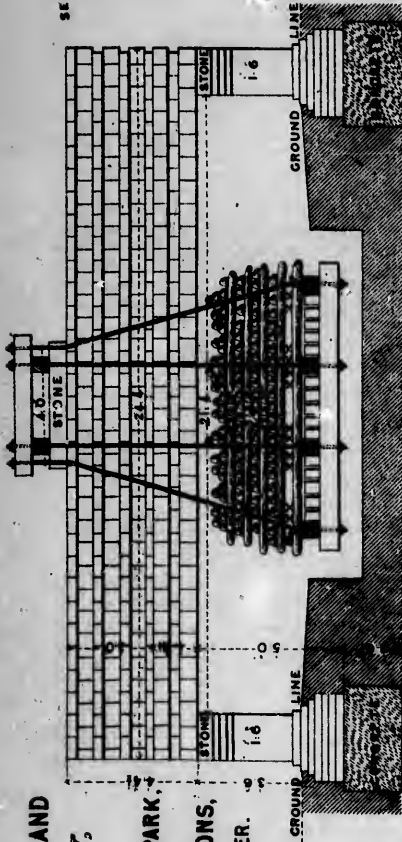

APPEARANCE OF THE BEAM WHEN BROKEN DOWN.

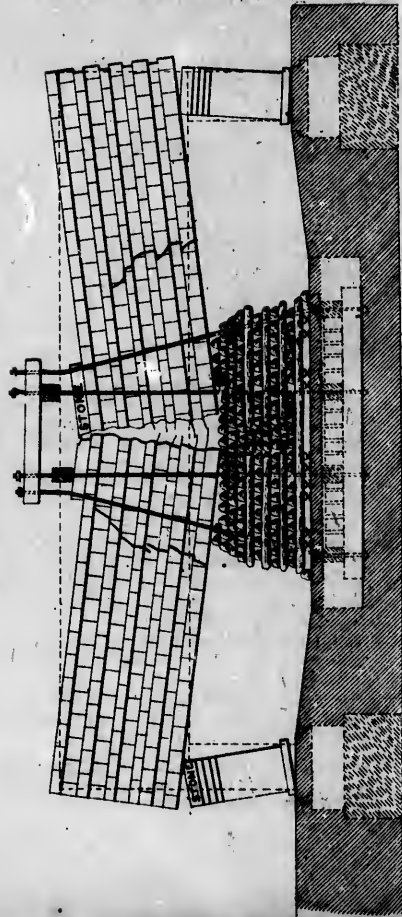

This Beam was made to exhibit the superiority of Portland Cement over Roman Cement. The dimensions correspond as nearly as possible with those of a heavy built of Roman Cement brick at New Stone in the year 1836, which was broken down at the end of 16 months with a weight of 50652 lbs.

The hollow brick beam was built at the end of April 1851 and was loaded on the 20th June in presence of the Jury, Class 27, with 5500 lbs weight of Iron and was broken down at 10.15. At the 12th June the loading was removed. On 11.1800 lbs. a crack appeared in the centre, and on the 23rd June the central rib of the centre line (indicated by the diagonal line) being vertical and passing undisturbedly through the bricks to the top.

Making allowance for the variation of the hollow bricks and the difference in pattern of the 2 beams, the experiment exhibited a difference in favor of Portland Cement of 2 1/2 to 1. In other words, if the Roman Cement beam had been built of solid bricks and been of equal pattern, it would have broken down with about 107,750 lbs. in having been so done.

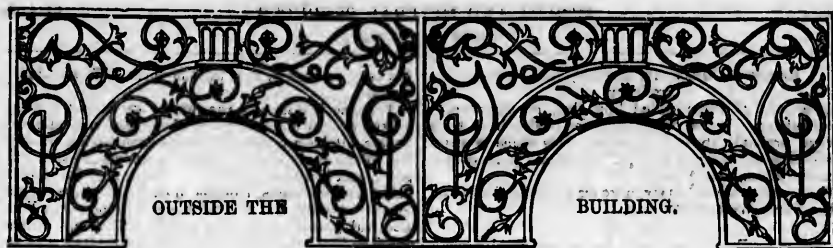

## MINING AND MINERAL PRODUCTS

### INTRODUCTION.

THE objects placed in this position are so in consequence either of their size, or of their peculiar fitness for such a site. On the southern side of the Western Entrance the objects are principally those which belong to Classes 1 and 27. Among these are fine specimens of the mineral fuel forming so valuable a feature in the geology of this country. Several of the blocks of coal have been raised from deep pits by the ordinary lifting tackle, and present, from their size, a favourable idea of the mechanical facilities of extraction and means of transport possessed by the miners and railroads of England. The blocks of granite, of slate, of serpentine, of stone for grindstones, and of artificial cement, will likewise attract due notice. On the northern side of the West Entrance are large anchors, as those used in the Navy, a fine column of granite, specimens of colossal earthenware, life-boats, the atmospheric recorder, hothouses, &c. The space within the Building, occupied by any of these articles, would have been great, while their intrinsic attractiveness might scarcely have been adequate to it. In their present position they are also better placed for examination.—R. E.

#### WESTERN END.

- 1 ORGAN, JOHN, *Penzance, Cornwall*—Manufacturer.  
Large block of serpentine from the Lizard, partly polished.

[The serpentine of Cornwall is a green mineral, passing into yellow and red, the colour being often veined, spotted, dotted, and clouded. It is soft in the quarry, but becomes hard on exposure, and cuts readily, but its fracture is irregular. It is soft to the touch, but not greasy like steatite or talc; is indented by a blow of a hammer; is infusible before the blowpipe; but parts with water by calcination, and hardens by exposure to heat. It is slightly acted on by acids.

As a rock, serpentine is often mixed with other minerals, so that different specimens do not yield the same result on analysis. It usually contains, when pure, silica 42 to 44, magnesia 36 to 38, water 12 to 13, and is therefore a silicate of magnesia. Its colour is due to oxide of chromium, but it contains often much iron, and is sometimes magnetic.

The serpentine of Cornwall is considered to exhibit four varieties, differing much in hardness—these are called precious, common, steatitic, and calcareous; but the best kinds for ornamental purposes on a large scale are those found at Kennack Cove, the Balk, and Cadgwith, where large blocks can be obtained. The block placed outside the Building near the south-western exit will show the magnitude and capability of such blocks.

A considerable quantity of the serpentine of the Lizard was formerly shipped to Bristol, for the manufacture of carbonate of magnesia.—D. T. A.]

- 2 BOARD, —, (Agent, JAMES O'DONOVUE, 5 Quicoast Row, New Road).  
Two figures in artificial stone.

- 3 TRAGLE, R. & W., 42 Hertford Street, Chelsea—  
Inventors and Manufacturers.

A figure of Lazarus, in artificial stone; cast taken from a carved wood figure.

- 4 RAYDALE, W.—Producer.

Blocks of gypsum used in the manufacture of plaster.

- 5 ROBINS, ASPDIN, & COX, *Northfleet, and Great Scotland Yard, Whitehall*—Manufacturers.

Slab of Portland cement. Iron testing-socket, for proving the strength of the cement. Bricks cemented together, equal to a pressure of three tons on the first brick, Beam of cement. Bricks, joined together with one portion of cement and four of sand. Step of Portland cement. Block of cement, which bore a pressure of upwards of 250 tons, tested by Bramah's hydraulic press. Similar block, one portion of cement, and four of sand, which bore a pressure of 120 tons. Block of Portland stone of like dimensions, which broke under pressure. Brick beam, one portion of cement and three of sand; sustaining a weight of 3½ tons. Bricks, joined together with one portion of cement, and three of sand, bearing a weight of one ton. Blocks of the hardest Yorkshire stone, joined by one portion of cement, and one of sand, sustaining a weight of three tons.

[Portland cement is formed by calcining together lime-stone and some argillaceous earth, the result being a mass which rapidly absorbs a certain quantity of water, and then becomes solid, as a hydrous silicate of lime. The advantages over natural hydraulic limes consist generally of greater hardness and durability, arising from the mixture of material being more perfectly under command.—D. T. A.]

The objects placed in this position are so in consequence either of their size, or of their peculiar fitness for such a site. On the southern side of the Western Entrance the objects are principally those which belong to Classes 1 and 27. Among these are fine specimens of the mineral fuel forming so valuable a feature in the geology of this country. Several of the blocks of coal have been raised from deep pits by the ordinary lifting tackle, and present, from their size, a favourable idea of the mechanical facilities of extraction and means of transport possessed by the miners and railroads of England. The blocks of granite, of slate, of serpentine, of stone for grindstones, and of artificial cement, will likewise attract due notice. On the northern side of the West Entrance are large anchors, as those used in the Navy, a fine column of granite, specimens of colossal earthenware, life-boats, the atmospheric recorder, hothouses, &c. The space within the Building, occupied by any of these articles, would have been great, while their intrinsic attractiveness might scarcely have been adequate to it. In their present position they are also better placed for examination.—R. E.

6 MORPHET, JONATHAN, *Studfold, near Settle*—  
Producer.

Specimens of stone called blus flag, or Grauwacke. Obtained from Horton Wood quarries, which have been worked probably about 100 years. This stone is principally used for cisterns and partitions, and is useful for curriers' tables, tanks, &c.

The quarries are about six miles from the Settle Station of the North-Western Railway.

7 GRAEVES, R., *Warwick*—Proprietor and Producer.

Blue lias limestone, with samples of the lime in the lump and ground.

Models in lias, Portland, and improved Roman cement.

Blocks of concrete, made in lias, Portland, and Roman cement, and ground-lias lime.

Brick-work out from the Copenhagen tunnel in the Great Northern Railway, and set in lias lime. Ornaments out and set in the same, to show the adhesiveness of the mortar.

Lias flag-stone, adopted for hall, church, and house-floors, being hard and dry.

Lithographic stones.

Floors in lias stone and lias cements.

[The beds of lias in many parts of England, consisting of carbonate of lime mixed with from 20 to 35 per cent. of alumina, are well adapted for the manufacture of hydraulic cements, and the nature of the clay greatly affects the value of the cement. Samples of the raw material, with various applications of it, are, therefore, of great practical importance. The lithographic stones from the lias are not unlike those from Germany, but they have hitherto been little used.—D. T. A.]

8 OLD DELABOLE SLATE COMPANY (by J. CARTER),  
*Carnelford*—Proprietors.

Slate slab, as raised from the quarries at Delabole.

Slate cistern for holding water, liquid manure, oil, acids, &c., capable of containing 2,000 gallons. If used for water for domestic purposes, a self-supplying filter is attached, so that the water withdrawn at the tap passes through the filter.

9 STIRLING, J., jun., *Belvidere Road, Lambeth*—  
Designer, Inventor, and Manufacturer.

Specimens of slate.—(See Class 1, No. 209.)

10 WHITE & SONS, *Westminster*—Manufacturers.

Illustrations of the strength of cement.—(See Class 1, No. 130.)

11 SEELEY, JOHN, *Keppel Row, New Road*—  
Manufacturer.

Mercury, after *Glov. da Bologna*, in artificial stone.

## 12 WELSH SLATE COMPANY.

BARWIS, W. H. B., *Secretary, 1 New Boswell Court*—  
Producer.

Rough block of slate from the quarry of the Welsh Slate Company, at Festiniog, Merionethshire.

Slabs of slate, sawn and planed.

Roofing and other slates.

[The slates of Festiniog are of admirable quality, and obtained in slabs of very large dimensions, adapted to all the more important uses of the material. The quarries are extensive, and give employment to a large population.—D. T. A.]

13 SINCLAIR, J., *Forse, Thurso, Scotland*—  
Producer.

A cistern or bath of Forse-Rockhill flag. Samples of the stone, showing the natural surface, the half-rubbed, and the full-rubbed surface. Three portions of a passage of twenty-four feet long by six feet broad each, laid with

the same pavement, showing the three different kinds of surface.

The principal uses of the article are laying footways, courts, railway stations, floors of manufactories and warehouses, kitchens, cellars, cottages, entrance halls, churches, &c. When used with iron girders, it renders mills, &c. fire-proof, and is useful for farm buildings, and for cisterns, baths, manure tanks, troughs in chemical works, coping, for garden walls, &c. The pavement is found at the Forse-Rockhill quarries, four miles west from Thurso, Caithness, and it is there manufactured chiefly by machinery. It is said to be of a hard, close, strong, and uniform quality, and impervious to wet. It occurs in beds of various thickness, from one inch to three or four inches, and from one foot to eighty or a hundred feet superficial. The stone has been worked for more than twelve years, and is sent in large quantities to London, Glasgow, and other towns.

[The Caithness flags are well known and much used for various economic purposes, chiefly paving. They are quarried from the middle division of the old red sandstone (Devonian) series, as developed in the north of Scotland. The schists yielding them are often dark coloured and highly bituminous, slightly micaceous and calcareous, and often resembling rocks of much greater geological antiquity. Obscure vegetable impressions, and the remains of extinct fishes, are very frequently found in them, and these are often of considerable interest in the natural history of the ancient inhabitants of our globe.—D. T. A.]

14 FREEMAN, W. & J., *Millbank Street, Westminster*—  
Producers.

An obelisk in granite. Sundry large slabs and blocks of stone.

16 STRUTHERS, WILLIAM SAMUEL, *7 Holywell Street, Westminster*—Manufacturer.

Slate water filter, the water being filtered in its ascent.

[The filtration of water by ascension is a simple mechanical process, of considerable use in the arts, and capable of many modifications. The cistern, in such case, is furnished with two perforated shelves or false bottoms, between which the filtering medium is packed. At some distance above these is a third shelf, with a water-tight communication through the intervening chamber and the filter-bed, and opening into the bottom of the cistern. The foul water being let into the upper chamber, a cistern passes down into the bottom one by means of the tube, and is then forced up through the filter-beds by the presence of the water in the column. The pure water is thus delivered into the intervening space, whence it may be drawn off at convenience. Slate is an admirable material for cisterns of all kinds, from its great strength, perfect cleanliness, and complete impermeability to water.—D. T. A.]

## 17 ROYAL DUBLIN SOCIETY—Producers.

Specimens of Irish flagging.

18 SHARP, SAMUEL, *Commercial Road, Lambeth, Agent to ALEXANDER ADAM, Wick, N. Britain*—  
Proprietor.

Rockhill paving stones, from the original quarries, shipped from the port of Wick, showing the different thicknesses as they naturally arise in the quarries.

19 FURSE, THOMAS WM., *96 High Street, Whitechapel*—  
Inventor and Manufacturer.

Specimens of waterproof artificial stone, as applicable for sewers and drains of large dimensions; for flooring churches, vestibules, public buildings, hospitals, and damp cellars. Drains for railways, &c. Drop-stone. Cistern of the same, containing bricks united with fusible

## OUTSIDE THE BUILDING.

mineral cement, to prevent the ascent of damp in foundations, &c. Ornamental brick of the same.

Sample of fusible mineral cement, which when gauged with 150 per cent. of dry sharp sand, unites bricks and stones so firmly that they cannot again be separated.

20 **CARNEGIE, W. F. L.,** *Kimblethmont, Arbroath, Scotland*—Proprietor.

Flagstones and freestones, known as Arbroath pavement, from Leysmill Quarries, dressed by Hunter's stone planing machine.—(See Class 1, No. 198.)

22 **HAYWOOD, JONAS,** *Ardsey, near Barnsley*—Producer.

Grindstones from the Ardsey Oaks Quarry, Barnsley, used principally in Lancashire and Yorkshire, for the grinding of machinery, files, edge tools, needles, &c., and for building purposes.

23 **DOVE, DUGALD,** *Nitshill, Hurler, near Glasgow*—Producer.

Freestone block, from Nitshill quarry. Grindstone from the same quarry, three feet in diameter by six inches thick.

[The sandstones and greenstones of Nitshill are chiefly or entirely of the carboniferous period, and include several kinds of various degrees of excellence.—D. T. A.]

24 **BEDFORD, BONSON, DRAKE, & Co.,** *Oaks Quarry, near Barnsley*—Producers.

Grindstones from the Oaks Quarry, near Barnsley, 9 feet 7 inches in diameter and 14½ inches thick, for grinding machinery; 4 feet in diameter and 6 inches thick, for grinding tools; 2 feet 6 inches in diameter and 9 inches thick, for grinding files.

25 **RAYNES, LUPTON, & Co.,** *Liverpool*—Producers.

Specimens of pure limestone, from Pentregwyddel quarries, near Abergele, Denbighshire; used in the rough state, in chemical manufactures, and as building cement (lime); and in the manufactured state, as a lithographic stone, &c.

Specimens of stone, from Graig-lwyd quarries (Penmaen-mawr, Carnarvonshire), cut into paving, channel, and kerb-stones, and arranged in a frame as they would appear in a street pavement; and shown in a block, used as wheelers, or tram-road stones, channels, &c.

[The stone from Penmaen-mawr, here exhibited, is an extremely hard compact rock of igneous origin, admirably adapted, from its toughness, for all kinds of paving purposes. It is much used in the neighbourhood of Liverpool, and is also exported largely.—D. T. A.]

26 **PENZANCE SERPENTINE COMPANY**—Producers.

A block of rough serpentine.

27 **TOWLER, EDWARD,** *Market Rasen*—Producer.

Stones adapted for paving, walling, road-making, and polishing, from Kirton Lindsey's Tunnel Stone Works, containing 95 per cent. of carbonate of lime.

Blue lias and hydraulic cement.

28 **FRANKLIN, P. S.,** *Galway, Ireland*—Proprietor.

Block of stone, partly polished. Block of marble and paving-stones.

29 **BROWN, RUSBY, & BOOTH,** *Sheffield*—Producers and Manufacturers.

Flags and steps. Block of sandstone, weight four tons.

30 **LOCAL COMMITTEE,** *Falmouth and Penryn*—Producers.

Sundry paving-stones.

34 **OAKELEY, EDWARD,** *Coed Talon, near Mold, Flintshire, Wales*—Producer.

Steam-coal from Coed Talon and Leeswood collieries, near Mold, North Wales.

[This noble column of coal, said to weigh 16 tons, is from the main coal of the Flintshire coal-field, a seam nine feet thick, accompanied by five other beds of coal and four beds of ironstone. The quality of the coal is bituminous, and the proportion of ash less than 3 per cent. The Flintshire coal-field is a narrow strip, partly covered with new red sandstone, and extends 40 miles from north to south, with an ascertained breadth of from two to 12 miles, being cut off by a north and south fault. The mines supplying the specimen extend over 1,300 acres, and were opened about 30 years ago. About 2,000 tons of coal per week are raised from them.—D. T. A.]

35 **BUCKINGHAM, J.,** *13 Judd Place East, New Road* (Agent to Messrs. MYERS & Co., *Bonville's Court Collieries*)—Producer and Importer.

Anthracite coal, from Tenby, South Wales. Specimens of patent artificial stone.

36 **ROUND, D. G.,** *Hange Colliery, Typton, near Birmingham*—Producer and Proprietor.

Specimens of iron ore.

Specimen of coal from the thirty feet, or thick-coal seam of South Staffordshire, cut out of the solid coal. This specimen is of the largest dimensions that could be brought out of the mine up a seven-feet circular shaft. It measures eighteen feet in circumference, and weighs five tons.

The rope used in lifting it is also exhibited; it was manufactured by Mr. Wm. A. Chubb, of Woodpark, Devonport.

The chains used in sending the coal out of the mine are shown in connexion with the rope; the block was raised by means of the ordinary machinery employed in the colliery. The picks used in heaving the coal.

[The thick coal-seam of Staffordshire, of which a complete section is given by the exhibitors, and of which also a fine block weighing five tons is shown by Mr. Round, does not extend over a very large area, consisting, in fact, of the accidental junction of several seams with very thin and carbonaceous bands. The whole are necessarily worked together, and below them are no less than eight other seams (one of them 9 feet thick) worked near Wolverhampton. The district yields much ironstone, and the coal is being rapidly abstracted: it is used to an enormous extent for manufacturing purposes and iron-smelting in the neighbourhood of Birmingham.—D. T. A.]

37 **JAMES & AUBREY,** *Swansea*—Producers.

A large block of anthracite, or stone coal, from Cwm-lynnfell, in the Swansea valley.

[The great South-Welsh coal-field includes, at a moderate estimate, as much as 1,000 square miles of country, unequally divided between bituminous coal and anthracite, the dividing line being nearly coincident with the Neath Valley, and the anthracite portion extending to the west. The anthracite has only recently been introduced into use, but is now recognised as a very important material, the different kinds being of great value for special purposes, and yielding sometimes as much as 92 per cent. of carbon. The pure Welsh anthracite has been found to evaporate 10 lb. 8½ oz. water, by one pound of coal, the best bituminous coal not evaporating more than 8 lbs. There is no reason to suppose any difference in



geological age between the bituminous and anthracite coals.—D. T. A.]

38 INCE HALL COAL & CANNEL COMPANY, Wigan—

Producers.

Blocks of Arley and Pemberton coal.

39 CAMERON'S COALBROOK STEAM COAL AND SWANSEA AND LOUGHOR RAILWAY COMPANY, 2 Moorgate Street—Producers.

Specimen of steam coal (of a quality intermediate between bituminous coal and anthracite), from the mines near Loughor, in the county of Glamorgan, South Wales, which have been worked about eight years. It is exported from the ports of Swansea and Llanelly in the Bristol Channel.

40 HAINES, RICHARD, & SONS, Denbigh Hall, Tipton, Staffordshire—Proprietors.

Large specimen of the Staffordshire thick, or ten-yard coal; height, 9 feet 6 inches; circumference, 21 feet 10 inches; weight, 13 tons. Brought 70 yards underground to the bottom of the shaft, and raised from a depth of 165 yards by the ordinary steam-engine, with no other apparatus than that regularly in use.

41 BARROW, R., Staveley Works, near Chesterfield, Derbyshire—Producer.

Coal from the mines of Staveley, county of Derby, raised from a shaft 459 feet deep. The block is estimated to weigh 24 tons.—(See Class 1, No. 255.)

42 JONES, SELLS, & Co., 55 Bankside, Southwark—Agents.

Anthracite coal, from Llanelly, South Wales.—(See Class 1, No. 258.)

43 DAVIS, D., Hirwaun, near Merthyr Tydfil, Wales—Proprietor.

The Blaengwawr steam coal, from Aberdare.

44 NEATH ABBEY COAL COMPANY, Glamorganshire—Proprietors.

Brynddwy (or Bryndorway) coal. Obtained under a mountain lying between the vales of Neath and Swansea, and about three miles from the sea. The coal known by the name of Graigola is from the same seam.

Anthracite coal—obtained from an eighteen-foot seam under the mountains, on the western side of the vale of Neath, and about twelve miles from the sea.

45 PRICE, T. P. & D., Tillery Colliery, near Newport, Monmouthshire—Producers.

Steam coal, from Tillery, near Newport, Monmouthshire, the produce of a newly-opened colliery (in the South Wales coal basin), upon the steam-coal vein, "the Elled," a 5-foot vein; the "big coal," an 8-foot vein; and the "2 coal," an 8-foot 7-inch vein; all of superior quality. The coal is obtainable in masses of 50 tons weight, and is adapted for steam purposes, and for exportation.

Analysis of Cwm Tillery Coal.

|                           | Three-quarter Coal.         | Elled Coal. | Big Vein Coal. |
|---------------------------|-----------------------------|-------------|----------------|
| Carbon . . . . .          | 830                         | 660         | 680            |
| Coke . {                  | Silica . . . . .            | 32          | 36             |
|                           | Alumina . . . . .           | 12          | 18             |
|                           | Oxide of iron . . . . .     | 2           | 4              |
|                           | Carb. of magnesia . . . . . | 4           | 2              |
|                           | Carb. of lime . . . . .     | 0           | 0              |
| Volatile matter . . . . . | 320                         | 280         | 272            |
|                           | 1000                        | 1000        | 1000           |

These seams of coal are said to be as rich, perhaps, as any in the South Wales basin. They lie upwards of 660 feet in depth, and are brought up by two steam-engines of 100-horse power each (high pressure). The colliery is a new one, and capable of producing 1000 tons per day.

47 THE BRYMBO COMPANY, Wrexham, Wales—Producers.

Block of coal, from Brymbo, near Wrexham, North Wales.

48 FITZWILLIAM, EARL CHARLES WILLIAM, Wentworth House, near Rotherham—Producer.

Pillar, exhibiting a complete section of the Barnsley thick bed of coal, from the Elmscot colliery, and showing the different portions applicable for steam-engines and manufacturing purposes, and for domestic uses.

[The Barnsley coal is well illustrated in the Exhibition, as there will be found no less than three columns of it; two representing the whole thickness of what is called the thick bed, and the other from Silkstone, showing a beautiful variety of coal also found in the district. The situation of Barnsley, in the centre of the great coal-field of Yorkshire, and the abundance and quality of its coal, render it important among the inland towns producing mineral fuel. There are three principal varieties, viz., hard-stone coal, soft or tender coal, and cannel. The iridescent or peacock coal may almost be regarded as a fourth. The coal is worked long-wall method.—D. T. A.]

49 ABERCARN COAL COMPANY—Producers.

Block of steam coal.

50 GILMOUR, A., & Co., Kilmarnock, Scotland—Proprietors.

Coal from Hurford and Skerrington Colliery, near Kilmarnock, exported from the port of Troon, and used principally for steam purposes. The colliery has been worked for upwards of forty years. Thickness of seam, 11 feet.

[The Kilmarnock coal-field, in Ayrshire, closely adjoins, and perhaps forms part of that worked a little to the south-west at Ayr. The coal is anthracitic for the most part, especially when near the trap dykes that intersect the district; but there are in the neighbourhood many seams of bituminous quality. As much as 150,000 tons of coal are exported from the Kilmarnock district.—D. T. A.]

52 CRUTTWELL, ALLIES, & Co., Cwm Celyn and Blaiza Iron Works, Abergavenny—Producers.

Fossil tree from the coal measures.

[This fossil is one of those called by paleontologists "Sigillaria," appearing like the trunk of a tree stamped with a pattern in the regular rows in direction of its length. It is probably the trunk of the same kind of tree as that of which roots are found in infinite abundance in the fire clays beneath coal-bands. It was very common during the coal period. The stems exhibit no woody structure internally, having been for the most part hollow or succulent, and easily crushed; but they had a central woody axis, and an outer coating of bark, which is often found turned into coal. Leaves were probably originally attached to the scars, and were connected through the bark with the central woody axis.—D. T. A.]

53 BAGNALL & GESSON, West Bromwich, near Birmingham—Producers.

Column of South Staffordshire thick coal—showing the different working seams as they exist in vertical section.



[The South Staffordshire coal-field is remarkable, in a geological point of view, for the absence of the mountain limestone and millstone grit, and the immediate superposition of coal measures on the Silurian limestones; and it differs also from other formations of the same kind by having a great preponderance of shales, and few intervening beds of sandstones. It is quite clear that the circumstances of deposition must have been different, but the nature and extent of the difference it is not so easy to discover.

The coal measures in Staffordshire are thus the only representatives of the carboniferous system, and they are almost entirely made up of shales, alternating with seams of coal and ironstone.

The number of coal seams is only eleven, but the main bed in the middle of the deposit is upwards of 30 feet in thickness, and it comprises, in fact, several beds of coal, separated by partings of shale so thin that the whole is worked together. This *ten-yard coal* crops out near Bilston, and extends from thence entirely across the southern half of the coal-field, where it forms the principal object of mining operations.—D. T. A.]

54 **CHEESEWING GRANITE COMPANY.**—Agent in London, EDWARD TURNER, *Belvidere Road, Lambeth*—Producer.

Granite column upon a pedestal about 30 feet high, from the Cheesewing granite quarries, on the Manor of Rollaton, near Liskeard, Cornwall, belonging to the Prince of Wales. The pedestal, cap and base to the column, worked at the Cheesewing granite wharf, Belvidere road, Lambeth, and the shaft at the quarries.

[The quarries which have produced this noble column have not hitherto been much worked, but are capable of great extension, the magnitude of the blocks obtainable from them being almost unlimited. The granite will be seen to be of excellent quality.—D. T. A.]

55 **RODGER, Lieut. W., R.N., 9 Shaftfield Street, King's Road, Chelsea.**—Inventor and Patentee.

Large anchor, manufactured by Fox, Henderson, and Co.

57 **LONCRIDGE & Co.**—Manufacturers.

Large anchor.

58 **BROWN, Sir S. LENNOX, & Co.**—Manufacturers.

Large anchor.

59 **BATEMAN, —, Inventor.**

Two life-boats.

60 **YOUNG, C. & Co., Edinburgh**—Inventors and Manufacturers.

Simultaneously-acting level-crossing gates for railways.

61 **DENCH, —, Producer.**

Two greenhouses on a new construction. The chief points of novelty are—1st. That by the peculiar construction of the lights, and the selection made in the materials to be used, putty and all other adhesive compounds are entirely avoided. 2nd. That the glass can be put in or removed with such facility, that the bars and frame can be painted, the glass cleaned, and the whole effectually repaired at an immense saving upon the old system. 3rd. That it will not require such frequent repairs as ordinary greenhouses. 4th. That in the event of a fracture, it will not be absolutely necessary to wait for the assistance of a glazier to repair the same; the simplicity of the contrivance enabling any one to become his own glazier. 5th. That leakage—a universal com-

plaint in the old system—is here guarded against by a peculiar grooved bar, which likewise assists to carry off evaporation, and renders ventilation more complete. 6th. That the glass being moveable, persons can erect greenhouses upon the property of others, and remove the same securely at the expiration of lease or rental terms.

62 **KENT, A., Chichester**—Inventor.

New mode of glazing greenhouses.

63 **PHILLIPS, CHARLES, Weston-super-Mare**—Manufacturer.

Flower, rhubarb, sealake, layer, and salad pots, of superior clay, for forcing, protecting, and strengthening the plants.

Flower guards and seed basins. Garden tiles. Strawberry tiles. Water tables. Striking pans. Cress tiles.

64 **DOULTON & Co., Lambeth**—Manufacturers.

Large pipe in stone ware, and other articles.

65 **SINGER & Co., Vauxhall Pottery**—Manufacturers.

A still, and other articles in stone ware.

66 **FERGUSON, MILLER, & Co., Heathfield, near Glasgow**—Manufacturers.

Pipes and other large stone ware.

67 **GREEN, S. & Co.**—Manufacturers.

Large stone ware, adapted for chemical manufactures, household and other purposes.

[Salt-glazed stoneware—of which there are many fine specimens exhibited by the above and other persons—differs from porcelain both in the quality of the clay of which it is constructed, and in the mode of glazing.

The clay is obtained from Cornwall, Devonshire, and Dorsetshire, and consist largely of silica, the proportion of alumina being rather small, and the quantity of iron and lime inconsiderable. If either of these latter substances is present in too large a proportion, it acts as a flux, and the material cannot withstand the intense heat of the furnace. If also any impurities exist that are destroyed during firing, a hole would be the result, which would completely destroy the value of the object if required for chemical use.

The glazing of these vessels is effected by throwing into the vessels a quantity of very coarse salt shortly after the last charge has been added to the furnace-pipe; the salt is at once converted into vapour, and a perfect coating of glass is formed on every part of the vessels exposed, the soda of the salt uniting with the silica of the clay, while the liberated chlorine takes up the iron from the clay and escapes. Acids have no effect upon vessels thus prepared.—D. T. A.]

68 **GRANGEMOUTH COAL COMPANY, Grangemouth, Sunderland**—Manufacturers.

Sundry objects in stone ware, and fire clay; consisting of chimney cans, &c.

69 **GARNEIKER COMPANY (SPROT, M. & T.)**

Sundry articles in stone ware.

70 **RAMSAY, G. H., Derwent Haugh, Newcastle**—

Inventor.

Fire-clay goods.

71 **FRANCIS & SONS, Nine Elms**—Manufacturers.

Drain pipes manufactured by machinery.

**75 HOSKEN, RICHARD, Penryn, Cornwall—**  
Manufacturer.

Granite obelisk and base (two pieces), being together 20 feet high, weighing about 15 tons. Exhibited to show the quality of the Cornish granite. Taken from the quarries at Carnseu, near Penryn. Of this material a great quantity was used in the construction of new London bridge.

[The granite best known as *Cornish*, is that obtained from near Penryn, which has been long and extensively used for various public works in England. It is obtained from various localities, and several qualities are employed, the finer kinds being very good. The whole quantity shipped at Penryn varies exceedingly in different years, amounting sometimes to nearly 20,000 tons, but is generally far less, often not a fourth part. The approximate value may be stated at about 1s. 9d. per cube foot before export, and the weight is usually taken at 14 cubic feet to the ton.—D. T. A.]

**76** At some distance from the western extremity of the building is a colossal equestrian statue of Richard Cœur de Lion, by the Baron MAROCHETTI.

The paving in the South Enclosure is laid down by three exhibitors, Mr. SINCLAIR, Caithness; Messrs. BROWN, RUSBY, and Co. Yorkshire; and Mr. FRANKLIN, Ireland.

**EASTERN END.**

**100 KULLORIN, Sweden.**

Monument of granite in form of a cross, cut out of a single block, remarkably fine grained.

**101 STANDISH & NOBLE, Bognor—Importers and**  
Producers.

*Cupressus funebria*, or weeping cypress, 80 feet in height, from the green-tea country, Whoychow (Hwuy-chow), in the north of China, where it is used for ornamental planting, and in burial grounds, whence it takes its name. Live plants were first imported into this country in the spring of 1849.

Pieces of polished wood from the same tree.

**102 —, France.**

Life-boat, as at present in use in the French navy.

**103 LEGLER, —, Paris.**

Ornamental fountain in cast-iron bronze, with figures, statuettes, &c.

**104 —, India.**

Tent, the material manufactured at the Jubulpore School of Industry, in India, by Thugs.

The pavement at the eastern entrance is laid by the SEYSSSEL ASPHALTE COMPANY, in their prepared asphalt.

The pavement at the South, *vs.* Transept Entrance, consists of slate slabs from Festinog, North Wales.



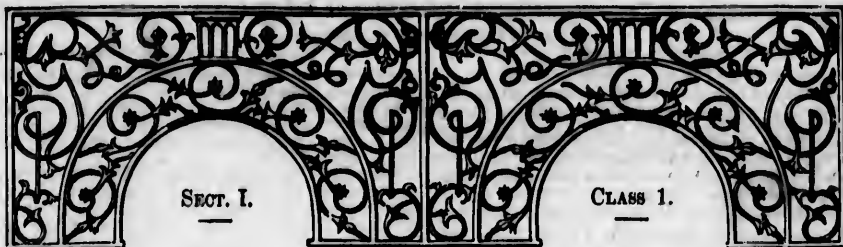

## MINING AND MINERAL PRODUCTS.

### INTRODUCTION.

THE intention in the collection of the objects in the four Classes of the first section—Raw Materials and Produce—has been to give a practical illustration of those substances in the mineral, animal, and vegetable kingdoms, which human industry is constantly occupied in converting into the varied forms of manufactured articles, or which are themselves, as in the case of fuel, the indispensable sources of manufacturing power. If, therefore, it is desired to obtain a philosophical view of this Exhibition and its multifarious contents, it will be found useful to commence the study by the examination of those materials, which, in other departments, have been caused to assume forms so diversified. From the raw mineral it is thus possible to proceed through the various stages of its manufacture, until it is finally seen embodying the conceptions of the mechanic, the architect, or the artist. Many of the objects comprehended under these four Classes have little or no external beauty, and present, consequently, no appreciable value to the un instructed. But if it be considered that, in the preparation of these materials for use, and in their application to the purposes of life, consists the daily toil of multitudes of the human family, then the Classes of raw materials appear to take on a new and interesting aspect.

The present Class is divisible into the following sub-classes:—A. Mining and quarrying operations. B. Geological maps, plans, and sections. C. Ores and metallurgical operations. D. Non-metallic mineral products. It comprises all that relates to the procuring of metal yielding mineral substances, to their mutual geological relations, and to the operations necessary for subduing them to the requirements of the manufacturer. It also includes the extraction of minerals used as fuel, of marine minerals used in construction, of minerals used in manufactures, for ornament and for agriculture. Specimens illustrative of each of these subjects are to be found in this Class; and if it be studied attentively it will be discovered that objects representative of all that properly belongs to the Class are contained in this collection.

This Class is partly contained within Avenue S. of the Building, and extends from the western entrance to the Sculpture Room. If the study of it be commenced at the Sculpture Room and proceeded with to the western extremity of the Avenue, it will be found that the metalliferous minerals and the objects illustrative of metallurgical processes generally, are first encountered, and subsequently the non-metallic minerals, fuels, stones, and geological specimens. The arrangement of the objects in the Catalogue is, however, in the opposite direction. Upon the walls of this avenue are arranged maps, plans, and geological sections, in addition to specimens of decoration belonging to Class 27, which have a certain relation with the present Class.

Among the groups of objects which present themselves most prominently on entering the avenue at the Sculpture Room are large specimens of lead ore and of lead in various stages of preparation. Specimens of silver extracted from lead by the crystallizing process of silver and gold, of iron, copper, tin, zinc, and other metals, are arranged in order along the Avenue. To these succeed mining apparatus of various kinds, and models illustrative of mining processes. Mineral fuels, containing every variety of coal, with specimens of cannel coal in manufactured state, cokes, peat, and artificial fuels come next. Slates, with illustrations of their economical application, building stones, china-clays, cements, and artificial stones follow these, and are succeeded by geological specimens, gems, &c., up to the western termination of the avenue.

This Class is also illustrated by several large objects placed outside the Building; among these are artificial cements applied to various purposes, specimens of slate, flagstones, blocks of anthracite and other coal, pillars of coal exhibiting sections of beds of that substance, and columns formed of single blocks of granite. Several of these specimens are remarkable for their size, and furnish good illustrations of the mechanical facilities of extraction and of transport possessed by this country.

The whole of this Class may be considered well illustrative of the mineral wealth of Britain. If our supplies of the more precious metals are limited, the resources of power and wealth are given to this country in the exhaustless stores of minerals yielding the viler metals, and a fossil fuel with which it has been endowed. The ore, the fuel for its reduction, and the material for the necessary processes, are all to be found in abundance, and generally in direct geological proximity to each other. The possession of these materials, added to the development of the means of their employment, and of the applications of their products, lie at the foundation of the present commercial and productive greatness of Great Britain.—R. E.

1 Fossil fishes from the old sandstone (*Cephalaspis*).  
[The fossil fishes found in certain parts of the old red sandstone formation are of considerable value in marking the age of the deposit where the mineral character of the beds is very different from that ordinarily recognised. The specimen above referred to will be found to show very perfectly the general form of an animal so widely and clearly distinct from that of common fishes, that some doubt may be felt as to the identification. The relation has, however, been made out very satisfactorily, and several allied genera have been found in rocks of similar ancient date.—D. T. A.]

2 POWELL, WILLIAM JOHN, *Tisbury, near Hodon, Wilt*—Proprietor.  
Geological specimens:—A species of coral, from the sand of the upper oolite formation at Tisbury, found in a vein extending northward, and now converted into flint and chert. The hardest flints from this locality were originally manufactured into gun flints.

[The town of Tisbury is on the Portland stone; but the lower beds of the Purbeck series, as well as the uppermost oolites, are quarried in the neighbourhood. A continuous bed of flint, about two inches thick, is seen in one of the quarries, and from this band are obtained beautiful specimens of coral in chalcodony. Some of the oolite of the neighbourhood is very fine-grained.—D. T. A.]

3 CARTER, J., *Delabole, near Carnelford, Cornwall*—Proprietor.  
Two specimens of rock crystal, taken from the slate quarries at Delabole, near Cornwall; used for jewellery.  
[The use of rock crystal in the arts is still very considerable, as it is employed extensively in making spectacle glasses and for other optical purposes. It was formerly used for cups and various ornaments, and many finely cut specimens are exhibited from India, China, &c. The finest and largest crystals are from Madagascar, Switzerland, and North America.—D. T. A.]

4 BONITTO, J. NELSON; BALLERAS, G. E., of *London*, Exhibitors; and PARIS, E.—Producer.  
Specimens of emerald in the matrix from the mine of Muso, New Granada.  
[Emeralds of large size and perfect clearness are extremely rare, and of great value, but found with flaws they are not so uncommon. They occur chiefly near granite in Siberia, Sweden, and New Granada, and in Africa, between Egypt and Ethiopia. The lightly coloured varieties are called beryl, and are found in the East Indies and Brazil. Emeralds have also been obtained from various parts of France, Ireland, Saxony, the Tyrol, and Connecticut, in the United States. Emerald is harder than quartz; its specific gravity is 2.73 (heavier than beryl), and it is generally found crystallised in a prismatic form. It is a silicate of alumina and a rare earth called *glucina*, coloured by chrome.—D. T. A.]

5 & 138 LENTAIGNE, JOHN, *Tallaght House, Dublin*—Proprietor.  
A specimen of limestone inclosing granite.  
Specimens of iron pyrites, from the great sulphur lode, Ballygahan mine, Wicklow; exported to Liverpool, &c. Sulphuret of copper, from same place. Sulphuret of lead, or galena; white carbonate of lead; sulphate of barytes, with crystals of phosphate of lead; all from Glenmolure mine, county Wicklow.  
Native gold, and imitation of a large piece (found some years ago), from the gold mines, county Wicklow.

Silver (the property of Mr. Donegan, Dublin), from the Irish Mining Company's lead mines.

Specimens of stratified breccia, composed of angular fragments of granite embedded in calc or impure limestone, and of granite, from Crumlin quarry, near Tallaght, county Dublin.

Sulphuret of lead, from Killing mine, county Dublin; from Clontarf mine; from Lyrus, county Kildare; and other counties. Black oxide and other copper ores from Ballystein, county Limerick. Sulphurates of lead and copper, in fluates of lime, from Inverain, near Galway. Peacock copper ore, from Killarney mines. Oxide of manganese, from Glendore, county Cork. Bog iron ore, from Howth, county Dublin. Crystals of quartz, weighing 84 lbs., from Donegal.

[The iron pyrites of Wicklow is used in the chemical works of St. Helen's, and other places near Liverpool, for various processes where sulphur is required. It contains, when pure, iron 48.67, sulphur 53.33.

This material is associated with the copper ores of Wicklow, and occurs in a vein traversing the copper lodes in a north-eastern and south-western direction. It is found at the surface, and is raised in large quantities, down to the depth of 50 feet, the lode varying in width from 4 to 36 feet.

The native gold of Wicklow is remarkable for the comparatively large quantities in which it has been found, some of the lumps weighed from 18 to 22 ounces, and 945 ounces were collected during some operations carried on by Government some years ago. The gold is associated with iron and quartz, in a bed of detritus varying from 20 to 50 feet deep.

Considerable quantities of silver, as well as gold, have been found in Ireland at various periods in the history of the country.—D. T. A.]

6 Block of carboniferous limestone containing shells of *Productus*.

7 BREADALBANK, Marquis of, *Taymouth, Aberfeldy, Perth*—Producer.  
Specimens from the silver-lead mine of Corriebuie, on the south side of Loch Tay, Perthshire.  
Specimens from the lead mines of Tyndrum, Perthshire.  
Chromate of iron, from the mine of Corriecharraig, in Glenlochry, Perthshire.  
Hematitic iron, from Glenquach, Perthshire.  
Rutile, or oxide of titanium, from the north side of Loch Tay, Perthshire.  
Brown quartz, from Ben-Lawers, north side of Loch Tay, Perthshire.  
Granite and porphyry, from the forest of Glenorchy, in Argyllshire.  
Granite, from the quarries of Barrs and Inverliver, on Loch Etive, Argyllshire.

[The mineral products of Perthshire, illustrated above, is obtained from systems of veins, some of which, running N.W. and S.W., contain copper ores of various kinds, with some ores of iron; and others, running N.N.E. and S.S.W., contain chiefly lead ore. The veinstone is generally quartz, and the ores include several interesting minerals.—D. T. A.]

8 LEBSON, Dr. H. B., *Greenwich*—Inventor.  
Models, crystalline minerals, and engravings; illustrative of the exhibitor's system of crystallography.

The following are the principles upon which these models have been constructed:—

When the atoms of any description of matter have arranged themselves through the intervention of certain natural forces, in a form characterized by the evident order and angular disposition of its bounding surfaces, such solid form is termed a crystal.

Every crystal may be referred to one or other of three classes or systems.

These three classes are dependent on the relative direction of three lines not all in the same plane, indicative of the direction from a common centre of origin of the natural forces by which the crystal has been formed; such three lines are termed the gubernatorial axes.

The three classes are as follows:—

Class I. Rectangular. All the axes at right angles to each other.

Class II. Oblique rectangular. One axis oblique to the other two, which are rectangular.

Class III. Oblique. All three axes making equal oblique angles with each other.

All the axes are of equal length, and in the second and third class the prevailing angle of obliquity is nearly (if not invariably)  $101^{\circ} 49' 9''$ , and its supplement  $78^{\circ} 10' 50''$ .

It is a very simple but important law, easily demonstrated, and greatly facilitating crystallographic investigations, that any plane of any crystal whatever must belong to one or other of the three following forms, which may be designated and defined as follows:—

Trisecant. Cutting all three gubernatorial axes.

Duosecant. Cutting only two axes, and therefore parallel to the third.

Ultimate. Cutting only one, and therefore parallel to the other two.

A set of fundamental forms, similarly constituted, belongs to each of the three classes.

This circumstance, viz., the existence of such a set of forms, characterizes a class or system.

Each fundamental form is produced by six similar and equal four-sided pyramids, one being placed at each end of every gubernatorial axis, so that the diameters of the base of the pyramid coincide with or bisect the other two gubernatorial axes.

When the diameters of the base of the pyramid coincide with or are parallel to the gubernatorial axes, the form produced is trisecant. When, on the contrary, the diameters of the base of the pyramid bisect or are parallel to the line of bisection of the gubernatorial axes, the form produced is duosecant.

The series of fundamental forms is produced by a successive diminution in the height of the pyramid, according to a regular law. The diameter of the base of the pyramid in the trisecant series, and the sides of the base in the duosecant series, being a multiple of its height by some integer. When the diameter of the base becomes infinitely extended, or the height of the pyramid becomes 0, we arrive at the ultimate form, which is a cube in the rectangular class, a right rhombic prism in the oblique rectangular class, and a rhombohedron in the oblique class.

The most frequent, if not the only series, is that in which the ratio of height in the pyramid to the diameters or sides of its base is as 1 to some power of 2, those actually observed being  $2^1$ ,  $2^2$ ,  $2^3$ , and  $2^4$ . In this series we may pass from the trisecant to the duosecant, and from the duosecant to the trisecant forms, by a continual replacement of edges by planes. Thus commencing with the octohedron, and replacing its edges by planes, we pass to the dodecahedron, or first duosecant form. Thence to the trapezohedron, or second trisecant form. Thence to the pyramidal hexahedron, or second duosecant form. Thence to a flatter trapezohedron, and so on, till we arrive at the ultimate form, or cube, when, by replacement of its edges, we may return to the dodecahedron, or first duosecant form.

A new set of forms is produced by rotating, inverting, or altering the position of the pyramids  $45^{\circ}$ , so as to make trisecant pyramids duosecant, and duosecant pyramids trisecant; and next, by combination of two equal and similar fundamental forms, a set of forms having an eight-sided pyramid is produced at each end of the gubernatorial axes: thus, two octohedrons joined together produce the triakis octohedron; two trapezohedrons joined together produce the hexakis octohedron, and so on.

It appears as if these forms, like macled crystals, arise

from a simultaneous development of two crystals in opposite directions, and then what would be re-entering angles are filled up, so that only the edges of the two crystals remain. Thus each eight-sided pyramid consists of planes joining the four lateral edges of one pyramid with those of the four lateral edges of another equal and similar pyramid. Lastly, from the forms thus described an infinite variety of others are obtained, first by the unequal development of particular planes, and next by composition of two or more forms.

In natural crystals, it is frequently observed that certain planes are extended more than others; indeed, it will be found that unequal development is the rule, and perfect forms are the exception. In the case of the diamond, which very commonly crystallises in the regular octohedral form, the octohedron is constantly unequally developed, giving rise to the various forms exhibited in the drawing.

When unequal development does not occasion the loss of any plane, the form is termed simply imperfect; but when, as in the passage of the octohedron into the trapezohedron, or into the rhombohedron, certain planes are obliterated, the form is termed defective.

The law of unequal development shows that whatever forms can be produced thereby from the series of forms already described, they may possibly have existence without any dimorphism in the substance examined. Proceeding on this basis, the exhibitor has discovered that all the unequal-axed crystals are merely unequal developments which have concealed the true character of the crystals, but which have been abundantly and conclusively explained by the small remnants of planes to which little attention has been heretofore directed, but which become of great significance in relation to the law in question.

9 MITCHELL, REV. WALTER, *St. Bartholomew's Hospital*—Designer and Inventor.

Series of models in paper, representing all the primary and secondary forms of crystals, and the most important combinations of these forms.

10 DYER, WILLIAM, *Little Hampton, near Arundel*—Proprietor and Inventor.

Sussex coast agates, found on the sea-beach; many containing specimens of petrified sponges, sea anemones (*Chœnites Königii*), and other zoophytes. Specimens fashioned and polished for ornaments.

[The agates on the Sussex coast are, to a great extent, if not entirely, chalk flints in a peculiar state; and they frequently exhibit very beautiful indications of organic structure. The definition of agate generally in mineralogy has reference to an apparently banded structure, or concentric arrangement of silicious matter, often showing different tints of colour. When of considerable size, the central part is generally clear. The essential material is, in all cases, silica, and the colour is, no doubt, due to metallic oxides, chiefly of iron and manganese.—D. T. A.]

11 SLATER & WRIGHT, *Whitby*—Manufacturers.

Specimens of rough jet, and articles manufactured from jet for ornamental purposes.

[Jet is a variety of coal occurring abundantly in certain localities, but not associated with true coal. At Whitby it is found in the lias beds of that district, and has long been known and worked. It is also common in France (Languedoc), the Alps, Spain (the Asturias), and Galicia, and in the United States at Massachusetts. Very large quantities are used for ornamental purposes, and for rosaries, crosses, &c., in Roman Catholic countries. The true jet is much lighter and pleasanter to wear than the numerous imitations that abound everywhere.—D. T. A.]



12 WEBB, —, *Caloot Farm, Reading*—Producer.

Portion of a fossil silicified tree from the sand. The horn of an ox dug up from the peat.

13 ELLIS, R., *Harrowgate*—Producer.

Collection of the different mineral waters of Harrogate, and their analyses.

14 TENNANT, JAMES, 149 *Strand*—Mineralogist.

Four cases of minerals and fossils for educational, scientific, and ornamental purposes.

A magnificent and gigantic crystal of emerald, the property of His Grace the Duke of Devonshire, by whose permission it is exhibited.

[This collection includes, among other objects, a series of crystals of gems of very great interest, illustrating the modes in which such objects are found and may be distinguished. It also exhibits a series of fossils useful in identifying rocks.—D. T. A.]

15 NELIS, JOHN, *Omagh, County Tyrone, Ireland*—Proprietor.

Pearls, with specimens of the shells in which they are formed; found in the deepest parts of the river Strule (fresh water), at the town of Omagh, county Tyrone.

[The shell-fish from which these specimens of native pearl are derived is the *Unio margaritifera*, and the pearls are second only in quality to those obtained from the true pearl-oyster, *Melagrina margaritifera*. Pearl consists of concentric layers of membrane and carbonate of lime, and is partially soluble in acid.—E. F.]

16 COWIE, A., & RAE, W., *Ellon, Scotland*—Proprietors.

Pearls from the river Ythan, Aberdeenshire.

17 HORNE, —, *Camberwell*—Producer.

Petrified eggs and nest from Gores Island, west coast of North Africa, lat. 63° 13'.

18 MAYO, WILLIAM, 17 *Silver Street, Wood Street, Cheapside*—Inventor.

Glass pipes for the conveyance of aqueous or aeriform fluids. The novelty consists in the invention of a perfect joint. A metallic flange is firmly attached to the ends of the pipes without the use of any cement; the flanges are abutted, and secured together by screw couplings. By means of these joints, glass pipes can be laid down by any ordinary workman; they can be altered, extended, or removed at pleasure, the same joints being available for any length of time.

The glass pipes and joints exhibited are manufactured by Swinburne and Co., South Shields; the patentees, Mayo and Warrington.

## 18A LOWRY, J. W.—Producer.

Diagrams of fossils.

## 19 COOK, A.—Proprietor.

A large crystal of black quartz. (BATTEN, A., Agent.)

## 20 MACDONALD, Major C.—Proprietor.

A large series of turquoises in the matrix, in unpolished fragments, and manufactured into various ornaments.

[Turquoise is a well-marked mineral of a peculiar blue colour—opaque, or only slightly translucent at the edge; it is hard, and takes a good polish, infusible, and unaffected by acids. It is a hydrous phosphate of alumina, with a little oxide of copper as the colouring matter. It occurs chiefly in rounded lumps in Persia and Arabia. Large lumps are rarely pure, and the price is about that of the opal. False turquoises are common, and are manu-

factured of the teeth of animals coloured by phosphate of iron. They are much less hard than the true stone.—D. T. A.]

21 OLDFIELD, Rev. —, *Dublin*—Proprietor.

A mass of crystalline quartz adapted for various useful and ornamental purposes.

## 22 TOLAN, W.—Producer.

A collection of polished agates from the Isle of Wight.

[These Isle of Wight agates resemble those found on the Sussex coast, and exhibited by Mr. Dyer (10). The finest agates are from Oberstein (near a village of that name in the palatinate of Bavaria, situated on the river of Nahe, which enters the Rhine at Bingen), and from India. Very beautiful specimens of the latter are exhibited by the East India Company.—D. T. A.]

23 HIGHLEY, SAMUEL, jun., 32 *Fleet Street*—Collector and Preparer.

*Sulphur Minerals.*

1. Native sulphur in rhombic crystals, from Sicily.
2. Native massive sulphur.
3. Native earthy sulphur.
4. Iron pyrites, or sulphuret of iron, from Cornwall, &c.
5. White iron pyrites from Littmitz, near Carlsbad.
6. Radiated pyrites, from the chalk of Surrey and Isle of Wight.
7. Cockscomb pyrites, from Derbyshire.
8. Copper pyrites in crystals, from the Banat, &c.
9. Copper pyrites massive, from Staffordshire, &c.

*Crude Sulphur of Commerce.*

10. Crude Sicilian sulphur.
11. Crude drop sulphur.

*Refined Sulphur.*

12. Lump sulphur.
13. Roll sulphur.
14. Sublimed sulphur.
15. Sulphur vivum.
- 16 and 17. Sulphur precipitation, pure and (17) adulterated.

*Crystallized Sulphur.*

18. Crystals of sulphur from its solution in bi-sulphide of carbon.
19. Crystals from solutions of sulphur in camphine, made at temperatures varying from 77° cent. = 170° 6° Faht. to 138° cent. = 280° 4° Faht.
20. Crystals of sulphur deposited from sulpho-pentachloride of phosphorus.
21. Crystals obtained by the fusion of sulphur.

[Sulphur occurs native, in rhombic crystals; also massive with earthy and bituminous impurities, and occasionally with arsenic and selenium. It is generally found in volcanic districts and near hot springs in formations of various geological date. It occurs abundantly with iron and copper (iron and copper pyrites), and also with the common ores of lead, &c. It is used in chemical manufactures, and in medicine; also for matches and gunpowder; and in preparing vermilion, sulphuric acid, vulcanised caoutchouc, &c. About 80,000 tons of crude sulphur are annually furnished from Sicily.—D. T. A.]

24 THISTLETHWAYTE, HENRY F., *The Vine House, Sevenoaks, Kent*—Producer.

A collection of gems and precious stones, chiefly illustrative of such as are used for personal ornament. The principal part of this collection was formed by Mr. Hertz, with a view to show the great variety of shades of colour in each species of stone, and to prove the connection of some classes; such as the corundum, where the tints of the ruby, sapphire, and topaz, are distinctly seen in the same stone. In the class of zircons and jargons, the same connection of colours is exhibited. The specimens of diamond are interesting in point of crystallization as



well as colour. The collection of pearls exhibit many varieties of colour both in the margarita and conch-shell specimens.

[The colours of certain minerals are extremely useful to the mineralogist in the determination of species, and are presented in great varieties in distinct series, but sometimes in very unconnected order. The most striking examples of series are found amongst gems, and are well illustrated in the collection described above, which is worthy of very careful observation and study.

The gems which best exhibit series of colours are diamond, corundum (oriental ruby and sapphire), topaz, emerald, garnet, and tourmaline. The zircons and jagoons are also remarkable, and highly interesting.

In most cases, minerals that are nearly allied, and are homomorphic, present similar series of colour; but in other cases, as in the diamond, the usual crystalline forms exhibit a more or less complex series in themselves. The principal colours of the gems are white, as opal, which is milk white; grey; black; blue, as some sapphires, which are Prussian blue, or the variety corundum, called ceylonite, which is indigo blue; green, as emerald; yellow, as topaz; red, as some zircons, garnets, ruby, &c.; and brown, as zircons.

The varieties of colour in pearls, extend from white and lead grey, through yellowish and pink, to black; the latter being, however, remarkable and rare exceptions, and the bluish or lead grey, being less valuable than more distinct tints. Some pearls exhibit much play of colour.—D. T. A.]

25 JAMIESON, GEORGE, 107 Union Street, Aberdeen—Proprietor.

Cairngorm stones from Cairngorm, Aberdeenshire, in the natural state, and cut into gems for jewellery.

Aberdeen and Peterhead granite, cut and mounted in brooches and other fancy articles, as buttons, studs, desk seals, pen-holders, &c.

A ram's head mounted in silver, as a snuff-box.

Scotch pearls found in the rivers Don, Ythan, and Ugie, Aberdeenshire. The shell from which the pearls are obtained.

[The Cairngorm mountain, one of those forming the granite nucleus of the Grampians, and rising to the height of 4,080 feet, is well known, and has been long celebrated for the fine quartz crystals of white, pink, dark brown, and black colours which take their name from it, and are found either in the cavities in the rock or the debris of rivers. Of these crystals, the deep-yellow varieties, when well cut and set, are sold as topazes, and sometimes called Scotch topaz, while the darker varieties are called smoke topaz.—D. T. A.]

26 CASSELS, ALEXANDER, Edinburgh—Proprietor.

Two curling stones used in Scotland in the national game of curling, made of the rock of Ailsa Craig, in the Firth of Clyde.

A specimen of the rock in the rough state.

The game of curling is practised upon ice during the winter. The Royal Caledonian Curling Club, of which His Royal Highness Prince Albert is patron, is composed of above 10,000 members.

[Ailsa Craig consists of a single rock of grayish compact felspar, with small grains of quartz, and very minute particles of hornblende. The height is stated to be 1100 feet, its length 3300, and its breadth 2200. On the east it rises by steps, but from the south, round by the west to the north, it is more perpendicular, and divided into columns. It rises abruptly from deep water, about 10 miles west of the coast of Ayrshire, and 15 miles south of the Isle of Arran.—D. T. A.]

27 KAY, J., Hayhill, Ochiltree—Manufacturer.  
Curling stone, made of greenstone trap.

28 MAJENDIE, ASHHURST—Producer.

White topaz from Van Diemen's Land. Rough and cut.

28A WATKINS, Rev. C. F., Vicar of Brixworth, Northamptonshire—Producer.

Silicious fossils from the chalk beds of South Wilts in quartz agates, calcedony, &c.

A collection of chalk flints chiefly formed in some organic nucleus.

[The very beautiful series of specimens here exhibited admirably illustrates a variety of forms of organic bodies, which have been perpetuated by chalk flints, and which can have been only retained by a very rapid conversion of the original into siliceous. The bodies were in most cases either soft or readily decomposed, but are now surrounded by, as well as converted into, flint, the structure of which, under the microscope, often betrays the most minute details of the animal substance. Collections such as that here exhibited are of great value to the naturalist, and are calculated to be of general use for purposes of instruction in an important department of geology.—D. T. A.]

29 HOWARD, THOMAS, C.E., Bristol—Producer.

Collection of the sands, clays, building stones, marbles, coals, metals, and other minerals, belonging to the Bristol basin; a district bounded on the north by Thornbury and Tortworth, on the east by Chipping Sodbury, Bath, and Wells, on the south by the Mendip Hills, and on the west by the Bristol Channel; including a geological range from the Silurian rocks up to the Oolites, with some alluvial and diluvial deposits.

Geological map of England, showing the extent and position of the Bristol basin, relatively to the rest of the country.

Part of the Ordnance Survey of Great Britain, coloured geologically, showing the details of the Bristol district. Sections from north to south, and from west to east.

List of specimens of building stones, marbles, &c., in six-inch cubes:—

Oolite.

Upper oolites, from the neighbourhood of Bath.  
Inferior oolite, from Dundry Hill, near Bristol.

Lias.

Blue lias (hydraulic lime when burnt), from Keynsham, near Bristol.

White lias, from Radstock and Poulton, Somerset.  
"Landscape" lias, from Cotham, Bristol.

New Red Sandstone and Calcareo-Magnesian Conglomerates.

New red sandstone, found at Bristol.  
Coarse sandstone, from Easton, Bristol.  
Indurated red sandy marl, from Chew Magna, Somerset.  
Fine-grained yellow conglomerate, found near Harley Place, Clifton.

Fine-grained crystalline calcareous conglomerate, found near Durdham Down.

Indurated red sandstone with calc spar.  
Re-cemented magnesian conglomerate, from Clevedon, Somerset.

Conglomerate with quartz, limestone, &c., from Sea Mills, below Bristol.

Conglomerates from Clifton, Bristol; and from the tunnel of the Bristol Waterworks, Harptree, Somerset.

Silicious conglomerate with jaspers iron-stone, from Brandon Hill, Bristol.

Conglomerate, from the Mendip Hills.

Gypsum (sulphate of lime), from Windford, Somerset.

Coal Measures.

Pennant sandstones, from the middle part of the coal series.

Fine siliceous grit (millstone grit, or miner's "farewell rock"), from Bristol.

*Carboniferous or Mountain Limestones.*

Series of limestones and marbles from the defile of the river Avon, Clifton, Bristol.

*Old Red Sandstone, Silurian, &c.*

Old red sandstone, from the banks of the Avon, below Bristol.

Grey sandstone, from Tortworth, Gloucestershire.  
Red siliceous conglomerate, from Markham Bottom, near Bristol.

Transition limestone and sandstone, from Tortworth and Charfield, Gloucestershire.

[The neighbourhood of Bristol is remarkable for the great variety of mineral produce which it yields, and the extended series of rocks observable within a moderate distance.

It presents in the oolites, a series of building stones universally known throughout England; in the lias, a number of useful materials used for lime, cement, and other purposes; in the new red sandstone, mineral soils rich in agricultural produce; in the coal measures, a very large store of mineral fuel; and in the carboniferous limestone, admirable and beautiful building material, adapted for almost every variety of circumstance. The Mendip Hills supply an important series of metalliferous ores; and, in addition to these sources of interest, many illustrations of the extinct natural history of our country are obtained from almost all the formations down to those of the latest date.—D. T. A.]

Amygdaloidal trap rock, from Damory, Gloucestershire.

Samples of the brick and pottery clays, with specimens of the manufacture.

Samples of sands, used for commercial purposes, and of the deposit from which the "Bath scouring brick" is made. This brick is manufactured by Messrs. Ford & Son, Bridgewater.

Samples of ochre, reddle (oxide of iron), fullers' earth, &c.

Samples of strontian, massive and fibrous; gypsum, massive and fibrous; barytes (sulphate of); lime, white and the brown, or hydraulic.

Iron ores—hematite, compact, siliceous, stalactitic, reniform, &c.

Ores of zinc: Blende (sulphuret); calamine (carbonate).

Ores of lead: Galena (sulphuret); white lead ore (carbonate). Phosphate and muriate of lead.

Manganese ore (black).

Antimony ore (sulphuret).

Specimens of quartz crystals (Bristol diamonds); crystals of calc spar; geodes (locally, potato-stones), containing various crystals, agates, &c.

Series of the various seams of coal, worked in the Bristol coal basin, showing the cleavage, fracture, &c.

Maps and sections illustrative of the position and localities of the specimens are exhibited with them.

[This series of rocks, illustrating the economic geology of the Bristol district, is of considerable interest, as showing a large succession of beds, and the result, in some measure, of their close association at the surface. Of the substances used economically, the sands for Bath bricks, ochres, quartz crystals, and geodes, are worthy of notice. Of the ochres, the red and yellow are found in considerable quantities and of very good quality. They are friable, and stain the finger. The red is of deep colour, between crimson and purple, and of strong body; the yellow of fine gold colour. They are dry and mix

well. The Bristol diamonds are clear quartz crystals, chiefly found near Clifton.—D. T. A.]

30 FAHIE, JAMES K., Tipperary, Ireland—  
Producer.

Copper ore, found on Lord Stanley's property, near Tipperary, and from Hollyford.

Lead ore, found at Oola, near Tipperary.

Minerals from several parts of the country.

Anthracite coal, from Killanuale.

Building limestone, found near Tipperary.

Black and white marble, found at Mitchelstown, county Cork. Red and grey marble, found at Cloyne.

Hydraulic limestone, found near Tipperary; a natural cement, produced in powder and biscuit.

Artificial cement, prepared from chalk, alluvium, and pit clay; and stucco, for interior work; prepared from gypsum found in a limestone quarry near Tipperary.

White clay, in its rough state, found near Caher, and prepared in biscuit and small bricks, used for stone ware and pottery. Black clay, in its rough state, found at Killanuale. Black fullers' clay, found near Caher, in a stratum over white clay.

Felspar, from Lord Kingston's cave, county Cork.

Draining tiles and pipes, made on Lord Stanley's property, near Tipperary.

Sands, white silica, found at Killonan, useful for heavy iron castings and other purposes. White silica, found near Caher, used for pottery, &c. Manganese, found at Springhouse.

Inorganic vitreous matter, the produce of green ash and elm, calcined in a brick-kiln by the exhibitor.

Water, from a well in the rock of Cashel, lately discovered, about 150 feet above the general level of the surrounding surface.—

32

A collection of minerals from the Mendip Hills, Somersetshire.

33

TALLING, —, Truro—Producer.

Sundry minerals from Truro.

34

Minerals from Liskeard, Cornwall.

35

IPSWICH MUSEUM COMMITTEE, by the  
Rev. J. HENSLOW, President—Producer.

Sundry minerals obtained from the neighbourhood of Ipswich, and used in the arts, as manure, for cement, and for some other purposes.

[These minerals from the neighbourhood of Ipswich include the cement stores found at Harwich and dredged off that coast; the recently obtained nodules, containing phosphate of lime, now rendered available for agricultural purposes, and existing abundantly near Felixtow; and some other materials, all tending to illustrate the mineral riches of the district. Similar collections for other localities would be of great interest in local museums, and might be collected on a large scale at very small cost.—D. T. A.]

36

PAINÉ, JOHN M., Farnham—Producer.

Phosphoric fossils and marls from the upper greensand, the gault, and the upper part of the lower greensand formations. These fossils are stated to contain as high a percentage of phosphate of lime as ordinary bones; and they have been proved to be useful in fertilizing land. They are easily converted into superphosphate of lime, by the agency of sulphuric acid. The clean fossils contain from 50 to 70 per cent. of bone-earth phosphate; the green marl (without fossils) contains from 4 to 15 per cent. The substances found are characterised by the almost total absence of carbonic acid, and are, therefore, the more valuable as a material for forming superphosphate of lime. These phosphoric fossils are to be found in greater or less quantities at the bottom of the chalk range of

hills throughout England. The fossils and marls are chiefly dug from the lands of the exhibitor at Farnham, in Surrey.

Transverse section of pocket of hops of the choicest "Golding" variety, grown upon the phosphoric marl of the "upper greensand." Entire pocket of the same as prepared for sale.

Specimens of phosphoric fossils from the mammaliferous crag of Suffolk; and of the "Mineral Phosphate of Lime" or "Apatite," from Estremadura, in Spain, and from New Jersey, in the United States.

[The concretions of phosphate of lime, which were discovered by Mr. Paine in the cretaceous rocks near Farnham, in a state well adapted for economic use, and which are much employed for agricultural purposes, appear to exist in two or three bands in the upper greensand and gault, not extending into the true lower greensand. The concretions are occasionally formed about an organic centre, and appear to be instances of segregations of a mineral substance at one time generally distributed in a bed while being deposited at the bottom of a sea. The phosphoric nodules are usually found in the Farnham district associated with green earth.—D. T. A.]

37 LANCE, EDWARD JARMAN, *Frimley, Bagshot, Surrey*—Producer.

Specimens of minerals, in their raw state, as used in the arts (as iron from the Wealden formation, and the coal measures, &c.), arranged in trays, and named.

Specimens of minerals, used as manures, as phosphate of lime and magnesia; sulphate of lime and alumina; Cornwall sand, shell marl, &c.

Specimens of cultivated soils or earths, arranged as they occur from London to Cornwall, being the abstractions of minerals.

Specimens of corn produce; the effect of the admixture of fertilizing minerals and culture on silicious sand, in illustration of the preceding collection.

Geological map of the British Isles.

38 GILL, WILLIAM EATHORNE, *Truro*—Inventor.

Specimen of Normal guano, a manure: prepared from the refuse of the fisheries, as a superior fertilizer.

This manure is obtained from precisely the same source as the Peruvian guano; the sample exhibited was a conger-eel. It is chemically prepared with all its agricultural advantages undiminished. Fish refuse has ever been a well-recognised manure, especially along our coasts; but the demand has, for obvious reasons, been irregular, and the supply, as a consequence, still more so. By adopting, in our fisheries, the process of manufacture shown in the specimen, a regular market at all seasons of the year would be established, and the normal guano would thus become a means of supplying our farmers with a portable, cheap, and valuable manure.

[The large quantities of fish, particularly pilchards, mackerel, and hake, which are caught around the coast of Cornwall, render the preparation of a manure from the refuse, on most occasions, a comparatively easy undertaking. The value of fish manure has been long known, and it is not at all uncommon for farmers to go to considerable expense to obtain the offal from the nearest fishing towns; and they value highly the refuse salt, which they obtain after the pilchard season, from the curing-houses, on account of the great quantity of pot-ash it contains.—R. H.]

39 \_\_\_\_\_  
Clay and chalk.

40 SWEETMAN, JOHN, *Sutton, County of Dublin*—Proprietor.

Blue limestone, containing about 90 per cent. of carbonate of lime. Dolomite, containing about 40 per cent.

of carbonate of magnesia. Cement made with dolomite. Quartz rock for road metal. Steatite clay, for pottery or silicated soap. Silicated soap. Hematite iron ore. Black oxide of manganese, containing about 55 per cent. of oxygen. Umber. Yellow and brown ochre. White sand, for manufacture of glass.

[Dolomite occurs in various places in Ireland, in veins in the limestone districts, particularly where intruded rocks are near. On the south side of Belfast Lough, at Holywood, it appears also as a distinct rock in a stratum about 60 feet thick. The best kinds contain from 18 to about 22 per cent. of magnesia.—D. T. A.]

41 TESCHEMACHER, E. F., *4 Park Terrace, Highbury*—Producer.

Collection of mineral and other manures.

42 HARRIS, J., *2 Hart Street, Mark Lane*—Inventor and Manufacturer.

Faecal manure, deodorised, containing the fertilizing properties essential to vegetation, and suitable for every description of soil and climate.

43 \_\_\_\_\_  
Silt, sand, turf, &c., from the Isle of Ely.

44 RAMSAY, G. H., *Newcastle (Agent, A. HURST, 65 Mark Lane)*.

Artificial manure, bone dust, and superphosphate of lime.

45 MITCHELL, W. B., *Sheffield*—Producer.

Sandstones, for purposes of construction, and grindstones.

1. Millstone grit—Bull Hill Quarry. 2. Millstone grit—Reeves' Edge Quarry. 3. Blue sandstone—Green Moor Quarry. 4. Brown sandstone—Green Moor Quarry. 5. Blue sandstone—Brinkcliffe Edge Quarry. 6. Brown sandstone—Grenoside Quarry. 7. Brown sandstone—Wickersley Quarry. 8. Magnesian limestone—Steeley Quarry.

Clay.

9. Fire clay and brick—Dore Moor Mine. 10. Fire clay, for crucibles—Storr's Mine. 11. Balbro brick clay; pressed brick.

Coals.

12. From Soap House Colliery—Sheffield Bed. 13. From Birley Vale Colliery—Sheffield Bed. 14. From Mortomley Colliery—Sheffield Bed. 15. Handsworth converting coal. 16. Tinsley Park high hazel coal. 17. Tinsley Park furnace coal.

46 NESBITT, J. C., *Kewington*—Producer.

Phosphate fossils for manure.

47 CAWLEY, JAMES, *Pendell, Bletchingly*—Producer and Manufacturer.

Stone from the surface of fuller's earth, used for building purposes.

Fuller's earth in the raw state, blue and yellow.

Fuller's earth, blue and yellow, dried and prepared for use in the manufacture of woollen cloths, flannels, blankets, Scotch tweeds, and tartan shawls.

Specimen of the spar found in the strata of the fuller's earth.

All the above specimens were found and dug at the "Cockley pits" at Nutfield, Surrey.

[The fuller's earth pits of Nutfield, near Reigate, are extensively worked, and supply large quantities of this substance to the clothing districts. There are two kinds, one greener than the other, owing to the presence of silicate of iron; but both exist under the same geological conditions, occurring in the lower cretaceous series, and differing little in chemical condition.

Fuller's earth consists of about 45 silica, 20 alumina, and 25 water. When placed in water it almost dissolves,

and when exposed to great heat it melts. It combines readily with grease, forming a kind of earthy soap, and for this reason is valuable in the manufacture of cloth made of animal fibre.—D. T. A.]

48 GAWKROGER & HYNAM, 7 Prince's Square, Finsbury—Manufacturers.

Fuller's earth, and purified dried fuller's earth, from Chart Lodge, Reigate, Surrey, and Cormonger's Pits, Nutfield, Surrey.

[Fuller's earth, and its localities in England, are above described. The following is the mode of purifying and preparing the raw material for use:—

The fuller's earth, after it comes from the pit, is baked or dried by exposure to the sun, and then thrown into cold water, where it falls into a powder, and the finer parts are separated from the coarser by a method of washing in several tubs, through which the water is conducted, and where it deposits the different kinds in succession. These are used for different kinds of cloth, the coarser part for the inferior and the fine for the better kinds of cloth. The soapy combinations formed by fuller's earth with the greasy portions of cloth during the process of fulling, are supposed to serve the purpose of mordants in some measure.—D. T. A.]

49 WILSON, SIR THOMAS MARYON, Charlton, Kent—Producer.

Sands and loams for casting, from Charlton, next Woolwich; sands used for glass and house purposes from Hamstead.

50 ROCK, JAMES, jun., Hastings—Producer.

Lignite found in the summit tunnel of the Hastings and Ashford railway, 1½ miles to the N.N.E. of Hastings, about 90 feet from the surface, and 300 feet above the sea level. The strata dip from N.W. to S.E. at an angle of about 65 degrees.

Clinker, containing a considerable quantity of iron, from an ancient cinder-bank on the property of Hercules Sharpe, Esq., Sedlescomb, Sussex.

Claystone, said to contain oxide of chromium.  
Fine white sand, from Hastings cliffs.

[The lignite of the Hastings sand formation, near Hastings, has been long known, and corresponds in every particular with the lignites from Tilgate Forest. It occurs in nearly horizontal bands, thinning out into a mere film, and the largest masses do not exceed a few inches in thickness. It is very brittle, and burns with a bright flame; resembles jet, and contains included fragments of ligneous character. It is not unlike the Bovey coal.

Ironstone was formerly extracted from some of the ferruginous sands of the Wealden, either in irregular concretions, hard, compact, and of steel-grey colour inside, or laminated, and often concentric. In some places it is of excellent quality, and when the country was covered with forest was much used in the manufacture of charcoal iron.—D. T. A.]

51 ROSS, THOMAS, Claremont, Hastings—Producer.

Iron ore from the neighbourhood of Hastings.  
Tilgate stone from the East Cliff, Hastings.  
Hastings "granite" (locally so called).  
Clay, from a large bed lying under the sand-cliffs to the eastward of Hastings.  
Hastings hone-stone, rough and prepared.

[The clay near Hastings underlies a thick deposit of white sand and friable sandstone, called the "Worth beds." The clay itself contains undulating seams of lignite. It overlies another bed also including lignite.—D. T. A.]

52 Specimen of fossil orthoceratite.

53 WHITTAKER, JAMES, *Wiviswarth*, Derbyshire—Proprietor.

Specimens of marble, and vase made of the same.  
Specimens of grit sand, used for fine castings.  
White sand, used for scouring, &c.  
White lead ore, and stalactite.

54 BRODIE, PETER B., F.G.S., *Down Hatherley*, Gloucester—Producer.

1. Limestone, from the Purbeck strata in the Vale of Wardour, Wiltshire, applicable to purposes of lithography.
2. Ironstone, from the top beds of the lower lias, Robinswood Hill, near Gloucester, Hewlett's Hill, near Cheltenham, and Chipping Campden, Gloucestershire; it occurs in beds, and occupies a considerable area in the Cotswold hills.
3. Septaria, found in the upper beds of the lower lias, Robinswood Hill, near Gloucester, in sufficient quantities to be used for cement.
4. Iron pyrites, or sulphuret of iron, found in digging a well in the lias at Gloucester.
5. Limestone, forming an extensive bed in the lower lias near its base, and extending through Gloucestershire and Somersetshire.
6. Hard limestone of the lower lias, near Bidford, in Warwickshire. This stone takes a polish, and could be used as a marble.
7. Bone bed, a thin but extensive band at the base of the lower lias, charged with fragments of bones, teeth, and coprolites, which might be beneficial as a manure. It occurs at Wainlode Cliff, Coombe Hill, near Gloucester, Westbury-on-Severn, Somersetshire, and Wales.

[All the above specimens, except the first, are from the lias, a deposit of calcareous clay widely distributed in the west of England, and ranging from the coast of Dorsetshire, at Lyme Regis, to the coast of Yorkshire, at Whitby. The upper and lower beds are often shaly, and yield materials for the manufacture of alum and other substances. The middle portion is more calcareous, and includes some bands of compact limestone. Where the carbonate of lime forms into nodules somewhat argillaceous, there are found septaria well adapted to the making of cement. In many places, the iron disseminated through the clay has collected into bands of impure ironstone, which, however, is not likely to come into successful competition with other ores. The bone-bed may, if the expenses of transport be inconsiderable, be worth working as a cheap and effective mineral manure.—D. T. A.]

55 RIDDELL, SIR JAMES MILLS, Bart., *Strontian*—Proprietor.

Various specimens of minerals.  
Harmotome, in large crystals, on calcareous spar.  
Morvenite, a variety of harmotome, on calcareous spar, amber colour.

Crystallized calcareous spar, with annular iron pyrites, enclosing radiated sulphate of barytes.

Brown calcareous spar.  
Crystallized calcareous spar, of a pink colour.  
Calcareous spar, on hexahedral tables enclosing icositetrahedral crystals.

Hexahedral prismatic calcareous spar, penetrated with crystals of the same, of a different form, the obtuse solid angle of which partly protrudes from the terminal plane of the prism.

Brewsterite, discovered near Strontian.  
Crystallized carbonate of strontian.  
Massive fibrous carbonate of strontian, with heavy spar.  
Sulphate of barytes with phosphate of lead.  
Sulphuret of iron.

Gneiss. Gneiss passing into granite. Gneiss with red felspar.

Junction of gneiss with granite, intersected by a vein of felspar.

Fine-grained granites. Syenites.  
Porphyritic granites.  
Syenite, with a vein of felspar.  
Rock, of carbonate of lime and serpentine.  
Granite studded with garnets, from the summit of Ben Rosipole, a mountain above 3,000 feet in height.  
A very large specimen of the same.  
Quartz rock.  
Sulphuret of lead, in a matrix of calcareous spar, from the Smithy Vein (Feedonald district).  
Sulphuret of lead with calcareous spar, a continuous string of lead ore, from the red vein of Feedonald.  
Crystallized sulphuret of lead (the primary cube), from the same vein.

Sulphuret of lead, with sulphuret of zinc and crystallized calcareous spar in the cavities.  
Sulphuret of zinc and calcareous spar, from Corantee.  
Cubic sulphuret of lead with calcareous spar.  
Sulphuret of lead in calcareous spar, from Clashgoram mine (middle district).  
Sulphuret of lead; sulphuret of lead, embedded in calcareous spar; and sulphuret of lead, partly crystallized with calcareous spar—from Belgrove Mine.  
Junction of granite and mica slate.

Lias limestone; from the north side of the promontory of Ardnamurchan.  
Lias limestone, from the south side of the promontory.  
A large mass of sulphate of barytes, a substance constituting much of the matrix or veinstone of lead ore.

[At Strontian, in the western part of Argyllshire, a boss of granite is seen penetrating the gneiss, which abounds in the district; and a little further to the west, a large quantity of porphyry and trap occurs, covered, in two or three places near Ardnamurchan, by deposits of the eolithic and liassic period. In the granite, and near its junction with the gneiss, mineral veins are found, containing lead and copper; and in one of these was first observed the mineral thence called *strontianite*, or *strontites*, a carbonate of strontia, usually associated with calc-spar, sulphate of barytes, and galena. The metal called *strontian*, obtained from this mineral, was first described by Sir H. Davy, and resembles barium in its properties and appearance. Carbonate of strontia is chiefly used in the production of the nitrate which is employed in giving a red colour to fireworks.

Harmotome and mervenite are hydrous silicates of alumina and barytes. Brewsterite is also a hydrous silicate of alumina, but contains strontia as well as barytes. The other minerals are well known. The lias is one of several small patches round the trap rocks of Ardnamurchan, Morven, and the Isle of Mull, and contains numerous organic remains.—D. T. A.]

56 DANN, THOMAS, *Reigate*—Producer.  
Greystone lime, from the lime-works, at Reigate Hill, on the estate of the Countess of Warwick.

57 WORTHINGTON, WILLIAM, *Northwich, Cheshire*—Proprietor.  
Specimens of rock salt, as produced from the mines near Northwich, Cheshire.  
Specimen of refined salt, for curing fish.  
Fine high-dried table salt.  
Malvern salt, much esteemed for table use.  
Large-grained bay salt, used for various purposes.

[The salt-mines of Cheshire are worked in the new red sandstone of that county, the salt being in large masses of irregular form associated with marl and gypsum. In its natural state it is of dull red colour, semi-transparent, and though sometimes cubical in crystal, more usually massive. The number of saliferous beds in the

district is five, the thinnest of them being 6 inches, but the thickest nearly 40 feet thick, and they are worked at a depth of from 50 to 150 yards below the surface.

The mode of working the thick bed is not much unlike that adopted in South Staffordshire for coal; but the roof being generally uniform and tolerably tough, and the mine without noxious gases, the works are more simple. The salt is blasted, and large pillars are left to support the roof. Upwards of 60,000 tons of salt are obtained from the Cheshire mines, and a large quantity is also manufactured from brine-springs and other similar sources, in Cheshire and Worcestershire. The greater part is exported from Liverpool.—D. T. A.]

58 HILL, JOHN, *Ringsend, Dublin*—Manufacturer.  
Basket and pink salt for table use; Irish fine, or butter salt, and coarse or provision salt.

[There are no natural deposits of salt in Ireland, and the various kinds exhibited by and prepared in that country are generally procured from the English salt mines.—D. T. A.]

59 BRASSINGTON, *Derbyshire*—Producer.  
Wad and white-lead ore.

60 ROAKE, JAMES WHITE, *Newbury, Berkshire*—Producer.

Specimens of soils which surround Newbury, Berks, and the uses to which they are applied.

Nos. 1 to 4. Various clays. 5. White. 6. Red. 7. Yellow ochre. 8. Fine white sand. 9. Coarse sand. 10. Ferruginous sand. 11. Ochreous sand, used by iron founders. 12. Green sand, with oysters embedded. 13. Gravel, rough and pebbly. 14. Calcined pebbles, reduced to coarse and medium grit. 15. Fine pebbles, with stucco made from it, to compare with a coloured fragment and tessera from Herculaneum. 16. Chalk from Kintbury, with shells peculiar to that deposit. 17. Whiting. 18. Limestone. 19. Stone lime. 20. Chalk lime, through which gas has passed. 21. Peat from the Kennet valley. 22. Peat, condensed by Cobbold's patent process. 23. Peat, pulverised for horticultural uses, and disinfecting purposes. 24. Peat ashes, for the agriculturist.

Samples of bricks, tiles, and pottery.  
[Newbury is situated on the lower tertiary beds immediately overlying the chalk, which crops out at a short distance from London to the north, south, and west. The river Kennet crosses the chalk from the west, runs through the town towards the east, and enters the Thames near Reading. The tertiary deposits here include a moderate thickness of the London clay overlying the mottled clays and sands of the lower or plastic clay series, including a pebble bed, mottled red clays and sands, and the whole covered up with a little gravel.—D. T. A.]

61 COWPER, JOHN, *Alston, Cumberland*—Proprietor and Producer.

Crystal of sulphate of barytes; the largest on record, weighing 112 lbs.

Specimens of witherite, or carbonate of barytes, remarkable for their beauty and crystallization; taken from a lead and carbonate of barytes mine at Fallowfield, near Hexham, Northumberland, where it is raised in the lump, in great abundance. It is extensively used in the manufacture of glass, chemicals, porcelain, &c. This extensive mine, now the property of Walton and Cowpers, was thrown away as of no value, until lately, when the present proprietors bought the mines, and introduced the article, as a mining product, into the market.

Sulphate of barytes, found in witherite.  
Beaumontite (baryto-calcite) on bittern-spar and pseudo-morphous quartz; from Brownley Hill. Barytes and galena, from Fallowfield. Coal, galena, shale, &c. Carbonate of lime, from Alston.



62 DYER, WILLIAM BUNT, *Mold*—Proprietor.

White lead ore, carbonate of lead ore, from Jamaica mine. Assay, 60 per cent. for lead, and four ounces of silver per ton of lead.

Blue lead (galena) and sulphure of lead ores from Jamaica mine. Produce 80 per cent. lead and four ounces silver per ton of lead. It is used by painters for the purpose of smoothing earthenware glaze.

63 CAIRNS, J., jun., 96 *Charlotte Street, Manchester*—Producer.

Carbonate of barytes, with specimens of lead ore, from Anglezark Moors, near Chorley, Lancashire.

64 BROOKMAN & LANSDON, 28 *Great Russell Street*—Proprietors.

Specimens of black lead from Cumberland, in the raw state, and as hardened for use. Specimens of other minerals.

[The Cumberland graphite is obtained from a large and very irregular vein cutting through the green slate and porphyry; and the mineral occurs in large lumps, found here and there expanding and thinning out with no apparent order. About 50 years ago, one of the largest masses ever discovered was suddenly met with, and yielded about 70,000 lbs. of the purer kind of black lead. Since then there has been nothing found of any value. The mines are near the head of Borrowdale, the entrance being about 1,000 feet above the sea, and as much below the summit of the mountain.—D. T. A.]

65 BROCKEDON, W., 29 *Devonshire Street, Queen Square*—Patentee and Manufacturer.

Native plumbago:—Samples from the mines of Borrowdale in Cumberland, fine and crude: from Ceylon, Davis Straits, Spain, Bohemia (called Mexican), Greenland, California, France (Poligny): nodules from India, &c.

Samples of Cumberland black lead, prepared for condensing into blocks by patent process.

Specimens in powder, purified from grit, and in fine powder, ready for condensing, which has passed through apertures  $\frac{3}{16}$ th of an inch in diameter.

Blocks which have been condensed by a pressure of 5,000 tons.

Slices of the blocks for pencil-makers; points for Mordan's ever-pointed pencils; cedar pencils, by various makers, of Brockedon's patent Cumberland lead.

Blocks made of Ceylon and other plumbagos, &c.

The plumbagos exhibited in their natural state, are—Three very fine samples of the old black-lead, formerly found in Cumberland. The only native plumbago which could be cut into slices, and used in its natural state; the miners have long failed to supply such specimens. Two samples of Cumberland lead, containing too much grit to be used without purification. Samples of plumbago from Ceylon, crystalline and fibrous: this is the purest plumbago known, being 98.55 pure carbon; but it is too fragile for use in cedar. Two samples from Davis's Straits and Greenland. One from California. Others from Spain and Bohemia (called Mexican), of these two the common pencils are made, when hardened by sulphur. From none of these can a fine pencil be made, but the Cumberland.

The manufactured blocks are from the second variety of the Cumberland, freed from grit, and reduced to an impalpable powder, of which a quantity is shown to form one of the blocks. From this powder the air is exhausted, when it is condensed in a dry state by an enormous pressure, which consolidates a mass weighing seven ounces under a force, in two blows, with a force of 5,000 tons, leaving it as compact as the natural; and from these blocks slices are cut, as shown: these are inserted in channels in the cedar. It is also cut into the lengths of the block as square threads; these are rounded, then cut to the proper lengths for the ever-pointed pencils.

For the process by which the Cumberland lead can

be freed from grit, and then solidified, the exhibitor obtained a patent, and pencil manufacturers use it only for their finest drawing pencils.

[Graphite or Plumbago, a form of carbon commonly called black-lead, and sometimes, but incorrectly, regarded as a carburet of iron, is a well-known soft mineral, crystallized in small hexagonal plates of laminated structure, infusible, burning with great difficulty under the blowpipe; consisting of from 85 to 98.55 per cent. of carbon, and having a specific gravity of 2.09 to 2.25; the purest being the lightest. It is found in metamorphic, generally in schistose, rocks, of various geological age, in masses or veins parallel to the lamination or stratification. The pure and valuable kinds are very rare, and have been obtained almost exclusively from the localities mentioned above. The variety from Ceylon is remarkably pure but soft; that from Greenland is also pure, but very hard. The latter, according to an analysis recently made by T. H. Henry, Esq., yields carbon 98.6, ash 3.4; but does not seem adapted for extensive use in pencil-making, owing to its hardness and paleness. It appears that the presence of a certain quantity of iron is favourable for its use in the arts.

The method by which Mr. Brockedon has rendered several of the softer and less compact graphites available, and has also brought into use the fragments formerly too small for pencils, has been successfully applied to other materials for various useful purposes.—D. T. A.]

66 REEVES & SONS, 113 *Cheapside*—Inventors and Manufacturers.

Cumberland lead and cedar wood, in the different forms in which they are used in the manufacture of drawing pencils.

67 ADAIR, R., *Maryport*—Manufacturer.

Various materials used in black-lead pencil making; with specimens of pencil manufacture, in its different stages.

The cedar used is imported into London and Liverpool chiefly from South America. The foreign plumbago, of which common pencils are manufactured, is imported from Germany, the East Indies, Spain, and Mexico. The Cumberland black-lead is found only in Borrowdale, and is used only for the best pencils.

68 WOLFF & SON, *Church Street, Spitalfields*—Manufacturers.

A specimen of pure Cumberland lead, without grit, as produced from the mines at Borrowdale. Block of the same compressed. Specimens of prepared and compressed Cumberland lead.

[The Cumberland mines having failed to produce a continual supply of the pure plumbago, or black lead, for the use of artists, &c., the exhibitors are enabled, by their process of cleansing and compressing the crude or gritty lead, to produce solid blocks of pure plumbago equal to the finest quality originally supplied from the mines.]

Specimen of Ceylon black lead. East India, as produced from the mine. Block of Ceylon lead, prepared and compressed.

Specimen of Malaga black lead (Spain), as produced from the mines. Block of Malaga lead, prepared and compressed.

[Plumbago, or graphite, improperly called black lead, is a carburet of iron: the best quality of this is used for artistic purposes; the inferior is employed in the manufacture of crucibles, or chemical furnaces, as it stands a high temperature. It is adulterated with lump black, sometimes to the amount of 60 per cent., when sold for domestic purposes.—R. H.]



69 BANKS, SON, & Co., *Greta Pencil Works, Keswick—Manufacturers.*

Specimens of pure Cumberland lead, and composition used in the manufacture of black-lead pencils. Specimens of the various stages of manufacture from the raw materials to the complete pencil. Specimens of pencils in various styles of finish.

70 ROGERS, SAMUEL SANDILANDS, *Douglas, Isle of Man—Producer.*

Specimens of the earths and sands of the Isle of Man.

71 TENNANTS, CLOW, & Co., *Manchester—Manufacturers.*  
Large groups of crystals of sulphate of copper.72 THOMPSON, J., *Northwich—Producer.*

Crystalline block of rock salt, quarried out of one of the exhibitor's mines, near Northwich. In the neighbourhood of Northwich are to be found the only mines of rock salt in England, numbering altogether about twenty distinct quarries. Rock salt has been an article of trade in this neighbourhood since the year 1670; it was then carried on the backs of horses to the nearest point of embarkation. Now the exports to foreign countries alone, are about 70,000 tons. The total consumption being about 100,000 tons. The rock salt is found from 45 to 50 yards below the surface, the intervening layers being composed of soil, gravel, quicksand, clay, marl, gypsum, &c. The first bed of rock salt is about 25 yards in thickness, but inferior in quality; underneath this, is a bed or stratum of stone or indurated clay, blue and brown, about 10 yards in thickness; below this is the second great formation, which is also about 25 yards in thickness; the lower five yards of which is the only portion excavated, the greater mass being very impure. That within five yards, however, contains but few impurities, and is readily dissolved into brine, from which is manufactured the purest and best of salt.

The above specimen is not selected as a rare and pure block, but as a fair representation of the bulk of what is obtained from the mine.

## 73 CLAXTON, J.—Producer.

Sands from Alum Bay, Isle of Wight.

74 SQUIRE, JOHN & WILLIAM, *Yarmouth, Isle of Wight, Hampshire—Producers.*

Specimen of pure white sand, used in the manufacture of best flint glass, taken from horizontal and vertical beds in the cliffs in Alum Bay, near the Needles, on the estate of William George Ward, Esq. It is exported from Tarnworth, and is extensively used by glass-makers, for its silicious properties.

[The geological position of these beds of sand is at the base of the tertiary series, as exhibited in the British Islands, corresponding with the white and other sands at Woolwich, and the lignites and plastic clays of Paris. The thickness of this part of the series at Alum Bay is very remarkable; and the sands being nearly free from iron and alkaline earths, are well adapted for glass-making.—D. T. A.]

75 COLLINSON, CHARLES, *Mansfield—Proprietor.*

Red casting sand, found only at Mansfield, and of value in the production of fine castings. Its qualities are fineness of grain, porosity, great purity and smoothness, which latter property contributes to give a high face to castings.

76 RELE, S., *Reigate, Surrey—Producer.*

White sand, from the Tunnel Caves at Reigate (called in use "silver sand"), dug from the rock.

77 MORRISON, GEORGE, Agent of EARL SOMERS, *Reigate—Producer.*

Sand from the common, named Reigate Heath, valued for its grit, and used in the manufacture of glass.

[These sands are from certain beds of the lower greensand series much developed in Surrey, and frequently exhibiting extensive tracts of sand, often with it admixture of any argillaceous or calcareous matter.—D. T. A.]

78 LONG, J., C.E., *Limerick—Producer.*

Building and ornamental stones from Limerick, &c. Sands and earths from the river Shannon.

Nos. 1 to 18.—Marbles of various colours, obtained from the top beds of unworked quarries. The lower beds contain specimens of a better quality, and free from the blemishes which these exhibit. Worked in the counties of Limerick, Clare, King's County, Longford, and Galway.

Nos. 19 to 28.—Building-stone, of various qualities of limestone and grit, from quarries at Limerick, and at various points along the Shannon. No. 23 yields the hydraulic lime, now used in building the new docks at Limerick. No. 59 is a stone adapted for inside staircases, and not readily soiled. These stones are suitable either for marble or building stone.

No. 29.—Iron-stone; No. 30, iron nodule; and No. 31 bituminous coal, from county Leitrim. No. 32, anthracite coal. The iron ore and coal, Nos. 33, 34, 35, are found in the same district on the verge of the Shannon, near its source, whence a steam navigation extends to Limerick. Limestone, suitable for flux in smelting, as well as moulding sand, fire-clay, fire-stone, &c., are found in the same locality. The iron-stone is productive, nearly equalling the black band ore of Glasgow, and exceeding the Staffordshire and Welsh ores; the richest giving 61 per cent. of iron. The coal (No. 35) produces  $\frac{3}{4}$  parts of good coke, and is useful for illuminating purposes. Anthracite coal (No. 36) is found in Tipperary, Limerick, Kerry, and Clare, where extensive coal fields exist; but owing to the abundance of peat fuel in the district, they remain unworked, except for local purposes, such as burning lime, drying corn, &c.

Nos. 37, 38.—Turk, heavy and light, found in abundance, and chiefly used for domestic purposes.

No. 39.—Gypsum, obtained on the shores of Lough Allen, at the head of the Shannon, near the coal and iron mines, county Leitrim.

No. 40.—Fire-clay. This clay is found of excellent quality, and equal to the Stourbridge clay, formerly imported into Limerick.

Nos. 41, 42.—Moulding sand; the same, prepared for use. These sands are used in the Limerick foundries.

Nos. 43, 44.—Building sands; dredged out of the bed of the river at Limerick, and requiring no screening or washing previous to use.

No. 45.—Plaster sand; dug in pits near Limerick.

No. 46.—Lime; produced from the building stones of the locality, which are found in abundance throughout the whole length of the river.

[The coal worked near Limerick is from a number of small basins or troughs, ranges of hills running east and west, and the strata dipping on either side often at high angles. The coal is all anthracitic, and there appear to be six distinct seams, three of them however yielding the principal supply. The iron-stone of Ireland is generally rich, some of it especially, averaging as much as 40 per cent. of iron in the natural state. The fire-clays from beds alternating with the coal, and others in the counties of Clare and Tipperary, afford admirable material for crucibles, and replace Stourbridge clay for various purposes.—D. T. A.]

No. 47.—Flags. Flags of this kind of large dimensions are obtained in the county Clare. Exported from Limerick.

No. 48.—Copper ore, from the Hollyford mines, county Tipperary.

Lead ore, from Ballyhickey mines, formerly worked, but not now in operation. Within four miles of the shipping port of Clare. Average, by assay, 77 per cent. for lead, and 15 ounces for silver in the ton of lead.

Shell marl; dredged in abundance out of the Shannon; it forms the subsoil of the lowlands skirting the river. Silica. This silica is suitable for pottery purposes.

[Shell-marl, such as alluded to in the above list, is usually the remains of the deposits formed by the ancient pleistocene sea. The organic remains which give richness to this marl, and enhance its value for agricultural purposes, are remarkable for being of an arctic character. They appear to indicate the ancient extension of an icy sea like that of Greenland over the greater part of the British Isles during the geological epoch immediately preceding the present era.—E. F.]

79 ROUSE, Capt., & WHITLEY, N., *Truro*—Producers.

Specimens of sands, from various parts of Cornwall, used for agricultural and building purposes: the agricultural sands from Gwithian, Falmouth harbour, and Perran Porth; the others used for building purposes.

[A very large quantity of fine white calcareous sand, consisting chiefly of minute fragments of shells, and containing much animal matter and some salt, is annually removed from the coast of Cornwall, in some places, to the interior, and used for agricultural purposes, for which it is well adapted. It has been estimated that as much as from six to eight millions of cubic feet of sand are annually thus removed.—D. T. A.]

80 FLATHER & HADEN, 1 *Castle Mills*, and 2 *Broad Lane, Sheffield*—Producers.

Prepared Trent sand, or wharpe, used for buffing up, or bringing to a surface, German silver, Britannia metal, brass, copper, &c.

Prepared Welsh rotten-stone, used for producing the fine polish on silver, Britannia metal goods, &c.; when mixed with one-sixth its weight of rape or sweet oil, it forms the polishing paste used for cleaning Britannia metal, brasses, tin ware, and other bright metal goods.

[Most substances employed under the name of rotten-stone, or Tripoli, are essentially composed of silica in a peculiar state of subdivision, the actual particles of which the whole is made up being crystalline, but the mass earthy, and often reduced by compression to a solid state, having a slaty fracture. In most cases, the origin may be traced to the remains of infusorial animalcules, and occasionally the presence of carbon, and a little resinous organic matter which shows this still more clearly. The name Tripoli is generally understood to apply to all the earthy varieties (of which there are several) in which silica exists nearly pure, but in a very minute state of subdivision. Rotten-stone is limited to those which are light and friable, and of very fine grain. It occurs rather abundantly near Bakewell, in Derbyshire, amongst the carboniferous limestones, but is often met with in other rocks.—D. T. A.]

Prepared lime, used for producing the bright black polish upon German silver, electro-plated, and silver goods.

81 SOLOMON, THOMAS, *Truro*—Producer.

Varieties of hone-stones, used for sharpening edge-tools, from Perran Porth, near Truro; Lostwithiel; Feock, near Truro; Kenwyn, near Truro; and other localities.

82 SCRAMPTON—*Leicester*—Producer.

Specimens of Whittle Hill whetstones and hones.

84 MEINIG, CHARLES, 103 *Leadenhall Street*—Manufacturer and Dealer.

Circular grindstones, for glass, mineral teeth, fine tools, &c.; made of sandstone, from the exhibitor's quarry in Bohemia, producing fine edge, and polished surface.

Grinding lathe, mounted with these grindstones, with circular oilstones, &c. Mounting for flat oilstones, sharpening differently on different sides. Specimens of dressed oilstones.

Multiplying hand-frame for circular grindstones; oilstones and polishing stones on Mr. Eden M'Donnall's principle.

Multiplying hand-frame, with horizontal movement.

[Grit stones or grinding stones are, all of them, varieties of sandstone; their abrading or polishing powers depending upon the degree of hardness of the stone; the size of the particles constituting the mass, and the silicious character of the stone. The Bohemian stones have long been imported from Germany, and used by jewellers for polishing small works, such as the settings around gems. These stones are fine and silicious, and for small work cut well, and keep a good point.—R. H.]

This large and important series of grindstones includes almost every kind used for manufacturing purposes in London, and obtained for various parts of the world. The qualities of the stones, their relative excellence, and their respective uses will be easily understood by a careful examination of the series.—D. T. A.]

85 SNOW, W. P.—Producer.

Specimen of rock from the Arctic Regions.

86 BANK PARK PYROPOLITE WORKS—Manufacturer.

Figure in terra-cotta; a bas-relief ornament.

87 POTTER, WILLIAM, & Co., 87 *Abgate, and Cromford, Derbyshire*—Proprietors and Manufacturers.

Specimens of fluor spar, calcareous spar, calamine, white-lead ore, lead ore, sulphate of barytes, and sulphate of barytes manufactured as a pigment. From the Dinah, Goodluck, and other mines in the vicinity of Cromford, Derbyshire.

88 FALMOUTH LOCAL COMMITTEE—Producer.

Quartz, pebbles, and sand, from Swan Pool, near Falmouth.

89 NICHOLLS, J., *Truro*—Producer.

Fire-clay, used for stopping furnaces.

90 WHITEWAY, WATTS, & Co., *Wareham, Dorsetshire, and Kingsteignton, Devonshire*—Producers.

Blue clay, used in potteries, raised from the exhibitors' pits called Furzbrook, near Wareham, Dorsetshire.

Black and carbonaceous clay, for pottery purposes. Pipe clay, for making tobacco pipes. Top clay, for brown stone-ware purposes. Alumina clay. Draining clay, for draining tiles; all from the pits of Kingsteignton.

91 KING & Co., *Stourbridge*—Producers and Manufacturers.

Glass-house pot, made of Stourbridge fire-clay, for melting the ingredients of flint glass.

Model of glass-house furnace in fire-clay.

Segment of D-shaped gas retort, made of Stourbridge clay. Segment of round gas retort. These retorts are of greater durability than those made of iron.

Crucibles used in fusing metals.

Specimen of best clay, in its raw state, used in the manufacture of glass-house pots, peculiar to the Stourbridge district, and obtained from the mines of the exhibitors; and of the best black clay, used in the manufacture of crucibles, for melting steel.

[The well-known Stourbridge fire-clay consists of a material of considerable purity, existing in beds underlying coal in the coal-measures of the district. Similar beds of fire-clay, though rarely so good, occur elsewhere, and are extensively worked; but none have attained a reputation equal to that of Stourbridge in the manufacture of retorts and other fire-clay goods which have to sustain long-continued and intense heat. The chief excellence consists in the absence of iron and of alkaline earths (which would produce fusion of the clay), and a certain amount of porosity admitting of a little expansion and contraction. In the raw goods, the quality is not seen, but in those that have been fired, paleness of colour and the absence of cracks are considered good marks of excellence.—D. T. A.]

92 JENKINS & BEER, *Truro*—Producers.

Ochres, three in a powdered state, of different shades of colour, and one in lumps of two shades of colour; produced at Kea, near Truro; used in the manufacture of paints, paper-hangings, &c. Exhibited on account of their clearness, fulness of colour, body, and cheapness.

93 JENKINS & COURTNEY, *Truro*—Producers.

Specimens of Cornish china-stone, exhibiting its natural fracture; raised in the Great Bodilla china-stone quarries, St. Stephen's, Cornwall, and largely used in the potteries for the manufacture of the finer descriptions of china and earthenware.

[China-stone and china-clay, both of which are most extensively used in the potteries, are produced in the neighbourhood of the great granite ranges of Cornwall and Devonshire: in the former county chiefly from the St. Austell granite, and also from Tregorming Hill to the south of Helstone, and from the southern granite of Dartmoor in the latter county. The decomposed granite of St. Stephen's, and the uses to which it and the clay produced from it could be applied, were discovered in 1768 by Cookworthy of Plymouth, who was the first person who made hard porcelain in this kingdom. To this discovery is due entirely the manufacture of porcelain, similar to that of china.

The composition of this kaolin, or porcelain clay, varies in different localities, the average of the best Cornish clay giving an analysis—alumina, 24.6; silica, 44.30; lime, magnesia, and potash, 1.60; water, 8.74. The pure kaolin of Dartmoor being, alumina, 36.81; silica, 44.25; lime, magnesia, and potash, 2.20; water, 12.7.

With the increase of our porcelain and fine earthenware manufacture, the demand for these clays has largely increased; and to this must be added a large trade in the china-stone itself, which is used principally for glazing fine ware, the ordinary glaze being composed of decomposed granite, lime, flint, litharge, and borax.

A large quantity of this clay of an inferior quality is used, by the paper-makers and calico-dressers, for the purpose of giving weight and body to their fabrics.

Men, women, and children are largely employed on these clay-works, which, when the clay is being dressed, present a scene of active and curious industry.—R. H.]

94 THRISCUETT, C., *St. Austell*—Producer.

China-clay as dug out of the earth, from Caudledown Clay-works; prepared, burned, and calcined.

95 WHITLEY, N., *Truro*—Producer.

Clays of the district of Truro.

97 MINTON, H. & Co., *Stoke-upon-Trent*—Manufacturers.

A collection of the various materials used in the manufacture of all kinds of porcelain and earthenware.

1. *Raw material*.—Cornish clay in its natural state; and the same prepared for use; both from the Cornish Clay Company; the same fired. Cornish clay as prepared at Mr. Thriseutt's works, Caudledown; the same fired. Cornish stone from the Cornish Clay Company; the same ground and fired. Swedish felspar; the same ground and fired. Blue clay, from Fayle's works, Dorsetshire, in the raw state; the same fired. Blue clay from Whiteway's works in Dorsetshire; the same fired. Gravesend flint in its natural state. Flints calcined. Flints calcined and ground.

2. *Glazing Materials*.—East Indian tinical, or borax in its imported crude state. Boracic acid. Borax crystallized, from Mr. E. Woods of Liverpool. Oxide of lead. Fritt for glaze. Paris white. Soda. Potash. Nitre.

3. *Colouring Material*.—Oxide of copper. Protoxide of nickel. Oxide of chromium. Oxide of tin. Peroxide of manganese. Oxide of zinc. Peroxide of cobalt. Smalt-blue. Oxide of antimony. Granulated gold. Granulated silver.

98 HIGHLEY, SAMUEL, jun., 32 *Fleet Street*—

Importer.

Collection of rocks and fossils, stratigraphically arranged, to illustrate modern works on geology; from Dr. Krantz's establishment at Bonn.

99 GREAVES, V., *Warwick*—Proprietor and

Producer.

Two busts of Sha. ware, in cement.

100 FAYLE, BENJAMIN, & Co., *Old Swan Lane, Upper*

*Thames Street*—Proprietors.

Specimen of blue potters' clay, as dug from the pits at Norden, Isle of Purbeck, county of Dorset; used for the manufacture of earthenware; said to possess greater strength of body, and to shrink less than many other clays when exposed to high heat.

101 PHILLIPS, WILLIAM, *Morley Works, near Plympton*

—Producer and Proprietor.

1. Specimen of disintegrated granite from Morley Works, Devon, in which the felspar is in a decomposed state, pure, and in a large proportion, compared with the quartz, schorl, and mica.

2 and 3. Prepared china clay, or decomposed felspar, the result of washing; used chiefly in porcelain, fine and common pottery, calico-dressing, and paper-making.

4. Specimen of clay for fire-bricks and crucibles.

5. Plymouth porcelain, made by Cookworthy, the discoverer of china-clay in this country.

6 and 7. Porcelain made from Morley clay.

8 and 9. Pottery from this clay, made of 80 per cent. of clay, with flint and china-stone.

[A large quantity of china-clay is found on the south side of the Dartmoor granite, the quality of the clay being excellent, and the position exceedingly favourable for the supply of the Staffordshire potteries by railway carriage. The china-clay of Devonshire possesses much interest, not only by its excellent quality, but also as the material from which Mr. Cookworthy, the first manufacturer of porcelain in England, probably obtained his material. The process of purifying china-clay is at present simply mechanical, but is capable of much improvement, and the coarse parts of the clay are well adapted to the manufacture of brick of various kinds. The china-clay is obtained from the decomposition of particular varieties of granite.—D. T. A.]

10 and 11. Pottery of ordinary manufacture, with small proportions of china-clay, flint, and stone.

12 and 13. Bricks made from clay.

14, 15, and 16. Pottery and china, illustrative of the application and uses of this china-clay, which has a larger proportion of alumina than other china-clays, and is free from metallic oxides.

[The china-clay and china-stone used in the manufacture of the finer kinds of porcelain are chiefly obtained from decomposed granite; the felspar of the granite, under certain circumstances, yielding to the action of the weather, and parting with its alkaline earths, and the harder, heavier, and coarser parts of the granite removed by mechanical washing, either naturally or artificially. The purified material thus obtained is called *kaolin*; its specific gravity is from 2.21 to 2.26. Some of the finer kinds contain, when boiled for a short time in a solution of potash, about equal parts of silica and alumina, upwards of 10 per cent. water, and from 2 to 10 per cent. of free silica; the mineral being therefore represented by the formula  $A : S : + 2 Aq.$

The formula for felspar is  $3 A : Si_2 + K : Si_2$ , the potash being often replaced by soda, and the nature of the change may thus be understood. The best china-clay in England is obtained from Cornwall and Devonshire.—D. T. A.]

102 PIKE, WILLIAM & JOHN, *Wareham, Dorsetshire*—Producers.

Potters' or blue clay, from the island of Purbeck, Dorsetshire, used in British and foreign potteries.

[The greater part of the best pottery produced in various parts of the world has Dorsetshire clay for its principal ingredient. Blue, or potter's clay, for making fine ware, should mix tough, be free from sand, burn a good colour, and bear a large proportion of flint. This clay is said to possess these qualities; and a piece of earthenware made by Messrs. T. J. and J. Mayer is exhibited, which contains no other but china-clay.]

Stoneware clay, used in the London and Bristol potteries for the manufacture of stoneware and drain pipes.  
Pipe clay, for the manufacture of tobacco pipes.  
Alum clay, for the manufacture of alum.

[A considerable quantity of clay fit for ordinary potters' work, and for the manufacture of tobacco-pipes, besides some alum schist, is obtained in the small peninsula called the isle of Purbeck, on the Dorsetshire coast. This little tract of land contains a curious series of cretaceous. Wealden, and oolitic deposits; among the latter is the Kimmeridge coal elsewhere described, and above the whole series are clays of the Hampshire basin, in the manufacture of which the coal is used. These plastic clays belong to the lowest tertiary deposits.—D. T. A.]

WEST OF ENGLAND CHINA STONE & CLAY COMPANY, *St. Austell, Cornwall*—Producer.

Specimens of china-stone and clay in the different stages of decomposition to which it is subjected prior to its being used in the potteries and bleaching manufactories in various parts of the old and new world.

They are obtained from the most extensive and ancient china-stone quarries and fallow clay beds in Cornwall. The Company holds the exclusive right of working over 3,000 acres of this county. These products have taken the first position in the markets hitherto, especially in Staffordshire, where they are most extensively used, and highly valued.

The china-stone is exhibited in the state in which it naturally occurs; it forms the partially-decomposed granitic ranges which stretch through the centre of Cornwall, where quarries are formed for the purpose of raising it; and next in the state after it has been subjected to the heat of the oven for the purpose of testing its vitrifying properties.

The china-clay, or still further decomposed granite (the china-stone being, as it were, an intermediate stage), is found in large beds, where it is mixed up with the sand which formed a component part of the granite: this is termed the clay stone, of which there are one or two specimens; by trituration with water the clay is sus-

pended and carried off from the sand, which is deposited in the passage of the clay water, to the pits in which it is allowed to stand, so that the suspended particles may fall to the bottom, and the supernatant liquor flow off; the clay deposit is then placed in pans, exposed to the warmth of the sun, and bleaching power of the atmosphere; when thoroughly dry, it is sent to the potteries in the state shown in the case, in large heaps of about 1 foot square: the process to which it is next subjected, that of burning, serves as the best test of its quality,—in which state there are one or two samples; and lastly, the combination of clay and stone shown in the manufactured article, the china cards of the Company.

104 TRUSCOTT, CHARLES, *St. Austell*—Producer.

Cornwall china-stone in its native state; as calcined; as ground; and as ground and calcined. Cornwall china-clay in its native state; as calcined; in a state for porcelain; and in a state for bleaching and paper manufacturing purposes.

105 GRIMSLEY, HENRY, *Oxford*—Designer and Modeller.

Terra-cotta statue of a female figure holding a dial, made in clay obtained from Shotover Hill, near Oxford. Clay, sand, and ochre, from the same place, showing fourteen different strata, to the depth of 25 feet.

106 BURNETT, NICHOLAS, *Black Hedley, Gateshead, Newcastle-upon-Tyne*—Producer.

Specimen of clay, found near Black Hedley. Articles manufactured from the clay, by Messrs. Thos. Fell and Co., Newcastle.

[This clay is of particularly fine quality, and the material manufactured from it exhibits marks of this in the surface it presents, and its uniform tint.—D. T. A.]

107 MARTYN, ELIAS, *St. Austell*—Producer and Manufacturer.

Specimens of china-clay, or kaolin, used in the Staffordshire potteries, in bleaching, and in paper-making. China-stone.

108 WHEELER, PHILIP, & Co., *St. Austell*—Proprietors.

China-clay, or "kaolin," for the manufacture of earthen and china ware.

Bleaching clay, used in the cotton and paper manufactories.

Clay, exported to France, &c., for the extraction and manufacture of alum.

China stone from quarries in the parish of Germoe, Cornwall.

[The china-clay quarries in the adjoining parishes of Germoe and Breage, were the first worked in this country; and from this clay the earliest Plymouth china was made.—R. H.]

109 BROWNE, WILLIAM, *St. Austell*—Proprietor.

Specimen of china-clay, derived from the decomposition of felspar, extensively used in the manufacture of china, porcelain, and parian, for ornamental vases, busts, and all articles that require particular care and delicacy in moulding; and employed in the patent manufacture of ornamental stone, facing, flooring, and tiling, various articles of furniture, &c.

[A very large quantity of valuable china-clay and china-stone are found naturally, and prepared artificially in Cornwall and Devon, chiefly from the St. Austell decomposing granite, and the southern granite of Dartmoor. About 14,000 tons of prepared and 30,000 tons of natural china-clay are annually exported, chiefly to the potteries.—D. T. A.]



- 110 MICHELL, SARAH, *St. Austell*—Producer.  
White china-clay, for manufacturing china and earthenware, also for bleaching paper, calico, &c.
- 111 WANDESFORDE, HON. CHARLES, *Castlemoore*—Proprietor.  
Specimens of anthracite coal. Iron-stone. Fire-clay for fire-bricks. Slate-clay, for flooring-tiles, milk-pans, flower-pots, &c. Clay for making draining-tiles. Sand, for fire-bricks and moulding.
- 111A Specimens of china-stone and china-clay.
- 112 BEANISH, —.  
Carbonate of barytes in lump and powdered.
- 112A Specimens of fire-clay.
- 113 PHIPPAUD, THOMAS, *Wareham*—Proprietor.  
Potters', and pipe or brown clay, from Carey pits, with ware and tobacco pipes made from them; also silicious sand, for the manufacture of glass.
- 115 KING, GEORGE, *Demidge Lodge, Gazeley, near Newmarket*—Manufacturer.  
Red brick earth as dug from the pit. Red building bricks, pavement bricks, and coping bricks made from the earth.
- 116 ENNISKILLEN, the Earl of, *Florence Court*.  
Two kinds of clay, and drain pipes and tiles made of them.
- 117 SQUIRES & SONS, *Stourbridge*—Producer.  
Model of a glass-house furnace, with pots of Stourbridge fire-clay, showing one in a working state; and of a pot, in which the glass is melted.
- 118 ANSTEY, S., *10 Devonshire Street, Hoxton Fields*—Manufacturers.  
Pots for melting iron, brass, gold, silver, antimony, &c.
- 119 FISHER, FREDERICK, *Woolpit, Suffolk*—Manufacturer.  
Specimens of Woolpit brick-earth.  
White building bricks.  
Pavement bricks and draining pipes.
- 120 WALKER, R., *Victoria Works, Beverley*—Manufacturer.  
Carbonate of lime, from the quarry, Victoria Works, Beverley; and Paris white, manufactured from it.
- 121 DEERING, JAMES, *Middleton, Cork, Ireland*—Producer.  
Various materials obtained at Rostellan, county of Cork, Ireland, adapted for use in the manufacture of the better kinds of porcelain and earthenware. These include samples as raised from the mine, which was opened in 1850, and the different substances as used in the arts, and articles of earthenware and glass, manufactured from them.
- 122 PEASE, JOSEPH, *Darlington*—Producer.  
Coal, from Pease's West Collieries, used for general purposes.  
Coke manufactured from the coal.  
Fire-clay, from above and below the coal. The same material in different stages of manufacture.  
Ware produced from the fire-clay.  
Fire-bricks, pipes for sewerage and agricultural drains, coping ridge-tiles, paving quarries, &c.
- 123 HODSON, Sir G., Bart., *Hollybrooke Bray, County Wicklow, Ireland*—Proprietor.  
Silicious sand formed by the decomposition of the quartz rock of the Sugar-loaf Mountain in County Wicklow. It is found in all shades of colour, from pure white to dark orange, the latter being acquired by its admixture with a metallic substance. It is used in the manufacture of porcelain.
- 123A LONG, JOHN E. E., *County Roscommon*—Producer.  
Specimens of drain pipes.
- 124 SMEDLEY, THOMAS, *Well Street, Holywell*—Producer.  
Sand for glass making, and clay from Landidno.
- 124A JOHNSTONE, WILLIAM, *County Leitrim*—Producer.  
Specimens of drain pipes.
- 125 LEE, JOHN, LL.D., *Hartwell, near Aylesbury*—Proprietor.  
Samples of fine washed sand, from a sandhill in the parish of Stone, near Aylesbury.  
White, yellow, blue, and green glass prisms, made from the same.  
Two spheres of white glass, made from the same sand.  
[These sands are from soft beds of the lower green-sand series, of which there is a considerable thickness, forming a knoll at Stone. There is about 8 feet of whitish sand below 7 feet of sand and sandy clay, containing impure fuller's earth. The lower green-sand terminates a little to the west, and is succeeded by the beds of Portland stone, forming a distinct ridge near Hartwell, but covered and obscured by beds of gravel.—D. T. A.]
- 126 MERRISON, DAVID, & SONS, *Kirkcaldy, Scotland*—Manufacturers.  
Drain pipes, with collars; registered drain-pipes, with improved methods of joining, to save collars. Drain-pipes, showing a new method of joining the leading drains with the main. Sewer or water pipes.  
Ventilating roof-tiles, for stables or granaries.  
Vandyke border edgings.  
Mugs; a new method of dipping turning; a cheap imitation of painting.
- 127 NORTH DEVON POTTERY COMPANY, *Anney, near Bideford*—Manufacturers.  
Raw clay as raised from the pit.  
Gravel or sand, from the bed of the River Torridge, near Bideford.  
Mixture of clay and sand, prepared for manufacturing. Sewerage pipes of different dimensions and forms.  
Strong and cheap water-closet pan, for cottages, &c.  
Hollow brick, ornamental ridge and garden tiles, &c. made from the same.
- 127A  
Pipe-clay pipes, and sand for glassmaking.
- 128 BULLER, T. W., *Bovey Tracey Pottery, Devon*—Producer.  
Specimens of lignite or Bovey coal.  
Specimens of earthenware fired with Bovey coal, and showing the colour of the Kingsteignton clays. This is the only instance in which lignite has been successfully applied to the firing of earthenware in England. Extensive deposits of lignite exist both in France and Germany; but De Brogniart (*Traité des Arts Céramiques*, vol. i., p. 222) says, that no one has yet succeeded in the manufacture of earthenware with this fuel except at Elbogen, where it is used mixed with other coal.  
Patent stilts and cockspurs used in the manufacture of earthenware.  
[The Bovey coal is a thick bed of lignite, of comparatively modern date, and existing in the state of bituminized wood, generally coniferous. It is brittle, and leaves a considerable quantity of white ash when burned. It seems a lacustrine deposit, and extends seven or eight miles, having in some places eighteen or twenty beds of lignite, varying in thickness from one to three feet.—D. T. A.]
- 128A GORE, CHARLES WILLIAM, *Moreton-in-Marsh*—Proprietor.  
Brown ochre, in its raw state, used for staining and





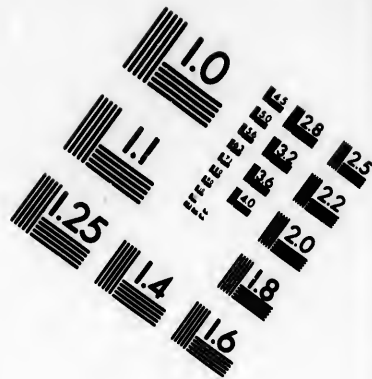
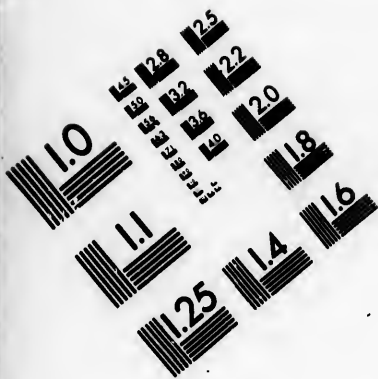

**IMAGE EVALUATION  
TEST TARGET (MT-3)**

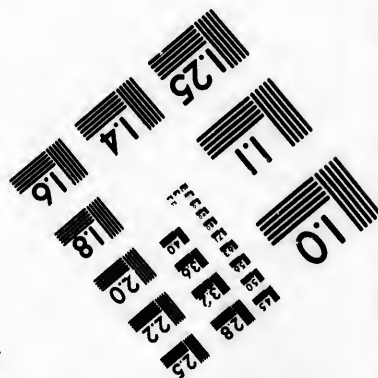
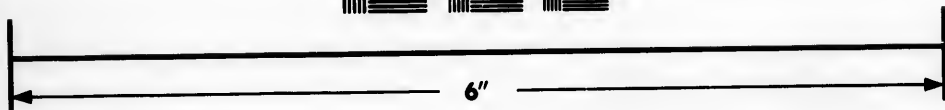
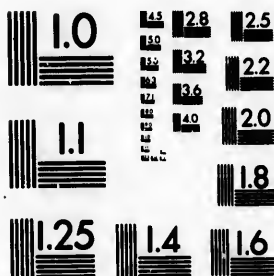

**Photographic  
Sciences  
Corporation**

23 WEST MAIN STREET  
WEBSTER, N.Y. 14580  
(716) 872-4503

13 128 125  
14 132  
15 122  
16 120  
17 118

18  
19  
20  
21  
22  
23  
24  
25  
26  
27  
28  
29  
30  
31  
32  
33  
34  
35  
36  
37  
38  
39  
40  
41  
42  
43  
44  
45  
46  
47  
48  
49  
50  
51  
52  
53  
54  
55  
56  
57  
58  
59  
60  
61  
62  
63  
64  
65  
66  
67  
68  
69  
70  
71  
72  
73  
74  
75  
76  
77  
78  
79  
80  
81  
82  
83  
84  
85  
86  
87  
88  
89  
90  
91  
92  
93  
94  
95  
96  
97  
98  
99  
100

for common purposes. In its raw state it is a stone colour, and is used for houses, glass-houses, &c. When calcined, it is of a deep brown colour, and is used for facia, iron-work, &c.; it has a strong grit, and requires the use of machinery to pulverize, grind, and prepare it.

129 FAHIE, J. K., *Tipperary, Ireland*—Producer.  
White and black clay. Draining tiles and pipes. Felspar, from Cork.

129A COOPER, S.—Producer.  
Specimens of drain pipes from the river Shannon.

130 WHITE, JOHN DAZLEY, & SONS, *Westminster*—Manufacturers.

Case, containing specimens of cement stones and those producing plaster of Paris, as used in England for building purposes; showing the raw stone, the powder calcined and ground, and cubes of cement in a set state. There are two kinds of cement stones; of each kind, as well as the gypsums, it may be well to say a few words.

1st. Natural cement stones. These include the Sheppey stone (Kent), and the Harwich stone (Essex), which produce different varieties of the cement known as Roman cement, introduced by Dr. Parker about 50 years ago. These are both from the older tertiary deposits, and so also are the Hampshire cement stones found at Christchurch, Romsey, &c., which produce the Medina cement. The Whitby stone (Yorkshire), is found in the lias formation, the cement produced being known as Atkinson's cement. At Wolverhampton and in Derbyshire cement stones occur in connection with iron-stone, which imparts to them a ferruginous tint. At Weymouth (Dorsetshire) similar materials are obtained from the Kimmeridge clay, but these are not extensively used for building purposes. Other districts yield natural cement stones, but the above mentioned are those most known in commerce: they are used very largely, both as mortars and stuccoes.

2nd. Artificial cements:—Portland cement is composed of carbonate of lime and the argillaceous deposit of the Medway and other rivers. These materials produce a cement of superior quality, both as to strength and colour. A large panel on a wall, representing a Roman Doric window opening, shows the colour of this cement, and its adaptation for external stucco. In illustration of its strength as a connecting material between bricks, stone, &c., are shown:—a beam of brickwork, loaded with a heavy weight, indicating the value of bond courses of brickwork in cement, and the resistance they oppose to superincumbent weight and cross strain. A beam of tiles bedded in Portland cement, adapted for flooring purposes. Cubes of stone connected by Portland cement, showing its adhesive power as great in stone as in brick. Bricks made of Portland cement, to test its resistance to tensile force. Blocks of Portland cement which have been subjected to hydraulic pressure, to prove its resistance to compression. Portland cement combines with gravel, rubble-stone, &c., to form excellent concrete or beton; specimens are to be seen in parts of a block in concrete stone made at the Digue of Cherbourg, under the direction of Mons. l'Ingénieur Reibell; size of blocks, 15ft. by 8ft. by 8ft.; weight, 45 tons; specimen two years old. Part of a block made at Dover Harbour works, under the direction of James Walker, Esq., which has been exposed during three years in an isolated position to the action of the sea and shingle. Part of a block of concrete stone, made at Alderney harbour works; composition, 1 part cement to 10 parts gravel; weight of blocks 4 to 6 tons. Part of a block of concrete stone, 2 years old; the cement was used in a liquid state.

Gypsums, or sulphates of lime, are found in many parts of England, particularly Derbyshire, Nottinghamshire, and Cumberland; and when calcined and ground they produce the material known in commerce as plaster of Paris; and in combination with alum they produce the hard artificial cements known as Keene's, Martin's, and

Parian patent cements. Keene's cement is composed of sulphate of lime and alum; the intimate chemical combination of these materials effected by calcination imparts to the stuccoes made from them, extreme hardness, by which they are adapted for use in those parts of buildings where strength and durability are required, such as skirtings, columns, pilasters, and mouldings of all sorts; and they are not liable to be injured by fire, vermin, &c. As specimens of Keene's cement are shown—a skirting moulding, worked in the common quality of Keene's cement; two pavements, of which the ground is the common quality, and the inlaid borders of the finer quality; large panel on wall, second quality, adapted for painting. Specimens, showing that in combination with colours, brilliant and forcible imitations of marbles, granites, &c., may be produced, the effect being aided by gilding and inlaying; large panel on wall, and pavement, illustrating the effect of colouring in this material, and its applicability to inlaid work, after the style of Florentine mosaic, at a cost not much exceeding the price of polished vein marble.

[There are three very different processes of manufacture in the case of hydraulic cements and artificial stone, the one consisting of an admixture of caustic lime (with or without magnesia) with silica in a gelatinous state, thus producing in the final result a hydrous silicate of lime; a second, consisting of sulphates of lime burnt with alum; and the other, composed entirely of lime, and forming, in fact, a kind of glass. Each class of artificial stones will be found noted in describing the objects exhibited by different persons. The hydrous silicates of lime, manufactured artificially, consist, as noticed above, of carbonate of lime mixed with agillaceous earth, and calcined with sand or powdered flint, when the alkali, acting on the silica at a bright red heat, produces a mass which, with the subsequent addition of water, becomes permanently solid.—D. T. A.]

130A PIPER, T. & W., and WHITE & SONS—Importers and Manufacturers.

Wall panel executed in *French plaster*, showing its application as a hard and quick-setting internal stucco in place of lime rendering.

131 BLITH & JACOBS, 44 *Baldwin's Gardens, Gray's Inn Lane, Holborn*—Manufacturers.

Gypsum dug from the pits; calcined, and prepared for manure. Specimens of plaster of Paris, with a collection of articles in the same.

[Gypsum (hydrous sulphate of lime) occurs in various ways and various places very abundantly. In a semi-crystalline form it is called *alabaster*, and in crystals *selentic*. In the same combination without water, it is called *anhydrite*.

Most of the gypsum used in the manufacture of plaster of Paris is obtained from tertiary deposits, of which enormous masses exist in the neighbourhood of Paris, especially at the heights of Montmartre. This stone contains above 7½ per cent. carbonate of lime, and 3 per cent. clay, which greatly improves the strength of the cement made from it. It lies between marly beds, and is of fresh-water origin; but other beds equally extensive are of the triassic series occurring with common salt, and others again in the colites of the Alps.

Large quantities of gypsum are obtained from Lincolnshire (Newark) and also from Derbyshire—the best from the latter place.

The gypsum, heated from 250° to 270° Fahr., parts with the whole of its water, and is changed into an anhydrous sulphate. In this state it is reduced to a fine powder, and then, on being again mixed with water, becomes warm, and rapidly solidifies. This is not the case, how-

ever, if the temperature of calcination has been too high, since if it reaches 320° the water is absorbed very slowly. The mode of calcining varies with the object required, the plaster used in constructions being less carefully burnt than that intended for fine casts. A harder and more perfect plaster than the common kind is sometimes made by adding alum during the process of calcination. This material dries more slowly, but is smoother than the ordinary plaster, and has a certain degree of transparency. The use of gypsum as manure depends on its supplying to certain soils lime and sulphuric acid.—D. T. A.]

131a M'ANASPIE, P. & T., 31 Great Brunswick Street, Dublin.—Manufacturers.

Various samples of hydraulic and Portland cements, adapted for all kinds of building work, both useful and decorative:—they are the first ever manufactured in Ireland, and are all taken from the Irish mines.

Specimens of Oriental marbles, in scagliola, used for the interior decorations of houses.

Specimens of green granites, verd antique, Sienna, black and gold, rousse brocade, and brocade-la.

Specimens of green, blue, and yellow cements, adapted for tessellated and mosaic flooring, &c.

[The ancient Romans paid particular attention to their cements and mortars, the durability of which is attested by the remains of their walls: their renowned hydraulic cement is said to have been prepared with a mixture of volcanic sand and lime. Hydraulic cements are such as have the property of hardening under water, and are prepared by the calcination of argillaceous limestone, or with mixtures of lime and argillaceous earth. It appears from the acute researches of M. Vicat, that silica is an essential element in the formation of a good hydraulic cement, the setting of which he attributes to the basis, silicate of lime, passing to the state of hydrate by the absorption of water; for he found that alumina and magnesia did not give to lime the property of hardening under water, although they do not prevent the process of induration: he believes that the oxides of iron and manganese do not contribute in any way to the goodness of the cement.—W. D. L. R.]

131b DYE, C. K.—Producer.

Patent metallic cement.

131c Block of gypsum from county Monaghan, Ireland.

132 GOWANS, JAMES, Edinburgh.—Proprietor.

Group in freestone, designed and executed by A. Handyside Ritchie, 92 Prince's Street, Edinburgh.

This stone is from Redhall quarry. According to the analysis of Dr. George Wilson, of Edinburgh, the average percentage of peroxide of iron is not more than .052. It is said to possess the property of hardening by exposure to the weather, and of retaining its primitive surface.

Specimen of freestone, from Binny quarry, forming the plinth of the group.

Dr. Wilson, in his analysis, says, "This building stone which has been in use for many years in Edinburgh, has been analysed by me, and found to contain the same percentage of peroxide of iron as the Redhall freestone, and I find that it exhibits the peculiarity of having diffused through it a quantity of native bitumen or asphaltum which acts as a protective varnish to the stone, and defends it from the action of the atmosphere."

Specimen of Binny quarry bitumen candles, made from the nearly solid bitumen or mineral wax, which is diffused through the stone, and exudes in considerable quantity between its layers. Owing to its abundance, the workmen use it for domestic purposes.

Specimen of bitumen from Binny quarry, in its natural state. It has been found by Dr. Wilson to yield, on distillation, paraffine, and a liquid hydro-carbon analogous to naphtha.

Model of a steam crane, with travelling gear, worked from a horizontal shaft, and capable of raising 20 tons.

Drawing of a steam crane, worked by crab gearing, attached to a horizontal steam-engine, and capable of raising 50 tons.

Drawing of a boring machine, capable of boring holes to a depth of 40 or 50 feet, from 3 to 6 inches in diameter; used in conjunction with a galvanic battery for separating the large masses of rock in the quarry. It is stated that masses weighing upwards of 6,000 tons have been dislodged by this operation from their beds. It is proposed to apply the same method to the working of coal-mines, blasting of submarine rocks, &c.

133 FRESTON, WILLIAM, Hawthorn Cottage, Stroud.—Producer.

Building-stone from Painswick Quarries; from Sheepscombe, and from Nailsworth Quarries.

134 MAXWELL, WELLWOOD, Munches, Dalbeattie, Scotland.—Proprietor.

Slab of granite from Craignair quarry, near Dalbeattie, Stewartry of Kirkcubright, showing some of the styles in which that stone may be dressed and polished. The value of this granite has been tried in the Liverpool docks and similar works; it is adapted for ornamental architecture.

135 VOSS, JAMES, Woodyhide, Corfe Castle.—Proprietor.

Purbeck marble, from quarries at Woodyhide, Corfe Castle, used in decorating the interior of the Temple Church, London; also used for dairies, hall tables, mantelpieces, &c.

[The Purbeck series of beds occurs at the base of the Wealden formation, and immediately overlies the Portland series. It is best developed in the Isle of Purbeck, where it has a thickness of 275 feet, 55 feet of the upper part of which is useful stone. The beds called Purbeck marble consist, for the most part, of small *Paludina*, cemented by carbonate of lime with much green matter. Other beds are composed of bivalves of the genus *Cyclas*. They are all used for building purposes.—D. T. A.]

136 KING, THOMAS, Morpeth.—Producer.

Block of freestone, from a quarry at Hartford Bridge, Northumberland, belonging to the Earl of Carlisle, with the proprietor's coat of arms cut thereon.

The quality is shown by the fact, that a bridge adjoining the quarry was built of this stone more than 600 years ago, and the marks of the mason's chisel are still visible on it. The same stone was used in the building of Miss Burdett Coutte's church in Westminster; and in repairing Windsor bridge. This stone is quarried by the exhibitor and shipped at the port of Blyth.

137 SIM, WILLIAM, Inverary, Argyllshire.—Producer and Manufacturer.

Granite from the quarries at Inverary and Bonaw, Loch Etive, and from the Island of Mull, manufactured and arranged so as to illustrate their capabilities for works of utility, and for ornamental purposes.

Model of a street, with the causeway, gutter, and kerbstones full size, in their respective positions.

Cubes of granite, showing the various kinds of workmanship generally put on granite; namely, coarse picked, fine picked, ridged, or axed, and polished.

Three ballusters of Bonaw fine-grained granite, hewn with the hammer and chisel.

Three slabs of polished granite.

The granites of Inverary and the fine-grained granite of Bonaw are remarkable for hardness and extraordinary

resistance to tear and wear. They have been extensively used in paving the streets of Glasgow; and officially certified by the Lord Provost and Town Council of that city to be the best ever used for that purpose.

[The granite of Inverary consists of distinct patches, protruding through the gneiss. The granite is of fine quality, and much used. It is of two kinds, the one containing mica and red felspar, and the other hornblende and white felspar with the quartz.—D. T. A.]

138 LENTAIGNE, J., *Tallaght House, Dublin*—Proprietor.

Limestone from Sutton, county Dublin, and from Clane, county Kildare. Porphyry, from Lambay Island, county Dublin.

139 GELLING, FREDERICK LAMOTHE, *Castletown, Isle of Man*—Producer.

Marble, obtained from Coshnahawin and Skillicore, in the parish of Malew, Isle of Man, exhibited in several forms, to show its capabilities—in the rough, with one face polished; table in five pieces; turned specimens; a vase, &c. It can be raised of large size, and of great variety.

Red porphyry, and agate or pebble, with polished faces.

[The limestone of Skillicore and Coshnahawin is of the carboniferous period, and is broken up into rhomboidal blocks, the intervals being often filled with quartz. The rock exhibits a beautiful variegated appearance, but is too much fractured, and appears to be too hard to be worked with profit as a marble.—D. T. A.]

140 COLLES, A., *Marble Works, Kilkenny, Ireland*—Manufacturer.

Bust pedestal of Kilkenny marble, from the Black Quarry.

141 MEREDITH, JAMES HENRY, *Fowey, Cornwall*—Proprietor.

Slab of black porphyry, polished on both sides.

Slab of red porphyry, polished on both sides.

Slab of green porphyry, polished on one side, and partly polished on the other.

Tessellated porphyry table, containing 54 specimens of indigenous stones raised in the parish of Withiel, in the county of Cornwall, from a porphyry quarry, which has been worked for fourteen or fifteen years; it was polished in the mills at Fowey Castle Mine, in the parish of Tywardreath.

Porphyries are principally used for ornamental architecture, such as floorings, ceilings, and sides of rooms, passages, porches, and entrances of various descriptions; tables, recesses, tessellated pavements, monuments, columns, &c.

142 ROSSMORE, Lord, *Rossmore Park, Monaghan, Ireland*—Proprietor.

Specimen of green granite from Rossmore Park, county Monaghan.

143 COURTOWN, EARL OF, *Courtown House, Wexford*—Producer.

Block of jasper.

144 FRANKLIN, PLINEAS LEWIS, *Galway, Ireland*—Proprietor.

Block of black marble, with polished surface. Black marble columns for statues, from quarries on the banks of Lough Corrib, near Galway; used also for ornamental marble works, monuments, tombs, &c.

145 MALAHIDE, LORD TALBOT DE, *Malahide Castle, Londonderry*—Producer.

Specimens of Irish verd antique.

146 HALL, JOSEPH & THOMAS, *Marble Works, Derby*—Manufacturers.

Series of pieces of Derbyshire black marble, arranged

in a columnar form, showing the process of turning, polishing, &c., from the rough block to the finished article. Similar series in Derbyshire alabaster, to illustrate the mode of manufacturing from the raw material.

148 MANDERSON, W.—Producer.

Marbles of Ireland, of various colours, prepared at the Killaloe marble works, on the banks of the Shannon, and raised in the neighbouring districts. Exported from Limerick.

149 DAMON, T., *Weymouth*—Proprietor.

Polished slabs of septaria, or turtle stone, from the Oxford clay formation, Weymouth, Dorset.

[The septaria, of which these are favourable specimens, are obtained from all the principal clays found in England, and consist of concretionary portions in which the carbonate of lime, at first disseminated through the whole mass, had collected, during or before the final drying of the bed. The carbonate of lime, afterwards crystallizing, occupied a still smaller space, as it was deprived of all extraneous matter, and the crevices thus formed, have subsequently been filled up. There is often an organic centre to the concretions of which the septaria is formed. The name septaria is derived from the Latin *septum*, an inclosure.—D. T. A.]

150 MONTEIRO, LUIS ANTONIO, 2 *Upper Phillimore Place, Kensington*—Producer.

Specimen of stalagmite, or Oriental alabaster, veined in colours, from Granada.

151 QUILLIAM & CREER, *Castletown, Isle of Man*—Producers.

Slabs of Poolvash black marble, inlaid with red and yellow composition, to imitate encaustic tiles. Invented and designed by the Rev. J. G. Cumming.

Plain polished slab of Poolvash black marble.

Table of Poolvash grey shelly marble, with enorinical column.

National tile one foot square. Poolvash black marble, with the arms of England, Scotland, Ireland, Wales, and the Isle of Man, in figures inlaid in red.

Slab of black marble, for chess table, inlaid with various marbles of the Isle of Man.

Marble candlesticks.

Wreath of flowers in Poolvash black marble.

152 ———  
Building material found in Sussex.

153 ———  
Specimens of Irish building stones.

153A TRENCHARD, TRENCHARD JOHN—Producer.

Specimens of stone from the Roxwell quarry, near Weymouth.

154 SPARKS, W., *Creekerne*—Collector.

Specimens of stone from the counties of Dorset, Somerset, and Devon:—

Greensand; a silicious stone, from Blackdown Hills, Devon, used as a whetstone for scythes, &c.

Purbeck marble; Purbeck stone; Portland stone. Building stone from Ridgway; and limestone from Langton Herring, near Weymouth.

Building stones, white and calcareous, from Bothenhampton, near Bridport, and Beaminster, Dorset; also from Bath, Douling, near Wells, and Crewkerne, Somerset.

Ferruginous stone, for public buildings, mill-dams, &c., from Hamdon Hill, Somerset.

Blue lias limestone, for docks, railways, &c., from Lyme Regis, Dorset, from Curry Rivell, near Langport, and from Keinton, Somerset.

White lias, from Beer Crowcombe, and from Twerton, Somerset. Gypsum, from the former place.  
New red sandstone, from Bishop's Lydiard, near Taunton, Somerset.  
Millstone grit, for paving, &c., from the Pennant quarries, Hanham, near Bath.  
Carboniferous limestone, from St. Vincent's rocks, Clifton; from the Breakwater quarries, Plymouth, from Newton-Abbott; and from Kingakerwell, near Torquay, Devon.  
Granite, from Dartmoor, Devon, used for Government works, Stonehouse.  
Marlstone or middle lias, from near Ilminster, Somerset.  
Limestone from the Mendip Hills, near Shepton Mallett, Somerset.

[Many of the stones referred to in the above list are of considerable value and interest. The whetstones first alluded to are manufactured from hard sandy concretions, found in the lower cretaceous rocks on the west part of the Blackdown hills, and quarried from galleries driven as much as 300 yards into the hill side. These concretions vary from 8 to 18 inches in diameter, and form a bed about 4 feet thick, available for scythe-stones. The beds above and below are employed for building purposes.

The inferior oolites, worked at Crewkerne as building stones, are not specially remarkable for excellence, but the Hamdon-hill stone is durable and valuable. The Pennant grit is a rock much employed for building and engineering purposes, and belongs to the coal measures.

The granite of Stonehouse and Dartmoor is a valuable and durable material.—D. T. A.]

155

Slab of green Connemara marble from the D'Arcy estate.

156

Mountain limestone from Weardale.

157 CUMMING, REV. JOSEPH GEORGE, *Castletown, Isle of Man*—Producer.

Pale marble (carboniferous limestone), from Scarlett, Isle of Man. Exported from Castletown. Castle Rushen (900 years old), King William's College, St. Thomas's church, Douglas, and Castletown pier, are built from these quarries. It is durable, and easily raised.

158 CHAMPERNOWNE, H. *Dartington House, Totness*—Proprietor.

Cubes of polished Devonshire marbles.

159 TENNANT, JAMES, 149, *Strand*—Mineralogist.

The maps of the Ordnance Survey, geologically coloured by the officers of the Geological Survey of the United Kingdom.

160 FREEMAN, WILLIAM & JOHN, *Millbank Street, Westminster*—Producers.

Several varieties of material used for constructions, namely:—

Granites from Lamorna, near Penzance; from Constantine, near Helston; from Carnsew, Mabe parish, and Polkanago, Stithian's parish, near Penryn; from Zennor, near St. Ives; and from Rosemorrnan, Gulval, Cornwall. Foggintor granite, county Devon; Aberdeen granite, and Peterhead granite, from Stirling Hill quarries, Aberdeenshire; Dalkey or Dunleary granite, county Dublin; Ireland, and Guernsey and Herm granite used for macadamising roads. Polyphant stone from Lewannick, near Launceston.

Limestones.—Purbeck marble, from Swanage, Dorset; and the top vein in the quarry, used anciently in churches and cathedrals. Purbeck stone, called Laning vein, the

second stratum from the top, used chiefly for door steps and street kerbs; freestone, third vein, used chiefly for building; stone, from Down's Vein, fourth from the top of the quarry, used for footway paving; stone, called feather, fifth vein, used in church building; stone, five bed and cap used for carriage-way paving and building purposes; Portland. Portland stone, from West Cliff and from Bill quarries; from the Waycroft quarries; from the Trade quarry, and from the Vera Street quarry, all in the Isle of Portland. Portland roach, the upper part of the regular stone beds; the lowest bed, used for troughs, sinks, &c. Bath stone, from the Farleigh Down quarries; from the Box quarries, and from Coombe Down quarries. Limestone, from Hooe lake, Plymouth; used for agricultural purposes, for footway pavements, and building. Caen stone, from the quarries of M. Jobert.

Magnesian limestone, from the estate of the Misses Gascoigne; Huddleston stone, near Sherburne, Yorkshire.

Sandstones.—Darley Dale stone, from Standiliff quarry, near Bakewell, Derbyshire; Cromwell bottom stone, from the estate of Samuel Freeman, Esq., Southowram, near Halifax, Yorkshire. Bradford stone, from the quarries at Heaton. Potter Newton stone, and Gipton wood stone, from the neighbourhood of Leeds. Bramley Fall stone, from Meanwood quarries, near Leeds; and from Horsforth quarries, near Leeds. Gazby stone, from quarries near Bradford.

Kentish rag, from the quarries of Mr. Bousted and Mr. Seager, near Maidstone.

Fire-stone, from the quarries of Mr. Stedall, Godstone, Surrey.

Slates and Schists.—Caithness slabs, used very extensively for paving.

Valentia slate stone, from the island of Valentia, Kerry, Ireland; the slate is non-absorbent; experiments made by Messrs. Bramah showed that inch cubes required nearly six tons to crush them.

Marble.—Green, and black marble, from the estate of Mr. Martin, county Galway, Ireland.

[Most of the materials commonly used in construction in London are illustrated in the above collection. The Cornish granites and the Portland stones may, however, be selected as requiring notice here. Of the former, those shipped from Penryn are the best known; but the quantity annually exported varies very greatly, and the qualities are also variable. The different kinds exhibited will give some idea of their appearance. The Portland stone is well known, and very excellent, but costly, and rather heavy; it contains 95 per cent. carbonate of lime, 1 silica, and 1 carbonate of magnesia; specific gravity = 2.145, and cohesive power moderate. The upper beds above the freestone are the *top-cap*, *skull-cap*, and *roach*, the latter forming a good stone; the next bed is the best or *top-bed*, from 3 to 8 ft. thick, and this is succeeded by the middle or *curf-bed*, and an inferior bottom bed. The position of the Portland stone is in the upper part of the upper oolites.—D. T. A.]

161 HUTCHISON, JOHN, *Monyray, near Peterhead*—

Proprietor

Bust and pedestal in blue Peterhead granite.

162 NICHOLLS, JOHN, *Trehensing, St. Colomb*—

Proprietor.

Block of porphyry or elvan-stone, raised near Newquay, Cornwall; it is said to resist the action of the weather.

163 LOCAL COMMITTEE, *FALMOUTH AND PENRYN*—

Producer.

Stone, from Porkellis, Wendron, suitable for building, roads, chimney-pieces, or tables. Stone from Forest-gate, Stithians; and from Church Town, about two miles distant; from Mylor, near Penryn; and from Wendron.

Granite, from Wendron.

Stone, for road-making, extensively used on the Truro, Penryn, and Redruth trusts, from Pasko and Treluswell



quarries, Gluvias. Stone, from Steven's quarry, Higher Trelluswell, Gluvias; and from Newham, Kea.

Specimen of porphyry, found near Swan Pool, Fal-mouth, containing crystals of rhomboidal quartz.

Quartz pebbles and sand, from Swan Pool beach.

Magnetic iron ore, from Trelluswell, near Penryn.

[A large quantity of excellent road-stuff is obtained in Cornwall from the "elvans," or porphyritic dykes, which traverse many parts of the county: these elvans also supply the chief building stones of the district. They are, however, not unfrequently met with in a decomposing state, and are then quite unfit for use. The stones obtained from Porkellis, near Wendron, sometimes nearly resemble sandstones. Many excellent stones, both granite and elvan, are obtained near Penryn. The decomposing porphyries and elvans yield occasionally a valuable fire-clay.—D. T. A.]

164 HICKS, THOMAS, *Truro*—Producer.

Varieties of porphyry, for various purposes.

[The porphyries of Cornwall and other districts, where the primary and protrusive rocks prevail, have been neglected up to the present time. In the decoration of Osborne, and some other of the royal residences, ornamental stones of British porphyries, and other ornamental stones, have been used. Many of them are of a beautiful description, susceptible of the highest polish, and all very durable. The greenstones, or as they are sometimes called ironstone porphyries, are now being introduced into London for road-making, and it appears to prove an exceedingly good material for that purpose.—R. H.]

165 WHITLEY, NICHOLAS, *Truro*—Producer.

Varieties of porphyry.

166 ST. AUSTELL COMMITTEE—Producer.

Specimens of building material.

167 LINKEARD COMMITTEE—Producer.

Specimens of building material, prepared in cubes.

168 CLUGAS, T., jun., 8 *L'Hyveruse Terrace, Guernsey*—Proprietor.

Specimens of granite, porphyry, and pot-stone, from Guernsey, Herm, and Sark, used for building and macadamizing.

169 RODD, T. H., Esq., *Trebatha Hall, near Launceston*—Proprietor.

Varieties of porphyry, for ornamental and building purposes.

170 JENKINS & STICK, *Truro*—Proprietors.

Varieties of porphyry, from Tremone, in Withiel.

170 A

Specimens of limestone glazed.

171 SOWDEN, MATTHEW, *Burley, near Leeds*—Producer.

Hard delf-stone grit, from a quarry at Burley, near Leeds, close-grained, strong, and durable; suitable for headstones, steps, &c., and generally for erections exposed to the weather.

172 FREEMAN, SAMUEL, *Cromwell Bottom, near Halifax*—Producer.

Laminated flagstone, from Pearson Brow Quarry, in Hipperholme, Yorkshire, and from Northowram, near Halifax, from Cromwell Bottom and Southowram, and from Hove Edge and Elland Edge, Yorkshire.

Blackstone, from Ringby, near Halifax, and from the Elland Edge Quarry, a bed free from laminae.

All these stones lie above the two known lowest beds of

coal in England, and below the level of the other beds. The laminated stones are split into flags for paving, &c.

Sandstone from the quarries at Greetland, near Halifax, Yorkshire; it lies below the level of any of the known beds of coal.

[The lower coal measures of Yorkshire contain some excellent grits, well adapted for building and paving. Some of the latter are well known and very widely used throughout England.—D. T. A.]

173

Set of dressed blocks of oolitic freestone.

174 HAIGH, JOHN, *Godley Cottage, near Halifax*—Producer.

Specimens of freestone from Northowram quarries, near Halifax. Block, in its natural state; block, variously dressed.

Flag, for causeways and floors of buildings.

Millstone grit, from Halifax.

175 JOHNSTONE, GEORGE, *Craigleith, Edinburgh*—Producer.

Stone from Carlingnose quarry, North Queensferry, Scotland. This stone has been extensively used in Scotland, England, and Wales; more especially at Her Majesty's dockyards at Woolwich, Sheerness, and Chatham; for the breakwater at Warkworth (Northumberland); at Newcastle, Sunderland, and Hartlepool; and in paving the Imperial Museum at St. Petersburg.

Stone from Barton Mount quarry, near Edinburgh; this stone can be procured in large blocks, and in any quantity. Specimen of paving stones from the same granite quarry.

Specimen of stone from Craigleith quarry, near Edinburgh; much used for stairs, landings, and fine pavings; may be seen applied to those purposes at the British Museum, Royal Exchange, Custom-house, &c., London.

[The Craigleith stone is a sandstone of the carboniferous series, consisting of fine quartz grains with a silicious cement, and occasional plates of mica. It is obtainable of any practicable length and breadth, and up to 10 feet thick. Weight, per cubic foot, 140 lbs. It consists of more than 98 per cent. of silica, and 1 per cent. carbonate of lime.—D. T. A.]

176 LUARD, BEEDHAM, & Co., *Caen, Normandy, and Caen Sufferance Wharf, Rotherhithe*—Proprietors.

A specimen of Caen stone, wrought on face.

Four specimens of ancient Caen stone, from St. Stephen's Chapel, Westminster, 16th century; St. Stephen's Church, Caen, 11th century; and Kingston Church, Sussex, 14th century; all in good preservation.

Four specimens of Aubigny stone, wrought.

Three specimens of ancient Aubigny stone from churches at Calvados department, and from the old castle of William the Norman, of the 12th, 16th, and 17th centuries.

A specimen of Ranville stone, from quarries near Caen.

Three specimens of Scotch granite, of which 1 looks of 30 tons can be obtained.

[The Caen stone, obtained in large quantities and of the finest quality from the quarries at Allemaigne, has been long worked, and is well known in all parts of England and France, being used in many of our cathedrals and other public buildings. The quarries are entered by narrow galleries opening from the steep banks of the river Orne, and thus have the advantage of direct water communication at very small cost.

The stone is soft in the quarry, of very beautiful rich cream colour and very even texture. It stands exposure well in France, but is better adapted for internal work in the climate of England. Several very beautiful works in this material will be found amongst the mineral manufactures (Class 27), and in other parts of the building.—D. T. A.]

**177 SMITH, TILDEN, Vine Hall, Hurst Green—**  
Proprietor.

Limestone, raised from a quarry on the property of Samuel John Nicoll, Esq., in the parish of Mountfield, Sussex.

Two blocks of concrete, formed with the Mountfield stone lime. One block has been kept in a damp place since 1850; the other has been kept dry. The Mountfield lime is especially adapted for submarine works, as it possesses the valuable property of hardening under water.

[The limestones of the middle part of the Wealden formation occur in the lower or Ashburnham group, and include a series of shelly limestones and shale resembling the Sussex marble. Extensive lime-works have been long carried on near Battle, and the rocks are found to be much disturbed with faults.—D. T. A.]

**178 BARRY & BARRY, THOMAS and JACOB, Mavgan**  
*St. Columb—Producers.*

Firestone, a soft-grained elvan or porphyry, from quarries near Newquay, used for lining limekilns and furnaces.

[The elvans (porphyritic dykes) of Cornwall are used for various purposes of construction, but it is only occasionally that they yield firestones.—D. T. A.]

**179 KIRK & PARRY, Sleaford, Lincolnshire—**  
Proprietors.

Specimen of Ancaster stone, of the lower colite formation, from the quarry at Wilsford, near Sleaford, Lincolnshire. It is said to be a durable building material, used chiefly for dressings and architectural decorations, and adapted for sculpture and ornaments of various kinds. It rises in beds, varying from 10 to 24 inches in thickness; the texture is close and uniform; and it is stated that although it can be cut with an ordinary peg-tooth saw, like the Bath colite, it will carry an arris equal to that of Portland stone.

[Ancaster stone is a fine cream-coloured colite, cemented by compact, and, often, crystalline carbonate of lime. There are numerous beds, the entire depth of workable stone being 13 feet, and blocks of 3 to 5 tons being obtainable. The stone weighs 139 lbs. 4 ozs. per cubic foot; absorbs very little water; cohesive power tolerably high; composition—carbonate of lime 93·6, carbonate of magnesia 2·9, with a little iron and alumina, and a trace of bitumen. Belvoir Castle, Belton House, and numerous mansions and churches in Lincolnshire are constructed of this stone.—D. T. A.]

**180 FOOT, JOHN, Abingdon Street, Westminster—**  
Proprietor.

Specimens of Best Bed Portland stone, and Whit Bed Portland stone, showing different samples of workmanship.

Specimens of Rosch Portland stone. The backs show natural fractures.

**181 STAPLE, THOMAS, Stoke-under-Hamdon, near Yeovil**  
—Proprietor.

Blocks of Ham-hill stone (colite), partially prepared to show the quality of the stone.

**182 RUTHERFORD, JESSE, Stone Merchant, Wingerworth,**  
*near Chesterfield—Producer.*

Stone from Wingerworth quarry, near Chesterfield, Derbyshire.

Stone from Lion quarry, Wooley Moor, near Wingerworth, Chesterfield.

Stone from Bramley Fall quarry, Wingerworth, near Chesterfield: this stone is generally used in heavy works

such as docks, bridges, &c.; the quarry has been known upwards of 500 years: the stone is obtained in blocks 45 feet long, 20 feet broad, and 18 feet thick, each block weighing about 1000 tons.

[The Bramley Fall stone is a light ferruginous brown sandstone, with an argillo-calcareous cement and very little mica. It weighs 142 lbs. 3 ozs. to the cubic foot.—D. T. A.]

**183 WALSH, JOHN, Executors of, Leeds—Proprietors.**

Sandstone, from the millstone grit series, used for docks, bridges, locks, engine beds, &c.  
Potternewton stone, used for landings, sills, &c.

**184 PRICE, J., High Street, Gateshead, Newcastle-upon-**  
*Tyne—Proprietor and Inventor.*

Freestone, from a quarry in Gateshead, used for building furnaces for glass-houses.

**185 GRISSELL, THOMAS, 11 New Palace Yard,**  
*Westminster—Producer.*

1. Specimen of magnesian lime stone, used in the construction of the New Houses of Parliament, Westminster, from quarries at Anston, in Yorkshire, belonging to the exhibitor, on the estate of the Duke of Leeds.

2. Specimen of this stone, dressed and polished.  
Specimen of the same stone, forming part of an enriched parapet, at the New Houses of Parliament, Westminster.

[The magnesian limestone used in the outside work of the Houses of Parliament was selected on the recommendation of a Royal Commission, and after careful examination, as the finest available material to be obtained. It is a compact semi-crystalline rock, consisting of nearly equal proportions of carbonate of lime and carbonate of magnesia. It is of uniform and elaborate hardness; not very costly, either to obtain or work; weathers well, and of good colour, and is remarkable for its power of resisting compression. It is much heavier than most limestones, weighing upwards of 150 lbs. to the cubic foot.—D. T. A.]

**186 TOWNSEND, RICHARD, Clearwell, near Monmouth—**  
Producer.

Forest stone for steps, coping, &c.  
Ashlar blocks for paving, grave stones, wharf walls, and all kinds of buildings; from the Forest of Dean.

**187 LINDLEY, CHARLES, Mansfield—Proprietor.**

Twelve-inch cube of magnesian limestone, or dolomite from the Mansfield Woodhouse Quarries, re-opened 1840, after a lapse of several centuries, to obtain the supply of stones for the erection of the new Houses of Parliament at Westminster. Chemical analysis:—Carbonate of lime, 51·65; carbonate of magnesia, 42·60; silica, 3·70; water and loss, 2·05. The debris is largely used for the production of carbonic acid gas and Epsom salts.

White calcareous sandstone. Chemical analysis:—Silica, 51·40; carbonate of lime, 26·50; carbonate of magnesia, 17·98; iron alumina, 1·32; water and loss, 2·08.

Red calcareous sandstone. Chemical analysis:—Silica, 49·4; carbonate of lime, 26·5; carbonate of magnesia, 16·1; iron alumina, 5·2; water and loss, 2·8. From quarries which have been in work for four hundred years.

These two sandstones are the connecting link between the magnesian limestone and the new red sandstone formations, partaking of the characters of both.

[The magnesian limestones, valuable for building purposes, are chiefly or entirely those which present equal proportions of carbonate of lime and carbonate of magnesia in a semi-crystalline state. Such stone has a peculiarly pearly lustre when broken, but its colour, when worked, is light yellowish brown, not changing by expo-

sure. Its specific gravity is very high, the stone weighing upwards of 150 lbs. the cubic foot. The cohesive power is very great, and hardly rivalled by any limestone.—D. T. A.]

188 STOCKS, MICHAEL, *Shebden Hall, near Halifax*—Proprietor.

Specimens of ashlar building stone, from the Shebden-head quarries, near Halifax. The seam from which the specimens are obtained is between the lowest, or "Halifax beds," and the "Lowmoor beds" of coal; and between the lowest of the latter, or "better bed" coal, and the Northwram flag-stone. The Halifax beds of coal immediately overlie the millstone grit.

[The coal grits of Yorkshire supply a very good building material, well adapted for local purposes. Where there is not too large a proportion of organic impurities, the sandstones of the coal measures may often be depended on; but there is apt to be a want of cementing ingredients to bind the sand and gritty particles together.—D. T. A.]

189 BELL, JOHN, 25 *Buckingham Place, Fitzroy Square*—Designer and Manufacturer.

Specimen of oolitic limestone, from the Oreston Bank Works, Stottesden, Cleobury Mortimer, Shropshire. Chiselled, sanded, ground, and polished marble, adapted for columns, pedestals, &c.

190 CLARK, GEORGE HOUSTON, *Rotherhithe*—Agent.

Specimen of Devon Haytor granite, from the quarries of the Duke of Somerset, Haytor Rocks, South Devon. Blocks of the largest dimensions can be produced from these quarries. London Bridge, Fishmongers' Hall, the columns in George IV.'s Library, British Museum, part of Tothill Fields Prison, and the pillars to the gates of Christ's Hospital, are all of this granite.

Specimens of Bramley Fall stone, from the Fair Head quarries, Yorkshire, and from the quarries at Marshall Meadows, Berwick-on-Tweed.

Specimen of Spanish marble, polished.

190A SMITH, CHARLES—Producer.

Specimen of oolite limestone and blue granite.

191 WILLIAMS, WILLIAM, 1 *Wellington Street, Cardiff, Wales*—Proprietor.

Freestone from the Quarrella quarry, near Bridgend, Glamorganshire. It contains 99 per cent. of silica. Specific gravity, 2.288.

192 SEYMOUR, ZECHARIAH, *Street, near Glastonbury*—Producer.

Model of a flight of stone steps cut from the blue lias stone, and specimens of workmanship.

193

Porphyritic granite from Wexford.

194 JENNINGS, BENJAMIN, *Hereford*—Proprietor.

Specimen of sandstone, from the Three Elms quarries, near Hereford. Exhibited on account of its strength and durability: it is said to stand equally well on its edge or on its bed; and to be suitable for cider-mills, sea-walls, railway purposes, &c.

195 CUMMING, REV. JOSEPH GEORGE, *Castletown, Isle of Man*—Producer.

Black flagstone (Posidonia schist), from Poolvash, Isle of Man. Exported from Castletown. The quarries have been wrought upwards of 200 years. The steps of St. Paul's Cathedral are from these quarries; they were presented by Bishop Thomas Wilson. Used largely for flooring, chimney-pieces, tomb-stones, and, as suggested by the exhibitor, inlaid with a red composition to imitate encaustic tiles. Easily and economically wrought.

Grey marble (enorinital and shelly limestone), from Poolvash. Exported from Castletown. Used for tables and chimney ornaments.

Black marble (lower carboniferous limestone), from Port St. Mary, Isle of Man. It is hard and durable, and takes a good natural polish; raised in blocks and flags of great size. Used for piers, floorings, tomb-stones, and burnt into a strong lime.

Spanish-head flagstone (clay schist). It is exported from Port St. Mary, used for lintels and gate-posts, and in ancient times for Roman monuments, and is durable and slightly elastic in thin flags, and can be raised in squares of 18 feet each way.

Peel freestone (old red sandstone), from Craig Mallin, Isle of Man. Exported from Peel. A large portion of Peel Cathedral was built of it in 1226.

Granite, from South Barrule, Isle of Man. Quarries lately opened, and the church of St. John built from them. Old fountains on the island, were formed from boulders of this granite. Exported from Douglas, Peel, and Castletown.

Porphyritic greenstone, from Langness, Isle of Man. Good road material. May be obtained and shipped in any quantity at Derby haven.

Hæmatite. Iron ore from the globe vein, Maughold, Isle of Man. Exported from Ramsey.

All the quarries on the island belong to the Crown.

[The different building and road materials, above referred to, will be found to present some rocks of considerable interest, hitherto little used for economic purposes. The marbles and other calcareous rocks are all from the carboniferous limestone, and entirely confined to the southern extremity of the island, near Castletown, where they occupy about 16 square miles, for the most part covered by tertiary gravel. The sandstones, schists, and granites are more abundant, but less valuable.

Of the calcareous rocks, the black flagstones of Poolvash contain much carbon and some argillaceous matter, and are very durable. The different marbles have the same properties as the carboniferous limestones of Derbyshire; and the porphyritic rocks are generally of good quality.—D. T. A.]

196

Stones used at Liverpool for building purposes.

197 POWELL, FREDERICK, *Knareborough, Yorkshire*—Collector.

Building stones, from quarries in the immediate vicinity of Knareborough.

197A RAYNES, LUPTON, & Co., *Liverpool*—Producers.

Specimen of limestone for lithographing from Pentre-gwyddel, near Abergale.

198 CARNEGIE, W. F., *Lindsay, Kintlethmont, Arbroath*—Proprietor and Manufacturer.

Flagstones, rough and planed, from Leysmill Quarries, Forfarshire, and freestone from Borden Quarries, the property of the exhibitor.

Flagstone, rough and planed, from Lord Panmure's quarries at Carmyllie, and freestone from Loches Quarries, belonging to the Harbour Commissioners of Dundee, of which the harbour and dock are constructed.

Flagstone from Balgavies Quarries, belonging to Mr. Baxter, of Ellangowan. Flagstone, rough and planed, from Balmashanner Quarries, belonging to Mr. Watson Carnegie, of Lower.

Old red sandstone shale, or stone-clay, and brick and tile from the same, manufactured by the exhibitor.

Flagstone from Gaynd Quarries, belonging to Mr. Pierson.

All these flagstones are generally exported from Arbroath, and are known as "Arbroath Pavement."

- 190 **LONG, W.—Producer.**  
Flags from County Clare.
- 200 **HILL, J., C.E.—Producer.**  
Building material from Kilrush.
- 201 **TAYLOR, JOHN, Stamford—Producer.**  
Marbles, sandstones, slate, limestone, &c., all obtained within six or seven miles of Stamford.

202 **POWELL, W. J., Tisbury, near Hindon, Wilts—Producer.**  
Varieties of hard and soft building stone, from Tisbury. The hard from Chicksgrove quarry, 20 feet below the surface, forming part of the Portland bed. The soft from Tuckermill quarry, 5 feet deep. The hard is used for steps, pavements, tablets, monuments, &c. The soft, for fronts of houses, cornices, and general building purposes. Both are adapted for resisting the influence of the weather.

A fish from the oolite formation at Tisbury. Specimen of part of a fossil tree from Tisbury, found in an excellent state of preservation in the oolite formation.

203 **DRIVER, WILLIAM, 4 Lyon's Inn, Strand—Producer.**  
Specimens from the Chevin stone quarry, Otley, Yorkshire.

204 **THE LESSEES OF THE STANHOPE LIMESTONE QUARRIES—Proprietors.**  
Polished specimens of the oolite strata in the carboniferous limestone; from Weardale in the county of Durham.

Specimen of the same in the rough state. The lime manufactured from this stone is valuable as an agricultural manure. It is used as a flux in smelting iron ore; also for purifying gas; for tanning, and for other chemical purposes. The analysis is as follows, viz.:

|                             |       |
|-----------------------------|-------|
| Carbonate of lime . . .     | 95.1  |
| Carbonate of magnesia . . . | 2.5   |
| Earthy matter . . .         | 1.3   |
| Residuum . . . . .          | 1.1   |
|                             | 100.0 |

205 \_\_\_\_\_  
Slab of sawn slate, from Glanmore, county Wicklow, Ireland.

206 **SINCLAIR, J., Forse, Thurso, Scotland—Manufacturer.**  
Slab of paving stone, from Forse Rock Hill Quarries. (See Outside, No. 13.)

207 **ROYAL DUBLIN SOCIETY—Producer.**  
Specimens of Valencia flags.

208 **DAWBARN & Co.—Producers.**  
Manufactured slate.

209 **STIRLING, THOMAS, jun., Belvidere Road, Lambeth—Designer, Inventor, and Manufacturer.**

Slate cabinet, illustrating the applicability of slate to the formation of strong-rooms, powder-magazines, larders, venison-houses, partitions to rooms, water-closets, &c. The covering of the cabinet is formed by the bottom of a slate cistern, consisting of slabs of slate secured together in panels by a method invented by the exhibitor. The same method is also applicable to the covering of the roofs of mansions with slate.

Slate is adapted for use in fitting up the floors and compartments of public baths and wash-houses; and for stables, being applicable to mangers, stall divisions, linings, floors, and drains. It is also adapted for balconies, larders, wine-cellar, dairies, and various other purposes.

Articles exhibited in the cabinet, &c., and in general use:—

Patent self-acting filter on stand. Filter, which can be supplied by hand or made self-acting. Small slate cistern. Pickling trough. Samples of slate roll ridge; common saddle-back slate ridge. Sunk channel in slate. Solid slate sink. Slate sink constructed of five pieces. Washing-basin for water-closet, &c. Ornamental loo-table top. Sofa and side-table ornamental tops. Chess, or ladies' work-table tops. Inkstand. Water-closet supply box for slate cistern. Waste, union screw, and drawing-off tap for slate cistern. Samples of various nails and screws used in slate work. Half of roof covered with Delabole slab slates. Specimen of Bangor slab slating.

Specimens of roofs covered with imperial slates from the Bangor quarries; rag slates from the old Delabole quarry; rag slates and green rag slates from Llanberis quarry; red duchess slates with three green slate diamonds; slates from Festiniog quarries, as cut by Mathews' patent cutting machine; open space new quarry duchess slates from Llanberis quarry; imperial slates from Aberdovey quarries, near Machynlleth.

Slate bed-room and dining-room chimney-pieces, from old Delabole quarries—in imitation of marble.

Carved head-stone; out clock face.

[The collection of slates referred to in the above description is calculated to give an idea of the best qualities introduced into the London market, with the kind of use to which most of them are applied. The chief localities are Cornwall (Delabole), Wales (Festiniog, Penrhyn, Llanberis, &c.), Lancashire, and Westmoreland. The Delabole is especially adapted for church and other roofs, and has been much used for this purpose.

The slates, lettered A, are from the great quarries at Penrhyn, and shipped at Bangor. These quarries have as many as 10 levels, and employ upwards of 2,000 persons. Those marked B, are from Llanberis; C, from the Dorthea Slate Company's quarries, near Carnarvon; D, E, from quarries at Festiniog, shipped at Port Madoc; F, G, from near Machynlleth, North Wales, shipped at Aberdovey; H, from Delabole, Cornwall, shipped at Padstow; I, K, L, M, from near Ulverstone, in Lancashire, including some of the Westmoreland quarries, and shipped at Ulverstone.

The present consumption of slate in London is to the extent of from 30,000 to 40,000 tons per annum. One third of this quantity is in slabs, and the rest in roofing-slates, which are in nine sizes, called respectively "ladies," "countesses" (3 sizes), "duchesses" (2 sizes), "queens," "rags," and "imperials." From "ladies" (16 inches by 8) to "duchesses" (24 by 12), the slates are sold per thousand (of 1,200 slates), but above that size by the ton. The "ladies" weigh 25 cwts. the 1,200 slates, and the "duchesses" 3 tons. The regular-sized slabs vary from 1 to 6 feet in length, and 1 to 3 feet in breadth. A large quantity of slate slabs is now used for ornamental purposes.—D. T. A.]

210 **GREAVER, JOHN W., Port Madoc, Carnarvon, Wales—Proprietor.**

Slabs and slates from the quarry at Festiniog, with tools used in manufacturing the same. Blue lias lime.

[Slate is extensively used in slabs for water cisterns and for covering roofs of slight inclination. For both these purposes it is jointed, and the joints are made with a cement, aided, as roof covering, by tongues in the joints and by covering fillets. But the most extensive employment of slate is for roof covering, in the form known familiarly as *slates*. Slates are rent and dressed to sizes, and laid to lap and bond. Jointed slating is apt to fail

from the expansion and contraction of the material, whilst lapped and bonded slating adapts itself to movement from changes of temperature or otherwise, without any derangement that can lead to failure.—W. H.]

211 **BRADALMANE, Marquis of, Taymouth, Aberfeldy, Perth**—Producer.

Slates from the quarries of Easdale, &c., in Argyllshire.

[The Easdale and other slate quarries of Argyllshire which have been worked for upwards of three centuries, employ about 200 men and boys, and export about 10,000,000 of slates annually, in about 300 vessels. The slates are not obtained generally in very large slabs, but most of the quarries supply a fair proportion of the larger kinds, used for roofing, and measuring 2 feet by 12 inches (Duchesses). They are worked in Easdale, Seil, and other small islands of clay slate, a little south of Oban, and near the large island of Jura. The quarries are of various dimensions; that of Ellenabeich being 300 feet long, 100 feet deep, and 150 feet broad; the quality improving in the depth. The other quarries are smaller; but those of Easdale are very valuable, and the quality excellent. The stratification of the beds of slate rocks is very much disturbed; but the cleavage is invariable, running N.E. and S.W., and dipping 50°.—D. T. A.]

212 **LIMERICK LOCAL COMMITTEE**—Producer.

Roofing slates. These slates are from the Imperial Company's quarries near Killaloe; and, from their great durability, they have been adopted for use by the Board of Ordnance in Ireland.

213 **GEORGE, J., 43 Edgeware Road**—Inventor, Patentes, and Manufacturer.

Model of a dwelling-house; a method of building with wrought iron and slate slabs, glass, and other materials, intended to secure stability, durability, and freedom from damp and vermin, to save space, and improve temperature and ventilation.

Slate manger, with double swivel, to prevent crib-biting. Fencing in slate and iron.

214 **OLD DELABOLE SLATE COMPANY (by JAS. CARTER), Cumeford**—Proprietors.

Specimen of Davey's patent ridge slate.  
Slate slab, used for flooring, landings, cisterns, &c.  
Roofing slates.

[The magnificent quarries of Delabole have been opened for at least three centuries, and have supplied a large quantity of excellent slate. They are worked in the Devonian slates, near Tintagel, where they are chiefly shipped. The quality is good, combining lightness with strength, and resisting exposure perfectly.

This slate is used not only for roofing, but also in large slabs for various purposes.—D. T. A.]

215 **WILLIAMS, D., Bangor**—Producer.

Patent slate ridges and hip, from Bangor, Wales.

217 **CADELL, HENRY, Dalkeith, Scotland**—Producer.

Coal from Dalkeith Colliery, as a specimen of the general coal-field of Midlothian, with section showing the strata in the coal-field at a depth of 523 fathoms.  
Steelyard, with improvements.

[The Midlothian coal-field is not very distinctly bounded, but contains some kinds of coal much esteemed for household use. It is estimated that the district contains in all, 24 distinct seams, having a total thickness of 94 feet of coal.—D. T. A.]

218 **PENNOCK, TIGAN, & Co., Grose Hill Works, Beverley, and Hull**—Manufacturers.

Stucco paint to be used in oil or water. Beverley Cliff stone, or pure Paris white. Sulphate of barytes from Yorkshire stone. Prepared Yorkshire carbonate of barytes. Beverley Cliff-stone, or carbonate of lime. Yorkshire sulphate of barytes.

219 **HUNTER, L.**—Producer.

Model of a coal mine.

220 **LANGDALE, DAVID, Edinburgh**—Mining Engineer.

Six sections of the Scotch coal field, from the upper red sandstone, to the carboniferous limestone, with specimens of the coals and ironstones of Fifeshire and Ayrshire.

221 **BITUMINOUS SHALE COMPANY, 145 Upper Thames Street, and Wareham, Dorset**—Manufacturer and Producer.

Specimen of bituminous shale, known as the Kimmeridge coal, obtained from the cliffs at Kimmeridge, in the isle of Purbeck, in the county of Dorset. The quarries were opened in August, 1849. It is a combination of bitumen with clay, and from it are obtained, by distillation, volatile mineral oil, grease, asphaltum, and manure—specimens of each of which are exhibited.

[Bituminous schists or shale are not confined to any peculiar geological or topographical limits, and are probably, in most cases, the result of the decomposition of large quantities of animal remains.

The Kimmeridge coal is of high specific gravity (1.319), of dark-brown colour, and without lustre; it effervesces slightly with acids, and burns readily with a yellowish, rather smoky, and heavy flame. It is a very local deposit.—D. T. A.]

222 **CAHILL, M., Ballyconra House, County Kilkenny, Ireland**—Producer.

Peat charcoal, for deodorizing, mixing with manure, smelting, &c.; manufactured in Urlingford Bog, county Kilkenny.

223 **TURNER, SAMUEL, Orchard Place, East India Docks**—Manufacturer.

Coal, and products of its distillation.  
Products from caoutchouc and from wood.

[A number of highly remarkable and peculiar substances arise from the distillation of coal, caoutchouc, and wood. Coal yields, in addition to illuminative gaseous products, various volatile oils, tar, ammonia in several forms, and a complex number of singular chemical substances in a state of vapour, or fluid. Caoutchouc yields a volatile oil in which it is itself soluble, and is largely distilled for the sake of this product, which is used in caoutchouc solutions and varnishes. Wood yields an inflammable fluid called wood spirit, and an impure acetic acid, and tar.—R. E.]

224 **AZULAY, BONDY, Rotherhithe**—Producer.

Patent artificial fuel, made of coal dust by pressure, without the admixture of any other substance.

Coal-dust prepared for pressing.  
Charcoal made of refuse tan, by extracting pyroligneous acid, tar, &c., from refuse matters.

[The immense compression obtained by the hydraulic press, has been employed in the arts for producing cohesion between loose particles of various substances. In the present instance, the same force is used to unite the separate particles of coal dust into a solid mass. A block of great density is the result of the pressure.—R. E.]



225 OXLAND, ROBERT, *Buckland Street, Plymouth*—  
Inventor and Manufacturer.

A series of specimens of Dartmoor peat, and the products obtained by its destructive distillation in cast-iron retorts. The top out of the peat; the under out; peat charcoal; pyroxylic spirit; chloroform made from it; peatine; heavy oil; paraffine; tar; acetate of lime; sulphate of ammonia; and solution of caoutchouc in peatine.

226 LYON & Co., *Swansea*—Producers.

Two bricks of patent fuel.

227 EVANS, GEORGE, 6, *John Street, Adelphi*—  
Producer.

Specimens of peat, and its products, treated under Stone's patent processes, by the exhibitor.

*Peats and Charpeats.*

*Localities whence Obtained.*

*Proprietors of the Lands.*

Devonshire (Dartmoor).  
Somersetshire.  
Lancashire.  
Flintshire.  
Scotland.  
Ireland.

H. R. H. the Prince of Wales.  
— Waring, Esq.  
Lord Burlington.  
Sir John Hanmer.  
Lord Willoughby de Eresby.  
Colonel Chatterton.

Patent compound peat cooke, light and dense.  
Patent compound fuel, anthracite and peat charcoal.  
Ammoniacal liquor; watery product of the first distillation from peat.

Sulphate of ammonia; liquid ammonia; acetate of lime; and pyroigneous acid.

Paranaphthadipose; the general crude product of the first distillation from peat.

Peatole; the heavy oil from paranaphthadipose, first distillation; the same rectified.

Peatine, the peat from paranaphthadipose.  
Peupione, the light fatty oil of peat obtained from peatole.

Adiposole, fatty part of the residue of the distillation of paranaphthadipose.

Peatpitch, pitch-like part of the residue of the distillation of paranaphthadipose.

Adipolein, residue after the distillation of peatole and peatine.

Peocerine; waxy residuum of re-distillation of adiposole.

Paraffine, product of the forced distillation of adiposole.

Bisulphuret of carbon, or spirit of sulphur, obtained from sulphur and charpeat.

Sulphuretted peat charcoal, after having served to carbonise the spirit of sulphur (fit for making gunpowder).

Humic acid. Peat umber, obtained from certain peats.

Panel of oak, graining with peat umber. Panel of rosewood, graining with peat ulmine.

Peat blue; peat-varnish; and peocerine heel-balls.

Huminate:—Stone's patent manures. Peat fire-lighters and revivers; peat plate powder.

Digesting and mixing churn used in the preparation of the oils, &c., with prospectus.

Specimen of black oak from the Flintshire Fen's moss; and of larch from the same. Laths rent from these.

Specimens of lichens and mosses (Sphagna, &c.) concerned in the formation of peat.

228 CORBOLD, EDWARD, 1 *High Street, Kensington*—  
Inventor and Producer.

Peat, condensed without pressure.

Various products obtained from peat.

[The method adopted by the present exhibitor to prepare peat for economic use as fuel is altogether different from that adopted generally. He mixes the peat with a large quantity of water, reducing it to an impalpable mud, and then, by getting rid of the water, obtains a compact mass of considerable density. The mechanical means adopted are simple, and take advantage of centrifugal force—the water being thrown off during rapid revolution.—D. T. A.]

229 SKYSEL ASPHALTE COMPANY—Producer.

Raw material, and various products of asphalt.

230 PATENT FUEL COMPANY, 15 *St. Mary Axe*—  
Manufacturer.

Specimens of Warlich's patent fuel, consisting of the following series:—Welsh steam fuel, manufactured at Swansea; North country fuel, manufactured at Middlesborough-on-Tees; household fuel, manufactured at Deptford, from North country coal; and locomotive coke fuel, manufactured at Swansea; with samples of the tar and coal used in the manufacture.

[Warlich's patent fuel consists of bricks measuring 9 inches by 6½ and 5, and weighing about 13 lbs. They are dense and well made, require breaking before use, and when burning, give off little smoke, but they take some time to light. They contain carbon 90·02, hydrogen 5·56, sulphur 1·62, ash 2·91. They are made of the dust of various kinds of coal mixed up with bituminous matter, and partly charred. The above analysis has reference to those manufactured of Welsh coal.—D. T. A.]

231 GREAT PEAT-WORKING COMPANY OF IRELAND,  
*Offices, 1 Agar Street, Strand*—Producer.

Samples of their condensed peat, prepared by Gwynne and Hay's patent.

232 PARSONS, J., 2 *Wharf, Eagle Wharf Road, New North Road*—Producer.

Two blocks of the patent fuel, and a number of fire revivers.

233 FITZGERALD, REV. RICHARD, *Clare Vein Tarbert, County Kerry, Ireland*—Producer.

Small specimen of peat in its natural state.

240 ROGERS, JASPER W., 88 *St. James's Street*—  
Inventor and Patentee.

Peat-fuel and peat-charcoal, made from peat moss, or sphagnum, produced from the peat or turf bogs of Ireland (which extend over 3,000,000 acres): known in France as "tourbe." Peat-fuels.

Peat charcoal powder, for refiners and pyrotechnists, and for medical purposes.

Granulated peat charcoal, for sanitary uses, in deodorization, &c.

Peat charcoal manure, composed of equal parts of granulated peat charcoal and sewage matter.

Specimens of peat moss, taken from the bog of Allen, Ireland.

241 ANSTED, D. T., Professor, *King's College, London*,  
—Proprietor.

Diagram of a group of coal plants.

242 THE BIDEFORD ANTHRACITE MINING COMPANY.  
MAXWELL, JOHN GOODMAN, Chairman, *Bideford, Devon*—Producer.

Anthracite coal, used for drying malt, lime-burning, &c.

Compressed fuel, moulded in blocks.

Mineral black paint, in powder, and mixed with oil or coal tar: mixed with the latter article, it is said to form a cheap, durable, and preservative varnish; applicable to shipping, out-buildings, &c.

[The Bideford anthracite occurs in certain rocks of the carboniferous system, occupying a considerable portion of the county of Devon, and generally called the culmiferous series. The beds have been worked for upwards of a century, producing a moderate quantity of coal; but the workings are not likely to be greatly extended. The thickness is very variable, averaging as much as seven feet, but sometimes diminishing to a few inches, and sometimes being 12 or 14 feet. To the depth of 8 or 10 fathoms it



has been generally removed by old miners by means of adit levels, but shafts have been sunk more recently.

The pigment referred to is a variety of the anthracite, probably formed by decomposed parts of it, and has been much used.—D. T. A.]

243 MALLETT, ROBERT, C.E.—Producer.  
Anthracite coal from Castlecoomer, Ireland.

244 BAGOT, CHAS., 12 *Charlemont Place, Ireland*—Producer.

Specimen of turf, or peat. The products of turf are tar and a watery liquor; the former divisible into paraffine, heavy oil and light oil; the latter containing ammonia, carbonic acid, acetic and pyrolic acid, and pyroxylic. The gaseous products are, carbonic acid, oxygen, hydrogen, and nitrogen. 100 tons of peat are said to give 10,000 gallons of liquor, 1,000 gallons of tar, 6,269 feet of inflammable gas. The 1,000 gallons of liquor afford one ton of sulphate of ammonia, sufficient acetic acid to give 13 cwts. of grey acetate of lime, and 53 gallons of pyroxylic spirit. The tar yields 300 tons of paraffine, 200 gallons of light hydro-carbonaceous oil, and 100 gallons of more dense and heavy oil.

Anthracite, or stone coal, from the coal-fields of Kilkenny, county Tipperary, on the estate of Ambrose Goring, Esq., of Ballyphilip.

[The Kilkenny coal district includes a series of basins, or troughs, separated into three or four parts by carboniferous limestone. The strata are sandstones and shales, with fire-clay and several workable beds of anthracite coal. The portion in the county of Tipperary extends for about 20 miles in length by 6 in breadth in the widest part. The beds are inclined at a high angle and undulate, the coal being worked by shafts to the centre or deepest part of the trough, and then upwards on both sides. There are only three beds in this district; two of them 2 feet each, and the other 9 inches. It is estimated by Sir R. Kane that 50,000 tons per annum are raised. The coal is considered to be of fair quality. It yields from 8 to 8 or 10 per cent. of red ash, and contains 9 or 10 per cent. of volatile matter.—D. T. A.]

245 Specimen of bituminous coal from the Coal Island Mine, county Tyrone, Ireland.

246 Specimen of Irish coal, iron, copper, and lead ores.

247 BUTLER, JOSEPH LAWRENCE, *Liverpool*—Proprietor.

Specimens of coal, cannel-coal, and coke, from different seams, worked by the Moss Hall Coal Company, at Ince, near Wigan.

248 O'BYRNE, WILLIAM CHARLES, 7 *Montague Street, Portman Square*—Proprietor.

Specimen of the exhibitor's Slievardagh coal.

[Slievardagh is in the county Tipperary, which contains a coal-field about 20 miles long, and 6 miles broad at the widest part; the coals lying in deep troughs, and consisting of three beds, one nine inches, and the others two feet deep. It was estimated by Sir R. Kane that 50,000 tons of coals per annum had been worked from this district up to the year 1845.—D. T. A.]

249 RUSSELL, JAMES, & SON, *Bathgate, Stirling*—Producers.

Specimen of cannel or gas coal, from Boghead, near Bathgate, Scotland, chiefly used for the production of gas, of which it yields 13,500 cubic feet per ton; the specific gravity being .775.

Chips of this coal are found to be so inflammable that, being lighted at a taper, they burn like a piece of wood.

252 WYLAN'S PATENT FUEL COMPANY—Producer.  
Patent fuel.

253 POWELL, THOMAS, *Gaer, near Newport, Monmouthshire*—Proprietor.

Specimen of Duffryn steam coal, raised at Aberdare in Glamorganshire, and exported at Cardiff; stated to be well adapted for steam marine purposes.

Specimen of bituminous coal from the Monythualoyne vein, raised at Lispenitwyn, Monmouthshire; adapted for household and smithy purposes.

Model of the apparatus used for the shipment of coals from boats or waggons at Cardiff dock, worked by a high-pressure steam-engine, and enabling vessels to ship 400 tons per day.

[The great coal-field of South Wales, presenting nearly 1,000 square miles of productive coal area, and divided into an anthracitic and bituminous portion, yields also, and abundantly, that intermediate semi-bituminous variety, called steam-coal, of which the above and some others are well known, and adapted for general use in the Steam Navy. The Duffryn steam coal is rather soft, free-burning, burns cleanly, without smoke, does not cake, and leaves a little white ash. Its specific gravity is 1.326. It yields 84.3 per cent. of coke, and contains—carbon, 84.26; hydrogen, 4.66; nitrogen, 1.45; oxygen, 0.60; sulphur, 1.77; ash, 3.26. Its relative calorific value (carbon being unity) is 87.7.—D. T. A.]

254 BUCKINGHAM, JAMES, 13 *Judd Place East, New Road*—Producer and Importer.

Specimens of anthracite from J. P. M. Myers & Co.'s Bonville's Court Collieries near Tenby, Pembrokeshire, South Wales, which have been worked 25 years. This anthracite has a crystallized structure, ignites quickly, and requires no stoking; it makes no clinkers or smoke, and evaporates one-fifth more water than the best coke. It is uninjured by exposure to weather, having no pyrites.

A fuel is manufactured into blocks from the small coal (sulm) of this anthracite, which burns readily without smoke, and gives great heat.

The anthracite is composed of—

|          |             |          |            |
|----------|-------------|----------|------------|
| Carbon   | . . . 84.18 | Sulphur  | . . . 0.50 |
| Hydrogen | . . . 2.99  | Nitrogen | . . . 0.50 |
| Oxygen   | . . . .78   | Ash      | . . . 0.98 |

Its specific gravity is 1.4119.

255 BARROW, RICHARD, *Staveley Works, near Chesterfield, Derbyshire*.

Coal, from the mines at Staveley, in the county of Derby, which belong to the Duke of Devonshire. This block of coal, 17 ft. 8 in. long, 6 ft. wide and 4 ft. thick, was raised from a shaft 459 feet deep. The coal is 8 ft. thick, and is valued for its cohesive strength and power of combustion, being in general use for steam-boats.

Three small pieces of coal, cut with a saw, from the same mine, intended to exhibit its utility as ballast, or for stowage in steam ships going long voyages. It is extensively used in the manufacture of iron.

[A gigantic specimen of this coal is placed outside the Exhibition Building. The southern part of the great central coal-field of South Yorkshire, and the adjoining counties of Derbyshire and Nottinghamshire, is now much worked, and contains several valuable beds of coal, and rapidly entering into general use. The pits are from 300 to 500 feet deep.—D. T. A.]

258 JONES, SELLS, & CO., 55 *Bankside, Southwark*—Agents for the Proprietors.

A block and pieces of anthracite from the Gwaun Cae Gurwen Colliery, near Llanelli, South Wales; particularly

adapted for use in kilns, in the manufacture of malt, and in drying corn. It is also adapted for use in close stoves, bakehouses, and wherever charcoal is used for heating or cooking, as it burns without smoke or soot. The seam from which the block is taken is 4 feet 6 inches thick.

**259 LLANGENNECH COAL COMPANY, Port of Llanelly, South Wales, & 6 Coal Ex. Langes—Producer.**

Specimens of free-burning, smokeless, steam coal, from the Llangennech colliery.

[The Llangennech coal is dull, soft, and fibrous, with irregular fracture, burning to a red ash, and weighing nearly 57 lbs. to the cubic foot. It contains—carbon, 85.46; hydrogen, 4.20; nitrogen, 1.07; sulphur, 0.29; oxygen, 2.44; and ash, 6.54. Like other semi-bituminous coals, it burns without much smoke, and is therefore adapted for use in the Steam Navy.—D. T. A.]

**260 WESTERN GASLIGHT COMPANY, 9 Holles Street, Cavendish Square—Producer.**

Specimens of the Newcastle cannel coal, from which the gas supplied by the Western Gaslight Company to the building of the Great Exhibition is made.

Specimens of the cannel coke, produced in the manufacture.

**261 ATKINSON, JOHN, Coleford, Gloucester—Producer.**

A complete set of specimens of the workable seams of coal and veins of iron ore, from the Forest of Dean, placed in compartments, showing the name and thickness of each, and also the name of the works from which they are produced; with two sections of the mineral basin, illustrative of the same. The case which contains the minerals is a specimen of the oak of Dean Forest.

[The Forest of Dean coal-field is understood to occupy about 45 square miles; the total thickness of the deposits being about 3,000 feet, of which there is a thickness of 52 feet of coal distributed in 23 seams. It is remarkable for the great regularity of the deposits over a large part of the area, the beds dipping steadily towards the middle of the basin, and the millstone-grit rising and surrounding it. There is, however, an extensive and remarkable fault crossing the field. The workable seams of the district are in three groups, the lowest of which have not yet been much worked, except near their outcrop, where they are reached by levels driven from the hill side. Some parts of the thicker seams measure as much as 12 feet.—D. T. A.]

**262 DAY & TWIBELL, Barnsley—Proprietors.**

A column of coal, three feet square at the base, showing the entire thickness, and all the different qualities of the seams or beds which are found together, and generally known by the name of the Barnsley thick coal, from the Mount Osborne Collieries, Barnsley, Yorkshire. About two-thirds of the entire bed or stratum produce house-fire coal, and one-third, coal for steaming, iron-smelting, &c.

**263 FIELD, COOPERS, & FAULDS, Worsbro' Dale, Barnsley—Proprietors.**

Silkstone Main house coal, from the Silkstone bed—thickness of bed 5 feet 6 inches.

Worsbro' Park hard or steam coal, and soft or house coal, from the Barnsley 10-foot bed.

[The Barnsley coal is obtained from part of the great central coal-field of South Yorkshire, Nottingham, and Derbyshire, a district extending from Leeds to Nottingham, and including as much as 650,000 acres of coal-field. The qualities of coal obtained are bituminous or house-

hold coal, steam coal, cannel, and anthracite, varying much in quality in different localities. There are about 12 workable seams, the total average thickness being upwards of 30 feet, and the thickest seam is 10 feet. The total thickness of the upper carboniferous series here is estimated at about 550 yards. Much of the coal is worked on the long-wall method, and is of good quality.—D. T. A.]

**264 FIRTH, BARBER, & Co., Oaks Colliery, Barnsley—Producers.**

Coal for steam ships, for converting iron into steel, and for smelting iron.

Coal for domestic fires, from the Oaks Colliery, Barnsley, Yorkshire.

**265 CORY, WILLIAM, & WILLIAM, JUN., Commercial Road—Manufacturers.**

London-burnt coke, for locomotive and foundry purposes.

[Coke is the fixed residuum obtained by burning coal in enclosed furnaces, and is generally obtained by the complete combustion of the volatile part of the coal, though large quantities are also produced by the economical distillation of coal in the manufacture of common gas. Coking on a large scale is performed in sets of ovens or furnaces of peculiar form, each charged every 48 hours with from 2 to 4 tons of fresh coal. The dome of the furnaces being heated (generally by the heat left since the previous coking), the coal is lighted from the top by a wisp of straw, all the doors and vents being open, and when in a state of combustion, the draught is so continued as to produce a gradual and slow combustion of the whole mass from above downwards, the gases being consumed. The calcination lasts about 40 hours, and the coal loses 20 to 25 per cent. of weight, but gains in about the same proportion in bulk. The texture of coke is peculiar, and determines its value.]

**266 CLARKE, ROBERT COULDWELL, the Executors of, Silkstone, near Barnsley—Producers.**

Coal, from the old Silkstone Colliery, near Barnsley, Yorkshire.

[The column of coal here exhibited is called peacock or iridescent coal, from the peculiar tints of colour which it shows, and which appear to be generally the result of some action of water on the surface and between the natural faces. This tarnish, rare in most collieries, appears to be particularly abundant in that from which the above specimens are taken. It is not quite clear whether it arises from a very thin film of foreign matter deposited on its surface, or whether the mechanical condition of the surface itself (as in the case of mother-of-pearl) produces the appearance of iridescence.—D. T. A.]

Models of roof, and set of tools, as used by colliers at work in the mines, and in raising coal from the pits.

**267 NIXON, JOHN, & Co., Cardiff—Producers.**

Mertbyr and Cardiff steam coal, obtained from the Werfa colliery near Aberdare and Merthyr Tydvil. This coal is used for steam purposes, more especially for steam ships going long voyages. Its weight is 82.29 lbs. per cubic foot; its specific gravity 1.31. It is said to produce very little smoke. The following is the analysis of this coal as given in the Second Report of the Commissioners (Sir H. De la Beche and Dr. Lyon Playfair) appointed by Government to test the coals suited to the Steam Navy:—

|                                            |        |
|--------------------------------------------|--------|
| Carbon . . . . .                           | 90·27  |
| Hydrogen . . . . .                         | 4·12   |
| Nitrogen, with traces of sulphur . . . . . | 1·83   |
| Oxygen . . . . .                           | 2·53   |
| Ash . . . . .                              | 1·25   |
|                                            | 100·00 |

268 INCE HALL COAL & CANNEL COMPANY, Wigan—  
Proprietor.

Cannel coal, with various veins, manufactured of cannel coal. The cannel coal yields 11·673 feet of gas per ton, which is composed of—

|                                                |        |
|------------------------------------------------|--------|
| Hydrogen . . . . .                             | 40·30  |
| Light carburetted hydrogen . . . . .           | 33·83  |
| Carbonic acid . . . . .                        | 11·35  |
| Olefant gas and divers hydro-carbons . . . . . | 8·50   |
| Atmospheric air . . . . .                      | 4·32   |
| Carbonic oxide and aqueous vapour . . . . .    | 1·53   |
| Nitrogen . . . . .                             | 0·19   |
|                                                | 100·02 |

Specific gravity of gas . . . . . 6·20  
Coke per ton produced 13 cwt. 18 lbs.

Specimens of the Arley and Pemberton coal, sent by the same exhibitors, will be found in the South Enclosure, beyond the western extremity of the Building.

[The Wigan coal-field is a portion of that known as the Lancashire and Cheshire, or Manchester, great coal-field, which ranges nearly fifty miles in length, with a breadth of ten miles on an average. The productive coal area is thus nearly 400,000 acres, and is divided into three principal portions, of which the middle one includes the thick coal seams; and these are worked in various places, Wigan being not the least important. The principal coals are a good caking coal (Arley main) and a very valuable bed of cannel; the former well adapted for domestic purposes, the latter yielding a large quantity of gas.

The total thickness of the carboniferous deposits is very considerable; but the number of seams of coal is large, and the thickness of many of them considerable.

The cannel is of fine quality, and takes a high polish, as seen in some of the specimens exhibited.—D. T. A.]

269 RAMSAY, G. H., *Derwent Haugh, Newcastle*—  
Inventor.

Cannel coal, with carved specimens.  
Coke, and sample of coal from which it is made.  
Samples of prepared manure, for different crops.

270 MITCHELL, Rev. W., A.M., *Woolwich*—Inventor  
and Manufacturer.

Specimen of coal, or bituminous mineral.  
Vase, from the same. Pillars, with statues of Her Majesty and Prince Albert.

Box, for holding postage stamps. Stamp for sealing letters. Railway or sea chessboard and men. Snuff-box, as made from raw material. Snuff-boxes, polished. Box, with bracelets; another with backgammon men; and one with shirt buttons. Razor and knife hones.

The specimen of coal exhibited has recently been discovered near Edinburgh, and can be applied to the fine arts. It is of a brownish colour, and ignites with facility: it does not soil the hands: and it admits of a brilliant polish.

271 RUSSELL, JOHN, *Risca, near Newport, Monmouthshire*  
—Proprietor.

Specimen of black vein coal, raised at Risca, and exported at Newport: the vein ranges from 9 to 16 feet in thickness, and is worked by pits at a depth of 144 yards.

Specimen of Risca rock vein coal: the vein ranges from 4 to 5 feet in thickness, and is worked by pits at a depth of 100 yards.

Specimen of new black vein coal, raised at Cwm Tillery, and shipped at Newport; the vein is about 5 feet in thickness, and is worked by pits at a depth of 130 yards: this coal is stated to be well adapted for steam vessels.

Argillaceous iron ores from the lower coal measures of the South Welsh basin, raised at Risca.  
Fire-bricks manufactured at Risca.

272 MORGAN, RICHARD, & SONS, *Llanelly, Wales*—  
Producers.

Stone-coal, or anthracite, from Cwm Amman, Llanelly, Gelly Ceidrin.

273 COAL TRADE OF NORTHUMBERLAND AND DURHAM,  
*Newcastle-upon-Tyne*—Producer.

Map of the coal-field of Durham and Northumberland, showing the pits and railways, with the faults and other remarkable interruptions.

Section of the coal-field, from and to given points, north and south; and a similar section from east to west. Synopsis of the coal seams, in explanation of the map and section.

Working plan of a colliery, exhibiting the system of working and ventilating the coal mines.

Various specimens of household, coking, manufacturing, and cannel coal.

Specimens of coal from the carboniferous limestone formation of Northumberland.

Specimens of the strata and rocks of the coal formation.

Specimens of the strata and rocks of the carboniferous limestone formation.

Specimens of coke.

Safety lamps, used in the Durham and Northumberland collieries.

Drawings representing sections of Walbottle Colliery engine pit, in which the engines, pumps, &c., are shown.

[The Newcastle coal-field is estimated to contain upwards of 360,000 acres of productive coal area in the county of Durham, and nearly 150,000 in Northumberland. Of this 67,000 acres are now worked, and the average thickness of coal may be regarded as 12 feet. An acre contains 4,840 square yards, and each cubic yard of coal is estimated to weigh a ton; so that it may be considered that the coal-field has contained more than 10,000 millions of tons of coal, of which about one-eighth part is probably consumed, and the present annual consumption may be estimated at ten millions of tons, including the quantity destroyed and rendered unserviceable.

The maps and sections exhibited illustrate the condition of the district and the details of the coal-field. The qualities of coal are three: the common caking kinds, coarser kinds called splint coal, and cannel coal. They are all bituminous, but the proportions differ. The average quantity of gas from the caking coals is about 8,000 cubic feet per ton, the weight of coke being from 10 to 12 cwt.

The cannel coal has been much and profitably worked within the last few years, and yields a very much larger quantity of gas, amounting to 10,000 or 12,000 cubic feet the ton.

The coal is worked in the Newcastle coal-field at a very great depth, exceeding in some cases 1,800 feet; and the areas worked from one set of pits are often very large, amounting to 500 or even 1,000 acres. The associated beds of the coal measures are grits and shales, and there are many slips and faults, some of them very considerable.

The method of extracting the coal in the Newcastle coal-field is that called *pillar-and-stall*, which consists in first working a certain proportion of the coal by opening

galleries at right angles to each other, leaving large pillars of coal to support the roof. These pillars are afterwards removed, and the roof allowed to sink down, forming what is technically called the *goaf*.

Owing to the large proportion of gas present in the coal, and the fact that such gas is given off readily from a newly-fractured surface, and on mixture with atmospheric air becomes highly explosive, it is necessary to take great care of the ventilation of the mines, and this more especially when the roof is partly fallen. The method of working has therefore reference to this, and the lights employed, where any danger is supposed to exist, must also be adapted to the peculiar condition of the mine. The models showing the mode of ventilation, and the structure of the ventilating furnace used to produce a strong current of air to circulate through the mine, together with the safety lamps (invented by the late Sir Humphry Davy), will illustrate these methods. The mechanical contrivances for drawing and screening the coals (separating the dust and small coal) are also very important in the economy of the district.

There are nearly 200 pits or collieries worked in the district: the number of men and boys employed is about 26,000; and the average price of the coal as shipped for London is not more than 11s. per ton. The estimated quantity of coal, sold in the year 1847, was about 7,730,000 tons.—D. T. A.]

274 THE BRYMBO COMPANY, *Wrexham, Wales*—  
Producer.

Minerals, &c., found at Brymbo, near Wrexham, Denbighshire, or in the neighbourhood.

Main coal got at the Brymbo colliery.

[The Brymbo colliery is in a part of the Flintshire coal-field illustrated by the specimen of coal exhibited by Mr. Oakeley. There will be found a magnificent squared block of this coal in the enclosure beyond the western extremity of the Building.—D. T. A.]

275 RANDALL, J., *Coalport, Salop*—Proprietor.

Minerals and their associated fossils, used in the manufacture of Shropshire iron. Also, specimens of clays, pottery, brick, tile, &c.

Cement from the curl-stone, manufactured by M. Brosely.

276 WATNEY, ALFRED, *Llanelly, Wales*—Producer  
and Manufacturer.

Specimen of pure anthracite coal, raised from a pit at Gwendraeth, Llanelly, Carmarthenshire.

Two models of anthracite blast furnace (scale half-inch to one foot), situated at Gwendraeth, Llanelly, Carmarthenshire.

Pig-iron of excellent quality for foundery, tin-plate and boiler-plate purposes.

Furnace cinder or slag, classified according to the quality of iron made simultaneously with each.

Raw coal used in a furnace; it burns without smoke, and bears the strongest heat without decrepitation.

Raw and calcined clay ironstone.

Limestone used as flux.

Sandstone used for lining hearths and boshes of furnace.

277 CLIVE, J. W.—Producer.

Raw and calcined specimens of a stratum of mineral substance found among the scaly iron ores of Clanway colliery, Tunstall, Staffordshire.

300 HUGGIE, BROTHERS, *Gatehead-on-Tyne*—  
Manufacturers.

Samples of plaited ropes for mining purposes.

400 BUTTERLEY COMPANY, *Alfreton*—Producer.

Specimens of coal and ironstone, and of organic remains in connexion with the Derbyshire coal-field, including analyses of the different coal strata.

Iron in its different stages of manufacture, including pig-iron, refined metal, puddled, and merchant bar-iron.

[The great central coal-field of England extends into Derbyshire, and the works at Alfreton and its vicinity have been long known as exhibiting in all no less than 30 seams of coal, whose aggregate thickness is 78 feet.

The iron ore associated with the coal in this district is of excellent quality, and very abundant.—D. T. A.]

401 BAUGH-DEELEY & Co.—Producers.

Iron chains used in coal mines.

Improved vice.

402 CRUTWELL, ALLIES, & Co., *Cwm Celyn and Blaina Iron Works, Aberystwyth*—Manufacturers.

Pieces of pig-iron, forge pig-iron, and refined metal; and cinder, or scoria, produced from them.

Puddled, merchant, and beat bar iron, with scoria.

Finished rail, showing fracture.

Specimen of sigillaria, from the lower coal measures, Cwm Celyn and Blaina Iron-works.

Rails connected, showing a new mode of fastening. The mode of riveting the rails to the chairs with lateral pins or rivets is the patent invention of H. D. Bird, Esq., of Petersburg, Virginia.

403 CAWLEY, P., *Soho, near Birmingham*—Inventor.

Complete model and section of a Staffordshire coal-pit, with apparatus for preventing explosions in coal-mines, by exhausting the combustible gases, and supplying pure air in its place, and for enabling the workmen to ascertain in what state the air is, in the workings of the mine, before going down.

[The thick coal of Staffordshire is worked in a manner altogether different from that adopted either in North-umberland or Yorkshire, as there is constant danger of accident from the fall of the roof, besides that arising from the presence of gas which necessarily accumulates in large quantities in the upper recesses of the mine.

The usual mode of getting the coal is by sinking a pair of shafts at convenient distances, and extending a pair of levels from the shafts. On reaching the intended limit of working, the coal is removed on one or both sides of the levels, for a distance of about 20 yards wide; but pillars of 7 or 8 yards square are left at intervals for the support of the roof. Between each *side line* of this kind a larger and more effectual barrier is left, 16 or 20 yards wide, and this is called a *fire-rib*, and serves not only to prevent a crush of the roof, but to allow of a dam being afterwards constructed to confine the gases. A large quantity of coal is left below by this process of mining, amounting sometimes to one-half or even two-thirds of the whole. The ventilation of the thick coal mines is generally imperfect, owing to the large body of air to be moved; but more accidents occur from falls of the roof than from explosions. The workings are generally left in the care of uneducated contractors called *butty colliers*.—D. T. A.]

404 BRUNTON, W.—Producer.

Model of a plan proposed for ventilating mines, with diagrams.

405 HARRISON, AINSLIE, & Co., *Newland Furnace, Uterston—Producers.*

Hematite iron ore, from Lindal Moor, in Furness, containing metallic iron, 86·47 per cent.; oxygen, 28·50 per cent.; silica, 3·43 per cent.; zinc, ·71; moisture and loss, ·89.

Charcoal pig-iron and furnace cinder, from Newland, Backbarrow, Duddon, and Lorn furnaces, said to be the only charcoal furnaces in Britain.

## 406 FARNLEY COMPANY—Producer.

Specimens of coal, coke, and iron-stone.

407 DICKINSON, THOMAS FRIEND, *Newcastle-upon-Tyne—Producer.*

Specimen of hematite, or kidney ore, exported from Balcarry Bay; used to mix with poorer iron-stone.

[These peroxides of iron vary in the quantities of iron they contain. Where they are crystalline they are usually found to consist—of iron, 70, and oxygen, 30. The uncrystallized varieties are generally not so rich, yielding oxygen, 30·66, and iron, 60·34. These ores afford a considerable portion of the iron manufactured in different countries; they are also, when ground, employed for polishing metals, and used as a colouring material.—R.H.]

408 MOORE, JOSEPH, M.D., *10 Saville Row—Proprietor.*

Iron ore, from the surface of the Arigna mines, on the western side of lake Allen, in the county of Roscommon. Calcined iron ore.

Limestone rock. Fire-clay, used for making bricks for kilns and furnaces. Fire-bricks, made from the same.

Moulding sand.

Specimens of coal found in the locality.

Peat turf, soft and hard. Charred peat for smelting. —Peat, called in Ireland turf, is used as fuel for domestic purposes; it may be used with advantage for smelting the iron ore, having all the effect of wood, and, when charred, of charcoal, which imparts to the iron the properties so highly prized in metal: prepared in wood furnaces.

Bar of iron, from the ore of Arigna. Bar of steel, converted from the same.

Crystallized rock, having a fine fracture, being the surface rock of the district.

Map of the works and section of the mine.

[The river Arigna divides the Connaught coal-field into two parts. The southern division consists of a great mountain ridge called Bhrilieve, at the base of which are the Arigna iron-works. The rocks within this district are similar to those of other coal-fields, consisting of sandstone, shale, clay-ironstone, and fine fire-clay. The shale, which varies in thickness from 300 to 600 feet, rests on limestone rock, and is remarkable for its rich beds of iron-stone.

Sir Robert Kane has given the following analysis of the clay-ironstone from Arigna:—

|                             |       |
|-----------------------------|-------|
| Protoxide of iron . . . . . | 54·42 |
| Lime . . . . .              | 2·23  |
| Magnesia . . . . .          | 2·02  |
| Alumina . . . . .           | 1·43  |
| Clay . . . . .              | 8·65  |
| Carbonic acid . . . . .     | 31·25 |

The mean of many analyses gives 40 per cent. of metallic iron, as the average produce of the iron ore of this district. Sir John Guest reported on the Arigna mines in 1804, and stated the cost of production to be as follows:—

|                                  | £. | s. | d. |
|----------------------------------|----|----|----|
| 5 tons of raw coal at 6s. 4d.    | 1  | 11 | 8  |
| 4 „ ironstone, at 6s.            | 1  | 4  | 0  |
| 1 „ limestone . . . . .          | 0  | 4  | 0  |
| Labour . . . . .                 | 0  | 10 | 0  |
| Rent and other charges . . . . . | 1  | 5  | 4  |
|                                  | £4 | 15 | 0  |

Mr. Griffith, in his report on the Connaught coal-field, estimates the cost of a ton of iron, produced in this locality, at only 3*l.* 2*s.* 5*d.* The real working cost appears, however, to be somewhat between the two. These statements are important, as directing attention to a very interesting iron-producing locality, which does not appear to have received the notice it merits.—R. H.]

409 SCHNEIDER, HENRY WILLIAM, *Uterstone—Producer and Manufacturer.*

Red hematite iron ore.

Pig-iron, from Scotland, used therewith.

Bar-iron, made from the two combined.

Blister-steel, made from a mixture of iron ore and Scotch pig-iron.

Cast-steel, made direct from the iron ore and pig-iron, without being first converted into blister steel.

Shear steel, made direct from the iron ore and pig-iron, without being first converted into blister steel.

410 SOLLY & Co., *Leabrook Iron and Steel Works, Tipton, Staffordshire—Manufacturers.*

Specimens of billet and bar-iron, made by the exhibitors.

Specimens of the finest wire, and of all kinds of steel made from the exhibitors' iron: as blistered, spring, double shear, and cast steel.

Specimens of saws, files, and a variety of other tools, and of fine cutlery, including a carriage-spring, all made from the steel manufactured from the exhibitors' iron.

411 BIRD, WILLIAM, & Co., *5 Martin's Lane, Cannon Street, City—Proprietors.*

Welsh pig-iron: cold blast, bright, mottled, and white pig-iron, and refined metal; from "Blaenavon" and "Coalbrook Vale" iron works. Anthracite, bright, mottled, and white pig-iron, and refined metal; from Ystalyfera and Yniscodwyn iron works.

Scotch pig-iron, from the Gartsherrie, Calder, Govan, and Forth Companies' iron works.

Bar-iron: common, best, and cable, marked GDP, made from Blaenavon pig-iron, and fractured, to show fibre and tenacity. The same made from Govan pig-iron. Staffordshire rounds, squares, flats, best and best scrap, boiler and sheet iron, BBH (crown) mark, with specimens of the fracture, and worked into different forms, to exhibit strength, tenacity, and quality, under various tests. A piece of chain,  $\frac{1}{2}$  inch diameter, proved to a strain of 19 tons. Staffordshire lion mark, made into chain and other forms, to show quality and great tenacity. Staffordshire bars in 10 feet lengths, from  $\frac{1}{2}$  inch to 6 inches diameter, as samples of JB & S (crown) mark. A bar 7 inches diameter, 20 feet 1 inch long, weighing 1 ton 2 owt. 3 qrs. 12 lbs. of best best iron. Staffordshire iron, in various fancy forms, for sash, angle, and half-round iron. Scotch bar-iron, made into screws, nuts, nails, railway-spikes, and boiler-rivets.

Railway-bars: a piece of rail of the usual quality, from the Pentwyn iron works, near Pontypool, fractured under Nasmyth's patent steam hammer, to show the great strength and applicability of red short iron for rails. Sundry rail sections.

Tin-plate iron, made at Brockmoor, Staffordshire, from



*Ystalyfera* anthracite pig-iron, and exhibited in the different processes, from the puddled ball to the tin and terne-plate. The same in wire.

Tin-plates; tin and black-plates, made at Llanelly, Glamorganshire, from Ynloedwyn anthracite pig-iron. Tin and terne-plates, of various sizes and thicknesses, of the brand (crown). Tin and black-plates from Lydbrook. TD.

Patent lap-welded boiler tubes, plain and enamelled, of various lengths and dimensions, brass ferruled. A tube 7 inches diameter, 13 feet 4½ inches long. Corrugated enamelled roofing-plates, in colours. Tire bars, fractured.

The above-mentioned specimens are not manufactured for any special purpose, but are the fair average quality of each particular mark. These marks are well known to the trade, and are extensively used alike for home consumption as for export.

[The iron furnaces of the United Kingdom, in number about 450, of which 7 per cent. may be out of blast, consume annually about 10,000,000 tons of coal, and 7,000,000 tons of ironstone, in order to make 2,400,000 tons of pig-iron, which is the estimated quantity for 1851, at an average cost of 48s. or 50s. per ton, taking all qualities, from No. 1 cold blast to No. 4 hot blast, in the range. The mill power (which can if necessary be extended) at present produces annually 1,000,000 tons of rails, bars, boiler-plates, hoop-iron, and the various descriptions of manufactured iron required for different industrial productions, for export and home consumption. The home consumption is an average in weight of about 14 cwt. per head for the population, and from the facility with which it is procured by every manufacturer in the United Kingdom, it affords the means of subsistence and profit to a larger amount of industrial hands than any other.]

412 THE EBBW VALE COMPANY, near Abergavenny, and 83 Upper Thames Street—Producer.

Samples of coal and iron-stone, with coals, from the Ebbw Vale iron-works, in Wales, and the Coalbrook Dale iron-works, in Shropshire.

Maps showing the strata, vertically, of the South Wales and Shropshire mineral fields. Model of the mineral workings, taken both vertically and horizontally, of the Ebbw Vale estate. Working model of blast furnaces, showing the mode of using the gases and economising fuel. Pieces of various pattern rails, bar-iron, angle-iron, &c. Samples of rails, full length, and other descriptions.

[The South Welsh coal-field has been elsewhere described. The Coalbrook-dale field contains 32 square miles of workable coal, the average number of seams being 17, and the average thickness of the principal seams three feet. The field is much faulted, some of the dislocations amounting to 600 or 700 feet. The coal is of the kind called slate coal, and contains from 1 to 3 per cent. ash. The percentage of carbon is 58 to 64. Very excellent iron is made from several seams of clay-iron ore interstratified with the coal, and yielding upwards of three tons of ore per square yard.

The Ebbw Vale coal is brilliant, brittle, lights easily, and yields a clear fire. It is light, weighing 53½ lbs. to the cube foot.

It contains 89.78 carbon; 5.15 hydrogen; 2.16 nitrogen; 1.02 sulphur; 0.39 oxygen, and 1.50 ash. The coal yielding the above analysis is that known as the "Ebbw Vale 4 feet steam coal." The mine is 400 to 500 feet deep.—D. T. A.]

413 SUTCLIFFE, JOHN CLARKESON, Barnsley—Producer.

Model of Honey Well Colliery, Barnsley, showing the manner in which it is worked and ventilated.

[The method of working coal, adopted in the Yorkshire mines generally, is that known as the *long wall*, and is distinguished from the Newcastle, or *pillar-and-stall* method, by extracting at once all available coal, instead of first taking a small proportion and leaving the rest in the form of pillars. The selection of the method of working should depend on the conditions of the mine; and generally the long-wall system may be considered admissible where ironstone occurs with the coal, the coal being thin or the floor and roof soft, the royalty small, the general superincumbent mass compact, and the water not very troublesome.

When, however, there is much gas, where the coal is deep and the quantity to be extracted from one set of workings very considerable, and the water troublesome, it cannot generally be recommended.

In working the long-wall method, it is usual to put a pair of levels from the shafts, and carry drifts at once to the extremity of the intended workings; and then, removing the coal from the end, the roof is allowed to fall, leaving only an air-way round the outside of the fallen mass (*gob*), cut in the solid coal. The gob is often partly filled with the rubbish removed in getting the coal.—D. T. A.]

413A JAMES, JOHN, Blairston, near Abergavenny, Wales—Inventor.

Model of a blast furnace for smelting iron ore.

[“Smelting” is the process of reducing an ore to the state of a metal. The ore is first calcined or roasted by being burned with coal in the open air, until the water, sulphur, and carbonic acid are driven off; which, if not separated before going into the furnace, would injure the quality of the iron. The roasted ore, coke for burning, and limestone for a flux, are then thrown into the furnace, in the proportions of 14½ tons of coke, 16 of roasted ore, and 6½ tons of limestone for every 7 tons of metal required. The “blast” is the stream of air thrown into the furnace by machinery, for promoting rapid combustion; the pipes conveying the “blast” are called the “tuyeres,” and the ends from which the air issues are called the “nose pipes,” or “nozzles.” Some of the large Welsh furnaces contain 150 tons of ignited material, and 20,000 cubic feet of air are forced into them per minute.—S. C.]

414 DICKINSON, J., F.G.S., Inspector of Coal Mines, Birmingham—Producer.

Section of the strata in the coal and ironstone mines at Dowlais and Merthyr Tidvil, South Wales.

415 BEECROFT, BUTLER, & Co., Leeds, and 8 Paneras Lane, London—Manufacturers.

Pieces of best double-fagoted railway axles, in the forged state, cut to show the mode of manufacture; and broken, to show the fibre in fracture.

Pieces of best quality of railway tire-bar, in the forged state, cut to show the mode of manufacture; and broken, to show the fibre in fracture.

Railway tires, and double-fagoted railway axles, best quality, and double-fagoted cart and carriage axles, in forged state, bent cold in different forms, to exhibit the toughness, soundness, and strength of the material.

[As the speed of the locomotive steam-engine became developed, many results presented themselves which were



as unlooked for by the mechanic and engineer as the speed itself had been wholly unexpected. Among these none has been the cause of more anxiety, and none perhaps of more real danger, than the change which wrought iron in axles and in the tires of wheels is found to undergo when exposed to the severe friction induced by rapid speed under heavy loads. Metal that had been deemed tough and fibrous became brittle, and broke like cast iron.

The specimens of railway tires and axles exhibited, in various conditions, and showing the structure of the metal in fracture, illustrate a method of obviating this result.—W. H.]

Double-worked cable-chain iron, bent cold.  
Tension bar-end, of best Kirkstall iron, torn asunder by 135 tons, by means of hydraulic pressure.  
Bar of iron in the rolled state.  
Walking-sticks made from the iron.  
Railway-carriage wheels of different materials and various construction.  
Wagon and mail axles on various principles.  
Improved Collinge's India and other axles.  
Registered self-acting regulating damper for high-pressure boilers.  
Registered improved moveable eccentric tumbler.

416 WINGERWORTH IRON CO., *Chesterfield, Derbyshire*—  
Manufacturer.

Iron ore and pig iron. Specimens of castings; wrought iron and steel made from the same.

417 BIDDULPH, JOHN, *Cum Acon Works, Taibach, Glamorganshire*—  
Manufacturer.

Bar iron, sheet iron, tin plates, naphtha, and minerals.

418 MILLS, ROBERT, *Fozhoh Colliery, near Swansea*—  
Inventor.

Model of an apparatus for opening and closing doors in mines, by a reversion of levers, one opening, and the other closing the door, on each side of the door; whether worked by the carriage drawn by a horse, or pushed by a man or a boy, the action is precisely the same. The principal advantage is to keep the doors regularly closed; the doors being at present attended to by boys, who are apt to fall asleep, leaving the doors open, and allowing the air to make its escape to the upcast pit; thus leaving the working part of the pit unventilated, and in many cases causes serious accidents. The Foxhoh Colliery, where this method is in practice, has been worked from 80 to 100 years; and there has not been an explosion of gas in it for the last 22 years.

419 THOMAS, JOHN TROTTER, *Coleford*—  
Producer.

Specimens of iron ores, from the Forest of Dean.

420 ULVERSTON MINING COMPANY, *Stainton*—  
Producer.

Furness iron ore (hematite) produced from mines belonging to the Earl of Burlington, and used in Staffordshire, Yorkshire, and South Wales, for mixing with inferior iron ores.

421 MONTAGUE, ARTHUR, *Lydney, Gloucestershire*—  
Proprietor.

Specimens of the iron ore produced from the mines of the Forest of Dean Iron Company, and smelted at their iron works at Parkend, Gloucestershire, with the pig-iron, refined metal, and furnace scoria produced from it, viz. :—

Argillaceous, calcareous, and silicious hematite iron-ore. Best forge pig-iron. Refined metal. Blast furnace scoria.

422 AINSWORTH, THOMAS, *Cleator, near Whitehaven*—  
Proprietor and Manufacturer.

Iron ore (*Hematite*) from mines in Cleator. No. 1. Pig iron from hematite ore only.

423 BEWICK, JOSEPH, *Grosmont, near Wally*—  
Producer and Agent.

Calcareous ironstones from the iron mines of Mrs. Clark, of Hollins House, Grosmont, in the valley of the Eak. Sandstone from the estate of Mrs. Clark, at Fairhead, near Grosmont.  
Petrified shells found in the ironstone beds.

424 BICKFORD, SMITH, & DAVEY, *Tuckingmill, Cornwall*—  
Inventors and Manufacturers.

Several kinds of safety fuse, adapted to convey fire to the charge in the blasting of rocks or of ice, or in submarine operations. The fuse consists of a small column of gunpowder, spun into the centre of a cord. The different kinds are made by adapting the coating to resist the pressure of water. Gunpowder not being allowed in the Exhibition, these samples are made with sand.

[The safety fuse is considered to possess three great advantages over the ordinary mode of firing a charge: first, that of certainty both as to time and resistance to damp; second, that of safety; and thirdly, that of economy.—D. T. A.]

425 PAGE, J. R., *Athenum Club*—  
Proprietor.

Specimens of ironstone, from the Leitrim coal and iron basin. Also some specimens of the same in a washed state.

Small pieces of the iron, from the same, reduced by means of peat charcoal.

426 MONKLAND IRON AND STEEL COMPANY (WILLIAM MURRAY, 33 *West George Street, Glasgow*)—  
Producer.

Specimens of the seams of coal, ironstone, limestone, freestone, fire-clay, and Roman cement, contained in the various strata of the mineral field of Lanarkshire.

Specimens showing the relative quantities of coal, raw and roasted ironstone, pig iron, refined iron, and puddled iron, required to produce malleable iron.

Specimens of white pig iron and malleable iron, square, round, flat and half round; rails, wheel-tires, angle iron, and nail-roads.

[The coal-field of Lanarkshire comprehends about 150 square miles in that county, and contains from 20 to 30 seams of coal, of which five or six are generally worked in one colliery, having an aggregate thickness of about 20 feet. None of the coals are caking, and one kind (the columnar glance coal) burns without flame or smoke.

About half the coal raised is used in the iron-works. The total consumption in 1845 was upwards of two millions of tons.—D. T. A.]

427 BLACKWELL, S. H., *Dulley*—  
Producer.

A series of iron ores, illustrating the general iron-making resources of the United Kingdom. The following remarks have reference to this series:—

The gross annual production of iron in Great Britain is now upwards of 2,250,000 tons. Of this quantity South Wales furnishes 700,000 tons; South Staffordshire (including Worcestershire) 600,000 tons; and Scotland 800,000 tons. The remainder is divided amongst the various smaller districts.

One of the principal causes of the advantages possessed by Great Britain in the manufacture of iron, arises from

the number and variety of the measures of argillaceous and black-band ironstones which alternate with the beds of coal in almost all its coal-fields; and in consequence of which, the same localities, and, in many instances, the same mineral workings, frequently furnish both the ore and the fuel required to smelt it.

So extensive are the ironstone beds of the coal measures, that they furnish in themselves the greater part of the iron produced in Great Britain; but the iron-making resources of the kingdom are by no means confined to them. The carboniferous, or mountain limestones of Lancashire, Cumberland, Durham, the Forest of Dean, Derbyshire, Somersetshire, and South Wales, all furnish important beds and veins of hematite; those of Ulverston, Whitehaven, and the Forest of Dean are the most extensively worked, and seem to be almost exhausted. The brown hematites and white carbonates of Alston Moor and Weardale also exist in such large masses that they must ultimately become of great importance. In the older rocks of Devon and Cornwall are found many important veins of black hematite, and in the granite of Dartmoor numerous veins of magnetic oxide and specular iron ore. The new red sandstone furnishes in its lowest measures beds of hematitic conglomerate. In the lias and oolites are important beds of argillaceous ironstones, now becoming extensively worked; and the iron ores of the greensand of Sussex, once the seat of a considerable manufacture of iron, will, in all probability, again soon become available, by means of the facilities of railway communication.

In the following classification, the number of the blast furnaces in each district is given, and the ironstones of the coal measures are arranged in the definite order in which they occur in the different coal-fields; so that their position, in reference to the beds of coal alternating with them, is at once seen. The more important of the coal-fields are also subdivided into districts, showing the changes which occur in each, and thus giving a concise view of their general character. The other iron ores are arranged according to the geological formations in which they occur.

The produce of the manufacture of iron in Great Britain in 1750 was only about 30,000 tons; in 1800, it had increased to 180,000 tons; in 1825, to 600,000 tons; in the following year the duties upon the introduction of foreign iron were either removed or rendered nominal, since which the production of iron has nearly quadrupled itself, being now about 2,250,000 tons.

SOUTH WALES.—(North Eastern Outcrop.)

| General No. | No. of Series. | PRINCIPAL WORKS:—                                                                                                                                                                | Blast Furnaces. |     |
|-------------|----------------|----------------------------------------------------------------------------------------------------------------------------------------------------------------------------------|-----------------|-----|
|             |                |                                                                                                                                                                                  | In              | Out |
|             |                | Clydach . . . . .                                                                                                                                                                | 4               | 1   |
|             |                | Nant-y-glo . . . . .                                                                                                                                                             | 7               | 1   |
|             |                | Coalbrook Vale . . . . .                                                                                                                                                         | 2               | 2   |
|             |                | Blaina . . . . .                                                                                                                                                                 | 2               | 1   |
|             |                | Cwm Celyn . . . . .                                                                                                                                                              | 2               | 1   |
|             |                | Beaufort . . . . .                                                                                                                                                               | 7               | 1   |
|             |                | Ebbw Vale . . . . .                                                                                                                                                              | 4               | 1   |
|             |                | Victoria . . . . .                                                                                                                                                               | 2               | 2   |
|             |                | Sirhowey . . . . .                                                                                                                                                               | 6               | 1   |
|             |                | Tredegar . . . . .                                                                                                                                                               | 7               | 1   |
|             |                | 50 Furnaces . . . . .                                                                                                                                                            | 48              | 2   |
|             |                | <i>Strata.</i>                                                                                                                                                                   |                 |     |
| 13, 14      | 1              | Soap Vein Mine, Coalbrook Vale.—Four courses, = 7 inches. Average yield about 2,500 tons per acre.                                                                               | Ft.             | In. |
| 15          | 2              | Black Band, Coalbrook Vale.—One course, not very generally worked: only very local.                                                                                              |                 |     |
| 16 to 16    | 3              | Soap Vein Coal . . . . .                                                                                                                                                         | 1               | 2   |
|             |                | Black Pits, Coalbrook Vale.—Ten irregular courses of nodules in about 15 feet of ground. Yield about 4,500 tons per acre.                                                        |                 |     |
|             |                | Killed Coal . . . . .                                                                                                                                                            | 3               | 4   |
|             |                | Big Vein Coal . . . . .                                                                                                                                                          | 5               | 6   |
| 19, 20      | 4              | Three-quarter Balls, Coalbrook Vale.—Worked with three-quarter coal: three courses (two irregular). Yield per acre very variable, averaging about 1,200 tons                     |                 |     |
|             |                | Three-quarter Coal . . . . .                                                                                                                                                     | 3               | 1   |
|             |                | Bwdeleg Coal . . . . .                                                                                                                                                           | 3               | 10  |
|             |                | Engine Vein Coal . . . . .                                                                                                                                                       | 3               | 2   |
|             |                | Yard Coal . . . . .                                                                                                                                                              | 3               | 2   |
| 21, 22      | 6              | Blackband, Nant-y-glo.—Worked with the Old Coal over which it lies, very local in extent, but of very good quality, and forming an important measure at Beaufort and Nant-y-glo. |                 |     |
|             |                | Old Coal . . . . .                                                                                                                                                               | 6               | 6   |
| 23, 24      | 6              | Spotted Pits, Coalbrook Vale.—Two courses = 4½ inches in 4 feet ground. Yield per acre, about 1,200 tons.                                                                        |                 |     |
| 25, 26      | 7              | Little Pits, Nant-y-glo.—Two courses = 5 inches in 3 feet ground. Yield per acre, about 1,400 tons.                                                                              |                 |     |
| 27 to 29    | 8              | Red Vein, Coalbrook Vale.—Three courses = 6½ inches. Yield per acre 1,200 tons.                                                                                                  |                 |     |
| 30          | 9              | Big Vein, Nant-y-glo.—Worked with bottom coal. Two courses = 6 inches. Yield per acre, about 1,700 tons.                                                                         |                 |     |
|             |                | Bottom Coal . . . . .                                                                                                                                                            | 1               | 2   |

The beds of coal in this division of the coal-field are all bituminous. The principal coals only are given in this section. The ironstones are principally argillaceous, although some important beds of blackband or carbonaceous ironstone exist locally. The total thickness of the coal measures, in this series, from the Soap Vein Mine to the bottom coal is about 150 yards.

SOUTH WALES.—(Northern Outcrop.)

| General No. | No. of Series. | PRINCIPAL WORKS:—                                                         | Blast Furnaces. |     |
|-------------|----------------|---------------------------------------------------------------------------|-----------------|-----|
|             |                |                                                                           | In              | Out |
|             |                | Rhymney . . . . .                                                         | 6               | 2   |
|             |                | Dowlais . . . . .                                                         | 11              | 3   |
|             |                | Ivry . . . . .                                                            | 5               | 1   |
|             |                | Penydarren . . . . .                                                      | 5               | 2   |
|             |                | Cyfartha . . . . .                                                        | 6               | 1   |
|             |                | Hirwaun . . . . .                                                         | 4               | 1   |
|             |                | Duffryn and Furnace Yeha . . . . .                                        | 4               | 1   |
|             |                | Ynysfach . . . . .                                                        | 4               | 1   |
|             |                | Aberdare . . . . .                                                        | 6               | 1   |
|             |                | Aberamanou . . . . .                                                      | 2               | 1   |
|             |                | Gadlys . . . . .                                                          | 3               | 1   |
|             |                | 70 Furnaces . . . . .                                                     | 60              | 10  |
|             |                | <i>Strata.</i>                                                            |                 |     |
| 32          | 1              | Gwrid Mine, Dowlais.                                                      | Ft.             | In. |
| 33, 34      | 2              | Soap Vein, Dowlais.—Three courses = 6 inches, worked with Soap Vein Coal. |                 |     |

SOUTH WALES.—(Eastern Outcrop.)

| General No. | No. of Series. | PRINCIPAL WORKS:—                          | Blast Furnaces. |     |
|-------------|----------------|--------------------------------------------|-----------------|-----|
|             |                |                                            | In              | Out |
|             |                | <i>Strata.</i>                             |                 |     |
|             |                | Cwm Bran . . . . .                         | 1               | 1   |
|             |                | Poutypool . . . . .                        | 2               | 1   |
|             |                | Abersyehan . . . . .                       | 2               | 4   |
|             |                | Pant-yu . . . . .                          | 2               | 3   |
|             |                | Ventig . . . . .                           | 2               | 1   |
|             |                | Gelwng . . . . .                           | 3               | 1   |
|             |                | Blainston . . . . .                        | 3               | 2   |
|             |                | 23 Furnaces . . . . .                      | 19              | 11  |
|             |                | <i>Strata.</i>                             |                 |     |
| 1           | 1              | Soap Vein Mine, Blaenavon.                 | Ft.             | In. |
|             |                | Soap Vein Coal . . . . .                   | 2               | 6   |
|             |                | Coal (not named) . . . . .                 | 2               | 6   |
| 2           | 2              | Black Pits, Blaenavon.                     | 4               | 0   |
|             |                | New Vein Coal, or Elled Coal . . . . .     | 4               | 0   |
|             |                | Dreading Coal, or Big Vein . . . . .       | 3               | 3   |
| 3           | 3              | Three Quarter Balls, Blaenavon.            |                 |     |
|             |                | Rock Vein, or Three Quarter Coal . . . . . | 6               | 0   |
|             |                | Yard Vein Coal . . . . .                   | 2               | 6   |
| 4           | 4              | Meadow Vein Mine, or Pwllon, Blaenavon     |                 |     |
|             |                | Meadow Vein Coal . . . . .                 | 6               | 10  |
|             |                | Old Coal . . . . .                         | 3               | 6   |
| 5           | 5              | Spotted Vein Mine, Blaenavon.              |                 |     |
| 6, 7        | 6              | Bottom Vein Mine, Blaenavon.               |                 |     |

SOUTH WALES.—(Northern Outcrop)—*continued.*

| General No. | No. of Series. |                                                                                                                             | Ft. | In. |
|-------------|----------------|-----------------------------------------------------------------------------------------------------------------------------|-----|-----|
| 36, 38      | 3              | <i>Soap Vein Coal.</i><br><i>Upper Black Pin, Downais.</i> —Three courses = 4 inches.                                       |     |     |
| 37, 38      | 4              | <i>Lower Black Pin, Downais.</i> —One course = 3 inches.                                                                    |     |     |
|             |                | <i>Yard Coal</i> . . . . .                                                                                                  | 3   | 6   |
|             |                | <i>Upper Four Feet Coal.</i> . . . .                                                                                        | 3   | 0   |
|             |                | <i>Downais' Big Coal</i> . . . . .                                                                                          | 3   | 0   |
| 39, 40      | 5              | <i>Black Pin Soap Vein, Downais.</i> —Five courses = 11 inches. About 17 yards beneath big coal.                            |     |     |
|             |                | <i>Ras Las Coal</i> . . . . .                                                                                               | 7   | 9   |
| 41          | 6              | <i>Brass Vein Mine, Downais.</i> —Two courses = 31 inches lying immediately on Brass Vein Coal.                             |     |     |
|             |                | <i>Brass Vein Coal</i> . . . . .                                                                                            | 3   | 0   |
| 42, 43      | 7              | <i>Little Pin, Downais.</i> —Eight courses = 15 inches.                                                                     |     |     |
|             |                | <i>Three Coals</i> . . . . .                                                                                                | 3   | 0   |
| 44          | 6              | <i>Little Vein, Downais.</i> —One course = 5 inches, lying over Little Vein Coal.                                           |     |     |
|             |                | <i>Little Vein Coal</i> . . . . .                                                                                           | 3   | 0   |
| 45, 46      | 9              | <i>Big Blue Vein, Downais.</i> —Three courses = 21 inches, lying 4 feet above Lower Four Feet Coal.                         |     |     |
|             |                | <i>Lower Four Feet Coal</i> . . . . .                                                                                       | 3   | 3   |
| 47          | 10             | <i>Spotted Vein, Downais.</i> —Three courses = 18 inches, in 3 feet ground, lying about 5 yards below Lower Four Feet Coal. |     |     |
| 48, 49      | 11             | <i>Red Vein, Downais.</i> —Four courses = 11½ inches in 3 feet ground, about 5 yards underneath Spotted Vein.               |     |     |
| 50, 51      | 12             | <i>Little Blue Vein, Downais.</i> —Six courses = 14 inches in about 12 feet ground.                                         |     |     |
| 52, 53      | 13             | <i>Jerkie Pin, Downais.</i> —Eight courses = 12 inches in about 10 feet ground.                                             |     |     |
| 54, 55      | 14             | <i>Lumpy Vein, Downais.</i> —Three courses = 6½ inches in about 6 feet ground, worked with Lumpy Vein Coal.                 |     |     |
|             |                | <i>Lumpy Vein Coal</i> . . . . .                                                                                            | 1   | 3   |
| 56          | 15             | <i>Top Rosser Mine, Downais.</i> —One course = 5 inches.                                                                    |     |     |
| 57          | 16             | <i>Bottom Rosser Mine, Downais.</i> —Three courses = 9 inches in about 5 feet ground.                                       |     |     |

Total average thickness of measures from Gwrdd Mine to Bottom Rosser Mine about 320 yards. In the last 100 yards of this, there are five workable beds of coal varying from 2 feet to 9 feet thick; and 62 distinct courses of ironstone varying from 1 to 5 inches thick, many of which, however, are necessarily not workable.

SOUTH WALES.—(Central Anticlinal District.)

| General No. | No. of Series. |                                                                                                                                                                                                                                                          | Blact Furnaces. |      |
|-------------|----------------|----------------------------------------------------------------------------------------------------------------------------------------------------------------------------------------------------------------------------------------------------------|-----------------|------|
|             |                |                                                                                                                                                                                                                                                          | In.             | (Out |
|             |                | <b>PRINCIPAL WORKS:—</b>                                                                                                                                                                                                                                 |                 |      |
|             |                | Cwm Avon . . . . .                                                                                                                                                                                                                                       | 4               | 2    |
|             |                | Oakwood . . . . .                                                                                                                                                                                                                                        | 2               | 3    |
|             |                | Garth . . . . .                                                                                                                                                                                                                                          | 2               | 3    |
|             |                | Maesteg . . . . .                                                                                                                                                                                                                                        | 4               | 2    |
|             |                | Llynvi . . . . .                                                                                                                                                                                                                                         | 10              | 10   |
|             |                | Neath Abbey . . . . .                                                                                                                                                                                                                                    | 10              | 10   |
|             |                | 20 Furnaces . . . . .                                                                                                                                                                                                                                    | 10              | 10   |
|             |                | <b>Strata.</b>                                                                                                                                                                                                                                           | Ft.             | In.  |
| 58          | 1              | <i>Upper Blackband, Llynvi.</i> —One course = 20 inches; worked at Llynvi, Maesteg, and Cwm Avon.                                                                                                                                                        |                 |      |
|             |                | <i>Albert Seam</i> . . . . .                                                                                                                                                                                                                             | 1               | 8    |
|             |                | <i>Victoria Seam</i> . . . . .                                                                                                                                                                                                                           | 3               | 0    |
| 59          | 2              | <i>Lower Blackband, Llynvi.</i> —One course = 18 inches. These beds, about 22 yards apart, are perhaps, for extent of area and general quality, the most important Blackbands yet discovered in the South Wales Coal-Field, although not nearly equal in |                 |      |

SOUTH WALES.—(Central Anticlinal District)—*continued.*

| General No. | No. of Series. |                                                                                                                                                                           | Ft. | In. |
|-------------|----------------|---------------------------------------------------------------------------------------------------------------------------------------------------------------------------|-----|-----|
|             |                | thickness to the Blackband in the parish of Gullygar, in the central part of this coal-field.                                                                             |     |     |
|             |                | <i>Yard Vein</i> . . . . .                                                                                                                                                | 2   | 0   |
|             |                | <i>Two and a Half Feet Vein</i> . . . .                                                                                                                                   | 2   | 0   |
|             |                | <i>Two Feet Vein</i> . . . . .                                                                                                                                            | 2   | 0   |
|             |                | <i>One David Vein</i> . . . . .                                                                                                                                           | 4   | 3   |
| 60 to 62    | 3              | <i>Cockshut or Scud Mine, Llynvi.</i>                                                                                                                                     |     |     |
| 63, 64      | 4              | <i>Fire Clay Vein, Llynvi.</i>                                                                                                                                            |     |     |
|             |                | <i>Fire Clay Vein</i> . . . . .                                                                                                                                           | 1   | 4   |
| 65 to 67    | 5              | <i>Yellow Vein, Llynvi.</i> These three courses                                                                                                                           |     |     |
| 68          | 6              | <i>Pin Baling, Llynvi.</i> of mine lie in about                                                                                                                           |     |     |
| 69, 70      | 7              | <i>Black Pin, Llynvi.</i> } 24 feet of ground, and are worked together in the patches or open works of this district.                                                     |     |     |
|             |                | <i>Upper Six Feet Coal</i> . . . . .                                                                                                                                      | 6   | 0   |
| 71, 72, 73  | 9              | <i>Double Pin, Llynvi.</i>                                                                                                                                                |     |     |
|             |                | <i>Two Coal</i> . . . . .                                                                                                                                                 | 2   | 0   |
|             |                | <i>Lower Six Feet Coal</i> . . . . .                                                                                                                                      | 2   | 0   |
| 74          | 9              | <i>Big Vein, Llynvi.</i> These three courses                                                                                                                              |     |     |
| 75          | 10             | <i>Pin Halkin, Llynvi.</i> } lie in about 36 feet                                                                                                                         |     |     |
| 76          | 11             | <i>Farnace Mine, Llynvi.</i> } of ground, and are worked together in the same way as Nos. 6, 8, and 7, in patches or open works.                                          |     |     |
|             |                | <i>Farnace Vein Coal</i> . . . . .                                                                                                                                        | 3   | 0   |
|             |                | <i>Seven Feet Coal</i> . . . . .                                                                                                                                          | 7   | 0   |
|             |                | <i>Coal and Mine Seam, Llynvi.</i>                                                                                                                                        |     |     |
|             |                | <i>Coal and Mine Vein</i> . . . . .                                                                                                                                       | 3   | 2   |
| 77          | 12             | <b>CWM AVON SERIES.</b>                                                                                                                                                   |     |     |
|             |                | <i>Wernddu Seam</i> . . . . .                                                                                                                                             | 2   | 0   |
|             |                | <i>Wern Fyngl Seam</i> . . . . .                                                                                                                                          | 1   | 2   |
|             |                | <i>Twr Myrddin Seam</i> . . . . .                                                                                                                                         | 2   | 2   |
|             |                | <i>White Seam</i> . . . . .                                                                                                                                               | 4   | 0   |
|             |                | <i>Jusak Seam</i> . . . . .                                                                                                                                               | 1   | 2   |
| 78          | 1              | <i>Blackband, Cwm Avon.</i> —Thickness varies very much, at Cwm Avon about 7 inches, Oakwood 2½ inches.                                                                   |     |     |
|             |                | <i>Cwm Hir Seam</i> . . . . .                                                                                                                                             | 1   | 6   |
|             |                | <i>Black Seam</i> . . . . .                                                                                                                                               | 1   | 6   |
|             |                | <i>Golden Seam</i> . . . . .                                                                                                                                              | 3   | 2   |
|             |                | <i>Cockshut Seam</i> . . . . .                                                                                                                                            | 1   | 6   |
| 79          | 2              | <i>Big Mine, Cwm Avon.</i> —Lies under Upper Cockshut Rock; one course of 12 inches.                                                                                      |     |     |
| 80          | 3              | <i>Middle Big Mine, Cwm Avon.</i> —Lies between two Cockshut rocks; one course of 8 inches.                                                                               |     |     |
| 81          | 4              | <i>Lower Big Mine, Cwm Avon.</i> —One course of 4 inches; sometimes worked with New Mine coal, about 9 feet under it.                                                     |     |     |
|             |                | <i>New Mine Vein</i> . . . . .                                                                                                                                            | 2   | 4   |
|             |                | <i>Balling Seam</i> . . . . .                                                                                                                                             | 2   | 2   |
| 82, 83      | 5              | <i>Balling Mine, Cwm Avon.</i> —Two courses.                                                                                                                              |     |     |
|             |                | <i>Finery Seam</i> . . . . .                                                                                                                                              | 2   | 0   |
| 84 to 86    | 6              | <i>Sulphury Mine, Cwm Avon.</i> —Three courses = 7 inches.                                                                                                                |     |     |
|             |                | <i>Sulphury Seam</i> . . . . .                                                                                                                                            | 2   | 0   |
|             |                | <i>Four Feet Seam</i> . . . . .                                                                                                                                           | 4   | 0   |
| 87          | 7              | <i>Cefn Gŵ Bult, Cwm Avon.</i> —This corresponds with the Farnace Vein at Llynvi and Maesteg, worked extensively there in patches: 16 inches worked at Cwm Avon by level. |     |     |
|             |                | <i>Big Seam</i> . . . . .                                                                                                                                                 | 2   | 0   |
| 88          | 8              | <i>Middle Clay Vein, Cwm Avon.</i> —One course.                                                                                                                           |     |     |
|             |                | <i>Clay Seam</i> . . . . .                                                                                                                                                | 1   | 9   |
|             |                | <i>Coal and Mine Seam</i> . . . . .                                                                                                                                       | 6   | 0   |
| 89, 90      | 9              | <i>Five Feet Plus, Cwm Avon.</i> —Two courses.                                                                                                                            |     |     |
|             |                | <i>Five Feet Seam</i> . . . . .                                                                                                                                           | 5   | 0   |
|             |                | <i>Lower Four Feet Seam</i> . . . . .                                                                                                                                     | 4   | 0   |
| 91 to 92    | 10             | <i>Jack Mine, Cwm Avon.</i>                                                                                                                                               |     |     |

The total thickness of measures from Wernddu Seam to Lower Four Feet Seam is about 800 yards. The beds of coal in this division are all bituminous. Several important beds of coal and various measures of ironstone are known to exist below the Lower Four Feet Seam coal; but the entire extent of the lower beds is not yet proved in this division of the South Wales coal-field.

SOUTH WALES.—(Western or Anthracite District.)

| General No.  | No. of Series. | Principal Works:—                                                                                                                                                                    | Blast Furnaces. |            |
|--------------|----------------|--------------------------------------------------------------------------------------------------------------------------------------------------------------------------------------|-----------------|------------|
|              |                |                                                                                                                                                                                      | In              | Out        |
|              |                | <b>PRINCIPAL WORKS:—</b>                                                                                                                                                             |                 |            |
|              |                | Vesali . . . . .                                                                                                                                                                     | 3               | 3          |
|              |                | Yatalyfra . . . . .                                                                                                                                                                  | 5               | 6          |
|              |                | Ynacedwin . . . . .                                                                                                                                                                  | 3               | 4          |
|              |                | Banwon . . . . .                                                                                                                                                                     | 2               | 3          |
|              |                | Omlwyn or Brin . . . . .                                                                                                                                                             | 2               | 2          |
|              |                | Cwm Ammon . . . . .                                                                                                                                                                  | 2               | 2          |
|              |                | Tryn Soreu . . . . .                                                                                                                                                                 | 2               | 2          |
|              |                | Owendraith . . . . .                                                                                                                                                                 | 2               | 2          |
|              |                | Brsnere . . . . .                                                                                                                                                                    | 2               | 2          |
|              |                | <b>34 Furnaces . . . . .</b>                                                                                                                                                         | <b>19</b>       | <b>22</b>  |
|              |                | <b>Strata.</b>                                                                                                                                                                       | <b>Ft.</b>      | <b>In.</b> |
| 94, 95       | 1              | Blackband, Yatalyfra.—14 inches thick, very local. Yields about 2,750 tons per acre.                                                                                                 |                 |            |
| 96, 97       | 2              | Black Plas, Yatalyfra.—Two courses = 8 inches. Yields about 2,400 tons per acre.                                                                                                     |                 |            |
| 98           | 3              | Slop Vein, Yatalyfra.—Three courses = 6 to 10 inches. Yields about 2,750 tons per acre.                                                                                              |                 |            |
| 99           | 4              | Soft Vein Coal . . . . .                                                                                                                                                             |                 |            |
|              |                | Penny Plas, Yatalyfra.—Three courses with scattered balls. Yields about 2,500 tons per acre.                                                                                         |                 |            |
| 100          | 5              | Pentwyn Coal . . . . .                                                                                                                                                               | 3               | 0          |
|              |                | White Plas, Yatalyfra.—Sometimes called Coshilda Mine: Four courses about 16 inches in 14 feet ground. Yields about 4,800 tons per acre.                                             |                 |            |
| 101, 102     | 6              | White Vein Coal . . . . .                                                                                                                                                            | 1               | 6          |
|              |                | Black Vein Mine, Yatalyfra.—Two courses = 8 inches. Yields about 2,400 tons per acre.                                                                                                |                 |            |
| 103a to 103d | 7              | Black Vein Coal . . . . .                                                                                                                                                            | 4               | 0          |
|              |                | Little Vein Mine, Yatalyfra.—Ten courses in 18 feet ground, got with Little Vein Coal. Yields 7,000 tons per acre. This is the most important measure of ironstone in this district. |                 |            |
|              |                | Little Vein Coal . . . . .                                                                                                                                                           | 3               | 0          |
| 105          | 8              | Billets, Yatalyfra.                                                                                                                                                                  |                 |            |
| 106          | 9              | Haruto Mine, Yatalyfra.—Two courses.                                                                                                                                                 |                 |            |
|              |                | Haruto Coal . . . . .                                                                                                                                                                | 2               | 0          |
| 107          | 10             | Big Vein, Yatalyfra.—Two courses = 6 inches. Yielding 1,800 tons per acre when worked by level: If worked in patches 15 feet ground, all interspersed with stone.                    |                 |            |
|              |                | Big Vein Coal . . . . .                                                                                                                                                              | 5               | 6          |
|              |                | Black Vein Coal . . . . .                                                                                                                                                            | 2               | 0          |
| 108          | 11             | Brass Vein, Yatalyfra.—Five courses in 13 feet of ground. Yielding 2,500 tons per acre.                                                                                              |                 |            |
|              |                | Brass Vein Coal . . . . .                                                                                                                                                            | 4               | 0          |
|              |                | Three Coal Vein . . . . .                                                                                                                                                            | 3               | 0          |
|              |                | Bryalvey Vein Coal . . . . .                                                                                                                                                         | 3               | 0          |
| 109          | 12             | Little Brass Mine, Ynacedwin.                                                                                                                                                        |                 |            |
|              |                | Little Brass Vein . . . . .                                                                                                                                                          | 2               | 0          |
|              |                | Middle Vein Coal . . . . .                                                                                                                                                           | 2               | 6          |
| 110, 111     | 13             | Cwm Fil Mine, Ynacedwin.—Three courses.                                                                                                                                              |                 |            |
|              |                | Lower Vein Coal . . . . .                                                                                                                                                            | 3               | 0          |
| 112          | 14             | Little Blue Vein, Ynacedwin.                                                                                                                                                         |                 |            |
| 113          | 15             | Big Blue Vein, Ynacedwin.                                                                                                                                                            |                 |            |
| 114          | 16             | Ganypog Mine, Ynacedwin.                                                                                                                                                             |                 |            |
| 115          | 17             | Pin Mawr Mine, Ynacedwin.                                                                                                                                                            |                 |            |

The beds of coal in this district are all anthracite. The measures of ironstone extremely numerous and important, but principally worked in patches or open works. All the measures in this series bear the appearance of having been subjected to an extremely high temperature; which has been in all probability the cause of the conversion of its beds of coal into anthracite.

SOUTH WALES.—(Southern Outcrop.)

| General No. | No. of Series. | Principal Works:—            | Blast Furnaces. |          |
|-------------|----------------|------------------------------|-----------------|----------|
|             |                |                              | In              | Out      |
|             |                | <b>PRINCIPAL WORKS:—</b>     |                 |          |
|             |                | Pentrych . . . . .           | 1               | 1        |
|             |                | Tendin . . . . .             | 1               | 2        |
|             |                | Cefn Cribbw . . . . .        | 1               | 1        |
|             |                | Dinas . . . . .              | 3               | 3        |
|             |                | <b>11 Furnaces . . . . .</b> | <b>7</b>        | <b>4</b> |

SOUTH WALES.—(Southern Outcrop)—continued.

| General No. | No. of Series. | Strata.                                                   | Ft. | In. |
|-------------|----------------|-----------------------------------------------------------|-----|-----|
|             |                |                                                           |     |     |
| 116, 116a   | 1              | Six Feet Ironstone, Cefn Cwsc.—Four courses = 9 inches.   |     |     |
|             |                | South Nine Feet Coal . . . . .                            | 9   | 0   |
| 117, 117a   | 2              | Nine Feet Ball, Cefn Cwsc.—Seven courses = 17 inches.     |     |     |
|             |                | Flery Vein Coal . . . . .                                 | 4   | 0   |
| 118, 118a   | 3              | Flery Vein Ironstone, Cefn Cwsc.—Six courses = 14 inches. |     |     |
|             |                | Five Quarter Vein . . . . .                               | 4   | 6   |
|             |                | Great Gribber Vein . . . . .                              | 6   | 0   |
| 119         | 4              | Gribber Balls, Cefn Cwsc.—Two courses = 6 inches.         |     |     |
| 120         | 5              | Upper Spotted Vein, Cefn Cwsc.—Two courses = 4 inches.    |     |     |
| 121         | 6              | Spotted Balls, Cefn Cwsc.—Two courses = 4 inches.         |     |     |
| 122         | 7              | Middle Spotted Vein, Cefn Cwsc.—Two courses = 8½ inches.  |     |     |
| 123         | 8              | Lower Spotted Vein, Cefn Cwsc.—Two courses = 4½ inches.   |     |     |
| 124, 124a   | 9              | Farlegated Pins, Cefn Cwsc.—Two courses = 2½ inches.      |     |     |
| 125, 125a   | 10             | Yellow Vein and Balls, Cefn Cwsc.—Two courses = 8 inches. |     |     |
| 126         | 11             | Upper Red Vein, Cefn Cwsc.—Two courses = 3 inches.        |     |     |
| 126a, 126b  | 12             | Upper Red Vein Balls, Cefn Cwsc.—Two courses = 4 inches.  |     |     |
| 126c        | 13             | Lower Red Vein, Cefn Cwsc.—Two courses = 4 inches.        |     |     |
| 126d        | 14             | Pin Rhyber Balls, Cefn Cwsc.—One course = 3 inches.       |     |     |
| 126e        | 15             | Black Balls, Cefn Cwsc.—Two courses = 3 inches.           |     |     |
| 126f        | 16             | Double Balls, Cefn Cwsc.—Two courses = 6 inches.          |     |     |
| 126g        | 17             | Black Plas, Cefn Cwsc.—One course = 3 inches.             |     |     |
| 126h        | 18             | Upper Blue Veins, Cefn Cwsc.—One course = 4 inches.       |     |     |
| 126i        | 19             | Blue Vein Balls, Cefn Cwsc.—Two courses = 4 inches.       |     |     |
| 126j        | 20             | Lower Blue Veins, Cefn Cwsc.—Two courses = 3 inches.      |     |     |
| 126k        | 21             | Lumpy Balls, Cefn Cwsc.—One course = 5 inches.            |     |     |
| 126l        | 22             | Pin Gurs Balls, Cefn Cwsc.—Two courses = 8 inches.        |     |     |
|             |                | Small Gribber Coal . . . . .                              | 2   | 9   |

The iron ore principally used at the Pentrych works is hematite, from the carboniferous limestone on the south of the South Welsh coal-field. The annual production of iron on the south outcrop is about 25,000 tons.

SOUTH WALES.—(Upper or Red Ash Series.)

|               |    |                                                                                                                                                                                                                                                                                                                                                           |  |  |
|---------------|----|-----------------------------------------------------------------------------------------------------------------------------------------------------------------------------------------------------------------------------------------------------------------------------------------------------------------------------------------------------------|--|--|
| 126n to 126o. | .. | Blackband; Jas. Leitch, & Co.—Colfath Colliery, Gellygcer, Glamorganshire. This Blackband lies in four courses, respectively 32, 4, 6, and 6 inches thick. Total thickness, 3 feet 6 inches. It lies in 6 feet of ground, and yields upwards of 7,000 tons per acre. Its position is very high in the coal measures above the Mynyddis-mwyn Vein of coal. |  |  |
|---------------|----|-----------------------------------------------------------------------------------------------------------------------------------------------------------------------------------------------------------------------------------------------------------------------------------------------------------------------------------------------------------|--|--|

The South Wales Coal-field extends over an area of upwards of 800 miles. Both from its extent and the varied character of its numerous beds of coal and iron, it may be considered as the most important of all our coal-fields. The upper measures furnish the best Red Ash coals for household purposes, whilst its lower measures are well adapted for iron-smelting, and for steam coal.

Seam to beds of ironstone on coal; proved

The number of furnaces now in blast is 143, averaging about 100 tons of iron each per week; or a gross annual production of 700,000 tons, and requiring 2,000,000 tons of ironstones, principally furnished from this coal-field. The annual production of coal is estimated at from 5 to 6,000,000 tons.

In 1780, the annual production of iron in South Wales was 34,011 tons, and in 1823, 182,325 tons; since which time the production has been nearly trebled.

In the eastern part of the district the coals are bituminous; as they approach the west they gradually become semi-anthracitic; and in the western district all the coals are anthracitic.

From the great area of this coal-field, and the great variety in character, both of its beds of coal, and its measures of ironstones and blackband, it will, in all probability, long remain the most important iron-making district in the world.

NORTH WALES.

| General No. | No. of Series. | PRINCIPAL WORKS:—                                                                                                                                                    | Blast Furnaces. |     |
|-------------|----------------|----------------------------------------------------------------------------------------------------------------------------------------------------------------------|-----------------|-----|
|             |                |                                                                                                                                                                      | In              | Out |
|             |                | Rhuabon . . . . .                                                                                                                                                    | 2               | 1   |
|             |                | Brymbo . . . . .                                                                                                                                                     | 1               | 1   |
|             |                | 5 Furnaces . . . . .                                                                                                                                                 | 3               | 2   |
|             |                | Strata.                                                                                                                                                              |                 |     |
|             |                | Three Yard Coal . . . . .                                                                                                                                            | 9               | 0   |
|             |                | Brassy Coal . . . . .                                                                                                                                                | 2               | 3   |
| 187—190     | 1              | Upper Yard Ironstone, Rhuabon.—Four irregular courses (No. 1 to No. 4), averaging about 7 inches.                                                                    |                 |     |
|             |                | Upper Yard Coal . . . . .                                                                                                                                            | 2               | 8   |
| 191—193     | 2              | Red Coal Ironstone Balls, Rhuabon. Red Coal . . . . .                                                                                                                | 1               | 2   |
| 194—197     | 3              | Stone Coal Ironstone, Rhuabon.—Four courses (No. 4 to No. 8). Stone Coal . . . . .                                                                                   | 2               | 9   |
|             |                | Half-yard Coal . . . . .                                                                                                                                             | 1               | 8   |
| 198         | 4              | Two Yard Coal Ironstone, Rhuabon.                                                                                                                                    |                 |     |
| 199         | 5              | Lower Yard Coal Ironstone, Rhuabon.                                                                                                                                  |                 |     |
|             |                | Lower Yard Coal . . . . .                                                                                                                                            | 3               | 0   |
| 140—148     | 6              | Wall and Bench Ironstone, Rhuabon.—3 courses = 18½ inches (No. 12 to No. 17), lying in about 7 feet of ground.                                                       |                 |     |
|             |                | Wall and Bench Coals . . . . .                                                                                                                                       | 3               | 0   |
| 146—160     | 7              | Llysionion Ironstone, Rhuabon.—18 courses (No. 18 to No. 35), averaging 30 inches, all worked with the coal in three lifts. Will yield 8,000 to 9,000 tons per acre. |                 |     |
|             |                | Llysionion Coal . . . . .                                                                                                                                            | 1               | 6   |

The production of iron in this district is very limited: the coals are principally thin, but good in quality; and the ironstones, although lean, furnish very good iron. The only important works now in blast are the Rhuabon and the Brymbo. The Brymbo series appear by themselves.

SHROPSHIRE.

| General No. | No. of Series. | PRINCIPAL WORKS:—       | Blast Furnaces. |     |
|-------------|----------------|-------------------------|-----------------|-----|
|             |                |                         | In              | Out |
|             |                | Madeley Wood . . . . .  | 3               |     |
|             |                | Madeley Court . . . . . | 2               | 1   |
|             |                | The Castle . . . . .    | 2               | 1   |
|             |                | Light Moor . . . . .    | 2               | 1   |
|             |                | Home-bay . . . . .      | 1               |     |
|             |                | Lawley . . . . .        | 1               |     |
|             |                | Hinkahay . . . . .      |                 | 3   |
|             |                | Stitchley . . . . .     | 4               |     |
|             |                | Dark Lane . . . . .     |                 | 3   |
|             |                | New Lodge . . . . .     | 1               | 1   |
|             |                | Donnington . . . . .    | 2               |     |
|             |                | Sneds Hill . . . . .    | 2               |     |
|             |                | Langley . . . . .       | 1               | 1   |
|             |                | Ketley . . . . .        | 1               | 1   |
|             |                | 33 Furnaces . . . . .   | 23              | 10  |

SHROPSHIRE—continued.

| General No. | No. of Series. | Strata.                                                                                  | Blast Furnaces. |     |
|-------------|----------------|------------------------------------------------------------------------------------------|-----------------|-----|
|             |                |                                                                                          | Ft.             | In. |
| 161         | 1              | Chance Penrynstone, Donnington Wood. Fougus Coal . . . . .                               | 3               | 0   |
| 162, 163    | 2              | B'achstone, Donnington Wood.                                                             |                 |     |
| 164, 165    | 3              | Brick Measures, Donnington Wood.                                                         |                 |     |
| 166, 167    | 4              | Bilstone, Donnington Wood. Top Coal . . . . .                                            | 3               | 6   |
|             |                | Three Quarters Coal . . . . .                                                            | 2               | 0   |
|             |                | Dumble Coal . . . . .                                                                    | 2               | 10  |
| 168, 169    | 5              | Yellow Stone, Donnington Wood. Yard Coal . . . . .                                       |                 |     |
| 170, 171    | 6              | Blue Flats, Donnington Wood.                                                             |                 |     |
| 172         | 7              | White Flats, Donnington Wood.                                                            |                 |     |
| 173—176     | 8              | Main Penrynstone, Donnington Wood (No. 1), Madeley Court (No. 2). Sulphur Coal . . . . . | 7               | 0   |
|             |                | Clunch Coal . . . . .                                                                    | 2               | 0   |
|             |                | Two Feet Coal . . . . .                                                                  | 2               | 0   |
|             |                | Clod Coal . . . . .                                                                      | 2               | 4   |
|             |                | Little Flint Coal . . . . .                                                              | 2               | 0   |
| 178         | 9              | Crawston, Madeley Wood.                                                                  |                 |     |
| 177         | 10             | Black Flats (position not given).                                                        |                 |     |

Annual production of iron about 90,000 tons. This field was one of the first important iron-making districts of the kingdom; but from its limited extent, the production of iron in it has remained, for a considerable period, nearly stationary. The quality which it produces is very good. The coal measures of Shropshire were probably once connected with those of South Staffordshire—indeed, of the identity of some of the measures in the two districts there can be little doubt. This is especially evident in the Whitestone and Cakes of the one, and the Penrynstone of the other; and a great resemblance between all the measures of the two fields may also be traced, the difference in their thickness, &c., not being greater than might be expected at such distant points, judging from actual changes that are known to occur in some of the South Staffordshire beds, over comparatively a small space of ground.

SOUTH STAFFORDSHIRE.

| General No. | No. of Series. | Strata.—DUDLEY DISTRICT.                                                                 | Blast Furnaces. |     |
|-------------|----------------|------------------------------------------------------------------------------------------|-----------------|-----|
|             |                |                                                                                          | In              | Out |
|             |                | 148 Furnaces . . . . .                                                                   | 105             | 43  |
|             |                | Brooch Coal . . . . .                                                                    | 2               | 6   |
| 178—179     | 1              | Brooch Ironstone, Dudley. Little Coal (not worked.)                                      |                 |     |
| 180, 181    | 2              | Pine Ironstone, Dudley.                                                                  |                 |     |
| 182, 183    | 3              | Penny Earth Ironstone, Dudley.                                                           |                 |     |
| 184         | 4              | Ten Foot Stone, Dudley. Thick Coal . . . . .                                             | 30              | 0   |
| 185—187     | 5              | Grains Ironstone, Dudley.                                                                |                 |     |
|             |                | Gabbins Ironstone, Dudley. Gabbins. Cannock. Rabble. Brown Stone. Heather Coal . . . . . | 3               | 0   |
|             |                | Bottom Henkes Coal . . . . .                                                             | 2               | 8   |
| 189, 193    | 7              | White Ironstone Binds, Dudley.                                                           |                 |     |
| 194, 195    | 8              | White Ironstone, Dudley.                                                                 |                 |     |
| 196, 197    |                | White Ironstone, Brochmoor.                                                              |                 |     |
| 198, 199    | 9              | Cakes, or Blusstones, Dudley. Sulphur Coal . . . . .                                     | 4               | 8   |
|             |                | New Mine Coal . . . . .                                                                  | 2               | 8   |
|             |                | Fire Clay Coal . . . . .                                                                 | 2               | 6   |
| 200, 201.   | 10             | Fire Clay Balls, Dudley. Bottom Coal . . . . .                                           | 2               | 0   |

The Dudley Division of the South Staffordshire and Worcestershire coal-field is principally celebrated for the Ten Yard, or Thick Coal, so named from its being 30 feet thick, and which may well be termed, *par excellence*, "The Thick Coal." This is the largest and most important bed of coal in the kingdom, and is of excellent



SOUTH SIDE—AREAS S. 1 TO S. 27.

quality, both for household purposes and for the manufacture of iron. When undisturbed by faults, and of average quality, this bed of coal, with the associated thin coals and ironstones, is worth at least 1,000l. per acre. The quality of iron made is very superior. It was in this district that coal was first used, in the year 1619, for the purpose of smelting iron.

The Gubbin and White Ironstones are the principal ironstones of this district. The Gubbin measures will average about 1,500 tons per acre; the White Ironstone varies much both in quantity and richness. It yields from 1,000 to, occasionally, 3,000 tons per acre; 1,500 tons may be taken as about the average.

| WOLVERHAMPTON DISTRICT. |   |                                  |  | Ft. | In. |
|-------------------------|---|----------------------------------|--|-----|-----|
|                         |   |                                  |  | 8   | 0   |
|                         |   |                                  |  | 6   | 8   |
|                         |   |                                  |  | 9   | 0   |
| 908, 903                | 1 | Pyar Robin's, Bunker's Hill.     |  |     |     |
| 904                     | 2 | Fire Clay Bulls, Bunker's Hill.  |  |     |     |
| 905                     | 3 | Rough Hill White, Darlaston.     |  |     |     |
|                         |   | Bottom Coal                      |  | 10  | 0   |
| 906, 907                | 4 | Gubbin and Bulls, Bunker's Hill. |  |     |     |
|                         |   | Mealy Grey Coal                  |  | 2   | 2   |
| 908, 909                | 5 | Blue Flats, Bunker's Hill.       |  |     |     |
| 910, 911                | 6 | Bristol Diamonds, Darlaston.     |  |     |     |

The space of ground occupied by the above measures from the Sulphur Coal to the Bristol Diamonds is about 90 yards. These measures occupy a position in the general coal series, below the Thick Coal of the Dudley District; and attain in the Wolverhampton Field a much greater thickness and importance than at Dudley, where scarcely any of the above measures of coal and ironstones prove workable. The ironstones are all of extremely good quality, averaging from 80 to 85 per cent. From the low cost at which they are generally raised, the number and variety of the measures both of coal and ironstone contained in so small a space of ground, and the superior quality of the iron produced, the Wolverhampton Division of the South Staffordshire coal-field may be considered as one of the most important, in proportion to its area, of any of our iron-making districts.

| BENTLEY AND BRICH HILLS DISTRICT. |   |                                                                                                                                                                                                                                                                                                                    |  |
|-----------------------------------|---|--------------------------------------------------------------------------------------------------------------------------------------------------------------------------------------------------------------------------------------------------------------------------------------------------------------------|--|
| 912, 913                          | 1 | Brown Stone, Blawick.—This is the only measure of Blackband in the South Staffordshire Coal-field. It lies underneath the lowest Heathen Coal, in two courses averaging about 12 inches, and does not prove south of Bentley. The other measures of this district do not vary greatly from those of Wolverhampton. |  |

The annual production of iron in South Staffordshire and Worcestershire is nearly 600,000 tons. It is considered to be the second most important iron-making district in the kingdom; for although the production of pig-iron in Scotland is equal to that of this district, yet it far surpasses Scotland in the manufacture of wrought-iron; whilst the superior quality produced also gives it pre-eminence over that of Wales.

|          |   |                                                                                                                                                                                                                  |  |
|----------|---|------------------------------------------------------------------------------------------------------------------------------------------------------------------------------------------------------------------|--|
| 914, 915 | 1 | Coventry and Bedworth Coal Field. Bedworth Balls, Bedworth.—Two courses, forming an exceedingly good and important measure of ironstone, raised extensively for transport to the South Staffordshire Coal-field. |  |
|----------|---|------------------------------------------------------------------------------------------------------------------------------------------------------------------------------------------------------------------|--|

NORTH STAFFORDSHIRE.

| General No. | No. of Series. | Principal Works.      | Blind Furnaces. |     |
|-------------|----------------|-----------------------|-----------------|-----|
|             |                |                       | In              | Out |
|             |                | Silverdale . . . . .  | 1               | 4   |
|             |                | Apedale . . . . .     | 2               | 2   |
|             |                | Kidgrove . . . . .    | 3               | 1   |
|             |                | Goldendale . . . . .  | 2               | 1   |
|             |                | Etruria . . . . .     | 3               | 1   |
|             |                | Loogton . . . . .     | 2               | 1   |
|             |                | 91 Furnaces . . . . . | 13              | 9   |

NORTH STAFFORDSHIRE—continued.

| General No. | No. of Series. | Series.                                                                                                                                                                                                                                                        | Blind Furnaces. |     |
|-------------|----------------|----------------------------------------------------------------------------------------------------------------------------------------------------------------------------------------------------------------------------------------------------------------|-----------------|-----|
|             |                |                                                                                                                                                                                                                                                                | Ft.             | In. |
|             |                | Gutter Coal . . . . .                                                                                                                                                                                                                                          | 2               | 0   |
|             |                | Red Shag Coal . . . . .                                                                                                                                                                                                                                        | 2               | 0   |
| 230         | 1              | Bassey Mine, Foley Colliery, Longton.—Four courses; thickness 2 to 3 feet; in some places (as at Apedale) it attains the great thickness of 6 feet.                                                                                                            |                 |     |
|             |                | Bassey Mine Coal . . . . .                                                                                                                                                                                                                                     | 2               | 2   |
|             |                | Spencer's Coal . . . . .                                                                                                                                                                                                                                       | 4               | 0   |
|             |                | Great Run Coal . . . . .                                                                                                                                                                                                                                       | 2               | 0   |
|             |                | Cannel Row Coal . . . . .                                                                                                                                                                                                                                      | 2               | 0   |
| 231         | 2              | Wood's Mine, Foley Colliery, Longton.—Four courses = 10 inches.                                                                                                                                                                                                |                 |     |
|             |                | Wood's Mine Coal . . . . .                                                                                                                                                                                                                                     | 1               | 0   |
| 232         | 3              | Deep Mine, Foley Colliery, Longton.—Four courses.                                                                                                                                                                                                              |                 |     |
|             |                | Deep Mine Coal . . . . .                                                                                                                                                                                                                                       | 2               | 2   |
| 233         | 4              | Chalby Mine, Foley Colliery, Longton.—Four courses.                                                                                                                                                                                                            |                 |     |
| 234         | 5              | New Mine, Foley Colliery, Longton.—Two courses.                                                                                                                                                                                                                |                 |     |
|             |                | New Mine Coal . . . . .                                                                                                                                                                                                                                        | 1               | 2   |
| 235         | 6              | Hanbury Mine, Foley Colliery, Longton.—Two courses.                                                                                                                                                                                                            |                 |     |
| 236         | 7              | New Ironstone, Foley Colliery, Longton.—Five courses = 16 inches in 24 feet of ground.                                                                                                                                                                         |                 |     |
|             |                | Knowles Coal . . . . .                                                                                                                                                                                                                                         | 6               | 0   |
| 237         | 8              | Prior's Field Mine, Foley Colliery, Longton.—Three courses.                                                                                                                                                                                                    |                 |     |
| 238         | 9              | Knowles Mine, Foley Colliery, Longton.—Four courses = 2 feet 5 inches.                                                                                                                                                                                         |                 |     |
|             |                | Bay Coal . . . . .                                                                                                                                                                                                                                             | 2               | 2   |
|             |                | Rider Coal . . . . .                                                                                                                                                                                                                                           | 2               | 0   |
|             |                | Asa Coal . . . . .                                                                                                                                                                                                                                             | 7               | 0   |
| 239         | 10             | Little Mine, Foley Colliery, Longton.—Little Mine Coal . . . . .                                                                                                                                                                                               | 4               | 0   |
| 230to236    | 1 to 7         | Series from Shelton Colliery, Hanley. Red Shag Ironstone. Gutter Mine. Bassey Mine. Penny Stone. Deep Mine. Chalby Mine. Gubbin Stone.                                                                                                                         |                 |     |
| 237to239    | 1 to 10        | Series from Apedale, near Newcastle. Blackband Ironstone—4 to 5 feet thick. Red Shag—6 feet thick. Red Mine—5 feet thick. Bassey Mine—7 feet thick. Cannel Mine. Black Mine. Rusty Mine. Chalby Mine. Little Mine. New Mine. Brown Mine. Thickband. Gold Mine. |                 |     |

These last two series are not numbered according to their position in the coal measures. Many of them belong to the same measures as those of the Foley Colliery, Longton, although named differently.

The North Staffordshire coal-field, although not of great importance directly, as an iron-making district, its annual produce being only about 55,000 tons, is yet of great importance from the amazing extent of ironstone which it contains, and the large quantities sent thence to the South Staffordshire, and the North Welsh iron districts. No other known coal-field contains anything like an equal number and extent of ironstone measures. From the Bassey Mine to the Knowles Mine, a series of measures at the Foley Colliery, Longton, of only 250 yards in thickness, there are nine distinct workable measures of ironstone. At Apedale, the Blackband, Red-shag, Bassey Mine, and Red Mine, ironstones, are respectively 4, 6, 7, and 9 feet thick. In consequence of so large a proportion of the cheapest worked ironstone measures being Blackband or carbonaceous, and also from the inferior quality of its coals, the iron of this district is inferior. The thickness of the coal measures already known, is upwards of 1,100 yards, containing 32 seams of coal, varying in thickness from 5 inches to 8 feet. Of these, there are 14 beds below the Little Mine coal, all of which, excepting one, are from 2 to 7 feet thick.



| YORKSHIRE.—(Northern District.) |                |                                                               |                 |     |
|---------------------------------|----------------|---------------------------------------------------------------|-----------------|-----|
| General No.                     | No. of Series. | —                                                             | Blast Furnaces. |     |
|                                 |                |                                                               | In              | Out |
|                                 |                | <b>PRINCIPAL WORKS:—</b>                                      |                 |     |
|                                 |                | Bowling . . . . .                                             | 3               | 2   |
|                                 |                | Low Moor . . . . .                                            | 1               | 2   |
|                                 |                | New Begin . . . . .                                           | 2               | 0   |
|                                 |                | Shelfs . . . . .                                              | 2               | 1   |
|                                 |                | Bierley . . . . .                                             | 2               | 1   |
|                                 |                | Varnley . . . . .                                             | 1               | 0   |
|                                 |                | 13 Furnaces . . . . .                                         | 10              | 8   |
|                                 |                | <b>Strata.</b>                                                |                 |     |
|                                 |                | <b>1 White Bed Mine, Bierley.—Yield per acre, 1,800 tons.</b> |                 |     |
|                                 |                | Top Flats . . . . .                                           |                 |     |
| 300                             |                | Loz Flats . . . . .                                           |                 |     |
| 303                             |                | White Balls . . . . .                                         |                 |     |
| 302                             |                | Middle Balls . . . . .                                        |                 |     |
| 304                             |                | Low Measure . . . . .                                         |                 |     |
|                                 |                | <b>Coal</b>                                                   |                 |     |
|                                 |                | <b>2 Black Bed Mine, Low Moor.</b>                            |                 |     |
| 305                             |                | Top Balls . . . . .                                           |                 |     |
| 306                             |                | Flat Stone . . . . .                                          |                 |     |
| 307                             |                | Middle Balls . . . . .                                        |                 |     |
| 308                             |                | Rough Measure . . . . .                                       |                 |     |
| 309                             |                | Low Measure . . . . .                                         |                 |     |
| 310                             |                | Basset Stone . . . . .                                        |                 |     |
|                                 |                | Black Bed Coal . . . . .                                      | 2               | 2   |
|                                 |                | Better Bed Coal . . . . .                                     | 2               | 0   |

Annual production of iron about 25,000 tons. The quality of iron made, very superior. The Low Moor and Bowling marks are especially celebrated. The beds of coal in this district are exceedingly thin. The Better Bed Coal is the only one used for iron-making purposes. The White Bed and Black Bed Mines of this district probably correspond with the Thorncliffe White Mine and the Clay Wood Mine of the southern division of this field.

| YORKSHIRE.—(Southern District.) |                |                                                                                |                 |     |
|---------------------------------|----------------|--------------------------------------------------------------------------------|-----------------|-----|
| General No.                     | No. of Series. | —                                                                              | Blast Furnaces. |     |
|                                 |                |                                                                                | In              | Out |
|                                 |                | <b>PRINCIPAL WORKS:—</b>                                                       |                 |     |
|                                 |                | Worbro' Dale . . . . .                                                         | 1               | 1   |
|                                 |                | Elsecar . . . . .                                                              | 1               | 3   |
|                                 |                | Milton . . . . .                                                               | 1               | 1   |
|                                 |                | Thorncliffe . . . . .                                                          | 1               | 1   |
|                                 |                | Chapelton . . . . .                                                            | 1               | 1   |
|                                 |                | Holmes . . . . .                                                               | 1               | 1   |
|                                 |                | Parigate . . . . .                                                             | 1               | 1   |
|                                 |                | 13 Furnaces . . . . .                                                          | 5               | 8   |
|                                 |                | <b>Strata.</b>                                                                 |                 |     |
|                                 |                | <b>1 Swallow Wood Mine, Milton.—Yields about 1,900 tons per acre.</b>          |                 |     |
| 311                             |                | Flats . . . . .                                                                |                 |     |
| 312                             |                | Balls . . . . .                                                                |                 |     |
| 313                             |                | Bottom Measure . . . . .                                                       |                 |     |
|                                 |                | <b>2 Ledgett Mine, Milton.—Yields 1,800 tons per acre.</b>                     |                 |     |
| 314                             |                | Flats . . . . .                                                                |                 |     |
| 315                             |                | Balls . . . . .                                                                |                 |     |
| 316                             |                | Bottom Measure . . . . .                                                       |                 |     |
|                                 |                | <b>3 Tankersley Mine, Milton.—Yields 4,000 tons per acre.</b>                  |                 |     |
| 317                             |                | Top Measure . . . . .                                                          |                 |     |
| 318                             |                | Middle . . . . .                                                               |                 |     |
| 319                             |                | Bottom Measure . . . . .                                                       |                 |     |
|                                 |                | <b>4 Thorncliffe, or O'4 Black Mine, Parigate.—Yields 1,500 tons per acre.</b> |                 |     |
| 320                             |                | Balls . . . . .                                                                |                 |     |
| 321                             |                | Holling Measure . . . . .                                                      |                 |     |
|                                 |                | <b>5 Thorncliffe White Mine, Parigate.—Yields 1,900 tons per acre.</b>         |                 |     |
| 322                             |                | Flats . . . . .                                                                |                 |     |
| 323a                            |                | Balls . . . . .                                                                |                 |     |
| 323b                            |                | Holling Measure . . . . .                                                      |                 |     |
|                                 |                | <b>6 Black or Clay Wood Mine, Parigate.</b>                                    |                 |     |
| 324                             |                | Balls . . . . .                                                                |                 |     |
| 325                             |                | Brown George . . . . .                                                         |                 |     |
| 326                             |                | Whetstone . . . . .                                                            |                 |     |
|                                 |                | Siltstone Coal . . . . .                                                       | 4               | 0   |
|                                 |                | Mortonley Coal . . . . .                                                       | 3               | 0   |

Annual production of iron about 20,000 tons. Thickness of measures from the Hobbimer to Mortomley beds of coal, about 430 yards. The entire thickness of the coal series is, however, much more. The measures thin out rapidly towards the north.

| DERBYSHIRE. |                |                                                                                                                                                                                      |                 |     |
|-------------|----------------|--------------------------------------------------------------------------------------------------------------------------------------------------------------------------------------|-----------------|-----|
| General No. | No. of Series. | —                                                                                                                                                                                    | Blast Furnaces. |     |
|             |                |                                                                                                                                                                                      | In              | Out |
|             |                | <b>PRINCIPAL WORKS:—</b>                                                                                                                                                             |                 |     |
|             |                | Unston . . . . .                                                                                                                                                                     | 1               | 1   |
|             |                | Benishaw . . . . .                                                                                                                                                                   | 1               | 1   |
|             |                | Esvelley . . . . .                                                                                                                                                                   | 2               | 1   |
|             |                | Duckmanton . . . . .                                                                                                                                                                 | 1               | 0   |
|             |                | Hirmlington Moor . . . . .                                                                                                                                                           | 1               | 1   |
|             |                | Newbold . . . . .                                                                                                                                                                    | 1               | 0   |
|             |                | Wingerworth . . . . .                                                                                                                                                                | 1               | 1   |
|             |                | Clay Cross . . . . .                                                                                                                                                                 | 1               | 1   |
|             |                | Mosley Park . . . . .                                                                                                                                                                | 2               | 1   |
|             |                | Alfreton . . . . .                                                                                                                                                                   | 2               | 1   |
|             |                | Butterley . . . . .                                                                                                                                                                  | 2               | 1   |
|             |                | Codnor Park . . . . .                                                                                                                                                                | 1               | 1   |
|             |                | West Hallam . . . . .                                                                                                                                                                | 1               | 1   |
|             |                | Stanton . . . . .                                                                                                                                                                    | 2               | 1   |
|             |                | 22 Furnaces . . . . .                                                                                                                                                                | 10              | 10  |
|             |                | <b>Strata.</b>                                                                                                                                                                       |                 |     |
|             |                | <b>1 Measure and Balls Rake, Staveley.—Yield per acre about 2,500 tons.</b>                                                                                                          |                 |     |
| 327-334     |                | Whetstone; Flampards; White Measure; Cub; Old Bear; First Balls; Flat Balls; Bottom Measure . . . . .                                                                                | 8               | 0   |
|             |                | Main Hard Coal . . . . .                                                                                                                                                             | 0               | 0   |
|             |                | Dunhill Coal . . . . .                                                                                                                                                               | 4               | 0   |
| 335-337     |                | <b>2 Swallow Wood Rake, Stanton.—Yield per acre 3,000 tons.</b>                                                                                                                      |                 |     |
|             |                | Tenall Coal (not worked) . . . . .                                                                                                                                                   | 2               | 0   |
| 338         |                | <b>3 Tin Yard, or Fowler Park Rake, Staveley.—Yield per acre 2,000 tons.</b>                                                                                                         |                 |     |
| 339         |                | Red Measure . . . . .                                                                                                                                                                |                 |     |
| 340         |                | Balls . . . . .                                                                                                                                                                      |                 |     |
|             |                | Cockle . . . . .                                                                                                                                                                     |                 |     |
| 341         |                | <b>4 Ruff, or Cement Rake, Alfreton.—Yield per acre 1,800 tons.</b>                                                                                                                  |                 |     |
| 342         |                | Top Measure . . . . .                                                                                                                                                                |                 |     |
| 343         |                | Balls . . . . .                                                                                                                                                                      |                 |     |
|             |                | Bottom Measure . . . . .                                                                                                                                                             |                 |     |
| 344         |                | <b>5 Brown Rake, Butterley.—Yield per acre 2,500 tons.</b>                                                                                                                           |                 |     |
| 345         |                | Balls . . . . .                                                                                                                                                                      |                 |     |
| 346         |                | Top Measure . . . . .                                                                                                                                                                |                 |     |
|             |                | Bottom Measure . . . . .                                                                                                                                                             |                 |     |
|             |                | <b>6 Black Rake, Butterley.—Yield per acre 2,000 tons.</b>                                                                                                                           |                 |     |
| 347         |                | Thin Coal (not worked) . . . . .                                                                                                                                                     |                 |     |
| 348         |                | Top Measure . . . . .                                                                                                                                                                |                 |     |
|             |                | Bottom Measure . . . . .                                                                                                                                                             |                 |     |
|             |                | <b>7 Puer Rake, Alfreton.—Yield per acre 900 tons.</b>                                                                                                                               |                 |     |
| 349a349b    |                | Yard, or Ell Coal . . . . .                                                                                                                                                          | 3               | 0   |
| 350         |                | Main Soft Coal . . . . .                                                                                                                                                             | 5               | 0   |
|             |                | <b>8 Blue Rake, Butterley.—Yield per acre 900 tons.</b>                                                                                                                              |                 |     |
| 351         |                | Lower Hard Coal . . . . .                                                                                                                                                            | 4               | 0   |
| 352         |                | <b>9 Spring, or Riding's Rake, Alfreton.</b>                                                                                                                                         |                 |     |
| 353         |                | <b>10 Dog-tooth Rake, Staveley.—Yield per acre 2,000 tons.</b>                                                                                                                       |                 |     |
| 354         |                | White Measure . . . . .                                                                                                                                                              |                 |     |
| 355         |                | Sugar Plum Measure . . . . .                                                                                                                                                         |                 |     |
| 356         |                | Marble Measure . . . . .                                                                                                                                                             |                 |     |
|             |                | Balls . . . . .                                                                                                                                                                      |                 |     |
|             |                | Snail Horn . . . . .                                                                                                                                                                 |                 |     |
|             |                | This rake is called Wallis' Rake, at Butterley, south of which it does not prove.                                                                                                    |                 |     |
| 357         |                | <b>11 Brown Measure, Clay Cross.—Yield per acre 800 tons.</b>                                                                                                                        |                 |     |
|             |                | <b>12 Nodule Rake, Mosley Park.—Yield per acre 1,600 tons.</b>                                                                                                                       |                 |     |
| 358         |                | Cinder Measure . . . . .                                                                                                                                                             |                 |     |
| 359         |                | Balls . . . . .                                                                                                                                                                      |                 |     |
|             |                | South of Clay Cross the Nodule Rake is known by the name of the Dog-tooth Rake.                                                                                                      |                 |     |
| 360         |                | <b>13 Three Quarter Balls, Clay Cross.</b>                                                                                                                                           |                 |     |
|             |                | Three Quirer Coal . . . . .                                                                                                                                                          |                 |     |
| 361-373     |                | <b>14 Black Shale Rake, Staveley.—Yield per acre from 1 to 2,000 tons.</b>                                                                                                           |                 |     |
|             |                | Whetstone; Chitter; Cheeses; Bear; Top Blues; Lower Blues; Old Man; Old Woman; Double Chitter; White Balls; Flampards; Red Measure; Dun; Beams; Roof Measure; Bottom Balls . . . . . | 2               |     |



KI

Gen

374

37

381

382

383

384

387

390

400

A  
this  
stor  
Ma  
mee  
wor  
ado  
in t  
Ela

Gen

M

40

406

409

411

| DERBYSHIRE—continued. |                |                                                                                                                                                                                 |            |
|-----------------------|----------------|---------------------------------------------------------------------------------------------------------------------------------------------------------------------------------|------------|
| General No.           | No. of Series. |                                                                                                                                                                                 | Ft. In.    |
| 374, 3, 6             | 15             | <i>Striped Rake, Kirk Hallam.</i> —Yield per acre 2,000 tons.<br>Clad Coal                                                                                                      |            |
| 377                   | 16             | <i>Green Close Rake, Morley Park.</i> —Yield per acre 1,000 tons.<br>Balls.<br>Bottom Measure.                                                                                  | 5 6        |
| 378                   | 17             | <i>Holly Close Rake, Morley Park.</i> —Yield per acre 1,500 tons.<br>Balls.<br>Measure.                                                                                         | 3 0        |
| 379                   | 18             | <i>Black, or Kettle's Rake, Morley Park.</i> —Yield per acre 2,000 tons.<br>Three Measures.                                                                                     |            |
| 381—393               |                | Balls.                                                                                                                                                                          |            |
| 382-393               | 19             | <i>Broom Pitch Rake, Alfreton.</i>                                                                                                                                              |            |
| 386                   | 20             | <i>Yew Tree Rake, Morley Park.</i> —Yield per acre 1,000 tons.<br>Coal . . . . .<br>Kilburne Coal . . . . .                                                                     | 1 6<br>3 0 |
| 387-394               | 21             | <i>Honeycroft Rake, Stanton.</i> —Yield per acre 6,000 tons.<br>Chitters; Tuffy Halls; Barren Root; Grindstone Measure; Grinder's Wife; Big Balls; Bottom Flats; Brick Measure. |            |
| 395-399               | 22             | <i>Chilly Rake, Stanton.</i> —Yield per acre 4,000 tons.<br>Rachell Measure; Chance Balls; Bottom Measure; Chitters; Coal Measure.                                              |            |
| 400-404               | 23             | <i>Dale Moor Rake, Stanton.</i> —Yield per acre 2,000 tons.<br>Clunch Balls; Roof Measure; Balls; Bottom Balls.                                                                 | 2 3        |

Annual production of iron about 60,000 tons. Average thickness of coal measures, from magnesian limestone to Kilburne, or lowest worked coal, 600 yards. Many of the beds of ironstone lie in such a thickness of measure as only to be workable to advantage by open work or bell-pits. Where these means of working can be adopted, the produce per acre is oftentimes very large; in the Honeycroft Rake it is 6,000 tons per acre; in the Black Shale 8,000 tons.

| NORTHUMBERLAND, CUMBERLAND, and DURHAM. |                |                                                                                                                                                                                                                                                                                                                    |                 |
|-----------------------------------------|----------------|--------------------------------------------------------------------------------------------------------------------------------------------------------------------------------------------------------------------------------------------------------------------------------------------------------------------|-----------------|
| General No.                             | No. of Series. |                                                                                                                                                                                                                                                                                                                    | Blast Furnaces. |
|                                         |                | <b>PRINCIPAL WORKS:—</b>                                                                                                                                                                                                                                                                                           | In Out          |
|                                         |                | Wallas . . . . .                                                                                                                                                                                                                                                                                                   | 2 .             |
|                                         |                | Tyne . . . . .                                                                                                                                                                                                                                                                                                     | 2 .             |
|                                         |                | Wylam . . . . .                                                                                                                                                                                                                                                                                                    | 1 .             |
|                                         |                | Hareshaw . . . . .                                                                                                                                                                                                                                                                                                 | . 3             |
|                                         |                | Redesdale . . . . .                                                                                                                                                                                                                                                                                                | . 3             |
|                                         |                | Birtley . . . . .                                                                                                                                                                                                                                                                                                  | 1 3             |
|                                         |                | Wilton Park . . . . .                                                                                                                                                                                                                                                                                              | 3 1             |
|                                         |                | Taw Law . . . . .                                                                                                                                                                                                                                                                                                  | 2 3             |
|                                         |                | Consett and Crookhead . . . . .                                                                                                                                                                                                                                                                                    | 7 7             |
|                                         |                | Stanhope . . . . .                                                                                                                                                                                                                                                                                                 | 1 .             |
|                                         |                | 39 Furnaces . . . . .                                                                                                                                                                                                                                                                                              | 19 19           |
|                                         |                | <b>Strata.</b>                                                                                                                                                                                                                                                                                                     | Ft. In.         |
| 405                                     | 1              | <i>Blackband, Hedley, Northumberland.</i>                                                                                                                                                                                                                                                                          |                 |
| 408, 407                                | 2              | <i>Blackband, Haydon Bridge.</i> —This bed probably occupies the position of one of the beds of coal underneath the Great Limestone, and forms an interesting instance of the manner in which thin beds of Coal sometimes change into beds of Blackband Ironstone. It averages, probably, three feet in thickness. |                 |
| 408-410                                 | 3              | <i>Ballstone, Haltwhistle, Northumberland.</i>                                                                                                                                                                                                                                                                     |                 |
| 411, 412                                | 4              | <i>Ballstone, Nent Head, Cumberland.</i> —These measures (Nos. 3 and 4) lie in the Plate bed over the Great Limestone, and in about 4 yards of ground they have been worked extensively on some parts of the out-crop. Average yield 30 to 35 per cent.                                                            |                 |

| NORTHUMBERLAND, CUMBERLAND, and DURHAM—continued. |                |                                                                                                                                                                                                                                                                                                                                                           |         |
|---------------------------------------------------|----------------|-----------------------------------------------------------------------------------------------------------------------------------------------------------------------------------------------------------------------------------------------------------------------------------------------------------------------------------------------------------|---------|
| General No.                                       | No. of Series. |                                                                                                                                                                                                                                                                                                                                                           | Ft. In. |
| 413                                               | 5              | <i>Brown Hematite, Kibbles Fell, near Nent Head.</i> —This bed corresponds with the Full Top Limestone bed of this district; which in this locality is converted into a bed of Brown Hematite, probably owing to its being intersected by a considerable number of small veins carrying iron "riders." It is from 2 to 7 feet thick, and of good quality. |         |
| 414, 415                                          | 6              | <i>Brown Hematite, Nent Head.</i> —This bed corresponds with the little limestone bed of this district. It is about 7 feet thick, quality very variable.                                                                                                                                                                                                  |         |
| 416, 417                                          | 7              | <i>Brown Hematite, Silly Hole Vein, Alston.</i>                                                                                                                                                                                                                                                                                                           |         |
| 418                                               | 8              | <i>Brown Hematite, Moor House Vein, Alston.</i>                                                                                                                                                                                                                                                                                                           |         |
| 419                                               | 9              | <i>Brown Hematite, Nent Vein, Alston.</i>                                                                                                                                                                                                                                                                                                                 |         |
| 420                                               | 10             | <i>Brown Hematite, Stanhope, Durham.</i>                                                                                                                                                                                                                                                                                                                  |         |
| 421                                               | 11             | <i>Brown Hematite, St. John's Chapel, near Stanhope.</i>                                                                                                                                                                                                                                                                                                  |         |
| 422                                               | 12             | <i>Carbonate of Iron, Stanhope.</i>                                                                                                                                                                                                                                                                                                                       |         |
| 423                                               | 13             | <i>Carbonate of Iron, Alston.</i>                                                                                                                                                                                                                                                                                                                         |         |

Annual production of iron about 90,000 tons. The iron works of this district are gradually increasing in importance, the cost of fuel being so low as to permit ores to be brought from many different localities. The black bands of Scotland and of Haydon Bridge, the brown hematites and white carbonates of Alston and Weardale, and the argillaceous ironstones of the llae of Whitby and Middleborough, are all used for the supply of the iron-works of this district.

The brown hematites deserve especial attention. They are found associated in very large masses, with the lead veins of this district, and occasionally they occur as distinct and regular beds. They contain from 20 to 40 per cent. of iron. Sometimes they exist as "riders" to the vein, sometimes they form its entire mass, and, in this case, they occasionally attain a thickness of 20, 30, and even 50 yards. Their employment for iron-making purposes is only recent; but the supply of ore which they can furnish is almost unlimited, and when some better means of separating the zinc and lead associated with them shall have been discovered, they will, doubtless, be found to be of great importance. Remarkable changes sometimes occur in the character of the metalliferous veins of this district; the same vein which at one point bears principally lead ore, changing to a calamine vein, and then again to brown hematite.

| LANCASHIRE and WEST CUMBERLAND. |                |                                                                                              |                 |
|---------------------------------|----------------|----------------------------------------------------------------------------------------------|-----------------|
| General No.                     | No. of Series. |                                                                                              | Blast Furnaces. |
|                                 |                | <b>PRINCIPAL WORKS:—</b>                                                                     | In Out          |
|                                 |                | Cleator Iron Company . . . . .                                                               | 3 Furnaces      |
| 424-429                         | 1-6            | <i>Hematite, Cleator Iron Ore Co., near Whitehaven.</i>                                      | Ft. In.         |
| 430                             | 7              | <i>Hematite, Harrivern, Ainstlie &amp; Co., Ulverston.</i> —Clay ore lylog close to surface. |                 |
| 431                             | 8              |                                                                                              |                 |
| 432                             | 9              |                                                                                              |                 |

The production of iron in this district is very limited, being confined to the Cleator works, and one or two small charcoal works in the Ulverston district. The quality of the latter, charcoal being used for fuel, is very superior, and the produce commands the highest prices, as it combines, with the fluidity of cast-iron, a certain malleability, especially after careful annealing. The iron of the Cleator Works is smelted with coal, and though, in consequence, not equal to the other, is yet of superior quality. The ore, both of the Whitehaven and the Ulverston and Furness districts, is raised most extensively for shipment to the iron works of Yorkshire, Staffordshire, and North and South Wales. In quality, these ores may be considered as the finest in this kingdom, and the supplies which these districts are calculated to produce are very great. The large percentage of iron which they contain, from 60 to 65 per cent., and their superior quality, also enable them to bear the cost of transport, and they

are becoming every day of greater importance. They are found, both as veins traversing the beds of the mountain limestone formation, transversely to the lines of stratification, and also as beds more or less regular. The former is the general character of the Ulverstone and Furness ores, no clearly defined bed being, as yet, known in that district, whilst at Whitehaven there are two, if not more beds of irregular thickness, but with clearly defined floors and roofs, and oftentimes subdivided by regular partings. These beds attain a considerable thickness, occasionally 20 or 30 feet. The area over which they extend is not as yet well known; but they have been worked extensively for many years, and the workings upon them are rapidly increasing. They lie beneath and close to the coal measures, which both furnishes the necessary fuel, and also important beds of argillaceous ironstones for admixture.

## FOREST OF DEAN.

| General No. | No. of Series. | PRINCIPAL WORKS:—                                     | Blast Furnaces. |     | Ft. | In. |
|-------------|----------------|-------------------------------------------------------|-----------------|-----|-----|-----|
|             |                |                                                       | In              | Out |     |     |
| 433-438     | 1 6            | Ulverston<br>Forest of Dean Company<br><br>5 Furnaces | 3               | 2   |     |     |
|             |                |                                                       |                 |     | 5   |     |
|             |                |                                                       |                 |     |     |     |
|             |                |                                                       | Ft.             | In. |     |     |
|             |                | Hematite.                                             |                 |     |     |     |

Annual production of iron about 30,000 tons. The ores of the Forest of Dean are carboniferous, or mountain limestone ores, lying beneath the coal measures, which are not here productive in argillaceous ironstones as in the other principal coal-fields of the kingdom. Besides the limestone ore, there is a bed of ore in the millstone grit measures; but which is only worked very locally. The limestone ore occupies a regular position in the limestone measures, although in itself exceedingly irregular, assuming rather the character of a series of chambers than a regular bed. These chambers are sometimes of great extent, and contain many thousand tons of ore, which is generally raised at an exceedingly low cost, no timbering or other supports for the roof being required. The supply of ore producible in the Forest of Dean is almost unlimited. The iron made from it is of a red short nature, and especially celebrated for the manufacture of tin plates. Its superior quality always commands a high price. This ore is raised extensively for shipment to the iron-works of South Wales. It was worked at a very ancient date either by the Romans or the Britons, as is evident from the remains of old workings along the outcrop of the ore bed. This ore averages from 30 to 40 per cent.

| General No. | No. of Series. | Geological Formation: Granite and the Older Rocks.                                                                                                                                                                                                                 | Ft. | In. |
|-------------|----------------|--------------------------------------------------------------------------------------------------------------------------------------------------------------------------------------------------------------------------------------------------------------------|-----|-----|
| 439         | 1              | Compact Micaceous Iron Ore, Henneck, Devon.—Found in lodes varying from 1 to 12 feet wide, bearing east and west. These lodes are in coarse grained porphyritic granite. The ore is associated with Quartz, Clay, Schist, and Hornblende. It contains 60 per cent. |     |     |
| 440         | 2              | Soft Micaceous Iron Ore, Henneck.—Found associated with No. 1.                                                                                                                                                                                                     |     |     |
| 441         | 3              | Magnetic Oxide, Hnylor, Devon.—Found inter-stratified with a compact felspathic and Hornblende Slate. It is associated with Asbestos, Actynolite, Garnet, Opal, Quartz, and Clay. It contains 70 per cent.                                                         |     |     |
| 442         | 4              | Compact Brown Iron Ore, Blakpington, Devon.—Found in irregular masses, in Limestone. It contains 60 per cent.                                                                                                                                                      |     |     |
| 443         | 5              | Compact and Crystallized Brown Iron Ore, Bisham, Devon.—Found in irregular masses, in Limestone. It contains 55 per cent.                                                                                                                                          |     |     |
| 444         | 6              | Red Hematite, Shevick, Cornwall.—Found in lodes in Clay Slate.                                                                                                                                                                                                     |     |     |
| 445         | 7              | Brown Hematite, Shevick, Cornwall.                                                                                                                                                                                                                                 |     |     |

The micaceous iron ores and the magnetic oxides of Dartmoor (Henneck, &c.) are only just beginning to be known. The quality of iron which they produce is of a superior description, and is calculated to make the finest steel. These ores are not at present raised extensively; but will doubtless become more so when their character is better known, and the localities in which they are found more thoroughly explored. They are sent principally to the South Wales Iron District.

| General No. | No. of Series. | Geological Formation. Granite and the Older Rocks. | Ft. | In. |
|-------------|----------------|----------------------------------------------------|-----|-----|
| 446         | 1              | Plynthite Iron Ore, Tremadoc, Carnarvonshire.      |     |     |
| 447         | 2              |                                                    |     |     |
| 448         | 3              |                                                    |     |     |

These iron ores have, at different periods, been worked to a considerable extent for transport to South Wales. They are of inferior quality; but the large masses in which they lie, enable them to be raised at a very trifling expense. They are found at Tremadoc, Pwllheli, Carnarvon, Island of Anglesea, and many other localities round the North Welsh coast; and will doubtless at some period, prove of importance, from the great extent to which they are there developed.

| General No. | No. of Series. | Geological Formation. Grauwacke.                                                                                                                                                                                                                                               | Ft. | In. |
|-------------|----------------|--------------------------------------------------------------------------------------------------------------------------------------------------------------------------------------------------------------------------------------------------------------------------------|-----|-----|
| 449         | 1              | Hematite, Brendon Hills, Somersetshire.                                                                                                                                                                                                                                        |     |     |
| 450         | 2              | Soft Hematite, Brendon Hills, Somersetshire.—Found in lodes varying from 1 to 6 feet in thickness, in Grauwacke and Gray Slate. These lodes are not at present worked extensively; but they form the site of very old and extensive workings, probably by the Ancient Britons. |     |     |

| General No. | No. of Series. | Geological Formation. New Red Sandstone.                                | Ft. | In. |
|-------------|----------------|-------------------------------------------------------------------------|-----|-----|
| 451         | 1              | Fine Hematitic Conglomerate, Newent, Gloucestershire.                   |     |     |
| 452         | 2              | Hematitic Conglomerate, Newent, Gloucestershire.                        |     |     |
| 453         | 3              | Hematitic Conglomerate, Brochoell, near Wotton Courtney, Somersetshire. |     |     |
| 454         | 4              | Hematitic Conglomerate, Brochoell.                                      |     |     |
| 455         | 5              | Hematitic Conglomerate, Frampton Citterell, Somersetshire.              |     |     |
| 456         | 6              | Hematitic Conglomerate, Cowbridge, South Wales.                         |     |     |

These hematitic conglomerates are found at the base of the New Red Sandstone, and generally occupy the position of its lowest bed. Their character as working ores is very variable, being sometimes mixed up with so much extraneous material as almost to be worthless; but occasionally they exist in regular beds, and contain so large a proportion of hematite as to become of considerable importance.

| General No. | No. of Series. | Geological Formation. Lias, &c.                                    | Ft. | In. |
|-------------|----------------|--------------------------------------------------------------------|-----|-----|
| 457         | 1              | Ironstone, Wiltby.                                                 |     |     |
| 458         | 2              |                                                                    |     |     |
| 459         | 3              |                                                                    |     |     |
| 460         | 4              | Ironstone, Middlesborough.                                         |     |     |
| 461         | 5              |                                                                    |     |     |
| 462         | 6              | Silicious Ironstone, Szeilly, near Lincoln.—Bed 2 to 3 feet thick. |     |     |
| 463         | 7              | Silicious Ironstone, near Northampton.                             |     |     |
| 464         | 8              |                                                                    |     |     |

The clay ironstones of the lias are only just beginning to add to our iron-making resources. They furnish an instance of the unexpected development of national wealth, arising from the facilities afforded by railroads. Nos. 1, 2, and 3, are raised along the outcrop of the beds along the coast from Whitty to Scarborough. The cost of raising is trifling. Nos. 4 and 5 are from an important bed recently opened at Middlesborough. The thickness

of the bed is very irregular, sometimes attaining a thickness of 12 or 14 feet; its average thickness is about 6 feet. Nos. 7 and 8 are from the colite, near Northampton. They are at present of no commercial value; but are curious, as showing the almost universal dissemination of this important ore.

| General No. | No. of Series. | Geological Formation. | Ft. | In. |
|-------------|----------------|-----------------------|-----|-----|
| 465         | 1              | Ironstone, Sussex.    |     |     |
| 466         | 2              |                       |     |     |

These specimens are of great interest, as belonging to the formation which was formerly one of our principal sources of iron; but which, furnishing with its ores no fuel to smelt them, was abandoned, upon the exhaustion of its forests, by the iron trade for the coal-fields, where all the requisites for this manufacture exist. Perhaps, like the lias of Whiteby, &c., the greensand of Sussex may again, by means of railroads, at no distant period, furnish the iron trade with additional supplies of this important ore.

428 STIRLING, J. D. MORRIES, F.R.S.E., Scotland, and 13 Great Cumberland Street, London—Inventor and Producer.

Pig iron:—Scotch, hot blast.

A. Same iron containing malleable iron scrap.—Process patented in 1846.

A a. The same mixture of malleable and cast-iron melted together, and the pig (or ingot) broken to show the complete union of the metal.

B. Specimens of castings of the mixture, called "toughened cast-iron," and the breaking weights.

Cc. Improved patent malleable iron, showing the fibrous structure produced in iron naturally cold short. Process: the addition of zinc or calamine to iron in the puddling furnace. The strength of the iron is thus greatly increased.

D. Hardened, or anti-laminating iron, for the top bar of rails, tires of wheels, &c. This iron, or alloy of iron, has the character of steel, is said to wear well, and not to laminate.

E. Rails composed of Cc and D, to show the difference of the two sorts of iron.

F. Tires of Cc and D.

G. Bell metal, consisting chiefly of iron.

G g. Bells of the same metal, stated to be superior in tone to common bell metal, at a diminished cost.

H. Common zinc cake, broken to show the fracture.

H h. Zinc alloyed with about five per cent. of iron, to show the difference in fracture from the preceding.

I to O c. Alloys of copper and other metals with the alloy of zinc and iron.—Patented in 1846-48.

P. Sheets of zinc, and alloys of zinc covered with tin, and alloys of tin.

Q. Sheets of iron covered with zinc, and alloys of zinc, and subsequently with tin, and alloy of tin.

Several other alloys and specimens exhibited for strength, structure, and cheapness.

[The Report of the Commissioners appointed to inquire into the application of iron to railway structures, gives the following as the results of experiments on Mr. Morries Stirling's iron. The tensile strength of No. 1 Calder hot-blast iron is, per square inch, 13,735 lbs., or 6'131 tons. The same iron, mixed with about 20 per cent. of malleable iron scrap, breaks with a weight of 25,764 lbs., or 11'502 tons.

Bars of Brymbo iron 1 inch square, and 4 feet 6 inch bearing, of Nos. 1 and 3, break respectively at 365 lbs. and 416 lbs. The Calder No. 1, not given by the Commissioners, breaks at about 390 lbs. to 400 lbs. With 20 per cent. malleable iron, the Calder breaks at 623 lbs.; and when the proper proportion of scrap is used, the breaking weight is about 800 lbs.

A square inch of Calder, No. 1, is crushed by 72,193 lbs., or 32'229 tons, and 75,983 lbs., or 33'921 tons.

A square inch of Morries Stirling's mixture as above, by 125,333 lbs., or 55'952 tons, and 119,457 lbs., or 53'329 tons.—R. H.]

429 BANKART, FREDERICK, & SONS, Redjacket Copper Works, near Neath, Wales—Inventors and Manufacturers.

Various stages of the process of copper smelting, as practised at Redjacket Works, according to the exhibitors' patent process.

[This process is as follows:—Copper pyrites reduced to a fine state of division are roasted at a moderate temperature: the result is, that the sulphur of the ore combines with the oxygen of the air, and thus becomes converted into sulphuric acid. The copper is also oxidized; and the acid combining with it, a sulphate of oxide of copper is produced. A second roasting, with an addition of rich sulphur ore, converts all the metal into this salt. It is now dissolved in water, and the copper precipitated by iron. It has been found that the copper thus prepared is of remarkable purity.—R. H.]

Patent fuel made from small coal, without any foreign admixture; invented and patented by William Rees, Pembrey, Carmarthenshire.

Pure native carbon, found in the collieries of Messrs. Penrose and Starbuck, Vale of Neath, and electrodes manufactured from it by the exhibitors.

430 ABERCARN AND GWYTHEN COLLIERIES COMPANY, Newport, Monmouthshire, Proprietors—E. ROGERS, F.G.S., Exhibitor.

Block of Abercarn stone; a hard compact sandstone, which resists the action of the weather and of fire: it forms a part of the carboniferous (or coal-bearing) strata in South Wales. Weight 168 lbs. to the cubic foot. The block is formed in the shape of an obelisk, for the purpose of exhibiting on each face different modes of workmanship in the dressing of the stone.

Block of Abercarn and Gwythen charcoal-vein coal, adapted for steam-ships, and used in the steam marine of the English, French, and Spanish Governments, the Hon. East India Company, &c. This coal is said to resist the action of the weather in any climate, and reference is made to another specimen of this coal, placed at the Western Entrance of the Building, which has been raised and exposed to the weather some years.

Block of Abercarn rock-vein coal, used as a fuel for domestic purposes in the West of England and Ireland.

Specimens of charred coal and tin plates manufactured from the same; this charred coal is stated to be prepared by a process which deprives it entirely of sulphur, and gives it a peculiar mechanical structure, making it as light and pure as wood charcoal, and entirely superseding the necessity of wood charcoal for retining or smelting iron.

A complete set of tools used in mining, and plans, showing the application of electricity to blasting in mines. In a paper accompanying these, the exhibitor states:—It has been often noticed, that, since the application of gunpowder for blasting, few if any improvements have been made in the methods adopted for cutting through hard rocks; and the great expense of maintaining engine power for pumping and winding during the long period required to sink shafts through such rocks has been and is still the sole cause of some of the best and richest tracts of minerals in Great Britain lying idle and unproductive, and has been the principal cause of the loss of life, so serious and often occurring from explosions in mines.

The improvements, or rather the new system, now introduced will be better understood, after a review of the methods and tools heretofore used.

The oldest method of pumping or taking up the water from the bottom of the shaft during sinking was the



Hogar pipe; this was about four feet in length, made of leather, and stiffened by rings of metal; the constant damage this was liable to in blasting caused it to be almost abandoned, and in its place the stock and slide pipe was introduced. This consists of two cast-iron pipes sliding into each other as a telescope, and kept tight in the joint by a stuffing-box; this contrivance is not only expensive in first cost, but liable to breakage and heavy to handle. Both these modes of pumping are subject to a still greater defect; the pump can only be made nearly under the pump trees, so that during a long time of the sinking it often occurs that only two or three men can be effectually employed in the shaft; this, in some of the large shafts (say, in a common size used in South Wales, 18 feet by 10 feet) causes serious delay to the progress of the work.

In boring, it has been customary to use a borer, the body of which was made of wrought iron, and the bit or end of the borer of shear steel welded on to the iron. No attempt appears ever to have been made to fix any definite proportion between the size of the stock or handle and the breadth of the bit; and from this cause a very great portion of the power of the striker has been uselessly expended.

The use of cast-steel borers is, in some respects, entirely new as applied to mining, and by the superior hardness of cast steel as compared with shear steel, greatly expedite the process of boring, and save expense; they have also an advantage in transmitting the force of the hammer to the bit, on account of their stiffness or

rigidity; and, further, to prevent loss of power, it is of importance that the bit should be so proportioned to the handle or stock as to work freely in the bore-hole, and, at the same time, spring or bend as little as possible under the blow of the hammer. The following proportions appear to answer these conditions:—

| Diameter of<br>Octagon Cast Steel. | Breadth of<br>Face of Bit. |
|------------------------------------|----------------------------|
| 1 inch                             | 1½ inch                    |
| 1¼ "                               | 1¾ "                       |
| 1½ "                               | 2 "                        |
| 1¾ "                               | 2¼ "                       |
| 2 "                                | 2½ "                       |

The suction-pipe now used by the exhibitor is about 20 feet in length, is made of gutta percha, and supersedes the use of the leather Hogar, and stock and slide; it is not liable to accident, and can be repaired easily; it enables the pump-hole to be made in any part of the shaft, and a greater number of men to work in the shaft at one time.

The introduction of electricity as the power for blasting in connection with the improvements before explained, may be said to constitute a new era in the history of mining.

The apparatus at present used for blasting is a Grove's battery of six inches square: this is placed in some convenient position near the top of the shaft; two copper wires, coated with gutta percha, are carried down the shaft, and these are connected to other wires inserted in a small cartridge which is placed in the charge of powder for blasting; the cartridges are formed thus—

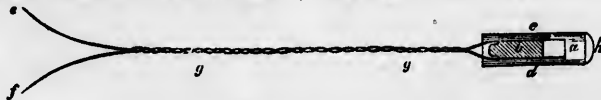

*e, f*, are two thin copper wires covered with gutta percha, and twisted together at *g, g*, to any length required, according to the depth of the hole; *b* is a piece of wood placed to separate the wires to the distance of about ¼ths of an inch apart, so that the fine platinum wire inserted and soldered into the copper at *a* shall not be liable to be broken in tamping, or otherwise injured; and further to guard against this, a thin case or tube of pine

wood is tied over the wire and distance piece of wood at *c, d*, and the platinum wire covered with fine powder, the end of the tube secured at *h* by paper covering, and the whole case varnished over with a solution of shellac in naphtha. This plan of preparing the cartridge is found by experience very certain and effective; but many other modes can be easily used to obtain the same end.

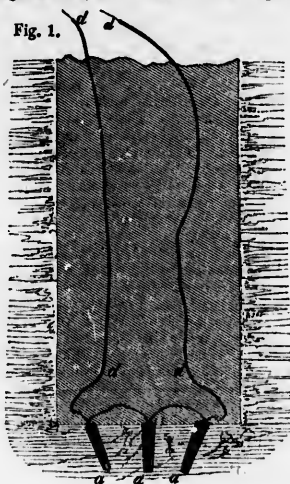

Fig. 1.



Fig. 2.

Let fig. 1. be the section, and fig. 2. the plan of a shaft in course of sinking. Let *d, d, d*, be the wires leading to the electric battery, then at *a, a, a*, is shown the manner

in which the holes are placed to first penetrate a stream of rock (or "enter it" as termed by miners); where one hole only can be fired, the difficulty and delay of entering

very hard rock is often serious, and a work of great cost and time. By the method now used three or more holes are bored as shown at *a, a, a*, and all fired at the same instant of time from the electric battery: the effect of this is to lift up and separate the entire rock contained in the space between *a, a, a*; after this as many holes as are required are bored in the position shown at *b, b, b, b*, and simultaneously exploded; the effect of this is to rend the rock from the side of the shaft in masses weighing tons each; three or four holes if well placed when fired simultaneously produce more effect than double the number of holes would do if fired separately. Perfect safety from accident to the miners while blasting is secured; and it is not necessary for any workman to leave the bottom of the shaft until the arrangements for firing are completed, and the power of the battery to produce the blast tested.

[The Abercorn stone, worked in the coal-grit of Monmouthshire, has an argillo-silicious cement, and is rather micaceous. There are 25 feet of workable stone, and large blocks can be procured. It is very durable, and not expensive. It weighs about 168 lbs. to the cubic foot.—D. T. A.]

431 WALES, J., Newcastle—Producer.

Model of coal mine, old flint wheel, and Davy-lamps.

432 WOOD, H. L., Newcastle—Producer.

Underground working of coal.

434 TAYLOR, R., F.G.S., London—Proprietor.

Model of the machinery and apparatus used for dressing the inferior copper ore called halvans, at the Tywarthale mines, the property of His Royal Highness the Prince of Wales, in the Duchy of Cornwall, consisting of—  
Crushing mill, which pulverizes the ore more effectually than the common stamping mills.

Reservoir for receiving the pulverized mineral, and passing it, by the action of a stream of water, to the shaking trunk.

Self-acting shaking-trunk, in which the mineral is separated into proper sizes, for the subsequent processes, by means of a revolving cylindrical sieve, instead of the ordinary process of shaking or stirring it with shovels in a stream of water.

A tye, for cleaning the rough grain ore which does not pass through the cylindrical sieve, and preparing for sale part of the ore which settles at the head.

Double lever jiggling machine, for dressing the poorer portion of the mineral from the tye, technically called the tails: by a single operation of this machine, the earthy matter is separated from the ore, and rendered fit for sale. With some qualities of halvans, the use of the tye is dispensed with, and the rough grain comes direct from the shaking sieve to the jiggling machine.

Round buddle, for dressing the fine-grained mineral, which passes through the sieve and settles in the shaking-trunk; the ore which it contains is rendered fit for sale by being twice buddled.

Slime pit, for receiving those portions of the mineral which are reduced to so fine a powder as to be carried away, in the shaking and other processes, by the stream of water.

Self-acting trunks, for removing a large proportion of the earthy matter contained in the slimes; when thus concentrated, the slime ore is rendered fit for sale, by being twice buddled.

Specimens of the mineral in its several states of preparation, and of the clean ore, accompany the model.

435 RUEL, HUGH WILLIAM, 175 High Holborn—

Manufacturer and Producer.

Crucibles for assaying, &c.

436 MOREWOOD & ROGERS, Steel Yard Wharf, Upper Thames Street—Inventors and Manufacturers.

1. Patent galvanized tinned iron corrugated sheet, used in the erection and roofing of buildings; fire-proof,

and not liable to be attacked by vermin. Possesses great strength, combined with lightness.

2. Patent galvanized tinned iron sheet, corrugated, and curved; used in the construction of roofs, verandahs, &c.

3. Patent galvanized tinned iron sheet, applicable to most of the purposes for which zinc, iron, or tin-plate are used.

4. Sheet of galvanized tinned iron.

5. Patent stamped tile of galvanized tinned iron, used for roofing of buildings. Is more easily fixed than any other kind of metallic roofing; is less liable to be disturbed by the wind, or otherwise get out of order; and also packs close for shipment.

All the above possess the strength of iron, with perfect protection from rust.

6. Sample of exhibitors' patent tin-plate, more durable and cheaper than the ordinary tin-plate; used for many of the purposes to which tin-plate is applied, and is manufactured in various-sized sheets up to 8 feet long and 3 feet wide.

7. Specimens of moulded gutters and architectural mouldings, made of exhibitors' patent galvanized tinned iron.

8. Samples of Morewood and Rogers's patent plumbic zinc. A new article, consisting of sheet zinc encased in lead; combines the strength of zinc with the power of lead in resisting the action of acids, &c.

9. Sample of patent ferric sheet lead. A new article, combining the pliancy (and power of resisting weather and acids) of lead with the strength of iron. Used for roofing, and other purposes to which sheet lead is applied. May be used much thinner than sheet lead, which renders it cheaper than that material, and it is not liable to pucker and crack from the action of the sun.

10. Sample of exhibitors' patent compound iron and copper wire, the copper being external; possesses the strength of iron combined with the durability and conducting power of copper. Used for electric telegraph and most purposes to which copper wire is applied.

11. Sample of exhibitors' patent compound iron and brass wire, the brass being external.

12. Sample of exhibitors' patent compound iron and lead wire; possesses the strength of iron with the durability and economy of lead.

437 VIELLE MONTAGNE ZINC MINING COMPANY.  
H. F. SCHMOLL, General Agent, 12 Manchester Buildings, Westminster—Producer.

Colossal statue of The Queen on her throne, in the attributes of royalty, eighteen feet high, in imitation of bronze, sculptured by M. Dantin, sen., and cast in zinc by M. Paillard, Paris. (*Nave—Foreign side.*)

Busts of The Queen and H.R.H. Prince Albert, life size, in imitation of bronze, sculptured by Francis.

Statuette of Sir Robert Peel, two feet high, in imitation of bronze, sculptured by Noble.

Eos, favourite greyhound of H.R.H. Prince Albert, life size, in imitation of bronze, sculptured by Francis; all cast in zinc by Karl Schröder, of London.

Model of sections of Her Majesty's ship "Albion," two-decker, of 90 guns, bolted with zinc bolts and painted with zinc paint; by Philip Trant, working shipwright of the Royal Dockyard, Plymouth; these bolts and butts do not rust like iron bolts; they have great strength and durability, and are cheaper than copper bolts.

Model of a frigate of 50 guns, sheathed with zinc and painted with zinc paint; also by Trant.

[Castings in zinc are bronzed in two ways: one is simply the application of a kind of paint, and the other is by producing on the surface an actual coating of copper by electro-chemical action. The use of zinc bolts is of very recent introduction; they appear less liable than iron to corrosion, unless they form part of a galvanic current, when they are rapidly destroyed. Zinc castings bronzed are very durable, and can be produced at a moderate cost.—R. H.]

437A JACK, CHARLES, 8 and 9 Tottenham Court, New Road, and 80 Upper Thames Street—Importer and Manufacturer.

Specimens of perforated zinc, of various patterns; mouldings, sash bars, blinds, and other articles of general utility; manufactured from the zinc imported by "La Vieille Montagne Zinc Company of Belgium."

438 GLOVER, T., Clerkenwell—Inventor and Manufacturer.

Meters; and the large gas-meter for measuring the gas supplied to the Exhibition Building.

439 BERGER, FREDERICK, 12 Cornhill—Producer.

Specimens of native red and grey copper ores, from Trenance mines, Cornwall. These deposits were taken from the lode now working in the serpentine formation, being part of a slab of copper of 30 feet in length; produce 96 per cent. The grey ore produces 78 per cent.

[The general condition of copper in the serpentine rocks is curious. Fissures running through these rocks are filled in with heterogeneous matters, an occasional slab of native copper being found in the crack. It has not hitherto been usual to discover more than a few isolated patches of copper ore; and Trenance mine, on the junction of the serpentine with the hornblende slate, is a remarkable exception, producing native copper, the grey sulphuret of copper, and the red oxide of copper.—R. H.]

440 BOLITHO, EDWARD, Penzance—Producer.

Model of a reverberatory tin smelting furnace and circular table, 51 inches in diameter. The table revolves on rollers. The model stands in the centre of the table, and is surrounded by specimens of various ores prepared for smelting, as well as products from the smelting works.

[Near this is placed a model of the dressing floors, in one of the mines of the Duchy of Cornwall, in which will be found illustrations of the mode of washing, &c. The tin ores containing arsenic and sulphur are submitted to a roasting process to expel these, and such as contain wolfram are treated by some chemical method, such as that devised by Mr. Oxland, and elsewhere described. The tin ores are then submitted to the smelting process, as shown in this model, a portion of carbon being employed to prevent the oxidation of the metal.—R. H.]

441 LONGMAID, WILLIAM, London—Manufacturer.

Rock salt, chloride of sodium, from Cheshire. Ore, cupreous pyrites, containing sulphur, copper, silver, oxide of tin, iron, silica, &c., from Cornwall. Salt and ore, mixed and ground. Sulphate ash, the calcined product of the former, containing sulphate of soda, chlorides of silver and copper in a soluble state, and oxides of tin and iron, silica, and other insoluble matters. Bleaching powder, hypochlorite of lime, the chlorine of which is obtained by passing a current of dried air through a close furnace (heated externally) in which the ore and salt are in process of calcination. Silver and copper precipitate, and their produce. Glauber's salts, crystallized sulphate of soda. Salt cake, anhydrous sulphate of soda. Black ash, containing caustic and carbonated soda, sulphide of calcium, and coal. Crude alkali, the lixiviated product of crocus. Purified alkali, or carbonate of soda, obtained from the former. Crystallized carbonate of soda. Bicarbonate of soda. Insoluble portion of sulphate ash. Crocus, oxide of iron, separated from the former by elutriation—iron the produce. Tin ore, binocide of tin, obtained from the residual matters of the insoluble portion of sulphate ash, by further elutriation, as practised at the mines of Cornwall and Devon, in heating tin ores—tin the produce. Roman, or blue vitrol, sulphate of copper, obtained from copper precipitate, by oxidizing the precipitate and treating it with sulphuric acid. Carburetted oxide of

iron. Black ash waste. Black and brown iron paint. Limestone, carbonate of lime.

[The following is a simple explanation of the essential details of this process:—

Copper pyrites (the double sulphuret of copper and iron) is combined with salt (*chloride of sodium*), and roasted at a certain moderate temperature. By this, a double decomposition is effected. Sulphate of soda is produced by the combination of the sulphur of the ore with oxygen, to form, first, sulphuric acid, which then unites with the soda of the chlorides of sodium. The copper is also converted into a soluble sulphate, the iron being left in a state of peroxidation, and the chlorine liberated, which is employed in the manufacture of bleaching powder.—R. H.]

441A RICHARDS, ALFRED, Redruth, Cornwall—Designer.

Sectional model of East Pool Mine copper lode, Cornwall; showing its direction by an east and west line marked at the base of the model, and the underlies by a perpendicular shaft. The excavations show where the lode has been developed, and whether it has been worked profitably; the levels, winzes, pitches, &c., are labelled.

This method of modelling is considered to have an advantage over sections drawn on paper, as it shows the direction and underlies of the lodes.

442 BREADALBANE, Marquis of, Taymouth, Aberfeldy, Perth—Producer.

Specimens from the copper mine of Tomnadashin, on the south side of Loch Tay, Perthshire.

443 REDRUTH LOCAL COMMITTEE, Redruth—Collectors and Producers.

Specimens of copper ore from various mines in Cornwall: illustrations of the various processes it undergoes in preparation for the market, together with the methods for determining the percentage of pure copper. Specimens of the stratum in which the ore is found.

| No. | Description of Ore.     | Mine.           | Parish. | Stratum.         |
|-----|-------------------------|-----------------|---------|------------------|
| 1   | Yellow ore . . .        | Alfred Consols  | Gwinear | Slate.           |
| 2   | Yellow with fluor spar. | Wheal Buller.   | Redruth | Granite.         |
| 3   |                         | Tywarthayle.    | Illogan | Slate.           |
| 4   |                         | Wheal Buller.   | Redruth | Granite.         |
| 5   |                         | East Crofty . . | Illogan | Slate.           |
| 6   | Yellow ore . . .        | Treviskey . .   | Gwennap | Granite & Slate. |
| 7   |                         | South Frances   | Illogan |                  |
| 8   | Yellow, grey, and black | Carn Brea . .   | Illogan |                  |
| 9   | Grey ore . . .          | Treviskey . .   | Gwennap |                  |
| 10  | Grey ore . . .          | South Bassett.  | Illogan | Granite.         |
| 11  | Black and grey . .      | South Frances   | Illogan |                  |
| 12  | Black in Gosan . .      | Wheal Buller.   | Redruth |                  |
| 13  | Black in Gosan . .      | South Frances   | Illogan |                  |

[The county of Cornwall is the most important mineral district of the United Kingdom, for the number of its metalliferous minerals, many of which are not found in any other part of our islands. At a very early period of our history, mines were worked around the sea-coasts of Cornwall, of which the evidences are still to be seen at Tol-pedden-Penwith, near the Land's End; in Gwennap, near Truro; and at Cadgwith, near the Lizard Point. The traditional statements that the Phœnicians traded for tin with the Britons in Cornwall, are very fairly supported by corroborative facts; and it is not improbable that the *Ictes*, or *Iktis*, of the ancients was St. Michael's Mount, near Penzance.

In the reign of King John, the mines of the western portion of England appear to have been principally in the hands of the Jews. The modes of working must have been very crude, and their metallurgical processes exceedingly rough. From time to time the remains of furnaces, called *Jews' houses*, have been discovered, and small

blocks of tin, known as *Jew's tin*, have not unfrequently been found in the mining localities.

Till a comparatively recent date, tin was the only metal which was sought for; and, in many cases, the mines were abandoned when the miners came to the "yellows," that is, the yellow sulphuret of copper. The greatest quantity of tin has been produced by "streaming" (as washing the debris in the valleys is termed); and this variety, called "stream tin," produces the highest price in the market.

The conditions under which these deposits occur, are curious and instructive. At the Carnon Tin Stream Works, north of Falmouth, the rounded pebbles of tin are found at a depth of about 50 feet from the surface, beneath the bottom of an estuary, where trees are discovered in their place of growth, together with human skulls, and the remains of deer, amidst the vegetable accumulations which immediately cover the stanniferous beds. According to Mr. Henwood's measurement, the section presents first about 50 feet of silt and gravel; then a bed of 18 inches in thickness of wood, leaves, nuts, &c., resting on the tin ground, composed of the debris of quartz, slate, and granite, and the tin ore. At the Pentuan Works, near St. Austell, similar deposits occur, proving a material alteration in the level during the period expended in the formation of this deposit. Tin is also worked out of the lode in many parts, the ore occurring both in the slate and the granite formations. The modes of "dressing" the tin ore, preparing it for the smelter, and the processes of smelting, are illustrated in the Exhibition.

There has been a remarkable uniformity in the quantity of tin produced in Cornwall during a long period, as will be seen from the following table:—

| Years. | Tons. | Price per Cwt. |    |
|--------|-------|----------------|----|
|        |       | £.             | s. |
| 1750   | 1,600 | ..             | .. |
| 1760   | 1,800 | ..             | .. |
| 1770   | 2,000 | ..             | .. |
| 1780   | 1,800 | 3              | 0  |
| 1790   | 2,000 | 3              | 15 |
| 1800   | 1,500 | 5              | 0  |
| 1810   | 1,400 | 7              | 0  |
| 1820   | 1,700 | 3              | 5  |
| 1830   | 3,500 | 3              | 0  |
| 1840   | 5,000 | 3              | 15 |

The produce of this metal within the last few years has been as follows:—

| Years. | Tons.  |
|--------|--------|
| 1844   | 7,507  |
| 1845   | 7,739  |
| 1846   | 8,945  |
| 1847   | 10,072 |
| 1848   | 10,176 |
| 1849   | 10,719 |

The copper mines, now so important, were so little worked until a recent period, that, in 1799, we are told in a Report on the Cornish mines, "it was not until the beginning of the last century that copper was discovered in Britain." This is not correct, for in 1250, a copper mine was worked near Keswick, in Cumberland. Edward III. granted an indenture to John Ballanter and Walter Bolbolter, for working all "mines of gold, silver, and copper;" but that the quantity found was very small is proved from the fact, that Acts of Parliament were passed in the reigns of Henry VIII. and Edward VI., to prevent the exportation of brass and copper, "lest there should not be metal enough left in the kingdom fit

for making guns and other engines of war, and for household utensils;" and in 1635, the calamine works are encouraged by the Government, as "the continuing these works in England will occasion plenty of rough copper to be brought in."

At the end of the seventeenth century, some "gentlemen from Bristol made it their business to inspect the Cornish mines, and bought the copper for two pounds ten shillings per ton, and scarce ever more than four pounds a ton." In 1700, one Mr. John Costar introduced an hydraulic engine into Cornwall, by which he succeeded in draining the mines, and "he taught the people of Cornwall also a better way of assaying and dressing the ore."

The value and importance of the copper mines since that period has been regularly increasing. During a term of about 30 years, 220 mines have sold their ores at the public sales. The following table, from a report by Sir Charles Lemon, Bart., M.P., represents the progress of copper mining, from 1771 to 1837:—

| Years. | Tons of Ore. | Tons of Copper. | Total Value of Ores. | Standard Value per Ton. |
|--------|--------------|-----------------|----------------------|-------------------------|
|        |              |                 | £.                   | £.                      |
| 1771   | 27,896       | 3,347           | 189,609              | 81                      |
| 1780   | 24,433       | 2,932           | 171,231              | 83                      |
| 1799   | 51,273       | 4,223           | 469,664              | 121                     |
| 1800   | 55,981       | 5,187           | 550,925              | 133                     |
| 1802   | 53,937       | 5,228           | 445,094              | 111                     |
| 1805   | 78,452       | 6,234           | 864,410              | 170                     |
| 1808   | 67,867       | 6,795           | 495,303              | 100                     |
| 1809   | 76,245       | 6,821           | 770,028              | 243                     |
| 1812   | 71,547       | 6,720           | 549,665              | 111                     |
| 1814   | 74,322       | 6,369           | 627,501              | 130                     |
| 1816   | 77,334       | 6,697           | 447,959              | 98                      |
| 1818   | 86,174       | 6,849           | 686,005              | 135                     |
| 1821   | 98,426       | 8,514           | 605,968              | 103                     |
| 1825   | 107,454      | 8,226           | 726,353              | 124                     |
| 1827   | 126,710      | 10,311          | 745,178              | 106                     |
| 1831   | 146,502      | 12,218          | 817,740              | 100                     |
| 1837   | 140,753      | 10,823          | 908,613              | 119                     |

The produce of the copper mines of Cornwall, since 1845, has been as follows:—

| Years. | Ore      | Copper   | Money Value. |    |
|--------|----------|----------|--------------|----|
|        | in Tons. | in Tons. | £.           | s. |
| 1845   | 162,557  | 12,883   | 919,934      | 6  |
| 1846   | 150,431  | 11,851   | 796,182      | 6  |
| 1847   | 155,985  | 12,754   | 889,287      | 0  |
| 1848   | 147,701  | 12,422   | 720,090      | 0  |
| 1849   | 146,326  | 11,683   | 763,614      | 0  |
| 1850   | 155,025  | 12,254   | 840,410      | 0  |

With the improvements in the construction of the steam-engine, the facilities for working the mines have been increased. The first steam-engine employed in the county was set to work at Huel Vor Tin Mine, near Helstone, in 1713, by Newcomen; but it was not until the reconstruction of the engine was effected by Watt, that steam power was generally employed for draining the mines. The rapid advance made by Cornish engineers in the perfection of their engines will be seen by the following return of the duty, that is, the performance of each, which is reckoned by the number of millions of pounds lifted a foot high by the consumption of a bushel of coals:—

| Name of Mine.                      | Highest Duty. |
|------------------------------------|---------------|
| Stray Park, 1813 . . . . .         | 29,000,000    |
| Dolcoath, 1816 . . . . .           | 40,000,000    |
| Consolidated Mines, 1822 . . . . . | 44,000,000    |
| Consolidated Mines, 1827 . . . . . | 67,000,000    |
| Fowey Consols, 1834 . . . . .      | 97,000,000    |
| United Mines, 1842 . . . . .       | 108,000,000   |

A brief statement of the quantity of coals consumed per month, in a few of the principal mines, will show the extent to which steam power is now employed.

|                               | Bushels of 4 lbs. |
|-------------------------------|-------------------|
| Fowey Consols, 1835 . . . . . | 101,246           |
| Godolphin, 1839 . . . . .     | 129,801           |
| Fowey Consols, 1840 . . . . . | 203,699           |
| United Mines, 1842 . . . . .  | 84,882            |

Two examples of Cornish engines may be seen near the Metropolis, one at the East London Water Works, and the other at Brentford.

The lead mines of Cornwall have produced of the argentiferous sulphuret, during five years, the following number of tons of ore:—

|                                 | 1845  | 1846  | 1847  | 1848  | 1849  |
|---------------------------------|-------|-------|-------|-------|-------|
| Callington . . . . .            | 950   | 1,138 | 1,249 | 957   | 623   |
| Huel Mary Ann . . . . .         | 166   | 166   | 192   | 394   | 573   |
| Cornblan . . . . .              | 420   | ..    | ..    | ..    | ..    |
| E. and W. Haven . . . . .       | 16    | ..    | ..    | ..    | ..    |
| Huel Trelawney . . . . .        | 240   | 529   | 893   | 413   | 1,296 |
| Camelford . . . . .             | 120   | ..    | ..    | ..    | ..    |
| E. Huel Rose . . . . .          | 7,893 | 5,191 | 6,424 | 5,333 | 4,754 |
| N. Huel Rose . . . . .          | 30    | ..    | 94    | 30    | 73    |
| Cargol . . . . .                | 55    | 306   | 951   | 964   | 501   |
| Oxname . . . . .                | ..    | 189   | 47    | 470   | 269   |
| Huel Rose . . . . .             | 37    | 375   | 378   | 399   | 107   |
| Huel Penrose . . . . .          | 116   | 11    | ..    | ..    | ..    |
| Holmbush . . . . .              | ..    | 12    | 60    | 154   | 102   |
| New Quay . . . . .              | 73    | ..    | ..    | ..    | ..    |
| Porthleven . . . . .            | 8     | 82    | ..    | ..    | ..    |
| Pentire . . . . .               | ..    | 34    | ..    | ..    | ..    |
| Cubert . . . . .                | ..    | 136   | 354   | 68    | ..    |
| Leman . . . . .                 | ..    | 30    | 73    | ..    | ..    |
| Huel Concord . . . . .          | ..    | 30    | ..    | ..    | ..    |
| Huel Trehane . . . . .          | ..    | ..    | 312   | ..    | 459   |
| Herodscombe . . . . .           | ..    | ..    | 37    | ..    | ..    |
| Herodfoot . . . . .             | ..    | ..    | 375   | 721   | 1,040 |
| Great Callstock Moors . . . . . | ..    | ..    | 109   | ..    | ..    |
| Callstock . . . . .             | ..    | ..    | 116   | 179   | ..    |
| Treyorden . . . . .             | ..    | ..    | ..    | ..    | 28    |
| Huel Penhale . . . . .          | ..    | ..    | ..    | ..    | 50    |
| Huel Golden . . . . .           | ..    | ..    | ..    | ..    | 80    |
| Carthen Consols . . . . .       | ..    | ..    | ..    | ..    | 43    |

The produce of zinc is not easily attainable, but it is now somewhat considerable, as is also that of arsenic, and of the iron pyrites, used in the manufacture of sulphuric acid.

The number of individuals employed in 59 Cornish copper mines, was computed by Sir Charles Lemon, in 1837, to be—

|                    |        |
|--------------------|--------|
| Men . . . . .      | 10,624 |
| Women . . . . .    | 3,802  |
| Children . . . . . | 3,490  |

The men alone work underground; the women and children are employed on the surface, picking and dressing the ore.

Mr. W. J. Henwood estimates the number employed at—

|                    |        |
|--------------------|--------|
| Men . . . . .      | 18,472 |
| Women . . . . .    | 5,764  |
| Children . . . . . | 5,764  |

30,000

Beside the minerals peculiarly industrial, a very large variety of beautiful mineralogical specimens are produced in the county. A large trade in kaolin—china-clay—is carried on; and of the building and ornamental stones of Cornwall, granites, slates, porphyries, serpentines, and other kinds, a considerable variety in the natural state, and wrought into articles of use and ornament, will be found in the Exhibition. The accompanying map is intended to furnish information as to the metalliferous mineral wealth of Great Britain generally, and the site of different mines is represented by symbols which will render the map intelligible as a means of reference in studying the metalliferous minerals in Class 1.—R. H.]

444 GRAYLS, S., & REDRUTH COMMITTEE—Producers.  
A large mass of copper pyrites.

445 LEAN, J., *West Caradon Mine, Liskeard*—Producer.  
Grey and native copper ore.

446 PUCKET, JOHN, *St. Blazey, St. Austell*—Agent.  
Mass of copper ore, about 1,500 lbs. in weight, from Par Consols Mine, St. Blazey, Cornwall. This specimen contains some quartz and chlorite, and shows the "walls" and inclination of the lode.

[The produce of this mine for some years has been as follows:—

| Years. | Ore in Tons. | Copper in Tons. Cwts. | Total Value. £ |
|--------|--------------|-----------------------|----------------|
| 1845   | 5,655        | 464 10                | 30,881         |
| 1846   | 6,065        | 557 12                | 35,144         |
| 1847   | 6,101        | 625 10                | 42,953         |
| 1848   | 8,470        | 914 8                 | 52,353         |
| 1849   | 12,228       | 738 9                 | 47,249         |
| 1850   | 7,152        | 641 2                 | 44,090         |

—R. H.]

447 WELLBORNE, W., *Bodmin*—Producer.  
Specimens of iron ore.

448 TAYLOR, J., *Cornwall*—Producer.  
Iron ores from Restormel.

449 DREW, JOSEPH, *St. Austell*—Producer.  
Iron ore, magnetic and oxidulated, from the Trerank mine, near St. Austell. Brown hematite, from the same mine. Iron ores. Red hematite, from Treverbyn mine.

450 BENNETT, CARR, & Co., *Moorgate Street*—Producers.  
Copper ores, gossan, &c., St. Brenard, Cornwall.

451 TAYLOR, R.—Producer.  
Mining tools, as used in the Cornish mines.

452 DUCHY OF CORNWALL—Producer.  
Sections of Cornish copper mines.

453 DEVON GREAT CONSOLIDATED COPPER MINING COMPANY, *Tavistock*—Producer.  
Specimens of copper ore.

454 SECOCMBE, SAMUEL, *Phoenix Mines, Liskeard*—Producer.  
Specimens of tin and copper ore, and gossan. Pieces of copal and of the stratum from the side of the lode.—All from one lode in Phoenix mines in the parish of Lenkingborne, near Liskeard.  
Specimens of fire-bricks.  
Specimen of native copper from West Caradon mine.  
Piece of barytes from Wheal Mary Ann.

455 WELLBORNE, W., *Bodmin*—Producer.  
Specimens of tin ore and tin.

456 READWIN, T. A., *Winchester Buildings*—Producer.  
Tin stone, from Wheal Augusta, St. Just.

457 DIAMOND, J., *Tavistock*—Producer.  
Specimens of tin ore, from Wheal Mary.

457A BIRD, J., *Walleyd, Merioneth, Wales*—Proprietor.  
Specimen of silver lead ore, weighing 350 lbs., containing 16 cwt. 3 qrs. 10 lbs. of lead per ton, 82½ oz. of silver per ton of lead, extracted from the great Cowarch silver lead mine, which has been in work seven years, and is situate on the Brodddwy estate, the property of the exhibitor. Exported from Aberdovey, North Wales.

458 COLLETT, WM. R., *Gort, County Galway*—Producer.  
Cahriglissan silver-lead ore; found in carbonate of lime between Gort and Kinvara, County Galway, Ireland. The parting assay of Messrs. Johnson is—



|                                  |       |
|----------------------------------|-------|
| Lead . . . . .                   | 45    |
| Copper . . . . .                 | 21    |
| Sulphur . . . . .                | 23    |
| Antimony and arsenic . . . . .   | 8     |
| Silver . . . . .                 | 1.1   |
| Earthy matter and loss . . . . . | 1.9   |
|                                  | 100.0 |

About 30 tons of this ore have been raised last year. It is much esteemed in the market.

459 BLEE, ROBERT, *Redruth*—Inventor.

Safety bucket to be used in mines for drawing up persons or produce. This bucket is furnished with guides to run in grooves which extend along the whole depth or shaft of the pit. To the guides are fixed strong crooks to which the drawing-rope is attached. So long as the tension of the rope continues, the crooks are held in over the bucket. Should the rope break, and its tension consequently cease, the crooks are immediately thrown out by springs, which constantly act on them, and cause the crooks to take hold on the iron staves of strong ladders fixed at the back of the grooves throughout their length.

460 POLKINGHORNE, W., *Fowey Consols Mine, Tyewardreath*—Inventor.

A synopsis of the Cornwall ticketings for copper ore from 1800 to the present time; together with a synopsis of the Swansea ticketings from 1815 to the same period; which contains the following information, viz., the standard, produce, price, and quantity of copper ores sold, amount of money realised, and the quantity of fine copper produced, with the respective fluctuations for each year, as well as for every six years; exhibiting also the totals and averages for the whole period collectively. The object of this synopsis is to show to all interested in the copper trade, at one glance, the state of the copper market during the past half century. The novelty of this document consists in its arrangement, and the invention of the diagram, which shows the different valuations of the standard each year by coloured lines, differing in length, so that for the highest, lowest, or intermediate years, the observer, by following the line, can at once obtain the information he requires without scanning the columns. This synopsis, from its valuable tabular matter, will be useful not only to miners, but to statisticians in general.

461 MICHELL, F.—Producer.  
Pick for dressing granite.

462 ARTHUR, J.—Inventor.  
Apparatus for lifting pumps from mines full of water.

463 EDDY, J.—Inventor.  
Apparatus for lifting pumps.

464 TRESIZE, T., *Perran Foundry*—Maker.  
Model of improved smelting furnace.

465 VINCENT, T., *Redruth*—Producer.  
Model of a steam-engine by a working miner.

466 HOSKING, R., *Perran Foundry, Fulmouth*—Producer.  
Model of compound valve for pumps.

467 THE TRURO LOCAL COMMITTEE—Producers.  
Articles illustrating lead, from East Wheel Rose, near Truro, Fentire Glaze, near Wadebridge, and other Cornish mines.

[Wheel, or wheel, appended to the names of most of

the Cornish mines, is a corruption from an old word, probably Cornish, Huel, which was employed to signify a mine.

East Wheel Rose has proved the most productive lead mine in the west of England, the returns of lead from this mine being for a few years as follows:—

| Years. | Ore in Tons. | Lead in Tons. |
|--------|--------------|---------------|
| 1845   | 7,883        | 5,191         |
| 1846   | 4,729        | 3,114         |
| 1847   | 6,424        | 3,854         |
| 1848   | 4,758        | 2,850         |
| 1849   | 5,333        | 3,191.—R. H.] |

468 THE TRURO LOCAL COMMITTEE—Producers.

Articles, illustrating tin, from various Cornish mines (supplied by George Nicolls Simmons, Mr. Henry Borrow, of Truro; Capt. Webb, of St. Austell; Capt. Evans, of St. Agnes; Mr. J. N. R. Millett, of Penzance; and other gentlemen, from Great Beam Mine, near St. Austell, Budnick Mine, in Perranzabulal, Rocks Mine, in St. Agnes, Friendly Mines, in St. Agnes; Mineral Court Mine, in St. Stephen's, and from various mines in the Penzance district), exhibiting the ore in its various stages until it leaves the miner's hands as black-grain tin. A block of white tin very free from impurity, the produce of Mineral Court Mine, supplied by the shareholders, and a rude smelted block of tin supplied by Mr. G. N. Simmons, found in Ladock, near Truro, and supposed to have been smelted when the Phœnicians traded to Cornwall for tin.

[Tin appears to have been raised in Cornwall from a very early period. Traditionary evidence, supported by strong corroborative facts, appears to prove that the kingdoms around the Mediterranean Sea were supplied with tin from Cornwall by the Phœnician merchants at a very early date. The circumstance of this metal being found in the beds of streams, and in deposits at the base of the primary rocks, from which it could be obtained without much labour, may have been the cause of its being early known to the Britons.

The oxide of tin is usually found deposited in beds in water-worn pebbles, and mixed with the debris of the neighbouring hills. There can be but little doubt that these tin deposits are the result of the disintegrating action of the atmospheric causes and of water; some of the tin beds, 30 or 50 feet from the present surface, contain vegetable matter, as branches of trees, and large logs of wood; and at Carnou stream works, human skulls were discovered amidst the debris, 53 feet below the surface.

Tin is also found in the lode, either as peroxide, cupreous-sulphuret of tin, or tin pyrites, the analysis of the peroxide giving—peroxide of tin, 96.265; silica, 0.750; peroxide of iron and manganese, 3.395.

Many indications of early tin-mining are to be found in Cornwall, as stated in a preceding note. For many centuries the Dukes of Cornwall drew a large revenue from its tin. The tin when smelted into blocks was forwarded to the nearest coinage town, there to be stamped by the Duchy officers, who cut a piece off the corner of each block, which was retained as the Duchy's dues. In 1337, Edward the Black Prince was created Duke of Cornwall, and then the average profit of the coinage was 4,000 marks per annum. In 1814, the revenue to the Duchy from tin was about 8,500*l.*, and the average tin revenue from 1820, to the abolition of the coinages in October, 1838, has been estimated at 12,000*l.* per annum. In 1750, about 2,000 tons of tin were produced in Cornwall, and in 1838, about 5,000; since that period the quantity cannot be accurately ascertained, the trade in tin being in the hands of a few, and the purchases of ore being usually made by private contract.—R. H.]



469 LOCAL COMMITTEE, *St. Austell*—Collector.  
Alluvium, in which stream tin ore is found. The ore as prepared for sale. Specimens of pebbles of tin ore. Building stones from the vicinity of *St. Austell*, prepared in cubes.

470 WELBORNE, J. W., *St. Austell*, and 38 *Albemarle Street*—Producer.  
Slab of rosin tin ore, from the *Par Consols Mine*, near *St. Austell*, *Cornwall*.  
Stone of the magnetic oxide of iron, from *Roche Rook iron mine*.  
Sulphuret of copper, or yellow copper ore, from *Bodmin Wheal Mary Consols*, near *Bodmin*.

471 WHITE & GRANT, *Dalmarnock Road, Glasgow*—Inventors and Manufacturers.  
Patent safety cage and detaching catch for mine-shafts, to prevent accidents from the breaking or over-winding of ropes or chains.

472 HOSKING, R., *Perran, Cornwall*—Inventor.  
Reversing apparatus, for horse whim and stamping machinery.

473 SWANSEA COMMITTEE, *Swansea*—Manufacturers.  
Specimens of copper ore, and of calcined ore, blistered and refined copper, &c.

474 TAYLOR, JOHN, *London*—Producer.  
Collection of rare and metalliferous metals.

475 THORNE, WILLIAM, *Barnstaple*—Proprietor.  
Pseudomorphic sphathose iron, showing the structure of box and slipper specimens; yellow sulphuret of copper; pea-cock copper; foliated mundio and crystallized white quartz; from the *Virtuous Lady Mine*, near *Tavistock*, *Devon*.

[These singular formations are due to the deposit of the sulphuret of iron upon crystals of sulphate of lime, which have been dissolved out subsequently. They have been rarely met with in any other mine.—R. H.]

Crystallized white iron, with lead and Fahlertz ores, containing silver, from the *Combmartin Mines*, in *North Devon*.

Specimens of killas, or clay slate, white iron, crystallized white quartz, mundio, and lead and Fahlertz ores, from the *Wheal Golden Mine*, *Perranzabuloe*, *Cornwall*.

Hydraulic cement and raw mineral paint, from *Bickington Quarry*, near *Barnstaple*, *Devon*.

Ashlar-stone, hone-stone, clay, and granite gravel, from *Tavistock*, near *Barnstaple*.

476 GOODHALE & REEVES, for the *Ringerige Nickel Work, Vigersund, via Drammen, Norway*—Proprietors and Producers.

Nickel ore; from mines in the district of *Ringerige*, in *Norway* (about thirty miles north-west from *Christiania*), worked only last year: containing 2.80 per cent. nickel, with 40.46 sulphur, 56.03 iron, and 0.40 copper.

[The *Norwegian* mines have lately attracted much attention in this country on account of the cobalt and nickel ores they contain.—R. H.]

477 JOHNSON & MATTHEY, 79 *Hatton Garden*—Manufacturers.

Specimens of metals and metallic compounds:—Platinum crucibles, with capsule covers; and with ordinary covers. Capsules, spatula, and large basin of this metal; oxide and sponge platinum.

Palladium; part of an ingot; a cup, soldered with fine gold; another, smaller, raised with the hammer; alloy of silver and palladium used by dentists and philosophical instrument makers; oxide of palladium; and its salts, red and yellow.

Iridium; pure metallo in vase; and the native alloy, as used for nibs of pens; its oxide and salts.

Rhodium; metallo in vase; its crystal of sodo-chloride; oxide; and phosphuret.

Uranium; its oxide; glass vessel showing the colour produced by the oxide of uranium.

[Platinum was discovered by *Ulloa* in 1735, but it was first rendered available by *Dr. Wollaston*. The largest supply of the metals platinum, palladium, iridium, rhodium, and uranium, is obtained from the *Uralian Mountains*; some is procured from the alluvial deposits of *Brazil* and other parts of *South America*. These metals, except uranium, are commonly found combined. Uranium is procured from pitchblende, uranite, and other minerals found in *Cornwall* and *Bohemia*.—R. H.]

[The colour produced by mixing a minute portion of the oxide of uranium in a mass of molten glass is one of the most beautiful colours obtained by art. It is a charming golden green of an opaline lustre, so peculiar as to distinguish it from all other colours in glass.—R. E.]

478 PIMM, HENRY, & Co., 29 *Newhall Street, Birmingham*—Manufacturers.

Gold and silver leaf, and bronze powders.

479 MATHISON, G. F., *Royal Mint Refinery*—Producer.  
Sulphuric acid process of separating gold, silver, and copper.

480 PATTINSON, HUGH LEE, *Newcastle-upon-Tyne*—Inventor.

Specimens to illustrate the exhibitor's process for the separation of silver from lead: viz., original lead; crystallized lead; slabs of lead, to show the form of the crystals; rich lead; plate of silver obtained by submitting rich lead to cupellation. Large drawing to illustrate the process.

[This process of desilverizing lead is founded on the physical fact, that lead crystallizes at a temperature above that at which silver solidifies, and in this process of aggregation, the silver is separated from the commoner metal. It is effected by the use of hemispherical cast-iron pans, holding about three tons of metal, which are heated by a fire below them; the argentiferous lead is placed in these, and melted, after which the fire is withdrawn, and all made air-tight below. The workman now begins to agitate the mass, which he does with an iron rake, removing the solid parts from the edges, as solidification takes place. With an iron strainer the solid crystals are removed as fast as they are formed; these are nearly pure lead, the liquid mass left behind being rich in silver. This process is repeated three or four times, the mass left after the last operation, which contains from 3 to 400 ounces of silver to the ton, is then submitted to the process of cupellation, by which the lead is oxidized, and the silver left in a state of purity behind.

By the original method, lead ores containing less than 20 ounces of silver to the ton scarcely paid the expense of working. By this process, ores containing only three ounces to the ton, are made to yield their silver.—R. H.]

481 HALLETT, GEORGE, *Broadhall, Blackfriars*—Manufacturer.

Antimony. Sulphuret ore, from *Sarawak*, *Borneo*, *Leghorn*, *Tuscany*; oxide ore, from *Algeria*. Refined sulphuret of antimony, commercially known as "Crude Antimony;" used in medicine, dyeing, pyrotechny, and chemistry.—Metallic antimony, commercially known as "Regulus," with fracture shown; designated as "Best bowl Regulus." Metallic antimony, more highly refined, exhibiting its naturally crystallized, or fernlike surfaces, and its fracture; commercially known as "Best French qua-

the native alloy,  
ita.  
of sodo-chloride;  
wing the colour

1735, but it was  
n. The largest  
n, iridium, rho-  
Uralian Moun-  
deposits of Brazil  
metals, except  
i. Uranium is  
other minerals

pute portion of  
en glass is one  
by art. It is a  
tre, so peculiar  
urs in glass.—

hall Street,  
s.  
rs.

ry—Producer.  
old, silver, and

upon-Tyne—

process for the  
final lead; crys-  
form of the crys-  
by submitting  
to illustrate the

ounded on the  
emperature above  
rocess of aggre-  
mmoner metal.  
cast-iron pans,  
are heated by a  
placed in these,  
drawn, and all  
begins to agi-  
rake, removing  
on takes place.  
re removed as  
pure lead, the

This process  
ft after the last  
nces of silver  
of cupellation,  
left in a state

ning less than  
t the expense  
ng only three  
silver.—R. H.]

skfrars—

wak, Borneo,  
oria. Refined  
n as "Crude  
rotechny, and  
ly known as  
ed as "Best  
ighly refined,  
like surfaces,  
t French qua-

COAL FIELDS OF EUROPE.

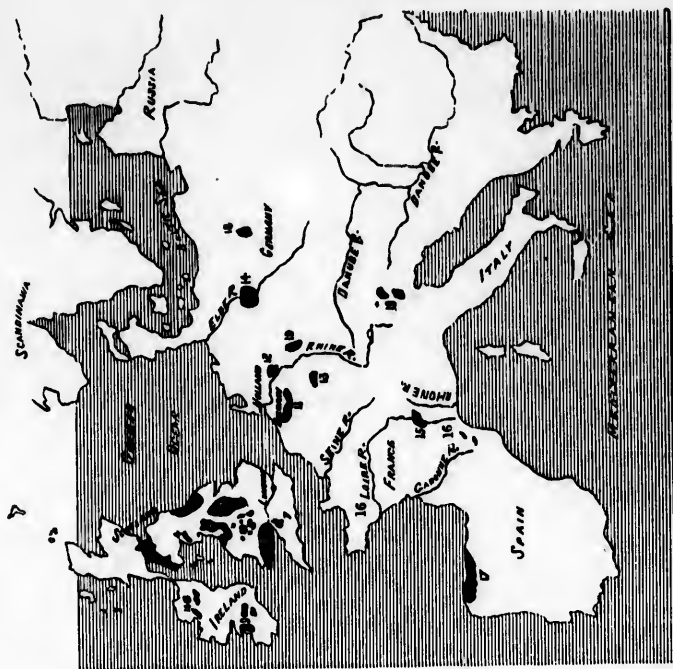

27. Illinois Coal Field.
26. Michigan Coal Field.
24. Missouri Coal Field.
23. Pennsylvania Coal Field.
22. Richmond (Virginia) Coal Field.
21. Coal Field of Franco-Belgian Islands and Cape Breton.

16. Small Coal Fields of France.
15. Coal Field of Silesia.
14. Coal Field of Bohemia.
13. German Brown Coal.
12. Great Allegheny Coal Field.
11. Small Coal Field of Pennsylvania.

10. Irish Bituminous Coal Fields.
9. Belgian Coal Fields.
8. Silesian Coal Field.
7. Sauer Coal Field.
6. Coal Fields of Bohemia.
5. Coal Field of St. Euzemie.

COAL FIELDS OF THE UNITED STATES AND BRITISH NORTH AMERICA.

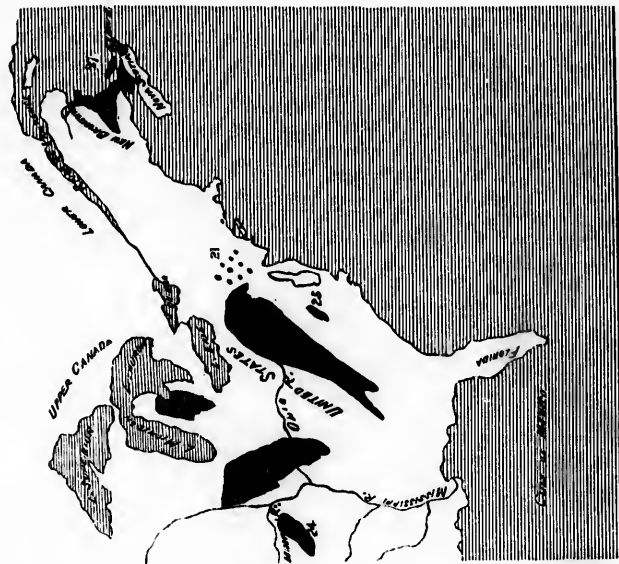

4. Staffordshire, Shropshire, Warwickshire, and Worcestershire Coal Fields.
3. South Wales Coal Field.
2. Scotch Coal Fields.
1. Irish Anthracitic Coal Fields.

1. Newcastle Coal Field.
2. Great Yorkshire and Midland Coal Fields.
3. Great Pennsylvania and North Welsh Coal Fields.
4. Whitehaven Coal Field.

King

lity  
duct  
with  
or  
it b  
way  
for  
by  
sum

482

M  
Brit

483

C  
leac  
becl  
and  
hea  
sup  
Cor  
dist  
T

No.

- 1
- 2
- 3
- 4
- 5
- 6
- 7
- 8
- 9
- 10
- 11
- 12
- 13
- 14
- 15
- 16
- 17
- 18
- 19
- 20
- 21
- 22
- 23
- 24
- 25
- 26
- 27
- 28
- 29
- 30
- 31
- 32
- 33
- 34
- 35
- 36
- 37
- 38

lity Regulus."—Used principally to harden of the soft and ductile metals; viz., with lead and tin for printing types; with copper and tin (and sometimes lead), for Britannia or Queen's metal, pewter wares, &c. Melted with tin, it has of late been used as an anti-friction alloy for railway axles and other bearings, in metallic rings or collars for machinery, &c. As this alloy is not so much heated by friction as the harder metals, less grease is consumed.

482 HUNT, JOHN (per C. BOYD, 15 Addison Road, Kensington)—Inventor.

Machine for washing poor silmy ores, employed in Brittany.

483 A COLLECTION OF MINERALS,

Contributed by agents and workmen connected with the lead mines of Allendale, Alston Moor, Weardale, Caldbeck, and Keswick, including 2,000 specimens, arranged and cemented together by Mr. ISAAC ROBINSON, of Nenthead, for the Great Exhibition of 1851, under the general superintendence and direction of Mr. T. SOPWITH, and a Committee of Mining Agents connected with the above districts.

The following is a catalogue of the above minerals:—

| No. | NAME OF MINERAL.                                                      | Locality.             | Contributor.       |
|-----|-----------------------------------------------------------------------|-----------------------|--------------------|
| 1   | Matrix of quartz . . .                                                | West Allendale        | Matthew Millican.  |
| 2   | Quartz . . . . .                                                      | Nenthead . . .        | Isaac Robinson.    |
| 3   | Sulphuret of zinc and carbonate of iron . . .                         | Nenthead . . .        | Isaac Robinson.    |
| 4   | Quartz . . . . .                                                      | Nenthead . . .        | Isaac Robinson.    |
| 5   | Carbonate and sulphuret of iron . . . . .                             | Nenthead . . .        | Thomas Cain.       |
| 6   | Fluor, capped with quartz . . . . .                                   | Allenheads . . .      | W. B., LEAD MINES. |
| 7   | Carbonate of lime . . . . .                                           | Nenthead . . .        | Isaac Robinson.    |
| 8   | Sulphuret of zinc, with carbonate of iron . . .                       | Nenthead . . .        | Jacob Walton.      |
| 9   | Fluor . . . . .                                                       | Teesdale . . .        | Thomas Watson.     |
| 10  | Sulphuret of zinc with carbonate of iron . . .                        | Nenthead . . .        | Isaac Robinson.    |
| 11  | Madrepore coral, crystallized with quartz and carbonate of iron . . . | Nenthead . . .        | Thomas Cain.       |
| 12  | Quartz . . . . .                                                      | Nenthead . . .        | Isaac Robinson.    |
| 13  | Quartz, with carbonate of iron and sulphuret of zinc . . . . .        | Nenthead . . .        | Jacob Walton.      |
| 14  | Fluor and sulphuret of iron . . . . .                                 | Allenheads . . .      | W. B., LEAD MINES. |
| 15  | Fluor, capped with quartz . . . . .                                   | Allenheads . . .      | W. B., LEAD MINES. |
| 16  | Sulphuret of zinc, with iron pyrites . . . . .                        | Allenheads . . .      | W. B., LEAD MINES. |
| 17  | Fluor, capped with quartz . . . . .                                   | Allenheads . . .      | W. B., LEAD MINES. |
| 18  | Sulphuret of zinc and carbonate of iron . . .                         | Nenthead . . .        | Isaac Robinson.    |
| 19  | Carbonate of iron and lime with sulphuret of zinc . . . . .           | Alston Moor . .       | Robert Broadwood.  |
| 20  | Quartz . . . . .                                                      | Nenthead . . .        | Isaac Robinson.    |
| 21  | Fluor . . . . .                                                       | Allenheads . . .      | W. B., LEAD MINES. |
| 22  | Carbonate of iron . . . . .                                           | Nenthead . . .        | Thomas Cain.       |
| 23  | Quartz . . . . .                                                      | Nenthead . . .        | Isaac Robinson.    |
| 24  | Fluor, capped with quartz . . . . .                                   | Weardale Mines        | W. B., LEAD MINES. |
| 25  | Fluor, covered with arragonite . . . . .                              | Nenthead . . .        | William Wallace.   |
| 26  | Quartz . . . . .                                                      | Nenthead . . .        | Isaac Robinson.    |
| 27  | Quartz with sulphuret of zinc . . . . .                               | Nenthead . . .        | Isaac Robinson.    |
| 28  | Fluor, with carbonate of iron . . . . .                               | Allenheads . . .      | W. B., LEAD MINES. |
| 29  | Carbonate of lime . . . . .                                           | Garrigill . . .       | William Hayton.    |
| 30  | Sulphuret of zinc and carbonate of iron . . .                         | Nenthead . . .        | Isaac Robinson.    |
| 31  | Carbonate of iron, sulphuret of zinc with quartz . . . . .            | Nenthead . . .        | Jacob Walton.      |
| 32  | Brown blend . . . . .                                                 | Allenheads . . .      | W. B., LEAD MINES. |
| 33  | Fluor . . . . .                                                       | Nenthead . . .        | Isaac Robinson.    |
| 34  | Sulphuret of zinc and arragonite . . . . .                            | Nenthead . . .        | William Hayton.    |
| 35  | Sulphuret, capped with quartz . . . . .                               | Nenthead . . .        | Isaac Robinson.    |
| 36  | Fluor and carbonate of iron . . . . .                                 | Nenthead . . .        | Jacob Walton.      |
| 37  | Quartz, with sulphuret of zinc . . . . .                              | Nenthead . . .        | George Rutherford. |
| 38  | Carbonate and sulphuret of iron, with sulphuret of zinc . . . . .     | Nenthead . . .        | John Froest.       |
| 39  | Quartz and sulphuret of zinc . . . . .                                | Nenthead . . .        | Isaac Robinson.    |
| 40  | Fluor and quartz . . . . .                                            | Allenheads . . .      | Isaac Robinson.    |
| 41  | Arragonite . . . . .                                                  | West Allendale        | Wallace Millican.  |
| 42  | Quartz, capped with iron, and sulphuret of zinc . . . . .             | Nenthead . . .        | Jacob Walton.      |
| 43  | Sulphuret . . . . .                                                   | Nenthead . . .        | Isaac Robinson.    |
| 44  | Carbonate of zinc and sulphuret of zinc . . .                         | Nenthead . . .        | Thomas Watson.     |
| 45  | Fluor, capped with quartz . . . . .                                   | Allendale . . .       | W. B., LEAD MINES. |
| 46  | Carbonate of iron and fluor . . . . .                                 | Allendale . . .       | W. B., LEAD MINES. |
| 47  | Carbonate of lime . . . . .                                           | Garrigill . . .       | William Hayton.    |
| 48  | Fluor, covered with quartz . . . . .                                  | Weardale . . .        | W. B., LEAD MINES. |
| 49  | Quartz upon sulphuret of zinc . . . . .                               | Nenthead . . .        | Isaac Robinson.    |
| 50  | Fluor . . . . .                                                       | Allenheads . . .      | W. B., LEAD MINES. |
| 51  | Sulphuret of zinc, carbonate of iron, and quartz . . . . .            | Nenthead . . .        | Joseph Hayton.     |
| 52  | Yellow fluor, capped with quartz . . . . .                            | Nenthead . . .        | William Wallace.   |
| 53  | Carbonate of lime on quartz . . . . .                                 | Garrigill . . .       | William Thompson.  |
| 54  | Carbonate of lime on quartz . . . . .                                 | Garrigill . . .       | William Wallace.   |
| 55  | Quartz, capped with carbonate of iron . . .                           | Nenthead . . .        | Jacob Walton.      |
| 56  | Quartz . . . . .                                                      | Nenthead . . .        | Isaac Robinson.    |
| 57  | Carbonate of lime . . . . .                                           | Nenthead . . .        | William Wallace.   |
| 58  | Phosphate of lead . . . . .                                           | Caldbeck Fells.       | Sam. Merryweather. |
| 59  | Fluor, with carbonate of iron . . . . .                               | Allenheads . . .      | Isaac Robinson.    |
| 60  | Carbonate of lime . . . . .                                           | Allenheads . . .      | Isaac Robinson.    |
| 61  | Sulphate of barytes . . . . .                                         | Westmoreland          | Isaac Robinson.    |
| 62  | Sulphuret of lead . . . . .                                           | Nenthead . . .        | Thomas Wilkinson.  |
| 63  | Sulphuret of lead with iron pyrites . . . . .                         | Garrigill . . .       | Joseph Walton.     |
| 64  | Quartz . . . . .                                                      | Nenthead . . .        | Isaac Robinson.    |
| 65  | Sulphuret of lime upon quartz . . . . .                               | Nenthead . . .        | William Hayton.    |
| 66  | Fluor . . . . .                                                       | Allenheads . . .      | W. B., LEAD MINES. |
| 67  | Arsonite . . . . .                                                    | Nenthead . . .        | William Hayton.    |
| 68  | Iron pyrites . . . . .                                                | Allenheads . . .      | W. B., LEAD MINES. |
| 69  | Quartz . . . . .                                                      | Nenthead . . .        | Jacob Walton.      |
| 70  | Fluor, with iron (sulphuret) . . . . .                                | Allenheads . . .      | W. B., LEAD MINES. |
| 71  | Fluor and carbonate of iron . . . . .                                 | Allenheads . . .      | W. B., LEAD MINES. |
| 72  | Sulphate of barytes, tinged with iron . . .                           | Keswick . . .         | Jacob Walton.      |
| 73  | Sulphate of barytes, tinged with iron . . .                           | Keswick . . .         | Jacob Walton.      |
| 74  | Fluor . . . . .                                                       | Allenheads . . .      | W. B., LEAD MINES. |
| 75  | Fluor and carbonate of lime . . . . .                                 | Allenheads . . .      | W. B., LEAD MINES. |
| 76  | Sulphuret of lead and yellow fluor . . . . .                          | Allenheads . . .      | W. B., LEAD MINES. |
| 77  | Fluor upon quartz . . . . .                                           | Allenheads . . .      | W. B., LEAD MINES. |
| 78  | Quartz . . . . .                                                      | Nenthead . . .        | Isaac Robinson.    |
| 79  | Sulphuret of zinc and carbonate of iron . . .                         | Nenthead . . .        | Isaac Robinson.    |
| 80  | Carbonate of lime . . . . .                                           | Teesdale . . .        | Thomas Watson.     |
| 81  | Quartz upon fluor . . . . .                                           | Weardale . . .        | W. B., LEAD MINES. |
| 82  | Fluor, capped with quartz . . . . .                                   | Garrigill . . .       | Joseph Walton.     |
| 83  | Fluor and carbonate of lime . . . . .                                 | Allenheads . . .      | W. B., LEAD MINES. |
| 84  | Green carbonate of copper and sulphuret of copper . . . . .           | Caldbeck Fells.       | Sam. Merryweather. |
| 85  | Yellow fluor . . . . .                                                | Nenthead . . .        | Joseph Thompson.   |
| 86  | Arsenic, phosphate of lead and manganese . . .                        | Hesketh . . .         | Joseph C. Cain.    |
| 87  | Arsenic, phosphate of lead, and manganese . . .                       | Hesketh . . .         | Joseph C. Cain.    |
| 88  | Carbonate of lime . . . . .                                           | Alston Moor . .       | Joseph C. Cain.    |
| 89  | Fluor, covered with carbonate of iron . . .                           | Allenheads . . .      | W. B., LEAD MINES. |
| 90  | Limestone, with a weak string of lead . . . . .                       | Nenthead . . .        | Isaac Robinson.    |
| 91  | Plate . . . . .                                                       | Nenthead . . .        | Isaac Robinson.    |
| 92  | Hazle . . . . .                                                       | Nenthead . . .        | Isaac Robinson.    |
| 93  | Green carbonate of copper . . . . .                                   | Stavely, Westmoreland | Joseph C. Cain.    |
| 94  | Quartz . . . . .                                                      | Green Castle . .      | T. B. Leonard.     |
| 95  | Carbonate of lime . . . . .                                           | Nenthead . . .        | Thomas Watson.     |
| 96  | Sulphuret of zinc and quartz . . . . .                                | Nenthead . . .        | Isaac Robinson.    |
| 97  | Arsenic, phosphate of lead . . . . .                                  | Caldbeck Fells.       | Joseph C. Cain.    |
| 98  | Arsenic, phosphate of lead . . . . .                                  | Caldbeck Fells        | Joseph C. Cain.    |
| 99  | Green carbonate of copper . . . . .                                   | Caldbeck Fells.       | Sam. Merryweather. |

| No. | NAMES OF MINERAL.                                             | Locality.                | Contributor.       |
|-----|---------------------------------------------------------------|--------------------------|--------------------|
| 100 | Carbonate of barytes . . . . .                                | Alston . . . . .         | Isaac Robinson.    |
| 101 | Sulphuret of copper . . . . .                                 | Nenthead . . . . .       | Isaac Robinson.    |
| 102 | Carbonate of lead . . . . .                                   | Weardale . . . . .       | Isaac Emerson.     |
| 103 | Blue and green carbonate of copper . . . . .                  | Hesketh . . . . .        | Joseph C. Cain.    |
| 104 | Fluor, capped with quartz . . . . .                           | Weardale . . . . .       | W. B., LEAD MINES. |
| 105 | Earthy carbonate of lead . . . . .                            | Teedale . . . . .        | William Wallace.   |
| 106 | Fluor spar and sulphuret of lime . . . . .                    | Nenthead . . . . .       | Isaac Robinson.    |
| 107 | Sulphuret of zinc and carbonate of iron . . . . .             | Nenthead . . . . .       | Isaac Robinson.    |
| 108 | Arsenic, phosphate of lead with manganese . . . . .           | Caldbeck Fells.          | Joseph C. Cain.    |
| 109 | Sulphuret of lead and carbonate of iron . . . . .             | Nenthead . . . . .       | Isaac Robinson.    |
| 110 | Spalden . . . . .                                             | Allenheads . . . . .     | W. B., LEAD MINES. |
| 111 | Carbonate of lime . . . . .                                   | Nenthead . . . . .       | James Armstrong.   |
| 112 | Arsenic, phosphate of lead, and sulphate of barytes . . . . . | Caldbeck Fells.          | Joseph C. Cain.    |
| 113 | Quartz . . . . .                                              | Nenthead . . . . .       | Isaac Robinson.    |
| 114 | Copper . . . . .                                              | Drigwith . . . . .       | Joseph Peart.      |
| 115 | Arragonite . . . . .                                          | Nenthead . . . . .       | Wm. Stephenson.    |
| 116 | Quartz . . . . .                                              | Nenthead . . . . .       | Jacob Walton.      |
| 117 | Carbonate of zinc . . . . .                                   | Cross Fell . . . . .     | Jacob Walton.      |
| 118 | Blue carbonate of copper . . . . .                            | Caldbeck Fells.          | Sam. Merryweather. |
| 119 | Fluor, capped with quartz . . . . .                           | Allenheads . . . . .     | W. B., LEAD MINES. |
| 120 | Cyular arragonite . . . . .                                   | Alston . . . . .         | J. Farrell.        |
| 121 | Fluor and copper pyrites . . . . .                            | West Allendale . . . . . | Matthew Millican.  |
| 122 | Phosphate of lead . . . . .                                   | Caldbeck Fells.          | Sam. Merryweather. |
| 123 | Blue fluor . . . . .                                          | Allenheads . . . . .     | W. B., LEAD MINES. |
| 124 | Quartz . . . . .                                              | Alston Moor . . . . .    | Jacob Walton.      |
| 125 | Carbonate of barytes . . . . .                                | Northumberland . . . . . | Jacob Walton.      |
| 126 | Sulphate of barytes . . . . .                                 | Westmoreland . . . . .   | Isaac Robinson.    |
| 127 | Fluor and carbonate of iron . . . . .                         | Allenheads . . . . .     | W. B., LEAD MINES. |
| 128 | Carbonate of lead . . . . .                                   | Alston . . . . .         | Jacob Walton.      |
| 129 | Sulphate of barytes . . . . .                                 | Westmoreland . . . . .   | Isaac Robinson.    |
| 130 | Fluor . . . . .                                               | Allenheads . . . . .     | W. B., LEAD MINES. |
| 131 | Oxide of manganese . . . . .                                  | Caldbeck Fells.          | Joseph C. Cain.    |
| 132 | Carbonate of lime . . . . .                                   | Nenthead . . . . .       | William Hayton.    |
| 133 | Fluor . . . . .                                               | Allenheads . . . . .     | W. B., LEAD MINES. |
| 134 | Fluor and carbonate of lime . . . . .                         | Allenheads . . . . .     | W. B., LEAD MINES. |
| 135 | Green carbonate of copper . . . . .                           | Caldbeck Fells.          | Sam. Merryweather. |
| 136 | Carbonate of iron and quartz . . . . .                        | Nenthead . . . . .       | Thomas Cain.       |
| 137 | Matrix of quartz . . . . .                                    | West Allendale . . . . . | Matthew Millican.  |
| 138 | Arragonite . . . . .                                          | West Allendale . . . . . | Wallace Millican.  |
| 139 | Quartz, bleas, and carbonate of iron . . . . .                | Nenthead . . . . .       | John Frost.        |
| 140 | Phosphate of lead . . . . .                                   | Caldbeck Fells.          | Sam. Merryweather. |
| 141 | Quartz . . . . .                                              | Green Castle . . . . .   | Ralph Lindsay.     |
| 142 | Sulphuret of iron . . . . .                                   | Nenthead . . . . .       | Isaac Robinson.    |
| 143 | Carbonate of barytes . . . . .                                | Northumberland . . . . . | Jacob Walton.      |
| 144 | Green carbonate of copper . . . . .                           | Caldbeck Fells.          | Sam. Merryweather. |
| 145 | Blue carbonate of zinc . . . . .                              | Caldbeck Fells.          | Sam. Merryweather. |
| 146 | Fluor . . . . .                                               | Allenheads . . . . .     | W. B., LEAD MINES. |
| 147 | Fluor and carbonate of iron . . . . .                         | Allenheads . . . . .     | W. B., LEAD MINES. |
| 148 | Fluor and carbonate of iron . . . . .                         | Allenheads . . . . .     | W. B., LEAD MINES. |
| 149 | Fluor and quartz . . . . .                                    | Allenheads . . . . .     | W. B., LEAD MINES. |
| 150 | Sulphate of zinc and carbonate of iron . . . . .              | Nenthead . . . . .       | Isaac Robinson.    |
| 151 | Sulphate of zinc and carbonate of lime . . . . .              | Nenthead . . . . .       | Isaac Robinson.    |
| 152 | Fluor, quartz, and carbonate of lime . . . . .                | Weardale . . . . .       | W. B., LEAD MINES. |
| 153 | Blue and green carbonate of copper . . . . .                  | Caldbeck Fells.          | Sam. Merryweather. |
| 154 | Green malachite . . . . .                                     | Caldbeck Fells.          | Sam. Merryweather. |
| 155 | Arsenic, phosphate of lead . . . . .                          | Caldbeck Fells.          | Joseph C. Cain.    |
| 156 | Fluor . . . . .                                               | Allenheads . . . . .     | W. B., LEAD MINES. |
| 157 | Carbonate of lime . . . . .                                   | Nenthead . . . . .       | William Wallace.   |
| 158 | Sulphate of barytes . . . . .                                 | Westmoreland . . . . .   | Isaac Robinson.    |
| 159 | Sulphate of zinc . . . . .                                    | Nenthead . . . . .       | Jacob Walton.      |
| 160 | Quartz . . . . .                                              | Nenthead . . . . .       | Isaac Ruthesford.  |
| 161 | Fluor and carbonate of iron . . . . .                         | Allenheads . . . . .     | W. B., LEAD MINES. |
| 162 | Carbonate of lime . . . . .                                   | Alston Moor . . . . .    | Joseph C. Cain.    |
| 163 | Sulphuret of zinc and carbonate of iron . . . . .             | Nenthead . . . . .       | Isaac Robinson.    |
| 164 | Sulphuret of zinc and carbonate of iron and fluor . . . . .   | Nenthead . . . . .       | William Wallace.   |
| 165 | Carbonate of lime . . . . .                                   | Nenthead . . . . .       | William Wallace.   |
| 166 | Arsenic, phosphate of lead . . . . .                          | Caldbeck Fells.          | Joseph C. Cain.    |
| 167 | Carbonate of lime . . . . .                                   | Alston Moor . . . . .    | Joseph C. Cain.    |
| 168 | Phosphate of lead . . . . .                                   | Caldbeck Fells.          | Sam. Merryweather. |
| 169 | Carbonate of lime . . . . .                                   | Alston Moor . . . . .    | Joseph C. Cain.    |
| 170 | Carbonate of lime . . . . .                                   | West Allendale . . . . . | Wallace Millican.  |

484 SOPWITH, THOMAS, F.R.S., &c., *Allenheads, Northumberland*—Inventor and Producer.

Specimens of lead ores and associated minerals, with examples of the various stages of progress, from their being excavated in the mine and carried through the several departments of washing and smelting, until furnished and ready for the market in the form of a cake of silver, and a pig, or piece of lead, known as W. B. Lead. The specimens of minerals usually associated with lead ores are collected from various mines, and are fitted together in a separate case, under the direction of the exhibitor, by Messrs. Cain and Wallace of Nenthead, and others.

The general arrangement of the strata in which these ores and minerals are found, is exhibited by a section of part of the lead-mining district belonging to Wentworth Blackett Beaumont, Esq., at Allenheads, in the county of Northumberland, and from whose mines the specimens of lead ores and examples of processes during conversion into lead and silver are taken; and a further illustration of the geological structure of this part of England is given by an isometrical plan and section by the exhibitor, showing a considerable tract of mining ground in the manor of Alston Moor, in the county of Cumberland.

The principal phenomena of mineral veins and displacement of the strata in which lead ore is obtained in the north of England, are shown by dissected models invented by the exhibitor, and examples of the finished products are contained in a separate case, from Mr. Beaumont's smelt-mills, under the direction of his agent, Mr. Thomas Steel.

This collection, the general nature of which is here briefly indicated, is intended to illustrate the geological position and usual products of the north of England lead-mines. The following is the order of the five several portions, and which are more particularly described under these several heads in the sequel:—

- I. SECTIONS OF STRATA AT ALLENHEADS AND ALSTON.
- II. MODELS TO ILLUSTRATE MINERAL VEINS, ETC.
- III. MINERALS ASSOCIATED WITH LEAD ORES.
- IV. EXAMPLES OF THE VARIOUS STAGES OF PROGRESS FROM THE MINE TO THE MARKET.
- V. LEAD AND SILVER PREPARED FOR SALE.

I. As the express object of this collection is to afford a general view of the whole of the principal features relative to the extensive and important departments of British industry connected with lead-mining, and as this information is more expressly intended for the use of those who are not locally conversant with the physical conditions under which lead ores are usually obtained, the exhibitor has, in the first instance, thought it necessary to present clear and distinct views of the geological structure of the district in which the chief lead-mines of the north of England are situated, in order that, without going into purely technical details, which are only of local interest, the several strata and order of superposition may be readily understood.

As an approximate comparative view of produce, it may be considered that the lead raised in Mr. Beaumont's mines amounts to about one-fourth of the quantity raised in England, about one-sixth of the produce of Great Britain, and about one-tenth of that of the whole of Europe, including the British Isles. They have been extensively worked from time immemorial; part of them are situated in the manors belonging to Mr. Beaumont in the dales of East and West Allen, in the south-west part of Northumberland, and others are situated in the wild district of moors which forms the western extremity of the county of Durham.

This part of the country happens to be at once the centre of the island of Great Britain, and by far the most elevated part of it, which is thickly populated, for, scattered over hills and dales which present an aspect of verdant cultivation, mixed with heathy moors, are to be found some thousands of inhabitants, nearly the whole of them either employed in lead-mines or smelting-mills,



or indirectly deriving a livelihood from some connection with lead-mining business. Allenheads forms a central position in the midst of these mines, and the agent's house, shown on the section, is exactly 1,400 feet above the level of the sea, and is the highest house of its magnitude in Great Britain,—nor are many of the cottages of shepherds, and other moorland habitations, of greater elevation.

The datum, or base line of the ALLENHEADS SECTION, is 700 feet above the level of the sea. The drawing, 10½ feet in length, is on a true scale of 100 feet to an inch; by a true scale being meant, that the lengths and heights are projected to the same scale or proportion, so that a true miniature profile of the country is given, as well as a correct reduction of the relative size of the various rocks. The extent of country thus shown is not quite 4 miles, being 3 miles 1,220 yards.

The spectator is supposed to be looking to the north, and the section commences at a point about half a mile eastward from a place called Killhope Head, which is conspicuously marked in all English maps, inasmuch as the three counties of Northumberland, Durham, and Cumberland all meet in one spot. At about three-quarters of a mile from the point of commencement, the section represents the hill called Killhope Law; it is on the boundary line of the counties of Northumberland and Durham, and is the highest point of land in the last-named county, being 2,206 feet above the level of the sea. But out of the limits of this section, and about 10 miles south-west from Killhope Law, the same strata which are here delineated reach an altitude of 2,901 feet above the sea, and this is the highest elevation attained by the rocks which form the carboniferous or mountain limestone of the north of England.

Such being the stratification of the central portion of the narrow part of the island, of which the coal-fields of the Tyne and Wear form the extremity on the east, bordering the German Ocean for some distance north and south of Newcastle, while a similar coal-field is found at the western extremity near Whitbaven, it may be observed, with reference to these coal-fields, that they lie over or upon the mountain limestone formation. The coal-beds so extensively worked in the Newcastle and Durham coal-mines, or collieries, gradually rise to the west, and one by one crop out, or basset, according to the undulations of the country. At length, at about 20 miles west of the German Sea, the lowest of the coal-beds crops out, and from beneath it gradually appear the limestone strata, which continue to rise nearly coincident with the general rise of the country until they reach the summit of Cross Fell (2,901 feet); and this general and very gradual inclination of the strata, a feature of the greatest importance in practical mining, is clearly and accurately delineated in this section.

In a thickness of about 2,000 feet of the alternating beds of sandstone, clay, and limestone, which form the strata of the mining districts of Allendale, Alston, and Wardale, there is one single stratum of limestone called the "great limestone," the veins in which have produced nearly, if not quite, as much ore as all the other strata put together. This stratum is delineated on the section, and may be observed lying at a depth of about 850 feet below the summit of Killhope Law. Somewhat exceeding 2 miles eastward of this, at Allenheads the top of the great limestone is 230 feet from the top of a shaft called Gin-hill Shaft. Its thickness, which is tolerably uniform over several hundred square miles of country, is about 60 feet, and it is from this stratum of limestone that nearly all the specimens in this collection have been obtained.

The dislocations of strata which constitute for the most part important mineral veins, are exhibited more in detail in the series of geological models which form a part of this collection; but some of the great features of displacement may be noticed on the section.

At about a quarter of a mile to the west of, or left-hand direction from, Killhope Law, the great limestone and all other associated beds are thrown down a depth of about 150 feet for a space of nearly 700 feet; and again,

at the distance of nearly a mile from Allenheads, a vast dislocation takes place, by which the great limestone, it will be seen, is brought nearly to the surface, the amount of displacement being about 400 feet. It is in the great limestone that by far the most extensive portion of the workings of Allenheads lead-mines are situated, and the galleries drawn on the section convey a general idea of the position of the mines. In a great thickness of strata above the great limestone only two beds of that rock are found. One of these is called "little limestone;" it is from 10 to 12 feet thick, and is 75 feet above the top of great limestone; the other is still more inconsiderable, being only 3 or 4 feet thick, and is 440 feet above the great limestone. It is remarkable with what exactness this thin bed is found near the summit of hills, the intervening spaces having apparently been removed by denudation, so as to form in one case a gap of 6½ miles, and in another of 1½ miles, in which the Tell Top limestone is entirely cut off.

But beneath the great limestone, as will be seen by the lines of blue colour, are several beds of the same description of rock, viz., at distances respectively of 30, 106, 190, 250, and 287 feet, and the thickness 2, 24, 10, 15, and 35 feet. These are known by descriptive local names, and comprise all that are of significance as regards lead-mining operations.

The Allenheads mines being situated for the most part at depths from the surface varying from 200 to 600 feet, are drained partly by ordinary water-wheels, some of which are shown on the section, and partly by the new hydraulic engines invented by Mr. W. G. Armstrong, and four of which are now in use for draining and other mining purposes at Allenheads mines.\*

THE ISOMETRICAL PLAN AND SECTION OF Nentsberry, by the exhibitor, is intended to exemplify the manner in which isometrical projection may be used in the delineation of mines and mining districts. In ordinary plans and sections, only one plane, or set of parallel planes can be truly represented, but by this method of projection three several planes may be combined in one drawing, and lines crossing at right angles, as, for instance, north and south lines intersecting east and west lines, may be correctly projected, and vertical lines added on the same projection.

The area represented by this drawing is about one-fourth of a square mile, each side being nearly half a mile in length. It is situated on the River Nent, midway between the source of that river at Nenthead and the market town of Alston. It includes some of the most interesting and prominent features of the strata and mines in that district, and amongst others the aqueduct called Nentfine Level, originally projected by the celebrated Smooton, the engineer, who held the agency of these mines in 1775.

A copy of this section is deposited in the Government Office of Mining Records, and a further account of the several mining and other details is given in vol. ii. of "The Transactions of the Natural History Society of Northumberland, Durham, and Newcastle-upon-Tyne."

II. MODELS TO ILLUSTRATE MINERAL VEINS.—Plans and sections, although of great use, and indeed indispensable for all well-conducted mining operations, are yet incapable of conveying information relative to solid forms in so complete a manner as may be accomplished by the use of models, which are, in fact, a reduced representation of the actual form of objects. The utility of models is further increased when they are made in separate portions, so as to admit of being dissected and put together again. By this means, not only the surface of the earth, but even the interior of mines may be correctly represented.

The models contained in the series now exhibited are exact duplicates of a series made for the Museum of Practical Geology, and copies of which, on a smaller scale, are published. The details which accompany the published models may be had separately; and the following catalogue briefly indicates the principal points illustrated, as having a bearing upon the lead-mining districts:—

\* See Transac. Civil Engineers, 1850 and 1861.



MODEL No. 1 represents a square mass of part of the carboniferous, or mountain limestone strata. The little and great limestone are both represented in this model, and the upper portion admits of being removed to show the result of the extensive denudation which is so conspicuous throughout the mining dales of the north of England.

MODEL No. 2 represents the principal seams or beds of coal in the district east of the lead-mines of the north of England, and situated, as regards geological sequence, above the mountain limestone strata.

MODEL No. 3 separates into four sections, in order to illustrate the displacement of strata by what is called the "throw" of mineral veins, and the effects of denudation, which take away all surface indications of such displacement.

MODEL No. 4 is intended to illustrate the deceptive appearances which are often presented at the surface by the successive outcrop of the same beds of coal, limestone, or other strata. Conditions which require the most careful considerations in agriculture as well as mining, and which are especially deserving of attention in the exploration of newly discovered lands.

MODEL No. 5. Dislocations of strata require not only to be studied as regards the virtual section, but also as regards both horizontal and inclined planes. Whether the object of search be coal, limestone, or any other member of a series of stratified rocks, it will be obvious, on examining the divisional plane of this model, that an adit or level may be driven upon this plane so as to intersect the desired stratum, or wholly avoid it.

MODEL No. 6. This represents the intersection of mineral veins and the disruption of strata caused thereby. The apparent shifting of a vein from its ordinary bearing is here shown to be only a result of ordinary mechanical displacement.

MODEL No. 7 represents the surface denudation of mineral veins, by which an apparent complexity of form is introduced, as regards the outline of the strata on the curved contour of the surface.

MODELS 8 to 12 represent various conditions of stratified rocks in relation to their inclination, as compared with that of the surface, presenting conditions highly explanatory of facts which are of constant occurrence in mining, and of the first importance in geological surveys; but any detailed explanation of such phenomena would exceed the proper limits of this description.

III. MINERALS ASSOCIATED WITH LEAD ORES.—The plans, sections, and models already described convey a general idea of the geological and mining conditions of the district from whence the specimens illustrative of lead-mining have been chiefly obtained. The remainder of the collection is arranged with a view to exhibit, first, THE PRODUCTIONS upon which the industry of the lead-miner has to be exercised; secondly, THE PROCESSES by which he renders these productions fit for use; and thirdly, THE RESULTS of his labour.

In considering the best manner of following out any classification of this natural order or arrangement, the exhibitor had in view to exhibit the first named in a separate case, containing labelled specimens of the principal rocks, ores, and spars of Allendale and Alston, then in a series of cases to show the various processes, and finally, in another separate case, corresponding with the first, to exhibit the finished products of lead and silver. As regards the second and third divisions of this arrangement no alteration was made; but the first, now under description, was modified and altered under the following circumstances.

A number of agents and other parties interested in lead-mining, and chiefly residing in Alston Moor, were anxious to send a collection of minerals collected from lead-mines to the Exhibition, and a working miner, Mr. Isaac Robinson, who was one of the parties, was anxious to fit up this case in a manner corresponding to some small collections which he had cemented together, and which had been much admired. As such a collection formed, in point of fact, the essential feature of the first division, which had been contemplated, being speci-

mens of the minerals associated with lead, it was considered, at a meeting of the parties concerned, that it should be fitted up as proposed by Mr. Isaac Robinson, under the general superintendence and direction of the exhibitor and others. This was accordingly done, and the case contains upwards of 2,000 specimens fitted together, not as a representation of any particular cavern, but grouped so as to present to view an example of almost every mineral substance usually found in immediate connection with lead-ores. Some of the examples are interesting as ornamental spars. But spars are not alone useful as ornaments: they are partly used in the arts, and they also afford instructive indications in tracing the course of mineral veins. The whole of this case was cemented together by Mr. Isaac Robinson during the intervals of his ordinary hours of work.

IV. EXAMPLES OF THE VARIOUS STAGES OF PROGRESS FROM THE MINE TO THE MARKET.—This part of the collection is arranged in five cases, each containing six boxes of one square foot each, being in all thirty boxes.

Fifteen of these boxes, in a line furthest from the front edge of the counter, contain specimens of lead-mining from the excavation of the ore in the mine, and showing the several stages of progress until ready to send to the smelt-mill; and the other fifteen boxes, in a line nearest to the front of the counter, contain specimens of the ore as prepared for smelting, and its various stages of progress, until manufactured into lead and the silver separated; these finished products being contained in Division No. 5 of this collection.

CASE No. 1.—Lead ore, as first separated from the vein in which it is found, and which in this state is called "bouse" in the north of England lead-mines, and the places in which it is deposited at the surface are called bouse teams. The depositing of the ore in these places is greatly facilitated at Allenheds by the use of tipping frames, of a new construction, by Mr. W. G. Armstrong, of the Elswick Engine Works, near Newcastle-on-Tyne. This example is from a "flat" vein in Allenheds mines, in the great limestone, which rock forms the curiously laminated matrix with which the ore is intermixed. The ore and rock thus intermixed require to be separated, as is exhibited by the following examples. By a flat vein, or "fiatts," is meant a horizontal extension of mineral substances to a considerable distance from the ordinary vertical or steeply inclined veins, which extend in the manner of fissures through the various beds of rock forming the district. The regular lamination of the ore is worthy of attention, as leading to speculations on the origin of mineral veins; a subject of great practical importance. The example here shown is taken from a part of the "flatt workings," at a distance of about 20 feet from the principal or nearly vertical part of the vein.

CASE No. 2. "Bouse," or lead ore, as extracted from the vein, and showing an example of the curiously polished surface, which is a frequent characteristic of veins, and which would appear at first sight to have been very carefully polished by artificial means, many of the surfaces being sufficiently clear to reflect the images of objects in a tolerably definite form. The local name of such bright and polished surfaces is "*slickensides*;" and the suggestion mentioned in the notice of the last specimen, as to the value of scientific inquiry, applies with still greater force to the class of phenomena of which this is one of the most curious indications.

CASE No. 3 contains a portion of the ordinary bouse, or ore, as newly worked from the vein, and much intermixed with the materials contained in Cases 1 and 2, as well as with other earthy and sparry contents of veins. The produce of mineral veins varies from pure galena, of which some pieces are shown, to masses of rock in spar, in which the ore is so thinly disseminated as not to repay the trouble of extraction.

CASE No. 4. The intermixed rocks and ores shown in the preceding cases are first subjected to the "picking," and then to "washing," on a grata. The first of these operations separates from the general mass all such pieces of galena as are either not mixed with other substances, or which can be readily separated with a hammer on what

are called "knocking-stones," and the second has the effect of clearing away all earthy matter. These specimens, picked from the heap and washing-grate, are ready for smelting after being reduced with a hammer to the size of the ore contained in Case No. 9.

CASE No. 5 contains ordinary "bouse," or lead ore taken from the *trunking-box* after passing through the *washing-grate*, being, in fact, a process of *washing and sizing*, with a view to the further operations exhibited in the following cases.

CASE No. 6 contains specimens of ordinary bouse, which from the size of the pieces and intermixture of rock and ore, require to be passed through the rollers of the crushing-mill.

CASE No. 7. Specimens of the same bouse, or ore, after having passed through the rollers of the crushing-mill.

CASE No. 8. So far the processes have consisted simply of extraction of the ore from its place in the mine,—of the pure samples of ore being picked out and washed and sized, ready for being smelted at once, without further operations,—of the remainder or poorer samples being washed and separated by an iron grate or sieve into two sizes, the larger having to be ground between rollers to reduce it to the same size as the smaller, which had passed the grate, and when reduced to this stage, the whole is ready for an operation called "hotching," which consists in placing the ore in a tub with water—the bottom of this tub is a sieve—and the whole is subjected to a rapid vibratory vertical movement, or shaking, by which a separation of the ore takes place. The water so far lessens the weight as greatly to facilitate the downward movement of the ore, which of course is much heavier than the spar and other materials connected with it. The vibratory movement is sometimes given by manual labour: a long arm, moving with a spring, is jerked up and down by a strong lad jumping on a raised stand, so as to produce the required motion. The same results may be obtained by machinery; and a model of a hotching apparatus accompanies these specimens. It represents the mode in which the hotching tubs are worked in some of Mr. Beaumont's mines in West Allendale; and both the mode of applying the machinery, and the manufacture of the model representing it, are due to the ingenuity of Mr. Joseph Hetherington, one of the engineers or wrights employed at these mines.

The ore prepared as has already been described, and after being shaken in the "hotching-tub," the upper part is entirely waste or refuse, and is called "cuttings," of which this case, No. 8, contains a specimen.

CASE No. 9 contains lead ore as obtained from the bottom of the hotching-tub, and is ready for being smelted.

CASE No. 10 contains what is called "undressed smiddum," being what has passed through the sieve of the hotching-tub into the box or case of water in which the hotching-tub vibrates.

CASE No. 11 is the "smiddum," after being dressed or cleared from all foreign substances in what is locally called a "buddle," and the ore, in being so washed, is said to be "buddled."

CASE No. 12. In all operations where a stream of running water is employed to wash lead ores, it is obvious that many of the smaller particles will be carried away with the stream. These particles are allowed to settle by their specific gravity in what are called slime-pits, being merely reservoirs in which the water passes over a long space with a very tranquil movement. In the Case No. 12 is an example of the *slime* or deposit in these slime-pits, undressed.

CASE No. 13 contains a specimen of what is called "slime ore," having been extracted or separated from the slime shown in Case No. 12. This separation is effected by manual labour in what are called "*nicking-trunks*," and is made ready for a final washing or separation in the "dolly-tub."

CASE No. 14 contains slime ore obtained, not by manual labour, but by means of a patented invention of Mr. Brunton's, by which the slime, being first freely mixed

with water, is allowed to fall on a revolving canvas cloth, inclined at a moderate angle, and upon which also drops of water are constantly falling, so as to keep the surface well wetted. The heavier particles of ore being thus free to move, are carried up the slightly inclined surface of the canvas, and so pass round a roller to a cistern below, in which they are deposited, while the lighter particles of earthy matter and spar are at once carried down the canvas by the stream of water. The ore thus obtained requires finally to be washed in the dolly-tub, after which it is fit for being smelted.

CASE No. 15 contains slime ore as taken from the dolly-tub, which is the last operation connected with the washing and dressing of lead ores, as usually practised in the lead-mines belonging to Mr. Beaumont, and in the lead-mines generally of this part of the kingdom.

The German buddle is also occasionally used in dressing slime ores. A considerable improvement was made in this apparatus about 30 years ago by Mr. Robert Stagg, of Middleton, in Teesdale.

CASE No. 16 exhibits a specimen of "selected" or superior lead ore, in the form in which it is sent to and deposited at the smelt-mill, ready to be smelted.

CASE No. 17 contains an example of the ordinary or common lead ore, as prepared and ready for smelting.

CASES Nos. 18 and 19 contain the same ores (select and common) after having undergone the operation of being "roasted," or exposed to a suitable temperature in a reverberatory furnace, the object being to free it from the sulphur contained in galena, pure specimens of which consist of lead 86·6 and sulphur 13·3. By this process the ore is rendered more easily reducible.

CASE No. 20. Grey slags formed in the process of ore hearth smelting, and from which the lead is afterwards obtained at the slag hearth.

CASE No. 21. Black slags, being the residuum obtained from the slag hearth, and which assume the granulated form from being made to flow, when in a melted state, into water.

CASES Nos. 22 and 23 contain examples of the crystals of selected and common lead, as formed in the process of separating or desilvering the ore: patented by Mr. H. L. Pattinson, and first brought into operation at Mr. Beaumont's smelt-mills.

CASES Nos. 24, 25, and 26, contain specimens of the fume or deposit in the long flues connected with the smelt-mills: that in No. 24 being the ordinary fume collected in the flue, No. 25 the same, after being roasted for the ore hearth, and No. 26 the same, roasted for the slag hearth. The flues or chimneys are built of stone, 8 feet by 6 feet inside, and are upwards of 8½ miles long.

CASES Nos. 27, 28, and 29.—Litharge in the ordinary round state, and two varieties of *Timsed litharge* which have been passed through a sieve.

CASE No. 30.—Skimmings from the surface of melted lead, showing iridescent hues, which are frequently of great intensity and beauty.

V. LEAD AND SILVER PREPARED FOR SALE.—The following are contained in the large upright case which completes the several objects sent in illustration of lead-mining, viz. :—

No. 31. LEAD made from roasted lead ore, and placed in a model-mould, same as No. 37.

No. 32. Grey slag lead, in mould.

No. 33. Selected lead, in mould.

No. 34. Common lead, in mould.

No. 35. Lead made from ore-hearth fume, in mould.

No. 36. Lead made from slag-hearth fume, in mould.

No. 37. Empty mould, marked W. Blackett, which name, or its initials, viz., W. B., form the well-known mark of the lead produced from Mr. Beaumont's mines.

No. 38. A pig, or piece of common lead, weighing 12 stones, or 14 cwt.

No. 39. A pig, or piece of selected lead, weighing 12 stones, or 14 cwt.

In the above examples, Nos. 31 to 37 are models of reduced size. The dimensions of the ordinary pieces of lead, as manufactured for sale, are shown in Nos. 38 and 39. The number of pieces usually manufactured at these

mines in a year, if laid in one continuous line, would extend upwards of 70 miles in length.

No. 40. A cake of silver produced from lead raised in Mr. Beaumont's mines, and weighing 8,000 ounces.

**485 OXLAND, ROBERT, *Buckland Street, Plymouth—***  
Inventor and Manufacturer.

A series of specimens illustrative of an improved process for dressing ores of tin; containing wolfram (the tungstate of iron and manganese). Invented by the exhibitor, for the separation of the wolfram from the ores of the Drake Walls Tin Mine, on the Cornish side of the river Tamar. This process is now in regular operation at the mine. In consequence of the specific gravity of wolfram, which is from 7.100 to 7.500, being greater than that of the black tin of the mines or the pure native oxide of tin, which is only from 6.3 to 7.00, it has been found impossible to separate the wolfram from the tin oxide by the usual mechanical process of washing in a stream of water. This led to the necessity of adopting the patent chemical process explained with the description of the series of specimens.

No. 1. "Tin witts:" the ore obtained from the stamp-floors, where, subsequently to its having been crushed or stamped down to a suitable size, it has been washed in a stream of water, in order to separate the earthy particles with which it was associated. The clean "witts" contain native oxide of tin; black tin, or rosin-tin and wolfram, with iron and arsenical pyrites, generally containing some copper. In the course of washing, the "witts" are sorted into different parcels, according to the size of the particles, and are known as jigged, marked A; fucan, B; smalls, or "smalls," C; slime, D; roughs, or rows, E. The "witts" are calcined in a reverberatory furnace, usually constructed of fire-brick throughout, but the furnace, of which a drawing is exhibited, has been found to be as well adapted for this purpose, as for the process for which it was originally intended. The calcination is continued until all the sulphur and arsenic is evolved.

The residue No. 2 contains black tin, or native tin oxide, peroxide of iron, wolfram, some sulphate of copper, and a small quantity of earthy matter. By a series of washing operations on the burning house floors, the peroxide of iron, sulphate of copper, and earthy matters are removed, and the product obtained is No. 3, which consists of oxide of tin, with most of the wolfram. The process is in the next place employed for the removal of the wolfram. Its proportion having been ascertained by analysis, a quantity of sulphate of soda, or salt cake, is mixed with the ore sufficient to supply a slight excess of the equivalent of soda for the quantity of tungstic acid present; but with the sulphate of soda, must be mixed sufficient coal dust or charcoal to afford carbon or carburetted hydrogen, for the decomposition of the sulphuric acid and the conversion of sulphate of soda into sulphide of sodium. The mixture is exposed to heat on the bed of the furnace described below; a smoky or reducing flame is at first employed, but after the whole of the charge has been at a red heat for some time, an oxidating flame is necessary to complete the operation. Thus the sulphate of soda is first converted into sulphide of sodium, then the tungstic acid of the wolfram combines with the soda, producing tungstite of soda, setting the sulphur free as sulphurous acid, and leaving the iron in the condition of a light finely divided peroxide.

The product No. 4, is drawn from the furnace into the wrinkle, or chamber beneath, and is thence removed whilst still hot into tanks containing water, which quickly dissolves the tungstate of soda. The solution is run off into receivers, and the residue is removed to the burning house floors, where, by a series of washings, the peroxide of iron is removed, and the native oxide of tin obtained pure and ready for the smelting house, as seen in No. 5. An ore which had fetched only 4*l.* per ton has by this operation been so much improved in quality as to obtain 56*l.* per ton.

The tungstate of soda, No. 6, is obtained in the crystalline form by the evaporation to the crystallizing point

of the solution in which it was separated from the tin. It is proposed to be used as a substitute for stannate of soda as a mordant for dyeing purposes.

Tungstic acid, No. 7, may be employed for the same purpose, or for the manufacture of tungstate of the tungstous oxide with soda, a compound much resembling gold.

The tungstate of lead, No. 8, and tungstate of lime, No. 9, are good white pigments (manufactured from the tungstate of *so<sup>2</sup>*), from which was also obtained the metallic tungsten, No. 10, and sulphuret of tungsten, No. 11. The former is for use in the manufacture of metallic alloys; the latter has been proposed as a substitute for black-lead. The furnace is constructed in the usual manner, excepting that a cast-iron bed has been employed to prevent the loss that would arise from the reaction of the silica of the bricks, the soda, and the tin oxide on each other. The fire, after passing over the bed, is also made to circulate beneath it before passing away to the chimney.

**486 BRUCCIANI, D.—Producer.**

Fac-simile of the largest piece of gold found in California.

**486A IRETTSON, CAPT.—Producer.**

A model of the Isle of Wight, in metal.

**487 JORDAN, C., 37 *Chapman Street, Manchester—***  
Producer.

Case containing 176 specimens of the useful metals and alloys:—

Gold—Grain, standard, and red jewellers'.

Silver—Virgin and sterling. Platina.

Wrought iron—Best and common Coalbrook Dale; best scrap for screws and rivets; Low Moor and common Horton's; also, S. R., I. B., common, Horton's, and Keller's.

Steel for mills—Wonders; cast steel, Turton's, and Turton's softened; and shear-steel, all showing surface and fracture.

Cast-iron—Rich Welsh pig, from Leeswood; and rich Scotch pig from Gartsherrie, Glengarnock, Clyde, Dalmellington, and Dundymon; Yorkshire, Low Moor and Leeswood; cast in sand, chilled, pig, and rich chilled; also short pig, Staffordshire, rich mottled Welsh, and cast in sand, showing surface.

Nickel and Lead—Pure and commercial.

Copper—Tile, native, shot cast, and malleable, all showing surface and fracture.

Tin—Block and grain.

Zinc—Chilled and sand, showing surface and fracture.

Bismuth—Chilled and sand, showing surface and fracture.

Antimony—Chilled, showing fracture and longitudinal section.

Arsenic, cobalt, mercury, manganese, potassium, sodium, iridium and osmium, cadmium, and palladium.

Alloys—Copper and tin, in various proportions, showing surface and fracture, &c.

Alloys of copper, zinc, tin, and lead, in various proportions, showing the same.

Tutania, for hardening tin, bobbin-bushes, &c.

White bush metal, of zinc, tin, and tutania, variously combined.

Type metal, of tin, antimony, lead, and bismuth.

Stereotype metal, of lead, antimony, and bismuth, in various states.

Common type and music plates, of lead and antimony.

Compositions of copper, tin, zinc, and lead in different states.

Bleached copper, antimony and copper, and German silver, electrum, common and plate.

Standard measure, composed of copper, tin, and lead.

Manheim gold, of copper, tin, and zinc.

Speculum metal, of copper and tin, in various mixtures.

Speculum of chilled copper and tin; Mr. Potter's, with trace of arsenic, and others.

Nickel and iron; fusible alloy; tutania, for type-metal; iron and antimony; iron and zinc (not magnetic), will not rust; spelter solder; silver solder; tinman's and plumber's solder.

These specimens display the surface, and where practicable, the fracture of all the useful metals and alloys. Many of the alloys are new combinations, and are valuable in point of utility and economy. Some of the alloys are intended for the small steps of machinery, &c., composed of 16 oz. copper, 8 oz. zinc, 4 oz. lead,  $\frac{1}{2}$  oz. tin. This alloy has been used very extensively; it works well under the file and turning-tool; and its lasting properties are great. This is the cheapest metal that will answer for machinery purposes, especially if made from brass turnings. The alloy made from pig iron and zinc turns and files very well, and is adapted for shaft-bearings, particularly for such work as requires exposure to the weather. Portions of this metal have been exposed for several weeks without any appearance of rust. It is intended as a substitute for brass in many cases, being much cheaper. The magnetic properties of the iron are entirely neutralized; hence, for some purposes, it will be superior to any other metal or combination. In speculum metals, the proportions of Newton (163 and 164), when cast in a hot chill, will take a more brilliant polish, and retain the brilliancy longer than any other combination: being cast in a hot chill prevents too sudden contraction, and the brittleness so often experienced. These cabinets of metals and alloys are intended as illustrations for the lecture-table, and for general reference in the manipulations of metals.

488 GARLAND, THOMAS, Fairfield, Redruth—  
Manufacturer.

Impure oxide of arsenic, obtained from tin ores (containing arsenical pyrites) by calcination.

Commercial oxide of arsenic, obtained from the foregoing by sublimation in reverberatory furnaces, and afterwards ground to an impalpable powder.

A finer quality of the preceding.  
Lump arsenic, obtained from the preceding by sublimation in close retorts.

[Arsenic is found native occasionally, but is more frequently combined with other metals, of which iron, cobalt, nickel, silver, copper, antimony, and manganese are the chief. It is very soft but brittle, and volatilizes readily at a temperature of 365° Fahrenheit. It combines with oxygen in white arsenic (arsenious acid), and with sulphur in realgar and orpiment. The former substance is used in medicine, in the manufacture of glass, &c. The sulphurets are valuable pigments, both in dyeing and in the fine arts.—D. T. A.]

489 LOWE, J., 30 Gracechurch Street—Part Proprietor.  
Copper, from the exhibitor's patent works, Penclawdd.

490 ROWLANDSON, THOMAS, 7 Esher Street,  
Kennington—Patentee.

Bluestone—a compound of bisulphuret of iron, sulphuret of lead (galena), bisulphuret of copper, sulphuret of zinc (black jack), &c., some silver and gold, obtained at the Isle of Anglesey; also at the Vale of Ovoca, Wicklow, Ireland.

The zinc salts can be converted into chloride of zinc and sulphate of soda; these can be employed in a variety of forms for preserving animal and vegetable substances, deodorizing, &c.

Specimens illustrating the processes by which the sulphuret is converted into sulphate of zinc, which is washed out, and leaves the lead, gold, and silver to be extracted in the ordinary mode by smelting.

Specimens of ores and products from the Cwm-eisian Gold Mine, Merionethshire.

[The existence of gold in many of the rocks of Wales has been long known. There is every reason for believing that the Romans worked the mine at Gogofan, near Pumpsant, Caermarthenshire. This is not only proved by the remains of mine workings, which have been lately examined by the mining geologist to the Geological Survey, but by the gold ornaments which have been found in the Vale of Cothy, near this spot, which are evidently of Roman workmanship. The mine at Cwm-eisian yielded gold disseminated through the quartz, but not being sufficiently remunerative, the works have been abandoned.—R. H.]

491 HARRISON, J., Bakervale, Derbyshire—Producer.  
Lead ore, from Mogshaw mine, Bakervale.

492 ROWE, RICHARD, Laxey Glen, Douglas, Isle of Man—  
Joint Proprietor.

Silver lead ore, and blende ore, being the produce of the Laxey Mines, in Laxey Glen, parish of Lonan, Isle of Man.

[Mines were worked at an early period in the Isle of Man, but the neighbourhood of Laxey first attracted attention at the commencement of the present century. In 1811, only three hands were employed; in 1848, there were at least 300 in the mine. The mine is situated about a mile and a half from the sea, up the Laxey Valley, where an adit is driven 400 fathoms into the heart of the mountain; from this adit the shaft has been sunk about 130 fathoms. The returns of lead ore for the last five years have been as follows:—

| Years. | Lead Ore.<br>Tons. | Lead.<br>Tons. |
|--------|--------------------|----------------|
| 1845   | 327                | 155            |
| 1846   | 220                | 104            |
| 1847   | 375                | 247            |
| 1848   | 695                | 461            |
| 1849   | 815                | 546            |

In addition to this, about 200 tons of the sulphuret of zinc are annually raised.—R. H.]

492A COATES, W.—Producer.

Specimens of lead ore from Tullyratty Mine, Strangford, Ireland, the property of Lord de Ros.

493 CUMMING, J. G., Isle of Man—Producer.

Argentiferous galena, from the Foxdale Mines, containing 36 ounces of silver to the ton.

[This lead ore is procured from a granite vein, running N.N.W. and S.S.E., nearly magnetic; it improves in quality, and increases in quantity downward, which is an unusual occurrence. It is now being worked at 50 fathoms from the surface.—R. H.]

494 BYERS, JOSHUA, Stockton-on-Tees, Durham—  
Producer and Manufacturer.

Lead ore from Grasshill Mine, Teesdale. Silver and litharge from the same mine. Refined, common, and slag lead. Thin sheet-lead and lead pipe.

495 BURR, THOMAS, WILLIAM, & GEORGE, Shrewsbury—  
Producers and Manufacturers.

Mineral specimen, raised at the Snailbeach lead mines, Shrewsbury, weighing 12 cwt., containing cubes of lead and zinc ore, in conjunction with carbonate and sulphate of barytes.



[The produce of the Snailbeach Mines since 1845 has been as follows:—

| Years. | Lead Ores.<br>Tons. | Lead.<br>Tons. |
|--------|---------------------|----------------|
| 1845   | 3,000               | 2,000          |
| 1846   | 3,852               | 2,700          |
| 1847   | 3,486               | 2,440          |
| 1848   | 3,463               | 2,436          |
| 1849   | 3,198               | 2,301          |

The returns for 1850 are not yet completed.—R. H.]

Composition tube, being an amalgam of certain metals, calculated to resist the action of acids contained in water or gas.

496 **THE DUKE OF DEVONSHIRE, and his Agent, Capt. EDDY, Grassington—Producers.**

Specimen of the Devonshire lode at Grassington mines.

Specimen of the gritstone, in which the lead occurs. Vein specimens from other lodes.

Transverse section of the Devonshire lode.

[The lode in the Grassington mines offers an exception to the common rule of lead veins in England, the whole produce being obtained in gritty beds alternating with the limestone and shale, and not in the limestone, as it usually occurs. The veins worked in this district are generally with faults, and the veinstone is chiefly calc spar, fluor spar, and barytes.—D. T. A.]

497 **PATTINSON & CAIN, Newcastle-upon-Tyne—Producers.**

Specimens of a peculiar ore of lead, viz., arsenio-phosphate of lead, rarely found in such large masses. From Dry Gill Mine, near Hesket New Market, Cumberland.

[This appears to be the mineral called by Breithaupt, Kampylite, an arseniate of lead, in which the arsenic is partially replaced by phosphorus.

The arsenio-phosphate of lead from this mine has been employed in glass manufacture, for the purpose of giving high transparency to the best flint or crystal, which appeared to be produced by the formation of a lead glass, which may be regarded as a phosphate of lead and silica.—R. H.]

498 **BENNETT, THOMAS, 11 Woodbridge Street, Clerkenwell—Manufacturer.**

Specimen of uniform leaf gold, manufactured by steam machinery, for gilding large plain surfaces, and for exterior decorations; of an extra deep colour, for gilding looking-glasses, cornices, &c.

499 **SMITH, R., Blackford, Perthshire—Inventor.**

Minerals from the Ochills, collected by the exhibitor. Two new alkaloids, "cytsuine," found in the bark of the laburnum; a combination with meconic acid; and euphorbins, from *Euphorbia officinalis*. Starch, from the tubers of the *Lunaria biennis*; and Iodine, from the *Polytrichum undulatum*.

500 **PHILLIPS, SMITH, & Co., Llanelly, Wales—Manufacturers.**

Series of specimens illustrative of the manufacture of tin plates.

[To prepare tin plates, sheets of iron are carefully cleaned from all oxidation and from every trace of organic matter: then being dipped into a saline solution, which serves as a flux, they are dipped into melted tin, which is diffused by heat over the surface, and the tin plate is completed.]

Pig-iron, as received from the blast furnace.

Rough bar made from pig-iron, first melted and refined by blast and coke fuel, and converted into malleable iron in a charcoal fire, stamped and rolled into a rough bar.

Bar-iron made from the rough bar heated with blast and coke in a hollow fire, hammered and rolled into a finished bar.

Sheet-iron, known as black plate, rolled in case-hardened rolls from the bar-iron.

Black plate cleaned in a preparation of sulphuric acid passed through planished rolls, and softened by heating in pots previous to being coated with tin.

Sheet of black plate, partly tinned.

Wooden boxes, each containing a specimen of finished sheets of different sizes and thickness.

501 **DOWNMAN, H. H.—Producer.**

Wood impregnated with black tin.

502 **JENKINS, WILLIAM HARRY, Truro—Producer.**

Specimens of arsenic:—White arsenic, arsenious acid, used in glass manufactories, in patent shot manufactories, for washes for sheep, to preserve the wool and prevent the fly, and for preventing smut in wheat, &c.; white arsenic, in crystals, and sublimated, for the same purposes. Realgar, sulphuret of arsenic, used by painters as orange red pigment; orpiment, used by painters as yellow pigment.

Varieties of rarer minerals from various parts of Cornwall.

Specimens of wolfram from various tin mines in Cornwall, used as a mordant in dyeing calicoes.

Varieties of mundics, or pyrites, from various mines in Cornwall—Mangan Mine, an arsenuriet of iron. Wheel Withey, near Truro; Baldher Mine, near Truro; Royal Polberrow Consols Mine in St. Agnes; Wheel Andrew and Nsngles, near Truro, and others, a sulphuret of iron. Assorted specimens of pyrites of various qualities, from different mines, by the use of which, in combinations, a large produce of sulphuric acid is obtained.

[The arsenical pyrites, and the copper and iron ores containing arsenic, are the common sources for this substance. The ores are first roasted in "burning houses," and the volatile matters, sulphur and arsenic, collected in the flues. These are afterwards separated from each other by a more delicate process, so as to sublime one and not the other.

Wolfram, tungstate of iron, has only lately been introduced into the market. The tungstate of soda and tungstic acid are proposed to be employed as a mordant, and a new crimson pigment is an oxide of tungsten.—R. H.]

503 **DAVEY, STEPHEN, Redruth—Miner.**

Specimens of ores of zinc.

504 **COLE, EDWARD JOSEPH—Producer.**

Rich specimen of tin ore, estimated to contain 60 per cent. black tin, raised January, 1851, from Risehill mine, near Tavistock.

504A **NICHOLSON, Sir N., Fetlar, Zetland—Producer.**

Specimens of clays, chromate of iron, black lead, and magnetic sand from Fetlar, Shetland Islands.

[The chromate of iron is chiefly used in the production of chromate of potash, the ore being cleaned, pounded, calcined with a certain proportion of nitre, and evaporated after lixiviation with water. From the neutral chromate thus obtained, or the bichromate, are produced chromate of lead (chrome yellow); a green oxide used as an enamel colour in porcelain (chrome green); and a beautiful vermilion (subchromate of lead). Chromic acid is also manufactured from the same mineral. Chromate of iron is obtained in England principally from the Shetland Islands.—D. T. A.]

505 WILLIAMS & SONS, *County Wicklow, Ireland*—  
Producer.

Sulphur ore; manganese ore, from Glandore Mining Company.

[What is here not improperly called "sulphur ore" is iron pyrites (sulphuret of iron), found very abundantly in and largely exported from the county of Wicklow. It is used to an enormous extent, in chemical works, for the manufacture of the various sulphur salts, as sulphate of soda, &c. The Wicklow pyrites is better adapted for such purposes than the Cornish, as it decomposes very readily on exposure.—D. T. A.]

506 GREY, JOHN, *Dilton, Corbridge*—Agent.

Blende and calamine from Alston Moor, Cumberland. Four plates of spelter, two whole, and two broken, produced from the same.

507 GENERAL MINING COMPANY FOR IRELAND, THOMAS MAGUIRE, Secretary, 2 *Burgh Quay, Dublin*—Producer.

Silver-lead ore (argentiferous galena), from Shallee mines, Tipperary; exported from Dublin to the river Dee, in North Wales. This ore produces 75 per cent. lead, and from 44 to 54 ounces of silver to the ton.

[The Shallee mines made their first return of lead in

1847, it being then 209 tons of lead ore, which produced 125 tons of lead. Since that time the quantity raised has been regularly increasing.—R. H.]

Silvery-copper ore (argentiferous sulphuret of copper), from Gurtuadyne, near silver mines, county Tipperary; exported from Dublin to Swansea, South Wales. This ore produces 12½ per cent. copper, and about 27 ounces of silver to the ton of ore.

Copper ore (sulphuret of copper), from Ballynoe, near silver mines, county Tipperary, exported from Dublin to Swansea, South Wales. Average produce, about 40 tons per month. This ore produces 25 per cent. of copper. Copper ore, from Lackamore, county Tipperary, similarly exported. This ore produces 36 per cent. of copper.

Specimens of all these ores, as taken from the mine, and as dressed for market.

508 ROYAL DUBLIN SOCIETY OF IRELAND—Producer.

Specimens of lead ore in its various stages; lead, lead-pipe; patent shot; sheet of copper.

509 HIS GRACE THE DUKE OF BUCLEUCH, *Drumlanrig Castle*—Producer.

Model of the furnaces and pots employed on the Duke of Buccleuch's mines, at Wanloch Lead-hills, in Dumfriesshire, for separating pure silver from the rich lead ore of that district.

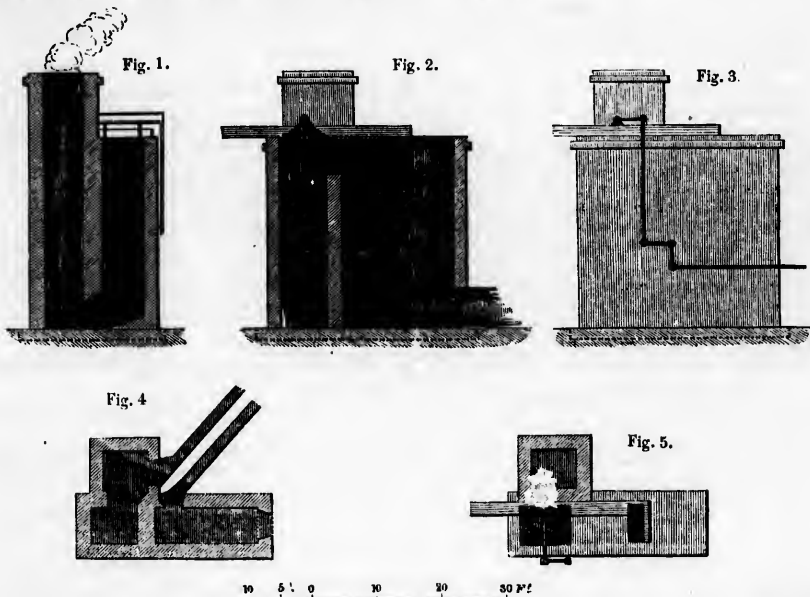

These engravings represent an elevation and sections of the peculiar arrangements adopted in these smelting works. Fig. 1 represents the section of the chimney with the fue entering it from below. Fig. 2 shows the arrangement adopted for deprecating the fumes as they pass upwards, and also the hydraulic trap at the summit of the vertical fue of the exhausting chamber. Fig. 3 shows the mechanical arrangement for communicating a reciprocating horizontal movement to the hydraulic slide plate over the top of the chamber. Fig. 4 shows the

slide plate seen from above. Fig. 5 is a ground plan of the chambers, chimney, &c.

The following illustrations accompany the model.

A block of pure silver, weighing more than 140 lbs.; separated from the rich lead, and purchased by silversmiths as "unalloyed."

(a) Original lead as brought from the mines after smelting, containing 7 oz. 9 dwts. 8 grains of silver.

(b) Crystals of lead after passing through one process of crystallization.



- (c) The same, after a second crystallization.  
 (d) Rich lead, containing 81 oz. 1 dwt. 3 grains of silver; and now ready for the last process of oxidation, by which the silver is finally separated from the lead.  
 (e) Marketable lead from the crystallizing process; and which contains from  $\frac{1}{4}$  to  $\frac{1}{2}$  of an ounce of silver per ton.  
 (f) Models of the great ingot moulds employed for forming the pigs of lead of commerce.  
 (g) Model of the great strainers employed for separating the pure, or nearly pure lead, from the molten liquid.

The operation depends upon the property which lead possesses in weak alloys of crystallizing at a certain temperature, by which means those crystals, at the moment of forming, can be extracted, and thus separated from the silver mass.

By a particular manipulation in transferring the concentrated lead and silver from pot to pot, the mass is at last reduced to an alloy, containing some 80 or 90 ounces of silver to the ton of lead, and much beyond which point it is not found advantageous to crystallize.

The rich lead is now simply melted in the refining furnace, on a very large cupel, formed of bone ash, exposing a great surface to the draught of air passing over it. The oxygen of the atmosphere is rapidly imbibed by the lead, which becomes the litharge of commerce. This is raked off as quickly as it forms; and finally, the silver is left perfectly, or very nearly, pure, and run into ingots for the market.

(g) Is the litharge or minium thus withdrawn from the melted surface.

Model of the lead vapour-condensing apparatus, at Wanlock Lead-mines, as improved by the exhibitor.

A collection of minerals from the Wanlock Lead-mines, or Lead-hills.

[In all great smelting works of this class, the smoke rising from the furnaces is highly charged with noxious vapours, containing, besides other poisonous matter, a large quantity of lead; many attempts have been made to obviate this nuisance, and the system adopted by the exhibitor has been found to be very successful.

An oblong building in solid masonry, about 30 feet in height, is divided by a partition wall, into two chambers, having a tall chimney or tower adjoining, which communicates with one of the chambers at the bottom. (See engraving.) The smoke from the various furnaces, eight in number, and about 100 yards distance from the condenser, is carried by separate flues into a large chamber; from thence, by a larger flue, it enters the first chamber of the condenser at the very bottom, and is forced upwards in a zigzag course towards the top, passing four times through a shower of water constantly percolating from a pierced reservoir at the summit of the tower. The smoke is again compelled to filter a fifth time, through a cube of coke some two feet square, through which a stream of water filters downwards, and which is confined to its proper limits by a vertical grating of wood.

The smoke having reached the top, is now opposite the passage, into the second, or vacuum chamber. This is termed the exhausting chamber, and is about five feet by seven feet inside, and 30 or more feet in height. On its summit is fixed a large reservoir, supplied by an ample stream of water, always maintaining a depth of 6 to 10 inches. The bottom of this tank is of iron, having several openings, or slots, 12 in number, about an inch in width, and extending across the whole area of the reservoir, communicating directly with the chamber beneath. On this iron plate, works a hydraulic slide-plate, with openings corresponding in one position with those in the reservoir. This plate receives a horizontal reciprocating motion from a water-wheel or other power, driven by means of a connecting-rod and crank.

In the middle of every stroke, the openings in the plate correspond with those in the bottom of the reservoir, and a powerful body of water falls as a shower bath, the whole height of the vacuum chamber, and in doing so, sweeps the entire inside area, carrying with it every particle of insoluble matter held suspended in the vapours coming from the furnaces.

The atmospheric pressure, of course, acts in alternate strokes as a blast at the furnace-mouths, and causes a draught sufficiently strong to force the impure vapours, through the various channels, in connexion with the water, the wet coke and exhausting chamber, until it passes purified and inert into the atmosphere.

The water, saturated with particles of lead, &c., held in mechanical solution, finally passes into great dykes or reservoirs, excavated for the purpose; and there deposits its rich charge of metal.

(h) Is the lead collected from this "fume," or deposit, which contains about 33 per cent. of pure lead, and about 4 oz. 17 dwts. and 7 grains of silver to the ton.

(i) The condensed fume roasted.

The results of this arrangement are most apparent, and beneficial to the surrounding neighbourhood. Formerly, the noxious fumes passing from the shafts of the furnaces, poisoned the neighbourhood; the heather was burnt up, vegetation destroyed, and no animal could graze, or bird feed near the spot. Now, the heather is seen in luxuriance close around the establishment, the sheep graze within a stone's throw of the chimney's base, and game on all sides take shelter.—J. A. L.]

510 WALLACE, WILLIAM, & COWPER, T., *Nenthead*,  
*Alston*—Proprietors.

Carbonate of lead, from Little Egglesthope Lead Mine, in Teesdale, county of Durham.  
Minerals from Alston.

511 BARRETT, Captain—Producer.

Cobalt and copper ores from Coniston mines, near Kendal, Lancashire.

512 BLEE, R., *Redruth*—Producer.

Cobalt ores, from Cornwall.

513 LISKEARD COMMITTEE—Producers.

Various specimens, including iron pyrites; hornblende, and antimony.

514 MUSCHAMP, WILLIAM, *Derwent Lodge*, *Sunderland*—  
Producer.

Specimen of Cally copper ore, a portion of a large block weighing 6 cwt., recently raised at the Cally mines, near Gatehouse of Fleet, Kirkcudbrightshire, Scotland. The rock in which it is found, is brown killas, or clay slate. The lode is from 2 feet 8 inches to 4 feet wide, and is composed of sulphate of barytes, gossan, and other mineral soils. The ore generally lies in solid ribs or bunches, and is mostly unmined with any matrix or vein stuff. In some places it has been found 4 feet wide. The ore is of very rich quality, being a compound of the green and blue carbonates of copper, black, grey, and yellow copper, yielding from 25 to 30 per cent. of metallic copper. It has been sold in the market from 20l. to 25s. per ton.

515 DUBLIN SOCIETY—Producer.

Copper ore, from Knockmahon mines, Waterford.

516 TENNANT, J., *Strand*—Importer.

Copper ore, from Lake Superior.

517 **GRAHAM, JOHN, Barrhead, near Glasgow**—Producer.  
Greenstone, showing native copper, as found in the rock when broken. Native copper, as found in the fissures and crevices of the rock, from Boyleston quarry, Renfrewshire.

[The greenstone of Renfrewshire occurs both above and below the coal-grits and coal. It is an intruded rock of variable but often very considerable thickness and extent, and is likely to contain small quantities of various metalliferous substances and native metals.—D. T. A.]

518 **BERGER, J.**—Producer.  
Native copper, from the Lizard.

519 **BRUNTON, W., Cornwall**—Inventor.  
Safety fuse for blasting.

520 **COPELAND, G. A., Pendennis, Falmouth**—Inventor and Manufacturer.  
Safety blasting cartridges, adapted for all kinds of blasting; intended to afford protection to the workmen from premature explosions, &c. The expedition in search of Sir John Franklin was furnished with them, by order of Her Majesty's Government, for ice-blasting in the arctic regions.

521 **OFFLAHERTIE, H.**—Producer.  
Lead ore, from Glengola mines.

521A **MURCHISON, J. H.**—Producer.  
Specimens of copper ore from the island of Kawaw, New Zealand. Specimens of the matrix of the silver-lead ore at Beeralston, Devonshire.

522 **FORBES, A. C., 12 Old Burlington Street**—Producer.  
Two specimens of Cinnabar, from the mines of New Almaden, in Upper California; one of 14lb. 1oz., the other of 13lb. 2oz. On analysis by Dr. Hoffman, they are found to consist of—Mercury, 67.25; Sulphur, 10.33; Insoluble matter, 22.55. The insoluble matter consisting chiefly of silica, alumina, and traces of iron. On distillation with lime, 3,750 grains yielded 2,625 grains of mercury, or 70 per cent.  
The mine has been worked one year; and in the month of November 1850, it yielded 127,500 lbs. of pure mercury. This is exported from San Francisco to the ports of Spanish America.

[Cinnabar is the only important ore of mercury, but is found in several states, sometimes in crystals, in laminated and granular masses, in a fibrous condition, and mixed with bitumen to the extent of 6 or 8 per cent. It is soft: specific gravity = 8.1 when pure, and is a sulphuret of mercury (Hg. S.). The mines of Almaden, in Spain, and Idria, in Carinthia, are those from which the chief supply has hitherto been obtained; but the discovery of mercury in the mountains on the coast of California, some years since, promises to affect the supply very considerably, when sufficient means are employed to work the mines extensively.—D. T. A.]

523 **DAVIES & TAYLOR, Aberystwith**—Producers.  
Specimens of lead ores.

[The Cardiganshire mines were worked at a very early period, probably by the Romans. Henry VII. encouraged mining by several grants, involving privileges to those who would work these mines. In the reign of Queen Elizabeth, there was a grant made of all these mines to Thomas Thurland and Daniel Houghsetter, Germans, who worked them for some time. They eventually passed into the hands of Sir Hugh Middleton, who realized a large profit by working them.

The present value of the Cardiganshire mines will be seen by the following list of their produce:—

| MINES.                             | Lead Ore Returns. |             |
|------------------------------------|-------------------|-------------|
|                                    | Tons. Cwts.       | Tons. Cwts. |
| Leiburne Mines . . . . .           | 2,738 0           | 1,904 0     |
| Cwm-y-est-tyth . . . . .           | 583 0             | 333 0       |
| Egalfhir . . . . .                 | 55 0              | 33 0        |
| Cwm-sebon . . . . .                | 298 0             | 134 0       |
| Llanfair Clydogan . . . . .        | 1,160 0           | 768 0       |
| Goginan . . . . .                  | 131 0             | 87 0        |
| Gogerdan Mines . . . . .           | 12 0              | 7 0         |
| Nant-y-creiau . . . . .            | 10 0              | 7 0         |
| Pen-y-bont-penn . . . . .          | 638 0             | 425 0       |
| Cefn-cwm-brwyno . . . . .          | 177 0             | 109 0       |
| Bwlch Co. soles . . . . .          | 31 0              | 20 0        |
| Nanteos . . . . .                  | 40 0              | 28 0        |
| Aberystwith (small mines). . . . . | 116 0             | 78 0        |
| Llanymaron . . . . .               | 29 0              | 20 0        |
| Llanbadarn . . . . .               | 28 15             | 14 0        |
| Bron-berllan . . . . .             | 32 0              | 21 0        |
| Brynarian . . . . .                | 18 0              | 12 0        |
| Cwm-erfin . . . . .                |                   |             |
| Daren . . . . .                    |                   |             |
| Elsteddfoed . . . . .              |                   |             |
| Llwyn Malya . . . . .              |                   |             |
| Bwlch-cwm-erfin . . . . .          |                   |             |

R. H.]

524 **HUNT, ROBERT**—Producer.  
Mining map of Cornwall.

525 **ARKANSAS MINING COMPANY**—Producer.  
Sample of Arkansas lead ore in a lump as cut from between the solid walls of a vein, measuring 24 by 20 inches, and 9 inches thick. Its weight is nearly 11 cwt. It contains also copper and iron ore, and the sulphuret of zinc, and is coated over with quartz mixed with barytes.

526 **HAWKE, E. H., Scorrier, Cornwall**—Producer.  
Specimens of safety fuse.

529 **KNIFE, J. A., Clapham, Surrey**—Designer and Proprietor.  
Geological map of the British Isles, and part of France. This map shows, besides the sites of the various mineral productions, and numerous geological sections of the soil (explained in English, German, and French), the inland navigation by rivers and canals, and the inland traffic by railways and principal roads; also, the soundings and tidal observations round the coast, from surveys by the Admiralty, Trinity House, and Dr. Whewell.  
Geological and mineralogical map of England and Wales, with parts of Scotland, Ireland, and France. This map contains a select number of sections and notes of economic geology, the sites of minerals, and rivers, canals, &c., with their heights above the level of the sea. The preceding maps are published by H. Bailliere, 219 Regent Street; and Johnston, Edinburgh.

530 **MARRIOTT, MRS. FREDERICK, 3 Eastbourne Terrace, Hyde Park**—Producer.  
Specimen of gold ore from the Mariposa mine, California, estimated to contain 45 per cent. of gold. Another specimen. (Main Avenue East.)

531 **DEVONSHIRE, Duke of**—Producer.  
Large quartz crystal. (Main Avenue East.)

532 **ERSKINE, JAMES, Scotland**—Producer.  
Specimens of lead ore from the Black Craig Mines.

533 **WEBB, JOHN & CHARLES, Rosoman Buildings, Islington**—Manufacturers.  
Specimen of pipe as used at the exhibitors' soda-water works; and diagram of the London strata. (South Wall.)

534 **SAMUEL, M. A., 23 Morland Square, Notting-hill**—Producer.  
Specimen of sulphate of iron from Shakespere's Cliff, Dover.

## AN ACCOUNT OF THE NATURE AND EXTENT OF THE VARIOUS DEPOSITS OF MINERAL FUEL IN VARIOUS PARTS OF THE WORLD.

Accompanied by a Map, showing the extent and position of the principal Coal-fields of Europe and  
North America.

By D. T. ANSTED, M.A., F.R.S., &c., Prof. Geol., K.C.L.

### 1. General Account of Materials used for Fuel.

The chief supplies of valuable fuel are, and always have been, derived immediately or distantly from the vegetable kingdom. Whether in the form of wood, peat, lignite, or coal of various kinds, the original substance of all fuel has been found to have this origin, and thus it would seem that the power of vitality exerted in producing woody fibre has been from time to time stored up, as it were, into vast reservoirs, where it might be preserved safely and permanently for an indefinite period.

In warm climates, where the growth of vegetation is extremely rapid, and comparatively little fuel is needed; or in the early periods of civilization, before men congregate in large masses in towns, or are actively employed in manufacture, there is little need of more fuel than is supplied by the natural growth of forests; but under other circumstances, where forests are gradually removed, and the consumption of fuel at the same time increases, the reserved stores are greatly needed, and must ultimately be reckoned among the main sources of a country's wealth. The accumulations of mineral fuel in the British islands may be ranked as one of those natural advantages without which our country could not possibly have taken up and held for a long time the position she occupies among the nations of the earth; and thus, as one of the great and principal sources of its mineral treasure, the coal deposits of England demand and deserve our careful attention. The relative supply of other countries, and the activity and energy displayed in taking advantage of the existence of mineral fuel, must also be worthy of attention, as illustrating and explaining the condition of many manufactures, and the probable advance of the inhabitants of such districts in the refinements of civilization. Since the introduction of steam-power for all purposes of machinery, the consumption of coal has very greatly increased, and at present it would be difficult to set any limits to the use of so valuable a material.

The changes undergone by vegetable matter when buried in the earth and accumulated in large quantities, and the length of time needed to produce any marked alteration, are subjects rather more interesting, it may seem, to the chemist than to the practical man, who looks only for fuel that he may employ economically. But inasmuch as the real condition of coal varies considerably, and different kinds are valuable for different purposes, it is desirable that the whole history of coal and lignite beds, and of peat and turf, should be generally understood by every one using any or all of these substances extensively.

Vegetable matter consists of particles of carbon with minute proportions of several other elements arranged round minute cavities or cells, many of these being mechanically connected to form the varieties of vegetable fibre. A large quantity of water is also present, and so long as the vegetable lives there is a constant change and circulation of material particles kept up, replacing and renewing the different portions. When death takes place there is a tendency to decomposition, or the separation of the whole into minute atoms, having no further relation to each other. But this is frequently checked by various conditions, such as the presence of some substances derived from plants themselves, or the absence of sufficient oxygen gas to allow the change to take place, by mixing with the carbon, and becoming carbonic acid gas, the first step in the process of destruction. These causes operate constantly, but partially, and thus a large quantity of vegetable matter is always in the course of decomposition, while, in particular spots, a large quan-

tity is constantly being accumulated. The latter condition is seen in our climate in the gradual but steady increase of peat bogs. The former is too common to require further notice.

### 2. Peat and Turf.

Accumulations of vegetable matter may be chiefly composed either of succulent vegetation, grasses, or marsh plants, or of trees, and the structure and condition of woody fibre is well known to be very different from that of grasses and succulent plants. There are thus two very distinct kinds of material preserved, the one undergoing change much less rapidly than the other, and perhaps much less completely. It is easy to prove that, from the accumulation of forest trees has been obtained the imperfect coal called lignite, while from marsh plants and grasses, mixed occasionally with wood, we obtain peat, turf, and bog. All these substances consist to a great extent of carbon, the proportion amounting to from 50 to 60 per cent., and being generally greater in lignite than in turf. On the other hand, the proportion of oxygen gas is generally very much greater in turf than in lignite. The proportion of ash is too variable to be worth recording, but is generally sufficiently large to injure the quality of the fuel.

As a very large quantity of turf exists in Ireland, covering, indeed, as much as one-seventh part of the island, the usual and important practical condition of this substance as fuel can be best illustrated by a reference to that country. This will be understood by the following account of its origin abstracted from the "Bog Report" of Mr. Nimmo. He says, referring to cases where clay spread over gravel has produced a kind of puddle, preventing the escape of the waters of floods or springs, and when muddy pools have thus been formed, that aquatic plants have gradually crept in from the borders of the pool towards their deep centre. Mud accumulated round their roots and stalks, and a spongy semi-fluid was thus formed, well fitted for the growth of moss, which now, especially species of *Sphagnum*, began to luxuriate; this absorbing a large quantity of water, and continuing to shoot out new plants above, while the old were decaying, rotting, and compressing into a solid substance below, gradually replaced the water by a mass of vegetable matter. In this manner the marsh might be filled up, while the central or moister portion, continuing to excite a more rapid growth of the moss, it would be gradually raised above the edges, until the whole surface had attained an elevation sufficient to discharge the surface-water by existing channels of drainage, and calculated by its slope to facilitate their passage, when a limit would be, in some degree, set to its further increase. Springs existing under the bog, or in its immediate vicinity, might indeed still favour its growth, though in a decreasing ratio; and here, if the water proceeding from them were so obstructed as to accumulate at its base, and to keep it in a rotten fluid state, the surface of the bog might be ultimately so raised, and its continuity below so totally destroyed, as to cause it to flow over the retaining obstacle, and flood the adjacent country.

In mountain districts the progress of the phenomenon is similar. Pools, indeed, cannot in so many instances be formed, the steep slopes facilitating drainage, but the clouds and mists resting on the summits and sides of mountains, amply supply their surface with moisture, which comes, too, in the most favourable form for vegetation, not in a sudden torrent, but incessantly and gently, drop by drop. The extent of such bogs is also affected by the nature of the rock below them. On quartz they are shallow and small; on any rock yielding

by its decomposition a clayey coating, they are considerable; the thickness of the bog (for example in Knock-laid, in the county of Antrim, which is 1,685 feet high) being nearly 12 feet. The summit bogs of high mountains are distinguishable from those of lower levels, by the total absence of large trees.

As turf includes a mass of plants in different stages of decomposition, its aspect and constitution vary very much. Near the surface it is light-coloured, spongy, and contains the vegetable matter but little altered; deeper it is brown, denser, and more decomposed; and finally, at the base of the greater bogs, some of which present a depth of 40 feet, the mass of turf assumes the black colour, and nearly the density of coal, to which it approximates very much in chemical composition. The amount of ash contained in turf is also variable, and appears to increase in proportion as we descend. Thus, in the section of a bog 40 feet deep, at Timahoe, those portions near the surface contained  $\frac{1}{4}$  per cent. of ashes, the centre portions  $\frac{3}{4}$  per cent., whilst the lowest four feet of turf, contained 10 per cent. of ashes. In the superficial layers, it may also be remarked, that the composition is nearly the same as that of wood, the vegetable material being but little altered, and in the lower we find the change into coal nearly complete. Notwithstanding these extreme variations, we may yet establish the ordinary constitution of turf with certainty enough for practical use, and, on the average specimens of turf selected from various localities, the following results have been obtained:—

The calorific power of dry turf is about half that of coal; it yields, when ignited with litharge, about fourteen times its weight of lead. This power is, however, immensely diminished in ordinary use, by the water which is allowed to remain in its texture, and of which the spongy character of its mass renders it very difficult to get rid. There is nothing which requires more alteration than the collection and preparation of turf; indeed, for practical purposes, this valuable fuel is absolutely spoiled as it is now prepared in Ireland. It is cut in a wet season of the year; whilst drying it is exposed to the weather; it hence is in reality not dried at all. It is very usual to find the turf of commerce containing one-fourth of its weight of water, although it then feels dry to the hand. But let us examine how that affects its calorific power. One pound of pure dry turf will evaporate 6 lbs. of water; now in 1 lb. of turf, as usually found, there are  $\frac{3}{4}$  lb. of dry turf, and  $\frac{1}{4}$  lb. of water. The  $\frac{3}{4}$  lb. can only evaporate  $\frac{3}{4}$  lb. of water; but out of this it must first evaporate the  $\frac{1}{4}$  lb. contained in its mass, and hence the water boiled away by 1 lb. of such turf is reduced to  $\frac{1}{2}$  lb. The loss is here 30 per cent., a proportion which makes all the difference between a good fuel and one almost unfit for use. When turf is dried in the air, under cover, it still retains one-tenth of its weight of water, which reduces its calorific power 12 per cent., 1 lb. of such turf evaporating  $\frac{5}{4}$  lbs. of water. This effect is sufficient, however, for the great majority of objects; the further desiccation is too expensive and too troublesome to be used, except in some especial cases.

The characteristic fault of turf as a fuel is its want of density, which renders it difficult to concentrate within a limited space the quantity of heat necessary for many operations. The manner of heating turf is, indeed, just the opposite to that of anthracite. The turf yields a vast body of volatile inflammable ingredients, which pass into the flues and chimney, and thus distribute the heat of combustion over a great space, whilst in no one point is the heat intense. Hence for all flaming fires turf is applicable, and in its application to boilers it is peculiarly useful, as there is no liability to that burning away of the metal, which may arise from the local intensity of the heat of coke or coal. If it be required, it is quite possible, however, to obtain a very intense heat with turf.

The removal of the porosity and elasticity of turf, so that it may assume the solidity of coal, has been the object of many who have proposed mechanical and other processes for the purpose. It has been found that the

elasticity of the turf fibre presents great obstacles to compression, and the black turf, which is not fibrous, is, of itself, sufficiently dense.

Not merely may we utilize turf in its natural condition, or compressed, or impregnated with pitchy matter, but we may carbonize it, as we do wood, and prepare turf charcoal, the properties of which it is important to establish. The methods of carbonization are of two kinds:—1. By heating turf in close vessels; by this mode loss is avoided, but it is expensive, and there is no compensation in the distilled liquors, which do not contain acetic acid in any quantity. The tar is often small in quantity, and the gases are deficient in illuminating power, hence the charcoal is the only valuable product. Its quantity varies from 30 to 40 per cent. by weight of the dry turf. The products of the distillation of 1,157 lbs. of turf were found by Blavier to be—charcoal, 474 lbs., or 41 per cent.; watery liquid, 226 lbs., or 19.3 per cent.; gaseous matter, 450 lbs., or 39 per cent.; and tar, 7 lbs., or 6 per cent.; but the proportion of tar is variable, sometimes reaching to 24.5 per cent. when coked in close vessels.

The economical carbonization of turf is best carried on in heaps, in the same manner as that of wood. The sods must be regularly arranged, and laid as close as possible; they are the better for being large—15 inches long, by 6 broad, and 5 deep. The humps, built hemispherically, should be smaller in size than the heaps of wood usually are. In general 5,000 or 6,000 large sods may go to a heap, which will thus contain 1,500 cubic feet. The mass must be allowed to heat more than is necessary for wood, and the process requires to be very carefully attended to, from the extreme combustibility of the charcoal. The quantity of charcoal obtained in this mode of carbonization is from 25 to 30 per cent. of the weight of dry turf.

The charcoal so obtained is very light and very inflammable; it possesses nearly the volume of the turf. It usually burns with a light flame, as the volatile matters are not totally expelled. This is shown by the composition of a specimen analyzed with the following result:—

|                           |        |
|---------------------------|--------|
| Carbon . . . . .          | 89.90  |
| Hydrogen . . . . .        | 1.70   |
| Oxygen and nitrogen . . . | 4.20   |
| Ashes . . . . .           | 4.20   |
|                           | 100.00 |

For many industrial uses the charcoal so prepared is too light, as, generally speaking, it is only with fuels of considerable density that the most intense heat can be produced; but by coking compressed turf, it has been already shown that the resulting charcoal may attain a density of 1,040, which is far superior to that of wood charcoal, and even equal to that of the best coke made from coal. As to calorific effect, turf charcoal is about the same as coal cokes, and little inferior to wood charcoal.

It is peculiarly important, in the preparation of the charcoal from turf, that the material should be selected as free as possible from earthy impurities, for all such are concentrated in the coke, which may be thereby rendered of little comparative value. Hence the coke from surface turf contains less than 10 per cent. of ash, whilst that of the dense turf of the lower strata contains from 20 to 30 per cent. This latter quantity might altogether unfit it for practical purposes.

The above account of turf and its value, for which we are much indebted to the work of Sir Robert Kane, on the Industrial Resources of Ireland, will be found to apply in an important way to many experiments lately tried with this kind of fuel, and illustrated by several objects exhibited by Mr. Cobbold, Mr. Reece Rees, Mr. J. Rogers, and others. The products obtained for economical use, by the more careful distillation of turf and peat, will be fully described by reference to the body of the Catalogue.



### 3. Lignite.

Lignite also occurs in Ireland, especially on the shores of Lough Neagh, where it is partly used as fuel. The vast quantity of the lignite may be judged from a boring at Sandy Bay, described by Mr. Griffith. In 76 feet of depth there occurred three beds of lignite, one of 20, one of 25, and one of 15 feet thick, giving a total thickness of strata of fuel of 80 feet; the remaining 16 feet were clay. Elsewhere, the beds of lignite are not so much developed; but as the area of this tertiary basin extends over 100 square miles, the quantity of fuel therein contained may be considered of much public interest.

This lignite is intermediate between wood and coal, and is found on examination to present all the structure of wood, and is of a deep brown colour. When ignited, it gives off gaseous matter, which burns brilliantly, and leaves a dense black charcoal. Specimens are found to contain from 53.7 to 57.7 volatile matter, 30.0 to 33.6 carbon, 8 to 16 ash.

The economic value of the lignite appears from these analyses about two-thirds that of average coal. The heat which it produces is more diffused than that from coal, and less intense. Indeed, in all respects as to application to industrial uses, the position of lignite is between those of coal and wood. The attempts hitherto made to render this fuel available for various economic purposes have not been very successful.

At Bovey Tracy, in Devonshire, and at Brora, in Sutherlandshire, other beds of lignite occur, and have been partially used; and in various oolitic beds in Yorkshire similar mineral fuel exists to a small extent. None of these, as at present worked, present any features of considerable interest. Some beds of bituminous shale at Kimmeridge, Dorsetshire, and elsewhere, have been employed chiefly for local purposes.

But the lignite of Ireland is far inferior, both in extent and calorific power, to that of Germany, where fuel of this kind exists in several places, and to a vast extent. On the banks of the Rhine, in Nassau and its vicinity, and in the east of Europe, in Silesia, and in parts of Styria, deposits of this kind are exceedingly remarkable, and of great economic importance. Their thickness is sometimes enormously great, reaching to 120 feet, and even more, but the beds are generally detached and small, and more resemble drift accumulations than regular deposits. The value of these lignites for the manufacture of iron must ultimately be very considerable, as there exist abundant supplies of iron ore in the immediate vicinity of the fuel, both in Austria and on the Rhine, and also in Silesia.

The lignites of Germany often exhibit distinct woody structure, and can be referred to coniferous trees. They contain a somewhat large per centage of ash, do not form good and compact charcoal, and will not stand the blast of a blacksmith's forge. They are generally so wet as to require some drying before being used, and when exposed to the air they often crack. In texture they are tough, and sometimes exhibit sufficient remains of their origin as to resist effectually the blow of a hammer, or, if breaking, only parting in the grain of the wood. The change they have undergone has, therefore, been too small to have given them any of the essential characters of true coal, but they still are so far reservoirs of carbon that we cannot doubt of their being ultimately rendered available.

### 4. Nature and Distribution of Coal.

True coal is so much altered from its original vegetable condition as to have left scarcely any traces of its true history. It is generally, however, associated with sands and clays, exhibiting numerous fragments of the ancient vegetation that obtained at the time of its formation; but these fragments are so far removed in every respect with the existing form of vegetation, as to afford little clue to the ancient condition of the earth in this respect. In coal all trace of true woody fibre has disappeared; the water originally present, and so injurious in the less altered forms of vegetable fuel, is entirely absent, or,

if present at all, is so rather mechanically than chemically, while the water originally in the plant appears to have undergone decomposition, the hydrogen uniting with some part of the carbon to form carburetted hydrogen gas, often existing in the cells and between the plates of the coal, under considerable pressure, and the oxygen being almost entirely removed. The former vegetable has now become a mineral substance, and lies in vast beds of variable thickness, and overlying each other to the extent sometimes of more than a hundred in a single district; such beds being regularly interstratified with deposits of sand and clay, and occupying a distinct geological position, being, with only a very few exceptions, confined to rocks belonging to the newer part of the palaeozoic series.

Between the Arctic Circle and the Tropic of Cancer repose all the principal carboniferous formations of our planet. Some detached coal deposits, it is true, exist above and below those limits, but they appear, so far as we know, to be of limited extent. Many of these southern coal-fields are of doubtful geological age: a few are supposed to approximate to the class of true coals, as they are commonly styled; others are decidedly of the brown coal and tertiary period; while the remainder belong to various intermediate ages, or possess peculiar characters, which render them of doubtful geological origin.

The coals of Melville Island and Byam Martin's Island certainly appear to be of the true coal period. We know that coal exists at numerous intermediate points, from the 75th to the 27th degree of north latitude in America, and also that it is worked on the Sulado and Rio Grande rivers in Mexico, for the use of the steamers.

Southward of the Tropic of Cancer, the existence of coal, corresponding with the European and American hard coal, is somewhat uncertain. There seems to be none on the South American continent, unless it be at Ano Paser, which needs confirmation, or in the province of Santa Catharina, in Brazil. On the African continent we have had vague accounts of coal in Ethiopia and at Mozambique, also at Madagascar; and quite recently we have had intelligence of large quantities of coal in the newly-ceded territory above Port Natal, on the eastern side of Africa; but we believe no geologist has examined those sites. In the Chinese and Burmes empires only brown coal appears to approach the tropic, but true coal seems to exist in the northern provinces. Southward of the Asiatic continent we are uncertain of the exact character of the coal deposits, such as occur abundantly at Sumatra, Java, and Borneo, and neighbouring islands. Coal, however, exists in these islands, and is of fair workable quality.

In New South Wales, the great coal-range on the eastern margin of that continent has sometimes been described as resembling the Newcastle coal in England, and sometimes it is described as of more ancient date. This coal differs essentially from that of any known European formation, but bears a strong resemblance to the Burdwan coal of India.

We have not yet arrived at the period when we could pronounce with any approach to certainty on the actual number of coal-basins in the world; the total number must, however, amount at least to from 250 to 300 principal coal-fields, and many of these are subdivided, by the disturbed position of the strata, into subordinate basins.\* These basins or coal districts are, however, grouped into a comparatively small number of districts, and even many of these are little known, and not at all measured. The greater number occur in Western Europe and Eastern North America, while Central and Southern Africa, South America, and a large part of Asia, are totally without any trace of true carboniferous rocks. The remarks, therefore, that will follow, chiefly refer to the coal of our own and adjacent countries, or of the United States and British North America.

There are various kinds of coal obtained from mines worked in the true coal-fields, which may be grouped into bituminous coal, steam coal, and anthracite. Of

\* Taylor's "Statistics of Coal," Introduction, p. xxxvii.

the first the cannel is a remarkable variety, the coarser kinds of it being called in Scotland "parrot," and sometimes splint coal. It contains from 40 to nearly 60 per cent. of volatile matter, and the proportion of carbon varies within the same limits. It burns readily, taking fire like a candle, and giving a bright light, and much smoke. The ash varies from about 4 to 10 per cent. This coal yields on destructive distillation a very large quantity of gas, and is profitably used for that purpose. The gas is not only large in quantity, but remarkably pure, and of excellent quality for purposes of illumination. There is a large quantity of this kind of coal in the Scotch coal-fields, and it has also been found in the Newcastle district, in the Wigan portion of the Lancashire coal-field, and in the Yorkshire and Derbyshire coal-fields. America yields cannel coal in Kentucky, Indiana, Illinois, and Missouri. Cannel coal passes into jet, and may like jet be worked into various ornaments; but it is brittle, and not very hard. The seams are generally rather thin, although there are several important exceptions in which the quantity is very considerable. The coal of Belgium from one basin (that of Mons) seems to be of this kind.

Another and far more abundant kind of bituminous coal is that obtained abundantly in Northumberland and Durham, and commonly used in London and everywhere on the east and south coast of England. This kind is also highly bituminous, burns with much flame, and takes fire readily, but it swells and alters its form while burning, often assuming a striking and very peculiar appearance, illustrated by a column of coke exhibited by Mr. Cory, and also by other cookes shown by the coal trade of Northumberland and Durham. This caking coal, as it is called, yields, on an average of several analyses, about 57 per cent. of carbon, about 37.6 volatile matter, and 5 per cent. ash. Its specific gravity is 1.257, but sometimes higher. It leaves a red ash in an open fire, but requires to be deprived of its volatile matter before being exposed to a strong blast, owing to its tendency to cement together in a solid mass, and prevent a free draft through the grate or furnace in which it is employed. Not only the coals of the Newcastle coal-field in England, but those of France and Belgium generally, of Bohemia, and Silesia, in Europe, and of Ohio, in North America, are of the caking bituminous kind.

The coals of Staffordshire, Yorkshire and Derbyshire, Lancashire, North Wales, and many other districts, contain nearly or quite as much bituminous and volatile matter as that of Newcastle, but does not cake and swell in the fire, and may, therefore, be employed directly where strong heat is required without previous coking. The coke obtained from this coal is little altered in appearance. The coal burns freely, will flame and give much heat, but is generally considered somewhat inferior for household purposes to that of Newcastle. It yields 50 to 60 per cent. carbon, 35 to 45 volatile matter, and a small quantity, often less than 5 per cent., of ash. The ash is often white. Most of the coals from the inland counties readily show white lines on the edges of the beds, owing to the pressure of argillaceous earth which effloresces. In this respect they are less adapted for general use than the Newcastle coal, but many of them are of excellent quality.

Next in order to the coals of the midland counties generally, are those of some parts of North Wales, and many districts in South Wales, which contain a larger per centage of carbon, very little volatile matter and bitumen, and often but little ash; which burn, however, freely and without smoke, and are well adapted for steam purposes and the manufacture of iron, or where a strong blast and great heat is required. Such coals exist not only in England, but in France, Saxony, and Belgium to some extent. They are often tender or powdery, dirty-looking, and of comparatively loose texture, but they often stand exposure to the weather without alteration or injury. They are called steam coals, and the inferior kinds are known as culm. They contain carbon 81 to 85, volatile matter 11 to 15, ash 3, or thereabouts. Several varieties well known in commerce are exhibited by different proprietors, and the respective

analyses will be found in many cases in the body of the Catalogue.

The last kind of coal is that called "anthracite," and it consists almost exclusively of carbon. This coal is also called non-bituminous, as the steam coal is semi-bituminous. The anthracites contain from 80 to upwards of 95 per cent. carbon, with a little ash, and sometimes a certain small per centage of volatile matter. They are heavier than common coal, take fire with difficulty, but give an intense heat when in full combustion with a strong draught. Anthracite occurs abundantly in the western part of South Wales, in the south of Ireland, in France, Saxony, Russia, and in North America, and the use of them is greatly on the increase. Amongst other things it is used for hop and malt drying, and lime burning with great advantage, but its chief use is in the manufacture of iron. The appearance is often bright, with a shining irregular fracture; the coal is often hard, but some varieties are tender and readily fractured. The ash of anthracitic coal is generally white. As a general rule the anthracites are deficient in hydrogen, but contain a certain proportion of oxygen gas.

The following table represents the weight of water evaporated by one pound each of several principal varieties of coal, and is, therefore,—other things being the same—a good index of the relative value of these fuels:—

|                                       | Lbs. | Oz. |
|---------------------------------------|------|-----|
| Common Scotch bituminous coal         | 5    | 14  |
| Hastings Hartley main, Newcastle      | 6    | 14½ |
| Carr's West Hartley, Newcastle        | 7    | 5   |
| Middling Welsh anthracite             | 7    | 15½ |
| Merthyr bituminous coal (South Wales) | 8    | 0   |
| Llangenech steam coal, South Wales    | 8    | 14  |
| Cameron's steam coal, South Wales     | 9    | 7½  |
| Pure Welsh anthracite, South Wales    | 10   | 8½  |

The relative importance of mineral fuel in various countries, as indicated by the actual coal area and the real production of different districts, may be understood by a reference to the subjoined table. These and other statistical facts are based chiefly upon the authority of Mr. Taylor,\* but have before been given in their present form by the author of the present essay.†

| COUNTRIES.               | Coal Area in Square Miles. | Proportion of whole Area of the Country. | Annual Production in Tons. |
|--------------------------|----------------------------|------------------------------------------|----------------------------|
| British Islands          | 12,000                     | 1-10                                     | 32,000,000                 |
| France                   | 2,000                      | 1-100                                    | 4,150,000                  |
| Belgium                  | 520                        | 1-22                                     | 5,000,000                  |
| Spain                    | 4,000                      | 1-52                                     | 550,000                    |
| Prussia                  | 1,200                      | 1-90                                     | 3,500,000                  |
| Bohemia                  | 1,000                      | 1-80                                     |                            |
| United States of America | 113,000                    | 1-20                                     | 4,000,000                  |
| British North America    | 18,000                     | 2-3                                      |                            |

It will thus be seen how extremely important the coal-fields of the British Islands really are when compared with any others elsewhere. This is the case not merely in the total annual production and the proportionate extent of the deposit, but also in the great number of points at which the coal can be advantageously worked. This will be best seen by reference to the table appended.

The beds with which the coal is generally associated in the British Islands are various sands and shales (imperfect slaty beds) of different degrees of hardness; but the actual coal seams themselves often repose directly on clay of peculiar fineness, well adapted for fire-brick, and generally called under-clay. The under-clay is used in many coal districts for various purposes of pottery. Bands of ironstone (impure argillaceous carbonate of iron) are very abundant in certain coal districts, but are almost absent in others. The Scotch coal-fields near Glasgow, the South Welsh, Yorkshire, and some others, are rich in ironstone, which is the chief source of the vast quantities of iron manufactured in this kingdom.

\* "Statistics of Coal," by R. C. Taylor (London, J. Chapman, 1850).  
 † "Elementary Course of Geology" (London, 1848).



TABLE of the Principal Coal-Fields of the British Islands.

|                                                                | Estimated Workable Area in Acres. | Number of Workable Seams. | Estimated Total Extent of Coal in Feet. | Thickness of Coal in Feet. | Total thickness of Coal-bearing Measures in Feet. |
|----------------------------------------------------------------|-----------------------------------|---------------------------|-----------------------------------------|----------------------------|---------------------------------------------------|
| 1. Northumberland and Durham Districts:—                       |                                   |                           |                                         |                            |                                                   |
| Newcastle Coal-Field . . . . .                                 | 800,000                           | 18                        | 80                                      | 7                          | .                                                 |
| 2. Cumberland and Westmoreland, and West Riding of Yorkshire:— |                                   |                           |                                         |                            |                                                   |
| Whitehaven and Akerston . . . . .                              | 80,000                            | 7                         | .                                       | 8                          | 8,000                                             |
| Appleby (three basins) . . . . .                               | 17,000                            | 1                         | .                                       | .                          | .                                                 |
| Skegbyham (Cumberland) . . . . .                               | .                                 | 1                         | 8                                       | 3                          | .                                                 |
| Kirkby Lonsdale . . . . .                                      | 3,000                             | 4                         | 17                                      | 9                          | .                                                 |
| 3. Lancashire, Flintshire, and North Staffordshire:—           |                                   |                           |                                         |                            |                                                   |
| Lancashire Coal-Field . . . . .                                | 844,000                           | 75                        | 150                                     | 10                         | 8,000                                             |
| Flintshire . . . . .                                           | 120,000                           | 5                         | 28                                      | 9                          | 800                                               |
| Pottery, North Staffordshire . . . . .                         | 40,000                            | 24                        | 38                                      | 10                         | .                                                 |
| Chesdale . . . . .                                             | 10,000                            | .                         | .                                       | .                          | .                                                 |
| 4. Yorkshire, Nottinghamshire, Derbyshire, &c.:—               |                                   |                           |                                         |                            |                                                   |
| Great Yorkshire Coal-Field Darley Moor, Derbyshire . . . . .   | 850,000                           | 18                        | 39                                      | 10                         | .                                                 |
| Shirley Moor . . . . .                                         | 1,500                             | .                         | .                                       | .                          | .                                                 |
| 5. Shropshire and Worcestershire:—                             |                                   |                           |                                         |                            |                                                   |
| Coalbrook Dale, Shropshire . . . . .                           | 12,000                            | 17                        | 40                                      | .                          | .                                                 |
| Shrewsbury . . . . .                                           | 10,000                            | 8                         | .                                       | .                          | .                                                 |
| Brown Cler-hill . . . . .                                      | 1,300                             | 3                         | .                                       | .                          | .                                                 |
| Titterstone, Cleo-hill . . . . .                               | 5,004                             | .                         | .                                       | .                          | .                                                 |
| Lickey Hill, Worcestershire . . . . .                          | 680                               | .                         | .                                       | .                          | .                                                 |
| Bewdley . . . . .                                              | 45,000                            | .                         | .                                       | .                          | .                                                 |
| 6. South Staffordshire:—                                       |                                   |                           |                                         |                            |                                                   |
| Dudley and Wolverhampton . . . . .                             | 58,000                            | 11                        | 67                                      | 40                         | 1,000                                             |
| 7. Warwickshire and Leicestershire:—                           |                                   |                           |                                         |                            |                                                   |
| Nuneaton . . . . .                                             | 40,000                            | 9                         | 30                                      | 15                         | .                                                 |
| Ashby-de-la-Zouch . . . . .                                    | 40,000                            | 5                         | 33                                      | 21                         | .                                                 |
| 8. Gloucestershire and Gloucestershire:—                       |                                   |                           |                                         |                            |                                                   |
| Bristol . . . . .                                              | 130,000                           | 50                        | 90                                      | .                          | .                                                 |
| Forest of Dean . . . . .                                       | 86,000                            | 17                        | 37                                      | .                          | .                                                 |
| Newent, Gloucestershire . . . . .                              | 1,000                             | 4                         | 15                                      | 7                          | .                                                 |
| 9. South Welsh Coal-Field . . . . .                            | 800,000                           | 30                        | 100                                     | 9                          | 18,000                                            |
| 10. Scottish Coal-Fields:—                                     |                                   |                           |                                         |                            |                                                   |
| Clyde Valley . . . . .                                         | 1,000,000                         | 84                        | 800                                     | 13                         | 8,000                                             |
| Lanarkshire . . . . .                                          | .                                 | .                         | .                                       | .                          | .                                                 |
| South of Scotland, several small areas . . . . .               | .                                 | .                         | .                                       | .                          | .                                                 |
| Mid-Lothian . . . . .                                          | .                                 | 24                        | 94                                      | .                          | 4,400                                             |
| East Lothian . . . . .                                         | .                                 | 60                        | 180                                     | 13                         | 8,000                                             |
| Kilmarnock . . . . .                                           | .                                 | .                         | .                                       | .                          | .                                                 |
| Ayrshire . . . . .                                             | .                                 | 3                         | 40                                      | 30                         | .                                                 |
| Fifehire . . . . .                                             | .                                 | .                         | .                                       | .                          | .                                                 |
| Dumfries Coal Region . . . . .                                 | 45,000                            | 10                        | 55                                      | 6                          | .                                                 |
| 11. Irish Coal-Fields:—                                        |                                   |                           |                                         |                            |                                                   |
| Ulster . . . . .                                               | 800,000                           | 9                         | 40                                      | 0                          | .                                                 |
| Connaught . . . . .                                            | 300,000                           | .                         | .                                       | .                          | .                                                 |
| Leinster, Kilkenny . . . . .                                   | 150,000                           | 6                         | 23                                      | .                          | .                                                 |
| Munster (several) . . . . .                                    | 1,000,000                         | .                         | .                                       | .                          | .                                                 |

In this basin are 18 beds of bituminous coal, and in the immediate neighbourhood several smaller basins, containing anthracite. Other valuable localities are in Alsace, several in Burgundy, much worked by very deep pits, and of considerable extent; some in Auvergne, with coal of various qualities; some in Languedoc and Provence, with good coal; others at Arveyron; others at Limousin; and some in Normandy. Besides these are many others of smaller dimensions and less extent, whose resources have not yet been developed. The total area of coal in France has not been ascertained, but is probably not less than 2,000 square miles. The annual production is now at least 4,000,000 tons.

There are four coal districts in Germany, of the carboniferous period, besides several districts where more modern lignites occur. The principal localities for true coal are near the banks of the Rhine, in Westphalia; on the Saare, a tributary of the Moselle; in Bohemia; and in Silesia. The total annual production exceeds 2,750,000 tons.

Of these various localities, Silesia contains very valuable and extensive deposits of coal, which are as yet but little worked. The quality is chiefly bituminous, the beds few in number, but very thick, amounting in some cases to 20 feet. Some anthracite is found. Bohemia is even more richly provided than Silesia, the coal measures covering a considerable area and occupying several basins. More than 40 seams of coal are worked, and several of these are from four to six feet thick.

The basin of the Saare, a tributary of the Moselle, near the frontier of France, affords a very important and extensive coal-field, which has been a good deal worked, and is capable of great improvement. No less than 103 beds are described, the thickness varying from 18 inches to 15 feet. It is estimated that, at the present rate of extraction, the basin contains a supply for 80,000 years. On the banks of the Ruhr, a small tributary to the Rhine, entering that river near Dusseldorf, there is another small coal-field, estimated to yield annually nearly 1,000,000 tons. The whole annual supply from Prussia and the German States of the Zollverein, or Customs' Union, is considered to exceed 2,750,000 tons.

Hungary and other countries in the east of Europe contain true coal-measures of the carboniferous period; but the resources of these districts are not at present developed. On the banks of the Donetz, in Russia, coal is worked to some extent, and is of excellent quality, but it belongs to the older part of the carboniferous period.

Spain contains a large quantity of coal, both bituminous and anthracitic. The richest beds are in the Asturias, and the measures are so much broken and altered in position as to be worked by almost vertical shafts through the beds themselves. In one spot upwards of 11 distinct seams have been worked, the thickest of which is nearly 14 feet thick. The exact area is not known, but it has been estimated by a French engineer that about 12,000,000 of tons might be readily extracted from one property, without touching the portion existing at great depths. In several parts of the province the coal is now worked, and the measures seem to resemble those of the coal districts generally. The whole coal area is said to be the largest in Europe, presenting upwards of 100 workable seams, varying from 3 to 12 feet in thickness.

There are in North America four principal coal-areas, compared with which the richest deposits of other countries are comparatively insignificant. These are the great central coal-fields of the Alleghanies; the coal-field of Illinois, and the basin of the Ohio; that of the basin of the Missouri; and those of Nova Scotia, New Brunswick, and Cape Breton. Besides, there are many smaller coal-areas which, in other countries, might well take rank as of vast national importance; and which, even in North America, will one day contribute greatly to the riches of various States.

The Alleghany, or Appalachian coal-field, measures 750 miles in length, with a mean breadth of 85 miles, and traverses eight of the principal states in the American

The principal coal areas of Europe, apart from those of the British islands, are those of Belgium, France, Spain (in the Asturias), Germany (on the Ruhr and Saare), Bohemia, Silesia, and Russia (on the Donetz). Of these the Belgian are the most important, and occupy two districts, that of Liège and that of Hainault, the former containing 100,000, and the latter 200,000 acres. In each the number of coal-seams is very considerable, but the beds are thin, and so much disturbed as to require special modes of working. The quality of the coal is very various, including one peculiar kind, the Flenu coal, unlike any found in Great Britain, except at Swansea. It burns rapidly with much flame and smoke, not giving out an intense heat, and having a somewhat disagreeable smell. There are nearly fifty seams of this coal in the Mons district. No iron has been found with the coal of Belgium.

The most important coal-fields of France are those of the basin of the Loire, and of these, St. Etienne is the best known and largest, comprising about 50,000 acres.

Union. Its whole area is estimated at not less than 65,000 square miles, or upwards of 40,000,000 of acres.

The coal is bituminous, and used for gas. In Kentucky, both bituminous and cannel-coal are worked in seams about three or four feet thick, the cannel being sometimes associated with the bituminous coal as a portion of the same seam; and there are, in addition, valuable bands of iron ore. In Western Virginia there are several coal-seams of variable thickness, one, nine and a half feet; two others, of five, and others, of three or four feet. On the whole, there seems to be at least forty feet of coal distributed in thirteen seams. In the Ohio district, the whole coal-field affords, on an average, at least six feet of coal. The Maryland district is less extensive, but is remarkable as containing the best and most useful coal, which is worked now to some extent at Frostburg. There appears to be about 30 feet of good coal in four seams, besides many others of less importance. The quality is intermediate, between bituminous and anthracitic, and it is considered well adapted to iron making. Lastly, in Pennsylvania, there are generally from two to five workable beds, yielding, on an average, about 100 feet of workable coal, and amongst them is one bed traceable for no less than 450 miles, consisting of bituminous coal, its thickness being from twelve to fourteen feet on the south-eastern border, but gradually diminishing to five or six feet. Besides the bituminous coal, there are, in Pennsylvania, the largest anthracite deposits in the States, occupying as much as 250,000 acres, and divided into three principal districts.

The Illinois coal-field in the plain of the Mississippi is only second in importance to the vast area already described. There are four principal divisions traceable, of which the first, or Indiana district, contains several seams of bituminous coal, distributed over an area of nearly 8,000 square miles. It is of excellent quality for many purposes; one kind burning with much light, and very freely, approaching cannel-coal in some of its properties; other kinds consist of caking, or splint coal. In addition to the Indiana coal-field, there appears to be as much as 48,000 square miles of coal-area in the other divisions of the Illinois district, although these are less known, and not at present much worked. 30,000 square miles are in the state of Illinois, which supplies coal of excellent quality, and with great facility. The coal is generally bituminous.

The third great coal-area of the United States is that of the Missouri, which is little known at present, although certainly of great importance.

British America contains coal in the provinces of New Brunswick and Nova Scotia. The former presents three coal-fields, occupying in all, no less than 5,900 square miles; but the latter is far larger, and exhibits several very distinct localities where coal abounds. The New Brunswick coal-measures include not only shales and sandstones, as is usual with such deposits, but bands of lignite, impregnated with vitreous copper ore, and coated by green carbonate of copper. The coal is generally in thin seams, lying horizontally. It is chiefly, or entirely bituminous.

In Nova Scotia there are three coal regions, of which the Northern presents a total thickness of no less than 14,570 feet of measure, having 76 seams, whose aggregate magnitude is only 44 feet, the thickest beds being less than four feet. The Ficton, or central district, has a thickness of 7,590 feet of strata, but the coal is far more abundant, one seam measuring nearly 30 feet; and part of the coal being of excellent quality, and adapted for steam purposes. The southern area is of less importance. Besides the Nova Scotia coal-fields, there are three others at Cape Breton, yielding different kinds of coal, of which one—the Sydney coal—is admirably adapted for domestic purposes. There are here 14 seams above three feet thick, one being 11, and one 9 feet.

Coal, existing generally in beds of moderate thickness, inclined at a small angle to the horizon, and often at very considerable depth beneath the surface, is extracted most commonly by the aid of pits or shafts sunk to the bed, and galleries (levels or drifts) cut horizontally, or in the

plane of the bed to a certain distance. By a number of such galleries, cut at right angles to each other, the whole bed, within certain limits, is completely laid open, the overlying beds being supported by the masses of coal (pillars or columns) left untouched between the galleries. In this way about one-third of the coal can be extracted, and afterwards, on the supporting columns being also removed, the roof falls in, and the work is regarded as finished. This method is called technically "the pillar and stall method," and is adopted in the Newcastle coal-field. In Yorkshire, and elsewhere, instead of such columns being left, the coal is removed entirely, and at once, without columns; the roof falling behind the work as it advances. This is the long-wall method. Other modes are occasionally followed when the condition of the coal requires it.

Owing to the gaseous substances contained in coal, and given off not only on exposure to heat, but also to a certain extent by pressure, many kinds of coal cannot safely be left during the process of extraction, without some defence from the open lights required by the miner in the mechanical operations of removing the coal from its bed, and conveying it to the pit bottom. An explosive gaseous compound is usually produced by the admixture of the gases given off by the coal, with common air, made to circulate through the workings, and, if neglected, this compound accumulates and travels on till it meets with flame, and then explodes, causing frightful destruction not only to the property of the mine-owner, but also to the life of the miner. Many contrivances have been suggested from time to time; on the one hand, to improve the ventilation of the mines, and on the other, providing means of illumination which would render accidents from explosion less probable, by removing the immediate cause. Examples of both will be found amongst the models and instruments exhibited in this class, and to these the reader is referred. It is not likely that any contrivances can render absolutely safe an employment which of necessity involves so many and such serious risks as are connected with coal-mining; but much may, no doubt, be done to diminish the danger both from imperfect ventilation and open light.

In concluding this notice of mineral fuel, it may be worth while to draw attention to the vast and overwhelming importance of the subject, by a reference both to the absolute and relative value of the material, especially in the British Islands. It may be stated as probably within the true limit, if we take the annual produce of the British coal-mines at 35,000,000 tons, the value of which is not less than 18,000,000*l.* sterling, estimated at the place of consumption, and therefore including, to a certain amount of transport cost, necessary to render available, the raw material. At the pit mouth the value of the coal is probably about half this, or 9,000,000*l.* sterling, and the capital employed in the coal trade is estimated at 10,000,000*l.* The average annual value of all the gold and silver produced throughout the world has been estimated to have amounted, in 1847, to nearly thirteen millions and three quarters sterling. We have therefore the following summary, which will not be without interest:—

|                                                                                                     |               |
|-----------------------------------------------------------------------------------------------------|---------------|
| Value of the coal annually raised in Great Britain, estimated at the pit mouth . . . . .            | £. 18,000,000 |
| Mean annual value at the place of consumption . . . . .                                             | 9,000,000     |
| Capital engaged in the coal trade . . . . .                                                         | 10,000,000    |
| Mean annual value of the precious metals obtained from North and South America and Russia . . . . . | 5,000,000     |
| Total value of precious metals raised throughout the world in 1847 . . . . .                        | 13,710,000    |
| Mean annual value at the furnace, of iron produced from British coal . . . . .                      | 8,000,000     |

(See the adjoining map for the relative positions of the coal-fields of Europe, and of the United States, and British North America.)

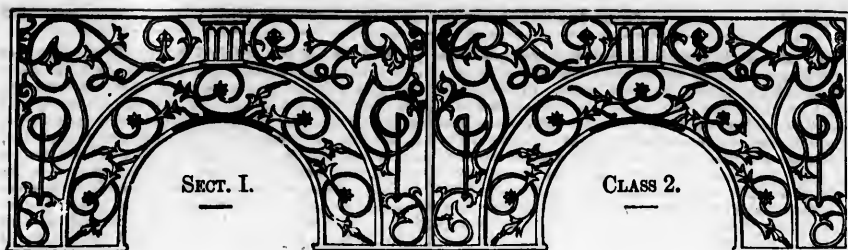

## CHEMICAL AND PHARMACEUTICAL PRODUCTS.

### INTRODUCTION.

THE results of the science directly illustrated by this Class will probably be more generally appreciated than the means by which such results are attained. But these are not to be sought among the chemical and pharmaceutical products, any more than are the beautiful mechanisms of other Classes to be found in association with the raw mineral which supplied the material for their formation.

This Class is principally contained in the SOUTH GALLERY, and is most conveniently reached by ascending the stair near the south entrance at the transept. The objects in the Class are immediately encountered on gaining the Gallery. The Class is divisible into the following heads:—A. Chemical substances used in manufacture. B. Rarer chemical substances for the scientific chemist; and C. Chemical substances used in medicine.

The objects in this Class do not admit of more than a general grouping, into the chemicals of the chemical factories, and the more delicate and refined compounds produced in the laboratory. The former of these, inclusive of large specimens of alum, protosulphate of iron (copperas), and soda are interesting as representing a department of British commerce which has grown into importance within a very recent period. The manufacture, especially of caustic and carbonate of soda on the great scale, has originated and developed itself in a degree almost unparalleled in the history of commerce within twenty or thirty years of the present time. The fires of the kelp burners on the shores of the islands of Scotland are scarcely now extinct, when vast factories, employing large numbers of individuals appear to produce in enormous quantities the same alkali, which was until recently scantily derived from the fused ashes of marine plants. The manufacture of this alkali, by an ingenious decomposition of common salt by the simple aid of sulphuric acid, chalk, sawdust, and coal, is now prosecuted to a vast extent for the supply of the industrial arts generally, the quantity used in medicine and pharmacy being comparatively insignificant. At some alkali works fifty and sixty tons and upwards of common salt are decomposed every week, and converted into caustic or carbonate of soda. The alum factories are not less extensive. At these establishments crystallizations on a scale emulating those of nature are constantly in progress. Some very large specimens of these crystals, and of those of other chemical compounds are placed in the CENTRAL AVENUE, some of the masses being 8 feet in height. The manufacture of sulphuric acid, and of the compounds used by the dyer and calico-printer, also occupies a prominent feature of commercial enterprise. The prussiates of potash forming large masses of yellow and red crystals, and the green, but perishable crystals of copperas, are illustrations of substances largely used in the arts, and the colours and dyes produced by their assistance, present themselves in every direction, when the classes relating to textile printed fabrics are examined.

The chemical works of this country are principally situated at Liverpool, at Newcastle-upon-Tyne, and at Glasgow. The area of ground occupied by some of them equals that covered by the Exhibition Building, and in the various departments as many as five or six steam-engines are employed. The chimneys of these works are in one or two instances 500 feet in height, and the workmen employed form a little population resident in the immediate vicinity of the works.

The application of scientific chemistry to the purposes of medicine is scarcely less recent than the commercial development of chemical manufacture. Medicinal substances appeared for a period to have been overlooked by the chemist, and little attention was given to their preparation. This cannot now be said. The specimens of vegeto-alkaloids, the minerals used in pharmacy and of their compounds—of beautiful crystalline forms, indicate the progress made in the application of philosophic chemistry to the production of pharmaceutical preparations. A variety of compounds obtained by delicate chemical reactions, and from substances requiring great carefulness in manipulation, are also included in this Class.

The whole Class, though not an extensive one, represents the growing attention of men of eminence to chemistry as a manufacture; and of men of science to the application of chemical philosophy to the processes carried on on the smaller scale in the laboratory. The same facilities which exist in this country for the prosecution of other departments of commercial and industrial enterprise have carried chemical manufactures to their present important and commanding position. The direct dependence of many of the arts upon the existence of and the accuracy of production in these chemical works cannot now be questioned.—R. E.

1 PONTIFEX & WOOD, *Shoe Lane, Fleet Street*—  
Manufacturers.

A series of chemical and metallurgic products, illustrating the different processes employed for the reduction of lead from its ores, and its subsequent conversion into white lead.

Specimens of various colours and pigments, employed by artists and paper-stainers; crystals of tartaric and citric acid, sulphate of copper, &c.

2 MELINCBYTHAN CHEMICAL COMPANY, *Neath, Wales*—  
Manufacturer.

Sugar of lead, or acetate of lead.

3 BUTTON, CHARLES, *146 Holborn Bars*—  
Manufacturer.

Chemical products:—Acids—boracic, chromic, carbazotic, gallic, pyrogallic, metagallic, phosphoric and glacial anhydrous, and uric.

Alum—pure ammonia—chrome—potash—and soda alums.

Ammonia nitrate, benzoate, and oxalate; and bin-oxalate (impure), remarkable for the size of the crystals.

Arsenic iodide; barium chloride—oxide, and oxide hydrate; barytes nitrate; bismuth chromate and nitrate; cadmium chromate; calcium phosphuret; cerium oxide and oxalate; cobalt acetate, nitrate, phosphate, and chloride; copper protoxide and suboxide; glucina iron sulphuret; lead nitrate, pure; lead chromate, fused; manganese sulphate; mercury nitrate, bichromate, and bichromate; nickel sulphate; phosphate of soda and ammonia; potash, pure; potash chromate, silicate, and arseniate; potassium iodide, bromide, and fluoride; silver nitrate; soda, pure; soda, nitrate; strontia nitrate; tin bisulphuret; tungstic acid; tungstate of soda; bitungstate of ammonia; uranium nitrate and oxide; zinc chloride and sulphate, pure; phosphorus; iodine, pure; and bromine, pure.

3A READE, Rev. J. B., F.R.S., *Stone Vicarage, Aylesbury*—  
Inventor and Patentee.

Cyanidide of iron, or soluble Prussian blue, and iodide of potassium free from alkaline reaction.

These products, the first of them being a new compound, are obtained by adding iodide of iron, with iodine in excess, to yellow prussiate of potash, the quantities being in proportion to the equivalents of the final products. Prussian blue remains on the filter, and is perfectly soluble when washed and dried; and pure iodide of potassium, as a residuary product, is obtained by evaporating the colourless filtered liquor, fusing and crystallizing.

*Equivalent of Cyanidide of Iron.*

|                             |             |               |       |
|-----------------------------|-------------|---------------|-------|
| Iron . . . . .              | 7 . . . . . | 196 . . . . . | 30.8  |
| Cyanogen . . . . .          | 9 . . . . . | 234 . . . . . | 36.8  |
| Potassium . . . . .         | 2 . . . . . | 80 . . . . .  | 12.6  |
| Iodine . . . . .            | 1 . . . . . | 126 . . . . . | 19.8  |
| Cyanidide of iron . . . . . |             | 636 . . . . . | 100.0 |

|                                                    |         |       |
|----------------------------------------------------|---------|-------|
| Hence, if we take prussiate of potash              | Grains. | 145.0 |
| Iodine 126 } to form iodide of iron . . . . .      |         | 154.0 |
| Iron . . . 28 } . . . . .                          |         | 37.2  |
| Iodine in excess to be dissolved in iron . . . . . |         | 336.2 |

We have, on the whole, the following elements and final products:—

| Elements.           | Products, vis, Prussian Blue, from | Iodide of Potassium from |
|---------------------|------------------------------------|--------------------------|
| Iron . . . . .      | 50                                 | ..                       |
| Cyanogen . . . . .  | 61                                 | ..                       |
| Potassium . . . . . | 20.4                               | 41.6                     |
| Iodine . . . . .    | 32.2                               | 131.0                    |
|                     | 336.2                              | 172.6                    |

Thus the iron and cyanogen, with a portion of the potassium and iodine, form Prussian blue of an intense colour, and perfectly soluble; and the remainder of the potassium and iodine form iodide of potassium, which, unlike the purest that can be purchased, has no alkaline reaction, when dissolved, on turmeric paper.

The properties of this new Prussian blue make it valuable as a writing fluid and a dye; and the pure iodide of potassium, produced by this new process, is found to possess advantages in the preparation of calotype paper.

In the preceding experiment water is not decomposed, and there is no formation of hydriodic acid; but iodine appears to play the part of oxygen, and imparts to the Prussian blue the same rich tone that is obtained from a per-salt of iron. Without excess of iodine, the precipitate is nearly white, but rapidly absorbs oxygen from the atmosphere, and is soluble.

4 BUCKLEY, J., the Trustees of the late, *Manchester*—  
Manufacturers.

Crystal of copperas, or sulphate of iron.

[This substance is in reality an impure sulphate of iron. The copperas of commerce is obtained by exposing heaps of bisulphuret of iron, or iron pyrites, to moisture and air for a considerable period. The elementary constituents of the iron pyrites, sulphur and iron, are oxidized, and a sulphate of the protoxide of iron is obtained, which is washed out and crystallized. It is largely used in the arts for dyeing, ink-making, and also in chemistry and medicine.—R. E.]

5 EVANS, F. J.—Manufacturer.

Naphthaline, from coal.

6 WILSON, JOHN, *Glasgow*—Manufacturer.

Alum slate, raw, in the condition of bisulphuret of iron and alumina; found resting on the top of the coal in the mines. Three other specimens of the same slate, showing the progressive stages of decomposition.

Sample of the same slate calcined.

Tub of alum in the last stage of manufacture.

Crystals of alum. Large specimen of the same.

Bisulphuret of iron (iron pyrites).

Iron pyrites decomposed.

Sulphate of iron (copperas) obtained from the same ore.

Sulphate of ammonia obtained from ammoniacal water, one of the products of the distillation of coal.

Naphthaline, obtained from naphtha; rare, in consequence of its size and purity.

A group of the crystals of sulphate of iron is exhibited in the engraving, page 186.

7 SPENCE, PETER, *Pendleton Alum Works, Manchester*—  
Inventor and Manufacturer.

Iron pyrites.—Bisulphuret of iron, obtained in nodules interspersed in coal; its most general use is to furnish copperas or sulphate of iron by spontaneous decomposition, when spread on the ground, on what are technically called copperas beds.

Refuse pyrites, after being burned for the manufacture of sulphuric acid; used for the patent manufacture of copperas, by digesting it with sulphuric acid diluted.

Copperas crystals.

Sulphate of protoxide of iron, manufactured by patent process.



Crystals of Sulphate of Iron.

The forms of the crystals of sulphate of iron are represented in the above cuts.

Shale, or schist, found overlying and underlying all the coal veins, and brought up in immense quantities in nearly all the coal workings, and also in the ironstone mining, the nodules of ironstone being imbedded in the shale. By a patent process, its own weight of alum can be produced, by acting on it with sulphuric acid, &c., one ton of shale, of average quality, yielding one ton of alum. Shale, calcined for the manufacture of alum.

Shale in the process or manufacture of alum.

Alum of the first and second crystallization.

Alum finished for the market.

Patent zinc cement, or hydraulic mortar.

Specimens of the waste materials from which the cement is manufactured.

Bust composed of the cement.

The cement laid on to wall. Manufactured entirely from refuse matters.

The refuse shale, after the patent alum process, affords the silica and alumina; the refuse lime, after purifying gas for illumination, affords the calcareous ingredient; and the metallic constituent, zinc, is obtained as sulphate of zinc from the refuse of Wicklow pyrites, after its use in the manufacture of sulphuric acid. The cement is hydraulic; the affinity of oxide of zinc for oxygen prevents the oxidization of any iron, and its deleterious

effect on vegetation prevents the growth of moss on its surface.

[Iron pyrites may be made to yield at least two valuable chemical products, sulphur, and sulphate of iron, or coppers. The first is obtained by heat, sulphate of iron by simply exposing the iron pyrites, which is a bisulphuret of iron, to the weather. The mass absorbs oxygen from the air, a sulphate of iron is formed, and is washed out and crystallized. The shale or schist employed in the alum manufacture is a slaty clay found both overlying and underlying coal strata, and containing much pyrites.—R. E.]

7A TENNANTS, CLOW, & Co., Manchester—  
Manufacturers.

Sulphate of copper. Sulphate of zinc. Muriate of tin in crystals. Bichloride of tin. Nitrate of lead. Bichromate of potash. Prussiate of potash. Prussiate (red). Chlorate of potash. Garancine. Stannate of soda. Bisulphate of potash. Soda-ash. Sal-ammoniac; and pink salt.

[The compounds here exhibited furnish a remarkable illustration of the extensive applications of chemistry to modern arts and manufactures. The series exhibited



contains many compounds unknown to commerce a few years ago. They are all employed in various processes of either dyeing or calico-printing.—R. E.]

7b YOUNG, J., *Ardwick Bridge, Manchester*—Inventor.

Mineral oil. Paraffine. Stannates, with models of apparatus

[This mineral oil occurs as a natural spring in a coal-pit at Riddings, near Alfreton. It is used largely for machinery, the paraffine being very anti-frictional. Paraffine is one of the most remarkable of products, and has received its name from its not having chemical affinity for any substance whatever. It is a result of the distillation of tar-oils.—R. E.]

7c BROWN & Co.—Manufacturers.  
Muriate of ammonia. Sulphate of ammonia.

7d DICK, DAVID, & Co., *Burgh Chemical Works, Carlisle*—Manufacturers.

Copperas manufactured by Spence's patent process.

8 DENTITH, W., & Co., *Manchester*—Manufacturers.

Ornaments of bichromate of potash, and of nitrate of lead.

Chromate of potash, prussiate of potash, and Whitby alum, used by calico-printers and dyers.

Green oxide of chromium, and oxide of zinc, used by china and earthenware manufacturers.

[By taking advantage of the elegant forms which various chemical substances assume on crystallizing, and inserting baskets of wire, or similar articles, into a crystallizable solution, the form of the article is preserved, but the character is altered by the development of exquisite crystals, which give the objects a peculiar and remarkable appearance.—R. E.]

9 KURTZ & SCHMERSAHL, *Cornbrook Works, Manchester*—Manufacturers.

New colouring matters, and preparations for printing and dyeing in cotton, linen, silk, and wool.

Specimens of printing and dyeing by means of the preparations.

Ultramarine, in different qualities.

[Lapis lazuli is usually found in granite and crystalline limestone. The finely-coloured varieties are employed for vases, in mosaics and furniture, and are much prized. The pigment ultramarine is prepared from the mineral, by slightly igniting it, shaking the mass in water, and after reducing it to fine powder, mixing it with a resinous paste. This paste is then kneaded in cold water, which washes out the ultramarine, the impurities being retained by the paste. From the costliness of ultramarine its use was formerly confined to the artist; since, however, the discovery by M. Grumet (guided by the analysis of the pigment by MM. Clement and Desormes) of a method of preparing it artificially, its price has become gradually so much reduced as to admit of its very general employment in the arts. For, although M. Grumet kept his process a secret, M. Gmelin and other chemists have published prescriptions for its production, and its manufacture has been of late years much extended, particularly in Germany, though only very recently introduced into England. Ultramarine is a very permanent colour under atmospheric influences, but is decolorized by the presence of acids with liberation of hydro-sulphuric acid; hence, in its employment, the presence of acids should be avoided. Artificial ultramarine may be prepared, according to C. Gmelin, by rapidly igniting a mixture

of equal parts of silica, carbonate of soda, and sulphur, first adding a sufficient quantity of a solution of soda to dissolve the silica. The result is a bluish-green mass, which, by ignition in contact with air, becomes blue. Ultramarine consists essentially of silica, alumina, soda, and sulphur; a small quantity of iron appears to be beneficial, but an excess impairs the beauty of the colour.—W. D. L. R.]

10 HATMEL & ELLIS, *9 Sugar Lane, Manchester*—Manufacturers.

Copper and its compounds—Copper ore from the Burra-Burra mine, Australia; sheet, oxide, and sulphate of copper.

Lead and its compounds—Lead ore; protoxide of lead; nitrate of lead.

Tin and its compounds—Tin ore from Cornwall; tin granulated; tin salts, or protochloride of tin; sulphate of soda, or salt cake.

Sulphur—Rough sulphur from Sicily; roll, flowers, crystallized, lac, and black sulphur.

Archill—Orchella weed from Angola; red archill; blue archill; cudbear.

Ammonia—Muriate and sulphate of ammonia.

[Copper, lead, and tin furnish highly important compounds for the use of the dyer and calico-printer. Sulphate of copper, or blue vitriol, nitrate and acetate of lead, and protochloride of tin are the compounds most largely in use for these purposes, and are consumed in quantities altogether enormous in the Lancashire print-works.—R. E.]

11 HOWARDS & KENT, *Stratford, Essex*—Manufacturers.

Barks yielding quinine and cinchonine, viz. 1, Various descriptions of calisaya bark (*Cinchona calisaya*). 2, Carabaya bark (*Cinchona ovata*). 3, Cusco bark (*Cinchona pubescens*). 4, Carthagena bark (*Cinchona cordifolia*). 5—8, Specimens of red, crown, grey, and loxa barks. 9, Various descriptions of barks used for adulteration. 10, *Cinchona Australis*. 11, *Cascailla macrocarpa*. 12, *Cascailla corua*. 13, *Cascailla magnifolia*. 14, *Buena hexandra*. 15, *Exostema Peruviana* or *tacumea* bark. 16, *Laplacea quinoderma*.

Salts of quinine and cinchonine:—Disulphate, sulphate, citrate, hydrochlorate, phosphate, and tartrate.

*Nectandra Rodiei*, or green-heart bark, and its alkaloid bebeerine.

[The tree from which the green-heart bark is obtained belongs to the natural order *Lawsonia*, a family of plants yielding many powerful and valued medicinal agents. *Nectandra Rodiei* has been shown by Dr. MacLagan to contain an important alkaloid, called from the native name of the tree (*Beberu*) *Beberine*, or *Biberine*. Its effects are comparable to those of quinine. The tree flourishes in Demerara, and its wood is extremely hard.—R. E.]

Refined camphor, with different kinds of rough camphor, &c.:—1, Japan or Dutch camphor. 2, China or Formosa camphor. 3, Borneo or native camphor. 4, Refined camphor. 5, Camphor in the glass in which it was sublimed.

[The tree which yields camphor is *Laurus camphora*. Japan camphor is considered the best, and is imported in tubs into the United Kingdom, but not in large quantities. Crude camphor from China is principally obtained from the island of Formosa, whence its commercial designation. Crude camphor is obtained from the trees yielding it by chopping up the branches and boiling them in water, when the camphor is separated either by cooling or sublimation. It is refined in this country by being re-sublimed.—R. E.]

Refined borax, and articles from which it is made:—1, Commercial boracic acid. 2, Purified boracic acid. 3,



Tincol, or natural borax. 4, Artificial tincol. 5, East India refined borax. 6, English refined borax. 7, Modified crystals. 8, Octohedral borax.

[The origin of boracic acid is extremely interesting. Its principal sources are the celebrated lagoons of Tuscany, where it is obtained by a singularly simple and ingenious process. It rises with steam from the heated earth in a region where volcanic tumult is conspicuously manifest, and was formerly avoided by the superstitious peasantry in its vicinity. This steam is condensed by being passed into basins partly filled with water, the boracic acid is held in solution, purified, evaporated, and crystallized. From 10,000 to 12,000 lbs. of this acid are thus obtained every day. Boracic acid is chiefly employed as a source of borax.]

Borax consists chemically, when pure, of a bborate of soda. It is, in its impure state, the tincol of commerce, and is obtained in large quantities from a lake in Thibet, on the edges of which it crystallizes, and is collected by the natives. It is also procured from lakes in China and Persia. The greater part of the borax of commerce is obtained from the saturation of boracic acid with soda. Borax is greatly used in the arts as a flux, and for glazing porcelain; also in medicine, and pyrotechny for making "green fire."—R. E.]

Tartaric acid, with specimens of the argols and tartars from which it is made:—1, Argols, various kinds. 2, Tartars, various kinds. 3, Crystallized tartaric acid. 4, The same, in the first stage of manufacture. 5, Powdered tartaric acid.

Citric acid and the articles from which it is made:—1, Concentrated lemon juice. 2, Citrate of lime. 3, Crystallized citric acid. 4, Citric acid, in the first stage of manufacture.

Antimony and preparations:—1, Antimony. 2, Black sulphuret of antimony. 3, Oxy-sulphuret of antimony. 4, Emetic tartar. 5, Antimonial powder. 6, Kermes mineral.

Silver and preparations:—1, Silver. 2, Lunar caustic. 3, Crystallized nitrate of silver.

[Nitrate of silver, commonly called *Lunar caustic*, is a preparation obtained by the solution of metallic silver in nitric acid. Chemical union takes place, and the solution being evaporated and crystallized, a solid nitrate is obtained. This is, for medical purposes, fused and run into moulds. This compound of silver, in a pure state, is of special value as a re-agent to the chemist; it is also extremely useful in the hands of the physician and surgeon. Very pure crystallized nitrate of silver is employed for the production of photographic pictures on paper, glass, and porcelain. When deposited on these surfaces, under peculiar circumstances, it is highly sensitive to the light.—R. E.]

Bismuth and preparations:—1, Bismuth. 2, Oxide of bismuth. 3, Pearl white.

Iron and preparations:—1, Iron. 2, Ammonio chloride of iron. 3, Tartrate of iron. 4, Oxide of iron. 5, Green vitriol. 6, Ammonio citrate of iron. 7, Ammonio tartrate of iron. 8, Citrate of iron and quinine.

Mercury and preparations:—1, Mercury. 2, Oxide of mercury. 3, Binocide of mercury. 4, Red precipitate. 5, White precipitate. 6, Crude calomel. 7, Crystallized calomel. 8, Calomel. 9, Hydro-calomel, sublimed under water. 10, Corrosive sublimate. 11, Sub-sulphate of mercury.

Magnesia and preparations:—1, Magnesian shale. 2, Magnesian limestone. 3, Epsom salts. 4, Carbonate of magnesia. 5, Calcined magnesia.

[The well-known substance called Epsom Salts is an important preparation of magnesia. It is, in some instances, procured by an ingenious system of employing the

residual hydrochloric acid of alkali works, which is made to act upon native magnesian limestone; the lime is dissolved out by the acid, and the residual matter, consisting chiefly of magnesia, is dissolved in sulphuric acid, purified and crystallized. In other cases it is largely obtained by simply acting upon magnesian limestone with diluted sulphuric acid; it is also obtained from the residual salts of sea-water, from which common salt has been separated.—R. E.]

Preparations of potassium:—1, Potashes. 2, Pearlashes. 3, Carbonate of potash. 4, Bicarbonate of potash. 5, Sulphate of potash. 6, Soluble tartar. 7, Commercial saltpetre. 8, Purified nitre.

[The difference in the chemical composition of the potashes and pearlashes of commerce, is, that the one is chiefly a caustic form of the alkali, and the other contains more of the carbonate. Both are alike derived from the combustion of wood. America is the chief source of this alkali at present. Her immense primeval forests, upon which the efforts of man make but little impression, present an inexhaustible source of this valuable alkali. The wood is piled up in a pyramidal heap, and the ashes are collected, partly purified, and fused. Pearlash is prepared from the "black salts," or impure caustic and carbonated alkali, by fusion in an open furnace. Potash is largely employed in medicine and the arts. About 100,000 cwt. are annually imported into Great Britain from America alone.—R. E.]

Preparations of sodium:—1, Soda ash. 2, Subcarbonate of soda. 3, Subcarbonate of soda, absolutely pure. 4, Sesquicarbonate of soda. 5, Bicarbonate of soda. 6, Rochelle salt in the first stage of manufacture. 7, Pure Rochelle salt. 8, Rochelle salt, powdered. 9, Phosphate of soda. 10, Cubic nitre. 11, Purified nitrate of soda. 12, Glauber salts. 13, Hyposulphate of soda.

[The last-named preparation of soda—hyposulphate of soda—is a substance of great importance and peculiar interest to the photographer. It is readily soluble in water, and the solution dissolves, with great facility, the compounds of silver. After a Daguerrotype picture has been taken and developed by mercurial vapour, the coating of iodide and bromide of silver formed on the surface of the plate is instantly dissolved by washing it with this solution. The picture is afterwards dried and gilded. In the Talbotype, hyposulphate of soda is employed to remove the sensitive coating of silver, and thus fix the impressions so as to render them insensible to the further influence of light.—R. E.]

Zinc and its preparations:—1, Zinc. 2, Oxide of zinc. 3, Acetate of zinc. 4, White vitriol.

Iodine and its preparations:—1, Seaweed, yielding iodine. 2, Kelp. 3, Commercial iodine. 4, Resublimed iodine. 5, Hydriodate of potash. 6, Biniodide of mercury.

Opium and its preparations:—1, Opium. 2, Morphia. 3, Acetate of morphia. 4, Muriate of morphia.

[Morphia is a powerful alkaloid, being the active principle of opium. The acetate and muriate are its most common preparations for pharmaceutical purposes.—R. E.]

12 BELL, ISAAC LOWTHIAN, *Washington Chemical Works, Newcastle-upon-Tyne*—Manufacturer.

Specimens of Pattinson's patent oxichloride of lead; also three landscape pictures, painted with colours prepared from the same.

13 KING, JOHN, *Glasgow*—Manufacturer. (Sole partner of the Hurler and Campsie Alum Company.)

Alum, slate, or schist, from the mines of Campsie, Stirlingshire, in three different strata, overlying each other in the coal measures.

The same ores in process of decomposition, and in a state of complete decomposition. The insoluble portion of the decomposed ores mixed with alum schist in its natural state, after having been subjected to combustion. Muriate of potash, used in the alum manufacture. Manufactured alum, once, twice, and thrice crystallized; or finished alum. A miniature roasting tun, showing the mode in which the finished alum is crystallized. Iron pyrites. Specimens of prussiates of potash.

[At the foot of the Campsie hills there occur two or three beds of coal of the South Scotch coal-field, and some beds of alum slate, which decompose on exposure to the air. The beds have been much disturbed, and often exhibit intruded masses of trap.

In preparing the alum obtained in an impure state from the decomposition of the bituminous and pyritous schist, much careful management is necessary. The admixture of a certain quantity of muriate of potash in these processes, renders the whole rather a mineral manufacture than a simple preparation of raw material.—D. T. A.]

14 MAY & BAKER, *Battersea, Surrey*—Manufacturers.

Specimens of nitric acid. Crystals of nitrate of silver. Trinitrate of bismuth. Rough camphor, as imported. Refined camphor in refining glass; camphor, prepared for sale. Precipitated chalk. White precipitate of mercury. Corrosive sublimate. Crude calomel. Prepared calomel. Red precipitate of mercury. Turpith mineral. Ponderous magnesia. Acetate of potash; acetate of zinc. Oxide of zinc. Sulphate of zinc, and chlorate of potash.

[Nitric Acid.—The aqua-fortis of commerce consists of impure nitric acid. It is obtained from the distillation of concentrated sulphuric acid mixed with nitrate of potash or soda. The commercial substance called Chilian, or Peruvian saltpetre, is nitrate of soda, and has largely been used lately in the preparation of this acid. This acid is of immense importance in the arts, chemistry, and medicine.—R. E.]

15 COOK, THOMAS AINSLEY, *Newcastle-upon-Tyne*—

Manufacturer.

Crystallized carbonate of soda. Manufactured by the Walker Alkali Company.

16 LINDSAY, G., *Sunderland*—Manufacturer.

Green vitriol, or copperas of commerce, a proto-sulphate of iron, extensively used in dyeing silks, woollens, and cottons, making writing inks, Venetian red, &c. It is manufactured from iron pyrites, procured from the coal mines, exposed to air and moisture; the excess of acid being saturated by digesting the lixivium with iron plates and turnings.

[By heating proto-sulphate of iron to redness, it is decomposed, sulphurous and sulphuric acids being evolved, and sesqui-oxide of iron (Venetian red, colcothar, jeweller's rouge) remaining.—W. D. L. R.]

17 MORRELEY, W., *Mulgrave Alum Works, Landsend,*  
*near Whitby*—Producer and Manufacturer.

Raw alum shale, as cut from the cliff, showing embedded nodules of cement stone; the same after calcination. Alum meal, or alum as first crystallized. Half a cask of finished alum.

Rough sulphate of magnesia, being the residuum obtained in the manufacture of alum, used for making refined Epsom salts. Refined sulphate of magnesia, or Epsom salts, purified by a new patent process.

Patent double salt of ammonia and magnesia, for a manure for top dressing.

Bones dissolved in sulphate of magnesia, for a manure.

[Alum is manufactured at Whitby, by the combustion of the schists of the upper lias, which contain a certain

quantity of iron pyrites and bituminous, or carbonaceous matter. The temperature being properly regulated, and water occasionally supplied, a double decomposition takes place, producing sulphate of alumina and sulphate of iron, together with a portion of sulphate of magnesia, if any magnesia is present in the alum schist. A subsequent separation of the ingredients takes place. A certain quantity of the sulphate or muriate of potash is added, and the alum is crystallized. Alum is a triple salt consisting of a hydrated sulphate of alumina and potash, soda, or ammonia; but a portion of the alumina is occasionally replaced by iron.—D. T. A.]

18 PATTINSON, WILLIAM WATSON, *Gateshead,*  
*Newcastle-upon-Tyne*—Manufacturer.

Large mass of crystallized alum, or sulphate of alumina and potash. Masses of pure sulphate of alumina, called in commerce concentrated alum. Specimen of bi-carbonate of soda.—Manufactured at the Felling Chemical works.

[The alum of English commerce is obtained in large quantities from manufactories at Whitby, in Yorkshire. A horizontal bed of fuel, composed of brushwood or of small coal, is first made, and upon it pieces of aluminous rock are piled. The fuel being kindled, the whole mass slowly ignites. More rock is piled upon it, until, in some instances, a vast heap of inflated material, 100 feet high and 200 feet square, is raised, and continues to burn for months. The aluminous schist being thus disintegrated, and its chemical constitution changed, is lixiviated, the solution evaporated in large cisterns and purified, and sulphate of potash or ammonia is then added. The alum thus formed is dissolved, and crystallized by pouring the solution into casks made with moveable staves, called "rocheing casks." On removing the staves, an apparently solid barrel of alum is exposed. This is pierced with an instrument near the bottom, when the uncrystallized solution runs out. The mass, broken into lumps and dried, is the alum of commerce. The shipments of alum from Whitby in 1841 amounted to 3,237 tons. Alum is employed in medicine, in chemistry, and in the arts. Its most important use is as a mordant for dyers.—R. E.]

19 RICHARDSON BROTHERS & Co., 17 St. Helen's Place,  
and 11 East Street, City Road—Manufacturers.

Specimens of refined saltpetre or nitrate of potash, obtained chiefly from the East Indies, and shipped from Calcutta. This substance is used in the manufacture of gunpowder, oil of vitriol, aqua-fortis, and other chemical products, and also in curing provisions.

[Saltpetre is distinguished as the special natural product of the surface soil of warm countries. India, Egypt, Persia, Spain, and Italy, yield our chief supply. It is obtained from the soil, on the surface of which it makes its appearance like hoar, by lixiviation. The solution is then filtered, evaporated, and crystallized. It is principally imported into Great Britain from Calcutta and Madras. The amount imported from the East Indies and Ceylon in 1841, was 261,552 cwts. Its uses in chemistry, medicine, and the arts are familiar.—R. E.]

20 STEVENSON, WILLIAM, *Jarrow Chemical Works,*  
*South Shields*—Manufacturer.

Crystals of soda converted into bi-carbonate of soda by exposure to carbonic acid gas.

21 TULLOH, A., *Waltham Abbey*—Producer.

Saltpetre, charcoal, and sulphur, used in the manufacture of gunpowder at the Royal Gunpowder Mills at Waltham Abbey.

22 MASON, CHARLES, & SON, 11 *Munster Street, Regent's Park*—Manufacturers.

The royal premier blacking, shown on new calf-skin, blocked on large model of a foot; polished 12th April last. The same on old calf leather; polished 29th Nov., 1850.

The French varnish, shown on ordinary calf leather.

The waterproof varnish, shown on cow-hide shooting boot and patent leather harness.

23 HILLS, F. C., *Deptford*—Patentee and Manufacturer.

Nitrate of potash (saltpetre), made by the decomposition of muriate of potash (chloride of potassium) by nitrate of soda, a patent process; the muriate of potash being obtained from sea-weed or kelp.

Dome of sal ammoniac, sublimed from rough muriate of ammonia, made from the ammoniacal liquid produced at gas works, by the addition of muriatic acid.

Cake of sesqui-carbonate of ammonia, or common smelling salts, sublimed from rough sesqui-carbonate of ammonia, made by the decomposition of sulphate of ammonia by carbonate of lime; the ammonia being produced at gas-works.

[Nitrate of soda has lately assumed high commercial importance from its value to the chemical manufacturer, and to the agriculturist as a manure for wheat. It is found in immense quantities in South Peru, being obtained by lixiviation of the saline deposit in the soil, and is then evaporated and crystallized, dried and packed in bags, and conveyed to the coast by mules. In 1841, the imports of this article from Iquique amounted to 173,884 quintals.

The term "kelp" is applied to the fused ashes of several species of sea-weeds. The plants are collected, dried, and burnt, and the ashes form a melted mass, consisting of sulphates, carbonates, and chlorides of potash and soda, together with carbonate and sulphate of lime, alumina, and silica.—R. E.]

24 HEMINGWAY, A. W., *Portman Street*—Producer.  
Double salts of iron.25 PONTING, THOMAS CADBY, 32 *High Street, Bristol*—Inventor and Manufacturer.

Marking ink and illustrative specimens; for writing and drawing on linen, silk, and cotton, without preparation. Shaving cream. Medicinal vegetable fluid extracts, made with cold water.

26 CLIFFORD, G., 5 *Inner Temple Lane*—Producer.

Specimens of deeds, writings, books, maps, engravings, &c., injured by fire, water, age, dirt, smoke, &c., in a restored and unrestored state.

The specimens exhibited show an indenture that was taken from the ruins of the great fire at Lincoln's Inn, January 14, 1849. The restored half, "without having been separated from the dirty half," cleansed, and flexibility imparted to it; having become hard, horny, and brittle, from the effects of the fire and water, any ordinary attempt to open it would have broken it. The writing on it has sustained no injury by the process. Two leaves of a book, two leaves of the "Jurist" newspaper, and portions of parchment taken from the same fire, which were injured by fire, water, &c., are exhibited, with the one-half of each cleansed; also the halves cleansed of a map and several engravings injured by age, smoke, mildew, water, and dirt, &c., the whole having been previously in the dirty state.

27 BRAMWELL, THOMAS, *Heworth Chemical Works, Newcastle-upon-Tyne*—Manufacturer.

Crystals of prussiate of potash of commerce. Ferrocyanide of potassium of chemists, used for dyeing blue in place of indigo.

[*Ferrocyanide of potassium* is one of the most important chemical products to the dyer and callio-printer. It is obtained on the large scale by fusing animal matter with carbonate of potash and iron filings; cyanide, and subsequently ferrocyanide of potassium, are produced. Its compound, formed on the addition of a salt of iron to ferrocyanide of potassium, is of the most beautiful blue colour, and is called Prussian blue.—R. E.]

28 WINSOR & NEWTON, 88 *Rathbone Place, and North London Colour Works, Kentish Town*—Manufacturers.

Artists' pigments, in the raw and manufactured states, and in the various forms of preparation, for use in water-colour and oil painting, and in decorative art; including manufactures and preparations of the madder colours, cochineal, lapis lazuli, uranium, cadmium, chromium, and all the rarer kinds of chemical pigments.

Sable, badger, hog hair, and other brushes and pencils employed in drawing and painting.

Preparations of canvas, panels, millboard, apparatus, and boxes fitted for the use of artists. Palettes, and various other implements and materials employed in the fine and decorative arts.

Oxide of zinc.

[Several of the rarer metals yield oxides, which form brilliant pigments. Some of these are useful in enamel painting, in consequence of their not undergoing alteration by the heat employed in that art. Oxide of zinc has lately been much employed as a substitute for white lead.—R. E.]

29 FAWCETT, BENJAMIN, *late of 73 Snow Hill, and 7 Sumner Street, Southwark*—Producer.

Plain and ornamental specimens in graining or flatting, produced by a kind of paint free from noxious effluvia, and adapted for purposes to which white lead may be applied.

30 CHESHIRE, JOHN, jun., *Northwich*—Manufacturer.

A pyramid of best table salt, with several other specimens of salt. The salt springs in Cheshire are the greatest in Europe, and their annual production is upwards of 800,000 tons of salt.

31 SPENCER, JOHN ALEXANDER, 9 *Westbourne Place, Hyde Park*—Manufacturer.

Case, containing chemical preparations:—Naphthaline (from coal-tar); sulphate of magnesia (Epsom salts); benzoic acid (prepared by sublimation); caffeine (prepared from coffee); hydriodate of uranine; samples of cod-liver oil, 1849-50.

32 WATSON, WILLIAM, *Dunchattan Chemical Works, Glasgow*—Manufacturer.

1. Sea-weed, collected dry on the sea-shore; which is burned and converted into
2. Kelp; which, on lixiviation, is crystallized for
3. Sulphate of potash; and
4. Chloride of potassium; and
5. Carbonate of soda (crude).

The liquor is then decomposed by sulphuric acid, converting the iodides contained in the liquor into hydriodic acid; which, on oxidation and sublimation,

6. Iodine, is separated from it.

33 PICCIOTTO, MOSES HAIM, 8 *Crosby Square*—Inventor and Manufacturer.

Specimens of decolorized and purified gum arabic, obtained by a patent chemical process. When dissolved, it forms a clear mucilage, and may be used for pharmaceutical purposes, for confectionery, for dressing silks, lace, tulle, printing, &c.

Sample of the original gum arabic from which the specimens were prepared.

Specimen of ultramarine blue, for the first time manufactured in London by Hochstaetter's process.

Pure crystallized mannite, prepared in Italy, and used for medicinal purposes.

[Mannite is obtained from manna, the concrete juice of a species of ash (*Ornus Europæa*), by dissolving in hot alcohol and crystallizing. It is a peculiar variety of sugar.—R. E.]

34 BULLOCK, JOHN LLOYD, 22 Conduit Street—  
Manufacturer.

A series of chemical products derived from substances used as food or medicine.

35 NAYLOR, WILLIAM, 56 James Street, Oxford Street—  
Manufacturer.

Decorative copal varnish, made from Sierra Leone gum copal. White hard varnish, made of picked gum sandarach; and mastic varnish, made of picked gum mastic. Specimens of deal wood, stained to imitate different woods, without sizing; calculated to endure exposure, and admit of polish or varnish. The novelty claimed is the production of the stain without sizing.

36 NISSEN & PARKER, 43 Mark Lane—Inventors.

Specimens of tinted paper, chemically prepared in the pulp, for printing bank cheques upon. The chemical preparation renders any extraction of the writing by acids or alkalis immediately apparent.

37 BULLOCK, EDWARD, & Co., Galway, Ireland—  
Producers.

Artan kelp, muriate, nitrate, chlorate, and sulphate of potash.

Sulphate of soda, pure sulphur, commercial iodine, pure sublimed iodine, iodide of potash, iodide of lead, biniodide of mercury.

Preparations from sea-weed.

38 SPURGIN, T., Saffron Walden—Producer.

Root, stem, flower, and stigmata of saffron.

[This plant is said to have been brought to England in the reign of Edward III. It was first planted at Walden, in Essex, a town to which it afterwards gave its name as a phenomenon.]

39 HAWTHORNE, JAMES, 77 Charrington Street—  
Inventor.

A new ink for staining oak and mahogany. Specimen of a common oak stave, cut in pieces, and stained various shades of colour. A stained mahogany frame.

40 HALL, JOSIAH, Queenborough—Producer.

Specimen of coppers, from the works at Queenborough, in the Isle of Sheppey, with specimens of pyrites and of coppers in a granulated form. It is used in dyeing and in the composition of colours, and, in its new and granulated form, may be used for purifying gas. The pyrites are found on the shore of the north-east side of the Isle of Sheppey; about eight tons are produced weekly. The granulated form is claimed as the peculiar merit of the specimen; it is effected by a refrigerator, and is used for dry mixing.

River coppers has hitherto been objected to as being crystallized in a soft and imperfect manner: the present specimen is freed from such defects by a strict attention to the coppers bed.

[Coppers is chemically an impure protosulphate of iron, and is obtained commercially by the decomposition of iron pyrites, or bi-sulphuret of iron, by atmospheric oxygen and water which is poured upon the beds.—R. E.]

41 HOPKIN & WILLIAMS, 5 New Cavendish Street—  
Manufacturers.

Pure tannin.

Crystallized chromic acid.

Beuzoate of ammonia.

Bin-iodide of mercury.

Pure aconitine, used in neuralgic affections.

Valerianate of zinc, iron, quinine, bismuth, and of iron and quinine.

Cardole, said to be a new and powerful vesicating agent.

Bromoform, per-bromide of formyle, a new anæsthetic agent said to be of greater power than chloroform.

Dutch liquid, chloride of olefant gas, a new anæsthetic agent, said to be less irritating than chloroform.

Iodoform, periodide of formyle.

Pyrogallio acid, used in photography.

Cyanuret of potassium.

Citrate of iron and quinine.

Sulphate of iron and quinine, a new and powerful tonic.

Arsenate of soda, containing 15 atoms of water.

Kreatine, from the juice of the flesh.

Iodide of iron and quinine.

[Tannin (tannic acid) is obtained from nut-galls, and exists in the bark of all the oak tribe. It is the active agent of the barks used in the art of tanning, forming insoluble compounds with the components of the skins of animals (leather), which it preserves from putrefaction.

Chromic acid is a compound of the metal chromium and oxygen of a fine red colour: it parts readily with half its oxygen, and hence is a powerful oxidizing and bleaching agent. The salts of chromic acid are termed chromates, they are chiefly of a yellow colour; the chromates of baryta, strontia, and lead are beautiful yellow pigments much used in distemper and oil painting and printing.

Aconitine is a poisonous vegetable alkaloid, obtained from aconite (wolfstane, monkshood); it is used as a remedy in neuralgia.

Valerianic acid (valeric acid) is a volatile acid belonging to the same class as acetic acid: it is obtained by oxidizing hydrated oxide of amyle (oil of potato spirit), as acetic acid (vinegar) is obtained by oxidizing hydrated oxide of ethyle (alcohol). It exists ready formed in the aromatic root of the *Valeriana officinalis*, from which it is obtained by distillation with water. Valerianates (valerate) are compounds of valerianic acid with bases. Used as a nervous stimulant.

Formyle is a compound of carbon and hydrogen: it bears the same relation to wood spirit (hydrated oxide of methyle), as acetylene does to ordinary alcohol (hydrated oxide of ethyle): it is the radical of formic acid, as acetylene is of acetic acid. Its compounds with iodine and bromine are iodoform and bromoform.

Dutch liquid (oil of the Dutch chemists, olefant gas) is the hydrochlorate of chloride of acetylene: it is obtained by mixing equal volumes of moist chlorine gas and olefant gas.—W. D. L. R.]

[Pyrogallio acid is obtained by heating the dried extract of gallnuts, when it is collected by sublimation. In photography it is employed in extremely minute quantities. The pictures come out without requiring to be developed by a second wash. But the action of this agent is so energetic that it is extremely difficult to manage. A solution of the proto-nitrate of iron possesses similar properties for the use of the photographer.—R. E.]

42 BOWER, J., Hunslet, Leeds—Manufacturer.

Carbonate of soda, containing 59 parts soda, and 41 carbonic acid, particularly adapted for scouring wool or woollens, as it removes grease without injuring the animal fibre.



43 JENKINS, WILLIAM HARRY, *Two*—Inventor.

Arsenical powders—"Arsenical compound," a general preventive of foulness, barnacles, &c., on ships' bottoms, buoys, &c., and of dry-rot in buildi'gs.

44 FOX & BARRINGTON, 9 *Clarence Street, Manchester*—Manufacturers.

Common salt. Brimstone (sulphur). Salt cake (of soda). Barilla, or black ash (ball soda). Soda-ash (impure carbonate of soda). Bleaching-powder. Nitrate of lead. Chlorate of potash. Super-sulphate of soda. Tin crystals (chloride of tin). Blue or Roman vitriol (sulphate of copper). Nitrate of copper. Yellow prussiate (ferrocyanide of potassium). Red prussiate (ferricyanide of potassium). White, mottled, and yellow soda-soaps.

45 BARNES, JAMES BENJAMIN, 143 *New Bond Street*—Manufacturer.

Valerianic acid—produced from the hydrated oxide of amyle, or oil of corn spirit, by oxidation with chromic acid.

Valerianate of potash and soda—employed in the formation of most of the following salts:—Valerianate of ammonia, baryta, strontia, lime, magnesia, alumina, oxide of chromium, protoxide of nickel and cobalt, and oxide of manganese.

Valerianate of oxide of iron, sesqui-oxide of iron, and oxide of zinc—employed in medicine as tonics and antispasmodics.

Valerianate of oxide of lead—oxide of silver—sub-oxide of mercury—oxide of mercury—ter-oxide of bismuth—oxide of copper—oxide of cadmium—ter-oxide of antimony—oxide of tin—morphia—quina—cinchonia—strychnia—and oxide of ethyle.

[This Valerianic acid and series of its salts, have been manufactured by the exhibitor, in the laboratory of Messrs. Savory & Moore, New Bond Street. Valerianic acid was discovered some years since, by Prince Lucien Buonaparte, and by him successfully introduced into medicine. It is of considerable interest to the chemist from the fact of its having been artificially prepared by M. Dumas, by acting upon amylic alcohol (oil of corn spirit) with caustic potash.

The valerianic acid is naturally contained in the volatile oil obtained by the distillation of the *valerian root*, in very small proportions. The same acid, however, may be produced artificially, by the indirect oxidation of the fusel-oil separated from crude spirits in the process of rectification, which is the cause of the whisky flavor of grain spirit before rectification. The fusel-oil is heated with a large proportion of caustic potash, when hydrogen is disengaged and valerianate of potash remains. The acid is easily separated from the remaining valerianate of potash by distillation with sulphuric acid.

This offers a beautiful and striking example of the artificial formation of an acid naturally formed by the process of vegetation of the officinal valerian. It has the same composition and properties as the latter, and may therefore be advantageously substituted for it in all pharmaceutical preparations.

The valerianates comprised in the series exhibited, were prepared with the artificial acid and obtained by oxidising the amylic alcohol with chromic acid; it is a colourless oily fluid, having a peculiar and disagreeable odour, and possesses all the properties and qualities of that which is obtained from the root of valerian; it forms soluble salts with bases, which are distinguished by the disagreeable smell of the acid, and also by a sweetish taste. The first specimen in the series consists of the pure acid; then follow the salts, being twenty-three in number, namely,—those of potash, soda, ammonia, baryta, strontia, lime, magnesia, alumina,

chromium, nickel, cobalt, manganese, sesqui-oxide of iron, zinc, silver, sub-oxide of mercury, bismuth, copper, cadmium, antimony, quinine, morphia, and the oxide of ethyle (valerianic ether). Of these the potash salt resembles phosphorus in appearance, is soft like it, and when cut has a waxy lustre, is deliquescent, and when struck with any hard body produces a peculiar metallic sound, somewhat like that occasioned when a ball of camphor is struck in a similar manner. The valerianate of soda is in masses made up of small crystals and is deliquescent. The valerianate of ammonia, also in crystals, and likewise deliquescent; of baryta, and of strontia also crystalline; of lime in crystalline scales; of alumina as a white powder; of chromium as a grey, of nickel as a green, and of cobalt as a beautiful peach-coloured powder; of manganese in fine rose-coloured scales; the per salt of iron, orange yellow, pulverulent, and soluble in alcohol; zinc as a granular crystalline powder; silver as a grey, mercury and bismuth white powders; copper blue and pulverulent; cadmium in white crystalline scales; antimony white and pulverulent; quinine, in no definitely formed crystals; morphia, in fine tufts of acicular crystals. The valerianic ether is a colourless fluid of a penetrating and disagreeable odour, its specific gravity is 0.894. Of the foregoing the valerianates of zinc, iron, and quinine have been the most extensively and the most advantageously used in medicine, and there exists no doubt but that those of potash, soda, ammonia, bismuth, oxide of ethyle, and other bases may be also very beneficially employed by the physician.]

46 PARROTT, W., 7 *Cleveland Street*—Producer.

Illustrations in oil and water colour, of an intense and semi-transparent brown colouring substance, derived from the smut of corn.

47 WOOD & BEDFORD, *Leeds*—Manufacturers.

Specimens of the varieties of lichen used in the manufacture of cudbear, orchi and litmus, including *Roccella fuciformis*, *Roccella tinctoria*, *Ramalina farinacea*, *Parmelia perlata*, *Parmelia tartarea*, *Umbilicaria pustulata*, and *Gyrophora murina*.

Substances obtained from the preceding, by chemical analysis, including erythric, lecanoric, and roccellic acids, picro-erythrine, orctine, and ashes of *Roccella fuciformis*. Specimens of cudbear and orchil, and of their applications in dyeing and staining.

[Chemists have shown the presence of a variety of singular chemical principles in lichens used by the dyer. The colouring principles are *Orcine*, *Erythrine*, *Vulpuline*, *Strychnochromine*, *Lecanorine*, *Umine*, &c. The colouring matter is used largely by the dyer, and by the chemist for the preparation of test-papers.—R. E.]

48 BLUNDELL, SPENCE, & Co., *Hull*, and 9 *Upper Thames Street*—Inventors and Manufacturers.

Brunswick or chrome greens, of various tints and shades, used in oil painting and paper-staining.

Greens.—For painters, paper-stainers, &c., having a base of copper, viz., emerald green, green verditer, mineral greens, &c., &c.

Blues.—Chinese, Prussian, refiners, verditers, ultramarine, &c.

Ochres.—Yellow, red, brown, &c.

Yellows.—Chromes, all shades, King's yellow, patent yellow, Dutch pink, &c., &c.

Reds.—Red chrome, mineral and vegetable reds.

Lakes.—Carmines. Lakes of all colours and shades.

Browns.—Vandyke brown, umbers, terra de Sienna, York brown, &c.

Blacks.—Vegetable, animal, and mineral.

Whites.—Oxide of zinc, Cremlits white, flake white, enamel white, satin white, Paris white, barytes (sulphate and carbonate), &c.

Leads.—Red, orange, grey, black, white (carbonate). White lead (oxi-chloride); a new invention, patented by H. L. Pattinson, Esq., of Newcastle-upon-Tyne.

Paints ground in oil, of every colour and variety of shade. Zinc white paint.—Unaffected by sulphurous gases, employed for a delicate dead white oil paint. Also a specimen of new drying oil, which assists its drying without impairing the delicacy of colour. Permanent and Paris green paints. Brunswick green paint. Metallic red paint. Anti-corrosion, of all colours and shades. Stucco paint, an oil paint used with water; invented by the exhibitors. Patent dryer. Composition for ships' bottoms. Oils.—Linseed oil, raw, refined, and boiled. Rape oil.—Brown, refined for locomotive engines, and double refined for burning in lamps.

Varnishes for coachmakers.—Body, carriage, filling, black japan.

Varnishes for painters.—Oak, mahogany, black japan, furniture, japanners' gold size, quick-drying copal for furniture. Mastic or picture. White hard spirit. Paper varnish. Turpentine varnish.

Green varnish for Venetian blinds, &c.  
Black varnish for ships and iron work.  
French polish.

49 BANKART, F., *Swansea*—Producer.  
Crystals of sulphate of iron.

50 GODSON, SEPTIMUS H., *Tenbury, Worcestershire, and Rutland Gate, London*—Proprietor.

Samples of native mineral waters.  
These mineral waters concentrated and tested, to show their mineral constituents.

A phial showing the bromine present in the waters, extracted by ether, and floating in it.  
A phial with salts found in the Tenbury mineral water.

51 DINNEFORD & Co., *172 New Bond Street*—Inventors and Manufacturers.

Specimens of magnesia minerals, and chemicals.  
Samples of Dinneford's pure fluid magnesia.

[The principal minerals, of which magnesia forms an important part, are the sulphate (Epsom salts), the carbonate (magnesite), the silicate (meerschaum, talc and serpentine), and the carbonate of lime and magnesia (dolomite). From any of these may be obtained the hydro-carbonate much used in pharmacy (*magnesia alba*), and also the earth *magnesia* (prot-oxide of magnesium); but they are chiefly manufactured either from the carbonate or sulphate.—D. T. A.]

52 SCHILLING & SUTTON, *Brighton*—Manufacturers.  
Samples of soda, Seltzer, and Fachingen water.  
Effervescing lemonade.

52A STRUVE & Co., *Royal German Spa, Brighton*—Manufacturers.

Artificial mineral waters, of similar composition to the springs at Spa, Pyrmont, Marienbad, Kissingen, Seltzer, Fachingen, Pullna, and Vichy. The factitious chalybeates are said to contain the carbonate of iron in solution, whereas in those imported, a part, or the whole is precipitated.

53 KANE, WILLIAM JOSEPH, *Dublin*—Manufacturer.

Specimen of salt cake (sulphate of soda), made in brick furnaces, with complete condensation of the muriatic acid evolved.

Specimen of bleaching powder, made from the muriatic acid condensed.

[Bleaching powder is procured by exposing, in a stone chamber, powdered hydrate of lime, or slaked lime, to the fumes of chlorine gas, developed from a mixture of bin-

oxide of manganese, chloride of sodium (common salt), and diluted sulphuric acid. After an exposure of certain length, the lime absorbs, and appears to combine with the chlorine, which it afterwards retains. It is, therefore, valuable for all purposes where the powerfully bleaching effects of chlorine are required, and is employed in vast quantities in the calico bleach-works, and similar establishments for the bleaching of linen and other goods.—R. E.]

Specimen of iron pyrites (bi-sulphuret of iron), from Messrs. Williams and Sons' Tigronev Mines, county Wicklow, Ireland.

Specimen of manganese ore, containing 90 per cent. of per-oxide of manganese, from Glاندore Mines, county Cork, Ireland.

54 WARD, SMITH, & Co., *Glasgow*—Manufacturers.

Iodine. Muriate of potash. Sulphate of potash. Alkali salt.

55 FOWLER, JOHN, *35 Bedford Street, Covent Garden*—Chemist.

Specimens of pure benzoic acid.

56 LAWRENCE, WILLIAM, *163 Sloane Street*—Manufacturer.

Specimens of cod-liver oil.

57 BROWN, FREDERICK, *12 Ecolston Place, Pimlico*—Patentee and Manufacturer.

Colours manufactured from the oxide of zinc, applicable for painting in distemper, on porcelain and boards, for paper staining, and for oil-cloth.

The qualities of these paints are stated to be their freedom from noxious properties, their permanency, and economy. They are not acted upon by gases. Specimen board painted with various colours in zinc paint.

58 ELLAM, JONES, & Co., *Markeaton Mills, Derby*—Manufacturers.

Emery—Granular rhombohedral corundum-stone, from Naxos, in Asia Minor: consisting of alumina, 86.0; silica, 3.0; oxide of iron, 4.0; and crocus (oxide of iron), for polishing fine steel and plated ware.

Mineral and vegetable colours (native and manufactured).

Mineral—sulphate of barytes, carbonate of barytes, carbonate of lime, aenite, cannel coal, mineral white, mineral black, blue-black, lapis calaminaris, dream ochro, gold ochre, mineral yellow, metallic red, umber, white rotten-stone, brown rotten-stone, bole armeniac.

Vegetable colours—Dutch pink, English pink, Brunswick green, Saxon green, Derby red.

59 RUSSELL & ROBERTSON, *Omoo Foundry, Holytown, Lanarkshire*—Inventors.

Specimens of white-lead paint, or ceruse, yellow chromate of lead, and red di-chromate of lead; manufactured by a new process, and solely in the humid way.

The usual mode of converting blue lead into white lead, by the action of acetic acid, occupies six weeks or two months, whereas by the new process the same end is attained in one day, without endangering the health of the workmen.

[White lead is the well-known pigment, which when ground in linseed oil is used in house painting. It is a carbonate of lead, generally containing hydrated oxide of lead, which is sometimes combined in the proportion of one atom of hydrated oxide to two of carbonate of lead. The most usual method (the Dutch) of manufacturing white-lead is likewise the oldest. It consists in exposing lead to the joint action of acetic acid vapour, moist air, and carbonic acid gas. The lead is cast in the form of stars or gratings, and supported a little above the bottom of earthen pots (in shape like garden pots), into each of which a small quantity of weak acetic acid is placed. The



pots are then built up in alternate layers, with spent tanner's bark, until a stack is formed; each layer of pots being covered with boards. The fermentation, which soon takes place in the tan, serves the double purpose of furnishing carbonic acid, and raising the temperature of the stack, which reaches 140° Fah. After a lapse of six or eight weeks the metallic, or blue lead, as it is called, is converted into porcelain-like masses of white lead, which are levigated in water, washed and dried. About 16,000 tons are annually made in England by this process. A very small quantity of acetic acid suffices for the conversion of a large amount of metallic into white-lead; as, after it has combined with a portion of lead oxide to form neutral acetate of lead, this salt dissolves another atom of lead oxide, which is removed by the carbonic acid as carbonate of lead, and the neutral acetate set free, again to take up a fresh portion of newly-formed oxide of lead, produced by the action of the air on the metallic lead. Most of the new processes depend on similar reactions, with this difference, that oxide of lead (litharge) is employed instead of metallic lead: it is either made into a paste, with a small quantity of acetate of lead and water, or else dissolved either in a solution of neutral acetate, or neutral nitrate of lead, and submitted to the action of carbonic acid, produced by the combustion of coke or charcoal, which precipitates the dissolved litharge, leaving the acetate or nitrate at liberty to dissolve fresh portions. Another of the new plans consisted in precipitating a neutral salt of lead (the nitrate, for example) with an alkaline carbonate.—W. D. L. R.]

60 JOHNSON, J. R., 12 *Bankside*—Inventor.

Extract of muneet. Patterns of calico printed and dyed with the extract. Extract of madder. Patterns printed "topically" with the extract. Exhibited to illustrate a new process of extracting, economically, the colouring principle of the Rubiaceae.

Printed calicoes, to illustrate a new process of madder dyeing, which is intended to replace garanine.

Pieces of calico printed topically with extract of madder.

[Extract of muneet, or muneeth, is obtained from the roots of *Rubia cordifolia*, an East Indian plant. It is imported into England from Calcutta. It is not so largely used as madder, which is furnished by the roots of another plant allied to *Rubia cordifolia*. The colour produced is said not to equal that of madder in brilliance and permanence.—R. E.]

61 SCOTT, LANGSTON, 41 *Moorgate Street*—Manufacturer.

Large vase and small glasses containing white oxide of zinc.

Various small painted boards.

Patent white zinc is principally used for house-painting in lieu of white-lead as being less noxious; but may be applied in the manufacture of crystals, paper-staining, card-enamelling, bleaching of lace, glazing of ware, for the down of artificial flowers, &c. It possesses great whiteness, gives a fresh tone to all colours, renders the paint or material prepared impervious to the action of gases, damp, &c., reflects artificial light, and preserves the materials. It is produced by destructive distillation, from zinc ore, or spelter, which is principally imported in large flat slabs from Silesia, Galicia, and Prussia; Russia, Belgium, and China. send smaller supplies; the great European depot is Hamburgh.

[Oxide of zinc is now largely employed instead of ceruse, and is much less noxious than that preparation of lead.—R. E.]

62 DAVY, MACKMURDO, & Co., *Bermondsey*—Manufacturers.

Samples of carbonate of ammonia; corrosive sublimate;

salomet; benzoic acid; citric acid; gallic acid; oxalic acid; salt of sorrel; acetate of zinc; nitrate of silver; chloride of barium; nitrate of baryta; tartar emetic crystals; sulphite of soda; nitrate of ammonia; acetate of lead; glycerine; blauphate of mercury; red precipitate; calomel in powder.

63 DAUPTAIN, GORTON, & Co., 17 *Wharf Road*, *City Road*—Manufacturers.

Four samples of ultramarine.

64 ESTCOURT, SAMUEL, 2 *Green Terrace*, *New River Head*—Inventor and Manufacturer.

Sample of refined Indian blue, for the laundry.

65 COPPOCK, JOHN, *Brickport*—Inventor.

A chemical liquid for imparting the colour of mahogany and rosewood to common woods. A specimen of the prepared wood, polished, with a bottle containing the liquid; the sides of the block are left unstained, to show the natural wood.

[The liquid commonly employed for staining wood so as to communicate to it the appearance of antiquity is a caustic solution of potash. The same effect is also produced by the use of soap leys, simply in consequence of the free alkali contained in that liquid. Other chemical fluids are likewise used for the same purpose.—R. E.]

66 BELL, GEO., & Co., 2 *Wellington Street*, *Goswell Street*—Manufacturers.

Mineral paints, which quickly dry under water, and on metals exposed to extreme heat. They are suitable for ships' bottoms, or for damp walls.

67 LEIFCHILD, J., *High Hill Ferry*, *Upper Clapton*—Producer.

Specimens of dyes for silk.—Carmine from safflower, blue from indigo, and blue from prussiate of potash.

[Safflower is yielded by a plant known botanically as *Carthamus tinctorius*, belonging to the *Asteraceae*. The flower is alone used in dyeing. The plant is an annual, cultivated in Egypt, the Levant, &c.—R. E.]

68 MARSHALL, JOHN, *Leeds*—Manufacturer.

Nos. 1, 2, & 3. Acid and neutral extracts of indigo.  
4 & 5. Carmine and liquid extract from purified indigo.  
6. Refined indigo.

[Indigo is the produce of plants belonging chiefly to different species of indigo-tree; it is also obtained, to a smaller extent, from others. The state in which it exists in the juice of these plants is not well understood. It appears to be in the form of a colourless, soluble compound, and is generally obtained by fermenting the bruised plant, during which ammonia is evolved, and a yellow liquor obtained, which, on the addition of lime-water, and exposure to the air, deposits the insoluble blue substance called indigo. For the purposes of dyeing, the indigo is dissolved in sulphuric acid, with which it forms a distinct chemical compound.—E. F.]

7 & 8. Red and blue orchil paste.

9 & 10. The same, of medium quality.

11 & 12. The same, of fine quality.

13 & 14. Red orchil liquor for silk dyeing.

15 & 16. Concentrated red and blue orchil liquor.

17 & 18. Cudbear.

19 & 20. The same, of good and best quality.

21 & 22. Violet carmine, and best concentrated cudbear.

23, 24, 25, & 26. Valparaiso, Angola, Madagascar, and Cape de Verd orchella weed.

[These substances are prepared from various lichens, amongst which the *Rocella tinctoria*, *R. coralina*, *Lecanora*

*tartarea*, *Vartolaris lactea*, and *V. dealbata*, have been especially resorted to. These lichens are found on rocks on the sea-coast. The modes of treating them for the manufacture of the different dyes is the same in principle, though varying slightly in detail. They are carefully cleaned, and ground into a pulp with water, an ammoniacal liquor is from time to time added, and the mass constantly stirred, in order to expose it as much as possible to the action of the air. Peculiar substances existing in these plants are, during this process, so changed by the combined action of the atmosphere, water, and ammonia, as to generate the colouring matter, which, when perfect, is pressed out, and gypsum, chalk, or other substances are then added, so as to give it the desired consistency; they are then prepared for the market under the forms now exhibited.—E. F.]

27, 28, 29, 30, 31, 32, 33, & 34. Ground lac-dye.—K, OO, O, A (medium quality), D (medium quality), G (good quality), H (fine quality), and I (finest quality).

35. Essence of lac-dye.

[The lac-dyes are prepared by extracting the peculiar colouring matter of the "stick-lac" of commerce. This latter is a resinoid substance, the result of a secretion of several different plants—the *Ficus Indica*, *F. religiosa*, *Croton lacciferum*, and others—occasioned by the punctures of a small insect (the *Coccus flos*) made for the purpose of depositing its ova. The branches become encrusted with a reddish-coloured concretion, which consists of the inspissated juice of the plant, imbued with a peculiar colouring matter derived from the insect. The preparation of them is usually carried out in India, the remaining substances, seed-lac and shell-lac, being also articles of commerce. The colouring matter, or dye, is extensively used as a substitute for cochineal.—E. F.]

36. Ground Bengal turmeric.

[Prepared from the roots of the *Curcuma longa*. Used as a dye, and also as a condiment.—E. F.]

Specimens of 36 kinds of European and native manufacture of lac-dye in India.

60 LEE, CHARLES, 119 *Lower Thames Street, City*—Importer.

Newly-invented black dyeing material, for dyeing silk.

70 DAVIES, JOHN, *Cross Street, King Street, Manchester*—Inventor and Manufacturer.

Preserved size, clear and strong, for any climate; suitable for carvers and builders, bounnet-makers, paper-hangers, and varnishers.

71 LAMPLUGH, HENRY, 83 *Snow Hill*—Inventor and Proprietor.

1. Sootrine Aloes, obtained from *Aloes perfoliata*.
2. Common Aloes, from *Aloes Barbodensis*.
3. *Smyrna Opium*, from *Papaver Somniferum*. Nat. Ord.—Papaveraceae.
4. Myrrh, from *Balsamodendron Myrrha*. Nat. Ord.—Bursaraceae.
5. Russian Castor, from *Castor Feber*. Class.—Mammalia. Order.—Rodentia.
6. Aleppo Scammony, from *Convolvulus Scammonia*. Nat. Ord.—Convolvulaceae.
7. Brown Annulated Ipeacuanha, from *Cephaelis Ipeacuanha*. Nat. Ord.—Cinchonaceae.
8. Red Annulated Ipeacuanha.
9. Rhubarbs—English Rhubarb.
10. Dutch Trimmed Rhubarb.
11. Chinese or Indian Rhubarb.
12. Russian Rhubarb.

Residual salts from the destructive decomposition of animal substances. Specimens of chlorophosphate of soda

and potash; of effervescent salts; of crystals of prussiate of potash; and of sulphate of iron.

Specimen of Prussian blue.

72 COULSON, JAMES, & Co., 12 *Clements Lane, Lombard Street*—Proprietors.

Mineral substances used for the manufacture of paint; in their natural state, and pulverised.

73 FRACOCK, GEORGE, *Southampton Docks*—Inventor.

New description of metallic paint or composition, named "Anti-Burgasian," for protecting the bottoms of ships, &c., from the attack of the "Teredo-navalis;" preserving iron and copper sheathing from wear or fouling, and preventing wood from decay, with specimens of iron, wood, and copper, in the protected and unprotected state.

[Those substances which prevent the decay of wood by chemical means, are generally such as combine with its nitrogenous principles, and in such a manner as to prevent or retard those principles from undergoing putrefactive change. Experience has fully proved the fact that the ordinary duration of unprepared wood exposed to causes of decomposition varies with different kinds, but that decay ultimately takes place in all. By the saturation of timber with different fluids, it is possible to avert or defer considerably these changes, and to communicate to the wood a durability far exceeding that originally possessed by it.—E. E.]

74 STEPHENS, HENRY, 54 *Lower Stamford Street, Blackfriars*—Inventor and Proprietor.

Samples of wood stained by the colour manufactured by the exhibitor, intended to show that deal or other woods may be ornamented, and the beauty of the natural graining exhibited to the best effect, thus saving the expense of painting and graining.

75 HAYES, P., & Co., *Salford*—Manufacturers.

Rosin in the raw state. Spirits extracted from rosin, used for making varnish. Refined rosin oil, for coarse machinery, ships' masts, &c. Common rosin oil, for tramways, &c.

Pine tallow, manufactured from rosin, for railways. Pitch. Rosin acid. Pine varnish made from rosin, for vessels.

76 DUNCAN, WILLIAM L., *Sydenham, Kent*—Inventor and Producer.

Cotton waste, used for cleansing purposes by railway and steam navigation engineers, &c.

Sample, in its dirty state, after having been used for railway purposes.

Cotton waste after a cleansing process, by which it is again reclaimed to its original value and usefulness.

77 MASON, MRS. BETSKY, 38 *Doughty Street, Mecklenburgh Square*—Inventor.

Pooloo's Chinese cement, for repairing china, glass, porcelain, marble, all kinds of wood, jewellery, musical instruments, furniture, and metals; useful to the manufacturer of and dealer in all goods, in the construction of which an adhesive composition is employed, especially for their repair. It is impervious to warm or cold water, and will resist the effects of intense heat. It also possesses the advantage of being perfectly clean, and free from any unpleasant smell.

Specimens of articles repaired by the cement.

[The cement commonly used for joining broken china and glass is composed of isinglass soaked in water till it is soft and then dissolved in alcohol; to this is added a little solution of gum resin, ammonia, or galbanum and resin mastic, also in alcohol. When applied, it has to be gently heated to liquify it.—D. T. A.]

78 HUMFREY, C., *Furness Place, Southwick*—Inventor and Manufacturer.

Colours produced by the combination of fatty acids with metallic oxides and peroxides. Candles and refined fatty matters.

79 DICKSON, GEORGE, & CO., 43 *Dundas Street, Edinburgh*—Manufacturers.

Medicinal cod-liver, ling-liver, and skate-liver oils. Used in cases of pulmonary consumption, asthma, lumbago, rheumatism, glandular swellings, and all diseases of a scorbutic or strumous nature.

[Cod-liver oil has been long employed in the arts, but its use in medicine is recent. It has been given very extensively within the last two years in a variety of diseases. It appears to be principally efficacious in tuberculous affections, in the treatment of which many other remedies are often employed without success.—R. E.]

Cod-liver ointment. Ninety per cent. of the constituents of the oil is contained in this ointment.

80 BREAREY, WM. ARTHUR, *Douglas, Isle of Man*—Inventor.

Refined oil. Pure oleine, for watches, clocks, chronometers, fine machinery, and instruments; free from acid or mucilage; not affected by change of temperature, and having no chemical action on metals.

[For some purposes in the arts it is necessary to separate oil into its proximate constituents, *elaine*, or *oleine* and *stearine*. The former is the fluid portion, the latter the solid part which separates, at low temperatures, from the oleine. The separation is effected by cold and pressure.—R. E.]

81 ROBERTSON, W., *Banff, Scotland*—Manufacturer.

Cod-liver oil, manufactured by the exhibitor. Extracted by steam-heat, and rendered almost colourless, without the use of charcoal or any other decolourising agent. Manufactured at the various fishing villages along the coast of the Moray Firth.

Skate-liver oil. Manufactured by the same process. This article is more difficult to obtain. Change of temperature scarcely affects it. By some it is preferred to cod-liver oil.

Sulphate of baryta and chloride of barium.

[Chloride of barium is a crystalline compound of chlorine and barium, soluble in water. Its solution produces a white insoluble precipitate of sulphate of baryta in sulphuric acid and solutions of sulphate; hence its use as a chemical re-agent for the detection and quantitative determination of sulphuric acid in analysis.]

Sulphate of baryta (permanent white), is a compound of sulphuric acid and oxide of barium; artificially prepared, it is extensively used as a pigment for water-colouring, but has not sufficient body to be employed as an oil paint. The native sulphate of baryta is used as an adulterant of white lead paint.—W. D. L. R.]

82 LINKLATER, J., 5 *Stoney Street*—Producer.

Specimens of cod-liver oil.

83 OWEN, CHARLES, *Edinburgh*—Manufacturer.

Specimens of pure cod-liver oil.

84 KING, WILLIAM WAUDEY, *Soho Street, Liverpool*—Manufacturer.

Effervescent citrate of magnesia, manufactured by the exhibitor.

This article is exhibited as an agreeable and efficient saline aperient, adapted for family use, for travellers and residents in warm climates, and as an economical medicine in general. Mixed with cold water it forms a pleasant effervescent draught equal to soda water or lemonade.

85 BURT, STEPHEN JOHN, 26 *Farringdon Street*—Proprietor.

Cantharides (*Cantharis vesicatoria*), imported from Russia.

Cantharidine, the active principle of the cantharides, alone, and in combination with alkaline and other bases. Cantharidine and potassa. Cantharidine and soda. Cantharidine and lead.

[The *Cantharis vesicatoria* of pharmacy is an insect belonging to the order *Coleoptera*, or beetles. Sicily, Spain, and Astracan are sources of our supply. In the present instance Russia has furnished the insect, and there is a large annual importation from that country. The Russian insects are larger than those of other countries. Cantharidine is obtained from an alcoholic tincture of the powdered insect, and possesses in an intense degree the blistering properties of the powdered cantharides.—R. E.]

86 HUBBISON, J., W. & H., 77 *Swinton Street, Gray's Inn Road*—Manufacturers.

Crystals of the following chemical substances:—

1. Bi-carbonate of soda.
- 2, 3. Rochelle salts, refined and unrefined.
4. Iodide of potassium.
5. The same, commercial.
6. Iodide of lead.
7. Bin-iodide of mercury.
8. Iodide purified.
- 9, 10. Tartaric acid and citric acid crystals.
11. Acetate of zinc.
12. Sulphate of potash crystals.
13. Purified sulphate of zinc.
14. Phosphate of soda.
15. Sulphate of iron crystals.
16. Carbonate of soda.
- 17, 18. Purified nitrate and bi-carbonate of potash.

87 MURRAY, SIR JAMES, M.D., *Monkstown, Dublin*—Inventor.

Bi-carbonate of magnesia, dissolved in distilled water; free from impurities. Specimen of fluid omphar and magnesia. Carbonate of magnesia in crystals, a dentifrice.

88 STURGES, JOSEPH, *Kettering*—Inventor.

Preparation for preserving the turnip plant from the ravages of the fly.

[The turnip-plant often suffers in its earliest growth, from the attacks of a small beetle, called the *Haltica nemorum*, which devours its cotyledon leaves, and thus arrests its further growth. A fine tilth and plenty of good manure generally ensure such a vigorous growth that the plant is enabled to throw out its second pair of leaves before any serious injury has been sustained.—J. W.]

A proposed remedy for the smut in wheat, and also a preventive from the ravages of the slug, grub, and wire-worm.

89 WARD, JOHN, *Ramelton, County Donegal*—Producer.

Specimens of kelp manufactured from sea-weed.

Iodine, muriate of potash, sulphate of potash, and alkali salt; all manufactured from kelp.

90 KENT, JAMES HENRY, *Stanton, near Bury St. Edmunds*—Inventor and Manufacturer.

Dried pharmaceutical indigenous plants, in glass vessels, the lower parts of which exhibit the plants prepared for pharmaceutical purposes, and the upper portions of some of which display the botanical characters of the plants.

Powdered conium, digitalis, and other indigenous pharmaceutical plants.

Dried roots of indigenous pharmaceutical plants.

Dried immature poppyheads, and extract made from the same.

Specimens of pharmaceutical extracts, prepared from indigenous plants.

[The plan commonly practised for preparing herbs is as follows:—The herb collectors in the country put both stalks and leaves of the medicinal plants in bunches to dry on kilns. These bunches are afterwards hung up in the herbalists' shops, and exposed to the decomposing effects of light and of the atmosphere.

The present plan is to reject all the stalks and dead leaves of the plants, to collect them fresh, and dry them immediately in a room heated with currents of pure air, and preserve them in glass or tin vessels free from the access of light and air. They will keep thus for an indefinite period of time.—R. E.]

91 TRUMAN, HANBURY, & BUXTON, 174 Brick Lane, Spitalfields.—Producers.

Malt and hops of various qualities, exhibited in the proportions used in brewing one gallon of porter and one gallon of ale, of medium strength.

[Some conception of the quantity of hops annually produced in Great Britain, principally in Kent, Sussex, Worcester, and Hereford, may be obtained from the fact that in 1842, the duty (2d. per lb.), amounted to 200,078*l*. The plant belongs to the same natural family as hemp, *Cannabaceae*. Its botanical name is *Humulus lupulus*.

Of malt, the year 1842 produced in England and Wales, alone, nearly 31,000,000 bushels, the duty on which amounted to 4,176,742*l*.—R. E.]

92 GODFREY & COOKE, 31 Southampton Street, Covent Garden, and 30 Conduit Street.—Manufacturers.

Carmine, the colouring matter of cochineal (*Coccus cacti*). Lake, from cochineal, soluble in alkalies and ammonia. Oxide of bismuth. Carbonate of ammonia, the basis of smelling salts, spirit of sal volatile, &c. Oil of amber. Salt of amber. Artificial musk, and tincture of artificial musk. Watchmakers' oil, for fine machinery. Spirit of sal volatile. Essence of ambergris. Tincture of myrrh, and sundry drugs and chemicals.

[The beautiful pigment, *Carmine*, is a result of the precipitation of an infusion of the cochineal insect (*Coccus cacti*) in water, by means of alum. The carmine of commerce is so costly an article, that it is seldom to be met with in a state of purity. Pure carmine dissolves in ammonia. It is said, by some manufacturers, that a bright and clear state of the atmosphere is necessary to the preparation of carmine of the most brilliant colour.—R. E.]

93 SQUIRE, PETER, 277 Oxford Street.—Inventor and Manufacturer.

A variety of pharmaceutical extracts and preserved juices of medicinal plants. Liquor of taraxacum (dandelion). Solution of bi-meconate of morphia. Fluid extract of Jamaica sarsaparilla. Cod-liver oil. Red rose leaves (dried without heat). Fine crystals of red ferro-prussiate of potash. Large perfect crystals of yellow ferro-prussiate of potash.

[Pharmaceutical extracts were, for a considerable period, the most fallacious of all medicinal preparations. The high temperature to which they were subjected in the manufacture destroyed the active principle sought to be concentrated. Of late they have been prepared, in some instances, by evaporation in the cold; a current of air being driven over the surface of the liquid. They are also safely obtainable by using an apparatus similar to that employed in the sugar manufacture.—R. E.]

A chloroform and ether inhaler. An apparatus for preparing infusions.

94 SMITH, T. & H., 21 Duke Street, Edinburgh, and 69 Coleman Street.—Inventors and Manufacturers.

Specimens of aloine, the cathartic principle of the aloes, discovered by the exhibitors in 1850; of gallic

acid, in crystals; of crystallised mannite, extracted from dandelion root; of crystallised mannite, extracted from monkshood root, also discovered by the exhibitors in 1850; and of cantharidine, in crystals, the blistering principle of the Spanish fly, one part being equal to 400 parts of the powder of Spanish flies.

95 BASS, JAMES, 81 Hatton Garden.—Inventor.

Specimens of concentrated medicinal infusions and decoctions, intended to obviate the inconveniences connected with infusions and decoctions as usually prepared.

[The infusions of medicinal substances prepared in the ordinary way are extremely liable to decomposition, and soon become covered with fungi. The concentration of such infusions in a form in which they can be preserved for some time is consequently of importance. The preparations are used medicinally by dilution with water; the infusions in their concentrated form preserving a degree of strength above that which it is advisable to adopt for medicines in their administration.—R. E.]

96 McCULLOCH, CHARLES, Covent Garden Market.—Producer.

English and American herbs and roots.

97 TUSTIAN, J., Melcombe, near Banbury.—

Manufacturer.

Petals of the red rose. Confection of the red rose. Extract of henbane.

98 TUSTIAN & USSER, Melcombe, near Banbury.—Manufacturers.

English rhubarb, trimmed and untrimmed, and in powder.

[Many attempts have been made to cultivate in Europe the rhubarb plant for the sake of its medicinal roots. In France, more especially, a place called Rheumpoli has been the scene of a great experiment in this culture; and in the like manner Banbury, in Oxfordshire, has long been celebrated in the source of English supply. All these European rhubarbs have been found very inferior to that imported from Asia, the natural country of the drug.—J. L.]

99 JENNINGS, H. C., 97 Leadenhall Street.—Producer.

Starch, gums, and vegetable wax, from potato and wheat starch.

100 HOPWOOD, HENRY, Richmond, Surrey.—Proprietor.

Sugar of milk, crystallized in the usual manner; and crystallized at a temperature of 120° Fahrenheit, in the dark.

101 TENNANT, M. B., Brighton.—Producer.

A chemical production for labels or artists' designs, a product of a silvery hue to be thrown over drawings of every description by means of chemical agency said to be hitherto unknown.

102 KEATING, THOMAS, 79 St. Paul's Churchyard.—Importer.

Kuosso, from Abyssinia (*Brayera anthelmintica*).—The blossom of a tree 20 feet high, the native remedy so much esteemed for the removal of tape worm.—Discovered by Dr. Brayer.

Sarsaparilla, from Paraguay (*Smilax Papyracea*).—The finest species of sarsaparilla known. The product of which has been found to possess valuable medicinal properties, especially in its direct efficacy on the system, in the cure of a number of chronic complaints. Introduced by Dr. H. Scott.

Radix Jalape and Croci in Fomo, from Asia Minor.—Exhibited as the first medicinal products of these species imported from that country.

Matico.—The new medicinal styptic, and vegetable astringent; efficacious in the suppression of hæmorrhage from wounds, leech bites, dysentery, diarrhoea, and the



dangerous prognosis of cholera, introduced by the late Dr. Jeffry, of Liverpool.

103 WATTS, JOHN, 107 *Edgware Road*—Manufacturer.

*Daphne Mezereum*, bark of the root and stem. *Daphne Laureola*, bark of the root and stem. Cod-liver oil, made without water. Oleine of cod-liver oil. Tincture of hops, made with home-dried hops; and made with kiln-dried hops. Hydrochlorate of morphia, pure, in crystalline mass.

The following extracts are prepared in open vessels, at a temperature of from 110° to 130° Fahrenheit:—Acetic extract of colchicum, from the fresh corms. Extract of gentian, from the dried root. Pure aqueous extract of aloes, from hepatic aloes. Extract of deadly night-shade, from the flowering plant. Extract of liquorice, from the fresh root. Extract of Turkey rhubarb, from the dried root. Extract of fetid goosefoot, from the flowering plant. Extract of hemlock, from the flowering plant. Elaterium, from the fresh fruit when nearly ripe. Inspissated ox-gall. Extract of henbane, from the flowering biennial plant. Extract of white poppies, from the fresh capsules. Extract of dandelion, from the fresh roots monthly, from October to February. Powdered hemlock, the leaves of the flowering plant. Powdered foxglove, the leaves of the flowering plant.

104 DUNCAN, FLOCKHART, & Co., *Edinburgh*—Manufacturers.

Specimen of chloroform.

[The inestimable results which have attended the introduction of the anæsthetic or painless mode of operating in surgery, renders the principal medical product employed highly interesting. For this purpose it is inhaled from various forms of apparatus, and the inhalation is continued at intervals during the period of operation. Chloroform is obtained by distilling alcohol with a solution of chloride of lime. Its peculiar fruity odour has also rendered it available for the production of artificial fruit essences.—R. E.]

105 LEA, ALFRED, 150 *Oxford Street*—Inventor.

Specimen of myrrhine, a preparation for medical use.

106 MORSON, THOMAS N. R., & SON, 19 *Southampton Row*, and *Hornsey Road*—Manufacturers.

Specimens of crystallized salts of morphia, strichnine, cinchonine, with the pure alkaloids from which they are obtained, of pure aconita and veratric, gallic, tannic, and meconic acids, pyro-gallic and pyro-meconic acids, kreosote, &c.

[To the chemist the preparations known as alkaloids, or vegeto-alkaloids, present many features of peculiar interest. They are also of the highest medicinal importance, acting, as many of them do, with extraordinary power over the animal economy, and supplying to the physician remedies of such energetic action as to enable him, in many cases, to reduce the bulk of medicine from an inconvenient and uncertain, to a convenient form. The crystallization of the vegeto-alkaloids is peculiarly beautiful, and their chemical constitution is extremely complicated. Morphia, quina, strychnia, and brucia, are among these peculiar products, and possess intense medicinal energies.—R. E.]

107 MACFARLAN, JOHN FLETCHER, & Co., 17 *North Bridge*, *Edinburgh*—Manufacturers.

Series illustrative of the manufacture of the salts of morphia, embracing opium, impure muriate of morphia, pure muriate, and sulphate of morphia.

Specimens of gallic and tannic acids, embracing galls; tannic acid, impure and pure; gallic acid, impure; commercial, pure.

Specimens of sulphate of bebeerin, from green-heart bark, embracing the bark, and impure and commercial sulphate and of the alkaloid.

[Green-heart bark is yielded by the *Bebeeru* tree of Guiana. Its active principle, bebeerin, is employed in the form of sulphate, as a febrifuge tonic.—R. E.]

108 POUND, MATTHEW, 198 *Oxford Street*—Importer and Manufacturer.

Imports from Calcutta: Indian bael, bela, bliva, matura; the sliced and dried half-ripe fruit of the *Ægle Marmelos*, a native of the East Indies, more particularly the Malabar coast; a perfect ripe fruit also accompanies it. Extract of bael; combining all its properties, soluble both in spirit and water. Wine of bael, prepared with sherry; its medicinal properties consist in a modification of tannin, combined with a large proportion of mucilaginous and aromatic principle. Bark of the root of the *Ægle marmelos*, much esteemed on the Malabar coast for melancholia, hypochondriasis, &c.

Soap berries, the fruit of a *Sapindus*; used in the East Indies instead of soap for washing. Capsul' of the same, the portion in which its peculiar properties exist; its medicinal preparations are the tincture and extract of the capsules, which are tonic and detensive.

Jujube fruit, from the *Zizyphus vulgaris* of the south of Europe—imported from Paris; its properties are nutritive, mucilaginous, and pectoral, and from the jelly of this fruit the jujubes of commerce are prepared. Flaked cold cream. Ammonia tartrate of iron; ferri ammonio tartaras; tartrate of iron and ammonia, a tonic.

[*Ægle marmelos*, called "Bel" in India, and by the English "Bengal quince," is a shrub of the orange tribe, producing a very delicious fruit, the astringent rind of which affords a yellow dye.

The soap-worts to which the genus *Sapindus* belongs are tropical plants. The fruit of many species of *Sapindus* is used as a substitute for soap, as *Sapindus saponaria*, a West Indian plant, and *Sapindus acuminata*, *Laurifolius emarginatus*, and *Detergens*, all East Indian plants. The species alluded to by the exhibitor is probably that last named.

The jujubes of the South of Europe are the fruit of *Zizyphus vulgaris*, those of India of *Zizyphus jujuba*, both plants of the buckthorn tribe.—E. F.]

109 COLLINS, ROBERT NELSON, *Oxford Court*, *Cannon Street*—Inventor and Producer.

Disinfecting powder, for the removal of offensive smells.

110 HATTERSLEY, W., 15 *Lisle Street*, *Leicester Square*; and 136 and 137 *St. George's East*—Inventor.

Elixir of sarsaparilla prepared without heat.

111 DAVENPORT, JOHN THISTLEWOOD, 33 *Great Russell Street*, *Bloomsbury*—Producer.

Iodide of iron, saccharated 50 per cent. in brilliant lamellæ, neutral and soluble, remains unaltered by the air; iodide of quinine in a neutral crystalline form; iodide of quinine and iron, in the form of syrup; iodide of iron, in the form of syrup; iodide of lead, crystals. Chloride of lead, crystals. Citrate of prot-oxide of iron, powder. Ammonia, citrate of prot-oxide of iron lamellæ. Citrate of sesqui-oxide of iron in lamellæ. Ammonio-citrate of sesqui-oxide of iron (lamellæ). Quinine, neutral sulphate, crystals, soluble. Citrate of quinine and iron, neutral soluble. Phosphate of iron, soluble lamellæ; phosphate of quinine and iron, soluble lamellæ. Benzoic acid, crystals. Caffeine, crystals. Hydrochlorate of morphia, crystals. Collodion, liquid plaster. Nitrate of silver, crystals. Fluid extract of dandelion, prepared by spontaneous inspissation of the pure juice. Solution of bi-meconate of opium entirely free from narcotine. Preparations of cotyledon umbilicus.

[Collodion is a remarkable fluid prepared by dissolving gun cotton in rectified ether. It is used in surgery. Cotyledon umbilicus has lately been used as a remedy

## SOUTH GALLERY.

for epilepsy. Its employment has been attended in several instances with success.—R. E.]

112 NIXET, W. G., 22 Moor Street, Soho—Producer.  
Specimen of cement.

113 OYLER, S., 2 York Street, Camden Town—Producer.  
Lint made of linen of different degrees of fineness.

114 AUSTIN, JAMES B., Banbury—Manufacturer.  
Decoctions and infusions of medical substances. Super-phosphate of lime. Sulphate of lime or gypsum. Fine white sand, found at Todmorton, near Banbury.

115 SAVORY & MOORE, New Bond Street.  
Koussou; a new remedial agent, imported by the exhibitors, for the removal of tape worm. That it is destructive of that parasitic disease has been satisfactorily shown. The plant has long been known in the East, and actively employed in Abyssinia. Dr. Pereira has given an elaborate account of this plant, which is known by the name of *Brayera anthelmintica*, from its properties and the name of its discoverer, Dr. Brayer. Wittstein and Martin have given chemical analyses of the plant.

Sumbul; another new medicine, the introduction of which into practice in this country is due to the exhibitors. It is very beneficial in many nervous diseases, and in the treatment of epilepsy. Dr. Granville has given a minute account of its medicinal properties.

116 BELL, J., M.P.  
Cod-liver oil, stearine, sarsaparilla, juice of taraxacum, otto of roses, &c. Salt, from the Droitwich Patent Salt Works.

117 THE LONDON DRUGGISTS—Producers.  
Balsams, &c.: Copaiba, storax calamita, black Sassafras, balsamito, and of Tolu.

Barks: Canella, cusparia, winter's, mezereon, cascarilla, Simaruba, Mudar, pomgranate, crown, ashly crown, loxa and jaen.

Extracts, &c.: Dragon's blood, catechu, liquorice, aloes, churrus and rhatany.

Expressed oils: Mace, cod-liver, linseed, castor, and croton.

Essential oils: Peppermint, mint, dill, anise, angelica, geranium, citronelle, cloves, cinnamon, camomile, winter green, ginger grass, cubeba, cajuputi, verbena, Indian grass, bitter almond, lavender, saffras, &c.

Roots: Rhubarb, orris, cassava, angelica, mezereon, calumba, hellebore, ipecacuanha, marshmallow, rhatany, smilax aspera, sarsaparilla, ginseng, salep, palaria brava, valerian, colchicum cornus, cuscus vitiver, &c.

Seeds: Cardamoms, castor-oil, croton-oil, colchicum, cumin, anise, cedron, angelica, cocculus indicus, &c.

Woods: Calumba, quassia, jalap, guaiacum, myrspermum of Sassafras, sanders, &c.

Spices, peppers, &c.: Guinea pepper, chillies, nutmegs, mace, cassia lignea, cinnamon, cubeb pepper, cloves, almonds, calamine, camomiles, patchouli, gangah, manna, litmus, crabstones, pearls, red coral, dolichos, lactucarium, chiretta, &c.

Fruits, &c.: Colocynth, pomgranate, tamarinds, vanilla, tonka, and cassia fistula.

Gums and resins: Ammoniacum, bellium, frankincense, galbanum, gamboge, benzoin, styracum, larca turpentine, New Holland resin, mastic, myrrh, Arabic, olibanum, sarocol, scammony, opopanax, sagapenum, tragacanth, lacamahua, guaiacum, &c.

Leaves, &c.: Petals of damask and cabbage roses, senna, buchu, koussou, myrspermum, &c.

Mosses: Ceylon, Corsican, Iceland, and Irish.

118 COPNEY, WILLIAM, Plough Court, Lombard Street—Manufacturer.  
Crystals of citric acid, sulphate of copper, sulphate of magnesia, and octahedra of alum.

119 STURGE, JOHN EDMUND, Birmingham—Manufacturer.

Specimen of amorphous phosphorus, and crystallized chlorate of potass.

120 OXLAND, J. & R., Plymouth—Manufacturers.

Specimens of sugar, produced by the patent process of refining, invented by Robert and John Oxland, in which the acetate of alumina is used as a substitute for the blood and animal charcoal usually employed for defecation and the removal of colour.

121 PINTO, PEREZ, & Co., Chemical Works, Limehouse—Manufacturers.

Specimen of acetate of lead, in very large crystals, rhombic prisms, slightly coloured, but exhibiting in a high degree its peculiar crystalline structure. Another specimen, in large groups of crystals, perfectly pure, and freed from colour.

This salt is prepared from pyroligneous acid and litharge, which, when combined and purified by repeated crystallizations, yields such crystals as are exhibited. The salt is extensively employed in the colouring arts, especially in calico printing, and is also a powerful medicinal agent. It is highly poisonous.

122 STEVENSON, J. C., Jarrow Chemical Works, South Shields—Manufacturer.

Large crystal of soda.

123 RILEY, E., Museum of Practical Geology, Piccadilly, and Wandsworth, Surrey—Producer.

Specimens of hippuric acid and compounds.

124 GREENISH, T., 20 New Street, Dorset Square—Manufacturer.

Superphosphate of iron; a new preparation of iron recently introduced by Dr. Routh, supposed to be the same salt contained in the blood. It is free from any ferruginous taste, and so, well adapted for children; believed to be more speedy in its action than the other salts of iron in cases of nervous debility, where there is a large quantity of phosphates voided by the urine, probably because it supplies directly to the brain the phosphorus, on the undue diminution of which the nervous derangement depends. Syrup of superphosphate of iron, adapted for administering the remedy to children, and probably the best form for general use.

Syrup of poppies, deprived of vegetable albuminous matter, without injury to its medicinal properties; it may by this means be kept without the possibility of fermentation.

Syrup of saffron, deprived of vegetable albumen, so that it may be kept without the deposition of the colouring matter.

Tincture of columba and tincture of hops. Both tinctures are deprived of the albumen, and perfectly bright.

125 TRIX, J., Exeter—Producer.

Extract of henbane from the wild herb.

126 DIXON, SON, & Co., Newton Heath, Manchester—Producers. ARTHUR ALLBRIGHT—Patentee.

Specimens of matches, made with Professor A. Schroter's amorphous phosphorus. These matches are free from offensive smell, and from effluvia injurious to the workers while they are making them. They give out a brilliant and sure light, when rubbed on the sanded part of the box. They will not take damp so readily as matches made in the usual way. They will keep in hot or cold climates, and in dry or comparatively damp places. They are as cheaply and easily made as the common matches, and are less liable to fire in the process of making. They can be made to light sulphured wood, or stearine matches. The patent safety phosphorus employed in their manufacture may be known by its producing no light in the dark under 400 degrees.



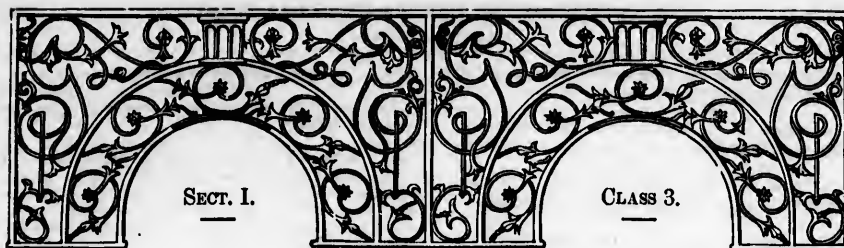

## SUBSTANCES USED AS FOOD.

### INTRODUCTION.

Most of the objects exhibited in this Class are so familiar as to require little preliminary notice. Substances used as food are derived either from the animal or from the vegetable kingdom, and may, consequently, be arranged under these two divisions—Animal and Vegetable. The latter are necessarily the most varied and the most important. Vegetable substances used as food may be arranged under the following heads:—A. Agricultural produce, such as cereals, pulses, oils, seeds, &c.; B. Dried fruits and seeds; C. Substances used in the preparation of drinks; D. Intoxicating drugs, fermented liquors, &c.; E. Spices and condiments; F. Substances belonging to the starch; and G. Substances belonging to the sugar series. Preserved meats, soups, honey, gelatine, &c., belong to the subdivision of animal substances.

This Class is situated in SOUTH GALLERY P, and is entered immediately on leaving the preceding Class, situated in the same gallery. Like the last, the amount of space occupied by it is very moderate, but the substances it comprises are interesting, and deserve attention, not, as in the last case, from their connection with commercial enterprise and prosperity, but from their relation to the support and healthy condition of the artificer himself.

The Class comprises a variety of agricultural produce—wheats of various kinds and of differing degrees of productiveness, together with specimens illustrative of the remarkable effect of hybridization, or the crossing of one variety of wheat with the pollen of another. Wheat is also shown in its various states of preparation for the purposes of food, or for the preparation of fermented liquors. Extensive collections of seeds of grasses, fodder-plants, and others for cattle food, are also exhibited, together with an arranged series of the vegetable productions of Scotland, including plants cultivated for their farinaceous seeds; plants cultivated for their herbage or forage, for their roots, for their uses in the arts, manufactures, &c.; for their medicinal properties, and for their timber. Preserved fruits and seeds of various countries are also contained within this Class, representing those articles of luxury removed by their character and costliness out of the ordinary category of human food. Specimens of hops of different varieties, adapted for different purposes, are also shown, and represent a department of agriculture more important in this country than in any other in the world. It has been estimated that upwards of 52,000 acres of land are devoted in England to the cultivation of this plant, about the half of which is in the county of Kent. The duty on hops amounts to about a quarter of a million sterling annually.

A variety of substances used in the preparation of drinks is comprised in this Class. Specimens of different kinds of cocoas, in the natural and manufactured state, of coffee, and of tea, represent the ingredients contributing to form the liquid diet of millions of the human race, and each containing, according to recent discoveries, a peculiar nitrogenous principle, identically similar in each, though recognised under different names. New substances are also shown, intended to form substitutes for these articles. Starches, spices, and condiments represent the remaining division of vegetable substances.

The division—animal substances—includes a variety of articles of preserved food; among these are cases containing food preserved in air-exhausted canisters for lengthened periods. Isinglass, gelatine, honey, preserved soups and meats, belong also to this division. There are also some preparations from blood, and combinations of vegetable and animal substances for the purposes of food, together with milk reduced by evaporation to a dried state.—R. E.

- |                                                                                                                                                                                                                                                                                                                                                                               |                                                                                                                                                                                                                                                                                                                                            |
|-------------------------------------------------------------------------------------------------------------------------------------------------------------------------------------------------------------------------------------------------------------------------------------------------------------------------------------------------------------------------------|--------------------------------------------------------------------------------------------------------------------------------------------------------------------------------------------------------------------------------------------------------------------------------------------------------------------------------------------|
| <p>1 LIGHTON, JAMES, <i>Frampton, near Boston, Lincolnshire</i>—<br/> <span style="padding-left: 2em;">Producer.</span><br/> Glass of honey, 19 lbs., produced under an improved system of bee management.<br/> The honey is worked in the glass by the bees, and the glass requires no protection except a small piece of black calico, 18 inches square, to stand upon.</p> | <p>3 CARLETON, EDWARD, <i>Blaris, Lisburn, Ireland</i>—<br/> <span style="padding-left: 2em;">Producer.</span><br/> Specimen of camomile flowers.</p>                                                                                                                                                                                      |
| <p>2 DOUBLEDAY, H., <i>Coggeshall, Essex</i>—Producer.<br/> Fino specimen of honeycomb.</p>                                                                                                                                                                                                                                                                                   | <p>4 BENTLEY, JOHN FLOWERS, <i>Stamford, Lincoln</i>—<br/> <span style="padding-left: 2em;">Producer.</span><br/> Specimens of honey in the comb, free from pollen and brood cells, collected under Nutts' system of management, by ventilation. The weight of the produce of one stock of bees in 1849 is stated to have been 50 lbs.</p> |

The accompanying out represents the combs produced in the glass hives of the exhibitor.



5 KITCHENER, WM. CRIPPS, *Newmarket, Cambridgeshire*—  
—Producer and Inventor.

Two specimens of honey taken in 1850, from the same hive, and at the same time.

Ventilated communicator, for obtaining honey free from impurity or discoloration.

6 DUTTON, ROBERT WILLIAM, *146 Fleet Street*—  
—Proprietor.

A glass containing a honeycomb.

6A HAMILTON, GEORGE & PETER, *Oldham*—  
—Manufacturers.

Specimens showing the different stages in the manufacture of flour from the wheat to the biscuit.

7 HILLS & UNDERWOOD, *Eastcheap*—Inventors  
and Manufacturers.

Samples of malt vinegar when first acetified, and when clarified; samples of brown malt vinegar, distilled vinegar, and distilled vinegar with vegetables.

8 BIVEN & Co., *St. John's Lane, Gloucester*—  
—Manufacturers.

Six bottles of champagne wine, manufactured in England from rhubarb stalk.

10 ROBERTS, WILLIAM HENRY, *British Wine Works, Laverock Bank, Edinburgh*—Maker.

Samples of "champagne and sparkling hock," made in 1847 from Valentin raisins, grapes, sugar, sugar-candy, and honey, the extract being duly fermented.

"Madeira," made in 1836, from malt and sugar extract.  
"Constantia and Frontignac," made from Valentin raisins, sugar, and sugar-candy. The "Frontignac" is flavoured by an infusion of elder flowers distilled.

"Keeping beer," brewed in February, 1845, and October, 1847.

In the manufacture of this beer, which was not made for sale, sugar was introduced as an auxiliary to the malt and hops. Its value in this connection is great, as the beer thus brewed will keep sound for an unlimited period. The method of manufacture is described in two works published by the exhibitor, viz., the "Scottish Ale Brewer and Practical Maltster," and the British "Wine Maker and Domestic Brewer."

11 COPLAND, BARNES, & Co., *46 Botolph Lane, Eastcheap*—Producers.

Specimens of a new process of preserving fruits, jams, jellies, provisions, &c. These are hermetically sealed,

and retain for years all their freshness of flavour and quality; and are prepared for use in the East and West Indies, and other tropical climates; also for passenger ships on long voyages.

12 GAMBLE, JOHN HENRY, *33 Royal Exchange*—  
—Manufacturer.

Canister, containing boiled mutton, found by Captain Sir John Ross, on Fury Beach, in latitude 72 deg. 47 min., and longitude 91 deg. 50 min. This is one of the canisters of preserved food, prepared by the exhibitor for the Arctic Expedition in 1824. It was landed from H.M.S. "Fury," on the beach where the ship was wrecked in Prince Regent's Inlet, and found by Captain Sir John Ross, in August, 1833, still in a perfect state of preservation, although annually exposed to a temperature of 32 deg. below, and 80 deg. above, zero. In 1849, when Captain Sir James Ross visited Prince Regent's Inlet in H.M.S. "Investigator," he found the provisions still in excellent condition. That the canister exhibited has been preserved above twenty-six years, and is still fit for food, is attested by Captain Sir John Ross. The food in this canister was preserved without salting.

Three canisters of preserved mutton and vegetables, preserved by the same process by Donkin, Hall, and Gamble, at Blue Anchor Road, Bermondsey, in the year 1813.

Canisters of preserved fresh beef, mutton, and veal; of fresh milk, cream, and custards; of fresh carrots, green peas, turnips, beetroot, stewed mushrooms, and other vegetables; of fresh salmon, oysters, cod-fish, haddock, and other fish; and of real turtle soup, mock-turtle soup, ox-tail and other soups.

Preserved hams for use in India, China, &c.  
Callipash, callipee, and green fat for making real turtle soup, all preserved by the same process. Also soup and bouilli, for emigrants and troops at sea.

Pheasants, partridges, &c., preserved. The whole preserved so as to keep in any climate, and for an unlimited length of time.

[This method is the invention of M. Appert, in France, and was first practised in England by Messrs. Donkin, Hall, and Gamble. The process consists in placing the partially-cooked provisions into tin canisters, with a little bouillon or juice of the meat, then soldering on the covers, which have a small hole perforated therein. The tins are, after this, immersed, to a great portion of their depth, in a saline-bath heated above the boiling point of water, and left therein until the air has been expelled as completely as possible by the steam generated within them; the hole in the cover is now hermetically closed with a little solder, the tin being momentarily touched with a damp sponge to stop the egress of steam. The minute portion of oxygen still remaining in the tins enters into combination with the animal or vegetable matter at the induced temperature, and thus, further change is prevented. After the sealing of the tins, they are submitted to the ordeal of the testing-room, heated to a temperature above 100° Fahr.; if putrefaction takes place, the generated gases burst the tins, but those which pass uninjured remain perfectly good.—W. D. L. R.]

13 COLQUHOUN, J. L., *Lieut.-Col., R.A.*—Producer.

Fruit of the plantain (*Musa paradisiaca*) dried in the sun when fully ripe, and in that state analogous to the dried fig, raisin, date, &c.; from the province of Jalisco (Gundalajarra), Mexico, called "Platano pasado."

It is prepared in considerable quantities in the hot region (*tierra caliente*) of the western coast of Mexico, for consumption in the elevated districts of the interior.

The specimen exhibited was imported in 1835, and is the remainder of a package of 75 lbs. weight, made up as customary in the leaves and fibre of the plant, after

having been subjected to considerable pressure. The cost of production is very moderate.

14 SMITH, MICHAEL, *Copper Alley, Dublin*. (Agent in London, J. KENDELL, 8 *Harp Lane, Great Tower Street*)—Producer.

Preserved pig; large and small hams, cured upon the "mild-cure" principle.

15 RITCHIE & McCALL, 137 *Houndsditch*—Producers. Specimens of preserved meats, poultry, fish, &c., the produce of the United Kingdom; and of beef, the produce of Moldavia, preserved at Galatz. "Goldner's Patent." The process is by forming a vacuum in the canister by means of steam, and preserving the meat, &c., in that vacuum.

[It is a well-known fact that, in the absence of atmospheric oxygen, putrefaction is suspended, often entirely so. Such is the principle upon which the patent here adverted to depends. The vacuum must be very complete to render the preservation of food successful.—R. E.]

17 CLAY, JOHN, *Woodley Corn Mills, Bridbury, near Edgeley, Stockport*—Producer.

Specimens of maize or Indian corn, with a specimen of American hominy produced from Maize, as used in America; imported at Liverpool from New York.

Specimens of English manufactured hominy from maize, and maize flour as a substitute for rice, flour, meal, potato, &c.

20 LEONARD, J. & T. P., *Hull*—Proprietors.

Beef, prepared, cured, and rolled, so as to keep good for any length of time. The process of curing and mode of preparing were invented by John Tupling, in the exhibitors' employ.

21 WARRINER & SOYER, 7 *Upper St. Martin's Lane*—Producers.

Osmazone, or essence of meat.

22 PAYNE & SON, 328 *Regent Street*—Importers and Manufacturers.

Specimens of curry powder, curry paste, mulligatawny paste, Delhi obutnee, and curry sauce. Pickled mangoes (*Mangifera*), Limes (*Citrus acida*), bamboo (*Bambusa*), and green and red bird's-eye chili, from the East Indies. Bengal Club chutnee and curry and mulligatawny pastes, manufactured in Calcutta. Pistachia nut and kernel (*Pistacia*), used in confectionery, East Indies. Cashew nut (*Anacardium*), West Indies. Betel nut, the fruit of the *Areca catechu*, East Indies. Soy bean (*Soja hispida*), from which soy is made. Wild liquorice seed (*Glycyrrhiza*). Turmeric root and prepared turmeric (*Curcuma*), East Indies. Dahl, a species of lentil, much used in India. Paddy, rice in the husk. Gram (*Cicer arietinum*). Preserved ginger, from the East and West Indies; candied ginger, China; green ginger, West Indies. Cum-quot, or China orange, preserved in China. Guava jelly, Jamaica. Litchis, East Indies.

23 UNDERWOOD, G. H., *Penleton, Manchester*—Inventor and Proprietor.

Preserved meat. This article is preserved without the use of salt, and it may be kept an indefinite length of time without deteriorating its quality; when cooked, it retains its nutritious qualities, and eats almost as fresh as recently-killed meat.

24 LINKLATER, J., 5 *Sidney Street, Commercial Road*—Producer.

Specimens of preserved meats.

26 WHITNEY, JAMES, *Calver Hill, Hereford*—Inventor.

Beef preserved in a dry state, peculiarly adapted for the use of sailors, being free from salt.

27 WEATHERLEY, H., 54 *Theobald's Road*—Manufacturer.

Specimens of honey-drops.

27A WHEELER, FREDERICK, *Rochester*—Importer.

Specimens of free-labour produce, as distinguished from the slave-labour produce of Cuba, Carolina, Brazil, &c.

28 SNOWDEN, ROBERT, *City Road and East Road*—Inventor and Patentee.

Samples of coffee, showing the woody fibre. Sample of the whole berry coffee, roasted in patent enamelled cylinders.

Specimen of the crushed berry, showing the woody fibre, which is removed before grinding, by patent process.

Sample of the woody fibre removed from the heart of the coffee berry, which, by the ordinary processes, is ground up with the coffee.

Sample of patent purified coffee nibs, ready for grinding.

29 LEBAIQUE, HONORE, 10 *Little Titchfield Street*—Importer and Manufacturer.

Trinidad cocoa pod; cocoa from Grenada, St. Lucia, red Trinidad, grey Trinidad, Guaysquil, Maragnan, Caracas; Jamaica sugar, lump sugar, powdered sugar, arrow-root, tapioca; Iceland moss; Persian salep; cinnamon from Ceylon; cassia from China; vanilla from Mexico.

Chocolate and cocoa, showing the various stages of manufacture: roasted cocoa, cocoa nibs, cocoa milled, butter of cocoa, cocoa mixed with sugar, chocolate, cocoa powder, chocolate powder.

Chocolate of different kinds and shapes, and coffee.

Samples of chocolate for invalids. Imitations of Lisbon, Italian, and Spanish chocolate, in cake. Fancy chocolate in drops, silvered, marbled, &c. Vanilla, coffee, cinnamon, pistachios, liqueurs, pralines, cream, cigars, &c. Cake of chocolate, three hundred pounds weight.

30 PARIS CHOCOLATE COMPANY, 252 *Regent Street*—Manufacturers.

Large and small tablets of chocolate, of various qualities.

Bourbon chocolate, of different kinds and qualities. French syrup of all kinds of fruit; almond and gum eyrup.

New chocolate-pot; new coffee-pot; and other articles. Chocolate is said to be superior to cocoa in powder, or, as it is called, "soluble cocoa," for its nutritive qualities, and its facility of digestion. The new chocolate-pot is intended to render the preparation of this article for food more easy over a common coal fire.

31 FRY, JOSEPH STORRS, & SONS, *Bristol*—Producers.

Specimens of the leaves, flowers, branches, and other parts of the cocoa-tree (from Trinidad) *Theobroma Cacao* (*Theobroma* signifies "Food of the Gods").

Trunk of the cocoa tree.

Cocoa, or cacao nuts.

Specimens of the ripe fruit from Trinidad and Grenada, with some cut open, showing the nuts within the pods.

Cocoa nuts—dark red, grey, pale red, and Spanish cured, imported from Trinidad.

Cocoa nuts—dark, ripe, and bright; imported from Granada.

Cocoa nuts—imported from Guayaquil and Para.

Other varieties from South America.

Vanilla pods from South America, used for giving a flavour to chocolate.

Roasted cocoa nuts from Trinidad and Grenada.

Husks of the nuts, called in commerce "cocoa shell." The kernel of the nuts, called in commerce "cocoa nibs."

Pure chocolate and cocoa, ground and fit for use.

Specimens of some of the chief varieties of chocolate and cocoa. Paste chocolate. Broma and chocolate powder. Granulated, soluble, and flaked cocoa.

View of Port of Spain, in Trinidad, the principal shipping port of cocoa.

View of Naperima in Trinidad, the chief locality for the growth of cocoa.

Illustrations of the cocoa tree.

Drawing, showing the processes of the manufacture of chocolate and cocoa.

View of a "drying house" and "cocoa walk" at Arima, in Trinidad, which was constructed solely with the timber of one single tree of the cedar kind.

[*Theobroma cacao* is the tree which yields the cocoa of commerce. It belongs to the natural order *Byttneriaceae*. Large forests of this tree, which does not attain a great size, exist in Trinidad, from which island, in 1841, upwards of two million pounds were imported into Great Britain. The total imports in the same year were upwards of three million pounds.—R. E.]

32 WHITE, GEORGE BAILEY, 147 *Shoreditch*—Importer and Manufacturer.

Different specimens of the West India cocoa, raw, roasted, and manufactured. Chocolate in its various stages of manufacture, with samples of the different kinds.

33 SHINTON, RICHARD, 29 *Spencer Street, St. George's-in-the-East*—Inventor.

Samples of fine cocoa, free from all deleterious properties.

34 MONTEIRO, LUIS ANTONIO, 2 *Upper Phillimore Place, Kensington*—Manufacturer.

Samples of sweetened chocolate, made of Caracacas cocoa, without any adulteration or farinaceous admixture; of Caracacas and British West India cocoas; and of British West India Islands' cocoa. Chocolate lozenges and confection of Caracacas cocoa, with other ingredients.

35 LANE, WILLIAM RAYNERD, 226 *Strand*—Inventor and Manufacturer.

Essence of coffee, manufactured by a machine invented by the exhibitor.

36 GRUT, BENJAMIN, 1 *Sambrook Court*—Importer.

Cocoa (*Theobroma cacao*), a variety known in commerce as Caracacas cocoa; little known in England, and consumed chiefly by the Spaniards of Spain and South America. It is produced on a plantation in the interior of New Granada; will keep in any climate, and improve with age, if kept safe from moisture.

37 BUDD, JOSHUA THOMAS, 82 *Mount Street, Grosvenor Square*—Manufacturer.

Extract of cocoa.

38 BENHAM, W. A., *Cross Street, Queen's Square, Bloomsbury*—Producer.

Samples of Trinidad cocoa in its separate stages; the cocoa-nut (cacao), in its raw state, as imported from Trinidad; the nut as roasted; nibbed and divested of its outer bark or shell; and finally, its manufactured state.

[The consumption of cocoa, as an article of food, has greatly increased within the last few years. The West Indian kinds generally contain a larger proportion of the peculiar fatty matter (oil or butter of cocoa) than that which comes from New Grenada, and consequently are not so much valued. It forms a very digestible nutritious aliment, containing a peculiar azotized compound, *Theobromine*, analogous to that contained in tea and coffee.—J. W.]

39 BENSON, W., 133 *Oxford Street*—Importer.

Samples of Flor de Cabanas, Martinez, and Havanna cigars. Samples of tobacco.

40 LAMBERT & BUTLER, 141 and 142 *Drury Lane*—Manufacturers.

Tobacco imported from America, Havanna, Holland, &c.; and specimens of the articles manufactured from it.

[The total quantities of tobacco retained for home consumption, in 1842, amounted to nearly seventeen million pounds. Professor Schleiden gives a singular illustration of the quantity of tobacco consumed. North America alone produces annually upwards of two hundred million pounds of tobacco. The combustion of this mass of vegetable material would yield about 340 million pounds of carbonic acid gas, so that the yearly produce of carbonic acid gas from tobacco-smoking alone cannot be estimated at less than 1,000 million pounds—a large contribution to the annual demand for this gas, made upon the atmosphere by the vegetation of the world.—R. E.]

41 BREMNER & TILL, 60 *Fenchurch Street*—Producers. Samples of tobacco.

42 JONAS & BROTHERS, 42 and 43 *Leman Street, Whitechapel*—Manufacturers.

Specimens of cigars of home manufacture; and of tobacco, imported from the Havanna; with samples of the raw material.

43 JONES, BEN., & CO., 39 *Brunswick Square*—Importers.

Chest of foreign cigars, and various smaller boxes of British manufactured cigars.

44 LUNDY FOOT & CO., *Dublin*—Inventors and Manufacturers.

Snuff: Lundy Foot's high toast, Scotch, and stalk snuff, made solely from the leaf and stalk of Virginia tobacco. Cavendish, negrohead, and other forms of tobacco, manufactured in imitation of the foreign or American.

45 TAYLOR, THOMAS GEORGE, *Grove Street, Hackney*—Grower and Manufacturer.

Tobacco of English growth and manufacture. Leaves of the plant prepared by exposure in a confined, dry, light, and warm place. Samples of manufactured tobacco dressed with treacle and oil. Cigars, free from dressing. Snuff, resembling high-dried Welsh, pure. The stem of the leaf roasted and ground.

[The botanical name of the tobacco plant is *Nicotiana tabacum*. Its cultivation in England is said by Mr. Loudon to be restricted to the extent of half a pole, and that only for botanical or medicinal purposes.—R. E.]

46 HYAMS, M., 79 *Long Lane, City*—Manufacturer and Inventor.

Cigars solely of British manufacture. Samples of cigars made of Havannah leaf, Columbian and Cuba tobacco, &c. A sample of straw cigars, as made in London, up to the year 1837, to show the improvement in the make of cigars. An improved cutting-board for making cigars. A case of clay pipes, the large bowls made of clay from the river Thames. A nest of racks; a model used for drying cigars. Implements for bundling and pressing cigars. A table cigar-case. A specimen carrot of Cuba leaf tobacco. Small samples of leaf tobacco, the produce of Columbia, Giron, Havannah, Germany, Florida, Maryland, &c. Sample of tobacco in its original state, and after having been adulterated with a preparation for flavoring.

47 SALES, POLLARD, & CO., 57 *Red Cross Street, Cripplegate*—Manufacturers.

Cigars manufactured from Yara tobacco. It is shipped from the port of Manzanilla.

48 BUCKLAND & TOPLISS, *Barrington Crescent, Brixton*—Inventors and Manufacturers.

Specimens of "the aromatic cigarilla," for the use of smokers, being composed chiefly of British herbs, and diffusing an agreeable perfume. Other aromatic and medicinal cigars.

- 49 **COHEN & ORR, 41 St. James's Street**—Importers.  
Raw tobacco, and tobacco made into cigars by hand-labour at Havana.
- 50 **GOODER, GEORGE & SAMUEL, 12 Prinod's Street, Spitalfields**—Manufacturers.  
Samples of British manufactured cigars; also, an arranged series, showing the process of manufacture.
- 52 **RICHARDSON BROTHERS, Edinburgh**—Manufacturers.  
Tobacco, imported from Virginia into Leith. Specimens of the raw material, as imported with the stalk on it, known as "leaf," or "unstemmed," tobacco; of the stalk extracted; and of "strip," or "stemmed" tobacco, which, after being damped with water, is manufactured into "twist," and made up into rolls; a cord is then wrapped round each 150, and put into a press for about a month, under a pressure of nearly five tons. The article, then, is "roll" tobacco.  
Leaf tobacco and stalk.  
Snuffs: black rappee, Scotch, and brown rappee.
- 53 **THE LONDON SPICE TRADE**—Importers.  
Samples of spices and the places of shipment:—  
No. 1. Mace, from Penang.  
No. 2—4. Nutmegs; brown, from Penang; luted, from Batavia; and wild, from Singapore.  
Nos. 5—7. Cloves, from Penang, Amboyna (Dutch produce), and Zanzibar.  
Nos. 8, 9. Cinnamon, from Ceylon.  
Nos. 10, 11. Cassia, from Canton.  
No. 12. Pimento, from Jamaica.  
Nos. 13—17. Black pepper, from Bombay, Tellicherry, Singapore, and Batavia.  
Nos. 18—21. White pepper, from Tellicherry, Penang, Singapore, and Batavia.  
Nos. 22—27. Ginger, from Jamaica, Cochin China, Calcutta, Sierra Leone, and Bombay.  
Nos. 28—30. Caraway seeds, from Holland and Mogadore, and English.  
Nos. 31, 32. Coriander seeds, from Madras, and English.
- 54 **FAULKNER, RICHARD & CHARLES, 44 Jermyn Street, St. James's**—Manufacturers.  
Specimens of English tart fruits, preserved in bottles, without sugar.
- 55 **FORTNUM, MASON, & Co., 182 Piccadilly**—Importers.  
Preserved and dried fruits, and edible seeds, from various countries. Varieties of honey.
- 56 **CLEMENS, JOHN, 25 Mining Lane, and Malaga**—Producer.  
Specimens of Jordan almonds and raisins.
- 58 **SPUR, GEORGE, Boston**—Manufacturer.  
Specimens of linseed cake prepared from English linseed.
- 58A **GRACE, D, Brighton**—Patentee.  
Specimens of patent mushroom spawn.
- 59 **RICHARDSON, TIMOTHY, & Sons, 6 Duke Street, Southwark**—Proprietors.  
1. Golding hops, grown in the district called "The Hill," in Mid-Kent, used for the finest ales.  
2. Golding hops, grown in East Kent, used for the same purpose as No. 1.  
3. Golden hops, grown in the heart of Mid-Kent, and used for the best brown beers.  
4. Jones's hops, grown in various parts both of Kent and Sussex.  
5. Grape hops, also grown generally through the hop plantations.
6. Colegate hops, a hardy plant, but of inferior flavour; the cultivation of it has much increased of late years.  
7—9. Hops grown in Essex, Suffolk, and Worcester.  
[These hops are samples of the varieties in most estimation for the purposes of the brewer. The Goldings take their name from that of the grower who first introduced them; they are considered to be the finest, richest, and most valuable in the market, varying, however, according to the soil in which they are grown, and the treatment they receive. Jones's are of a shorter growth than the others, and are thus useful by enabling the grower to make use of the poles which would be too short for the Goldings or other varieties. Colegates are hardy, but backward at harvest, running much to vine, and capable of growing in comparatively poor soils. These qualities are, however, of advantage, as the inferior soils may thus be beneficially occupied by them, and their harvest takes place after the finer sorts are all in. The grape hop takes its name from its habit of growing in clusters like the grape. It is hardy, not so particular as to soil as the Goldings, and is generally very productive in yield.—J. W.]
- 60 **ASHBURNHAM, JULIANA, The Downer Lady, Broonham, near Hastings**—Producer.  
A bag of hops, grown within three miles of the sea, in the parish of Guestling, Sussex.
- 61 **ATTFIELD, CHARLES, Farnham**—Producer.  
Pocket of Farnham hops.
- 62 **PAINE, J. M., Farnham, Surrey**—Producer.  
Samples of hops of the "Golding" and "Farnham white blue" varieties, grown at Farnham. Other specimens are exhibited in Class 1, in connection with the rich phosphoric fossils which abound in the neighbourhood where these hops are cultivated.
- 63 **GOLDING, ROBERT, Hunton, Maidstone**—Manufacturer.  
Pocket of Mid-Kent hops.
- 64 **PLIMLEY, FRANCIS, Maidstone**—Designer.  
Drawing of a magnified view of the formation and growth of the hop fungus, from its earliest to its latest stage.
- 65 **MASTERS, ALGERNON, Tonbridge**—Proprietor.  
Four branches of dried hops. Samples of the same.
- 66 **PETERSON, THOMAS, Trinity Chambers, Water Lane, Tower Street**—Agent.  
Specimens of oilseed cakes. Vegetable oils and manures.
- 68 **BURN, ROBERT, North Merchiston House, Edinburgh**—Importer and Manufacturer.  
Cotton seed, seed-cotton, with oil, and oil-cake imported from the colonies.  
[Were the cotton with the seed to be imported, and the seed separated from it at home, it might be applied to agricultural purposes at a greater profit. The cost of seed, freight included, was 2d. per lb. from Charlestown to Port Glasgow. Cotton oil-cake is now ordered at the same price as linseed cake. The produce of oil-cake and oil from cotton-seed, is two gallons of oil to one cwt. of seed, leaving about 96 lbs. of cake; 8 lbs. is the daily allowance for cattle in England. The exhibitor has a machine at work at Port Glasgow for extracting or separating seed from cotton wool.]
- 70 **SHEPPARD, ALFRED, Ipswich**—Proprietor.  
"Eggshell white" wheat, and "Chevalier" malting barley, grown in Suffolk. Malt manufactured at Ipswich.



Wheat 65 lbs. per bushel; chevalier barley 56 lbs. per bushel; and malt 43 lbs. per bushel.

71 **THE TRURO LOCAL COMMITTEE—Producers.**

Specimens of Cornish agricultural grains:—Black barley, skinless barley, grown and supplied by J. D. Gilbert, Esq., of Trellisick, near Truro. Indian corn, grown and supplied by Colonel Scoble, of Nansalvern, near Penzance.

Cornish red wheat, grown on the granite soils, especially adapted to the exposed situations in the neighbourhood of Penzance, and Cornish white wheat; the best sort to be grown on the high and exposed land of Cornwall; supplied by Mr. John Michell, of Fock, near Truro. Cornish barley, grown and supplied by the same, adapted for malting and grinding purposes. Agricultural produce, grown and supplied by the Rev. R. M. N. Eusticke, of Penwarne, in Mawan, adapted for feeding cattle and poultry; grown on the poor and exposed peat soils of Cornwall.

72 **WEBB, RICHARD, Calcut Farm, Reading—Producer.**

Mummy Talavera wheat. Three grains of this wheat are said to have been found in the hand of an Egyptian mummy, and sent to Mr. Dobre, President of the Agricultural Society in Guernsey, who planted the same in his garden, and forwarded the produce to Col. Blagrove the following year. This produce he has successfully grown as a spring crop, and from it the present sample, grown by the exhibitor, is a specimen, the quality and crop being alike good.

[Much doubt has been raised as to the origin of the mummy wheats. The Egyptian wheat (*Triticum compositum*) is very different from the variety of common wheat (*Tr. vulgare*), called "Talavera." The Egyptian wheat has a head composed of three spikes, one erect in the centre, similar to the common wheat, and on either side another, not quite so large, attached to the base of the centre, and standing out at a small angle from it. Our climate is not suited to its growth, as, in the course of one or two years, the side spikes entirely disappear, and a coarse, thick-skinned grain is produced.—J. W.]

Specimen of the Wellington apple.

73 **RAYNBIRD, ROBERT, Hengrave, near Bury St. Edmunds—Producer.**

Sack of Kessingland wheat, grown upon a light soil, at Hengrave, Suffolk; this is a productive and new variety of wheat.

Sack of Chevalier barley, grown at Hengrave.  
Sack of tick beans with white eyes, grown at Hengrave; a variety, called "Manchester white eyes."

74 **RAYNBIRD, HUGH, Laverstoke, Andover Road, Hampshire—Producer.**

Specimens of wheat produced by hybridization. Specimens of Hopetoun and Piper's thickest wheat—the variety from which the hybrids were obtained, by fertilizing its pistile with pollen from the stamens of the Hopetoun wheat. To effect this, the stamens of the flower of the thickest variety were removed before they had reached maturity, by opening each of the glumes and carefully picking out the stamens upon the point of a needle: the pistile of the flower being left perfect, were a few days afterwards fertilized by dusting them with the pollen from stamens brought from the Hopetoun variety of wheat; this produced a great number of varieties, partaking more or less of the parent stocks, and from these the four specimens exhibited were selected.

[In the hybridization of plants experiments are always of much interest, and often productive of very important results, as the good qualities of two varieties may be obtained, or their bad qualities be counteracted. Hybrids obtained by the judicious intermixture of species, frequently produce seeds capable of giving origin to plants

combining the characters of the two different parents; but hybrids produced by species closely allied but really distinct gradually lapse into the one or the other of the originals, and thus become extinct.—J. W.]

75 **KENDALL, JOHN, Treverin, Truro, Cornwall—Producer.**

Sheaf of white wheat, named "The giant straw wheat;" grown by the exhibitor in quantities of from 10 to 15 acres for the last 10 years. This wheat is stated to have produced, on an average, 60 bushels per acre. Its superiority consists in the length, size, and stiffness of the straw, and in its abundant produce.

77 **TAYLOR, JOHN, & SON, Bishop Stortford, Herts—Manufacturers.**

Varieties of malt, viz.:—  
Amber, used in brewing ordinary ales and portor.  
Coloured, used for same purpose.  
White, used in brewing pale ales.  
Brown, used in brewing porter to give it flavour and colour.

[The various colours described are given to the malt by the different temperatures to which it is submitted after the germination is stopped. The essential oil contained in the barley is acted upon by heat, and different flavours are also produced. In the brown malt the saccharine matter is partially carbonized, and a peculiar empyreumatic flavour obtained.—J. W.]

78 **WELLSMAN, JOHN, Moulton, near Newmarket—Manufacturer.**

Sample of pale malt, manufactured from Chevalier barley.

79 **MAUND, BENJAMIN, F.L.S., Bromsgrove—Producer.**

Specimens of wheat, artificially hybridized, showing that its exterior form, and probably its chemical properties, can be modified, and its productiveness improved.

80 **WRENCH, R., & SON, London Bridge—Producers.**  
Specimens of various kinds of grain most familiar to the London market.

82 **PAYNE, H., Birdbrook Moat, near Halstead—Producer.**

Varieties of grain.

83 **STRANGE, WILLIAM, Banbury—Producer.**

Samples of beans grown, in 1850, on stiff clay soil, without phosphate of lime or magnesia, and in cultivation, with 22 per cent. of phosphate of lime and magnesia.

85 **MILNE, WM., Rhynie, Scotland—Producer.**  
One quarter of Scotch barley oats.

86 **WALKER, WILLIAM, Mossal, near Aberdeen—Producer.**  
Sample of Kildrummie oats.

88 **COUSENS, S., Great Bentley, near Colchester—Producer.**  
White wheat, new variety; weight of imperial bushel, 64 lbs. net.

90 **FOX, JOHN JAMES, Devizes—Proprietor.**  
Specimens of red straw-white Essex wheat, and of Nursery, Lammas, and Talavera red wheat, grown in Wiltshire.

90A **CAHILL, M., Ballyraggt, Kilkenny—Producer.**  
Samples of whes' oats, and barley grown at Grove, Kilkenny.

91 **STEVENS, RICHARD, Stamford—Producer.**  
Sample of wheat, Collyweston white.



- 92 **CROUGHTON, WILLIAM PEEL, Tenterden, Kent—**  
Producer.  
Hoary white wheat; produce stated to be over five quarters per acre.  
Golden pod beans; produce, from which the sample is taken, stated at four quarters and six bushels per acre.
- 93 **ASPREY, JAMES, Sandlesford, near Newbury, Berks—**  
Producer.  
White trump wheat, grown on a very poor soil; weight, 67 lbs. per bushel.
- 94 **FORDHAM, THOMAS, Snelsmore Hill East, near Newbury—**Producer.  
Samples of hybridized white wheat; weight stated to be 66½ lbs. per bushel.  
Prolific beans; weight stated to be 70 lbs. per bushel.
- 95 **JUSON, W., Red Hill, Shrewsbury—**Producer.  
Samples of grain and fine flour.
- 98 **KEENE, WILLIAM, 42 Cornhill—**Proprietor.  
Specimens of the "forty-day maize" grown in England, from new sorts cultivated by the exhibitor in the Pyrenees.
- 99 **IRWIN, ELIZABETH, Ballymore, Boyle, Roscommon—**Producer.  
Black barley, grown at Ballymore, in the county of Roscommon, Ireland, from African seed.  
[Black barley is a variety of the common two-rowed barley (*Hordeum distichum*). In the course of cultivation the dark colour gradually disappears. It is a heavy cropper, and requires care at harvest, as, when the grain is ripe, the straw below the ear becomes very brittle and apt to break off.—J. W.]
- 100 **BEXLEY, Lord, Footscray, Kent—**Producer.  
Bushel of white chittim wheat.
- 102 **GIBSON, CHARLES, Pitlochry, Perth—**Producer.  
Four bushels of English barley, grown by the exhibitor near Pitlochry, about 600 feet above the level of the sea.  
Hand-spun and hand-woven shepherd check plaid, composed of natural black and white wool from black-faced Highland sheep.  
Hand-spun and hand-woven shepherd check plaid, composed of blue dyed and white wool from black-faced Highland sheep.
- 103 **GUILLEREZ, ACHILLE FRANÇOIS, 37 Castle Street, Edinburgh—**Producer.  
The lentil, or *Errum lens* of botanists—known and extensively cultivated in the earliest ages, especially in the East, being probably similar to the "red pottage" of Esau. The exhibitor has cultivated lentils at South Queensferry, near Edinburgh, for two years; he has successfully grown and ripened in soil manured by sea-weed, the small lentil and the large red (the common, or Egyptian).  
[In Egypt, Syria, and Hindustan, lentils form at the present day a chief article of food among the labouring classes. They are also a common ingredient in French cookery.—J. L.]
- 103A **SADLER, WILLIAM JAMES, Swindon, Wilts—**Producer.  
"Lawrance's prolixus," crystal white. This wheat has qualities which are considered to render it highly deserving of cultivation. The root is adapted to draw nourishment from an unusual depth in the soil, produces a strong straw, effectually resists the storm, affords a prolific yield; and its colour and weight are good. Yield of sample shown, stated at 66½ lbs. per bushel.
- 104 **GIBBS, THOMAS, & Co., Half-Moon St., Piccadilly—**Importers and Producers.  
Collection of dried specimens of grasses used in laying down land for permanent pasture, with seeds of the same. Specimens of wheat, barley, &c.; collection of various agricultural, kitchen garden, and other seeds.
- 105 **LAWSON, PETER, & SONS, Edinburgh—**Producers.  
Specimens of the vegetable productions of Scotland, comprehending all substances used for food in the chemical arts and medicine, in manufactures, and in house and ship building.  
This collection is divided into six sections, as follows:—  
1. Plants cultivated for their farinaceous seeds, together with their straw or haulm.  
2. Plants cultivated for their herbage and forage.  
3. Plants cultivated chiefly for their roots.  
4. Plants cultivated for their uses in the arts, manufactures, and for various economical purposes.  
5. Plants cultivated for their medicinal properties  
6. Plants cultivated for their timber.  
A detailed account of each specimen is contained in a catalogue printed by the exhibitors.
- 106 **JONES, G., Redland, Bristol—**Producer.  
Specimen of wheat, grown by spade culture and dibbling.
- 107 **H.R.H. PRINCE ALBERT—**Producer.  
Three samples of grain grown on the Royal Farm at Windsor, consisting of wheat, oats, and beans, one bushel of each.
- 107A **WRIGHT, HENRY, Antingham, near North Walsham—**Manufacturer.  
Malt, manufactured from barley grown by the Rev. Cremer Cremer, of Beoston, near Cromer, Norfolk.
- 108 **GENTILE, JOSEPH PASCAL, Harbertonford Works, near Totness, Devon—**Manufacturer.  
Macaroni and Italian pastes. Prepared flour.  
[The hard wheats are best adapted for the manufacture of these substances. They contain more gluten than the soft wheats.]  
Prepared flour and cocoa as a chocolate.  
Vegeto-animal food; a compound of the nutritious principles of meat and wheat, &c.
- 110 **WATT, GEORGE, Upper Balfour, Banochry, Scotland—**Producer.  
Sample of barley, grown after turnips, in a five-course rotation, turnips, barley, hay, pasture, oats, with the ordinary farm-yard manure. Exhibited for quality.
- 112 **SUTTON, JOHN, & SONS, Reading—**Producer.  
Specimens of grain. Skinless Chevalier barley, a new variety. Purple-topped yellow hybrid turnip, valuable for late sowing, as a substitute for swedes. Lincolnshire red turnip, from the stock of Philip Pusey, Esq., M.P.
- 114 **M'KILLICAN, JAMES, Piperhill, Cawdor, Scotland—**Producer.  
Sample of perennial rye-grass seeds (*Lolium perenne*), raised on the farm of Piperhill, Nairnshire. They are the produce of the third year's crop; weight 37 lb. 3 oz. per bushel.  
Sample of white wheat, the produce of the first crop, from land formerly worthless, on the same farm, manured by 300 lbs. weight of Peruvian guano to the acre. Produce per imperial acre about five quarters; weight per bushel, 65 lbs. 1 oz.
- 115 **ILLINWORTH, ALEXANDER, Banochry Ternan, Scotland—**Producer.  
English barley, weighing 59½ lbs. per bushel. Scotch birley oats, weighing 44 lbs. per bushel. Perennial rye-grass seeds, weighing 30½ lbs. per bushel.

116 **BATTY & FEAST, 15 and 16 Pavement, Finsbury Square**—Inventors and Manufacturers.

Vegetable productions preserved in distilled vinegar. A pine apple, with roots and leaves. An orange-tree, branches, and fruit, and branches of citron and fruit. Cucumbers, grown in England. A variety of preserved fruits and other comestibles.

117 **COLMAN, J. & J., 9 College Hill, City**—Manufacturers.

Specimens of starch, from wheat and rice, mustard, British gum, indigo blue, &c.

The "satin glaze rice-starch" of the exhibitors possesses the following advantages:—From its extreme fluidity it is more economical than common starch; it is free from mucilaginous matter; it does not require boiling, and the clearness, colour, and glaze, which it imparts are permanent. It is particularly adapted for lace, and the finer fabrics of linen, cotton, &c.

["British Gum" consists in reality of torrefied starch. The granules of starch, in its ordinary form, are enveloped in a thin pellicle, insoluble in cold water. By roasting the starch, the membranous envelopes are burst open, and their granular contents are then readily soluble in cold water. It is used, among other purposes, for thickening the colours of calico printers.—R. E.]

118 **NOAE, W. & JOHN, Covercroft Salt Works, Droitwich**—Manufacturers.

Sample of the brine from the salt-works at Droitwich, obtained at the depth of 173 feet below the surface.

Specimen of rock salt: only a small quantity of this is obtained in the neighbourhood.

Specimen of bay salt; an article supplied to druggists. Hopper or Maldon salt; used as a dessert with wine, instead of olives.

Coarse broad salt; exported for the fisheries.

Brisk salt; used for chemical purposes, fisheries, and exportation.

Lymington grained salt; used for curing bacon and butter and for exportation.

Best cooking salt, superfine table salt, and refined table salt; used for various domestic purposes.

Pickings, or cattle lickings, a valuable and useful article for sheep or cattle, which they eagerly seek after and enjoy.

[The salt manufacture of Droitwich, Worcestershire, existed at a very early period: it is mentioned as in operation at the time of the Roman invasion; then it was carried on in a primitive style, and at considerable expense. The brine-springs here extend over a very limited space of land, and are comprised within a circle of about 200 yards in diameter. Formerly the brine was obtained by boring; this process made it rise to the surface and run to waste; for, ascending through and mixing with the fresh-water springs, it was very much lowered in strength, and the manufacture of the salt, which was conducted by evaporation, was attended with great expense, owing to the quantity of fuel required to vaporize the water.

Within the last 50 years an improvement was effected by casing the pit with wood, and thus partially preventing the fresh water mixing with the brine. More recently, the principle was introduced of sinking a shaft quite through the fresh-water springs, and then making the bottom and sides of the pit secure with iron cylinders, before boring down to the brine springs. By this means the brine is obtained at its full saturation, or about 42 parts of salt in the 100; whereas formerly it varied between 28 and 37 per cent.

The exhibitors recently obtained a patent for improvements in manufacturing salt; and, by using very large evaporating pans of an improved construction, they obtain

larger quantities of salt, at a considerable saving of labour to the workmen, who obtain better wages and longer intervals of rest.

The source of the brine in Droitwich is inexhaustible, and exhibits no diminution of strength or quality: it lies at a depth of 173 feet from the surface, but as soon as it is reached by boring it rises up to the level. The salt manufactured here is exported largely from the ports of London, Gloucester, and Bristol. There are upwards of 70,000 tons per annum manufactured, of which 40,000 tons are used for domestic and agricultural purposes; the remainder is used chiefly for chemical decomposition and exportation. The Droitwich salt has always been celebrated for its strength and purity.]

119 **DEWAR, THOMAS, Newcastle-upon-Tyne**—Manufacturer.

Specimens of brown and white mustard seed, from which mustard for table use is made.

[The mustard of commerce belongs to the family of cruciferous plants. Its introduction as an article of extensive employment at the table, only dates from the beginning of the last century. It is principally cultivated in the North Riding of Yorkshire.—R. E.]

120 **LEVY, WALTER, 2 White Row, Spitalfields**—Manufacturer.

Specimen of Taganrog wheat; the same, granulated, with the flour and bran extracted.

Samples of macaroni celery and vormicelli.

121 **TUCKER, RICHARD GRANT, Lenton, near Nottingham**—Manufacturer.

Starch, used by the lace-dressers in Nottingham. Gum substitute, used by cotton, silk, woollen, and wall-paper printers, for giving consistence to colours. Adhesive, or label gum, suitable for postage stamps. The residue, or glutinous matter, remaining after starch is extracted from wheat.

[A large number of plants and vegetable substances contain starch. It is found in seeds, roots, tubers, and stems. It is often obtained from wheat which has become accidentally damaged. From its insolubility in cold water, it is easily washed out of any vegetable tissue which may contain it, and thus it may be partially separated from other substances present in the matter operated upon. But there are some from which it cannot be thus separated, and here, by an ingenious method, chemical decomposition is employed to get rid of them. The liquor in which some of the starchy particles are contained is allowed to ferment. By this means the gluten, albumen, &c., become, in a great measure, dissolved, and the starchy particles are left unaltered, and separate themselves by precipitation. The largest source of starch of late years has been the potato, from which it is obtained simply by rasping and washing.—R. E.]

122 **TUCKER, EDWARD, Belfast**—Manufacturer.

Glue and starch, produced at Belfast. [The manufacture of the common and useful substance, glue, forms an interesting branch of the industrial arts. It is procured from the parings of hides, parchment, and refuse leather of all kinds. Such matters, after a preparatory cleaning in alkaline water, are hoiled in large vessels for some time. The liquid is then run off and is found to be charged with an impure solution of gelatine; on cooling, the sheets of glue are left in frames to dry. This part of the process is often singularly affected by atmospheric vicissitudes. The state of the air during thunder-storms produces a remarkable effect on the glue, and

often spoils the manufactured product. The substance commercially called "gelatine" is a very pure description of glue obtained, like it, from animal substances carefully selected and purified, so as to be fitted for human consumption. It has been largely used of late as a substitute for isinglass.—R. E.]

123 BROWN & POLSON, *Thrushcraig, near Paisley*—Manufacturers.

Patent powder starch, manufactured from sago flour (the exhibitors being inventors of this article).

Patent soluble starch, granulated, manufactured from potato flour.

Patent wheat starch, manufactured from wheat.  
Arrow-root, manufactured by the exhibitors.

124 WOTHERSPOON, ROBERT, *Glenfield Starch Works, Macvetton, near Paisley*—Manufacturer.

Specimen of Glenfield patent powder starch, manufactured from sago; a new material, from which the starch is made.

125 RECKITT, ISAAC, & SON, *Hull*—Manufacturers.

Patent imperial wheat starch, white and blue.

Patent soluble starch, blue and white, made from potato flour.

Patent sago starch.

Potato flour, used as a raw material in the manufacture of starch, and for stiffening Manchester calicoes, muslins, &c.

Wheaten starch powder, used in perfumery and confectionery.

126 SHAND & MUCKART, *Montrose*—Producers.

Samples of starch.

127 MILLER, DAVID & WILLIAM, *Musselburgh, near Edinburgh*—Producers.

Starch: household white, bleachers' wheaten, Royal blue, and sago flour. Scotch farina, Nos. 1 and 2. Arrow-root.

128 JONES, ORLANDO, & CO., *Battersea*—Inventors, Patentees, and Manufacturers.

Specimens of starch manufactured from rice, and of rough starch, hair powder, and gluten, obtained in the process of manufacture.

The process (patented in 1840) is the result of the discovery that a weak caustic alkaline solution has the property of separating starch from the gluten and fibrin with which it is combined in farinaceous substances. This process has enabled the patentee to substitute rice for wheat in the manufacture of starch: this substitution, besides other advantages, possesses that of preserving wheat for the more important purposes of human food. This starch requires no boiling—a point of great importance in its use; and, being less hygroscopic than wheat starch, retains a more permanent stiffness and glaze. The rough starch obtained in the process is valuable for feeding purposes, and for stiffening coarse fabrics.

129 PIESSE, SEPTIMUS, 43 *Molyneux St., Marylebone*—Inventor and Manufacturer.

Lactine or artificial milk, composed of yolk of eggs, gum acacia, honey, and salad oil; manufactured by the exhibitor.

This material contains all the elements of natural milk from the cow:—Caseine, albumen, gum, grape sugar, and fatty matter. On gradually mixing it with water, it forms either cream or milk, according to the rate of its dilution. Chemically, it resembles milk in its action towards reagents, and, as in milk, we have the true emulsion of fatty matter (butter) in water, without the intervention of any alkali.

Lactine keeps well for one or two years. On being mixed with water, it forms artificial milk, for the use of

sallors on a long voyage. With coffee, tea, and chocolate, it acts like ordinary milk, from which it can scarcely be distinguished.

Pistachio nuts (*Pistacia vera*) and pistachio-nut kernels, from the shores of the Mediterranean; imported by the exhibitor. The latter forms a cooling emulsion. The fecula, prepared like starch, is used as a cosmetic. It is very oily, sweeter than almonds, and is commonly eaten in the south of Europe and in India, at the dessert, and for confectionery.

Pistachio-nut powder (the fecula of pistachio kernels), manufactured by the exhibitor. This powder is used for whitening and enamelling the skin, for removing redness of the features, for drying the hands, and preventing perspiration—an advantageous substitute for the preparations of bismuth, largely used for the same purposes.

Patchouly plant (*Pogostemon patchouly*), a native of India and China; and essence of patchouly, a perfume distilled from it by the exhibitor.

Sulpho-nitro muriatic acid, or overlasting chlorine, for disinfecting purposes and deodorising the sick chamber; invented by the exhibitor. The materials, employed slowly generate chlorine, and continue in action for several months.

130 BERGER, SAMUEL, & Co., *Bromley, Middlesex*—Manufacturers.

Specimen of rice starch, blue and white, made under the exhibitors' patent; also, samples of Madras and Bengal rice, from which this article is usually made.

131 HALL, THOMAS, *Lenton, near Nottingham*—Manufacturer.

Patent starch.

132 M'GARR & SONS, *Palmerstown and Ashtown Mills, Dublin*—Manufacturers.

Specimens of linseed and refined rape oils. Linseed and rape cakes. Specimen of Irish mustard. Specimens of copper plates and lead pipes.

133 McCULLUM, MALCOLM, 12 *Cannon Street, Leith*—Discoverer and Producer.

Specimens of the rhizome, or creeping stem, of *Typha latifolia*, or "large red mace." The Gaelic name is "morthan;" the central part is edible in its raw state; when dried and separated from the fibres, it affords a meal, or flour, of a sweet and agreeable taste, which can be made into bread or starch.

Sample of the meal. The fibres of the stem are a substitute for lint. This plant grows in abundance in lakes and marshy places, and is very prolific.

134 EDWARDS, HENRY, 32 *Great Windmill Street, Haymarket*—Inventor and Manufacturer.

A mass of "custard powder," capable of producing 896 quarts. Composed of flour and other ingredients.

138 ST. ETIENNE, MADAME DANIELE, *Harberton Ford, Tullness*—Agents, TOOTAL and BROWNE, 73 and 74 *Piccadilly*—Producer.

Specimens of wheat-gluten, mixed with wheat flour, or potato-flour. Used chiefly as food, especially for invalids, in the form of soups, puddings, biscuits, &c.

Specimens of vegeto-animal compounds for long voyages, &c.; prepared with wheat-gluten, and beef, veal, mutton, gelatine, poultry, fish, &c.; the same with fruits. Used in the preparation of soups, puddings, pies, and other dishes.

Specimens of chocolate, biscuits, &c., improved in nutritive power by the addition of wheat-gluten.

Specimens of starch and potato-flour, artificial sago, tapioca, arrow-root, &c.

Specimens of gums. Potato-flour and starch gums, all soluble in cold water.

Inferior gum-arabic, cleaned and granulated, with improvement in the quality. All these gums used as substitutes for natural gum for printing, chemical, and general purposes.

## SOUTH GALLERY.

**130 MOORE, EDW. DUKE, Ranton Abbey, Eccleehall, Staffort—Patentes.**

Essence of milk, requiring only the addition of water to produce perfectly fresh milk. Samples combined with chocolate, cocoa, and coffee.

[In specimens similar to that described, inconvenience is often occasioned by the crystallization of the sugar of the milk, which is but sparingly soluble.]

**140 FADKUILNE, V. B., 19 Newington Crescent, Surrey—Patentes, Manufacturer, and Inventor.**

Consolidated milk for long sea voyages, and for medicinal and domestic use. After being dissolved in boiling water and reproduced in the form of milk, the solution will keep perfectly pure for four or five days; it may be boiled as often as required without "breaking;" and is miscible with all kinds of spirits.

[The preservation of the substance in question is due to the entire expulsion, by evaporation, and various other processes, of the watery constituents of milk. In the absence of a certain quantity of water putrefactive changes cannot proceed.—R. E.]

**141 GLASS, GEORGE MICHAEL, Brandon Street, Watworth—Inventor and Manufacturer.**

Gelatine for culinary and manufacturing purposes.

**142 GARDNER, JOHN, M.D., 51 Martimer Street—Discoverer.**

Leaves of a tree, said to contain a nutritive crystalline principle, identical with that of Chinese tea (*Theine*), showing the leaves in their natural state, simply dried, also in various forms after having undergone the necessary preparations for use.

**143 ASSAM COMPANY, 30 Great Winchester Street, City—Producer.**

Samples of tea, the produce of Assam (*Thea Assamica*). Assam became a British possession in 1826, at the conclusion of the Burmese war. The tea-plant was found to be indigenous there, but this fact was not generally known until the year 1834. In 1839, the Assam Company was formed. It is incorporated, and its object is the cultivation and manufacture of tea. Owing to impediments of various descriptions, its early operations were checked, and have been confined to the cultivation of about 1,000 acres. Until recently the results of the cultivation and manufacture of tea in a commercial point of view have not been ascertained. They are now fully established.

The tea realizes in England high prices, and is considered to be of fine qualities. It is entirely manufactured by natives of India.

**144 SAUNDERS & GATCHILL, Dublin—Agents.**

Chicory in all its stages, from the kiln-dried root to the ground dust, fit for use.

"Chicory" and ondive greens, the root of which is used as a substitute for coffee. The leaves are also largely used in a manufactured state, as a dye-stuff, called "pastel," or imitation wood," of which they form

the principal ingredient, for the purpose of rendering the colour permanent in woollen cloths.

[Chicory is the *Cichorium intybus*, a plant of the order Compositae, indigenous in most parts of Europe.—E. F.]

**146 POOLE, SARAH REBECCA, Kingston-on-Thames—Producer.**

Patent crystallized malt, used by porter brewers. Upon breaking a grain it will be seen that its substance has been converted into sugar; its properties consist in producing double the quantity of extract, and giving porter the desired flavour.

**149 PERKINS, HENRY, Hanworth Park, Middlesex—Producer.**

A loaf of sugar, made by W. J. Evans, M.D. in Mr. Perkins' kitchen at one operation, and without filtration through animal charcoal, from canes grown by Henry Perkins in his hothouse, Hanworth Park, Middlesex.

A bottle of rum which was also made at the same time, from the same canes, by Dr. Evans.

**150 KIDD & PODGER, Isleworth, Middlesex—Manufacturers.**

Specimens of extra superfine flour dressed through Swiss silk machines, and manufactured from English wheat and Australian wheat.

**152 MARRIAGE, E., Colchester—Producer.**

Samples of flour.

**153 M'CANN, JOHN, Diamond Mill, Drogheda—Manufacturer.**

Coarse cut oatmeal, used for making stirabout, or porridge, in Ireland.

**154 STONEHOUSE, ALEXANDER, Farina Works, Dunning, Perth, and 43 Molyneux Street, Bryanston Square—Producer.**

Specimen of farina, used as food, and in manufactures.

**157 STYLES, THOMAS, 148 Upper Thames Street—Manufacturer.**

Ashby's prepared groats, barley, and pea-flour, for the production of pure gruel, barley-water, light puddings, and food for infants, pea-soup, &c.

**159 CHITTY, EDWARD, Guildford—Manufacturer.**

Specimens of flour.

**160 FITCH, FRED. CHS., Steeple Bumpstead, Essex—Producer.**

Sack of fine wheaten flour, manufactured from Essex wheat.

**161 SMITH, J., Hare Craig, Dundee—Manufacturer. Agent in London, W. J. ROBERTSON, 48 Deconshire Street, and 35 Walbrook, City.**

Samples of patent oat flour.

**162 BUCK, P., & SON, Danby Mills, near Middleham, Bradford—Producers.**

Double superfine flour; fine flour; wheat meal and oat meal. Exhibited for colour and quality.



## VEGETABLE AND ANIMAL SUBSTANCES USED IN MANUFACTURES.

### INTRODUCTION.

The present Class concludes the first section relating to Raw Materials and Produce. Within the limits of the present Class are included a great variety of substances employed in the arts and in manufactures. The Class is subdivided generally into substances of vegetable, and substances of animal origin. The former division comprises gums and resins, oils, acids, dyes and colours, tanning materials, fibrous and cellular substances, timbers, and miscellaneous articles applied to various economical purposes. The latter division includes materials for textile fabrics, for the production of chemical substances, and for pigments and dyes.

The objects included in this Class are placed in SOUTH GALLERY P, and succeed those belonging to the preceding Class in order of arrangement. The Class, although embracing a variety of substances, is not an extensive one, regard being had to the space occupied. Among the substances of vegetable origin of interest in the arts, are oils of various kinds, together with their solid and fluid principles; stearine and oleine, varnishes made by the solution of a variety of resinous substances in alcohol or wood spirit; specimens of wax, and of the same in a manufactured state. Interesting series of dyes and colours are also exhibited. The beautiful colours derived from various lichens by a curious chemical process, are shown with their application to textile fabrics, and gum. The splendid colours yielded by safflower, indigo, and other vegetable substances are also illustrated. This Class is particularly rich also in its illustrations of the fibrous materials used for cordage and clothing. Specimens are shown of China grass, a fibrous product from *Urtica nivea*; of New Zealand flax; of hemp of various growths—Indian, Egyptian, Belgian, American, and Russian; and of flax from various countries. The fibrous substance commercially known as jute, is also illustrated. The fibrous material obtained from the husk of the cocoa-nut is exhibited in its various stages of manufacture and in its applications to the production of fabrics. Specimens illustrative of the application of new processes to the preparation of flax for spinning have also a place in this Class, and appear to promise useful results in the employment of this material in textile manufactures. Corks of different kinds, and new fibrous substances applicable to textile purposes and for paper, are also shown. The specimens of different timbers used for construction and ornament have great technical interest. The botanical names, habitata, and uses of the trees producing these woods are attached to their description in the Catalogue. This will enable the merchant to supply himself with accurate information upon a variety of fancy woods hitherto only recognized under their commercial appellations. In the space allotted to the preceding Class will also be found illustrations of various useful timbers. The preservation of timber is illustrated by several series of specimens indicating the progress of decay, and its arrestation in wood equally exposed.

The substances derived from the animal kingdom include specimens of whalebone in different stages of manufacture; wools of various kinds in the raw state, and as cleansed from some impurities. Mohair, horse-hair, in various conditions of manufacture; down and feathers. Some interesting results of the attempt to breed the silkworm in England, are exhibited in raw silks obtained, and in manufactured specimens. Raw and thrown silks of their natural colour and variously dyed are also shown. Animal oils, gelatine, glues, and pigments and dyes of animal origin are also included in the objects contained within this Class.

The four Classes comprised within this section deserve and demand attentive study. The objects comprised by them form the materials out of which all that is beautiful and useful in this great collection has been created, and indicating in their various states the preliminary application of human industry to their preparation for further usefulness. The study of them is a valuable introduction to that of the other Classes, in which constructive industry is illustrated as contrasted with that preparative series of operations exhibited by the objects included within the first section. The consideration of results is more generally interesting than that of the processes leading to them; but the latter study is unquestionably the most instructive. To the philosophic inquirer into the objects of this Exhibition, this section will probably appear the most interesting of all, as the development of raw material in all the varied forms assumed, in those sections is observed in Machinery, Manufactures, and Fine Arts.—R. E.



1 GAIGOR, J., & Co., *Nurseries, Forres, Scotland*—  
Producers.

Native Scotch pine plants, of various sizes and ages, some of which are raised by a new method, which produces fibrous roots, and adapts them for bare and exposed situations. Larch plants of various sizes and ages. Weeping birch, one year old, from seed produced by native trees on the banks of the Fludhorn, Morayshire; sown April 30, 1850.

2 KING, EMMA, *Church Street, Edmonton*—  
Producer.

Specimens of anatomised plants, arranged as an ornament.

2A COOKE, E. W., *The Ferns, Victoria Road, Kensington*—  
Producer.

Preserved pitcher plants. These natural pitchers are appended to the leaves of a plant, a native of the East Indies, growing in stagnant, swampy places; it possesses the faculty of distilling the purest water. The pitcher during the period of its growth remains closed; but when quite expanded and full of water the lid opens. The pitcher of some species will contain nearly one quart. The case contains specimens (which were dried in hot sand to preserve their form) of the following species, viz.:—*Nepenthes Rafflesiana* (Singapore); *N. ampullacea* (Singapore); *N. Loddigesii* (Singapore); *N. distillatoria* (Ceylon).

Also specimen of *Sarracenia*, and a species of *Cephalotus*; which both grow on the ground. The palm and other seed-vessels are introduced merely for ornament.

3 STEVENS, WILLIAM, *1 Rock Place, Tottenham Road, Kingsland*—Inventor.

Preserved flowers, retaining their natural form; intended to form cabinet illustrations of botany.

3A CROWCHER, C., JUD., *Chapel Place, Liverpool Road*—  
Producer.

Specimen of calcolned straw.

4 PURSEY, WILLIAM HENRY, *14 Spring Street, Sussex Gardens, Paddington*—Manufacturer.

Flowers used as ornaments for garnishing meats, &c.; cut out of vegetables, such as carrots, turnips, beet-roots, &c.

[This curious art gives exclusive employment to several persons in the Metropolis.]

5 ROCK, MARV, *6 Stratford Place, Hastings*—Producer.

Ornamental stand, formed chiefly of a species of grass which grows on the cliffs at Hastings, and is used for ladies' work-baskets, table-mats, &c. The stand contains specimens of Hastings pebbles.

[The Hastings pebbles are from the calciferous grit of the Tilgate beds which form the "White Rock" of Hastings, but are often elsewhere seen in more tabular masses, resting on a very compact conglomerate, enveloping large rolled pebbles of variously-coloured quartz, and jasper and smaller ones of pure white quartz and flinty slate.—D. T. A.]

5A TILLEY, Lieut., R.A., *Fivehead, Taunton, Somerset*—  
Designer.

A series of beautiful specimens of the leaves of various trees, anatomised, prepared, and arranged by the exhibitor.

Perfect skeletons of the leaves of the sycamors, poplar, aspen, ivy, lime, and wild or wood-medlar trees (or of the *Pseudo-platanus*, *Populus*, *Populus tremula*, *Medora helix*, *Tilia*, and *Mespilus diffusa* of Linnæus), grouped, dyed black, and displayed on a white drawing-board, to show their contrast in kind, texture, shape, and shade.

Groupings of some of the above leaves, dyed and undyed, on a blue and white drawing-board, and placed

in a glassed frame, divided into compartments, one of which contains a vegetable or leafy picture of the year, shown by twelve growing and fading changes of the sun leaf (*Ulmus campestris*). Also strawberry leaves (*Fragaria vesca*), displayed under the similitude of a snake, from their spotted resemblance to the skin of that reptile, overlaid by ferns brought from the island of Madeira by Mrs. Susan Farrent. In this specimen is exemplified one of the most difficult operations in vegetable anatomy. In a small circular gilt frame may be seen two anatomized pear leaves (*Pyrus*), having the appearance of three, the one being whole, the other divided from the tip to the leaf stalk or stem, and the two parts laid open right and left. The minutest threads in the texture of the one side having its counterpart in that of the other; a task of no small difficulty, when it is considered that they previously undergo the double process of anatomy and dying, added to the frail and delicate nature of the material operated on. Some of the arrangements are under-lettered with letters cut from the leaf in its different stages of growth and decay.

[The whole of these specimens owe their origin to the accidental circumstance of the operator's going to the pond-side for water to refresh his flowers in the dry summer of 1840, when the fragment of an elm leaf floating into the dipper in its skeleton state suggested the idea of effecting its anatomy by artificial means. He was then in his sixtieth year, and had never seen or attempted anything of the kind before.]

6 HARRISON, RICHARD & JOHNS, *Full*—Producers.  
Specimens of English and Foreign Woods.

|                                                                                                                                                                                                                                                                                                                                                                                                                                                                                                                                                                                                                                                                                                                                                                                                                                                                                                                                                                                                                                                                                                                                                                                                                                                                                                                                                                                                                             |                                                                                                                                                                                                                                                                                                                                                                                                                                                                                                                                                                                                                                                                                                                                                                                                                                                                                                                                                                                                                                                                                                                                                                                                                                                                                                                                                                                                                                                                                         |
|-----------------------------------------------------------------------------------------------------------------------------------------------------------------------------------------------------------------------------------------------------------------------------------------------------------------------------------------------------------------------------------------------------------------------------------------------------------------------------------------------------------------------------------------------------------------------------------------------------------------------------------------------------------------------------------------------------------------------------------------------------------------------------------------------------------------------------------------------------------------------------------------------------------------------------------------------------------------------------------------------------------------------------------------------------------------------------------------------------------------------------------------------------------------------------------------------------------------------------------------------------------------------------------------------------------------------------------------------------------------------------------------------------------------------------|-----------------------------------------------------------------------------------------------------------------------------------------------------------------------------------------------------------------------------------------------------------------------------------------------------------------------------------------------------------------------------------------------------------------------------------------------------------------------------------------------------------------------------------------------------------------------------------------------------------------------------------------------------------------------------------------------------------------------------------------------------------------------------------------------------------------------------------------------------------------------------------------------------------------------------------------------------------------------------------------------------------------------------------------------------------------------------------------------------------------------------------------------------------------------------------------------------------------------------------------------------------------------------------------------------------------------------------------------------------------------------------------------------------------------------------------------------------------------------------------|
| <p>Alder, English.<br/>Apple-tree, English.<br/>Ash, English.<br/>Ash, American.<br/>Birch, African.<br/>Beech, English.<br/>Beech, Dutch.<br/>Birch, English.<br/>Birch, American.<br/>Birch, Russian.<br/>Blackwood, East Indian.<br/>Blackthorn, African.<br/>Butternut, American.<br/>Boxwood, Turkey.<br/>Boxwood, Brazilian.<br/>Boxwood, European.<br/>Brazilletto, Jamaica.<br/>Brazilwood, Pernambuco.<br/>Camplinwood, Brasilia.<br/>Canewood, African.<br/>Canarywood, Brasilia.<br/>Canazuetta.<br/>Cedar of Lebanon.<br/>Cedar, Havannah.<br/>Cedar (pencil), North America.<br/>Cedar (red), New South Wales.<br/>Cedar (white), New Brunswick.<br/>Cherry-tree, English.<br/>Chestnut (horse), English.<br/>Cocus, West Indies.<br/>Cocus (cut endwise), West Indies.<br/>Coromandel, Ceylon.<br/>Cotton-tree.<br/>Cypress, Egypt.<br/>Cypress, English.<br/>Ebony (black), African.<br/>Ebony (green), West Indies.<br/>Ebony (marble), Ceylon.<br/>Elm, English.<br/>Elm (hard), English.<br/>Elm (rock), American.<br/>Fir, Scotch.<br/>Fustic, South American.<br/>Gilliflowd.<br/>Greenheart, Demerara.<br/>Gumwood (blue), New South Wales.<br/>Gumwood (red), New South Wales.<br/>Hackmatack, Canada.<br/>Harewood, English.<br/>Hemlock, New Brunswick.<br/>Hickory, United States.<br/>Holly (white), English.<br/>Hornbeam, English.<br/>Horsetail-wood, Rio Janeiro.<br/>Ironwood, Brasilia.</p> | <p>Jakwood, East Indies.<br/>Klaboon, or Amboyna (trunk of), Singapore.<br/>Kishooa, or Amboyna (burr of), Singapore.<br/>Kingwood, Brasilia.<br/>Kingwood, African.<br/>Laburnum, English.<br/>Lancewood (red), Cuba.<br/>Lignum-vitæ, St. Domingo.<br/>Lemon-tree, Sicily.<br/>Lime-tree, English.<br/>Locust-tree, North America.<br/>Logwood, Bay of Campeachy.<br/>Mahogany, Cuba.<br/>Mahogany, St. Domingo.<br/>Mahogany, Jamaica.<br/>Mahogany, Honduras.<br/>Mahogany, Iahama.<br/>Mahogany, Panama.<br/>Mahogany, Africa.<br/>Mahogany, South Australian.<br/>Maple, English.<br/>Maple (Bird's-eye), American.<br/>Maracaybo, Bay of Mosatallia, Rio Janeiro.<br/>Mulberry, Valparaiso.<br/>Niagara-wood, from the Falls, Oak, English.<br/>Oak Pollard, English.<br/>Oak, Memel.<br/>Oak, Canada.<br/>Oak (wainscot), Riga.<br/>Oak, Dutch.<br/>Oak, Botany Bay.<br/>Oak, New Zealand.<br/>Oak (live), North American.<br/>Oak, Africa.<br/>Oak, South American.<br/>Olive-wood, Leghorn.<br/>Orange-tree.<br/>Palm-tree, Palmetto, Palmyra, India.<br/>Paralboo.<br/>Partridge-wood, Brasilia.<br/>Pheasant-wood, Brasilia.<br/>Pear-tree (plain), English.<br/>Pear-tree (stained), English.<br/>Pear-tree (figured), English.<br/>Pine and Fir, American White.<br/>Pine and Fir, American Red.<br/>Pine and Fir, Baltic Red.<br/>Pine and Fir, Baltic White.<br/>Pine and Fir, American Spruce.<br/>Pine, Swiss.<br/>Pine and Fir.<br/>Pine (Pitch), United States.</p> |
|-----------------------------------------------------------------------------------------------------------------------------------------------------------------------------------------------------------------------------------------------------------------------------------------------------------------------------------------------------------------------------------------------------------------------------------------------------------------------------------------------------------------------------------------------------------------------------------------------------------------------------------------------------------------------------------------------------------------------------------------------------------------------------------------------------------------------------------------------------------------------------------------------------------------------------------------------------------------------------------------------------------------------------------------------------------------------------------------------------------------------------------------------------------------------------------------------------------------------------------------------------------------------------------------------------------------------------------------------------------------------------------------------------------------------------|-----------------------------------------------------------------------------------------------------------------------------------------------------------------------------------------------------------------------------------------------------------------------------------------------------------------------------------------------------------------------------------------------------------------------------------------------------------------------------------------------------------------------------------------------------------------------------------------------------------------------------------------------------------------------------------------------------------------------------------------------------------------------------------------------------------------------------------------------------------------------------------------------------------------------------------------------------------------------------------------------------------------------------------------------------------------------------------------------------------------------------------------------------------------------------------------------------------------------------------------------------------------------------------------------------------------------------------------------------------------------------------------------------------------------------------------------------------------------------------------|



Larch, Scotch.  
Pine.  
Pine Fir.  
Pine Cordie, New Zealand.  
Plane-tree Lacewood, Levant.  
Pium-tree, English.  
Poplar, English.  
Quassia-wood, West Indies.  
Quassia-wood, Brazil.  
Red Sanders, or Rubywood,  
East Indies.  
Rosetta, or Dansonwood, East  
Indies.  
Rosewood, East Indian.  
Rosewood, Mexican.  
Rosewood, Brazil.  
Rosewood, African.  
Rosewood, Honduras.  
Sabiola, Cuba.  
Sandalwood.  
Sapanwood, Siam.  
Satinwood, St. Domingo.  
Satinwood, East Indian.

Satinwood, Porto Rico.  
Sassafras-wood.  
Sash, East Indies.  
Shubwood, Surinam.  
Sycamore, English.  
Teak, Mouline.  
Teak, African.  
Tombokie.  
Tortaro.  
Tulipwood, Brazil.  
Tulipwood, Botany Bay.  
Tulipwood, French.  
Veliparais wood.  
Violaceous, Brazil.  
Walnut, English.  
Walnut (black), Mexican.  
Walnut (black), American.  
Willow, English.  
Yellow-wood, East Indies.  
Yew, English.  
Zebra-wood, Brazil.  
Several specimens of unknown  
wood.

7 BURNETT, Sir W., M.D., K.C.B., F.R.S., 53 King  
William Street, London Bridge—Producer.

Specimens of Burnettized and un-Burnettized timber, canvas, cotton, and woollen cloth, and raw hides, tested to demonstrate the efficacy of the process. Specimens of antiseptic and disinfecting solutions, and a drawing of the hydraulic apparatus employed for the preparation of timber.

8 FITCH, F. C., Steeple Bumpstead, Chelmsford—  
Producer.

Specimens of English woods.

9 SANDERS, W. WILSON, Wandswoth—Proprietor.

Collection of woods, amounting to upwards of 700 specimens, from various parts of the world, arranged geographically; with scientific name, native or local name, native country, weight per cubic foot, principal uses or peculiarities; with specimens of veneers of the more beautiful or interesting woods. The block specimens are without varnish of any kind. The veneers are varnished so as to show the beauty of the woods.

9A EVANS, WILLIAM, Castle Street, Swansea—  
Inventor.

Pieces of Welsh oak, prepared by a peculiar process, as a substitute for fancy wood, and useful for turners and cabinet-makers: the process is both simple and cheap.

A cannon lock of peculiar construction, designed to fire a gun by percussion.

10 STOWE, HENRY, Buckingham—Inventor.

Specimens of wood, stained without heat or moisture; the process being equally applicable to it when carved.

14 HOLTZAPFEL & Co., 64 Charing Cross, and 127 Long  
Acre—Proprietors.

Specimens of woods commonly employed in England for turnery.

15 GILLOW & Co., 176 Oxford Street, and Lancaster—  
Proprietors.

Specimens of St. Domingo mahogany.

16 ENDERSON, HENRY JOHN, 140 Praed Street,  
Paddington—Producer.

Grained imitation of bird's-eye maple and other fancy woods, on deal. Imitation of inlaid marbles and fancy woods, on slate.

19 SCOTT, E., & Co., 83 Devon Street, Soho—  
Manufacturers.

Walnut and rosewood veneers.

20 NEWTON, CHARLES HENRY, Plough Bridge,  
Rotherhithe, Surrey—Manufacturer.

Specimens of English and Foreign woods, prepared on

one side and rough on the other, to show the application of the patent desiccating process in the seasoning of woods. By this process, wood is seasoned and made fit for use in a few weeks. The moisture is evaporated by rapid currents of hot air, by which decay and dry rot are, in a great measure, prevented.

21 BETHELL, JOHN, 8 Parliament Street, Westminster  
—Inventor and Patentee.

Specimens of wood saturated with oil of tar, by the process called "creosoting."

Creosoted sleepers, which have been in use for years on the Northern and Eastern, and London and North Western Railways. A piece of unprepared wood, showing the ravages of the *teredo naucalis*. A piece showing those of the *limoria terebrans*, with a few holes bored by the teredo.

Two slices, cut from creosoted piles, which have been four years in the sea, at Lowestoft harbour.

Specimens of fish, prepared for manure, by the creosote oil.

[Several plans have been patented, having for their object the prevention of timber from decay by injecting certain fluid substances into its pores, and by chemical and mechanical action preventing the growth of fungi—viz., Mr. Kyan's patent, in 1832, for impregnation with corrosive sublimate; Sir W. Burnett's, in 1836, for injecting chloride of zinc; Mr. Bethell's, in 1838, for impregnation with oil of tar; and Mr. Payne's, in 1841, for impregnation with metallic oxides or alkalies.—S. C.]

21A SAMUELS, DAVID, 71 Lebon Street, West Ham, Essex  
—Inventor and Manufacturer.

Picture frame of various English woods.

22 CLASSON, J., Industrial Depot, Northumberland  
Buildings, Dublin—Manufacturer.

Denoters of time, exhibiting days, months, and dates, and made of bog-yew, bog-oak, and various fancy woods, the growth of Ireland. Letter racks. Chimney-piece what-nots. Book carriers. Inkstands. Paper and envelope cases. Ticket trays. Nests of boxes, and frames for different purposes: made of the same materials. Packages of scouring powders.

[These powders are produced from a preparation of freestone and alkali, and possess both mechanical and chemical properties, which render them valuable for cleansing railway carriages covered with smoke and grease, and for purifying culinary utensils in general.]

Different qualities of peat or turf, and peat charcoal, adapted for manufacturing purposes, deodorizing and manure.

Specimens of fancy woods, the growth of Ireland; part of a mulberry-tree, perfectly sound, from the gardens of Trinity College, Dublin; known to be more than 400 years old, presented by the Rev. Dr. Luby.

23 BROTHERTON, WILLIAM, & Co., Hungerford Wharf  
—Importers and Manufacturers.

Samples of rape seed, the produce of Holland and the East Indies. Rape seed bruised previous to extracting the oil. The oil as extracted, refined, and purified. Olive oil in its original state; and as refined for machinery. Almond oil as extracted; and as refined for the finer descriptions of mechanism.

24 BARCLAY & SON, 170 Regent Street—  
Manufacturers.

Specimens of bleached wax; wax candles, white and coloured; sperm candles, white and coloured; stearine candles; candles of mixed materials; wax and composition mortars for night lights and for heating dishes; with sundry small articles.

## 25 FREEMAN, MESSRS., 3 Wignore Street, Cavendish Square—Manufacturers.

Fine transparent wax and spermaceti lights, with plated wicks, and other candles and night lights. Materials in the unmanufactured state. Refined oils, &c.

## 26 BAUWENS, L. F., Grease Works, Wakefield—Manufacturer.

Products of various patent processes used in extracting pure oils and greases from the refuse soap-suds of woollen, silk, and other manufactories.

## 27 ROSE, WILLIAM ANDERSON, 66 Upper Thames Street—Manufacturer.

Palm-oil grease, for fast trains. White grease, for machinery, &c. Liquid grease, for mining purposes.

Clarified machinery oil, will nut gum or olog. Clarified burning oil, to burn equal to sperm oil. Body, carriage, and oak varnishes.

Ironwork black, equal to black japan, dries in half-an-hour.

Red, blue, yellow, and purple paints supplied to Messrs. Fox, Henderson, & Co., for decorating the Exhibition Building.

White zinc antiozide paint for ironwork, stucco, &c.

## 28 HILLAS, FLEMING, 5 Ordnance Row, Lewisham Road, Greenwich—Inventor.

Purified animal, vegetable, and fish oils for lubrication and perfumery.

## 29 MILLER, TAVERNER JOHN, Dorset Wharf, Westminster—Importer and Manufacturer.

Spermaceti oil in its original state, as imported from the South Seas.

Rough spermaceti, when separated by filtration and pressure from the oil.

Filtered spermaceti oil, used for illuminating purposes and for lubricating machinery.

Block of refined spermaceti, the inside being hollow, to exhibit its natural crystallization.

Bust formed of refined spermaceti, a new application of the article.

[The sperm whale, *Physeter macrocephalus*, called also cachalot, is a carnivorous cetacean, living chiefly on cuttlefish, and having its mouth armed with teeth instead of whalebone. It is gregarious, and inhabits the open oceans of both eastern and western hemispheres, ranging between 60° N. L. and 60° S. L., but abundant and pursued chiefly in the region of the line-currents between 7° N. L. and 7° S. L. It grows to a large size, the male to 60 feet in length, the female to half that dimension. The former yields 70 to 90 barrels of sperm-oil, the latter 20 to 30. The spermaceti is contained in cellular cavities, occupying the anterior and upper parts of the unwieldy head; from 200 to 500 gallons of this "head-matter" are yielded by a whale. One-sixth of the entire produce is the usual proportion. This matter is placed in hair bags, submitted to strong pressure, melted, and boiled with a weak solution of potash and in alcohol, then cast into moulds, when it becomes the crystalline substance called spermaceti, which is itself a peculiar species of stearine. *Cetine* is its purified state.—E. F.]

## 30 EWEN, JAMES, 17 Garlick Hill, City—Manufacturer.

Samples of clarified fats.

## 31 DURANT, RICHARD, jun., 11 Copthall Court—Proprietor.

Samples of raw silk, the produce of the various silk-producing countries, Italy, China, India, Turkey, &c.

## 32 DODGE, Mrs. CATHERINE, Godalming, Surrey—Producer.

Silk produced by the silkworm, fed upon the leaves of the white mulberry, at Godalming, it being a first production.

Specimens of the silk manufactured.

## 34 HANDS &amp; LEAVESLEY, Coventry—Silk Dyers.

Specimens of dyed silks.

## 35 DOXAT &amp; Co., Bishopsgate Street Without—Importers.

Sample of Italian raw silk.

## 36 HOWE, JOSEPH, &amp; Co., Coventry—Dyers.

Specimens of self-colours dyed from thrown silk:—yellow gum; specimens of shade dyeing; showing permanency of colours for several years.

## 37 JACQUEMOT, JOHN MARE, 36 Old Broad Street—Importer.

Skeins of raw silk, the produce of a filature near Geneva, Switzerland.

## 39 OLIVER, WILLIAM, 89 John Street, Fitzroy Square—Producer.

A slab of bird's-eye maple.

## 40 SECTIONAL COMMITTEE ON VEGETABLE KINGDOM, Exhibition Building—Producers.

Samples of the ordinary flax and hemp of commerce.

French flax; Flemish flax; Dutch flax; Friesland flax; Archangel flax; Riga flax; English flax; Egyptian flax; New Zealand flax.

Petersburg clean hemp; Petersburg half-clean hemp; Riga Rein hemp; Riga Pass hemp; American hemp; Egyptian hemp; brown India hemp; India scum hemp; Manila hemp; Italian hemp; Jute hemp.

## 41 TRENT, EDWIN WARD, Park Hemp Works, Old Ford—Manufacturer.

New Zealand flax as imported. New Zealand flax cleansed, from the same; cleansed by machinery, invented by the exhibitor.

Tow, made in the operation of cleansing the flax. Fishing-lines, made from the same, showing what can be made from the least valuable portion of the flax.

Samples illustrating the different modes of laying ropes or lines. Coil of rope made from yarn spun by the exhibitor's improved machinery, combining all the advantages of hand and machine spinning, without their defects.

## 42 WRIGHT, LEMUEL WELLMAN, &amp; Co., 75 Cheapside—Inventors and Manufacturers.

Specimens of China grass (*Urtica nivea*) as it comes from India (Assam) and China; and in various stages from the raw material, as manufactured in India and China.

Also flax and China grass as prepared in this country, for spinning into yarns for finer purposes. Specimens of broad cloth, in which it is mixed with wool in various proportions. Specimens of various kinds of paper made from wheat straw.

## 43 DONLAN, M. J. J., 4 St. Peter's Square, Hammesmith—Inventor.

The seeds of flax and hemp chemically prepared, by which their germinating powers are said to be augmented.

Flax straw, produced from prepared seed, and flax straw produced from seed not prepared, sown on the same day, and on the same land; also samples of flax in dif-

ferent stages of preparation, produced from unsteeped flax straw.

Samples of the ligneous or woody particle from the flax straw; these, when mixed with other ingredients, are used for the feeding and fattening of cattle.

Samples of sail-cloth, produced from unsteeped flax straw. Sail-cloths produced by these processes are said to have been used during five years without being affected with mildew, heating, or premature decay.

Samples of the *Phormium tenax*, or New Zealand flax, in different stages of preparation, and sail-cloth manufactured from the same.

[The *Phormium tenax*, or New Zealand flax, is a plant of very different nature from the common flax (*Linum usitatissimum*). The former is an endogen, the latter an exogen. The New Zealand flax is a liliaceous plant.—E. F.]

Samples of fine textures, threads, &c., produced from unsteeped flax straw, brought into a similar state to cotton incorporated with German wool; and also specimens of similar manufacture, produced from the *Phormium tenax*, or New Zealand flax plant.

The above specimens are said to have been produced by new and peculiar processes.

#### 44 GILLMAN, EDWARD, *Twickham*, Agent for Tao Nui, a New Zealand Chief—Producer.

Specimens of the most useful of the New Zealand woods. Gum of the Kawri tree (*Dammara australis*) called Tino; a good varnish can be made from this substance.

Bark of the Hinau tree (*Dicra dentata*); used by the New Zealanders to prepare the flax for dyeing.

Flax (*Phormium tenax*), prepared for dyeing by steeping in a strong decoction of the Hinau bark.

Flax dyed black, by kneading and rubbing in black mud from a freshwater river.

Shrimp net (*Kotutu*), made from shreds of flax, the pulp of the leaf not removed.

Flax partially disengaged from the leaf; also the shell (*Kuku*) used for the purpose.

Flax in the first stage of preparation (*Muka*).

Small cord made from the flax in the first stage of preparation.

Flax prepared for weaving, by soaking it for two days in water, then twisting it into hanks, and beating it with a mallet on a stone. Mantles wove from flax.

#### 45 HIVES & ATKINSON, *Leeds*—Importers and Manufacturers.

Samples of flax grown in the Courtrai district, Belgium; line, silver-roving, and yarn, from the flax.

Fine cloth, manufactured from 280 warp and 320 weft.

[The preparation of flax at Courtrai differs in no essential respect from the ordinary method adopted at home. But the bundles, instead of being steeped in stagnant pools, are sunk in the clear waters of the River Lys. It is said that the waters of this stream have a peculiar effect in producing flax fibre of extraordinary whiteness and purity. The bundles, after having been steeped, are untied and spread out on grass to be dried. On the completion of this process, the flax is again made up into bundles and undergoes its preparation for the market.—R. E.]

Samples of flax from the Lokeren district, Belgium; line, silver-roving, and yarn, 50 leas to 200 leas, from the flax.

[The total annual production of flax in Belgium amounts, by a recent estimate, to about forty millions of pounds. Its total value is calculated at about two millions and a half sterling. This flax is of very superior quality, and is principally employed in the manufacture of the finest class of fabrics. Attempts are being now made on a large scale to cultivate this important plant in

England and Ireland. Belgium exports about five millions of pounds of flax to England. The flax grown in the Courtrai district is universally considered to be of the finest quality.—R. E.]

Samples of yellow flax, grown by John Warnes, Esq., Trimmingham, Norfolk; of blue flax, grown in Yorkshire. Line, silver-roving, and yarn, from 50 leas to 200 leas, from the flax.

Piece of brown cloth and piece of bleached cloth, 100 warp and 150 weft.

Specimen of Chinese reed.

Samples of China grass (a kind of nettle) in the raw state; softened; prepared for cutting and heckling; half-bleached and full-bleached line from this grass; silver-roving from full-bleached line; tow; 250 leas spun from full-bleached line; 100 leas from tow; dyed line, yarn, and tow from the same.

Piece of cloth, 200 leas warp and 200 leas weft.

["China grass" is known botanically under the name, *Urtica nivea*. It is extensively imported into this country from Assam, and from China.—R. E.]

#### 46 CATOR, NELSON, & Co., *Selby*—Manufacturers.

Line stumps, or the raw flax plant with the seed attached, as pulled and dried; grown in Yorkshire.

Flax manufactured from the line stumps, and prepared for the flax-spinners. The seed is taken off, the stumps then retted by an artificial process, and afterwards broken and scutched by machinery.

#### 47 LONG, J., C.E., *Limerick*—Producer.

Specimens of Irish woods. Bog oak; bog yew; bog deal; oak; elm; ash; beech; copper beech; black oak; sycamore; cherry; apple; holly; poplar; maple; alder; spruce; Scotch fir; larch; walnut; arbutus; laburnum; and evergreen oak. These timbers are the growth of former ages, and are found embedded in the bogs of Ireland.

[These timbers represent ancient forests, the remains of which are now buried beneath accumulations of peat and water, but in which wandered not only species of existing British mammals, but extinct races, like that of the *Megaceros hibernicus*, "leading into the times when elephants, hyenas, and other extinct quadrupeds appear to have tenanted this country."—J. L.]

The black oak is used for fancy and ornamental work. The yew is a fine-grained timber of different shades. It appears to be a suitable timber for cabinet work, such as pianos, &c., being durable and capable of taking a high polish. The deal is useful for rough work.

These timbers are in general used in carpentry and joinery, ship-building, house-building, coach-building, cabinet-making, machinery, farming implements, &c. The ordinary timbers, such as oak, elm, ash, beech, larch, maple, &c., are considered of superior quality and large growth.

Specimen of Carrigeen moss; found in great abundance on the sea-shores in the counties of Clare and Kerry.

["Carrigeen," or "Irish moss," is a sea-weed. It is the *Chondrus crispus* of botanists, a fucus which grows abundantly on all the rocky shores of the British Isles. It is most plentiful at the edge of low-water mark. *Chondrus mammillosus* is another species often mixed with and used like the former. The plant is gathered from the rock, then washed and laid out to dry and bleach in the sunshine. It has emollient and demulcent properties.—E. F.]

Specimen of oak bark. This bark is supplied from the various counties around Limerick to the tanners of the city and neighbourhood.

#### 49 ADAMS, —, *Ballyderritt, Coleraine*—Producer.

Sample of flax.

SOUTH GALLERY.

51 ROBERTSON, HENRY, 7 Salisbury Street, Strand—  
Producer.

A vegetable fibre, indigenous to the British Isles, applicable to the manufacture of fine thread and paper.

53 PICCIOTTO, MOSES HAIM, 3 Dean Street, Finsbury Square—Producer.

Specimens of fine flax, prepared in Italy by a peculiar process, applicable to all sorts of flax, steeped or unsteeped. By this process coarse produce may be brought to a great degree of fineness.

54 MASON, GEORGE, Yately, Hartford Bridge, Hants—  
Producer.

1. Flax grown, steeped, and prepared for market at Yately, North Hants. 2. Produced in South Hants. 3. Produced at Cobham, Surrey. 4. Flax grown and scutched at the Farnborough workhouse. 5. Flax scutched by prisoners in county gaol, Winchester. 6. Refuse tow and flax manufactured at Yately. 7. Coarse tow and flax. 8. Models of tools used.

55 MARSHALL & Co., Leeds—Importers and  
Manufacturers.

Sample of Chinese grass, *Urtica nivea* (Ma, Chinese name), the white-leaved nettle of China, commonly called grass, in the state in which it is imported from the province of Canton, in China. Sample of heckled fibre from the same, ready for the spinning process, after it has undergone a steeping similar to that of flax, and also a chemical or mechanical treatment, by which it is cleansed and softened.

Samples of sewing thread, dyed and bleached, and of thread for lace, from No. 30 to 300 lea, made from this material, showing its capacity of taking a good colour, and producing an even wiry thread. Samples of fine drill, from the same material, bleached and coloured, showing the same qualities.

Samples of Courtral flax and of dressed line, also of sewing thread dyed and bleached, No. 25 to 240 lea, from the same, exhibited for quality and finish.

56 BARSHAM, JOHN, Kingston-on-Thames—Inventor  
and Manufacturer.

The outer shell or husk of the cocoa nut (*Cocos nucifera*).

Fibre separated from the same by a patent process. Brushes, manufactured from the fibre, instead of bristles.

Door mat manufactured from the fibre. The fibre is cheap, and is preferable to bristles for durability.

57 NIGHTINGALE, WM. & CHARLES, 64 Wardour Street, Soho—Importers and Manufacturers.

Bed feathers and dowels, mostly used in England: the produce of the country, of Ireland, and of the northern portions of Europe and America.

Horsehair and the hair of other animals, English and American, in various stages of manufacture for the purposes of weaving, stuffing, brush and sieve making, &c.

58 MORRELL, HENRY, 149 Fleet Street—  
Manufacturer.

Specimens illustrating the manufacture of lead pencils: Black lead (*plumbago*), exported from Germany and other parts. Specimen of purified lead, and lead cut into plates. Cedar wood from North America, cut into veneer, and bottoms and tops for pencils.

1st stage.—Bottoms grooved and machine for grooving. 2nd stage.—Bottoms, showing the plate of lead inserted and tool used for cutting off.

3rd stage.—Tops, and tops glued on to bottoms.

4th stage.—Rounding machine and pencils in stages of rounding to completion.

Paring tool to finish the ends. Specimens of rough and finished ends.

Stamping machine and pencils stamped, &c. Pencils in various packages and sorts.

Specimens illustrating the manufacture of sealing wax: 1.—The resins. Stick lac, a secretion from trees punctured by an insect (*Coccus lacca*), in the form of a reddish-brown resinous substance, having a crystalline fracture, enclosing the insect. Shellac produced from it. Lac dye, exported from the East Indies to England, and again exported into Germany, Russia, &c.

2. The colouring matter.—Mercury. Sulphur. Sulphuret of mercury or vermilion, the colouring matter used for red sealing wax.

Rough sealing wax. Stick of sealing wax moulded, partly polished, and finished and stamped. Sealing-wax in packages, and of various qualities.

Specimens illustrating the manufacture of wafers:

Wafer tonge. Sheets of wafer, as produced from tongs by the wafer composition being baked in them. Punches for cutting wafers of various sizes, with samples of the wafers cut.

Specimens of quills.

59 HEAL & SON, Tottenham Court Road—Importers  
and Dressers.

Specimens of bed feathers; Irish, English, Russian, Hudson's Bay, and Dantzic, in the raw state, and steamed and dressed.

Specimens of Russian down, in the raw state, and steamed and dressed.

Specimens of Greenland eider-down dressed.

An eider-down quilt, composed of a fine satin centro, and surmounted by a border of white satin, embroidered with flowers and ornaments. Executed by James Houlkeworth and Co., of Manchester.

A quilt of fine Greenland eider down, covered with blue and gold brocaded silk, designed and adapted to lay across the foot of a bed.

60 BLYTH, HAMILTON, & BLYTH, 52 Little Britain, London, and Henry Street, Liverpool—Importers  
and Manufacturers.

English and Dantzic goose bed feathers, in a raw state, white and grey; and in a dressed and purified state.

English black horse-hair in a curled and manufactured state; and in the raw state.

61 ENGLISH'S PATENT CAMPHINE COMPANY, Hull—  
Manufacturer.

Oleaginous seeds, tar, and turpentine, and their products.

62 BARKER, THOMAS, & Co., Breams Buildings, Chancery Lane—Inventors and Manufacturers.

Spirits of turpentine, prepared by a new process, so as to render paint inodorous as soon as dry. Mastic varnish, for paintings, preventing bloom, &c.

British Eau-de-Cologne and a variety of other scents essential oils, manufactured and purified by the above process. Hair dyes, essences, extracts, and perfumes.

63 MANNING, JAMES, 18 Coles Terrace, Barnsbury Road, Islington—Manufacturer.

Varnish composed of various gums and pure spirits of wine: the materials are put into a glass barrel and made without the aid of heat. Portraits, &c., varnished to show its clearness.

64 PENNEY, HENRY, 4 York Place, Baker Street—  
Manufacturer.

Colourless linseed oil and copal varnish. A door on which the varnish has been applied.

65 SMITH, BEN. THOS. & CHAS., 12 Church Street, Mile End New Town—Manufacturers.  
Emerald green.  
Chrome yellow, three shades. Ultramarine, three qualities (imported from Nuremberg). Chinese red. Pure blue. Oxalic acid, two qualities. Oxalate of potash. Chromate of potash. Nitrate of lead. Oxymuriate of tin. Colours of various kinds.

66 JEWELBURY, H. W., & Co., 1 and 2 Mincing Lane—Brokers and Producers.  
Varieties of cochineal from Honduras, Mexico, Teneriffe, Java, and the West Indies.

[Cochineal is an insect, the dried body of which yields the beautiful red dye for which it is valued in commerce and the arts. The insect is obtained in large quantities from Mexico, the British West Indies, the United States, and Guatemala. It is bred with great care, and feeds on the *Cactus cochinealifer*. Upwards of a million pounds were imported ten years since into the United Kingdom, and in every pound are contained not fewer than 70,000 insects! Cochineal, from its resemblance to seed, was formerly considered to be really a vegetable product. In the cactus stove at Kew the insect may be seen alive feeding upon the cactus of its native habitat.—R. E.]

Varieties of lac-dye from Calcutta.

["Lac-dye" is a term commercially applied to a colouring matter extracted from stick-lac. The latter is considered to be the resinous secretion of a tree on being punctured by an insect common in many districts of Eastern India. This insect is called *Coccus lacca*, and is found in enormous numbers in the forests of the mountains on the sides of the Ganges. The insect, when about to deposit its eggs, attaches itself to the branches of trees, and soon becomes enveloped in a layer of gummy matter which hardens on exposure. The insect dies, and her body shrivels into an oval bag containing a minute drop of red fluid. This is extracted from the lac, and, when formed into small masses, becomes the lac-dye of commerce. In 1848, 1,221,308 lbs. were imported into the United Kingdom.—R. E.]

68 SMITH & SON, 14 Corbet Court, Spitalfields—Producers.

Lichens from which archil and cudbear can be produced by steeping them in prepared ammoniacal solutions, so that the oricine they contain may, by combination with water, ammonia, and oxygen, develop colouring matter:—

No. 1. Angola Orchilla weed (*Roccella montagnei*), from Angola, coast of Africa. 2. Thick Lima Orchilla weed (*R. tinctoria*), from Lima, South America. 3. Lima Orchilla weed (*R. fuciformis*) from Lima, South America. 4. Canary Orchilla weed (*R. tinctoria*), from the Canary Islands. 5. Canary rock moss (*Parmelia perlata*), from the Canary Islands. Pustulatus moss (*Gyrophora pustulata*), from Norway.

Eight samples of archil and two of cudbear, all made from Angola lichen, and used for dyeing and printing woollen, silk, cotton, mixed fabrics, and leather, all shades of crimson, violet, blue, and chocolate; used also in making stone blue and lake pigments.

Samples Nos. 8, 9, and 10. Blue, violet, and red archil weed and liquor, as taken from steeping backs, used for dyeing leather and silk. 11 and 12. Red and purple archil liquor, for printers' use. 13. Extract of red archil, for printers' use. 14 and 15. Red and blue archil paste, for dyeing wool and silk. 16 and 17. Cudbear, of two qualities, for dyeing wool and silk.

Specimens of woollens, silks, velvets, cottons, mixed fabrics and leathers, dyed and printed with archil and cudbear, also of stone blue and lake made with archil.

[Lichens are flowerless plants of very low organization,

living on air and growing usually on the ground, or on the surface of rocks and trees, in the form of crusts or branching leathery expansions. Many kinds of lichens are available for dyeing. The species of *Roccella* are most useful, but various kinds of *Lecanora* (as *L. perella*, which is the *Perelle d'Auvergne*, and *L. tartarea*, the cudbear), *Variolaria*, *Urocolaria*, *Isidium*, *Lepraria*, *Parmelia*, *Sticta*, *Solorina*, *Gyrophora*, *Umea*, *Evernia*, *Alectoria*, *Ramalina*, and *Cenomyce*, many of which are not at present used, would produce colouring matter.—E. F.]

70 COONEY, CHARLES, 60 Back Lane, Dublin—Manufacturer.

Samples of Irish manufacture in starch, indigo blues, vegetable gums, and blacking.

71 SAUNDERS & GATCHELL, Dublin—Producers.

Pastel, or imitation wood, made from the leaves of the chicory plant, used in the dye-vat for fixing colours in woollen cloths.

72 ROBINSON, JAMES, & Co., Huddersfield—Inventors and Manufacturers.

Archil paste and cudbear, patent process. Liquid archil for dyeing and printing.

Samples of worsted yarn dyed in best cudbear.

74 BRUCE, G., 52 Nelson Street, Liverpool—Inventor.

Black varnish, for painting and preserving wood and iron-work, either for land or marine purposes. Blue-coloured composition for covering wood or iron, with or without a thin priming of paint. Red composition for the use of agriculturists, machinists, engineers, ship and steamboat builders. Green and stone-coloured composition, applicable to general purposes. Spirit varnish for wood-work.

75 LONG & REYNOLDS, Hackney—Manufacturers.

*Carthamus tinctorius* (Indico), safflower. The colouring matter shown in the liquid and dry state. Used for the purposes of dyeing silk, cotton, &c. Specimens of its effects on those materials.

[The colouring matter yielded by this plant is obtained exclusively from the flowers. It is of a beautiful pink colour, and is employed by dyers to produce the peculiar colour called *ponceau*. It does not, however, bear exposure to light well. Safflower is also employed in the preparation of the most costly descriptions of rouge. About 6,000 cwt. are imported annually into Britain, the greater part from the East Indies.—R. E.]

76 SADLER, J., 2 Gloucester Terrace, Regent's Park—Proprietor.

Mexican black and white cochineal, produce of the department of Oaxaca.

The imports of cochineal (*Coccus cacti*) from Mexico, were, in 1839, 194,903 lbs.; but, in 1841, they had diminished to 20,678 lbs. The cochineal of white silvery lustre is most esteemed.—R. E.]

77 BURCH, WILLIAM, Sewardstone Mill, Woodford, Essex—Manufacturer.

A series of substances and combinations used in the art of dyeing; showing, in various states, the woods, roots, flowers, metals, &c., from which dyeing colours are obtained, with aqueous decoctions and dried extracts. Various acids, and solutions of metals in acids; dyeing precipitates caused by the action of various metallic solutions on vegetable colouring matters; and samples of the general effect of the colouring matters on cotton, silk, and wool.



Samples of London skein silk, woollen, and cotton dyeing, in colours and shades.

Samples of cotton, dressed as hard silk, and of fast cotton dyeing for Lisle thread gloves. The woollen dyes by P. J. Chabot, of Spitalfields; the silk dyes, by Reynolds & Son, Temple Street, Hackney Road (for further specimens by the above dyers, see Class 18).

Opaque or precipitant colours used in oil painting and printing, and as water-colours on paper, book muslin, &c.

An illustration of the art of block printing. Various gums and substances used in dyeing, printing, painting, dressing, &c., and in the preparation of colouring matters.

78 MOORE, JOHN, *Littlecott Farm, Peasey, Wilts*—Proprietor.

Southdown ewe (stuffed), bred by the exhibitor, seven years old, but never shorn. Length of the wool 25 inches, weight 36lbs.

80 HENDERSON, RICHARD, *Wooler, Northumberland*—Producer.

Fleeces of Cheviot wool, grown at an elevation of 2,600 feet above the level of the sea.

81 DORRIEN, C., *Seuncots, near Chichester*—Producer.

Specimens of merino wool, produced from two-year old sheep, sufficiently long and fine for shawl manufacturers; average weight of the fleece of each sheep, nearly 8 lbs.

83 PRICE'S PATENT CANDLE COMPANY, *Bolmont, Vauxhall*—Manufacturer.

Specimens of candles, vegetable tallow, palm oil, &c.

84 REBOW, J. G., *Witenhoe Park, near Colchester*—Producer.

Southdown sheep's wool.

85 MILLNER, ROBERT, *Dublin*—Proprietor.

Fleeces, long wool, wether and ewe, and male and female hoggets; grown in the counties Meath and Galway. Fleeces, long and short wool, hogget, wether and ewe, mountain grown in the county Wicklow.

85A SECTIONAL COMMITTEE ON ANIMAL KINGDOM, *Exhibition Building*—Producers.

Various kinds of wool.

86 MANNINGS, GEORGE, *Wedhampton, near Devizes*—Manufacturer.

Diamond teg matching wool, for combing; and diamond clothing wool, from Southdown fleeces, the produce of the county of Wilts.

88 SANDS, WM., & Co., *Mortimer Street, Leeds*—Producers.

Specimens of "burry" wool in the original state, with specimens of the same cleaned by machinery.

[By "burry" wool is meant, in the language of commerce, wool containing a quantity of "burrs" or thorny particles derived probably from the spinous and other thorn-bearing plants of Australia. These it is necessary to remove previous to the preparation of the wool for textile purposes, and by ingenious machinery this is successfully accomplished.—G. T.]

90 MOTLEY, T., *Leeds*—Producer.

Wool from Sydney, New South Wales.

91 PRELLER, C. A., *31 Abchurch Lane*—Patentee and Manufacturer.

English wether and hog wool.

Mohair and fine Australian wool, in the raw state as imported; washed; and carded and baled.

Tops, being the long fibres in slivers, to be spun into yarn for the manufacture of worsted stuffs, shawls, and hosiery.

Noils, being the shorter fibres used by blanket and cloth manufacturers.

Yarn, No. 70, spun from the Australian wool (commonly called Botany) tops. The peculiar process of combing by which the above tops have been manufactured is patented.

[By the ordinary process the combs are heated to a high temperature, and oil is applied to the wool before being drawn out in the sliver. On the press at plan the heat employed is not so great, but more equable, and the use of oil can be dispensed with. The tops are thus preserved clean and white, and better suited therefore for all fine fabrics. The specimens now exhibited are produced without oil.—G. T.]

91A CAHILL, M., *Ballyraggit, Kilkenny*—Producer.

Fleece of Leicester wool, from the flock bred by the exhibitor, at Grove, county Kilkenny.

94 IRVING, G. VEBE, *Newton by Leadhills, Lanarkshire*—Producer.

Fleece of an aged ewe of the black-faced Highland breed, unladen.

95 GOOD, FLOODMAN, & Co., *Hull*—Importers.

Specimen of white Iceland wool.

95A BREADALBANE, Marquis of, *Tynmouth, Aberfeldy, Scotland*—Proprietor and Producer.

Specimens of woollen yarn, made from the wool of the bison.

97 LIPPERT, DAVID, *66 Albion Street, Leeds*—Importer.

Fleeces of German wool.

[Wool is a kind of hair, characterised by an imbricated scaly surface, when viewed under the microscope, on which depends its remarkable felting property and its consequent value in manufacture.

Most quadrupeds possess the woolly variety of hair as an under-clothing, but in a small proportion, and hidden by the smooth exterior coarser kind of hair. In the wild sheep (*Ovis ammon* and *Ovis musimon*), the woolly variety is developed in excess; and in the domesticated varieties the fleece has become improved by care and breeding until its original coarse character has disappeared.—R. O.]

101A SMITHSON, T., *Bramley, Leeds*—Producer.

Samples of wool.

103 HORAN, H., *7 Stud Street, Islington*—Manufacturer.

Prepared Greenland whalebone of different colours, for covering whip handles, walking sticks, and telescopes, and various other purposes, with portions of black and white whalebone as cut from the palate.

[The whalebone or *Baleen*, as it has been called, consists of numerous parallel laminae, descending perpendicularly from the palate of the *Balaena mysticetus*. Its object, in the economy of the animal, is to form an efficient strainer for its food, which is taken in with the water; and the latter, when the mouth is partially closed, is expelled, leaving the small crustacea and other animals, which constitute the nourishment of the whales, entangled, as it were, in the laminae of whalebone. Although all the species of *Balaena* possess this substance, it is furnished



in the largest quantities and of the finest quality by the *Balena mysticetus*, which is the object of incessant and eager pursuit, not only for the value of this substance, but for the immense supply of oil which is obtained from the thick layer of blubber or cutaneous fat in which the body is enveloped. The length of the largest pieces of baleen in a whale 80 feet long, is frequently as much as 12 feet; and the laminae are ranged in two series, each containing about 300 in number.—T. B.]

104 WESTALL & Co., 69 Aldersgate Street—  
Proprietors.

1. Fins of whalebone from Greenland (*Balena mysticetus*).
2. Fins from the north-west coast of America.
3. Fins from the South Pacific Ocean.
4. White fins, from the western coast of Australia (*Balena Australis*).
5. Finner, of the hump-backed whale (*Balanoptera Boops*).
6. Thirty-four specimens of whalebone.

[The fins or plates of "baleen," or whalebone, are of an inequilateral triangular form, the largest, which are of most value in commerce, being arranged in a single longitudinal series on each side of the upper jaw of the "whalebone whales" (*Balænitæ*), descending vertically, and ending in a fringe of bristles: the smaller plates are arranged in oblique series, internal to the marginal ones. The base of each plate is hollow and is fixed upon a pulp developed from a vascular germ, which is attached to a broad and shallow depression occupying the whole of the palatal surface of the maxillary bones. The plates are so disposed as that their fringed terminations are directed downwards, and inclining towards the back part of the mouth, and they prevent the escape of the small marine animals which constitute the food of the great whales (*Balænitæ*), and for the prehension of which this singular substitute for the teeth is adapted. The baleen plates are smallest at the two extremities of the series; the large intermediate ones sometimes attain the length of 15 feet, being above a foot broad at their base. There are about 200 plates in the outer row on each side of the mouth in the "true whale" (*Balena mysticetus*). Each plate consists of a central coarse fibrous substance and an exterior compact fibrous layer: but this reaches to a certain extent only, beyond which the central part projects in the form of a fringe of bristles. The chemical basis of baleen is albumen, hardened by a small proportion of phosphate of lime. The baleen plates of the finners or hump-backed whales (*Balanoptera*) are smaller, and of less value than those from the true whales (*Balena mysticetus*).—R. O.]

105 CLAUSSEN, PETER, 26 Gresham Street, London—  
Inventor and Patentee.

Samples of flax prepared by the exhibitor's process, intended to show the universal applicability of flax fibre to the purposes of textile manufactures.

The first set of samples are intended to show the various processes resorted to in the preparation of flax into a material capable of being spun alone, or mixed with various proportions of cotton upon any of the ordinary cotton-spinning machines. The samples show, 1st, the flax in the straw as pulled from the ground, cut into appropriate lengths by suitable machinery. 2nd. As it appears after having undergone the first process of saturation in a solution of soda required to remove the glutinous substance adhering to the fibres. 3rd. The fibres as seen after the removal of the "shove," or woody part of the plant. 4th. The flax transformed into a cotton-like substance by the expansive force of carbonic acid gas produced by the action of an acid upon the soda, taken

up by the fibres in the previous stage. The 5th, 6th, and 7th shows the same bleached, dried, carded, and ready for spinning. The remaining articles in this series are samples of mule and throwing yarn of various numbers, some of which are composed entirely of flax, and others of various proportions of flax and cotton. Both these descriptions of yarn are exhibited, bleached and dyed in various colours for the purpose of showing that flax, prepared upon this process, is capable of receiving the same opaque dye as cotton, and, in the mixed yarns, no difference can be distinguished in point of colour or of shade between the two materials. Samples of grey and bleached, dyed and printed cloth woven from the yarns, prepared as above, are also exhibited. The yarns formed of a mixture of flax and cotton are termed "flax-cotton" yarns.

The second series of samples consists of yarns formed of various proportions of flax and wool called "flax-wool yarns," the flax being prepared, in many respects, in the same manner as when required for spinning on cotton machinery. The mixed woollen and flax yarns were spun on the ordinary woollen machinery. Samples of flannel and of woollen cloths, milled and dyed, woven from these mixed yarns, of various colours.

The third series contains samples of flax prepared for spinning alone or combined with short silk upon the ordinary silk machinery. The flax so prepared is shown, dyed various colours, and possessing, unlike the samples prepared for the cotton machinery, the brilliancy of colour which is peculiar to silk. The yarns formed of equal or other proportions of flax and silk, which are termed "flax-silk yarns" are shown dyed; and, as in the case of the "flax-cotton," no difference of shade or colour is perceptible in the two materials. A quantity of silk, woven from "flax-silk" yarns, is also shown in this series.

In the fourth series, samples illustrative of the exhibitor's mode of preparing flax for spinning upon the ordinary flax machinery, and for its manufacture into linen fabrics.

A fifth series consists of various samples of hemp, jute, and the fibrous substances prepared, either in whole or in part, as above; and samples of cloth woven upon the Chevalier Clausen's circular loom for the purpose of showing the applicability of the invention to articles of hosiery.

The advantages claimed as arising from the process, illustrated in the fourth series for preparing flax for the linen manufactures, are its simplicity, rapidity, certainty, and cheapness. By this process a fibre nearly free from colour is procured, so that the after process of bleaching is greatly facilitated: the fibre is also pure when produced, so that the same weight, or nearly so, of yarn, can be spun from a given weight of fibre; and the loss in bleaching is very small, as it consists only of the removal of accidental impurities received in the process of manufacture.

The three first series of samples are intended to show the applicability of the flax fibre for textile manufactures, other than linen or cambrics. It can also be spun alone, on cotton machinery, by the ordinary cotton process.

It has long been a desideratum with woollen manufacturers of all classes to obtain a material cheaper than wool, possessing the same felting or "milling" properties. Cotton and China grass have not this property. The flax fibre is said to be stronger than the wool, and to mill equally with it. The sample shown was milled from 54 inches wide (as it fell from the loom) to 28, its present width. To prove its felting properties fully, hats have been made from the fibre mixed with an insignificant portion of rabbits' hair.

1. Flax-seed and flowers (in wax).
2. Flax-straw with the seed-bolls on.
3. Flax-straw ripped or deprived of the seed-bolls.
4. Flax-straw as prepared by the farmer (by the exhibitor's machine). By this operation the straw is freed from the greater portion of the wood, and is reduced to one-third of its original bulk and weight, and the fibre is left uninjured, and in a fitter state for the next process.

5. Flax straw, as above, after having undergone the alkaline part of the process.

6. Flax-straw, as above, after having undergone the acid part of the process.

7. The fibre, as above, unbleached, scutched.

8. Flax-straw prepared, unbleached, and scutched.

9. Flax-straw prepared whole by processes 5 and 6, or not having undergone the breaking process described in No. 4.

10. Flax-straw, prepared and bleached as above, in the straw.

11. Flax, prepared, bleached, and scutched in the straw whole.

12. Flax-straw, prepared, broken by the exhibitor's machine (No. 4) and bleached in the bulk.

13. The same scutched.

14. Flax split according to the exhibitor's natural colour.

15. The same, bleached.

16. Linen yarns spun from fibre prepared by the above processes, *i. e.*, from fibre, natural colour, whole; from the same, split; from fibre, bleached in the straw, whole; from the same split.

17. Linen cloths woven from each of the above-described yarns.

#### Short Fibre.

18. Flax-straw cut into lengths for producing fibre to spin on cotton machinery, wool or silk, whole.

19. The same, having been partially deprived of its refuse (process No. 4), cut into short lengths.

20. The same, after the alkaline process.

21. The same, after the acid process.

22. The same, fibre split.

23. Flax-fibre, separated from the refuse, unbleached.

24. The same, separated from the refuse, bleached in the straw.

25. The same, unbleached and carded, fit for spinning on cotton machinery.

26. The same, bleached and carded for cotton machinery.

27. The same, in slivers.

28. The same, in rovings.

29. The same, in yarn.

#### Flax Cotton.

30. Flax-cotton—half cotton and half flax in wool,—as above.

31. The same, slivers.

32. The same, rovings.

33. The same, yarns, mule, and throstle.

34. Cloths, all flax, spun and woven on cotton machinery.

35. The same, flax and cotton, spun and woven on cotton machinery.

36. Flax-cotton yarns, dyed by the ordinary cotton processes, showing that flax fibre takes colour exactly in the same manner as cotton.

37. Flax cloths, dyed and printed.

38. Flax-cotton cloths, dyed and printed.

#### Flax Silk.

39. Fibre prepared for spinning on silk machinery.

40. Slivers of flax and short silk, mixed in various proportions.

41. Rovings made from such slivers.

42. Yarns made from such rovings.

43. Cloths made from such yarns.

44. Flax fibre (pure) dyed by the ordinary process for dyeing silk, showing the greater brilliancy of the flax when prepared by the patent process.

45. Flax-silk cloths dyed and printed.

#### Flax Wool.

46. Flax fibre for mixing with wool (carded).

47. Flax and wool mixed together in equal parts.

48. Slubbings from the same.

49. Yarns from such slubbings.

50. Cloths produced from such yarns, woven on the exhibitor's circular loom.

51. Flax and wool mixed for flannels.

52. Yarns produced from the same.

53. Cloth produced from the same.

54. The same dyed.

55. Various samples of cloths produced from flax, flax-cotton, flax-silk, flax-wool, woven on Chevalier Claussen's circular loom, and intended to show the applicability of the invention to hosiery, &c.

56. Various samples of hemp, and other fibrous plants, prepared either in whole, or in part, as above.

106 ROYAL BELFAST FLAX IMPROVEMENT SOCIETY—  
Producer.

Specimens of flax.

107 ROYLE, J. FORBES, M.D., F.R.S., Acton Green—  
Collector.

Specimens of cotton.

108 PUCKRIDGE, FREDERICK, 5 and 6 Kingsland Place,  
Kingsland—Patentee and Manufacturer.

Goldbeater's skin. The raw material, or skin of the gut of oxen. The material in its various conditions, as used for other purposes. The raw material manufactured into goldbeater's skin. <sup>1</sup>/<sub>2</sub> and of skins, as used in France and Belgium, in which leaf gold is beaten out for gilding.

Flexible fine gold, silver, and other metals, for ornamental purposes, in sheets of any length.

[Goldbeater's skin is a membrane separated from animal intestine, attenuated by beating with a hammer, and subsequently prepared so as to resist putrefaction.]

109 STAIGHT, THOMAS, 12 Wallbrook—Manufacturer.

Specimens of turning and carving in ivory, *viz.*, vase, pedestal and flowers; carved ivory candelabra; pedestal thermometers; ivory paper knives.

Graydon's registered ivory chessmen, carved, the Crusaders.

Specimens of carving in pearl, *viz.*, card cases, work boxes, watch cases, paper knives, and tablets.

111 TEBBITT, W., 4 North Crescent, Bedford Square—  
Manufacturer.

Ornamented box, calculated to contain four packs of playing cards, manufactured entirely from the two shells known in commerce as the mother-of-pearl and the New Zealand green-ear; surrounded by an elegant specimen of pierced work, intended as a border for the cover of a drawing-room table book; the cover to be of blue velvet.

[The mother-of-pearl shell is a bivalve of the genus *Acrida*. Several species are used in commerce. The "New Zealand green-ear" is a univalve of the genus *Haliotis*, of which a kind lives in the seas of the Channel Islands, and is used also for the purposes of inlaying.—E. F.]

Lady's visiting card-case; subject, Belisarius.  
Taper candlestick; shoe-slip; door-handle; paper-knives; umbrella-hooks; and a ten-inch rule.  
The whole made by hand, and wrought exclusively by English workmen.

114 MAREWICK, MARK, 32 King William Street—  
Manufacturer.

Specimens of Markwick's patent "epithems" for medical, surgical, and veterinary purposes.

"Impermeable spongio-piline," for applying heated fluids to the surface of the body, in lieu of poultices and fomentations. A spongio-piline sock; knee-cap; finger-stall; and breast-poultice.

Impermeable water-dressing. This material is intended for the application of lotions, either simple or medicated, to ulcerated surfaces.

Impermeable "piline," for affording protection against cold and wet, &c.; in various forms, fitted in various parts of the person, and applicable to different uses.

[The material here described consists of a soft and absorbent layer of sponge, or similar material, placed upon a sheet of thin caoutchouc. The impermeability of the latter prevents the evaporation of the liquid, and the combined material becomes a convenient substitute for an ordinary poultice.—R. E.]

- 115 GRANVILLE & Co., 9 Gresham St. West—Proprietor;  
BURKE, WM. H., Tottenham—Manufacturers.

India-rubber waterproof silk and cotton garments, seamen's coats, and hats. Silk, satin, and cotton-covered air-proof cushions. Cotton air-proof pillow and swimming belt. Different makes of India-rubber webs. Mohair and genappe braids, India-rubber thread for weaving into webs. Patent mineralized rubber, unaffected by heat, cold, or grease, and without any of the efflorescence or smell of sulphurized or vulcanized rubber.

[In addition to its combination with sulphur, caoutchouc has been mechanically united, by mastication, with other substances, such as antimony, &c. It is difficult to determine whether a true chemical union takes place in such combinations. But the caoutchouc undergoes considerable alteration in its properties, and acquires some new ones.—R. E.]

- 116 REA, EDWARD, 117 Wardour Street—  
Manufacturer.

Lac insects, or *coccus lacca*; lac stick, Siam and Bengal. Products—Seed lac, orange and ruby; shell lac, orange and ruby, lump and button. Lac lake and lac dye, shell lac, lacquers, &c. Polish, varnishes, sealing wax; &c.; white lac, lac wax, yellow and white. Gum elemi, thus, or frankincense; sandrac; mastic, and varnishes. Dragon's blood, grass-tree gum, gum kauri, or Australian copal, gum animi; copal; damur; rosin, rough turpentine, Canada balsam, varnish resin, oil varnish, colourless paper varnish, resin varnish, &c.; purified rough turpentine, and spirits of turpentine, varnish, &c.

[Gum elemi and frankincense are furnished by plants of the order *Amyridæ*, a family allied to the orange tribe; they are tropical.

Gum sandrac, or sandarack, is the product of a North African tree allied to the juniper, probably the *Callitris quadrivalvis*.

Mastic is derived from species of pistachia, natives of the Mediterranean region; they belong to the cashew-nut tribe (*Anacardiaceæ*), a family furnishing many varnishes.

Dragon's blood is produced by the *Dracæna draco*, a liliaceous plant; the *Callitris draco*, a palm; and the *Pterocarpus Draco*, a sandal-wood tree, of the pea tribe; from the wood of the first and last named, and from the fruit of the second; they are all tropical.

Grass-tree gum is from *Xanthorrhæa*, an Australian plant of the lily tribe. Gum animi is from the *Hymenæa courbaril*, and copal from other tropical species of the same genus, belonging to the pea tribe.

The balsams and turpentine are resinous secretions from trees of the pine tribe. Canada balsam is from the *Abies balsamea*, or balm of Gilead fir. Damur is from *Damara*, a New Zealand pine.—E. F.]

- 117 SIMPSON, HUMPHREY, & VICKERS, 23 Little  
Britain—Importers and Manufacturers.

Various specimens of isinglass, cut and uncut.

[Isinglass is the swimming bladder of sturgeons caught in the Caspian and Aral seas, and in all large rivers in Siberia; an inferior kind is also taken from fish found in

the rivers of South America, in the Demerara and Berbice rivers, and in the East Indies. Formerly isinglass was torn up by hand, or cut with scissors; it is now rolled and cut by machinery.]

- 118 DAWSON & MORRIS, 96 Fenchurch Street—  
Importers and Manufacturers.  
Specimens of Russian and Brazil isinglass.

- 119 SWINBORNE, T. C. & G., & Co., Coggleshall, and  
1 Great Tower Street, London—Manufacturers.  
Refined isinglass and gelatines.  
Clarifying isinglass and gelatines.  
Glues, and manufacturer's gelatines.

- 120 WATT, W., & SON, Dumfries, Scotland—  
Manufacturers.

Glue made from pieces of hides and skins, principally used by cabinet-makers and joiners.

- 121 ABBOTT & WRIGHT, Needham Market, Suffolk—  
Manufacturers.

Two cakes of crown glue, manufactured from the hides and feet of cattle.

- 122 NINMO, THOMAS, & Co., Linlithgow, Scotland—  
Manufacturers.

Specimens of glue.—Strong, for the use of joiners, &c.; refined, for paper-makers, &c.; and extra-refined gelatine.

- 124 TUCKER, E., Belfast—Manufacturer.  
Specimens of glue.

- 125 DUFAVILLE, W., Broughton House, Islington—  
Manufacturer.

Culinary articles: fish, crystal, brilliant, and various other gelatines; British isinglass, &c.; loose and in gelatine wrappers.

- 125A MULLER, F., 2 Hill Street, Hackney Road—  
Manufacturer.

Specimens of gelatine and glue, adapted for general use; but especially delicate cabinet-work.

- 126 CURTIS BROTHERS & Co., 19 Coleman Street—  
Factors.

Substances used for tanning leather: oak bark (*Quercus pedunculata* and *sessiliflora*?), English tree, in the rough, cleaned, chopped, and ground; coppice, in the rough, chopped, and ground; Flemish tree and coppice, cleaned and chopped; Dutch tree, cleaned and chopped. Larch bark (*Abies larix*), Scotch, in the rough, and ground. Mimosa bark (*Acacia*), New South Wales, in the rough and ground. Babool bark (*Acacia Arabica*), Calcutta. Cork-tree bark (*Quercus suber*), Larache and Rabat. Hemlock spruce (*Abies Canadensis*), United States, in the rough and ground. Sumach (*Rhus coriaria*), Sicily. Valonia (*Quercus agrifolia*), Smyrna. Valonia (*Cumata*), Dragomestra, Morea. Divi-divi (*Cesalpinia coriaria*), Maracaibo, Rio de la Hache, Savanilla. Myrobalans (*Terminalia*), Calcutta. Terra Japonica (*Nuclea Gambiæ*), Singapore, in import package, and loose. Cutch (*Acacia catechu*), Pegu, in import package, and loose.

[The active principle for which all these articles are valued in the process of tanning leather is *tannin*, or *tannic acid*. It exists in greater or smaller proportions in each vegetable product named, being found principally in the bark. Except for the purposes of chemistry and medicine, tannin is not extracted from these substances, which are consequently employed, in a more or less comminuted state, in the conversion of the gelatine of the hides, &c., into tannate of gelatine, or leather.—R. E.]

126A KITCHIN, J., 42 Commercial Sale Rooms, Mincing Lane—Producer.  
Shumak, in the leaf, and ground, from Palermo, used in tanning sheep and calf skins, morrocos, &c.

127 FRENCH, BEAL, 51 Crutched Friars—Importer and Manufacturer.  
Cork, raw material; cork, manufactured by hand.  
[Cork is the exterior bark of *Quercus suber*, a species of oak native, cultivated in Spain, Portugal, and the south of France. A tree is ready for barking when it reaches 15 years in age, and between that and 30 years may be barked several times.—E. F.]

128 HOLT, EDWARD, 24 White Rock Place, Hastings—Inventor and Manufacturer.  
Mosses, collected from various places in East Sussex, arranged in the form of a vase, and placed in an oak frame, with a description of the uses of the plants.  
Sea-weeds, zoophytes, corallines, &c., found on the rocks and coast of Hastings and St. Leonards, ornamentally displayed in the form of a wreath, and placed in a carved gilt frame; with the various uses of the plants, for medicinal and other purposes, briefly described.  
Collection of sea-weeds, called the "treasures of the deep," with shells and specimens of Hastings' pebbles, under a glass shade, collected and dried by Mary Ann Holt.

130 FIELD, J. C. & J., 12 Wigmore Street, Cavendish Sq., and 38 Upper Marsh, Lambeth—Manufacturers.  
Specimens of stearine, produced entirely from tallow; exhibited for hardness, whiteness, and transparency. A combination of stearic and margaric acids for candle-making and several other purposes of minor importance.

131 GROVES, NICHOLAS, 58 Watling Street, Dublin—Manufacturer.  
Specimens of parchment and glue of Irish manufacture.

132 PEET, THOMAS, 6 Frederick Street, Regent's Park—Manufacturer.  
Corks, solely of British manufacture; cut by hand.

134 BREADALBANE, Marquis of, Taymouth, Aberfeldy, Perth—Producer.  
Four squares of flooring, showing specimens of some of the woods grown in Perthshire and Argyllshire.  
Table, chair, and chest of drawers, veneered with roots of the natural Scotch fir, dug from peat bog in the forest of Glenorchy, Argyllshire.

135 FAUNTLEROY, ROBERT, & SONS, Potters Fields, Tooley Street—Producers.  
GROUND FLOOR. S. 11, 12, 13, and 14.  
An extensive collection of foreign, hard, and fancy woods.  
An elephant's head, with tusks and grinders.  
A variety of teeth of elephants, hippopotamus, and walrus. Horns of the sea unicorn.  
Mother-of-pearl shells. Corozo nuts, or vegetable ivory. Coquilla nuts, &c.

| Names.                                                                | Places of Produce.                                                                                            | Purposes.                                                   |
|-----------------------------------------------------------------------|---------------------------------------------------------------------------------------------------------------|-------------------------------------------------------------|
| Boxwood ( <i>Buxus sempervirens</i> ).                                | England, Spain, &c. . . . .                                                                                   | Turning.                                                    |
| Boxwood . . . . .                                                     | America . . . . .                                                                                             |                                                             |
| Boxwood . . . . .                                                     | East India . . . . .                                                                                          |                                                             |
| 8. Brazil wood ( <i>Cassipouira brasiliensis</i> ).                   | The Brazil . . . . .                                                                                          |                                                             |
| 9. Brasilletto ( <i>Cassipouira Bahamensis</i> ).                     | Jamaica and the Bahamas . . . . .                                                                             | Dyeing and turning.                                         |
| 10. Cam wood ( <i>Baphia nigrifolia</i> ).                            | Africa, West Coast                                                                                            |                                                             |
| 11. Camphor wood ( <i>Campshora officinalis</i> ).                    | China, Borneo, &c.                                                                                            | Cabinet-work.                                               |
| 12. Canary wood ( <i>Laurus indica</i> ).                             | The Brazil, &c.                                                                                               | Cabinet-work and turning.                                   |
| 13. Cedar (penell) ( <i>Juniperus virginiana</i> ).                   | The United States.                                                                                            | Penells, and cabinet-work.                                  |
| 14. Cedar (Cuba) ( <i>Cedrela odorata</i> ).                          | West Indies, Havana . . . . .                                                                                 | Cabinet-work.                                               |
| 15. Cocus wood ( <i>Amerinum ebenus</i> ).                            | Cuba . . . . .                                                                                                | Turning, &c.                                                |
| 16. Coromandel or Calamander ( <i>Diospyros Marila</i> ).             | East Indies (Ceylon, Manila, &c.)                                                                             | Cabinet-work and turning.                                   |
| 17. Ebony (black) ( <i>Diospyros melanocorym</i> ).                   | Africa, W. Coast                                                                                              |                                                             |
| Ebony (black) ( <i>Diospyros ebenum</i> ).                            | Mauritius and Madagascar.                                                                                     | Turning and cabinet-work.                                   |
| Ebony (black) ( <i>Diospyros ebenaster</i> ).                         | Ceylon . . . . .                                                                                              |                                                             |
| Ebony (black) ( <i>Diospyros melanocorym</i> ).                       | Bombay, &c., Sumatra, &c.                                                                                     |                                                             |
| 18. Ebony (Green) ( <i>Amerinum ebenus</i> ).                         | Jamaica and the Bahamas . . . . .                                                                             |                                                             |
| 19. Fustic ( <i>Mociera tinctoria</i> ).                              | W. Indies (Cuba, also Caymanilla).                                                                            | Dyeing and turning.                                         |
| Fustic ( <i>Rhus Cotinus</i> ).                                       | Ionian Islands (Zante).                                                                                       | Dyeing.                                                     |
| 20. Hickory (billets) ( <i>Carya alba</i> ).                          | The United States                                                                                             | Handspikes, fishing-rods, &c.                               |
| 21. Ironwood ( <i>Sideroxylon</i> , &c.)                              |                                                                                                               | Machinery and turning.                                      |
| 22. Jackwood ( <i>Artocarpus integrifolia</i> ).                      | East Indies.                                                                                                  | Cabinet-work and turning.                                   |
| 23. Kingwood . . . . .                                                | The Brazil . . . . .                                                                                          | Turning and cabinet-work.                                   |
| 24. Lancewood spars ( <i>Quercus terigata</i> ).                      | West Indies (Cuba, Jamaica).                                                                                  | Gig shafts, archery bows, &c.                               |
| 25. Letterwood or Shakedown ( <i>Brosimum aubletii</i> ).             | Guiana and the Brazil.                                                                                        | Turnery and archery bows.                                   |
| 26. Lignum vitae ( <i>Guaicum officinale</i> ).                       | (West Indies (St. Domingo, Jamaica, Porto Rico, Cuba, Honduras, the Bahamas) . . . . .<br>Australia . . . . . | Sheaves for ships' blocks, turning, and machinery.          |
| Lignum vitae ( <i>Guaicum officinale</i> ).                           |                                                                                                               | Turning.                                                    |
| 27. Logwood ( <i>Hamatrylion campechianum</i> ).                      | West Indies, also Central America.                                                                            | Dyeing.                                                     |
| 28. Madagascar red wood . . . . .                                     | Madagascar . . . . .                                                                                          | Turning and cabinet-work.                                   |
| 29. Maple (bird's-eye and Rock) ( <i>Acer saccharinum</i> ).          | North America                                                                                                 |                                                             |
| Maple (Russian) ( <i>Acer tataricum</i> ).                            | Siberia, &c. . . . .                                                                                          | Cabinet-work.                                               |
| Maple (English) ( <i>Acer campestre</i> ).                            | England . . . . .                                                                                             |                                                             |
| 30. Nicaragua wood ( <i>Cassipouira Hamatrylion</i> , &c.)            | Central America, &c.                                                                                          | Dyeing.                                                     |
| 31. Nutmeg wood ( <i>Areca catechu</i> ).                             | The Brazil (Para) . . . . .                                                                                   |                                                             |
| 32. Palm-tree (black) ( <i>Coccoloba</i> ).                           |                                                                                                               |                                                             |
| Palm-tree (red and brown) . . . . .                                   | East and West Indies . . . . .                                                                                |                                                             |
| Palm-tree (prickly irown) ( <i>Coccoloba guianensis</i> ).            |                                                                                                               | Turning and cabinet-work, umbrellas and parasol sticks, &c. |
| 33. Partridge wood (brown and red) ( <i>Helicteria coccinea</i> ).    | The Brazil and West Indies . . . . .                                                                          |                                                             |
| 34. Pheasant wood ( <i>Helicteria coccinea</i> ).                     |                                                                                                               |                                                             |
| 35. Princess wood ( <i>Cordia Guianensis</i> ).                       | West Indies (Jamaica).                                                                                        |                                                             |
| 36. Purple wood ( <i>Copaifera rubiflora</i> ) . . . . .              |                                                                                                               | Turning and cabinet-work, umbrellas and parasol sticks, &c. |
| 37. Queen wood, or Jugca wood ( <i>Laurus chloroxylon</i> ) . . . . . | The Brazil and West Indies . . . . .                                                                          |                                                             |
| 38. Red sanders wood ( <i>Pterocarpus santalinus</i> ).               | East Indies (Calcutta, &c.)                                                                                   | Dyeing and turning.                                         |
| 39. Rosewood ( <i>Triplaloea</i> ).                                   | The Brazil (Rio de Janeiro and Bahia) . . . . .<br>Honduras, &c. . . . .                                      | Cabinet-work, turning, and brush-making.                    |
| Rosewood ( <i>Amgris balsamifera</i> ).                               |                                                                                                               |                                                             |
| Rosewood ( <i>Dalbergia latifolia</i> ) . . . . .                     | East Indies . . . . .                                                                                         |                                                             |
| 40. Rosetta wood . . . . .                                            |                                                                                                               |                                                             |

| Names.                                                  | Places of Produce.          | Purposes.                                   |
|---------------------------------------------------------|-----------------------------|---------------------------------------------|
| 1. Amboyna, or Klabooka ( <i>Pteropermum indicum</i> ). | E. Indies, Borneo, Amboyna. | Cabinet-work.                               |
| 2. African black wood (Cocobolo prieto).                | Africa, Madagascar, &c.     | Turning.                                    |
| 3. Angica . . . . .                                     | The Brazil . . . . .        | Cabinet-work and turning.                   |
| 4. Barwood ( <i>Baphia nitida</i> ).                    | Africa, (W. Coast)          | Dyeing and turning.                         |
| 5. Beefwood, or Bully tree ( <i>Rubinia panicata</i> ). | Guiana (Demerara)           | Machinery and turning.                      |
| 6. Botany Bay Oak ( <i>Casuarina stricta</i> ).         | N. S. Wales . . . . .       | Turning and brush-making.                   |
| 7. Boxwood ( <i>Buxus balcanica</i> ).                  | Turkey . . . . .            | Turning, machinery, and wood engraving, &c. |

| Names.                                                                                                                     | Place of Produce.                                           | Purposes.                                |
|----------------------------------------------------------------------------------------------------------------------------|-------------------------------------------------------------|------------------------------------------|
| 41. Babou . . . . .                                                                                                        | Cuba . . . . .                                              | Ship-building and furniture.             |
| 42. Sandalwood ( <i>Santalum album</i> ) . . . . .                                                                         | East Indies . . . . .                                       | Perfumery and cabinet-work.              |
| 43. Sapanwood ( <i>Cassipouia Sapan</i> ) . . . . .                                                                        |                                                             | Dyeing.                                  |
| 44. Sapodilla ( <i>Fagara pterocarpa</i> ) . . . . .                                                                       | Honduras . . . . .                                          | Machinery and turning.                   |
| 45. Satin wood . . . . .                                                                                                   | East Indies . . . . .                                       |                                          |
| Satin wood ( <i>Chloranthus</i> , (S. Domingo, Porto Rico, & the Bahamas)) . . . . .                                       | (West Indies)                                               | Brush-making, cabinet-work, and turning. |
| 46. Tulip wood . . . . .                                                                                                   | The Brasils . . . . .                                       | Cabinet-work and turning.                |
| 47. Walnut wood ( <i>Juglans regia</i> ) . . . . .                                                                         | Italy and Belgium . . . . .                                 | Cabinet-work and gun-stocks.             |
| 48. Yew tree ( <i>Taxus baccata</i> ) . . . . .                                                                            | England and Spain . . . . .                                 | Archery bows and turning.                |
| 49. Zebra wood ( <i>Omphalobium Lambertii</i> ) . . . . .                                                                  | The Brasils . . . . .                                       | Cabinet-work and turning.                |
| An elephant's head, with tusks and grinders complete.                                                                      | Africa, W. Coast . . . . .                                  |                                          |
| Elephants' tusks . . . . .                                                                                                 | Africa—Cameroon, Gold Coast, Angola, and The Cape . . . . . | Cutlery, turning, carving, &c.           |
| Elephants' tusks . . . . .                                                                                                 | Calcutta, East Indies, and Alexandria . . . . .             |                                          |
| Elephants' grinders . . . . .                                                                                              | Africa . . . . .                                            |                                          |
| Sea-horse, or Hippopotamus, teeth (curved and straight).                                                                   | East Indies and Africa . . . . .                            | Dentists and turning.                    |
| Sea-cow, or walrus, teeth                                                                                                  | Hudson's Bay . . . . .                                      |                                          |
| Sea-unicorn's horns . . . . .                                                                                              | Singapore . . . . .                                         |                                          |
| Mother-of-Pearl shells (white edge).                                                                                       | Manilla . . . . .                                           | Button-making, turning, and fancy work.  |
| Mother-of-Pearl shells (yellow) . . . . .                                                                                  | Tahiti . . . . .                                            |                                          |
| Mother-of-Pearl shells (black) . . . . .                                                                                   | Bombay . . . . .                                            |                                          |
| Mother-of-Pearl shells (Bombay)                                                                                            | S. America . . . . .                                        |                                          |
| Mother-of-Pearl shells (Buffalo)                                                                                           | Brasils . . . . .                                           | Turning.                                 |
| Coquille nuts ( <i>Asteris fuscifera</i> ), a kind of palm tree, which yields the fibres now in use for coarse brooms, &c. |                                                             |                                          |
| Coroso, or Coroso nuts ( <i>Hyaleptis macrocarpa</i> ) . . . . .                                                           | Colombia . . . . .                                          |                                          |

IN THE NAVE.—A circular slab of Honduras mahogany, 7 ft. 3 in. in diameter.

136 CROSS, SAMUEL, 57 *Bunhill Row*—Proprietor.

English-grown woods, with their botanical names and some of their various uses.

FOREST AND PARK WOODS.

| No. | Botanical Name.                                       | Popular Name.                            | Habitat—Uses.                                                                                                                                                                                                           |
|-----|-------------------------------------------------------|------------------------------------------|-------------------------------------------------------------------------------------------------------------------------------------------------------------------------------------------------------------------------|
| 1   | <i>Robinia Pseudacacia</i>                            | Acecia Locust-tree                       | Chair-making; cricket-stumps and turnery; posts, &c.                                                                                                                                                                    |
| 2   | <i>Thuja occidentalis</i> , or <i>T. orientalis</i> . | American Arbor Vitæ or Chinese . . . . . | Asia and America (scarce).—Fancy cabinet-work, inlaying, &c.                                                                                                                                                            |
| 3   | <i>Fraxinus excelsior</i> .                           | Ash . . . . .                            | Europe and North of Asia.—Every description of carriage building, agricultural implements, and fellos for wheels; handles of every kind; various turnery; bent for hoops and measures, &c.                              |
| 4   | <i>Pyrus aucuparia</i>                                | Ash, Mountain                            |                                                                                                                                                                                                                         |
| 5   | <i>Pyrus</i> . . . . .                                | Ash, Drooping                            |                                                                                                                                                                                                                         |
| 6   | <i>Alnus glutinosa</i>                                | Alder . . . . .                          | Europe and Asia.—Patterns clogs, hat-blocks, broom-sticks, brush-boards, rollers for silk goods, and various toy and turnery; makes the best charcoal for copper-smiths and gun powder; the bark used in light tanning. |
| 7   | <i>Populus tremula</i>                                | Aspen, see Poplar.                       |                                                                                                                                                                                                                         |

FOREST AND PARK WOODS—continued.

| No. | Botanical Name.                      | Popular Name.           | Habitat—Uses.                                                                                                                                                                                                                                                                                                                                                                                                                                                                                                                      |
|-----|--------------------------------------|-------------------------|------------------------------------------------------------------------------------------------------------------------------------------------------------------------------------------------------------------------------------------------------------------------------------------------------------------------------------------------------------------------------------------------------------------------------------------------------------------------------------------------------------------------------------|
| 8   | <i>Fagus sylvatica</i>               | Beech . . . . .         | Europe.—Foundations of large edifices, and building in general; oil mill stampers, cabinet, chair, and bedstead making; saddle tree and lat making; cut for screws; plane making, and tool handles; wheelers' work, and fellos for wheels; large letters for printing, brush-boards, and bottoms of ships and barges; turnery, firewood for pastry-cooks, and glass-bending.                                                                                                                                                       |
| 9   | <i>Fagus sylvatica</i>               | Beech, White            | North America.—The same purposes.                                                                                                                                                                                                                                                                                                                                                                                                                                                                                                  |
| 10  | <i>Betula alba</i> . . . . .         | Birch . . . . .         | Bottoms of pattens and clogs, turnery, reels, and toys.                                                                                                                                                                                                                                                                                                                                                                                                                                                                            |
| 11  | <i>Buxus sempervirens</i> .          | Box . . . . .           | Europe and Turkey.—Wood engraving, turnery, fancy work, &c.                                                                                                                                                                                                                                                                                                                                                                                                                                                                        |
| 12  | <i>Abies Cedrus</i> . . . . .        | Cedar of Lebanon.       | Valuable as an ornamental tree; available for fancy book-making, cabinet and other fancy work.                                                                                                                                                                                                                                                                                                                                                                                                                                     |
| 13  | <i>Æculus Hippocastanum</i> .        | Chestnut, Horse,        | Inlaying cabinet work, Tom-bridge ware, brush boards, stained ornamental work, and common buildings.                                                                                                                                                                                                                                                                                                                                                                                                                               |
| 14  | <i>Castanea vesca</i> . . . . .      | Chestnut, Spanish.      | Europe.—Carving, interior of ecclesiastical and other buildings, cabinet-work, &c.                                                                                                                                                                                                                                                                                                                                                                                                                                                 |
| 15  | <i>Pyrus Malus</i> . . . . .         | Crab . . . . .          | (Very hard).—Engineering purposes, turnery, &c.                                                                                                                                                                                                                                                                                                                                                                                                                                                                                    |
| 16  | <i>Cornus sanguinea</i>              | Dogwood . . . . .       | Chiefly for skewers (small).                                                                                                                                                                                                                                                                                                                                                                                                                                                                                                       |
| 17  | <i>Ulmus</i> . . . . .               | Elm . . . . .           | Europe.—For bottoms of ships and barges, ships' blocks, gun-carriages, mast caps, piles for foundations, railway sleepers, wheelwrights' and millwrights' purposes; lored for pipes and pumps; large turnery, and culinary purposes; naves for wheels; collars, bellows, scale-board making, &c.                                                                                                                                                                                                                                   |
| 18  | <i>Ulmus</i> . . . . .               | Elm, Dutch, or Sand.    | Press-making, &c.                                                                                                                                                                                                                                                                                                                                                                                                                                                                                                                  |
| 19  | <i>Ulmus montana</i>                 | Elm Wych . . . . .      | Boat-building, and some of the above-mentioned uses.                                                                                                                                                                                                                                                                                                                                                                                                                                                                               |
| 20  | <i>Abies Larix</i> . . . . .         | Larch Fir . . . . .     | Cabinet-work, building purposes, railway sleepers, fencing, posts, gates, &c.; the bark used for tanning.                                                                                                                                                                                                                                                                                                                                                                                                                          |
| 21  | <i>Pinus sylvestris</i> .            | Scotch Fir . . . . .    | Chiefly used for building purposes, railway sleepers, fencing, &c.                                                                                                                                                                                                                                                                                                                                                                                                                                                                 |
| 22  | <i>Abies Picea</i> . . . . .         | Silver Fir . . . . .    |                                                                                                                                                                                                                                                                                                                                                                                                                                                                                                                                    |
| 23  | <i>Abies excelsior</i> . . . . .     | Spruce Fir . . . . .    |                                                                                                                                                                                                                                                                                                                                                                                                                                                                                                                                    |
| 24  |                                      | White Fir . . . . .     |                                                                                                                                                                                                                                                                                                                                                                                                                                                                                                                                    |
| 25  | <i>Corylus Avellana</i>              | Hazel . . . . .         | Hoop handles, small turnery, fishing-rod, cotton-reels, pea-sticks, &c.                                                                                                                                                                                                                                                                                                                                                                                                                                                            |
| 26  | <i>Carpinus Betulus</i>              | Hornbeam . . . . .      | Cogs for mill-wheels, mallets, skittles, and hard-turnery.                                                                                                                                                                                                                                                                                                                                                                                                                                                                         |
| 27  | <i>Ilex Aquifolium</i>               | Holly . . . . .         | Engraving blocks for silk and calico printing, fancy cabinet-work, whip-sticks, small turnery.                                                                                                                                                                                                                                                                                                                                                                                                                                     |
| 28  | <i>Cytisus Laburnum</i> .            | Laburnum . . . . .      | Used for turnery.                                                                                                                                                                                                                                                                                                                                                                                                                                                                                                                  |
| 29  | <i>Tilia europæa</i> . . . . .       | Lime . . . . .          | Carving purposes, musical instruments, piano-forte keys, cutting-boards, &c.                                                                                                                                                                                                                                                                                                                                                                                                                                                       |
| 30  | <i>Syringa vulgaris</i>              | Lilac . . . . .         |                                                                                                                                                                                                                                                                                                                                                                                                                                                                                                                                    |
| 31  | <i>Acer campestre</i> .              | Maple . . . . .         | Fancy cabinet-work, veneering; chair, musical instrument, and frame making.                                                                                                                                                                                                                                                                                                                                                                                                                                                        |
| 32  | <i>Cerasus avium</i> . . . . .       | Merry, or Wild Cherry   | Chair-making, &c.                                                                                                                                                                                                                                                                                                                                                                                                                                                                                                                  |
| 33  | <i>Quercus pedunculata</i> . . . . . | Oak . . . . .           | Ship-building timbers as, futtocks, knees, stem and stern posts, top-timbers, floors, and planks for covering the frame; barge and boat-building, duck-gates, and large buildings generally; railway carriage building, liquor-hack making, and engineers', wheelwrights', and carpenters' purposes; railway sleepers, piles, collars, and furniture generally; stocks and cokes for wheels, posts, rails, and cleft-pales for fencing, &c.; the red for fancy cabinet-work; the bark the principal ingredient in tanning leather. |
| 34  | <i>Quercus cerris</i> . . . . .      | Turkey Oak . . . . .    | (Scarce.)                                                                                                                                                                                                                                                                                                                                                                                                                                                                                                                          |
| 35  | <i>Quercus ilex</i> . . . . .        | Evergreen Oak . . . . . | (Scarce.) Used by millwrights, &c., for cogs for water-wheels.                                                                                                                                                                                                                                                                                                                                                                                                                                                                     |
| 36  | <i>Platanus</i> . . . . .            | Plane Tree . . . . .    | House buildings, brush-boards, and many purposes for which beech is used.                                                                                                                                                                                                                                                                                                                                                                                                                                                          |



SOUTH GALLERY.

FOREST AND PARK WOODS—continued.

| No. | Botanical Name.                | Popular Name.       | Habitus—Uses.                                                                                                                      |
|-----|--------------------------------|---------------------|------------------------------------------------------------------------------------------------------------------------------------|
| 37  | <i>Populus canescens</i>       | Poplar, or Abele.   | Breaks of railway carriages, and need in paper-mills; leather-cutters' boards, and rough buildings, and some times for life-boats. |
| 38  | <i>Populus nigra</i>           | English Poplar.     |                                                                                                                                    |
| 39  | <i>Populus fastigiata</i>      | Lombardy Poplar.    |                                                                                                                                    |
| 40  | <i>Acer Pseudo-platanus</i>    | Sycamore            | Musical instruments, churns, turnery, bread plates, carriage, chair-making, brush-boards, &c.                                      |
| 41  | <i>Salix caprea</i>            | Sallow, see Willow. |                                                                                                                                    |
| 42  | <i>Pyrus domestica</i>         | Service             | (Scarce.) Used as lime-tree.                                                                                                       |
| 43  | <i>Liriodendron tulipifera</i> | Tulip-wood          | (Very scarce.) Fancy cabinet and box-making.                                                                                       |
| 44  | <i>Crataegus Oxyacantha</i>    | Whitethorn          | (Hard.) Used by millwrights for cogs.                                                                                              |
| 45  | <i>Prunus spinosa</i>          | Blackthorn          | (Small) Whip-stocks and walking sticks.                                                                                            |
| 46  | <i>Rhamnus cathartica</i>      | Buckthorn           | (Scarce and small.)                                                                                                                |
| 47  | <i>Salix</i>                   | Willow              | Cricket-bats and small turnery split and wove for ladies' bonnets, foundations of hats, &c.                                        |
| 48  | <i>Salix</i>                   | Willow, Weeping.    |                                                                                                                                    |
| 49  | <i>Taxus baccata</i>           | Yew                 | Fancy cabinet work and inlaying; bows for archery; rustic chairs, whip-stocks, &c.                                                 |

ORCHARD WOODS.

|    |                           |         |                                      |
|----|---------------------------|---------|--------------------------------------|
| 50 | <i>Amygdalus communis</i> | Almond. | Chair-making, turnery, &c.           |
| 51 | <i>Pyrus Malus</i>        | Apple   |                                      |
| 52 | <i>Cerasus</i>            | Cherry  |                                      |
| 53 | <i>Cerasus</i>            | Damson  | Fancy chair, furniture, and turnery. |

ORCHARD WOODS—continued.

| No. | Botanical Name.           | Popular Name. | Habitus—Uses.                                                                |
|-----|---------------------------|---------------|------------------------------------------------------------------------------|
| 54  | <i>Sambucus nigra</i>     | Elder         | Shoemakers' pegs, &c.                                                        |
| 55  | <i>Juniperus communis</i> | Juniper.      |                                                                              |
| 56  | <i>Mespilus germanica</i> | Medlar        | (Scarce.)                                                                    |
| 57  | <i>Mespilus</i>           | Mulberry      | Fancy work and turnery.                                                      |
| 58  | <i>Pyrus communis</i>     | Pear          | Blocks for engraving on silk, cotton, &c., paper-staining, chair-making, &c. |
| 59  | <i>Prunus domestica</i>   | Plum          | Fancy cabinet-work.                                                          |
| 60  | <i>Juglans regia</i>      | Walnut        | Furniture and fancy cabinet work; gun and pistol stocks. The same purposes.  |
| 61  | <i>Juglans nigra</i>      | Black Walnut  |                                                                              |
| 62  | <i>Cydonia vulgaris</i>   | Quince,       | Best wood for receiving a black stain.                                       |
| 63  |                           | Wild Pear     |                                                                              |

NOTE.—The woods not marked with their uses are valuable for their fruit-bearing or ornamental properties.

137 MURRAY, Sir Wm. Keith, Bart., *Dunnottar, Stonehaven*—Proprietor.

Plank of Scotch Fir (*Pinus sylvestris*).  
Section of Scotch Oak (*Quercus montana*).

138 DILLON, Viscount C. H., *Loughlyn House, Loughlyn, Ireland, and Dytchley, Oxfordshire*—Proprietor.

Slabs of yew, oak, and fir, from trees found in the bogs.

139 PAYNE'S PATENT TIMBER PRESERVING COMPANY, *Whitehall Wharf, Cannon Row, Westminster*—Producer.

Specimens of English woods subjected to Payne's patent preserving process.





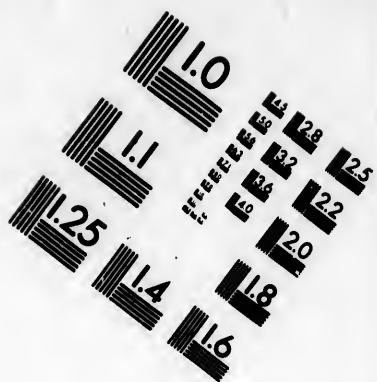
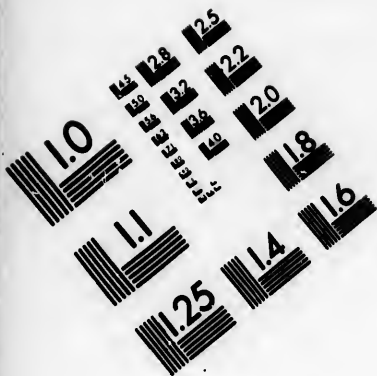

**IMAGE EVALUATION  
TEST TARGET (MT-3)**

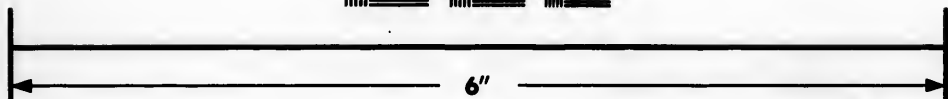
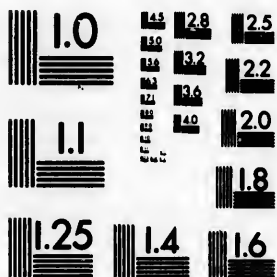

**Photographic  
Sciences  
Corporation**

23 WEST MAIN STREET  
WEBSTER, N.Y. 14580  
(716) 872-4503

1.8  
2.0  
2.2  
2.5  
2.8  
3.2  
3.6  
4.0

10  
11  
12  
13  
14  
15  
16  
17





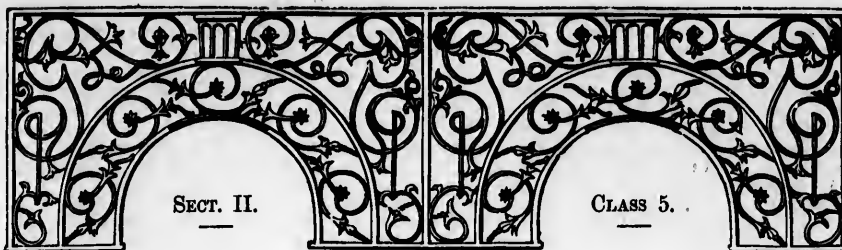

## MACHINES FOR DIRECT USE, INCLUDING CARRIAGES, RAILWAY AND MARINE MECHANISM.

### INTRODUCTION.

THE objects contemplated by this Class form the most important series exhibited. They develop the application of a source or sources of power, either derived by man from simple combinations of elementary things, or supplied to him in the active forces of nature—in the winds, tides and rivers—or obtained by him from adaptations of dynamical laws. They represent also the means employed in effecting change of place, whether of inanimate matter or of man himself. The Class is a very large one, occupies a considerable amount of space, and, as the most direct representation of one of the principal sources of the industrial success and prosperity of Great Britain, it must receive a large amount of study and attention.

The Class is subdivided into machines for direct use, including Carriages, Railway and Naval Mechanism, and Carriages generally, not including Railway Carriages, or similar vehicles. The first of these divisions is the most important, and comprehends—A. Steam-engines and Boilers, Water and Wind Mills, and various other prime movers; B. the separate parts of Machines, specimens of Workmanship, &c; C. Pneumatic Machines such as Air-pumps; D. Hydraulic Machines; E. Locomotives and Railway Carriages; F. Railway Machinery and Permanent Way; and G. Weighing, Measuring, and Registering Machines for commercial purposes. The several divisions include—A. Carriages for Town use; B. Travelling Carriages; C. Carriages for general use; D. Public Carriages; and E. Carts and Waggons—not agricultural.

The arrangement of the objects included in this Class, within the Building, extends over a large area. Commencing at Avenues C. D. Prime Movers in action will be found scattered in different positions down those avenues, and on entering Avenues A. B. C. lower down, they are still found as low as Areas 30. Avenues D. E. and F. from Areas 19 to 30, contain some highly interesting Engines and Machines comprehended within this Class. Avenues F. G. are occupied by Locomotives, Railway Carriages, and Railroad Apparatus generally. Avenues G. to I., from Area 1 to 14, are filled with Carriages of every description. In Areas G. H. and I., from 19 to 22, are found the largest specimens of Prime Movers exhibited, representing that peculiar form of steam-engine applied to the purposes of marine propulsion. The Prime Movers being employed in communicating motion to machines belonging to the next Class, are necessarily distributed among those machines; but the other objects regarded by the Class have, as far as possible, been grouped in immediate proximity to each other. A number of Models, illustrative of Class 5, are found at the eastern end of that part of the Building containing machinery in motion.

Steam-engines are so directly in relation with the prosecution of manufactures and locomotion, that they must always demand a certain degree of superior interest. A great variety is exhibited: these belong chiefly to the high-pressure class; and motion is communicated to them by steam conveyed in pipes clothed with hair-felt running under the flooring. These pipes derive their supply from five boilers, arranged in the boiler-house, at a little distance from the north-west corner of the Building. The system adopted of clothing the pipes with thick hair-felt, and over that with a casing of painted canvas, has rendered it possible to carry high-pressure steam to a distance before thought to be impracticable. The pipes are supplied at intervals with globular water-traps, in which the water resulting from the condensation of the steam is collected, and whence it can be readily removed. The system of non-conduction is so complete, that no perceptible heat is experienced rising through the open flooring.

The beam engines of a former period appear to be becoming replaced, in high-pressure engines, by those forms in which a direct communication of power is made from the piston to the crank, either mediately through connecting arrangements, or immediately by the attachment of the piston rod to the crank itself. To the latter class belong the steam-engines with vibrating or oscillating cylinders; to the former, those in which the cylinder is fixed, and in which the rectilinear movement of the piston rod is converted into the curvilinear one of the crank and shafting, through the medium of vibrating mechanism attached to it. Several varieties of both these kinds of steam-engine are exhibited in motion driving cotton-spinning, weaving, and other machines. Rotary steam-engines of different kinds are also exhibited: in most of these the curvilinear motion necessary for driving machinery is obtained without the intervention of the crank, and power is led off by bands from the shafting directly operated upon by the engine. Some of these machines present the most singular and anomalous forms. There are some examples of new methods of converting rectilinear into curvilinear motion.

The Marine Engines, which are not in motion, form an extremely interesting study. The ponderous engines from the Soho Works, of the collective power of 700 horses, for driving the screw propeller by direct action, form a remarkable illustration of the revolution effected by progressive science, not only in the form, but also in the application, of the steam-engine. The time existed when the great improver of the steam-engine questioned the probable application of steam to ocean navigation; and it is remarkable to find these immense engines, exclusively adapted to steam navigation, proceeding from the works founded by James Watt himself. Upon these engines are wooden models of an attempt at steam locomotion made as early as 1785.

Separate parts of machines and specimens of workmanship are also exhibited. Among the former will be recognised the enormous connecting rod, adapted to marine steam-engines, of the collective power of 800 horses. Some beautiful specimens of straight edges and flat surfaces are also shown. Hydraulic presses of various kinds are exhibited, and among them the vast machine which was employed to lift the Britannia tube into its place. The application of the same powers is also shown in other directions. Cranes of various kinds are found in this class—the peculiar form of the tubular iron crane, of the Derrick, and other cranes, will attract attention. The Derrick crane was employed in the construction of the building, and in placing the heavy machinery *in situ*.

The high reputation enjoyed by the locomotive engine-makers of England is adequately sustained by the magnificent and costly engines found in this department. The stupendous wide-gauge engine—the “Lord of the Isles”—illustrates the peculiar features of construction introduced on that system, and conveys an overwhelming impression of speed and power. In contrast are the beautiful engines for express travelling—the Cornwall, and another, built on Crampton's patent: the driving wheels of the latter are eight feet in diameter. These engines are calculated for a high degree of speed, with great power. Corrugated iron carriages, carriages built of Moulmein teak, breaks, trucks, turn-tables, signals, specimens of permanent way, and all that relates to the railroad system, are therein abundantly represented.

Carriages of every description are found in their proper place. Some of these are of new form and design, others combine new mechanical adjustments or adaptations, and others exhibit improvements instituted for particular purposes, as for convenience in travelling or for the removal of invalids. Public carriages, of new forms, are also found among others.

This Class, viewed as a whole, indicates in what direction the current of industrial activity has been most successfully conducted in Great Britain. The workmanship employed in the reduction of ponderous masses of material into forms capable of exercising movement and developing force, is of necessity of the highest order; for an error of adjustment were fatal to the operation of these mighty engines, and the difficulty of accurate adjustment presents itself, at a rough estimate, proportionately to the size of the objects concerned. But specimens of the successful application of mechanical skill in every direction, and to objects great and small, are found, and appear in forms which indicate that compactness and completeness of execution are not less regarded than perfection of adaptation. As the practical display of the sources of power at the command of this country, whether in their application to production or to locomotion, Class 5 is complete, and offers a wide field of fruitful investigation to the inquirer.—R. E.

1 **ATRENTON, CHARLES, Dockyard, Devonport—**  
Inventor.

Pair of marine steam-engines of 25-horse power, constructed with a view to apply the sway-beam principle in driving the submerged screw propeller.

Drawing, to show the mode of applying the same principle to large engines for ships of war, which require the engines to be below the water-line of the ship. The air-pump valves are adapted for being worked with great speed, and the eccentrics and slides are arranged for being easily managed so that the engines may be quickly reversed. The patent expansion gear is intended to be made one of the principal means of registering the variations of expansion during the working of the engine, in order that the indicated working power and the corresponding consumption of fuel may be duly recorded; thus applying to marine engines a system of inquiry which has been attended with great advantage in the case of mining engines.

Model of the expansion slide.

2 **POWELL, EDWARD JAMES, 11 Hartland Terrace,**  
*Camden Town—Designer.*

Drawing illustrative of the various forms of patent screw propellers.

3 **SMITH, Captain. F. P., Greenwich.**  
Various screw propellers.

4 **STOUGHT, SLAUGHTER, & Co., Avonside Iron Works,**  
*Bristol—Inventors and Manufacturers.*

Patent combined propeller engine, patented by Edward Slaughter. This system, which has reference only to condensing propeller engines, purports to combine the advantages of a direct action, quick working engine, with those of the indirect slow working engine. In the latter,

the speed requisite for the propeller is obtained by means of accelerating gearing driving on to a second-motion shaft. The new engine claims to avoid the disadvantages of both. It is assumed that, to attain the best possible form and angle of screw, it is in all cases desirable to give a speed to the propeller shaft unsuited to the vacuum, supply, and bilge pumps, but especially to the former; and that whereas the required number of revolutions presents no practical difficulty in those portions of the engine where the passage of steam only is in question, very great difficulty, and an undue amount of wear and tear, as well as loss of power, attach to the rapid opening, closing, and constantly repeated shocks of large and numerous valves, required for the passage of water through the vacuum pumps for the process of condensation. So greatly is this difficulty estimated by some of the first naval engineers of the day, that the indirect engine, with its cumbersome and costly gearing, is preferred to the light, simple, and inexpensive direct-action engine; and this preference obtains in spite of the very strong prejudice entertained against the employment of gearing in any form on shipboard. Under the present system, direct-action to the screw shaft from the steam pistons is obtained, in connection with a reduced speed of the vacuum apparatus, by means of gearing of a lightness proportioned to the fraction of power required, say  $\frac{1}{4}$  part of the entire power of the engine. It may be said that direct-action engines are in successful operation, in which the vacuum apparatus is made to work, without difficulty, at the same speed as the steam pistons. Now, if this cannot be denied, it is submitted that the speed, and therefore the angle of the propeller, must be lowered to the speed suitable for the vacuum apparatus; that they do so work at a considerable loss of power, by reason of the unduly large relative capacity of the air pumps, at a much increased ratio of wear and tear of machinery, and, as it can scarce-

ly be doubted, with much greater risk of accident. It will be readily understood that the system must be considered irrespective of the particular arrangement exhibited which had in view to economise space in the vessel longitudinally; and that cylinders, disposed horizontally or otherwise, are equally applicable, and the horizontal disposition would be adopted for war steamers. In illustration of the above, the marine condensing engine exhibited (100 horses power), may be regarded as divided into two parts comparatively distinct one from the other, the steam portion working directly on to the screw shaft with all the simplicity of a high-pressure engine, at a speed of 120 revolutions per minute; the vacuum apparatus, as well as the supply and bilge pump, being made to work at the reduced speed of 40 reciprocations, or about the approved speed of paddle-wheel engines of same power. It may here be well to state that the relative capacity of the vacuum pumps and the steam cylinders must be calculated in reference to the difference of speed; and that, in practice, the vacuum produced in the condensers, is found to be as perfect as that in any existing engines, viz., 28 and upwards. A pair of engines, identical with these, is at work in the Bristol Channel. The system has been proved with equal success in a small experimental vessel, in which the speed of vacuum apparatus is only  $\frac{1}{2}$  instead of  $\frac{1}{3}$  of that of the steam pistons. The following advantages are claimed:—High speed upon the screw shaft, in connection with slow speed of vacuum apparatus, in the same machine. No reasonable limit to the high speed required for screw shaft, giving facility for securing the best form and angle for propeller. No reasonable limit to the reduction of speed required for vacuum apparatus, with diminished risk of accident resulting therefrom. Saving of power by reason of relatively reduced proportion of vacuum pump, and consequent saving of fuel. The Plate represents elevations and a plan of these engines as applied to river steamers.

5 TAPLIN, R., 7 Upper Woodland Terrace, Woolwich—Inventor.

Model of a telescopic funnel or chimney for marine boilers. This telescopic funnel or chimney is on the compound principle, and not simply telescopic. It is designed to accomplish the desideratum of striking the funnel of any steam vessel below the upper deck; and the principle may be applied in a variety of ways. To paddle-wheel vessels it affords the power of working the sail nearest the funnel; and while under sail, the vessel is not hindered by its resistance to the air. To the screw vessel, in particular, it offers more advantages, as by relieving the deck of the cumbersome and unsightly appearance, as well as inconvenience of the funnel, it enables the vessel to chase or approach an object almost unobserved; and if the masts, rigging, &c., be dispensed with, which is also possible, nothing but the hull might be

seen, when steaming to effect some special purpose, as a secret expedition, &c.

6 WATT, JAMES, & Co. (late BOULTON & WATT), 18 London Street, and Soho, Birmingham—Designers and Manufacturers.

Marine engines, of the collective power of 700 horses, with four cylinders, 52 inches diameter, and 3 feet strokes, designed for driving the screw propeller by direct action at 65 revolutions per minute.

The object of the inventor has been to combine lightness and compactness relatively to the power, with simplicity of arrangement. These engines can be placed in the ship entirely below the water-line, whereby they are protected from the effects of shot in vessels of war; and in the mercantile marine the decks are left clear for passengers or cargo.

Two working models, made in the year 1785, by Mr. William Murdoch of Soho, who was at that period connected with the firm of Messrs. Boulton, Watt, & Co. The first is of a "locomotive," showing the original application of steam for the purposes of travelling; and tried upon the common road in Cornwall, in 1785 and 1786. The second is a model of an oscillating engine, constructed at that early period for the purpose of illustrating Mr. Watt's patent of 1784, for making the cylinder work on its axis.

7 ROUGHTON, R., Dockyard, Woolwich—Inventor. Improved slide-valve.

8 PENN, JOHN, & SON, Greenwich—Manufacturers.

Pair of marine oscillating engines. One paddle-wheel is fitted on the patent feathering principle; and the other on the ordinary plan. Collective power, 24 horses.

Pair of patent marine engines on the trunk principle, arranged and adapted for the driving of the screw-propeller direct. Collective power, 60 horses.

Fig. 1 represents a section of the patent marine trunk engines, the piston being at half stroke.

Fig. 2 (p. 212) shows a section of the marine oscillating engines at the air-pump.

Working model of a pair of marine oscillating engines, as made and fitted on board H.M. steam-frigate "Sphinx." Collective power, 500 horses.

Working model of a pair of oscillating engines, used in river vessels.

Working model of a pair of patent trunk engines, as fitted on board H.M. steam-frigate "Arrogant," 46 guns, and H.M. steam-sloop "Encounter," 12 guns. Collective power, 360 horses.

An auxiliary or "donkey" engine for pumping water into marine boilers when the larger engine is not at work.

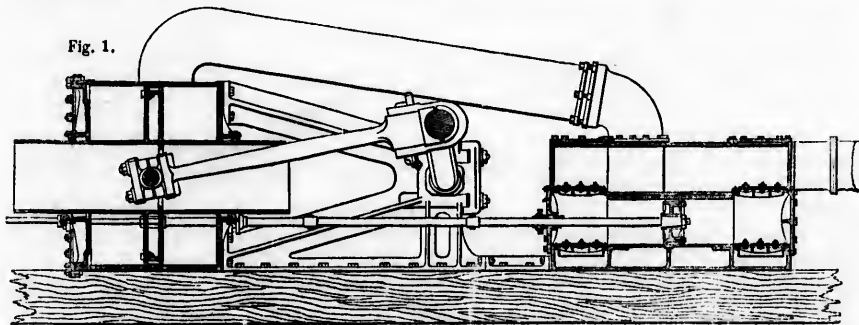

Penn & Son's Patent Marine Trunk Engines.

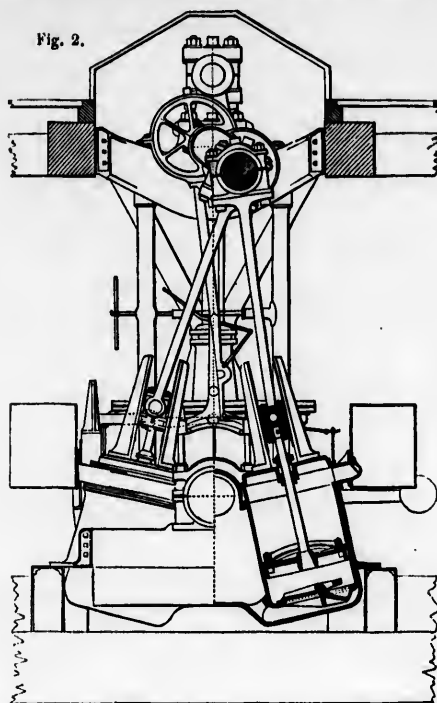

Penn &amp; Son's Marine Oscillating Engines.

- 10 **FOSSECK & HACKWORTH, Stockton-on-Tees—**  
Manufacturers and Inventors.  
High-pressure steam-engine boiler, with improvements.  
Locomotive and carriage, buffer and draw spring.
- 11 **HAWTHORN & Co., Leith—Manufacturers.**  
High-pressure oscillating steam-engine, of simple construction, without slide-valves, eccentrics, or gearing.
- 12 **EDWARDS, THOMAS, Islington Foundry, Birmingham—**  
Manufacturer.  
A five-horse-power patent direct-action high-pressure steam-engine, applicable for all purposes where steam power is required.  
The advantages of this engine are stated to be simplicity of construction, few bearings, its occupying little room, and less liability to derangement than the ordinary beam-engine.
- 13 **HICK, B., & SON, Bolton—Manufacturers.**  
The steam-engine which drives Hibbert and Platt's cotton machinery in the Exhibition Building.
- 14 **SIMPSON & SKIPTON, Trafford Street, Manchester—**  
Manufacturers.

The improved short-stroke reciprocating high-pressure steam-engine, which drives Parr, Curtis, and Madely's cotton machinery in the Exhibition.

The advantages claimed for this invention are as follow:—The piston, receiving a reciprocative action from the steam, by reason of its mechanical arrangement, gives

out a revolving motion, thus reducing the impetus at each return stroke; and from the fact of its containing the properties of the piston and crank combined, it is not subject to the same straining of parts. Although the full effective pressure of the steam (when the valve is open), there are positions of the stroke when this is useless, as when the crank is "on the centre," consequently the shock is sustained on the several cottars and parts, which is much felt in overloaded engines; but by the arrangements submitted, the crank shaft, which is the piston shaft, receives this shock, which is somewhat diminished on account of the piston itself gliding gradually out of equilibrium into full effect (the same as the common crank, though divested of the intermediate parts). An advantage is also obtained by working a short stroke with a large effective area of piston, and, consequently, a great speed, with slow velocity of the piston through space, is obtained, compared with the ordinary engine,—thus the first motion can be attached direct to the main shaft, thereby not only dispensing with all intervention of wheel-work, and its necessary appendages, but also producing a steadier motion, consequent upon the engine not having multiplying gear, which must only increase any inequalities in the stroke. This arrangement of engine requires but slight foundations, compared with others, from the peculiar manner in which the power and resistance are compounded together, and from the fact of the capability of these engines to run at high speed, a large power can be concentrated into a small space; hence if such results be obtained, and the multiplying gear be dispensed with, and the number and weight of the parts be reduced, not only economy in first cost will be gained from its close approximation to the ordinary reciprocating engine, but also economy in fuel.

16 DAVIES, JONAH & GEORGE, *Albion Foundry, Tipton, Staffordshire*—Inventors.  
Pair of patent elliptic revolving steam-engines.  
Self-acting steam-regulating damper, for high and low pressure steam.  
Feed nozzle for boilers.  
Patent sluice valve, for air, steam, or water.  
Equilibrium valve.  
Double beat for nozzles.  
Patent revolving blowing apparatus.

20 JOYCE, WILLIAM, *Greenwich*—Manufacturer.  
Steam-engine, high pressure, four-horse power, called the pendulous steam-engine.  
The principal advantages of this engine are:—1st. Its great economy of fuel, the average consumption being 3lbs. of coals per horse power per hour; 2nd. Its great simplicity; 3rd. It effects a saving of about one-half the space usually occupied by engines of similar power. Fig. 1 represents a side, and Fig. 2 a front, elevation of this steam-engine.

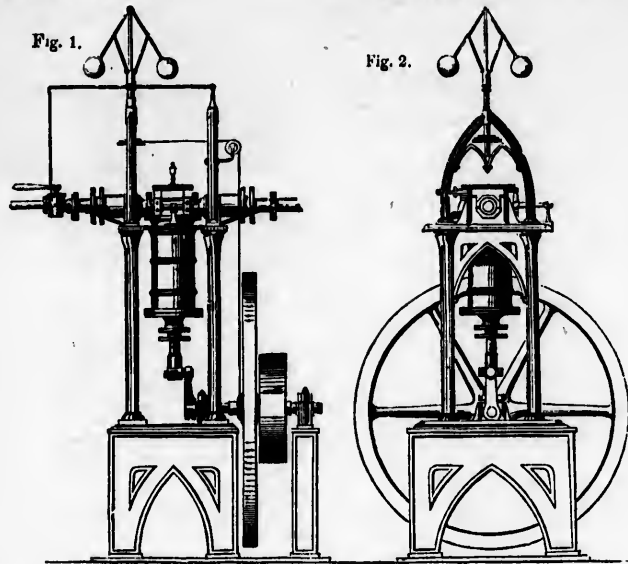

Joyce's Pendulous High-pressure Engine.

22 McNAUGHT, WILLIAM, *26 Robertson Street, Glasgow*—Inventor.  
Patent double-cylinder engine; a modification

of "Woolf's double-cylinder engine," in which steam is admitted at a high-pressure into a small cylinder, from which it passes into a larger one, where it expands, and

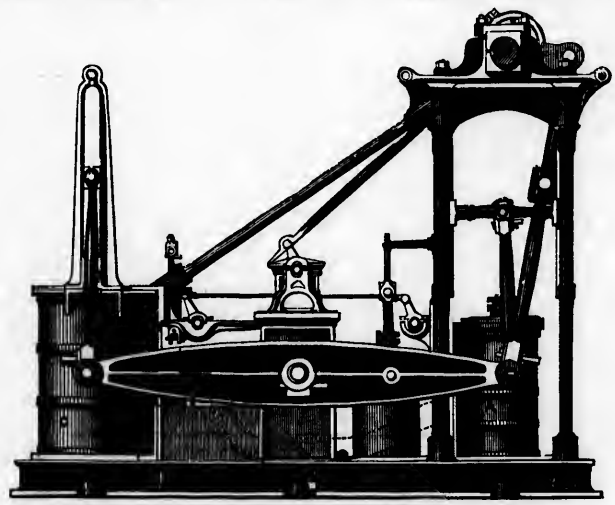

McNaught's Patent Double Cylinder Steam-engine.

petus at  
containing  
l, it is not  
ough the  
as the full  
is open),  
seless, as  
ntly the  
ts, which  
arrange-  
ne piston  
inished  
ly out of  
common  
ts). An  
rokr with  
y, a great  
space, is  
thus the  
in shaft,  
ntion of  
also pro-  
e engine  
increase  
ment of  
ed with  
ower and  
e fact of  
speed, a  
; hence  
gear be  
he parts  
e gained  
roccating



whence it finally escapes into the condenser. The present arrangement is designed to admit of the application of high-pressure steam, and the expansive principle, to engines originally constructed for working low-pressure steam. This is effected by placing the high-pressure cylinder at one end of the beam, and the low-pressure cylinder at the other. Power being thus applied at the two ends of the beam neutralises the strain upon the main centre, and removes the cause of the shaking of the machinery and building, experienced in ordinary beam engines when heavily loaded. In the example exhibited, the arrangement is adapted for marine-engines, and offers the means of obtaining increased power in a limited space, with equable motion and strain.

Montgomery's self-acting break for railway carriages. To the axle of each carriage is attached a break, acted on by a spring; the shackle of each carriage is fixed to this spring, so that when the tractive power is withdrawn, the pressure of the breaks is applied.

24 LYNCH & INGLIS, Garratt Road, Manchester—  
Manufacturers and Designers.

One-horse portable steam-engine, for driving agricultural or other machinery.

25 CROSSKILL, WILLIAM, Iron Works, Beverley—  
Patentee and Manufacturer.

A steam-engine.

26 FAIRBAIN, W., & SONS, Manchester—Inventors  
and Manufacturers.

Six-horse steam-engine.

28 MACINTOSH, JOHN, 5 Gray's Inn Square—Inventor.

1. Patent rotatory steam-engine. The novelty consists principally in the use of the flexible outside belt, whereby the friction is greatly diminished, and unequal wear obviated.

2. Patent rotatory steam-engine. Applicable where a great speed is required direct from the shaft.

3. Patent rotatory steam-engine. Applicable to the same purpose as the preceding. The peculiarity of this engine is in the construction of the piston.

29 HODGE & BATLEY, 9 Adam Street, Adelphi—  
Manufacturers.

Steam-engine.

30 RANSOMES & MAY, Ipswich—Inventors and  
Manufacturers.

A five-horse power steam-engine.

34 BUTTERLEY Co., Alfreton, near Derby—Producer.

Oscillating steam-engine, of 10-horse power, without a alide valve, the steam being admitted and exhausted through the trunnions by the motion of the cylinder.

35 CARRETT, WILLIAM ELLIOT, 13 Rockingham Street,  
Leeds—Inventor and Patentee.

A steam-pump, combining a high-pressure engine, and an improved suction and force pump, designed and constructed for filling low or high pressure locomotive, stationary, or marine steam-boilers, and for fetching or forcing water any distance or height; it may, by disconnecting the pump, be used as a steam-engine for driving portable machinery for engineering works, the household or farm-yard, for working hydraulic presses, water-crane, &c.

A portable steam-pump, for lifting or forcing water. Applicable to the supply of steam boilers—locomotive, marine, and stationary. Also as a water-lift to work hydraulic presses, water cranes, &c. Fig. 1 shows a front, and Fig. 2 an end, elevation of the steam-pump.

This apparatus is a simple form of high-pressure engine, with a lifting and a force pump combined; is portable and complete in itself, requiring no other fixing than the attachment of the steam and water pipes.—Invented by W. E. Carrett, engineer, Leeds, and registered Aug. 31, 1850. It is constructed to fetch or force water any required distance in one continuous stream, without shock

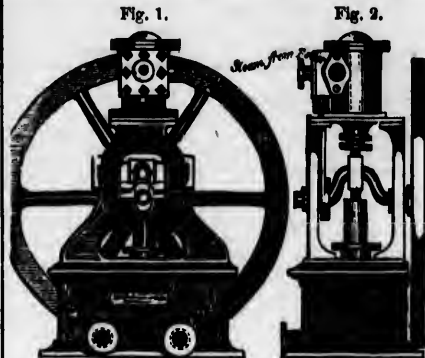

Carrett's Steam-pump.

or injury to the pipes or machinery; and at an effective velocity. The pump can also be disconnected, when the engine is to be used singly for driving small machinery of the household or the farm-yard.

[This patent steam-pump, which was adopted by the Royal Commissioners, in the Boiler-house, at the Exhibition Building, is an example of the application of steam-power for lifting or forcing water under any pressure, and for every variety of purpose. It supplies an important want frequently experienced in engineering, agricultural, and manufacturing works, of a ready means of lifting and conveying water supplies, without involving the trouble and expense of fixed machinery of complicated construction. It can be adjusted to work under all varieties of pressure at a uniform speed, and is capable of fetching or forcing water, at a maximum velocity, any required distance, without shock or concussion to the pipes. Size No. 1 of this apparatus is constructed to deliver 10 gallons per minute, at a pressure of 50 lbs. per inch, or 100 feet high. It will be obvious that, by increasing the size of the pump-ram, twice this amount of water can be raised one-half the height, or in any other quantity or proportion. For pumps from 2-horse power and upwards, side-rods and slide-bars are substituted in place of the cross-head movement, shown in the cut; and the size of the whole apparatus, in both cases, being little more than that of the diameter of its own fly-wheel. The engine is complete and perfect in itself, and can, by its simple disconnection from the pump-ram, be used as a rotative power to work suitable machinery, &c. A peculiar feature of improvement in this pump, may be said to consist in the introduction of two accumulating vessels in connection with the influx and efflux passages—these, by their action, producing a continuous stream of water throughout the whole length of the pipes.

Without a provision of this nature, the barrel of the common pump is only partially filled at each stroke, and the ram is consequently driven against the surface of the water with a serious shock at each down-stroke. In this pump, the lower valve, at each ascent of the plunger, drains its water-supply from the bottom of the induction air-vessel; which again is fully replenished by the suctional power from the reservoir. When the plunger descends, the water in the barrel is driven through the upper valve into the discharge air-chamber, and makes its escape thence in a continuous stream, under the pressure of the contained air. Thus the pump has a noiseless and perfectly smooth action, with a uniform delivery. Hence its capability to fetch or force water any required distance, at a much more effective velocity than has hitherto been accomplished, without the usual and expensive resort of a trio of lesser pumps in neutral connection, driven by a three-throw crank.

The peculiar advantages of this continuous stream will be obvious; for, since the water is always in motion



in one direction throughout the pipes, it has not to be stopped and started at every return-stroke, and is therefore better able instantly to follow the pump-ram the moment it changes the direction of its motion.]

A portable high-pressure boiler of two-horse power, weighing 6 cwt. Complete in itself, and independent of all fixings and foundations. Constructed for working the steam-pump, and for several other engineering, agricultural, and domestic uses. The funnel is capable of being unshipped and stowed away, thus rendering the whole easy of removal from place to place.—Provisionally registered.

A portable high-pressure boiler, so constructed as to be convenient for removal from place to place.

37 EVANS, JOHN, & SON, 104 Wardour Street, Oxford Street—Manufacturers.

Six-horse power high-pressure oscillating steam-engine. Exhibited for simplicity of construction, economy in working, and portability. Patentees, Richard Want and George Vertum, Enfield Lock, Middlesex.

38 MAUDSLAY, SONS, & FIELD, Lambeth—Designers, Manufacturers, and Proprietors.

A small double cylinder direct-acting high-pressure steam-engine, for working a coining-press.—See No. 228, Class 6.

A model of a gun-metal screw-propeller, so constructed that the blades can be turned fore and aft from their proper position for propelling, and thus assume a line with the keel of the ship, so that, when steam-power is not used, and the vessel is put under canvas alone, no necessity exists for taking the propeller out of the water, as the blades will not offer any resistance to the progress of the ship. The exhibitors have fitted 23 vessels with screw machinery (some of the screw propellers being on this plan) of the collective nominal power of 4,380 horses.—Patented by Joseph Maudslay.

Fig. 1 represents this screw-propeller when in use. Fig. 2 shows it when the vessel is under canvas alone.

A connecting rod, fitted with its bolts and brasses; the latter lined with soft metal, and adapted to a pair of patent double cylinder marine steam-engines, of the collective nominal power of 800 horses.

A model of a pair of direct-acting double cylinder marine steam-engines, fitted with paddle-wheels and im-

proved feathering floats. On this plan the exhibitors have constructed marine machinery, since the patent was taken out, of the aggregate power of 19,130 horses, and some of them of 800 horses collective nominal power.—Joseph Maudslay & Joshua Field, patentees.

Figs. 3 and 4 represent these engines.

A model of a pair of direct-acting marine steam-engines, with oscillating cylinders; on which principle the exhibitors have constructed engines of the aggregate nominal power of 2,100 horses.—Joseph Maudslay, patentee.

Figs. 5 and 6 represent these engines.

A model of a pair of direct-acting double piston-rod marine steam-engines, peculiarly adapted to shallow river navigation. The exhibitors have made engines on this plan for the Rhone, Indus, and Sutlej, of the aggregate nominal power of 545 horses.—Joseph Maudslay & Joshua Field, patentees.

Figs. 7 and 8 represent these engines.

A model of a pair of marine beam steam-engines, on which plan the exhibitors have completed 103 pairs, of the aggregate nominal power of 11,358 horses.

Figs. 9 and 10 represent an end and side elevation of these engines.

A model of a pair of direct-acting annular cylinder marine steam-engines, fitted with paddle-wheels and improved feathering floats. These engines have been fitted to some of the fastest packets in the Channel, and on this principle the exhibitors have manufactured 23 pairs, of the aggregate nominal power of 2,250 horses.—Joseph Maudslay, patentee.

Figs. 11 and 12 represent these engines.

A model of a pair of horizontal cylinder direct-acting marine steam-engines for driving a screw-propeller; so constructed as to occupy little space, and to be altogether below the water line.

Figs. 13 and 14 represent an end and side elevation of these direct-acting engines.

[These models are extremely interesting as illustrations of the various forms of the steam-engine applied in modern times to navigation. Propulsion by the paddle and by the screw, each require a peculiar adaptation of prime movers; and those forms exhibited appear to combine the features of construction deemed best adapted for these purposes. The connecting rod gives a forcible impression of the power of these stupendous engines.]

Fig. 1.

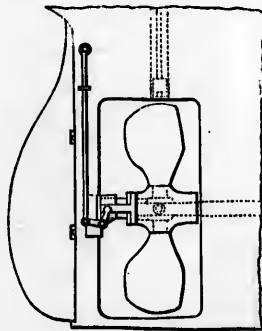

Maudslay's Patent Feathering Screw-propeller in Action.

Fig. 2.

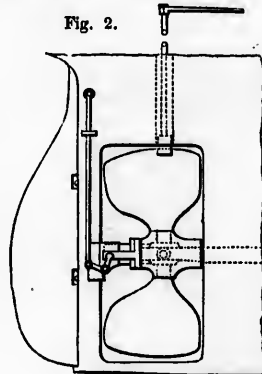

Maudslay's Screw-propeller, out of Gear.

Fig. 3.

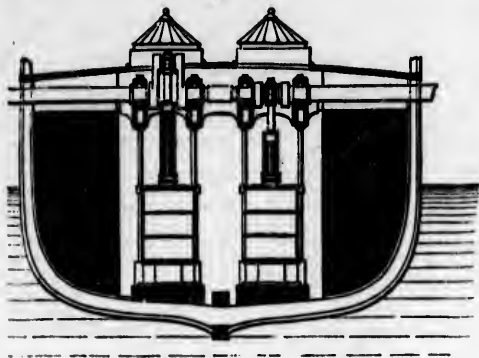

End Elevation.

Maudslay's Double Cylinder Marine Engines.

Fig. 4.

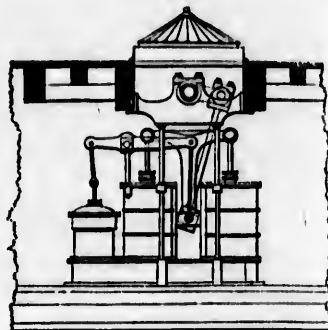

Side Elevation.

Fig. 5.

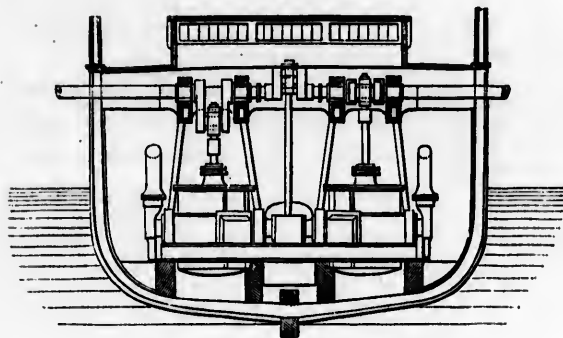

End Elevation.

Maudslay's Direct-acting Oscillating Cylinder Steam-engines.

Fig. 6.

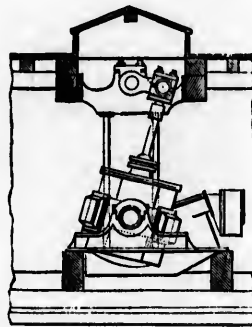

Side Elevation.

Fig. 7.

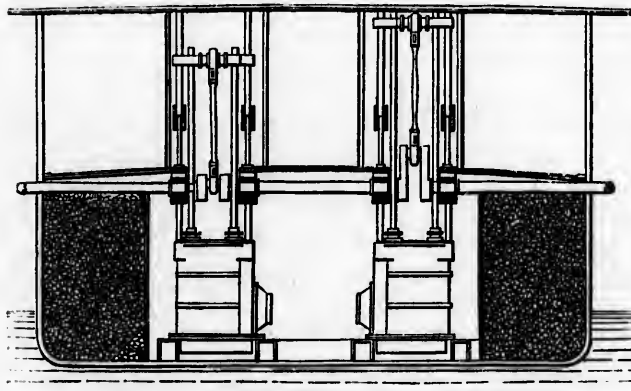

End Elevation.

Maudslay's Double Piston-rod Engines, for Shallow River Navigation.

Fig. 8.

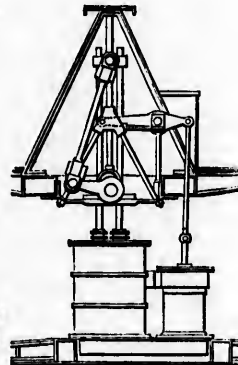

Side Elevation.

Fig. 9.

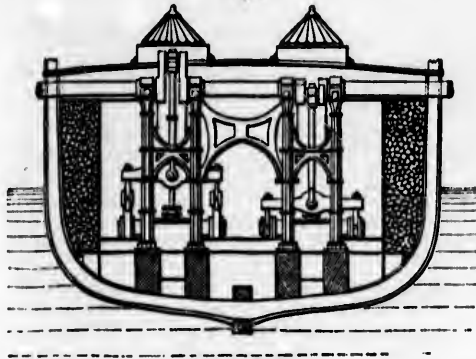

End Elevation.

Pair of Mandalay's Marine Beam Steam-engines.

Fig. 10.

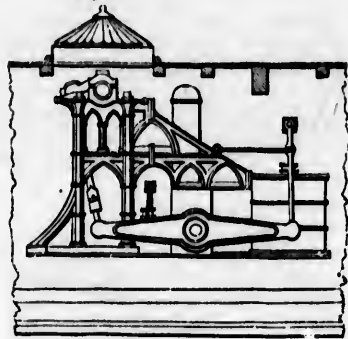

Side Elevation.

Fig. 11.

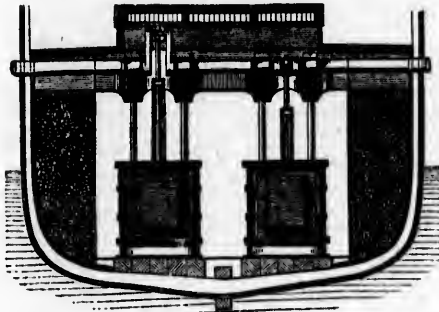

End Elevation.

Mandalay's Annular Cylinder Marine Engines.

Fig. 12.

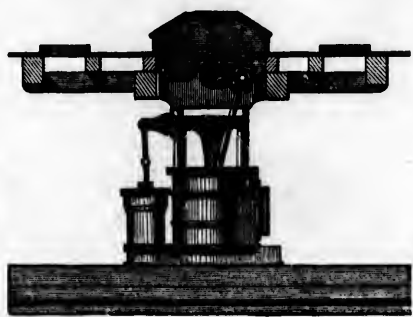

Side Elevation.

Fig. 13.

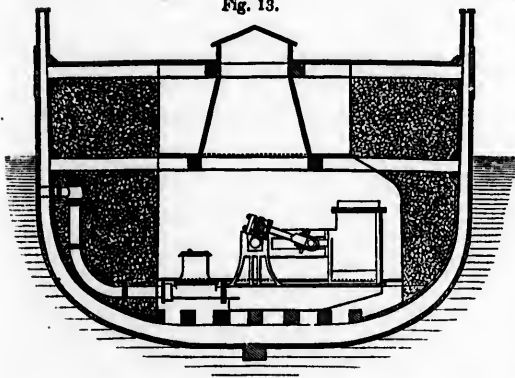

End Elevation.

Mandalay's Horizontal Direct-acting Marine Engines for Screw-propulsion.

Fig. 14.

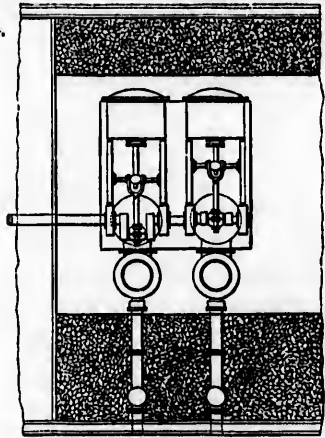

Side Elevation.

39 CLAYTON, SHUTTLEWORTH, & Co., Lincoln—  
Manufacturers.

Eight-horse power fixed steam-engine of an improved construction. This engine is of the description known as having an oscillating cylinder, which reduces the number of working parts, rendering it very simple and less liable to get out of repair. It is well adapted for working fixed barn machinery, saw-mills, corn-mills, &c. The following cut represents the steam-engine fixed and ready for work. The power may be communicated by a leather band over the fly-wheel, or through the medium of a spur-wheel and pinion.

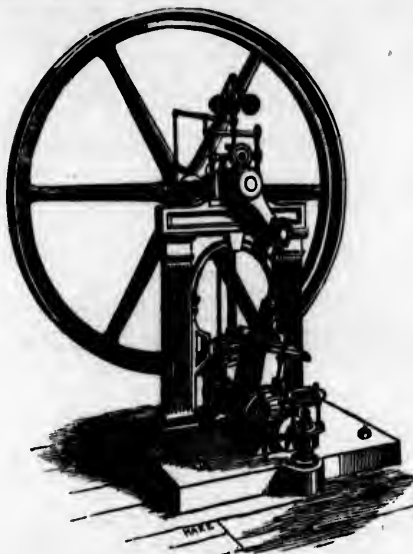

Clayton, Shuttleworth, &amp; Co.'s Oscillating Engine.

40 POPE, WILLIAM, & SON, 81 Edgware Road, and Grove  
Foundry, Lisson Grove—Manufacturers and Designers.

Improved oscillating cylinder steam-engine of four-horse power, with parallel valve gear acted on by an eccentric; its object is to effect economy of space, and efficiency in action.

41 NASMYTH, J., Manchester—Inventor.  
A steam-engine.42 DONKIN, BRYAN, & Co., Bermondsey—  
Manufacturers and part Inventors.

Patent disc water-meter. Patent improved disc engine, intended to effect rotary action, with high speed, and in little space; it is free from dead points. Disc pump, with a rotatory instead of an alternating motion, and producing a continued stream of water without air-vessels or valves.

## 44 ARMSTRONG, W. G., Newcastle-upon-Tyne—Inventor.

Model hydraulic crane, for railway stations, docks, or quays. The power may be supplied either from the water pipes of a town, where the pressure is considerable, or from the action of a steam-engine with an accumulating reservoir.

Model steam-engine, with plunger pumps, especially adapted to the working of hydraulic lifting machinery.

Model of accumulator, for equalizing the working of the engine.

Model corn-lift, worked by hydraulic power, for corn warehouses.

Model of machine for unshipping coals by hydraulic power.

45 LLOYD, EDWARD, Glyndwr, near Corwen,  
Wales—Inventor.

Patent steam-engine, on the double-cylinder expansion principle.

46 SIEMENS, CHARLES W., Summerfield Cottage,  
Birmingham Heath, Birmingham—Inventor.

Chronometric governor for a fifty-horse power engine. It consists of a conical pendulum, which is maintained in motion by a permanent power, independently of the velocity of the engine. This power is obtained by simply attaching a weight to the throttle-valve lever. A uniform angle of rotation is insured by means of a break, which is acted upon by the pendulum on reaching its desired inclination, and absorbs any excess of driving power which the weight may supply. A differential motion between the conical pendulum and the engine at once adjusts the valve to the altered condition of load or power.

In Watt's centrifugal, and other governors, the power necessary to move the valve is only gradually accumulated by an actual change in velocity, and the valve is maintained in its altered position on condition of an altered speed of the engine.

The action of the chronometric governor is, on the contrary, immediate, and the regulation of speed absolute, however great the variation of load may be.

This governor has been applied successfully to steam-engines, Barker's mills, and by the astronomer royal, to give smooth and accurate motion to astronomical instruments.

Model of simplified chronometric governor, in which an expanding fly-wheel has been substituted for the more delicate conical pendulum. The action of this governor is illustrated by preventing a fly-wheel from being turned above a certain speed.

Model of a variable expansion valve, consisting of a revolving cylinder divided in two in a helical curve corresponding with a helical aperture in the outer shell. The governor moves one portion of the revolving cylinder endways, and thereby varies the time for the admission of steam to the engine. This valve should be applied in connexion with the improved chronometric governor, which has sufficient power to work it with certainty.

Model of a surface condenser, showing an effective and simple arrangement of condensing surface.

Water-meter, in action, working under pressure. The novelty consists in the water impinging, in its passage, on two sets of helical blades which travel in opposite directions (being right and left handed), whereby deflection of the current and the effect of local currents are compensated. Its advantages are simplicity and efficiency of action.

Model of regenerative condenser, which possesses the new and useful property of returning the condensing and condensed water at the initial temperature of the steam, 212° Fah., previous to its release from the working cylinder, producing nevertheless an effective vacuum. When applied to high pressure-engines it allows a large proportion of the waste steam to escape, and condenses the remainder with a minimum of condensing water.

It has been applied to engines of different sizes, where it has been found to effect a considerable saving of fuel.

If applied to high pressure-engines, it produces an additional atmosphere's effective pressure upon the working piston, with a quantity of injection water little exceeding the quantity of feed-water for the boiler. A portion of the steam escapes uncondensed, and may be used to produce draught (in the case of the locomotive engine), or other purposes. The power required to work the air-pump of a common condenser is saved. The boiler is supplied with boiling-hot feed-water, &c.

Working model of a regenerative evaporator, applicable to the evaporation of brine, cane-juice, and other solutions, and to the distillation of sea-water (converting it into fresh water), spirits of wine, &c.

A circulating current of air is passed along the surface

of the evaporating liquid, and absorbs vapour at first from the cooler end, by degrees, from the hotter end thereof. It then passes under the metallic bottom of the pan, and in proceeding toward the cooler end, the vapour which it contains is condensed, and yields its latent heat again to the evaporating liquid. Heat is continually supplied at the hotter end, and is abstracted at the cooler end, where the cold liquid enters the apparatus. The circulating current is divided into the principal current, which traverses the whole length of the apparatus, and into secondary currents, which return at intermediate points, and are essential to the economical working of the system. The fire burns under a boiler, which supplies a steam chamber at the hottest end of the apparatus, and proceeds through flues traversing the evaporating current in its progress towards the chimney. By this means the evaporating current is superheated throughout its course to a temperature exceeding that of the liquid by about 15 per cent., and its evaporating power is greatly increased.

The regenerative evaporator has been found to save about three-fourths of the fuel usually required to evaporate liquids. It has been applied on a large scale to the evaporation of brine, producing six tons of salt for every ton of fuel from a concentrated solution, instead of 1½ tons, which are usually obtained from a ton of fuel.

48 BUNNETT, JOSEPH, & Co., 28 Lombard Street, City, and Deptford, Kent—Inventors, Patentees, and Manufacturers.

Patent concentric reciprocating steam-engine for high or low pressure. The steam is worked expansively without gear or tappets. This direct-acting engine requires neither guides nor parallel motion; it is compact, and adapted for stationary, locomotive, or marine purposes.

49 COLLINGE, CHARLES, & Co., 65 Bridge Road, Lambeth—Designers and Manufacturers.

Improved portable direct-acting high-pressure steam-engine of 5-horse power.

52 RENNIE, GEORGE, & Sir JOHN, 6 Holland Street, Blackfriars—Manufacturers & Licensees.

Working model of Bishop's patent disc engine of 40-horse power, fitted as auxiliary power to drive a screw propeller, in a model of part of the hull of a merchant vessel of 300 tons. One-fifth the full size. Engine 2-horse power.

Disc engines have been used in factories, mills, &c., for several years past, and they may be employed to drive the screw-propeller in steam-vessels by direct action. The disc engine acts with a uniform force in a direction tangential to the crank throughout the revolution, without any rotary motion taking place within the cylinder; although such an engine be only half the bulk and weight of the engines at present applied to the screw-propeller, yet at the same velocity of the piston it makes three times as many revolutions in a given time as other engines. The disc engines on this construction are said to be equal to the best engines in economy of fuel; and are, on this account, better adapted to vessels, as expansion can be carried to a great extent without straining either the frames or the vessel.

Model of H.M. Steamer "Samson's" engines.—Power of engines, 467-horse power; burthen in tons, 1,299; direct action weight of engines, 12 cwt. per horse-power.

Model of H.M. Steamer "Bull-dog's" engines.—Power of engines, 500-horse power; weight of engines, 12 cwt. per horse-power.

Model of a pair of marine engines, with four cylinders of the joint power of 800 horses, proposed for transatlantic steamers.

Models of paddle-wheels.—Common paddle-wheel. Modifications of the common paddle-wheel on Mr. Rennie's patent principle.

Model of a vessel fitted with patent paddle-wheels.

[In the direct-action marine-engine, circular motion is communicated to the paddle-shaft immediately from the piston-rod, without the intervention of side levers, &c. This arrangement saves space, weight, and friction.—S. C.]

53 GREEN, E., *Phanis Finstry, Wakefield*—Inventor and Manufacturer.

Patent fuel economiser, applicable to steam-boilers, for heating the feed-water with the spare heat from the boiler flues.

An apparatus for supplying rooms and buildings with pure warm air.

56 WATKINS & HILL, 5 Charing Cross—Manufacturers.

1. Sectional model, to illustrate the construction of a condensing steam-engine. One face showing the whole of the valves and pumps moving at their exact times, and the other presenting an outside view of the engine.

2. Sectional model of a condensing steam-engine, with section of the boiler and furnace. These models are constructed in metal for use in tropical climates.

3. Sectional model to illustrate the construction of the locomotive steam-engine. One face showing the formation of the tubular boiler, and the action of the various working portions, and the other presenting the exterior appearance of the engine.

4. Improved mercurial barometric steam vacuum gauge, combined on the same metal frame and scale, with an atmospheric barometer, to give an accurate comparison of the vacuum and atmospheric pressure.

5. Sectional model to illustrate the construction of the marine steam-engine, without the boiler. One face showing the action of the pumps and valves, the other presenting the exterior appearance of the engine.

57 FITZ MAURICE, THE HON. WM. ED., *Hamilton Lodge, Prince's Gate*—Inventor.

Patent rotary steam-engine; stated to be light, simple, and cheap in construction, and not liable to get out of order; for driving the screw or other power it acts without requiring gearing of any kind. It is free from vibration, being its own fly-wheel.

[The superiority of one piece of mechanism over another, designed to produce the same effect, depends not on any saving of power, or on any increased mechanical advantage, but on the adaptation of the construction to lessen friction, to prevent straining, to preserve the elasticity of some parts, and to secure the rigidity of others; as also on the economy of space and material.—J. B.]

Model of a patent steam-engine, illustrating a new method of converting rectilinear into rotary motion, by the Rev. J. Booth, F.R.S. Constructed by J. Aspinall, London.

Fig. 1.

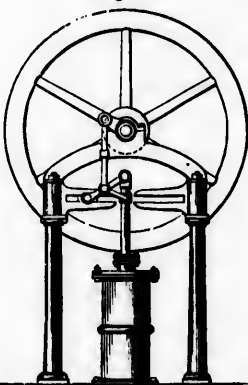

This model (fig. 1) illustrates a new method of converting rectilinear into rotary motion. It is a practical application of the geometrical principle, that if the extremities of a given straight line in motion always rest upon two fixed straight lines, at right angles to each other, the middle



point of the moving line will describe a circle. The distance between the top of the cylinder and the axis of the shaft need not be more than half the length of the stroke. This permits the machinery to be comprised in a very small compass. The friction on the slides is inconsiderable, and vanishes altogether when the engine is producing its maximum effect. The motion is produced by a combination of levers, identical in principle with the common crank. This crank, called the *sliding crank*, is equivalent in power to a common crank of the same radius, having an infinite connecting rod, and the parallel motion of the connecting rod is exact.

58 WHITELAW, JAMES, *Johnstone, Renfrewshire, Scotland*—Inventor.

Improved steam-engine, for driving the screw-propeller direct, without wheels or other intermediate gearing, and for all kinds of machinery which work at a considerable speed.—(Drawing.)

Centrifugal atmospheric churn.—(Model.)

Centrifugal pump, for short lifts.—(Model.)

60 WILDING, WILLIAM HENRY, *2 Chesterfield Street, King's Cross*—Inventor.

Patent steam-engine, exhibiting a new method of converting reciprocating rectilinear motion into rotatory motion. Model, illustrating a modification of the same.

Model of a patent submerged paddle wheel, combining the power of the ordinary feathering wheel, with the advantages of the screw, in being wholly under water.

61 LEIGH, EVAN, *Miles Platting, Manchester*—Inventor.  
Patent steam-engine.

63 WILLIAMS, D., *Thornhill, Llundilo, Wales*—Inventor.

A furnace, for burning anthracite or smokeless coal, in marine, locomotive, and other steam-engines.

64 DODDS & SON, *Rotherham*—Inventors & Manufacturers.

Four-horse portable steam-engine; for all purposes to which portable engines are usually applied, but more especially for thrashing, &c. The particular features are, the direct motion given to the slide-valve by a return crank, and the arrangement of the cylinder face and valve, without the intervention of other machinery than the valve connecting-rod, no weigh-bar or cross-shaft being required; it is also easily accessible to repair.

Model of locomotive engine, without boiler, fitted with the exhibitors' patent wedge expansive (cam) motion. Its simplicity consists in having only two eccentrics, instead of four, for working the valves, the strokes of which are adjusted or reversed by means of wedges or inclines; the motion to the valve is direct (without weigh-bars or other intermediate machinery, except the valve connecting-rod).

A piece of Jessop's patent steeled tire-bar, for railway wheels. The wearing surfaces of the tire are converted into steel (either in the bar or after being welded into a hoop), but only so far as is necessary to maintain the working surface, by which all the toughness and ductility of the iron are retained, while the steel parts may be hardened and ground up.

A piece of railway bar, with the wearing surfaces converted into steel by Jessop's patent process. Being steeled, the bar is of greater strength and durability; it does not laminate or splinter, and it presents a uniform hard-wearing surface. The process is believed to increase the strength of wrought-iron, and consequently allows rails to be made much lighter.

Model of a railway bar straightening press, on truck. The straightening press does not indent the surface of the rail, as the hammer does, and will straighten much quicker.

65 SURMON, HENRY, & CO., *New North Road, Hoxton*—Manufacturers.

Jukes's patent smoke-consuming furnaces.

36 REDMOND, ANEDEE FRANÇOIS, *Birmingham*—Importer and Inventor.

Working model of a steam-engine, showing three different constructions of slide-valves: short slide, and long D valve; and the exhibitor's patent double independent slide valve, to prevent back pressure from the exhausted steam. This model is worked by steam, and is furnished with an indicator, to show the comparative effect of different slide-valves.

67 EBBW VALE COMPANY, *83 Upper Thames Street, and Abergavenny*—Producer.

An improved double-cylinder steam-engine, one-horse power. Invented and designed by Evan William, a blind man.

68 CLAY, JOHN, *Edgeley, Stockport*—Inventor.  
Smoke-consuming furnace.

69 WHITNEY, JAMES, *Calver Hill, Hereford*—Inventor.

Apparatus for preventing the bursting of steam-engine boilers, and other steam apparatus, by an improvement in the composition and adaptation of fusible metallic plates.

70 CONSTABLE, WILLIAM, *Photographic Institution, 57 Marine Parade, Brighton*—Inventor.

Model of the "Compensating Fly-wheel," an invention for converting a fluctuating into a constant force.

The fly-wheel, as ordinarily applied to steam engines, affects two purposes—it carries the engine through the dead points of the crank revolution, and it does this effectually; it also, in a measure, corrects the variations inseparable from a power communicated through a crank; this latter service, however, it performs only approximately, and being fixed upon the main shaft, it transmits all its uncorrected irregularity through any train of machinery connected with it, in many cases to the great detriment of the manufacturing work it has to perform, and often occasioning the rapid destruction of the gear-work through which the power is transmitted. This defect is incurable under the existing method of using the fly-wheel; for although every augmentation of its weight will bring its oscillatory movements within a more limited range, yet no weight of metal will ever entirely correct them. In the scheme involved in the model, the hopeless task of compelling the fly-wheel to steadiness is abandoned, it being permitted to take up its oscillatory motion according to the force applied, while all the subsequent machinery is secured from partaking, in the slightest degree, of these oscillations.

The means for effecting this, consists in releasing the fly-wheel from its rigid connection with the main shaft, and substituting for it a spring or springs, through which the force is conveyed, and then, by a further device, correcting the small remaining irregularity that results from the reaction of the springs when under different degrees of enforcement. It will be apparent to every mechanic that constructive arrangements comprehending these principles of action may assume a great variety of forms and combinations. The following is that adopted in the model, the essential parts of which are shown in its accompanying diagrams. It consists of a fly-wheel 3 feet in diameter, having six arms, hanging loose upon a cylindrical end of the main shaft; immediately behind the fly-wheel are three other arms, issuing from a boss which is fixed on the same main shaft. On the face of each alternate one of the fly-wheel arms there lies a spiral spring, which is partially compressed between two studs which are fixed to the arms of the wheel; a bolt passes freely through the springs and studs, which being drawn upwards (towards the rim of the wheel), forces the spring, by means of a collar at the lower stud, into closer compression. The bolt is connected with a roller on the rim, by a leather strap; the spindle of this roller passes through a hole in the rim, and carries, on the other side, a second roller, which, in like manner, is fastened by a second strap to a pin at the upper end of an arm of the boss.

The fly-wheel, during the part of its revolution in



which the steam has a power superior to the resisting force, will advance by acceleration, but the fixed arm not partaking of the increased speed, the space between the second roller and the arm of the boss will be increased, and by the action of the rollers the spring will be compressed; that period being passed, and the impelling power falling below the resisting power, the latter will prevail, and bring back the wheel again to the place, with respect to the mean place, from which it started. Now, when the fly-wheel advances, by its oscillating movements, it will leave the arm of the boss behind, and the strap connecting it with the second roller will occasion the roller to move on its axis, which will result in the drawing up of the bolt, and compressing the spring; and the reverse will happen when, through its oscillations, the fly-wheel loses speed; and thus the fly-wheel will go on oscillating twice in every revolution, the oscillations playing smoothly and harmlessly upon the spring.

Now, if both the rollers be cylinders of the same diameter, the reactive force of the compressed spring, and the force dragging the led arm and main shaft, will be equal; and as constant variations will take place in the compression of the spring, an equal variation will occur in the force leading the arm; and although, to a great extent, an equalization will have been effected, the problem of the conversion of a fluctuating force into a constant force has, as yet, received no solution.

But the rollers are not both cylinders; the second roller is bounded by an irregular curve, a part of which—called the isodynamic curve—is so formed that, in its rotary motion, the lever of resistance within it, through which, and the second strap, the fixed arm acts against the force of the spring, shall become lengthened as that force increases, the curve offering in every position a lever of resistance proportional to the force of the spring. With this final appliance, a perfect uniformity of force is obtained, and the problem proposed is solved.

In order to explain the actual working of a specific steam engine with these appliances, suppose the model extended, in all its parts, linearly in the ratio of 3 to 10: the fly-wheel will then be of 10 feet diameter, and will have 1,500 pounds weight in its rim. The engine to be of 10-horse power, clear of all loss by friction or otherwise, in its own parts; strokes, 40 per minute. The steam may be applied to the piston at any amount of pressure, and be worked expansively, or not. The springs, as in the model, to be 3: coiled of steel wire,  $\frac{1}{4}$  inch in diameter; the coils to measure  $2\frac{1}{2}$  inches in diameter to the middle of the wires; the space between the coils, when the spring is relaxed, to be equal to the diameter of the wires; the number of coils, 70; its whole length, when uncompressed, consequently, will be 35 inches. Such a spring will suffer compression of 1·17 inch for every 10 pounds of compressive force. It is proposed that each spring shall be confined between the studs, with a force of 40 pounds, by which the length will be reduced to 30·32 inches: this compression is not necessary to its proper action, but it keeps the length of the spring within convenient compass. The breadth of the rim to be 7 inches; therefore, the circumference of a circle, at the middle of the rim, will be 29·6 feet; and the speed, at this place, will be 1,184 feet per minute. The mean force communicated, at any point in this circumference, will be equal to 279 pounds. Let this force be transmitted, through 3 springs to the arms, then we shall have a force of 93 pounds applied to each arm.

A wheel thus circumstanced will have an oscillating motion of 1·26 inch from its mean place, and the measure, between the extremes of its oscillations, will be 2·52 inches; and as the axis of the rollers is placed in this circle, the variations in the compression of each spring will be of the same measure (2·52 inches).

Now, since the compression of the spring is 1·17 inches, with a force of 10 pounds, a compression of 2·52 inches will be the exponent of a force of 21·54 pounds, and 21·54 pounds will be the variation of force communicated from the fly-wheel to the fixed arm; and since the mean force, applied to one arm, is 93 pounds, the maximum force, when the fly-wheel is at the extreme of its

advance, will be 103·77 pounds, and the minimum, in the contrary position, 82·23 pounds; and this variation is so moderate, that, for most of the purposes to which steam-engines are applied, it would scarcely have any appreciable disturbing effect.

For the final correction of this remainder, the isodynamic curve must have a length equal to the extent of the action or the springs, or the wheel's oscillations, 2·52 inches; and the radius of resistance of the minimum force must be to that of the maximum, as the smallest force of the spring is to the greatest, that is, as 82·23 to 103·77.

With respect to the minimum weight of fly-wheel that may suffice in a given engine, under these arrangements, it must depend upon the range of action that can be obtained in practicable springs. In the case assumed, the wheel is supposed to have a rim of 1,500 pounds; if half that weight had been taken, the length of the arc of oscillation would have been doubled; and if we could employ springs in which the range of compression would be twice as great as in those proposed, when acted on by the same force, we should have a regulating power of the same efficiency; and if we desire to perfect the uniformity of force, we might do so by employing an isodynamic curve of twice the length, keeping the radii which constitute the levers of resistance of the length proposed in the first case, and the action of the engine would be the same.

This invention claims not only to improve, but to perfect the action of the Reciprocating Steam Engine; it is simple, of easy and inexpensive construction, and but little liable to go out of repair. A proper method of trying the action of the model is, to stand at the right-hand side, holding one of the arms of the fly-wheel in the left hand; then applying the palm of the right hand to the fixed arm in advance, and forcing the arms apart. It will require a force of about 40 pounds to bring the springs into action.

76 **CRADDOCK, THOMAS, Ramelagh Works, Pinlicko—**  
Inventor and Manufacturer.

Patent high-pressure, expansive, and condensing steam-engine, with tubular boiler and regulating damper. The novelty consists in the mode of condensing the steam and obtaining the vacuum without cold water, in the mode of fixing the cylinders of the engine at an angle, so that the two connecting-rods take hold of the same crank-pin, and in the construction of the valves, the expansive gear, and the regulating damper.

78 **FERGUSON, DANIEL, Kilkenny, Ireland—**Inventor.  
Registered boat-propeller and water-wheel.

82 **MORRELL, G., 149 Fleet Street—**Inventor.

Patent rotatory engine, fitted as a steam-engine. It may also be used as a pumping and forcing-engine, or as a blowing apparatus for blast-furnaces. The following cut represents the front elevation of the engine, and

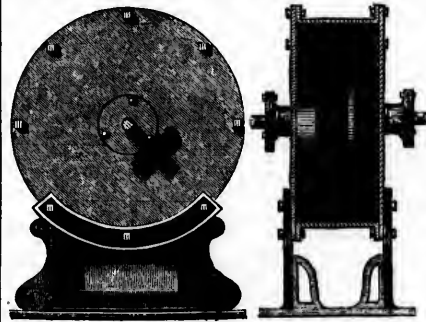

Front Elevation.

Section.

section, or side elevation, with part of the side removed to show the internal construction.

88 JENKINS, GEORGE, 4 Nassau Street, Soho—  
Inventor and Patentee.

New hydro-pneumatic engine. The object of which is to employ water pressure to drive the piston of the engine in one direction, and a vacuum being produced, to make use of atmospheric pressure to drive it in an opposite direction.

90 READ, STEPHEN KING, 50 Paradise Street, Rotherhithe—  
Inventor and Maker.

Double-action metallic pump, for domestic purposes; by fixing a hose on the nozzle, it will act as a powerful fire-engine.

91 REED, JOSEPH HATTHORNE, Westbourne Lodge,  
Harrow Road—Inventor.

Model of a new patent propeller, attached to a boat.

92 PHILLIPS, WILLIAM HENRY, 16 York Terrace,  
Camberwell New Road, Kennington—Inv. and Pat.

The fire annihilator, a portable machine, for extinguishing fire. This apparatus will, when occasion requires, instantaneously discharge, with the power of steam, an atmosphere of gases and vapour, possessing the property of suddenly subduing and rapidly extinguishing fire, without saturating the unburnt property. The vapour emitted from the machine, by its expansive force, intermixes with the fire, whether in a confined space or in the open air, while the air about the fire is rendered innocuous. The property the vapour has of circulating in the flames, and permeating amongst the burning goods, gives it the power to extinguish fires that may be unapproachable and inextinguishable by water. The machines and the chemical charges are not liable to get out of order by time or change of climate, and the management is so simple and easy that any one may use and recharge them.

*Directions for Use.*—With the knob of the stopper strike down the pin beneath it. A dense cloud of vapour instantaneously rushes forth, which being cast upon the burning materials extinguishes the fire.

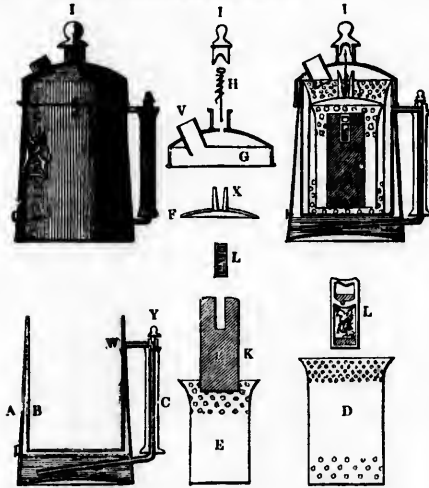

*Description of the Apparatus.*—A and B, cases forming a close chamber to contain water up to the level of the screw vent-plug Z, and the air in the annular space above. C, a pipe forming the handle, and a screw-cap, Y; this pipe may be stopped with a plug of soap at W.

D, a perforated cylinder.

E, the charge-case, also perforated.

F, the inner lid, having a neck, X, to keep it down in its place.

G, the cover, having a discharge-pipe, V.

H, an iron-pin supported by a special spring.

I, the stopper.

K, the charge; composition of nitre and gypsum.

L, the igniter, being a glass sheath, containing a bottle of mixture a chlorate of potass and sugar, and a small bottle of sulphuric acid.

The action is as follows:—the pin being forced down breaks the igniter bottles; the sulphuric acid, falling on the chlorate of potass and sugar, ignition takes place; the flame of the ignition mixture spreading over the upper surface of the charge, the charge instantaneously ignites, and evolves heated gases, which, in their passage through the perforated cylinder, impinge against cylinder B, expand the contained air, and produce steam between A and B, by which the water is forced up through the tubular passage. The vapour of the water, mixing with the hot gases, escape together from the discharge tube, in a dense expansive cloud, and are continuously delivered until the charge and the water are expended.

93 FIRE ANNIHILATOR COMPANY, Office and Depot  
105 Leadenhall Street, City—Producer.

Patent machine for extinguishing fire in buildings, in ships, and in mines, invented by W. H. Phillips, Esq.

94 HILL, WILLIAM, Blackheath Road, Greenwich—  
Inventor and Manufacturer.

Registered fire-boiler and furnace for hot-water apparatus, as applied for warming buildings.

96 SIMONS, W. VAZIE, South Shields—Inventor.

Electro-magnetic machine.

97 RHONE, EDW., 7 Cooper's Gardens, Hackney Road—  
Inventor.

Models of two revolving blade paddle wheels fixed on a skeleton hull, for propelling steam vessels. Their submersion in the water obviates the lifting of back water and the creation of a great swell; the action of the wheels can be reversed on deck or below without altering the speed or reversing the engine; and the motion of the wheels being uniform, they can be fixed either horizontally or perpendicularly.

98 SCOTT, MICHAEL, 6 John Street, Adelphi—  
Inventor.

Hydraulic machine for raising water or producing a vacuum in any situation where there is a fall of water or a running stream.

100 ERSKINE, DANIEL, Clerk Street, Edinburgh—  
Inventor and Manufacturer.

New land beam engine, having balance valves, with a new method of reversing, and other improvements for

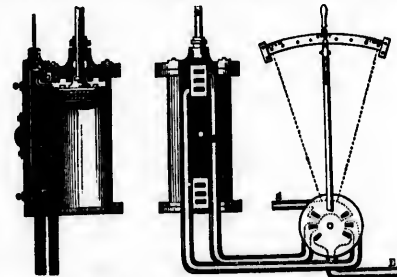

Erskine's Balance Valves, &c., in Section.

NORTH AREAS A. B. 10 to 34; C. D. E. 1 to 10, & 19 to 33; F. 1 to 32; G. H. 1 to 13, & 19 to 26.

working the pit apparatus, and shutting off the steam at the pit's head. The figure represents the balance valves, and shows their method of action.

New self-reversing beam engine, for planing machines and other purposes.

Silver locomotive and railway, with a new method of reversing and of disconnecting locomotives and carriages when falling from the perpendicular.

Circulating steam boiler for generating steam at experimental lectures.

New hydraulic locomotive for propulsion.

Horizontal water-wheel for large rivers, from 3 to 6 feet fall.

Self-acting valve cock without ground surfaces.

Gas water-meter, having a direct spindle which dispenses with meter wheels; index and stop-cock.

Highland shield.

#### 101 WHYTEHEAD, W. K., *Cornhill*—Proprietor.

1. McNaught's steam-engine indicators, for measuring and recording pressures; used principally for ascertaining the power and working order of steam-engines, for which purpose a communication is made between the cylinder of the engine and the cylinder of the indicator. The varying pressure of the steam acting on the piston of the indicator, raises or depresses the pencil in opposition to the internal spiral spring, and registers itself on the paper.

[To ascertain by this apparatus the pressure at various points of the stroke of the engine, the paper is moved by a string attached to some working part of the engine, so that its motion may coincide with that of the engine piston. By the shape of the diagram thus traced, the exact power given out by the engine (as distinguished from "nominal power"), the most advantageous adjustment of the valves, the friction of the engine, the power required by any portion of the machinery, the neglect or attention of the engine-driver, and the friction of the machinery when using different oils, can be ascertained. The instrument is fitted with two springs and a double scale, one for high-pressure steam divided to a small scale, and one for low pressure, to a scale of twice the size. The importance of an indicator may be estimated from the enormous amount of fuel consumed in this country for steam-power, a large quantity of which would be saved were the value of the indicator better understood by the proprietors of steam-engines.]

2. Drawing of section of large indicator, showing the construction.

3. Indicator diagrams to an enlarged scale.

4. McNaught's oil-testing machines. In spinning, weaving, &c., a large number of small spindles are kept in rapid motion, and if lubricated with an inferior oil, their friction, and consequently, the non-productive load on the engine, is materially increased. A small quantity of the oil to be tested is poured into the cup, a plate is then placed on the top of the oil, and the cup set in rapid motion. The plate is dragged round also, by the tenacity of the oil, and raises the weight on the steel-yard; by adjusting which, until an equilibrium is established, the friction of the oil can be read off on the scale. Invented by W. McNaught, C.E., of Glasgow.

5. Design for the application of McNaught's patent expansive principle to a 30-horse engine. By this plan, high-pressure steam can be applied with safety to engines which have been designed originally for low-pressure steam only. A small cylinder is applied at the crank end of the beam, at about half-stroke, and the steam from it passes into the existing cylinder, where it expands, and whence it finally escapes into the condenser, in the usual way. By this means, a saving of from 30 to 40 per cent. of fuel is effected, and the power of the engine may be increased, if desired, to the same extent.

#### 102 POTTS, J., *Stockton-on-Tees*—Manufacturer.

Complete working model of the high-pressure steam-engine, with several parts made of glass, as the cylinder and steam chest, showing the working of the piston and steam slides, and the internal structure of the engine.

[This may be called the transparent high-pressure steam-engine, the invisibility of the steam being a cause of wonder to many observers. Such a model is of the greatest utility to lecturers and others engaged in teaching the principles of practical science.]

#### 103 HODGES, B. J., *Grove House Lodge, Outer Circle, Regent's Park*—Inventor.

Working sectional model of a marine condensing steam-engine, for the use of schools and institutions.

#### 104 SHARP, WILLIAM DOUGLAS, *Swindon, Wilts*—Inventor.

Steam-engine, with improved valves, valve-gear, &c. The valves may be described as an elongation of the cylinder at each end in which the valves work; they are formed similar to, and of the same diameter as the piston, only that they are made hollow, with openings left in them large enough for the exhaustion. The ports form narrow openings extending quite round the circumference of the cylinder. The advantage of this description of valve is, that it gives a free inlet and outlet to the steam, which cannot be obtained with the slide-valve, especially at high velocities, as in the locomotive-engine, where the loss arising from this cause ranges from 30 to 50 per cent. Another advantage which this valve also possesses is, that the pressure on the back of the valve, which is so detrimental to the working of the slide-valve in locomotives and other high-pressure engines, is avoided.

Although the eccentric is quite applicable for working this description of valve, a motion is substituted which has many advantages; which, with the reversing motion, will be understood from inspection. One valve-shaft is sufficient for a pair of engines, care being taken to make the angle between the point of contact of the cams with the valve-rods the same as that formed by the cranks.

The mode of working expansively is only indicated by the cross-rod and the double joint on valve-rod.

#### 105 BEVAN, HOPKIN, *Llanely*—Inventor.

Plan of a locomotive steam-carriage for common roads.

#### 106 BECKETT, E. G., *3 Joynton Street, Strangeways, Manchester*—Manufacturer.

High-pressure steam-engine, suitable where small power is required.

#### 108 WEBSTER, BENJAMIN, *5 Stracey Street, Stepney, near Commercial Road East*—Maker.

Working model of a pair of oscillating engines, of 300-horse power, on a scale of  $\frac{1}{4}$  inch to the foot, with eccentric paddle-wheels connected, showing the working of the engines, and the feathering of the floats.

#### 112 PERRY, HENRY, *Bromley, Bow*—Manufacturer.

Model of a condensing engine and boiler, complete and constructed to scale.

#### 113 SHAW, B. L., *Newhouse, Huddersfield*—Inventor.

Model of Whitham's patent hydraulic engine, designed as a substitute for the steam-engine in certain localities. This engine is said to have opened a great extent of mining ground in Swaledale, Stoneydale and Covedale in Yorkshire, and in Weardale in Durham.

#### 116 LINTON, JOHN, *Selby, Yorkshire*—Inventor and Manufacturer.

Model of an improved engine working high-pressure steam expansively, with power to cut off the steam at any part of the stroke, and finally condensing it, so as to effect a saving of fuel.

118 FITT, WILLIAM, *Ponder's End*—Designer.

Working models of wind, water, and steam engines. Exhibited for economy and improved construction; the steam-engine is on the high-pressure principle, and has a peculiar arrangement for working the fly-wheel shaft with a single crank. The correcting machinery is so arranged as to admit of any one of the three engines to work separately.

119 FIRTH, T. & J., *Eliza Street, Belfast*—Inventors.  
Improved hollow furnace-bars.

Fig. 1.



Fig. 1 of the drawings is an elevation of this furnace-bar; Fig. 2, a cross section of three of these bars; *AA* are the bars, *B B* the bearers upon which they rest. The

Fig. 2.

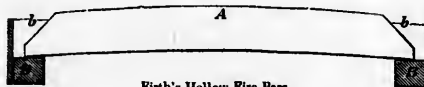

Firth's Hollow Fire Bars.

bars are slightly arched, so that they may, with a given amount of material, be stronger than if straight. The

lower edge has a channel, *C*, cut in it from end to end, as shown in the cross section. The air rushing along these channels keeps the bars partially cool, and escapes in a heated state into the furnace at each end of the bars through the openings at *a a*, formed by cutting off the top corners, *b b*, of the bars.

122 HURRY, H. C., *81 King Street, Manchester*—Inventor.

A model, showing improvements in lubricating. Patent dated May, 1830. The novelty consists in forming a chamber for the oil within or about the part to be lubricated. The advantage assumed is, that perfect lubrication is thus obtainable without waste of oil. The annexed illustration represents, in section, a portion of the cylinder and piston of a stationary steam-engine, showing the improvements exemplified by the model, as applied to stuffing-boxes, and to fibrously packed pistons; *a a* is a perforated hoop placed in the middle of the packing, to form a chamber for the reception of oil about the part to be lubricated; *c c* is a reservoir for containing the supply; *b b* are tubes of communication between the reservoir (*c*) and the hoop (*a*); *e f g*, is an apparatus for charging the reservoir (*c*) periodically; this is also, in some cases, effected by a hole drilled down the piston-rod, or by a plug-hole in the cylinder cover, and an independent funnel of peculiar form.

[In order to render the lubrication of machines effectual, the surfaces should be supplied with a fine stream continually flowing. The apparatus in question is intended to effect this result with a smaller amount of loss of material than usual.—S. C.]

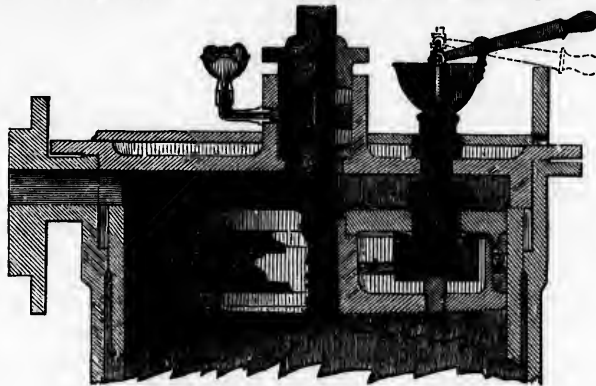

Section showing Hurry's Lubricating Improvements.

124 GALLOWAY, WILLIAM & JOHN, *Manchester*—Manufacturers.

Patent lifting jacks, for raising, moving, or turning over heavy bodies; made of wrought-iron, and case-hardened.

Patent steam-engine boilers, with new internal flues, by which the gases from two additional fires within the boiler are united and brought into admixture in a chamber, or throat, immediately beyond the fire-bars of the grates, so that by alternate ignition, the smoke of the newly-made fire is effectually consumed. The vertical water-cones, in the back portion of the flue, being acted upon by the flame, are active agents in the generation of steam, and keep up a constant circulation of the water. One of these land-boilers of thirty-horse power is in operation in the Exhibition.

125 FLYNN, W. P., *16 Summer Hill South, Cork*—Inventor.

Improved paddle-wheel, combining the action of the screw with that of the wheel. Provisionally registered.

126 TERRETT, RICHARD, *2 Homer Street, Lambeth*—Inventor.

Feathering paddle-wheel, and feathering windmill—constructed on an improved principle. Intended to save power, and prevent strain and friction.

127 VALLANCE, P., *1 Davies Street, Berkeley Square*—Producer.

Horizontal wind-mill.

128 WILLISON, ROBERT, *Alloa, Scotland*—Manufacturer and Inventor.

Model of double-acting force and vacuum pump, adapted for mines.

## 129 —

Model copper boiler.

NORTH AREAS A. B. 10 to 34; C. D. E. 1 to 10, & 19 to 33; F. 1 to 32; G. H. 1 to 13, & 19 to 26.

130 JUDGE, THOMAS, *Hampstead*—Inventor and Manufacturer.

Crank to pass the centres without the use of a fly-wheel or second steam-engine. Two cranks, intended as a substitute for four bevel wheels used in turret clocks, to show the time on the dial.

Gas consumer, which receives the soot that passes through the burner, and destroys it by effect of the same light.

Carriage steps. Self-adjusting spirit level.

131 BICKLE, WILLIAM, 18 *Reading Street, Swindon*—Designer and Manufacturer.

Working model of a pair of non-condensing steam-engines, which stands within the compass of a shilling, and weighs three drachms; made, with the exception of the piston rods, of a fine white metal.

132 ECCLESHALL, THOMAS, 2 *Great Ruston Street North, Birmingham*—Inventor.

Submarine propeller for steam vessels. Its purpose is to supersede the present means of producing motion by the paddle-wheel or the screw, more especially the paddle-wheel.

An atmospheric propeller for the purposes of navigation. Its object is to increase the speed of navigable vessels, and to avoid the expense of the mast and rigging of sailing vessels; the delays arising from contrary winds, so that a vessel may take her course direct; and to diminish many of the present causes of shipwreck from shoals, &c., when driven by stress of weather, as well as the risk of human life attendant upon rough weather.

133 DAY, HENRY JAMES, 2, *Lower Northampton Street, Clerkenwell*—Manufacturer.

Oscillating-cylinder marine-engine, exhibited for workmanship. Diameter of cylinders, one-fifth of an inch; length of stroke, one-fourth of an inch.

134 HEMMING, GEORGE, 44 *Lucas Street, Commercial Road East*—Designer.

Bird's-eye view of a 145-horse power marine engine, shown at an angle, and drawn to a scale from working drawings; illustrative of a method of laying down machinery or buildings, so as to avoid the expense of a model.

Bird's-eye view of a 280-horse power direct action marine steam-engine, shown perpendicularly.

136 STEVENS, JOHN LEE, 3 *Copthall Buildings*—Inventor.

Models of a surface-propeller for steamers, &c.; of a water-wheel; of a registered omnibus ventilator; and of Robinson's registered safety-plug for boats, &c.

Drawings of registered improvements in umbrellas, fire-tongs, and shovel.

138 RICHARDS, THOMAS, 2 *Kild Street, Woolwich*—Manufacturer and Designer.

Model of an apparatus for connecting and disconnecting the engines from the paddle wheels, by a new method, intended to dispense with the friction strap.

Models of propellers now in use, made to scale.

140 KEASLEY, W. H., 7 *Smithfield Bars*—Inventor.

A new application of the Archimedean screw, for propelling small vessels by hand. Applicable to canals, the screw creating no swell.

141 SMITH, GEORGE, 49 *Lime Street*—Inventor.

Improved method of feathering the float of paddle-wheels. The novelty is in the simplicity of its action, increased speed, and less straining of the vessel.

143 HODGSON, ROBERT, *Exwell, near Epsom*—Inventor.

Patent parabolic submarine propeller, for steam-ships. The novelty consists in the application of the hollow paraboloid, as the form of the machine to operate on the water. By this means, its resistance, acting in parallel straight lines, is concentrated to the focus, which forms a mo-

mentary fulcrum for propulsion. The water is then thrown off in the direction of the axis or plane of the vessel's course.

148 PATERSON, THOMAS, 15 *Rupert Street, Haymarket*—Inventor.

Model of a rotatory steam-engine. The invention consists in having each piston alternately fixed as a point of resistance to the steam, and revolving as a moving power.—Provisionally registered.

151 HAYCRAFT, WILLIAM TUTIN, *Greenwich*—Patentee.

Model of the "anhydrous" steam engine; designed to work with "dry" steam, by means of a "separator" of new construction, and a "slicator," to which is added an expansion valve; this valve is specially applicable to locomotive engines, from its readiness of action. The object of this engine is to prevent boiler explosions. The cylinder is provided with a steam jacket, which is essential to its operation.

[The object of this invention is to separate the steam from the water which generated it, and to apply it, in its separated state, to the working of the engine. For this purpose an apparatus called a "separator" is employed; another called a "slicator" is also used to keep up the heat of the steam in its separate state, otherwise it would condense and lose its power.]

152 ELDER, D., *Royal Adelaide Steamer, Leith*—Inventor.

Model of an oscillating marine steam-engine, so arranged as to dispense with the ordinary slide valves, eccentrics, &c.

154 SCOTT, G., 22A *Winchester Street, City*—Inventor.

Boiler cleanser.

156 JONES, WILLIAM, 4 *Tabernacle Square, Finsbury*—Inventor.

Model of an improved paddle-wheel, in which the paddles rise vertically from the water, which prevents back water, and the consequent loss of power. The floats may be formed of sheet-iron, in one or more pieces, to slide into iron framework, and to move in plunger blocks fixed to the arms of the wheel, but not represented in the model.

158 DEANE, C. A., 7 *Henry Street, Hampstead Road*—Manufacturer.

Working model of a high-pressure pedestal steam-engine.

160 PYM, JOHN, 52 *Threadneedle Street*—Inventor.

Model of a submerged paddle-wheel, for propelling vessels, to work wholly or partially under water. The wheel has two shafts, one within the other: the inner one is a screw, the arms of the wheel have blades at their extremities, for a double-bladed paddle. On the arm or centre of each paddle (within the main shaft) is a pinion worked by the screw shaft, giving to the paddle a rotatory or propelling position at one part of the revolution of the wheel, and in a vertical or feathered position during another part of the revolution.

162 COLGRAVE, FRANCIS EDW., *Round Hill, Brighton*—Inventor.

Model of a cylinder, fitted with patent slide valve, for diminishing friction.

200 TUCK, JOSEPH HENRY, 22 *Pall Mall*—Manufacturer.

Lariviere's patent pneumatic governor for regulating the speed of steam-engines.

201 CARNELL & HOSKING, *Perran Foundry and Engine Works, near Truro*—Inventors and Manufacturers.

Treble-beat hydraulic valves and seats, particularly adapted for water-works, where large pumps are required.



The improvement in these treble beat hydraulic valves consists in making the outer beats as near as possible of one size, and allowing the water to act against the middle plate to lift the valve, which will give a third beat, and a third discharge of water, and consequently reduce the lift, prevent concussion, and increase the durability not only of the valve, but other parts of the machinery.—Registered 1851.

202 ASHBY, JONATHAN, *Croydon Common*—Inventor.  
Screw friction clutch, for engaging and disengaging machinery, while the moving power is in motion.

204 LEES, T., *Stockport*—Inventor.  
Water-gauge, alarm valve, &c.

205 NEWCOMB, THOMAS, *12 Norfolk Place, East Lane, Wulworth*—Inventor and Maker.  
Brass model of machine, for rolling tanned hides. Its objects are, increased speed in drying hides, less power in working, and a finer finish in the leather. The pressure on the hides may be varied from 1 cwt. to 2 tons.  
Brass model of patent furnace for marine or stationary steam engines; it supplies itself with fuel, consumes its own smoke, and burns small coal.

206 HASKETH, —, *Redruth*—Inventor.  
A lubricator for machinery.

208 GADD & BIRD, *Manchester*—Inventors.  
An expansive piston.

300 LLOYD, GEORGE, *70 Gt. Guildford Street, Southwark*—Inventor and Manufacturer.  
Patent centrifugal disc blowing machine.  
The centrifugal exhauster differs from the ordinary

blower in requiring no outside case; the air or gas is drawn through the pipes, and discharged through the opening in the periphery, into the atmosphere.

301 NAPIER, J. R., *Vulcan Foundry, Glasgow*—Inventor.  
Portable rivet-heater, for iron ship builders or boiler makers.

304 KENNEDY, M., *3 George Street, Camden Town*—Designer and Manufacturer.  
Improved blast-fan, for blowing smiths' forges, and founders' furnaces, applicable also for ventilating and fumigating.

305 WHEELER, EDMUND, *2 North Buildings, Finsbury Circus*—Inventor and Patentee.  
Equilibrium slide valves for steam engines, to relieve the valve from the pressure due to the elastic force of the steam.

400 DALY, JOHN, *Brass and Lead Works, Limerick, Ireland*—Manufacturer.  
Bronze bell, mounted between two brass pillars, with the bust of Shakspeare on the top.  
Improved brass pump, for supplying kitchens, water-closets, cisterns, stable-yards, &c.

401 MERRYWEATHER, MOSES, *63 Long Acre*—Manufacturer.  
Carriage fire-engine to be drawn by two or four horses, London Fire Brigade pattern (Simpkins' patent), with 7-inch gun-metal cylinders, and spherical copper air-vessel; gun-metal pistons and valves in separate valve chambers; handles for 30 men, to fold up fore and aft; improved wrought-iron fire carriage, patent axles and springs; double delivery screws for attaching two lines of hose. Fully equipped with hose, suction-pipes, nose-pipes, jet-spreader, &c. Fig. 1 represents this engine, and the peculiar dress of the fire brigade.

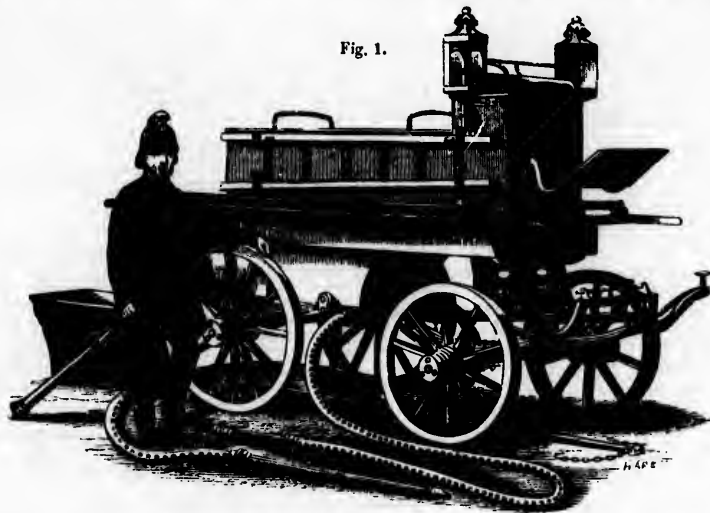

Merryweather's Carriage Fire-engine.

Light carriage fire-engine, Simpkins' patent; country pattern for post-horses, with handles for 20 men. Equipped and furnished like the preceding.

Patent metallic fire-engine, for tropical countries, to be drawn by hand.

Ship fire-engine for six men; on the patent principle, with suction-pipes, delivery-hose, branch-pipe, &c.

Cabinet fire-engine (fig. 2, p. 227), for mansions, picture galleries, &c.

Two portable conservatory engines.

A coil of best leather-hose, copper-riveted, with gun-metal union screws—London Fire Brigade pattern.

A coil of patent seamless canvas hose, screw, &c., as before.



NORTH AREAS A. B. 10 to 34; C. D. E. 1 to 10, &amp; 19 to 33; F. 1 to 32; G. H. 1 to 18, &amp; 19 to 26.



Fig. 2.

Merryweather's Cabinet Fire-engine.

An improved short branch-pipe and nozzle fitted with Baddeley's jet-spreader.—Registered 1842.

An improved metal breeching for connecting two separate lines of hose into one, or for dividing one line into two.—Invented by Lord Thurlow; registered 1844.

Improved preventor (or fire-hook), capable of being lengthened indefinitely.—W. Baddeley, Inventor.

Six improved japanned leather helmets, and leather belts and axes, for firemen.

Leather and canvas fire-buckets.

Set of seven portable fire-escape ladders on hand carriage, with guide wheels, safety-belt and rope, as supplied to the City police, &c.

Domestic family fire-escape, simple and easily applied.

Fireman's leather morion, as made at the establishment of the exhibitor in the early part of the 18th century.

Old English leather black-jack, of the same period.

Old English leather plate-basket, of the same period.

402 SHALDERS, WILLIAM, jun., *Bank Place, Norwich*—  
Designer and Manufacturer.

Patent fountain pumps, engines, and hydraulic working parts, in various metals, for beer, &c., and for house or garden cisterns.

The advantages claimed consist in their reciprocating and rolling action, which is effected without leakage, friction, or liability of choking from such particles as are not easily prevented from entering without blocking up the entrance to their suction-pipes, as small stones, shingle, &c., or from cargoes of grain, pepper, rice, beans, &c., the evolutions of the connector quickly expelling such matters, without receiving material injury, but which with the valve leathers are the only parts that suffer at all; they will pump up even from the bottom of deep wells, and drive up to a higher level any puddled soil or half sand and half water, and that more economically than by other means. Fountain pumps admit of more economical and simpler construction than the common piston and cylinder pumps, and by their admitting of either quick or slow motion without leakage or loss of power, they are easily applied to any motive force; they are cheap, simple, and durable, and, with common smiths' tools, the most complex are readily examined or repaired.

403 STOTHERT, RAYNO, & PITT, *Newark Foundry, Bath*—  
Improvers and Manufacturers.

Iron crane for a dock or wharf, with improvements in the gib, and in the general arrangement and proportion of the parts.

403A STOTHERT, H., *Bath*—Inventor.

Model of a plan for removing the sewage of London without disturbing the present arrangement of drains.

404 FOX, HENDERSON, & Co., *London Works, Birmingham*—  
Inventors.

Derrick crane and model. Proving press and patent pipes.

[This crane was put into actual service in lifting the heavy machinery around it into their present places, and is equally applicable for their removal at any future time. It was also employed in the construction of the building, and particularly in unloading and testing the cast-iron girders.]

405 BERRIEDALE, Lord, *17 Mill Street, Berkeley Square*—  
Inventor.

Double-acting fire-engine, for private houses; exhibited for power and ease of working.

406 FOURDENIER, E. N., *38 Barclay Street, Sunderland*—  
Inventor.

Patent safety apparatus, for preventing loss of life and property when a rope or chain breaks in shafts of mines and collieries.

407 BEGG, W. G., *20 Market Street, Edinburgh*—  
Inventor and Manufacturer.

Safety cages, for mine shafts, to prevent the loss of life and destruction of property in mine shafts, when the rope or chain snaps.

408 EASTON & AMOS, *Grove, Southwark*—Part  
Inventors and Manufacturers.

Improved patent hydraulic ram, originally invented by Montgolfier, in France, and patented by him in 1797; the English patent has passed into the hands of the exhibitors.

[This machine, which is self-acting, is composed of an air vessel and three valves, two for the water, and one for keeping up the supply of air. Upon pressing down the valve in the conducting tube, which opens downwards, the water escapes from it, until its momentum is sufficient to overcome the weight, when the valve immediately rises and closes the aperture. The water having then no other outlet than the inner valve, rushes through it, by its generated force, compressing the air in the air vessel until equilibrium takes place, when the air reacts by its expansive force, closing the inner valve, which retains the water above it, and driving it up the ascending tube. By this reaction, the water is forced back along the conducting pipe, producing a partial vacuum beneath the outer valve, which immediately falls by its own weight. The water then escapes until it has acquired sufficient force to close this, when the action proceeds as before. It is best adapted for the raising of moderate quantities of water, as for household or farming purposes.]

409 BADDELEY, WILLIAM, *29 Alfred Street, Islington*—  
Inventor and Manufacturer.

A portable, and simple farmers' fire-engine. It is also applicable as an agricultural force-pump.

A portable fire-engine; two sizes.

410 SHAND & MASON (late TILLEY), *245 Blackfriars Road*—Manufacturers.

Improved brigade fire-engine, with complete set of tools and implements, worked by 28 men; is drawn by horses, and carries the firemen; has improvements in suction or inlet cock, air-vessel, and exit pipe; by means of the latter two, right angles are avoided in the passage of the water. This engine is represented in the accompanying Plate.

Mansion or factory fire-engine, for 20 men.

Metallic fire-engine, for 14 men, suitable for any climate.

Ship's fire-engine, for 6 men, mounted on wheels.

The above are each fitted with metallic valves, draw water through suction-pipe or from cistern, and are mounted on four wheels, with locking-carriage and drag-handle.

Hall fire-engine, for the interior of public buildings and mansions.

Galvanised iron garden-engine, with improved lever. Improved portable fire-pump, introduced by the London Fire Brigade, and found of great utility at the commencement of a fire. The same with pail, into which it can be instantly fixed.

Hose-reel, with implements complete. Hose and suction-pipes of various sorts, also various descriptions of fire-cooks. A series of experimental jet-pipes, used in determining the best form. Fire-buckets, fire-axes, London Brigade firemen's helmet, &c. Branch and jet-pipes, as used in floating fire-engines, for 120 men.

The improved brigade fire-engine, several hose-reels, and 18 portable fire-pumps, have, at the request of the Executive Committee, been placed at their disposal, to be used in the event of fire. They will be found in various parts of the Building, under the care of firemen of the London Establishment.

411 JAMES, JOHN, & CO., 24 Leadenhall Street—Manufacturers.

A patent weighing crane (fig. 1). This crane is adapted for raising heavy goods, and, at the same time, obtaining their weight by an adaptation of the principle of the steelyard.

Fig. 1.

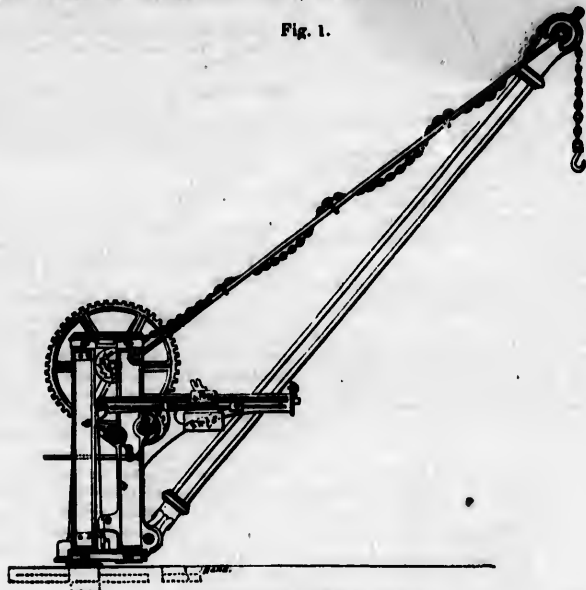

James & Co.'s Patent Weighing Crane.

Fig. 2.

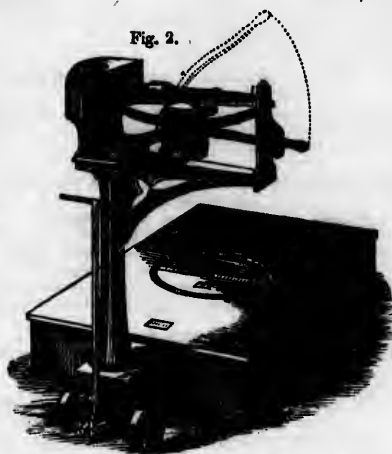

James & Co.'s Small Patent Weighing Machine.

A small weighing machine for warehouse purposes (fig. 2). This machine is intended to weigh any description of merchandise from 1 lb. up to 21 cwt., and the principle upon which it is constructed is applied to weighing machines of all sizes. Its novelty is comprised in the absence of all loose weights, in the counterpoise being so arranged as to admit of the free oscillation of the beam, and in the weights by which the goods are weighed being attached to, and forming part of, the machine itself. The large weight moves on a circular scale, and the small weight along a straight scale, the one indicating cwt., the other lb.—Patented.

412 THE BANK QUAY FOUNDRY COMPANY, Warrington—Manufacturer and Proprietor.

Large hydraulic press, used for raising the Britannia Tubular Bridge.

Explanation of the engravings (Plates 18, 19, 20) of the hydraulic press used for raising the tubes of the Britannia Bridge; executed by the Bank Quay Foundry Company, Warrington.

A—Wrought-iron Sandwich girders, weighing 12 tons each.

B B—Cast-iron beams, 5 tons each.

C—Jacket of cast and wrought iron, weight 8 tons.

D D—Cylinder, cast-iron, weight 15 tons.

E—Ram, 3 tons 13 cwt.

F—Crosshead, cast-iron, 13 tons.

[UNITED  
to 26.

hose-reels,  
rest of the  
to  
found in  
of firemen

is adapted  
obtaining  
ole of the

es (fig. 2).  
ption of  
principle  
hing ma-  
the ab-  
being so  
e beam,  
ed being  
elf. The  
e small  
g cwt.,

ington—  
Britannia  
)) of the  
Britannia  
company,  
12 tons

ONS.

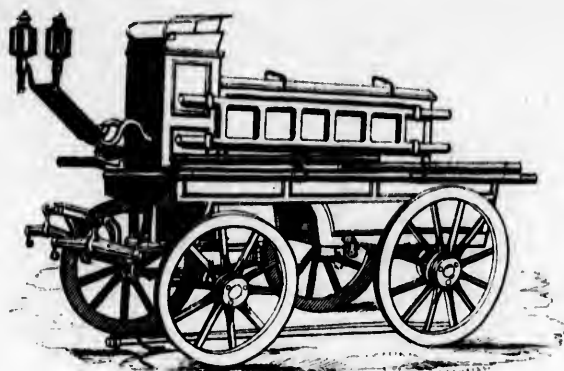

IMPROVED BRICADE FIRE ENGINE.

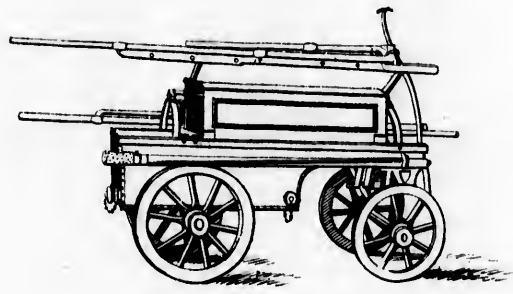

METALLIC FIRE ENGINE.

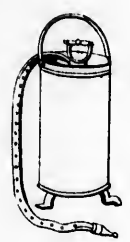

PORTABLE  
FIRE PUMP  
WITH PAIL.

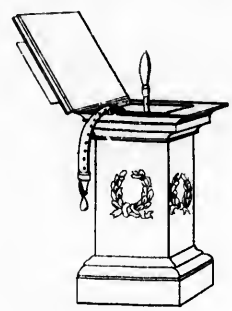

HALL FIRE ENGINE.



PORTABLE FIRE PUMP  
AS USED BY  
THE LONDON FIRE BRICADE.

MESSRS SHAND & MASON'S FIRE ENGINES & APPARATUS.

London, England

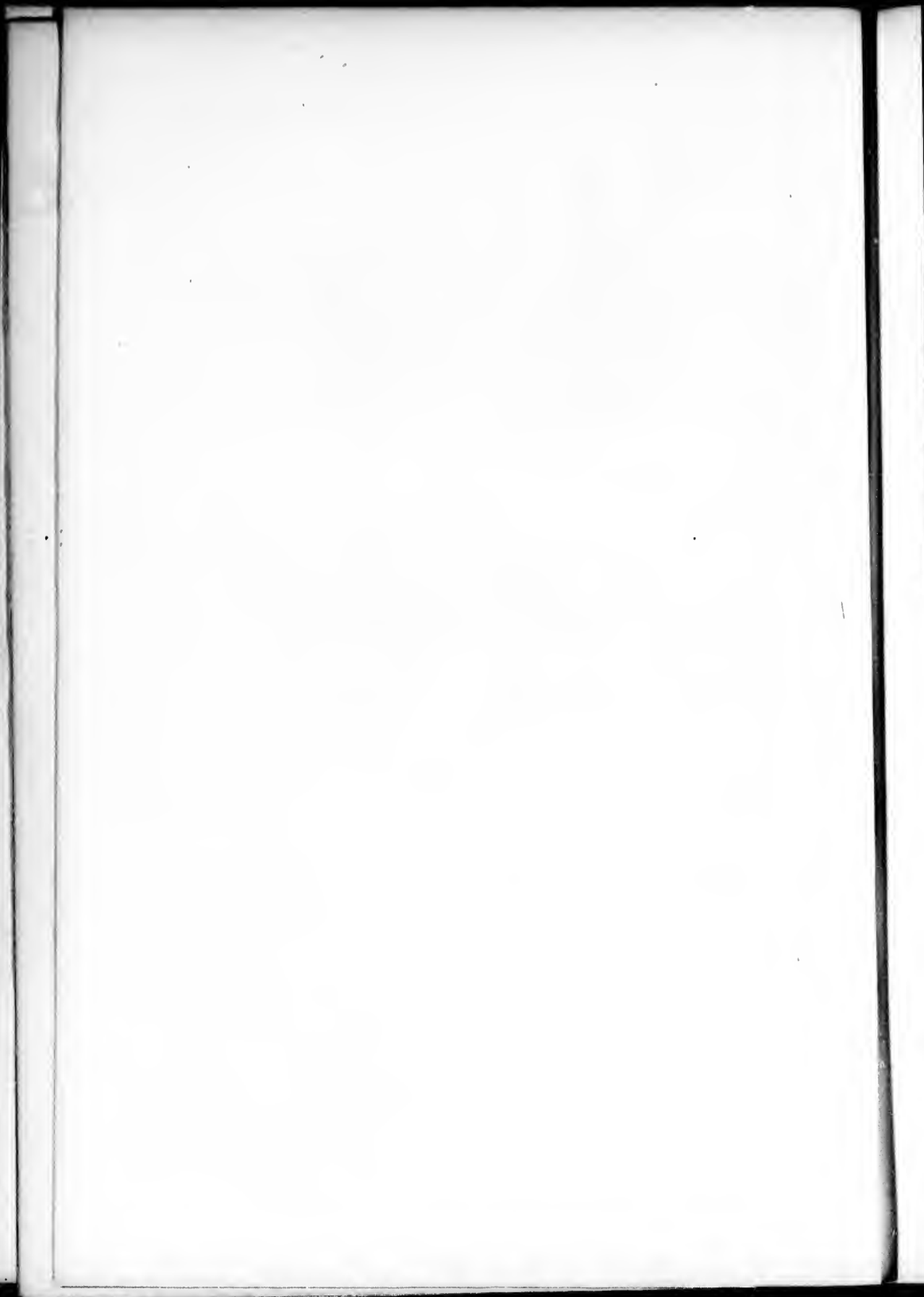

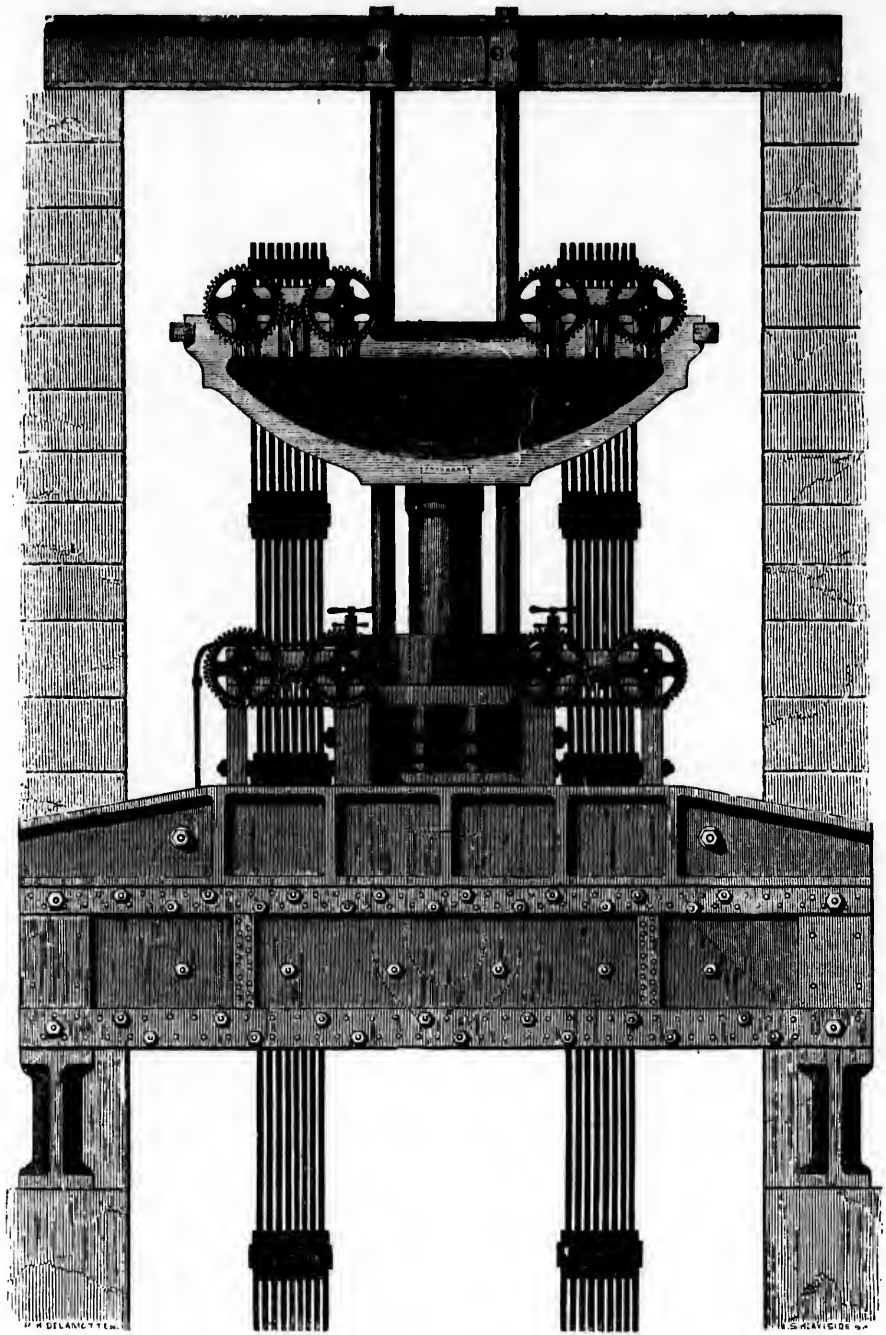



L



11



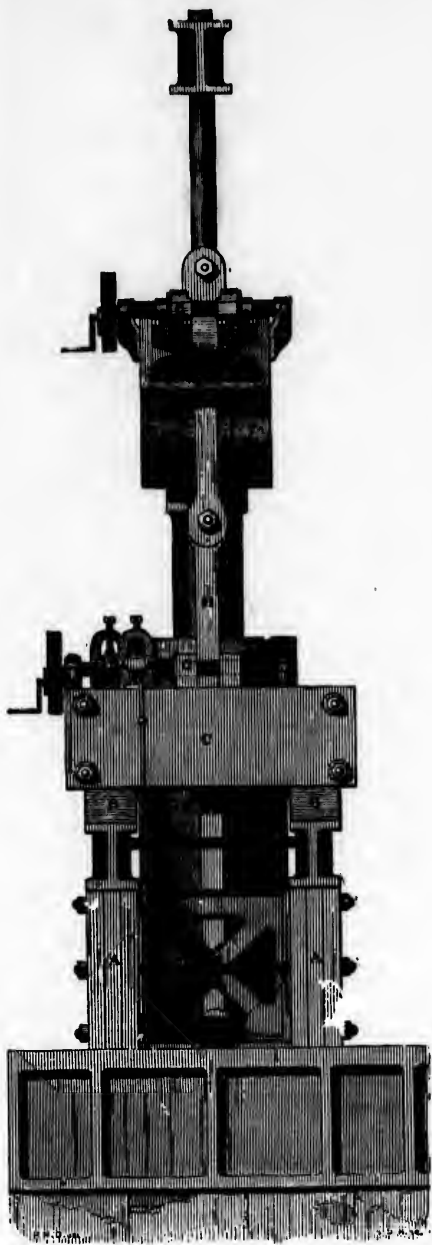

II. THE PRESS SHOWN IN OPERATION—THE TUBE PARTLY LIFTED.

19.

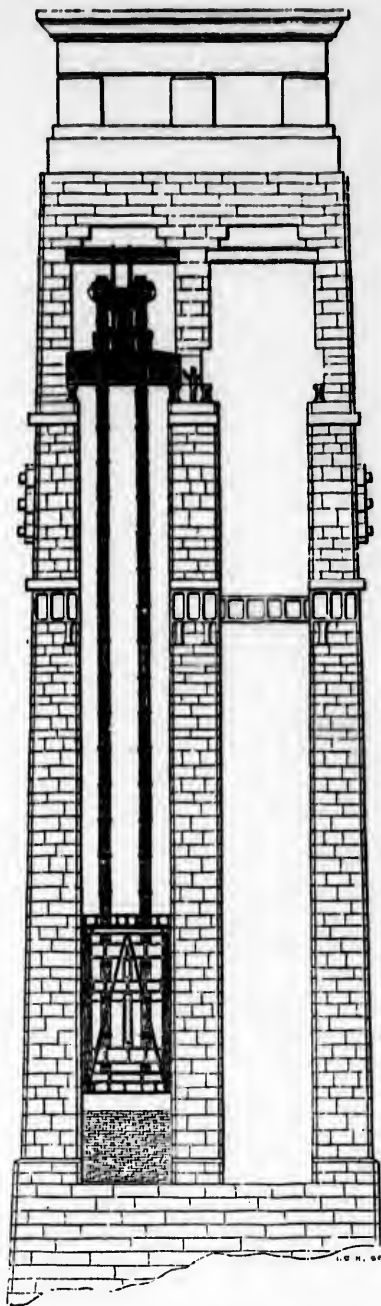

III. END ELEVATION.

20.

KING  
No

G G  
H—  
I I—  
K—  
L L  
M—

girder  
Pla  
Plate  
tion is  
lifted.

The  
diameter  
the cy  
thickness  
cylinder  
in the  
which  
A A;  
in at  
subject  
strength  
each,  
allow  
tons  
finish  
weight  
state  
after  
and o  
of sur  
below  
after  
coat  
it was  
ten d  
appro  
of dra

The  
six v  
vertic  
space  
that  
The t  
wrou  
The t  
by 1  
each  
at th  
wood

The  
was  
2,000  
4 inch  
truly  
it.  
6 inch  
press  
the n

The  
cross  
liftin  
cast-i  
for s  
press  
are i  
iron  
slotte  
with  
turni  
draw  
paral  
by a  
one n  
raise  
from  
Th  
& Ra  
Amo

NORTH AREAS A. B. 10 to 34; C. D. E. 1 to 10, & 19 to 33; F. 1 to 32; G. H. 1 to 13, & 19 to 26.

G G G G—Clamps.

H—Chains.

I I—Guide rods, wrought iron.

K—Guide rod beam.

L L—Valves.

M—Distance pieces between wrought-iron Sandwich girders.

Plate 18 represents a front elevation of the press; Plate 19 an end elevation; and Plate 20 shows its application in raising the Britannia tube, with the latter partly lifted.

The internal diameter of the cylinder is 22 inches, the diameter of the ram is 20 inches, the external diameter of the cylinder is 42 inches, external length 9 feet 1½ inch; thickness of metal 10 inches; the water is forced into the cylinder through a pipe and valve L, the press is placed in the jacket C, and rests upon the cast-iron beams B B, which again are supported by the wrought-iron beams A A; the cast-iron crosshead F has wrought-iron links let in at the top, for the purpose of strengthening the part subject to tensile strain; the sides of the jacket also are strengthened with wrought-iron slabs, weighing 30 cwt. each, expanded first by heat and then fitted on hot, and allowed to contract. To cast the cylinder, it required 22 tons of fluid metal, the additional quantity beyond its finished weight being required for the head, or pit, which weighed 2½ tons. This head, or pit, was kept in a fluid state for six hours after the run, by replacing the material after it became stiff with metal fresh from the furnace, and of the highest attainable temperature, for the purpose of supplying the space in this immense body of metal below, consequent upon the contraction. In three days afterwards the cylinder was partly denuded of its outer coat of sand, when it was found red hot; in seven days it was lifted from the pit in which it was cast, and in ten days, or 240 hours, it was sufficiently cool to be approached by men well inured to heat, for the purpose of dressing the remaining sand off it.

The A A beams, for supporting the press, consisted of six vertical ribs of boiler plates, ¼ths thick, united by vertical strips, to preserve them in form; the 2½ inch spaces between ribs were filled with American elm, so that the vertical rib was a sandwich of elm and iron. The top and bottom flanges were each formed by twelve wrought-iron bars, extending the whole length of beam. The top bars 7 inches wide, and the bottom bars 9 inches by 1½ inch; the whole riveted together. The weight of each girder was 12 tons. In order to prevent the crushing at the ends, cast-iron plates were inserted instead of the wood.

The weight actually supported by one pair of beams was 1,177 tons, but they were capable of sustaining 2,000 tons. The length between the bearing was 17 feet 4 inches. The ram was cast hollow and turned to bed truly, beneath the crosshead, which was bored to receive it. The crosshead was guided by two wrought-iron rods, 6 inches diameter, fitted in sockets on the top of the press, and keyed above into a cast-iron girder, K, built in the masonry.

There were two sets of clamps: the one placed on the crosshead and rising with it, was immediately used for lifting the chain and tube, the under set was fixed on the cast-iron girders which support the press, and was used for securing the chain at the end of each lift, while the press was lowered, and the upper set of links removed; they are in all respects similar to each other. The wrought-iron clamping cheeks are slotted to fit closely beneath the slotted shoulder in the head of the links; they are withdrawn or closed by right and left handed screws, on turning which the cheeks recede from each other, or are drawn into close contact with the chain. To insure a parallel action, the screws are moved simultaneously by a winch and gearing; they are thus easily worked by one man. Thus at each stroke of the press the tube was raised 6 feet, the time occupied in one lift being usually from 30 to 45 minutes.

The lifting chains were manufactured by Messrs. Howard & Ravenhill; the clamps and valves by Messrs. Easton & Amos. The superintendence of the designs and con-

struction of this machinery were entrusted by Mr. Robert Stephenson, the engineer, to Mr. Edwin Clark.

The greatest weight lifted by the press at the Britannia bridge was 1,144 tons; the quantity of water used for each 6 feet lift 81½ gallons. "The pressure at 3 tons per circular inch equals 8'819 tons per square inch, which would raise a column of water 5'41 miles in height; this pressure would, therefore, be sufficient to throw water over the highest mountains on the globe." This extraordinary fact is derived from Mr. Edwin Clark's work on the Britannia and Conway bridges. The following additional extract shows indirectly the vast power of this machine:—

"If it were required that 1 lb. should raise the tube, or 2,000 tons, then one arm of the lever must be 448,000 times as long as the other; but if the 1 lb. move through a space of 1 inch, the tube will be only lifted  $\frac{1}{448,000}$ th part of an inch; and in order to raise the tube 100 feet the pressure of 1 lb. must be continued through a space of 83,522 miles; and, conversely, a pressure of 2,000 tons through a space of 100 feet, would raise 1 lb. 83,522 miles; thus the descent of a clock-weight through a space of 6 feet overcomes the friction of the machine, and moves the extremity of an ordinary seconds-hand through a space of two miles in a week, and the descent of the tube to the water would maintain the going of an ordinary clock for 240,000 years," or the power expended by the press in lifting the tube 100 feet, if applied to an ordinary clock, would work it for a period of 240,000 years.

After the first tube was raised, the cylinder met with an accident, described in the following terms by Mr. Clark:—

"In a little more than a fortnight after this operation the presses were removed ready for raising the next tube. They were lowered and raised again by means of capstans, with an 8-inch rope; and in this operation another accident occurred with the unlucky press. The cylinder was lowered from a cat-head at the top of the tower; the rope from the blocks led to a capstan on the beach, on which three turns only were taken; while the cylinder, weighing 15 tons, was suspended at an elevation of 140 feet above the water, the rope unexpectedly surged on the capstan, and was dragged out of the hands of the men who were holding it; the cylinder descended with fearful velocity, dragging the rope through the block tackle and round the capstan, which fortunately became palled by the jerk. As the velocity increased, the cat-head in the tower gave way, and the cylinder fell on the stone shelf below, fracturing the masonry, and gliding off 50 or 60 feet into the Straits. Several men were injured, and a sailor who was serving out the coil of rope was dragged round the capstan and killed. None of the tackle was broken, and the press was easily raised by the ropes attached to it, and was found to be uninjured by the fall."

[The weight raised by this single press at the Britannia bridge was 1,144 tons, and this was effected with ease by the hydraulic press exhibited. A popular error prevails on the subject of gaining power by the application of machinery, and particularly with relation to the hydraulic press, in which it appears that a small applied force produces immense results. In this case, however, as in all others, the power is only transferred and distributed. Water, and indeed all fluids, possess the property of pressing equally in all directions. If water is enclosed in an iron box, and the force of one pound is applied to but one square inch of its surface, this pressure is at once communicated to every square inch of the surface of the box. Bramah rendered this force available by applying a packing around the moving pistons, which made them perfectly water-tight under any pressure. By the force pump, pressure is applied to the water in the small cylinder of the pump, and this fluid being connected with that in the large cylinder of the press, whatever force is applied to the water in the first,

is increased according to difference of the capacity between it and the last, which was in this case as 1 to 354.3.

Four such cylinders have been cast at Bank Quay Foundry, and they are, perhaps, the most powerful machines ever constructed.—R. H.]

**413 HOWARD, RAVENHILL, & Co., King and Queen Iron Works, Rotherhithe—Inventors, Patentees, and Manufacturers.**

Link of a suspension bridge chain, formed of eleven bars, to illustrate the method for rolling bars for suspension bridges, and similar purposes.

This process produces the bars of the form required at one heat, and is intended to supersede the uncertain and insecure method of welding on the heads; and to carry the fibre of the iron in the proper direction around the eye to resist the strain of the coupling pins. The bars exhibited form a link of the chains in all respects similar to those manufactured for the suspension bridge over the Danube at Pesth. The tubes of the Conway and Britannia bridges, the latter weighing 2,000 tons, and lifted 100 feet, were safely raised by chains made on this principle.

[With a force of about 10 tons per square inch of sectional area, the elasticity of wrought iron is wholly excited, and in some cases surpassed. Engineers, therefore, do not subject it to this strain, even when the iron is perfect in the texture of all its parts; but as in the case of chains with welded heads, the texture can never be perfect, a still larger margin must be left; probably the strain permanently acting on it should not much exceed 5 tons per square inch. If by any process of manufacture these defects can be certainly removed, greater safety may be gained by a less expenditure of metal.—S. C.]

**414 GOSSAGE, J., 71 Florence Road, Deptford—Inventor.**

Improved portable engine-pump, designed for the use of ships, particularly for men-of-war. It may be used for a fire-engine, watering-engine, and wash-deck pump. It is available for all the purposes of a lift or force-pump; also, as an auxiliary to, or substitute for, any fixed pump in use on board ships, in case of need, and can be used to wet the ship's sails, or worked in a boat to wash the ship's side, and extinguish fire.

The principal peculiarities are, its portability and capacity of working in less space, greater durability under action of sea-water, and its not being so liable to be injured from accident, nor to get out of order; metallic valves are used in lieu of leather, with vulcanized India-rubber discs between the piston caps, and its general construction is suited for all climates. It is not rendered inefficient by not being in constant use, or by being kept free from water.

**415 GREATOREX, DAN., 9 Desborough Terrace, Harrow Road, Paddington—Inventor and Manufacturer.**

Model (scale  $1\frac{1}{2}$  inch to a foot) of an improved hoisting machine, for raising or lowering goods; the machine can be worked by hand or steam, and its whole operation requires but one man. The principle is applicable to dinner-lifts for hotels and mansions.

**416 BELLHOUSE, E. T., & Co., Eagle Foundry, Manchester—Inventors.**

Hydraulic press for packing cotton, or other material in bales; worked by two hand-pumps; with illustrative drawings.

Model of the exhibitors' fire-proof hoist for mills and warehouses. This plan prevents the rapid communication of fire from one story to another, by the interposition of fire-proof doors between each story; an arrangement is introduced which causes the doors to shut by their own gravity, when the cradle is removed.

Model of the iron shell of a cottage.

Brick-pressing machine, with W. Percy's self-lubricating piston.

Small hydraulic press, adapted for making experiments in the compression of material.

**417 FAIRBAIRN, W., & SONS, Manchester—Inventors and Manufacturers.**

Patent tubular crane, manufactured by the exhibitors.

[The following observations on this crane are extracted from a paper contained in the Reports of the British Association, communicated by Sir David Brewster:—

“These structures indicate some additional examples of the extension of the tubular system, and the many advantages which may yet be derived from a judicious combination of wrought-iron plates, and a careful distribution of the material in all those constructions which require security, rigidity, and strength.

“The projection or radius of the jib of these cranes is 32 feet 6 inches from the centre of the stem, and its height 30 feet above the ground. It is entirely composed of wrought-iron plates, firmly riveted together on the principle of the upper side being calculated to resist tension, and the under, or concave side, which embodies the cellular construction, to resist compression. The form is correctly that of the prolonged vertebra of the bird from which this machine for raising weights takes its name; it is truly the neck of the crane tapering from the point of the jib, where it is 2 feet deep by 18 inches wide to the level of the ground, where it is 5 feet deep and 3 feet 6 inches wide. From this point it again tapers to a depth of 18 feet under the surface, where it terminates in a cast-iron shoe, which forms the toe on which it revolves. The lower or concave side, which is calculated to resist compression, consists of plates forming three cells, and varying in thickness in the ratio of the strain; as also the convex top, which is formed of long plates chain-riveted with covers; but the sides are of uniform thickness, riveted with T iron, and covering plates  $4\frac{1}{2}$  inches wide over each joint. This arrangement of the parts and distribution of the materials constitute the principal elements of strength in the crane. The form of the jib, and the point at which the load is suspended, is probably not the most favourable for resisting pressure. It nevertheless exhibits great powers of resistance; and its form, as well as the position, may safely be considered as a curved hollow beam having one end immovably fixed at A, and the other end, C, the part to which the force is applied. Viewing it in this light, the strengths are easily determined, and taking the experiments herein recorded,

we have by the formula  $W = \frac{AdC}{e}$  a load of 63 tons,

the weight it would require to break the crane. With 20 tons the ultimate deflection was 3.97—.64 of a permanent set = 3.33 inches, the deflection of the jib due to a load of 20 tons. The following constitute the experiments made at Keyham Docks:—

“Experiments made to ascertain the resisting powers of a new wrought-iron tubular crane, erected at Keyham Dockyard, Devonport, November 8, 1850.

| Weight of Cargo in Tons. | Deflection at the point of the jib in inches. |                                                                                                          |
|--------------------------|-----------------------------------------------|----------------------------------------------------------------------------------------------------------|
| 2                        | .32                                           | } With 5 tons suspended the crane was turned completely round, without any alteration in the deflection. |
| 3                        | .50                                           |                                                                                                          |
| 4                        | .65                                           |                                                                                                          |
| 5                        | .90                                           |                                                                                                          |
| 6                        | 1.05                                          |                                                                                                          |
| 7                        | 1.20                                          |                                                                                                          |
| 8                        | 1.35                                          |                                                                                                          |
| 9                        | 1.50                                          |                                                                                                          |
| 10                       | 1.70                                          |                                                                                                          |

With this weight the crane was again turned round; the

NORTH: AREAS A. B. 10 to 34; C. D. E. 1 to 10, & 19 to 33; F. 1 to 32; G. H. 1 to 13, & 19 to 26.

deflection in eight minutes increased to 1.85 inches, when it became permanent after sustaining the load during the whole of the night, a period of about 16 hours.

"On 9th November the experiments were resumed as follows:—

| Weight of Cargo in Tons. | Deflection at the point of the Jib in Inches. | Weight of Cargo in Tons. | Deflection at the point of the Jib in Inches. |
|--------------------------|-----------------------------------------------|--------------------------|-----------------------------------------------|
| 11                       | 2.05                                          | 16                       | 3.00                                          |
| 12                       | 2.22                                          | 17                       | 3.20                                          |
| 13                       | 2.40                                          | 18                       | 3.50                                          |
| 14                       | 2.60                                          | 19                       | 3.73                                          |
| 15                       | 2.80                                          | 20                       | 3.97                                          |

On again turning the crane round with a load of 20 tons there was no perceptible alteration in the deflection, and the permanent set, after removing the load, was .64 inches.

"From the above experiments, it appears that the ultimate strength of the crane is much greater than is requisite either in theory or practice, and, although tested with nearly a double load, it is still far short of its ultimate powers of resistance, which it will be observed are five times greater than the weight it is intended to bear.

"The advantages claimed for this construction are its great security, and the facility with which bulky and heavy bodies can be raised to the very top of the jib, without failure. It moreover exhibits, when heavily

loaded, the same restorative principle of elasticity strikingly exemplified in the wrought-iron tubular girder. These constructions, although different in form, are nevertheless the same in principle, and undoubtedly follow the same law as regards elasticity and their powers of resistance to fracture."

Description of the annexed engraving of the Keyham tubular crane:—

Fig. 1 is a side view of the crane, with a portion of the side removed to the foot, in order to show the cast-iron cylinders built in the masonry, the rollers which encircle the body of the crane and support the stem vertically, with its rollers and bearings acting against the interior recess of the large circular plate *a a*, between the plate and the frame, which embraces the crane in a ring which contains the rollers, giving a rotatory motion to the crane in any direction. Immediately above the rollers, is a platform of 12 feet in diameter attached to the stem, on which the men stand to work the crane. This platform also enables a man, by turning a handle, to move the crane round in any direction at pleasure.

Fig. 2 is a section of the body of the crane taken above the quay wall. The cells are carried along the concave side of the jib, where they terminate in two cells near the top, and also in two cells near the bottom, where the stem enters the cast-iron shoe already described.

Fig. 1.

Fig. 2.

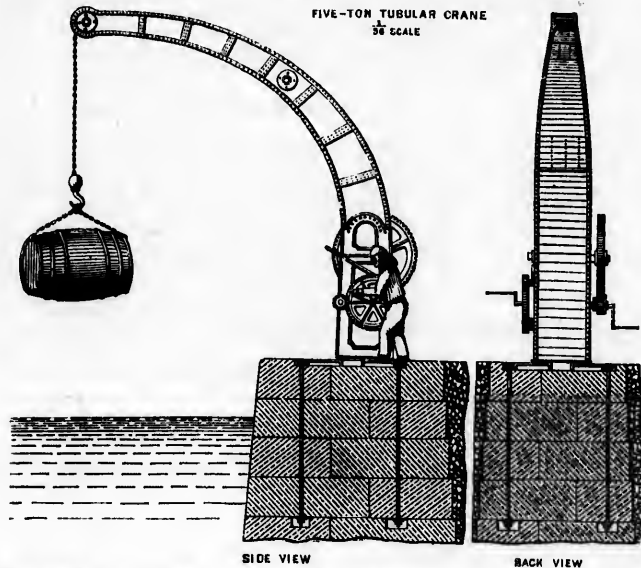

FIVE-TON TUBULAR CRANE  
1/4" SCALE

SIDE VIEW

BACK VIEW

418 The DEVONSHIRE GREAT CONSOLIDATED COPPER MINING COMPANY, 17 Barge Yard Chambers—Producer.

Models of two water-wheels, of 140-horse power each, erected at the mines of the above Company, for the purpose of pumping water from the one shaft by a plunger, and from the other by a drawing lift. Scale 1 inch to the foot.

1. Model of a wheel, 40 feet in diameter, by 12 feet in breast, pumping from the depth of 115 fathoms, or 690 feet, with 14-inch pumps, 7 feet 6 inches stroke, discharging 60 gallons of water per stroke, and lifting at each stroke 69,000 lbs., the average velocity being 4½ strokes per minute.

This wheel works a line of 3¼ inch round iron rods, 390 fathoms or 2,340 feet; not exhibited on the scale of the model of the wheel, for the want of space, over pulleys, ascending a hill, at an elevation from the wheel to the shaft of 384 feet above the wheel.

This wheel pumps the water from the mine called "Wheal Josiah."

2. Model of a wheel of 40 feet in diameter, by 12 feet in breast, pumping water from a depth of 80 fathoms; 60 fathoms, or 360 feet, with 12-inch pumps; and 20 fathoms, or 120 feet, with 20-inch pumps, of 8 feet stroke, discharging 98 gallons of water per stroke; it lifts at each stroke 40,600 lbs.

This wheel works a line of rods of 3¼ inch round iron,

NORTH AREAS A. B. 10 to 34; C. D. E. 1 to 10, &amp; 19 to 33; F. 1 to 32; G. H. 1 to 13, &amp; 19 to 26.

530 fathoms, or 3,190 feet, over pulleys; in connection with the shaft at the mine, called "Wheal Anna Maria."

The water supplying these wheels is derived from the river Tamar, by the means of a lead two miles long, and by the water collected from the dressing floors on the various mines.

The mines belonging to the Company, exhibiting the above-mentioned models, are situated about four miles west of Tavistock, in the county of Devon, on the banks of the river Tamar, which here forms the boundary of the counties of Devon and Cornwall. They are Inlands, the property of his Grace the Duke of Bedford, who granted a lease of the mining set, from March 1844, for 21 years, at one-twelfth dues.

The mining set, which is about 1½ miles in length, by 1½ in breadth, containing 1500 square acres, consists of the mines called "Wheal Maria," "Wheal Fanny," "Wheal Anna Maria," "Wheal Josiah," and "Wheal Emma," on the principal or champion lode, running east and west; "Wheal Frementor" on the southern part, where an adit has been driven from the surface, near the Tamar, to intersect parallel lodes; and "Wheal Thomas," also near the southern boundary, where a shaft has been sunk to the depth of 40 fathoms, and an adit driven with a view of proving the ground in that direction. The ore is found in the killas, or clay slate, of the country, and consists of black, grey, and yellow copper ore, the latter predominating. Operations at the mines were commenced in August, 1844, and the great lode, from which the following large quantities of ore have been extracted, was out in November following, at a depth of 17½ fathoms from the surface. The first sale of ore took place in February, 1845; since which date, monthly sales have been regularly made, and the returns to the end of March, 1851, with the amount realized, and dividends paid, are as follow:—

|                    | Returns of Ore. | Amount Realized. | Dividends Paid. |
|--------------------|-----------------|------------------|-----------------|
|                    | Tons. cwt. qrs. | £ s. d.          | £               |
| To Dec. 31. } 1845 | 13,674 12 0     | 120,392 14 5     | 55,296          |
| 1846               | 14,398 9 0      | 94,628 17 10     | 37,888          |
| 1847               | 14,413 6 3      | 102,889 12 3     | 15,360          |
| 1848               | 16,580 17 2     | 100,761 14 5     | 30,720          |
| 1849               | 15,431 18 0     | 104,624 1 7      | 34,304          |
| 1850               | 17,290 15 3     | 117,364 12 2     | 40,960          |
| To Mar. 31. } 1851 | 4,554 0 0       | 26,860 13 6      | 15,360          |
| Tons               | 96,343 17 8     | £667,510 6 2     | £229,888        |

Engineer and designer of the models, Mr. Nathaniel Smith, Mary Tavy, near Tavistock.

420 APFOLD, J. GEORGE, 23 Wilson Street, Finsbury  
—Inventor.

Centrifugal pump for draining marshes, contains one gallon; it discharges its contents 1,400 times in a minute, and does 73 per cent. duty. This pump is adapted for a large quantity of water, with a low lift; has no valves in action; and is adapted for a tide pump. Manufactured by Easton & Amos, Grove, Southwark.

421 BESSEMER, HENRY, Baxter House, St. Pancras Road—  
Patentee and Manufacturer.

1. A centrifugal disc pump for land and sewer drainage, which is said to be capable of discharging 20 tons of water per minute, and will drain one acre of land per hour, if covered with one foot depth of water. The distinguishing features of this apparatus are, its combination with the steam-engine (the disc and shaft of the pump serving also the purpose of fly-wheel and shaft to the engine), and the absence of all intermediate gearing, or any form of piston, slider, valve, stuffing-box, or rubbing surface of any kind whatever in the pump; its great power in proportion to its weight, the small space it occupies, and the cheap rate at which, from its simplicity, it can be manufactured in comparison with other descriptions of pump.

2. Model of a pump for steam-ships, being a precise copy of the exhibitor's original patent for the centrifugal disc, dated 5th December, 1845. The model will lift one ton per minute 20 feet high. The pump-case is divided into two compartments, in one of which is a centrifugal disc, and in the other a pair of emissive steam-arms, fixed on the axis of the pump, whereby a rotary motion is given to the disc, whenever steam is admitted to the arms. It therefore contains its own steam power, and may be used at any time to pump the ship, even though her engines may be disabled.

The full-sized pump, with a case of 3 feet 6 inches in diameter and 20 inches wide, will discharge from the ship 10 tons of water per minute.

3. A centrifugal disc pump for locomotive engines; it is self-acting, and will therefore supply water to the boiler while the engine is at rest. It consists of only one moving piece; has no valve, piston, slider, or stuffing-box; therefore neither steam nor water can leak from it. It is intended to run the vertical axis on a mineral bearing, which requires no oil or lubricating matter: all heat from friction of the axis is prevented, by the axis being situated in the cold water supply-pipe; the action of the stone upon the axis gives it brilliant polish, but does not wear it away; and as there are no other rubbing surfaces, its stoppage or derangement is almost impossible, particularly as there are moving parts exterior to the case. The only material used is an alloy of copper, tin, and nickel. This pump is applicable to marine and stationary boilers, as it will supply them with water when the ordinary pump may be out of repair, or when the engine is stopping. The one exhibited will supply 900 gallons per hour, equal to a boiler of 130 horse-power.

4. A small model worked by hand to illustrate the principle of the centrifugal disc.

422 STOCKER, SAMUEL & GEORGE, 4 Arthur Street,  
New Oxford Street—Manufacturers.

Patent pillar beer machines of various designs, and pump. Recess counters, having separate compartments for spirits and beer, designed by Samuel Stocker, jun. Patent seven-motion and other beer machines. New design for a spirit tap. Patent lift pumps for spirit warehouses, &c. Newly invented patent jar or bottle, intended to dispense with corking and uncorking; may be opened or closed instantaneously; is air-tight, and capable of being locked and secured without waxing, capsule, wire, or spring. Patent new pewter pot which cannot be melted. Decanter and water bottle, with self-acting stoppers. Tapping cocks which cannot be injured by being driven into the cask; and anti-corrosive tap, made of oak and pewter. Apparatus for icing or warming ale and other liquids.

423 SLACK, JAMES, 46 Commercial Road, Lambeth  
—Inventor.

Polished slate cistern, with an improved patent rapid purifier, 5 ft. long, 4 ft. deep, and 3 ft. wide; calculated to produce 3,000 gallons per day of pure soft water.

Portable stone-ware rapid purifier, to be fixed upon the floor.

424 WARNER, JOHN, & SONS, 8 Crescent, Jewin Street—  
Manufacturers.

1. Overshot water-wheel, with three pumps, in iron frame, for raising water to gentlemen's houses from a river, pond, or spring. This wheel is represented in the following cut (page 233).

2. Horsewheel and improved pumps for raising water from deep wells.

3. Double barrel pumps and air vessel, in iron frame, for raising water from shallow wells.

4. Double barrel pumps, in iron frame, for raising water out of shallow wells.

5. Treble barrel brewers' pumps, in iron frame, to be worked by steam, horse, or water power.

6. Patent vibrating standard pump on plank, for the supply of water to closets and all house purposes.



ing a pre-  
the centri-  
model will  
the pump-  
of which is  
of emissive  
whereby a  
r steam is  
is its own  
pump the  
3 inches in  
from the  
gines; it is  
the boiler  
ne moving  
; therefore  
ntended to  
h requires  
ion of the  
n the cold  
n the axis  
y; and as  
ge or de-  
there are  
y material  
is pump is  
as it will  
up may be  
The one  
equal to a  
strate the

Street,  
gins, and  
partments  
cker, jun.  
es. New  
for spirit  
or bottle,  
ing; may  
ight, and  
t waxing,  
pot which  
with self-  
e injured  
sive tap,  
or warm-

abeth  
ent rapid  
calculated  
ater.  
xed upon

Street—  
, in iron  
s from a  
ed in the  
ng water  
on frame,  
or raising  
ne, to be  
, for the  
.

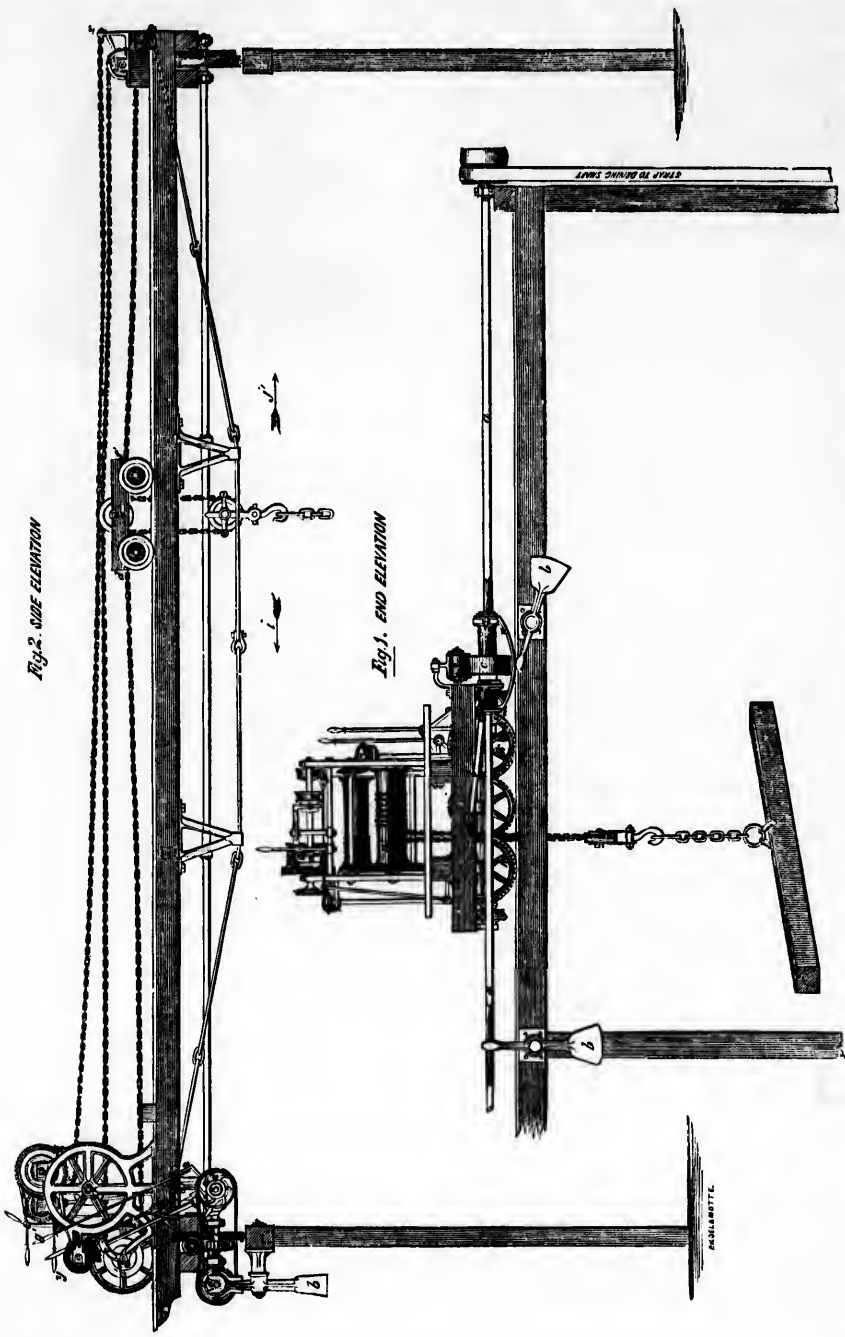

PATENT STEAM TRAVELLING-CRANE. MESSRS. M'NICOLL AND CO. LIVERPOOL.

7. F  
manur  
8. H  
9. M  
10. L  
mansh  
The  
the ex

425

We  
mode  
econc  
of pu  
attac  
liver  
lator  
supp  
ratur

426

A  
con  
of  
the  
roc  
ten  
wre

sup  
de  
pr

427

428

429

430



Warner and Sons' Overshot Water-wheel.

7. Patent vibrating standard iron pump, for ponds or manure tanks.
  8. Patent vibrating standard iron lift pump on plank.
  9. Patent garden engine, with registered spreader.
  10. Fire engine, with folding handles, for the use of mansions and small parishes.
- The articles numbered 6, 7, 8, and 9, are patented by the exhibitors.

425 CLARE, GEORGE DELIANSON, 12 London Street, Greenwich—Inventor's Agent.

Water-filter, a model in action, exhibiting a new mode, on the principle of natural filtration, self-acting, economical, and applicable on a large scale for the supply of pure water to towns and districts. Model of same attached to a house-cistern, filtering the water as delivered from the main; connected with a self-acting regulator or water-meter, which governs and registers the supply with accuracy; and also connected with an apparatus for cleansing sewers with waste water.

426 DEANE, JOHN, 1 Cross Wall, Dover—Designer and Inventor.

A working model of a diver in his diving apparatus, consisting of a helmet, submarine dress, &c., in a reservoir of plate glass, containing about sixty gallons of water, the bottom of which represents the bed of the sea, with rocks, wreckage, &c., and the top a fortification, mounting ten brass guns, formed from metal recovered from the wreck of the Royal George by the constructor.

A glass model of a diving bell, representing two men supplied with air by a three-cylinder brass rotatory condensing engine. Model diving helmet, submarine waterproof dress, &c.

427 BYWATER, WITHAM M., 99 Piccadilly—Designer and Manufacturer.

Water-meter, suitable to any pressure.

428 TURNER, E. W. K., 31 Praed Street, Paddington—Inventor.

Model of an invention for improving the water supply.

429 BOTTEN, CHARLES, Clerkenwell—Manufacturer.

Appold's self-regulating friction-break. The resistance of this machine when loaded to any fixed strain on the handle will not vary, whether it be well oiled and working freely, or dry and with considerable friction. It is adapted for measuring labour in prisons, or ascertaining the amount of work performed by steam engines and other machines. Patented by J. G. Appold, Esq., Wilson Street, Finsbury Square.

434 McNICOLL & VERNON, Brunswick Steam Saw Mills, Liverpool—Proprietors. (JOHN McNICOLL, Inventor and Patentee.)

Working model of patent steam travelling crane, for lifting and removing heavy weights at the goods-depôt of railways, in timber-yards, foundries and other manufactories, and for the loading and discharging the cargoes of vessels. The three motions—the horizontal, the transverse, and the hoisting—may be worked simultaneously, or independently, or any two in combination.—(See Plate 23.)

1. This machine is adapted for the purpose of lifting and removing heavy weights at the goods-depôts of railways, in timber-yards, foundries, and other manufactories, and for the loading and discharging the cargoes of vessels.

2. This is the first instance of the threefold motions of a travelling crane being worked from a stationary engine. The three motions, the horizontal, the transverse, and the hoisting motions, may be worked simultaneously, or either of them may be worked independently, or any two of them may be worked in combination. The model will exhibit the mechanical arrangements by which these effects are produced.

3. The efficiency of these machines may be judged from the circumstance that one of them, with a 50-foot span, will travel 100 feet in a horizontal direction, with a load of three or four tons attached to it, in 45 seconds; and during the time the whole platform with the load is so moving, the load may be moving across the platform at right angles with the motion of the platform itself; at the same time, also, the weight may be raised or lowered as required. Cranes, on this principle, are being erected where the span is 53 feet, and the length of the tramway on which the platform travels is 266 feet, so that with one of these machines, the steam power is enabled to command an area of 14,098 feet.

4. In addition to the immense saving in time that is effected by these machines, the saving in the wages of labour is very great: one youth, at ten shillings per week, who travels on the machine for the purpose of moving the handles in and out of gear, displacing the labour of six men, at the same time doing the work more efficiently. At a recent experiment, this machine removed 13 logs of timber, containing 1,050 cubic feet, and weighing 19½ tons, a distance of 100 feet (one log at a time), and piled them in 27½ minutes, at an expense in wages of about threepence. The machine had thus travelled 2,600 feet, and made 26 stoppages in the time named, with an average load of 30 cwt. for half the distance.

Steam power can, by this plan, be readily applied to the ordinary hand-travelling cranes.

The following are the particular features, to which attention is directed:—

Its novelty, see paragraph 2, above.

Its cheapness, inasmuch as one of these machines will displace two or three cranes of the most approved principles, hitherto in use.

The great annual saving it effects in wages, as seen in paragraph 4, above.

The rapidity and precision of its operations: see paragraph 3, above.

Its freedom from liability to derangement. Several of these machines have been in use for upwards of six months, working daily from morning to night, without stopping one hour for repairs.

This machine, like the ordinary hand-travelling crane, moves upon a tram-road laid upon longitudinal beams, raised from 15 to 20 feet above the level of the ground, the beams being supported at intervals by uprights. A square shaft, *a* (2½ inch diameter), runs the entire length of the tram-road, and is attached to the longitudinal beams by moveable supports *b, b, b*. This shaft is connected at one extremity to the engine. Upon it and revolving with it, is placed a drum, *c*, which works, by means of a leather belt, the pulley *d* attached to the moving platform; the pulley *d* is fixed on the shaft *e*, upon which are placed the bevil-wheels, which impart the

threefold motion to the crans. The bevil-wheels *ff*, which revolve on the shaft, are made so as to turn the bevil-wheel *g*, by means of the clutch-box *h*, which is attached to the shaft; so that by withdrawing the clutch-box from one of the bevil-wheels, and putting it in gear with the other, the motion of the bevil-wheel, *g*, is reversed, and when the clutch-box is out of gear, the bevil-wheel *g* is stationary. The bevil-wheel *g* is fastened upon the small shaft *i*, to the other end of which is attached the pinion *j*, which works the spur-wheel fixed to the roller-wheel *k*, and imparts the longitudinal motion to the whole platform. As the platform would otherwise move away from the drum *c*, which communicates the motion, it is made to slide freely upon the shaft, and being attached to the moving platform by means of the rod *l*, it always preserves its relative position with regard to the pulley *d*. The difficulty of making the drum pass over the numerous brackets that a long shaft must necessarily have to support it, is overcome by making the brackets swing on a centre, so that when the drum *c*, protected by the guard *n*, comes in contact with one of the brackets *bb*, it yields, as shown in fig. 1, and allows the drum to pass over it. Immediately it has so passed, the weight of the lower extremity of the bracket causes it to resume its position, and the machine passes on to the next bracket, where the operation is repeated. In order to prevent the shock that would be felt in putting in motion so heavy a body as a travelling crane of 50-feet span, carrying in addition to its own weight a load of three or four tons, a friction-roller, *o*, is made to press upon the leather belt that passes round the drum *c* and the pulley *d*, so that before putting the machine in gear the friction-roller is raised; the machine is then put in gear, and the friction-roller gradually lowered. The momentary slipping of the belt round the pulley *d*, when the weight of the friction-roller is only partially resting upon it, causes the machine to move forward with an easy motion; and, directly it is under way, the friction-roller is allowed to bear with the whole of its weight, and the crane then moves forward with its load at its usual speed of 100 feet in 45 seconds. The hoisting motion is obtained by communicating the power through the bevil-wheels *qg*, and the shaft *r*, to the barrel *s*, round which the chain revolves. In order to render the hoisting motion independent of the transverse motion, the hoisting chain passes from the barrel round which it is coiled to the truck *t*, and after passing over the pulley *u*, under the snatch-block *v*, and over the pulley *w*, it is finally attached to the point *x*, at the extreme end of the platform. To hoist a weight, therefore, it is merely necessary that the handle *y*, which communicates with the clutch-box *z*, should be moved a few inches.

The transverse motion is imparted to the load by means of the barrel *a*, which is worked from the shaft *e*, by the bevil-wheels *b'b'*, and clutch-box *c*, in the same manner as the longitudinal and the hoisting motions. Two chains are attached to the barrel, in such a way that one winds when the other unwinds. One of these chains is attached to the small truck *t*, at *d*, and the other is carried round the pulley *e*, and fastened to the truck at *f*, so that by alternately putting the clutch-box *c* in gear with one or other of the bevil-wheels *b'b'*, by means of the handle *y*, the truck, and with it the load, is moved backwards and forwards along the platform at right angles with the motion of the platform itself.

Each of the above, the longitudinal, the transverse, and the hoisting motions, can be used independently of either of the others; or any two of the motions may be used in combination; or the whole three may be used simultaneously. For instance, at the same time that a weight attached to the hook *h'* is being raised from the ground by the barrel *s*, the truck *t*, and consequently the load suspended on the chain, may be moved in the direction *i* or *j*, at the same time that the whole platform may be moving in a longitudinal direction.

[The saving effected by the use of well-designed machines at railway stations, &c., to the reduction as much as possible of manual labour, is very great. A waggon of heavy

merchandise taken to a crane, can be unloaded and placed in a road-waggon by three men in one hour; without the crane, double the number of men working a whole day would be required to do the same work. Cranes that can be moved to the waggons are often advantageous.—S. C.]

436 **TEBAY, J.**, *Aldine Chambers, Paternoster Row*—Inventor and Manufacturer.  
Patent water-meter.

438 **FELL, RICHARD**, *33 Nicholas Lane*—Inventor.  
Sea-water regenerator, to supply pure fresh water from salt or sea water, in whatever situation it may be required. For shipping purposes it supercedes the necessity of embarking water. The expense is comparatively trifling.

Patent self-cleansing filter; a peculiar feature consists in its being applicable either for a large reservoir or for a portable or house filter.

New motive power, intended to supersede the use of all steam locomotives, by introducing compressed air to propel carriages upon railways, by maintaining a uniform pressure or force throughout the line, and having at all times a perfect command of the engine or carriages.

Preservator; for obviating the necessity of bottling all kinds of liquors, requiring preservation from the atmosphere. By this machine, wines, spirits, stout, &c., can be kept on draught, and not only retain their full flavour, but they can also be removed from one vessel to another without being exposed to the atmosphere.

440 **SIEBE, A.**, *5 Denmark Street, Soho*—Inventor.  
Improved self-pressure cock for steam boilers.

444 **FLETCHER, THOMAS**, *161 Westgate Street, Gloucester*—Inventor and Manufacturer.

Improved slide-tap apparatus for supplying fire-engines with water from the street plugs. It opens a two-inch waterway through the slide, and having a curved neck, it offers no obstruction to the passage of the water when in use. Double connecting branch for the supply of two engines. Improved slide tap to be attached to hose and swan's neck at the engine, so as to enable the fireman in attendance at the engine to shut off the water when desired.

445 **SUMPTON, J.**, *14 Ebury Square, Pimlico*—Inventor.  
Plug or cock-box, on a new principle, for water-works or gas-works.

447 **BROUGHTON, R. H.**, *Park Street, Brighthelm*—Inventor and Manufacturer.  
Self-acting machine, for regulating the supply of water in steam boilers.

448 **CHEAVIN, SQUIER**, *Spalding*—Inventor.  
A floating filtering pump.  
Specimens of metallic paste or cement, intended to prevent damp in walls, and to keep out wet.

449 **SMITH R. & SON**, *St. Mary Cray, Kent*—Inventors.  
New high-pressure fire-engine, for large public buildings, docks, warehouses, and ships.

Model of a newly-invented double-motion pump, with transparent glass tubes, showing the moveable parts of the inside of the pump.

Figs. 1, 2. These figures represent the application of the fire-extinguishing apparatus to a private dwelling. The water-spreader, Fig. 3, *e*, being placed under the ornament in the centre of the ceiling at *e*, Fig. 2.

Fig. 1 shows the mechanical arrangements for obtaining the requisite supply and pressure of water: A is the water-pump; B the reservoir for water; C the suction-pipe; *g* is the air-pump; and E the air-vessel. The supply pipes are represented by the letters *ppp*.

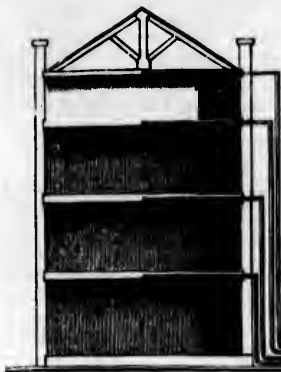

Fig. 2.



Fig. 3.



Fig. 1.

Smith and Son's High-pressure Fire engine.

- 450 NEVILL, JOHN PATMORE, 8 *Crutched Friars*—  
Inventor.

Model of a machine to work by hand in a ship's hold, for discharging loose cargo. When used for oorn the buckets serve as measures.

- 452 SELFE, HENRY, *Kingston, Surrey*—Manufacturer  
and Inventor.

Common pump with reserve chamber; improved valves, and bucket of new construction. Models of several useful machines on improved principles.

- 462 FREEMAN & ROE, 70 *Strand*—Manufacturers.

Hydraulic ram for raising water to the tops of houses, where a fall can be obtained.

[The hydraulic ram is a simple machine, containing a pulse-valve; a valve between the air-vessel and the body of the ram; and by a falling column of water acting on the pulse-valve closes it, thus letting a portion of water into the air-vessel. By a continuation of this action the air becomes compressed, and a portion of water finds its way to the top of the column; it is beautifully adapted for the supply of small towms, mansions, farms, &c.]

Fountain basins of iron, for pleasure grounds, with all kinds of ornamental jets. (*North Transept*.)  
One of these fountains is shown in the cut.



Freeman and Roe's Ornamental Fountain.

- 466 KEITH, GEORGE, 36 *Piccadilly*—Inventor.  
Liquid meter.

- 467 BEERE, GEORGE, *Galloway House, Bath*—  
Manufacturer.

Archimedean screw for raising fluids; constructed with square canals.

- 468 BILLINTON, WILLIAM, C.E., 31 *Regent Street*—  
Proprietor.

Patent improved water-meter.

- 471 BURGESS, D., *Glasgow*—Manufacturer.  
Hydrostatic press.

- 472 FIRTH, THOMAS, *Huddersfield*—Manufacturer.

Plates of machines in gilt frames. Working model of improved hydraulic press, with indicator and check. Hydrostatic press.

- 474 DOWNTON, J., 4 *Conant Place, Commercial Road, Limehouse*—Patentee and Manufacturer.

Patent engine-pump, used in the Navy; the principle of which consists in its having three boxes working in the same cylinder, with a three-throw crank, by which means a continued stream of water is kept up.

- 475 CLUNES, T., 100 *Lock Street, Aberdeen*—Inventor  
and Manufacturer.

Registered rotatory pump, that will act either as a common lift or force pump, and may be applied with advantage for a portable fire-engine, &c.

- 476 LITTLE, Major ROBERT J., 4 *Queen's Terrace, Woolwich Common*—Inventor.

An improved watercock, with double plug, for connecting pipes without breaking joints, with sectional drawings of the same. Designed by the exhibitor, and manufactured by Frost, Noakes, and Vincent, 195 Brick Lane, Whitechapel.

- 478 LAMBERT & SON, *Short Street, Lambeth*—  
Manufacturers.

Union joints and water-taps, with a new application of vulcanized caoutchouc. Locomotive and steam fittings.

Description of the patent vulcanized India-rubber water taps: *a* is the body of the valve; *b* is the cover; *c* is the flexible diaphragm, confined at its edges, serving the purpose of a stuffing-box; *d* is the valve, which is held to its seating by the pressure of the water; *e* is the handle or knob, by means of which the valve is opened; by this arrangement it cannot be left open: there are other methods for opening and closing the same; the arrows denote the waterway when open.

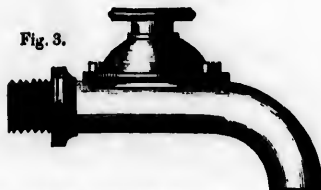
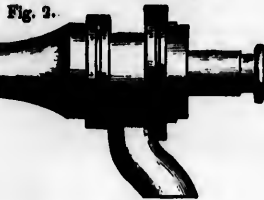
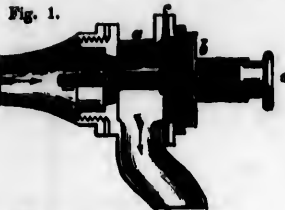

Lambert and Son's Patent Vulcanized India-rubber Water Taps.

## 430 WRIGHT, JAMES, 95 Nelson Street, Tradeston, Glasgow—Inventor.

Water-wheel and small cistern for regulating the water. The latenary water-wheel is intended to give more effect than can be obtained from the same quantity of water applied upon an overshot wheel of the best construction. The power is at once applied at the greatest extent of the leverage, without any increase in the diameter of the wheel.

## 432 COLLINGE &amp; Co., 65 Bridge Road, Lambeth—Manufacturers.

Specimens of screw-lifting jacks.

## 434 ENGLAND, G., Hatcham Iron Works, New Cross—Inventor and Manufacturer.

Patent traversing screw-jack, for raising and moving heavy bodies, both vertically and laterally. It is particularly applicable to railway purposes, as in case of an engine being off the line of rails, two men, with this simple machine, can reinstate the engine upon the rails in less than half the time that 50 men could without it, although they may have all other known means at command to assist them.

## 435 BAYMAN, HENRY, 35 Old Gravel Lane, Ratcliffe—Inventor and Manufacturer.

Double and single purchase improved screw lifting jacks. The principal feature in these jacks is, that one man can raise twice as much as by the common jack, without fear of accident, as they will not run down while taking up or lowering a weight. The single purchase is equal to the ordinary double, and is lighter. Adapted for railways, engineers, storing wool on board ships, &c.

## 436 HALEY, —, Frome Street, Somerset—Producer.

Specimens of lifting jacks.

## 438 GLADSTONE, JOHN, jun., &amp; Co., Liverpool—Manufacturers.

Railway screw jack of simple construction, easily carried about by one man, and capable of lifting heavy weights. A jack is necessary in case of accident, such as collisions, carriages running off the rails, or in the event of either wheels or axles giving way, and as an aid in the removal of obstructions.

## 440 THORNTON, J., &amp; Sons, Birmingham—Manufacturers.

1. Patent coupling for railway waggons and carriages. Thornton and McConnell's patent. The carriages are secured together by means of hooks and links with cross bars, which are moved from the outsides of the carriages, and prevent the dangerous practice of going underneath and between the carriages for the purpose of coupling and uncoupling them. See figure annexed.

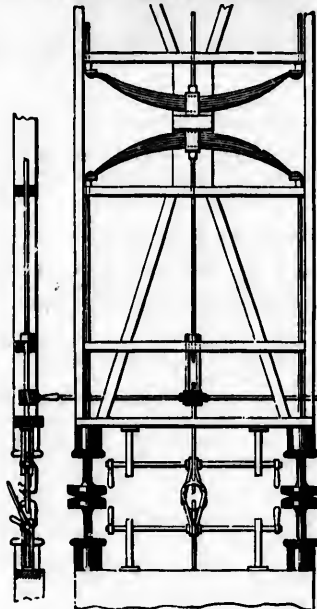

Thornton's Patent Coupling for railway Waggons.

2. Patent steam-engine piston. Exhibitors' patent. The packing rings of this piston are adjusted by means of two conical surfaces, acted on by a spring and elastic discs.

3. Improved carriage axles, exhibiting different constructions, manufactured from the Patent Shaft and Axle-tree Company's iron, each axle being composed of at least nine different bars of iron welded together, prepared for this purpose, and insuring greater safety.

4. Hydraulic lifting jack for railway engines and carriages. Its advantages are, the ease and steadiness with which a great weight can be raised by one person, the facility with which the lowering of the weight can be regulated without labour, and its economy, since one man with this jack may lift 15 to 20 tons.

Fig. 1 represents the hydraulic lifting jack. *a* is a hollow vessel forming the base of the jack, and also a reservoir for the water; *b*, the cylinder; *c*, the ram; *d*, the pump; *e*, the plunger; *f*, the slide; *g*, the pump-lever; *h*, conical pointed pin; *i*, a small air-tap.

5. Improved crown-head lifting screw jack; powerful, portable, and quick in its action. (See fig. 2.)



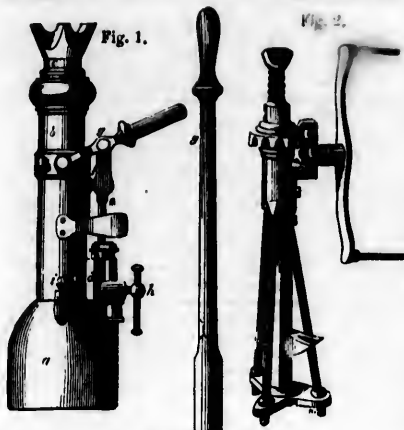

Thornton's Lifting Jack.

6. Improved double bar wrench with solid handle for locomotive purposes; manufactured for the exhibitors, by Thewlis & Griffith of Warrington.

7. Railway shovels for engine stokers, coke, and soughing; of improved shapes.

501 & 506 GREAT WESTERN RAILWAY COMPANY,  
16 Lawrence Lane, Cheapside—Producer.

Locomotive engine and tender, constructed at the Company's works at Swindon.

One of the ordinary class of engines constructed by this Company for passenger traffic since 1847. It is capable of taking a passenger-train, of 120 tons, at an average speed of 60 miles per hour, upon easy gradients. The evaporation of the boiler, when in full work, is equal to 1000-horse power, of 33,000 lbs. per horse—the effective power, as measured by a dynamometer, is equal to 743 horse power.

The weight of the engine, empty, is 31 tons; coke and water, 4 tons—engine in working order, 35 tons.

Tender empty, 9 tons; water, 1,600 gallons, 7 tons 3 cwt.; coke, 1 ton 10 cwt.—total 17 tons 13 cwt.

The heating surfaces are, fire-box 156 feet; 305 tubes 1,759 feet.

Diameter of cylinder, 18 inches; length of stroke, 24 inches; diameter of driving-wheel, 8 feet; maximum pressure of steam, 120 lbs.

The actual consumption of fuel in practice, with an average load of 90 tons, and an average speed of 29 miles, including stoppages (ordinary mail train), has averaged 20·8 lbs. of coke per mile.

A traversing-frame as used upon the Great Western Railway, manufactured by Mr. G. Hennett, Bridgewater, for transferring railway carriages from one line of rails to any other parallel line. Short inclined planes are attached to each end, up which the carriage is run upon the flanges of the wheels, and which are there raised clear of the rails by means of a pedal. The main lines of rails are usually lowered about an inch at the place where the frame is placed, so as to diminish by about half the amount what the carriage has to be raised.

A model of a safety stop or switch for a siding, worked together with the signal by the same lever as the switch of the siding; also of double signals for a junction line worked by the switchman. Manufactured by Mr. Richard Brotherhood, Great Western Railway, Chippenham, Wilts.

The engine and traversing frame are placed upon a portion of permanent way of the construction adopted upon the Great Western Railway.

502 BROTHERHOOD, RICHARD, Chippenham.—Inventor.  
Railway signal and stops, and patent tilt waggon.

503 BARRERS, GUSTAVUS EDWARD, Great Western Railway, Paddington—Inventor.

Registered self-acting railway siding stop.

The object of this contrivance is to prevent accidents on railways caused by carriages or trucks getting accidentally out of siding, and thereby occasioning collisions with passing trains, and by carriages or trucks being pushed into a siding, but cannot come out again without being purposely removed.

507 LEE, JOHN, Long Acre—Inventor and Patentee.

Full-sized under carriage, with Lee's patent railway breaks and axle-box. These breaks act directly from the axle and box of the wheels with a wedge-power shoe, which bears against the wheels and rails. The shoe has a long surface bearing on the rail of 18 inches of compound adhesive metal. The inefficient breaks commonly in use produce only five-eighths, or at most one inch, of bearing or friction from the wheel on the rail, which greatly destroys the wheel tyre and rails, and is insufficient as a stopping power. The friction on the rail of the exhibitor's break has the advantage of 18 to 1 over other breaks, by securing a certainty of biting the rails in wet, foggy, and slippery weather. This break being independent of the frame of the carriage, is free from the unpleasant tilting motion and mephitic smell of the old breaks. It is brought into action by one revolution of a powerful screw; another half turn of the screw throws the whole weight of the carriage upon the wedge block-bearing of the break against the wheel and rail, thus freeing the tyre of the wheels from friction, and raising the wheels clear of the rails one-sixteenth of an inch, further rise being prevented; thereby saving the expensive wear and tear of the wheels' tyre and rails—a matter of great consideration in the current cost of the stock of railway companies. These breaks can be brought into action on inclines, and relieved again without stopping the train.

Full-sized pair of Lee's patent carriage-wheels, with axletrees and axle-box. This patent invention is designed to prevent accidents when the axletree breaks—a circumstance not of unfrequent occurrence with public conveyances and railway trains, and is applicable to all kinds of carriages and machinery. When the axletree breaks the wheel will still retain its position, revolve, and carry on the carriage with safety to any distance. The bearings are more than triple the strength and utility of the solid axle. The draught of the horse is greatly reduced by it, and the bearing is proof against the heating or setting fast of the wheel: it carries a large supply of oil to last more than twelve months, and is protected from grit, &c. These wheels can be readily detached and replaced again. It very greatly obviates the sudden unpleasant jerk caused by the wheels coming in contact with projecting substances.

508 CRAMPTON, THOMAS R., South Eastern Railway Company, 15 Buckingham Street, Adelphi—Inventor and Patentee.

South Eastern Railway Company's London and Paris express locomotive engine, the "Folkstone," Crampton's patent.

[This engine is suspended from three points at the ends of the machine, the object being to insure the weights on the wheels being at all times the same, and thus producing the greatest amount of steadiness. Attention is also called to the fact that the whole of the machinery is independent of the road: it is thus similar in its action to a fixed engine, and the risk of breaking the crank axle, which frequently occurs in inside cylinder engines, is considered to be thus avoided.]

509 ENGLAND, GEORGE, Hatcham Iron Works, New Cross—Inventor and Manufacturer.

An improved locomotive engine.

This class of engine is intended to reduce the locomotive expenses in proportion to the amount of traffic. The

principal dimensions are the following:—Cylinders, 9 inches in diameter; stroke, 12 inches; driving-wheels, 4 feet 6 inches; and weight, in full working order, 13 tons. It has been proved that this engine is capable of working express trains, of six first-class carriages, at a speed of 60 miles per hour, consuming only 8 lbs. of coke per mile; while, from the centre of gravity being very low, and from the consequent steadiness of working at the highest velocities, an increased degree of safety is obtained, besides doing little injury to the permanent way. It carries coke and water for stages of 50 miles, and is capable of ascending an incline with a greater load than any other engine, in proportion to the size of cylinders or expenditure of fuel.

510 ADAMS, W. BRIDGES, 1 Adam Street, Adelphi—  
Patentee and Designer.

Light locomotive engine for railways, named "Ariel's Girder," on four wheels, coupled to a four-wheeled composite tender; it makes a steady eight-wheeled machine, capable of lateral flexure for sharp curves. The tender contains water beneath the floor, and has a sledge break of peculiar construction, acting with friction on the rails to save the wheels; its handle being within reach of the driver.

Eight-wheeled double railway carriage for first and second-class passengers. The wheels are left free to move laterally by means of swinging links and shackles, which enable the carriage to run round curves of 250 feet radius. A sledge break of peculiar construction is suspended from this carriage. The locomotive engine produced at the Airedale Foundry, Leeds, by Kitson, Thompson, and Hewitson; the carriage portion produced at Birmingham by Brown and Marshall.

A spring for the locomotive engine, formed of patent ribbed steel; the rib, working in a corresponding hollow of the adjoining plate, reduces the friction and preserves the parallelism of the plates.

Patent grease-tight axle-box.

Model of a patent fish-jointed rail, bedded to the upper lip in longitudinal timber sleepers. Drawings illustrating the mode of forming this railway. Drawings of patent carriages, &c., low-hung for agricultural railways. A non-recoiling patent atmospheric railway buffer for terminal stations.

512 LONDON AND NORTH WESTERN RAILWAY COMPANY—  
STEWART, C. E., Euston Square Station—Secretary.

Patent express locomotive engine, "Liverpool,"—diameter of cylinders, 18 inches; length of stroke, 24 inches; diameter of driving wheels, 8 feet; heating surface in tubes, 2136 feet; and in fire-box, 154 feet; weight in working order, 32 tons; coke and water, 4 tons. The evaporation of the boiler at full work is equal to 1,140-horse power. Pressure of steam 120 lbs. per square inch. The engine has a very low boiler, and the greatest weight is on the extreme wheels, which insures steadiness. Exhibited for the great amount of heating surface, and the general construction. Made by Messrs. Bury, Curtis, and Kennedy, of Liverpool. The patentee, T. R. Cramp-ton, 15 Buckingham Street, Adelphi, London. (See Plate 50.)

513 LONDON AND NORTH WESTERN RAILWAY COMPANY—  
STEWART, C. E., Euston Square Station—Secretary.

Narrow-gauge express engine, the "Cornwall" (see the following engraving), designed by Mr. Trevithick, one of the locomotive superintendents of the London and North Western Railway. Cylinders, 17½ inches in diameter; length of stroke, 2 feet; diameter of driving wheels, 8 feet 6 inches; weight, 27 tons. Exhibited for improved construction, in the form and position of the boiler, the size of wheels, &c. Made at the Locomotive Works of the London and North Western Railway at Crewe.

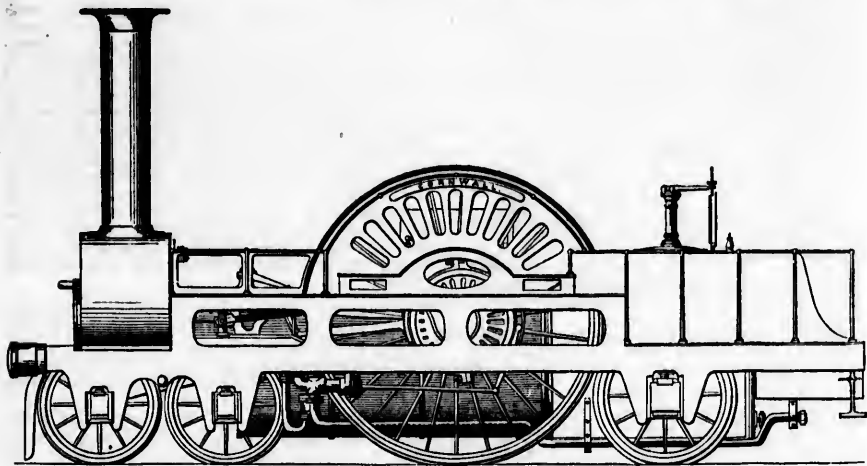

The "Cornwall" Express Narrow-gauge Engine.—London and North Western Railway Company.

[The amount of power obtainable in a locomotive steam-engine is to be measured by the diameter of the cylinder, or rather by the area of the piston working in the cylinder, and the pressure of the steam; and the effect with which the power can be applied to produce speed as a result is dependent upon the rapidity with which steam can be produced in the boiler; whilst the economy with which power can be obtained and effect given to it are estimated by the

fuel consumed and by the absorption of power by the machinery, and the demand which the engine itself and its tender make upon the otherwise available power.

The high pressure which yields power, and the rapid evaporation which gives the means of applying the power directly to obtain speed, are dependent upon the effect with which heat can be applied to the water in the boiler; and hence the amount of surface exposed by a boiler in any

to the upper  
illustrating  
of patent  
railways. A  
offer for ter-

COMPANY—  
Secretary.  
"pool,"—dia-  
s, 24 inches;  
g surface in  
; weight in  
tons. The  
ial to 1,140,  
square inch,  
atest weight  
liness. Ex-  
scoe, and the  
ary, Curtis,  
i. H. Cramp-  
don. (See

COMPANY—  
Secretary.  
"wall" (see  
Trevithick,  
the London  
1/2 inches in  
r of driving  
hibited for  
ition of the  
Locomotive  
Railway at



by the ma-  
self and its  
r.  
l the rapid  
g the power  
effect with  
boiler; and  
ler in any

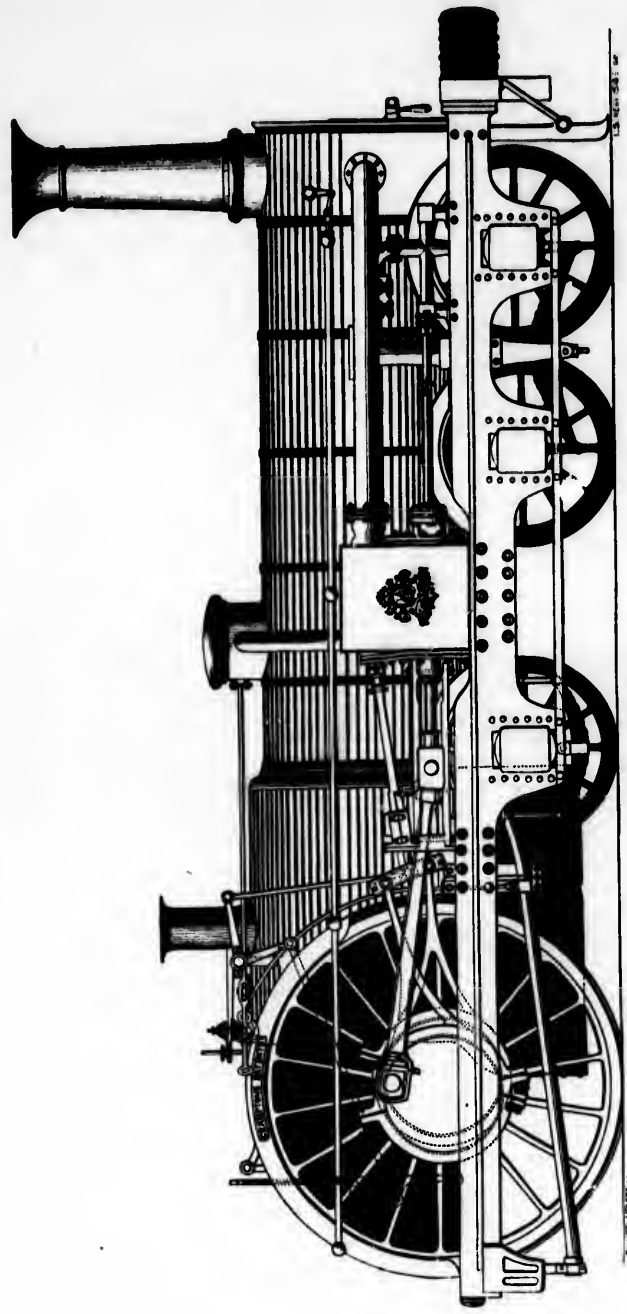

SCALE OF FEET  
CRAMPTON'S PATENT EXPRESS ENGINE. LONDON AND NORTH WESTERN RAILWAY COMPANY.

manner  
or to h  
of tub  
the hea  
furnac  
respec

The  
and th  
gine, a  
meter  
and th  
the bo  
by the  
the cy  
requir  
motio  
body  
but i  
quire  
there  
stroke

I  
Mo  
var  
rep

[  
tin  
rec  
sid  
na  
dis  
bo

m  
a  
at  
b  
e

NORTH AREAS A. B. 10 to 34; C. D. E. 1 to 10, & 19 to 33; F. 1 to 32; G. H. 1 to 13, & 19 to 20.

manner to the action of the fire in the furnace or fire-box, or to heat arising from it—that is to say, whether by means of tubes running through the boiler and forming flues to the heat from the fire, or by a casing about the fire in the furnace—is the measure of the capability of the engine in respect of both power and speed.

The diameter of the cylinder, the length of the stroke, and the diameter of the driving-wheel of a locomotive engine, act and react upon one another. Increase in the diameter of the cylinder increasing the area of the piston, and thereby its means of applying the power generated in the boiler, is an advantage checked in a slight degree only by the consequent increase of the friction of the piston in the cylinder: increase in the diameter of the driving-wheel requires increased power to put and keep the wheel in motion, but it gives increased speed to the locomotive as a body with the same speed of the piston in the cylinder; but increase in the diameter of the driving-wheel requires increased strength in the cranks of its axle, and thereby greater length of stroke, whilst greater length of stroke increases the time of the stroke, and conse-

quently the time of a revolution of the driving-wheel.—  
W. H.]

514 KNOX, G., *Tottenham, near Wolverhampton*—Inventor.  
Model of railway break carriage.

522 FAIRBAIRN, W., *Manchester*—Manufacturer.  
Locomotive tank engine.

526 WILSON, E. B., & Co., *Leeds*; and 2 *Poets' Corner, Westminster*—Manufacturers.

A locomotive double boiler tank engine and screw-moorings. The peculiar features of this engine are, its having two separate fire-boxes and boilers, so arranged that the stoking can be performed at alternate intervals in each box. The class of engines is six-wheeled, having four wheels coupled by outside rods with inside cylinders and crank axle; the centre of gravity is low, and the greater portion of the weight is carried by the coupled wheels securing a large amount of adhesion. The figure represents a side and half-end elevation of the engines.

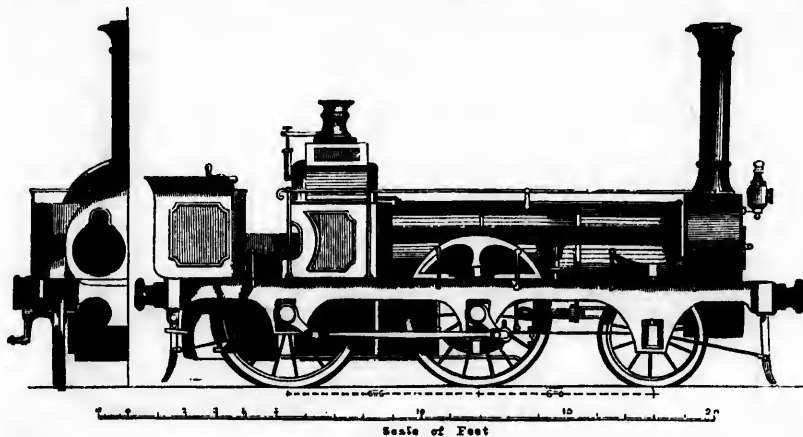

Wilson & Co.'s Locomotive Tank Engine.

530 WILLIAMS, CHARLES CAVE, *Glasshouse Yard, Goswell Street*—Inventor and Manufacturer.

Railway carriage constructed entirely of East India Moulmein teak, unpainted, the object being economy. As varnish only is used instead of paint, a carriage can be repaired and got ready for work in a few days.

[East Indian teak is perhaps one of the most valuable timbers for all purposes where lightness and strength are required. It is extremely durable, and resists to a considerable extent the invasions of fungi and insects. Its native habitat is the mountains of Malabar and other districts, where it grows to an enormous size. Its botanical name is *Tectona grandis*.—R. E.]

532 HENSON, HENRY H., *Pinner, near Watford*—Inventor.

Patent improved covered waggon for the conveyance of merchandise by railway, constructed of wood and iron on a new principle. When closed, this vehicle is fireproof and waterproof, and any portion of the side or roof may be easily opened to load or unload. Fig. 1 shows an end, and Fig. 2 a side, elevation of this waggon.

Fig. 1.

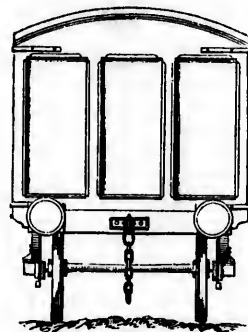

Henson's Covered Waggon. End Elevation.

Fig. 2.

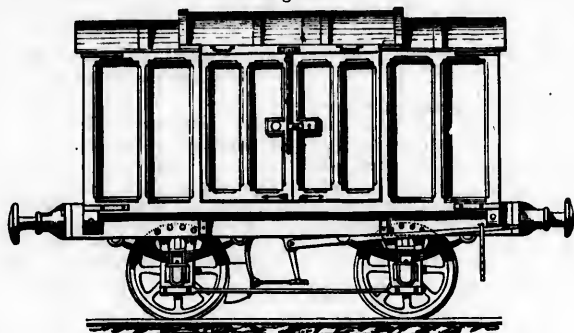

Henson's Covered Wagon. Side Elevation.

534 KITSON, THOMPSON, & HEWITSON, Leeds—  
Manufacturers.

Locomotive tank-engine. Its dimensions are, cylinders, 11 inches diameter, with 22 inch stroke. Is carried on six solid wrought-iron wheels. The pair of driving wheels is 6 feet diameter, and two pairs of carrying wheels, 3 feet

6 inches diameter. Constructed to run light express trains: will run without tender; having two water tanks beneath the boiler, and foot-plate to carry 500 gallons of water, and sufficient coke space upon the foot-plate to run for a journey of 50 miles.

The figure represents a side elevation of this engine.

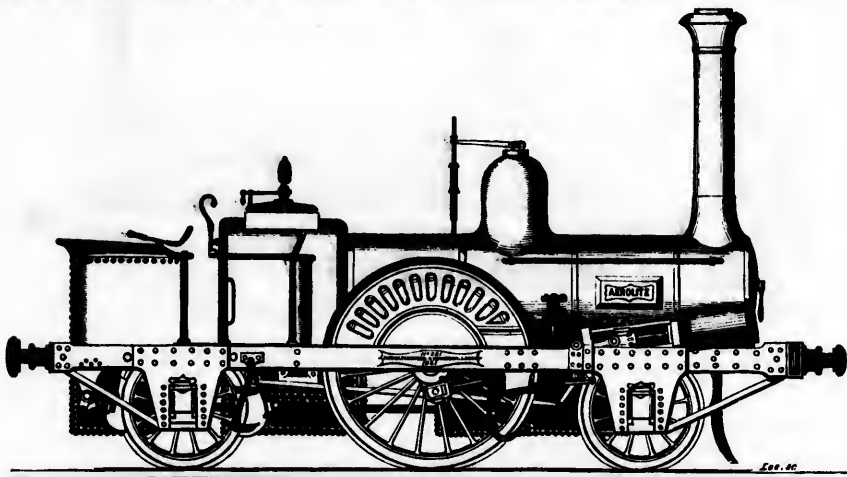

Kitson, Thompson, and Hewitson's Locomotive Tank Engine.

536 HAWTHORN, R. & W., Newcastle-upon-Tyne—  
Manufacturers.

First-class patent passenger locomotive engine. The weight of the engine is distributed more uniformly than usual upon the wheels and axles. The slide-valves are relieved from the extreme pressure of steam, and the link motion, together with the action of the slide-valves, is improved. This engine is represented in the accompanying cut, page 241.

The slide valves are relieved by the arrangement represented at *a* from the extreme pressure of the steam. The link-motion, the arrangement of which is indicated by letters *b b*, is also improved, and greater security is thus obtained.

539 MCCONNELL, I. E., Wolverton—Inventor.  
Model of railway passenger carriage.541 HADDAN, JOHN COOPE, 29 Bloomsbury Square—  
Inventor.

Specimens of patent papier maché for the exterior of railway carriages.

Patent railway carriage—the wooden panels grooved or rebated in the framing, show the ordinary and the painted part, the improved construction, which consists of a covering of papier maché in large pieces, laid over and against flush framework. Exhibited for cheapness and durability; the paper panels will not shrink, and there are no grooves to retain wet, which rots the framing.

Patent railway wheel, formed with wooden wedges to check vibration, and with wrought-iron nave, with tires not liable to burst from being in a state of tension.

Railway wheel formed of plain bars and filling-up pieces; the bars are so bent, and the filling-up pieces so shaped, that the heat requisite for welding on the checks of the nave does not burn or injure the bars, while at the same



light express  
to water tanks  
600 gallons of  
foot-plate to  
his engine.

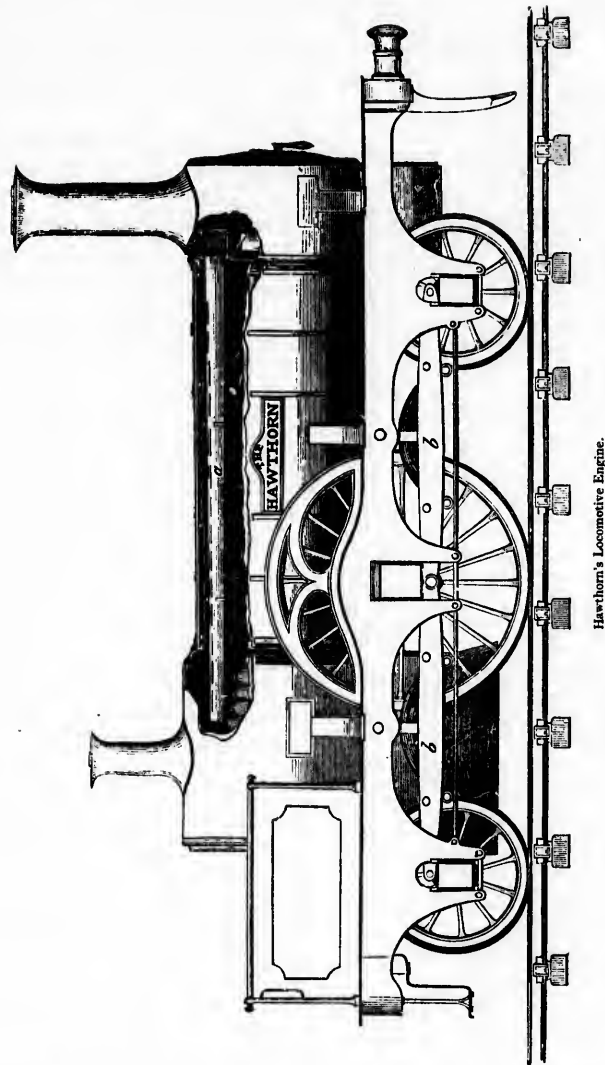

Hawthorn's Locomotive Engine.



Square—  
exterior of

wheels grooved  
ary and the  
which consists  
es, laid over  
or cheapness  
shrink, and  
the framing,  
n wedges to  
, with tires  
ision.  
g-up pieces;  
so shaped,  
eeks of the  
at the same

time the spokes better resist torsion: vibration is checked by curving the spokes.

Another, constructed of plain bars, one end of each being bent so as to overlap or lie round the one next to it, and form a wrought-iron nave; parts of the wheels before being welded together.

543 PATENT SHAFT AND AXLE TREE COMPANY. *Brunswick Iron Works, Wednesbury, Birmingham*—Manufacturer.

Patent railway-carriage axle, as finished by the forge hammer.

Patent fagot, previous to its being welded and shaped into a patent axle.

Central bar, used in the formation of the patent fagot radial bar, fractured to indicate the quality.

Axle end, showing the perfect union of the radial and central bars in the welded fagot.

Patent axle (broad gauge), four and a half inches diameter, bent and twisted, without fracture, in consequence of receiving the shock of a heavy train, going at the rate of sixty miles an hour.

The patent mode of manufacture makes the axles equally strong throughout; the fagot is made in a cylindrical form by the external bars being rolled so as to fit accurately around a central bar. Such a fagot, however large, is perfectly welded throughout its whole length at one heat.

NORTH AREAS A. B. 10 to 34; C. D. E. 1 to 10, &amp; 19 to 37; F. 1 to 32; G. H. 1 to 13, &amp; 19 to 26.

Patent link for suspension bridges, rolled into form at one heat; by avoiding the necessity of welding, and by the arrangement of the fibres of the iron in the same direction, throughout its whole length, a greater and more uniform strength is obtained.

550 ROBERTS, J. E., *Holywell, Wales*—Inventor.  
Electric railway whistle.

552 DE BEERCUE, CHARLES, *9 Dougate Hill*—Inventor and Manufacturer.  
Specimens of patent vulcanized India-rubber buffers for railway carriages; they consist of alternate rings or blocks of vulcanized India-rubber and metal plates with a rod passing through both rings and plates; intended to be lighter, more compact, more easily applied, and less liable to injury than steel or other springs. When acted upon, these buffers offer a gradual and greatly increasing resistance.

Patent station buffer, which acts by friction; the resistance being given by a tapering hulk of timber passing between plates of metal acted on by India rubber; its power of resistance is progressive, like the former.

[In these springs the peculiar elastic properties of vulcanized India-rubber are made use of. Experiments have shown that by separating the elastic rings by non-elastic plates of metal, the effective elasticity is greatly increased. In action, their ratio of resistance increases with the amount of pressure; thus rendering them equally sensible to light as well as to heavy concussions.—J. W.]

554 SANDFORD, OWEN, & WATSON, *Phanis Iron Works, Rotherham*—Inventors, Designers, and Manufacturers.  
Patent railway wheels, three feet in diameter, made of wrought-iron, and welded into one piece. The manufacture is effected by machinery, and is scarcely more expensive than that of the common wheel, while it is much more secure, from its construction.

Wheel, 3½ feet in diameter, made by the patented process, and similar to the former, excepting that the spokes are welded to an inner rim, which is turned, and the tire shrunk on and secured in the ordinary manner.

555 SPENCER & SON, *Newcastle-on-Tyne*—Manufacturers.  
Baillie's patent volute springs for railway and other purposes, applied in various forms.

555A SPENCER, THOMAS, *Twizdale, Tipton, Staffordshire*—Manufacturer.  
Chambers' patent wrought-iron wheel.

556 LACY, H. C., M.P., *Richmond*—Producer.  
Patent railway sleepers.

557 CRESTADORO, PROFESSOR ANDREW, *22 Peel Street, Salford*—Inventor.  
Model of a machine for applying animal power to the working of railways, consisting of a carriage, on which animals are placed to work the driving-wheels; with illustrated drawings, showing the recent improvements by the exhibitor.

558 WARREN, PETER, *Foley Fenton, Staffordshire Potteries*—Inventor.  
Model of a driving wheel for railway engines, devised to prevent slipping when going up inclines. By the use of this wheel the engine may be reduced in weight, and the wheel rendered stronger, whilst it takes no more room than that now in use.

[The power of a locomotive railway engine is available for onward motion only by the *bite* or *grip* of the surface of the driving-wheel on the rail, and as the *bite* is created by the weight upon the wheel, the surfaces in contact being practically smooth, as the weight of the engine is reduced the *bite* becomes less tenacious, and

the power of the engine may be expended in making the driving-wheel revolve without corresponding onward motion of the train. The method exhibited appears to promise to obtain the requisite *bite* or *grip* of the driving wheel, or to prevent the wheel from slipping, or from turning round without onward progress, by means independent of weight upon the wheel.—W. H.]

Two pair of couplings for railway carriages, one for luggage and the other for passenger carriages, to prevent the breaking away; they may be used with or without springs, and may be connected to any other carriage or waggon.

Model of a weighing and lifting crane that will weigh and wind in two inches square, without drum or wheels. By this crane it is stated that a man can lift and weigh one ton with more ease than he can half a ton with the common lifting crane.

559 PIZZIE, W., *Albourne Mills, Marlborough*—Inventor.  
Railway break, which can be instantly applied to every wheel in the train.

560 DILLON, JAMES, *28 Upper Buckingham Street, Dublin*—Inventor.

Railway break. The friction-slides are attached to the support beams, which rest on the axle of the wheels by means of six iron lifters, which are moveable on pivots, but equally distant and equal in length, so as to lift the wheels of the carriage one-third of an inch off the rail, when brought into a vertical position, by means of the guard turning a screw, which gives motion to the friction-slides; it would be made simpler if the lifters were fitted to the axle of the wheels, and the friction-slides made equal to the distance between the axle of the wheels.

561 COOLEY, JAMES, *Spalding*—Inventor.  
Model of self-acting apparatus for making signals on railways. The arrival of a train, or the removal of carriages from sidings on to or over the main line, is immediately denoted by the action of the carriages themselves.

562 PERRY, HENRY JAMES, *3 Greenwich Road, Greenwich*—Inventor.  
An atmospheric railway vacuum, obtained by gutta percha tubing, in connection with an engine. Can either be worked by compression or exhaustion.

564 TENNANT, M. B., *Trafalgar House, Brighton*—Inventor.  
Brass models of five patent railway carriages linked together, with auxiliary safety-wheels, and traverse bolts and socket buffers.

The models are provided with apparatus showing that railway trains may be prevented from going off the rails either from the effects of collision or dangerous obstructions, and from the danger of delay or stoppage occasioned by the slippery state of the rails, as in the case of Clay Cross Tunnel.

1st. The auxiliary safety wheels are intended to be applied to every fourth or fifth carriage, midway between the front and hind-wheels; they turn each on its own axis or pivot, *i. e.*, without an axle arm; they rise up and fall down, on passing over obstructions, to the extent of 10 or 12 inches, enabling the train to surmount the obstacles, hitherto so fatal, without verging off the rails; they may be set to a greater or less height, and made to drop down 10 or 12 inches below the level of the other wheels when they are forced up by accident, always retaining possession of the rails, and to turn acute curves with great speed and safety.

2nd. The bolt and socket buffers are placed transversely instead of longitudinally; they rise and fall simultaneously on a bolt or pivot at each side of the chain link, and are kept within each other by means of spiral springs introduced into the necks, having been closely wound up by the shackle, which tends to prevent oscillation of the carriages.

3rd. To guard against delay or stoppage of the train occasioned by the slippery state of the rails in snowy or bad weather, a leading carriage precedes the engine, loaded with sand, and has a seat for a look-out-man, who has the command of a handle to let sand out on the rails when required. The carriage is pointed in front to cut through the air, and has a grated fender in front to remove all obstructions. As no great quantity of sand is at all times required, heavy goods could be substituted to give sufficient gravity and tenacity of the wheels to the rails; and as the seat for the look-out man would necessarily be much exposed, glass shields could be formed.

In proof of the efficacy of the above plan, the models have been tested on a circular railway 60 feet in circumference, by a train which was propelled at the rate of 40 miles per hour, over obstructions adequate to 12 inches in height, with unerring certainty, but which, without the apparatus, would fly instantly off in a tangent; and it is to be remarked that as the safety wheels bear no part of the weight of the carriages to which they are attached, old wheels, on the score of economy, can be employed; and on the other hand, the adoption of the principle would not be attended with great expense, and railroad travelling would be rendered comparatively safe on the only transit now left open to the public.

Model showing the four processes of permanent flat roofing, impervious to rain. This species of roofing has been adopted at Queen's Road Colonnade Hotel, near the terminus at Brighton.

566 MURRAY, W., 20 University Street, Bedford Square—Manufacturer and Licensee.

Eccentric coupling for railway carriages. Loop coupling, for taking up "the slack" between two carriages without recourse to the screw.

568 CLARKSON, T. C., 111 Strand—Inventor.  
Railway buffers.

570 SANDESON, C., Baker Street, Reading—Inventor.  
Instrument for setting out railway curves.

572 STEVENS, J., St. Leonard Station, Edinburgh—Inventor.  
Railway signal.

574 HEMMINGWAY, A., Halton, near Leeds, and 12 Denham Street, Vauxhall—Inventor.  
Model locomotive.

576 CRIPPS, W. NORRIS, 352 Bell-Barn Road, Birmingham—Inventor.

Model locomotive tender and carriage for reducing the danger of collision on railways, and for affording refuge to the engine-driver and stoker. The novelty of the invention consists in the construction of a carriage with longitudinal tubular beams and rods, in lieu of the solid timber or iron beams at present used, and in the arrangement of elliptical springs, forming together a perfectly expanding and collapsing carriage, capable of sustaining an immense shock without receiving injury. Any description of body may be placed on the carriage; and a portion of the arrangement of springs is so designed as to be capable of being adapted to the form of every carriage in present use. It is considered that a train so fitted would suffer but little injury from shocks from front or rear.

580 DODDS & SON, Rotherham—Manufacturers.  
Model locomotive.

581 FOUNNESS, WILLIAM, St. James's Street, Leeds—Inventor and Designer.

Alarm for locomotive engines, steam-packets, or other useful purposes. The sound is produced by the action of steam upon metallic reeds.

582 LOCKYER, JOSEPH HOOLEY, Leicester—Inventor.

Model of a patent self-acting railway signal, for locomotive engines, &c., to signal the arrival of a train at any fixed spot, applicable for signalling trains in the rear, in a rapid curve, or approaching a station.

586 MACBAY, WILLIAM, Royal Artillery Barracks, Woolwich—Inventor.

Train of railway carriages, with break or luggage-van; containing self-acting collision-breaks, and other apparatus connected with the carriages, intended to prevent the destruction of the carriages and injury to the passengers.

Design for connecting the various railway termini of the metropolis, and affording suitable railway communication to all metropolitan large towns.

A section of a street, with improved kerb, for keeping the pavement clean; furnished also with a fire-annihilator and life-preserver.

588 SNOWDEN, WILLIAM FRANCIS, St. Thomas Street, Weymouth, and King's Cross, Gray's-Inn Road—Inventor.

Working model of a new mode of assisting engines with carriages up and down hills on railways; it requires no alteration to be made on the engines, carriages, or rails in common use, and is chiefly intended to save the expense of deep cuttings, tunnels, &c.

Model of a new method of reducing the labour of horses, with carriages going up and down hills on common roads or streets.

Two models of mangles, showing a new application of a roller attached to the centre of the frame of such machines, and acting on the top of the mangle-box. The roller being made of galvanized iron, prevents rust; and being heated by one or more heaters, or otherwise, it improves the gloss and removes the damp of mangled articles.

591 PARSEY, A., 455 Oxford Street—Inventor and Patentee.

Compressed air-engine, for locomotive and stationary purposes.

600 YOUNG, CHARLES, & Co., Edinburgh—Inventors and Manufacturers.

Simultaneous-acting level-crossing gates for railways, for the prevention of accidents; consisting of four gates or levers, all of which act together, on one being moved by the gate-keeper.

These gates are placed outside the building, at the west end.

601 BARLOW, PETER WILLIAM, Blackheath—Inventor.

Model of cast-iron permanent way, as constructed on a portion of the South Eastern Railway. Also, models of sleepers for points and crossings for railways. The novelty consists in casting the chairs upon a cast-iron plate, which takes the place of a wooden sleeper or a stone block.

The advantages over the ordinary constructions are stated to be, greater durability, and an increased number of chairs or points of supports, which, being planed true as to line and level, afford the means of obtaining greater accuracy in railroad construction.

602 BARLOW, W. H., Derby—Inventor and Patentee.

Wrought-iron permanent way for railways. The rail is made to form its own bearing-surface in the ballast, without the aid of sleepers, chairs, &c. In use on the Midland Railway.

609 STEVENS & SON, Darlington Works, Southwark Bridge Road—Manufacturers, Proprietors, and Patentees.

Model of railway junction semaphore signals. The platform is raised from the ground from four to eight feet, to afford the signal-man a good view of the line. The two signal-posts represent the meeting lines of railway. The arms and lamps are worked by the foot of the signal-man, leaving his hands at full liberty to pull

over the switches or shifting rails; on the removal of his foot from the stirrup and his hand from the switch lever, the signals re-adjust themselves, the arms standing out at right angles, and the lamps "red," stopping both lines.

Model of a double station signal, provided with an arm and lamp working simultaneously on each side of the post, to command both lines by moving either of the hand levers.

610 DE FONTAINE MOREAU, PETER A., 4 South Street, Finsbury—Importer and Proprietor.

Vidie's patent Warner, an apparatus intended to be placed above carriages, from which metallic plates descend into the carriages, indicating the name of the place or station towards which they are proceeding, or are stopping. On one side of the carriage an apparatus is intended to be placed, which can be put in action from the inside of the carriage, and serves to give an order or warning to the guard. At the time of starting all the metallic plates of a train can be reversed by turning a crank arm for that purpose; and the apparatus closes simultaneously with the door of the carriage.

614 HOBY, JAMES WARD, Renfrew, near Glasgow—Inventor and Manufacturer.

Patent system of permanent way for railways, comprising a length of 18 feet of single line, with double-headed rails, cast-iron longitudinal sleepers, folding keys, and cross ties. The following cut represents a cross section of this permanent way.

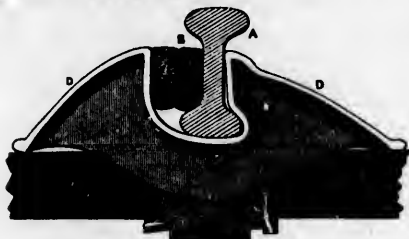

Cross section of Hoby's patent Permanent Way.

A is the rail, and B the folding-key. The part C is a cast-iron piece, with a stirrup, or recess, cast through it, which holds the wrought-iron bearer, and receives in the stirrup a wrought-iron cross-bar, D, set on edge, for the purpose of securing the gauge and the tilt of the rails.

Two cast-iron longitudinal sleepers reversed, to show the mode of securing the tie-bar.

Specimen of the folding keys applied to an ordinary chair and double-headed rail.

Specimen of a wrought-iron sleeper, with cast iron folding keys, applied to a double-headed rail.

615 GRAVES, H., 4 Ordsall Terrace, Manchester—Inventor.

Iron surface-packed railway sleepers, with rails; a substitute for wood-sleepers.

[The decay to which the timber substructure of railways is subject renders the substitution of some indestructible material advisable, even presuming the first cost to be greater.—S. C.]

616 SAMUEL, JAMES, C. E., 3 Duke Street, Adelphi—Inventor.

Patent cast-iron, timber-bedded, wedge-trough permanent way for railways.

Patent fish-chair, or improved joint-chair, applicable to existing railways without removing the present sleepers; and giving continuity to the rails.

[There are two kinds of rail-bearings, the chair bearings, and continuous bearings for rails.

With chair bearings the rails are supported at fixed points, from 3 feet to 4½ feet apart, the rail bridging near the intervals.

With continuous bearings the rails are laid or bedded upon timbers, termed sleepers, which are in their turn bedded upon the ground, or rather, upon that preparation of the railroad for the permanent way, ballasting. The connection between the rail and the sleeper is made so that the two act together, and are borne in every part alike by the ballast.

A transverse tie is required to keep the rails in gauge, or immovably at the same distance apart; as the conical form given to the face of the tire of the bearing wheels of railway carriages, to enable them to run upon curves without dragging, induces a constant effort to force rails. At low speeds, this tendency is not felt; but at high speed, this derangement is very manifest. The sleeper commonly used is of timber in the log, cut into two halves, so as to present its section uppermost, and its round hard surface to the earth. The joint chair is intended to secure the abutting ends of the rails.—W. H.]

Patent improved "donkey-engine," for pumping water into steam boilers, to be used in locomotives instead of the present "feed-pumps."

Sectional model of patent double-cylinder "continuous expansion" steam-engine, in which the steam is made to exhaust from the first to the second cylinder, the cranks being set at right angles.

618 DUNN, T., Windsor Bridge, near Manchester—Inventor and Manufacturer.

Apparatus for removing carriages from one line of rails to another. The following cut represents an end view of a traversing machine, patented by the exhibitor, and is shown in the act of removing a carriage from one line of rails to another. The principal feature in the invention is the rail or shelving at the lower edge of the machine. In the engraving the carriages are mounted thereon by easy inclined planes, A A, attached to the end of the traverser, and working inwards and upwards at the same time on spiral joints.

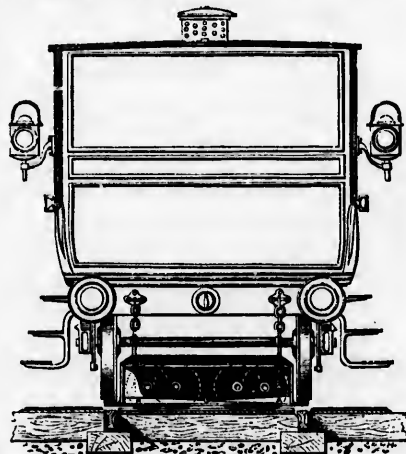

Dunn's Patent Traversing Machine.

Models, to scale, of traversing machine, being modifications of the same; with drawings.

Drawings of patent skeleton rail, or turn-table; of an improved chain-cable testing machine; of a hydraulic

machine, for forcing railway wheels on and off their axles, with improved regulating and revolving carriage; and of a patent improved portable copying press.

624 ORMEROD, R., & SON, *St. George's Foundry, Manchester*—Patentees and Manufacturers.

Patent traversing machine. The improvement consists in applying an oscillating frame, forming an inclined plane, up which the carriage is run, and which, when brought to a horizontal position, can pass over the

rails. Its claim to superior efficiency arises from its not in any way interfering with the fixedness of the permanent line of rails. Figs. 1 and 2 represent a side elevation and plan of this traversing machine.

Dunn's patent turn-table—the rails of the platform are supported throughout their entire length by inclined planes or wedges, which are brought into action when required, and render the table perfectly rigid whilst a train is passing over. Figs. 3, 4, and 5, represent a section and plan of the patent turn-table.

Fig. 1.

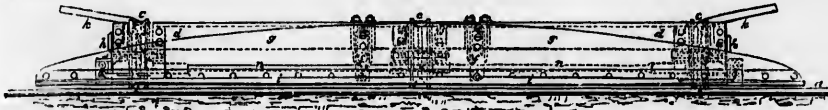
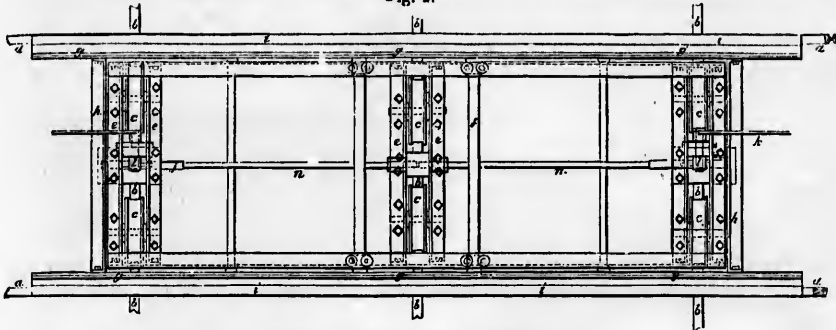

Fig. 2.



Ormerod and Son's Patent Traversing Machine.

Fig. 3.



Fig. 4.

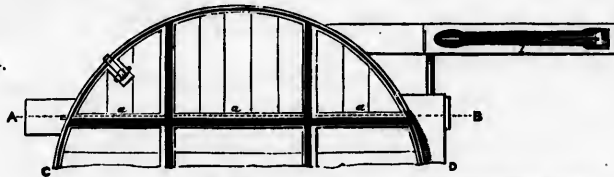

Fig. 5.



Plan and Sections of Dunn's Patent Turn-table.

The advantages claimed are, that the carriage to be removed may be received, sustained during the traverse, and discharged, by means of one and the same pair of rails, laid continuously, or without break, on an oscillating frame, and the carriage may be thereby transferred from one line of rails to another, without disturbing the fixedness of the permanent rails.

In figs. 1 and 2, *aa* are the permanent rails of the line. *bb* are the traverse rails, fixed at such a level as to allow the flanches of the wheels (*cc*) of the truck to pass over the permanent rails of the line.

*dd* and *ee* are the sides and ends or framing of the truck, supported by six wheels (*cc*) running upon the traverse rails already described.

By the sides (*dd*) of the truck is supported the axes (*ff*), upon the extremities of which axes are secured the two sides (*gg*) of the oscillating frame. *hh* are two transverse pieces, connecting the ends of the two sides (*gg*) of the oscillating frame together. To the sides (*gg*) of the oscillating frame are attached the rails (*ii*) upon which the carriage is supported during its removal from one line of rails to another.



The raising or lowering of the oscillating frame, together with its rails (*i i*), is effected by the wedges (*j j*) acting upon the transverse connecting pieces (*A A*); and through the medium of the levers (*k* and *l*) and rods (*n*) either end of the rails (*i i*) may be depressed, and made to meet and rest upon the permanent rails (*a a*) of the line.

On the carriage being received upon the rails (*i i*) of the oscillating frame, the oscillating frame must be brought into the horizontal position by means of the wedges, and after the truck and its load are removed to the desired line of rail, the carriage may then, by the same means, be allowed to descend upon those rails in either direction, as required.

In figs. 3 & 4, *a, a*, is a section of rail on the main line of way; *b*, is the girder upon which the rail is fixed; *c*, is a sliding beam, the top surface of which is planed, so that by the lever (*l*) and the wedge-shaped bearings (*d*), this sliding beam may be raised in contact with the under and planed side of the girders (*b*), whereby the

platform is made rigid. When the platform is required to be turned, the sliding beam is lowered by the lever (*l*), and the platform is left to turn upon the friction pulleys (*e e*), two of which are shown in fig. 5.

628 CUBITT, J., *Great George Street*—Producer.

Permanent way of the Great Northern Railway, with Ransomes' and May's patent chairs, trenails, and wedges.

636 THORNEYCROFT, G. B., & Co., *Wolverhampton*—  
Inventors and Manufacturers.

Specimens of Briggs' patent compound railway axle. Piece of the pile from which the axle is made.

Patent axle. Patent charcoal tire for railway wheels and rails, showing the arrangement of the charcoal and fibrous iron; the same after it has been subjected to the action of acid, showing the physical construction of the part upon which the friction more particularly bears.

The figures 1, 2, and 3 show the arrangement of the charcoal and fibrous iron in this metal.

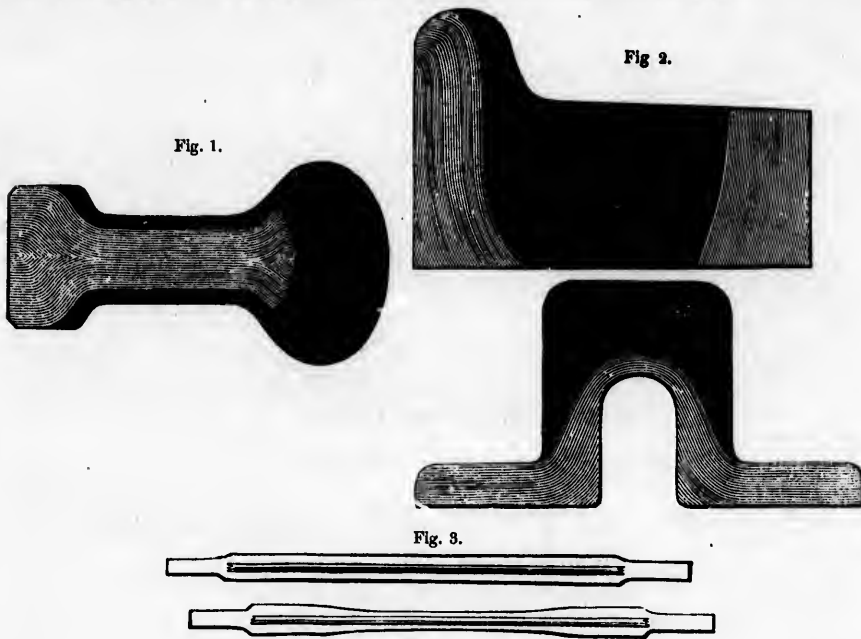

Thornycroft's Patent Axles.

637 WORSDELL, GEORGE, & Co., *Warrington*—  
Manufacturers.

Railway axle-forged, hammered, showing process of manufacture; bent cold, and having borne a pressure of 84 tons.

Railway wheel-tire, forged and hammered: showing process of manufacture. Patent railway axle-box.

638 ERW VILE COMPANY, 83 *Upper Thames Street*,  
*London*, and *Abergavenny*—Manufacturer.

Section of every description of railway bars used on different railways.

639 POTTER, WILLIAM, 33 *Green Street*, *Wellington Street*,  
*Blackfriars Road*—Manufacturer.

Gut wheel-bands used for all kinds of machinery, manufactured from the long or running gut of the sheep;

this band can be split into three in its entire length, and worked as fine as the finest cotton. It is used by watch-makers and others for the drilling-bow.

640 RANSOMES & MAY, *Ipswich*—Manufacturers.

Barlow and Heald's patent machines:—Railway turntable for turning engines or carriages.

Wild's railway switch or turn-out rail.

Barlow's iron sleeper, as in use on a portion of the South Eastern Railway.

Permanent way of the Great Northern Railway; with chairs, trenails, and wedges, on the exhibitors' patent.

Registered water cranes, for supplying the tenders of locomotive engines with water.

Patent railway chairs, with patent compressed trenails and wedges.



Compressed wooden trenails and keys, for railway chairs, and previous to compression.

Patent compressed ship trenails, in various stages. Chilled cast-iron pedestal, or axle bearing. Broken pedestal, showing the depth to which the chilling has penetrated.

641 COALBROOK DALE COMPANY, *Shropshire*—Manufacturer.

Square, round, flat, half-round and oval, bar iron; angle T and girder iron; sash bar and moulding iron; tire iron; engine-floor, and foot-plate iron.

642 PARSONS, PERCEVAL M., C.E., 6 Duke Street, *Adelphi*—Patentee and Designer.

Patent switches adapted to the ordinary double T rail. Single patent switch, adapted to Barlow's patent broad flange rail.

Patent crossing for railways, adapted to the ordinary double T rail.

Normanville's patent axle-box. The lower chamber of the axle-box, which contains the journal and bearing, is cast in one piece, and closed by means of an apparatus fitted to it, for the purpose of excluding grit or dirt, and preventing the waste of grease.

Patent machine for dressing mill-stones, with a mill-stone to illustrate its action. With the aid of this machine, it is stated that a boy can dress a pair of stones in less time and with greater ease than a millwright on the old plan.

643 BAINES, WILLIAM, *Birmingham*—Inventor.

An improved railway switch. The mode of forming the tongue of this switch gives it stiffness and a broad base to slide upon; when closed, it is locked under the main rail, and the point prevented from rising. The tongues clear their own track, by driving the dirt under the main rail, and not against it, as in the old switch. The cost of construction is less than in the ordinary mode of forming the tongue, which prevents them shutting close, obviating the necessity of personal attendance to keep them in working order, and also the liability of accident if neglected.

An improved joint chair, the object of which is to support more firmly the joints of the rail.

An improved intermediate chair. The two jaws of the chairs are made exactly alike, and are oblique, instead of opposite to each other. The chairs are slipped on diagonally, and when brought to right angles support the rail without any key or wedge.

644 KENNARD, R. W., *Falkirk Iron Works, Scotland*, and 67 Upper Thames Street, *London*—Manufacturer.

Specimens of various switches.

645 BIDDULPH, JOHN, *Cwm Avon Works, Talbach, South Wales*—Manufacturer.

One large flanch rail, 63 feet long, 56 lbs. per yard. One small flanch rail, 4 lbs. per yard.

646 BEECROFT, BUTLER, & Co., *Kirkstall Forge, Leeds*, and 6 Pancras Lane, *London*—Manufacturers.

Specimens of railway wheels and axles, particularly adapted for express and fast trains, viz., entire wrought-iron wheels, with solid wrought-iron bosses, forged in one piece, with single and double spokes respectively.

Specimens of the same, with wrought-iron disc centres and wrought-iron bosses; the tires of the latter being dovetailed to the discs to supersede rivets and insure greater safety.

Specimens of wrought-iron wheels, with wrought-iron spokes, and cast-iron centres, for ordinary and other trains.

All the above wheels have tires, combining hardness of surface with toughness of texture, and double-faggoted axles of improved Kirkstall manufacture.

Specimens of tires and axles of above manufacture, bent cold, in a variety of forms, to show toughness and superior quality.

Specimens of 28 different kinds of improved patent axletrees, for carriages, phaetons, omnibuses, cabs, drays, and other vehicles, manufactured upon the newest and most approved principles, from best double-faggoted Kirkstall iron.

A self-acting regulating damper for high-pressure boilers.

A registered improved moveable eccentric tumbler, for the valves of steam-engines.

647 DERWENT IRON COMPANY, *Shotley Bridge, Newcastle*—Manufacturer.

A rolled malleable iron-beam plate, used in the construction of marine engines, 17 feet 1 1/2 inch long, 4 feet 6 inches broad, and 1 1/2 inch thick, weighing 1 ton 5 cwt.

A rolled malleable iron plate, used in the building of iron ships, 20 feet long, 3 feet 6 inches broad, 5/8ths of an inch thick.

A piece of rolled keel iron, used in building iron ships.

A railway bar, measuring 66 feet 9 inches in length, 88 lbs. to the yard, and weighing 17 cwt. 1 qr. 26 lbs.

A railway bar, 65 feet 9 inches long, 12 lbs. per yard.

648 RICHARDSON, J., 9 Woburn Buildings, *Tavistock Square, St. Pancras*—Designer.

Table of the weights of wrought iron in ounces and decimals, from 1/4 of an inch square to six inches by three inches, extending to 1,058 different sizes, advancing successively by 1/8th of an inch in each dimension of breadth and thickness. Also the weights of round iron of all the sizes usually manufactured, to six inches diameter. And the weight of hoop iron to six inches wide, advancing by one-sixteenth in thickness.

649 MERSEY IRON COMPANY, *Liverpool*—Manufacturer.

Samples of patent rolled iron.

650 LEADBETTER, JAMES G., *Gordon Street, Glasgow*—Inventor and Patentee.

Patent inventions:—Canal-lift, or hydro-pneumatic elevator; a substitute for canal-locks. The same principle applied to a ship-lift, a substitute for slip-docks and grid-irons; and to a wreck-lift, for raising sunken ships. Railway turn-table, or weighing-machine. Swivel-bridge elevator. Furnace-lift. Crane. Tippling-machine. Air-pump.

651 RICHARDSON, ROBERT, 39 Moorgate Street—Inventor and Patentee.

Patent "fish joint" for rails.

Wrought and cast iron "fishing pieces."

652 GOMPERTZ, LEWIS, *Kennington Oval*—Inventor.

Railway trains constructed to prevent collision, by means of a lever curved two ways, which acts on all the wheels and projects beyond the carriage, which is met by a roller on the reverse side of the opposing carriage, so as to turn the one out of the other's way.

Square carriage wheels, termed *saopars*, intended to prevent the obstacles and friction of the road, and to travel with great facility and diminution of labour. Their object is to advance by steps as in walking, without jolting the carriage.

654 CUNNINGHAM & CARTER, *Addison Road, Kensington*, and at *Sydenham*—Inventors and Patentees.

Model of an atmospheric railway on a new principle, and models of carriages.

655 HARLOW & YOUNG, *Paradise Street, Rotherhithe*—  
Inventors and Patentees.

Model of patent atmospheric railway, with metal valves and discs.

656 JONES, THOMAS MORETON, *Southampton Chambers, 53 Chancery Lane*—Inventor.

Model of a railway train and breaks. The invention is intended to stop railway trains within a short distance by means of breaks fixed to the carriages, of such a form as to take the wheels off the rails with ease and safety. The breaks are successively brought into action with a rapidity proportionate to the velocity of the train, so as to avoid the danger of sudden jerking. They only require the application of a lever near the engine, to set in motion a rod, which passes underneath the carriages and communicates with the separate breaks. By moving the train backwards, the wheels immediately become free of the breaks. A simple spring buffer is substituted for those at present in use.

659 CRUTWELL & Co., *Newport*—Inventors.

Model of permanent way for railroads.

660 BOYDELL, JAMES, *54 Threadneedle Street*—Inventor and Manufacturer.

Pair of wheels placed under a truck, for facilitating the draught of heavily-laden carriages, especially on soft grounds. Applicable to the wheels of railway carriages, in certain circumstances.

661 STANTON, ROBERT, *73 Shoe Lane*—Inventor and Manufacturer.

Electro-magnetic engine.  
Locomotive steam-engine.

662 LONG, CHARLES ALBERT, *1 King St., Portman Square*—Inventor.

Railway signal, worked by the agency of electricity; intended to obviate the danger of one train overtaking another. By the use of this signal, trains may always be kept at a given distance apart; a train on passing the signal-post causes a red board to be exposed in daytime, and a red light at night, which signals remain until the train has proceeded a certain distance in advance. The changing of the signal depending on the distance passed over, and not on the time which may elapse after passing the post.

666 BANKS & CHAMBERS, *German Street, Manchester*—Manufacturers.

Railway-carriage wheel, upon Banks' patented invention for inserting steel segments in that part of the tire which is most exposed to friction by running upon the rail.

Another, with part of one of the steel segments left out, so as to show the shape of the dove-tailed groove in the tire.

The improvement consists in turning a dove-tailed groove in the hollowed or worn part of the tire, and inserting solid steel of a particular kind, instead of turning away the surface of the tire to the level of the worn part, or re-tiring the wheel. It is stated that the steel segments do not cost half as much as new iron tires, and that the wheel wears twice as long by this method.

[The surface of the tire of a wheel running upon edge-rails—and all railways of recent construction, for travel-

ling at least, are laid with edge-rails—bears upon a very narrow breadth of the rail, whilst the whole of the breadth of the rail is small compared with the requisite breadth of the bearing-surface of the tire. As the swerving of the wheel, and of its tire, is in practice very small, that part of the tire which bears upon the rail becomes worn and rendered concave, while the flange and the remaining surface of the tire remain unworn. In this condition the wheel no longer runs freely and smoothly over the rail, and it becomes necessary to put it into the lathe, and then reduce the uneven part of the tire to obtain a new and even face at the depth of the concave groove, or to put a new tire on the wheel, unless the groove can be filled in and the worn part be restored without subjecting the wheel to either of the two processes.—W. H.]

668 COPLING, J., JUN., *The Grove, Huobney*—Inventor.

Railway signal, for instant communication between the guards, passengers, and engine-driver.

670 LIPSCOMBE, FREDERICK, *233 Strand*—Inventor and Manufacturer.

Contrivance for preventing vibration in railway wheels, and making them run without noise.

Portable fountains, for drawing-room tables, conservatories, &c.

672 EASTWOOD & FROST, *Mortledge Iron Works, Derby*—Manufacturers.

Rolled bar, forming when bent a segment of a wheel; bar, forming the centre of a wheel, viz., the boss, arms, and rim. Wheel-centre, complete, for carriages; and for engines. The wheel is made of wrought-iron, from a rolled bar, so as to give strength and lightness to the arms and rim, and so secure uniformity of weight throughout.

674 DICKER, JOHN, *Clarence Terrace, 2 Rotherfield Street, Islington*—Inventor.

Improved automatic apparatus for transferring mail bags or parcels, on railways, at any speed, and capable of receiving and delivering them, from the weight of a single letter to that of 70lbs.

This apparatus consists of a wooden frame and net attached, shown in plan A; and an iron post B, fixed in the ground at the side of the railway in a direct line with each other; and a corresponding apparatus affixed to the side of the carriage C, viz., a projecting arm D, to support and deliver the envelope E (with bags or parcels enclosed), into the net A, which is fitted with conveying guidelanes F, to receive them. These lines are of great importance, the acute angle being the part in which the envelope is gripped to detach it from the locks; it also prevents the possibility of escaping. G is a folding-net attached to the side of carriage to receive the envelope from the standard B. This apparatus has been long employed with uniform success on the South Eastern Railway. Fig. 1 is a ground plan, and Fig. 2 an elevation of this apparatus.

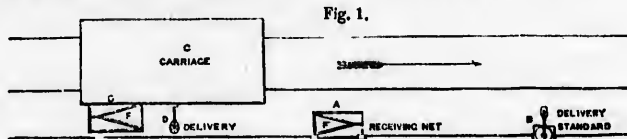

Dicker's Automatic Apparatus for Mail Trains.

Fig. 2.

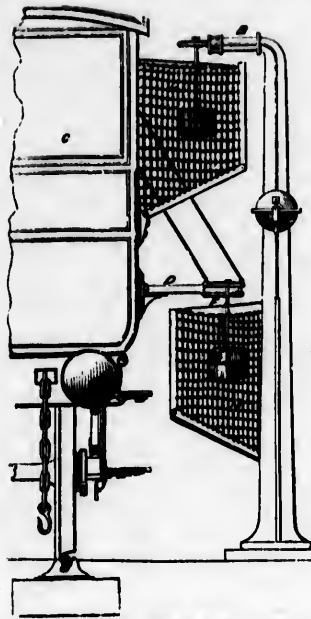

Dicker's Automatic Apparatus for Mail Trains.

681 Tabor, J. A., Colchester—Inventor.  
Improved application of the whistle to locomotive steam-engines. The advantages are said to be as follows:—

The steam cannot be turned on the engine without first sounding the whistle.

The signal is uniformly given at suitable intervals of time and space, without the agency of the engine-driver.

It distinguishes an "up" from a "down" train, and also branch from trunk lines.

The whistle is placed at the front, instead of the back of the engine, thereby throwing the sound farther upon the line, and removing the vapour from the eyes of the driver, and the noise from the driver and the passengers.

682 JACKSON, P. R., Salford Rolling Mills, Manchester—Manufacturer.

Locomotive and carriage tires: manufactured by a patent process.

Spur-wheel, moulded by a patent machine, which moulds wheels or pulleys of any size, form, or number of cogs.

Registered stench-trap.  
Model of the patent powerful hydraulic press, capable of lifting upwards of 3,000 tons. The cylinder is very light and strong, and the press has been at work for years.

684 CHABOT, CHARLES, 9A Skinner Street, Snow Hill—Improver.

Models of three railway carriages, exhibiting the following improvements:—A rotary and self-acting break, by means of which a train in motion can be stopped without shock, and without wear and tear of the wheels or rails. The braking power is communicated to each carriage in succession throughout the train. Locked buffers, by means of which oscillation is diminished, and the concussion occasioned by collision received upon the line of buffer-rods, instead of the carriage frames, by which the

separation of the carriages and their liability to be thrown off the rails is prevented. An economical form of spring, applicable to the buffer and draw-rods, and other purposes.

686 McNAUGHT, W., 26 Robertson Street, Glasgow—Producer.

Montgomery's self-acting railway-break.

690 HANDLEY, WILLIAM, 26 Great Earl Street, Seven Dials—Inventor.

Patent break for railway trains, designed to obviate the serious defects of the common railway break. The first advantage it presents is an improvement as to the permanent way, which is effected by the use of the long shoe; this, by having 18 inches of bearing surface upon the rails, will slide over the soft or bad places hitherto made worse by the application of the ordinary break, the wheels having only about one inch of surface. The ends of the rails will not be jumped up or flattened by the wheels coming in contact with them, which is now the case, as the wheels resting upon the shoe will in fact press such irregularities down.

The second advantage is that, in the locomotive department, the wheel tires are always preserved perfectly circular; and the shoe, by bearing upon the wheel when the break is applied, prevents the flat spots being formed, and also torsion upon the axles. The wheels, whether of wood or iron, are saved from being strained, and the tires, rivets, bolts, &c. are not so liable to get loose, an evil which is caused by their becoming heated. The carriage frame is also saved from being racked and twisted, as the patent break is suspended upon the axle only. This will cause a great saving in the repair of break carriages. By the adoption of this break, a power is gained when applied to two wheels only, fully equal to the usual breaks applied to six, a feature of no slight importance in cases of danger. This power in retarding a train is also always the same, which is not the case with the common break. The different weights with which the carriages are loaded are continually altering the position of the blocks, which varies the number of turns of the screw necessary to apply the ordinary break; while in wet, greasy weather, it is almost impossible to skid the wheels. The patent break can be applied in less time, and with two or three turns only of the screw, whereas six or seven turns are required with that hitherto in use. It is also free from the usual unpleasant noise, smell, and sensation from friction.

Lastly, considerable saving is effected, both in the amount of stock required and in the wear and tear of railway apparatus.

The necessity for the introduction of an improved railway break is universally admitted by all engineers and practical men. The breaks in common use are very injurious, both with regard to the durability of the wheels and rails. Timber blocks of poplar wood are made to bear hard upon the peripheries of the wheels, so as to stop their revolution. The result is the grinding of many flat places on the tire of the wheels and the abrasion of the rails, occasioning frequent renewal.

691 CHESHIRE, EDWIN, Birmingham—Inventor.

Model, showing the principle of an invention for lessening the danger of collisions on railways. This object is proposed to be attained by suspending in bearing sockets, under the centre of the framework of every carriage of the train, a strong iron rod or tube with an expanding head at each end, to be called a "safety buffer," and moving, when acted upon, in a longitudinal direction; and also by attaching at the hinder end of the train a strong van with a low centre of gravity, for the purpose of receiving the first shock of a collision, should it take place from behind; the engine tender being made to answer a similar purpose should the collision occur at the front. The force of the shock will throw the "safety buffers" into one continuous inflexible rod, by means of which its force will be transmitted to the opposite end,

so as to protect the intermediate carriages. In the case of one train overtaking another, the latter, it is conceived, would be completely protected by this apparatus.

692 HARRY, D., 3 *Cunning Place, Pentonville Hill*—  
Inventor.

Models of a locomotive tender and carriage, on a scale of one inch to the foot; fitted with Harry's patent safety machine, for railway carriages, to disconnect the locomotive from the passengers' carriages in the event of the former starting off the line of rail.

693 WALKER, WILLIAM, *Strawbury*—Inventor.  
Railway break.

[The "break" is to the railway train what the shoe, skid, or lock is to an ordinary road-carriage, a means of checking its speed, by pressure upon the wheels of some of the carriages, so that they may revolve less freely, and thus destroy the momentum of the machine when it is desired to stop it. The master-break of a train is applied to the wheels of the tender, and is worked by the stoker, under the direction of the driver, whilst the guards act in aid only upon the carriage-breaks an occasion arises.—W. H.]

694 GRAY, GEORGE, 42 *Woodcock Street, Birmingham*—  
Inventor and Manufacturer.

Model of a four-wheeled railway carriage or guards' van, fitted with a new and improved "break," of great power and instantaneous effect; it forms a direct communication between the guard and driver, and acts on the rails only. Amount of rail friction obtained, 15 feet; ordinary breaks have only four inches: its object is to effect a great saving in wear and tear both to wheels and "permanent way," by rendering the "locking or skidding" the wheels unnecessary, and to prevent collisions, by stopping the train at one-quarter of the distance required at present. A lamp in the centre lights the interior of the van, and it can be also made, by moving a snag, to exhibit a signal to the driver and guard to stop. The space under the guard's seat is for dogs, extra lamps, and tools, &c. Adapted to run either first or last in a train, and requires no "turning." The "blocks" of this break are composed of alternate plates of metal and blocks of wood placed the cross way of the grain.

A six-wheeled model of a similar van and break: a portion of the roof is removed, showing the internal arrangements. The "blocks" of this break are of one piece of wood, "shod" with metal plates. It has rather less friction than the former. Scale of both—two inches to a foot. Provisionally registered.

697 WILSON, CHARLES, Engine-driver on the Leeds and  
Thirsk Railway—Inventor.  
Small locomotive engine.

698 GREENWAY, CHARLES, *Southport*—Inventor.

Patent turn-table for railways, consisting of a "cradle" or frame divided into compartments, in which are placed spheres or balls on which the table top rests, the whole revolving round a common centre.

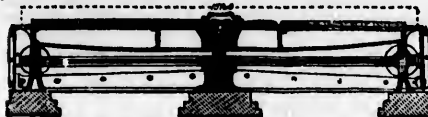

Greenway's Patent Railway Turn-table.

Patent anti-friction axle. The novelty consists in a "cradle" or frame, by which rollers are kept in their proper position.

Patent castor, for furniture. The novelty consists in the spindle being surrounded by friction rollers.

699 COWPER, EDWARD ALFRED, 3 *Kensington Park Road, Notting Hill*—Inventor.

Detonating fog and accident signal for railways. It consists of a small flat tin box about two inches in diameter, with a slip of lead soldered to it to fasten it to the rail. It is filled with gunpowder, and contains a match which takes fire when crushed.

700 LESTER, THOMAS, C.E., 15 *Ure Place, Glasgow*—  
Inventor.

Elevation of an outside cylinder passenger tank engine, and first-class carriage, for the Glasgow, Paisley, and Greenock Railway. Among some of the advantages of this engine are its lightness, being only about 13 tons, with its complement of water; the fact of engine and tender being combined and placed on one frame; the extreme lowness of the centre of gravity, giving an angle of stability of 75°; and its large heating surface. The carriage is constructed with great regard to the comfort of passengers, and will hold about three times the number of the ordinary carriages. The engine and carriage constructed at Greenock by Robert Sinclair.

701 HATTERSLEY, WILLIAM, 137 *St. George's Street, St. George's East*—Inventor.

Passengers' signal for railway and other carriages; for ready communication with drivers, guards, &c. It consists of a cylindrical tube or casing to be affixed to the top of each carriage, or at the side in an elevated position; within the casing is placed a lamp which is secured by a spring lock, and remains hidden until, wishing to give the signal, a bell-pull conveyed to each compartment is pulled, the spring lock is withdrawn, the lamp is forced up, and the signal is made. It is equally available by day and by night.

702 ELLIOTT, THOMAS, *Queen Street, Stockton-on-Tees*—  
Inventor and Manufacturer.

Working model of a rotatory locomotive steam engine: intended to save 25 per cent. in steam.

703 JACKSON, JOHN, 5 *Victoria Grove, Baywater*—  
Inventor.

Model of a railroad, with stationary engine for propelling carriages by compressed air.

704 GREEN, WILLIAM, 28 *Frederick Street, Hampstead Road*—Maker.

Model of a first-class railway carriage, on an inch scale, without trimming, showing the framing complete.

705 STOR, HUGH, 22 *Ann Street, Lambeth*—Inventor.

Model of an invention intended to stop, almost instantly, the engines and carriages on railways. It is under the command of the stoker or guard; it acts on the wheels of every carriage, and can be put in action or relieved in a moment.

[Power in the hands of the stoker or of the guard of a train, if acting with instant and certain effect upon the wheels of every carriage of the train, to break the speed and bring the whole body to rest as quickly as may be consistent with safety, having regard to the speed to be broken, is a desideratum.—W. H.]

706 SQUIRE, JOHN, & Co., 5 *Barge Yard, City*—  
Manufacturers.

Specimens of the following articles, all manufactured of Dewrance's patent metal:—Locomotive axle and connecting rod. Rocking shaft bearings. Locomotive slide blocks. Bushes for levers. Carriage axle bearings.

Carriage axle bearings, and various other machinery bearings, of Babbit's patent metal.

Improved carriage axle-boxes.

Meads' patent reciprocating gas-meter.

Model of direct-acting steam-engine, and sugar-mill with latest improvements.

NORTH AREAS A. B. 10 TO 34; C. D. E. 1 TO 10, & 10 TO 33; F. 1 TO 32; G. H. 1 TO 13, & 10 TO 26.

Sample of patent metal machinery for cotton woff.  
Crank shaft bearings, of Habbit's patent lined metal,  
for a 300-horse engine.

707 TYDMAN, RICH., 3 Jamaica Row, *Bermontsey*—  
Manufacturer and part Proprietor.

Working model of James Smith Trotter's patent passengers' railway and steam-boat time signal; a simple instrument by which passengers are informed at one view of the exact number of minutes that are to elapse before the starting of a train or steam-boat; and which provides a mode of notification to passengers as they are on their way to the station.

708 MELLING, R., jun., 5 *Croyland Street, Green Heys*—  
Manufacturer.

Model of a royal state railway carriage, 14 inch to the foot (broad gauge), with promenade round the outside.

709 PEARCE, T. B., 93 *Newman Street, Oxford Street*—  
Inventor.

A railway revolving fog signal-light. A red or green light is produced by triggers being struck by a stop placed at the side of the tram-road.

710 HOY, JOSEPH, 6 *Pickering Place, Paddington*—  
Inventor and Manufacturer.

Railway signal (for day and night); to indicate "all right," "caution," "danger" or "obstruction," or "order to stop;" by one and the same movement, or action of a small lever. It can be elevated to any convenient height. This signal is shown in the annexed cut.



Hoy's Triform Railway Signal.

711 ALLAN, A., *Cress, Cheshire*—Inventor.

Model of hydrostatic or floating turn-table, for turning engines and carriages on railways, &c., on the floating principle; made entirely of wrought iron.

Model of an improved crane, for lifting and moving weights.

712 WATSON, THOMAS, 79 *Protest Street, City Road*—  
Inventor.

A day or night signal for railways, &c.

[The most perfect code of railway signals is that which is the most simple; one sign, either by day or night, must tell the engine-driver what he has to do, without chance of error; improvements in the machinery by which the signs are made, viz., by moveable discs, or arms, by day, and different-coloured lamps by night, tend to secure certainty of action, and, therefore, are of great public importance.—S. C.]

713 WHARTON, WM., *Euston Station*—Inventor.

Patent railway wheel. The body is principally of wood, the chief features are the radial bolts and wedges, to compensate for shrinkage. Model of the same, quarter full size, with wood felloes: the tires can be put on cold instead of being shrunk on in the usual manner. Model of the same, composed wholly of iron.

714 HINITT, JAMES, 22 *Vauxhall Row, Vauxhall*—  
Inventor.

Locomotive engine and tender, working model; scale, inch and a half to the foot.

715 MANELL, RICHARD CHRISTOPHER, *Asford, Kent*—  
Inventor.

Patent safety wheel for railway purposes, having its tire so secured that, in the event of a breakage, no part can leave the wheel, which would still remain serviceable. The tire has no holes through it, is made conical on its inner diameter, and is pressed tightly while in a cold state on the disc or body of the wheel, which is made to receive it; it is furnished with an endless groove on each side, and is secured to the body of the wheel by means of two flanged retaining rings, which have their flanges placed into the grooves of the tire, and are bolted laterally through the end of each wedge, forming the timber disc or body. The iron boss is made in two parts, and constructed so as to be tightened in the event of any shrinkage of the timber.

Manufactured by Messrs. Fox, Henderson, & Co., London Works, Birmingham, and other railway wheel manufacturers.

16 ANGUS, FRANCIS JOHN, 21 *King Street, Bath Street, City Road*—Inventor.

Railway accident detector, to give instant notice when the carriage is going off the line from the breaking of a spring or axle, or the connecting-chain; it can also be set in motion by any person in or on the carriage. It is equally useful in buildings where valuable property is kept, to detect any tampering with locks or windows.

Model of a life-boat.

726 FAURE, THEODORE, 2 *Little Argyll Street, Regent Street*—Inventor.

New snow-sweeping engine, for clearing railways and roads from snow. Its power may be increased according to the duty required, and the same engine may be applied to railways and common roads by changing a pair of wheels.

728 SHAW, JOSEPH, & Co., 91 *Padlock, near Huddersfield*—  
Inventors.

Patent signals and points or switches on railways.

732 FAIRBAIRN, W., & Sons, *Manchester*—Inventors and  
Manufacturers.

Locomotive tank engine, adapted for working with economy light passenger traffic.

739 ASHBEUR, —, Inventor.

Model of a railway truck.

750 WATTS, THOMAS, 3 *Pelham Place*—Inventor.

Model of a girder suspension bridge for railways, intended to be suspended upon aerial supports at a distance of every 300 feet, proposed to establish a communication by railway between England and France.

752 BARBER-BEAUMONT, G. D., *Twickenham*—Inventor.

Patent locomotive machinery; applicable to all operations of draught, as a steam-tug, or as a substitute for an animal drawing in the traces, on the road or at the plough.

753 BURSILL, GEORGE HENRY, 9 *York Terrace, Queen's Road, Hornsey Road, Holloway*—Inventor and  
Manufacturer.

Improved pressure gauge, of easy adjustment. The graduated scale has, in addition to the two columns of resistance usually engraved upon it for a high-pressure gauge, a third column, which is the sum of the other two.

754 GUNN, JOSEPH, 3 *Ebenzer Terrace, Turner Street, London Hospital*—Inventor.

Machine to be propelled by hand-power.

756 BOWLER, JOHN, *Birmingham*—Inventor.

Model of a carriage to run on the rim of the wheels instead of the axles: there is no friction whatever on the axles. The wheels are one inch in diameter; in one



revolution of the wheel the carriage gets as far again as the circumference of the wheel, and the propelling wheel does not touch the rail. By this method the carriage cannot slip on an incline.

758 DEURY, FRANCIS, 26 Albert Terrace, Barnsbury Road, Islington—Inventor and Manufacturer.

Model of street church bell, invented, designed, manufactured, and registered by the exhibitor. The weight of the bell is 2 cwt., corresponding in strength of tone, to the ordinary bell of 6 cwt., and in depth of tone to a bell of 14 cwt. Forged from one ingot of cast steel.

764 MORRIS, WILLIAM, Priory Place, Dover—Inventor.

A working model of a machine for ascertaining and recording the weight of goods. This machine is represented in the annexed cut.

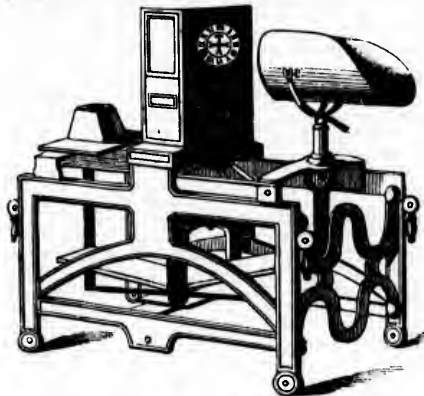

Morris's Weighing Machine.

765 SLIGHT, J., 35 Leith Walk, Edinburgh—Manufacturer.

Model of Henderson's patent Derrick crane for moving heavy weights.

766 CADELL, H., Thornycroft, Dalkeith—Inventor. Weighing machine.

770 NICHOLL, WILLIAM LEWIS, & Co., 16 Aldersgate St.—Manufacturers.

Specimens of improved square-end scale-beams. Exchequer standard scales, weights, and measures; and various improved scales and weights, including a complete set of scales for bankers.

Improved lever weighing-machines. Dial weighing machine. See the annexed cuts.

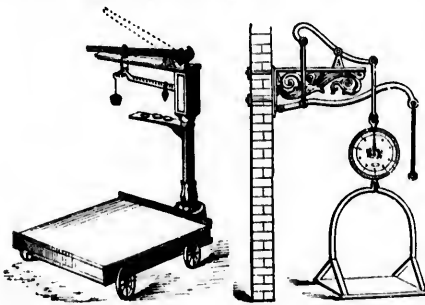

Improved Lever Weighing Machine.

Dial Weighing Machine.

771 OLLIFFE, CHARLES RICHARD, Ramsgate—Inventor and Proprietor.

Fraud-preventor, for indicating the number of people admitted into a public vehicle, or exhibition room. The construction is contained in a small box, which can be made to any size, and to indicate any number up to 1,000,000. The model exhibited will indicate any number up to 10,000.

772 DAY & MILLWARD, 118 Suffolk Street, Birmingham—Manufacturers and Inventors.

Patent weighing machines. Platform weighing machine. Inverted counter machines. Druggist's scale for counters. Specimens of fishing reels.

774 DAVIDSON, JONATHAN, & Co., Barony St., Edinburgh—Inventors and Manufacturers.

A variety of steelyards or weighing machines of different constructions, simple and accurate in performance; easily turned when fully loaded.

The particular advantages claimed are compactness, durability, and accuracy; the under levers, beams, supports, &c., are made of malleable iron, with welded steel centres, the bearers are lined with welded steel, &c.

775 RICHMOND, JOHN, Bow, Milllessex—Inventor and Manufacturer.

Improved engine counter, applicable also to turnstiles for bridges, &c. This machine is represented in the annexed cut.

Description of the counter:—The number of strokes made by the engine can be read off at one view without calculation. The leading or unit hand traverses the entire circumference of the large dial, and the hands of the three small dials, Nos. 2, 3, and 4, all revolve in the same direction. The first motion is given by a sliding bar and fixed spring, instead of a double pallet, so that the first wheel cannot be thrown more than one tooth by one stroke of the engine. No skip-wheels are employed, and the hands are all moved by a train of wheels and pinions, so that the motion is regular and progressive.

It will be seen that the arrangement is very simple. No. 1, or the large circle dial, contains 100 divisions, and the large hand traverses one division at each beat or stroke. No. 2 dial also contains 100 divisions, each one of which is equivalent to one entire revolution of No. 1 hand, thus registering 10,000 strokes. No. 3 dial is divided in the same manner, registering 100,000 strokes; and No. 4 dial is divided into 100 parts, registering 1,000,000 strokes. Thus any amount can be read off without error.

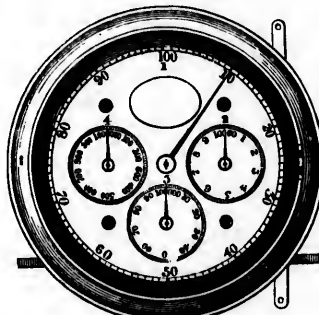

Richmond's Engine Counter.

776 CRAIG, JOHN, 51 Cornwallis Street, Liverpool—Designer and Manufacturer.

Portable weighing machine, furnished with an enamelled scale-plate to be used at pleasure (see fig. 1).

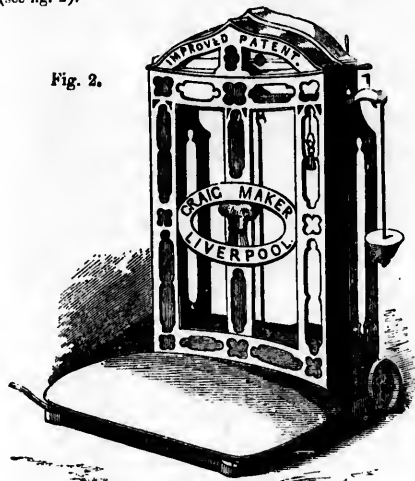

Fig. 1.



Cotton, sack, or bale weighing machine, on wheels (see fig. 2).

Fig. 2.



Craig's Weighing Machines.

Library machine for weighing, also for measuring the stature.

Chimney-arch and smoke-damper, to be applied in the first construction of chimneys. Its use is to allow the cold air of the apartment to mingle regularly with the

heated air in the chimney, and prevent smoke. The damper is worked by a small rod at the back of the grate, and can be regulated at pleasure. When shut, it prevents all down-blasts, and is serviceable when the chimney is on fire. It can be removed when the chimney is to be cleaned, and easily replaced.

A smoke-damper, to be applied to chimneys already built.

777 YATES, WILLIAM, *Bromley, Middlesex*—Inventor.  
An indicator, for registering and detecting change of speed in steam-engines or machinery.

778 GOODFELLOW, JAMES, *4 James Street West, Devonport*—Inventor.  
Gauge for showing the height of water in steam-boilers, talc being used instead of glass. No change of temperature will cause the talc to break.

779 HOWE, GEORGE, *119 Great Guildford St., Southwark*—Inventor and Manufacturer.  
Registered transparent water-gauge, for showing the exact level of the water in steam-boilers, consisting of a glass tube fixed in the brass sockets, with vulcanized India-rubber rings, to prevent it from being broken by the expansion or contraction of the metal; when the tube is broken by accident, it can be tightly replaced in a few minutes.

780 MEDHURST, THOMAS, *465 Oxford St.*—Manufacturer.  
Improved portable compound lever weighing machine.

782 DONRAYAND, W., *95 Great Ancoats Street, Manchester*—Manufacturer.  
Bright steel box and scale-beam, mounted upon a brass pillar.

784 POOLEY, HENRY, *Liverpool*—Inventor and Manufacturer.  
Patent locomotive engine weighing tables, which give the gross weight, and also the impact upon the rails of each pair of wheels and of each wheel separately. Their use is to enable the superintending engineer to adjust the springs of engines so as to obtain the proper amount of tractive power which is consistent with safety from tendency to run off the line at curves.

Drawing, in plan and sections, showing the construction, and mode of erecting the same.

Fig. 1.



Pooley's Locomotive Engine Weighing Tables.

Fig. 2.

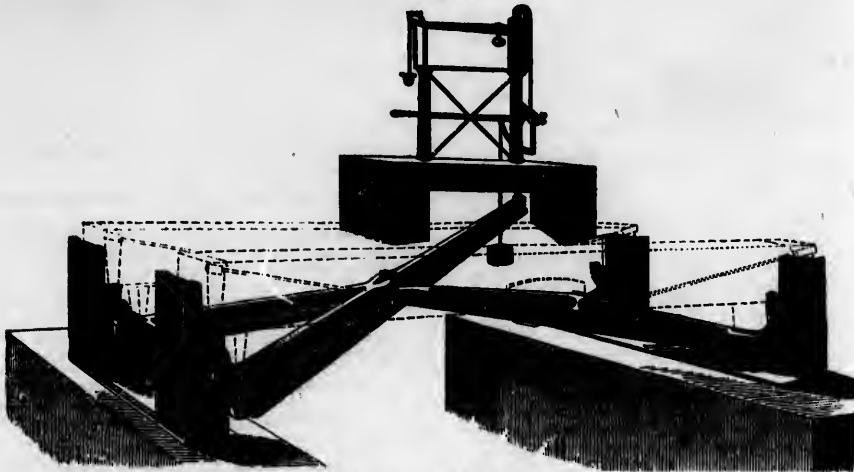

Pooley's Locomotive Engine Weighing Tables.

Drawing, in perspective, showing the construction of the patent railway weigh-bridge. The rails being omitted, this drawing will represent the weigh-bridge as used for carts or waggons on common roads. The adjustment is concealed and cannot be tampered with. There is no strain or wear except while weighing.

Fig. 1.—Elevation of office and weigh-bridge.

Fig. 2.—Shows the internal construction and arrangement; the walls, platform, &c., being removed.

Fig. 3.



Pooley's Weighing Machine.

Drawing in plan, elevation, and sections of a patent lock weighing engine, for weighing canal boats and their cargoes.

Patent dormant platform weighing machine, flush with the floor, to weigh from  $\frac{1}{2}$  lb to 2 tons, as used in the merchandise department of the London and North Western and other Railways, and for general weighing in warehouses. The accuracy of the results by this machine is equal to that of the beam and scales, whilst the economy of labour, space, and cost, is at least 50 per cent. It is only by such means that the heavy merchandise traffic could be despatched with sufficient rapidity.

Fig. 3.—The warehouse machine, as it is seen inside.

Machine of similar principle, on wheels, for use on wharfs, &c., to weigh 1 ton.

Machine of similar principle, as used in parcel office and shops, to weigh 8 cwt.

Machine of similar principle, for weighing animals, as used by agriculturists, made of various sizes.

Machine for counter use, from  $\frac{1}{4}$  oz. upward.

Drawings, in plan and detail, of the first large establishment in England, of baths and wash-houses for the poor, erected by the Corporation of Liverpool, 1845-6.—Architect, Joseph Franklin; Engineer, Henry Pooley, Assoc. Inst. C. E.

[In the Whitechapel baths there were 137,519 bathers last year, two-thirds of whom were second class. The charge for a second-class warm bath is 2d., for a cold bath 1d. The washers during the last quarter, ending December, were 7,888.]

801 ANDERSON, JOSEPH, *Elgin, Scotland*—Inventor and Manufacturer.

Victoria car, a two-wheeled vehicle, seated for four, and convertible into a two-seated gig or car by a single turn of the key. Made with light springs, high wheels and low seats, to avoid danger from accidents.

802 ANDREWS, RICHARD, *Southampton*—Manufacturer.

Light outside car, with imitation caning, on a new principle.

803 ANDREWS, J., 42 *Great Brunswick Street, Dublin*—Producer.

Irish car.

804 BASKCOMB, GEO. H., *Chislehurst*—Designer.

Model carriage, with four wheels. It indicates the distance of ground it travels over, and marks the same minutely on a dial, placed so as to be always in view to the driver; it has spiral springs placed under the seat of the driving-box; an elastic bar, so placed as to relieve the feet from vibration; four preventive wheels, in case of accident; two arms provided with roller wheels, which protect the vehicle from collision, and a screw-break, by which the driver acts upon the wheels, so as to ease the vehicle down hill, or stop its further progress.

Model carriage, intended as a curriole, or single-horse dog-cart, for two or four persons.

Registered sporting trap, for three persons, tandem or single; adapted either for travelling, sporting, or trotting. It has high wheels, shifting basket for dogs, and a wire basket for game; is light, and of new construction.

805 BISHOP, JAMES, 343 Strand—Inventor.  
Model of a public conveyance, in two compartments, with improved accommodation, front and back. The front is in the form of a chariot, for six passengers; the back is for eight.

806 BLACK, HENRY, & Co., 1 Berners Street—Manufacturers.  
A spheroid-back brougham; its object is lightness of appearance and draught, and additional interior space.

807 PARSONS, —, Islington—Inventor.  
Model of an omnibus.

808 CABLE, G.—Inventor.  
Model of a coach.

809 BOOKER, E., & SONS, 13 Mount Street, Grosvenor Sq.—Designers and Manufacturers.  
Improved "sociable," forming an open or close carriage at pleasure. See the annexed figure.

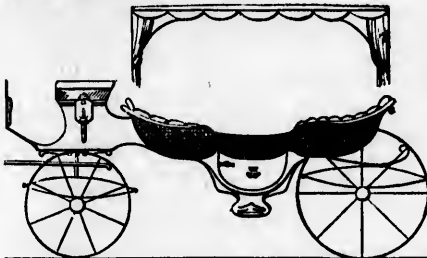

Booker's Improved Sociable.

810 WHEATLEY, J., Greenwich—Inventor.  
Model of an omnibus.

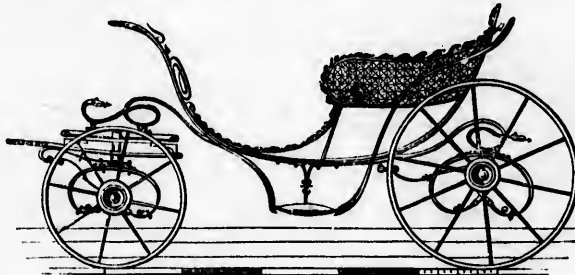

Cook, Rowley, & Company's Patent Park Phaeton.

817 COLLINGS, CHARLES, & Co., 65 Bridge Road, Lambeth—Designers and Manufacturers.  
Patent axletrees. The right and left-handed screwed nut lynch-pin and cap at the end of the arm are intended to prevent the wheel coming off.

818 CORBEN & SONS, 30 & 31 Great Queen Street, Lincoln's Inn—Manufacturers.  
Registered carriage.

819 CHARD & MUNRO, Bristol—Manufacturers.  
A Coburg conveyance.

811 BAYCOS, GEORGE, & Co., 45 Wymore Street, Cavendish Square—Designers and Manufacturers.  
Town-travelling chariot and mail phaeton.

812 BROWN, MARSHALL, & Co., Birmingham—Manufacturers.  
Improved safety cab, mounted on Aitken's patent iron suspension wheels.  
New light cab phaeton, intended to combine the elegance of the single phaeton with the utility of the double; similarly mounted.  
Aitken's patent cart wheel, with part of axle.

813 BROWN, OWEN, & Co., Lichfield Street, Birmingham—Coach and Carriage Builders.  
Park phaeton, of light construction.

814 BROWNE, WILLIAM, 39 Grafton Street, Dublin—Manufacturer.  
Irish jaunting cars, common and improved.

815 COATES & BLEZARD, Park Lane—Manufacturers.  
A brougham.

816 COOK, ROWLEY, & Co., King Street, Regent Street—Manufacturers.

Patent brougham, having the carriage fitted up with inverted double C springs, and registered transverse connectors, bands, and braces. By the application of these springs to light carriages, the unpleasant motion felt in elliptic spring carriages is obviated, and the easy motion of a perch carriage, with upper and under springs, obtained.

Patent park phaeton; the body is attached to the carriage by plated snake hoops, and the carriage fitted up with inverted double C springs. This phaeton is represented in the following cut.

Models for public carriages. A cabriolet to carry five persons in separate compartments, and an omnibus divided into compartments, by which the annoyances so frequently complained of in the common vehicles will be prevented. The carriages are patented, the invention of Monsieur J. A. Franklinski.

820 COUSINS, W., & SON, Oxford—Inventors and Manufacturers.  
Light two-wheeled sporting carriage, adapted, by a concealed propelling screw, to carry two or four persons.

824 CROALL, WILLIAM, jun., & Co., Greenside Place, Edinburgh—Designers and Builders.

Oriental demi-cabriolet. Hung on a new principle, uniting great ease of motion with lightness of draught and facility of access.

826 CROSKILL, EDMUND, *Vauxhall Wheel Works, Liverpool*—Inventor.

Specimens of improved patent wheel. The particular features consist in the turning of the spoke with strong double-shouldered ends, turning the rims, and boring double-shouldered sockets in the felloes; the hoop-tire is also bent, bevelled, affixed, and turned by patent machinery. The cuts exhibit an elevation, side view, and section of this wheel.

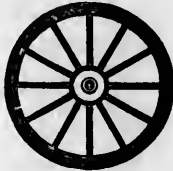

Elevation of Croskill's Patent Wheel.



Side view.

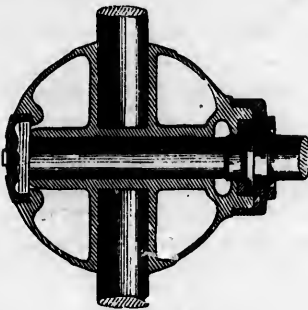

Section of Globular Nave.

Liverpool town float, lorrie and coal cart; each complete.

Specimen of a sporting cart, mounted on new patent wheels and axles, &c., by Messrs. Puckering and Houlgate, Beverley. (See also Class 9.)

828 DAVIES, DAVID, 15 *Wigmore Street, Cavendish Square*—Inventor and Manufacturer.

Full-sized light carriage, of new design, with dome roof, patent wheel-plate lock, and patent automatic moveable steps.

Basterna brougham, with patent inverted springs, patent wheel-plate lock, and patent automatic invisible steps.

Light summer carriage, specially adapted for hot climates, with patent quadrangular umbrella to form a canopy, &c.

Model of patent railway-carriage break, on a scale of 1½ inch to a foot.

New single wheel revolving carriage.

Model of accommodation carriage.

830 DAWSON, F. W., 19 *Fork Street, North Polygon, Bath*—Inventor and Manufacturer.

Wheel chair for the use of invalids.

Pedomotive, or self-propelling carriage.

842 DRABBLE, JOSEPH, & CO., 8 *Pancras Lane*—Inventors and Manufacturers.

Patent conical arms and axletrees for waggons and carriages, with various improvements.

843 FOWLER & FRY, *Bristol*—Inventors.

Low-bodied dog-cart, which, when fitted with luggage-body, answers all the purposes of the ordinary dog-cart,

and is also adapted for park use; the lowness of the body and the height of the wheels render the draught easy. See the following Illustration.



Fowler &amp; Fry's Low-bodied Dog-cart.

844 DUFFIELD, JOHN E., & CO., 114 *Aldersgate Street*—Manufacturers.

Highly-finished light phaeton, for a pair of cob horses. Set of double harness with plated furniture, adapted for the same. Best quilted Somerset saddle and Weymouth bridle.

845 FULLER, GEORGE & THOMAS, *Bath*—Manufacturers.

Landau carriage, with improvements. The head is made to open clear of the heads of the persons inside. The front springs are elastic. The hind ones are divided, and the number of plates being divided also, great easiness of motion is produced.

846 GEARY, STEPHEN, 19 *Euston Place, Euston Square*—Inventor.

Model of a patent street watering-cart, with fire-engine combined.

848 GIBSON, THOS., 8 *Weaman Street, Birmingham*—Manufacturer.

Railway bearing-spring. Registered elliptic spring with India-rubber bearings. Grasshopper spring with scroll irons. Elliptic spring.

Patent mail and Collings's axletree. Samples of coach ironmongery.

[The application of India-rubber to obviate the unpleasant action arising from the friction of springs at their two points of junction is here attempted. A square block of the material alluded to being placed between the springs, the three thicknesses are held together by a bolt, sufficient play being allowed, and the whole is covered with a brass box.

Springs of carriages of all kinds are hammered out of steel bars, in the ordinary method employed to produce steel goods. They are bent to suitable gauges, corresponding to the degree of elasticity required, are hardened by being plunged into water, and tempered by being brought back to a straw, or blue, colour. Elliptic and grasshopper are names given to the different varieties, and are at once understood by the trade.—W. C. A.]

849 DART & SON, 12 *Belford Street, Covent Garden*—Manufacturers.

Lace for carriages.

856 GREVILLE, J., 36 *Mary Street, Dublin*—Manufacturer.

Irish jaunting car.

858 GRISDALE, JOHN EDWIN, 285 *Strand*—Inventor.

Working model of spring carriage wheel; the springs are enclosed in the nave of each wheel, and revolve with them when in motion. Any shock caused by the unevenness of the road, &c., is received on the springs alternately, and thus the unpleasant motion which is produced by the reaction of the ordinary springs is prevented. The axletrees fitted to these wheels are less liable to break, as the vibration is removed from them.

NORTH AREAS A. B. 10 to 34; C. D. E. 1 to 10, & 19 to 33; F. 1 to 32; G. H. 1 to 13, & 19 to 26.

860 HADLEY, J., *London Road, Worcester*—Inventor and Manufacturer.

Eastern clarence and brougham. Their wheels are double-tired; the under tire keeps the wheel upright and preserves the fellos when the outside tire is worn out. The furniture is made of Worcester china.

862 HALLMARKE, ALDERBERT, & HALLMARKE, *57 Long Acre*—Inventors and Manufacturers.

Underspring step piece barouche. New Park phaeton, designed by one of the exhibitors. Drawings of a state carriage. Demi-state carriage. State railway carriage, &c.

864 HARDING, W. & Co., *68 Long Acre*—Designers and Manufacturers.

Specimens of carriage laces, linings, and carpets, showing the progressive improvements in their manufacture; also of tassels, bullions, fringes, and other upholstery ornaments.

868 HEATH, JAMES, *4 Broad Street, Bath*—Inventor and Manufacturer.

Light open park wheel chair, designed to show the adaptation of glass to the panels of Bath chairs, and other vehicles, for ornamental purposes.

Bath Albert wheel chair, with folding head and shut-up glass front.

Newly-invented reclining and elevating spinal bed wheel chair, designed to enable invalids to take airings without inconvenience.

Close clarence Bath chair.

Marlin invalid room chair, with wheels intended for self-propulsion.

Four-wheel Bath park chair, with shifting shafts, handle, and dashboards, for a small pony

872 HOLMES, HERBERT & ARTHUR, *Derby*—Manufacturers.

Light park phaeton, having the upper part of the fore-carriage and the requisite branch stays, &c., wrought in one piece of iron-work.

Dog-cart, or sporting-buggy. Set of single buggy harness.

A set of winter shoes for horses, fitted with screwed chisel-points and plain studs.

A series of modern carriage drawings.

874 HOOPER, GEORGE, *28 Haymarket*—Inventor, Designer, and Manufacturer.

Brougham carriage, for one horse; of improved construction and design, hung by leather braces on an under carriage, with a double set of springs.

Barouche landau, with improvements.

Series of designs of new and improved forms of modern carriages.

Working model of a brougham carriage; scale  $\frac{1}{2}$  in. to a foot. (By W. Hooper, jun.)

880 HORNE, WILLIAM, *93 Long Acre*—Manufacturer.

A patent segmental brougham. From its peculiar construction, it contains the same room as a chariot; and it may be made to accommodate three or four persons. The distance between the wheels is greatly shortened by the application of the eccentric double perch bolt lock in the turning of the fore carriage. The inside is fitted up with an ornamental couch or sofa back; and the improvement in the opening of the doors facilitates the ingress and egress.

A patent segmental chariot, exhibiting all the improvements of the patent brougham; the peculiar serpentine form of the front boot which sustains the coachman's seat, is a new feature in this description of carriage. It is made sufficiently light for one horse; and it is very easy of access, the body being low.

882 HUTTLY, F., *10 Lamb's Conduit Street*—Manufacturer.

Coach lace patterns, silk vellum, cut on terry lace, drawn on terry, and relief, cut on terry. Figured silk ground laco. Registered design.

884 HUTTON, JOHN, & SONS, *Summerhill, Dublin*—Coach Builders.

Clarence, with front circular lights and concealed quarter spring curtains.

Brougham, with excentric fore carriage.

Park phaeton on C and under springs, with hind seat and head.

Car on a new construction, with sliding power and dog-box, to answer either as car or dog-cart.

888 JORDAN, WILLIAM HEATH, *Cumberland Basin, Clifton, near Bristol*—Designer and Manufacturer.

Invalid three-wheel chairs, for one or two persons, to be drawn by hand, with reclining apparatus for spinal complaints, broken or injured limbs, &c.

892 KENT, RICHARD, *Saffron Walden, Essex*—Designer and Manufacturer.

Carriage with a low body, for easy ingress and egress, and forming an invalid's pony chaise.

894 KESTERTON, E., *80 Long Acre*—Designer and Manufacturer.

The "amempton" carriage. A close double-seated carriage, of novel design; by a simple contrivance it can be converted into a light, open, step-piece barouche, adapted for summer and winter.

Fig. 1.

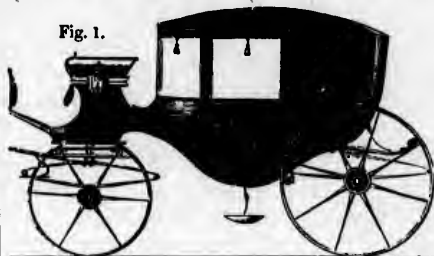
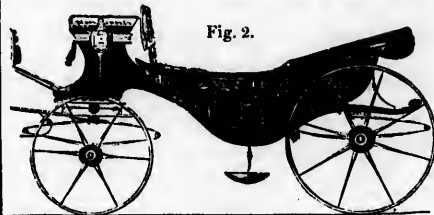

Fig. 2.



Kesterton's "Amempton" Carriage.

The engraving represents an improved registered carriage, capable of conversion into an open or close carriage, as may be required. Fig. 1 represents the carriage closed, or what is termed the amempton; which can be readily converted into a step-piece barouche. Fig. 2 is the carriage thrown completely open and constructed as an ordinary open carriage, with a half head, which is raised and lowered in the usual manner, with a solid folding knee-flap.

The front portion of the amempton is formed of a framework with circular front glasses, and furnished with doors; the door-glasses and front glass are made to rise and fall at pleasure, and are furnished with silk spring curtains; the whole being armoured or covered with a roof. This framework is secured to the head with a new kind of fastening; the door-glasses, when down, are received into the lower part of the doors; the back instead of being flat is of a curved form.



895 KINDER & WHEELER, *Granby Place, Leicester*—  
Designers and Inventors.

An Albert phaeton, either for one or a pair of ponies, with an improved fore-carriage.

896 KINGS, W., *101 Long Acre*—Designer and Maker.

Cabriolet domestique. Its objects are commodiousness, lightness of appearance, and draught. Both bodies being exactly of the same shape and dimensions, the hood is transferable to either in a few seconds.

898 KINROSS, WILLIAM, & Co., *Stirling, Scotland*—  
Manufacturers.

City omnibus, sufficiently commodious for carrying nineteen passengers inside, with a large well on the roof, fitted up with ornamental glass and ventilators, so that on all occasions there is abundant ventilation, and the passengers, when going out and in, can walk upright. The well also makes a comfortable seat for outside passengers. It is constructed upon the lightest principle for draught consistent with strength, having double hind springs, so that when it is lightly loaded the motion is easy, and when heavily loaded both springs come into action, which

cause it still to retain the same motion. It is adapted for two or three horses abreast, with equalizing bars, so that each horse may have an equal proportion of the draught.

902 LEWIS, CHARLES B., *14 King Street, St. James's*—  
Inventor.

An invention to facilitate the ingress and egress of omnibus passengers.

908 MARKS, JOHN ISAAC, *Langham Place, Cavendish Square*—  
Manufacturer.

Patent noiseless wheel, with Collings's axle, revolving on a model granite pavement. The wheel (in addition to an iron tire) is shod with a solid band of vulcanized India-rubber, said to be as durable as iron. Bath or invalid chair, fitted with the patent noiseless wheels. R. W. Thomson, C.E., Inventor and Patentee of the noiseless wheels.

910 MASON, WILLIAM HENRY, *Kingsland Road*—  
Inventor.

A pony carriage, of light and simple construction. This carriage is represented in the cut below.

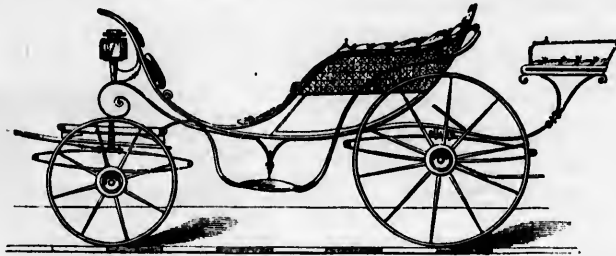

Mason's Pony Carriage.

912 MENZIES, ANDREW, *Glasgow*—Proprietor.

Model of an omnibus, with three horses abreast, drawing from equalizing bars or levers, connected with the splinter-bar, so that all must have equal draught.

913 RAWORTH, B. P., *Sheffield*—Manufacturers.  
Carriage axles, &c.

914-916 MIDDLETON, WILLIAM & CHARLES, *40 Long Acre*—  
Manufacturers and Inventors.

Improved conveyable carriage, to be used either open or closed.

Model of a fore-carriage, with registered centripetal wheel-plate, for the purpose of bringing the hind and front wheels of four-wheeled carriages closer together.

918 MITCHELL, REV. GRAHAM (L.L.D.), *Whitburn, Linlithgowshire*—Inventor and Proprietor.

Model of a safety carriage, with diagram. The carriage, in any perilous circumstances, can be stopped from the inside with facility and safety. (The design of this invention described in 50 different languages).

919 MITCHELL, REV. WILLIAM, A.M., *Woolwich*—  
Inventor.

Model of railway engine, carriages, &c., with plan to preserve human life, and prevent serious accidents. A bell is attached to the last carriage, and another at the side of the engine-driver, by which, when danger is apprehended, or when the axle is broken, and the carriage on fire, by pulling a string attached to the inside of each carriage, so as to communicate instantly with the guard and engine-driver, the train can be stopped in a few seconds. This invention is peculiarly applicable to express trains.

922 MULLINER, FRANCIS, *Northampton*—Manufacturer  
and part Inventor.

Pilentum, suspended on elliptic springs and patent axletrees, with imitation cane-work on body, painted and lined blue; constructed with an improved mode of locking the fore-carriage.

924 MULLINER, HENRY, *Leamington Spa*—  
Manufacturer.

New four-wheeled carriage, or improved brougham. The improved design and construction of the carriage-front affords more room inside either for two additional passengers, without the usual heavy appearance of such additions, or increased comfort as an ordinary single-bodied carriage. The novelty is the substance of the registration; being two distinct curves instead of only one in the front part, and trimming inside at the back. Its lightness (7 cwt.) and compactness of wheels, and consequently reduced draught, render it suited for one horse. A further improvement in this carriage is the principle of communicating with the coachman; the voice-conductor being entirely concealed, and the mouthpiece at each side, instead of at the middle of the back as usual, and suspended from the roof. The design is registered.

A series of drawings showing an improved system of curriole-driving, and also of posting with a two-wheel carriage.

Designs of various dog-carts, riding vehicles, &c.

926 NEWHAM, JOHN, *Market Harborough, Leicestershire*—  
Manufacturer.

New pony carriage, with pole and shafts complete, and hind seat removable; constructed of iron.



928 NEWNHAM, BEN., 19 Broad Street, Bath—  
Manufacturer.

Bath wheel chair, to be drawn by hand or small pony, having a moveable glass front and solid knee-flap for bad weather, together with the hood and the summer apron attached. A ventilator is fixed in the hood.

932 NURSE & Co., 43 Crawford Street, and 200 Regent St.—  
Inventors and Manufacturers.

Curricie and cabriolet brougham, to be used with shafts and one horse, or with a pole and curricie appointments and two horses.

934 OFFORD, ROBERT, 79 Wells Street, Oxford Street—  
Inventor and Manufacturer.

Four-wheel carriage for horses.  
New carriage: the "semicircular clarence."

936 PATERNOSTER, T., 13 Charlotte Street, Fitzroy Square—  
Designer and Manufacturer.

Lace, in thread, worsted, and silk, for carriage decoration.

PETERS & SONS, Park Street, Grosvenor Square—  
Manufacturers.

A light step-piece shaped park barouche, with lee and under springs.

940 QUAN & SONS, 10 Talbot Street, Dublin—  
Manufacturers.

Improved Irish jaunting cars.

946 HARVEY, JOSEPH, 41 Bridge Road, Lambeth—  
Designer and Patentee.

The Richmond car, a patent two-wheel open carriage, suitable for ladies: being hung low, it is very easy of access, and remarkably safe. The seats are spacious, and capable of accommodating four or six persons. The wheels, which revolve under the body instead of the outside, effectually prevent any mud or dust being thrown up. It also has capacious boxes for baggage, &c. May be fitted with a pole, for a pair of horses.

947 RIGBY & LEE, 7 Park Lane, Piccadilly—  
Manufacturers.

Private carriage—brougham—adapted for one or for a pair of horses.

950 ROBINSON & Co., 12 Mount Street, Grosvenor Square—  
Designers, Inventors, and Manufacturers.

Britannia phaeton of new design, with registered look or wheel-plate in the front part of the carriage, which

enables a single horse or a pair to be brought near to the driver, or dashing leather, giving the advantage of a high front, bringing the wheels nearer to each other, and allowing any description of carriage to be kept at any elevation from the ground.

952 ROCK, JAMES, jun., Hastings, Sussex—Inventor and  
Manufacturer.

Patent carriage spring of two plates, weighing 11 lbs. 8 oz., and possessing greater strength and elasticity than an ordinary laminated spring of five plates.

Common carriage spring of five plates, weighing 21 lbs. Improved spring on the same principle as the former, but with only one plate, and weighing 7 lbs. 4 oz.; equal in strength and elasticity to a common spring of three plates. Spring of three plates of the ordinary kind, weighing 14 lbs. 6 oz.

These springs placed on a testing machine, for comparing the new springs with those of the old construction.

954 ROCK & GOWAR, Hastings—Manufacturers.

Patent omnibus for the conveyance of passengers, constructed with the upright part of the framework so placed as to apportion to each passenger his proper share of space on the seat, namely, 16 inches. The window frames are made to slide in such a manner as to give considerable additional internal width to the body, without increasing the external dimensions. The front and hind ends are circular, and the door is made to open both ways, so as to enable passengers to get upon the step from either side of the road with safety.

956 ROCK & SON, Hastings—Inventors, Designers, and  
Manufacturers.

Patent diorpha, or two-headed carriage, combining, in one, a clarence, or pilentum coach, complete with all its appointments; a barouche, with folding head, and threefold knee-flap; and an open carriage. The heads can be removed or exchanged, with facility, by means of a pulley attached to the ceiling of the coachhouse, aided by a counterpoise weight. The folding steps are on a new principle. The silk of the lining was supplied by Messrs. Draper of High Holborn; the lace by Messrs. Cooper and Blackford of Long Acre; and the axles by Mr. Thrupp, proprietor of Collinge's patent. The whole of the carriage and its appointments (except the silk) are from the designs of James Rock, jun.

Patent pony carriage on improved principles, constructed with single-leaf springs. These springs, which are seven in number, weigh only 12½ lbs.; they have been proved with 4 cwt., without taking any "set" or permanent deflection. They are shown on a testing-machine,

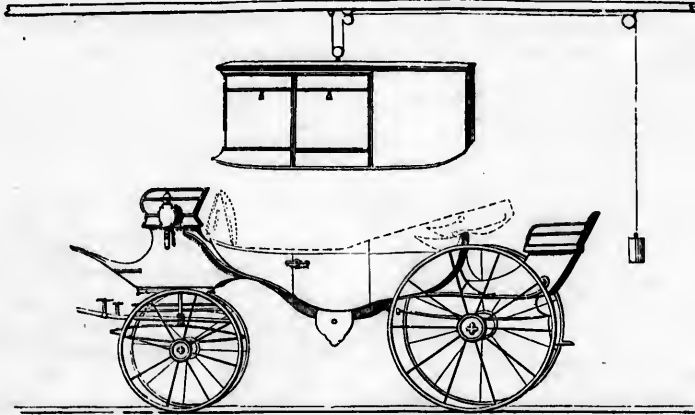

Rock and Son's Patent Diorpha.

by means of which they may be compared with springs of the ordinary kind.

The illustration represents the carriage described above, with the Clarence-head suspended over it, ready to be lowered when wanted. The barouche-head and fittings for summer use, are shown by dotted lines. These are removed when the Clarence-head is put on. The third form of the carriage (without either head) is shown.

958 SAUNDERS, CHARLES, *New Yard, Great Queen Street*—Inventor.

Newly-designed park brougham with circular front glasses, and round back; also an elegant double sofa back, with fluted roof, and self-acting ventilators, in glass frames. It has a detached driving boot, connected to side cranes that pass under the body, connecting the hind axle-tree, and dispensing with perch carriage, this being much tighter. By this mode, the body has the ease and motion of a chariot. Being hung with long braces, it destroys all the drumming noise which is too frequently heard in close carriages. It has also got the exhibitor's newly invented double lever wheelplate, locking on two centres to shorten the carriage as much as may be required. This carriage is exhibited as combining lightness and cheapness with elegance.

960 SAWYER, WILLARD, *St. James's Street, Dover*—Inventor and Manufacturer.  
A velocipede.

962 SHANKS, ROB. H., *4 Great Queen Street*—Manufacturers.  
Step-piece landau, on elliptic springs.

964 SHILLIBEK, GEORGE, *1 Commercial Place, City Road*—Inventor, Patentee, and Manufacturer.  
A patent funeral carriage, expanding and contracting at pleasure.

965 CLARKE & WILLIAMS, *447 West Strand*—Inventors.  
Spring propeller.

966 SHILTON, THOMAS, *Baddesley Ensor, near Atherstone*—Inventor and Manufacturer.  
A carriage-wheel, with spoke of improved construction, intended to give greater elasticity and strength to the parts. The same construction may be applied to agricultural purposes.

968 SILK & BROWN, *8 Long Acre*—Designers and Manufacturers.  
Barouche hung upon improved horizontal springs. Carriage, hung upon a swan-neck perch and C, and under springs.

970 HILL & STONE, *21 Little Moorfields*—Inventors.  
A park phaeton, with head to put up or down by the sitters, at pleasure.

971 SHUFF, WILLIAM, *1 Dover Street, Islington*—Inventor and Manufacturer.  
Public and private carriage retarder.

972 SMITH, O. H., *Pimlico Wheel Works, Upper Belgrave Place*—Proprietor.  
Wheels for gun carriages, railways (wood), agricultural machines, Scotch carts, dog carts, brewers' drays, safety cabs, trotting carts, broughams, and carriers' vans, made and put together by machinery.

976 SWAIN, THOMAS, *15 Charles Street, Hackney Road*—Designer.  
A card-board model for a church, painted in oil; the same for a mail coach pulling up to unskid, with country scenery.

978 THOMSON, G., *Stirling, Scotland*—Manufacturer.  
Four-seated gig, not liable to cut. By shutting up the hind foot-board, the vehicle is altered in the balancing, and adapted for the use of two persons only.

979 THORN, W. & F., *10 John Street, Oxford Street*—Inventors and Manufacturers.

Brougham, with equimotive springs, self-acting invisible step, and a new system of ventilation.

982 TRUPP, CHARLES JOSEPH, *269 Oxford Street*—Designer and Manufacturer.

Four-wheeled carriage, a landaulet brougham, of a new shape. Two-wheeled carriage, the shamrock car.

984 TILBURY, JOHN, *35 Gloucester Place, New Road*—Manufacturer.

Light sporting phaeton, with patent noiseless wheels, pole, splinter-bar, and shafts.

988 VEZEY, R. & E., *Long Acre, Bath*—Inventors and Manufacturers.

Newly-designed sovereign sociable, with the exhibitors' springs and axles, having India-rubber bearings of new construction, registered 12th March 1851.

The advantages of the improved elliptic carriage spring, with registered hoop or cap, are—1st. That the cap gives greater elasticity to the spring, and imparts to it an easy and quiet motion. 2nd. The concussion, or jar, communicated to the spring by the rotation of the wheels upon the road, is received by the blocks of elastic material, which, acting as a non-conductor, prevent any vibration being given to the upper half of the spring to which the upper beds and body of the carriage are attached, thus producing a soft, easy, and pleasant motion, and releasing the body from the disagreeable noise and vibration caused by the action of the old elliptic spring. One of the new springs is exhibited as a testing machine.

989 WALKERS, GEORGE, JAMES, & HENRY GILDER, *16 White Lion Street, Norton Folgate*—Inventor and Manufacturers.

Registered single brougham carriage; with additional front, to form double brougham at pleasure. Improvement in lamp-irons, in order to throw light inside the carriage.

Prepared caoutchouc round-robins to hind springs.

990 WARD, J., *41 Paris Street, Exeter*—Manufacturer.

A cab park-phaeton, on springs, with leather robins and axles on Collinge's principle, having a platform behind so constructed that a seat is formed which can be raised if required, and arranged so as to sit forward, or the contrary; when as a platform, it is an opera-board to turn up. The platform seat is applicable to any carriage.

991 WATTS, CHARLES, *Parkhurst, Isle of Wight*—Inventor and Manufacturer.  
Velocipede, consisting of three wheels.

992 WILLOUGHBY, SOLOMON, *John Street, Oxford Street*—Inventor and Manufacturer.

Carriage by which invalids with fractured limbs, or severely afflicted, may be removed from their beds without change of position or fatigue.

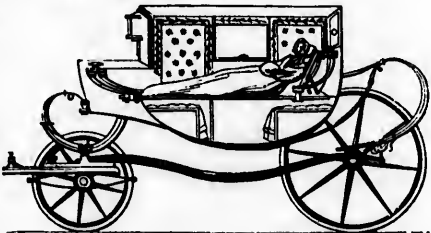

Willoughby's Invalid Carriage.

NORTH AREAS A. B. 10 to 34; C. D. E. 1 to 10, & 19 to 33; F. 1 to 32; G. H. 1 to 13, & 19 to 26.

993 FULLJAMES & Co., 4 Brownlow Mess, Gray's Inn Road  
—Manufacturers.  
A carriage jack.

995 WILSON, JACOB, 26 Portland Street, Walworth—  
Designer.

Improved velocipede, constructed principally of iron, adapted for exercise or amusement.

996 WYBURN, MELLER, & TURNER, 121 Long Acre—  
Manufacturers.  
Dress chariot.

997 WARD, JOHN, 5 Leicester Square—Designer and  
Manufacturer.

Four-wheel pleasure-ground Victoria chair, in framed carriage, upon C elliptic, and body springs, with patent vulcanized India-rubber tires; to be drawn by hand or pony. The chair is lined with blue figured satin, designed and woven by Messrs. Draper of Holborn.

Improved recumbent chair for invalids, spring stuffed, covered with Utrecht velvet, mounted on brass wheels, and adapted for a bed or couch; with shifting elbows, for the convenience of the patient; double action leg-rest, reading-desk, sconces, &c.

Spanish mahogany portable folding-chair, adapted for invalids, and easily drawn; covered in scarlet morocco; mounted on patent noiseless wheels, engine-out cog, silver handles, shifting foot-rest, cylindrical guide-wheel, &c.

998 DUNN, J., Rainton Colliery, near Durham—  
Inventor.

A new railway for reversing locomotive engines, &c. instead of a turn-table.

The utility of this reversing railway is stated to be to give quick despatch to the engines and trains, it being unnecessary to disengage them, as is the case when turn-tables are employed. Another convenience is, that there are no facing switches in the up or down lines.

999 DURHAM, Earl of, Lambton Castle, Durham.

Improved coal drop, for loading ships, extensively used in the exhibitor's mines, collieries, &c.

1000 TUNSTALL & WILLIAMS, Bath—Inventor.

Self-acting invalid chair, enabling the invalid to alter the recumbent posture with facility.



[UNITED  
19 to 26.

ord Street—  
self-acting Invi-

ord Street—  
ham, of a new  
ck car.

New Road

noiseless wheels,

Inventors

the exhibitors'  
arrangings of new

carriage spring,  
the cap gives  
to it an easy  
or jar, com-  
of the wheels  
cks of elastic  
prevent any  
the spring to  
carriage are at-  
sant motion,  
ble noise and  
lliptic spring.  
ing machine.

HENRY GILDER,  
ate—Inventor

th additional

throw light

l springs.

manufacturer.

leather rubins  
tform behind  
can be raised  
ward, or the  
board to turn  
carriage.

Wight—

Oxford

and limbs, or  
ir beds with-



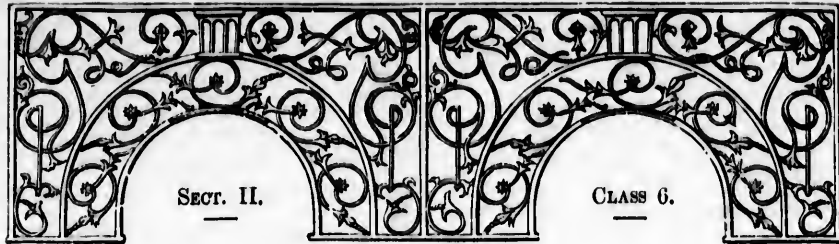

## MANUFACTURING MACHINES AND TOOLS.

### INTRODUCTION.

THE preceding Class illustrates the development of manufacturing power; the present is intended to represent its applications to the purposes of manufacture. The machinery included in this Class has this distinguishing feature, that it is the representative of man himself engaged in industrial production. Many of the machines to which attention will be drawn in this part of the Catalogue are so constructed as to fulfil functions which were accomplished formerly only by direct human labour. And, what is also highly deserving of notice, the perfection of their execution and the certainty of their operation exceed that attainable in most instances by the highest exercise of human skill. The productive power of such machines, capable of being driven at a high velocity, and of an almost indefinite multiplication of individual producing parts, is limited only by the means of the manufacturer. As the machines in Classes 5 and 6 are intimately related to each other, so as to render the perfection of the one necessary to that of the other, it is deserving of notice that both in the production of admirably-contrived prime movers, and in that of manufacturing machines, the mechanists of this country have made astonishing progress during the last half-century.

The Class includes manufacturing machines and tools employed in the manufacture—A., of Spun, Woven, Felted, or Laid Fabrics; B. in the manufacture of Metals; C. in that of Mineral Substances, together with Mining Machinery; D. in the manufacture of Vegetable Substances; and E. of Mineral Substances. It also comprises F. Machinery and Apparatus for Brewing, Distilling, and manufacturing Chemistry.

The position in the Building of the machines and systems of machinery, included in this Class, is at its north-western extremity and side. It is approached either from the western end of the Nave, at its proper commencement in the room chiefly occupied by cotton-spinning machinery, or it may be reached from other portions of the Nave by penetrating through the Areas on its northern side. The Class commences at Areas C. D. and E. 1, and extends through the same to 10. This part of the Building is partitioned from the rest, partly with a view of obtaining the requisite degree of temperature for cotton-spinning, partly to exclude the noise, and also the light dust which always fills the atmosphere of rooms in which this process is carried on, and which is destructive to objects in other departments of the Exhibition. Entering another part of the Building at A. B. C. 10, machines in this Class will be found extending to Areas 30 of those letters. And in D. E. F. from 19 to 27, they are also met with.

The recorded history of cotton-spinning, and its connexion with that of our country, have been rendered familiar to every person; but the interesting illustrations of the progress and perfection of this department in manufacturing industry, presented in this Class, convey a lesson more forcible and permanent of its kind. A complete series of machines is exhibited in one room, by virtue of the operation of which the raw cotton is opened, carded, doubled, spun, warped, and woven. At one extremity of the space occupied, cotton, from the bags is made to enter the preparatory machine, while at the other it emerges completely fabricated and fit for use. Various parts of these machines are likewise shown. The beautiful automaton card-setting engine for making cards for the cotton-carding machines is also in motion, producing those ingenious ribbons of iron-wire brush. The whole of the cotton-spinning machinery exhibited combines the latest improvements, and demonstrates that perfection of workmanship which is capable of uniting in a manufacturing machine facility of motion, compactness and elegance of arrangement, precision of action, and power and speed of production.

A number of looms of different kinds are likewise among the important objects of this Class. The Jacquard loom, with its hundreds of cards and complicated harness, for the production of the patterns of woven goods, and the ordinary power-loom occupied in manufacturing the commonest sort of calico, are alike shown. Factories exist in this country in a single floor of which many hundreds of these looms are in continuous action, impelled by steam-engines of vast size and power. An old loom, of fifty years' date, forms an instructive contrast to the smaller but more powerful and productive engine by its side.

The manufacture of flax is represented by various powerful machines in operation. Several recent improvements are exhibited in these machines, and their product is presented to examination and investigation. The difference of fibre between flax and cotton necessitates the adoption of a somewhat modified system of manufacturing machines: these are shown in motion. Silk throwing and winding are illustrated by the elegant machines specially fitted to that purpose. The production of lace, bobbin-net, &c., by the wonderful mechanical arrangements contrived for that purpose, is also represented, together with the machine employed in the curious process of "gassing," or singeing off by gas-flames, the loose fibres of lace, &c., without injury to the fabric.



to represent  
distinguishing  
machines to  
s which were  
e, the perfec-  
y the highest  
igh velocity,  
means of the  
nder the per-  
of admirably-  
y have made

oun, Woven,  
together with  
ces. It also

at its north-  
commence-  
r portions of  
D. and E. 1,  
with a view  
se, and also  
nd which is  
ing at A. B.  
from 19 to

en rendered  
partment in  
ts kind. A  
w cotton is  
: from the  
and fit for  
engine for  
of iron-wire  
and demon-  
facility of  
ction.

e Jacquard  
goods, and  
Factories  
n, impelled  
trast to the

at improve-  
tion. The  
of manu-  
the elegant  
mechanical  
the curious  
fabric.

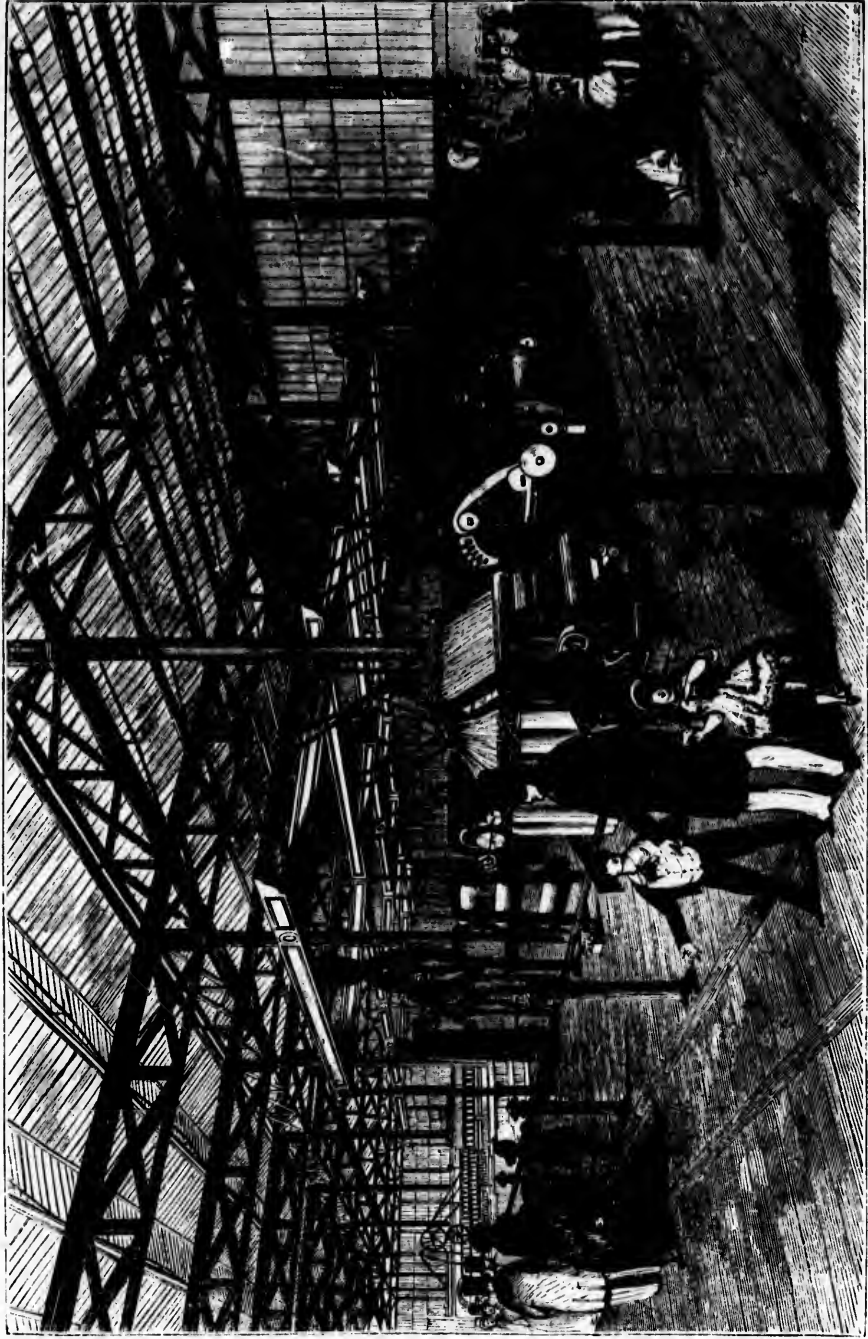

122. PERSPECTIVE VIEW, LOOKING EAST, OF MESSRS. HIBBERT AND PLATT'S COTTON MACHINES, AND MESSRS. HICK AND SON'S HIGH-PRESSURE STEAM-ENGINE AND DRIVING GEAR. THE MACHINE IN FRONT IS THE LAP MACHINE, AND BEYOND IT ARE THE CARDING MACHINES.





122. PERSPECTIVE VIEW, LOOKING EAST, OF MESSRS. HIBBERT AND PLATT'S COTTON MACHINES, AND MESSRS. HICK AND SON'S HIGH-PRESSURE STEAM-ENGINE AND DRIVING GEAR. THE MACHINE IN FRONT IS THE LAP MACHINE, AND BEYOND IT ARE THE CARDING MACHINES.





123. PERSPECTIVE VIEW, LOOKING WESTWARD, OF MESSRS. HIBBERT AND PLATT'S COTTON MACHINERY, AND MESSRS. HICK AND SON'S STEAM-ENGINE AND DRIVING GEAR. THE MACHINES IN FRONT ARE THE POWER LOOMS, THE THROSTLES AND MULES ARE BEYOND.

Paper-making machines are illustrated by models; but several large printing machines are exhibited in operation. Several varieties of these are found: the "flat" machine, the horizontal cylinder machine, and the recently-invented vertical machine, capable of performing a very large amount of work in a short space of time. An envelope-folder, and other apparatus connected with paper and printing, are also found among the machinery in this Class.

Many powerful machines employed in metal manufactures are met with. The drilling, punching, and clipping engines, together with the slotting, chasing, and planing machines, and the large power-lathes for turning heavy castings, borings, &c., are extremely interesting, although essentially consisting of simple parts. Mills for various purposes, mineral and vegetable, presses, aerating, and a variety of other machines included in the Class, are represented in various parts of the Building appropriated to it.—R. E.

1 HIBBERT, PLATT, & SONS, *Hartford Works, Oldham*,  
Inventors and Manufacturers.

An improved patent opening and cotton-cleaning machine. This machine differs from others used for the same purpose, inasmuch as all fibre cleaned in it is passed between cylinders so constructed that all motes, seeds, &c. &c., are thrown down beneath it, making the operation of cleaning simple and cheap. The diameters of the cylinders of this machine are 9 and 12 inches, and the width 36 inches, making about 500 revolutions per minute, they consequently require less power than is necessary to drive the machines constructed upon the old principle. The power required for cleaning 3,000 lbs. per day, is from 1 to 1½ horse, according to the state of the material.

[Cotton or cotton-wool is the hairy covering of the seeds of several species of *Gossypium* growing in South America, India, Egypt, &c. It is separated from the seeds by a machine called a cotton-gin, then packed with strong pressure in bags, in which state it is received in this country.

The cotton is cleaned in a willowing machine, or in a batting, or scutching and blowing machine. The willow consists of a conical drum, the axis of which is placed horizontal or nearly so. The surface of the cone carries a series of projecting pegs or spikes, and the upper portion of the case which covers and partly encloses the cone is furnished on its inner surface with a similar series of spikes, the spikes of the cone moving in the intervals between the spike of the case. This machine is fed at the smaller end of the cone by means of an endless apron formed of thin spars of wood, each about three-quarters of an inch broad and half an inch apart, fixed at the ends to two endless leather straps which move round rollers. The cotton being placed upon this creeping apron, is slowly introduced into the willow, where it is seized by the revolving spikes, and whirled round with increasing velocity, due to the increasing surface of the cone, until, in a few seconds, it arrives at the large end, where it falls upon a moving apron, which carries it away or turns it out upon the floor. While the cotton is being teased out by the spikes of the cone, the heavier impurities, such as twigs, sand, stones, &c., fall out through the open lattice or grid-work which forms the bottom of the machine. The lighter impurities, such as dust, &c., are driven by centrifugal force to the large end of the cone, where they pass out through a spiral cage sieve into square pipes which convey them away.—C. T.]

Single scutcher and lap-machine, used for taking out the remaining sand, &c., and for forming the cotton into laps to feed the breaker carding-engine. The novelty in the construction of this machine consists chiefly in the application of the "patent consolidating calendar rollers," by which the "felting" of the cotton is performed in a superior manner, and its bulk so compressed as to admit of an increase of 40 per cent. on the "lap" roller. By this means a considerable saving of labour is effected at the carding-oungues.

[The batting or scutching and blowing machine carries on the work of cleaning the cotton which has been begun by the willow, and serves also to open the matted tufts. The cotton being spread upon a feeding apron, is introduced into the machine by means of feeding rollers; as soon as it gets within the machine it comes under the beating action of flat bars, which are moved round with great rapidity, and strike with their fans upon the cotton fibres as they slowly escape from between the feeding rollers. It is then conveyed out of the machine and turned out upon the floor. It is next passed to another scutching machine, in which, after being battled, it is formed into a cylindrical roll or lap, ready for the carding engine.

In many cases, however, the scutching machine and the lapping machine are combined, in which case the willowed cotton is spread by hand upon a feed-apron to the thickness of about 2 inches, and this is carried forward at the rate of about 3 feet per minute between a pair of coarsely fluted iron feed-rollers, which are pressed together by a weight acting through a lever on the brass bearings of the top roller. There is also a wooden roller, which serves to keep the cotton close to the apron, so as to allow it to pass readily between the feed-rollers. As the cotton passes into the machine between the feed-rollers it is struck by the first beater, which consists of two flat bars fixed at right angles upon the arms of a shaft revolving 2,000 times per minute. The cotton, on being struck and whirled round by the beater, is at the same time struck against the edges of long flat bars, arranged in the form of a quadrant of a cylinder. The cotton tufts are thus opened, and the filaments wafted upon an endless apron, near the end of which is a revolving cage cylinder, enclosed under the general cover of the machine; over this cage is a pipe communicating with a rotatory fan, which, by rarifying the air, causes the dust of the cotton to escape through the cage into the pipe, whence it is carried away: the cage also serves to spread smoothly upon the apron the loose cotton filaments into a level mass or lap. This is conveyed away under a wooden roller, and passed between a second pair of feed-rollers, to be exposed to a second scutching by beater-bars revolving more rapidly than the former. This second beater delivers the filaments to a second apron, which passes it under a second revolving sieve cylinder connected with the fan ventilator, by which means the cotton is again formed into a lap, which is passed out of the machine by the rotation of rollers. It is then carded between two pairs of iron rollers, the upper of which are loaded, which compress the filaments and form them into a kind of felt. This felt or lap is delivered to a wooden lap-cylinder, the axis of which is loaded, and thus made to bear down between two rollers which revolve both in one direction, and carry round by their friction the lap-cylinder. As this increases in diameter it rises up,

PERSPECTIVE VIEW, LOOKING WESTWARD, OF MESSRS. HIBBERT AND PLATT'S COTTON MACHINERY, AND MESSRS. HICK AND SON'S STEAM-ENGINE AND DRIVING GEAR. THE MACHINES IN FRONT ARE THE POWER LOOMS, THE THROTTLES AND MULES ARE BEYOND.

together with the links at the ends of the axis, which carry the weights, and thus the pressure continues uniform. When the coil of lap has attained a certain size, the rollers which turn the aprons, cages, and feed-rollers are thrown out of gear, while the rollers which support the lap coil continue to revolve. By this contrivance the lap is torn across; the attendant then removes it, puts an empty lap-cylinder in its place, and throws the machine into gear.

The laps from different machines are frequently combined into one lap, for the purpose of further equalizing the quality of different varieties of cotton. This is done at a lap machine, in which an endless apron moves between a frame, on which are slot-bearings for receiving the ends of the pins which support the laps. There are as many pairs of slot-bearings on this frame as there are different laps to be mixed. Each lap being unwound by the motion of the apron, the different laps are carried forward in parallel layers lying over each other; they are then all scutched and formed into one single lap as before. This is sometimes called a spreading machine.

For the finer varieties of cotton the laps are formed by hand.—C. T.]

Breaker carding-engines: used for further cleansing, combing, and laying the fibres of the cotton. The laps from the scutcher feed this machine, and are reduced by it into continuous webs, which are delivered into cans at the front of the machine. The novelty of these machines consists, first, in the method of feeding the card by means of a dish, straight-edge, and large roller. Secondly, in the cylinders, doffers, rollers, and strippers being made of iron. And, thirdly, in the method of adjustment of the bearers or carriers for the rollers and strippers. By means of the dish, straight-edge, and large roller, the fibres of the cotton are held until combed away by the cards of the licker-in, and can be adjusted to suit any length of staple of cotton. These machines, being constructed of iron, are not liable to "warp" from variation of temperature, and the method of applying the bearings for carrying the rollers, is so simple as to be capable of the finest adjustment.

Lap-machine: used for making laps to feed the finishing carding-engine. The cans from the breakers feed this machine, and the cotton is again formed by it into laps for the next operation. The patent consolidating calenders are also applied to this machine with the same advantage as in the scutcher.

Finishing carding-engines. The laps made in the last machine are taken in by this; and the fibres are again drawn, combed, and so completely straightened as to insure a more perfect evenness in the web, which is then delivered and coiled into cans. These machines are supplied with the same improvements as the breaker carding-engines.

Grinding machine: used for grinding and sharpening the teeth of the cards on the rollers, and flats of the carding-engines.

[In the laps thus formed, the cotton filaments are in a compressed state, crossing each other in all directions. In the next operation, which is carding, they are made parallel, or brought into a state favourable for parallelism. In this operation also any remaining impurities are completely removed. Carding is a sort of double combing. If we suppose the teeth of one comb to be set or bent in one direction, and the teeth of another comb to be set in an opposite direction, and that these two combs be moved against each other, with a tuft of cotton between them, the fibres will be seized by the teeth, those of one card will pull them one way, those of the other card will pull another way, and by repeating the operation many times the curls, and twists, and crossings of the cotton will be opened and drawn out, and the fibres will be arranged in

parallel lines. In the carding-engine the teeth are formed of thin iron wire, arranged on bands or fillets of leather, or other suitable material, made of uniform thickness, and attached to a set of cylinders and curved surfaces, the former being made to revolve so as to sweep over the surfaces of the latter at rest; or a number of parallel cards on the surface of a large drum work against the surfaces of smaller cylindrical cards moving with a less velocity. The two plans may, however, be combined in the same engine. The tufts of cotton are held by the stationary or slow-moving cards, while the quick-moving cards comb out the fibres, and gradually disentangle them.

The main carding cylinder or drum has attached to its surface strips of card-leather, equal in length to the width of the drum. Over a portion of this drum is a number of long strips, the under surfaces of which are covered with card-leather; these strips are called card-tops, and their ends rest on the heads of adjusting screws, projecting from the side framing. Nearly in contact with the large drum are a number of small rollers, called *urchins* or *squirrels*, covered with card fillets, wound spirally round them.

The lap roll, prepared by the lapping machine, is mounted at one end of the carding-engine; and being gradually unwound, passes along the surface of a feed-board, between a pair of feed rollers, until it comes in contact with the first roller-card, or licker-in, which draws in the filaments of the cotton. As this card, No. 1, rotates, its teeth come in contact with the teeth of the large drum, which strip off the filaments; but the rotation of the drum almost immediately brings it in contact with the squirrel, No. 2, which strips off the filaments from the drum, and, by its revolution, transfers them again to No. 1, which again delivers them to the drum, together with fresh filaments taken up from the feeding-rollers: the filaments which escape the action of Nos. 1 and 2 are seized by No. 4, which is placed much nearer to the drum; the cotton thus taken up by No. 4 is combed out by No. 3, which is nearly in contact with it but moving with greater speed. From No. 3 it is again transferred to the drum, to be carded out again by No. 4, and any filaments which still remain are arrested by the first flat top-cards, and held until they are disentangled by the revolution of the drum. In this way the filaments become gradually arranged on the surface of the drum in nearly parallel lines, which is the condition sought for, and in this state they are not teased off by the urchins, but pass round to the opposite end of the machine, and are removed from the drum by a smaller drum card, called a doffer or stripper, on the surface of which the cards are arranged in spiral lines. The fine fleece of the transparent web is removed from the doffer by means of a doffing knife, the lower edge of which is toothed like a fine comb, and this, by the action of a crank, is made to strike down with a rapid motion over the points of the cards. The fleece thus shaved off is equal in breadth to the length of the card on the doffer, and it is disposed of in one of two ways. There are usually two carding engines, the first called the breaker-card, and the second the finisher-card, and the cotton is passed through both. In the breaker-card, as the fleece is taken off by the crank and comb, it is wound upon a large wooden roller, which, when filled, is removed and used for feeding the finisher-card. As the fleece is removed from the finisher-card it is contracted into a narrow riband, by being passed through a funnel, then through three pairs of rollers, the bottom roller of each pair being finely fluted, and the top roller of each pair covered with

leather, and the top rollers are pressed upon the bottom ones by weights suspended from their axes. The middle pair of rollers moves at a greater speed than the first pair, or that nearest to the engine, so that while the first pair delivers the filaments the second pair pulls them, before it delivers them to the third, the effect of which is to draw and straighten the fibres, and spread them out into a flat riband, called a card-end or sliver. But before this sliver passes to the third pair of rollers it is opened out and made spongy in texture, by being passed through an upright slit situated between the second and third pair of rollers; it is then passed between the third pair, which are but slightly pressed together, and the sliver is finally received into a tall tin can.—C. T.]

**Drawing-machine:** used for doubling and drawing the web or sliver prepared by the finishing carding-engine, and delivering and coiling it into cans for the next operation. This machine is furnished with a series of self-acting guides, which stop the machine as soon as the sliver breaks, in passing from the can to the roller. It is also fitted up with the collers and revolving motions to the cans.

**Slubbing-machine,** 28 spindles: used for drawing the slivers prepared by the last machine, and afterwards twisting and winding them on bobbins.

**Second slubbing or intermediate machine,** 54 spindles: used for doubling and drawing the slubbings, and twisting and winding them on bobbins for the creels of the roving machines. This machine is introduced in order gradually to reduce the sliver, so as to obtain a more even and a fuller thread.

[The next operation is intended to carry out, in a still more perfect manner, the operation which was commenced at the close of the carding, namely, drawing out and elongating the slivers, straightening the filaments, and laying them as parallel to each other as possible. Another object is still further to equalise the quality of the cotton, and make the slivers of uniform strength and texture, by combining many slivers into one; this is called doubling; and all these objects are attained at the machine called the drawing-frame. This consists essentially of three pair of rollers, of which the second pair moves with greater speed than the first, and the third more quickly than the second. These rollers are similar to those used in the finisher-card, with one or two additions. A mahogany bar, faced with flannel, rests upon the top rollers and strips off all the loose fibres; similar bars are also made to press up against the under-fluted rollers. The distance between the first and second pairs of rollers must not exceed the length or staple of the filaments of cotton, or the sliver might be torn apart by the pulling of the second pair, while the first pair held it firmly. The sliver is stretched most in passing from the second to the third pair.

The card-ends are usually supplied to the drawing-frame from the cans filled by the finisher-card, a number of them being guided along the channels of a metal plate, at the top of which they unite and pass between the first pair of rollers, which reduces them to one sliver, the second pair extends every inch of this compound sliver into about two inches; and the third pair extends these two inches into ten. The length of the sliver thus produced is generally equal to the sum of the lengths of all the separate slivers or card-ends employed. The single sliver, formed by the doubling or union of all these separate slivers, is passed between smooth iron rollers, which condense it, and it is then received into a can on the opposite side of the frame. When a number of cans have thus been filled, the *drawings*, as they are now called, are again doubled and drawn out

into one, and, by repeating the operation several times, the defects of individual slivers or drawings are absorbed and got rid of, and uniformity is produced.—C. T.]

A roving-machine of 120 spindles: used for the same purpose as the last, and twisting and winding the slubbings on still smaller bobbins for the creels of the spinning machines. The improvements in the construction of these machines consist, *first*, in the self-acting motions for stopping the machine when the sliver breaks (used for the slubber only); *secondly*, in the patent bearing or collars in which the spindles work, and the methods of fitting the flyers on the tops of the spindles whereby a greatly increased speed is obtained; *thirdly*, in the application of the double patent pressure to the flyers, which preserves the equilibrium of the spindles whilst working, whether the bobbin be full or otherwise.

[By the preceding operations the cotton has been cleaned and the fibres laid parallel. It is now in the form of a loose porous cord, too thick to be spun or twisted into yarn. By the next machine, the bobbin and fly-frame, the drawing is again elongated, and partially spun, and the roving, as it is then called, is wound upon a bobbin. The spindle which, by rapidly revolving, puts twist into the drawing, is furnished with a two-pronged fork, called a fly or flyer. One prong of the fly is solid and the other hollow. The bobbin on which the roving is to be wound is threaded upon the spindle, and revolves with it at a different rate, and by a perfectly distinct movement. One frame contains from 30 to 120 spindles, and the action, which is alike in all, is as follows:—The sliver, as prepared by the drawing and doubling frame, is brought in cans to the bobbin and fly-frame, where it is elongated by passing between three pairs of rollers, and twisted, by the rapid revolutions of the spindle, into a soft cord or roving: this is passed into a hole at the top of the spindle, and then down the hollow arm of the fly; it is next twisted twice round a steel finger, which winds it upon the bobbin with a certain pressure. The finger, however, does not move up and down the bobbin, but the bobbin moves up and down upon the spindle, against the finger, by which means the roving is equally distributed upon the bobbin. It is necessary, however, gradually to slacken the velocity of the bobbin, as it increases in thickness by the winding, otherwise the roving would be improperly stretched or broken. The velocity of the front pair of rollers, which delivers the cord, and of the spindle which twists it, is constant; the motion of the bobbin which winds up the roving is quickest when it is empty; and its speed goes on gradually slackening until it is full. This diminution of velocity is occasioned by causing the strap which drives the bobbins to move slowly along the surface of a conical drum, which, revolving with a constant speed, the strap at the small end of the cone would of course impart a greater velocity than when it had arrived at the large end.

The roving is wound on the bobbin by causing the fly and the bobbin to revolve at different rates. If the bobbin, for example, revolve 50 times while the spindle revolve only 40, these 40 turns of the bobbin have nothing to do with the winding; the 10 turns of the bobbin above those of the fly perform the winding; so that while 40 turns of the spindle produce twist, 50 turns of the bobbin produce 10 coils of roving, upon its barrel. In some cases the winding is effected by the spindle revolving quicker than the bobbin, and in fine spinning, two rovings are doubled, and passed a second time through the frames.—C. T.]

A throstle of 160 spindles.

[The rovings thus prepared are finished at one of two machines, namely, the throstle and the mule jenny; the



one spins the hard yarns, which are chiefly used in warps, and the other the softer yarns of wefts. This, however, is by no means a general rule.

The bobbins filled with rovings from the bobbin and fly-frame occupy the upper part of the throstle-frame. Each roving is passed through three pairs of drawing rollers, which draw it out to the proper degree of fineness. On quitting the front pair, the roving is guided by a small ring or a notch of glass let into the frame, towards the spindles, which revolve with great rapidity, and produce, by the motion of their flyers, a low musical hum, which is said to have given the name to this machine. By the rapid motion of the spindle, the roving is twisted into yarn, which, passing through an eyeslet at the end of one of the prongs of the flyer, proceeds to the bobbin, which is threaded upon the spindle, and is wound upon it. The bobbin fits loosely on the spindle, its lower end resting upon a shelf, called a coping-rail, which has a slow up-and-down motion, and thus distributes the yarn equally upon the bobbin. The motion of the bobbin upon its axis is derived from the tension of the yarn in winding; for while the flyer is spinning, the yarn drags the bobbin after it, but its weight and its friction on the coping-rail cause it to hang back; by this contrivance the yarn is kept stretched, and is wound upon the bobbin by the more rapid revolutions of the flyer.—C. T.]

Weft self-acting mule, 402 spindles: used for drawing or elongating the fibres, and twisting and winding the yarn on cops, for the shuttles of the looms.

Twist self-acting mule, 348 spindles. The same kind of machine as the one last described, but used for spinning thread or yarn for the warp instead of weft.

The improvements in these mules consist, first, in an improved patent drawing-out motion for the carriage, which can also be used, if required, for the purpose of "jacking or after-draft," in spinning fine numbers of yarn. Secondly, in the securing of the carriage by means of a back-shaft, which secures steadiness whilst traversing; and is, consequently, of great utility in long mules. Thirdly, in a new mode of winding-on the yarn by a "catch-box," which dispenses with all the springs and levers previously used, thereby preventing the frequent breaking of the yarn, and the wear and tear of the machine.

[The mule or spinning-jenny consists essentially of two principal portions: one, which is fixed, containing the bobbins of rovings and the drawing rollers; the other a carriage moving upon iron rails, and capable of being drawn out to a distance of about 5 feet from the fixed frame. The carriage carries the spindles, to which a rapid rotatory motion is given by means of slender cords passing round them and a drum. There is one drum to about every 24 spindles, and as many as 1,000 to 1,200 spindles in one mule. At the commencement of the spinning, the carriage is run up close to the drawing rollers, which by their revolutions give out the roving which is twisted by rapidly revolving round the points of the spindles; the carriage is then moved away from the roller-beams somewhat more quickly than the rovings are delivered, by which means the yarns become stretched and equalised. When the carriage has been drawn out about 54 to 64 inches from the drawing rollers, it is said to have completed a stretch; the drawing-rollers cease to give out roving, but hold it firmly, while the spindles now whirling with increased rapidity complete the spinning into yarn. In spinning the finer yarns, the carriage makes a second stretch, during which the spindles are made to revolve with great rapidity. Any threads which may happen to break, are now pieced, or mended by children called, "piecers" or "pieceners." This drawing, stretching, and

twisting of a length of yarn being completed, the mule is disengaged from the parts of the machinery by which it was driven out, and the spinner then proceeds to do his part of the work, which consists of three simultaneous operations: he pushes the carriage in with his knee; he depresses with one hand a coping wire, which places the yarns in such a position with respect to the spindles, that they can be wound up upon them; and, thirdly, he moves with the other hand a fly-wheel, which sets all the drums and consequently all the spindles in motion. He causes the spindles to revolve backwards for a moment, in order to slacken the yarns just completed, and to throw them off the points of the spindles. Considerable skill is required to perform these three operations successfully. The spinner must guide the coping wire so as to insure the regular winding of the yarn on the spindle; he must regulate the velocity of the spindles, and he must push the carriage in at such a rate as to enable the spindles to take up the proper quantity of yarn without stretching or breaking. These difficult and delicate operations can now be accomplished by self-acting machinery: the self-acting mule does the work in many respects better than it can be done by the spinner.

The quantity of yarn collected upon each spindle is called a cop. The yarn is wound from the cops, or from the bobbins of the throstle-frame, upon a six-sided reel, one yard and a half in circumference. The reel is mounted in a frame containing the cops or bobbins, and when the reel has made 80 turns, a check is struck, or a bell rung, which warns the attendant that a ley or rap of 120 yards has been wound. Seven of these raps make a hank of 840 yards. The size of the yarn is ascertained by weighing the hanks in a quadrant balance. The number of hanks to the pound may vary from 2 to 600. The hanks are made up in cubical bundles of 5 or 10 lbs. weight, by a machine called a bundling press.—C. T.]

A doubling machine: used for doubling and twisting a number of spun yarns into thread.

[The better descriptions of yarn are gassed, or passed two or three times through a gas flame, in order to get rid of loose fibres, and to make it more level and compact. Two or more yarns, doubled and twisted together in an opposite direction to the twist of the yarns themselves, form thread, properly so called.—C. T.]

A winding-machine: used for winding the yarn from the mules and throstle, and preparing it for the warping-machine. One side of this machine winds from cops spun in the mule, and the other from bobbins spun on the throstle. A warping-machine.

[When the yarn is required for weaving, it is prepared in different ways, according to the purpose for which it is intended. The yarns for the warp or long thread of a woven fabric are wound upon bobbins from which they are drawn in the process of warping. The warping-mill or machine is a large reel or frame-work of wood, with 12, 18, or more sides, which serve to measure the total length of the warp. This reel is mounted on a vertical axis, to which motion is given by an endless band, connecting the lower part of the axis with a wheel set in motion by the warper. One-sixth of the number of the bobbins of yarn required for the warp, is usually mounted loosely upon upright spindles, in a frame called a traverser. The yarns pass from these bobbins to the large reel, through an instrument called a heck-box, which is made to slide up and down between two upright posts, by being suspended by a cord which, passing over a pulley at the top of the posts, is made fast to the axle: so that as the reel revolves, the heck is gradually raised from the



bottom to the top, and when the mill is turned the other way it descends by its own weight, and thus the band of warp-yarn is wound in a spiral line from the top to the bottom of the reel. The use of the heck is to divide the warp-threads into the lease, or two alternate sets, one set for each heald of the loom. To effect this, the heck-block contains 120 or more steel pins, with an eye in the upper end of each, through which a yarn passes in the process of warping. The pins are arranged alternately in two frames, either of which may be raised at pleasure. The threads being passed through the eyes of the heck, the ends are knitted together, and fixed to a pin upon the mill. The mill is then turned slowly until the top lease pins come nearly opposite the heck. The warper then, lifting half of the heck-frame, raises half the threads, which he places upon one pin, and the other half upon another pin of the mill. In this way every alternate thread is crossed, and the lease is formed. When the warp has described a spiral line round the frame, from the top to the bottom, the threads are again passed over pins, the motion of the frame is reversed, and the warp forms another spiral line in a contrary direction. The operation is thus repeated until the whole length of warp is run out. The lease or crossing of the threads is secured by a band tied through them at the top, and another at the bottom. The warp is then removed, and wound up into a ball.

The bundles of yarn thus formed are spread out upon cylinders or yarn-beams; and, in order to distribute them equally, the threads are passed through a separator or ravel, formed of a number of shreds of cane fixed in two rails of wood. A dressing of glue, size, or paste is next given to the warp-yarns to increase their strength and tenacity, and to lay down the minute fibres which feather the yarn.\* In the dressing machine the yarn-beams are mounted in a frame at one end; the threads are passed through a reed to keep them distinct, and then between rollers covered with felt, one of which dips into a trough containing the paste or other dressing. The lower roller gives paste to the yarn, while the upper roller squeezes out the superfluous quantity. The dressing is also rubbed into the fibres of the yarn, and smoothed over by means of cylindrical brushes, one above and the other below the warp, and moving in a direction contrary to that of the yarns. The warp is dried by being passed over a box or chest filled with steam, and a current of air is made to stream over it by means of a revolving fan. The warp is passed to the main yarn-beam of the loom, on which it is regularly wound, the threads being kept distinct by passing through a reed.

The warp-beam thus filled is suspended by its axis, so that the ends of the warp-threads may hang down, and the weaver then draws every yarn through its proper eye or loop in the healds. The alternate crossing of the threads is preserved by the *lease-rods*, and in drawing in, as the operation is called, the weaver can easily make each thread to cross the one next to it. When the threads have been passed through the eyes of the healds they are next drawn through the splits of the reed. The lease-rods preserve the lease of the threads, and the arrangement is as follows:—The first thread passes over the first rod and under the second, the next thread passes under the first and over the second, and so on alternately, the third rod divides the warp into splits, two threads passing alternately over and under it.—C. T.]

Power-looms, the novelty in which consists, first, in the patent uniform winding or taking-up motion, which

is effected by surface-rollers, without the aid of ground glass or emery, and is applicable to looms for weaving both light and strong cloths; and, secondly, in the method of holding the edges of the cloth during the process of weaving by an improved "temple."

[The loom used in plain weaving consists of—1. An apparatus for stretching the warp. 2. An arrangement for raising one-half of the threads of the warp and depressing the other half alternately, so as to open a space for introducing the weft. 3. A shuttle for casting the weft into the opening thus made. 4. Means for striking each weft-thread close up to the one previously thrown. The common loom consists of four upright posts with cross beams at the top and bottom. At one end is the beam or roll containing the warp, at the other end the cloth-beam, on which the work is wound as it is woven. The warp is kept stretched between the two by weights slung over the ends of the warp-beam. The alternate arrangement of the warp-threads is preserved by means of lease-rods. One-half of the warp-threads is alternately raised and depressed by the healds, which consist of a number of twines, looped in the middle or furnished with glass eyes, each alternate thread being passed through the loops of one heald, while the intermediate threads are passed through the loops of the other heald. The two healds are united at the upper part by a rope passing over a pulley, and at the lower part a rope proceeds from each heald to a treadle, by which means the lowering of one heald causes the other to rise. The yarns are also passed through the teeth of a reed, which is set in a moveable swing frame, called the lay or batten. At the bottom of this frame is a channel, called the shuttle-race, along which is thrown the shuttle, a boat-shaped piece of wood containing, in a hollow in the middle, the cop of yarn which is to form the weft or cross-threads of the web of cloth. At the side of the shuttle is a small hole, through which the weft-yarn runs freely as the shuttle is shot along. The shuttle is sometimes furnished with wheels on the under side, and may be shot backwards and forwards by hand or by pickers or peckers, as in the fly-shuttle; in which case, the two ends of the shuttle-race are closed, and two pieces of wood, called pickers, move along wires. To each picker a string is attached, and both strings meet loosely in a handle, which is held in the right hand of the weaver. When the shuttle is at one end of the race a smart jerk of the picker projects it along to the other end, and another jerk in the contrary direction urges it the other way. Every time a thread of weft is to be thrown across the warp the weaver has to perform three distinct operations—1. To press down one of the treadles, by which means every alternate thread of the warp is depressed, forming what is called the *shed*. 2. To throw the shuttle across so as to lay a thread of weft in this shed. 3. To drive the thread of weft close up to the web by means of the batten. As the web is completed it is wound round upon the cloth-beam, and the breadth of the unwound portion is kept extended by two pieces of wood, called temples, furnished with sharp points at the ends.

In plain weaving, the warp and the weft-threads are of the same colour and usually of the same degrees of fineness. By introducing yarns of different degrees of fineness, at regular intervals, a striped cotton is produced. By having the warp-threads of one colour and the weft-threads of another colour, shot patterns are formed. Coloured stripes are formed by introducing coloured yarns into the warp. In these and various other cases every thread of the warp and weft cross alternately at right angles. In twilled or twilled cloths only the third, or the fourth,

\* The dressing machine is not exhibited.

fifth, or sixth, &c., threads cross each other. Figures, flowers, or patterns of any kind are produced by dividing the warp between a number of heads which can be raised or lowered at pleasure, while threads of different colours may be either concealed or brought forward upon the face of the fabric, or be made to change places according to the pattern. The Jacquard loom, as it is called, is a contrivance attached to a loom for raising or concealing different threads.

In the power-loom, the services of the weaver are dispensed with, the various movements being performed by self-acting machinery, driven by the steam-engine.—C. T.]

Messrs. Benjamin Hick and Son, Soho Foundry, Bolton, are the makers and exhibitors of the steam-engine (6-horse power), together with the mill-gearing and framing for turning the above machinery.

The card clothing on four of the carding engines was manufactured by Joseph Sykes and Brothers, Lindley, near Huddersfield; and that on the other two by Mr. Horsfall, of Manchester.—See Plates 122 and 123.

#### 2 BOOTH & Co., Preston, Lancashire—Manufacturers.

Mule spindles, with buttons and drum warves, and mule spindles with buttons and cylinder warves, for spinning cotton and silk; they are made capable of revolving at the speed of about 7,000 revolutions per minute. The shape of the top of the spindle lessens the vibration of the yarn, and consequently the breakages.

Throstle spindle and fly, for spinning cotton, silk, flax or worsted.

Roving spindle and fly, for spinning cotton. The fly is supplied with Iver's patent spring, &c.

Winding spindle, for winding cotton, silk, &c.

Spindle, for reeling cotton, silk, &c.

Skewer, for winding cotton, silk, &c.

#### 3 CRABTREE, THOMAS, Godley, near Halifax—Manufacturer.

Card-setting machine; which accomplishes the entire manipulation for producing the complete card from the wire and leather or cloth in their primary state; it will make cards for wool, cotton, or silk; used in the manufactory of Messrs. J. Sykes and Brothers, card manufacturers, Acre Mills, Lindley, near Huddersfield.

[A card, for carding cotton, wool, and other analogous fibrous substances: it consists of a series of forked wires, both ends of which are inserted through holes made in a strap of leather, and then bent very regularly to the required inclination. Cards in the carding engine seem to lay all the fibres of cotton or wool in one direction, accumulating it into a loose mass called a fleece, preparatory to the process of spinning. The first card-making machine was patented by J. C. Dyer, of Manchester, in 1811, and is said to have been the invention of an American named Whittemore. It is a most beautiful and efficient piece of mechanism.—W. D. L. R.]

#### 4 DALTON, JOHN, Mottram-in-Londendale—Inventor.

Machine for printing calicoes, de laines, and other textile fabrics. By one process a corresponding or varied pattern is printed on each side of the fabric. It may be employed as a double printing machine, for printing on one side two pieces at the same time. The construction is applicable to printing machines generally, and consists in substituting for the ordinary iron printing cylinder, a newly-invented cylinder, constructed with the exterior surface of gutta percha, and in dispensing with the use of the endless web or blanket, and the lapping, which is required in the ordinary machines, to afford a yielding surface to the action of the engraved roller. These new cylinders possess in a great degree the properties of permanence and elasticity, and are superior to other appliances, from their increased efficiency and economy. A more accurate and uniform impression of the pattern is obtained, and a

saving of one-third of the power required to work the ordinary machines is effected. When used in two or more coloured machines, the fitting-in of the pattern will be correct, and without variation; and no allowance, as usual at present, will need to be given to the engraved rollers to compensate for the extension of the web.

#### 5 PRESTON, FRANCIS, Manchester—Manufacturer.

Spindles and flyers used in preparing, spinning, and doubling of cotton, silk, worsted, woolen, and flax.

[Several American machines exhibited in this portion of the Building.]

#### 6 PARR, CURTIS, & MADELEY, Manchester—Manufacturers and Patentees.

1. Carding engine, made with rollers and clearers.

2. Drawing frame of three heads, three boxes to each head, with four rows of rollers, patent collars, and revolving can-motion, and patent stop-motion.

3. Slubbing frame, with patent improvements, which consist in the application of a coiled spring to the presser, giving it a more uniform pressure, and reducing the weight of the flyer. A frame is fastened to the beam, on which a carriage moves, carrying the tension weight for lightening the cone strap instead of allowing it to rest on the grooved shaft, and gearing is applied to the shortening and traverse motions.

4. Roving frame with the same patent improvements as applied to the slubbing frame.

5. Patent self-acting mule, 1½ inch gauge, similar to Sharp and Roberts, with patent improvements, which consist in the application of a positive motion to produce the required changes, dispensing with the use of the cam shaft, and other important advantages.

6. Patent self-acting mule, 1½ inch gauge. An adaptation of Sharp's radial arm to Smith and Robertson's mangle wheel and stripping mule, with patent improvements.

7. Patent self-acting mule, 1½ inch gauge. Arranged with the headstock at one end, with patent improvements, which consist in the peculiar arrangement of the headstock, and in the novel motion applied to wind the yarn on to the spindles.

8. Planing machine for metals; self-acting in the horizontal, vertical, and angular cuts. Its chief objects are strength and simplicity.

9. General shaping machine, for shaping metals. It planes horizontal, vertical, angular, circular, and polygon work, and hollows down to half an inch radius. Motion is given to the crank by a pair of wheels bored eccentric.

10. Slide and screw cutting lathe, fitted with geared head-stocks, having conical mandril, and case-hardened steel bearings and collars; guide screw the whole length; compound slide rest, self-acting in the longitudinal and transverse direction.

11. Drilling machine for drilling holes to 1½ inch diameter, with self-acting feed motion; the pressure regulated by an improved friction break, or given by the foot.

#### 7 LEACH, THOMAS, Oldham Road, Rochdale—Manufacturer.

Doffing and cleaning plates, for cotton and wool machinery. Temple teeth and springs for power-loom, Springs and under clearers for throstles and mules.

#### 8 WILD, WILLIAM, 26 Broughton Road, Salford, Manchester.

A cask made by machinery.

#### 10 & 46 MASON, J., Globe Works, Rochdale—Joint Inventor and Maker

Single carding engine, lap machine, and self-acting feeder; the same, with condenser attached, intended to produce a number of endless cardings or slubbings, and dispense with the use of the billy machine, and the hands required to work it.

Patent condenser, or endless carding engine for wool, and self-acting feeder for any second or finisher carding engine. *Action of the Machine.*—The wool is removed from the

work the or-  
two or more  
tern will be  
ance, as usual  
graved rollers

ufacturer.  
spinning, and  
and flax.

this portion of

ester—

clearers.  
boxes to each  
s, and revol-

ments, which  
bring to the  
and reducing  
to the beam,  
ension weight  
ving it to rest  
to the short-

improvements

ge, similar to  
ments, which  
tion to pro-  
n the use of  
res.

An adapta-  
son's mangle

vements.  
e. Arranged  
improvement  
ment of the  
to wind the

in the hori-  
f objects are

metals. It  
and polygon  
us. Motion  
d eccentric.  
with geared  
so-hardened  
hole length;  
itudinal and

1½ inch dia-  
measure regu-  
by the foot.

ide—

d wool ma-  
power-looms.  
mules.

ford,

Joint

self-acting  
tended to  
bbings, and  
d the hands

r wool, and  
ing engine.  
d from the

doffer of the first carding engine by a comb as usual, and is drawn by a pair of rollers fixed at the side of the frame through a revolving tube, which imparts an amount of false twist to the sliver. It is returned between a lower pair of rollers to the lap machine in front of the engine, which is arranged to form a lap 16 inches diameter, and 4 inches wide. When the required length of sliver is wound on, notice is given by a bell; and if not attended to, another movement doffs the lap, so as to ensure each one being of the same uniform length.

These narrower laps are placed side by side upon rods, so as to form four rows, *a, b, c, d*, fig. 1, each row being the whole width of the engine, which are turned off into the engine by the unlapping rollers *e, f, g, h*. Each sliver passes through a guide or reed as it enters the feeding rollers to keep it in its proper place. The quantity of sliver thus put up at the feeder end of the machine will last a whole day.

The wool having passed through the engine, and been carded in the usual manner, is removed from the main

cylinder by the condenser doffers, *i, k*, which are provided with ring of cards, and alternate blank spaces, so that the wool which is left upon the cylinder by the top doffer is removed by the lower one.

The stripper rollers, *l, m*, take the bands of wool from the doffers, after which they pass between the doubled endless twisting straps, *n, o*, in order to receive a degree of false twist, sufficient to enable them to carry forward to be spun. They then pass between the delivery rollers, *p, q*, to the bobbins, *r, s*, on which they are lapped by friction of contact with the drum *t, u*.

When the bobbins are fitted they are removed direct to the mule to be spun, where they are unlapping in a similar manner by drums.

The advantage of this system consists in a great economy of labour; three operations being entirely dispensed with, viz., feeding, slubbing, and piecing. With the addition of the self-feeder condenser, yarns are found to be more regular and level than those produced by the ordinary method; a greater quantity of work is turned

Fig. 1.

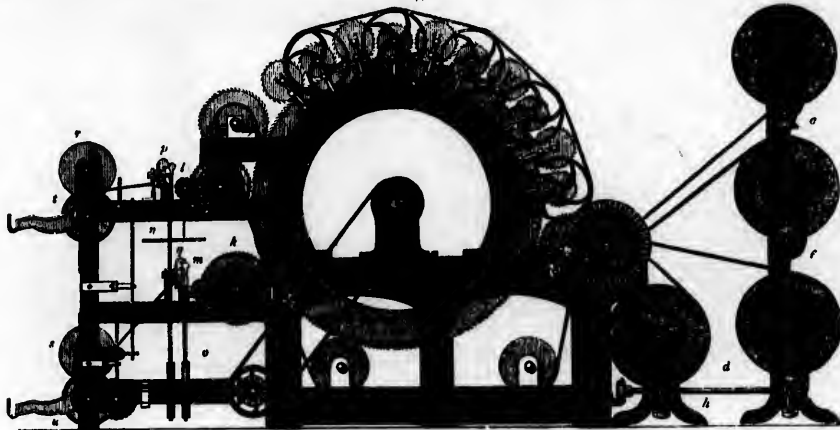

Mason's Carding Engine.

off; the threads are more nappy or oozy, which increases the felting quality in milling; causes a firmer texture in the cloth, and a corresponding fulness of bottom and richness of appearance when finished, not attained by the methods formerly in use.

Mule loom grinding-frame.

The patent driving bands made by J. H. Whitehead, Saddleworth.

Slubbing-frame, with Mason and Collier's patent collars or bearings for the spindles: separating plates for the slubbings, and the break motion for readily stopping the machine.

Patent slubbing and roving frames.

This improvement gives a firmer support to the spindles, obtaining greater speed with greater steadiness.

It is accomplished by making the collar in the lifting rail longer (shown detached in fig. 3), and continuing it through the wheel *b*, up the inside of the bobbin-barrel to the top of it, where the bearing for the spindle is formed as shown at *a*, figs. 2 and 3.

The collars are chambered inside, so that the spindle fits only their ends, and they are firmly screwed to the lifting-rail *d*, the wheels and bobbins running loosely around them, as represented.

The separating plates *e*, prevent the broken threads becoming entangled with the other spindles.

Roving frame, with patent collar, separating plates, and additional improvements.

Patent power-loom, for weaving fancy goods by an improved method of working the healds, to form the figure on the cloth. A vice.

Fig. 2.

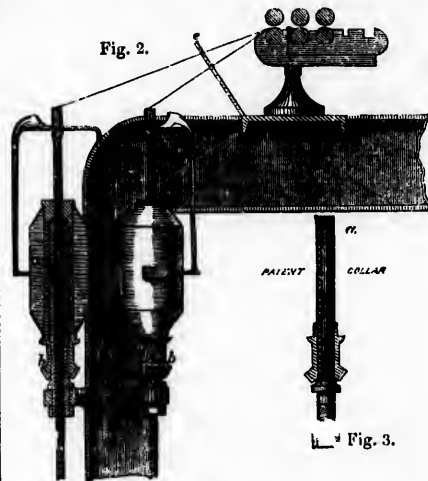

Fig. 3.

Mason's Patent Slubbing and Roving Frame and Collars.

14 HIGGINS & SONS, *King Street, Salford*—  
 Manufacturers and part Inventors.

Cotton machinery:—Patent roving frame of 72 spindles; double self-acting radial mule, 800 spindles.

Long-line flax machinery:—First drawing frame, four bosses; second, 4 heads, 4 bosses each; patent roving frame, 6 heads, 80 spindles; spinning frame, 144 spindles.

15 SHARP BROTHERS, *Manchester*—Inventors.  
 Danforth throstle, for spinning.

16 MATHER, W. & C., *Salford Iron Works*—Manufacturers.  
 Calico-printing machine, for printing eight colours at one operation, with drying apparatus. Sewing machine, and patent pistons.

17 SAKON, ABEL, *Manchester*—Manufacturer.  
 Metallic bobbins.

18 HARRISON, J., *Bank Foundry, Blackburn*—Manufacturer.  
 Power-loom adapted for fabrics of light materials, in cotton, wool, and flax, and not more than 18 or 20 "picks" or "shots" of weft in a quarter of an inch; and for "tweeled" goods up to four leaves.

Power-loom, adapted for heavy and tweeled goods. Power-loom, made 50 or 60 years ago. These looms are represented in the engravings below.



Modern Power-loom.

Old Power-loom.

19 GIBSON & CO., *Glasgow*—Manufacturers.  
 Case containing specimens of shuttles.

20 HORNNY & KENWORTHY, *Blackburn*—Inventors  
 and Manufacturers.

Patent sizing or dressing machine, with a peculiar arrangement for laying out the yarn in the form of a "sheet," "tape," or "beers," for "leasing," "boiling," "drying," "registering," and "beaming."

Model of patent warping-machine, with a self-acting backing-off motion. This series of models, together with a model of the loom named below, is represented in the engraving on the next page.

21 BULLOUGH, J., *Blackburn*—Inventor and  
 Manufacturer.

Model of patent power-loom: which stops the motion when the weft thread breaks; it has a self-acting temple, and it coils the taking-up motion.

22 SMITH, MARK, *Heywood, near Manchester*—  
 Inventor and Maker.

Loom for weaving naval canvas, Dutch and Venetian carpets, and applying the rising-box motion to Scotch and Kidderminster carpets. The speed of this loom is 120 picks per minute; it drives a shuttle that will weave a yard of cloth from one bobbin.

Loom for weaving strong fustians, strong ticks, linen,

damask, and woollen cloths, on the same principle, with the addition of self-acting temples. It weaves 5 lb. No. 2 cotton weft, or 100 hanks in ten hours; and works safely at 200 picks per minute.

Loom with rising and falling box motion for weaving plaids, checks, ginghams, fancy drills, quiltings, and calicoes.

Loom for weaving silks, fitted up for plain cloths, but applicable to satins and figured work by attaching the necessary cams or tapets, or the Jacquard machine.

Working model, comprising most of the motions of these looms.

23 TAYLOR & SON, *Halifax*—Manufacturers.

A large Jacquard loom, exhibited in the operation of weaving worsted damask goods. (See engraving, page 272.)

[This vast machine, with its array of cards, and confusing lines of harness, furnishes a striking example of a loom constructed on the principle discovered by Jacquard.]

24 MACINDOE, GEORGE PARK, *Glasgow*—Inventor and  
 Patentee.

Self-acting mule for spinning cotton wool into yarn, with oscillating or vibrating lever for taking in or putting up the carriage, and a mode of putting down the faller from any of the twist pulleys by centrifugal disengaging catches.

*Iron Works—Manufacturers.*  
 printing eight colours at  
 apparatus. Sewing machine,

*er—Manufacturer.*

*Blackburn—Manufacturer.*  
 ics of light materials, in  
 not more than 18 or 20  
 a quarter of an inch; and  
 leaves.  
 avy and tweelled goods.  
 rs ago. These looms are  
 slow.



the same principle, with  
 les. It weaves 5 lb.  
 ten hours; and works

x motion for weaving  
 drills, quiltings, and

o for plain cloths, but  
 work by attaching the  
 guard machine.  
 t of the motions of

manufacturers.  
 l in the operation of  
 (See engraving, page

y of cards, and con-  
 striking example of  
 iple discovered by

ow—Inventor and

wool into yarn, with  
 in or putting up the  
 the faller from any  
 engaging catches.

E'S  
 171  
 MULI  
 ING.

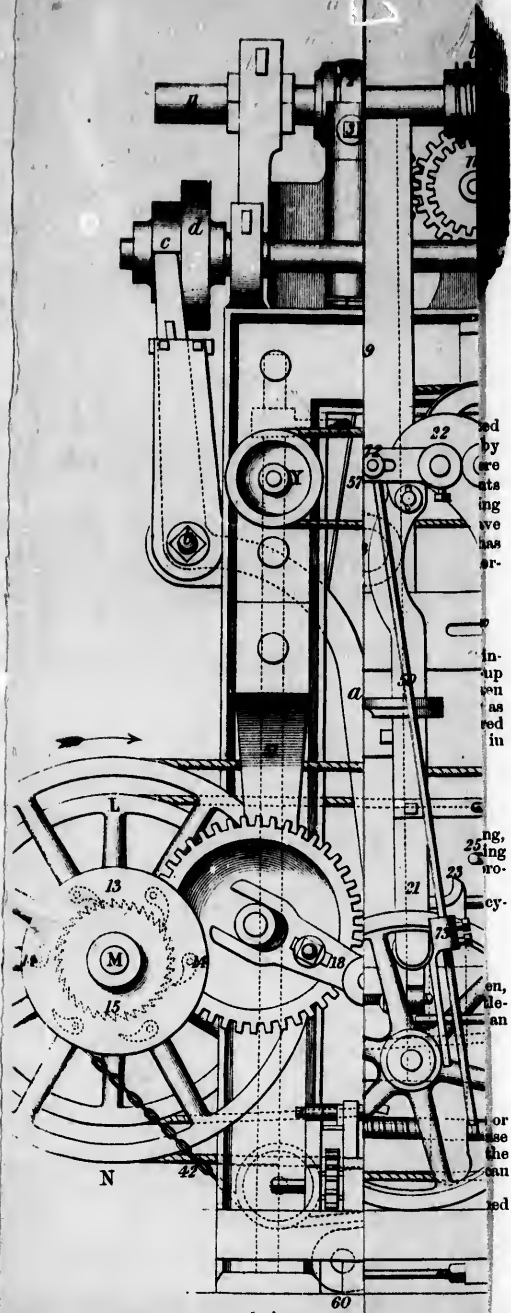

ed  
 by  
 are  
 ats  
 ing  
 we  
 has  
 ar-  
  
 in-  
 up  
 ven  
 as  
 red  
 in  
  
 ng,  
 22  
 ing  
 wo-  
  
 cy-  
  
 on,  
 de-  
 an  
  
 or  
 use  
 the  
 can  
 red



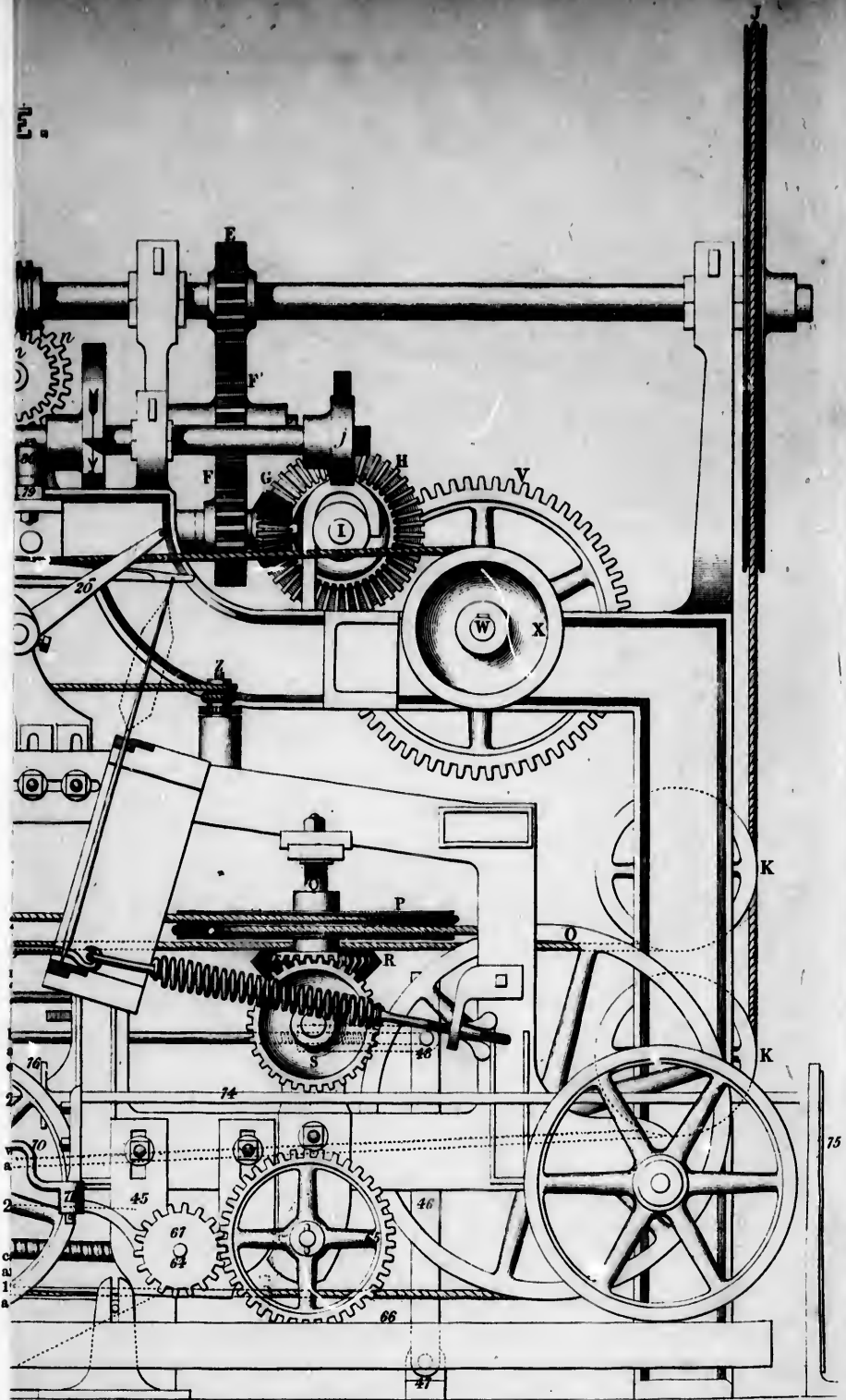



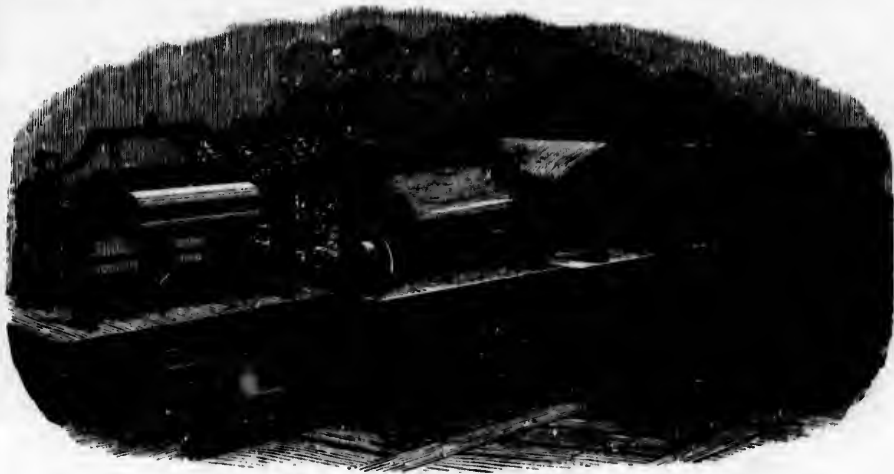

Hornby &amp; Kenworthy's Models of Patent Sizing and Warping Machine.

This mule, for which letters-patent were obtained in 1849-50, by the exhibitor, presents a combination of simple and efficient mechanical movements. The side elevation of the head-stock given in the accompanying Plate, explains how far the attempt at economy, construction, and convenience of arrangement, has succeeded; but the great features of the improvement are comprehended under the following nine heads:—

1. The mode of regulating the twist of the yarn, in direct communication with the spindles. By this plan, the movements of the spindles, and the twisting action, are made to work in complete concert—a point, which every cotton-spinner will appreciate.

2. The taking-in or pulling-up of the carriage by an oscillating or vibrating lever (marked 36 in the Plate). This movement possesses the peculiar feature of causing the carriage to start at a slow yet steady pace, gradually increasing in speed until half way, when its rate diminishes in a similar ratio up to the roller beam. This action is also three or four seconds quicker at each stretch than ordinary mangle-wheel mules, and is not affected by any change which may be made in the mule, to suit particular numbers.

3. The adaptation of a counterpart to the radial arm and screw, for winding on the yarn, as marked 59 in the Plate.

4. The extension of the main driving shaft A, over the whole length of headstock, so as to distribute the various movements in the most convenient manner, and dispensing with additional connections.

5. The extension of the cam shaft *c*, from the drawing rollers at *i*, forward to the front end of the headstock.

6. The power of applying the headstock in the centre of the carriage, without the use of cranks, or connecting rods and joints for connecting the guides, which are in one length—this arrangement being advantageous for new mules, and capable of easy adaptation to old ones.

7. The backing-off motion, being worked by wheels, is capable of regulation to the greatest nicety.

8. The second draw, which is necessary for fine yarn.

9. The use of disengaging pulleys or friction pulleys *g*, with their peripheries indented at certain points, for the purpose of starting and stopping the several movements in connection with the cam shaft, with a steady and unbroken action.

The steel Plate represents Macindoe's patent self-acting mule. In this description, owing to the complication of the references in the plate, only those are given which render clear the peculiar principles of the mule.

[It appears that the first self-acting mule was invented in 1793 by Mr. W. Strutt, of Derby, and the second by Mr. W. Kelly, of Lanark Mills, in 1792, but both were abandoned. About 35 years afterwards, two patents were granted on one day to two parties for self-acting mules. Since these were granted, about 20 others have been obtained for a like purpose, and their success has been as varied as their number. The machine is a wonderful industrial automaton.—R. E.]

25 McNAUGHT, WILLIAM, 26 Robertson Street, Glasgow  
—Inventor.

Coats's patent self-acting bobbin-making machine, intended for the manufacture of spools used in making-up sewing thread. It is capable of turning off two dozen of spools per minute, or about three times as many as can be done by the hand-machine. These are delivered on the lathe arbor, and are finished, and withdrawn in the finished state, by the machine.

27 CALVERT, F. A., 32 Cannon Street, Manchester—  
Inventor and Patentee.

Patent machines for wool-burring and cotton cleaning, for carding and cleaning fibrous substances, and for ginning cotton, or separating the seed from the fibre, as produced on the plantation.

Patent method of constructing burring and carding cylinders.

28 PATERSON, T. LUCAS, Glasgow—Inventor and  
Patentee.

Model of a patent machine for winding worsted, woollen, cotton, or linen yarn from the hank, upon the shuttle-cop or pirn; its object is to save waste, and produce an improved "build of cop," at reduced cost.

29 JORDAN, WILLIAM, 43 Hilton Street, Manchester  
—Inventor and Manufacturer.

New warping-mill iron-creel, for silk. The bobbins or reels are made to pass each other, forming the lease instantly, instead of the warper soiling and ruffling the ends with his fingers, so that the twister-in or weaver can separate every end in the warp with facility.

Warping-mill heck, of 224 eyes, with (new) inclined crossing motion, for cotton.

M  
SELF  
P

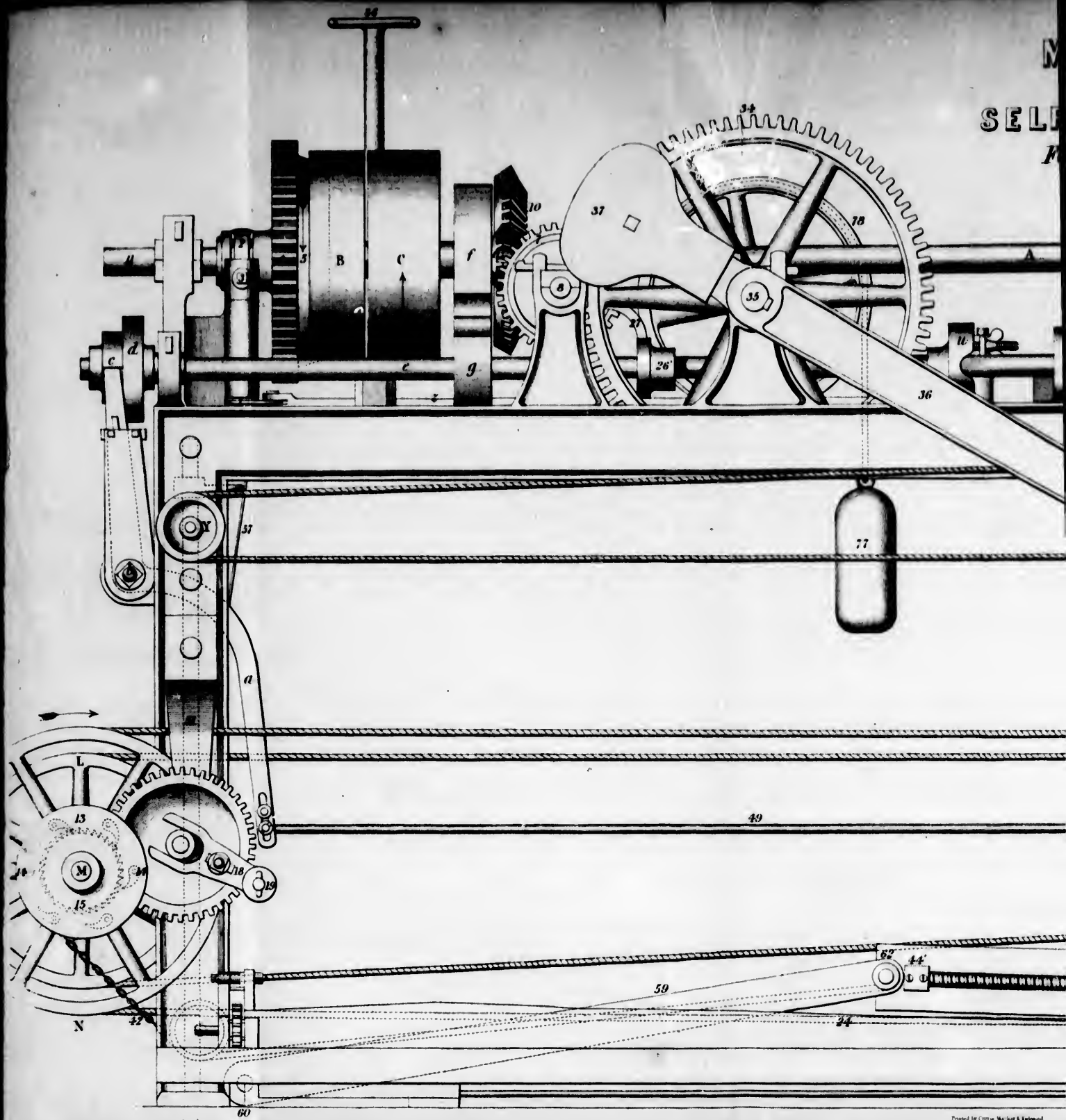

# MACINDOE'S SELF-ACTING MULE. FOR COTTON SPINNING.

*W. Johnson, Patent Office,  
London, Glasgow & Edinburgh.*

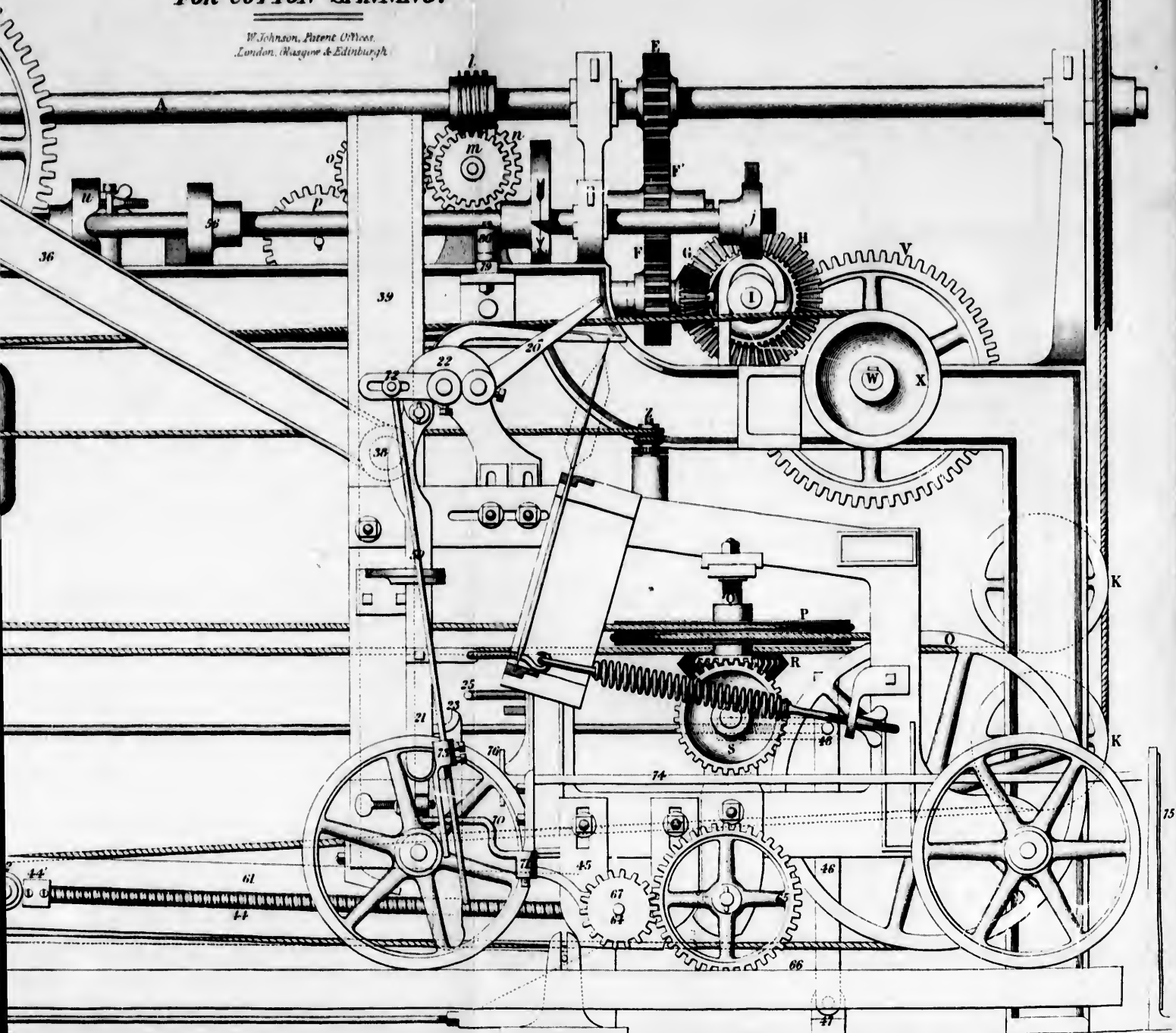

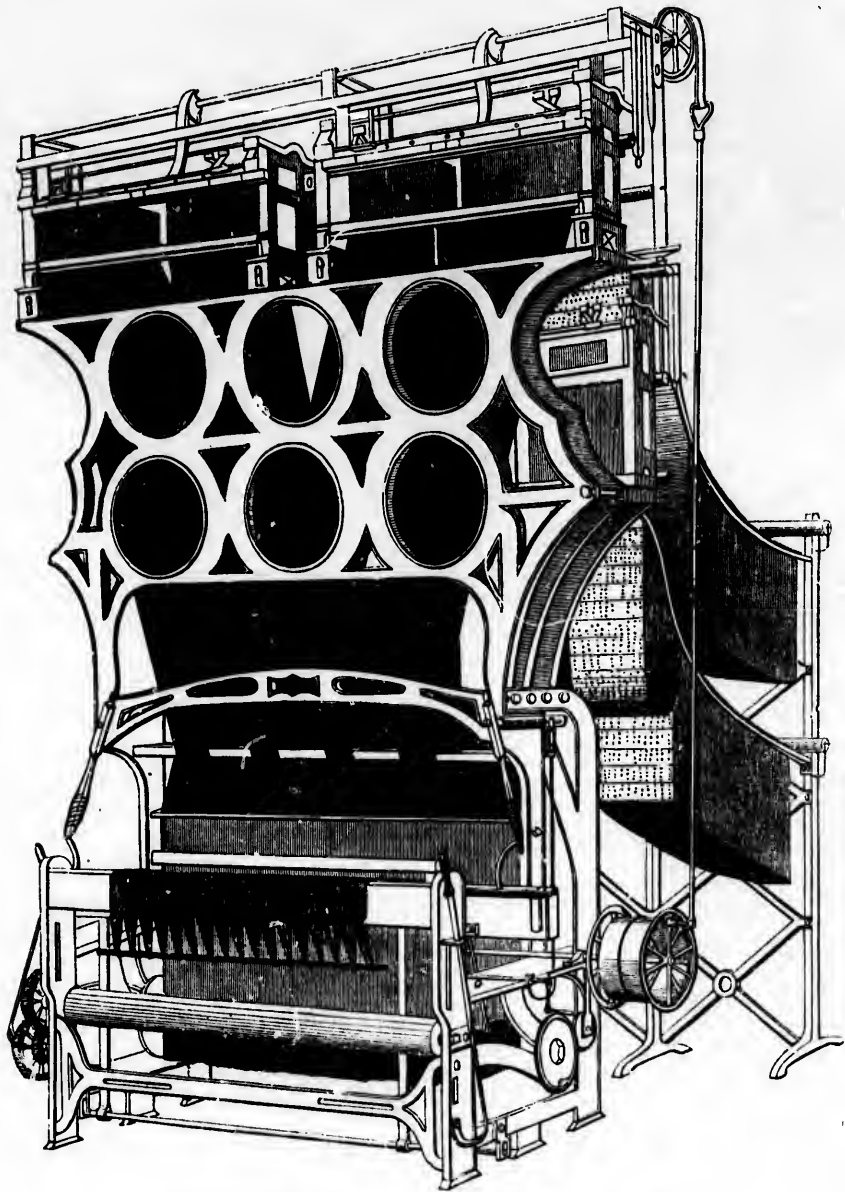

Taylor &amp; Son's Large Jacquard Loom for the production of Figured Furniture Damask.

NORTH AREAS A. B. 10 TO 31; C. D. E. 1 TO 10, &amp; 19 TO 33; G. H. 25, 26.

**30 DE FONTAINE MOREAU, PETER A., 4 South Street, Finsbury—Importer and Proprietor.**

Novel apparatus for the working of spindles without straps or cords, for spinning all fibrous substances, and adapted for all spinning machines. The advantage is said to consist in the suppression of cords and straps, in the production of a regular and invariable rotation to the spindles, and consequently a regular tension to the threads. The friction and, consequently, the wear and tear, are said to be diminished, and less than the usual amount of power to be required.—Patented.

Apparatus for replacing the Jacquard machine for weaving figured fabrics and tissues; composed of a cylinder, provided with moveable pegs. When the cylinder rotates, the hammer, in contact with the pegs, is thrown back, and raises the threads of the warp: the apparatus has only 120 pegs, but can have any required number. It is stated that, by this invention, the cards so expensive in the usual Jacquard machine are dispensed with.—Patented.

Apparatus for extracting ores from mines and coal-pits. The object of this apparatus is said to be to replace all kinds of machines hitherto used, and especially the ropes, and to economise time.—Patented in England.

Elevator syphon apparatus, to work which an elevation of at least 33 feet is required: it is stated that the water taken at the curve of the syphon can be employed without any expense, as a motive power.

**32 CHALMERS, D., Manchester Wire Works—Inventor.**

New damask power-loom.  
Railway-break, calculated to prevent collision, and to act without shock.

**35 CRICHTON, D., 165 Bradford Road, Manchester—Inventor.**

Model loom, exhibiting a new principle of mechanical action on the yarn and cloth rollers, which impart their required velocities throughout the process of weaving. A mechanical movement, exhibiting the application of the principle in the loom; also its application in the roving-frame, to give the required velocity to the bobbins and the lifting-rail.

**36 CRICHTON, W., & Co., Great Bridgewater Street, Manchester—Machinists.**

Cotton-opener, on Samuel Hardacre's patent principle, being the application of the batting-stick in such a manner as to open from 40,000 lbs. to 50,000 lbs. per week of 57½ hours, requiring only 1½ to 1¾ horse power.

Framed drawing of double-beater lap machine, with fan attached.

**37 NIMMO & SON, 211 Cowgate, Edinburgh—Manufacturers.**

Spinning wheel, for spinning fine flax.  
A check reel, made to the uniform standard measure of Scotland.

A model wheel in brass, for producing fine yarn or twisted thread.

**38 MILLIGAN, WM., Bradford, Yorkshire—Inventor.**

Patent power-loom made by Hodgson & Haley, to show the taking-up motion. It is stated that this loom will put any number of picks into a given length of warp, and the number of picks may be altered without change-wheels or altering the weight on the yarn-beam, so that the warp may be kept as tight as its strength will bear, without making the cloth uneven; it has this advantage over any friction motion, that it will neither slip, nor fray the cloth; and it will weave wet web as well as dry.

**39 MACKENZIE, DUNCAN, 52 Burton St., Tavistock Square—Inventor.**

A reading machine for frames and Jacquard looms, including in one machine four different apparatus, namely

—the reader, the press, the repeater, and the knife; facilitating labour and economising expense; reducing to mathematical exactness operations which have hitherto been matters of uncertainty, and enabling manufacturers to employ persons of ordinary care and attention to read, punch, and recut their designs or patterns with quickness and ease.

**40 DONISTHORPE, GEORGE EDMUND, Leeds—Inventor and Proprietor.**

Double wool-combing machine.

**41 BARLOW, CHARLES, 89 Chancery Lane—Importer.**

Patent machine, for uniting by stitches all kinds of woven goods, and useful in making articles of wearing apparel. Two distinct threads are used, one of which appears at the back, and the other at the front of the fabric, so that each stitch forms an independent fastening. The seam thus produced is firm and regular.

**42 SUTCLIFFE, R., Idle, near Bradford—Inventor.**

Patent spinning frame, for spinning and doubling cotton, &c. The part patented is represented in the annexed cut. The dead spindle, or stud C, is fixed to the rail R, and traverses in the rail H. In the top of the stud a cavity is drilled, and in this cavity a small cylindrical spindle, B, revolves. This small spindle is attached to

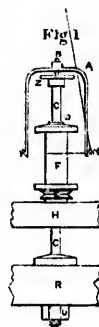

Sutcliffe's Patent Spinning Frame.

the flyer A, the flyer is drawn by the bobbin F, the bobbin is carried upon a revolving tube D, and the revolving tube is driven by a band from the cylinder. G is the eye of the flyer, which carries the thread. To prevent the small spindle and flyer from being jerked or raised from its place, it is made thicker at the lower end, and a brass cap Z, fitted accurately to the spindle, is screwed on the top of the stud, and thus the spindle is kept securely in its place. In this cap the patent consists. The drag is produced by the friction of the small spindle against the stud, and by the resistance of the atmosphere against the wings of the flyer.

[The objects attained by this process are a high degree of velocity, and a regularity in the tension or drag, so as to produce perfect evenness in the yarn. This frame works with a speed of upwards of 6,000 revolutions per minute.—G. T.]

**43 HENNING, JOHN, Cambray House, Waringstown, County Down, Ireland—Inventor.**

Cambrie loom; damask loom; machine for weaving damask, or other figured fabrics, on the Jacquard principle.

**44 SANDENAN, HECTOR, Tulloch Bleachfield, Perth—Manufacturer.**

Machine for stretching cloth after it has shrunk in the processes of bleaching, scouring, dyeing, printing, &c.



45 DE PERQUE, C., 9 *Dovegate Hill*—Inventor and  
Manufacturer.

Specimens of dents, and reeds or combs, complete, for weaving every description of fabrics, manufactured by patent machinery. This invention is intended to insure regularity in the reed, and uniformity in the fabric and in the shape and finish of the dents, so as to be less liable to cut or break the threads.

47 MARSLAND & Co., *Blackfriars, Manchester*—  
Manufacturers.  
Cotton-winding machine.48 BERRY, B., & SONS, *Bowling, near Bradford*—  
Manufacturers.

Machinery for the manufacture of worsted yarns, exhibited in operation; consisting of double gill box, open drawing, first process; double gill box, two spindles, second process; drawing head, two spindles, third process; finishing head, four spindles, fourth process; roving head, six spindles, fifth process; spinning frame, sixteen spindles on each side or thirty-two spindles, sixth process.

[This machinery exhibits the processes ordinarily employed in the preparation and spinning of worsted yarns, after the wool has been washed and combed. The slivers, or long fibres of combed wool, are prepared by being gradually drawn out in passing through a series of rollers of regularly-increasing velocity. When thus sufficiently extended and attenuated, they are sent forward to the spinning frame, where they are further drawn out, receive the twist requisite to give strength to the yarn, and are wound upon the bobbins. A yard of these slivers is thus drawn out into about 2,000 yards of yarn.—G. T.]

49 HUNT, ENOCH, *Nailsworth*—Inventor and  
Manufacturer.

A gig-mill, on an improved principle, for dressing cloth, by which the process of dressing with teasels is proposed to be finished in considerably less time than usual, and without removing the cloth from the machine.

50 ELLIOTT & HEYS, 93 *Mill Street, Manchester*—  
Inventors and Patentees.  
Improved loom.51 TAYLOR, J., *Victoria Road, Leeds*—Manufacturer.  
Specimens of heckles.52 JUDKINS, CHARLES FIOT, *Manchester*—Patentee.

Heald machine.—The machine shown in the drawing, fig. 1, is so constructed as to double and twist the single yarn, and at certain points it braids or plaits the yarn, thus forming the eye or loop of the heddles, without knots of any description, the whole shade or leaf being of one continuous cord. The drawing also shows a small sample of the healds made by the machine, with the eye or loop, as described, which is coated, lined, or covered with a metallic substance suitable for the purpose, which coating or covering has also been patented by the same party. The assumed advantages of these healds are as follows:—One set will outlast fifteen sets of any other sort; more yards of cloth can be produced through them per week, and at the same time the cloth is more perfect, and will weigh heavier per piece, owing to there being less friction upon the warp than is usually caused by the ordinary healds.

Set of healds produced by the machine.

Patent self-acting machine, for closing metal upon the eyes or loops of healds.

Sewing machine (Fig. 2).—This machine is very simple in its construction, and suited to sewing either a circle,

curve, or straight line, at the rate of 500 stitches per minute. But for a circle or curve the straight rack is removed, and one of a circular form applied to the side of the machine. This rack, in which the cloth is placed, is moved forward by means of a spring, at a given distance for every stitch. There are two threads employed, one of which is carried in the shuttle, and the other taken from a reel on the top of the machine, and passed through the cloth by the point of the needle, so that when it is withdrawn from the cloth both threads have been locked together, forming a firm and durable stitch.

Fig. 1.

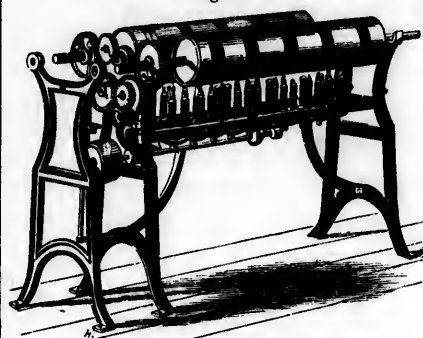

Judkins' Heald Machine.



Sample of Healds.

Fig. 2.

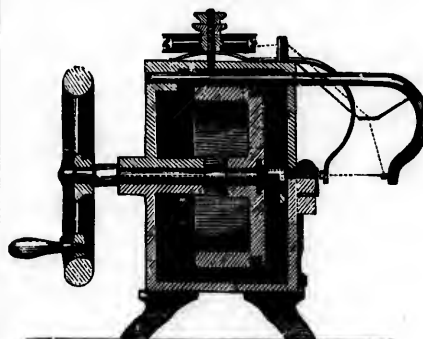

Judkins' Sewing Machine.

53 PLENTY, JAMES & EDWARD PELLEW, *Newbury, Berks*—Inventors.  
Machine for tarring yarn.54 ROBINSON, RICHARD, *Belfast, Ireland*—Inventor,  
Designer, and Manufacturer.

Flax-seeding machine, intended as a substitute for the common process of beating off the seed vessels, or rippling them on an iron comb, and then breaking them to release the seed. These operations are performed at once by this machine. It may also be used for crushing linseed, corn, or beans for feeding.



Flax straw (*Linum usitatissimum*; Fr. *Paille de lin*; Ger. *Fluchstropf*), grown in the county Down, Ireland, to show the application of the machine.

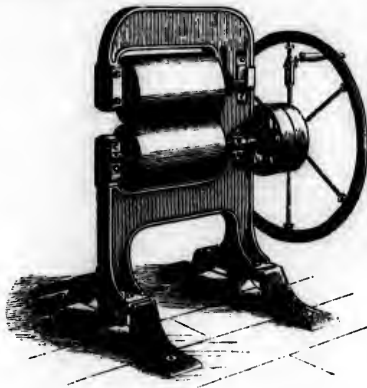

Robinson's Flax-seeding Machine.

55 BINNS, WILLIAM, *Bradford*—Manufacturer.  
Six-pitch wool combs, used in the preparation of wool for the Bradford worsted stuff trade.

56 BROWNE, THOMAS BEALE, *Hampton Andover's Ford, Cheltenham, Gloucestershire*—Inventor.  
Loom for sail-cloth.  
Tarpauling, without seam.  
Flax tube sacks of mixed flax and hemp, wove without seam.  
Flax coats, perfectly waterproof.  
Flax damasks, cambrics, velvets, and cords.

57 & 58 GAINES, SANDERS, & NICOL, *Birchin Lane, Cornhill*—Manufacturers.  
A model showing the manufacture of silk hats on cork and linen bodies, with the workmen as employed in the different processes.  
A model showing the manufacture of felt caps or jerries, with the workmen employed in the processes of bowing, felting, blocking, &c.  
Finished ventilating hat on cork body covered with French velvet. Finished felt cap or jerry, with samples of the different materials of which it is composed.  
Model of a hat factory.

59 SMITH, J., *Orchard Street, Galston, Ayrshire, Scotland*—Inventor.  
Improved spelf-machine, applicable to fabrics of small design, out of the range of traddles.

60 GATENBY & PASS, *Manchester*—Manufacturers.  
Reeds or combs, applied for weaving textile fabrics, manufactured by steam-power. Designed to improve the appearance of the cloth, and allow coarser yarns to pass through the same reeds than can be done by the ordinary method.

61 ILES, CHARLES, *Bardesley Works, Birmingham*—Inventor and Manufacturer.  
Machine for sticking pins in circular tablets, to be worked by steam power. The use of the above machine is to fill patent circular embossed tablets or pin-holders in an ornamental character, which are made of various materials, but generally card-board.

62 DICKINS, T., *Middleton, Lancashire*—Inventor.  
Working model of a mill, or apparatus for warping silk or other fibrous threads, by which a large number of bobbins may be employed; exhibited for equality of tension, accuracy, and ease in working.

63 RIGOE & Co., *Kendal*—Manufacturers.  
Sheets of card, of different qualities, used for carding wool.

[The card for cotton wool is a peculiar instrument, formed of a leather foundation, in which are inserted large numbers of minute wire teeth. Cards are employed for the purpose of straightening out the fibres of cotton wool into a uniform sheet or lap. In cotton machinery, the card is applied to the surface of a wooden drum, which acts upon similar drums, and which presents the cotton in a smooth and uniform sheet of great slenderness. In some ingenious machines the leather is cut, perforated; the wire bent, cut, and inserted by automatic arrangements.—R. E.]

64 CROSS, CHARLES, *19 Gutter Lane, Cheapside*—Producer.  
Model of loom for plain weaving.  
Model of loom for Jacquard weaving.

65 SEARLE, HENRY, *Hoxton Old Town*—Manufacturer.  
Lint machine, with the material in process of manufacture.

66 WATKINS, W. & T., *Bridge St., Bradford*—Inventors.  
Ironstone porcelain guides, used in the roving and spinning of worsted, silk, cotton, flax, &c.

67 VICTORY, J., *St. Leonard's, Hastings*—Manufacturer.  
Specimens of lathe tools.

68 JAQUIN, CORNELIUS, *7 New Street, Bishopsgate Street*—Designer and Manufacturer.  
Fly-press for punching metal, &c., for buttons.  
Lever press, for raising, drawing, piercing, &c., discs of metal for buttons.  
Various tools, in sets, as used and fitted to the machines. Various specimens of articles as produced by the machines. Loop for label made by machinery.

69 SLATE, J.—Manufacturer.  
Twine-reels.

70 STEANE, J. BURGESS, *Nottingham*—Inventor.  
Carding machine, used in "making-up" or boarding gimps, bindings, or fancy trimmings.

71 THOM, J.—Inventor.  
Sulphuring apparatus.

72 TAYLOR, EDWARD, *Kinghorn, Scotland*—Manufacturer.  
Superior heckles for linen manufacture; two of these are for hand-dressing, and the rest for the finest description of machine heckling.

73 SMITH, J. W., *48 Fleet Street, Leicester*—Inventor.  
Needles, for stocking-frames.

74 PLUMMER, ROBERT, *Newcastle-upon-Tyne*—Inventor.  
Patent machines, viz., rotary disc scutching machine, for flax, hemp, &c; with straw holders, and with straw to scutch. Flax-breaking machine, for flax straw previous to being scutched. Flax-cutting machine, for preparing flax for the cut-flax heckling machine. Heckling machine, for dressing flax, hemp, &c.; with flax holders, and with flax to dress. Flax holders, of various improved forms, showing the application of gutta percha to these implements.

The engraving exhibits the metal disc for scutching flax, with the brushes fitted to it. The disc is seen in fig. 1 from above.

The cut, fig. 2, represents a front elevation of the rotary disc scutching mill. A is an axle having its bearings in an

Fig. 1.

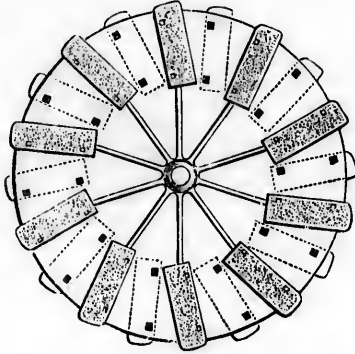

Fig. 2.

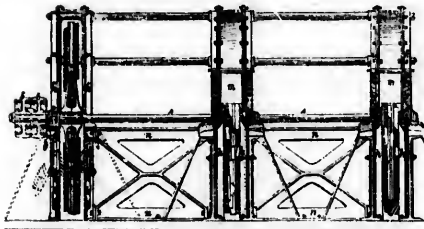
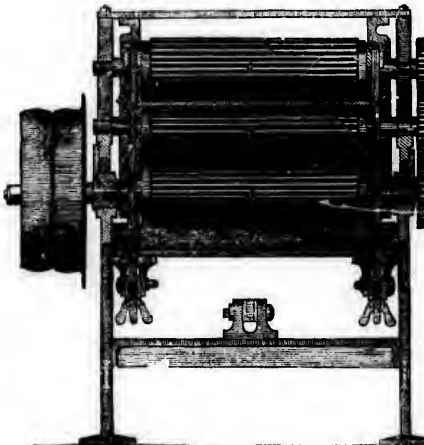

Fig. 3.



independent framing, *k* and *k'*, of metal; the upper portion being made open with a lining of dials, *l*, *l'*; the metal piece *m*, *m*, at the front end being secured by three bolts can be readily removed for the purpose by changing the brushes in the discs. The framing is stiffened by cross pieces, *n*, *n*; *b*, *b*, are pulleys by which a rotatory motion

is imparted to the axles. The top, *t*, of the scutching board, *h*, is placed a little above the centre of the axle, *A*. The heckle or comb *o'* is composed of steel wire.

Fig. 3 is a front, and fig. 4 is a side elevation of an improved flax-breaking machine. The letters *b*, *c*, and *d*, are placed upon the grooved metal rollers, to which the flax is presented, as seen in fig. 4, by the direction of the arrow.

Fig. 4.

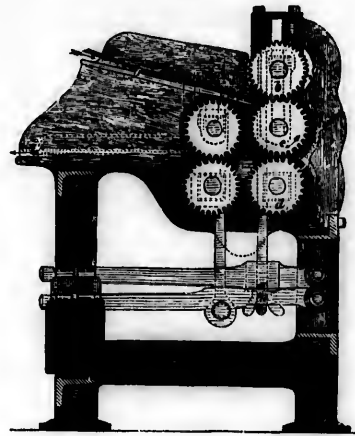

Fig. 5.

Fig. 6.



Figs. 5 & 6 represent improved holders for flax heckling.

Fig. 7.

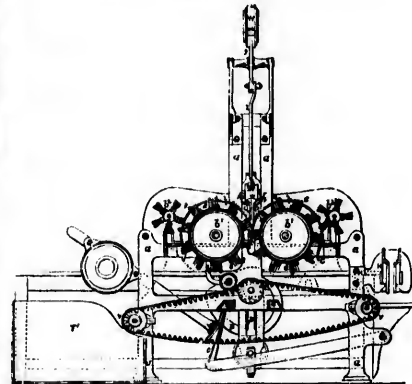

Figs. 7 & 8 represent a side and end elevation of the double cylinder heckling machine, adapted to the dressing cut or short flax, in which elastic brushes are combined with rigid heckles. There are two revolving cylinders, *b*, *b'*, mounted in a framework *a*, *a'*; added to their peripheries are sets of rigid heckles, *c*, intermixed with the

sets of elastic brushes *c*, *c* (in any way that may be deemed most advisable). The cylinders are also made to revolve inwardly or in opposite directions, and the rows of brushes and heckles on the one cylinder are placed in an alternating order in regard to those of the other cylinder, as before described. There are also loose stripping bars with guards, that, besides regulating the depth to which the heckles or brushes shall penetrate, doff or throw down the tow from the brushes and heckles, and two smaller cylinders *b'* *b'* fitted with brushes for cleaning the working brushes and heckles *c*, *c*'.

Fig. 8.

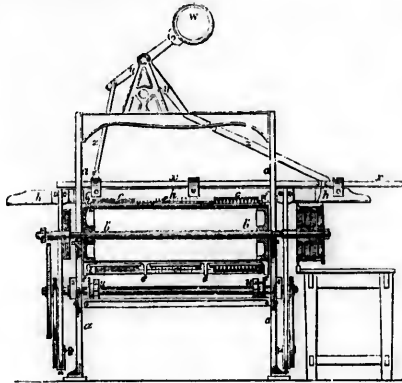

One of the cylinders, *b'*, may, if required, be made to oscillate by means of the link *A'*, *A'*, which, as it rises and falls with the lifter to which it is attached, moves the cylinder in a horizontal direction to and from the other cylinder; the bearings of the oscillating cylinder being made to slide, and attached by a rod to the radius arm to which the stud pin of the wheel *m'* is fixed, the whole of the wheels, *A*, *b*, *m'*, and *n'*, are thus kept in gear, to answer the varying position of the oscillating cylinder. Rotation is given to the rotating parts of this machine as in the one first described, but the holder is made to traverse or move forward in the trough (which movement may also be applied to the brushing machine) by the combination of a bell crank movement with the rising and falling motion of the trough, as afterwards described. The mechanism for lifting the trough *A*, is shown in fig. 8, and consists of a combination of pinions *k* *k*, wheels *m*, *n*, cam *p*, straps *o*, pulleys *q*, and levers *r*, *s*, such as is ordinarily used in heckling machines, and well known. When the trough is raised, it pushes up a rod *x*, which is connected to the long arm of the bell crank *y*, mounted on a standard affixed to the top of the frame-work *a*, when a weight *W*, which is attached to the opposite end of the arm, falls over, and causes the short arm of the bell crank to pull in a rod *z*, which draws forward a finger bar *x* (of the ordinary construction) to an extent sufficient to advance the holder the breadth of one set of heckles or brushes. The tow and shive or dirt doffed or thrown down from the heckles or brushes is in this case received upon an endless chain of bars *t*, *t* (instead of the inclined grating represented in the machine first described), which bars extend the whole length of the machine under the heckles and brushes, and are connected together by two side bands *l*, *l*. The chain of bars revolves round two friction pulleys *v*, *v*, and takes into two pinions *u*, *u* (one on each side); by means of which pinions rotation is given to the chain from the same first mover by which the other parts of the machine are put in motion. The shive or dirt falls through between the bars on to the floor, while the tow is carried forward on the top of the bars, and delivered into the trough *T*. To separate the tow doffed from each set of heckles or

brushes, the space between the endless chain of bars and the cylinders is divided by partitions *a*, *a'*, fig. 1, into as many compartments as there are sets of heckles or brushes; and the receiving trough *T* is also divided into a corresponding number of compartments.

A view of the holder, for this machine, is given in fig. 5, a cross section, and fig. 6, a longitudinal section. It consists of two plates, Nos. 1 and 2, connected transversely by a screw bolt *S*, and having flanges *A*, *A*, at their upper edges, by means of which they are supported in the trough *h*. The plate No. 2 has two flanges *B*, *B*, one on each end, which come within the flanges *A*, *A*, of the plate No. 1, and thereby confine the streak at the edges. The inner face of the plate No. 2 is planed perfectly true, and covered with felt, cloth, or some other soft or yielding material; *h* at the plate No. 1 is made on its inner face with flat beads *C*, and flat grooves *D*, in alternate order, so that the streak of flax or other material may be the more firmly compressed between the plates without being unduly crimped. At their under edges *E*, the plates are chamfered off to admit of the holder coming lower down. By this mode of construction, the pins or studs ordinarily made use of to confine the outer edges of the streaks, are dispensed with, and a greater breadth is obtained whereon to spread the streaks, and the holder is also narrowed and rendered more easy to work.

Raw materials in illustration:—English flax seed. Flax straw from Northumberland and Durham; and flax fibre cut dressed line. Russian, Irish, and New Zealand flax, as imported, and when rescutched; also Russian hemp rescutched.

Manufactures in illustration:—Yarn, from flax dressed by the patent heckling machine; and canvas woven from the same. Yarns, spun on Peter Fairbairn & Co.'s (Leeds) new patent long line, rotary gill, spinning frame; and canvas made from these yarns.

75 LAWSON, SAMUEL, & SONS, Leeds.—Inventors and Manufacturers.

Patent heckling machine for long flax.

Spiral flax-spreader for long-flax. The patent spiral or screw-gill frame was invented by Samuel Lawson and W. K. Westley in 1833. The spiral gill machine is adapted for drawing flax, tow, hemp, and silk waste. The sheet spreader or table was invented and used by Mr. Westley, at Hunslet Mill, near Leeds, in 1821. This simple contrivance was a great boon to the poor females employed in spreading flax, for by its assistance they can either sit or stand in a comfortable position; whereas, on the old plan, or long-board spreading, one girl was obliged to walk at least from 20 to 30 miles per day, in an inclined position, to spread one-tenth of the flax which she now effects in a sitting posture.

Spiral or screw-gill second drawing-frame for long flax.

Spiral or screw-gill roving-frame for long flax, with an improved spindle-steadier.

Circular iron tow-card, clothed with patent iron clothing made by Birkby.

Patent double-screw tow drawing-frame

Patent roving-frame, with improved spindle-steadier.

Tow spinning-frame, for dry spinning, with improved tension-pulley, for driving spindles which are always kept up to their speed.

Flax-cutter.

Pair of patent cylinder heckling machines for cut flax.

Spiral spreader for cut flax.

Spiral second drawing-frame for cut flax.

Patent spiral sliver roving-frame for cut flax, invented by W. K. Westley.

Spinning-frame for fine Nos. of yarn, with improved plan of driving the spindles, calculated for spinning the sliver rove.

Twisting-frame for making thread, with improved plan of driving the spindles.

[Common flax is the delicate tenacious fibre surrounding the stems of the *Linum usitatissimum*, a plant which is extensively cultivated in different parts of the world, not only for the sake of its fibre, but also for its seed (linseed).

the scutching of the axle, feel wire.

rotation of an s b, c, and d, to which the direction of



ax heckling.

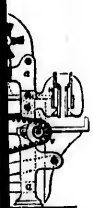

ation of the the dressing the combined cylinders, to their peri- with the

the oil of which is much used. Great Britain is supplied with flax from Russia, the Netherlands, Prussia, and France; small quantities are also received from America, Italy, and New South Wales. The cultivation of flax also forms an important part of the agriculture of Ireland.

When the crop has been pulled, the bolls or seed-heads are separated by rippling. The rippler is an instrument like a comb, with smooth round teeth of iron standing about 12 inches out of the wood, and placed so closely together, that the bolls cannot pass through. By drawing the flax, a handful at a time, through the teeth of this comb the seed-heads are separated from the stalks.

The flax is then steeped, or retted, in ponds or in running streams, in order that the fibre may be separated from the woody portion of the stem. When the flax is exposed to the influence of dews and rain, instead of being steeped, it is called dew retting. In mixed retting the flax is first macerated in water, and the retting is completed in the air.

When the flax is dry, the woody portion, or the *boon*, is separated by breaking. The common brake consists of four wooden swords fixed in a frame to which another frame with three swords is attached by means of a joint, the blades of one frame playing into the interstices of the other. The flax being placed between the two frames, the upper frame is pushed down upon the lower, and by moving the flax about, and repeating the operation, the boon is broken into fragments. The boon is also broken up more expeditiously by passing the flax between rollers.

The object of the next operation, scutching, is to separate the broken boon. This is done by striking the bruised flax with the edge of a flat wooden sword or *scutcher*, or when the operation of breaking is performed by rollers that of scutching is combined therewith: a number of arms projecting from a horizontal axis are made to strike the stalks in a slanting direction until the useless parts are beaten away.

The flax is next divided into lengths. The whole length of the flax varies from 26 to 30 or 36 inches. The part nearest the root is coarse and strong, the middle part fine and strong, and the upper part still finer but not so strong. The flax is divided into three lengths, and the parts from the bottom, middle, and top being collected into separate heaps, or stricks, several qualities of thread are afterwards formed from them. In some cases flax is divided into four or five lengths, called middle, ends, and middle and end-middles. In making these lengths, the ends are required to be rough or jagged; for which purpose the flax is held at both ends, and passed between two pairs of wheels, situated one pair on each side of a wheel furnished with oval teeth: the two pair of wheels hold the flax firmly while the centre wheel, moving with great velocity, divides or tears the flax asunder.

The flax is next heckled. By the process of heckling, the filaments of flax are cleaned, split, separated into fine fibres, and arranged in parallel order. The short fibres which are unfit for spinning, together with dust or dirt, are also removed. The heckle, or haeke, is a comb with iron or steel teeth one or two inches long, very sharp and smooth at the points, and arranged at equal distances upon a block of wood. A number of heckles are in use of various degrees of fineness. In using the heckle, the man seizes a strick, or lock of flax, by the middle, throws it upon the points of the coarse heckle and draws it towards him, at the same time with the other hand spreading the flax and preventing it from sinking too deeply among the teeth. By this operation

the flax is divided into two parts, namely, the short fibres forming tow, which remains between the points of the heckle, and is from time to time removed, and the long fibres called line, which remains in the hand of the heckler. One half of the length of the strick being properly heckled, the other half is turned round and prepared in a similar way. The process is then repeated on the fine heckle, and continued until a fibre of the required degree of fineness is produced.

In the heckling machine, a portion of the strick is spread out and held fast in an iron vice or holder. A number of these are then conveyed to a sort of revolving drum, and hooked on at distances of a few inches from each other, their unsupported ends falling on an internal drum covered with sharp heckling teeth, and revolving with considerable velocity, and in a contrary direction to the external one, the motion of which is slow. When one machine has performed its work, the holder is thrown off upon a rail from which the machine-minder removes it to the second heckling machine, where the other side of the strick is heckled; from the second it is removed to a third, where the points are finer, and so on until the line is sufficiently fine.

The tow produced in the above operation being similar to cotton in its fibre, cotton machinery in a modified form has been applied to the spinning of tow.

The heckled line is sorted according to its fineness, and is then converted into ribands or slivers. For this purpose it is arranged upon a feeding-cloth in such a way, that the ends of the second strick shall reach the middle of the first. As the heckled stricks are thicker in the middle than at the ends, a uniform thickness is thus preserved. The flax is passed between one pair of rollers, which deliver it through gills or heckling points to a second pair, which, moving with greater speed than the first, increase the length and diminish the thickness of the sliver, which is received into a tin can. A number of these cans being filled, the slivers are doubled and drawn, as in the manufacture of cotton yarn. The spinning of flax does not greatly differ from the throstle-spinning of cotton; but as the fibres of flax have not the same tendency to combine together as in cotton, it is necessary to moisten them with water to make them adhere to each other during the process of spinning, and also to render them more pliable and easy to twist. The water used is either of the ordinary temperature of the atmosphere of the mill, or is warmed to 120° Fahr. The water is contained in a trough which extends the whole length of the spinning frame.

Yarn is made into linen thread by doubling; it is then bleached and formed into balls or wound upon reels into hanks. The size or fineness of linen yarn is reckoned by the number of leas to the pound weight; this varies from 15 to 150 or 240, and from that to 300 and 400.—C. T.]

77 PARKER, C. E. & C., Dundee, Scotland—Inventors and Manufacturers.

Parker's patent mathematical power-loom for weaving navy sail-cloth, and other heavy fabrics. The warp is delivered from four beams at the same time, or from bobbins without any beams. The delivery of the warps regular and uniform, which secures uniformity in the weaving, the number of weft-threads being the same in any given space. The taking-up motion is so arranged that the tension or strain on the warp may readily be adjusted to yarns of different strengths or cloth of different weights, and uniformly maintained from the beginning to the end of the web. The loom is self-acting in all its parts, and from the commencement to the termination of the web, no change or alteration is required.

- 78 CRAWHALL, JOSEPH, *Newcastle-upon-Tyne*—  
Inventor.  
Improved patent machine for manufacturing ropes.

- 80 DAVENPORT, JOSEPH L., *Derby*—Manufacturer.  
Silk-throwing machinery, for the conversion of raw silk into threads, made at Derby, by Mr. William Abell.  
Engine for winding and cleaning. Mill for spinning or twisting one or more threads.  
Frame for doubling or uniting on one bobbin two or more threads, either before or after the process of spinning.  
Machine for reeling the thrown thread into skeins.  
"Dramming" apparatus, for ascertaining the relative thickness of the silken threads.

[The history of the manufacture of silk in England has peculiar associations with the town of Derby. Until the commencement of the eighteenth century, England was dependent entirely upon Italy for thrown silk for the purposes of the weaver. Machinery made at that time in England failed to accomplish the manufacture satisfactorily. A Mr. Lombe went to Italy, succeeded by artifice in gaining admission to the mills, and gained an entire insight into the method of manufacture. Escaping at the hazard of his life, he returned to England; erected a large mill on the Derwent, near Derby, where the manufacture was shortly established, and soon attained great prosperity. The machinery now employed for this purpose is of great ingenuity, and exhibits the peculiar characteristics of the mechanical workmanship of Great Britain.—R. E.]

- 82 BARLOW, ALFRED, *26 Bread Street*—Inventor.  
Patent double-action Jacquard loom, for the expeditious weaving of figured goods by the use of counterpoised griffs

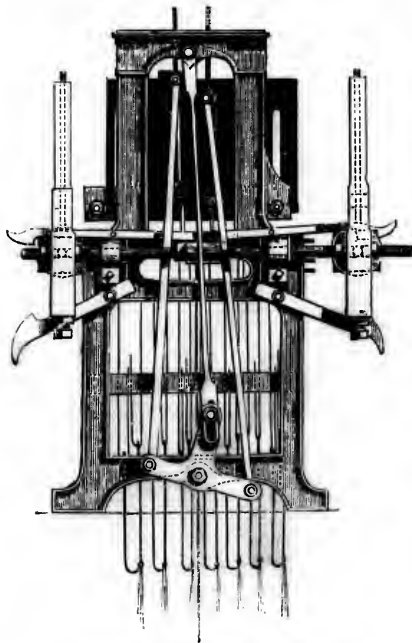

Barlow's Patent Double-action Jacquard Loom.

and apparatus for simultaneously raising and lowering different portions of the suspending wires; applying two barrels or cylinders and two sets of cards; and constructing hooked wires for giving motion to the harness or heddles.—Patented in Great Britain, Ireland, the colonies, France, Belgium, Prussia, and Austria.  
The figure represents the upper part of the loom, showing its peculiar principles.

- 84 FROST, J., *Macclesfield*—Inventor.  
Models of improved silk winding machine and cleaning frame.  
Model of a machine spinning and doubling at one operation.  
Model of a throwing mill, in which the spindles are turned by friction.  
Throwing mill, with spindles turned by friction. Iron roller inlaid with wood, placed in segments, turns a spindle with iron warf, is stated to give regular spin, take less power, and stands in less space than common throwing mills.  
Improved winding engine.  
Cleaning tram; the cleaners are fitted up with a slop, so as to be fixed on the guide rail, to answer the purpose of the eye or guide.  
Spinning and doubling machine, which works two operations by one process, and can be converted into a tram doubler.

- 85 REED, THOMAS SADLER, *Siddal's Lane Mills, Derby*—  
Inventor.  
Patent power-loom, for making fringes and like fabrics without the use of shuttles.

- 86 CLAUSSEN, P., *26 Gresham Street*—Patentee and partly Inventor.  
Circular hand-loom, for weaving looped fabrics, elastic cloth, &c.—Manlove and Alliott, proprietors.

- 87 GARDNER & BAZLEY, *Nottingham*.  
A 48-spindles' doubling frame, for the production of lace-thread, in which the motion is communicated to the spindles by conical contact, without the aid of cords or bands. During the Exhibition, it will be worked, and will produce No. 160 lace-thread.

- 88 HUDSON & BOTTOM, *Nottingham*.  
Lace-dressing machine.

- 89 CARVER, THOMAS & THOMAS GILBERT, *Nottingham*—  
Proprietors and Manufacturers.  
Model frame for weaving stockings.

- 90 BALL, DUNNICLIFF, & Co., *Nottingham*—Manufacturers.  
Warp-lace machine, making plain blonde.

- 91 COWSLADE & LOVEJOY, *Reading, Berks*—Inventors.  
Self-inking platen hand-printing press, consisting of an adaptation of an inking apparatus to the ordinary press. By one turn of a handle attached to a spindle, the carriage and tympan are rolled simultaneously in opposite directions, the type receiving ink at one end of the platen, and the tympan the blank sheet at the other. A reversed action of the spindle brings them together, beneath the platen, there to receive the impression. The printed sheet is freed from the form by springs attached to the tympan, which rises with the platen.

- 92 SEWELL, THOMAS ROBERT, *Currington, near Nottingham*—Inventor and Manufacturer.  
Machine for making bobbin-net lace. Figured and plain net, made by the machine.



94 BIRKIN, RICHARD, *Nottingham*—Manufacturer.

Machine, on Leaver's principle, for the production of bobbin-net lace, ornamented and embroidered by the Jacquard; adapted for the production of lace articles of different patterns, in either silk, cotton, or other filamentary materials.

95 FUSSELL, F. RALPH, *Nottingham*—Designer.

Two pictures illustrative of the Nottingham lace manufacture.

96 BURTON & EAMES, *Lenton Works, near Nottingham*—Proprietors.

Patent gassing machine, for burning the loose fibre from lace, muslins, and other goods, thereby giving them a more thread-like appearance, without injuring the fabric. Exhibited to show the process of gassing lace, as practised in the town and neighbourhood of Nottingham.

[The operation of "gassing" consists in causing lace, thread, or similar delicate tissues, to pass with such velocity through or between jets of gas as to singe off the loose fibres, without injury to the fabric itself. It was formerly effected by passing the fabric over heated iron cylinders.—R. E.]

100 FOURDRINER, G. H., *Hanley*—Inventor and Manufacturer.

Patent steam press, for printing the impressions which are to be transferred to earthenware or china.

Patent oscillating double-piston steam-engine, with potter's flint and colour mill.

Original model of the exhibitor's patent paper machine. Specimen of the exhibitor's pottery tissue paper, in one continuous length of upwards of  $2\frac{1}{2}$  miles. Manufactured from old coal-pit ropes and hawsers.

[The pottery tissue paper is prepared exclusively for the purpose of transferring the impressions of designs from copper plates to earthenware in producing the ordinary patterns.]

102 HARNING, PULLEIN, & JOHNSON, *Guildhall Chambers*—Proprietors.

Patent anotype machinery. Self-acting machine for the manufacture of printing type from copper, zinc, or other metal, without heat, by means of dies and powerful pressure; its object is to produce a letter of more exact form than usual; and it is stated that the metal, hardened by the compression to which it is subjected in the process of manufacture, attains a durability estimated at sixty times that of ordinary cast type.

Machine for dressing the letter after leaving the first machine.

Machine for regulating the height of the types, so that, when set up in pages, their faces may be perfectly even.

Other objects contemplated by this invention are economy of type and ink, and greater resistance to pressure.

103 UNDERWOOD, T., *Birmingham*.  
Lithographic colour press.104 SHERWIN, COPE, & Co., *5 Cumberland Street, Shoreditch*—Inventors and Manufacturers.

Printing press, for letter-press printing, possessing a simple combination of levers, and economising labour.

Arming-press, for bookbinders. By the simplicity of its parts great power is obtained, and the arrangement of its table allows of different thicknesses to lay on.

108 TIDCOMBE, GEO., *Watford*—Manufacturer.

Machine for cutting paper in the continuous sheet.

[Paper manufactured by machine is made into a continuous web the width of the machine. As it runs from

the drying apparatus it passes through the cutting-machine, where it is first slit into several continuous bands: this is effected by means of a series of circular shears formed of circular discs of steel, adjustable on two parallel axes common to the series. The bands then pass on to a kind of shears placed transversely, and acting at predetermined intervals, the paper being arrested at the point of division by the mechanism, without stopping its onward progress through the slitting-shears. Mr. T. B. Crompton, in conjunction with Mr. E. Miller and Mr. (now Professor) Cowper, obtained patents in the same year, 1828, for the cutting apparatus applicable to the above purpose: since this period several other very ingenious machines have been devised.—W. D. L. R.]

110 SHAW, W., *8 Bachelor's Walk, Dublin*—Manufacturer.

Improved machine for ruling paper.

112 WILSON, G., *27 St. Martin's Court, Leicester Square*—Inventor and Patentee.

Diagonal paper and mill-board cutting machine. Perpendicular paper-cutting machines.

114 GREIG, DAVID & JOHN, *Lothian Road, Edinburgh*—Designers and Manufacturers.

Iron lithographic press, 30 inches by 45 inches, with Gothic frame, eccentric pressure by side lever, and frame for registering coloured printing, counter-balance weights for bringing out carriage, and stoppers.

Iron lithographic press, 22 inches by 23 inches, with side levers, circular cross-head, ornamental frame, and stoppers for stopping carriage.

Iron lithographic press, 18 inches by 27 inches, with side lever, a kind of press much used.

Specimen of 18-inch copper-plate press, with single motion.

Portable fanners for cooling apartments in hot climates, suggested by Captain Davidson, 18th Bombay Infantry.

116 MARRIOTT, WILLIAM, *Leeds Road, Huddersfield*—Inventor.

Registered machine for packing in paper packets any dry substance, such as coffee, calico, &c.; with an improved and continuous printing apparatus for printing the label before pasting it on the packet.

118 COOKE, H., *High Street, Oxford*—Inventor.

Printing apparatus of a new construction, designed to give increased facilities to the compositor.

120 NELSON, T., jun., *Hope Park End, Edinburgh*—Inventor.

Working model of a new printing machine. Illuminated book-titles.

121 ULLMER, E. and W., *110 Fetter Lane, London*—Inventors.

Self-inking press.

122 INGRAM, HERBERT, *198 Strand*—Proprietor.

A printing machine, on the vertical principle, as used at the "Times" office.

The chief advantage of this new arrangement is, that the whole motion or circuit of the type can be made available for printing, whereas, in the flat machine, more than half the motion of the reciprocating type table is lost: and the reason for placing the cylinder in a vertical position is to obtain more easy access to the type, inking rollers, and other parts of the machine, and to permit more impressing cylinders to be arranged around the



the cutting-  
al continuous  
es of circular  
stable on two  
ands then pass  
and acting as  
erected at the  
t stopping its  
s. Mr. T. B.  
iller and Mr.  
in the same  
eable to the  
er very inge-  
L. R.]

Leicester  
achine. Per-

Edinburgh—  
inches, with  
r, and frame  
ance weights  
inches, with  
l frame, and  
inches, with  
with single  
hot climates.  
Infantry.

Mersfeld—  
packets any  
; with an  
for printing

entor.  
designed to

aburgh—  
ne. Illumi-

London—

rietor.  
yle, as used

ent is, that  
n be made  
hine, more  
pe table is  
n a vertical  
ypo, inking  
to permit  
around the

type drum than can be done when it is fixed horizontally.

The circumference of the central drum, or path of the type, is exactly 200 inches;—in the machines at the "Times" office eight impressing cylinders surround the type, which therefore print eight sheets at every revolution; but in those machines the type is not truly cylindrical, but is *segmental*, which involves the necessity of using large cylinders, but when the type is purely cylindrical smaller impression rollers may be used, and the produce very much increased.

The machine which is erected in the Exhibition is made to print circular woodcuts and type in the best manner. Each of the four impressing cylinders has 50 inches space for itself and its attendant inking rollers, and the form has the advantage of receiving its ink or colour from several rollers, each of which is well distributed or evenly covered with ink.

The vertical position of the inking rollers also conduces greatly to the production of good work; for the type or engraving is only touched on its extreme surface, while, on the flat principle, where the inking rollers act by gravity, the sides of the type are liable to receive colour. Another advantage is, that any dust in the paper is shaken out by the act of stopping, and falls upon the floor in place of being deposited upon the inking rollers and distributing table as in the flat machine: this is in practice a real advantage, for 50,000 impressions have been taken without once stopping to brush out the form or table. Another technical advantage in the printing of wood engravings, where delicate *overlaying* is required, is that the impressing cylinders are in direct connection with the type drum, so that no irregularity of motion can occur, and the *overlays* can be placed precisely where required without any fear of derangement.

Attention is also directed to the superior smoothness of the action of the vertical machine, as compared with the heavy blows produced in a flat or reciprocating machine at each change of motion in the ponderous type table and its appendages.

The action of the machine is very simple, the "layer on" draws a sheet of paper towards a small roller in rapid motion, which descends and causes the paper to enter between the vertical tapes which carry it downwards, when, having arrived at the proper position, it is suddenly

stopped by narrow upright strips of wood, which advance and slightly compress the sheet between them, the vertical tapes at the same moment releasing it;—the stoppers are then in their turn withdrawn, leaving the sheet of paper momentarily suspended by two small pulleys, mounted on delicate springs called finger rollers. The sets of vertical rollers seen in rapid motion on each side of the sheet now advance against it, and impel it sideways towards the impressing cylinder, where it receives the impression from the type; the sheet continues its side motion, supported only by a single pair of tapes, which at the proper place are stopped, leaving the printed sheet suspended until the "taker off" draws it down upon the taking-off table.

The diagram below will explain the action of the machine employed for the "Times;" *h, h, h*, represent the position of the laying-on tables.

The chases which hold the type are made with circular beds, and are securely fixed to the iron rings of the type drum. The column rules are converted by means of screws into tension bars, and they bind the sides of the chase or type-holder together, so that each column can be set up by means of a screw at its foot to any required degree of pressure. The inking rollers, which are seen in a vertical position between the impressing cylinders, are caused to press against the type and distributing table by long coiled springs, adjusted to a proper tension; they receive the ink from a circular distributing surface placed opposite to the type, and which, during its revolution, rises up and down by travelling upon an undulating railway. The ink is deposited upon the distributing table by a roller which occasionally vibrates against the ductor roller of the ink-box.

The wheels which connect the type drum and the impressing cylinders are beneath the machine, motion is communicated to the ink-box by the upper bevil wheel seen on the spindle of the type drum, and to the feeders by the lower bevil wheel.

The vertical principle admits of great variety of construction, and is equally applicable to perfecting machines for book work.

It is the patent invention of Mr. Augustus Applegath, of Dartford. Manufactured by Mr. T. Middleton, of Loman-street, Southwark.

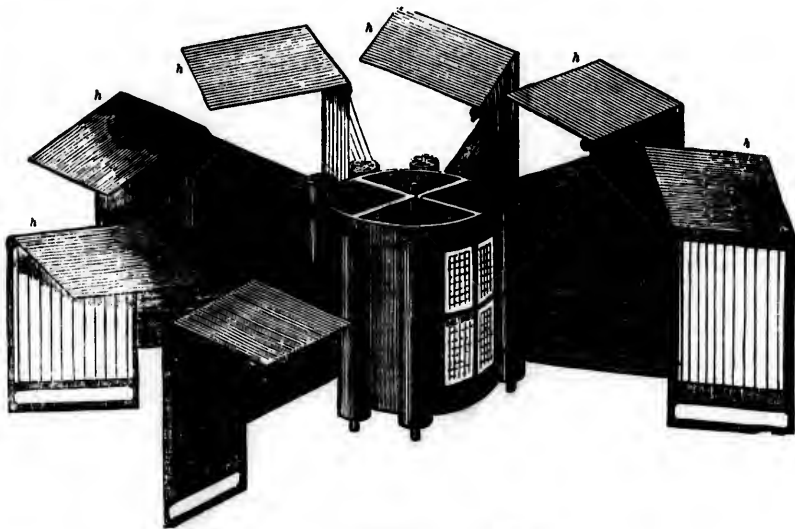

Applegath's Patent Printing Machine.

124 **CLYMER & DIXON, G. & S.**, 10 *Finbury Street, Finbury Square*—Patentees and Manufacturers.  
Deiny Columbian printing press.

128 **REDMOND, ALEXANDRE FRANÇOIS**, Birmingham—Inventor.

Working model, in wood, of a machine for dry-cementing envelopes, patented by the exhibitor. By this process, the envelopes can be immediately folded without requiring the tedious process of drying, in common use.

130 **DONKIN, BRYAN, & CO.**, *Bermondsey*—Manufacturers and part Inventors.

Model of a machine for making paper, with patent improvements.

132 **BREWER, JANE**, 19 *Surrey Place, Old Kent Road*—Manufacturer.

Endless brass wire cloth for a paper machine. Straight laid, spirally laid, and wove wire dandy rollers, for producing in paper, made by machine, the "laid" watermark, devices, names, &c.

Laid and wove wire paper moulds, used in making paper by hand.

Wove wire of different degrees of fineness.

[The use of dandy rollers of the kind described is to communicate to paper made by mechanical power the "wire" and other marks generally supposed to indicate the fact of hand-labour having been employed in the manufacture of the papers.—R. E.]

134 **COWPER, EDWARD, F.R.S.**, *King's College, London, and 9 Kensington Park Road, Notting Hill*—Inventor and Patentee.

Model of the printing machine now in general use. The Catalogue of the Exhibition is printed by these machines.

The model was made by T. B. Winter, Esq., a student in King's College, London.

[The following is a brief review of the progress of printing by machinery:—In 1790, Nicholson proposed placing both the types and paper upon cylinders, and also distributing and applying the ink by means of cylinders. Another plan was to place the types upon a table, and the paper upon a cylinder, and to cause the table and type to pass backward and forward under the paper cylinder. In 1813, Donkin and Bacon proposed placing the types upon a prism, and causing it to revolve against an irregular-shaped cylinder upon which the paper was placed. Neither of the above machines came into use, but in the latter, Donkin introduced the "composition" inking rollers (*i.e.* elastic rollers, made of treacle and glue), for distributing and applying the ink. In 1814, Koenig made the first working machine, and erected two of them at the office of "The Times" newspaper, each of which produced 1,800 impressions per hour, and they continued in use until 1827; he also made two machines for Mr. Bensley, one producing 800 impressions per hour, and the other printing 800 sheets, both sides, per hour. In 1816, Cowper made machines to print from curved stereotype plates, and in 1818, one to print from ordinary type. These machines printed from 800 to 1,000 sheets on both sides, or from 2,000 to 2,400 impressions on one side of the sheet. Machines to print only one side are generally called newspaper machines, and machines to print both sides are called book machines.]

The cut represents one of these book machines; it consists of a cast-iron frame, about 14 feet long and 4 feet wide, in which an iron table slides backward and for-

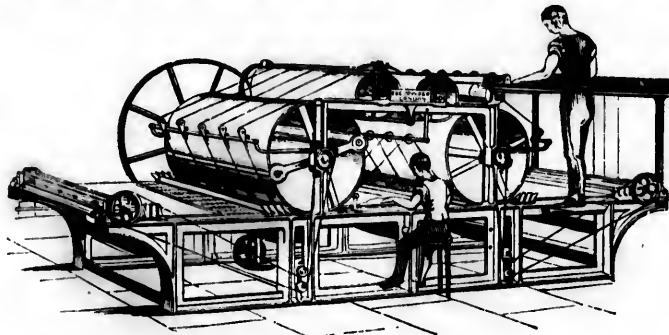

Cowper's Printing Machine.

ward, passing in its progress under two cast-iron cylinders, called the paper cylinders. Two sets of type, technically called the form, are fixed on the table at such a distance from each other that one form passes under one cylinder and the other form under the other cylinder, the sheet of paper being held on the cylinder by means of tapes. At each end of the machine is a reservoir, or trough, of ink, the trough being made by an iron roller, about 3 inches diameter, turning in contact with a flat iron bar, which only allows a very small quantity of ink to pass; this iron bar is the *abductor*, but is commonly called the "doctor," and the iron roller the "doctor" roller. An elastic composition roller is made to vibrate between the table and the abductor roller, and conveys the ink from the latter to the table. A number of composition rollers are placed across the table, their axes resting in notched bearings. As the table passes backward and forward under these rollers, the ink deposited by the vibrating roller becomes very evenly spread upon the table. This spreading, or

*distribution*, as it is called, is effected by three or four of the rollers (called the "distributing rollers") not only having a motion round their axes, but also a motion in the direction of the length of their axes, *i.e.*, in an *end* motion. This motion was produced in Mr. Cowper's first machines by giving an end motion to the frame, which supported the distributing rollers. Mr. Applegath suggested the more simple mode of placing the rollers in a diagonal or sloping position across the table, and making the axis long enough to slide in their notches. Three or four other rollers, called the "inking rollers," have no end motion; their office is to take the ink up from the table, and apply it to the types. Thus the "taking," "distributing," and "inking" is all done by the machine itself.

The sheet of paper is laid by a boy on a wove of tapes, whence it is carried forward, and enters between two sets of tapes; and as these tapes are carried round one paper cylinder, and then over and under two wooden "drums" to the other paper cylinder, the sheet of paper necessarily

134, a student in progress of print- ing proposed placing rollers, and also dis- cussing of cylinders. in a table, and the table and type to a paper cylinder. placing the types against an irregu- lar paper was placed. use, but in the "opposition" inking (oil and glue), for 1814, Koenig made two of them at which of which pro- ceed continued in 1815 for Mr. Bene- dit hour, and the curved stereotype ordinary type. 10 sheets on both on one side of side are generally used to print both

machines; it con- sists of a long and 4 feet wide and for-

travels with the tapes, and the sheet is thus conveyed from one paper cylinder to the other; in the course of its progress, the sheet is turned over, receiving one printed impression on one side from the first form, and the second impression on the other side of the sheet from the second form, and as the tapes leave the second cylinder they divide, and the printed sheet falls into the hands of another boy.

The machines are commonly known as "Applegath and Cowper's machines."

[Mr. Napier's machine differs from Applegath and Cowper's; his machine is described in a separate article. In 1827, Cowper & Applegath jointly invented the four-cylinder machine, which Applegath erected for printing "The Times" newspaper. It at once superseded Koenig's machines, which were taken down. This machine printed from 4,000 to 5,000 impressions per hour. The diagram will give a general idea of these machines, which are still in use at "The Times" office. They consist of a table, moved backwards and forwards under four iron cylinders (called the paper cylinders), about 9 inches in diameter, which are covered with cloth, and round which the sheets of paper are held between tapes. The form is fixed on one part of the table, the inking rollers lying on another part, on which to distribute the ink. Some of these rollers are placed in a diagonal position on the table, so that, as it moves backwards and forwards, they have a motion in the direction of their length, called the "end-motion," which, combined with the rotatory motion, causes the ink to be more effectually distributed. The ink is held in a reservoir or trough formed of an iron roller, called the ductor, against which the edge of an iron plate rests, and, by its pressure, regulates the quantity of ink given out. The ink is conveyed from the ductor-roller to the table by means of an elastic roller vibrating between them. The feeding is performed by four "layers-on," who lay the sheets of paper on the feeding boards, whence they enter the machine between three pairs of tapes, by which they are conveyed round the cylinders, and thence to the spot where the "takers-off" stand, into whose hands the sheets fall as the tapes separate.

The last great improvement in rapid printing was invented by Mr. Applegath, in May 1848, when he erected at "The Times" office two vertical cylinder machines, each producing 10,000 sheets per hour.]

#### 135 CHURCH & GODDARD, Birmingham—Manufacturers.

Machine for cutting cardboards into cards for printing and other purposes, capable of cutting from 300,000 to 600,000 cards per day, by the labour of one person.

Machine for manufacturing railway tickets, or printed cards. It cuts, prints, numbers consecutively, counts, and packs about eighty tickets per minute, without waste.

Machine for dating railway tickets. It gives a clear and distinct impression, which is intended to prevent the unpleasant disputes which frequently occur at railway stations, in consequence of the illegibility of the date on passengers' tickets.

#### 136 TAYLOR, W., Nottingham—Designer and Manufacturer.

Machine for forming hemispherical paper shades from flat discs of paper. Ornamental paper work, &c.

#### 138 BLACK, JAMES, Edinburgh—Manufacturer.

Patent folding machine.

#### 140 WHITAKER, RICHARD, Bury St. Edmunds—Inventor.

Patent bookbinding press, for rolling the backs of books, cutting the edges, and impressing the ornaments on the

back, intended to supersede the hammering process. Printers' types may be used. Manufactured by Messrs. Mordan and Son, City Road, London.

#### 142 STRAKER, SAMUEL, 80 Bishopsgate Street Within—Manufacturer.

Side-lever lithographic press, fitted with improved registering-machine, and adapted for every description of colour printing.

#### 144 BREWER, C. & W., Malcoba Works, Larkhall Lane, Clapham—Patentees, Inventors, and Manufacturers.

Plain ring and plain laid pattern dandy rollers for making endless paper.

Patent bank note moulds, of various patterns, for making notes by hand and vat.

Watered pattern moulds for fancy writing paper made by hand and vat. Angular moulds for making paper for envelopes. Autograph moulds for paper making.

Bundle of paper made from the moulds and rollers, to illustrate.

#### 146 RANSOMES & MAY, Ipswich—Manufacturers.

Model of patent excavator, for railways or canals. Henry Potter Burt, London, proprietor.

Models of improved apparatus and machinery, for preparing timber with cresote. Exhaust-pump. Force-pump. Tank for the solution. Steaming and heating apparatus. Moveable tramway and crab, for loading and unloading the cylinder.

The timber to be prepared is loaded on trucks, and drawn inside the cylinder; the cover is then closed, and the air-pump employed to exhaust the cylinder, and extract the sap or moisture from the timber. The air-pump is then disengaged, and a sluice valve communicating with a reservoir opened, which charges the cylinder with cresote, previously heated to 120° Fahr. Force-pumps are then employed, which work, until the timber in the cylinder has been saturated with from 7 to 10 lbs. of oil per cubic foot; this is found to be a sufficient quantity to effectually prevent decay, from the attacks of the "Teredo navalis," &c.

Leggat's Queen press, with self-inking apparatus. Shavings of iron.

#### 148 POPE, THOMAS, & Co., 56 St. Paul's Square, Birmingham—Manufacturers.

Screw press (called the "Lion Press"), for embossing paper, &c.

Screw press, with an arm, a substitute for a double-sided press.

A small powerful lever press, called "The Model," for embossing paper with dies up to one inch diameter; only  $4\frac{1}{4}$  by  $2\frac{1}{2}$  inches base; height  $3\frac{1}{2}$  inches; weight  $2\frac{1}{2}$  lbs.

"The Cornucopia" lever press for the same and other purposes, with dies  $1\frac{1}{2}$  inch diameter.

The portable desk press; base  $5\frac{1}{4}$  by  $2\frac{1}{2}$  inches diameter.

Large quarto screw copying press of improved construction, the pillars and beams being in one solid piece.

A small quarto screw copying press.

A folio screw copying press.

#### 150 COHN, T., 19 Portugal Street, Lincoln's Inn—Manufacturer.

Working model of iron printing press, with improvements by the exhibitor.

#### 151 HARRIS, C., Shalford, near Guildford—Inventor and Manufacturer.

Fly press, for stamping envelopes, note paper, &c., in colours. On the fly-spindle is fixed an inclined plane to give motion to the force spindle, which carries the force or die. On the top is a tooth wheel, which gives motion to other wheels for the colouring apparatus.

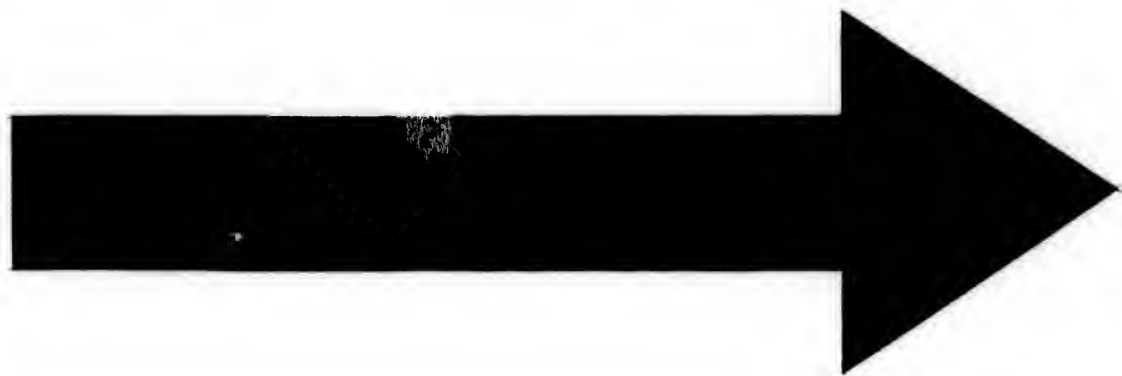

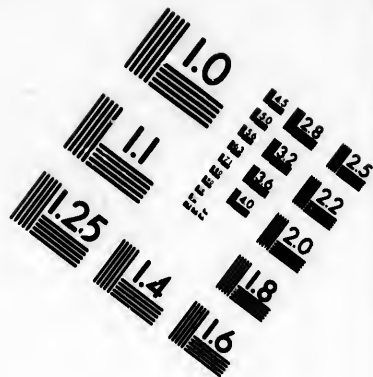
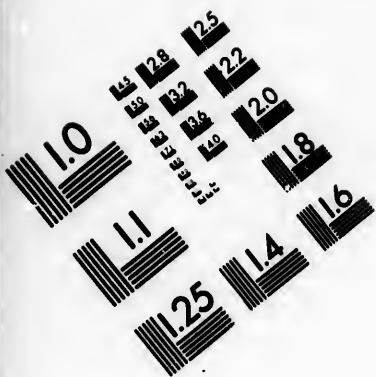

**IMAGE EVALUATION  
TEST TARGET (MT-3)**

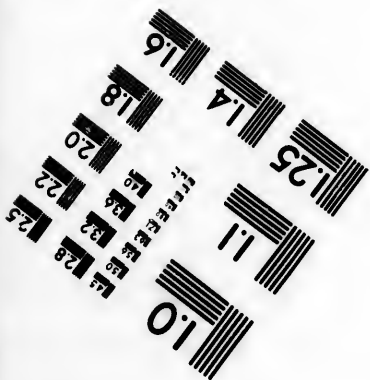
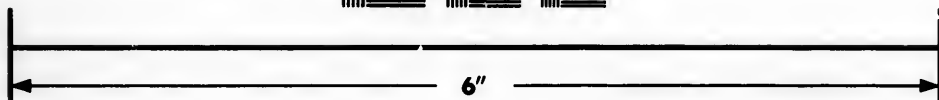
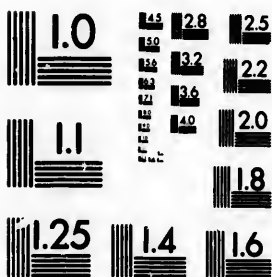

**Photographic  
Sciences  
Corporation**

23 WEST MAIN STREET  
WEBSTER, N.Y. 14580  
(716) 872-4503

15 28 25  
16 32 22  
18 20

11  
12  
13  
14  
15  
16  
17  
18  
19  
20  
21  
22  
23  
24  
25  
26  
27  
28  
29  
30  
31  
32  
33  
34  
35  
36  
37  
38  
39  
40  
41  
42  
43  
44  
45  
46  
47  
48  
49  
50  
51  
52  
53  
54  
55  
56  
57  
58  
59  
60  
61  
62  
63  
64  
65  
66  
67  
68  
69  
70  
71  
72  
73  
74  
75  
76  
77  
78  
79  
80  
81  
82  
83  
84  
85  
86  
87  
88  
89  
90  
91  
92  
93  
94  
95  
96  
97  
98  
99  
100



152 LIGHTFOOT, THOMAS M., *South Shields*—  
Inventor.

Patent beating engine for reducing rags into pulp.—The improvement consists in the introduction of a second beating roll, and a new adaptation of washing apparatus, which is said to enable the engine to produce four times the quantity of pulp produced by an ordinary engine in the same time.

154 JARRETT, GRIFFITH, 45 *Lee Street, Kingsland Road*  
—Inventor.

Improved embossing presses, constructed with steel levers, double enclosed springs, and prepared for moveable dies; the dies made of highly tempered steel, and furnished with copper counterparts.



Jarrett's Embossing Press.

155 COLLETT, C., 8 *Great Cambridge St., Hackney Road*  
—Inventor.

Specimens of embossing presses.

156 SULLIVAN, THOMAS, *Foots Cray, Kent*—Inventor  
and Manufacturer.

Improved double-sized, brass-bodied, laid dandy roller, for producing the water-mark, &c., in machine laid paper.

Interlinear laid roller for producing fancy designs.

Improved spiral laid roller.

Improved brass-bodied wove roller, with fancy designs.

Models.

157 HARRILD & SONS, 10, 11 & 12 *Great Distaff Lane,*  
and 22 *Friday St.*—Inventors and Manufacturers.

Improved galley press, used for pulling proofs in "galleys;" represented in the following cut.

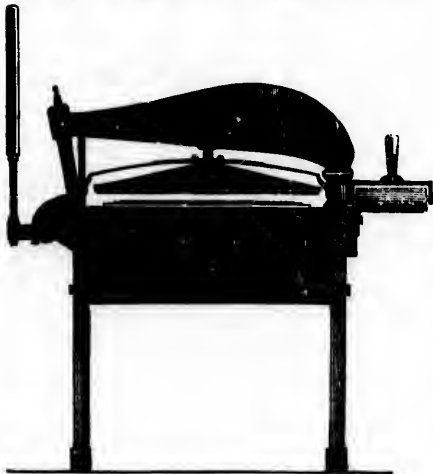

Harrild's Galley Press.

Registered plough cutting machine, calculated to cut with ease any kind of paper or card; represented in the following cut.



Harrild's Plough Cutting Machine.

Numerical printing apparatus, calculated to print a few lines with a number attached, which alters consecutively up to 99,999 with each impression, or alternatively, as may be required. The printing is effected by laying the paper on the surface, and then simply bringing the handle to a horizontal position and pressing on the paper, the action of which not only effects the inking of the type and figures, but the distribution of the ink and printing. This apparatus is represented in the following cut.

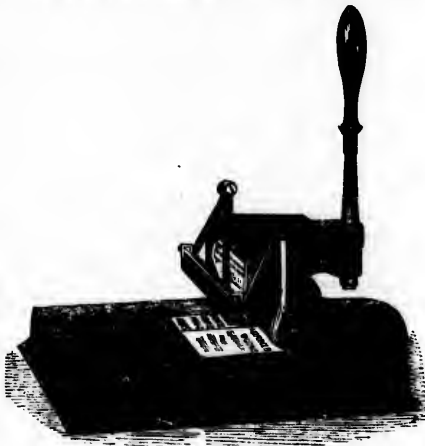

Harrild's Numerical Printing Machine.

Seamless composition printing rollers for wood-cut and fine printing.

Improved composition balls for printing.

[These rollers and balls are intended to distribute the ink evenly over the surface of the type.

In fine printing and wood-cut printing, the equal distribution of the ink is of great consequence to the perfection of the work.]

158 NAPIER, D., & SON, *Lambeth*—Inventors and  
Manufacturers.

A captain's patent registering compass. This instrument registers on paper the exact compass course which a vessel has been steered for 24 consecutive hours. Its object is to enable the captain at any time, by mere inspection, to ascertain if the ship has been steered correctly, and if not,

to show immediately the period and amount of the deviation. This machine is represented in the annexed out.

Letter-press perfecting and printing machine, worked by a small steam engine; when in operation, it is arranged with a combination of tapes and grippers, by which the "flying" of the sheet in laying on, required in tape machines, is rendered unnecessary.

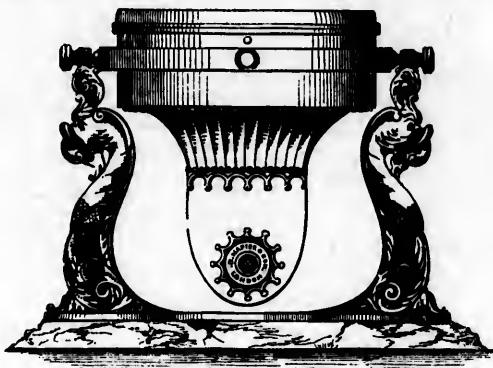

Napier's Registering Compass.

Another machine, of the same description, for a larger form.

Single cylinder letter-press printing machine, suitable chiefly for bookwork.

Patent self-feeding and self-discharging centrifugal apparatus suited to the separation of the molasses from the crystal in sugar manufacture, also to other purposes. Exhibited as a novel and useful invention. The advantages are, a continual discharge and supply of the matter to be operated upon, and, consequently, great saving of time and labour; as the machines at present used must be stopped, discharged, and re-discharged by men in attendance. The time saved by the improved machine not only includes that now consumed in taking out and filling the charge (which, on an average, must be done every eight minutes), but that necessary for stopping and starting the machines, the working speed being 1,500 revolutions per minute, and which is very considerable. There are many other advantages which might be named, such as its suspension, whereby the vibrations consequent upon the excessive speed of the machine are not transmitted to the building, the simple and efficient means of liquoring, &c.

160 M'CLURE & Co., *Box Churchyard, Cheapside*—  
Producers.

A lithographic press.

162 HOPKINSON & COPE, *14 New North Street, Finsbury*  
—Inventors and Manufacturers.

The Albion printing press.

Holm's patent Scandinavian printing machine.

164 WATERLOW & SONS, *London Wall*—Producers.

Printing machine. Patent self-feeding envelope machine, producing envelopes folded, gummed, and embossed. Machine for numbering bank notes, &c. Patent autographic press.

165 WATSON, HENRY, *Newcastle-upon-Tyne*—  
Manufacturer and Inventor.

Improved pulp strainer, for paper manufacturers.

Hydro-electric machine. This machine is represented in the annexed out.

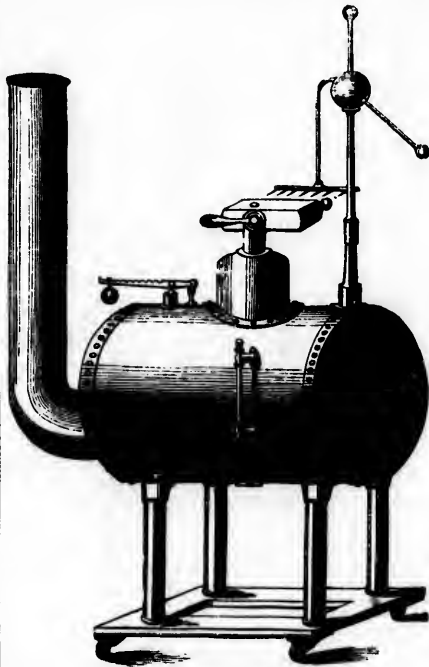

Watson's Hydro-electric Machine.

Patent valve for fluids; represented in the annexed cut.

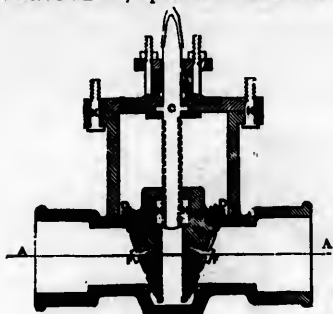

Watson's Patent Valve.

The cut shows a vertical section of a straight cock. A A is the water-way represented, as closed by the block or key B B, made to move vertically up and down by turning the screw C, which works through a nut H H, fitting loosely into the key. The dark line is an elastic facing, which may be of leather, gutta percha, India-rubber, felt, or any material most suitable for the purpose to which the cock is intended to be used, and is secured in its place by the brass ring D D, three screws through which prevent the possibility of its afterwards moving, or the facing material becoming displaced. F F is a bolt screwed into the centre, having a plate which draws the elastic material tightly over the face, and fitting closely the seat G G G. The horizontal section or plan through the line A A, shows the form of the cock; E E are guides for the key working freely up and down when moved by the screw C.

166 COWAN, ALEX., &amp; SONS, 45 Upper Thames Street—Manufacturers.

Paper pulp-meter. Patented by Charles Cowan, Valley-field, near Edinburgh. The object of this apparatus is to measure out a uniform and exact supply of pulp to the paper-machine, according to any width and thickness of the web of paper which it may be desired to make. The pulp, after having been prepared in the engines, and mixed in ascertained proportions of raw materials and of water, is kept in the pulp or stuff chest. The cup of the pulp-meter, which is driven in connection with the paper machine, is made to dip into a box, which, by means of a ball-cock or valve, is always kept full of pulp from the pulp-chest, and lifts and delivers the requisite quantity of pulp to make the width and thickness of the web required. This is done by means of the slide upon the cup, which can be set even while the apparatus is in motion, so as to deliver the number of cubical inches of pulp at each dip required for the particular paper to be made, which can be ascertained by a very simple calculation. In this way uniformity of thickness in every sheet of the paper manufactured is readily obtained.

168 SCHLESINGER &amp; Co., 8 Old Jewry—Producers.

Faging and numbering machine.  
Ticket printing machine.  
Machine for printing bank notes.

200 FAIRBAIRN, W., &amp; SONS, Manchester—Inventors and Manufacturers.

Patent riveting machine, for riveting boilers, and other vessels, constructed of wrought iron. The moving slide and die are worked by the action of a revolving cam upon an elbow joint, which gives a variable motion, and exerts the greatest force at the closing of the joint and the finishing of the rivet. The following figures represent this machine.

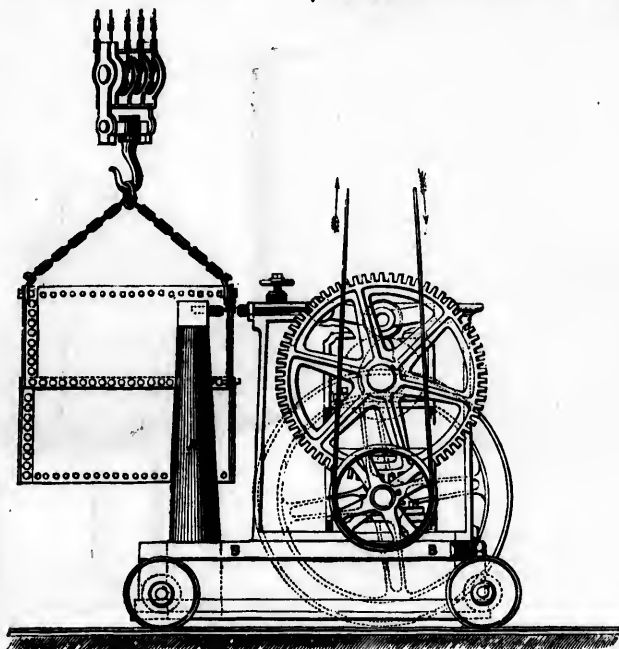

Fairbairn's Patent Riveting Machine. Side Elevation.

Thomas Street—

les Cowan, Val-  
of this apparatus  
supply of pulp to  
th and thickness  
desired to make.  
the engine, and  
materials and of  
The cup of the  
n with the paper  
ch, by means of  
f pulp from the  
quits quantity  
e of the web re-  
le upon the cup,  
is in motion,  
ches of pulp at  
er to be made,  
ple calculation.  
every sheet of  
d.

Producers.

Inventors

boilers, and  
The moving  
revolving cam  
le motion, and  
the joint and the  
ures represent

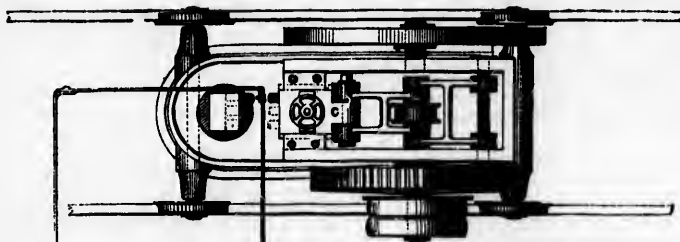

Fairbairn's Patent Riveting Machine. Plan.

[The invention of the riveting machine originated in a turn-out of the boiler-makers in the employ of the exhibitor about fifteen years ago. On that occasion the attempt was made to rivet two plates together by compressing the red-hot rivets in the ordinary punching-press. The success of this experiment immediately led to the construction of the original machine, in which the moveable die was forced upon the rivet by a powerful lever, acted upon by a cam. A short experience proved the original machine inadequate to the numerous requirements of the boiler-maker's trade, and the present form was therefore adopted about eight years since.

The large stem, A, is made of malleable iron, and having an iron strap, BB, screwed round the base, it renders the whole perfectly safe in the case of the dies coming in contact with a cold rivet, or any other hard substance, during the process. Its construction also allows the workman to rivet angle iron along the edges, and to finish the corners of boilers, tanks, and cisterns; and the stem being now made 4 feet 6 inches high, it renders the machine more extensive in its application, and allows of its riveting the fire-box of a locomotive boiler or any other work within the given depth.

In addition to these parts, it has a broad moving slide, C, in which are three dies corresponding with others in the wrought-iron stem. By using the centre die every description of flat and circular work can be riveted, and by selecting those on the sides it will rivet the corners, and thus complete vessels of almost every shape. This machine is in a portable form, and can be moved on rails, with care, to suit the article suspended from the shears.

The introduction of the knee-joint gives to the dies a variable motion, and causes the greatest force to be exerted at the proper time, viz., at the closing of the joint and the finishing the head of the rivet.

In other respects the machine operates as before, effecting by an almost instantaneous pressure what is performed in the ordinary mode by a long series of impacts. The machine fixes in the firmest manner, and completes eight rivets of  $\frac{1}{4}$  inch diameter in a minute, with the attendance of two men and two boys to the plates and rivets; whereas the average work that can be done by two riveters, with one "holder on," and a boy, is 40  $\frac{1}{4}$ -inch rivets per hour; the quantity done in the two cases being in the proportion of 40 to 480, or as 1 to 12, exclusive of the saving of one man's labour. The cylinder of an ordinary locomotive-engine boiler, 8 feet 6 inches long, and 3 feet diameter, can be riveted and the plates fitted completely by the machine in four hours; whilst to execute the same work by hand would require, with an extra man, twenty hours. The work produced by the machine is likewise of a superior kind to that made in the ordinary manner; the rivets being found stronger and the boilers

more free from leakage, and more perfect in every respect. The riveting is done without noise, and thus is almost entirely removed the constant deafening clamour of the boiler-maker's hammer.]

201 WHITWORTH &amp; Co., Manchester—Manufacturers.

Self-acting foot lathe, fig. 1, with motions for sliding, screwing, and surfacing, including double-gear head-stocks, conical steel mandril and bearings, case-hardened, compound slide-rest, with quick hand traverse. Guide screw, with disengaging nut, and 24 change wheels for screw cutting. Anti-friction treadle motion, crank and speed pulley for band, with equal tension. Hand-rest with eccentric lock, two-face plates, elements driver, drill, bell, and cup chucks.

Fig. 1.

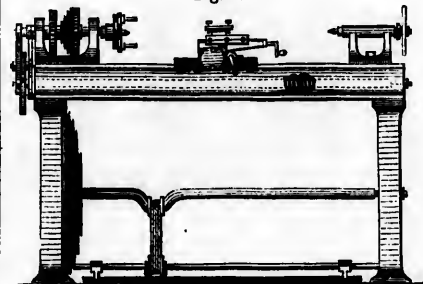

Whitworth's Self-acting Foot Lathe.

This lathe is intended for amateur use, and exhibits a complete sliding, screwing, surfacing, and boring lathe. Ornamental chucks can be applied to this as to other lathes.

Patent self-acting duplex lathe, fig. 2, with two cutting tools, for sliding screwing, and surfacing, having double-

Fig. 2.

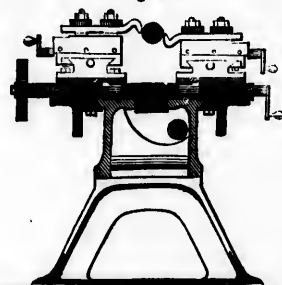

Whitworth's Patent Self-acting Duplex Lathe.

geared headstocks, with conical steel mandril and bearings. Slide-rest, with quick hand traverse, two compound top rests, one on each side of the lathe centres, with independent adjustments, two extra slides, with right and left screw for working the top rests simultaneously. Guide screw, disengaging nut, and 23 change wheels for screw cutting; two-face plates, clements driver, drill, and bell chucals.

[The duplex principle consists in the employment of a cutting tool at the back of the lathe opposite to the tool in front, and in inverted positions to each other. The transverse forces are thus balanced, the work produced is more correct, and is accomplished in less time than by the ordinary lathe.]

Patent self-acting compound duplex lathe, with four cutting tools, for sliding, screwing, and surfacing.

[The arrangement of this lathe is similar to the foregoing, except that this has a duplicate independent series of self-acting motions and tools, which may either be

worked separately or simultaneously. The bed is of great length, in one casting, and may be used for two distinct lathes, by employing an extra set of headstocks. The lathe, though suited for general work, is intended more particularly for sliding long shafting, and for cutting screws. In sliding a shaft, the two series of tools commence in the middle of its length, and proceed in a direction right and left. There is, consequently, a balance of force longitudinally, as well as transversely.]

Patent self-acting duplex railway-wheel turning-lathe, fig. 3, including two sets of double-g geared headstocks and face plates, driven independently, to prevent torsion of the axle; four compound slide rests, with separate self-acting motions to each, and swivel plates.

[Four cutting tools are employed, two acting upon opposite sides of each wheel. Both wheels are turned at once upon their axle, and the slide rests are readily removable in order to get the wheels into and out of the lathe.]

Fig. 3.

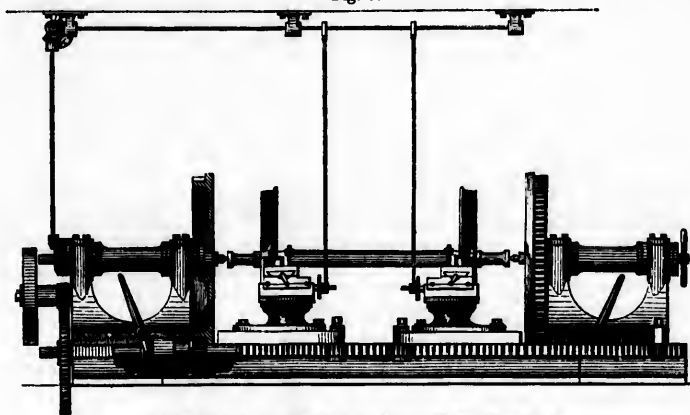

Whitworth's Patent Self-acting Duplex Railway Wheel Turning Lathe.

Patent self-acting planing machine, with reversing tool, to plane both ways; grooved table, with screw traverse, by which the driving is removed from the middle to the end of the bed. Self-acting motions, for horizontal, vertical, and angular planing.

Self-acting planing machine, to plane one way, with quick return motion. (Fig. 4.)

The arrangement of this is similar to the foregoing, except that this has a quick return motion applied to the screw, and has a fixed tool instead of a reversing tool. The tool-holder is fitted with a segment wheel and worm, for shaping internal curves, and has a self-relieving motion. It is self-acting in all cuts.

Patent self-acting crank planing machine, uniform in cutting, with a quick return motion. The tool holder is fitted with segment wheel and worm, and has a self-relieving motion as in the last machine. The general arrangement of parts, such as the bed, table, uprights, and cross-slide, is the same. The motion from the crank is imparted to the table by means of a grooved lever, in which the crank pin slides, a connecting rod being attached to the top end of this lever and to the table. The connecting rod consequently vibrates through a very small arc, and enables the ordinary V slides to be used in the bed and table.

Patent self-acting universal shaping and planing machine, fig. 5, with adjustable crank, acting uniformly in cutting, with a quick return motion; with bed grooved on

the front side, two tables for fixing the work, movable vertically and longitudinally; horizontal slide moving the full length of bed, for planing flat work; transverse

Fig. 4.

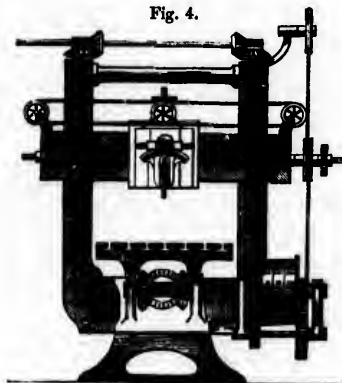

Whitworth's Self-acting Planing Machine.

The bed is of  
 be used for two  
 of headstocks,  
 work, is intended  
 ng, and for cut-  
 o series of tools  
 and proceed in a  
 consequently, a  
 transversely.]  
 el turning-lathe,  
 headstocks and  
 ent torsion of the  
 arate self-acting

two acting upon  
 ils are turned at  
 s are readily re-  
 and out of the

slide and tool-holder, with segment wheel and worm for internal curves; vertical slide and swivel for angular work; conical mandril, with worm and wheel for circular work.

Fig. 5.

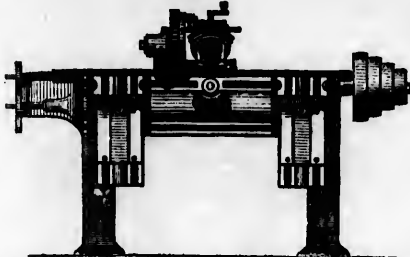

Whitworth's Patent Self-acting Universal Shaping and Planing Machine.

These machines are used for shaping and planing levers, cranks, straps, cross-heads, &c., and for curves and planes in general. They have five independent self-actions, viz.: for flat, vertical, angular, and circular work, and for internal curves.

Patent self-acting slotting and shaping machine, fig. 6, with independent upright framing, adjustable crank and quick return motion; vertical slide and tool holder; table for holding the work, fitted with two series of transverse slides; worm-wheel for circular work; self-acting transverse and circular motions.

Fig. 6.

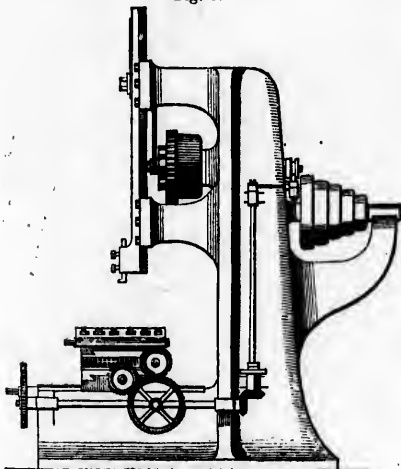

Whitworth's Patent Self-acting Slotting and Shaping Machine.

These machines are used for cutting keyways in wheels, and for shaping work in general. The upper series of transverse slides give increased facility in chucking work to be shaped.

Patent self-acting bench slotting and shaping machine, similar to the foregoing, but adapted particularly to small work.

Small self-acting vertical drilling machine, single geared, with independent framing, drill spindle in tube, with variable down motion, plain elevating table.

The spindle, by passing through a tube and not re-

volving in bearings, undergoes very little wear. It may be quickly raised by hand.

Self-acting vertical drilling and boring machine, fig. 7, double geared, with independent framing, drill spindle in tube, variable down motion, and radial table, with vertical and horizontal slides.

Fig. 7.

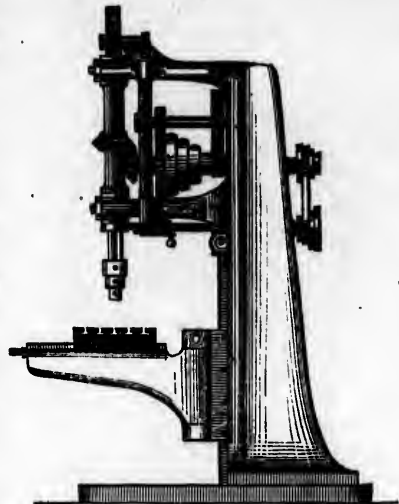

Whitworth's Self-acting Vertical Drilling and Boring Machine.

The radial table affords greater facility than a fixed table for chucking work; and any number of holes may be drilled after once fixing without disturbing the work till finished.

Self-acting radial drilling and boring machine, fig. 8 (medium size), with independent framing, vertical elevating slide, radial arm, moveable through an arc of 190°, slide carrying drill spindle, with variable self-acting down motion.

Fig. 8.

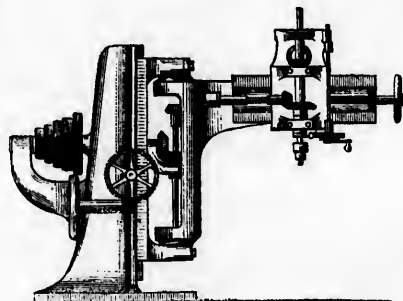

Whitworth's Self-acting Radial Drilling and Boring Machine.

These machines are used for drilling the end plates of tubular boilers, and for work in general. All holes within the range of the machine can be drilled without removing the work till finished. These machines are also adapted for work of a massive character, such as large cylinders, &c., which could not be conveniently

work, move-  
 al slide moving  
 rk; transverse



lifted and placed on the table of the ordinary drilling machine. A pit should be provided in front for objects of great length.

Punching and shearing machine, fig. 9, for hand or power, with separate slides for the two operations, one on each side of the machine, worked by eccentrics. Apparatus for raising the punch quickly without stopping the machine. Small shears for cutting off bars of any length. Punching and shearing, or bar cutting, may be carried on at the same time without interruption.

Fig. 9.

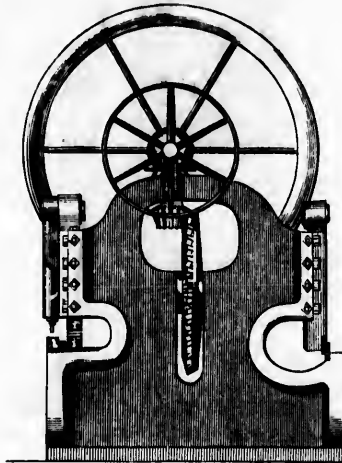

Whitworth's Punching and Shearing Machine.

Hand-punching and shearing machine, with single slide, worked by eccentric, only one process being carried on at a time.

Self-acting wheel-cutting and dividing machine, fig. 10, for bevel spur and worm wheels, with headstocks and dividing wheel, moveable horizontally for different diameters of wheels, cutter frame, with universal adjustment, self-acting traverse for cutter, self-adjusting driving pulleys, change wheels, for all numbers up to 100.

Fig. 10.

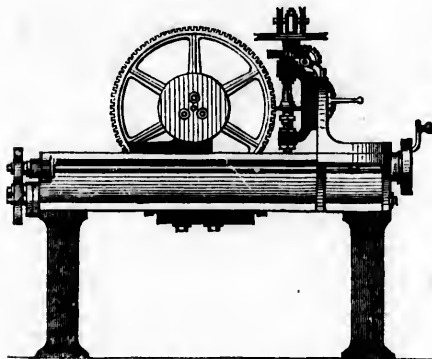

Whitworth's Self-acting Wheel-cutting and Dividing Machine.

Self-acting bolt-head and nut-shaping machine, fig. 11, with two circular cutters, for shaping two sides at once, two concentric chucks, for two objects to be operated upon at the same time. Duplicate compound slides, with independent self-acting and self-disengaging motions to prevent injury from the cutters.

Fig. 11.

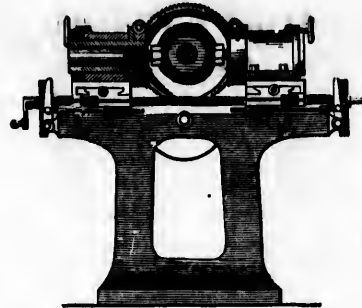

Whitworth's Self-acting Bolt-head and Nut-shaping Machine.

The chucks are respectively placed on opposite sides of the centre of the circular cutters, by which the forces are balanced, and a much greater quantity of work is produced than if one chuck only were used. These machines are applicable for shaping and squaring nuts, ends of shafts, &c. The concentric chucks are removable, so that other work may be shaped and squared.

Patent screwing machines, for bolts and nuts, with hollow mandril, die holder, with four radial dies, two on each side of the centre, complete sets of dies and taps, with chucking apparatus for bolts and nuts. The radial die holder is similar in principle to the patent guide screw stock. The dies are cut by master taps, of double the depth of thread larger in diameter than the working taps, so that the circle of the dies in contact is the same size as the screw blank. A perfect guide is thus obtained, and a thread of correct pitch is formed at the commencement. The inner edges of the dies being filed off to an acute angle, they cut with ease without distorting the thread; and by the direction in which the dies are moved, their cutting power is preserved for the full depth of thread. Their action in cutting is similar to the chasing tool, which they resemble in form, and may in like manner be sharpened on a grindstone.

Patent screwing apparatus, fig. 12, including the patent guide screw-stock and dies, working taps, master taps, for cutting up the dies, hobs, for cutting screw tools, and case-hardened tap wrenches. The dies of the screw stock are cut by a large master tap, and their action is the same as explained in the bolt-screwing machines. The diameter of the working taps are made to standard gauges; the angle of the thread in all cases is  $55^\circ$ , rounded off at top and bottom to two-thirds of a complete angular thread; small fractional pitches are avoided, and the principle of uniformity in pitch, form of thread, and diameter, is rigidly adhered to.

Measuring machine, and standard yard measure.

Internal and external standard cylindrical gauges, of sizes from 1-8th to 6 inches diameter, tested by the measuring machine.

Set of stepped gauges, external only from 1-8th to 6 inches.

Patent knitting machine, knits one stitch at a time, similar to hand knitting: may be worked by hand or power.

machine, fig. 11,  
two sides at once,  
be operated upon  
d slides, with in-  
g motions to



shaping Machine.

on opposite sides  
which the forces  
ity of work is pro-  
used. These ma-  
ing nuts, ends  
are removable, so  
ared.

s and nuts, with  
radial dies, two on  
of dies and taps,  
nuts. The radial  
the patent guide  
er taps, of double  
than the working  
ntact is the same  
is thus obtained,  
at the commence-  
ing filed off to an  
ut distorting the  
h the dies are  
for the full depth  
e similar to the  
orm, and may in  
e.

cluding the patent  
aps, master taps,  
ing screw tools,  
lies of the screw  
their action is the  
y machine. The  
standard gauges;  
o, rounded off at  
omplete angular  
voided, and the  
hread, and dia-

l measure.

dical gauges, of  
sted by the mea-

y from 1-8th to

itch at a time,  
ked by hand or

Fig. 12.

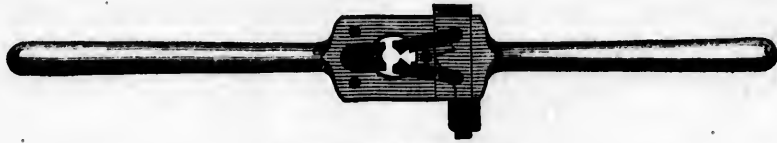

Whitworth's Patent Screwing Apparatus.

202 FOSTER, T., *Manchester*—Inventor.

Apparatus for preserving the surface of copper rollers and steel dies, with a coat of stoking ground, so as to resist the action of nitric-acid, for the purpose of deepening the engraving.

203 LYONS, MORRIS, 143 *Suffolk Street, Birmingham*—Inventor.

Apparatus and specimens to illustrate the process of bright electro-plating, gilding, electro-engraving, and deposition of copper for the formation of tubes. This process differs from others, in at once depositing the metal

in a bright state, requiring no after polishing. Hence it is particularly adapted for embossed works of art. The economy of this process consists in its requiring less battery-power, and a smaller consumption of the precious metal.

[Bright electro-plating has been effected by mixing a few drops of the sulphuret of carbon with the silver or gold solution in the precipitating trough.—R. H.]

204 SHARP BROTHERS, *Manchester*—Inventors.  
Lathe, slotting-machine.

Powerful self-acting planing machine; represented in the following engraving.

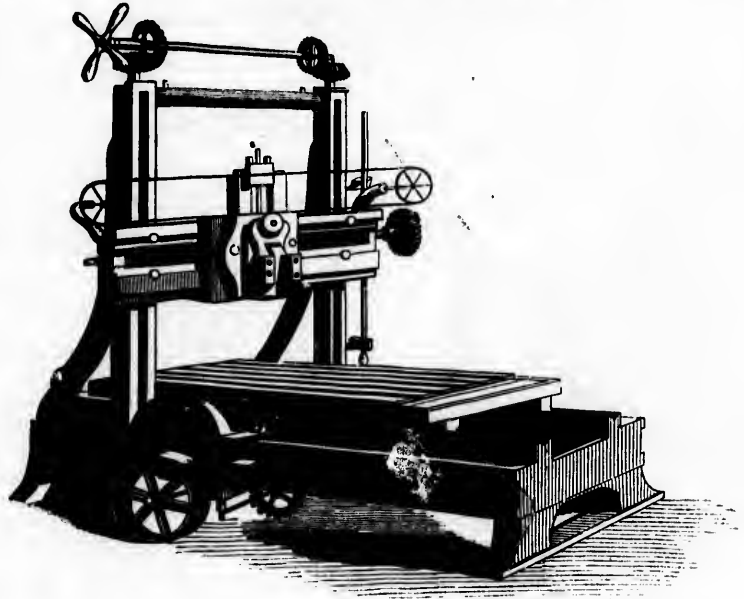

Sharp's Powerful Self-acting Planing Machine.

205 MORDAN, SAMPSON, & Co., *City Road*—Manufacturers.

Bright steel fire-proof jewel-box, decorated with ornamental engravings.

Carved inkstand, inlaid with pearl and gilt ink-glass attached, with gold pen.

Large frame containing an assortment of every description of gold pens, and gold pen-holders.

Complex self-acting rose engine and tracing machine.

Combination copying and seal-press, on a stand; which combines the double purpose of a seal or embossing-press, and a copying-press.

206 MUIR, WILLIAM, *Salford, Manchester*—Manufacturer.

Amateur foot lathe, slide rest, eight gun-metal chucks, joiner's bench, tool-chest, and German cramp.

Large and small patent coffee-mill for grocers and private use.

Screw embossing press, for stamping envelopes, with dice, sets of alphabets, &c.

Lever embossing presses, for embossing crests, &c.

Copying presses.

Screw-stocks, taps, master-taps, and tap-wrenches.

Machine taps and hand-screw tools.

Oil-testing machine. Invented by Emanuel Thomas, of Manchester.  
Registered theodolite. Designed by Henry Goss, of Salford.  
Specimens of embossing. Lithographs of copying and embossing presses.  
Soap-cutting machine. Invented by Walter Storey, of Manchester.

207 HUNT, JOHN, per C. BOYD, 15 Addison Road, Kensington—Inventor.

A mineral washing-case, designed for the more expeditious and effectual washing of gold, silver, tin, copper, and lead ores, and applicable to all kinds of mineral, the specific gravity of which is greater than the foreign matter with which it is mixed. The superiority is said to consist in the great ease, rapidity, and economy, with which ores can be treated, as compared with the ordinary system, the latter requiring that the mineral to be operated upon should be previously separated from clay, adhesive matter, and stony particles. The inventor states that chiefly by means of this washing-case, he has been able to recover about 550,000 francs' worth of silver and lead ores from the "débri" of the ancient mine of "Pont-pean," near Rennes, in France, of which he is the occupier.

208 GARFORTH, WILLIAM, JOHN, & JAMES, Dukinfield Iron Works, near Manchester—Manufacturers.

Steam riveting machine, having direct action. The following engraving gives the form of the machine, which consists of a strong cast-iron frame, a cylinder 36 inches in diameter, with piston and rod, on to which high-pressure steam is alternately let and discharged; the riveting portion being acted on directly by the piston rod, and the plates are thus closed and the rivet formed.

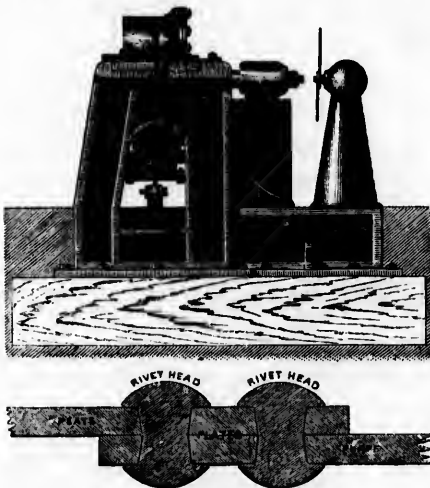

Garforth's Steam Riveting Machine.

With this machine, one man and three boys can rivet with perfect ease, and in the firmest manner, at the rate of six rivets per minute, or three hundred and sixty per hour.

Annexed to the drawing of the riveting machine is a section of two pieces of boiler plate, riveted together by this machine, and planed through the centre of the rivet, to exhibit the accuracy of the work.

209 LEWIS, FRANCIS, & SONS, Manchester—Manufacturers.

Wheel-cutting and dividing engine for cutting bevel-spur and worm wheels.  
Model of Lewis and MacLardy's patent roving and slub spindle for cotton, wool, flax, and other fibrous substances, and of spindle for doubling any descriptions of yarns on the same principle.

210 SHANKS, ANDREW, 6 Robert Street, Adelphi—Inventor and Manufacturer.

Bolt screwing and tapping machine. This machine cuts a perfect screw at one operation, and not by successive cuts.  
Improved high-pressure steam engine.  
Detail planing machines, one being for hand power for opticians and amateurs.

212 JOHNSON, R., & BROTHER, Dale Street, Manchester—Manufacturers. (Agents in London, Messrs. TOOTAL & BROWNE, 73 & 74 Piccadilly.)

Wire-drawing benches, showing the process of drawing strong and fine sizes of iron wire.  
Specimens of fine-drawn iron wire.

213 PARR, CURTIS, & MADELEY, Manchester. Planing-machine. Lathes, &c.

214 TAYLOR, W., 33 Little Queen Street, Holborn—Inventor.

Metal press used for striking medals for the Exhibition.

215 BENNETT, JOSEPH, 1 Thistle Street, Oldham Road, Manchester—Designer.

Shaded drawing of a large and powerful self-acting slide lathe for surfacing. Headstocks 42 inches high.  
A lathe of this nature has been manufactured by Messrs. J. & D. Glasgow, Manchester, for Her Majesty's Dockyard, Plymouth.

218 HICK, B., & SON, Bolton—Designers and Manufacturers.

Model of exhibitors' improved compound hydraulic press. This model shows the arrangement of an improved press, now at work on the premises of the exhibitors at Bolton, having four cylinders of such area as in the aggregate to be equal to 2,500 tons pressure. Among the various advantages attributed to this plan, are, that the four cylinders may be worked together or two at a time; and much better castings are obtained in consequence of the diminished weight, each of the cylinders weighing only two tons (about eight tons for the four), whereas one cylinder equal in power would weigh 20 tons. The model pumps and apparatus attached are equal in power to a single press with cylinder six inch diameter. Accompanying this model are several blocks of iron, eight inch diameter, which have been punched cold by the large press. The pressure necessary for such an operation, being, for iron, 1½ in. thick, 700 tons; 2 in. thick, 950 tons; 2½ in. thick, 1,250 tons; 3 in. thick, 600 tons, and 3½ in. thick, 2,050 tons. Fig. 1 represents this machine.

[The hydrostatic press was invented by the late Mr. Joseph Bramah, A.D. 1796. Motion is communicated to the ram by injecting water (or other fluid capable of sufficient resistance) into the cylinder, within which the ram moves. The amount of force given to the ram depends upon the proportion between the area of the plunger of the injecting pump and that of the ram, and the force can be indefinitely increased, either by extending these proportions or by increasing the leverage of the

Fig. 1.

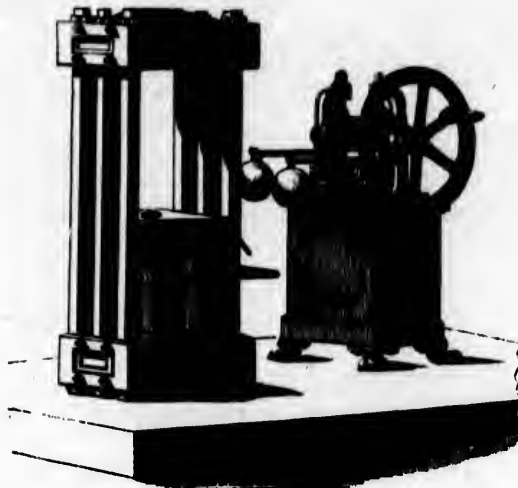

Hick's Hydraulic Press.

Fig. 2.

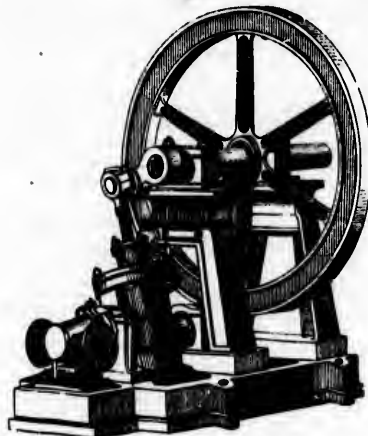

Hick's Two-horse Oscillating Steam-engine.

pump handle. These machines are most valuable for lifting great weights, testing the strength of girders, and packing compressible goods into a small space, &c.—S. C.]

Two-horse high-pressure non-condensing oscillating engine of very simple construction, the steam being admitted to the top and bottom of the cylinder by its own movement from side to side, the ordinary valve motion and eccentric being dispensed with. This engine is almost incapable of disarrangement; it is represented in fig. 2.

Portable smiths' hearth, with fan attached, for the use of ship-builders and others.

Smiths' hearth (of another description) for artillery purposes, adapted for fixing upon the back of a horse or mule, its weight being only about 180 pounds.

Improved ball safety-valve, invented by the late

Mr. Hick: it consists of a brass globe or sphere filled with lead, and merely resting over and closing a circular orifice, having no joints or levers connected with it; it will always blow off steam at a given pressure, thus preventing the possibility of accident from over-pressure.

Wheat-cleaning machine. This machine consists of two conical cylinders, formed of a series of files which are placed vertically, and are secured at top and bottom by means of cast-iron rings; a space is left between the inner and outer cylinders, which can be increased or diminished as required, the inner cylinder revolves rapidly upon its axis. The object of the machine is to separate and remove the smut and other impurities from the grain, which it accomplishes in the most effectual manner, and will clean about 200 bushels per hour.

Model of exhibitors' patent open-ended three-cylinder locomotive engine with a tender.

Radial drilling machine (full size). This will drill holes up to 4 in. diameter, and extending over a circle 11 ft. 6 in. diameter; the job can be raised or lowered at pleasure, by means of a square threaded screw cut upon the upright spindle, and moves freely round with its spindle on a series of small rollers placed under the rising block or nut.

Models of a pair of condensing steam-engines of 120-horse power each; the models are made on the scale of 1½ in. to the foot.

In addition to the above, the exhibitors have sent an engine of six-horse power, together with a considerable amount of mill-gearing and framework, supported upon a number of ornamental columns. This mill-gearing and steam-engine give motion to the machinery contributed by Messrs. Hibbert, Platt, & Sons, of Hartford New Iron Works, Oldham.

Improved mandrils.

219 GLASGOW, JOHN, *Manchester*—Inventor.

Improved screwing machine, with dies, taps, chucks, &c., complete.

220 SHEPHERD, HILL, & SPINK, *Hunsted Road, Leeds*—Manufacturers.

Self-acting side lathes, for longitudinal, conical, and transverse surfaces, complete; with screw-cutting apparatus, self-acting surface motion, and improved disengaging motion.

221 **COTTAM & HALLEN, 2 Winsley Street—**  
 Inventors and Manufacturers.

Hydrostatic press for proving girders. The improvements consist in the addition of a dial index, to denote the weight applied by the pump, and of a dead hand to mark the weight at the time, if the object under trial be fractured.

222 **RYDER, W., Bolton—Inventor and Patentee.**

Forging machine, to forge, draw down, and swage by steam-power small articles up to two inches, round or square, such as rollers and spindles for cotton and other machinery, bolts, studs, shaft-ends, &c., without the use of hammer or anvil. The following figure represents this machine.

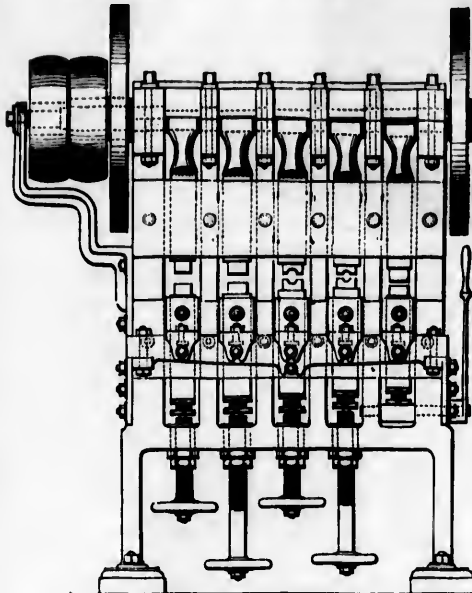

Ryder's Patent Forging Machine.

This machine is driven by Messrs. Hick and Son's oscillating steam engine.

Selection of articles the machine is capable of producing:—Slubbing, roving and throstle spindles and flye, and all kinds of rollers for cotton machinery.

223 **SANDFORD, OWEN, & WATSON, Phoenix Iron Works, Rotherham—Inventors, Designers, and Manufacturers.**

Improved screw-cutting lathe, exhibited for simplicity of construction and economy in working. The improvements consist in working the saddle, and throwing out the back gear of the fast headstock. The saddle is worked thus: the nut is solid with a spur wheel cast upon it, working into another spur wheel on a back shaft, on which there is a bevelled pinion; the latter works into a bevelled wheel, and is keyed on an upright shaft working through the saddle; there is another bevelled wheel, keyed upon the top of that shaft, working into a bevelled pinion upon the handle-shaft, which moves the saddle backward and forward at pleasure; in addition to this, there is an index disc upon the handle-shaft, which divides the screws into as many threads as are required, without interfering with the change wheels. The bevelled wheels

on the saddle communicate motion to the screw in the saddle, which acts of itself transversely. The improvements in the fast headstock consist in a worm and wheel for throwing out the back gear.

224 **EADES, W., & SON, Birmingham—Manufacturers.**

A small four-foot screw cutting and slide lathe on iron stands, with back gear, &c.; quadrant slide rest; traverse screw, with reversing motion; a set of change wheels; fly wheel and treadle motion; face plate; universal and other chucks; tools and apparatus complete.

A plain useful foot lathe on stands, quadrant slide rest, fly wheel and treadle; division, and spring face plate, and several useful chucks.

A small portable foot lathe on stands, fly wheel and treadle. One a size smaller.

Set of screw stocks, dies, and taps, for engineers, smiths, &c.

Screw plate and taps, for engineers, for pins and nuts.

226 **DALGETT, ALEXANDER, Deptford—Inventor and Manufacturer.**

Self-acting and surfacing lathe, with set of eighteen gun-metal change wheels, for screw cutting, from three threads in a foot, to 95 in an inch.

Self-adjusting chuck, with three jaws always working parallel to each other, for fixing any sized wire perfectly central, from the smallest needle to a bar  $\frac{1}{2}$  inch in diameter; particularly adapted for holding drills of various sizes, and making small screws.

Self-adjusting boring collar, for supporting various sized bars or tubes, from  $\frac{1}{4}$  to 2 $\frac{1}{2}$  inches in diameter.

Self-adjusting face chuck, for holding circular flat surfaces from  $\frac{1}{2}$  to 7 inches diameter.

228 **MAUDSLAY, SONS, & FIELD, Cheltenham Place, Lambeth—Manufacturers.**

Coining-press, in which the motion to give the impression is obtained by an eccentric, instead of by screw or lever. This press is represented in the cut below.

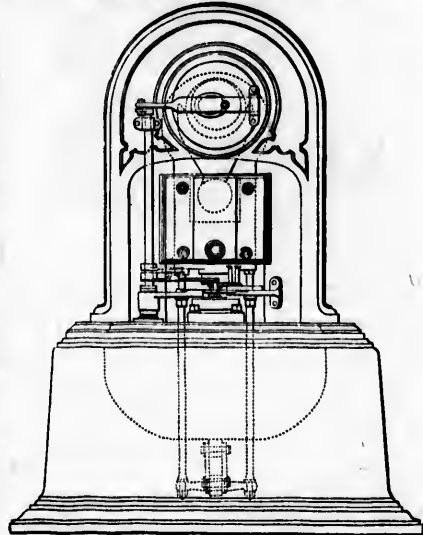

Maudslay & Co.'s Coining Press.



230 SMITH, BRACOCK, & TANNETT, Leeds—  
Manufacturers.

Self-acting slide lathes, with bed 18 feet long, head-stock 15 inches, self-acting surfacing motion, slide-rest, self-acting rack; traverse motion; leading-screw and change-wheels for cutting screws; index-plate for showing the wheels to be used for cutting various pitches of thread, face-plate and screw-keys.

Self-acting drilling-machine, with cross-slide and revolving table-gearing for slow motion; drills, cutter-bar, and steady bush; different speeds from 5 to 500 revolutions per minute; slide-vice for gripping work that cannot be readily fixed on the table.

Self-acting planing machine, for planing straight and circular work, with 6 inches stroke, and 16 inches traverse, table raised and lowered by rack and pinion, and slide-vice.

232 HOLTHAPFEL & Co., 64 Charing Cross, and  
127 Long Acre—Manufacturers.

A five-inch centre lathe for amateur ornamental turning. Eccentric, oval, spherical, conical, geometric, and other chucks. Compound sliding rest, with screw-cutting and overvillener apparatus.

Drilling instrument.  
Vertical, horizontal, universal, eccentric, and elliptical cutting frames.

Sets of engine tools, drills, and cutters.  
Sets of turning tools, &c., in ivory and hard wood handles.

Instruments for sharpening tools and drills.

Turning squares, bevellers, callipers, &c.

Decimal, parallel, and sliding gauges.  
Sliding centres.

Polishing apparatus.

Geological hammers.

Engine-divided scales in cardboard.

Odontographs.

Parlour printing apparatus.

Aportadometer, for taking offsets in land-surveying, &c.

Specimens of plain and ornamental turning by amateurs, in ivory and other materials; cannel coal, &c.

234 WILLIAMS, J., 18 Westgate Buildings, Bath—  
Manufacturer.

A one-horse portable steam-engine, for amateurs, designed by the Rev. C. R. Davy, Bath.

A self-acting foot-power slide and screw-cutting lathe, double-gear head-stocks, a new tool-holder, &c.

Foot-power drilling machine, with moveable bed, flat plates and experimental straight edges. Model of a private door. Ornamental cutting apparatus for lathes.—The above articles designed by the exhibitor.

Bolt and nut shaping machine for slide-rest, invented by John Wilson, Esq., Bath.

Ornamental screw-lifting jack, designed and made by the Rev. C. R. Davy, Bath.

236 NASMYTH, J., Manchester—Inventor.  
Steam hammer.

[This steam hammer is capable of adjustment of power in a degree highly remarkable. While it is possible to obtain enormous impulsive force by its means, it can be so graduated as to descend with power only sufficient to break an egg-shell.—R. E.]

## 238 STEWART, D. Y., &amp; Co., Glasgow—Manufacturers.

Model of patent mould-making machine for cast-iron pipes. Model of box or flask, in which the moulds are made. Model of core carriage, with core bars upon it. Pipes from 44 inches diameter downwards, cast in moulds made by the machine. Ten tons of pipes have been moulded in an hour. This machine is represented in the following page.

Machine for testing the strength of cast-iron.

[In making hollow castings, an inner mould, of the exact contour of the intended hollow, is formed in loam; it is, when dry, inserted in the sand-imprint of the pattern, the shape of the outside of the required casting. This inner mould is called the core, and when the casting has been made, is sufficiently friable to be easily broken away.—W. D. L. R.]

240 MORRALL, A., Studdy Works, Warwickshire—  
Inventor and Manufacturer.

Knitting-pins. Steel, gilt, and plated bodkins. Needles in the different stages of manufacture. Specimens of machinery for making needles. Stamp-press, or eyeing machine. Filing, heading, and curing machine. London agent, T. Linnell, 134 Upper Thames Street.

242 VAUGHAN, G., Westmoreland Street, Marylebone—  
Inventor.

Machine for setting the teeth of saws.

## 244 CHURCH, J., Chelmsford—Manufacturer.

Model lathes, with vice attached.

## 246 CAMPBELL, GEORGE, Charlton, Woolwich—Inventor.

Portable steam forge, with blowing apparatus.

301 BEART, R., Godmanchester, near Huntingdon—  
Inventor.

Patent brick and tile machine, combining grinding, screening, and pressing of clay through die. Specimens of the bricks and tiles made by the machine; and of the clay of which the bricks were made.

Patent brick and tile machine, to be worked by hand, combining the same objects except the grinding of the clay.

Model of a patent apparatus for boring Artesian wells. The "debris" broken up by the boring tools is carried up the boring pipes by a current of water.

Patent apparatus for boring stone. A current of water is applied to remove the grit, and keep the cutter cool.

Machine, worked by steam or other power, for cutting thin plates of stone, by means of vertical knives or saws.

Sand-stone filter, containing 5,000 superficial inches of sawn surface.

## 304 BRUNTON, W., jun.—Inventor.

Machine for washing ores.

305 WARING, C. H., Neath Abbey, Glamorganshire—  
Inventor and Manufacturer.

Machines for cutting or working coal, &c., horizontally and vertically.—Provisionally registered.

306 CLAUDET & HOUGHTON, 89 High Holborn—Props.  
(Invented by A. CLAUDET.)

Machine for cutting round, square, and oval glass shades. The diamond being always kept on its cutting point by a spring and two castors, and being mounted on moveable apparatus, it is in only necessary to push the apparatus slightly by the hand. With some modifications in the means of supporting the glass, but with the same apparatus for holding the diamond, this machine is used to cut the ends of the cylinders, which are the first form assumed by sheet glass.

Machine for cutting round shades exclusively.

308 HART, JAMES, 5 Seymour Place, Bryanston Square  
—Inventor and Manufacturer.

Patent portable brick machine. When set in motion, two boys at one end of the machine place the empty moulds on the chain, which are then carried by the chain



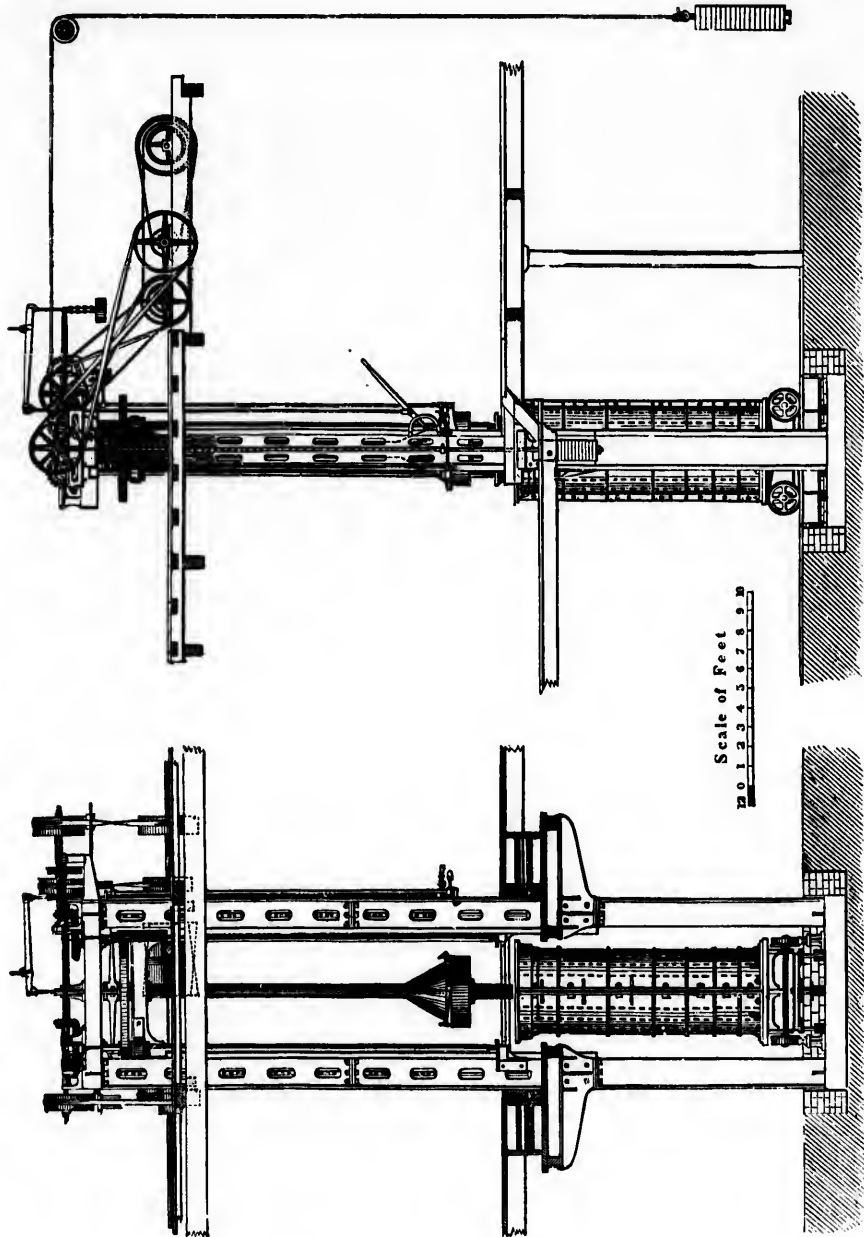

STEWART'S PATENT MOULD-MAKING MACHINE.

under the pug mill to the other end of the machine, where two other boys remove a perfect brick ready for the drying ground.

Two-horse steam engine and boiler.

Machine for drilling holes in machinery, exhibited as a specimen of mechanical skill.

New patent portable tile machine, to be worked by hand. This machine is represented in the annexed cut.

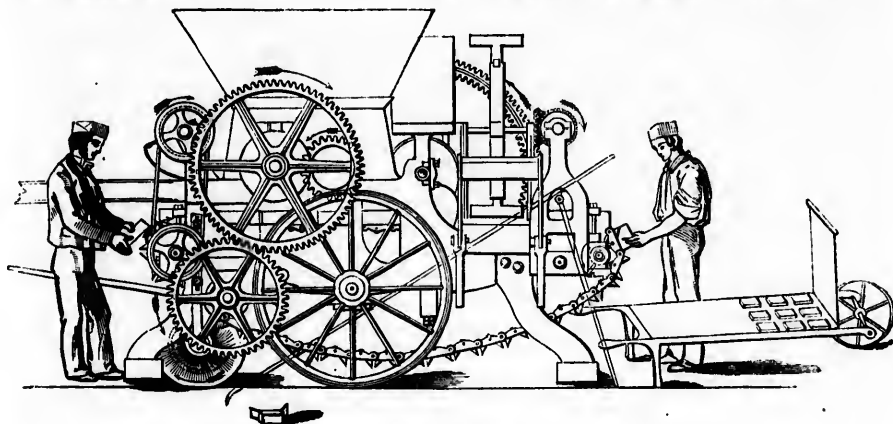

Hart's Patent Tile Machine.

310 BRADLEY, R., & Co., Wakefield—Inventors and Manufacturers.

A machine for moulding bricks, of various sizes and shapes.

A working model of a colliery, on a scale of one inch to a foot, showing the operations both above and below ground; with the latest improvements

312 HUNTER, J., Leysmill, Arbroath, Scotland—Inventor.

Working model of Hunter's stone-planing machine, with specimens of planed stones from Leysmill Quarries, near Arbroath.

314 MACKENZIE, JOHN STAFFORD, Newark-upon-Trent—Inventor and Manufacturer.

A triturator, consisting of a mortar, fixed in a wooden frame, and a pestle, to which, by means of apparatus attached, a rotatory motion is given. This machine is useful for triturating or levigating various articles used in chemistry, particularly mercurial preparations, paints, printers' inks, and such articles as require continued friction and agitation.

317 MARSDEN, BENJAMIN, Leeds—Manufacturer.

A washing, wringing, and mangling machine, the novelty being the fitting-up and action of the machinery in the interior of the cylinder, including oscillating frames, springs, &c., and resembling the action of the human hands. Occupies little room; is easily removed, and is capable of washing and wringing four blankets in ten minutes. Can be worked with ease by a girl; saves time, soap, and labour; and with it, infected linen and other articles unfit to be washed with the hand can be easily cleansed. The principles and details are equally applicable to a machine on a large scale to be worked by steam power.

324 RANDELL & SAUNDERS, 14 Orange Grove, Bath—Inventors.

Patent machine for driving saws, for the purpose of cutting stone in its natural beds. The novelty consists in driving saws from one end only, and in placing the guide frame on the same axis as the crank shaft by which

the saws are driven; by this arrangement the saws adapt themselves to their work at any angle. Each saw is allowed an independent action.

Traversing crane driven by steam power, and constructed for working in underground quarries.

Patent saw frame for cutting blocks of stone, marble, &c., balanced, and turning on the same axis as the crank shaft by which the saws are driven.

Patent portable saw frame.

328 RADCLIFFE, AUGUSTUS, 67 St. John's Street Road—Inventor and Manufacturer.

Model of a trigger for shutting off the steam of a locomotive engine, and stopping it in cases of danger.

Improved shifting quarry-board, for cutting to any angle at which the window may be set out.

Circle-board for cutting block, barometer, compass glasses, &c.

Glaziers' diamonds for cutting plate, sheet, crown, and all kinds of window glass; a portable circle cutting machine, or beam compass diamond, and a cylinder or shade cutting machine.

Artists' diamonds or points for etching, dragging, ruling, medallion engraving, &c.

330 SPELLER, W., 14 York Street, Blackfriars Road—Manufacturer.

Well-boring implements for procuring water from the main spring at whatever depth. Also suitable to ascertain the strata of the earth for mining, railways, &c.

400 BESSEMER, HENRY, Baxter House, Old St. Pancras Road—Patentee and Manufacturer.

A model of a slate table for holding plate-glass during the grinding and polishing process: this is effected by atmospheric pressure acting on the upper side of the plate, while a partial vacuum is formed below it by an air-pump or steam jet; for this purpose the two pieces of slate forming the table have a series of grooves formed between them, which communicate with the holes upon the surface, so that whenever a plate of glass is laid upon the table, a cock is opened communicating with an exhausted vessel, when the plate will be firmly held thereon, but which may be instantly removed by again

admitting the air. The plan in general use for holding down sheets of glass is to imbue them in plaster of Paris, which operation has to be performed four times for each plate, and which, in some establishments, consumes 40 tons of plaster per week. Patented and manufactured by the exhibitor.

An improvement on the centrifugal machine for separating molasses from crystals of sugar. The peculiarity of this machine consists in the mode of driving it by a pair of emissive arms on the same axis as the centrifugal drum, thereby dispensing with the upper driving gear, and also in making the centrifugal drum to lift on and off the machines, so that the operator removes the charge of finished sugar from one drum, and recharges it with matter to be operated upon while the other drum is in use upon the machine; by which arrangement one man with this machine can operate upon as much material as two men and two of the original machines were capable of doing. Patented by the exhibitor, Proprietors, Messrs. Rotch & Finzel, 2 Furnival's Inn, London.

#### 401 FURNESS, WILLIAM, *Liverpool*—Patentee.

Patent machines for working in wood. Power mortising machine, stated to be simple in adjustment and operation, and self-acting in its half-rotary reverse motion, which changes the face of the chisel.

Foot mortising machine; to be used with any size of chisel, from an eighth of an inch to two inches; the peculiar form of the chisel enables it to hold the cone and lift it out of the mortice at each return stroke.

Tenoning machine; to be worked either by hand or steam power. The tenon is finished at one operation, without gauging or setting out the work.

The annexed cut represents this machine.

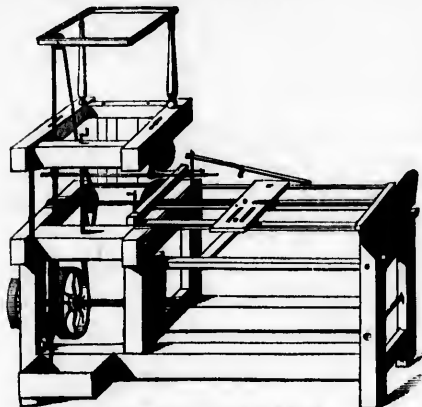

Furness's Patent Tenoning Machine.

Planing machine; adapted for squaring up hard or soft wood, from four to fifty feet in length, from eight to forty inches in width, and from one quarter of an inch to thirty inches in thickness.

Moulding machine. Any description of joiners' mouldings can be cut by this machine with great rapidity, and in such an accurate manner as not to require the use of any other tool. It is equally useful in sash-sticking, either in hard or soft wood. Its construction is simple, and is easily kept in order.

#### 402 SCHIELE, C., *Manchester*—Inventor and Manufacturer.

Specimens of the construction of revolving rubbing surfaces by a patent rule which determines the form best adapted to reduce friction to a minimum under any

given strain. Form for a strain in the direction of the axis.

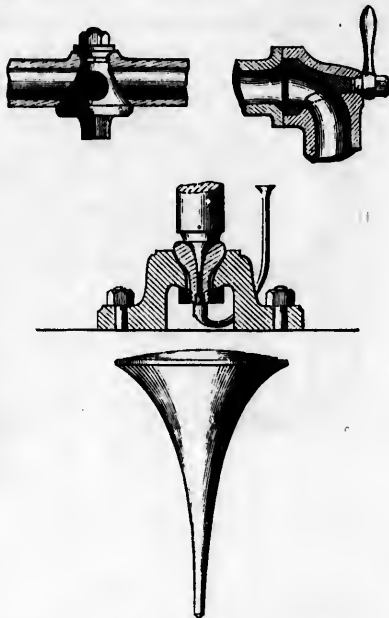

The preceding figures are intended to represent various applications of the peculiar form for rubbing surfaces. The lower figure represents this form.

Portable grinding mill, driven by Lloyd's steam-engine, with the exhibitor's condenser attached, and with the rubbing surfaces formed according to the patent rule.

A similar mill, fitted as a handmill.

Four-and-a-half-inch cock.

Spindle-joint, used on locomotive regulators, instead of stuffing-box. 1½-inch stop-cock, with pump-valve attached. Steam whistle.

Glass water-gauges: in which the packing is tightened by direct pressure without any twisting strain on the glass. Gauge-cock.

Self-acting feed regulator for a ten-horse power boiler, with curved surfaces.

Fire-cock, with stand pipe.

Glass taps for acids, filters, &c. Lathe spindle.

Samples of screws and nuts.

Instruments for describing the curves required in the construction of the foregoing articles. Equation and formulae relative to the antifriction curve.

Ventilator for exhaustion or compression.

#### 403 FAIRBAIRN, W., & SONS, *Manchester*—Inventors and Manufacturers.

Specimens of corn-mill work:—Improvements in the manner of driving, in the means employed for adjusting and regulating the grinding-stones, and in the means of feeding.

#### 404 CROSSKILL, WILLIAM, *Iron Works, Beverley*—Patentee and Manufacturer.

Patent mills for grinding vegetable substances. They consist of—mills for steam, of two and four horse power, for grinding broken bones into fine powder, at the rate of about 25 bushels per hour, suited for fine manure;

another for grinding malt, also oats, barley-meal, &c. Fig. 1 shows this machine.

Fig. 1.

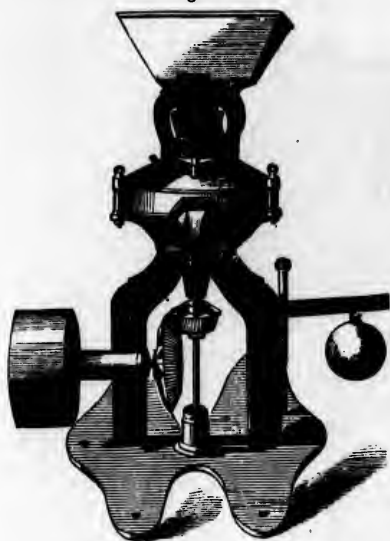

Crosskill's Mill for Vegetable Substances.

Mills for power or hand use, for grocers, druggists, confectioners, &c.

Patent mills for grinding mineral substances. The particular features in these mills consist in their strength

Fig. 2.

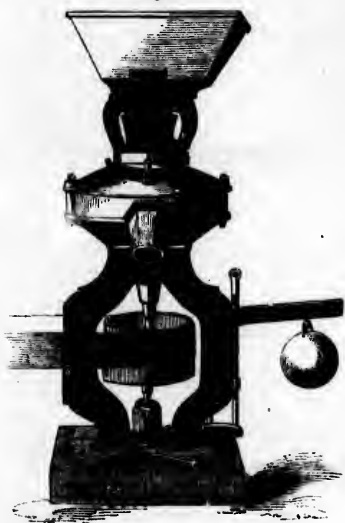

Crosskill's Mill for Mineral Substances.

as power-mills; their adaptation, by changing finer or coarser plates, for grinding various mineral substances to fine dust; and, from the position of the two centres, the peculiar eccentric motion is obtained for each of the revolving metal plates. They consist of—mills for steam, of four-horse power, for grinding iron, zinc, copper, and gold ores, plumbago, manganese, &c.; another for grinding raw or calcined flints for pottery purposes, also quartz, &c.; will grind 8 to 10 cwt. of raw flints per hour by the first process, and by the second process reduce 12 to 15 cwt. per hour to the finest powder. Fig. 2 shows this machine.

Mill for steam, of two-horse power, for grinding paints or liquid substances.

Mill for hand or power, for grinding paint or liquid substances. With this mill a boy will grind from  $\frac{1}{2}$  to 1 cwt. per hour.

Improved portable and fixture steam-engines for manufacturing or agricultural purposes.

405 ROTCH & FINZEL, 2 Furnival's Inn—  
Inventors.

Centrifugal machine for separating molasses from sugar. Manlove and Alliot, manufacturers.

406 BIRCH, JOHN, Edward Street, Regent's Park—  
Inventor.

Model of a machine designed and used for the purpose of cutting sash and roof bars, and applicable to the preparation of mouldings, &c. It is so contrived as simultaneously to work the two sides of the bars or mouldings. The cutter blocks are so contrived as to work seven bars at the same time.

407 MAIDLOW, JOHN, 24 Queen's Terrace, St. John's  
Wood—Inventor.

Improvement in carpenters' bench screw, check, and stop, having two screws to the check, both acting at the same time with one lever, causing the check to work parallel, and have equal pressure at both ends; adapted for joiners, cabinet-makers, bookbinders, &c. The stop is so arranged that, by turning a screw which is let into the top of the bench, it will rise to any height required.

[The bench-screw is to the joiner and cabinet-maker what the vice is to the smith, the moveable block or check and the fixed block which is fixed in and to the bench, and which contains the matrix of the screw forming the jaws of such vice. That the check should press upon the body to be held equally is highly important to the ease of the workman and to the strength of the work; and any arrangement that tends to secure the parallel movement and even binding of the check, up to and upon the side of the bench which covers the fixed block, the counterpart of the check is worthy of consideration.

The "stop" is an end-grained block of wood passing through the top of the bench and capable of being made to stand more or less above the surface of the piece of stuff to be tied up or otherwise planed, and to resist pressure; the use of the stop being to hold the work up to the plane as the workman pursues the operation of planing.—W. H.]

408 DAKIN & Co., St. Paul's Churchyard.

Patent apparatus for roasting coffee in silver. The illustration in the following page represents the arrangement adopted in this apparatus.

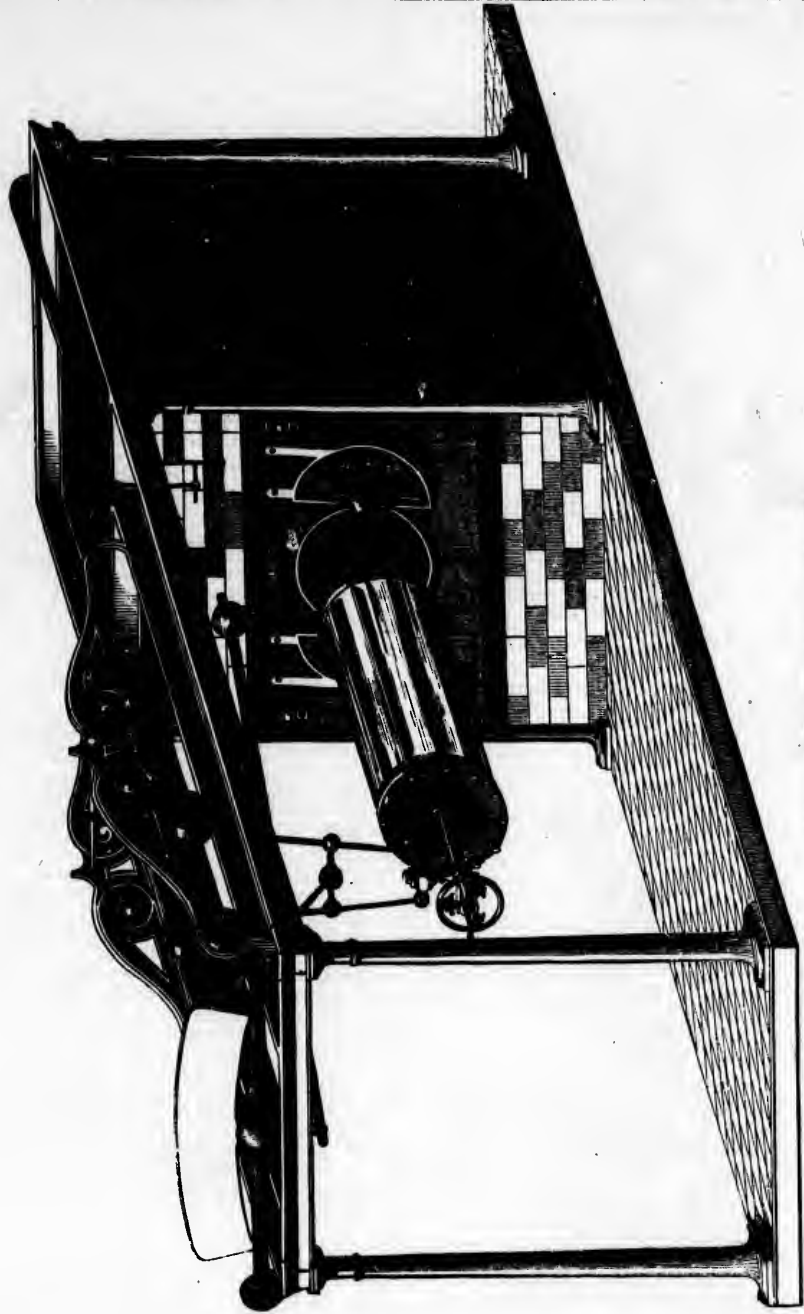

DAKLY'S PATENT COFFEE-ROASTING APPARATUS.

DAKIN'S PATENT COFFEE-ROASTING APPARATUS.

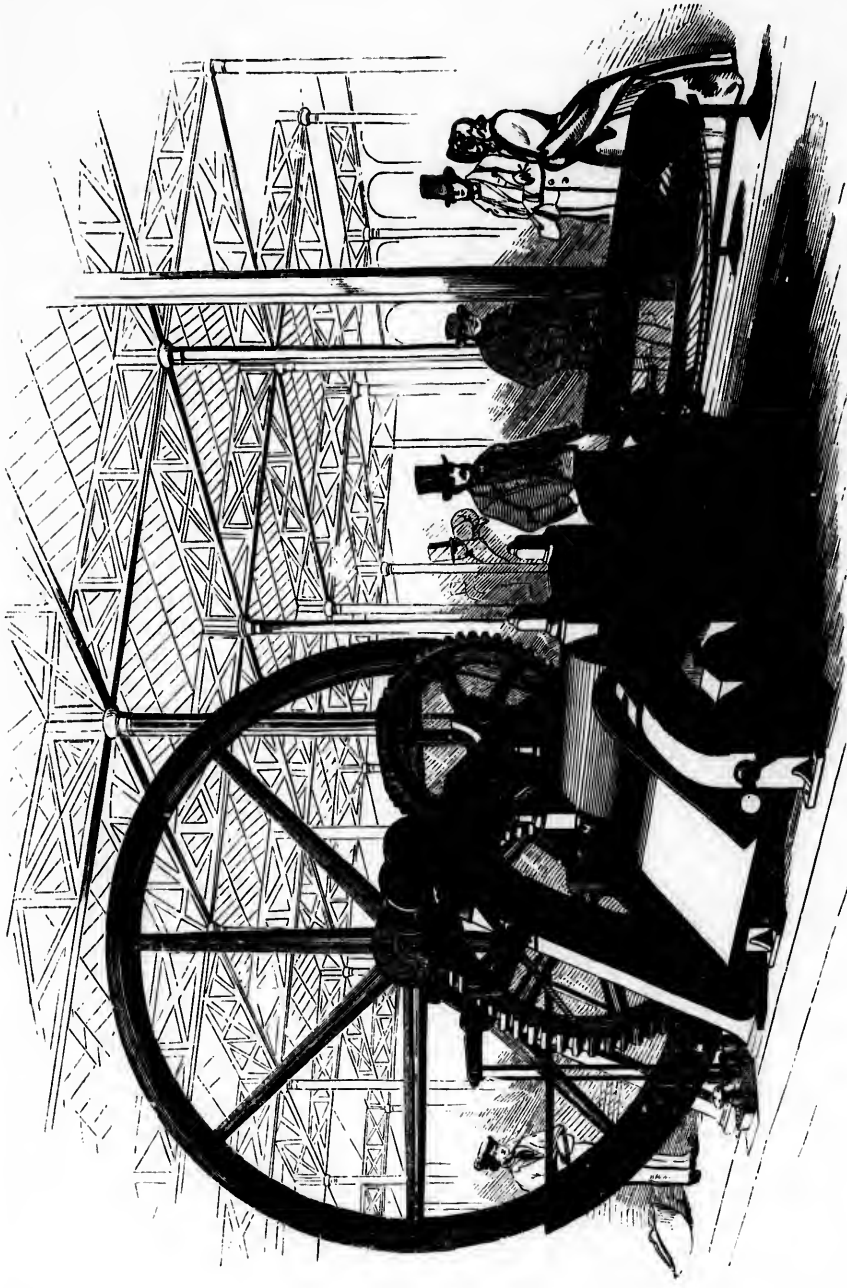

ROBINSON'S STEAM SUGAR-CANE CRUSHING MILL.





NORTH AREAS A. B. 10 TO 31; C. D. E. 1 TO 10, &amp; 19 TO 33; G. H. 25, 26.

**410 BARRETT, EXALL, & ANDREWS, *Kategrove Iron Works, Reading*—Manufacturers & Inventors.**

A combination of machinery, by which flour, &c., is passed through the various processes of manufacture to the complete preparation of the biscuit. The flour, &c., is put into the first machine, where it is thoroughly mixed; it then passes to the breaking-machine, where it is kneaded until it becomes sufficiently tenacious to be passed through rollers. From these rollers it is conveyed to the adjusting rolls which reduce it to the required dimensions. It then passes in a continuous sheet, by means of an endless canvas, to another machine, where it is cut, dooked, crimped, and stamped. The biscuits are then divided from the waste dough, and conveyed to the oven. The waste dough is collected and passed by means of a shute to be re-rolled.

**412 WASLEY, JAMES, *Pool, near Redruth*—Inventor.**

Trammel for striking helices or spiral lines.  
Frame for "setting up" mitre joints.

**414 HURWOOD, GEORGE, *College Street, Ipswich*—Inventor and Patentee.**

Patent metal mills for grinding wheat, barley, Indian corn, peas, and beans, fitted on a stand, and arranged with a series of four cutting rings on each grinding plate, to work horizontally by gearwork and pulleys. The surface plates are prepared to receive the cutting parts, which are made in a series of rings. Fans are fixed to the periphery of the revolving plate, to cause a current of air to pass between the grinding surfaces. Adjusting screw fitted in shoot to arrest stones and other objectionable materials.

Surface plate, with four cutting rings attached, to show the grinding surface.

Single cutting ring detached from the plate.

Patent ventilating apparatus fitted to case, and model of a pair of stones for grinding wheat (full size), for the purpose of supplying a current of air between the grinding surfaces.

**416 CORCORAN, BRYAN, & Co., *36 Mark Lane*—Designers and Manufacturers.**

Model of an improved drying kiln for malt and all other grain, on a scale of one inch to a foot. The improvements are said to consist in economy of fuel, regularity of heat, and the prevention of condensation of steam.

Flour-dressing machine, consisting of a case containing a mahogany cylinder lined with woven wire, enclosing brushes hung with regulating screws upon a shaft, which, revolving rapidly, separates the flour from the bran.

Samples of very fine wire:—No. 150, woven brass (or 22,500 holes in a square inch), 18 inches wide. No. 100 by 650, twilled brass. 3,252 feet of iron wire-thread, weighing only two ounces. 3,900 feet of brass wire-thread, weighing only one ounce. Paper-machine wires, 7 feet wide joined. A woven wire malt-kiln floor, 20 feet by 16 feet, with flat seams. A corn-meter's shovel, bushel measure, and other implements used in the corn trade.

Millstones for grinding wheat made of French burr-stones, as generally in use in this country.

Portable corn-mill made of French burr-stones, to be worked by two or three horse power, and intended for the use of emigrants, and others.

[French burr-stones are in great request for the purposes of grinding in this country. They possess both geological and lithological characters of much interest. They are met with only in the Paris basin and the adjoining districts, in the Isoustrine, or fresh-water deposits (*Pleistocene*), occurring in beds either continuous or interrupted, and generally mixed up with beds of sand or of ferruginous marl, which penetrate between them, filling up their fissures and honeycomb cavities. The beds sometimes contain no organic forms, at others they seem to be full of fresh-water shells and land plants, which have assumed a silicious character. The texture

of the stones is occasionally cellular, the cells or cavities being irregular in number, size, and shape, and they are frequently traversed by thin plates, or coarse lines, of silica. They are quarried close to the surface, and are cut on the spot into paralleloppedal pieces called "pans," which are bound together by iron hoops, and then form millstones.—J. W.]

**417 BARKER, CHARLES M., *23 Portsmouth Place, Kennington Lane*—Inventor, Patentee, and Manufacturer.**

A curvilinear sawing machine, or ship's timber and ordinary sawing frame, for sawing one or any number of curves in timber, with bevels of various degrees. The machine requires only one attendant, and obtains a speed of 120 revolutions per minute.

A circular sawing, or rack bench. The machine consists of a number of circular saws (in segments) upon one shaft, so that by one direct feed the saws cut a piece of timber or deal into any desired number of parallel planks or boards.

**418 ROBINSONS & RUSSELL, *Mill Wall Works*—Inventors.**

Patent steam sugar-cane mill, in which the engine, gearing, and mill, are all combined upon the same base plate, to render it portable and independent of the expense of masonry.—(See Plate 53.)

**420 BLUNDEL, SPENCE, & Co., *Hull, and Upper Thames Street*—Manufacturers.**

Hydraulic seed presses. The figure in the next page represents the ground plan and elevation of these presses, drawn to scale. The press No. 1 contains ten cakes of 3 lbs. each, No. 2 contains four cakes of 8 lbs. each.

A pair of presses, when fixed with the pumps attached thereto, occupy a space of 9 feet by 3 feet. They are usually placed on a stone landing of this size, to which the pump cistern is securely bolted, as shown on the drawing; and this is all the fixing required.

The presses are so portable in their construction, that they can be fixed up, or removed in two or three days by any competent mechanic.

The pumps and valves are made of the best gun-metal and workmanship.

A pair of presses with the pumps will weigh altogether from nine to ten tons.

The pumps are driven from the lever end by a connecting rod, at a speed of about thirty-six strokes per minute, and do not require more than one-horse power to work them.

With a pair of presses, No. 2, one man and a boy working the usual hours of a "single spell" (say from 6 A.M. to 6 P.M.) will make from 28 to 35 cwt. of linseed cake.

The whole of the oil is extracted from linseed by one operation of pressing. But in the manufacture of rapeseed, it is in most cases necessary, in order to obtain all the oil, that the cake should be worked over a second time; it is therefore desirable, when working on a large scale, to have a press expressly adapted for the first operation, which is called clodding.

The current expense for wear and tear on these presses is small, and chiefly confined to the occasional renewal of the leathers or packings of the pumps and cylinders.

**421 FAIRBAIN & Co., *Manchester*—Manufacturers.**

A flour-mill.

**422 HUNT, JOHN, *Botley Mill, near Orford*—Inventor and Manufacturer.**

Flour-dressing machine, on a new principle.

**424 GUTTA PERCHA COMPANY, *Wharf Road, City Road*—Manufacturer.**

Printing, folding, and cutting machinery for working from gutta-percha castings.

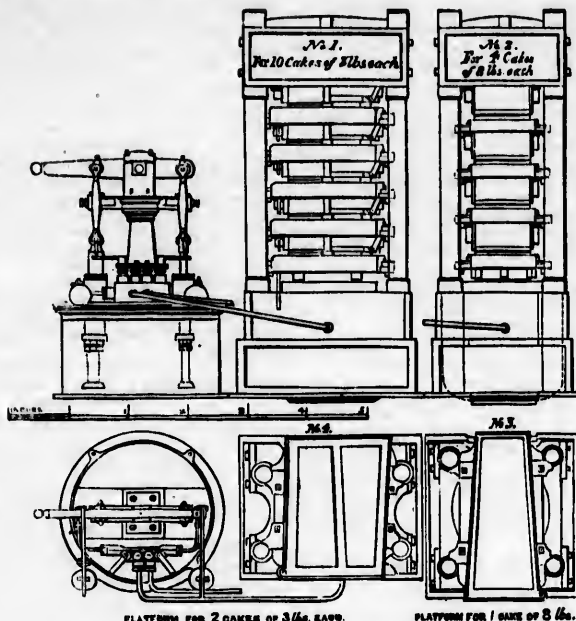

Blundel, Spence, and Co.'s Hydraulic Seed Presses.

426 BEDFORD, JOSEPH, *Mill Hill, Leeds*—Manufacturer.  
 Flour-dressing machine, complete.

428 BLACKMORE, WALTER, *Wandsworth*—Proprietor.  
 Model (half size) of an improved bolting-mill, showing the mode of dressing flour through patent bolting cloths, without seams, with gutta-percha flaps revolving on the outside of the cloth, for clearing the cloth while dressing. Improved by James Ayton, of Norwich.

429 ADAMS, S. & C., *Oldbury, near Birmingham*—  
 Inventors, Patentees, and Manufacturers.  
 Patent durable steel hand mill for grinding flour for colonial and domestic use. New cutters may be applied in lieu of the old ones when necessary. The grinding part only of the revolving cutter touches the grain, whereby much friction is avoided. The grain is forced in between the cutters by a series of inclined planes, rendering short cutters only necessary.

430 THOMSON, W., *Shotts Foundry, Edinburgh*—  
 Designer and Manufacturer.  
 Planing-machine of novel construction. Tool for cleaning off flooring-boards and deck-planking.

432 COLLINOE, CHARLES, & Co., 65 *Bridge Road, Lambeth*—Designers and Manufacturers.  
 Patent horizontal sugar mill, intended to be worked by cattle, wind, or steam power.

436 SPILLER, J., *Battersea*—Inventor.  
 Flour-dressing machine.

438 SHORE, THOMAS, *City Road*—Inventor.  
 Patent atmospheric flour-dressing machine.  
 The usual mode of dressing flour is to brush it through a cylinder clothed with wire, by means of brushes revolving on a spindle or shaft within. The object

of this patent is to supersede the use of brushes by means of fans of steel plate, or other suitable material, which, being placed at a certain angle within the cylinder, are found to possess the following advantages:—

The fans being placed at some distance from the wire clothing the cylinders, the ordinary friction between wire and brushes is avoided; whereby the wire is prevented from wearing, and a considerable saving of power effected.

The flour is perfectly separated from the offal, and, being fanned instead of brushed through the wire, it is much more free from specks or greys than flour dressed in the usual method, while the strong current of air to which it is subjected causes an improvement in the quality, and the wire also is kept constantly clear while dressing.

Brushes are a continual source of expense, whereas it is scarcely possible to wear out a set of fans. The case or box which contains the cylinder is furnished with a hole at each end for the purpose of supplying the air required by the fans, which air, when it has been driven, together with the flour, through the wire clothing of the cylinder, is carried off by means of a chimney into the meal-hutch above.

The speed varies from 14 to 16 sacks per hour with an 18-inch cylinder, from four to five sheets being used for flour.

440 SHARP, STEPHEN, *Stamford*—Inventor and  
 Manufacturer.

Sugar-cutting machines.  
 Model of a printing machine, in which the crank is applied.  
 Model of oscillating steam-engine.

441 WEATHERLEY, H., 54 *Theobald's Road*—  
 Inventor and Manufacturer.  
 Machine for cleaning currants by a simple process, and rendering them perfectly free from grit.

**442 WESTRUP, WALTER, 282 Wapping—Inventor.**

Patent corn mill, made at the works of Mr. Thomas Middleton, Lomax Street, Southwark.

This mill consists of two pairs of stones, with conical grinding surfaces, fixed on one shaft. The upper pair crushes the wheat, the finer parts of the flour produced thereby are instantly driven away through a cone of wire placed under them; the residue of the meal then passes through the lower pair of stones, where the grinding is completed.

The superior advantages of this system of grinding are—  
1st. Eight to ten bushels of wheat can be completely and perfectly ground per hour.

2nd. Is a very considerable saving of power.

3rd. The meal is delivered from the stones quite cool, having undergone no pressure; the flour will consequently keep in good condition, and be therefore less likely to be injured by any atmospheric change.

4th. A better quality of flour is produced than by the common mode of grinding.

5th. The stones are more easily kept in truth, and take much less time in dressing.

**443 FIELDHOUSE, G., & Co., Wolterhampton—Inventors.**

Mills on pillar-stand for grinding coffee and pepper, with two fly-wheels, friction boxes, and multiplying wheels.

[The ordinary mill in use for grinding coffee, pepper, &c., is extremely simple in its construction, and consists of a conical cylinder, which is cut into a series of ridges in its internal diameter: a taper piece of steel fits into this, and its outer diameter is cut with a corresponding series of ridges, but in the reverse direction; a temper pin regulates, by its projection, the fine or coarse quality of granulated particles, and the whole is set in motion by a winch handle. The addition of fly and multiplying wheels are not essentially parts of the mill, but they very materially facilitate the operation of grinding.—W. C. A.]

**444 COOMBE, BENJAMIN, & Co, 30 Mark Lane—Manufacturers.**

A smut-machine and corn-screen combined. The objects of this machine are stated to be to produce on the surface of the wheat the utmost amount of friction that it can bear without breaking or injuring the grain; to fan it at the same time; scour off the fibrous end and all that adheres to it, and thus clean the wheat of all dirt-clods, smut, &c. The best wheat is said to be considerably improved by passing through this machine. This machine according to its size will clean ten to fifteen quarters of wheat per hour.

A model of a flour-dressing machine, with registered fan-brushes and flanges complete; also samples of brushes and fine wire-cloth used in the above.

Specimens of wove and twist wire in brass and copper, containing 500 picks or shoots in an inch, which is said to be the finest wire-cloth ever manufactured; also other specimens of very fine wove wire-cloth, and wove wire for covering kiln-heads.

**445 GRAHAM, WEST, & Co., 304 Wapping—Manufacturers.**

Model, made to the scale of  $1\frac{1}{2}$  inch to a foot, of a horizontal mill, for crushing sugar canes. Instead of three, the usual number, this mill has five rollers, which are so arranged that the canes, in passing once through the mill, are pressed four times, whereas in a single passage through one of the three-rollered mills they are pressed but twice. The two upper rollers of the mill are held down by six bolts, the lower ends of which go through, and are secured to two wooden spring beams, so that, in the event of the rollers being subjected to any extraordinary strain, the spring-beams yield, and prevent the mill from being damaged.

Model, made to the scale of  $1\frac{1}{2}$  inch to a foot, of one of the old vertical sugar-cane mills.

Model, made to the scale of 1 inch to a foot, of a set of evaporating pans, in common use for sugar-cane juice.

**446 HUXHAMS & BROWN, Exeter—Inventors and Manufacturers.**

Mill to grind bark for tanners, adapted for horse, steam, or hand power; it operates upon the long bark as it is usually delivered at tan-yards, and saves the cost of chopping the bark separately. This mill is exhibited in the annexed engraving.

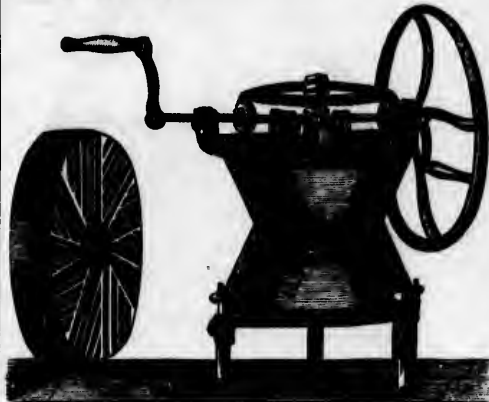

Huxhams and Brown's Bark Mill.

Emigrants' or domestic flour-mill, with a new method of working by hand.—Registered.

Millstones to grind wheat.

**447 GILBERT, J., 79 Wardour Street, Soho—Inventor.**

Guillotine cutting machine, for cutting end joints in wood to any angle with facility and accuracy; for mouldings and other work in joinery and cabinet-making, &c.

**448 ADOFFO, J. N., 6 Golden Square—Inventor and Patentee.**

A machine for making cigarettes. It performs 14 different operations from a single motive axis, and is capable of making, simply from paper and tobacco, 80 to 100 cigarettes in a minute, and neater than those made by hand.

Machines for making cigarettes, in the French and Spanish styles, and for making cigars in Havannah, Manilla, or Mexican style.

Patent accessory machines, employed in the manufacture of the above articles.

**449 SQUIRE & Co., Great Dover Street, Borough—Inventors.**

Direct-acting sugar-mill.

**450 GATTI & BOLLA, 129 Holborn Hill—Manufacturers.**

Model of a machine for the manufacture of French and Italian chocolate. The good qualities of the cocoa are intended to be retained by the process.

**454 MANLOVE, ALLIOTT, & SEYRIG, Lenton Works, Nottingham—Inventors.**

Centrifugal washing and drying machine, for washing or cleansing, by forcing water centrifugally through goods requiring to be cleansed, and subsequently drying them

in the same machine. It is also used in the separation of moisture from starch, and other finely divided substances.

Fig. 1 is an engraving to show the form of this machine adapted for hand-power; part of the outside cover is removed to show the interior.



Manlove, Allott, and Co.'s Centrifugal Washing and Drying Machine.

Circular looped fabric machine frame for the manufacture of woollen cloths and hosiery goods; exhibited for the great speed and economy of labour with which goods can be manufactured, and elasticity given to them by its application.

Fig. 2 is an engraving to show the form of this machine adapted for steam power, with the gearing attached.

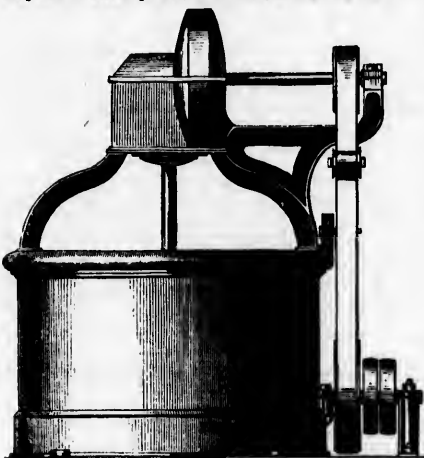

Manlove, Allott, & Co.'s Centrifugal Washing and Drying Machine.

455 STAIGHT, DANIEL, & SONS, 35 Charles Street,  
Hatton Garden—Proprietors.

Ivory comb-cutting machine, capable of cutting 120 teeth in one inch of ivory.

Part of an elephant's tusk. Other parts of the same, out into continuous rolls, applicable for veneering, &c., with the remaining part. Pieces of ivory cut and prepared for miniature painting.

Lady's work-table, exemplifying the utility of cutting ivory, upon the new principle. Piece of ivory cut upon the old method. Various articles in ivory.

456 PROSSER & HADLEY, 20½ Clifton Street,  
Marylebone—Manufacturers.

Patent ornamental sawing machine, adapted for curvilinear cuttings, both in outline and perforation.

457 TONS, G. BAILEY, & Co., East India Chambers—  
Importers and Agents.

French millstones, made at La Ferté-sous-Jouarre, to which is applied Hanon Valoke's patent aëriator. By the rapidity of the rotation of the runner, the air is driven into the deep canals made for it, and escapes by the furrows of the stones. An active circulation of fresh air is thus brought into contact with the meal, and it is continually renewed and dispersed by the centrifugal action of the stone.

458 SAVAGE, A., 43 Eastcheap—Manufacturer.

Mill for grinding coffee, &c., ornamentally finished in gold bronze, to stand on floor. Mill, finished bright, for hand or steam power. Bronze mill of smaller dimensions, for counter.

Mills for grinding wheat, malt, &c.; for bruising oats, and coarsely grinding other corn; for splitting beans, grinding coffee, cocoa, drugs, &c., and for crushing raw sugar.

Improved portable lever roaster, for coffee, malt, &c. Sample roaster.

Portable vibrating woven-wire-bottomed cooler, and iron stand, for rapidly cooling coffee, chicory, malt, &c., after roasting. Machine for sifting. Mills for making chocolate.

459 HUGHES & SONS, 1 Great Dover Street, Borough—  
Manufacturers.

Millstone made of French burrs, with wind-chest and ventilating holes, for grinding with Bovill's patent air-blast, by which the meal is delivered at once from between the grinding surfaces of the stones on its production, and in a cool state, so that it can be dressed as soon as it is ground. The stones, by this patent, grind eight bushels per hour.

Two millstones of a superior manufacture, for grinding wheat.

460 LAW, W., 31 St. Andrew's Square, Edinburgh—  
Inventor.

Machine for roasting coffee. The globe-roaster, with double rotatory motion, is heated in an atmosphere of hot air through a cast-metal casing. The constant complex motion presents every part of the machine, in regular rotation, toward the source of heat. The following cut shows this machine.

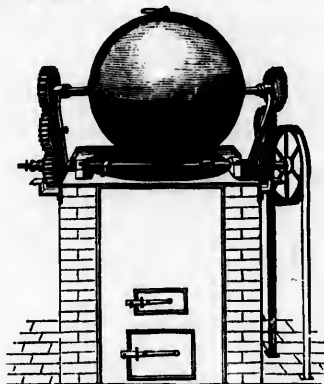

Law's Globe-roaster for Coffee.

tility of cutting  
ivory cut upon  
ry.

Street,  
apted for curvi-  
rotation.

Chambers—

sous-Jouarre, to  
erator. By the  
the air is driven  
escapes by the  
tion of fresh air  
meal, and it is  
the centrifugal

factor.  
tally finished in  
shed bright, for  
aller dimensions,

urising coats, and  
beans, grinding  
g raw sugar.  
offee, malt, &c.

ooler, and iron  
malt, &c., after  
making chocolate.

et, Borough—

wind-chest and  
mill's patent air-  
l at once from  
as on its produc-  
dressed as soon  
tent, grind eight

ure, for grinding

Edinburgh—

be-roaster, with  
atmosphere of hot  
stant complex  
hine, in regular  
the following cut



462 MILLINGTON, BRYAN & EDWIN, *Newark-upon-Trent*—  
Inventors and Manufacturers.

Patent smut machine, for cleaning corn of all soft impurities; it consists of the six-wire brushes, revolving at a speed of 800 revolutions per minute, within the frustum of a cone, lined with woven wire of a sufficient fineness to prevent any corn from going through; after the operation of this machine, the corn passes a small blower attached, which may be regulated so as to take out the inferior kind.

Samples of the grain, cleaned and uncleaned.

466 RANKIN, RICHARD & JOHN, *Liverpool*—  
Manufacturers.

Patent vertical smut machine and corn screen. The internal rotary cylinder with beaters is made of wrought iron, and the external stationary cylinder of cast iron. A strong continuous current of air is made to pass through the wheat, while it is between the two cylinders, carrying off the dust, at the upper part of the machine, as soon as it is disengaged from the wheat by the beating process. A separator is attached, for extracting sand, seeds, and small grain.

Registered portable driving apparatus; invented for driving the above machine.

Models of both machines, to be driven by hand.

467 SQUIRE, CHARLES, 20 *Old Fish Street, Doctors' Commons*—Inventor.

Timber-preserving apparatus.

468 BURT, H. P., 238 *Blackfriars Road*—Inventor.

Timber-seasoning apparatus.

470 ASHEY, W., 8 *Prospect Place, Sheffield*—Inventor.

Upright flour-dressing machine, which cools the meal in the process, and separates it into the required parts, with an economy of power.

472 HALL W., *Castlecomer, Ireland*—Inventor.

Model of grinding-mill.

501 PERRY, HENRY JAMES, 3 *Greenwich Road, Greenwich*—  
Inventor.

Model of a sausage chopping-machine.

502 MANSSELL, THOMAS, 94 *Bull Street, Birmingham*—  
Inventor and Manufacturer.

Patent fly press for cutting with steel tools or knives on an even surface of steel, with accuracy. By the system of "bod and punch," and the still more imperfect mode of cutting on a bed of lead, zinc, or wood, both beds and tools are soon out of repair and destroyed; by the patent press both remain uninjured, being accurately adjusted to each other, so that every part of the tool has an equal bearing on the steel bed.

Patent boot-blocking machine, to complete the shape in about one-eighth of the time employed in the usual method, and also to preserve the upper leather of boots from breaking under the joints.

503 THOMPSON, W., *King's College*—Inventor.

Hair-working machine.

504 WAIT, JOSEPH, 12 *Duke Street, Portland Place*—  
Inventor.

A series of machines to supersede the necessity of clickers in the cutting of women's and children's goods in the boot and shoe trade. The process is the sole inven-

tion of the patentee, and has been in operation for upwards of twelve months. The advantages of this new system are as follow:—That six hundred dozens of boot-linings can be properly prepared for the binders in twelve hours; and that the skins used in the above manufacture can be prepared for the binder in one-tenth part of the time now required, and at a less cost.

A machine for modelling instep pieces for ladies' and children's boots and shoes.

A series of pattern-printing blocks for printing every description of leather, &c., used in the boot and shoe trade.

506 BIERTUMPFEL, HENRY, 68 *Albany Street*—  
Manufacturer.

Improved mould frame, for the production of superior candles from various materials.

508 GILBERTSON, JOSEPH, *Hertford*—Inventor.

Model of furnace for preventing effluvia in boiling fat, &c.

602 PONTIFEX & WOOD, *Shoe Lane, Fleet Street*—  
Proprietors.

Vacuum pan, as used in sugar refineries and in sugar works in the West and East Indies, and in beet-root sugar manufactories.

Defecator, or clarifier, for clearing the saccharine liquor before evaporation.

Heater, as used in sugar-works.

Set of pumps, used in manufactories. Liquor pumps, used in West India distilleries. Copper pipes. Pumps, for house and other purposes. Brass cocks.

[The vacuum pan was the invention of Howard, the chemist, and answers, more completely than any other arrangement, the refiner's purpose of safety and expedition. It consists of two hemispheres (the inferior one being double, so that it may be surrounded by steam), which are secured by bolts and screws, and rendered, by packing, perfectly air-tight. An air-pump is attached, by which the air is removed from the interior, and by the heat of the steam, which is in the lower steam-chest, the sugar syrup is brought to boil at a low temperature, the atmospheric pressure being removed. These pans usually contain about 100 gallons of syrup, and yield at each discharge about 11 cwt. of granulated sugar. It will be understood that the air-pump is also employed to remove the aqueous vapour as fast as it is formed from the boiling syrup. Formerly the chest was merely filled with steam; but a recent improvement has been made by applying heat to the syrup by means of steam, at the temperature of nearly 250 degrees, circulating through pipes, by which the evaporating power is greatly increased.—R. H.]

604 LAWRENCE, JAMES, sen., *Cobbrook, Slough*—  
Designer and Inventor.

Distributor, consisting of an iron block with six outlets, in which to screw six perforated pipes.

Patent refrigerator, having six iron pipes, with several divisions, coupled together by cast-iron ends. Each of the iron pipes contains seven tinned copper pipes, fastened at either end by a flange and nut. The iron pipes are for the purpose of passing cold water around the copper pipes, while the copper ones convey hot wort or water in an opposite direction; the whole showing how quickly the heat of the wort can be transmitted to the water. The figure on the next page illustrates the arrangement of this apparatus.

Patent store-cask or vat, made with oak staves, having a tinned copper attenuating pan, with air-tight lid, for the purpose of containing cold water to regulate the heat of the ale or beer with which it may be filled.



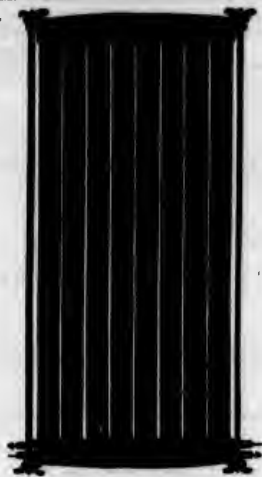

Lawrence's Patent Refrigerator.

605 TYLER, HAYWARD & Co., 85 Upper White Cross Street, St. Luke's—Inventors and Manufacturers.  
A patent double soda-water machine for two bottlers,

capable of making 800 dozen per day. The gaseometer and generator are not exhibited for want of space.

The annexed cut represents a patent continuous-principle soda-water machine, made by the exhibitors.

This machine will supply two bottlers, one at each end, and is capable of producing from 300 to 400 dozen per diem. The general arrangement combines two distinct machines in one frame, which can be worked together, or separate, as may be required. A, is the condenser of gun-metal, tinned or silvered inside, and separated by a partition in the middle, thus forming two condensers in one. Each half provided with an agitator, driven by the wheels B, for intermixing the gas and water. C, C, are two condensing pumps, each having regulating cocks, D, D, for the admission of gas water. E, E, are two bottling cocks, attached to their respective halves of the condenser A. The pumps are worked by a beam F, similar to that of a steam engine, having a connecting rod at one end attached to a crank, with fly-wheel and two handles. The pumps are attached to the beam by side rods at G, G. When the crank is in action, the beam by its reciprocating motion causes the plungers H, H, underneath the pumps, to ascend and descend in the barrels of the pumps, forcing at each successive stroke, the gas and water together into the condenser. About ten minutes is required to get the charge up, and when this is done, the bottling goes on without interruption. The machine is kept constantly going during the bottling. The corks having been properly regulated and the supply kept up, as much carbonic acid gas and water will be forced into the condenser as will equal that which is being drawn off by the bottlers, thus keeping a continuous supply.

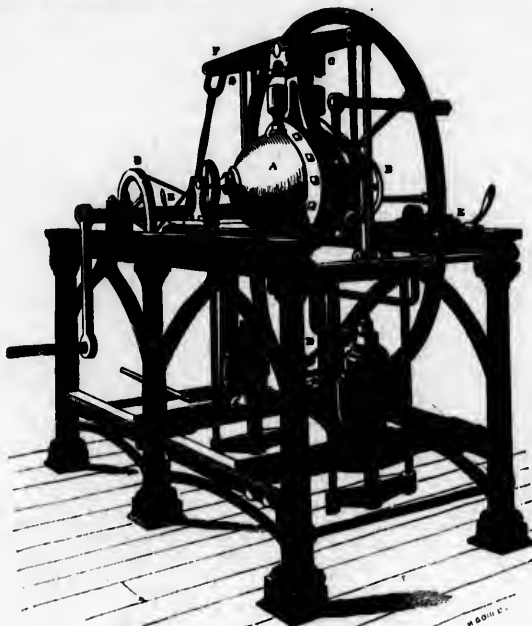

Tyler, Hayward, and Co.'s Soda-water Machine.

606 TYLER & SON, Warwick Lane, Newgate Street.

Small fountain soda-water machine, with electro-plated fountain with two cocks.

Double soda-water machine, complete, with improved form and arrangement, by which it may be used either as

a single or double machine. By placing the two bottles at the opposite ends of the machine, they are out of the way of the fly-wheels, the index cocks being in the most convenient position, one on the right and the other on the left hand. See figure in the next page.



Tylor and Son's Soda-water Machine.

Well engine-pump, fixed in iron frame, for raising water to a great height.  
Bottle or corking-machine, &c.

608 COX, WILLIAM, *Manchester*—Patentee.

Improved apparatus for the manufacture of aerated waters and other liquids by means of which the impregnating gas may be sustained at a pressure sufficient to cause its absorption by the water or other liquid to be aerated, without the aid of force pumps or other mechanical means; also an improved construction of cock or tap, to be employed with this or other apparatus of a similar nature.

609 SADDINGTON, SAMUEL & WILLIAM, 63 Wood Street, *Cheapside*—Manufacturers.

Drum sieve, for sifting freely all kinds of powders required by druggists and others. Straining sieve, of silk lawn, for straining starch, colours, &c.

## 610 BOURRA, LOUIS AIME, 31 Rathbone Place—Inventor, Patentee, and Proprietor

Patent colour-extractor apparatus. The apparatus turns over on a pivot, to empty the substance extracted.

611 ASKEW, CHARLES, 27½ Charles Street, *Hampstead Road*—Inventor and Manufacturer.

Model refrigerator, for cooling beer; the quantity to be cooled, and the degree, are regulated by the supply of cold liquor at the different inlets.

612 DAWSON, JOHN, *Green Park Distillery, Linlithgow*—Inventor.

New distiller or rectifier's recording close safe, for the purpose of protecting from fraud and dishonesty the process of distillation. It is close in all its parts, and covered with plate glass; it is accessible for samples at all stages of the process of distillation; but no quantity of spirit can be drawn unrecorded. The mechanism is composed of gauges, valves, and fixed and movable conduits, acted on by horizontal and vertical rods, by means of which the safe can be applied to any method of distillation, or to any number of stills.

613 BARLOW, H. B., *Manchester*, for LE FORMETIER, AIME, *Havre*—Proprietor.

Model of a press for making wine, with improved gearing. Cask for excluding the air, and registering the contents, (invented by Louis Hervot, Havre).

615 COFFEY, THOMAS, 4 Providence Row, *Finsbury Square*—Inventor.

Refrigerator, of a new construction, in two parts, showing the perpendicular or horizontal form of each. In cooling worts, or condensing steam, it exposes a great cooling surface in a small space. It is easily cleaned, and is applicable on a large scale.

617 HALLIDAY, A. P., 6 Bank Place, *Salford, Manchester*—Inventor.

Patent apparatus for the manufacture of pyroligneous acid from saw-dust and spent dye-wood.

618 HULLS, J., *High Wycombe*—Manufacturer.

Wheeler's patent refrigerator, to cool 10 barrels (from 120° to 60° Fahrenheit), the cooling fluid being 52°.  
Wheeler's patent condenser, to work a 30-gallon still.

619 HILL, EVANS, & CO., *Worcester*—Proprietors.

Model of a patent vinegar apparatus. The process of acetification is conducted in a close vessel, and instant combination of the oxygen of the atmosphere ensues. By this apparatus the use of sulphuric, pyroligneous, or other foreign acid, is rendered unnecessary.

621 MASTERMAN, JOHN & THOMAS, 38 Broad Street, *Ratcliff*—Inventors and Patentees.

Apparatus for bottling liquors, and machine for corking bottles. The principle of the bottling apparatus is the filling of bottles through syphons, from an open vessel, into which the liquor flows from the cask, in a stream so regulated as always to maintain the liquor in the vessel at nearly the same level.

[The principle of the corking machine, is, to force the cork into the bottle through a conical tube in contact with its mouth, so placed as to form one continuous tube with its neck, and having the lower orifice so small that the cork must be considerably compressed in passing through it.]

## 623 THOMSON, ANDREW, &amp; YOUNGER, W., &amp; Co.—Designers and Inventors.

Apparatus for heating and cooling worts in the process of fermentation.

[Wort is the fermentable infusion of malt. In the apparatus for heating and cooling worts, the hot liquor is passed through a series of pipes encased in others, through which the cold liquor passes in a contrary direction, thus the hot liquor meets a progressively cooler medium, and, on the contrary, the cold liquor comes in contact with a hotter. The object is the saving of fuel.—W. D. L. R.]

624 COOPER & BURSILL, *Eastbourne, Sussex*, and 9 York Terrace, *Hornsey Road*—Proprietors.

Patent aerating machine; a carbonating machine, adapted to the manufacture of aerated waters.

630 TIZZARD, W. L., *High Street, Aldgate*—Proprietor.

Model brewery, in operation.

631 PLINSELL, S., *Sheffield*—Inventor.

Improved warming apparatus.

ny. The gas-  
ed for want of

continuous-prin-  
hibitors.  
one at each end,  
dozen per diam.  
distinct machines  
har, or separate,  
er of gun-metal,  
by a partition in  
s in one. Each  
the wheels B, for  
two condensing  
D, for the admis-  
cocks, attached  
A. The pumps  
of a steam engine,  
ched to a crank,  
umps are attached  
n the crank is in  
otion causes the  
o ascend and de-  
at each succes-  
to the condenser.  
a charge up, and  
without interrup-  
going during the  
y regulated and  
nd gas and water  
equal that which  
keeping a conti-

the two bottles  
y are out of the  
ing in the most  
d the other on  
go.

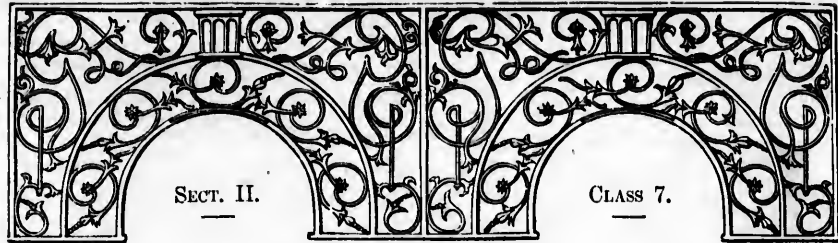

## CIVIL ENGINEERING, ARCHITECTURE, AND BUILDING CONTRIVANCES.

### INTRODUCTION.

THIS Class embraces a variety of objects directly or indirectly connected with the purposes of construction. While the preceding had reference to the personal or domestic wants of mankind, this occupies a wider field, and includes contrivances adapted to the preparation of public works, as well as of private dwellings, and embraces the sciences of architecture and civil engineering in their most extensive sense. The general title of the Class, "Civil Engineering, Architecture, and Building Contrivances," sufficiently indicates its extent and defines its limits.

The following subdivisions include all that can be properly said to belong to this department of the Exhibition:—A. Comprises Foundations and Building Contrivances connected with Hydraulic Works, such as Piles and Pile-driving, Coffer-dams, Diving-bells, Boring Tools, &c. These are necessarily represented by models only, or in great part, as the works themselves are of too great magnitude for exhibition. B. Scaffolding and Centerings for the erection of Chimneys, Columns, Towers, Bridges, &c.; Portable Scaffoldings, Ladders, Fire-escapes, &c.; Centerings for Arches, Domes, Vaults, &c. C. Forms an important subdivision, comprehending Bridges, Tunnels, and Engineering contrivances for crossing ravines, &c. D. Relates to Dock, Harbour, River, and Canal Works. E. Lighthouses and Beacons. F. Roofs, Buildings, and contrivances for covering large areas. G. Water-works, and the Engineering contrivances connected with the obtaining, storing, and distribution of Water in towns. H. Gas-works, and contrivances connected with the economical production of Artificial Light. I. Sewerage, Cleaning, Paving, and the contrivances connected with the sanitary conditions of towns. J. Warming and Ventilating Domestic Residences, and contrivances for such purposes.

Objects in this Class are found in the Building at the western end of the North Gallery, and also in the Areas and Avenues partly occupied by Classes 5 and 6 in the Ground-floor, North side. Several beautiful models connected with this Class have likewise a place in the Central Avenue or Nave.

Containing a number of costly and beautiful models of many of the great triumphs of civil engineering and architecture, this Class presents an interesting view of the state and capabilities of the sciences it represents at the present day. Among the objects included under the subdivision of Bridges, &c., will be found some of the most elaborate and accurate models probably ever constructed. Some of these are so minutely correct, that it is stated that even the threads of the screws are reduced to a scale. Tubular, suspension, and other bridges, are represented by some of these models, which are on a large scale. Chain-piers, and piers of other descriptions, each indicative of their applicability to the particular purposes for which they are designed, or to the positions occupied by the originals, are also exhibited in their models. The application of iron chain-cables to purposes of this kind, and its history, are recorded in this Catalogue and illustrated in the Exhibition. A variety of bridges on new principles, or upon new modifications of principles already known, are also shown, and their respective merits are capable of being ascertained in the models.

Dock and harbour works are also adequately represented by their respective models. Among others is a model of the Breakwater in Plymouth Sound, executed in limestone, and presenting a favourable idea of that great work. The lens-apparatus of lighthouses, in most recent and improved forms, is exhibited not by models but by the apparatus itself. A large number of models are of works proposed to be executed, and convey a strong impression of the various directions in which inventive skill is exercised. Interest will be excited by many well-executed models of structures in cast and wrought iron. The application of these metals to the purposes of construction, so largely illustrated in the Exhibition Building itself, forms an important feature in the history of modern architecture, and is also represented by various models of conservatories, such as the great Palm-house at Kew, roofs of railway stations, &c. The miscellaneous contrivances connected with the simpler construction and arrangements of private dwellings are found in great numbers. Many of these relate to ventilation, to windows, doors, and chimneys, and appear to promise improvements of importance in these respects.

The study of this Class is instructive, as the means of attaining an approximate idea of the present state of the sciences of civil engineering, architecture, and construction in our own country. The objects illustrating the Class can scarcely be said adequately to represent the subjects embraced by the Class, since they lose the advantage of being seen of their due dimensions. While in Class 5 it is possible to exhibit the actual machine engaged in raising the Britannia Tube to its site, in the present Class the Tube itself, the most wonderful engineering structure of its kind, can only be exhibited in a model, bearing but a small proportion to the size of the original. This is of little moment to the engineer or architect, but to others, unaccustomed to estimate from a scale, Class 7 does not appear so imposing as the preceding Classes, although in reality it contains practical representations of the most mighty works of construction undertaken by any nation in recent times.—  
R. E.

1 **SIEBE, AUGUSTUS**, 5 Denmark Street, Soho—  
Inventor and Manufacturer.

Three-motion diving machine air-pump, with a figure of a man equipped in a diving dress and helmet for working under water. The annexed figure represents the diver's dress, &c.



Figure representing the Diver's Dress.

Vase made of the wood and metal of the wreck of the Royal George, sunk at Spithead in the year 1782.

2 **GEARY, STEPHEN**, 19 Euston Place, Euston Square—  
Inventor.

Model of a patent stationary fire-engine, fitted up within the pedestal of a lamp or other post, or fixed in a cast-iron framed box under the pavement, containing hose-pipe, &c.

Improved Venetian perforated blind and shutters.

Model of stone-paving for streets, &c., by trains framed on a new principle.

Model of improved railway carriages, containing open coupes and accelerating driving-wheels, with model of a railway truck for running narrow gauge trains on the broad gauge lines.

3 **GREEN, BEN.**, 3 Arcade, Newcastle-upon-Tyne—  
Designer.

Model of the central arch of the Ouse-burn and Willington viaducts of the Newcastle and North Shields Railway, erected by John and Benjamin Green, in 1837-8.

Geometrical drawing and view of the Ouse-burn viaduct; also of the Willington viaduct.

The piers and abutments are of stone: each arm is composed of three ribs, formed to the proportionate curve shown in the model. Every rib is put together with 3-inch doek deals, in lengths of from 20 to 45 feet, and two of the deals in width. The first course is formed of two whole deals in width, and the next of one whole and two half deals; and so on alternately until the whole rib is formed. Each rib consists of 15 deals in height or thickness, and the ends are butted one against the other, breaking joint, so that no two of the horizontal or radiating joints shall come together; the whole are connected with oak trenails, or pins, each of which passes through three of the deals in thickness. Between every deal a layer of brown paper, dipped in boiling tar, is laid, to secure the joints from being affected by wet, and so as to make the timbers bed tightly one upon another. The ends of each rib are inserted into large cast-iron shoes or sockets, which are first fixed to the springing stones of the masonry, and secured with long iron bolts, four to each plate, run in with lead; the three ribs are connected together with diagonal braces and iron bolts.

The spandrils formed by the arches, being great, on account of the span, the framing is made in proportionate

strength. A beam, 14 inches square, is fixed about the middle of the spandrill, inclining upwards to the crown of the arch, from which struts are carried, both above and below it; the above, are perpendicular to the longitudinal beams of the roadway, — and those below, are radiating to the centre of the arch.

The longitudinal beams under the roadway are 14 inches square, and transverse joists, 3 feet 6 inches apart, and projecting about 2 feet on each side, are laid across to receive the 3-inch planking, which is covered with a composition to form a roadway.

The spandrill-framing is connected and bound, both to the roadway and to the ribs, by means of iron bolts, straps and keys, in the different situations shown on the model. One of the radiating struts in each spandrill is carried on from the rib to the longitudinal beams, passing through and run down the piers about 8 feet.

In this system of timber-bridge building, the straight trussing in the main principle of support is dispensed with, for the spandrill-framing must not be looked upon as such; it is merely a combination of wood-work, to convey the weight coming upon the roadway on the simple curved rib, and all timbers in a state of tension are avoided; for when a weight comes upon a roadway, the whole structure undergoes compression.

[The cost of the Ouse-burn viaduct was 24,500*l.* That of the Willington viaduct was 23,002*l.* It was when engaged in designing the bridge for crossing the River Tyne at Scotswood, in 1827-8, that Mr. Green first projected the luminated arch; but the depth of water, its rapidity during floods, and the uncertainty of the foundations, rendering the building of many piers expensive, caused Mr. Green to recommend a suspension bridge at this spot. On the day of opening of this suspension bridge, 12,000 persons rushed on at once, when the weight on its centre was not less than 468 tons, and it proved capable of sustaining this weight.—S. C.]

Model of the monument erected on Pensher Hill to the late Earl Durlan, in 1844.

Geometrical drawing, in colour, of the first proposed wooden bridge with stone piers across the Tyne, at Newcastle-on-Tyne, at a high level, in 1838.

Geometrical drawing, in colour, of design for the proposed high-level bridge, in stone and iron, at Newcastle-on-Tyne, in 1841.

Plan from Gateshead, through Newcastle, in the line of the high-level bridge, 1841.

View of Scotswood wrought-iron suspension bridge over the Tyne, erected in 1828-9.

View of the monument erected on Pensher Hill.

Model of the Grey Column at Newcastle-on-Tyne, 1837.

View of Grey Street, Newcastle-on-Tyne, as designed previous to its commencement.

View of the interior of the library of the Literary and Philosophical Society, Newcastle-on-Tyne.

4 **M'KINDY, J. G.**, Birkwood, Lesmahago, Scotland—  
—Producer.

Model of a wooden bridge, for foot passengers, 46 feet span, besides 2 feet of bearing at each end. All the principal timbers incline to one centre, thereby forming, as it were, three arches. It may be erected (on piers, rocks, or piles) at little expense beyond the materials.

5 **ASSER, LOUIS**, 147 Regent Street—Inventor.

Model of a bridge. The invention consists of blocks of a form which may be applied to stone, iron, wood, or other materials in the construction of bridges, tunnels, breakwaters, &c. From the form of these blocks, and their mutual bearing, the pressure is equally distributed over the whole mass.

6 **RIDDELL, THOS.**, 1 Market Terrace, Southgate Road, Islington—Inventor.

Model of a building, showing how talc may be used instead of glass.

7 **TURNER, R., Hammersmith, Dublin—Inventor.**

Model (scale,  $\frac{1}{4}$  inch to the foot) of the segmental curved patent iron roof at the London and North Western Railway station, Lime Street, Liverpool. The area, roofed over, extends from the façade in Lime Street, to the viaduct, over which Hotham Street passes; and from the new offices to the parcel offices on the opposite side; the extreme length is 374 feet, and the breadth 153 feet, in one span.

Model (scale,  $\frac{1}{4}$  inch to the foot) of section of the great iron and glass palm house, in the Royal Botanic Gardens at Kew. The building contains upwards of 40,300 superficial feet of glass, or nearly an acre. The total length of the building is 362 feet 6 inches, the centre portion being 137 feet 6 inches long, and 100 feet wide, and 69 feet high to the top of the lantern light, the wings are each 112 feet 6 inches long, and 50 feet high. It is heated by hot water, on an improved principle.

Brass model (scale,  $\frac{1}{4}$  inch to the foot) submitted to His Majesty the King of Prussia, for a winter garden at Berlin, to cover half an English acre.

Model (scale,  $\frac{1}{4}$  inch to the foot) of the winter garden, in iron and glass, curvilinear form, in part erected for the London Botanic Society, at their garden in the Regent's Park.

Model (scale,  $\frac{1}{4}$  inch to a foot) of a curved iron roof for a wet dock, sufficient to cover a man of war, in full sail, on entering for examination and repair previous to being sent out to sea.

Model (scale,  $\frac{1}{4}$  inch to the foot) for a dockyard, curved iron roof, for man-of-war ship building. The two pre-

ceding models were submitted to the Admiralty by the exhibitor.

Models and sections of the structures proposed for the Great Exhibition Building, by the exhibitor. One of these is the only model out of the 243 submitted in competition, that had the Transept, which with the Nave was to be semicircular, and was all throughout 110 feet high in the centre.

Brass model of one of the modes of constructing the 200-feet dome of metal zones and ribs, with wrought-iron chain bars within, by the exhibitor.

Double range of columns and galleries, to form the support in lieu of walls for the said 200 feet dome.

Models of a railway, a range of conservatory, and a round conservatory. (With Class 6.)

8 **CLARK, GEORGE DELIANSON, 12 London Street, Greenwich—Producer.**

Iron castings to be used for architectural purposes, in combination with, or instead of, bricks or stone. Specimen wall—showing the mode of using them.

9 **FINCH & WILLEY, Windsor Foundry, Liverpool—Manufacturers.**

Model of a wrought-iron bridge to carry the South Wales Railway over the river Wye at Chepstow. Designed by I. K. Brunel, Esq., C.E., and now in course of construction by Finch and Willey, of Liverpool, engineers. The following engraving represents this bridge. (Main Avenue West.)

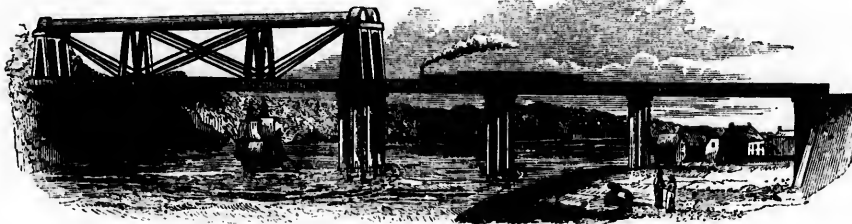

Brunel's Wrought-Iron Bridge over the Wye.

Working model of a high-pressure steam engine, having a glass cylinder and glass valve box, through which the piston and valves can be seen working while the engine is in motion. Maker, William Pemberton.

10 **OATES, WILLIAM, Mirfield, near Leeds—Inventor.**

Two self-acting cloughs, which divide the fall of water into two parts, drawing at half fall. A boy could draw one made to any size, or with any depth of fall. It would answer for drains into tideways. The power to draw increases in exact ratio with the pressure.

11 **COLES, W., 3 Charing Cross—Inventor.**

Two anti-friction pulleys.

Two models of anti-friction railway carriages.

12 **REDMAN, J. B., 5 New Palace Yard, Westminster—Designer.**

Model of the royal terrace pier at Milton-on-Thames, next Gravesend, designed by the exhibitor, and made by

Salter of Hammersmith. The pier is constructed of iron by Fox and Henderson. The pillars are founded upon piers of brickwork and masonry below the bed of the river, resting upon the solid chalk substratum, at a level of 14 feet below low water of spring tides. These foundation piers were erected without the expensive aid of cofferdams, by the novel means of cast-iron cylinders six feet in diameter, kept always above the rise of the tide, the upper portions being removed as each pier was finished.

13 **BERMINGHAM, THOMAS, Clarendon Lodge, Sandy-mount, Dublin—Improver.**

A box of improved patent compasses. The legs, which draw out, have fine needle points, and a pen and pencil to turn on a swing, forming a useful set of instruments in one. This instrument is made after the pattern of Désiré Lobrun, by Elliot, London.

In the following cut, A A represent the stems of the compasses. B B, elongated bars which run into the stems worked by screws. C C, the screws. D, pen, and

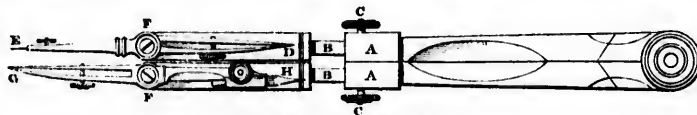

Birmingham's Improved Compasses.



Admiralty by the

proposed for the  
bitor. One of  
mitted in com-  
h the Nave was  
at 110 feet high

constructing the  
h wrought-iron  
s, to form the  
et dome.

servatory, and a

ndon Street,

al purposes, in  
stone. Specim-  
m.

, Liverpool—

rry the South  
hepstown. De-  
now in course  
of Liverpool,  
represents this



constructed of iron  
founded upon  
ne bed of the  
tum, at a level  
These founda-  
ve aid of coffer-  
nders six feet  
of the tide, tho  
was finished.

idge, Sandy-

The logs, which  
n and pencil to  
ments in one.  
ern of Désiré

s stems of the  
run into the  
. D, pen, and



E, needle point, either of which may be turned to the end by pivot F. G, H, pen and pencil, worked same as D, E. The entire forms but one instrument.

A model of Thénard's moveable flood-gates or lifts, called "hauses," for rendering rivers navigable, and supplying the place of fixed stone weirs, which exhibits a mode of fixing the lifts, or hauses, at the bottom of the river, so as to prevent stonework impeding the current. They are cheaper than weirs; prevent the flooding of adjacent lands; and are useful in fisheries, mill-power, arterial drainage, and navigation. They are in operation in the river L'Isle, in France.

14 JEFFERY, ROBERT, *Upper North Place, Gray's Inn Road*—Inventor.

Railway tunnel signal, intended to prevent accident to a train while in a tunnel, from being overtaken by another train. At present, if from slackness of speed, temporary stoppage, or any impediment, a train is detained in a tunnel, great alarm is felt by the passengers, lest the following train should overtake it. This invention exhibits a large white disc by day, and a lamp by night, either of which is self-acting; and it is displayed conspicuously at the upper edge of the arch, immediately on the train entering, remaining in sight until the train leaves the other end of the tunnel, when it instantly disappears. This is repeated whenever a train enters and quits the tunnel, without any assistance. The following train is always reminded by the presence or absence of the disc or lamp, whether the tunnel is clear or not. It also indicates to the authorities, by any unusual length of time during which the disc is in sight, the existence of some interruption in the tunnel.

15 HAMMOND, RICHARD CHARLES, *45 Baldwin's Gardens, Leather Lane, Holborn*—Inventor and Manufacturer.  
Model of a convex-chain suspension bridge.

16 PRATT, Major, *7 Upper Area, Hungerford Market*—Inventor.

Moveable flight of steps, for tidal rivers. The steps are entirely independent of each other.

New self-acting trap for street drains; it can be easily fixed or moved, without displacing the brick-work on which the grating rests.

17 GREEN, JOSEPH, *Calcuttan Road*—Inventor.

Model of moveable dam for river operations; and of a new plan of shifting a dam for constructing sea-walls for docks, piers, harbours, &c.

18 CLARK, CHARLES, C.E., *Sea-side Hotel, Hastings*—Inventor.

Model of a proposed grand ship canal through the isthmus of Suez, to save 5,000 miles of sea passage, or half the distance to India.

19 JAMES, JAMES, *28A Broad Wall, Lambeth*—Manufacturer and Designer.

Model bronzed fountain, with steam-engine for supplying it. (*Main Aconuc West.*)

20 WATT, W., *Glasgow*—Manufacturer.

Hydro-pneumatic lift, for canal locks.

Hydro-pneumatic elevators.

Patent hydro-pneumatic ship-lift.

Application of compressed air for the prevention of vessels from sinking.

21 WEST & GREGSON, *Union Street, Oldham*—Designers and Manufacturers.

Model station-meter for gas-works.

Experimental meter, for ascertaining the consumption of gas per hour, of any description of burner, in cast-iron case.

Consumers' gas-meter; patent enamelled inside, whereby the iron is preserved from oxidation.

24 MORTON, SAMUEL & HUGH, *Leith Walk, Edinburgh*—Inventors and Manufacturers.

Model of a patent slip, for hauling up ships, of the largest class, for repairs—a cheap substitute for dry docks—with model of a frigate.

[Slips for hauling up ships for repair were very early used at the Mediterranean ports; but the mechanism which removed the excessive labour of the operation was invented and patented by Mr. Morton in 1818. Before this system was adopted, the cost of hauling up a ship of 500 tons was 170*l.*; it is now reduced to 3*l.* A slip may be constructed for one-eighth part of the expense of a dry dock. Upon a well-constructed slip, a steam-engine exerting 1-horse power for every 100 tons will draw a ship at the rate of 2½ feet per minute.—S. C.]

25 MARTIN, JOHN, *Lindsey House, Chelsea*—Designer and Inventor.

Self-acting valves for sewer and house-traps.

Plan and model of railway, invented 1834. This principle of rail has been adopted on the Great Western line.

Section of rail and laminated beam. This beam is employed on the South Western and South Eastern Railways, and in other structures.

Sections of fire-proof and laminated beams, and their application to strong, light, and durable roofs.

Elevation of proposed bridge at Westminster.

Elevation and sections of centre arch of bridge, showing the laminated beams, stays, and cast-iron planting; the general principle of construction being applicable to all bridges across rivers with low banks.

Model of framework cube used in the construction of ships, floating batteries, harbours, and piers.

Plans and sections showing the application of framework cube and laminated fire-proof beams to ships, harbours, &c.

Lighthouse for the sands, and sand indicator, invented 1829. Lighthouses on this principle have been erected on the Maplin Sand, and elsewhere.

Cleaving anchors, with piles and cables of wood laminated with iron.

Drawing and model of life-boat.

Mode of working and ventilating coal mines.

Drawing and model of pipes and couplings, which can be quickly connected together, or disunited.

Drawings and models of filter drain pipe and mode of laying.

26 FORSTER, JAMES, *5 South John Street, Liverpool*—Inventor and Patentee.

A fountain, and four household filters; the whole of the water being filtered by the apparatus in its passage through the service pipe. The sole manufacturers are, Cochrane and Co., Woodside Iron Works, Dudley. (*Central Aconuc.*)

27 RENEZYNSKI, Captain GEORGE ALEXANDER, *31 Tonbridge Place, New Road*—Inventor.

Self-sustaining suspension bridge, which may be built of wrought-iron or wood; free from side oscillations, and having little deflection.

Steam-power engine for railways or turnpike roads, with six wheels, and self-feeding boiler, requiring no tender; with locomotives, &c.

A hand-power-speed machine for railways and turnpike roads.

An improved quadrant stand.

28 STUART, WILLIAM, M. I. C. E., *Plymouth, Devon*—Designer and Superintendent of the Plymouth Breakwater Works.

Model, in limestone, of the breakwater in Plymouth Sound, on a scale of 1 inch to 42 feet, with silver lighthouse and beacon, made for the Exhibition, under the direction of the Lords of the Admiralty. The breakwater



was commenced on 12th August, 1812, agreeably to a Report dated 21st April, 1806, of the late John Kenne, civil engineer, and of Joseph Whidbey, a Master of the Royal Navy; and has been constructed under the auspices of the Lords of the Admiralty. Its length is 5100 feet at the top, and about 1 mile or 5280 feet at bottom, being nearly three times the length of the Exhibition Building. At the top, it is 45 feet wide, and has a slope to seaward of 5 to 1, and a slope to landward of 2 to 1. It is already composed of 3,768,879 tons of stone. It has been 38 years in construction, and has cost the nation about 1,500,000*l*. The area of Plymouth Sound is 1800 acres, and within the breakwater there is anchorage for 40 line-of-battle ships, besides a fleet of merchant vessels. The exhibitor of the model, who is the resident engineer, has been connected with this undertaking for 40 years. The lighthouse and beacon on the breakwater were designed by Messrs. Walker and Burgess, civil engineers.

Polished marble slab, on pedestals, from the breakwater quarries.

Model, in limestone, of a general section taken through a part of the centre of the breakwater, with wood-jetty and crane, showing dove-tailed stones and truck on jetty.

Model, in limestone, of a section of the breakwater, taken through the buttress and foundation of the lighthouse, with inverted arch at the west end; and showing dove-tailed stones.

Circular lewis, used in lifting and setting stones at the breakwater, invented by the exhibitor in 1808.

Model, in mahogany, of a breakwater stone vessel.

Models of the breakwater and lighthouse, set in marble. (*Main Avenue West.*)

[The breakwater in Plymouth Sound is formed by the deposit of stone in unshapen blocks of various sizes, but disposed upon a regular plan as a huge, rough, broad-based wall, mole, mound, or dike, massive enough, if it be compact enough, to check, if not wholly to stop the roll of the sea under the influence of gales of wind, and to render the part of the Sound within it a safe anchorage during gales from the south-west. The Isle of Wight is a breakwater afforded by nature to Portsmouth, and the breakwater in Plymouth Sound is the result of an endeavour to supply Plymouth with some compensation for its natural deficiencies.

The breakwater is a mass of rock-like blocks of stones deposited in a heap at random, as far as regards the placing of the blocks of stone, though the heap takes the form, in plan and section, which the model exhibits. In this circumstance, that it is a deposit and not a construction, the weakness of the breakwater consists. The blocks on the outer slope, or foreshore, are liable to be taken up singly and displaced by the action of the sea upon it, deprived as every loose block is (and the bulk of the work still consists of loose blocks) of two-fifths of its weight when immersed in sea-water; and probably no heavy sea runs into Plymouth Sound without occasioning change of place to some of the blocks of the outer slope. The blocks range from one ton to five tons in weight—a block of limestone weighing five tons being in bulk equal to a cube of 4 ft. 6 in. or a yard and a half on every side. The greatest quantity of the material is of the smaller sizes, and is known as rubble; but many blocks have been deposited of considerably more than the largest size named, and many even of these have been known to be taken up by the sea from the outer slopes and thrown upon the crest of the mound, whilst thousands of tons, have since the commencement of the work been thrown over the mound from the outer to the inner slope. It may be questioned whether the breakwater is not, at this time, from this cause, further up the Sound than when it was originally planned.

The breakwater is disposed in three connected compartments—the central, or main body, which is 1000 yards long, and the eastern and western parts respectively, which are each about 350 yards long, above high water.

The Digue, or breakwater, at Cherbourg, opposite to Plymouth on the other side of the Channel, is, in like manner, mainly a mass of deposited rubble, but of generally smaller-sized stones. It is more than double the length of Plymouth breakwater, or about 2½ miles.—W.H.]

#### 29 THE ROYAL SCOTTISH SOCIETY OF ARTS, *Edinburgh*— Producer.

A square bar of Low Moor iron, of superior quality, 2½ inches square, twisted, in a cold state, into a spiral form by the action of the steam-engine, while carrying the borer of a cylinder which had suddenly stuck fast.

Model of a suspension bridge, designed to show the best position of the under stays (which are not placed symmetrically, but at irregular distances from either end of the bridge) to prevent the destructive effects of vertical oscillation.

[After the most careful calculation of the strength of iron, when subjected to the application of force, in the direction of its length, or its tensile resistance, bridges constructed of iron-chains and rods, which promised to last as long as those made of stone, have suddenly given way. The principal cause of the sudden disruption of the rods or chains of an iron suspension-bridge, and its consequent fall, is the tendency to vibration or oscillation in the whole structure from its uniformity and catenarian form. A chain-bridge, from its very nature has a tendency to swing to and fro, and unless this be prevented by ties or fastenings to some rigid structure fixed in the ground, it will, after a certain number of regular oscillations, snap in two at the weakest part, in consequence of the momentum acquired by the swinging mass.—R. W.]

Model of a steam-boat, constructed for an inkstand.

#### 30 ROEBUCK, JOSEPHUS JAGGER, *Huddersfield*—Producer.

Model and drawings of No. 4, skew arch of the Huddersfield viaduct, built in stone, over the Bradford Road. Scale one inch to three feet.

Model of one of the springer quoins, showing the oblique checks for the insertion of the voussoirs of the spiral courses of masonry.

Model of springer course complete, showing the whole of the checks.

Models of two of the arch quoins, showing the form and twist of Nos. 4 and 5 arch quoins of the obtuse angle of the arch.

Model of one of the spiral courses of the voussoirs, showing the spiral plane from the acute angle of the arch.

Drawing of No. 4 skew arch of the Huddersfield viaduct, by which the above model and detail models were constructed. Scale one inch to six feet.

[Skew, or oblique arches, are those the faces of which are not at right angles with the abutments. It is believed that the first skew bridge was built by Mr. W. Chapman, in 1787, over the Kildare Canal, near Naas. The method of finding the directions of the courses of brickwork or masonry, and the shapes of the various moulds for the latter, are explained fully in treatises on oblique arches.—S. C., jun.]

#### 31 HURWOOD, GEORGE, *College Street, Ipswich, Suffolk*— Inventor and Patentee.

Window made to open and close in one or in several parts by the application of the patented apparatus. Used for ventilating the Exhibition Building.

Various models, showing the mode of applying the invention to different windows.  
Patent ship-lights and scuttles.  
Model and drawing of a breakwater.

32 SANKEY, WILLIAM H. V., *Civil Engineer—Inventor and Manufacturer.*

1. Drawing of a tubular bridge, to be called the "compound hollow girder bridge."
2. Drawing to show sections and details of the above bridge.
3. Model of the "compound hollow girder bridge," showing a proposed form of piers for bridges to be built over rivers.
4. Drawing of a proposed railway carriage, with a new guide-rail for preventing carriages running off the rails.
5. Drawing of a proposed method of building stone bridges.

33 LOVE, WILLIAM, *Belton, near Grantham—Inventor.*

Model of a portable bridge, for the use of an army in crossing rivers; and adapted for a landing stage in a tidal river, when fixed on a wharf, as it can be worked out, or in, to suit the ebb and flow of the tide, leaving clear the whole width of river at high water. It might also be used to form communications with the upper floors of detached warehouses, &c.

34 BAIN, CHARLES, *Morden Street, Greenwich—Inventor.*

Radial gauge cock for steam boilers, to show the height of the water within by the index hand on the outside.

Elevating machine, to be used in the construction and repair of towers, chimneys, &c. The platforms are alternately closed on the building, and elevated or depressed by the vertical screws.

Compound bridge, to allow the passage of masted vessels without interrupting the roadway.

Tubular bridge, the pressure in which is sustained by the fluid in the tube.

35 GANDELL, EDWARD FREDERICK, *3 Princes Street, Westminster—Designer.*

Model of a method for erecting a lighthouse on the Goodwin Sands.

[The difficulties that have attended the erection of a lighthouse on the Goodwin Sands have hitherto been insurmountable, owing to their great depth, and their constant liability to shift. No erection can be considered secure that does not at least rest upon the chalk, and possess gravity or strength in itself sufficient to resist the violent action of the sea: the greatest observed pressure per square foot of surface, exposed to the action of the waves, is 4,335 lbs.—S. C.]

36 BYNE, RALPH HORACE, *10 Eccleston Street, South, Pimlico—Draftsman and Modeller.*

Model of a design for an iron girder railway bridge.

37 HUNT & GANDELL, *3 Princes Street, Westminster—Designers.*

Design for the new bridge at Westminster. Spans, 250 feet, 300 feet, and 250 feet; headway, 27 feet; inclination, 1 in 36.

38 SACRED HARMONIC SOCIETY, *Office, Exeter Hall—Producer.*

Model of the orchestra of the Sacred Harmonic Society, Exeter Hall, an amateur society established, in 1832, for the performance of oratorios, &c. Its orchestra comprises 114 stringed instruments (including 16 double basses), 31 wind instruments, and chorus of 500 voices, numbering in all 845 performers (there is also a large organ), conducted by Mr. Costa. The model was executed by Mr. Phidias Clarke, on a scale of half an inch to the foot. (*Main Avenue West.*)

39 TOWNLEY, WILLIAM, *99 Holborn Hill—Inventor.*

Specimens of machinery, &c., accompanied by a model of the surface or superstructure of London Bridge, upon a scale of three-quarters of an inch to the foot; and working models illustrative of a new system for washing and watering streets, lanes, courts, alleys, &c. (*With Classes 5 & 6.*)

40 NICHOLSON, G., JUN., *1 Harcourt Street, Marylebone—Inventor.*

Model of railway spring-buffer carriage, with self-acting spring life preserver appended; of scaffolding for building purposes; of a fire-escape; and of a machine for simultaneously watering and sweeping streets, &c.

41 CLIVE, JOHN HENRY, *12 Stanhope Place, Hyde Park, and Tunstall, Staffordshire—Inventor.*

An illustrative model of a bar-trellis suspension bridge, to make a more secure and cheap roadway over rivers, without obstructing the navigation by high-masted vessels. The greatest part of the weight is laid on the lower parts of the suspension towers, by tapering the construction throughout from the base, beginning with strong suspending bars, and decreasing their strength to the summit, so that the tops of the towers shall have the least possible weight upon them, trussing and bracing together the suspension bars. The shortest suspension bars being made the heaviest, and the longest bars the lightest, without affecting their efficiency, each being constructed so as to be equal to its task, expense is saved by lessening the quantity of material to be used, and undulation and lateral motion as in chain bridges avoided, the bracing and trussing giving rigidity and a united hold.

42 WOODS, F. F., *5 Pelham Terrace, Brompton—Inventor, Patentee, and Manufacturer.*

Patent union paving, for public and private roads; a new application of materials, being a combination of wood and stone; designed to possess the following advantages:—Less noise than stone-paved roads; less mud than roads made with loose stones; less slippery than wood paving; besides having a better foothold for horses, and being more durable than the latter.

The principle of this invention consists in the application of stone and wood to the construction of a paving material, which is effected in the following manner: the stone which is employed for the purpose, is broken into pieces, and inserted in grooved or perforated blocks of wood, as in fig. 1, which is a section of one of the blocks, showing the position of the broken pieces of stone in the grooves or holes of the block.

Fig. 1.



Block of Woods' Union Paving.

The grooves or holes in the wood are about 3 or 4 inches deep; 2 or 2½ inches wide, and 2 inches apart. The pieces of stone are driven into the grooves tight with a hammer, and their angles or corners are made to penetrate the wood at each side, so as firmly to retain their position. The pieces of stone are driven hard on to the wood at the bottom of the grooves or holes, which are previously lined with a small portion of a composition consisting of small gravel and ground lime. When the grooves or holes are filled up with the pieces of stone, a portion of the same composition is poured over the surface, and compressed with a brush or otherwise, in order to fill up any interstices that may remain between the stones and the wood. There are various designs which may be formed for the arrangement of the grooves, either for beauty or utility; and circular holes may be also used, according to a variety of patterns. These ought to be of 3 or 4 inches diameter, and within an inch or half an inch of each other. When straight grooves are used, which are most easily constructed, the

illustrations in fig. 2 and fig. 3 will show the appearance which the paving will assume. These designs may be applied to blocks of any size.

Fig. 2.



Straight grooved Blocks; parallel and continuous.

Fig. 3.



Straight grooved Blocks; parallel and discontinuous.

When the grooves are cut in a zig-zag form, the illustration, fig. 4, shows the appearance of the pavement. This design is to be applied to planks 3 inches by 11 inches.

Fig. 4.



Zig-zag grooved Planks.

The fourth illustration, fig. 5, shows a design intended for the use of round timber, and causing but small waste in preparation. The holes in these blocks are cut in the form of squilateral triangle.

Fig. 5.



Equilateral perforated Blocks.

The fifth design, fig. 6, is applicable to blocks of any size and, instead of grooves, has circular holes in the blocks. The angles of the stones are seen in this figure as well as in the other figures projecting into the wood.

Fig. 6.



Circular perforated Blocks.

The sixth design, fig. 7, is intended for the same use as that in fig. 5. The holes in this design are circular, and so disposed that five holes are contained in every block, which is constructed of the hexagonal form.

Fig. 7.



Hexagonal perforated Blocks.

The blocks can be placed on thin boards, laid close to assist in keeping the under soil from coming up through

the joints between the blocks; to aid in distributing the load passing over the blocks more equally; and to promote the under-drainage of the paving. (*Outside, West Entrance.*)

43 BODLEY, —, 2 Queen Square Place, Westminster—  
Inventor.  
Revolving window-sash. (*With Classes 5 & 6.*)

44 TEASDELL, WILLIAM, Great Yarmouth—Inventor  
and Designer.  
Model of a coffer-dam, on a new principle.  
Model of a life-boat and carriage.

45 CHAPMAN, JOS., Frome—Designer and Manufacturer.  
Model of a bridge across the Wylye, at Upton Lovel, Wilts. Span 42 feet. Each parapet is formed by trussing a beam of red pine, on the system of Herr Laves, of Hanover; but to increase its rigidity an additional beam, 9 x 5½, is bent to form an arc, chord 38 feet, versed sine 23 inches; the ends abutting into cast-iron shoes, through which the outer suspending bolt is made to pass. The solid ends of the trusses have their bearings on stone piers, and the outer transverse girders have bearings on corbels in the abutment walls. The roadway is suspended by inch screw-bolts, and rises nine inches towards the centre.

46 DONKIN, BRYAN & CO., Dermondsey—Producers.  
Model of the shield or frame invented by the late Sir M. I. Brunel, and used by him in the construction of the Thames Tunnel.

47 GROUT, ABRAHAM, 8 Shepherd Street, Tenter Ground, Spitalfields—Inventor and Manufacturer.

Wire bridge for pieces of ornamental water in gentlemen's parks, &c.; in which all the weight is borne by the hand-rail; its object is lightness and durability.

48 ASKEW, C., 27½ Charles Street, Hampstead Road—  
Inventor.

Improved and ornamental shutters, either in metal or wood, adapted for shops and private houses.  
Patent filter. Paddle-wheels.

49 BRUFF, PETER, Spaich—Designer.

Model for a proposed national harbour of refuge on the east coast of England, with two entrances, one from Hollesley Bay westward of Orfordness; and the other from Aldborough Bay, eastward of that point.

50 GARDNER, HANNIBAL, 3 Essex Street, Islington—  
Inventor.

Double cone blocks, or artificial hollow stones for building wharf and sea walls, docks, harbours, breakwaters, lighthouses, baths, warehouses, &c. The object is to facilitate building in water to any depth without darning, and with unusual rapidity; when the cavities are filled in with cement or concrete, a solid mass is formed.

51 BEADON, WILLIAM, 1 Crescent, Tunton, and Otterhead, Churchstanton, Honiton—Inventor.

Patent door; and with Classes 5 & 6, the following—  
New patent water-shoots, for security against drip, made of clay, stoneware, glass, cement, and other substances; applicable to thatch, and not influenced by temperature or exposure.

New patent barge coping;  
Patent water-shoot coping; which saves brackets and wall plates; and combines water-shoot, wall-plate, and coping. Its object is to supersede external wood work connected with roofs.

52 TODD, C., Leeds—Inventor and Designer.

Model of a girder (*with Classes 5 & 6*), or the vertebral arch, representing its most simple form; originally invented and designed for a bridge to cross the river

distributing the  
ally; and to pro-  
(Outside, West

Westminster—

5 & 6.)

South—Inventor

ple.

d Manufacturer.

t Upton Lovel,  
med by trussing  
Herr Lavoce, of  
additional beam,  
feet, versed sine  
shoes, through  
to pass. The  
bearings on stone  
ave bearings on  
way is suspended  
as towards the

Producers.

by the late Sir  
struction of the

Tenter Ground,  
cturer.

water in gentle-  
is borne by the  
ility.

instead Road

ther in metal or  
os.

er.

f refuge on the  
oes, one from  
and the other  
int.

Islington—

ow stones for  
s, breakwaters,  
e object is to  
without dam-  
he cavities are  
ass is formed.

n, and Otter-

entor.

following—  
against drip,  
and other sub-  
sented by tem-

a brackets and  
all-plate, and  
solid wood work

gnior.

the vertebral  
originally in-  
ss the river

Mersey, at Runcorn Gap, in one span of 1,263 feet. The span of the arch of this model is 81 feet, being about 1/16th of the span proposed for the bridge. The principle was suggested by considering the construction of the back-bone of an animal.

53 HEINKE, CHARLES E.—Inventor and Manufacturer.

Patent submarine helmet, dress, and apparatus, for examining and repairing of ships' bottoms, at sea or in dock, for the recovery of property from sunken vessels, and for making and repairing the foundations of viaducts and harbours.

Patent helmet air valve, for protecting the diver's life in case of any accident happening to the air-hose. It contains a sufficient quantity of air (say from ten minutes to a quarter of an hour) to give the diver time to ascend.

Patent helmet slide, which the diver can instantaneously close should the glass be accidentally broken.

Improved connecting joints, calculated to resist powerful pressure, having a double safety-asp attached.

New-invented signal dial, by which the diver is enabled to make known his wants.

[The earliest mention of the use of the diving-bell in Europe was in 1509: in 1687 treasure was brought up from a sunken ship by William Philippe, a native of America. But the first practically useful diving-bell was the invention of Dr. Halley, in 1720, who also contrived a helmet to enable the diver to go out of the bell, and walk at the bottom for a considerable time. These diving helmets and dresses have been improved from time to time, and are now extensively used by engineers in hydraulic operations.—S. C.]

54 DEVEY, GEO., 16 Great Marlborough Street—Inventor.

Model, illustrating a proposed method for obviating the nuisance arising from the smoke of ordinary house fires,

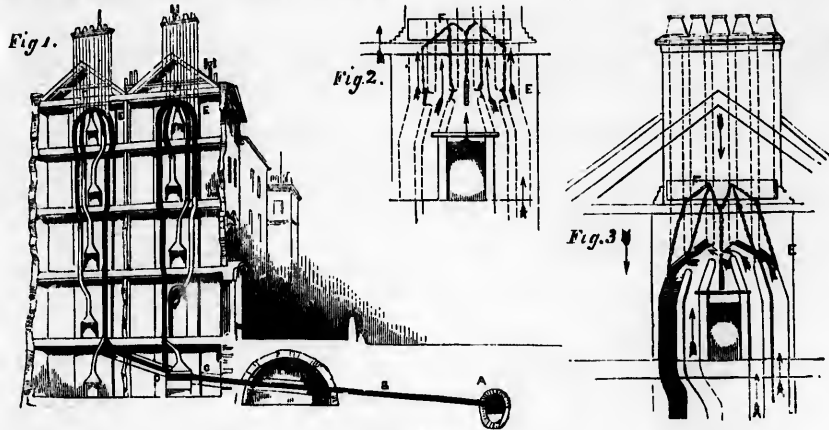

Devey's Smoke Removal Plan.

55 BANKS, LANGLEY, 23 Parliament Street, Hull—Designer and Manufacturer.

Twin geometrical staircase. It requires the space of one flight only, admitting persons to ascend and descend independently of each other. Adapted for confined places, and particularly for public buildings where show-rooms are required.

56 BOYDELL, J., 54 Threacettle Street—Inventor and Manufacturer.

Skeleton frame of a building, iron and wood, exhibiting a new method of joining iron joists and rafters to wood, and framing a roof by wedging iron laths in grooved

by combining with the present sewerage a general system of underground smoke drainage.

The preceding cut shows the mode of application to existing buildings, and the general arrangement proposed:—

1. By connecting the ordinary flues with the sewer in the streets.

2. By adapting these flues, now formed for transmitting the smoke upwards, to the downward current proposed.

3. By providing, in these arrangements, for the present action being resumed at any time, for the purpose of inspection or repair.

Fig. 1. A, Sewer.

B, Horizontal connecting flue from chimney in kitchen.

C, Valve, or register for regulating opening.

D, Junction (by present flues from basement,) of flues from chimneys above; the smoke from which, ascending in the usual way on reaching the openings at E, would be drawn down by the current produced by exhaustion in the sewer; the action being assisted by the heat from the kitchen fire.

E E, Openings forming passage for smoke across chimney-breast, cut through partitions or withs, with a valve set in each. By means of a balance weight, these would be made to act simultaneously, and remain open or shut as required; forming, when open, a downward passage for the smoke under the action of the new system, and, when shut, a passage upwards by the existing flues. Thus, allowing the ordinary action upwards to be instantaneously resumed in case of accident, or during any operation, such as cleansing or repair.

F F, Stone to front of chimney-breast in roof, to take down for access to valves.

Fig. 2. Openings at E E to larger scale, with valves shut for passage of smoke upwards as at present.

Fig. 3. Openings at E E; open for passage of smoke downwards as proposed.

rafters. Also a light framework of iron, rolled at once into the shape required to form a ceiling, and receive the usual plaster. Its object is to limit the ravages of fire.

Door to be used in a fire-proof house.

Section of a ship's side, showing a method of casing iron ships with wood, without using bolts or rivets. By the introduction of a non-conducting substance (that used in the model being silex and gutta percha), between the wood and the iron, a vessel may be coppered without risk of decomposition from contact of the copper with the iron.

New method of framing the sides of iron ships, the object of which is to obtain greater strength at less cost.

57 **DOBBS, WILLIAM**, 2 *Hewell Place, Southampton Street, Camberwell*—Inventor.  
Self-adjusting chimney-sweeping machine. (WMA Classes 5 & 6).

58 **GRISDALE, JOHN EDWIN**, 289 *Strand*—Inventor.  
Model of a wind-guard for smoky chimneys.

59 **MORRELL, G.**, 149 *Fleet Street*—Inventor.  
Registered iron abutments and tension rods on piers.

60 **HERRING, C.**, 177 *High Holborn*—Inventor.  
Patent window and model. A new and simple invention for taking out both sashes to clean, &c.

61 **SADLER, JOHN H.**, *Leeds*—Inventor and Patentee.  
A bridge for railways or other purposes, composed of a series of girders balanced upon piers, presenting singly the appearance of the letter T. The entire bridge is composed of a chain of these girders and piers, TTT; the girders are firmly locked together at the centre of the arch, each having teeth, like those of a spur-wheel, cast on both sides at each end, and plates with similar teeth cast on them, which are nicely fitted, teeth within teeth, and bolted firmly together, making a very strong joint; the bolt-holes through the girders being made oblong, an allowance for contraction or expansion is provided.

[A continuous beam, or bridge girder, resting on several piers, is stronger than if the girders were disconnected at their points of support, in the proportion of about 5 to 3.—S. C.]

62 **LOWE, ALICE, & Co.**, *Salford, Manchester*—Inventors and Patentees.  
Patent effluvia trap gratings or grids, applicable to public streets, courts, passages, hospitals, houses, and sink stones, for preventing the noxious effluvia in main sewers and drains from escaping to the surface. (See the annexed outs.) A sewer grating.

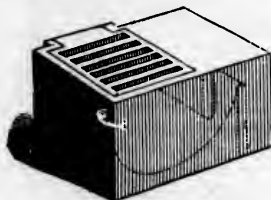
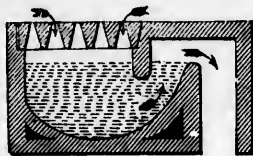

Low & Co's. Patent Traps.

The application of these traps may be seen in the model cottages erected by H.R.H. Prince Albert, opposite to the Exhibition Building.

63 **BELL, WILLIAM**, 40 *Piobharing Place, Puddington*—Inventor.

Suspension-bridge for railway purposes, made rigid by girders attached to the suspension chain. Suspension-bridge on the same principle, designed for northern rivers,

thickly frozen in winter, so as not to impede the passage of the ice when it breaks up.

Bridge of one arch, of 250 feet span, designed for ornamental waters. Constructed on the tenaille principle, and calculated to support with safety a load of 472 tons.

Roof, of 400 feet span.

Self-acting flood-gate, for keeping up a uniform head of water in mill-dams, weirs, &c.

[The power of the same water wheel depending upon the quantity of water admitted upon it, and uniform motion being requisite in the prime mover of all machinery, it follows that the height of water in the mill-dam should be maintained at an uniform level, or a self-acting sluice worked by a varying head, added so as to regulate the supply. If the first can be attained with certainty, it will ensure more perfect action.—S. C.]

64 **NAYLOR, WILLIAM**, 56 *James's Street, Oxford Street*—Inventor.

New glass registered ventilators, opened and shut by the means of a rack and pulley, as a sun blind.

65 **OLIVER, O.**, 68 *John Street, Tottenham Court Road*—Inventor.

Registered ventilator and chimney-pot.  
Fire-escape, applicable to all the storeys of a building at the same time.

66 **HURST, G.**, *High Street, Bedford*—Designer and Inventor.

Model of a partition, to rise from and sink into the floor, as required.

67 **HORN, ARCHIBALD**, 39 *Baker Street, Pentonville*—Inventor.

Self-acting iron shutter for the protection of shop-windows or doors, bankers' or merchants' safes, ground-floor windows, &c.: claiming, in use, convenience, portability, and freedom from friction.

68 **HILL, SAMUEL**, *Clifton, York*—Inventor.

Model of a window, with six panes to open and shut separately, swinging top-heavy to ensure their remaining open, and fastened with a spring.

Model of a fireplace with ventilating air chamber behind.  
Sliding guard, intended as a protection against accidents by fire.

69 **BATES, T.**, 9 *Donningo Street, Old Street*—Inventor and Manufacturer.

Mode of sash-frame and sashes, to open inwards, for being cleaned.

70 **REMINGTON, G. W. & J.**, 138 *Sloane Street*—Inventors.

Model No. 1 represents an engine with a straight-working shaft. Upon it are fixed two levers, which are connected together by means of a spindle, which carries a circular bolt; this bolt is fitted into an opening formed in the centre of the plate which connects the piston. By this arrangement of parts being applied to the inside of a cylinder, the reciprocating motion of the piston is converted into rotary motion, and an engine of great simplicity is obtained.

Model No. 2 represents an engine. The reciprocating motion of the piston is changed into rotary motion by means of cylindrical wedges, two of which are fixed upon the working shaft, and the third is placed between; to the centre wedge is attached the piston, which is retained in a right line by means of the covering pipe and cross-heads shown outside the cylinder. The power of this engine is uniform throughout the stroke: its con-



struction is simple and difficult to derange, and is suited for farm and agricultural purposes.

Breakwater model, No. 1.—The chief part of the superstructure is to be composed of wrought iron, forming a square or other rectangular figure of any required dimensions; the inside is strengthened with diagonal and longitudinal ties and braces. Tiers of masonry are to be constructed at intervals, and each section of the breakwater will extend from the centre of one pier to the centre of another, leaving bays or openings between the piers, below the level of low water, for the free passage of the tide; and in this way harbours formed by enclosures from the sea deep water may be always maintained.

Breakwater model, No. 2.—This model is upon the same principle of construction as the above, but designed for harbours in less depth of water. The superstructure is composed of wrought iron; the cross sections are circular. This is applicable to landing-stages, piers, and jetties.

1. Plans, drawings, and description of metropolitan railway union, and great central station, proposed by the exhibitors.

2. Elevation of the proposed iron breakwater.

3. Drawings of patented locomotive engines.

4. Drawings and description of an improved fire-escape.

71 GILES, ALFRED, 9 *Adelphi Terrace*—Designer.

Model of a curved timber roof, suitable for warehouses, &c.

Model of a repairing or dry dock, constructed of brick, with stone copings. The form of the dock, and the use of brickwork for such a purpose is stated to be new, and the economy, as compared with stonework, considerable.

72 M'LEAN, CHARLES, 110 *Fleet Street*—Inventor.

Models for shop fronts.

73 BOUCH, THOMAS, *Edinburgh*—Inventor and Designer.

Model of an apparatus for shipping and unshipping the trains of the Edinburgh, Perth, and Dundee railway, at all states of the tide. The large steam vessels, in connexion with the apparatus, were designed and constructed by Mr. Napier, of the Lanefield engine works, Glasgow.

74 HARRIS, J. C., *Bristol*—Inventor.

Model of a shop front.

75 JACKSON & CLAY, 21 *Homer Street, Lambeth*—Inventors.

Fire-escape, in the form of an ordinary piece of furniture, to be fixed to the floor by thumb-screws opposite a window. Provisionally registered.

76 SPURGIN, JOHN, *Guildford Street*—Inventor.

Endless ladder and crane, intended to obviate the chances of being upset at the summit.

Patent paddle apparatus for boats and steam-boats, to prevent backwater.

Model of a patent vertebrate or jointed bridge, its strength being derived from wrought iron on the edge, by an arrangement which allows of flexibility in one direction, but effects a resistance or abutment in the other; its object is strength, facility of construction, and portability.

77 PEILE, J. J. & Co., 74 *Market Place, Whitehaven*—Inventors and Manufacturers.

Specimens of ship screws.

78 RUSSELL, HENRY HEATHCOTE, C.E., 20 *George St., Adelphi*—Inventor and Designer.

Invention for a tidal staircase for landing passengers from craft at any elevation of tide, which by its arrange-

ment (upon the Archimedian screw principle) revolves as the water ascends or descends, and thus preserves the steps perfectly dry.

Model of a jetty, or landing-pier, designed for Douglas, Isle of Man, upon the same principle, constructed of wire rope, in lieu of chain plate and rods, the vertical rods are composed of iron tubing, the whole supported on screw piles, with a tidal staircase at the extremity.

[The screw pile, the invention of Mr. Alexander Mitchell, of Belfast, is one of great interest and value; it has been employed for the foundations of lighthouses, beacons, jetties, and other submarine works (see Minutes of Proceedings of the Inst. of Civil Engineers, February 22, 1848).—S. C.]

Speedy louis, invented to expedite the hoisting of light stones in the erection of buildings, &c. By this contrivance it will be seen that it is impossible to lose any of the component parts, as may be the case in the ordinary louis, which consists of five separate pieces, the loss of any of which renders the remainder useless. This model has been tested by the hoisting of a block of 5 tons of Portland stone with safety. An ordinary louis for comparison.

Model of suspension-bridge, upon the exhibitor's patent principle, whereby undulatory and vibratory motion is prevented, and the bridge rendered sufficiently rigid for the purposes of railway trains, marching troops, or other transit.

Competition design, upon the same principle, for the railway suspension and lift bridge uniting Cologne and Deutz. (*On Wall*.)

Improvement upon Taafé's slating; registered by the exhibitor. By this mode each slate is secured at all the four angles, with the advantage that any single slate may be taken out and repaired, without disturbing the rest.

Skeleton model of a Gothic tie-beam roof, to show the comparative modes of slating, the arrangement of the rafters, the saving of timber, &c.

Design and proposed site for a bridge at Westminster, to harmonize with the New Houses of Parliament, and preserve the present approaches; dispensing with the necessity of erecting a temporary wooden bridge for the traffic during its erection; thereby saving 40,000*l*. (*On Wall*.)

Design for a new bridge at Cologne.

79 SHIELD, JOSEPH, *Newcastle-upon-Tyne*—Producer.

Model, showing the process of manufacturing shot from lead.

[Shot are made by melting lead, with which, usually, some arsenic is combined, at the top of a high tower. The melted metal passes through a cullender, and falling through a large column of air, at length falls into a water butt on the ground. The heights of these towers vary from 200 to 300 feet. In the progress through the air, the sphericity of the shot is obtained, and after being cooled in the water, they are selected, mixed with a little plumbago, and put into a small octagonal cask, which is made to revolve by mechanical power—in this way all roughness is removed, and the shot are polished.—R. H.]

80 HOOKE, THOMAS, 80 *New Cut, Lambeth*—Inventor and Manufacturer.

Registered portable bed-room fire-escape.

81 NAYLOR, MATTHEW, 121 *Radnor Street, Hulme*—Producer.

Illustration of sewerage, paving, &c., at Manchester.

82 WELLS, GEORGE, *Admiralty Office*—Inventor.

Universal telegraphic lighthouse, intended to prevent mistake as to its identity; this is accomplished by cutting



four or more apertures in the present buildings just below the lantern, and fitting the openings with ground plate glass painted so as to leave the illuminated initial of the particular lighthouse distinct. The annexed figure represents the proposed lighthouse.



Wells' Universal Telegraphic Lighthouse.

[Owing to the difficulty of identifying lights on a coast, the least number that can be employed is the best; but if some distinguishing mark can be fixed to a lighthouse, by which all possibility of mistake is prevented, some objections to frequent lights would be removed.—S. C.]

84 LAVANCHEY, JEAN BAPTISTE, 9 Richmond Buildings,  
Dean Street, Soho—Inventor.

Model of a portable bridge (known in France under the denomination of Pont portatine), extending or retracting on grooves.

86 HAWES, CRAWSHAY, & Co., Gateshead, Newcastle-upon-Tyne—Manufacturers.

Model of the high-level bridge across the Tyne, at Newcastle-on-Tyne.

Samples of cable and other chain, as used in Her Majesty's navy, from the greatest diameter to the least.

90 DUNHILL, THOMAS, C.E., 19 Fortress Terrace,  
Kentish Town—Projector.

Model of an aggregate cattle market, abattoir, carcass market, &c., occupying together 65 acres, and proposed to be established in the N. by W. suburb of the British metropolis, and embodying in detail the following arrangements:—

A principal entrance, with 500 feet frontage for offices, &c., flanked with buildings, their interior areas forming carcass and other markets. The market would occupy an area of 23 acres, and would accommodate 6,000 oxen 40,000 sheep.

Calf and horse markets are also provided for, with abattoirs, &c.

Pasturage and layrage would surround the market, &c., on all sides.

91 HADLEY, CHARLES—Producer.

Specimens of patent paving.

92 TIPLER, T. W., Rugby—Inventor.

Model of a fire-escape.

93 LEGRAS, L. N., 2 Tennyson Street, York Road, Lambeth—Inventor.

Various inventions in connexion with sewerage, &c.

94 ELL, GEORGE, 3 Tottenham Court, New Road—Inventor and Improver.

Adjustable scaffold observatory or fire-escape, applicable to a variety of purposes, and may be adjusted to

any height within its range, supporting itself with safety, independently of any attachments.

The machine consists of a series of hollow rectangular frames, sliding one within another, after the manner of the tubes of a telescope; mounted upon wheels, and hoisted or lowered by ropes and pulleys, by means of winch handles, turning a barrel, round which are twisted the lower ends of the ropes of the second frame. By a repetition of this arrangement each frame is raised out of the frame below it, at an equal rate with all the others, but the absolute velocities of all the frames successively are in arithmetical progression.

Adjustable ladder; supports itself by means of swinging pole attached to the back, braced by light iron work; can be easily taken to pieces, and put away in a small compass.

Wheelbarrow, for the use of excavators and others.

Folding steps, with bowed sides, suitable for general household purposes.

95 BREMNER, JAMES, DAVID, & ALEXANDER, C.E.,  
Glasgow—Inventors.

Model of an apparatus for building sea-walls in deep water.

Models of life-boats, with a large chamber in the centre, in which are three paddles worked with cranks instead of oars.

Model of the means used for raising the iron steamship, "Great Britain."

Model of cranes used in making the harbour of Lossiemouth, Scotland.

Scale of the models,  $\frac{1}{2}$  of an inch to a foot.

96 SMITH, B., Bron Sciont, Carnarvon, Wales—Inventor.

Models of a double line of railway (of four-rail mixed gauge), for the assimilation of railway gauges; see the engraving on page 319.

Models of two tunnels in wood, and one in glass.

Models of five railway carriages.

The accompanying two diagrams are in illustration of a new system of working railways, intended to dispense with all break of gauge.

The plan suggested is to convert the narrow-gauge railways into broad-gauge lines, by laying down rails of the seven-foot width on the outer sides of the present narrow-gauge railways, so as to form them into four-rail mixed-gauge lines, until the traffic be entirely transferred from the narrow-gauge to the broad-gauge rails, when the inner or narrow-gauge rails would be permanently removed. The new form of carriage here proposed, as shown in the diagrams, has three pairs of large wheels placed on the outer sides of the body.

Description of the Engraving.—The arch represents one of the tunnels on the London and North Western Railway; in height 22 feet above the rails, and in width 24 feet.

The horizontal line across the arch and above the carriages represents the height above the rails of the lowest bridge between London and Holyhead, being 14 ft. 3 in.

A. End section of the new wide-gauge second-class carriage, intended to form part of this plan and to hold 48 passengers.

B. End section of one of the narrow-gauge second-class carriages in use on the London and North Western lines, which holds 24 passengers.

c. End sections of the (seven feet) wide-gauge rails, to be laid down on the outer sides of the narrow-gauge lines.

d. End sections of the (4 ft. 8½ in.) rails, forming the present narrow-gauge lines.

The four lines of rails taken together represent the four-rail mixed gauges, to be temporarily laid.

E. Side section of the new wide-gauge second-class carriage, intended to form part of this plan, and to hold 48 passengers; and be the steadiest at high velocities, owing to the wheels being placed nearer to the ends.

self with safety,  
low rectangular  
r the manner of  
on wheels, and  
s, by means of  
hich are twisted  
nd frame. By a  
is raised out of  
h all the others,  
nes successively

NDER, C.E.,  
a-walls in deep  
r in the centre,  
cranks instead  
the iron steam-  
bour of Loois-  
ot.

Notes—  
our-rail mixed  
gauges; see the  
in glass.  
Illustration of a  
d to dispense

narrow-gauge  
down rails of  
of the present  
into four-rail  
ly transferred  
e rails, when  
permanently  
proposed, as  
large wheels

represents one  
Western Rail-  
l in width 24

above the car-  
of the lowest  
g 14 ft. 3 in.  
second-class  
and to hold

second-class  
Western lines,  
auge rails, to  
-gauge lines.  
forming the

represent the  
l. second-class  
and to hold  
h velocities,  
e ends.

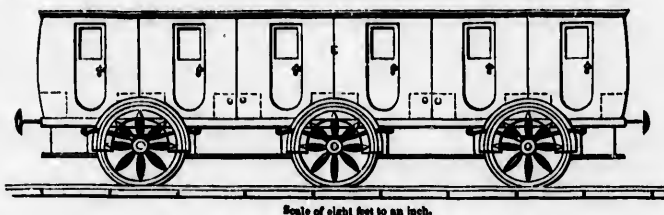
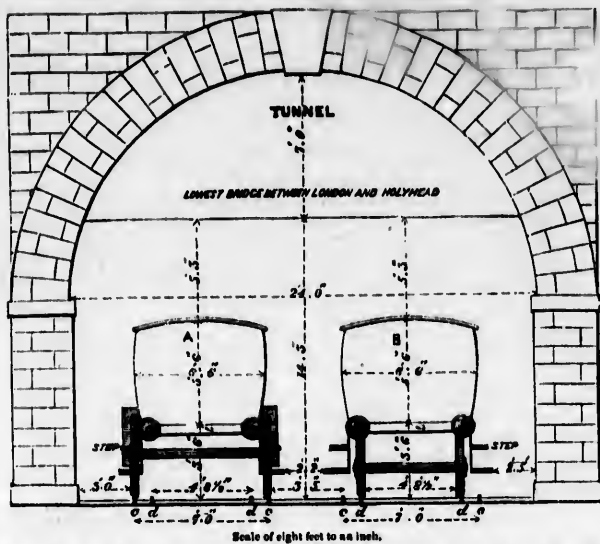

Smith's Assimilation of Railway Gauges.

97 WILSON, M., *Middle Church Street, Whitehaven*—  
Inventor.

Vertical water-wheel, to be used as a breast-wheel, or undershot-wheel, having governor-paddles so constructed as to obviate the back-water, and increase the efficiency of the wheel. Its peculiar features consist in the feathering action of the paddles, and the application of the balance-balls in connection with them, to adjust their gradual descent upon the abutments at each revolution, by which repeated rotary concussions are avoided.

98 RENNIE, G., *21 Whitehall Place*—Inventor.

1. Model of a stone bridge proposed for Westminster, and submitted to the Committee of the House of Commons in 1846. Total length, 827 feet; number of arches, 7; total waterway, 768 feet. Spans of arches—Middle arch, 130 feet; two arches, each 120 feet; two arches, 100 feet; two arches, 95 feet. Height above Thames high water—Middle arch, 27 feet; two arches, each 25 feet; two arches, 23 feet; two arches, 20 feet.

2. Model of a bridge proposed for Westminster. Total length, 752 feet; number of arches, 5; total waterway, 690 feet. Middle arch, 150 feet; two side arches, 140 feet; two side arches, 130 feet. Height above tidal waterway—Middle arch, 27 feet 6 inches; two side arches, 25 feet; two side arches, 24 feet.

3. Model of a bridge proposed for Westminster. Number of arches, 7; spans, each 100 feet; height above Thames high water, 26 feet.

4. Model of a bridge recently constructed over the river Meuse, in Belgium, for the Namur and Liege Rail-

way, at Val St. Lambert. Length, 525 feet; number of arches, 5; width, 26 feet; spans, each 80 feet; versed sine, 10 feet.

5. Model for a bow and string girder bridge, proposed to carry the Prussian Railway over the Rhine at Cologne, agreeably to the programme of the Prussian Government. Span of each opening, 572 feet; span of drawbridge, 96 feet, by George Banks Rennie, jun.

6. Model of a design of a Harbour of Refuge for Dover, submitted to the Commissioners, by the same.

99 THE COMMISSIONERS OF NORTHERN LIGHTHOUSES,  
*Edinburgh*—Proprietors. Mr. ALAN STEVENSON,  
Engineer.

Revolving dioptric apparatus of the first order (same as that at Skerryvore). This apparatus consists of two parts. The principal part is a right octagonal hollow prism, composed of eight large lenses, which throw out a powerful beam of light whenever the axis of a single lens comes in the line between the observers and the focus. This occurs once in a minute, as the frame which bears the lenses revolves, in eight minutes, on the rollers placed beneath. The subsidiary part consists of eight pyramidal lenses, inclined at an angle of 50° to the horizon, and forming together a hollow truncated cone, which rests above the flame like a cap. Above these smaller lenses (which can only be seen by looking from below) are placed eight plane mirrors, whose surfaces being inclined to the horizon at 50° in the direction opposite to that of the pyramidal lenses, finally cause all the light made parallel by the refraction of these lenses, to leave the mirror in a

horizontal direction. The object of this part is to turn to useful account, by prolonging the duration of the flash, that part of the light which would otherwise escape into the atmosphere above the main lenses. This is effected by giving to the upper lenses a slight horizontal divergence from the vertical plane of the principal lenses. Below, are five tiers of totally reflecting prisms, which intercept the light that passes below the great lenses, and by means of two reflections and an intermediate reflection project them in the shape of a flat ring to the horizon.

Fixed dioptric apparatus of the first order (same as that at Isle of May, with various improvements). The principal part consists of a cylindrical belt of glass, which surrounds the flame in the centre, and by its action refracts the light in a vertical direction upwards and downwards so as to be parallel with the focal plane of the system. In this way it throws out a flat ring of light equally intense in every direction. To near observers, this action presents a narrow vertical band of light depending for its breadth on the extent of the horizontal angle embraced by the eye. This arrangement, therefore, fulfils all the conditions of a fixed light, and surpasses in effect any arrangement of parabolic reflectors. In order to save the light which would be lost by passing above and below the cylindrical belt, curved mirrors, with their common focus in the lamp, were formerly used; but on the suggestion of the present engineer, the adaptation of *catadioptric* zones to this part of the apparatus was, after much labour, successfully carried out. These zones are triangular, and act by total reflection; the inner face refracting, the second totally reflecting, and the third, or outer face, a second time refracting, so as to cause the light to emerge horizontally. The apparatus has received many smaller changes by the introduction of a new mode of grouping the various parts of the framework, by which the passage of the light is less obscured in every azimuth. During the last four years, these improvements have been introduced into the lighthouses in Scotland.

[The dioptric system of lights was invented by M. Fresnel A.D. 1819.—S. C.]

Model of the Bell Rock Lighthouse, lighted in 1811. This lighthouse was executed according to the design, and under the superintendence, of the late Robert Stevenson, Esq., F.R.S.E., Engineer to the Commissioners of the Northern Lighthouses. The model shows the progress of the work; the temporary barrack-house of timber; the railway, stone lighters, and cranes used in its construction; and on the pane at one end of the case, the courses of masonry, with their dovetails and joggles. Cost 61,331*l.* 9*s.* 2*d.* The bird on the top of the model was carried against the lantern in a gale, broke a pane of glass, injured one of the reflectors, and fell dead on the floor of the lightroom.

Model of the Skerryvore Lighthouse, on the same scale as No. 3. The light was exhibited in 1844. The lighthouse was executed according to the design and under the superintendence of Mr. Alan Stevenson, LL.B. F.R.S.E., the present engineer. Cost 86,977*l.*

Model of balance cranes; designed by the late Mr. Robert Stevenson, and used by him in the erection of the Bell Rock Lighthouse, for raising and setting the stones at any distance from the centre of the tower, in which the stone and the counterpoise balance each other by being continually kept at an equal distance from the shaft of the crane.

Model of the apparatus of an intermittent light. Designed by the late Mr. Robert Stevenson, and introduced by him at the lights of Tarbertness, Barrahead, and Mull of Galloway, on the coast of Scotland. This apparatus eclipses the light suddenly for half a minute of time, and as suddenly reveals it to view, when it continues in sight for two and a half minutes, and is again suddenly eclipsed; thus producing its whole effect in three minutes of time. The suddenness of its eclipse and reappearance, and the inequality of the periods of light and darkness, form a marked contrast to the gradual waxing and waning which precede the brightest phase and dark periods of a revolving

light, all the phenomena of which recur at equal intervals of time.

Model of a lighthouse lantern, on the diagonal arrangement. Designed by Mr. Alan Stevenson, for the purpose of avoiding the unequal distribution of the light to which the old lanterns were liable from the interception of rays in certain azimuths by means of the vertical astragals. Great rigidity and strength are also insured by this arrangement, and the triangular form of the panes renders them less liable to be broken by the force of impinging bodies.

Mechanical lamp of four wicks, in which the oil is kept continually overflowing by the means of pumps, which raise it from the cistern below; the rapid carbonization of the wicks which would be caused by the great heat is thus avoided. The flames of the lamp reach their best effect in three hours after lighting, *i. e.*, after the whole of the oil in the cistern, by passing and re-passing over the wicks repeatedly, has reached its maximum temperature. After this the lamp often burns 14 hours without sensible diminution of the light, and then rapidly falls. The light varies from 16 to 20 times that of the Argand flame of an inch in diameter; and the quantity of oil consumed by it is greater nearly in the same proportion.

Holophotal arrangement of lighthouse apparatus, prepared by Mr. Thomas Stevenson, C.E., in which the whole sphere of light is brought under instrumental action thus:—The posterior hemisphere of light is reflected by the hemispherical mirror (and in some cases by reflecting hemispheres of glass), and passes with the usual loss by reflection again through the flame, where it is parallelized, partly by refraction at the lens, and partly by the parabolic mirror which is truncated in the parameter. The anterior hemisphere of light is also parallelized partly by the action of the lens, and partly by the parabolic mirror. In this manner there is no loss of the posterior portion as in the lens, nor of the anterior portion as in the mirror.

100 STEVENSON, THOMAS, F.R.S.E., 84 George Street, Edinburgh—Inventor.

Revolving light, with axial rotation, by which one-half the number of reflectors, and one-half the quantity of oil, are designed to be saved. Intended for illuminating any arc of not more than 180 degrees. The intervals of time of illumination are equal within the whole of the illuminated arc, instead of unequal as in the reciprocating light. The reflectors are also of a new form, consisting of parabolic strips of different focal distances.

Ordinary parabolic reflector, rendered holophotal (where the entire light is parallelized) by a portion of a catadioptric annular lens. The back part of the parabolic conoid is cut off, and a portion of a spherical mirror substituted, so as to send the rays again through the flame. All the light intercepted by the annular lens is lost in the ordinary reflector.

Holophotal catadioptric annular lens apparatus (unfinished). This is a combination of a hemispherical mirror and a lens with totally reflecting zones; the peculiarity of this arrangement is, that the catadioptric zones, instead of transmitting the light in parallel horizontal plates, as in Fresnel's apparatus, produce, as it were, an extension of the lenticular or quaquaversal action of the central lens, by assembling the light around its axis in the form of concentric hollow cylinders.

(The above instruments belong to the Board of Northern Lights.)

[The early method of illuminating lighthouses was by coal or wood fires contained in "chaffers." The Isle of Man light was of this kind until 1816. The first decided improvement was made by Argand, in 1784, who invented a lamp with a circular wick, the flame being supplied by an external and internal current of air. To make these lamps more effective for lighthouse illumination, and to prevent the rays of light escaping on all sides, a reflector was afterwards added: this threw the light forward in

recour at equal

agonal arrange-  
for the purpose  
light to which  
option of rays  
tical astragala.  
sured by this  
e panes renders  
ce of impinging

the oil is kept  
pumps, which  
carbonization of  
eat heat is thus  
their best effect  
e whole of the  
over the wicks  
erature. After  
without sensible  
alls. The light  
and flame of an  
consumed by it

apparatus, pre-  
in which the  
Instrumental  
light is reflected  
some cases by  
asses with the  
flame, where it  
lens, and partly  
encated in the  
f light is also  
ens, and partly  
there is no loss  
of the anterior

George Street,

which one-half  
quantity of oil,  
luminating any  
ervals of time of  
the illuminated  
ng light. The  
ng of parabolic

ophotal (where  
on of a catadi-  
the parabolic  
mirror substi-  
the flame. All  
is lost in the

apparatus (un-  
spherical mirror  
e peculiarity of  
ones, instead of  
al plates, as in  
n extension of  
the central lens,  
in the form of

rd of Northern

houses was by  
The Isle of  
e first decided  
who invented  
supplied by  
to make these  
nation, and to  
es, a reflector  
at forward in

parallel rays towards such points of the horizon as would be useful to the mariner. Good reflectors increase the luminous effect of a lamp about 400 times; this is the "catoptric" system of lighting. When reflectors are used there is a certain quantity of light lost, and the "dioptric" or *refracting* system, invented by the late M. Augustin Fresnel, is designed to obviate this defect to some extent: the "catadioptric" system is a still further improvement, and acts both by *refraction* and *reflection*. Lights of the first order have an interior radius or focal distance of 30-22 inches, and are lighted by a lamp of four concentric wicks, consuming 570 gallons of oil per annum.—S. C.]

101 TUCKEY, H., *Hampton Court Palace*—Inventor.  
Proposed fire-escape.

102 MAXWELL, JOHN, *Stokeford Foundry, Dumfries*  
—Manufacturer.

Hatch-window for house-roofs.  
Another, of plate-glass.  
Cottage-windows, all of cast-iron.  
Iron skylights and iron sashes.

104 HOPKINSON, JOSEPH, *Chapel Hill, Huddersfield*—  
Inventor.

Bobbin ladder for vessels in port or in distress, and suitable for a fire-escape or other purposes.

105 VIGNOLES, CHARLES, *4 Trafalgar Square*—  
Designer.

Model of the wrought-iron bar-chain suspension bridge at Kioff, now erecting across the river Dnieper, by command of H. I. M. the Emperor of Russia. Its length is about half an English mile, and breadth 52½ English feet. The area of the roadway is 140,000 superficial feet. (*Central Avenue*.)

The bridge of which this is a model is the largest work of the kind hitherto undertaken; the chains on the right, or Kioff side of the Dnieper, are moored in an isolated abutment, built in the river, at a sufficient distance from the shore to allow vessels to pass. This is effected by a drawbridge, 52½ feet broad, spanning an opening of 50 feet. The supports are hollow beams of wrought iron, about 130 feet long; the drawbridge revolves in one leaf, and centres like a railway turn-table; the counterpoise required is very small. The whole weight of the drawbridge is about 150 tons.

The four principal suspension spans are each of 440 English feet. Each chain extends over the five river piers and through the two abutments, and is more than half an English mile long.

The platforms are suspended from the chains by wrought-iron rods of 2 inches diameter. The roadway is made peculiarly stiff, to resist the various strains to which it is liable.

The total quantity of iron employed in constructing the bridge, including the machinery used, is 3,500 English tons (3¼ millions of French kilogrammes, 78,000 German centners). The whole was manufactured in England; the chains by Fox and Henderson, Birmingham.

Sixteen vessels were employed in transporting the iron from Liverpool to the port of Odessa, whence it was conveyed on bullock-carts to Kioff, a distance of 400 English miles.

The channel of the river Dnieper at the bridge is about 35 feet deep in summer, but the spring floods increase the depth to 50, and sometimes to 55 feet.

Eight coffer-dams were required for getting in the foundations, and 10 steam-engines were employed on the works, two being of 50-horse power each.

The foundations are on piling and concrete; the piers and abutments are brick, faced with granite. About 1,000 tons (English) of granite ashlar are inserted in each abut-

ment as an extra mass, for the mooring plates of the chains to bear upon.

The granite was brought across a country destitute of hard roads, from a distance of nearly 100 English miles. The hydraulic cement employed is prepared artificially, according to the system pointed out by the celebrated French engineer, Vicat.

Cost of the bridge about 400,000*l.* sterling. Time of building will have been about five years; but from the climate and other circumstances not more than 100 working days in each year could be calculated on for the principal and more difficult parts of the work.

The whole of the piers and abutments will be brought to the level of the roadway in the course of the present summer (1851); two of the river piers will also be carried to their full height; and the bridge will be completely finished in the autumn of 1852.

Every part of the model is in exact proportion to the original bridge. The scale is 1 inch to 8 feet.

The two views in chromolithography, which illustrate this bridge, are from drawings executed on the spot.

[Suspension bridges of iron were introduced about the year 1741, at which date one of 70 feet span was thrown over the river Tees. Scamozzi, "Del Idea Arohi," published 1615, conveys some notion of these structures, but Bernoulli first explained their true principles. The Union bridge over the Tweed, 449 feet span, constructed by Capt. Sir S. Brown, in 1820, was the first large bar chain bridge erected in Britain. The Newhaven and Brighton suspension piers were also erected by the same engineer. The great bridge by Telford across the Menai Straits is 370 feet span; it was commenced in May, 1819, and completed in December, 1825. The Haamersmith bridge, 422 feet span, by Tierney Clark, was completed in 1824. The Montrose bridge, by Rendel, 412 feet span, was erected in 1829; and the Hungerford bridge over the Thames, 676½ feet span, by Brunel, was built in 1844. The *wire-rope* bridge of Freiburg is 820 feet span. The roadways of suspension bridges must not merely be hung from the chains, but be rendered stiff to resist the undulatory motion caused by the wind. See Minutes of Proceedings of the Institution of Civil Engineers, Feb. 16, 1841, on this subject.—S. C.]

106 CLARK, EDWIN, *48 West Strand*—Producer.

Model of the Britannia bridge, and of the apparatus used in floating and raising the tubes. Scale 1-8th of an inch to the foot. Engineer, Robert Stephenson; model executed for Charles Mare, Esq., by Mr. Jabez James. (*Central Avenue*.)

[This bridge consists of a tube, formed of iron plates rivetted together, and of sufficient dimensions to allow a loaded train to pass through each. It crosses the Menai Straits, and connects the Isle of Anglesey with South Wales. It was commenced August 10, 1847, and was finished March 5, 1850, and on the 18th of the same month was opened for traffic. The total expense of erection was 601,860*l.*, of which the iron work cost 443,160*l.*, and the masonry 158,700*l.* It contains 1,500,000 cubic feet of masonry, 9,480 tons of wrought iron, and 1,988 tons of cast iron.—S. C.]

107 LEATHER, JOHN W., *Leeds*—Designer.

Model of suspension aqueduct over the river Calder, at Stanley, near Wakefield. (Designed by George Leather and John W. Leather, civil engineers, Leeds, and executed under their direction.) This aqueduct is represented in the following engraving.

The canal which is carried over the river Calder by means of this aqueduct is navigable for sea-going vessels of 7 feet draught of water, and 120 tons burthen.





Leather's Suspension Aqueduct over the Calder.

This model and unique mode of construction was adopted in order to preserve the whole width of the waterway of the river free and uninterrupted by piers, which was important.

The tank or trough is 9 feet deep, and 24 feet wide within, and it contains between the points where it rests upon the abutments, 940 tons of water, more than is contained in the whole 19 arches of the celebrated Pont-y-Cysyllte aqueduct in Wales.

There is a towing-path on each side, which projects partly over the water within, and partly on the outer side of the trough. By the introduction of a colonnade and entablature (of the Grecian Doric order) terminated by an octastyle portico and pediment on the abutment at each end, the heavy and unsightly appearance which so large a surface of tank would have presented, is got rid of, and a light and elegant character is given to the structure. The suspending-rods pass through the columns to the ends of the transverse bearers; and the steps upon which the columns appear to rest serve to conceal the transverse bearers, as well as further to maintain the architectural effect.

The following are the principal dimensions and particulars:—

|                                                                                 |            |
|---------------------------------------------------------------------------------|------------|
| Span of the suspending arcs . . . . .                                           | 155 feet.  |
| Width between the suspending rods . . . . .                                     | 30½ "      |
| Length of trough between the abutments . . . . .                                | 165 "      |
| Width of trough . . . . .                                                       | 24 "       |
| Depth of trough . . . . .                                                       | 9 "        |
| Depth of water (sometimes 8½ feet) ordinarily . . . . .                         | 7½ "       |
| Diameters of suspending rods . . . . .                                          | 2½ inches. |
| Thickness of tank-plates (cast-iron) . . . . .                                  | 3½ "       |
| Weight of each suspending arc . . . . .                                         | 101 tons.  |
| Total weight of iron—cast, 730 tons, wrought, 30 tons . . . . .                 | 760 "      |
| Weight of the water in the tank (8½ feet deep) . . . . .                        | 940 "      |
| Total weight supported by suspending arcs, including their own weight . . . . . | 1,700 "    |

First pile for the foundations driven July 20, 1836.  
Aqueduct opened August 8, 1839.

Iron-work executed by Messrs. Graham, Milton Iron Works, near Sheffield.

Masonry by Hugh McIntosh, contractor, Bloomsbury Square, London.

[The first cast-iron aqueduct was erected by Telford, A.D. 1793, to carry the Shrewsbury canal over the river Tern.

In 1794-5 he designed the celebrated cast-iron aqueduct to convey the Ellesmere and Chester canal, at an elevation of 127 feet, over the river Dee at Pont-y-Cysyllte: since that time many have been erected. The advantages of cast-iron aqueducts over those of stone, which are of considerable antiquity, are their security from leakage, and their economy in point of cost.—S. C.]

2. Model of a cast-iron bridge over the river Aire at Leeds. This bridge is represented in the following engraving.

The objects aimed at in this design have been to combine with apparent lightness, real strength, and by taking advantage of the facilities afforded by the metal, to give, as in the case of the Calder aqueduct, almost without additional expense, a pleasing, ornamental, and purely architectural character to a useful engineering work.

The following are the principal dimensions and particulars:—

|                                          |           |
|------------------------------------------|-----------|
| Span of the arch . . . . .               | 120 feet. |
| Rise of arch from springing . . . . .    | 12 "      |
| Width of roadway . . . . .               | 30 "      |
| Width of each footpath . . . . .         | 6 "       |
| Total width outside to outside . . . . . | 43½ "     |
| Weight of cast-iron . . . . .            | 410 tons. |
| Weight of wrought iron . . . . .         | 5½ "      |

First pile for foundations driven May 1, 1841.

Bridge opened to the public, July, 1842.

Iron-work executed by Messrs. Booth & Co., Park Iron Works, Sheffield.

Masonry executed by Mr. James Bray, contractor, Moor Park, Harrogate.

Both the above models were made by Mr. Stephen Salter, Elvan Cottage, Hammersmith, London; carved by hand from crayon paper made into cardboard, and show (as nearly as can be done on so small a scale) the details of the iron-work, &c. (*Main Avenue West.*)

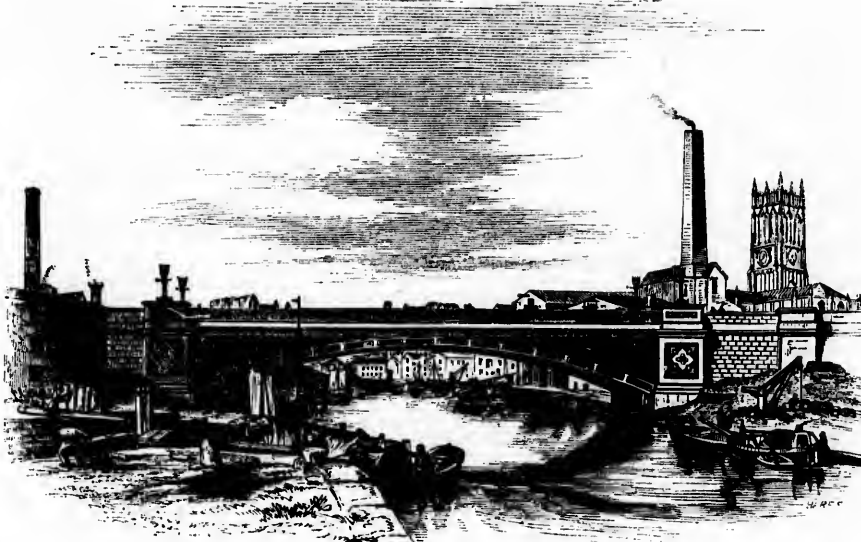

Leather's Cast-Iron Bridge over the Aire.

109 WILLIAMS, CADOGAN, *Bridgend, Glamorganshire, Wales*—Inventor.

Models of machines for pressing, tearing, and clearing the surface of land; for grubbing; for breaking stones for roads; for working the surface of land and mixing manure with it; and for preparing land for planting sugar-canes in it.

Specimen of artificial stone for lining water-tanks and pools. Model of a filter. Models of pumps on a new principle.

Model of a new plan for raising weights, and propelling vessels, so that emigrants might assist to expedite their voyage.

Model of a plan for taking carriages over the Avon, and of a plan for making a footpath under the iron bar across the Bristol river, at Clifton, without interrupting its navigation.

Hints for fire-escapes, and removing soot from chimneys by an artificial current of air; for economising heat, and for boiling water by means of a current of air.

110 CROGGMAN & Co., *2 Doggate Hill, City*—Inventors.

Patent asphalt roofing felt, particularly applicable for warm climates. It is a non-conductor. It is portable, being packed in rolls, and not liable to damage in carriage. It effects a saving of half the timber usually required. It can be easily applied by any unpractised person. From its lightness, weighing only about 42 lbs. to the square of 100 feet, the cost of carriage is small. The felt can be laid on from gable to gable, or across the roof from eaves to eaves. It is essential that it should be stretched tight and smooth—overlapping full one inch at the joinings, and closely nailed through the overlap, with twopenny fine clout nails (heated in a shovel, and thrown when hot, into grease, to prevent rust), about 1½ inches apart, but copper nails are preferable. The whole roof must have a good coating of coal tar and lime (about two gallons of the former to six pounds of the latter), well boiled together, kept constantly stirring while boiling, and put on hot with a common tar mop, and while it is soft some coarse sharp sand may be sifted over it. The coating must be renewed every fourth or fifth year, or more or less frequently, according to the climate. The gutters

should be made of two folds, one over the other, cemented together with the boiling mixture.

Inodorous felt, for damp walls, and for damp floors, under carpets or floor-cloths.

Patent felted sheathing, for covering ships' bottoms, &c.

Dry hair felt, for covering steam-boilers, pipes, &c., preventing the radiation of heat, and saving 25 per cent. of fuel.

111 WILLETT, FRANCIS, *5 Edward Street, Portman Square*—Proprietor.

Models in timber and slate; in timber and glass; and in glass and iron; with diagram to show the principle of "Taaffe's patent" for the roofing of houses and other buildings.

Williams's patent locks, without a keyhole.

112 THOMPSON, F. JUN., *C.E. Water Works Chambers, Orange St., Leicester Square*—Inventor.

New apparatus for economising the consumption of gas, and increasing its powers of giving light; it may be attached to any existing gas fittings.

113 WILSON, THOMAS HOOD, *Twickenham*—Inventor.

Slides on a pair of folding doors, for excluding the wet and the cold from hall doors and shutters; also for hatchways and portholes of ships.

Invention for securing carriage gates and coach-house doors, being self-acting; stops and bolts for the same.

114 DONSON, JOHN, *Newcastle-upon-Tyne*—Designer.

Model of the roof erected over the passenger shed of the Newcastle-upon-Tyne Central Railway Station.

Model of a roof for Messrs. Smith's ship-building yard, St. Peter's, near Newcastle-upon-Tyne.

Model of a rolling machine, designed by Mr. Thomas Charlton, used in rolling iron for the circular principals of the passenger-shed roof of the Central Railway Station.

Model of original design for the portico and arcades of the Central Railway Station.



- 115 PRATT, HENRY, *St. Scithin Street, Worcester*—  
Inventor.  
Design of a mill and new power machine for various purposes.  
Wooden model of the building, with drawings and explanations.
- 116 McCLELLAND, D., *3 Palace New Road, Lambeth*—  
Producer.  
Model of roof of 100 feet span. Scale  $\frac{1}{4}$  inch to a foot.
- 117 BARCLAY, JOHN, *Tonque, by Goldspie, Scotland*—  
Designer and Inventor.  
A portable pressing machine, designed for copying letters and for other purposes.  
Model of a wooden float bridge and appendages; applicable to narrow straits or rivers in calm situations.  
Mechanical time and tide tables, for ascertaining the number of days from any period in one year, to any other period in the same or following year; the day of the week or month; the state of the tide at any given port; the moon's age, &c.
- 118 TUTTON, JOHN, *20 South Audley Street, Grosvenor Square*—Inventor and Patentee.  
Models of patent improvements in the construction and arrangement of the window spaces of dwelling-houses. A window fitted up to combine a water-closet, a washhand-stand, and a dressing glass, representing, when shut, a neat piece of cabinet furniture.  
A window fitted up as a knee-hole writing-table, with drawers, &c., for papers, which may be rendered fire-proof. The exterior has a sunk flower-box, with glass shade, applicable to different forms of windows.
- 119 WALKER, E., *Cardington Street, Hampstead Road*—  
Inventor.  
Patent wire window blinds.
- 119A SMITH, J., *50 Bartholomew Close*—Inventor.  
Model of a door.
- 120 EVERY, SIMON FREDERICK, *Quorndon, near Derby*—  
Inventor and Manufacturer.  
Patent Vulcan chimney-sweeper.  
Circular and oblong chimney-sweeping machines. Ob-long self-adjusting machine, for sweeping difficult chimneys.  
Full-sized drawing, representing one of these machines in action.
- 121 NEALE, W. J., *30 Basinghall Street—Hon. Sec. to Chimney-sweeping Machinery Committee*—Producer.  
Prize machinery for sweeping chimneys.  
Prize plans and estimates for altering, at the least expense, in conformity with the Act of Parliament, difficult and awkward chimneys.
- 122 ALLAN, JAMES, sen., *Glasgow*—Manufacturer.  
Portable apparatus for the manufacture of gas from resin, having a steam-boiler for the purpose of cooking food for cattle, heating conservatories, halls, &c.  
Gas candelabrum of cast-iron with globes, adapted for vestibules, halls, &c.
- 123 NESS, MARY, *24 Mold Green, Huddersfield*—  
Inventor.  
Window-cleaner, for the protection of female servants from fatal accidents and public exposure, by enabling them to work from within the apartment.—Provisionally registered.
- 124 HILL, ORMOND & JULIAN, *37 Great George Street, Westminster*—Improvers.  
Modification of Dr. Arnott's ventilating curtain pump, arranged so as to be worked by a weight and to be portable.
- 125 MACKENZIE, J. S., *Newark-upon-Trent*—Inventor.  
The vulcan spring for closing doors, &c.
- 126 MACKIE, WILLIAM, *141 Lower Bagot Street, Dublin*—Inventor.  
Patent safety window fittings, which may be applied to old or new sashes.
- 127 ROBERTS, B. E., *2 Nelson Place, Clifton, near Bristol*—Inventor.  
Newly-invented safety window-sash, to obviate the necessity of cleaning or painting the glass or frames, &c., on the outside of the house. The window sash may be taken out and again replaced in its air-tight groove with the usual bondings.
- 128 WILLIAMS, L., *14 Upper Marylebone Street, Portland Place*—Inventor and Manufacturer.  
Man-help, made of iron, to hold a painter's brush to paint ships, houses, &c.  
Registered concave-bottom tea-kettle and stand, of tin and copper, to boil water in five minutes.  
Improved safety cot for children.
- 129 BRAMHALL, THOMAS, *1 Union Street, St. George's Hill, Southwark*—Inventor and Manufacturer.  
Iron and zinc plate machine—"the anti-boreas," an invention to assist the draught, and prevent the downward current in chimneys; intended to cure them of smoke.
- 130 BROWN, ROGER, *Sheffield, Yorkshire*—Designer and Manufacturer.  
Model of magnetic lighting conductor (scale half size), with weather vane. Mounted upon a sectional model of a church spire, showing an improved mode of securing perfect and continuous insulation of the electric rod, without which a building is endangered.  
The conductor at the apex of the spire has twenty-five quadrangular magnetic points, diverging at various angles, by which the sphere of their attractive influence is greatly multiplied; all lateral discharge is prevented, and the conductor prevents any accumulation over a vastly extended circuit, within which it exercises absolute control.  
Five-pointed diverging magnetic conductor (full scale detached). Mounted upon an electric rod; intended for mansions, engines, chimneys, and general application.
- 131 BAYLISS, T., *273 Strand*—Inventor.  
Specimens of fire escapes.
- 132 HOLLAND, THOMAS, *40 South Audley Street*—  
Inventor.  
Improved brass cock for kitchen boilers &c., giving out hot and cold water, and filling itself.  
Shop front with improved shutters, adapted for sun-blind, sign-board, and other purposes.  
Three-wheeled almanack.
- 133 ENGLISH'S PATENT CAMPHINE COMPANY, *Hull*—  
Producer.  
Model of an apparatus for generating heat from bituminous substances, and for the prevention of smoke; applicable to furnaces, boilers, &c.; and for enabling railway locomotives to be driven by the use of small coal as well as they are by coke.
- 134 BOOTH, GEORGE ROBINS, *9 Portland Place, Wandsworth Road*—Inventor and Manufacturer.  
Vegetable gas apparatus, for lighting private buildings, public halls, &c. The novelty consists in the mode in which the apparatus is made and in the substances used for the production of the gas, in order to ensure greater cheapness and purity. It is stated that an apparatus for affording 50 lights for 24 hours would not require more fuel than a single spadeful of coke or cinders per hour. The gas may be used without injury to furniture, silks, books, pictures, or gilded ornaments.

137 **SAMPSON, THOMAS, Lambre, near Swansea, Glamorganshire—Inventor.**

A high-pressure steam-boiler, with self-feeding apparatus and still, for generating steam and for chemical purposes in general.

The water is admitted into the boiler without pumping, by simply moving a hand, similar to the hand of a clock, one quarter of a revolution.

A retort for generating gas, or for chemical purposes, with a revolving agitator to keep the charge in motion.

A condenser for gas, so constructed that by opening one joint, the whole of the condensing surface is rendered visible, and is within reach, for the purposes of cleansing; the condensed liquor is discharged at five different pipes, so that five different qualities are produced by the same operation.

139 **VAUGHAN, WILLIAM, Maidstone—Inventor.**

Machine to facilitate the construction of marble, stone, slate, or other chimney-pieces by economising labour, and insuring accuracy in the work.

The present mode of adjusting the several pieces of a chimney-piece jamb, is, by the use of wooden gauges, prepared to the various dimensions required, and by squaring up the sides (inside slip and outground) from the face of the jamb, then temporarily fixing them with square blocks against each outside, till the whole is secured with plaster of Paris and pieces of stone fixed inside the jamb. For every jamb the same operation has to be performed.

In this machine provision is made for constructing jambs, varying from 6 inches to 14½ inches in width, by moveable standards fitted accurately in the grooves of the brass plates which are fixed flush with the face of the slate. These standards render the use of a square unnecessary. The graduated plates supersede the necessity of a rule, and the triangular brass gauge not only dispenses with the use of all other gauges, but ensures great accuracy.

The transverse and longitudinal stops being fixed to the required heights above the top of the front of the jamb, and the ends of the side pieces being placed against them, exact provision is made for the depth of the capping and frieze to be afterwards fixed thereon.

For the construction of the jamb to the opposite hand, it is only necessary that the longitudinal stop should be placed as much below the centre line on the graduated plate as it now is above. The other part of the machine remaining unaltered, both jambs will necessarily have the same form and dimensions.

When several chimney-pieces of the same dimensions are required (a common circumstance), the whole number of jambs may be put together without moving any other part of the machine than the longitudinal stop once; thus ensuring, not only the same form in them all, but effecting an important saving of time.

The box gauge, which may be applied to any width of chimney jamb fitted within the standards, presses the inside-slip and outground against the standards, thus preventing any derangement of the several pieces, whilst they are being fixed together with pieces of stone and plaster of Paris.

140 **FARRELL, ISAAC, 210 Great Brunswick Street, Dublin—Manufacturer.**

Model of a registered circular window.

141 **HARPER, THOMAS, 15 Upper Seymour Street West—Inventor.**

Model of a window, designed to serve as an entrance to a garden or pleasure ground; presented to the Royal Dublin Society by the exhibitor.

142 **M'NEILL, F. & Co., Banhill Row, Finsbury—Manufacturers.**

Specimen of the mode of applying waterproof bituminous felt for lining damp walls.

Pattern of a frame and covering of asphalted felt for gardeners' covering-pits, to protect plants from frost, as a substitute for Russian mats.

Specimen of patent asphalted roofing felt; composed of a mixture of flax and hair, saturated with mineral bitumens, and finished by machinery.

Samples of the asphalted felt in various stages of manufacture, and in application to various useful purposes.

Specimens of patent thin ship sheathing felt, for use under copper. Sample of a thicker description used under wood sheathing.

Samples of very thick hair felt, for clothing the boilers, pipes, and cylinders of steam-engines. The same, principally used by builders for deadening sound in thin partitions, under floors, for placing under slate, zinc, or lead flats to top rooms of houses. Section of roof, illustrating the economical construction of wood-work for the application of the asphalted roofing felt.

143 **ROCK, J., jun., Hastings, Sussex—Inventor.**

Model of a street barricade.

144 **ANDERSON, GEORGE, Rothbury, Northumberland—Inventor and Manufacturer.**

Model of an improved window. The sashes are so constructed that by lifting the bottom sash up the top one will come down. The outside shutters to slide behind the stone or brickwork, and the inside to slide on the floor, and behind the architrave. The roller for sun-blind to be hid, and work up and down with one cord.

145 **LOWE, GEORGE GREGORY, 2 High Street, Portland Town—Inventor.**

Self-cleansing sanitary cistern. By affording facility for the rapid and entire discharge of its contents, it is invention proposes to prevent the accumulation of filth and sediment in house cisterns; and, by conducting the waste and discharge pipes into the house drain, both to preclude local dampness arising from overflow, and effectually to cleanse the latter by constant flushing.

Though the cylindrical form of cistern with a conical base is, in all cases, preferable, the principle of this invention is equally applicable to any other form which may be topically convenient, and to any material used in the construction of cisterns.

146 **QUINCEY, HARCOURT, 82 Hutton Garden—Inventor and Patentee.**

Working model of two revolving iron safety shutters, with patent convex laths (one fixed above and one under the window), with improved gearing; and of a patent corrugated office blind of perforated metal. Brass model of a dwarf Venetian blind, with patent convex perforated laths.

Registered ornamental and self-supplying pedestal coal vase, presenting for use only sufficient coals to charge the hand scoop, when a fresh supply is given from the upper chamber. Patent hand lamp, for burning solar or common oil; and table lamp, for burning solar or common oils, with patented folded shade. Plaster model of a fireplace in Buckingham Palace.

147 **THEOBALD, JOHN, 21 Brunswick Street, Blackfriars Road—Inventor.**

Improved window-sash, capable of being cleaned from the inside, with prevention against thieves, an alarm, and a fire-escape.

148 **WALBY, JAMES, 59 Greek Street, Soho Square—Inventor.**

Universal fire-escape.

The novelty of the plan is stated to be that of passing persons from the window of the house on fire to the near window of the neighbour's house adjoining, in a direct horizontal line, right or left, in lieu of lowering them down as in the ordinary way. This is accomplished by having bracket-hooks of a peculiar construction, projecting about 12 inches from the face of the brickwork, permanently fixed to the front of the house at the uppermost floor, by passing the end or stem of the hook through the brickwork, and screwing it up tight by plates and

nuts inside. By the assistance of the neighbour at the adjoining window, a rope is attached to the hooks; a basket or cradle (which traverses upon a friction-roller) is then hung upon the rope, which, by the person therein placed, or by a person at the adjoining window, with the assistance of a hook stick provided for the purpose, may be moved forwards or backwards as the case demands.

150 IRISH ENGINEERING COMPANY, *London Office,*  
11 John Street, Adelphi—Producer.

Finch and Willey's patent safety railway wheel. The peculiarity of this wheel consists in the rim of the skeleton or inner wheel being firmly imbedded in a dovetailed recess in the tire, throughout its whole circumference, rendering all other fastening, as bolts, &c., unnecessary, and preventing the possibility of accident from the breakage or throwing off of the tire. The tire can also be worn much thinner than ordinary.

151 ALLEN, T., *Clifton, near Bristol*—Inventor  
and Manufacturer.

Model of registered iron roof, scale of 2 inches to 1 foot, with drawing, showing the principle applied to a roof of 60 feet span, fire proof, with iron battens, and new mode of securing the slates.

152 BUNNETT, JOSEPH & CO., *28 Lombard Street, City,*  
and *Deptford, Kent*—Inventors, Patentees, and  
Manufacturers.

New patent curvilinear lath-revolving iron safety-shutters. The same in principle as Bunnett's original patent iron shutters.

Ornamental brass window, formed of patent brass sash bars and mouldings.

Patent ventilating sashes, for admitting fresh air into a room, without creating draughts.

Patent brass and other metal sash-bars and mouldings.

Improved joiners' bench cramp.

Improved flooring cramp.

Patent self-acting doubly-trapped water-closet; which, without cistern, may take its supply of water from any source at a sufficient elevation, or may be laid directly on to the main (if always charged).

Patent improved ship's water-closet, for use below the water line, which may be fixed with or without a cistern.

Patent improved ship's water-closet, for use above the water line, which may draw its supply of water from the sea by a double-action pump, or may be used with a cistern.

Patent self-acting effluvia-traps for sewers, drains, &c.

155 TROTMAN, SANDERS, *Clarendon Road, Notting-hill*  
—Inventor and Manufacturer.

Fountain for drawing and dining rooms, or boudoirs; requiring no supply laid on, or waste carried off, mechanical pressure forcing the water through the jet, which again falls into the reservoir, with the addition of a musical arrangement.

Night dial. A lamp is suspended upon a lever, the light from which is thrown upon each hour as it arrives.

Printing on glass for ornamental purposes, such as glazing conservatories, windows, &c., and for philosophical purposes, such as dissolving views, &c. Coloured printing on glass.

156 WHYTOCK, ANDREW, *494 New Oxford Street*—  
Manufacturer.

Model of emigrants' house, about one-fourth full size, made of Morewood and Rogers' patent galvanised tinned iron, corrugated.

The full size weighs about half a ton, and can be packed in two cases. When once seen put together, it may be erected by two persons in as many days.

Furniture of the house, made chiefly of the same material.

Table and chairs with camp legs.

Bath, answering the purpose of a sofa, or a bedstead, which can be solidly packed.

Stove for warming and cooking.

157 WILKINS, WILLIAM CRANE, *24 Long Acre,* and  
T. LETOURNEAU, *37 Allée des Veuves, Paris*—  
Inventors and Manufacturers.

Improved patent revolving catadioptric apparatus of short eclipses, for a lighthouse of the first class. Represented in fig. 1.

Fig. 1.

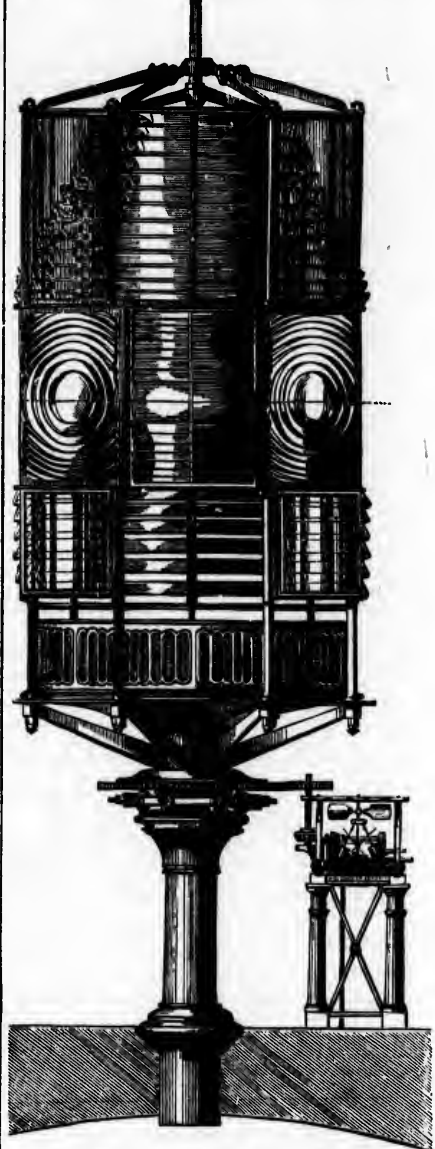

Wilkins and Letourneau's Catadioptric Apparatus.

That appearance of light, called short eclipses, has hitherto been obtained by the following arrangements:—

24 Long Acre, and  
des Veuves, Paris—  
s.  
ptic apparatus of  
first class. Repr-



pparatus.  
rt eclipses, has  
arrangements:—

An apparatus for a fixed light being provided, composed of a central cylinder and two zones of catadioptric rings, forming a cupola and lower part, a certain number of lenses are arranged at equal distances from each other, placed upon an exterior moveable frame, making its revolution around the apparatus in a given period. These lenses, composed of vertical prisms, are of the same altitude as the cylinder, and the radius of their curves is in opposite directions to those of the cylinder, in such a manner that at their passing they converge into a parallel pencil of light; all the divergent rays, emitted horizontally from the cylinder, producing a brilliant effect, like that obtained by the use of annular lenses at the revolving lighthouses.

The first improvement exhibited has a special reference to the light, and produces a considerable increase in its power, whilst the simplicity of the optical arrangements is also regarded. It consists, firstly, in completely dispensing with the moveable central cylindrical lenses. Secondly, it replaces these by a single revolving cylinder, composed of four annular lenses, and four lenses of a fixed light introduced between them; but the number of each varying according to the succession of flashes to be produced in the period of revolution.

The second improvement, of which already some applications that have been made serve to show the importance, consists in a new method of arranging the revolving part, experience having shown that the arrangements at present in use are very faulty. A short time is sufficient for the action of the friction rollers, revolving on two parallel planes, to produce, by a succession of cuttings, a sufficiently deep groove to destroy the regularity of the rotatory movement. To obviate this great inconvenience, the friction rollers are so placed and fitted on an iron axis, with regulating screws and traversing between two bevilled surfaces, that when an indentation is made in one place, they can be adjusted to another part of the plates which is not so worn.

The third improvement produces the result of an increase of the power of the flashes in revolving lighthouse apparatus, to double what has been obtained hitherto. By means of lenses of vertical prisms, placed in the prolongations of the central annular lenses, the divergent rays emerging from the catadioptric zone are brought into a straight line, and a coincidence of the three flashes is obtained.

The whole of the prisms, lenses, and zones are mounted with strength and simplicity, accurately ground and polished to the correct curves, according to their respective positions, so as to properly develop this beautiful system of "Fresnel." The glass of which they are composed is of the clearest crystal colour, and free from that green hue which so materially reduces the power of the light, and is considered objectionable for apparatus of this kind. The lamp, by which the apparatus is to be lighted, consists of a concentric burner with four circular wicks, attached to a lamp of simple construction, the oil being forced up to the burner by atmospheric pressure only, so that there are no delicate pumps or machinery to become deranged.

Improved lantern and revolving apparatus for a light-vessel, represented in fig. 2. The principal improvement consists, in constructing the machinery to work beneath the deck, instead of in the lantern as formerly. A vertical rod, working in metal bearings, is attached to the mast, with a large gun-metal pinion fixed to the top of the rod, at the height to which it is necessary to hoist the lantern, wherein a train of cog-wheels are placed to connect with the pinion, and communicate the motion obtained therefrom to the traversing apparatus that supports the lamps and reflectors. The advantages of this arrangement are, that the lanterns can be made much lighter, the rolling of the vessel caused by so great a weight at the mast-head is greatly diminished, and the machinery being more under control and better protected, works with greater regularity and precision.

An idea of the utility of these improvements may be gained by reflecting that the situations in which the light-vessels are placed, are at all times difficult of access,

and in stormy weather, when accidents are most likely to occur, quite unapproachable; so that it will be obvious any alteration which reduces the liability to derangement is greatly to be appreciated.

Fig. 2.

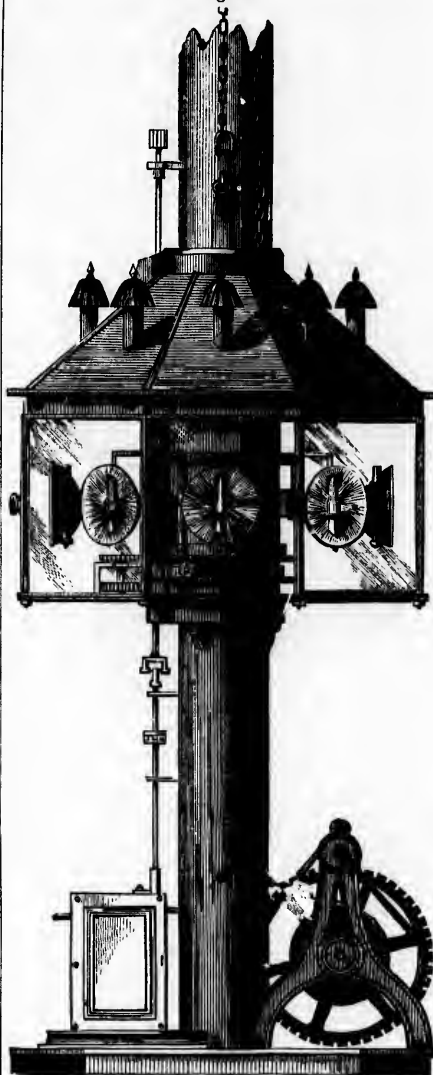

Wilkins and Letourneau's Lantern.

There is also an advantage derived from the novel construction of the lamps and gimbal work which, by a movement, exactly coinciding with the motion of the vessel, causes a perfect level to be always maintained, and ensures the proper flow of oil to the burners, however irregular that motion may be. This improvement is not of so recent an introduction as the former, but when it was first invented by one of the exhibitors it pro-

duced a complete revolution in the apparatus for floating lights, and enabled the beautiful Argand lamps, with parabolic reflectors, to be used instead of the old lamps with smoky flat wicks. (*Main Avenue.*)

158 COCHRANE, A., 17 Bryanstone Street, Bryanstone Square—Inventor.

Patent lock, to be entitled the "Catal-key Lock." When a picklock, or false key, or even when the real key is introduced into the lock, it is immediately caught and cannot be released except by the owner.

Smoke condenser, air conductor, and animal food and vegetable preserver by means of a machine or apparatus.

159 RETTIE, ROBERT, *Edinburgh*—Inventor.

Inventions for use at sea, consisting of lamps, lights, lighthouse apparatus, reflectors, signals, life-boats, fire-extinguisher, breakwater, &c. The following cut represents the marine signals.



Rettie's Patent Marine Signals, &c.

Inventions for use in mines, railways, towns, and houses, consisting of safety lamps, "corves" or cages, shields, ropes, and traps; signals, fog, day, &c. Ventilating apparatus; sewer and effluvia traps; portable closet, glazed-jointed pipes, &c.

Stoves for heating large buildings, ramoneurs, smoke-preventers, vegetable-steamers, bottling cranes, fire-protectors, &c.

160 KING, WILLIAM, 8 Woodstock Street, Bond Street—Inventor and Manufacturer.

Section of a model of a floating breakwater for a harbour of refuge. Scale 3-8ths of an inch to the foot.

Section of a model for a foundation of a lighthouse, or place of refuge, on the Goodwin Sands. Scale 3-8ths of an inch to the foot.

162 PERKES, S., & Co., Emerson Street, Southwark Bridge—Producers.

Bearers for principal beams in buildings. Models of patent combination bridges, &c.

163 ROVERE, FELIX PAULIN, C.E., 2 New Inn, St. Clement's—Designer.

Design for a wrought-iron girder bridge at Westminster; consisting of a combination of wrought and cast iron girders, to allow of the maximum water headway, the site of the present bridge being preserved.

164 MAPLIN, — Producer.

Model of a lighthouse, from designs by Messrs. Walker and Burgess, founded on Mitchell's screw piles. (*In Locomotive Passage.*)

165 SMITH, WILLIAM HENRY, 1 Royal Exchange Buildings—Inventor.

Recoil breakwater, with drawings—the principle of which is applicable to harbours, groynes, coffer-dams, clearing away of shoals, protection of the shore from sea encroachments, piers, landing places, &c.

This breakwater is moored by lewis bolts, mushroom anchors, screw or atmospheric piles, or Smith's anchor pile. If a ship runs foul of any part, she will strike a yielding buttress, the braces of which are equal to a dozen cables: all injurious shock is converted into a steady downward pressure. The structure is in separate lengths, each having an independent spring.

Lighthouse breakwater—applicable to beacons and marine batteries, in all situations.

Tubular suspension girder bridge, designed to prevent vibratory action: adapted for railways.

Plan for a suspension tunnel.

166 FOX & BARRETT, Thames Chambers, 12 George Street, Adelphi—Proprietors.

Specimens of patent fire-proof flooring or roofing.

169 NASMYTH, G., 7 Park Road, Kensington—Inventor and Patentee.

Two models of wrought-iron girders; a small quantity of materials being used, combined so as to sustain the greatest weight. (*With Classes 5 and 6.*)

170 NEWNHAM, THOMAS GARRETT, Newtown, Montgomeryshire, Wales—Architect and Inventor.

Model, to a scale of one inch and a half to the foot, of a portion of the roof of a church in course of erection at Dolfor, near Newtown.

Model, to a scale of one inch to the foot, of open roof, constructed with ribs of terra cotta, supporting rafters and slating battens, similar to the former.

Model, to a scale of from one-half to one-third full size, of stone, or of terra cotta, mullioned windows, with sliding sashes.

171 YOUNG, J., Gas Works, Selkirk, Scotland—Inventor.

Model of coal-gas apparatus, with set of retorts, washer, purifiers, valves, condensers, and gas-holders, constructed on a new arrangement, and adapted for a provincial town. The condensers and purifier can be cleaned out whilst in operation.

172 METROPOLITAN ASSOCIATION FOR IMPROVING THE DWELLINGS OF THE INDUSTRIOUS CLASSES.

CHARLES GATLIFF, Sec., 19 Coleman Street; WILLIAM BECK, Architect, 33 Finsbury Square.

Model dwellings for artisans, in Albert Street, Mile End New Town, erected by the exhibitors.

173 MACKHORY, F., 4 Milton Terrace, Vauxhall Bridge Road, Finsbury—Inventor and Manufacturer.

Newly-invented window to prevent the entrance of dust and wet, and the noise caused by the wind.

174 NIXON, THOMAS, Kettering—Inventor, Manufacturer, and Designer.

Registered design for a self-ventilating garden-light, or sky-light, which can be made water-tight.

175 REMINGTON, ANNE, 138 Sloane Street, Chelsea—Inventor.

Improved roasting apparatus, with self-acting baster and heat reflector.



176 **HOLMES, JAMES**, *East Ham, Essex*—Designer.  
Two cottages in one, designed for the convenience, economy, and comfort of the poorer class of labourers.

177 **FREEMAN, J.**, *19 Artillery Place, Finsbury*—  
Producer.  
Model of the railway-bridge, crossing Westminster bridge road. (South Western Railway.)

178 **MOORSON, W. S.**, *Captain, 17½ Great George Street, Westminster*—Designer and Superintendent.  
Prize design for the great bridge over the Rhine, proposed by Prussian Government to be erected at Cologne. The Piers are to be of stone, and the arches of wrought iron.

|                                                                                                     |             |
|-----------------------------------------------------------------------------------------------------|-------------|
| Length of the bridge and approaches . . . . .                                                       | 2,015 feet. |
| Span of each of the large arches . . . . .                                                          | 600 "       |
| Span of the lifting-arch . . . . .                                                                  | 100 "       |
| Height from foundation to top of towers . . . . .                                                   | 147 "       |
| Height from water to underside of arches . . . . .                                                  | 44 "        |
| Height from water to underside of lifting-arch when raised . . . . .                                | 97 "        |
| Width of the bridge (inside the parapets) . . . . .                                                 | 60 "        |
| Strength of each arch to bear, if distributed over it . . . . .                                     | 5,700 tons. |
| Cost, if erected by contract at Prussian prices, as arranged with a Prussian manufacturer . . . . . | £236,000    |
| (If erected at English prices, about one-fifth less).                                               |             |

The principle of this bridge is that of the trellis or lattice beam combined with the arch.

The arrangement of the cross bracing is novel and peculiar, and affords separate spaces for the great highway, the railway, and the footway.

The lifting-arch is to be worked by water power; the water being contained in tanks on the tops of the towers, and being elevated to those positions by tide-wheels of peculiar construction, placed below the possibility of contact with ice, and worked by the river current.

The arches are believed to be the largest in the world, proposed of rigid construction (not suspension), and calculated for the passage of locomotive engines at speed, and of artillery at the gallop.

Railway viaduct over the river Nore, near Kilkenny, Ireland.

The arch is constructed of timber, and the piers of stone.

|                                                                 |           |
|-----------------------------------------------------------------|-----------|
| Length of the bridge and approaches . . . . .                   | 428 feet. |
| Span of arch . . . . .                                          | 209 "     |
| Height above foundations . . . . .                              | 85 "      |
| Width at the level of the rails . . . . .                       | 26 "      |
| Strength of the arch, to bear, if distributed over it . . . . . | 600 tons. |
| Cost, complete . . . . .                                        | £8,100    |

This is believed to be the largest work of the kind in the United Kingdom.

180 **ROSE, JOHN THOMAS**, *Regent Street, Leith*—Designer.  
Design for a timber viaduct of great span, suitable for railway or other purposes. Its object is to unite great strength with simplicity; the beams forming it, are interwoven like basket-work, and the greater the stress thrown upon it, the more rigid it becomes. The same principle may be adapted to large roofs without the use of cross-ties, since the outward thrust upon the walls would be but small.

Supplementary model illustrating the principle.

181 **MACLACHLAN, JOHN**, *Douglas, Isle of Man*—  
Inventor.  
Model of a house, and plans for purifying towns, destroying putrescence affording economical means of removing manures (inoffensively) by rail; and precluding the necessity of cleansing drains, &c.

182 **DANIELL, WILLIAM**, *Truro*—Inventor.  
Fire-escape, consisting of a rope-ladder wound about a reel contained in the window-seat, or in a box fixed inside

a window, to be thrown out, and the lower end secured by a bystander.

183 **BENGIN, MARMADUKE OSBORN**, *8 George Street, Cork, Ireland*—Inventor.  
Working model of a registered self-acting fire extinguisher, applicable to smouldering fires, to machinery liable to ignition by friction, to spontaneous combustibles, and to highly inflammable substances.

184 **HENDY, JAMES**, *1 Bouverie Street, Fleet Street*—  
Inventor.  
Model for a new national fire-escape; its object is simplicity of arrangement and rapidity of motion.

185 **WEBSTER, W. BULLOCK**, *2 St. James's Place, Hampstead Road*—Inventor and Manufacturer.  
Model of a fire-escape, available for a long range or block of houses of different heights.

186 **GREEN, ISAAC**, *3 Vittoria Place, Euston Square*—  
Inventor.  
Wind-guards for chimney tops, to cure smoke. The following cut represents this apparatus, and is intended to illustrate its method of action.



Green's Wind-guard.

187 **NUNN, ALICIA**, *2A Welbeck Street, Cavendish Square*—Producer.  
New apparatus and method of diffusing heat and equalising the temperature of apartments, and disseminating the warmth from one ordinary fire into several apartments. Applicable to residences, warehouses, railway and other carriages, and for safety on ship-board.

188 **WILSON, THOMAS HOOD**, *Tweickenham*—Inventor.  
Slides on a pair of folding doors, for excluding the wet and the cold from hall doors and shutters; also for hatchways and port-holes of ships.  
Invention for securing carriage gates and coach-house doors, being self-acting; stops and bolts for the same.

190 **MUDGE, JOHN**, *78 Tottenham Court Road*—Inventor.  
Private fire-escape, the machinery so constructed as to be fixed to any part of the house, and worked from the street as well as in the room.

191 **BEESTON, J.**, *Swails's Cottages, Hammersmith*—  
Inventor.  
Wind-guard for chimney tops.

192 **ADCOCK, THOMAS, jun.**, *Penkridge, Staffordshire*—  
Inventor.  
Simultaneous gates for railway crossings. Exhibited for safety, economy, and despatch. They are intended to supersede the present wood gates, as the ironwork to the heels will show; for iron rail gates, the heels would be in one length, everything being in accordance. The posts are intended to be of cast iron, the supports fixed

upon blocks of stone 4 feet square, by 12 or 15 inches thick, and set upon a bed of brickwork, as shown. The small iron doors over the same, are intended to be opened occasionally for the purpose of filling the reservoir with oil, and for adjusting the rods by means of the nuts and screws, and also for taking out the wheel if necessary; all this is done in a very short time. The rods are all pulling rods, and the rollers under, revolve; the gate with the bolt attached is the leading one, being nearest the station-house. The bolt on this gate is so contrived that it will secure or liberate all the four large gates at once; to open them, the bolt is raised out of the groove of a spindle, to which is attached a wire, running across the road close under the rails, in a groove an inch wide, to the lever on the opposite side, which immediately drops just below the surface of the road, so that there is no stumbling-block. On closing the gates, the bolt slides into the groove of the spindle, and by turning it to its proper position, it raises the bolt on the opposite side, and the self-acting catch secures all the four large gates. This saves time and trouble in crossing the line to unbolt them, and they are more secure. The wheels, &c., are merely cased with rough boarding; or brick on edge may be used. The oak cases to rods are represented as being fixed upon brickwork; the wire may be protected by an iron plate laid over it. The machinery for skew gates would be the same, with the exception of two of the wheels, which would be smaller.

193 STUCKEY, W., *Mitre Chambers, Fenchurch Street*  
—Inventor.

Four-wheeled carriage crane, for transporting and raising merchandise to a given height; also forming a portable scaffold for decorating the interior and exterior of large buildings; it will also serve for a fire-escape.

194 TAYLOR, HENRY, *6 John Street West, Barnsbury Road, Islington*—Inventor.

Machine for sweeping chimneys.

195 WILSON & WOODFIN, *Hull*—Inventors and  
Manufacturers.

Various double traps and gratings for drains.

196 HOOPER, WILLIAM H., *12 Great Cumberland Place, Hyde Park*—Inventor.

Model section of a rotary floating breakwater, formed of a double line of rollers, and a strong centre roller placed horizontally, inserted in an open frame, circular convex ends, the whole revolving upon its axis. The sections are to be moored at each end in a continuous line, so as to form a floating barrier to the force of the waves.

Model of an improved omnibus: the improvement upon those now in use, consisting in a few inches extra width, circular ends, nearly central side doors, set in as far as the width of the seats will admit (to avoid obstructing foot passengers), with fenders on each side the steps; a small umbrella-stand in the centre, with a strong ring top, convenient to hold by getting in; also a raised top for roof for seats, with ventilators let in all round it, and suitable steps and rails to reach the roof seats; a small window or trap at the end to speak to the conductor.

197 BAIN, WILLIAM, *141 High Holborn*—Inventor.

A contrivance for rendering buildings fire-proof. A main-pipe, supplied with water on the high-pressure system, is carried up one corner of the building, communicating with smaller pipes running between the joists of every floor, the small hose and pipe attached to the main being always ready for use, in case of fire occurring in any part of the building.

[The mains which supply a town with water should be kept constantly full, and under such pressure that, upon opening a cock in the street, the water may be conducted by means of hose over the highest houses, and applied to

any fire that may occur. Pipes or hose permanently fixed through a building, from which water may be taken at any time, would probably be advantageous.]

Machine for saving life and property from shipwreck on the coast. The model is on the scale of half an inch to the foot; it represents a platform resting on piles driven into the ground, with the machine and its accompaniments, covered with a tent, which may be closed or open when necessary. The machine is a double lift; the upper drum works a cable to tug any disabled vessel to shore; the lower drum works a constant communication with the wreck. The means of first communication is by firing a shot from the gun, attached to a line, the line being secured to the blocks which are worked by the cables of the machine; the gallery and flag-staff are for observation and signals. The table on which the machine is built may be turned to any point of the compass.

[The first apparatus for saving lives from shipwreck was invented by Captain Manby. A wooden plug, instead of an iron shot, fired from the gun has been found of advantage, as in the case of the schooner "Nanteos," off Carnarthen, 23rd February, 1851, &c. By means of this simple apparatus the safety of the ship was secured together with that of her crew.—S. C.]

Floatable life-preserving cape cloak; blue cloth cloak, braided with the emblematical design of the rose, thistle, and shamrock, and lined with quilted satin; the inner lining is composed of pieces of cork, so arranged that when in the water it forms a floating body of great buoyancy by which the wearer is preserved on the surface.

198 BOULANGER, CHARLES THOMAS, *Alice Street, Bermundsey New Road*—Inventor.

A fumigator, with refrigerator or cooler, applicable to the destruction of insects in tender plants, in animals, and in houses; also to bleaching substances requiring the vapours of sulphur, and to administering vapour or aromatic baths at a small cost.

The fumes of tobacco, used in fumigating, are cooled by being passed through the cooler, so that they do not injure the tender plants. Patented.

199 INGLIS, ALEXANDER, *Park Street, South Shields, Durham*—Inventor.

Model of a ventilating machine.

201 JACKSON, HENRY, *62 Westbow Street, Pinlicko*—  
Inventor and Manufacturer.

Fire-escape dressing-table, intended to be always ready and in instant motion, without the least preparation, and to be drawn up from above or below as many times as there are persons to be rescued. The first motion of raising the table-top opens the window, and lets down iron blinds to any number of lower windows.

202 BROWN, JOSEPH, *71 Leadenhall Street*—Inventor  
and Manufacturer.

Model of a navigable balloon, to ascend and descend in the air without the aid of ballast.

203 FRIARSON, MARK, *20 Westbourne Park Road, Paddington*—Inventor.

Registered ventilating shield cowl, for the prevention of smoky chimneys.

204 DUNN, MATTHIAS, *Newcastle-upon-Tyne*—  
Inventor.

Fire-escape, consisting of a web of cloth affixed to a wooden pole, and attached to the window sill.

205 HEARDER, J. H., *34 George Street, Plymouth*—  
Inventor.

Rarefying apparatus, for producing a draught in the underground flues of stoves or ventilating shafts, &c.

206 LAMB, JAMES, *Nile Street, Sunderland*—Inventor.

Model of a tubular gas apparatus for heating baths. It is stated that by means of this apparatus 32 gallons of water, at 43°, may be heated to 100° in 35 minutes, with the consumption of 25 cubic feet of gas.

## 215 TAYLOR, J. W., Rear Admiral—Producer.

Models of patent breakwater; life and anchor boats.

216 STAFFORD, DANIF *Sloane Terrace, Sloane Street, Chelsea.*

Interceptor cowl: an apparatus attached to the cowl of a chimney.

The interceptor is made air-tight at each angle and at the bottom, so as to prevent the cold air, received at the apertures, from entering immediately into the flue or chimney, and from taking a downward or cross direction, instead of being reflected upwards, as is the case from the application and construction of the interceptor.

A second interceptor is placed at a short distance above the one already described, giving the air a more powerful and direct upward current, and at the same time forming an efficient resistance and protection against all descending gusts of wind.

The external form or shape of the cowl may be varied to suit the architectural uniformity of any building.

217 TEAGLE, R. & W., *Chelsea*—Inventors.

Patent chimney-sweeping apparatus.

*In Main Avenue West.*

## 220 WYATT &amp; BRANDON.

Model of the new County Assize Courts, at Cambridge; erected by the exhibitors.

## 221 SCOTT, G. G.

Model of St. Nicholas Church, Hamburg.

## 222 JEE, A. S.

Model of the Dinting Vale viaduct, on the Sheffield and Manchester Railway.

223 WILLOCK, E. P. & Co., *Manchester.*

Model of a decorated Gothic church, at Lever Bridge, Bolton, Lancashire; designed by E. Sharpe.

## 224 WALKER &amp; BURESS.

Railway-bridge across the Ouse.

Also 9, 19, 26, 28, 38, 105, 106, 107, and 157.

334 BROWN, SIR SAMUEL, R.N., *Vanbrugh Lodge, Blackheath*—Inventor.

Iron cables invented and introduced into the Royal Navy by Captain Sir Samuel Brown, R.N., K.H., in 1810.

Nos. 1 and 2. Patterns of the twisted and plain parallel-sided chains, the iron  $1\frac{1}{2}$  inch diameter without stay-pins, which was proposed by the exhibitor to the Admiralty as a substitute for hempen cables in 1810. The twisted chain was preferred by the Board for this purpose, by reason of its resemblance to the strands of a rope, and on that account supposed to be more easily managed as a working cable.

No. 3 is a single link of the same dimensions, with a short scarf ready for welding in the end; this, which was practised in all the Royal Dockyards, and by all the chain-makers in the country, was radically bad, because the weld is inevitably the weakest part; was subjected to a transverse strain at the point of resistance, where a small defect was more detrimental than any other part; the inventor therefore adopted the plan of forming the weld in the direction of its length in the side, where the strain is equally divided.

No. 4 is a single link showing the long scarf in the side ready for welding, as above mentioned.

*Origin of the Stay-pins.*—When the chain-cables were first brought into use (which was in the Navy) there was no means of testing their strength, and two ships, the "Plique," 38-gun frigate, and the "Pylades," sloop-of-war, having both parted their cables in a heavy gale and sea, it was found that the links, in the technical phrase, had drawn in the strain. The inventor of the iron cables thereupon devised a powerful compound lever-machine for testing all cables to a given strain. The first cable to be tested was a twisted cable, welded in the side with long double scarp, but without stay-pins,  $2\frac{1}{2}$  inches diameter, against a piece of new 24-inch cable, which was the largest size made; the cable and the chain were shackled together, so that the strain was reciprocal. The trial took place at the manufactory in Shadwell, in July, 1810, in the presence of Lord Melville, First Lord of the Admiralty; Sir J. B. Thompson, Comptroller of the Navy Board; the Chancellor of the Exchequer, Mr. Vanaitart; the Surveyor and Commissioners of the Navy, and several Naval Captains. In the course of the trial, as the hempen cable continued to stretch, and the chain to collapse, the machine was at that time stopped; and then three wrought-iron pins similar to those shown in No. 5 were inserted in the middle of the links; the process recommenced, and the pins were in a short time set fast. Four hours had been occupied in this interesting experiment, when the hempen cable began to give way, and was ultimately broken in the direction of its length with a force of 84 tons; no fracture had taken place in the iron cable, and the links which had been distended with the pins preserved their shape; but all the others had collapsed and become perfectly rigid, and, of course, totally useless. The improvements thus introduced in the construction of the iron cables, and the system of testing, were of infinitely more importance than the original invention, and which were all carried into effect in 1810, two years before any other chain-cable manufactory was in existence.

No. 5. Pattern of the parallel-sided chain, proposed by the inventor to supersede the twisted cables in 1812. The first cable was supplied to His Majesty's frigate "Crescent" in that year, which, being favourably reported on, he received directions from the Admiralty to prepare a schedule, in conjunction with Mr. Goodrich, mechanical engineer at the Royal Dockyard, Portsmouth, of the form and dimensions of chain-cables, which, with very little modification, is at present the standard for all classes. The chain cables, which are of oval shape, are susceptible of still further improvements, for it has been observed, in the course of an extensive practice, that, in testing chains to prove the quality of the iron, links gradually collapse, and that the rupture does not take place till the sides are drawn nearly into contact; it therefore occurred to the inventor that the inverted oval link, No. 7, as approximating in some degree to this ultimate form of resistance, was stronger, inasmuch as the present distended oval link is a departure from it; and there can be no doubt that, as the convex links fit more uniformly to the cylindrical bells or windlass, they would work smooth, and with less jolting in veering.

[It was this invention of Capt. Brown which first rendered the knowledge of the strength of malleable iron indispensable. Chain cables with the simple oval link resist a strain of  $21\frac{1}{2}$  tons per square inch, the mean strength of wrought-iron being 25 tons per square inch. When stays between the sides of the links are introduced, the strength is very nearly equal to that of the iron in the simple bar form, so that a stay may be said to increase the strength by about 1-6th part. The links of Mr. Price's chains are made with parallel sides, so that the fibres of the iron are kept in the direction of the strain; their strength is therefore greater than that of the simple oval links, which have a tendency to alter in form, or elongate.—S. C.]

Picture, in oil, of the Union Suspension Bridge, erected over the Tweed in 1820, connecting England and Scotland,

being the first iron bar bridge constructed for carriages, and all the ordinary purposes of the country. Dimensions, 420 feet span between the points of suspension, supported by 12 lines of cylindrical wrought iron bars, containing 24 square inches.

#### Models.

Fig. 1. Model of an inclined plane, or patent marine slip and cradle-carriage, similar to the "Queen Charlotte Slip," at the Royal Dockyard, Deptford (which may be constructed on the shore of any other river or harbour), on which Her Majesty's frigate "Solebay" was drawn by a single capstan in three-quarters of an hour, and which would have been accomplished with a 20-horse power steam-engine in ten minutes. The cradle-carriage is mounted on the periphery of iron rollers, which circulate over the carriage by an endless chain under the ship's bottom when in motion; and in some situations the cradle-carriage is moved on a continuous line of rollers laid down on the ways. In either case, there is a total absence of friction; and, as a mechanical power, the superiority of the rollers over the multiplicity of small wheels employed for the same purpose exceeds, in some cases, 50 to 1; that is to say, it requires 50 times less force to move a line-of-battle ship laterally on the ways in the Arsenal on a line of connected rollers, than upon truck wheels of the same diameter, and a proportionate diminution of force would take place in drawing ships in the inclined planes. An important feature in the proposed system is, that whatever may be the extent or situation of the arsenal, that only one slip or one cradle carriage, and one sliding-off carriage are required for the whole establishment; that ships intended to be laid up in ordinary, may be disposed of at the more remote part of the yard; that ships could be more expeditiously and economically repaired; that any ships may be selected from the line, and transported fully rigged and equipped, without disturbing any other ship, and launched to be completed afloat for sea.

Fig. 2 is a line-of-battle ship, supposed to be laid up in ordinary, shored up, and the keel resting on the same rollers on which she was drawn up.

Fig. 3 is another line-of-battle ship similarly supported, with her lower mast in, supposed to be under repair, or in the course of fitting for sea.

Fig. 4. Masting shears, to which any ship may be moved, masted, un-masted, and returned to her position. The acquisition of this new motive power, which reduces the propulsive force or traction, by 50 to 1 over fixed axles, renders it perfectly practicable to construct railways (except where tunnels are unavoidable) for the conveyance of ships, adapted for all the ordinary purposes of trade and manufacture traffic, with a velocity of 10 to 15 miles an hour, as shown in fig. 5.

Fig. 6. Model of a basin or floating dock, containing an invariable depth of water for the largest ships of war, which may be constructed either by excavation or impermeable embankments.

Fig. 7. Shows the inclined plane laid down at low water, extending to and carried over the boundary wall, and ascending with the same gradient into the basin to float the ship off, and no locks or dock gates are required; the evaporation or leakage may be supplied by a sluice at high water, or from any other source inland. The same system, as shown in fig. 8, of raising ships, barges, or other vessels from one level to another, so as to render locks altogether unnecessary, may be applied to all the

canals and inland navigation in the country, and our colonies abroad.

Fig. 8. Model of the royal chain pier, Brighton, constructed on a scale of 14-inch to a foot, a perfect representation in detail of the whole structure. The iron chains supporting the platforms are secured to iron retaining plates in the cliff; the outer chains are supported by diagonal shores in the centre of the outer pier-head; the lower extremities are backed on each side by two 74-gun ship anchors, driven to a considerable depth into the chalk rock. It was begun in November, 1822, and finished in November, 1823.

[The Brighton chain-pier, opened in November 1823, was designed by Capt. Sir Samuel Brown, R.N., who first suggested that the chains should be made of long flat bars with holes drilled in their ends, by which they might be connected together by short links and pins. He patented this invention in 1817.—S. C.]

Fig. 9. Model of the mariners' compass, exhibiting the points on a vertical belt or zone, where they may be seen in all directions, at any desired altitude above the deck.

Fig. 10. Model of a brass columnar bearing and distance revolving light-house, designed for the great Hanois rock, on the south-west coast of the Island of Guernsey. The centre of the light would be 130 feet above high-water mark, spring-tides, and distinctly visible in clear weather, at the distance of 12 miles; the second altitude would be seen at the distance of 10 miles; and the third altitude 8 miles. The metal dome, 10 feet in diameter, would be tempered into a bell the largest and most sonorous in the world, and would be struck at intervals, during fogs or thick weather, to warn against danger.

There would be ample accommodation for the light-keeper; and also, provisions and stores for four months, or longer, if necessary. The total expense of erecting and completing the brass column ready for the reception of the light of the first order would be 10,000*l.*; time of execution not exceeding six months; and its stability would be guaranteed for seven years.

[Sea water has an injurious action upon cast-iron; brass, however, effectually resists its effects, hence its value for the tower of a lighthouse erected in the sea. Double lights are used as distinguishing them from neighbouring lights. Lights are obscured by fog, and therefore a contrivance, such as a fog-bell, by which the seamen can be warned of danger is desirable.—S. C.]

Fig. 11. Model of part of a railway, with a centre guide rail to prevent the engine or carriages from running off the rails. Model of a set of railway carriages; the axles pass between the bodies of two, which places the weight below instead of above the centre of motion and traction, and admits of an increase of the diameter of the wheels in the ratio of five to three, diminishing resistance to the motive power in the same ratio. They may also be adjusted to suit both gauges.

Fig. 12. Model of the main and after body of a ship fitted with submarine steam propellers; applicable also to a life-boat.

Fig. 13. Model of two pair of midship timbers, or ribs, of a line-of-battle ship; the butt end secured with wrought-iron or gun-metal plates, let in flush, which renders the joints nearly as strong as the solid timber.

Fig. 14. Model of an equiposed bed, or sofa, undisturbed by the ship's motion at sea.

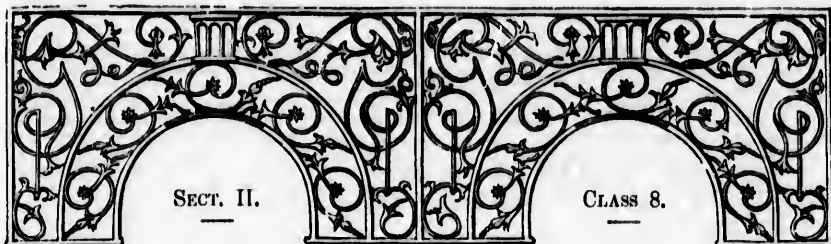

## NAVAL ARCHITECTURE, MILITARY ENGINEERING, GUNS, WEAPONS, ETC.

### INTRODUCTION.

THE present Class will be regarded with much interest by those who are concerned in the maritime and military position of this country. The objects it includes, and which are fully exhibited in many instances by models, present a favourable picture of the resources of Great Britain, particularly in her marine. They also represent her means of defence and general military equipment.

The classification of objects here included comprises the following subdivisions:—A. Illustrations by Models of Shipbuilding for the purposes of Commerce, such as Ships, Boats, Brigs, Schooners, Luggers, &c. B. Illustrations by Models of Shipbuilding for the purposes of war, such as Ships of the Line, Frigates, Corvettes, &c. C. Illustrations by Models of Shipbuilding for the application of Steam or other Powers, such as great War Steamers, Steam Vessels for long passages, Steam Vessels for Inland Navigation. D. Vessels used for Amusement, and small Vessels generally, such as Sea-going and River Yachts, Rowing-Boats, Fishing-Boats, Life-boats, &c. E. Comprises Rigging, Anchors, Windlasses, Capstans, and other articles connected with Practical Seamanship, and saving of Life from Shipwreck. F. and G. relate to Army Clothing and Accoutrements. H. To Camp Equipage. I. Naval Gunnery. J. Artillery Equipments for the Garrison and Field, and Machinery for Transporting Ordnance. K. Includes Ordnance and Projectiles. L. Small Arms; and M. Military Engineering generally.

The Class is not confined in the Building to one locality. Objects comprised by it are found in the South Gallery West, where some models of fortifications, together with a variety of guns, pistols, and swords are dispersed. The interspace between the South and North Galleries contains some costly and beautiful models exhibited by the Lords of the Admiralty. North of the Great Organ, a variety of models illustrating methods of rigging, capstans, windlasses, &c., are placed; and a space extending along the North Gallery eastward, contains models of ships, rafts, &c. On the Ground-floor, at the eastern extremity of the space devoted to machinery in motion, are also some objects related to Class 8. The remainder of this Class is to be sought in the Southern Galleries, on the foreign side of the Building, in Avenues P. and Q., extending from 62 to 70.

The progress of naval architecture forms an interesting study in the objects included in this Class. The transition from the inconvenient and unsightly forms of antiquity to the graceful outlines and imposing contour of a modern first-class ship is no less remarkable as an indication of progress in this science, than instructive as a practical evidence of the consistency of beauty of form with those qualities deemed essential in these structures. The beautiful discoveries of the laws and forms of wave-movement in fluids—a study at first without apparent direct practical application—have been successfully reduced to practice, and have led to the adoption, in a few instances, of that form of construction which theory indicated to be the most suitable. A prolonged experience will probably justify this application. The beautiful models of frigates, and other ships, showing the bow, stern, and transverse section, will receive much attention.

A very large collection of models of boats for saving life at sea is exhibited: so great a number of ingenious methods of constructing life-boats, assumed to be incapable of being upset or swamped, was probably never previously brought together. Some of these are on the twin principle, some are of caoutchouc, and some of gutta-percha.

Ordnance and projectiles for purposes of war are sparingly exhibited. It appears to have been felt that this was an institution of peace. But of small arms, adapted chiefly for field and forest purposes, a great display is made at the end of the South Gallery West. Rifles, fowling-pieces, pistols, swords, &c., some of which exhibit skill in their construction, coupled with elaborateness of ornament. Several of them indicate the application of new principles for prevention of accidental discharge, and some of new propulsive power. The remarkable properties of vulcanized caoutchouc, coupled with the discovery of the cumulating power of bands of this material, have been applied with success to various projectiles, and appear to promise new and important results.

Out of the miscellaneous collection of objects grouped together in this Class, some adapted for recreation—some for utility—some for offence and defence—a selection for particular study may well be made by the visitor to the Building. But probably no part of this Class will be regarded with more interest than that which illustrates the early, progressive, and present application of the steam-engine to navigation. The models illustrative of this subject form a most instructive part of the collection.—R. E.



1 **CLAYTON, RICHARD**, 9 *Gresham Street*—Inventor.  
The swimming glove, designed and formed after the web-foot shape.

2 **CLARKSON, T. C.**, 111 *Strand*—Inventor.  
Models of life-boats, formed of cork, &c.

3 **EXALL, W.**, *Reading*—Inventor and Manufacturer.  
Anchor without beam or stock, and having three flukes or grapples, all of which will lay hold at the same time.

4 **MURRAY, JAMES**—Inventor.  
Model of harpoon gun.

5 **LIGHT, E.**, 216 *High Street, Wapping*—Inventor and Designer.

Models of life belts and buoys.  
Model life-boat, 5 feet long, fitted with patent "buoyancy" material, and apparatus, tubes and valves complete.  
Model of another, for light transport in exploratory expeditions, and to cross rivers, lakes, &c.

Piece of patent "buoyancy" material, as fitted and adapted in ships, yachts, boats, and belts.

Specimen of ladies' and gentlemen's yachting jacket; its object is to completely support the body in case of accidental immersion in the water.

Model of a yacht's boat with patent "buoyancy" arrangements.

6 **REEKES, T.**, 50 *Husker Street, Chelsea*—Inventor.  
Nautical cap, which can be immediately converted into a safety swimming belt.

7 **FOSTER, J., R.N.**—Inventor.  
Specimen of wood and India-rubber joinings.

8 **VICKERS, WM. RANDALL**, 32 *Baker Street, Portman Sq.*—Designer.

Geometrical floating life-belt, made of sail canvas, and divided into five compartments, stuffed with cork-cuttings. Models of strong sail-canvas, made up for stuffing. Samples of the sail-canvas, and two sample bags of the cork cuttings. The life-belt can be folded up (nearly in the form of a cube) and made to serve as a cushion on board ship. If one of these compartments should be torn, the rest would still form a useful belt. It is made to surround the body of the wearer and leave his arms free.

9 **HOLEBOOK, J. N.**, 4 *Remington Street, City Road*—Inventor.

Polar life-preserver.

Wood raft, to be carried on board ships.

Tubular raft for same purpose.

Large round floater, to be thrown out to drowning persons.

Captain's life-preserver.

Gentleman's fishing-stand, for the middle of rivers.

Ladies' bathing machine, by which they may with safety go far out, in fine weather, and obtain the full benefit of the sea, and be brought to shore by a line attached.

Small bottomless life-boat.

The same made of copper, to be placed on the sea shore.

Model of an iron bottomless life-boat, 26 feet long. It is suitable for the roughest sea and actual service, in case of fire or shipwreck. The boat is made entirely of wrought and sheet iron, lined and covered with strong netting. Its dimensions are 26 feet long, 8 feet wide, and 3 feet deep, with iron gunwale 21 inches high; the rod and bar iron is about 800 feet, with 6 floaters made of 105 pieces of sheet iron, filled with 300 feet of tubing formed into 150 air and waterproof barrels, with 15 tanks, holding 222 gallons for fresh water; provisions, warm clothing, compass, alarm apparatus, fuel, fireworks, rockets, with 1,000 feet of line attached. The whole is firmly secured together with about 400 screws and bolts, and riveted with 10,000 rivets. There is in the figure-head a simply constructed kettle, by the same inventor, that will boil in 10 minutes, 8 quarts of coffee. The

rudder can be shipped or unshipped in a few seconds, and oars and sail applied if required; the total weight is 20 cwt.

The boat having no bottom renders it almost impossible to capsize, and should its six floaters become punctured, full of holes, and all filled with water, the numerous barrels inside will be amply sufficient to prevent it sinking—such is the buoyancy, that it will carry nearly 150 persons and food for many days.

Model of a life and body preserver.

White glass ginger-beer bottle, and green glass soda-water bottle, in the use of which no cork, string, or wire is required; they are also suitable for ale, porter, wine, &c. The stopper will not give the liquor any unpleasant smell or taste.

10 **LEE, THOMAS**, 4 *Broad Street Hill*—Designer and Manufacturer.

Improved life-preserver, or swimming-belt, to sustain the wearer in an upright position in the water.

11 **SPENCER, EDWARD**, 116 *Fenchurch Street*—Manufacturer.

Patent buoyant and water-tight trunk, capable of sustaining fifteen persons in the water.

13 **HELY, ALFRED AUGUSTUS**, 16 *Manchester Buildings, Westminster*—Inventor.

The catamaran, or life-raft, composed of waterproof canvas cylindrical cases, filled with bedding, clothing, provisions, stores, or any matter of less specific gravity than water.

Salvage boat, wholly composed of metallic tubes, forming atmospheric and hydraulic chambers, with loaded keel and self-shifting wheels.

Life-girdle, composed of spherical floats strung upon an endless elastic band.

Patent cork-driving apparatus and vent-bottle.

14 **BELL, HUGH**, *Baltic Wharf, Millbank, Westminster*—Inventor and Manufacturer.

Model of a "water gupnel," or "deep sea anchor."  
Model of a "submarine boat," to pass closed under water, seals one inch to the foot.

Model, on the same scale, of a "locomotive diving bell," which may be used as a common diving bell, with the apparatus usually attached for forcing in air.

Life boat, for the beach, on the scale of one inch to the foot.

15 **ROYAL HUMANE SOCIETY**—Proprietors.

Ice-boat, presented to the Royal Humane Society by the society established at Hamburg, constructed, for lightness, of wicker-work, and covered with raw hides; being placed upon rookers, this boat may be propelled on the ice with great facility, and in cases where a number of skaters break through in one spot, it has proved invaluable for saving lives.

Breaker ladder, a simple ladder with two air-tight barrels fixed at its broad end; being secured upon two wheels it may be used by one man with ease. On the immersion of a skater, the broad end of the ladder is pushed into the hole; the buoyant power of the barrels allows the drowning man to climb on to the machine; and to walk along it to its narrow end, which, resting upon the sound ice, affords the means of escape.

Ice sledge, composed of two canoes united by three thwarts, forming thereby a floating platform. It can be used on the ice with ease; it has great buoyant power (being capable of sustaining as many persons as could cling to it), and cannot be capsized.

Rope drag, used for dragging in deep water with a tide or running stream. When persons fall into the water from vessels or steam-boat piers, this machine can be used with greater certainty and in less time over a given space than any other kind of drag. The above apparatus is provided by the Royal Humane Society at stations on the River Thames, and on canals, docks, and places where they are most needed.

## WEST END GALLERY AND SOUTH-WEST GALLERY.

Pole drag, used in shallow water and where there is no stream. To the timely use of this machine many bathers and skaters owe their lives.

A pole drag, with an air-tight cylinder placed in its centre, to render it a floating drag. It is used for rescuing persons who have broken through the ice and have been drawn under its surface.

16 HART, C., *Lowestoft, Suffolk*—Inventor.  
Model of a life-boat.

17 SPARK, W., *Exeter, Devon*—Inventor.  
Model of a life-boat.

18 ROBERTSON, JOHN, *Limehouse Hole, Poplar*—  
Manufacturer.

Coils of cordage, manufactured from tarred Russian hemp, white Manila hemp, and tarred New Zealand flax (*Phormium tenax*). (In Classes 5 and 6.)

[The valuable and remarkable product, commercially known as New Zealand flax, is the fibre of a plant indigenous in that country and in Norfolk Island. The fibre is obtained from the leaves of this plant, and in many respects rivals that of hemp for toughness. The plant belongs to the natural family *Liliaceæ*: its cultivation in other than its native districts has hitherto been attended with indifferent results.—R. E.]

Patent gun trumpet, for fog or alarm signals.  
Models, showing Rapson's patent slide tiller.

19 KING, P. H. F., *Sydney Cottage, Herelett Place, Cheltenham*—Inventor.

Marine table for preventing breakages at sea. The exhibitor states that the top of this table will remain perfectly level without any regard to the rolling of the ship; it is portable, and may be taken apart in nine pieces. Registered.

20 HOLTUM, WILLIAM, *Widmer, Deal*—Inventor.

Model of an apparatus for propelling a line to a vessel in distress at a short distance from the shore, intended to supersede the use of gunpowder; with a model of a wicker boat to travel on a bawser from the shore to the vessel.

21 JERNINGHAM, ARTHUR WILLIAM, Commander H.M.S. "Excellent," *Portsmouth*—Inventor.

Model of an anchor to be fired from a mortar of 5½ inch bore, with a charge of 10 ounces of powder, to carry a two-inch Manila line out 200 yards to sea, for the purpose of hauling a life-boat off through the surf when the wind is on shore.

22 MANN, G. W., *Great Yarmouth*—Inventor.  
Model of life-boat and mortar apparatus.

23 AYCKBOURN, FREDERICK, *120 Strand*—Sole Inventor and Manufacturer.

Patent float, or invisible life-preserver, and swimming-belt. This apparatus may be worn without inconvenience, may be instantly rendered available in cases of shipwreck at sea, and may be used as a support in learning to swim. It is portable, easily managed, and will last for years.

Models of life-boats and portable boats, invented by the exhibitor.

25 OFFORD, D., *Great Yarmouth*—Inventor.

Grapple shot, to assist the hauling of life-boats, &c., off the beach through heavy surfs.

26 OFFORD, D. & BRADBEER, S., *Great Yarmouth*—  
Inventors.

Rock life-preserving apparatus.

27 LEFTWICH, W. H., *43 Cumberland Market, Regent's Park*—Inventor.

Model of a heavy-armed cutter, constructed from portions of various old men-of-war and of other oak from places of notoriety. On a stand of the surplus wood.

28 PURSER, JOSEPH, *73 Shaftsbury Street, New North Road, Hoxton*—Inventor.

Self-acting fire-escapes, with some useful practical improvements; exhibited for cheapness.  
Bomb-shell.

29 CARTER, ALEXANDER GORDON, *Citadel, Hull*—  
Inventor and Manufacturer.

Pocket apparatus for throwing a line to a stranded ship.

Self-acting life-buoy, invented in 1831; by its means, since 1838, the lives of nearly 400 persons have been saved.

Sea-service rocket apparatus, for throwing a line from a vessel to the shore, or to another in distress at sea.

Self-adjusting cork life-belt.

Alarm-signal, for the protection of houses, out-houses, plantations, &c.

30 DITCHBURN, THOMAS JOSEPH, *Blackwall*—Designer and Builder.

Models of the following vessels, &c.—

War steam-vessel of 1,200 tons and 400-horse power, named "Vladimere," built in 1848 for the Emperor of Russia.

Steam-rocket, named "Taman," built for the Russian Government.

Screw steam-vessel, for coast defence, named "Sharpshooter," built for Her Majesty's service.

Steam-rocket, named "Wonder" (one of five packets), built for the conveyance of passengers and merchandise between Southampton and the Channel Islands.

Iron cutter yacht "Mystery," built for Lord Alfred Paget, M.P.

The first passenger steam-rocket on the river Thames, in the ferry between London and Gravesend, built 1813; of 40 tons burthen, and 9 horse-power.

"Earl Spencer," one of the last passenger sailing packets that plied between London and Gravesend, built 1796.

The "Fairy," screw steam-yacht, built for Her Majesty.

Iron schooner sailing yacht, named "Volna," built for the Grand Duke Constantine of Russia.

A River Thames passenger steam-boat.

James Watt's experimental steam-boat, "Caledonia," fitted with two 14-horse engines, which made several trips from London to Margate in 1810, and ascended the Rhine to Coblenz in 1817.

A passenger steam-rocket, "Favorite," 40-horse power, built 1817, expressly to run between London and Margate.

Wrought-iron caisson, built to supersede the use of entrance gates to the new stone docks at Woolwich.

31 LATARS, JOHN, *Bridge Street, Bristol*—Inventor.

Models of a floating buoyant settee, for the decks of passenger steamers, resembling in shape, size, and appearance the usual settees, and capable of being converted into a raft. The seat is composed of two boxes, which fold on each other, each box containing an air-tight gutta percha case.

32 SLOGGETT, RICHARD, *Devonport*—Designer and Producer.

Specimen of naval architectural drawing, and a new design, representing the profile and bow of a war steamship of 500-horse power. The profile of the bow shows all the interior fittings, while the front view exhibits the exterior fittings, anchors, &c., which are transferred from the profile and half-breadth plans.

33 SIMONS, WILLIAM, *Greenock, Scotland*—Designer and Manufacturer.

Model of a screw frigate; model of a yacht.

34 WALTERS, H., *Monmouth Court, Dorset Place, Pall Mall*—Inventor.

Model of fire-escape and scaling-ladder.

- 35 MOORE, WILLIAM F., *Plymouth, Devon*—Manufacturer.  
Half model of the cutter yacht, "Pixey."  
Half model of the schooner yacht, "Haleyon." Built at Plymouth by the exhibitor. Exhibited for asserted speed and weatherly qualities of the original.
- 36 WHITE, JOSEPH, *Essex, Isle of Wight*—Designer and Manufacturer.  
Design for a new 90-gun ship. Models of H.M.S. Victory, Phaeton, 50-gun steam-ship *Ternagant*, and brig *Waterwitch*, *Daring*, and *Contest*.  
Lengthened bow of the *Fox* frigate.  
Old and new bow of the *Amphion*.  
Models of a schooner and a cutter-yacht, and *Victoria yacht*, built for the Emperor of Russia.
- 36A WHITE, T. J. & R., *West Cowes, Isle of Wight*—Inventors, Designers, and Manufacturers.  
Model of the steam-ship, "Vassetei Tigaret," built for the Turkish Government, 1847.  
Designs for a 50-gun frigate, 1838, and for the first transatlantic steam-ship to New York, 1838.  
The "Medina" steam-ship, built for the West India Royal Mail Company.  
Design for an ocean steam-ship of 3,000 tons.  
Steam-ship "Vectis," built for the Peninsular and Oriental Company.  
Sixty-gun frigate, designed for Turkish students studying naval architecture at Cowes.  
Design for fast-sailing or screw-ships, for the China trade, of 1,600 tons.  
Model of the "Samuel Enderby," Southseaman.  
Models of life-boats, &c.  
Model of a 50-gun frigate.  
Model of the "British Queen" steamer.  
Screw steam and sailing-ships of 2,500 tons.  
Model of the missionary ship, "John Wesley."  
Model of clipper barque built for Messrs. C. Ivens & Co., Bristol.  
Two China clippers, one of 1,000 tons, and another of 1,475 tons.
- 37 TOVELL, GEORGE RANDFIELD, *Mistley, Manningtree, Essex*—Inventor.  
Model of a ship's hull, of parabolical form. The novelty claimed consists in the uniformity of its lines, and the ease with which a ship on this principle can be laid down.
- 38 MURRAY, W., 20 *John Street, Adelphi*—Manufacturer and Licensee.  
Model of a harpoon gun.  
Tucker's tapping-up apparatus for propelling.  
Normanville's ship-scrubber.
- 39 AZULAY, B. *Rotherhithe*—Inventor.  
Model of a sailing vessel, with auxiliary screw-propeller, worked by the men on board. It has also a backward motion.
- 40 DEANS, W., 9 *America Square*—Inventor.  
Two models of triangular-bottomed ships' hulls.
- 41 GIBSON, A., 2 *Ernough Place, Cheltenham*—Inventor.  
Steam-ship, with improved paddle-wheels, with paddles attached to endless-chains to run over two extra wheels.  
Small dragon to drive a gutta percha tail to act as a propeller.  
Railway in place of a gunwale and space in front, to carry four guns.
- 42 GEORDESON, JAMES—Inventor.  
Method of reefing the sails by lowering the masts.
- 45 ERSKINE, DANIEL, *Clark Street, Edinburgh*—Inventor and Manufacturer.  
Two new life-boats; the one propelled by new pinion wheels and self-acting marine syphon-pump; the other fitted with air-tight cylinders made to revolve on axles; life-protecting rings and other improvements.
- 46 RICHARDSON, H. T.—Inventor.  
Model of a life-boat.
- 47 ACHESON, J., 102 *Leadenhall Street*—Inventor.  
Model of a life-boat.
- 49 BONNEY, WILLIAM WOLFE, *Claremont Villa, St. John's, Fulham*—Inventor and Proprietor.  
New life-boat, with numerous cells, composed of gutta percha, of peculiar forms, together with gutta percha life-buoys. It is not easily capsized, and when turned bodily over, rights itself immediately. It rows or sails equally well both ways, and steers with oars or rudders.  
A life-boat, 30 feet long, 8 feet beam, 3 feet deep, built upon this principle, is said to be capable of saving 300 persons, and to be perfectly manageable when full of water and persons. A boat of gutta percha has lately been employed in the Arctic Seas with advantage.
- 50 HODSON, J., *Sunderland*—Inventor.  
Model of a life-boat.
- 51 ALLAN, J. H.—Inventor.  
Model of a life-boat.
- 52 WHITE, THOMAS, jun., *Cowes, Isle of Wight*—Designer, Inventor, and Manufacturer.  
Four models for the entire navy, from one design. 50-gun frigate and corvette upon parabolic sections. Heaving-up slip, with recent improvements in doubling the power with the same machinery. Work on naval architecture illustrative of the whole.
- 53 HAWKSWORTH, A.—Inventor.  
Model of a life-boat.
- 54 REED, JOHN, 7 *Silver St., Stockton-on-Tees*—Inventor.  
A life-boat, which is said to right itself under any circumstances, without the aid of an iron keel or deadweight. It may be built of any size, and can be constructed of wood or any of the metals at present used in boat or ship-building.
- 55 TREDWEN, RICHARD, *Padstow*—Inventor.  
Model of a life-boat.
- 56 WIGRAM, MONEY, & SONS, *Blackwall*—Inventors.  
Half-models of ships, &c.
- 57 ROBSON, JONATHAN, *Gateshead, Newcastle*—Proprietor.  
Model of an iron steam-tug or passenger steamer, being the first used for towing on the Lower Danube; length of keel 98 feet, and of deck 115 feet. Breadth of beam 17 feet 3 inches. Area of midship section, 62 feet 3 inches. Draught of water 4 feet 1½ inch at each end, with 14 tons of coal on board. Single lever engine of 41 inches cylinder, and 4 feet 3 inches stroke; with the ordinary flue and boilers.
- 58 PETLEY, T., 7 *Great Hermitage Street*—Inventor.  
Model of iron steam-tug.
- 59 GREENER, W., *Birmingham*—Inventor and Manufacturer.  
Pair of double guns in case, 10 gauge, 7½ lbs. weight each, barrels made of laminated steel. Double rifle in case; barrels of laminated steel.  
Patent harpoon gun, as used in the "Arctic Seas," with lines, gun harpoon, and model of the head of a whale-boat ready for use. Harpoon gun, &c., as used in the South Seas, or sperm-whale fishing.

Rocket gun and rocket lines for saving lives from shipwrecks, fixed upon a model of the exhibitor's life-boat. Is calculated to effect communication up to 600 yards with accuracy, and obviate the present defect of the rocket being deflected from the intended aim.

Registered stanchion gun for wild-fowl shooting. Fired by percussion tubes.

Military musket, of a lighter construction, and greater durability and range than those now in use. Double military rifle on a new construction.

Pair of newly-finished gun-barrels in the piston proof frame, prepared for proving. In this process the cylinders of the barrels are closed by steel plungers, and the charge is allowed no vent for escape but through the orifice of the nipples. Thus the capacity of the barrels to resist the confined force of any given quantity of gunpowder is ascertained.

Specimens of laminated steel in various shapes, showing its tenacity, tenuity, and density.

Gun harpoons, lances, rockets, &c., as ornaments.

60 DYNE, W., 17 *Basing Place, Kingsland Road, and Brighton Station, London Bridge*—Inventor and Proprietor.

Model of a patent life-launch, which cannot be stove in, clears itself of surplus water, and is capable of stowing away provisions and water for one month, and of supporting more persons than could attach themselves to it.

Model of an overland or emigration patent life-boat, ten of which can be stowed in the space of a common boat.

Model of a "stone life-boat."

Model of a diagonal or lattice-frame registered life-boat.

Model of a patent collapsible life-raft, for pontoons or bridges.

Model of a stone buoy.

Model of a bottomless life-boat, that can be thrown from the deck of a vessel for immediate use.

Model of a patent cattle life-preserver, equipped on a horse, showing a method of buoying up cattle while in the water.

Model of a patent buoyant box, the system being applicable for portmanteaus, mail bags, &c.,

Model of a life-boat comb, or apparatus for the safety of boats when boarding wrecked or distressed vessels in heavy surf.

Model of a patent life-buoy. While buoying up an individual out of the water it provides him with rockets, blue and other lights, to show what position he is in, should it be in the night; these ignite upon being taken out.

61 BROWN, LENOX, & Co., 8 *Billiter Square*—Inventors and Manufacturers.

Model of an Admiralty regulation anchor—the largest used. Part of the largest chain cable, 2½ inch diameter of iron, exhibiting a swivel, a joining shackle (with Lenox's plan of fastening the pin), and an anchor shackle.

The smallest anchor and part of the smallest cable used in the Royal Navy.

A patent windlass purchase. The motion is obtained by friction of metal bands upon metal barrels; no wheels, or pulleys, or other machinery required; cable can be given to the ship at any moment by slackening the bands with the lever in front.

Registered pit chain, used in coal and other balanced pits. The three chains are fastened together by metal plates inserted in the block of wood.

Patent malleable cast-iron blocks or pulleys for ships, engineering, and other purposes, intended as a substitute for wooden blocks and wrought-iron or brass blocks; cast to any shape, and rendered tough or malleable afterwards.

62 FAWCETT, FRANCIS, *Mount Pleasant, Douglas, Isle of Man*—Proprietor.

Models of life-boats, on the twin principle, completely decked over, and divided into twenty air-tight compartments, which can neither be swamped nor upset; and as

the keel forms both stem and stern-post, they are well adapted for landing in a heavy surf, no point presenting itself as a fulcrum by which they can be capsized.

63 BETTELEY, J., *Liverpool*—Manufacturer.

Model of ship's windlass, with patent propeller. Patent anti-friction sheaves.

64 BAILLIE, BENJAMIN, 118 *Wardour Street, Soho*—Inventor.

Model of a vessel, with improved rigging, mast, and sails. Intended to give to a fore-and-aft rigged vessel, or to a lugger, the advantages over one square-rigged, in working to windward. The sails being bent to booms, which are pivoted or hung by their own leverage, will adjust themselves to the required angle, without the labour required to brace the yards, as in square-rigged vessels; at the same time, being brought up to windward by the booms, will lessen the pressure to leeward incidental to ordinary fore-and-aft rigged vessels.

65 PEARSON, J. W., *Mill Dam, South Shields*—Inventor. Model of an oar.

66 THOMPSON, THOMAS, Commander, R.N., 3 *George Street, Leith*—Inventor.

Safety-plug, for boats and vessels, constructed of gun-metal or brass, for the prevention of casualties arising from the loss or misplacing of the ordinary loose boat-plugs, and for greater security from leakage and facility of adjustment.

67 PARKER, CHAS., *Newark, Notts*—Inventor.

A screw valve, consisting of a circular brass plate, of about three inches diameter and a quarter of an inch thick, having a hole in the centre to admit the valve, which is opened or closed by means of a screw attached to it; the latter works in another screw fixed on the plate, immediately over the valve-hole. Intended to supersede the present plug in ships' boats. Being a fixture it cannot be lost, as the plugs often are.

This screw-valve is large enough for an ordinary-sized boat: it is exhibited in a rough model of a boat, one foot long.

68 HOPWOOD & ARMSTRONG, 184 *St. George Street, Wellclose Square*—Inventor.

Registered brass side scuttles, with metal doors, for ships, also for light and ventilation.

68A ROBINSON, Lieut., W. F., R.N.

A self-acting safety plug for life-boats, barges, and other vessels.

69 GREGORY, ALFRED, 54 *St. George Street East*—Inventor.

Safety-plate, to cover the aperture of a ship's scuttle, instead of the whole scuttle being covered with lead, copper, or wood. It is an external plate, put on from the inside, making it a solid compact body of brass. It is designed to save expense in the usual way of covering, the nails of which injure the ship's sides; also the multiplied expenses of coverings, this mode lasting until the scuttle is worn out; to make the windows safe in case of storm in the space of one minute, and, being water-tight, to prevent any inrush of water; thus tending to the preservation of human life, &c.—Registered.

71 LONG, JOSEPH & JAMES, & Co., 20 *Little Toner Street*—Inventors and Patentees.

Curvilinear steering apparatus. By the simple action of the hand upon the steering wheel, the curvilinear lever is brought to bear on a convex cogged tiller, fixed to the rudder head. It possesses such leverage, that a boy can steer the ship. As the cogged tiller is always in a parallel line with the centre of the lever, the rudder becomes a fixture when not operated upon by the helmsman; thus securing him from accident or strain.

- 72 DENHAM, Captain HENRY MANGLES, R.N., F.R.S.,  
*United Service Club*—Inventor. COOPER &  
MACLEAN, 12 *Billiter Square*, Agents.  
Model, with a drawing and description, of the registered "jury tiller," for steering a ship when the usual helm fittings become disabled through fire abaft, the rudder-tree or head being shattered by shot or a wringing strain, the inboard tiller breaking short off, or the wheel gear breaking down suddenly in a gale or a tide-way. It consists of an auxiliary appendage to the rudder at the water-line, and can be thrown into gear in an instant.
- 73 HALL, Wm. EDWARD, *Moreton, Bideford*, and 55  
*Great Marylebone Street*—Inventor.  
Mechanical apparatus for the application of the catenarian curve to the lines of ships, which might advantageously be used by engravers on copper, steel, or wood.  
Copper model of an 18-gun brig or corvette.  
Series of diagrams, illustrating a theory of naval architecture.
- 74 BAIRD, JOHN R., 210 *Strand*—Inventor.  
Method of lowering a ship's boat when hanging out of the water, with speed and safety, in cases of accident, by preventing one end of the boat going down quicker than the other. A man in the boat can lower her into the water, or raise her to a level with the ship's deck, by pulling a single rope.
- 75 ORR, M., *Greenock, Scotland*—Inventor.  
Model, drawing, and explanation of angulated jibs.  
Treatise on the area of sails for open boats.
- 76 WATSON, T., 79 *Provost Street, Horton*—Inventor.  
Model of a plan for the correct measurement of tonnage in ships, steam-boats, &c.
- 77 POOLE, J., jun., *Copper House, Cornwall*—Inventor.  
Model of an improved paddle-wheel.
- 78 SLATER, W., 332 *High Street, Wipping*—Proprietor.  
Improved patent copper powder-barrel, which preserves gunpowder in perfect safety against fire and damp.
- 79 GALE, J. & R., *Whithy*—Inventors and  
Manufacturers.  
Model of life-boat, emptying itself, when full of water, in the short space of four seconds, by means of two apertures in the bottom.
- 80 LADD, CHAS. P., Lieut. R.N., 10 *Walcot Place, Lambeth*—Designer and Inventor.  
Marine table to prevent breakage of glass and spilling of liquids at sea in rough weather. The invention consists in its being made to swing freely in the middle of a saloon table, fixed by screws to the cabin floor.
- 81 MASON, EDWARD, *Brompton Post Office*—Inventor,  
Designer, and Builder.  
Model of a steam-boat, "Queen of the Ocean," built of cedar wood out of the old "Gibraltar," Spanish ship of war.  
Model of a self-acting life-boat, calculated to right herself immediately, with the crew lashed to her thwarts, in the event of being upset, without the assistance of any additional weight or balance, &c.  
Midship section of a ship's deck, with concealed fastenings.
- 82 CORTON, JOHN, *Erechtheum Club, St. James's Square*  
—Designer and Inventor.  
Model of a sailing-vessel and life-boat, constructed and propelled on new principles.
- 83 BREMNER, J., *Wick, Scotland*—Inventor.  
Model of a life-boat.
- 84 FERGUSON, C. A. & T., *Poplar*—Inventors.  
Model of a gun-carriage.
- 85 ALLAN, JOHN H., 2 *Leadenhall Street*—Proprietor.  
Model of a South Shields cable.  
Model of truss-work, introduced by Sir Robert Seppings, for the internal fastening of ships, and on the same principle as the girders of the Exhibition Building. It represents a section of the between-decks of the East India ship "Sir Robert Seppings," built at Moulmein, in the Tenasserim provinces, and is made of part of her teak planking.
- 86 LYONS, GEORGE, 8 *Britain Street, Portsea*—  
Manufacturer and Inventor.  
Model of a screw-propelling rudder.
- 87 MARGARY, —, Inventor and Patentee.  
Specimens of patent canvas. Upwards of half a million yards have been prepared for the Honourable Board of Ordnance by the process of the exhibitor.  
Various pieces of prepared and unprepared canvas in different stages of decay.  
The same process is extensively used in the preparation of sleepers and timber for railway and other purposes. Specimens of its application.
- 88 PARSEY, WILLIAM, 455 *Oxford Street*—Inventor.  
Working model of a bell-buoy for warning vessels of danger. Motion is obtained by the action of the surface current or tide on a water-wheel, placed between two floats or barges, which is communicated to the hammer for striking the bell and giving the alarm.
- 89 KINCAID, T., *Greenock, Scotland*—Inventor.  
Models of fan propeller, variously applied.
- 90 BEADON, GEO., Captain, R.N., *Creechbarrow, Taunton, Somersetshire*—Inventor.  
Prince Alfred's mirror: a glass mounted upon a nautical adjustment for glasses.  
Universal rowlocks, applicable for any description of oar.  
Whale gun, for projecting harpoons with precision.  
Boat safety reel, to prevent the upsetting of boats in squalls.  
Life-raft for ships; a folding catamaran bung at the stern, and occupying little room; the operation of lowering prepares it for use.  
Mast clamp, to facilitate stepping or lowering boats' masts.  
Gun elevator, for artillery.  
Illustrations of a new system of propulsion, upon a scale of  $\frac{1}{2}$  of an inch to a cubit.  
Indicating or filter cock, to draw off liquids without disturbing the sediment.  
Phaeton hood-lifter, for raising or lowering heads of phaetons.  
Improved door, obviating draughts, &c.  
Universal tractor.  
Nearly all these inventions comprise certain parts for which patents have been taken.
- 91 CLARK, JOSEPH, 10 *Parliament Street, Westminster*—  
Inventor.  
Model of the bunk life-boat. To be used as a cot, occupying the space of the bunk or berth, and forming a life-boat always ready for use. Model of a flexible life-boat.
- 92 YOUNG, DOWSON & Co., *Poplar*—Manufacturers.  
Ship's improved rudder fastenings, by the use of which, when the old pintles are broken, new pins can be fitted on board, without the necessity of the ship putting into port for that purpose.



93 GRANTHAM, JOHN, *Orange Court, Liverpool*—Inventor.

Model of the section of an iron ship, showing an improved method of sheathing the plates with wood, to enable them to be copped. The sheathing is attached without the use of bolts. The object is to prevent fouling in tropical climates, and to preserve the iron.

Iron model on a larger scale, showing the mode of construction.

94 SMALE, WILLIAM, 13 *Charlton Terrace, Woolwich*—Inventor.

Model of an anchor, which can be taken to pieces and stowed in one-third less room than an ordinary anchor.

95 HONIBALL, JAMES, 42 *Cornhill*—Patentee.

Models of Porter's patent anchors, tested by order of the Lords of the Admiralty.



Porter's Patent Anchors.

These anchors (see fig.) are considered to possess superiority in strength and holding power.

The advantages peculiar to their construction are—the protection of ships from accidents common with anchors of fixed arms, viz.: preventing fouling either at single anchor or otherwise; affording quick bite in all kinds of ground, hard or soft, and with short scope of cable will bring the ship up instantly; preventing damage to vessels in overlaying the anchor, or in passing over it in shallow water, as the upper fluke rests on the shank, it cannot enter the ship's bottom; preventing vessels, while in crowded anchorage, from being hooked by the cables of other vessels; convenient for stowing on board, by disconnecting the arms from the shank; easy of transport to or from a vessel in two boats, when the anchor is too heavy for one boat; and as, in proportion to the superior power of these anchors, less weight is required, thereby affording relief to ships' bows, and enabling them to sail with greater speed.

97 BETTELEY, J. & Co., *Brunswick Dock, Liverpool*—Inventor.

Model of a windlass.

98 COTTEW, J. E. 19 *South Street, Lambeth*—Inventor.

Model of an improved windlass for raising ships' anchors.

99 INGLESFIELD, EDWARD AUGUSTUS, R.N., 9 *Portsea Place, Connaught Square*—Inventor.

Model of H.M. brig "Flying-Fish," fitted with a screw-propeller, to be worked by the capstan; also gearing for connecting the screw-shaft with the chain-pumps. A new application of the capstan, and of the chain-pumps.

A small lever handle throws the screw into gear with the chain-pumps, and the revolution of the screw, consequent on the motion of the ship through the water in a gale, or even at anchor (in a tide-way), will pump the vessel out, without any manual labour.

An anchor without a stock, and both flukes taking the ground, when in use. It is stated that this anchor cannot be fouled, nor can a ship damage herself should she ride over it. It has double the hold of an ordinary anchor; it takes into two pieces; is easily catted and fished, and is simple in manufacture.

100 ROBINSON, JOHN, 6 *Pattison Street, Stepney*—Inventor and Proprietor.

Three life-boats, which will free themselves speedily of water, and immediately right themselves in the event of being upset.

Three patent steering machines, for ships or other craft, intended to economise space, with a spring rudder.

Two patent machines, for raising weights, weighing anchor, &c., with facility, giving the ship chain, without surging on the windlass.

Patent new pumping machine, for raising water from the hold of a vessel.

101 MUNTZ, GEO. FRED, M.P., *Lincolns*—Inventor.

Patent ships' sheathing metal; intended to supersede the use of copper for that purpose.

Patent metal rod for ships' fastenings.

102 WOOD, HENRY & Co., *Liverpool*. WOOD, GEORGE, & Co., 275 *Wapping*—Manufacturers.

Models of patent windlass purchase and spindles; Lamport's patent ship's winch; M'Sweny's patent steering barrel; Porter's patent anchor; chain, cable-iron, &c.

103 BROWNING, SAMUEL J., 66 *High Street, Portsmouth*—Manufacturer and Inventor.

Brass urn-shaped binnacle of new construction, with newly-invented compass. The same, bronzed by a new process.

Brass urn-shaped binnacle, ornamented, on a painted and gilt pedestal. Invented by the exhibitor for Her Majesty's steam yacht "Victoria and Albert."

Skeleton compass, with cards to show their application to Mr. Browning's newly-invented compass.

Marine target of new construction.

104 BERTHON, REV. E. LYON, *Fareham, Hants*—Inventor.

Patent perpetual log, for indicating the speed and leeway of ships. Its novelty consists in the compensation, by which disturbing causes are neutralized.

Patent clinometer, for showing the list and trim of ships. Collapsible life-boat, combining strength and capacity within small limits of stowage. The act of lowering expands, and of raising collapses it; when open it contains a great volume of air in its longitudinal cells.

105 TAYLOR, JANET, 104 *Minorics*—Manufacturer.

A bronze binnacle, with compass, designed from the water lily.

106 HEMSLEY, THOMAS, 11 *King Street, Tower Hill*—Inventor and Manufacturer.

Improved ship's binnacle, containing a compass, fitted with transparent card and reflecting lamp; the lamp can also be used as a signal-light to other vessels, when required.

108 PARKES, HENRY PERSHOUSE, *Dudley*—Inventor, Patentee, and Manufacturer.

An anchor-shackle, swivel, and connecting shackles, as used in chain cables.

A wrought-iron stud mooring-chain, made to supersede the chains formerly made with cast-metal stay, for holding the floating light ships off Liverpool.

A patent flat pit chain or band. A solid link flat pit chain, intended to supersede the open link chain.

109 WEST, Commander, 1 *James Street, Adelphi*—Inventor.

Marine compass, constructed on a principle which prevents the magnetic needle from oscillating more than one degree. Without this prevention the magnetic needle can oscillate forty-five degrees, viz., till the lower part of the cone touches the pivot, causing continual revolutions and vibrations. On the exhibitor's principle, the magnetic needle is always steady, and in the heaviest weather only vibrates four or five degrees.

110 SOULBY, JOHN, 126 *High Street, Wapping*—Manufacturer.

Model of a safety windlass, made of two parts.

CAPTAIN COOK'S QUADRANT AND COMPASS, THE IDENTICAL INSTRUMENT USED BY THAT CELEBRATED MARINER IN HIS VOYAGE ROUND THE WORLD.

- 111 JENKINS, JAMES, 2 Union Row, Minorics—  
Manufacturer.  
Boat binnacle, containing compass and lamp.
- 112 FATER & ROBINSON—Manufacturers.  
Model of a steering wheel.
- 113 SCULLER, JAMES, 65 Argyll Street, Glasgow—  
Inventor.  
Fog signal-light, for shore and ship signals.
- 114 HASTINGS, JAMES, 24 Billiter Street, City—  
Proprietor.  
Model of a windlass, employed for raising and lowering ships' anchors, &c., fitted with Johnstone's patent double-action lever purchase, also fitted with Gryll's patent whelps, which adjust the cable as it comes in, causing the turns to shift laterally; thus the leading turn is always in a line with the hawse-pipe, and the necessity of using a forebit stopper, and of fleeting over the cable, is obviated. The whelps being flat upon the face, and the links of the cable dropping into the cavities between, and abutting against the edge of the whelps, the cable is found to hold on, and is not liable to run out, except to the extent of a few links under a very heavy strain. The dangerous and troublesome operation of hooking up the cable, and fleeting it over upon the windlass, being got rid of, much time and labour is saved.  
Model of a ship's capstan, for raising anchors, &c., fitted with Johnstone's patent rim or cable-holder, which affords the advantage of being adapted for working chain-cables of various sizes; also fitted with Gryll's patent non-surgng whelps.
- 115 ALLISON, EDWARD WENMAN, 36 Nottingham Place, Stepney—Inventor.  
A steering wheel, to prevent accidents at sea. This wheel is entirely under the command of one man; and should any accident happen to him, it will remain without moving until another is sent to take charge of it.
- 116 SALTER, JOHN, West Street, Commercial Road—  
Inventor and Manufacturer.  
Model of improved ship's capstan.
- 117 SPENCELEY, JOHN, Whitstable, near Canterbury—  
Inventor and Proprietor.  
Patent pillar and screw apparatus, for preventing ships from "hogging," and for restoring hogged ships to their original shear, for taking all strain off the side fastenings, and preventing the butts from working. It can be used at sea, and the ship straightened without going into dock or laid ashore, and is applicable to steam-boats, men-of-war, and merchant vessels of all descriptions.
- 119 MATHEWS, T., 83 Berwick Street, Soho—Inventors.  
Model of a paddle-wheel.
- 120 GILBERT, EDWARD, Fulmouth—Inventor.  
Registered marine signal lamp, which yields a light equal to a blue light. The wick, which is chiefly composed of metal, may be used for a very long period. The lamp and wick represented in the annexed cut,

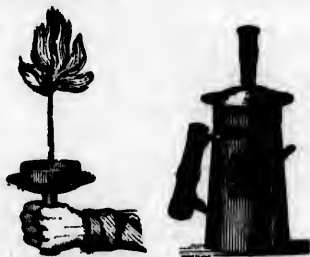

Gilbert's Registered Marine Signal Lamp.

This lamp consists of a metal vessel of about the size of a two or three pint measure; it may be made of tin-plate or copper. It has a cover to prevent the waste or evaporation of the material used for producing the light, to which the wick is attached. In this vessel is suspended by the cover, a coil of metallic wire, interwoven or coiled with cotton or any other fibrous matter, for the purpose of holding a portion of the inflammable spirit, which may be either turpentine or any other of the well-known inflammable liquids. The metallic wick is held in the hand whilst exhibiting, and may be carried to any part of the ship without injury or danger, or be swung rapidly round with the arm; thus forming a large circle of flame resembling a wheel rocket.

- 121 CHAPMAN, J. T., 328 Wapping—Inventor and Patentee.  
Brass models of patent shroud blocks, for setting up ships' rigging, and raising weights, as a substitute for the wooden dead-eye now in use. One man can raise, with a pair of these blocks, a weight of three tons. A patent portable screw winch, for setting up ships' rigging, and for hoisting in cargo or raising great weights on shore.
- 123 BURGESS, FRANCIS, 18 Salisbury Street, Strand—  
Proprietor.  
Model of main and top masts, formed by splicing small pieces of wood; these may be made at sea should the masts of a ship be carried away, and no spar be on board; they are bound with iron hoops, shown by black stripes in the model. The object of this invention is to give increased strength and elasticity; the step and top being formed alike, should the step give out or decay, the mast may be reversed and so made good.
- 124 SIMMENS, J.—Producer.  
Model of Mounts Bay fishing-boat.
- 125 SMITH, STEPHEN, Ship Yard, Waterford, Ireland—  
Inventor.  
Spring machine, for modelling ships of any form or dimensions.
- 126 EDAILE & MASGRAVE, City Saw Mills, Regent's Canal—Manufacturers. BOTHWAY, J., R.N.—Inventor.  
The 20-inch cat and general purpose block, which had its strength proved by the testing-machine in H.M.'s dockyard, at Devonport, Oct., 1848, and bore the strain of 50½ tons (with hurt); its weight only 2cwt. 1qr. 0lb.  
Two models of masts and yards made to scale; one rigged with the old rope-strapped blocks &c., the other with the inventor's internal-strapped blocks, to show the contrast and the superior qualities to all others.  
Two models of cat-heads, with the old iron-bound cat-block and inventor's of reduced size, with weights to prove the difference in their comparative power, with a variety of blocks (from two sheaves in the pair up to fifteen).
- Models and drawings of lower yards fitted with inventor's slings and portable gear-blocks, which have been so successfully used in the largest ships in H.M.'s Navy so many years—and other inventions.

- 127 RUSSELL, T. SCOTT, 37 Great George Street, Westminster—Inventor.

Models of ships constructed on the wave principle:—  
1. War steamer, with paddle-wheels, constructed by Messrs. Robinson and Russell, at Millwall, showing the new patent system of armament, which enables a steamer to carry double the usual armament; capable of being fired parallel to the keel. This vessel is 550 tons; has 160-horse power; steams 15½ miles an hour when light, and 13½ when at her deepest immersion, with stores, ammunition, water, and provisions, and fuel for 2,500 miles.  
2. War steamer, with paddle-wheels, on the same principle, of 1,200 tons, and 400-horse power; armament, twelve 68-pounders.

3. Paddle-wheel frigate, on the wave principle; same class as the "Terrible."

4. Sailing corvette, on the same principle, proposed by Captain Fishbourne, and constructed by Dr. Phipps.

5. Various models of yachts and steamers, on the same principle.

128 **ORDNANCE SURVEY DEPARTMENT.**  
By Lieut.-Col. HALL—Producer.

Description of Specimens forwarded by the Ordnance Survey Department:—

I.—The Ordnance map of England and Wales, on the scale of one inch to a mile (equal to  $\frac{1}{63360}$ th part of the real size) in its present state of progress, consists of 90 sheets, double elephant size, mounted on linen, and forming a connected map 28½ feet by 23 feet 5 inches nearly, the more recently published sheets having, for greater convenience in engraving, been divided into four parts.

The first sheets of part of Essex were published in 1805, and the last sheets included in this map, consisting of parts of Lancashire and Yorkshire, were published in 1844.

The sheets of the north of Lancashire and Yorkshire, now in course of preparation, are obtained by reduction from the six-inch map of those counties; it being intended to publish the remaining portion of the map of England and Wales on the one-inch scale.

The greatest number of impressions from any one plate sold to the public has been 5,500 for sheet No. 7, published in 1822; and on account of the large number of impressions that have been taken from the plates generally, many of them are now in want of extensive repair. This will, however, be avoided in future, by preparing duplicate plates by the electrotype process, as new plates are finished.

II.—The Ordnance map of Lancashire, on the scale of six inches to a mile (equal to  $\frac{1}{10560}$ th part of the real size), mounted on linen, and forming a connected map 40 feet by 27 feet.

The survey was commenced in 1841, and the engraving of the 112 sheets (each 3 feet by 2 feet), of which it is composed, has just been completed.

The physical relief and features of the ground are exhibited by a series of contour lines, or lines of equal altitude, at every 25 feet vertical distance apart; and these contour lines, together with the altitudes (above the mean level of the sea), of a large number of bench marks made on convenient and permanent sites, are recorded on the map.

A very large proportion of the ornament (woods and hedge-rows), and the whole of the altitude figures, are engraved on the copper-plates by the aid of stamps, and the tinting or shading on noblemen's and gentlemen's parks and demesnes, as well as that of the lands, is performed by steam machinery, recently introduced.

III.—The Ordnance map of the city of Dublin, on the scale of five feet to one mile (equal to  $\frac{1}{1320}$ th part of the real size), mounted on calico, and forming a connected map 20 feet by 14 feet 6 inches.

The survey was made in 1838, but the principal details have been corrected to 1847. To render it more peculiarly applicable to the purposes of sanitary improvement, the present sewerage and the pipes for the supply of water have been inserted, together with contours at equal intervals of five feet in height. This map is published in 33 sheets, each sheet 3 feet by 2 feet.

IV.—The Ordnance map of the town of Liverpool, on the scale of five feet to one mile (equal to  $\frac{1}{1320}$ th part of the real size), mounted on linen, and forming a connected map of 25 feet by 15 feet.

It is engraved in outline, and coloured by hand. The survey was completed in 1849, and the engraving was finished in September, 1850.

It is published in 50 sheets (each sheet 3 feet by 2 feet), and it is considered to be on as large a scale as can be put together for any connected public map. The ornament (trees and shrubs), figures, and small words and initials, are engraved by stamps.

The altitudes are given above the mean level of the sea.

V.—Specimens of hill drawings made by G. W. Carrington, Esq., formerly employed on the Ordnance Survey, prepared for and used by the engraver as a guide in etching the hill features of the one-inch map of England and Wales.

VI.—Specimens of hill engravings of the same sheets, by which the fidelity with which the engravers have followed the drawings may be seen.

VII.—Two engravings of hills, in trio-tinto, by Mr. James Duncan, principal engraver at the Ordnance Survey Office, Dublin.

1. Map on the scale of one inch to a mile of part of the county of Kilkenny, Ireland.

2. Map of the same, on the scale of half an inch to a mile.

The natural features of the country have been engraved on these maps (which have been reduced from the Ordnance Contoured Survey) in a new and peculiar style, which has been named trio-tinto by the inventor, Mr. Duncan, because it combines the effects of mezzotinto, aquatinta, and stippling. It is not a tedious or a costly process, and is applicable to other subjects in art, as well as that of engraving hills upon maps.

VIII.—Contoured index map to the townland survey of the county of Kilkenny, Ireland; mounted on a model of the ground in papier-mâché, by Mr. William Dalgleish, engraver at the Ordnance Survey Office, Dublin.

As there is no limit to the number of models which may be cast in a single mould, maps mounted in a similar manner can be produced at a cost very little exceeding that of the same maps unmounted, and such maps will be of essential service in elementary schools, by giving the pupils a more correct knowledge than they would otherwise obtain, of the relief traced out by the contour lines.

IX.—1. Engraved sheets of part of the Ordnance Survey of the county of Kilkenny, on which the hills have been shaded by aid of the contour lines. Scale six inches to one mile.

2. Outline map of the same, reduced from the above. Scale one inch to a mile.

3. Part of the contoured index map of the county of Kilkenny. Scale half-an-inch to one mile (equal to  $\frac{1}{2640}$ th part of the real size).

These specimens are intended to show the facilities afforded by the contours on the Ordnance maps for drawing the hills upon them, and for giving a correct delineation of the features of the country.

X.—1. South-east and north-east quarters of sheet 91, of the one-inch map of England and Wales, showing the physical relief of the country by contour lines, or lines of equal altitude, at equal vertical distances apart; reduced from the six-inch map of Lancashire and Yorkshire.

2. The same sheets shaded as hill drawings for the guidance of the engravers in executing the one-inch map of England and Wales, prepared entirely from the information afforded by the reduction of the contour lines from the six-inch map.

XI.—Small model of a portion of country near Bangor, in North Wales, and corresponding drawing of the same, by G. W. Carrington, Esq., late of the Ordnance Survey.

XII.—Plan of the borough of Southampton, on the scale of six inches to a mile, by Charles Holland, pensioner from the corps of Royal Sappers and Miners. Reduced from the five-foot map of the borough, prepared by the Ordnance Survey Department for the use of the local authorities in 1847.

XIII.—Diagram showing the principal triangulation of the United Kingdom of Great Britain and Ireland, of which an account is now being prepared for publication.

XIV.—Specimens of electrotyping:—

1. A copper-plate of the townland survey of the county of Donegal, engraved in 1837, and an impression from it.

2. An electro-matrix of No. 1, with the details erased, which have undergone alteration since the townland Survey was made.

3. An electro-duplicate from the matrix, No. 2, on which contour lines and other additions and alterations have been engraved, from the Ordnance survey in 1846-8, and two impressions of it, one of them taken immediately after its separation from the matrix, and the other taken from it in its present finished state.

These specimens show more particularly the manner in which the process of electrotyping is applied to the purpose of revising the maps of the Ordnance Survey of the northern counties of Ireland, which must without its aid have been engraved entirely anew, as it would have been impossible to have carried out, on the original copper-plates, the extensive alterations which are necessary.

4. An original copper-plate of the Ordnance Survey of the City of Dublin, and an impression of it.

5. An electro-matrix of No. 4.

6. An electro-duplicate of No. 4, and an impression of it.

7. An unfinished copper-plate (as an index to the 5-foot plans of Manchester and Salford), prepared by electrotyping matrices from three different plates of the Ordnance map of Lancashire, on the scale of 6 inches to a mile =  $\frac{1}{10000}$ ; removing the detail exterior to the town portion from the matrices, filing off the edges of the matrices at the junction lines of the sheets, and then depositing a duplicate plate on the joined matrices.

129 ELLIS, F. A., Commander R.N., *Great Yarmouth*—Inventor.

Model of a yacht, with a sliding keel, to enable her to go up shallow rivers and over bar-harbours. A method of suddenly lowering the mast to a level with the deck in a gale of wind. A projecting bow, which tends to keep the vessel up in a sea-way.

130 MACNAB, JOHN, 25 *York Place, Edinburgh*—Inventor.

Model of an improved first-class sea-going steam-ship.

131 GREEN, RICHARD, *Blackwall*—Owner.

Model of the "Owen Glendower" East Indiaman, built at Blackwall.

132 HOWE, JOSEPH, *Newcastle-upon-Tyne*—Maker.

Model of a clipper merchant schooner, complete and in working order.

133 DOWNS, HENRY, *Mile Town, Sheerness*—Designer.

Model of a corvette of 20 guns, regularly built, fitted, armed, and rigged.

134 LAMFORT, CHARLES, *Workington*—Designer.

Model of one of Messrs. Lindsay & Co.'s line of ships to Calcutta; 800 tons register.

135 CLARKE, JOSEPH AUG., 7 *Hamilton Sq., Birkenhead*—Designer.

Model of a steam vessel to a scale of half an inch to the foot; intended to represent a steam vessel of improved construction, and to show how increase of speed may be obtained by using wheels with moveable floats, instead of wheels with fixed floats: wheels with moveable floats are attached to the model.

136 NORTHUMBERLAND LIFE-BOAT COMMITTEE, *Somerset House, London*—Producer.

Models of life-boats, sent in to compete for the premium of 100 guineas, offered by the Duke of NORTHUMBERLAND, with the names of the designers or builders. Communicated by Captain WASHINGTON, R.N., F.R.S.

1 AINSWORTH, JOHN, *Bridlington, Yorkshire*.

Model of life-boat. Scale, 1 inch to a foot: length, 34 feet; breadth, 9 feet; depth, 4½ feet.

2 ANDERSON, THOMAS, *North Shields, Northumberland*.

Model of life-boat. Scale, 3 inches to a foot: length, 40 feet; breadth, 11½ feet; depth, 4 feet.

3 BEECHING, JAMES, *Great Yarmouth, Norfolk*.

Model of life-boat. Scale, 1 inch to a foot: length, 36 feet; breadth, 9½ feet; depth, 3½ feet.

4 BERTRAM, JAMES, 16 *East Street, Manchester Square, London*.

Model of life-boat. Scale, 1 inch to a foot: length, 30½ feet; breadth, 9 feet; depth, 2½ feet.

5 BLAIR, ROBERT, *South Shields, Northumberland*.

Model of life-boat. Scale, 1 inch to a foot: length, 35 feet; breadth, 12 feet; depth, 4½ feet.

6 BOSCH, P. VAN DEN, *Oosterhout, Netherlands*.

Model of life-boat. Scale, 1 inch to a foot: length, 24 feet; breadth, 4½ feet; depth, 2 feet.

7 BREMNER, JAMES, *Wick, Scotland*.

Model of life-boat. Scale ½ inch to a foot: length, 33 feet; breadth, 12 feet; depth 3½ feet.

8 BROMLEY, GILBEE, *Sheerness, Kent*.

Model of life-boat. Scale, 1 inch to a foot: length, 32 feet; breadth, 7 feet; depth, 3 feet.

9 BROWNE, JOHN HARCOURT, *Moorgate Street, London*.

Model of life-boat. Scale, 1½ inches to a foot: length, 23 feet; breadth, 6 feet; depth, 3½ feet.

10 COSTAIN, THOMAS, *Liverpool*.

Model of life-boat. Scale, 1 inch to a foot: length, 30 feet; breadth, 9½ feet; depth, 3½ feet.

11 EDMOND, JOHN, *Scarborough, Yorkshire*.

Model of life-boat (coble). Scale, 1 inch to a foot: length, 27 feet; breadth, 7½ feet; depth, 2½ feet.

12 FALKINGRIDGE, WILLIAM, *Whitby, Yorkshire*.

Model of life-boat. Scale, 1 inch to a foot: length, 35½ feet; breadth, 8 feet; depth, 3½ feet.

13 FARROW, GEORGE, *South Shields*.

Model of life-boat. Scale, 1 inch to a foot: length, 30 feet; breadth, 10 feet; depth 3½ feet.

14 FRANCIS, JOSEPH, *New York, United States*.

Model of surf life-boat. Scale, 1 inch to a foot: length, 27 feet; breadth, 7 feet; depth, 2½ feet.

Model of cutter. Scale, 1 inch to a foot: length, 27½ feet; breadth, 6½ feet; depth, 3 feet.

Model of life-car. Scale, 1 inch to a foot: length, 26½ feet; breadth, 7½ feet; depth, 6½ feet.

15 GALE, JOHN & ROBERT, *Whitby, Yorkshire*.

Model of life-boat. Scale, 1 inch to a foot: length, 30 feet; breadth, 11 feet; depth, 3½ feet.

16 GALE, G. HAMILYN, *Swansea*.

Model of life-boat. Scale, 1 inch to a foot: length, 28½ feet; breadth, 7½ feet; depth, 2½ feet.

17 GAZE, THOMAS, *Mundesley, Norfolk*.

Model of life-boat. Scale, 1½ inch to a foot: length 30 feet; breadth, 10 feet; depth, 4½ feet.

18 GRANT, WILLIAM, *Southsea, Hampshire*.

Model of life-boat. Scale, 1 inch to a foot: length, 25 feet; breadth, 7½ feet; depth 2½ feet.

19 GREENER, WILLIAM, *Birmingham*.

Model of life-boat. Scale, 1 inch to a foot: length, 37 feet; breadth 12 feet; depth, 2½ feet.

20 GURR, CHARLES, *Portsea, Hampshire*.

Model of life-boat. Scale, 1 inch to a foot: length, 30 feet; breadth, 7½ feet; depth, 3 feet.

21 HALL, MESSRS., *Aberdeen*.

Model of life-boat. Scale, 1 inch to a foot: length, 33½ feet; breadth, 8½ feet; depth, 4 feet.

22 HARDING, J. & J., *Whitby, Yorkshire*.

Model of life-boat. Scale, 1 inch to a foot: length, 30 feet; breadth, 10½ feet; depth, 3½ feet.

23 HARVEY, T. & SON, *Halifax, Ipswich*.

Model of life-boat. Scale, 1½ inches to a foot: length, 41 feet; breadth, 11 feet; depth, 4 feet.

24 HATT, CYPRIAN, *Lowestoft, Suffolk*.

Model of life-boat. Scale, 1 inch to a foot: length, 35 feet; breadth, 12 feet; depth, 4½ feet.

## WEST END GALLERY AND SOUTH-WEST GALLERY.

h, Norfolk.  
foot: length, 36

chester Square,  
a foot: length,

umberland.  
foot: length, 35

therlands.  
foot: length, 24

land.  
foot: length, 33

Kent.  
foot: length, 32

reet, London.  
a foot: length,

Yorkshire.  
a foot: length,

ts.  
foot: length, 30

I States.  
sh to a foot:  
feet.

ot: length, 27½

t: length, 26½

orkshire.  
ot: length, 30

t: length, 28½

olk.  
ot: length 30

hire.  
t: length, 25

m.  
t: length, 37

ire.  
t: length, 30

: length, 33½

re.  
t: length, 30

ch.  
foot: length,

t: length, 35

- 25 HAY, THE RIGHT HON. LORD JOHN, *Devonport*—  
Superintendent of H.M.'s Dockyard.  
Model of life-boat. Scale 1½ inches to a foot: length 32 feet; breadth, 7½ feet; depth, 3 ft. 7 in.; weight, 32 cwt.
- 26 HINKS, HENRY, *Appledore, Devon*.  
Model of life-boat. Scale, 1 inch to a foot: length, 30 feet; breadth, 9 feet; depth, 3½ feet.
- 27 HODGSON, JOSEPH, *Sunderland*.  
Model of life-boat. Scale, 1 inch to a foot: length, 30 feet; breadth, 9 feet; depth, 2½ feet.
- 28 HOUTEN, WILLIAM VAN, *Rotterdam*, President of the South Holland Shipwreck Institution.  
Model of life-boat and carriage. Scale, ¾ inch to a foot: length, 25 feet; breadth, 8 feet; depth, 3 feet.
- 29 JONES, JOSIAH, jun., *Liverpool*.  
Model of life-boat. Scale, ¾ inch to a foot: length, 30 feet; breadth, 8½ feet; depth, 4½ feet.
- 30 LEE, GEORGE, *Tweedmouth, Berwick*.  
Model of life-boat (coble). Scale, 1 inch to a foot: length, 28 feet; breadth, 9 feet; depth, 4 feet.
- 31 LYONS, GEORGE, *Portsea, Hampshire*.  
Model of life-boat. Scale, 1 inch to a foot: length, 24 feet; breadth, 6½ feet; depth, 3½ feet.
- 32 MILBURN, GEORGE, *Blyth, Northumberland*.  
Model of life-boat (coble). Scale, 2 inches to a foot: length, 37 feet; breadth, 8 feet; depth, 6 feet.
- 33 ORTON, REGINALD, *Bishopwearmouth, Durham*.  
Model of life-boat. Scale, 1 inch to a foot: length, 26 feet; breadth, 6 feet; depth, 2½ feet.
- 34 PALMER, GEORGE, *Nazing Park, Essex*.  
Model of life-boat. Scale, 1 inch to a foot: length, 26 feet; breadth, 6½ feet; depth, 3½ feet.
- 35 PATTERSON, WILLIAM, *Bristol*.  
Model of life-boat. Scale, 1 inch to a foot: length, 35 feet; breadth, 9½ feet; depth, 3½ feet.
- 36 PLENTY, JAMES, & EDWARD PELLEW, *Newbury, Berkshire*.  
Model of life-boat and carriage. Scale, 1½ inch to a foot: length, 24 feet; breadth, 8 feet; depth, 4 feet.
- 37 ROBINSON, ALEXANDER, *Hartlepool*.  
Model of life-boat. Scale, 1 inch to a foot: length, 34 feet; breadth, 11 feet; depth, 4 feet.
- 38 ROBINSON, DANIEL, *Gosport*.  
Model of life-boat. Scale, 1 inch to a foot: length, 30 feet; breadth, 7½ feet; depth, 4 feet.
- 39 ROBINSON, WILLIAM WHARTON, *Hartlepool*.  
Model of life-boat. Scale, 1 inch to a foot: length, 36 feet; breadth, 12 feet; depth, 4 feet.
- 40 SAXBY & BRAIN, *Bonchurch, Isle of Wight*.  
Model of life-boat. Scale, 1 inch to a foot: length, 30 feet; breadth, 7 feet; depth, 4 feet.
- 41 SEMMENS, J., & THOMAS W., *Penzance*.  
Model of life-boat. Scale, 1 inch to a foot: length, 30½ feet; breadth, 7½ feet; depth, 8½ feet.
- 42 SEVERN, HENRY AUGUSTUS, 21 *James Street, Buckingham Gate, London*.  
Model of double life-boat. Scale, ¾ an inch to a foot: length, 30 feet; breadth, 8 feet; depth, 4½ feet.
- 43 SHARPE, BENJAMIN, Lieutenant, R.N., *Hanwell Park, Middlesex*.  
Model of life-boat. Scale, 1 inch to a foot: length, 30 feet; breadth, 5 feet; depth, 3 feet.
- 44 SINCLAIR, DUNCAN, 122 *Oxford Street, London*.  
Model of life-boat. Scale, 1 inch to a foot: length, 30½ feet; breadth, 11 feet; depth, 4½ feet.
- 45 SLATER & WRIGHT, *Whitby, Yorkshire*.  
Model of life-boat. Scale, 1 inch to a foot: length, 31 feet; breadth, 9 feet; depth, 3½ feet.
- 46 SPARKE, WILLIAM, *Exeter, Devon*.  
Model of life-boat. Scale, 1 inch to a foot: length, 35 feet; breadth, 7 feet; depth, 4 feet.

- 47 TEASDEL, WILLIAM, *Great Yarmouth, Norfolk*.  
Model of life-boat. Scale, 1 inch to a foot: length, 32 feet; breadth, 10½ feet; depth, 3 feet.  
Model of life-boat. Scale, 1 inch to a foot: length, 36 feet; breadth, 10½ feet; depth, 3½ feet.
- 48 THOMPSON, JOHN, *Rotherhithe, London*.  
Model of life-boat. Scale, 1 inch to a foot: length, 32 feet; breadth, 10 feet; depth, 3½ feet.
- 49 TREDWEN, RICHARD, *Padstow*.  
Model of life-boat. Scale, 1 inch to a foot: length, 32 feet; breadth, 6 feet; depth, 3½ feet.
- 50 TURNER, GEORGE, *Devonport*, Senior Assistant to Master Shipwright in H.M.'s Dockyard.  
Model of a safety gig for the coast guard. Scale 1½ in. to a foot: length, 30 feet; breadth, 5 ft. 10 in.; depth, 2 ft. 7 in.: weight of boat and gear, 18 cwt.
- 51 WAKE, THOMAS, & SON, *Sunderland*.  
Model of life-boat. Scale, 1 inch to a foot: length, 34 feet; breadth, 10½ feet; depth, 3½ feet.
- 52 WAKE, W. M., & R. F., *Sunderland*.  
Model of life-boat. Scale, 1 inch to a foot: length, 36 feet; breadth, 9 feet; depth, 4 feet.
- 53 WHITTEM, JAMES, *Portsea, Hampshire*.  
Model of life-boat. Scale, 1 inch to a foot: length, 26 feet; breadth, 7½ feet; depth, 2½ feet.
- 54 WHITE, THOMAS & JOHN, *Cowes, Isle of Wight*.  
Model of life-boat. Scale, 1 inch to a foot: length, 32 feet; breadth, 8 feet; depth, 3 feet.  
Model of a safety galley. Scale, 1 inch to a foot: length, 25 feet; breadth, 7 feet; depth, 2½ feet.

- 136A HAWES, W. R., *Plantation House, Robin Hood's Bay, near Whitby*—Inventor and Manufacturer.  
Model of life-boat, emptying itself, when full of water, in the short space of four seconds, by means of two apertures in the bottom.
- 137 FAWENS, GEORGE—Inventor.  
A life-boat, of wood and cork. It is provided with 12 air-tight compartments, lined with gutta serena, containing nearly 100 cubic feet of air, and three scuppers on each side of her keel for the egress of water.
- 138 MILBURN, G., *Blyth, Northumberland*—Inventor.  
Model of a life-boat.
- 139 McLAREN, WILLIAM, 74 *High Street, Camden Town*—Manufacturer.  
Model of an 80-gun line-of-battle ship, fully rigged, sails bent, &c. Built entirely of variegated woods.
- 140 CONSTABLE, HENRY, 22 *Queen's Gardens, Brighton*—Designer.  
Model of Lord Nelson's mode of attack on the combined fleet off the Cape of Trafalgar.
- 141 BILBE, THOMAS, & Co., *Nelson Dock, Rotherhithe*—Inventor.  
Model of a merchant ship. The frame timbers are arranged diagonally, by which great additional strength is given to the fabric, with the same thickness of materials as formerly used. This plan is economical from the smallness of the bevellings and elongation of the curves.
- 142 COLEGRAVE, FRANCIS EDWARD, *Round Hill House, Brighton*—Inventor.  
Model of a brigantine, rigged and fitted with patent anchor, spring cable, and lanyard springs.  
The patent spring is intended to diminish the strain on the rigging and anchor cable of vessels.
- 143 BROOKES, HENRY, 46 *Mornington Pl., Hampstead Road*—Proprietor.  
Patent canal and river steam-tug, for hauling vessels on canals or narrow rivers, having neither paddles, wheels, nor screw propeller, with a double keel, and a well or trough between them, which may be closed at top



or bottom, or both, to form a hollow chamber or tube, inclined from the centre to the bottom at each end. Across this well at the centre are two wooden wheels, one over the other, which are driven by the steam engine. Along the bottom of the canal or river a flexible iron band or rail is laid about two inches and a half wide by one-eighth of an inch thick. This band being raised up into the well and laid between the two wheels, the upper wheel is screwed down and it becomes tightly compressed between them. As these wheels revolve, the band is drawn rapidly through them from stem to stern, when it again sinks to the bottom.

144 MUMFORD, WILLIAM THOMAS, 19 Edward Street, Deptford—Inventor.

A model of the paddle-box of a steam frigate of 600 horse-power, with wheel and paddle-box boat, illustrating a plan for shipping and unshipping the boat. The machinery consists of two straight davits, 8 feet 6 inches long, and two vertical stanchions, 11 feet 6 inches long, blocks and rigging, by the application of which the boat may be hoisted on or off with facility.

Model of a gun-carriage for working a gun at a bow, broadside, or stern-port; it can be used with ease when the ship's bow or stern flares out at an angle of 25 degrees, and when wanted at a broadside port, the fore trucks can be fixed, and the slides removed immediately.

145 ADMIRALTY, SOMERSET HOUSE—Producer.

Series of Half-Models of Ships-of-War, fitted with Screw-Propellers :—

1. St. Jean d'Acre, of 100 guns, building at Devonport.
2. Agamemnon, of 90 guns, building at Woolwich.
3. Impérieuse, of 50 guns, building at Deptford.
4. Arrogant, of 46 guns, at sea.
5. Tribune, of 30 guns, building at Sheerness.
6. Highflyer, of 20 guns, building at Blackwall.
7. Archer, of 12 guns, at sea.
8. Cruiser, of 16 guns, building at Deptford.
9. Reynard, of 10 guns, at sea.

146 ADMIRALTY, SOMERSET HOUSE—Producer.

Series of Half-Models of Sailing Ships belonging to the Royal Navy :—

1. The Queen, of 116 guns, flag-ship in the Mediterranean.
2. Albion, of 90 guns, employed in the Mediterranean.
3. Hannibal, of 90 guns, building at Deptford.
4. Caesar, of 90 guns, building at Pembroke.

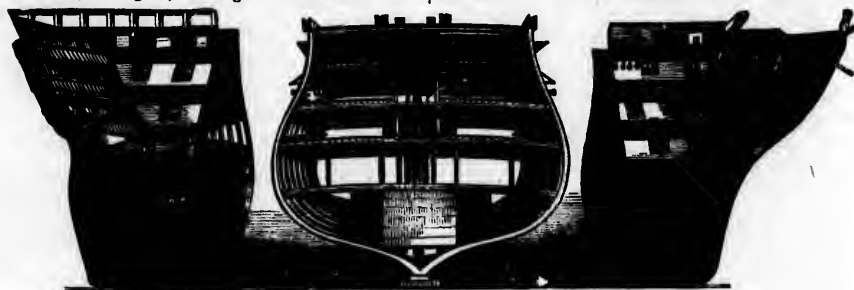

Bow, Stern, and Transverse Sections of H.M.S. "Queen."

Bow and stern of H.M.S. Albion.

Bow, stern, and transverse section of H.M.S. Vanguard and H.M.S. Pique.

Stern of a 50-gun and a 60-gun frigate.

Series of models of ships' boats.

147 CAMPBELL, ALEXANDER F., Great Plumstead, Norwich—Inventor and Patentee.

Patent ship propeller in the model of a vessel with steam machinery, two blades revolving.  
Model of a screw steamer.

5. Superb, of 80 guns, employed in the Mediterranean.
6. Cressy, of 80 guns, building at Chatham.
7. Cumberland, of 70 guns, flag-ship in the West Indies.
8. Emerald, 60-gun frigate, building at Deptford.
9. Narcissus, 50-gun frigate, building at Devonport.
10. Dianoid, 28-gun frigate, in ordinary at Sheerness.
11. Archino, 18-gun sloop, at Devonport.
12. Siren, 16-gun brig, at Sheerness.
13. Pilot, 12-gun brig, employed in the East Indies.
14. Britomart, 10-gun brig.

Series of Half-Models of Experimental Frigates of the Royal Navy :—

1. The Arethusa, of 50 guns.
2. Indefatigable, of 50 guns.
3. Leander, of 50 guns.
4. Phaeton, of 50 guns—all of the Experimental Squadron.
5. Raleigh, of 50 guns, in ordinary at Portsmouth.
6. Nankin, of 50 guns, in ordinary at Chatham.
7. San Fiorenzo, of 50 guns, building at Woolwich.
8. Thetis, of 38 guns, employed on south-east coast of America.
9. Inconstant, of 36 guns, in ordinary at Devonport.
10. Eurydice, of 26 guns, in ordinary at Portsmouth.
11. Spartan, of 26 guns, in ordinary at Devonport.

Series of Half-Models of Experimental Brigs in the Royal Navy :—

1. Flying-fish, 12 guns, West Coast of Africa.
2. Espiegle, 12 guns, in ordinary at Sheerness.
3. Daring, 12 guns, in ordinary at Chatham.
4. Osprey, 12 guns, wrecked at New Zealand.
5. Mutine, 12 guns, wrecked in the Mediterranean.
6. Waterwitch, 10 guns, in ordinary at Chatham.
7. Pantaloon, 10 guns, Cape of Good Hope Station.

Whole Models of Ships belonging to the Royal Navy :—

1. The Queen, of 116 guns, flag-ship in the Mediterranean.
2. Royal Albert, 120 guns, building at Woolwich.
3. Vanguard, 80 guns, in ordinary at Devonport.
4. Cumberland, 70 guns, flag-ship in the West Indies.
5. Vernon, 50-gun frigate, in ordinary at Chatham.
6. Pique, 40-gun frigate, in ordinary at Portsmouth.
7. Siren, 16-gun brig, in ordinary at Sheerness.

Models of Bows, Sterns, and Transverse Sections of Her Majesty's Ships :—

Bow, stern, and transverse sections of H.M.S. Queen. These sections exhibit the most important features in the construction of the ship—the arrangement of her decks and the mould of the bow and stern :—

148 TWYMAN, H., Ramsgate—Manufacturer.

Model of a lugger used on the coast for rendering assistance to vessels in distress.

149 MARE, C. J. & Co., Orchard Yard, Blackwall—Designers and Manufacturers.

Model of Her Majesty's iron screw steam-yacht, "Fairy."

Model of iron steam-vessels built for the Emperor of Russia, the Viceroy of Egypt, &c.

the Mediterranean.  
hatham.  
in the West Indies.  
in Deptford.  
g at Devonport.  
ary at Sheerness.  
port.

to East Indies.

1 Frigates of the  
undefatigable, of 50  
4. Phaeton, of 50  
quadron,  
at Portsmouth.  
at Chatham.  
g at Woolwich,  
south-east coast of

y at Devonport.  
at Portsmouth.  
at Devonport.

Brigs in the Royal

f Africa.  
sheerness.  
hatham.  
Zealand.  
Mediterranean.  
at Chatham.  
Hope Station.

the Royal Navy:—  
in the Mediterra-

t Woolwich.  
Devonport.  
the West Indies.  
y at Chatham.  
at Portsmouth.  
sheerness.

Sections of Her

F H.M.S. Queen.  
ent features in the  
ent of her decks



Manufacturer.  
for rendering

, Blackwell—

steam-yacht,

the Emperor

150 HARRIS, SIR WILLIAM SNOW, Plymouth—Inventor.

Practical models, illustrative of the system of conductors employed to protect Her Majesty's ships from lightning:—1. General plan and construction of the conducting plates, showing the alternate jointing of the plates. 2. Line of conduction on the masts from the vane to the

Fig. 1.

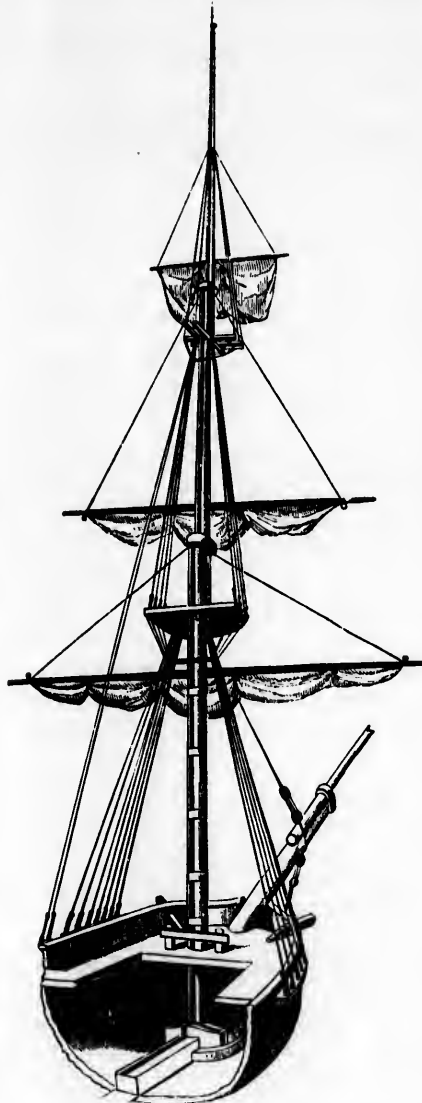

Sir W. S. Harris's Lightning Conductors.

step. 3. The conductor as applied to a topmast 4. General plan of the hull, with connecting branches and bolts communicating in various points with the sea, viz.: by

the keel, at the sides; and at stem and stern. 5. Preparation of the step of the mast, with part of the keelson. This method of preserving ships against the effects of lightning has proved efficacious; and it requires no care or interference on the part of the officers or crew. Since the full employment of this system in the Navy, no damage from lightning has been recorded.

Fig. 3.



Fig. 2.

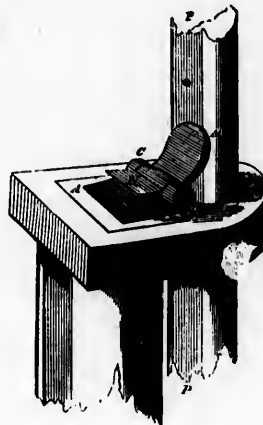
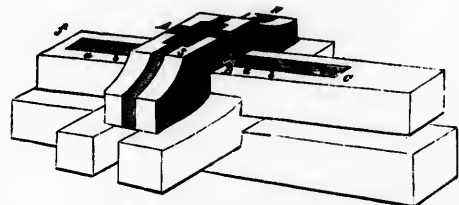

Fig. 4.



Sir W. S. Harris's Lightning Conductors.

Fig. 1 shows the line of conduction on the masts from the vane spindle to the step.

Fig. 2 represents the moveable tumbler at the junction with the caps, in which A D is a copper plate fixed on the cap, N M an angular plate set on the hinge C D. P the conductor on the mast. This hinge is sometimes covered with a small saddle of wood, to prevent its being damaged.

Fig. 3. The vane spindle; in which *s t* is the portion inserted into the royal mast; *s* the thread of a screw for securing it; *D* a thick cylindrical base, with a hole at *D* for a small lever.

Fig. 4. The step of the mast and portion of keelson. *A B, M N* the transverse and longitudinal branches passing round the step, and through the mortise at *S*. *f c* the branch over keelson; bolts *a b c*.

[The several nautical and scientific conditions, which this system of lightning-conductors in ships professes to satisfy, are as follow:—

The conductors are capacious, and always in place, consequently ready to meet the most unexpected danger, at all times, and under any circumstances, in which the general fabric in all its casualties may become placed. The system of conductors, whilst being permanently fixed throughout their whole extent, still admit, upon demonstrable principles of electrical action, the perfect motion of the sliding masts one on the other, or of any part of the mast being removed either by accident or design, without for an instant interfering with the protecting power. The conductors are independent of the officers or crew of the ship; so that the sailors are never required to handle or replace them, often a very perilous and annoying service. The conducting plates are quite clear of the standing and running rigging; the whole series is calculated to resist external violence, and at the same time yield to any flexure or strain incidental to the spars to which they are applied. Finally, the whole system is so arranged, that a discharge of lightning falling on any part of the ship could scarcely enter upon any circuit in its course to the sea, of which the conductors did not form a part; hence arises that perfect security which experience has shown to be derived from such a system.

In the original conception of this system, the inventor was led to consider the electrical discharge, as seen in the phenomenon of lightning, to be an explosive form of action of some unknown agency in nature when forcing its way through resisting matter, such as air, all vitreous and resinous bodies, and some other kinds of matter; whilst in traversing other bodies, offering but a very small resistance to its progress, this explosive form of action we call lightning becomes transformed into a sort of comparatively quiescent current. The attempt was, therefore, to bring a ship, as far as possible, into that passive or non-resisting state which she would possess as regards the electrical discharge, supposing the entire mass were metallic throughout, so that, from the instant the agency of lightning struck upon any portion of the masts aloft, the explosive action would vanish, and the electrical discharge be prevented from traversing the vessel under the form of lightning. The following extract from the official journal of H.M.S. Conway, 28, whilst proving, by a great natural experiment, in common with numerous other cases, the truth of this deduction, is of no ordinary interest in practical science:—

“Port Louis, Isle of France, 9th March, 1846, 11.45 A.M. The pendant staff at main-top mast-head was shivered in pieces by lightning, Harris's conductor carrying off the fluid without further damage.”

The ship was refitting at this time, and the top-gallant masts on deck, so that a small spar was set up at the top-mast head as a temporary support for the pendant; this spar had not, consequently, any conductor on it. It is seen by the ship's journal, that the spar was shivered in pieces by the explosive action, which became immediately transformed into a comparatively quiescent current on reaching the line of conduction.

The report of the thunder was as if one of the main-

deck guns had been fired. The gunner, who was sitting in his berth, immediately under one of the lateral branches of the conductor passing through the ship, saw, through the scuttle port, a brilliant blaze of light from the ship upon the sea, but experienced no inconvenience.]

151 HUSBAND, J., *Mylor, Falmouth*—Inventor and Constructor.

Model of a new life-boat.

Frame of a merchant ship, showing a plan of securing heads and heels of timbers, without chocks or dowels.

152 ALDERERT, I., *57 Lowy Acre*—Inventor.

Model of a first-class frigate.

153 TURNBULL, ROBERT, *South Shields*—Designer.

Model of the hull of a merchant ship, of 867 tons O. M., built according to Lloyd's rules, on a scale of a quarter of an inch to the foot.

154 TURNBULL, EDWIN, *Whitby, Yorkshire*—Manufacturer.

Models of a 74-gun ship, of the time of Lord Nelson, and of the steam-ship “Phoenix.”

156 HALL, JAMES, *Bronley, Bow, Middlesex*—Proprietor.

Models of ships' rudders, and a plan for wearing a ship without a rudder.

157 BELL, HUGH, *Balric Wharf, Millbank*—Inventor and Manufacturer.

Life-boat, for the beach, on the scale of 1 inch to the foot. One end of the boat. The lines representing the manner in which the two layers of planks should cross each other, and the keel and keelson in single planks from gunwale to gunwale. It is intended that there should be a waterproof elastic material between the layers of planks, to prevent escape, and to diminish the effect of concussion.

Gutta-percha canister fitted into the boat. Copper canister, which may fit the same end of the boat. Scoop to bale out the water after the plugholes are stopped. Cradle for transmitting every kind of boat from place to place on land. A set of boats in the position of a ship's long boat, intended for emigrant passenger, troop ships, and men-of-war.

158 BROWNE, WM. CHESELDEN, *Tutness, Devonshire*—Inventor.

Model of “The Princess Royal,” 120-gun ship, made of wood and card-board.

159 HARVEY, D., *3 Cumming Place, Pentonville Hill*—Inventor.

Model of Her Majesty's royal yacht “The Victoria and Albert,” on a scale of one-eighth of an inch to the foot; and of “The Fairy,” screw yacht, on a scale of one-eighth of an inch to the foot. A tender to the same. Also of a 46-gun frigate, on a scale of three-eighths of an inch to the foot. It is not modelled in the usual way, but is practically built, with frame timbers, and planked over, having one plank streak left out to show the disposition of the timbers.

160 GRAY, JOHN, *Newhaven, Sussex*—Ship-builder.

A mechanical model of a South Sea whale fishery ship, on a scale of  $\frac{1}{4}$  inch to the foot, with all the lengths of timbers, plank, &c., properly shifted, butted, and fastened as required by Lloyd's rules to Class 12 A 1 in the registry; as also in every other part of the model as far as it is completed. There are in the frame 611 separate timbers, 19 lower and 22 upper deck beams, 1,844 treenails, 4,710 bolts.

161 HORN, HENRY, *Victoria Cottage, Kingston, Portsea*—Manufacturer and Designer.

Model of a 12-gun brig, on a slip for launching; scale a quarter of an inch to a foot.

WEST END GALLERY AND SOUTH-WEST GALLERY.

- 162 **WHITE, —, Producer.**  
Model of the "Samuel Enderby."
- 163 **MILLER, RAVENHILL, & Co., Ratcliff and Blackwall**  
—Engineers and Ship-builders.  
Model of the "Jupiter" steam-boat, running between Blackwall and Gravesend. Designed by Edward Passo.
- 164 **ROSE, JOHN THOMAS, Regent Street, Leith—**  
Designer.  
Model, in oak, of a Roman war-galley (Quadrirème), illustrative of Mr. Howell's theory of the Polyurota. According to this theory, the "banks" were reckoned in the direction of the galley's length, and not from the number of tiers as generally supposed. On the common theory, Ptolemy Philopater's galley, of forty banks of oars, must have been nearly two hundred feet in its height from the water; on the above theory it need not have exceeded ten feet. The oars (40 in number) are put in motion by a handle at the side.
- 165 **SMITH, HENRY, 208 Rotherhithe Street, Rotherhithe**  
—Manufacturer.  
A built model of the barque "Faling Grove," on a scale of one-third of an inch to a foot, one side left open to show the construction.
- 166 **HOLL, J. & Co., Vauxhall Wharf—Inventor.**  
Model of a barge.
- \*.\* From 167 to 180 in East End Prussian Gallery South.
- 167 **WENTZELL, A., Lambeth—Manufacturer.**  
Light gig, built of mahogany, maple, and sassafras, with carved back and morocco seat. Racing boat, built of mahogany and maple.  
Model of a registered life-boat, built with tumblehome sides, the sides and ends divided into compartments, the bottom perforated so that the water finds its level as fast as the sea breaks over it.
- 168 **FORSTER, JOHN & THOMAS, Strathearn—Inventors.**  
Boat, built of wood coated on both sides with a compound of gutta percha and India rubber. Sections of boats and small cases, of the same. Samples of water-proofing. Accoutrements made of the same. Specimens showing the effect of shot.
- 169 **SEARLE, GEORGE, & SONS, Stungate, Lambeth—**  
Manufacturers.  
Model of the state barge of the Lord Mayor of London—scale, 1 inch to a foot. (Main Avenue West.)  
Boat, called, on the Thames, a pair-oared gig.

Fig. 1.

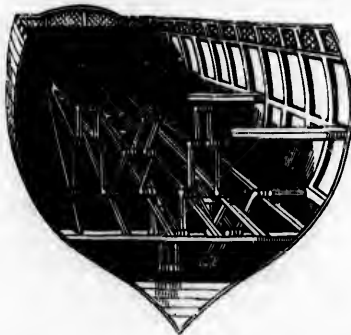

- 169A **BROWN, JOSEPH, 71 Leadenhall Street—**  
Inventor and Manufacturer.  
Registered portable raft for the preservation of life from shipwreck, &c.  
Patent double-action sofa bed, intended to prevent sea sickness.  
Patent fire escape; it forms a raised platform, and may be used as a scaffold, for exterior decorations, &c.
- 170 **LAPTHORN, JAMES, Gosport, Hants—Sailmaker.**  
Model of a brig yacht, 450 tons, with spars and sails.
- 171 **RUTHVEN, MORRIS WEST, New Street, Edinburgh—**  
Inventor and Patentee.  
Model of a steam-vessel, with improvements in propelling and navigating. To the engine shaft is attached a wheel, working in a water-tight case, to which water is supplied, and from which it is allowed to escape by a pipe, terminated by a nozzle on either side the ship, which by universal joints can be raised or depressed to any angle, directed forwards, backwards, or downwards simultaneously or alternately, thereby giving a greater or less speed to the ship either ahead or astern, or causing her to remain stationary; or by placing one nozzle ahead and the other astern the vessel is made to go about or alter her course, so that if the rudder be carried away those on deck can affect her motion or speed without altering that of the engine.

- 172 **SMULDHAM, MOLYNEUX, Melton, Woodbridge—**  
Inventor.  
Patent revolving masts, &c. The assumed utility of the invention consists in causing the masts to revolve, by which manual labour in the evolution of "tacking" is avoided.  
These masts are adapted to yachts, despatch vessels, and coast cruisers; but more particularly to coasters or vessels voyaging in intricate navigations, or in the Arctic Seas.  
Illustrations of a method of ballasting vessels, combined with the revolving rig.  
A boat made to show a method of constructing a revolving mast, adapted for small boats, and for two-masted luggers, up to 20 tons, by the aid of a spreader for one, or a pair of shrouds, with an apparatus to show that the plan is also adapted for small pleasure-boats.

Fig. 2.

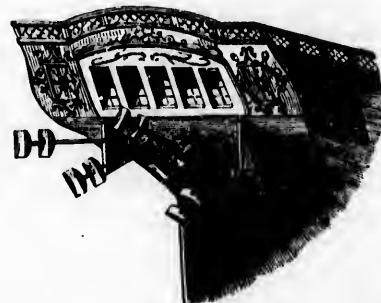

Pennice's new Propeller for Steam vessels.

Figs. 1 and 2 represent this propeller, seen from the inside and from outside the stern of the vessel. These figures also indicate the peculiar mechanical arrangements, giving the propellers their propulsive movement.

174 **DEMPSTER, HENRY**, 1 Cannon Street, *Hamburgh Place, Leith*—Inventor.

Drawing of a simple telegraph, being a system of sea signals, which, by means of colours, indicate the letters of the alphabet, numbers, and the points of the compass. Mast with model flag of the true size.

176 **PILKINGTON, JOHN**, *Goole, Leeds*—Inventor.

A wrought-iron keelson, for wood-built ships. Its object is to give a greater degree of strength and durability, without any additional dead-weight, and to obviate the great difficulty in obtaining suitable lengths and sizes of oak timber. This keelson, being tubular and perfectly water-tight, assists in ballasting vessels when clear of cargo, by opening a valve to admit water; it is afterwards let off into the bottom of the ship, and pumped out in the ordinary way. The keelson may be used as a water-tank.

[By lowering the centre of gravity of a ship its stability is increased: the best position for the ballast, therefore, is the lowest, viz., the keelson.—S. C.]

177 **CORTE, —**, Inventor.

Model of a rocket apparatus.

178 **NOULTON & WYLD**, *Fore Street, Lambeth*—Manufacturers.

London out-rigger sculling boat, for racing; the body of this boat is in one plank, from head to stern, and side to side, without a join or reel, and "is the first boat so built;" by this means a more beautiful mould can be obtained, and less resistance is offered to the water.

Model of an eight-oared shallop, with awnings; with an improved mould of floor and bow.

179 **BIFFEN, WILLIAM**, *Hammermith*—Inventor and Builder.

A rigged portable boat, the length of which may be reduced from 30 feet to 10. In case of accident to any compartment this boat will still float with her rower.

180 **HUBBARD, CHARLES**, *Dickleburgh, near Soale, Norfolk*—Inventor.

Gutta percha portable boat, for crossing detached inland waters; it carries two persons, and weighs only 30 lbs.

Miniature working model of a portable machine for climbing precipices; illustrated by a model of the crags on the Orkney coast.

Case of ornithological specimens.

\*. From 181 to 197 with Class 5, Ground Floor North.

181 **BROOKER, JAMES**, *Maryport*—Designer.

Figure-head: Ceres picking up the veil of her daughter Proserpine.

182 **GLADSTONE, JOHN, JUN., & Co.**, *Liverpool*—Manufacturers.

Model of ship's windlass purchase, for raising anchors, chain-cables, and other heavy weights on board ships. Sufficient to ride the ship without the possibility of having the windlass upset. With this machine less than half the usual number of hands are required to weigh the anchor, &c.

[The ordinary ship's windlass is a spindle-shaped beam, polygonal in transverse section, acting horizontally at right angles to a line bisecting the ship from stem to stern, and working in and bearing upon stanchions, called "knight-heads," strongly fixed to the ship's deck and deck timbers, immediately abaft the foremast. The use of the windlass is to raise or weigh the anchor by means of the cable, which is made to take a turn round the windlass beam, whose spindle shape enables it to present

itself at right angles to a line drawn from either hawse-hole, under which the anchor may lie, for the ship is hove short upon her anchor by means of the more quickly moving but less powerful capstan, before the windlass is called into action. The "purchase" of a windlass is the power applicable to work it, or rather the means provided, as the handspike levers in ordinary use, of applying the power of the men to turn the beam, and wind or hoist up the anchor by its cable. Nothing can exceed the simplicity or the strength of the ordinary ship's windlass, having regard to the size and strength of the ship herself; but there is room for improvement in the power and in the speed of a windlass, and the means of doing the same work with fewer hands would be a great advantage.—W. H.]

184 **FERGUSON, C. A. & T.**, *Mast House, Mill Wall, Poplar*—Inventors and Manufacturers.

Model representing a mast 99 feet long and 33 inches diameter: the principal objects of which are, economy in the first cost of materials, and the practicability of building large masts with small timber.

An improved fid for ships' or steam-vessels' topmasts and topgallantmasts, also for cutters' bowsprits, to facilitate striking the same, without any necessity to ease off lanyards, or heaving on the heel rope.

Also a model of the fid, showing its action.

Two models of sections of deck, stanchions, &c., of a ship of war, with improved gun, for increasing the angle of horizontal pointing, and for projecting outboard at bows, sterns, and quarters, where the rake is so great; fitted with angle-meter, which will show the true position of the gun. (Gun invented by H. R. Caselli.)

Registered gun-carriages and appurtenances, showing the action of the improvements for working them.

Blocks, with sheaves and pins for them, showing the different improvements introduced.

The old principle, wood sheave and pin. The iron-coated sheave and iron pin. The brass-coated sheave and turned iron pin. The anti-friction gun-metal roller-coated sheave and turned iron pin; and the highly compressed leather-coated sheave, and turned iron pin.

185 **ANSELL, CHARLES**, *Tottenham*—Designer.

Sailing gun punt on a new plan, with water-tight bulk-heads, and the mast so placed as to allow the gun to be fired when under sail. Tackle for the same, capable of being stowed within board. Adapted for wild-fowl shooting on the coast.

Stanchion gun, with stub twist barrel, and improved spring, composed of discs of vulcanized india rubber, to ease the recoil. Range, 150 yards.

186 **WELD, JOSEPH**, *Intworth Castle, Wareham*—Designer.

Model of a 12-gun brig-of-war, built on scientific principles, calculated to insure fast sailing.

187 **ANDERSON, J.**, *North Shields*—Inventor.

Model of a life-boat.

188 **JEFFERY, WALSH, & Co.**, *Marine Glue Works, Limehouse*—Inventors.

Specimens of patent elastic, adhesive, and insoluble marine glue, showing its utility in naval architecture, and its durability and cleanliness.

Piece of the mast of the "Curacoa," found inseparable, even by the wedge, on return from South America.

Piece of mast tested by the hydraulic press—22 tons required to remove one splinter—joints remaining perfect, giving an additional strength dispersed over the internal surfaces of a first-rate's main of 1,304 tons.

Section of the same, showing fracture.



Jib tongued and joined with glue.  
Block of elm joined with glue and exploded with powder; the joint remaining entire.

Place of glued deck; the interior of the vessel destroyed by fire.

Oak cannon ball joined and fired with 8 oz. powder at Woolwich, in 1842, at an angle of 45 degrees, at the request of the late Sir I. M. Brunel, to try the effect of concussion on the joint when rebounding on the earth in its fall; the joint remaining entire.

Deal block; square foot of surface glued; wood broke at 4 tons, thus giving, at 3 tons per foot, upwards of 25,000 tons additional strength dispersed over the hull of a first-rate.

Model mast exploded with powder, rending the timber but not the joints; the glue confining the splinters; with section of the same.

Model mast, made of northern seasoned timber; durable and strong; with section of the same.

Circular timber, converted from the straight by means of the glue.

Mahogany deck, payed with marine glue.

Two seams payed with glue, and two with pitch, exposed to the same temperature; showing the effect of the sun on top-sides of vessels under the line.

In the construction of masts, the marine glue admits of small seasoned Dantzic, or northern timber, being used instead of yellow pine. Upwards of 2007, it is said to be saved in one mast, in its first construction, and upwards of 25,000 tons additional strength dispersed over the hull, and 6,384 tons over the internal surfaces of the masts of a first-rate ship. This calculation is under the actual strength, being calculated at three tons per square foot instead of four—the timber's breaking strain.

A Commission recently appointed by the Admiralty, to collect evidence and report their opinion on the value of the marine glue, for the use of the invention in Her Majesty's Navy, collected evidence to this effect, viz.:—That out of the 130 vessels which have been glued in the Royal Navy, one caulking and paying with glue has been found equal to three times with pitch; besides other valuable evidence as to its cleanliness, security, and comfort to crews.

At an examination, some months since, in Sheerness yard, of the masts and bowsprits of five line-of-battle ships, all made since 1841-2, of yellow pine timber without marine glue, 16 out of 20 were found rotten and condemned, although the masts of three of the ships had never been in commission; while all the masts and yards made with marine glue, in 1842-3, have been found, on their return from foreign service, inseparable even by the wedge, as testified in official reports.

The rapid rotting of yellow pine masts made on the old method is well known; and it was as a remedy for this that the committee of master shipwrights attached the highest importance to the marine glue; stating—"that should it be found to retain its great adhesive force, after years of trial in a tropical climate, masts for the future might be made of small seasoned timber, and a great saving effected throughout the navy."

[Decks, or rather the joints between the planks which form the floors or decks of ships, are usually caulked with oakum; the joints being merely narrow spaces which the caulking fills up. The joints are made open, that the planks, being of wood, may have room to swell when wetted, and the caulking ought to be so elastic as to yield to compression, and return again upon the shrinking of the planks in dry weather, and capable at the same time of resisting water. These requisites, oakum, with the admixture of a little tar, is found to possess in a great degree, and, aided by a paying of pitch on the surface of the seam, answers very well for the caulking of lower decks. Pitch is useless for this purpose on upper decks. Any substance possessing the qualities above alluded to as requisites, being impervious to the weather, not liable to be destroyed by moisture, as ordinary animal glue is,

and yet capable of being used and of acting adhesively, as being durable and cleanly, must be of value.

"Made-masts" are masts not in one tree, log, or spar, as to its transverse section, but made up or built of several pieces fitted together and hooped, as a cask is. It is difficult in practice to fit and bring together the parts of a made-mast so closely as not to require some packing in the joints, to aid the hoops in preventing movement among them, and to keep out water from the body of the mast. The glue referred to is intended to supply the packing, to cause adhesion of the parts of a made-mast, and to exclude the water.—W. H.]

180 O'CONNOR, HUGH, *Limerick*—Inventor.

Model of a rotatory boat pump.

190 ANDERSON, ROBERT, *Westoe, South Shields*—Inventor.

Small pattern life-boat, clinker-built, fitted with air-tight ceiling, feathered and grooved up to her gunwales, forming an air-tight inner skin. This boat has a well or tank in her centre bottom, holding 44 gallons of water, with which it is ballasted when in the water with the crew on board;—and when the well is full, the valves shut down tight by their own weight. The boat is also provided with air-tight compartments in her bottom surrounding the well, to the sides and ends, rising at each end with nearly the same sheer as the gunwale and in other parts. The boat is intended to answer either for beach service or for a passenger ship or steamer; for the latter purpose it is fitted with two small self-working lug-sails, and a jib and a rudder to use when under sail. The well, in this service, can be filled with fresh water, and the air-cases with bread and provisions.

This boat has been severely tested in heavy broken water on the hard sand, and could neither be swamped nor upset.

191 TRAIL, ARCHIBALD, *8 Upper East Smithfield*

—Inventor and Patentee.

Patent storm sails: the novelty consists in the application of narrow corded bands of one inch in breadth, with cords woven therein, being sewn in reversed angular directions, on the fore and after part of the sail, the ends of which are spliced into the bolt rope. By this means the destructive effects of the wind are confined within the limit of the diamond (being about 4½ inches), and the sail wears much longer, by equalizing the strain over all its parts.

192 ADDISON & GILBERT, *Emmett Street, Poplar*—

Inventors.

Two models, one of a patent main-top-sail, and the other of a patent jib, showing the graduated variation in the width of the seams used in making sails; intended to give greater strength and durability to the sails, with less canvas.

193 ROBINSON & RUSSELL—Builders.

Model of a Prussian war steamer.

194 CARPENTER, E. J., Capt., *Senior United Service*

*Club*—Inventor and Patentee.

Duplex rudder and screw propeller.—The engraving represents a stern view of a vessel with two rudders and two screw propellers, fitted in new positions for improved steering and propelling. From the midship section of the vessel to the stem, no alteration is introduced into the form of the hull; but abaft this point they commence. First, the keel, with the dead wood, stern-post, and rudder, are removed, and the flooring above receives a suitable form for strength. Two additional keels lie in a line parallel with the former keel, but placed at a distance of two or more feet, according to the size of the vessel, on either side of it, terminating at the midship section in the fore-part, and in a line with the former

stern-post in the after-part. Framework is carried down to these keels, leaving a free channel for the water to run between them in the direction of the midship keel. A stern-post is placed at the end of the additional keels, and upon each of them hangs a rudder.

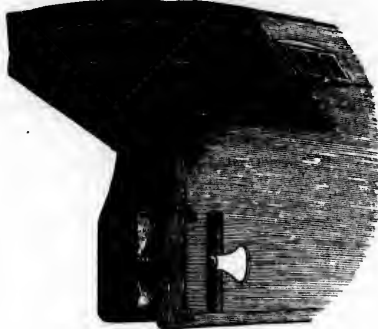

Carpenter's Duplex Rudder and Screw-propeller.

A screw-propeller works in an orifice in each framework, on the common arrangement. One of the propellers is a little more aft than the other, to allow full play to both, and yet economise space in the mid channel.

The appearance of the vessel in the water is not altered in the side view, neither is it much changed in the stern view.

The consequence of this new arrangement is, that the rudders and propellers are acting with double effect in each case. The rudders are receiving an increased power, because the impact of the water upon them takes place at an angle which is constrained by the situation of the keels, and which is the most favourable that can be had. The two propellers, also, revolving as they do in water confined in a limited space, are working to considerable advantage. The effect actually produced is, that, when required, a vessel can be turned about in nearly half the space that a single rudder can turn it, and the two propellers will give a proportionate increase of speed.

The advantages gained by the new construction of the vessel are considerable. There will be more strength, more bearings in the run, and more breadth for cabin room. The rolling and pitching will be reduced very considerably. The vessel will not make lee-way as formerly; the vibration, or tremulous motion, will be lessened. The safety of the vessel will be very much increased, because the duplex rudder will have the effect of instantaneously changing the direction should she be running into some unexpected danger; also, if one rudder should be damaged, the other can be used to steer with. The propellers also can be used separately when required. For river navigation, the advantages obtained by the two rudders and two propellers will jointly enable the screw principle to be applied to steam-boats plying in shallow water, such as the Thames above London Bridge, or to vessels having small draught of water. For Transatlantic ships the use of the two rudders and two propellers will jointly ensure their making a passage in less time and at less expense than before, also with more certainty and safety than can possibly be done by a single screw or paddle-wheels.

The duplex rudder is applicable to paddle-wheel as well as screw steam-boats.

195 LAURIE, R. W., 8 Carlton Place, Lawrieston,  
Glasgow—Inventor and Patentee.

Various articles for the preservation of life and property at sea. Buoyant mattresses, mattresses forming boats, cushions, pillows, bolsters, and portmanteaus, constructed to support from one to ten persons in water.

Life-floats and belts, self-inflating, without valves.

Model of a life-boat, fitted with self-acting valves, and traversing shot-balls. Should the boat, by accident, be upset, it will instantly right itself on either side, and empties itself of water in one minute. Constructed by Messrs. Forrester & Co., boat-builders, Limehouse.

Model of an apparatus called the "Otter," for manœuvring vessels at sea.

The two latter inventions are patented by the exhibitor.

197 TAYLOR, FRANCIS, 6 Lawrie Street, Leith—  
Inventor and Maker.

Marine chair, that will support three persons in the water in case of accidents at sea; it is propelled by two short oars.

Deck seat, capable of supporting two persons in the water.

A portable chair or camp stool, on which two or three persons, each of them having an air-pillow attached to the breast, can propel themselves while in the water.

Model of a seat intended for steam-vessels, to a scale of three inches to a foot; a seat of this construction, eight feet long, will support upwards of twenty persons in the water, seven being placed in the middle compartment and the others holding on by the sides and ends.

The following models are made to a scale of one inch to a foot:—

Models of life-boats, which, if upset, will right themselves again, on carriages for conveyance, and for launching when brought to the sea.

Model of a substitute for a life-boat, seated for sixteen persons, which may be constructed by four or five men in a few hours, if materials be at hand, viz., two logs of light wood, or the yard of a ship cut across the middle, or a few planks of fir, and also timber for seats, &c., two large casks to be fastened at the extreme ends on the upper side. This, if upset, will right itself again; if thick boards can be got, long prismatic boxes may be made for the sides, which are much lighter than the solid sides.

Model of a life-boat, for eleven persons, the framed part considered to be a ship's fender of great length, and carried always with the ship, the tins on the extreme ends representing two water casks emptied and bunged up.

Model of a ship's fender; while used as such, having the gunwale-pieces and foot-board placed temporary on the outside of the frame.

Model of a substitute for a life-boat, supposed to be made of two halves of the yard of a large ship, and with other pieces of light wood, as fir.

Model of a ship's seat, to carry two persons, and having the oars fixed ready for using.

199 NAYLOR, ISAAC, Monk Bretton, near Barnsley—  
Inventor.

Patent alarm-gun for the protection of property and game. The number of barrels in the gun may be varied from four to twenty. It will explode at intervals of half a minute, in all kinds of weather.

200 WILKINSON & SON, 27 Pall Mall—Manufacturers.

1. A large stanchion, or punt gun, with gun-metal stock and spiral recoil spring, for wild-fowl shooting, on improved principles, with loading rods and apparatus, and a moveable butt to admit of greater elevation in the boat.

2. A pair of best double-barrel fowling pieces, made to reverse (i. e. either pair of barrels to fit either stocks) with case and apparatus complete.

3. A patent rifle with the lock on the under side; the whole mechanism of lock, guard, trigger, and trigger-plate, consisting of only four pieces. Invented and manufactured by the exhibitor.

4. A series of illustrations, showing the different stages of the manufacture of gun-barrels:—

- (A.) Horse-shoe nails, or stubs.
- (B.) Old coach-springs, cut up by means of shears.
- (C.) Scrap stub-iron.

(D.) A gun-barrel in its various stages, made of a mixture of stubs and steel (A. and B.), first twisted into a spiral, then partially welded by jumping, then completely welded, and the figure of the iron brought out by acids.

(E.) A bar of iron made from scrap (C), for Damascus twist.

(F.) A bar of steel, made from scrap (B.), for Damascus twist.

(G.) Twenty-one bars of iron and steel (E. and F.), packed alternately for welding.

(H.) Twenty-one bars (G.) welded together.

(I.) A square rod made by drawing out the mass (H.) between rollers.

(J.) The square rod (I.) twisted round its own axis, and then flattened, showing the figure produced.

(K.) Specimen to show the manner in which the figure called Damascus twist is produced; two bars or rods (I.), are first twisted round their axis the whole length, the one to the right and the other to the left, then flattened and welded together, then twisted spirally to form the barrel as in (D.), partially welded by jumping, and the welding completed, filed at the end, and the figure produced.

(L.) A similar specimen, finer; composed of two bars of 48 alternations of iron and steel.

(M.) A similar specimen, composed of three smaller bars of 21 alternations.

(N.) A similar specimen, called "chain twist."

(O.) A similar specimen, called "steel Damascus."

(P.) A finished barrel, composed of seven different kinds of twist.

5. Presentation cimeter, of arabesque pattern, standard silver richly chased and gilt, ornamented with 104 precious stones, consisting of emeralds, rubies, turquoises, jacinths, topazes, amethysts, chrysolites, carbuncles, garnets, moonstones, &c. The blade made of temper equal to those of Damascus or Toledo, combines embossing with engraving on tempered steel, bluing and gilding, so as to form two elevations of ornamental pattern above the dead gold groundwork. Also, a gold sword-knot. The whole in mahogany case, lined with crimson velvet. purple and gold cord waist-belt, of oriental patterns with chased clasp, ornamented with precious stones, emeralds, jacinths, and large amethysts. (See figure.)

6. A series of all the regulation swords in use in the British army and navy, as originally submitted to the Commander-in-Chief and to the Lords Commissioners of the Admiralty, by the exhibitor, and approved and adopted by general orders:—

(a.) Regulation Infantry sword, as by general order dated March 10, 1845. (b.) Regulation sword for Royal Engineers. (c.) Light Cavalry and Royal Artillery sword. (d.) Heavy Cavalry sword. (e.) 1st Life Guards' sword. (f.) 2nd Life Guards' sword. (g.) Royal Horse Guards' (Blues) sword. (h.) Regulation Highland claymore. (i.) General officers' cimeter. (k.) Admiral's dress cimeter. (l.) Regulation sword for Royal Navy, as per Admiralty order, dated November 23, 1847.

7. A sword worn by some of the Irregular Cavalry in India; the hilt of steel, electro-plated with silver; the scabbard of German silver.

8. A coat of chain mail, of tempered steel, electro-plated with silver; also a pair of gauntlets, bridle, &c., of the same material, as worn by some of the Irregular Cavalry in India.

9. Two helmets, covered with electro-plated steel chain mail, in gold and silver, to be used without a plume.

10. A Highland claymore, copied from an old one by Andrea Ferrara.

11. Regulation and other sword belts.

12. A Highland dirk, as designed and manufactured by the exhibitor, for Her Majesty's 74th Highlanders.

13. A series of illustrations, showing the different stages of the manufacture of sword-blades:—

(a.) Swedish bar iron. (b.) Blistered steel. (c.) Ingot of cast-steel. (d.) Bar, tilted down from ingot (c.) (e.) Double sword mould, tilted down from bar (d.) (f.) One sword mould, or (e) broken in two. (g.) Sword mould, partly forged and prepared to receive the iron



Wilkinson's Presentation Cimeter.

tang (h). (A.) Iron tang. (i.) Iron tang welded to blade (g). (k.) Forging of blade completed. (l.) Blade hardened. (m.) Blade tempered. (n.) Blade ground. (o.) Blade polished. (p.) Blade embossed and finished. (q.) Sword hilts, scabbards, &c., in various stages of manufacture.

[The weapon so long celebrated under the name of Andrea Ferrara, was an excellent description of broadsword used chiefly in Scotland. This name is found engraved on all the Scottish broadswords considered of peculiar excellence. The name and the works of this celebrated maker form the sole record of his existence. His manufactory, and even the period when he flourished, are buried in oblivion. It has been supposed he was a Spanish or Italian artificer, brought over by James IV. or James V., to instruct the Scots in the manufacture of sword-blades. When genuine, the blades were always marked with a crown.

The material for swords is obtained from Sheffield, in the form of a piece of steel sufficient for two swords, and technically called a "mould." This is first beaten out to the proper length by the forger; it is then hardened and tempered by alternate heating and dipping in cold water; after this the blade is ground by a millstone driven by steam-power. The blade is subsequently proved by striking it on the flat side, with all the force of a powerful man, against a stone, and in other ways. The sword is then polished, ornamented, and mounted.—W. C. A.]

201 JENNENS & Co., 56 Conduit Street—Manufacturers.

Specimens of military officers' cap-plates, breast-plates, and buttons; and naval, fancy, and livery buttons.

202 ALLEN, W. D. & Co., 124 New Bond Street—  
Inventors and Manufacturers.

A new ventilating hat; the ventilation is in the lower crown. For hot climates it allows a current of air between the sun and head. For cold climates, it acts as a ventilator without exposing the head to the weather.

203 WITTON, DAW, & Co., 57 Threadneedle Street—  
Manufacturers.

Double rifle, for India. Two-ounce rifle, for Africa. Double fowling piece. Duelling pistols.

204 LONDON & MORLAND, 17 Jernyn Street, St. James's—  
Designers and Inventors.

New officers' infantry helmet, manufactured of papier maché. This helmet is shown in the adjoining cut.



London and Morland's new Infantry Helmet.  
Privates' helmets.

205 HAWKER, Col. PETER, Longparish House, near  
Whitchurch, Hants—Inventor.

A stanchion gun, with improved waterproof ignition; forged and stooked on a new principle: intended to supersede patent breechings.

Model of a two-handed punt, containing double stanchion gun, gear, &c., for wild-fowl shooting, and mounted on the carriage to convey it by land.

Model of a two-handed punt for a single gun.

A new double gun, (1851). The novelty of this gun is the self-adjusting primers, without cover or spring, that will not only defy wet weather, but also the saline atmosphere in sea-coast service—in which he has proved the failure of all copper-caps and fine powder. This new gun has conical breechings that will admit, when required—as in wet weather, or at sea—the use of the largest grain cannon-powder. The proportions of this gun are the result of forty years' experience. With the improved ignition—when applied to a single gun,—the patent breeching is wholly superseded by a saucer-plug, that gives a direct and instantaneous communication, and also extra force, by getting rid of the centre-hole—which is as injurious to the shooting of a detonator as it was advantageous to that of a flint-gun. Agents for double guns on the new plan, William Moore and Grey, 78 Edgware Road. For duck-guns and other single guns, Alfred Clayton, Lympington, Hants, who has invented and registered an improved handle for the primers of this ignition.

206 BRAZIER, J. & R., Wokerhampton—Manufacturers.

Specimens of gun manufacture.

Double gun-tube locks, with self-acting tube spring, double gun-bar actions.

[The manufacture of guns supplies a recent illustration of the division of labour, and to this, no doubt, is attributable the present reduction of price in those articles. The sphere of usefulness in which the forger moves is a limited one, and consists in hammering into shape, assisted by "swages," the numerous small pieces which make up the lock and breech; even this has been replaced by the introduction of butt plates and guards, cast out of malleable iron, which are, in many instances, ground, instead of being filed.—W. C. A.]

Double rifle-locks, bolt and detant; the same articles in forged state. Musket percussion-locks. Gun cleaning-rod; loading-rod, and nipple-keys and knife-keys, all with apparatus. Patch-cutters, &c.

207 POTTS, THOMAS HENRY, Haydon Square, Minorities—  
Inventor and Manufacturer.

1. A double-barrel gun (finished), with improved breeches, bolted triggers, &c.
2. Similar gun, in a bright (unfinished) state.
3. An instrument for drawing the breeches, applicable to all sorts of fire-arms.

208 COX, N. F., Great Peter Street, Westminster—  
Manufacturer.

Fencing implements.

209 MOORE & GREY, 78 Edgware Road—Manufacturers.

Double fowling-pieces, on the spring tube and copper cap principles. Double and single two-grooved rifle, on the copper cap principle. Two-grooved rifled pistols.

210 POWELL, ROBERT, 28 Poland Street, Orford Street—  
Designer.

Design for a military cloak coat, with sleeves and spring guards, for protecting the epaulettes.

211 FIRMIN & SONS, 153 Strand, and 13 Conduit Street,  
Bond Street—Manufacturers.

Specimens of buttons worn by military officers; of livery buttons; and of different club and uniform buttons;

some finished in enamel, and gilt in different ways. Fancy buttons, finished in various styles.

The Star of the Order of the Garter, the Thistle, and of St. Patrick, all finished in enamel and bright cut silver.

Plates for shoulder-belts of officers of infantry, new in design, finished in enamel, and chased; and for shakos of officers of infantry.

Swords for officers in the army and navy. Fancy swords for full court dress. Highland dirk.

212 **HAWKES & Co., 14 Piccadilly**—Inventors and Manufacturers.

Specimens of military and other head dresses, and of English military accoutrements and appointments.

Embroidered banner, designed in the style of ancient banners.

213 **BERINOTON, JAMES, Hoxton**—Inventor.

Three full-length figures, representing British soldiers in uniform, showing the inventor's improved knapsack, belt, and pouch; and those at present in use.

214 **ROBINSON, A., 41 Whitcomb Street, Haymarket**—Manufacturer.

Best Damascus gun barrels.

215 **GIBBS, GEORGE, Clare Street, Bristol**—Inventor and Manufacturer.

Improved registered double-barrelled gun, in which missing fire is prevented in wet or damp weather, by the introduction of an iron cover to shut over the cap and nipple; the cover is raised by the action of the hammer falling upon the percussion cap, which it fires in the usual way, and is moveable, so that the gun may be used with or without it.

216 **BEATTIE, J., 205 Regent Street**—Manufacturer.

Two-groove rifle, double guns, duelling pistols, small double holsters, set of best double gun furniture, hog-skin flasks, shot pouches, loading rod, with swivel.

217 **MANTON, J., & Son, 6 Dover Street, Piccadilly**—Manufacturers.

Pair of double guns; double rifle; and pair of duelling pistols; all in mahogany cases, and furnished with apparatus.

218 **NEEDHAM, W. & J., 26 Piccadilly**—For S. NEEDHAM, Proprietor.

Patent self-priming gun; in which a lever places the ordinary copper cap on the nipple by the simple action of cocking, the muzzle of the gun being previously lowered to allow a cap to pass from the groove or reservoir (which is formed on each side of the stock from the butt end to the lock, and contains 120 caps) to a recess in the lever.

Patent self-priming gun, with this difference, that the caps are so formed as to allow a closer communication to the charge; and with the addition of an improved safety-apparatus.

Self-priming musket, to use the military flange cap; the construction similar to the preceding, with the exception of the groove or reservoir being down the fore end of the stock, as more suitable for muskets.

Safety stop-lock gun. This invention consists in the introduction of an extra sear to the lock, which acts in unison with the hand-spring of the guard; as soon as the hammer is lifted off the nipple it is caught by the stop or sear in the tumbler of the lock, and the cap cannot be exploded unless the gun is up to the shoulder in the position of firing.

Game registers, double and single guns to load at the breech; intended to combine safety and economy, by improvements in the construction.

Self-loading carbine on the same principle, with the addition of a simple apparatus for self-loading, not liable to get out of order.

219 **BOSS, THOMAS, 73 St. James's Street, Pall Mall**—Manufacturer.

Central fire double-gun; sight shields in centre of the breast of hammers. Other single and double guns.

Double gun in an unfinished state. Specimen of the manufacture of a gun-barrel previous to its being welded together. Barrels welded in a black forged state; barrels filed, put together, and "proved." Locks in black forged state, and in bright filed state. Gun furniture in black forged state, and in bright filed state in various forms. Various articles useful in the equipment of firearms.

220 **BECKWITH, HENRY, 58 Skinner Street, Snow Hill**—Manufacturer.

Fowling-pieces, blunderbusses, and other fire-arms.

221 **BENTLEY, JOSEPH, & SON, 12 South Castle Street, Liverpool**—Inventors and Manufacturers.

Patent central double-fire percussion guns.

222 **TRULOCK, E., & SON, 9 Dawson Street, Dublin**—Manufacturers.

Double-bar gun, with Damascus and plaited twist barrels. Centripetal double gun, back action. Double gun, with safety guard, and long strap. Double rifle, with shot barrels to fit stock, and with single hair-trigger.

Back-action single and double guns, with cases. Double bar gun.

Back-action single rifle, two grooves. Single rifles. Air gun. Bar-lock double guns, with double-rifle barrels, the barrels and locks to same fit.

Rifle for rook shooting, with barrel drilled from the solid cast-steel bar, and small bore.

Double pistols, with bar locks. Double back-action pistols. Six-shot revolving pistols, with cases, complete. Pair of double and single pistols. Double pistols, one trigger.

Gun barrels in the forged state, and ground and bored.

Gun locks, in the filed state. Rifle-barrel, bored and ground. Pair of rifle barrels. Single barrel rifle, many grooves. Bullet moulds.

223 **DEANE, ADAMS, & DEANE, 30 King William Street, London Bridge**—Manufacturer.

Patent spiral raised rib rifles. Patent safety stop-lock guns. Patent gun locks, fowling pieces, Indian and African rifles, pistols, &c.

223A **DEANE, GEORGE & JOHN, 30 King William Street, London Bridge**—Manufacturer.

Double guns, in mahogany case complete, and with varied style of engraving. Double and single rifles. Single guns. Specimens of double and single hot-ter pistols. Electro-plated silver revolving pistol, ebony stock, silver studded. Electro-gilt pistol, with ivory stock, gold studded. Small pocket secret pistols, ivory stocks. Officers' double and single belt pistols. Specimens of malleable twisted steel barrels, from the scraps to the finish; and of the new patent rifling, the new patent safety, and the new patent lock. Double gun, in its stripped state. Double trade guns. Single birding gun.

224 **PARKER, FIELD, & SONS, 233 Holborn**—Manufacturers.

Double-barrelled fowling and rifle guns, in cases, complete. Inlaid and ornamental pistols. Air-gun in case, complete. New spring belt for carrying shot cartridges.

Percussion musket and bayonet, as employed in the Hon. East India Company's service. Percussion fusil. Sapper and Miner's carbine. Cavalry carbine and pistol. Flint and steel single gun, used by the Hudson's Bay Company as a trade gun.

Truncheons, rattles, spring handuffs, leglocks, and spring-hilted cutlass, used by the metropolitan and city of London police. Brass pocket staff and pistol used by the inspectors and superintendents.

Chain, with wrist shackles and lock, used at prisons for removing prisoners.



[The manufacture of manacles is carried on principally at Birmingham. A recent account states that 4,000 pairs are annually manufactured at that town, of which one-half are for foreign and colonial purposes. Large numbers are exported to the southern states of America for slaves. Manacles for felons are light, and highly polished.]

225 ELEY, WM. & CHARLES, 38 Broad Street, Golden Square—Inventors and Manufacturers.

A series of illustrations in the manufacture of patent wire cartridges, for shooting game at long distances; and in the manufacture of percussion caps, rendered thoroughly impervious to water. Varieties of gun wadding.

226 LANG, JOSEPH, 7 Haymarket—Manufacturer.

Double gun and rifles of various sizes. Pocket and other pistols of single and double barrels, the turnover 4-shot and 6-shot revolvers of all sizes.

Greyhound starters, a retriever slip, and a gun sling. A patent walking-stick gun, with rifle and shot barrels.

227 INSKIP, H., Hertford—Inventor.

United service flask. The novelty of this flask is, that the powder and shot are served from the same head, so that the same measure of each will constitute the load. Provisionally registered.

Improved egg-boiler.

228 GOLDING, W., 20 Davies Street, Berkeley Sq.—Inventor and Manufacturer.

Double gun, for sporting purposes; with several improvements.

229 WOOLFELD, THOMAS, Hertford—Inventor and Manufacturer.

Single gun of simple construction; of use where a workman is not at hand.

230 WOODWARD, JAMES, 64 St. James's Street—Inventor.

Double gun (fowling piece) of a different construction to ordinary guns, possessing detached waterproof lock.

231 YEOMANS, & SONS, 67 Chamber Street, Goodman's Fields—Manufacturer.

An assortment of muskets.

232 EGG, HENRY, 1 Piccadilly—Manufacturer.

Self-priming percussion fowling-piece, very simple. Double-barrel copper cap fowling-piece, ornamented.

233 FAIRMAN, JAMES, 68 Jermyn Street—Manufacturer.

Double cross-eyed gun, for gentlemen who have lost their right eye, to be used from the right shoulder and left eye.

Double gun in soft state. Single gun. Single rifle, two grooved.

Improved game markers, used for marking the killed and missed shots.

Caps, and chemically prepared waddings.

234 OSBORNE, CHARLES, 1 Lichfield Street, Birmingham—Manufacturer.

Improved central-fire double gun, with chain-twist barrels, 14 bore; the same, 13 bore, in a soft or unfinished state.

Bar-slide double gun, 16 bore, carved pistol hand-stock; and single gun, 14 bore, with improved safety lock and guard.

Tube single gun, hollow top end to end, cut-up sides, 12 bore.

Large single gun, with Col. Hawker's improved ignition, maple stock, 7-8 inch bore, flat top rib, for wild-fowl shooting; all fitted with fine stub-twist barrels.

Large five-barrel revolving pistol, stock inlaid with silver, and lion's head carved on butt.

Pair fancy pistols, fluted, barrels, inlaid with silver.

Pair officer's pistols, German silver body, electro-plated, cap-box inlaid with silver. Pair ladies' small pistols (700 balls to the pound), in tortoiseshell case, complete. Double-barrelled pistol, with swivel rod, bolted and bayoneted. Improved alarm gun, for setting in plantations, lawns, gardens, rick-yards, &c.

235 GODDARD, SAMUEL ASPIAL, Birmingham—Manufacturer.

Fowling gun for sportsmen, with barrels of laminated steel.

American ducking gun.

Fowling gun, of good medium quality for the foreign trade.

Fowling gun, with twist patent breech barrels, for the wholesale foreign trade.

Pattern musket, and common African musket.

"California protector" gun, invented by the exhibitor.

Pair of gun barrels in the filed state.

Pair of gun barrels cut open, to show the manner in which the inside of barrels are finished.

236 RIGBY, WILLIAM & JOHN, 24 Suffolk Street, Dublin—Manufacturers.

Complete Indian or Highland outfit, consisting of a double rifle, double shot gun, and pair of extra barrels, forming, when required, twin double guns, with additional rifle barrels, and the locks, stocks, &c., all adjusted to one fit.

Double rifle with extra shot barrels, back-action locks, and single removable hair trigger, with cases and equipments. Bar-lock double rifle, single trigger, cases and equipments complete, with or without telescope attached. Double-shot gun, with bar locks attached. Double gun, back-action locks, and double rifle on improved plan, with cases complete. All constructed with continuous mountings, lift-out triggers, and solid slide-bolts.

Bar-lock double gun, without ramrod. Bar-lock single rifle and back-action; cases complete.

Double-rifle pistol for bison shooting, with single hair trigger and cases. Small horizontal double pistol and case; and various other pistols. Improved six-shot revolving pistols, with detachable barrels, safety-bolt, and other improvements, in case, &c. Cavalry officer's holster pistols in case.

Bar-lock single rifle, in unfinished state, prepared for adjusting in the field. Different parts of a gun in preparatory states.

Specimens of bullet moulds, with improved mould, in which a solid bullet can be cast. Single gun, back-action locks, in case.

237 REILLY, EDWARD M., New Oxford St.—Manufacturer.

An assortment of double guns, rifles, air-canes, pistols, &c.

Double-barrelled rifle, Ordnance bore, the size of Government; compressed ball, and suitable for belted, conical, or plugged bullets. Extra barrels for small shot, fitting in the same stock; being, with case and apparatus, a complete outfit for India, the Colonies, or any service.

Specimens of embossing and chasing, for ornamenting fowling-pieces and pistols.

Improved air-rifle and air-canes, for shooting with ball, shot, and harpoon, in numerous sports and amusements; they are portable, durable, and effective.

Practising pistols of new construction, for ball practice, without noise or report, within-doors, in gardens, &c.

238 DAVIDSON, DAVID, Captain, Bombay Army, per C. H. DAVIDSON, Haddington—Inventor. Manufactured by J. ROBERTSON, Haddington.

Double and single barrelled rifles; double and single 10-inch rifled pistols; single 6-inch pistol; all with telescopic sights. These rifles are furnished with grooved bullets.

The telescopic sight can be fixed to the piece in a

moment; it in no way interferes with the usual sights. In the use of the common sight the unassisted eye cannot observe with distinctness, at the same instant of time, two or more objects at different distances from it; and as the breech sight, the muzzle sight, and the object aimed at, are necessarily at different distances from the eye, it is difficult to bring them at once into line, and at the same time to give the proper elevation to the piece. This disadvantage is obviated by the use of the telescope, since the lines placed in the focus of the eye-piece, and the object aimed at, as seen through the glass, appear equally distinct to the eye.

The grooved bullet sustains the spinning motion, so that the pointed end goes foremost throughout the longest flight. The groove in the zone reduces the friction, gives the rifling a firmer hold so as to prevent stripping, and secures its longer axis continuing in the axis of the piece. It is less affected by wind, and has greater power of penetration than the round bullet.

The telescopic sight also enables the sportsman to estimate the distance of the deer.

238A WATKINS & HILL, 5 *Charing Cross*—Manufacturer.  
Rifle fitted with a telescope for taking the sight, attached to the barrel on a principle suggested by Professor Potter.

239 BULL, JOHN, *Bedford*—Manufacturer.  
Double-barrelled gun, with the modern improvements.

240 RICHARDS, WESTLEY, & SON, *Birmingham*—Manufacturers.  
Best double and single rifles, of various bores.  
Double tiger guns, of different bores, in an unfinished state.

Punt gun, of a new construction.  
Best duelling pistols. Double and single holster pistol. Pocket pistols, secret triggers. Pair turn-over double-barrel and bulldog pistols. Revolving six-barrel pistols; revolving rifle. Copper caps; the same, twenty-two years old.

Registered improved corkscrews and carving forks, with improved registered guard.

241 COOPER, J. R., & Co., 24 *Legge Street, Birmingham*—Manufacturers.

Patent self-cocking pocket-pistol. When loaded and capped, it is ready for use, without the preparatory cocking action. Its working parts are seen on the outside. Holster pistol. The ramrod serves as the hammer-spring, by which the cap is fixed. A safety bolt is introduced into the trigger, which prevents the pistol from being fired unless the bolt is released by the finger.

Six-barrel revolving pistol, central fire, with safety bolt.

Twelve-barrel revolving pistol. One side of the stock is removed to show the working parts of the lock.

Pair of ladies' pistols.

242 WALKER, RICHARD, *Graham Street and Broad Street, Birmingham*—Manufacturer and Patentee.

Specimen of percussion caps (in boxes), gold and silver. Metallic gun-wadding.

[Per percussion caps are produced by pressure: the blanks are cut out of thin rolled copper, and are afterwards formed by punches into the required shape. The priming is a work requiring care and attention—they are charged by touching the bottom of the cap with an adhesive substance, into which the fulminating powder is dropped.—W. C. A.]

243 TOWNSEND, JAMES, 11 and 12 *Sand Street, Birmingham*—Manufacturer.

Improved 1½-inch diameter walking-stick air-gun, with silver steel rifle barrel, fancy twist air receiver, pump, and apparatus complete. Maple-colour walking-stick air-gun, to load at the breech, with stub twist rifle and shot

barrels, pump, apparatus, &c. Three-quarter-inch diameter Malacca-colour walking-stick air-gun, with rifle barrel, one hundred and sixty balls to the pound, pump, apparatus, &c. Bar slide butt air-gun, with rifle barrel, pump, &c. Stub twist walking-stick air-gun, to load at the breech. Air-rifle, game twenty-six balls to the pound, to load at the breech. Improved ¾-inch diameter black walking-stick air-gun, with rifle barrel, &c.

244 REEVES, GREAVES, & Co., 28 *Bartholomew Street, Birmingham*—Manufacturers.

Officer's dress sabre and field-sword. Officer's dress sabre, with scabbard and mounting of the finest cast wrought-steel; and field-sword, blade, scabbard, and hilt of the finest cast steel, wrought; Scotch claymora. Series illustrative of the manufacture of sword-blades, of cast-steel.

[While Sheffield is the great source of supply for the best cutlery, Birmingham is the place where the great bulk of swords and matchets for home purposes or for exportation are manufactured. The manufacture calls into requisition no small proportion of the industry of the district. Swords are made by hammering out pieces of steel received from Sheffield, and called sword moulds. In each of these there is sufficient steel to form two swords; the flutes or creases on the back of the blade are formed by means of various shaped pieces of steel fastened to the anvil, corresponding to the indentation to be made: they are then curved or fitted, if straight, into a gauge; the process of "hardening" succeeds, which consists simply in heating the steel very regularly, and immersing it in water; it is then tempered (brought back to a straw colour), tested by striking on the back and edge against a wood block, and if it stands this, is passed to the grinder, who, seated before an enormous grindstone, speedily removes all the irregularity of the hammering. To clean the grooves, stones with raised beads are used; glazing follows on bobs of wood with emery attached thereto by glue; and the sword is finally polished on a wheel with fine emery and oil; powdered iron-stone, or crocus, gives the brilliant polish. Where the swords are highly ornamental, the deep rich blue is produced by heat: the gilding of the ornaments on blades, when introduced, is said to be a secret process. Damascening, however, with precious metals, a more intricate mode of ornamentation, is known, and consists in making an incision in the article to be adorned, and introducing by pressure threads of gold or silver. This affords an opportunity for the exercise of taste, and as such it was eagerly embraced by the middle-age artists. Proofs of their excellence therein is testified by numerous specimens in public and private collections. Etching, another mode of ornamentation, is performed by covering the blade to be etched with a ground upon which the design is sketched, and finally cutting through this to the steel. A suitable acid is applied (acetic and nitric); this, after remaining a sufficient time, is removed, the ground cleansed off, and the design is found on the weapon perfect in proportion to the skill displayed by the artist. Steel sheaths are made by bending thin plates of steel round suitably formed mandrils; they are soldered at the junctures, are ground, and finally polished by the processes already described as being used in the polishing of swords.—W. C. A.]

245 HART, HENRY, 54 *New Canal Street, Birmingham*—Manufacturer.

Pair of highly-finished double-barrel guns. Double-barrel gun, pistol hand-stock; gamekeeper's gun. Single gun, pistol hand highly finished, with raised top rib.

Small pistol-hand double gun. Small single gun.—All with stub-twist barrels.

Specimens of gun-barrel manufacture in every state, from the old horse-nail stubs of the earliest period to the latest improvements.

[The serious accidents arising from the bursting of gun-barrels have led manufacturers to seek the means of preventing their recurrence as far as possible; fibres of iron strictly parallel would fail to impart the necessary strength, as also would iron if of a uniform crystalline composition. A better construction of material has been found in the welding together portions of iron and steel; these become interlaced in the various processes of hammering from the bundle of iron and steel called the "bloom," until the barrel passes finished from the hands of the forger. The twisted appearance which is observed on the best barrels, even after the rich brown stain is removed, arises from the ribbon-like form which the "bloom," after being drawn into a strip, takes when wound spirally round a mandril previous to welding; these are known as Damascus barrels. Barrels of a more common kind are produced from "blooms" made exclusively of stub-nails, while a more common class still are produced of a cheaper material, not wrapped in a spiral form, but welded in the length by one heat by means of a pair of rollers; they are ultimately extended to their proper length by the same process. Guns are bored out in large manufactories by means of steam or other power, the instrument being a rod of steel, with its cutting portion 8 or 10 inches long, and its square sides made up with pieces of wood. Rifling, viz., imparting to the interior of the barrel a series of spiral curves, by means of which a perfectly direct motion is given to the bullet, involves care, attention, and skill in its preliminary stages, but is in reality a simple operation. Ordinary gun-barrels are finished by being ground on large grindstones; those of a superior quality are turned. Breeching, or fitting in the plug at the butt which stops the end, and upon which is fitted the nozzle for the percussion cap, requires nicety and careful workmanship. Gun-barrels are coloured by means of acid; repeated coats are given until the deep rich brown is obtained; they are then polished.—W. C. A.]

246 **BROOKES & SON, 28 Russell St., Birmingham—**  
Manufacturers.

Fowling-piece, double barrel, silver steel twisted.  
Fowling-piece, with single barrel.

Rifle gun, for shooting long distances, with telescope.  
Four-barrel revolving gun (used in India).

Walking-stick gun, to pack in a portmanteau.  
Military guns—British, French, and Piedmontese muskets.

South American (Buenos Ayres) and Spanish carbines or cavalry.

African trading guns used in barter, chiefly for palm oil, &c.

Dane guns, black and red stocks, brass and iron mounted.

Buccaneer red stocks, heavy and light mountings.  
Carolina gun, similarly furnished. Indian pistols, silver handles, rifled barrels. Six-barrel revolving pistol. Safety water-tight nipples.

247 **TIPPING & LAWREN, Birmingham—**Manufacturers.

Specimens of iron and steel in various stages of preparation, to show the manufacture of gun barrels.—Horse-nail stubs. Scrap steel. A mixture in a partially welded state.

Specimens, showing a twisted stub-barrel in the various stages of manufacture, from the first process. The stubs and scrap-steel are first welded into a rod, which is afterwards rolled out into a flat bar; it is then coiled

round a mandril, and welded into a barrel; it is afterwards ground and filed, and finally brought to a finished state.

Lengths, showing the various stages of manufacture of Damascus and laminated steel barrels.

Double gun, the barrels made of twisted stubs.

Several guns, of varied construction, and one entirely in pieces, to show all the parts of a gun separately, especially the internal work of the stock.

Double and single rifle guns.

Single and double guns; varieties both of fowling-pieces and military guns.

Air-gun; barrel of best twisted stubs, with improved roller breech, the butt made of twisted stubs.

Air-cane, twisted stubs, with improved roller action, pump, &c., complete.

Small walking-stick air-cane, with rifled barrel, of improved construction. Air-cane lock.

Six-barrelled revolving pistols, ivory stock, silver inlaid; walnut stock, silver inlaid; and chequered stock. Various pistols.

248 **MOLE, ROBERT, Brood Street, Birmingham—**  
Manufacturer.

Gilt-mounted sword, blade of finest cast-steel, richly blued and gilt, the scabbard of crimson velvet, embroidered in gold, with elaborately worked gilt furniture.

Highly-mounted Mamaluke sword, with blade ornamented in dead gold, the scabbard of polished steel, with elegant gilt mountings.

Officers' regulation swords, used in the cavalry, infantry, and naval services.

Two matchets of best cast steel, as exported to America and the West Indies. Patterns of those used in the plantations of South America, the West Indies, and Africa.

[In addition to swords, Birmingham produces an article called a matchet, which in some countries is used to cut down sugar-cane, in others as a weapon of war, or to remove vegetable obstructions which impede the traveller in his progress through "the bush" or the tangled overhead of an American forest. The labour expended upon them is small: a great portion of it is performed by the tilt-hammer; they are hardened and ground, slightly glazed, and handled with common beech timber. Some idea of the consumption may be learned from the fact that one manufacturer has for the last six months been producing at the rate of 500 dozen per week.—W. C. A.]

249 **POWELL, WILLIAM, L. SON, Carr's Lane, Birmingham—**  
Manufacturers.

Double-barrel rifle, with apparatus.  
Double-barrel gun complete, and in a certain process of finish.

Miniature gun.  
Single and double barrel pistols.  
Improved safety trigger guard.  
Pair of lock actions.

250 **WINTON, HARRY, 53 Cleveland Street, Birmingham—**  
Inventor and Manufacturer.

Improved safety guns.

251 **CARRON, WILLIAM, Birmingham—**Inventor.  
Alarm gun.

251 **BAVLES & SON, 8 St. Mary's Row, Birmingham—**  
Manufacturer.

Gun implements.

252 **HOSKINS, JOHN, 31 Frith Street, Soho Square—**  
Inventor and Manufacturer.

Double gun, with safety; on a new and simple principle.

253 DAVIS, J., 1 Duke Street, North Parade, Bath—  
Inventor and Manufacturer.

Soldier's musket, substituting the blade of the bayonet for the ramrod.

254 SHAW, J., Glossop—Inventor and Patentee.

India-rubber air-gun. The novelty consists in the absence of a reservoir of condensed air, or separate pump, or valve of any kind; the requisite pressure of air for one discharge is instantly obtained from a pull of the trigger, by means of a single stroke of a condensing syringe, which is acted upon by a previously extended India-rubber spring. This gun is represented in the annexed cut.

Flattened bullets, being specimens of its effect on an iron target at 20 yards.

Without any previous pumping, the requisite pressure of air for one discharge is procured instantly at the pull of the trigger, by a single stroke of a condensing syringe, actuated by a previously extended India-rubber spring. There is no separate pump, no reservoir of condensed air, nor valve of any kind.

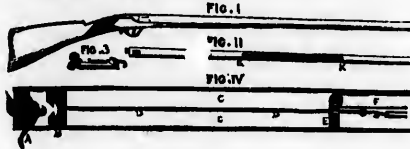

Shaw's India-rubber Air-gun.

Fig. I. represents the gun complete. Fig. II. is an underneath view of the gun unstocked, showing a slot (κ κ) in the case, through which are visible the piston-rod and bend, with a portion of the India-rubber hereinafter described, and in the state in which they appear after one discharge, and prior to preparation for another. Fig. III. represents a longitudinal section of about one half of the breech end of the gun unstocked: A is the trigger; B, the piston; C, C, the insides of the pump barrel or condensing syringe; D, the piston-rod; E, the pump top perforated in the centre for the piston-rod to work through, and at the top edge for the reception of the end of the shot barrel; F; G is the bullet, held in its present situation by a slight contraction of that end of the shot barrel. I is one end of the India-rubber spring, attached to the hooked end of the piston-rod and similarly attached by its other end to a hook in the inside of the muzzle-end of case; J, J are portions of the case, enclosing the shot-barrel and India-rubber, the lower shaded part being one end of the slot (κ κ, Fig. IV.) The section, Fig. IV., shows the gun in act of discharge; the trigger being just pulled, releases the piston, which, by the reactive power of the India-rubber spring, rushes to the opposite end of the syringe, condensing the air therein, which air forcibly ejects the bullet.

To prepare the gun for discharge, the ball, if the barrel be a rifled one, must first be rammed down; an adapted hook must then be introduced into the slot (κ κ), between the bead (H, Fig. IV.) and the hooked end of the piston-rod, as plainly indicated by Fig. 3. The butt-end of the gun must then be placed against the top part of the thigh, and the hook pulled with both hands, in the direction of the breech, until the trigger, by means of the small spring at its back, catches the piston. With a smooth or unrifled barrel, 400 discharges per hour can be made; the bullet in that case requiring no ramming, it being drawn down the barrel by the partial vacuum caused by drawing down the piston. The spring consists of from sixteen to eighteen India-rubber bands.

Patent valve-bugle. The patent valves are applicable to all brass instruments, and are manufactured by Mr. J. Köhler, Henrietta Street, Covent Garden.

255 FLETCHER, THOMAS, 161 Westgate Street, Gloucester—  
Inventor and Manufacturer.

Double guns, with improved lock, jointing, and breeching, so as to render them perfectly waterproof.

The improvements consist in the following peculiarities:—1st. The whole of the percussioning is on the breeching, the nipple being placed in the centre, thus avoiding the joints between the breeching and the break-off. 2nd. Peculiar construction of the break-off, giving greater facility for placing the barrels in the stock. 3rd. The closeness of the cocks covering the caps and nipples, confining the gas from the explosion of the caps. 4th. The application of platina in the percussioning of the breeching to prevent corrosion by the copper caps.

256 FORSYTH & Co., Leicester Street, Leicester Square—  
Inventors and Manufacturers.

Patent safety gun, which cannot be discharged either in carrying when loaded, or during the time of loading, until brought up to and placed against the shoulder, and the trigger pulled in the firing position. In its use the chances of the occurrence of an accident, even at full-cock, are entirely obviated, the cock being checked in its descent by the projection of the safety-stop.

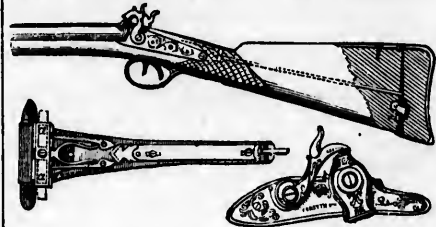

Forsyth and Company's Patent Safety Gun.

The preceding cuts represent the apparatus for working the safety stops from the heel-plate of the gun; the safety-stops themselves, and the original percussion lock.

Also, an original percussion gun, illustrating the first application of the principle of percussion by the exhibitor to the purposes of fire-arms. This gun contains a reservoir of percussion powder sufficient for a day's shooting.

[Fire-arms have been discharged by three different methods, by the direct application of a lighted match, by the ignited particle of steel produced by the flint lock, and by the ignition of an explosive powder through the heat developed by percussion. This is the exact historical order of these applications. The flint-lock is now passing rapidly into disuse, and the principle of percussion, in various forms, but essentially the same, is obtaining universal application. This principle was first discovered and applied by Mr. Forsyth in 1819, and was then patented. The explosive powder was contained in a small magazine attached to the locks, and by turning it on its axis a few grains of the powder were conveyed beneath a striking pin, and were ignited on the descent of the hammer. The copper cap has now supplied the place of these magazines.]

257 ERSKINE, JAMES, Newton Stewart, Scotland—  
Inventor and Manufacturer.

Two guns:—Gun No. 1, newly invented to prevent accidental discharge, combining in the same action a complete waterproof for the cap. Gun No. 2, invented for the same purpose, has been improved and registered.



Erskine's Waterproof Gun.

- 258 RIPPINGILLE, E., 81 King Street, Manchester, and 87 Albany Street, Regent's Park.—Inventor.  
An improved gun-lock, with stock.
- 259 HASWELL, ROBERT, 13 Upper Ashby Street—Proprietor.  
Air-pistol on a new principle.
- 260 NEEDHAM, HENRY, 4 Vine Street, Regent Street—Inventor, Patentee, and Manufacturer.  
Self-priming gun and safety lock.
- 261 BRIDER, JOSHUA, 4 Clifton Cottages, Denmark Street, Camberwell.—Inventor and Manufacturer.  
German silver telescope loading rod for fire-arms, with knob and forcer, for general use; adapted for the pocket.
- 262 BRIDER, GEORGE, 30 Bow Street, Covent Garden—Inventor and Manufacturer.  
Rifle mallet for hot climates, having a head of gun metal, with leather faces, (purple wood handle,) and gun-metal forcer.
- 263 BAKER, THOMAS KERSLAKE, 88 Fleet Street—Inventor and Manufacturer.  
Improved patent gun-lock for preventing accidents from the use of fire-arms.
- 264 GOLDEN, W., & SON, Huidersfeld.—Manufacturers.  
Bentley's patent double gun, with improved locks, &c.
- 265 WEBSTER, W., Hampstead Road.—Inventor.  
Fusée musket.
- 266 SHORMAN, JOHN, 6 Great Pulteney Street, Golden Square.—Producer.  
Specimens of inlaying with gold, silver, and other substances, and ornamental engraving on the ironwork of guns, &c. Impressions on paper, taken from engraved and inlaid work.
- 267 MORTIMER, THOMAS ELSWORTH, 97 George Street, Edinburgh.—Manufacturer.  
Superior finished double rifle, with simple safety and improved conical ball.  
Highly finished double fowling-piece (for long shots), with low front sight to give elevation to the shot.  
Pair of silver-mounted inlaid Highland pistols.  
Specimens of improved conical and other balls.  
Specimen gun-case, Edinburgh make, with fittings complete.
- 268 STAINES, EDWARD, 9 Salisbury Place, New Road—Proprietor.  
Models and plans illustrating a system of Fortification.
- 269 HODGES, R. E., 44 Southampton Row, Russell Square—Inventor.  
Patent application of India-rubber to projectile purposes.
- 270 PARSONS, WILLIAM, Swaffham, Norfolk—Manufacturer.  
Pair of improved double guns, 2 feet 8 inch barrels, 10 bore, central fire, elevated false breech, &c.  
Loading rod and socket.  
Pair of double guns, 13 bore, 2 feet 8 inch barrels.  
Pair of double guns, 20 bore, 2 feet 7 inch barrels.  
Wainscoat and leather case for each pair of guns.
- 271 HALL, Lieut.-Colonel, R. E., Southampton—Producer.  
Model of the Tower of London, after the destruction of the Armoury at the great fire on the 30th October, 1841. Modelled by R. Davis, under the superintendence of the exhibitor.
- 272 MOULIN, C., 24 Stanley Street, Chelsea.—Designer.  
Model of a fortified town, defended by six fronts of fortification on three different systems; Vauban's, as modified by Cormontaigne; Coehorn's; and Carnot's. The works of attack and defence are moveable.
- 273 LILLWHITE, JOHN, Frederick Street, Portsea—Manufacturer.  
Metal model of a gun of 95 cwt., with carriage and slide, on a scale of 1½ inch to the foot.
- 274 BEARFOOT, RICHARD, 11 Warwick Street, Woolwich—Manufacturer.  
Two magazines, especially adapted for the safe storage of powder, wills, documents, &c.; they are also waterproof. The one is made of copper outside and wood inside, and the other, the reverse; with India-rubber joints instead of bees-wax and tallow, and one lock instead of two.
- 275 TILDEN, Capt. JOHN, R. Artillery, Woolwich—Maker.  
Models of British ordnance; a light 6-pounder field-piece and carriage. A 32-pounder garrison gun, with carriage, on tr. rsing platform. A 10-inch howitzer, on garrison carriage. A 13-inch sea-service mortar and bed.
- 276 ROUSSON, JAMES, 20 Langham Place.—Inventor.  
Model, on a scale of 1 inch to 40 feet, showing eight different modes, in which the front of fortification of the usual dimensions may be fortified according to a new system. Its objects are, an immense reduction in the cost of construction, and greater capability of defence.
- 277 JOYCE, FREDERICK, & Co., 57 Upper Thames Street—Inventors and Manufacturers.  
Improved anti-corrosive waterproof percussion gun-caps. Military percussion musket-caps. Improved percussion tube primers. Chemically prepared indented cloth and felt gun-waddings. Improved patent wire-cartridges.
- 278 GRAINGER, JAMES, Wolcorthampton—Manufacturer.  
Tube and bar-action gun and rifle gun-locks.
- 280 GARDNER, W. T., 22 Mead Row, Lambeth—Inventor and Manufacturer.  
Model of a ship's gun, adapted for loading at the breech.
- 281 KING, THOMAS JOHN, 16 Whiskin Street.—Designer.  
Pistols, inlaid, the iron-work with gold, the stock with silver. Small iron scent-bottle, inlaid with silver.
- 282 MUNRO, JAMES, JUN., 4 High Street, Lambeth—Manufacturer.  
Model of a nine-pounder brass gun-carriage and limber, scale 1 inch to a foot; and of a twenty-four pounder brass battering gun and carriage, scale ½ inch to a foot.
- 283 FITZ MAURICE, The Hon. WM. ED., Hamilton Lodge, Prince's Gate.—Producer.  
Model of 68-pounder gun-carriage, which, by means of a rack and pinion inserted in the platform at the rear of the gun, can be worked with great accuracy by one man; it now requires six.  
Model of a mortar platform, worked upon the same principle, the endless screw being substituted for the rack and pinion.
- 284 WALKER, SARAH, & Co., 12 Legge Street, Birmingham.—Manufacturers.  
Specimens illustrative of the manufacture of percussion-caps for military and sporting purposes: piece of rolled copper from which blanks are cut and caps made. Similar piece of copper, showing perforations out of which blanks have been cut by steam-power.  
Blanks for musket-caps, as used in Her Majesty's service and in the Honourable the East India Company's service.



## WEST END GALLERY AND SOUTH-WEST GALLERY.

sea—Designer.  
by six fronts of  
; Vauban's, as  
; and Carnot's,  
eable.

reet, Portsea—  
with carriage and

street, Woolwich

r the safe stow-  
; they are also  
er outside and  
; with India-  
tallow, and one

Woolwich—Maker.  
6-pounder field-  
-rison gun, with  
ach howitzer, on  
mortar and bed.

dace—Inventor.  
t, showing eight  
-fication of the  
rding to a new  
eduction in the  
ty of defence.

er Thames  
-percussion gun.  
Improved per-  
-aped indented  
-ed patent wire-

-Manufacturer.  
locks.

Lambeth—  
r.  
loading at the

reet—Designer.  
h, the stock with  
th silver.

Lambeth—  
age and limber,  
y-four pounder  
ch to a foot.

, Hamilton  
er.  
h, by means of  
h at the rear of  
y by one man;

upon the same  
ed for the rack

Street,  
s.  
e of percussion-  
-pieces of rolled  
s made. Simi-  
-out of which

c Majesty's ser-  
-dia Company's

Cap-shells, made from preceding caps when finished.  
Blanks to make caps for ordinary sporting guns; cap-  
-shells made from the same.

Caps when finished.  
Improved blank to make waterproof caps for wild-fowl  
and duck-shooting, forming that part of the cap solid  
which contains the charge caps shells made from the same.  
Waterproof caps furnished and lined with metal.

285 RICHARDSON, R., 21 *Tonbridge Place, New Road*—  
Manufacturer.  
Models of tents, marquees, and rick cloth.

286 SYMINGTON, WILLIAM, 41 *Gracechurch Street*  
—Inventor and Proprietor.  
Gun wads, a substitute for the rope wads at present  
used in gunnery.

287 SQUIRES, WILLIAM, *Cottage Grove, Mile End*  
—Inventor and Manufacturer.  
New rifle, calculated to project a ball a great distance  
with a small charge.

288 McGETTRICK, FRANCIS, 82½ *Philip Street, Kingsland*  
*Road*—Inventor.  
Model of a war-engine. It is stated that this engine  
will fire 10,000 charges of ball cartridges in ten minutes.

289 TRUSCOTT, JOSHUA, 111 *Fore Street, Devonport*—  
Inventor.  
Rotatory sprinkler, for watering roads and streets, or  
using liquid manure. When the water sinks below the  
axle, its action is that of a syphon.

Portable life-boat or raft, applicable to vessels which  
carry many passengers. It occupies a small space when  
closed; but when opened, it presents a large surface,  
sufficient to support many persons. In the event of a  
ship sinking, it could be opened out on the deck and  
made ready for use in a few minutes.

290 RHIND, WILLIAM GREENE, *Ross, Herefordshire*—  
Inventor.

Model of a marine life-preserving deck seat, representing  
the deck seat of a steam packet or sailing vessel, so con-  
-structed that in three minutes it can be changed into a  
safety raft, capable of sustaining eight people on the  
water. The back and seat are lined with cork, and joined  
by hinges, the legs being made moveable.

Model representing the deck seat, as changed into a  
raft; this change is effected by loosening the elbows,  
clearing the back and seat together, and putting in the legs  
at right angles. Four of the seats, when spread out, are  
adapted for the construction of a great raft, which might  
be made by putting empty casks underneath, and spars,  
gratings, &c. as a deck; the raft, also, with a low Bermu-  
-dian sail, might be used to convey a rope to the lee shore.  
The deck seat can also be instantly made into a couch,  
table, or litter, being equally adapted for garden seats in  
pleasure-grounds or hospitals.

291 RIGMAIDEN, JAMES, Lieut. R.N., 6 *Harley Place*—  
Inventor and Manufacturer.

Model of lanyard-plates, to set up standing rigging of  
ships, in lieu of rope lanyards and dead-eyes; the small  
space occupied by the plates allowing quarter-deck and  
forecastle guns to be trained to any angle, and not liable  
to fire, as with rope lanyards.

292 ALLEN, JAMES, *Greenock, Scotland*—Inventor and  
Proprietor.  
Model of a new patent safety anchor.

292 BENNETT, EDWARD, 2 *Victoria Place, Woolwich*—  
Inventor.

Universal wedge block, in stone, wood, or brick, ap-  
-plicable for piers, dock and sea-walls, foundations, water-  
-wheel aprons, fire-proof floorings or roofings, and all  
descriptions of furnace work, &c., or for any situation

requiring great resistance to lateral pressure. The prin-  
-ciple of these blocks rests upon their pure geometrical  
-construction, for a weight or pressure cannot pass beyond  
the centre of the stones, and they are better than stone  
altogether solid.

294 ROYAL YACHT CLUB—Producer.

Models of yachts belonging to the Royal Thames  
Yacht Club.

| Name of Yacht.       | Tons. | By whom Built.                  | The Property of               |
|----------------------|-------|---------------------------------|-------------------------------|
| 1 Nancy Dawson       | 163   | R. H. Camper, of Gosport.       | The late Robert Sheddin, R.N. |
| 2 Cynthia . . .      | 50    | T. Wankill, Poole, 1849         | John Wicks, Esq.              |
| 3 Volante . . .      | 50    | T. Harvey, Ipswich.             | J. L. Craigie, Esq.           |
| 4 Avenger . . .      | 49    | Hanson, Cowes . . .             | H. Moseley, Esq.              |
| 5 Masquito . . .     | 50    | C. Mare, Blackwall .            | Ld. Londesborough.            |
| 6 Fleur-de-Lis . .   | 33    |                                 | W. H. Birch, Esq.             |
| 7 Foam . . . . .     | 20    |                                 | T. Harvey.                    |
| 8 Frolic . . . . .   | 12    | T. Harvey, Ipswich              | Alfred Cox, Esq.              |
| 9 Esk . . . . .      | 10    |                                 | J. Richardson, Esq.           |
| 10 Sam Sly . . . .   | 7     |                                 | T. Harvey.                    |
| 11 Haring . . . . .  | 31    | Moors, Plymouth . .             | G. Cook, Esq.                 |
| 12 Jockey . . . . .  | 24    | J. Duthie, jun., Aber-<br>deen. | W. Hogarth, Esq.              |
| 13 Lady Louisa . .   | 12    | W. Smith, London,<br>1820.      | T. Smith, Esq.                |
| 14 Brilliant . . . . | 10    | W. Smith, London,<br>1820.      | W. Bucknall, Esq.             |
| 15 Belvedere . . .   | 25    | Ditchburn and Mare.             | Major H. Boys.                |
| 16 Mystery . . . .   | 25    | T. Ditchburn . . . .            | W. Kingsford, Esq.            |

The first of these yachts has circumnavigated the globe; the third and sixth are new; and the rest are all winners of many prizes.

295 HAUGHTER, V.—Inventor.

Model of a traversing gun on platform.  
Model of a life-boat.

296 HITT, T., *Bridport*—Inventor and Manufacturer.

Life-boat (one of a pair) for enabling a person to sustain  
himself in water.

297 CHERRETT, D. *Grossener Mares, Berkeley Square,*  
*Working Gunmaker.*

An improved two-groove rifle pistol, with inviolable  
lock, which throws a ball 250 yards, and can be used as a  
pistol, or from the shoulder.

298 SCAMP, W., *Admiralty, Somerset House*—Inventor.

Model of a great preservative dry dock for the reserve of  
the Royal Navy, designed for laying up ships of war out  
of commission, or ships "in ordinary," high and dry,  
thereby preventing their rapid deterioration and pre-  
-mature decay, &c., without dismantling them, or remov-  
-ing the machinery; for examining, repairing, and refitting  
ships, and selecting from the reserve for commission with  
certainty, facility, despatch, and economy; for building  
ships, seasoned and dry; and also for laying up ships in  
frame for seasoning.

299 WILSON, J., *Stratford, Essex*—Inventor.

Models of life-boats.

301 DUTHOIT & Co., 6 *Finsbury Place South*—  
Designers and Manufacturers.

Aerial tent, about 12 feet by 6. Framework of Malacca  
canes and mahogany. Covering of Spitalfields silk, suitable  
for lawns.

Registered umbrella tent, suitable for emigrants,  
officers, and field purposes at home and abroad. Its  
object is portability, being contained in a bag measuring  
7 feet by 1, and easily fixed. (*Cross Gallery, between  
North and North Central Gallery.*)

302 EDGINGTON, BENJ., 2 *Duke Street, London Bridge*—  
Inventor and Manufacturer.

A tent, 12 feet by 8 feet, poles with table. Four cots  
can be hung from the frame-work; it is waterproof, easily  
erected, and forms a complete room.

Military tent, 12 feet square; peculiar in its construction; few lines are used, and the tents can be placed close to each other. Its most important feature is the increased power of ventilation.

Stoves and cooking apparatus for tents.  
Trophy of flags.

303 BLAIR, J., *Irvine, Ayrshire*—Inventor.  
Portable camp-cot, combining a tent, bedstead, and couch.

304 CROID, R.—Inventor.  
Model of a life-boat.

305 SMITH, THOMAS & WILLIAM, *Newcastle-upon-Tyne*—Proprietors.  
Model of the merchant frigate *Blenheim*, built in July, 1848, at St. Peter's Dockyard, Newcastle-upon-Tyne.

306 TRIGENZA, R.—Producer.  
Models of two Falmouth fishing-boats.

307 HEDLEY, GEORGE, *Yorke Street, Monkwearmouth, Sunderland*—Manufacturer.

Model of a merchant-vessel of the first class, on the scale of a quarter of an inch to the foot. The dimensions are as follow:—Extreme length, 172; length of keel, 161; breadth of beam, 35½; depth of hold, 23; length of poop, 48; length of fore-castle, 33 feet. The ship is framed all round, instead of having a separate stern-frame, and is built up in the usual manner. It has five keelsons, one at the bottom of the hold, two on the footlocks, and two on the second footlocks or bilge. It is stated that as juck-screws are used in the building of this ship, she will possess one great advantage over others, whose shores being made in the ordinary way, are liable, when loaded, in a storm, to be thrown out, and cannot be put in again. The screws adopted in this ship, if likely to be thrown out during the working of the vessel in a heavy sea, can be screwed up again from the deck by a brass plate let into a plank of the deck, and by turning the key to tighten the screw, without the least injury to the vessel or cargo. The twist-beam staple-knees are made half-circle, so that the two throat-holes go in the upper stroke or plank, and the other three holes in the stroke or plank below. In between decks and lower hold are diagonal straps, 78 feet long. The iron fastenings, hooks, riders, and crutches are all secured the same as forward, across the stern-post; diagonal straps are placed on the hold and deck beams, to prevent the vessel straining, when rolling and labouring athwart in a head sea. There are eight ventilators in the covering-boards, to ventilate the timbers, and she is fitted with Mr. Hughes' new windlass and steering apparatus, a larger model of the latter of which is in the Exhibition.

308 SWALLOW, J. C.—Inventor.  
Model of a life-boat.

309 ROYAL NATIONAL INSTITUTION FOR THE PRESERVATION OF LIFE FROM SHIPWRECK.—Producer.  
Model of life-boat.  
Specimens of gold and silver medals.

309A COLLARS, J. B.—Inventor.  
Model of a life-boat.

310 MARINERS' FRIEND SOCIETY, 58 *Fenchurch Street*—Inventors.

Model of a station for affording assistance in case of wreck. It provides residence for one man, with whom a brigade is connected for the same purpose, and contains various articles for rescuing life and property, and recovering the apparently drowned.

Model of a village station for similar purposes. The large room, which is intended as a reception room, may also be used for educational purposes, for the benefit of seamen, fishermen, and their families.

Life-belt worn by the brigade.  
Wager or racing boat, for one pair of sculls, built of mahogany and maple, with outrigger rowlocks.

312 SLATER & WRIGHT, *Whitby*—Inventors.  
A life-boat and carriage, not liable to upset on being struck by a sea on one side. An under current or back sweep acting upon the bottom in an opposite direction, would only have the effect of causing the air-box to revolve.

313 SPARROW, ROBERT, *Wexford*—Inventor.  
Model of a life-boat on an improved principle.

314 WILLIAMS, WILLIAM—Inventor.  
Model of a life-boat.

315 LAING, JAMES, *Sunderland*—Builder.  
Model of the ship "Vinniera," 1,020 tons, belonging to Messrs. D. Dunbar & Sons, of London, built by James Laing. Proportion of length to beam 5 to 1: it is said to be remarkable for fast sailing and large capacity.

Principal dimensions—  
Length . . . . . 165 feet.  
Breadth . . . . . 33 "  
Depth . . . . . 23 "

Length from head to taffrail 196 feet.

One side represents the ship in the finished state, and the fastening applied in securing her; the other side shows the disposition of the framing, and the various descriptions of knees used in connecting the beams to the sides of the ship. This side is so arranged as to open, and show the internal structure of the ship.

The model was made by Thomas Hardy.

316 HODGSON, MOSES, 6 *Moor Street, Sunderland*—Manufacturer.

Model of a pilot coble, with its oars, sail, and other appointments. It is similar to those which ply out of the port of Sunderland.

317 MONTEAGLE, The Right Hon. Lord, 7 *Park Street, Westminster*—Producer.

Model of a curragh, or light row-boat, portable by one man; used for fishing on the north-west coast of Ireland.

[Of the western coast of Ireland, which to a considerable extent is "iron-bound," the ancient Celtic boat called the curragh (carabus), or nivogue (navicula), has been constructed so late as the present century. It was constructed with a frame of osiers woven in basket-work, and covered over with a hide. It is accurately described by Julius Solinus, as well as in the following passage from Cæsar:—"Imperat militibus Cæsar ut naves—faciant cujus grueris eum superioribus annis usus Britannicæ docuerat. Carina primum ac statumina ex levi materia fiebant, reliquum corpus navium viminibus contextam coriis integelantur."—*De Bello Civ.*, lib. i. § 54.]

This ancient boat has been superseded within the last 40 years by the modern curragh, or canoe, of which the present model is given on a scale of an inch to a foot. Strained canvas, coated with tar, is now used in preference to horsehide, as less liable to stretch when exposed to sea-water.

These peculiar boats are well adapted to the coasts of Ireland; they are easily hauled up by the fisherman, and carried to his own cottage. Against a heavy sea and wind they possess great superiority over boats built with wood. But they are only suited to line fishing, from the necessity that the men should remain steady to their seats.

When going before the wind, a light lug-sail is sometimes set, and though apparently unsteady and unsafe, these curraghs, when managed with dexterity, bear a heavier sea than any other open boat. They are usually manned by four rowers, each using two paddles.

The original curragh, or carabus, as it is called by Latin writers, was well known in ancient times. "Carabus parva Scaplia ex vimine facta, que contexta crudo cordio genus navigii præbit."—*Isidor.* .xix. 1.

Inventors.  
to upset on being  
or current or back  
opposite direction,  
ing the air-box to

Inventor.  
principle.

entor.

Builder.  
0 tons, belonging  
on, built by James  
5 to 1; it is said  
arge capacity.

feet.

"  
"  
"  
inished state, and  
; the other side  
and the various de-  
the beams to the  
anged as to open,  
ship.  
rdy.

Sunderland—

s, sail, and other  
which ply out of

d, 7 Park Street,

or.  
t, portable by one  
t coast of Ireland.  
hich to a consider-  
cient Celtic boat  
ue (navicula), has  
ent century. It  
woven in basket-

It is accurately  
in the following  
us Cæsar ut naves  
us annis unus Bri-  
tatamina ex levi  
m viminibus con-  
Civ., lib. i. § 54.  
ed within the last  
noe, of which the  
nch to a foot.  
used in preference  
when exposed to

d to the coasts of  
the fisherman, and  
a heavy sea and  
r boats built with  
fishing, from the  
ady to their seats.  
lug-sail is some-  
eady and unsafe,  
dexterity, bear a  
T 7 are usually  
paddles.

s it is called by  
t times. "Carna-  
e contexta crudo  
ix. i.

The Commentator on Cæsar (Notes Var.) observes:—  
"Non dubito quia vox Carabus vox sit Britannica aut  
Belgica."—Anglice, coracle. See farther, Charnock's Na-  
val Architecture, vol. i. p. 222.]

317A WARNER, Captain—Inventor.  
Specimens of bomb-shells, &c.

318 HUGHES, JOHN, *Sunderland*—Inventor.  
Model of steering apparatus. This consists of two  
cast-iron standards, with two traverse boxes at the top.  
These boxes are screwed on to a toothed rack, which has  
a pinion on the upright shaft to which the steering-wheel  
is affixed, so that when the steering-wheel is turned  
either way, motion is given to the rack, and thence com-  
municated to the rudder by means of two connecting  
rods leading to the tiller, which is placed on the head of  
the rudder. The apparatus, or steering-machine, is de-  
tached altogether, and is placed on the under side of the  
deck beams of the ship, and is free from any obstruction.  
When the sea strikes the rudder it runs amidships; the  
great leverage that the helmsman has gives him a proper  
command.

Model of masting-shears, capable of lifting a boiler of  
20 tons weight, and shears on this principle may be con-  
structed to raise any weight that may be required. They  
are also adapted to put masts into ships. The model is  
made on a half-inch scale. The machinery is under cover,  
to protect it from corrosion, and to keep it in proper  
order. The middle storey is intended as a warehouse or  
loft for fitting up the rigging of larger vessels.

320 ROOE, GEORGE HENRY, *Landport, Portsmouth*—  
Working Shipwright.

Model of Her Majesty's steam-yacht tender "Fairy,"  
to the scale of a quarter of an inch to a foot. The yacht,  
with her entire fittings on the deck, the carving and the  
gilding, and her masts and rigging, are closely imitated.  
The model, in a glass case, appears to be floating on  
water; but the representation of the surface of the water  
may be withdrawn, and the vessel displayed resting upon  
blocks similar to those on which ships are built. The  
screw-propeller is then seen; and its action may be ex-  
hibited on turning a little machinery by means of a pipe-  
key, to be applied on the deck. (*In Class C.*)

322 DRUERY, JOHN, *Hartlepool*—Inventor.

Model and plan of a ship and shore sheet-iron life-boat,  
intended to recover herself when upset. Provided with a  
cabin for the better protection of the ship's crew. Fitted  
with 21 separate air-tight vessels for the purpose of keep-  
ing the boat afloat in case of external damage. The valves  
of the pipes for ventilating the cabin are so constructed  
as to admit the air when the boat is upright, and to  
exclude the water when upset.

323 GALE, GEORGE HAMLIN, 38 *Wind Street,*  
*Swansea*—Inventor.

Hydrostatic apparatus for life-boats, ships, &c., made  
of gutta-percha; intended to discharge water from life-  
boats, &c., without manual or mechanical power.

Model of a life or surf-raft or boat, which presents the  
same form, whichever side is immersed; with life-buoys,  
jacket, or belt.

324 BEE, BENJAMIN—Inventor.  
Model of a life-boat.

325 BOWEN, AUGUSTUS F., *Botley*—Inventor.  
Clear anchor.

327 ETRICK, ANTHONY, *HIGH BARNES, near Sunderland*  
—Inventor.

Model, to a scale of one inch to a foot, exhibiting a new  
method of launching the long-boat of a merchant or other  
vessel; principally adapted for coal vessels. The boat can  
by this method be launched by one man, without the  
masts, or removed to the side of the vessel, clear of the  
hatchway. Transverse wheels are shipped on, so that  
the boat can be run fore or aft the vessel as required.

Portable punching, slotting, and stamping apparatus,  
of new construction. The screw being all in one piece  
does not revolve, but is worked up and down by the collar  
to which the handle is attached; it is fitted with five  
punching and two cutting tools, one with edges for  
cutting out mortise holes, the other for shaping and  
cutting devices in iron or other metals.

Bogie, or timber-lifting apparatus, exhibiting a new  
application of the screw.

In descending a hill, the chain is quickly shifted to give  
greater weight before or behind, so as to act as a drag.  
The model is made to a scale of one inch to a foot.

Registered travelling-bag or portmanteau, of new con-  
struction.

329 MACDONALD, JOHN, 13 *Henry Street, Vauxhall*—  
Inventor.

Binnacle and ship's compass; intended to reduce local  
attraction; to neutralize the dip of the needle; to give  
an extraordinary binnacle light; speedy adjustment of the  
bowl; and to enable an azimuth to be taken at any hour  
of the day or night.

Engine pump for various important ships' purposes,  
with double cylinders, worked with new single valve,  
and parallel motion.

Silent water-closet, and exhauster of effluvia; acting  
without trap.

Steam chest and valve, applicable to double cylinders.  
Lantern and lamp for ship's head, and general pur-  
poses. This lamp throws a reflection of light from 160  
degrees of its circle.

330 PEARCE, THOMAS BLEWETT, 93 *Newman Street*  
—Inventor.

Railway fog-signal lamp, with red and green lights to  
be used at pleasure. One small lamp is sufficient on each  
engine.

Fishing tackle. Improved walking-stick, convertible  
into a seat, umbrella, and landing-net handle, adapted for  
the pocket or fishing-basket. Fishing-rod, with winch and  
running tackle. Self-acting top, which instantly strikes  
the fish when he bites; to be used with or without a float.  
Folding live-bait kettle. A gaff, hook-clearing ring, and  
drag-hook in one. Float made out of elder pith, with  
newly invented caps, to be instantly detached from the  
line.

332 WILLIAMS, THOMAS, *Red Lion Street, Clerkenwell*—  
Inventor.

Self-acting machinery for pumping ships by the move-  
ment of the vessel, with improved pump.

333 LONGRIDGE & Co., 4 *Mansion House Place*—  
Manufacturers.

The largest and the smallest anchors used in the British  
Navy. Manufactured by the Bedlington Iron Company,  
Northumberland.

\*.\* The following are exhibited outside the Building, at the  
West end.

335 BATEMAN, JONAS, 101 *Upper Street, Islington*  
—Inventor and Patentee.

Patent life-boat, constructed for 30 persons. The object  
of the exhibitor has been to render it incapable of being  
stove, sunk, or upset by any sea under any circumstances.  
It has been exposed to the most violent testing on the  
coast for four months.

Patent life-boat, constructed for six persons, on a pre-  
cisely similar principle, and having had the same testing.

336 RODGER, WM., Lieut. R. N., 9 *Shawfield Street,*  
*King's Road, Chelsea*—Inventor.

Improved patent small palmed anchor, with improved  
iron stock.

Improved patent small palmed keedge anchor, con-  
structed on the same principle.

Manufactured by Fox, Henderson, & Co.

337 STURDEE, A. B., *Royal Dockyard, Woolwich*—  
Inventor.

Working model of a twin-stern steam ship, with a protected propeller, prepared in 1848 at Bermuda by the inventor, to elucidate the advantages of his plan over the ordinary mode of fitting screw steamers, of which the following are the principal:—

First, as regards safety and speed:—

1. The propeller is entirely protected from accident by shot, floating ice, pieces of wreck, buoys, hawsers, seaweed, fishing nets, and from a heavy sea. 2. Expense of wear and tear of propeller is reduced. 3. In the case of the ship being driven on shore, the greater portion of the dead wood may be knocked away without injury to the propeller. 4. The fluid thrown off laterally by the propeller being reflected by the tunnel, vents itself aft with considerable force, like the stream of a rotatory pump, and acting against the after draught of the vessel, which flows in the opposite direction, assists in propelling the vessel; while, in the ordinary construction, the power expended in driving the fluid laterally, is wholly lost. 5. However much the form of the screw may be perfected, the fluid thrown off laterally must always be considerable at starting. It will, therefore, be seen that the first revolutions of the screw will be much more effective in the twin-stern steamers than in vessels of the ordinary construction, and a great advantage be thus gained in extricating the ship from difficult situations.

6. A more direct flood, and a more free passage for the water to the propeller, the line of current being direct with the axis of the propeller.

Second, as regards construction:—

1. The stern-frame of the ship is much stronger than that of an ordinary sailing vessel, has additional displacement, and dispenses entirely with ponderous overhanging quarters. 2. The stern-post is not, as now, nearly severed by an enormous hole being bored through it and the sternson knee, for the screw shafts. 3. Greater stability is obtained, and the heavy rolling so much complained of in the present screw ships greatly reduced. 4. Vibration of stern, when under steam, is nearly removed. 5. The twin-rudder, which can be worked by a single tiller, acts with increased effect; but in case of accident to one, the remaining one will be found sufficient for ordinary work, enabling the carpenter's crew to effect a proper repair of the injured one, or to fit a temporary rudder to the sister stern-post. A single rudder can, however, be adopted, if preferred. 6. On a foreign station, or in the absence of a dock or slip, the ship may be grounded abaft to effect any slight repairs to the propeller shaft, &c.

Third, as regards the application of sails:—

1. The propeller can be housed without incommoding the working of the ship or guns. 2. The lateral resistance is increased on the inclination of the ship, by the leeward keel having more immersion than when the ship is upright, thereby adding to her weatherly qualities. 3. The form of the water sections being preserved before each rudder, they have more power than that of the present screw ships, where the water from the leeward side of the vessel passes through the cavity for the screw to the weather side of the rudder. 4. In the case of the ship getting on shore or striking abaft, and having an inclination or list at the time, by tacking or wearing, as the case may require, she will immediately be brought upright, and in many instances free herself, when in that position, as her draught of water abaft will then be less than at the moment she struck.

Lastly, as regards armament:—

1. The propeller, and well for raising it when under canvas, can be fitted clear of the pivot gun, both when housed and in action. 2. The additional strength and support to the stern-frame, already alluded to, and the absence of quarters overhanging by many yards the section of load displacement, as in the case of the ordinary screw ships, render the stern capable of sustaining much heavier metal, and which can be better handled or worked from the increased dimensions of the after part of the quarter deck.

The illustration represents a quarter view of the

ship, with two stern-posts and two rudders to work simultaneously. The space between the stern posts, regulated by the diameter of the screw, forms a tunnel for the propeller to work in, which tunnel, extending towards the fore part of the ship, gradually resolves itself into the ordinary hull of the vessel near the mainmast, from whence the original model is preserved.

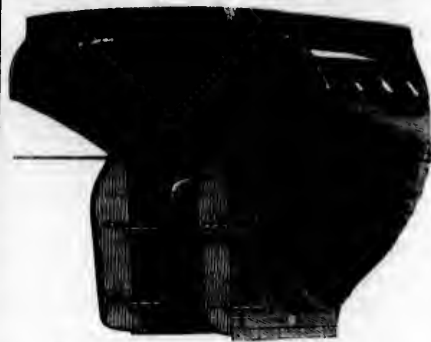

Sturdee's Working Model of a Twin-stern Steam Ship.

The sister keels which are substituted for the dispensed-with midship one abaft, are fixed at equal distances from the middle line, parallel to each other, forming bilge keels amidships, and the foundation of the arched roof of the tunnel abaft.

To the roof of the tunnel is given that form which will insure the most effective delivery of that portion admitted of the displaced fluid, and the most free access of the water to the screw.

The engines are placed and fitted in the ordinary way, and the ship may be built of either wood or iron.

In the event of a screw steamer fitted in the ordinary manner being driven on shore, the first two or three shocks would render the ship unmanageable, upon getting off again, both under steam and canvas, with the loss of rudder and propeller, as in the case of a corvette on the North American coast, in 1850. It is also said of the "Great Britain," that, immediately after the first shock she received on going on shore, the screw was jammed or locked, thereby preventing any hope of assistance from her engine of 1,000 horse power, which was thereby rendered useless at the time it was perhaps most required for the safety of the ship.

The experience of nautical men and others connected with the screw proves, that from its present exposed position many instances have occurred of hawsers being taken up by, and coiled around, the propeller, completely choking it, and endangering the engines as well as the ship, causing a detention of many days to cut them off piecemeal; in some cases it is not accomplished effectually without placing the vessel on shore, or in a dry dock.

The eddy formed on starting the engines, before the ship gathers way, has, in more than one instance, drawn the boats made fast astern into the propeller, which has literally smashed and sunk them.

The blades of the screw have also been knocked off by striking against projecting shelves of rock, buoys, &c. &c.]

Drawings of the "Balsa" life-boat, in two positions, also the mode of launching in a heavy surf, with the carriage used for that purpose and transporting along-shore. Provisionally registered.

Sketches of a paddle-box boat, constructed on the "Balsa" principle, showing her both under sail and stowed in place.

## WEST END GALLERY AND SOUTH-WEST GALLERY.

The principles on which the "Balsa" life-boat have been constructed are those of the twin-stern steamer, with protected propeller, exhibited in Class 5, so applied as to combine the qualities recommended by the Committee appointed to examine the plans which competed for the Northumberland premium.

The term "Balsa" is taken from the name of the boats of "South America," famed for their qualities as surf-boats, &c. The boats so styled are each propelled by one man using a double paddle through the heavy breakers and surf on the coast of South America, frequently carrying a cargo of a ton weight.

338 HUDSON, J., jun., 12 Hanover Square—Producer.

Model of H.M. steam-ship "Medea," on the scale of 1/4-inch to a foot. This splendid war-steamer has the reputation of being one of the fastest paddle steamers under canvas in the Royal Navy; and was designed and built by Oliver Lang, Esq., master shipwright in the Royal dockyard at Woolwich; last year she was the bearer to this country of the celebrated Koh-i-noor diamond, on which occasion she performed the quickest passage on record from the Cape of Good Hope to England.

This model is represented in the annexed illustration.

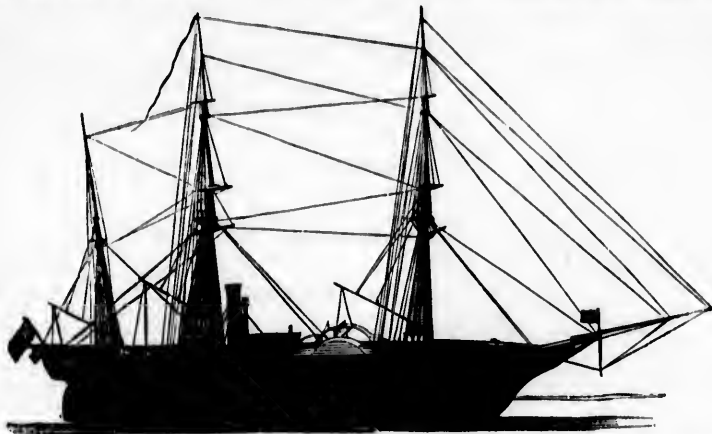

Hudson's Model of H.M. Steam Ship "Medea."

- 339 FAIRLY, E.—Inventor.  
Method of raising a stranded vessel.
- 340 WARD, —, Inventor.  
Model of a steam-vessel. (In class 5).
- 341 M'CRAE, J.—Inventor.  
Model of a life-boat.
- 342 RICKARDS, C.—Inventor.  
Steersman's indicator.
- 343 MARCUARD, C. R.—Inventor.  
Model of an 18-gun brig.
- 344 JONES, T.—Inventor.  
Model of a propeller for canal navigation.
- 345 EGG, D.—Inventor.  
Pistols, inlaid with gold and silver.
- 346 LANCASTER, C.—Inventor.  
Guns and rifles, smooth-bored.
- 347 Admiralty compass.
- 348 SEARS, M. W.—Inventor.  
Patent needle-gun.
- 349 HALL, H. W., Lieut. R.N.—Inventor.  
Model of an anchor.
- 350 REID, Captain, J. H.—Inventor.  
Model of a fan-propeller.
- 351 RANKINE, ADAM, *Lanecfield Foundry, Kirkcudbright*—Inventor.  
Working model of an iron planked war steam-ship, with screw motion, and propelled by a pair of direct oscillating

engines; showing the principle of the ball passing through the ship, with improved tubular boilers.

352 BAILY, J., *Middle Street, Deal*—Inventor.  
Model of a Deal lugger of 20 tons. Exhibited for lightness of construction, and sufficiency of strength to stand in a storm.

353 PUOH, EDWIN, *Whitstable, Kent*—Inventor.  
New ballast, called "water ballast," possessing the following advantages over the present mode of ballasting: No delay in taking in ballast; a sufficient quantity at all times; any quantity can be discharged when requisite; no choking of the pumps; no shifting of the ballast; a greater choice of freights; greater security from leakage; greater security from fire; a saving of labour, and rest to the crew; a greater number of voyages; a greater saving to the vessel, wear and tear of ropes, &c.; strengthening of the vessel when in ballast; saving in provisions, &c.; prevention of the vessel foundering; and saving the expense of ballast.

This apparatus is constructed to last for years, at a trifling annual cost. It is simple in its arrangement, so that a sailor can easily understand it. It requires no alteration after it is fixed, and if by accident it should be damaged, it is soon repaired. The expense of the purchase is liquidated in the first twelve months.

354 Captain DWYER, *Woolwich Dockyard*.  
Model of life-boats and anchors.

355 Mr. LANG, *Woolwich Dockyard*.  
Various methods of steering vessels.  
New plan for dead-eyes, and system of ventilating ships.

356 PEAK, JAMES, *Woolwich Dockyard*.  
Model of a brig, on slip.

358 Model of a 78-gun war-ship, in a small decanter.



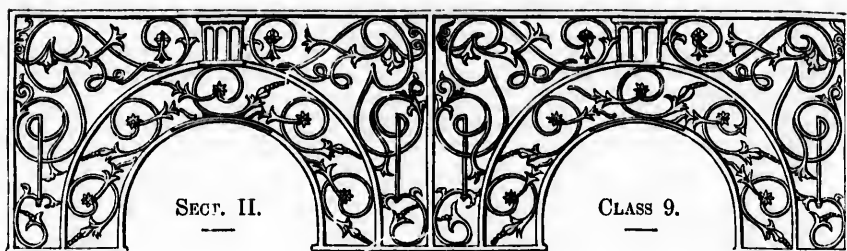

## AGRICULTURAL AND HORTICULTURAL MACHINES AND IMPLEMENTS.

### INTRODUCTION.

THE application of the mechanical genius of this country to Agriculture is illustrated by the present Class. In respect of the space occupied by it, it may be considered the largest Class in the Exhibition; but in the number of exhibitors it does not equal many other Classes. In consequence of the annual exhibitions of agricultural implements held in different towns, the exhibitors in this Class have had a degree of experience in their preparations for exhibiting, not enjoyed by those in other Classes, to whom a public display of their productions has presented itself as a new undertaking.

This Class divides itself into the following sub-classes:—A. Implements for Tillage, such as Ploughs, Harrows, Scarifiers, Clod-crushers, &c.; B. Drilling, Sowing, Manuring, and Hoeing Machines, such as Drills, Dibblers, Hoes, &c.; C. Harvesting Machines, as machines for cutting corn, &c., Rakes, Tedding, and other machines; D. Barn Machinery, as Steam-engines, Horse-works, Thrashing-machines, Winnowing, Hummelling, and other machines; E. Field, Fold, and Yard machinery, as Turnip-cutters, steaming, feeding, weighing, and watering machinery; F. Agricultural Carriages, Harness, and Gear, such as Waggon, Carts, &c.; G. Drainage Implements, as Pipe, Tile, and Brick-making machines, Irrigators, &c.; H. Dairy Implements, as Churns, Presses, &c.; I. Miscellaneous Implements used in Agriculture; and J. Garden-engines and Tools.

In the Building the implements and other apparatus of this Class will be found in Avenues P. Q. and R., extending from the western wall of the Building to the Sculpture Court. Some of the machines in motion, such as mills for farm produce, together with some of the steam-engines adapted for agricultural purposes, are found in the space generally occupied by Classes 5, 6. Outside the Building, also, at its western end, are gates, hurdles, &c., which properly belong to this Class.

The results of much effort, in calling in the powers of the steam-engine to the aid of agriculture as to that of manufacture, are evident in this Class. The agricultural steam-engine is itself an interesting object. For its practical application, great simplicity, combined with efficiency and strength in the working parts, is absolutely necessary. The mechanism requires to be such as shall not be easily deranged, or if deranged to be capable of easy adjustment. The elements of lightness and portability, with simple but efficient working power, naturally offer themselves, as of the first moment, in the construction of an engine to be managed by agricultural labourers, to be dragged into the fields, and often over bad ground and roads.

The oscillating cylinder-engine is used in some of the instances exhibited, and in others the cylinder is placed horizontally, and is fixed, the slide-valves being acted on by an eccentric in the usual manner. These engines have been put to actual service, together with the other machines in this Class; having been tested in the trial-yard on their way to the Building. Upon the result of these experiments will principally depend the report of the Jury for this Class.

A variety of ploughs and pulverizers are shown, the peculiar form and construction of which are submitted to practical agriculturists for their approbation. A large amount of attention has been given to the form of the share and furrow-turner, with a view to their adaptation to soils of varying tenacities and degrees of resistance. Many of the iron ploughs are deserving of notice from their compactness and lightness of construction. Some are made especially for convenience of stowage for emigrants. The drilling, sowing, and manuring machines exhibit features of interest. In many of these, vulcanized caoutchouc has been serviceably applied for conducting the seed, manure, &c., to the coulters. The steering of many of these machines exhibits ingenious arrangements. Attempts have frequently been made to substitute mechanical for hand-labour in harvesting operations. Some curiously-contrived forms of apparatus are found in this Class adapted for cutting corn and grass, and thus in a degree dispensing with the labours of the reaper and the mower. Barn machinery is also well represented in a variety of chaff-cutters, winnowing, thrashing, and other machines and mills, which afford an instructive view of the present extensive applications of machinery to agricultural uses. The implements connected with the all-important subject of drainage are specimens exhibiting much inventive skill. The pipe, brick, and tile machines are highly interesting, and some are exhibited in operation, automatically producing, from well-kneaded clay, those various articles, the ordinary manufacture of which requires the labours of several individuals. The pipe-making machines present a singular aspect when in work, discharging an endless row of pipes of wet clay, which are divided by the alternate rise and fall of horizontal wire. By a simple arrangement the length of these pipes can be adjusted to any required extent.

In no other country, of late years, has agriculture been rendered so largely an object of experiment as in the United Kingdom, and in none other do the requisite amount of capital, and the supply of means for such experiments, proportionately to the area of the soil occupied, exist. Perhaps it may be added, that in no other country does there exist the same absolute necessity for the complete development of the productive capabilities of the soil. The application of philosophy to this art is recent, but promises favourable results. Chemistry has been applied to, for the knowledge of the properties of various earths, and Mechanics become the next object of study with a view to reduce the soil to the conditions required by the cultivator.—R. E.

**1 STANLEY, WILLIAM PROCTON, Market Place, Peterborough—Manufacturer.**

1. A two-horse portable steam-engine, with an improved boiler, invented by John Medworth, of Nottingham. The fire is surrounded by water; and across the fire-box, is a circulating chamber or water bridge, in the form of a square box, with about two inches inside water space. It has inlet pipes at bottom, and outlet pipes at top, into the body of the boiler. The water circulates through this box, and its violent ebullition liberates the steam as rapidly as it is generated. The cut, fig. 1, represents this steam-engine.

Fig. 1.

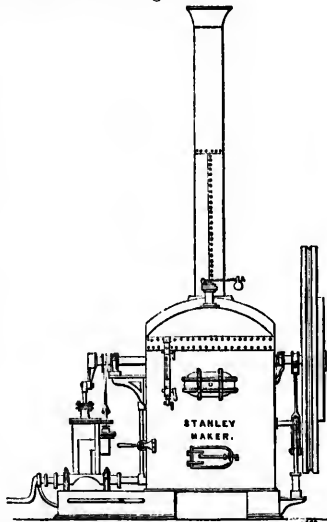

Stanley's Two-horse Portable Steam-engine. (End Elevation.)

2. The farmers' registered steam-cooking apparatus. This apparatus is shown in the adjoining cut, fig. 2.

Fig. 2.



Stanley's Registered Steam-cooking Apparatus (for Farmers).

3. Rape and linseed cake-breaker, for breaking cakes for sheep, cattle, and manure.

4. Registered roller mill, or corn and seed crusher, for crushing linseed, oats, barley, malt, beans, and Indian corn.

5. Chaff engine, with safety lever, and apparatus for stopping or reversing the motion in case of accident, to cut chaff from  $\frac{1}{8}$ ths of an inch to 5 inches long. This engine is represented in the annexed cut, fig. 3.

6. A machine for cutting roots for sheep and cattle, and known as the Royal Albert turnip-cutter: this, as also Nos. 2, 3, 4, and 5, are intended to work, at the same time, from the two-horse engine.

Fig. 3.

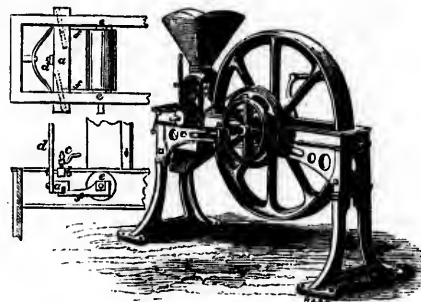

Stanley's Chaff Engine.

The side cuts represent the safety lever seen from above and at the side; *d* is the lever acting through the pieces *a* and *f*, on the roller *c*, *e*; *c* is a tightening screw.

7. Drawings of windmills for grinding corn.

8. Drawings of a roller mill, and of a steam generator.

**3 GUEST, JOHN, Bedford—Inventor and Manufacturer.**

Three-row steering drill on the flat, or two rows on the ridge, for turnips or mangol-wurzel, with manure.

Eight-row cup drill, for corn and seed, with self-acting box, and independent steering, by which the drill-man is enabled to steer it perfectly straight, independently of the horses, and thus to facilitate the use of the horse-hoe between the rows.

**4 DEAN, THOMAS, Wishaw, Scotland—Inventor.**

Cutlery apparatus attached to a tile and pipe machine, for forming overlaps in tiles and pipes as they come through the die; intended to prevent the tiles or pipes from sinking in soft lands, and to keep them in one continuous line, so as to supersede collars. Two men and a boy can cut and make an average of 4,000 daily. The one pipe is cut out of the other, so that the overlaps are very complete in the fitting. The machine will be worked to exhibit the process.

**4A SMITH, ALEXANDER KENNEDY, Exminster—Inventor and Maker.**

Rotary screening machine, for screening earths, manures, coke, coal, stamped ores, &c., having a rotary motion, constantly changing the position of the article to be screened.

**11 CROSSKILL, E., Liverpool—Manufacturer.**

Cart, waggon, and patent wheels.

**13 HARDING, EGERTON, Oldsprings, Market Drayton—Inventor.**

One-horse cart, the wheels running vertically, and the axle revolving as well as the wheels.

Set of whippetrees.

15 BUSBY, WILLIAM, *Newton-le-Willows, Bedale*—  
Manufacturer.

Single-horse cart, and light single-horse cart, for farming purposes.

A light horse-hoe, for ridge work, improved by the exhibitor. Strong horse-hoe for ridge work, with five tines.

Horse-hoe, with expanding motion.

Deep plough. Plough for general purposes. Light two-wheeled plough. Swing plough. Ribbing drill.

16 HARVEYS & TAIT, *Strathaven, Scotland*—  
Inventors and Manufacturers.

Clydesdale tilt-cart, in working order, with concealed fastening; intended for farm work, and adapted for jobbing on parks, lawns, or ornamental grounds.

Farm kitchen fire-place crane, with improved machinery for adjusting cooking vessels.

17 CAMPBELL, A. F., *Great Plumstead, Norfolk*—  
Manufacturer.

Patent four-wheel parallel-motion harrow.

17A GREGORY, RICHARD, *Beverley*—Inventor and  
Manufacturer.

Model of a draining-machine.

18 STENT, WILLIAM, *Stockwith, Gainsborough*—  
Inventor and Manufacturer.

New supporter for peas, intended to supersede the common sticks, and calculated to last, with care, for a considerable time. This supporter is neat, and can be obtained in lengths of 23 yards.

20 NICHOLLS, R. H., 11 *Elizabeth Street, Eaton Square*  
—Inventor.

Patent dibble, with locomotive machine attached, for planting corn; and so constructed as to work upon any description of land without chocking; progression is obtained by a new arrangement of mechanical powers.

Machine for giving motion with power to all rotatory machinery.

21 WILKIE, J., & Co., *Uddingston, near Glasgow*—  
Manufacturer.

Parallel drill grubber, made of wrought-iron, and adapted for cleaning and loosening the earth between the rows of mangel-wurzel, potatoes, and turnips sown on the ridge, having two wheels, one in front and one behind, and regulated to the required depth by a lever.

Turn-wrist plough, made wholly of malleable iron, and adapted to lay the furrow to the right or left at pleasure; the mould boards and coulter are shifted by a simultaneous motion; the bridle is self-acting, and adjusts itself in the turning of the horses, having two wheels in front to regulate the depth.

Two-horse sowing plough, adapted for general purposes. It is greatly improved by welding the left handle, beam, sheath, and heel in one solid body, thus dispensing with joints and mortices.

Subsoil plough, invented by Mr. Smith, and improved by the exhibitor, with frame-work and land-breakers, and a leading wheel to regulate the depth, which, running in the bottom of the furrow previously made by the common plough, makes it work more evenly and easily.

Friction-wheel plough, having a friction-wheel in the sole for ease of draught.

21A REVIS, THOMAS, 8 *Cleave Place, Larkhall Lane,*  
*Stockwell, Surrey*—Inventor.

Single-seed planter.  
Single-seed dibbler.

22 EATON, JOHN, *Woodford, near Thrapstone*—  
Inventor and Manufacturer.

A patent seed-dibbler, adapted for hand or horse power. Registered ornamental sheep-crib, for hay, roots, cake, &c. Invented by William Knight, Esq., of Titchmarsh.

23 HARKES, DAVID, *Mere, near Nutsford*—Inventor  
and Manufacturer.

Plough, with the joints welded instead of being connected by bolts and screws, and improved mould-board; it can be used with or without wheels.

Parallel expanding horse-hoe, for hoeing between turnips, potatoes, &c.; it can be set to any required width by a lever fixed between the handles, without stopping the horses.

Cheese and cider press, operating on the principle of a steelyard, which can be regulated to any pressure.

Hay-cutter.

Machine for screening clay for bricks, tiles, pipes, &c.

24 BRADY, JAMES, & SON, *Duke Street, Stamford Street,*  
*Lambeth*—Inventors and Manufacturers.

New application of springs to a caravan, or waggon, in which the perch bolt is placed behind the centre of the axletree, to allow a higher fore wheel, and give a greater amount of lock.

Machine for weighing coals, attached to the hind part of the caravan or waggon.

25 WINDSOR, JOHN, *Osuestry*—Manufacturer & Improver.

Winnowing machine, for wheat, barley, oats, beans, peas, &c. The improvements claimed are the peculiar construction of the riddle-case, and the placing of a fly-wheel on the fan spindle to regulate the speed, and produce an under-current of wind at the bottom of the cylinder to blow off any light substances.

Clover seed drill, for sowing all grass seeds and turnips on the flat. The bottom of the box is formed so as to cause the seed to fall to the brush until empty, and there is a movement for throwing the connecting spindle out of gear.

25A ALSOP, DANIEL, 6 *Boone Street, Lee, Kent*—  
Inventor and Manufacturer.

Sulphurator and fumigator, to diffuse powdered sulphur for destroying mildew; with a tobacco-chamber.

25B KINGSWELL, FREDERICK, *Upper St. Martin's Lane*  
—Inventor.

Model waggon.

25C GINGELL, W. J., *Nelson Street, Bristol*—Inventor.

Model uniform corn and seed meter, producing a uniformity of weight and measure of corn or seed at the same time.

26 ROBERTSON, GEORGE, *Allaridge Street, Stonehaven,*  
*Scotland*—Inventor.

One-horse cart for agricultural purposes; with a sliding axle, by which the weight on the horse's back is regulated in going up or down hill; it has the advantage of keeping the cart always on a level. This invention is intended to prevent horses being at one time crushed with too much weight, and choked at another with too little.

27 ALCOCK, THOMAS, *Roadcliffe, near Nottingham*—  
Inventor and Manufacturer.

Chaff-cutter, with improved rising roller.

Improved two-wheeled iron plough.

Improved swing iron plough.

28 LOWCOCK, HENRY, *St. Peter's Street, Tiverton*  
—Inventor and Patentee.

Patent turn-wrist plough (invented by the exhibitor, and manufactured by R. Adams, of Marlton, Devon), for turning furrows in one line of direction, and parallel to each other. With this implement the whole under surface of the furrow-slice is clean cut out at each ploughing; the weeds are clean cut; and the upper surface of the soil, especially when brought into tilth, is kept more level, and is less trodden.

28A FOWLER, JOHN, jun., *Temple Gate Implement*  
*Factory, Bristol*—Inventor and Proprietor.

Improved draining plough, (patented for the United Kingdom, France and Belgium) capable of effectually ex-

cutting any drainage that may be required above the depth of 4 feet, at less than half the cost of the present system, and without disturbing the surface soil.

The following engraving shows the machine just as it is finishing the drain. When commencing work, the plough is taken to one end of the field, and the capstan is moored at the other; the wire rope being run off the drum of the capstan and attached to the plough (either singly in shallow draining or soft soils, or returned round a single sheave when greater power is required), as shown in the

cut. The plug and coupler are then dropped into a hole prepared for them, and the pipes threaded on a rope are attached to the back of the plug, the hole being sloped off backwards to allow them to enter easily. The horses are attached to the horse levers of the capstan, and by walking in a circular course, wind the wire rope on to the drum, and pull the plough forward with the pipes attached. When the required length of drain is completed (which may be any length under 225 yards), the plough is run into another hole, and the rope on which



Fowler's Improved Draining Plough and Windlass.

the pipes are strung, being unhooked, is pulled out backwards, and the drain is complete. As it would be inconvenient to have the pipe-rope in one length, it is made in pieces of 50 feet each and by a simple contrivance, as one rope enters, the other is attached to the end. It does not occupy more than one quarter of an hour from the time of finishing one drain to commencing another. The accuracy with which the clay pipes are laid cannot, it is said, be equalled by any hand work; and from the bottom being undisturbed, they are not liable to sink, as is sometimes the case even in the best-executed hand-draining.

By this process, not only is the cost of burying the tiles reduced in many cases 50 per cent., but from the quickness and neatness of the operation it can be done at any season of the year, without injury to any short crop or interfering with the common farm operations, the surface soil being untouched, except at the headlands; and where the hedges are low, the capstan can often be fixed in the next field. In undulating or flat lands, the levels are kept, or a fall insured, by working the coupler up and down in the body of the plough, by means of the worm and worm-wheel, shown in the cut, the ploughman's eye being guided by a try-sight balanced on the plough, and a cross staff erected at the end of the field.

Several of these ploughs are now in constant work, and though great lengths of the drains have been opened in the presence of large numbers of agriculturists, in no instance have tiles been found incorrectly laid.

The quantity of draining that can be done per day will vary with each particular field, but in common clay land when the depth does not exceed three feet, between 6,000 and 7,000 feet will be completed with four horses in the common working day; but when the depth exceeds three feet, from two to three horses will not do more than half that quantity. Where it is possible, this draining would be much more cheaply done in summer; as twice the quantity of work may be done by having two teams of horses out, and the other expenses would not be increased in proportion.

28u FOWLER & FRY, *Temple Gate Implement Factory, Bristol*—Designers and Manufacturers.

Registered firm cart, adapted for harvest and winter purposes. The shafts are adjusted with bent iron stays, so as to keep the body low and the wood shafts straight; the tipping apparatus is also adapted for rapid and easy delivery.

29 ELLS, 3 & 6 *Tottenham Court Road*—Inventor. Wheelbarrow on an improved principle.

30 CARPENTER, W., *Banbury*—Inventor. Anti-stiction thrashing machine.

31 SAWNEY, WILLIAM, *Beverley*—Inventor. Winnowing-machine. Iron model bridge.

32 BENDALL, JAMES, *Woodbridge*—Manufacturer. Patent self-adjusting cultivator, for skimming, cleaning, pulverizing, or subsoiling land, with a double-action lever on the axle, and crescent plate, to regulate its depth; improved key mortice, for prongs; new arrangement of shares, and new mode of regulating front wheels. Patent crushing machine for corn, beans, peas, barley, &c.

33 BLACKHALL, JAMES, 22 *Upper Gray Street, Edinburgh*—Inventor.

Model of high-pressure boiler, for steaming bones for manure; with additional tanks for retting flax; also, for steaming straw, turnips, and other food for cattle.

Specimen of steamed bone-manure, prepared at Blackfaulds, Linnithgowshire; containing, for its preservation, 5 per cent. of salt and 5 per cent. of gypsum.

The process of steaming bones, and afterwards dissolving them in sulphuric acid, is intended to supersede the usual method of crushing them by expensive machinery.

34 BEART, R., *Godmanchester, near Huntingdon*—Inventor.

Patent land cultivator or scarifier, having traction wheels, to prevent the implement, when paring hard land, from moving out of the line of the draught of the horses.

35 MARSHALL, Lieut.-Col. WILLIAM, *Newfield Cottage, Craigellachie, Scotland*—Inventor.

Cereal seed-planting and simultaneously-operating machine, constructed to show the advantage of thin seeding.

36 WINDUS, T., F.S.A., *Stamford Hill*—Inventor. (J. Rendall, Maker, Stamford Hill).

Two centripetal barrows.

37 BURRELL, CHARLES, *Thetford, Norfolk*—Designer and Manufacturer.

A six-horse power portable steam-engine, adapted for driving a thrashing-machine, saw-mill, &c. It has an im-

proved tubular boiler and reversible motion. The speed can be varied from 90 to 110 revolutions per minute, without stopping the engine. The following cut represents this engine.



Burrell's Six-horse Portable Steam Engine.

Registered machine for making hurdles or gates. It consists of a circular saw bench, fitted with a machine for boring and morticing at the same time. An extra frame is also supplied for putting the hurdles or gates together; it is also adapted for morticing posts for fencing. This machine is represented in the annexed cut.

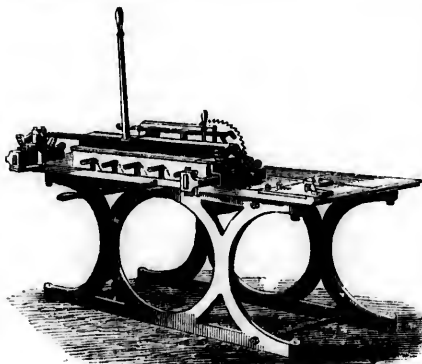

Burrell's Hurdle-making Machine.

Registered gorse-cutting and bruising machine. It first cuts the gorse as chaff, and then passes it through one pair of rollers, one of which has a pressure, by means of a leverage, of four tons weight. It is also fitted with an

extra hopper when used for crushing. This apparatus is shown in the cut.

A thrashing-machine, with straw-shaker attached, invented, improved, and manufactured by the exhibitor. This machine is upon double carriages, and is well adapted for a portable steam-engine.

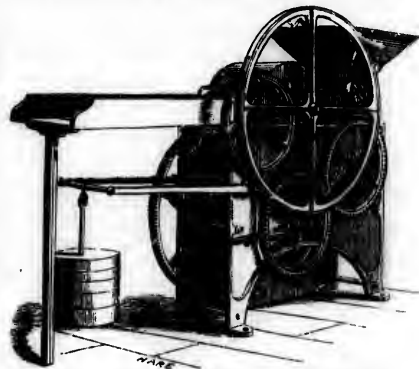

Burrell's Registered Gorse-cutting and Bruising Machine.

A spirit-level, for laying draining-pipes or tiles, invented by John Matthews, and improved by the exhibitor.

38 STEEVENS, WM. DAN., 157 High Holborn.—Inventor. Model of a new plan for an agricultural railway, with a new engine for the same, without steam or horse power, and carriages, trucks, &c., for farming purposes.

38A ARMITAGE & COMPANY, Mouschole Forge—An improved plough.

38B MURPHY, D. J., Chamber of Commerce, Cork—Inventor.

Model of the Archimedeian agricultural machine for cutting, turning up, and pulverising the soil, so as to prepare it in the one operation for receiving the seed, and thereby economising much of the time, labour, and expense heretofore incurred. It can be worked either by steam or horse power, and even, on a reduced scale, by manual, for horticultural purposes.

41 ELLIOTT, JOHN, Southampton—Inventor.

Deodorizing water-closet.

Model of farm buildings.

Model of cottages for labourers.

Portable draining level.

Specimens of clay tubes, for building roofs and walls of cottages, farm buildings, &c. Manufactured in 1848, at the brick and tile works of the Duke of Richmond.

41A FYFE, WILLIAM WALLACE, 30 Hamilton Place, Edinburgh—Inventor.

Syphon apparatus, for the washing of sheep, and for improving the growth of wool by the copious application of pure water.

[Though employed in a rude form in the case of Canadian sheep or store farming, the use of the syphon in this country is unknown in sheep-washing, a process which is performed either by "leaping" or "rough-handling" the animals, to their great injury and that of the wool. There is reason to believe that the free application of water, promoted by the use of this apparatus, will improve the woolly fibre, by precluding irregular growth, and the formation of knots or joints, besides conducting to the health of the sheep. A prejudice exists against giving water to sheep, yet the necessity of washing is admitted.]



ON THE SOUTH SIDE: AREAS N. O. 1; P. Q. R. I TO 27.

This apparatus  
er attached, in-  
y the exhibitor.  
s, and is well

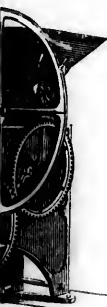

ng Machine.

es or tiles, in-  
y the exhibitor.

orn.—Inventor,  
railway, with a  
or horse power,  
reposes.

ic Forge—

roc, Cork—

al machine for  
soil, so as to  
ving the seed,  
he, labour, and  
worked either  
reduced scale,

entor.

fs and walls of  
red in 1848, at  
diamond.

lton Place,

sheep, and for  
ous application

a the case of  
of the syphon  
ing, a process  
"rough-  
jury and that  
that the free  
use of this  
by precluding  
ots or joints,  
ep. A preju-  
the necessity

42 SLIGHT, J., 34 Leith Walk, Edinburgh—  
Manufacturer.

A Tweeddale subsoil trench plough; an improvement on Read's by the Marquis of Tweeddale.

The Tweeddale trench plough, invented by the same, for the purpose of taking a furrow slice fourteen inches deep as a precursor to the former.

Model of Henderson's patent Derriek crane.

43 STARKEY, THOMAS, Farthinghoe, Brackley, Northamptonshire—Inventor, Designer, and Maker.  
Clod-crusher, on travelling wheels, shifting into a plain roller.

Telescope ladder, extending from six feet, to 26 feet, shifting into one, two, three or four ladders, and forming a single or double flight of steps.

Ship-propeller, exhibited for simplicity and power.

Table, convertible into a bed or wardrobe, a suite of drawers, a seat, a closet, &c.

Two tables, as specimens of British woods.

Seat, to shut-up, for the pocket.

44 RACE, EDWARD, Beverley—Inventor and  
Manufacturer.

Model of a new tipping waggon. This waggon has a screw in the middle pole acting upon the fore-end of the waggon, so that one man can tip the body, and discharge a load of four tons weight.

45 GOLDING, ROBERT, Huntton, Maidstone—  
Manufacturer.

"Improved Grecian" beehive: constructed with bars or slips of wood, to which the combs are suspended, so as to allow of their being extracted and returned uninjured. Adapted either for making observations, or for taking the honey without destroying the bees. A portion of the hive, consisting of three bars, is removed, and a similar

piece, with combs attached, from another hive, substituted to show the arrangement of the comb and mode of action.

"Improved Huber's leaf-hive," which opens in the manner of a book, and admits of particular examination, for the purpose of observing the proceedings of the bees.

45A GOLDING, EDWARD, Hurstbourne Priors, Andover Road—Inventor and Manufacturer.

Improved rolling barley chumper, to break the beard from the grain by rolling it backwards and forwards over the barley when spread on the floor. Its effects are doubled by inserting wires between and underneath the bars.

46 DAVIS, THOMAS, Guy St. Nicholas, Warwick—  
Inventor.

The drum part of a registered thrashing-machine, worked by steam or horse, adapted to thrash all kinds of grain (leaving the straw for boltings or otherwise), with revolving drum, the circumference of which is formed of a series of flutes or concave plates, and the beaters attached to the said drum and concave fixed in the interior of the same cylinder in which the drum works. These plates have teeth or sharp-edged flutes on their faces. The said teeth are not concentric with the axis of the drum, but (regarded in the direction in which the drum revolves) the second of each set advances on the first, and the third on the second.

47 CLAYTON, HENRY, Atlas Works, near Dorset Square—  
Inventor and Manufacturer.

Patent double action machine for screening the clay for the manufacture of all kinds of drainage pipes and tiles, roofing and paving tiles, and hollow or solid bricks; it combines the vertical and horizontal plans of working. This double-action machine is illustrated in the annexed cut.

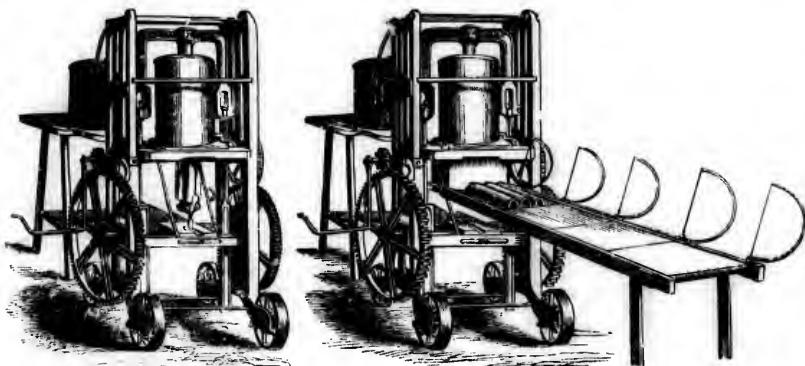

Clayton's Brick, Tile, and Pipe-making Machine.

Patent gratings and dies for cleansing clay, being perforated metal plates instead of wires or bars.

Cycloidal shape and other various improved draining tools, for cutting the drains in every description of soils. Patent drain consolidator and chuser, adjustable to every depth of drain, for the tiles to be laid in.

Working drawings (to scale), for the erection of kilns, drying sheds, &c. Improved plan for drying shelves, for drainage tiles, pipes, hollow and solid bricks. Specimens of common and other tiles, and of Roberts' patent bonded hollow bricks.

48 MORRISON, JOHN, & SON, Banff, Scotland—  
Producers.

Four bulbs of golden yellow turnip, and sample of seed, which have been cultivated in Banffshire and Aber-

deenshire for several years. Four bulbs Aberdeenshire, or Gordon yellow turnip, and sample seed. Four bulbs of Williamson's Swedish turnip, and sample of seed. Four bulbs of Birchomb yellow turnip, and sample of seed, which produces heavy crops on poor soils.

48A PALMER, RICHARD, Bideford, Devon—Inventor and  
Manufacturer.

Machine for cutting, and reducing to a pulp, turnips, carrots, mangold-wurzel, potatoes, &c., and mixing meal, if required. This machine may also be applied to grinding apples for cyder.

49 DRUMMOND & SONS, Stirling—Proprietors.

A grubber or cultivator, made by Mr. Lewis Pottor, Bothkennar, near Stirling. The principal improvement

on the spot, in "airish mows," before the evening, where it remains for months, free from heat and injury, until it suits the grower to house or otherwise dispose of it. Each mow contains generally about 200 sheaves.

[In wet harvests it is desirable to adopt some method for keeping the cut corn as dry as possible, in order to avoid sprouting and other injury. In the north of Europe light frames are erected in the field, on which the sheaves are placed with their heads downwards, and the top ridge is then lightly thatched; or hurdles may be set up, inclined towards each other at any desired angle, and the sheaves placed on them in layers and then thatched. In many counties in England the practice is to set up a certain number of sheaves to form a stack, which is "capped" or "headed" by other sheaves placed on it with their heads downwards. In Northumberland a practice still exists called "gaiting."—A single sheaf is taken; the band is tied higher up than usual; the butt, by a peculiar movement of the workman, is spread out, and the sheaf is then set up by itself. By thus separating the straw the wet does not lodge so much as it otherwise would do. The practice of making "airish mows" has generally declined, even in Cornwall and Devon:—smaller mows are now made in the form of a conical heap, and containing about a load of sheaves. The object in all, is to protect the corn from wet, and at the same time to secure a good ventilation.—J. W.]

53 COOCH, JOSHUA, *Harleston, near Northampton*—  
Inventor and Manufacturer.

Patent machine for winnowing or dressing corn and seeds.

Barley hummeller, for breaking off the haulm or beard

A self-acting feeding trough for poultry.

60 BECKFORD, T., & GOSLING, W., *Highfield Farm, Wargrave, Henley-on-Thames*—Inventor and Manufacturer.

Model of a circular mowing and tedding machine, drawn on three wheels, by one horse, regulated with a lever by the driver, according to the nature of the land. The mowing machine can be used with or without the tedder.

61 RODENHURST, W. & J., *Market Drayton*—  
Manufacturers.

Compound screw and lever cheese-press, having more power than the ordinary rack and pinion press, and therefore requiring a less weight and a shorter lever.

Hay or straw cutting machine.

62 GILL & WARD, *Orford*—Manufacturers.

Improved portable copper steam generator, with force-pump and supply-cistern, complete.

Two iron vessels for boiling or steaming food.

63 WATT, JAMES, *Biggar, Scotland*—Improver and  
Manufacturer.

Improved broad-cast sowing-machine, for grain and grass seeds, having jointed seed-chests, adapted for passing gates, and the small wheel behind for ease in working, and saving of the grain. Drawn by one horse, and sowing from 30 to 35 acres per day. This machine is represented by a side elevation in the annexed cut.

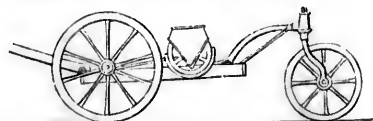

Watt's Broad-cast Sowing Machine.

*Farm, Wargrave,*  
manufacturer.  
g machine, drawn  
d with a lever by  
the land. The  
out the tedder.

*Drayton—*

...ssa, having more  
press, and there-  
r lever.

...cturers.  
...ator, with force-

...g food.

...prover and

... for grain and  
adapted for pass-  
case in working,  
horse, and sowing-  
machine is repre-



same time, four times the space which the present irons pass over. Should the hooks become fastened at the bottom of the river, they will straighten. The hanging-chain with the hooks will detect a body lying behind a rock or large stone. It is made to take into pieces, so that it can be easily repaired.

69 **JOLLY, JOSEPH, Vale of Aylesbury—**Manufacturer.  
Churn and stand; large and small milk-pails; oval butter-tub; butter prints and boards; milk-strainer.

70 **JENNISON, JOHN, Frodingham, Duffield, Yorkshire—**  
Inventor.  
Yorkshire corn stacks, showing the position in which sheaves are laid.  
Stack level, to assist the stack-builder.  
Hedge models, &c.

72 **HART, CHARLES, Wantage—**Inventor.  
A registered universal portable grinding-mill. The first part consists of two plates, with steel cutters, the bottom one running horizontally; the grain, in passing through which, is split into small pieces; it is then conveyed between two stones, one stationary and the other running vertically, where it is reduced to fine meal.

72A **PHILLIPS, G., Harrow-on-the-Hill—**Manufacturer.  
Improved collateral beehive, made of wood, glass, and zinc. In this hive, the bees do not swarm, nor require to be destroyed to take the honey; and the progress of their work can at any time be ascertained without danger.

73 **FRANCE, ARCHIEALD, Stirling—**Manufacturer and Designer.  
A drill-plough for green crops.  
A green-crop grubber.

...from the outer to the inner edge, so that a clod, being squeezed in, will necessarily fall into the interior, and be broken.

Mill for mixing provender, and preparing manures for drill-sowing. The rollers are composed of double-toothed rings, working into each other; with strong gearing, heavy fly-wheel, with brass bushes, and hard-wood frame.  
Gorse-cutting machine, with eight knives, fixed on a cylinder, which revolves in brass bearings, with fluted rising feed rollers, and case-hardened cutting plate.

Mill for kibbling or crushing beans, oats, &c., on hard-wood frame, with case-hardened diagonally machine-fluted rollers, working in brass bushes. The feed apparatus is regulated by a screw from behind.

Oilcake crusher, for crushing oil or rape cake. The rollers are composed of double-toothed rings, bored out, and fitted with a key on a round shaft. It has double pickers for cleaning the rollers, and sliding bars, with regulating screw in the centre, giving a parallel motion to the roller.

76 **WOODBOURNE, JAMES, Kingsley, near Alton—**  
Manufacturer.

Iron machine for bagging hops by pressure. The power is obtained by one pair of wheels, rack, pinion, and lever; and it is provided with an iron case, screw, and step, for the reception of the bag, to prevent its being torn by the pressure.

77 **PEARCE, W., Poole, Dorset—**Inventor.  
Clod-crusher, cider-mill, gorse-cutting and bruising machine, ploughs, &c.

78 **G'LETT, JOHN, Brailes, near Shipston-on-Stour—**  
Inventor and Manufacturer.

1. Chaff engine, for cutting hay and straw with double-action knife, having two edges, cutting in its ascent and descent; the apparatus which regulates the length of the

consist in the easy adjustment of the tine frame, by means of lever and pulley.

A two-horse iron swing-plough, made by Mr. John Barrowman, of Saline, Fifeshire; with long handles and short beam.

50 NICHOLSON, W. N., *Newark-on-Trent*—Inventor and Manufacturer.

Oil-cake breaking machines.

Mill for grinding barley, beans, &c.

Improved double blast corn-dressing or winnowing machine.

51 SEAWARD, WILLIAM, *Outton, Wakefield*—Designer.

Tree remover, for transplanting large shrubs and trees.

[When the earth has been removed round the roots of the tree, so that a large and compact ball remains, the plate is placed as far under the ball as it will admit; the longest rope is then crooked on to the ring at the corner of the plate at the furthest distance from the ball, and passed round the under part of it, until it returns to the opposite corner; the power is then applied to the end of the rope, by which means the tree is easily removed to the centre of the plate in its erect position, and therefore conveyed to its intended place.]

Tree supporter, to support cypresses, arbor-vitæ, and shrubs, the branches of which are liable to be bent and broken down by snow, &c.

52 JONES, EDWARD, 138 *Leadenhall Street*—Inventor.

"Airish mow," adapted to the preservation of corn in the harvest-time of rainy seasons.

In Cornwall and Devonshire the farmers, when cutting their crops in unfavourable weather, commence early in the morning and have the produce of whole fields stacked on the spot, in "airish mows," before the evening, where it remains for months, free from heat and injury, until it suits the grower to house or otherwise dispose of it. Each mow contains generally about 400 sheaves.

For wet harvests it is desirable to adopt some method

of barley, without injury to the corn. It is also made with a self-acting apparatus for feeding the hopper.

Patent sack-holder, invented by Henry Gilbert, of St. Leonard's-on-Sea, for opening the mouth of a sack while being filled; with improvements by the exhibitor.

55 ABBOTT, WM., *Bideford, Devon*—Inventor.

Common plough, diminished in weight and friction, by the introduction of a wheel behind, and improved by raising the share, and continuing the iron-work of the handles to the spill.

Machine or apparatus for drying malt.

56 CHENEV, S., *March Cross*—Inventor.

Land-presser, particularly adapted for fen-land.

56A FRIS, BENJAMIN, 9 *Lower Terrace, Islington*—Designer.

Lady's garden rake, consisting of a hoe, spud, and rake, all in one, by which weeds may be extracted from between closely-planted flowers, and the necessity of treading on the flower-beds or stooping to pull them up with the hand prevented.

57 NEWBERRY, W., *Hooknorton, Chippingnorton*—Inventor.

Five-row dibbling machine.

58 ROYCE, GEORGE, *Fletland, Market Deeping*—Inventor.

Patent self-acting reeing-sieve, which takes out of corn all sprouted, damaged, and mouldy kernels; and dirt from oats, wheat, or barley.

Patent smut-machine, and general corn-cleaner. The cleaning power of this machine is due to the operation of the revolving cylinder, which carries away dirt as soon as it is detached from the grain.

59 WHISHAW, F., *John Street, Adelyhi*—Inventor.

A self-acting feeding-trough for poultry.

60 BECKFORD, T., & GOSLING, W., *Hilthfield Farm, Waryprare, Henley-on-Thames*—Inventor and Manufacturer.

Model of a circular mowing and tadding machine, drawn

ON THE SOUTH SIDE: AREAS N. O. 1; P. Q. R. 1 TO 27.

65 **BIGG, THOMAS**, *Leicester House, Great Dover Street, Southwark*—Inventor and Manufacturer.  
Improved apparatus for sheep-dipping, which, with

the assistance of five men, is capable of dipping 500 sheep per day. The annexed cut represents this apparatus.



Bigg's Sheep-dipping Apparatus.

66 **GREEN, T.**, *97 North Street, Leeds*—Manufacturer.  
Wire aviary and ornamental seat.

66A **AMOS, JOSEPH**, *King Street, Bristol*—Manufacturer.  
Barrel-churn and stand of English oak, with improvements in the bung, vent-peg, whey-tap, and gudgeons.

67 **SHANKS & SON**, *Arbroath, Forfar*—Inventor.  
Grass and hay-cutting machines.

68 **WHITFIELD, JAMES ALEXANDER**, *Pelaw Staith, near Gateshead*—Inventor.

Improved grappling or dredging-iron, for drawing from the water the bodies of persons apparently drowned.

The improvement consists in its passing over in the same time, four times the space which the present irons pass over. Should the hooks become fastened at the bottom of the river, they will straighten. The hanging-chain with the hooks will detect a body lying behind a rock or large stone. It is made to take into pieces, so

74 **SHERRIFF, THOMAS**, *West Carns, v Dunbar*—Inventor.

1. A machine for sowing grain, being an improved drill.
2. A machine for dressing grain, being an improved winnowing machine.

75 **BENNETT, HENRY**, *Liverpool*—Manufacturer.

Model of a self-cleaning roller, for crushing clods, rolling growing crops, and freeing land infested with wire-worm. The rings, of which the roller is composed, are fastened by bolts running through bored bosses into the solid ends. The contrivance for self-cleaning is effected by having two of the holes in each alternate ring larger than the other, so as to allow half the roller parts to rise twice in the revolution, sufficiently to cut out all clods which may rise between them. The rings are also tapered from the outer to the inner edge, so that a clod, being squeezed in, will necessarily fall into the interior, and be broken.

Mill for mixing provender, and preparing manures for drill-sowing. The rollers are composed of double-toothed

It is also made  
the hopper.  
ry Gilbert, of St.  
h of a sack while  
exhibitor.

Inventor.  
t and friction, by  
and improved by  
iron-work of the

inventor.  
fen-land.

Islington—

hoe, spud, and  
e extracted from  
the necessity of  
g to pull them

ington—

ping—Inventor.  
akes out of corn  
; and dirt from

n-cleaner. The  
the operation of  
y dirt as soon as

—Inventor.

Farm, Warpage,  
nufacturer.  
nachine, drawn



cut, and stops the feed during the action of the knife; and the double mouth-piece, by which the feed gets a bearing on both sides, prevents the corners from being left uncut. The annexed cut represents this chaff engine.

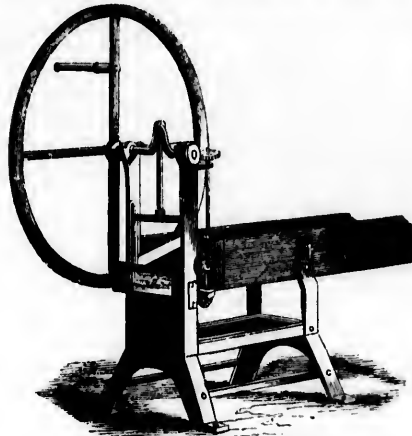

Gillett's Chaff Engine.

2. Patent chaff engine, with lever beam for horse power.
3. Model of a patent rick ventilator, for ventilating hay and corn ricks.
4. Mill for splitting, bruising, and grinding beans, oats, and barley. In this mill there is but one roller which has a double-action flute: by simply reversing the fly-wheel, the different operations of splitting beans, and bruising or grinding oats and barley, are performed.
5. Patent self-acting alarm gun, for preserving corn, fruit, and seeds from the depredations of birds or game. This machine consists of a barrel with twelve holes, to contain as many charges of powder; one of which, by means of clock-work, is discharged every hour, giving a report as loud as a gun.

80 SWAN, ROBERT FRANCIS, *Borford, Suffolk*—  
Inventor and Manufacturer.

Model of a tipping waggon (on a reduced scale). The novelty consists in the three wheels, the locking, the manner of tipping, the form, the concentration of the weight or load upon one axletree near to the horses' shoulders, and its adaptation to single or double shafts. It may be used as a two-wheel cart, by removing the hind carriage-work.

81 MACKAY, WM. HENRY, *Swansea*—Inventor.  
Machine for mowing hay or cutting corn.

82 WOODS, JAMES, *Stonmarket, Suffolk*—Inventor and  
Manufacturer.

Registered iron-crushing and grinding mill, for linseed, oats, barley, Indian corn, rice, lentils, malt, &c. It crushes and grinds separately, or does both at the same time, as two distinct hoppers are provided, and no alternation of machinery is required. The crushing is performed on the surface of a large wheel, 4 feet diameter, in conjunction with a small roller, 7 inches diameter. A steel roller is attached to the axis of the large wheel for grinding beans and peas, so that friction from increased bearings is avoided. The annexed cut shows the form of this mill.

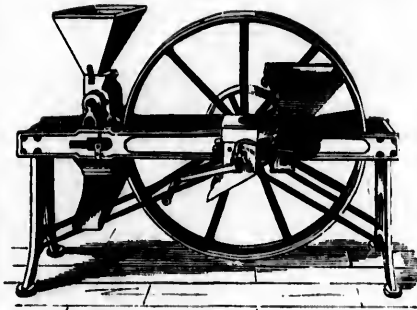

Woods' Registered Crushing and Grinding Mill.

83 CORNES, JAMES, *Burbridge, near Nantwich, Chester*—  
Inventor and Manufacturer.

Registered chaff-cutting machine, with three knives; invented, and manufactured by the exhibitor. It is applicable to hand, horse, or steam power, and cuts five different lengths of chaff; one length of 4 inches for litter. The annexed cut represents this machine.

A chaff-cutting machine, with two knives.

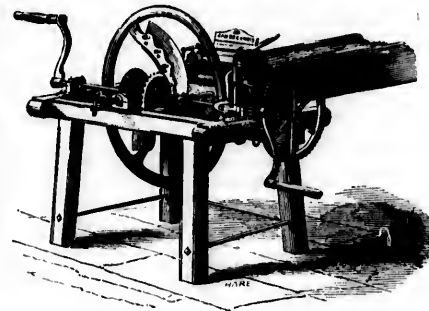

Cornes' Registered Chaff-cutting Machine.

84 ROE, FREEMAN, *70 Strand*—Manufacturer.

Four-horse portable steam-engine, for agricultural and other purposes.

85 SELLAR, GEORGE, & SON, *Hanthy, near Aberdeen*—  
Inventors and Manufacturers.

Double mould, or drill plough, with improved mould-boards. Swing plough.

86 JAMES, JOHN & CO., *24 Leadenhall Street*—  
Manufacturers.

Patent weighing-machine, without loose weights; the weights by which the goods are weighed being attached to, and forming part of, the machine itself.

Three ton machine, or small patent weigh-bridge, for weighing carts, live cattle, and farm produce generally.

Six hundred-weight patent machine, for weighing sheep, pigs, &c.

Three hundred-weight machine, for weighing sacks of corn, &c.

Machine for weighing potatoes, turnips, and other root-crops in the field.

ON THE SOUTH SIDE: AREAS N. O. 1; P. Q. R. 1 TO 27.

- 87 ROWLEY, JOHN J., *Bowthorne, near Chesterfield*—  
Inventor.

Patent improved machine for dropping or depositing pulverized substances, such as peat, charcoal, bone-dust, &c., at any required distance from 8 to 18 inches. Turnip, rape, or mangold seed can be deposited with the manure. Registered corn-dressing machine, with new motion in separating corn from the chaff and short straw, as delivered from the thrashing-machine.

- 88 DRUMMOND, PETER ROBERT, *Perth*—Inventor and  
Manufacturer.

Anti-metallic table churns, with six actions. The base is a box for containing hot or cold water. Atmospheric air is carried down through the plunger staff. To the larger size, any kind of animal power can be applied.

- 89 READ, RICHARD, *35 Regent Circus*—Inventor and  
Manufacturer.

New patent garden watering engine, fitted with an improved metallic (jointed) tube. Horticultural machine, with metal tube, &c.; and syringe, with angle branch. Stomach pump, in case, new patent. Aperitive fountain, with reservoir, and metal tube. Injecting instruments for removing obstructions in the bowels of horses and other animals.

Improved hollow probangs for relieving hoven or choked bullocks, calves, sheep, &c.

- 89A BLAIKIE, J., *71 Stockwell Street, Glasgow*—  
Inventor.

Model reaping and mowing machine.

- 90 WOOD, G., *Altwick, Northumberland*—Inventor.

Improved cottage beehive.

- 90A HOLMES, J., *1 Wellington Terrace, Newcastle-on-Tyne*  
—Inventor.

Garden-seat and plant stands.

- 91 BROWN, DAVID STEPHENS, *2 Alexandrian Lodge, Old Kent Road*—Improver.

Patent instrument for fumigating plants, to destroy insects, &c. Tobacco is placed in the magazine at top, and lighted, in the same manner as an ordinary smoking pipe. A draught of air is produced for its combustion by the revolutions of a fan, which draws the smoke in at one part of the cylinder, and drives it forcibly out at another, in a cool state, concentrated, and in any direction. In fumigating turnips, orchards, &c., other moistened substances may be substituted for tobacco. The annexed cut shows the form of this apparatus.

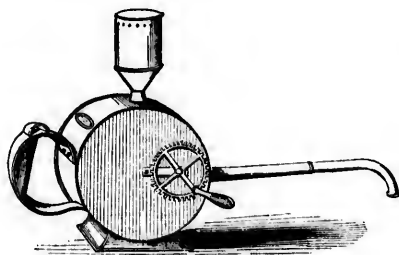

Brown's Patent Fumigator.

- 91A JORDAN, THOMAS, *Billerica, Essex*—Inventor  
and Manufacturer.

Improved plough.

- 92 PETTIT, WYATT JOHN, *Sudbury, Suffolk*—  
Inventor and Manufacturer.

Temple beehive, from which the honey may be taken without destroying the bees. This beehive is represented in the annexed cut.

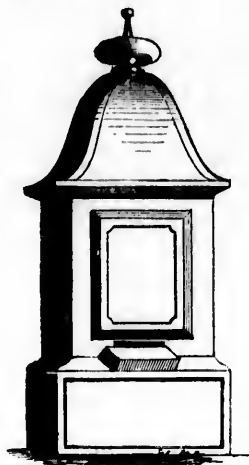

Pettit's Temple Beehive.

The construction is intended to effect the total exclusion of drows bees from the surplus, or glass hives; to give convenience for ventilation; to supply a simple method of taking glass hives when filled, together with convenience for observation; and to prevent the necessity of swarming.

Collateral beehive, possessing all the advantages of the temple hive, with the addition of a surplus-box placed collaterally, and intended for the inside of an apiary.

- 92A NUNN, ALICIA, *2A Welbeck Street, Cavendish Square*  
—Inventor.

A new self-cleaning solid pulp-blotting roller; a hand instrument for drying ink or colour writings.

New chemical churn, and apparatus for churning butter; a new process by which butter is preserved from becoming rancid.

- 93 MARYCHURCH, JOSEPH, *Haverfordwest, South Wales*—Manufacturer.

Winnowing-machine. The blast is concentrated, and the machine occupies but little space. The riddles may be placed in various positions, to suit different qualities of grain; they rise and fall independently of the case, which moves only in a lateral direction.

Chaff-cutter, having the fly-wheel placed on a transverse spindle on one side of the trough, and giving at the cutting end a circular motion to the knives; it has three rollers, all worked by one compound-wheel. The mouth-piece is serrated above and below, and its lower jaw is moveable, being acted upon by a flexible lever working from the fly-wheel shaft. In consequence of the knives being placed on a spindle, instead of being thrown round within the area of the fly-wheel, they are reduced in size, and less power is required to work them. The fly-wheel is also situated alongside of the trough, and a case is fitted over the knives and gearwork.

Turnip-cutter, formed of a cylindrical barrel, on which the large knives for slicing are placed in a diagonal position. The small knives for cutting strips (which are also diagonal) are fixed upon moveable segments, and attached to the barrel directly under the large knives.

94 LAW, R., *Shettleston, Glasgow*—Inventor.  
A farm cart, iron plough, and model turn-wrist plough.

90 CROWLEY & SONS, *Newport Pagnell, Bucks*—  
Inventors and Manufacturers.  
One-horse cart, with new tipping apparatus. Hames.  
One-horse universal hoe.

98 BRODIE, WILLIAM, *Airdrie, Scotland*.  
A registered drain-tile and pipe-machine. This machine is driven by steam or horse-power, and when wrought at a speed by which two women take away the pipes, makes from 10,000 to 12,000 two-inch pipes per day. By putting the rope which is attached to the driving-power on a smaller pulley, to bring up the speed, the produce is from 12,000 to 18,000 pipes in 10 hours. Various sizes of tiles and pipes, for leading drains, can also be made when required. By putting on a set of grating dies, this machine is capable of cleaning the stones from clay, after passing through a pug-mill, sufficient to make from 16,000 to 20,000 two-inch pipes per day.

99 CLARK, JOHN, *Kirkton Blentyre, by Hamilton, Scotland*—Manufacturer.  
Plough.

100 ISTANCE, R., *Carmarthen*—Inventor.  
Beehive ventilator.

101 EPPS, WM. JAMES, *Maidstone*—Inventor.  
Machine for throwing flour of sulphur upon horticultural and agricultural crops, for the purpose of destroying the mould or mildew.  
The hopper contains the sulphur, and at the bottom is placed a box containing a sieve; through the box is a spindle, attached to a spring and lever outside the hopper, and the whole is fixed before a fan-blower; the brass wheel (which moves the latter) catches the lever attached to the box in the hopper, and causes an oscillating and tapping motion, which sifts the sulphur into the arch-chamber of the blower; whence it is blown in one continued cloud with great force.

103 BRIGGS, T., *Donley Pottery, Derbyshire*—  
Manufacturer.  
Improved beehive.

104 PONTON, GEORGE, *Grangefoot, Lindlithgow, Scotland*—  
Manufacturer.  
Improved two-horse swing-plough, for lea and general purposes.  
Two-horse plough, for forming drills; reduced in draught, and adapted for any soil.  
New one-row bean-sowing machine, which can be thrown out of gear at the turnings, to save labour.  
All invented, or improved and made by the exhibitor.

105 THOMPSON, GEORGE, 18 *Great George St., Westminster*—  
Inventor.  
Patent machine for digging and turning over earth, which may also be used as a cultivator or scarifier, by substituting one or more hoes or coulters, in place of each spade.

Working model of part of another digging-machine, of a lighter construction; to be worked in a similar manner, but having only one row of spades; for use on light soils, and adapted for forming broad or narrow ridges.

106 HALSTEAD, CHARLES, & SONS, *Chichester*—Inventors  
and Manufacturers.  
Improved iron ploughs, either for light or heavy soils.  
Improved oil-cake breaker, made entirely of iron.

107 SEWELL & CO., *Longtown, Cumberland*, and 30 *Spring Street, Hyde Park*—Manufacturers.  
Netherby plough, designed to cut, displace, and leave in a proper position, furrows of various widths and

depths on moderately stiff soils, where the more "springy" action of a lighter plough increases the traction, and deteriorates the appearance of the work done.

It is sufficiently strong for almost any soil, but for very stiff clays, it requires another form of mould plate; for, like other tools, ploughs should be made for their assigned duty, to prevent disappointment to the farmer.

On observing three or more oxen drawing a single surface plough, it is difficult to resist the conclusion, that only from some constructive or other remediable error, can so much power be required to displace a small quantity of soil only a few inches. This will appear more clearly, by comparing the useful effect of a horse in drawing a waggon and in drawing a plough. The tractive power of a horse is about 150 lbs., which gives 450 lbs. for three horses. The friction of a waggon on a road is from 72 to 90 lbs. per ton, which, taken at the highest estimate, gives five tons that the three horses could draw on a good road.

Now, if about a cubic foot of earth be in motion at once in ploughing, and, with the plough, weighs—say 370 lbs., it gives the comparison—as 370 lbs. is to five tons, or as one is to thirty, so is the practical effect in ploughing to traction on a road. Thirty to one is a discrepancy so wide, that it should induce the matter to be seriously considered by those who till their soil at such a great cost of power, increased by not unfrequently more than one guide.

The principal resistances in ploughing are, the quiescent tenacity of the soil, and its rubbing friction along the mould-plate. The first is the most important; for since the friction of a body at rest is much greater than its moving friction, it follows, that in a well-formed mould-plate, the rubbing friction of the soil can only be limited. To start, displace, and replace the soil with least power, are therefore the requisites of a good plough.

Those qualities obtained, a few pounds more or less weight in the implement itself could make no material difference; as the actual weight should depend upon the nature of the soil to be removed. The attachment of the tractive power, however, is of importance; since it should be in, or as near to the direct line of the greatest resistance, as is practicable. The greatest resistance will be between the cutting edge of the coulter and that of the share which fairly starts the soil into motion, as is testified by the greater wear of these parts. Since this point is near the land side, it is evident that horses walking in the previously displaced furrow are pulling at an angle of several inches from the land, requiring some compensating resistance to keep the plough to the land.

When one horse, however, is attached on each side, and as near to the line of resistance as they can be, their angular traction balances each other, and results in their combined force forming a diagonal line of traction in the direct line of resistance, requiring less power and less guidance to produce straight uniform furrows.

The Netherby plough seeks to lessen resistance by the anti-frictional curvature of the mould plate, allowing the displaced soil to press with less intensity over a larger surface, thereby preventing abrasion; and by the attachment of one horse on each side of the line of resistance, as sufficient power for all ordinary surface work.

108 REEVES, THOMAS, ROBERT, & JOHN, *Bratton, Westbury, Wills*—Manufacturers.

Patent liquid manure-distributing cart. The liquid is distributed by means of revolving troughs, which throws it on two sloping boards or aprons, whence it falls on the land in a thin or thick sheet, as may be required; the cistern may also be turned up to empty itself, by turning a handle.

Patent liquid manure drop-drill; it works on the same principle as the preceding, by means of a succession of small buckets, which throws the liquid into tubes, into which the seed is conveyed from a seed-box. It drills the seed and liquid, either at intervals or continuous, as may be required.

ON THE SOUTH SIDE: AREA N. O. 1; P. Q. R. 1 TO 27.

where the more "springy" craves the traction, and the work done.

most any soil, but for very form of mould plate; for, be made for their assigned it to the farmer.

men drawing a single sur- sistent the conclusion, that other remediable error, to displace a small quan-

This will appear more effect of a horse in draw- a plough. The tractive lbs., which gives 450 lbs. of a waggon on a road is ch, taken at the highest e three horses could draw

of earth be in motion at the plough, weighs—say n—as 370 lbs. is to five is the practical effect in

Thirty to one is a dis- induce the matter to be ho till their soil at such y not unfrequently more

oughing are, the quiescent bbing friction along the ost important; for since is much greater than its in a well-formed mould- soil can only be limited. he soil with least power, ood plough.

ew pounds more or less ould make no material ould depend upon the

The attachment of the ortance; since it should e of the greatest resist- atest resistance will be

the couler and that of the into motion, as is testi- parts. Since this point t that horses walking in re pulling at an angle of uiring some compensa-

to the land, attached on each side, es as they can be, their ter, and results in their l line of traction in the g less power and less rm furrows.

oosen resistance by the uld plate, allowing the intensity over a larger on; and by the attach- the line of resistance, surface work.

& JOHN, Bratton, ufacturers.

ng cut. The liquid is troughs, which throws hences it falls on the may be required; the npty itself, by turning

it works on the same ns of a succession of liquid into tubes, into a seed-box. It drills vals or continuous, as

These machines were invented by Mr. Thomas Chandler Alibourne, Hungerford, Berks; and were improved and manufactured by the exhibitor.

109 MAYNARD, ROBERT, *Whittesford, near Cambridge*—Inventor and Manufacturer.

Universal oil-cake crusher; exhibited for new arrangement of gear, combining strength and simplicity of working parts. Recent improvements have reduced the friction, and rendered the machine better adapted for preparing the cake for feeding purposes.

Engine for drawing clover and trefoil seeds, invented by Mr. Constable, of Cambridge, and manufactured by the exhibitor. This machine is for separating the husk or hull from the seed, which it does at the rate of about two or three bushels of clover seed, and about double that quantity of trefoil seed, per hour, when worked by four horses.

Weighing-machine, for ascertaining the weight of any article from a quarter of a pound up to twenty stone.

109A COTTAM & HALLEN, *Windsor Street*—Inventors and Manufacturers.

Pipe-tile machine. Winnowing machine. Litter and chaff-cutter. Subsoil plough. Two-wheel drawing plough. Skim or paring plough. Universal potato. One-row seed and manure drill. Oat bruiser. Patent manure pump. Hand-power gauge. Odometer. Ornamental cast-iron vases.

Set of stable fittings, viz., rack, manger, and water-trough, enamelled. The annexed cut represents these fittings.

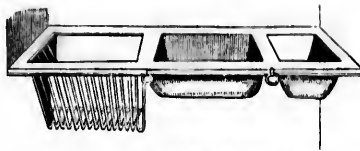

Cottam and Hallen's Enamelled Stable Fittings.

Wrought-iron basins, enamelled. Cast-iron ventilators. Improved horse-pot for stables. Cast-iron dog trough. Wrought-iron circular and corner hay-racks. Cast-iron mangers for centre and corner of stall. Set of draining tools. Cast-iron rick stand. Stand of patent metallic churns.

Lawn mowing machine. Level for agricultural drain- ing. Circular saw-table for agricultural purposes. Serrated chain harrow. Well-boring tools. Indian corn thrashing-machines.

110 CARSON, H., *Warrminster, Wilts*—Manufacturer.

Scraper, invented and manufactured by the exhibitor. This implement has seven shares or tines, of which there are two sets, broad steel shares or couching tines, for cutting, breaking, and pulverizing the soil. The shares are easily fixed into the frame by means of a wedge. The frame containing the shares is raised or lowered by means of a lever, at a single operation; and by the stop for regulating the lever, uniform depth of work is obtained.

Patent turnip-cutter, by Edmund Moody, of Maiden Bradley.

Cheese press, with double lever; constructed with a compound lever and screws. The screw, which is of wrought-iron, can be easily adapted to any depth of cheese.

A set of six harrows, adapted for wet lands, which can be adjusted to the width of any ridge, whilst the horses walk in the furrow. Their form is peculiar, the frame of each being forged into one piece, and the tines are so arranged that each follows in a distinct track.

112 PARSONS, JAMES, *Caron Farm, Stamford Hill*—Inventor and Maker.

Model of a digging-machine, for breaking up the ground in an efficient manner, and at a small expense.

114 HAYWARD, OILES, *Creekerne, Somerset*—Inventor and Manufacturer.

Plough, with drilling-machine attached, adapted for sowing all kinds of corn and turnip-seed, particularly in a dry season, with or without dry manure.

115 BUTLIN, WILLIAM, *Northampton*—Designer and Manufacturer.

Four-horse power portable steam-engine.

116 HODGES, JOHN, & SONS, *16 Westmoreland Street, Dublin*—Manufacturers.

Improved safety kettles, with valves on the spouts, to prevent scalding.

Improved steaming apparatus, for dressing food for cattle.

117 HAYES, JAMES, *Elton, Huntingdonshire*—Designer, Inventor, and Manufacturer.

Grinding-mill, adapted to steam or horse power, which makes 120 revolutions per minute, and requires three horses to draw it; adapted to grind barley into soft meal for pigs, and to split beans.

119 HUNTER, W. & J., *Samuelston, Haddington, Scotland*—Inventors and Manufacturers.

Lever grain drilling-machines, having the gauge separate from the shut, or stopping of the seed; also having a horizontal marker.

120 SHOLL, JAMES, *33 Lamb Street, Spital Square*—Inventor.

Castle beehive, as in use at the royal farm, Windsor. Observatory beehive, on the principle of taking pure surplus honey without destroying the bees. Glasses of honey taken from one observatory hive last season.

121 GLOVER, WILLIAM, *Warwick*—Manufacturer.

One-horse cart for general purposes.

122 MAYNARD, JOHN, & SON, *Bedford*—Designers and Manufacturers.

Improved Bedfordshire one-horse cart, having the body without either slot or mortice; mounted on an improved iron axle. The wheels are made with an improved iron hub, oak spokes, and ash felloes, patent half-round hoop tire. The side and front raves are fixtures, broad, and set nearly flat, so that the load may be carried up wide and square; the side raves, being arched over the wheels, admit of the body lying direct on the axle, bringing the floor of the cart near the ground, which is an advantage in draught and loading. The shafts, being bent, bring the body level when at work. It is furnished with an iron regulator, of simple construction, which is used when emptying manure in small heaps upon the land, or, when descending steep hills, it is fitted with hind and front ladders. Constructed to carry 30 cwt. with one horse.

122A SERVICE, W., *8 Rutland Terrace, Hornsey Road, Holloway*—Inventor.

Archimedean sifting machine. The filling and discharging apparatus consists of a spiral passage formed throughout the length of a wire cylinder, and revolving with the cylinder; and an arrangement for varying the action of the sifter.

123 WEIR, EDWARD, *351 Oxford Street*—Inventor and Manufacturer.

Irrigator liquid manure pump, fire, and garden-engine, with hose and hose reel. As a fire-engine it will throw 20 gallons of water per minute to a height of 40 feet from the end of the nozzle.

Improved draining level; the level is found by means of the spirit tube. It stands on three legs, requiring no driving into the ground or fixing, and when once adjusted to its level by means of the regulating screws, it may be turned in any direction; the most convenient fall or





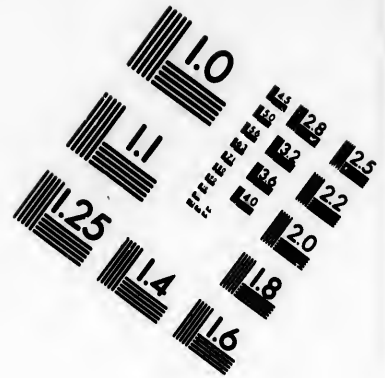
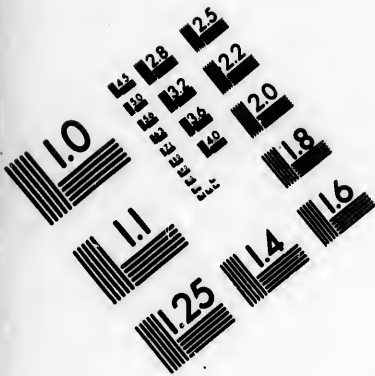

**IMAGE EVALUATION  
TEST TARGET (MT-3)**

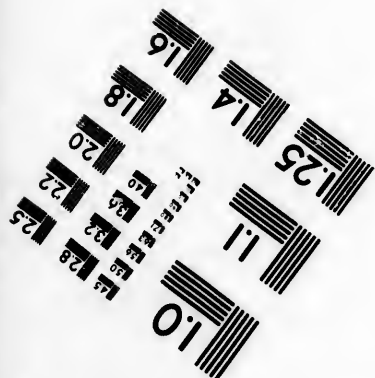
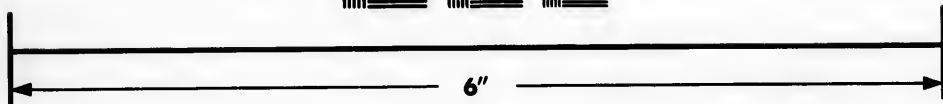
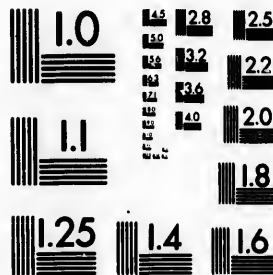

**Photographic  
Sciences  
Corporation**

23 WEST MAIN STREET  
WEBSTER, N.Y. 14580  
(716) 872-4503

1.8  
2.0  
2.2  
2.5  
2.8  
3.2  
3.6  
4.0

0.1  
0.2  
0.3  
0.4  
0.5  
0.6  
0.7  
0.8  
0.9  
1.0

outlet for the drain may then be easily found, without the instrument requiring any re-adjustment. The index tells off immediately the rise or fall in inches, in every yard.

123A USHER, JAMES, *Edinburgh*—Inventor.

Model of patent locomotive steam-plough. The novelty consists in reversing the action of the ploughs, and making them rotatory. The ploughs revolving behind the carriage act as propellers. This model is represented in the annexed cut.

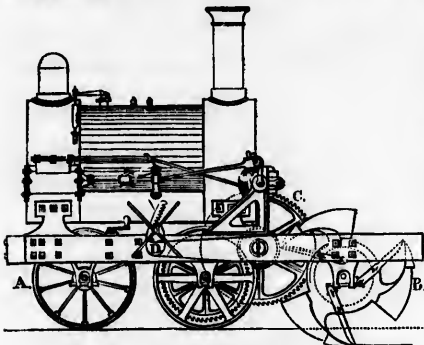

Usher's Patent Locomotive Steam Plough.

A b are the front wheels, which are turned on a pivot by a rack and screw; B e are a series of revolving ploughs behind the engine, which, while at work, propel the carriage; C g is a spur-wheel, driven by pinion P, which gives motion to the ploughs; D i is a frame which is moved up and down by the rack, I m, by means of which the ploughs are elevated or depressed at pleasure.

123B JONES P., *High Street, Fulham*—Proprietor.

Portable hand garden-engine, with the cylinder so constructed that it forms an air-vessel, and forces the water in a continuous stream upwards of forty feet.

124 RANSOMES & MAY, *Ipswich*—Inventors and Manufacturers.

Patent iron ploughs; double breast or moulding ploughs; West Indian, double furrow, universal, broad share, and subsoil ploughs; trussed whippetrees; Biddell's scarifier; Indian cultivator; corn and seed-dropping machine; portable steam-engine; fixed steam-engine; thrashing-machines; cane-top cutter; crushing-mill; oil-cake breaker; barley awner; chicory cutter; Scotch cart, &c.

124A DUFAUR, HARRY, & Co., 21 *Red Lion Square*—

Proprietors. Dr. S. NEWINGTON, Inventor & Patentee. Agricultural implements:—Eight depositor hand-dibble, for all kinds of corn, pulse, &c. The cups drop any required number of grains in each hole. The same, on wheels; each box will shift to any required distance.

Hand-cultivator and drill-hoe, which, by adjusting long or short slots, can be used between rows of any width; for stirring or cultivating the land, the tines only are used; for hoeing, shares suited to the width of each row are fitted on the tines. To the frame can also be adjusted coulter for drawing furrows for different depths; also potato-moulder with expanding wings.

Single-horse subsoil plough and pulverizer with shares for paring and hoeing, either on the ridge or flat. When used as a subsoil pulverizer, three strong chisel-shaped tines adjustable to any depth, are fitted behind one another in the wrought-iron beam in such a way as to pulverize the whole space, after the furrow slice has been removed. When used as a hoe, a slot is attached to the beam, to which two of the tines are fitted, shifting in the

slot to any required width. To these tines shares of any width can be adjusted. By removing the shares, a cultivator or stirrer is formed. By removing the slot and shares, and adjusting to the beam a strong coulter with expanding wings, the implement forms a moulding-plough for striking out furrows; also for earthing up potatoes, &c.

Hand dibble-drill with three shifting boxes, fitted with cups suited for all seeds.

Hand implement for distributing pulverized artificial manures, intended to supersede the broad-casting by hand, of guano, soot, nitrate of soda, &c.; also useful for dusting with lime, wheat infested with slug, or turnip infested with the flea or fly; it is also made for horse-power of any width.

[The refreshment of autumn-sown wheat in spring, by the application of artificial manures in powder over the surface of the field, is an improvement extending among good farmers. The principle of Dr. Newington's machine for this purpose was approved at the Exeter meeting of the Royal Agricultural Society.—Ph. P.]

Horse dibble-drill, with six shifting boxes and manure distributor attached; it deposits any kind of seed at defined distances in the furrows, and any required quantity per acre according to the size of the cups used; and any number of grains can be deposited at each drop; with an apparatus for distributing artificial manures beneath the seed in any required quantity.

Single-horse cultivator, with fittings for hoeing.

124B COWAN, HUGH, *Corstorphine, Edinburgh*—Inventor and Manufacturer.

Self-cleansing two-horse grubber.

125 PAXTON, J., *Ealing, near Brentford*—Inventor.

A registered improvement on water-power, for grinding corn, &c.

126 ROBINSON, WILLIAM, *Halsham*—Inventor and Manufacturer.

Corn-dressing machine, for dressing, blowing, hariffing, and blowing and hariffing combined, for the use of millers or farmers.

Hariff machine, for cleaning wheat.

Patent straw-shaker, for separating corn from straw; consisting of a series of flaps, or flys, that revolve and keep parallel to each other; it beats and propels the straw, and turns the corn to the floor.

127 WEDLAKE, MARY, & Co., *Fairkyles Works, and 118 Fenchurch Street, City*—Manufacturers.

A furze or gorse-bruising machine for hand or horse-power.

A new machine, called the Utilitarian, properly registered, for cutting straw into chaff, and for bruising oats, peas, lentile, barley, and linseed; both operations at once, or alternately, for hand-power, represented in the annexed cut.

A fixed steam-engine for farming operations, complete, with boiler, occupying but the space of two square feet.

A simple and effective chaff-cutter, for hand-power. A smaller one.

A simple and effective chaff-cutter, for horse-power.

A small oat, pea, barley, and linseed crusher.

A double and single-action turnip-cutter, invented by the late Mr. Thomas Wedlake, which, by reversing the action of the wheel, cuts for either beast or sheep, viz., large slices, or small pieces for sheep.

An improved Scotch cart, particularly light and handsome, with ladders complete, so as to be used as a dung or harvest cart.

An improved haymaking-machine, with double action, for throwing up the hay and then tedding or spreading it about.

A general mill, bruising all kinds of grain or pulse.

A very powerful oil-cake breaker.

Light and heavy wood and iron harrows, differently constructed.

times shares of any  
g the shares, a cut-  
moving the slot and  
strong coulters with  
orms a moulding-  
so for earthing up

g boxes, fitted with

pulverized artificial  
broad-casting by  
&c.; also useful for  
with slug, or turnip  
o made for horse-

wheat in spring, by  
in powder over the  
it extending among  
ewington's machine  
Exeter meeting of  
P.]

boxes and manure  
nd of seed at defined  
quired quantity per  
pa used; and any  
t each drop; with  
l manures beneath

for hoeing.

burgh—Inventor

ford—Inventor.  
power, for grinding

Inventor and

blowing, harriking,  
l, for the use of

corn from straw;  
at revolve and keep  
propels the straw,

Works, and 118  
facturers.  
for hand or horse-

rian, properly re-  
and for bruising  
&c.; both operations  
er, represented in

operations, complete,  
t two square feet.  
or hand-power. A

or horse-power.  
crusher.

utter, invented by  
by reversing the  
ast or sheep, viz.,

ly light and hand-  
be used as a dung

th double action,  
ng or spreading it

grain or pulse.

rows, differently

An excellent ten-coulter drill, for sowing all kinds of seeds.

A three-hoed scarifier. Five-hoed scarifier.

A set of three machines, to be worked by the same

power, either man, horse, or steam, singly, or the three together, or alternately: a piece of machinery much approved of by good judges of agricultural machinery.

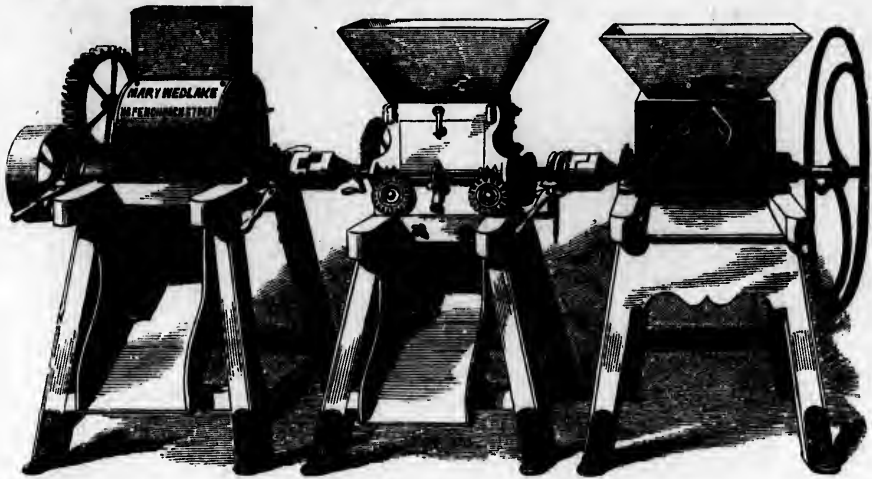

Wedlake's Union Mill for Splitting and Bruising Seeds.

A simple and cheap winnowing machine for cleaning all kinds of grain, also currants; very extensively used in Greece for the latter purpose.

A scarifier for hop-grounds.

A surface or skim-plough, for destroying weeds after a crop.

A mould-up plough.

A simple and most effective subsoil plough.

The Essex light two-horse plough, effecting a great saving in the expenditure of that operation.

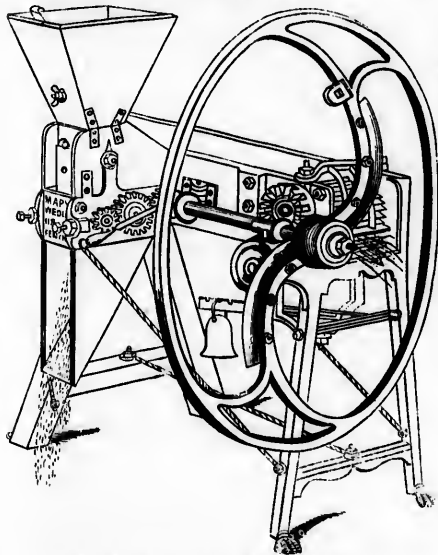

Wedlake's Chaff-cutting and Oat-bruising Machine.

128 BARRETT, EXALL & ANDREWS, *Katesgrove Iron Works, Reading*—Manufs. and Inventors.

A model of a machine-house with models of steam-engine and thrashing, cutting, and crushing-machinery; with steaming apparatus, pumps, &c., complete, as required for a farm of about 400 acres, with plans for an entire model farm-yard and buildings.

A four-horse power high-pressure portable steam-engine. It is fitted to work expansively from one-third to full steam. The engine is fitted and fixed to a separate cast frame, relieving the boiler from all vibration or strain. The boiler takes about 40 minutes to get up the steam to the working pressure, and requires about 36 lbs. of coals to generate the steam, the water being at 60° to steam at 45 lb. pressure, and is said to consume about 8 lbs. of coal per horse per hour to keep up the steam. This engine is represented in the annexed cut.

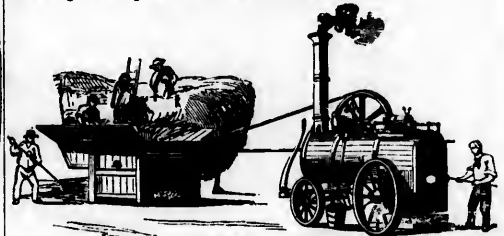

Barrett and Co.'s Four-horse power Portable Steam-engine.

Six-horse power patent bolting and thrashing-machine with shaking apparatus; mounted upon four travelling wheels. The frame of this machine is of wood. The breasting is in a complete iron frame, and bolted to the sides of the machine. The patent consists in the method of altering the breastwork, which is accomplished in one minute. In front of and partly underneath the machine is attached a shaking apparatus which passes the straw from the machine, and at the same time separates all the corn from it. Intended to thrash from 30 to 50 quarters of wheat per day.

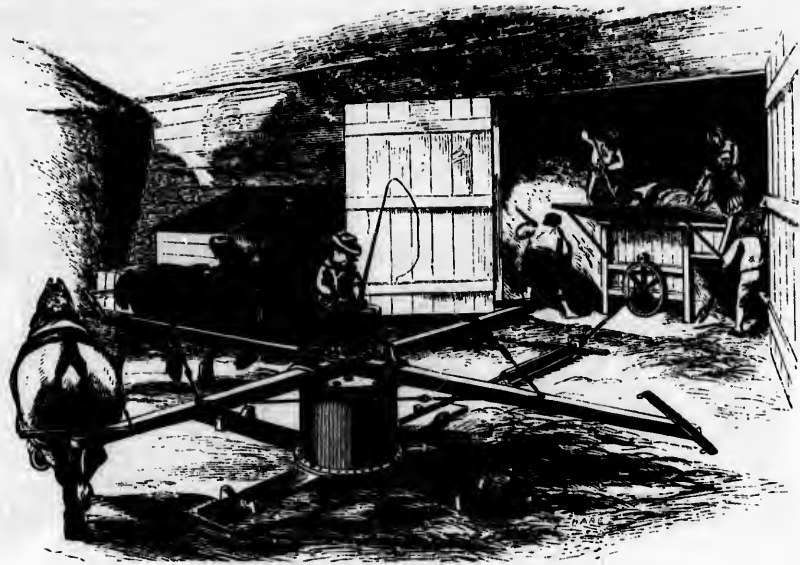

Barrett and Co.'s Four-horse power Thrashing Machine.

Four-horse power thrashing-machine with four-horse power patent gear attached. The preceding cuts represent this machine and the patent horse-gear. The thrashing-machine consists of a wooden frame with wire breastings and open beater drum. The patent safety gear-work consists of a moveable cap working upon an upright cylinder, and carrying three idle wheels, equidistant from the common centre round which they revolve. These wheels

are put in motion by a rack on the inner edge of the cylinder, and they communicate motion to an upright shaft, on which are fixed the necessary wheels for getting up a speed of 3 to 11, or any other speed. The upright cylinder contains all the gear-work within itself, so as to equalise the strain and to exclude everything calculated to injure it; by the position of the three loose wheels friction is removed from the bearings.

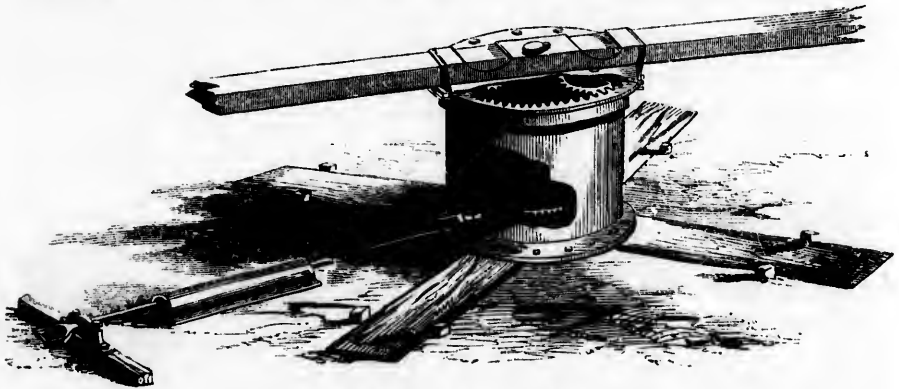

Barrett and Co.'s Patent Horse-gear.

Two-horse power patent thrashing-machine, with two-horse power patent gear. The machine is constructed entirely of iron. The machine and gear-work are made portable upon a pair of iron wheels, and can be unloaded and set to work by two or three men in a quarter of an hour—intended to thrash from 12 to 15 quarters of wheat per day.

One-horse power patent thrashing-machine with patent safety horse-gear. Will thrash by horse-power from 6 to

8 quarters, and by hand-power from 4 to 6 quarters of wheat per day.

Hand-power patent thrashing-machine, made entirely of iron, with the exhibitors' new patent breastings. Intended to be worked by manual power. Claiming simplicity of construction, and not being liable to get out of order, and intended to thrash all kinds of grain and seeds with less injury than the common flail. This machine is represented in the annexed cut.





Barrett and Co.'s Patent Iron Thrashing Machine.

Furze or gorse-cutting and bruising-machine, with three horse-power patent safety gear attached. The gorse, in passing through, is very finely cut by means of knives revolving on a cylinder acting against a mouth-piece with feed-rollers, and then passes through two pairs of rollers, by which it is effectually crushed. The machine is made of iron, and may be applied to either horse, steam, or water power.

Barley aveller or hummeller. This machine is for the purpose of breaking off the haulm, which, with the light corn, falls through the wires of a wire cylinder. The good sample is carried through the cylinder, and delivered by a chute at the end of the machine.

Registered cam chaff-cutter, No. 2. This machine is nine inches wide in the mouth, and is made entirely of iron. The straw or hay is drawn to the mouth-piece to be cut by means of two grooved rollers. The mouth-piece is case-hardened, and the machine cuts any length of chaff under  $1\frac{1}{4}$  inches. The annexed cut represents this machine.

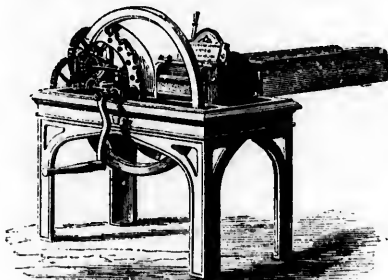

Barrett and Co.'s Cam Chaff-cutter.

Cornes' pattern chaff-cutter, No. 1. This machine is twelve inches wide in the mouth, with an anti-choking top roller, and mouth-piece. It has three knives on the fly-wheel, and cuts five different lengths of chaff, viz., four for horses, cattle, and sheep, and one four inches long for litter. By the addition of a clutch, the feed rollers can be reversed to withdraw the feed, should any accident

happen or any substance injurious to the knives be introduced with the hay or straw.

Cornes' pattern chaff-cutter, No. 2. The mouth-piece of this machine is ten and a half inches wide. The fly-wheel has two knives, and it cuts four lengths of chaff. The gearing is so arranged that it may be worked by one or two men or by horse-power.

Universal crushing-mill for hand-power, fixed in an iron frame, for crushing malt, oats, &c., or for splitting beans or peas. The inside of the mill may be easily inspected should any derangement take place.

Universal crushing-mill for one-horse power, to crush all kinds of grain, adapted for either manual or horse power. Requires two men or one horse to work it.

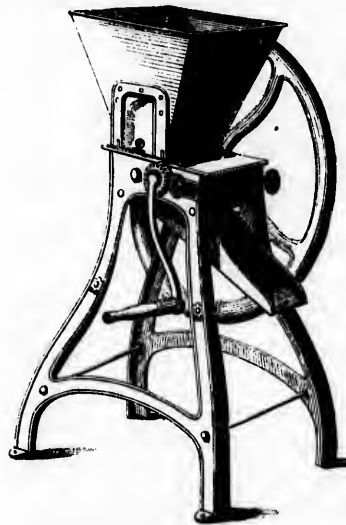

Barrett and Co.'s Universal Crushing Mill.

inner edge of the  
on to an upright  
wheels for getting  
d. The upright  
in itself, so as to  
anything calculated  
ree loose wheels

to 6 quarters of

made entirely of  
ting. Intended  
simplicity of  
out of order,  
and seeds with  
machine is re-

The universal crushing-mill for hand-power, for crushing malt, oats, barley, and linseed, or for beans, shown in the preceding cut. The capabilities of this mill are, oats or barley, 4 bushels per hour; linseed, 1 bushel; beans, 6 bushels. Barley by being passed twice through this mill is sufficiently meal for cattle feed, and if mashed in hot water, for pigs.

The universal crushing-mill, of one-horse power, to crush all kinds of grain, and adapted for either manual or horse power.

Two-horse power universal crushing-machine.

Oil-cake mill, No. 2. For the purpose of crushing oil-cake for sheep or cattle. Fitted with sliding bearings to

regulate the breaking of the cake to different degrees of fineness.

Two-wheel plough, marked A G A B, shown in the annexed cut. Made entirely of iron, and workable either as a swing or two-wheel plough, the horses going either abreast or in a line. The turn-furrow is made in the shape of a coarse screw, is fitted with the patent round coulter, and with skim coulter to take off the surface and weeds when working in low grounds and stubbles. The draft chain is fitted to the body of the plough. The wearing parts can be easily removed and new ones attached by the ploughman.



Barrett and Co.'s Iron Two-wheel Plough.

One-wheel plough marked D. P. Light in draft.

Swing plough, marked G. A. B. Made entirely of iron, and adapted to work in woodland countries and upon foul land.

Universal plough. It is a D.P. one-wheel plough, and by the application of a right-handed mould-board, it forms an expanding earthing-up plough. By removing both mould-boards and attaching a bar to the beam, and two hoes which are fitted and supplied with it, it forms a horse-hoe, and thus makes the three implements of one.

Read's patent sub-pulverizer, of which the exhibitors are the proprietors. This plough is readily converted into a mole-plough or paring-plough, by the addition of the requisite shares.

Two-share subsoil plough. The mechanical construction of this plough is simple and light. The under share, which can be shaped as a D or an O, leaves a drain to carry off the water to the main drains.

The Ducie cultivator, constructed entirely of iron, and fitted with either five or seven tines, which are set so as to draw lines eight inches apart; their curved shape and length prevent their clogging in the foulest land. The frame and tines are raised and lowered by turning a handle.

Set of registered circular harrows. In these harrows the tines follow a different course, and yet all combine in covering the ground at exact equal distances.

Set of patent iron harrows.

Norwegian harrow, four feet wide.

Registered hay-making machine, composed of two drums with rakeheads attached, revolving upon a spindle, which is supported by two carrying-wheels.

Portable cavalry forge, constructed entirely of iron, with coal and water trough of the same material, fitted with a fan placed horizontally, out of the reach of injury or inconvenience; it is worked either by the foot or hand.

Grist or corn mill, of two-horse power, adapted for general use. It is enclosed in a cast-iron frame. The stones are of French burr, and the mill is furnished with a cast-metal plate turned up perfectly true for proving the stones, enabling a workman to dress them as well as an experienced millwright, by the old process of wooden staves.

Specimens of improved Scotch cart. The body of this cart is made to hold exactly a one-horse load. It combines great strength with lightness.

129 GIBSON, MATTHEW, *Newcastle*—Inventor and Manufacturer.

Northumberland clod-crusher; for working on land when wet as well as dry, it is not liable to become clogged,

and it makes the land much finer. Also used on young wheat for the wireworm, as well as for making drills for the reception of clover and other seeds.

130 LAMPITT, CHARLES, *Banbury*—Inventor and Manufacturer.

A horse seed-dibbler, patented. The peculiarities consist of a tumbler for depositing the seed in the earth, an eccentric motion for closing the tumbler, a motion for working the revolving scraper, independently of its action on the dibbles, and a break to aid in lowering the dibble-wheels to the earth.

131 MAPPLEBECK & LOWE, *Birmingham*—Manufacturers. Weighing machines, mills, and draining tools.

132 BALL, W., *Rothwell, near Kettering, Northamptonshire*—Inventor and Manufacturer.

Criterion plough, made of iron, with steel or cast-iron turn-furrow.

Criterion plough, without wheels.

Two-horse waggon, either with pole or shafts, with patent axles and perpendicular wheels.

133 JONES, EDWARD, *Great College Street, Camden Town*—Inventor.

Machine for moulding bricks and tiles, with pug-mill attached for tempering the clay by the same operation, worked by one horse or steam power.

Model of the exhibitor's patent, with important additions and improvements, which can be adapted to heavy drain tiles and blocks, or moulded bricks of large dimensions.

134 LAYCOCK, J., *Winkaton, Newcastle-upon-Tyne*. Subsoiler and plough.

135 CROSSKILL, W., *Iron Works, Beverley*—Patentee and Manufacturer.

Patent serrated roller or clod-crusher; for crushing clods, compressing soft or fenny soils. This roller consists of cast-metal discs or roller parts, placed loosely upon a round axle so as to revolve independently of each other. The outer surface of each roller part is serrated and has a series of sideway projecting teeth, which act perpendicularly in breaking clods. This machine is represented in the annexed cut.

different degrees of  
B, shown in the an-  
d workable either as  
horses going either  
row is made in the  
h the patent round  
h the surface and  
and stubbles. The  
plough. The wear-  
new ones attached

Also used on young  
or making drills for

Inventor and

peculiarities con-  
ed in the earth, an  
dril, a motion for  
adently of its action  
owering the dibble-

Manufacturers.  
ing tools.

Northamptonshire  
rrier.

steel or cast-iron

e or shafts, with

reet, Camden Town

des, with pug-mill  
e same operation,

h important addi-  
adapted to heavy  
s of large dimen-

u-upon-Tyne.

-Patentee and

er; for crushing  
This roller con-  
, placed loosely  
ndently of each  
part is serrated  
teeth, which act  
machine is repre-

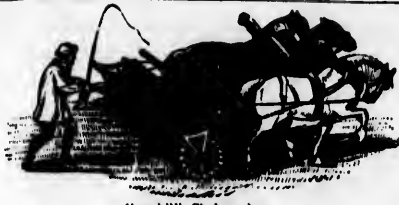

Crosskill's Clod-crusher.

Improved Norwegian harrow; for pulverising without consolidating the soil. When used immediately after ploughing, it breaks and pulverises the furrows, leaving from three to four inches depth of fine mould properly prepared for seed; and will work moist land without clogging. The annexed cut represents this harrow.

The frame and side levers are made stronger, with a new-invented horizontal regulator. The true incline of the harrow spikelets or rowel parts, when working in the soil, is by this regulator so exactly adjusted as to work with best effect, and saves a horse-power in draught.

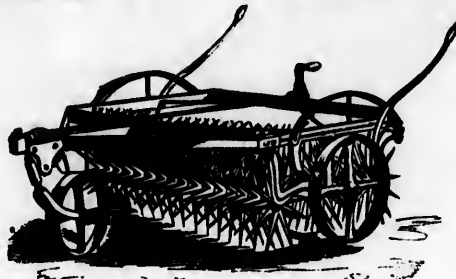

Crosskill's Norwegian Harrow.

Earl Ducie's drag harrow, or Uley cultivator and scarifier. For paring the land, cleaning out roots and weeds, and effectively stirring the land.

Yorkshire wold swing or two-wheel plough. For working light or heavy land.

Patent diagonal iron harrows. The teeth are so constructed that each tine cuts a separate track; and the draught is from the centre.

Emigrants' implement box. This box measures 11 feet long, two feet wide, and one foot deep.

Yorkshire wold corn, turnip, and manure drill, to sow six rows of corn or three rows of turnips.

Road Implements.

Patent wheels and axles in sets; for farm, road, or street work.

Model one-horse cart. Exhibited for workmanship, economy, and lightness of draught. Represented in the annexed cut.



Crosskill's One-horse Cart.

"Norwich and Exeter" cylindrical wheel prize one-horse cart. Fitted with harvest raves complete, for general farm work.

Improved "Norwich and Exeter" one-horse cart; with new front tipper, loose raves, &c.

"Norwich and Exeter" prize pair-horse waggon, with double break. Two horses will draw and run easy with three-ton loads. Fitted with a double break, acted upon by a hand-wheel in front of the waggon. Also, fitted with a pole and pair of shafts. See annexed cut.



Crosskill's Pair-horse Waggon.

Improved liquid manure cart and pump. Fitted with pendulum watering apparatus for six feet broadcast; or with box-trough and flexible tubes for four rows of turnips, &c. See the following cut:—

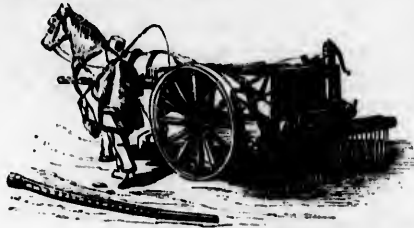

Crosskill's Liquid Manure Cart.

The tank body is made of iron plates securely cemented and bolted together, and fitted with a brass outlet valve acted upon by an iron lever rod, with which the driver opens and closes the valve while walking by the side of the horse.

Portable farm railway, with trucks, turn-tables, &c. This railway will convey, over the land, manure, marl, lime, &c.; and take off the land all kinds of green crops, as turnips, potatoes, and other produce. It is also useful for removing earth—to level, excavate, and embank. It will compete with carts, and prove far more expeditious and less expensive, especially in wet weather, when the land is so heavy as to become almost impassable for carts. The rails, manufactured in parts or lengths, are 15 feet long by 2 feet 11 inches wide, and 2 feet 6 inches in gauge; the ends fit into iron sockets. The wood rails are made of red deal, strongly put together and edged with iron. The rails when packed for delivery are four lengths in one package 15 feet long, 12 inches square, weighing about four hundred weight and a half only.

Permanent farm railway. To carry 40 cwt. loads. The permanent rails are made in 15 feet lengths, three feet in gauge; and for the portable rails 12 feet in length; with sets of ironwork with dog-nails, also sets of wheels and axles for trucks.

Fixture or portable steam-engine, for agricultural and manufacturing purposes. Exhibited as combining sim-

ilarity with security, cheapness, and effective power, represented in the annexed cut:—

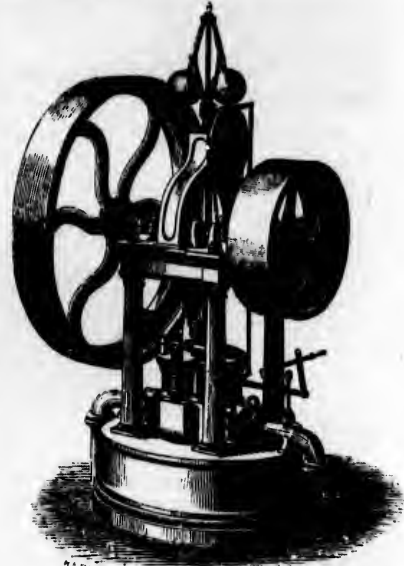

Crosskill's Steam-engine.

Bolting or thrashing machine. For thrashing the corn without bending, bruising, or breaking the straw.

Four-horse driving part. For driving a thrashing machine, patent mill, or other machinery.

Two-horse colonial thrashing part. Exhibited as a simple, powerful, and cheap machine, well adapted for small farms, or for colonists, and easily moved from one farm to another, represented in the annexed cut:—



Crosskill's Heater Machine.

New patent two-horse driving part. Fitted with an upright shaft, and exhibited ready for working upon a stage, overhead a thrashing machine, universal power mill, and straw cutter.

Patent two-horse universal mill. For grinding, cutting, and hulling purposes; will grind every kind of farm produce.

New patent four-horse mill. For reducing coprolites to fine dust, and broken bones to bone-dust.

Two-horse power straw cutters. To cut five sizes; with fly-wheel and feeding apparatus.

Beverley corn-dressing machine and blower. With two screens and six riddles for winnowing corn, beans, peas, &c. By removing the screen and riddles it may be used as a blower. It is improved in the fan and made larger inside.

Archimedeian root-washer. For washing potatoes, turnips, carrots, &c. The roots are delivered into a hopper, and pass thence into an inclined cylinder having two chambers, in the first of which they are confined and washed by turning the handle in one direction; and when thoroughly cleaned, by turning the handle the other way round, they pass into the second chamber, which is constructed in the form of a spiral, along which they pass until they drop into a spout outside. The following cut represents this machine.

Archimedeian Egyptian bean and wheat washer. Fitted with a zinc cylinder and perforated holes, and constructed on the same principle as the root washer.

Improved liquid manure fixture pumps.

Improved portable pump and tripod stand.

Forr's patent fixture iron pig trough.

ON THE SOUTH SIDE: AREAS N. O. 1; P. Q. R. 1 TO 27.

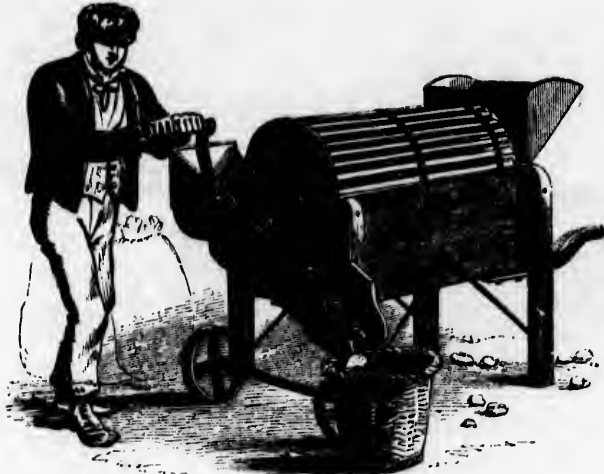

Croskill's Archimedean Root-washer.

## 136 GRIMSLEY, T., of Oxford, and RANDALL &amp; SAUNDERS, of Bath—Inventors.

Patent inventions.—Brick and tile press, with corrugated rollers, and perpetual cutter attached. The rollers gearing into one another, crush all stones or other substances as the clay passes through, tempering and compressing it so as to produce ware of very firm and regular texture. The press can be constantly refilled, and the goods cut off to any required length, without arresting its operations.

Brick and tile screw press, with perpetual cutter attached. Right and left handed screws working into each other. Perpetual cutter.

Model of nest of brick or tile kilns, with drying-room over.

Patent draining brick or tile, giving a drain either egg-shape or circular, to any size required; are concave on their upper surface, and rebate into one another.

Hollow bricks and tiles, for walls and flues.

Bricks and tiles for fire-proof roofs, floors, and walls.

Wall-coping bricks.

Model of fire-proof cottages, constructed of hollow brick, with provision for heating, ventilation, and drainage.

## 137 RICHMOND &amp; CHANDLER, Manchester—Inventors and Manufacturers.

Corn-crusher, applicable for hand-power; another, for horse, water, or steam power.

Two-knife chaff-cutting machine, combining self-adjusting feed, with Richmond's tooth rollers.

Grain-crusher, for crushing malt, barley, oats, &c., with fine machine-fluted rollers.

Chaff-machine: the feed is brought forward by the tooth-rollers, and pressed into a compact body by a weight suspended upon the raising lever.

Chaff-machine, the mouth of which is made to adjust itself to any given feed by a weight appended to the extremity of the lever.

## 138 GILLAM, JOHN, Woodstock—Inventor.

Registered seed-cleaner and separator. This machine is adapted for separating the various kinds of grass, sainfoin, and other seeds, and for correcting their samples, wheat, barley, &c. The annexed cut represents this machine.

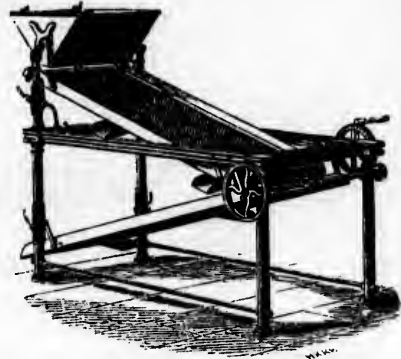

Gillam's Seed-cleaner and Separator.

The machine consists of two sieves worked by means of cranks and driven by gearing, over which the seed or corn is passed, dividing the samples which pass out at spouts fixed under the bottom of the sieves.

The sieves may be arranged at any suitable angle according to the condition of the seed.

The hopper is supplied with a shaking apparatus, and with slide to regulate the quantity passing on to the sieves. The whole of the work is fitted in a cast-iron frame, and bolted in wrought iron.

## 139 TAYLOR, G., Bury, Lancashire—Inventor.

Locomotive shearing and moving machine, to be worked by hand; it cuts and lays a sheaf at every stroke, ready to bind. With this machine, it is stated that one man cutting, and two binding, will do as much as six or seven in the ordinary way.

## 139A ROBINSON &amp; SON, Coventry—Manufacturers. Model churn.

## 140 HILL, EDWARD, &amp; Co., Brierley Hill Works, Dudley—Inventors and Manufacturers.

A wrought-iron skim. This implement, of which a woodcut is annexed, is generally used for paring or skin-



ming stubbles, immediately after harvest; it may also be used for paring turf, as a pair-horse scarifier, for working fallow ground, and for many other purposes. It has the great advantage of simplicity of construction, and will work easily three acres per day with a pair of horses. The handles act as a lever, by bearing on which (see engraving) the implement can be instantaneously thrown out of

work; the coulters following the knives are very useful for dividing into smaller portions, or "harrowing the surface pared by the knives, which precede them. This operation has the effect of exposing the roots of weeds, &c., more perfectly to the action of the sun; thus preventing the possibility of their growing again, even though the land should be left in this state for several days.

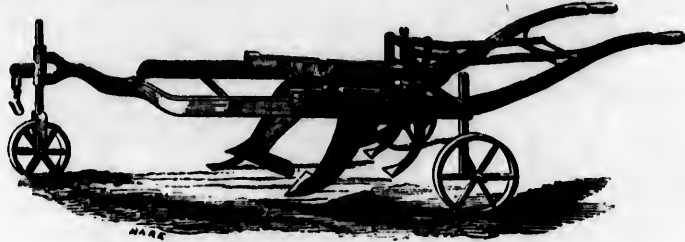

Hill's Wrought-iron Skim.

A wrought-iron expanding horse-hoe. This implement is intended for hoeing turnips, potatoes, &c., and is constructed on an entirely new system of expansion, which enables the workman to alter the width of the knives without stopping the hoe. This is effected instantaneously without the adjustment of any screw or pin, by simply opening or drawing together the handles of the implement (see annexed engraving). The perfect command

over the cutting part of the hoe, which this new expansion movement affords the workman, will enable him to avoid any sudden irregularity in the ridge or drill, or in the track of the horse, as readily as he would if hoeing by hand. It is furnished with a small Norwegian harrow behind, for the purpose of throwing to the surface the weeds removed by the hoe; but it may be used with or without this, as may be required.

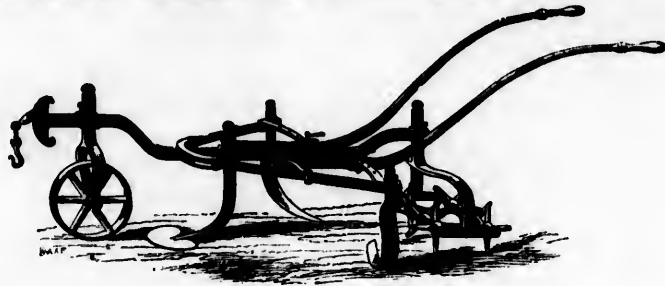

Hill's Expanding Horse-hoe.

An iron field-gate and posts. It is made entirely of wrought iron; the hangings are made to slide over the top of a hanging-post, resting upon a collar (as represented by the annexed woodcut), which renders it difficult for any one to unhang the gate. It is furnished with

poss. It is cheaper and neater in appearance than a wooden gate and posts, besides being so much more durable; and it can be fixed in one fourth the time.

A wrought-iron entrance or field-gate and posts. This gate is so constructed as to combine great strength and neatness of appearance with a lightness of material, which admit of its being sold at a low price. It is hung on neat round cast-iron posts, and is fitted with a revolving or quadrant hinge, so that the gate will always shut itself. The dimensions are about 9 feet 6 inches by 4 feet high.

Two specimens of continuous iron fencing. This fencing is well adapted for the enclosing and subdividing of parks, pleasure grounds, common land, and all places where fencing may be required. From its peculiar construction it possesses great advantage over iron hurdles, or other kinds of fencing, as regards economy, strength, lightness of appearance, and general efficiency; it packs up into bundles for the convenience of carriage, and is conveyed across the country at a trifling expense. The facility with which it can be erected, and adapted to any irregularity in the surface of the ground, and its cheapness, are two of its greatest advantages.

Two specimens of wrought-iron hurdles. These are intended for feeding sheep on turnips, or for eating off green crops. Annexed is a woodcut, representing the form of the hurdle when placed for use, from which it

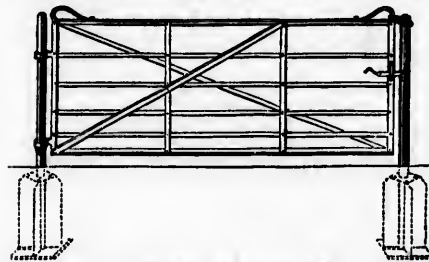

Hill's Wrought-iron Gates and Posts.

catch complete. The posts, when well set in stiff soil, are quite sufficient to carry the gate, the bases of them being specially constructed to accomplish this, and therefore no brickwork or concrete is required for this pur-

ON THE SOUTH SIDE: ARWAS N. O. 1; P. Q. II. 1 TO 27.

ves are very useful  
or "harrowing the  
oceds them. This  
the roots of weeds,  
the sun; thus pre-  
again, even though  
or several days.

ch this new expan-  
will enable him to  
ridge or drill, or in  
the would if hoeing  
Norwegian harrow  
to the surface the  
may be used with or

appearance than a  
ng so much more  
h the time.

te and posts. This  
great strength and  
of material, which

It is hung on neat

ith a revolving or

always shut itself.

hes by 4 feet high.

eing. This fencing

ndividing parks,

l all places where

cular construction

hurdles, or other

strength, lightness

it packs up into

e, and is conveyed

ase. The facility

ted to any irregu-

its cheapness, are

rdles. These are

or for eating off

representing the

se, from which it

will be seen that the bars are vertical, and placed so far apart as to allow the sheep to eat through them without treading on the food, like eating through a rack. This is considered a great advantage in eating off turnips or other green crops, as it enables the farmer to have them eaten without any of the food being spoiled by the treading of the sheep; it is consequently eaten much closer, and with greater advantage to the sheep; and the ground is more regularly trodden and manured. It does not require setting in the ground, but on it, resting upon stays in a leaning position, as represented in the cut, so that they are easily placed and removed. These stays are fixed to the hurdle, and when taken up fall to its side, so as to occupy little room.

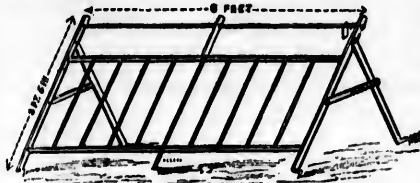

Hill's Wrought-iron Hurdles.

## 141 LYDES, —, Inventor.

Improved mode of boxing horses for conveying them by railway.

142 GARRETT & SON, *Leiston Works, Saxmundham, Suffolk*—Inventors and Manufacturers.

1. Drill for seeding and manuring land. All kinds of grain and seeds may be deposited by this machine at any required intervals apart, and at any depth, either with or without compost or artificial manures. They are constructed of various sizes and widths, to suit lands ploughed on the flat or in ridges, and suited for all descriptions of soil. The corn or seeds may be deposited down the same conductors with the manure if required; but separate coulters are provided for each, by means of which the manure may be buried 2 or 3 inches deeper than the seed, and 10 to 12 inches in advance of it, and a portion of mould placed between them. The jointed levers are especially adapted for this purpose, the coulters for seed acting independently of those for manure, and being pressed into the ground by separate weights, allow both seed and manure to be deposited regularly any depth, on all descriptions of land, however hilly or uneven. The improvements claimed consist, first—in constructing the boxes in which the manure and seed are contained, so as to be equally suitable for drilling on side hills as on level ground. Secondly—in the application of separate slides to each department of the manure box. Thirdly—in fixing the slides which regulate the seed to a horizontal bar, extending the width of the drill. This machine is represented in the annexed cut.



Garrett and Son's Seeding Drill.

2. Drill for turnips and manure on the flat. This drill is made to deposit two, three, or four rows of turnips or other seeds with compost, or artificial fertilisers, on either flat or ridged ploughed lands. It is fitted with separate

seed boxes for each row, which are fixed to a horizontal bar, and may be shifted to suit the varied intervals between the rows, so as to come directly under the delimiting spouts, and allow them to work freely. These small boxes are partitioned off into two departments, one larger than the other, that when drilling beet and turnip seeds together, sufficient of each to last an equal time may be put into the boxes at once. This drill is also adapted for side hills, like No. 1, and is shown in the annexed cut.

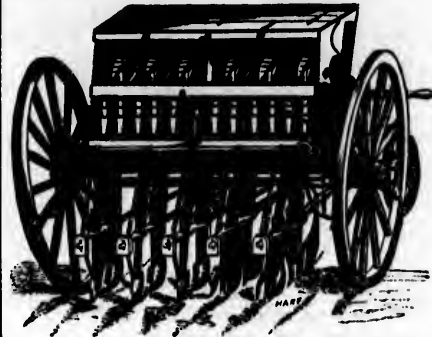

Garrett and Son's Turnip Drill.

3. A lever corn and seed drill. This drill is for the purpose of drilling in rows, at any distance apart, wheat, barley, beans, peas, oats, and other grain, and by changing the cup barrel, turnips or mangold-wurzel seeds without manure. It is fitted with a swing steering, that when drilling lands or ridges of twice the width of the drill, the two rows where the drill joins on the top, may be kept equidistant with the rest.

4. Drill for small farms—adapted for drilling all kinds of grain, turnips, and other seeds: the quantities may be regulated by means of cog wheels, to deposit from 2 to 12 pecks of grain, or from 1 to 8 lbs. of seed per acre. The distance of the rows apart may be varied as required, from 6 inches upwards, to suit different crops; and the whole arrangement of the working parts is completely within the management of the attendant. The drill is especially made for lands ploughed on the flat, and to the draught of one horse.

5. Barrow hand seed-drill, for sowing grass seeds broadcast. The box is made in two departments, one for heavy seeds, such as clover, trefoil, &c.; the other for lighter seeds, such as rye grass: the former being delivered from cups, and the latter by means of revolving brushes, down the same conductors with it.

6. Hand lever seed-drill, for sowing turnips and other seeds, on ridge or flat ploughed lands, without manure. It is constructed with two small levers, working independently of each other, which may be varied in distance from 16 to 30 inches apart, and will deposit from 2 to 6 pints of turnip, and 2 to 6 lbs. of beet seed per acre.

7. Garrett's patent horse-hoe—adapted to all the prevailing methods of drill culture, either for cleaning crops drilled on the level surface, or on ridges, the axletrees of the wheels being movable at both ends to suit the varied intervals between the rows of plants. The steering is considered an improvement on account of its precision in guiding the hoes without injury to the corn or plants. From 10 to 15 acres per day may be hoed with one horse, and a man and boy. Represented in the following cut.

8. Bolting thrashing-machine, for thrashing grain of all descriptions, without injury to the same, or bruising the straw, like the flail. It is fed lengthways instead of vertically, as in other machines; and the straw is delivered on to a lattice platform, ready to be tied up in trusses or bolts for sale, or other particular purposes.

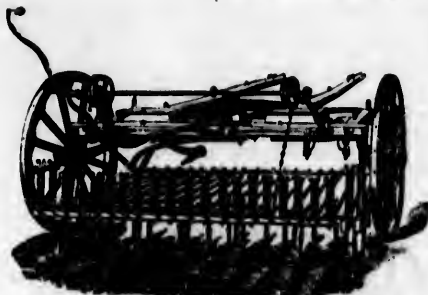

Garrett and Son's Patent Horse-see.

9. Patent thrashing machine for barn work; adapted for thrashing all kinds of grain without damaging the corn or straw, thrashing from 60 to 70 bushels of wheat per hour when applied to steam power.

10. Patent thrashing machine, with registered straw shaker and riddle. This machine is adapted for thrashing grain of all descriptions in large quantities, and may be applied to steam, water, or horse power; it is fitted with a screen for the purpose of riddling away all loose ears, short straws, rubbish, leaf, and chaff, leaving the corn ready for the dressing machine, without further preparation; and with a registered straw shaker, for separating the corn from the straw, which is by this means done much more effectually than by the usual process by hand. Barley may also be thrashed for malting purposes with these machines, and in many cases is preferred by maltsters to that thrashed by hand. The whole of the machine may be mounted on travelling wheels and conveyed from place to place with two horses. This machine is represented in the annexed cut.



Garrett and Son's Patent Thrashing Machine.

11. Horse-power driving machinery for thrashing machines. This machinery is adapted to the power of six horses, for driving the thrashing machine barn works, Nos. 8 & 9.

12. A portable steam-engine for agricultural purposes. Exhibited for simplicity of construction, economy in fuel, and portability. It is fitted with governors, hair,

felt, and iron jacket, steam and water gauges, and other necessary apparatus, mounted on four strong carriage-wheels, with shafts; and is adapted for driving machinery, for the purposes of thrashing, dressing, grinding, and cutting agricultural produce, pumping water, sawing timber, and other stationary labour on a farm or estate. This machine is represented in the annexed cut.

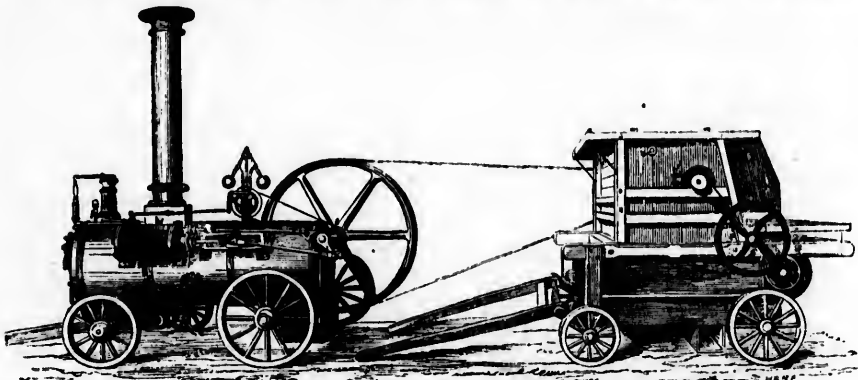

Garrett and Son's Portable Steam-engine.

13. A barley aveller or hummelling machine. This machine is fitted for horse or steam power, but may be used by hand if required. It is for the purpose of rubbing the horns or avels off barley (which it performs in an expeditious manner), and screening away all loose rubbish from the corn, leaving the kernels clean and the sample perfect.

14. A corn-dressing machine, worked by steam, horse, or hand power. It is particularly suited for receiving the corn from the thrashing machine, No. 10, which it will dress in one operation at the rate of 12 to 15 quarters per hour.

15. Patent chaff-cutter, adapted for horse or steam power. It may be altered by means of toothed wheels to

ON THE SOUTH SIDE: AREAS N. O. 1; P. Q. R. 1 TO 27.

work; adapted for  
arranging the corn  
chela of wheat per

a registered straw  
adapted for thrash-  
quantities, and may  
er; it is fitted with  
way all loose ears,  
leaving the corn  
at further prepara-  
for separating the  
means done much  
process by hand,  
ing purposes with  
ferred by malt-  
the whole of the  
illing wheels and  
two horses. This  
cut.



gauges, and other  
strong carriage-  
for driving ma-  
dressing, grind-  
pumping water,  
pour on a farm or  
the annexed cut.



by steam, horse,  
ed for receiving  
No. 10, which it  
f 12 to 15 quar-

horse or steam  
both wheels to

cut chaff  $\frac{1}{4}$ ,  $\frac{1}{2}$ , or  $\frac{3}{4}$  inch long. The rollers are so constructed as to adjust themselves to any thickness of feed, and act independently of the mouthpiece or pressure-plate, so as always to keep a uniform pressure on the hay or straw, and prevent the machine from choking.

16. Portable stone mill for grinding wheat and other farm produce: the stones are 32 inches diameter, and enclosed in a metal and wood framing; the top stone is hung on an upright shaft, and worked by a pair of bevel wheels, from which the attachment may be made to either steam, water, or horse power: its construction admits of the stones being adjusted for grinding wheat, barley, beans, and peas. A late improvement consists in the application of a clutch box to the small feed roller, which affords great facility in starting the machine, by allowing this roller to be taken out of work, and admits of the process of crushing being instantly discontinued without stopping the mill.

17. A lined, malt, and oat mill, fitted in an iron frame, and is for the purposes above mentioned; the crushing being performed between the smooth surface of a large wheel, 4 feet diameter, and a small smooth roller.

18. A rape and lined cake crusher, for the purpose of breaking cakes of any size and thickness. It is fitted with two sets of barrels which may be adjusted, as required, to break cake into different-sized pieces for bullocks or sheep, or powder for manure: a screen is fixed between these barrels, through which as much of the cake as is sufficiently broken in passing through the first is sifted, to insure uniformity of size, and to avoid the unnecessary labour occasioned by that which is sufficiently broken passing through the bottom rollers with that which is not.

19. Iron plough for general purposes, made with wrought-iron beam and handles, and cast-iron body, and may be adapted for all descriptions of soil, by having suitable mould-boards or breasts. It is fitted with improved coulter and fastening, and case-hardened shares.

20. Hand-power chaff-cutter, for small occupations, to be worked by one or two boys or men. It is made with a 12-inch box and 10-inch mouthpiece, and will cut 30 to 40 bushels an hour.

21. Corn-dressing machine, intended for all kinds of grain and seeds, and is adapted for hand labour: a man and a boy will dress from 6 to 8 quarters of wheat per hour, depending on its quality and condition. This machine may also be used as a blower when required, for separating all light kernels, dirt, &c., from the corn.

22. Corn-reaping machine, of new construction, adapted for reaping wheat and other grain by horse power: the operation is performed by a series of angular knives, intersecting a like series of stationary iron tines or points: a vibrating horizontal motion is communicated to these knives by means of a crank shaft, and as the corn is driven by the motion of the machine between the tines, it is cut with cleanness and regularity. As much as 20 acres per day may be reaped with one horse and a man.

23. Models of agricultural machinery. Specimens of coprolite and grass seeds.

24. Set of iron harrows. These harrows are constructed with wrought iron, with the ends of the balks turned round to prevent injury to the horses.

143 COMINS, JAMES, *Smith Molton*—Inventor and Manufacturer.

A small wrought-iron horse-hoe for hoeing turnips, mangold-wurzel, &c.

A wrought-iron horse-hoe for working, both on the ridge and flat.

One-way turn-over, or turn-wrist plough, for hilly land. The share turns over at each end of the furrows, and the coulter and mould-plates are changed at the same time by means of a lever between the handles.

One-way turn-over, or turn-wrist plough, made of iron. Subsoil pulveriser.

Horse-hoe on the flat, for hoeing from two to six drills at a time.

Set of light harrows.

144 SQUIRES, WILLIAM, *March, Cambridgeshire*—Manufacturer.

Road waggon for conveying agricultural produce to market, &c.

Improved plough.

144A ELLIOTT, GEORGE, *Furnham*—Inventor and Manufacturer.

Machine, of new construction, for bagging hops when dried, constructed to bag two tons of hops a day.

145 TROTTER, WILLIAM, *Bywell, Stockfield, near Gateshead*—Inventor.

Model of reaping machine for cutting corn with revolving knives. The knives being attached to two separate sets of arms, which revolve on different centres, are kept parallel to each other, in consequence of which their action closely resembles that of the scythe of the mower. The angle at which the knives strike or cut the corn is at the command of the attendant. The knives cut at the side of the machine, the motion being reversed to make them cut either to the right or to the left.

146 PONDER, WILLIAM RICHARD, *Goldhanger, near Maldon, Essex*—Inventor.

Bee-house, or hive.

148 GROUNDSELL, WILLIAM, *Louth, Lincolnshire*—Manufacturer.

Improved patent drop drill, to deposit seed and manure at intervals, delivering the manure only where the seed is intended to remain for a crop.

Self-feeding registered corn-dressing machine, to dress corn taken from the thrashing machine.

Registered corn and turnip hoe, worked by horse, to hoe five rows of corn at once, and three rows of turnips.

149 HENSMAN, WILLIAM, & SON, *Castle Works, Woburn*—Inventors and Manufacturers.

Four-horse power portable steam-engine; with a tubular boiler. It may be driven either from the fly-wheel by band, or from the crank-shaft by spindle. It is furnished with an improved governor, spring balance, whistle, gauge cocks, water gauge, &c.

Four-horse power patent bolting thrashing-machine, complete; the straw being admitted into it lengthways, is delivered from the machine straight and unbroken as from the sheaf. Adapted for thrashing barley for malting.

Eight-row patent cup-drill, to be worked by a pair of horses, and fitted with an improved swing steering, by which it can be guided independently of the horses. The axletrees are made to slide, so that the wheels can be set to any width. The coulters are fixed upon separate levers, to adapt them to the surface of the land; the corn box, being self-acting, always finds its level, deposits the corn, &c., on any ground.

Patent hand thrashing-machine. The drum-besters are of a Vandyke, or tooth shape, and revolve through similar notches in the concave; it is adapted for thrashing all descriptions of corn and seeds.

Patent plough, with two wheels, made principally of wrought iron. It may be worked with either one or two wheels, or as a swing; it is adapted for one or two pair of horses; and is fitted with round coulter, and patent coulter fixing. The skim-coulter is fitted with round stem, and is also secured by patent fixing. The wearing parts are made of cast-iron.

Patent iron plough, with two wheels, similar to the preceding, but fitted with high wheels, deep turn-furrow, &c., and made stronger for deep ploughing.

150 GRAY, R., & SONS, *Uddingston*—Manufacturers.

One-horse farm cart. Two-horse and four-horse ploughs. Subsoil pulveriser. Five-tined drill grubber. Parallel horse shoe. Canadian chaff cutter. Equalising three-horse yoke. One way, or turn-wrist plough. Scotch thrashing-machine.

151 WILLIAMS, W., *Bedford*—Inventor & Manufacturer.  
Set of patent 4-bear iron harrows, for general purposes. Their form is diagonal, and the set consists of



Williams' Patent Iron Harrows.

three, drawn by two horses. The teeth are so constructed that each cuts a separate track. These harrows are shown in the adjoining cut.

Patent wrought-iron plough, with two wheels, for general purposes, marked G. V. The plough is fitted as a swing or wheel plough, for two or three horses. The mould-board or furrow-turner is new, the bearings of which have an equal pressure from the point of the share to the heel of the breast, which gives lightness of draught, and also causes the furrow-slice to turn over without breaking. This plough is represented in the annexed cut.



Williams' Patent Wrought-iron Plough.

Patent wrought-iron plough, with two wheels, for strong land and deep ploughing. A skim coulter may be fitted to it.

Chaff-engine, with two knives, and 10-inch mouthpieces. Top and sides of iron, and legs of wood. Calculated to be worked by two men. This engine is shown in the cut.

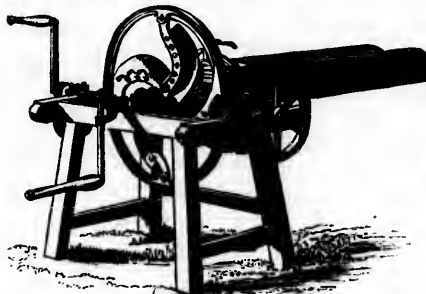

Williams' Chaff-engine.

A machine for making drain pipes and tiles. This machine is represented in the annexed cut.

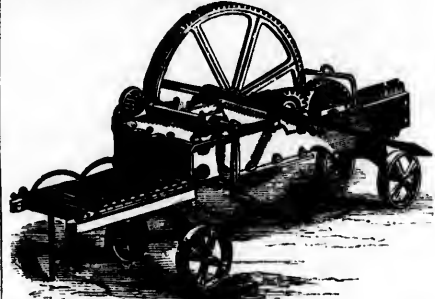

Williams' Drain-Pipe and Tile Machine.

It is calculated to be worked by one man and a boy. The box contains 1,450 square inches of clay.

A patent horse-drag rake, invented by Samuel Taylor, of Cotton End, improved by the exhibitors. It is shown in the annexed cut.

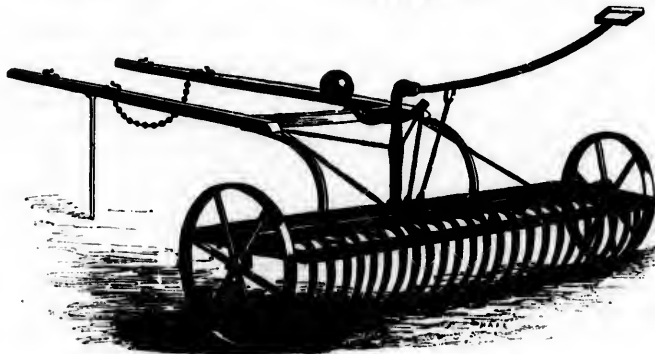

Williams' Patent Improved Taylor's Horse-drag Rake.



The improvement in this implement consists, first, in the construction of the teeth fitting into iron sockets and working on the front rod, so that one or more teeth can be removed at pleasure; secondly, the teeth, acting on a bar running parallel underneath the frame, gives it greater facility in relieving it of its load; thirdly, the ball, acting upon the leverage of the handle, keeps the teeth in their work, so that they cannot lose their yealm. It is simple in construction and cannot get out of order.

The preceding figure represents this rake.

152 ROME, ROBERT M., *Langholm, Dumfries*—Designer and Manufacturer.

Sheep-dipping machine, for applying sheep-washing compositions, to improve the wool and destroy vermin in sheep.

It consists of a trough, in which the sheep are dipped, and a platform forming the body of the carriage for them to stand on, while the superfluous liquid drips off them and flows back into the trough. With this machine, three men can dip or wash 800 sheep in a day.

[It has become a common practice thus to dip half-

grown lambs in a solution of corrosive sublimate, which poisons the ticks that burrow in the skin without injury to the animals themselves.—Ph. P.]

152A MOREWOOD & ROGERS, *Steel Yard Wharf, Upper Thames Street*—Inventors.

Model of farm-yard and buildings, constructed chiefly of patent galvanized tinned iron, surrounded by a fence of the same material.

Models of galvanized agricultural implements, including barrows, sieves, &c.

154 BLYTH, R. J., *Norwich*—Inventor and Manufacturer.

Four-horse power portable horse works.  
Four-horse power registered portable bolting thrashing machine, for steam or horse power; with light spindle flanges, and round hollow beaters, so formed as to meet small resistance from the atmosphere, and having little friction; it will thrash about 70 quarters of wheat per day, with four horses. The annexed cut represents this machine.



Blyth's Four-horse Bolting Thrashing Machine.

154A COODE, GEORGE, 473 *Oxford Street, Bloomsbury*—Inventor.

Patent irrigator for grass land, or low crops; applicable also to watering roads. It may be worked by two boys, and it distributes water or liquid manure with great regularity: from 10 to 20 acres may be done in a day.

Patent irrigator for high-standing crops, of a similar description, except that it requires more power.

155 FAIRLESS, THOMAS, *Corbridge, near Hexham, Northumberland*—Inventor.

Reaping machine for cutting corn and hay.  
Improved pump.

156 SADLER, WILLIAM JAMES, *Bentham Parson, near Swindon, Wilts*—Inventor.

Agricultural chimney filter drain. The portions exhibited, represent the external filter pipes, *a, b,* and *c,* to slide in the chimney, *d, e,* for conveying to the drain any surface water which may accumulate in low places on stiff clay soils, through which it cannot penetrate to the drain, till it has considerably injured the crop. The pipes act as filters, retaining in the bottom the mud or other matter which might choke the drain. The pipes

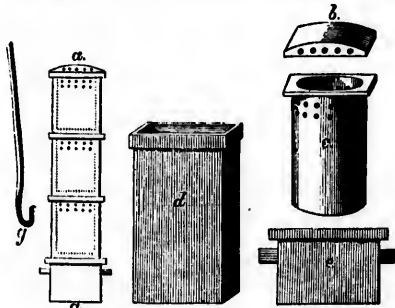

Sadler's Agricultural Chimney Filter Drain.

are lifted out of the chimney to unfit them, and may be left out when sufficient water has accumulated to flush the drain, if it should be required. These drains are shown in the preceding cut.

Draughting tools:—Paring knife; spade for surface; top bit; crumpler for the same; pick and tomahawk; bottom bit; crumpler for the same; rammer for leveling bed for pipes; tool for placing pipes, *g,* in the preceding cut, and drag for filling in.

157 RUDD, T., 16 *Ebury Square, Picnic*—Inventor and Manufacturer.

Improved patent hand-thrashing machine; mounted upon carriage wheels, and remaining so when at work. Working model of improved machinery, for working marble, stone, &c.

158 HALL, A., *Bank Buildings, Manchester*—Inventor.

Garden net, a substitute for glass in hot-houses, &c.

160 CRUMP, THOMAS, *Derby*—Inventor and Manufacturer.

Garden-engine, or portable fire-engine, two sizes, with jet and spreader, for watering plants, greenhouses, &c.; the hose-pipe will discharge 18 gallons of water per minute, at 60 feet distance, or 50 feet altitude.

Liquid manure pump, made of galvanized sheet-iron.  
Instrument for singeing horses with gas.

161 NIXON, T., *Kettering*—Inventor and Manufacturer.

A garden light or skylight.

170 WILMOT, EDW. W., *Conyngton*—Designer.

Model of farm buildings for a farm of about 300 acres, with plans of farm-house, labourers' cottages, and explanatory drawings.

180 DEANE, DRAY, & DEANE, *Swan Lane, Upper Thames Street, London Bridge*—Manufacturers.

Patent cesspool and tank cleanser, for the speedy and innoxious removal of stagnant water, &c. The following cut represents this machine.

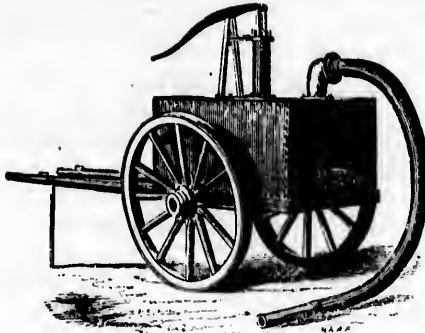

Deane and Co.'s Patent Tank-cleaner.

Patent engine for raising water. The annexed cut re-

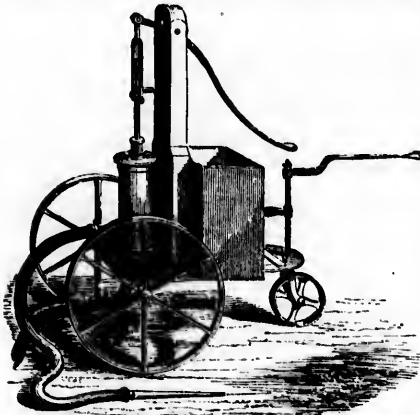

Deane and Co.'s Patent Water-engine.

presents one of these machines, for the purpose of throwing to a considerable height a volume of water. This form of engine is provided with a tank.

Force and other pumps. The force-pump has the advantage of a double action, drawing the water from any depth, and forcing it fifty feet at the same operation; so that while it is well adapted for general domestic purposes, it is equally so for other applications.

Patent portable forge, which may be worked in a barn, or removed into the open air. It is compact, cheap, and strongly made. There are various sizes of these forges, all of which are equally portable.

Patent plate glass lantern, combining safety and economy.

Iron pig-troughs. Enamelled milk pans.

Patent enamelled mangers, of various descriptions.

Double weighing-machines, adapted for commercial and agricultural purposes.

Howard's J K plough. This plough is intended as a substitute for the large four-horse Kentish plough, and fitted with mould boards or breasts, which turn the furrow over round, leaving a perfect seam, in the same manner as the Kentish turn-wrist plough. It is used with a pair of horses, but occasionally with three or four. It is capable of ploughing any land, however dry and hard. It may be fitted with an extra large breast or furrow-turner, for very deep ploughing. The skin coulter, shown in the following cut, is a most useful appendage. It is of great importance when ploughing loamy ground and stubbles; it precedes the common coulter, paring and turning into the furrow the herbage upon the surface, so that when the soil is turned over by the plough, nothing of grass or weeds is left to grow out between the furrow; consequently the vegetable matter thus buried, instead of living upon the soil, decomposes, and serves to enrich the land. It will also be found most useful when ploughing in dung, mustard, tares, &c., for with the addition of "a drag-chain," all may be turned in completely. With a new registered lever, for regulating the wheels. The cut represents this plough, and the wheel having its fulcrum at *b*, and its point of action at *a*.

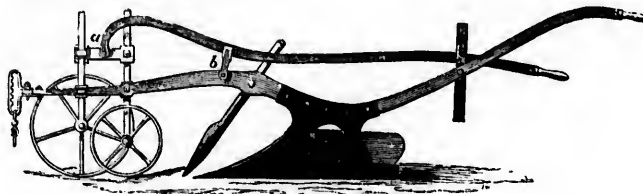

Deane and Co.'s Howard's J K Plough.

Howard's J A plough. The annexed cut represents this plough, which is adapted for heavy land.



Deane and Co.'s Howard's J A Plough.

ON THE SOUTH SIDE: AREAS N. O. 1; P. Q. R. 1 TO 27.

purpose of throw-  
the water from

-pump has the  
same operation;  
al domestic pur-  
s.

orked in a barn,  
pact, cheap, and  
of these forges,

ing safety and

s.

descriptions.

for commercial

is intended as  
Kentish plough,  
which turn the  
am, in the same  
gh. It is used  
with three or  
ad, however dry  
tra large breast  
ing. The skim  
a most useful  
when ploughing  
s the common  
ow the herbage  
l is turned over  
is left to grow  
the vegetable  
upon the soil,  
ad. It will also  
dung, mustard,  
drag-chain," all  
new registered  
represents this  
m at 6, and its

Improved horse-rakes. The horse-rake is adapted for raking barley and other corn stubbles; also cut grass after it is strewn in the process of making hay. Each tooth works independently on a separate lever, so as to fall to the irregularities of the surface, and the oblique direction of the teeth is altered by raising or lowering the ends of the levers, so that the teeth may rake lightly or heavily, as the quality of work or nature of the surface may require. There is also attached a simple lever-purchase, so as to enable a lad to raise the teeth without stopping the progress of the implement, to relieve them of their load, and leave it neatly raked up in rows.

The hay-making machines are made with iron wheels. The rake-cylinders are in two lengths, which eases the working of the machine; and, as they have a double motion, it is immaterial which way they are turned.

Hay-making machines, with reversing motion. In the first process of tedding or making hay, it goes across the swarths, throwing the grass in the usual manner; when, having laid for a short period, the motion can be reversed, and it will throw it out loosely, so that the air can operate on it much more speedily than when heavily laid down.

Mills, of various descriptions, for agricultural produce.

Patent economic corn-mill, effecting a saving of time and labour. This machine is shown in the annexed cut.



Deane and Company's Patent Corn Mill.

A vegetable washer, constructed with a rack and pinion, so that the cylinder enclosing the vegetables, may be raised out of the water, and emptied into a trough or barrow, with the greatest ease.

A chaff-engine, applicable for hand, water, or steam power. It is constructed to cut various lengths. This machine is used in the West Indies, for cutting cane tops.

Sussex butter-churn, of block-tin.

Patent American butter-churn.

One row turnip-drill.

Gardner's patent turnip-cutting machine.

Liquid manure pumps.

181 WHITE, JAMES, 266 High-Hoborn—Inventor and Manufacturer.

Gorse reducer, for converting gorse into nutritious food for cattle, crushing corn and linseed, and rasping beet-root for sugar making.

Patent cider mill, which cuts the pipe, improves the flavour of the cider, and makes it keep longer.

Wheat mill and dressing machine, to enable families to grind and dress their own wheat.

182 TURNER, E. R., Ipswich—Inventor and Manufacturer.

Four-horse power portable steam-engine, for agricultural purposes. This engine is shown in the annexed cut.

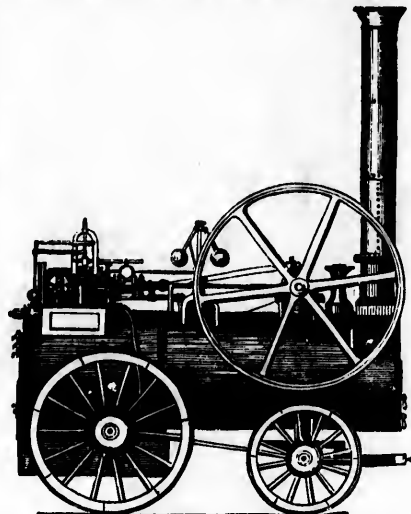

Turner's Four-horse Portable Steam-engine.

Apparatus for regulating the supply of water to a high-pressure steam-boiler whilst the engine is at work, consisting of a small vessel into which the force-pump discharges, and from which the boiler takes its supply by means of a ball valve. Adapted for stationary engines. This apparatus is shown in the annexed cut. By the arrangements represented, a deficiency of supply is indicated by the steam whistle.

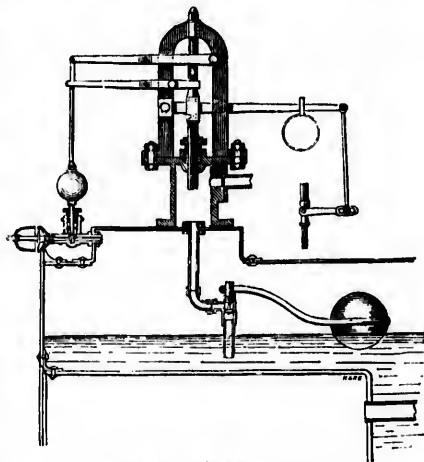

Turner's Steam-boiler Feeding Apparatus.

Mill, composed of two smooth rollers, for crushing corn and seeds; it also grinds beans, peas, maize, &c., by a serrated roll at the bottom of the hopper, which acts as a feed roller when the mill is used for crushing purposes. This engine is represented in the annexed cut.

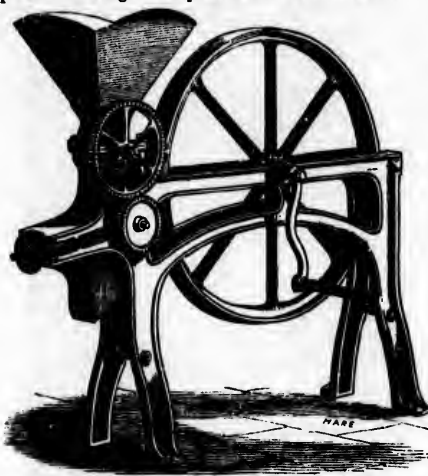

Turner's Crushing Mill.

- 183 ROGERS, JASPER W., 88 St. James's Street—  
Inventor and Patentee.

A deodorizing chamber, intended for use in public places and establishments: the receptacles being partly filled with peat charcoal. The animal matter is deodorized, and entirely absorbed by the charcoal, the combination producing a valuable manure.

- 185 SAMUELSON, B., Banbury—Manufacturer.

Patent double-action turnip-cutter, for cattle and sheep, on a wrought-iron or wooden frame; the slicer-knife for cattle may be dropped when the seed-knives are in action; the hopper is on a hinge to facilitate the cleaning of the barrel.

[The turnip-cutter is one of the most valuable improvements in English farming; for fattening flocks it is indispensable. By thus sparing the animal the labour of chewing its food, their condition is improved 20 per cent.—*Ph. P.*]

Chaff-cutter for hand or horse power, on an angle iron frame; cuts two lengths. Universal mill, adapted to crush all kinds of grain except linseed. Improved bean mill. Small oil-cake breaker. Registered atmospheric churn. General purpose plough, but especially suited to heavy clay soils. Horse-hoe, with three tires, which may be set and firmly secured at a variable distance; also two sets of revolving rowels. Skim and paring plough, &c.

- 186 BATES, F., Sunnertown, Oxford—Inventor.

Implement to facilitate the removal of plants in pots.

- 190 WINDER, RICHARD, 2 Ingram Court, Fenchurch Street—Inventor.

Model of a machine for mowing corn or grass by rotary horizontal knives, having a considerable velocity; proposed to be worked by one or two horses, according to the size the machine is required to be made. It is suggested, that two shafts (as in the model) are an improvement, by offering no impediment to the falling corn in the centre space, in allowing the machine to turn within its own length, and allowing free action to the knives

while the machine is turning. Also, the means of throwing the machine in or out of gear are considered as economical and effective, as well as the means of sharpening the knives, and the distribution of the falling corn.

- 191 HENTON, JOHN—Inventor.

Hand roller. The object of this roller is to combine efficiency with lightness of draught.

- 192 SMITH, HENRY, 12 Rufford's Row, near the Church, Islington—Inventor and Manufacturer.

Registered horticultural hot-water gas stove; consisting of two cylinders, the external 18 inches diameter, internal 5 inches diameter, with top and bottom containing water; and internal pipes. The gas is lighted at the lower end.

- 193 KEENE, W., 24 Great Queen Street, Lincoln's Inn—  
Engineer.

The multiple box hive, invented by the exhibitor. One of the objects of this hive is to permit the bees to have access at the points most convenient for their work, which always begins from the top of the hive, and proceeds downwards; the natural hives chosen by them having generally access from the top, and not from below. The common cottage hive admits the bees at the bottom, and gives them much additional labour to carry their load upwards, instead of relieving them by taking it in with their descent. It is found by experience that when the bee is admitted at the top, the hive fills much more rapidly with comb and honey. In the multiple hive every box is formed exactly alike; they may be placed one on the other, and their order inverted at pleasure, in such way as may be best suitable for the operations of the bee-keeper. Any single box will form a sufficient hive for any swarm during the first season; but when this box is filled, a second is added, presenting to the bees additional room, of the same form and size as that to which they have been accustomed; they take to it at once; swarming is prevented; and without loss of time the new box is filled with comb and honey. The bees rarely deposit any larvae in this box. The colony chiefly retires to the lower one, keeping guard on the contents of the upper, and ample provision against "a rainy day," in the lower box. When the upper one is filled, and a fine box of pure clean honey in the comb is wanted, it may be removed, and replaced by an empty one, which in due season they will also fill; the hive below remaining an undisturbed domicile.

In course of time the combs in which the larvae have been deposited become uncomfortably dirty; these boxes then offer the greatest facility for shifting the family into clean quarters. Suppose an upper box is full, or partially full, of comb and honey, the lower one may be made so uncomfortable as to oblige the colony to mount into the upper, and then the lower may be removed, putting what was the upper box into its place. If the queen or any bees have remained in the box taken away, by upsetting it, and putting a piece of plank on an inclined plane, so as to form a bridge from it to the box which remains on the stand, they will not only all go into it, but very quickly carry away the honey from the dirty comb into the clean hive, and be soon ready to begin to fill another box. The bee-keeper can thus multiply his colonies of bees without permitting them to swarm; or he can produce off-casts, if he prefer to multiply his hives.

The covered way by which the bees enter is pierced with openings both downwards and upwards, so that the bee, once alighted, is free to choose either direction. When the hives are in position, one on the other, a bell glass may be placed over the upward opening, if it be desired to have honey in such a receptacle. A feeding-box may be put over it, if it be needful to give them food; and either the glass or the feeding-box may be covered by a common straw cap, or by an additional box.

New mode of preparing seed for sowing, consisting of wadding-rope and matured seed-wadding for inclosing

ON THE SOUTH SIDE; AREAS N. O. 1; P. Q. R. 1 TO 27.

the seed previous to its being laid in the ground. Adapted for poor and generally unproductive soils. In the article exhibited, there are seven different kinds of manure; that from the farm-yard or stable being in the greater proportion. Guano, bones, peat, charcoal, all-plate of lime, urate, and fecal manure, may all be inclosed in just such quantities as shall be found sufficient for the benefit of the plant. The advantages are—saving of manure, increase of crop, regularity of growth, and saving of seed,—sufficient to outbalance the cost of material when manufactured by machinery on a large scale, and enable about half the quantity of manure to produce crops equal to those obtained in the ordinary way of using it.

195 WILLOUGHBY DE ERESBY, Lord, 142 Piccadilly—Inventor.

Machinery to plough land, having a moderately-even surface. The heavy engine is not required to move up and down the field with the ploughs, but is stationary whilst they are working from the hedge on each side up to the engine, when it is advanced the width of the part ploughed each trip. These ploughs are made to travel at five miles per hour.

196 TEDDUTT, CHARLES PRENTICE, Bluntisham, near St. Ives, Huntingdonshire—Designer.

Model farmstead, for 250 or 300 acres; containing stabling for 10 horses, well-sheltered yards for about 40 beasts; cattle-boxes for 16 fattening cattle; cow-house for six cows; pigsties, &c.

197 BELL, FREDERICK & CO., 7 Noble Street, City—Inventors and Manufacturers.

Patent ventilating waterproof cloth for stack, rick, wagon, and cart covers, tents, marquees, sail-cloths, &c., of extreme lightness and pliability, prepared without oil, paint, grease, or tar.

198 ALEXANDER, E., Taylorton, Stirling—Inventor and Manufacturer.

Models of draining ploughs:—

First furrow plough, drawn by from ten to twelve horses, which cuts a depth of from fifteen to eighteen inches, width at top sixteen inches, and at bottom seven inches.

Second, or finishing plough, which cuts a further depth of from ten to twelve inches, finishing the drain to the exact breadth of the tiles, and which, after pulling the cleaner along, shows a flat smooth bottom to lay the soles upon; performing at the rate of about one acre per hour; distance of drains sixteen feet apart.

199 BOYD, JAMES E., 70 Lower Thames Street—Inventor and Manufacturer.

Patent self-adjusting scythe; can be put together without the assistance of a blacksmith, and shuts up like a knife.

200 CABORN, JOHN, Denton, near Grantham—Inventor.

Portable seven-horse power steam-engine, with governors and tubular boiler, for thrashing corn, &c.

Portable thrashing machine, with straw shaker to attach to the portable steam engine, upon four wheels. A corn-dressing machine.

202 DE PORQUET, FENWICK, 11 Twistock Street, Covent Garden.

Models:—Haymaker's horse bay rake, skim plough, dressing machine, turnip cutters, light ploughs, &c. Improved machine for bruising oats, &c. Mill for splitting beans, &c.

204 PANNELL, JOHN, Feltham, Hounslow—Inventor.

Working model of registered heating apparatus, for heating hothouses, pinneries, &c., by hot water; whereby a moist bottom heat and a dry top heat can be obtained at the same time from the same boiler; and the circulation round the pipes, for top heat, can be turned off or on at pleasure.

205 BLAND, JOHN GEORGE, Market Harborough—Inventor and Designer.

A two-knife hand-power chaff-cutter, made by Cornes of Barbridge, with multiplying power, so as to increase the speed of the knives.

Model of a farmstead, adapted for a farm of from six to seven hundred acres. The buildings are so arranged that by the aid of a two-horse power steam-engine the whole of the usual operations required on such a farmstead may be performed.

208 RESTELL, RICHARD, 85 High Street, Croydon—Inventor and Manufacturer.

Metallic flexible garden and conservatory labels. Metallic flexible wall and standard tree-holders.

208A HAYES, M., Enfield Highway—Inventor and Manufacturer. Beehive.

208B BEADON, Capt. R.N., Taunton—Inventor.

Model cart. Improved apparatus for drawing off liquor from casks. Frame for tilting casks.

208C KENNEDY, Dr., Dublin—Inventor. Machine for watering plants.

210 TOBY, HENRY, & SON, King's Road, Chelsea—Inventor.

Model of a green-house, with potting shed and fruit-room, showing the boiler and hot-water pipes, with improved ventilation, &c., on a scale of 1 inch to the foot.

211 THORNTON, DAVID, Ratho, by Edinburgh—Designer.

Design for an arrangement of farm building, in which accommodation is provided for storing the grain crops under cover, in order to protect them from the weather, incendiaries, or thieves.

Model of a cheap form of field-drain, adapted for districts where neither tiles nor stones are available.

212 TYTHERLEIGH, WILLIAM, 350 Coventry Road, Birmingham—Inventor and Manufacturer.

Winter and summer, or self-temperature butter churn.

213 STEWART, CHARLES, & CO., 22 Charing Cross—Proprietors.

Patent potato germ extractor. Anti-putrescent preparation, into which the germs extracted, day by day, may be immersed, until the proper season for planting. Potato-germs modelled in wax, exhibiting the mode of extracting the eye.

214 FERGUSON, J., Bridge of Allan, Stirling—Inventor.

Model of a draining plough.

215 PADWICK, WILLIAM FREDERICK, Manor House, Hayling Island, Hampshire—Inventor.

Hand-drill for depositing garden and other seeds; adapted for patching where seed has failed, for allotments or for rough uneven ground.

Improved planting line, for the purpose of obviating the necessity of setting the ordinary garden-line used in planting at the end of every row. By merely releasing a pin, it changes the position of the line to any required distance.

Improved dibbler, or transplanter, by which seeds may be dibbled or roots transplanted in the driest soil.

215A TYSON, ISAAC, Selby, Yorkshire—Designer.

Model of farmstead and buildings where steam power is used for thrashing, grinding, cutting, and steaming, or cooking food for cattle, pigs, &c.



**216 COLEMAN, RICHARD, Chelmsford—Inventor and Manufacturer.**

Patent drag harrow and scarifier, for breaking up, clearing, and pulverising land. The frame at the top is suspended about six inches above the lower frame, parallel with which, by means of a lever, it is moved backwards or forwards; it is made with five or seven prongs, according to the width of land intended to be cut.

Patent drag-harrow and scarifier, on the same principle, with the addition of side levers, by which it is regulated when used on furrow land.

Patent subsoil harrow, for drawing out furrows, and grubbing or raising the subsoil after the plough.

Patent expanding lever-harrow. This implement is made in four compartments, each three feet, and being constructed on the principle of a parallel ruler, it may be expanded or contracted at pleasure: it is drawn by five chains attached to double hooks which move on the long whippletree.

Patent expanding harrow, constructed on the same principle, but without wheels and levers.

**216A WHEELER, E., 16 Faulkner Street, Manchester—Inv.**

Portable machine for bagging hops, wool, or cotton; pressing the hops without breaking the leaf.

Hand machine for bagging hops, with rack to rise and fall by pinion and double-purchase wheels.

**217 BENTALL, EDWARD HAMMOND, Heybridge, near Maldon, Essex—Inventor and Manufacturer.**

Patent broad-share and subsoil plough, combined in one implement, with beam of wrought T iron. By divesting it of its side-arms, hind-wheels, and tines, it becomes a subsoil and root plough. It can be adjusted according to circumstances, by moving the transverse cutters inserted in the frame. A point, three feet long, precedes the share on the same frame for loosening the ground. This machine is represented in the annexed cut.

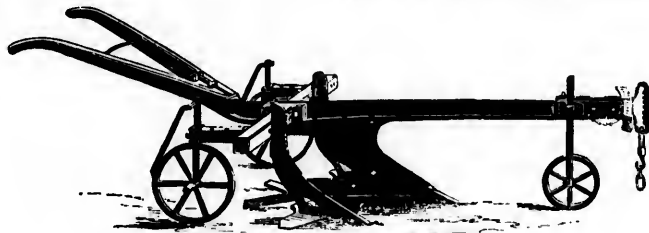

Bentall's Patent Broad Share and Subsoil Plough.



Patent mangold, or ridge hoe, on the same principle, with pair of breasts, for moulding up root crops.

Patent double tom, with wrought-iron beam, having a double breast or mould-board cast in one piece of metal.

Patent N G H plough. A moveable lever, with a share attached in a way which renders it adjustable, and prevents any wear on the sole of the plough.

The original goldhanger plough, called the "Essex plough."

Round hogs' troughs. Stack pillar.

Patent dynamometer, for the purpose of ascertaining the draft of implements presenting irregular resistance. The arrangement of the parts prevents the vibration of the index without diminishing the accuracy of the instrument.

**218 NUNN, J. P. & E. B., 17 Stratford Place, Oxford Street—Inventors.**

Instrument for elevating and holding a beehive immediately under a swarm of bees hanging from a bough; and instrument for grasping and shaking the bough, which, if the hive be held in a proper position, will cause the bees to fall into it, when they may be easily secured.

**219 SMITH, GEORGE, 3 Francis Court, Berkeley Street, Clerkenwell—Prodnocr.**

Registered enamelled garden labels.

**220 WILKINSON, THOMAS, 309 Oxford Street—Improver and Manufacturer.**

Improved Baker's patent mangle; having three rollers, two of which revolve with the linen rolled upon them under the heavily-loaded box, while a third is being pro-

pared with other linen to replace the first and continue the process.

Improved patent box churn. The top or cover has perforations for admitting atmospheric air, and the beater is of the form found by experience to be best calculated for agitating the cream, and forcing the air through it, so as to improve the quality and increase the quantity of butter.

**221 FARLOW, J. K., 5 Crooked Lane, London Bridge—Inventor.**

Netting for protecting fruit and flowers.

**222 SMITH, THOMAS, 1 Hamor Cottages, Harsey Road, Islington—Inventor.**

Hycynth glass, and glass support fixed by glass eyes. Circular earthenware enclosure, and support for the fruit and foliage of the strawberry plant, by which the blossoms and fruit are protected from slugs, and kept free from grit caused by rain. Provisionally registered.

**224 RITCHIE, W. & J., Ardee, Ireland—Manufacturers.**

Improved drill plough. Improved subsoil plough, furnished with two wheels.

**226 ROBERTS, JOHN, 34 Eastcheap—Manufacturer.**

Strawberry tiles. Melon tiles. Grape tiles. Celery sockets. Ventilating flower-pot. Transplanting flower-pot. Flower supporters. Cylindrical brick.

**227 VIVIAN, —, Inventor.**

Model machine for drying corn.

**228 SCRAGO, THOMAS, Turporley, Cheshire—Inventor and Manufacturer.**

A double-action machine for making draining-tiles and pipes. It has, as a substitute for racks and pinions, a chain which winds round a roller, and presses the clay through the dies.

**230 BARKER, JOHN, Dunnington, near York—Inventor and Manufacturer.**

Iron wheel-plough and wood swing-plough. Expanding parallel horse-hoe, with a Norwegian harrow

attached, and two sets of coulters; made to expand and contract, so as to suit either curved or straight ridges.

Iron sliding horse-hoo, with shares; adapted for different soils; with wheels and Norwegian harrow attached.

One-horse Yorkshire cart, with a tipping apparatus; side-boards, as a manure cart; and a set of shelvings, for harvest work; the spring end door secures the shelvings. Set of box whipple-trees, or two-horse draughts.

232 ENNISKILLEN, Earl of—Manufacturer.  
Draining pipes and collars. Draining tiles. Water pipes. Roofing tiles. Flooring tiles.

233 HORNSBY, RICHARD, & SON, *Spittlegate Iron Works, near Grantham*—Manufacturers, Designers, & Inventors.

Patent drill-machine, for corn, &c., adapted for hilly ground, and fitted as a ten-row corn and seed drill, and nine-row corn, seed, and manure drill.

Ten-row patent corn and seed drill, fitted with the patent India-rubber tubes for conducting the seed to the coulters; Improved slides for regulating the quantity of seed to the delivering barrel; two coulters-bars to equalise the pressure upon each coulters; and patent independent fore-carriage steering, represented in the annexed cut.

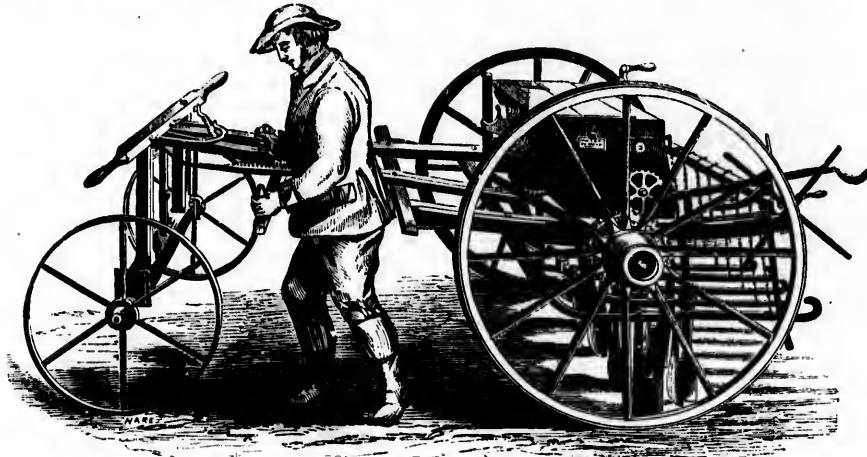

Hornby's Patent Seed Drill.

Four-row patent drill, to deposit turnip or mangold-wurzel seed, with bones, compost, and manures, with double-action levers, represented in the annexed cut.

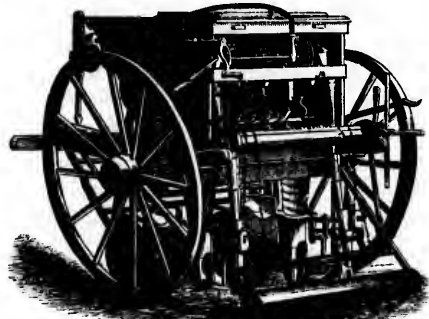

Hornby's Patent Manure Drill.

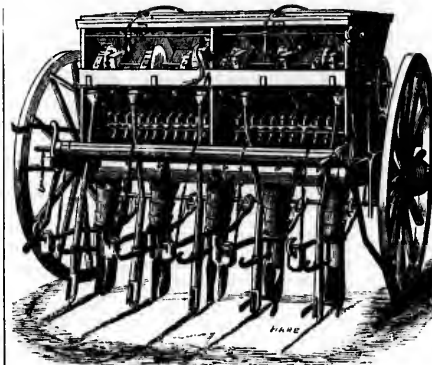

Hornby's Patent Drill Machine.

Six-horse power patent portable steam-engine, adapted for thrashing, grinding, sawing, pumping, &c.; mounted upon four carriage-wheels, with shafts complete for travelling. The cylinder, and pipes connected therewith, being placed inside the boiler or steam-chamber, are protected from the weather; represented in the following cut.

Four-horse power improved portable thrashing-machine, with travelling apparatus complete.

Patent corn-dressing or winnowing machine, fitted with a spike-roller working through a grating, so arranged as to form a hopper. It may be used for separating the corn

ected on the same  
ers.

t, Manchester—Inv.  
wool, or cotton;  
e leaf.  
rack to rise and  
eels.

Heybridge, near  
manufacturer.  
h, combined in one  
iron. By divesting  
ines, it becomes a  
adjusted according  
verse cutters in-  
long, precedes the  
the ground. This  
cut.



rst and continue

or cover has per-  
and the beater is  
est calculated for  
through it, so as  
quantity of butter.

London Bridge—

rs.

, Hornsey Road,

nd by glass eyes.  
support for the  
t, by which the  
slugs, and kept  
ally registered.

Manufacturers.  
subsoil plough,

manufacturer.

e tiles. Celery  
planting flower-  
ack.

—Inventor

aining-tiles and  
and pinions, a  
resses the clay

—Inventor

h.

wegian harrow

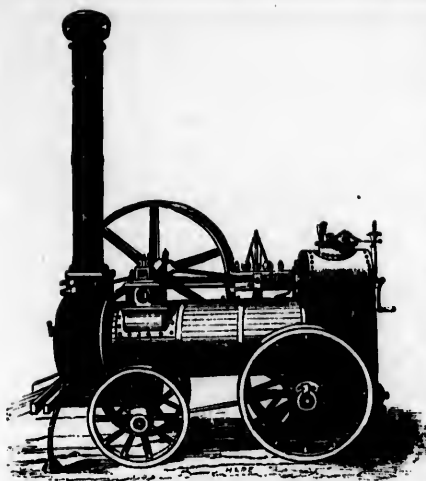

Hornaby's Patent Six-horse Power Portable Steam-engine.

from the chaff, in the rough pulpy state, as it comes from the thrashing-machine, without having been previously riddled. It is fitted with a double-shaking screen at the bottom, &c., for cleaning the corn from all kinds of small seeds, and preparing it for market. Represented in the annexed cut.

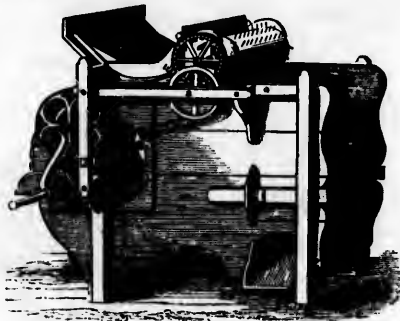

Hornaby's Patent Corn-dressing Machine.

Double crushing machine, for breaking oil-cake for beasts or sheep, and rape-cake for manure; fitted with two sets of cutters, with hardened points.

Single crushing machine, fitted with one set of cutters.

234 SMITH & Co., *Stamford, Lincolnshire*—Inventors and Manufacturers.

1. Double-action wrought-iron hay-making machine, for spreading and turning hay; fitted with wrought-iron wheels.

2. Two-knife cane-top litter and chaff-cutting machine, for hand, horse, or steam power.

3. Iron balance-lever horse-rake, for hay, corn, &c.

4. Lever hand-rake, in iron frame, and mounted on very light wheels; the teeth, made of spring steel, act independently of each other.

5. Three-knife gorse and chaff-cutting machine, for hand, horse, or steam power.

6. Improved lever cultivator or scarifier.

7. Fat-cutting machine, for tallow-melters.

8. Park or luggage cart, mounted on springs, with patent tall-board, tip movement, and wrought-iron wheels.

9. Wrought-iron wheels and axles for light and heavy carriages.

10. Set of machine models.

Patents have been taken by the exhibitors for Nos. 1, 2, 3, 4, 5, 8, and 9.

235 CHARD & MUNRO, *Bristol*—Manufacturers.

Light one-horse harvest cart, of an improved construction. The advantage consists in its being kept low, for the diminution of labour in loading.

Light cart, for pony or small horse, adapted for an errand or market cart. Light Cobourg.

237 KEY & MITCHELL, 103 *Newgate Street*—Proprietors or Agents.

Patent American churn (English) by Charles James Anthony, of Pittsburgh, U. S.; the improvement consists in the arrangement of apparatus so as to introduce a larger quantity of air into the cream or milk.

Kase's force and suction pumps. The valves are so arranged, as to prevent them from being choked; and, if occasion should require, a common blacksmith could replace them.

Patent double-acting turnip-cutter, for cutting turnips, mangold wurzel, &c., as food for cattle or sheep; also applicable for cutting chicory; the knives with the greatest cutting surface, represented in the annexed cut.

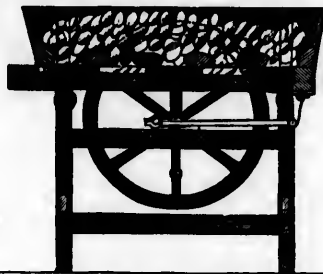

Messrs. Key and Mitchell's Patent Double-acting Turnip-cutter.

Hose for liquid manure, fire-engines, and shipping purposes, made of canvas, lined and coated with gutta percha.

Registered union joint, for connecting lengths of hose, made of gutta percha.

Lift pump, made entirely of gutta percha, for acids, liquid manure, &c.; manufactured by the Gutta Percha Company.

Davy's patent India-rubber elastic and water-proof saddles and collars; the former affording a firm seat to the rider on an elastic material; the latter, as well as the former, protecting horses from being wrung in the shoulders, back, withers, &c.

238 CAMBRIDGE, WILLIAM, *Temple Gate, Bristol*—Inventor and Patentee.

Patent press-wheel roller, or clod-crusher, composed of wheels with thin cutting edges, revolving separately on a round spindle; used for lands affected with wire-worm or slug, leaving the land so firm that they cannot work through.

239 WHITEHEAD, JOHN, *Preston, Lancashire*—Inventor and Manufacturer.

A machine for the manufacture of draining-pipes and tiles, with screening apparatus for separating stones and roots from the clay. It will make pipes or tiles of any

ON THE SOUTH SIDE : AREAS N. O. 1 ; P. Q. R. 1 to 27.

form or size, from 1 to 15 inches in diameter, and of any length to 27 inches.

New machine for making and pressing bricks.  
 Drain-pipe and tile-machine, with a clay-box at each end, so that tiles may be made at one end and clay screened at the other, or vice versa.

240 HOWARD, THOMAS & FREDERICK, *Belford*—  
 Inventors and Manufacturers.

Patent iron plough, with two wheels, marked X, of a small size, made principally of wrought-iron, and intended for ordinary ploughing, to be used with a pair of horses. The annexed cut represents this plough.



Howard's Patent Iron Plough.

Patent iron plough, with two wheels, marked XX. The moving and cutting parts of this are the same in principle as the former, but fitted for deeper cultivation and for stronger lands.

Patent iron plough, marked XXX. This plough is of large size, and intended for extra deep ploughing. Every part is made so strong as to resist large stones or roots. It is also fitted with mould boards or breasts, which turn the furrows over round in the same manner as the Kentish turn-wrist plough.

Patent iron plough, with two wheels, marked J. A. fitted with a furrow-turner, and a novel appliance to the wheels, by which the depth of furrow may be regulated whilst the horses are in motion.

Patent iron swing-plough. Intended to be used without wheels, made with wrought-iron framework, &c.

Patent iron double breast or moulding-plough. Intended for earthing up or forming ridges or bouts, for turnips or other roots, or for striking water furrows.

Patent subsoil-plough.

Patent double-furrow plough. This plough is like two ploughs made into one, for the purpose of ploughing two furrows at one time, and is used upon light land with three horses abreast, and one man.

Set of patent iron harrows. This set consists of three 4-beam harrows with whippetree; covers 9½ feet of ground, and is intended for two horses. The annexed cut represents these harrows.

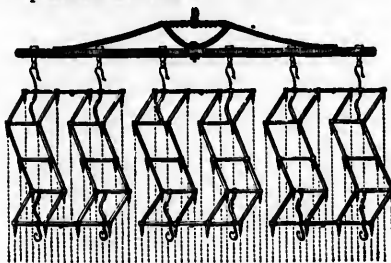

Howard's Patent Iron Harrows.

Set of patent iron harrows. This set consists of three 3-beam harrows with whippetree, covers 8 feet of ground, and is intended for two horses.

Set of patent jointed harrows. Pair of patent drag harrows. These are used on rough fallows, and are made to draw backward and forward: the latter way to answer the purpose of a scarifier; the former for breaking clods.

Patent horse rake, intended for raking hay, corn, stubble, or twitch grass. The draft irons are furnished with a joint and quadrant, by which the teeth may readily be altered, so to rake upon their points, or set more or less off the ground.

Improved double-action corn-mill, intended for kibbling or grinding into fine meal, barley, oats, malt, &c., and by simply reversing the motion of the fly-wheel, it will split beans or peas at a rapid rate. It is fitted to be driven by horse or steam power, but it can be worked by hand.

Improved horse-power gear-work, intended for driving the corn-mill and other machines requiring horse power.

Set of trussed whippetrees, intended for ploughs, harrows, &c., where draught bars are required. Sundry fittings for the plough, &c., and models of implements.

241 HOLMES & SONS, *Prospect Place, Norwich*—  
 Inventors and Manufacturers.

Machine for thrashing grain, and shaking the straw after it is thrashed; the concaves can be adjusted to any width parallel, and at three different points, by a new arrangement of eccentrics; the drum and concaves are made so as not to injure any grain. Represented in the annexed cut.

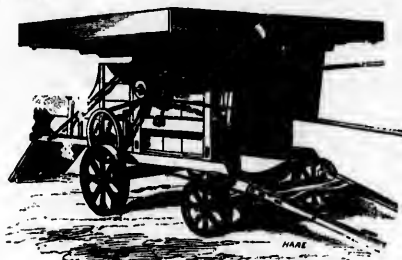

Holmes's Thrashing Machine.

Machine for all purposes of drilling.  
 Machine for the purpose of sowing broadcast or in rows, any kind of artificial manure, as top-dressing, either in a moist or dry state, such as guano, nitrate of soda, salt, soot, &c.; fitted with the registered wheels, slides, &c., by which a sliding motion as well as rotary is given to the stirrers: with other improvements. Represented in the annexed cut.

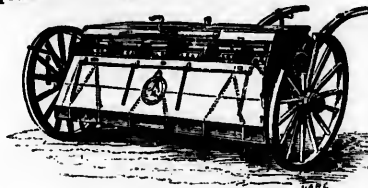

Holmes's Manure Sowing Machine.

Registered horse-lever rake for gathering hay and corn; it may likewise be used for couch or stubbles.

Machine for drilling turnips and mangelwurzel seeds, with or without manure, either on the ridge or flat.

Barley aveller, or hummelling machine, for taking off the haulms of barley. The spindles are made to work quite through, admitting an extra crank at the lower end, which, running in half boxes, can be screwed down as it wears, with other improvements.

Corn-dressing, or winnowing machine. The spindles are made to work in half brasses, which are placed in a strong iron frame.

Hand-barrow drill, for depositing two rows of turnips, mangelwurzel, and carrot seeds, on the ridge or flat, and at any required distance.

Newly invented machine for sowing grass seeds, to be worked by hand.

Turnip and mangelwurzel, and manure-drilling machine, with one lever, fitted with two boxes, one for manure and the other for turnips and mangelwurzel seeds, &c.

One-row lever drill for turnips and mangelwurzel seeds, adapted for ridge ploughed lands or flat work.

Turnip and mangelwurzel cutter, which can be altered in a few minutes to cutting for beasts or sheep.

242 CLAYTON, SHUTTLEWORTH, & Co., Lincoln—  
Manufacturers.

Six horse-power portable steam-engine, of an improved and simple construction, mounted upon four wheels, which, from its extreme lightness, is easily moved from place to place; the whole arrangement is simple and compact. It has a starting lever and safety valve (which are acted upon by Salter's spring balance), a water and steam gauge-cock, feed-pump, and steam whistle, all within reach of the driver, and is well adapted for agricultural, builders', and contractors' purposes, such as threshing, grinding, sawing, pumping, &c. The annexed cut represents this steam-engine in the state in which it is ready for use. Power is communicated by a leather band round the fly-wheel, or the pulley on the other side of the fly-wheel.



Clayton and Shuttleworth's Six Horse-power Portable Steam-engine.

Improved registered grinding-mill, suitable for all grain, consisting of a pair of portable registered French mill-stones, 2 feet 8 inches in diameter, adapted for steam or for water-power, and are fixed in a metal cylindrical frame. This arrangement is represented in the annexed cut.



Clayton and Shuttleworth's Mill.

Improved registered combined thrashing, saking, riddling, and blowing-machine. The annexed cut represents this machine.



Clayton and Shuttleworth's Threshing Machine.

The chief novelty in this machine is the registered vibrating trough, which is suspended by four links, and extends the whole length of the machine and straw-shaker, having a reciprocating motion given to it by means of a crank. But by means of the vibrating trough, the whole quantity of the pulse, as it drops from the thrashing-drum and straw-shaker, is caught and passed over a riddle under which the blast is directed; thereby effectually separating the corn, chaff, and pulse from each other, each being discharged into the places assigned for them.

243 MARRIOTT, JOSEPH, 74 Gracechurch Street—  
Designer and Manufacturer.

New cottage beehive, for obtaining honey without destroying the bees. Bell glasses of honeycomb, as worked by the bees from the same. Glass box of honey, as specimen of finished and unfinished comb. Glass jars of pure run honey granulated. Clarified honey. Specimens of queen and other bees. Improved beehives, &c.

246 WEST, WILLIAM, Leicester—Inventor and  
Manufacturer.

Drill, for sowing corn and turnips. Hand seed-drill, to work with cups; and for sowing turnips, mangelwurzel,



ON THE SOUTH SIDE : AREAS N. O. 1; P. Q. R. 1 TO 27.

onions, or grain, peas, &c., either on the ridge or on the flat, and in any given quantity.

248 **M'CARTNEY & DRUMMOND, Cumnock**—Designers and Manufacturers.

Threshing-machine, in cast-iron framing, with riddles, fans, and elevators. The riddle is placed under the machine. The grain is raised by elevators to the fans placed on the top of the machine for dressing the grain. It has an improvement for shifting the rollers and drum-cover, by a hand-wheel and levers in front, to suit the different kinds of grain.

Improved construction of horse-wheel, and other parts of gearing, for safety to machinery from a sudden start of the horses; also for preventing the drawing shafts from coming on the horse, when stopped, by the velocity of inside machinery.

A peg-hummeller, for threshing barley.

The fans, though placed on the top of the machine, can be placed in the granary above, or under it, when more convenient.

248A **WEEKS, J., & Co., King's Road, Chelsea**—Inventors and Manufacturers.

Cylindrical revolving furnace bars, consuming the smoke, and diminishing the consumption of fuel. A slow rotary movement is given to each of the cylinders, which presents cool bars to the heat of the fire about every fifteen minutes, and equally distributes the fire throughout the furnace.

Model of an ornamental conservatory, with improvements in ventilation. This conservatory is represented in the annexed cut.



Weeks and Co.'s Conservatory.

Boiler, for rapidly heating water.

Glazed light, for a common forcing-house or pit; of new construction, with improvements in ventilation.

Pedestal, for warming buildings by hot water, exposing a heating surface of 70 superficial feet.

Stack of pipes for warming buildings by hot water, exposing a heating surface of 50 superficial feet.

248B **THOMPSON, HENRY A., Leves**—Manufacturer.

Set of improved entrance gates, with cast-iron piers, constructed upon improved principles: they are composed of iron and wood, without mortice, mitre, dovetail, nail, screw, cement, or glue, and combining strength with durability. They are trussed-braced with salter crosses between uprights, with bevelled abutments, similar to the king-post which supports a barn roof.

The plan of these gates prevents their dropping from long wear or ill usage; and their power of resistance is very great. They are hung to, close by themselves, and the mountings are of peculiar construction; the upper ride hook oscillates to adapt itself to the position of the gate, and the lower joint is a combination of levers to produce an elliptical and eccentric motion, necessary to make the gate shut itself: in the latch, is a friction roller, and a secret fastening to enable it to be locked with a key. These improvements enable them to swing without sustaining that severe shock in their oscillating motion, when they arrive at the centre, as in gates hung on the common method.

Portable steam cooking apparatus, for cooking all kinds

of vegetables, linseed compounds, cut-stuff hay, &c. It consists of a cylindrical steam-generating boiler, with dome top, supported on iron legs, between which is an iron ash-pan, containing water to prevent danger from sparks, &c. On one side of the boiler is placed an iron cooking vessel, with perforated double bottom, for steaming vegetables, which is supported on centre gudgeons, so that the contents may be tipped into a wheelbarrow or other receptacle without dismantling the vessel. There is also attached to the boiler, a patent compound tube for cooking linseed, compost, or for boiling water. On the opposite side is a syphon pipe, dipping near to the bottom of cooking compost in the tub, through which the waste steam passes; the agitation occasioned by this supercedes the necessity of stirring.

Set of cast-steel measures for corn, seeds, &c., from a quart to a bushel; intended to supersede wooden measures. The top of each is strengthened by a steel hoop, which is hardened, to prevent wear; enclosed by this hoop, and visible on the inside, is a copper medallion, to receive the inspector's stamp.

Portable liquid manure-forcing pump, agricultural fire-engine, and irrigating machine, with an air-vessel upon a peculiar principle, and arranged on an iron wheelbarrow.

Portable pump or tripod-stand, adapted for raising liquid manure or water out of tanks, ponds, &c. The hose-pipe is made of patent vulcanised India-rubber: it has a helical wire-spring running through its entire length, to prevent it from collapsing; and at the end is a strong copper strainer. The pump has a metallic bucket, and metal seats to all the valves. The valves are all formed of vulcanised India-rubber, with metal tops; and the bucket packing of gutta percha.

249 **WILSON, JAMES, Kelso, Roxburghshire**—Designer.

Model of an improved seed-box for a turnip-sowing machine.

250 **BROWN & ARCHBOLD, Horsley, Tyne Side, Newcastle-upon-Tyne**—Inventors and Manufacturers.

Miniature model machine for cleaning corn and grain.

252 **PHILLIPS, CHARLES, & Co., Baptist Mills Foundry, Bristol**—Manufacturers.

Patent turnip-cutter, to cut for sheep by turning it one way, and, by reversal of motion, to cut for other purposes. In this machine the knives that cut for sheep have an oblique edge; there is a grating under the barrel of the machine, by which the last piece of each turnip is prevented from escaping unalut; and the hopper has a rocking motion, by which the wedging-up of the turnips is prevented.

253 **FLEMING, GEORGE, Trentham, Newcastle-under-Lyme**—Inventor.

Machine for destroying weeds, moss, lichens, &c., on gravel-walks, court-yards, &c., it consists of a boiler, holding 30 gallons of water, with a furnace and iron-pipe chimney, and moves upon three broad wheels. In every gallon of water about 2 lbs. of common salt are dissolved; the mixture, when in a boiling state, is applied to the walks, &c., through a horizontal tube fixed behind the machine, under the furnace door.

254 **RALSTON, W., Malletsheugh, Newton, Renfrewshire**—Inventor and Manufacturer.

Machine for winnowing all kinds of grain; with a cloth and revolving brush, for separating the grain from burrs.

255 **STOKES, WILLIAM, Dean, near Shepton Mallet, Somerset**—Inventor.

Treble cheese-press, and curd-mill.

255A **SIEBE, AUGUSTUS, 5 Denmark Street, Soho**—Inventor and Manufacturer.

Patent rotatory garden and house fire-engine pump, with improved hose and jet. This apparatus is shown in the following cut.



Siebe's Patent Rotatory Garden Pump.

250 SMITH, JOHN, *Abcote Iron Works, Uxbridge*—  
Inventor.

Patent chaff-cutter, cylindrical iron sifter, thrashing-machine, barley hummeller, oat and bean mill, iron skin plough, winnowing machine, turnip-cutter, &c. This machine is represented in the annexed cut.

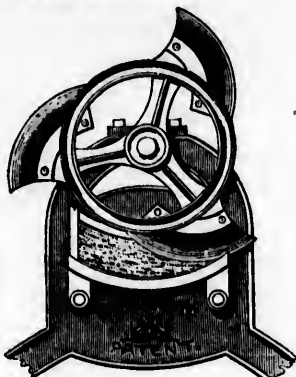

Mr. J. Smith's Patent Chaff-cutter.

The novelty claimed for this machine consists in placing the axle upon which the knives are fastened within the range of the long way of the mouth-piece, instead of the short way, as in others; thereby placing the shaft directly over the work, and having the weight of the fly-wheel upon the stuff. The friction on the bearings is thus reduced, and the active power of the knife is increased.

257 WARREN, JOSEPH, *Heybridge, near Maldon, Essex*—  
Inventor and Manufacturer.

Novel regulation ploughs.

Turn-wrist or perpetual furrow plough, to turn the land or furrows all in one direction, and dispense with all waste of open furrow.

Adjustable screw plough. Revolving calendar roll.

Hand machine adapted for hoeing all kinds of corn and root plants, mounted on wheels.

Broad share or triangle plough, for top cleaning and paring off the weeds, and general cultivation.

Alarm gun, giving four distinct reports, which may be heard at a considerable distance.

Spring alarm. When placed in a box, it works a rick wheel, and communicates with a bell, on which is fixed a wire, that causes it to ring by the lightest touch.

Skin plough for hoeing and cleaning land.

257A JOHNSON, THOS. (with Mr. KINNEAR) *Newcastle-upon-Tyne*—Inventor.

Model of a machine for sowing wheat and barley, with a harrow attached.

258 McPHERSON, P., *Norton Place, Edinburgh*—Importer.

Improved mill for breaking, skutching, and preparing flax, and adapting it for hackling.

250 SPURGIN, JOHN, M.D. *Guldford St., Russell Square*.

Double hoe. Shark's-tooth-shaped hoe and spud.

250A WINTON, H., *Birmingham*—Manufacturer.

Spades and other agricultural implements.

250B BURCHAM, CHARLES, *Heacham, near Lynn*—  
Inventor and Manufacturer.

Model of a steam and hand-power tillage machine and irrigator.

250C HAY, JAMES, *Florabank, Haddington*—Inventor.

Implement for cutting turnips for sheep and cattle.

202 SEAL, S., *Wakefield*—Manufacturer.

Scythe-stones. Grindstones.

202A CRAIG, JAMES, & CO., *Paisley*—Manufacturers.

Various sizes of drain pipes and tiles, for field drainage, manufactured from common clay.

202B ROWBOTTOM, JOHN, *Halifax*—Inventor.

Beehive, or beeskip, with ornamental embellished pedestal, for taking honey without destroying the hive or bees.

203 DIGGES LA TOUCHE, REV. THOMAS, *Killenaule, Ireland*—Inventor.

1. Model of a cart, made without mortises.
2. Model of a carriage, which admits of high fore-wheels, turning on their own centre; and requires no private bolt.
3. Model of a grubber, pulverising to the depth of 15 inches.
4. Model of a harrow, on wheels, intended to clear the ground of weeds.
5. Model of a scuffler, of light draught, for cleaning between green crops.
6. Model of a turnip-dibbler.
7. Apparatus for making butter without handling.
8. A ball-iron, which leaves the ball at the root of the tongue, without startling the horse.

204 LOW, ALEXANDER, *72 Orerigate, Dundee*—Inventor.

A mouth-bag for horses; the front being made of net or gauze-wire.

Double water-furrow roller plough, having the roller placed on the bottom of the stilt behind the double mould boards, and a bulge on the centre to form the water furrow, and also to press down the sides of the furrow, making the ridge broad, and the water furrow narrow.

205 DANIELL, J. C., *Simpley Stoke, near Bath*—  
Producer.

Samples of manure and food for cattle.

206 SMITH, ALEXANDER & WILLIAM, & CO., *Woodside Works, Paisley*—Inventors and Manufacturers.

Registered centrifugal churn for making butter. The novelty consists in the milk being drawn up from the bottom by the velocity of the cone or disc, and thrown out at the top, in broken portions, with great force, so that none of the milk escapes thorough agitation. These machines are constructed to churn from 5 to 100 gallons. New steaming apparatus, for preparing food for horses, cattle, &c. The boiler and vessels are of malleable iron. Corn and bean-bruising machine.

ON THE SOUTH SIDE: AREA N. O. 1; P. Q. H. 1 TO 27.

Hay and straw cutting-machine.  
Cart and cattle weighing-machine; showing the weight of cattle and sheep, and farm produce, from 1 lb. to two tons. It is contained in a cast-iron case.  
Jack weighing-machine, for barn purposes, to weigh from 1 lb. to three cwt.  
Model of water-wheel and sugar-mill.

267 GRANT, JOSEPH COOKE, *Stamford*—Inventor and Manufacturer.

Patent lever horse-rake, for collecting hay, corn, stubble, twitch, &c.

Patent lever pony-rake.

Pair of patent lever self cleaning harrows.

Lever horse-hoe.

Implements with improvements:—

Haymaking machine.

Three-knife chaff machine.

Two-knife chaff machine.

Weighing-machine, with wrought-iron beam.

Iron ploughs for heavy and light land.

Iron tube whippetrees for four horses.

Light-iron tube whippetrees.

Wooden whippetrees.

New garden drill for sowing garden seeds.

Mill for grinding beans.

Uley cultivator, with wrought-iron frame.

Norfolk dock or thistle extractor, in iron and wood.

Linseed corn and bean mill.

Norfolk hand-drill, for sowing turnips when the crop has partially failed.

Sundry models.

268 STUART, J., *Aberdeen*—Designer and Manufacturer.

Two-horse plough, adapted for either double or single mould-board, with shifting coulter.

Two or three horse double or single mould-board plough, convertible into a subsoil plough.

269 JONES, C. E., B.A., *Birk House, Huddersfield*—Co-inventor.

Double cottage beehive, with regulating doorway in the floor-board, invented by the exhibitor.

Specimen of the adaptation of the common cottage straw hive to certain improvements, made also by the exhibitor.

Double rim for enlarging the double cottage beehive previous to swarming; with an improved method of obtaining virgin honey in the comb without disturbing the bees in the parent hive; invented by J. Beaumont, Netherton, near Huddersfield.

269A FORBES, R. B., *Glasgow*.

A Scotch farm cart.

269n SANDERS, S., *Birmingham*—Manufacturer.

Improved garden spades, draining tools, and shovels.

270 SMITH, WILLIAM, *Kettering, Northamptonshire*—Inventor and Manufacturer.

Improved double-blast winnowing machine, for dressing corn and seeds. A portable board is turned back on the hopper, so that it gives the rollers the power of pulling the corn in a rough state through from the thrashing machine, without stoppage.

New horse-hoe, simple in construction, and principally formed of wrought iron. It is drawn with shafts; and the wheels may be expanded or contracted, so as to be kept between the rows of the plants.

A similar machine for hoeing on the ridge or on the flat.

271 TURFORD & SONS—*Boston and Skirbeck Iron Works, Boston, Lincolnshire*—Manufacturers.

Patent six-horse power portable housed steam-engine, for thrashing, grinding, sawing, pumping, and general agricultural purposes. The improvement consists in arranging the working parts, and enclosing them in a box or house, to protect them from the grit and dirt of

farm work, from the weather, and from all improper interference, by being locked. The cylinder being upright, it will not wear oval as when placed horizontally.

Four-horse power engine, on the same principle as the preceding.

272 PLENTY, J. & E. PELLEW, *Newbury, Berks*—Inventors and Manufacturers.

Four-horse power portable thrashing machine to thrash on its wheels.

Machine for pressing or bagging hops.

274 FERRABEE, JOHN, & SONS, *Phenix Iron Works, Stroud*—Manufacturers.

Chaff-cutter, with the knives set obliquely, and having serrated edges; also, for cutting hay, straw, &c.

Patent grass-cutter, for cutting the grass on lawns, pleasure grounds, &c., represented in the annexed cut.



Ferrabee's Patent Grass-cutter.

Set of registered screw-wrenches.

275 LOMAX, WILLIAM ROTHWELL, *Birmingham*—Inventor and Patentee.

Patent chaff-cutter. The novelty of this machine consists in the position of the shaft or axis upon which the knives are fastened; this being within the range of the long way of the mouth-piece, gives the knives about six times the usual amount of draught, and causes them to cut, instead of chopping. The weight of the fly-wheel is directly upon the stuff, which reduces the friction upon the bearing, and renders the cut lighter. The shaft has a bearing on both sides of the knives, so that they cut clear.

Patent turnip-cutter.

277 UFFELL, E., *Birmingham, Warwick*.

Wrought-iron sheep-fold.

Hay-rack for feeding sheep.

Improved apparatus for melting pitch and tar.

Tree guard.

278 RICKMAN, W. C., *21 Park Side, Hyde Park Corner*—Inventor.

Farmer's level.

(In North Transept Gallery.)

290 NEIGHBOUR, GEORGE & SON, *127 High Holborn*,—Inventors and Manufacturers.

The improved cottage beehive working bell-glasses, from which a glass of the purest honey may be taken during the most vigorous period of the gathering season without injury to the bees. It consists of a stock-hive,

having three windows, with a thermometer affixed across the centre one.

The ladies' observatory hive, made of stout glass, with a cover neatly made of straw; adapted for advancing and perfecting the knowledge of the habits and economy of the honey-bee.

The improved single-box hive, constructed on similar principles to the former; furnished with a ventilator between the stock-hive and the glass above; thus effectually preventing any impurity of the honey deposited therein.

Natt's collateral hive, for the humane management of

honey-bees, and from its construction obviating the necessity of swarming.

Taylor's amateur's beehive, consisting of three boxes, with bars fitted at proper intervals, thus rendering available each comb for separate extraction.

Specimens of honey and honey-comb taken from the above in 1850.

Newly-invented bee-feeders, made of zinc, glass (with a supply fountain), wood, &c.

Honey-cutters or bee-knives, &c. Also, closely adjoining the group of unantanted beehives are three living hives, with the bees industriously at work.



Neighbour's Cottage, Observatory, and other Beehives.

291 MILTON, JOHN, 10 Great Mary-le-bone Street—  
Producer.

The "Royal Alfred Hive." This is the centre hive in the annexed illustrations. This hive is conveniently

adapted for the purpose of taking the honey without destroying the bees; and is suitable for the conservatory, library, or any room where the sun's rays come during some portion of the day.

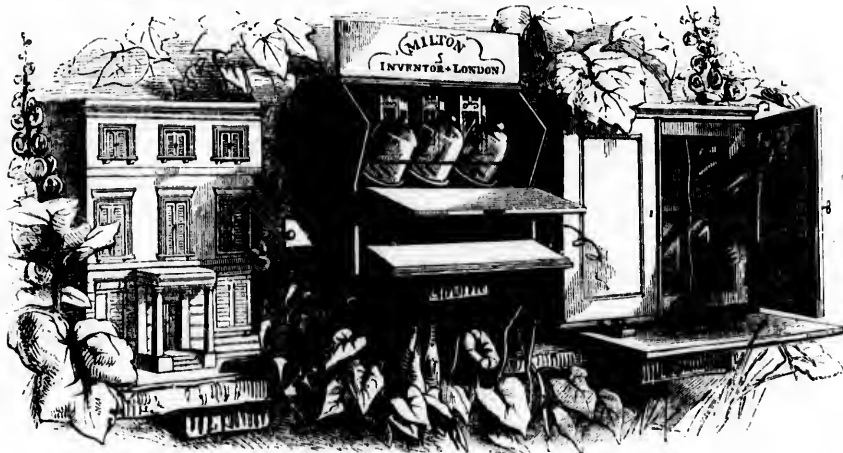

Milton's Bee-Hives.

The Town Mansion Hive. The inmates of this hive consist of four first swarms of July, 1850, from four distinct families or stocks of bees; thus demonstrating that a very considerable number of bees from various queens will work together in perfect harmony. They have

been kept until now in a secluded spot bordering upon a henth.

The Unicomb or Mirror Hive. The "unicomb," or one-comb hive, is so constructed that the movements of every bee can be observed.

ON THE SOUTH SIDE: AREAS N. O. 1; P. Q. R. 1 TO 27.

In addition to the bees contained in the glass case, are various beehives made of cork, wood, and straw. There are also models of beehives and apiaries, and a glass of honey gathered in the year 1837. This specimen is exhibited to prove the extraordinary length of time pure honey can be preserved. It weighs 26 lbs.

Bar and frame hive, invented by William Augustus Munn, Esq., Throwley House, near Feversham, Kent.

The advantages claimed consists in the whole of the interior of the hive being open to inspection at any moment,

and a choice can be made of the combs containing the most honey, &c., and this without the assistance of smoke, as each bee-frame, and the bees and combs contained in it, can be drawn up and examined in the observation frame (as shown in the adjoining sketch) without interfering with any other part of the hive, or occasioning the loss, or even escape of a single bee. The hive is shown in operation, with the comb brought into the observation frame; one frame is also seen through the side of the box, to show how it is suspended in the triangular case.

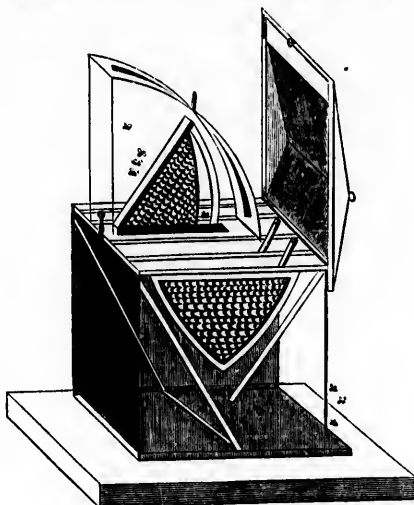

Munn's Bar and Frame Beehive.





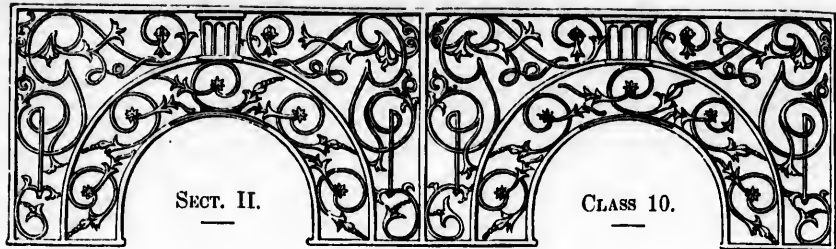

## PHILOSOPHICAL, MUSICAL, HOROLOGICAL, AND SURGICAL INSTRUMENTS.

### INTRODUCTION.

THE advance of physical science receives its illustration in a variety of directions among the objects collected together under this Class. The progress of experimental philosophy may be gathered, in a degree, from the perfection of the instruments it employs; for while it is certain that in some sciences much has been accomplished by the aid of rude and imperfect means, it is equally true that in others the perfection of the apparatus is essential to that of the knowledge sought to be established by deductions drawn from its indications. The delicacy of a balance is necessary to the accuracy of a chemical experiment, and therefore to that of the facts it is used to develop, as also is the achromatism of a microscope, or a photographic lens to the development of the optical images, and to the results sought to be obtained therefrom: chemistry, microscopical sciences, and photography, are consequently largely dependent for their progress upon the instruments by the use of which they are to proceed. The same cannot be said of surgical instruments, for in their use the operator may command success by his skill, notwithstanding the imperfections of his apparatus. Nevertheless, the present state of surgery, and the attention bestowed upon it, may be gathered from the inspection of the refined and complicated apparatus offered for its advancement. As one of the results of the splendid and enduring system of knowledge, and of its pursuits—promulgated by Bacon in the "Novum Organon," the system since called Experimental Philosophy—objects in this Class wear a peculiar interest, representing the means employed by man for the establishment and development of inductive science.

This Class includes instruments employed for a variety of philosophical purposes; it also comprises musical, horological, and surgical instruments and apparatus. It may consequently be considered under three Sub-Classes. The first comprehends—A. Instruments for the measurement of space, such as Transit Instruments, Quadrants, Sextants, Telescopes, Microscopes, Theodolites, &c.; B. Instruments to measure the effects of mechanical and physical forces, as Dynamometers, Balances, Thermometers, &c.; C. Instruments to illustrate the Laws of Mechanical and Physical Science; D. Application of mechanical and physical science to useful purposes not included in any of the preceding or subsequent sections, such as instruments connected with Mechanics, Sound, Light, Heat, Magnetism, and Electricity; E. Comprehends Chemical and Pharmaceutical Apparatus. The Sub-Class, Musical Instruments, comprises—A. Wind Instruments, in wood and metal, as Flutes, Bassoons, Horns, Trumpets, &c.; B. Stringed Instruments, as Harps, Guitars, &c.; C. Keyed Instruments, with fixed tones, such as Organs, Pianofortes, Accordions; D. Instruments of percussion, as Drums and Cymbals; E. Automatic Instruments; and F. Miscellaneous articles in connexion with musical instruments. The Sub-Class, Horology, contains—A. Great Clocks for Churches and Public Buildings in general, including Electric or Magneto-Electric Clocks; B. Astronomical Clocks; C. Clocks applied in registration. D. Clocks showing different phenomena; E. Clocks for ordinary purposes; F. Clocks of an ornamental description; G. Sundries applicable to clocks; H. Marine Chronometers; I. Pocket watches of various descriptions; J. Watches for different markets. The remaining Sub-Class, Surgical Instruments, includes a variety of apparatus adapted to the performance of operations in different parts of the human body, together with the philosophical apparatus employed by the surgeon in the investigation and treatment of disease. It also embraces the instruments employed in Veterinary Surgery.

The large astronomical telescope in the Nave, mounted upon a stand, having equatorial movements and complete adjustments, is an interesting member of this Class. It is a refracting instrument, and possesses an object-glass nearly 12 inches in diameter. Telescopes of a smaller calibre, and adapted for different purposes, are also exhibited near it. But the general arrangement of the objects representative of this Class is to be sought in the Central North Gallery. This gallery is reached by ascending the stairs near the North Transept. On entering it, and proceeding past the articles in glass, which are also placed here, the commencement of this Class is met with at Area I. 22. From this point it extends to the western termination of this gallery. The interspace between the North and South Central Galleries is also devoted to it, and a portion of the South Central Gallery, from M. 3 to M. 8, contains various articles included in this Class. Proceeding westward, in the Central North Gallery, musical instruments are first encountered, including a variety of organs, harps, pianos, &c. Succeeding to these are philosophical instruments, electric telegraphs, daguerreotype apparatus, and specimens of photography: beyond are globes and astronomical apparatus. In the South Central Gallery are watches and clocks. A part of the North Gallery, devoted to surgical instruments, and occupying the space between F. 15 and F. 21, also belongs to this Class.



GICAL

The science of horology is illustrated on the great as well as on the small scale in the large clocks and the minute chronometers exhibited in this Class. The large electric clock, the hands of which are seen projecting over the south entrance of the Transept, is an interesting example of the application of the force of electromagnetism to move mechanical arrangements for the measurement of time. A small galvanic battery keeps this large instrument, and several other clocks in the Building, in regular movement. The ribs of the Transept have been made to represent the dial, and show the hours from 6 A.M. to 6 P.M. Other electric clocks on a smaller scale are shown, and exhibit various ingenious arrangements intended to effect the same end. Self-registering, astronomical, and other clocks are likewise exhibited. In some of the large clocks for churches and public buildings, one of which is in the Nave, and others are at the termination of the Galleries, new principles of suspension and compensation of the pendulum and of escapement are introduced. Much ingenuity has often been expended upon clocks with a view of communicating to them the power of indicating, in addition to ordinary time, that of different places, and of different periodical occurrences, as the rise and fall of the tide, the day of the month, &c. Several of these clocks are shown, and particularly one which occupied its patient constructor thirty-four years in its manufacture. The watches and chronometers exhibited have also their peculiar claims to attention. The escapements of some of the latter are in part new, and appear to promise favourable results. Several different specimens of watches, adapted for different markets, afford a curious illustration of the variation of natural tastes—the variety of methods in which compensation for the changes resulting from variations of temperature is obtained both in chronometers and in astronomical and other clocks. Extremely small watches, as specimens of minute workmanship, are exhibited. The parts of watches and clocks are likewise included in this Class.

The philosophical instruments exhibited comprise a large number connected with the display of the phenomena of heat and electricity: the aneroid barometer, in which the mercurial column is dispensed with, and various forms of the ordinary barometer are among them. Electric communications are now effected by a variety of apparatus of greater or less facility of application. Printing electric telegraphs, in which a message is recorded by this agency, upon a chemically-prepared paper, appear in various forms with the ordinary needle telegraph. The methods of electric insulation for telegraph uses are also exhibited. Among these will be regarded with interest the wires adapted for submarine communication between this country and the Continent. The magnetic and electric machines, with electro-magnets of great power, are also interesting.

British manufacturers have for some time been making great efforts with a view of producing good optical glass, and a skilful method of working it into the forms desired for optical purposes. These efforts have been so highly successful that the glass produced in England is not unfrequently exported and again re-imported as foreign glass at a much higher price. The production of lenses has also greatly improved; and achromatic glasses of considerable size, as well as of a smaller kind, are made with success in this country. Microscopes, telescopes, and the minor philosophical instruments, are now of excellent quality and highly-wrought character.

Photography is included in this Class, both on plates of silver and glass, and on paper. The most beautiful specimens of sun-drawn pictures are exhibited. Daguerreotypes of every kind, plain and coloured, "enamelled," and "crayon,"—improvements of recent introduction, and applied to a variety of purposes,—are found here. The largest daguerreotype probably yet produced, a group of sculpture, is placed in this Class. The talbotypes are also very beautiful, and present a charming evidence of the fidelity and artistic effects capable of being produced by the pencil of Nature. Photographic apparatus of various kinds, together with the results of curious photographic experiments, illustrative of the distinct existence of luminous and actinic rays in the solar beam, are also represented.

A great variety of miscellaneous philosophical apparatus, for popular illustration, and for the purposes of the experimentalist, is also displayed, and must attract notice. The musical instruments exhibited include several powerful organs. That over the West Entrance possesses 80 stops. The organ over the Eastern Entrance exhibits a new and pleasing arrangement of pipes, and possesses a powerful set of stops. The organ over the South Transept Entrance is devoid of a case, and exhibits the internal mechanism; it possesses a powerful reed stop, and other stops. Pianos, harps, seraphines, of new modes of construction, and decorated in a remarkable manner, are likewise found here. The instruments of the surgeon have a purely professional value, and will be sought by those interested in that pursuit.

Regarding this Class as representing the culminating point of mechanical skill, it forms an appropriate conclusion to those devoted to machinery generally. Delicacy and precision of workmanship are absolutely requisite in the industry occupied in producing philosophical apparatus. It will be found, on inspection, that the genius of this country, so remarkably developed in mechanics applied to commercial purposes, is not less successful in its application to the higher pursuits of experimental and practical philosophy.—R. E.

objects collected  
 degree, from the  
 has been accom-  
 of the apparatus  
 indications. The  
 that of the facts  
 development of  
 ical sciences, and  
 the use of which  
 perator may com-  
 the present state  
 refined and can-  
 conduring system  
 stem since called  
 eans employed by

omprises musical,  
 under three Sub-  
 sit Instruments,  
 are the effects of  
 ents to illustrate  
 science to useful  
 s connected with  
 l Pharmaceutical  
 d and metal, as  
 D. Keyed Instru-  
 sion, as Drums  
 musical instru-  
 ings in general,  
 in registration,  
 of an ornamental  
 various descrip-  
 udes a variety of  
 gether with the  
 disease. It also

movements and  
 and possesses an  
 fferent purposes,  
 is Class is to be  
 North Transept.  
 encement of this  
 is gallery. The  
 on of the South  
 ng westward, in  
 of organs, harps,  
 ptype apparatus,  
 Central Gallery  
 occupying the

1 **BENNETT, JOHN, 65 Cheapside—Inventor and  
Manufacturer.**

A regulator, which beats half-seconds, with mercurial pendulum; adapted for reading-rooms, railway stations, and other places where an exact time-keeper is required at a small expense, and where economy of space is an object.

Hall clock—in a carved oak case, of new design; chiming the quarters, and striking the hours on a gong. Finished specimen of marine chronometer.

Model watch, on a magnified scale; constructed to show the most compact form of the modern watch, with all the recent improvements; to which is attached a peculiar mode of regulation, by which the wearer, with one touch of the regulator (fixed on an endless screw) can correct any variation of time.

Model watches in gold cases for pocket use; jewelled in thirteen holes. Comprising, in a simple form, essentials for its correct performance in all climates; with a gold chain of new design. Exhibited to show the introduction of a variety of ornamental detail, coloured by means of different bases of alloy, without the aid of either enamel or precious stones.

Time-keeper, for railway guards, constructed to combine cheapness, strength, and exact performance.

Specimens of standard thermometers, with ivory and box-wood scales.

Bennett's registered illuminated night timepiece, attached to a Palmer's candle lamp, by the burning of which a spring gives motion to the hands of the dial with great exactness.

Carriage clock, in rosewood case, with detached lever escapements and compensation balance.

A regulator, beating lead seconds, with mercurial pendulum, in the simplest form of case and movement compatible with strict nicety of performance.

Cathedral clock dial of plate-glass, and of new design; weather-proof; with a movement in action.

A wind dial in action from a vane above the roof of the Exhibition Building, with a self-recording machine for registering the wind's force.

2 **ADAMS, F. B., & SONS, 21 St. John's Square,  
Clerkenwell—Manufacturers.**

No. 1. Gold open-face, double-back, cased watch; enamel dial, first class, full plate movement, lever escapement, capped, eight holes jewelled, and compensated balance, &c. This description of watch is used in the northern states of America.

No. 2. Similar watch, with gold dial. This is made at one-third the cost of Nos. 1, 3, or 8.

No. 3. Gold watch; enamel dial, first class, three-quarter plate movement, duplex escapement, 10 holes jewelled, compensated balance, &c.

No. 4. Watch like the preceding; three-quarter plate movement, lever escapement, five holes jewelled, and gold balance.

Nos. 5, 6, 7, 8. Gold watches; first class, three-quarter plate movement, lever escapement, full jewelled, compensated balance, &c.

Nos. 9, 10. Gold watches; gold dial, full plate movement, lever escapement, jewelled, plain balance (for ladies).

Nos. 11, 12. Gold watches; first class, three-quarter plate movements, lever escapement, eight holes jewelled, compensated balance, cases enamelled, and ornamented with diamonds.

No. 13. Gold watch; enamel dial, showing seconds from the centre, without additional train.

No. 14. Gold, engraved, double-back, hunter-cased watch; first class, three-quarter plate movement, duplex escapement, 12 holes jewelled, compensated balance. This description of watch is used in the East Indies, Persia, Spain, and South America.

No. 15. Silver, open face, double-back, cased watch; lever escapement, capped, and four holes jewelled.

No. 16. Silver hunter engine-turned watch, vertical escapement.

No. 17. Silver pair of case watch; vertical escapement. Nos. 15, 16, and 17, are used by artisans and labourers.

No. 18. A three-quarter plate finished movement lever escapement; eight holes jewelled, gold balance. This description of movement is adopted for the purpose of obtaining a thin watch.

No. 19. A full plate finished movement, lever escapement, eight holes jewelled, compensation balance, &c.

No. 20. A finished movement, vertical escapement.

The same workmen, in their various branches, were employed upon No. 1, the largest, and No. 11, the smallest of those watches.

3 **OLORENSHAW, JOSEPH, & Co., 8 Charles Street,  
Northampton Sq. and Oxford Terrace, Coventry—  
Manufacturers.**

Two-day marine chronometer.

Specimens of gold and silver watches and watch movements in three-quarter and full plates, with duplex, patent diamonds, and detached lever escapements. Various jewelled and finished.

4 **ORDNANCE SURVEY DEPARTMENT.—Lieut.-Col. HALL  
—Producer.**

*Base-measuring Apparatus.*—Two compensation bars, and one connecting compensation microscope.

These compensation bars and microscope form part of a base-measuring apparatus, invented by Major-General Colby, Royal Engineers, formerly Superintendent of the Ordnance Survey.

*Description of Compensation Bar.*—1. The compensation bar consists of two bars of brass and iron, 10 feet 1.5 inch long, 0.5 inch broad, and 1.5 inch deep, placed 1.125 inch apart, supported on brass rollers, at one-fourth and three-fourths of their length, and firmly fixed together at their centres by transverse steel cylinders 1.5 inch in diameter, and being free to expand from or contract towards their centres independently of each other. At the extremity of, and at right angles to, each of these bars is a flat steel tongue, 6.2 inches long, 1.1 inch broad, and 0.25 inch thick; projecting 3.25 inches on the side of the iron bar, and moving freely on conical brass pivots, riveted into the brass and iron bars, each axis being perpendicular to the surface of the tongue, allowing it to be inclined at slightly different angles to these bars, according to their expansion from, or contraction to, their centres. The centres of the two axes are at 0.5 inch and 2.3 inches from the end of the tongue next the brass bar. On the tongue, and flush with its upper surface, near the extremity, is inserted a silver pin, with a dot marked on it, as the compensation point.

The bars are placed in wooden boxes (made of well-seasoned straight-grained deal), to the bottoms of which are fixed the plates that hold the brass rollers on which they are supported, and having in the middle a vertical brass stay, screwed to the box, and passing upwards between two steel cylinders, to prevent the bars being moved longitudinally in their casing. To protect the tongue carrying the compensated point (which projects beyond the wooden box) from injury, nozzles are fixed to the boxes, having a small circular orifice with a lid on the upper side to allow the dot, or compensation point, to be seen.

On one side of the connecting steel cylinders, and attached to the brass bar only, is placed the longitudinal level, the lid of the box being furnished with a glass window and shutter, to enable it to be observed. Over the rollers which support the bars are two pieces of metal, for preventing any sudden jar from striking the bars against the lid of the box. At each end, on the outside of the bar-box a thick metal plate is screwed, for the purpose of firmly fixing a three-armed groove-stand, intended to support the tripod of the compensation microscope; and at each end of the box are two vane sights (which shut down with hinges into grooves), used for placing the bars approximately in line.

vertical escapement. Brass and labourers, and movement lever balance. This device the purpose of ob-

ment, lever escapement balance, &c. Escapement. Various branches, were and No. 11, the

3 Charles Street,  
Coventry—

es and watch move-  
tes, with duplex,  
over escapements.

—Lieut.-Col. HALL

compensation bars, and  
scope form part of  
by Major-General  
intendent of the

The compensation  
n, 10 feet 1.5 inch  
eep, placed 1.125  
at one-fourth and  
ly fixed together  
ylinders 1.5 inch  
from or contract  
each other. At the  
h of these bars is  
inch broad, and  
on the side of the  
s pivots, rivetted  
ing perpendicular  
to be inclined at  
according to their  
ir centres. The  
d 2.3 inches from  
. On the tongue,  
the extremity, is  
on it, as the com-

s (made of well-  
ottoms of which  
ollers on which  
middle a vertical  
ing upwards be-  
the bars being  
To protect the  
(which projects  
zzles are fixed to  
with a lid on the  
tion point, to be

ylinders, and at  
the longitudinal  
ed with a glass  
erved. Over the  
ces of metal, for  
the bars against  
e outside of the  
r the purpose of  
intended to sup-  
roscope; and at  
ts (which shut  
for placing the

On both sides, at one-fourth and three-fourths of the length, are brass plates, with holes for receiving the screw which clamps the plate of the tripod-stand (technically called a *camel*) to the box, for the purpose of adjusting the bar in a longitudinal direction. The compensation bars are six in number; the weight of each bar, with its two brass ends, is 136 lbs.

*Description of Compensation Microscope.*—2. The compensation microscope consists of three microscopes, placed three inches from centre to centre, connected by two bars of brass and iron, 7 inches long, 0.6 inch broad, and 0.375 inch thick, 2.5 inches apart, firmly secured together by means of a brass collar and cylinder, forming part of the tube of the centre or telescopic microscope.

The two bars, carrying with them the outer microscopes, of two inches focal distance, being free to expand from, and contract towards, the central microscope, independently of each other; and thereby forming with it small angles of inclination similar to the stool tongues of the compensation bars. The compensated point of each is so adjusted as to be in the outer focus of its object glass. The microscopes revolve on the axis of the telescopic microscope in a tube fastened to a horizontal plate attached to a tripod-stand with levelling screws, and furnished with longitudinal and lateral adjusting screws. On one side, secured to the brass bar, is the spirit-level, for levelling the microscopes, and on the other, firmly fixed to the centres of the bars by a brass plate, is a telescope, embraced by a brass collar, with a small cylinder projecting from one side, which turns in a socket attached to the plate; thus affording it a vertical motion, allowing objects to be seen in opposite directions. The telescopic microscope is provided with an adjusting screw, for altering the focal distance within certain limits, as well as moveable object glasses of different focal lengths fitting into the lower end of the tube. The compensation microscopes are seven in number, the weight of each being 7 lbs.

[All the methods adopted in the measurement of base lines in trigonometrical surveys which had been in use previous to the survey of Ireland, depended more or less for their accuracy on the knowledge of the temperature of the bars, &c., used in measuring; but as the time which substances occupy in heating or cooling is dependent upon their nature, mass, &c., it did not appear that any application of thermometers would give the true temperature of a bar throughout its whole length, particularly when the temperature of the air itself was undergoing constant change.

This circumstance led to the application of the principle of compensation used in gridiron pendulums, to devising an apparatus for measuring a base line. As metals have different capacities for heat, and their surfaces have different powers of radiation, experiments were made to equalize the effects of varying temperature in the brass and iron bars; and for this purpose the brass bars were bronzed and varnished, and the iron bars were browned, lacquered, and smoked, and the amount of lamp-black so produced was gradually removed, on successive experiments, till the desired effect was obtained. —J. G.]

6 VEITCH, JAMES, 6 *Orington Square, Brompton*—  
Inventor.

An invention denominated the medico-chirurgical ambulance, for surgical use on the field of battle, with an operating table attached thereto. The solid structure is 3 feet 4 inches in length, 2 feet in breadth, to which there is affixed an inclined plane to raise the shoulders when required. The flap is 2 feet 6 inches in length, and of the same breadth as the solid structure, and is supported when necessary by a moveable beam that can be promptly projected from

under the table, which is 2 feet 11 inches in height. Under the body of the table and in the centre there is a square box of 16 inches in all directions, with 4 exterior and lateral divisions of 2 inches in breadth each, 16 inches in length, and 8 in depth, for receiving the cases of amputating, trepanning, miscellaneous, and cupping instruments, and they are exteriorly so marked. When amputation of the thigh, or any other extremity is required, the necessary instruments are laid out on the inside of the cover of the box just adverted to, beginning with the letter nearest to the limb to be removed, the first instrument wanted to be placed opposite A, and the second opposite B, and so on, according to the order in which they are required during the operation. If a shoulder is to be removed, the same arrangements are to be adopted as in the amputation of a thigh, with the difference of placing the instruments at the head instead of the lower extremity of the table. The divisions in the centre are intended to receive bandages of 6, of 5, of 4, and 3 yards in length, and 3 inches in breadth, and they are capable of giving accommodation to 200 of the description noticed. The drawers in front marked ligatures are intended to keep these essential agents of surgery in constant readiness. The drawers marked slips of adhesive plaster indicate the propriety of their being at all times in readiness for operations and wounds. The compartment marked fractures is for keeping the splints and bandages necessary for the treatment of such accidents. The department marked dislocations indicates that all instruments required for the reduction of such dislocations are there to be found.

With these arrangements the surgeon can never be taken by surprise, and is consequently always in a condition to remedy the effects of wounds and other accidents.

7 HUTTON, JOHN, 9 *Lucas Place, Commercial Road East*  
—Inventor and Manufacturer.

Lady's gold watch, with patent single compensation stud. Gold watch, and silver lever and silver hunting-watches, with the same improvement.

Clock, with patent compensation pendulum and barometric contrivance, to prevent the variation of rate arising from the changes in the density of the atmosphere.

Marine chronometer, with patent pneumatic auxiliary compensation, for obviating errors in extremes of temperatures; this is effected by means of a metallic thermometer, which varies the air space in which the balance oscillates.

Gold first class watch (called Hutton's patent lever chronometer).

Patent lever escapement, showing the parts separately.

Silver pocket chronometer, with improved adjustments.

Gold first class watch, with patent escapement and spiral spring.

Gold watch, with patent double compensation spring, stud and patent escapement; adapted for riding, &c.

8 CRAGG, JOHN, 8 *Northampton Square, Clerkenwell*  
—Manufacturer.

Varieties of gold and silver watches, and a model of lever movement.

9 YATES, THOMAS, *Preston*—Inventor, Patentee,  
and Manufacturer.

Patent clock, on the detached dead-beat principle. The wheel-work is so arranged that each vibration of the balance measures half a second, while in the ordinary detached lever each vibration measures a quarter of a second. The teeth of the escape-wheel are not so much undercut as in the ordinary lever. The pallets from the point of rest are drawn a complete circle to the escape-wheel teeth; so that when the balance returns and unlocks the escapement, there is no recoil. This escapement will carry a heavier balance with less motive power, and consequently will require a stronger balance-spring.

Gold watch, heating dead half seconds.

**10 LOWRY, S., 3 Lower Charles Street, Northampton Square, Clerkenwell—Inventor and Manufacturer.**

Lever watch, to show dead seconds on the one train only, with the usual number of vibrations or beats. Invented and registered by the exhibitor.

Gold chronometer, with compensation balance, isochronal spiral, spring rated, and adjusted with other modern improvements.

Model of the chronometer, or detached escapement, on an enlarged scale.

Small watch, with compensation balance, hard pendulum spring, &c. Plain lever watch.

Movements of different watches in their rough and finished state.

Marine chronometers, &c., to show dead and complete seconds on the ordinary train.

**11 CONNELL, WILLIAM, 83 Cheapside—Manufacturer.**

Pair of two-day marine chronometers, Earnshaw's detached escapements; compound balance adjusted for high temperatures.

**12 LOSEBY, E. T., 44 Gerrard Street, Islington—Inventor.**

Mercurial compensation balance, exhibiting four modifications.

A regulator, illustrating a new principle in clocks, and showing an improved form of mercurial pendulum. An arc compensation.

**13 HOLL, FREDERICK RICHARD, 8 Weymouth Terrace, City Road—Inventor, Patentee, and Manufacturer.**

Gold index pocket-chronometer, with short angle-

locking spring to the escapement, set-hands at the pendant.

Gold centre seconds eight-day pocket chronometer, independent seconds, train, and stop work, with left-sided, short, angle-locking spring to the escapement.

Silver thirty-hour pocket chronometer, with right-sided short angle-locking spring, &c.

Gold compensated duplex index watch, gold dial, set-hands at the pendant.

Gold compensated lever index watch.

Gold lever index watch (lady's), gold dial.

Silver lever index watch, set-hands on the dial, with a key, locking spring.

The object of the short angle-locking spring is to make the angle of the escapement so short that the balance, being more detached, the chronometer cannot stop in the pocket from the balance receiving a motion.

The index watches are a new invention, intended to answer the double purpose of supplying a lever to bend the main-spring, and also to indicate the number of hours the watch will go before the power is exhausted.

Gold centre seconds eight-day pocket chronometer, independent seconds train and stop work.

Silver thirty-hour pocket chronometer.

Gold compensated duplex index watches.

Gold and silver lever index watches.

Index watches, upon a new principle, kept going from day to day by simply pushing the index.

**14 ADAMS, THOMAS, 36 Lombard Street—Manufacturer.**

Black marble timepiece, of chronometrical movement, blending the Grecian and Egyptian styles.

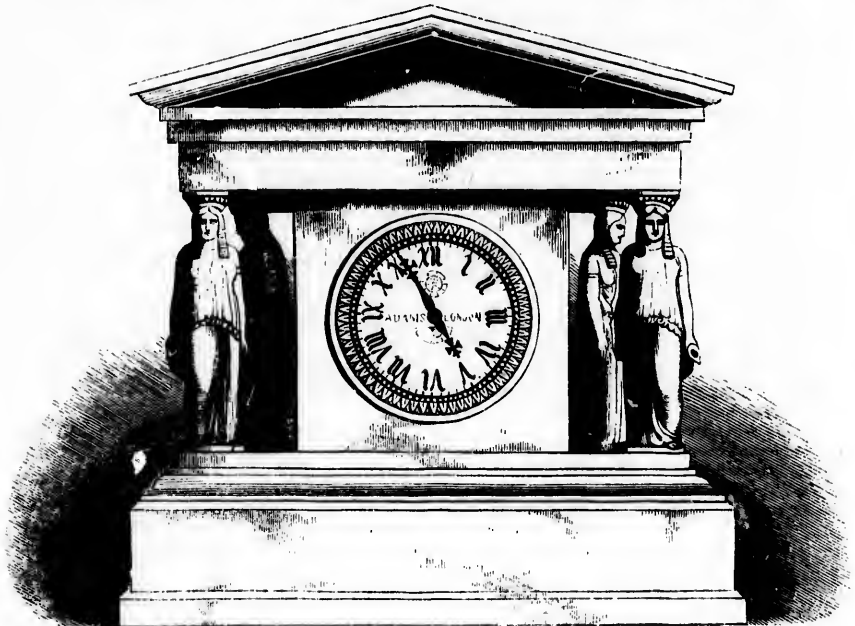

Black Marble Timepiece, by Adams.

Imitation oak timepiece represented in the following engraving.

Timepiece, with self-acting model of the Royal Observatory, with staff and ball, to rise and drop at one o'clock, as at Greenwich. Marine chronometer.

**16 HOWELL, JAMES, & Co., 9 Regent Street—Manufacturers.**

Large or-molu clock, representing Jupiter, the twelve Hours of the Sun, Apollo, and Diana, and Spring and Autumn strewing flowers and fruit on the earth.



set-hands at the  
pocket chronometer,  
top work, with left-  
the escapement.  
eter, with right-sided

watch, gold dial, set-  
ch.  
d dial.  
is on the dial, with  
ing spring is to make  
at the balance, being  
ot stop in the pocket

ention, intended to  
ying a lever to bend  
the number of hours  
exhausted.

ocket chronometer,  
ork.  
ter.  
tches.

le, kept going from  
ex.

ect—Manufacturer.  
metrical movement,  
les.

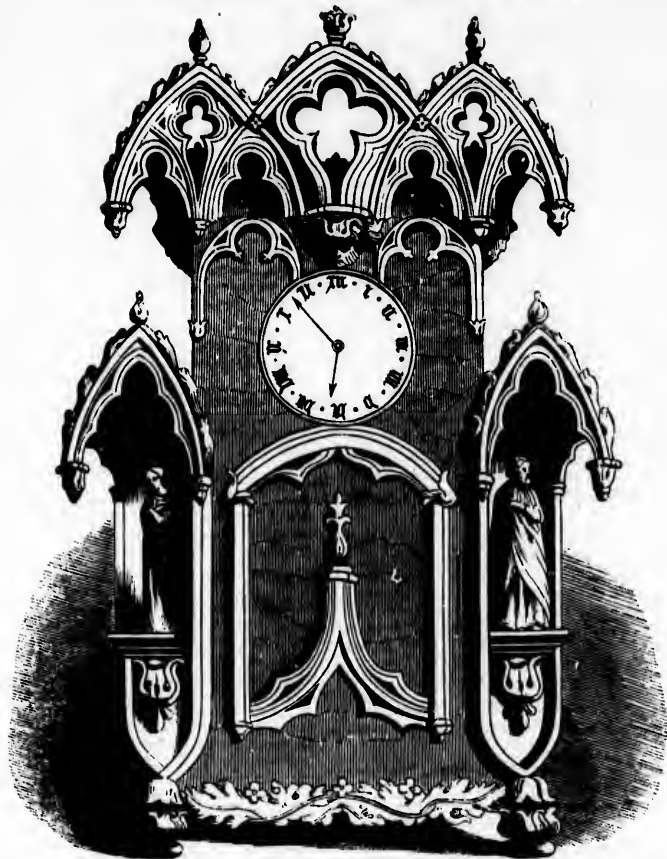

Imitation Oak Timepiece, by Adams.

Or-molu clock, representing the four Ages by female figures, and the Seasons by boys, in basso-relievo, and intermingled with foliage, illustrative of the Seasons.

Both designed and modelled by G. G. Adams, Esq.

17 WEBSTER, RICHARD, jun., 74 Cornhill—Inventor and Manufacturer.

Newly-invented train remontoir clock, the novelty of which is the combination of magnetism with clockwork so as to obviate friction.

Black marble Egyptian clock.

18 VENTURA, ANGELO BENEDETTO, 17 Charles Street, Cavendish Square—Inventor and Manufacturer.

Harp Ventura, played like the guitar, combining the tone of that instrument and the harp. Lyra Ventura. New British Ventura. The Venturina. Ventura; new English Cetra.

19 DELOLME, HENRY, 48 Rathbone Place, Oxford Street—Designer and Manufacturer.

Seven gold watches, and two marine chronometers, with isochronous pendulum springs. The adjoining cut represents one of the chronometers.



Delolme's Chronometer.

Specimen of the movements of the preceding, as made in Lancashire to the exhibitor's calibre.

Two specimens of watch movements, to the exhibitor's calibre.

Stethometer, to measure the comparative mobility of the chest in cases of disease of the lungs.

[The effect of most diseases of the lungs is to diminish the extent of the motion of the walls of the chest. It becomes consequently often of considerable importance to ascertain the amount of variation from health in this respect, since this points out, with approximative accuracy, the extent of the disease. The diminished mobility of one side as compared with its opposite thus affords important results. The instrument which reveals the fact is of very simple principles, and was originally invented by Dr. Sibson, F.R.S. It consists essentially of a dial plate with a moveable index, which is acted upon by the pressure of the walls of the chest against a projecting stud. The extent of the circle described by the index points out the amount of motion possessed by the walls of the chest in the side to which it is applied. In the present instance a tape is placed upon the chest at one end, and is in connexion with the index of the instrument at the other. Both ends being fixed by gentle pressure, the degree of expansion of the chest is easily read off by the extent of the motion of the index on the dial-plate.—R. E.]

20 NEWINGTON, S., *Hastings*—Inventor.

Patent clock, or regulator. A common clock with spring and balance-wheel; having the hands and dial-plate removed, and a dial substituted, which revolves in the same way as an hour-hand. This clock is placed in a flat round box, and is arranged to show whether a person has been at a particular spot at any required time.

21 GIBBS, H., 2 *Nelson Street, City Road*—Maker.

Watch, showing double time, with improved stop-work.

22 PHILCOX, GEORGE, 89, *Great Norfolk Street, Borough*—Inventor and Patentee.

Patent marine time-keeper. This time-keeper is intended to give correct time in taking observations, where a chronometer is not at hand, or as a companion to a chronometer. It is adapted for use in locomotive railway engines, to show the engineer the rate of his speed, being the only species of escapement not affected by the motion or tremor of a railway carriage. The construction of the calibre for the train is a going barrel. The advantage is getting the motive power close to the centre, and by an extra wheel in the train taking the escapement further from the centre, the defects or irregularities of the main spring have less effect on the time, consequently the action, or the arcs of vibration, are more regular, and the time more correct. This train is well adapted for chronometers and watches. The timepiece should be wound up every day, though constructed to go two days. The escapement beats dead half seconds.

Model of the patent "diamond escapement," as intended for the use of marine chronometers. It is much less expensive than the detent escapement now in use; it is not affected, as that is, by the sudden motion and tremor of the vessel, and is not so liable to stop in cold climates. The locking is intended to be jewelled. This compensating balance differs from others, having the arms resting on the brass plate.

A model of a new compensating pendulum. This pendulum is adapted for astronomical and other purposes requiring correct time, showing how to correct the error caused by the expansion and contraction of the pendulum rod. The two brass arms, fixed at each end of a bar of hammered steel, will, as they become heated, expand, and increase the arc of the circle, thus taking up

the elongation of the steel rods. The brass expanding about two-thirds more than the steel, will show the proportions required; and should the expansion of the arms be found more than required for the steel rod, an adjustment of the two screws will correct the error, and, once adjusted, will always correct itself. This compensating pendulum is more simple and correct than mercurial and other pendulums.

Patent "double spring." This new principle possesses many important advantages: it eradicates an error now existing in the chronometer spring in present use. With the patent spring the balance of the chronometer will at all temperatures remain in the same position unaffected by heat, and at the extremes of temperature make one uniform rate (the patentee in this instance uses the compensating balance), thus removing the great effect produced on the old principle.

23 CHEVALIER, BENJAMIN, 41 *Brunswick Street, Stamford Street*—Manufacturer.  
Chronometer cases.

25 BROOKES, JOSEPH, 5 *Berkley Court, Clerkenwell*—Manufacturer.

A chronometer main-spring for a two-day marine chronometer.

26 FUNNELL, EDW., 2 *Clarence Place, Brighton*—Producer.

Small lever watch, the size of a silver three-halfpenny piece of the present reign.

27 GOWLAND, JAMES, 52 *London Wall*—Inventor and Manufacturer.

Improved free pendulum regulator, for the isochronal division of time.

Patent tourbillon remontoir chronometer, in which the impulse is imparted to the balance through the balance spring, its stud being advanced one degree or tooth of the locking-plate at each oscillation.

Large model of the escapement.

Model of Earnshaw's escapement.

Skeleton clock with improved compensation pendulum.

Model of an improved anemometer and wind-dial and vane; and of an electric clock.

Various specimens of watches, including gold keyless hunting lever watch, winding and setting the hands through the pendant, and also unlocking the cover of the case by the same means. A gold keyless repeater, indicating the hours, quarters, and minutes, &c.

28 TANNER, WILLIAM, 83 *Upper Street, Islington*—Inventor.

The polyhorion (or many-hour clock) exhibits, in addition to the local time, the time at Dublin, Paris, and Edinburgh; it can be made to show the time at any other four places. This clock is simple and not liable to get out of order, as one movement and pendulum regulate the different times. This clock is represented in the following cut.

Lever watch, set to Liverpool and Greenwich time; but it can be set to the times of any two places more convenient.

30 DAVIS, WILLIAM, 37 *Gracechurch Street*—Manufacturer.

Watch, horizontal escapement, made entirely by hand. Watch movement, duplex-escapement, made entirely by hand. Made by H. A. Davis, 57 New Street, Birmingham.

31 COLE, THOMAS, 2 *Upper Vernon St., Lloyd Square, Clerkenwell*—Inventor, Designer, and Maker.

Inkstand, containing requisites for writing; and showing the time, the day of month, and the day of week, with thermometer. In metal, engraved and gilt, inlaid with malachite.



Tanner's Polyhorion.

Design for a portable eight-day timepiece, showing the months and days of the week and the month.

Design for a flat, portable clock, with calendar; metal, engraved and gilt, inlaid with malachite.

Eight-day night and day timepiece, or horological lantern.

Small eight-day clock. Improved calendar, in metal frame.

Flat eight-day striking clock, to repeat the hours and quarters, in engraved and gilt case.

[The substance here called "malachite" is also known as *mountain green*. It is a beautiful mineral of a fine green colour, variegated in a pleasing manner. It consists chemically of carbonate of copper, and is found native in Cornwall and Cumberland.—R. E.]

32 JACKSON, W. H. & S., *Red Lion Street, Clerkenwell*—Inventors and Manufacturers.

Registered solicleve lever watch : exhibited for cheapness and various improvements. Specimens in gold of various styles ; specimens in cases enamelled, set in gems, and painted with designs ; the enamelling the work of this district.

A gold three-quarter plate lever watch, with enamelled dial, jewelled in six holes, of the same construction.

Gold lever watch, with compound balance crystal dome, showing the motion of the escapement.

Duplex time piece with whole or dead seconds from centre ; a new calibre.

Lever watch, with whole or dead seconds.

Gold pocket chronometer.

Two-day marine chronometer, and a compensation balance, with adjustment for extremes of temperature.

Parts of watches, showing their construction.

33 MOORE, JOHN, & SONS, *38 Clerkenwell Close*—Manufacturers.

Chiming skeleton clock to go a month. Chiming clock in rosewood case. Skeleton clock.

34 BARRAUD & LUND, *41 Cornhill*—Inventors and Manufacturers.

Marine chronometer, with a model of a newly-invented compensation balance, constructed for exact adjustment to all temperatures.

Marine chronometer, of ordinary construction. Very small gold pocket chronometer, a specimen of minute English manufacture.

35 PARKINSON & FRODHAM, *4 Change Alley, Cornhill*—Manufacturers.

Astronomical clock, with mercurial pendulum, in mahogany case.

Eight-day chronometer with ordinary compensation.

Lever watches with compensation.

Gold chronometers for pocket.

Gold watch-cases and carriage clocks.

36 FAIRER, JOSEPH, *17 Bishopgate Street Without*—Inventor and Manufacturer.

Improved railway guards' timekeeper. Improved railway station clock, showing the day of the month.

Pocket watch for engineering purposes.

Improved electric clock, to show uniform time, irrespective of distance, from one prime mover.

37 ROBINSON, P., *Bishop Auckland*—Designer and Manufacturer.

Skeleton spring clock, which strikes the hours and quarters on modulated bells ; with a compensator for counteracting temperature. The clock and framework are a representation of the clock-tower and entrance to the palace of the Bishop of Durham, at Bishop-Auckland.

39 ELISHA, CALEB, *13 New Bond Street*—Inventor and Manufacturer.

An eight-day time-piece (regulator), to go by a weight, in a mahogany case, with a compensating pendulum. This pendulum has a brass ball, seven inches diameter, and three-quarters of an inch thick, on the face of which is screwed a brass rim, a quarter of an inch thick and one inch broad ; on the inside of this is a steel rim, secured to the brass, one-eighth of an inch thick. The outer diameter of this rim, composed of brass and steel, is also seven inches. This rim is divided or separated at the bottom of the ball, leaving two arms of equal length ; at the end of each is screwed a brass cup, to admit glasses of a conical shape containing mercury, about  $4\frac{1}{2}$  inches high, the lower diameter being about  $1\frac{1}{2}$  inch, and the upper about the half. The adjustments for variations in temperature are made by the compensation rim with mercury in the glasses. The escapement of the clock is of George Graham's construction, dead-beat, but the pallets are jewelled. The vibration is made as short as possible.

A silver lever watch, with compensation radii, composed of brass and steel united. The proportions are about 1 of steel and 2 of brass. The bar is screwed on to the upper plate at one end, and at the other end a hole is drilled, to admit the pendulum or regulating spring, where it is pinned in.

A silver lever watch, with compensation radii, composed of brass and steel, fixed on the index on the cock, the two shifting together, and acting up and down the spring as the regulator is shifted. In the outer end of this radii compensation, are drilled two holes for the pins, between which the pendulum spring plays.

Model of a mahogany door, with machinery. In the posts of the inside of the door are fixed two staples. An iron chain, case-hardened, rather longer than two widths of the door, is drawn through the staples, and when on the outside, the chain is pulled, so as just to admit the hand to secure a padlock into the links of the double chain. The chain is then drawn, with the padlock, out of sight. The lock catch must also be case-hardened.

40 BROCKBANK & ATKINS, *6 Cooper's Court, Cornhill*—Inventors.

A fifty-six hours' marine chronometer, on spring gim-bals, enclosed in improved box with glazed sides and front, for the better admission of light.

The same inverted, showing the interior mechanism.

- 41 WALTER, FRANCIS, 9 *Devonshire Place*—Inventor.  
Agent—Mr. HAWLEY, 123 *Regent Street*.

Model of a new design for giving a moral and religious application to the dial indications of a clock. The subject has been the study of five years.

- 42 LAMB, J., *Bicester, Oxfordshire*—Manufacturer.  
Skeleton clock: to go 400 days.

- 43 THORNELOE, C., *Lichfield*—Designer and  
Manufacturer.  
Clock, which strikes quarters, and goes 32 days.  
Design, Lichfield cathedral.  
Gothic skeleton clock.

- 46 GRANT, P., 20 *Lower William Street, St. John's Wood*  
—Designer.  
Timepiece-stand, composed of ivory, tulip-wood, and  
ebony.

- 46A COPLAND, C., M.A., *South Villa, Kennington Oval*—  
Proprietor.  
A watch once the property of King Henry VIII.  
Silver watch, of same character and date, finely  
engraved.  
Gilt watch, 150 years old, chased, Henri Quatre style.

- 47 HARVEY, W., *Stirling, Scotland*—Inventor and  
Manufacturer.  
Improvement in horology, dispensing with striking  
work. Only one wheel is used, which is placed under  
the hour-wheel, and receives motion from it. This im-  
provement can be applied to almost any other timepieces,  
especially to skeleton timepieces. The article exhibited  
is the original invention.

- 49 BENNETT, GEORGE WEEDON, *Blackheath, Kent*—  
Manufacturer.  
A public clock, showing time on four dials, and  
intended to be fixed in an ornamental case at the inter-  
sections of streets, or the approaches to bridges, entrances  
to parks, village greens, the quadrangles of baronial halls,  
in collages or other public places, in order to supply cor-  
rect time, independently of church clocks (which are,  
from their lofty and exposed position, almost always  
wrong), and to serve as useful ornaments in the streets.  
It has a two-seconds' pendulum, pin-wheel escapement,  
lantern pinions, gun-metal wheels, and slate dials; and  
the whole is constructed with every regard to accuracy  
of performance. Two designs for cases accompany it; but  
these would necessarily be adapted to the locality and  
taste of the purchaser.

- 52 DONEGAN, JOHN, *Upper Ormond Quay, Dublin*—  
Manufacturer.  
Gold and silver watches, of Dublin manufacture.  
Specimens of Irish gold and silver, from Ballycornis  
works.

- 52A AUBERT & KLAFTENBERGER, 157 *Regent Street*  
—Manufacturers.  
Regulator remontoir, and of continual power. The  
movement consists of two barrels, centre, third, fourth,  
and escapement wheels: the axis of the fourth wheel  
traverses the upper plate, and receives a wheel which  
is fixed on the axis of the pinion above, the object of which  
is to wind up the weight of the maintaining power; this  
movement maintains the oscillation of the half-second  
pendulum.

The escapement wheel, and the second wheel exposed  
in the dial, form part of the independent train, which  
has to maintain the oscillation of the mercurial pendulum.

The principal and medial trains are brought into com-  
munication by means of the third wheel, seen in the dial:  
this wheel is fixed in the centre of a rack mounted on an  
axle, which is pivoted between the frame; a wheel here

forms a depth into the rack, and upon the axle on which  
this wheel is placed, is fixed a double pulley, on one side  
of which is suspended a small weight, and on the other  
the half-second pendulum. The weight and pendulum  
draw contrary ways, and as the weight is heavier, it gives  
the power to the independent train.

The third wheel of the principal train, which forms the  
depth with the medial wheel seen in the dial, will dis-  
place it from right to left; by which means, if the two  
wheels, having the same number of teeth, turn equally  
quick, the intermedial wheel will be set in motion, but  
its axle will not change in position, and consequently the  
rack, and also the wheel in which the rack works, will be  
immovable, and the hand fixed to the axle of the pulley  
will point to zero.

The independent train receiving thus a *force constante*,  
and maintaining the oscillation of the mercurial pen-  
dulum, will not be susceptible of variation. Any differ-  
ence of quickness in the action of the second wheel upon  
the medial wheel in the dial, can only be occasioned by  
the principal train, through the action of the half-second  
pendulum, which, if not perfectly regulated, will occasion  
an advance or *retarde*.

If the half-second pendulum should advance, the prin-  
cipal train will raise the weight of the *force constante*, and  
the half-second pendulum, acting in a contrary sense, will  
cause it again to fall, and consequently the pendulum  
will then *retarde*. If, on the contrary, the half-second  
pendulum loses, the principal train will not raise the  
weight of the *force constante* sufficiently quick, and the  
pendulum will then drop; but the regulator acting in a  
contrary manner will again shorten it, which will then  
cause it to advance.

Two-day marine chronometer.

Repeating watch, in gold case, striking the hours, quar-  
ters, and half-quarters; with lever escapement and com-  
pensation balance, showing, on the dial plate, the age of  
the moon, the day of the month, the hours, minutes, and  
seconds.

Pocket chronometer, in gold case, with enamel dial.  
Duplex and lever watches in gold cases.

- 53 PENNINGTON, JOHN, *High Street, Camberwell*—  
Inventor and Manufacturer.

Marine chronometer, with improved compensating  
balance weight, to remedy the defect produced in ordinary  
chronometers by extremes of temperature.

A A represents levers with weights attached, B B, acting  
on pivots, C C, held against bankings, D D, in middle  
temperature when not in action, by springs, E E, moved  
towards centre of balance in extreme heat by point of  
screws, F F, and the same by shoulder of screws, G G, in  
extreme cold.

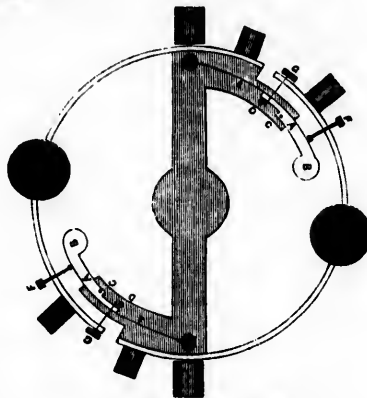

Pennington's Compensated Balance.

54 TAFFINDER, —, *Rotherham*—Manufacturer and Designer.

An eight-day skeleton clock with lever escapement Design taken from Rotherham cathedral.

## 55 DENT, EDWARD JOHN, 61 Strand, 33 Cockspur Street, and 34 Royal Exchange—Inventor and Manufacturer.

1. Gold "tao" watch. The term "tao" implies that the time is ascertained by turning round the large external gold hand until it is stopped. The time is then known by determining the place of the hand with reference to the twelve projecting ribs on the edge of the case by the touch. The interval of time can be thus determined to about a minute. This description of watch supersedes the usual striking repeater, is less liable to derangement, and is less expensive. It is wound up and the hands set without the usual detached key.

2. Similar watch, with hunting-case, and small opening in the centre to know the time without opening the cover.

3. Hunting case watch, with case-springs outside, and to wind up and set the hands without a detached key. For use in India, and may be considered air-tight, by which arrangement frequent cleaning is avoided.

4. Gold open-faced watch, with compensation-balance, &c. A specimen of the best description of English watch.

5. Gold watch, with compensation-balance, &c., and two seconds' hands in the centre. The under one (as shown stationary at the 45 seconds or minutes) drops instantly on pressing a nib at the end of the pendant of the watch. This auxiliary hand remains still as long as required. Intended for delicate experiments where small intervals of time are required to be noted.

6. Chased watch, with compensation-balance, &c., having a drop seconds' hand. It is wound up, and the hands are set, without the usual detached key; made for the son of the Viceroy of Egypt.

7. Engraved watch, with compensation-balance, &c.; a specimen of watches intended for the Spanish market.

8, 9. Watches, with compensation-balances, as specimens for the Turkish market.

10. Watch, with compensation-balance, &c., as a specimen for the Persian market.

11. Watch, with compensation-balance, English style.

12, 13. Ladies' watches, with compensation-balances, &c.

14, 15. Ladies' gold watches of the usual construction.

16, 17. Gentlemen's gold watches, with compensation-balances, &c.

18, 19, 20. Gentlemen's watches of the usual construction, without compensation-balances.

21. Marine chronometer, with a glass balance-spring, glass balance, and compensated, for temperature, by means of platinum and silver. This glass balance-spring has been tried at the Royal Observatory, and on board H.M. surveying ship, "Fairy" (for official rates, see "Nautical Magazine," xxix).

22. Patent marine chronometer, having the steel balance-spring, gilded by the electro-metallurgic process.

23. Patent marine chronometer, having a secondary compensation, by which the compensation weights are made to move so as to counteract the effect produced by the changes of temperature.

24. Marine chronometer of the ordinary construction.

25. A compass which can be inverted; the magnetic needles are placed on a vertical axis, and the divisions are engraved on both sides of the silver ring (or compass-card), so that one reading can be made before, and the other after, inversion. The mean between these two readings gives the error of the zero on the card; therefore the true magnetic bearing of any observed object can be determined.

[The ordinary way of fixing the card and needle of a compass is upon an inverted cup resting on a fine point. The application of the chronometer suspension to compasses, as above, is with the view of avoiding the great friction upon the fine point, caused by great vertical oscillations.—J. G.]

26. An azimuth and altitude compass. The principle is the same as in the former, with the addition of a telescope carrying cross wires, and a divided arc for altitudes; the rays from the observed object pass through the telescope, whilst those from the card, reflected by the prism, pass to the eye of the observer.

27. A steering compass, with the needle gimballled on a vertical axis, by means of which the effect of the violent motions of the ship on the compass-card, and the effect of variation of dip, are neutralized. The superiority of this over the ordinary compass, in which the point of suspension of the card is higher than the centre of gravity, is most evident in steamers where the speed is great, and where the motion occasioned by the sea, as well as that from the vibration of the engine, disturb the usual compass-card, which obeys the laws of a pendulous body; whilst the compass-card placed on a vertical axis is not disturbed from any such causes.

28. An eight-day quarter striking turret clock, with compensated pendulum, 8 feet long, and weighing above 2 cwt.; vibrating half seconds, with pin-wheel, and dead escapement, but with a small recoil. All the wheels in the clock are of cast-iron, except the scape-wheel, which is brass, of only 4 inches diameter, containing 40 pins, and turning in 2 minutes.

The scape-wheel is driven by a small spiral spring fixed to a pinion, which turns on a stud set in the same line as the scape-wheel arbor, and carrying one of the pivot-holes of that arbor. This spring is wound up a quarter of a turn by the clock, at every quarter of a turn of the scape-wheel.

The dial-work is all driven by the great wheel, without the intervention of any pinion; and it is consequently very strong, and capable of working four very large dials. The dials in the great avenue of the Exhibition are 7 feet in diameter. The hands are adjustable by means of hand-screws, and a small regulating-dial set on the clock; this dial is reversed, in order to provide for the case of the external dial being on a level with the clock, and the hands driven directly by the prolonged arbor of the regulating-dial. The hands are counterpoised outside the dials; because, when the counterpoises are within, the force of the wind on the hands is not counterpoised at all; and the weight of a large hand, when unbalanced, tends to loosen the hand on its arbor, and so make it point behind the true time from 6 to 12, and before it from 12 to 6.

The maintaining power for keeping the clock going while winding, is of a new construction. Before winding, the maintaining weight must be raised sufficiently high to keep the clock going about seven minutes, and when wound up, it can be thrown out of action immediately.

All the great wheels are set in the great frame, and the small triangular frames can be taken off without moving the great wheels and barrel, or the pendulums, which may also be suspended from the wall. The smaller wheels will also take out separately. The weights are hung by wire ropes, and they require a fall of about 40 feet, with a single pulley. The pulleys are 1 foot in diameter.

The hammers are raised by cams cast on the great wheels, of such a shape as to raise them with the least friction. They are strong enough for an hour-bell of several tons weight, and quarters to correspond, though the great wheels are only 18 inches in diameter. The hammers all stand ready to fall as soon as they are discharged by the going part. The 1st, 2nd, and 3rd quarters begin exactly at those quarters; the 4th begins half a minute before the hour, and the hour-hammer falls exactly at the hour.

The object aimed at in this clock, is to combine the greatest accuracy of time-keeping with great strength, and the cheapest mode of construction which is consistent with good work.

29. A patent dipteleidoscope, to be used as a fixed meridian instrument. The optical arrangement consists in two silvered parallel reflecting glasses placed at an angle of about 60° behind the front glass. The image of the sun is reflected from the front glass, and the sun's rays



which pass through, impinge first on one plane, and are reflected to the other, they then pass out through the front glass. By this optical arrangement, two suns are visible to the eye of the observer moving in opposite directions, and when they coincide, it is the instant of apparent noon. The time can be ascertained by this instrument with considerable precision. The diploidoscope allows of three observations of the sun: 1st, when the limbs touch; 2nd, when the images coincide; and 3rd, when the limbs separate.

[The diploidoscope was invented, a few years since, by G. M. Bloxem, Esq., and, when accurately fixed, the time of apparent noon can be determined by it within one or two seconds. Two bright and sharp images of the sun are seen, which approach each other, and exactly coincide at apparent noon.—J. G.]

30. A diploidoscope fitted up equatorially, which admits of observations being taken from 9 A.M. to 3 P.M., and is rendered portable by having a magnetic needle. When the instrument is set by the needle, the magnetic declination of the place requires to be allowed for.

31. A superior astronomical clock, with a remontoire dead-beat escapement, invented by G. B. Airy, Esq., Astronomer Royal (see paper in "Royal Astronomical Society's Monthly Notices," Nov. 11, 1842, by Mr. Airy.) A large church clock. (*Main Arcade.*)

56 **DRURY, JAMES**, 16 North Avenue, North Street, Pentonville—Designer and Manufacturer.

Clock dial-case in brass, adapted for clocks in hot climates, at sea, and in bakers' shops, as they are not affected by steam and heat.

57 **FRODSHAM, CHARLES**, 84 Strand—Chronometer Maker.

1. Astronomical clock, with mercurial pendulum, and Graham's dead-beat escapement.

[Mercurial pendulums, and Graham's dead-beat escapement, are now used in nearly all astronomical clocks. The number of such clocks now in London exceeds 200; about 80 of these, chiefly the property of eminent chronometer makers, are rated on Greenwich mean time, and

it is found that their performance is such as to adapt them for astronomical uses. They certainly reflect great credit on the various artists engaged in the science of horology.

The mercurial pendulum is so called from the circumstance of the bob being of mercury enclosed in a cylinder, screwed to the bottom of a steel rod. Gridiron pendulums were in use before mercurial pendulums were adopted: they consisted of an assemblage of brass and steel rods so arranged that, owing to the difference in the expansion of brass and steel, the brass rods carried the bob up, while the steel ones let it down. The shape of pendulum bobs is important. Until lately they were of the form of a double convex lens, this form offering but little resistance on passing through the air, when its edge was always in the plane of motion; but, as it was liable to be a little twisted, a varying resistance was offered; and which is not the case in the adoption of the form of the cylinder, which probably is the best shape for the bob.

It is usual to call these clocks astronomical which are used in observatories for determining the right ascension of the heavenly bodies, and they are such, including every appendage which contributes to accuracy in the measurement of time under all the changes of atmospheric temperature.—J. G.]

2. Marine chronometers, on a new calibre, with Arnold and Earnshaw's detached escapement; the compensation balance is of the ordinary kind, with Arnold's bar as auxiliary compensation. This new calibre is based upon the plan of the diameter of barrel, fusee-wheel, and extreme diameter of the balance being the same, namely, one inch and five-tenths. The total weight of the compensation balance is 5 dwts., being as the contents of the barrel. Thus if a barrel, one inch in diameter, by three-tenths of an inch in depth, will carry a balance weighing 20 grains, a barrel of the same diameter, and of double the depth, will carry a balance weighing 40 grains. The balance-spring is 15 inches long; the diameter  $\frac{1}{16}$ , the thickness of wire  $\frac{1}{16}$ , by  $\frac{1}{16}$  broad, and the number of turns 10 to 12. The wheels (escapement-wheel included) are each five times the diameter of their respective pinions—that is, the pinion upon which the

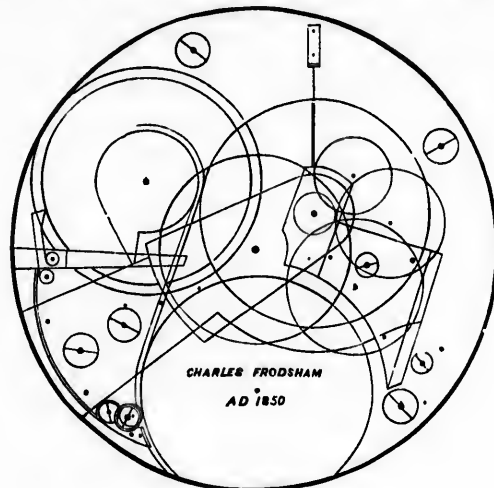

Frodsam's new Calibre for Watches.

such as to adapt  
certainly reflect great  
d in the science of

d from the circum-  
ary enclosed in a  
steel rod. Gridiron  
al pendulum were  
lage of brass and  
he difference in the  
se rods carried the  
wn. The shape of  
ately they were of  
a form offering but  
lr, when its edge  
t, as it was liable  
tance was offered;  
ion of the form of  
shape for the bob.  
ronomical which  
mining the right  
d they are such,  
ributes to accuracy  
l the changes of

ibre, with Arnold  
the compensation  
Arnold's bar as  
re is based upon  
fuzee-wheel, and  
the same, namely,  
weight of the  
as the contents  
ch in diameter,  
l carry a balance  
e diameter, and  
balance weighing  
ches long; the  
y is broad, and  
le (escape-wheel  
eter of their re-  
upon which the

wheel revolves. The fuzee-wheel has 90 teeth, centre wheel 90, centre pinion 14, third wheel 80, third pinion 12, fourth wheel 80, fourth pinion 10, and scape pinion 10, scape-wheel 15.

3. Specimens of gold pocket chronometers and lever watches, reduced from the calibre of the chronometer; with improvements in the form of the teeth of wheels and pinions, in the balance-springs, and in the mode of attaching the spring.

4. The double rotatory escapement. This is a specimen of a new calibre movement, by which a powerful watch may be made in a flat case; a method which might have been adopted at the period when flat watches were first introduced, as it has all the advantages of a thick watch, by taking the contents of the barrel in diameter and depth as the basis of power.

5. Day-of-the-month watch, with lever escapement and double rollers. The calibre of this watch may be called more simple than the preceding one, only because it more closely resembles that which is daily made. The number of the teeth of the wheels is peculiar. The centre-wheel is much enlarged, with 100 teeth working in a pinion of 10, whilst the third wheel is diminished, which has 60 teeth working in a pinion of 10; the fourth wheel 63 teeth in a pinion of 7. Although this is a good working calibre for a superior watch, yet if power is admitted to be a principle in watch-making, it is impossible to get the same depth of barrel in this watch, unless the calibre of No. 1 is used.

In producing the foregoing calibres, all technical sizes have been rejected, and the common measurement of inches, tenths, hundredths, and thousandths adopted; so that from one calibre, a watch of any size may be made by proportion.

6. Specimen of gold lever watches, with the split-centre seconde-hand movement. This watch, being a complete time-keeper, is capable of determining the precise time of any observation to a quarter of a second, by means of an extra seconde hand, with which it is provided, and which in the ordinary state of the watch lies under the principal seconds hand, and travels with it.

In taking an observation, the observer keeps his eye steadily fixed upon the object, and his finger in readiness to touch a spring, which allows the registering hand to fall simultaneously upon the face of the watch, where it may be allowed to remain upwards of 40 seconds for reading off the time; this being done, the finger is to be immediately removed in order to free the register, which instantly returns to its place ready for the next observation, without having in the least degree interfered with the correct performance of the watch.

7. Specimen of railway watches.
8. Specimen of English pinions for astronomical clocks, showing the true curve of the teeth.
9. Specimen of carriage clocks.
10. Specimen of portable chime clock.
11. Specimen of chronometer and watch movements.
12. Diagrams of calibres of chronometers and watches.
13. Gauges for admeasurement of watch-work to the thousandth of an inch.
14. Specimens of gold watch cases.
15. The new calibre, by means of which the manufacture of watches and chronometers is greatly improved and facilitated, and the expense considerably reduced. The cut in the preceding page represents this new calibre.
16. Five stages of the process of manufacture in the compensation balance.
17. Auxiliary compensation for the adjustments of the extremes of temperature.

[Power being an indispensable element in time-keeping, it is of the utmost importance that the motive force should be transmitted with a constant velocity-ratio from wheel to pinion throughout the train, without its being absorbed by the increased friction and wear consequent upon improper curves.

The correct forms of curve were described, a century ago, by Camus, and recently in a work on the Principles

of Mechanism, by Professor Willis, of Cambridge, 8vo, London, 1841.

In watch-work, the wheel is the driver, and the alidendum to the tooth beyond the pitch-line is of the epicycloidal form, which, to the general eye, may be familiarly explained as resembling a Gothic arch, or a bishop's mitre. The pinion is the follower, and has the two flanks of its leaf formed by radial lines direct to the centre; and the alidendum upon the pitch-line is a semi-circle whose diameter is the breadth of the leaf. The specimen will explain the rest.

The new calibre by the exhibitor is shown as a general improvement in chronometers and watches.]

60 HALL, GEORGE FREDERICK, *Norfolk St., Fitzroy Square*—Inventor.

An astronomical and meteorological clock, for mean time, and for registering the hourly variations of the barometer and thermometer. The escapement of the clock is a new vertical dead-beat escapement; the pendulum has a new micrometrical compensation adjustment for temperature, provided for the self-registration of natural phenomena.

Fig. 1 is a plan of the escapement, half-size. A is a vertical wheel of seven teeth, which move in a horizontal plane. B is a concentric circle, with two ruby pins moving in a vertical plane: if the pins are circular or chamfered, the action is dead during the coincidence of the two planes; but as the pins vibrate, the top of the teeth strike, and escape, and slide, under the circular or chamfered surface of the ruby pins, and give the necessary impulse to the pendulum.

Fig. 1.



Fig. 2 is the pendulum with the micrometrical adjustment for temperature, which is effected by a compound rod of brass and zinc, in the proportion of 20 brass and 10 zinc, joined just above the bob; a zinc screw is soldered into the top of the brass tube, and a steel screw into the zinc cylinder, both of the same pitch. The length of compensating rod is first obtained by calculation; then, if the pendulum is compensated plus, the rod is turned to the right, which shortens the zinc screw, and increases the steel; the difference between the expansion of zinc and steel is the amount rendered minus in the compensation. If the pendulum is compensated minus, the rod is turned to the left, which increases the zinc, and shortens the steel; the difference of expansion is the quantity rendered plus. The pendulum is made of two glass tubes expanding downwards, and the compound compensating rod expanding upwards; the bob being placed upon studs fastened to the inner glass tube, and passing through the outer. The black line in the drawing is the compensating rod.

Fig. 3 is the elevation of the clock one-eighth real size, with the dial-plate removed, showing the meteorological registering apparatus. A a are two revolving cylinders

Fig. 2.



Fig. 3.

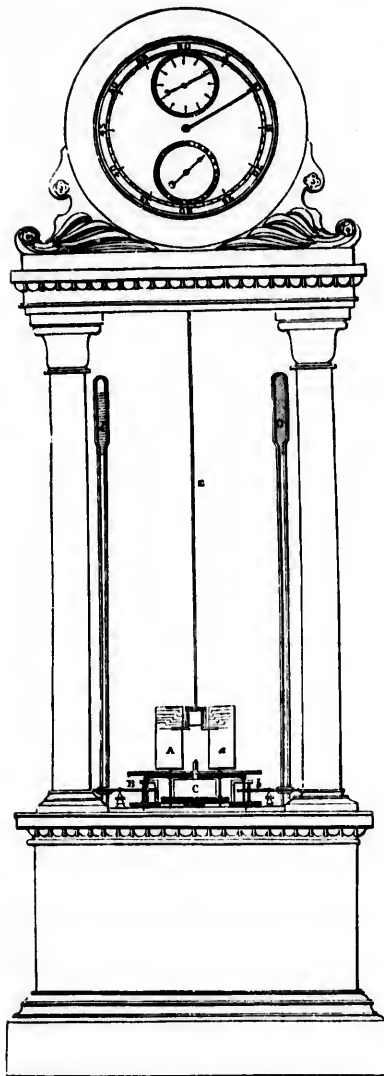

Hall's Astronomical and Meteorological Clock.

fastened to the arbors of the first wheels of the train, and which revolve (upon the average) once in three hours. *B b* are the escape wheels of the train, of the same kind as the clock (the vertical dead beat), of 25 teeth. *c* is the going barrel to impel the two independent trains. *D d* is the thermometer and barometer. *E* is the rod to which is fixed the marking apparatus in connection with the revolving cylinders *A a*. *F* is the escape hour-wheel of 24 pins, with a barrel to receive the chain of the rod *E*. *G* is a wheel with a logarithmic spiral, the groove of which receives the pin of the bar *H*.

*I* is the clock-frame. The action of this entirely new invention is as follows:—*D d*, the thermometer and barometer, are made to vibrate continually by the escapement *B b*, as inverted pendulums; the radii of the gyrations of which are continually affected, either by the pressure of the atmosphere, or by the change of temperature: thus *d*, the Torricellian barometer, will, if the mercury fall one inch, increase the number of its vibrations per hour by 1,000, every one of which is registered on the revolving cylinder *A*, which gives a line in length equal to the number of vibrations given by the barometer *d* per hour; a similar effect is produced by the thermometer *D*, by any change of temperature, and its variation registered on *A*. The hourly measure is marked by breaking the lines, which is effected by the escape of the wheel *F*, and the descent of the rod *E*, with its attached apparatus.

Patent diplometer for railway purposes; the tickets are stamped with the date and the number of tickets issued, with the amount paid.

62 HINTON, CHARLES, 10 Corporation Lane, Clerkenwell  
—Designer and Manufacturer.

English hard white enamel watch dial, with sunk centre and seconds, allowing free motion of the hands, with a flatter glass than usual.

64 JONES, JOHN, 338 Strand—Manufacturer.

Gold and silver watches of peculiar construction.

No. 1. The Rose Watch, showing Time and its doings. On one half of the margin around the back is engraved, on blue enamel, "Man cometh forth as a flower, and is cut down." On the surface of the richly engraved gold back is a Maltese cross, in white enamel, and on its four limbs are depicted the four seasons of life—in the bud, blossom, decay, and death of a rose. On the other half of the margin is engraved, "It is sown in dishonour, it is raised in glory." The dial represents, in enamel colours, the rose window of Westminster Abbey. On the twelve compartments indicating the twelve hours, are the names of the twelve Apostles. On the bezel that holds the glass is engraved, in blue enamel, "He that taketh not his cross daily is not worthy of me."

No. 2 shows, when viewed through a magnifying power, a series of cubical crystals, that being the primary crystal of gold.

No. 3 is a new and simpler mode than hitherto employed of producing dead seconds, with sunk centre in the dial, also a novelty.

No. 4 shows comparative merits of English and foreign work at equal prices.

No. 5. Centre seconds hunter with compensation balance, isochronal spring, and lever escapement.

66 KAISER, JOSEPH, 30 Park Terrace, Regent's Park—  
Inventor and Manufacturer.

Improved detector clock, on a novel principle, indicating, at a glance, the days of the week and of the month, also the name of the month. It goes eight days, and requires no attendance after winding.

66A MOORE, Major W., 3 Cornish Terrace, Rathmines,  
Dublin—Inventor.

A surgical instrument for use previous to operation for lithotripsy, &c.

67 MACDOUAL, E. J., 12 Dorset Place, Pall Mall East  
—Inventor and Manufacturer.

Patent escapement for chronometers, watches, and clocks, without escape wheel. The same spring by India-rubber.

Drill-stocks: Archimedean; centrifugal Archimedean; vibrating; and duplex, simple, and centrifugal.

A new method of converting rectilinear into rotary motion.

A new decomposition cell. Medals made by the process.

NORTH, NORTH CENTRAL, AND SOUTH CENTRAL GALLERIES.

68 **MACDOWALL, C., 4 Hyde Street, Bloomsbury—**  
Inventor.

Clock-movement, with a dead escapement of a new construction, in which the escape-wheel consists merely of a small disc, with a single pin in it. The parts are arranged for the purpose of exhibiting the action of the escapement. The advantages claimed are—the impulse takes place at the middle of the vibration of the pendulum, as in the common dead escapement; it is given chiefly by direct action instead of oblique, and requires little oil; the construction is easy, and may be made with a ruby for the escape-pin as cheaply as with a common recoil escapement. It is applicable to watches as well as clocks.

(E. J. Dent, Manufacturer and Patentes, by assignment.)

69 **MAPPLE, D. D., 17 Hull's Place, John's Row, St. Luke's—**Producer and Designer.

Registered skeleton timepiece, with improved lever escapement.

Improved clock-winder.

70 **DAVIS, J., 119 High Holborn—**Inventor and  
Manufacturer.

An instrument, on a new principle, to survey without calculation.

71 **MARCHAND, LUCIEN, 1 Red Lion Street, Holborn—**Manufacturer.

Very small gold lever watch.

Musical clock, with four overtures, independent seconds, and amusing figures. Size, three feet high, two square.

73 **PAYNE, WILLIAM, & Co., 163 New Bond Street—**  
Inventors and Manufacturers.

Quarter clock, on eight bells, in Amboyna wood, and or-molu case, made for the Sultan of Turkey.

Timepieces, in buhl and or-molu case; and in tulip wood and or-molu case.

Clocks, with lever escapement, in engraved gilt case with patent musical chiming; and in black marble case, with half dead beat-escapement.

Small carriage clock, with lever escapement.

Astronomical clock, with chronometer escapement, perpetual day of month, moon's age, noon and night, day of week, repeat hours and quarters, and zodiacal signs, in engraved gilt case.

Timepiece in square buhl case.

Clock, in square rosewood case, with lever escapement. Lever timepiece, in satin-wood case.

Small clock, in rosewood case, with patent musical chiming.

Half-regulator, in mahogany case, new style.

Small timepiece, with thermometer.

Clock, in ebony case, with silvered ornaments.

Clock with or-molu ornaments, old English style.

Patent pedometer, for measuring walking distances; pedometer attached to a repeating watch, with patent winding, showing seconds and day of month.

Odometer, for measuring carriage distances.

74 **RIX, ISAAC, 21 Conduit Street, Westbourne Terrace—**Inventor.

Skeleton chronometer time piece, slow motion, beating only once in three seconds; the escapement so contrived as to allow the pendulum to vibrate two seconds every beat without touching anything; a perfectly dead escape.

78 **TOBIAS & Co., Liverpool—**Manufacturers.

Registered compound-seconds watch movement, a new configuration produced by combining a quarter-seconds train of wheels with an independent full-seconds train, in such a manner as to cause the seconds hand of the independent seconds train to perform one revolution in the same space of time that the quarter-seconds train is performing four revolutions.

Gold watch, dome case, made from similar movement. Three-quarter plate movement, combining soundness and utility.

Gold watch, with same movement. Lady's watch, with ornamental engraving, and engine-turned case.

Gold hunting watch, with ornamented and engine-turned case.

Silver lever watch, as used in Turkey.

Horizontal movement, jewelled in five pair of holes; extra chronometer-balance, adapted to all climates.

Left-handed movement, extra-jewelled, gold balance.

Silver hunting and plain watches.

Railway guards' timepiece, secured in case.

79 **GILLETT, W. S., Upper Harley Street—**Inventor.

Models of a system of thin rings or discs of metal, which being conical or disked, may by pressure be shortened, and thereby extended either inwards or outwards; applicable to pistons, stuffing-boxes, and other similar purposes; also to the construction of hollow cylinders to bear pressure from within.

80 **THOMSON, ADAM, 25 New Bond Street—**Inventor  
and Maker.

Anto-chronograph: for the instantaneous marking or printing of time, giving the month, day, and hour (night and day), with the minutes and portions of minutes.

The machine requires setting but once a-month. The clock must be wound once a-week. The register may be extended to any required length, and the date, with the exact time, may be stamped or printed in one second of time.

The attendance of guards and of workmen can be correctly noted; and the presence or substitution of particular individuals can be known by their signature upon the register.

The commencement and duration of any event can be correctly registered within a few seconds of time, and all the work of a "time-clerk" correctly done. Provisionally registered.

81 **PETTIT, W., & Co., 2 Crombie's Row, Commercial Road, East—**Inventors.

A watch, keeping time, though suspended in a glass globe, filled with water, and surrounded with gold and silver fish. The object of the invention is to secure the protection of time-keeping and other instruments from water, sea-damp, rust, &c.

85 **HARDY, G., 5 Wellington Road, St. John's Wood—**  
Inventor.

Electro-magnetic motive engine; exhibiting a new mode of employing electricity as a motive power.

85A **WATKINS, A., 7 Weymouth Terrace, City Road—**  
Inventor and Manufacturer.

Original eight-day chronometer, striking the hours; being a self-acting repeater, chiming the quarters upon a set of five bells, and showing the day of the month; each set of works detached; the whole comprising 200 pieces of mechanism in a diameter of not more than two inches.

Chronometers of three-quarter plate construction, with hard cylindrical springs, jewelled with rubies in every hole; presumed to be the smallest ever made of the same construction, the diameter being nearly that of a guinea.

86 **COUBENS & WHITESIDE, 27 Davies Street, Berkeley Square—**Inventors and Manufacturers.

A sporting watch, the novelty of which consists in its determining the time to one-sixth of a second, by means of an independent hand acting from the centre, and detached from all the other hands, with stopping and starting springs. It has a detached lever escapement, is jewelled in 14 holes, and is particularly adapted for racing and other purposes. It may be considerably reduced in size.

87 **ALLIS, J. H., Bristol—**Inventor and Manufacturer.

Bracket-regulator timepiece, with a new description of compound pendulum, which vibrates seconds, though less than half the length of a usual seconds pendulum. Adapted for compensation against the effects of heat and cold.

- 90 **BARLING, JOSEPH**, 90 *High Street, Maulstone*—Designer.  
Dial of a clock, exhibiting a new pattern figure.  
Table and dessert spoons and forks, ornamented in a novel manner, with enamel.
- 91 **VIEYRES & REFINCON**, 129 *Regent Street*—Manufacturers.  
Two-day marine chronometer, in temporary gimbal, for the convenience of exhibition.  
Gold and silver watches, of various fashions, for the home trade and for South America.  
Steel for chronometer pendulum springs, by A. General.
- 92 **BLAYLOCK, JOHN**, *Long Island, Carlisle*—Inventor and Manufacturer.  
Motion-work for the hour and minute hands of a turret-clock with four dials.  
Apparatus for turning on and off gas for illuminating dial, self-acting and self-regulating for each half-year.
- 94 **BOLTON, THOMAS**, *Coventry*—Manufacturer.  
German silver watches, plated with silver.  
Gold-plated watch.
- 95 **MOUILLARD, PIERRE FORTIME VICTOR**, 71 *Albany Street, Regent's Park*—Inventor.  
The artificial leech. It is composed of a body of cylindrical form, about three and a quarter inches long, and about one inch in diameter. Towards the bottom end is a small cylinder, slightly flattened at its lower part, containing a small spoon of about two-thirds of an inch of elevation on its upper part, the opening of which is slightly oblique, of an oval form. This tube, including the spoon, is about two inches long by about half an inch in diameter. The other extremity of the body of the pump is furnished with a piston, which, on being drawn back, empties the pump. This piston, being entirely drawn out to its full length, and pressed by the thumb, releases an interior spring in which the lancets are fixed, and these pierce the skin raised by its suction. The operation is not painful, as the lancets do not remain an instant in the wound.
- 95A **BRISCALL, JAMES**, 48 *Constitution Hill, Birmingham*—Designer and Manufacturer.  
Self-correcting clock, with a detached lever escapement; it goes a month; and shows the day of the week and month. At the end of each month, and in leap-year, it corrects itself.
- 96 **BRUTTON, CHARLES**, *Exeter*—Proprietor.  
A clock, in a case, which occupied thirty-four years in its completion. The movements are as follow:—moving panorama of Day and Night; Day represented by Apollo in his car drawn by four coursers, accompanied by the twelve Hours; and Diana in her car, drawn by stags, attended by the twelve Hours, representing Night. Two figures which salute each other, as the panorama revolves, and the bells are ringing. Perpetual almanac, showing the day of the month on a semicircular plate, and the equation of time, regulated only once in 130 years. Circle, the index of which shows the day of the week, with its appropriate planet. Circle showing the leap-year, the index revolving only once in four years. The sun in his course, with the correct time of rising and setting by a horizon receding or advancing as the days shorten or lengthen; and the moon, showing her different quarters, age, &c. Two female figures, one on each side of the dial-plate, representing Fame and Terpsichore, which move in time when the organ plays. Movement regulating the clock as a repeater. Saturn, the god of time, who beats in movement when the organ plays. Circle on the face, showing the tunes played by the organ every four hours. Belfry, with six ringers. Bird organ, which plays when required. This clock is shown in the annexed Plate, 33. It was made by Jacob Loudan.
- 99 **CHURCHILL, GEORGE**, *Downton, near Salisbury*—Manufacturer.  
An eight-day spring-clock, with music attached, playing a tune every three hours: cast and manufactured by a blacksmith.
- 100 **DELL BROTHERS**, *Bristol*—Inventors and Manufacturers.  
Specimens of ordinary clock-work. Transparent time-piece for the bedroom: a small light is placed behind the dial, showing the time distinctly; the time-piece has a lever escapement, going two days.  
Specimens of iron and brass wheel-cutting, for clock-work, lathe-work, &c.; and wood-pattern cutting, for cast-iron and other wheels.  
Pianoforte music-box, playing six overtures, made by Nicole Freres, of Geneva.
- 102 **DRIVER, J.**, *Silver Street, Wakefield*—Designer and Manufacturer.  
Chime-clock, showing simultaneously upon the dial the time in any part of the world.  
A compensating clock, with a lever escapement, and without pendulum.
- 103 **EDWARDS, JAMES THOMPSON**, *Dudley*—Manufacturer.  
Portable spring time-keeper, to go 426 days.
- 104 **EDWARDS, JAMES**, *Stourbridge*.  
Large transparent skeleton spring timepiece, made of a combination of brass and glass: the wheels consist of cut flint-glass centres, hooped with brass teeth rims, engraved glass dial-plate, and crystal cut pendulum ball; it goes eight days.  
New skeleton quarter-day spring timepiece, made of cut flint-glass centres, hooped with brass teeth rims, having engraved glass dial-plate, and glass pendulum ball; it goes three months, and is kept in motion by a new clock-movement propeller.
- 104A **GRAY, JAMES, Dr.**, *Perth*—Inventor.  
Medical walking-staff, containing an enema—syringe, a catheter, a test tube and test paper, a pair of forceps, a number of wax matches, and a pill-box, divided, containing in each division pills of various medicines.
- 105  
Clock on carved mahogany pillar.
- 106 **EVANS, WILLIAM F.**, *Soho Street, Handsworth, near Birmingham*—Manufacturer.  
Gothic skeleton clock, detached lever escapement.  
Elizabethan timepiece, chronometer escapement.  
Skeleton lever clock, with representation of Sir Walter Scott's monument, Edinburgh.  
Cabin clock, detached lever escapement.
- 109 **GERARD, ALEX.**, *Gordon's Hospital, Aberdeen*—Inventor.  
"Spherical-trigonometer," or an instrument adapted to the mechanical solution of problems in spherical trigonometry and nautical astronomy.  
Portable, or field transit instrument, for finding the time on shore, laying down meridian lines, &c.  
Water-meter, for registering the quantity without interrupting the pressure.  
Clock, with conical pendulum.  
Marine clock, with two pendulums.  
A centrifugal, or conical pendulum clock; capable of performing much heavy work with great accuracy.
- 113 **HART, WILLIAM, & Co.**, *Christchurch, Hants*—Manufacturers.  
Chronometer and watch fusee chains, of different sizes.
- 115 **LAWRENCE, I.**, *North Curry, near Taunton*—Inventor.  
Sun-dial, to suit any latitude in the northern hemisphere. Hand-drill. Turner's centre, with friction rollers. Spring screw-wrench. Dividers.



... near Salisbury—  
 ... music attached, play-  
 ... and manufactured by

... Inventors and  
 ... k. Transparent time-  
 ... light is placed behind  
 ... ly; the time-piece has  
 ... sel-cutting, for clock-  
 ... t-pattern cutting, for  
 ... x overtures, made by

... likefeld—Designer  
 ... er.  
 ... bously upon the dial  
 ... ver escapement, and

... on, Dudley—  
 ... o 426 days.

... rbridge.  
 ... g timepiece, made of  
 ... the wheels consist of  
 ... brass teeth rims, en-  
 ... cut pendulum ball;

... mepiece, made of cut  
 ... es teeth rims, having  
 ... s pendulum ball; it  
 ... otion by a new clock-

... Inventor.  
 ... an enema—syringe, a  
 ... a pair of forceps, a  
 ... ox, divided, contain  
 ... medicines.

... et, Handsworth,  
 ... acturer.  
 ... ver escapement.  
 ... r escapement.  
 ... atation of Sir Walter

... ment.  
 ... ital, Aberdeen—

... instrument adapted  
 ... olems in spherical  
 ... ent, for finding the  
 ... lines, &c.  
 ... antity without inter-

... n clock; capable of  
 ... eat accuracy.

... church, Hants—

... s, of different sizes.

... r Taunton—

... che northern hemi-  
 ... v, with friction rol-  
 ... s.





- 117 PACE, J., *Bury St. Edmunds*—Inventor, Designer, and Manufacturer.

Skeleton clock, which goes three years. This period is obtained by the use of six springs, the united force of which is 250lbs. They are enclosed in six barrels or boxes: three are connected with chains to a fusee on the right hand, and three to one on the left.

Pyramidal skeleton timepiece, which goes three months. The dial is placed at the bottom of the clock to show the motion of all the wheels; with Graham's dead-beat escapement, and the hands moved by a simple mechanism.

Barometer of highly-polished brass, containing three glass tubes supported by scroll-work. The centre tube is the barometer, and those on each side move an index which rises and falls by turning a nut at the base of the stand; by means of wheel-work, they turn the hands on two dials, one for night and the other for day, indicating the state of the barometer.

- 119 RADFORD, JONAS, 339 *High Street, Cheltenham*—Inventor and Designer.

Design and diagrams of a geographical clock or watch; model made by F. Drury, 26 Albert Terrace, Penton Street, Islington.

Two timepieces. Provisionally registered.

- 121 WRIGHT, WILLIAM, *Exchequer Row, Aberdeen*—Designer and Manufacturer.

A clock, showing the minutes, hours, days of the month, and months of the year; the time of the sun's rising and setting; the diurnal revolution of the sun and moon; the moon's age; phases; time of her meridian passage and position relative to the sun; the time of high water at Aberdeen, both superior and inferior tides, and its depth at the bar; and the state of the tide at some of the principal sea-ports of Great Britain, Ireland, France, North and South America, Spain, Portugal, Holland, and Germany; it goes twelve months.

[By adding one or two wheels below the great wheel, and by greatly increasing the usual weight of a clock, it can be made to go for a year. Occasionally such clocks are furnished with two barrels, for the purpose of avoiding the great strain upon the teeth of one large wheel and pinion.—J. G.]

- 122 BROADBENT, JOHN, *Ashton-under-Lyne*—Exhibitor.

Peal of small bells to ring changes; worked by springs. Scale for pitching wheels. Time piece.

- 123 ROSKELL, JOHN, *Church Street, Liverpool*—Designer and Manufacturer.

Watch and clock machinery.

- 124 ROTHERHAM & SONS, *Coventry*—Manufacturers.

Gold and silver watches. Specimens illustrative of the progressive stages of manufacture of a lever watch.

[A large number of watches are made at Coventry, not only for home, but also for colonial trade. The best forms of the common English watch, together with patented and others of a superior manufacture, are here prepared and completed. The manufacture has had its local establishment in Coventry about 80 years.—R. E.]

- 126 MAPPLE, H., *Child's Hill, Hampstead*—Inventor.

Machine for saving life on railways, now used in America. Fire alarm, on the principle of the telegraphic alarm now used on the English lines. Resonant spring for English clocks. Compensation pendulum. Supporting telegraph wires on tripods of iron rods. Improved clock escapement; system of railway signals; and mariners' compass needle. Electric telegraph. Specimen of insulated wire for telegraphic purposes. Compensation for pianoforte strings. Improved system of collecting lamp black; and of making permanent magnets. Improvements

in electric timekeepers. Implement for shoemakers. Model to illustrate a theory for crossing any expanse of water by electric currents, for telegraphic purposes.

- 127 EINSLE, EDWARD, 46 *St. Martin's Lane*—Manufacturer.

Syphon douche, invented by Dr. Charles Jones.

Model of an improved syphon, for brewers, distillers, &c., dispensing with the suction-pipe.

Stomach-pump, with several useful adaptations. Complete case of amputating and other instruments. Double-action enema pump, enclosed in bronze. British plate and electro-plated reservoirs; the valves so arranged that they work freely, and are not likely to get out of order.

Double-action enema apparatus, with metallic folding joints, suitable to warm climates; the same with flexible tube. Portable enema apparatus, with metallic joints. Improved enema apparatus, in round reservoir, discharging the contents with one stroke of the piston. Veterinary enema and stomach pump, with useful tubes and pipes, for hove cattle, &c. Common enema apparatus. Model, to show the action of the double-action enema pumps.

- 127A TAYLOR, G., *Wolverhampton*—Inventor and Manufacturer.

Registered self-correcting eight-day date clock, showing the day of week, day of month, &c.

- 128 SHEPHERD, CHARLES, 53 *Leadenhall Street*—Inventor and Patentee.

Patent electro-magnetic striking clock. From the pendulum of this clock, a number of dials may be worked. The greatest novelty consists in the method of giving the impulse by means of a remounter escapement, by which the variations of the battery take no effect on the time measured. The novelty of the Large Clock in the Transept of the Exhibition Building, in connexion with the former, is in the method of locking the escape wheel, to prevent the train from running by the action of the wind on the hands.

Two dials, five feet in diameter each.

A skeleton electro-magnetic striking clock, showing how the number of blows to be struck is regulated.

Small turret bell, illustrating the method of applying electro-magnetism to move the hammer.

The power employed for keeping in continual action the electric clock, is one of Smee's batteries in connexion with a powerful horse-shoe magnet. In the case of the mechanism of the great clock now under consideration, a series of such magnets is used, the connexion of which, with their armature, is shown in fig. 1.

Fig. 1.

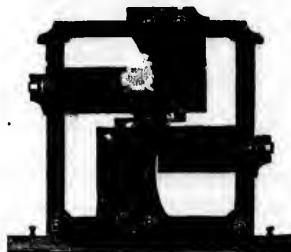

These are surrounded by 25,000 feet, or nearly five miles of No. 18 copper wire, the total weight of which is about 160 lbs. As weights are entirely dispensed with, the frame containing the wheel-work is much lighter than usual; the escape-wheel, a, a, fig. 2, is 10 inches in diameter, and is in two parts, the teeth of each being reversed; the click and ratchet escapement, which is moved by the electro-magnets, acts on the teeth of one of the parts,

while the teeth of the other part are used for the purpose of locking the train, in order to prevent it running forward from the action of the wind on the extra-sized hands which present a large surface. A central vertical wheel, *b*, of larger diameter (see fig. 2 and fig. 3,) which works into a pinion, *c*, on the arbor of the escape-wheel, gives motion to the wheel-work in

connexion with the hands, which are at a height of 40 feet above the pedestal in the South Gallery of the Transept on which the machinery is placed, the communication being effected by a 12-inch bevelled wheel, *d*, which rotates on the end of the spindle of the great wheel, and works into a horizontal bevelled wheel, *e*, with which a vertical shaft, *f*, made of brass tubes of 1½ inch diameter, and

Fig. 2.

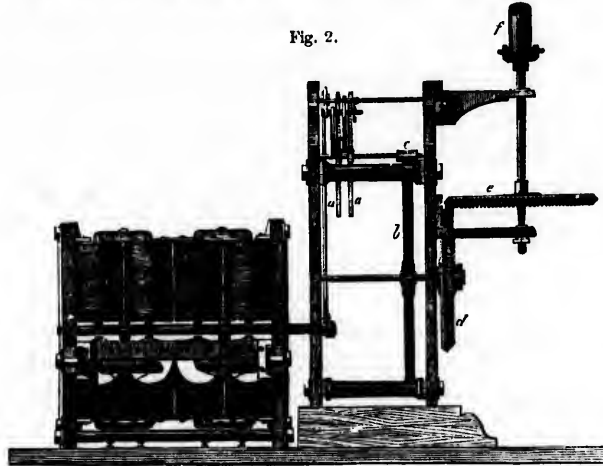
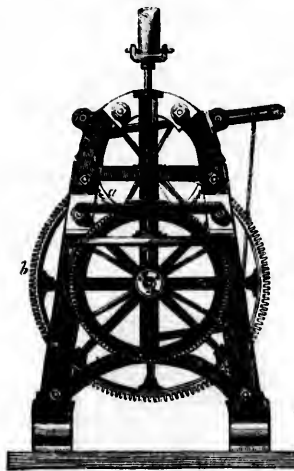

Fig. 3.



screwed together in several lengths, revolves, and which, in connexion with wheel-work at top, gives motion to the hands.

In order that the clock-face might harmonize with the design of the south elevation of the Transept, it was considered that the conventional form of a circle for the dial might be dispensed with; the figures were accordingly arranged in a semicircle, and placed at the intersections of the radial bars with the second semicircle from the centre of the great fanlight.—(See fig. 4.) As is the case in ordinary dials, so in the present instance, XII. is at the top, I. to VI. following on the right

hand side of the semicircle; while on the left side the figure VI. is repeated, and the remaining figures up to XI. inclusive follow in the usual order. In order to render the new form of dial perfectly useful, it was necessary to have two minute hands, and also two hour hands; so that when one of the minute hands, for instance, leaves the figure VI. on the right hand, the other minute hand also points to the corresponding VI. on the left hand. The two minute hands together are 16 feet, and the two hour hands 12 feet in length respectively. Two smaller dials, each of five feet diameter, are fixed up inside the

Fig. 4.

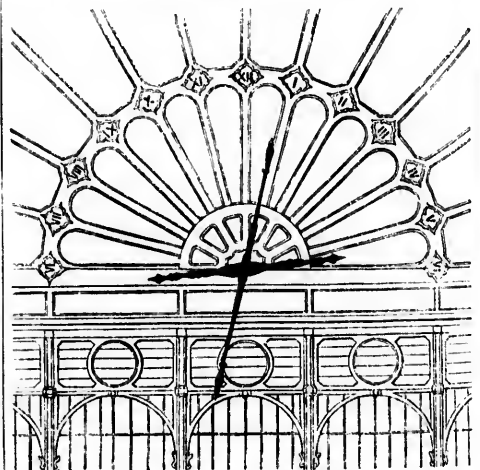

Shepherd's Patent Electro-Magnetic Clock.

building; one in front of the cross gallery at the east end of the central aisle, and the other in front of the south gallery of the transept. All the dials are regulated by one pendulum, represented in fig. 5, and which

Fig. 5.

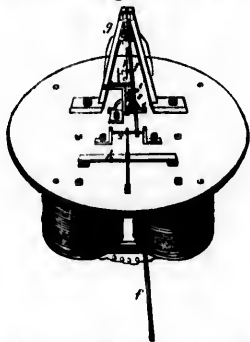

is suspended from a triangular frame, *g*, resting on a bed-plate, to which it is secured by screw-bolts in the ordinary way. The pendulum has a mercurial compensation for heat and cold, and is kept in motion by electro-magnetism by a method entirely different to any previously invented. Instead of applying directly the attractive and repulsive forces of electro-magnetism to the pendulum, according to all the previous methods, the power of an electro-magnet is here employed to bend a spring to a certain fixed extent, the reaction of which gives the necessary impulse to the pendulum, by which means the variations which are continually taking place in the batteries have no effect on the time measured. The arrangement of the spring for giving the impulse is represented at *s* (fig. 5), in which *b* is the impulse spring, consisting of a short steel spring, to which are attached two arms, *c* and *d*, at right angles to each other; *e* is the detent, or catch, for holding this spring when bent by the action of the magnet; *f* is the pendulum-rod carrying the two screws, *h* and *i*, which may be called the impulse and discharging pallets. As the pendulum vibrates to the left, the discharging-pallet pressing against the perpendicular arm of the detent, *e*, forces it into the position indicated by the curved lines; the impulse spring is thus liberated and immediately falls against the impulse pallet *h*. As the pendulum returns to the right, the impulse spring by its elasticity urges the pendulum forward with the exact power required to continue its vibration. The spring is limited in its motion by a screw, *o*, by screwing or unscrewing which the length of the stroke of the spring, and consequently the power may be regulated to the greatest nicety. The pendulum, continuing its motion to the right, comes in contact with a slight spring tipped with platinum, which completes the circuit of the galvanic battery through the coils of the electro-magnet, which is placed immediately underneath the bed-plate in an inverted position, the poles of which pass through the bed-plate. An armature, *k*, consisting of a flat bar of iron, is placed immediately above the poles, being attached to a horizontal arm at right angles thereto, which arm moves freely on an axis *x*, properly supported at either end on a bracket. On the opposite side of the axis is another arm also projecting at right angles, but considerably longer than the first. The use of the second arm, in connexion with an adjustable weight, is to raise the armature from the poles of the magnet. When, therefore, a current of electricity is made to pass through the coils of wire which surround the magnet, the armature is attracted towards the poles, and consequently the long arm with the adjustable weight is elevated in the opposite direction. It is evident that this arm cannot be raised without lifting the arm, *d*, of the impulse spring, *b*, bending the impulse

spring, and locking the upper end of the arm, *c*, on the detent, ready for the next impulse.

[A point of importance in the construction of this clock is the method of making and breaking contact for the electric currents. When the circuit is broken, a spark is seen to pass between the points of contact. The continued action of this spark causes the points between which it passes to become oxidised; and as the metallic oxides are non-conductors of electricity, it follows that the passage of the electricity will be thereby interfered with and prevented.

In the first clock constructed, a piece of steel-wire was used as a break spring, touching against the side of the pendulum-rod; but the points of contact oxidised so rapidly, that the clock would not go for more than a few days without stopping. The steel spring was then removed, and one of gold substituted, and a small plate of gold was soldered to the side of the pendulum-rod. The difficulty appeared to have been entirely overcome; but in six weeks the quantity of electricity passing was considerably reduced, and at the end of two months the clock stopped.

Platina was next tried, in the same manner as the gold, in a new clock, completed in 1848, since which time the points of contact have never required cleaning, the circuits being completed at the present time with as much certainty as when the clock was first put together. These points of contact present some peculiarities when examined with a lens. With metals having a great affinity for oxygen, a black spot forms immediately at the point of contact; while in the case of platina the immediate point of contact remains perfectly clean, a rim of black forming around it. This black rim has been found to be quite capable of conducting electricity. The probable conclusion, therefore, is, that the black rim is platina in a very fine state of division, and not an oxide of the metal.

The battery best adapted for these clocks is that of Mr. Smee, both on account of its simplicity and the ease with which it is recharged. The amalgamated zinc employed in this battery is subject to rapid local action, by the quantity of impurity which it contains, consisting usually of lead, iron, copper, tin, and cadmium; all these metals having less affinity for oxygen than zinc, become negative when immersed in dilute acid, and form a voltaic circle with the surrounding particles of zinc. The use of amalgamation is to stop this action, which, when the amalgamation is fresh, it accomplishes; but in a few days the local action again commences, and increases until the acid is neutralised, or the whole of the zinc dissolved.

This may be obviated by standing the zinc plate loose in the jar, resting on the bottom, and pouring in an ounce or two of mercury. This is found to answer remarkably well; the quicksilver soaking up the zinc plate, keeps it thoroughly amalgamated. The zinc may be melted, and after being mixed with mercury, cast in moulds; the quicksilver would then form one of the impurities present: and should local action take place at any one point, the solution of the zinc would not only liberate the other metals present, but liberate at the same time sufficient quicksilver to cover them, and stop the local action.

It is well known that the zinc of a battery is acted upon more severely at the surface of the liquid than elsewhere, by which the lower part is wasted. This appears to depend on the presence of oxygen; for it does not go on, where the battery has been enclosed in a bottle to collect the hydrogen evolved. A double advantage results

at the left side the  
g figures up to XI.  
in order to render  
it was necessary to  
no hour hands; so  
or instance, leaves  
other minute hand  
on the left hand.  
feet, and the two  
ely. Two smaller  
zed up inside the

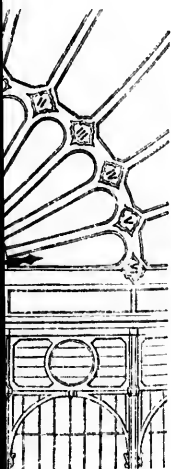



from making the batteries air-tight; not only is this peculiar action stopped, but the evaporation of the water prevented. In batteries required to act for long periods, one zinc plate should be employed, as when two are used, one of them almost always becomes negative to the other; and although this action is very slight, yet when it continues constantly for several months, its effect is very perceptible.

This clock, although quite equal to that of St. Paul's Cathedral, occupies far less space; the heavy weights, with the room necessary for their descent, being of course dispensed with. One of the most obvious advantages in electro-magnetic clocks is, that precisely similar time will be kept by any number of dials situated in the different parts of a large establishment, and connected with one pendulum. Such a series has been in operation for some time at an extensive commercial warehouse. The whole of the dials are regulated by one pendulum, situated in the counting-house. The wire required to communicate between the pendulum and the dials in the different departments of the warehouse is upwards of a quarter of a mile in length.]

129 SMITH & SONS, JOHN, LANCELOT, & WILLIAM,  
*St. John's Square, Clerkenwell*—Manufacturers.

Regulator and case, with self-adjusting pendulum, suited to any temperature, by its own action; with barometer, thermometer, &c.

[Astronomical clocks are sometimes made, and yet not used in observation, but kept by clockmakers themselves, for the purpose of being used as a standard by which to adjust other clocks, chronometers, and watches not yet brought to time; and such clocks, when so used, are called *regulators*, from the use to which they are put; and when they have good compensating pendulums, and the best escapements, they differ from astronomical clocks only in the name.—J. G.]

Detector clock, or watchman's timepiece, for indicating the precise time of absence or neglect of duty in watchmen, nightwardens, &c.; forming also a bracket time-piece.

Eight-day office dials. Eight-day church or turret clock. Church clock to chime the quarters.

Skeleton timepiece and almanac, which goes twelve months with once winding, and shows seconds, minutes, and hours, with the days of the week, and the month, on one dial. Skeleton quarter clock, which chimes the quarters on eight bells, and strikes on steel wire gong.

Whishaw's uniformity of time clock and telegraph instruments.

130 ROBERTS, RICHARD, *Globe Works, Manchester*—  
Proprietor.

Patent alpha (church or turret) clock, the wheels and pinions made of cast-iron, with the teeth retaining the scale; it has only one weight to actuate both the going and striking trains, and the chain or cord, requiring no lateral traverse, can be taken off in any direction. The pendulum (compensation) and the escapement (remontoire) are adapted to keep the clock at an almost uniform rate, whilst the hands being advanced at intervals of thirty (or, if preferred, sixty) seconds, afford opportunity for ascertaining the time to a second.

[The striking of the hour is effected through means by which the blows are given at equal intervals of time, thus avoiding both the irregularity of the fan and the expenditure of power to drive it. The upper part of the case in which the clock stands shows a simple mode of constructing a turret, to consist of four pillars connected together by as many dials, which turret it is proposed should be placed diagonally with reference to the building on which it is to stand, in which position the dial will be better seen in all directions.]

Watch which beats dead (centre) seconds with only one train of wheels, &c.

Patent recorder watch with double hands.

Patent normal drill, for drilling all the pivot, screw, and steady pin-holes in the frame-plates of watches, chronometers, and small clocks. A boy may drill with this machine any number of watch frame-plates, so precisely alike, that the parts that fit one of the frames will fit all or any of the others.

[It will be seen that by varying the distance of the drill from the fulcrum of the graduated beam, any size of watch-plate may be drilled from the same model-plate; and that by changing the model-plate, the arrangement of the holes may be varied at pleasure.]

Patent synchro-meter model, to show that by the application of pneumatics, a clock may be made to indicate simultaneously the time of day on dials in various places at a distance from each other.

Patent wheel sector. By this instrument the external and pitch line diameters of wheels and pinions of any pitch and number of teeth are accurately ascertained.

Electro-magnet, 2½ inches square, the iron of which weighs only one pound four ounces and a half; capable of sustaining upwards of 500 lb.

Electro-magnet, three inches square, the iron of which weighs only two pounds six ounces; capable of sustaining 678 lb.

131 YOUNG, J., *Knareborough*—Manufacturer.  
Skeleton timepiece.

137 RUSH, G., *Eisenham Hall, Bishop Stortford*—  
Inventor.

Design for the improvement of the dial-plate, and registering of the aneroid barometer; so that by the addition of a table engraved upon the face, it will enable the traveller to determine approximate altitudes by simple inspection of the dial.

138 GRAY & KEEN, *Liverpool*—Designers and  
Manufacturers.

Wheel barometer, designed for use in naval establishments.

Gothic wheel barometers.

140 ABRAHAM, JOHN ABURHAM, 87 *Bold Street,*  
*Liverpool*—Inventor.

Barometer, designed to show, without adjustment, the true height of the mercurial column.

141 JONES, W. & S., 30 *Holborn.*

A mountain thermometer.

144 BROOKE, CHARLES, 29 *Keppel Street*—Inventor and  
Designer.

Photographic self-registering magnetic and meteorological apparatus.

The object of this apparatus is to obtain a more perfect knowledge of magnetic and meteorological phenomena, by continuous observation of all the changes that occur simultaneously in the various instruments. As the magnetic changes are too minute to actuate continuously any mechanism, however delicate, a record can be obtained by an imponderable agent only, as light.

Even with a staff of assistants so large that the eye of one of them should be constantly applied to every telescope, the results would be liable to errors of observation; besides which, the magnetic changes occasionally occur too rapidly to be continuously recorded by an observer. Since the apparatus has been employed at the Royal Observatory, Greenwich, the number of the staff has been reduced, and the fatiguing process of nocturnal observations in the magnetic department has been entirely superseded. The apparatus consists of—

1. A declinometer.
2. A bifilar magnetometer.

In these instruments, the torsion circle from which the suspension skin hangs is supported by eight brass tubes

springing from the four corners of a marble slab (which, when in actual operation, would be cemented on the top of a stone pillar firmly fixed in the ground, and insulated from the floor of the observatory): these tubes, about 4 feet long, converge alternately to four points of the torsion plate; they thus compose a framework possessing great stiffness. To the suspension-frame of each magnet, a plane glass mirror and a concave metallic speculum are attached. The plane mirror is for the purpose of making eye-observations with a telescope in the usual manner. A gas-light or lamp is so placed at a distance of about two feet in front of each speculum, that an image of a small slit in the burner chimney surrounding the burner may fall on the sensitive paper attached to—

3. The registering apparatus. This is placed midway between 1 and 2, and consists of a stand supporting horizontally on friction rollers two concentric glass cylinders, round the inner of which is wrapped a sheet of prepared

photographic paper: the outer or covering cylinder keeps the paper moist during the 24 hours it remains in action. A bent arm, attached to the axis of these cylinders, is carried round by a fork at the end of the hour-hand of a time-piece specially constructed for the purpose. The horizontal motion of the tracing point of light, combined with the vertical motion of the paper, traces out the magnetic curve, which, when the paper is removed from the cylinder, is developed and fixed by the usual photographic processes. A third light is attached to the registering apparatus, for the purpose of drawing a standard or base line on the paper; by the varying distance of any point of the magnetic curve from this line, the magnetic variation is determined. At the distance at which these instruments are placed, an angle of  $1^{\circ}$  is represented by 2 inches on the paper; but the scale valve may be enlarged at pleasure, by placing them further apart. This instrument is shown in fig. 1.

Fig. 1.

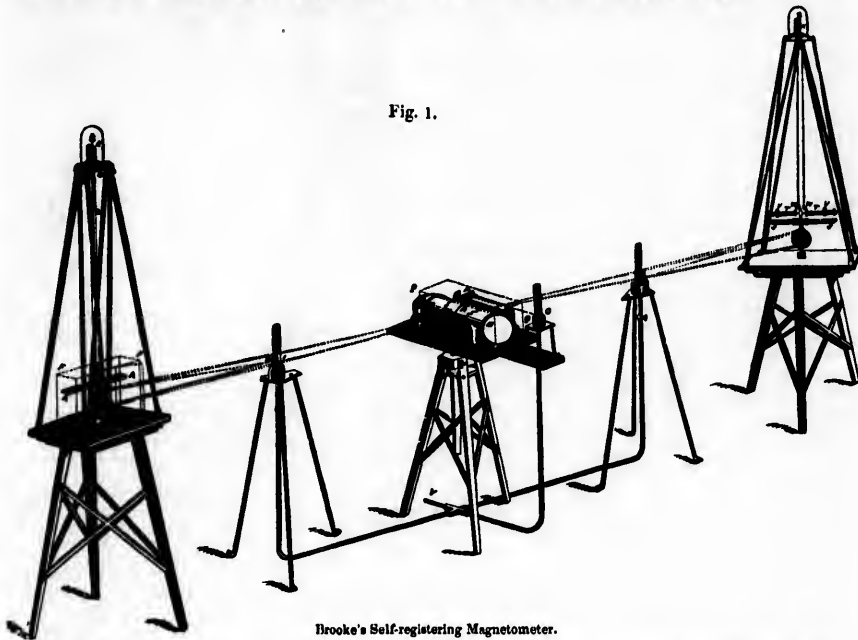

Brooke's Self-registering Magnetometer.

AA, the declination magnet.

B, a concave speculum attached to the magnet.

C, a plane glass mirror also attached to the magnet, for making observations by a telescope, on the old method, when required.

D, the torsion plate, reading to minutes by two verniers. E, a frame standing upon the torsion plate. A hook capable of being raised or lowered by a screw, is attached to this frame, from which the magnet is suspended by a skein of untwisted silk fibres.

FFF, a glass box, in which the magnet and its appendages are enclosed, to protect them from the air; for the same purpose, the suspension skein is enclosed in a glass tube G, which passes through a stuffing box H, in the lid of the box.

I, a gas-burner enclosed in a brass chimney, from which no light can escape, except a small pencil which passes through a narrow slit K, capable of being adjusted by a screw; on the breadth of this slit, the breadth of the register line depends.

LL, a combination of two plano-convex lenses. The pencil of light passing through K, falls on the mirror B,

and is reflected to the cylindrical lenses; by these, the image of the slit is condensed to a point of light on the surface of

MM, the registering apparatus, consisting of two concentric cylinders, between which the photographic paper is placed.

N, the magnetic curve traced by the point of light.

O, a gas-burner, fixed to the stand on which the cylinders rest.

P, a plano-convex prismatic lens, attached to the top of QQ, an opaque box, which protects the photographic paper from extraneous light. A pencil of light from O passes through P, and is brought to a focus on the surface of the paper.

R, the base line, described by the point of light.

SS, the bifilar, or horizontal force magnetometer.

TT, the apparatus for producing an automatic temperature compensation; this consists of two zinc tubes, which are clamped to a glass rod by two adjustable clamps VV, the suspension skein passes over a pulley X, and the ends are attached to two hooks WW; as the temperature rises, these hooks are approximated to each other by a quantity

equal to the difference of the expansion of the glass rod and the zinc tube, between the clamps VV; and thus the torsion force is diminished; the position of the clamps is so adjusted, that the diminution of the torsion force shall be equivalent to the loss of power in the magnet; and *vice versa*, when the temperature falls. The magnet, its appendages, and the suspension skein are enclosed similarly to the declination magnet; the glass box, &c., is omitted to avoid confusion. The registration of its movements is likewise similarly effected on the opposite side of the cylinders.

4. A blackened zinc case, which is placed over the cylinders, when in actual operation, to prevent any light from falling on the paper, except the two pencils which describe the magnetic curves, and another which passes through a prism on the top of the case, and draws the base line. N.B.—This prism is placed on the top of the glass case, to show its proper position.

5. A case of the same material, which covers the whole of the apparatus, to protect the sensitive paper from any stray light, as well as to defend the whole from dust, &c.

6. A balanced magnetometer, supported by agate knife-edges, resting on agate planes. The variations of this instrument are similarly recorded on—

7. A registering apparatus, similar to the preceding No. 3, except that the axis of the revolving cylinder is vertical. The top of the inner cylinder rests on a turn-table, which is carried round by the hour-hand of a time-piece. In this and in the preceding apparatus, the lines of light reflected from the specula are each reduced to a point, by passing through two cylindrical plane convex lenses placed near the sides of the cylinders.

8. A self-registering barometer. The short arm of a lever carries a float which rests on the surface of the mercury in the lower end of a syphon barometer tube. The long arm carries a light screen with a small aperture in it, which is interposed between the revolving cylinder of No. 5, and a light. The small pencil of light passing through the screen marks the photographic paper, and thus records the changes in the mercurial column. The same light which registers the barometer serves also to describe the base line for the magnetic curve, by a pencil conducted from the back of the chimney through a tube with a right-angled prism at each end of it. This instrument is shown in fig. 2.

AA, a self-registering barometer, enclosed in a case, resting on a stand.

BB, the upper and lower ends of a syphon barometer, which are of the same diameter, and of large size.

C, a float resting on the surface of the mercury, which hangs in a notch on the short arm of a lever.

D, the pivot on which the lever turns.

E, the long arm of the lever, which carries at its extremity an opaque screen F, with a small aperture, through which a small pencil of light passes.

G, a plate on which the tube rests, which is raised or lowered by a screw.

H, a stand supporting a gas-burner.

I, the register line, described by this pencil of light. The screen F will evidently rise and fall with the column of mercury, and the indications will be amplified in proportion to the length of leverage.

K, a tube with a plano-convex prismatic lens at each end of it, placed at the back of the burner; through this, a pencil of light is conducted in the direction indicated by the dotted line, and describes the base line L. By this arrangement, two pencils are derived from the same source of light, which fall perpendicularly on two remote points of the paper.

M, the balanced magnetometer.

N, a concave speculum connected with the magnet by a bar, to which are attached agate knife edges; these rest on agate planes attached to the supporting frame.

O, a plane mirror for making observations with a telescope in the usual manner.

P, a gas-burner, from which a pencil of light is reflected from the speculum N, and passing through a combination of two plano-cylindrical lenses in the frame Q, describes the register line R.

Fig. 2.

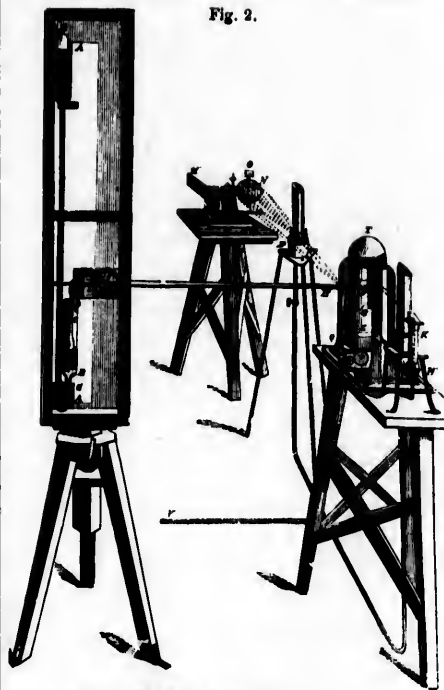

Brooke's Self-registering Barometer.

S, a frame supporting a turn-table.

T, the cylinder resting on the turn-table.

V, the gas-pipe supplying the burners.

9 and 10. Zinc cases analogous to 4 and 5.

11. A wet and dry bulb thermometer, and apparatus for registering the temperature they indicate. The registering apparatus consists of a pair of vertical concentric cylinders, similar to No. 7, supported on a table. The bulbs of the thermometers are underneath the table, through which the stems pass vertically, and are placed between the opposite sides of the cylinders and two lights. A narrow vertical line of light brought to a focus by a cylindrical lens, falls on the stem of the thermometer, and passing through the empty portion of the bore, affects the paper. The boundary between the darkened and undarkened portion indicates the position of the mercury in the stem of the thermometer. Five wires are placed across the slit in the frame, through which the light falls on the stem. They intercept narrow portions of the light, and thus the scale of the thermometer is continuously impressed on the register, as well as the temperature. This instrument is shown in fig. 3.

1, 2, camphine lamps.

3, 4, cylindrical lenses, by which a bright focal line of light is obtained.

5, the psychrometer, or wet-bulb thermometer.

6, the dry-bulb thermometer.

7, two concentric cylinders, between which the photographic paper is placed.

8, the register, as it appears after the impression is developed.

9, one of the rollers of a turn-table, on which the cylinders rest.

10, the frame which contains the timepiece.

11, a bent pin, or carrier, attached to the axis of the cylinders; this is carried round by a fork at the end of the hour-hand of the time-piece.

Fig. 3.

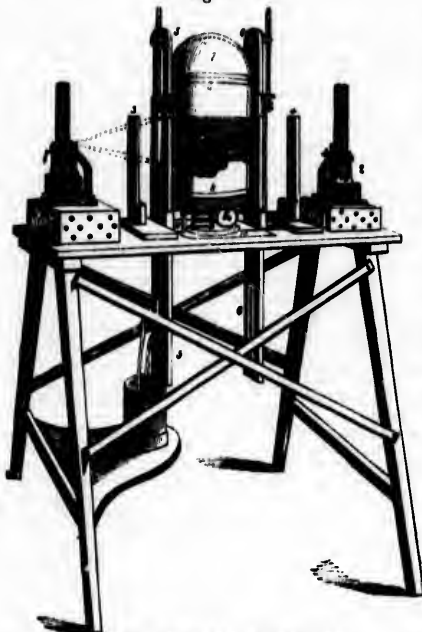

Brooke's Self-registering Thermometer.

As this apparatus is necessarily placed in the open air, when in actual operation, it is provided with—

12. An inner cylindrical zinc case, with sliding doors, to protect the sensitive paper from light, when the cylinder is removed from, and brought back to, the photographic room.

13. An outer wind and water-tight zinc case, with water-tight doors, for removing and replacing the cylinders, and for trimming the lamps, if lamps are used.

14. A timepiece, to show the arrangement of the train. In order to avoid the unsteadiness of the hour-hand, which in ordinary movements results from the play of the motion-wheels under the dial, the central axis which carries the hour-hand is in the train, and the axis which carries the minute-hand is placed out of the centre. As the forked or carrying arm is firmly attached to the axis, another moveable hand or pointer is added, which travels with the former, and points to the hour. The compensating-bars of the balance of this piece are composed of brass and palladium, to prevent the rate being influenced by proximity to the magnets. The numbers of the leaves in the pinions are all prime to the numbers of the teeth in the wheels with which they are in gear, to diminish the chance of irregular motion from wear, as the face of the piece must necessarily be exposed.

15. An elastic scale of vulcanized India-rubber, stretched on a brass frame, for readily marking the subdivisions of time on the registers, which differ slightly in length.

16. Specimens of the registers obtained by similar apparatus.

17. A lithographic fac-simile of one day's work of all the instruments employed at the Royal Observatory, from the volume of "Greenwich Magnetical and Meteorological Observations for 1847," to which the reader is referred for further details, as well as to a series of papers by the inventor, published in recent volumes of the "Philosophical Transactions." The most recent improvement of this apparatus is an automatic temperature compensation, adapted to the horizontal-force magnetometer, 2;

and to the vertical-force magnetometer, 6. In the former instrument, this object is attained by approximating the lower ends of the bifilar suspension, by the excess of the expansion of a zinc tube, over that of a glass rod: in the latter, by the weight of a small quantity of mercury enclosed in a thermometer tube attached to the magnets, passing from one side of the centre to the other.

[The skilful application of photography, by Mr. Brooke, to register natural phenomena, with no more labour than that of supplying the cylinder punctually with prepared paper, is one of the most useful and beautiful uses to which photography has yet been applied. The paper is prepared so as to render it extremely sensitive to light, being first washed with a solution of isinglass, bromide of potassium, and iodide of potassium, in the proportion of 1, 3, and 2, respectively; and when required for use, it is washed with an aqueous solution of nitrate of silver, which causes the paper to be sufficiently sensitive to the action of light, so that if a beam of light be allowed to fall upon it, an impression is made upon that part where the light falls, which becomes visible on being washed with a solution of gallic acid, with a small admixture of acetic acid. A light is placed near a small aperture, through which rays pass and fall upon a concave mirror carried by a part of the suspension apparatus of the magnet, and this reflection falls upon a plano-cylindrical lens of glass placed at the distance of its focal length from the paper on the cylinder. As the magnet is ever varying and making small excursions on one or other side of its mean position, the point of light traces a corresponding zigzag line on the paper. The thermometer apparatus has no mirror and no reflector, the mercury in the tubes themselves intercepting the pencils of light; and thus this apparatus, throughout the day and night, is constantly recording the slightest change of position of the magnets, and the smallest changes of temperature.]

The object of the self-registering magnetometer above described is to determine the direction and intensity of the earth's magnetism. Its direction is generally found by suspending a piece of steel previously magnetized, or in other words, a magnet, by parallel threads of untwisted silk, and the bar settles in that position in which magnetism causes it to rest, and which is called the magnetic meridian. The angle between the astronomical meridian and the magnetic meridian gives the magnetic declination, which is the subject of research with the declination magnetometer; at present this value in London is about  $22\frac{1}{2}^{\circ}$  west of the astronomical meridian.

Having determined the declination, the vertical plane is determined in which the force of magnetism is exerted.

The angle which the magnet makes, when freely suspended on this plane from the horizon, is termed the dip. At present, the dip at London is about  $68^{\circ} 40'$ . The force of magnetism exerted in this inclined direction can be resolved into two forces, the one acting in a horizontal direction, the other in a vertical direction, so that conjointly they shall produce exactly the same force as the single force. The bifilar, or horizontal force magnetometer, is intended for measuring the variations of the horizontal component of the variations of the force of magnetism. It consists of a magnet suspended by two halves of a skein of untwisted silk, kept at a certain distance apart. If an unmagnetized bar were thus suspended, it would remain at rest only in that position in which the two parts of the suspension skein were without twist, and if it were turned out of this position, it would endeavour to resume its former position, with a force proportionate to its weight, and the angle through which it had been turned. This principle is made the means of measuring the force of



magnetism. A freely-suspended magnet always endeavours to rest in the magnetic meridian.

The variations in the vertical component of the magnetic dip are the subjects of investigation with the vertical force magnet, which is a magnet placed nearly at right angles to the magnetic meridian. It is kept horizontal, or nearly so, by weights balanced with extreme accuracy, and made to vibrate like a balance; and from its different inclination, the variation of the vertical force of magnetism is determined.—J. G.]

145 DOLLOND, GEORGE, *St. Paul's Churchyard*—  
Inventor.

Atmospheric recorder. This instrument self-registers simultaneously, on paper, the varying pressures of the atmosphere, the change of the temperature of air and evaporation, and those of the electrical states of the atmosphere, the fall of rain, the amount of water evaporated from a surface of water, and the force and direction of the wind.

[Self-registering instruments, which move equally by clock-work or otherwise, and are made subservient to the registration of natural phenomena, are of the highest importance, and particularly so in meteorological investigations, where the changes of every element of research are perpetual, and those which accrue during the night are of equal importance to those happening during the day.—J. G.]

The atmospheric recorder will correctly register the slightest change which takes place during any period of time, according to the length of the paper.

The apparatus is composed of a frame of about two feet by three feet six inches, firmly supported upon four pillars, the sides of the frame being strongly bolted together at two feet from each other. At one-fourth from each end of the frame, a roller of one foot in circumference is introduced. To one of these rollers an eight-day clock is attached, which moves it round once in twenty-four hours. At half right angles above that roller is another of the same dimensions, so arranged as to press upon it equally throughout its length. The last-mentioned roller is for the purpose of keeping the paper in contact with the driving or clock roller.

The apparatus is represented in the annexed Plate.

The roller at the other end of the frame acts as a rest for carrying the paper to be registered to a platform in the middle of the frame, which has its face in the same plane as the upper sides of the rollers.

Near the end of the frame, which is placed towards the north, is a strong bar, upon which all the fulcrums of the indicators or markers are placed, from which arms of one foot in length, having spring points at their ends for the barometer, thermometer, and hygrometer, are struck into the paper every half hour by a falling lever or frame. For the electrometer, rain, evaporator, force and direction of the wind, ever-pointed pencils are used, which make a continuous mark upon the paper, with a weight pressing upon them so as to render the marks perfectly distinct without interrupting their proper motion.

Beyond the fulcrums there are continuations of the arms of the indicators, to which are applied, by various contrivances, the powers which give motion to the indicators, in those proportions which are required by the scales of the eight instruments which mark the various changes of the atmosphere. Each indicator has its proper scale placed near to the line of the registering points and pencils, so that the last indentures or marks on the paper may be compared with their respective scales, and the time referred to at which the indication took place.

There are also a set of liners which separate each department, and form zero or boundary lines throughout the whole run of the paper, commencing at the point or place of the indicators, from which any movement or hygrometric change of the paper may be referred to for correction.

On each side of the frame, there is a marker for time; these are governed by a wheel attached to the clock roller, which, by a lever and inclined planes, are made to register the time correctly at every half-hour, and sixth hour more strongly, for the convenience of counting. The advantage of thus marking the time on both the edges of the paper is very considerable; for when the paper is taken off, or at any time examined, a line drawn across, corresponding with the opposite marks, will show the correct period at which any change in the atmosphere took place.

Having described the general formation of the apparatus, it will be requisite to give a detailed account of those parts which are more immediately acted upon by the atmosphere, and the manner in which they are made to register the results.

The barometer is upon the siphon principle of a large bore. Upon the surface of the mercury, in the shortest leg, is placed a float very accurately counterpoised, leaving only sufficient weight to compel it to follow the mercury, and correctly adjusted to that part of the apparatus which moves the indicator, when the pressure of the atmosphere is at thirty inches. The connection of the float with the indicator is so arranged as to give a scale of three to one, which has been found to maintain the register in the most perfect manner, under comparison with an excellent instrument of the best construction.

The thermometrical arrangement consists of ten mercurial thermometers of a peculiar form. These are suspended upon an extremely delicate and accurate balance, by which a correct register of all the various changes in this climate have been found to agree with the best thermometers of the usual construction. They are placed at the north end of the frame, and are screened from the effects of the wind and rain by perforated plates of zinc.

The hygrometer consists of a slip of mahogany cut across the grain. This was placed in a cylinder filled with water, and suspended from the upper end, with a weight of two pounds at the other end, until it was found by repeated examination to be completely saturated, and no longer to increase in length. The length was then referred to an accurate scale, and the slip of mahogany placed by the side of the pipe of a stove, under the same suspension and weight, until its shortest length was obtained. The difference of the two results being carefully taken, the scale was formed accordingly. It is placed in a tube, open at both ends for a free passage of air, outside the observatory. It is suspended, and weighted as before, with full power to act upon the arm of the indicator, quite free from the action of the sun or rain, and is found to be extremely active and firm in its operation, showing upon an open scale every hundredth of its extremes in dryness and moisture.\*

The next part of the arrangement to be described is the electrometer for thunder-storms and electric changes. This is constructed by placing a well-insulated conductor upon the highest convenient place, from which a wire is brought down to an insulation on the top of the observatory, and from thence to a standard through another insulation to a metal disc, between which and a spring there is a moveable disc attached to a glass or insulating arm, for the purpose of connecting it with an accurate support upon which it can move with the greatest facility. In connexion with this arm and disc there is a pencil carried forward to the line of indication. The spring before stated is fixed to a standard at about three inches from the first disc; to this a wire is attached and carried into the earth. By this arrangement, the electricity put in motion by a thunder-cloud is received and registered. The effect of this arrangement during a thunderstorm is extremely interesting. When a cloud charged with the electric fluid comes within the range of the conductor, the moveable disc begins slowly to pass from the first disc to the spring, discharging each time a proportion of the electricity, and increasing in rapidity of motion until the discharge of the cloud by lightning takes place. It then falls back to the

\* This method of constructing a hygrometer was recommended by Henry Lawson, Esq., F.R.S., from one in his possession made for and used by the late Dr. Benjamin Franklin, which now performs with precision, although made more than half a century ago.



is a marker for time; it to the clock roller, are made to register, and sixth hour counting. The ad- in both the edges of when the paper is a line drawn across, will show the correct atmosphere took place. nation of the appa- detailed account of tely acted upon by hich they are made

principle of a large ury, in the shortest nterpolated, leaving llow the mercury, of the apparatus pressure of the at- ection of the float ive a scale of three a the register in the n with an excellent

nsists of ten mer- . These are sus- l accurate balance, arious changes in with the best ther- They are placed screened from the d plates of zinc.

of mahogany cut yllinder filled with nd, with a weight l it was found by aturated, and no was then referred hogany pla ed by e same suspension e obtained. The efully taken, the d in a tube, open ide the observa- before, with full eator, quite free s found to be ex- howing upon an es in dryness and

be described is electric changes. ulated conductor hich a wire is of the observa- ough another in- d a spring there ulating arm, for ccurate support est facility. In a pencil carried ng before stated s from the first into the earth. in motion by a . The effect of e extremely in- e electric fluid , the moveable c to the spring, electricity, and discharge of the slls back to the

recommended by sion made for and w performs with gco.

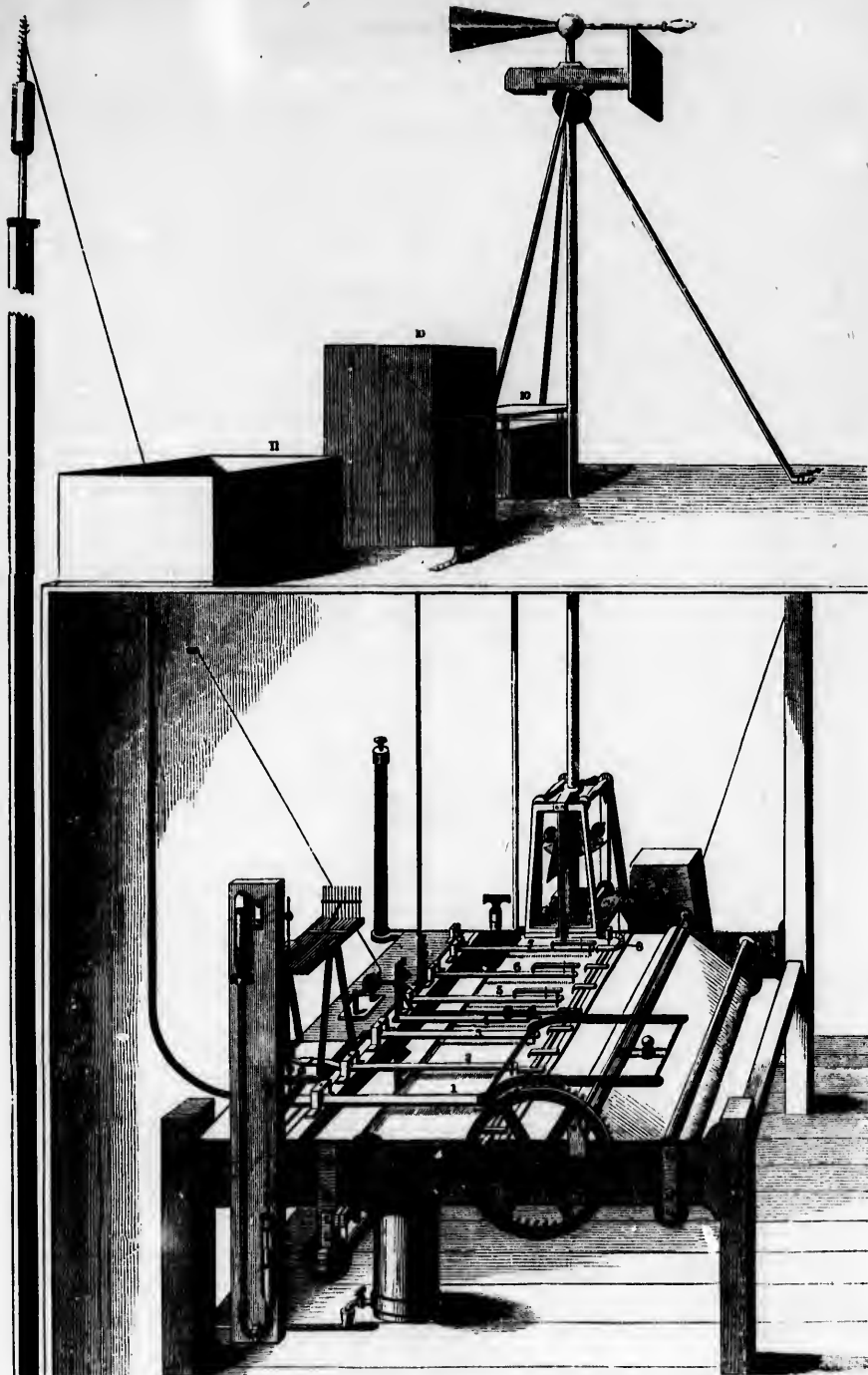

K  
—  
fr  
tri  
wi  
of  
  
is  
is  
ob  
fr  
th  
re  
im  
ap  
of  
in  
m  
pe  
to  
th  
in  
sc  
re  
qu  
m  
T  
in  
th  
  
w  
is  
v  
e  
re  
s  
e  
s  
b  
t  
it  
  
b  
P  
s  
P  
I  
c  
v  
c  
  
E  
K  
J

first disc, and remains perfectly quiet until the next electric cloud approaches. If, in the interim, a cloud charged with rain only should descend or pass over, no movement of the disc takes place.

The pluviometer, or that part of the apparatus which is arranged for registering the quantity of rain that falls, is formed in the following manner:—On the top of the observatory there is a receiver of one foot square, clear from all surrounding matter that might interfere with the direct fall of the rain upon its surface. From this receiver a pipe conducts the rain into another receiver inside the observatory, directly under the registering apparatus; in this there is an air-float, connected with a set of inclined planes, each inclined plane being equal to one inch of rain. These inclined planes, as they pass up, move the indicator across the destined proportion of the paper; showing, as it proceeds, the result of each drop to the hundredth part of an inch in superficies, and continues to advance until it arrives at one inch. It is then instantly discharged, and returns to the zero of the scale, or commencement of another inch. The internal receiver is calculated to contain six inches of rain, a quantity that seldom falls in this island during one month. The register will show when it is nearly full. The water can then be drawn off without the slightest inconvenience, and the float be re-adjusted to the zero of the first inch.

The evaporator, 10, is an open cube of one foot square, which is supplied with water from the larger vessel, and is connected with the cube by a pipe underneath the two vessels, 10-10. From that connexion the indicator of evaporation is carried to the marker or arm, 6, of the registering paper, and is supported by a float from the surface of the water in the larger vessel. The cube or evaporator is covered by a plate of glass at an angle of sufficient elevation to prevent rain from falling into it, but not so close as to resist the air from freely acting upon the surface of the water. When the water is exhausted, it may be refilled from the pump in the observatory.

The power or force of the wind is registered by a combination of suspended weights, acted upon by inclined planes or edges, in connexion with a board of one foot square to receive the impression; this board is kept in opposition to the direction of the wind by a powerful vane, its motion being as free from friction as possible, every part being correctly counterpoised. When the board is acted upon by the wind, it raises the suspended weights by a chain passing over a pulley in a line with the direction of the wind, and well secured from the weather. The suspended weights in connexion with an inclined lever carry the pencil of indication along the scale, which registers the weight lifted in ozs. and lbs. avoirdupois; the scale having been found, by repeated trials, to be correctly equal to the weights recorded upon it.

The direction of the wind is also registered at the same time by another pencil, which marks the course upon the paper, throughout the whole circle of the horizon, or that proportion through which it passes.

For the convenience of placing upon the instrument the paper to be registered, there is a roller, with a flange at each end, to keep it from being deranged as it is unrolled, for which proper receptacles are provided for the pivots underneath the frame, and parallel to the rollers above.

The cut represents one day's work of this instrument.

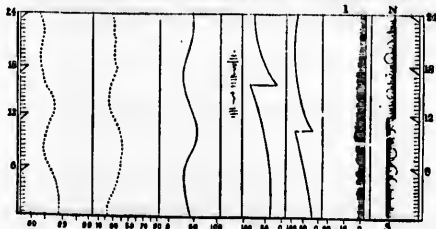

The end of the paper is carried from this roller over the one above, at the north end of the frame, and conducted under the indicators, and over the platform to the driving and pressing rollers; it is then to be drawn forward until it reaches a similar roller to that on which it was first rolled, also underneath the frame; to this roller it is then to be fastened by springs prepared for that purpose. This roller has attached to one of its pivots a worm, upon which a weight is wound up; which weight is equal to the power requisite to wind up the paper as it comes from the driving roller, leaving a space between them, which gives the observer an opportunity of seeing what has been registered during the last twenty-four hours.

For the purpose of reading off the register when removed from the apparatus, there are a set of scales in combination, corresponding correctly with those upon the instrument.

The whole may be placed in a room six feet square, having an opening to the north for the convenience of placing the thermometer out of the range of the sun's rays, and the better for the action of the hygrometer. For the convenience of the lightning conductor and vane, an upper room would be preferable.

References to Plate 95.—1. Barometer. 2. Thermometer. 3. Hygrometer. 4. Electrometer. 5. Pluviometer. 6. Evaporator. 7. Force of the wind. 8. Direction of the wind. 9. The Clock. 10. Receivers for Pluviometer and Evaporator.

Lawson's meteorological thermometer stand: this apparatus consists of a frame (fig. 1) of white deal boards, and can be formed or constructed by any carpenter. It is represented in the cut. It is made of an oblong trunk, T, 12 inches by 8 inches outside measure; to the opposite sides of which are nailed boards, b, b, at the distance of three-quarters of an inch, and projecting about six inches from it towards the north. Outside of these are nailed other thin boards, c, c, full half an inch distant, and projecting about four inches beyond the last-mentioned boards, also towards the north. These sides or shades prevent the sun from heating the interior of the stand where the thermometers are placed. The top, or pent board, P, is made double, and the boards are placed at full three-quarters of an inch distant from each other, and come forward so as to overlap, by a full inch, the right index thermometer, placed immediately beneath, for the purpose of preventing rain or dew from falling perpendicularly upon the bulb of the thermometer. The legs, L, L, of the stand are merely the continuation of the sides of the trunk. The board, F, F, is loaded, or the feet fixed to the ground, to sustain the force of the wind. The interior, T, is blackened to prevent strong reflections of light.

The whole is to be painted white, and no other colour; except the face of the trunk, which may be black, to prevent strong reflections of light.

Fig. 4 is a ground plan, or bird's-eye view of the machine, which will assist any intelligent workman in its construction. The sides and wood-work generally are of half-inch white deal. The distance between the sides of the trunk T (fig. 1), and the board, or inner side, i, s, (fig. 4) is three-quarters of an inch; and the distance from that board to the outer side, o, s (fig. 4), is full half an inch. The narrow boards, s, s, (fig. 4), are to be nailed, with studs intervening, to the middle board or side i, s; and are designed to prevent the sun from shining between the trunk and the sides. o, s, and i, s, when near the meridian. The sides are fixed, one upon the other, at the required distance (viz., three-quarters of an inch, and half an inch), by numerous wooden studs, shown in figs. 1, 2, and 3, about three quarters of an inch diameter; the nails or screws passed through the sides and studs, fixing the whole firmly together. The whole is to be painted white, except the face of the trunk T, which may be black, to prevent strong reflection of light.

Fig. 2 is the view of the north side of the stand. No. 1 is an index thermometer, to give the greatest heat of the air in the shade each day. No. 2 is an index spirit thermometer, to give the greatest cold of the night. No. 4

are two thermometers, with finely-graduated scales, which are called the wet and dry bulb thermometer, to show the power of air to evaporate water. V is a conical vase of considerable size to hold water for the wet bulb thermometer; it is of glass, for the purpose of seeing when it requires re-filling, and conical, to prevent its being broken by frost.

Fig. 3 is the view of the south side of the stand. No. 3 is an index mercurial thermometer, with a black bulb, to give the greatest solar heat of each day. R is a rain gauge, which conveys the rain into the bottle, B, enclosed within the trunk, T (fig. 1). From the bottle, B, the water is to be poured into the gauge tubes, provided for the purpose of showing the quantity of rain that has fallen.

The meteorological thermometer stand, as above arranged, will be found to possess the following advantages. It can be placed in any eligible spot that may suit the convenience of its owner. Its four sides being placed to face the cardinal points, it commands a true north and

south aspect. It can be visited on every side, and be free from all surrounding objects. The instruments or thermometers used can be read off with the greatest facility; and the whole will be at a known distance from the ground. Those instruments placed on the south face will have the meridian sun; and those on the north face will be always in the shade, in consequence of the projecting wings. It can be employed by any meteorologist, wherever residing. It is of a determinate form, height, and size. The instruments may be read off with promptitude, so as to prevent or reduce errors arising from the person of the observer being too long in the vicinity of the thermometers. By the general adoption of this stand, instruments placed upon it will all be used or observed, under similar circumstances; and deductions therefrom be more correctly drawn than at present. It follows, therefore, that observations made either in Europe, Asia, Africa, or America, if drawn from instruments thus similarly placed, can be compared with each other more accurately than heretofore.

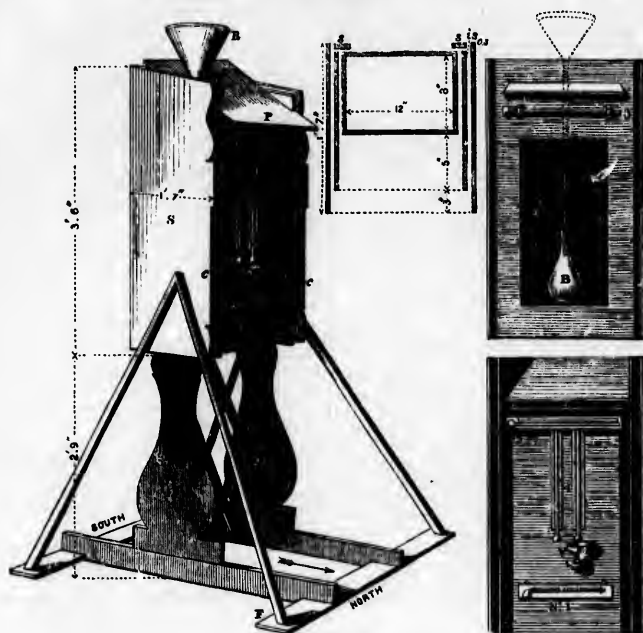

Lawson's Thermometer Stand

In using instruments a certain adroitness is necessary; but a little practice will render the use of the thermometer stand in every respect easy. The thermometers used should have their bulbs perfectly free from the scales, whether of metal or wood, and a space of at least half an inch should be interposed between the bulb of each thermometer and its scale, and the place whereon it is fixed; as in some states of the atmosphere great errors will be the consequence of their touching any surrounding body. The metallic indices in the tubes of registering thermometers are apt to tarnish and cease to slide with the required ease, which may be prevented by passing them up and down the tube, half a dozen times, at every notation of the thermometer. When the thermometers are put by, and out of use, the indexes should be moved to the end of the tube furthest from the bulb, and left there.

146 GOOD, S. A., *H.M. Dockyard, Pembroke*—Inventor.

New method of transmitting motion, applied to a globe for illustrating the effect of the earth's diurnal motion upon the plane of a pendulum's oscillation at any latitude. Provisionally patented.

148 SCHOLEFIELD, DANIEL, *Freeman's Sq., Huddersfield*—Manufacturer.

Portable metronome, for denoting time in music; it weighs less than half an ounce, and can be carried in the waistcoat pocket.

149 HARRIS, WILLIAM, & SON, *50 High Holborn*—Manufacturers.

Patent compensating portable barometers for measuring the heights of mountains, and peculiarly applicable

every side, and be free  
The instruments or ther-  
th the greatest facility;  
own distance from the  
ced on the south face  
those on the north face  
consequence of the pro-  
d by any meteorologist,  
terminate form, height,  
be read off with promp-  
errors arising from the  
long in the vicinity of  
adoption of this stand,  
ll be used or observed,  
deductions therefrom  
present. It follows,  
either in Europe, Asia,  
instruments thus simi-  
each other more accu-

for marine purposes. House barometer. Patent pocket travelling barometer.

New and improved self-registering thermometer. Patent micrometrical and double-image telescope, and "coming-up glass," according to Brewster, for measuring distances either on sea or land. Applicable as a micrometer for the purposes of practical astronomy; as a naval telescope, for measuring distances at sea; and as a "coming-up glass," for ascertaining whether a ship is approaching or receding from the observer.

151 MERRYWEATHER, GEORGE, M.D., *Whitby, Yorkshire*—Designer and Inventor.

"Tempest prognosticator," or, atmospheric electromagnetic telegraph, conducted by animal instinct; for the protection of life and property.

152 HEWITSON, J., *Newcastle-upon-Tyne*—Inventor and Manufacturer.

Self-acting and self-registering tide gauge and tidal indicator, recording with accuracy any variation of the tide, and requiring no supervision. Time is kept by an astronomical clock, with pendulum vibrating seconds. Hours, minutes, and seconds shown on their respective circles, with the height of the tide at the moment of observation, exhibited on the opposite dial. In connexion with the instrument, other machinery is applied to exhibit to an observer, on a large scale, and to be seen at a great distance, the depth of water on the bar, or over shoals, or, in short, at any given place.

154 BRYSON & SONS, *Edinburgh*—Inventors and Manufacturers.

Five models, exhibiting the various escapements of watches at present in general use. Self-registering barometer clock.

157 ROSS, ARCHIBALD HILSON, *25 Bridge St., Sunderland*—Inventor and Designer.

A self-compensating barometer, having the scale which denotes the height of the mercurial column attached to float on the surface of the mercury in the cistern, to show the height of the barometrical column, which is the exact distance between the two surfaces. Design, a Corinthian column, supporting a figure of the late Sir Robert Peel.

157A CASELLO, LOUIS P., & Co., *23 Hatton Garden*—Manufacturers.

Combined comparative barometer; designed, arranged, and manufactured by the exhibitor; exhibiting the Torricellian, the Cartesian, and wheel barometers, and sypiesometer, acting in combination; with varying scales of 1, 11, 4, and 2 inches respectively.

Improved self-registering window thermometer, which, while it protects the scale from the weather, admits of setting and correct reading without opening the window.

Small pocket barometer, adapted for measuring heights. Brown's registered barometer, made by the exhibitor, and exhibited for accuracy and cheapness.

158 LOVEJOY, G., *Reading*—Proprietor.

A novel timepiece, consisting of a dial of glass, in the centre of which an index-hand turns and points out the time, without any visible mechanism. It keeps correct time; strikes the hours and half hours; and requires only to be wound up once in twenty-one days.

159 GRIMOLDI, HENRY, *31 Brooks Street, Holborn*—Maker. Improved pediment barometer in carved gilt frame.

160 SANDERSON, G., *Mansfield, Nottingham*—Designer.

Map of the country twenty miles round Mansfield, in the county of Nottingham, upon a scale of one inch to 36 chains, or 2,376 feet.

160A NEGRETTI & ZAMBRA, *11 Hatton Garden*—Inventors and Manufacturers.

Standard open cistern barometer, with adjusting scale. Self-registering barometer.

New pocket barometer. Pocket sypiesometer or air barometer.

Standard thermometer, with comparative scales for atmospheric and chemical purposes.

Rutherford's thermometer. Sixes' self-registering thermometer.

Set of very sensitive thermometers, for delicate experiments.

Registered thermometer for out-door exposure.

Three of the most approved hygrometers now in use: a Daniel's hygrometer; a dry-bulb and wet-bulb thermometer, and Regnault's condenser hygrometer; the latter instrument is so constructed as to be used like the preceding one, having been altered from Regnault's original form, by substituting black glass for silver caps, to avoid the necessity of cleaning the caps, an operation rendered necessary by the oxidation of metal caps.

Two distinct thermometers in one stem.

Simple and improved pressure gauge, less liable to get out of order than the ordinary mercury gauge.

[The dry and wet bulb thermometers consist of two of these instruments, whose readings, when under the same circumstances, are identical. In use, one of the bulbs is covered with thin muslin, and moistened by means of water passing by capillary action from a vessel containing that fluid, and will take a temperature depending on the amount of moisture in the air. If the air be saturated with moisture, there will be no difference in the readings of the two thermometers; but if the air be not saturated, it will take up additional vapour: this vapour will be combined with heat, and the reduction of temperature will be shown. The different readings of the two thermometers will be according to the quantity of heat which has been required to change the state of water on the bulb to vapour. From the readings of the dry and wet bulb thermometers, nearly all hygrometrical problems can be solved. Ether is more generally used for evaporation with Daniell's hygrometer.—J. G.]

161 ORCHARD, JOHN, *Kensington*—Designer and Manufacturer.

Standard barometer, with various improvements. Series of rack slides for magic lanterns, to show the varied movements of the planets.

Air-pump—having no valve to interfere between it and the receiver, so that the air can be exhausted from the receiver to such an extent as to freeze a vessel of water placed over sulphuric acid for desiccation.

162 PIZZALA, FRANCIS AUGUSTUS, *19 Hatton Garden*—Designer and Manufacturer.

Wheel barometer or weather glass, with rack-work motion, intended to supersede the use of ordinary glass weights. The case is carved in walnut, of novel design, representing the leaves, buds, blossoms, &c., of the lilac, larkspur, collomia, potato-bloom, Solomon's seal, and other plants. The dial-plate is engraved with a globe in the centre, surrounded by the signs of the zodiac.

163 TREBLETT, RICHARD, *9 Albemarle Street, St. John's Sq., Clerkenwell*—Inventor and Manufacturer.

Marine barometer in metal frame, with thermometer, &c., and enamelled metal scales and springs, to check oscillation.

166 DOBBIE, WILLIAM, *Falkirk, Scotland*—Manufacturer.

Barometer, on an improved construction, which has two indices, the one of the common range, and the other



pointing out the thousandth part of an inch in the rise and fall of the mercury.

This instrument is represented in the annexed cut.

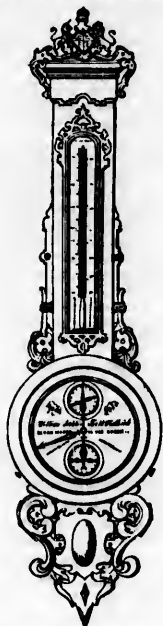

Dobbie's Improved Barometer.

168 COLLARD & COLLARD, *Cheapside*—Manufacturers.

Grand pianoforte, in British mottled oak, with gold decorations, in the style of Louis Quinze; bichord pianoforte, square semi-pianoforte, vase form, and grand cabinet pianoforte, all with the patent check and repeater action.

Pianoforte for the people.—(*Grand pianoforte in Main Arcade.*)

175 LIST, G. B., *Southampton*—Inventor.

An apparatus for setting fractures, and as a rest for the treatment of other accidents and diseases of the lower extremities. Manufactured by J. R. Stebbing, Southampton. It is stated that a surgeon, by the use of this apparatus, can, without any other assistance, set simple, compound, and compound-comminuted fractures of the lower extremity; that it keeps the fractured ends of the bone in apposition, without the aid of splints for the after treatment; that tight straps or bandages encircling the limb above the injury, are not employed; that the limb, when the bone is set, can immediately, or at any time during the healing process, be put into any position that may be most comfortable to the patient without inconvenience. This apparatus is also stated to be an excellent rest for the treatment of fractured patella, diseased hip-joints, popliteal aneurism (by compression), varicose veins, ulcers, and other accidents and diseases of the lower extremities.

181 MATTHEWS, WILLIAM, 10 *Portugal Street, Lincoln's Inn Fields*—Manufacturer.

Stethoscope—the ear-piece, subserving the uses of both a conductor and sounding board, is of large dimensions, so as to transmit the vibrations of the instrument undiminished.

[The science of medicine is indebted to Laennec, a French physician, for the discovery of the stethoscope.

This physician first made known the important fact, that diseases of the heart and lungs might be rendered perceptible to a practised ear by the intervention simply of a hollow cylinder of wood. The instrument in all its forms is merely a medium for the conveyance of sound, healthy or morbid, to the ear of the physician. Stethoscopes are made in various materials; those of light deal are to be preferred.—R. E.]

Specula for the ear, &c., made of glass, silvered with silver leaf, and covered with cotton cloth and elastic gum. Gilbert's patent fulcrum and chair, for extracting teeth.

This apparatus is shown in the annexed cut:—

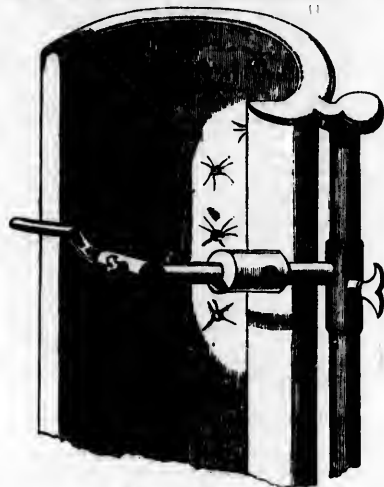

Gilbert's Tooth Extractor.

New ewinging apparatus for the treatment of fractures of the leg; to prevent the bed-clothes from interfering with the motion of the leg.

Inhaler, for opium and other medicines requiring the aid of heat for their inhalation.

Inhaler, for administering chloroform in surgical operations, with water-bath to regulate the evaporation.

Inhaler, for hydrocyanic acid, conicine, and other medicines. Table knives.

187 BATEMAN, JOSEPH, LL.D., *East India Road, and Inland Revenue Office*—Designer and Proprietor.

Centrifugal machine, illustrating planetary motion.

The object of this machine is to exhibit the remarkable tendency of all bodies, having a longer and shorter axis, to revolve upon their shorter axis: a tendency common to all the planetary bodies, as far as we are acquainted with their motions, as well as to all bodies on or near the earth's surface. To illustrate this tendency, a model of the planet Saturn is suspended by its longer axis, and set in revolution by means of a machine which, in the present instance, is regulated by clockwork. As soon as it is in motion, the model, of its own accord, quits its vertical position, and assumes a horizontal one, so as to spin on its shorter axis, and this it continues to do as long as the motion is kept up,—just in the same way as the planet itself is revolving at millions of miles distance. The machine is fitted up in open brass-work, the escapement for which has been arranged by Mr. Jennings, of Birmingham. It is mounted on a kind of triumphal arch, executed by Mr. Flint and Mr. Stokes, of the same place. And the model planet revolves in a circular space, representing the solar system, surrounded by the signs of the zodiac, painted on glass by Mrs. Bateman, and Mr. Mason, of Exeter.

the important fact, that  
might be rendered per-  
intervention simply of  
an instrument in all its  
conveyance of sound,  
the physician. Stetho-  
als; those of light deal

of glass, silvered with  
a cloth and elastic gum.  
r, for extracting teeth.  
annexed cut:—



reatment of fractures  
eases from interfering

ceins requiring the

rm in surgical opera-  
evaporation.  
e, and other me-

ast India Road, and  
er and Proprietor.  
sanitary motion.  
hibit the remarkable  
r and shorter axis,  
endency common  
are acquainted with  
n or near the earth's  
model of the planet  
and set in revolu-  
present instance,  
s it is in motion,  
vertical position,  
spin on its shorter  
ng as the motion  
the planet itself is  
. The machine is  
ment for which  
Birmingham. It  
rch, executed by  
e place. And the  
p, representing the  
the sodiac, painted  
on, of Exeter.

188 RICHARDS, N., 3 Somerset St., Aldgate—Proprietor.  
Globe, with an endless rotary action, named "the geo-  
graphical instructor."

189 MORRISON, JAMES DARRIE, 6 Rankellor Street,  
Edinburgh—Manufacturer.

Mineral teeth in gold plate, with compound swivels, by  
means of which the mouth may be opened wide, without  
displacing the plates from the gums.

Set of teeth, the under gold-screwed, the upper gold-lined.  
Set of carved teeth made from the hippopotamus' tusk;  
with a variety of other teeth of different styles and manu-  
factures.

190 RYLES, MOSES, Cobridge, Staffordshire Potteries—  
Inventor.

An apparatus, of a peculiar construction, showing the  
ebb and flow of the tides.

191 PAXON, WILLIAM, Hampstead—Proprietor.

Lunarian, with improved contrivance for showing the  
phases of the moon.

193 MATHEWS, MARY, 16 Westbourne Street,  
Hyde Park Gardens—Inventor.

"Astrorama," with a sketch explaining its use. A con-  
cave representation of the heavens, with the apparent  
diurnal motion of the stars, and the real paths of the  
planets, folding up in the form of an umbrella.

194 ASHE, W. AUSTIN, 15 Drompton Crescent—  
Proprietor.

Great circle course indicator, invented by Lieut. E. D.  
Ashe, of the Royal Navy. Its object is to point out the  
course which a ship must steer in order to sail on a great  
circle between any two places on the globe, instead of  
steering by the true bearings of the port to which she  
is bound, and thereby materially shortening the voyage,  
in some instances to the amount of 600 miles.

[It is well known that the shortest line which can be  
drawn between any two places on the surface of the globe  
is the arc of the great circle intercepted between them;  
great circle sailing, however, cannot always be practised,  
but it may be usefully combined with other sailings.  
This instrument is adapted as a companion to Mr.  
Towson's tables for "Great Circle Sailing," lately pub-  
lished by order of the Lords of the Admiralty.]

195 FAY, RICHARD, Wapping Wall—Designer and  
Manufacturer.

A vertical orrery, exhibiting the diurnal and annual  
motion of the planets; also, showing the path of a  
comet whose perihelion distance is less than the mean  
distance of Mercury, and whose aphelion distance extends  
beyond the farthest known planet in the solar system.

196 LITTLE, Major R. J., Woolwich Common—Designer.  
Apparatus, and a few small tools in a case, contrived to  
meet the loss of the right hand: its objects—simplicity,  
durability, and cheapness. Manufactured by Gaze, 14  
Beresford Street, Woolwich.

This apparatus is shown in the annexed cut.



Major Little's Artificial Hand.

197 ROPER, W., Bath—Manufacturer.

The "reclinia." Invented by Henry Lawson, Esq.,  
for the purpose of enabling astronomers to use large tele-  
scopes with greater speed and comfort.

198 JOHNSTON, W. & A. K., Edinburgh—Manufacturers.

A terrestrial globe, 30 inches in diameter, showing the  
geological structure of the earth, the currents of the air  
and of the ocean, the trade winds, trade routes, mon-  
soons, and isothermal lines, or lines of equal temperature.  
The stand is carved in walnut, and was designed and  
manufactured by W. Davidson. It has, at the four corners  
of the base, heads emblematical of the four seasons. Sur-  
rounding the compass-box are figures which represent the  
four quarters of the globe, with their appropriate emblems;  
and the circular supports of the horizon are composed of  
clusters of fruit, indigenous to the quarters of the world  
over which they are suspended.

[The temperature of any particular month, or any place,  
varies very much in different years, and its true value can  
only be determined from observations made during a long  
series of years. Professor Dove, of Berlin, has collected  
the observations made at nearly 900 stations on the globe,  
and from them he has constructed maps of the isothermal  
lines, by joining those places, by lines, whose temperature  
was found to be the same.—J. G.]

200 FLETCHER, PETER, 11 South St. Andrew Street,  
Edinburgh—Manufacturer.

Pair of globes, terrestrial and celestial, with cases;  
showing the various stages in globe making.

201 ALLAN, THOMAS, 20 St. Andrew's Square, Edinburgh—  
Inventor.

Two pairs of patent electric telegraphs.

[The general principle upon which electric telegraphs  
depend for their indications, is the remarkable fact dis-  
covered by Professor Oersted, that a magnetic needle  
freely moving on its axis is capable of being turned to one  
side by the transmission of an electric current through a  
wire placed parallel and near to it. It was subsequently  
found, that by placing the needle so as to surround it  
with a coil composed of many lengths of insulated wire,  
this effect was immensely multiplied, and a very feeble  
current became sufficient to deflect the needle so placed.  
The galvanometer was thus invented, and subsequently  
—the needle-telegraph. It is obvious that a means of  
communicating signals was discovered when this fact was  
first developed, since a needle thus placed might be ar-  
ranged at any distance, and being connected with the  
operator by insulated wires, he could cause it to turn to  
one side at pleasure. Such is the principal feature of the  
needle-telegraphs. These instruments consist essentially  
of the following parts—a source of the electric current,  
or voltaic battery, a medium through which it can be  
conveyed without loss, or insulated wires, and a magnetic  
needle arranged so as to be influenced by its passage,  
which is generally suspended in front of the index-plate  
of the apparatus, upon which certain marks are arranged.  
The movements of two such needles, and the combina-  
tion of signals which these obviously afford, form the  
alphabet, or signal code of the electric telegraph.—B. E.]

202 MURDOCH, JAMES, Rothes, Fochabers, Elgin,  
Scotland.

Mechanical indicator of eclipses, without mean motions,  
intended to unite simplicity and expedition in opera-  
tions. Invented by the exhibitor.

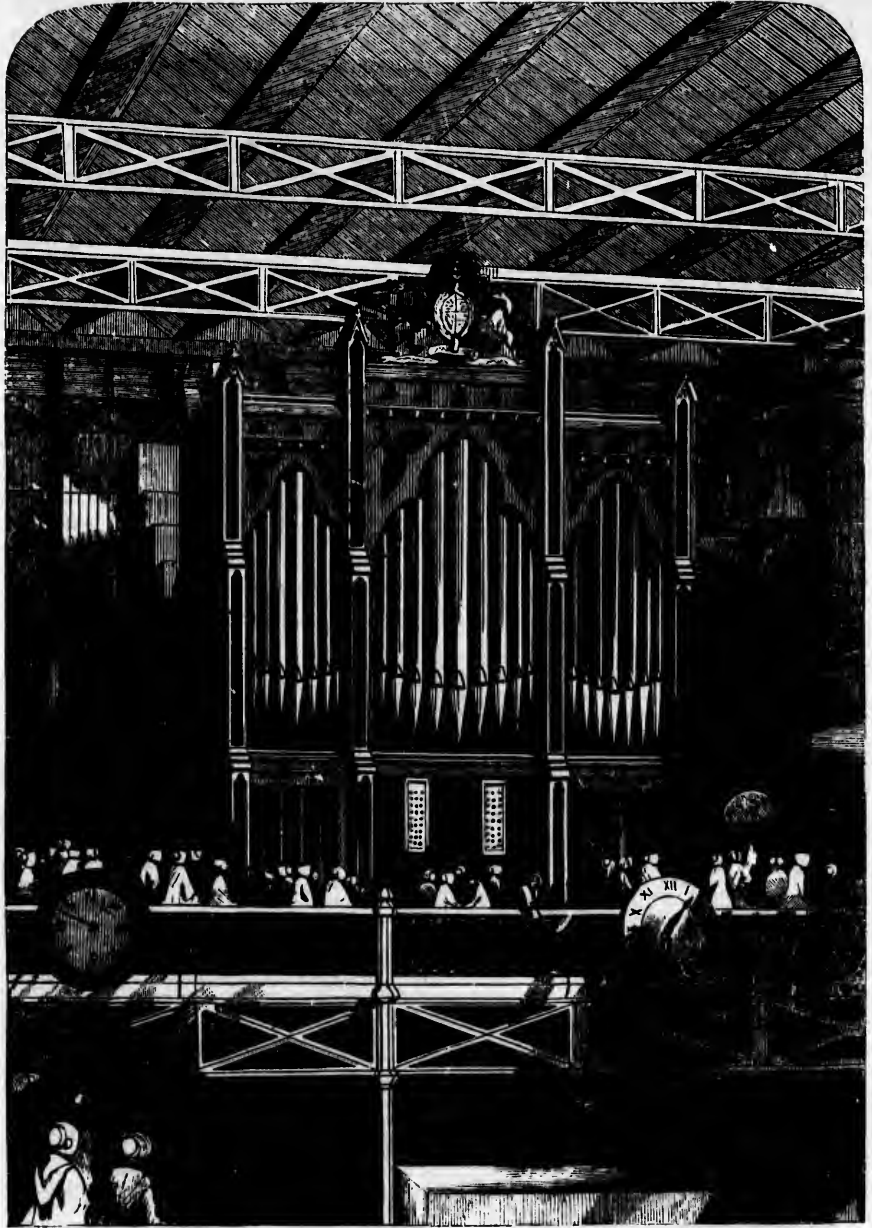

Willie's Grand Organ.

**204 STOKER, JOHN, *Doncaster*—Inventor and  
Manufacturer.**

Angular terrestrial globe, adapted for the ready solution of geographical problems, and particularly to show the true motion of the earth in its orbit.

Spherical geographical clock, intended to show the difference of time between two given places. Provisionally registered.

**205 SAUNDERS, GEORGE, & SON, 278 *Strand*.**

An original revolving kaleidoscope. The object of this instrument is to afford useful information to designers, pattern-drawers, &c.

Octagon temple, containing metallic tablet, razor strops with four sides.

Mechanical revolving pictorial kaleidoscope.

Metallic tablet razor strops.

**207 EDKINS & SON, 16 *Salisbury Square, Fleet Street*—  
Manufacturers.**

Pair of 18-inch globes.

**208 WOOD, P., 18 *Market Street, London*—  
Inventor and Produce.**

Mechanical indicator for teaching geography, designed and manufactured by the exhibitor.

The means used are studs placed in their proper position, as on the map, which on being pressed down raise others at the index, and thus indicate the correctness of the places wanted.

**209 WILLIS, HENRY, 18 *Manchester Street, Gray's Inn  
Road*—Designer and Manufacturer.**

An organ, with three rows of keys, and two octaves and a fifth of pedals. This instrument is built upon the German plan, viz., 8 feet manuals, and 32 feet pedals; it contains 77 stops, nearly 4,500 pipes, the largest being CCCC 32 feet, the smallest C  $\frac{1}{2}$  of an inch. The great and swell organs are played by means of the pneumatic lever, applied vertically, and worked without the aid of additional wind pressure. In the choir and pedal organs are introduced two newly-invented patent valves, over which the pressure of the air has little influence; also a patent movement in connexion with a compound application of the pneumatic lever, which brings the instrument entirely under the performer's command. The mechanism includes several new arrangements, and in the various bellows there are five different pressures of air. This organ is represented in the opposite page as it stands in the Exhibition.

[The superiority of the German plan for building organs chiefly consists in its preserving a balance of power amongst its various masses. The attention of our native builders has been profitably directed to this essential point for some time past, and we hope the time will soon come when an instrument will not be considered complete without a commensurate pedal organ.—H. E. D.]

An organ, consisting of a swell, with 22 stops.

A choir organ of 14 stops.

A great organ of 20 stops.

A pedal organ of 14 stops, and several coupling stops, exhibiting various improvements, including an extensive use of the "pneumatic lever."

[Organs on the pneumatic principle were first introduced into churches by Pope Vitalianus, anno 666. Coupling-stops are used for combining two or more keyboards, so that playing on one produces the effect of both.—H. E. D.]

**210 DUNIN, Mx. C. DE, *London*—Inventor, Manufacturer,  
and Patentee.**

Piece of mechanism intended to illustrate the different proportions of the human figure: it admits of being expanded from the size of the Apollo Belvidere to that of a colossal statue.

The external part of the figure consists of a series of steel and copper plates sliding upon each other, and kept in contact by screws, nuts, and spiral springs; attached to these plates, and within the figure, are metal slides, having projecting pins at their extremities: these pins are inserted in curved grooves cut in circular steel plates; the curvature of these grooves being so arranged that when the steel plates are put in revolution by a train of wheels and screws the slides belonging to each particular part of the figure are expanded or contracted in correct proportion. The elongation of the figure is accomplished either by sliding metal tubes, provided with racks, and acted upon by a combination of wheels, or by screws and slides, as found most applicable for each particular part. Besides the general adjustments described, each part of the figure has an independent and separate adjustment, by which it can be put out of its correct likeness to the Apollo Belvidere, and made to represent the deformities or peculiarities of form of any individual. The varieties of figure and size of the human body are so numerous that it necessarily requires a great number of movements to represent them. Some idea may be formed of the number of mechanical combinations included in the figure, from the following list of the parts of which it is constructed, viz.—875 framing-pieces, 48 grooved steel plates, 163 wheels, 202 slides, 476 metal washers, 482 spiral springs, 704 sliding plates, 32 sliding tubes, 497 nuts, 3500 fixing and adjusting screws, and a considerable number of steadying pinions, &c., making the number of pieces, of which the figure is composed, upwards of 7000. It is stated that this invention could easily be made applicable in the artist's studio; but that its more immediate object is to facilitate the exact fitting of garments, more especially in cases where great numbers are to be provided for, as in the equipment of an army, or providing clothing for a distant colony; that personal attendance is not required, since there is adapted to the figure, a new system of measurement which enables any person to take the exact size and form of an individual; and from the measurement so taken, the figure can be adjusted to represent correctly the person to be fitted, so that the clothing may be tried on, and, if necessary, altered with as much facility as if the original person, whose measure had been taken, were present.



Count Dunin's Mechanical Figure.

An establishment provided with three or four of such figures, would be sufficient to fit perfectly, and without any subsequent alteration, the clothing of an army of several hundred thousand men, at whatever distance they might be from the establishment.

The inventor states it as his intention to present this figure to His Majesty the Emperor of all the Russias.

**212 NEWTON, WM., & SON, 66 Chancery Lane, and 8 Fleet Street—Manufacturers.**

Large manuscript celestial globe, 6 feet in diameter, in which the positions of the stars are laid down from Flamsteed's Catalogue, brought up to the year 1850.

Pair of 25-inch globes, in carved rosewood frames.

Slate globes of various sizes, with the meridians and parallels of latitude marked upon them, so that outline maps may be drawn by the student with pencil.

Variety of globes of various sizes, and in different kinds of mounting.



Newton and Son's Terrestrial Globe.

Complete orrery, or planetarium, in which the motions of the earth and moon, and of the planets and their satellites, are effected by mechanism, actuated by clockwork.

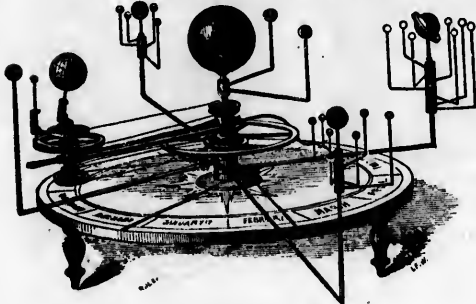

Newton and Son's Planetarium.

Orreries, for educational purposes.

Armillary sphere, mounted in a brass meridian, and attached to a brass stand.

Spherical sun-dial for a lawn.

[A celestial globe is an inverted representation of the heavens, on which the stars are laid down according to their relative positions. The eye is supposed to be in the centre of the globe. A terrestrial globe is a representation of the surface of the earth as far as it is known. The diurnal motion of this globe is from west to east, whilst that of the celestial globe is from east to west, to represent the apparent diurnal motion of the sun and stars.—J. G.]

**213 BENTLEY, JOSEPH, 13 Paternoster Row—Inventor and Publisher.**

Plano-globe. The northern and southern hemispheres are printed on circular pieces of pasteboard; each is confined to its revolving movement, by a brass meridian, allowing the same facility in working problems as the ordinary globe.

**215 PLANT, FREDERIC, Nottingham—Inventor.**

Mechanical orrery: the sun being represented by a luminous body.

Model of a self-regulating steam-boiler feeding apparatus, being a substitute for the common force-pump and regulating float, &c.

**218 ADORNO, J. N., 6 Golden Square—Inventor and Patentee.**

A machine designed to measure and exhibit the ratio between the periphery and diameter of the circle.

A machine or instrument designed to draw ellipses derived from cylinders and cones, and also the other conic sections, as parabolas and hyperbolas.

A terrestrial and celestial globe combined, with the constellations arranged for facilitating the solution of astronomical problems, and for geographical and nautical purposes; with an apparatus to show the passage of the earth among the signs of the zodiac in its annual orbit, and the position of the sun in the opposite signs.

A terrestrial globe, capable of separation into pieces, which may be used as convex maps for navigation, and other geographical purposes.

Twelve patent convex maps of the earth, invented by the exhibitor, to form a geographical sphere, or to be used separately for marine purposes, and to constitute useful and ornamental fittings for rooms or cabins.

**220 HORNE, THORNWAITE & WOOD, 123 Newgate Street—Manufacturers.**

Electro-galvanic machine and set of instruments, for medical galvanism. The current of galvanism produced by this machine "flows only in one direction," and the quantity and intensity of the current are capable of being easily regulated. Represented in the following cut:—

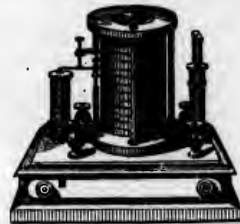

Horne and Co.'s Electro-Galvanic Machine.

Apparatus for exhibiting dissolving views, chromotropes, &c., by the oxyhydrogen lime light, with illustrative



paintings and apparatus, showing the method of producing the light, the arrangement of the lenses, and contrivance for dissolving the pictures.

Oxyhydrogen microscope and apparatus, in case.  
Daguerrotype apparatus, consisting of an adjusting back camera, with compound achromatic lens, an improved bromine and iodine box, with contrivance for transferring the prepared plate to the frame of the camera, mercury box, plate-box, chemical-chest, buff, plate-holders, gilding stand, tripod, &c. The parts of the apparatus are so arranged that the process may be entirely performed in the light, without the necessity of a dark room.

Registered portable folding calotype camera, with achromatic lenses, for portraits and views, &c.

Improved reversing frame, for producing positive pictures from calotype negatives and other photogenic processes.

Registered improved agricultural drainage-level.  
Balance galvanometer, for indicating the strength of galvanic currents in grain weights.

"Optometer," an instrument for ascertaining the existence of any defect in the refracting media of the eye, and for determining the range of adjustment for distances which it possesses.

Patent electric indicator, for fire and thieves.  
Planning rule, comprising the chief scales required by architects and surveyors, with a peculiar arrangement of the odd and even scales, and reading from the edges.

Chemico-mechanical voltaic battery.  
Registering hygrometer.  
Bust of Napoleon Bonaparte, from a model by Canova, executed by the electrotype process.

Similar bust of Sir Walter Scott, from a model by Chantrey.

Transparency, exhibiting the appearance of the lunar disc when in direct opposition to the sun, as seen through Herschel's 40-foot reflecting telescope.

233 GRAHAM, GEORGE, 8 Liverpool Street, Watworth—  
—Inventor.

Invention for directing an aerial machine.

234 GILBERT, G. MOURRAY, Ealing—Proprietor.

Patent portable celestial and terrestrial globes, inflated with atmospheric air, manufactured of superior tissue paper. The celestial globe is particularly adapted for the use of lecturers on astronomy: a view of the stars in their true position may be thus obtained.

The terrestrial globe is inflated by means of an air-pump, or simple movement of the hand.

[A view of the stars in their true position, relatively to each other and to the observer, can only be obtained by placing the eye inside of the celestial globe at its centre. A view of the countries of the earth in their true position can only be obtained by placing the eye outside of the terrestrial globe, at an infinite distance; but this being impossible, the greater the distance, the more accurate is the view.]

Charvolant, or carriage drawn by kites.

237 LUNTLEY, JOHN, New Broad Street Court—  
—Inventor and Manufacturer.

Model of a self-propelling rotary balloon. Provisionally registered.

Specimens of engraving by the ruling machine, composed of circular, elliptical, spiral, straight, and graduated lines. Designed to prevent fraudulent imitation; with a border in chromo-lithography.

248 PRITCHARD, ANDREW, 162 Fleet Street—  
—Inventor and Manufacturer.

An achromatic microscope.

249 HETT, ALEXANDER, 24 Bridge St., Southwark—  
—Preparer.

Variety of injected microscopic objects, showing the application of this mode of preparation, for displaying the structure of parts and organs, and also serving to illustrate the utility and importance of the microscope in its application to the sciences of physiology and pathology. Microscope to exhibit the objects.

[The injection of coloured substances into the minuter vessels of the animal frame is an art peculiar and difficult. Leuwenhoek succeeded perhaps better than any previous, and the majority of subsequent observers, in preparing minute injections, many of which are still preserved as precious relics by the Royal Society. The injections employed consist of substances fluid when warm, and partially solidifying when cold. The apparatus employed is a powerful pump, the taper nozzle-piece of which is inserted into an artery.—R. E.]

250 FIELD, ROBERT, & SON, 113 New Street, Birmingham—  
—Manufacturers.

Large and small achromatic microscopes, with moveable stage.

Dissecting microscope, with Wollaston's doublets.  
Compound achromatic lenses for photographic purposes.

Calotype pictures; scene: Forest of Arden, Warwickshire; staircase, Haddon Hall, Derbyshire; and Wyck Elm, Packington churchyard, Warwickshire.

[The calotype picture is a negative one, in which the lights of nature are represented by shades; but copies from them can readily be made in which the lights are conformable to nature.—J. G.]

252 POULTON, CORNELIUS, Southern Hill, Reading—  
—Manufacturer.

Objects prepared and mounted for the microscope, with illustrative drawings by Mr. M. S. Legg.

253 SMITH, JAMES, & BECK, RICHARD, 6 Coleman Street—  
—Manufacturers.

Glass case; in the top, are stands for compound achromatic microscopes, constructed so as to avoid tremor, with adjustments and complete apparatus. In the middle, are the requisites for mounting microscopic objects, the cells, slips, thin glass, fluid covers, &c., and a few preparations as specimens. The bottom is a new form of cabinet for the objects.

Two tables, with revolving tops, for successively turning the microscope to two or three persons who can conveniently sit round.

[A compound achromatic microscope consists of two or more combinations of lenses, by one of which an enlarged image of the object is formed, and by means of the other, or eye-glass, a magnified representation of the enlarged image is seen.]

254 ROSS, A., 2 Featherstone Buildings, Holborn—  
—Inventor and Manufacturer.

Astronomical telescope, the diameter of the object-glass is 11½ inches, mounted on a stand, with equatorial movements and complete adjustments. The optical part wrought by Ross's improved system and machinery.

This instrument is exhibited in the Western Nave.

[The grinding of an object-glass of 11½ inches in diameter to a good figure, and free from both spherical and chromatic aberration, is very difficult. The advantage of a large object-glass will be seen from the following consideration. The principal reason of the superior distinctness of a telescope over unassisted vision arises from the fact, that the pupil of the eye takes in a certain

number of rays of light; but, on looking through a telescope, it takes in as many more rays in proportion as the object-glass is larger than the pupil itself, and the object appears as brilliant as it would were the pupil of the eye to be enlarged to the size of the object-glass.—J. G.]

Chemical pottery wares. Complete apparatus for distillation and condensation. Manufactured in terra cotta chemical-stone ware, to stand great heat, and lined with acid-proof glaze.

Astronomical telescope, 3½ inches in diameter, mounted on an equatorial stand.

Astronomical telescope, 2½ inches in diameter, mounted on a pillar-and-claw stand.

Improved microscopes, with new method of illumination.

Improved photographic camera obscura.

254A READE, Rev. J. B., F.R.S., *Stone Vicarage, Aylesbury*—Inventor.

Positive solid eye-pieces. (*Main Avenue West.*)

The solid eye-piece (see the following out) consists of two double convex lenses, *c* and *e* of crown glass, with an intermediate double concave lens, *d*, of flint, having the contact

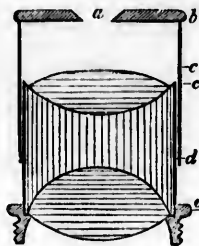

Reade's Solid Eye-piece.

surfaces cemented together. The cap, *b*, contains a small eye-hole, *a*. Its novelty consists in its construction, which secures a large and flat field of view, together with the removal of spherical and chromatic aberration. In consequence of the purity of its achromatism, the webs of the transit instrument and micrometer are seen as fine black lines, and hence it is found by experiment that observations are made more perfectly than with the common positive eye-piece which is not achromatic. No light is lost, as in the usual construction, by inner reflections, and there is no formation of the false image or "ghost" of planets and the brighter stars. From the following data the curves of the lenses may be determined for a given focal length:—

|                                    |                    |
|------------------------------------|--------------------|
| Index of refraction of flint . . . | 1.600              |
| Index of refraction of crown . . . | 1.523              |
| Ratio of dispersive powers . . .   | 0.657              |
| Thickness of flint lens . . .      | 0.775 $\times f$ . |

where  $f$  = whole focal length for parallel rays.

256 HUDSON, FREDERICK THOMAS, *Greenwich*—Producer and Designer.

Microscopic objects—being minute parts of animal, vegetable, and mineral tissues, and structures, prepared for examination by the microscope.

257 VARLEY & SON, 1 *Charles Street, Clarendon Square*—Inventors and Makers.

Graphic telescopes, by which general views or images of objects, either far or near, may be accurately traced, of any size.

Reversing camera, by which pictures or objects may be traced the reverse way.

Microscope, in which the moveable stage is kept parallel to one position whilst freely moved about in any direction.

Reflecting telescopes.

Model of the apparatus for mounting together and changing three small speculums of large Gregorian telescopes, so as not to lose sight of the object; thus the power may be doubled, or quadrupled, or reduced without loss of time.

Air-pump, with crank motion and double-acting single barrel.

New double-acting exhausting air-pump, with increased power.

Portable electrical apparatus: on moving the inner tubes to and fro, the outer tube becomes charged in the same manner as the Leyden phial.

258 JACKSON, E. & W., 315 *Oxford Street*—Inventors.

Thin glass, used for microscopic purposes, and for the polarization of light. Cells for mounting microscopic objects. Slides for microscopic purposes; exhibited for economy in production.

259 CHADBURN BROTHERS, *Sheffield and Liverpool*—Manufacturers.

Specimens of glass in the rough state, suitable for spectacles.

Glass, cut round and oval, ready for cementing on the blocks.

A block of glasses ready for grinding, being plane or parallel.

A block of glasses ground to the required radius. The focus of the glass depending on the radius of the lap in which they are ground.

A lap, 12 inches radius; glasses when ground on both sides in it, are 12 inches focus.

A block of glasses, ground and polished, ready to be taken off.

Tool used for polishing the glasses.

A block of concave glasses finished; being cemented in the lap, they are ground hollow.

Glasses ready for fitting into spectacles. The exhibitors grind 750 dozen per week, on the average.

Provisionally registered portable barometer. The improvement consists in making the cistern of glass (which is covered) with a flexible cover, which can be pressed down, so as to prevent the mercury oscillating when the barometer is carried about or packed for travelling.

Optical lenses, of various kinds. Spectacles—reading and magnifying glasses, &c. Opera glasses and small telescopes. Day or night ship and signal telescopes. Large and portable achromatic telescopes. Simple and compound microscopes. Magic lanterns and views. Camera-obscura and diagonal mirrors. Agricultural and surveyors' levels, &c. Horse-shoe and other magnets. Steam and vacuum gauges. Barometers, &c. Garden and window syringes. Galvano-electric machines. Ship's berth or side illuminators and ventilators. Working models of steam-engines, &c. Craig's charactograph.

263 ABRAHAM, ABRAHAM, & CO., 20 *Lord Street, Liverpool*—Manufacturers.

Tripnopic prismatic lantern, with apparatus for making oxygen gas, viz.: gas bag, retort, and purifier, invented by the Rev. St. Vincent Beechey. It combines the powers of three lanterns, with one small lamp of intense brightness. A disc of 25 feet for each tube may be obtained, and each disc is capable of being darkened to any required extent, without shadow on any portion of the picture.

Dioptric prismatic lantern, producing two in lieu of three discs.

Compound microscope, exhibited for workmanship.

Portable sketching camera obscura. In the optical arrangement, a meniscus and prism are employed in lieu of a lens and mirror, and a vivid flat picture is obtained.

[The tripnopic and dioptric lanterns exhibited, are for the purpose of producing panoramas and other pictures, generally displayed by means of the phantasmagoria lanterns and dissolving-view apparatus. The lamp employed is an oil-lamp, supplied with oxygen gas, on the principle of the Bude light.]

264 RICHARDSON, T. W., *Breds, near Northam, Sussex*—  
Inventor.

A reflecting telescope, for observing the sun's surface: the reflector, made of crown glass, is part of a paraboloid of revolution.

Improved screw for straining wire fences. Hop-tallies. Specimens of the prismatic colour on glass, &c.

265 WILLATS, T. & R., *28 Ironmonger Lane, Cheapside*—  
Inventors and Manufacturers.

Improved portable photographic camera and stand, for obtaining pictures by any known photographic process, on metal plates, paper, glass, &c.

The advantages of this form of camera are, the facility with which it can be packed into a small compass; the adjustments for placing the paper or plates at the proper focus, without exposing them to the daylight; and the comparatively small weight of the apparatus: thus rendering the practice of photography easy to a traveller.

Improved registering thread calculator, or linen prover, to ascertain the number of threads in a given space, of silk, linen, or cotton fabric, and to register this number on paper.

It is of importance in purchasing any woven fabric, to ascertain the number of threads, warp, and woof contained within a square inch, as the knowledge of these enables the purchaser to judge of its strength and durability. This instrument is devised to render the operation easy to the merchant.

266 SALMON, WILLIAM JOHN, *254 Whitechapel Road*—  
Manufacturer.

Day or night telescopes for ships' use.

267 CRICKITT, R. E., *Doctors' Commons*—Designer.

Universal equatorial telescope-stand, to revolve round the polar axis without altering, and at the same time to secure steadiness.

268 CALLAGHAN, W., *45 Great Russell Street, Bloomsbury*—  
Manufacturer.

An improved deer-stalking telescope.  
A pair of portable steel spectacles.

269 PILLISCHER, MORRICE, *398 Oxford Street*—  
Designer and Manufacturer.

Large and small achromatic microscopes, with the stage movements simplified.

Students' microscope, capable of forming a portable dissecting, as well as clinical microscope, with all the necessary apparatus.

Double achromatic opera-glass. Opera-glasses, mounted in tortoiseshell and gilt, and mounted in ivory.

Newly invented compasses, for describing ellipses of any size.

Six's thermometer in ivory, for registering maximum and minimum temperatures.

270 CARPENTER & WESTLEY, *24 Regent Street*—  
Manufacturers and Proprietors.

Phantasmagoria lanterns, with the latest mechanical and optical arrangements. Set of lenses, and a set of sections of the apparatus to show the optical principle.

Paintings of natural history, with some of the same subjects in outline, as printed from copper plates, and supplied to artists.

Series of astronomical diagrams. Paintings adapted to dissolving lanterns.

[The phantasmagoria lanterns exhibited are a scientific form of magic-lantern, differing from it in no essential principle. The images they produce are variously exhibited, either on opaque or transparent screens. The light is an improved kind of solar lamp. The manner in which the beautiful melting pictures called dissolving views are produced, as respects the mechanism employed, deserves to be explained. The arrangement

adopted in the instruments exhibited is the following:—

Two lanterns of the same size and power, and in all respects exactly agreeing, are arranged together upon a little tray or platform. They are held fast to this stand by screws, which admit of a certain degree of half-revolving motion from side to side, in order to adjust the foci. This being done in such a manner that the circle of light of each lantern falls precisely upon the same spot upon the screen, the screws are tightened to the utmost extent, so as to remove all probability of further movement. The dissolving apparatus consists of a circular tin plate, japanned in black, along three parts of the circumference of which a crescentic aperture runs, the interval between the horns of the crescent being occupied by a circular opening, covered by a screwed plate, removable at pleasure. This plate is fixed to a horizontal wooden axis, at the other end of which is a handle, by which the plate can be caused to rotate. The axis of wood is supported by two pillars, connected with a flat piece which is secured to the tray. This apparatus is placed between the lanterns in such a manner that the circular plate is in front of the tubes of both, while the handle projects behind the lanterns at the back. The plate can, therefore, be turned round by means of the handle, without difficulty, from behind. A peg of wood is fixed into the axis, so as to prevent its effecting more than half a revolution. The widest part of the crescentic opening in the plate, is sufficiently so to admit all the rays of the lantern before which it happens to be placed. On the plate being slowly turned half round, by means of the handle behind, the opening narrows until it is altogether lost in one of the horns of the crescent. The light of that lantern is gradually cut off as the aperture diminishes, until it is at length wholly shaded under the moveable cover occupying the interval between the horns of this crescentic opening. In proportion as the light is cut off from one, it is let on from the other tube, in consequence of the gradually increasing size of the crescent revolving before it, until at length the widest part of this opening in the plate is presented before the tube of the second lantern, the first being, as we have seen, shaded. This movement being reversed, the light is cut off from the second lantern, and again let on from the first, and so on alternately. Thus while the screen always presents the same circle of light, yet it is derived first from one lantern, then from the next.

When in use, a slider is introduced into each lantern. The lantern before the mouth of which the widest part of the opening in the plate is placed, exhibits the painting on the screen, the light of the other lantern being then hid behind the cover. On turning the handle, this picture gradually becomes shaded, while the light from the second lantern streams through the widening opening. The effect on the screen is the melting away of the first picture, and the brilliant development of the second, the screen being at no instant left unoccupied by a picture.

The principle involved in this apparently complex, but in reality simple mechanism, is, merely the obscuration of one picture and the throwing of a second in the same place on the screen. And it may be accomplished in a great variety of ways. Thus, by simply placing a flat piece of wood, somewhat like the letter Z, on a point in the centre, so that alternately one or the other of the pieces at the end should be raised or depressed before the lanterns, a dissolving scene is produced. Or, by fixing a moveable upright shade, which can be pushed alternately before one or the other of the lanterns, the same effect is produced.

Individuals exist in this metropolis whose sole occupation consists in painting the minute scenes or slides used for the phantasmagoria lanterns. The perfection to which these paintings are brought is surprising. There are two methods by which the slides now employed are produced. In one of these, the outline and detail are entirely the work of the artist's pencil. For pictures representing landscapes, or wherever a spirited painting is required, this is the exclusive method employed. The colours are rendered transparent by being ground in Canada balsam and mixed with varnish. The other method is a transfer process. The outlines of the subjects are engraved on copper plates, and the impression is received from these on thin sheets of glue, and is then transferred to a plate of glass, the impression being burnt in the same manner as is effected in earthenware. Slides produced in this way receive the distinctive name of copper-plate slides. The subject is merely represented in outline, it being left to the artist to fill up with the necessary tints, &c. The advantages of this method for the production of paintings of a limited kind are obvious. Latterly photography on glass has been employed to obtain pictures for the magic lantern.—R. E.]

271 **DIXEY, C. W., 3 New Bond Street—Manufacturer.**

Carved oak barometer. Barometer showing the action of the mercury. Improved nautical sextant. Assortment of spectacles. Eye-glasses. Binocular opera-glasses. Thermometers. Registered thermometers. Telescopes. Mathematical drawing instruments. Ivory rolling parallel rule (fully divided).

273 **BAYLEY, ROBERT, 18 Half Moon Crescent, White Conduit House—Manufacturer.**

Gold and steel spectacles.

274 **GODDARD, JAMES THOMAS, 35 Goswell Street—Manufacturer.**

Achromatic object-glass for a telescope of 9 inches aperture, and about 16 feet focus.

[The larger glass placed in telescopes, or that which is placed the furthest from the eye, is termed the object-glass. If this glass consists of a single lens, the image of a circular object will not be a perfect circle, as it ought to be, for such a lens will not refract all the rays falling upon it to a single point, and will cause an image in its focus to be both distorted and coloured; the former defect arises from the fact that no spherical lens will produce a perfect image; and the latter, from the unequal refrangibility of the coloured rays which, united, form a perfectly colourless image, and thus the image will be surrounded with several colours. The most important improvement in object-glasses was made in the year 1757, by Dollond. This was effected by making the object-glass double, one portion being made of flint glass and the other of crown glass, of different refractive powers, which mutually correct each other, and thus give a pencil of light entirely colourless. Such object-glasses are called achromatic.—J. G.]

274A **EVANS, W., Brecknock, South Wales—Inventor and Manufacturer.**

Artificial leg, to enable persons who have lost the knee either to walk or ride. By a concentric action a stiffness is given to the knee-joint, which causes a pressure in the stirrup equal to nature, and requires only a touch of the finger outside the trousers or breeches, under the knee-joint, before mounting; by a similar touch on the front of the thigh, before dismounting, the pressure is removed, when the person may walk with ease.

276 **CLARK, F., 13 Park Side, Knightsbridge—Inventor and Manufacturer.**

Newly-invented adjusting spectacles and opera-glasses.

278 **HYAMS HYAM, 50 Cornhill—Inventor and Manufacturer.**

New object-glass, acting as a telescope or opera-glass, and consisting of only a single piece of glass or lens, in the shape of a truncated cone, having a convex surface at the base or large end, and a concave surface at the other. Improved Stanhope lens of a conical shape.

279 **WEAVER, HENRY, 120 Oxford Street—Manufacturer.**

Invisible steel spectacles; gold spectacles, and a variety of other spectacles, and hand-glasses.

280 **WHITEHOUSE, NATHANIEL, 2 Cranbourn Street**

—Proprietor and Manufacturer.

Artificial eye. Artificial silver nose. Solid silver opera-glasses. Gold spectacles to fold in a walking-stick. Tortoiseshell spectacles. Improved sketching spectacles, without rim to obstruct vision. Invisible spectacles; the frame being let in, the glass is concealed.

281 **WOODMAN, JAMES T., 6 Commercial Place, Commercial Road, Peckham—Inventor and Manufacturer.**

Portable self-adjusting leg and foot rest. Its advantages consist in the facility of being raised to the required height, and its immediate self-adaptation to the position in the leg or foot may be placed. If necessary the whole action may be made rigid without removal of the limb. As to size, it can be packed in a common carpet bag.

283 **BRAITHWAITE, S., 169 Kirkgate, Wakefield—**

Inventor and Manufacturer.

Registered ventilating eye-shades.

284 **STARK, ROBERT M., 1 Hope Street, Edinburgh—**

Inventor and Manufacturer.

Microscopic objects of vegetable origin, prepared in gutta percha cells; intended as a substitute for glass cells, being equally durable, and produced at less cost. They are adapted for most vegetable and animal tissues, requiring to be kept in a liquid medium.

Slides for exhibiting opaque objects under the microscope. The groove in the centre, to receive the cover, is made with a circular bit designed for that purpose.

[It is an evidence of the progress of microscopic knowledge, that the preparation of objects of the kind described constitutes at present a distinct art.—R. E.]

285 **JORDAN, CHARLES, 37 Chapman Street, Manchester—Inventor and Manufacturer.**

Case of optical instruments for surgical and other purposes:—

No. 1 is an instrument for the inspection of the internal parts of the ear. The instrument as seen in the case, with silver truncated tube, is for the ear only. The silver tubes Nos. 2 and 3, the two long brass tubes, the sliding tube No. 4 (with magnifier), and the large brass tube, are used for other internal parts of the body.

No. 5 is an instrument for the Eustachian tube; an elastic tube is made to slide inside a silver one, and inside the elastic tube, is a steel spring wire for the purpose of giving curvature to the elastic tube, when introduced into the Eustachian tube.

Before introducing the instrument the elastic tube must be partially withdrawn from the silver tube, and when the orifice of the Eustachian tube is felt, the elastic tube must be gently slid therein, when the spring wire will adapt itself to the required curve.

The wire is intended to convey a feeble galvanic current through the membranous tympani, through a little aperture at the end of the elastic tube; when the wire is withdrawn, fluid or vapour may be injected.



No. 6 is a lamp for illuminating the deep cavities of moulds in iron-founding, &c. Much inconvenience has often been felt by moulders in large foundries for a right method of directing light down the deep parts of moulds.

Ivory concentric shells, turned from the solid ball. The ball is five inches diameter; there are 14 shells, the inner ones being 1-20th inch thick and the space 1-16th inch between each shell. The tusk from which the ball was turned weighed 160 lbs.

Specimens of all the useful metals and alloys, showing the surface and fracture.

286 **SOLOMON, JOSEPH, 22 Red Lion Square—**  
Manufacturer.

Registered paper maché opera glasses. Eye protectors, &c.

287 **KING, THOMAS D., Bristol—**Designer and  
Manufacturer.

Compound achromatic microscope mounted on a pyramidal tripod, with mechanical stage, traversing in rectangular planes by micrometer screws, achromatic condenser, polariscope, double refracting goniometer, cobweb micrometer and other eye-pieces, insect forceps, and various accessories. In this microscope the weight is equally distributed over the base, and when inclined at its working angle, the chief portion is brought below the point of suspension; the traversing stage has divided scales and verniers, whereby admeasurements can be accurately determined.

Student's compound achromatic and single microscope. Improved spherical prismatic illuminator, for transparent and opaque microscopic objects, enabling the rays of light to be thrown either obliquely or vertically.

289 **BRAHAM, JOHN, 17 St. Augustine's Parade, Bristol—**  
Manufacturer and Inventor.

Spectacles, from their earliest invention: various modes adopted by Sir Isaac Newton, Drs. Kitchiner, Wollaston, and Herschel. Perfect and imperfect lenses. Lenses, from 60 inches to 1½ inch focus. Meniscus and double-convex lenses.

Specimens of Brazilian crystal.  
Mode of producing convex and concave lenses for spectacle-eyes.

Improvements on Wollaston's principle of curved lenses. Model of the eye.

Spectacles without rims; and hand-frames.  
Patent pantoscopic spectacles, in gold, silver, steel, and shell mountings.

Double pantoscopic lens, for near and far sight; the same worked in one disc of glass (two pairs). Registered trigonometer, for measuring and protracting angles from a centre.

Herauth's registered gas blow-pipe.

290 **ROWLEY, J., Waterhampton—**Manufacturer.

Front of a pair of spectacles worked out of a solid piece of cast-steel.

Improved spectacles, the sides being so formed that they may be used without being placed upon the head; they also include Brahan's patent.

Pair of spectacles, with several improvements.  
Spectacles, exhibited for their extreme lightness, worked out of best cast-steel; weight, 2 pennyweights.

Globular glass travelling spectacles. Wire-gauze eye-preserving spectacles. Horse-shoe eye-preserving travelling spectacles. Another pair (finer). Small oval eye spectacle, preserver glasses. A similar pair, oblong. Small octagon eye spectacles. Folding hand-spectacle, or double eye-glass. Inclosed spring hand-spectacle, or double eye-glass. Folding hand-spectacle, or double eye-glass. Oval single eye-glass for reading. Octagon single eye-glass for reading. Hexagon single eye-glass for reading. Eye-glass handle, a preservative for the glass.

291 **MAYALL, J. E., 433 West Strand—**Producer.

Daguerreotypes of various kinds.  
Daguerreotype panoramas.—Niagara Falls. Fairmount Water Works, Philadelphia. Birthplace of Shakespeare. River Avon, with a view of Stratford Church. Ann Hathaway's House.

[By a little expenditure of ingenuity, it is perfectly possible to take daguerreotype views of nature in the open fields, by the river side, or on the sea-shore. All that is necessary is to obtain a means of transferring the prepared plate, and also of mercurializing it when impressed, in the dark; and by a small amount of manual dexterity, with the assistance of a piece of black velvet, this may be accomplished.—R. E.]

Daguerreotype pictures to illustrate poetry and sentiment, the backgrounds in some cases being sketched, and the sitters posed so as to make the whole harmonise together. The Soldier's Dream (Campbell), an illustrated poem (from life), in four tableaux. The Venerable Bede blessing an Anglo-Saxon child (after nature). The Lord's Prayer, in a series of ten designs (from life). The Fisher Boys, a study from nature; and a variety of others.

[The application of the daguerreotype to the production of the pictures referred to is effected in the following manner:—The sitter, or the persons comprising the group, dressed in appropriate costume, are artistically posed so as to form a *tableau vivant*, and in this position are taken by the ordinary process. The background is procured either by placing the sitters in front of a scene painted upon canvas, in which case the plate receives the impression as usual, and the scene appears as a natural background to the figures; or, in other cases, the plate is painted with a fine brush, and the landscape, &c., are thus artificially sketched upon its surface. The practised eye will immediately decide which of these methods have been adopted.—R. E.]

Frame of interesting specimens, including a portrait of Daguerre, the inventor of the art.

[The daguerreotype is marked pre-eminently as a result of the advanced science of the present age. The discovery by M. Daguerre of the sensitiveness to luminous impressions of an iodized silver plate, and of the development of the picture by mercurial vapour, was first announced to the French Academy of Sciences, by M. Arago, in January, 1839. The original process of M. Daguerre is not now pursued, bromine and iodine, in combination or succession, being employed to render the plate sensitive to light.—R. E.]

Daguerreotypes of sculpture, and novel applications of the art to a variety of subjects, comprising everything that is known up to this period.

"Crayon daguerreotypes."

[This peculiar process is understood to be a French invention. In No. 1197 of the *Athenæum*, Mr. Mayall has described, in the following terms, the method of producing crayon daguerreotypes:—

"First. Take a daguerreotype image on a prepared plate as usual, taking care to mark the end of the plate on which the head is produced. When taken, and before mercurializing, remove the plate and place on it a plate of glass, prepared as follows: Second. Cut a piece of thin plate glass of the same size as the daguerreotype plate; gum upon one side of it a thin oval piece of blackened zinc, the centre of the oval to coincide with the centre of the image upon the plate. Having carefully placed the glass thus prepared, with the centre of the zinc disc, upon the centre of the image, expose the whole to daylight for twenty seconds. The action of the light will obliterate



every trace of the image from every part of the plate, except that which is covered with the blackened zinc, and also from the thickness of the glass the action will be refracted under the edges of the zinc disc, and will soften into the dark parts. Third. Mercurialize the plate as usual; the image will be found with a halo of light around it, gradually softening into the background. By grinding the glass on which the disc is fixed, and by altering the size and shape of the disc, a variety of effects may be produced."

The appearance of these pictures is extremely singular. The fact that the exposure of plates already impressed with an image in the camera obscura to daylight entirely removed the original impression, is one of the practical discoveries made by every daguerreotypist who has accidentally lifted the shutter of the plate-holder after removing it from the camera. But such an application of this fact could scarcely have been anticipated.—R. E.]

Specimens of photography, on glass.

[The art of photography on glass is more recent than either the daguerreotype or talbotype processes. But the principles upon which it is successfully practised are essentially similar to those involved in the latter art. In consequence of the inequality of the texture of photographic paper, it became desirable to obtain some more homogeneous medium for the reception of the negative talbotype picture. Glass and porcelain have been employed with great success for this purpose. In order to render the surface sufficiently retentive of the sensitive coating of silver, the plates of glass are covered in the first instance with a thin layer of the albumen of an egg, containing a few drops of a solution of iodide of potassium. The sensitive washes are then applied, and the plate is exposed to the lenticular image in the camera. The picture is developed in the usual manner. The "prints" from glass plates are of the most exquisitely beautiful character.—R. E.]

291A LADD, W., 29 *Penton Place, Watworth*—  
Manufacturer.

Box of apparatus for showing experiments in pneumatics, consisting of an air-pump and 14 other instruments.

[The air-pump was invented by Otto Guericke, a citizen of Magdeburg, in Prussian Saxony, about the year 1654. He illustrated the pressure of the atmosphere by the beautiful experiment of exhausting a hollow sphere, composed of two pieces accurately fitting at their edges, which before the experiment were slightly rubbed with fat. On pumping out the air, the external atmosphere pressed the hemispheres together with such force that, to the great astonishment of the spectators, a number of horses were unable to pull them asunder. In the hands of Boyle and Mariotte it served shortly afterwards for the discovery of the principal mechanical properties of the atmosphere.—W. D. L. R.]

Compound microscope, with chain and spindle, in lieu of rack and pinion now in use. Registered.

292 BEARD, RICHARD, 85 *King William Street, City*—  
Producer and Patentee.

Photographic pictures by a new patent process, whereby daguerreotypes are "enamelled."

[The enamelling referred to would appear to consist in removing the glare of the polished plate by a transparent covering, resembling a varnish. The present method of fixing a daguerreotype picture is by gilding, with a solution of the hypo-sulphite or chloride of gold.—R. E.]

294 KILBURN, WILLIAM EDWARD, 234 *Regent Street*—  
Producer.  
Photographic miniatures.

295 PAINE, WILLIAM, 5 *Trinity Row, Islington*—  
Producer.

Photographic pictures, to exhibit the progress of the art.

296 CLAUDET, ANTOINE FRANÇOIS JEAN, 18 *King William Street, Charing Cross*—Inventor.

Multiplying camera-obscura, to represent on the same surface a number of different pictures, or the same in various aspects, the portraits of several persons, &c. The novelty consists in moving the prepared plate by means of racks and pinions in a vertical and in a horizontal direction, thus making several parts of the surface pass alternately before an opening placed at the focus of the lens. A sculptor being supplied with seven different aspects of the features of the same person, is enabled, without seeing that person, to make a perfect bust or mc l.

Photographometer, to measure the intensity of the direct photogenic rays, and to compare the sensitiveness of various photogenic preparations.

[It is of the utmost importance in practice to know, at all times, the amount of chemical agency (*actinism*) which may be associated with the light of the sun, as they bear no direct relation to each other; the light may be intense and the chemical power very deficient, or the contrary; hence the value to the daguerreotypist of an instrument of this kind.—R. H.]

Dynaactinometer, to measure the intensity of the reflected photogenic radiation, and to compare the power of lenses or object glasses.

[Lenses vary very considerably in their powers of transmitting radiations; the difference arising from the molecular condition of the glass itself, which varies, and also from very slight deviations from the true curve, which in the delicate operation of grinding it is exceedingly difficult to avoid.—R. H.]

Focimeter. It is impossible to obtain well-defined, photographic pictures, without previously ascertaining the exact position of the photogenic focus, which is easily done by taking the image of the focimeter on a photographic surface, and comparing the segments of the apparatus with the image, then on the ground glass and on the photographic surface.

[Mr. Towson first observed that the focus of the chemical rays was not identical with the luminous focus; that the best photographic picture was always produced at a short distance nearer the lens, than the point at which the most perfect visible image is produced: M. Claudet has shown that this applies equally to achromatic as to non-achromatic lenses; and this instrument is for the purpose of determining the chemical focus with facility.—R. H.]

Screens, to modify the action of light on the various parts of the figure in taking portraits, and thus obtain artistic effects.

Patent photographic camera-obscura. The novelty consists in its being possible to adapt to it with the greatest facility any system of object-glasses, to change them at will according to the power wanted, and also to use plates of any size; each having a separate moveable frame, in which the ground glass and plate fit the same groove. Without the least alteration it will serve for silver plates or paper, and answer either for views or portraits.

[The photographic camera is a modified form of the camera obscura, invented by Baptista Porta, the principle in both cases being the same, the arrangements only being modified to allow of the easy introduction of the daguerreotype plate or photographic paper. The princi-

ple is often popularly studied by simply making a hole in the window shutter of a dark room and examining the images of external objects on a sheet of paper at a certain distance from it.—R. H.]

Dark boxes, for containing the prepared plates, and carrying them to and from the camera-obscura.

Brass frames, to hold two plates, face to face, without contact.

Mercury box. The novelty is that a number of plates of various sizes may be mercurialized at once, in a vertical position, and that the heat is applied by the uniform temperature of boiling water.

Apparatus for cleaning and finishing a daguerreotype plate, without burning the oil which has been used for the polishing, and without employing cotton wool, spirit of wine, or any powder.

Bromide of iodine. Iodine and bromine combined in proportions found to afford means of giving the plate the highest state of sensitiveness.

[In preparing a daguerreotype plate, it is essential that the agent employed to act chemically on the polished silver surface should be in such a condition, that the affinity may be easily upset by solar agency. This is peculiarly the case with compounds of bromine, iodine, and chlorine. The balance of action is very easily disturbed, and hence the extreme sensibility of plates prepared with these compounds.—R. H.]

Daguerreotype pictures, plain and coloured. Representation of objects of art, scientific experiments on the effect of the various rays, illustrations of the non-coincidence of the visual and photogenic foci, portraits from nature, taken by means of a prism placed before the object glass, in order to obtain a non-inverted picture.

[The effects shown in these experiments illustrate the influences exerted by various media, natural and artificial, upon the solar rays. In some examples, the luminous rays are shown to act as protecting the plates from change, and in others the energetic power of the chemical rays (*actinism*) is separated to a great extent from the luminous rays (*light*). The general result is to prove that the radiations which give rise to photographic phenomena, although associated with light and heat in the sunbeams, are not identical with it in their action on material bodies.—R. H.]

Photographic table; showing that photographic productions may be employed in various ways, as the ornamental part of drawing-room furniture.

Daguerreotype plates, perfectly plane and free from specks, forming true mirrors.

[Daguerreotype plates are of copper, plated with silver; by placing two pieces of these metals in contact with very clean surfaces, and thus passing them through steel rollers, they are pressed so closely together that the full action of cohesive force is exerted between their particles, and they adhere with great firmness. The silver is subsequently polished, and by nice manipulation prepared for the use of the daguerreotype artist.—R. H.]

Photogenic paradox, showing that what is light for the eyes is darkness for the photogenic action; a frame containing, on one half, the portrait of the Queen, covered with yellow glass, and on the other half the portrait of Prince Albert, covered with deep blue glass, being represented on a daguerreotype plate. The result is that the yellow glass, although showing clearly to the eyes the picture of Her Majesty, has prevented the photogenic action, and that the deep blue glass, although completely hiding the portrait of Prince Albert, the photogenic rays reflected by his picture through the blue glass have had the same action on the daguerreotype as if the engraving had been covered with transparent glass, or with no glass at all. This experiment proves why

when light appears yellow on account of vapours existing in the atmosphere, the photogenic action is always so feeble and altogether impeded.

Frame containing six specimens—

(1) Light of a candle represented on a daguerreotype plate.

(2) Image of a statue produced by the continued action of light on a daguerreotype plate, without any mercury; the white forming the image is due to a fine precipitate of the silver combined with iodine, taking place under the action of light during the decomposition of the compound.

(3) Negative portrait produced on a plate first exposed to light, and in that state having received the image of the camera obscura through yellow glass; this proves the destructive action of the yellow rays in the photographic operation, and that the yellow rays are not only antagonistic to the photogenic rays, but that they destroy the effect produced by the last.

(4) Image of the sun produced during a clear atmosphere.

(5) Image of the sun produced when it appears red through a fog.

(6) Image of the moon produced during a clear night.

Frame containing four specimens—

(1) Image of the solar spectrum on iodide of silver.

(2) Image of the solar spectrum on bromo-iodine of silver.

(3) Experiment of the focimeter, showing the difference between the visual focus and the photogenic focus and their variation.

(4) Experiment of the dynactinometer, showing the intensity of the photogenic light at any given moment, for various spaces of time in a geometrical progression. It is curious to observe the small difference produced by a double intensity.

Image of clouds, taken instantaneously during boisterous weather. Interesting study for artists.

Frame containing the various colours of water colour, and another the daguerreotype representation of the first. This experiment shows that all the tints of blue, indigo, and violet produce white in photography, and that all the tints of green, yellow, orange, and red, produce black, or rather that they have no photogenic action.

297 HENNEMAN & MALONE, 122 Regent St., Westminster—Designers.

1. Talbotype apparatus of improved design, made by J. Newman, of 122 Regent Street.

2. Talbotype pictures produced on paper, silk, and other fabrics; and on porcelain, coated glass, stone, steel, wood, and ivory.

3. Talbotypes treated with caustic potash and a lead salt, in order to produce an agreeable tint of colour, and to render more secure the fixation.

4. Specimens of Sir J. Herschel's cyanotype and chrysotype, and of Mr. Robert Hunt's chromatotype pictures.

[Talbotype is the name applied, in the first instance, by Sir David Brewster, to the calotype pictures, his object being to distinguish by the name of the discoverer a photographic process which is little, if anything, inferior to the daguerreotype of the French. Paper being covered with a pure iodide of silver, is rendered sensitive to luminous radiations by being washed over with a mixture of gallic acid and nitrate of silver; and after the paper is taken from the camera, a dormant picture being produced upon it, it is developed by a second application of gallic acid.

Sir John Herschel's cyanotype and chrysotype processes admit of many modifications, the former consisting of the change of a persalt of iron into a protosalt by the solar rays; the paper being then washed with a compound of

cyanogen (hence its name), the picture is represented in Prussian blue.

The latter is in most respects similar, only that a solution of gold is applied to the altered iron salt, and oxide of gold is formed in the place of Prussian blue.

The chromatypé is formed by washing paper with a mixture of the bichromate of potash and sulphate of copper; and after the picture has been faintly developed by the chemical principle of the solar beam, it is washed with nitrate of silver, by which a *positive* picture, or one with correct lights and shadows, is produced by one operation.—R. H.]

298 HAYWARD BROTHERS, 196 Blackfriars Road—  
Inventors and Proprietors.

Gauge for measuring the thickness of metal and other plates, rods, or bars:—The principle of this gauge is the progressive movement of an accurately cut screw, to which is affixed a dial or circular index, which may be divided so that each space shall indicate that the screw has advanced the 1000th part of an inch, or otherwise marked as may be required, such as to show the aliquot parts of an inch, the weights per foot super., &c., of any particular metals, alloys, or other material, whose specific gravity is known, or with any arbitrary line of numbers, such as the ordinary wire gauge.

The gauge which is exhibited has the outer circle set out, so that each minor division is equal to 1 oz. per foot super. of sheet-iron sp. gr. 7·68, the quarters and lbs. being shown up to 20 lbs. to the foot. The relative weights per foot super. of any other metals, &c., may be found from the sliding or circular scale of equivalents which accompanies the gauge. The next circle has a line of numbers, which are suggested by the inventor of the gauge, as an improved scale for universal adoption; the advantages being that each whole number will tell its own particular value in 100ths of an inch, with fractions added, expressing 1000ths; and if written thus, "12, 14, &c., could not be mistaken for the whole numbers, 12, 14, &c., as might be the case in ordinary commercial transactions. If placed with the decimal point only, for substances less than 100ths of an inch, the numbers might be written 01, 02 to 09, each representing 1, 2 to 9 thousandths of an inch respectively. The inner circle gives the numbers of the present Birmingham wire gauge, or (as commonly known) "the wire gauge," by which are measured iron, brass, and black steel-wires, iron and steel sheets, and many other articles.

If the weight per foot superficial of sheet-iron be required, the screw is turned to the left until there is more than sufficient room to admit the plate to be measured; then the instrument being supported with the fingers of the left hand in such a manner as to press the three points against the under side of the plate, and the thumb being placed on the plate to hold the gauge firmly, leaving the screw perfectly free, from the relative position which this bears to the three points, it will rise and descend at right angles with the face of the plate. Now the screw being turned slowly to the right, until its further progress is obstructed, in the outer circle on the dial, against the perpendicular line inside the case, will be shown the weight of the plate in ounces and lbs. to the foot superficial of sheet-iron, sp. gr. 7·68.

For measuring wire, the screw should be turned to the right, until the wire cannot pass between it and the point immediately under it; then the wire being gently pressed between the two, and the screw turned slowly to the left until the wire passes, the number of the wire will be found in the inner circles on the dial.

Sliding and circular scales of equivalents for weights:—If the weight per foot superficial of any other material than iron be required, it is placed in the gauge, and then on the outer circle is found the weight which it would be if sheet-iron; this weight being found on the slide, and placed against the "iron-sheet," opposite to the name of the material on the fixed part of the rule, on the slide, will be shown the weight per foot superficial of that

which is under examination; and against all the rest, their respective equivalents. The scale is also applicable to all other calculations of relative weights; thus, the weight of a casting in iron is found from the weight of the model, by finding its weight on the slider and placing it opposite to the article of which it is made; then on the slider opposite to cast-iron, will be found its weight in this material, the customary allowance being made for the shifting of the model, and the contraction of the iron as it cools. If the whole numbers, instead of being called lbs., are taken as cwts., then the ounces will each represent 7 lbs. If the lbs. are called ounces, then the ounces will represent drachmas.

Circular scale:—In this scale the same results are obtained by moving the various articles which are set off on the centre, opposite to the weights on the stationary margin.

299 TYREE BROTHERS, 44 Regent's Circus, Piccadilly—  
Inventor.

Daguerrotypes, including several, in which is introduced a new and ornamental process. The colouring by Mr. Alfred Tyree.

[In these daguerrotypes an effect somewhat resembling that of an engraved border has been produced. Such a result is capable of being attained by means of a perforated plate of metal laid over the picture and momentarily exposed to the light. The action of the light through the perforated parts will then produce, on exposure to the mercury, the engraved appearance.—R. E.]

301 SADD, WILLIAM, East Hill, Wandsworth—  
Designer, Manufacturer, & Proprietor.

Model of an aerial machine, which consists of two revolving wheels for propelling, and a rudder at each end to steer the machine; and two floats to raise or lower it without the aid of ballast. The whole is sustained by two cylindrical balloons, placed horizontally. This constitutes the apparatus, which is said by the exhibitor to be as much under control as a ship on the seas; and that, notwithstanding contrary currents of air, it can be stored in any course that may be indicated, with equal facility.

302 BINGHAM, ROBERT JAMES—Producer.

Photographs, from paper negatives.

303 COLLS, R. & L., 168 New Bond Street—Producers.

Sun pictures, on paper.

[The art of producing pictures by the aid of sunlight, commonly called photography, is due, so far as the processes on paper are concerned, to Mr. Fox Talbot. Other methods of obtaining photographic pictures on paper, equally expeditiously, are known; but the principles embodied in Mr. Talbot's patent are those which in actual practice produce the finest and best pictures.—R. E.]

304 RIPPINGHAM, W., Great Prescott Street.

A case of photographic portraits, on paper, from negatives, taken with collodion on plate glass.

306 LEONARD, SAMUEL WILLIAM, 11 Upper  
Stamford Street—Designer.

Microscopical drawings, illustrating the use of the microscope for detecting adulterations in articles of food, and for discoveries in minute anatomy.

308 SHARP, SAMUEL, New George Street, Sheffield—  
Manufacturer.

Set of ten lenses for a single microscope, from 1-10th to 1-100th of an inch focal length.

309 WRAY, WILLIAM, 43 Havering Street, Commercial  
Road East—Inventor and Manufacturer.

A seven-foot achromatic telescope, four and a half inches in aperture, upon a new principle, in which the difficulty

against all the rest, scale is also applicable to weights; thus, the weight from the weight of the slider and placing it in its scale; then on the weight of its weight being made for the contraction of the iron wheels, instead of being in the ounces will each of the ounces, then the

same results are also obtained which are set off on the stationary

*Circus, Piccadilly—*

in which is introduced. The colouring by

somewhat resembling produced. Such a means of a perforated and momentarily extending light through the exposure to the [R. E.]

*Windsor—*

Proprietor. The whole is suspended horizontally, which is said by the inventor as a ship on the currents of air, may be indicated,

Producer.

*Street—*

Producers.

the aid of sunlight,

so far as the process of Talbot. Other

figures on paper, at the principles

which in actual cases.—R. E.]

*Street.*

paper, from negative.

*11 Upper*

er. the use of the microscope, articles of food,

*t, Sheffield—*

pe, from 1-10th

*et, Commercial*

returer. and a half inches in the difficulty

of obtaining large discs of flint glass is overcome by the employment of a solid substitute.

This substitute is a combination of a resinous substance, with a very highly refractive and dispersive essential oil, and its application is extremely simple and effective, as well as comparatively inexpensive. From its homogeneous nature, it would appear that a finer telescope might be constructed with lenses of this substance, than with lenses of flint-glass; for it has been found a matter of extreme difficulty to produce the dense flint-glass perfectly homogeneous, and free from striae. The substitute for flint-glass is highly transparent, of a pale straw colour, and is unalterable by light air, moisture, and moderate heat; it fuses at about 200 degrees, and is applied in a fluid state between crown-glass lenses. It becomes solid on cooling, and remains so at all atmospheric temperatures. Its refractive index and dispersive power allow a shallower system of curves than flint-glass usually does, and consequently a better correction of the spherical aberration. On account of the composition being in perfect contact with the two crown-glass lenses between which it is put, little light is lost by reflection at the four interior surfaces, which is not the case with the ordinary achromatic object-glass.

[An achromatic glass is a compound lens formed of two kinds of glass, which act differently upon the rays of light transmitted by them. The effect of their united action is to bring all the rays of light to a common focus, which ordinary single lenses will not effect. Objects seen through achromatic lenses are not surrounded with those fringes of colour which encircle them when examined by a single lens. Hence the term achromatic. In the case in question, the disc of flint-glass is substituted by a solid resinous substance.—R. E.]

317 DENTON, J. B., *Gray's Inn Square*—Inventor.

Specimens of model or relief mapping, finished and in skeleton, accompanied by a beam-level, for ascertaining heights and distances, with plans and tools elucidating the method of construction.

Model mapping is designed for the representation of districts where works of drainage and other hydraulic operations are contemplated, as the best means of developing the natural capabilities of an undulatory surface, and of displaying the geological formation of the substrata.

Workman's draining-level—particularly designed for labourers incapable of using the spirit-level, but who are familiar with the properties of the plumb-bob.

Improved workman's level, similar in principle, but capable of greater facility of adjustment, with or without the spirit-level.

318 PENROSE, FRANCIS CHAMNER, *4 Trafalgar Square*—Inventor and Proprietor.

Registered screw and sliding heliograph for drawing volutes, scrollwork, and spirals of various kinds. The curves may be drawn on paper by means of an impression obtained from the disc by transfer paper; they may be drawn in ink or with pencil by the sliding heliograph.

Fig. 1. Sliding heliograph. A heavy frame BB' slides upon a smooth straight bar AA', which passes through the guide sockets GG', forming part of the frame. Attached to the bar AA' is a point C, on which the instrument turns as a centre. Within the frame is a circular ring, carrying the axle of a small wheel or disc, D, fixed to one of its diameters. This ring, and the disc connected with it, may be placed at any angle with respect to the frame. The middle part of the frame is hollow, so that the wheel rests on the paper. By means of a gauge screw at E, and the carriage on castors FF', the instrument is adjusted to the proper level. A bar HK, which turns horizontally round K, a point in the frame, is provided with a pen-and-pencil socket, so that the describing point may be placed at any point within its range. The centre of gravity of the frame is so arranged that its whole weight falls directly upon the wheel, and the edge

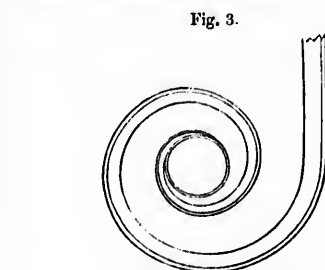
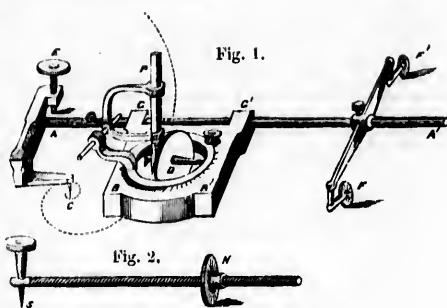

Penrose's Registered Heliographs.

of the latter is milled so as to ensure its taking a firm hold of the paper, while the frame slides on the smooth bar. The spiral motion results from the obliquity of the axis of the wheel with respect to the smooth bar AA' when the instrument is made to revolve about the point C; the rate or pitch of the spiral depending upon the angle which the axis of the wheel makes with the frame. The graduations on the instrument are given on one side in degrees, and on the other in such angles as to make the longer and shorter radii in one revolution, to each other as the numbers 2: 1, 3: 1 . . . 10: 1, &c. The point C is placed at the same distance from AA' as the point where the circumference of the wheel touches the paper. The path of the wheel is the logarithmic spiral, when the instrument is made to revolve about the point C, and the pen P placed as near as possible to the wheel. To describe a volute (fig. 3), the instrument is made to revolve about its centre, when the wheel turns round, and causes the frame to slide uniformly along the bar, until it carries the describing point as near to the centre as required. The frame being simply brought back along the bar, all the adjustments remaining unaltered, and the pen placed upon other points, a riband will be formed, preserving an uniformly decreasing thickness all the way. If a parallel line be desired, the pen must be shifted along the line of the axis of the wheel, and the latter made to traverse the same path as it did when the first line was drawn.

In drawing a volute, or other figure composed of several lines, it will generally be necessary that all the lines should be drawn either towards the eye, or away from it; as owing to a change in the action of the guide-sockets upon the smooth bar, when the motion is reversed, the angle is slightly affected. This does not impair the equiangular truth of each individual line.

Fig. 2 is the screw heliograph; S, the fixed centre; and N the wheel which works upon the screw.

320 ELLIOTT & SONS, *56 Strand*—Manufacturers.

Magazine case of drawing instruments. The same, containing every requisite for drawing circles from the

1-100th of an inch to 6 feet in diameter; elliptical instruments, complete set of scales, standard measure and triangles, also complete set of water-colours.

Improved dumpy-level, being simple in its adjustments, and strengthened by having the bar which supports the telescope placed vertically instead of horizontally. The same with compass. 5-inch and 6-inch transit theodolites. 30-inch transit instrument.

New instrument for measuring the distance of accessible and inaccessible objects.

Opisometers, or map-meters, for measuring curved lines.

Wheel and pediment barometers, carved to illustrate the four seasons. Gothic barometer. Ebony and gold barometers.

Astronomical telescope. Naval and military telescopes. Opera-glasses, with variously-coloured bodies.

Scale, with slide, for comparing the following measures:—Swedish, Turkish, Bavarian, Spanish, Portuguese, Moscow, Russian, Amsterdam, Rhymland, French, and English.

Standard English yard.

Improved slide-rule, adapted for the use of the practical engineer, having all the necessary tables for calculating metal, earth, and wood works, with useful foreign measures.

Thermometers. 15-inch azimuth and altitude instrument.

### 322 LLOYD, Lieut.-Col. J. A., F.R.S.—Inventor.

Typhodeictor, (from *τυφῶν* or *tyfose*, and *δεικτής*, or *deictes*) or storm-pointer, an instrument for obtaining, by inspection, the bearing and relative position of a revolving storm or hurricane. Manufactured by Elliott & Sons.

It is now a well-ascertained fact that great storms have a rotary motion like whirlwinds. The theory, commonly

called the "law of storms," as made known in several publications by Colonel Reid, has been established from thousands of well-authenticated observations in different parts of the world, and extending over several years. It proves that during a gale of wind, particularly near to the tropics, the winds blow with the greatest fury round a common centre. At this centre, there is little or no wind, even a perfect calm, but there is, generally, a terrific and confused sea.

The most violent and dangerous part of these revolving gales is somewhere near this central calm, the wind there blowing the most fiercely, acquiring, it is stated, a velocity of even 100 miles per hour. These storms sweep both land and sea, in certain parts of the globe; their track and direction are pretty well known; and they travel bodily, from their place of origin to their destination at variable speeds; sometimes at not more than the rate of 4 to 6 miles an hour; sometimes, but seldom, at that of 20 to 30 miles an hour, although the wind within their range is blowing round with the fury above mentioned.

If a ship, unhappily, becomes entangled within the range of these terrible gales, she is in great peril; many have foundered, and others have pursued their fearful course round and round, until they have been reduced to helpless wrecks, dismasted and water-logged.

In the northern hemisphere, these winds blow round the compass from east-by-north to west, or the contrary way to the hands of a watch; whereas, in a southern hemisphere, it is just the reverse, blowing round as the hands of a watch would go. This principle must be always borne in mind, as the very foundation of all the information to be sought hereafter.

On these most valuable data, instructions have been drawn up by Colonel Reid and others, how to ascertain the relative position of a gale, so as to know whether it is approaching to, or going from a ship, travelling by its side, or passing across its path. The following cut represents the Typhodeictor.

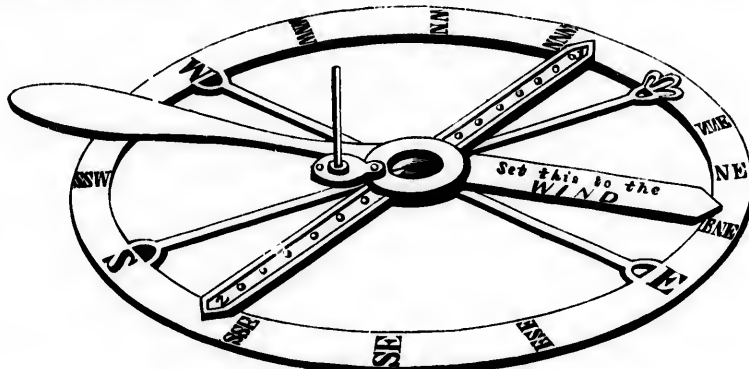

Colonel Lloyd's Typhodeictor.

The object of the instrument is, by graphic illustration, to show that, when the wind blows from a particular point of the compass, you can only be in one relative position in regard to the centre of the whirlstorm, so that, either the storm is approaching the ship, or the ship approaching the storm, and first of course encountering the outer edge.

As a consequence of the law of rotation, the wind, supposing the whirl to be circular, *must* blow at a tangent, or at right angles to the point of the compass, where the ship or observer may be, but under diametrically opposite conditions, as far as regards the two hemispheres.

Thus, in a northern hemisphere, if the wind blows east, the centre of the storm *must* be due south of the observer; blowing north, the vortex east; coming from the west, the centre of the gale is due north; and, lastly,

with the wind south, the gale is due west. Of course, in the intermediate points of the compass, the bearings are likewise different.

In a southern latitude, the whirlstorm blows round just the contrary way. With an east wind, the storm centre bears north; with a north wind, west; with a west wind, south; with a south wind, east.

Bearing in mind these facts, and with sea room, it is easy not only to avoid a hurricane, but to make it subservient in many cases to the ship's ultimate course.

#### Instructions.

When the barometer is falling and the wind increasing, set the large pointer of the instrument marked in red (*set this to the wind*), to the true point of the compass from whence the wind blows, corrected for variation.



de known in several  
een established from  
ervations in different  
er several years. It  
particularly near to  
greatest fury round  
there is little or no  
ere is, generally, a

art of these revolving  
alm, the wind there  
is stated, a velo-  
These storms sweep  
of the globe; they  
own; and they travel  
their destination at  
ore than the rate of  
seldom, at that of  
e wind within their  
above mentioned.  
led within the range  
peril; many have  
their fearful course  
en reduced to help-  
ed.

winds blow round  
at, or the contrary  
eas, in a southern  
owing round as the  
inciple must be  
undation of all the

uctions have been  
ow, to ascertain  
know whether it is  
swelling by its side,  
ing out represents



. Of course, in  
the bearings are

m blows round  
wind, the storm  
east; with a west

sea room, it is  
to make it sub-  
ate course.

wind increasing,  
arked in red (see  
compass from  
ation.

The glass plate is to represent the wind: spin it, to the left when in a northern hemisphere, to the right in the southern, it will give a good idea of the course of the winds around the centre.

Now lay the instrument down on the chart or map, with the N. point engraven on the metal corresponding with the north of the chart. Move the whole instrument backwards or forwards, always preserving the identity of the two N. points until the ship's place on the chart is beneath the hand marked "ship's place"—No. 1 for the northern hemisphere, No. 2 for the other hemisphere.

Unship the revolving glass, representing the circular, or nearly circular gale, push back the moveable centre and pivot, and beneath, is the centre of the storm nearly. A good sailor then knows his duty, and will give it a wide berth accordingly.

NOTE.—The use of the several holes along the arms in the transparent horn marked "ship's place," is to adapt the instrument to any scale on a chart—bearing in mind that the usual diameter of one of these hurricanes or tornadoes is about 300 to 500 miles in extent.

Example.—Suppose, in a southern hemisphere, in lat. 19°, and long. 60° 30' E., the barometer is falling, a swell is encountered, and the wind is S.S.E. Place the NED arm of the instrument at S.S.E. on the ring; lay the instrument on the chart, with the north point on to the meridian of the arm No. 2, at the ship's place. The vortex of the gale is E.N.E. of the ship; and, as its path is approximately known, the most violent part of the hurricane would sweep over the ship if it remained in that place. A sailor will immediately get out of its way as he would from a dangerous reef.

Again—if a ship coming from India towards Mauritius, and in the same spot, had encountered a N.W. wind and a troubled sea, the intelligent commander would immediately know that he was coming up to a hurricane, the centre of which was south-west of him; and if he pursued his course, and did not wait a few hours, he would run the risk of foundering. In a northern latitude the circumstances are just opposite. The following extracts from the *Nautical Magazine* for September, 1849, from a letter by the inventor, will show how the rise and progress of these terrific gales may be made subservient to human intelligence:—

"The history of our first few days' adventures at sea, will go far to illustrate the perfect truth and beauty of the theory of circular storms. We sailed in our excellent ship, the *Sir Robert Seppings*, on Wednesday afternoon, the 4th of April. The gentle breeze just served to waft us clear of the shores, when it so far failed us, that even at noon of the next day we yet discerned Round Island.

"Excepting our lack of wind (which we had not long to complain of), the weather was most lovely and serene, but very sultry; and our next day (Friday) was ushered in with a most magnificent sun, very calm, but a heavy swell from the south-east. The day was passed in listless apathy, when at dark, a clear moon and a fine and fair breeze gave us some energy, and gratified our best wishes. The ship increased her speed. The increase from a gentle whisper to a rapid gurgle of the water, and from that rather suddenly, to a continuous roar beneath the stern windows, with the increased motion and the clank of the tiller-chains, spoiled our slumbers. A look out on the lovely and apparently mild night, showed enough in the haze of the moon, and the "burr" of the planets, with a fleetly-passing scud, to convince us that our dreams of mortal discomfort were about to be realized. However, Saturday's light appeared with a spanking breeze, and our worthy commander in good spirits, with the ship close-hauled, and nothing to spare. Whatever might be our inward thoughts, we all appeared extremely lively in having so unexpectedly found the trades.

"It would not do: the increasing gale, the heavy clouds, and the murky gloom to the south-east, the onward and hurried, and even furious, career of the scud, told us that we must prepare. There were no signs of the trades; and the tremendous and irregular sea, the

inexplicable heaping up of the troubled waves, the roar and whistling through the rigging, and the labouring of the ship, spoke to all our perilous position. It was becoming so, at least; for although we were to windward of the Island of Cargados Garajás, and the intricate banks, we had run on sufficiently to make the heart of them a lee-shore; not so close as to make it an immediate cause of anxiety, but sufficiently near to leave us little choice for shaping our course in an approaching hurricane, of which, by the direction of the wind, we knew we were then steering for the centre.

"The beautiful precision of Col. Reid's theory, so well worked up, and supported by Messrs. Thom's and Piddington's labours, was now about to undergo a severe and practical test, through the very means they have so anxiously desired and invited, namely, the judgment and intelligence of a daring English sailor. We consulted the Horn card on the chart, and, with a radius of 400 miles for the hurricane, asked his advice. He gave it to us nobly. Our commander, Captain Stuart, saw his position and the approaching peril, and that he would be "hobbed." He knew his ship, too, and, after consulting the elements, computing the time he required to get a clear sea way, and asking his barometer leave, away he stood boldly on. All precautions were in the mean time taken—hatches down, dead-lights, &c. in, masts and yards hoisted, and all made snug, and the lower rigging of the heavy masts secured by preventers and trapped (swifted). So passed Sunday; we could keep our course no longer; the furious gusts and the mountains of seas overwhelmed us; it would have been madness to stand on any longer; one object was attained—we had secured ample sea room. A pull at the weather braces, and a rather easing the lee ones, made a fair wind of our dreaded enemy, and, with all necessary and seamanlike precaution, away we went by a N.N.E. course, for the outer edge or limit of the fearful sway of the gathering storm. An extract from Captain Stuart's log, a copy of which I send you, will show how we made a fair wind and a true course towards our destination with such means; it will show, in fact, how we employed a wind from south-east, or S.E. by E., to very nearly south, going round by the west, and with a precision and a confidence quite wonderful even in these times. I observed sufficient to find that it was a gale extending to a great radius, permitting us as it did to stand on so long."

*Extract from the Sir R. Seppings' Log.*

Saturday, 7th April, 1849.—In moderate breezes from the eastward and fine weather. Ship under all sail. At 4 A. M. ditto, ditto. At 8 A. M. ditto ditto. Meridian, fresh breezes and cloudy, with a strong S.E. swell, lat. 17° 50', long. chron. 59° 10', bar. 29° 90'; at 4 P. M. fresh breezes, unsettled looking weather; at 8 P. M. ditto. Single reefed the topsails; at midnight strong breezes from the S.E.; squally; bar. 29° 90'.

Sunday, 8th—Commences with strong breezes, and puffy, and a very threatening appearance to the south; bar. 29° 85'; in, topgallant sails and double reefed topsails. At 8 A. M. fresh gales, with a heavy confused sea; stowed the mainsail, jib, and mizen; ship labouring and straining heavily. Meridian, strong gales with heavy squalls of wind and rain; close reefed topsails, sent down royal yards; every appearance of a hurricane raging to the southward. Shaped course N.N.E., lat. 16° 58', long. chron. 60° 15'; bar. 29° 90'. P. M. Strong gales with heavy squalls and rain, a confused cross sea running, causing the ship to strain and labour heavily; at 8 P. M. ditto weather. Midnight—still blowing hard in squalls, and the appearance of the sky very threatening.

Monday, 9th—Strong gales continued, and very threatening weather; at 8 A. M. bar. 29° 90'. At noon, a more settled appearance; wind at S.W.; shaped course E.N.E.; sounded on the Cargados Bank with Erickson's patent machine; 18 fathoms water; lat. obs. 14° 30', long. chron. 60° 48', E. bar. 29° 90'. P. M. 9th. The weather at 4 P. M. again assuming a threatening appearance, and barometer falling to 29° 75'; every indication of a severe hurricane blowing to the S.W.; heavy wild-looking

clouds rising in that quarter, and a tremendous south and south-westerly swell, causing the ship to roll and labour fearfully. At 8 P. M. no appearance of a change; again ran the ship to the northward; soundings 55 fathoms. At 10 P. M. still very unsettled; ship under close-reefed topsails; bar. 29° 80'. At midnight more moderate; wind at W.S.W. and barometer rising; shaped course N.E., and made all necessary sail.

Tuesday, 10th.—At 4 A. M. bar. 29° 9' and the weather having a more settled appearance; wind at west; all necessary sail set, the lower rigging set up fore and aft. At noon fair settled weather, lat. ob. 12° 23' S; long. chron. 62° 30'; bar. 30°.

There are many works of reference on the subject of rotary storms, and of the greatest value, as *The Laws of Storms*, by Colonel Reid; *The Nature and Course of Storms*; the same, by Thom; *The Hand-book of Storms*, by Piddington.

323 DONSON, J., 268 High Holborn—Manufacturer.

Complete magazine set of drawing instruments in electrum or British metal.

A variety of smaller sets in brass and electrum.

324 TREE, JAMES, & CO., 22 Charlotte Street, Blackfriars Road—Manufacturers.

Ewart's improved cattle gauge and key to the weighing machine, on the principle of the slide rule, for computing by inspection, matters relating to practical husbandry, and for ascertaining the carcass-weight of cattle, in any weight in use in the United Kingdom.

Ewart's circular cattle gauge, with logarithmic circle of natural and square numbers on the reverse side.

Ivory, boxwood, and electrum scales, for architectural surveying, and mathematical purposes; of improved arrangement. Ivory and electrum protractors. Marquis scales, for military drawing, fortification, &c., in ivory and electrum. Rolling parallels, in ivory, ebony, brass, and electrum. Engineers' rules, arranged by Bolton and Hawthorn, made in ivory. Architects' rules, in ivory mounted in electrum, new arrangement of dividing.

325 PURVIS, J., Newcastle-upon-Tyne—Inventor.

Mechanical square, containing plumb-rule, spirit-level, square-level, foot-rule, and slide-rule.

326 DE FONTAINE MOREAU, PETER A., 4 South Street, Finsbury—Producer.

Aneroid barometer; aneroid gauge, Lucien Vidie's invention.—Patented in England.

[From the extreme portability and sensibility of this recently invented barometer, it has justly come into very general use. Its action depends on the varying effects produced upon a metallic box, exhausted or nearly exhausted of air, and these small vertical motions are converted into large horizontal motions, by a system of lever and spiral springs. The instrument is not adapted for meteorological investigations, but is well suited for most other purposes to which a barometer is applicable.—J. G.]

327 TOWNS, WILLIAM, 19 Stangate Street, Lambeth—Inventor.

Spirit meter, on a new and simple principle.

328 HAGGARD, WILLIAM DEBONAIRE, Bank of England—Inventor.

A double protractor, three inches square.

329 SINCLAIR & HOCKLEY, 42 Gervard Street, Soho—Designers and Manufacturers.

Mechanical arrangement for supplying artificial teeth, and making up the deficiency of the right half of the upper jawbone. Sets of mineral teeth, mounted on gold embossed and bone gums.

Various specimens of mechanical dentistry.

330 BEST, THOMAS, Oldham—Manufacturer.

Micrometer measuring and dividing machine.

Twelve-inch and six-inch rules, marked and divided by the above machine, and intended as standard rules for opticians, mathematical instrument makers, &c.

331 GRIFFITH, JOHN, Darley Parsonage, near Derby—Designer.

Standard barometer, manufactured by John Davis, Derby, designed to give observations accurately to one-thousandth of an inch.

332 YEATES, GEORGE, 2 Grafton Street, Dublin—

Proprietor and in part Designer and Manufacturer.

Standard barometer. A barometer, with registering apparatus attached, the mercury in the cistern of which can be cleansed without disturbing that in the column.

Small theodolite. Simple theodolite, for road work, drainage, &c. Simple and effective air-pump.

Improved prismatic compass, capable of taking altitudes. The same, on tripod, having spirit level attached. Optic square, for measuring inaccessible distances. Various specimens of spectacles.

333 DE GRAVE, SHORT, & FANNER, 59 St. Martin's-le-Grand—Manufacturers.

Assay balances and weights. Hydrostatic balances and weights. Balances and weights for weighing diamonds to 500 and 100 carats.

Letter-balances and weights; portable, and with three beams, as used in the Post Office.

Beams and scales mounted, with brass pillar, and weighing-machine, on mahogany pedestal, for shop counters. Bankers' scales.

Bronzed beam for weighing 1,000 ounces of gold or silver. Gilt beam, used by inspectors of weights.

Complete set of imperial standard measures from bushel to half-gill. Imperial standard yard, bed, and rod.

Complete set of standard avoirdupois weights, from 56 lbs. to  $\frac{1}{4}$  drachm, of spherical shape. The same, from 50 lbs. to 1 lb. bell shape; and from 8 ounces to  $\frac{1}{4}$  drachm, flat shape.

The fine assay balance will turn with the thousandth part of a grain.

334 OERTLING, LUDWIG, 13 Store Street, Bedford Square—Manufacturer.

Balance, to carry  $\frac{1}{4}$  cwt. in each pan, and turn when loaded with  $\frac{1}{3}$  of a grain. Chemical balance, to carry 1 lb. in each pan, and turn when loaded with  $\frac{1}{100}$  of a grain. Balance to carry 1,000 grains in each pan, and turn when loaded with  $\frac{1}{100}$  of a grain.

In the two latter, the knife-edges are made of agate, and the suspending pieces for the pans are provided with agate planes.

[The sensibility of these balances may be expressed by saying, that the first turns with about the 1,300,000th part of the weight which it can weigh; the second with the 1,400,000th part; and the third with the 1,000,000th part. The value of such balances is perceived in delicate chemical analyses, in which a fractional error has often led to important mistakes.—R. E.]

335 BROWN, S., 6 Marlborough Place, Kennington Cross—Inventor.

Patent power-engine, being a water-meter and a power-engine. Patent water-meter, capable of adjustment under varying pressure. Patent meter, for measuring or weigh-

Errard Street, Soho—  
Manufacturers.  
Applying artificial teeth,  
the right half of the upper  
mounted on gold em-

dentistry.

Manufacturer.  
ing machine.  
marked and divided by  
as standard rules for  
t makers, &c.

onage, near Derby—

red by John Davis,  
ns accurately to one-

Street, Dublin—  
and Manufacturer.  
ter, with registering  
the cistern of which  
that in the column.  
elite, for road work,  
air-pump.

able of taking alti-  
spirit level attached.  
accessible distances.

59 St. Martin's-lc-  
ers.

rostatic balances and  
eighing diamonds to

able, and with three

a brass pillar, and  
pedestal, for shop

ounces of gold or  
s of weights.

measures from bushel  
bed, and rod.

pois weights, from  
e. The same, from  
ounces to  $\frac{1}{4}$  drachm,

th the thousandth

Street, Bedford  
r.

n, and turn when  
alance, to carry 1 lb.  
with  $\frac{1}{16}$  of a grain.  
an, and turn when

re made of agate,  
are provided with

ty be expressed by  
at the 1,300,000th  
the second with  
th the 1,000,000th  
ceived in delicate  
l error has often

Kennington Cross

eter and a power-  
adjustment under  
asuring or weigh-

ing the liquid by an overshot wheel, and working in com-  
pressed air without cock or valve.

Patent water and spirit meter, self-acting, capable of  
adjustment under varying pressures. Patent spirit-meter,  
showing at the same time the quantity measured and its  
money value, in order to obviate mistake or fraud.

The novelty of the power-engine consists in its being a  
water-meter and a water-pressure engine, and also in its  
being applicable to steam power without alteration of its  
parts. It is represented in fig. 1.

The machine consists of an outer case or cistern, con-  
taining two collapsible measuring-vessels, connected by  
pipes or tubes to a four-way tap or slide-valve at the  
lower part, and at the upper part they are connected by  
a beam working on a centre, one end of which centre  
passes through the outer case, and gives motion to the  
indicating chain of wheels, and also to a beam and  
quadrant connected with driving gear. The liquid is ad-  
mitted through the upper part of the case, and with-  
drawn at the lower part, after having passed through the  
collapsible measuring vessel. Attached to the four-way  
tap or valve is an arrangement of rods or chains connect-  
ing it with a tube containing a weight, or a weight other-  
wise arranged, so that, as the measuring vessels rise and  
fall, the tap or valve is acted upon and the motion is  
reversed, the liquid is allowed to rise in the case until  
the measuring vessels are immersed, and as the pipe by  
which the liquid is conveyed to the case is not connected  
with the four-way tap or valve, the liquid flows freely  
in at all times, according to the pressure, thus the mea-  
suring vessels, having the same pressure without as  
within, are not exposed to undue strain.

On turning the tap to withdraw the liquid and start  
the machine, the measuring vessels to which the four-  
way tap or valve is open, will descend and empty the  
other measuring vessels, at the same time rising and  
filling until a certain point is attained, when, by the ac-  
tion of the weights and rods, the action of the tap or  
valve is reversed, and consequently that of the vessels  
also, and thus motion will continue as long as there is  
liquid to pass through, or until the tap is turned to  
stop it. The motion is converted into a circular one by  
the rack and pinion represented in fig. 2.

The patent meter (fig 3), in construction, resembles the  
one before described, but has no external apparatus except  
the indicator. There is no loss of power in the liquid pass-  
ing through the meter to a high level. It is perfect in  
adjustment under varying pressures, and consists of two  
cylinders, containing a float in each; to these floats are  
attached a rod having a projecting pin at the upper part,  
with a pointer attached. A moveable beam is fixed over  
and between the cylinder, having rods and chains at-  
tached, to work the indicating chain of wheels, and to  
turn the four-way tap at the lower part of, and between  
the cylinders. On the top of the cylinders are placed  
inmoveable ketches and chambers, to allow of the escape of  
air as the cylinders are being filled, and to admit air as  
they are being emptied. Also on the top of each cylinder  
there is an indicator, graduated to small quantities,  
having a slot in it through which passes the pin of the  
float-rod with the pointer, indicating the quantity drawn  
off as the float descends. Both cylinders having been  
filled with liquid, the one float is held down by the pin  
at the end of the rod, being under the ketch on the top  
of the cylinder; the other float is up and has forced the  
beam to an inclined position, by its rising as the cylinder  
filled. On turning the tap to withdraw the liquid, the  
float descends, showing in its descent, by the pointer on  
the scale, the exact quantity drawn off, until, in its de-  
scent, the pin at the top of the rod comes upon the  
ketch, forcing it back and passing by it; but in forcing  
it back, as the ketch is attached to the other ketch on  
the opposite cylinder by a rod, the float held down is  
now released, and rising through the liquid, reverses the  
beam, thereby turning the four-way tap, and indicating  
one measure of liquid passed. The empty cylinder is  
now filled, the float being held down as before, and so  
the motion and indicating go on as long as there is liquid  
to flow, or until the tap is turned to stop it.

Fig. 1.

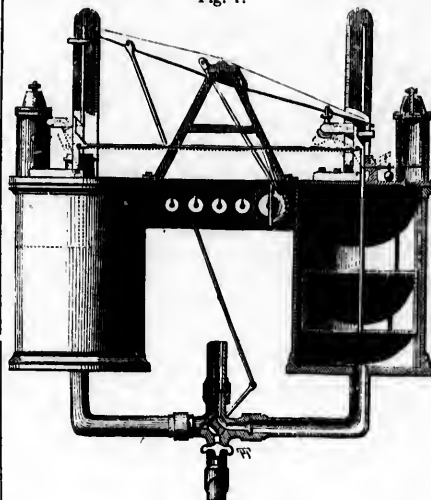
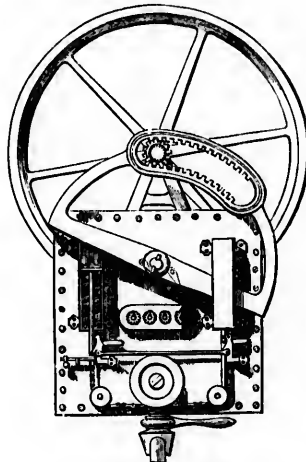

Fig. 2.



Brown's Patent Power-engine.

The power obtained will, of course, depend upon the  
amount of pressure applied by either steam or water  
that may be the prime mover.

Fig. 3.

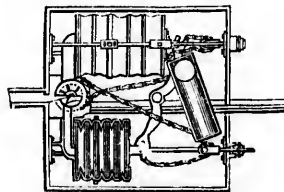

Brown's Patent Meter.

336 **LANGLANDS, J.**, 71 *High Street, Camden Town*—  
Inventor.  
Patent compound tap, with meter.

337 **PARK, S. H.**, *Kingswood, Wotton-under-Edge, Gloucestershire*—Designer and Manufacturer.

Set of improved spanners, registered, comprising nine different sizes.

The use of the instrument is to find the most accurate centre in round or square iron, for the lathe.

338 **SANG, JOHN**, *Kirkaldy, Scotland*—Inventor and Manufacturer.

A planometer or self-acting calculator of surface.

This instrument is used for measuring the area of figures drawn on paper, which it does in an accurate and rapid manner, the operator merely requiring to guide the point of a pen round the outline of the figure, however irregular it may be. It measures any figure, but its great advantage consists in determining the area of those of irregular forms, the measuring and calculating of which by scales in the common manner is a laborious process, and one requiring to be repeatedly performed and revised, in order to ensure minute accuracy, and to do away with the chance of arithmetical errors. Adapted for the use of surveyors of land and engineers, and also calculated to assist students of physical geography, of geology, and of statistics; to the latter it affords the means of indicating from the best maps, with little trouble, the extents of states and other subdivisions, and of correcting the approximations given in published tables.

In order to use the planometer it is to be laid on the figure in such a manner that the tracer can be carried round its outline. The handle is to be held like a pen in writing, and the tracer is to be brought on the outline and pressed very slightly into the paper, so as to make a small mark. The index is to be read. The tracer is then to be carried along the outline until the mark be again reached. The index is to be read again, and the difference between the two readings is the area of the figure in square inches, tenths and hundredth parts, or the area may be got without subtraction, by setting the index at zero at the commencement, but the former is the preferable mode. When the boundary consists of straight lines the process is aided by using a straight-edged ruler to guide the tracer, as in drawing.

The numbers engraved on the silver index indicate square inches, which are divided by lines into tenths, and further by a vernier in the common manner into hundredth parts. This index reads up to 20 inches; the brass index carries on the divisions as far as 100 square inches. The instrument will measure any figure not exceeding  $\frac{1}{2}$  inches in breadth and 22 in length. If the figure's of greater size it is to be divided by pencil lines into parts, which are to be treated separately. The only adjustment required is, when the instrument is lifted out of its case, to make the two indices read zero at the same time, which is readily done by lifting up the brass one and turning it a little forward or backward. If the tracer be carried round the figure in the direction that the hands of a watch move, the first reading is less than the last. If it be carried in the opposite direction, the first reading is greater. This machine is represented in the annexed cut.

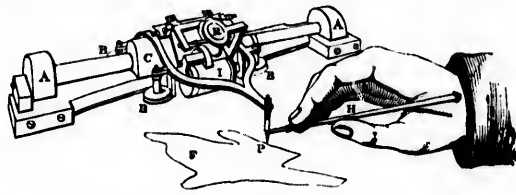

Sang's Planometer.

The mode of action is very simple. The rollers (A, A) are attached to the same axis, on which there is also a cone, which revolves with them; they are exactly of equal size, so that as they move up and down the paper; the axis of the cone is always parallel to the same line. The four friction rollers, of which three (B, B, B) are shown in the drawing, carry a frame and the tracing point to the right or left, parallel to that line which it is possible to trace on the surface of the cone parallel to the paper. Attached to this frame is the index wheel (I), the edge of which touches the cone in that line, and is made to revolve by it; consequently, the revolving motion of the index-wheel is in proportion to the motion of the tracer up or down the paper, multiplied by the right and left distance of the wheel from the apex of the cone; and therefore, when the tracer is made to describe any complete perimeter, the whole rotatory motion of the index-wheel represents the algebraic sum of the products of ordinates to every point in that perimeter, multiplied by the increment of their co-ordinates; or it is a measure of the included space.

It is obvious that while this arrangement of motions should in theory indicate the product of the ordinating lines by the increment of their co-ordinates, the result of mechanical imperfections in the motion is also a product, so that very great care and nicety must be used in the construction of the instrument. The specimen exhibited is the first model made by the inventor's own hands; it performs its work nevertheless very correctly. It is true that the area of a three or four-sided figure will be found a little more accurately by a scale and calculation than by

the instrument. This may be tested by measuring the same figure a few times each way, and observing the difference of the results; but on the other hand, an irregular or curved figure will be measured more accurately by the instrument than by the scale, and with infinitely less labour, which may be tested in the same way. This is not because the instrument measures the irregular figure more accurately than it does the simple ones, but because the scale measures them less so. The accuracy meant is the absence of minute errors. In respect to great errors, caused by mistaken figures in calculation, the instrument is exceedingly preferable, even for simple boundaries, as it is not liable to faulty arithmetic.

339 **BRIDGES, GEORGE**, *Hampton Wick, Kingston*—  
Inventor.

Instrument for "ascertaining the distances of objects, either by day or night, by inspection and without reference to tables."

340 **ROOKER, JOHN & ALFRED**, 26 *East Street*,  
*Foundling*—Manufacturers.

Sliding rule of involution, presenting at one view the series of powers arising from the successive multiplication of whole or fractional numbers. Questions relating to the increase of population, to the calculation of probabilities, to compound interest, &c., are resolvable by this instrument.

Specimen of hand dividing.

**341 MARRIOTT, M., *Montpelier Square*—Inventor.**

Balance for chemical analysis; the beam, made of pine, weighs less than one-third of an ounce; when loaded with 1,000 grains in each scale it will turn with the  $\frac{1}{100}$ th of a grain, and with the  $\frac{1}{100}$ th of a grain when light.

**342 ROSS, WILLIAM, *Strathsteven, Golspie, Sutherland*—Inventor.**

Graduator. An instrument for the approximate determination of the heights and distances of objects, in miles, chains, yards, or feet, as found by reference to tables adapted for its use; it also shows the time of day by the sun in any part of the globe.

**343 WILLIAM, BARTON HUGH, *Waterfoot, Ireland*.**

An instrument designed to take angles and bearings in the field, and transfer them mechanically to paper, without reading off.

This instrument consists of two rulers, with sights attached to each. These rulers turn on a pivot, and a compass is fixed in the lower valve. It is designed to take angles and bearings in the field, and transfer them mechanically to paper without reading off. It is particularly intended to take the place of Sir Howard Douglas's reflecting instrument, and Schmalcalder's compass and protractor, the offices of all three of which instruments it undertakes to perform.

**344 DOVER, JOHN, *14 Little New Street*—Producer.**

Delicate balance contained in mahogany lantern case, with weights packed in a drawer for chemical analysis and assaying.

**346 DOBBS, GEORGE, *37 St. Alban's Street, Lambeth*—Inventor.**

Universal spirit level, adapted for levelling all kinds of machinery.

**347 COX, GEORGE, *5 Barbican*—Manufacturer.**

A portable instrument for ascertaining correct time by equal altitudes of the sun, and intended for rating time-pieces, watches, and chronometers.

The "periphon," an instrument for facilitating the study of astronomy and astronomical geography; intended to explain many phenomena which cannot be illustrated by a common globe.

Beam draining-level, with adjusting parallel plates on tripod stand, giving by inspection the rise and fall of land intended to be drained; useful in laying tiles, levelling, and building operations.

The A-level for the above purposes, without parallel plates or tripod stand.

**348 HARDY, JAMES, *5 Wellington Road, St. John's Wood*—Inventor.**

Metrograph, an instrument to enable a person to draw any object from nature, by actual measurement.

**349 BARRETT, ROBERT M., *4 Jamaica Terrace, Limehouse*—Manufacturer.**

Improved lunar sextants. Their object is increased facility in reading off by night. Plain sextant. Improved brass quadrant, divided to half minutes.

**350 TAYLOR, JANET, *104 Minories*—Manufacturer.**

Sextant for measuring angular distances between the heavenly bodies.

**351 HEATH, GEORGE, *Erith, Kent*—Manufacturer.**

Solid bell-metal ivory arched sextant, divided to 10 seconds, combining the clearness of ivory with the dura-

bility of metal. Owing to the extreme minuteness of the divisions on instruments divided to 10 seconds, the difficulty of reading them off is great. This is avoided by the use of ivory, as a black mark on a white ground presents a much greater contrast than a self-coloured mark on metal.

Improved action magnifier. In other instruments, the magnifier placed to facilitate the reading of the divisions moving in a smaller circle than the arch, distorts the divisions upon approaching the extremity of the vernier, by their being thrown out of the centre of the lens. This is avoided by the present plan.

Improved spring hollow leg, thus to avoid the possibility of altering the adjustments of the instrument in placing it down.

Improved ivory arch metal quadrant, possessing, in respect to the ivory, the qualifications of the before-mentioned sextant; the ivory being dovetailed into the metal, cannot come out or shrink.

**352 WILLIAMS, WILLIAM, *57 Johnson Street, Somers Town*—Inventor and Manufacturer.**

A radiator, or instrument for artists, designers, or draughtsmen, to enable them to draw lines radiating from a centre.

**353 ADCOCK, JOHN, *4 Marlborough Road, Dalston*—Inventor.**

Model of a new machine for measuring and mapping roads, &c., on the scale of  $1\frac{1}{2}$  inch to a foot. In its use the slightest tendency to error from accidental displacement, an unevenness of the road, &c., can easily be detected by placing a compass upon one of the right lines of the map, which will enable the least deviation from the original or starting position to be at once perceived.

**354 BRAKE, R., *Glastonbury, Somersetshire*—Inventor.**

Model of an instrument for explaining solar and lunar phenomena. Its novelty consists in the means adopted for showing the daily increase or decrease of the sun's declination, for explaining the nature of eclipses and the causes of the harvest-moon, and of the difference between true and apparent time. There are two small appendages, one for measuring the sun's altitude, and the other for describing his apparent diurnal motion in the ecliptic, and for showing the angle which, at any particular time, the latter makes with the horizon. The model (six inches in diameter) is complete, but only about one-third the proposed size of the instrument.

**355 GRAHAM, JOHN, *High Row, Darlington, Durham*—Inventor.**

A rule for showing the circumference of a circle when the diameter is given, and *vice versa*; and for showing also the side of the square equal in area to a circle whose diameter or circumference is given.

**356 CAMERON, PAUL, *87 London Street, Glasgow*—Inventor.**

Azimuth compass, adapted to solve various problems in nautical astronomy, practical navigation, and civil engineering.

Engineer's improved indicating level.  
Mathematical and nautical slide rule, for the use of engineers and naval officers.

Improved thermometer, steam and vacuum gauge.

**357 MACDONALD, DR., *4 Coburg Place, Upper Kennington Lane*—Inventor.**

Instrument to facilitate the finding of the longitude at sea.



- 358 SIEBE, AUGUSTUS, 5 Denmark Street, Soho—  
Inventor and Manufacturer.

New-constructed dial weighing machine, with measuring apparatus. The annexed cut shows the form of this machine.



Siebe's Dial Weighing and Measuring Machine.

Self-acting water supply or steam-boiler feeder, with a patent joint to connect lead pipe without soldering.

- 359 SMITH, W., 6 Wygatt Street, Maidstone—  
Inventor.

Early-calling machine. The object for which this is intended is, by the aid of a clock, to awake persons at any hour required without noise.

- 361 MILLER, JAMES, JUNR., 30 Thomas Street,  
Woodrich—Inventor.

A radiator, an instrument for drawing lines to a point or centre, with a graduated arc, fitting the instrument for being used as a protractor.

[The manner of using this instrument is by placing the centre of the glass over a given point, and keeping one arm fixed, whilst drawing all the lines required by the inner edge of the other.—J. G.]

- 362 LIDDELL, JOHN JOSIAH, Edinburgh—  
Designer and Manufacturer.

Spirit levels of various kinds, used in draining, road-levelling, &c.

- 363 THOMPSON, JOHN, 4 Wellington Place, West  
India Dock Road, Limehouse—Inventor.

Trigonometrical machine, for drafting every description of coat, jacket, waistcoat, trowsers, and riding-habit.

- 364 ADCOCK, J., Teignmouth—Inventor and Designer.

Registered approximative comparative scale of the diameter and quadrant of the circle, designed to facilitate the measurement of standing timber.

Drawing of a paddle-wheel, illustrative of an arrangement by which the paddles may be made to enter and leave the water at the most effective angle.

Drawings of an invention for determining and registering the duration of the courses of the wind at stationary places within any given time; of a new water-wheel, applicable to falls of any height, and capable of working under water without much diminution of effect; and of a new tug-boat, intended for canal tunnels of great length, which have not a towing-path, and where steam power cannot be applied.

- 365 GARDNER & Co., 21 Buchanan Street, Glasgow—  
Manufacturers.

Optical instruments.

- 366 YOUNG & SON, 5 Bear Street, and 46 Cranbourn  
Street—Inventors and Manufacturers.

A seat scale weighing machine of multiplying power. A table weighing machine. This is represented in the annexed cut.

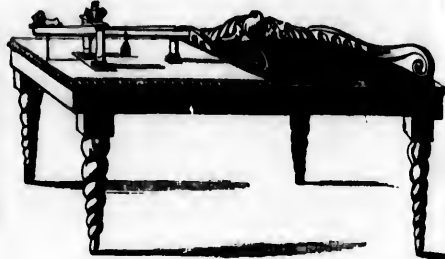

Young's Table Weighing Machine.

- 367 BLYTH, ROBT., 2 Cheltenham Place, Westminster  
Road, Lambeth—Inventor.

Patent indicating level, for carpenters, masons, builders, &c. (adapted with telescope and stand).

- 368 ACKLAND, WILLIAM, 19 Dorset Street,  
Portman-square—Inventor.

Machine for the graduation of hydrometers, thermometers, &c. Scale for an hydrometer, showing specific gravities. Another, showing per centages, according to Traalles. Hydrometer in a finished state, showing Twaddell's scale.

In hydrometers showing specific gravities and per centages, the divisions are of unequal magnitude. By this machine, the subdivisions are placed so that each shall be in its true mathematical position; it is applicable to the subdivisions on the scales of thermometers, barometers, verniers, the lines of sines, secants, tangents, semi-tangents, chords, logarithmic numbers, and, indeed, to all straight scales requiring equal or unequal divisions. A brass hydrometer for showing specific gravities.

[An hydrometer is an instrument originally designed for the purpose of measuring the gravity, density, &c., of water; but the knowledge of the specific gravities of bodies, both fluid and solid, is so essential, that there have been many contrivances for their determination.—J. G.]

- 369 BESANT, —, Wiltshire—Manufacturer.  
Music stands.

- 371 NUNN, RICHARD MADDOCK, Wexford, Ireland—  
Inventor.

Hydrometer, for ascertaining the specific gravity of liquids from 0.600 to 2.000. The weights are introduced into the instrument below the centre of gravity.

Pump for medical and other purposes, stomachicemata, &c.

Door-spring, to act without noise.

- 372 BLUNT, H., Shrewsbury—Producer.

Model of a lunar crater (Eratosthenes), diameter of the crater about 28 miles.

- 376 HAY, WILLIAM, 113 Union Street, Aberdeen—  
Designer and Proprietor.

Foot gauge, by which all the measurements of the foot are taken at once. Useful to shoemakers, &c.

377 **FOX, R. W., Fulmouth—Inventor.**

**Magnetic balance.** The beam is supported by fine cylindrical axles, of polished steel, moving in holes of very small depth, made in agates, or hard metal: it is furnished with an apparatus for diminishing the friction of the axles in the holes, so that the ten-thousandth part of

a grain sensibly affects the balance; the beam is magnetized, and it may, when required, be adjusted at O, by means of the index at the back, which is connected with a magnet within the box—the point of the pin being rubbed during the operation. The following cut is a front view of this balance.

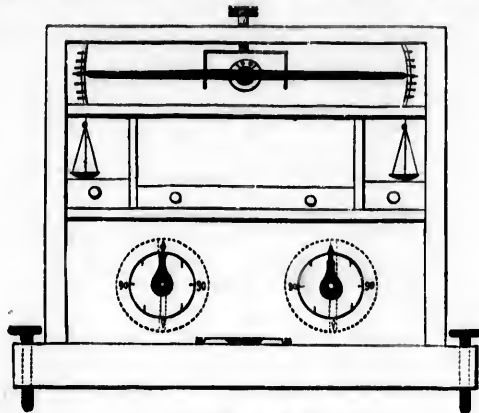

Fox's Magnetic Balance.

[In this balance the body is weighed against the force of magnetism, instead of that of gravitation, as in the ordinary balance. The beam is itself a magnet, and its position is governed and adjusted by the repulsive action of another magnet.

To adjust the instrument for use, it must be carefully levelled by the screws. The beam is then brought to the zero points by turning the deflectors. The weight and materials to be weighed are then introduced, and the sliding door closed; the beam being released takes its position with great accuracy, showing the difference of the materials and weights by the small space passed over by the points of the needle; or weights may be added till the beam becomes perfectly horizontal.—R. H.]

378 **YATES, EMMA JANE, 9 Portland Place, Wandsworth Road—Inventor.**

Instrument for the approximate determination of the problem of squaring the circle.

379 **DYER, HENRY, Great Western Railway, Hungerford—Inventor.**

Registered office-index and tablet-memento. The revolving circular plate, being properly adjusted at the end of each month, shows the month, the day of the month, and the day of the week, throughout that month.

382 **TOLLPUTT, W. B., Folkestone—Inventor.**

Instrument for teaching the blind to write.

383 **DARNELL, J., 3 King Edward Terrace, Liverpool Road, Islington—Inventor.**

Portable house alarm, for the detection of fire and robbery.

Universal sun-dial, which may be adjusted to any latitude in the northern or southern hemisphere.

385 **DAVIDSON, A. Nairne—Inventor.**

Instrument for taking the girth of trees.

386 **WEARE, R., Prince's Road, Plumstead Common—Inventor.**

Fire annihilator.

387 **WERTHEIMER, D. J., 5 Charing Cross—Patentee and Manufacturer.**

Calculating machine, performing the operations of the four arithmetical rules, viz., addition, subtraction, multiplication, and division, simply by mechanical action; and applicable for addition and subtraction of English money, from one farthing up to one million pounds sterling.

Calculating machines for Indian, American, Russian, Prussian, Brazilian, Portuguese, Neapolitan, Roman, French, Turkish, and Chinese money.

Counting machine, for showing the number of strokes made by a steam-engine, or any other piece of machinery; and which can also be used for telling off scores, &c.

[Automaton calculation of this kind is effected by a number of toothed wheels, each turning freely about its own centre, and the "value" of the operations depend upon the number of teeth in those wheels: thus, if a wheel have 12 teeth, it may be used for pence; another with 20 teeth may be used for shillings, and so on. But, notwithstanding the skill and ingenuity bestowed upon such instruments, their power is very limited.—J. G.]

389 **DARVELL, WM. JOHN, Chesham, Bucks—Inventor.**

An improved cooler, or refrigerator, for cooling malt liquors.

392 **BOYLE, —.**

Reflecting telescope.

395 **MATTHIAS, JOHN HENRY, 47 Hatton Garden, and 1 Dorset St., Bull's Pond—Inventor and Maker.**

New invention for dividing lines, upon a geometrical principle; made of German silver and of box.

396 **BAKER, HENRY, 90 Hatton Garden—Inventor and Manufacturer.**

Steam gauge, upon the compressed air principle, showing the pressure per square inch, and also the temperature of the steam at various pressures. (See fig. 1.)

Vacuum gauge, with sliding scale; the glass tube is protected by a bronze covering. The same in a brass case, showing a scale of 22 inches and upwards, intended for

sugar boiling, or situations where space is an object. (See fig. 2.)

Fig. 2.



Fig. 1.



Baker's Steam and Vacuum Gauges.

New steam gauge. Rain gauge, upon a simple plan. Thermometric alarm, for giving an alarm at any required temperature; useful in case of fire, overheating, &c. It consists of a bent glass tube, with a bulb at each end, one of which is open to the external air, a certain quantity of mercury is poured into it. The other vapour in one bulb acts as a thermometer, and by its expansion displaces the mercury, which flows into the other; the tube rests upon a pivot, and is by this movement overbalanced. The brass tube over the glass one contains a ball, which then rolls down and falls upon a lever in the upright pillar, which sets the clockwork in motion, giving an alarm which will continue for some time. It will also act as a thief-alarm, by means of wires being fixed from it to the doors and windows.

Horticultural and other thermometers. Barometers, for the working classes. Glass hydrometer for testing the strength of spirits, in a box, with a thermometer. Glass saccharometers, for testing beer. Glass lactometer, for showing the quality of milk; also the per centage of cream by measure. Urinometers, fitted up in various ways, with bottles, lamps, and test tubes.

399 CHAMBERLAIN, WILLIAM, jun., *St. Leonards-on-Sea*—Inventor.

Large model of a patent machine, to be used in recording votes by ballot.

Model of a similar patent machine making votes on divisions.

401 HUGHES, WILLIAM, *Governor of the Blind Asylum, Manchester*—Inventor.

Registered portable typograph. A new mechanical contrivance for the use of the blind. See the annexed cut.

By the aid of this instrument persons who can read the common embossed Roman letters (even of double the ordinary size) may communicate, by letter, after a few minutes' instruction. This typograph is calculated to give, at pleasure, any letter or figure in the eighth part of an inch; and, if required, a blind person may with ease put sixty-four distinct letters within the space of a square inch. The typograph is applicable to many

other purposes, such as printing uniform labels for museums, &c.

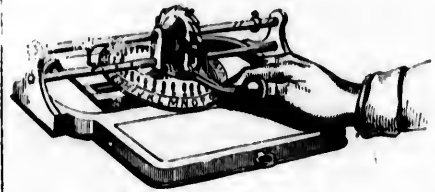

Hughes's Registered Typograph.

The typograph, a similar instrument, constructed for embossing, or printing in relief.

402 WILTON, WILLIAM, *St. Day, Truro*—Manufacturer.

Fox's magnetic dip and intensity instruments, various sizes, for showing the exact dip of the magnetic needle, and for measuring relative magnetic intensities. See the annexed cut.



Fox's Magnetic Dip and Intensity Instrument.

This instrument consists of the following parts:—

1st. Of a horizontal plate, traversing within a graduated limb mounted upon a tripod of brass, and adjusted by screws to the true level, by a ground-glass spirit bubble.

2nd. Of a strong ring fixed at right angles to the former, within which are two graduated limbs, the outer one divided to 15°, and the inner one to 30°, and so fixed to the instrument as to direct the eye in reading off from the points of the needle, thereby avoiding error from parallax.

3rd. Of a solid back with a graduated limb outside, and an armature carrying a telescope, with verniers made to revolve thereon.

4th. Of a concentric ring, revolving in the centre of this, and carrying a plate with bracket and appendages for the needles.

5th. Of a magnetic needle attached to a strong steel axle, terminating at the extremities in very fine, but perfect cylinders of hardened and polished steel; these fit into jewelled holes, which may be moved around with the concentric ring, and which suspend the needle in a vertical plane, making it very steady, yet allowing it perfect freedom to settle in the magnetic dip.

6th. Of a small brass stud projecting behind, and so fixed as to form a continuation from the axle of the needle; against this, is employed a small ivory disc as a rubber, which counteracts the friction of the needle on its axle.

7th. Of a fine concentric brass pulley on the axle of the needle, over which passes a fibre of unspun silk, carrying a small hook at each end, for the purpose of testing magnetic intensities by the employment of small weights, a series of which are furnished with the instrument.

8th. Of a pair of small cylindrical magnets fitted into brass tubes, and made to screw into the armature behind; when the verniers of the armature are placed to read off the same degree as the points of the needle, then the points of these magnets are exactly opposite thereto, and

uniform labels for

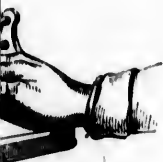

graph.

ment, constructed for

Travo—Manufacturer.  
instruments, various  
the magnetic needle,  
intensity. See the

Instrument.

Following parts:—  
ing within a graduated  
glass, and adjusted by  
glass spirit bubble.  
Right angles to the  
steel limbs, the outer  
one to 30°, and so  
the eye in reading  
easily avoiding error

uated limb outside,  
with verniers made

ing in the centre of  
screw and appendages

ed to a strong steel  
in very fine, but  
sheathed steel; these fit  
around with the  
needle in a verti-  
allowing it perfect

ing behind, and so  
in the axle of the  
small ivory disc as a  
on of the needle on

ley on the axle of  
re of unspun silk,  
for the purpose of  
employment of small  
ed with the instru-

magnets fitted into  
the armature behind;  
placed to read off  
the needle, then the  
posite thereto, and

are employed in deflecting the needle from its true position, and thereby determining magnetic forces, and also of correcting the dip.

Of a thermometer, for registering temperature, when observations are made with the instrument.

Lastly, of an extra needle, to be employed for correcting errors, arising from accident or otherwise, in the needle generally used. This is effected by taking the mean of several readings of the dip of this needle, with the face of the instrument towards the east, moving the horizontal limb through 180°, and taking the mean of several readings west, then of reversing the poles of the needle, and again taking the mean of several readings east and west, and lastly of taking the mean of these two results; if these correspond with the dip shown by the needle regularly employed, then the dip is correct. A mean of several readings will generally give the dip within a minute or two. The instrument may also be employed for measuring angles in azimuth and altitude, or be used as a theodolite. In using it as a magnetic variation, or declination instrument, the true meridian can be ascertained in the usual manner, by means of the telescope and the vertical and horizontal movements. The magnetic meridian can be exactly determined by reading off the azimuths when the needle is vertical, or rather when one of its poles, or points, is at 90° facing north as well as south, and the mean of the azimuths gives the magnetic meridian. These observations may be multiplied by turning the face of the needle towards the back of the instrument, and also by employing the other needle to repeat the observations. The method of different azimuths may also be employed *ad libitum*, reading off when the point of the needle is 1°, 2°, &c., on each side of 90° in succession. In all cases the rubbing of the point of the stud, or pin at the back, should be continued till the needle has settled in its place of rest. It should be gently done, especially at the last.

[Fox's dipping-needle deflector has now been employed by Ross, Stanley, Belcher, and others, for determining the variations of the dip, and intensity of magnetic force, for many years, with the most marked advantage; as it enables the observer to determine, with great accuracy even at sea, various points of interest in connexion with the phenomena of terrestrial magnetism. The needle being brought to its true bearing at any spot on the earth's surface, a small balance is hung on the disc around the centre of suspension, and the weight required to bring the needle back to zero is the measure of the intensity of the magnetic force in action. For a detailed account, the Second Annual Report of the Royal Cornwall Polytechnic Society should be consulted.—R. H.]



Fox's Miner's Theodolite.

Practical miner's theodolite, or improved dial and quadrant, used for underground and surface surveying, and constructed so as to answer all the purposes of the scientific and practical miner, while it may also be used as a surveyor's theodolite. This instrument is shown in the preceding cut.

403 ANDERSON, JAMES, *Queensferry South, Edinburgh*—Inventor.

Perspective drawing machine.

404 GRIFFITHS & LE BEAU, *15 Coborn Road, Mile End*—Producers.

Daguerreotype portraits and pictures, with electrotype copies taken from them.

[The daguerreotype picture being produced by a film of mercury upon a silvered plate, there is necessarily an irregularity over its surface. If a plate thus prepared is connected with a galvanic battery, and placed in a solution of sulphate of copper, the copper precipitated on the surface receives a most delicate impression of the daguerreotype image. In addition to the differences produced by the varying thickness of the mercurial film, there is not unfrequently a slight difference in the colour of the copper deposited over those parts thickly coated with mercury, and those over which the silver is exposed.—R. H.]

404A HEYWOOD, WILLIAM, *95 Duke Street, Manchester*—Inventor.

Experimental air-pump, with self-acting exhaust-tap placed in immediate contact with the bottom of the cylinder.

406 BEAUFORD, R., *Hastings*—Inventor.

Registered daguerreotype accelerator. This consists of a properly-constructed lens, applied in a particular manner to the ordinary daguerreotype instrument. Its advantages are assumed to be as follow:—

The actinic rays (which have their primitive source in the solar beam, and which produce the photographic effect) diverge from the object of which an image is to be produced on the photographic plate. These rays are made, by the action of the ordinary daguerreotype instrument, to converge to a point at a certain distance within the camera. By applying the accelerator, these rays are made to converge more rapidly; and, by putting the prepared plate more forward, a smaller image is procured by means of the accelerator than could be obtained without it. Hence, by means of the accelerator, the actinic rays are condensed into a smaller area, and the intensity of the effect is heightened.

This latter fact is considered to include three others, namely—photographic effects can be obtained by the application of the accelerator, when, without its aid, the desired effect could not be obtained; as, for instance, on a dark and cloudy day. Again, all other things being the same, the image of the object is much more intense and well-defined with the accelerator than without it—the fitness and clearness generally observable in photographic portraits being exchanged for a roundness of surface, and a natural projection or “bringing out” of the parts, which constitute an effect highly pleasing. A third benefit secured by the accelerator is observable in the diminished time required for producing a photographic effect, owing to the actinic rays being intensified by the introduction of the accelerator. The time required for producing a photographic picture with the aid of the accelerator, is only one-half or two-thirds of that required with the ordinary apparatus alone.

A further advantage obtained is the economy of space. When the daguerreotype instrument is used without the accelerator, the artist, if he wish to obtain actinic rays of less divergence (which is often the case), must remove from the object. In removing further, he must use (in most cases) a large instrument. Such inconvenience is avoided by means of the accelerator; for,

when this is stated to be applied, the rays can be at once refracted into the right course, whereby the increase of distance and the change of instrument are avoided; the accelerator therefore favours not only the economy of space, but also the economy of means, the use of the larger instrument being in this case obviated. This will appear to be still further the case, when we consider that by applying accelerators of different foci, we can produce portraits or views of proportional magnitudes; so that from one daguerreotype instrument both large and small plates can be produced.

Another advantage of the accelerator is, that it prevents that distortion of the image often observable in photographic portraits. Without the application of the accelerator, the image produced is of such a size that any exaggeration of relative magnitude, due to the superior forwardness of any part of the object, is magnified to an inconvenient extent. The image produced by the accelerator is reduced in size, and this exaggeration is reduced in an equal degree, so that it appears free from all distortion; by this means, the ingenious but troublesome contrivances hitherto adopted to avoid this source of annoyance are superseded.

407 GOGERTY, ROBERT, 72 Fleet Street—Inventor.

Model of a pair of direct-acting steam-engines, with paddle-wheels.

Plate electrical machine to exhibit negative and positive electricity.

Double-barrel air-pump with iron plate.

Delicate galvanometer, &c.

408 BRYAN, Rev. JOSEPH, 8 Haymarket, Norwich—

Inventor.

Improved air-pump without valves, having a rotary motion and double action, exhausting both by the rise and fall of the piston; it will also condense as well as exhaust.

409 MARRATT, J. S., 63 King William Street,

London Bridge—Manufacturer.

Five-foot achromatic telescope, the vertical and horizontal motion produced by endless screws.

Seven-inch transit theodolite, reading to 15" in altitude and azimuth, furnished with inverting and diagonal eye pieces, needle box, tripod staff, and locking plate, axis level, &c. It can be used with or without tripod, as may be required; and is adapted for surveying, tunnelling, magnetic, or astronomical purposes.

411 PHILLIPS, JOHN, F.R.S., St. Mary's Lodge, York—

Inventor.

An electrophorus, (fig. 1.) which differs from that of ordinary construction, by having metallic conductors

Fig. 1.



Fig. 2.

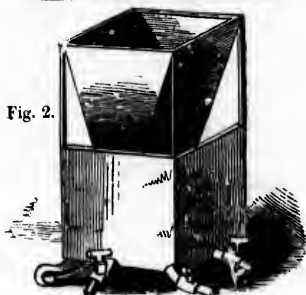

Phillips's Electrophorus with its Cover, and Rain-gauge.

through the resin to the base on which it is placed. By this contrivance it is unnecessary to touch with the hand the metallic cover, which as often as it is lifted and replaced will give powerful sparks.

Rain-gauge (fig. 2.), with one horizontal and four vertical receiving funnels, each furnished with a stopcock. By a simple calculation from the measures of water collected in the funnels after a shower, not only the depth of rain which has fallen, but also the direction in which it came, and the angle of inclination of its descent, become known. These instruments are shown in the preceding cut.

Maximum thermometer, with a separated column of mercury for the index, instead of the wire, which is liable to get entangled in the mercury, and demands a large-sized instrument. By the construction exhibited, these defects are avoided, and the use of the instrument is extended.

Anemometer, for collieries, hospitals, &c. The pressure is received on a semicircular disc, suspended by the diameter, and measured on a graduated arc. By tables

calculated for the equation  $vel. = M \sqrt{\frac{\sin \theta}{\cos^2 \theta}}$  the velocity is obtained in terms of the angle.

Air barometer, of very cheap construction, suited to collieries, in which a large scale is desirable for rendering the changes of atmospheric pressure obvious.

413 ALLEN, EDWARD ELLIS, Steel Yard Wharf,

Upper Thames Street—Inventor.

Electro-magnetic railway-train alarm, for communicating with the engine-driver from any part of the train. The alarm consists of the ordinary steam whistle worked by an electro-magnet, the current passing through the side-chains; thus any additional connexion between the carriages after they are attached in the usual way is avoided.

414A PARKS, W. J., 25, Newington Crescent—

Manufacturer.

Gold plate with mineral teeth mounted on it. Complete upper set, with natural teeth on the one side, socketed in hippopotamus ivory, and imitated on the other.

414 NICHOLS, W., Cambridge—Inventor.

Electro-magnetic alarm, for protection against robbery or fire; with a model showing the arrangements.

417 CRESSWELL, JOHN, Winchester Hill, Edmonton—

Inventor.

Electro-magnetic engine, for the production of motion. The principal novelty in this engine consists in the mode of applying the attractive power.

419 WHISHAW, FRANCIS, 9 John Street, Adelphi—

Designer and Inventor.

Telekophonon, or speaking telegraph. Consisting of gutta percha, glass, metal, or other proper tubing, with mouthpieces of ivory, hard wood, or metal; furnished with whistles, organ-pipes, and other means of calling at-

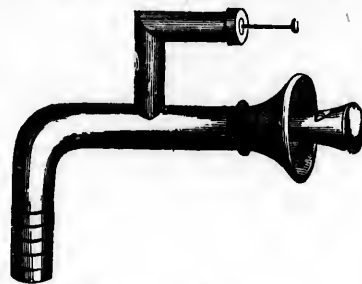

Whishaw's Index Mouth-piece.



which it is placed. By touching with the finger as it is lifted and

vertical and four vertical with a stopcock. By a series of water collected by the depth of rain in which it came, the amount, becomes known. preceding cut.

separated column of wire, which is liable to demands a large-sized battery, these defects are remedied. The pressure is suspended by the insulated arc. By tables

$M \sqrt{\frac{\sin \theta}{\cos \theta}}$  the angle.

construction, suited to rendering obvious.

Yard Wharf, Inventor.

for communication, for the main part of the train. A steam whistle worked passing through the connection between the tubes in the usual way is

on Crescent—

mounted on the one side, and imitated on the

Inventor. Protection against robbery arrangements.

Hill, Edmonton—

production of motion. The consists in the

ect, Adelphi—

r. Consisting of proper tubing, with metal; furnished means of calling at-



ce.

tention. The index mouthpiece attached to one end of the tube has an indicator to show from which room the call has been made. See the preceding cut.

Gutta percha telephone.

Railway trains communicator, for communicating between guard and driver, or passengers and driver, a telephophonon, in different lengths, with screw joints to suit the lengths of the carriages and the spaces between them.

Gutta percha tube and lathe-band, as first made by the exhibitor in 1845.

Subaqueous insulated electric telegraph conductors.

Battery protector.

Telegraphic private code box. Model to illustrate the hydraulic telegraph.

Index electro one-wire telegraph, with perforated conversation codes.

Centimetre chronometer, made by Johnston, Clerkenwell. By means of tabulated velocities on a moveable ring, the speeds of railway trains, &c., are accurately ascertained to the hundredth part of a minute, by observation merely, and without calculation.

Comparative plan of that part of the City of London which was destroyed by the Great Fire in 1666; showing its state at that period, and the alterations and improvements effected up to 1829, with historical and other notices.

Patent glass pipes to insulate and protect the wires of electric telegraphs when placed under ground. Patent multitubular pipes, of glazed earthenware. Manufactured by William Northen, Vauxhall.

Chess-board, enamelled slate, executed by Mr. Magnus, Fimlico.

Whishaw's uniformity-of-time clock and telegraph; mechanical domestic telegraph; and index electric telegraph.

[The mechanical domestic telegraph consists of an arrangement of tubes formed of gutta percha, and supplied with metallic and other mouthpieces, to which a whistle is attached. By blowing into the tube the whistle is sounded in a remote apartment, and the message can then be delivered with scarcely any elevation of the voice through the tube, which transmits sound in a remarkable manner.—R. E.]

Wrought-iron chain pipes, with swivel joints, for protecting the wires of electric telegraphs under water.

420 HARRISON, C. W., & J. J., Richmond—Inventors.

Electro-magnetic engine, for producing a motive power on a new principle.

421 McNAIR, A. & Co., 33 Oswald Street, Glasgow—Inventors and Manufacturers.

Conductor for electric telegraphs consisting of a copper wire insulated with gutta percha, and inclosed in a leaden tube.

422 BRETT, ALFRED, 138 Holborn Bars—Proprietor.

Brett and Little's patent electric telegraph, alarm bell, bell handle, and battery.

The electric telegraph. The various letters or numerals represented on the dial are made by the motions of either or both of the indicators; the number of the motions for each letter or numeral is defined by the figures on the centre of the dial, commencing at all times with the indicator on the side next the letter or numeral, and when both indicators are used, finishing with the opposite one. The helices are double, and of a circular form; and the magnet is in the form of a ring or horseshoe, suspended in the centre of the helices, and is deflected either to the right or to the left, according to the direction of the current. The poles of the magnet being equidistant from the earth, the magnet is rendered astatic, and not affected by the terrestrial magnetism.

These magnets move parallel with the coils of wire and planes of electricity. The indicators, not being magnets, are perfectly free from vibration, and the indication is therefore distinct and certain.

The alarm bell, for calling the attention of the attendant, being liberated by a motion similar to that of the telegraph, gives three distinct blows; and should it, by any chance, be liberated by a current of atmospheric electricity, the apparatus would not be deranged.

The deflector on the left of the instrument enables the current to be transferred from the telegraph to the bell, and vice versa; and it can also be used in case of an instrument getting injured, to pass the current along the line, without stopping the communications at other stations; with this, one wire only is required to enable every station on a line of railway to communicate with the whole by means of one instrument only at each station.

The battery is of the ordinary form, except that the cells are of porcelain and separate, and the plates are connected with binding screws.

By the use of an underground arrangement of conductors (as exhibited in combination) the cost in the first instance, with wire encased in lead, is very little more than posts with wires suspended in the air; and with wire, encased in gutta percha only, much less; while the cost of maintenance is greatly reduced, and the liability of interference from atmospheric influence avoided.

423 WINTER, J., 44 Littlewood House, Leeds—Manufacturer.

Galvanic walking-stick, made of a kind of oak, from Australia. It contains an electro-galvanic machine and battery complete. On holding the knob in the hand, a shock is slightly felt; and by taking a piece of silver or copper in each hand, and touching the knob on each side, the shock is greatly increased.

424 SMITH, GEORGE RICHARD, 16 De Bowoir Terrace, Cuford Road—Inventor.

Comic electric telegraph and key board, which consists of a mahogany case, having in front a comic face, and three signs concealed by shutters, the features of the face and the shutters being capable of simultaneous motion by an electric current, which also rings a bell placed inside. With three signs, it not only conveys every letter in the alphabet, but exhibits distinctly the ends of letters, words, and sentences. By the bell arrangement, it intimates when a message is about to be sent, and is made to facilitate the deciphering of the signs. Magnetic polarity, as an indicator, being dispensed with, no electric disturbance in the atmosphere can render it ineffective; the internal arrangement being very simple, it will not soon be disordered by use.

425 BURDETT, JOSEPH, 28 Hanover Square, Clapham Road—Inventor.

Domestic telegraph, requiring only one bell for any number of rooms. All the rooms being numbered, wires are brought to corresponding numbers on this machine, so that when the wire of any room is agitated, the bell will ring and the indicator will point out the number of the room on the dial where attention is required.

426 ALEXANDER, WILLIAM, F.R.S.E., 52 West Register Street, Edinburgh—Inventor.

Model of an electro-magnetic telegraph, worked by means of voltaic currents through metallic conductors, deflecting magnetic needles, and thus unravelling the letters of the alphabet in the order required for any communication. The model was exhibited at the meeting of the Royal Scottish Society of Arts, on 15th November, 1837, after previous experiments throughout the year, to test the practicability and efficiency of the plan, made through a metallic circuit of four miles in the chemistry class-room of the University of Edinburgh. It is believed by the inventor to be the first definite plan for an electro-magnetic telegraph ever shown in operation before the public or a scientific society. In 1837, the applicability of electro-magnetism to telegraphic purposes was matter of doubt and uncertainty, and the object of the inventor was to solve the problem by apparatus of the most simple

construction, and which might lead to future improvements. The perfection to which electric telegraphs have since arrived, their superiority over all other methods for conveying intelligence between distant places, and their

inconceivable importance and utility, are now well known and established, and are justly considered one of the wonders of the age. The following cut represents this early telegraph:—

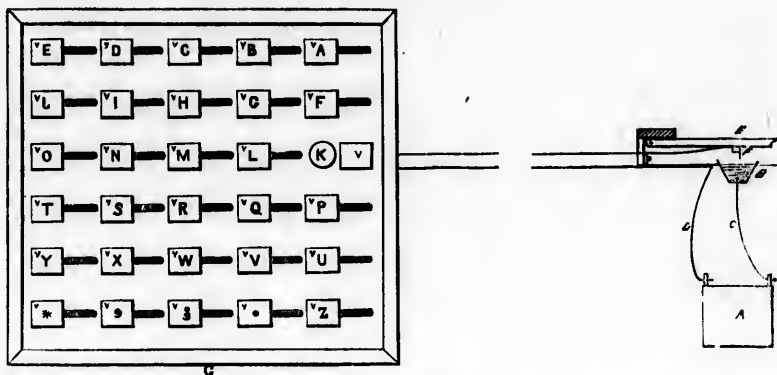

Alexander's Electric Telegraph.

A is a voltaic battery; B, a trough filled with mercury; C, a wire connecting the zinc plate in the battery with the trough of mercury; D, the return wire connected with the copper plate of the battery; E, a key to be pressed down by the finger of the operator, like the key of a pianoforte; F, is a pendant wire which dips into the mercury when the key is depressed, and completes the circuit formed by the wires C and D, extending from one terminus of the telegraph to the other.

G is the distant dial upon which the whole letters of the alphabet and stops are marked. These are not seen when the magnetic needles—poised horizontally in free space behind the dial—are in their natural position of North and South, with screens or veils marked V, attached to each of their North poles, and concealing the

letters, but when the circuit is completed by the depression of the key E, the corresponding magnetic needle is deflected to the West, and exposes, as at K, the letter previously concealed. Thirty copper wires and a return wire extend from the keys to the magnetic needles.

A metallic rod may be advantageously substituted for the trough of mercury below the keys.

427 REID, WM., 25 University Street, Bedford Square—  
Inventor, Patentee, and Manufacturer.

Pair of electric-telegraph instruments, adapted for hotels, &c.; the same adapted for public companies, &c.; domestic telegraph, adapted for dressing-rooms, &c. See the following cuts:—

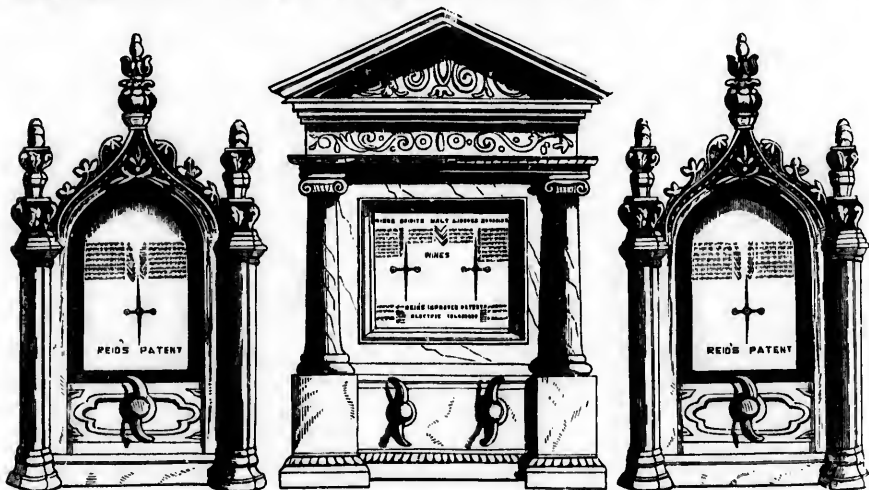

Reid's Electric Telegraphs.

An electrical apparatus for ringing bells in large mansions, brought into instantaneous action by pulling a

cord or lever; and capable of performing at the distance of 50 miles, with as much ease and rapidity as at 50 yards.

are now well known  
considered one of the  
g cut represents this

Electric-telegraph instrument, for the purpose of conveying general intelligence over the country.

Specimens of insulated wire, for submarine electric telegraphs; specimens taken from the English Channel, used in the electric telegraph between Dover and Cape Grinez, near Calais.

428 HENLEY, WILLIAM THOMAS, 46 St. John's Street Road, Clerkenwell—Inventor and Manufacturer.

Large permanent horse-shoe magnet, weighing 6½ cwt. Patent electric telegraphs, worked by the magneto-electric current.

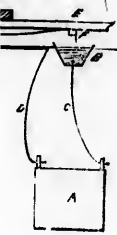

ted by the depression  
magnetic needle is  
as at K, the letter  
r wires and a return  
magnetic needle,  
usly substituted for  
s.

t, Bedford Square—  
manufacturer.

ments, adapted for  
olic companies, &c.;  
ing-rooms, &c. See



y at the distance of  
y as at 50 yards.

Fig. 1.

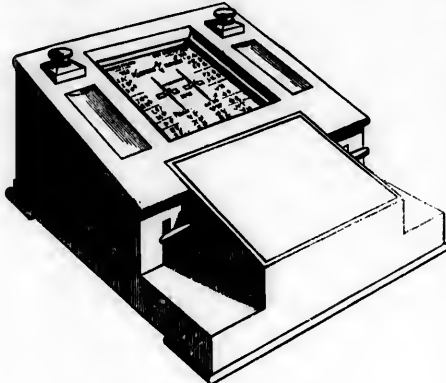
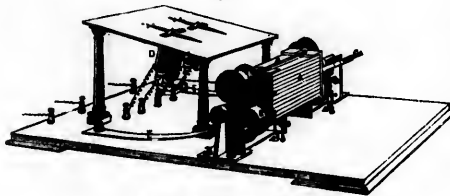

Fig. 2.



Henley's Patent Electric Telegraph.

Fig. 3.



Henley's Magneto-Electric Machine.

Magneto-electric machine, illustrating the application of the electric current derived from magnets, to the purposes of electro-chemical decomposition, electro-metallurgy, &c.

The telegraphs have been tested in the worst insulated line in the country, during the most unfavourable weather, and found to work any distance that it was possible to try them, without any diminution of their power. Working without the aid of a voltaic battery, they are always ready for use, without any preparation or expense. Fig. 1 represents the telegraph with its cover, as in use; fig. 2, the same with its cover removed, each consists of two parts, one for producing electricity, the other for receiving it, and indicating the signals; the parts of each telegraph are alike. The first part consists of two compound bar magnets A A, the ends of each being capped with soft iron, to bring the influence of all the plates to any particular point. B B, two armatures, wound with fine-covered copper wire, each placed on a separate axis, and moved by the levers C C, seen projecting through the case in fig. 1; the ends of the wire are carried from the armature through the pieces of ivory in the axis to the wood base, and from thence to the distant instrument, every motion of the lever and armature producing a current of electricity, the downward motion giving a current in one direction, and the upward motion a current in the opposite. The second part of the apparatus consists of a dial, containing the alphabet and certain marks corresponding to the motions of the needles on the face of the dials; for instance, opposite the letter A is seen a single mark inclining to the left, signifying one motion of the left-hand needle; the letter B, two marks; letter C, three marks, signifying three motions of the same needle; the letter D, one mark to the right; E, two; and F, three; G, one right and one left; L, one left; and once both needles together, and so on. Under the dial are placed two electro-magnets D D, each having four poles, formed by two semicircular pieces of iron with a magnetic needle, suspended freely within, placed on the same axis as the corresponding needle, or pointer, seen on the dial. The downward motion of the lever deflects the corresponding needles of all the instruments that may be included in the circuit, as well as its own; the needles remain so, until the lever is allowed to return by the force of the spring E, when the needles all return to their position, and this taking place with certainty, although the instruments may be at any distance.

The current obtained from the apparatus represented in fig. 3 is very powerful, and capable of producing electro-chemical decomposition, and all the effects obtained from a powerful voltaic battery. The horse-shoe magnet A, with the revolving armature B, formed of hoop-iron, is placed on the mahogany case C, and the whole fixed on the iron framework, on which is suspended the large wheel and treadle, for giving motion to the armature by the pulley D; the magnet has soft caps, and is arranged the same as the telegraph, so that the poles of the magnet are always connected with some part of the iron of the armature, and by that means it always retains its power. The two springs E E rub on the breakpiece F, which is so arranged that the current flows in one direction; the knob G moves a slide to divert the current to the mercury cup H for showing the spark; the cam I moves the point on the spring in and out; the other knob is to make a shock with the two terminals L L.

Electro-magnet capable of sustaining, when excited, 4 tons; the sphere of attraction extends much further by being made of iron hooping.

Large steel permanent magnet, weighing 6½ cwts., capable of sustaining about 1 ton.

[The received theory of magnetism is, that the attracting power of the bar of steel, which we call a magnet, is due to the circulation of electric currents around the bar. It was discovered by Faraday, that when a metallic mass is

moved in proximity to the poles, a current is induced in it: upon this principle magneto-electric machines are constructed. The soft iron armature, or keeper of the permanent magnet, is fixed on an axle, which is made to revolve by some mechanical contrivance, so that a continued and rapid reversal of its poles takes place. By this alone a magneto-electric disturbance is effected; but for the purpose of accumulating the force, coils of copper-wire are fixed on the armature, and every time they approach or leave the poles of the magnet in the course of rotation, an induced current passes through the wire, and the reversal being extremely rapid, though the current is only instantaneous, the result is what may be regarded as an uninterrupted stream of electricity.

The magneto-electric machine was first employed for telegraphic purposes, by Professor Wheatstone. The battery is however usually preferred in this country.—R. H.]

429 BRETT, JACOB, & JOHN, 2 Hanover Square—  
Patentees and Proprietors.

1. An electric printing telegraph, which, by the aid of a single wire only, prints in Roman (or other) letters, with the certainty of action, and under the control of the distant correspondent; it is worked either by galvanic or magnetic electricity, and controlled by hydraulic or atmospheric regulators, combining also a signal bell. Size, 12 inches by 7 inches, height 12 inches.

2. Similar telegraph with additions for registering in duplicate, indicating by dials or signal bells; by the same simple means and certainty of action. Size, 12 inches by 8 inches, height 12 inches.

3. The communicator, or corresponding apparatus, by means of which any one may at first sight print communications at a distant station; the opening and shutting at the commencement and close of a correspondence by its action, taking, or giving the electric current, from or to the main line. Size, 4 inches by 4 inches, 2 inches deep.

4. A similar one, with pianoforte arrangement; the touching of the keys with the finger acting on the main wire, and printing the required or corresponding letter at the distant station.

5. Communicator, adapted as a pocket apparatus for guards of railway trains, for communicating with distant stations on the instant of an accident. Size, 3 inches by 3 inches, 2 inches deep.

6. A circuit regulator for the absolute control of any number of stations from one given point, by the aid of an independent wire. Size, 3 inches by 3½ inches.

7. A portion of the experimental wire passed along the bottom of the channel in August last, when messages were printed by this telegraph from England to France, preparatory to the great undertaking now in progress, which, by the aid of eight permanently-protected wires, will, it is expected, in June next, place Great Britain in constant and instantaneous communication with all the great capitals of Europe.

8. Specimens of an iron protecting cable for enclosing the covered submarine wires, where great strength is required. (Invented by Thos. W. B. Brett.)

9. Electric bells for division signals in the new Houses of Parliament, by which any number may be brought under instantaneous control.

10. Specimens of the printing executed at 200 miles distance.

11. The grants of Louis Philippe and Louis Napoleon to the Messrs. Brett, for the exclusive privilege of establishing electric communication between France and England.

This printing telegraph effects all the purposes of telegraphic communication by a single wire only; printing in Roman, or other letters, recording in duplicate with the rapidity of a compositor, indicating by dials, or signalling by bells. The telegraphs in general use formerly required 8 or 5 wires for vibrating the single or double

needles only, and an independent wire in all cases for a single bell.

It requires but a single wire, and no attendants for watching, copying, or transcribing.

If adapted, at a General Office in London, for the reception of correspondence from all parts of Europe, during the night when the offices are closed, and no attendant present, the whole of the communications of the night from the different capitals of Europe, will, on the arrival of the attendants in the morning, be found accurately printed; and during the day, a signal-bell will announce when, and from where, a communication had been made, requiring attention only to reply to it.

For sending a communication, it is required only to move the hand or strike the key of either of the communicators, Nos. 3, 4, 5, by which a current of electricity is sent through the wire to the distant station, bringing into action the given or required letter on the periphery of a wheel, which instantly impresses itself on part of an endless scroll of paper, rolling printed from an aperture in the instrument, as the shocks or currents of electricity are conveyed by the action on the corresponding letters of the distant communicator.

The telegraph is comparatively self-supplying as the colouring or printing material requires renewal only once a month, according to regulation.

[The insulation of the wires for submarine electric communication is effected by covering them with gutta percha. They are covered in the following manner: a mass of gutta percha in a soft state is contained within a cylinder, and being acted upon by a piston, is driven out through a small die, in the centre of which is the wire. The latter being slowly drawn forward, becomes surrounded with an uniform covering of gutta percha, the thickness of which varies with the diameter of the die-hole through which it is compressed. The coated wire is then drawn through a trough of cold water and wound on a drum. Its insulation is afterwards tested by passing an electric current through it while under water, and observing the deflection, or rather the absence of the deflection, of a magnetic needle.—R. E.]

430 WALKER, C. V., *Tonbridge*—Inventor.

Insulation of telegraph wires, exhibited as *in situ* on a pole-head, and detached on the table. The earthenware cone by which the telegraph wire is suspended is so shaped that the point of contact with the wire is small, is sheltered, and is far from the pole. The shackle frame used for insulating the wire at winding-posts is glazed iron; and its earthen cylinders are so constructed as to give a great length of insulating material.

Insulation of telegraph wires in tunnels, exhibited as in actual use. The wire is covered with gutta percha by Mr. T. Foster's patent process, and is placed in grooved boards, prepared with varnish, and fixed against the tunnel walls.

[Mr. Forster's process of covering telegraphic wires is as follows:—The gun, after being cleared, is macerated by steam machinery in a heated iron vessel. It is thence transferred, lump by lump, to a pair of heated grooved rollers, between which it is passed and pressed into solid cylinders three or four feet in length. It is now ready for the covering machine to which it is carried, and where it is used while warm and soft. This machine consists of two pair of hollow polished iron flapping rollers, heated, as occasion requires, by steam, and of a pair of small grooved cutting rollers. The cutting rollers vary both in the number and the size of the grooves, according to the character of covering required. The wire employed in the tunnels on the South-Eastern Railway, and which are under the superintendence of Mr. Walker, is No. 16 copper, and is covered by six grooved rollers, six wires being covered at one operation.

wire in all cases for a  
no attendants for

London, for the recep-  
sions of Europe, during  
the night, and no attendant  
will, on the arrival  
of the bell will announce  
on had been made,

is required only to  
either of the com-  
ment of electricity  
at station, bringing  
it on the periphery  
of an aperture  
from an aperture  
of electricity  
corresponding letters

supplying as the  
renewal only once

submarine electric  
them with gutta  
in the following manner: a  
containing within  
is driven out  
which is the wire,  
is surrounded, becomes sur-  
gutta percha, the  
center of the die-hole  
coated wire is then  
and wound on a  
by passing an  
or water, and ob-  
of the deflec-

inventor.

and as *in situ* on a  
The earthenware  
suspended is so  
wire is small, its  
shackle frame  
posts is glazed  
constructed as to

els, exhibited as  
gutta percha by  
is secured in grooves  
ed against the

phic wires is as  
macerated by

. It is thence  
heated grooved  
d pressed into  
gth. It is now

is carried, and  
This machine  
iron flapping  
eam, and of a  
cutting rollers  
of the grooves,  
required. The  
South-Eastern  
intendence of  
covered by six  
one operation.

The diameter of the wire, with its covering, being one-fourth of an inch. The two pairs of flattening rollers are placed one over the other, with a small interval between them. The six wires traverse the interval between the two pairs of flattening rollers, and pass between the six grooved cutting rollers with one of the sheets of gutta percha above them and another below, and appear on the other side as a perfect band of six covered wires. They are pulled apart when single wires are required, or left undisturbed when required in a band.—J. G.]

Movable studs, fitted to Cooke and Wheatstone's electric telegraph, to counteract deflections of the needle arising from meteorological phenomena. When the needles are deflected by extraneous causes, so as to touch the ivory studs, or stops, the latter are to be moved in the direction of the deflection, until they are again made equidistant.

Compound needle, consisting of several small needles secured on an ivory disc.

Bell transferer, an ebony cylinder so inlaid with brass and combined with springs as to transfer the telegraph bell to the up or the down side of an intermediate station, according as that station is talking down or up the line.

Let A B C be a telegraph wire of any length, having instruments at A, B and C; B being the intermediate station, and having the bell and the needle on the said wire. If the bell is so connected as to be on the A side

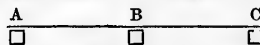

of the needle at station B, when B and C are in communication, it is required to transfer it to the C side, when A and B are in communication; so that while B talks to A, with the rest of the line cut off, he can hear if C rings; or while he talks to C, he can hear if A rings.

This effect is produced, by selecting some convenient place inside the instrument for dividing the wires, and placing springs at these spots. These springs, six in number, press, three above and three below, on brass laid in the ebony cylinder, visible on the left side of the instrument.

When the word up, on the stud in front of the instrument is vertical, the springs are connected in pairs, as 1, 2; 3, 4; 5, 6. When the word up is horizontal, the springs are connected in pairs, as 1, 4; 5, 3; 2, 6, thus transferring the bell to the other side of the needle.

The same operation that transfers the bell to the C side of B, cuts off the C half of the line, by the other springs not concerned in this description.

Branch double turn-plate, being a box-wood cylinder, so inlaid with brass and combined with springs as to enable a junction station to put a branch line of telegraph in communication with either direction of the main line; and completing a perfect circuit for the other portion of the main line.

Lightning conductors, for telegraph wires, shown *in situ* as fitted in telegraph offices, and shown on the table in parts.

Graphite battery; a common sand battery, charged with diluted acid, but having the negative plate constructed of slices of corrosion from gas retorts, instead of copper. Such batteries last longer than the others, there being no salt of copper present to produce action on the zinc.

Up and down ringing key, a contrivance for sending the electric force from an intermediate station to ring bells in the required direction only; the apparatus when at rest constituting part of a complete circuit.

432 THE BRITISH ELECTRIC TELEGRAPH COMPANY.

SAWARD, GEORGE, Secretary.

Higton's patent electric telegraphs and apparatus. Printing telegraph, adapted to one or two wires; another by which any one of 26 symbolical characters is printed by a single touch of a key.

Morse's arrangement of telegraph, worked by secondary power.

Telegraph for showing the letters of the alphabet instantly, by the touch of a single key; with a revolving pointer and a revolving disc.

Series of indicating and pointing telegraphs, worked by various descriptions of coils, and steel magnets; and by coils acting on soft iron.

Series of telegraphic alarms, worked by electro-magnetism, excited in the metal nickel; also by coils and magnets, and by coils and soft iron.

Lightning extractors, for extracting from the wires of a telegraph, charges of atmospheric electricity.

Arrangements for telegraph posts, by means of which a great saving may be effected in the construction of electric telegraphs.

Specimens of wires for a submarine telegraph, protected by means of a covering of wire cable.

[Electric telegraphs admit of a great variety of mechanical arrangements, by which the modes of signalling are modified. In all, the electric current does the work; in some, by deflecting the magnetic needle directly, and in others, by inducing magnetism in soft iron, the force of which acts upon some clock-like arrangement, and thus, by a mechanical contrivance, gives the required signal. Most printing telegraphs are of the latter character. In some, when connexion is made and broken with the battery, electro-chemical decomposition is effected at the opposite end of a line; in others, letters actually inked by mechanical means are made by the induced magnet to print, by being pressed on paper. In this series these several varieties are shown.]

The specimens of wire for a submarine telegraph are designed to overcome the action of breakers, which proved fatal to the telegraph across the Channel, than which nothing otherwise could be more successful; if the wires can be buried deep enough in the sands to place them below the breaker action, there would be no difficulty in communicating readily with the Continent.—R. H.]

433 BAKEWELL, FRED. COLLIER, 6 Haverstock Terrace, Hampstead.—Inventor and Patentee.

Patent copying electric telegraph, for transmitting facsimiles of the handwriting of correspondents, so that their signatures may be identified. Its objects are, authentication of communications, increased means of secrecy, rapidity of action, and economy, as it requires only a single wire.

The transmitting and the receiving instruments are counterparts of each other. Trains of wheels impelled by weights are employed to impart equal movements to cylinders on each instrument. Screws placed parallel to the cylinders, and rotating with them, serve to carry metal styles, which press lightly on the cylinders, from end to end. The metal styles are insulated by being attached to ivory arms connected with brass nuts that traverse on the screws. One of the poles of the voltaic battery is connected with the cylinder of each instrument; the other pole of the battery is connected with the metal styles, so that the electric current may pass from the styles to the cylinders. The message to be transmitted is written on tin-foil with a pen dipped in sealing-wax varnish, and it is placed on the transmitting cylinder. When the instrument is set in motion, the metal style presses on the writing as the cylinder revolves, by which means the electric circuit is broken every time that the varnish interposes. Upon the cylinder of the receiving instrument, paper, moistened with an acidulated solution of prussiate of potash, is placed, and the metal style employed being a piece of steel wire, the electro-chemical decomposition that occurs whenever the electric current passes, produces a line of Prussian blue on the paper. If there were no varnish-writing to interrupt the electric current, the revolution of the cylinder, and the gradual advance of the marking point by the screw, would draw a number of continuous blue lines spirally on the paper, but so close together as to appear parallel. The



Interruptions, however, caused by the interposition of the varnish-writing on the transmitting cylinder, break the electric circuit in those points, and cause a cessation of marking whilst the style is passing over each letter. As the style traverses several times over each line of writing, the successions of interruptions, by corresponding with the forms of the letters, produce an exact copy of whatever is written or drawn on the tin-foil message; the writing appearing of a pale colour on a ground of closely-drawn blue lines.

The regulation of the separate instruments, so that they may rotate exactly together, is effected by an electro-magnet or electro-magnets brought into action by local voltaic batteries. When a single wire only is used, contact with the local voltaic batteries of the electro-magnets is made and broken by pendulums, each instrument having a pendulum in connexion with it; by which means the electro-magnets act at regular and quickly-succeeding intervals. Levers, attached to the armatures of the magnets press against eccentric wheels fixed upon one of the arbors of each instrument, and retard the motion of the mechanism so long as they bear against them. The instruments are thus regulated at every beat of the pendulums by having their speed retarded. The degree of retardation depends on the amount of weight applied to impel the cylinders; care being taken that the ungoverned speed should be always somewhat greater than it is required to be, to allow for the regulating action. When there are two wires employed, the regulation of the instruments may be effected without pendulums by bringing the regulating magnet of one instrument into action by a make-and-break contact-wheel fixed on to a corresponding arbor of the other instrument. To assist in adjusting two distant instruments, a "guide line" is employed, which consists merely of a strip of paper placed perpendicularly to the lines of writing on the transmitting instrument. When the corresponding instruments are set in motion, the interruptions of the electric current by the guide line indicate exactly, on the paper of the receiving instrument, how much faster or slower the transmitting instrument is moving; and by adding or taking off weights at the receiving instrument, its average speed may be adjusted to that of the transmitting one, so that the marks or gaps in each successive line drawn on the paper may fall under each other. When the instruments are regulated by pendulums, the guide-line serves to show whether they are beating together; and thus affords the means of adjusting them with great accuracy. The following cut shows the telegraph.—

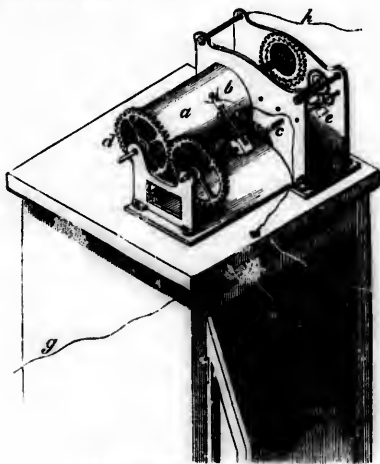

Bakewell's Copying Electric Telegraph.

*a*, the cylinder of one of the instruments; *b*, the metal style, connected by the wire *g*, with one pole of the voltaic battery; *c*, the ivory arm to which the metal style is attached, and which insulates the style from the screw; *e*, the screw on which the style traverses as the cylinder revolves; *d*, cog wheels to turn the screw; *e*, a fan to regulate the speed of the instrument; *f*, the impelling weight; *A*, the wire connected with the distant instrument.

The copying electric telegraph is not yet in operation; but its practicability has been successfully tested by the transmission of messages to and from different stations of the Electric Telegraph Company, with the experimental instruments exhibited.



This figure represents the character of the printing effected by this telegraph.

434 BAIN, ALEXANDER, *Beevor Lodge, Hammersmith—*  
Inventor.

Patent electric clocks, suitable for halls of mansions, offices, steeples, &c., kept in action by a small galvanic battery, or the electricity of the earth.

Time-ball, to be discharged by electricity sent by an ordinary regulator clock.

Pair of electro-chemical telegraphs, stated to be capable of transmitting and recording communications at the rate of 1000 letters, or even 1000 words, per minute.

Patent electro-chemical copying telegraph, said to be capable of copying any figure, such as profiles, autographs, stenography, &c.

Patent electric telegraph, for printing all the letters of the alphabet in the Roman character.

[The copying telegraph referred to, depends for its principle upon the decomposition of certain chemical substances placed on paper, by means of the electric current transmitted through the wires.—R. E.]

435 FRENCH, WILLIAM HENRY, *Cardiff, Wales—*  
Inventor.

Hydraulic printing telegraph, enabling one person simultaneously to print telegraphic communications at different distant stations or towns.

"Hydro-fluid" distributor, or water, telegraph, gas, and fire-engine controller, for forming a communication with any particular station or town; or any number of stations or towns connected with the hydraulic telegraph, and for the control of gas, water, and vapour service pipes.

Electric printing telegraph, similar to the former, but altered and improved.

Electric telegraph turn-plates, for changing the wires and circuits from main to branch lines and *vice versa*.

Portfolios, for filing newspapers, periodicals, music, manuscripts, letters, bills, receipts, &c.

436 DERING, G. E., *Lockley's Welwyn, Herts—*  
Inventor and Patentee.

Electric telegraph apparatus, illustrative of a variety of improvements.

437 MEINIG, CHARLES LUDOVIC AUGUSTUS,  
103 *Leadenhall Street—*Agent.

Portable galvanic battery of 120 elements, occupying the space of 12 cubic inches. Clockwork, for making and breaking contact. Patent portable galvanic chain battery, of 24 elements.

Portable interruptor for this chain. Invented by Mr. T. L. Pulvermacher.

438 EDWARDS, JOHN BAKER, *Liverpool*—Producer and Manufacturer.

Series of glass retorts, beakers, evaporating basins, and other glass and porcelain vessels for chemical purposes, electro-coppered. Vessels thus coated accelerate solution and distillation, and require a minimum of heat to con-

duct these processes, while the copper conducting the heat equably over the surface of the glass, preserves it from fracture and unequal expansion, and at the same time protects it from external casualties. The cut represents several of these vessels.



Edwards' Copper-covered Glass Apparatus.

[The covering of glass and porcelain vessels with copper was first exhibited at the French Exposition in 1844. These vessels excited great curiosity, and occasioned much perplexing speculation as to the mode of their production. The coating of metal was applied in so smooth, perfect, and uniform a manner, as to render it evident that none of the ordinary methods of metallurgy had been adopted in their manufacture. These vessels were coated by electrotype process, and similar apparatus is now made for chemical purposes in England. The surface of the glass or porcelain is first varnished, then brushed over with bronze-powder, in order to form a conducting surface on which to deposit the copper, and the vessel is then placed in the decomposition-cell, in connexion with a battery. In a few days the whole external surface is covered with bright metallic copper.—R. E.]

438A RUNDALL, W. W., *Falmouth*—Inventor and Manufacturer.

Carbonized cast-iron magnet. The cast iron is carbonized with prussiate of potash and oil, and is hardened and tempered, by which the magnet is improved at a small expense.

Impressions and specimens of seals, executed by machinery.

439 HEARDER, J. N., *34 George Street, Plymouth*—Inventor and Manufacturer.

Cast-iron compound horse-shoe permanent magnet, applicable to purposes requiring high magnetic power. The application of cast iron is new. This magnet consists of 24 plates, 2 inches wide,  $\frac{3}{8}$  of an inch thick, cast in the form of a horse-shoe, which is 16 $\frac{1}{2}$  inches long from the poles to the outside of the bend; the poles are 1 $\frac{1}{2}$  inches as under, and the inside of the bend 3 $\frac{1}{2}$  inches wide. The 24 plates weigh about 72 lbs., and are fastened together with three bolts and nuts. The poles are capped with cast iron, which concentrates the magnetic power in an extraordinary manner. The construction is very simple: the bars are cast from No. 1 pig iron as hard as green sand can make them, and they require no preparation to

adopt them for magnetization. The soft-iron caps render the grinding of the poles unnecessary. The attractive power of the magnet is scarcely inferior to that of a steel magnet of the same dimensions, whilst the economy in construction is nearly as 4 to 1; the cast-iron magnet weighing 72 lbs., lifts 140 lbs.

Powerful horse-shoe steel magnet, of 100 plates, adapted for purposes requiring high magnetic power. It weighs about 39 lbs., and will support nearly 250 lbs. with a round-faced keeper.

[The Rev. Dr. Scoresby appears to have been the first to employ thin sheet steel for the construction of powerful permanent magnets. His idea being that, as magnetism appeared to reside principally on the surface of the metal, by multiplying the number of surfaces, the power of the compound bar would be increased. Mr. Hearder, many years since, constructed powerful magnets from cast iron, and was certainly the first to use that material for the purpose; and the power which can be induced is certainly very great with the soft-iron caps.—R. H.]

Medico-galvanic apparatus, with graduated regulator, employed to administer galvanic electricity. Its improved construction consists in the proper adjustment of the length and thickness of the generating or primary coil to the electro-motive force of the battery, by which the battery-surface is much reduced, and a higher amount of magnetism produced in the iron core.

440 JOULE, JAMES PRESCOTT, F.R.S., *Acton Square, Salford*—Inventor.

Electro-magnet, constructed of a plate of well-annealed wrought iron, tapered to the poles. The iron is rendered magnetic by transmitting the voltaic electricity through the bundle of copper wires (fifty yards long, and weighing one hundredweight) with which it is enveloped. Armature to the same.

Pair of tapered armatures, to concentrate the magnetic force when the electro-magnet is excited by a feeble voltaic current, and to direct the magnetic action to any required object.

Surface electro-magnet, consisting of a thick piece of wrought iron, enveloped by a bundle of copper wires. Armature to the same. A battery of moderate power produces such a powerful attraction between the electro-magnet and its armature, that a weight of more than one ton has to be applied in order to draw them asunder.

[The peculiarity of the former electro-magnet, which is adapted for diamagnetic experiments, the magnetization of steel bars, &c., consists in the great comparative breadth of the iron core, by means of which the full effect of the coils of wire is secured, even in the case of their being removed to the distance of one or two inches from the surface of the iron. The form of iron adopted admits of a much greater quantity of electro-magnetic coils, and consequently of a much greater magnetic effect, than can be obtained from the usual cylindrical shape.

The peculiarity of the latter, or surface electro-magnet (which is the first of the kind ever constructed), consists in the comparatively great surface of contact which it presents to its armature. The principle of its construction, and of that of others of its class subsequently constructed by the exhibitor and other parties, is derived from the law of electro-magnetic action discovered by the exhibitor, viz., that the maximum attractive power of an electro-magnet for its armature is about 300 lbs. for each square inch of transverse section of the magnetic circuit.]

441 WAITE, GEORGE, 2 Old Burlington Street—Inventor.

Electro-galvanic apparatus for the teeth, furnished with a platinum point, safety key, elevators, forceps, and other instruments used in dental surgery.

Sets of teeth with gold jewelled blocks or masticators. Sets of electro-gilded teeth, fitted with novel blocks for mastication.

Six other pieces, with pearl blocks and plates.

444 WESTMORELAND, JOHN, Derby—Designer.

Patent gutta-percha electrical machine.

446 GREEN, SAMUEL, 7 Helmet Row, Old Street—Manufacturer.

Various compasses and sun-dials. Dump detectors. Angle-meters. Ivory circular thermometers with compass or magnetic sun-dial. Miners' compass, with sights, &c.

450 WEIGHT, SAMUEL, 14 Burton Street, Cheltenham—Inventor and Manufacturer.

Model of a machine for expelling fire-damp out of coal-pits, and foul air out of wells, brewery vats, or other places where they collect. Provisionally registered.

451 PALMER, W. V., Somers Town—Producer.

Electrotypes, and engravings from electrotypes.

452 CRICHTON, JOHN, 112 Leadenhall Street—Manufacturer.

Solid arch sextant, with improved reflector to vernier; double-limb sextant; 4-inch sextant; box sextant; coast-surveying sextant, as made for the Trinity yachts; ebony sextant.

Quadrants, plain, and with tangent screw to index, and with tangent screws to index and horizon. Quadrants with spring vertical adjustment, and with two and three back shades to horizon. Quadrant, with handle, telescopes, and mahogany case, divided to 30 seconds.

Azimuth compass, prismatic, large and small sizes. Sympiesometer; marine barometer; artificial horizon, with iron bottle and improved iron trough.

Gravatt's levels, bronzed and bright; 5-inch theodolite. Naval telescopes, 3 feet and 2 feet, with signals. Achromatic night-glass; day or night telescope; gunner's quadrant with level; gunner's callipers, large and small; and shell callipers, for side and bottom, as made for the Honourable East India Company.

453 KNIGHT, GEORGE, & SONS, Foster Lane—Manufacturers.

Commercial chemical cabinet. Urino-chemical chest, containing all the instruments and re-agents necessary for a chemico-pathological examination; designed by Dr. Venables.

Portable universal chemical furnace, on the principle of Dr. Black. It is constructed of stout sheet-iron, lined with fire-bricks; it is suited for the reduction and assay of metallic ores, cupellation of the precious metals, distillations of every kind, decompositions of substances by passing them through heated media, and for nearly every operation for which a furnace is required. With sand-baths, stoppers, crucibles, muffles, tongs, &c.; also an improved hood by the aid of which noxious fumes arising from evaporations pass readily into the flue of the furnace.

Portable assay furnace and apparatus, adapted for the use of mining companies.

Various blowpipes, and blowpipe apparatus, for the examination of minerals on a small scale.

Patent improved air-pump by which a good vacuum can be obtained in a short time. Invented by Mr. C. W. Siemens. The air-pump consists of two cylinders differing in magnitude, of which the smaller is on the top of the larger, while the valved pistons belonging to each respectively, are attached to the same piston-rod. The air withdrawn from the receiver or other vessel intended to be exhausted is condensed in the upper cylinder into one-fourth part of its original volume, and, consequently, always possesses sufficient elasticity to pass through the discharging valve and escape into the atmosphere, the opposing pressure of which on that valve is thus counteracted in a novel manner.

Plate electric machine, on Woodward's arrangement.

Galvanic battery; Professor Daniell's arrangement, consisting of a series of six cells; each cell comprises a copper cylindrical vessel, to be filled with a solution of sulphate of copper; in the centre is a porous tube containing an amalgamated zinc rod, and filled with dilute sulphuric acid.

Galvanic battery; Professor Groves' arrangement, consisting of a series of six cells, each cell being a glass vessel containing an amalgamated zinc plate, to be filled with dilute sulphuric acid, having in the centre a flat porous cell containing a platinum plate, and filled with nitric acid.

Galvanic battery; Alfred Smee's arrangement, consisting of a series of six cells, each cell being a glass vessel to contain dilute sulphuric acid; to each cell is fitted a platinised silver plate, having on each side of it an amalgamated zinc plate; the whole of these plates being connected in series to one rod or bar, they can be readily raised from or lowered into the exciting liquid.

Galvanic battery; Maynooth arrangement, consisting of a series of ten cells, each cell being a cast-iron trough to be filled with dilute nitric acid, in the centre of which is a porous cell containing an amalgamated zinc plate, and charged with dilute sulphuric acid.

Galvanic battery, for telegraph purposes; the cells formed of gutta percha, filled with sand saturated with dilute sulphuric acid; each cell containing a copper and amalgamated zinc plate.

Working model of an electro-magnetic motive engine, being a modification of Dr. Ritchie's arrangement.

Working model of an electro-magnetic motive engine, being a modification of Bain's arrangement.

Improved electro-magnetic coil machine, with conductors, &c., for medical purposes.

Larger and more powerful instrument, in which the primary or secondary current can be applied, with two batteries, water-regulator, conductors, &c.

Arrangement of the coil machine, consisting of a primary and secondary coil in a vertical position. Contact is broken and renewed by the rotation of a soft iron-bar mounted between two brass pillars, situated immediately over the axis of the coil in which is placed a bundle of iron wires. The electric current from the battery passes through one of the brass pillars, and the axis carrying the iron-bar; contact is broken and renewed by a small

Foster Lane—

all the instruments  
ico-pathological exa-e, on the principle of  
ut sheet-iron, lined  
roduction and assay  
corrosive metals, dis-  
of substances by  
and for nearly every  
quered. With sand-  
tongs, &c.; also an  
xious fumes arising  
a flue of the furnace,  
tus, adapted for theapparatus, for the  
ale.a good vacuum can  
ted by Mr. C. W.  
cylinders differing  
n on the top of the  
ing to each respec-  
ton-rod. The air  
vessel intended to  
r cylinder into one-  
ant, consequently,  
o pass through the  
o atmosphere, the  
ve is thus counter-'s arrangement,  
arrangement, con-  
omprises a copper  
lution of sulphate  
tube containing an  
dilute sulphuricarrangement, con-  
sisting of a glass  
plate, to be filled  
the centre a flat  
b, and filled withgement, consisting  
a glass vessel to  
well is fitted a pla-  
of it an annular  
plates being con-  
y can be readily  
liquid.ent, consisting of  
st-iron trough to  
centre of which is  
zinc plate, andoses; the cells  
aturated with  
ing a copper andmotive engine,  
ngement.motive engine,  
t.ine, with con-  
t, in which the  
plied, with twoisting of a pri-  
tion. Contact  
a soft iron-rod  
immediately  
d a bundle of  
battery passes  
axis carrying  
ed by a small

platinum point fixed to the spindle, dipping, as it revolves, in and out of some mercury placed in a cup mounted on a brass pillar, through which the circuit is completed. The instrument is provided with two pair of binding screws, one pair for communication with the battery, the other for giving shocks and other electrolytical effects.

Photographic apparatus, an horizontal lathe, or machine of a novel construction, for cleansing and polishing daguerreotype plates. Invented by the exhibitor.

Daguerreotype sliding camera, fitted with various plate-frames on different plans.

Improved double box with sliding covers and frames, for applying the sensitive coatings.

Portable mercury box.

Plate-holders on different plans.

A series of buffs, with the different preparations necessary for cleaning plates.

Focimeter, an instrument for ascertaining the difference in the lengths of the optical and chemical focus of photographic lenses.

Camera-stand, designed by W. Matthews, Esq.

Camera-stand, and head-rest, with a series of ball and socket joints, designed by the exhibitor.

Portable folding camera and stand, for paper processes, with frames on different plans.

Pressure frames on different plans.

Glass and porcelain dishes for preparing sensitive paper and glass plates.

454 COFFEY, J., & SMITH, J., 4 Providence Row,  
Finsbury—Proprietors and Manufacturers.

Improved chemical apparatus, containing a still head, with suite of moveable pans for decoctions, extracts, &c.; a drying closet, a condenser for steam, and worm for other stills, the chamber containing them, acting as a stand and condensing tub. The temperature can be regulated by means of steam-cocks and valves. There is also attached an improved feed for boiler, steam-gauge and thermometer, safety-valve and alarm.

456 STATHAM, W. Esq., 4 Rotherfield St. South, Lower Road,  
Islington—Inventor and Manufacturer.

Portable chemical cabinets and laboratories for amusement, analysis, and chemical research.

Hydro-pneumatic apparatus, containing a large pneumatic trough, a gæometer, and an hydraulic blow-pipe, lamp, and tongs complete. Larger apparatus of the same kind for the lecture-table and laboratory.

457 GRIFFIN, JOHN J., & Co., 53 Baker Street—  
Manufacturers.

Graduated glass instruments for chemical testing in the arts; applicable to the examination of soda, potash, ammoniac, the mineral acids, vinegar, bleaching powder, limestones, solutions of iron, silver, and other metals, salt-springs, white lead, and other chemical products; graduated measures for liquids, showing the usual divisions of the imperial gallon; and for gases.

Set of decimal weights and measures, founded on the imperial gallon and the avoirdupois pound, with explanatory tables.

Set of hydrometers, with Twaddell's scale of improved oval form.

Stokes' hydrometer for determining the strength of spirits of wine at any temperature, according to the degrees of Sikes', by means of one glass spindle, having two scales without weights, but with a thermometer.

Ammoniameter, or hydrometer for liquid ammonia. A glass spindle with a scale of 100°; every degree shows one test-atom or 212.5 grains of dry ammonia in a gallon of solution.

Small chemical apparatus, in a portable cabinet, adapted for analytical researches by naval and military officers, colonial engineers, &c.

Cabinet apparatus for use in colonial sugar-works, in determining the density of cane-juice, and the exact amount of lime required for properly clarifying the juice. Invented by Dr. Shier.

Apparatus for the chemical analysis of urine. Portable collection of chemical apparatus for elementary experiments.

Set of apparatus for testing the hardness of waters invented by Professor Clark.

[Clark's test for the hardness of water consists in adding a standard solution of soap to water until it produces a lather, the quantity used indicating the degree of hardness. Most waters contain lime in the state of carbonate, with some sulphate of lime, and chloride of sodium. The waters supplied to London give these substances in the following proportions, according to the analyses of Mr. Richard Phillips:—

Brentford. Barnes. Chelsea.

|                                |        |        |        |
|--------------------------------|--------|--------|--------|
| Carb. of lime                  | 10.000 | 10.900 | 10.500 |
| Sulph. of lime, chl. of sodium | 3.400  | 1.700  | 2.900  |

Dr. Clark has shown that a certain measure of his test, solution of soap, is required to combine with each grain of carbonate of lime, and that the whole of it which is present in the water must combine with the soap before a lather will form. The apparatus exhibited is for measuring the soap solution with great accuracy, and for adding it drop by drop to the water under examination. The Board of Health requires that every new source of water supply should be thus examined, and the number of degrees of hardness stated according to Dr. Clark's scale. Some chemists have lately pointed out sources of error in this process, but Dr. Clark states these may be avoided by care.—It. H.]

Chemical thermometers for corrosive liquors. Set of blowpipe apparatus for the examination of minerals. Collection of small specimens of minerals, in a portable cabinet, adapted for travellers in the colonies. Models of crystals executed in pottery. Apparatus for teaching agricultural chemistry in parish schools. Test-bottles, with indelible inscriptions, for chemical use. Glass vessels for holding chemical liquors, made in Bohemia. Books of test-papers. Circular filter-papers. Frame with pegs for test-tubes. Stoneware lamp-furnace for chemical operations. Beale's furnace for executing combustions in organic analysis by gas. Beale's gas furnace for heating crucibles. Improved achromatic microscope and polariscope, for naturalists and physicians. Ackland's improved combination of Smee's galvanic battery, in which the kind and amount of power can be readily modified. Ackland's improved form of medico-galvanic machine, with single current, producing great power in a small compass.

458 ALLMAN, FENNEL, 12 Stanhope Place, Hyde Park—  
Inventor.

An electric table-lamp, suitable for a room, with a gæometer, illustrating the way in which the dynamic effect of the current is made to govern the lamp. The most important features of the invention are the employment of electricity as a substitute for coal gas, oil, candles, &c.

The novelty consists in the employment of the dynamic effects of the electric current to produce the conditions necessary for the maintenance of a constant light. The great simplicity of the lamp, consisting of only three parts, render it very durable and economic. Patented.

459 INNERTON, Capt. L. L. BOSCAWEN, Clifton House,  
Old Brompton—Inventor.

Electrotypes from the animal and vegetable kingdom. Ornamental castings in various metals; also castings, &c., in iron, and covered with metallic surfaces, by a new method.

Trigonometrical model of the Undercliff, Isle of Wight. The new feature in this model is, that an extent of country has been modelled from a trigonometrical survey, the vertical heights being on the same scale as the base, three feet to a mile. The model was carried to the spot and modelled, and the hypotenuse lines made to correspond with the base. Upwards of 20,000 heights were







ory is replaced by a  
ays.

Baker Street,  
Manufacturer.

1 Golden Square—

d pianoforte,  
orte.

orte Manufactory  
r.

on the exhibitor's new  
ounding-board, instead  
ached to the wooden  
metallo attachments,  
of its being tightly  
s letters A, B, C in the  
able metallo attach-

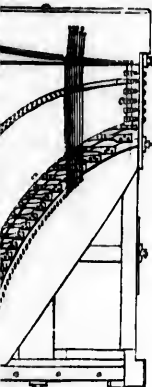

in the same principle  
ng the application of  
d of pianofortes.

Chapside—

a cottage pianoforte,  
nary repetition, and

omy, and excellence

cturer.

Street, Fitzroy

ass joint generally  
iated when opening  
permits the instrum-  
om. Embroidered  
stool. This instru-



Urinar end's Registered Pianoforte.

475 METZLER, GEORGE, 37 Great Marlborough Street  
—Manufacturer.

Small size cottage pianoforte, made in pollard oak,  
"O. G." or arched fall, with ornamental shell front.

476 MOORE, JOHN & HENRY, & Co., 104 Bishopsgate  
Street Within—Designers and Manufacturers.  
Grand cottage pianoforte, of new design.

477 LUFF, GEORGE, & SON, 103 Great Russell  
Street, Bloomsbury—Manufacturers.

Albert cottage pianoforte, of new construction.  
Harmonium, an instrument played like the pianoforte  
or organ, claiming powerful tone and simplicity of con-  
struction.

[The peculiar tone of the harmonium class of instru-  
ments is produced by metal springs set in motion by a  
stream of air.—H. E. D.]

477A HUNT, RICH., 22 Blake Street—Inventor.

The registered tavola pianoforte. A dining or drawing-  
room table, stands upon a centre-block or pedestal, and

contains a pianoforte (opening with spring-bolts) on the  
grand principle, with a closet containing music composed  
by the inventor. This pianoforte has the ordinary power  
of tone, although occupying half the usual space, and can  
be made the piccolo or grand size.

479 ENNEVER & STEEDMAN, 31 George Street, Euston  
Square—Manufacturers.

Elegant walnut marquetry semi-cottage pianoforte,  
new design, with double action. The pearl and tortoise-  
shell keys made by T. and H. Brooks, 31 Cumberland  
Market.

Plain walnut square-fall piccolo, or microchordian piano-  
forte, with single action.

480 ALLISON, ROBERT, 69 Regent Street—Manufacturer.

Walnut-wood registered cottage pianoforte—the keys  
of the finger-board being alternated in colour, to show all  
the scales, major and minor, according to a single rule  
for each mood, founded on the place of the semi-tonic  
interval, which renders the seven notes to be touched for  
an octave of each of the other eleven scales, as evident as  
the scale of C. This pianoforte is shown on next page.

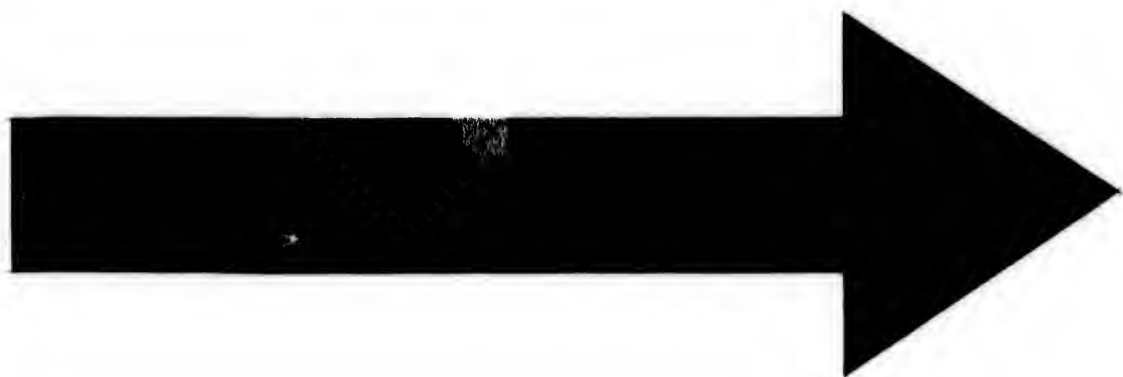

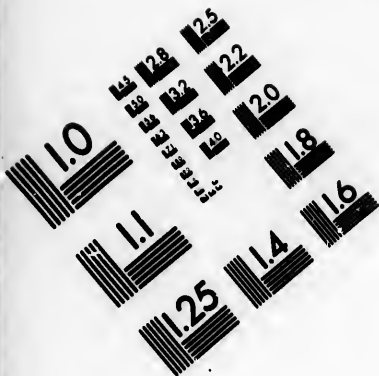

**IMAGE EVALUATION  
TEST TARGET (MT-3)**

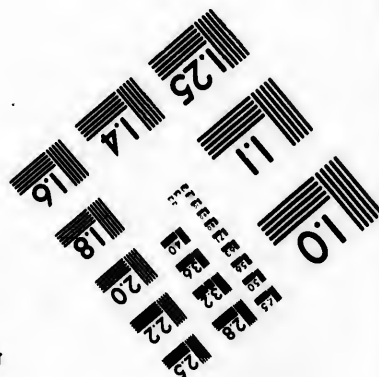
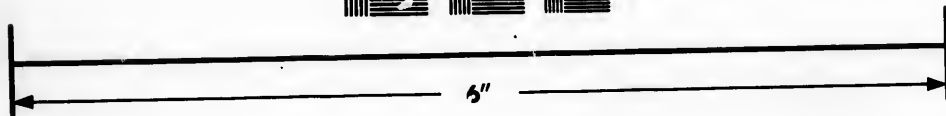
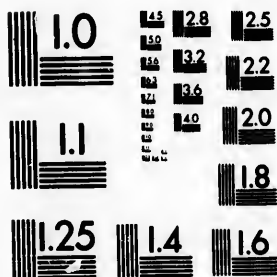

**Photographic  
Sciences  
Corporation**

23 WEST MAIN STREET  
WEBSTER, N.Y. 14580  
(716) 872-4503

1.4 1.8  
1.6 2.0  
1.8 2.2  
2.0 2.5

01  
01  
01

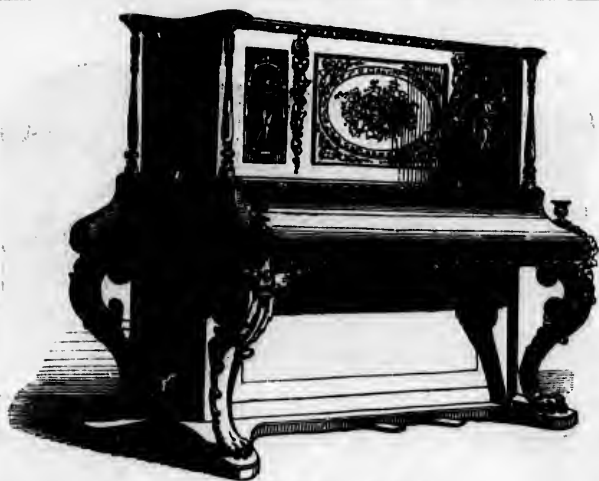

Allison's Registered Cottage Pianoforte.

481 JONES, JOHN CHAMPION, 21B Soho Square—  
Inventor and Manufacturer.

A double or twin semi-cottage pianoforte, having two fronts and sets of keys, one on either side, suitable for any

number of performers, from one to six; case of walnut-tree. The letters of reference in figs. 1 and 2, indicate the position of corresponding parts in the front and side views of this twin pianoforte; *a, b, c*, representing the case; *e*, the keyboard; and *g, g*, the pedals.

Fig. 2.

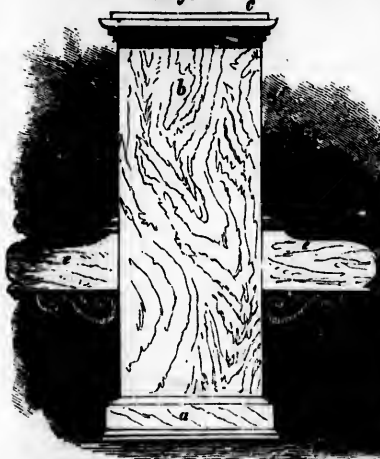
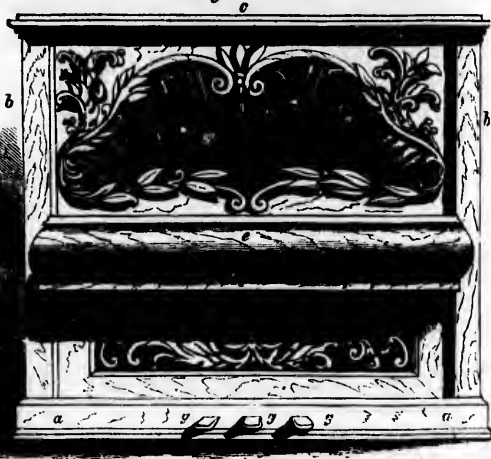

Fig. 1.



Jones's Twin Semi-cottage Pianoforte.

482 HOLDERNESSE, CHARLES, 444 New Oxford Street  
—Manufacturer.

Cottage grand pianoforte,  $6\frac{1}{2}$ -octave, in a carved walnut-tree wood case (the design registered); with repeating check action.

483 ALLISON, RALPH, 108 Wardour Street, Soho, and 34  
Brook Street, New Road—Manufacturer.

A walnut-tree cottage pianoforte, with carved figures, and inlaid with flowers in woods of natural colours, check repetition action, &c.

484 JENKINS, WM. & SON, 10 London Street, Fiteroy  
Square—Inventors and Manufacturers.

Registered expanding and collapsing pianoforte for

gentlemen's yachts, the saloons of steam-vessels, ladies' cabins, &c.; only 13 $\frac{1}{4}$  inches from front to back when collapsed.

Cabinet pianoforte in figured walnut-tree, carved and ornamented in the Elizabethan style.

486 HUND, FREDERICK, & SON, 21 Ebury Street, Piccadilly  
—Inventors and Manufacturers.

New kind of cottage pianoforte, called the "Lyra."—Provisionally registered.

The "Lyra" stands on a peculiar constructed platform, or sound conductor, into which the bass strings extend; and although the instrument is only 3 feet 5 inches in height, it produces a tone equal to a semi-grand.



x; case of walnut.  
s. 1 and 2, indicate  
the front and side  
representing the  
pedals.



am-vessels ladie  
ont to back when  
t-tree, carved and

ury Street, Pimlico  
urers.

led the "Lyra."—

structed platform,  
ass strings extend;  
3 feet 5 inches in  
mi-grand.

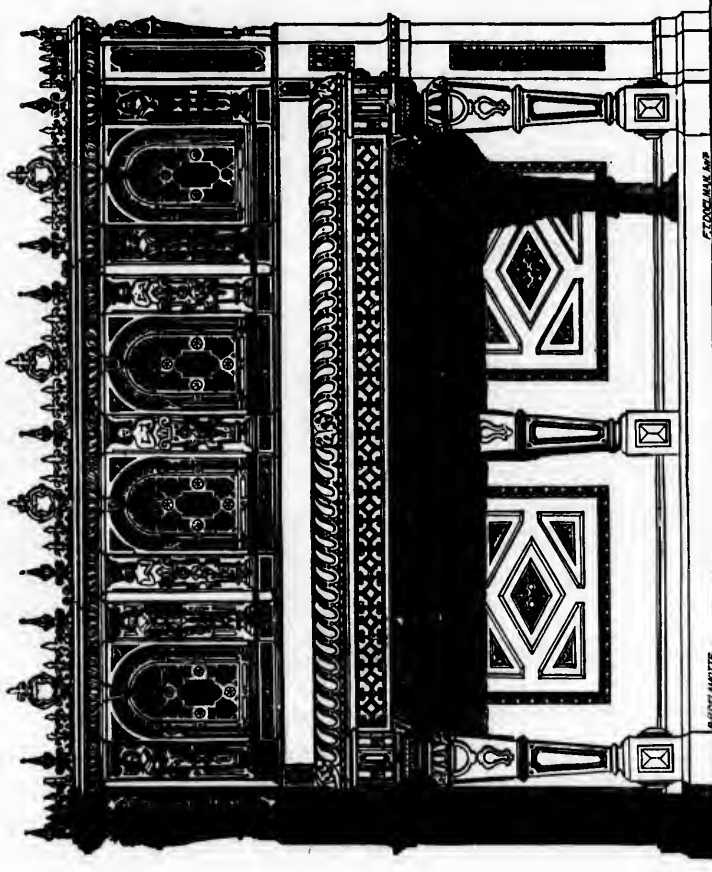
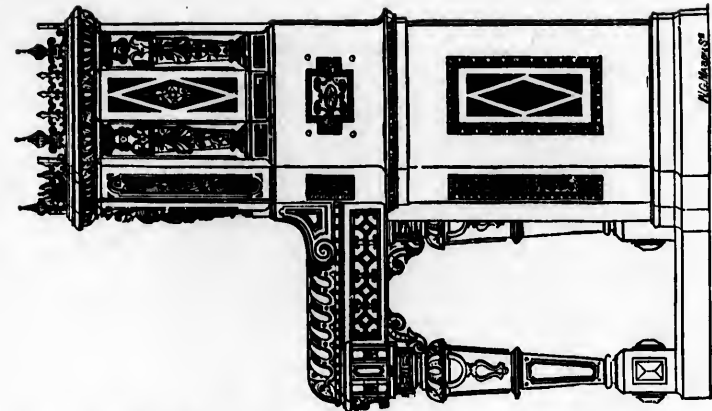

ERARD'S ELIZABETHAN NEW PATENT GRAND OBLIQUE PIANO-FORTE.



KING  
 The  
 great  
 487  
 A  
 music  
 key,  
 hammer  
 action  
 telling  
 been  
 can,  
 sent,  
 three  
 488  
 Pl  
 carri  
 489  
 Re  
 mech  
 touc  
 pane  
 term  
 and  
 Itali  
 490  
 Pl  
 the  
 prec  
 pres  
 mov  
 of th  
 491  
 A  
 pea  
 of a  
 iron  
 the  
 in a  
 sub  
 49  
 49  
 49  
 lit  
 so  
 fr  
 G  
 sh  
 H  
 4  
 is  
 v  
 r

The instrument has a grand check action, with levers of great power and elasticity.

487 ADDISON, ROBERT, 210 Regent Street—Patentee and Proprietor.

A transposing pianoforte. This piano will transpose music five semitones higher or lower than the written key, if necessary. Its novelty consists in the key-board, hammers, and strings being immovable. The internal action cannot be shifted or deranged. To make this intelligible, the first two bars of the National Anthem have been selected, which, if written thus—

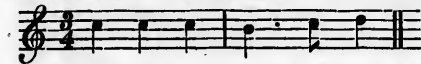

can, by striking the same ivory keys as the above notes represent, be immediately transposed into three higher and three lower keys.

488 AGGIO, GEORGE H., Colchester—Designer and Manufacturer.

Pianoforte, fitted up in plate-glass case, and gold carvings, with embroidered curtain front.

489 DIMOLINE, ABRAHAM, Denmark Street, Bristol—Designer and Manufacturer.

Registered compensation pianoforte, seven octaves. The mechanism, by its lightness, &c., produces an agreeable touch; improved plan for uncovering the keys; the panels are paintings of mother-of-pearl on glass. Registered semi-cottage, seven octave: with same mechanism, and papier-maché case with inlaid mother-of-pearl, in the Italian style.

490 AKERMAN, WILLIAM H. H., Bridgwater, Somerset—Inventor and Manufacturer.

Pianoforte, with new improvement; a bevel action for the dampers, applicable to all kinds; intended to give precision of touch by the certain rising of the key. It preserves also the dampers by gentle instead of jerking movement. Octave action at pleasure, to use the octave of the key struck.

491 SMYTH & ROBERTS, Birmingham—Inventors and Manufacturers.

A 7-8va cottage pianoforte, with grand action and repeat, having a sounding-board and back on the principle of a violoncello, &c., obtained by the application of an iron frame well secured between the sounding-board and the strings, which causes the sounding-board to tighten, in a different manner from other pianofortes. They are suited for hot climates.

493 WOOLLEY, T., Nottingham—Patentee and Manufacturer.

Equilibrium patent pianofortes, for all climates. Grand pianoforte, and "utiliton" pianoforte, 7 octaves each.

493A HARWAR, JOSEPH, 28 Bloomsbury Street—Manufacturer.

Pianoforte with transposing mechanism, metallic equilibrium string frame, adjusting tension rods, and improved sound-board, fitted up in newly designed case with sliding front.

[The first transposing pianoforte was invented by a German named Rolla. The keys in this instrument were shifted; the modern system is incomparably superior.—H. E. D.]

494 TOWNS & PACKER, 20 Oxford Street—Manufacturers.

Grand transposing pianoforte: the pitch can with facility be raised or lowered two notes from the original key, without affecting its touch or durability.  
Microphonic cottage pianoforte up to A in alt. of economical construction.

496 ERARD, PIERRE ORPHEUS, 18 Gt. Marlborough Street—Inventor, Designer, and Manufacturer.

New patent pianofortes:—ornamented extra-grand; extra-grand with pedal keys; small grand, improved new scale; grand oblique, ornamented in the Elizabethan style, adapted to extreme climates; grand cottage; reduced cottage; extra-grand and grand oblique.

The plate 22 represents a front and side elevation of the Elizabethan pianoforte.

New patent metal frames for pianofortes, intended to carry the principal part of the weight or pull of the wires, independent of the wood frame, with a new screw apparatus for tuning attached to the same; particularly adapted to extreme climates.

Harpa:—full and second size, newly improved; third size; highly ornamented; fourth size, adapted for young beginners. "Prince of Wales" harp," decorated.

[The difficulty of keeping harps in order in extreme climates is greatly lessened by always placing them, when not used, in a common mahogany case.—H. E. D.]

498 MOTT, ISAAC HENRY ROBERT, 76 Strand—Inventor and Manufacturer.

Patent metallic cottage grand pianofortes, not liable to be affected by change of climate or weather.

Horizontal grand pianofortes, with metallic frames, above and beneath the strings, capable of resisting change of climate, or great tension, without interfering with the freedom or vibration of the sounding-board. The compass is nearly eight octaves, also an additional key-board of five more octaves, they have the notes in unison with and an octave below the pianoforte, with an improved and peculiar action, which, by means of small rollers, &c., produces a quick repetition of the touch.

499 WORNUM, ROBERT, Store Street—Inventor and Manufacturer.

Improved piccolo pianoforte.  
Semi-bichord grand pianoforte, upon the patent overstruck principle.

[In the ordinary pianoforte action, the springs are struck from below, in this instrument the hammers strike down, hence the term overstruck.—H. E. D.]

500 HOPKINSON, JOHN & JAMES, 18 Soho Square—Manufacturers.

Horizontal grand pianoforte with patent action, on an entirely new principle, giving increased power and certainty to the touch, and adding the tremolo similar in effect to that produced by the voice. Mata, inventor.  
Rosewood boudoir pianoforte, 6 $\frac{1}{2}$  octaves.

500A TURNBULL, WILLIAM, 6 Frederick Street, Regent's Park—Manufacturer.

Set of pianoforte keys.

502 PEACHEY, G., 73 Bishopsgate Street Within—Manufacturer.

Improved Pollard oak "Victoria" piccolo pianoforte.  
Improved rosewood "Albert" piccolo pianoforte.

503 GREAVES, E., 56 South Street, Sheffield—Manufacturer.

Æolian pitch pipes, German silver, electro plated, and gilt, in sets of 4 for violin, 8 for guitar, 8 for harp key E flat, 8 for the diatonic, and 13 for the chromatic.

Æolian violin mute, a combination of pitch pipe and mute.  
Chromatic æolian pitch pipe, one vibrator sounding 13 semitones.

[The natural key of the old single-action harp is E flat, and of the double action C flat. The mute is a small instrument which is fixed on the strings of a violin, over the bridge, to soften and thin the tone. The uncertainty which at present exists with regard to the pitch is a source of great annoyance. The modern pitch varies 2 I. 2

half to a whole tone sharper from that used in the time of Handel.—H. E. D.]

Blued steel sostenuto tuning-forks, philharmonic and Wilhelm's standard pitch; Lilliput size, in case, philharmonic pitch; and French-shape, with foot and case; case of 13 tuning-forks.

Pair of chromatic tuning-forks, sounding the 13 semitones, in an octave, both equal temperament, philharmonic; and Wilhelm's standard pitch; case of amateur pianoforte tuning instruments. The chromatic tuning-forks are useful for tuning the pianoforte, &c.

Tuning-keys for horizontal and cabinet pianofortes.

Registered portable metronomes, in brass, German silver, silver, pearl, tortoiseshell, electro-plate and gild, silver, silver and pearl, silver and shell. These form a convenient substitute for the large metronome. In principle this is a variable pendulum, the tape winding up within the case, which forms the weight or bob.

504 KOENIG & PASK, 441 Strand—Manufacturers.

A complete set of brass horns with valves (soprano to contra bass). French horn, trombones, and trumpets. Trombones with slides. Ophicleide with keys. Euphonion with four valves. Cornet à pistons in various designs. Clarionets, from a new design, and in metal. Flutes, on a new system.

Drums—bass, tenor, and side, for military purposes.

505 DODD, EDWARD, 112 Fawcett Walk, Lambeth—Manufacturer.

Violin, violoncello, double bass, and harp strings.

506 DRURY, JAMES FRANCIS, Cheshunt, Herts—Manufacturer.

Box of musical bells.

507 GIBBORNE, JAMES, 37 Suffolk Street, Birmingham—Inventor and Manufacturer.

Corno-peans. Trombo cornuta, or drawing-room corno-pean. Sax horns in B flat alto, and E flat soprano. Keyed bugle. Long valve trumpet. Double sax horn in A flat alto, and E flat tenor: the performer while playing upon this peculiar instrument, can, by using the extra valve with the left hand, without taking the instrument from his lips, glide from the alto to the tenor cleff, and vice versa, with facility.

508 HENRYS & CO., 2 Budge Row—Proprietors.  
Newly-invented musical instrument, called "Flotina," adapted for concerts, and as an accompaniment to other instruments.

509 FORSTER, SIMON A., 13 Macclesfield Street, Soho Square—Manufacturer.

A violin, viola, violoncello, &c., made (according to modern improved gauges) after the models of the exhibitor's grandfather, popularly known as "Old Forster."

510 HEAPS, JOHN KNOWLES, Leeds—Manufacturer.

Violoncello constructed upon principles producing increased vibration, and superior quality and quantity of tone.

511 ANELLI, JOSEPH, 76 Queen Street, Edinburgh—Inventor.

Centripetal regulating pegs and pins, which cannot draw back or give way, by which instruments can be tuned and regulated gradually in all their divisions, in less than half the time formerly required.

Also, a spring "capo-tasto," attached to the handle of the guitar, changing at once the diapason of the strings, so as to play in all keys without altering the printed notes or the position of the hand and fingers.

512 McNEILL, JOHN, 140 Chapel Street, Dublin—Inventor and Proprietor.

Cambridge cavalry field-trumpet bugle, for executing trumpet and bugle field calls without having recourse to a second instrument.

Bulb corno-pean; the bulbs are substituted for angles, and curved passages are thus obtained for the wind without enlarging the valves, or increasing the friction, which gives improved quality of tone and facilitates the execution.

514 CHURCH, G., 12 Berkeley Place, Bristol—Inventor.

Wrist-supporter, for securing a good position in playing the pianoforte.

Improved guitar: by means of two bars introduced within the instrument, and fixed in the blocks, greater strength is secured.

Improved finger-board for the violoncello, and other bowed instruments: groove runs the whole length of the finger-board under each string.

516 EDWARDS, ROBERT JAMES, Church Street, Burslem—Inventor.

An instrument invented to assist instrumental performers. It resembles the pianoforte in appearance, but, when acted upon, is perfectly silent. The keys are of porcelain. The degree of action is regulated by turning the screw at the back of the instrument.

517 PACE & SONS, 49 King Street, Westminster—Inventors and Manufacturers.

Corno-peans, trumpet, and valve horn. The improvements consist in the small diameter of the valves, the removal of angular turnings, and the hardness and quality of the metal employed.

[The modern brazen trumpet was invented at Nuremberg; but a similar instrument has been known from time immemorial.—H. E. D.]

518 BROADWOOD, JOHN, & SONS, 33 Great Pulteney Street—Manufacturers.

Four grand pianofortes, of different constructions:—  
No. 1. In ebony case; 7 octaves, G to G; inlaid, carved, and gilt. Designed by E. M. Barry, Esq.; inlaid by G. Watson; carved by J. Thomas; and gilt by G. J. Morant. Straight bracing.

No. 2. In ambony case; 7 octaves, G to G. Designed, carved, and gilt by Mr. G. J. Morant. Diagonal bracing.

No. 3. In ambony case; 7 octaves, G to G. Diagonal bracing.

No. 4. In walnut case, inlaid; 7 octaves, G to G. Inlaid by G. Watson. Straight bracing.  
(Main Avenue West.)

519 BETTS, ARTHUR, 27 Royal Exchange—Manufacturer.  
Two violins.

520 OATES, J. P., Lichfield—Inventor.

Improved brass musical instruments:—  
The "gem cornet," model, with the ordinary valves. The improvement consisting in the more direct course of the current through the main tube, a greater proportion of which is placed below the valves.

Cornet, with the "central valve" (invented 1845), in which the right angles in the open notes are obtused, and the tone improved.

Cornet. Improvement of the last by the introduction of a bow, obviating the angles in the valve note. Invented 1845.

Cornet, with the bulb valves. In the perfect central valve: the piston casing is widened at the turn of the current by a hollow "bulb," or "bulge," half the diameter of the tube, the other half being formed in the piston.

Cornet, with the "equi-trio-lateral valves." The "equi-tone cornet." The "pista-cor," a new drawing-room instrument. Improved "Sax-horn," upon the equitone principle. Transposing "military trumpet, combining the C bugle with the E flat trumpet. Both complete instruments.

The "Staffordshire horn."

The seven preceding articles are provisionally registered.

522 PRINCE, MISS ABELINDE, 29 Norfolk Crescent,  
Hyde Park—Inventor.

Gloc di Euterpe; a new musical game, intended to assist beginners in the knowledge of the relative value of musical characters, and to render them good theorists.

523 JORDAN, JAMES, 34 Manchester Street, Liverpool—  
Inventor and Manufacturer.

1. Newly-invented euphonio serpentoleide. The pitch is an octave lower than the ordinary serpent, and the bore being much larger, it has a more powerful and mellifluous tone. The keys (eleven) and stays are tubular, thus rendering the instrument extremely light in proportion to its size. The springs, which are spiral, can be regulated or renewed by the performer, a desideratum in the military or naval service.

2. Newly-invented euphonio horn, contra-bass in B flat, compass from double A flat; though more powerful in tone than the ordinary bombardon, is yet more portable, and is consequently peculiarly suited for military, naval, or concert bands.

3. Newly-invented tenor valve ophioleide, silver mounted.

4. Newly-invented German-silver cornopean, with improved transposing slide and water-conductor. On this instrument the keys B flat and A flat (which are the keys most in use by the military) can be produced immediately, thus saving the unnecessary carriage of crooks whilst marching.

5. Newly-invented cornopean. This improvement consists in substituting fixed bows outside the valves for angular turns inside the pistons, without enlarging the tubing, relieving the action from extra weight and friction, and the instrument from leakage.

524 DOBROWOLSKI, B. W., 20 Norton Street, Portland  
Place—Inventor.

Semibreve guitar. This newly-invented instrument is improved from the Spanish guitar: its advantages are, that it contains one octave and a half more in the treble, and that it is more easy to play; the sounding-board is larger, and produces very powerful and melodious notes, and the instrument can be held with great ease and grace. Registered.

525 PANORMO, LOUIS, 31 High Street, Bloomsbury—  
Manufacturer.

Enharmonic guitar (inventor and proprietor, T. Perrotet Thompson, Eliot Vale, Blackheath), capable of being arranged in the perfect ratios for upwards of 20 keys; the strings can be lengthened separately at the bridge, to correct the defects of the depression to the neck, or of false or worn strings.

526 WHEATSTONE, WILLIAM, & Co., 20 Conduit Street,  
Regent Street—Patentees and Manufacturers.

Treble concertina, with 48 keys, for the performance of violin, flute, hautboy, or concertina music singly, or in concert; the same, displaying the whole internal mechanism.

Baritone concertina, with 48 keys, for the performance of harmonized music, especially psalmody, in the same register as sung by four voices.

A concert tenor concertina, with 48 keys, for vocal tenor, tenor violin, or wooden wind instrument music, singly or in concert.

A concert bass concertina, with 56 keys, for violoncello or bassoon music, singly or in concert; the same, of a smaller size, for the use of ladies.

Double concertina, with 50 keys, so disposed that a melody may be played by one hand, and an accompaniment by the other.

A symphonion, with a single vibrator, acted on by rollers moved by stops, so as to produce any note required.

A tonimeter, which produces any note in the chromatic scale merely by finger pressure.

An enharmonic tonimeter, which produces any sound in the enharmonic scale.

Portable harmoniums, for producing expression, which can be played alone, or be placed in front of the key-board of a pianoforte, and played by the same performer; adapted for wooden or stringed instrument solo, or part music.

527 WARD, CORNELIUS, 36 Great Titchfield Street—  
Inventor, Patentee, and Manufacturer.

Kettle-drum, which can be adjusted to any required note, within the range of one octave, with rapidity and accuracy, and also may be set to any note without sounding it.

Base drum, both the heads of which can be tuned at once by one operation. Base drum, wherein the tension of the heads is quickly adjusted by means of iron rods, whereby permanent order is obtained. This drum contains cymbals, and both drum and cymbals can be used at pleasure together or separately. Thus precision is insured; one man required in lieu of two, and the cymbals are safe from accident.

Side or signal drum, with iron bracings and two sets of snares adjustable at once. Drum, both the heads of which are adjusted by one screw.

Flute, with the natural proportion of tube required for each note of its scale.

Bassoon of new construction.

All patented or provisionally registered.

[The bassoon or fagotto is the bass hautboy. The word bassoon is derived from *bass sound*, and fagotto from *fagot*, it being composed of several pipes bound together.—H. E. D.]

528 SNELL, ROBERT, Bull's Pond—Inventor and  
Manufacturer.

Seraphine, with bichromatic or double scale of notes, producing perfect harmony in every key, without the aid of temperament; the improvement effected by an octave of pedals, one being put down, corrects the scale for the key required.

[That the musical scale cannot be perfectly tuned on instruments with fixed sounds, is a fact that can only be stated, within the limit of a note; temperament signifies the equal adjustment of the imperfection of the scale on an organ, or similar instrument.—H. E. D.]

529 STORER, JOSEPH, 26 Piccadilly—Inventor,  
Patentee, and Manufacturer.

Percussion Æolophon, with two sets of vibrators, one an octave higher than the other, with appropriate stops, intended as an economical substitute for an organ.

Portable Æolophon, for taking flute or violoncello parts, or for chamber use.

530 FAULKNER, EDWIN, 11 York Street, St. James's  
Square—Designer.

Accordion stand. An apparatus to assist in playing the accordion with greater facility and effect; it will incline to any position suitable for the convenience of the performer, and by the action of a spring-stop, it can be instantly fixed in that position. Provisionally registered.

531 BRAY, JOHN, 26 Westmoreland Street, Dublin—  
Manufacturer.

Double-action harp, with additional notes, Gothic pillar embellished in ultra-marine and gold, and music-stool, desk, and stand.

[The double-acted harp possesses greater powers of modulation than that with the single action, and can also produce enharmonic passages; in which respect it is a perfectly unique instrument, excepting those of the violin class. Every major and almost every minor key can be distinctly produced on it. The exceptions are A♯, D♯, and G♯, minors.—H. E. D.]



532 SIMPSON, THOMAS, *Sea-Lion Hotel, Hanley-in-the-Pottories*—Inventor.

Norma virium, or musical accentuator, intended to supersede the metronome. It marks the first note in every bar, loud and distinct, in all measures of time; and gives in weaker beats the sectional divisions.

[The word "metronome" is derived from *μετρον*, measure; and *νομος*, division. The instrument was invented by John Mielzel, in Austria, 1814. The more modern kinds of this instrument exhibit an improvement analogous to the principal feature of the Norma Virium, viz.; a distinct separation of the first, from the following beats in a bar, which is effected by the striking of a small bell at the first beat.—H. E. D.]

533 JONES, BASSETT, *Cardiff, Wales*—Designer and Maker.

Grand triple-strung Welsh harp, worked in Welsh plane wood, carved in bold relief, the designs being emblematic of the country, in oak, mistletoe, &c., with two dragons in front, cut in round relief. On the comb is an equilibrium bearing-plate, to cause equal tension on the three rows of springs.

[The triple-strung Welsh harp was an ingenious but laborious contrivance to enable the performer to take semitones, and to modulate into different keys. It is now superseded by the pedal harp, particularly that with the double action, invented by Erard. The two outer rows of strings are diatonic and unisonic; the centre row comprises all those sounds necessary to complete the thirteen semitones belonging to each octave. This instrument is described by Mersennas in his "Harmonie Universelle," 1636.—H. E. D.]

535 SICCAMA, ABEL, 135 *Fleet Street*—Inventor, Patentee, and Manufacturer.

Diatonic flutes, retaining the old system of fingering while affording numerous additional fingerings, on a system strictly based upon acoustic principles. Their tone is said to be powerful and brilliant. They are easier of execution, and therefore require less exertion to play than the ordinary flute. There are three middle C's on this flute, all of the same quality, and perfectly in tune.

[There are two scales commonly understood—the DIATONIC, from *διὰ τὴν φύσιν*, by, and *εὐρεσι*, the tone; and the CHROMATIC, from *χρῆματι*, colour: the first proceeding by tones and semitones, and the second by semitones alone. But there is a third scale, the ENHARMONIC, that is not so well known. It can be thus explained: Notes have their pitch determined by a certain number of vibrations. By this we find that C♯ and D♭, though one sound on a keyed instrument, have distinct sounds in reality. The Enharmonic scale then is a succession of every possible note according to its vibratory intensity, e. g. G, D♭, C♯, D, E♭, D♯, E, and so on.—H. E. D.]

536 RUDALL, ROSE, & Co., 38 *Southampton St., Strand*—Proprietors and Manufacturers.

Richard Carte's patent flutes, with new and old fingering, made of silver or other metal, or of wood; possessing all the latest improvements arising from equidistant and equal-sized holes and open keys. The arrangement of the holes, and contrivance of the mechanism are available either with Boehm's parabola and cylinder bore, or Rose's improved conical bore.

Patent flute, constructed on the principles first introduced by Boehm, viz., equidistant and equal-sized holes, and open keys. The patent was granted for a parabola-shaped head-joint, and cylindrical body-joints.

Improved ordinary flute—its merits are said to consist in the improvement of the tone, arising from the novel proportions of its conical bore. The fingering and arrangement of holes and keys remain as usual.

537 PURDY & FENDT, 74 *Dean Street, Soho*—Manufacturers.

Violin, violoncello, double bass. To exhibit oil varnish equal to that used on the Cremona instruments; the art of making which is supposed to have been lost.

538 POTTER, HENRY, 2 *Bridge Street, Westminster*—Manufacturer.

Clinton's flute, on acoustic principles, being the only one with the old fingering throughout, with equality of tone and perfection of tune.

540 KOHLER, JOHN, 35 *Henrietta Street, Covent Garden*—Patentee and Manufacturer.

Patent three-valve instruments—lever cornetto, in E♭; oboean, in B♭; trumpet, in E♭; trombone, in B♭; trumpet, in G; patent clarivior and bombardone, each with four valves in E♭; and French horn, with two valves in E♭; patent lever trumpet in E♭ with two valves; small pocket corneopan in A with two valves; cylinder corneopan in B♭ with three valves; cylinder tenor horn in D with three valves; and Harper's improved chromatic slide trumpet in E♭.

541 GUINNESS, RICHARD, 58 *East Street, Manchester Sq.*—Inventor.

Violin and violoncello. Self-acting pegs for the tuning of violins, violoncellos, and tenors.

542 SPURGIN, THOMAS, *Saffron Walden*—Maker.

Violin made from a description of one invented by Mons. Savart of Paris. The figure represents this violin.



Spurgin's Violin.

543 DODD, JAMES, *Image Cottage, Holloway*—Manufacturer.

Bows for the violin, tenor, and violoncello, mounted with gold and tortoise-shell. Silver strings for the violin, violoncello, and harp.

544 CHIDLEY, ROCK, 135 *High Holborn*—Designer, Manufacturer, and Proprietor.

Concertinas, in ivory, with gold stops, working on levers only supported by springs; another in ebony, with glass stops, mounted with gold.

[Though an exceedingly sweet instrument, the concertina is considered to be deficient in forgando effect.—H. E. D.]

545 CASE, GEORGE, 32 *New Bond Street*—Manufacturer.

Concertina, on which may be played any description of music, within the compass of three octaves and a half, in single notes or chords.

546 CARD, WILLIAM, 29 *St. James Street*—Designer and Manufacturer.

Silver flute, with rods, rings, and levers, equal to twelve keys.—Stirling's British gold flute. Electro-silvered flute. Cognas wood flute, with silver mountings and keys. The following cut represents the silver flute.

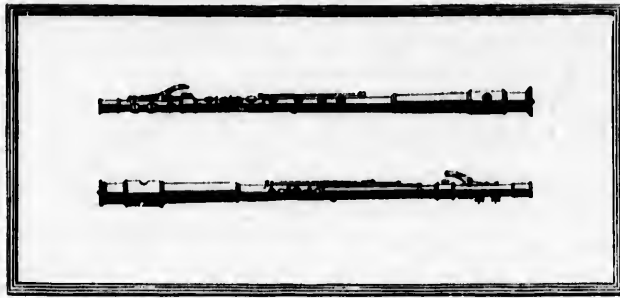

Card's Silver Flute.

547 CALLCOTT, JOHN, 31 Admiral Terrace, Vaushall Bridge Road—Inventor and Manufacturer.

Newly invented French horn; the novel feature being its portability, the loose crooks commonly used being dispensed with: to change the key, a continuous tube is graduated into thirteen parts, each part being a semitone, at each of which again an opening is made, into which is inserted a short tube, leading from the belt of the horn to the centre of the hoop, and there turning in any direction, which receiving the wind as it passes through the horn bears it away to the belt.

Cornet & piston, on the same principle.

548 ROOME, THOS. FRED., 67 John Street, Fitzroy Square—Manufacturer.

Organ metal pipes, in plain and spotted metal—trumpet, hautboy, cremona, flute, open diapason, viol de gambe, and kerwolophon.

[The best metal for organ pipes is pure tin; this, however, being expensive, it is frequently mixed largely with pewter. Cremona is a corruption of *krumhorn*, an obsolete German wind instrument.—H. E. D.]

549 GROOME, JOHN, Watton, Norfolk—Inventor and Manufacturer.

Transparent music, in which the notes can be distinctly seen at a distance, either by day or candle light, adapted for instructing large classes.

550 MATHEWS, W., 5 St. James Street, Nottingham—Inventor and Manufacturer.

Model, exhibiting the string frame of an upright pianoforte with lever tuning apparatus; the object being to sustain the pressure of the strings, and prevent the instrument getting out of tune.

An upright pianoforte, in which an apparatus is introduced to keep the instrument in its upright position. It is also simple in action, and contains an apparatus whereby various degrees in quality of tone may be produced.

551 ANDREWS, RICHARD, 4 Palatine Buildings, Manchester, and 34 Oxford Street—Inventor.

Apparatus for giving a good position to the hands, arms, and fingers of pupils commencing the pianoforte; also for strengthening the fingers in exercises for that instrument.

553 BISHOP, J. C., 1 Lisson Grove South—Designer and Manufacturer.

Cabinet organ, containing composition pedals, by which the performer can command any combination of stops, without the aid of the hands or confinement of the feet; the wind being also perfectly steady and free from tremor.

[Composition stops are used for changing the arrangement of organ stops, without the aid of the hands, and vary in different instruments.—H. E. D.]

554 DAWSON, CHARLES, 395 Strand—Inventor.

Autophon. An improvement of the organ, the tunes,

which are unlimited, being produced by means of perforated sheets of mill board; it enables any person, unskilled in the art, to perform pieces of music with ease.

555 GRAY & DAVISON, 9 New Road, Fitzroy Square—Designers and Manufacturers.

A grand church organ of the first class, consisting of three full rows of keys or manuals, from CC 8 feet, to F in alt., and an independent pedal organ of two octaves, and a third, from CCG 16 feet, to E; two bellows, horizontal, with double feeders of wind of different weights, and six composition pedals for changing the stops, which are 39 in number,—13 in the great organ, 9 in the swell, 8 in the choir, 4 in the pedal organ, and 5 for coupling the manuals, and the manuals and pedals together. All the latest improvements are adopted in the construction of this instrument. The case is of novel character, made of solid oak, carved with double impost mouldings, supporting four towers of speaking-pipes, which are decorated: the whole from designs by Mr. Albert Howell, architect.

A small church organ, with one manual, from CC 8 feet, to F in alt., and pedals of two octaves and two notes, in extent from CCC 16 feet, to D, with Bourdon stop. The whole of the manuals are enclosed in a Venetian swell, and there are two pedals for changing the stops. The case is of Gothic design, made of deal stained and varnished.

Patent improved church barrel-organ, playing any number of tunes, without the necessity of shifting the barrels in and out of the instrument. The change from one tune to another, on whatever barrel, is made in the simplest manner possible, and an index always shows the name of the tune about to be played.

556 FINE, W., & Co., Tottenham Court Road—Designers and Manufacturers.

Finger organ with two sets of channels; compass from CC to F, with separate sound-boards on extra pressure of wind, containing a reed stop of great power, separate pedal sound-board of two octaves and a half from CCC; the whole of the channels placed in a swell box; the composition and drawing of the stops being on a new principle.

This organ contains two manuals, a great organ of ten stops, and an echo organ of five stops. Both are enclosed in swell-boxes, the echo organ being in a box which opens into the larger one. The mechanism is upon an entirely new construction, and is much simplified. The stops are drawn by means of keys, to which is attached the pneumatic apparatus, so that a trifling pressure of the finger only is required to change them. The composition pedals also, by acting upon the above keys, are remarkably light, and effect the changes in the stops with much greater ease than those on the old plan. A new system of valves has been introduced to the great organ, which secures lightness and equality of touch. The organ also contains a new stop, of immense power and volume of tone, called the "tuba mirabilis," the invention of the exhibitors.

[The sound-board of an organ is the upper part of the wind chest in which the mouths of the pipes are inserted, and, by the removal of a small valve, *sounded*. The manuals are the stops played by the hand: the term also is synonymous with *key-board*. Pedals were invented by a German, called Bernhard, about 1400. The swell was invented by an Englishman, in the last century, the idea having been suggested, it is said, by the modified intensity of sound from a pianoforte, produced by the opening and closing of the door of a room in which it was played. The channels convey the wind to the pipes.—H. E. D.]

557 HOLDICH, GEORGE MAYDWELL H., 4 Judd Place East, King's Cross.—Manufacturer.

Small choir-organ; having a stop, called the "di-octon" which makes every single stop as good as two distinct ones; having, therefore, double the power and variety of an ordinary organ.

[The choir organ, properly so called, is that part of a large organ which is used for accompanying the choir of

singers in a church or cathedral, and is softer voiced than the rest of the instrument.—H. E. D.]

558 NOLAN, W. H.—Inventor.  
Artificial teeth.

550 RONSON, T. J. F., 101 St. Martin's Lane—Manufacturer.

Enharmonic organ; presenting the power of executing with the same ratios in twenty keys, with a correction for changes of temperature. By Lt.-Colonel T. Perronet Thompson.

The object of this instrument is, first, to determine the proportions which make music in a single key, and then to transfer the same proportions to a variety of keys, beginning from some of the previously established sounds as a new key-note.

The same process was attempted by the ancients, constituting what they called the Enharmonic; but it broke down and was finally abandoned, in consequence of making an unfortunate division for a single key.

The leading principle involved in this instrument, is, that the Dissonances are *double*, or have each two forms, one of which makes harmonious combinations with the Fifth of the Key and the Third, and the other with the Fourth and the Sixth. Hence, if the one set is coloured white and the other black, the similarity of colour will help to point out the connexion. The best way of illustrating this will be to refer to the lowest or C board, in the representation of the finger-boards annexed, taking no notice for the present of the smaller manuals resembling the keys of a flute. The key-note C is coloured red; which in the Plate is represented by longitudinal lines, as done in Heraldry.

The same process is applied on the middle board for the key of E, and on the uppermost board for the key of D'. When this was done, it was plain that by the addition of a comparatively small number of manuals, several more keys might be produced; which was accordingly done, by the addition of the manuals which, from the likeness formerly described, may be called the *flutes*.

A further addition was made of the manuals on the middle and uppermost boards, which from their form may be denominated *buttons*; giving the power of making E $\sharp$ , B $\sharp$ , and F $\times$ . There is also a provision of spare pipes for G $\flat$  and C $\flat$ , by means of which preparation may be made for playing in five and in six flats.

On the whole, the number of keys amounts to twenty, extending from eight sharps (or as generally called, six sharps and a double sharp) to six flats. In many cases, there are keys for the two forms of the same note, which may be called for according to circumstances. The different sounds which, are displayed in the Table which follows (next page). Though adapted to 53 divisions, they are not the sounds of the division into 53 equal intervals, but the accurate sounds, as may be proved by examination of their *Measures*. A line drawn over any number of figures implies that they form a recurring decimal. Though the appearance of such a number of sounds is formidable, it has been proved

Front View and Profile of the FINGER-BOARDS, on a Scale of One Fourth.

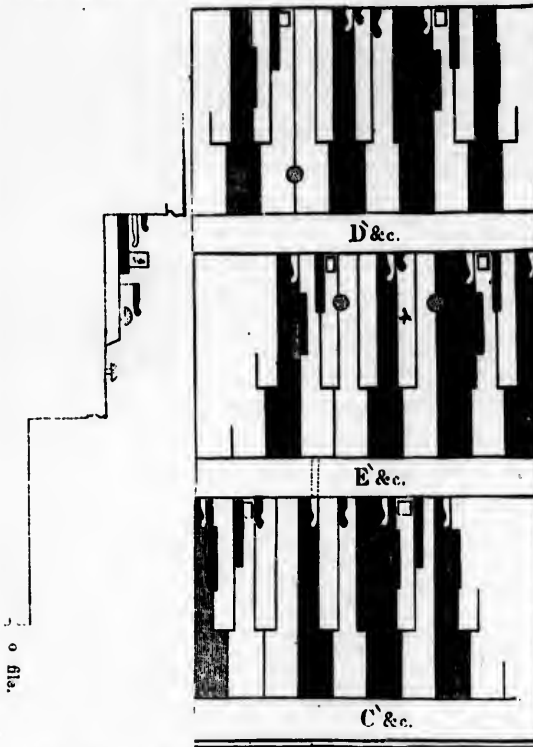

Lowest board contains Keys of C', F', G', B $\flat$  Major, B $\sharp$  Major, E $\flat$  Major, A $\flat$  Major, D' Minor; and by having Exchangeable pipes for G $\flat$  and G $\sharp$ , C $\flat$  and C $\sharp$ , the Keys of D $\flat$  Major, G $\sharp$  Major, B $\flat$  Minor, B $\sharp$  Minor, E $\flat$  Minor. Middle board, Keys of E', B', G' Major, D' Major, C' Major, and (with help from the D' board) A', C $\sharp$ , G $\sharp$ . Uppermost board, the Keys of D', A', F' Major, B $\flat$  Major, G', and (with help from the E' board) B', E', and F $\sharp$ .

by experience, that three weeks are sufficient for acquiring the same facility as on an ordinary instrument; and

directions are appended to the instrument, by which any performer who will consent to follow them may, at a first sitting, perform with inconsiderable risk of error in a limited number of keys.

The tuning is effected by means of what is called a *Phonometer*, being a monochord with a wire of four feet, stretched by a weight capable of very accurate adjustment. The compass is what is called the German scale, or from *CC* to *f* in alto. The pipes are of wood, of what is called Stopped Diapason, and each is tuned with a screw, the whole number being 155, besides those which may be denominated Exchangeable. The swell is divided in two at middle *c*, and each part has a quick movement and a slow. The dimensions of the instrument are, in extreme height 8 feet 5 1/2 inches English measure (7 feet 11 inches French); length 7 feet 5 inches; depth 3 feet 7 inches.

TABLE OF SOUNDS IN ENHARMONIC ORGAN.

| Pipes in Primitive Key. | Harmonies in which found.     | Numes.         | Indices.       | Measure, in denarii. |       |
|-------------------------|-------------------------------|----------------|----------------|----------------------|-------|
| Key-note . . .          | C E D                         | C <sup>1</sup> | 0              | 1                    |       |
|                         | C <sup>2</sup>                | C <sup>2</sup> | 1              | 96704320             |       |
|                         | D                             | C <sup>3</sup> | 2              | 979                  |       |
|                         | F D                           | C <sup>4</sup> | 3              | 96                   |       |
| Grave Min. 2nd          | E <sup>a</sup>                | C <sup>5</sup> | 4              | 941481               |       |
|                         | C                             | D <sup>b</sup> | 5              | 9375                 |       |
|                         | Acute Min. 2nd                | C              | D <sup>b</sup> | 6                    | 98995 |
|                         |                               |                | 7              |                      |       |
| Grave Maj. 2nd          | C E D                         | D <sup>1</sup> | 8              | 9                    |       |
|                         | C E                           | D <sup>2</sup> | 9              | 989                  |       |
|                         |                               | 10             |                |                      |       |
|                         | Acute Maj. 2nd                | C E            | D <sup>3</sup> | 11                   | 964   |
| Minor Third . . .       | E                             | D <sup>4</sup> | 12             | 953                  |       |
|                         | C <sup>a</sup> D              | E <sup>b</sup> | 13             | 91975                |       |
|                         | C D                           | E <sup>b</sup> | 14             | 933                  |       |
|                         |                               | 15             |                |                      |       |
| Major Third . . .       | D                             | E <sup>a</sup> | 16             | 91                   |       |
|                         | C E D                         | E <sup>1</sup> | 17             | 9                    |       |
|                         | E <sup>a</sup>                | E <sup>1</sup> | 18             | 790123456            |       |
|                         |                               | 19             |                |                      |       |
| Fourth . . .            | D†                            | E <sup>2</sup> | 20             | 768                  |       |
|                         |                               | 21             |                |                      |       |
|                         | C E D                         | F <sup>1</sup> | 22             | 75                   |       |
|                         | C   E                         | F <sup>1</sup> | 23             | 740740               |       |
| Tritone . . .           |                               | 24             |                |                      |       |
|                         | E D                           | F <sup>2</sup> | 25             | 72                   |       |
|                         | C E                           | F <sup>2</sup> | 26             | 711                  |       |
|                         | C <sup>2</sup>                | G <sup>b</sup> | 27             | 703125               |       |
| Fifth . . .             | C <sup>2</sup>                | G <sup>b</sup> | 28             | 794                  |       |
|                         | C <sup>2</sup>                | G <sup>b</sup> | 29             | 68266                |       |
|                         | C <sup>a</sup> D              | G <sup>1</sup> | 30             | 675                  |       |
|                         | C E D <sup>a</sup>            | G <sup>1</sup> | 31             | 666                  |       |
| Minor Sixth . . .       |                               | 32             |                |                      |       |
|                         | D <sup>a</sup>                | G <sup>2</sup> | 33             | 648                  |       |
|                         | E D                           | G <sup>2</sup> | 34             | 64                   |       |
|                         |                               | 35             |                |                      |       |
| Major Sixth . . .       |                               | 36             |                |                      |       |
|                         | C                             | A <sup>b</sup> | 37             | 625                  |       |
|                         |                               | 38             |                |                      |       |
|                         | C E D <sup>a</sup>            | A <sup>1</sup> | 39             | 6075                 |       |
| Gravo Min. 7th          | C <sup>a</sup> E <sup>a</sup> | A <sup>1</sup> | 40             | 6                    |       |
|                         |                               | 41             |                |                      |       |
|                         | E <sup>a</sup>                | A <sup>2</sup> | 42             | 592392               |       |
|                         | E                             | A <sup>2</sup> | 43             | 576                  |       |
| Acute Min. 7th          |                               | 44             |                |                      |       |
|                         | C C                           | B <sup>b</sup> | 44             | 5688                 |       |
|                         |                               | 45             |                |                      |       |
|                         |                               | B <sup>b</sup> | 46             | 5625                 |       |
| Grave Maj. 7th          |                               | 47             |                |                      |       |
|                         | C C                           | B <sup>1</sup> | 47             | 55                   |       |
|                         |                               | 48             |                |                      |       |
|                         | C E D <sup>a</sup>            | B <sup>1</sup> | 48             | 531                  |       |
| Octave . . .            | C <sup>2</sup>                | C <sup>2</sup> | 49             | 52734375             |       |
|                         | C <sup>2</sup>                | C <sup>2</sup> | 50             | 50833                |       |
|                         | E†                            | B <sup>2</sup> | 51             | 512                  |       |
|                         | C E D                         | C <sup>a</sup> | 52             | 51625                |       |
|                         | 53 or 0                       |                | 5              |                      |       |

\* Flutal. || Hook. † Button. ‡ Exchangeable Pipe.

560 HEWITT, D. C., *Twickenham*—Inventor.  
The musical ratiometer. (*South Wall*.)

561 WALKER, J. W., 21 *Francis Street, Bedford Square*—Manufacturer.  
An organ (in the Tudor style, designed by Banks and Barry), adapted for a hall or music room. This organ is represented in the cut on the following page.

562 FORSTER & ANDREWS, *Hull*—Manufacturers.  
Original model of the transposing organ, which enables the performer to change the pitch of his instrument five semitones higher or lower from a given pitch, by an easy turn of a small key. The manuals remain stationary.

[The method generally employed by musicians when transposing (i. e. changing the key of) a piece of music, is to suppose it written in another clef, e. g. original key

C.  key required D, suppose the music written in

the alto clef  and the note indicated becomes D. — H. E. D.]

565 GROSSMITH, W. R., 175 *Fleet Street*—Inventor and Manufacturer.

Artificial legs, for amputation above and below the knee; or at the ankle, allowing the free use of the natural knee-joint. The same for contracted knee (foot amputated), with locking joints. Common socket and pin leg, with knee-joint. Artificial eyes. Spring braces for the prevention of round shoulders and stooping; with other instruments.

567 EAGLAND, THOMAS, *Leeds*—Manufacturer.  
Teale's trusses for inguinal and femoral hernia. Bandage for prolapsus of the rectum. Knee-joint extensor.

568 MILES, JAMES, *Street, near Glastonbury*—Inventor.  
Improved double truss for hernia, invented by a labouring man.

569 MASTERS, MOSES, 12 *St. David Street, Newington*—Manufacturer.  
Artificial leg, for amputation above the knee.

570 CAPLIN, JEAN FRANÇOIS ISIDORE, *Strawberry Hill, Pendleton, Manchester*—Inventor and Manufacturer.  
Gymnastic apparatus, and orthoschidic instruments, for deformity of the spine, &c.

570a CAPLIN, Madame, 58 *Berne's Street, Oxford Street, and 55 Princess Street, Manchester*—Inventor and Patentee.

The Hygeianic corsets. The registered corporiform corsets, plain and mechanical. The new contracting belt. Abdominal supporters. Medical belt and chest expander. Spinal corsets. The child's boddice; also the reverso-tractor, to prevent children standing on one leg, with a variety of other Hygeianic adaptations made in accordance with the science of anatomy and physiology.

571 SWITHENBANK, J., 100 *Bridge Street, Bradford, Yorkshire*—Manufacturer.  
Artificial legs.

572 LONGDON & TURNER, *Derby*—Inventors and Manufacturers.  
Elastic surgical stockings, knee-caps, belts, &c., which require no lacing, and may be washed in hot water.

573 SMITH, S., 1 *High Holborn*—Manufacturer.  
Various trusses of different constructions, bandages, belts, &c.

Leg instrument, for right leg.  
Elastic knee-cap, to lace, used to support the knee-joint  
Ankle-sock, to lace, used to support the ankle-joint.

Lace stocking, for producing pressure on swollen veins  
in the legs.  
Syringes, silver catheters, bougies, pessaries, &c.

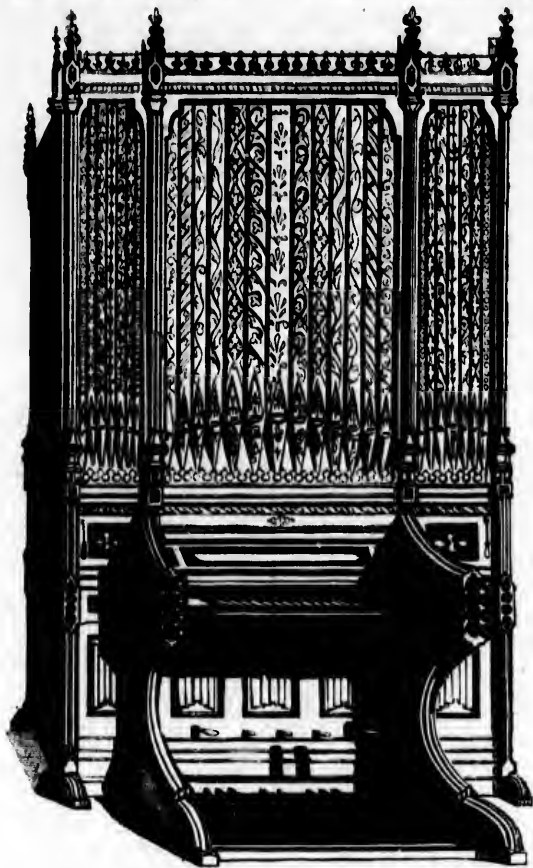

Walker's Organ.

574 GHRIMES, SAMUEL, 71 Baker Street, Portman Square,  
—Designer and Producer.

Casts of mouths. Sets of artificial teeth. Various  
cases of artificial teeth.

575 HORNE, JAMES, West Regent Street, Glasgow—  
Designer and Manufacturer.

Three models of mouths, with artificial cases of teeth,  
showing a plan of fitting teeth in the mouth so as to  
obviate the necessity of applying wires or bands of metal  
to the sound teeth.

Models of irregular sets of teeth, showing a plan of  
correcting them by means of palladium plates. These  
plates are tasteless and economical, and may be made so  
as to gradually press the teeth into the true position.  
There are three specimens of each regularity, showing  
improvements in progress.

The models No. 1 represent deformed teeth in their  
original state.

The models No. 2 represent deformed teeth at first, and  
afterwards as pressed out with the plate, and drawn in  
with silk.

The models No. 3 represent deformed teeth made  
straight by fastening silk round the teeth, and pins at each  
side.

576 LAURIE, S., 36 Argyll Street, New Road—Designer.  
Artificial teeth, carved in hippopotamus ivory.

577 JAMES, JOHN HADDY, F.R.C.S., Exeter—Inventor.  
Surgical instruments and apparatus.

A collar, resting below, on the collar bones; above,  
supporting the base of the jaw and cranium, with hinges  
and screw, by which the face and head may be raised in  
cases of contraction; disease of the cervical vertebra; and  
in wry neck; with two casts illustrating its effects.

A pair of forceps, which may be designated a bone-  
holder. Its use is to grasp the projecting end of any bone  
which it may be necessary to saw off; with this instrument  
a firm and steady hold can be obtained, and the bone as  
readily sawn through as if it were entire. It is applicable  
to cases of compound fracture; conical stumps or bones  
left too long in; common amputations; and nonunited  
fracture.



An improved saw, which may be advantageously substituted for the various forms of metacarpal saws, or small saws commonly in use for surgical purposes. This saw was invented by the exhibitor for the purpose of sawing through the lower jaw, parallel with and close to the base, in a case of tumour.

Model of an apparatus employed in the treatment of fractures of the thigh, with accompanying sketch, showing its use.

578 **ASH, CLAUDIUS, & SONS**, 8 and 9 Broad Street, Golden Square—Manufacturers.

Improved mineral teeth, with gold tubes. Two sets of teeth, mounted, and some smaller pieces; also single teeth of various forms and colours.

[Artificial teeth, for a considerable period, were exclusively made of the tusk of the hippopotamus, a material closely resembling in colour human teeth, and susceptible of a fine polish. A large number, inclusive of those described, are now made of a peculiar description of porcelain, so intensely hard as to resist steel files; they are consequently united with corundum. They closely resemble natural teeth, and are made of different shades of colour.—R. E.]

579 **PARKS**, 25 Newington Crescent, Kennington—Inventor.

Artificial teeth.

581 **PERCINS, WILLIAM**, 175 Prospect Place, Maida Hill, Paddington—Designer and Manufacturer.

Artificial teeth, carved from the hippopotamus tooth. Mineral teeth on gold, with side springs complete. Natural teeth, set in hippopotamus tooth sockets. Specimens of partial cases.

582 **ROBINSON, JAMES**, 7 Gower Street, Bedford Square—Inventor.

Artificial teeth, with gold masticators, on suction principles. Elastic gold lever, used for turning irregular teeth in the upper jaw. Spiral spring for correcting deformities in teeth.

583 **REID, R.**, 19 Heriot Row, Edinburgh—Inventor.

Compress for alveolar hemorrhage, with expanding plate and turn-screw; adapted to a model head and chin, to show the mode of attachment and working of the apparatus on both jaws.

584 **RANSOM, ROBERT**, 3 Verulam Place, Hastings—Manufacturer.

Case of artificial teeth.

585 **MOLLISON, JAMES**, 3 Grove Terrace, St. John's Wood—Inventor.

Pedestal planisphere, giving a natural representation of



Mollison's Pedestal Planisphere.

the heavens at any given time. It is intended to solve the chief problems of the globe, and preserve the forms of the constellations. See preceding out.

587 **WHITE, JOHN**, 228 Piccadilly—Manufacturer.

Various single and double trusses, known as the "Patent Movable Lever Truss."

588 **TOD, D.**, 5 Upper Fitzroy Street, Fitzroy Square—Inventor.

Improved single and double trusses.

590 **THOMSON, HUGH, M.D.**, Greenock, Scotland—Inventor.

Apparatus intended for fractures of the thigh with the knee bent, or in a straight position, for fractures of the leg. The proposed advantages of this apparatus are: 1st. The power of making suitable extension and counter-extension whilst the knee is bent. 2nd. By means of the pelvic portion, a more advantageous angle is obtained for making counter-extension. 3rd. The bandages containing steel springs, which encircle and grasp the limb, being fixed to the splint, serve for making extension and counter-extension. 4th. Numerous points for making extension and counter-extension are obtained, so that no part may suffer from an undue pressure. The proper angle of flexion of the knee is maintained by the screw for that purpose at the knee-joint, and by pillows placed below the limb.

591 **SPARKS, J., & Co.**, 28 Conduit Street, Regent St., and 115 New Bond St.—Manufacturers.

Splint machine, with elastic spring crutches, for weakness of the spine. Registered.

Dr. Foucart's spinal rectifier, and chest-expander.

Dr. Foucart's improved splints for fracture of tibia and fibula.

Extending knee instrument for contracted knees.

Portable spring crutch, for convenience in travelling, &c.

New elastic single and double spring trusses, with vulcanized Indian-rubber pads. Umbilical truss, with air pads. Bathing truss, covered in India rubber.

Elastic spiral silk stockings, ankle-socks, and knec-caps, for relief and cure of varicose veins, and for giving support after fractures, dislocation, sprains, &c.; elastic silk belt for giving support, &c.

Elastic steel backboard, with vulcanized India-rubber arm-straps, for stooping of the shoulders, &c.

Young lady's boot, for weak ankles.

Moulded leather hip, knee, and ankle splints, for confining the motion of the limb during disease.

Hydrostatic, or water bed, invented by Dr. Arnott.

India-rubber water-pillow, for holding hot or cold water.

Waterproof silk coat.

Portable cloak boat, for crossing rivers and lakes; can be worn as an ordinary cloak, being waterproof and light, and can be instantly inflated. Hand paddles for cloak boat.

592 **FULLER, JOHN**, 239 Whitechapel Road—Inventor.

Artificial leg, eyes, and nose. Improved scarificator, with shifting pinions, for cupping. Improved truss. Antique metal-gilt oval watch, made in the reign of Charles I., by "Francois Nawe, at London."

594 **SALMON, ODY, & Co.**, 292 Strand—Inventors and Manufacturers.

Patent single and double self-adjusting trusses, for inguinal hernia. Truss for umbilical and right femoral hernia.

New resisting, anti-pressure, self-adjusting truss, with regulating spring, suggested by Dr. Arnott.

596 **BRUNTON, J.**, Huddersfield—Manufacturer.

Artificial leg.

597 L'ESTRANGE, FRANCIS, 39 Dawson Street, Dublin—  
Inventor.

Various patent trusses.  
Stricture instrument.  
Apparatus for the reduction of dislocations; having a windlass and pulleys; and a disengaging apparatus, with extension and counter-extension hooks.

Apparatus for the cure of fractures of the lower jaw, composed of two parts, the divaricator, and the horse-shoe splint with the cramps.

Lithotrite instruments, composed of the sound and sounding-board, the screw lithotrite, and drill.

598 HUXLEY, EDWARD, 5 Vere St.—Manufacturer.

Stockings, knee caps, calf-pieces, and anclets, for varicose veins, weakness, sprains, fractures, and all cases in which bandages can be applied.

601 MILES, EDWARD, 15 Liverpool Street, Bishopsgate—  
Proprietor.

A set of mineral and curved teeth. Several whole and partial highly-finished sets of teeth. Gold palates.

601c CHAPMAN, T., & ALDERMAN, J., 8 Denmark St., Soho—  
Inventors and Manufacturers.

General invalid couch, which is capable, by mechanism, of being changed into any required position, without disturbing the patient; the change of position being so gradual that it is almost imperceptible.

It will form an easy chair, with arms, which adjust themselves without trouble, or can be taken off if required, without unscrewing.

It is also suitable for surgical cases, as every variety of position can be obtained. When converted into a level couch, the moveable scroll end at the head may be turned into a writing table and reading desk, so that a patient, while reclining, may read and write with comfort.

The mattress is elastic, resting upon an elastic-adjusting foundation, by which all pressure can be taken off from any part of the patient, in cases of long illness.

The following cut represents the couch.

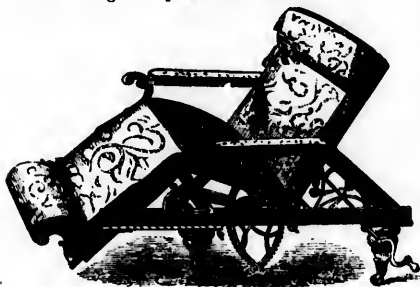

Chapman's Invalid Couch.

601d MACMAHON, CHARLES, Upper Camden Street, Dublin—  
Inventor.

1. The jaw-lever, a newly-invented instrument for keeping open the mouth of the horse, ox, dog, or any other animal whilst administering medicine or performing an operation. The advantages are simplicity, without injury to the animal's mouth, and protection to the operator.

2. A temporary horse-shoe, to fasten on without nails; useful where a foot is unsound, or where it may be necessary to remove the shoe frequently.

602 FINZI, S. L., 6 Dalby Terrace, City Road, Islington—  
Inventor and Manufacturer.

Universal drill, designed and made for the purpose of removing decay from teeth to prepare them for stopping. Can be used at all angles of the mouth without inconvenience.

Upper and under set of teeth, carved entirely from a tooth of the hippopotamus.

604 HALFORD, H., 8 St. John Square—Manufacturer.

Artificial human eyes. Eyes for figures life-size. Eyes for miniature figures—animals, dolls, and birds—of various sizes and colours.

605 ATKINSON, BENJAMIN FREDERICK, 26 Strand—  
Inventor and Proprietor.

Registered anal truss. The instrument consists of an elastic pad, which dispenses with the necessity for steel springs round the body.

Rectum-supporter of ordinary construction. Artificial leg for below the knee. Artificial hand and arm.

Instruments for correcting distortion of the bones of the leg, and for weak knees, when they incline inwards. Variety of trusses. Improved bandage for prolapsus.

606 BUNNEY, CHARLES, 27 Lower Eaton Street, Pinlick—  
Manufacturer.

Surgical belts, &c.

607 WHIBLEY, EBERNEZER, 12 Lloyd's Place, Brompton.

Surgical operating table; a contrivance for placing the body and legs of the patient at various elevations and inclinations.

609 PUCKRIDGE, F. L., 4 York Place, Watworth—  
Inventor and Manufacturer.

Transparent waterproof membrane plaisters.  
Tinted goldbeaters' skin and court plaister.

610 BINYON, ALFRED, 3 Great Marlborough St., Regent St.—  
Inventor and Manufacturer.

Elastic chest-expanders.

612 SPRATT, WILLIAM HENRY, 2 Brook Street, Hanover Square—Manufacturer.

Single and double trusses; the new truss devised by Dr. Arnott. Pads, belts, and bandages, of various constructions. Elastic laced stocking.

New spinal chair, which may be used as a bed, chair, sofa, or in a carriage, designed by R. Druitt, Esq.

613 LINDSEY, MARK, 264 High Street, Borough—  
Inventor and Manufacturer.

Various trusses for hernia in adults and children.

614 LEE, JOHN, Bideford—Inventor and Manufacturer.

Bedstead, which is so constructed that the patient may be raised by machinery, the bed made up under him, and he may recline in any position most easy to himself; all with the assistance only of one attendant.

615 HEEPS, JOHN HENRY, 46A Liverpool Street, City—  
Inventor and Manufacturer.

Pulpit, containing a gutta-percha hearing apparatus, for the deaf in churches, chapels, lecture-rooms, &c.; a gutta-percha funnel is placed out of sight, to which the tubing is attached, and carried under the wood-work or floor, to the pew in which the deaf person sits. The end of the tube is applied to the ear.

Self-adjusting prolapsus spring-bandage and abdominal supporter, with gutta-percha pad; also self-adjusting abdominal spring-belt.

617 ROBINSON, RICHARD, 27 Cumberland Street, Portsea—  
Inventor.

An artificial leg; with the foot constructed so as to dispense with steel springs; the invention being adapted to an amputation either above or below the knee-joint.

619 ARNOTT, J., M.D., 34 Baker Street, Portman Square—  
Inventor.

Current apparatus for regulating the temperature of morbid parts with precision, and combining an appropriate temperature with equal pressure.

ved entirely from a

—Manufacturer.  
figures life-size. Eyes  
balls, and birds—ofk, 26 Strand—  
tor.  
ment consists of an  
necessity for steelstruction. Artificial  
nd arm.  
ion of the bones of  
ey incline inwards,  
e for prolapsus.

n Street, Pimlico—

Place, Brompton.  
nce for placing the  
ose elevations ande, Walworth—  
r.  
plaisters.  
plaister.ough St., Regent St.  
r.ok Street, Ilmocer  
r.r truss devised by  
s, of various con-  
ed as a bed, chair,  
ruitt, Esq.t, Borough—  
r.  
and children.nd Manufacturer.  
that the patient  
made up under  
ion most easy to  
one attendant.ol Street, City—  
r.paring apparatus,  
re-rooms, &c.; a  
ht, to which the  
e wood-work or  
n sits. The ende and abdominal  
o self-adjusting

Street, Portsea—

ructed so as to  
n being adapted  
e knee-joint.

ortman Square—

temperature of  
g an appropriate

Apparatus for applying a very low or anæsthetic temperature in various inflammatory and painful diseases.

[The object of the apparatus here described is to supply a constant source of pressure, combined with a constant abstraction or supply of caloric. This is useful in the treatment of inflammatory and irritative diseases, and has been found of service in the relief of the pain of ulcers and diseased joints. A waterproof cushion is applied to the part, and its contents are changed by a current of water from a small reservoir elevated above the patient. A uniform temperature, whether below or above the standard of the body, is thus supplied. It is a singular fact that pain may be actually extinguished by benumbing cold, and the apparatus for supplying this degree of temperature has been successfully used in the relief of inflammatory and neuralgic diseases. The term anæsthetic is applied to agencies which remove the power of perceiving pain. The perpetual siphon exhibited is used in the application of this temperature to internal diseases, and for other purposes in surgery. An anæsthetic temperature may also be substituted for chloroform in many surgical operations.—R. E.]

Apparatus for removing contractions or obstructions in the excretory canals by the dilatation of fluid pressure.

[Dilatation by fluid pressure was suggested as a remedy in the cases described by Dr. Neil Arnott. It excels some modes of treatment in the quickness and safety of its action, and in the permanence of its effects. The principle of this dilator is illustrated by the suspended distensible tube; its construction by the instruments in the glass case. A fluid pressure dilator, used in the extraction of stone, and another used in dystocia, are also exhibited.—R. E.]

620 LEARD, ARTHUR, *Oulart, Wexford, Ireland*—

Inventor.  
Double stethoscope, made of gutta-percha.

624 SIMPSON, G., F.R.C.S., *6 Bedford Street, Bedford Square*—Manufacturer and Inventor.

Anatomical model of the human figure, in papier maché and gutta-percha. On the right of the figure, are represented the external layer of muscles, the superficial arteries, veins, and nerves; on the left, are shown the second and third layers of muscles, with the deep-seated vessels and nerves. The chest and abdomen are moveable, in order to exhibit the internal organs; and the skull-cap, to show a vertical section of the brain. The arteries are coloured red, the veins blue, and the nerves white.

Anatomical model in gutta-percha, being a vertical section of the human head and neck, exhibiting the brain, spinal marrow, membranes, and sinuses; together with the nose, mouth, larynx, fauces, the large blood vessels, and parts concerned in the cavity of the mouth.

625 TOWNE, JOSEPH, *Guy's Hospital*—Producer.

Deep section of the head, showing the distribution of the fifth nerve, the internal ear, the muscles and nerves of the orbit, and the muscles, large vessels, and nerves of the cervical region. Model showing the muscles, blood vessels, and nerves of the neck, upper extremity, and chest. From dissections by John Hilton, Esq., F.R.S., of Guy's Hospital.

Twelve models from the egg of the goose, exhibiting the progress of development during incubation. Twenty models from the egg of the common fowl, exhibiting the same.

627 BROWN, JOHN, & SON, *Grey Street, Newcastle-upon-Tyne*—Manufacturers.

The railway tourniquet, exhibited for efficiency and simplicity of application.

The aneurismal compress, for the application of the treatment of pressure to aneurism.

Dilators for stricture. The ostraicde, or oyster opener.

628 SALT, M., & SON, *21 Bull Street, Birmingham*—Manufacturers.

1—7. Cases of surgical instruments: for amputation; post-mortem examination; minor operations, by Cooper; dissection; catheters, for strictures; for the pocket; and Kidston's mechanical leeches.

[The principle of the mechanical leech is identical with that of the ordinary cupping apparatus. The scarificator is composed of three lancet points, which inflict a wound of the same form as that given by the leech. The puncture is instantaneous, and is produced by the operation of a spiral spring, which, released, projects the points into the flesh; a vacuum pump is attached, the piston of which is withdrawn, also by the operation of a spiral spring, into the barrel of which the blood flows; when filled, it is removed, and another small pump is applied, the piston being at the lower part of the cylinder, and the operation of the spiral spring withdrawing the piston and forming the vacuum alluded to.]

8—13. Salt's registered spontaneous, and enema apparatus.

[The spontaneous action syringe or enema is produced by the compression of the air, which operates upon the surface of the fluid by its elasticity, and forces it out by its reaction or desire to regain its equilibrium. The operation is, of course, less powerful towards the conclusion of the discharge, but it is still sufficiently so to effect the intention.]

14. Improved medical galvanic apparatus.
15. Five patterns of stethoscopes.
16. Five patterns of midwifery forceps.
17. Four patterns of uterine specula.
18. Skey's new tourniquet, for amputations.
19. Scarificator for cupping.
20. Tooth-extracting instruments, including Salt's compound.
21. Two chloroform inhalers.
22. Fifty varieties of surgeon's pocket instruments.
23. Salts, improved pessary, for prolapsus uteri and bandage.
24. Six trusses for hernia.
25. Models of elastic stockings, fracture apparatus, and instrument for club feet.
26. Sundry instruments and appliances.

629 REIN, CHARLES, *108 Strand*—Inventor.

New instrument for aiding the hearing, which requires no spring, and is not observable; the length of the tube is 18 inches.

Various instruments of the same kind, which may be worn without being seen.

Acoustic chair, vases, bells, walking-sticks, telescopes, &c., adapted for various useful purposes.

Conical flexible whispering-tubes; domestic telegraph; ear-caps or reflectors; acoustic pulpit, and group of acoustic instruments.

Continual stream enema reservoir; several kinds of aperitive vases and enemata.

Ear springs of different constructions. Registered, self-acting lactatory. A variety of tubular ear specula and other instruments.

630 GREENHOW, T. M., *Newcastle-upon-Tyne*—Inventor.

Fracture bed, for the treatment of patients having fractures of the thigh and leg.

631 FERGUSON & SONS, *21 Giltspur Street*—Manufacturer.

Complete set of surgical instruments, for capital and minor operations.

Specimens of forceps, scissors, knives, and tourniquets, including Mr. Skay's, and Dr. Malan's. Case of gilt catheters. Mr. Wakley's stricture instruments.

Speculums. Instruments for lithotomy.  
Dental, polypl, and midwifery instruments.  
Splints and inclined planes for the different fractures.  
Dr. Burgess's apparatus for fumigations in diseases of the hair.

Apparatus used in orthopedic surgery, showing the latest improvements for the treatment of contractions of the neck, hip, knee, foot, arm and hands, including apparatus for lateral and posterior spinal curvatures.

631A WEISS & SON, 62 Strand—Inventors, Manufacturers, and Patentees.

Complete cabinet of surgical instruments, containing all that are necessary for general operations in surgery, and combining the latest improvements. In this cabinet, the instruments are so arranged that each set is complete, and the drawers and trays are so planned that the instruments may be seen at once. The handles of the instruments are made of pressed buffalo horn, this substance being light and durable, and calculated to prevent their splitting or breaking.

The screw lithotrite, invented by the exhibitor.  
The lithotrite, as used by Professor Fergusson, substituting the rack and pinion for the screw.

Invalid bed couch or bearer. When carefully placed on the bed by an attendant, it will enable the patient, with little assistance, to place himself in an easy position, as in a self-acting arm-chair. By means of a broad band placed underneath, he can be lifted out of bed and taken up or down stairs; and by a board sliding between the arms, it is rendered convenient for reading, writing, or refreshment.

Improved enema syringe, without valves or stop-cock.  
Osteotome or rotary saw, for the excision of diseased or fractured bone.

Splint, with extending screw, for fractured leg or thigh.

Apparatus for contracted knee.  
Support for the head in paralysis.  
Jointed forceps for extracting foreign bodies from the throat.

Patent fleam, for bleeding horses or cattle, in which the depth of the lancet can be nicely regulated, and danger avoided.

The preceding articles are the inventions of the exhibitors.

Avery's lamp and reflector for examining the ear, throat, and different canals of the body. The peculiar features of this apparatus are, the employment of a lamp and mirror with an opening in the centre, which enables the operator to look immediately upon the object; and the use of gaseine, in the lamp, which gives a more brilliant light than can be obtained either from oil or from a candle: to this is added the necessary tubes, specula, &c.

Avery's new instrument for facilitating the operation of lithotomy: by this instrument an operation is performed with certainty.

Bulley's splint for fracture of the thigh. The advantages of this splint are, that while extension is kept up by means of a screw at the foot, the long continued and injurious strain upon the knee is taken off by the use of a soft band passing above, and all excursion of the thigh is prevented, by a short regulating splint passing within the long one.

Hulley's double tourniquet for compressing the artery in aneurism. The advantages of this instrument are, the firmness with which it sets upon the limb, and the peculiarity of its form, adapting itself more completely to the form of the limb when compressed by the pads.

Dr. Jarvis's surgical adjuster, for reducing dislocations, adjusting fractures, and maintaining coaptation. By means of this instrument an extending and counter-extending force, equal to that of twelve men, may be employed; all or any part of which can be applied to the limb at pleasure, and yet the limb remains perfectly moveable and free for manipulation.

Rynd's instrument for applying fluid to the nerves in tic doloureux.

Wakley's stricture instruments. The great advantage of these instruments is, that where the required passage is once secured, it need not be surrendered until the proper end is gained.

Whitehouse's safety apparatus for transfusion. By means of this apparatus the operator is enabled to detect the presence of any globules of air in the fluid to be injected, and to prevent their entering the veins.

Yearsley's aecometer, or instrument for ascertaining the different degrees of deafness, by a series of modulated sounds.

Yearsley's tympanotome, and instruments for artificial tympanum. Instruments for the excision of the tonsils, nasal probe, bottle, and tube.

Dr. Tyler Smith's peridoscope.  
An assortment of razors and table cutlery; among the latter are some table-knives made from the materials of old London bridge.

631B ELLIS, JOSEPH, 41 Spring Street, Sheffield—Manufacturer.

Amputating and post-mortem instruments.  
Pocket instruments, and scalpels.  
Lancets of various qualities.  
Trusses of various kinds, for hernia.

633 HARNETT, WILLIAM, 4 Francis Street, Brewer Street, Golden Square—Manufacturer.

Dental instruments, mineral teeth, and materials used by dentists.

634 DOWNING, CHARLES TOOGOOD, M.D., 42 Great Russell Street—Inventor.

The aneuralgicon, an apparatus used for the application of warm medicated vapour, in the treatment of tic doloureux, and other neuralgic affections.

The aneuralgicon is extremely simple in construction, and consists, essentially, of three parts: a cylinder, for igniting the vegetable matter; bellows, for maintaining a current of air through the burning material; and tubes and cones for directing the stream of vapour.

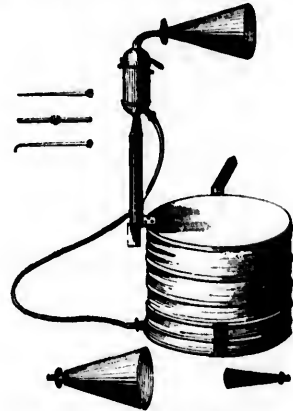

Dr. Downing's Aneuralgicon.

The cylinder is a silver vessel, of a cylindrical shape, about two inches in length, and one inch in diameter. It has a metallic plate at the lower part, perforated with many holes, on which the burning materials lie. Beneath this is an opening for the admission of air, and a socket into which an ivory handle is made to screw. The dome-shaped lid fitting accurately to the top of the vessel, allows the vapour to escape through an orifice and tube at the summit.

fluid to the nerves in

The great advantage  
the required passage  
under until the pro-

for transfusion. By  
is enabled to detect  
in the fluid to be in-  
the veins.

ent for ascertaining the  
series of modulated

instruments for artificial  
division of the tonsils,

cutlery; among the  
from the materials of

rect, Sheffield—

instruments.

Street, Brewer Street,  
cutlery, and materials used

M.D., 42 Great Russell

and for the application  
treatment of tic dou-

ple in construction,  
parts: a cylinder, for  
s, for maintaining a  
material; and tubes  
vapour.



cylindrical shape,  
in diameter. It  
t, perforated with  
als lie. Beneath  
air, and a socket  
rew. The dome-  
p of the vessel,  
orifice and tube

The bellows consist of two plates of mahogany, of an oval shape, and about eight or nine inches in length. These are joined together by thin leather, maintained in its proper position by ribs at suitable distances. A strong spring is fixed in the interior, to keep the plates apart, and react against the pressure of the hand. A socket to hold the ivory handle of the cylinder is fixed upon the upper plate. In order to apply the vapour the cones are attached to the cylinder. For different parts of the body cones of various sizes have been constructed. These are tubes shaped like extinguishers, covered with leather, and lined with sheet lead. By this arrangement they retain the shape given them by the hand.

[This apparatus consists of a receptacle for medicinal substances which are kindled, and an air bellows which impels a stream of air through the mass into a tube, by which it is directed upon the painful part. It has been said to give relief in the cases mentioned.—R. E.]

635 PRATT, JOSEPH, 10A Charles Street, near Middlesex Hospital—Manufacturer.

Scarificators. Cupping-glasses. Graduated cupping-glasses. Tea-pot spirit-lamp, used in cupping. Portable ball lamp or torch; and portable case of cupping instruments, for general practitioners, with extra sets of lancets.

636 GODDARD, LEMUEL, 6 Crescent, Minorities—Importer.

Patent instrument, with shifting spring-jaws, for extracting teeth by means of a fulcrum and lever attached. The invention of Edward Bourne, of New Bedford, Mass.

639 GORDON, J., Bristol—Producer.  
Anatomical figures.

640 WEEDON, THOMAS, 41 Hart Street, Bloomsbury—Manufacturer.

Surgeons' instruments and cutlery.  
Various patterns of small knives, scissors, cutting and spring forceps, and other instruments, used in the minute dissection of insects, flowers, or morbid matter, for investigation under the microscope; also, instruments used in the preparation of birds and animals previous to stuffing.

Specimens of tooth forceps, electro-plated and polished steel; also stoppers, scalars, and levers, in agate handles. Specimens of cutlery, mounted in the Haliotia pearl shell, plain pearl, and agate handles.

641 PHILP & WHICKER, 67 St. James's Street—Manufacturers.

Cutlery and surgical instruments.

642 SIMPSON, HENRY, 55 Strand—Manufacturer.

Regulation case of instruments, for a surgeon in the Royal Navy.

(Proposed) case of instruments for a surgeon in mercantile passenger ships.

Cases of amputating, trephining, cupping, operating, pocket, teeth, dissecting, post-mortem, eye instruments, &c.

Improved horse and cattle fleams, and various small cases of surgical instruments.

Various specimens of surgical instruments, viz., knives, splints, improved extension splints, stethoscopes, ear-trumpets, trusses, &c.; and fine cutlery, including cases of razors, knives, scissors, and patterns of London-made table-knives, &c.

643 WOOD, W. R., German Place, Elington—Manufacturer.

A series of mechanical adaptations for regulating and preventing the irregularities of the permanent teeth.

643A EVANS & Co., 10 Old Change—Manufacturers.  
Surgical instruments.

645 GOWING, THOS. WM., Camden Town—Inventor.

Complete set of dental instruments for operations in treating diseases of the teeth of the horse.

Leg apparatus for fractures occurring to race-horses or other valuable animals.

Tracheotomy tube, with adjusting-shield and chain-director.

Neurotomy scissors and knife for dividing nerves.

646 KIDSTON, W., & Co., 18 Bishopsgate Street Without—Inventors and Manufacturers.

Mechanical leech, for the purpose of local bleeding, for the gums or any part of the body. It is always available; the mode of using is very simple, and any quantity of blood may be drawn, in much less time than by the natural leech, with diminished risk of erysipelas. It is also important for use on shipboard, and in many parts where the natural leech cannot be procured.

647 EVARD, JEAN, Charles Street, Middlesex Hospital.

Adjusted tooth forceps.

Specimens of the manufacture of these instruments in the various stages.

Enamel cutters, used by dentists for scaling the teeth. Specimen intended to show the hardness of steel necessary for that operation.

Instruments for lithotripsy, with specimens of the various stages of manufacture.

Artificial nose and chin, made of gutta percha.

Sporting knife, fitted up with screws, so as to be taken more easily to pieces, for the purpose of cleaning.

New pattern of nail-nippers.

648 HESS, RICHARD, 16 Little New Street, Shoe Lane—Manufacturer.

The registered "Osteotom," a surgical instrument for cutting bones.

649 BARKER, JOHN, M.D., 45 Mountjoy Street, Dublin—Inventor.

Thoracitone, a new medical instrument, for the purpose of rendering more efficient and certain the act of percussion in disease: by using the instrument with one hand, transmitted sounds can be employed in the diagnosis of diseases.

651 SMALL, THOMAS, Boston, Lincolnshire—Inventor.

Apparatus for restoring suspended animation in persons apparently dead. It consists of a box with a hole in the lid, and bellows. The body is placed in the box, the lid put on, the face exposed through the hole, the mouth kept open, and the India-rubber kept adjusted to the cheeks, forehead, and chin, so that no air can pass by the sides: the bellows are now worked gently upwards and downwards, just as fast as a healthy person breathes, till animation be restored.

The electro-magnetic apparatus, bottles containing restoratives, &c., can be kept fitted ready in the inside, near the feet, and the box may be mounted on wheels. It is peculiarly serviceable for the still-born.

652 JONES, P., High Street, Fulham—Inventor.

Improved metallic shield for the nipple.

653 BLACKWELL, WILLIAM, 3 Bedford Court, Covent Garden—Inventor and Manufacturer.

Registered guard razor and corn knife. Surgical apparatus.

654 MACHELL, THOMAS, 2 Carlisle Street, Soho—Inventor.

Patent improved method of raising water and other fluids.

Surgical instruments.

655 FARQUHARSON, JAMES, Ealing, near Brentford—Inventor.

Spring stump for a wooden leg, which gradually receives the pressure of the wearer, gives assistance to



the next step, and takes off the jerk and jarring usually experienced.

656 JONES, THEODORE, 28 Lombard Street—Inventor and Proprietor.

Registered silent alarm bedstead. The movement of the hand of a common watch will turn any one out of bed at any given hour when attached to this bedstead.

657 BOTTOMLEY, GEORGE, Croydon, Surrey—Inventor.

New splint for fractured thigh, with a leather belt for the chest, perineal band, boot and knee straps. The object of this apparatus is to apply and maintain firm extension, in a line parallel with the axis of the body, which can be exactly regulated by means of the thumb-screw at the end; also by keeping the limb uncovered (as by bandages, &c.) to permit the free use of local applications and adjustments.

Model of the same, upon a lay figure, showing the mode of application.

659 WATKINS & HILL, 5 Charing Cross—Manufacturers.

Three feet plate electrical machine, with all the recent improvements, having positive and negative conductors, on the plan suggested by Sir William Snow Harris.

Very sensitive and delicate galvanometer of the most approved form, for measuring the feeblest currents of voltaic electricity.

Electro-magnetic engine; microscopes; aerometric balance; sextants; rain-gauge; Polariscopes; theodolite; levels; &c.

660 COLES, WILLIAM, 3 Charing Cross—Inventor, Patentee, and Manufacturer.

Patent trusses. An internal spring is fixed in the cushions or pads, at every point of bearing.

Medicated band, for the relief of sciatica, lumbago, rheumatism, &c.

661 RENEZYNSKI, Capt. G. A., Stirling, Scotland—Inventor.

Portable telescope stand, with desk for artists, engineers, and surveyors, &c., with various useful improvements and apparatus.

663 SIMONS, WILLIAM VARIE, South Shields—Designer and Manufacturer.

Electro-magnetic machine, with an improved arrangement of the primary coil and contact breakers, &c.

664 WARD, N. B., 14 Clapham Rise—Inventor.

Closed cases, by which plants may be grown in any locality, even in the centre of the most crowded cities, or conveyed from one country to another with complete success.

A bottle, in which the experiments accidentally originated in 1829. There are now in this bottle one or two ferns which have not received any fresh water for more than seventeen years. Several seedling ferns may be observed springing up in various places.

Improved travelling case, as at present used by Lodgides.

A case with two palms, phoenix dactylifera and rhapsis flabelliformis, planted in it fifteen years ago. The other plants are of recent introduction. This case has always stood in a room with a southern aspect.

A case containing hymenophyllum and other ferns, which have been enclosed between two and three years, has always been placed in a room with a northern exposure.

Irish case, likewise containing ferns planted in 1846, and placed in a shady position in the open air. The bottom of this case is filled with inverted empty garden pots to insure efficient drainage.

Case with two larger roses, which have been enclosed for eight years, five of which were in London. The case has always been in the open air, fully exposed to the south, and the roses have flowered during three or four

months in every year. It remains to be seen whether, in the Exhibition Building, they will flower as well, under the adverse conditions of increased heat during the night, and diminished amount of solar light in the day.

New terra-cotta case, manufactured by Mr. Dralton; all the ferns recently planted.

Fern case, lent by E. W. Cooke, Esq., Kensington. When Mr. Cooke first planted this case, in 1848, he found that the ferns planted on the top of his conical mass of stone suffered from want of sufficient nourishment. In remedying this deficiency, the ferns in the lower part of the case suffered from redundancy of wet, and some perished. To obviate this, and to ensure a more equal distribution of moisture, Mr. Cooke removed the upper stones to about  $\frac{1}{2}$  from the case, and inserted a small zinc dish, one inch deep. The stones were then replaced, some resting in the dish, and others packed around it, so as effectually to conceal it from observation. Whenever the plants required water, the dish became full, and thus the stones at the apex were kept as moist as those below.

Fern-case, likewise the property of E. W. Cooke, Esq. Case, containing cactuses, enclosed in 1848, the property of Mr. Deane, Clapham Common.

The use of these cases was first suggested to the inventor in the summer of 1829. For many years previous he had endeavoured, by a most careful imitation of their natural conditions, to grow various plants, particularly ferns and mosses, at the back of his house in Wellolose Square, a locality surrounded by numerous manufactories, and constantly enveloped in their smoke. Vain was the attempt; the plants perished. New light and fresh impetus were given by the following incident.

Wishing to obtain a perfect specimen of a sphinx, he had buried its chrysalis in some moist mould in a bottle covered with a lid. Two or three days before the insect assumed its perfect form, a seedling fern and a grass made their appearance on the surface of the mould. In this condition all their wants were supplied. They had sufficient light; whilst the lid, at the same time that it excluded the noxious soot, prevented the escape of the moisture. The law which enforces the diffusion of gases secured a constant circulation of the air, and its quiescent state enabled the plants to bear variations of temperature, which in open exposure would have proved injurious. Various experiments carried on with hundreds of plants, and extending over several years, established the conclusion, which has been fully carried out by the results,—that all plants whose natural conditions can be fulfilled, can be grown in these cases in any locality, even in the centre of the most crowded cities, or conveyed from one country to another with complete success. The importance of duly and properly supplying the wants of the plants cannot be too strongly impressed upon the mind of the experimenter, so numerous have been the failures arising from want of thought or of knowledge in the attempts to associate plants of different habits. Many plants require very little light, but need constant moisture and a pure atmosphere, such as the *Trichomanes speciosum* and *Oxalis acetosella*. Others require a large amount of solar light to bring them to perfection.

In June, 1833, the first experimental cases were filled with plants, furnished by Messrs. Lodgides, and sent to Sydney under the care of Capt. Mallard. Placed on the deck of his ship, fostered with a genial atmosphere, fed with proper food, and protected alike from the noxious effects of salt spray and dust, they arrived in perfect health at Sydney, in January 1834. The cases were refilled at Sydney in February, the thermometer then being between 90° and 100° Fahr., and in their passage to England encountered very varying temperatures. The thermometer fell to 20° in rounding Cape Horn, and the decks were a foot deep in snow. At Rio Janeiro, the temperature rose to 100°, and in crossing the line to 120°. In November, after an eight months' voyage, they arrived in the British Channel, the thermometer having fallen to 40°. The plants were in the most vigorous condition, and the beautiful appearance of the fronds of *Gleichenia microphylla*, then, for the first time, seen alive in Europe, created great surprise. Since 1834, the use of these cases in the trans-

portation  
governor  
plants to  
light and  
addresses  
petually  
which the

Mr. F.  
cases by  
new met  
commun  
lished in  
vol. iii.,  
and sur  
Fortune  
good con

The se  
—even t  
been the  
and dur  
and flour  
gallons  
sweet b  
was like  
and pro  
growth  
most cr  
in nume

664 C

Sever

665

Five  
watches  
baromet

666 R

Bled  
cupping  
body.

J. Scho

The  
made t  
circula

a glass

acrew,

Larger

cious

forms,

the lar

being

new, a

667

Mic

Fossil

insect

668

Hy

spirit

670

Se

calot

670

Se

stre

tan

In

hay

ven

portation of plants has become universal. Col. Reid, whilst governor of Bermuda, made use of them in procuring plants to stock the Bermuda Islands. These were made light enough for two sailors to carry by hand. Double addresses were painted on the boxes, and they were perpetually travelling by sea between different countries, by which their vegetable productions were exchanged.

Mr. Fortune, who was sent out to China with glazed cases by the Horticultural Society, comparing the old and new methods of conveying plants, says that, "in a paper communicated by Mr. Livingstone, of Macao, and published in the Transactions of the Horticultural Society, vol. iii., it is stated, that then only one plant in a thousand survived the voyage from China to England." Mr. Fortune put 250 plants into the cases, and landed 215 in good condition.

The same principle is applicable to the animal kingdom—even to man. For several years gold and silver-fish have been the constant inhabitants of the inventor's fern house, and during his residence in Wellose Square, they lived and flourished in an earthen vessel, containing about 20 gallons of water, which was never changed, but kept sweet by the aquatic plants growing in it. A robin was likewise an inmate for six months. The same pure and properly-moistened atmosphere which favoured the growth of the most delicate plants in the heart of the most crowded cities would be of incalculable advantage in numerous diseases. (*North Transcript.*)

664A COOKE, E. W., *The Ferns, Victoria Road, Kensington.*  
Several closed cases for ferns, exotic and British.

665 BRYSON & SONS, *Edinburgh*—Inventors and Manufacturers.

Five models, exhibiting the various escapements of watches at present in general use, and a self-registering barometer clock.

666 ROSS, ANDREW, *2 Featherstone Buildings*—Agent.

Bleeding instruments, as substitutes for leeches and cupping instruments, adapted to apply to any part of the body. Invented by Baron Heurteloup; manufactured by J. Scholl, Berwick-street, Soho.

The cutting instrument, consisting of a circular cutter made to revolve by a pulley and cords, makes a slight circular incision of equal depth. The pump, or sucker, is a glass tube, with a piston of cork or felt, worked by a screw, while the effect is observed through the glass. Larger pumps are made to cover three or more small incisions. The glass tubes have metallic ends, of various forms, to apply to different parts of the body, which, in the larger ones, serve as a diaphragm to prevent the skin being drawn into the tube. This invention is perfectly new, and is patented.

667 TOPPING, C. M., *4 New Winchester Street, Pentonville Hill*—Preparer.

Microscopic objects. Test objects and fossil earths. Fossil and recent vegetable structures. Dissections of insects. Bone, teeth, shell, &c. Injected preparations.

668 DURHAM, J. D., *16 Linton Street, New North Road, Islington*—Inventor.

Hydrometer, with all the recent improvements, with spirit tube. Thermometer, and book of instructions.

670 OWEN, H., *3 Somerset Terrace, Bristol*—Producer.

Series of views in Somerset, Wilts, and Devon, by the calotype process, from negatives on paper.

670A EVANS, SPARKE, *Hungerford, Berks*—Inventor.

Self-acting instrument, for easily determining the strength of oak bark, valonia, cutch, divi divi, and other tanning materials.

Instrument for determining the heat of newly-made hay-ricks; and when ventilation, or turning over, to prevent firing, are required.

671 PARKES, JAMES, & SON, *5 St. Mary's Row, Birmingham*—Manufacturers.

Rosewood case of mathematical drawing instruments, containing beam compasses, proportional divider, triangular compasses; a set of fine steel spring bows with needle points; full set of 6-inch double jointed instruments, the compasses and bows having improved screw needle points; also tube compasses, pillar compasses with bars, and Napier compasses, each of which combines in itself a complete set of drawing instruments.

Set of 6-inch drawing instruments, electro-plated on German silver, with solid silver cheeks, in rosewood case.

Russia case, of 3¼ inch drawing instruments, with very fine spring bows.

Case of new portable drawing instruments, electro-plated on German silver.

Architect's companion—a complete set of portable instruments, in small morocco pocket-book, with silver pencil and gold pen.

Botanist's companion—a double lens microscope, with tweezers, dissecting needle, fine scissors, &c., in neat morocco pocket-book.

Ivory 2-foot slide rule, with spirit level and graduated scale, for taking angles.—Registered.

Self-acting tapes, with improved spring tops, &c.

Surveyor's measure, with multiplying action, by which a hundred turns of the hand are saved, as the tape is wound up. Invented by J. Parkes.

Assortment of pocket compasses.

Portable sun-dial and pocket compass combined.

Portable compass, with thermometer, in morocco case.

A portable galvanic battery, for medical purposes, capable of very sustained action.

Gilt watch-keys; and in various states of finish, illustrating the progressive stages of their manufacture.

Watch-keys and seals, containing mariners' compasses.

[Mathematical drawing instruments are used in drawing circles, circular lines, parallel lines, &c. Bow compasses are of great use in spherical projections, in drawing fine circles. Proportional dividers are of value in dividing circles into any number of sides, or to inscribe polygons in circles, and to reduce and augment figures in a given proportion.—J. G.]

671A WEBSTER, W. BULLOCK, *2 St. James's Place, Hampstead Road*—Inventor and Manufacturer.

Fire escape. Percussion carbine musket, with rotary primer. Omnibus passenger register. A mileometer. Small weighing machine. Cannon, with improved percussion-lock.

672 TAYLOR, T., *Dublin*—Inventor.

Hydraulic safety-lamp, to prevent explosion in coal-mines: water being used to prevent its becoming heated, and mica to give an increase of light.

Revolving self-amalgamating galvanic battery. The zinc plate dips into a mercurial trough; motive power is applied to the zinc plate; the gutta-percha shaving is placed between the plates to prevent a superfluous amalgamation on the zinc plate, and also local action.

672A NEWCOMB, THOMAS, *12 Norfolk Place, East Lane, Waltham*—Inventor and Maker.

Brass model of machine, for rolling tanned hides. Its objects are, increased speed in drying hides, less power in working, and a finer finish in the leather. The pressure on the hides may be varied from one cwt. to two tons.

Brass model of patent furnace for marine or stationary steam engines; it supplies itself with fuel, consumes its own smoke, and burns small coal.

Improved bass strings for pianofortes—the body and covering of the same material, viz., hard-drawn steel wire, which produces a finer tone than either copper or brass.

Lamps, intended to burn common pale seal oil, without smell, smoke, or shadow.

673 MACTARLANE, G., 85 Newman Street—Designer.

Improved cornsman (cornet & piston), with short action valves, direct passage of the air, and can be played with ease.

673A BURSILL, G. H., 9 York Terrace, Hornsey Road, Holloway—Inventor.

Patent compensating cistern barometer; the mercury, by a self-acting contrivance, is always preserved upon a level within the cistern, notwithstanding any alteration of temperature, or any rise or fall of the barometrical column.

Artificial hand, possessing elastic properties; which enable those who require it to pick up, seize, and even make use of minute objects. Invented by Sir G. Cayley, Bart.; improved and manufactured by Mr. James Buckingham, 13 Judd Place East.

674 NEWMAN, J., 122 Regent Street—Inventor and Manufacturer.

Standard barometer. The frame consists entirely of metal; the cistern, when required for long journeys, is all of iron, so arranged as to be made portable for travelling, by the lower part shifting a quarter of a turn; thus obviating the objection so long made to the wood cistern and leather bag. The scale is marked off from an authentic standard scale (verified by the late Mr. Baily), and terminates in a point; it is capable of being adjusted with great accuracy to the surface of the mercury in the cistern, and when the vernier at the upper part of the scale is adjusted to the surface in the tube, the exact length of the column of mercury is in this way measured; the diameter of the tube is 0.6.

Portable mountain barometer; consists of a metal frame, with the iron cistern similar to the standard barometer, and has all the data marked on it for the corrections, for reducing the observations to those of the standard barometer.

Standard thermometer, divided to fifths of a degree.

Maximum and minimum register thermometers.

Maximum thermometer, with black bulb for solar radiation.

Minimum thermometer in the focus of a mirror, for terrestrial radiation.

Daniell's dew-point hygrometer.

Mason's wet and dry bulb hygrometer.

Lind's wind gauge.

The foregoing meteorological instruments are described by the Committee of Physics and Meteorology, in their Report published by the Royal Society, and made by the exhibitor for the various magnetic observatories.

Usual copper rain gauge, with accurately turned circle 12 inches diameter.

Howard's rain gauge and evaporator.

Sykes' thermometer and boiler, for measuring heights by the boiling point.

Miners' safety-lamp, as made for Sir H. Davy.

Miners' safety-lamp, as improved by the exhibitor.

Improved air-pump with metallic valves, and ground glass plate, which exhausts to within  $\frac{1}{10}$ th of the Torricellian vacuum.

Rain and wind gauge, contrived to register the quantity of rain and direction of the wind, at the precise time, on a cylinder which has motion given to it by a clock; the register paper is replaced at the end of each month.

Self-registering tide-gauge; consists of a cylinder, moved by means of a clock 1 inch to the hour, and a pencil moving by the float 1 inch to the foot. The pencil, by being attached to a chain carried over two small brass cylinders, the one containing a spring, is so contrived that there is no loss of time in marking the change of the tide; so that the exact moment of the commencement of its rise or fall is registered, and its progress for every portion of time, from the highest to the lowest point, is traced on the paper. The paper for this instrument was laid down by the Admiralty, and is used with metallic pencils. On the face of the clock is shown the height of the tide during observation, and it also registers the highest and lowest for the day.

674A STEPHENSON, R., Great George Street, Westminster—Inventor.

Machine for tracing.

675 NEWSON, HENRY, 18 Percy Street, Tottenham Court Road—Inventor.

Patent wire trusses, single and double, the latter passing round one hip only.

675A OAKBY, H., 81 Dean Street, Soho—Inventor.

New musical atlas, a work on the theory of music, which consists of a series of moveable diagrams, by the aid of which all the intervals, scales, chords (nearly 700 in number), inversions, &c., are brought to view; and the difficult problems in the science may be solved instantaneously by musical amateurs at any period of their studies. Guide to harmony, and treatise on the musical atlas.

676 BRIGG, H., & SON, 29 Leicester Sq., and 9 St. Thomas's Street, Southwark—Manufacturers, Inventors, & Proprietors.

Patent artificial leg, constructed without metallic or external springs; colour, that of the natural limb; surface, admitting of ordinary soap and water washing.

Artificial hand with jointed fingers, and apparatus for enabling the wearer to use it as a natural hand.

Spinal supports, for lateral posterior curvature, and anterior curvature; and for vertebral and muscular weakness.

Self-acting spring crutches.

Instruments for fixed contraction of the knee (*nuchlyosis*); fractured patella; clubbed foot, (*talipes valgus et varus*); and contracted heel (*talipes equinus*).

Trusses:—P. Aston Key's, with pad, whose surface is continually changing; L'Estrange's patent for radical cure of hernia; Bigg & Son's convolute; and for umbilical hernia.

Instrument for support of prolapus ani.

Aneurism needle; hernia knife; omyriptomist; and explorer, invented by the exhibitors.

676A BROWN, DAVID STEPHENS, Alexandria Lodge, Old Kent Road—Inventor.

Registered barometer, 30 feet high, range of scale 27 feet, manufactured by Casello and Co., 23 Hatton Garden.

677 READHOUSE, CHARLOTTE, Newark-on-Trent—Designer and Producer.

Lunar globe: a model of the moon, giving a general idea of the relative position of the mountains, valleys, and plains of our satellite, in relief.

[The distinctive structural peculiarities of the lunar regions are,—1st. A vast distribution of annular mountains, thrown up like ramparts round plains or valleys, having rugged ridges, and a conical hill rising out from the centre of many of them. Sir John Herschel, who computes the height of the highest of these mountains, at 1½ English miles (though Schroeter gives 5 miles as his calculation), testifies that they offer, in its highest perfection, the true volcanic character, and, speaking from his own observation, says that, "in some of the principal ones, decisive marks of volcanic stratification, arising from successive deposits of ejected matter, may be clearly traced with powerful telescopes."

2. Extensive plains, having the appearance of alluvial soil—relieved, however, with a number of crater-formed mountains (Copernicus, Kepler, Aristarchus, &c.), and small rocky eminences, with here and there circular cavities of various dimensions. These "large regions" (to use Herschel's term) are scattered over with fragments of rock, ashes, &c. They are given in neutral tint on the model.

3. Hundreds of cup-shaped valleys dimpling the general surface in every direction, and giving the idea of a contraction or settling down of the exterior on the receding

interior, according to a theory proposed by Mr. Naamyth at the last meeting of the "British Association."



Readhouse's Lunar Globe.

The model illustrates the more reflective localities of the moon in dull gold bronze, displaying a number of bright rays, which seem to spread over a large section of the southern regions of the hemisphere, and diverging from a common centre (Tycho).]

**677A SHADBOLT, G., 2 Lime Street Square—Inventor.**

Sphero-annular condenser, for condensing light in a peculiar manner, on transparent objects while under examination by the microscope. Diagrams and description, illustrative of the action and construction of the condenser.

**678 JACK, W., 38 Devonshire Street, Portland Place, and 14 Ratcliff Row, St. Luke's—Manufacturer.**

Mr. Clendon's new form of tooth-forceps and elevators. Improved adjusted forceps. Forceps for irregular front teeth. Forceps for roots of teeth. Now stopping instrument, invented by the exhibitor.

**678A MORTON, Professor, Royal Veterinary College, Camden Town—Inventor.**

Medicated cotton for setons.  
Galvano-arsenical apparatus.

**679 BELL, THOMAS, 19 Homer Street—Inventor.**

Watches, to go for one or three years, keep correct time, and show the day of the month; some are furnished with centre and others with ordinary seconds and quarter seconds; maintaining power whilst winding; duplex and other escapement; and composition balances.

Time-pieces and clocks, on the same construction.

A turret clock, to strike the hours and quarters; with best gun metal wheels and bosses, or holes; tempered and polished steel pinions of high numbers; dead-beat escapement, with adjusting palette; tempered steel escape wheel, and tempered steel racks, snails, and hammer tails to the striking work; and improved pendulum, with adjustment of the same.

Interior hour, minute, and seconds hands, and dial for regulating and setting the hands upon clock faces, by patent metal lines instead of cords, to suspend weights. Balanced hands, &c.

**670A BETTLE, PHILIP, 11 Regent Street, City Road—Maker or Producer.**

Model of a steam-engine, of new design and workmanship. It is worked by machinery contained in the pedestal.

**680 OFFORD, D., Great Yarmouth—Inventor.**

The improved truss for hernia.  
Improved instruments for the treatment of uterine diseases.

**681 RICKMAN, WILLIAM CHARLES, 21 Park Side, Hyde Park Corner, and Polo Mole, Wexford—Inventor and Designer.**

Road level: two varieties of an instrument for use in agriculture, drainage, and other purposes. This instrument enables a person unacquainted with the practice of levelling, and without calculation, or the aid of an assistant, to know the level of the ground, and also its rise or its fall. Only one observation is necessary, and the result is then found stated upon the dial. J. Peirce, maker, Wexford.

**681A SOMALVICO & Co., Hatton Garden—Manufacturers.**

Wheel barometer; ornamental gilt frame, improved porcelain plates.

Barometer in papier maché inlaid with pearl; ebony sides.

Standard pediment barometer, with extra large tube, and improved glass cistern showing the rising and falling of the mercury in the tube.

Improved mariner's barometer; combined marine tube, siphon tube, and hygrometer, to indicate the changes quicker than the ordinary marine barometer; making a complete and sensitive instrument for ascertaining the variations of the atmosphere correctly.

New siphon pedestal, or pocket barometer, 8 inches long.

Improved engineer's guide gauges, combined with barometer for correction.

Vacuum steam-pressure gauge, on a new principle: a great improvement on the former; prevents the water mixing with the mercury.

Steam-engine indicator: for showing the working quality of the exhibitors' patent brewers' liquid prover; requires no tables. Engines, walking-stick telescopes, with compass and hygrometer, and with double eyeglasses to spring out of the stick.

Improved sextant, with patent universal lunar lamp, which may be set to any angle, the observer being able to read off the sextant during rough weather or at night.

Solid limb sextant.

Model representing the circulation of the blood.

Improved self-generating coffee-pot, and for producing hot water in a few minutes, with an extinguisher which puts out the flame of the lighted spirit at any moment required; and portable cistern for travelling.

Case of mathematical instruments, &c.

**682 COXETER, JAMES, 23 Grafton Street East—Manufacturer.**

Aneurism needle, for facilitating the tying of deep-seated vessels. Scissors gullotine, for removing the tonsils. Scissors for excising the uvula. Artificial leech without piston or spring. A compound needle for injecting small cysts, designed by John Marshall, Esq., assistant-surgeon to University College Hospital. Forceps, for applying ligatures to arteries. A forceps so constructed that the ligature might be readily slipped over the points on to the vessel, originally designed by James Luke, Esq., improved by the exhibitor by adding Liston's spring catch and tenaculum teeth, and cutting out the head, so as to leave only, as it were, four fine wires for

the ligature to slide over. This enables the operator to take up a deep-seated vessel, and tie it without assistance, in cases of emergency.

A new description of India-rubber air-pad trusses. India-rubber dilator, for stricture of the rectum. These instruments are introduced uninflated, by means of a concealed flexible stilette, and when in the stricture, are filled with air; thus the parts are dilated without the pain produced by the usual method. As soon as the dilatation is accomplished, the air is allowed to escape, and the dilator is then easily withdrawn.

Tubes for stomach pumps and enema syringes. The ordinary tubes (however carefully made) when taken to a warm climate, soon become melted on the surface, and utterly useless. The exhibitor claims the merit of introducing and applying vulcanised India-rubber, having a metal head firmly fixed, as a tube that will bear the heat of any climate, and which will be less liable to

receive injury by coming in contact with the teeth. Double action enema syringe. This instrument secures a well supported, continuous stream, is simple in its construction, and does not occupy more space than the syringe in common use.

The stethometer. An instrument for assisting in the diagnosis of diseases of the lungs, by measuring the comparative mobility of opposite sides of the chest, by Dr. Quain, Assistant-Physician to the Hospital for Consumption. Various other useful and important instruments.

683 OETZMANN & PLUMB, 56 Great Russell Street, Bloomsbury—Inventors and Manufacturers.

Cottage and cabinet pianofortes, with newly-invented tubular supporters, patent double repeating check action, and other improvements. This pianoforte is represented in the annexed cut.

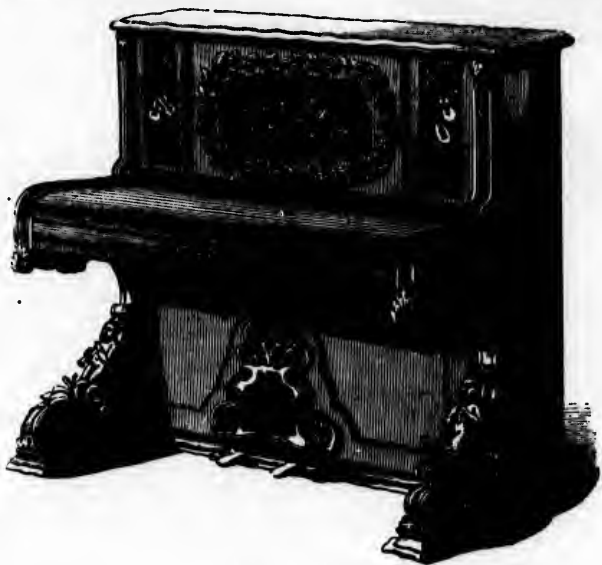

Oetzmann and Plumb's Pianoforte.

683A MUDIE, DAVID (of the Firm of GOURLAY, MUDIE, & Co.), Dundee, Scotland—Proprietor & Manufacturer.

A salinometer. This instrument is represented in the following cut (next page).

The apparatus is placed outside the boiler, a pipe from which, A, communicates with the branch on the brine-receiver, B, which is cast in brass, with a solid closed bottom, but open at the top, to receive a slightly convex lid, which is bolted upon it. In this receiver is contained the hollow salinometer float, C, which is also of cast brass, with a solid top, the bottom being fitted in and made tight by a separate disc screwed on. In the centre of the top and bottom of the float are light vertical rods, the ends of which carry the disc piston-valves, D, D, fitted to work accurately in the upper and lower cylinders, E, E, like pistons. The upper cylinder is cast in one piece with the cover of the brine-receiver, into which it opens, to receive the upper piston-valve of the float. The lower cylinder is screwed into the centre of the bottom of the receiver, on which there is a short collar formed to receive it. It projects for a short distance into the receiver, and forms a rest for the float, when the latter is in its lowest position, as shown in the cut. Both cylinders have a series of ports, F, disposed in a ring near the upper ends of each;

and it is by these ports that the brine escapes when the valves are open, passing along in the direction of the arrows, by the upper and lower copper branch pipes, G, G, to the main discharge pipe, H. A small spindle, I, passes up from the upper valve, to carry the adjusting weights, as well as to act as the salinometer index, by projecting into a glass index tube, L, carried upon the top of the small chest, which is screwed on to, and covers, the upper cylinder, M.

684 HARNETT, JOHN, 45 Museum Street, Bloomsbury—Manufacturer.

Instruments and materials used by dentists.

Specimens of mineral teeth.

Natural specimens showing the growth of the teeth.

684A MACPHERSON, DANIEL, 7 Salisbury Street, Edinburgh—Inventor and Manufacturer.

A weighing-machine, to be used in the same way as the common balance, the levers on either side of the fulcrum being of equal lengths.



with the teeth.  
instrument secures  
is simple in its  
space than the

assisting in the  
measuring the com-  
the chest, by Dr.  
ital for Consump-  
ant instruments.

Russell Street,  
ufacturers.

h newly-invented  
ing check action,  
te is represented

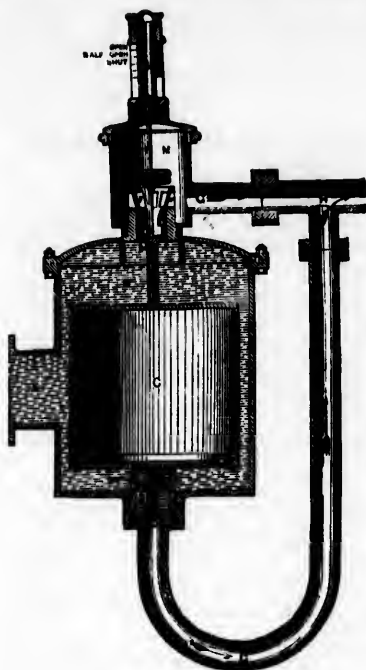

SCALE OF INCHES  
Mudie's Sallinometer.

685 COOK & WILLIAMS, 10 Princes Street, Hanover Square—Inventors and Manufacturers.

Respiratory organ and chest protectors. Registered.

No. 1. For ladies.—Can be raised or lowered at pleasure. In the former case, adjusting itself by an elastic hold over the mouth and nose as required; and in the latter case, assuming the form of a neck-ruff. It is fastened by ribbons drawn from behind and tied in a bow in front.

No. 1. For gentlemen.—Is of a stock configuration and adjustment, and is put on over the ordinary cravat, unless made to answer the double purpose of in and out of door wear.

No. 2. For gentlemen. Is of simpler and lighter construction, but effecting a similar purpose. A curtain, shaped to the configuration of the parts covered, is sustained over and to the mouth and nose as required, by an elastic cord, which passes over the head, resting upon the ears.

No. 3. For clergymen.

These instruments are useful in severe weather, or under sudden transitions of temperature, as affording comfort and protection against colds, and affections of the throat and lungs; enabling those suffering from these affections, or from tooth-ache, to take out-of-door exercise without injury from atmospheric influences, and with certain benefits of convenience and health.

686 MARSHALL & COMPANY, 4 Park Side, Hyde Park Corner—Inventors and Manufacturers.

“Corset a tous ressorts.” An invisible sling for paralysis of leg and foot, with belt. An invention of improved means of supporting and sustaining various parts of the human body.

687 WHITE, JOHN, 228 Piccadilly—Manufacturer.

Trusses and lacing stockings with muc-main patent lever truss.

687A GALL, JAMES, Myrtle Bank, Edinburgh—Inventor.

Gall's triangular alphabet for the blind, which, by its similarity to the common Roman alphabet, is easily read by the eye, and may be taught without previous instruction. This alphabet is considered as an improvement on circular alphabets, by its angular form; the letters are rendered more distinct to the touch; and by the exclusion of the capitals, the attention of the blind is concentrated upon 26, instead of 52 letters, and the size of the printing may be reduced.

Volume, containing the Epistle to the Ephesians, printed for the blind, in Gall's triangular alphabet, with the letters serrated.

Gall's apparatus for writing by and to the blind. The blind can, by this invention, readily correspond by post, and can keep books and other memoranda. The apparatus consists of a stuffed frame on which the paper is placed; of a cover with bars to guide the lines, which are written from the bottom upwards; and of small stamps, with the letters formed of common pins, which are pricked through the paper and read on the opposite side. By means of the two register points on each side of the frame, and by shifting the cover one half line up, the paper is written on both sides, each perfectly legible either by the fingers or the eye.

688 NASMYTH, J., Manchester—Inventor.

Map of the moon: exhibiting the relative positions and character of the most striking features of its surface, as they appear when seen under the most favourable circumstances in respect to light and shade, with drawings from nature of certain portions of the lunar surface, as seen by the aid of a very powerful telescope.

[The number and magnitude of crater-formed mountains with which every portion of the moon's surface appears to be covered, seems to lead to the conclusion that these are really the orators of extinct lunar volcanoes; the frequent occurrence of the central cone being considered as the result of the last eruptive efforts of an expiring volcano, a feature of volcanic craters on the earth's surface. This central cone has been shown to exist in the majority of the lunar craters; and the conclusion consequently appears probable, that they are the result of the same kind of action which has produced them on the volcanoes of the earth.]

The cause of the vast numbers of such volcanic mountains with which the lunar surface is covered has been assigned by some to the rapid consolidation and contraction of the crust of the moon; whose mass or bulk being only 1-64th of that of the earth, while its surface is the 1-16th, has, in consequence of these proportions, a radiating or heat-disposing surface four times greater than that of the earth in relation to its bulk. From this consideration it has been suggested by the exhibitor that, by the rapid cooling and collapse of the crust of the moon on its molten interior, the fluid matter under the solid crust has been by this action forced to find an escape through the superincumbent solid crust, and come forth in those vast volcanic actions which in some remote period of time have covered its surface with the myriads of craters and volcanic features that give to its surface its remarkable character.

The vast magnitude of the lunar craters, it has also been suggested, are due to this rapid collapse of the moon's crust on its molten interior,—the action as regards the wide dispersion of the ejected matter being enhanced by the lightness of the erupted matter, seeing that the force of gravity which gives the quality of weight

scapes when the  
direction of the  
anch pipes, G, G,  
spindle, I, passes  
justing weights,  
x, by projecting  
the top of the  
and covers, the

Bloomsbury—

tists.

of the teeth.

Street, Edinburgh

er.

same way as the  
of the fulcrum

to matter on the moon, as on the earth, is less on the surface of the moon than on the earth,—so that the collapse action had to operate on a very light material.

The causes of those vast ranges of mountains seen on the moon's surface has been suggested to be produced by the continued progress of the collapse action of the solid crust of the moon crushing down or following the contracting molten interior, which, by the gradual dispersion of its heat, would retreat from contact with the interior of the solid crust, and permit the crust to crush down and so force a portion of the original surface out of the way, and in consequence of this action, cause such to assume the form and arrangement of mountain ranges. In illustration of this important action, the familiar case of the wrinkling of the surface of an apple, by reason of the contraction of the interior and the inability of the surface to accommodate itself to the change otherwise, has been adduced.

The origin or cause of those bright lines which radiate from certain volcanic centres on the moon's surface (Tycho, for instance) has been illustrated by the experiment of causing the surface of a globe of glass filled with water to collapse on the fluid interior, by rapidly contracting the surface while the water had no means of escape. The result was the splitting or cracking up of the surface of the globe in a multitude of radiating cracks, which bear the most remarkable similarity to those on the moon. This subject is also illustrated by reference to the manner in which the surface of a frozen pond may be made to crack by pressure from underneath—so yielding radiating cracks from the centre of divergence where the chief discharge of water will take place, while simultaneously all along the lines of radiating cracks the water will make its appearance:—thus explaining how it is that the molten material, which had in like manner been under the surface of the moon during that period of its history, appears to have come forth simultaneously through the cracks, and appeared on the surface as basaltic or igneous overflow, irrespective of surface inequalities.]

689 OXLEY, W., *Manchester*—Manufacturer.  
Smith's patent steam indicator and water indicator.

689A DUNN, T. *Edinburgh*—Inventor.  
Electro-magnetic machine.

690 GORE, G., 31 *New St. Birmingham*—Inventor.  
Medical galvanic apparatus.

691 HUGHES, J., *Queen St., Ratcliffe*—Manufacturer.  
Compass.

693 PERIGAL, H., jun—Inventor.  
Lunarian.

696 LOOT, —, Manufacturer.  
A galvanometer, with the names Brett and Little, patentees, engraved on the dial.

697 WALKER, JOHN, 48 *Princes Street, Leicester Square*—Manufacturer.

Drawing-room clock, from a design by Mr. C. Grant; with subjects in panels embossed by Mr. G. Abbott. The case of the clock, which is electrotyped, consists of a base and a pedestal of turquoise blue glass, surmounted by figures indicating the progress made in the civilisation of this island. This is illustrated by seven subjects revolving at the base: the savage life of ancient Britons—the Roman governor introducing agriculture—the encouragement given to Flemish weavers to settle in the island—

introduction of printing by Caxton—the improvement of the steam-engine by James Watt—the opening of the first railway at Liverpool—and the movement which led to the Great Exhibition. The clock shows the hours and minutes on an open dial, supported by appropriate figures. The signs of the zodiac are made to represent the months, and seven subjects, embossed in silver, facsimiles of those in the pedestal, have been grouped so as to be seen at one view. The accompanying plate represents this clock.

698 TROTMAN, S., *Notting Hill*—Inventor.

Night clock. A lamp is suspended upon a lever, the light from which is thrown upon each hour as it arrives.

700 VULLIANT, B. L., 68 *Pall Mall*—Inventor.

Model of a peculiar method of suspending the pendulum of a large turret clock.

Model of a method not generally known of suspending a pendulum. Supposed to have been only twice reduced to practice; firstly, in the case of a clock the property of Her Majesty, and now at Osborne; secondly, in the great clock at the Post Office. The suspension of a pendulum upon the bases of four isosceles triangles is probably the best denomination for this method of suspension.

This model is made to a scale of six inches to a foot. It was proposed in this clock to employ a two-seconds pendulum, which is preferable to any other for a large clock. In the model, the length of the pendulum is regulated by the height of the stand from the floor.

The principal pieces forming this suspension are the following:—A base upon which the support rests; four supports connected together two and two; eight steel bearings; and the beam to which the pendulum is attached.

As the following description must necessarily be very brief, an attempt is made, first, to describe the construction, and then to point out a few of its advantages.

The apex of the triangles is the centre of motion; this, for the convenience of construction, is made continuous in reference to the two triangles on the same side, of which the centres of motion are in practice very small cylinders, answering the purpose of pivots, prolonged from the one to the other. The reverse ends of the four supports, though very short, are the bases of the triangles, which, when placed in their proper situation relative to each other (which is done by means of the two counter-weights), form the four supports upon which the pendulum rests. The pendulum is itself immediately suspended from a beam, the underside of which terminates in a small cylinder, which in a similar manner, as in the case of the triangles, answers the purpose of two pivots. The pivots of the triangles work in sinks instead of holes, in four pieces of steel made perfectly hard, which pieces of steel are kept in their places by the pressure of the supports. The bearings upon which these four pieces rest are arcs of circles which, should any inaccuracies occur in the execution of the work, secure for the pivots a full bearing upon the four pieces. The tops of the supports (upon which the four pieces of steel are, in which the pivots of the beam rest) are in like manner, and with the same intention, made arcs of circles; the four pieces that rest upon them are also loose pieces made of steel and perfectly hard. By this arrangement, all inconvenience from any inaccuracy in the construction is obviated, and a full bearing given to the pivots of the beam. There is an arm attached to and projecting from the base of each of the supports, terminated by a weight. These weights act as counter-weights, to retain the supports in their proper position. The weights move upon screws, for the greater convenience of regulating their distance from the centre of motion.

The action of the parts will now be very easily explained. The pendulum being set in motion, the pivots of the beam, and the bases of the triangles upon which they bear, roll together, the friction being removed to the

Improvement of  
opening of the  
movement which led  
shows the hours  
by appropriate  
made to represent  
ed in silver, fac-  
been grouped so  
aying plate repre-

ventor.  
upon a lever, the  
hour as it arrives.

Inventor.  
inding the pendu-

n of suspending  
y twice reduced  
ok the property  
econdly, in the  
ension of a pen-  
triangles is pro-  
thod of suspen-

nches to a foot.  
y a two-seconds  
ther for a large  
ndulum is regu-  
floor.

ension are the  
port rests; four  
two; eight steel  
e pendulum is

ecessarily be very  
e the construc-  
vantages.

f motion; this,  
e continuous in  
side, of which  
small cylinders,  
i from the one  
four supports,  
angles, which,  
relative to each  
two counter-  
ich the pendu-  
mediately sus-  
ich terminates  
ner, as in the  
of two pivots.  
stead of holes,  
hich pieces of  
e of the sup-  
ur pieces rest  
acies occur in  
pivots a full  
the supports  
ich the pivots  
with the same  
eces that rest  
eel and per-  
venience from  
d, and a full

There is an  
se of each of  
ese weights  
orts in their  
rews, for the  
nce from the

y easily ex-  
), the pivots  
upon which  
moved to the



pivo  
ene  
pre  
pol  
whi  
bee

A  
mod  
roll  
ove  
roll  
the  
the  
fol  
be  
dis  
wh  
the  
wh  
is  
mu

I  
and  
by  
rev  
ben  
fro  
bel  
me  
du  
wh  
up  
vil  
the  
vil  
du  
em  
so  
vi  
wo  
an  
de  
pr  
ra  
au  
to  
w  
no  
sh  
It  
li  
t  
th  
v

o  
e  
w  
t  
s  
h

pivots of the triangles; but the quantity of motion is so exceedingly small that it would be very difficult to express it by a decimal fraction: it is just perceptible at the points of the arms which carry the counter-weights, and which are of the same length as the supports of the beam.

At first sight, this suspension might be considered as a modification of the well-known application of friction-rollers as supports, to a pendulum; to which mode, however, it bears no resemblance. In the case of the friction-roller, though the motion is alternately both ways, still the wheels ultimately revolve, which sufficiently proves that the motion backwards and forwards is not equal: it follows that the total circumference of the wheels must be of the same material; and as yet, no material has been discovered of sufficient hardness to make friction-rollers, when employed to support heavy weights, or which in practice did not become indented and then wear into hollows: when this commonness they cease to be rollers, and friction is speedily engendered to a degree that renders them much worse than useless.

In this suspension, the case is quite different in principle and execution. The triangles which form the supports by which the pendulum is carried have no tendency to revolve, because the places where the pivots of the beam bear (which are geometrical lines at the shortest distance from the centre of the pivots) and the eight bearings, being detached pieces, afford the convenience of being made of steel, and being perfectly hard. When the pendulum is set in motion, two of the supports ascend while two descend, moving an equal quantity each way up and down, those that ascend when the pendulum vibrates in one direction, descending when it vibrates in the other: their motion, expressed by the angle they vibrate, is determined by the arc of vibration of the pendulum. It must be specially noticed that the practical effect of this motion is to raise the beam, and consequently the pendulum, and the longer the arc of vibration, the more it is raised; but the quantity raised would with a long arc of vibration be so exceedingly small that it would be difficult to express it by a decimal fraction, consequently it is not attended with any practical inconvenience. That the pendulum must be raised is evident from the circumstance, that a line supposed to be drawn from the centre of the lower pivot to the termination of the geometrical line on the base, on which the pivot bears when the pendulum is at rest, is necessarily, from the principle of this suspension, the shortest that can be drawn between these two points. It follows that whichever way the supports move, that line must be lengthened, because the sides of an isosceles triangle, however short the base, are necessarily longer than a line that bisects into equal angles, the angle at the vertex or apex of the triangle.

There are many advantages attendant upon this mode of suspension, the principal of which may be briefly enumerated as follows:—

The power of dispensing with the pendulum spring, which renders any compensation for change of temperature in reference to the alterations in the strength of the spring caused by alteration of temperature, unnecessary, and enables a very heavy bob to be carried by a very light rod.

The omission of the crutch, by which the friction of two pivots and other inconveniences are avoided.

The facility afforded to employ a much heavier bob than can safely be suspended by a spring.

The power of giving a pendulum, with a bob of a given weight, a certain arc of vibration with much less maintaining power than would be required to produce the same arc of vibration from a similar pendulum hung by a spring; a circumstance which necessarily reduces the wear and tear of the machine.

The power of determining the exact length of the pendulum hung by a spring.

The avoidance of the whole train of evils which result from the breaking of the suspension spring, an accident which does sometimes occur, and never without great detriment to the machine.

702 EDGE, THOMAS, *Great Peter Street, Westminster*—Manufacturer.

Photometer; to ascertain the illuminating power of gas as compared with any other description of light; it is compact and portable, the disc is fixed at a certain distance from the standard light. Diagram to show the instrument in use.

[It is difficult to determine with accuracy the comparative intensity of light. If we suppose the quantity of light falling on a body to be the same as would have fallen on the place occupied by its shadow, it follows that the intensity of light decreases as the square of the distance increases, and therefore the denseness of the shadow of an interposing body becomes a means of determining the comparative intensities of light; for, if they appear of unequal density, it is sufficient to move the luminous bodies to those distances till the densities of the shadows be equal; then the intensities of the light or luminous bodies will be to each other as the squares of their respective distances from the interposing body.]

Instruments for the purpose of determining the intensity of one light with another; of one strong light with several smaller lights; the comparative intensities of the light of the moon, and of that of a candle; the light of the heavens by night and by day, &c., have been invented at different times.—J. G.]

703 LIPSCOMB & Co., 233 Strand—Manufacturers.  
Two patent pneumatic fountains.

704 TUDSBURY, R., *Edwinston*—Inventor.  
A "volta subito" turn-over desk and stand.

705 BROOKS, GEORGE, *St. Albans, Herts*—Proprietor.  
"Clavic attachment," for facilitating the performance on the violin, violoncello, and double bass, and enabling the student to play with correct intonation.

706 TOOTAL & BROWN, 73 Piccadilly—Manufacturers.  
Pianoforte.

707 DEARLOVE, M. W., *Leeds*—Manufacturer.  
Miniature model of an Antonius Stradivarius' violin and a miniature double-bass.

708 BARTON, H. W., *The Waterfoot Pettigo, Ireland*—Inventor.  
Military sketching compass.

709 BELOE, W. LINTON, *Cokistream*—Producer.  
Copy of Antonius Stradivarius' violin.

710 MOYLE, SAMUEL, *Dowico House, Truro*—Producer.  
Model of a floating breakwater.  
Mountain barometer, on an improved plan, for measuring heights by boiling water.

711 BIERMANN, AUGUSTUS, *Camden Street, Golden Turn*—Producer and Manufacturer.  
Geographical illustrations, consisting chiefly of physical and statistical maps of the world.  
Specimens in manuscript, drawn with the pen and brush, and comprising plans and maps to show the physical configuration of certain countries.  
Specimens engraved on metal (steel and copper). The various shadings and tints produced partly by machinery, partly by aqua-tint; this latter method is very rarely employed for mapping, on account of certain difficulties in the combination of the shading with the outline and writing; when successful, it produces effects correcter and finer than other methods.  
Specimens engraved on stone. The process of engraving maps and plans on stone is very little used in



this country, although it possesses considerable advantages over drawing them on stone, or engraving them on metal.

712 CLAPHAM, JOHN KIRKLEY, 6 *Briggate, Leeds*—Proprietor.

A county map of the United States of America, from a steel plate, on Goodyear's gum elastic.

713 BROWN, JOSEPH, 71 *Leadenhall Street*—Inventor and Manufacturer.  
Aerial machine.

714 MASON, EDWARD, *Brompton Post Office*—Inventor and Manufacturer.

A model of a navigable balloon, which works by sails, helm, and mariner's compass. Scale  $\frac{1}{2}$  inch to a foot.

715 BELL, HUGH, *Baltic Wharf, Millbank*—Inventor and Manufacturer.

Model of a "locomotive balloon." The steering apparatus has the motions of a bird's tail; the car is so arranged with buoyant apparatus at the ends, as to be a life boat in case of a descent being made into the sea, and the balloon and machinery may be stowed away in it. Improved valve for a balloon.

Model arrangement for a "locomotive parachute," equipped for service.

716 PLUMMER, H. LORENZO, 112 *Powis Street, Woolwich, Kent*—Inventor.

Working model of an aerial machine, with wings, which is put in motion by a clock-spring.

717 WATT, G. T., 2 *William Street, Albert Gate, Hyde Park*—Inventor.

Dentistry: consisting of specimens of artificial palates, models of the mouth and jaw, and sets of teeth of various construction, of hippopotamus tusk, porcelain, &c.

718 DINDALE, CUTBERT, *Newcastle*—Manufacturer and Inventor.

Model of artificial gums, composed of incorrodible material, showing a metallic artificial alveolar process. Patented in England, Scotland, and France. Wax models of the human head. Model of a dissected human head. Series of wax models, showing the different stages of incubation in the egg of the barn-door fowl.

[The mysterious changes which occur in the egg on the application of the stimulus of heat, and the progress of the germ up to its perfect condition, have long attracted the attention of physiologists.—R. E.]

719 ROSE, J. E., 68 *Mount Pleasant, Liverpool*—Manufacturer.

Artificial teeth, with models of the mouth.

720 TRUMAN, E., 40A *Haymarket*—Inventor.

Patent artificial teeth, with gutta-percha gums. Set of mineral teeth, mounted in gutta-percha.

Small case, intended to illustrate a further application of the principle.

Specimens of pure gutta-percha, such as used in the preceding articles, before the colouring process.

721 HARRINGTON, G., 84 *St. Thomas Street, Portsmouth*—Inventor and Patentee.

New description of patent artificial teeth.

Model teeth for taking the mould and dimensions of the required set.

Gauge for adjusting the set, and machinery for pressing tortoiseshell for the bed and palate.

722 LAWRENCE & Co., *Islington Place, Park Road, Islington*—Manufacturers.

Patent improved horse-hair flesh gloves and straps, for friction of the skin. Gloves and straps for use in the bath, not injured by wet. Flesh brushes of a new design, with hat, cloth, velvet, and horse brushes.

723 BOSSINGHAM, B., *Wisbeck*—Inventor.  
Artificial leg.

724 GRAY, PETER, 47 *Hanover Street, Edinburgh*—Inventor.

Model of an invalid bed, made by Thomas Sturrock, 1 Duke-street, Leith.

725 KENNEDY, EVORRY, M.D., *Merrion Square, Dublin*—Inventor.

Siphon, adapted to green-house or garden watering. The principle is the substitution of an elastic caoutchouc chamber, for the suction pump to procure exhaustion, the water being directed in its course by double ball and socket valves. The pressure of the hand or carriage handle expels the water, and its own elasticity procures the exhaustion. The siphon has a sustained or continuous action, by means of an external exhausted air-chamber.

Siphon adapted to medical purposes, as a substitute for the pumps at present in use for throwing fluids into internal cavities. The exhaustion is produced by the elasticity of the India-rubber bag itself, the fluid being propelled by the pressure of one hand leaving the other free to guide the instrument; the material is not acted upon by the usual chemical agents.

726 SELTZER, SOPHIA, 7 *Upper Ranelagh Street, Pimlico*—Inventor.

Chair for spinal curvature.

727 HIGHLEY, SAMUEL, 32 *Fleet Street*—Producer.

An anatomical statuette, height, 27 inches, exhibiting the external muscles of the human figure; carefully modelled, and expressly adapted for the use of artists, and others interested in the study of anatomy; accompanied by a key, containing outline views of the statuette in its several aspects, with references to the names of the muscles.

727A TITTERTON—Inventor.

Instrument for slaughtering cattle.

728 LANAGAN, FRANCIS, 12 *Brownlow Street, Bedford Row*.  
Apparatus, and shoes for the cure of bunions.

729 EWART, GEORGE, 19 *Quicket Row, New Road, Regent's Park*—Manufacturer.

Zinc spirometers, for ascertaining the capacity of the lungs; zinc mouldings for the decoration of buildings, internal and external; and samples of manufactured zinc.

[The spirometer is an instrument invented in order to determine the capacity of the human lungs. Its principle is extremely simple. It is merely an inverted zinc cylinder, balanced by a weight, and rising and falling within another outer case containing water: it has, consequently, a close resemblance to a gas-holder. The extremity of a tube leading into the inner cylinder is applied to the mouth of the individual, who is directed to expel the air from the chest as far as it is possible to do so. The inner cylinder rises, carrying with it a measured scale, on which the cubic capacity of the lungs is easily read off. When this scale indicates an unusual departure from an ascertained average, disease is generally found to exist.—R. E.]

730 RITTERBRANDT, DR. L. A., 7 *Northumberland Street, Strand*—Inventor.

Galvanic bath. The principle of this bath is simple; it consists of a vessel constructed of two different metals, separated by a non-metallic substance which not merely fulfils the purpose of an ordinary bath, but at the same time acts as a perfect battery.

The metals employed are zinc and copper, the latter being plated with silver. This combination, however, is not the only one that may be employed. Any other two

Inventor.  
Edinburgh—

Thomas Sturrock,  
Dublin

garden watering.  
elastic caoutchouc  
procure exhaustion,  
by double ball  
hand or carriage  
elasticity pro-  
has a sustained or  
external exhausted

es, as a substitute  
throwing fluids into  
produced by the  
elf, the fluid being  
d leaving the other  
aterial is not acted

elagh Street,

—Producer.  
inches, exhibiting  
figure; carefully  
the use of artists,  
anatomy; accom-  
of the statuette  
to the names of the

Street, Bedford Row,  
bunions.

New Road,  
rrier.

the capacity of the  
tion of buildings,  
manufactured zinc.

vented in order to  
lungs. Its prin-  
y an inverted zinc  
rising and falling

ater: it has, con-  
holder. The ex-  
r cylinder is ap-  
ho is directed to

is possible to do  
with it a measured

the lungs is easily  
usual departure  
generally found to

umberland Street,

bath is simple;  
different metals,  
which not merely  
but at the same

opper, the latter  
ion, however, is  
Any other two

metals differing in their electrical relations—that is, positive and negative to each other—will afford in a more or less degree the same result; as, for example, zinc and iron, iron and copper, &c.

This bath is a simple apparatus for causing a current of electricity to pass through the body of the bather. The fluid employed is common water. By connecting the wires attached to the two metals a strong current of electricity will be made to pass through the body of the bather, which will be attested by the deflection of the needle of the galvanometer attached to the bath. If, instead of cold water, warm water be employed, the deflection of the needle will increase in proportion to the temperature of the water. If a small quantity of common salt, or any soluble salt be added, or sea or mineral spring water employed, the current of electricity will still further increase; notwithstanding which, however, it will pass so mildly and imperceptibly through the body as to obviate any unpleasant sensation.

In cases where it is necessary to make use of electricity of greater intensity than that producible by the bath, this may be effected by combining it with one or more cells of an ordinary battery, so as constitute one compound battery. Where it is necessary to pass shocks through the body of the patient it can be effected, in the bath, in several ways:—1. By closing two of the caps of a single coil with a wire, and connecting the other two by wires attached to the bath. 2. By connecting one or more cells of a battery with the caps of a primary coil, and connecting the two ends of the secondary coil with the wires of the bath; care being taken that the direction of the current from the coil coincides with that of the bath. 3. By using a single coil, connecting two of its caps with a battery, and the two others with the two wires of the bath—viz., the positive wire of the coil with the negative wire of the bath, or with the wire attached to the zinc, and *vice versa*. In this manner the patient will receive shocks from the electricity of the coil, while his body will be affected by the electricity from the bath.

732 BADCOCK, JOHN, Brighton—Producer.

Photographic specimens of vaccine, produced by inoculating the cow with small-pox, showing the character of the vesicles in their different stages. The specimens, furnished by Mr. Constable of Brighton, show the genuine vaccine vesicle and its characteristic areola as described by Dr. Jenner.

[The production of vaccine virus is a subject of much importance. The exhibitor states that he has proved the efficiency of virus thus obtained, and suggests that by proceeding in the manner described, a supply of virus may be procured without the loss of time caused by sending, in some instances, many thousand miles for vaccine.—R. E.]

733 HAMILTON, HENRY G., R.N. 71 Eccleston Square—Producer.

Collection of ancient Greek coins electrotyped by the exhibitor.

734 BLACKWELL, WM., 3 Bedford Court, Covent Garden—Inventor.

Apparatus for fractures, trusses, and surgical instruments.

735 BRYCESON, HENRY, 5 Tottenham Court New Road, St. Pancras—Manufacturer.

Powerful church barrel organ of superior construction in a gothic case.

736 GOWING, J. W., Camden Town—Inventor.

Instruments for operating on the teeth of horses. Apparatus for fractures, &c. Neurotomy knife, and scissors for dividing nerves.

737 WOOD, J. W., Manchester—Inventor.

Trusses. Support for curvature of the spine and surgical instruments.

740 TAYLER, G. R., Sunderland—Inventor.

Geographical clock. (South East Corner, United States Department.)

741 SIMMS, WILLIAM (surviving partner in the firm of TROUGHTON and SIMMS), 138, Fleet Street—Inventor and Manufacturer.

An equatorial instrument, adapted for the latitude of 25°, and mounted generally after the method of Frauenhofer; it is furnished with a clock-work motion, so that the telescope moves so as to counteract the effect of the earth's rotation; the diameter of the object-glass is four inches and nine-tenths of an inch, and its focal length is about 7 feet.

The declination axis is open and exposed between its two supports; its ends are cylindrical, and admit of the application of a spirit-level, by this means the adjustment of the instrument is facilitated, and it is readily brought to the meridian, and thus, observations of transits over the meridian can be made sufficiently near for identifying an object.

The illumination of the telescope is regulated by the application of the throttle valve of a steam-engine, and is as effective as the more elaborate methods hitherto in use.

A best spider line position micrometer, of which extensive use has been made in measurements of the relative position and distance of binary stars. The position circle is divided to one minute of arc, and the reading is by means of opposite verniers upon the edge of the circular plate to which the micrometer is fixed; the value of the micrometrical divisions, however, depend on the focal length of the telescope with which this instrument is employed.

An annular micrometer, and a set of negative eye-pieces are shown with this instrument.

An equatorial instrument adapted for the latitude of London, on the same principle as the preceding, but without clock motion. It has been arranged as an inexpensive, but at the same time an effective instrument. The diameter of the object-glass is 3½ inches, and its focal length is about 45 inches; it is provided with a spider line position micrometer of the second order, in which one screw motion only is given.

The whole is supported upon an iron column with suitable arrangements for its final adjustments.

[An equatorial instrument consists of a telescope fixed to a graduated circle called the declination circle, and of a polar axis, to which is fixed a circle called the hour circle. When the instrument is adjusted the polar axis is parallel to the axis of the earth, and perpendicular to the plane of the hour circle, and to the axis of the declination circle, &c. In its use, the declination circle can be turned about the polar axis, and the telescope can be directed so as to be inclined at all angles to the earth's axis, and by the means of these two motions, the telescope can be directed to any point in the heavens, and if a clock-work motion be applied, an object when viewed through the telescope seems to be without motion, affording the opportunity of examining it minutely.—J. G.]

The altitude and azimuth instrument, known as the "Westbury Circle," so called from the valuable observations made with it at Westbury by John Pond, Esq., the late Astronomer Royal, by which a change of figure in the great mural quadrant at the Royal Observatory was clearly demonstrated.

This instrument was made originally by the late E. Troughton, and subsequently repaired and re-divided by the exhibitor. The re-division was effected by the process invented by Troughton, and described by him in the Philosophical Transactions for 1809.

The diameter of the altitude circle is 30 inches, and of the azimuth 24 inches. The spaces upon the respective circles measure five minutes of arc, which are subdivided to single seconds by two opposite micrometer microscopes. Five revolutions of the micrometer screw being, by the optical arrangement, made to measure five minutes of arc upon the circle; the 60th part of a revolution of the

micrometer screw is, therefore, equal to one second of arc. The positions of the azimuthal micrometers are unalterable; those of the altitude circle are fixed to the extremities of an arm which is moveable upon a centre, an arrangement which admits of their positions being altered relatively to the zero of the circle, and hence the readings obtained upon particular objects are changed in every new series of observations. Such errors as are due to the graduation are by these means much diminished if not entirely eliminated. The axes are adjusted by means of spirit-levels, in addition to which the instrument is furnished with a plumb-line apparatus.

A portable altitude and azimuth instrument: each circle is 15 inches in diameter, graduated upon bands of silver to five minutes of arc, upon Mr. Simms' new self-acting dividing engine. There are two micrometer microscopes to each circle showing single seconds of arc. The microscopes have achromatic object-glasses. This instrument is furnished with the nadir point apparatus, or central collimator, the invention of the exhibitor, which consists of a telescope in the interior azimuthal axis, around which the superior parts of the instrument revolve. The spider lines, in the form of an acute cross upon the diaphragm of this central collimator, being placed in the principal forms of its object-glass, can be seen in the telescope of the instrument when it is directed downwards, or towards the Nadir; and their intersecting point serves as an object to which every observation made with the instrument can be referred, and therefore supersedes the use of an artificial horizon, or other extraneous means having the same object in view. The transit collimation can also be adjusted by its means, without reference to any external object, and it supplies the place of the riding level for the transit axis, in the event of its being broken.

A transit circle, 2 feet diameter, with two reading micrometer microscopes having achromatic object-glasses; the divisions upon the circle are sub-divided to single seconds by the micrometers. This circle was also graduated upon the self-acting dividing engine invented by the exhibitor, as were also the circles of the altazimuth and the transit circle lately made for the Royal Observatory at Greenwich.

The telescope is achromatic and has an aperture of  $3\frac{1}{4}$  inches, and a focal length of about 46 inches. The apparatus by which the field of view is illuminated is the invention of the exhibitor, and has been adapted to the great transit circle at the Royal Observatory. The field of view and the wires interchange the conditions of light and darkness; hence, if the object be a bright one, the field of view can be illuminated, and the wires appear as dark lines upon it; but if the object be a faint one, the field can be made dark, and the wires luminous. This change is brought about instantaneously by either drawing outward or pressing inward a small cylindrical plug placed conveniently for the observer.

The illumination of the divisions upon the circle is effected by the same lamp which illuminates the field of the telescope, as follows:—

A prism adjoining the microscope object-glass receives the light from a lens in the side of the lantern, which is condensed upon the graduated face of the circle as a disc of light, which just covers the extent of the field of the micrometer microscope, and is so arranged that a normal to the face of the circle bisects the angle formed by the incident and reflected rays.

The instrument is supported upon wooden models of the stone piers upon which it will be ultimately fixed; and the whole may be taken as a representative of the class of instrument which is now rising in the estimation of British astronomers.

A transit instrument  $3\frac{1}{2}$  feet focal length, and  $2\frac{1}{2}$  inches aperture, with two setting circles upon the telescope tube, axis level, micrometer in the eye-piece, &c., as is usual in the most perfect instruments of this class; but as this instrument has been made for the coast survey of the United States, now being carried on under the direction of Professor A. D. Bache, and is intended for observations both in the meridian and prime vertical, the exhibitor has introduced two additional parts to fit it the

better for its work. Firstly, a reversing frame by which the telescope can be lifted from the Y's, turned end for end and again lowered into its bearings without being subjected to any handling, or other operation by which the parts may be unequally expanded and the adjustments deranged; the operation is safe and expeditious. Secondly, both the pivots are perforated, in one of which a diaphragm with cross lines and an eye piece is fitted, and in the other an object-glass of suitable focal length is fixed, and hence the axis becomes a telescope. Now, if this telescope be directed to any object, such as the cross lines of a collimator or any terrestrial mark that presents itself, or is set up at a considerable distance from the instrument, and the axis be made to revolve, the form of the pivots may be thereby examined, or (which in the instrument exhibited, is its primary purpose) this telescope may be used for turning the principal telescope  $90^\circ$ ; that is to say, for changing its meridional to a prime vertical position, or the reverse.

This instrument is supported upon a cast-iron stand.

[The transit instrument consists of a telescope placed in the meridian. It is fixed to two arms, the extremities of which are turned into two equal cylindrical pivots, which turn in Y's on the top of two piers, placed east and west of the centre of the telescope. The centres of the pivots, or their axes are in the same straight line, which is called the axis of the instrument. In order to observe the instant that a celestial object passes the meridian, there is placed in the telescope, at the focus of the object glass, a system of fine cobweb wires perpendicular to the horizon, and one placed horizontal. At the instant an observation is made, the star's image coincides with the intersection of these wires. An arrangement of this kind is absolutely necessary, as the field of view of the telescope is not a mere point.

The transit instrument is used in connexion with an astronomical clock, adjusted to sidereal time. A clock so adjusted that it completes a circuit in a sidereal day, and indicates 0h. 0m. 0s., when the first point of Aries is on the meridian, and having its dial-plate divided into 24 equal spaces; hence, when the transit instrument is adjusted, and the clock goes correctly, at the instant the first point of Aries is on the meridian, the time shown by the clock is 0h.; when this point is  $15^\circ$  or  $30^\circ$  west of the meridian, the time shown by the clock is 1h. or 2h. respectively, and so on.—J. G.]

A diagonal transit instrument, in which the means of illuminating the field of view is new in this class of instrument, and is the invention of the exhibitor.

The mode hitherto adopted has been the placing of a reflecting surface in front of the object-glass, and receiving light upon this plate from a lamp or candle placed in a distant part of the observatory. The objections to this mode are, the difficulty of throwing light upon the reflector at all, under such circumstances; besides, for every observation, a new arrangement of the light has to be made; and further, by the reflector being placed in front of the object-glass, part of its light is lost off.

In the instrument exhibited, the light passes through the axis, and this is effected by placing a lens, of which a very large segment, nearly an annulus, projects beyond the edge of the diagonal reflector within the axis. The light, passing through a small lens fixed in one of the pivots in the usual way, diverges upon the open segment of the interior lens, and is thereby converged to the opposite pivot, where the diaphragm is placed.

An isometrical elliptograph invented by the Astronomer Royal, G. B. Airy, Esq., by which ellipses in isometrical perspective can be drawn with great facility and accuracy. The exhibitor is the manufacturer.

Three Imperial standard yards, made for Her Majesty's Commissioners for the restoration of the Standard of Weights and Measures, with the supports invented by Professor Miller and the Rev. R. Sheepshanks.

ing frame by which  
s, turned end for  
ags without being  
operation by which  
f and the adjust-  
and expeditious.  
d, in one of which  
ye piece is fitted,  
table focal length  
telescope. Now,  
bject, such as the  
estrial mark that  
siderable distance  
ade to revolve, the  
ined, or (which in  
urpose) this tele-  
pical telescope 90°;  
lional to a prime

cast-iron stand.  
telescope placed  
s, the extremities  
ylindrical pivots,  
rs, placed east and  
he centres of the  
raight line, which  
n order to observe  
es the meridian,  
ocus of the object  
pendicular to the  
At the instant an  
incides with the  
ment of this kind  
w of the telescope

onnexion with an  
l time. A clock  
in a sidereal day,  
t point of Aries is  
e divided into 24  
instrument is ad-  
t the instant the  
he time shown by  
or 30° west of the  
clock is 1h. or 2h.

ich the means of  
this class of in-  
hibitor.

n the placing of a  
glass, and receiv-  
candle placed in  
objections to this  
ght upon the re-  
besides, for every  
light has to be  
g placed in front  
t off.

t passes through  
a lens, of which a  
projects beyond  
n the axis. The  
nd in one of the  
he open segment  
verged to the op-  
ced.

y the Astronomer  
ses in isometrical  
ity and accuracy.

for Her Majesty's  
the Standard of  
orts invented by  
anks.

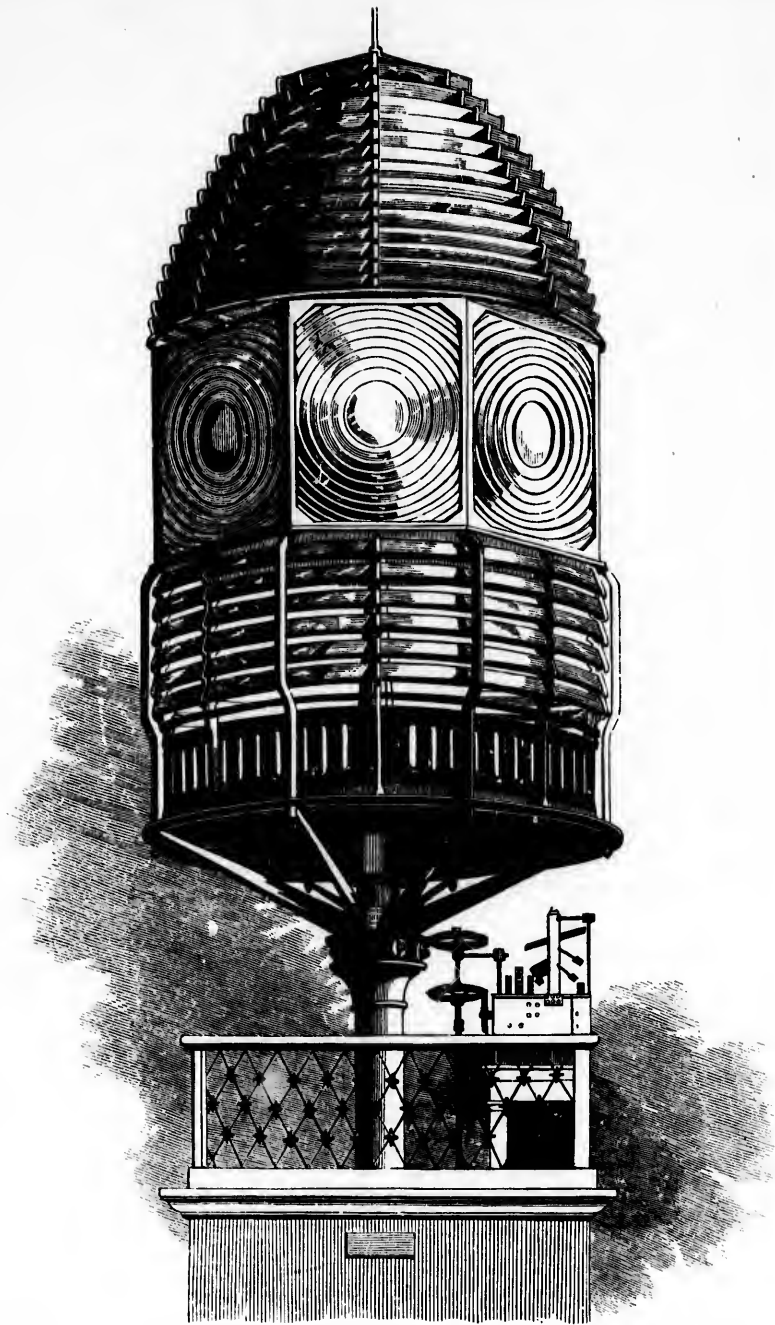



The bars, which are one inch square, are an alloy of copper with tin and zinc, the proportions of each constituent is engraved upon the bar, and these proportions were determined by the late F. Baily, Esq., after very careful experiments.

The planes upon which the divisions are cut, showing the standard yard, are at the bottom of cylindrical holes, and in the neutral axis of the bar. The divisions are upon pins of gold, and their situation is well calculated to defend them from everything but wilful injury.

Professor Miller's support consists of a system of levers by which an equal degree of support is given to eight equi-distant points in the bar.

Mr. Sheepshanks' support is simply a trough of mercury in which the bar floats, and is prevented from turning over by means of a stirrup in the middle of its length, with pivots resting in two V bearings. To this apparatus is added two of Mr. Sheepshanks' recently made thermometers.

A 5-foot standard bar, and the 5-foot tubular scale, No. 4, of the late F. Baily's Report, are the property of the exhibitor, and have been used in the formation and comparison of many existing standard scales, both for this and for foreign countries.

A Troughton's reflecting circle, of the usual kind, the circle being cast in one piece. This circle was arranged as an improvement to that by Borda, and substitutes the reading of six verniers in a complete observation, for the repetition of the angle as practised with the older instrument.

A Troughton's sextant, having the advantage of lightness and strength in its construction.

A transit theodolite in which the ordinary vertical arc is extended to a complete circle, and is read by opposite verniers. The range of the telescope is unlimited, like that of a transit instrument, and by means of a diagonal eye-piece observations can be made even in the zenith.

The axis of the telescope is perforated, and the field is illuminated by a lamp attached to one of the supports, it is, in fact, an altitude and azimuth instrument equally well-adapted for the surveyor and the scientific traveller.

Five achromatic object-glasses, one of 9 inches, two of 8 inches, one of 6 $\frac{1}{2}$  inches, and one of 4 inches, effective aperture, all worked by the exhibitor. The discs of glass in the first-mentioned being of English manufacture.

[A telescope furnished with an achromatic object glass is termed an achromatic telescope. The distance of the point from the object-glass, where the image of an object is formed, is called the focal length of the telescope. The magnifying power of a telescope depends upon the following considerations,—if it be directed to the sun or moon, and a piece of transparent paper be held in its focus, an image of the object will be formed upon the paper. Now the size of an object depends upon the angle under which it is seen, and the image formed upon the paper will subtend exactly the same angle when moved to that distance from the eye which is equal to the focal length of the telescope, as the object itself, when viewed with the naked eye, or in other words, if held at such a distance from the eye as the focal length of the telescope, it will exactly cover the object itself. Suppose this distance be seven feet, we can with unobstructed vision view an object at the distance of six inches; if then we view the image at this distance it will appear fourteen times larger than the object it represents. By the application of another lens near the eye, termed the eye-glass, the image can be seen distinctly at a very much less distance, in fact, it can be viewed at the distance which is equal to the focal length of the eye-glass; and suppose this to be half-an-inch, then the image will appear twelve times larger than it did to the unassisted eye, and, therefore, fourteen multiplied by twelve, or one hundred and sixty-eight, would be the magnifying power of the telescope. Hence the rule for finding the magnifying power of a

telescope is to divide the focal length of the object-glass by the focal length of the eye-glass, and the quotient will give the magnifying power.—J. G.]

(Main Avenue West.)

CHANCE (BROTHERS) & Co., Glass Works, near Birmingham—Manufacturers.

Dioptric apparatus of the first order, for lighthouses, with revolving lenses and catadioptric zones; constructed according to the system of Fresnel. The upper and lower parts consist of a series of prismatic rings, each of which reflects at the internal surface of its base, the incident rays of light. The middle portion is refractive, and produces by its revolutions a succession of flashes or blazes of light, for the purpose of enabling the mariner to distinguish any particular lighthouse. This revolving part consists of eight annular lenses. Each of these great lenses is composed of a number of concentric rings round a central lens, so as to produce all the refractive effect of a single solid lens of corresponding dimensions, but with less loss of light. This apparatus is represented in the accompanying Plate 77.

(Main Avenue West.)

ELECTRIC TELEGRAPH COMPANY, Office, South Entrance to the Exhibition Building—Proprietors.

Electric Telegraphs.

1. Original five-needle telegraph invented by Cooke and Wheatstone in 1837, and worked on the Great Western Railway.
2. First complete telegraph for intermediate stations requiring four wires and a return circuit. Cooke and Wheatstone's patent of 1838.
3. Two-needle portable telegraph. Intended to be carried by guards of trains and attached at any required part of the line to the telegraphic wires, thus opening an immediate communication between the spot of an accident and the stations on the line. Cooke and Wheatstone's patent of 1838.
4. Ordinary two-needle telegraph of the construction now in use throughout the whole of England. Constructed under Cooke and Wheatstone's patents of 1837, 1838 and 1845.
5. Two-needle telegraph of the most recent form; constructed under the same patents as the last, but with modifications and improvements of parts.
6. Ordinary single-needle telegraph, used for small and second-rate stations. Constructed under the patents of 1837, 1838, and 1845.
7. Portable galvanometer, or detector used for tracing out faults on the lines. Patent of 1837.
8. Portable single-needle telegraph to be carried by guards of trains. The dial arranged in a sloping position to facilitate the reading of the signals. Patent of 1845.

Electro-magnetic Alarums.

1. Electro-magnetic alarm: patented in 1847 by Cooke and Wheatstone. In this alarm the magnet operated directly to impel the hammer against the bell. A secondary battery was brought into action to excite the magnet.
2. Electro-magnetic alarm of 1837; the magnet only operating to release the striking machinery.
3. Electro-magnetic alarm of 1838. The striking machinery released by the deflection of a magnetic needle.
4. Small decomposition apparatus. This apparatus, or an ordinary magnetic needle, was used to bring into operation a secondary battery at the station where the signal was to be received.
5. Electro-magnetic alarm. The magnet excited by the direct current transmitted, and not by a secondary battery. Patents of 1837 and 1840.
6. Large alarm used for signalling at the entrances of tunnels at railway stations and other places where a loud sound may be required. Cooke and Wheatstone's patents of 1837 and 1845.

7. Another form of the same alarm.
8. Plan proposed by G. Little for sounding a bell by the self-action of an electro-magnet.

*Disc Telegraphs.*

1. Disc telegraph: the signals given by the step-by-step rotation, and pausing of a disc bearing letters or figures. The rotation produced by the action of an electro-magnet. Wheatstone and Cooke's patent of 1840.
2. Disc telegraph: the letters or figures pointed out by the rotation and pausing of an index or hand operating by electro-magnetic action. Patent of 1840.
3. Disc telegraph: similar to No. 1, except that signals are given by numbers.
4. Modification of the disc telegraph proposed by Nott.
5. Disc telegraph: the communicator, or signal-giving apparatus being conjoined to the instrument.
6. Modification of the disc telegraph arranged for a counter, or register of any successive movements or actions, such as persons passing through a door or gate, strokes made by a steam-engine, fly or other press, &c.
7. Magneto-electric communicator for the disc telegraphs: no battery is required, a permanent magnet furnishing a constant series of induced currents by the rotation of an armature and coils over its poles. Wheatstone's patent of 1841.
8. Second form of the magneto-electric communicator, adapted to work disc telegraph, giving signals by numbers.

*Double Index Disc Telegraphs.*

1. Double index disc telegraph: the two hands move independently, so that one may be set to give any required permanent signal, while conversation is carried on by the other. This instrument was arranged for working the atmospheric machinery on the South Devon Railway. It requires one wire only. Hatcher's patent of 1847.
2. Double index disc telegraph. The two hands revolve step by step in opposite directions. They would therefore indicate exactly at all stations on a single line the progressive movement and approach of two trains running in opposite directions. Patent of 1847.
3. Single index disc telegraph. The index can be made to rotate in either direction, so that the speed of signalling would be increased by the facility with which any position could be given to the index by a few movements. Patent of 1847.

*Printing Telegraphs.*

1. Elective magnet printing telegraph. The signals are printed in ordinary type, according to the first arrangement of Wheatstone in 1841. The current when sent in one direction moves the type wheel to the required position, and when reversed brings into operation the printing machinery. Hatcher's patent of 1847.
2. Second form of the elective magnet printing telegraph. Patent of 1847.
3. Third form of the elective magnet printing telegraph: the signals being printed not in type but in combinations of dots or points.
4. Type printing telegraph: the type wheel, after each signal is printed, is released from the machinery and regains its zero or quiescent position at one bound, thereby increasing the correctness of the operation by making

each signal wholly independent of the correctness or incorrectness of the preceding one. Barlow and Forster's patent of 1846.

5. Chemical printing telegraph: signals given by dots or spots arranged in two lines. The marks produced by the chemical action of the current on a prepared paper. Alexander Bain's patent of 1846.

6. Chemical printing telegraph: signals given by dots and lines combined in various ways. Bain's patent of 1846.

*Magneto-electric Machines.*

1. Magneto-electric machine. Currents induced by the permanent magnet can be sent in one direction by this machine. It is used for the sounding of alarms. No battery is required. Wheatstone's patent of 1841.
2. Magneto-electric machine for sending currents in either direction at pleasure. Used for working the double index telegraphs. Hatcher's patent of 1847.
3. Induced current machine: an inducing battery of small power is used with this form of machine. It sends currents in either direction like the last. It was used for working the double index telegraphs on the South Devon line. Patent of 1847.
4. Second form of induced current machine: arranged for working with the code of signals in use by the Admiralty. Patent of 1847.

*Galvanometers.*

1. Indicator or galvanometer in which the magnetic needle is replaced by a magnetised steel disc. Mapple's patent of 1847.
  2. Simple current director for causing the current to ring either of two bells or to actuate either of two instruments.
  3. Simple current director for ringing either of two bells as for an office.
  4. Current director, for causing the current to sound either of three bells, or actuate either of three instruments.
  5. Current director or switch for a line of telegraph with two wires to any one of three other lines of similar telegraph. Switches of this kind are extensively used in England.
  6. Punch or stamp used for cutting out in paper the signals or combinations of dots and lines to be transmitted by Bain's chemical telegraph. Bain's patent of 1846.
  7. Stick or rule of type used with Bain's printing telegraph.
- A series of insulators of various forms constructed under Cooke and Wheatstone's, Ricardo and Clark's, and Mapple's patents.

750 TRACY, W. M., 13 Hill Street, Berkeley Square.  
Bullet extractor.

751 AIRY, THOS., 67 Dale Street, Liverpool—  
Manufacturer.

Newly-invented sunk centre seconds watches. This invention admits of the seconds hand beating dead. Two seconds hands may be applied—one from the centre, and the other in the usual place.



**INSTRUMENTS.**

the correctness or in-  
Barlow and Forster's

signals given by dots  
marks produced by  
on a prepared paper.

signals given by dots  
s. Bain's patent of

ments induced by the  
one direction by this  
ing of alarms. No  
patent of 1841.

ending currents in  
working the double  
of 1847.

inducing battery of  
f machine. It sends  
at. It was used for  
on the South Devon

t machine: arranged  
in use by the Admi-

which the magnetic  
steel disc. Mapple's

using the current to  
e either of two in-

ing either of two

the current to sound  
of three instruments.

a line of telegraph  
other lines of similar  
extensively used in

ing out in paper the  
lines to be trans-  
Bain's patent of

with Bain's printing

as constructed under  
Clark's, and Mapple's

Berkeley Square.

Liverpool—

de watches. This  
beating dead. Two  
from the centre, and

**EXHIBITION**

**Official Illustrated Catalogue Advertiser.**

[For Classified Contents of the Advertiser see last Page.]



**WILLIAM S. BURTON'S GENERAL FURNISHING IRONMONGERY WAREHOUSE,**  
39 Oxford st. (corner of Newman st.), Nos. 1 and 2 Newman st., and Perry's Place, London.

**THE PERFECT SUBSTITUTE FOR SILVER.**

The REAL NICKEL SILVER, introduced 16 years ago by WILLIAM S. BURTON, when PLATED by the patent process of Messrs. Elkington and Co., is beyond all comparison the very best article next to sterling silver that can be employed as such, either usefully or ornamentally, as by no possible text can it be distinguished from real silver.

|                       | FIDDLER | THREAD | KING'S |
|-----------------------|---------|--------|--------|
| Tea Spoons, per dozen | 15s.    | 22s.   | 30s.   |
| Desert Forks "        | 30s.    | 44s.   | 58s.   |
| Desert Spoons "       | 30s.    | 44s.   | 58s.   |
| Table Forks "         | 40s.    | 54s.   | 70s.   |
| Table Spoons "        | 40s.    | 54s.   | 70s.   |

Tea and coffee sets, waiters, candlesticks, &c., at proportionate prices. All kinds of re-plating done by the patent process.

**CHEMICALLY PURE NICKEL, NOT PLATED.**

|                                              | FIDDLER | THREAD | KING'S |
|----------------------------------------------|---------|--------|--------|
| Table Spoons and Forks, full size, per dozen | 12s.    | 22s.   | 30s.   |
| Desert ditto and ditto                       | 10s.    | 21s.   | 25s.   |
| Tea ditto                                    | 6s.     | 11s.   | 12s.   |

**ALL THE NEW SHOWER BATHS.**

Portable Shower Bath, with curtains, from 7s. each; Pillar Shower Baths, with copper conducting tubes, brass force-pump and top, complete, with curtains, and japanned, from 60s.; Hand Shower Baths, japanned, 3s.

**IRON BEDSTEADS AND CHILDREN'S COOTS.**

A very large assortment of these Bedsteads in Iron and Brass, from 16s. 6d. each, and Cots from 20s. each, fitted with dove-tail joints and patent packing, and entirely free from screws, nuts, or pins.

The new Patent Portable Bedstead, 15s. 6d. each. Common Iron Bedsteads at 12s. 6d. each. Bedding of every description.

**LAMPS OF ALL SORTS AND PATTERNS.**

The largest as well as choicest assortment of PALMER'S MAGNUM and other CANDLESTICKS, CAMPHINE, ARGAND, and SOLAR LAMPS, with all the latest improvements, and of the newest and most recherché patterns, in ornolu, Bohemian and plain glass, or papier maché, in existence, is always on sale, at prices ranging from 6d. to 6 guineas.

Detailed Catalogues, with Engravings, as well as of every Ironmongery article, sent per post free. WILLIAM S. BURTON'S Stock of General Furnishing Ironmongery is literally the largest in the world; and as no language can be employed to give a correct idea of its variety and extent, Purchasers are invited to call and inspect it.

THE MONEY RETURNED FOR EVERY ARTICLE NOT APPROVED OF.

39 Oxford Street (corner of Newman Street), Nos. 1 and 2 Newman street, and Perry's Place, London.

ESTABLISHED (IN WELLS STREET) A.D. 1820.

**FENDERS, STOVES, AND FIRE-IRONS.**

Bright stoves with bronzed ornaments and two sets of bars, £2 14s.; ditto with ornolu ornaments and two sets of bars, £5 10s. to 20 guineas; bronzed fenders complete, with standards, from 7s. to £6; steel fenders, from 55s.; ditto with rich ornolu ornaments, from £2 15s. to 10 guineas; fire-irons, from 1s. 9d. the set to £4 4s. Sylvester and other Patent Stoves, with radiating hearth plates.

**PAPIER-MACHÉ AND IRON TEA-TRAYS.**

An assortment of Tea-Trays and Waiters wholly unprecedented, whether as to extent, variety, or novelty.

|                                                   |                              |
|---------------------------------------------------|------------------------------|
| Gothic-shape Papier-maché Trays, per set of three | from 90s. 6d. to 10 guineas. |
| Ditto from ditto                                  | from 15s. 6d. to 4 guineas.  |
| Convex shape, ditto                               | from 7s.                     |

**CUTLERY, WARRANTED.**

Three inches and a half ivory-handled table knives, with high shoulders, 10s. per dozen; dessert, to match, 9s.; if to balance, 1s. per dozen extra; larger sizes, in exact proportion, to 25s. per dozen; if extra fine, with silver ferrules, from 30s.; white bone table knives, 6s. per dozen; dessert, 4s.; black wood-handled knives and forks, 6s. per dozen; carvers, from 2s. per pair; table steels, from 1s. each. The largest stock of plated dessert knives and forks, in cases and otherwise, and of the now plated fish carvers, in existence. Also, a large assortment of RAZORS, PENKNIVES, SCISSORS, &c., of the best quality.

**DISH COVERS AND HOT-WATER DISHES,**

In every material, in great variety, and of the newest and most recherché patterns. Tin Dish Covers, 6s. the set of six; Black Tin, 11s. 6d. to 25s. the set of six; elegant modern patterns, 22s. to 53s. the set; Britannia Metal, with or without silver plated handles, 68s. to 102s. the set; Sheffield plated, £10 to £16 10s. the set; Black Tin Hot-Water Dishes, with wells for gravy, 11s. to 25s.; Britannia Metal, 18s. 6d. to 73s.; Sheffield plated, full size, £9 10s.

**THIRD SEPTENNIAL BONUS.**

**CROWN  
LIFE ASSURANCE COMPANY,**

33, NEW BRIDGE-STREET, BLACKFRIARS, LONDON.

**DIRECTORS.**

GEORGE H. HOOPER, ESQ., Chairman.  
SIR JOHN KIRKLAND, Deputy-Chairman.

JOHN CHAPMAN, ESQ.  
CHARLES CHIPPINDALE, ESQ.  
JAMES COLQUHOUN, ESQ., LL.D.  
B. D. COLVIN, ESQ.  
REAR-ADMIRAL DUNDAS, C.B., M.P.  
W. H. GÖSCHEN, ESQ.

GEORGE HANKEY, ESQ.  
THOMAS HARRISON, ESQ.  
JOHN NELSON, ESQ.  
OCTAVIUS OMMANNEY, ESQ.  
ALEXANDER STEWART, ESQ.  
WILLIAM WHITMORE, ESQ.

WILLIAM WILSON, ESQ.

**AUDITORS.**

J. C. H. COLQUHOUN, ESQ.      J. R. GARDINER, ESQ.      WALKER PITCAIRN, ESQ.

PHYSICIAN . . . . . SIR C. F. FORBES, M.D., K.C.H., 23, Argyll-street.  
SURGEON . . . . . JOHN SIMON, ESQ., F.R.S., 3, Lancaster-place, Strand.  
STANDING COUNSEL . . . . CHARLES ELLIS, ESQ.  
SOLICITORS . . . . . MESSRS. HALE, BOYS, and AUSTEN.  
BANKERS . . . . . BANK OF ENGLAND.  
ACTUARY . . . . . J. M. RAINBOW, ESQ.

On a **THIRD SEPTENNIAL INVESTIGATION** into the affairs of this Company, to the 25th March, 1846, a **BONUS**, amounting on the average to 31 per cent. on the Premiums paid for the preceding Seven Years, was assigned to all Policies of at least Three Years' standing, and effected for the whole duration of life.

To similar Policies the following **BONUSES** were declared at former Divisions, viz. :—

**FIRST DIVISION, in 1832.** On the average, upwards of 26 per cent. on the Premiums paid.

**SECOND DIVISION, in 1839.** On the average, 33 per cent. on the Premiums paid for the preceding Seven Years.

The true principles on which Life Assurance ought to proceed have been maintained by this Company, and are comprised,

**IN PERFECT SECURITY** to the assured.

**A RATE OF PREMIUM** graduated fairly to the risk at every age.

**A DIVISION OF THE SURPLUS** of the Company periodically to the Assured, strictly proportioned to their interest therein.

**A FAIR AND LIBERAL PERMISSION** to the Assured to proceed to all parts of the world, on due notice, and the payment of a premium equitably adjusted to the risk incurred.

**GENERAL FACILITIES** for the taking out, renewal, or purchase of Policies, the honourable settlement of Claims, and an exemption from all charges or deductions except for Government Stamps.

The accumulated Capital of the Company actually invested exceeds **£650,000.**

The Bonuses already allotted to the Assured exceed **£210,000.**

The Prospectus, Tables of Rates, &c., to be had at the Office in London, or of the Company's Agents.

# UNITED KINGDOM LIFE ASSURANCE COMPANY,

8, WATERLOO PLACE, PALL MALL, LONDON.



Capital.....£1,000,000.

ANNUAL INCOME UPWARDS OF £100,000, ARISING FROM THE ISSUE OF ABOVE 7000 POLICIES.

**TRUSTEES.**

Chas. Graham, Esq., F.S.A. F. C. Maitland, Esq.  
Charles Downes, Esq. E. Lennox Boyd, Esq., F.S.A.

**PRESIDENTS.**

Earl of Courtown Lord Viscount Falkland  
Earl Leven and Melville Lord Elphinstone  
Earl of Northbury Lord Belhaven and Stenton  
Earl of Stair William Campbell, Esq., of Tillichewan  
Earl Somers

**LONDON BOARD.**

Charles Graham, Esq., F.S.A., Chairman  
Chas Downes, Esq., Dep.-Chairman  
H. Blair Avarne, Esq.  
Edw. Lennox Boyd, Esq., F.S.A., Resident  
Chas. Berwick Curtis, Esq.

William Fairlie, Esq.  
D. G. Henriques, Esq.  
J. G. Henriques, Esq.  
F. Chas. Maitland, Esq.  
William Raitton, Esq.  
F. Hale Thomson, Esq.  
Thomas Thorby, Esq.

*Bankers*—The Bank of England; Messrs. Cocks, Biddulph, & Co.; and the Union Bank of London.  
*Surgeon*—F. H. Thomson, Esq.  
*Actuary*—John King, Esq.

**EDINBURGH BOARD.**

Adam Black, Esq. J. T. Gordon, Esq., Sheriff of  
Sir Alexander Gibson Maitland, Edinburghshire  
Hart. Jas. Hunt, Esq., of Pittenweir,  
C. H. Craigie Inglis, Esq. Moray-place  
Agent—F. H. Fraser, Esq., 51, George-street.  
*Medical Officers*—Alexander Gillespie, Esq., M.D.;  
James D. Gillespie, Esq., M.D.  
*Law Agents*—Messrs. J. & W. R. Kermack.

**GLASGOW BOARD.**

Robert Salmond, Esq., Banker, James Robertson, Esq., Banker,  
Glasgow Glasgow  
J. Bain, Esq., of Merriston William Connal, jun., Esq., Merch-  
Wm. Stirling, jun., Esq., Kenmore chant, Glasgow  
Agent—A. B. Seton, Esq., 19, St. Vincent-place.  
*Medical Officer*—Joseph Bell, Esq., Surgeon.  
*Solicitor*—A. Reid, Esq., 78, St. Vincent-place.  
*Secretaries*—Messrs. Tatham, Upton, Johnson, & Co.  
*Secretary*—Patrick Macintyre, Esq.

This Company was established in 1834, by a Special Act of Parliament, and affords the most perfect security in its large paid-up Capital, held by a large, numerous, and wealthy Proprietary.

The Tables have been formed on the lowest scale compatible with security, and constructed to meet the various wants of Assurers, and every risk to which protection by Assurance can be extended.

**EXTRACT OF TABLE OF RATES.**

| Age | Without Profit. | £1 18 10 | With Profit. | £1 18 8 per Cent. |
|-----|-----------------|----------|--------------|-------------------|
| 30  | 3 3 10          |          | 3 3 2        | ditto             |
| 40  | 3 19 1          |          | 3 3 4        | ditto             |

Premiums may be paid in almost any way to meet the convenience of the Public.

One-half the Annual Premium need only be paid for the first five years, the other being allowed to remain at five per cent. interest, thus affording parties desirous of effecting **SHORT TERM POLICIES** the advantage of having a **LIFE POLICY** at a scarcely increased outlay.

Parties insured with this Company are not restricted in their limits of travel, as in most other Offices, but may proceed from one part of Europe to another, in decked vessels, without licence, and to British North America, and many parts of the States, without extra Premium, by merely giving the ordinary notice of the intended visit.

Whole World Life Policies are granted at slightly increased Rates of Premium, thus rendering a Policy in Money Transactions a real Security.

Parties desirous to Participate in the forthcoming Bonus should lose no time in applying for immediate information to the Resident Director, Waterloo-place, London, or to the following Agents:—

Paris . . . . C. HARTWIG, Esq., 18, Rue Vivienne  
Brussels . . MESSRS. SALTER and BLOWD  
Amsterdam . JAMES ANNESLEY, Esq., H.B.M.C.  
Rotterdam . SIR J. H. TURNO, Bart., H.B.M.C.  
Malta . . . . GEORGE DALZIEL, Esq.  
Oporto . . . . DR. RUMSEY (Medical Referee)

New York . . . W. C. MATTLAND, Esq.  
Halifax, N.S. . A. G. FRAZER, Esq.  
St. John, N.B. . A. BALLOCH, Esq.  
Montreal . . . MESSRS. EDMONSTONE and ALLEN  
Quebec . . . . PETER SHEPPARD, Esq.  
Naples . . . . DR. COX (Medical Referee).

Besides Agents in every important Town in England, Scotland, and Ireland.



ANNUAL DIVISION OF PROFITS AND LARGE REDUCTION OF PREMIUMS.

# HAND-IN-HAND

## FIRE AND LIFE INSURANCE SOCIETY,

1, NEW BRIDGE-STREET, BLACKFRIARS, LONDON.

Instituted in 1696; extended to Life Insurance 1836.

*Immediate, Deferred, and Survivorship Annuities granted.*

**DIRECTORS.**

The Hon. WILLIAM ASHLEY.  
The Hon. Sir EDWARD CURT.  
JOHN LETTOM ELLIOT, Esq.  
JAMES ESDAILE, Esq.

HARVIN M. FARQUHAR, Esq.  
JOHN GURNEY HOARE, Esq.  
E. FULLER MATTLAND, Esq.  
The Hon. CHARLES JOHN MURRAY.

WILLIAM SCOTT, Esq.  
JOHN SPERLING, Esq.  
HENRY WILSON, Esq.  
ROBERT WINTER, Esq.

**AUDITORS.**

The Hon. Colonel CURT.

THOMAS FULLER MATTLAND, Esq.

JAMES ESDAILE, Esq.

Bankers—Messrs. GOSLINGS and SHARPE, 19, Fleet-street.

Physician—THOMAS K. CHAMBERS, M.D., 1, Hill-street, Berkeley-square.

Solicitors—Messrs. LUMLEY, NICHOLL, and SMYTH, 18, Carey-street.

Actuary—JAMES M. TERRY, Esq.

Secretary—ROBERT STEVEN, Esq.

### FIRE DEPARTMENT.

Although the lowest rates of premium, consistent with security, have been charged by the office, it has for many years been enabled to make very large returns to septennial insurers.

### LIFE DEPARTMENT.

The important advantages offered by the plan and constitution of the Life Department of this Society are—

That insurers are protected by a large invested capital upon which there is no interest to pay, and for which no deduction of any kind is made, which enables the Directors to give the whole of the profits to insuring members.

That the profits are divided annually amongst all members of five years' standing, and applied towards reducing life insurance to the lowest possible rates of premium.

The following table exhibits the abatement of premium that has been made for the past nine years to members of five years' standing:—

| Years of Division. | Rate of Abatement. | Years of Division. | Rate of Abatement. |
|--------------------|--------------------|--------------------|--------------------|
| 1842               | £45 per cent.      | 1847               | £60 per cent.      |
| 1843               | 45 „ „             | 1848               | 50 „ „             |
| 1844               | 45 „ „             | 1849               | 52½ „ „            |
| 1845               | 50 „ „             | 1850               | 52½ „ „            |
| 1846               | 50 „ „             |                    |                    |

A policy taken out on or before the 24th of June, 1845, at an annual premium of £100, will consequently be charged £47. 10s. as this year's premium; and it is expected that an equal abatement will in future be annually made.

That persons insuring their own lives, or the lives of others, may become members.

That persons who are willing to forego participation in the profits can insure at a lower rate than that charged to members.

The following table will show the effect of the reduction of premium made by the Society on members' policies that have been five years in force:—

| Age when Insured. | Sum Insured. | Annual Premium for first Five Years. | Reduced Premium.  |
|-------------------|--------------|--------------------------------------|-------------------|
| 30                | £ 100        | £. s. d.<br>2 13 5                   | £. s. d.<br>1 5 6 |
| 40                | 100          | 3 7 11                               | 1 12 3            |
| 30                | 500          | 13 7 1                               | 6 7 0             |
| 40                | 500          | 16 19 7                              | 8 1 3             |
| 45                | 1,000        | 38 19 2                              | 18 10 1           |
| 40                | 2,000        | 67 18 4                              | 32 5 2            |
| 45                | 5,000        | 194 15 10                            | 92 10 6           |

This system of reducing the premiums affords immediate benefit to the members, or enables them to insure a further sum upon their lives equal to more than one-third of the present policy, without any additional outlay.

[145]

ROBERT STEVEN, Secretary.

# LONDON ASSURANCE CORPORATION,

Established by Royal Charter, in the Reign of King George the First, A.D. 1700.

HEAD OFFICE, No. 7, ROYAL EXCHANGE, CORNHILL;

BRANCH OFFICE, No. 10, REGENT-STREET.

WILLIAM KING, Esq., Governor.

ROBERT COTESWORTH, Esq., Sub-Governor.

EDWARD BURMESTER, Esq., Deputy-Governor.

### DIRECTORS.

ROBERT ALLEN, Esq.  
JOHN ALVES ARBUTHNOT, Esq.  
RICHARD BAGGALLAY, Esq.  
GEORGE BANZA, Esq.  
HENRY BONHAM BAZ, Esq.  
HENRY BLANSHARD, Esq.  
JOHN WATSON BORRADALE, Esq.  
CHARLES CRAWLEY, Esq.

WILLIAM DALLAS, Esq.  
ROBERT DONNER, jun., Esq.  
JAMES DOWIE, Esq.  
JOHN FURSE, Esq.  
SAMUEL GREGSON, Esq.  
DAVID CHARLES GUTHRIE, Esq.  
JOHN ALEXANDER HANKEY, Esq.  
EDWARD HARNAGE, Esq.

CHARLES KERR, Esq.  
CHARLES LYALL, Esq.  
JOHN ORD, Esq.  
GEORGE PROBYN, Esq.  
PATRICK FRANCIS ROBERTSON, Esq.  
ALEXANDER TROTTER, Esq.  
THOMAS WEDDING, Esq.  
LESTOCK PEACH WILSON, Esq.

Secretary—JOHN LAURENCE, Esq.

Manager of the Marine Department—TIMOTHY GREATED, Esq. | Superintendent of the Fire Office—JOSEPH SPARKES, Esq.

Underwriter—JOHN ANTHONY RUCKER, Esq. | Actuary—PETER HARDY, Esq., F.R.S.

Superintendent of Branch Office—ABEL PEYTON PHELPS, Esq.

Physician—GEORGE BUDD, Esq., M.D., F.R.S., 20, Dover-street, Piccadilly.

Surgeon—THOMAS CALLAWAY, Esq., 7, Wellington-st., Southwark.

Solicitors—JOHN COVENDALE, Esq., 4, Bedford-row; Messrs. TATHAM, UPTON, JOHNSON, and Co., 20, Austin-friars.

Bankers—THE BANK OF ENGLAND; Messrs. WELLS and Co.

### LIFE DEPARTMENT.

THIS CORPORATION has effected Assurances on Lives for a PERIOD OF ONE HUNDRED AND THIRTY YEARS; their first policy having been issued on the 7th June, 1721, to William, Lord Bishop of Sarum.

Two-thirds of the entire gross profits are appropriated to the Assured,—the CORPORATION retaining the remaining one-third, out of which they PAY THE WHOLE EXPENSES OF MANAGEMENT; thus affording to the public advantages equivalent to those derived from Mutual Assurance, WITHOUT LIABILITY OF PARTNERSHIP, and with ALL THE SECURITY afforded by AN OLD AND OPULENT CORPORATION. Policies may be opened under any of the three following plans, viz. —

The Old Series, under which Assurers are admitted at very moderate Rates of Premium, without participation in Profits.

The Series 1831, under which Assurers are entitled, after the first Five Years, to an annual Abatement of Premium. The abatement at the last valuation was equivalent to a return of more than one-fourth of the Premium.

The Series 1846, under which Assurers are entitled to participate in the ascertained profits at the end of every five years, and to appropriate their share thereof, either as an immediate Cash Bonus, as an addition to the sum Assured, or it may be made a matter of special arrangement, and applied in any manner most convenient to the parties Assured. THE FIRST DIVISION under this Series took place on the 31st DECEMBER, 1850, and amounted, on an average, to A REVERSIONARY BONUS equivalent to about FIFTY-THREE PER CENT. upon the amount of Premiums paid.

TABLE showing the Actual CASH and REVERSIONARY BONUS added on the 31st December, 1850, to Policies effected in the Years 1846, 1847, 1848, 1849, and 1850:—

| Year. | Present Age. | Sum.  | Cash Bonus. | Reversionary Bonus. |
|-------|--------------|-------|-------------|---------------------|
| 1846  | 35           | 1,000 | £42 12 0    | £87 0 0             |
|       | 50           | 1,000 | 59 4 0      | 98 6 0              |
| 1847  | 35           | 1,000 | 35 0 0      | 71 10 0             |
|       | 50           | 1,000 | 47 18 0     | 79 10 0             |
| 1848  | 35           | 1,000 | 26 14 0     | 54 12 0             |
|       | 50           | 1,000 | 36 8 0      | 60 8 0              |
| 1849  | 35           | 1,000 | 18 8 0      | 37 12 0             |
|       | 50           | 1,000 | 24 0 0      | 39 12 0             |
| 1850  | 35           | 1,000 | 9 4 0       | 18 18 0             |
|       | 50           | 1,000 | 12 8 0      | 20 12 0             |

| PARTICIPATING.                                                             |          | NON-PARTICIPATING.                                                         |          |
|----------------------------------------------------------------------------|----------|----------------------------------------------------------------------------|----------|
| Annual Premiums for Assurance of £100 for the whole term of a Single Life. |          | Annual Premiums for Assurance of £100 for the whole term of a Single Life. |          |
| Age next Birthday.                                                         | Premium. | Age next Birthday.                                                         | Premium. |
| 20                                                                         | £2 0 2   | 20                                                                         | £1 15 11 |
| 25                                                                         | 2 5 0    | 25                                                                         | 2 0 8    |
| 30                                                                         | 2 10 8   | 30                                                                         | 2 5 11   |
| 35                                                                         | 2 17 0   | 35                                                                         | 2 12 1   |
| 40                                                                         | 3 5 1    | 40                                                                         | 3 0 0    |
| 45                                                                         | 3 15 10  | 45                                                                         | 3 10 10  |
| 50                                                                         | 4 10 7   | 50                                                                         | 4 5 7    |
| 55                                                                         | 5 9 11   | 55                                                                         | 5 3 4    |
| 60                                                                         | 6 12 5   | 60                                                                         | 6 5 11   |
| 65                                                                         | 8 4 11   | 65                                                                         | 7 16 9   |

### FIRE DEPARTMENT.

Fire Insurances may be effected at Moderate Rates upon every description of Property.

### MARINE DEPARTMENT.

Marine Insurances may be effected at the HEAD OFFICE of the Corporation. Policies for Sea Risks are also granted, claims on which are made payable in India and China, by the Corporation's Agents, at the following places:—Calcutta, Bombay, Madras, Canton, and Shanghai.

JOHN LAURENCE, Secretary.



## SCOTTISH WIDOWS' FUND LIFE ASSURANCE SOCIETY.

FOUNDED A.D. 1818.

ON THE PRINCIPLE OF MUTUAL CONTRIBUTION.

THIS Institution, notwithstanding its local name, has long been favourably known to all classes in Great Britain and Ireland, and a better proof of the confidence reposed in it by the public could not probably be wished, than the fact that the Average Amount of ASSURANCES effected during the last THIRTEEN YEARS has exceeded

**HALF A MILLION STERLING per Annum.**

Being a Mutual Assurance Society, the Members are the only parties in any way interested in the Funds; they are, in point of fact, their own insurers, and whatever is paid by way of Premium, over and above what is actually required for the risk of the Assurance, is appropriated for their behoof. This is done once in every period of Seven Years, when an Investigation into the affairs of the Society takes place, not less than one-third of the Profits, as then ascertained, being set aside as a Guarantee Fund to maintain the stability of the Institution, and the remaining two-thirds being immediately divided among the Assured—each member being entitled to elect whether he will have the value of his share handed over to him at once in cash, or have it applied as an addition to his Policy, or towards redemption of the future Annual Premiums.

As a proof of the working of this system it may be stated, that in the case of a Policy opened with this Society in the year 1819, and emerging in the present year (after payment of the Premium), the representatives of the Member would receive more than double the amount of the original Assurance.

THE CAPITAL OF THE SOCIETY, arising from the Accumulation of the Members' Premiums, amounts at this time to upwards of

**TWO MILLIONS AND A QUARTER STERLING.**

ANNUAL REVENUE, upwards of THREE HUNDRED THOUSAND POUNDS.

Every information can be readily obtained by application at the Society's Head Office, or at any of the Agencies.

JOHN MACKENZIE, Manager.

WILLIAM LINDSAY, Secretary.

HEAD OFFICE, 8, ST. ANDREW-SQUARE, EDINBURGH.

OFFICE IN LONDON, 4, ROYAL EXCHANGE BUILDINGS.—HUGH M'KEAN, Agent.

[139]

## EQUITY AND LAW LIFE ASSURANCE SOCIETY,

No. 26, LINCOLN'S-INN-FIELDS, LONDON,

AND

LAW SOCIETY'S ROOMS, MANCHESTER.

### TRUSTEES.

The Right Hon. Lord Monteaigle.  
The Right Hon. the Lord Chief Baron.  
The Hon. Mr. Justice Coleridge.  
The Right Hon. Lord Cranworth.  
The Hon. Mr. Justice Erie.  
Nassau W. Senior, Esq., Master in Chancery.  
C. P. Cooper, Esq., Q.C., LL.D., F.R.S.  
George Capron, Esq.

Policies do not become void by the Life Assured going beyond the prescribed limits, so far as regards the interest of third parties, provided they pay the additional Premium so soon as the fact comes to their knowledge.

"Free Policies" are issued, at a small increased rate of Premium, which remain in force, although the Life Assured may go to any part of the world.

The Tables are especially favourable to young and middle-aged Lives; and the limits allowed to the Assured, without extra charge, are unusually extensive.

Eighty per cent. of the Profits is divided at the end of every fifth year among the Assured.

At the First Division to the end of 1849, the addition to the amount assured averaged above 50 per cent. on the Premiums paid.

[159]

## THE CITY OF LONDON LIFE ASSURANCE SOCIETY,

FOR

ACCUMULATIVE AND GENERAL  
ASSURANCES.

## 2, ROYAL EXCHANGE BUILDINGS.

### Directors.

R. C. BACHE, Esq.  
W. BETTS, Esq.  
J. R. BENNETT, Esq., M.D.  
J. BLAKEWAY, Esq.  
C. COLLICK, Esq.  
G. M. DOWDESWELL, Esq.  
F. A. DURNFORD, Esq.  
R. KEATE, Esq., Serj.-Surg. to the Queen.  
S. H. LEE, Esq.  
JOHN POWIS, Esq.  
Lieut.-Colonel ROWLAND, R.A.  
W. SIMPSON, Esq.  
W. THACKER, Esq.  
W. A. THOMAS, Esq.  
F. WATTS, Esq., F.S.A.  
G. W. WOOD, Esq.

### Actuary.

G. S. FARRANCE, Esq., F.I.A.

Policies indisputable.

All the profits of the Mutual Branch divided amongst the Assured.

Every form of Assurance at equitable rates.

Policies granted from £20 applicable to all classes.

[187]

EDWARD F. LEEKS, A.I.A., Sec.

# BRITISH EMPIRE MUTUAL LIFE ASSURANCE COMPANY,

INCORPORATED BY ACT OF PARLIAMENT,

37, NEW BRIDGE-STREET, BLACKFRIARS, LONDON.

**DIRECTORS.**

BENNETT, C. Jun., Esq., Cophthall-court.  
BURNELL, Peter, Esq., Cheshunt.  
BURTON, John R., Esq., Dover-road.  
CANTWRIGHT, R., Esq., Chancery-lane.  
CUTHBERTSON, F., Esq., Aldergate-street.  
GARDINER, E. W., Esq., Princes-street, Cavendish-square.

GOVER, William, Esq., Highgate.  
GOVER, J., Esq., Cole-street North, Dover-road.  
GROSSER, W., Esq., Red Lion-street, Clerkenwell.  
LEWIS, G. C., Esq., Lowndes-terrace, Knightsbridge.  
MILLAR, R. J., Esq., Holland-grove, North Brixton.  
SANDERS, J., Esq., Sutherland-square, Waiworth.

**AUDITORS.**

BURON, Geo. W., Esq., Hackney-road.

PONTER, J. Long, Esq., Sloane-street.

**BANKERS.**

London and Westminster Bank, Lothbury.

**SURGEON.**

John MANN, Esq., Charterhouse-square.

**SOLICITORS.**

Messrs. WATSON & SONS, Bouverie-street, Fleet-street.

This Company is founded on purely mutual principles: there is no proprietary under any form to absorb any portion of the profits, which all belong to the Members at large, by whom also the Directors are appointed.

During the year 1850 the following new Policies were executed, in addition to the old business:—

|                           | No.           | Amount.            | Yearly.     |
|---------------------------|---------------|--------------------|-------------|
| Life Assurances . . . . . | 809 . . . . . | £136,365 . . . . . |             |
| Annuities . . . . .       | 14 . . . . .  |                    | £202        |
| Investments . . . . .     | 410 . . . . . | 27,964 . . . . .   |             |
| <b>Total . . . . .</b>    | <b>1233</b>   | <b>£164,329</b>    | <b>£202</b> |

There were advanced to the Members in the same period, on various descriptions of available security, 7220l.

This Company is adapted to meet all the varied wants of its Members. By its Life Policies provision may be made for the evils anticipated from the death of the party assured. By its Deferred Annuities a certain income may be secured when adequate years render labour less remunerative. By its Immediate Annuities a sum of money which now yields an inadequate support in the shape of interest may be rendered much more productive; while the Investment Assurances enable every one to make provision for the time of sickness or other calamity requiring pecuniary aid. The employment of the funds in advances to the Members places within their reach the means of enlarging their trade capital, or of making advantageous purchases as opportunities offer.

As there are many important towns in which Agents are not yet appointed, the Directors are open to receive applications from respectable persons in such places. If not already Members of the Company, they will be required to become so by effecting a life assurance.

Upon receipt of two postage stamps the Prospectus, with Forms, &c., will be forwarded, in which some important and novel applications of Life Assurance will be found.

January 15th, 1851.

W. S. GOVER, *Actuary and Secretary.*

FE SOCIETY.

ION.  
nesses in Great Britain and  
y be wished, than the fact  
exceeded

n the Funds; they are, in  
t is actually required for  
of Seven Years, when an  
then ascertained, being set  
thirds being immediately  
of his share handed over  
future Annual Premiums.  
d with this Society in the  
ves of the Member would  
remiums, amounts at this

ny of the Agencies.

nt. [1 139

LONDON  
SOCIETY,

ND GENERAL  
S.

E BUILDINGS.

q., M.D.

L., Esq.

g-Surg. to the Queen.

AND, R.A.

A.

q., F.I.A.

anch divided amongst

ble rates.

le to all classes.

EEKS, A.I.A., Sec.

# BRITISH EMPIRE

# MUTUAL FIRE ASSURANCE SOCIETY,

INCORPORATED BY ACT OF PARLIAMENT,

37, NEW BRIDGE-STREET, BLACKFRIARS, LONDON.

**DIRECTORS.**

BLYTE, John, Esq., Aldersgate-street.  
CANTWRIGHT, R., Esq., Chancery-lane.  
CUFF, J. H., Esq., Sutherland-square, Waiworth.  
CUTHBERTSON, F., Esq., Aldersgate-street.  
FREEMAN, G. S., Esq., Camberwell.

GOULD, G., Esq., Loughton, Essex.  
LOW, J., Esq., Gracechurch-street.  
MIERS, T., Esq., Upper Clapton.  
OLNEY, T., Esq., Borough.  
WILMSHURST, J., Esq., Kensington.

**AUDITORS.**

LATTER, R., Esq., Fenchurch-street.

FEWTRESS, J. W., Esq., Gracechurch-street.

**BANKERS.**

Messrs. BARCLAY, BEVAN, TRITTON, & Co., Lombard-street.

Messrs. WATSON & SONS, Bouverie-street, Fleet-street.

This Society (although entirely distinct in its funds and management) is conducted at the same Offices, and on the same principles, as the BRITISH EMPIRE MUTUAL LIFE ASSURANCE COMPANY.

It is designed to extend to Fire Assurance the Mutual principle which has been found so successful in its application to Life Assurance.

During the year 1850, 169 new Policies have been issued, assuring property to the amount of £856,423. A large amount of business was obtained in former years.

The Profits are divided every three years.

Less than One-Third of the Premiums have paid all the Losses.

Assurances can be effected daily at the Chief Offices, or at any of the Agents of the Society throughout the Empire.

January 15th, 1851.

W. S. GOVER, *Secretary.*

## UNIVERSAL LIFE ASSURANCE SOCIETY.

Established 1834.

EMPOWERED BY SPECIAL ACT OF PARLIAMENT.

1, KING WILLIAM-STREET, LONDON.

For the Assurance of Lives at Home and Abroad, including Gentlemen engaged in the Military and Naval Services.

### DIRECTORS.

Sir HENRY WILLOCK, K.L.S., *Chairman.*  
JOHN STEWART, Esq., *Deputy-Chairman.*

Major-Gen. Sir RICH. ARMSTRONG, C.B., K.C.T. & S.  
JOHN BAGSHAW, Esq., M.P.  
AUGUSTUS BOSANQUET, Esq.  
CHAS. DASHWOOD BRUCE, Esq.  
ELIAS WATKIN CUNLIFFE, Esq.  
WILLIAM KILBURN, Esq.  
FRANCIS MACNAUGHTEN, Esq.  
CHARLES OTWAY MATTHEW, Esq.  
WILLIAM ROTHERY, Esq.  
ROBERT SAUNDERS, Esq.  
JAS. DUNCAN THOMSON, Esq.  
CAPTAIN SAMUEL THORNTON, R.N.

BANKERS—BANK OF ENGLAND and Messrs. CURRIE & Co.  
SOLICITOR—WILLIAM HENRY COTTERILL, Esq.  
PHYSICIAN—G. BURROWS, M.D., F.R.S., 18, Cavendish-sq.

The principle adopted by the Universal Life Assurance Society, of an annual valuation of assets and liabilities, and a division of three-fourths of the profits among the assured, is admitted to offer great advantages, especially to those parties who may wish to appropriate their proportion of profit to the reduction of future premiums. This practice of an annual division is especially advantageous to persons of advanced years, who cannot hope to participate in many septennial or decennial divisions.

The ANNUAL REDUCTION has averaged considerably ABOVE 40 PER CENT., and in no one year has it fallen below that amount.

The attention of gentlemen connected with India is particularly requested to the regulations of this Society; as, on comparison with other offices, its terms will be found peculiarly advantageous, especially as regards the liberal plan adopted on the return of Indian Assurers to reside permanently in this country; and the Indian rates have been calculated from extensive data and tables, exclusively in the possession of this Society, by which the true risk of life during residence in India has been most accurately ascertained.

MICHAEL ELIAH IMPEY, Secretary.

**PROMOTER LIFE ASSURANCE AND ANNUITY COMPANY, No. 9, Chatham Place, Blackfriars, London.** Established in 1826.—Subscribed Capital, 240,000*l.*

This Society effects every description of Life Assurance, both Domestic and Foreign, on most advantageous terms, either on the Bonus or Non-Bonus systems.

Tables of Rates, with all further particulars, may be obtained at the Office.

M. SAWARD, Secretary.

## ESSEX ECONOMIC FIRE OFFICE,

CHELMSFORD.

Established 1824.

Chiefly for Insuring COGN-MILLS at moderate rates.

LONDON AGENTS:

B. WHITE, at Messrs. Kingsford & Lay's, Corn Exchange, Mark-lane.  
PHILIP BOWEN, 26, King William-street, West Strand. [138

TO SECRETARIES, MANAGERS, AND OFFICIALS IN BANKS, RAILWAYS, AND OTHER COMPANIES.

## THE UNITED GUARANTEE & LIFE ASSURANCE COMPANY.

Capital, fully subscribed, 100,000*l.*, with power to increase the amount to 500,000*l.*

OFFICES:

36, Old Jewry, London;  
34, Mosley-street, Manchester; 4, North John-street, and 5, Exchange-court, Liverpool.

DIRECTORS.

The Right Honourable Lord Erskine, *Chairman.*  
Joshua P. Brown Westhead, Esq., M.P., *Vice-Chairman.*  
Josiah Bates, Esq.  
John Field, Esq.  
Thos. Carlyle Hayward, Esq.  
Charles Podmore, Esq.  
John Mayson, Esq.  
Daniel Shears, jun., Esq.  
Richard Swift, Esq.  
Thomas Winkworth, Esq.

MANCHESTER LOCAL COMMITTEE.

Sir Elkanah Armitage, Knt., Ald., *Chairman.*  
Thomas Basley, Esq., *Vice-Chairman.*  
John Bannerman, Esq.  
Richard Birley, Esq.  
The Hon. Thomas Erskine.  
William Gibb, Esq.  
Thomas Greig, Esq.  
Matthew Lyon, Esq.  
John B. Markland, Esq.  
John Mayson, Esq.  
Simon Pinfold, Esq.  
Edward Tootal, Esq.  
C. J. S. Walker, Esq., Ald.

GUARANTEE DEPARTMENT.—A reduction of 20 per cent. on the sixth payment. An immediate and considerable reduction if a Life Assurance be combined with the Guarantee.

LIFE DEPARTMENT.—Profits of both departments divisible among the assured on the participating scale. Foreign and colonial risks on moderate terms. Payments taken quarterly, half-yearly, or annually. Medical referees paid by the company.

Prospectuses, forms of proposal, and other information may be obtained at 36, Old Jewry.

By order, JAMES KNIGHT, Secretary.

N.B.—No charge for Policy Stamps. [174

## THE MUTUAL LIFE ASSURANCE SOCIETY,

33, KING-STREET, CHEAPSIDE.

ESTABLISHED 1834.

DIRECTORS.

S. Adams Beck, Esq.  
John Clayton, Esq.  
Solomon Cohen, Esq.  
Charles Colles, Jun., Esq.  
R. F. Davis, Esq.  
W. F. A. Delane, Esq.  
Rear-Admiral Sir A. P. Green, K.C.H.  
W. Chapman Harnett, Esq.  
Valentine Knight, Esq.  
John Mollett, Esq.  
Richard Morris, Esq.  
J. Pennington, Esq.  
Samuel W. Rowwell, Esq.  
Folliott S. Stokes, Esq.  
James Whilkin, Esq.

The Society is constituted on purely mutual principles, the entire profits being divided amongst the Members.

The total number of policies effected up to the 31st December, 1850, was 1786, for assuring 1,256,628*l.*

In the past year 200 proposals were made for assuring 120,213*l.*, of which number 155, for assuring 86,015*l.*, were accepted and completed.

The Divisions of Profit are made annually on the 31st December. Every Member participates therein who has paid two annual premiums on his policy.

Every Member shares in the Profits in proportion to the number and amount of the premiums paid, accumulated at compound interest.

At 31st December, 1850, the Society had been established nearly seventeen years, and the additions then allotted to the three oldest policies were as follow:—

| Policy No. | Age at Admission. | Amount assured. | Premiums paid.   | Additions.       | Payable in case of death during 1851. |
|------------|-------------------|-----------------|------------------|------------------|---------------------------------------|
| 1          | 29                | £. 1000         | £. s. d. 408 0 0 | £. s. d. 906 3 0 | £. s. d. 1,306 3 0                    |
| 2          | 42                | 2000            | 1,218 6 8        | 767 3 0          | 2,757 3 0                             |
| 3          | 50                | 2000            | 1,541 6 8        | 858 4 0          | 2,858 4 0                             |

SAMUEL BROWN, Actuary.

The Directors are prepared to appoint suitable Agents in country towns. Further information may be obtained from the Actuary. [19



**EUROPEAN LIFE INSURANCE & ANNUITY COMPANY.**

Established, January, 1819. Empowered by Special Act of Parliament, 7 & 8 Vict. c. 48.  
OFFICE, 10, CHATHAM-PLACE, BLACKFRIARS, LONDON.

**Court of Directors.**

- John R. Carnac, Esq. . . . . 46, Devonshire-street, Portland-place.
- Henry H. Harrison, Esq. . . . . 1, Percy-street, Bedford-square.
- Charles Hill, Esq. . . . . 25, Hyde-Park-square.
- William P. Jervis, Esq. . . . . Twickenham.
- Capt. William Jesse . . . . . Maisonette, Ingate-street, Essex.
- George Lee, Esq. . . . . 23, Crutched Friars.
- William Sargent, Esq. . . . . Putney Heath.
- Frederick Silver, Esq. . . . . 10, James-street, Buckingham-gate.
- John Stewart, Esq. . . . . 25, Portman-square.
- George J. Sullivan, Esq. . . . . Wilmington, Ryde, Isle of Wight.
- Capt. W. G. H. Whish, R.N. . . . . 10, Cumberland-street, Hyde Park.

**Auditors.**

- Samuel Buller Lemon, Esq., Custom House, London.
- R. Mills, Esq., Taxing Master, Staple Inn, and Kilham.
- The Rev. Samuel Silver, M.A., Cambridge.

**Bankers.**

- Bosanquet, Franks, and Whatman, 75, Lombard-street.
- Sir W. P. Call, Bart., and Co., 25, Old Bond-street.

**Medical Officers.**

- Henry Davies, Esq., M.D., 18, Saville-row.
- Alexander Bridge, Esq., Surgeon, F.R.C.S., 66, St. James's-street.
- E. D. Silver, Esq., M.D., 11, Wimpole-street, Cavendish-square.

Solicitor.—Thomas W. Bolton, Esq., 4, Elm-court, Temple.

Secretary.—Wm. Barton Ford, Esq.

**ADVANTAGES OFFERED BY THIS OFFICE.**

Long standing—Established 1819. Undoubted security from a large paid-up capital and accumulated premiums. Deceased lives assured at equitable rates.

The participating or non-participating scales of Premium: If participating, 80 per cent. is appropriated to Policyholders every fifth year—if non-participating, the rates are as low as can with safety be charged. Liberty to the Insurer to proceed to, and reside in, places beyond the limits of Europe. Premiums on Policies received yearly, half-yearly, or quarterly, or on a descending scale; or half Premiums received for five or seven years.

Loans granted on Policies, or on Freehold, Leasehold, or Copyhold Securities, accompanied by Policies of Life Assurance. Loans granted on undoubted Personal Security.

Policies granted to meet every contingency. Medical men remunerated for their reports. A liberal commission to solicitors and others bringing business to the Society.

By the condition of the Policies issued by this Company, it is agreed "that the documents upon the faith whereof the Policy is granted shall be conclusive evidence of the age and state of health of the party assured, unless fraud or willful misrepresentation be discovered therein." No probability of Claims being disputed, the Company having paid to Policy-holders nearly 600,000*l.* without dispute or litigation.

Examples of Premiums for Insuring 100*l.* on a single Life.

| WITHOUT PROFITS. |              |          | Age next Birth-day. | WITH PROFITS. |              |            |
|------------------|--------------|----------|---------------------|---------------|--------------|------------|
| Quarterly.       | Half-yearly. | Yearly.  |                     | Yearly.       | Half-yearly. | Quarterly. |
| £. s. d.         | £. s. d.     | £. s. d. |                     | £. s. d.      | £. s. d.     | £. s. d.   |
| 0 9 4            | 0 18 1       | 1 14 5   | 30                  | 1 18 3        | 1 0 0        | 0 10 3     |
| 0 12 0           | 1 3 2        | 2 4 0    | 35                  | 2 5 1         | 1 5 3        | 0 15 0     |
| 0 15 8           | 1 10 6       | 3 18 0   | 40                  | 3 5 0         | 1 13 4       | 0 17 3     |
| 1 2 0            | 2 3 0        | 4 2 0    | 45                  | 4 8 8         | 2 6 3        | 1 3 9      |
| 1 14 6           | 3 7 6        | 5 8 6    | 50                  | 6 13 6        | 3 10 0       | 1 16 0     |

The next Bonus will be declared in 1855, and afterwards at the expiration of every fifth year. Every Bonus will be added to the sum insured; but the person entitled thereto may arrange with the Company at any time within three months after the declaration thereof to receive the value—In cash: or in an equivalent reduction of future Premiums; or if the Bonus amount to 50*l.* or upwards, may have a new Policy on the life, free from the payment of any Premium; or the Bonus may be dealt with as shall be specially agreed upon.

WILLIAM BARTON FORD, Secretary. [149]

**OFFICIALS IN BANKS, COMPANIES, NTEE & LIFE MPANY.**

with power to increase 00*l.*  
London;  
North John-street,  
Liverpool.

Chairman  
P. Vice-Chairman.  
Charles Poimore, Esq.  
J. Shears, junr, Esq.  
J. Ward Swift, Esq.  
Esq.

COMMITTEE.  
James Greig, Esq.  
John Lyon, Esq.  
B. Markland, Esq.  
Mayson, Esq.  
Fincoff, Esq.  
Ed. Tootal, Esq.  
W. Walker, Esq., Aid.

tion of 20 per cent.  
rate and considerable  
inbed with the Gua-

departments dividible  
scale. Foreign and  
payments taken quar-  
terly referees paid by  
and other information

KNIGHT, Secretary.  
Stamps. [174]

**ASSURANCE**

**APSIDE.**

mpson Harnett, Esq.  
ne Kilgilt, Esq.  
ollett, Esq.  
Morria, Esq.  
erhorne, Esq.  
W. Rowell, Esq.  
S. Stokes, Esq.  
Whlakin, Esq.  
mutual principles,  
the Members.  
l up to the 31st De-  
56,628*l.*  
made for assuring  
uring 86,015*l.*, were  
nually on the 31st  
s therein who has  
n proportion to the  
aid, accumulated at  
ad been established  
s then allotted to

Payable in case of death during 1851.

|       |           |
|-------|-----------|
| s. d. | £. s. d.  |
| 30    | 1,306 3 0 |
| 30    | 3,757 3 0 |
| 40    | 2,858 4 0 |

OWN, Actuary.  
suitable Agents in  
may be obtained  
[19]

**HOLDERS OF LIFE-ASSURANCE POLICIES,** and those who wish to effect LIFE ASSURANCES, are invited to write to HENRY AGGS, of 1A, Bishopsgate Street Within, London, who, without charge, will communicate important information. All letters are expected to be prepaid, but replies will be unstamped, unless provided. [1239]

**RELIANCE**

**MUTUAL LIFE ASSURANCE SOCIETY.**  
No. 71, KING WILLIAM-STREET, MANSION-HOUSE, LONDON.

The Entire Profits divided among the Assured.

**Directors.**

- VERNON ABBOTT, Esq.
- Lieut.-Colonel ABBY.
- GEORGE ASHLEN, Esq.
- H. J. HALL, Esq., R.N.
- JOHN JAMES, Esq.
- JOHN LEDGER, Esq.
- R. W. S. LUTWIDGE, Esq.
- JOHN YOUNG, Esq.
- HENRY T. PRINSEP, Esq.
- WILLIAM PHELPS, Esq.
- CHARLES H. SMITH, Esq.
- JAMES TRAILL, Esq.
- WM. FOSTER WHITE, Esq.
- GEORGE WHITMORE, Esq.
- EDWARD WINSLOW, Esq.

Advantages presented by this Society.

LIFE ASSURANCES may be effected upon Equal, Half-Premium, Increasing, or Decreasing Scales; also by Single Payments, or Payments for limited periods. Tables have been specially constructed for the ARMY, NAVY, EAST INDIA COMPANY, and MERCHANT SERVICES; also for persons voyaging to, or residing in, any part of the world.

ENDOWMENTS for Widows and Children, Pensions for retired Officers and Civilians, IMMEDIATE or DEFERRED ANNUITIES, and SURVIVORSHIPS.

The Bonus declared by the Society gave a Reduction of premiums, until next division of profits averaging 36 per cent. on Policies in force Five Years, or an addition to the Sums Assured, ranging from one-third to one-half of the total amount of Premiums paid.

E. OSBORNE SMITH, Actuary and Sec.

**ROYAL MAIL STEAM-PACKET OFFICES,**

52, GRACECHURCH-STREET, and 34, REGENT-CIRCUS, PICCADILLY, LONDON.

CONVEYANCE OF PARCELS, SAMPLES, PAPERS, &c.—The most expeditious method of forwarding such Packages to and from all parts of the Continent is through the

BRITISH AND CONTINENTAL DAILY EXPRESS PARCELS AGENCY,

SIMULTANEOUSLY WITH THE MAILS.

Parcels booked in London before 3 in the afternoon will arrive in Paris early the next morning; in Brussels, Antwerp, Ghent, &c., about noon; and at Cologne in the evening.

PARCEL RATES, including all charges excepting Customs Duties and Entries, if any.

| Between London and Cologne.      |     | Belgium. | France.                                                                |
|----------------------------------|-----|----------|------------------------------------------------------------------------|
| Under ½ lb. weight . . . . .     | 2 6 | 2 6      | Under 14 lbs. weight each.                                             |
| From ½ " to 2 lbs. . . . .       | 3 0 | 3 0      | Calais and Boulogne, 2s.                                               |
| " 2 " to 6 " . . . . .           | 4 6 | 3 6      | Paris, 6s.                                                             |
| " 6 " to 10 " . . . . .          | 5 0 | 4 0      | Lille, Roubaix, Tou-<br>colog, Valenciennes, &c.,<br>at Belgian rates. |
| " 10 " to 14 " . . . . .         | 5 6 | 4 6      |                                                                        |
| For every 2 lbs. extra . . . . . | 0 6 | 0 6      |                                                                        |

The Rates charged by Prussian post to places beyond Cologne are very moderate. Tables may be had of the Agents.

AGENTS.—London, GEO. HAYWARD, 52, Gracechurch-street.—Liverpool, H. RETEMER, Castle-street.—At Cologne, H. ITTELHUEBER and Co., through whom all parcels from Germany, Austria, Russia, Denmark, Italy, and Switzerland should be sent.—From Belgium through J. PIDDINGTON, 74, Montagne de la Cour, Brussels.—A. DAILE, Ghent.—LOUIS CARBON, Ostend.—From Antwerp and Holland through C. FROMENT.—J. FRIEND, Dover and Folkestone, Custom House Agent, to whom packages of Merchandise to and from Franco may be consigned. [1266]

## THE NATIONAL REVERSIONARY INVESTMENT COMPANY.

OFFICES,  
No. 63, OLD BROAD-STREET, LONDON, AND  
No. 10, HILL-STREET, EDINBURGH.

### Directors.

JOHN PEMBERTON HEYWOOD, Esq., *Chairman.*  
RICHARD E. A. TOWNSEND, Esq., *Deputy-Chairman.*  
BIGG, EDWARD SMITH, Esq. | GADESSEN, JAMES, Esq.  
COOPE, OCTAVIUS E., Esq. | KENDAL, JOHN, Esq.  
COWAN, ALEXANDER, Esq. | SCADDING, E. WARD, Esq.  
DICKSON, ROBT., M.D., F.L.S. | SHEPPARD, GEORGE, Esq.  
FUSSELL, THOMAS, Esq. | WILDE, CHARLES N., Esq.

### Solicitors.

Messrs. CARDALE, ILIFFE, and RUSSELL, Bedford-Row, London.

### Agents in Edinburgh.

Messrs. MENZIES and MACONOCHE, W. S.

The Directors are prepared to purchase Reversionary Interests, either absolute or contingent, and whether secured upon Real or Personal Estate, and also Life Interests or Annuities.

Forms for submitting Proposals for Sale may be obtained at the Offices of the Company. [i 214]

G. A. RENDALL, Secretary.

## PROVIDENT LIFE OFFICE,

50, REGENT STREET.

CITY BRANCH: 2, ROYAL EXCHANGE BUILDINGS.

ESTABLISHED 1806.

POLICY HOLDERS' CAPITAL, £1,192,818.

ANNUAL INCOME, £150,000. BONUSES DECLARED, £743,000.

Claims paid since the establishment of the Office, £3,001,460.

### PRESIDENT.

THE RIGHT HONOURABLE EARL GREY.

### DIRECTORS.

THE REV. JAMES SHERMAN, *Chairman.*  
HENRY BLENCOWE CHURCHILL, Esq., *Deputy-Chairman.*  
HENRY B. ALEXANDER, Esq. | WILLIAM OSTLER, Esq.  
GEORGE DACRE, Esq. | AFSLEY FELLATE, Esq.  
WILLIAM JUDD, Esq. | GEORGE ROUND, Esq.  
SIR RICHARD D. KING, Bart. | FREDERICK SQUIRE, Esq.  
THE HON. ARTHUR KINNAIRD. | WILLIAM HENRY STONE, Esq.  
THOMAS MAUGHAM, Esq. | Capt. Wm. JOHN WILLIAMS.

J. A. BEAUMONT, Esq., *Managing Director.*

### Physician.

JOHN MACLEAN, M.D., F.S.S., 29, Upper Montague Street, Montague Square.

Nineteen-Twentieths of the Profits are divided among the Insured.

Examples of the Extinction of Premiums by the Surrender of Bonuses.

| Date of Policy. | Sum Insured. | Original Premium. | Bonuses added subsequently, to be further increased annually. |
|-----------------|--------------|-------------------|---------------------------------------------------------------|
| 1806            | £. 2500      | £. s. d. 79 10 10 | £. s. d. 1922 2 0                                             |
| 1811            | 1000         | 33 19 9           | ditto. 231 17 6                                               |
| 1816            | 1600         | 34 16 10          | ditto. 114 18 10                                              |

### Examples of Bonuses added to other Policies.

| Policy No. | Date. | Sum Insured. | Bonuses added.    | Total with additions, to be further increased. |
|------------|-------|--------------|-------------------|------------------------------------------------|
| 521        | 1807  | £. 900       | £. s. d. 983 12 1 | £. s. d. 1882 12 1                             |
| 1174       | 1810  | 1800         | 1140 5 6          | 2940 5 6                                       |
| 3222       | 1830  | 5000         | 3558 17 8         | 8558 17 8                                      |

Prospectuses and full particulars may be obtained upon application to the Agents of the Office in all the principal towns of the United Kingdom, at the City Branch, and at the head Office, No. 50, REGENT STREET. [i 219]

TO CAPITALISTS.—20,000, to 50,000, required by the Advertiser, to introduce a celebrated form of Vessel, and the application of Machinery to Shipbuilding, whereby a saving of 20 per cent. will be effected in their construction. For further information (by Principals only) apply by letter first to R. A., care of Mr. CLARKE, 4, St. Dunstan's Alley, St. Dunstan's Hill, London. [i 208]

## COMMISSION AND FORWARDING AGENT.

THE SUBSCRIBER, having an opportunity of more extensively cultivating his business as COMMISSION and FORWARDING AGENT, is ready to enter into arrangements with first-class Firms desiring such aid. Representing in all Scotland first-class Houses, his knowledge of general business may be relied on.

The Subscriber intimates to his Customers and Friends that he has Removed from No. 91, CONSTITUTION-STREET, to JOHN'S-LANE, CHARLOTTE-STREET, LEITH, and solicits their Import Orders for Dutch, German, and Russian produce.

WILLIAM BLACK.

Agent for NICHOLAS H. LUTJENS, Hamburg.

" VAN DULKEN, VAN DORP, & Co., Rotterdam.

" CHARLES DEUBNER & Co., Bilsa.

John's-lane, Charlotte-street, Leith.

N.B.—On sale, on consignment, Prime KIEL BUTTER and GOUDA CHEESES. The Trade only supplied. [i 198]

## CAMBRIDGE MILITARY ASYLUM

for Widows of Non-commissioned Officers and Privates of Her Majesty's Land Forces. In Memory of His Royal Highness the late Duke of Cambridge.

Edw. FRED. LEES, *Hon. Sec.*

Office, 2, Charlotte-row, Mansion-house. [i 189]

## ROYAL ASYLUM OF ST. ANN'S SOCIETY.—

By Voluntary Contributions. Affording a Home, Clothing, Maintenance, and Education, to Children of the once in prosperity—Orphans or not—from every Nation.

E. F. LEES, *Secretary.*

Offices, 2, Charlotte-row, Mansion-house. [i 188]

## BRITISH LYING-IN HOSPITAL

FOR MARRIED WOMEN.

FOUNDED IN BROWNLOW-STREET, 1749.

REBUILT IN ENDELL-STREET, LONG-ACRE, 1849.

SUPPORTED BY VOLUNTARY CONTRIBUTIONS.

THIS HOSPITAL. (which was the first Institution of its kind) is capable of accommodating from 30 to 40 Patients; but to have the wards always occupied, additional support is necessary, as its resources are seriously reduced by the great and unavoidable expenses incurred in erecting the new building. Medical Attendance and Medicines are also provided for a large number of Patients at their own homes.

### MEDICAL OFFICERS.

Consulting Physician.—Dr. HENRY DAVIES.

Dr. ROBERT LEE, 4, Saville-row.

BENJAMIN BROOKES, Esq., 37, Bedford-street, Covent-garden.

Dr. JOHN CLARKE, 3, Clifford-street.

Secretary.—Mr. R. S. DAVIES, at the Hospital.

Banquers.—Messrs. HOARE, 37, Fleet-street.

By all of whom Subscriptions and Donations will be thankfully received. [i 217]

000. to 50,000. required since a celebrated form of machinery to Shipbuilding will be effected in their station (by Principals only) care of Mr. CLARKE, 4, St. II, London. [1 208

**WARDING AGENT.**

an opportunity of more business as COMMISSION is ready to enter into a desiring such aid. Res Houses, his knowledge

Customers and Friends CONSTRUCTION-FRAME, to LET, and solicits their and Russian produce. **WILLIAM BLACK,** Hamburg. Doan, & Co., Rotterdam. Co., Riga.

Prime **KIEL BUTTER** made only supplied. [1 198

**WOMEN'S ASYLUM** and Officers and Private in Memory of His Royal Age.

**FRED. LEERS, Hon. Sec.** [1 89

**WOMEN'S SOCIETY.** Affording a Home, to Children of those from every Nation. **E. F. LEERS, Secretary.** [1 88

**HOSPITAL**

**WOMEN.**

**Y-STREET, 1749.**  
**LONG-ACRE, 1849.**

**CONTRIBUTIONS.**

is the first Institution accommodating from 30 to always occupied, ad-resources are seriously the expenses incurred in Attendance and Medi-number of Patients at

**ERS.**  
**DAVIES.**  
le-row.  
Eq., 37, Bedford-

fford-street.  
the Hospital.  
et-street.  
d Donations will be [1 21

**PRAYER-BOOK AND HOMILY SOCIETY.**

Established 1812.

OFFICE, 18, SALISBURY-SQUARE, FLEET-STREET.

Patron.

His Grace the ARCHBISHOP OF CANTERBURY.

President.

The Most Noble the MARQUIS OF CHOLMONDELEY.

THIS Society is instituted for the circulation of the various Works which have been set forth by authority of the United Church of England and Ireland, both in the original and by means of translations.

Its funds, which arise from voluntary contributions, are employed in the active distribution of its various publications amongst those who are unable to procure them through the usual channels, either by free grant or by sale at less than the original cost.

Frequent testimonies are borne by Christian Missionaries, in various parts of the world, to the usefulness of the Society's labours, especially in the improvement and establishment of converts from heathenism, and in raising the tone of devotional feeling in congregations of native Christians.

The Society's labours at home may be exemplified by reference to its operations amongst Seamen and Emigrants. The agents visit almost every emigrant ship and large numbers of trading vessels in the port of London: the nature of the books which are offered is fully and candidly explained, and their use both individually and socially is affectionately urged upon the people. Social worship is frequently established on board in consequence of these persuasions, and by the help of the books supplied. A few years ago it was a very rare thing to hold divine worship on board ship; but now the crews of considerably more than half the ships visited in the port of London are assembled for that purpose on the Lord's Day.

The Society's *General Fund* is available for the expenses of translations, &c.

The operations on ship-board are supported by the *Special Fund for Emigrants and Seamen*; whilst the *Special Fund for Ireland* is devoted to efforts for spreading the light of the Gospel in that country.

Subscriptions and donations in aid of either of these funds will be thankfully received by the Secretaries.

The following list will give a general idea of the nature of the Society's publications:—

- Anglican: Portions of Liturgy; Articles of Religion; Homily, 'On Reading the Scriptures.'
- Bailom: Portions of Liturgy.
- Chinese: Portions of Liturgy.
- Danish: Homilies, 'On Reading the Scriptures,' &c.
- Dutch: Prayers; Homilies, 'Of Faith,' 'Of Repentance,' &c.; also for Christmas Day, Good Friday, &c.
- English: Prayer-Books of all sizes and prices; Arranged Services for Sundays; Family Prayer-Books; Collects and Catechism; Homilies, in volumes and tracts; Jewell's Apology; Nowell's Catechisms, &c. &c.
- French: Prayer-Book; Selection of Prayers; Homilies in tracts—various subjects.
- Gaelic: Family Prayers, and Homilies (in preparation).
- German: Prayer-Book; Arranged Services; Homily tracts on various subjects.
- Greek and Modern Greek: Prayer-Book.
- Hebrew: Prayer-Book; and (in Rabbinical Heb.) Homilies, 'On Reading the Scriptures,' and for Christmas Day.
- Indo-Portuguese: Prayer-Book; and Homilies, 'On Reading the Scriptures,' &c.
- Irish: Portions of Liturgy; Prayer-Book reprinting; Homilies in preparation.
- Italian: Prayer-Book (improved translation); Homily, 'Of Faith,' 'Of Prayer,' for Christmas Day, &c.
- Latin: The Thirty-nine Articles of Religion.
- Maori (New Zealand): Arranged Sunday Services; Family Prayers, nearly ready.
- Perseo: Portions of Liturgy.
- Polish: Prayer-Book.
- Portuguese: A Manual of Prayers; Homily, 'Against the Fear of Death,' &c.
- Spanish: Prayer-Book; Selection of Prayers; and Homilies, 'Against the Fear of Death,' &c.
- Swedish: Homilies, 'Of the Misery of all Mankind,' &c.
- Welsh: Prayer-Book; Homilies, 'Of Salvation by our Christ our Saviour,' &c. [1 180

**LIVERPOOL AND LONDON FIRE AND LIFE INSURANCE COMPANY.**

Established in 1835. Empowered by Acts of Parliament.

OFFICES.—8 and 10, WATER-STREET, LIVERPOOL; 20 and 21, FOUNTAIN, LONDON.

Trustees.

Sir THOS. BERNARD BIRCH, Bart., M. P.

ADAM HODGSON, Esq.

SAMUEL HENRY THOMPSON, Esq.

Directors in Liverpool.

WILLIAM NICOL, Esq., Chairman.

JOSEPH CHRIST. EWART, Esq., Deputy-Chairman.

JOSEPH HORNBY, Esq.

THOMAS BROCKLEBANK, Esq.

WILLIAM DIXON, Esq.

WILLIAM EARLE, Esq.

T. STEUART GLADSTONE, Esq.

GEORGE GRANT, Esq.

FRANCIS A. HAMILTON, Esq.

FRANCIS HAYWOOD, Esq.

ROBERT HOGGIN, Esq.

GEORGE HOLZ, Esq.

JOHN HORN, Esq.

GEO. HALL LAWRENCE, Esq.

HAROLD LITTLEDALE, Esq.

JOHN MARRIOTT, Esq.

EDWARD MOON, Esq.

CHARLES SAUNDERS, Esq.

HERMAN STOLTZBERG, Esq.

JOHN SWAINSON, Esq.

JAMES ASPINALL TORIN, Esq.

Secretary.—SWINSON BOULT, Esq.

Directors in London.

WILLIAM EWART, Esq., M.P., Chairman.

GEORGE FRED. YOUNG, Esq., Deputy-Chairman.

Sir W. P. DE BATHE, Bart.

WILLIAM BROWN, Esq., M.P.

MATTHEW FORSTER, Esq., M.P.

FREDERICK HARRISON, Esq.

JAMES HARTLEY, Esq.

ROSS D. MANGLES, Esq., M.P.

HON. F. PORSONBY.

JOHN RANKING, Esq.

J. M. ROBERTS, Esq.

SEYMOUR TRELON, Esq.

SWINSON BOULT, Esq., Secretary to the Company.

Resident Secretary.—BENJAMIN HENDERSON, Esq.

**CONSTITUTION.**

Liability of the entire body of Shareholders unlimited.

**FIRE DEPARTMENT.**

Agricultural, manufacturing, and mercantile risks freely insured. Foreign and colonial insurances effected. Premiums as in other established offices. Settlement of losses liberal and prompt.

**LIFE DEPARTMENT.**

Premiums as low as is consistent with safety. Bonuses not dependent on profits, being declared and guaranteed when the policy is effected.

Surrenders of policies favourably dealt with. Thirty days allowed for the renewal of policies. Claims paid in three months after proof of death. Policies not disputed except on the ground of fraud.

Full prospectuses may be had on application at the offices of the Company as above, or to any of its agents in the country. [1 154

**ECONOMIC**

**FUNERAL COMPANY,**  
29, New Bridge-street, Blackfriars,

ESTABLISHED JANUARY, 1843.

**UNDER DISTINGUISHED PATRONAGE.**

The object of this establishment is to offer every means of economy, combined with respectability, in FUNERALS, to any magnitude, at stated charges; and the public is respectfully invited to strictly examine the plans of this office, the first established in England for the observance of Funeral economy.

Artisan's Carriage Funeral, 3l. 18s. 6d. and 5l. 10s. 6d.

The deceased and mourners conveyed in separate carriages.

Tradesmen's ditto, with Hearse and Pair, and Coach and Pair, 7l. 12s. 6d.

First Class Funeral, including a Shell, Lead Coffin, and Outside Case, Hearse and Four Horses, Two Coaches and Pairs, with Plumes and full equipments of superior description, 27l. 12s. 6d.

The cortege and style adopted will be found unexceptionable.

"Those who have ever required the employment of an Undertaker in their family must feel the necessity of such an Establishment, and its great pecuniary advantages over the old system of conducting this business."—*Curtis Journal.* [1 179

# GOVERNESSES' BENEVOLENT INSTITUTION,

*Incorporated by Royal Charter, with power to hold Land by Gift, Purchase, or Bequest.*

Under the Patronage of

HER MOST GRACIOUS MAJESTY, HIS ROYAL HIGHNESS THE PRINCE ALBERT,  
HER ROYAL HIGHNESS THE DUCHESS OF KENT, HER ROYAL HIGHNESS THE DUCHESS OF GLOUCESTER,  
HER ROYAL HIGHNESS THE DUCHESS OF CAMBRIDGE, HIS ROYAL HIGHNESS THE DUKE OF CAMBRIDGE,  
HER ROYAL HIGHNESS THE HEREDITARY GRAND DUCHESS OF MECKLENBERG-STRELTZ.

President—The EARL OF HARROWBY.

## LADIES' COMMITTEE.

The Lady Ashley.  
The Hon. Mrs. Ashley.  
The Viscountess Barrington.  
Mrs. Hamire.  
Mrs. Booth.

Mrs. John Bullar.  
The Viscountess Canning.  
The Viscountess Feilding.  
Mrs. George Forbes.  
Mrs. Fox.

Mrs. F. H. Goldsmid.  
Mrs. Gresham.  
Mrs. William M. James.  
The Viscountess Jocelyn.  
Mrs. Laing.

Miss Pym.  
The Viscountess Sydney.  
Mrs. George Grenfell Glynn.  
Mrs. James Wigram.  
Mrs. Edward Wyndham.

## COMMITTEE FOR THE HOME.

The Lady Ashley.  
Mrs. Bayne.  
Mrs. Hamire.

Mrs. John Bullar.  
The Viscountess Canning.  
Mrs. Cox.

Mrs. Gresham.  
Mrs. William M. James.

Mrs. Laing.  
Lady Kay Shuttleworth.

## COMMITTEE FOR THE ASYLUM.

The Hon. Mrs. George Anson.  
The Lady Caroline Bathurst.  
Miss Blake.  
Mrs. Hamire.  
Lady Clark.

Miss Elliott.  
The Lady Georgiana Fullerton.  
The Lady Charlotte Guest.  
Mrs. S. C. Hall.  
Mrs. William M. James.

Mrs. Thomas King.  
Mrs. Knight.  
Mrs. Laing.  
Miss J. C. Lawson.  
Mrs. Malby.

Miss Maurice.  
The Countess of Rosebery.  
Miss Harriet Sotheby.  
The Lady Ann Tufnell.  
Miss Winn.

## BOARD OF MANAGEMENT.

The Hon. William Ashley.  
The Rev. Michael Higgs, M.A.  
E. B. Cabbell, Esq., M.P., F.R.S.,  
F. Patey Chappell, Esq. [F.S.A.  
Dr. Forbes, F.R.S.

John William Hale, Esq.  
S. Carter Hall, Esq., F.S.A.  
The Rev. Edmund Holland.  
Henry Howlett, Esq.  
The Hon. Arthur Kinnaird.

The Rev. D. Laing, M.A., F.R.S.  
Edward Frederick Leeks, Esq.,  
The Lord Lifford. [F.L.S.  
James Nisbet, Esq.  
Sir Stafford H. Northcote, Bart.

J. Tidd Pratt, Esq.  
Robert A. Stanley, Esq., M.P.  
W. Jesse Street, Esq.  
The Earl Talbot.  
Edward Thornton, Esq.

**Arbitrators**—John Bullar, Esq.; William Fox, Esq.; Mr. Secondary James W. A. Mackinnon, Esq., M.P., F.R.S., F.S.A.; Edmund Turner Watts, Esq.

**Auditors**—Thomas Hunt, Esq.; Henry Kingscote, Esq.; Capt. the Hon. Francis Maude, R.N.

**Treasurer**—Benjamin Bond Cabbell, Esq., M.P., F.R.S., F.S.A.

**Bankers**—Sir S. Scott and Co., 1, Cavendish-square; Messrs. Strahan and Co., Temple-bar.

**Secretary**—C. W. Klugh, Esq., 38, Sackville-street.

**Secretary to the Provident Fund**—Thomas Bayly Parker, Esq.

Membership consists in the payment of an Annual Guinea, or of Ten Guineas in one sum. Subscribers are entitled to vote for Annuitants in the proportion of one Vote for each Annual Half-Guinea, not in arrear, and for each Donation of Five Guineas. Subscriptions are due on the 1st of January, and can always be remitted by Post-office order, or by a cheque crossed "Sir S. Scott and Co."

THE GOVERNESSES' INSTITUTION has been established to raise the character of Governesses as a class, and thus to improve the tone of Female Education; to assist Governesses in making provision for their old age; and to assist in distress and age those Governesses whose exertions for their parents or families have prevented such a provision.

To facilitate the operations of the Institution, its proceedings are subdivided into the following branches; and every gift is devoted solely to the object for which it is given.

TEMPORARY ASSISTANCE to Governesses in distress, afforded privately and delicately through the LADIES' COMMITTEE.

ANNUITY FUND.—Elective Annuities to aged Governesses, secured on Invested Capital, and thus independent on the prosperity of the Institution.

It is necessary that a capital should be raised, from the interest of which Annuities may be given; as to profess to grant Annuities from annual subscriptions—from a fluctuating income, which any change of public opinion, or accidental circumstances, might destroy—would be to risk disappointment to the aged annuitants at (perhaps) the most painful and inconvenient time. Many Annuities have been founded by investments in the three per cent. Consols; and it is intended to elect at least two Annuitants in each succeeding May and November, should the funds be received. The candidates, who must be Governesses above fifty years of age, require to be approved by the Committee.

To carry out this design—the establishment of permanent Annuities, granted from funded capital—the Committee invite benevolent individuals of large fortune to found Annuities bearing their own name. Fellowships and scholarships are thus founded for those of the other sex who labour with the mind; and surely we should not be forgetful of those whose minds labour to mould the characters of English wives and mothers.

The Hon. Mrs. Ashley has most kindly opened a Fund to raise all the Society's Annuities to 204; and has already received 800, towards this desirable object. Any donations which may be kindly given may be addressed "The Hon. Mrs. Ashley to the care of the Secretary."

PROVIDENT FUND.—Provident Annuities purchased by ladies in any way connected with Education, upon Government Security, agreeably to the Act of Parliament.

This branch of the Institution has been very successful. Any lady can have the Tables of Rates and other particu-

lars forwarded to her, on application to the Secretary at the Office; and, if she will consult any gentleman connected with monied details, she will learn that she cannot otherwise have such terms with such security.

This branch includes a Savings-bank; each lady's money standing in her own name, and removable only by her own order.

A HOME for Governesses during the intervals between their engagements.

The Home—in Harley-street—is principally self-supporting, the ladies paying a certain weekly sum for board and lodging. The admission is by a Committee of Ladies, on written introductions. The facilities for re-engagements are so great to ladies from the country, and the arrangements are so private and comfortable, that the Home is in much request.

REGISTRATION FREE OF EXPENSE.—Books being provided at the Home, with lists both of vacant engagements and of disengaged Governesses, the nobility and gentry find the benefit of such opportunities for selection; whilst the immense connexion of the Society affords great advantages to the Governess, without the slightest expense.

A COLLEGE for Governesses has been established, named QUEEN'S COLLEGE, by Royal Permission. A Committee of Education has been formed of gentlemen of high standing and experience, by whom certificates of qualification are given to Governesses in any branch of instruction without fee. Any lady sending in her name, and stating in what subjects she seeks examination, will have an immediate appointment for the purpose. It will now read with parents to make engagements contingent, if they please, upon the production of certificates. Classes are open in all subjects of instruction.

About 340 certificates have been issued since the opening of the College; arrangements have been made for the FREE EDUCATION of a certain number of Pupils, dependent on Governess-relatives; and large evening classes have been established, with FREE LECTURES, for Governesses engaged during the day.

AN ASYLUM FOR AGED GOVERNESSES, built for Eighteen, but capable of enlargement to any extent. Additional apartments for two are estimated at 800; Endowments for each, 500*l.*, or 15*l.* per annum, legally and permanently secured. Age for admission, SIXTY; Election, as for Annuitant. The inmates are wholly maintained. [1153



**TUTION,**

LOUCESTER,  
F CAMBRIDGE,  
LTYZ.

Fym.  
Viscountess Sydney.  
George Grenfell Glyn.  
James Wigram.  
Edward Wyndham.

Laing.  
Key Shuttleworth.

Maurice.  
Countess of Rosebery.  
Harriet Sotheby.  
Lady Ann Tufnell.  
Winn.

dd Pratt, Esq.  
rt A. Stanley, Esq., M.P.  
esse Street, Esq.  
Earl Talbot.  
ard Thornton, Esq.  
M.P., F.R.S., F.S.A.;

R.N.  
David Laing, M.A., F.R.S.

has Bayly Parker, Esq.  
Subscriptions are due on the

on to the Secretary at the  
gentleman connected  
that she cannot otherwise

ank; each lady's money  
available only by her own

g the intervals between

principally self-support-  
ability sum for board and  
Committee of Ladies, on  
ices for engagements  
country, and the arrange-  
ment, that the Home is in

PENPENSE.—Books belong  
of vacant engagements  
nobility and gentry find  
r selection; whilst the  
ords great advantages  
st expense.

has been established,  
Permission. A Com-  
of gentlemen of high  
certificates of qualifica-  
branch of instruction  
r name, and stating in  
will have an immediate  
now rest with parents  
they please, upon the  
are open in all subjects

used since the opening  
men made for the Frazz  
Pupils, dependent on  
ing classes have been  
Governesses engaged

VERNESSES, built  
ment to any extent.  
estimated at 200l.; En-  
num, legally and per-  
n, Sixty; Election, as  
sily maintained. [1851]

**RELIGIOUS TRACT SOCIETY,**

INSTITUTED A.D. 1799.

**DEPOSITORIES :**

56,  
Paternoster-row ;  
  
65,  
St. Paul's Church-  
yard ;  
  
and  
164,  
Piccadilly,  
near  
St. James's-street.



**DEPOSITORIES :**

56,  
Paternoster-row ;  
  
65,  
St. Paul's Church-  
yard ;  
  
and  
164,  
Piccadilly,  
near  
St. James's-street.

Treasurer—JOHN GURNEY HOARE, Esq.

Honorary Secretaries—REV. W. W. CHAMPNEYS, M.A., Rector of Whitechapel, and REV. EBENEZER HENDERSON, D.D.  
Corresponding Secretary and Superintendent—MR. W. M. JONES. Assistant Secretary and Cashier—MR. W. M. TARN.

The Society has issued works in about 110 different languages and dialects; specimens of some of which are shown in the Great Exhibition.

The present annual circulation of the Society's works amounts to about TWENTY-FOUR MILLIONS; its receipts to about 61,000l.; and its total distribution, to March, 1850, including the issues of its foreign Societies, to about FIVE HUNDRED AND TWENTY-FOUR MILLIONS of copies.

The sale of the publications is made to cover all the expenses of production and distribution. Thus the whole of the subscriptions, &c., are applied to the gratuitous circulation of its works, without any deduction or charge whatever.

**THE INDUSTRIAL EXHIBITION.**

Extensive supplies of books and tracts, in many of the Continental languages, have been prepared for circulation among the foreign visitors to the Great Exhibition. To facilitate this object they have reduced the price of all tracts in foreign languages to the same scale as English tracts—equal to a reduction of one-fourth. All persons purchasing foreign tracts, for gratuitous circulation, to the amount of 20s., will be supplied at half the Catalogue prices. The Committee have engaged eligible premises at No. 164, PICCADILLY, as their WESTERN DEPOSITORY.

**PUBLICATIONS.**

**THE MONTHLY VOLUMES:** a Series of Popular Works, elegantly written, on History, Biography, Science, Religion, &c. Sixty-six volumes are already published. Each vol. contains 192 pages of good bold letterpress, and occasionally illustrated with engravings;—6d. in fancy covers; and 10d. in cloth boards, gilt edges.

**EDUCATIONAL SERIES,** for Schools and Families, consisting of the HISTORY OF GREECE to A. D. 1833, 12mo., with map, cloth, 2s. 6d.—HISTORY OF ROME, to the Fall of the Empire, 12mo., with three maps, 3s.—LIVES OF ILLUSTRIOUS GREEKS, 12mo., 3s.—A UNIVERSAL GEOGRAPHY, in four parts, Historical, Mathematical, Physical, and Political, with ten coloured maps, 12mo., boards, 5s.—PALEY'S HORÆ PAULINÆ, with notes and supplementary treatise, by Rev. T. R. Birks, A.M., with maps, 3s.—PALEY'S EVIDENCES OF CHRISTIANITY, with introduction, notes, and supplement, by Rev. T. R. Birks, A.M., with Map, 3s.

**THE ANNOTATED PARAGRAPH BIBLE:** containing the Old and New Testaments, according to the authorised version, arranged in paragraphs and parallelisms; with explanatory notes, prefaces to the several Books, and an entirely new selection of references to parallel and illustrative passages. Part I. The Pentateuch. Super-royal 8vo. 3s., neat cover.  
[To be completed in six parts.]

**POCKET PARAGRAPH BIBLE.** With maps. 4s. cloth boards; 5s. roan gilt; 6s. morocco; 7s. Turkey morocco.

**COMMENTARY, WITH THE HOLY BIBLE:** The Text according to the authorized version. The Comment from HENRY and SCOTT, and from other

authors; with marginal references, maps, and various useful tables. Super-royal 8vo. Complete in six vols. 2l. 14s. boards; 3l. 18s. half bound; 4l. 14s. calf; 5l. 6s. calf extra. With numerous engravings, portraits, &c., 60s. boards.

**COMMENTARY:** the same as above, without the Text. 12mo. 6 vols. neat, in cloth, 32s.; half bound 38s.; calf 44s.

**HISTORY OF THE REFORMATION.** By DR. MERLE D'AUBIGNÉ. Demy 8vo. 4 vols in 1. With new preface, and numerous additions. The 4th part being the English original. Cloth bds. 6s.; or in two vols. 7s. The Library Edition, in 4 vols., price 14s. boards.

**ANTIQUITIES OF EGYPT;** with a particular notice of those that illustrate the Sacred Scriptures. Many engravings. 8vo. 10s. cloth boards.

**HISTORY OF THE VAUDOIS CHURCH.** By ANTOINE MONASTIER, formerly Pastor in the Canton de Vaud. 12mo., with a map of the valleys, 4s. boards.

**LUTHER: his Mental and Spiritual History:** with special reference to its earlier periods, and the Opening Scenes of the Reformation. By BARNAS SEARS, D.D. 12mo. 4s. boards.

**THE HISTORY OF THE JEWS,** from the Call of Abraham to the Birth of Christ. Illustrated with steel and wood engravings. In 2 vols. 12mo., 8s. boards; 10s. half bound.

**THE JUBILEE MEMORIAL** of the RELIGIOUS TRACT SOCIETY; containing a record of its Origin, Proceedings, and Results. A.D. 1799 to A.D. 1849. By WILLIAM JONES, Corresponding Secretary, 8vo. with portraits engraved on steel, 7s. extra cloth boards.

\* \* \* Catalogues of the Society's Tract, Book, and Foreign Publications may be obtained at either of the above Depositories, or forwarded by post. Applications in reference to the funds and publications may be addressed to MR. WILLIAM JONES, 56, Paternoster-row, [113



*Published Monthly, Price 1s.,*

# The Journal of Design and Manufactures,

CONTAINING

ACTUAL FABRIC PATTERNS AND ENGRAVINGS.

THE JOURNAL OF DESIGN AND MANUFACTURES is addressed to the PRODUCERS and CONSUMERS of all DECORATIVE MANUFACTURES, as well the MERCHANT, the MANUFACTURER, the DESIGNER, the ART WORKMAN, as the GENERAL PUBLIC.

The JOURNAL of DESIGN and MANUFACTURES advocates—

*The Recognition of Sound Principles of Design, and the Necessity for a Faith in them.*

*The Application of these Principles to Manufactures and Purposes of Utility.*

*The Progress of Design in accordance with the Wants and Sentiments of the Present Age rather than a Slavish Repetition of the Ancient or Mediæval Art of Past Ages.*

*The Improvement of the Laws regulating Copyright of Design and the Extension of the Period of Copyright.*

*The Diffusion of Art-Education through all Classes, and the Increased Efficiency of Schools of Design. And*

*The Establishment of Public Exhibitions of Decorative Manufactures.*

Four Volumes of the JOURNAL OF DESIGN AND MANUFACTURES are now completed, price 7s. 6d. each, bound. During their progress, the effect and soundness of the principles advocated in them have been signally shown in the extension of Copyright of Design, in the amendment of the Schools of Design, in the general improvement of Decorative Manufactures; but, above all, in the success of the Great Exhibition of the Works of Industry of all Nations, which the JOURNAL OF DESIGN AND MANUFACTURES consistently supported as a theory, long before it became a great fact.

THE JOURNAL OF DESIGN AND MANUFACTURES is the only publication in Europe which inserts in its pages SPECIMENS OF ACTUAL FABRICS.

**DURING THE EXHIBITION** the *Journal of Design and Manufactures* will insert **SPECIMENS** of the finest woven fabrics, &c., exhibited.

PUBLISHED BY

CHAPMAN & HALL, 193, PICCADILLY, LONDON;

H. MANDEVILLE, PARIS; BOHAIRE, LYONS; LEBRUMENT, ROUEN; C. MUQUARDT, BRUSSELS.

**THE JOURNAL OF DESIGN AND MANUFACTURES**

*May be ordered of all Booksellers and Stationers.*

NEW AND COMPLETE  
WORKS OF READING AND REFERENCE,

PUBLISHED BY CHARLES KNIGHT, 90, FLEET STREET.

**Knight's Cyclopædia  
of the Industry of all Nations.**

A COMPANION TO THE EXHIBITION OF 1851,  
And a permanent Dictionary of Arts, Manufactures, and  
Commerce. With ELABORATE WOODCUTS.  
One Volume of above 1000 pages, bound, Eight Shillings.

KNIGHT'S  
**Cyclopædia of London.**

In 1851 there will be a gathering from all lands in this, the largest city of the world, whose inhabitants are in intercourse—commercial, political, literary, or religious—with almost the whole human race. We purposely select this period for producing a full, compact, and cheap book on London, that will endeavour to combine accuracy with amusement,—a *Guide for the Visitor*,—a permanent Volume in the National Library. With ELABORATE WOODCUTS.

One Volume of nearly 1000 pages, bound, Eight Shillings.

KNIGHT'S  
**Excursion-Train Companion.**

EXCURSIONS FROM LONDON.

Completes in One Volume, price 5s.

The following places are comprised in the Excursions:—

- No. 1. BRIGHTON.
2. HASTINGS.
3. DOVER AND CANTERBURY.
4. ISLE OF THANET, SANDWICH, AND DEAL.
5. BATH.
6. BRESTOL.
7. WINDSOR AND ETON.
8. OXFORD.
9. PORTSMOUTH AND CHICHESTER.
10. WINCHESTER, SOUTHAMPTON, AND SALISBURY.
11. THE ISLE OF WIGHT.
12. DORCHESTER, WYMOUTH, AND PORTLAND.
13. EXETER AND THE SOUTH COAST OF DEVON.
14. PLYMOUTH AND ITS ENVIRONS.
15. CHELTENHAM AND GLOUCESTER.
16. STRATFORD-UPON-AVON AND WARWICK.
17. WOOLWICH, &c.
18. GRAVESEND AND HALLS OF KENT.
19. CAMBRIDGE.
20. LEAMINGTON AND COVENTRY.

**Pictorial Half-Hours of  
London Topography.**

One Volume. Price Three Shillings and Sixpence.

**National Cyclopædia of Useful  
Knowledge.**

On the 1st of February, 1847, the publication of "The NATIONAL CYCLOPEDIA" was commenced. On the 31st of MARCH, 1851, THE WORK WAS COMPLETED.

THE PUBLISHER HAS FULFILLED THE CONDITIONS OF PUBLICATION IN EVERY PARTICULAR. It has been his endeavour to produce a popular Cyclopædia that within its necessary limits shall omit nothing of general importance; and, whilst it is peculiarly addressed to the greatest number of readers, shall satisfy the most critical inquirer.

Twelve Volumes, cloth, 25; half-bound, 25. 12s.

Six Volumes, half-russia, 25 12s. 6d.

**Half-Hours with the Best  
Authors.**

This Work, which contains *Specimens of Three Hundred Writers*, with biographical and critical notices, is arranged so as to furnish HALF AN HOUR'S READING FOR EVERY DAY IN THE YEAR, formed of Twelve Hundred and Forty pages, equal in quantity to six ordinary octavo volumes: with Sixteen Miniature Portraits, engraved on Steel.

In Four Volumes, cloth, Ten Shillings; in Two Volumes, half-bound, Twelve Shillings.

**Pictorial Half-Hours;**

OR, MISCELLANIES OF ART.

With Illustrative Descriptions.

Four Volumes, Fourteen Shillings; or in Two Volumes, half-bound, Sixteen Shillings.

**The Land We Live in:**

A PICTORIAL AND LITERARY SKETCH-BOOK OF THE  
BRITISH EMPIRE.

Profusely Illustrated with Woodcuts, and with splendid Line Engravings on Steel.

Forming Four Superb Volumes, 25. 6s.

This popular Work is completed in Forty Parts, each of which is perfect in itself, and may be purchased separately, price One Shilling.

**MAPS AND ATLASES OF THE SOCIETY FOR THE DIFFUSION OF USEFUL KNOWLEDGE.**

ATLAS COMPLETE, with Index, 212 Maps, plain, in 1 volume, half morocco or russia, 6l. 7s. Coloured, 1 volume, half morocco or russia, 9l. 14s.

LIBRARY ATLAS, 161 Maps, 1 volume, plain, 5l. 5s.; coloured, 7l. 7s.

FAMILY ATLAS, 54 Maps, plain, 2l. 2s.; coloured, 2l. 16s.

SCHOOL ATLAS, MODERN AND ANCIENT, 39 Maps, plain, 1l. 3s.; coloured, 1l. 13s.

OUTLINE MAPS, FOR LEARNERS. Part I., 12 Maps, 4s.; Part II., 8 Maps, 3s.

SINGLE MAPS, plain, 6d. each; coloured, 9d.

MAP OF LONDON, for the convenience of Visitors to the EXHIBITION, plain, 1s.; coloured, 1s. 6d.; bound in cloth, 3s.

The whole of the Maps are corrected to the present time; and a Prospectus, with full particulars, will be forwarded post-free on application to the Publisher, 90, FLEET STREET.

**JAMES BIGG AND SONS,**  
**PARLIAMENTARY BOOKSELLERS AND PUBLISHERS,**  
**53, PARLIAMENT STREET, WESTMINSTER.**

**PROCEEDINGS OF PARLIAMENT.**

**Debates.**—HARRARD'S PARLIAMENTARY HISTORY AND DEBATES, complete from 1665 to the close of 1849. 310 vols. royal 8vo. *Half-bound, 34s.*—MIRROR OF PARLIAMENT, containing accurate Reports of the Debates and Proceedings in both Houses of Parliament from 1626 to 1840. 59 vols. folio and 8vo. *Half-bound, 104. 15s.*—CLAVENDIN'S DEBATES OF THE HOUSE OF COMMONS during the 13th Parliament of Great Britain, with Illustrations of the Parliamentary History of the Reign of George III., by J. Wright. 7 parts, royal 8vo. 1841. 16s. **State Trials.**—A COMPLETE COLLECTION OF STATE TRIALS AND PROCEEDINGS FOR HIGH TREASON and other Crimes and Misdemeanours from the earliest period to the year 1820; with Notes by HOWELL, and JARVIS'S INDEX. 34 vols. royal 8vo. *Half-bound, 134. 12s.* **Speeches.**—THE JOURNALS OF THE HOUSE OF COMMONS from 1547 to 1841, with Index. 103 vols. royal 8vo. 30. 15s.—THE JOURNALS OF THE HOUSE OF LORDS from 1609 to 1840, with the Calendars and Indexes. 78 vols. folio. *Half-bound, 104. 10s.*—THE ROLLS OF PARLIAMENT from 1278 to 1803, with Index. 7 vols. folio. *Half-bound, 31. 10s.*

**Papers.**—A SELECTION OF THE MOST IMPORTANT PARLIAMENTARY PAPERS from 1715 to 1833. 486 vols. *Half-bound, 60s. 15s.*—A SERIES OF THE SESSIONED PAPERS from 1830 to 1848, containing the Bills, Reports, Evidence, Estimates, and Papers printed by order of the House of Commons from October, 1830, to the close of 1848. 961 vols. *Bound, 144. 3s.*

**Papers.**—A SELECTION OF THE MOST IMPORTANT PARLIAMENTARY PAPERS from 1715 to 1833. 486 vols. *Half-bound, 60s. 15s.*—A SERIES OF THE SESSIONED PAPERS from 1830 to 1848, containing the Bills, Reports, Evidence, Estimates, and Papers printed by order of the House of Commons from October, 1830, to the close of 1848. 961 vols. *Bound, 144. 3s.*

**Papers.**—A SELECTION OF THE MOST IMPORTANT PARLIAMENTARY PAPERS from 1715 to 1833. 486 vols. *Half-bound, 60s. 15s.*—A SERIES OF THE SESSIONED PAPERS from 1830 to 1848, containing the Bills, Reports, Evidence, Estimates, and Papers printed by order of the House of Commons from October, 1830, to the close of 1848. 961 vols. *Bound, 144. 3s.*

**PUBLICATIONS RELATING TO RAILWAYS.**

**Board of Trade.**—REPORTS OF THE RAILWAY DEPARTMENT OF THE BOARD OF TRADE on Schemes for extending Railway Communication, and on Amalgamations, with Index. 12mo. *cloth, 1840. 3s.*—MAPS OF THE SEVERAL PROJECTED RAILWAYS referred to in the Reports of the Board of Trade. 19 parts, 1845. 19s.—SPECIAL REPORTS OF COMMITTEES ON RAILWAY Bills relating to adoption or rejection of recommendations of Board of Trade. 12mo. 1845. 1s. 6d. **Practitioner of Committees.**—PAPER'S TABULAR on the FUNCTIONS OF COMMITTEES OF THE HOUSE OF COMMONS, with reference especially to Railway and other Private Bills. 8vo. *cloth, 1845. 5s.*

**Table Acts.**—A COLLECTION OF THE PUBLIC GENERAL ACTS for the REGULATION OF RAILWAYS IN ENGLAND, WALES, AND IRELAND, passed from 1825 to 1847 inclusive, with Index. 12mo. *cloth, 1849. 5s.* A similar collection of the PUBLIC ACTS for the REGULATION OF RAILWAYS IN SCOTLAND, 1838 to 1846, with Index. 12mo. *cloth, 5s.*

**Special Acts.**—AN ABSTRACT OF DIGEST OF THE SPECIAL ACTS authorizing the CONSTRUCTION OF RAILWAYS, passed in 1845, 1846, and 1847, with Tabular Abstract, Introduction, and Copious Indexes. 5 vols., 12mo. *cloth, 31. 18s.*

**Standing Orders.**—THE STANDING ORDERS OF BOTH HOUSES OF PARLIAMENT, relative to PRIVATE BILLS, as amended in August, 1850, with Indexes. 12mo. *cloth, 5s.*

**FIRE-PROOF WAREHOUSE,**

**For Deposit of Books and Printed Papers.**

J. BIGG AND SONS have recently erected, in THE FIREPROOF HOUSE OF PARLIAMENT STREET, a capacious WAREHOUSE, constructed solely of Brick, Iron, and Slate, with the view of providing a BUILDING where BOOKS and PRINTED PAPERS may be DEPOSITED in perfect SECURITY against ACCIDENT BY FIRE, and in which any quantity of Books and Papers can be so arranged that any Volume or Paper may be immediately referred to without the slightest delay.

THE TAXES (per annum) for Warehousing Books and Printed Papers (such as Parliamentary Reports, &c.), are as follow:—Any quantity not exceeding 5 cwt., 30s.; exceeding 5 cwt., and under 10 cwt., 36s.; exceeding 10 cwt., and under 15 cwt., 50s.; exceeding 15 cwt., and under 30 cwt., 63s.; and for each additional 5 cwt., 16s. The Warehouse Charges to be paid half-yearly, in June and December.—Any fractional part of 5 cwt. to be charged as 5 cwt., and any period less than twelve months to be charged as one year.

**Acts of Parliament.**—The Public, Local, and Private Acts (either in Volumes or separate Acts) constantly on sale. Indexes to all the Acts passed from 1600 to the present time can be consulted at 53, Parliament Street, by any gentleman desirous of obtaining the Statutes on any particular subject.

**New Works and Periodicals punctually supplied ON THE DAY OF THEIR PUBLICATION.**

**IMPORTANT PARLIAMENTARY REPORTS.**

**Selected from the Stock on Sale by  
 James Bigg & Sons.**

**Railways.**—Reports of Committees of the House of Commons, to whom the various Railway Bills were referred from 1836 to 1849, 13 vols. respecting *cloth, 12s.*—Reports of Committee on Railway Subscription Lists, 1837, 10s.—Reports of Commissioners on General System of Railways for Ireland, 1837-38, 31. 10s.—Reports of Committee on the state of Communication by Railway, 1839-39-40, 16s. Reports of Smith and Barlow respecting Railway Communication between London, Dublin, Edinburgh, and Glasgow, 1840-41, 20s.—Annual Reports of the Officers of the Railway Department of the Board of Trade, 1841-46, 32s. 6d.—Reports of Committee on Railways, 1844, 6s.—Alphabetical List of Subscribers to Railway Subscription Contracts, 1845-46, 8s. 6d.—Report of Committee on Atmospheric Railways, 1845, 2s.—Returns relative to Third Class Carriages, 1845, 3s. 6d.—Report of Commissioners on Uniformity of Gauge, 1846, 8s.—Report of Commissioners on Projects for establishing Railway Termini within the Metropolis, 1846, 18s.—Report of Committee on Condition of Railway Laborers, 1846, 3s.—Reports of Committee on Railway Acts Enactments, 1846, 7s. 6d.—Correspondence respecting Construction of Railways in Colonies, 1847, 2s.—Reports of Commissioners on Financial Condition of Railway Companies, with Index, 1847, 7s. 6d.—Annual Reports of the Commissioners of Railway, 1848-50, 9s.—Returns of Railway Amalgamations, 1848, 2s. 6d.—Report of Commissioners respecting Railway Communication between London and Birmingham, 1849, 20s.—Reports of Lords' Committee on Audit of Railway Accounts, 1849, 8s.—Returns of the Share Capital, Loans, Receipts, &c. of each Railway Company, 1849-50. 10s.—Report of Commissioners on Application of Iron to Railway Structures, 1849, 20s.

**EVIDENCES AND/OR LOANS' CONSTITUTIONS** relative to the following Railways:—Birmingham, 1832, 15s.—Brighton, 1836, 21s.—Chester and Great Western, 1836, 7s. 6d.—Chester and Birkenhead, 1837, 10s. 6d.—Claremont, 1839, 10s.—Colerston, 1833, 1s. 6d.—Direct London and Portsmouth, 1845, 4s. 6d.—Dublin and Droghda, 1836, 2s. 6d.—Edinburgh and Glasgow, 1836, 14s.—Furness (Chester and Holyhead) London, Brighton, and South Coast; and London and South Western, 1849, 4s. 6d.—Glasgow and Ayr, 1837, 7s.—Great Western, 1835, 31s. 6d.—Hull and Selby, 1836, 3s. 6d.—Irish Great Western, 1845, 3s. 6d.—London Grand Junction, 1836, 6s.—Manchester and Cheshire, 1836, 6s.—North Wales, 1849, 6d.—Oxford and Great Western, 1837-38, 12s.—Southampton, 1835, 16s.—Taff Vale, 1836, 2s.—Warrington and Newton, 1831, 1s. 6d.

**EVIDENCES AND/OR LOANS' CONSTITUTIONS** relative to the following Railways:—Birmingham, 1836, 1s.—Blackwell, 1836-39, 20s. 6d.—Brighton, 1836, 34s.—Chatterham, 1842, 1s.—Chester and Holyhead, 1837, 16s.—Claremont, 1839, 12s.—Croydon and Epsom, 1844, 2s. 6d.—Dublin and Droghda, 1836, 3s. 6d.—Eastern Counties, 1849, 1s. 6d.—Edinburgh and Perth, 1847, 1s.—Glasgow, 1846, 1s. 6d.—Irish Great Western, 1846, 2s. 6d.—Liverpool and Manchester, 1825, 15s.—Manchester and Birmingham Extension, 1839, 12s.—North Kent, 1846, 15s.—Oxford and Rugby, and Oxford, Worcester, and Wolverhampton, 1846, 6s.—South-Eastern, 1836, 14s.

**Harbours, Docks, and Piers.**—Reports, Evidence, and Papers relating to the following Harbours, &c.:—Birkenhead, 1844, 9s.—Bridlington, 1837, 3s.—Cork, 1849-50, 1s. 4d.—Dover, 1839, 3s. 1847, 3s. 6d.—1848, 5s.—Edinburgh and Leith, 1836, 2s.—Greenwich, 1832, 6s. 6d.—Harbours of Refuge, 1846, 4s.—1850, 1s. 6d.—Hartlepool, 1850, 4s. 6d.—Holyhead and Fort Dymallyn, 1844-47, 12s. 9d.—Hull, 1840, 2s.—Kingstown, 1844, 2s.—Leith and Newhaven, 1835-36, 6s. 1847, 1s. 6d.—Limerick, 1834, 1s. 6d.—Liverpool, 1839, 2s.—Milford Haven, 1837, 4s. 6d.—Newhaven, 1847, 1s.—Plymouth, 1848, 1s.—Port of London, 1839, 30s.—1836, 7s. 6d.—Portland, 1847, 2s.—Portland Roads, 1836, 3s. 6d.—Ramsgate and Margate, 1850, 3s.—Sunderland, 1832, 5s.—Sutton Pool, 1847, 1s. 6d.—Tidal Harbours Commission, 1845-47, 21s.—Trinity (North Leith), 1835-36, 7s. 6d.—Western of Ireland, 1834, 2s.

**Canals and Navigations.**—Reports and Papers relating to the following Canals, &c.:—Caledonian, 1803-50, 52s.—1839-49, 3s. 6d.—Dublin and Kingstown, 1833, 3s.—Ennis, 1849, 2s.—Lough Erne and Shannon, 1845, 2s.—Medway, 1836, 7s. 6d.—Norfolk Estuary, 1849, 1s. 3d.—Norwich and Lowestoft, 1826, 2s. 6d.—Parrett, 1836, 3s. 6d.—Severn, 1848-49, 6s.—Shannon, 1831, 2s. 6d.—1852-53, 12s.—1854, 1s.—1859-60, 30s.—1850, 1s. 6d.

**Bridges.**—Reports relating to the following Bridges:—Blackfriars, 1836, 1s. 6d.—London, 1820-21, 2s.—1829, 12s.—Manal, 1819, 1s. 6d.—Westminster, 1844, 2s.—1846, 6s.—1850, 1s. 2d.

**Turnpike Roads.**—Reports of Committees, 1806-11, 16s.; 1819-23, 2s.; 1824, 2s.; 1836, 1s. 6d.; 1839, 1s.—Reports of Commissioners, 1840, 6s.—Income and Expenditure of Trusts, 1824, 8s. 1833, 2s. 6d.; 1830-50, 19s. 6d.—Reports relating to the following Roads:—Highland, 1804-21, 18s.—1823-50, 11s. 6d.—Holyhead, 1810-22, 21s.—1820-30, 5s.—1824-50, 12s. 6d.—Liverpool, 1829, 2s.—Metropolis, 1829-50, 12s.—North Wales, 1844, 5s.—Turnpike Roads in Ireland, 1826-31, 2s. 6d.; 1833, 3s. 6d.





## KNIGHT'S COPYRIGHT SHILLING VOLUMES FOR ALL READERS.

- LORD BROUGHAM'S STATESMEN OF THE TIME OF GEORGE III. . . . . 6 vols.
- LORD BROUGHAM'S DIALOGUES ON INSTINCT . . . . . 1 vol.
- LORD BROUGHAM'S TREATISES ON THE OBJECTS, PLEASURES, AND ADVANTAGES OF SCIENCE, AND ON POLITICAL SCIENCE . . . . . 1 vol.
- LORD BROUGHAM'S EDITION OF PALEY'S NATURAL THEOLOGY . . . . . 4 vols.
- SIR C. BELL'S DISSERTATIONS ON NATURAL THEOLOGY, AND TREATISE ON ANIMAL MECHANICS . . . . . 4 vols.
- SIR JOHN DAVIS'S CHINESE. New edition . . . . . 3 vols.
- SIR JOHN DAVIS'S SKETCHES OF CHINA. New edition 1 vol.
- LORD NUGENT'S LANDS CLASSICAL AND SACRED. Second edition . . . . . 2 vols.
- MISS MARTINEAU'S FEATS ON THE FROD. New edit. 1 vol.
- MISS MARTINEAU'S BILLOW AND THE ROCK: A NEW TALE . . . . . 1 vol.
- MRS. JAMESON'S LIVES OF PAINTERS . . . . . 2 vols.
- KNIGHT'S VOLUME OF VARIETIES . . . . . 1 vol.
- KNIGHT'S RESULTS OF MACHINERY, and CAPITAL AND LABOUR . . . . . 1 vol.
- LAMB'S TALES FROM SHAKSPERE, with Scenes selected by C. KNIGHT . . . . . 2 vols.
- TASSO'S RECOVERY OF JERUSALEM, translated by Fairfax; with Lives of TASSO and FAIRFAX by C. KNIGHT . . . . . 2 vols.
- MIND AMONGST THE SPINDLES, a selection from the Lowell Offering; with Introduction by C. KNIGHT MEMOIRS OF A WORKING MAN; with Preface by C. KNIGHT . . . . . 1 vol.
- THE FOOD OF MAN. By DR. LANKESTER. A new edition . . . . . 2 vols.
- HISTORY OF LITERATURE AND LEARNING IN ENGLAND, with Specimens of the Principal Writers. By G. L. CRAIK, A.M. . . . . 6 vols.
- THE LOST SENSES—Deafness and Blindness. By DR. KITTO . . . . . 2 vols.
- POPULAR CUSTOMS AND RECOLLECTIONS OF ITALY. By C. MAC FARLANE . . . . . 1 vol.
- LANE'S ARABIAN TALES AND ANECDOTES. Selected from the Arabian Nights . . . . . 1 vol.
- BIRD ARCHITECTURE . . . . . 1 vol.
- MISCELLANIES . . . . . 2 vols.
- CURIOSITIES OF PHYSICAL GEOGRAPHY. By W. WITTICH . . . . . 2 vols.
- MOLIERE, RACINE, AND THE FRENCH CLASSICAL DRAMA. By M<sup>rs</sup>. BLAZ DE BUNT . . . . . 2 vols.
- THE CID. By G. DENNIS . . . . . 1 vol.
- THE SPANISH DRAMA. By G. H. LEWIS . . . . . 1 vol.
- LIFE OF GRESHAM, the Founder of the Royal Exchange. By C. MAC FARLANE . . . . . 1 vol.
- OLD ENGLISH NOVELTS:—The Camp of Refuge—The Dutch in the Medway—A Legend of Reading Abbey. By C. MAC FARLANE . . . . . 4 vols.
- KNIGHT'S LIFE OF CAXTON, the first English Printer 1 vol.
- RAMBLES BY RIVERS. By JAMES THORNE.—The Avon, 1 vol.—The Duddon; the Mole; the Arun and Wey; the Lea; the Dove, 1 vol.—The Thames, 2 vols. . . . . 4 vols.
- ROMANCE OF TRAVEL. By C. MAC FARLANE . . . . . 2 vols.
- FLOWERS AND THEIR ASSOCIATIONS; and THE FIELD, GARDEN, & WOODLAND. By Miss PRATT. 1 vol. each 2 vols.
- LIFE OF NAPOLEON BONAPARTE. By A. VIEUSSEUX . . . . . 2 vols.
- THE INDUSTRY OF THE RHINE, Agriculture Manufactures. By T. C. BANFIELD. 1 vol. each . . . . . 2 vols.
- THE BACKWOODS OF CANADA. A new edition. By a LADY . . . . . 1 vol.
- OREGON TERRITORY. By the Rev. C. G. NICOLAY . . . . . 1 vol.
- BIOGRAPHICAL HISTORY OF ANCIENT AND MODERN PHILOSOPHY. By G. H. LEWIS . . . . . 4 vols.
- THE MANUFACTURES OF GREAT BRITAIN. By G. DODD 6 vols.
- INSECT ARCHITECTURE. By JAMES RENNIE, A.M. . . . . 2 vols.
- DR. SOUTHWOOD SMITH'S PHILOSOPHY OF HEALTH. New edition . . . . . 4 vols.
- THE CABINET PORTRAIT GALLERY OF BRITISH WORTHIES. 72 Steel Portraits . . . . . 12 vols.
- THE CABINET HISTORY OF ENGLAND. By C. MAC FARLANE . . . . . 26 vols.
- SETTLERS AND CONVICTS . . . . . 2 vols.
- FEMALE EXAMPLES OF THE PURSUIT OF KNOWLEDGE UNDER DIFFICULTIES . . . . . 2 vols.
- PLANCIE'S BRITISH COSTUME . . . . . 2 vols.
- WORNUM'S HISTORY OF PAINTING . . . . . 2 vols.
- PROFESSOR LONG'S CIVIL WARS OF ROME. Select Lives from Plutarch . . . . . 5 vols.
- THE ELEPHANT, THE HORSE, AND THE DOG—the three Friends of Man. By C. KNIGHT and W. MARTIN 3 vols.
- SPENSER AND HIS POETRY. By G. L. CRAIK, A.M. . . . . 3 vols.
- BACON AND HIS WRITINGS. By G. L. CRAIK, A.M. 3 vols.
- HISTORY OF BRITISH COMMERCE. By G. L. CRAIK, A.M. 3 vols.
- THE ENGLISHWOMAN IN EGYPT. By M<sup>rs</sup>. POOLE . . . . . 3 vols.
- THE PURSUIT OF KNOWLEDGE UNDER DIFFICULTIES. New edition. By G. L. CRAIK, A.M. . . . . 3 vols.
- LANE'S MODERN EGYPTIANS. A new edition . . . . . 3 vols.
- CHAUCER—Pictures of English Life from Chaucer—Canterbury Tales from Chaucer. By JOHN SAUNDERS . . . . . 3 vols.
- HISTORICAL PARALLELS. By A. MALIN, A.M. New edition . . . . . 3 vols.
- SKETCHES IN NATURAL HISTORY—Mammalia, 600 Woodcuts . . . . . 6 vols.
- SECRET SOCIETIES OF THE MIDDLE AGES . . . . . 2 vols.
- A VISIT TO THE WESTERN COAST OF NORWAY. By W. WITTICH . . . . . 1 vol.
- PARIS: its Historical Buildings and its Revolutions. New edition, continued to the present time . . . . . 3 vols.
- PHYSICAL GEOGRAPHY OF THE HOLY LAND. By JOHN KITTO, D.D., F.S.A. . . . . 2 vols.
- POMPEII: its Destruction and Re-Discovery. New edition. 300 Woodcuts . . . . . 2 vols.
- HUDBRAS, and other Works of SAMUEL BUTLER. Edited by A. RAMSAY . . . . . 1 vol.
- THE BOOK OF TABLE-TALK. By several Contributors . . . . . 2 vols.
- SKETCH OF THE HISTORY OF MONKEYS. 100 Woodcuts 1 vol.
- POPULAR TOMULTS; illustrative of the Evils of Social Ignorance . . . . . 1 vol.

C. COX, 12, KING WILLIAM STREET, STRAND.



## PICTORIAL WORKS

ORIGINALLY PUBLISHED BY C. KNIGHT, AND NOW SOLD BY

C. COX, 12, KING WILLIAM STREET, STRAND.

### 1.

EXHIBITION OF 1851.—INSTRUCTIVE COMPANION.

## PICTORIAL GALLERY OF ARTS.

The Volume of "THE USEFUL ARTS," complete, with 1570 ENGRAVINGS, elegantly bound in cloth, price 16s. 6d.

"THE FINE ARTS," elegantly bound in cloth, price 18s. ARCHITECTURE—SCULPTURE—and the HISTORY OF PAINTING, by RALPH N. WORNUM, with 1650 Engravings.

### 2.

With 4000 WOODCUTS, in 27 Shilling Parts, or 34s. 6d. in 2 handsome volumes, cloth,

## THE PICTORIAL MUSEUM OF ANIMATED NATURE.

The reader, at the very smallest price, is put in possession of, by far, the most extensive collection that has ever been produced, of pictorial representations of all the important quadrupeds, birds, fishes, reptiles, and insects which fill the earth; with a corresponding description of the animal, its structure, its habits, its localities, its use; not given in a dry and repulsive form, but with that simplicity which may furnish just conceptions to all, but especially to the young, of the wonders and beauties of God's creation.

### 3.

With 1500 WOODCUTS and 18 COLOURED MAPS, forming a SCRIPTURE ATLAS; price 20s. in Parts, or in handsome cloth 24s.,

## THE PICTORIAL SUNDAY-BOOK.

By JOHN KITTO, D.D., F.S.A., EDITOR OF THE PICTORIAL BIBLE.

The publication now submitted to Christian families is intended to present, at the very cheapest rate, a series of Engravings illustrative of the Bible History, the Prophecies, the Psalms, the Life of Our Saviour, and the Acts of his Apostles; exhibiting the Scenes of the great Events recorded in Scripture, the Customs of the Jews, the Natural History of the Holy Land, and the Antiquities which throw a light upon the Sacred Writings, with a body of Scriptural Narrative and Explanation, continuing from number to number; each number forming, as it is judged, a fitting portion for a Sunday's leisure.

THE SCRIPTURE ATLAS, with the GEOGRAPHY OF THE HOLY LAND, is sold separately, price 7s. sewed, or 9s. cloth.

### 4.

A PICTORIAL COMPANION AND KEY TO EVERY HISTORY OF ENGLAND

With 3000 WOODCUTS and 24 COLOURED ENGRAVINGS, price 36s. in Twenty-four Parts, or 2 handsome Volumes, cloth, 2l. 5s.,

## OLD ENGLAND.

A PICTORIAL MUSEUM OF NATIONAL ANTIQUITIES.

This Work opens to all ranks, at the cheapest rate, a view of the REGAL, ECCLESIASTICAL, BARONIAL, MUNICIPAL, and POPULAR ANTIQUITIES of England, given in a chronological order; and thus the Work is a Companion and a Key to every English History. The Engravings embrace the most remarkable of our buildings from the earliest times—DRUIDICAL REMAINS, CATHEDRALS, ABBEYS, CHURCHES, COLLEGES, CASTLES, CIVIC HALLS, MANSIONS, SEPULCHRAL MONUMENTS of our Princes and Nobles; Portraits of British Worthies, and representations of localities associated with their Names; ancient Pictures and Illuminations of Historical Events; the Great Seals and Arms of the Monarchy; Coins and Medals; Autographs; with the fullest Pictorial indications of the INDUSTRY, the ARTS, the SPORTS, the DRESSES, and the DAILY LIFE of the People.

### 5.

Price 18s. in Parts, or 1l. 2s. 6d. in handsome cloth,

## OLD ENGLAND'S WORTHIES.

A Gallery of 72 Portraits on Steel, and 12 Splendid Illuminated Engravings of some remarkable place or monument associated with the Life of some one of "OLD ENGLAND'S WORTHIES," arranged in a chronological order, thus enabling the reader to become familiar with the greatest names of his countrymen, in illustrative succession.

**BOOKS published by JOHN W. PARKER and SON, West Strand, London.**

- Principles of Political Economy.** By J. STUART MILL. Second Edition. Two Volumes. Octavo. 30s.
- System of Logic.** By the same Author. Third and Cheaper Edition. Two Volumes. Octavo. 35s.
- Discourse on the Studies of the University of Cambridge.** By ADAM SEDGWICK, M.A., Woodwardian Professor. Fifth Edition. With Preliminary Dissertation and Supplement. (770 pages.) 12s.
- On the Influence of Authority in Matters of Opinion.** By G. CORNWALL LEWIS, M.P. Octavo. 10s. 6d.
- History of the Whig Ministry of 1801.** By J. AUSTIN ROXBURGH, M.P. Vols. I. & II.—to the Passing of the Reform Bill. Octavo.
- Histories of Normandy and of England.** By SIR FRANCIS PALGRAVE. Vol. I. Octavo.
- Elements of Logic.** By R. WHATELY, D.D., Archbishop of Dublin. With all the Author's Additions. Small Octavo, 4s. 6d. Library Edition, 10s. 6d.
- Elements of Rhetoric.** By the same Author. With all the Author's Additions. Small Octavo, 4s. 6d. Library Edition, 10s. 6d.
- Introductory Lectures on Political Economy.** By the same Author. 8s.
- History of the Inductive Sciences.** By W. WHEWELL, D.D., F.R.S., Master of Trinity College, Cambridge. Second Edition, revised. Two Vols. 29s.
- Philosophy of the Inductive Sciences.** By the same Author. Second Edition, revised. Two Volumes. Octavo. 30s.
- Indications of the Creator—Theological Extracts from the History and the Philosophy of the Inductive Sciences.** By the same Author. Second Edition. 5s. 6d.
- Elements of Morality, including Polity.** By the same Author. Second and Cheaper Edition. Two Volumes. 15s.
- History of the Royal Society, compiled from Original Authentic Documents.** By C. H. WELD, Assistant-Secretary of the Royal Society. Two Volumes. Octavo. 30s.
- Lectures on the Principles and Practice of Physics.** By T. WATSON, M.D. Third Edition. Two Volumes. Octavo. 34s.
- Cycle of Celestial Objects.** By CAPTAIN W. H. SMITH, R.N., F.R.S., Foreign Secretary of the Royal Society. Two Vols. I. Prolegomena; II. The Bedford Catalogue. Octavo, with Illustrations. 24s.
- Manual of Chemistry.** By W. T. BRANDE, F.R.S., Professor of Chemistry in the Royal Institution. Sixth Edition, much Enlarged, and Embodying all Recent Discoveries. Two large Volumes. 29s.
- Principles of Mechanism.** By R. WILLIAMS, M.A., F.R.S., Professor of Natural Philosophy, Cambridge. 15s.
- Mechanics applied to the Arts.** By H. MOSELEY, M.A., F.R.S., one of Her Majesty's Inspectors of Schools. 6s. 6d.
- Lectures on Astronomy.** By the same Author. Third Edition. 5s. 6d.
- Elements of Meteorology.** By the late Professor DANIELL. With Plates. Two Volumes. Octavo. 22s.
- Gout, Chronic Rheumatism, and Inflammation of the Joints.** By ROBERT BERTLEY TODD, M.D., F.R.S. 7s. 6d.
- Physiological Anatomy and Physiology of Man.** By Dr. TODD and W. BROWMAN, F.R.S. With numerous Illustrations. Part III., 7s. Volumes I., 15s.
- Connexion of Natural and Divine Truth.** By HADEN POWELL, M.A., F.R.S., Professor of Geometry, Oxford. 9s.
- Undulatory Theory as applied to the Dispersion of Light.** By the same Author. Octavo. With a coloured Chart of the Prismatic Spectra. 9s.
- The Philosophy of Living.** By HENRY MATEO, M.D., formerly Surgeon to the Middlesex Hospital. Third and Cheaper Edition, with Additions. 5s.
- Management of the Organs of Digestion in Health and in Disease.** By the same Author. Second Edition. 6s. 6d.
- Minerals and their Uses.** By J. R. JACKSON, F.R.S. With coloured Frontispiece. 7s. 6d.
- Lectures on Dental Physiology and Surgery.** By J. TOMES, F.R.S., Surgeon-Dentist to the Middlesex Hospital. Octavo. With 100 Illustrations. 12s.
- Instructions in the Use and Management of Artificial Teeth.** By the same Author. With Illustrations. 3s. 6d.
- Practical Geology and Mineralogy, and the Chemistry of Metals.** By JOSUA TRIMMER, F.G.S. Octavo, with Two Hundred Illustrations. 12s.
- Practical Chemistry for Farmers and Landowners.** By the same Author. 5s.
- Practical Geodesy, comprising Chain Surveying, the Use of Surveying Instruments, Levelling, Trigonometrical, Mining, and Maritime Surveying.** By BUTLER WILLIAMS, C.E. New Edition, with Chapters on Estate, Parochial, and Railroad Surveying. With Illustrations. 12s. 6d.
- Manual for Teaching Model-Drawing; with a Popular View of Perspective.** By the same Author. (Under the Sanction of the Committee of Council on Education.) Octavo, with shaded Engravings. 15s.
- Instructions in Drawing. Abridged from the above.** 3s.
- Chemistry of the Crystal Palace: a Popular Account of the Chemical Properties of the Chief Materials Employed in its Construction.** By T. GRIFITHS, Professor of Chemistry in St. Bartholomew's Hospital.
- Chemistry of the four Ancient Elements.** By the same Author. With numerous Illustrations. Second Edition. 4s. 6d.
- Recreations in Chemistry.** By the same Author. Second Edition, with numerous Illustrations, much Enlarged. 5s.
- Recreations in Physical Geography; or, the Earth as it is.** By MISS R. M. ZOANLIN. Third Edition. 6s.
- World of Waters; or, Recreations in Hydrology.** By the same Author. Second Edition. 6s.
- Recreations in Geology.** By the same Author. Second Edition. 4s. 6d.
- Young Italy.** By A. BAILLIE COCHRANE, M.P. Post 8vo. 10s. 6d.
- Wales: The Social, Moral, and Religious Condition of the People, considered especially with reference to Education.** By SIR THOMAS PHILLIPS. Octavo. 14s.
- Memoir of Edward Copleston, D.D., Bishop of Llandaff, with Selections from his Diary and Correspondence, &c.** By W. J. CORLETON, M.A., Rector of Cronhill.
- Schiller's Complete Poems, including all his early suppressed Pieces, together with the Poems introduced in his Dramatic Works, attempted in English.** By EDGAR ALFRED HOWLAND.
- Correspondence of Sir Isaac Newton and Professor Cotes, and other unpublished Letters and Papers of Newton.** Edited, with Synoptical View of Newton's Life, by J. BOLTON, M.A., Fel. Trin. Col. Cambridge. With Portrait. Octavo. 10s.
- Shipwrecks of the Royal Navy.** Compiled principally from Official Documents in the Admiralty. By WILLIAM D. S. GILLY. With a Preface by W. S. GILLY, D.D., Canon of Durham. Second Edition. 7s. 6d.
- The Saint's Tragedy; the true Story of Elizabeth of Hungary.** By O. KINOLEY, Rector of Eversley. With Preface, by Professor MAURICE. Cheaper Edition.
- Yeast: a Problem. Reprinted, with Additions and Alterations, from Fraser's Magazine.** 9s.
- The Professor's Wife: a Tale from the German of Auerbach.** 3s. 6d.
- Chance and Choice; or, the Education of Circumstances. Two Tales.—I. The Young Governour.—II. Claudine de Soligny.** 7s. 6d.
- Anchar: a Story of the North.** By RICHARD JOHN KING. 7s.
- Brampton Rectory; or, the Lesson of Life.** Second Edition. 8s. 6d.
- Compton Merivale: another Leaf from the Lesson of Life.** By the Author of *Brampton Rectory*. 8s. 6d.
- John Sterling's Essays and Tales.** Edited, with a Sketch of the Author's Life, by ARCHDEACON HARE. Two volumes, with Portrait. 21s.
- The City of God; a Vision of the Past, the Present, and the Future.** By E. HUDON, Rector of Bratton. 8s. 6d.
- Chronicles of the Seasons; or, the Progress of the Year: being a Course of Daily Instruction and Amusement, selected from the Popular Details of the Natural History, Science, Art, Antiquities, and Biography of our Father-land. In Four Books.** 3s. 6d. each.
- Travels in the Track of the Tea Thousand Greeks; a Geographical and Descriptive Account of the Expedition of Cyrus, as related by Xenophon.** By W. F. AINSWORTH, F.R.G.S. 7s. 6d.
- The Holy City; Historical, Topographical, and Antiquarian Notices of Jerusalem.** By G. WILLIAMS, B.D., Fellow of King's College, Cambridge. Second Edition, with numerous Illustrations and Additions, and a Plan of Jerusalem, from the Ordnance Survey. Two large Volumes. 22s.
- \* The Plan is published separately, with a Memoir, 9s.; or mounted on Rollers, 15s.
- History of the Holy Sepulchre.** By Professor WILLIS. Reprinted from Williams's Holy City. With Illustrations. 9s.
- Notes on German Churches.** By W. WHEWELL, D.D., Master of Trinity College, Cambridge. Third Edition. 12s.
- Handbook for New Zealand.** Recent Information, compiled for the Use of intending Colonists. 6s.

Strand, London.

Edward Copleston, D.D., Landaff, with Selections from his Correspondence, &c. By W. B. M.A., Rector of Cromhall.

Complete Poems, including suppressed Pieces, together being introduced in his Dramatic Works in English. By EDGAR WAIN.

Life of Sir Isaac Newton, with other unpublished Papers of Newton. Edited, with a Life of Newton's Life, by W. B. M.A. Fel. Trin. Coll. Camb. Portrait. Octavo, 10s.

Officers of the Royal Navy. Compiled from Official Documents. By WILLIAM B. GILLY, Esq. Preface by W. B. GILLY, Esq., Barrister. Second Edition. 7s. 6d.

Tragedy; the true Story of Hungary. By C. KINGOLD, Esq. With Preface, by W. B. M.A. Cheaper Edition.

Problem. Reprinted, with Alterations, from *Frazer's* 9s.

Author's Wife: a Tale from the Annals of Auerbach. 3s. 6d.

Choice: or, the Education of a Young Man. Two Tales.—I. The Education of a Young Man.—II. Claudine de Seignac. 2s. 6d.

Story of the North. By JOHN KING. 7s.

Rectory: or, the Lesson of a Year. Second Edition. 8s. 6d.

Merrivale: another Leaf from the History of a Young Man's Life. By the Author in Rectory. 8s. 6d.

Author's Essays and Tales. A Sketch of the Author's Life, from 1825 to 1845. Two volumes, with Illustrations. 10s.

of God; a Vision of the Present, and the Future. By the Rector of Stratton. 8s. 6d.

of the Seasons; or, the Year: being a Course of Instruction and Amusement, selected from the most popular Details of the Natural History, Art, Antiquities, and of our Father-land. In Four Parts. 4s. each.

the Track of the Ten Tribes: a Geographical and Historical Account of the Expedition of the Israelites, as related by Xenophon. By W. F. F. R.G.S. 7s. 6d.

City; Historical, Topographical, and Antiquarian Notices of the City of London. By G. WILLIAMS, B.D., Fellow of Trinity College, Cambridge. Second Edition, with numerous Illustrations, and a Plan of Jerusalem, from the Survey. Two large Volumes. 10s.

published separately, with a Map. Mounted on Rollers. 10s.

the Holy Sepulchre. By WILLIAM. Reprinted from *Willis's* City. With Illustrations. 9s.

Man Churches. By W. B. M.A., Master of Trinity College, Cambridge. Third Edition. 12s.

or New Zealand. Recent Discoveries, compiled for the Use of Inhabitants. 6s.

View of the Art of Colonization. By E. GIBSON WAKEFIELD. Octavo. 12s.

Commentary on the Cuneiform Inscriptions of Babylonia and Assyria. By Lieut.-Colonel RAWLINSON. Octavo. 3s.

Arundines Cami, sive Musarium Cambisidum Locus Canoni, coligit eque editit HENRICUS DRURY, M.A. Third Edition. 12s.

The New Cratylus; Contributions towards a more Accurate Knowledge of the Greek Language. By J. W. DONALDSON, D.D., Head Master of King Edward the Sixth's School, Bury St. Edmunds. Second Edition, Octavo, much enlarged. 18s.

Agamemnon of Æschylus, the Text, with a Translation into English Verse, and Notes. By J. CONINGTON, M.A., Fellow of University College, Oxford. 7s. 6d.

Æschylus translated into English Verse. With Notes, Life of Æschylus, and a Discourse on Greek Tragedy. By J. STUART BLACKIE, Professor of Latin in Marischal College, Aberdeen. Two Volumes. 16s.

Phædrus, Lysis, and Protagoras of Plato. Translated by J. WAGNOT, M.A., Master of Sutton Coldfield School. 4s. 6d.

Homeric Ballads: the Text, with Metrical Translations and Notes. By the late Dr. MAONIX. 6s.

Tacitus, the Complete Works, with a Commentary, Life of Tacitus, Indices, and Notes. Edited by Professor RITZER, of Bonn. Four Volumes. Octavo. 28s.

Aristophanis Comœdiæ Vndecim, cum Notis et Indice Historice, editit HENRICUS A. HODGINS, A.M. Coll. Trin. Cant. Socius. Octavo. 15s.

Aulularia and Menœchmi of Plautus, with Notes by J. HILDYARD, B.D., Fellow of Christ's Coll., Camb. 7s. 6d. each.

Antigone of Sophocles, in Greek and English, with Notes. By J. W. DONALDSON, D.D., Head Master of Bury School. 9s.

Pindar's Epinician Odes, and the Fragments of his Lost Compositions, revised and explained; with copious Notes and Indices. By Dr. DONALDSON. 16s.

Becker's Gallus; or, Roman Scenes of the Time of Augustus, with Notes and Excursions. Translated by F. METCALFE, M.A. Second Edition. 12s.

Becker's Charicles; or, Illustrations of the Private Life of the Ancient Greeks. Translated by F. METCALFE, M.A. 12s.

Speeches of Demosthenes, against Aphiæus and Onetor, translated, with Explanatory Notes, by C. HASEN KENNEDY, M.A., Fellow of Trin. Coll., Camb. 9s.

Cambridge Greek and English Testament. Edited by J. SCHLEIFER, M.A., Professor of Greek in the University. Third Edition. 7s. 6d.

Sacred Latin Poetry; with Notes and Introduction. By R. C. TARRANT, B.D. 7s.; or 14s. bound in antique calf.

New Hebrew Lexicon. Hebrew and English, arranged according to the primitive letters in each word. English and Hebrew. With a Hebrew Grammar, Vocabulary, and Analysis of the Book of Genesis. Also, a Chaldee Grammar, Lexicon, and Analysis of the Old Testament. By T. JABART, M.A., Professor of Arabic, Cambridge. Octavo. 21s.

Guide to the Hebrew Student. By H. H. HENNING, Teacher of Hebrew, Cambridge. 10s. 6d.

The Psalms in Hebrew, with Critical, Exegetical, and Philological Commentary. By G. FULTON, B.D., Fellow and Tutor of Queen's College, Cambridge. Two Volumes. 32s.

Elements of Syriac Grammar. By G. PHILLIPS, B.D. Second Edition. 10s.

Practical Arabic Grammar. By DUNCAN STEWART. Octavo. 10s.

History of the Christian Church. By the late Professor BUAYOR, of Oxford. Eighth and Cheaper Edition. 5s.

Outlines of Sacred History. Twelfth and Cheaper Edition. 2s. 6d.

History of the Church of England. By T. VOLZELER SMYTH, D.D., Bishop of St. Asaph. Fifth Edition. Octavo. 10s.

Burnet's History of the Reformation, abridged. Edited, with Additions, by H. E. COX, B.D., Norrison Professor of Divinity, and Master of Jesus College, Cambridge. 10s. 6d.

History of the English Reformation. By F. C. MASSINGHAM, M.A., Rector of South Ormsby. Second Edition. 6s.

History of Popery; the Origin, Growth, and Progress of the Papal Power; its Political Influence, and Effects on the Progress of Civilization. 9s. 6d.

The Anglo-Saxon Church, its History, Revenue, and General Character. By H. BOAKS, M.A., Chancellor of St. Paul's Cathedral. Third Edition. 10s. 6d.

Elizabethan Religious History. By the same Author. Octavo. 16s.

Ullmann's Gregory of Nazianzum. A Contribution to the Ecclesiastical History of the Fourth Century. Translated by G. V. COX, M.A. 6s.

Nonand's Julian the Apostate and his Generation: an Historical Picture. Translated by G. V. COX, M.A. 3s. 6d.

Dahlmann's Life of Herodotus, drawn out from his Book. With Notes. Translated by G. V. COX, M.A. 5s.

Student's Manual of Ancient History. By W. COOPER TAYLOR, LL.D. Fifth Edition. 10s. 6d.

Student's Manual of Modern History. By the same Author. Fifth Edition, with New Supplementary Chapter. 10s. 6d.

History of Mohammedanism. Cheaper Edition. By the same Author. 4s.

Crusaders; Scenes, Events, and Characters from the Times of the Crusades. By T. KNIGHTER. 7s.

Historical Sketch of the British Army. By G. R. GLAZIO, M.A., Chaplain General to the Forces. 3s. 6d.

Family History of England. By the same Author. With numerous Illustrations. Three Volumes. 6s. 6d. each.

School History of England, abridged from Glæbe's Family History of England; with copious Chronology, List of Contemporary Sovereigns, and Questions. 6s.

Familiar History of Birds. By E. STANLEY, D.D., Bishop of Norwich. Fifth Edition, with numerous Illustrations. 5s.

Lives of Eminent Christians. By R. B. HOWE, M.A., Archdeacon of Worcester. New Edition. Four Volumes. 4s. 6d. each.

Bishop Jeremy Taylor; his Predecessors, Contemporaries, and Successors. By HAV. R. A. WILMOT. Second Edition. 5s.

Lives of English Sacred Poets. By the same Author. Two Vols. 4s. 6d. each.

Notes on the Parables. By H. CHURCHMAN TAYLOR, B.D. Examining Chaplain to the Lord Bishop of Oxford. Fourth Edition. Octavo. 12s.

Notes on the Miracles. By the same Author. Third Edition. 12s.

Literature of the Church of England, exhibited in Specimens of the Writings of Eminent Divines, with Memoirs of their Lives, and Sketches of the Times in which they lived. By R. CATTELL, B.D. Two Volumes. Octavo. 25s.

Essays on Peculiarities of the Christian Religion. By R. WHATELY, D.D., Archbishop of Dublin. Cheaper Edition. 7s. 6d.

Essays on Difficulties in the Writings of the Apostles Paul. By the same Author. Cheaper Edition. 8s.

Essays on the Errors of Romanism having their Origin in Human Nature. Cheaper Edition. By the same Author. 7s. 6d.

Essays on Dangers to Christian Faith from the Teaching or the Conduct of its Professors. By the same Author. 10s.

Mission of the Comforter. By J. C. HAAR, M.A., Archdeacon of Lewes. Second Edition. Octavo. 12s.

The Victory of Faith. By the same Author. Second Edition. 5s.

Parish Sermons. By the same Author. Two Series. Octavo. 12s. each.

The Church a Family: Sermons on the Occasional Services of the Prayer-Book. By F. D. MAURICE, M.A., Professor of Divinity in King's College. 4s. 6d.

The Prayer Book; specially considered as a Protection against Romanism. By the same Author. 5s. 6d.

The Lord's Prayer. Nine Sermons. By the same Author. Third Edition. 2s. 6d.

The Religions of the World, and their Relations to Christianity. By the same Author. Cheaper Edition. 6s.

Lectures on the Epistle to the Hebrews; with a Review of Newman's Theory of Development. By the same Author. Octavo. 7s. 6d.

Christmas Day, and other Sermons. By the same Author. Octavo. 10s. 6d.

Lectures on the Characters of our Lord's Apostles. By a Country Pastor. 3s. 6d.

Lectures on the Scripture Revelations respecting Good and Evil Angels. By the same Author. 3s. 6d.

View of the Scripture Revelations respecting a Future State. Sixth Edition. By the same Author. 5s.

Twenty-five Village Sermons. By C. KINGSLEY, Jun., Rector of Eversley. 5s.

Churchman's Theological Dictionary. By R. EDEN, M.A., Chaplain to the Bishop of Norwich. Second Edition. 5s.

Statutes relating to the Ecclesiastical and Eleemosynary Institutions of England, Wales, Ireland, India, and the Colonies; with Decisions. By A. J. STEPHENS, M.A., F.R.S. Two large Volumes, with copious Indices, £3 3s.

Published by JOHN W. PARKER & SON, West Strand, London.

## STANDARD FRENCH SCHOOL-BOOKS,

BY THE LATE M. DE ROULLION.

1. **GRAMMATICAL INSTITUTES OF THE FRENCH LANGUAGE**; or, the Teacher's French Assistant: containing a Series of Theoretical, Practical, and Progressive Lessons, in which every difficulty is explained, either in Notes at the end of each Exercise, or by References to preceding Rules. 8th Edition, 5s. half-bound.—Key to the same, 3s.

2. **EXERCISES ON FRENCH CONVERSATION**; or, a Selection of English Sentences to be translated into French; and in which the difference of the Idioms, Genius, and Phrasology of the French and English Languages may be readily distinguished. 6th Edit. 18mo. 3s. 6d. half-bound.—Key to the same, 2s.

3. **THE TOURIST'S FRENCH COMPANION**; or, Familiar Conversations on every subject which can be useful to the Continental Traveller or the French Student in general. 13th Edit. 18mo. 4s. 6d.

\*.\* The sale of more than 30,000 copies of this work strongly attests its value. The sentences are expressed in elegant language, and, in order to facilitate the pronunciation, the *silent letters* are printed in italics.

London: LONGMAN and Co.; HAMILTON and Co.; SIMPKIN, MARSHALL, and Co.; WHITTAKER and Co.; W. ALLAN; and AYLOTT and JONES. Norwich: CLAS, MUSKETT. And all Booksellers. [1 157

## UNCLE TOM'S PICTORIAL MAGAZINE, Monthly.

Price Two-pence. With numerous Illustrations by GILKS. **THE LITTLE CHILD'S PICTORIAL MAGAZINE**: edited by UNCLE TOM.—"Is so cheap that it may have a place in every house; and so good that it cannot have a place anywhere without conferring benefit."—*Liverpool Times*.

London: KENT and Co., PATERNOSTER-ROW. [1 194

**FOREIGN BOOK DEPOT, 50, BURLINGTON-ARCADE**.—F. HORNCASTLE receives all new Foreign Books as soon as out; has always on hand the best French, German, Spanish, and Italian Works of all descriptions, and executes all orders from the Continent at the rate of a shilling per franc. Maps, Guide-books, &c.—Five languages spoken. [1 14

## THE HANDBOOK

## On the County Courts,

Price 3s.; bound in cloth, with Coloured District Map, 4s. 6d. By D. E. COLOMBINE, Solicitor, 87, St. Martin's-lane, and 3 (a), John-street, Brompton. [1 114

Published by SIMPKIN, MARSHALL, and Co., Stationers'-court,

## NEWSPAPER FOR THE FARMING AND GARDENING INTEREST.

Every Saturday is published, price Sixpence, free by Post, each Volume complete in itself,

Enlarged to Twenty-four Folio Pages,

## THE GARDENERS' CHRONICLE

AND

## AGRICULTURAL GAZETTE;

A Weekly Record of Rural Economy and General News.

THE HORTICULTURAL PART EDITED BY PROFESSOR LINDLEY

**THE FARMING PART** (under the Editorship of a practical Farmer) treats of—

*The Practice of Agriculture*  
*Agricultural Science*  
*Animal and Vegetable Physiology*  
*Improvements in Implements, described*  
*by Woodcuts whenever requisite*  
*Better modes of Husbandry*

*Results of Experimental Farming*  
*Growth and Rotation of Crops*  
*Management of Stock*  
*Veterinary Science*  
*Drainage*  
*Irrigation*

*Forestry*  
*Road-making*  
*Farm-Buildings*  
*Labourers*  
*Treatment of Poultry*  
*Agricultural Publications*

In short, whatever affects the beneficial employment of capital in land.

Reports are regularly given of the English, Scotch, and Irish Agricultural Societies and Farmers' Clubs—London Market Prices of Corn, Hay, Cattle, Seeds, Hops, Potatoes, Wool, Coal, Timber, Bark, &c., and the Weekly Averages.

**AS REGARDS THE GARDENING PART** (under the Editorship of Dr. Lindley), the principle is to make it a weekly record of everything that bears upon Horticulture, Floriculture, Arboriculture, or Garden Botany, and such Natural History as has a relation to Gardening, with Notices and Criticisms of all Works on such subjects. Connected with this part are

## WEEKLY CALENDARS OF GARDENING OPERATIONS,

given in detail, and adapted to the objects of persons in every station of life; so that the Cottager, with a few rods of ground before his door, the Amateur who has only a Greenhouse, and the Manager of extensive Gardens, are alike informed of the routine of Operations which the varying seasons render necessary. It moreover contains Reports of Horticultural Exhibitions and Proceedings—Notices of Novelties and Improvements—in fact, everything that can tend to advance the Profession, benefit the condition of the Workman, or conduce to the pleasure of his Emplo. or. Woodcuts are given whenever the matter treated of requires that mode of illustration.

**REPLIES TO QUESTIONS** connected with the object of the Paper are also furnished weekly.

Lastly, that description of **DOMESTIC AND POLITICAL NEWS** is introduced which is usually found in a Weekly Newspaper. It is unnecessary to dwell on this head further than to say, that the Proprietors do not range themselves under the banners of any Party; their earnest endeavours are to make **THE GARDENERS' CHRONICLE AND AGRICULTURAL GAZETTE** a full and comprehensive *Record of Facts* only—a Newspaper in the true sense of the word—leaving the Reader to form his own opinions: their object being the elucidation of the laws of Nature, not of Man. This reader is thus furnished, **IN ADDITION TO THE PECULIAR FEATURES OF THE JOURNAL**, with such information concerning the events of the day as supersedes the necessity of his providing himself with any other Weekly Paper.

A PROSPECTUS, WITH LIST OF CONTRIBUTORS, may be had on application, or by letter, at the Office, 5, Upper Wellington Street, Covent Garden, London. [1 75

**MAGAZINE**, Monthly. *Illustrations* by GILK. **PICTORIAL MAGAZINE**.—“Is so cheap that it is so good that it cannot conferring benefit.”

**PATERNOSTER-ROW**. [194] 50, BURLINGTON. **STLE** receives all new is always on hand the best *Illustrations* Works of all description on the Continent at the rate of Five Guide-books, &c.—Five [14]

**BOOK** *County Courts*, *Uncovered District Map*, 4s. 6d. *Cor. 87, St. Martin's-lane*, *not, Brompton*. [114] *and Co., Stationers'-court*.

**INTEREST.**

*itself*,

**CLE**

**News.** **LINDLEY**

*ing* *idings* *of Poultry* *ral Publications*

*ers' Clubs—London Market* *a Weekly Averages.* *ple is to make it a weekly* *Botany, and such Natural* *ects. Connected with this*

*ottage, with a few rods of* *ensive Gardens, are alike* *cover contains Reports of* *everything that can tend to* *Empire, &c. Woodcuts are*

*ually found in a Weekly* *do not range themselves* *ONICLE and AGRICULTURAL* *word—leaving the Reader* *Man. The reader is thus* *information concerning the* *aper.*

*office, 5, Upper Wellington* [176]

**MEDICAL WORKS LATELY PUBLISHED.**—  
1. On Neuralgia, Rheumatic, and other Painful Diseases. 2. On Headache. 3. On Cancer. 4. On Indigestion. 5. On Stricture of the Urethra. 6. On the present state of Therapeutical Inquiry.—By JAMES ARNOTT, M.D., formerly Superintending Surgeon (Hon. East India Company's Service) at St. Helena. JOHN CHURCHILL, 46, *Prince's-street, Soho*. [1256]

*Preparing for publication, in 1 Vol. 8vo.*  
**ESSAYS** on the ECONOMY OF SOCIETY; more particularly on the Causes, Prevention, and Punishment of Crimes—on Medical Police, and Disorders of the Public Health arising from Superstition and Misgovernment—and on the Management and Results of Institutions for Education and for the Poor. By BISSET HAWKINS, M.D. Oxon., F.R.S., late Inspector of Prisons, and Commissioner of Lunacy. [1231]

**A NEW and CHEAPER EDITION** OF MR. WEAVER'S HINTS ON COTTAGE ARCHITECTURE FOR AGRICULTURAL LABOURERS. Demy 4to., cloth, price 15s.

*Copy of a Letter from the Duke of Richmond.*  
“I beg to return you my best thanks for your work on Cottage Architecture, a publication which in my opinion was much required, and which does you very great credit.”  
“We heartily commend the work to the notice of the powerful and influential class to the use of which it is more especially directed.”—*Morning Chronicle*.  
London: HENRY POPE, 22, *Budge-row*; and by order of all *Booksellers*. [1247]

**NOW READY**, and sent free by post (only), from 63, LOWER KENNINGTON-LANE, in exchange for *eight post-paid stamps*, “THE FIRST FRUITS OF THE NATIONAL EXHIBITION EXPOSED.” By WILLIAM RADLEY, CH. E.—*These disclosures will amuse, surprise, and astound*. [1188]

**MOZART'S “DAVIDDE PENITENTE;”** adaptation to the Psalms by R. ANDREWS, as performed at the Norwich Festival, 1847; complete vocal score, full music size, 7s. 6d. The only complete edition published. London: R. ADDISON and Co., and RIEST and STAHL, *Regent-street*. [1222]

**BURNET ON PAINTING.**  
**A TREATISE ON PAINTING.**—In Four Parts. Illustrated by 130 Etchings and Woodcuts on celebrated pictures. By JOHN BURNET, F.R.S. 4to., 4l. 10s. cloth. The Parts may be had separately—  
1. On the Education of the Eye. 1l. 5s.  
2. On Composition. Sixth edition, 15s.  
3. On Light and Shade. Sixth edition, 18s.  
4. On Colour. Fifth edition, 1l. 11s. 6d.  
J. and J. LEIGHTON, 40, *Brewer-street, Golden-square*. [1251]

*Just published.*  
**A MAGNIFICENT PRINT OF**  
**THE CRUCIFIXION**, after the celebrated Painting of PETER PAUL RUBENS, at Antwerp; with a richly carved imitation Oak Frame, from the Original in the possession of JOHN FALSHAW PAWSON, Esq., of Littleberries, Mill-hill.  
Proofs . . . . . £1 11 6  
Prints . . . . . 1 1 0  
London: ACKERMAN and Co., *Strand*; and T. M. INCHNOLD, 13, *Paternoster-row*. [1224]

**A BALLOON VIEW OF LONDON** in 1851; Size, 42 by 25 in. (embracing 8 Square Miles), showing all the Railway Stations; the Great Exhibition; Rotunda for Wyl'd's Great Globe; all the Public Buildings, Squares, Streets, &c., with the names engraved thereon. To be had wholesale of BANKS and Co., Publishers, 4, Little Queen-street, Holborn; or of HARCOBT QUINCY, 82, Hatton-garden, *Agent for the Supply to Merchants and Shippers*. [1259]

**ADAMS'S BRITISH and FOREIGN NEWS-PAPER** and GENERAL ADVERTISING OFFICE, 3, PARLIAMENT-STREET, WESTMINSTER.—Orders and Advertisements received for every Newspaper published. London and Provincial Papers filed. Newspapers supplied in Town at the earliest hour, and regularly forwarded to the Country and every part of the Globe.—Papers lent to read. [1258]

**Complete Course of FRENCH INSTRUCTION**, in One Vol. DELILLE'S FRENCH GRAMMAR, Eighth Edition: with Engravings showing the position of the mouth for the French sounds, an Etymological Index, Vocabularies, Exercises, Reading Lessons, and a method of Tuition and Examination. 12mo., 5s. 6d.—Key to the Exercises of Deillie's Grammar, 3s.  
WHITTAKER and Co., *Ave-Maria-lane, London*. [161]

*Just published, in 8vo., price One Shilling.*  
**ENGLISHMEN INTRODUCED** to the FREE CHURCH OF SCOTLAND. By the Rev. DAVID C. A. AGNEW.  
London: JAMES NISBET and Co., 21, *BERNERS-ST.*; from whom may be had other pamphlets by the same Author. [189]

**WORKS BY PROFESSOR ANSTED, M.A., F.R.S., F.G.S., &c.**  
*Second Edition, post 8vo., 10s 6d., with 149 Illustrations.*  
**THE ANCIENT WORLD.** An Account of the Races of Animals and Vegetables that have from time to time inhabited our earth.  
“This is a very instructive and interesting book, bearing ample testimony to the knowledge and to the judgment of its author.”—*Examiner*.  
*In post 8vo., with 224 Illustrations, price 12s.*

**AN ELEMENTARY COURSE OF GEOLOGY, MINERALOGY, and PHYSICAL GEOGRAPHY.**  
“Amongst the numbers who have written successfully on Geology in this country the works of none take a higher position than those of Professor Ansted. No writer has more clearly and ably set out its great facts and principles.”—*Athenaeum*, Oct. 12, 1850.  
*And, in fcap. 8vo., price 3s. 6d.*

**THE GOLD-SEEKER'S MANUAL.**  
JOHN VAN VOORST, 1, *Paternoster-row*. [1117]

**To Tourists** {BLACK'S GUIDE-BOOKS & TRAVELLING MAPS.  
“They should find a corner in the portmanteau of every person about to undertake a journey of pleasure or business either in England and Wales, or Scotland.”—JOHN BULL.

Price 10s. 6d., a NEW EDITION, greatly enlarged, of **Black's Picturesque Tourist, and Road and Railway GUIDE-BOOK** through ENGLAND and WALES, containing 104 Routes, and 26 Maps and Charts, besides Views of the Scenery. The Index contains upwards of 5000 Names, with the Inns in all the Towns and Villages. The Volume is tersely written, closely printed, and portable.  
Price 10s. 6d., a THIRD EDITION (800 pp.), enlarged, of **Guide to the Highlands and Islands of Scotland**, including ORKNEY and ZETLAND, with Directions for visiting the Lowlands, Tables of Distances, Notices of Inns, and other Information. By GEORGE and PETER ANDERSON of Inverness.

Price 8s. 6d., an EIGHTH EDITION of **Black's Picturesque Tourist of Scotland—Highlands and Lowlands**—with 24 Maps, Plans, and Charts, and 50 Views of Scenery and Public Buildings.

**NEW EDITIONS OF**  
**Black's Guide to the English Lakes. 5s.**  
**Black's Economical Tourist of Scotland. 3s. 6d.**  
**Travelling Maps of England & Scotland. 2s. 6d. each.**  
**Black's County Maps of Scotland. 1s. each.**  
**Black's Maps of North & South Wales. 1s. 6d. each.**  
**Black's Tourist's Memorial of Scotland. 5s.**  
**Black's Iron Highways from London to Edinburgh & Glasgow; the one containing a Chart 64 inches long, the other a Chart of 46 inches. 1s. 6d. each.**

**Black's General Atlas OF THE WORLD—CORRECTED TO 1851.**  
With 61 Maps, and an Index of 55,000 Names. Folio, Half Bound in Morocco, Gilt Leaves, £3. 10s.

The work is in every respect accommodated to the present advanced state of geographical research; and, whether on the ground of accuracy, beauty of execution, or cheapness, the Publishers invite a comparison with any work of its class.  
“We are now in possession of an ‘Atlas’ which comprehends every discovery of which the present century can boast; it ought at once to supersede all other works of the kind, and no one, either in pursuit of truth on his own account, or attempting to direct the inquiries of others, will hereafter have any excuse for going astray.”—*United Service Gazette*.  
A. & C. BLACK, *Edinburgh*; and all *Booksellers*. [1207]



**NISSEN & PARKER,**  
STATIONERS, ENGRAVERS, AND PRINTERS,  
43, MARK LANE,  
Corner of Great Tower-street, London.

CHEMICALLY PREPARED PAPER FOR BANK CHEQUES.

**NISSEN AND PARKER** solicit inspection of their Printing for BANK CHEQUES on terms considerably lower than usually offered by the trade. *The enormous prices* that have been kept up by the London houses have long been an objection in establishments where the consumption of Cheques and Credit Letters is extensive.

The PAPER for Bank Cheques prepared by NISSEN and PARKER has proved to be the most effectual ever discovered for prevention of alteration by acids or alkalis; and during the past four or five years upwards of *Six Millions* of these Cheques have been supplied.

CHEQUES, on tinted paper (secure from any alteration by the application of acids), per ream of 4800, including all charges for engraving, &c. . . . 2l. 15s.

[Bound in slip books 1*l.* each, and numbered consecutively at a small additional charge.]

CONTRACTS ON A REDUCED SCALE FOR PUBLIC COMPANIES.

*Specimens and Designs free to all parts of the Kingdom.*

[copy.]

I have carefully examined, by appropriate Chemical Tests, the Paper for Bankers' Cheques prepared by Messrs. NISSEN and PARKER, and I think it to be well adapted to prevent the Writing upon them from being altered or effaced without leaving such traces as to insure detection.

(Signed) ANDREW URE, M.D., F.R.S.

London: 13, Charlotte-street, Bedford-square,  
Oct. 10, 1846.

[1 41

*Price Fourpence of any Bookseller, permanently enlarged to twenty-four large 4to. pages,*

**THE ATHENEUM** Journal of Literature, Science, and Art (Stamped to go free by post, 5*d.*), contains: Reviews, with copious extracts, of every important New English Book, and of the more important Foreign Works. Reports of the Proceedings of the Learned and Scientific Societies, with Abstracts of all Papers of Interest. AUTHENTIC ACCOUNTS of all Scientific Voyages and Expeditions. CARRICISMS ON ART, with Critical Notices of Exhibitions, Picture Collections, New Prints, &c. FOREIGN CORRESPONDENCE ON Subjects connected with Literature, Science, and Art. MUSIC AND DRAMA, including Reports on the Opera, Concerts, Theatres, New Music, &c. BIOGRAPHICAL NOTICES of Men distinguished in Literature, Science, and Art. ORIGINAL PAPERS and POEMS. MISCELLANEA, including all that is likely to interest the informed and intelligent.

The ATHENEUM is so conducted that the reader, however far distant, is, in respect to Literature, Science, and the Arts, on an equality in point of information with the best-informed circles of the Metropolis.

The ATHENEUM is published every SATURDAY, but is re-issued each Month stitched in a wrapper. [1 49

Now published, price 3*s.* 6*d.* cloth boards,

**THE PALACE OF FANTASY.**  
By J. T. HARDY.

SMITH, ELDER, and Co., 65, Cornhill.

[1 50

**NOTICES OF SEPULCHRAL MONUMENTS** IN ENGLISH CHURCHES, from the Norman Period to the present time; with numerous Illustrations, price 3*s.* 6*d.* By W. HASTINGS KELKE, Rector of Drayton Beauchamp.

London: C. Cox, 12, KING WILLIAM-STREET, STRAND.

"Such a Manual as Mr. Kelke's is most useful."—*The Britannia.*

"This book, we need not say, has considerable value."—*The Church and State Gazette.*

"Replete with interest; we may, in fact, call it a *maumet* in parvo of monumental lore."—*Leicester Journal.*

"A very interesting work, evincing considerable research."—*The Church of England Magazine.* [1 59

## DISSOLVING VIEWS.

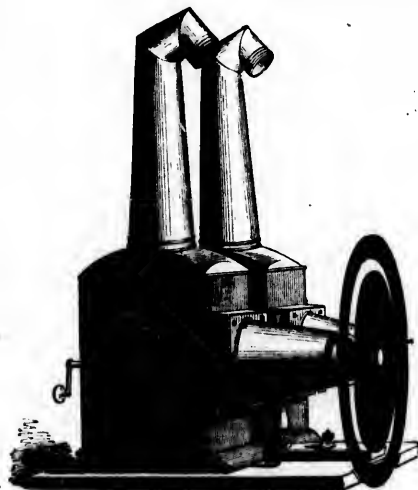

AMUSEMENT AND INSTRUCTION BY MEANS OF

**CARPENTER & WESTLEY'S**

IMPROVED

**PHANTASMAGORIA LANTERNS,**

WITH THE

CHROMATROPE AND DISSOLVING VIEWS,

AND EVERY POSSIBLE VARIETY OF SLIDERS,

INCLUDING

Natural History, Comic, Lever, Moveable and Plain,  
Astronomical, Views in the Holy Land,  
Scriptural, Portraits, &c.

No. 1 Lantern, with Argand-Lamp, in a Box, 2*l.* 12*s.* 6*d.*

No. 2 ditto, of a larger size, 4*l.* 14*s.* 6*d.*

A pair of Dissolving-View Lanterns, No. 2, with Apparatus, 1*l.* 11*s.*

*The Lamp for the No. 2 Lanterns is very superior. (The price of the Lanterns is without Sliders.)*

Public attention is called to the superiority of the Paintings executed for the Lanterns. A pair of the most IMPROVED LANTERNS, with Specimens of the Paintings, may be seen in the GREAT EXHIBITION.

*Paintings of any size or subject painted to order.*

Lists of the Sliders and Prices upon application to the Manufacturers, Messrs. CARPENTER & WESTLEY, Opticians, 24, Regent-street, Waterloo-place, London.

[1 24

permanently enlarged to 400 pages,  
 of Literature, Science, and Art, (by post, 5d.), contains: Royal Academy of Arts, Foreign Works, Reports of Societies, and Scientific Societies, Interest. AUTHENTIC Accounts of Expeditions, Carriages of Exhibitions, Picture Galleries, and Correspondence on Literature, Science, and Art. Reports on the Opera, Conventions, and Biographical Notices of the Living. Science, and Art. ORIGIN of Languages, including all that is new and intelligent. Selected that the reader, how- ever, of Literature, Science, and Art, of information with the most interesting. every SATURDAY, but is published in a wrapper. [149]

6d. cloth boards,  
**FANTASY.**  
 BY  
 J. B. BRYCE,  
 65, Cornhill. [150]

**MONUMENTS**  
 FROM THE NORMAN PERIOD,  
 WITH NUMEROUS ILLUSTRATIONS,  
 BY  
 J. B. BRYCE,  
 RECTOR OF DRAYTON BESSINGTON.

WILLIAM-STREET, STRAND.  
 Most useful.—*The Britannia*.  
 Considerable value.—*The Church*.  
 To be had, call it a *multum in parvo* of  
 considerable research.—*The*  
 [159]

BY MEANS OF  
**WESTLEY'S**

**LANTERNS,**  
 SHOWING  
 MOVING VIEWS,  
 AND SLIDERS,

Moveable and Plain,  
 of the Holy Land,  
 of the Alps, &c.

in a Box, 2l. 12s. 6d.  
 6d.  
 No. 2, with Apparatus,  
 superior. (The price of  
 Sliders.)

A pair of the most  
 GREAT EXHIBITION.  
 WESTLEY,  
 [194]

JUST PUBLISHED,  
*Third Edition, Price Twelve Shillings,*  
**SPECIMENS**  
 IN  
**ECCENTRIC**  
**CIRCULAR TURNING,**  
 WITH  
**PRACTICAL INSTRUCTIONS**  
 FOR  
**PRODUCING CORRESPONDING PIECES IN THE ART.**  
 Illustrated by Copper-plate Engravings, and Cuts referring to and explaining the different Figures to be executed.  
 BY **JOHN HOLT IBBETSON, Esq.**  
 WITH CONSIDERABLE ADDITIONS,  
 Including a Description and Copper-plate Engravings of the COMPOUND  
*Eccentric Chuck* constructed by the Author, and used by him in the execution of his Specimens.  
 LONDON:  
 LONGMAN, BROWN, GREEN, AND LONGMANS;  
 SIMPKIN AND MARSHALL.

[145]

### ENGRAVINGS at EDWARD LUMLEY'S, 56, Chancery-lane, London.

- ASCOT RACES, Return, very large. HENDERSON. *Finely coloured, 7s.*
- EPSON RACES. POLLARD. 6 plates, *elegantly coloured, 15s.*
- GRAND STANDS, Horses and Riders. TATTERSALL. 4 plates, *elegantly coloured, 12s.*
- ETAP HUNTING. 4 large highly coloured plates. TURNER. 10s.
- STEEPLE CHASE for 1000 guineas. ALKEN. *Highly coloured, 5s.*
- COACHING, Horses off, no Coachman. " *A pair, coloured, 8s.*
- SNOW STORM, Scenes of Distress. 4 coloured plates, 3s. 6d.
- HOUNDS, Queen's, at Ascot. LUCAS 1s.
- SHETLAND PONY, also Dog. 2 favourite specimens, coll., 3s. 6d.
- BULL FIGHT, Spanish, by LEWIS. *Highly coloured, 5s.*
- WHALE FISHERY, North Seas. *Exquisitely coloured, 5s.*
- " " Southern Seas. *A pair, finely coloured, 8s.*
- BURMESE WAR, with Descriptions. 24 plates, coloured, 15s.
- PHOENIX SLOOP attacking Gun-Boats, Java. Coloured, 3s.
- MADAGASCAR, War Steamer, on Fire. *Elegantly coloured, 5s.*
- PRINCE GEORGE, in Hurricane. Coloured, 3s.
- BENTONIC, Steamer, and Aden. HUGUINS. Coloured, 4s.
- BERENICE, War Ship, and Bombay Harbour, " " 4s.
- CLARENCE, Steamer, leaving Blackwall, " " 3s.
- CLYDE, in Hurricane, off Natal. " " 4s.
- COLUMBUS, Halifax Steamer, stiff breeze, " " 4s.
- COVES, and Lord Yarborough's Yacht. " " 4s.
- DEMERRA, George Town, Bark Caesar, &c. " " 4s.
- DUNDEE, Steamers, &c., very large view, " " 6s.
- EDINBURGH, Launch of, Blackwall, &c. " " 5s.
- FOLKESTONE, Sandgate, and Ship Melbourne, " " 4s.
- GRAVESEND, with Ship of War, *fine*, " " 5s.
- HAMBURGH, CALEDONIA, NEPTUNE, Steamers " " 5s.
- HARWICH, with Shipping, " " 4s.
- ST. HELENA, very fine view " " 5s.
- HINDOSTAN, and other Steamers; also
- " SOUTHAMPTON, " " 4s.
- LEITH, Monarch, Steamers, and Edinburgh, " " 4s.
- MADEIRA, Bay of Funchal, fine view, " " 4s.
- MALACCA, Pulo, Penang, Vessels, &c. " " 4s.
- MALTA and Vessels, very fine, " " 4s.
- CHINA, Lintin, Opium Ships, &c. *Brilliantly coloured, 4s.*
- " Whampoa, Junk, Rivers, fine scenery. *Exquisitely coloured, 6s.*
- CO. DONAL VIEWS.—CAPE COAST CASTLE, ALGOA BAY, GRAHAM'S TOWN, POINT ELIZABETH, TABLE BAY, HOBART TOWN, SYDNEY, MONTREAL, LAKE and FORT ERIE, SERRA LEONE, &c. *Very fine, and highly coloured. 4s. each.*
- POUSSIN. Holy Family, engraved by ANDERTONI, *very fine, 7s.*
- RAPHAEL. Madonna. SAV. 4s.
- CORREGGIO. Marriage of St. Catherine, 4s.
- REMBRANDT. Burgomasters. HOUSTON. 4s.
- WILKIE. Etard Boy. RAIMBEACH. 4s.
- VERNET. Storm at Sea. WOOLLETT. 4s.
- PARKER. Grace Darling and Survivors in Longstone Light-house. LEWIS. 5s.
- CARRACCI. ANNIBAL. Dead Christ and Maries, 4s.
- CALCOTT. Benevolent Cottagers. SCOTT. 2s.
- TENIERS. Temptation of St. Anthony. SULLIVAN. 4s.
- SPOTIARD. Blue Coat School Annual Orator, 91 portraits, 4s.
- WEIGALL. Death of Becket, High Altar, &c., 4s.
- SALVATOR ROSA. Jacob's Dream. REYNOLDS. 5s.
- VANDYKE. Time clipping Cupid's Wings. ARDELL. 4s.
- WESTALL. Girl at the Well. CHARLES HEATH. 2s.
- CLAUDE. Sun Rising; Sun Setting. MASON. *A pair, 4s.*
- CANALETTI. Views, *highly coloured, 4 plates, 2s.*
- REYNOLDS, SIR JOSUAH. Holy Family. SHARPE. 3s.
- " " New College Chapel Window. FACIUS. 3s.
- CRAIG. My Boy among the Roses. MAILE. 1s.
- STANFIELD. Portsmouth and Chatbam. *A pair, 2s.*
- COOPER, R. Stag, Roebuck, Deer. 3 prints, 2s.
- ADSLON. Angler, Milk Maid, and Izaak Walton. *A pair, 3s.*
- MARTIN. Macbeth and Witches. LUFTON. 3s.
- BEECHY. Hindoo Girl. PHILLIPS. 4s.
- HERRING. Tambourina, Italian Girl. LEWIS. 2s.
- SCOTT. Huguenot Family; Massacre of St. Bartholomew, 3s.
- LANE. Portrait Bishop Lincoln (*Dr. Kaye*). RYAN. 4s.
- PHOUT. Chartres Cathedral. *Splendid print. EGAN. 4s.*
- " " Rouen Palais de Justice, *finely coloured, 4s.*
- " " Louvain Hotel de Ville, " " 4s.
- " " Ulm Cathedral, " " 4s.
- CONEY. Certosa of Pavia, *superb building, 3s.*
- CATERMOLE. Westminster Abbey; Interior—Exterior.
- WOOLNATH. *A pair, 6s.*
- MALTON. York Minster. *Splendid engraving. LANDSEER. 2s. 6d.*

(See also Catalogue of Books and Prints.)

[1 233]

**ARTISTIC PRINTING ESTABLISHMENT,**  
19, LAMB'S CONDUIT-STREET, LONDON.—LEIGHTON BROTHERS respectfully invite inspection of their numerous and much-admired Works of Artistic Production in Drawing and Printing in the various styles of their Art.

**FAC-SIMILES OF WATER-COLOUR DRAWINGS,**  
(a style of Art of which they are the Inventors.)

LITHOGRAPHY, WOOD ENGRAVING, WOODCUT AND BLOCK PRINTING,

COMPRISING,

Portraiture (from life), Landscape, Figure, Architectural, and Anatomical Drawings; Book Illustrations and Illuminations; Music Titles, Plans, &c. &c., from the highest perfection of Colour-printing to the ordinary modes of Tinted and Plain.

LEIGHTON BROTHERS also lay themselves out for producing Manufacturers' Pattern Books, as in the 'Art Journal' of May (and the following months), and the various other styles.

[1 244]

To Advertisers in the Manufacturing Districts.

**THE MANCHESTER EXAMINER & TIMES** is one of the Provincial Journals of LARGEST CIRCULATION in the Kingdom, its average during the last year having exceeded 6000. The days of publication are *Wednesday and Saturday*. The EXAMINER AND TIMES, besides its Manchester circulation, is extensively read in all the chief towns of Lancashire, &c.—viz. Stockport, Bolton, Rochdale, Oldham, Bury, Ashton, Staleybridge, Wigan, Macclesfield, Preston, Warrington, Liverpool, Blackburn, Todmorden, Burnley, Bradford, Halifax, Huddersfield, &c. &c.

TERMS, CASH IN ADVANCE.

|          |                 |     |                 |      |                |     |
|----------|-----------------|-----|-----------------|------|----------------|-----|
| 10 lines | —one insertion, | 5/0 | six insertions, | 4/0  | 12 insertions, | 3/6 |
| 15 "     | "               | 6/6 | "               | 8/0  | "              | 4/5 |
| 20 "     | "               | 8/0 | "               | 9/6  | "              | 5/6 |
| 25 "     | "               | 9/6 | "               | 11/0 | "              | 7/6 |

An intermediate or greater number of lines charged in proportion. In estimating the number of lines, calculate nine words to each line. All communications, Post Office orders, &c., to be addressed to ALEXANDER IRELAND & Co., 22, Market-street, Manchester.

[1 233]

**ECROYD SMITH'S DESIGNS** for Ornamental Floors, faithfully restored from the Antique, in beautifully coloured Lithographs on the best paper, may be procured at No. 20, OLD BOND-STREET; or of Mr. J. RUSSELL SMITH, Publisher, 4, OLD COMPTON-STREET, SOHO, LONDON. For specimens, see Official Catalogue and Exhibition. [121]

**WAX FLOWERS**, by Mrs. TEMPLE, 46, COXNAUGHT TERRACE, HYDE PARK. The group exhibited contains a plant of the *Amherstia Nobilis* (one of the rarest plants in Europe), 16 species of very choice Orchids, some choice Climbers, and other exotic cultivated flowers, all modelled from nature, botanically correct, and executed by Mrs. Temple herself for the Exhibition. [1 287]

**ORLANDO JEWITT, ENGRAVER ON WOOD, OXFORD.**—For Specimens, see the following Works in the Exhibition:—Rickman's 'Gothic Architecture'; 'Glossary of Architecture'; 'Churches of Northamptonshire'; and 'Domestic Architecture.' Published by Mr. PARKER, of Oxford. [1 237]

**TO COIN COLLECTORS and OTHERS.**—A very extensive Collection of GOLD, SILVER, and COPPER COINS for SALE, in the Greek, Roman, and English series. Gentlemen forming cabinets can be supplied with selections at a moderate charge. The collection includes many rare reverses, and the Coins are mostly in fine condition. A great variety of Medals, amongst which may be mentioned Mudie's National Series, in silver and bronze; Dassler's Kings of England, War Medals, &c.; Mint Proofs of George IV., William IV., and Victoria; Cabinets of all sizes; and Numismatic Works, Antique Bronzes, Gems, Ivory Carvings, and other articles of taste. Apply to W. CHAFFERS, Jun., 20, OLD BOND-STREET, LONDON.

N.B.—A Catalogue, with the price attached to each Coin, is just published, price 1s.

A Museum of National Antiquities, a large Cabinet of Roman Glass, and other interesting objects of Ancient Art, may be seen any day between 2 and 5 P.M.

Coins and other Antiquities bought or exchanged. [1 216]

NEW AND VALUABLE WORKS.

To MEMBERS OF PARLIAMENT. *A New Edition, brought down to the present time.*

The Progress of the Nation,

IN ITS VARIOUS SOCIAL AND ECONOMICAL RELATIONS, FROM THE BEGINNING OF THE NINETEENTH CENTURY.

By G. R. PORTER, Esq., F.R.S., *Instit. Reg. Sc. Paris Cor.*

CONTENTS.

Section I.—POPULATION.—Increase.—Medical Statistics.—Occupations of the People.—Pauperism.—Emigration.  
 Section II.—PRODUCTION;—Agriculture.—Manufactures: Woven, &c., Fabrics; Iron, Steel, Brass, Copper, Plated Wares, Glass, Hardware; Machinery.—Mining.  
 Section III.—INTERNAL AND EXTERNAL COMMUNICATION.—Turnpike Roads.—Canals.—Steam Navigation.—Railways.—Coasting Trade.—Trade between Great Britain and Ireland.—Weights and Measures.—Foreign Commerce.—Progress of Trade in Foreign Countries.—Prussian Commercial League.—Currency.—Coinage.—Wages.—Measurement and Classification of Shipping.—Warehousing System.  
 Section IV.—PUBLIC REVENUE AND EXPENDITURE.—Financial Situation of the Kingdom at the Beginning of the present Century.—Public Income and Expenditure.—Produce of Taxes.—War Expenditure.—Miscellaneous Estimates.—County and Parochial Expenditure.  
 Section V.—CONSUMPTION:—Employment and Pecuniary Means.—Houses.—Bricks.—Male Servants.—Carriages.—Horses.—Plate.—Food.—Tobacco.—Paper.—Soap.—Candles.—Manufactures.—Metals.—Number.—Prices.  
 Section VI.—ACCUMULATION:—Conditions of Accumulation.—Increase of Personal and Real Property.—Investments of Accumulation for Public Objects.—Investments for Commercial Purposes.  
 Section VII.—MORAL PROGRESS:—Introduction.—Crime.—Manners.—Education.—Post-Office, &c.  
 Section VIII.—COLONIES AND FOREIGN DEPENDENCIES.—Advantages of Colonies.—Dependencies in Europe.—Dependencies in Asia.—Settlements in Australasia.—Dependencies in Africa.—British America.—West India Islands and Settlements.

JOHN MURRAY, Albemarle-street.

*Dedicated, by permission, to His Royal Highness Prince Albert.*

Now ready, in 2 vols. royal 8vo., cloth boards, price 1l. 5s. each,

THE ROYAL PHRASEOLOGICAL  
 French-English and  
 English-French Dictionary.

By J. C. TARVER, French Master, Eton College.

"Most readily do we acknowledge the flood of light which has been thrown on French phrases by M. Tarver. . . His work is really a valuable addition to our Dictionary shelf—the most important shelf in every man's library. The nice skill with which he has compared and contrasted the phrases of the two most influential of modern tongues can hardly be over-praised."—*Quarterly Review*, September, 1850.

DULAU & Co., Soho-square.

*Dedicated, by Royal Authority, to H. M. the Queen.*

This day is published, one vol. royal 8vo., price Two Guineas,

O'Byrne's Naval Biography  
 OF ALL LIVING OFFICERS,

FROM THE RANK OF ADMIRAL OF THE FLEET TO THAT OF  
 LIEUTENANT, INCLUSIVE.

"The Admiralty have awarded the compiler of that eminently useful and valuable book of reference, O'Byrne's Naval Biography, the sum of 100l., as a mark of their Lordships' appreciation of the labour and perseverance therein exhibited."—*Times*, Dec. 24, 1849.

Third Edition. 3 vols. post 8vo. 18s.

Family Arabian Nights.

Illustrated with 600 Woodcuts by WILLIAM HARVEY.

JOHN MURRAY, Albemarle-street.

NEW WORK BY SIR H. DE LA BECHE.

The Geological Observer.

By Sir HENRY T. DE LA BECHE, C.B., F.R.S., &c.  
 Director-General of the Geological Survey of the United Kingdom.

Third Edition, corrected, enlarged, and improved. In 2 vols. demy 8vo., price Two Guineas,

A Descriptive and Statistical  
 Account of the British Empire:

Exhibiting its Extent, Physical Capacities, Population, Industry, and Civil and Religious Institutions.

By J. R. McCULLOCH, Esq., Member of the Inst. of France.

CONTENTS.

Part I.—Extent, Physical Circumstances, and Civil Divisions of the United Kingdom.  
 Part II.—Population of the United Kingdom.  
 Part III.—Industry of the United Kingdom—Agriculture—Mining and Minerals—Fishes—Manufactures—Commerce.  
 Part IV.—Constitution and Government, Civil and Religious, of the British Empire—Rise and Progress of the English Constitution—Parliament, its Constitution, Procedure, &c.—Of the Executive—Courts of Justice, Civil and Criminal—Municipal Corporations—History, Constitution, Courts, &c., of Scotland—Political History, Constitution, Courts, &c., of Ireland—Religious Establishments of Great Britain and Ireland.  
 Part V.—Establishments for Public Education—Revenue and Expenditure—Defence: Army, Militia, &c., Navy—Crimes, Punishments, and Prisons—Improvements of Food, Clothing, and Lodging—Classification and Income of the People—Colonies and Dependencies—Vital Statistics—Suggestions as to the Means of promoting Health in Great Britain—Provision for the Poor—Origin and Progress of the English Language.

LONGMAN, BROWN, GREEN, and LONGMANS.

Price 3s. Third Edition of 3000 copies, with  
 A NEW CHAPTER ON POISONS

Household Surgery;  
 OR, HINTS ON EMERGENCIES.

With many additional Hints.

By JOHN F. SOUTH, Surgeon to St. Thomas's Hospital.

*Extract from Preface to the Third Edition.*

"It having been suggested that it would be advantageous in a little book, now on most folks' table, to add some hints of what should be done when poison has been accidentally or purposely taken, and the prompt determination and counteraction of which is of the first importance, I prevailed on my friend Dr. Gladstone to furnish me with a short notice of the more common poisons, and the mode in which they may be managed forthwith, in the absence or during the delayed attendance of a person of either of the three denominations; and he has executed his task with much ability and plainness, so that the most simple person may easily follow out his directions."

Price 13s. cloth, or in Twelve Shilling Parts, the

Works of William Shakspeare.

Illustrated by W. HARVEY.

CONTAINING HIS PLAYS AND POEMS, FROM THE TEXT OF THE EDITIONS BY CHARLES KNIGHT;

With Explanatory Notes and Facts connected with his Life and Writings.

C. Cox, 12, King William-street, Strand.

me, London.  
 EAST CASTLE, ALGOA BAY,  
 FISH TABLE BAY, HOBART  
 TOWN, and FORT ERIE, SIERRA  
 LEONE, &c. each.  
 Beautifully coloured. 4s. each.  
 By ANDERSON, very fine, 7s.

Merline, 4s.  
 Ouston, 4s.  
 Phil, 4s.  
 Pett, 4s.  
 Vivors in Longstone Light.

and Maries, 4s.  
 Scott, 2s.  
 Hon. SULLIVAN, 4s.  
 Oration, 9l portraits, 4s.  
 Altar, &c., 4s.  
 Reynolds, 5s.

Wings, ARDELL, 4s.  
 TABLES HEATH, 2s.  
 MASON, A pair, 4s.  
 4 plates, 2s.  
 SHARPE, 3s.

Window, FAGUS, 3s.  
 MAILLÉ, 1s.  
 Atham, A pair, 2s.  
 3 prints, 2s.  
 Isaac Walton, A pair, 3s.  
 LUFTON, 3s.

PS, 4s.  
 L. LEWIS, 2s.  
 of St. Bartholomew, 3s.  
 Dr. Kaye, RYAN, 4s.  
 finely print, EGAN, 4s.  
 3 prints, 4s.

" " 4s.  
 " " 4s.  
 building, 3s.  
 by; Interior—Exterior.

engraving, LANDSEER, 2s. 6d.  
 [1263]

SIGNS for Ornamental  
 the Antique, in beautiful  
 paper, may be pro-  
 of Mr. J. RUSSELL  
 STREET, SOHO, LONDON.  
 and Exhibition. [1211]

TEMPLE, 46, Cox-  
 The group exhibited  
 Nobilis (one of the rarest  
 choice Orchids, some  
 cultivated flowers, all  
 correct, and executed by  
 [1287]

RAVER on WOOD,  
 see the following Works  
 "Gothic Architecture;  
 riches of Northampton-  
 Published by Mr.  
 [1237]

and OTHERS.—  
 Gold, Silver, and Copper  
 and English series.  
 supplied with selections  
 on includes many rare  
 in fine condition. A  
 which may be mentioned  
 and bronze; Dacier's  
 Mint Proofs of George  
 objects of all sizes; and  
 Gens, Ivory Carvings,  
 W. CHAFFERS, Jun.,

attached to each Coin,  
 es, a large Cabinet of  
 objects of Ancient Art,  
 P.M.

or exchanged. [1216]



**C. CADBY,  
GRAY'S INN PIANOFORTE MANUFACTORY,  
LONDON,**

INVENTOR AND MANUFACTURER OF THE ROYAL PATENT  
**SUSPENDED AND ADJUSTABLE SOUNDING-BOARD.**

The great improvement in these Pianofortes consists in the construction of the Sounding-board, which, in place of being, as in the ordinary mode of construction, tightly glued to the wooden framing of the instrument, is in this patented method suspended by metallic clamps, springs, or screws, so as to admit of being wholly or partially tightened. Instead of the tone being partially absorbed and deadened by the attachment on ordinary sounding-boards to the framing, a defect inseparable from the old construction, the Patent Sounding-board, by its isolation, and by the arrangement of the springs or clamps, retains a much greater and longer vibration, and the tone is not dissipated, but flows on clearly and distinctly, giving to the ordinary Pianoforte much of the clearness and effect of the flageolet and diapason stops of the Organ. It is important to observe, that the usual arrangement of the Piano is in every other respect followed. There is no change in the method of playing, no difference is observed in fingering, and the pedal movements are identical with the ordinary instrument.

C. CADBY is the only Maker in London of the Patent Iron Truss Braced Pianoforte,  
which is so suitable for shipping.

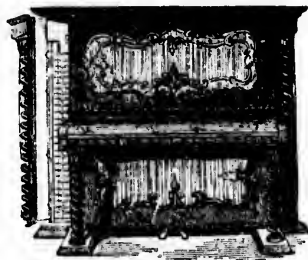

Fig. 1.

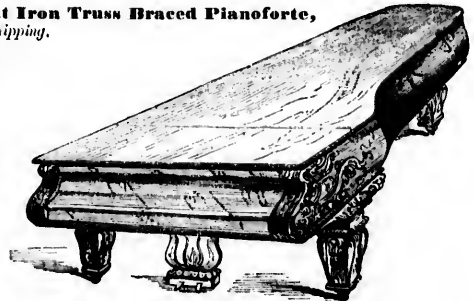

Fig. 2.

Fig. 1 shows a Semi-cottage Pianoforte with the left-hand side open, which presents a perfect view of the suspension principle. Fig. 2 is a drawing of a Grand Pianoforte upon the same principle, though not shown in this as in Fig. 1.

PIANOFORTES MADE AT THE SAME ESTABLISHMENT FOR THE MILLION,

Price, in MAHOGANY, for 6½ OCTAVES, 25 Guineas; in ROSEWOOD or ZEBRA, 26 Guineas.





**OPERA BOX OFFICE,**  
NO. 8, REGENT-STREET, WATERLOO-PLACE.  
**BOXES AND STALLS**  
May be obtained by the night in the best situations in  
**HER MAJESTY'S THEATRE:**

Also GALLERY STALLS and PIER TICKETS for all performances.  
At this Office every information can be given,  
and all languages spoken. [1 128

**MESSRS. ROBERT COCKS & CO'S**  
**VERY superior PIANOFORTES—PICOLOS,** of elegant exterior and brilliant quality of tone, in Mahogany, Rosewood, and Walnut-tree wood. Warranted to stand well in tune in all climates. 22 Guineas. A pamphlet gratis, containing rules for the preservation of Pianofortes. Descriptive price-lists gratis and postage free. Also an extensive assortment of other Musical Instruments.  
*New Burlington-street, London.* [1 111

**T. C. JONES and Co., MAKERS and INVENTORS** OF THE **TWIN or FAMILY PIANO** for Two, Four, or Six Performers. Provisionally Registered for the Great Exhibition of 1851. of the New Twenty-Guinea Piano, unsurpassed at the present time. Catalogue. [1 112

**MESSRS. TOWNS & PACKERS, 20, OXFORD STREET.—HORIZONTAL SEMI-GRAND TRANSPOSING PIANOFORTE.**—To transpose Music by semitone progression two whole tones higher or lower than the original Scale or Key in which it was composed, for the accommodation of Singers. Its novelty is attributable to the introduction of a power by which the *key-board is moved* for the purposes of transposition, and its superiority is the fact that the tone and touch are not in the least affected by the use of this moving power. This Instrument has the reputation to be so much approved of by the Profession in the Grand Pianofortes. [1 100



**SACRED HARMONIC SOCIETY,**  
**EXETER HALL.**

Conductor . . . . . **MR. COSTA.**

**THE COMMITTEE** beg to announce, that, in order to afford Visitors to the Great Exhibition the opportunity of witnessing the grand performances of this Society, the usual season will be extended, and a series of popular Oratorios be given on several **FRIDAY EVENINGS** during the months of **MAY and JUNE**, commencing with Mendelssohn's 'ELIJAH,' on the 2nd and 16th of May.

The most efficient Vocalists will be engaged, and the entire Orchestra, the largest available in **EXETER HALL**, will consist of (including Sixteen Double-basses) nearly

**SEVEN HUNDRED PERFORMERS.**

Prices of TICKETS of Admission, which should be secured early.

For the body of the Hall . . . . . *Three Shillings.*  
For Reserved Seats in Area or Gallery . . . . . *Five Shillings.*  
For Central Area do. numbered as Stalls { *Ten Shillings and*  
*Shillings each.*

To prevent disappointment and imposition, strangers are cautioned to observe that the headings of this Society's announcements are precisely as above; that the price of each saleable Ticket is legibly printed upon it; and that the Agents of the Society are prohibited from making any increased charge—the Honorary Secretary's name, as under, being engraved upon each Ticket.

The Society's solo Office is No. 6 Room, within Exeter Hall (at the end of the right-hand side of the passage entering from the Strand), where, or of Mr. BOWLEY, 53, Charing-cross, full particulars and Tickets may be obtained.

T. BREWER, Hon. Sec.

A model of the arrangement of the Orchestra has been placed in the Exhibition, and will be found in the Western Nave. [1 234

**NOVELLO'S**  
**MUSICAL PRESENTS.**

Novello's Cheap Editions of **ORATORIOS** (both Folio and Octavo) will be found appropriate Presents; combining elegance with a moderate outlay for a Standard Work.

Catalogues (gratis) on application to the  
**London SACRED MUSIC Warehouse,**  
69, Dean-st., Soho, or 24, Poultry. [1 7

**MUSIC.**

**MESSRS. ROBERT COCKS & CO., EXHIBITORS,**  
*Music Publishers (by Special Warrant) to*  
**HER MOST GRACIOUS MAJESTY THE QUEEN,**  
NEW BURLINGTON-STREET, LONDON.

"The Messrs. Cocks and Co.," says the *Court Journal*, speaking of the above firm, "commenced as music publishers some twenty-five years back. From that time they have been publishing standard works and novelties by the first professors of the age, both native and foreign, until their levianth catalogue has reached to a number of plates exceeding 250,000. No other music publishers in England—we should say, in Europe—possess a catalogue containing such variety, or such sterling, standard, and popular works, for every description of musical instrument, and for the science of music generally."

The following works may be cited as constituting a small portion of their valuable stock:—

- Boyeo (Dr.),** Collection of Cathedral Music, edited by Joseph Warren, 3 vols. large folio. (*Exhibited—see Catalogue.*)
- Albrechtsberger's, Cherubini's, & Weber's** Theoretical Works.
- Czerzy's** Royal Pianoforte School and School of Practical Composition.
- Warren's** Church Service, 373 Chants, Psalmody, and Organ Works.
- Beethoven, Haydn, & Mozart**—All their Quartets, Quintets, Trios, Overtures, Symphonies, &c. &c.
- Handel's** Oratorios—Messiah, Israel in Egypt, Samson, Judas Macabees, Acis and Galatea, &c., in Vocal Score, with Piano or Organ Accompaniment, by John Bishop.
- Bach (J. S.)**—All his Organ and Pianoforte Works, by J. Bishop.
- Rinck's** Organ School and Organ Works, by J. Bishop.
- Hamilton's** Celebrated Pianoforte Tutor, and all his Catechisms, and Dictionary of 3500 Musical Terms.
- Spoehr's and Campagnoli's** Methods for the Violin. Also, Otto and Dubourg on the Violin, &c. &c. by J. Bishop.

Catalogues of Music and Musical Instruments forwarded gratis and postage free. (See Catalogue.) [1 99

**Pianofortes at 20 Guineas,**  
**FOR SALE, HIRE, AND EXPORTATION.**  
**BALLINGALL & BALLINGALL,**

WHOLESALE MANUFACTURERS,  
**19, EDWARDS-STREET, PORTMAN-SQUARE, LONDON,**  
RECOMMEND to the notice of the Public their Superior **ROSEWOOD BUDOIR PICOLOS**, with 7 octaves, at **TWENTY GUINEAS.**

Also, their very Superior 7-octave **COTTAGES**, with elegant CARVED SHELLE FRONTS, manufactured in eight of the choicest Woods, at **TWENTY-FIVE GUINEAS** each.

All Pianofortes purchased at this Establishment packed and delivered, free, at any Railway Station in London. Warranted for Two Years, and exchanged if not approved of.

MERCHANTS, SHIPPERS, and COUNTRY DEALERS SUPPLIED. [1 101

**TORY,**

rd, which, in place of  
ent, is in this patented  
tightened. Instead of  
the framing, a defect  
gement of the springs  
clearly and distinctly,  
s of the Organ. It is  
There is no change in  
deal with the ordinary



t view of the sus-  
n in this as in Fig. 1.  
LION,  
**26 Guineas.**  
[1 183

**A CHINESE NOTICE.**—You are particularly requested to visit HEWETT'S celebrated Large CHINESE WAREHOUSES, where can be seen Thousands of Rare, Curious, and Beautiful articles at moderate prices.—18, *Fenchurch-street, City, London, and at the Great Exhibition.* [1 254

**HORTICULTURE.**—A Pamphlet, illustrating the uses of the Horticultural appliances exhibited by Mr. JOHN ROSEMARY, of 34, *Eastcheap, London*, can be had post-free by enclosing Six Postage-stamps, addressed to him as above. [1 264

**THE GROTO, OATLANDS PARK, WEYBRIDGE.**—This magnificent work of art, constructed by the Duke of Newcastle, at a cost of 40,000*l.*, is open on Saturday, Sunday, and Monday afternoons, from May till October. By railway from Waterloo-bridge, in one hour; from Hyde-park, 14 miles. [1 68

**A BILLIARD TABLE,**  
IN the ELIZABETHIAN STYLE, made of rich brown English Oak, grown in Woburn Park, on the estate of his Grace the Duke of Bedford. Designed and Manufactured by BURROUGHES and WATTS, SOHO-SQUARE, LONDON. (See *Official Catalogue.*) [1 290

**BEAUTIFUL AND RARE DARTINGTON MARBLE,**  
*Madrepore and Chocolate-coloured,*

**FOR** Altar-slab, Foot-piece, Font, Credence, Piscina, Tomb, Column, Shaft, &c., or for Table, Slab, Mantel-piece, Table and Chimney-piece Ornament.  
The attention of Architects, Decorators, Builders, &c., is invited to the beautiful Marble Columns, Table, and other specimens exhibited by, and executed under the direction of, the Proprietor, near his Quarries.  
Architects, &c., are requested to address (for the present) the Proprietor, HENRY CHAMPERNOWNE, Esq., DARTINGTON HOUSE, TOTNES, DEVONSHIRE. [1 290



MESSRS. MILLER & RICHARD, OF EDINBURGH AND LONDON,  
TYPE FOUNDERS TO HER MAJESTY FOR SCOTLAND,

Beg leave to call the attention of Printers to the BREVIER (Roman capitals and lower case) Type cast by them for the Metropolitan Division of the Great Exhibition Illustrated Catalogue; and also to their Specimen of the "BRILLIANT" Type in this Exhibition, which is the smallest Type ever manufactured in this country. Upon examination, it will be found the most perfect and most highly finished as yet produced, being cast by their improved and Patented process.

MILLER & RICHARD would direct the attention of Newspaper Proprietors to their Founts cut expressly for Newspaper work, which have long enjoyed the reputation of being the most durable that are produced. Their Type has been used for many years in "THE TIMES," "THE MORNING HERALD," "THE MORNING ADVERTISER," "THE MORNING CHRONICLE," and several other leading London journals; also in many of the principal Provincial papers, in England, Scotland, and Ireland.

They have, further, satisfaction in alluding to their Type in the Bibles, Testaments, and Prayer Books printed at the Clarendon Press, Oxford, which form beautiful Specimens of their Book Founts.

LONDON WAREHOUSE, 22, BARTLETT'S BUILDINGS, HOLBORN.

EDINBURGH, MARCH, 1851.

**TABLE, STYLE,** made of rich Woburn Park, on the east. Designed and Manufactured by **WATTS, SONO-SQUARE,** [1 290]

**TINGTON MARBLE,** slate-coloured, for Table, Slab, Mantel-piece, Credence, Piscina, Columns, Table, and other uses under the direction of **WATTS, SONO-SQUARE,** [1 290]

Address (for the present) **BERNOWN, Esq., DARTMOUTH,** [1 240]

**LITHOGRAPHY.**—**STANDIDGE and CO.,** of the OLD JEWRY, LONDON, in acknowledging the liberal support they have for so many years received from Architects, Engineers, Surveyors, the Patrons of Art, and the Public generally, beg to inform them they continue to execute with increased facility Drawings and Plans of every description, in Chalk, Chrome, and Ink Lithography, in the first style of the Art, and on the most reasonable terms. Fac-similes, Circulars, Show Cards, Certificates, Bill Heads, &c. &c., with the greatest despatch. Country communications promptly attended to. [1 161]

**TO PRINTERS, PUBLISHERS, AUTHORS, &c.**—**Mr. THOMAS GILKS, DRAUGHTSMAN and ENGRAVER on WOOD,** begs respectfully to announce that he continues to execute all orders intrusted to his care with promptness and a due regard to moderation in charges. Specimens of every variety of work may be seen at his offices; and estimates forwarded to any part of the kingdom.—170, FLEET-STREET, LONDON. [1 193]

**TO SURVEYORS and ENGINEERS.**—**PLATO-METER**—Self-acting Calculator of Surface. This elegant Instrument calculates, with the utmost rapidity and without the risk of arithmetical errors, the area of any figures drawn on a plan, by merely carrying the point of a tracer round their boundaries, however crooked or irregular they may be. Price 20*l.* Apply to **JOHN SARG, Kirkaldy.** [1 202]

### LONDON SACRED HARMONIC SOCIETY, EXETER HALL.

*President* . . . Rev. GEORGE ROBERTS.  
*Secretary* . . . Rev. W. S. AUSTIN.  
*Vice-President* Rev. F. J. STAINFORTH.  
*Leader,* Mr. H. BLAONOVE. *Organist,* Mr. JOLLEY.  
*Conductor* . . . Mr. SURMAN,  
 Founder of the Exeter Hall Oratorios.

**THE** object of this Society is to encourage the practice and performance of Psalmody, Chanting, Services, Anthems, Oratorios, &c., and to afford the Religious Public an opportunity of hearing the best Sacred Music of every description.

The Subscription is 1*l.* per annum, or for Reserved Seats 2*l.* 2*s.*, commencing upon any Quarter Day. Each Subscriber will be entitled to two transferable Tickets to each Subscription Concert.

Reserved-Seat Subscribers are presented annually by the Conductor with a copy of Handel's "Messiah," "Judith Macabean," or Haydn's "Creation," arranged for the Organ or Pinnepforte, with Vocal Score, bound in cloth, folio.

Members' and Subscribers' names will be received at the Office of the Society, No. 9, Exeter Hall, where may be had the Music as performed at Exeter Hall, printed by W. CLOWES and SONS. W. STANTON AUSTIN, Hon. Sec. [1 221]

### ROYAL ITALIAN OPERA, COVENT GARDEN. SEASON 1851.

**THE ROYAL ITALIAN OPERA, COVENT GARDEN,** will be open every TUESDAY, THURSDAY, and SATURDAY during the Season, and be supported by the following renowned Artists:—

**Madame GHISI and Madame VIARDOT, Madame CASTELLAN and Mademoiselle ANGRI,**  
**Madlle. MORRA, Madlle. COTTI, and Madlle. BERTRAND;**  
**Signor MARIO and Signor TAMBELLIE, Signori MELI, SOLDI, and MABALTI,**  
**Signor BONCONI and Signor SALVATORI, Signor BIANCHI and Herr FORMES,**  
**sig. FOLONINI, sig. ROMMI, sig. TAGLIATICO, Mons. ALEXANDRE, Madlle. L. TAGLIONI, &c. &c. &c.**  
 Director of the Music . . . Mr. COSTA.

Boxes and Stalls may be secured at the Box-Office (Bureau) of the Theatre, corner of Hart-street & Dow-street, from 10 till 5 o'clock every day. [1 220]

**A. PINTA, FRENCH LAWYER,** No. 8, CORNHILL.—Advice on French and other Foreign Law. Acts and Documents prepared in Foreign Languages. Notaries' Legal Business attended to. Languages translated. [1 257]

**EARLY DISCIPLINE and SOUND TEACHING** the surest Foundation of Success.—**PUPILS** from their sixth year are received and indefatigably prepared to encounter the difficulties and reap the benefits of our best Public Schools and Colleges, by a **CLEONMAN,** who, earnestly and wholly devoted to his task, confidently invites the attention and patronage of Parents, being himself gratefully sensible of the inestimable advantage he possesses in having been early trained to teach under a most able master, educated at and long connected with WINCHESTER COLLEGE. Number limited, Terms moderate, and arranged on a new plan.—Apply to Messrs. BOONE, 29, New Bond-street, or to the PRINCIPAL, 55, Westbourne-grove, Bayswater. [1 246]

**EDUCATION.—SOUTH OF DEVON.—OTTERY ST. MARY SCHOOL.**—The course of study pursued in the School embraces—

- 1st. A sound Religious Education, in accordance with the articles and liturgy of the Church of England.
- 2nd. A good Classical and Mathematical Education, to those who are preparing for the Universities, public Schools, Naval and Military Colleges, and Professions.
- 3rd. A superior commercial Education to those who are preparing for the counting-house and the several departments of commercial pursuits; embracing the modern European Languages, English Grammar and Composition, Writing, Arithmetic, Merchants' Accounts, Geography, History, &c.: in fact, a sound and liberal Education, keeping pace with the requirements of the age.

TERMS 20 TO 25 GUINEAS PER ANNUM.

OTTERY ST. MARY is situated in one of the most beautiful valleys of Devon. For young gentlemen of a delicate constitution, or coming from abroad, it possesses peculiar advantages, as it may be seen that the climate of Devonshire is most favourable for promoting the life and health of the young.—Prospectuses forwarded on application.

**WILLIAM REED, Principal,**  
 Member of the Royal College of Preceptors. [1 152]

### KENSINGTON HALL, NORTH END, FULHAM, NEAR LONDON.

**AN EDUCATIONAL ESTABLISHMENT** for YOUNG LADIES, particularly the daughters of professional and mercantile men, and of the more opulent members of the commercial community.

LADY SUPERINTENDENT, MRS. JOHNSON.

It is the object of this institution to combine the advantages of the most efficient School and College instruction with the comforts and educational privileges of a well-regulated home. The various departments of knowledge are taught by professors of the highest eminence. Conversational and Musical Meetings are frequently held; Lectures upon Literature, Science, and the Scriptures are regularly delivered; and to explain and illustrate the more substantial duties of life, there is an applied course on Household Economy, the Preservation of Health, and the Education of Children.

The terms are moderate, but at the same time sufficient to insure the utmost liberality in every department. Prospectuses forwarded to any address.—**Mrs. JOHNSON'S INQUIRY LECTURE,** developing the system, is published by WHITTAKER and Co., Ave-Maria-lane. [1 129]

**P. BOWES,**  
 26, KING WILLIAM-STREET, STRAND, LONDON,  
 CONSULTING AND PRACTISING  
**ACCOUNTANT,**  
 In all matters, whether Public, Corporate, Commercial, Fiduciary, or otherwise,  
 POSSESSES PECULIAR FACILITIES  
 FOR GIVING INSTRUCTION IN  
**FARM BOOK-KEEPING.** [1 11]



ND LONDON,  
 AND,  
 capitals and lower  
 inhibition Illustrated  
 n this Exhibition,  
 amination, it will  
 ing cast by their  
 rs to their Founts  
 ion of being the  
 in "THE TIMES,"  
 NG CHRONICLE,"  
 Provincial papers,  
 Testaments, and  
 ul Specimens of  
 DRN.  
 [1 112]

## SIG. A. B. VENTURA,

REMOVED FROM 47, RATHBONE-PLACE, TO 17, CHARLES-STREET, MONTIMER-STREET, CAVENDISH-SQUARE,  
Inventor and only Professor of the BRITISH VENTURA and VENTURA'S ENGLISH CETRA,

Begs to inform the Nobility and Gentry, and his former patrons, that he has resumed his Profession, and intends teaching the SPANISH GUITAR and the following instruments:—



No. 1. The new British Ventura. 2. The newly invented English Cetra. 3. The Vent rina. 4. The Harp Ventura. 5. The Lyre Ventura.

**PUBLIC LIBRARY, BELGRAVE SQUARE.**—  
Under Distinguished Patronage.—An early and liberal supply of all New Works in English or French Literature is constantly added to the extensive Stock at *Miland's Library*, 35, Chapel Street, Belgrave Square. Catalogues and Terms according to any requirements may be had on application. A large assortment of Books and every variety of Stationery are kept on sale at the most moderate prices. Office for the early supply of Newspapers. [183]

### ORGANS.

#### FLIGHT AND SON,

ORGAN BUILDERS,

36, St. Martin's-lane, London.

#### CHURCH AND CHAMBER ORGANS,

Built on the improved principle;

#### APOLLONICONS,

Self-acting and otherways, suitable for Hall or Chamber.

Concert Rooms supplied on the principle of these *FACON* AND *SON* have built for her Majesty's Theatre and the Royal Italian Opera, under the superintendence of Signor Costa.

ESTABLISHED A.D. 1770. [153]

THE Remains of the CISTERCIAN ABBEY of ST. MARY at TINTERN, Monmouthshire, founded A. D. 1131, completed A. D. 1268, now the property of his Grace the Duke of Beaufort, and by him carefully preserved from demolition. Modelled to a scale of one-eighth of an inch to a foot, by David Lewis, Ragland. [134]  
(See Catalogue).

TO THE NOBILITY and GENTRY.—G. HADGRAFT, NATURALIST, 9, MUSEUM-STREET, BLOOMSBURY. For the cheapest and best house for stuffing Birds and Animals; also mounting them on an improved style. Decorations warranted not to fade. Agent for the sale of Artificial Eyes. References to all parts of England. —Every care taken to imitate nature. [11]

**BEAUX TABLEUX PAR LES PLUS GRANDS MAITRES.** M<sup>r</sup>. C. DE C. WILSON reçoit la visite de MM. les Amateurs tous les jours de midi à quatre heures.  
26, Percy-street, Bedford-square. [184]

**J. BEMISTER JUN., WORKING BOOK-BINDER, 6, RYE-LANE, PECKHAM.**—Old Books or Manuscripts on vellum or paper cleaned, repaired, strengthened, and bound with the requisite care.—Without diminishing the neatness or the elasticity of a Book, J. B. binds it with unusual strength. [132]

**W. & A. K. JOHNSTON, 4, ST. ANDREW-SQUARE, EDINBURGH,** Geographers and Engravers to the Queen, Lithographers, Printers, and Globe Manufacturers. Agents in Scotland for the sale of the Maps of the Hon. the Board of Ordnance, the Admiralty Charts, &c. [155]

**THOMAS HARRY SAUNDERS, PAPER MANUFACTURER, DARTFORD, KENT.** All descriptions of writing and drawing papers made upon the most modern and improved principles both by hand and machines. Manufacturer of Bank-note and patent Cheque papers. Warehouses, Maldstone Wharf, and 10, Queenhithe, Upper Thames-street, London. [136]

Highly Improved Copying, Writing, and other Inb.

#### MESSRS. BLACKWOOD & CO.

Beg to call attention to these superior **INKS**, adapted to Steel and other Metallic Pens, together with their clean Conducting Bottles, with durable Cork. A beautiful bottle in purple glass made expressly for the use of ladies. Messrs. BLACKWOOD & Co.'s registered "**READY REFERENCE FILE**" will be found invaluable to all who wish a ready reference to their private papers, letters, receipts, &c., with the advantages of being kept clean, orderly, and not damaged as by the ordinary Wire File. May be had of all Stationers and Booksellers. Trade and Export Orders executed at the *Manufactory*, 26, Low Acre. [148]



STREET, CAVENTISH-SQUARE,  
 IN THE CITY OF LONDON,  
 AND INTENDS TEACHING



5. The Lyre Ventura.

X PAR LES PLUS  
 M. C. DE C. WILSON REÇUT  
 LES JOURS DE MIDI À QUATRE

WORKING BOOK.  
 PECKHAM.—Old Books  
 paper cleaned, repaired,  
 with the requisite care.—Without  
 elasticity of a Hook, J. B.

4, ST. ANDREW-SQUARE,  
 AND ENGRAVERS TO THE  
 AND GLOBE MANUFACTURERS,  
 OF THE MAPS OF THE HON.  
 ADMIRALTY CHARTS, &c.

INDERS, PAPER MA-  
 KERS, KENT. All descriptions of  
 paper upon the most modern and  
 improved machinery. Manufac-  
 turers of Cheque papers. Ware-  
 house, 10, Queenhithe, Upper

Writing, and other In-  
 struments, &c.

WOOD & CO.  
 Attention to  
 INKS,  
 and other  
 together  
 Conduct-  
 of durable  
 full bottle  
 made ex-  
 use of  
 BLACK-  
 registered  
 INK FILE  
 valuable  
 a ready  
 or private  
 receipts,  
 kept clean, orderly, and  
 Ink File. May be had of  
 Trade and Export Orders  
 any Acre.



**JOSIAH WESTLEY,**

OF

**PLAYHOUSE-YARD, adjoining "THE TIMES" OFFICE,  
 LONDON,**

IS DESIROUS TO DIRECT THE ATTENTION OF

WHOLESALE HOUSES, LITERARY INSTITUTIONS, LIBRARIANS, AND GENTLEMEN,

TO HIS

**BOOKBINDING ESTABLISHMENT,**

WHERE EVERY BRANCH OF THE BUSINESS IS CARRIED ON WITH ACCURACY, TALENT,  
 AND DESPATCH.

J. W. has recently made several important additions to his Establishment, which combine every improvement that mechanism and artistical skill can produce; thus he is enabled to offer great advantages to the proprietors of literary works, and is most anxious to obtain their valuable patronage.



**E. WOLFF & SON'S**  
NEWLY INVENTED  
**CRETA LEVIS, OR PERMANENT DRAWING CHALKS,**  
IN CEDAR, IN EVERY VARIETY OF COLOUR,  
23, CHURCH-STREET, SPITALFIELDS, LONDON.

E. WOLFF and Son beg to state that they have, by the introduction of great improvements in their CRETA LEVIS, enabled it to be used the same as the ordinary pencils; and effects can now be produced equal to Water Colour Drawings, without the use of water or any other fluid, the various colours blending together with perfect harmony, beauty, and richness. It can be cut to a fine point, and is thus capable of giving a very delicate outline.

For Sketching from nature, the great advantages resulting from the adoption of the CRETA LEVIS must be obvious, as, without the use of water, palette, brushes, &c., all the various tints can be obtained with a truthfulness that cannot be surpassed, and by their compact form may be carried any distance without the slightest inconvenience; thus superseding every other method in general use.

The drawings may be carried in a portfolio with safety, as, unlike other Crayons, they will neither rub off nor suffer injury by coming in contact with the usual contents of a portfolio.

The CRETA LEVIS, unlike the indolite or wax Crayons, will not be affected by heat or change of climate.

WOLFF & SON'S IMPROVED CALTON PAPER is the best for the CRETA LEVIS.

To be had of all Artists' Colourmen and respectable Stationers, in leather boxes, containing sets of 12, 18, 24, 36, 48 assorted colours. A pattern card containing the whole of the shades and colours, with their names and numbers attached to each shade, price 1s. each. CAUTION.—As there are several spurious imitations, it is necessary to observe that every pencil is stamped "CRETA LEVIS, E. WOLFF AND SON, LONDON," with the name of the colour. Creta Levis Drawings lent to copy. (See Specimens at the Great Exhibition, Hyde Park, Class 80.)

**E. WOLFF & SON'S PURIFIED CUMBERLAND LEAD PENCILS,**

PERFECTLY FREE FROM GRIT, MAY BE ENTIRELY ERASED, AND WILL MAINTAIN A FIRM POINT.

E. WOLFF and Son beg to inform Artists, Architects, and Engineers, that they have succeeded in so greatly improving their Black Lead, that they are now manufacturing a PLUMBAGO or BLACK LEAD PENCIL entirely free from grit, which will easily yield to India-rubber, and ensure perfect erasures; it possesses great brilliancy and depth of colour, and will maintain a firm point. They have attained to so great a perfection in the manufacture of this Lead, as to be able at all times to make the same strength and colour when once found to be suitable for any particular purpose, and have produced a pencil fully equal to those used in former years, when they were made of the finest Cumberland lead, which at the present time cannot be obtained from the mines sufficiently pure for the best pencils. The following are the degrees:—11, 11H, 11HH, 11HHH, F, FF, 11B, EHB, B, BB, BBB, BBBB, W.\* \* This pencil is particularly recommended for writing and counting-house use.

E. WOLFF and SON have the honour of supplying their PURIFIED BLACK LEAD PENCILS to Her Majesty's Stationery Office, the Admiralty, the Bank of England, several Railway Companies, and many other Public Establishments.

MANUFACTORY, 23, CHURCH-STREET, SPITALFIELDS, LONDON.

[ 299

**DIXONS & TOOKE,**  
WHOLESALE GOLDSMITHS, JEWELLERS,  
&c., DEALERS IN ENGLISH WATCHES, 28, ELY  
PLACE, HATTON GARDEN, LONDON.  
Importers of Geneva Watches, French Goods, &c. [ 1297

**W. DAVIDSON,**  
CARVER, Gilder, Upholsterer, and Manufacturer  
of Furniture, Modern and Antique Styles.  
37, Frederick-street, Edinburgh. [ 154

**J. M'LACHLAN, HOUSE PAINTER, DECO-  
RATOR, and GILDER, 35, ST. JAMES'S STREET,  
PICCADILLY,** invites the Nobility and Gentry requiring  
their Houses decorated to inspect his splendid patterns of  
Decorations and Paper-hangings. Bed-room Papers 1d. a  
yard, and upwards.—Designs and Estimates given for  
Decoration of Rooms, Glass Frames, Consoles, &c.—Old  
Frames cleaned, re-gilt, and restored.—Estimates for  
general repairs. [ 123

**JACKSON'S CHINESE DIAMOND CEMENT,** for re-  
storing to their original beauty and use China, Glass, Marble,  
Ivory, Ornaments, Toys, Cabinet Work, Earthenware, &c.  
For cementing Cabinet Specimens, Ladies' Fancy Work in  
Cardboard, Paper, &c., it is superior to any preparation  
hitherto used. In bottles, at 6d. and 1s. each.

**LESSEY'S MARKING INK,** so long and justly celebrated  
for its intensely black colour, has lately been tested by Dr.  
Ure, Analytical Chemist to H.M.'s Board of Excise, and by  
him declared to be both durable and safe, incapable of being  
washed out or injuring the fabric to which it is applied.  
Sold, 1s. each, by all Chemists and Stationers. [ 261

**GLOVER'S ENCRE à la VIOLETTE,—THE  
LADY'S WRITING INK.**—This beautiful pre-  
paration, from its exquisite colour resembling the flower  
whose name it bears, is the most elegant and unique ap-  
pendage to the fashionable writing-desk.—Sold in bottles,  
6d. and 1s. each, by GLOVER & Co., 19, Goodlye-street, Totten-  
ham-court-road, London, and all Stationers. [ 213

**T. J. & J. SMITH,**  
METALLIC BOOK MANUFACTURERS,  
WITH PATENT EVER-POINTED PENCILS,  
WHOLESALE AND EXPORT STATIONERS,  
83, QUEEN-STREET, CHEAPSIDE, LONDON. [ 1212



**H. DELOLME, CHRONOMETER & WATCH-  
MAKER,** 43, RATHBONE-PLACE, OXFORD-STREET,  
LONDON, begs to draw the attention of those who value a  
superior timekeeper to the Watches of his own peculiar con-  
struction, manufactured entirely in England under his own  
personal direction, in which every advantage of modern  
watchmaking is combined with additional solidity; the price  
of which will also be found comparatively moderate. [ 295

## EXOTIC NURSERY, KING'S ROAD, CHELSEA.

We regard this as a peculiarly favourable opportunity, and therefore avail ourselves of it, to thank our Patrons with sincere gratitude for the continued patronage with which this house, first under the Proprietorship and Management of **JOSEPH KNIGHT**, and more recently under that of **JOSEPH KNIGHT & THOS. A. PERRY**, has been honoured for nearly half a century, and to say that, during the whole of that period, increasing efforts have been made, by the extension of our various Collections, to enable us to supply every article connected with Gardening, of the best description. We have now too the satisfaction of adding that our prices, during the last few years, have been *very much* reduced, and that they are at present as low as a very moderate remuneration will admit of.



In soliciting the countenance and support of our Patrons, we beg respectfully to call their attention to the following, as being worthy of their notice:—

1. **HARDY ORNAMENTAL TREES AND SHRUBS**, in which are many novelties.
2. **RHODODENDRONS AND AZALEAS**, as well as other **AMERICAN PLANTS**, of the finest kinds known.
3. **CONIFERS**. Our collection of these may be seen from the work we have published on them.
4. **FRUIT-TREES**, of the finest kinds, founded on the Horticultural Society's Collection, and on those of the first Continental Pomologists.
5. **GREENHOUSE AND HOTHOUSE PLANTS**, of the most select and beautiful kinds.
6. **HARDY HERBACEOUS PLANTS, ROSES, &c.**, of the most admired sorts.
7. **VASES**, of the most Gardesque forms; and **GARDEN IMPLEMENTS**, of such construction as experience has proved to be most useful.
8. **CULINARY, AGRICULTURAL, AND FLOWER SEEDS**, of the first quality, and true to name.
9. **BULBS**, as imported, from the first Growers in Holland.

*We shall be proud to furnish detailed Lists of these.*

It is proper for us also to observe that we still continue, when applied to for **GARDENERS, FORESTERS, and LAND STEWARDS**, to recommend such only as we have substantial reasons to believe of blameless reputation and of first-rate professional ability.

**KNIGHT AND PERRY.** [1866

D 2

### HALKS,

in their CAPTA LEXIA,  
Water Colour Drawing,  
harmony, beauty, and rich-

is must be obvious, as  
fulness that cannot be sur-  
e; thus superseding every  
neither rub off nor suffer  
imate.

of 12, 18, 24, 36, 48 assorted  
numbers attached to each  
serve that every pencil is  
is Drawings lent to copy.

### D PENCILS,

FIRM POINT.

ed in so greatly improving  
free from grit, which will  
of colour, and will main-  
to be able at all times to  
nd have produced a pencil  
which at the present time  
degrees:—H, HH, HHH,  
writing and counting-house use.

PENCILS to Her Majesty's  
Public Establishments.

[1869

**MITH,**  
**MANUFACTURERS,**  
DINTED PENCILS,  
ORT STATIONERS,  
AFRIDE, LONDON. [1872



**OMETER & WATCH-**  
**NE-PLACE, OXFORD-STREET,**  
ation of those who value a  
hes of his own peculiar cer-  
y in England under his own  
very advantage of modern  
additional solidity; the price  
paratively moderate. [1875

**JOHN DRIVER,**  
MADEIRA,  
AND EXCHANGE ALLEY NORTH, LIVERPOOL.

PRICES, &c., OF THE FINEST OLD WINES,  
produced on the South Side of the Island of Madeira, selected  
from particular Vineyards, and of the most esteemed Vintages.

Bung.

Brand. In Pipes, Hhds., and  
**DRIVER.** Quarter-Casks.



In Bond at Liverpool, the entire cargo of the "Tally-Ho,"  
Capt. PILLARD, entered at Customs by DRIVER, April, 1851.

|                 |           |                                |      |
|-----------------|-----------|--------------------------------|------|
|                 | Per Pipe. | In Bottle, Duty paid, per Doz. |      |
| Direct Madeira  | 45s       | Direct Wine                    | 37/1 |
| Via West Indies | 60        | West India                     | 39/4 |
| Via East Indies | 65        | East India                     | 41/7 |

Samples forwarded, on application to the above Address. [1 280]

Lately published, 8vo., price 18s. cloth; or large paper, royal  
8vo., price 1l. 11s. 6d.

**A TREATISE ON THE CLIMATE and METEOR-  
OLOGY OF MADEIRA;** by the late J. A. MASON,  
M.D., inventor of Mason's Hygrometer. Edited by JAMES  
SHEPARD KNOWLES. To which are attached a Review of  
the State of Agriculture and of the Tenure of Land, by GEORGE  
PEACOCK, D.D., F.R.S., &c. &c., Dean of Ely, and Lew-  
nenden Professor of Astronomy in the University of Cam-  
bridge; and an Historical and Descriptive Account of the  
Island, and Guide to Visitors, by JOHN DRIVER, Consul for  
Greece, Madeira. London: JOHN CROUCHILL. Liverpool:  
DEIGHTON and LAUGHTON.

Messrs. DEIGHTON and LAUGHTON have constantly on sale  
a large assortment of Guide Books, Maps, Plans of Towns,  
&c., including Black's Guides to England, Scotland, Wales,  
&c.; CHIT'S, Parry's, and other Guides to Wales; and Mur-  
ray's Handbooks for the Continent.

Also lately published, Second Edition, price 1s., HINTS TO  
PEDESTRIANS.

No. 46, Church-street, Liverpool. [1 281]

**ORRERY GLOBE.**  
Challenge to all the World!

**JOHN D. HAILES' ORRERY GLOBE**, registered  
May 17, 1848, which, practically displays Joshua's Mi-  
racle (Vmo, May 22, 2348 A.M.: the variation and change of  
variations of the magnet from the Creation; also change of  
meridians eastward to Europe, with increase and decrease of  
latitude at different times and places, and that the magnetic  
point is the fixed pole of the terrestrial globe, and therefrom,  
with the centre of sun and pole of world, is obtained the true  
principle equation of time, which time varies a little nearly  
at every longitude around the earth. The said globe is now  
(and has been since June, 1848) exhibited at the Royal Poly-  
technic Institution, Regent-street, London; and J. D. H.  
CONTINUES TO CHALLENGE THE LEARNED OF THE WORLD  
TO DISPUTE ITS PRINCIPLES WITH JUSTICE.—JOHN DAVEY  
HAILES, Wigford House, Kingsbridge, Devon.

The above was inserted in the *Times* of April 10th, June  
2nd and 16th, 1849, and *Exeter Gazette*.

Soranz, the Lock of Bible Truth, all the Works Divine,  
Magnetic Key—unlock the Truth—Sun, Moon, and Earth give  
Time.

Joshua records the Sun vertical to Gibeon—Strabo after a time to  
Syene.

Many Europe increases in Latitude—Eclipses give past and future  
Time.

I have reason to believe that Solar with Mean Time varies a little  
nearly at every degree of Longitude around the Globe. For instance,  
in London they agree with each other April 16th, September 1st, and  
about the time of Summer and Winter Solstices. Not so I think in  
Ireland. I apprised the Earl of Rosse (who erected the large tele-  
scope in Ireland) on November 8th, 1844, and the Royal Society,  
London, on February 1st, 1848, that I considered these times to agree  
at the West of Ireland about April 9th, August 25th, and also near  
the time of solstices; but to this date I have received no reply from  
either party as to correctness or incorrectness.—May, 1851.

England is attaining a greater latitude, exactly in the same propor-  
tion as the solstices of the sun are retreating from England, which is  
yearly, a very small quantity.

The above principle is the true cause of the alteration in the varia-  
tion of the magnet. JOHN D. HAILES.  
287]

**M. BALL,**

JEWELLERS' PLAIN AND FANCY PAPER BOX MAKER,  
No. 35, Duncan-place, London-fields, Hackney.

Town and Country Orders punctually executed. [1 62]

**C. F. HANCOCK** (a Successor to STORR and  
MORTIMER), JEWELLER and SILVERSMITH,  
by Appointment, to all the principal Sovereigns of Europe,  
REMOVED to 39, Bruton-street, Berkeley-square. [1 20]

**PHILIP GEORGE DODD, SILVERSMITH,**  
JEWELLER, and WATCHMAKER, 79, CORNHILL  
(Royal Exchange side), respectfully invites attention to his  
very elaborately wrought Silver Plate, suitable for Wedding  
Presents, Presentation, and other purposes. For terms  
apply as above.—See Catalogue. [1 107]

**M. RETTIE & SONS, JEWELLERS.—SCOTCH**  
PEBBLE and ABERDEEN GRANITE JEWEL-  
LERY of the best description. SILVER CREST and  
MOTTO BROOCHES for Gentlemen's Bonnets and Plaids  
executed in a superior manner. 151, Union-street, Aberdeen.  
See page in Illustrated Catalogue. [1 66]

**IMITATIVE CAMEO WAFERS** are suitable for  
all climates, particularly the East Indies and other hot  
countries. In boxes containing 50, 5s. HENRY THOMPSON,  
Inventor and Maker, ALBERT Cottage, WEYBRIDGE Com-  
mon, Surrey. Orders by post attended to. A variety of  
large Cameos for Ornamental Work. [1 16]

**HAIR JEWELS and MEMENTOS MANUFAC-  
TURED** by B. LEE, Artist in Hair and Goldsmith,  
41, RATHBONE-PLACE, Oxford-street, London.—A book  
of designs and prices sent by post for six stamps [1 10]

**THOMAS BEST, Manufacturer of Pocketbooks,**  
Writing Decks, Dressing Cases, Razor Strops, Ladies'  
Companions, Bill Cases, &c., in Russia and Morocco  
Leather. No. 9, St. Mary's-row, Birmingham. [1 103]

**J. DOBBY, 95, STRAND,** has an Extensive Assor-  
tment of Ivory Table Knives, with fine Razors, and  
fine Scissors, Pen and Pocket Knives, with the best Needles.  
Has been established as a Manufacturer 25 Years.  
95, STRAND, next door to Ackerman's. [1 85]

**THE ORIGINAL FOUR-SIDED METALLIC**  
TABLET and RAZOR STROP, invented by G. SAND-  
ROSS, in the city of New-York, in the year 1817. It is used  
and recommended by the first cutlers in Europe. Self-shaving  
gentlemen are invited to bring in a razor that requires setting,  
and see the effect before they purchase.  
Dépôt, 278, STRAND. [1 32]

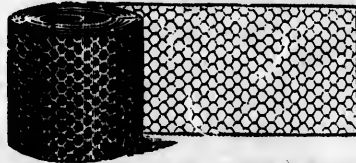

**WIRE NETTING and WINDOW BLIND**  
MANUFACTORY. To her Majesty's Hon. Board  
of Ordnance, and the Hon. East India Company.—Wire  
Netting 1d. per square foot; galvanized ditto, requiring no  
paint, 2d.; Wire Blinds, in mahogany frames, and bolts  
complete, 1s. 10d. per foot; Zinc ditto, 1s. 8d. per foot;  
Venetian, 8d. per foot; Holland, Transparent, and window  
Blinds of all kinds. Old Blinds repaired, repainted, and  
written upon. Wire-work for Flower Trainers, Garden  
Arches, Seats, Pheasantries, Aviaries, and Fowl Houses, of  
every description of pattern. Fire and Nursery Guards, and  
every article in Iron and Wire. At the City of London Wire-  
Work, Iron Fences, and Weaving Manufactory, 44, SKINNER-  
STREET, and 6 and 8, SNOWHILL, LONDON. Every infor-  
mation, with samples or specimens, and illustrated cata-  
logue, forwarded post free. Wove wire for paper-makers,  
millers, chemists, and for the East and West Indies.  
(See Catalogue.) [1 37]

**PAPER BOX MAKER,**  
on-folds, Hackney.  
[162]

**essor to STORR and**  
**R and SILVERSMITH,**  
al Sovereigns of Europe,  
Berkeley-square. [120]

**D, SILVERSMITH,**  
**MAKER, 79, CORNHILL**  
y invites attention to his  
ate, suitable for Wedding  
purposes. For terms  
[107]

**LLERS.—SCOTCH**  
**N GRANITE JEWEL-**  
**SILVER CREST** and  
on's Bonnets and Plaids  
Union-street, Aberdeen.  
*Catalogue.* [166]

**FERS** are suitable for  
ast Indies and other hot  
s. **HENRY THOMPSON,**  
**TAQE, WEYBRIDGE** Com-  
ended to. A variety of  
[116]

**ENTOS MANUFAC-**  
a Hair and Goldsmith,  
street, London.—A book  
for six stamps [110]

urer of Pocketbooks,  
es, Razor Strops, Ladies'  
Russia and Morocco  
Birmingham. [103]

as an Extensive Assort-  
s, with fine Razors, and  
es, with the best Needles.  
urer 25 Years.  
[185]

**IDED METALLIC**  
**PE,** invented by G. SAUN-  
s in year 1817. It is used  
s in Europe. Self-shaving  
razor that requires setting,  
ise.  
**LIAND.** [132]

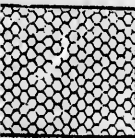

**WINDOW BLIND**  
r Majesty's Hon. Board  
ndia. Company.—Wire  
nixed ditto, requiring no  
gany frames, and bolts  
ditto, 1s. 8d. per foot;  
ransparent, and window  
repaired, repainted, and  
lower Trainers, Garden  
es, and Fowl Houses, of  
and Nursery Guards, and  
the City of London Wire-  
nufactory, 44, SKINNSA-  
LONDON. Every Infor-  
s, and illustrated cata-  
s, wize for paper-makers,  
and West Indies. [137]

**TO FOREIGNERS AND VISITORS**  
TO THE  
**GREAT EXHIBITION.**

Among the number of objects of interest besides the Exhibition which will engage the attention of the Visitors to the "World's Fair," London shops and their decorations are certain to challenge their notice when perambulating the metropolis. Pre-eminent among these, and in a direct line from the Crystal Palace, stands the extremely elegant Establishment lately opened by

**H. P. TRUEFITT,**

At 114, PICCADILLY;

being a branch of his far-famed Establishment at Nos. 20 and 21, Burlington-arcade (established upwards of thirty years). The Front, unequalled, it is believed, in any capital of Europe, is elaborately carved in Caen stone; whilst the spacious saloons for Hair-cutting, and private rooms for Hair-dressing, dyeing the Hair, and washing the head, are arranged with exquisite taste, and replete with every convenience. None but Assistants of first-rate talent are engaged; and in the shop will be found a splendid selection of every requisite for the toilet. The prices are in strict conformity with the economical spirit of the times. The charge for Hair-cutting is One Shilling. Everything in the same proportion.

**LADIES' HAIR-DRESSING.**—In this department H. P. TRUEFITT can now challenge the world, having secured the assistance of artists who are allowed to be unequalled; whilst his frequent visits to Paris secure every novelty in style, without the enormous prices charged by foreigners in this country. Lessons in Hair-dressing, without any extra charge for court hair-dressing. A splendid assortment of Ladies' fancy Twist Combs.—20, 21, *Arcade*; 114, *Piccadilly*.  
**CERTAINTY IN DYING THE HAIR** has at last been thoroughly effected by the "TINCTURA," a fragrant extract, by which any shade in brown or black is produced instantly and permanently. Those who have been deceived by any of the dyes in use at present will appreciate the value of this important discovery. Private rooms, replete with every convenience, are reserved expressly for its application.—114, *Piccadilly*.

**PERFECTION IN WIG-MAKING** is accomplished by the introduction of H. P. TRUEFITT's NEW DIVISION, which combines the durability of the skin with the transparency of the net parting, and perfectly avoids that great objection to ornamental hair, the DARK LINE ON THE FOREHEAD, it being now impossible to discover where the wig commences. This valuable discovery is applicable to ladies' bands, fronts, &c.—114, *Piccadilly*; and 20, 21, *Arcade*. [195]



**BROWN BROTHERS, 165, Piccadilly, Manu-**  
rurers. Patent Suspensory Chair, forming Couch or Bed, extremely portable and luxurious, eminently serviceable for invalids, the camp, or drawing-room. [147]

**RICHARD GUNTER'S BRIDE-CAKE ESTAB-**  
**LISHMENT,** corner of Motcomb and Lowndes street, Knightsbridge. Wedding Breakfasts, Dinners, Balls, and Parties furnished complete, with wines and attendants. [130]

**JAMES LAPHORN, SAIL-MAKER, GOS-**  
**PORT.**—A Suit of SAILS, on an inch scale, of the Brig Yacht "Anonyma," 450 tons. Also MODEL of same from the Water Line up. [1116]

**JAMES TOWNSEND, Manufacturer of every**  
description of AIR GUNS and CANES on the most improved principles, and POWDER WALKING-STICK GUNS in every variety.  
11 and 12, *Sand-street, St. Mary's-square, Birmingham.* [162]

**JOHN SANDERS, Manufacturer of the PATENT**  
**INDIAN RUBBER WATERPROOF UMBRELLA**  
**TENT,** Registered, 11, Fore-street, Cripplegate, London. Suitable for gentlemen's gardens, lawns, and pleasure-grounds, and to all climates. [124]

**CLASS 28. — SPECIMENS.—GUTTA PERCHA**  
**ESTABLISHMENT.—A. THORN and Co.,** by Appointment, 98, New Bond-street, London. Looking-glass, Picture, and Print Frames, Console Tables, and House Decorations, are now manufactured of Gutta Percha, gilt and unglit, resembling the finest Wood Carving, which will not break or crack. Inkstands, Card-trays, and many other fancy goods. Also every other article manufactured by the Gutta Percha Company, as at their Works, 18, *Wharf-road, City-road, London.* [1279]

**HENDRIE'S PERFUMERY,** patronized by the highest Circles for Eighty Years, continues to be favoured by a decided preference. PERFUMER to HER MAJESTY, 12 and 13, *TICHBORNE-STREET, QUADRANT.* [130]  
*See Catalogue.*

**RYDE, ISLE OF WIGHT.**  
**HOPGOOD'S CELEBRATED HAIR-CREAM**  
is forwarded to any part of England, in 1l. packages, free of carriage. May be had in London of the following Agents: G. W. COURT, 282, Regent-street; J. GOSNELL and Co., 12, Three King-court, City; J. H. DONAGAN, 58, Edge-ware-road; and DUFFY-GIBSON and HANNAY, 63, Oxford-street. Communications respecting the hair or scalp answered. [1278]

**MR. HAYES, SURGEON DENTIST, 42, St. MARTIN'S LANE,** begs to announce that he supplies every description of Artificial Teeth at moderate charges, and can only be consulted at 42, *St. Martin's Lane.* [1225]

**ANGLERS of the FOUR QUARTERS of the**  
**WORLD** visiting LONDON will find the best-selected stock of Fishing-rods, Flies, and Tackle, suitable for their various climates, at JONAS KING FARLOW'S Fishing Tackle Manufactory, 5, *Crooked-lane, London Bridge.* Catalogues of Prices gratis. [1252]

**VISITORS TO THE EXHIBITION** are respect-fully informed that MADAME TUSSAUD and SONS' HISTORICAL GALLERY having been enlarged, by desire of the Public, to double its original size, in honour of the Exhibition, no one need fear paying the Promenade a visit, as both space and ventilation are provided. The Collection, the largest in Europe, consists of 160 Public Characters, and has been established fifty years.  
"This is one of the best sights in the metropolis."—Times.  
Admittance, 1s. Napoleon Rooms and Chamber of Horrors, 6d. Open from 11 till 10 at night.  
**BAZAAR, BAKER-STREET, PORTMAN-SQUARE.** [1200]





**BY APPOINTMENT.**—MADAME MICHEL GUILLEL, Milliner and Dressmaker to Her Majesty, 1, Little Argyll-street, Regent-street, has just returned from Paris with unprecedented Novelties. [1 94]

**FOR SALE,** a fancy ornamental BED-QUILT, designed and worked by CATHERINE FANCOURT, of Grims-thorpe, Bourne, Lincolnshire. Price 50*l*. [1 127]

**MRS. GIBSON, 50, MORTIMER-STREET, CAVENDISH-SQUARE,** Dealer in, Repairer and Cleaner of, all kinds of Lace, Brussels, Honiton, and Point Lace exchanged for Ladies' or Children's Wardrobes; or Wardrobes purchased to any amount.—Every description of Lace-work done on the premises. [1 18]

**IRISH POPLIN or TABINET.**—The ONLY HOUSE for the exclusive Sale of this beautiful Manufacture, so much admired for Ladies' Dresses and Gentlemen's Waistcoats, is ELLOR's, removed from Pall Mall to 54, St. James's-street, Piccadilly. [1 108]

**BENNETT and CO.,** Manufacturers of **UTRECHT or MOHAIR VELVETS,** for the decoration of Furniture, lining Carriages, &c. Also **PLUSHES** and other Worsted goods.—London and Manchester. [1 50]

**C. and J. DANBY, FRINGE and GIMP MANUFACTURERS, &c.,** 14, COVENTRY-STREET, and 43, NEW BOND-STREET, beg to call the attention of the nobility and gentry to their extensive stocks of Fringes, Gimps, Tassels, Buttons, Cords, Laces, Bindings, &c., both for Dress and Furniture Trimmings. Every description of the above Goods made to order with accuracy and despatch. [1 140]

**THOMAS BARTLEET and SONS, FALCON HALL, SILVER-STREET, WOOD-STREET, LONDON,** and 126, Great Charles-street, Birmingham, **WOOLLEN WAREHOUSEMEN,** and all articles connected with Men's Mercery; also Manufacturers of Buttons, Needles, &c., in every variety. [1 155]

**SPLENDID CHINTZ FURNITURES.**—GRAND EXHIBITION CHINTZES.—CLARKSON and Co., Her Majesty's Furniture Printers, respectfully inform the nobility and gentry they have now on show their new Spring Stock of Magnificent Chintz Furnitures; some of which have been designed expressly for the Exhibition.—17, COVENTRY-STREET, opposite the Haymarket. [1 185]

**CAPPER and WATERS, Makers of the CORAZZA SHIRT,**

26, Regent-street, St. James's. Shirts of every description, from 3*s*. 6*d*. to 5*l*. each; excellent at 6*s*. and 8*s*. 6*d*. Every recent improvement. See Catalogue. [1 27]

**THE REGISTERED POLKA COLLAR.**—This COLLAR is the only one really adapted to **ONCE-ROUND CRAVATS.**—May be had of every respectable Hosiery and Draper in the United Kingdom: wholesale (only) of G. R. WOOLGAR, 36, WOOD-STREET, LONDON. [1 142]

**JOSEPH BRIE and COMPANY, FRENCH SHIRT MAKERS.**

The elegance of French make, combined with the durability of English materials, a desideratum long wished for, has now been satisfactorily obtained by Messrs. J. BRIE and Co.—Wholesale and Retail Establishment, 189, Regent-street.—Good Plain Shirts, from 6*s*. 6*d*. Linen Shirts, from 10*s*. 6*d*. Dress Shirts, from 8*s*. 6*d*. [1 104]

**RICHARD ATTENBOROUGH, 19, PICCADILLY,** begs to call attention to the "FAXTON SPOON" (see illustrative page), and the "ALRANY TEA AND COFFEE SERVICE," both elegant in design, agreeable to use, and yet less expensive than the ordinary patterns. Being registered, they can only be obtained as above. Orders by Post, containing a remittance or a reference, promptly executed. [1 92]

**THRESHER and GLENNY, HOSIERS TO THE QUEEN,** respectfully invite attention to the following Articles manufactured exclusively by them, and which can only be procured at their Warehouse, 153, Strand, next door to Somerset House, London.

**THRESHER'S INDIA GAUZE WAISTCOATS,** lighter, softer, and less expensive than the finest Flannels, and perfectly free from every irritating or disagreeable quality.

**THRESHER'S SUPERIOR HOSIERY,** comprising every kind of Silk, Thread, Cotton, Cachmere, and Woollen Stockings, Drawers, Waistcoats, Socks, and Gloves, of the very best description that can be manufactured.

**THRESHER'S SILKEN-THREAD HOSIERY,** a New Material for Summer Wear, exceedingly light, strong, and elastic, particularly adapted for Warm Climates.

**THRESHER'S SILKEN-WOOL HOSIERY,** a new description of Woollen Hosiery, warranted not to shrink in washing, and extremely thin, warm, soft, and strong.

**THRESHER and GLENNY, HOSIERS, SHIRT-MAKERS, AND OUTFITTERS,** 153, STRAND, next door to Somerset House. [1 91]

**JAMES FRY, GODALMING, SURREY,** Manufacturer of **FLEECEY** and other **HOSIERY**; and of every description of Underclothing for Ladies and Gentlemen, shaped from the frame, in Lamb's-wool, Segovia, Merino, and Cotton. Also, Ladies' Silk and Lisle Thread Stockings of the finest quality, plain and embroidered. [1 77]

### Rodgers's Improvements in Shirts.



RODGERS'S IMPROVED SHIRT, No. 84.

**THESE SHIRTS** are cut upon a new and improved principle, which insures a most correct and comfortable fit. Perfect satisfaction (as usual) is guaranteed, or the money returned. The Prices are,

31/6 or 37/6 the half-dozen.

The Ready-made Stock is the best, the cheapest, and the largest in London, and comprises Shirts of every description.

Superb Dress Shirts (for evening wear) in great variety, from 5/6 to 8/6, and upwards.

A Choice of 200 new designs in Regatta and other Fashionable Coloured Shirts,

Six for 20/-, or Six very best for 26/-.

New Patterns, Prices, and Directions for Self-measurement, gratis and post-free.

Hosiery, Gloves, Scarfs, Cravats, Ties, and Silk Pocket-handkerchiefs,

AT EXCEEDINGLY MODERATE PRICES.

**RODGERS & CO., SHIRT-MAKERS, HOSIERS, AND OUTFITTERS,** 59, St. Martin's-lane, Charing-cross, and No. 29, at the corner of New-street, Covent Garden, London.

(ESTABLISHED 60 YEARS.)

\*.\* Country Agents wanted to sell the "Improved Shirts." [1 48]



**HOSIERS TO THE** attention to the following by them, and which can be, 152, Strand, NEXT DOOR

**WAISTCOATS**, lighter, finest Flannels, and per- disassemble quality.

**BIERY**, comprising every mere, and Woolen Stock and Gloves, of the very factured.

**HEAD HOSIERY**, a New dingly light, strong, and arm Climates.

**HOSIERY**, a new de- rant not to shrink in a, soft, and strong.

**HOSIERS, SHIRT**, 152, Strand, next door [191]

**G. SURREY**, Manu- ther HOSIERY; and of g for Ladies and Gentle- n Lamb's-wool, Segoria, 's Silk and Lisle Thread in and embroidered. [177]

ents in Shirts.



SHIRT, No. 84.

on a new and improved correct and comfort- usual) is guaranteed, or re,

half-dozen.

est, the cheapest, and the shirts of every description.

wear) in great variety, and upwards.

in Regatta and other ed Shirts,

ry best for 26/-.

ons for Self-measurement, -free.

waits, Ties, and Silk chiefs,

GRATE PRICES.

CO.,

AND OUTFITTERS,

es, and No. 29, at the Garden, London.

YEARS.)

"Improved Shirts." [148]

1861.]



**EDUARD HARAND,**  
MANUFACTURER OF  
**ARTIFICIAL FLOWERS.**  
15,  
**RUE DE CHOISEUIL,**  
**PARIS.** [1302]

**HATS FOR EXPORT.**—TRESS and CO. will, on and after May 1st, 1861, show their New Designs, embodying great improvements, and well adapted for foreign climates, at their Manufactory, CHURCH-YARD, BLACKFRIARS-ROAD. (Exhibited in Class 20, No. 102.) [191]

**GRAND EXHIBITION.**—Messrs. VYSE, Mil- liners, and Manufacturers of British and Foreign Straws to the Queen and Royal Family, respectfully announce that they have ready for inspection the FASHIONS for the present year, composed from materials they have deposited in the Exhibition of All Nations. Ladies honour- ing their Magazin des Modes with their patronage will find a fixed price attached to every article. French and German spoken.—30, Ludgate-street, St. Paul's. [1228]

**TO PRESERVE LIFE IN SHIPWRECK.**

Laurie's Patent FLOATABLE MATTRESSES, PILLOWS, LIFE-BELTS, AND SUNDRY BUOYANT ARTICLES.

**S. W. SILVER & CO.,**  
SOLE LICENSEES.

**EVERY** Ship Mattress will sustain eight persons in the water for an indefinite period, and at a small in- crease on the usual cost of those in common use. Every pillow or seat-cushion will sustain one or more persons. The LIFE-BELTS are PREVENTIVES to sinking, the cheap- est yet submitted, very portable, and applied in an instant in case of accident. Thus, individuals going a long voyage, or a short trip, or yachting, boating, or ferrying, ought to be furnished with one of these various clever Preventives to sinking, which may be seen and tested at the Manufacturers',

**S. W. SILVER & CO.,**

CLOTHIERS, OUTFITTERS, and CONTRACTORS,

66 and 67, CORNHILL,

And 4, BISHOPSGATE-STREET, LONDON,

And at LIVERPOOL,

where Passengers may be supplied with the whole or any portion of their Outfit (including Folding Furniture for Cabin and after use) without sacrificing the too usual intermediate profit, SILVER & Co. being the Makers of the manifold articles in the Outfit, and supplying them at their Shipping Prices.

Department for Outfitting Cadets and Cabin Passengers generally, Naval and Military Uniforms, and Clothing for Home use, at 66, CORNHILL.

Department for Outfitting Ladies, and for Home use, with experienced Female Managers, 66 and 67, CORNHILL.

Department for very low-priced OUTFITS, 4, BISHOPSGATE-STREET, opposite the London Tavern, where a com- fortable Fit-out for a four months' voyage may be procured for Four Guineas, including a FLOATABLE MATTRESS.

DRAFTS on AUSTRALIA, 30 days' sight, at par. [180]

**ULLATHORNES and LONGSTAFFS**, No. 12, GATE-STREET, LINCOLN'S INN FIELDS, LONDON, Manufac- turers of Shoemakers', Sallers', and Harness-makers' Threads, and Ullathorne's Heel Balls for Shoemakers' use. Manufac- tory at Barnard Castle, county of Durham, England. Es- tablished in the year 1790. Number of hands employed 350 to 400. See Exhibition Official Catalogues. [169]

**ALLEN & SON, TREFFGARNE, HAVERFORDWEST,** SOUTH WALES, Designers and Manufacturers. IMPROVED WATERPROOF SHOOTS-BOOTS, consisting of a Tongue the elasticity of which admits the foot without folds; leg soft; the footing strong, impenetrable, and impervious to wet; combined with iron, which prevents slipping in going over fences and banks, or in ascending or descending hills, &c. To order, 2s.; wholesale, 2s. per pair. [184]

**SECTION III., CLASSES 19 and 15.**

**FREDERICK SCHWANN, HUDDERSFIELD and LEEDS.**—FANCY VESTINGS of all descriptions, fancy and plain Quiltings, Pantaloon Stuffs of all descrip- tions, of pure wool, and wool, or worsted, and cotton; Buckskins, Doeskins, Over-coat Cloths, Pailetto Beavers, Pilot Cloths, Petershams, Linings, Cassinets, Cashmerets, Merinos, Shoe and Boot Cloths, Barracans, Programs, Sum- mer Coatings, Cassimeres, Kerseys, plain Cloths (pure wool and with cotton), Paddings, Ponchos, Bajetas, Baltas, Cien Hilos, Blankets, Carpets, of all descriptions; ladies' and children's Dress Goods; Printed Paramattas and Merinos (for the Levant), Table-covers, Scotch and Irish Linen and Table Lirans, Linen and fancy Drills, Linen, Sewing and Shoe Thread, Linen and Worsted Yarns, Spun Silk, Genappe Cord, Worsted Knittings, Nails, Shorts, Flax, Hemp, &c. &c. &c. [133]

**GUNS, RIFLES, PISTOLS, AIR-GUNS.**—

The most extensive and magnificent assortments of Double Fowling Pieces, of every calibre, our own London manufacture, combining all the latest improvements and most superior workmanship, at prices according to finish and exterior ornament, from Ten to Twenty Guineas.—Superb Double Rifles, of the most highly improved construc- tion, accurate sighting and shooting, with round, belted, or cone moulds, included, Ten to Thirty Guineas. Extra Barrels, for shot, fitting in the same Stock, Ten Guineas, being, with case and apparatus, the most portable and com- plete outfit for India, or any foreign service, at Twenty Guineas and upwards.—Single Fowling Pieces and Rifles, of various calibre, from 2 ounces up to a pea-bullet, suitable for every purpose, at home or abroad, Five to Fifteen Guineas. Trial at our private Shooting Grounds, 300 yards. Pistols, Double and Single, in immense variety, in cases, with apparatus. Most perfect Self-acting Revolvers. Curious Ball-practising Pistols. Improved Air-Canes, from 6s. Orders packed and shipped, or forwarded overland, without delay or trouble to purchasers.—Terms, Cash. [1243]

REILLY, GUN MAKER, New Oxford-street, London.

**WALTER EVANS & CO.,**  
OF  
**Darley Abbey, near Derby.**

(But all transactions are dated **DERBY.**)



SPECIMENS OF  
**SUPERIOR SEWING COTTONS**  
AND  
**CROCHET COTTONS**  
(generally called **BOAR'S HEAD COTTONS**),  
AND OF  
**KNITTING COTTONS.**

The Boar's Head is the Family Crest of Messrs. EVANS and has been used by them as the distinguishing mark upon their Goods for nearly forty years. [129]

ESTABLISHED 1769.

**WAUGH & SON.**  
**LONDON CARPET WAREHOUSE,**

3 & 4, Goodge-street.

CARPET MANUFACTURERS AND MERCHANTS.

Designers and Proprietors of a Royal Velvet Pile  
Carpet. (See Catalogue.) [139]

**W. BLISS,**  
MANUFACTURER OF FANCY WOOLLENS,  
CHIPPING-NORTON, OXON.

**K**ERSEY and Prince's Checks, in variety, for Summer and Winter Horse-clothing. Worsted Webs, for Saddle-girths, Rollers, Brace, and Belts. Imperial stout elastic Tweeds, for Gentlemen's Trowsers, remarkable for substance and durability. Shawls—The Alpa Vicugna Royal Shawl, very soft, warm, and light.

The Royal Angola and Royal Beaver Shawls.  
The Royal Har's-down Shawl.

Press Bagging and Straining Cloth, for pressing and refining Oil.  
Venetian Cords, for lining Carriages and covering Furniture.

The Royal Bed and Cot Coverlets—registered.  
The Oxford Wrapper, or improved Railway Apron—registered. (See Catalogue.) [174]

**LONDON**  
**PAPER HANGING COMPANY.**

No. 42 AND 43, POULTRY,  
CORNER OF OLD JEWRY, CHEAPSIDE.

Established 1838.

**T**HE public may now obtain all the most beautiful PAPER HANGINGS, comprehending many hundred varieties of the richest designs, at unprecedented low PRICES.

The Patterns suitable for Bedrooms, Staircases, &c., vary from one halfpenny to three halfpence per yard. Chintz, Arabesque, Damasks, and Elizabethan Designs, printed in six or seven brilliant and durable Colours, for Drawing and Sitting rooms, at two pence per yard. Oak Paper one penny per yard.

Satin and Ornamental Papers equally cheap.

Estimates given and Patterns forwarded on application to  
[168] C. J. GORDON, Manager.

**THOMAS PEARCE AND SON,**

23, LUDGATE-HILL, LONDON.

**L**AMPS, CHANDELIERS, LUSTRES, CUT TABLE GLASS; DINNER, DESSERT, Tea, Breakfast, and Toilet Services; CLOCKS, first-class Bronzes, Alabaster, Ornamental China, and Bohemian Glass; CANDELABRA, Candlesticks, Inkstands, Plated Goods, Tea Trays, &c.

The attention of Merchants and Families furnishing is particularly requested to the above.—Every article is marked in plain figures. [167]

**HENRY TRAPNELL & SON,**

Cabinet-Makers, Upholsterers, and Undertakers; Paper-Hangers, Decorators, and Complete Furnishers.

**THE CITY CABINET MANUFACTORY,**  
2, St. JAMES'S BARTON, BRISTOL.

**D**ESIGNS, PLANS, and ESTIMATES given for Furnishing Houses in any part of the kingdom.

Blankets, Quilts, Counterpanes, and all kinds of Bedding. Spring Beds and Mattresses of every description, and on the best principles.

Carpets, Damasks, Silks, Chintzes, and every fabric for Upholstery, in immense variety, from the first English and Foreign Wholesale Markets.

The Proprietors of this Firm are genuine Manufacturers.

**N. B.**—Solid and portable Furniture for exportation.  
(See Catalogue.) [196]

**TO PURCHASERS OF FURNITURE,**  
CARPETS, CURTAINS, AND UPHOLSTERY.

**P**ERSONS in search of really good and substantial FURNITURE, at moderate prices, should visit the extensive FURNITURE SHOW-ROOMS of Messrs. ATKINSON and Co., 70, 71, 72, 73, 74, and 75, Westminster Bridge-road, Lambeth.

At these Warehouses the largest and most varied STOCK of CABINET FURNITURE, UPHOLSTERY, BEDSTEADS, BEDDING, CARPETS, CHINTZES, SILK and WOOL DAMASKS, CHIMNEY GLASSES, CORNICES, &c., is displayed for public inspection; and as all Messrs. ATKINSON and Co.'s GOODS are made of the very best Materials by first-rate Workmen, Purchasers may rely on meeting with Articles of good sterling value, and WARRANTED.

Books with Prices may be had on application.

It is requested THE ADDRESS may be particularly observed.

**ATKINSON AND COMPANY,**

70 to 75, WESTMINSTER BRIDGE ROAD, LAMBETH. [192]

**W. H. MASON'S CARRIAGE FACTORY,**



**KINGSLAND-ROAD BASIN, LONDON.**

Expenses are moderate in this neighbourhood. Several Noblemen and Members of the Conservative and Reform Clubs are standing customers for his superior light and roomy DROSCHIES, with or without heads; driving and light MAIL PHAETONS; small Park or George IV. PHAETONS; single and double BROUILLANS; which he flatters himself are surpassed by none for either quality, style, or real cheapness.

Let on hire, with option of purchase. Carriages built for hot climates. (See Catalogue.) [151]

**E AND SON,**  
 LONDON.  
 LUSTRES, CUT  
 DESSERT, Tea, Break-  
 CKS, first-class Bronzes,  
 Bohemian Glass; CAN-  
 nds, Plated Goods, Tea  
 Families furnishing in  
 bove.—Every article is  
 [167]

**ELL & SON,**  
 and Undertakers; Paper-  
 mplete Furnishers,  
**MANUFACTORY,**  
 ON, BRISTOL.  
 ESTIMATES given for  
 t of the kingdom.  
 and all kinds of Bedding,  
 every description, and on  
 es, and every fabric for  
 m the first English and  
 enuine Manufacturers.  
 ulture for exportation.  
 e.) [196]

**FURNITURE,**  
 D UPHOLSTERY.  
 y good and substantial  
 prices, should visit the  
 of Messrs. ATKINSON  
 and 75,  
 and, Lambeth.  
 and most varied STOCK  
 UPHOLSTERY, BED-  
 S, CHINTZES, SILK  
 NEY GLASSES, COR-  
 to inspection; and as all  
 OODS are made of the  
 rkmon, Purchasers may  
 good sterling value, and  
 application.  
 S may be particularly  
**MPANY,**  
 ROAD, LAMBETH. [102]

**AGE FACTORY,**  
  
 IN, LONDON.  
 elghbourhood. Several  
 nservative and Reform  
 his superior light and  
 eads; driving and light  
 e IV. PHAETONS; single  
 atters himself are sur-  
 e, or real cheapness.  
 Carriages built for  
 catalogue.) [151]

**MELTHAM MILLS,**  
 NEAR HUDDERSFIELD.  
**BROOK'S**  
 ROYAL IMPROVED, PATENT  
 SEWING COTTON

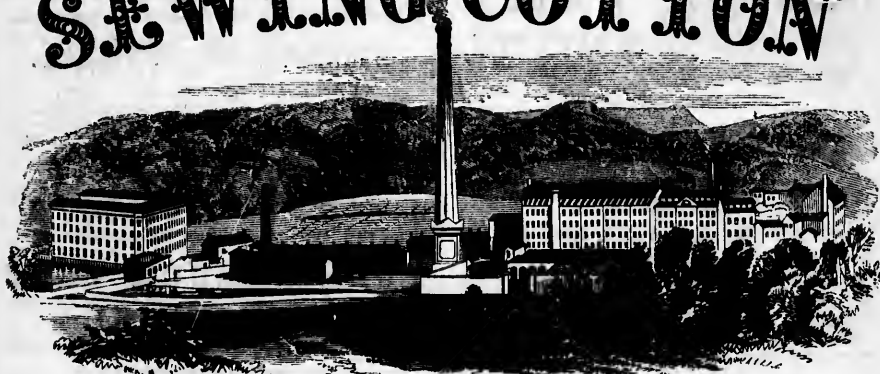

IN  
**2.3.4.6 & 9, CORD.**

VERY SUPERIOR  
**WIRE THREAD,**

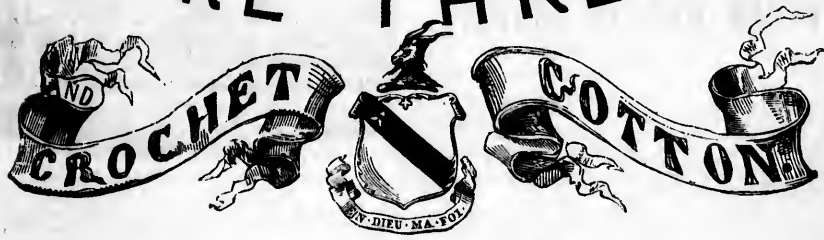

See EXHIBITION OFFICIAL CATALOGUES.

**JOHN BRYANT,**  
IMPORTER OF CIGARS OF THE FINEST BRANDS,  
285, REGENT-STREET; and ORIEL-STREET, OXFORD. [1 296

**SHERRY**, 23s., 27s., 30s., 36s. per dozen. Amon-  
tillado and Solera, 42s. Port, 25s., 28s., 32s. Old  
Cruet, 34s. to 48s. Claret and Burgundy, 24s. Sparkling  
Champagne, 40s. All pure and unadulterated. LEON  
FAMIN and CO., 21, Cooper's-row, Tower-hill. [1 242

### WEBB'S DOUBLE SODA,

**POTASH, SELTZER, and all other WATERS.**—  
The dangerous contact with lead and copper is avoided  
by their patented apparatus, the pipes of which are com-  
posed of glass, silver, earthenware, &c. These Waters have  
a pure and non-metallic taste, difforent to all others. Look  
on the cork for **WEBB'S DOUBLE SODA WATER**, prepared  
only at the Works, Islington Green, London. [1 115

### THOMAS DEWAR,



MANUFACTURER OF

**PURE  
MUSTARDS,**

NEWCASTLE-UPON-TYNE.

TESTIMONIAL from M. A. SOYER, author of "*Gastronomic  
Regenerator.*"

"I have with several friends at the Club fairly tried your mustard,  
and we pronounce the quality superior to any other as regards purity,  
flavour, and strength. "A. SOYER.

"Reform Club, Pall Mall, 20th Oct. 1846." (See Catalogue.) [1 160

### P. H. WOOD,

MANUFACTURER OF HIS CELEBRATED

**REFINING POWDER,**

For refining, colouring, and improving the flavour of Coffee,

In Boxes at 1s. each;

Also,

MANUFACTURER AND SOLE INVENTOR OF

THE CELEBRATED

**COLOURING FOR SOUPS, GRAVIES, &c.,**

In Boxes at 1s. 3d. each.

20, Redman's-row, Assembly-place, Mile-end,

LONDON. [1 125

### VICKERS'S GINGER BRANDY.

**ON** this Article public favour has impressed the  
stamp of perfection. It is a medicine without  
nausea, a LIQUEUR exhilarating and beneficial; it is an  
instant remedy for spasms, and causes nervousness to  
vanish away.

### VICKERS'S GINGER BRANDY

was intended for the Exhibition, but is excluded because  
it cannot be judged of by the eye; the Visitors are there-  
fore informed that it will be found serviceable to many,  
before going to the Exhibition, as it will render fatigue  
endurable, and prove there are merits which do not appeal  
to the sight. It may be obtained, as well as their re-  
nowned CURACAO PUNCH, at 3s. 6d. per bottle, of every  
Spirit Merchant in the kingdom. Also the ORANGE  
GINGEBETTE, and IMPERIAL LIQUEUR GENEVA  
(a very superior specimen of English Gin), in capped  
bottles, at 2s. 8d. each.

Wholesale at the Borough Market Distillery. [1 90

### Whitakers & Co., London. The Fifth Edition of THE BRITISH WINE MAKER AND DOMESTIC BREWER,

By WILLIAM HENRY ROBERTS,

Author of "*The Scottish Ale-Brewer and Practical Malster.*"

**THE ART OF MAKING CHAMPAGNE,  
HOCK, MADEIRA, and every HOME WINE,** with-  
out possible chance of failure, as well as LIQUEURS,  
ALES, BEERS, and PORTER. Describing the SACCHA-  
ROMETER and its utility in WINE-MAKING. Containing also  
A SUPPLEMENT, showing the juice of the Rhubarb-plant to be  
as valuable as a basis for the above Wines as that of the  
Grape.

### ROBERTS'S FERMENTED BRITISH WINES.

**THESE WINES** are made on the same principle as  
Foreign, and Specimens have been admitted to the  
EXHIBITION. ROBERTS'S CHAMPAGNE and sparkling Hock,  
at 28s. per dozen, are incomparably superior to any sold under  
60s. ROBERTS'S Hock, with twenty other kinds, is unrivalled.  
Assorted sample cases sent direct from the BRITISH WINE  
WORKS, Edinburgh, free, to Hull, for cash.

JOHN TEEDE, 85, BISHOPSGATE-WITHOUT,  
Sole Agent for London. [1 167

### VINAIGRE DE BORDEAUX.

### W. & S. KENT & SONS,

UPTON-UPON-SEVERN,

(PORTS OF GLOUCESTER AND BRISTOL.)

Invite attention to their Stock of

### PURE FRENCH WINE VINEGAR,

In Puncheons, Hogsheads, and Tierçons.

It is of finest quality, highest strength, well ma-  
tured, in colour and brilliancy like the Wine from  
which it is made; and for Pickling, Salads, and every  
domestic use, preferable to all other.

"KENT AND SONS' VINAIGRE DE BORDEAUX.—We some  
time ago received from Messrs. Kent and Sons a bottle of  
this Vinegar. The flavour is delicious, and the article  
very pure. We cheerfully give it our most cordial recom-  
mendation."—*Chemist* for Nov. 1850.

Shippers, masters of vessels, and others, can be  
supplied, for export, ships' stores, &c., from Bonded  
Warehouse, *ex duty*.

The public may obtain it, at a moderate price, of  
Chemists, Grocers, and Wine Merchants throughout  
the kingdom.

TERMS AND SAMPLES ON APPLICATION.

|                        |                                                              |
|------------------------|--------------------------------------------------------------|
| LONDON STORES . . .    | { 3, Queen-street-place, Cheap-side,<br>W. S. HURSET, Agent. |
| LIVERPOOL STORES . . . | { 23, Horatio-street,<br>JOS. LAYCOCK, Agent.                |
| HULL STORES . . . . .  | { 77, High-street,<br>HEADLEY & NEWBALD, Agents. [1 3        |

Fifth Edition of  
AND DOMESTIC

OBERTS,  
Practical Malster."  
CHAMPAGNE,  
WINE, with  
as LIQUEURS,  
cribing the SAOCCAO,  
Containing also  
the Rhubarb-plant to be  
Wines as that of the

TISH WINES.  
The same principle as  
is admitted to the  
and sparkling Hock,  
for to any sold under  
kinds, is unrivalled  
in the Barris Wine  
sh.  
TE-WITHOUT,  
[1 167

RDEAUX.

SONS,

ERN,

D BRISTOL.)

ook of

WINE

R,

Tierçons.

Strength, well ma-  
the Wine from  
Salads, and every

DEAUX.—We some  
d Sons a bottle of  
, and the article  
ost cordial recom-

others, can be  
., from Bonded

oderate pri s, of  
ants throughout

ATION.

, Cheapalde,  
agent.

gent.

ALL, Agents. [1 3

**READ'S PATENT INSTRUMENTS.**

**GARDEN WATERING ENGINES,**  
Garden Machines and Syringes upon the most improved principle,  
**STOMACH-PUMPS AND INJECTING MACHINES,**  
**DOUBLE-ACTION APERITIVE FOUNTAINS,**  
**INJECTING INSTRUMENTS** for Horses, Cattle, &c. &c., and  
**PROBANGS** for relieving Hoven or Choked Bullocks,  
Calves, Sheep, &c.

Manufactured only by  
**RICHARD READ,**  
Instrument Maker (by Special Appointment) to Her Majesty,  
35, REGENT-CIRCUS, PICCADILLY, LONDON.  
(See Catalogue.) [1 118

**T. F. SARSON,**  
BRAZIER, GAS-FITTER, AND BELL-HANGER,  
St. NICHOLAS-STREET, LEICESTER. [1 75

**JAMES AUSTIN,**  
Manufacturer of the Imperial Patent "sh, Clock, Blind, and  
Picture Line.  
8 & 9, PRINCES-STREET, FINSBURY, LONDON. [1 45

**ICE AND REFRIGERATORS**  
AS SUPPLIED HER MAJESTY.

**THE WENHAM LAKE ICE COMPANY'S**  
**REFRIGERATOR** (164A, STRAND, LONDON), under the  
patronage of her Majesty, the Royal Family, the Nobility  
and Gentry, the Admiralty, the Honourable Corporation of  
Trinity House, the Royal Mail Steam-Packet Company,  
and supplied to Royalty of nearly every nation, is the only  
Refrigerator that has stood the test in the hottest climates,  
and realised all that can be arrived at in the preservation of  
Ice, and cooling and preservation of Articles liable to  
injury in hot weather.

**THE COMPANY'S**  
**PURE SPRING-WATER ICE**  
is delivered in London daily, and forwarded to all parts of  
the Kingdom and the Continent, packed in a manner to  
prevent waste.

MANUFACTURERS OF  
**WINE COOLERS, ICE CREAM MACHINES,**  
**KNIFE CLEANERS,**  
AND THE  
**GLASS ENAMELLED CISTERNS.**

DEPÔT FOR  
**BIRD'S SYPHON FILTER,**  
the most perfect Water Purifier ever invented; can be  
adapted at once to any Cistern or Water-but, and will  
yield a constant stream of pure water. May be seen in  
operation and Prospectuses had.

**THE WENHAM LAKE ICE COMPANY,**  
164A, STRAND, LONDON. [1 52

**ALLSOPP'S**  
**EAST INDIA AND STRONG BURTON ALES.**

**FOREIGNERS** visiting England are particularly  
requested to ask for these favourite Ales.  
The Pale Ale has been long consumed in the East-Ind-  
ies and all hot climates for their highly wholesome and  
antibilious properties.  
The strong Burton Ale (as originally brewed by Wilson  
and Allsopp) have been celebrated throughout Russia,  
Prussia, and Germany.  
LONDON STORES . . . 61, King William-street, City.  
LIVERPOOL " . . . Cook-street.  
MANCHESTER " . . . Ducie-place.  
BIRMINGHAM " . . . High-street.  
SCOTLAND " . . . 33, Virginia-street, Glasgow.

The several Agents at the above places are empowered to  
give letters of introduction to all respectable Foreigners  
who may desire to visit the Brewery at BURTON-ON-  
TRENT. [1 40

**GELATINE** and **GLUE** for every purpose, of the  
purest kind: also Coloured Sheets. Manufacturer, F.  
Müller, Hackney: Agent, J. Maine, 7, Union Court, Old  
Broad Street, City. [1 93

By Her Majesty's Letters Patent.



**G. NELSON, DALE & Co.**  
14, BUCKLESBURY, LONDON,  
AND EMSCOTE MILLS, WARWICK.  
Manufacturers of

**The Patent Opaque Gelatine,**  
**Patent Refined Isinglass**  
Perfect substitutes for Russian Isinglass, for all culinary purposes.  
**Brilliant Gelatine, Gelatine Lozenges,**  
And every other description of Gelatines.

Extract from Dr. URE'S Testimonial.  
"I find Mr. G. Nelson's Patent Opaque Gelatine to  
be at least equal in strength and purity, IF NOT SUPERIOR to the  
BEST ISINGLASS, for every culinary purpose; it is entirely  
free from any impregnation of ACID, such as I have found to exist  
in the OTHER KINDS of Gelatine in the London Markets."  
In Packets from 6d. to 10s. each.  
A Sixpenny Packet makes One Quart of Jelly.

As these Articles will keep in any Climate, they are strongly  
recommended to Merchants, Captains and others; for exportation,  
also for the use of the Army and Navy Mess Tables, Club Houses  
and Hotels.

To be had of most respectable Chemists, Grocers and Oilmen,  
in the United Kingdom.

Norwich Barracks, 5 March 1861.  
Sir,  
As I constantly require to use your Opaque  
Gelatine, I have daily more and more admira-  
tion at the beauty, the quality, and the eco-  
nomy it possesses.

The Officers of the Regiment have assured  
me, that they never tasted any thing so deli-  
cious as the Jellies, Blancmange, and every  
thing else which I make from your ingenious  
Composition; and to have insured the testimony of their approval,  
is indeed much to gain.  
From my own experience in America,  
France and England, I have no hesitation in saying that I never found  
Jellies, &c. appear to have half so much brilliancy, as those I can  
produce from your Opaque Gelatine. The general want of cleanli-  
ness in the preparation of Calves' Feet for Jelly, which must leave a  
dullness in the Jellies, is guarded against by adopting the use of  
your Opaque Gelatine.  
Yours very truly,  
JULIEN SUZANNE,  
Messina 11th Hussars.



Mr. G. Nelson.



**NEWBOULD & BAILDON,**  
MANUFACTURERS OF  
**TABLE, PEN, POCKET, AND SPORTSMAN'S KNIVES,**  
SURREY WORKS, SHEFFIELD.



SOLE MANUFACTURERS OF

**"ROBERTS'S PATENT TABLE KNIVES,"**

the handles of which cannot be injured or loosened by hot water. They are fastened by means of a dovetail tang, as shown above, without resin or cement of any kind.

N. & B. beg to call attention to their new "REGISTERED" FAST-HANDLE IVORY TABLE KNIVES, which are made without the use of cement, and cannot become loose by being put into hot boiling water. They will be found to be the most durable article ever offered to the public, and may be had of any respectable Cutler or Ironmonger in London or the country. None are genuine unless marked in full NEWBOULD & BAILDON, *Registered, March 24, 1851, No. 2741.* [1274]

**HARCOURT QUINCEY, BIRMINGHAM** and **SHEFFIELD AGENT** for all descriptions of Export Ironmongery, 82, *Hatton-garden, London*; Patentee of Convex Iron Revolving Safety-Shutters; Corrugated Window-Blinds; In perforated Metal; common Oil-Lamps, with China Cones; Folded Paper Lamp and Candle Shades; and of the 1851 Pedestal Coal Vase. [1227]

**IBBOTSON BROTHERS & Co.,**  
SHEFFIELD, ENGLAND,

MANUFACTURERS OF EVERY DESCRIPTION OF  
**STEEL AND FILES**

FOR ENGINEERING PURPOSES; ALSO

**RAILWAY SPRINGS, SAWS, EDGE-TOOLS,**  
**SCYTHES,**

**CUTLERY, AND MACHINE KNIVES;**

AND

**GENERAL MERCHANTS.**

**CORPORATE MARK—"GLOBE."**

AGENT IN LONDON,

Mr. W. H. MAYBURY, 38, WALBROOK, CITY.

OFFICE IN NEW YORK, 218, PEARL STREET. [1178]

**JOHN WILSON & SON,**  
SYCAMORE-STREET, SHEFFIELD,

*The original Manufacturers of Shoe Knives, Butchers', Bread, Cooks', Carriers', Furriers', Glaziers', Palette, and Weavers' Knives, Butchers' Steels, &c. &c.,*

**DEEM** it right to apprise their friends that not only does their Mark continue to be **PIRATED** both in this Country and on the Continent, but that certain unprincipled persons, who are deterred from striking the said Mark only from a fear of being visited with legal proceedings, have resorted to another mode of imposition, and, in order to EVADE THE LAW, are vending Articles marked

I. WILSON, only; or, WILSON  
REFINED STEEL

or, WILSON OR, GEO. WILSON  
WARRANTED

In each case omitting the Corporation Mark.

OBSERVE.

All Knives, Steels, &c., of JOHN WILSON and Son's Manufacture, are stamped with their Corporation Mark, "Four Peppercorns and a Diamond," thus ☉☉☉☉, in one of the following forms:—

|              |               |
|--------------|---------------|
| I. WILSON    | ☉☉ I. WILSON  |
| ☉☉           | REFINED STEEL |
| ☉☉ I. WILSON | ☉☉ I. WILSON  |
| WARRANTED    | SHEAR STEEL   |

[1210]

BRITANNIA WORKS, SHEFFIELD.

**BROADHEAD AND ATKIN,**

PATR. ELECTRO SILVER-PLATERS & GILDERS,



MANUFACTURERS OF

Electro Plate, British Plate, Anglo Plated and Britannia Metal Goods. [1131]

**THOMAS PORTER, 9, SPRING GARDENS, MANCHESTER,** Commission Merchant for the Purchase and Sale of British, French, German, American, and other Manufactures, Produce, &c. &c. [1301]

**THOS. LINLEY & SONS, PATENT BELLOWS** and **PORTABLE FORGE MANUFACTURERS, 34, STANLEY-STREET, SHEFFIELD.** Patentees and Manufacturers of the Double-Blast Circular Bellows; improved Circular, Patent, and improved Portable Forges; and general Manufacturers of Bellows. Warranted superior quality. [1192]

**FISHER and BRAMALL (Hoyle Street Works), SHEFFIELD,** CONVERTERS and REFINERS of STEEL; MERCHANTS, and MANUFACTURERS of IMPROVED FILES, RASPS, SAWS, &c.; Importers of CELEBRATED MARKS or BRANDS of Foreign Irons for making BLISTERS, CASE, SHEAR, SHERT, RAILWAY and COACH SPRING, and every other description of STEEL used for Machinery and Engineering purposes. Approved CIRCULAR SAWS, of a proper degree of hardness for cutting AXLES, RAILS, and other Iron. [1272]

**CAST STEEL.**

**S. and C. WARDLOW, PRACTICAL STEEL** and **MANUFACTURERS, Roscoe Field Steel Works, Malin Street, Sheffield.**—Not having supplied specimens of Steel direct to the Great Industrial Exhibition, we take the present medium of informing the consumers of Cast Steel that a great portion of the finest qualities of Cutlery from Sheffield shown in the Crystal Palace is from steel of our Manufacture. One of the partners having been personally engaged in Refining Steel for upwards of 30 years, we are enabled to guarantee the utmost care and skill to parties intrusting us with orders for the Finest Qualities of Cast Steel. [1292]

In Furniture Class No. 26; and North Gallery, Class No. 28, at the Great Exhibition.



KNIVES,

dovetail tang, as shown  
LE KNIVES, which are  
found to be  
stronger in London or  
24, 1851, No. 2741. [1 274

SHEFFIELD.  
D ATKIN,  
PATENTERS & GILDERS,



Plated and Britannia  
[1 131]  
GARDENS, MAN-  
for the Purchase and  
merican, and other Manu-  
[1 301]

TENT BELOWS  
MANUFACTURERS, 34,  
and Manufacturers  
; improved Circular,  
; and general Manu-  
perior quality. [1 199

CTICAL STEEL  
Steel Works, Mo-  
supplied specimens of  
hibition, we take the  
sumers of Cast Steel  
ilities of Cutlery from  
is from steel of our  
having been personally  
of 30 years, we are en-  
-kill to parties intru-  
of Cast Steel. [1 292

LIST OF ARTICLES shown  
by the Gutta Percha Com-  
pany at the GREAT EXHIBI-  
TION OF 1851.

**Waterproof Applications.**  
Specimens of covered canvas, and  
patent waterproof Gutta Percha  
cloth.  
Waterproof soles for boots and  
shoes.  
Piece of solution jean for insoles.

Hydrophatic bandages.  
Waterproof heels with metal tips.

**For Agricultural Purposes.**  
Pumps for liquid manure.  
Stable bucket—Traces—Horse-shoe  
pad.

**For Manufacturing Purposes.**  
Flat and round bands for machi-  
nery.  
Bucket—Pump bucket—Valve.  
Cutting board for glove-makers.  
Piece of felt edging for paper-  
makers.  
Flax holders (Plummer's patent).

Specimens of packing for steam  
engines.  
Washers for cold-water pipes.  
Boxes for flax manufacturers.

Woven driving band, saturated  
with Gutta Percha.

Specimens of Gutta Percha sand  
cloth, of three and four piles; a  
substitute for leather for the backs  
of cards used in carding wool,  
cotton, and other fibrous sub-  
stances.

**For Maritime Purposes.**  
Anchor floats—Buoys—Fishing net  
floats—Life buoys, and air-tight  
life-boat cells.

Pilot's hat.  
Sou-wester hat.  
Colls of round band for signal hal-  
lards.  
Speaking trumpets.

**Decorative Applica-  
tions.**  
Brackets—Console tables—Cor-  
nices.  
Ceiling centres—Mirror and other  
frames.  
Picture frames—Friezes—Giran-  
doles.

An ornamental side-table, in pa-  
nels, representing the four Sea-  
sons, with glass frame, in three  
compartments. In the style of  
Gibbons.

Cheesman and stand.  
Frame for print of the "Anti-  
Corn-Law League."  
Panels.  
Mouldings in imitation of carved  
oak, rosewood, &c. &c., for the  
decoration of rooms, ships' sa-  
lons, cabinet work, &c.  
Pattern Book of Gilded Gutta Percha.  
Specimens of ditto.

LISTE DES OBJETS envoyés  
à l'Exposition de Londres  
de 1851 par la Compagnie fa-  
briquant du Gutta Percha.

**Articles Imperméables.**  
Echantillons de tissus brevétés im-  
perméables.  
Sermelles de souliers et de bottes,  
imperméables.  
Tissu préparé imperméable pour  
les semelles intérieures.  
Bandages hydrophatiques.  
Talons montés sur métal, imper-  
méables.

**Articles d'Usage  
Agricole.**  
Pompes pour engrais liquide.  
Seau d'écure—Bourrelet de fer à  
cheval.  
Bandes plates et circulaires pour  
les machines.  
Seau—Seau-de-pompe—Soupapes.  
Pianochette pour le coupe des gants.  
Hordure à l'usage des fabricants  
de papiers.  
Poignée brevetée par Plummer, pour  
le lin.  
Renfortage des platons des ma-  
chines à vapeur.  
Dagues de tuyaux à eau froide.  
Bonnets employés dans les ma-  
nufactures de lin.  
Bande tressée mécanique préparée  
avec solution de Gutta Percha.  
Morceau de toile cardée, en Gutta  
Percha, à trois et à quatre piles,  
employés au lieu de cuir pour le  
cardé des coton-laines et autres  
tissus.

**Articles employés dans  
les Manufactures.**  
Bandes plates et circulaires pour  
les machines.  
Seau—Seau-de-pompe—Soupapes.  
Pianochette pour le coupe des gants.  
Hordure à l'usage des fabricants  
de papiers.  
Poignée brevetée par Plummer, pour  
le lin.  
Renfortage des platons des ma-  
chines à vapeur.  
Dagues de tuyaux à eau froide.  
Bonnets employés dans les ma-  
nufactures de lin.  
Bande tressée mécanique préparée  
avec solution de Gutta Percha.  
Morceau de toile cardée, en Gutta  
Percha, à trois et à quatre piles,  
employés au lieu de cuir pour le  
cardé des coton-laines et autres  
tissus.

**Articles employés dans  
la Marine.**  
Floteurs d'ancre—Houées—Plot-  
teurs de filets—Bouées de sauve-  
tage, et cellules imperméables  
pour bateaux de sauvetage.  
Chapeau de pilote.  
Chapeau "and-wester" (de marin).  
Bandes circulaires pour signaliser.  
Porte-voix.

**Objets de Luxe et de  
Décoration.**  
Tasacous—Tables consoles—Cor-  
nices.  
Centres de plafonds—Cadres divers.  
Cadres de tableaux—Friezes—Giran-  
doles.  
Une table élégante avec des pa-  
neaux ornés représentant les  
quatre Saisons avec un chasie  
de glaces en trois compartiments.  
Echees et guéridon.  
Cadre pour la gravure de l'"Anti-  
Corn-Law League."  
Cadres pour daguerréotype.  
Panneaux.  
Moulures, imitations de chêne ci-  
selé, de bois de rose, &c. &c., pour  
décorer les salons, l'intérieur des  
bâtimens, &c. &c.  
Livre d'échantillons de ces articles.  
Ornemens dorés en Gutta Percha.

**Surgical and other  
Applications.**

Bed straps.  
Ear cornets.  
Ear trumpets.  
Hearing apparatus for the deaf in  
church, &c.—Pneumatics.  
Pieces of sheeting for splints.  
Pieces of thin sheeting for band-  
ages, &c.—Stethoscope.  
Dr. Foucart's clavicular splint.  
Set of teeth in Gutta Percha base  
or bed.

**Chemical and Electrical  
Applications.**

Acid scoop.  
Vessels for acids.  
Carboys—Chemical bottles—Che-  
mical flasks.  
Various specimens of submarine  
and other Electric Telegraph  
wire.  
Funnels—Insulating stool.  
Galvanic battery troughs, with 12  
or 24 cells.  
Galvanic battery cell.  
Specimen of lining for acid tanks—  
Siphons.

**Domestic Purposes.**

Basins—Bowls—Baskets—Bread  
platter—Bouquet holder.  
Bottles  
Bottling boot.  
Specimens of clothes line.  
Curtain rings.  
Decanter stands—Drinking cups.  
Finger cups—Inkstands—Ink cups.  
Lighter stands—Paper weights.  
Plates.  
Trays, ornamental, various patterns.  
Vases—Wafers hold-ers.  
Watch stands.  
Specimens of lining for water  
tanks, &c.  
Specimens of window blind cord.

**Miscellaneous Applica-  
tions.**

Architects' plan cases.  
Bouncing balls—Golf ball—  
Cricket balls.  
Communion plate.  
Carriage tubes.  
Specimens of corrugated sheet for  
wine packing.  
Dolls—Fire bucket.  
Piece of string for mourning  
coaches.  
Fencing-stick guard.  
Cornish miner's hat.  
Northumberland miner's hat.

Life-preservers—Médallions—Mu-  
sic case.  
Discs for official seals.  
Specimens of paper for damp walls.  
Police staff—Powder flasks.  
Railway conversational tubes.

Coll of sash line.  
Stop-cocks—Pairs of skates.  
Samples of thread.  
Tan barrels—Whips.  
Specimens of wetting cord for fe-  
male dresses.  
Specimens of tubing of various  
sizes—Speaking tube.  
Union joints for Gutta Percha tubing

**Applications Chirur-  
giques.**

Sangles de lit.  
Trompettes—cornet pour les sourds  
Trompettes à l'usage des sourds.  
Appareil à l'usage des sourds pour  
les tyglasses.—Pneumatics.  
Morceaux de toile pour éclipses.  
Morceaux de toile mince pour  
bandages, &c.—Stethoscope.  
Eclipses claviculaires du Dr. Foucart.  
Râtelier complet monté sur Gutta  
Percha.

**Applications Chimiques  
et Electriques.**

Ecupe pour les acides.  
Vases pour les acides.  
Carboys (cruches pour préserver les  
acides)—Bouteilles chimiques—  
Flasques chimiques.  
Plusieurs espèces de fil télégra-  
phique électrique sous-marin et  
autres.  
Étonnoirs—Tabouret électrique.  
Auges de machines galvaniques.  
L'une à 12 et l'autre à 24 divisions.  
Cercle galvanique simple.  
Méthode de doubler les réservoirs à  
acides—Siphons.

**Articles Usuels.**

Basins—Gamelles—Paniers—Pla-  
teau pour le pain—Porte-bouquet.  
Bouteilles.  
Bottes de remplissage de bouteilles.  
Cordes de blanchissage.  
Anneaux de rideaux.  
Portes-bouteilles—Gobelets.  
Doligrès—Bortettes—Encriers.  
Forces-lumières—Presses papiers.  
Asiettes.  
Plateaux divers et de luxe.  
Vases—Portes-pains à cacher.  
Portes-montres.  
Echantillons de doublures pour les  
réservoirs d'eau, &c.  
Echantillons de cordes de jalousies.

**Applications Diverses.**

Boîte à dessins d'architectes.  
Balles élastiques—Balls—Étuves  
égales.  
Asiettes pour amonées dans les  
Tuyaux de voitures.  
Echantillons de draps ridés d'em-  
ballage pour les vins.  
Poupees—Seau d'écure.  
Morceau de frange pour voitures de  
cauill.  
Garde porte-coup d'escrime.  
Chapeau de mineur Cornwallien.  
Chapeau de mineur du Northum-  
berland.  
Conserves—Médallions—Étuis de  
manique.  
Disques de cachets officiels.  
Echantillons de papiers pour les  
murs humides.  
Bâtons de sergents de police—  
Pulverins.  
Tubes de conversation de chemin-  
de-fer.  
Rouleau de corde de jalousies.  
Robinettes d'arrêt—Patines.  
Echantillons de fil.  
Violettes de robinets—Ponets.  
Echantillons de corde-à-borde pour  
robes de dames.  
Echantillons de tuyaux de dimen-  
sions diverses—Tuyau porte-voix.  
Jointures de tubes en Gutta Percha.

GUTTA PERCHA COMPANY, PATENTEES,  
18, WHARF ROAD, CITY ROAD, LONDON.

## THE IMPROVED WELL OR GRAVY DISH,

DULY  
REGISTERED,  
IN TERMS

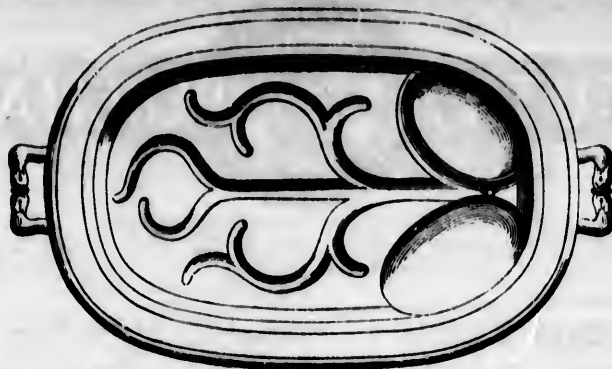

OF THE ACT  
OF  
PARLIAMENT.

Possesses the peculiar merit of **ENTIRELY SEPARATING** the liquid fat of roasted or boiled meat from the gravy, and of thus rendering **THE GRAVY** as it flows from the meat **AS PURE** as if the fat had been lifted off it whilst both were in a cold state.

### MANUFACTURED

IN SILVER AND PLATED METAL, by ELKINGTON, MASON, & Co., of Birmingham ;  
IN BRITANNIA METAL,—of which the one in the Great Exhibition is a specimen—by SHAW & FISHER, of Sheffield; and  
IN CHINA AND STONEWARE, by MINTON & Co., and some other houses, in the Potteries.

To obtain these dishes &c. call, the public will please apply to the respective tradesmen with whom they are in the habit of dealing.

**OPINION OF M. SOYER.**—"REFORM CLUB, 10th May, 1850. I certainly consider the Dish a great improvement and boon for epicures. I shall use it to-morrow for some of the first gourmets in the world, and let you know their opinion. "A. SOYER."

**WRITER AFTERWARDS.**—"THE Dish was highly approved of. Two or three of the party would have them. They should be extensively made known by advertisement, as no epicure would be without one. "A. SOYER."

**DIRECTIONS FOR USE.**—Shut the communication between the two Receivers. Dish your meat, place it on the dinner-table, and begin to carve; by which time all the fat collected in the first receiver will be floating on the top of the gravy therein, whilst the second receiver will be—and you must see that it really is—quite empty. Now open the communication between the two receivers, when the gravy only will run into the second; which done, again shut the communication between them, until another accumulation of gravy and fat, flowing from the meat, shall have taken place in the first receiver, when again proceed to separate them as before. The only caution of any kind requiring attention being, not to overflow the first receiver, and thereby to overflow the fat into the second.

EXHIBITED BY THE INVENTOR,

JOHN GRAY.

Edinburgh, No. 11, Inverleith-row, March, 1851.

[1 158



**JOHN & CHAS. RATCLIFF & Co.,**  
**PATENT ELECTRO PLATERS**

AND  
**GILDERS,**

**SUFFOLK-STREET WORKS,**  
**BIRMINGHAM,**  
AND  
**ARUNDEL-STREET, SHEFFIELD.**

The experience gained by J. & C. R. & Co. in carrying out an extensive Electro business during several years enables them most confidently to recommend its adoption by the Trade generally: by no other known process can those classic and elaborate designs hitherto confined to silver and gold be supplied, nor can perfect colour and clearness of surface be effected but by their patented improvements.

All Depositions made by J. & C. R. & Co., whether of Gold, Silver, Copper, or Brass, on German Silver, Britannia Metal, Iron, Steel, &c., they guarantee to be perfect in adhesion, colour, and durability, and at prices to meet the particular market of every manufacturer. [1 271

**TIMOTHY SMITH & SONS, BRASS FOUNDERS** and Manufacturers of Solar, Argyll, Carcel, Boat, and Ship Lamps, Pillars, Candelabra, Gas-Lamps, Chandeliers, and Mountings generally.—HARCOURT QUINCEY, Agent, 82, Hatton-garden, and at Birmingham. [1293

**MARTINEAU and SMITH, Manufacturers of** Patent and other Cocks of all descriptions. Also of House, Turret, Ship, and Hand Bells, &c.—HARCOURT QUINCEY, Agent, 82, Hatton-garden, and at Birmingham. [1283

**ROBERT SMITH and CO., GENERAL FACTORS** for all descriptions of Export Ironmongery, &c., for the Home or Foreign Trade. HARCOURT QUINCEY, Agent, 82, Hatton-garden, and at Birmingham. [1284

### IRON CRANES.

**STOTHERT, RAYNO, and PITT, Ironfounders** and General Engineers, invite the attention of parties requiring Cranes to the one exhibited by them in Sect. 1. 5. The numerous orders received for all sizes from Government, and the New Dock Companies and Railways, home and foreign, show the estimation in which they are held. Estimates given for all kinds of Railway Fittings, Steam, Gas and Water Work.—Newark Foundry, BATH. [1 176

**KITCHEN RANGES and VENTILATING STOVES.**—BROWN and GREEN'S PATENT RANGE is a certain cure for a Smoky Chimney, and for Economy, Cleanliness, and Convenience in Cooking is unrivalled. Their Self-acting Cottage Range, with Oven and Boiler, at 18s. 6d. each, and their Improved Ranges, with Patent Ovens, are strongly recommended. The Patent Portable Suspension Stove consumes the least Fuel, gives a genia' warmth, and thoroughly ventilates the apartment; it is the cheapest of any, and is suited for Bedrooms, Nurseries, Halls, Schools, Libraries, Greenhouses, Chapels, Churches, &c.—Manufactory, Luton, Beds; Wholesale Agents, R. W. KENNARD and Co., 67, Upper Thames-street, London. [1 219

CHARLES FARROW,

IRONMONGER, SMITH, BRAZIER, TINMAN, AND GAS-FITTER,
Manufacturer of Machines, Tools, and Utensils for the Wine and Spirit Trade,
18, GREAT TOWER-STREET, LONDON.
(See Illustrated Catalogue.)

WROUGHT-IRON WINE-BINS AND SCANTLING.

Copper Measures, Pumps, Cranes, and Funnels.
Corking Machines. Stools, Knots, Drivers, and Floggers.
Masterman's Patent Bottling Apparatus and Corking Machine.
Bottling Pliers and Wires. Hoses and Bins.
Bung and Cock Drivers.
Coopers' Adzes, Drivers, Beak Irons, and Hammers,
Chisels, Punches, Flaggings and Chiseling Irons.
Hammers, Shiva Vices, Tinklers, Corkscrews of all kinds.
Prets, Nippers, Marking Irons. Blot, Blot Rakes, Cork Drawers.
Shives, Tins, Spiles. Bung Tins, Tacks, Nails, Hammer Cord.
Sampling Irons. Oil Searchers. Glass Tube and Spitting Pens.
Betta's Patent Metallic Capsules. Stocker's Patent Beer-Engines.
Automaton Funnels with self-closing Valves.

Bottling, Hacking, and Screw Cocks. Electro-Plated Cocks.
Brand Irons, for casks and corks. Sunfall Plates, Ink, and Brushes.
Bottle Seals, with shifting centres. Sealing Wax. Tinfoil.
Wax Furnaces, Cement Pots, and Stoves. Filtering Bags and Irons.
Bottle Gauges, Bottle Sinker, and Bottle-Washing Machines.
Cellar Lamps, Oil and Cotton. Cellar Candlesicks, in great variety.
Wood Cans, Cellar Tubs, and Bottling Trays. Bottle Guards.
Vellineers, Filling Cans, Wastu Pots, Champagne Knives.
Bin Laths. Slate, Porcelain, and Painted Bin Labels.
Glass Vellineers and Siphons. Porcelain Funnels and Tap Troughs.
Leather, Indian Rubber, and Patent Woven Hose Pipes.
The Registered "Paris Fiasco" or Wine Handle.
Bottle Carriers, or Portable Cellars.

MONTEBELLO'S CORKING MACHINE.

(See Illustrated Catalogue.)

This machine, the invention of the Marquis Alfred de Montebello, of the firm "Duc de Montebello," Mareuil-sur-Ay, Champagne, obtained a prize at the French Exposition of 1844, as may be seen from the following:—

Extrait du "Rapport du Jury central sur l'Exposition des Produits de l'Industrie Francaise en 1844," tome 2, page 839.
M. Montebello (Alfred) du Château de Mareuil-sur-Ay (Marne), et à Paris, Rue Laffitte, 17.

"M. de Montebello a présenté un appareil d'une extrême simplicité destiné au bouchage des bouteilles. Cette machine, exempte de tout engrenage et ressort, agit à l'aide d'un contrepoint qui maintient la bouteille, d'un levier qui ouvre et ferme plus ou moins un cône creux, sorte de virole brisée, enfin d'un boulon à tête arrondie qu'il suffit de pousser pour faire pénétrer, dans le goulet de la bouteille, le bouchon allongé et rétréci entre les viroles du cône creux.

"On évite ainsi de tordre et de rompre la tête des bouchons: il en résulte une économie notable, et un service plus facile et plus prompt. Aucune attention n'est à redouter dans les organes d'un mécanisme aussi simple.

"Pour un perfectionnement sur lequel la pratique a déjà prononcé, le jury central décerne à M. de Montebello une médaille de bronze."

C. Farrow has much pleasure in referring to the annexed letter from the inventor to his correspondents in London:—

"Château de Mareuil-sur-Ay, Feb. 6, 1848.

"Dear Sirs,—I am gratified by Mr. Farrow's approval of my Corking Machine, and you may give him my full permission to make and sell as many as he can. I have little doubt but that it may prove as useful in England as we find it in Champagne. Herewith I send you the published proceedings of our last Exposition, when the medal for this machine was decreed to me. A full specification of it is there given, which you may let Mr. Farrow copy.

"I am, dear Sirs, with known regard,
Your obedient humble servant,
ALFRED DE MONTEBELLO.

"Messrs. Richard Symonds & Son,
"2, Ingram-court, Fenchurch-street, London." [196

GARNKIRK WORKS, NEAR GLASGOW.

THE GARNKIRK COAL COMPANY, MANUFACTURERS OF

FURNACES FOR SMELTING IRON, GLASS, &c., and SMALL FIRE-BRICKS for MALLEABLE IRON WORKS—for home sale and exportation.

Fine selected and prepared CLAY for Glass-house Pots, Crucibles, &c.

Also, ORNAMENTAL VASES and FOUNTAINS, to stand any climate, salt glazed TUBES for Water and Sanitary purposes.

From the great extent of the Works, large Foreign orders can be speedily fulfilled. Nearly Eight Millions of Fire Bricks are manufactured annually.

Office, 5, CATHCART-STREET, GLASGOW.

February, 1851. [179

CWM AVON IRON, COPPER, & TIN PLATE WORKS, TAIBACH, GLAMORGANSHIRE, SOUTH WALES.

JOHN BIDDULPH, MANAGER.

IRON.—Railway Bars, Angle, Tyro, and Knce Iron, Cable, and all other descriptions of Bars, Bolts, Sheets, Boiler-plates, and ("Glamorgan") Canada plates.

TIN PLATES.—Tole and Terme Plates.

COPPER.—Tiles, Cakes, and Ingots.

Naphtha, Limesalt, Sugar of Lead, &c., also manufactured here.

All Orders to be addressed as above.

The character of these Works for the superiority of their Tin Tole and Terme Plates has been established for thirty years, and the quality of the Canada Plates, Sheets, Cable Iron, and Railway Bars, having been submitted to the most severe tests by eminent Engineers, is admitted to be equal to any manufactured in South Wales. [144

TURNIP AND GRASS SEEDS.

J. MORRISON and SON, NURSERYMEN and SEED FARMERS, MONTGOMERY, ABERDEENSHIRE, and of BANFF, BANFRESHIRE, SCOTLAND, continue to execute orders for their celebrated GOLDEN YELLOW and other Turnip Seeds; as also GRASS SEEDS for Lawns and Pastures. [115

M. WEDLAKE and CO.'s NEW MACHINE for Cutting Straw into Chaff, and Bruising Oats, at same time or alternately, 42s. Plough Turnip-outer; Oil-cake Breakers; Haymaking Machine; Horse Hay-rake; Chaff Machine; Bean Mills; Gorse or Furze bruising Machine; Subsoil Plough; Seed and Manure Drills; Dressing or Winnowing Machines; Flour Mills; Threshing Machines; Scarifier or Grubber; Seed Machine; Iron Field-Roller; Barley Machines; Smut-cleaning Machines; Scotch Carts; Waggon; Harrows; Horse Hoe; Churns.—Liberal discount for cash.—On receiving six stamps, an illustrated list in English (i.e. in French, Italian, or German) will be sent. 118, Fenchurch-street. [182

PATENT MACHINES FOR PLANING, MOULDING, MORTISING, TENONING and BORING, either in hard or soft wood, which entirely supersede hand-labour for these purposes and make superior work at a greatly reduced cost. They are suitable for and used by Carpenters, Joiners, Builders, Coachmakers, Railroad Carriage and Waggon Builders, Cabinet Manufacturers, Pianoforte-makers, Engineers, &c. &c.

These very valuable Machines have been used in constructing the Exhibition Building, the Houses of Parliament, St. George's Hall, Liverpool, and also by the Honourable Board of Ordnance at the Woolwich Dockyard, and by most of the first Builders, Engineers, and Machinists in the Kingdom, which is considered a sufficient guarantee of their great utility, simplicity, and worth.

Sold by the Patentee,

WILLIAM FURNESS,

20, LAWTON STREET, LIVERPOOL, and at the GREAT EXHIBITION BUILDING, where all the Machines may be seen in daily operation. [182

DISH, OF THE ACT OF PARLIAMENT.

gray, and of thus rendered in a cold state. FURNACE, of Sheffield; and in the habit of dealing. Improvement and boon for them. They should be "A. SOYER." place it on the flimmer on the top of the gray even the communication between the first receiver, when not to OVERFILL the first JOHN GRAY. [158

S, BRASS FOUND. Ar, Argyll, Carcol, Boat, Gas-Lamps, Chandere, QUINCY, Agent, [1282

I, Manufacturers of descriptions. Also of "HARCOURT QUINCY, Birmingham. [1283

GENERAL FAC- Ironmongery, &c., QUINCY, Agent, [1284

PITT, Ironfounders the attention of parties by them in South Wales from Government, Railways, home and they are held. Esth- Fittings, Steam, Gas Bath. [1176

VENTILATING's PATENT RANGE is for Economy, Clean- Is unrivalled. Their and Boiler, at 18s. 6d. Patent Ovens, are Portable Suspension a genial warmth, and it is the cheapest of series, Mills, Schools, &c.—Manufacture- R. W. KENNARD [1219

## DR. ARNOTT'S SELF REGULATING STOVE.

OF the many new plans and devices that have from time to time been brought before the Public for Warming Rooms and Buildings, it may be said that not one in point of efficiency and economy has come up to the ARNOTT STOVE;—not the so-called Arnett Stoves, that has been as extensively abused as manufactured by various makers in the trade, but the Stove made upon the original simple and sound principles of Dr. ARNOTT; which, with the addition of the improvements made by the Doctor about eight years since, has become established as the most serviceable and efficient invention for Warming that the Public have yet seen. The peculiar advantages which the Stove possesses may be just stated. The temperature of the heat diffused by the Stove is comfortably warm and uniform, rendering every portion of the place perfectly and equally agreeable. There is very little trouble connected with the management of the Stove: it only requires replenishing with fuel twice in the twenty-four hours. The cost of the consumption of fuel is exceedingly moderate—more so, indeed, than that of any other Stove, especially considering the amount of heat diffused.

The Stove has been manufactured and in extensive use for many years in all parts of the country, and the truth of its superiority has become incontrovertibly tested: an evidence of which is in the large number of testimonials which F. E. possesses from parties who have had several years' experience with the Stove. One or two will here be presented:—

*From Messrs. S. COURTAULD, TAYLOR, and COURTAULD, Boching, Essex, and Carey-lane, Cheapside, London.*

"Sir,—Absence from home and many pressing engagements have prevented our replying to your letter before. In respect to the Arnett Stove, we have no hesitation in saying that we consider it very far superior to any other description of close stove we have ever seen, when so constructed as to carry out Dr. Arnett's principle; and we have pleasure in stating that your Stoves on this principle, of which we have had several in constant use through many winters, seem exceedingly well made, and have given us great satisfaction.

"We are, Sir,  
"Your obedient servants,  
"S. COURTAULD & Co.

*From the Rev. Dr. Brown, Chepstow.*

"Sir,—After trying various Stoves, said to be of Dr. Arnett's invention, all of which were more or less imperfect and unsatisfactory, I was directed by Dr. Arnett to those made by you. For about six years I have had your Stoves in use during the winter months, and have found them, for economy of fuel, cleanliness, safety, saving of time, and equality of healthy delightful temperature, all that I had looked for. Hence I have recommended Arnett Stoves, as made by you; and continue to recommend them to my friends with greatest confidence.

"I remain, Sir,  
"Your faithful servant,  
"T. J. BROWN.

"Mr. F. Edwards."

F. EDWARDS has models for 40 different sizes and patterns of Arnett Stoves.

A prospectus containing full particulars, with list of prices and sizes, &c., with some testimonials, to be had on application.

## DR. ARNOTT'S VENTILATING VALVE.

The attention of the Public has been of late much drawn to the subject of Ventilation; and Dr. ARNOTT'S VENTILATING VALVE is becoming universally applied as the most complete and efficient means that can be adopted to effectually ventilate rooms. But while great advantage has arisen through the use of Dr. ARNOTT'S Ventilator, many persons have met with great disappointment through having purchased articles which, through being imperfectly made, have become a nuisance by admitting smoke into the room, instead of being an absolute benefit. This misfortune has arisen through many in the trade (and some of them most respectable parties) having taken up the Ventilator, and have not fully understood, or have not paid sufficient attention to, its construction. The Public can only rest assured that they are having perfect articles by applying to F. EDWARDS, who has paid much attention to the Valve, and is the party who has made them under Dr. ARNOTT'S immediate direction. In most of the public buildings in London the Valve has been extensively applied, and carried out by F. EDWARDS with the greatest success. He has also put up many thousands in the private residences of all classes; and he has always found it to give universal satisfaction. Prices from 6s. to 36s. Prospectuses, with particulars and prices, to be had on application.

## SMOKEY CHIMNEYS. NO CURE. NO PAY.

With many years' experience in every branch of his business, F. EDWARDS is enabled to undertake the Cure of Smokey Chimneys on the above satisfactory terms, estimates for which would be previously given.

Parties furnishing houses would find it much to their advantage to purchase their Stoves and Kitchen Ranges of F. E., as all that are sold by him are fitted up in the most perfect manner, relative alike to the principles of radiation and economy as to the prevention of any chance of the escape of smoke.

**FREDERICK EDWARDS,**  
STOVE-MAKER TO HER MAJESTY,

42, POLAND-STREET, OXFORD-STREET, LONDON.

(See Exhibition Official Catalogues.)

[1856



**W. and P. STEELE'S**  
**First Class**  
**Patent Kitchen Range,**

As erected and shown at the  
**Great Exhibition,**  
 Hyde Park, London, 1851.

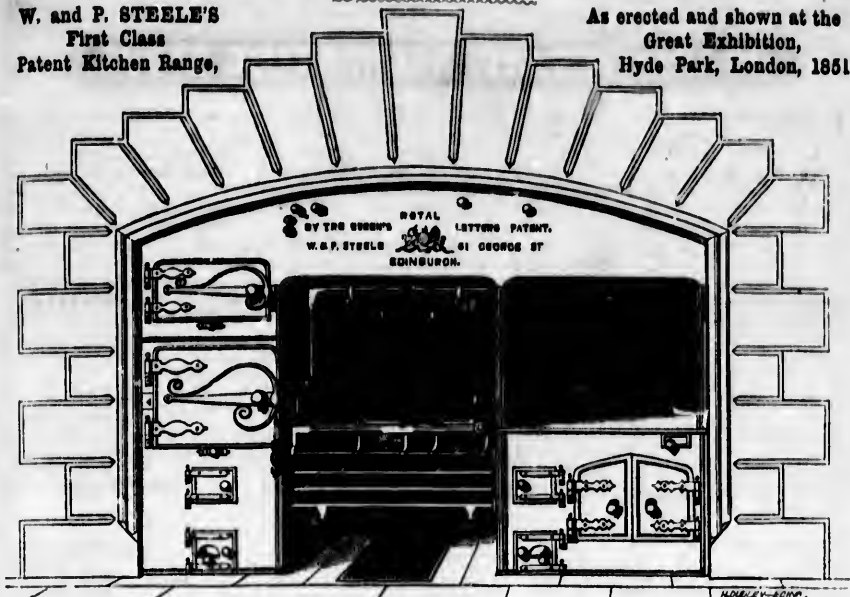

**W. & P. STEELE,**

MANUFACTURING AND FURNISHING IRONMONGERS TO THE QUEEN;  
 Patentees and Manufacturers of Improved Kitchen Ranges, Bath, Heating, and Culinary Apparatus, Stove Grates, &c.;  
 61, GEORGE-STREET, EDINBURGH.

**IMPROVED KITCHEN RANGES.**

*By the QUEEN'S Royal Letters Patent granted to*

**W. & P. STEELE**, of 61, GEORGE-STREET, in the city of Edinburgh, for **IMPROVEMENTS** in **KITCHEN RANGES** for **CULINARY PURPOSES**, and **APPARATUS** for **RAISING** the **TEMPERATURE** of **WATER** for **BATHS** and other uses.

The **PATENTEE**s beg leave to state that many of their **PATENT RANGES** are now in full operation; and wherever the **Apparatus** has been put up, it continues to give the most unbounded satisfaction. The **Patentees** have had the honour to receive several very flattering letters from families of distinction, for whom Ranges have been fitted up, bearing testimony, in the most unqualified terms, as to the **EFFICIENCY**, **USEFULNESS**, and **ECONOMY** in the **CONSUMPTION** of **FUEL**, by the use of the **Patentees' Improved Apparatus**.

The **Patent Range** is constructed in all its parts on **Scientific Principles**, and contains ample **Range Bars** for **Roasting** and **Boiling**, with one or more **Ovens**, and a **SPACIOUS BOILING-TABLE** or **HOT HEARTH**—all of which are fitted up on the principle of **PERFECT VENTILATION**. A large **Boiler** in the **Range** affords a constant and ample supply of **Hot Water**, and is suited to **Cook by Steam**; also, **APPARATUS** WHICH **GIVES THE POWER** of **HEATING** A **RESERVOIR** of **Water** at the **Top** of the **House**, one hundred feet more or less above the level of the kitchen, from which **Reservoir** **Hot Water** can be distributed all over the house, and by means of which a **BATH** MAY BE **GOT READY FOR USE AT A MOMENT'S NOTICE**, during any hour of the day, or even at midnight, in cases of sudden indisposition. Means are also provided for effectually and speedily **CLEANSING** out the **Boilers**, without further trouble to servants than merely turning one or two stop-cocks, so that **Hot Water** may at all times be had **FREE** of **SEDIMENT** and **PERFECTLY PURE**. The whole is effected by **ONE OPEN FIRE**, before which **Meat** may be **Roasted** in the usual manner, besides effecting a saving of at least **Half** the **Quantity** of **Fuel** used in apparatus of ordinary construction.

The above **Culinary Apparatus** is therefore confidently recommended to public notice as the best and most economical **Range** at present in use, and will be found admirably adapted for the **Mansions of Nobility and Gentry**, **Club-houses**, **Hotels**, or other similar establishments. The above **Improved Range** can be made on a limited or extended scale, to suit the accommodation required.

A **Prospectus**, containing a fuller detail of the **Range**, may be had, and every information furnished, on application at the **Patentees' Works**, No. 61, **George-street**, **Edinburgh**.

Plans furnished for all the requisite **Fireplaces** and **Fittings** in the **Culinary**, **Sill-room**, **Laundry**, and **Bath-room** departments, or for the supply of **Hot Water** for **Bath-rooms** and other domestic purposes throughout the mansion. Alterations, Erections, and general arrangements connected therewith, superintended by one of the **Partners** in town or country.

**Warming and Ventilating** of **Mansions**, **Dwelling-houses**, **Conservatories**, &c., on an improved principle, by **Hot Water** or **Heated Air**.

**W. & P. S.** manufacture every description of **Improved Culinary Apparatus**, including **KITCHEN RANGES**, with or without **Boilers** and **Ovens**; **SMOKE**, **WATER**, and **WIND-UP JACKS** of **Improved Construction**; **BOILING TABLES**, with or without **Grilling Stoves** and **Hot Press**. **Steam-cooking Apparatus** in sets or single. **Hot Closets**, **Charcoal Tables**, &c.

**W. & P. STEELE'S** extensive stock includes many very beautiful designs in **Drawing-room**, **Dining-room**, and **Parlour Grates**, &c., fitted up as **Registers**, or as **Kinnaird Grates**, so much recommended for **Curling Smoky Chimneys** and throwing out **Heat**, together with every requisite in **General Ironmongery**. **HOUSE FURNISHING**, all of first-rate quality, and moderate in price.

**W. & P. S.** beg also to state that, from their long experience and extensive practice in every department of **House Furnishing**, they are enabled to execute all orders intrusted to their care in the most prompt and satisfactory manner.

*Experienced Workmen sent to any part of the United Kingdom. Country Orders promptly attended to.*

**Self-heating, Plunge, Shower, Vapour, Nursery, and Chamber BATHS** in great variety.

E

ER. [1851

OVE

brought before the efficiency and economy as extensively abused simple and sound principle about eight years since, the Public have yet temperature of the heat place perfectly and stove; it only requires of fuel is exceedingly of heat diffused, the country, and the the large number of with the Stove. One

Chesham, London. Looking, Oct. 17, 1850. your letter before. In to any other description and we have pleasure in gh many winters, seem

ants, S. COURTNAULD & Co.

petow, Aug. 17, 1850. or less imperfect and had your Stoves in use of time, and equality of as, as made by you; and

ul servant, T. J. Brown.

estimonials, to be had

VE.

; and Dr. ARNOTT'S scientific means that can use of Dr. ARNOTT'S articles which, through of being an absolute respectable parties) attention to, its coning to F. EDWARDS, ARNOTT'S immediate applied, and carried the private residences 35a. Prospectuses,

PAY

d to undertake the riously given. and Kitchen Ranges to the principles of

[1856

AGRICULTURAL  
IMPLEMENT  
MAKERS



TO  
HIS ROYAL HIGHNESS  
PRINCE ALBERT.

**R. GARRETT AND SON,  
LEISTON WORKS, NEAR SAXMUNDHAM, SUFFOLK,**

MANUFACTURERS OF

AGRICULTURAL IMPLEMENTS AND STEAM ENGINES

OF EVERY DESCRIPTION,

IRONFOUNDERS, ENGINEERS,

AND EXPORTERS OF MACHINERY TO ALL PARTS OF THE WORLD.

R. GARRETT and Son beg reference to the Official Catalogue for descriptions of their Implements and Machinery exhibited at the Great National Exposition of 1851. They will have pleasure in supplying their Illustrated Catalogues, in the English and French languages, containing particulars and prices of all Implements and Machines required for Agricultural purposes, together with any further information that may be required, on application, by post or otherwise, at the Works, as above.

*All implements delivered carriage-free to London, Hull, or Newcastle-on-Tyne, or to any station on the Eastern Counties Railway.*

IMPLEMENTS PACKED AND SHIPPED FROM ANY PORT IN ENGLAND FOR ABROAD. (See Catalogue.)

[1137]

**PHOENIX IRON WORKS,  
NEAR STROUD, GLOUCESTERSHIRE.**

**JOHN FERRABEE AND SONS,  
ENGINEERS, MILLWRIGHTS, MACHINISTS, IRON AND BRASS FOUNDERS, AND MANUFACTURERS  
OF AGRICULTURAL IMPLEMENTS,**

UNDERTAKE THE CONSTRUCTION AND ERECTION, IN THE BEST STYLE, OF  
**STEAM ENGINES.**—Boilers and their appendages, Cast and Wrought Iron Cisterns and Tanks.

**WATER WHEELS.**

**MILL GEARING.**—Cast and Wrought Iron Shafting; Couplings; Spur, Bevil, and Mitre Wheels; Hangers, Pedestals, Fixings, Drums, Strap Wheels, &c.

**CORN-MILL WORK,**

Mill Hursts and Stones, Flour Machines, Smut Machines, Separators, Dusters, Meal and Corn Worms and Elevators, Holsting Tackle, Mill-stone Provers and Picks, Iron Sack Barrows, &c.

**MACHINES FOR THE MANUFACTURE OF WOOLLEN CLOTH,**  
Carding and Scribbling Machines, Spinning Machines (Mules), Power Looms, Fulling Stocks, Iron Washer Rollers, Iron Bolting Rollers & Cisterns, Gig Mills, Shearing Machines, Brushers, Grinding Machines, Indigo Mills, Hydraulic Presses, &c.

**MACHINES, PUMPS, TOOLS, ETC.,**

Leather Leveling Machines, Carpet and Hearth-Rug Shearing Machines, Hot-water Apparatuses, Lifting and Force Pumps, Circular-saw Benches, Cranes, Crabs, Windlasses, Lifting Jacks, Fan Blowers, Lock-gate Paddle Winders, Cart and Waggon Arms, Cast Axles, Screw Wrenches, Strap Punches, Strap Screws, Straps, &c.

**AGRICULTURAL MACHINES AND IMPLEMENTS.**

An improved and complete system of Machinery for Thrashing and Dressing all kinds of Corn, the whole of which may be worked in combination so as to deliver a perfectly clean and uniform sample of grain into the sacks at one operation, or the thrashing and dressing may be performed separately; Patent serrated Knife Machines, for cutting chaff or litter; Grinding Mills, with Stones made from French Burrs; Corn Crushers, Oil-oake Breakers, Turnip Cutters, Iron Ploughs, Subsoil Ploughs, "Ducio" Cultivators, Wrought-iron rhomboidal Harrows, Land Rollers, Presser and Clod-crusher Rollers, Horse Hoes, Haymaking Machines, Cast-iron P. g and Water Troughs, Mangers, Hay Racks and Pillars for Currier Stands, One-horse Carts, Wheels and Axles for Car s.

**BUDDING'S PATENT MOWING MACHINE,**

for Lawns, Pleasure-grounds, Bowling-grounds, &c. J. F. and Sons have manufactured and sold between 3000 and 4000 of these Machines—a conclusive proof of their utility. Messrs. RANSOMES and MAY, of Ipswich, are the sole wholesale Agents for the sale of them in London and the Eastern Counties. [1122]

TO  
KING  
ALBERT.



# R. W. WINFIELD, CAMBRIDGE-STREET WORKS, BIRMINGHAM.

## PROPRIETOR OF THE ORIGINAL PATENT FOR METALLIC MILITARY BEDSTEADS;

Patentee and Manufacturer of others upon improved principles; also Manufacturer of Brass Desk, Pew, Organ, and other Railing; Window Cornices, Patent Curtain Bands and Ends; Glass Cornice Hinges; Locomotive Railings and Mouldings; Brass and Zinc Name Plates for Shop Fronts; Sash Bars and Window Guards; Candle Chandeliers and Scones; Patent Tubes, by the New Patent Process, whether Paper or Double; Picture, Pulley, Curtain, Wardrobe, and Stair Rods, Astragals, and Beading; Window Fronts, Mouldings, Plates, and Guards; Balustrades; Fire Screen Stands and Arms; Bonnet, Hat, Cloak, and Umbrella Stands; Brass and Iron Rooling and other Chairs; Gas Chandeliers, Pillars, Branches, and Fittings of all kinds; Tubing of every description, rough and finished; Brass and Copper Wire, and Rolled Metals.

### SHOW ROOMS:

Cambridge-street Works, Birmingham; London, 141, Fleet-street; and  
Brussels, Corr Vander Maeren & Co.

R. W. WINFIELD'S Show Rooms contain Specimens of his Patent Metallic Military, Travelling, and House Bedsteads, so much in use at Home and Abroad; with many other Articles of Furniture in Brass, Bronze, Or-molu, and imitation of Silver; together with Gas Fittings of every Description, and a variety of other Articles of his Manufacture. The Portable Bedsteads are admirably adapted for use in the Camp, or for Travelling; and are also well suited for Officers in the Army and Navy. [1 291

Eastern Counties Railway.  
Catalogue.) [1 137

### SANITARY IMPROVEMENTS.

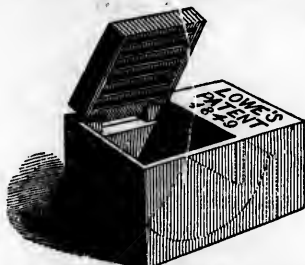

## LOWE'S PATENT EFFLUVIA-TRAP GRATINGS,



FOR  
PUBLIC SEWERS, AND DRAINS IN HOUSES, WORKS, YARDS,  
COURTS, PASSAGES, CELLARS, AND SINK-STONES.

Patronized and used at the Model Cottages in Hyde Park (opposite the Exhibition Building) now being erected for His Royal Highness Prince Albert, under the direction of Henry Roberts, Esq., F.S.A., Honorary Architect to the Society for the Improvement of the Condition of the Labouring Classes.

The advantages of the Effluvia-Trap Sewer Gratings, over the Bell, Syphon, Flap, or Drop Traps, consist in their combining, in a simple, cheap, and compact form, a Sewer or Sough Grating, an Effluvia-Trap, a Sediment-Trap, and a Vermin-Trap, all together; they are the only Effluvia-Trap which can be cleansed without allowing the effluvia to escape.

The simplicity of their construction, their general applicability, the ease with which they are examined and cleansed, their solidity of form and durability, perfect efficiency and cheapness, recommend them to the notice of Corporations, Architects, Surveyors, Builders, Contractors, the Trustees of Public Hospitals and Institutions, and all persons interested in the Sanitary Improvement of Towns, and to the Occupiers of all Houses where the Drainage is connected with the Main Sewers.

Upwards of twenty thousand of the Patent Grids are now in use by the Corporations, Surveyors, Commissioners of Sewers, or Local Boards of Health, in London and the principal Cities and Towns in the Kingdom.

### THE NUMBERS, SIZES, WEIGHTS, AND PRESENT PRICES, IN CAST IRON, ARE AS FOLLOW, viz.—

| No.   | Size.                   | Weight.      | £. | s. | d. | No. 7 Size (for Sink-stones), viz.—                                                   | s. | d. |
|-------|-------------------------|--------------|----|----|----|---------------------------------------------------------------------------------------|----|----|
| No. 1 | 18 by 18;—16 deep,      | about 5 cwt. | 9  | 5  | 0  | In Iron                                                                               | 9  | 0  |
| No. 2 | 20 by 12;—13 "          | about 2 cwt. | 0  | 17 | 6  | In White Metal, with Brass Top                                                        | 2  | 9  |
| No. 3 | 14 by 9;—9 "            | about 1 cwt. | 0  | 10 | 0  | All Brass                                                                             | 3  | 6  |
| No. 4 | 11 by 7;—7 "            | 55 lbs.      | 0  | 7  | 6  | Round Pattern, all Brass, with screw plug to open in case of the stoppage of the pipe | 3  | 9  |
| No. 5 | 9 by 5 1/2;—5 1/2 "     | 25 lbs.      | 0  | 4  | 9  |                                                                                       |    |    |
| No. 6 | 8 1/2 by 4 1/2;—4 1/2 " | 18 lbs.      | 0  | 3  | 8  |                                                                                       |    |    |

Any larger or intermediate sizes made to order, with either square or round bottoms, flat, concave, or convex tops, with or without flanges, and also with combined horizontal and perpendicular gratings. The usual trade allowance to Ironmongers; and a liberal discount to Corporations, Local Boards of Health, Contractors, and Architects.

Licensed Makers in London:—R. W. KENNARD and Co., 67, Upper Thames Street.  
Wholesale Agent, London:—W. K. WHYTEHEAD, Civil and Mechanical Engineer, 69, Cornhill.

Printed Lists of Testimonials and further particulars forwarded on application.  
Salford, Manchester, April 12th, 1851. A. LOWE and Co., Patentees. [1 294

IRE.  
MANUFACTURERS  
OF  
rns and Tanks.  
re Wheels; Hangers,  
orms and Elevators,  
CLOTH,  
on Washer Rollers, iron  
Hydraulic Presses, &c.  
ifting and Force Pumps,  
ie Winders, Cart and  
the whole of which may  
sacks at one operation,  
cutting chaff or litter;  
Cutters, Iron Ploughs,  
esser and Clod-crusher  
ks and Pillars for Corn-  
en 3000 and 4000 of these  
wholesale Agents for the  
[1 122

admitted by  
is spooled.



If atmospheric air is  
vent-peg, the liquor

### BARLOW'S

NEW INVENTED SELF-ACTING

### A SYPHON-TAP.

#### REQUIRES NO VENT-PEG!!!

Prevents ale, beer, cider, or other liquors from becoming flat or acid so effectually that the last pint shall be drawn as good as the first.

Warranted to repay its cost in two casks of ale.

Price 4s. 6d., or sent free to any part of England (if two are taken) at 5s. 3d. each. Ditto, electro-plated, much used for Sherries, &c., on tap, 8s. 6d. each.

The above engraving will explain its action. When the loose key is fitted on the top of the plug C (which has a hole opposite the air-tube H), sufficient air rushes through it into the cask to cause the liquor to run off freely; when the tap is turned off no more air can enter.

JAMES BARLOW,

14, KING WILLIAM-STREET, MANSION-HOUSE.

ESTABLISHED 1820.

None are genuine except stamped with his name and address.

N.B.—This tap is the most simple and least liable to get out of order of any yet invented. [126



### RIDGWAY'S

### PATENT KILNS,

FOR BURNING

POTTERY, BRICKS, TILES, &c.,

**COMBINE ECONOMY OF FUEL** with the production of first-rate goods, at a reduced loss and less cost in wear and tear. The construction differs materially from that of the old kilns. There is only one fireplace, which is beneath the kiln: the heat ascends by means of a central tube and the internal walls; and, as there is no opening at top, descends, thoroughly burning the goods, and passing off by well vents. The smoke is consumed, the management easy; and when built in pairs, or sets of four, the spare heat passes from one to the other, thereby still further increasing the saving.

For particulars apply to Mr. RIDGWAY, Caudon-place Wharf Staffordshire Potteries. [134

### CROSSKILL'S WHEEL AND MACHINE WORKS.

NEW ILLUSTRATED CATALOGUES may be had (per post) on enclosing six penny postage stamps. Address—Mr. Crosskill, Beverley. [138

**BELL and BLACK, 16, BOW-LANE, CHEAP-SIDE, LONDON,** Manufacturers of WAX VESTA MATCHES, CAMPHORATED ROUND WOOD and new PATENT CONGREVES, warranted not to be affected by climate, time, or exposure to damp.—Beware of spurious imitations. [173

PATENT  
BATH



SCOURING  
BRICKS,

R. FORD & SON'S PATENT; AND  
PATENT MALT-KILN TILE,

MANUFACTURED BY  
J. B. HAMMILL,

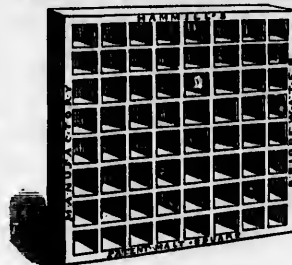

BRICK, TILE, & TIMBER  
WORKS,  
BRIDGEWATER.

J. B. HAMMILL'S PATENT.

N.B.—Foreign Orders punctually executed. [152

### GAS COOKING STOVES.

**THIS** superior method of Cooking being now generally recognised, Messrs. GRIGG and JENKINSON have devoted much time and expense to bring forward an apparatus embracing all the excellences and requirements of a complete GAS COOKING STOVE. It accomplishes to perfection Roasting, Baking (of Meat, Bread, Pastry, &c.), Boiling, or Broiling, and can be had either with or without a Boiler. If with a Boiler, steaming or warming any part of the house by hot-water circulation can be effected, or a warm bath had instantaneously, without additional trouble or expense. They are made of various construction, so as to meet the means and uses of all classes; and the prices range from a very low scale upwards.

The Public are respectfully invited to inspect the Stove in operation every day at the Manufacturers',

GRIGG & JENKINSON,  
FINSBURY IRON-WORKS,  
119 & 120, BUNHILL-ROW. [198

**REGISTERED IMPROVEMENTS IN STOVE GRATES.**—PIERCE'S newly invented PYRO-PNEUMATIC STOVE GRATE, the UNIVERSAL FIRE-LUMP GRATE, which requires no fixing, being made in one entire piece having capacious and safe hobs, strong octagon-shape bars, and double table-bar trivet.

Also PIERCE'S IMPROVED COTTAGERS' GRATES, for warming two rooms with one small fire.

The above are the BEST and CHEAPEST Grates for all useful purposes ever submitted to public notice, and are most strongly recommended by the entire public press.

Prices, from 11s. 6d. to 30s.

Prospectuses and every information afforded at the Warehouse and Manufactory, 5, JERMYN-STREET, REGENT-STREET. Detailed particulars of the above improvements will be found in the body of this work. [205



**MACHINE WORKS.**  
**CATALOGUES** may be  
 sent by penny postage stamps.  
 11, BEVERLEY. [1 138]

**DOW-LANE, CHEAP.**  
 MANUFACTURERS OF WAX VESTA  
 ROUND WOOD and new  
 invented not to be affected by  
 damp.—Beware of spurious  
 [1 73]

**SCOURING BRICKS,**  
 PATENT; AND  
**KILN TILE,**

**BRICK, TILE, & TIMBER**  
 WORKS,  
 BRIDGEWATER.

**PATENT.**  
 actually executed. [1 222]

**STOVES.**  
 being now gene-  
 rally and JENKINSON have  
 to bring forward an  
 improved and requirements  
 of the. It accomplishes  
 (Coal, Bread, Pastry, &c.),  
 and either with or without  
 firing or warming any part  
 can be effected, or a  
 without additional trouble  
 of construction, so as  
 classes; and the prices  
 are reduced to inspect the Stove  
 Manufacturers',  
**INSON,**  
**N-WORKS,**  
 L-L-ROW. [1 98]

**VENTS IN STOVE**  
 invented PATENT  
 FIRE-LUMP GRATE,  
 made in one entire piece



Grates for all use-  
 notice, and are most  
 public press.  
 to 30s.  
 afforded at the Ware-  
 house, BEVERLEY.  
 improvements will be found  
 [1 205]

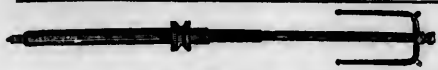

**JOHN & SAMUEL SMITH,**  
**SPINDLE AND FLYER**  
 MANUFACTURERS,  
 OF SUPERIOR QUALITY, FOR  
 SILK, COTTON, WORSTED,  
 AND FLAX,  
 LOWBRIDGE, KEIGHLEY,  
 YORKSHIRE. [1 172]

**H. BOOTH & CO.,**  
 PRESTON, LANCASHIRE,  
 MANUFACTURERS OF MULE SPINDLES,  
 ROVING, THROSTLE, AND FLAX SPINDLES AND  
 FLYS, &c.

A Mahogany Case (see Catalogue) containing SPECIMENS OF  
 MULE SPINDLES, THROSTLE SPINDLES and FLYS, &c.

**H. BOOTH & CO.**  
 are permitted to refer to the Spindles in the Spinning-mules of  
 MESSRS. HIBBERT, PLATT, AND SONS, OLDHAM,  
 AND  
 MESSRS. PARR, CURTIS, AND MADELEY, MANCHESTER,  
 NOW AT WORK IN THE EXHIBITION,  
 Amounting to 1642 Mule Spindles, all made by H. B. & Co.  
 They have also permission to refer to some of the largest Firms in  
 ENGLAND, SCOTLAND, AND ON THE CONTINENT,  
 INCLUDING

MESSRS. HORROCKSES, MILLER, AND Co., PRESTON,  
 Who have about 100,000 Mule Spindles at Work, all made  
 by H. B. & Co.  
 AND THE

RUSSIAN COTTON-SPINNING MANUFACTORY,  
 ST. PETERSBURGH, &c. &c. [1 223]

*Light, Cheap, and Durable Roofing.*  
**CROGON'S**  
 PATENT  
**ASPHALTE ROOFING FELT**  
 is perfectly impervious to Rain, Snow, and Frost, and has  
 been tested by a long and extensive experience in ALL  
 CLIMATES. Saves half the timber required for slates; can  
 be laid on with great facility by farm servants or un-  
 practised persons. Price, 1d. per square foot.

**CROGON'S**  
**PATENT NON-CONDUCTING FELT,**  
 FOR STEAM BOILERS AND PIPES,  
 Saves 25 per cent. of Fuel.  
 Samples and Testimonials sent by post on application to  
 CROGON & Co., 2, DOUGLASS-HILL, London, who also supply  
 SUIT-SHEATHING FELT, and INODOUS FELT for Dump  
 Walls, &c. (See Catalogue.) [1 243]

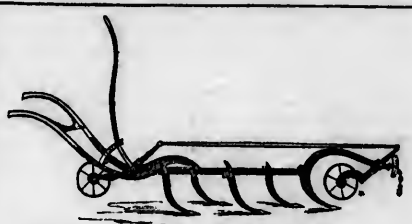

**J. WILKIE & Co.,**  
 AGRICULTURAL IMPLEMENT MAKERS,  
 UDDINGSTON, NEAR GLASGOW.  
 Agents in London, Messrs. BARTHAUM AND PRETTYMAN,  
 Upper Thames-street. [1 253]

**W. P. STANLEY, AGRICULTURAL IMPLE-**  
**MENT MAKER,** Peterborough, has for disposal  
 3 Brass Chandeliers for Candles, 2-Tier high, 6 Lights in  
 each Tier, 4 feet by 4 feet; one Chandelier as above, with  
 16 Lights, 4 feet 6 inches; eight Chandeliers as above, with  
 8 Lights each, 3 feet 6 inches. The above are modern, in  
 good condition, and suitable for a Church or Chapel. [1 215]

**CHAMPION PRIZE**  
**TILE, PIPE, AND BRICK MACHINE**  
 OF THE  
**ROYAL AGRICULTURAL SOCIETIES OF ENGLAND**  
 (1850).  
**SCOTLAND, IRELAND,**  
 North Lancashire, Great Yorkshire, North Staffordshire, &c.,  
 combining the practical advantages of the Vertical and Ho-  
 rizontal principles of working in one machine—least draught,  
 most rapid and greatest scope of manufacture, as proved by  
 Dynamometer. Vide Jour. Roy. Ag. Soc. Eng., Dec. 1850.  
 Also PRIZE FUGING MILLS, DRAINING TOOLS,  
 and implements, of

**H. CLAYTON, PATENTEE,**  
**SECTION 2, CLASS 9, STAND 47.**  
 where full particulars may be obtained, and at the Manufac-  
 tory, ATLAS WORKS, Upper Park-place, Dorset-square, Lon-  
 don, where the machines may be seen in operation daily, from  
 10 A.M. to 4 P.M.  
 Price of Machines from £13. (See Catalogue.) [1 119]



**DUTTON & CO., RUNCORN, CHESHIRE,**  
 MANUFACTURERS OF SCHOOL SLATES,  
**FOR HOME USE AND EXPORTATION.** [r 51]

**NEW and WONDERFUL PORTABLE GAS-LIGHT.**—The Patentee has invented a Self-generating Gas Apparatus, producing a light of surpassing power and brilliancy, which, for economy and utility combined, has never yet been equalled.

This extraordinary Lamp, without wick or glass, is constructed to generate Gas from a cheap liquid, by a self-acting and simple process, producing a FIRE BRILLIANT LIGHT, equal to the BEST GAS-BURNER, at the small expense of one farthing per hour. Can be carried about with perfect safety, and the light can be increased or reduced at pleasure by a stop-tap.

The tenacity of its flame renders it peculiarly available for Shops, Railways, Places of Worship, Mills, Streets, Booths, Market-stalls, Stables, Dye-houses, Breweries, Inns, Workshops, Schools, Steamers, Ships, &c. Its superiority over every other description of Lamp is beyond comparison, both in cost, simplicity of management, and quantity of light.

Though 20,000 have been sold the first winter, it still has the merit of novelty and utility; and is well worth the attention of Gas-fitters, Lamp-dealers, &c.

The original cost of Holliday's Apparatus, patented 1850, is from 6s. each (complete) and upwards, according to size and ornamental embellishments. It requires no connection to pipes or meters, thus avoiding the first expense of gas-fittings, and the misunderstandings which frequently take place between gas companies and gas consumers. The new Lamp is free from smoke, smell, or danger, and will burn for 14 hours *without attention*. In short, its cheapness, its utility, its brilliancy, and its simplicity of management, at once combine to render the invention one of the greatest acquisitions and triumphs in this department of modern science.

To be seen in every style, as well for the cottage as the mansion, and prospectus with engravings had, at READ HOLLIDAY and Co.'s Works, HUDDERSFIELD, and 128, HOLBORN-HILL, LONDON. [r 190]

**HYDRO-EXTRACTOR, OR CENTRIFUGAL DRYING MACHINES.**

MANLOVE, ALLIOTT, AND SEYRIG, PATENTEES,  
 LENTON WORKS, NEAR NOTTINGHAM.

**THESE MACHINES** are made to revolve at great speeds, and the centrifugal tendency thereby imparted to the materials intended to be dried causes the moisture contained therein to be nearly instantaneously extracted, without heat, wringing, or strain of any kind, so that the very finest fabrics that can be manufactured are not in the least injured by the process. The introduction and use of these Machines have caused very great improvements to be made in many of the most important branches of Manufactures, and almost every day develops new and valuable applications of their principle of action. They are now considered indispensable to Bleachers, Printers, Dyers, Silk-throwers, Woolen Manufacturers, and in finishing fabrics of almost every description, and are also applied with great advantage to the extracting of moisture from Starch and other crystalline and drainable substances. The Machines have also been applied with great success to the cleaning of Wool, Corn, or other substances, by passing water through the wool or other substance whilst in the Machine, previous to the drying operation, when the great force given to the water by the action of the Machine is by centrifugal tendency caused to pass with immense speed through the materials, and thus carries away with it all impurities. The Machines are adapted to work by hand as well as by steam-power, and have been found most economical, safe, and invaluable for the use of Baths and Wash-houses, Laundries, Asylums, Hospitals, and Union Workhouses, as by their use the wear and destruction of clothes produced by ordinary wringing is entirely avoided. For Asylums and Workhouses the remark made in reference to cleaning Wool applies with great force, as the clothes are thus entirely freed from all impurities, some of which can scarcely be removed by any other process. Further particulars may be had from the Patentees, who are the sole makers of the Machine.—Address, MANLOVE, ALLIOTT, and SEYRIG, Lenton Works, Nottingham. [r 209]

**COWLEY and JAMES, MANUFACTURERS OF PATENT WELDED WROUGHT-IRON TUBES, and every description of GAS-FITTINGS, CHANDELIERS, &c. Sole makers of Cowley and Hlokman's Patent Metallic Bedsteads.**—WALGALL, STAFFORDSHIRE; London Warehouse, HATTON-GARDEN.—JAMES MELROSE, Agent. (See Catalogue.) [r 78]

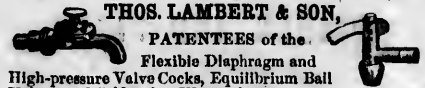

**THOS. LAMBERT & SON,**  
 PATENTEES of the  
 Flexible Diaphragm and  
 High-pressure Valve Cocks, Equilibrium Ball  
 Valves, and Self-acting Water-closets.  
 Manufacturers of Hydraulic, Gas, and Steam Fittings;  
 Tin, Lead, and Composition Pipes.  
 SHORT-STREET, NEW CUT, LAMBETH, LONDON. [r 13]

**HAYWARD TYLER & Co.'s**

MANUFACTORY FOR SUPERIOR

**SODA-WATER MACHINES,**

ON THE PATENT IMPROVED CONTINUOUS, AND  
 EVERY OTHER PRINCIPLE.

Established 1815, and since 1834 conducted by

HAYWARD TYLER & Co.,

85, UPPER WHITECHURCH-STREET, ST. LUKE'S, LONDON.

*Bramah's Original Continuous Principle, with Hayward  
 Tyler and Co.'s Improvements.*

|                           |                   |
|---------------------------|-------------------|
| No. 1, Maximum of product | 150 doz. per day. |
| 2, " " "                  | 100 " "           |
| 3, " " "                  | 80 " "            |
| 4, " " "                  | 60 " "            |

*Hayward Tyler & Co.'s Patent Improved Continuous Principle,  
 with Beam Action.*

|                                   |                   |
|-----------------------------------|-------------------|
| SINGLE.—No. 1, Maximum of product | 150 doz. per day. |
| 2, " " "                          | 100 " "           |
| 3, " " "                          | 80 " "            |
| 4, " " "                          | 60 " "            |
| DOUBLE.—No. 1, " " "              | 300 doz. per day. |
| 2, " " "                          | 200 " "           |

*Hayward Tyler & Co.'s Patent Improved Continuous Principle,  
 with Direct Action.*

|                                   |                   |
|-----------------------------------|-------------------|
| SINGLE.—No. 1, Maximum of product | 150 doz. per day. |
| 2, " " "                          | 100 " "           |
| 3, " " "                          | 80 " "            |
| 4, " " "                          | 60 " "            |
| DOUBLE.—No. 1, " " "              | 300 doz. per day. |
| 2, " " "                          | 200 " "           |

These Patent Soda-Water Machines are warranted superior in workmanship to any hitherto manufactured, and for solidity of construction, power, and simplicity, stand unrivalled. They are admirably adapted for exportation, as they could be packed in one case without taking them to pieces, and can be set to work, and Soda-Water made from them, in an hour after arrival at their destination.

Every other description of Soda-Water Machines, Improved Bottling Machines, Cylinders and Pillars for Soda-Water Fountains, &c. &c.

Diagrams sent to any part on application at the Manufactory.

To prevent disappointment and loss by the substitution of inferior and pirated imitations of their Machines, Hayward Tyler and Co. beg respectfully to request particular attention in copying the Address, 85, UPPER WHITECHURCH-STREET, LONDON.

*Extract from an Unsolicited and Spontaneous Report of the  
 Working of one of Hayward Tyler and Co.'s Machines.*

"Bombay, Aug. 31, 1850.

"The Double Soda-Water Machine which we got from you through Messrs. E. and Co. is still working beautifully, and has never required the least repair, though in constant use for upwards of four years, and left almost entirely to the management of natives." (See Catalogue.)

Hydraulic Presses, Steam Engines, &c. [r 241]

MANUFACTURERS of  
HT-IRON TUBES, and  
CHANDELIERS, &c.,  
man's Patent Metallic  
; London Warehouse,  
Agent.

[178]

**& SON,**  
of the  
m and  
ium Ball  
s.  
and Steam Fittings;  
tion Pipes.  
ENTU, LONDON. [163]



**ER & Co.'s**  
PENTON  
**MACHINES,**  
ONTINUOUS, AND  
IPLE.  
34 conducted by  
& Co.,  
T. LUKE'S, LONDON.

iple, with Hayward  
vements.  
50 doz. per day.  
00 " " "  
80 " " "  
60 " " "  
ed Continuous Principle,  
et 150 doz. per day.  
100 " " "  
80 " " "  
60 " " "  
300 doz. per day.  
200 " " "  
ed Continuous Principle,  
ct 150 doz. per day.  
100 " " "  
80 " " "  
60 " " "  
300 doz. per day.  
200 " " "

are warranted superior  
factured, and for soli-  
city, stand unrivalled.  
retation, as they could  
; them to pieces, and  
nise from them, in an  
Water Machines, Im-  
and Pillars for Soda-  
cation at the Manu-  
by the substitution of  
Machines, Hayward  
most particule atten-  
WHITECROSS-STREET,

aneous Report of the  
nd Co.'s Machines.  
hay, Aug. 31, 1850.  
which we got from  
working beautifully,  
though in constant  
f almost entirely to  
tology.)  
gines, &c. [124]

**BRYMBO COAL** (on the Admiralty list) is con-  
sidered to be the largest and finest that can be obtained  
in Great Britain. It is shipped with despatch from **BIRKEN-  
HEAD**, on the River Mersey (where the largest-sized ships  
lie afloat), and at **SALTNEY**, near Chester, at very moderate  
prices.

**FIRE CLAY and BRICKS**, of a very superior quality,  
also on sale.  
**BRYMBO COLLIERY**, WREXHAM, NORTH WALES.  
Office in Liverpool, 2, Sweeting-street, near the Exchange. [r 199]

**HORSES' FEET.**—**CHERRY'S** (*Her Majesty's*  
principal Veterinary Surgeon) **ELASTIC STOPPINGS** for  
Horses' FEET have stood the test of 25 years' experience,  
and their usefulness in supporting and preserving the Feet  
of Horses has led to imitations that are defective in the  
most essential properties. The original efficacious Stoppings  
have the Inventor's name branded on them, and are made  
only by **WARD**, Saddler, *Queen-street, Cheapside*, Manufacturer  
of every description of Saddlery, Harness, &c. &c., at the  
lowest possible prices. [r 243]

**FIRST-CLASS STEAMERS FROM HULL** to  
Hamburg, Antwerp, Bremen, Kampen, Yarmouth,  
Goole, and Gainsbro'. Also to London thrice a-week, at  
reduced fares; and to Copenhagen and St. Petersburg dur-  
ing the season. Inquiries by post, addressed to **BROWNLOW,  
PEARSON, and Co.**, General Forwarding Agents, Hull, will  
have prompt attention. [16]

**BELFAST and the NORTH OF IRELAND via**  
**FLEETWOOD.**—The Royal Mail Steamers "PRINCE  
OF WALES" and "PRINCESS ALICE" leave FLEETWOOD for  
BELFAST every MONDAY, WEDNESDAY, and FRIDAY Evenings,  
after the arrival of the 10 A.M. Train from London. See  
*Brutshaw's Guide*, p. 120; or apply to  
**KEMP & Co., Fleetwood.** [r 206]

**ELECTRIC TELEGRAPHS**  
**OF ANY KIND**, and of very Superior Workman-  
ship, supplied by **W. T. HENLEY**, Telegraph Engineer,  
Magnet Manufacturer, and Mechanician, and Patentee of  
the Magneto-Electric Telegraph, 46, St. JOHN'S-STREET-  
ROAD, CLERKENWELL, LONDON.

**W. T. H.** undertakes to erect Telegraph Works, in this  
country or abroad, at a very reduced charge, and, if re-  
quired, keep them in order; or when Railway Companies or  
others wish to erect their own Wires, he will supply them  
with Instruments of first-rate quality, as he has lately done  
(on Cook and Wheatstone's principle) to the South-Eastern  
Railway Company, for the Reading, Reigate, and Guildford  
and Hastings and Ashford Lines—the Telegraph Company  
being paid for a Licence for using the Patent. **W. T.  
HENLEY** also calls attention to his Magneto-Electric Tele-  
graph, the Patents for which he has assigned to the Magneto-  
Electric Telegraph Company. This Instrument requires no  
battery, and is the only Telegraph not affected by wet  
weather or bad insulation of any kind.

**W. T. H.** also manufactures Magnets, Magnetic, Magneto-  
Electric, or other apparatus, of any dimensions; also all  
descriptions of Clock-work Trains and other Machinery.  
Wire, covered with Silk, Cotton, Gutta Percha, or India-  
rubber, of any size or in any length. [r 260]

**ELECTRIC TELEGRAPHS.**  
**WILLIAM REID,**  
**ELECTRIC TELEGRAPH ENGINEER,**  
25, UNIVERSITY-STREET, LONDON,

**HAS** always on hand a large Assortment of **ELEC-  
TRIC TELEGRAPH INSTRUMENTS**, in various  
designs, for giving signals and sounding alarms.  
Also an extensive stock of materials for erecting **POLE**  
and **SUBTERRANEAN TELEGRAPHS**, consisting of  
Wire coated with Zinc, Gutta Percha prepared in various  
forms, Insulators of the most approved kind in Earthen-  
ware, Glass, Gutta Percha, &c.  
Patent prepared Wire, for Submarine and other Tele-  
graphs.  
**W. R.**, having been engaged in making Instruments and  
erecting Telegraphs for the last 13 years, is prepared to fur-  
nish tenders for the cost of Lines, and erect Telegraphs to  
any extent with the greatest possible despatch. [121]

**CONSTRUCTION OF RAILWAYS.**

**RANSOMES & MAY**, Ironfounders, Engineers,  
and Manufacturers of Agricultural Implements, *Ips-  
wich*, and *No. 3, Great George-street, Westminster*: who  
may be had particulars respecting Barlow's Patent Wrought-  
iron Railway Turntables and Cast-iron Sleepers; Wild's  
Patent Turntables and Switches; R. & M.'s own Registered  
Water-Crane; R. & M.'s Patent Compressed Tre-  
nails and Keys, &c., for Railways; Leggett's Queen Printing  
Press, with self-acting Inking Apparatus.  
For Agricultural Implements, and for Turntables, &c. &c.,  
see Official Illustrated Catalogue.

Also their Illustrated Catalogue of Implements and Ma-  
chines, on application to their London Office as above, of  
post-free by enclosing Six Postage Stamps. R. & M. call  
particular attention to their Patent Trussed Beam Iron  
Plough, marked Y. F. L., price as a swing 2l. 10s.; and to  
their new Broad-share, Scarifying, and Subsoil Plough;  
and their new Seed-dropper, Agricultural Steam-engines,  
and Threshing Machines. R. & M. continue to undertake  
the construction of Railway Bridges, and to supply Cast-  
iron Girders, Columns, &c. &c.; also the building of Castle  
and Goods Trucks. Ipswich is about 69 miles from London  
by Railway.

**INSTRUMENTS D'AGRICULTURE.**

**RANSOMES & MAY**, Ingénieurs, Fondeurs en Fer, et  
Lubrificateurs des Instruments d'Agriculture, à *IPSWICH, ANGLE-  
TERRE*. A vis un public:—On peut obtenir un Catalogue  
Illustré des Machines et des Instruments d'Agriculture à  
*No. 3, Great George-street, Westminster*, ou affranchi à tous  
les Départemens de la France, en envoyant une douzaine  
d'estampes de poste. Ipswich est éloigné de Londres de  
28 lieues (environ), partant de Shoreditch, par le Chemin de  
Fer des Eastern Counties, et y arrivant en trois heures et  
demie. On peut y aller et revenir le même jour sans se  
 gêner, et on donne des billets de retour pour la journée à  
prix réduit. Ils fabriquent aussi des

**PRESSES A IMPRIMER ;**

et ils ont à Hyde Park une autre Presse à imprimer fournie  
d'une mécanique à distribuer l'encre, qui s'agit de soi-  
même. [r 265]

**COCKERELL and CO.'S BEST COALS ONLY,**  
—always at the lowest Cash Price.—**PURFLEET  
WHARF, EARL-STREET, BLACKFRIARS, and EATON  
WHARF, BELGRAVE-PLACE, PIMLICO.** [r 64]

**HARRISON, AINSLIE, & CO., NEWLAND FUR-  
NACE**, ULVERSTON, exhibit a Case containing **HEMATITE  
IRON ORE**, from Lindal-Moor Mines, in Furness; analysed  
by **Dr. Sheridan Muspratt, F.R.S.E.**, and by him certified to  
contain—

|                                                |                 |
|------------------------------------------------|-----------------|
| Sesquioxide of Iron, { Metallic iron . . . . . | 68.47 per cent. |
| 94.97 per cent. { Oxygen . . . . .             | 28.50 " "       |
| Silica . . . . .                               | 3.43 " "        |
| Lime . . . . .                                 | 0.71 " "        |
| Moisture . . . . .                             | 0.24 " "        |
| Loss . . . . .                                 | 0.65—100.00     |

Charcoal Pig-iron and Furnace-cinder, from Newland  
Buchbarrow, Duddon, and Lorn Furnaces—the only Char-  
coal Furnaces in Britain. [r 201]



**ROYAL OSBORNE SAUCE,**

**PREPARED** by **HER MAJESTY'S CHEMIST** in the  
Isle of Wight, specially patronised by the **ROYAL  
YACHT SQUADRON**, is decidedly the best and cheapest  
Sauce extant, greatly excelling all in extraordinary rich-  
ness, piquancy, and fine goût. There is none like it for creating  
appetite, assisting digestion, and imparting a luscious the most  
exquisite to fish, game, chops, hot and cold meats, gravies,  
&c.; and, being quite clear, there is no waste with sediment.  
*Agent*—**RUMSEY**, 3, *Queen-street-pièce, Cheapside, London*.  
Retailcd by Sauce-vendors generally.  
(See Catalogue.) [r 275]

## NEEDLEWORK.

It is of the first importance to a nation that its requirements should be thoroughly understood; and every stride made towards better government is effected by a new ray of light having penetrated the darkness which originally covered the face of the whole earth. The more civilized a nation becomes, the more diversified are its legislative wants; and that which may with safety be left to adjust itself in the infancy of society, becomes, at a more advanced period, a paramount consideration. This is precisely the case with Needlework at the present day; it is impossible to overrate its importance. Ever the boon of a thoroughly satisfactory poor-law must dwindle into comparative insignificance beside an arrangement whereby tens of thousands of paupers would be enabled to maintain themselves without taking one shilling out of the pockets of the public. Class legislation is a word of retort in the mouths of all parties; but when one class seizes upon the labour of its inferior, and, through the overpowering agency of capital, buys up an extensive branch of native remunerative industry, turning tens of thousands of able-bodied and highly artistical producers into poverty-stricken paupers,—when the monopolised trade, far from flourishing under the talismanic influence of capital, yearly deteriorates through the waning energies of the producers,—when the public is robbed by the substitution of an inferior article on demand, and victimised in the shape of poor's-rates to make up for the inadequate wages given to the producers,—when this gigantic evil has entrenched itself, like the wolf in the story of Red Riding Hood, in the very inmost chambers of the houses of the British public,—and whilst the wives and daughters of the land are gathering the flowers that bedeck the pathway of life, the monster is lying carefully concealed under the mantles of fashion upon the beds of indolence, ready to spring forth at an unexpected time and devour the luxurious triflers. Surely it is well to warn the public against the dangerous pet they are fostering in their dwellings; and, however timid the Legislature may be of encountering the insidious foe, every one may hunt it out of their own houses. I believe that the most pressing necessity of this country at the present crisis lies in a satisfactory solution of the problem, How we are to provide work that will afford wholesome food, clothing, and shelter for our increasing population, and yet enable us to compete in the market with our less scrupulous—because less enlightened—neighbours of the world, who are favoured with a better climate? I believe that that which we are advocating for Plain Needlework, viz. the shaking off of unnecessary clogs in the form of investment of capital, or the undue interference of the capital in gold with the capital in time and sinews, lies at the root of the whole matter; but in trades where the assistance of capital is essential, to prevent its present despotism without prostrating its energies is one of the gravest subjects a nation ever had to deal with; yet it must be handled sooner or later. Justice to the capitalist,—justice to the producer,—and justice to the consumer, can alone sweep away from our entire trade the disgrace of the slop system, and banish the cry of starvation from the land. Are our capitalists so honest that not one law needs to cumber the statute-book, providing for the fair remuneration of time? We have laws against usury; and can no usury in labour be wrung from the starving operative? When we hear of a great West or East End House retiring from business with its £100,000 cleared in a few years, it would look well if we heard of some fifty out of the thousand producers of that wealth who were also retiring with a modest competency; but I believe that, could we trace them, we should oftener learn that hundreds of the producers of that wealth have died, or are dying, in the workhouse. Happily for Plain Needlework it has no need of the aid of capital, and it depends on the will of the public to emancipate it from its bondage without legislative interference.

To accomplish this end **A Plan for Registration Offices for Needlewomen** is submitted, the intention of which is to improve their condition and prevent their pauperism by securing to them the profits of their own work. The plan promises the consumer a superior article for his money, and to enable men, without any previous knowledge of the trade, to procure their garments as easily, and with as much economy, as experienced females can do. It also proposes to afford every facility to families in finding suitable needlewomen, either to work by the day or by the piece, and securing them against loss by damaged work or non-fitting garments. The expenses of Registration to be defrayed for the first year by subscription. After the public has placed confidence in the Society it will require no pecuniary aid.

### The Registration-Book.

To contain the names of Needlewomen alphabetically arranged—their ages, residence, and characters, as attested by the police and others—their qualifications, and whether they are cutters or not. Thus:—

| Name.                | Age. | Residence.            | Character.                                                            | Attestators.                               | Qualifications.                            |
|----------------------|------|-----------------------|-----------------------------------------------------------------------|--------------------------------------------|--------------------------------------------|
| Allwork, Agnes . . . | 29   | Skinner-street . . .  | Very timid; honest. Keeps an aged aunt.                               | Police . . . . .                           | Slop-sewer; cannot cut.                    |
| Bodkin, Mary . . .   | 28   | Batty-street . . .    | Respectable and honest; judicious in purchasing. Married; 2 children. | Mr. Gentle, Clergyman of Shepherd's Chapel | Fine worker and cutter.                    |
| Cutter, Susan . . .  | 13   | Holloway-street . . . | Idle; not to be trusted to purchase. Keeps a young brother.           | Mrs. Lumsden, Grocer's wife, Crown-alley.  | Pretty good needlewoman; cuts common work. |
| Darnaway, Rose. . .  | 40   | 19, Garlic-row . . .  | Honest and respectable; not judicious. Widow; five children.          | Mrs. Wise, of Fenchurch-street.            | Beautiful worker and cutter.               |

### Book of Patterns and Prices.

Wherein every house in town is invited to enter their patterns of materials, with prices and widths affixed.

### Book of Fashions and Price of Work.

Showing the most approved cuts of garments in general use; and these, being reduced to a scale, are sufficiently distinct for all cutters to follow without difficulty. To each drawing is attached a number, and the price of making the garment.

**Book of Calculation.**

Referring by numbers to the preceding book; thus:—

Shirt pattern No. 5, of linen; height, 5 ft. 10 in.; 2½ yards . . .  
 ¼ yard of cambric for the front . . . . .

It is evident that, knowing the quantity of material, the price per yard, and the cost of making, any one with common sense can arrive at the correct estimate of the just price of their garment, without any previous knowledge of the trade.

**Estimate of the Expenses of a Registration Office.**

Rent of premises, fuel, and cleaning . . . . .  
 Salary of Clerks . . . . .  
 Salary of Matron . . . . .  
 Incidental expenses . . . . .

Cutters would have no salaries, but be entitled to a fixed drawback from the price of the work.

When a lady wants a needlewoman, she can suit herself with one from the office without trouble, whether she desires her to cut out the garment or merely to make it,—whether she wishes her to purchase materials or to make them up. She can get a fine needlewoman at four shillings per shirt, or one to do coarse work at one shilling. She can get a trustworthy character; or, if she is willing to run the risk for a hitherto more unsteady fellow-creator, she can give her fewer things at a time and make the Christian experiment. But gentlemen want shirts, and they don't know what stuff they should be made of; they know that the one they have on—a cotton shirt, laced necks and wrists, cambric fronts—cost ten shillings and sixpence at a fashionable shop. The clerk hands the book of patterns; the matron matches the fabric—asks the gentleman's height—says, "Sir, I see by the Calculation-book, to which you can refer yourself (the clerk hands it), your shirt ought to cost so and so, because it takes so and so; have you any preference for a particular needlewoman?" Yes.—No. "Miss Bodkin will do them well; she is unemployed." A stamp sends Miss Bodkin notice; she repays it on being paid for the work. Along with the shirts, when finished, Miss Bodkin must hand the shop bill (paid) and her own. The gentleman, when he gives the order, deposits the money for the materials. When he gets home his shirts he pays Miss Bodkin, who signs a discharge. The gentleman may fairly be said, on the transaction, to save twenty per cent. If he bought shirts formerly of a fashionable shop at 10s. 6d., he will now certainly get a superior article for 8s. 6d., and, withal, have the satisfaction of improving the condition of the fiftieth part of our population. Supposing the books do not exhibit a trustworthy Miss Bodkin unemployed, Miss Scissors (the cutter up stairs) takes the job in hand, buys the cloth, cuts out the shirts, and subtracts what the Calculation-book allows her for her time from Polly Flighty's pay who does the work.

If the shirts do not fit, the matron passes her opinion upon the alterations required, and the needlewoman must do them. Some work may even be returned altogether for gross mistakes. This must be submitted to the Committee, who decide to what extent the mistake is to lower the recommendations of the worker; but in no case can more than one penny per shilling be subtracted from future wages for a fault of this nature. The Society must in all cases instantly remunerate the loser; but if needlework is lost or burnt, the culprit must refund it. Supposing gentlemen do not choose to come to the office to try on their shirts, a man will be sent to see them on in the mornings or evenings; but the gentleman must pay his time extra—only, he does not pay for the alteration. If a person wants six dozen shirts for an outfit, and he cannot wait more than a certain number of days, the clerk and matron must divide the shirts amongst all the hands for that class of work; and if these prove too few, the better hands whose work is in hand is not pushed for must take them, whether they like it or not, to keep up the credit of the establishment. In all such cases the clerk and matron must be cautious of forcing work, and it must be reported to the Committee, and entered in the books. It is obvious the establishment is meant only to suit cash payments, and cannot speculate; but it may undertake export orders, the cloth or price being deposited, if the payment suits the Calculation-book. It is impossible, in the limited space which a page of a Catalogue affords, to enlarge upon the benefits of this system. The aim of introducing the subject here is to give it as much publicity as possible, and, by directing general attention to a plain and practicable scheme, to endeavour to secure the blessing of independence for those who live by their Needle, and who form the most numerous Producing Class in every Civilized Nation. [1 250]

**BELGRAVIA REPOSITORY**

FOR

ENGLISH AND FOREIGN FANCY GOODS.

**JEWELLERY**, Buhl Enamel Goods, Desks, Work-Boxes, Writing Cases, Smelling Bottles, Knives, Scissors, Baskets, Chessmen, Fans, Souvenirs, Pursees, Stationery, Papier Maché Goods; Morocco, Walnut, and Ebony Envelope Cases and Blotters; Ladies' Companions and Necessaires, Gold and Silver Fencil Cases, Jet Bracelets, Brooches, &c. Also an extensive Assortment of

**Superior English and Foreign Toys,**

Including Rocking Horses, Baby Houses, Wax Model Dolls, Mechanical Toys, Games, Dissected Puzzles, Children's Books, Water Colours, &c. &c. At

**MILLER'S REPOSITORY,**

32, Lowndes-street, Belgrave-square,

Within ten minutes' walk of THE EXHIBITION. [1 46]

**GREAT WESTERN FURNITURE WAREHOUSES.**

**J. DENT & Co.,**

Cabinet-makers, Carpet & Bedding Manufacturers, Decorators, and General Furnishing Warehousemen, 30, 31, 32, and 99, CRAWFORD-STREET, BRYANSTONE-SQUARE, MARYLEBONE.

**SUBSTANTIAL NEW AND SECONDHAND FURNITURE.**—Every one in search of really good and cheap Furniture would do well, before purchasing elsewhere, to visit the unequalled spacious GREAT WESTERN FURNITURE WAREHOUSES, by very far the most extensive in the Metropolis (the smallest of which being upwards of 300 feet in length). The proprietors, relying upon a reputation acquired during a period of 25 years, confidently invite the attention of the public to their immense Superior Stock of Cabinet Furniture, Carpets, Upholstery, and Bedding, the whole of which is manufactured of the best seasoned materials, by first-rate workmen, and at one-third the prices usually charged at the west end of the town. Every article is warranted, the price marked in plain figures, and will be exchanged or money returned if not approved of. [1 288]



**MELNOTTE'S**

**LADIES' SHOE AND FANCY WAREHOUSE,**  
23, OLD BOND-STREET, LONDON,  
*Formerly 114, REGENT-STREET.*

**LADIES' BOOTS and SHOES, superior ELASTIC and RIDING BOOTS, and a variety of FANCY SLIPPERS;** French Silk Stockings, Plain and Embroidered Cambrio Handkerchiefs, Fans, Reticules, and Purses of Crochet and other work, and a most varied selection of Imitation Gold, Diamond, and Pearl Bijouterie, and other Parisian novelties.

**CHEILLE'S** unequalled Paris Kid Gloves kept exclusively. India and Wedding orders executed on the shortest notice. The high-standing reputation of Melnotte's house (established 35 years in London) sends all encomiums superfluous. Specimens to be seen in the French division at the Great Exhibition. **MELNOTTE'S, 23, Old Bond-street, London.** See Catalogue. [126

**PEAL'S WATERPROOF BOOTS.—CAUTION!**—Gentlemen are requested to observe that **BOOTS of PEAL'S WATERPROOF LEATHER** can only be obtained of the Manufacturer, **NATHANIEL PEAL, 11, Duke-street, Grosvenor-square;** and that this leather is not, under any circumstances, supplied to the trade. [138

**MORTLOCK'S,**

18, REGENT STREET, NEAR PICCADILLY.

*By special appointment to the Queen.*

**WILLIAM MORTLOCK** begs most respectfully to call the attention of the Nobility and Gentry to his extensive assortment of **CHINA, GLASS, and FAIENCEWARE,** comprising every description, both decorative and useful, and particularly adapted for foreign as well as home trade.  
18, Regent-street, near Piccadilly. [113

**IF** you desire really well polished Boots, use **Brown's ROYAL MELTONIAN BLACKING.** It renders them beautifully soft, durable, and waterproof, while its lustre equals the most brilliant patent-leather. Price the same as common Blacking. Made only by **E. BROWN,** the inventor and sole manufacturer of the **Le Gulche** Parisian Polish for Dress Boots and Shoes, and **Waterproof Varnish** for Hunting Boots. *Manufactory, 25, Broad-street, Golden-square, London.* Patronized by the Court and Nobility, and to be had of all the principal Bootmakers throughout the kingdom. [117

**ROYAL VICTORIA FELT CARPETING.**

**THE PUBLIC ATTENTION** is particularly directed to this manufacture. The Carpeting combines beauty of design, durability, imperviousness to dust, and economy in price—costing half that of Brussels. It has now been in general use many years, and become well established with the trade and the public, and can be purchased at all respectable Carpet-houses in London, and in nearly every town of the United Kingdom. **THE PATENT WOOLLEN CLOTH COMPANY, 8, Love-lane, Aldermanbury,** also manufacture Printed and Embossed Table-covers, in the newest designs, Window Curtains, Cloths for Upholsterers, Thick Felt for Polishing, &c. &c.—Manufactories at **LEEDS, and BONDING-ROAD, LONDON.** [171

**THE PATENT DESICCATING COMPANY** invite the attention of the Public to their **Drying and Seasoning Process.** By it, wood of the finest description can in the course of a few days be more thoroughly seasoned, and rendered less liable to subsequent shrinkage, than if dried or seasoned by the ordinary method of exposure to the atmosphere for six or seven years. The floor of the new Coal Exchange, which is composed of 4000 specimens of twelve different kinds of wood, some of which were growing, and all of which were seasoned, within three weeks of their being used, is adduced in proof of the above statement. The Company's process is very extensively used in Manchester and other manufacturing districts, where clean, uniform, expeditious, and certain drying is required; and it is equally fitted for the finest as for the coarsest kind of goods, and ensures a controllable temperature of any required degree of heat.—Certificates of the successful application of this invention to the drying of Wood, Flax, Paper, Printed Paper, Cotton, Grain, Coffee, Calico, Starch, Wool, Yarns, Fabrics, Wadding, Manure, &c., can be obtained by applying either personally or by letter to the Secretary,  
41, GRACECHURCH-STREET, LONDON. [156

**JEAN MARIE FARINA, COLOGNE, 23, RHEINSTRASSE; LONDON, 1, SALTERS-HALL-COURT** (by 82, CANNON-STREET, CITY); recommends his newly-exhibited **EXTRAIT D'EAU DE COLOGNE. 1l.** per Box of six Bottles (duty paid).—Stock in Bond for EXPORTATION—

|                                      |      |          |
|--------------------------------------|------|----------|
| Extrait d' Eau de Cologne . . .      | 24/. | per doz. |
| Double ditto . . .                   | 9/.  | "        |
| Single ditto . . .                   | 5/6  | "        |
| Eau de Lavande (first quality) . . . | 9/.  | "        |
| Ditto (second ditto) . . .           | 5/6  | "        |

Orders will be promptly executed to all parts. [144

**BURY'S ROYAL POMPADOUR POWDER,** for daily use, to remove that redness and irritation remaining on the skin after washing, or from any other cause; possessing the most cooling and softening qualities, and imparting an exquisite clearness to the complexion. 1s. and 2s. 6d. per packet; by post for 16 or 38 stamps uncut.

Alfred Bury, Perfumer, Exeter 'Change, London; and sold by perfumers and chemists throughout the kingdom. [119

**MACKAY'S PERSIAN OIL** surpasses all other Preparations in Cleansing, Restoring, Preserving, and Beautifying the Hair. It is agreeable, economical, and effectual. 1/4 lb. bottles, 1s. 6d.; 1/2 lb. bottles, 2s. 6d. each. Prepared and sold by **JOHN MACKAY, Chemist, 121, George-street, Edinburgh.** Wholesale Agent, **W. S. BUNSEY, 3, Queen-street-place, London.** [120

**HITCHCOCK & CO., CHYMISTS, of TAUNTON,** beg to inform their Friends and the Public generally that the increasing demand for their delicious and permanent perfume "*The Italian Bouquet*," has rendered it necessary to establish a depot for its sale in London; it will therefore be always on sale at **GIFFORD and LINDERS, 104, STRAND,** where also all H. and Co's., valuable preparations may be obtained.

To those who never used the Italian Bouquet, H. & Co. will only say it really is fully entitled to the name given it by those who have patronized it, as being the "*me plus ultra*" of perfumes.—Dated, North-street, Taunton, March 1851. [177

**METCALFE and CO'S NEW PATTERN TOOTH-BRUSH,** PENETRATING HAIR BRUSHES, and **SMYRNA SPONGES.**—The Tooth Brush searches thoroughly between the divisions of the Teeth, and cleans them in the most efficient manner, the Hairs never coming loose.—Penetrating Hair Brushes, with the durable unbleached Russia bristles, and every description of Brush and Comb for the Toilet, only at **METCALFE, BROWNE, and Co's, Brush-makers, by special appointment to H. H. Prince, Albert, 130a, Oxford-street.**—Beware of the word "from" (Metcalfe's) adopted by some Houses.—Metcalfe's Alkaline Tooth Powder, 2s. per box. [110

**A CABINET with SECRETARY and SECRET DRAWERS of BURNT BRITISH WOODS,** so disposed as to show the different grades of colour, either for new or old work.—This beautiful and much-admired product has been manufactured at the Wood-cringing premises, **RANELAGH-ROAD, THAMES-BANK, PIMLICO,** where the art has been brought to perfection at an outlay exceeding 40,000l. in France and England. The present Proprietor of the Factory, **MR. THOMAS HARRISSON,** owned the patent and plant in France, which is now joined to the plant in England, with great additions; and is well worthy the attention of a responsible, competent person to take an interest and the management of the concern. There is a show-room on the premises, under the management of **MR. THOMAS THOMPSON,** who designed and produced the above cabinet.  
See page in Catalogue for drawing and description. [123

**THE WORCESTERSHIRE SAUCE,** prepared by **LEA & PERRINS,** from the recipe of a Nobleman in the country, imparts the most exquisite relish to steaks, chops, and all roast meat, gravies, fish, game, soup, curries, and salad; and by its tonic and invigorating properties enables the stomach to perfectly digest the food. The daily use of this condiment has proved most conducive to health, and established its fame throughout the world. Sold wholesale by the proprietors, **LEA & PERRINS, 6, Vere-street, Cavendish-square; Crosse & Blackwell, Soho-square;** and other merchants, London; and retail by the principal dealers in sauces. [18



A, COLOGNE, 23,  
ON, 1, SAITERS'-HALL,  
Crry); recommends his  
AU DE COLOGNE. 17.  
id).—Stock in Bond for

. . . 24/ per doz.  
. . . 9/ "  
. . . 5/6 "  
. . . 9/ "  
. . . 5/6 "  
ected to all parts. [114

ADOUR POWDER,  
at redness and irritation  
g, or from any other cause;  
softening qualities, and im-  
the complexion. Is. and  
or 38 stamps uncut.  
Change, London; and sold  
hout the kingdom. [119

IL surpasses all other  
Restoring, Preserving, and  
reable, economical, and  
y lb. bottles, 2s. 6d. each.  
Ar, Chemist, 121, George-  
Agent, W. S. HUMSBY, 3,  
[1120

YMISTS, of TAUN-  
Friends and the Public  
and for their delicious and  
Bouquet," has rendered it  
s sale in London; it will  
FFORD and LINDELL'S,  
d Co's., valuable prepara-

an Bouquet, H. & Co. will  
to the name given it by  
ing in this kingdom; it will  
of London, March 1851. [1177

NEW PATTERN  
RINO Hair Brushes, and  
ush searches thoroughly  
and cleans them in the  
never coming loose.—  
the durable unbleached  
tion of Brush and Comb  
INOLEY, and Co's., Brush-  
11, R. H. Prince Albert,  
the word "from" (Met-  
Metalfo's Alkaline  
[1110

CARY and SECRET  
TISH WOODS, so dia-  
les of colour, either for  
and much-admired pro-  
Wood-carving premises,  
zico, where the art has  
tlay exceeding 40,000.  
Proprietor of the Fac-  
owned the patent and  
ed to the plant in Eng-  
well worthy the attention  
to take an interest and  
here is a show-room of  
of Mr. THOMAS THOMAS-  
above cabinet.  
and description. [1123

SAUCE, prepared by  
e of a Nobleman in the  
relish to steaks, chops,  
me, soup, curries, and  
ting properties enables  
food. The daily use of  
aducive to health, and  
world. Sold wholesale  
Vere-street, Chancery-lane;  
and other mer-  
principal dealers in  
[118

# PRIEST'S EXTENSIVE FURNITURE MART,

Nos. 1 & 2, TUDOR-STREET, WATER STREET, BRIDGE-STREET, BLACKFRIARS, LONDON.

(See ILLUSTRATED CATALOGUE.)



W. PRIEST begs to invite the attention of the numerous visitors to this country and its public in general to his extensive assemblage of Office, Library, and Household Furniture, his being the largest establishment of the kind in this kingdom, where may be found every article suited for the Office, the Study, or the Board-Room. Fire-proof Safes, Doors, &c. Also the greatest assortment of Household Furniture suited to either the Mansion or the Cottage. [1109

COALPORT, SHROPSHIRE.

**EDGE & SON,**

INVENTORS AND PRACTICAL MANUFACTURERS OF

**FLAT CHAINS FOR PITS,**

AND OF

**IMPROVED ROUND CHAINS**

FOR NAVAL AND MINING PURPOSES,

respectfully call the attention of Proprietors of Mines to the great superiority of their Chains.

Copies of testimonials to their safety and durability, from many eminent firms, may be had on application at their stall in the Great Exhibition, or at the Manufactory. [1133



**R. H. ROGERS,**

12 and 13, Prospect-rose, Walworth, London,

**IMPERIAL CABINET, GLASS-PAPER, and GLASS-CLOTH MANUFACTURERS,** and which is still unequalled in quality, and will be found worthy of the support of all who honour it with their patronage.

Price per ream as follows (for cash) :—

20s. 18s. 15s. 13s. 12s. 11s. 10s.

N.B.—All orders by post promptly attended to. [1128



**MESSRS. T. HOLLAND & Co.,**

LANGHAM FACTORY,

**GODALMING, SURREY,**

**SOLE PATENTEES of FLEECY HOISERY,** so highly recommended by the most eminent physicians, as an article pre-eminently calculated for under-clothing, whether in cold countries, or in the uncertain climate of Great Britain.

Original Inventors of **LADIES' DRESSES and WAIST-COATS;** also of **GENTLEMEN'S PANTALOONS and DRAWERS,** shaped from the frame.

Manufacturers of every article of **Ladies' and Gentlemen's Under-clothing,** whether in Fleecy, Segovin, Worsted, Lamb's-wool, Cotton, &c. &c., adapted for wear in every climate.

N.B.—Articles of the above manufacture sold by the principal Wholesale Houses in the City only; and retailed by all respectable Hoisiers in all parts. [1160

**SCARBOROUGH.—REED'S ROYAL HOTEL.**  
The above old-established Family Hotel is beautifully situated, commanding an extensive sea view, and possesses every requisite for the accommodation of Visitors to this celebrated Watering-place. [1233]

### SCARBOROUGH,

"QUEEN OF BRITISH WATERING-PLACES."

### SHARPIN'S CROWN HOTEL, ESPLANADE,

CONTIGUOUS TO THE SPA, SANDS, CLIFF-BRIDGE, AND PLEASURE-GROUNDS.

Families will find the above extensive Establishment most agreeably situated, commanding a splendid view of the ocean, combining every comfort and convenience.

TABLE D'HÔTE AT FIVE O'CLOCK.

### BILLIARD-TABLE AND BATHS IN THE HOUSE.

An Omnibus and Cabs at the Railway Station. [1233]

### HARROGATE,

THE

### METROPOLIS OF BRITISH WATERING-PLACES.

**HARROGATE** is situated in Yorkshire, within six hours of London, a short distance from York and the far-famed Fountains' Abbey, about equi-distant between the Northern Ocean and the Irish Channel. Its position on a table-land—a great height above the level of the sea—and its dry, sandy, highly-drained soil, combine to render it a peculiarly healthy and bracing residence. It is on account of the benefits which are to be gained from its different celebrated MINERAL SPRINGS and BATHS that Harrogate is chiefly frequented. These springs are many in point of number: as regards their properties and effects, they are no less various. They may, however, be subdivided into five great classes:—

- I. *The strong Sulphureous.*
- II. *The mild Sulphureous.*
- III. *The pure Saline.*
- IV. *The pure Chalybeate.*
- V. *The Saline Chalybeate.*

The two first classes are valuable, not only in Cutaneous, but also in various Dyspeptic Complaints, in derangements of the Liver, in Gout and Rheumatism, and in some particular cases of Female Disease. In fact, as many or most Cutaneous diseases depend more or less upon one or another of these diseases above named, the cure of the former (*the effect*) is more or less consequent upon the removal of those diseases which are the *cause*.

There are many cases where the third class above mentioned (the pure Saline springs) are highly useful.

It would be out of place in this notice to enumerate the numerous derangements of the system which are benefited by the fourth and fifth classes, viz.—the pure Chalybeate and the Saline Chalybeate. Suffice it to say that the Chalybeate springs are much stronger than most of a similar kind in this country; while the Saline Chalybeate springs are unique in Great Britain, and in point of analysis, as well as in their physiological and therapeutic effects, are closely analogous to the famous Ragozzi spring at Kissingen.

A case may now be seen at the Exhibition of all Nations, containing specimens of some of the principal Waters, with their respective analyses.

It only remains to be added that the accommodation for visitors, both at the hotels and lodging-houses, is of a first-rate description. [1133]

**HOTEL DE LILLE and ALBION, in PARIS,**  
322, RUE ST. HONORE, and RUE DE RIVOLI.—Hotel for Families and Gentry. Baths, Stables, and English Attendance.—The gardens of this Hotel conduct to the Tuilleries. [1187]

**HOTEL DE FOLKSTONE, 9, RUE CASTEL-LANE, PARIS; L. OLIVIER, Proprietor.**—This establishment, situated in the handsome quarter of the Madeleine, near the Boulevards, the Tuilleries, and the Champs Elysees, is specially frequented by English travellers. It is particularly noted for its elegant furniture, good management, cleanliness, and moderate charges. The attendance is made by English servants, and nothing is spared by the Proprietor to render this Hotel one of the most comfortable in Paris. Table d'Hôte at three francs; Bedrooms and Apartments at all prices. Interpreters for all languages. [1141]

### THE ISLE OF MAN,

**SITUATED** in the centre of the United Kingdom (within six hours' sail by steam from Liverpool, five from Fleetwood, seven from Dublin, and twelve from Glasgow), though comparatively so little known as such, is, in most respects,

UNEQUALLED AS A WATERING-PLACE and Residence. It is exempt from taxation. Its waters are pellucid—sea-bathing unrivalled—scenery magnificent—climate equable and salubrious—Collegiate and Scholastic Establishments excellent—the luxuries and necessaries of life attainable at moderate prices. The Island is well provided with first-rate Hotels and Lodging-houses, excellent Roads, cheap Conveyances, &c.; whilst there are no Turnpikes or Toll-bars to fret the temper of the Traveller on land, nor Harbour Dues to discourage the Yachtsman. To the Capitalist, the Annuitant, and the Visitedinarian a more agreeable, healthful Residence can scarcely be found in Her Majesty's dominions than in this Island. First-class Steamers, carrying Her Majesty's Mails, and commanded by able officers, leave Prince's Pier-head, Liverpool, every morning (Sundays excepted) at eleven o'clock during the summer months; and from Fleetwood, Dublin, and Glasgow, weekly. [1235]

### CHELTEMHAM,

### QUEEN'S HOTEL.

TO FOREIGNERS AND OTHERS VISITING THE EXHIBITION.

**THIS HOTEL** is situated in the most fashionable part of the town (in the immediate vicinity of the SPAS), and is one of the largest in England, having nearly 100 Bed-rooms, with Sitting Apartments fitted up in a style combining comfort with elegance; and from the retired situation of the Hotel there is no annoyance to visitors from the continual rattle of carriages, &c.; it is therefore admirably adapted for Invalids.

It has now been determined to reduce the scale of charges as follows, in order to obtain an extensive patronage from the public:—

|                                                |   |    |   |          |
|------------------------------------------------|---|----|---|----------|
| Board and Lodging, Table d'Hôte, per week each | 2 | 7  | 6 | £. s. d. |
| " " in Private Apartments                      | 3 | 0  | 0 |          |
| " " " if more than                             |   |    |   |          |
| two persons . . . . .                          | 2 | 12 | 6 |          |
| " " for a Servant . . . . .                    | 1 | 1  | 0 |          |
| Dressing-room . . . . .                        | 0 | 7  | 0 |          |
| Fires (when required) . . . . .                | 0 | 5  | 0 |          |
| Sitting-room from 42s. to 10s. 6d. per week.   |   |    |   |          |
| Beds . . . . .                                 | 0 | 2  | 0 |          |
| Breakfast, with meat or eggs . . . . .         | 0 | 2  | 0 |          |
| " without " . . . . .                          | 0 | 1  | 6 |          |

A MODERATE FIXED CHARGE FOR SERVANTS.

Omnibuses, Plys, Post-horses, Carriages, &c. &c. [1147]

and ALBION, in PARIS, BRE, and RUE DE RIVOLI.—Baths, Stables, and English of this Hotel conduct to the [187

STONE, 9, RUE CASTEL-LIVIER, Proprietor.—This handsome quarter of the Madeleine, the Tuilleries, and the Champs-Élysées, is frequented by English travellers. It is elegant furniture, good management, and moderate charges. The attendance is attentive, and nothing is spared by the Hotel one of the most comfortable in Paris. Rooms from three francs; Bedrooms and Bathrooms for all languages. [141

OF MAN, and the United Kingdom by steam from Liverpool, via Dublin, and twelve from Glasgow. So little known as such, is, in

A WATERING-PLACE exempt from taxation. Its waters unrivalled—scenery magnificent—schools—Collegiate and Scholastic—the luxuries and necessities of life are here. The Island is well provided with Lodging-houses, excellent &c.; whilst there are no Turnpike roads to temper the Traveller can be encouraged the Yachtman. To the north, and the Valentinianian residence can scarcely be found than in this Island. First-class Hotels, at Liverpool, every day at eleven o'clock during the month of August, Dublin, and Glasgow. [1235

ENHAM, HOTEL.

OTHERS VISITING THE RESORT. The most fashionable in the immediate vicinity of the best in England, having nearly all the apartments fitted up in a style of elegance; and from the retired situation, no annoyance to visitors from the noise of the sea, &c.; it is therefore admirably adapted to reduce the scale of charges to an extensive patronage from the Continent.

|                       | £. | s. | d. |
|-----------------------|----|----|----|
| Hotels, per week each | 2  | 7  | 6  |
| Apartment, „          | 3  | 0  | 0  |
| if more than          |    |    |    |
| „                     | 2  | 12 | 6  |
| „                     | 1  | 1  | 0  |
| „                     | 0  | 7  | 0  |
| „                     | 0  | 5  | 0  |
| d. per week.          |    |    |    |
| „ per night           | 0  | 2  | 0  |
| „                     | 0  | 2  | 0  |
| „                     | 0  | 1  | 6  |

CHARGES FOR SERVANTS. Coaches, Carriages, &c. &c. [147



[VICTORIA ESPLANADE AND JETTY, GREAT YARMOUTH.]

**GREAT YARMOUTH, NORFOLK.**

THERE are few places in the Kingdom which present greater attractions to those in pursuit of health or recreation than the Town of GREAT YARMOUTH. This ancient SEAPORT is placed at the extreme Eastern point of the English Coast, and has long been celebrated for the great purity and bracing quality of the air, which acts as a powerful yet wholesome stimulant to the human frame, whether worn down by care, anxiety, or disease. It has therefore been strongly recommended by the most eminent of the faculty, especially in cases of debility or of paralytic complaints. SEA-BATHING can here be enjoyed in perfection. The Sands are firm and shelving, free from rock and mud, perfectly safe for children, and are the best adapted of any around Great Britain for walking and riding. Great Yarmouth has now become a Bathing-place of great resort; and numerous HOTELS and LODGING-HOUSES, commanding Marine Views of considerable extent and beauty, have been erected, affording suitable accommodation to Families of Rank, as well as for all classes of Visitors, at reasonable charges. The Sea View is unrivalled, and presents an ever-changing Panorama, the charms of which it is impossible to exaggerate, as the number of Vessels which pass through Yarmouth Roads CROSS ISMERS is greater than on any other part of the Coast, or perhaps of the world; and during the Mackerel Fishery, from April to July, and the Herring Fishery, from September to December, this part of the Coast has a very animated appearance, and the labours of the Fishermen are a constant source of amusement and interest to Visitors; whilst for Marine Excursions, Yawls of a very superior build, combining swiftness with safety, are in constant readiness, and every facility for Boating is afforded by the Rivers Yare, Waveney, and Buro.

The Market is abundantly supplied with Meat, Fish, Poultry, and Game at moderate prices; and Yarmouth is celebrated for its Ale. The old town of Great Yarmouth is of considerable antiquity, is built on a plain unscen in any other part of the Kingdom, and presents many peculiar features.

The principal objects of interest and amusement in the town and neighbourhood are the Parish Church of St. Nicholas, a magnificent structure of the thirteenth century (where there is a daily service); St. Peter's Church, St. George's Chapel, a Roman Catholic Church, and other places of religious worship; the Column erected to the memory of Lord Nelson; the Jetty extending into the sea, and affording a delightful promenade; the Victoria Esplanade and Britannia Terrace, facing the ocean; the Denes (or Dowds) and Race-course, with ample space for equestrian exercise; the Quay, of unequalled extent and beauty; the Royal Military Lunatic Asylum; the Theatre; the Bath and Reading Rooms; Public Library; Gorleston Cliffs and Piers; the Roman Camp, called Garlanonum, at Burgh Castle; the ruins of the castellated mansion of Sir John Fastolfe, K.G., at Calster; many curious and highly interesting Churches in the adjoining parishes, some of them with the round towers peculiar to the district; whilst the ancient City of NORWICH, with its Castle, Cathedral, and numerous Churches, is within half an hour's distance by railway.

A MARINE REGATTA will take place in July, and the annual RACES on the 9th and 10th September. There is a direct Railway and Telegraphic Communication to all the most important towns in the kingdom. Trains leave by the Eastern Counties Railway at Shoreditch, and Steamers leave London Bridge every Wednesday and Saturday (fares—first cabin, 8s.; second, 5s.). The Hull, Newcastle, Leith, Aberdeen, and Inverness Steamers pass weekly through Yarmouth Roads.

The Principal HOTELS fronting the Sea are  
**The VICTORIA, ELLIS, ON THE VICTORIA ESPLANADE;**

**The BATH HOTEL and LODGING-HOUSE,**  
BLY, NEAR THE JETTY (WITH PIPES TO THE BATHS DIRECT FROM THE SEA);

**The ROYAL HOTEL,**  
BIRD, SOUTH BEACH (HOT AND COLD SEA-WATER BATHS CONSTANTLY READY);

**The NORFOLK HOTEL,**  
GEORGE BUCKHAM, PROPRIETOR, WINE MERCHANT, NORTH BEACH.

IN THE MARKET-PLACE, The ANGEL HOTEL, JOHN BROWNE. [304



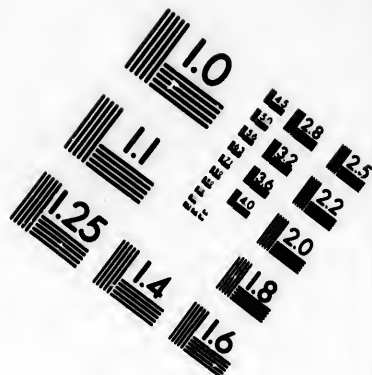
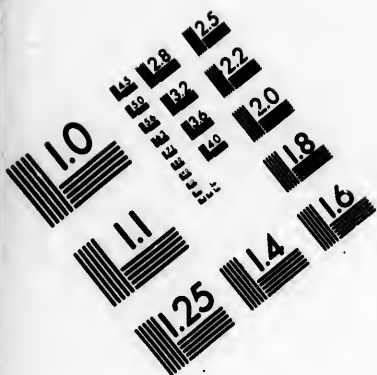

**IMAGE EVALUATION  
TEST TARGET (MT-3)**

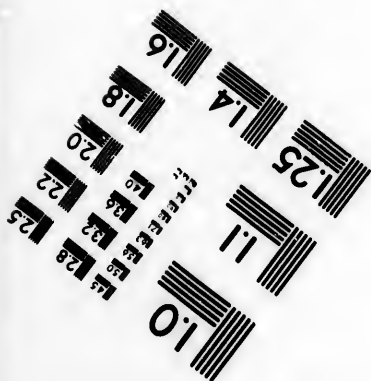
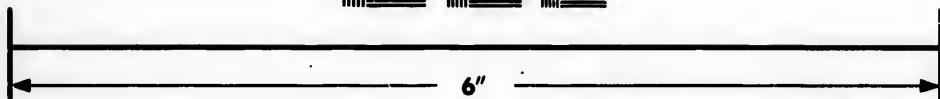
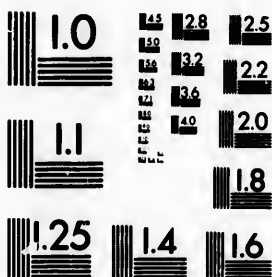

**Photographic  
Sciences  
Corporation**

23 WEST MAIN STREET  
WEBSTER, N.Y. 14580  
(716) 872-4503



2.4  
2.2  
2.0  
1.8

1.0

**SPECIMENS OF HOPS** (as prepared for Sale by J. M. PAINE) of the true GOLDING VARIETY, grown at Farnham, upon the Phosphoric Strata of the Lower Chalk Marl and Upper Green Sand. Hops abstract from the soil more phosphoric acid than any other cultivated crop; hence the saltiness of this remarkable soil for their perennial growth. Nearly the whole of Mr. J. M. PAINE'S extensive Hop Plantations are thus situated. Agents for sale, Messrs. S. GIBBONS & Co., 253, High-street, Southwark. [143]

*Under Patronage of Royalty and the Authority of the Faculty.*

### KEATING'S COUGH LOZENGES.

**A CERTAIN REMEDY** for Disorders of the PULMONARY ORGANS. In Difficulty of Breathing—in Redundancy of Phlegm—in incipient CONSUMPTION (of which COUGH is the most positive indication), they are of unerring efficacy. In ASTHMA, and in WINTER COUGH, they have never been known to fail.

KEATING'S COUGH LOZENGES are free from every deleterious ingredient; they may, therefore, be taken at all times, by the most delicate female and by the youngest child; while the PUBLIC SPEAKER and the PROFESSIONAL SINGER will find them invaluable in allaying the hoarseness and irritation incidental to vocal exertion, and consequently a powerful auxiliary in the production of MELODIOUS ENUNCIATION.

Prepared and sold in Boxes, 1s. 1½d., and Tins, 2s. 9d., 4s. 6d., and 10s. 6d. each, by THOMAS KEATING, Chemist, &c., No. 79, St. Paul's Churchyard, London. [1226]

### WHITE'S SACCHARIZED HYDRATE OF MAGNESIA.

**THIS** new and elegant Preparation is now offered to the Medical Profession and the Public. After having devoted several years to the preparation of the article, the Manufacturer with confidence, under the sanction of eminent Physicians, introduces it as a mild aperient and corrector of the acid of the stomach. From its agreeable, pleasant taste, it will be found much more palatable than any other preparation of Magnesia. Being most useful for Children, and peculiarly adapted for them, it may be relied on as a perfectly safe remedy in all cases where this medicine may be required. The Manufacturer has received testimonies of the efficacy of this medicine from some of the first Physicians.

Sold in bottles at 1s. each.

Agents in London: BARCLAY and SONS, 95, Farringdon-street; EDWARDS, 67, Paul's-churchyard; SANGER, 150, Oxford-street; HANNAY and CO., 63, Oxford-street; BELL, 393, Oxford-street; W. S. RUMSEY, wholesale agent, 3, Queen-street-place. Agents for Ireland: J. G. BOILEAU and Co., Mary's Abbey, Dublin. [1203]

**50,000 CURES** by DU BARRY'S REVALENTA ARABICA FOOD, without medicine, inconvenience, or expense (as it saves fifty times its cost in other remedies).—Cure No. 180: "Twenty-five years' nervousness, constipation, indigestion, and debility, from which I had suffered great misery, and which no medicine could remove or relieve, have been effectually cured by Du Barry's Revalenta Arabica Food in a very short time.—W. R. REEVES, Pool Anthony, Tiverton." Cure No. 4208: "Eight years' dyspepsia, nervousness, debility, with cramps, spasms, and nausea, for which my servant had consulted the advice of many, have been effectually removed by Du Barry's delicious health-restoring food in a very short time. I shall be happy to answer any inquiries.—Rev. John W. Flavell, Riddlington Rectory, Norfolk." Cure No. 1609: "Three years' excessive nervousness, with pains in my neck and left arm, and general debility, which rendered my life very miserable, have been radically removed by Du Barry's health-restoring food.—Alex. Stuart, Archbishop of Ross, Skibbereen." Cure No. 49,832: "Fifty years' indescribable agony from dyspepsia, nervousness, asthma, cough, constipation, flatulency, spasms, sickness at the stomach, and vomitings, have been removed by Du Barry's excellent food.—Maria Jolly Wortham, Ling, near Diss, Norfolk." Copies of testimonials of 50,000 cures (including those of Lord Stuart de Decles, Major-General Thomas King, Dr. Urs, Shorland, and Harvey) gratis. In canisters, with full instructions, 5lb., 11s.; 12lb., 22s. Super-refined, 5lb., 22s.; 10lb., 33s. The 10lb. and 12lb. carriage free.—DU BARRY and Co., 127, New Bond-street, London. [1273]

### SIR JAMES MURRAY'S FLUID MAGNESIA.

**PREPARED** under the immediate care of the Inventor, and established for upwards of thirty years by the Profession, for removing BILE, ACIDITIES, and INDIGESTION, restoring APPETITE, preserving a moderate state of the bowels, and dissolving uric acid in GRAVEL and GOUT; also as an easy remedy for SEASICKNESS, and for the febrile affection incident to childhood, it is invaluable.

On the value of Magnesia as a remedial agent it is unnecessary to enlarge; but the Fluid Preparation of Sir James Murray is now the most valued by the Profession, as it entirely avoids the possibility of those dangerous concretions usually resulting from the use of the article in powder. Sold by the sole Consignee, Mr. WILLIAM BAILEY, of Wolverhampton, and by all wholesale and retail Druggists and Medicine Agents throughout the British Empire. In bottles, 1s., 2s. 6d., 3s. 6d., 5s. 6d., 11s., and 21s. each.

The Acidulated Syrup, in bottles, 2s. each.

N.B.—Be sure to ask for "Sir James Murray's Preparation," and to see that his name is stamped on each label in green ink, as follows:—"James Murray, Physician to the Lord Lieutenant."

Drugs, Chemicals, Pharmaceutical and Medicinal Preparations of every description supplied to Merchants for shipment on the best possible terms. [1204]

### W. CULVERWELL'S Portable Domestic Vapour Bath,

TO BE SEEN AT THE GREAT EXHIBITION.

It is sold by most Chemists. Try, 12s. 6d.; Copper, 21s.

Ladies and Gentlemen who may be desirous of possessing so valuable a remedial agent as the Vapour Bath is acknowledged to be, are respectfully invited to see the above apparatus in action at

16, CHARLOTTE-STREET, BLACKFRIARS-ROAD,  
NEAR ROWLAND HILL'S CHAPEL.

#### TESTIMONIALS.

"31, George-street, Hanover-square.

"I bear willing testimony to the efficacy of Mr. W. Culverwell's Portable Domestic Vapour Bath; and as its price is very moderate, I beg to recommend its use to all those who are in the habit of employing a vapour-bath." "December 31, 1850." "B. G. BABINGTON, M.D."

"I can testify to the advantages that I have seen result from the use of Mr. Culverwell's Portable Domestic Vapour Bath: it has the advantages of being taken in bed, and of enabling the patient to be independent of a nurse."

"JOHN C. W. LEVER, M.D.,

"Physician-Accoucheur to Guy's Hospital." "December 31, 1850."

"I hereby certify that I have made use of Mr. Culverwell's Portable Vapour Bath, which I consider a very convenient, efficient, and economical, as well as ingenious apparatus, for the medicinal use of steam." "St. Thomas's Hospital, Jan. 3, 1851." "JOHN F. SOUTH."

"Having used Mr. Culverwell's Apparatus for the application of warm vapour to the body, I am pleased with its simplicity and efficiency; all the requirements of vapour, simple or medicated, appear to be capable of fulfilment through its means." "JOSEPH MOORE, M.D.,

"Consulting Physician to Queen Charlotte's Lying-in-Hospital." "10, Saville-row, Jan. 11, 1851."

"The Vapour-Bath constructed by Mr. Culverwell has been used in the Fever Hospital, and appears to answer every purpose. Its simplicity and easy application are recommendations in its favour." "A. TWEEDIE, M.D.,

"Physician to the London Fever Hospital." "April 11, 1851."

Testimonials in its favour have also been received from Drs. Barlow and Oldham, J. Hilton, Esq., and J. Stocker, Esq., of Guy's Hospital; H. Hancock, Esq., and J. Avery, Esq., of Charing-cross Hospital; R. D. Grainger, Esq., Lecturer on Physiology, &c.; Dr. Hodgkin; and Dr. Munk, Physician to the Royal Infirmary for Diseases of the Chest, &c. [1218]

## NESIA.

are of the thirty years  
ITIES, and  
rying a mo-  
ic acid in  
for SEAN-  
to child-  
it is unne-  
of Sir James  
ason, as it  
ous concre-  
in powder.  
BAILEY, of  
Druggists  
mpire, 21s. each.  
sch.  
y's Prepara-  
ch label in  
ician to the  
cinal Prepa-  
nts for ship-  
[ 1 204

## Bath,

ION.  
Copper, 21s.  
of possessing  
is acknow-  
above appa-

## RS-ROAD,

ver-square.  
Mr. W. Cul-  
as its price  
to all those  
h.  
TON, M.D.  
seen result  
estic Vapour  
bed, and of  
e.  
s Hospital.

Mr. Culver-  
a very cons  
ingenious

F. SOUTH.  
the applica-  
with its  
s of vapour  
of fulfilment

.D.,  
en Charlotte's  
n-Hospital.  
ilverwell has  
rs to answer  
ation are re-

r Hospital.

received from  
J. J. Stocker,  
and J. Avery,  
aining, Esq.,  
nd Dr. Munk,  
of the Chest,  
[ 1 218

## EAST INDIA AND COLONIAL AGENCY.

**MESSRS. HENRY CASSIN and Co., 9, OLD BROAD STREET, LONDON,** act as CONSIGNEES for MERCHANTS, SHIPOWNERS, and others; undertake to procure the English Staples of every description from the most eminent houses in Europe, with whom they are in constant communication; and at the instance of many distinguished members of the East India Company's service, the Agency is available for the supply of Stores for Regimental Messes, Public Institutions, Officers of the Naval, Military, and Civil Services, Native and European Residents.

Messrs. H. C. and Co. continue to receive periodical Consignments of the finest Champagne, Clarets, and German Wines of the most favourite vintages, direct from growers of known repute (the corks bearing the proprietors' brand). They also continue to supply the splendid Cabinet Champagne of Madame VV<sup>e</sup> CLICQUOT PONSARDIN; and as especial attention is paid to the corking and packing before leaving the Vineyards, parties in India and the Colonies may confidently rely upon receiving their Wines in perfect condition.

Complete instructions should be given, and all Orders accompanied by a remittance or reference for payment in England.

Insurances effected at Lloyd's, at moderate premiums. [ 1 14

## CHICORY

in all its stages, from the Raw Root to the Ground Dust, as used in mixing with, and instead of, COFFEE; also

## PASTEL, or IMITATION WOOD,

made from the leaves of the Chicory plant, and as used in the Dye Vat for the fastening of different colours in Woolen Cloths.

CHICORY, or "CICORIUM," a tap-rooted plant of the Endive family, the root of which is largely used as a substitute for COFFEE.

From its medicinal qualities, it is considered a valuable admixture to COFFEE, as it counteracts the astringent effects thereof.

It can also be sold at a much lower price, and, being of home produce, is recommended to the public, in connexion with COFFEE, as a wholesome and nutritious beverage, the consumption of which is now becoming very general. Though formerly believed to be a prejudicial admixture with COFFEE, it is now positively proved to be quite the contrary.

The leaves of this plant are also applicable to the manufacture of a valuable Dye-Staff called "PASTEL," or "IMITATION WOOD," of which they form a principal ingredient.

This article is very largely used by Wool Dyers, and is a valuable agent in the Dye Vat, for fastening colours in cloths.

The application of this plant to the above joint purposes is of recent date in Ireland. The first of the above-mentioned articles produced from this plant were manufactured and introduced into the English market with success by Mr. PAUL KING BRACKEN, from his manufactory in the neighbourhood of Dublin.

The samples now exhibited were grown and manufactured by ARTHUR HILL GRIFFITH, Esq., Gortmore, Ballymore, County Westmeath, under Mr. BRACKEN's directions.

Mr. GRIFFITH has established a Factory for the combined produce of CHICORY and WOOD, which is promising to be very successful, and gives very considerable employment to the poorer classes in the vicinity.

As an Agricultural Crop, and one suited to the soil and climate of Ireland, together with the large quantity of labour required for the bringing of these articles to perfection, this plant is considered of great national importance.

In an economic view, the advantages can be ascertained by a comparison of the respective prices of those articles which can be produced at double the remunerative prices of CHICORY or IMITATION WOOD, both of which substitutes are in most respects quite as efficient, and some superior to, their originals.

## SAUNDERS AND GATCHELL,

EXHIBITORS,

6 & 7, MOUNTFRITH-STREET, DUBLIN. [ 1 298

## EUGENE RIMMEL'S PERFUMERY,

Wholesale and for Exportation,

39, GERRARD-STREET, SOHO, LONDON; AND  
19, BOULEVARD DE LA GARE D'IRY, PARIS.

**VISITORS** to the Exhibition, and more particularly those who consume or deal in PERFUMERY, are invited to inspect the specimens of E. RIMMEL'S manufacture which they will find in the north-east gallery of the building. Price-lists and other particulars may be obtained at either of the Manufactories. E. RIMMEL begs to draw the attention of the Public to the fact that he is the only Perfumer possessing a manufactory in Paris as well as in London, which enables him to combine the well-known English soundness of quality with French taste and modicily of prices; an advantage which cannot fail to be appreciated by all intelligent home and foreign buyers. E. R. will conclude with a short notice of his articles most in repute.

RIMMEL'S TOILET VINEGAR, to supersede Eau de Cologne.

## For the Handkerchief.

Rimmel's Exhibition Bouquet.  
Rimmel's Jenny Lind Bouquet.  
Rimmel's Jockey Club Bouquet.  
Rimmel's Esq. Bouquet.  
Rimmel's Spring Flowers.  
Rimmel's Irrigators of all Perfumes.

## For the Hair.

Rimmel's Exhibition Pomade.  
Rimmel's Nutive Cream.  
Rimmel's Castor Oil Pomatum.  
Rimmel's Hair Wash.  
Rimmel's New Indelible Cosmétiques.  
Rimmel's Instantaneous Hair Dye

## For the Complexion.

Rimmel's Serbis des Sultanes.  
Rimmel's Crème d'Isphahan.  
Rimmel's Cold Cream.  
Rimmel's Amandine.  
Rimmel's Rose-Leaf Powder.

## Improved Soaps.

Rimmel's Illustrated Soaps.  
Rimmel's Ladies' Own Soap.  
Rimmel's Musk Brown Windsor.  
Rimmel's Saksikon.  
Rimmel's Cream of Almonds.

## For the Teeth.

Rimmel's Odontine.  
Rimmel's Elixir.

## Sundries.

Rimmel's Perfumed Almanacks,  
Flora's Fountains, Winter  
Bouquets, &c.

RIMMEL'S ARTIFICIAL HAIR, to imitate Human Hair.

## EUGENE RIMMEL,

39, Gerrard-street, Soho, London;  
and 19, Boulevard de la Gare d'Iry, Paris.

(See Illustrated Catalogue.) [ 1 25

## EAU DE MENTE PECTORALE DE DALMAHOY.

Avis aux Négocians, Maisons d'Exportations, et en général au Public de toutes les parties du monde.

**L'EAU DE MENTE PECTORALE**, renommée pour ses excellentes qualités et si largement employée depuis plus d'un demi-siècle en Russie et autres parties de l'Europe, se prépare chez ARTHUR STEPHEN HILL, 11, Little Britain, London, qui en est l'unique propriétaire, et dont le nom et l'adresse se trouvent sur chaque étiquette. Toute autre est contrefaite. Le propriétaire n'en fait que le débit en gros; mais elle se procure en bouteilles, on détail, chez JOHN COADES, Chimiste, Kensington, près la Grande Exposition.

Messieurs les Négocians venant de l'étranger sont prévenus que toute ordre en gros de drogues ou médicamens pour l'étranger sont exécutés avec soin et sous le moindre détal. Les meilleures qualités sont garanties.—Magasins en gros et d'exportation de drogues, ARTHUR STEPHEN HILL, 11, Little Britain, London. [ 1 72

## ABBOTT &amp; WRIGHT,

CROWN GLUE MANUFACTURERS,  
Needham Market, Suffolk. [ 1 51

**BOOKER and SONS, 13 and 14, MOUNT-ST., BROSSEVENOR-SQUARE, & EDMONTON, COACH-BUILDERS**, by Appointment to the Queen, continue to manufacture every description of Carriage in the best style, and on the most moderate terms. [ 1 65

## SEULS MAGASINS des TWEEDS et TARTANS

Ecosais de LOCKES, 119 and 127, REGENT STREET. Châles et écharpes plaids pour dames, grandes longueurs. Cachemires de Sole filée, 6/4. Linsey-Woolseys (Broosticles) pour robes, 8.

Plaids de voyage pour homme, et Tweeds Ecosais de couleurs les plus variées pour habits de classe, pantalons, &c., propres à tous les climats. (Class XII., No. 118.) [ 1 277

# AUX VILLES DE FRANCE.

## MAGASINS DE NOUVEAUTÉS.

51, RUE VIVIENNE, PARIS, RUE RICHELIEU, 104.

### ALL KINDS OF SILKS FOR DRESSES:

ANTIQUE WATERED SILKS, PLAIN AND FIGURED SARACENETS, CHECKED FOULARDS,  
SATINS, VELVETS, LINING SARACENETS.

### ALL-COLOURED MERINOS:

PLAIN AND PRINTED CASHMERE D'ECOSSE, PLAIN AND PRINTED  
MUSLINS DE LAINE.

### ALL KINDS OF FANCY TEXTURES:

PRINTS, PRINTED JACONETS, DIMITIES, ORGANDIES.

*All Kinds of Linen Goods and Cambrics, Handkerchiefs,  
All Kinds of Table Linen;*

### RIBBONS OF EVERY DESCRIPTION;

HOSIERY; WHITE COTTON GOODS;

### INDIAN SHAWLS,

CHINA CRAPES, FRENCH CASHMERE, SHAWLS OF ALL KINDS, CLOAKS AND MANTLES;

LACES OF ALL KINDS;

NECKERCHIEFS, BANDANAS, AND CRAVATS; FLANNEL, WOOLLENDRAPERY, AND WAISTCOATING;

### CARPETS, FURNITURE;

HABERDASHERY, GLOVES.

**RICHARDS' PRINTING-OFFICE, 100, St. MARTIN'S LANE.**—Established nearly Half a Century.—All kinds of Book-work, with or without Illustrations. Miscellaneous Printing neatly and expeditiously executed. Copperplate and Lithographic Printing. [1 318]

**A POLLONICON ORGAN ROOMS.**—THOMAS J. ROSSON, Organ Builder, 101, St. MARTIN'S LANE, CHURCH, CHAMBER, SELF-ACTING, and PALM-DIOLIC ORGAN MANUFACTURERS. (See Enharmonic Organ in Exhibition.) [1 315]

**EDWARD DODD, Manufacturer.**—Violin, Violoncello, Guitar, and Harp Strings. Silvered Strings of Superior Quality.—Manufactory, 113, VAUXHALL WALK, LAMBETH. Violin and Violoncello Bow Maker. [1 308]

**THE ST. HELEN'S  
CROWN, SHEET, AND PLATE GLASS  
COMPANY,**

ST. HELEN'S, LANCASHIRE,

MANUFACTURERS OF

All kinds of Blown Window Glass,  
GLASS SHADES,

AND

**ORNAMENTAL GLASS;**

ALSO OF

Church, Mansion, & other Windows,

IN THE MODERN AND ANTIQUE STYLES  
AND METHODS,

OR

Upon Single Plates of Glass,

AS EXHIBITED IN THE PRESENT EXPOSITION. [1 262]

**J. M. BLASHFIELD,  
AGRICULTURAL CHEMIST  
AND  
MANUFACTURER OF PATENT ARTIFICIAL  
MANURE,**

No. 3, NEW LONDON-STREET, MARK-LANE,  
AND MILL-WALL, POPLAR.

**THE** Patent Manure is sold under the name of COPROS or KOPROS, and is made by combining the soluble nitrogenous matter found on the mud-banks of the Thames and other places with salts of ammonia, silicates, and phosphates. It is a dry innoxious powder, and may be used by the drill or broad-cast. It is lighter in point of bulk than any other manure in use, and contains more ammonia and other soluble matter.

It has been largely used during the past year for Wheat, Oats, Barley, Turnips, Swedes, and Potatoes; and the Testimonials which the Patentee has received in its favour are of the highest character.

Also **SUPERPHOSPHATE OF LIME**, prepared only from Bones, and warranted free from Ashes, Gypsum, or any other adulterating substance—a fine Manure for Green Crops. Sulphate of Ammonia, Nitrate of Soda, Sulphate of Magnesia. Finely ground Gypsum, Coprolites, or Phosphates. [1 310]



**GLASS SHADES**

For the Covering and Preservation of  
Clocks, Statuettes, Wax Flowers, Alabaster, and other  
Ornaments and Articles of Virtu.

**CLAUDET AND HOUGHTON**

having considerably reduced their prices of Glass Shades, they may be appropriated advantageously not only as above, but also in  
**PROTECTING GOODS EXPOSED FOR SALE**  
from dust and the impurities of the atmosphere.

Wholesale & Retail Glass Shade Warehouse,  
**89 HIGH HOLBORN.**

**PAINTED & STAINED GLASS for WINDOWS,**  
ANCIENT OR MODERN, EXECUTED IN THE BEST STYLE, AND AT  
MODERATE PRICES BY

**CLAUDET AND HOUGHTON,**

89, High Holborn, London.

**WHITE ENAMELLED WINDOW GLASS,** of various patterns at very low prices. **EMBOSSD AND ENGRAVED GLASS COATS OF ARMS, CRESTS, &c. &c.** Designs furnished when required. Patterns and Specimens may be seen at their Warehouse,  
**89, HIGH HOLBORN.**

**CLAUDET AND HOUGHTON,  
WINDOW GLASS MERCHANTS,**

89, High Holborn, London.

**BRITISH AND PATENT PLATE GLASS, SHEET AND  
CROWN GLASS, ROUGH PLATE GLASS,**

And every other kind of Window Glass for Dwelling Houses, Conservatories, &c., &c., on the most moderate terms.  
\* List of Prices forwarded free on application.

Under the Patronage of Her Majesty.



**MR. CLAUDET'S  
DAGUERRETYPE PORTRAIT ESTABLISHMENTS**

Are Open Daily at No. 107, Regent Street (Quadrant) and at the Colosseum, Regent's Park.

**NOTICE.**—Mr. CLAUDET has removed his principal Establishment from King William Street, Strand, to larger and more convenient premises in Regent Street, No. 107 (Quadrant).

The Reception and Exhibition Rooms are on the ground floor, and Visitors have not to ascend higher than the first floor for having their Portraits taken.

The Exhibition Rooms contain a considerable collection of Portraits of Eminent Personages, English and Foreign.

**N.B.**—Mr. CLAUDET has on sale Engravings and Lithographs from Daguerreotype originals, taken by him of a number of distinguished persons, among which are the portraits of the Dukes of Wellington, Lord Gough, Lord Ross, Marquis of Northampton, Lord G. Bentinck, Lord Droughan, Monsieur Guise, &c., &c., &c.



**LIVERPOOL.—F. L. HAUSBURG, Old Post-Office Buildings, GOLDENHITS, JEWELLER, CABINET-MAKER, Manufacturer of CLOCKS, WATCHES, CHANDELIERS, LAMPS, &c.**

For more than twenty-six years this Establishment has stood unrivalled in Europe for the extent, excellence, and variety of its Stock and Manufactures, all of which have been purchased by F. L. Hausburg for cash, or made and finished under his own orders, and in his own workshops, on these premises, by the most experienced workmen, and of the very best materials and highest finish. To form an idea of this vast assemblage of useful and beautiful articles a visit is indispensable, and, whether for business or pleasure, is most respectfully solicited, with an assurance that, in either case, the utmost politeness and attention will be shown.

F. L. Hausburg begs permission to direct attention to some few of the leading articles of his stock: viz. CLOCKS, beautiful in exterior, suitable for every description of apartment, of the most excellent finish, and approved principles—warranted by the guarantee of the resident manufacturer. WATCHES, Gold and Silver, made on the best constructions, jewelled and finished on the premises by the most talented workmen. DESKS and DRESSING-CASES, of every possible variety and suitable material, elaborately inlaid and lined with Velvet, Satin, or Silk; or perfectly simple, fitted with Gold, Silver, or Steel necessities of the best description; or made of the most convenient sizes for travelling, and yet containing every requisite. BRONZES,—the finest Models, and finished to bear the most close observation, under the immediate superintendence of a resident agent in Paris. ITALIAN SCULPTURE—by artists of the highest standing; original works in Ewers and Vases; and copies of the finest Groups of the Ancient and Modern Schools. ENAMEL-PLATE—warranted to be by the Patentees, Pilkington & Co. Every article of JEWELLERY—comprising a brilliant and beautiful display, and consisting of suits of Jewels in precious stones and fine gold; Necklets, Brooches, Rings, Pins, Studs; Mourning Jewellery, Jet Ornaments; Hair in every fancy device &c. &c. CHANDELIERS—in Glass, Bronze, Or-molu, and Porcelain—for Gas, Oil, or Candles, suitable for every style of residence. The Celebrated AUREOLE, CANCEL, and CANDLE LAMPS, in China, Or-molu, and Bronze. WORK and WRITING TABLES, in Papier Maché, Rosewood, and Mahogany, and fitted with every requisite for ladies' work or writing, in Silver, Mother-of-Pearl, Ivory, and Steel. Bohemian and French Glass Vases, TAZZAS, LUSTRES, Scent-Bottles, Flower-Glasses, &c. &c. &c. Sevres and Dresden China; Powerful and Fine-toned Musical Boxes; Fans of every description, &c. &c. &c.—F. L. HAUSBURG, LIVERPOOL. [1 300

**POCKET SIPHONIA, Waterproof; Weight 10 Ounces; for Sportsmen and Travellers. None are genuine unless stamped inside**  
EDMISTON, 63, STRAND, LONDON. [1 314

**GEORGE ROGERS,**  
BEE-HIVE MILLS, BRADFORD, YORKSHIRE,

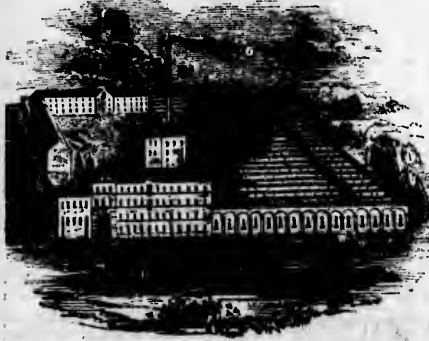

Worsted Spinner, and Manufacturer of Cobourgs, Henriettes, Mufflers, Shawl-Cloths, Alpaca Lustres, Orleans, &c.

The Cloths exhibited are made from Machine-combed Yarns. Prices and other information may be obtained by a Letter to the above address.

All widths made from 18 to 90 inches in the Grey. [1 57

**OXFORD** lies in the road to BATH, BRISTOL, CLIFTON, and the WEST OF ENGLAND; also to STRATFORD-ON-AVON; LEAMINGTON, WARWICK, KENILWORTH, BIRMINGHAM, and the NORTH; to CHELTENHAM, GLOUCESTER, and SOUTH WALS. In its neighbourhood are BLENNIKIN, NUNTHAM, and other places of interest.



VISITORS TO OXFORD,  
One hour and twenty minutes from London,  
ARE INVITED TO INSPECT

**SPIERS & SON'S ESTABLISHMENT,**

102 & 103, HIGH-ST., opposite ST. MARY'S CHURCH CORNER.  
Their stock, one of the largest and most varied out of London, includes goods of every description suitable for presents, or for remembrances of Oxford. Among those for the use of tourists are GUIDE-BOOKS and MAPS of the UNIVERSITY and NEIGHBOURHOOD of every description published; Ordnance Maps; engraved Views of Oxford, and Models of its Public Buildings; Desks, Dressing Cases, Cutlery, fancy manufactures, articles of taste and virth, &c. MANUFACTORY for DECORATED PAPIER MACHE,—consisting of Tables, Screens, Cabinets, Desks, Albums, Portfolios, Work Boxes, Tea Caddies, Card Cases, &c., ornamented with views of Oxford and its neighbourhood, to the extent of 200 subjects, by eminent artists.

SPIERS and SON are publishers of the "ILLUSTRATED MEMORIAL for VISITORS to OXFORD," containing views, maps, and general local information useful to the tourist. Information of every description readily afforded to strangers visiting their establishment.

In the Exhibition Building, their glass case, a semi-octagonal dome, is in the Central Avenue, next to De la Rue's. [1 181

Under Royal Patronage.



GIVE INSTANT RELIEF, AND A RAPID CURE OF  
Asthma, Consumption, Coughs, Colds, and all Disorders of  
the Breath and Lungs.

Small Books, containing many hundreds of properly authenticated Cures of Asthma and Consumption, may be had from every Agent.

In COUGHS.—The effect of these Wafers is truly surprising, as within ten minutes after taking a dose the most violent cough is subdued. THEY HAVE A PLEASANT TASTE. TO SINGERS and PUBLIC SPEAKERS these Wafers are invaluable, as by their action on the throat and lungs they remove all hoarseness in a few hours, and wonderfully increase the power and flexibility of the voice. NOTE.—Full Directions are given with every box, in the English, German, and French languages. PRICE, 1s. 1/4d., 2s. 9d., and 11s. per box. ALSO



HAVE A MOST PLEASANT TASTE.  
Price 1s. 1/4d., 2s. 9d., and 11s. per box.

This is an aromatic and aperient Medicine of great efficacy for regulating the secretions and correcting the action of the stomach and liver, and is the only safe remedy for all BILIOUS AFFECTIONS. It is mild in its action, and suitable for all seasons and constitutions, while its AGREEABLE TASTE renders it the best medicine for children. Also, DR. LOCOC'S FEMALE WAFERS. The best medicine for Ladies. Have a pleasant taste. Full directions are given with every box.

OBSERVE! that every genuine box has printed in the GOVERNMENT STAMP the words "DR. LOCOC'S WAFERS" and the signature of "DA SILVA & Co.," 26, Bride-lane, Fleet-street, London, is printed on the directions given with every box. SOLD BY ALL DRUGGISTS. [1 313

ONE THOUSAND HOUSES AND LODGINGS  
IN OR NEAR LONDON.

Now to be let Furnished, at Moderate Rents,

LAHER, 65, NEW BOND-STREET, AGENT.

[1 305]

BERNERS HOTEL, BERNERS-STREET.

MRS. ASHTON takes this opportunity of returning her grateful thanks to her numerous friends and patrons who for the last five-and-twenty years have visited her establishment, and begs to assure them that the same attention on her part to cleanliness, comfort, and regularity will ever be observed, so as to ensure a continuance of their favours.

[1 35]

TO RAILWAY DIRECTORS, ENGINEERS, AND MANAGERS.—BAINES'S PATENT IMPROVED SWITCHES. The Patentee begs to announce that a set of these Switches may be seen laid down at the East End of the Railway in the Great Exhibition Building.—Office in London, 17, Suffolk-street, Pall Mall East, where all necessary information may be obtained relative to the Switches and to BAINES'S PATENT IMPROVED PERMANENT WAY without KEYS.

[1 232]

EVERETT'S BLACKING, which is universally used by the COURT and NOBILITY of England, will be found infinitely superior to any in the world, although no higher in price than common Blacking. EVERETT'S POLISH for Dress Boots, and EVERETT'S WATERPROOF VARNISH for Boots, Harness, Carriage-heads, &c., are unrivalled. EVERETT, 51, FETTER-LANE, LONDON. Section 16 in the Great Exhibition.

[1 303]

OYSTERS, FISH, ICE, &c.—JOHN SWEETING, FISH and OYSTER MERCHANT, always has the largest daily supply of the best Fish, and the "BURNHAM RIVER NATIVE OYSTERS," which are the best in the World, at his Establishment, 159, CHEAPSIDE, CITY.—Superior Oyster Rooms, Reld's Stout, and Steed's Ale. [1 175]

ROMAN and other CEMENTS, manufactured by R. J. M. BLASHFIELD, successor to the Patentees, PARKER & WYATT, who in 1796 first introduced PARKER'S ROMAN CEMENT, which has now for upwards of fifty years been extensively used in most of the public and private buildings and other Works in this Country and throughout the World. Among the more recent Works in this Country, where it has been largely employed since the present proprietor became the manufacturer, may be named the Lyceum and St. James's Theatres; the Carlton, Reform, and Army and Navy Club-houses; the London Docks; the Thames Tunnel; the Winter Palace, St. Petersburg; the British Museum; the York Minster; the Royal Exchange; the Nelson Column; and the New Houses of Parliament.

When properly applied, it is the most perfect and economical cement for Hydraulic Works known; and when used as a stucco it will resist the action of heat and frost and preserve walls from damp. As a Mortar for Brickwork it surpasses any other material, and is nearly as cheap for such work as Mortar made of ordinary Lime. TERRAS, an Hydraulic Lime for setting masonry where slow induration is important so as to allow for the settlement of work—a cement of extraordinary tenacity and hydraulic properties, and with which the most ancient works in Lancashire have been executed. Hasell's Patent Mastic or Oil Cement, which may be pounded immediately after use; Keene's Cement, Portland Cement, Martin's Cement, &c. Genuine Plaster of Paris, prepared from the purest Gypsum, and of any degree of fineness required. Chimney-pots, Trusses, Paving Tiles, &c. *Manufactory*—MILL WALL, POPLAR; *Dépôts*—COMMERCIAL ROAD, LAMBETH, and PADDINGTON BASIN; *Counting-house*—No. 3, NEW LONDON-STREET, MARK-LANE, CITY. [1 311]

CATLIN'S AMERICAN INDIAN COLLECTION,

6, WATERLOO-PLACE, BOTTOM OF REGENT-STREET,

RE-OPENED, with new and interesting additions from the Rocky Mountains. 600 Paintings. Costumes and Weapons on Figures.—Promenade Lectures by Mr. CATLIN, with War-songs, War-whoops, &c., at 2 in the day, and half-price 3 in the evening. *Admission*, 1s.—Children, half-price.

CATLIN'S "Notes of Travel" and "Portfolio of Hunting Scenes," for sale at his Rooms. [1 360]

J. MERRICK,

DIE AND SEAL ENGRAVER, STAMPER, &c.,  
125, LONG ACRE.

*Inventor of the new style of Embossed Address Cards.* [1 319]

PIZZON MEN TAGP, MINERAL SPA OF BATH.—The celebrated Hot Mineral Waters of Bath possess all the Curative properties of the most esteemed Spas of Germany. The Pump-rooms and Baths are the most complete and elegant in Europe. The City of Bath is one of the most ancient and beautiful in England, and is now reached from London in two and a half hours, and admirably suited as a residence for the invalid.

For Printed Prospectuses and Terms, address the Proprietors, Messrs. GREEN & SIMMS, MINERAL SPA, BATH. [1 317]

COUNT STOLBERG WERNIGERODE,

PROPRIETOR OF IRON WORKS,

ILSENBERG, PRUSSIA,

AND

MANUFACTURER OF IRON CASTINGS,

made with Charcoal from the Ores of his own Mines, combining unusual economy of price with sharpness and delicacy of execution.

| PRICES OF ARTICLES EXHIBITED.              | £.   | s.   |
|--------------------------------------------|------|------|
| A Gothic Vase in form of a Basin . . . . . | 9    | 0    |
| A Window Frame . . . . .                   | 3    | 15   |
| A Garden Table, with extra top . . . . .   | 2    | 12   |
| A Table, with marble top . . . . .         | 3    | 0    |
| Two Stoves . . . . .                       | each | 6 12 |
| A Stag's Head . . . . .                    | 2    | 2    |

Attention is also solicited to the several fine Castings exhibited, including two Deers' Heads, a Boar, a Fan, Work-basket, Salamander, a Horned Beetle, and a Fruit-basket. [1 316]

MESSRS. BRAND & SCHIEDMAYER, acting as Special Commissioners to the Great Exhibition, for the kingdom of Wurtemberg, beg to inform the Public that they, as well as the Central Committee for Industry and Trade at Stuttgart, are ready to give every information as regards the produce of Wurtemberg; and, referring to the details given in this Catalogue, and calling the attention of the Public chiefly to the very moderate prices of Wurtemberg manufactures, they beg to invite the Public to address themselves to their office in this City, 6, FINNERS' HALL, OLD BROAD-STREET.

DIE HERREN BRAND & SCHIEDMAYER, bringen als Commissäre für das Königreich Würtemberg bei der grossen WELT-INDUSTRIE-AUSSTELLUNG an öffentlichen Kenntnis, dass auf ihren Bureau in 6 FINNERS' HALL, OLD BROAD-STREET, CITY, sowohl als dem Bureau der Central-Stelle für Handel und Gewerbe in Stuttgart, zu jeder Zeit die genaueste Auskunft über die Producte und Fabrikat ihrer Landes zu holen ist, und indem sie bei diesem Anlass auf die billigen Preise der Würtembergischen Erzeugnisse aufmerksam machen, laden sie das Publicum ein sich an sie unter obiger Adresse zu wenden.

MESSIEURS BRAND & SCHIEDMAYER, agissant comme Commissaires spéciaux près de l'Exposition Universelle ont l'honneur de prévenir le public que tout renseignement en égard des prix, etc., des produits du Wurtemberg peuvent être obtenus, soit à leur Bureau, 6, FINNERS' HALL, OLD BROAD-STREET, CITY, ou de la Commission Industrielle Centrale à Stuttgart. [1 309]

**T. DISSARD,**

57, KING-STREET, GOLDEN-SQUARE, LONDON,

AGENT OF

LOUIS OUDARD, Fils, & BOUCHEROT, Wholesale Confectioners,  
42, Rue des Lombards, Paris.TURPIN, late MAMON, Chocolate Manufacturer,  
28, Rue Richelieu, Paris.VEUVE T. MAYER, Bon Bon Papers, &c., for Confectioners,  
Manufacturer,  
22, Rue de la Vieille Monnaie, Paris.MAILLE & SECOND, Vinegar Distillers and Mustard Manu-  
facturers,  
14, Rue St. André-des-Arcs, Paris.LAURENT, Dressing-Cases and all kinds of Fancy Boxes  
Manufacturer,  
5, Rue Chapon, Paris.DUVAL & Cie., Lamps Moderateur sans rouages Manufacturer,  
1, Boulevard St. Denis, and 315, Rue St. Martin, Paris.

[1 307]

**FURNITURE, CARPETS, and BEDDING.—**

See our new Book of Estimates, with Designs, which may be had gratis and post-free, showing the price of each article, the cost of furnishing a separate room and a whole house. Every article is marked in plain figures, corresponding with the Book of Prices, and displayed in numerous Show Rooms, warranted seasoned and well made. FIRM BEDSTEADS, with Bedding and Curtains of different designs, fixed, ready for delivery, consisting of Mahogany four-post, Arabian, Parisian, French, and Iron. Purchasers can see their Beds and Mattresses made on the premises. Spring Mattresses on an improved principle, and Iron Bedsteads, at an immense reduction.

**S. A. ARNOTT & Co.,**

Upholsters and Cabinet Manufacturers,

CADOGAN HOUSE, SLOANE-STREET, KNIGHTSBRIDGE.

Country Orders carriage free.

100 Marble Washstands always on view.

Notes.—CADOGAN HOUSE. Established at Finsbury in 1815. Auctioneers, Valuers, Estate and House Agents. Appointed Agents to the County Fire Office, & Provident Life Office. [1819]

**PANTECHNICON,**

NEAR

**BELGRAVE SQUARE, LONDON.**

**T**HE Proprietor invites the attention of the Visitors of the Grand Exhibition to the above-named Establishment (which is within five minutes' walk of Hyde Park), where may be seen the largest and best-assorted STOCK of CARRIAGES and HOUSEHOLD FURNITURE of every description on sale in London. The materials and workmanship are of the best description. The prices will be found in keeping with the times. Warranties are given with new Carriages; and all Household Furniture is sold under a guarantee of Twelve Months. There are also departments for the Warehousing of Furniture, Books, Plate, Paintings, Musical Instruments, and every description of Property, in iron fire-proof rooms, to which parties may attach their own locks; private bins for warehousing Wines, which may also be locked by those who rent them; rooms for the sale of Paintings, Musical Instruments, &c. &c.; and the Proprietor intends setting apart a large portion of the South Building for the Exhibition and Sale of Works of Art, &c., which the owners may fail to secure space for in the Grand Exhibition.

January, 1851.

[15]

Army  
Albion  
Ander  
Auctio  
atres  
Bank F  
Bath H  
Bay T  
Bottle  
Bedfor  
Betsy  
Blue P  
Brett's  
Bridge  
British  
Brook  
Brunsv  
Café d  
Castle  
Castle  
Cathel  
Cosari  
Cheque  
Christi  
Christ  
City A  
City of  
Claren  
Claren  
Clark's  
Cloth  
Coal H  
Coburg  
Gros  
Cook T

Adelphi  
Albert  
Albion  
Albion  
Albion  
Bath I  
Bedfor  
Bedfor  
Bilton  
Buck's  
Bull H  
Bull H  
Bush I  
Café d  
Café B  
Castle  
Castle  
Christ  
Claren  
Claren  
Clifton  
Clifton  
Comm  
Comm  
Comm  
Crown  
Dolph  
Dougl

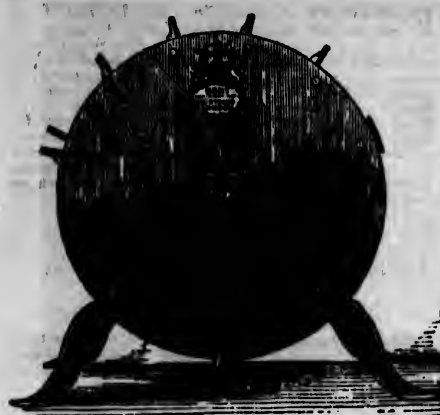

BY HER MAJESTY'S ROYAL LETTERS PATENT.

### KENT'S KNIFE-CLEANING MACHINE:

MANUFACTORY,

329, Strand, opposite Somerset-House, London.

KENT'S is the only invention for Knife-cleaning for which Her Majesty's Letters Patent have been granted, and is distinct from all others in every essential principle, however closely imitated in external appearance.

They are to be had of the PATENTEES, in SEVEN SHEETS, from 4l. 15s. to 14l. 14s.

The small ones for Families may be used by a Child.

The Patentee has been favoured with approving Testimony from (with full permission of reference to) a large number of the Nobility, Gentry, and Clergy, the Heads of Public Institutions, Colleges, and other Scholastic Establishments, with numerous Private Families in all parts of England, where his Machines are in constant use; as also in many parts of Ireland and Scotland; therefore Gentlemen wishing to be satisfied of the merits of this Invention, may be referred to parties in their own neighbourhood, who have it in use, by application to the Patentee; or it may be seen, and its merits ascertained, in almost every Hotel in the Kingdom, and has now been in constant use upwards of 5 years in the following Establishments:

#### LONDON REFERENCES.

Army & Navy Club, St. James's-sq.  
Albion Tavern, Aldersgate-street  
Anderson's Hotel, Fleet-street  
Auction Mart Tavern, Threadneedle-street  
Beech's Dining-rooms, Fenchurch-st.  
Bank Dining-rooms, Threadneedle-st.  
Bath Hotel, Piccadilly  
Bay Tree Tav., St. Within's-lane  
Bethlehem Hospital  
Bedford Hotel, Covent-garden  
Betty's Chop-house, Old Broad-st.  
Bliss Posts Hotel, Cork-st., Bond-st.  
Brett's Hotel, Holborn  
Bridges House Hotel, London-bridge  
British Hotel, Cockspur-street  
Brook's Club, St. James's-street  
Brunswick Hotel, Blackwall  
Cafe de l'Europe, Haymarket  
Castle and Falcon, Aldersgate-st.  
Castle Tavern, Guildhall  
Cathedral Hotel, St. Paul's-ch.-yd.  
Casarini's Hotel, Golden-square  
Chequer's Tavern, Abingdon-street  
Christie's Hotel, St. James's-street  
Christ's Hospital, Newgate-street  
City Arms Tav., Pope's-head-alley  
City of London Club, Broad-street  
Clarence Hotel, Aldersgate-street  
Clarendon Hotel, Bond-street  
Clark's Dining-rooms, Chancery-lane  
Clockworkers' Hall, Mincing-lane  
Coal Hole Tavern, Strand  
Coburg Hotel, Charles-street, Grosvenor-square  
Cock Tavern, Fleet-street

Colonnade Hotel, Charles-street, St. James's  
Commercial Travellers' School  
Coventry House Club, Piccadilly  
Coulson's Hotel, Brook-street  
Cox's Hotel, Jernyn-street  
Cremorne Gardens  
Crown and Scepter Tav., Greenwich  
Dr. Butler's Hd. Tav., Coleman-st.  
Deaf & Dumb Asylum, Kent-road.  
Dolly's Chop-house, City  
Drapers' Hall, Threadneedle street  
Drapers' Private Hotel, Saville-st.  
Easton Hotel, Euston-square  
East India Club, St. James's-square  
Edinburgh Castle Tavern, Strand  
Elphinst and Castle, Newington  
Ellis's Hotel, St. James's-street  
Erethrum Club, St. James's-square  
European Tavern, City  
Exchange Dining-rooms, Change-alley  
Exchequer Hotel, Palace-yard  
Exeter Hall Hotel, Strand  
Fenton's Hotel, St. James's-street  
Fishmongers' Hall, London-bridge  
Foundling Hospital  
Freemasons' Tav., Great Queen-st.  
George and Vulture, George-yard  
Gerard's Hall Tavern, Basing-lane  
Glimond's Hotel, Castle street  
Golden Cross Hotel, Charing-cross  
Green Dragon Hotel, Holborn  
Grey Inn Coffee-house, Holborn  
Grey's Dragoon Hotel, Bishopgate-street  
Gresham Club, King William-st.

Gresham Dining-rooms, Bechenbury  
Grillon's Hotel, Albemarle-street  
Grosvener Hotel, Park-street  
Groves's Hotel, Albemarle-street  
Guildhall Hotel, Guildhall  
Hanover Hotel, Hanover-square  
Highbury Barn Tavern, Highbury  
Home and Colonial School, Grey's Inn-road  
Horns Tavern, Kannington  
Hotel de l'Europe, Leicester-square  
Hotel de Provence, Leicester sq.  
House of Commons (Refreshment Department)  
Joe's Chop-house, Finch-lane. City  
John O'Grady's Tavern, Rupert-st.  
Junior United Serv. Club, Pall-mall  
King's Arms Hotel, Pall-yard  
Lake's Dining-rooms, Chesapeake  
Langbourne Coffee-house, City  
Law Club, Chancery lane  
Leopard Coffee-house, Borough  
London Tavern, Bishopgate street  
London Coffee-house, Ludgate-hill  
Man-in-the-Moon. King's-road, Chelsea  
Mansion House, City  
Morley's Hotel, Trafalgar-square  
Mercers' Hall, Ironmonger-lane  
Mullins' Hotel, Ironmonger-lane  
National Club, Pall-yard  
Nell Gwynne's Tavern, Strand  
New Hummums, Covent-garden  
Old Hummums, Covent-garden  
Osborn's Hotel, Adelphi  
Ox-ford and Camb. Club, Pall-mall

Pheasant Hotel, Idington  
Peel's Coffee-house, Fleet-street  
Piazza Hotel, Covent-garden  
Plough Tavern, Blackwall  
Post-office Coffee-house, Post-office  
Prince of Wales Hotel, Leicester-pl.  
Putney Hotel, Albemarle-street  
Queen's Hotel, Cork-st., Bond-st.  
Queen's Hotel, Post-office  
Rapp's Private Hotel, Golden-sq.  
Reform Club, Pall-mall  
Royal Hotel, Bishopgate-bridge  
Royal Naval School, New-cross  
Roy. Nav. Female School (Richmond)  
Russell's Private Hotel, Albemarle-street  
Salisbury Hotel, Leicester-square  
Saddlers' Company Hall  
Sulter's Hotel, Victoria-st., Holborn  
Supte's Coffee-house, Warwick-st.  
Sherwin's Dining-rooms, Clement's-lane.  
Slip & Turtle Tavern, Leadenhall-st.  
Skinners' Company Hall  
Somerset Coffee-house, Strand  
Tavistock Hotel, Covent-garden  
Taylor's Dining-rooms, Moorgate-st.  
Tom's Coffee-house, Cornhill  
Travellers' Club, Pall-mall  
Union Hotel, Cockspur-street  
United University Club, Pall-mall  
Virginia Tavern, Cornhill  
Warman's Dining-rooms, Thames-st.  
Windham Club, St. James's-square  
Wood's Hotel, Farnival's-inn  
Woodpack Tavern, St. Peter's-alley  
Yacht Tavern, Greenwich

#### PROVINCIAL REFERENCES.

Adolph Hotel, Liverpool  
Albert Hotel, Glasgow  
Albion Hotel, Brighton  
Albion Hotel, Glasgow  
Albion Hotel, Hastings  
Albion Hotel, Manchester  
Bath Hotel, Leamington  
Bedford Hotel, Brighton  
Bedford Hotel, Leamington  
Bilbon Hotel, Dublin  
Black's Head Hotel, Glasgow  
Bell Hotel, Cambridge  
Bell Hotel, Preston  
Bush Hotel, Carlisle  
Cafe de l'Europe, Manchester  
Cafe Royal, Edinburgh  
Castle Hotel, Richmond  
Castle Hotel, Windsor  
Christ's Hospital, Hertford  
Clarence Hotel, Brighton  
Clarence Hotel, Manchester  
Clarendon Hotel, Leamington  
Clifton Hotel, Gravesend  
Clifton Arms Hotel, Newark  
Commercial Hotel, Belfast  
Commercial Hotel, Yarmouth  
Crown Hotel, Worcester  
Dolphin Hotel, Southampton  
Douglas Hotel, Edinburgh

Elephant Hotel, Margate  
Eton College  
Fountain Hotel, Portsmouth  
George Hotel, Nottingham  
George Hotel, Portsmouth  
George Inn, Warwick  
Great Northern Hotel, Lincoln  
George Hotel, Cheltenham  
Groundwood Hotel, Richmond  
Guildhall Hotel, Bristol  
Harrison's Hotel, Brighton  
Hydrophatic Inst., Sudbrook-park  
Imperial Hotel, Cheltenham  
Imperial Hotel, Dublin  
Jesus College, Oxford  
Jude's Hotel, Grafton-st., Dublin  
Jury's Hotel, Dublin  
King's Arms Tavern, Richmond  
King's Head Hotel, Gloucester  
King's Head Hotel, Horsham  
King's Head Inn, Epsom  
King's Head Hotel, Margate  
Laudownde Hotel, Leamington  
London Hotel, Edinburgh  
Marine Hotel, Hastings  
Marlborough College, Marlborough  
May Pole Inn, Nottingham  
Montague Tavern, Bristol  
Morrison Hotel, Dublin

New Inn, Gravesend  
New Stone Hotel, Brighton  
Norfolk Hotel, Brighton  
Old Ship Hotel, Brighton  
Pavilion Hotel, Brighton  
Pavilion Hotel, Folkestone  
Pier Hotel, Brighton  
Plough Hotel, Cheltenham  
Queen's Hotel, Birmingham  
Queen's Hotel, Brighton  
Queen's Hotel, Manchester  
Quebec Hotel, Portsmouth  
Rampant Horse Inn, Norwich  
Red Lion Hotel, Dorking  
Red Lion Hotel, Postea  
Regent Hotel, Leamington  
Royal Albion Hotel, Ramsgate  
Royal Hotel, Edinburgh  
Royal George Hotel, Southampton  
Royal George Hotel, Poolestone  
Royal Hotel, Birmingham  
Royal Hotel, Plymouth  
Royal Hotel, Richmond  
Royal Hotel, Slough  
Royal Kent Hotel, Ryde, I. W.  
Royal Oak Hotel, Hastings  
Royal Pier Hotel, Ryde, I. W.  
Royal Victoria Hotel, St. Leonard's  
Royal Western Hotel, Bristol

Royal York Hotel, Brighton  
Saracen's Head Hotel, Lincoln  
Scarborough Hotel, Leeds  
Ship Hotel, Dover  
Spread Eagle Hotel, Gloucester  
Star and Garter Hotel, Portsmouth  
Star and Garter Hotel, Richmond  
Star and Garter Hotel, Worcester  
Thistle Tavern, Glasgow  
Three Swans Hotel, Salisbury  
Trafalgar Hotel, Greenwich  
Trinity College, Cambridge  
University Hotel, Cambridge  
Victoria Hotel, Hull  
Waterloo Hotel, Edinburgh  
Waterloo Hotel, Liverpool  
White Hart Hotel, Margate  
White Hart Hotel, Newark  
White Hart Hotel, Salisbury  
White Lion Hotel, Bath  
White Lion Hotel, Brighton  
White Lion Hotel, Bristol  
Wolverton Station refreshment-rooms  
Worwood's Dining-rooms, Manchester  
York House, Bath  
York Station refreshment-rooms.  
&c. &c. &c.

(For Sectional Drawings of the Machine see Catalogue, Class 22.)



**J. L. BENHAM AND SONS,**  
**FURNISHING IRONMONGERS, STOVE AND RANGE MANUFACTURERS,**  
**HOT-WATER ENGINEERS, AND GAS-FITTERS.**

**IMPROVED COOKING APPARATUS.**

The Oxford Roasting Range, with radiating firebricks back. Hot Hearth Plates and Broiling Stoves. Iron Hot Closets, heated by steam or hot water from the Range Boiler. Bright Iron Steam Tables for dishing up. Steam Kettles for meat, vegetables, or fish. Gas Cooking Stoves.

**BATHS, &c.**

Hot and Cold Baths, fitted up in copper, tin, marble, slate, or porcelain, and which may be supplied with hot water from the kitchen-range or from the servants' offices. Forcible Warm Baths, which may be heated at the bedside of an invalid. Shower Baths. Hip and Leg Baths. Forcible Vapour Baths.

**Manufactory and Showrooms, 19, Wigmore-street, Cavendish-square, London.**

(See Illustrated Catalogue, Class XXII., No. 98.)

[1 338]

**THE BEST TEETH.—EDW. MILES, Surgeon-Dentist, 15, Liverpool-street, Bishopsgate, London.—SETS OF TEETH VERY FAR IN ADVANCE. Fixed without pain. Hours, 9 till 4. (Exhibitor, 601, CLASS 10.)** [1 341]

**RAMSGATE.—ROYAL ALBION HOTEL, MERRYWEATHER & JENKINSON, Proprietors.**—Families and Gentlemen visiting the sea-side will find this Hotel replete with every comfort; viands and wines of the best quality. The Hotel is close to the Royal Harbour and Pier, and commands an extensive sea-view.—Ramsgate is the nearest and best route to the Continent. Steamboats run to and from Ostend daily. [1 146]

**A BERAMAN MERTHYR STEAM COAL, CARDIFF.**—By the Third and last Report by Sir Henry de la Beche and Dr. Playfair to the British Government, this Coal is the best ever tested—*vide* the Report. Practically, the actual number of pounds of Water converted into Steam by 1 lb. of Coal is 10·99 lbs., and averages 10·75. Guaranteed against spontaneous combustion. References and information given, and orders executed, by GEO. INSOLE & SON, Colliery Proprietors, CARDIFF. [1 339]

**ANDREW ROSS, 2, Featherstone Buildings, Agent.**—BLEEDING INSTRUMENTS as substitutes for leeches, and Cupping Instruments adapted to apply to any part of the body, invented by BARNON HEURTELLOUP.

Cutting instrument with four small pumps, with ends of various forms, complete in case . . . 2l. 2s.  
 Extra large pump, in case . . . . . 0. 15s.

*This invention is perfectly new, and is patented.*  
 (Class 10, No. 666.) [1 343]

**STOVES AND GRATES.**

The Patent Radiating Grates, with firebricks back—a certain cure for a smoky chimney. Drawing room Grates, from original designs, with enrichments in porcelain, polished steel, and ormolu. Not's Patent Stoves, which after 16 years' trial are allowed to be the best for churches, chapels, schools, &c.

**WARMING BY HOT WATER.**

Greenhouses, Halls, Drying Closets, &c., effectually warmed from the fire in the servants' offices or from separate boilers. Heating Apparatus on the Folemaise system.

N.B.—Plans and Estimates furnished in town or country.

**HUXHAMS and BROWN, Iron Founders, ExETER, DEVONSHIRE.**—Grates; Kitchen-Stoves, with open or close Fires, with latest Registered Improvements; Iron Castings, &c. [1 321]

**TO THE TRADE.—R. & M. H. ALLEN, Mercantile and Manufacturing Stationers, Letterpress and Copperplate Printers, Engravers, Lithographers, Bookbinders, Machine Rulers, and Wholesale Booksellers, LONGROW, NOTTINGHAM.** Proprietors of the "Model Time Tables," "The Great Midland Advertiser," "Poor Richard's Almanac," &c. &c. [1 331]

**PIANOFORTE MANUFACTORY, 108, Wardour Street.—RALPH ALLISON, Manufacturer of Pianofortes with the Check Repetition Action, begs to call the attention of the musical public to his varied stock of Instruments with the above action, which for elegance of design, power and volume of tone, with smoothness and elasticity of touch, are surpassed by none in the trade. Instruments prepared expressly for exportation. Pianofortes of all kinds for hire, and when purchased six months' hire allowed. [1 339]**

**W. R. LLOYD,**

**7, NEWHALL STREET, BIRMINGHAM,**  
**GENERAL COMMISSION MERCHANT** for the purchase and sale of METALS, ORES, and FOREIGN and COLONIAL PRODUCE, &c.

Orders for manufactured goods prepared for shipping, Neapolitan and Sicilian Vice-Consulate. [1 342]



**ALLEN'S GREAT MIDLAND ADVERTISER** AND ILLUSTRATED NATIONAL ALMANAC FOR 1852. Fourth Issue; guaranteed circulation, 10,000. Will be ready for delivery on October 1st, 1851. Advertisements received until September 30th by the London Agent, W. J. CLARK, Jew, 10, Nicholl-square, Aldersgate-street; or by the Proprietors, E. & M. H. ALLEN, Long-row, Nottingham. — *Prospectuses sent free by post.* [1 332]

**ALLEN'S MODEL TIME-TABLES AND RAILWAY GUIDES**, One Penny each.—1. London, with all the Railways and a correct Map. 2. The MIDLAND DISTRICTS and a Map of the Railways.—The cheapest, most portable, and most useful Guides published.—London, Victoria, Holywell-street; STRANGE, Paternoster-row; BARNES, Queen-street, Chesham; JENNOLD, St. Paul's Churchyard; and E. & M. H. ALLEN, Nottingham. [1 328]

*In the press, to be shortly published,*

THE STANDARD  
**PSALM-TUNE BOOK.**

*Music folio. 11. 1s. to Subscribers.*

Containing upwards of 630 TUNES, comprising the whole of the ENGLISH AND SCOTTISH PSALTER MUSIC, a large selection from the GERMAN and GERMAN Choral-books and Psalters, and numerous valuable additions from rare and scarce works in private collections, and the public libraries of London, Edinburgh, and Oxford. The whole is arranged with the ORIGINAL HARMONY, *i. e.* where assiduous and careful research could discover it, and an Accompaniment for the Organ. An Historical Preface and Notes will be prefixed, and the Music faithfully given from the ORIGINAL EDITIONS, which have been diligently examined by the Editor, HENRY E. DIBDIN, *Organist*, Trinity Chapel, Edinburgh.

LONDON: D'ALMAINE AND MARINLAY, 20, Soho-square, where Subscribers' names are received; also in Edinburgh, at the principal Music-shops. Glasgow: J. MUIR WOOD & Co., and D. BRYCE & Co., Buchanan-street. [1 334]

**PIANOFORTES.**—J. MANKTELOW & Co., Manufacturers of best description of Pianofortes, for sale or hire, at 432, OXFORD-STREET, and 12, HUNLEY-STREET, BEDFORD-SQUARE.—*Pianofortes expressly for exportation.* [1 335]

**OIL-COLOUR PICTURE PRINTING**, Invented by GEORGE BAXTER, the *Patentee*.—LICENCES will be granted to work the Process in Great Britain, France, Belgium, &c. &c. For particulars apply at the Patentee's Offices, 11 & 12, NORTHAMPTON-SQUARE, LONDON.—The Process will be fully explained to Licensees. [1 324]

**HUXHAMS AND BROWN, Engineers, EXETER, Devonshire.**—Tanners' Bark-mills for hand or power.—those worked by hand grinding 10 cwt. per day by two men; Tanners' Presses and Implements; Mill-work; French Burr Mill-stones; Flour-mills; Weighing-machines; Weigh-bridges; Ships' Purchases, Pumps, and Ship-work, and Caboozes; Steam-engines, Water-wheels, &c. [1 320]

**COMPANY**

OF THE

**PAPER-MILLS DU MARAIS ET DE SAINTE MARIE.**

ED. DOUMERC, DIRECTOR, PARIS.

**PAPERS** for Printing, Lithography, Copperplate, Drawing, Shading, Writing, and Account-books.

Pasteboards for Jacquard's Looms and for Boxes of various descriptions.

Fillgreed Papers for Bank-notes and Shares of Companies (these are not exhibited, for the security of the Banks and Companies).

This Manufactory supplies the Bank-notes of France, Greece, Hayti, Turin, Genoa, &c. &c. [1 326]

**STURM & Co., 55, GRACESHURCH-STREET, LONDON.**—COMMISSION MERCHANTS, FORWARDING AND GENERAL AGENTS.—Maritime Insurances effected. Advances upon Consignments.—Agents for Messrs. B. and E. FANUZZI, Châlons-sur-Marne. [1 335]

**PURCHASES AT THE EXHIBITION.**—Messrs. LIGHTLY & SIMON, of 123, FENCOURT-STREET, LONDON, Agents to the Governments of FRANCE, SPAIN, and SARINIA for the reception of Articles sent from those countries to the Great Exhibition, beg to inform persons desirous of making purchases that the Exhibitors may be communicated with through them. [1 326]

**PURCHASES at the EXHIBITION.**—Messrs. HENRY CASSIN & Co., of No. 9, OLD BROAD-STREET, LONDON, *East India Agents*, referring to their Advertisement in page 63 of the 1st Part of the *Official Illustrated Catalogue*, beg to inform persons desirous of making purchases of any of the Articles in the Great Exhibition, that the British and Foreign Exhibitors may be communicated with through them to secure the Articles, in conformity with the restrictions laid down by her Majesty's Commissioners. [1 325]

**BURFORD'S PANORAMA ROYAL, LEICESTER SQUARE.**

**NOW OPEN**, in the Large Rotunda, the Views of the astounding FALLS OF NIAGARA and of the eminently interesting CITY OF JERUSALEM. Admission, 1s.—in order to meet the present unprecedented season—to the two Views. The Views of the LAKES OF KILLARNEY and of LUCERNE are also now open. Admission, 1s. to each Circle, or 2s. 6d. to the Three Circles.—Open from 10 till dusk. Mr. Burford's is the oldest establishment of the kind in London, having been founded in 1786; and he, being desirous of producing two works in one circle, worthy of the present great period, has on this occasion divided the Large Rotunda, so as to present at the same time the Views of the Falls of Niagara and of Jerusalem—the two most grand and majestic in the world, and requiring such space as the vast extent and appliances of his Panorama can alone supply, with such effect and fidelity, and on a scale of such sufficient magnitude, as to do them justice; the Falls of Niagara being the most wonderful and magnificent of Nature's works—and the City of Jerusalem, beautiful in its ruins, and eminently interesting to every Christian as the scene of most of the principal events in the Life of our Blessed Saviour, of his humiliation, and of his death. [1 370]

**INDIA, MALTA, EGYPT, IONIAN ISLES.**—Her Britannic Majesty's PACKETS, possessing every requisite accommodation for passengers, keep up a regular communication between England and India, via Marseilles, Malta, and Egypt. Leave Marseilles for Malta 9th and 26th of the month, Malta for Marseilles about the 12th and 24th, performing the passage in about 68 hours. Leave Malta for Alexandria 13th, and Alexandria for Malta about the 21st, the passage performed in about 90 hours; the packet for England via Marseilles, and the Peninsular and Oriental Company's steamer for Southampton, wait her arrival. Leave Malta for Ionian Isles 2nd and 15th, returning on the 12th and 25th with passengers for England, via Marseilles or Gibraltar. Freight on specie—one per cent. on silver,  $\frac{1}{2}$ th on gold or jewels.

Every information may be obtained of A. and W. GALIGNANI, Paris; T. WOOLEY, Patras; JEAN BOUVER, 4, Rue de la Paix, Marseilles; Mr. DAVIDSON, Alexandria; BOMBAY TIMES OFFICE, Bombay; Mr. LAGAN, Singapore; G. MUIR, 217, Strada Reale, Malta, Superintending and Booking Agent to Her Britannic Majesty's Packets in the Mediterranean.

N.B.—Passengers leaving England by the Company's steamer from Southampton on the 29th are conveyed on to Alexandria by Her Majesty's packet leaving Malta on the 13th. Mr. Muir, the agent, will be on board to tranship their luggage, and give them any information. There is no expense attending it. London Referees, Messrs. G. W. WHEATLEY & Co., 156, Leadenhall-street; and Mr. G. W. DE BERNARDY, 20, John-street, Adelphi. [1 337]

**THE CASTLE MONA HOTEL,**

DOUGLAS, ISLE OF MAN (formerly a Ducal Residence).

GEO. HANCOCK has the honour to inform the Nobility, Gentry, and Public generally, that this magnificent and truly elegant edifice (originally built by the late Duke of Athol for his own private residence, at an expense of 40,000*l.*) has been, during the winter months, re-modelled and newly fitted up, so as to carry out the views of the proprietor to make it in every respect deserving of the extensive and liberal patronage it has hitherto been favoured with, for which he begs to return his sincere and grateful thanks.

It is now acknowledged to stand unrivalled for beauty of situation, comfort, style, and elegance, being situate on the margin of the beautiful and picturesque Bay of Douglas, surrounded by extensive pleasure-grounds, tastefully laid out, and abounding with the choicest plants, flowers, and shrubs, communicating with the woods and plantations by sheltered, romantic, and secluded walks, several miles in extent, and elevated several hundred feet above the level of the sea. The Castle Mona consists of a private Hotel, with suites of elegant and richly-furnished apartments, a salable d'hoté, splendid and capacious dining-room and magnificent saloon, coffee-room, billiard-room, baths of every description, and close to the hotel every accommodation for sea-bathing, which is acknowledged to be the finest in the world, and may be enjoyed any hour of the day.—The culinary department is under the superintendence of a grand chef and the best *cochonnas de cuisine* that could be engaged. The wines are recherche, and selected from the first houses and most approved brands.—In the stable department will be found horses and vehicles of every description, with lock-up coachhouses and extensive livery.

The Proprietor respectfully solicits parties going on pleasure excursions to give to Castle Mona a trial, and flatters himself they will find every comfort and luxury combined, with a moderate scale of charges, including attendance of every kind.

Board at the table d'hoté, 3*5s.* per week; in private, 4*2s.* 1 bed-rooms according to size and situation, from 7*s.* to 18*s.* 1 sitting-rooms from 3*s.* to 6*s.* per day. Servants' board and lodging, 2*1s.* per week. Attendance, 1*s.* 6*d.* per day; 7*s.* per week each. Port and sherry, 4*s.*; claret, 4*s.*, 5*s.*, and 7*s.* 1 champagne, 7*s.*; Madeira, 5*s.* [1 323

## MORISON'S VEGETABLE UNIVERSAL MEDICINES,

Depôt, 344, STRAND.

THE Partnership of MORISON, MOAT, & Co., of the "BRITISH COLLEGE OF HEALTH," having expired on the 25th of March last,

**MR. MOAT**

manufactures the above-named Medicines ("MORISON'S PILLS") from the Recipes of the late "James Morison, the Hygeist."

Mr. MOAT is duly qualified, and has devoted many years to the study of Medicine; by the employ of a matured judgment in the selection of drugs, and attention to the thorough combination and uniformity of mixture, he ensures certainty of effect with the least possible unpleasantness. He offers the Pills, thus made by himself, as a perfectly safe and efficient purgative, and recommends them to be taken in those cases of illness where the services of an immediate Medical Adviser are not felt to be requisite.

Sold, with directions, in the usual priced boxes, by all Medicine Venders. Foreign Houses dealt with in the most advantageous manner. [1 276

**GLENFIELD STARCH.**

The Ladies are respectfully requested to make a trial of the

GLENFIELD

**PATENT DOUBLE-REFINED POWDER STARCH,**

which, for Domestic use, now stands UNRIVALLED.

"Royal Laundry, Richmond, near London,"

14th May, 1881.

"Mr. Wetherpoon, 40, Dunlop-street, Glasgow.—The Glenfield Patent Powder Starch has now been used for some time in that department of the Royal Laundry where all the finest goods are finished for Her Majesty, Prince Albert, and the Royal Family, and I have much pleasure in informing you that it has given the highest satisfaction. (Signed) "M. WRIGHT,"

"Laundress to Her Majesty."

See also Testimonials from laundresses of the Countess of Eglinton, Marchioness of Breadalbane, and Countess of Dartmouth.

Sole Wholesale, in London, by Messrs. Pantin & Turner; Hooper Brothers; Batty & Co.; Croft & Innocent; Petty, Wood, & Co.; Twelvetrees Brothers; Charles C. B. Williams; Yates, Walton, & Co.; Mr. Snelling; and R. Wakefield, 35, Crown-street; and Retail by all Shopkeepers.

Agents wanted—apply to Mr. R. WETHERPOON, 40, Dunlop-street, Glasgow. [1 323

**PATENT RICE STARCH**, manufactured under the PATENT of WM. THOS. BERGER, granted 1850.—Messrs. SAMUEL BROWN & Co. beg to draw attention to the above article, as being very superior in all the essential requisites, viz. Purity, Strength, Colour, and Transparency, and being perfectly soluble without boiling.

Works, BROMLEY-BY-BOW, LONDON. [1 105

Class 28, No. 76, Exhibition, Hyde Park.

**CHAS. MACINTOSH & Co.,**

GENERAL MANUFACTURERS OF

**INDIA RUBBER,**

IN BLOCKS, SHEETS, FABRICS, &amp;c. &amp;c.,

AND

PATENTERS AND MANUFACTURERS OF

**VULCANIZED INDIA RUBBER**

IN ALL ITS APPLICATIONS.

73, ALDERMANBURY, LONDON; AND

CAMBRIDGE-STREET, MANCHESTER. [1 338

**CLASS XXII.—PATENT GUTTA PERCHA SKATES.**—These Skates possess the advantages of lightness, cheapness, superior excellence of material, improved shape and construction, great strength and durability, combined with novelty and richness of appearance. Manufactured only by the inventor, F. THOMPSON, WARRFIELD TERRACE, SHEFFIELD. London Agents—The GUTTA PERCHA Co., 18, Wharf-road, City-road. [1 330

**CLASS XVI.—EVERETT & CO., 51, FETTER-LANE.—CAUTION.** The very high celebrity which EVERETT'S BLACKING has attained has induced so many dishonest persons to send out spurious imitations of it, that EVERETT & Co. are compelled to request particular attention to their address, 51, FETTER-LANE, LONDON, and their signature, which is on every genuine bottle. "Everett's Blacking," "Polish for Dress Boots," and "Waterproof Varnish," may be inspected in Section XVI. of the Central Avenue of the Exhibition. [1 329

## NEW SHOW-ROOMS FOR BEDSTEADS.

HEAL & SON have erected some extensive Ware-rooms for the purpose of keeping a General Assortment of every description of BEDSTEAD, comprising

### IRON BEDSTEADS,

both for Servants' use, and those HANDSOMELY JAPANNED;

### BRASS BEDSTEADS,



### JAPANNED FRENCH BEDSTEADS, POLISHED BIRCH BEDSTEADS, AND MAHOGANY BEDSTEADS,

in all the varieties of FRENCH, ARABIAN, and FOUR-POST, of the Newest and Best Designs. And they have added to their Stock a General Assortment of

### Furniture Chintzes, Damasks, and Dimities,

for Bed Furnitures, so as to render their Establishment complete for the furnishing of

### BEDSTEADS AND BEDDING.

They also beg most respectfully to call attention to the particulars and illustration, in the Catalogue, of the

### SUPERB EIDER-DOWN QUILT

EXHIBITED BY THEM.

### HEAL AND SON'S LIST OF BEDDING,

Containing Full Particulars of WEIGHTS, SIZES, and PRICES of every description of Bedding, sent free by Post, on application to their Factory,

196 (Opposite the Chapel), TOTTENHAM COURT ROAD, LONDON.

**BENNETT'S WATCH MANUFACTORY, 65, CHEAPSIDE.**

**WATCHES FOR ALL NATIONS.**

J. BENNETT, 65, Cheapside, Clock and Instrument Maker to the Royal Observatory, the Board of Ordnance, the Admiralty, and to the Queen, respectfully invites all who value perfect Time-keepers to inspect his stock of Gold & Silver Watches, now the most complete in London, with all the recent improvements for performance, climate, taste, and economy.



**MONTRES POUR TOUT LE MONDE**

J. BENNETT, 65, Cheapside, Horloger et Fabricant d'Instruments d'Astronomie de l'Observatoire Royal, du Comité d'Artillerie, de l'Amirauté et de sa Majesté la Reine d'Angleterre, a l'honneur d'inviter les justes appréciateurs des bons Chronomètres à examiner ses magasins de montres d'Or et d'Argent confectionnées d'après les perfectionnements modernes à l'égard de la précision du mouvement, du climat, du goût et de l'économie.

**EVERY WATCH IN THE LATEST STYLE AND MOST CAREFULLY FINISHED, GOLD CASES AND JEWELLED. SILVER CASES AND JEWELLED.**

**GENTLEMEN'S.**

|                                                               | A.  | B.  | C.  |
|---------------------------------------------------------------|-----|-----|-----|
|                                                               | Gs. | Gs. | Gs. |
| Horizontal construction, enamel dial, 4 holes, jewelled ..... | 10  | 8   | 6   |
| Ditto, gold dial and strong case                              | 12  | 10  | 7   |
| Bennett's superior London-made patent Lever, jewelled .....   | 17  | 14  | 10  |

**LADIES.**

|                                    | A.  | B.  | C.  |
|------------------------------------|-----|-----|-----|
|                                    | Gs. | Gs. | Gs. |
| Horizontal construction, gold dial | 10  | 8   | 6   |
| Patent Lever (Geneva) .....        | 12  | 10  | 8   |
| Ditto (English) highly finished... | 16  | 14  | 12  |

For Medical Men, Dead Seconds, Gold—18 Gs. Silver—12 Gs.

**GENTLEMEN'S.**

|                                                      | A.  | B.  | C.  |
|------------------------------------------------------|-----|-----|-----|
|                                                      | Gs. | Gs. | Gs. |
| Horizontal construction, sound and serviceable ..... | 5   | 4   | 3   |
| Superior Lever (Geneva) 10 Jewels                    | 7   | 6   | 5   |
| Bennett's London-made Levers...                      | 8   | 6   | 4   |

**LADIES.**

|                                                                   | A.  | B.  | C.  |
|-------------------------------------------------------------------|-----|-----|-----|
|                                                                   | Gs. | Gs. | Gs. |
| Horizontal construction, neat and flat beautifully engraved cases | 5   | 4   | 3   |
| Superior Geneva Lever .....                                       | 6   | 5   | 4   |
| Elegant Silver Dial, 10s. 6d. extra.                              |     |     |     |
| Small London-made Levers .....                                    | 7   | 6   | 5   |

BENNETT'S PRICED CHRONOMETER, Gold, 20 Gs., Silver, 12 Gs.

**EVERY WATCH SKILFULLY EXAMINED, TIMED AND ITS PERFORMANCE GUARANTEED**

**BENNETT'S**  
 MANUFACTORY AND SHOW ROOMS,  
 Recently enlarged, now comprise the Watch, Clock, Plate, and Jewellery departments.  
 A Complete Assortment of GOLD & SILVER WATCHES and CLOCKS, Ornamental and Plain.  
 DIALS for HALLS, SHOPS, and OFFICES,—£3, £4, & £5 each.  
 CHURCH, CATHEDRAL, and RAILWAY CLOCKS Made to Order.  
 ANEMOMETERS and METEOROLOGICAL INSTRUMENTS.  
 A Splendid Assortment of GOLD CHAINS of the most Elegant Patterns.  
 Large & Beautiful Stock of RINGS & BROOCHES, set with Diamonds, Pearls, & other Jewels.  
 GOLD, SILVER, & PRECIOUS STONES, Bought and taken in Exchange.  
 ELECTRO PLATE IN GREAT VARIETY, FOR HOTELS AND FAMILIES.

**BENNETT'S CLOCK MANUFACTORY, 65, CHEAPSIDE.**

# JOHNSON, CAMMELL, & CO., CYCLOPS STEEL WORKS, SHEFFIELD;

JOHNSON, CAMMELL, & Co., No. 5, BARGE-YARD, CITY, LONDON;

JOHNSON, CAMMELL, & Co., HAMBURG;

JOHNSON, CAMMELL, & Co., No. 100, WILLIAM-STREET, NEW YORK,

Respectfully solicit MANUFACTURERS, MERCHANTS, and CONSUMERS generally, to inspect the various operations at their Works as above, and the extensive Assortment of Patterns at their LONDON, HAMBURG, and NEW-YORK HOUSES.

## JOHNSON, CAMMELL, & CO.

have availed themselves of every Improvement, and of all the facilities of railway transit, enabling them, combined with their FORGES, TILTS, and ROLLING MILLS, to produce their renowned and universally approved

### STEEL;

Namely, Cemented Blister  $\odot$  and other Bar; Double-refined Cast Steel; Warranted Double Sheer Steel; Improved prepared elastic Spring Steel, in plane, concave, double concave, and patent ribbed Plates or Bars; and every other description of Steel used for Machinery, Engineering, Locomotive, and Railway purposes.

## JOHNSON, CAMMELL, & CO.,

MANUFACTURERS and MERCHANTS, Importers of the most celebrated Brands of

### Russian, Swedish, and other Foreign Irons,

peculiarly adapted, from the purity of their ore, for STEEL PURPOSES, which are Carbonized, Converted, Melted, and Refused at their Furnaces at the CYCLOPS STEEL WORKS.

## JOHNSON, CAMMELL, & CO.,

MANUFACTURERS OF FILES,

on scientific and peculiar principles, producing their improved and celebrated quality, long known to the Engineering and Railway world;

INVENTORS OF THE NOW UNIVERALLY ADOPTED

### Curvilinear Tanged Files,

Registered No. 665;

SOLE MANUFACTURERS OF THE

### Continuous Tooth Concave and Convex Files,

for which the MEDAL of the SCOTTISH SOCIETY OF ARTS AND MANUFACTURES was awarded.

J., C., & Co. beg to observe, that in the Hardening and Tempering of FILES they have adopted such decidedly superior principles as to retain and fix in the Steel the greatest possible amount of Carbon, ascertained by considerable research and numerous experiments in chemical science, aided by those safe and invaluable guides, long practice and great experience.

## JOHNSON, CAMMELL, & CO.,

MANUFACTURERS OF SPRINGS

for LOCOMOTIVE ENGINES, TENDERS, RAILWAY CARRIAGES and WAGGONS; viz. Bearing, Buffing, Spiral, Patent Bow, Elliptic, Disc, and every description of SPRINGS in use.

In this department the Proprietors respectfully invite Consumers to visit their Works, and inspect the Machinery they have erected for producing exactness and uniformity.

MANUFACTURERS OF

### VICES, HAMMERS, SMITHS' AND SHIPBUILDERS' TOOLS, RAILWAY COUPLING SCREWS,

AND ALL USES IN STEEL AND IRON FOR RAILWAY WORKS.

IN THE SEVERAL DEPARTMENTS OF THEIR VARIOUS MANUFACTURES THE CYCLOPS STEEL WORKS STAND UNRIVALLED.  
CORPORATION MARKS—THE "CAMEL," AND "CYCLOPS."

SIDE.

LE MONDE

5, Cheapside,  
l'Instruments  
vatoire Royal,  
Artillerie, de  
de sa Majesté  
eterre, a l'phon  
les justes ap-  
bons Chro-  
examiner ses  
montres d'Or  
t confection-  
les perfec-  
modernes a  
a précision du  
du climat, du  
e l'économie.



SIDE.



## CLASSIFIED CONTENTS OF THE ADVERTISER.

- Accountant, *Page* 81.  
 Agents and Commission Merchants, 10, 44, 63, 67, 68, 70, 71.  
 Agricultural Chemist, 65.  
 Agricultural Implement Makers, 47, 50, 53, 55.  
 Air Guns and Canes, 37, 39.  
 Art and Science, 23, 24, 25, 28, 32, 36, 65, 71.  
 Asylums, 10.  
 Beds and Bedding, 75.  
 Bellows and Portable Forge Manufacturers, 44.  
 Billiard-table, 30.  
 Blacking-makers, 58, 67, 72.  
 Bookbinders, 32, 33.  
 Boot and Shoe Makers, 39, 58.  
 Brewers, 43.  
 Brick and Tile Makers, 52.  
 Brush-makers, 58.  
 Cabinet-makers, 40.  
 Carvers and Gilders, 34.  
 Cement Manufacturer, 67.  
 Charities, Public, 10, 12.  
 Chemists, 58.  
 Chislers, 63.  
 Chronometer-maker, 34.  
 Cigar Merchants, 42.  
 Clothiers, Outfitters, Tailors, 39.  
 Coach-builders, 40, 63.  
 Coal Merchants, 47, 55, 70.  
 Coins, 26.  
 Companies, Public, 11, 13.  
 Congreve and other Match Makers, 53.  
 Conveyances, Public, 9.  
 Creta Lavis (Drawing Chalk), 34.  
 Curiosity Dealers, 30.  
 Cutlers, 36, 44.  
 Dentists, 37, 70.  
 Desiccating Company, 58.  
 Diamond Cement, 34.  
 Distillers, 42.  
 Education, 31.  
 Effluvia-Trap Gratings, 51.  
 Electric Telegraphs, 55.  
 Electro Platers, 44, 46.  
 Engineers, 46, 50, 55, 71.  
 Engravers, 24, 26, 31, 67.  
 Exhibitions, 30, 37, 67, 71.  
 Fancy Goods, 57, 58, 66.  
 Felt-makers, 53, 58.  
 Fishing Tackle Maker, 37.  
 Florist, Artificial, 39.
- Founders, Iron, Brass, &c., and Workers in Metal, *Pages* 45, 46, 47, 50, 51, 52, 55, 59, 67, 70.  
 Fringe and Trimming Makers, 39.  
 Furniture Makers and Dealers, 34, 37, 39, 40, 57, 59, 68, 78.  
 Gas-fitters, 47, 54.  
 Gas-light, Portable, 54.  
 Glass, China, and Earthenware, 49, 65.  
 Glass Paper, &c., Manufacturer, 59.  
 Glue Manufacturers, 49, 63.  
 Goldsmiths, Silversmiths, Jewellers, 34, 36, 86, 57, 66.  
 Governesses' Institution, 12.  
 Gravy Dish, 46.  
 Gun-makers, 37, 39.  
 Hatters, 39.  
 Hops, 62.  
 Horticulture, 35.  
 Hospitals, 10.  
 Hotels, 60, 67, 70, 72.  
 House Agent, 67.  
 Ice and Refrigerators, 43.  
 India-rubber & Gutta Percha Workers, 37, 45, 72.  
 Ink-makers, 32, 34.  
 Insurance Companies (Fire and Life), 1—9, 10, 11.  
 Ironmongers, 1, 46, 47, 70.  
 Kilns, Patent, 52.  
 Knife-cleaner, 69.  
 Lamp-makers, 40.  
 Law, French, 31.  
 Literature, 14—27, 30, 32, 36, 42, 71.  
 Loan required, 10.  
 Machine and Instrument Makers, 43, 47, 50, 52, 54, 67.  
 Magasins de Nouveautés, 64.  
 Manufactures of Birmingham and Sheffield, 44, 46, 75.  
 Maps, 15, 66.  
 Marble, 30.  
 Medicine Venders, 62, 63, 66, 72.  
 Mercers, Linendrapers, Hosiery, Haberdashers, &c., 38, 64.  
 Metallic Bedsteads, 51, 54.  
 Milliners, Lace-dealers, &c., 38, 39.  
 Music, 23, 29, 31, 71.  
 Musical Instruments, 28, 29, 32, 65, 70, 71.  
 Naturalist, 32.  
 Needlewomen, proposed Registration Office for, 56, 57.  
 News and Advertising Agent, 23.  
 Nurserymen, 35, 47.
- Ornery Globe, *Page* 36.  
 Painters, Plumbers, Glasiers, &c., 34.  
 Paper Box maker, 36.  
 Paper-hangers, 40.  
 Paper-makers, 33, 71.  
 Parliament, Reports and Proceedings of, 16, 17.  
 Pastel, or Imitation Wood, 63.  
 Pencil-makers, 34.  
 Perfumers, 37, 58, 63.  
 Phacelasmagoria Lanterns, 24.  
 Pipe (Metal) Makers, 54.  
 Prayer-book Society, 11.  
 Printers, 24, 26, 31, 65.  
 Printing Press Makers, 55.  
 Publications, Periodical, 14, 22, 24, 26.  
 Purveyors, 37, 42, 43, 55, 58, 62, 63.  
 Razor Strops, 36.  
 Religious Tract Society, 13.  
 Sail-maker, 37.  
 School-slale Manufacturers, 4.  
 Seedmen, 47.  
 Shirt-makers, 38.  
 Shonis, 66.  
 Soda-water, &c., Manufacturer, 42.  
 Spindle Manufacturers, 53.  
 Starch-makers, 72.  
 Stationers, 24, 34.  
 Steam-packets, 9, 55, 71.  
 Steel-workers, 44, 45.  
 Stoppings for Horses' Feet, 55.  
 Stove and Range makers, 46, 48, 49, 63, 70.  
 Surgical Instruments, 70.  
 Siphon Tap, 52.  
 Tent-maker, 37.  
 Theatricals, 29, 31.  
 Thread Manufacturers, 39, 40, 41.  
 Type-founders, 30.  
 Undertakers, 11, 40.  
 Vapour Bath, 62.  
 Waters, Imitative Cameo, 36.  
 Watchmakers, 34, 74.  
 Watering-places, 60, 61, 67, 72.  
 Wig-makers, 37.  
 Wine-merchants, 36, 42.  
 Wire Netting, 36.  
 Wood-carving Factory, 58.  
 Woollen, Linen, &c., Manufacturers, 38, 39, 40, 59, 66.  
 Woollendrapers, 38, 58, 63.  
 Writing Desk and Dressing Case Makers, 36, 66.

[1851.]

iers, &c., 34.

Proceedings

1, 63.

, 24.

4, 22, 24, 26.

, 58, 62, 63.

3.

, 74.

urer, 42.

3.

rt, 55.

, 46, 48, 49,

, 40, 41.

36.

37, 72.

3. manufacturers,

3. Processing Case

13+

