

Technical and Bibliographic Notes / Notes techniques et bibliographiques

The Institute has attempted to obtain the best original copy available for filming. Features of this copy which may be bibliographically unique, which may alter any of the images in the reproduction, or which may significantly change the usual method of filming, are checked below.

L'Institut a microfilmé le meilleur exemplaire qu'il lui a été possible de se procurer. Les détails de cet exemplaire qui sont peut-être uniques du point de vue bibliographique, qui peuvent modifier une image reproduite, ou qui peuvent exiger une modification dans la méthode normale de filmage sont indiqués ci-dessous.

Coloured covers/
Couverture de couleur

Coloured pages/
Pages de couleur

Covers damaged/
Couverture endommagée

Pages damaged/
Pages endommagées

Covers restored and/or laminated/
Couverture restaurée et/ou pelliculée

Pages restored and/or laminated/
Pages restaurées et/ou pelliculées

Cover title missing/
Le titre de couverture manque

Pages discoloured, stained or foxed/
Pages décolorées, tachetées ou piquées

Coloured maps/
Cartes géographiques en couleur

Pages detached/
Pages détachées

Coloured ink (i.e. other than blue or black)/
Encre de couleur (i.e. autre que bleue ou noire)

Showthrough/
Transparence

Coloured plates and/or illustrations/
Planches et/ou illustrations en couleur

Quality of print varies/
Qualité inégale de l'impression

Bound with other material/
Relié avec d'autres documents

Continuous pagination/
Pagination continue

Tight binding may cause shadows or distortion along interior margin/
La reliure serrée peut causer de l'ombre ou de la distorsion le long de la marge intérieure

Includes index(es)/
Comprend un (des) index

Title on header taken from:/
Le titre de l'en-tête provient:

Blank leaves added during restoration may appear within the text. Whenever possible, these have been omitted from filming/
Il se peut que certaines pages blanches ajoutées lors d'une restauration apparaissent dans le texte, mais, lorsque cela était possible, ces pages n'ont pas été filmées.

Title page of issue/
Page de titre de la livraison

Caption of issue/
Titre de départ de la livraison

Masthead/
Générique (périodiques) de la livraison

Additional comments:/ Various pagings.
Commentaires supplémentaires:

This item is filmed at the reduction ratio checked below/
Ce document est filmé au taux de réduction indiqué ci-dessous.

10X	12X	14X	16X	18X	20X	22X	24X	26X	28X	30X	32X
									✓		

THE
CANADIAN PATENT OFFICE
RECORD.

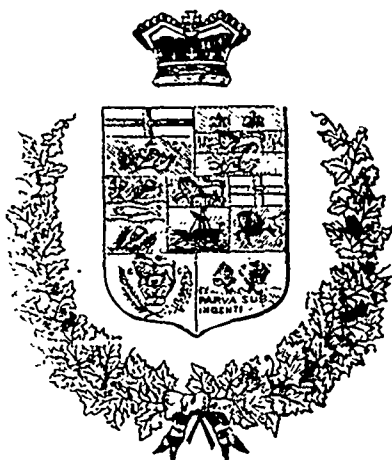

VOLUME IV.

OTTAWA:

PUBLISHED BY AUTHORITY.

1876.



VOLUME IV, 1876.—INDEX.

INDEX OF INVENTIONS.

Accoutrements, W. J. Oliver.....	6781	Barrel, D. S. Cornell et al.....	5549
Acid, acetic, H. M. Pierce.....	6654	" heads, J. W. Frevor.....	6437
Advertising device, M. E. Dow.....	5620	" paper, N. Keely.....	5988
" " R. D. Bannister et al.....	6007	" pulp, G. W. Laraway.....	6042
" " C. W. Reed.....	8205	Barrels, heating, H. H. Hale et al.....	6245
" " medium, E. Rawlings.....	5433	Bath, A. Slligsberg.....	6210
Air carburetting, J. F. Barker.....	6131	" " tub, C. A. Blessing.....	6784
Alarm, burglar, J. P. Kisingbury.....	6486	Bed bottom, C. W. and S. Purcell.....	5943
" log, G. Sweaner et al.....	6389	" " F. Schorn et al.....	5623
" " L. Smith et al.....	6482	" " spring, W. Crich.....	5741
" " &c., W. F. Thiers et al.....	6356	" spring, J. E. Townsbend.....	6241
Alkali, recovering, D. A. Fyfe.....	6056	" " J. Mulholland.....	5753
Alkalies " " H. C. F. Stormer.....	5756	" " T. DeWitt.....	6760
Ammonia, salts of, K. O. Patterson et al.....	5535	Bedstead, A. J. Goodwin.....	6745
Anchor, J. Williams.....	6504	" invalid, W. Spanner.....	6514
" " T. J. Whitcar et al.....	6179	" " E. S. Piper.....	5728
" " trippers, E. H. Emerson.....	5853	Beehive, H. Roush.....	6673
Animal matters, preserving, F. S. Barff.....	6515	Belts, endless, R. Thomson et al.....	6331
Arm, fire, James Lee.....	5844	Bench vice, A. Velleux.....	6554
" " C. B. Hunt.....	6370	Billiard, S. Bretzfeld et al.....	5599
Ashes, screening, J. Chalfour.....	6471	" table, H. W. Collender.....	6317
" sifter, P. W. Peckham.....	6649	Binding grain, bands for, D. Olmsted.....	5824
" " T. C. Jones.....	5976	Blind, G. M. Robinson.....	6534
Asphalt pavement, D. Ewart.....	6655	" closing, W. Jones.....	6630
Astronomy illustrating, M. MacVicar.....	5616	" folding, A. Le Roy.....	5508
Atomizer, T. J. Holmes.....	6507	Blood converting, H. O. P. Lissagaray.....	6722
Auger, core, O. W. Townsend.....	6038	Blower, T. S. Disston.....	6183
" earth, I. Ireland.....	6320	" hand, H. Pr6fontaine.....	5654
" fruit, W. McCormick.....	6492	Boat detaching device, R. and A. McNaugh.....	5766
" hollow, A. A. Wood.....	6503	Boats, propelling, M. Mathews.....	6209
Axle, A. Payette.....	5603	Boller plate cutting, E. Fisher.....	5555
" W. W. Kisner.....	6067	Bollers, steam, H. F. King.....	6097
" and box, J. B. Winchell.....	6046	Bolt blank, S. Vanstone et al.....	6747
" box and axle, A. Payette.....	5680	Bolt cutter, J. Dawson.....	6191
" boxes, R. W. Drew et al.....	5830	Bolting reels, L. V. Rathbon.....	6307
" " W. G. Beattie.....	6095	Book case, J. Danner.....	6371
" fitting skelns on, J. Fraser.....	6074	" cheque, G. E. Waring, Jr.....	6439
" nut, waggon, T. C. Stewart.....	5773	" copy, E. F. Goodman.....	6598
" turning, car, G. G. Lobdell.....	5825	" keeping, W. F. Lamb et al.....	5572
Backlash preventing, J. A. Hafner.....	6694	Boot and shoe heel counters, J. Kieffer.....	5955
Bag, H. Redden.....	6246	" " " polishing, L. Graf.....	6344
" catcher, A. B. Whipple.....	6542	" " " trimming, A. McDowell.....	5686
" flour, T. Phillips.....	6240	" " " insting, C. M. Hinckley.....	5952
" holder and truck, J. Hewitt.....	5755	" " " nail, H. T. Marshall.....	5625
" upholding, J. G. Waldoek.....	5841	" " " pegging stand, A. Stone.....	5429
" turning, R. S. Judson et al.....	6661	" " " sawing, L. L. Barber.....	5947
Baking oven, H. L. Parkin.....	6137	" brushing, C. L. Measkowsky.....	6568
Bale ties, J. R. Foster.....	5420	" lace fastener, T. A. and J. W. McDonald.....	6323
Baling tie, wire, P. K. Dederick.....	5646	" liling, C. Monohan et al.....	6185
Ballasting car, J. W. McDonald.....	6130	" sawing, C. Goodyear, Jr.....	6164
Ballot box, W. H. Nicolls.....	6593	" tree, J. H. Sampson.....	6300
Bands, manufacture of, L. Binns.....	5873	" " " J. K. Feick.....	6297
Bar and bearer, fire, G. Haworth.....	6349	Boots and shoes, C. E. Vaughan.....	6687
" plnob, spike and claw, D. Brennan.....	5581	" " " D. A. Sutherland.....	6513
" square and mitre, J. C. Rorick.....	5584	" " " J. E. Wheeler.....	6158
Barr, joint for fire, G. Haworth.....	6407	" " " J. R. Moffit.....	6408
Bark cutting, S. R. Thompson.....	6264	" " " W. H. Palmer.....	6311
" tan, J. Sherman.....	6122	" " " pegging, O. L. G. Noble et al.....	6085
		Bottle, maollage, J. P. Haseltine.....	6011
		" stopper, A. Christin.....	5541
		" " " C. de Quillfeldt.....	5629
		Bottles, wires for, L. Perrin.....	6203

Box, dumping, G. Seger.....	8391	Car street, E. Solomon.....	6061
“ “ J. W. Heat et al.....	8368	“ truck shifting, R. H. Ramsay et al.....	5784
“ stuffing, R. Bloomfield.....	8700	“ wheels, W. W. Lohdell.....	5855
Boxes, scale board, H. W. Hutchins.....	5578	“ turning, G. G. Lohdell.....	5326
Brake, car, J. F. DeLeon et al.....	8703	Carpet sweeper, J. J. Hothliger.....	5659
“ gun carriage, A. Krupp.....	8014	“ tacking, J. W. Breadshaw et al.....	5720
Bread baking, J. Carroll.....	5544	Carriage, I. H. Colp et al.....	5450
Breadstons, B. and C. Hickox.....	5834	“ J. Ecket.....	6179
Brewery plant, A. B. Walker.....	8763	“ R. Dunn.....	6305
Brick kiln, R. Carroll et al.....	8021	“ R. Murray.....	6780
“ machine, C. S. Bigler et al.....	5865	“ S. P. Graham.....	8257
“ “ J. Close.....	5795	“ axle, J. Kritch.....	6328
“ “ G. S. Tiffany.....	5591	“ beam, J. B. Lazier.....	6499
“ “ W. A. Graham.....	5829	“ cattle, F. H. Kelph.....	6720
Bricks, handling, W. E. Gurd.....	5610	“ hose, T. McCabe.....	5977
“ white, T. M. Clark.....	6089	“ rug, J. Milwain.....	6177
Bridge beams, P. Bilyen.....	6092	“ seat, C. K. Meilinger.....	6034
“ floating draw, H. H. Gorrings.....	5670	“ seats, S. W. Bench.....	5891
“ J. B. Winters.....	5597	“ shaft, W. M. Wilcox.....	6189
Broiler, rotary, J. Sch anker.....	5781	“ thill, O. O. Roberts.....	6291
Broom, A. Walrath et al.....	6742	“ top, F. P. Steadman.....	5984
“ S. M. Kellogg et al.....	6536	“ wheels, S. Vesot.....	5978
“ corn sizing, A. Walrath.....	6321	Carp, hand, J. M. Jones.....	6162
Brooms, J. D. Drescher.....	6400	Caster wheels, W. A. Perkins.....	5691
“ J. Ewing et al.....	5674	Catapults, J. A. Knight.....	6281
Brush, G. W. Scherm-thorn.....	6485	Cattle car, K. K. Ott et al.....	5678
“ J. L. Whiting.....	6782	“ steel, J. R. Marsh et al.....	5534
Brush bundles, J. L. Whiting.....	5613	Cement, J. M. Parent.....	6736
“ holder, J. O. Montignani.....	5594	“ hydraulic, A. W. Shaw.....	5555
Brushes, O. Jenness.....	6301	Cementing wood, &c., H. R. Wilcox.....	5831
“ making, J. L. Whiting.....	5660	Cemeters, J. J. Dunn.....	5928
Bucket machine, I. Hogeland.....	6024	Cesspool cover, &c., H. W. Clapp.....	6155
“ pump, W. B. Wilcox.....	6146	Chain stopper, D. N. B. Coffin, Jr., et al.....	5173
Buckets, sup. E. E. Spencer.....	5910	Chair and seat, T. Tox.....	6765
Buckle for garments, W. H. Barker.....	5517	“ base, W. T. Doramus.....	5851
Buggy shafts, W. M. Wilcox.....	6189	“ legs, pair for, W. T. Lither et al.....	5567
“ spring coupling, J. McBride.....	6752	Chairs, A. B. Steuen et al.....	6285
Bugeles, canopy for, G. R. McCrea.....	6016	“ J. A. Egan et al.....	5804
Bug, potato, D. Solder.....	5681	“ &c., tenon fastening for, L. D. Craig.....	5589
Building ventilating, R. Thomas.....	5903	Cheese safe, F. Nothrup et al.....	5726
Bungs and vents, H. R. Cornish.....	5717	Cheque bank, W. A. Smith.....	6480
Burys, sizer, J. M. Courtenay.....	6076	“ bond, &c., J. E. Winner et al.....	5958
Burzel sturn, A. R. Schutenburg.....	6257	“ look, G. E. Worling, Jr.....	6439
“ C. H. Williams et al.....	5729	Chimney cowls, A. J. Robinson.....	6345
Burner gas, H. Palmer.....	6498	“ sweeper, C. Chabonnenu.....	6008
“ lamp, H. C. Scott.....	6775	“ top, &c., J. B. Robertson.....	6140
Butter workers, J. Moene.....	6167	Chronometer erepaments, F. H. V. Igl.....	6432
Buttons, ornamenting, W. H. Isbell.....	5690	“ solar, M. Wheeler.....	5702
Bush cutting, O. Pickett.....	6767	Clare, C. H. Warren.....	6055
Cages, bird, A. F. Dunlop.....	5954	“ H. Felt.....	6336
Calendars, D. J. Miller.....	5691	“ W. H. Hoyt.....	6212
Camp, lounge, G. T. Barker.....	5872	“ dasher, A. G. Kerr.....	6074
Can opener, A. E. Ames.....	6617	“ powers, C. Edwards et al.....	5919
Cans, oil, S. W. Aldrich et al.....	6040	“ “ M. Hamley et al.....	5372
“ paper, &c., J. H. Stone.....	5768	“ “ T. Cole.....	6229
Canal door and vate, T. Mielte.....	5171	“ “ V. H. Tidale.....	6686
Candy heater, B. and H. Stern.....	5675	Churns, J. Macconche.....	6399
“ machine, B. and H. Stern.....	6267	“ J. Wood.....	5806
Cane, M. M. Copp.....	6195	“ P. Fryer.....	6389
Cannons, J. R. N. Owen.....	6222	“ T. Simmons.....	6423
Capstan, D. N. B. Coffin, Jr., et al.....	5477	“ W. D. V. H.....	6004
“ J. H. David.....	6083	Cider mill, E. Curtis.....	5653
Carbonates of soda, E. Soly.....	6581	Cigar bundling, M. Lesser et al.....	6506
Carbureting oil, J. F. Barker.....	6131	“ packing, C. Bonty.....	6030
Car axle, G. W. Albimont.....	6559	Cigarette, J. R. Louder.....	6077
“ lubricato, G. M. Mills.....	6103	Clamp, barrel, J. R. Foster.....	6430
“ ballasting, J. W. McDonald.....	6130	Cloth stocking, H. N. Sater.....	5514
“ brake, E. Farnsworth.....	6611	Clothes dryer, M. A. B. Sulpham.....	6015
“ “ J. F. DeLeon et al.....	6701	“ “ N. P. Don.....	6136
“ brake, J. Blushon.....	6384	Clothes horse, C. H. Warren.....	6699
“ coupler, J. B. Smith.....	5899	“ “ J. A. Mooty et al.....	6528
“ “ J. B. Winters et al.....	5814	“ “ S. B. Danton.....	5791
“ “ J. King.....	6133	“ ironing, A. G. Beau.....	6093
“ “ J. Mealey.....	6057	“ line, F. Gugen-tu.....	5692
“ “ W. Dunn.....	5662	“ “ J. L. Cain.....	6186
“ couplers, G. Jones.....	6219	“ measure, P. Kilb.....	5982
“ “ J. C. Mitchell et al.....	6188	“ washing, C. Packham.....	6239
“ coupling, A. Wald.....	6721	“ wringer, J. Hayward et al.....	5979
“ “ F. M. Andrews.....	6718	Cover thrasher, G. J. Utendorf.....	5116
“ “ G. W. and A. D. Green.....	6110	Coal, &c., hoisting, G. Stanchiff et al.....	5861
“ “ J. A. Richard.....	6191	“ scuttle, G. F. Sawyer.....	5513
“ “ J. Singer.....	6458	“ “ P. W. Peckam.....	6050
“ “ J. W. Bates et al.....	6069	“ after.....	6618
“ “ N. H. Dison.....	6748	Coat hook, C. Kinney.....	5667
“ “ W. V. Perry.....	6393	Coffee mill box, R. L. Webb.....	5465
“ refrigerator, J. H. Wickes.....	6148	“ “ J. G. W. Hubbard.....	6135
“ “ J. M. Ayer.....	6620	Coffin, J. Richey et al.....	6589
“ stack, J. R. McPherson.....	5782	Coin package, C. F. Trout.....	6543

Fruit preserving, S. Peebles et al.....	6266	Grate, furnace, J. Reynolds.....	6760
Fuel, securing combustion, &c., of, J. C. Ramsden.....	5422	Grates for stoves, &c., G. W. Swett et al.....	6200
Fatting mill, W. H. Mace et al.....	6741	" stove, T. B. Griffith.....	5900
Funnel and sprinkling pot, R. S. Galbraith et al.....	5833	Grators, R. Soper.....	5787
Furnace, C. Dion et al.....	6604	Grating, sewer, &c., H. W. Clapp.....	6455
" C. Thonger.....	5710	Grinding machine, J. J. Webster.....	6774
" J. E. Werten.....	6525	Grindstone frame, G. A. Whitney.....	6512
" J. L. Sundry.....	6163	Groats, preparation of, M. Tindale.....	6140
" blast, A. Smith.....	6103	Gun carriage brake, A. Krupp.....	6014
" for gas retorts, D. Davidson.....	5937	" covers, G. W. Havens et al.....	6081
" grate, J. Reynolds.....	6759	" machine, J. P. Taylor et al.....	5476
" hot air, A. Laddlaw.....	5730	Hair restorer, J. McCormack.....	6091
" " J. B. Pierce.....	5767	Hame fastener, A. J. Park.....	5515
" ore roasting, R. M. Fryer.....	5772	Hams, preparation of, A. B. Richardson.....	6217
" puddling, A. Smith.....	6098	Harness, C. Colo.....	6193
" smokeless, J. W. Bonta.....	6144	" F. Walsh.....	6448
" steam boiler, W. S. Hutchinson.....	6727	" H. C. Mahurin et al.....	6067
Furnaces, charcoal, E. G. Adams.....	6173	" J. W. Boulden.....	6037
" coal, H. M. Smith.....	5427	" breast irons, B. and C. Hickox.....	5634
" " stoves and, J. F. Stewart.....	5821	" buckles, J. Challenger.....	5500
" cupola, J. Blakeney.....	6446	" pad press, W. Dippert.....	5188
" glass, C. W. Foster.....	5925	" plough, E. Coleman.....	6426
" &c., grates for, G. W. Swett et al.....	6200	Harrow, S. Frank.....	6583
" or stoves, E. Hawkes.....	6153	" A. H. and M. S. Whiteside.....	6721
Fuse lighter, J. W. Platt.....	5893	" H. Meill.....	5669
Gaff fastenings, J. H. David.....	5788	" W. T. McGhee et al.....	6237
Garment fastening, F. G. Farnham.....	6086	" revolving, H. Wells.....	5546
Gas, M. H. Strong.....	6756	" sulky, M. Wilson.....	5607
" T. H. Hicks et al.....	6109	" wheel, F. Bramer.....	5636
" apparatus, G. Diabol.....	6149	Harvester, C. C. Bradley.....	5990 6572
" " T. S. C. Lowe.....	6175	" J. F. Gordon.....	6743
" burner, B. Palmer.....	6498	" S. Noxon.....	6039
" " and regulator, J. Ellis.....	5424	" R. Thomson et al.....	6329
" burners, G. H. Larnib et al.....	5911	" knife heads, G. W. Harrison.....	6447
" for burning, T. B. Redwood.....	6547	Harvesting machine, R. Thomson et al.....	6332 6334
" for eating purposes, W. G. Wood.....	5762	Hat and coat hook, C. Kinney.....	5667
" generating, C. A. White.....	6701	Hatchets, J. A. Thayer.....	6338
" generator, A. I. Griffin.....	5657	Hay loader, C. W. Williams.....	5461
" illuminating, H. Aiken et al.....	6357	" press, C. G. C. Simpson.....	5501
" " J. H. Needels.....	5736	" ruck, waggon, &c., P. Williams.....	5636
" " J. McLitty.....	6006	" rake, M. Wilson.....	5607
" " M. H. Strong.....	5688	" " S. Frank.....	5533
" " T. W. Lion.....	5593	" " and ladder, T. Curtis.....	5510
" " and hearing, J. P. Gill.....	5823	Head rest, G. A. Shaw.....	6066
" sawy, C. E. Bell.....	6062	Heat extracting, H. Purdy.....	6358
" manufacture, S. C. Salt-bury.....	6585	Heater, J. L. Mistle.....	5613 5614
" manufacturing, H. Bray.....	6216	" drum, W. P. Buckbee.....	5624
" motive, R. D. Brad ev.....	6770	Heating liquid, W. Lawrence.....	6749
" motor, N. A. Otto.....	6479	" tire, S. G. Reed et al.....	5689
" pipe, C. C. Watworth.....	6497	" water, T. M. Carroll.....	5545
" regulator, C. C. Place.....	6712	Heel and sole protector, H. E. Van Benschoten.....	5458
" " C. H. Edwards et al.....	6149	" counters, J. Kieffer.....	5955
" retorts, D. Davidson.....	5937	" trimming, A. M. Dowell.....	5686
" " &c. closing, H. Conison.....	5425	Hide handler, O. W. Bean.....	6741
" stoves, C. Burnham et al.....	5808	Hinges, J. B. Winters et al.....	5905
Gate, A. D. Cable et al.....	5456	" J. W. Vaughan.....	584
" J. Kessler.....	6629	Hoe, J. B. Reynolds.....	6616
" W. T. Czebuda.....	6750	Holting apparatus, A. Letch.....	5663
Gates, automatic, L. Flogg.....	5539	" coal, &c., G. Stuchiff et al.....	5861
" E. Way crossing, H. A. Stearns.....	5929	" machine, hydraulic, W. Askwith.....	5893
" " T. Martin.....	526	Hoof spreading, C. H. Shephard.....	5598
" farm, J. Y. Williams.....	5962	Hook, fish, B. F. Smith et al.....	6660
" hanger for, L. A. Cook.....	5971	" hat and coat, C. Kinney.....	5667
" lock, E. V. Bodwell et al.....	5986	" meat, L. it. Iowse.....	6189
Gelatine desiccating, J. J. Rogers.....	5949	Hoop cutting, J. B. Pike.....	6010
Geography illustrating, M. MacVicar.....	5615	" cutting, G. V. Griffith.....	6171
Glass, J. N. Tarbox.....	6196	Horse collar, E. Stroud.....	6418
" crucible, J. N. Tarbox et al.....	5431	" detaching apparatus, J. W. Glover.....	5438
" furnaces, C. W. Foster.....	5925	" overshoe, A. C. Snowden.....	5495
" melting, J. N. Tarbox.....	5677	" pad, H. G. White.....	6283
Glasses, eye, I. Alexander.....	6172	" power, G. Gibson.....	6437
Glove, W. F. Foster.....	6478	" " link, B. L. Olds.....	6288
" fastener, F. G. Farnham.....	6086	" rake, F. G. Butler.....	5565
Glucose, manufacture of, S. H. Johnson.....	5761	" " P. Patterson.....	5679
Gold, extraction of, P. Cadell.....	6259	" shoe, E. L. Tevis et al.....	5895
Grain binder, J. Parker.....	6396	" " H. H. Gilmore.....	6166
" binders, E. R. Whitney et al.....	5893	" " J. O'Sullivan.....	6138
" binding, D. Ormsted.....	5824	" " calks sharp ending, E. Gleason et al.....	5835
" " S. L. Whitney.....	6239	" " nail, D. Armstrong et al.....	5957
" ce ending, J. Higginbottom et al.....	6273	" " J. B. Wills.....	5735
" cradle, C. P. Kelsey et al.....	6117	" " finishing, C. W. Woodford.....	5813
" drill, C. E. Patric.....	5652	" " machine, N. W. Goodertch.....	5796 5797
" mashing, J. T. C. Cove.....	5892	" curling flat footed, J. Ziellinski.....	5985
" scouring, M. D. Bearislee.....	6017	Hose and pipe nozzle, M. Clemens.....	6016
" separator, A. Laddlaw.....	6735	" carriage, T. McCabe.....	5977
" separators, H. Kurth et al.....	6001	Hosiery sewing machine, W. Pearson.....	5644
" treating, R. d'Heureux.....	6584	Hub, L. N. Bewley et al.....	6092
Grate, G. H. Stanbury et al.....	6603	Hydrants, C. F. Rapp.....	5637 5628

Hydrants, J. P. Gallagher.....	6200	Lock, G. A. Shaw.....	6177
" J. V. Hays et al.....	5783	" combination, I. and J. Gaffney.....	5638
Hydraulic hoisting machine, W. Askwith.....	5803	" " R. P. Goucher.....	6125
" machinery, J. Cannan.....	5915	" safety, J. A. Quesnel.....	6102
Hydro-carbon burner, A. J. Griffin.....	5657	Locks, chronometric, J. Burge.....	6181
" burning, M. Boynton.....	6131	" door springs and, W. H. Myers et al.....	6017
Ice breaking vessel, E. J. Weederman.....	5714	Locomotive water, W. H. Howell.....	6063
India rubber compounds, G. MacLellan.....	5601	Locomotives, J. D. Murray.....	5812
Injectors and ejectors, G. H. Little.....	5611	" highway, J. G. and H. Meriyweather et al.....	6050
Iron converting, C. L. Jessfords.....	5558	" tram, &c., H. Hughes.....	6070
" enamelling, F. G. and W. F. Niedringham.....	6308	Logging dogs, O. H. Smith.....	6127
" heater, sad, J. B. Christian.....	6450	Loom for suspenders, &c., C. H. Chapman.....	5916
" holder " S. J. Ward.....	6394	" hand, S. H. Gowers.....	5769
" welding, J. B. Wills.....	6218	Lubricating compounds, H. Von P. Draper.....	5687
Ironing clothe, A. Gibeau.....	6093	" cups, R. W. Drew et al.....	5588
" board, J. K. Butler.....	6190	Lubricator, car axle, G. M. Morris.....	6133
" machine, J. Martin.....	6125	" N. Lebert.....	5163
" shirt fronts, I. Ducharme.....	5810	" R. C. Luce et al.....	6065
Jack, L. O'Hara et al.....	6473	Lumber, grooved, P. C. Joseph.....	6064
" carriage, J. McLeod et al.....	6178	Machinery, backlash of, J. A. Hafner.....	6091
" lifting, D. T. Welch.....	5519	Mail bag, A. B. Whipple.....	6512
" " G. W. Hunter et al.....	6315	Malt crusher, E. S. Higgins et al.....	6105
" waggon, C. D. Knapp.....	5759	Mangling machine, C. A. Mallory.....	5411
" " W. Haritt.....	5732	Manure, G. A. Kay.....	5655
Jar cover, F. L. Bodine.....	6269	" spreader, T. A. McDonald.....	6051
Journal boxes, W. S. Mead.....	6340	Maps, charts, &c., J. Brown.....	6155
Kerosene, &c., C. Godfrey.....	6134	Mats, door, O. Rice.....	6060
" oil, measuring, J. D. Muller.....	6075	Meal, pumpkin, T. F. Guy.....	6619
Kettle, cover, G. Clements.....	6460	Measure and sprinkling pot, R. S. Galbraith et al.....	5833
" tube, B. Temple.....	5157	" liquid, J. W. Wilkinon.....	6304
Kiln, brick, R. Carroll et al.....	6021	Measures, rotary, A. Chambers.....	6275
" drying, E. Davee et al.....	5520	Meat hook, L. R. Hoves.....	6189
" grain drying, W. Stewart et al.....	6404	" machine, T. Will et al.....	6587
" lime, A. Smith.....	6033	" preserving, K. Knott.....	6252
Kneading trough, F. Beauchemin.....	5559	" " W. Leland.....	6395
Knife, curd, A. and E. B. Sedgwick.....	6929	Medicinal composition, J. L. Johnston.....	6101
" handle, H. Funke.....	6660	Melons and organs, G. T. McLaughlin et al.....	5959
" polishing powder, G. T. Stickells.....	5715	Metal punching, I. S. Van Winkle.....	6776
Knitting loom, C. L. Spencer et al.....	6301	" shearing, sheet, A. O. Kittridge et al.....	5820
" machine, J. Hineckley.....	5809	" shears, T. Berridge.....	5953
Labelling " J. Bigelow.....	5770	" smoothing sheet, A. O. Kittridge et al.....	5828
Laces, restoring, A. J. Shriver.....	6531	" working, H. W. Moore.....	6740
Ladder and fire escape, D. Sanford.....	5631	Metals, amalgamating, T. A. D. Forster et al.....	6302
" step, C. H. Warren.....	6696	" heating, A. Smith.....	5554
" " O. Sherwood, Jr.....	6701	Meter, liquid, A. S. Libbey.....	5738
Ladders, J. Gagné et al.....	6193	" " A. Post.....	5683
" extension, O. Sherwood.....	5856	" " E. R. Carpenter.....	5792
Lamp, C. T. Spencer.....	6707	Meters, pumps and engines, W. Carey et al.....	5914
" G. D. Burton.....	6570	" water, N. W. Knowlton.....	5983
" burner, H. A. Chapin.....	5758	Middlugs purifier, B. Barter.....	5942
" chimney mica, E. D. Wright et al.....	5648	" " H. M. Charlesworth.....	5989
" " W. H. Shapley et al.....	5527	" " L. Gathman.....	6020
" extinguisher, A. E. Edholm.....	5574	Milk cooler, M. Beauregard.....	6638
" glass, H. Dillaway.....	6753	" " N. D. Ferguson.....	6174
" holding for sewing machines, W. Vassie.....	5645	" cooling, W. G. Watson.....	5866
" lighter, J. Chapman.....	5609	" pan, G. G. May.....	5932
" post, W. DeLany.....	6761	" " G. Smith.....	6716
" street, J. S. Wood.....	6274	" pans, H. A. Hannum.....	5896
" wick, H. C. Scott.....	6775	" safe, J. F. Pool.....	6777
Lamps, C. Godfrey.....	6194	" strainers, P. S. Ryan.....	6397
" G. M. Stevens.....	6207	" tester, A. Middaugh.....	5974
" R. H. Webb.....	6143	Milker, C. I. Calvert.....	6653
" W. J. Armstrong.....	6323	Milking stool, H. A. Stearns.....	5690
" cooking, J. W. Cole.....	5832	Millet seed cleaning, F. Savote.....	5712
" &c., filling, W. Sedgwick.....	5848	Mill, corn, W. C. Woodbury.....	6339
" lettering street, W. H. McElcheran.....	6681	" grinding, L. B. McDonald.....	6641
Land roller, J. H. Holland.....	5452	" quartz, D. D. Mallory.....	6550
" " J. Woodbridge.....	5132	" stone, B. Barter.....	6021
Lantern reservoir, street, E. Patterson et al.....	6041	" " A. Defor.....	6151
Latho, A. Fleck.....	6022	" " dressing, T. Mathewson.....	5994
" J. Beaudry.....	5825	" stones, F. A. Howland.....	6218
" turning car wheels, &c., G. G. Lobdell.....	5698	" stones, dressing, G. T. Smith.....	5876
Lard, fining and cooling, R. Bullymore.....	6679	" trams, F. G. Wallace.....	6136
Leather crimping, J. E. Wheeler et al.....	5849	Moccasins, C. Beaupré.....	6319
" converting, H. O. P. Lissagaray.....	6711	" " S. Lee.....	5472
" shaving, J. Smith.....	5491	" " M. Langevin.....	5983
" whitening and buffing, J. E. Fisk.....	6670	Mop holder, J. O. Montagnani.....	5594
Letter file, N. S. Otis.....	6540	" wringer, J. Lang.....	5483
Life preserver, J. Roch et al.....	5622	Mortises on sashes, S. W. Dickinson.....	6027
" preserving stool, H. H. Nash.....	6671	Motor, gas, N. A. Otto.....	6179
" raft, G. Thompson.....	6149	" spring, E. Lambkin.....	6556
Lifting weights, C. O. Brown.....	5711	Moulding machines, D. Cameron et al.....	5951
Lightning conductor, H. W. Spang.....	5411	Mouldings, dressing wood, M. A. Owens.....	5740
" " J. C. Schoonmaker.....	5400	Mowers and reapers, L. H. Hichert.....	6415
" rod ".....	5367	Mowing machine, R. Thomson et al.....	6330
" " J. Hewitt.....	6033	" " frames, N. Cossitt.....	5596
Lime kilns, A. Smith.....	6093	" and reaping machines, J. H. Grant.....	5561
Lobsters, preserving, J. C. Ayer.....	6093	Mucilage bottle, J. P. Haseltine.....	6011

Musical instrument mouth piece, C. G. Conn.....	6707	Pegging machine, E. P. Richardson.....	5529
" sounds, transmitting, E. Gray.....	6201	Pen, J. M. Might et al.....	6402
Nail assorter, J. Coyne.....	6064	" extractor, J. A. Hard.....	6072
" blank machine, T. T. Wood.....	6364	Percolator, regulating, G. McPherson.....	6418
" boot and shoe, H. F. Marshall.....	6625	Petroleum, D. M. Lamb.....	6631
" cutting machine, C. A. Shaw.....	6612	" purifying, J. R. Minblinick.....	3746
" horse shoe, C. W. Woodford.....	6813	" refining, J. S. Robinson.....	6580
" " " D. Arn strong et al.....	6957	" tanks, preventing fires in, J. H. Connolly.....	6861
" " " G. P. Clapp et al.....	6280	Photograph, C. C. H. Franke.....	6632
" " " J. B. Wills.....	6735 6776	" mounting, R. Sheane.....	6824
" " " J. M. Laughlin.....	6719	Photographic paper, T. Doney.....	6380
" " " J. Varney.....	6590	Piano, W. H. Wool.....	6281
" " " N. W. Gooterlich.....	5790	" hand rest for, W. Bohrer.....	5802
Nailing " C. T. Brandon.....	6211	" pedals, W. Muth.....	6315
Navigators' bearing indicator, J. D. Leach.....	6594	" upright, C. E. Rogers.....	5815
" protractor, J. D. & S. Leach.....	6591	Picture frame, M. L. Baxter.....	6427
Neck ties, G. G. Strulair.....	6068	" photo-ceramic, A. L. Henderson.....	6079
" " J. B. Carter.....	6807	Pipe and hose nozzle, M. Clemens.....	6046
" yoke leathers, J. B. Relyea.....	6163	" elbow, sheet metal, G. Lypton.....	5499
Needle machine, F. W. Mullett.....	5690	" steam, etc., C. C. Whitworth.....	6197
" whipping, W. W. Clay.....	6819	Pipes and holdfasts, conductor, T. Linklater.....	5703
Netting for fishing, etc., B. Arnold.....	5941	" joints for water, R. Thomas.....	5904
Newspaper labelling, R. Dick.....	6121	" manufacture of, G. M. Fuller.....	5598
Nickel ore, W. B. Tatro.....	6714	" thawing water, T. J. Sloan.....	5616
Nut, A. Marland.....	5180	" tobacco, M. Thomson.....	6106
" lock, C. P. Baghoit et al.....	5010	" venger, R. M. Broas.....	5934
" " D. Dull.....	6353	Pistols, E. P. Boardman.....	5878
" " J. B. Atwood.....	6582	Piston packing, J. Richards et al.....	6653
" " S. Brunson.....	6167	" " W. W. St. John.....	5617
" " and washer, C. Corby.....	6050	Pistons and valves, W. G. Beattie.....	6094
Oakum manufacture, J. Pike.....	6011	Plater, side, C. E. Carpenter.....	5610
Oat cutter, F. Schumacher.....	5763	Planing machines, S. J. Anderson.....	6090
" meal cutter, " " " ".....	5765	Plane guide, H. P. Taylor et al.....	6018
" " " E. S. Higgins et al.....	6105	Planing lumber, E. Benjamin.....	6406
Oil burning stove, E. G. Adams.....	5745	" machine, I. F. Thompson et al.....	6557
" cans, &c., cap for coal, J. H. Stone.....	6768	" wood, C. H. Warren.....	6183
" " S. W. Aldrich et al.....	6040	Planter and plough, J. Fay et al.....	6144
" measuring, kerosene, J. D. Muller.....	6073	" hand corn, G. W. Robinson.....	5553
" retainer, J. S. Robinson.....	6580	" seed, &c., F. H. Saxton et al.....	5531
" squeezer, E. Rawlings.....	5802	Planting corn, &c., C. D. Oakes.....	5917
" stove, A. Q. Allis et al.....	5528	Plum curing, S. Thomson.....	5640
" tank, N. W. Wilson et al.....	5525	Plate outfit, boiler, E. Fisher.....	5655
Ore, nickel, W. B. Tatro.....	6714	" lifter, D. M. Sktuner et al.....	6099
Ores, amalgamating, L. Carvel.....	6220	Plough G. Whard et al.....	6881
" copper, T. H. Cobley et al.....	6152	" J. K. Underwood.....	6679
" pulverizing, R. M. Fryer.....	6253	" J. Snickel.....	6472
" reducing, A. Smith.....	6103	" M. R. Hubbell.....	6490
" roasting, R. M. Fryer.....	5772	" S. Smith, Sr.....	6644
" smelting, A. Smith.....	5554	" casting, D. Clinton.....	6403
" washing, T. A. D. Forster et al.....	6402	" clovers, J. G. Miller.....	5724
Organ, H. Smith et al.....	6521	" ditching, H. Derby.....	6671
" R. E. Lenton.....	6406	" gang, A. Fisher.....	6213
" R. McMillan.....	6549	" " B. W. Walton.....	5668
" reed, G. Blitchford.....	5570	" " J. Currie.....	4931
" " J. S. Robinson.....	6761	" " W. P. Plant et al.....	5451
Organs and melodions, G. T. McLaughlin et al.....	6950	" harness, E. Coleman.....	6426
Oven, baking, H. L. Parkin.....	6137	" point J. L. Dawes.....	6366
" flat iron heater and, J. C. Harper.....	6022	" " W. H. Trissler.....	6835
Over-shoes, J. H. McMechan.....	6103	" snow, W. M. Orton.....	5846
Oxides and sulphides, H. Knight.....	5182	" trench, H. Larose.....	6277
Ozone machine, R. Heuagel et al.....	5434	Plough, G. and J. Thomson.....	5976
Packing boxes, H. N. Hart.....	6255	Plumbers' trap, F. N. DuBok.....	5460
" metallic, R. Bloomfield.....	6700	Pomade, F. J. Cleaver.....	6663
Packings, piston, J. T. Wright et al.....	6233	Portemanteau, &c., D. S. Matthews.....	6424
Pad, bosom, J. C. Tillman et al.....	6178	Postage stamp, L. H. G. Ehrhardt et al.....	6682
" horse, H. G. White.....	6283	" " T. G. Palmer et al.....	6678
Pail car, W. Warren.....	6026	Post hole digger, I. M. Perry.....	6279
Pails and tub, J. S. McMurray.....	6454	Pot cover, G. C. Coments.....	6166
Paint brush brider, T. Snell et al.....	5470	" covers, W. H. Barker.....	5754
" " " " " " " ".....	5532	" measure and sprinkling, R. S. Galbraith et al.....	5833
" " " " " " " ".....	6128	Potato bugs, D. Snider.....	6581
" " " " " " " ".....	6050	" " " " " " " ".....	6568
" " " " " " " ".....	6365	" " " " " " " ".....	6619
" " " " " " " ".....	6028	" " " " " " " ".....	5633
Pans manufacture of, H. Martyn.....	6028	Press, plate printing, J. Milligan.....	5742
Paper bag, A. S. Denison et al.....	5474	" " " " " " " ".....	6364
" " " " " " " ".....	5521	Printers' galley, C. A. Scodding.....	5461
" barrels, N. Keely.....	5988	" " " " " " " ".....	5493
" dampeners, C. G. C. Simpson.....	6225	Printing, autographic, T. A. Edison.....	6608
" " " " " " " ".....	6380	" " " " " " " ".....	6813
" " " " " " " ".....	6352	" " " " " " " ".....	5780
" " " " " " " ".....	5410	" " " " " " " ".....	6380
" " " " " " " ".....	6360	Propellers, screw, E. B. Porter.....	5836
" " " " " " " ".....	6244	Prunello, waterproof, E. D. Westgate et al.....	6638
Paraffine, P. X. Byerley.....	6655	Pulley, A. L. Bricknell et al.....	6663
Pavement, D. Ewart.....	6398	" " " " " " " ".....	5543
" " " " " " " ".....	6828	Pulp, wood, I. W. Bowers et al.....	6145
" " " " " " " ".....	6802	Pulverizing machine, J. J. Webster.....	6774
Pent, D. Atkman.....	6617		
" " " " " " " ".....	6435		

Pump, E. F. Adsett et al.....	6041	Rake horse, J. F. Thomas.....	6003
" G. Wells.....	6067	" horse, J. Henderson et al.....	6573
" G. W. Johnson.....	5557	" and loader, hay, J. G. Krouse.....	5893
" H. Port.....	5510	" seeder attachment, to, J. Watson.....	5989
" I. Cosgrave.....	5481	" horse, P. Patterson.....	5679
" J. E. & J. H. Nute et al.....	5485	" horse, W. S. Archer et al.....	5960
" J. Woodville.....	6036	Rattan ware, S. H. Penley et al.....	5918
" O. E. & F. O. Furber.....	6037	Reapers, J. Huggert.....	6030
" W. Carey et al.....	5914	Reaping machine, D. Maxwell.....	6772
" W. Adair.....	5838	" machine, I. Mills.....	6314
" W. McGuire.....	6160	Reels, thread, J. Clarke.....	6009
" W. Scott.....	5996	Rein holders, G. A. Shaw.....	6223
" W. D. Andrews.....	6117	Relms, detaching check, J. McLean.....	6052
" bucket, W. B. Wilcox.....	6116	" driving, P. Merney et al.....	6202
" " for chain, A. D. Crosby.....	5542	Receptacles, refuse, &c, A. Schmidt.....	6355
" " " S. C. Hamlin.....	5613	Refrigerating liquid, W. Lawrence.....	6749
" chain, O. Baldwin.....	5991	" " room, M. Kimball.....	6373
" force, C. Green.....	6392	Refrigerator, D. Y. Howell et al.....	5504
" ship's, J. Brookeshire.....	5980 6728	" " E. B. Jewett.....	5998
" steam, T. Northey.....	5566	" " E. L. Gould.....	6126
" " W. H. Laurie.....	6280	" " E. S. Piper.....	5733
" valve, L. Hubbard et al.....	5800	" " J. H. Wickes.....	5621
" well, P. A. Garner.....	5704	" car, J. M. Ayer.....	6820
" wooden, J. W. Frazee.....	5775	" milk, J. F. Pool.....	6777
Pumping engines, steam, W. H. Law.....	5817	Register, fare, G. Beadle.....	6509
Pyrites, copper, T. H. Cobley et al.....	6152	" " C. A. Shaw.....	5632
Quartz mill, D. D. Mallory.....	6550	Resonance to metallic bottles, B. Millman et al.....	5575
Rack, wagon body & hay, P. Williams.....	5635	Rostorer, hair, J. McCormack.....	6091
Racking and riving, S. Parker.....	6190	Rheumatism, ointment for, L. N. Fontaine.....	5447
Radiator, W. Fleeton et al.....	5734	Ring, finger, W. Eisele.....	6429
" heat, E. C. Angell.....	5771	Rivet drilling, M. Bray.....	5923
Railing, W. T. Cleveland.....	6759	" making, G. A. Gray, Jr.....	6081
Railroad car adjuster, C. Bignouette.....	6322	" setting, M. Bray.....	5922
" car coupling, G. W. & A. D. Green.....	6110	Roof, C. M. Warren.....	6606
" crossing and switch, J. S. Williams.....	5902	" metallic, J. Power.....	6115
" grain car door, R. Bryden.....	5695	Roofing, metallic, E. Watson.....	5739
" rail joint, &c., R. Long.....	6128	Road scraper, E. Huber.....	6372
" signals, J. W. Hawley.....	6452	" " W. J. Nichols.....	5647
" tie, G. D. Blaindell.....	6530	Robes, lap, J. Millwall.....	6176
Rails, switch, J. Haggas.....	6422	Rock and stump elevator, J. McBatchelor et al.....	5924
Railway, C. Hughes et al.....	6553	" " machine, A. Berry.....	6053
" brake, E. Farnsworth.....	6631	Rods, rounding, &c., F. S. Mallock.....	5637
" " J. F. Degnon et al.....	6703	Rollers, land, P. Blyen.....	6078
" braking and signalling, J. Steel.....	5507	Root cutters, N. and T. Lubut.....	6105
" car, J. M. Ayer.....	6620	Rowing gear, W. Lyman.....	5416
" " axle, J. S. E. Dixon et al.....	5524	Rudder supporter, F. S. Manton.....	6757
" " lubricator, G. M. Morris.....	6403	Rug, carriage, J. Milwain.....	6177
" " brakes, J. Blunshan.....	6384	Salt evaporator, H. Harrison et al.....	6574
" " coupler, G. Jones.....	6249	Sap evaporators, J. P. Baldwin.....	6272
" " " J. C. Mitchell et al.....	6186	" " spout, H. A. Lawrence.....	6208
" " " J. King.....	6133	" " spouts, G. Scott et al.....	5743
" " coupling, A. Wald.....	6720	Sash, balance, J. Berndt.....	5779
" " platform, C. B. Crease.....	5909	" balanced, W. Cooper.....	5840
" " coupling, F. M. Andrews.....	6718	" fastener, F. Stannard.....	6754
" " " J. A. Richard.....	6494	" holder, C. E. Steller.....	6441
" " " J. C. Mitchell et al.....	6343	" " H. Gillmore.....	5545
" " " J. W. Bates et al.....	6069	" holders, H. Lear et al.....	6204
" " " N. H. Dolson.....	6196	" pulley, A. Willifmson.....	6738
" " " W. V. Perry.....	6393	" window, W. Milner.....	6049
" " refrigerator, J. H. Wickes.....	6148	Sashes, marking mortises on, S. W. Dickinson.....	6027
" " street, E. Picard.....	6376	Saw clamps, E. B. Cady.....	6142
" " ventilation, W. J. M. Jones et al.....	5684	" collars for grooving laths, P. W. Hart.....	5414
" carriage coupling, W. Jorr.....	5533	" dressing circular, W. Potter.....	5671
" cattle car, K. Knott et al.....	5678	" dust burning, R. Hodson.....	6290
" crossing gate, H. A. Stearns.....	5929	" file guides, E. Root.....	5963
" dumping platform, J. W. Harrison et al.....	5506	" fret, S. B. Fuller.....	6025
" flange cleaner, T. Temple et al.....	5946	" gummer, J. M. Smith.....	6214
" freight cars, A. Willson et al.....	5413	" " M. O. Smith.....	6132
" frog, J. Cumming.....	5439	" hand, H. Diston.....	5661
" rail joints, J. Forbes.....	5794	" " J. Gives.....	6715
" signal, A. Chambers.....	5448	" horse, C. H. Warren.....	6897
" " D. Rousseau et al.....	6537	" mill, B. F. Crabtree.....	5798
" " T. Sills.....	6114	" " F. A. Beckwith et al.....	6675
" station indicator, A. Ramsay.....	5536	" " W. P. Widdifield.....	6386
" stock cars, J. R. McPherson.....	5377	" " carriage, A. Rodgers.....	6077
" switch, R. Dickson et al.....	5985	" " dog, A. Mephum.....	6762
" track clearing, I. H. Schell et al.....	6035	" " " J. A. Fondon et al.....	6047
" " Hifer, D. B. McDonald.....	5889	" " " J. Van Norman.....	6661
" wheels, A. Atwood.....	6263	" scroll, M. Broughner.....	6705
" " A. Krupp.....	5995	" sharpening, J. A. Miller.....	6440
Rake, hay, C. I. Corbin.....	6551	" " R. Henschel et al.....	6118
" " S. Frank.....	6683	" " W. L. Covel.....	5750
" horse, A. Howell.....	5777	" teeth, S. P. Randolph.....	6044
" " A. Wood.....	5858	" teeth, swaging, F. Cubam.....	6085
" " C. C. Bradley.....	6058	Sawing lumber, te, E. Benjamin.....	6401
" " C. LaDow et al.....	6433	" " machine, T. B. Fox.....	5774
" " C. Lundy et al.....	6187	Scale pans, J. McLean.....	5489
" " D. P. Sharp.....	6120	Scales, I. P. Magoon et al.....	6717

" L. O. Woolley.....	5699	Sted propelling, D. W. DeForest.....	5463
" weighing, H. Willard.....	6156	" shoe, W. G. Calkins.....	6388
Scoop and sifter, J. Baker.....	6564	Sleigh, H. F. Sweet.....	6719
Screw blank, S. Vanstone et al.....	6732	" brake, G. Campbell et al.....	6611
" machine, C. D. Rogers.....	6410	" " R. Molary.....	6609
" making, A. W. Gifford.....	6600	" lance, A. Corbett.....	5415
" propellers, E. B. Porter.....	5836	" robe, F. L. Blakely.....	5453
" stocks, S. Vanstone et al.....	6690	" shafts, attaching, W. Fairweather.....	5718
" threading, F. P. Sheldon.....	6276	Smut mill, A. Laidlaw.....	6735
" wood, C. D. Rogers.....	6411	Soap, A. J. Stewart.....	6633
" " E. A. Leland.....	6161	" F. J. Cleaver.....	6658
Screws and shafting, A. Stewart.....	6576	" H. Delowia.....	6235
" manufacture of, J. Frearson.....	5950	" boiling, A. O. Glass.....	6412 6582
Scribblers, floor, F. A. Balch.....	6430	Soda, carbonates of, E. Solvay.....	6581
Scuttle, coal, P. W. Peckham.....	6659	" cask, Ira N. Herrick.....	5518
Seat, C. B. Record.....	6287	" water bottle, L. Perrin.....	6203
" and chair, T. Tostevin.....	6765	Sofa bedstead, H. F. Hoyer.....	6783
" school, F. C. Charterand.....	5705	Soil, night, R. S. Gillespie.....	6268
Seed drills, B. Kuhns et al.....	6723	Sole and heel protector, H. E. VanHenshoten.....	5458
" planter W. V. Burgess.....	5939	" channelling, J. E. Wheeler.....	6158
" " J. T. Carr.....	6065	Sower, W. S. Winner.....	5818
Seeder to horse rakes, J. Watson.....	5909	" fertilizer and seed, R. L. Galer et al.....	5861
" tooth, J. Y. Hammond.....	6326	" seed, J. Harris.....	5857
Seeders and cultivators, R. Sylvester.....	5900	" " and plaster, J. W. Gamble.....	5722
Seeding machine, C. E. Patric.....	5652	Sowing, plaster, &c., C. D. Oakes.....	5917
" " G. J. Barclay.....	5824	Spirits, wood, H. M. Pierce.....	6654
" " J. H. Holland.....	5445	Spittoon, P. C. Ste. Marie.....	6640
" " P. Milne.....	6113	Spring bed, T. DeWitt.....	6760
Sewage tanks, R. A. McCauley.....	6294	" " and seat, J. Mulholland.....	5753
Sewer, A. Brittain.....	6311	" " bottom, W. Cribb.....	5741
" cover, &c., H. W. Clapp.....	6450	" coupling, buggy, J. McBride.....	6752
" trade, J. Soper.....	6943	" do., A. A. S. motor et al.....	6886
Sewing machine, C. F. Ritchie.....	5872	" " C. T. Sabin.....	6569
" " C. Schunoff.....	6548	" " W. H. Myers et al.....	6017
" " E. S. Norcombe.....	6979	" equalizers, W. Smith et al.....	6129
" " G. L. DuBois.....	5879	" motor, E. Lambkin.....	6556
" " G. W. Simmons.....	5751	" vehicle, A. A. Crosby.....	6375
" " J. C. Burton.....	6108	" " J. J. Stock.....	5926
" " J. E. Wheeler.....	6119	" " S. Newcomb.....	5935
" " J. Keith.....	5509	" " W. F. Whitney.....	5789
" " M. P. Carpenter.....	5965	Sprinklers, street, G. Trimble.....	6230
" " R. M. Mellush.....	5984	Square, W. Ascough.....	6267
" " S. W. Wardwell, jr., et al.....	6359	" and mire bar, J. C. Rorick.....	5584
" " W. W. W.	6708	Stakes, W. A. Durrin.....	5618
" " attachment, S. J. Baird.....	6168	Stamps, cheques, &c., J. E. Winner et al.....	5958
" " boot, C. Goodyear, jr.....	6140	" " postage, W. W. Bierce et al.....	6700
" " hostery, W. Pearson.....	5614	Stand for maps, &c., J. Brown.....	6155
" " lamp, W. Vassie.....	5619	Starch manufacture, A. S. Macrae.....	5973
Shaft coupling, A. B. Cook.....	6758	Station indicator, G. Allau et al.....	6019
" " R. Poole.....	6755	Stave jointing machine, B. Barker.....	5568
Shafting & screws, A. Stewart.....	6576	Steam boiler, B. S. Koll.....	6615
Shearing metal, A. O. Kittridge et al.....	5820	" " C. W. Pierce.....	6523
Shears.....	5953	" " H. F. King.....	6097
Shingles, edging, J. Austin et al.....	5790	" " J. H. Kelley et al.....	6206
Ship's pump, J. Brokenshire.....	6729	" " W. R. Parks et al.....	6517
Ships' rudders, G. H. Conrette et al.....	5869	" and heating, G. J. Tandy.....	5551
Ship ventilator, &c., W. T. Tibers et al.....	6356	" " furnace, W. S. Hutchinson.....	6727
Shirt front, A. J. Minkin.....	5630	" " injector, W. T. Messinger.....	5709
" " board, H. Woodward.....	5724	" " removal, &c. of scale in, L. E. Hurl.....	5540
" " " S. B. Morrell.....	5578	" " tubular flues for, H. Bailey.....	5480
" " stretcher, J. Elliot.....	6735	" cocks and valves, J. Malinson.....	5419
Shoe hoses, O. Durocher.....	6157	" cylinder lubricator, R. C. Luce et al.....	6665
" sole burnishing, J. W. Dodge et al.....	6243	" engine, A. W. Eblridge.....	6643
" vamp, J. W. & R. H. Lorkin.....	6659	" " C. T. Sleeper et al.....	6751
Shovel, ditch, L. Guyon.....	6131	" " H. D. Dunbar et al.....	6112
Shutter casting, W. Jones.....	6630	" " J. and E. Metcalf et al.....	6198
" fastener, C. J. Ferguson.....	6656	" " S. Warrick.....	5656
" or door, S. J. Sanford.....	6431	" " W. H. Law.....	5807
Side plaiters, J. M. Cooley.....	5414	" " boilers, water for, H. Walker.....	5725
" walk fastener, W. Brisley.....	5913	" " condensers, &c., F. H. Cummet.....	5725
Sieve for millet seed cleaning, F. Savoye.....	5712	" " rotary, O. Adams.....	5605
Sifter and scep, J. Baker.....	6561	" " generators, J. G. and F. Firmenich.....	6518
" ash, P. W. Peckham.....	6619	" governor, D. La F. Chase.....	5467
" coal.....	6649	" " J. E. Wilson.....	6150
" ashes, T. C. Jones.....	5976	" " W. Yates.....	6012
Signal, J. S. Gisborne.....	6667	" pipe, C. G. Walworth.....	6197
" " J. W. Hawley.....	6152	" pumping engines, W. H. Law.....	5817
" buoys, J. M. Courlebay.....	6076	" pumps, W. H. Laurie.....	6286
" railway, D. Rousseau et al.....	6537	" radiator, W. B. Snow.....	6698
" " T. Stiles.....	6111	" trap, G. W. Harrold.....	6318
Shks, chancing, R. A. McCauley.....	5906	" " J. J. Royle.....	6590
Skate fastenings, E. L. Fenerty.....	5694	Steel manufacture, J. W. Hoxie.....	5673
Skates, C. Brewster.....	6327	Stench trap, J. M. Reed.....	6506
" " J. A. Whelpley et al.....	6221	" " R. Girard.....	6428
" " J. M. Lamb.....	6616	Still columns, E. Melchers et al.....	5883
" " P. D. Helderwick.....	6144	Stock car, J. R. McPherson.....	5930
" " P. Hoher.....	5571	Stool legs, C. E. Haynes.....	6088
" roller, F. E. B. Beaumont et al.....	6381	" life preserving, H. H. Nash.....	5622

Stool milking, H. A. Stearns.....	5690	Tire heating, S. G. Reed et al.....	5089
Stone, apparatus for cutting, &c., J. D. Brunton.....	5757	Tobacco, &c., drying, J. Sealos.....	5801
“ artificial, L. L. Leathers.....	6773	Tool holder, &c., A. J. New et al.....	6567
“ “ W. H. Smith.....	6169	“ socket, E. C. Jones et al.....	6169
“ extractor, J. Fillon.....	6614	Track clearing, I. H. Schell et al.....	6035
“ and stump extractor, E. Graves et al.....	5831	Trainway, J. Canan.....	5524
“ “ “ T. Jones.....	5665	Trap, stench, J. M. Reid.....	6506
Stove, C. Dion et al.....	6191	Traps, plumbers', C. S. Watson et al.....	5727
“ G. H. Stansbury et al.....	6603	Treadle, D. E. Lillis.....	5479
“ J. Norris.....	6533	Treenall machine, S. H. Newcomb.....	5905
“ J. W. Elliott.....	6693	Trowsers, overall, J. L. Griffin.....	6192
“ S. S. and J. Jewett et al.....	6084	Truck and apparatus for handling bricks, W. E. Gard.....	5610
“ base plate, J. W. Elliott.....	5882	“ bag holder and, J. Hewitt.....	5755
“ board, G. F. Sawyer.....	5512	“ hand, H. H. Baltzly et al.....	5169
“ “ S. Magill.....	6284	Tub, J. S. McMurray.....	6627
“ coal, G. Bingleman.....	6532	“ M. V. Dodsworth.....	6484
“ cook, C. Faucet.....	5747	“ and pail, J. S. McMurray.....	6454
“ cooking, E. Bartlett.....	6293	“ car, W. Warren.....	6626
“ “ G. W. Johnson.....	6459	Tube wells, D. H. Zavitz et al.....	6182
Stove doors, D. Moore et al.....	5731	Turbine, water, A. J. Slott et al.....	6657
“ drum, T. J. O'Sullivan.....	5563	“ “ A. G. Wagner.....	6768
“ dumb, G. W. Kennedy.....	5530	Tuyeres, J. Spooner.....	5987
“ “ W. Parsons.....	5972	Twine waxing, R. and W. C. Blakiston.....	6507
“ grates, T. B. Griffith.....	5960	Type, C. S. Westcott.....	6535
“ heating, J. F. Quimby.....	6048	“ distributing, S. W. Green.....	5993
“ oil burning, E. G. Adams.....	5745	“ “ W. D. C. Pattyson.....	5920
“ pipe, G. Taylor.....	6546	“ rubber printing, W. I. Scott.....	5449
“ “ J. Briggs.....	6618	“ setting, S. W. Green.....	5997
“ “ damper, S. Schoun.....	5520	“ “ W. D. C. Pattyson.....	5920
“ “ elbow, A. Syversen.....	5626	Umbrella, M. M. Copp.....	6197
“ “ fastener, R. Malver.....	5812	Umbrellas, J. P. Onderdonk.....	5822
“ “ joint, J. Draper.....	5934	“ and sun protectors, H. Palmieri.....	6069
“ “ shelf, J. C. Schoonmaker.....	5486	Valve, and piston, W. G. Beatie.....	6094
“ pipe thimble, J. T. Hall.....	6005	“ F. Behr et al.....	6612
Stoves, J. R. Armstrong.....	6421	“ globe, N. C. Locke.....	6002
“ W. Doyle.....	6423	“ indicator, J. S. Wallace.....	5719
“ and furnaces, coal, J. F. Stewart.....	5821	“ oscillating, J. Fairburn.....	6107
“ and ranges, T. R. Timby et al.....	5890	“ pump, L. Hubbard et al.....	5800
“ for barrels, H. H. Halo et al.....	6245	“ safety, E. B. Kunkle.....	6134
“ gas, C. Burnham, et al.....	5857	“ safety, C. H. Thomson.....	6601
“ heating, G. M. Goodve.....	5851	Vegetable matters preserving, F. S. Barf.....	6515
“ or furnaces, E. Hawks.....	6153	Vehicle, W. Buckridge.....	6516
“ &c., grates for, G. W. Swett et al.....	6200	“ axle and box, J. B. Winchell.....	6045
Strainers, liquid, H. Hassingling.....	6424	“ heating, distance, T. Bournann et al.....	5511
Straw cutters, A. Anderson.....	5912	“ fifth wheel, La F. Bialr.....	5511
“ “ A. and D. Tolton.....	6236	“ “ P. B. Cunningham.....	6441
“ “ A. Hillman.....	6465	“ gear, H. S. Clark.....	5496
“ “ L. Cossitt.....	5945	“ gearing, J. McPhall.....	6645
Studs, shirt, J. B. and W. Bennett.....	5899	“ propelling, M. Mathews.....	6209
Stuffing box, C. T. Sleeper et al.....	6751	“ seat, E. A. Rice.....	5499
Stamp extractors, E. Farnsworth.....	6227	“ spring, A. A. Crosby.....	6575
“ machine, R. P. Cory.....	5887	“ “ J. J. Stock.....	5926
“ and rock elevator, J. McButcher et al.....	5924	“ “ S. Newcomb.....	5935
“ “ machine, A. Berry.....	6053	“ “ W. F. Whitney.....	5789
Sulphides and oxides, H. Knight.....	5482	Velocipede, ice, C. M. Day.....	6374
Surgical appliances for insteps, R. Ames.....	5847	Veneer cutting, H. T. Barthol.....	6123
Table bedstead, E. Kiss.....	6766	“ “ S. Wallace.....	5885
“ legs, C. E. Haynes.....	6088	Ventilating buildings, R. Thomas.....	5903
Tack, C. P. Weaver.....	6771	Ventilation of “ &c., J. H. Morroll.....	5454
Tackle blocks, F. S. Barr.....	6188	“ “ care, W. J. M. Jones et al.....	5684
Talites, J. French.....	6170	Ventilator, J. Briggs.....	6618
Tan bark, J. Sherman.....	6122	“ &c., J. B. Robertson.....	6140
Tanning, P. J. Dussaud et al.....	6311	“ ship, &c., W. F. Thiers et al.....	6356
“ apparatus, H. Reed.....	5487	Vents and bungs, H. R. Cornish.....	5717
“ extracts, J. Foley.....	5880	Vessel, cattle carrying, F. H. Reiph.....	6726
“ hides, C. Richter.....	6232	“ cylindrical, J. Risor.....	6250
“ “ J. Angus.....	5117	“ elevating on, G. Milson.....	6596
“ leather, G. Goodwin.....	6133	“ ice breaking, E. J. Weederman.....	5714
“ skins, H. W. Woodruff.....	5503	Vice, bench, A. Veilleux.....	6554
“ “ J. and C. Smith.....	6170	Voltic battery, J. E. Watson.....	6721
“ solution, J. Foley.....	6672	Waggon axle, J. R. Lantz et al.....	5492
Tap, E. Carroll.....	6464	“ nut, T. C. Stewart.....	5773
Tea kettle handle, W. S. Polwin.....	5440	“ body and hay rack, P. Williams.....	5635
Telegraph, G. Allan et al.....	6156	“ brake, E. H. Wheeler.....	6282
“ copying, W. E. Sawyer.....	5579	“ dumping, I. W. Van Norman.....	6028
“ electro harmonic, E. Gray.....	6101	“ jack, C. D. Knapp.....	5759
“ insulators, R. B. McMicking.....	5860	“ “ W. Hartl.....	5732
“ transmitting sounds, E. Gray.....	5496	“ rack elevating, J. McLennan.....	6142
Tent folding frame, F. A. Guthrie.....	6073	“ seat lock, J. Hill.....	6414
Textile fabrics, S. Van Benschoten.....	6121	“ tongue support, J. McCarter.....	5706
Thill coupling, C. I. Calvert.....	6652	“ “ W. Burgess.....	5786
“ “ O. O. Roberts.....	6291	Wardrobe hook, J. E. Bryan.....	6662
Threshing machine, J. Abell.....	5888	Warp tension regulator, A. M. Fyfe.....	5752
“ “ J. W. Waterman.....	6737	Wash board, E. J. Duff et al.....	5573
“ “ R. Burl.....	6029	Washer, nut lock and, C. Corby.....	5650
“ “ cylinder, J. Brown et al.....	5676	“ steam, H. P. Robbins.....	5901
Timed, plate, G. E. Taylor.....	5407	Washing clothes, C. Packham.....	6289
Tire, H. A. R. Horton et al.....	6467	“ machine, A. D. and A. N. Ferris.....	6739

Washing machine, A. Kilne.....	5137
" " F. Vézina.....	6502
" " J. J. Shotwell.....	6588
" " J. M. Grover.....	6520
" " J. M. Rodkey.....	6226
" " L. Cartwright.....	5927
" " M. Schmidt.....	6501
" " P. Schwellhart.....	6042
" " R. S. Morse.....	5595
" " S. Williams.....	5870
" " T. M. Wilson.....	6195
Waterproof bag, A. S. Deunkon et al.....	5175
Watch, A. H. Potter.....	5442
" case spring, A. S. Buckelov.....	5562
Watchman detector, H. A. E. Lefort et al.....	5612
Water closet, R. D. O. Smith.....	5564
" conductor, J. Archer.....	6561
" elevator, D. Conrad.....	6549
" filter, P. De la Nouvelle.....	5593
" pipe, C. C. Watworth.....	6197
" supply of buildings, &c., J. H. Morrell.....	5451
" wheel, A. J. Stott et al.....	6757
" " A. G. Wagner.....	6668
Waxing twine, R. and W. C. Bakiston.....	6507
Weather strip, J. Johnston.....	6116
" " W. Milner.....	5560
" " W. P. Widdifield.....	5547
Weaving temples, J. B. Paton.....	6413
Weeding land, D. N. Ford.....	6461
West stop, F. O. Tucker.....	6635
Weights lifting, C. O. Brown.....	6149
" " L. A. Melburn.....	6256
" " W. H. Solomon.....	6341
Well auger, W. W. Jilz.....	5592
" digger, I. M. Perry.....	6279
" driven, J. Suggett.....	5559
" pumps, P. A. Garner.....	5701
" tube, D. H. Zavitz et al.....	6182
" walling, A. Moore.....	6116
Wheel, G. H. Stevens.....	6378
" car, W. W. Lobdell.....	5855
" carriage, S. Vessot.....	5978
" emery, J. D. Huntington.....	6521
" fifth, P. B. Cunningham.....	6141
" paddle, R. Forward.....	5484
" railway, A. Atwood.....	6263
" turbine water, W. S. Phelps.....	5881
" water, J. H. Staples.....	5992
" " O. Jull.....	5168
" " T. Talt.....	5693
Wheels, railway and other, A. Krupp.....	5995
Whimbletree, S. F. Humphrey.....	5509
Whimbletree, S. White.....	6467
Whip socket, J. J. Shuter.....	6636
Whisks, manufacture of, J. Ewing et al.....	5671
Windlasses and capstans, D. N. B. Coffin Jr., et al.....	5177
Wind mill, M. Crossman.....	5371
Window, W. West et al.....	5875
" blind, O. A. Doekham.....	6412
" fastener, J. Shend.....	5478
" fastener, J. G. Filman.....	5737
" " L. D. Gillman.....	6278
" sash, W. Milner.....	6049
" fastening, L. H. Moutross.....	5799
" shade, E. Metcalf.....	6342
Winnowing machine, C. Ethler.....	6168
Wood binding " E. A. and O. S. Gillett.....	5666
" mouldings, dressing, M. A. Owens.....	5740
" pavement, D. Ewart.....	6655
" planing, C. H. Warren.....	6183
" pulp, I. W. Bowers et al.....	6145
" transferring the grate marks of, J. R. Cross.....	6608
" treating, H. M. Pierce.....	6654
Wool separating, L. R., and C. F. Broadbent.....	6089
" &c., converting, H. O. P. Lisagaray.....	5849
" transferring, H. McKenzie.....	5143
Wrench, E. H. Knight.....	6247
" " J. W. F. Finlay.....	5850
" " J. W. Powers et al.....	6057
" " P. Campbell.....	5749
" " pipe, E. G. Clinch.....	5874
Wringer, A. Page.....	5474
Wringing machine, C. A. Mallory.....	5811
Yeast mill, F. Beauchemin.....	5559

INDEX OF PATENTEES.

Abbott, J. B., et al., clothes wringer.....	5979
Abell, John, threshing machine.....	5888
" " portable engine.....	6560
Adair, William, pumps.....	5838
Adams, Edwin G., oil burning stove.....	5745
" " charcoal furnaces.....	6173
" " J. L., et al., dryer.....	6316
" " Orwin, rotary steam engines.....	5605
Adsett, E. F., et al., pump.....	6041
Alkman, David, peat.....	6617
Altken, H., et al., illuminating gas.....	6357
Aldrich, S. W., et al., oil can.....	6040
Aldridge, W., et al., barrel.....	5549
" " and cylindrical box.....	5550
Alexander, Isaac, eye glasses.....	6172
Allan, Alfred F., fences.....	5778
" " G., et al., telegraphs.....	6156
" " G., John and Jas., et al., station indicator.....	6019
Allis, Abram Q., et al., oil stove.....	5528
" " E. P., et al., grain separators.....	6001
Ames, Alfred A., can opener.....	6647
" " Reginald, surgical appliance for insteps.....	5847
Anderson, Alexander, straw-cutters.....	5912
" " Samuel J., plaiting machine.....	6090
Andrews, Francis M., car-coupling.....	6718
" " William D., pumps.....	6117
Angell, Emerson C., heat radiator.....	5771
Angus, John, tanning raw hides.....	5417
" " W., et al., railway.....	6553
Archer, G. A., et al., horse rakes.....	5966
" " Joseph, water conductor.....	6561
Armstrong, A. P., et al., ship ventilator, &c.....	6356
" " D., et al., horse shoe nail.....	5957
" " James R., stoves.....	6121
" " William J., lamps.....	6383
Arnold, B., et al., netting.....	5941
Ascough, William, squares.....	6267
A-skwith, " hydraulic hoisting machine.....	5803
Atwood, Anson, railway wheel.....	6263
" " James B., lock nut.....	5582
" " et al., book-keeping game board.....	5572
Aubut, N., et al., root cutters.....	6105
Austin, J. E., et al., edging shingles.....	5790
Ayer, John M., refrigerator car.....	6620
" " Joseph C., preserving lobsters.....	6695
" " freezing.....	6586
Baghot, C. P., et al., lock nut.....	5619
Bagslan, Joseph, fences.....	6385
Balley, Henry, tubular flues for steam boilers.....	5460
" " Dexter S., elevators.....	6367
Baird, Samuel J., attachment for sewing machines.....	5785
Baker, H. M., et al., lifting jack.....	6345
" " Joseph, scoop.....	6564
" " William B., et al., drying kiln.....	5526
Baleh, Frederick A., floor scrubbers.....	6430
Baldwin, John P., sap evaporators.....	6272
" " Oren, chain-pumps.....	5991
Ball, Charles F., gas lamp.....	6062
Ballauntine, J., et al., moulding machines.....	5951
Baltzy, Henry H., et al., hand truck.....	5409
Baneroff, J. W., et al., amalgamating ores.....	6220
Bannister, R. D., et al., advertising device.....	6007
Barber, Lyman L., sewing machines.....	5917
Barclay, George J., seedling.....	5894
Barff, Frederick S., animal matters, &c.....	6515
Barker, Benjamin, stove jointing machines.....	5568
" " Gardner T., camp lounge.....	5872
" " John F., air carburettng.....	6131
" " William H., pot covers, (extension).....	5754
" " buckle for garments.....	5517
Barlow, Charles, machine for rocking cradles.....	5770
Barnes, J., et al., foot powers.....	6068
Barter, Benjamin, middlings purifier.....	5942
" " mill stone.....	6621
Barthel, Lewis, et al., fanning mill and separator.....	5538
Barlett, Edward, digging and picking potatoes.....	5633
" " stove.....	6293
" " Henry T., veneer cutting.....	6121
Bates, J. W. & J. W., Jr., et al., car-coupling.....	6669
Baxter, John, et al., machine gun.....	5476
" " Myron L., picture frame.....	6427
Baylis, J., et al., stove.....	6491
" " furnace.....	6604
Beach, Sylvester W., carriage seats.....	5891
Beadle, George, fare register.....	6509

Bean, Otis W., hide handler	6741	Brokenshire, John, ship pump	5980	6728	6729
Beardslee, Marcus D., grain scouring	6047	Bronson, E. D., et al., broom machine			6742
Beattie, William G., valves and pistons	6094	Brothers, Francis W., et al., salts of ammonia			5535
Beauchemin, Fulgence, kneading trough and yeast mill	5559	Broughner, Miller, scroll saw			6705
Baudry, Joseph, lathe	6622	Brown, E. P., et al., dental apparatus			5938
Beaumont, F. F. B., et al., roller skate	6381	" J., et al., threshing machine cylinder			5676
Beaupré, Charles, moccasins	6319	" James, map stand			6155
Beauregard, Michel, cooler	6038	" J. W., et al., telegraphs			6156
Beck, W. F., et al., dumping box	6363	Brunson, Sterne, nut locks			6157
Beckwith, F. A., et al., saw mill	6075	Brunton, John D., cutting stone			5757
Beebe, H. T., et al., device indicating the distance travelled by vehicle	5511	Bry an, James E., wardrobe			6062
Beecher, E. F., et al., ship ventilator, &c	6356	Brydon, Robert, railway grain car door			5695
Behr, F., et al., valve	6012	Brymer, J. C., et al., printing form			6313
Bell, Ira, et al., cattle stalls	5534	Buckbee, William P., drum heater			5624
Bellinger, James H., jr., air coolers	6082	Bucktelew, Ansel S., watch case spring			5502
" Jacob P., curl	6532	Buckeridge, William, vehicle			6316
Benjamin, Edward, ro-sawing lumber	6401	Bullock, Milan C., drills			6270
" Edwin, planing lumber	6106	Bulymore, Richard, fling and cooling lard, &c			5698
Bennett, J. B. and W., shirt studs	5499	Bulman, J., et al., rotary engines, &c			5914
Benschoten, Samuel Van, textile fabrics	6121	Burge, John, chronometric locks			6184
Bent, Silas, compass	6174	Burgess, William, wagon tongue support			5786
Berndt, John, sash-balance	5779	" William V., seed planter			5939
Berridge, Thomas, metal shears	5953	Burland, J. B., et al., ventilation of railway cars			5684
Berry, Austin, stump machine	6053	Burnham, C., et al., gas stoves	5857		5808
" W. H., et al., tool holder	6567	Burns, J., et al., gas machine			6409
Besse, Charles G., flat iron heater	6022	Burr, Frederick S., tackle blocks			6183
Bewley, L. N., et al., hub	6092	Burt, Robert, threshing machines			6029
Beyer, L., et al., saw sharpening	6118	Burtles, Mahlon, fences			6382
Bierce, W. W., et al., postage stamp	6709	Burton, George D., lamp			6570
Bignett, Charles, car adjuster	6322	" John C., sewing machines			6106
Bigelow, Jonathan, labelling machine	5776	Buteau, G. E., et al., skates			6221
Bigler, C. S., et al., brick machine	5865	Butler, Francis G., horse rake			5565
Billings, Simon R., door checks	6234	" Jacob K., ironing board			6190
Bilyen, Peter, lund roller	6078	Byerley, Francis X., paraffine			6214
" " rods for bridge booms	6092	Cable, Austin D., et al., rendering doors and gates self-acting			5456
Bingleman, George, stove	6552	Cadell, Philip, extraction of gold			6259
Birks, Leedham, manufacture of corals, &c	5873	Cady, Edson B., saw clamps			6112
Bird, Frederick J., mordant for dyeing	6224	Cain, Jesse L., clothes line			6486
Blair, LaFayette, fifth wheel for vehicles	5514	Calkins, D., et al., pump			6041
Blaisdell, George D., railroad tie	6530	" William G., s'ed shoe			6388
Blake, G., et al., horse rake	6187	Calvert, Callender I., thill			6632
" W. E., et al., grain drying kiln	6404	" " milker			6653
Blakeley, Frederick L., sleigh robe	5453	Cameron, D., et al., moulding machines			5951
Blakeney, James, furnace	6146	Campbell, G., et al., sleigh brake			6611
Blakiston, R. & W. C., twine waxing	6507	" Peter, self-adjusting wrench			5749
Blanchan, Jacob, car brakes	6784	" T., et al., horse rake			6573
Blatchford, George, reed organ	5570	Canan, James, tramway			5523
Blessing, Charles A., bath	6784	" " hydraulic machinery			5915
Blizard, Howard, et al., gang plough	5451	Carey, William, threshing machines			6020
Bloodin, J. G., et al., dryer	6316	" W., et al., rotary engines, &c			5914
Bloomfield, Robert, stuffing box	6700	Carnrike, J. A., et al., stretching and tacking carpets			5720
Boye, Alphonso W., et al., oil tank	5525	Carpenter, Charles, door knob			5587
Boardman, Edward P., pistols	5878	" Calvin, F., slide plaster			5640
Bodine, Francis L., jar cover	6269	" Edward R., liquid meter			5702
Bodwell, E. V., et al., lock gates	5986	" J. R., et al., postage stamp			6582
Bobrer, William, hand rest for pianos	5602	" Mary P., sewing machine			5765
Bondy, Charles, cigar package	6680	Carr, James T., seed planter			6065
Bonta, James W., furnace	6444	Carroll, Edward, tap			6164
Booth, R., et al., fog alarm	6182	" John, baking bread, &c			6544
Borgersrode, C. O., et al., car-coupling	6669	" R., et al., brick kiln			6021
Bourden, John W., harness	6637	" Thomas M., heating water			5585
Bourmann, Thomas, et al., device for indicating the distance travelled by vehicle	5511	Carter, John B., neck ties			5897
Bowers, I. W., et al., pulp	6145	Cartwright, Lucy, washing machine			5927
Bowman, W. K., et al., fish hook	6666	Carvell, Louis, amalgamating ores			6220
Boyd, William A., et al., seed, &c., planters	5531	Cattnell, Frederick W., liquid cooler			6730
Boyle, Robert K., electric telegraph	5493	Chadwick, H., et al., copper			6529
Boynton, Mathew, burning hydrocarbons	6434	Chaffour, Joseph, screening ashes			6171
Bradley, Christopher C., harvesters	5990	Challenger, Joshua, harness buckles			5500
" " horse rake	6058	Chalmers, W., et al., ploughs			6154
" Robert D., gas	6770	Chambers, Austin, railway pneumatic signal	5522		5448
Bradshaw, J. W., et al., stretching and tacking carpets	5720	" Adam, odometers			6275
Bramer, Frank, wheelbarrows	5636	Chandler, Vashiti, dish drainer			6309
Brandon, Charles T., nailing machines	6211	Chaney, Nathan P., feather			6663
Bray, Henry, gas	6216	Chapin, Henry A., lamp burner			5738
" Melleu, rivet setting	5922	Chaplenn, G., et al., watchman detector			5612
" " drilling	5923	Chaplin, W., et al., tool socket			6169
Brennan, Dennis, pinch, spike and claw bar	5581	Chapman, Charles H., looms for suspenders, &c			5916
Bretzfeld, S., et al., recording apparatus for billiard	5599	" James, lamp lighter			5609
Brewster, Charles, skates	5630	Charbonneau, Césaire, chimney sweeper			6008
Bucknell, A. L., et al., pulley	6668	Charles, John W., et al., paint brush bridle			5170
Bridges, E. P., et al., railway car for cattle	5673	Charlesworth, Henry M., middlings purifier			5980
Briggs, Johnson, ventilator	6618	Charterand, F. C., school seat and desk			5708
Brisley, William, side-walk fastener	5913	Chase, Daniel La F., steam governor			5467
Brittain, Alfred, sewers	6347	" T. L., et al., lifting jack			6345
Broadbent, C. F. & L. R., separating wool, &c	6089	Christlan, John B., iron heater			6150
Broas, Richard M., veneer pipes	5936	Christin, Arthur, bottle stopper			5541
		Christy, David E., et al., drying kiln			5526
		Churchill, Albert, carriage jack			6378

Clapp, G. P., et al., horse shoe nails	6280	Cunningham, Peter B., fifth wheel	6111
" Henry W., sewer cover, &c.	6155	Curtle, John, gang ploughs	6031
Clark, Benjamin F., meat hook	6489	Curtis, D. A., et al., pulp	6115
" Clara P., corsets	6153	" Enos, elder mill	5653
" H. F., et al., postage stamp	6078	" Thomas, hay rake and loader	5516
" Hurry S., vehicle gear	5406	Cuthbertson, James W., brooms	6109
" Seth, et al., ozone machine	5131	" " refrigerators	6126
" Thomas M., white bricks	6689	Danner, John, book case	6371
" W. H. and J., et al., sheet metal shearing smoothing sheet metal	5820 5828	Dargun, James, sole channelling	6158
Clarke, C. E., et al., fruit preserving	6266	Davee, Ezra, et al., drying kiln	5520
" James, thread reel	6009	David, James H., gaff fastening	5788
Clay, William W., whipping frame needle	5819	" " capstans	6083
Cleaver, Frederick J., soap, &c	6658	Davie, J. G., et al., prunello	6688
Clegg, C. B., et al., horse rakes	5966	Davis, Henry T., fare registering	6175
Clements, George, hose and pipe nozzle	6016	Davison, Darfus, gas retort furnace	5937
Clements, George, pot cover	6166	Danceel, Christian, boot sewing machine	6161 6168
Cleveland, William T., fence	6750	Dawes, Jonathan L., plough point	6366
Clueck, Edward G., pipe wrench	5871	Dawson, James, bolt cutter	6191
Clinton, David, plough casting	6303	Day, Charles M., ice velocipede	6371
Close, Joseph, brick machine	5795	Dederick, Peter K., wire balling tie	5646
Cobley, T. H., et al., copper ores	6152	Defor, Augustine, millstone dresser	6451
Codley, James N., plough point	6366	DeForest, David W., mechanism for propelling sleds	5163
Coffin, David N. B., Jr., et al., chain stopper	5173	DeGnon, J. F., et al., car brake	6703
" " " capstans and windlasses	5177	DeLany, William, lamp post	6761
Colas, J., et al., life preserver	6510	DeLoe, H., et al., sap-spouts	5713
Colby, C. W., et al., edging shingles	5790	DeLwis, Henry, soap	6235
Cole, Cornelius, harness	6193	Dennis, James H., sulphate of copper	5944
" John W., cooking lamps	5832	Dennis-on, Albert S., et al., paper bag	5471
" Truman, churn power	6229	" " " water proof bag	5475
Coleman, Edwin, plough harness	6426	Denton, Samuel B., clothes horse	5791
" A. R., et al., but	6692	Derby, Hugh, plough	6571
Collard, Henry, cultivator	5970	DeWitt, Thomas, bed	6760
Collender, Hugh W., billiard table	6310 6317	D'Heureux, Rudolph, heating grain	6584
Collins, James, envelope	6527	Dick, Robert, machine for labelling newspaper	5121
" J., et al., saweets	6150	Dickerson, Henry J., blind	6534
Collinson, Henry, closing gas retorts, &c	5425	Dickson, Charles W., type setting	5997
Conant, T., et al., gradu binders	5893	" " " distributing	6000
Conn, C. G., musical instrument mouth-piece	5707	" Samuel W., marking mortises	6027
Connelly, J. H., fire extinguisher	5805	Dickson, R., et al., railway switch	7685
" " " in petroleum tanks	5861	" William, Jr., fire extinguisher	4108
Conrad, Daniel, water elevator	6519	Dillaway, Hiram, glass lamp	6753
Cook, Asa B., et al., dead pulleys	5918	Dion, C., et al., stove	6191
" Leeds A., hanger for doors	5971	" " furnace	6601
" " shaft coupling	6758	" Napoleon P., clothes dryers	6136
Cooley, James M., side platters	5144	Dipper, William, harness pad press	5488
" Orville, harvesters	6429	Diston, Henry, hand-saw	5661
" " mowing machines	6330	" Thomas S., blower	6483
" " belts and endless chains	6331	Djvell, William, churns	8001
" " harvesting	6332	Dixon, J. A., et al., copper cres	6152
" " reapers	6333	" Theron S. E., et al., railway car axle	5521
" " reaping	6334	Doekham, Ogden A., window blind	6312
Coon, E. S., et al., bias cutters	5746	Dodge, J. W., et al., sole burnishing	6243
Cooper, William, balanced sash	5840	Dodsworth, Mark V., tub	6181
" H., et al., jack	6173	Dolson, Ninian H., car coupling	6196 6718
Copp, Monroe M., cane-umbrella	6197	Doney, Thomas, photographic paper	6380
Corbett, Adolphe, sleigh lance	5115	Doremus, William T., chair base	5651
Corbin, Charles I., rake	6551	Dorman, A. J. & R., et al., rattan ware	5918
Corby, Cady, nut lock and washer	5650	Dorr, Warren, railway carriage coupling	5533
Cornell, David S., et al., barrel	5519	Dow, Myron E., advertising device	5620
" " " and cylindrical box	5550	Doyle, William, stoves	6123
Cornish, H. R., bungs and vents	5717	Draper, Henry Von P., lubricating compounds	5687
Cory, Randolph P., stump machine	5887	" John, stove-pipe joint	5934
Cosgrave, Isaac, pump	5481	Dresser, James D., brooms	6100
Cossitt, Newton, mowing machine frames	5596	Drew, R. W., et al., axle boxes	5830
" Levi, straw-cutter	5915	" " " lubricating cups	5588
Courtenay, John M., signal buoys	6076	Drolet, George, gas apparatus	6449
Courette, G. H., et al., ship rudders	5869	Brullard, S., et al., hydrants	5753
Cove, Joseph T. C., grain grinding	5892	Dubois, Frederic N., plumber's trap	5166
Covel, William L., saw sharpening	5759	Ducharme, Isaac, iron shirt fronts	5810
Coy, F. W., et al., leather crimping	6079	Duchez, J., et al., tanning	6511
Coyne, John, nail-sorter	5661	Duff, Eliza J., et al., wash board	5573
Crabtree, Benjamin F., saw-pills	5798	Dubaney, George L., sewing machine	5879
Craig, Lee D., tenon fastening for chairs, &c	5589	Dull, Daniel, paper pulp	6452
Crease, Charles B., car platform	5908	" " nut lock	6354
" John F., filters	5818	Dunbar, H. D., et al., steam engine	6112
Creveling, Hermin G., ear muller	6513	Dunlop, Alexander F., bird cages	5951
Crevier, Toussaint, cooking range	6713	Dunn, James J., censers	5928
Crich, William, spring bed-bottom	5741	" Robert, carriages	6305
Crompton, Frederick, corset	6676	" William, self-acting car-coupler	5662
Crosby, Abel A., vehicle spring	6575	Durocher, Olivier, shoe hoses	6157
" Adon D., bucket for chain pump	5512	Durrin, Warren A., stakes	5618
Cross, John R., wood	6608	Dussaud, P. J., et al., tanning	6511
Crossman, Montgomery, wind-mills	5871	Dyer, H. B., self-cooking apparatus	5705
Culham, Francis, saw-teeth	6085	Eaket, John, carriage	6779
Culp, Isaac H., et al., carriage	5150	Eastman, George C., harness	5967
Cummer, Franklin D., condensers for steam engines	5725	" William E., picture frame	6427
Cumming, James, railway frogs	5439	Edgar Butler, ear muller	6513
		Edholm, Axel E., lamp extinguisher	5574

Edison, Thomas A., printing.....	6508	Gamble, James W., seed and plaster sower.....	5722
Edwards, C., et al., churn powers.....	5919	Garand, René, stench trap.....	5128
" C. H., et al., gas regulator.....	6139	Gard, Walter E., truck for handling bricks.....	5610
Ely, William D., and James N., sawing mill.....	5536	Gardner, Joseph W., knife.....	6660
Ehrhardt, L. H. G., et al., postage stamp.....	6582	Garner, P. A., well pumps.....	5701
Eisele, William, finger rings.....	6429	Gathmann, Louis, middlings purifier.....	6020
Edridge, Alonzo W., steam engine.....	6053	Gauthier, Charles W., freezing apparatus.....	6292
Ehhard, William, cutting bolt nipper.....	5194	" " preparation of fish.....	6682
Elliot, John W., stove.....	6693	Géllin, Luc D., window fasteners.....	6278
" " base plate.....	5882	George, J., et al., organ.....	6521
" " James, shirt stretcher.....	6738	Ghent, Samuel H., drum heater.....	5155
EMIS, Frederiek R., tire bar.....	6107	Gibeau, Adolphe, ironing board.....	6093
" John, gas burner and regulator.....	5121	Gibson, George, horse powers.....	6337
" Robert J., tire bar.....	6319	Giboid, Albert W., screw.....	6600
Ely, Andrew, sewer traps.....	6013	Gilbert, Ebenezer E., drilling apparatus.....	6595
Emersen, Ezekiel H., anchor trippers.....	5856	" L. P., et al., brick machine.....	5865
Eno, J. A., et al., chairs.....	5804	Gill, Joseph P., illuminating and heating gas.....	5823
Ethier, Calkte, winnowing machines.....	6168	Gillespie, Richard S., night soil.....	6268
Ewart, David, pavement.....	6655	Gillett, E. A. & O. S., wood bending machine.....	5666
Ewing J., et al., brooms, &c.....	5674	Gillis, George, cultivator.....	5970
Fairburn, John, oscillating valves.....	6107	Gillmore, Harmon, sash holder.....	5545
Fairweather, William, sleigh shafts.....	5718	" " stove.....	5552
Farnham, Frank G., glove fastener.....	6086	Gilmore, Henry H., horse shoe machines.....	6166
Farnsworth, Enoch, stump extractors.....	5619	Gilzinger, Sebastian, vehicle spring.....	6575
" " brake.....	6227	Gisborne, John S., signal.....	6607
Faucet, Charles, cook stove.....	6631	Gives, John, hand saw.....	6715
Fay, J., et al., ploughs.....	5747	Glass, Archibald O., soap.....	6412
Felck, Joseph K., boot tree.....	6154	" " " boiling.....	6562
Felt, Hannibal, churn.....	6297	Glenson, E., et al., sharpening horse shoe calks.....	5835
Fenerty, E. L., skate fastening.....	6336	Glover, Joshua W., horse detaching apparatus.....	5138
Ferguson, Charles J., door fastener.....	5694	Goddard, R. L., et al., steam boiler.....	6517
" " Nelson D., milk pan.....	6650	Godfrey, Cornelius, lamps.....	6191
Ferris, A. D., and A. N., washing machine.....	6174	Gold, Samuel F., damper.....	6625
Fineid, C. S., et al., sole burnishing.....	6739	Gonne, William H., door knobs.....	6242
Fillon, Joseph, stone extractor.....	6243	Goodale, Stephen L., fish extract.....	5764
Filman, Jacob G., window fastener.....	6614	Goodrich, N. W., horse shoe nail machine.....	5796
Filshie, Archibald, ploughs.....	5747	Goodeve, George M., heating stove.....	5851
Finlay, James, W. F., wrenches.....	6213	Goodman, Eugene F., book.....	6598
Firman, G. J., et al., amalgamating metals.....	5800	Goodwin, Asabel J., bed-tead.....	6745
Firmenich, J. G., and F., steam generator.....	6312	" " " George, tanning leather.....	6432
Fisher, Ebenzer, cutting boiler plate.....	6518	Goodyear, Charles, Jr., boot sewing machine.....	6161
Fisk, Joseph E., whitening and builing leather.....	6655	Goold, Edward L., refrigerators.....	6126
Flegg, Ly-sander, automatic gate.....	5491	" " " et al., lamp chimney.....	5527
Fleck, Alexander, lathe.....	5539	Gordon, J. H., et al., gas burners.....	5911
Fleeton, W., et al., radiator.....	6614	" " " James F., harve-ter.....	6743
Foley, James, tanning extracts.....	5731	Gorringe, Henry H., floating draw-bridg.....	5670
" " " solution.....	5850	Goucher, Robert P., lock.....	6125
" " " John, printer's quoin.....	6672	Gould, E., et al., plate lifter.....	6099
Fondon, J. A., et al., saw mill dogs.....	5498	Graf, Leopold, boot and shoe heels.....	6344
Fontaine, Louis N., liniment for rheumatism.....	6147	Graham, J. M., et al., flour bolt.....	6415
Forbes, John, clips for railway rail joints.....	5794	" " " Simon P., carriages.....	6257
Ford, Daniel N., weeding land.....	6461	" " " William A., brick machine.....	5829
" " " J., et al., brooms, &c.....	5674	Grant, John H., mowing and reaping machine.....	5561
Foster, T. A. D., et al., amalgamating metals.....	6302	Graves, E., et al., stump and stone extractor.....	5821
Forward, Ross, paddle wheel.....	5184	Gray, Elisha, transmitting musical sounds telegraphically.....	5496
Foss, J. M., et al., steam engine.....	6112	" " " " electro-harmonic telegraph.....	6101
Foster, Charles W., glass furnaces.....	5925	" " " " George A., Jr., rivet making.....	6081
" " " Jonathan R., barrel clamp.....	5430	Green, A. D. & G. W., car coupling.....	6110
" " " " bale ties.....	5426	" " " " Cyrus, pump.....	6392
" " " " William F., glove.....	6178	" " " " J., et al., hoisting coal, &c.....	5864
Fox, H. K., et al., stamps, cheques, &c.....	5958	" " " " James A., stretching curtains.....	5906
" " " " J. M., et al., door springs and locks.....	6017	" " " " Samuel W., type setting.....	5968 5993 5997
" " " " Tobias B., horse power sawing machine.....	5774	" " " " William, cultivators.....	6109
Frank, Solomon, hay rake.....	6583	Griffin, Alvah J., hydrocarbon burner, &c.....	5657
Franks, Clara C. S., photograph.....	6632	" " " " John L., trowsers.....	6192
Fraser, John, fitting skelns on axles.....	6074	" " " " Robert A., peat.....	5435
Frazee, Josha W., wooden pumps.....	5775	Griffith, George V., hoop cutting.....	6171
Frearson, John, screws.....	5950	" " " " Thomas B., stove grates.....	5960
French, John, tallies.....	6170	Grocock, Samuel P., floors.....	6254
Frevor, William W., barrel heads.....	6437	Grover, Johnson M., washing machine.....	6520
Frigon, P., et al., ship rudders.....	5889	Guénette, François, clothes line roller.....	5692
Fryer, Patrick, churus.....	6369	Guthrie, Franklin A., tent frame.....	6075
" " " " Robert M., furnace for roasting ores.....	5772	" " " " James F., ejector condensers.....	6096
" " " " " " " pulverizing ores.....	6253	Guy, Theodore F., meal.....	6639
Fuller, George M., pipes.....	5598	Guyon, Louis, ditch shovel.....	6151
" " " " Hiram E., steam cooking.....	6731	Hafner, John A., backlash of machinery.....	6694
" " " " " " " " Sylvester B., fret saws.....	6025	Hagas, Joseph, switch rails.....	6422
Funke, Herman, knife.....	6660	Haggard, John, reapers.....	6030
Furber, F. O. & O. E., pump.....	6037	Haldeman, J., et al., piston packing.....	6555
Furbish, Henry H., paper pulp from wood.....	5410	Hale, H. H., et al., barrels.....	6245
Fyfe, Alexander M., warp tension regulator.....	5752	Hall, A. A., et al., pulley.....	6668
" " " " David A., recovering alkali.....	6056	" " " " John T., stove-pipe thimble.....	6005
Gaffney, J. & L., burglar-proof lock.....	5638	Hamer, E., et al., steam engines.....	6198
Gagné, J., et al., ladders.....	6195	Hamilton, R., et al., horse shoe calks.....	5835
Gain, Thomas, cutting paper bags.....	5521	Hamilton, Solomon C., canal pump.....	5543
Gatbath, R. S., et al., measure and springling pot.....	5843	Hammond, John Y., seeder and cultivator.....	6326
Galer, R. L., et al., seed sowers.....	5961	Hammun, Henry A., mill pans.....	5972
Gallagher, Joseph P., hydrants.....	6260	Hantley, M., et al., churn power.....	6073

Miller, J. H., et al., railway feeler	5946	Palmer, Bonnet, gas burner	6108
Milligan, James, plate printing press	5742	" Milton J., soap	6112
" S., et al., advertising devices	6007	" T. G. et al., postage stamp	6078
Millikin, Alexander J., shirt front	5030	" William H., boots and shoes	6311
Mills, Isaac, reaping machines	6314	Palmeri, Henry, umbrellas, &c.	6069
Milne, Peter, seedling	6113	Parent, Jean M., cement	6736
Milner, E., et al., tuba wells	6182	Park, Alfred J., hano fastener	5515
" William, weather strip	5560	Parker, John, grain binder	6306
" window sash	6049	" Stillman, riving machine	6490
Milsom, George, elevating and weighing	6596	Parkin, Henry L., baking oven	6137
Milmore, George W., car axle	6559	Parks, W. R., et al., steam boiler	6517
Milton, W., et al., track-clearing	6035	Parsons, William, dumb-stove	6972
Millwald, James, carriage rugs	6177	Paterson, Robert O., et al., salts of ammonia	5535
" " lap robes	6176	Paton, James B., weaving temples	6113
Mimbinnick, John R., petroleum	6746	Patrick, Charles E., grain drill	6852
Mitchell, Thomas L., et al., waggon axle	5492	Patten, O. P., et al., scales	6717
" " J. C., et al., car-couplers	6348	Patterson, Ephraim, et al., lantern	5432
Moffitt, John R., boots and shoes	6408	" " John S., curtain stretching	6515
Monahan, C., et al., " lining	6185	" " P., horse rakes	6679
Montgani, John, O., mop and brush holder	5594	Pattysion, William D. C., type setting	5920
Montross, Levi H., window sashes	5789	" " " distributing	5921
Moody, J. A., et al., clothes horse	6528	Paxton, Etholbert B., et al., refrigerator	5501
Moore, Azariah, wells	6116	" " " freezing meat and fish	5505
" D., et al., stove doors	6731	Payette, Adolphe, axle box	5580
" Dartel, dredging machine	6064	" " " P., et al., oatmeal crusher	6405
" E. Y. & S. H., door roller	6725	Pearson, William, sewing hosiery	5644
" Hollis W., metal working	6740	Pease, J. H., et al., fences	6102
" S. H., et al., door hanger	6295	Peckham, Peter W., ash sifter	6649
Morrell, John H., water supply, &c., of buildings, &c.	5451	" " " coal	6648
" Sidney B., shirt	5578	" " " scuttle, &c.	6650
Morris, George M., journal lubricator	6103	Peebles, S., et al., fruit preserving	6206
Morse, Russell S., washing machine	5595	Peer, Perry A., barn door fastening	6351
Mosely, Randolph L., et al., doors and gates	5156	Penley, H., et al., rattan ware	5913
Moyer, Cyrus E., waterproof felt	6023	Perdue, F. A., et al., plane guide	6018
Muir, R., et al., threshing machine cylinder	5676	Perkins, W. A., castor wheel	5691
" " William, sewing	6708	Perrin, Leonard, wires for bottles	6203
Mulholland, John, bed and seat spring	5753	Perry, Isaac M., well digger	6279
Muller, John D., measuring kerosene oil	6075	" " " S. W., et al., grates	6200
Multer, J. L., et al., grain cradle	6117	" " " " William V., car coupling	6393
Mumler, William H., gelatine plates	5780	Peterson, R. E., et al., postage stamp	6582
Munn, Hector, fanning mill	6577	Pbaris, I. R., et al., oil can	6040
Munroe, Andrew, feather renovator	6778	Phelps, Willis S., water wheel	5881
Murphy, A. A., et al., fire extinguisher	5907	Phillips, Thomas, grocery bag	6240
Murray, John D., locomotives	5842	Picard, Eugene, street car	6378
Muth, William, reaping machines	6315	Pickering, Oliver, bush cutting	6767
Myers, W. H., et al., door springs and locks	6017	Pierce, Charles W., steam boiler	6523
Nash, Henry H., life-preserving stool	5622	" " " Henry M., treating wood	6654
Nearing, Joe, wine and cidre presses	6354	" " " John B., hot air furnace	5767
Needels, James H., illuminating gas	5736	Pike, John, oakum	5611
Nerney, P., et al., driving reins	6292	" " " John B., hoop colling	6010
Neuville, Paul de la, water filter	5583	Pilkington, W., et al., roller skate	6381
New, A. J., et al., tool holder	6567	Pillow, J. A., et al., horse shoe nails	6280
Newcomb, Samuel H., treenail machine	5908	Pingree, S. W., et al., knitting loom	6301
" " Silas, vehicle spring	5935	Pipor, Edward S., bedsteads	5728
Newell, Augustus, et al., dead pulleys	5548	" " " " refrigerator	5733
Newton, William H., hydraulic dredges, &c.	5497	" " " " Enoch, packing fish	5827
Nicholls, Willoughby H., ballot box	6592	Place, Charles C., gas regulator	6712
Nichols, William J., road scraper	6047	Piant, William P., et al., gang plough	5451
Niedringhaus, F. G. and W. F., enamelling	6308	Platt, John W., fuse lighter	5863
Noble, O. L. G., et al., pegging boots	6085	" " " " removing broken drills	5958
Norcombe, Edmund S., sewing machine	6070	Plough Co., Acton, plough	6643
Norman, Joseph Van, saw mill	6661	Peloquin, J. B., et al., ladders	6195
Norris, James, stove	6533	Pool, Joseph F., milk safe	6777
" " J. P., et al., lifting jack	6345	Poole, Robert, shafting coupling	6755
Northey, Thomas, steam pump	5566	Port, Henry, pump	5510
Northrup, F., et al., cheese-safe	5728	Porter, Elbert B., screw propellers	5836
Noxon, Samuel, Jr., harvester	6039	" " " " William, pavement	6602
Nute, James E., et al., pump	5485	Post, Alfred, liquid meter	5683
Oakes, Charles D., planting corn, &c.	5917	Potter, Albert H., watch	6442
Oakey, I., et al., sleigh brake	6611	" " " " William, circular saws	6671
O'Connor, W., et al., fancets	6350	Potwin, William S., tea kettle handle	5440
O'Hara, L., et al., jack	6173	Powell, J. M., et al., anchors	6179
Old, Barnard L., horse power	6288	Power, John, metallic roofs	6115
Oliver, William S., accoutrements	6781	Powers, J. W., et al., wrenches	6057
" " G., et al., churn power	6672	" " " " Samuel H., hand loom	6769
Olmsted, David, blinding grain	5824	Pratt, George M., drill chuck	6734
Onderdonk, John P., umbrellas	5822	Préfontaine, Herméngilde, hand blower	5651
Orr, John B., enamel paint	6364	Prosser, T. T., et al., pegging boots	6855
Orton, William M., snow-ploughs	5846	Pulvermacher, I. L., electric appliances	6180 6181
Osborn, E. H., et al., door springs and locks	6017	Purcell, C. W. & S., bed bottoms	5943
O'Sullivan, Jeremiah, horse shoes	6138	Purdy, Hiram, heat extracting	6358
" " Thomas J., stove drum	5503	Pütz, Andrew A., fire places	6165
Otis, Newton S., letter file	6670	Quesnel, Joseph A., safety lock	6100
Otto, Nicolaus, A., gas motor	6479	Quillfeldt, Charles de, bottle stopper	6628
Owen, Joseph R. N., cannons	6222	Quimby, Julius F., heating stove	5842
Owens, M. A., wood mouldings	5740	" " " " J. F., et al., grates	6205
Packham, Catterick, washing clothes	6289	Ramsay, Alexander, railway station indicator	5536
Page, Augustus, wringer	5412	" " " " R. H., et al., car truck shifting	5784

Ramsay Thomas, enamel paint	6364	6365	Schmidt, Andrew, refuse receptacles.....	6356
Ramsden, John C., securing combustion and utilizing gases from fuel.....	5422	5422	" Moritz, washing machine	6501
Randolph, Simon P., saw teeth.....	6044	6044	Scholz, C., et al., seed drill.....	6723
Rapp, Christian F., hydrants.....	5627	5628	Schoonmaker, John C., lightning conductor	5411
Rathbun, Lewis V., bolting reels.....	6307	6307	" " " rod standard	5459
Rawlings, Edward, advertising medium.....	5433	5433	" " " lightning rods.....	5490
" " " oil squeezer	5802	5802	" " " stove pipe shelf.....	5496
Read, C. D., E. D. & J. A., corn sheller	6519	6519	Schorf, F., et al., bed bottom.....	5623
Record, Charles B., seats.....	6287	6287	Schranker, John, rotary boiler.....	6781
Redwood, Thomas B., gas.....	6547	6547	Schuelkhart, Philip, washing machine.....	6042
Reed, Cullen W., advertising devices.....	6206	6206	Schueble, M., et al., piston packing.....	6233
" Harvey, tanning apparatus.....	5187	5187	Schulenburg, Albert R., burglar alarms.....	6251
" John M., stench trap.....	6506	6506	Schumacker, Ferdinand, oatmeal cutter	6700
" S. G., et al., tire heating apparatus	5689	5689	" " " oat cutter.....	5703
Redden, Henry, bags.....	6246	6246	Schunoff, Charles, sewing machine.....	6548
Relph, Francis H., cattle carrying.....	6726	6726	Scott, G., et al., saw spouts.....	5743
Relyea, Jerome B., neck yoke leathers	5162	5162	" Henry C. lamp.....	6775
Reynolds, Andrew J., fruit dryers.....	6346	6346	" J. E., et al., lock gates.....	5986
" Jesse, grate.....	6756	6756	" William L., printing rubber type.....	5449
" John B., hoe	6616	6616	" William, pumps.....	5996
Rice, Everett A., vehicle seat	6469	6469	Sedgwick, William, device for filling lamps, &c.....	584
" G. N. W., et al., collar folding, &c	5741	5741	" A., et al., curd knife ..	6299
" Orrin, door mats.....	6060	6060	Seger, Garret, dumping boxes.....	6391
Richard, Joseph A., car coupling.....	6194	6194	Selden, Samuel, stove pipe damper.....	5520
Richards, J., et al., piston packing	6555	6555	Seltzberger, Arnold, bath.....	6210
Richardson, Alden B., hams.....	6217	6217	Semple, Robert W., lock.....	6477
" Everett, pegging machine.....	5529	5529	Sewell, H. R., et al., fog alarm.....	6380
" John, cultivator	6593	6593	Shackell, Margaret P. R. B., et al., lubricating cups	5538
Richey, J. et al., coffin.....	6539	6539	Sharfer, John J., whip.....	6636
Richmond, Gilbert M., shaving leathers.....	5839	5839	Sharpley, William H., et al., lamp chimney.....	5521
Richter, Charles, tanning.....	6232	6232	" Martin W., portable engine.....	6120
Ritcheb, Charles F., sewing machines	5852	5852	Sharp, Dennis P., horse rakes.....	6120
Robbins, Henry R., steam washers.....	5901	5901	Shaw, Angus W., hydraulic cement.....	5555
Roberts, Osmore, O., thill coupling.....	6291	6291	" Charles A., nail cutting machine.....	5642
Robertson, Charles C., corset and supporter.....	5146	5146	" " fare register.....	5682
" John B., ventilator	6140	6140	" E. A., et al., barrels.....	6245
Robinson, Andrew J., chimney cowls	5845	5845	" G. W., " sewing machines.....	6359
" George M., blind.....	6534	6534	" George A., head rest.....	6068
" George W., hand corn planter.....	5553	5553	" " lock.....	6477
" John S., petroleum, &c.....	6590	6590	" " rein holders	6223
" James S., organ.....	6764	6764	Sheane, Robert, mounting photographs	6324
" W. A., et al., stove doors	5731	5731	Shedd, Joel, window blind fastener.....	5478
Roby, C. W., et al., car couplers.....	6186	6186	Sheldon, Frank P., screw threading.....	6276
Roch, J., et al., life preserver	6540	6540	Shepard, Charles H., spreading hoods.....	5898
Roiden, William H., tool handle.....	6169	6169	Sheraton, A. B., et al., skates.....	6221
" " fork	6481	6481	Sherman, Jonathan, tan bark.....	6122
Rodgers, Alexander, saw mill carriage.....	6077	6077	Sherreden, C. H., et al., chairs.....	5804
Rodier, Peter, skates.....	5571	5571	Sherwood, Obediah, extension ladders	5856
Rodkey, Jacob M., washing machines.....	6226	6226	" " Jr., step	6704
Rogers, Charles D., screw machine.....	6410	6411	Shickel, Joseph, plough.....	6472
" " wood screws.....	6702	6702	Shitman, Montagu A. B., clothes dryer.....	6015
" " screw.....	5815	5815	Shotwell, John J., washing machine	6588
" Charles E., upright plano	5949	5949	Shriver, Aaron J., crape	6531
" John J., gelatine desiccating.....	5485	5485	Sillman, James R., et al., freight cars	5413
Roode, James, et al., pump.....	5831	5831	" Benjamin et al., resonance to metallic bodies ..	5575
Rooney, T., et al., stump and stone extractor	6634	6634	Sills, Thomas, railway signals.....	6114
Rout, F. H., et al., stove	5863	5863	Simmons, George W., sewing machines.....	5751
Roth, Elias, saw file guides.....	5584	5584	" Thomas, churns.....	6323
Rorick, John C., square and mitre bar	5727	5727	Simpson, Charles G. C., hay press	5501
Rose, J., et al., plumbers trap.....	6129	6129	" " " paper dampers	6225
Rouse, J. W., et al., spring equalizers	6673	6673	" " " skate	6262
Roush, Henry, beehive.....	6537	6537	Sims, E., et al., fences.....	6402
Roussenu, D., et al., railway signal.....	6590	6590	Singer, Jacob, car coupling	6458
Royle, John J., steam trap	6128	6128	Skinner, D. M., et al., plate lifter.....	6099
Russell, Oscar, paint dryers.....	6397	6397	" W. E., et al., curtain fixtures.....	6238
Ryan, Patrick S., milk strainers.....	5617	5617	Slagle, E., et al., flour bolt.....	6445
St. John, William W., piston packing.....	6640	6640	Slater, Horatio N., flocking cloth	5544
Ste. Marie, Pierre C., spittoon.....	6569	6569	Sleeper, C. T., et al., stuffing box	6751
Sabin, Charles T., door spring.....	5836	5836	Sloan, Thomas J., thawing water pipes	5616
" C. T., et al.,	6585	6585	Slott, A. J., et al., turbine.....	6657
Sallebury, Silas C., gas.....	6061	6061	Smith, Ananias, heating metals and smelting ores ..	5554
Salomon, Etienne, starting street cars.....	6300	6300	" " Hme kiln.....	6033
Sampson, James H., boot tree.....	5967	5967	" " puddling furnace	6098
Sanburn, L. W., et al., harness.....	6431	6431	" " blast	6103
Sanford, David, ladder and fire escape	5712	5712	" B. F., et al., fish hook.....	6066
" Sidney J., doors or shutters.....	5512	5512	" C. & J., tanning skin	6470
Savote, Francois, sieve for millet seed.....	5512	5512	" George, milk pan	6716
Sawyer, George F., stove board.....	5513	5513	" " T., dressing millstones.....	5876
" " coal scuttle.....	5579	5579	" Horatio M., et al furnace.....	5127
" William E., copying telegraph.....	5531	5531	" H., et al., organ.....	6524
Saxton, Francis B. H., et al., seed planters.....	5461	5461	" James B., car coupler.....	5999
Scadding, Charles A., printers' galley.....	5801	5801	" Jason, leather shaving.....	6711
Scales, Joab, drying tobacco, fruit, &c.....	5784	5784	" Joseph M., saw gummer.....	6214
Scarlett, G. N., et al., car truck shifting	5959	5959	" John C., fire proof paint.....	5532
Scanlan, T. F., et al., reed organ.....	6036	6036	" L. et al., fog alarm.....	6482
Sobell, I. H., et al., track clearing.....	6185	6185	" Marvin O., saw gummer.....	6132
Schermerhorn, George W., brush	6185	6185	" Otis H., logging dog.....	6127
			" Robert D. O., water closet.....	5504

Smith, Sidney, Sr., plough.....	6643	Taylor, James P., et al., machine gun.....	5476
" William A., checks.....	6480	Temple, Benjamin, tube kettle and cooking apparatus.....	5157
" " H., artificial stone.....	6169	" " T., et al., railway feeder.....	6948
" W., et al., spring equalizers.....	6139	Tonny, A. J. M., et al., station indicator.....	6019
" W. C., " railway signal.....	6537	Torwilliger, S., et al., fulling mill.....	6744
Smyth, David L., sewing machine.....	6708	Tevie, Edwin L., horse shoes.....	5895
Snell, Theodore, et al., paint brush bridle.....	5470	Thayer, John A., hatchets.....	6338
Snider, Daniel, killing potato bugs.....	5681	Theobald, Lewis, fanning mill.....	5423
Snow, John, sewer trap.....	6042	Thiers, W. F., et al., ship ventilator, &c.....	6356
" W., et al., measure and sprinkling pot.....	5933	Thomas, John F., horse rakes.....	6003
" William B., steam radiator.....	6098	" J. E., et al., saw mill dogs.....	6147
Snowden, Arthur C., horse over shoe.....	5495	" Robert, ventilating buildings.....	5008
Solomon, William H., lifting weights.....	6341	" " water pipe.....	5904
Soper, Robert, graters.....	5787	Thompson, Charles H., valve.....	6601
Spaith, J., et al., curtain fixtures.....	6238	" George, life raft.....	6671
Spang, H. W., lightning conductor.....	5711	" I. F., et al., planing machines.....	6557
Spanner, Walter, invalid bedstead.....	5931	" J. W., et al., lock nut.....	5619
Spencer, C. L., et al., knitting loom.....	6301	" Samuel R., bark cutting.....	6264
" Charles T., lamp.....	6707	Thomson, G. and J. ploughs.....	5975
" E. E., et al., seed sowers.....	5961	" Mark, tobacco pipes.....	6106
" Eljah E., sap buckets.....	5910	" R., et al., harvesting.....	6332
" J. C., et al., postage stamp.....	6709	" " reapers.....	6333
Spooner, Johnston, tuyeres.....	5987	" " reaping.....	6334
Stanciffl, G., et al., hoisting coal, &c.....	5864	" " harvesters.....	6329
Stannard, Elbert, sash fastener.....	6754	" " mowing machines.....	6330
Stansbury, G. H., et al., grato.....	6603	" " belts and endless chains.....	6331
Staples, John H., water wheel.....	5992	" Smitb, plastering.....	5030
Steadman, Elihu P., carriage tops.....	5984	" William Y., cooking vessel.....	6541
Stearns, Henry A., milking stool.....	5690	Thonger, Charles, furnaces.....	5710
" " railway crossing gate.....	5929	Tiffany, George S., brick and tile machine.....	5591
Stebins, Timothy, hydraulic elevator.....	6706	Timby, T. R., et al., cooking stoves.....	5890
Steel, James, railway braking, &c.....	5507	Tindale, Mathew, preparation of groats.....	6140
Steller, Charles E., sash holder.....	5441	Tisdale, Valentine H., churn power.....	6286
Stern, B. & H., steam candy heater.....	5675	Talton, A. and D., straw cutters.....	6698
" " candy machine.....	6265	Tostevin, Thomas, chair.....	6765
Sternheimer, F., et al., billiard recording.....	5599	Townsend, Owen W., core augers.....	6038
Stevens, A. B., et al., chairs.....	6285	" Townsend, John E., beds.....	6241
" George H., wheel.....	6578	Trimble, George, street sprinklers.....	6230
" Grenville M., lamps.....	6207	Trissler, William H., plough points.....	6335
" John, paper vessels.....	6360	Trout, Charles F., coin package.....	6543
" Philetus J., eye cups.....	6297	Tucker, Frederick O., west stop.....	6635
" T. A., et al., gas machine.....	6409	Turner, W. P., et al., gas machine.....	6409
Stevenson, William, plough.....	6643	Underwood, John K., plough.....	6579
Stewart, Alexander, turning shafting, &c.....	6576	Utendorf, Garat J., clover thrasher and huller.....	5816
" Andrew J., soap.....	6633	Valpey, J., et al., boot lining.....	6185
" John F., coal stove and furnaces.....	5821	Van Benschoten, Henry E., sole and heel protector.....	5458
" Thomas C., wagon axle nut.....	3773	" " Samuel, textile fabrics.....	6121
" W., et al., grain drying kiln.....	6404	Van Norman, Isaac W., dumping wagon.....	6023
Stickells, G. T., knife polishing powder.....	5715	Vanstone, S., et al., screw stocks.....	6690
Stickney, N., et al., salt evaporator.....	6574	" " " blanks.....	6748
Stimson, A. A., et al., door spring.....	5886	Van Winkle, Isaac S., metal punching.....	6776
Stock, G. B., et al., filtering medium.....	6159	Varner, Henry, fruit gatherer.....	5692
" James J., vehicle spring.....	5928	Varney, Joseph, nail.....	6599
Stockton, J. K., et al., sofa.....	6783	Vassie, William, lamp holding attachment.....	5645
Stoll, Lyman A., feather duster.....	5862	Vaughan, Charles E., boots and shoes.....	6687
Stone, Andr�, boot and shoe pegging stand.....	5429	Vailleux, Anselme, bench vice.....	6554
" John H., screw cap for cans and jars.....	5708	Vessot, Samuel, carriage wheels.....	5978
Stonner, Henry C. F., recovering alkalies.....	5756	Vezina, Ferdinand, washing machine.....	6502
Strond, Ezra, horse collar.....	6418	Volgt, Fredric H., chronometer escapement.....	6432
Strong, Myron H., illuminating gas.....	5608	" H. C., et al., burglar alarm.....	5729
" " " gas.....	6443	Wade, Jonathan, cultivators.....	6228
Strubar, George G., neck ties.....	5608	Wagner, Anna G., turbine.....	6768
Sturdy, John L., furnace.....	6463	Walt, G. W., et al., piston packing.....	6555
Suggett, James, driven well.....	5859	Wald, Andrew, car coupling.....	6720
Sullivan, F. W., et al., bosom pad.....	6178	Waldock, John G., upholding bags.....	5841
Susand, Henry E., railway dumping platform.....	5506	Walker, Andrew B., brewery plant.....	6763
Sutherland, Daniel A., boots and shoes.....	6613	" Hiram, water for boilers.....	5701
Swanson, C. D., et al., fence.....	6623	" T., et al., amalgamating ores.....	6220
Sweaner, G., et al., fog alarm.....	6389	Wallace, Ferrand G., mill trams.....	6436
Sweet, Benjamin F., sleigh.....	6710	" John S., valve indicator.....	5719
Swett, G. W., et al., grates.....	5200	" " Samuel, veneer cutting.....	5436
Syversen, Andreas, stove pipe elbow.....	5626	" " " barrel machinery.....	6111
Sylvester, Richard, seeders and cultivators.....	5900	Walrath, Alphonso, broom corn.....	6321
Tait, Thomas, water wheel.....	5693	" A., et al., " machine.....	6742
Talte, J. G., et al., gas stove.....	5857	" A., et al., pad for chair legs.....	5567
Tallman, J. C., et al., bosom pad.....	6178	Walsh, Frederick, harness.....	6446
Tandy, George J., boilers for steam and heating.....	5551	Walton, Brooks W., gang ploughs.....	5638
Tanner, William, door alarm.....	6084	" Watson, G., cooling milk.....	5866
Tarbox, John N., glass.....	6496	Walworth, Caleb C., pipe.....	6497
" " " melting.....	5877	Ward, Samuel J., sad iron.....	6394
" " " et al., glass crucible.....	5431	" George H., et al., railway car axle.....	5524
Tatro, William B., nickel ore.....	6714	Wardon, A., et al., gun covers.....	6030
Taylor, C. W. H., et al., pen.....	6462	Wardwell, S. W. J., et al., sewing machines.....	6369
" George, stove-pipe.....	6546	Waring, G. E., Jr., cheque book.....	6439
" George E., tinned plate.....	5407	Warner, Robert D., harvester.....	6572
" H. H., et al., car brake.....	6703	Warren, Charles H., churn.....	6055
" H. P., et al., plane guide.....	6018	" " wood planing.....	6183
" J., et al., fire extinguisher.....	5907	" " " step ladder.....	6696

" " saw horse.....	6697	Willi, T., et al., meat machine.....	6587
" " clothes horse.....	6699	Williams, A. R., et al., harvester.....	6329
" Syrus M., roof.....	6806	" " " mowing machines.....	6330
" William, pail and tub.....	6826	" " " belt and endless chains.....	6331
Warrick, Samuel, steam engines.....	5656	" " " harvesting.....	6332
Waterhouse, Electa A., corset.....	6724	" " " reapers.....	6333
Waterman, Jonathan W., threshing machine.....	6737	" " " reaping.....	6384
Waters, J., et al., harrows.....	6287	Charles W., hay loader.....	5464
Watkins, A. H., et al., tile heating.....	5689	" C. H., et al., burglar alarm.....	5729
Watson, John E., voltaic battery.....	6721	" John Y., farm gates.....	5982
" " seeder to horse rakes.....	5969	" Joseph, anchor.....	6504
" Elliphalot, metallic roofing.....	5739	" Joseph S., railroad crossing.....	5902
" C. S., et al., plumbers' traps.....	5727	" Porter, waggon body and hay rack.....	5835
Watt, William, distilling apparatus.....	5420	" P., et al., car couplers.....	5814
Weaver, Charles P., back.....	6771	" " hinges.....	5905
Webb, Thomas, feed cutter.....	5446	" Samuel, washing machine.....	5870
" Rodolphus L., box coffee mill.....	5465	Williamson, Adam, sash pulley.....	6783
" Robert H., lamps.....	6143	Wills, John B., horse shoe nail.....	6271
Webster, Jerome J., grinding machine.....	6774	" " welding iron.....	6248
" H. W., et al., saw mill.....	6675	Willson, Alfred, et al., railway freight car.....	5413
Weederman, Erich J., ice breaking vessel.....	5714	Willmot, Samuel, fish hatching.....	6054
Welch, David T., lifting jack.....	5519	Wilson, John E., steam governor.....	6150
Weller, Marvin E., et al., pads for chair legs.....	5567	" J. F., et al., sash holders.....	6204
Wells, C. H., et al., radiator.....	5734	" Melvin, harrows and hay rakes.....	5607
" Henry, revolving harrow.....	5546	" Newell W., et al., oil tank.....	5525
" George, engine.....	6667	" Thomas M., washing machine.....	6405
" John B., horse shoe nail.....	5677	Winchell, James B., axle and box.....	6045
West, W., " windows.....	5875	Winper, J. E., et al., stamps, cheques, &c.....	5958
Westcott, Charles S., type.....	6535	Winters, John B., bridges.....	5597
Westgate, E. D., et al., prunello.....	6688	" J. B., et al., car coupling.....	5814
Wetherbee, G. C., et al., broom.....	6538	" " " hinges.....	5905
Whoeler, D. A., et al., axle boxes.....	5820	Wisner, Wareham S., sower.....	6510
" Ellsha H., waggon brake.....	6282	Wood, Albert A., hollow auger.....	6603
" J. E., et al., planting machine.....	6557	" Alexander, horse rakes.....	5858
" " " leather crimping.....	6679	" E. M., et al., ".....	5966
" John E., sowing machine.....	6119	" Frank O., fence post.....	6505
" " " sole channelling.....	6158	" John, churns.....	5806
" Marshal, solar chronometer.....	5702	" Thomas T., nail blank machine.....	5854
Whelpley, J. A., et al., skates.....	6221	" William G., gas for heating.....	5762
Whipple, Alfred B., mail bag.....	6542	" " H., piano.....	6261
" Lyman W., napped fabrics.....	6375	Woodbridge John, land roller.....	5569
White, Charles A., gas.....	6701	Woodbury, William C., corn mills.....	6339
" Henry G., horse pad.....	6283	Woodford, Charles W., horse shoe nail.....	5813
" Henry J., fruit loosener.....	5981	Woodruff, G. S., et al., lubricator.....	6665
" Stephen, whiffletree.....	6467	" Horace W., tanning skins.....	5503
Whitecar, T. J., et al., anchors.....	6179	Woods, Joseph S., street lamp.....	6274
Whiteside, A. H., et al., harrows.....	5721	Woodville, John, pumps.....	6036
Whiting, John L., making brush handles.....	5643	Woodward, Benjamin, et al., chain stoppers.....	5473
" " " brushes.....	5660	" " " capstans, &c.....	5477
" E. R., et al., grain binders.....	5893	" Henry, shirt front board.....	5724
" George A., grindstone.....	6512	Woolley, L. G., scales.....	5699
" Sarah L., grain binding.....	6239	" J. W., et al., grain drying kiln.....	6404
" William F., vehicle spring.....	5789	Woolner, John, burglar alarms.....	6251
Wiard, G., et al., ploughs.....	6337	Wooton, William S., desks.....	6343
Wikes, James H., refrigerator.....	5621	Wotten, John E., furnace.....	6525
Widdifield, W. P., door strip.....	5547	Worthington, J., et al., railway switch.....	5685
" " saw mill.....	6386	Wright, B. S., et al., driving reins.....	6202
Wilkes, James H., refrigerator cars.....	6148	" E. D., et al., mica lamp chimney.....	5648
Wilcox, Henry R., cementing stone, wood, &c.....	5834	" J. T., et al., piston packing.....	6233
" Horace C., et al., resonance to metallic bodies.....	5575	Yate, L. T., et al., cooking stoves.....	5890
" William B., pump bucket.....	6146	Yates, William, steam governor.....	6012
" William M., carriage shafts.....	6189	Young, W., et al., illuminating gas.....	6357
Wilkinson, John W., liquid measure.....	6304	Zavitz, D. H., et al., tube wells.....	6182
Willard, Hosea, weighing scales.....	6456	Zielinski, Jacob, curing flat footed horses.....	5965

The Canadian Patent Office

RECORD

Vol. IV.—No. 1.

JANUARY, 1876.

Price in Canada \$2.00 per An.
United States - \$2.50

CONTENTS.

INVENTIONS PATENTED.....	I
INDEX OF INVENTIONS.....	XI
INDEX OF PATENTES.....	XI
ILLUSTRATIONS.....	II

INVENTIONS PATENTED.

No. 5406. Improvements on Vehicle-Gears.

(*Perfectionnements aux trains des voitures.*)

Harry S. Clark, Tawanda, Pa., U. S., 24th November, 1875, for 5 years.

Claim.—The combination with the side springs fifth wheel and rigid bars *b, b*, intersecting at the king bolt of the spring extensions *a, a*, bolted to the ends of said bars *b, b*.

No. 5407. Manufacture of Timed-Plates.

(*Fabrication des plaques étamées.*)

George E. Taylor, Philadelphia, Pa., U. S., 24th November, 1875, for 5 years.

Claim.—1st. Plates of sheet iron tinned on both sides and at all the edges and shaped for conversion into or forming parts of articles of tin ware without being sheared prior to such conversion; 2nd. The mode of preparing plates of tinned iron for the manufacture of tin ware, that is to say, first cutting the plates from sheet iron to the desired shape and then tinning the shaped plates.

No. 5408. Fire-Extinguisher. (*Extincteur d'incendie.*)

William Dickson, jr., Richmond, Que., 24th November, 1875, for 5 years.

Claim.—The combination of a pump *P*, with a portable reservoir *A*, hose *M*, faucet *F*, and leg rest *T*.

No. 5409. Hand-Truck. (*Camion à bras.*)

Henry H. Baltzly, Assumption, Ill., and Loyall A. Hoyt, Parishville, N. Y., U. S., 24th November, 1875, for 5 years.

Claim.—1st. A vertically adjustable platform for hand-trucks, which when not in use lies flat upon the truck, but is elevated in the act of loading or transporting a load, and depressed in unloading the same; 2nd. A platform for a hand-truck bevelled from underneath at its outer end so as to more readily get hold of the load to be lifted; 3rd. The combination of the platform *B*, with the truck *A*, crank arms *a, a'*, and levers *d, d'*; 4th. The combination of the handle and lever with the axle at the centre of the axle whereby the lever applies power to the centre of the platform.

No. 5410. Process for the Manufacture of Paper Pulp from Wood.

(*Procédé de fabrication de la pâte à papier avec du bois.*)

Henry H. Furbish, Yarmouth, Me., U. S., 24th November, 1875, for 5 years.

Claim.—1st. The mode of cutting the wood across the grain around the periphery of the log and into veneer clips; 2nd. The water to make a steam bath for the saturated clips applied after the unabsorbed liquor has been drawn off and before the cooking process is begun; 3rd. The mode of washing the cooked and disintegrated mass in a high narrow vessel or tank; 4th. The method of raising the strength of the solution of recovered ash; 5th. The process of saving the heat and steam and the fibre which might otherwise be lost; 6th. The process as described, to wit, of reducing clips of wood to pulp, washing the same, saving the unabsorbed liquor, reclaiming the spent lees from the percolating tank, recovering, recausticising and raising strength of the ash liquor.

No. 5411. Lightning Conductor. (*Paratonnerre.*)

John C. Schoonmaker, Geddes, N. Y., U. S., 24th November, 1875, for 5 years.

Claim.—A lightning conductor constructed of a Tube *A* or tubes of metal wrapped with metal wires *b* and *c*.

No. 5412. Improvements on Wringers.

(*Perfectionnements auxessoreuses.*)

Augustus Page (Assignee of C. E. Haynes), Boston, Mass., U. S., 24th November, 1875, for 5 years.

Claim.—The bent spring with a bearing for the upper roll in its free end, in combination with the standard formed with a bearing for the lower roll, and a seat upon which the spring is fixed and held.

No. 5413. Improvements on Freight-Cars.

(*Perfectionnements aux wagons à fret.*)

Alfred Willson, Bell-Ewart, and James B. Silliman, Toronto, Ont., 24th November, 1875, for 5 years.

Claim.—The longitudinal foot way *B* and hand rails *a*, in combination with the cross foot ways *B'*, *B''*, cross hand rails *b, b*, sloping hand rails *c* and *d*, the stands *a', a'*, *a'', a''*, *a''', a'''*, and *a3, a3*.

No. 5414. Improvements on Saw-Collars for Grooving Laths.

(*Perfectionnements aux collets des scies à canneler la latte.*)

Philo W. Hart, Camden, N. Y., U. S., 24th November, 1875, for 5 years.

Claim.—A saw collar *C*, provided with teeth *d*, on its face or periphery.

No. 5415. Sleigh Lance.

(*Appareil de propulsion des traîneaux.*)

Adolphe Corbett, Hicksville, N. Y., U. S., 24th November, 1875, for 5 years.

Claim.—1st. The sleigh lance consisting of a shaft and a pointed head; 2nd. The combination of the staff *A*, provided with the ferule *B*, and socket *D*, and the pointed head *E, a, b*, provided with the screw-threaded nipple or boss *c*; 3rd. The lance head consisting of a taper core or body *E*, provided with two series of longitudinal ribs *a* and *b*.

No. 5416. Improvements on Rowing Gear.

(*Perfectionnements aux appareils à ramer.*)

William Lyman, Middlefield, Ct., U. S., 24th November, 1875, for 15 years.

Claim.—1st. An oar constructed in two parts, each hung to the gunwale, and connected one to the other by a jointed connection whereby the oarsman is enabled to face the direction in which the boat is propelled; 2nd. An oar constructed in two parts, each hung to the gunwale by a universal joint, and the two connected by a rod jointed to the handle part inside the gunwale, and to the oar part outside the gunwale.

No. 5417. Process of Tanning Raw-Hides and Skins with the Hair Left on and Composition of Matter used in the Said Process.

(*Procédé de tannage des peaux avec le poil et composé pour cet objet.*)

John Angus, Saint Stephen, N. B., 24th November, 1875, for 5 years.

Claim.—1st. The process of tanning hides and skins without removing the hair by the use of the sulphuric acid and water in which to soak the hides and skins, and the use of the tanning liquors composed of salt, alum, borax, sweet fern and water in the proportions described; 2nd. The tanning compound composed of salt, alum, borax, sweet fern and water in the proportions described; 3rd. The stuffing compound composed of beef, tallow, light foot *a, a, z*, oil, straits oil and green tar.

No. 5418. Improvements in Regulating Percolators. (*Perfectionnements aux filtres-régulateurs.*)

George McPherson, Chicago, Ill., U. S., 24th November, 1875, for 5 years.

Claim.—1st. The combination with a percolator of a suitable faucet provided with depressions *K, K*, for controlling and regulating the admission of air; 2nd. The percolator provided with the air tight fitting cap *B*, faucet shell *A*, and plug *E*, the latter provided with orifices and depressions *K, K*; 3rd. In combination with the closed top percolator *A, B*, the faucet shell and plug *C, E*, the latter provided with the long handle *F*; 4th. The combination with a percolator of the faucet provided at its top with a funnel; 5th. The combination with a percolator provided with a closed top *B*, faucet

E, and depressions K, K, of a suitable pump, or air compressing apparatus. 6th. In combination with the percolator provided with the closed top B, faucet E, and funnel D, the removable nipple C; 7th. The percolator consisting of the body or shell A, perforated diaphragm b, perforated weight c, air tight cap B, shell c and faucet E.

No. 5419. Improvements on Steam and other Cocks and Valves.

(*Perfectionnements aux robinets et soupapes de vapeur et autres.*)
James Mallinson, Welwyn, Eng., 24th November, 1875, for 5 years.

Claim.—1st. The combination of cocks which are rendered fluid tight by packing with the packing applied on lines c, c, down the side of the water ways a, or passage a, through the shell and with a hollow space e, between them; 2nd. The construction of sluice and slide valves rendered fluid tight by packing c, applied around the water ways or passage a, a, such packing being confined in its position and compressed; 3rd. Protecting the packing of cocks and valves which are kept fluid tight by packing, by covering the packing with thin sheet metal c'.

No. 5420. Distilling Apparatus.

(*Appareil de distillerie.*)

William Watt (Assignee of J. W. Reford), New York, U. S., 24th November 1875, for 5 years.

Claim.—1st. In a liquor apparatus, the combination of two or more stills each having a perforated boiling bottom and surrounded with a steam jacket and connected by pipes having suitable cocks whereby each still may be operated independently or all in conjunction; 2nd. The combination with a steam superheater and connecting pipes of a series of independent jacketed stills whereby the distilling capacity may be varied at pleasure; 3rd. The combination of a still, the steam superheater, the chamber H, and mechanism therein and the pipes K, M; 4th. The combination of the steam superheater, the series of jacketed stills, the heater D, with the pipes K, Q, R; 5th. The combination of the steam superheater, the still, the heater D, and the doubler E, for effecting the first separation of the low proof liquors and their return to the still; 6th. The combination of the steam superheater, the still, the heater D, the doubler E, and the return liquor chamber F, and its pipe for effecting the second separation of the low proof liquors and their return to the still; 7th. The combination of the heater D, return liquor chamber F, and its return pipes, and the safety condenser N, and its return pipes; 8th. The combination of a gravimeter with a still and connecting with its boiling chamber whereby the specific gravity of its contents may be at any time determined; 9th. The combination of a horizontal revolving cylinder containing purifying material through which the spirit is passed by suitable pipes, and an enclosing chamber to be supplied with heated air; 10th. The combination of a series of horizontal revolving cylinders, filled with purifying material and pipes connecting their ends; 11th. The mechanism for effecting the continuous distillation of spirits and consisting essentially in the combination of the stills, the superheater, the heater, the doubler for making the first separation, the return liquor chamber and the pipes o, o, for making the second separation, the safety condenser, the main condenser, and the connecting pipes.

No. 5421. Machine for Labelling Newspapers.

(*Machine à étiqueter les papiers nouvelles.*)

Robert Dick, Buffalo, N. Y., U. S., 24th November, 1875, for 5 years.

Claim.—1st. The combination with the shell M, of the slide way A, A, made adjustable to the blade P; 2nd. The combination with the shell M, of the buffing roller D; 3rd. The combination with the shell M, of the slide way A, A, and the buffing roller D.

No. 5422. Method of, and Apparatus for Securing the Combustion of Fuel and for the Utilization of the Gases arising therefrom.

(*Méthode et appareil pour assurer l'embrassement du combustible et en utiliser les gaz.*)

John C. Ramsden, Lightcliffe, Eng., 26th November, 1875, for 5 years.

Claim.—1st. The capillary tubes for supplying the liquid fuel; the coil steam pipes B, in the construction of steam boilers heated by liquid fuel, having generators B, in the vessel f, and pipe e.

No. 5423. Fanning Mill. (*Tarrare-cribleur*)

Lewis Theobald, Plainfield, Mich., U. S., 26th November, 1875, for 5 years.

Claim.—1st. The combination of the crank F, slotted lever E, and the links a, d, with the elbow-lever b, and shoe C, and the rock-bar g, and shoe D; 2nd. In combination with the slotted-lever E, connected with the shoes, the crank F, attached to the fan-shaft and provided with a roller on its wrist; 3rd. The combination of the shoe D, with the body provided with the notches, or seats m, and the adjustable bar k; 4th. In combination with the shoe D, having the projection p, the rollers n; 5th. In combination with the shoe C, and removable screens s, the notched plates or bars u, attached to the rear end of the shoe; 6th. In combination with the vertically adjustable shoe D, the forked arm e, and rock bar g.

No. 5424. Gas Burner and Regulator.

(*Bec-régulateur à gaz.*)

John Ellis Lynn, Mass., U. S., 26th November, 1875, for 5 years.

Claim.—1st. The chamber c, having connection with the orifice b, of burner base A, in combination and having communication by means of apertures d, with the chamber D and burner tip F; 2nd. In combination with the first claim, the plug G, or the screw plug I.

No. 5425. Improvements on Closing Gas Retorts and other Vessels Hermetically.

(*Perfectionnements dans la manière de fermer hermétiquement les cornues à gaz et autres vaisseaux*)

Henry Collinson, Boston, Mass., U. S., 26th November, 1875, for 5 years.

Claim.—1st. In combination with a seat or bearing A, a plate or cover B, fitting against the same and having a sliding or grinding movement

thereon in other than a straight line; 2nd. In combination with a seat or bearing A, a lid or cover B, arranged to have a sliding and rotating movement thereon; 3rd. In combination with a seat or bearing A, a lid or cover B, mounted loosely on an eccentric rotating support and arranged to receive a pressure against the seat during the rotation of said support; 4th. In combination with a seat or bearing A, a lid or cover B, mounted on the eccentric end of a pressure screw in such manner that it can rotate thereon; 5th. In combination with a seat or bearing A, a lid or cover B, forced against the same with a yielding or spring pressure and at the same time giving a grinding or sliding movement thereon; 6th. In combination with a stationary seat or bearing A, a lid or cover mounted and arranged to rotate on the eccentric end of a pressure screw mounted on a hinged cutter bar, having a yielding or spring support at one end; 7th. The combination of the seat A, lid B, eccentric head C, screw D, hinged cutter bar E, spring G, and latch F; 8th. In combination with the lid or cover B, and the screw d, or equivalent supporting and pressing device the eccentric skeleton plate constructed as described.

No. 5426. Bale Ties. (*Cercles d'emballage.*)

Jonathan R. Foster, Springvale, Me., U. S., 26th November, 1875, for 5 years.

Claim.—A bale tie formed of the hoop slot b, in the end a, of the hoop A.

No. 5427. Improvements on Furnaces for the Combustion of Coal.

(*Perfectionnements aux fourneaux consommant le charbon.*)

Horatio M. Smith, Chicago, Ill., U. S., 26th November, 1875, for 5 years.

Claim.—1st. The combination with the rear grate surface and its supporting jaw, of a descending partition arranged to form a throat or chamber at the juncture of the grate and wall the same adapted to be partially banked up with fuel; 2nd. The combination with the rear grate surface and its supporting wall, of a descending partition arranged to form a throat or chamber at the juncture of the grate and wall and air supply pipes or openings debouching at the crown or in front of said arch; 3rd. The grate G, partition F, and dead plate t, combined with the bridge wall D.

No. 5428. Stench Trap. (*Trappe d'égout.*)

René Garand, Montreal, Que., 26th November, 1875, for 5 years.

Claim.—A stench trap A, having a cover B, and weight C.

No. 5429. Boot and Shoe Pegging Stand.

(*Forme fixe pour cheviller les chaussures.*)

André Stone, Ticonderoga, N. Y., U. S., 26th November, 1875, for 5 years.

Claim.—1st. The combination of the stop jointed rods D, with the plate C, and hinged leaf E; 2nd. The combination of the jointed rods D, plate C, hinged leaf E, and pivoted plate B; 3rd. The pivoted cam K, provided with the projection K, and detachable arm J, having the support H, in combination with the arm f, having projecting pin p, adapted to receive the last L.

No. 5430. Improvements in Clamps for Assembling Staves of Barrels.

(*Perfectionnements aux mordages d'assemblage des douves de barils.*)

Jonathan R. Foster, Springvale, Me., U. S., 26th November, 1875, for 5 years.

Claim.—A shock clamp consisting of bottom piece A, side bars C, C, top piece G, and set screw I, with disc m.

No. 5431. Glass Crucible. (*Crucet de verrerie.*)

Austin Kenny, John N. Tharbox and Edward R. Kent, Hamilton, Ont., 30th November, 1875, for 5 years.

Claim.—The opening b, in the top of a glass crucible A, and provided with the projection d, together with the cover c, for the same, for melting the glass of any colour.

No. 5432. Improvements on Reservoir for Street Lanterns.

(*Perfectionnements aux réservoirs des lampes de rues.*)

Ephraim Patterson, David A. Hutchinson and John G. Hunter, (Assignees of A. H. Watkins), Cornwall, Ont., 30th November, 1875, for 5 years.

Claim.—The tapering reservoir C, having its outlet end of larger area in cross section than its opposite end, and its bottom inclined down toward the outlet.

No. 5433. Advertising Medium.

(*Appareil d'annonce.*)

Edward Rawlings, (Co-inventor with and Assignee of A. M. Neave), Montreal, Que., 30th November, 1875, for 5 years.

Claim.—1st. An advertising medium containing the advertisement in combination with a match scratch B, and match receptacle D, having an ornamental feature; 2nd. The combination for an advertising medium of an advertisement with the match scratch B, and cut or vignette C.

No. 5434. Ozone Machine. (*Machine à ozone.*)

Robert Heneage and Seth Clark, Buffalo, N. Y., U. S., 30th November, 1875, for 5 years.

Claim.—1st. The generating chamber A, fire chamber D, alkaline chamber E, and washing and forcing chamber F; 2nd. The combination of the generating chamber A, and fire chamber D; 3rd. The tube or tubes I, in combination with a water receptacle H, for drawing and forcing the ozone; 4th. The washing and forcing chamber F, provided with compartments formed by the partition J, K, L, M, in combination with the receptacle H, and tube I; 5th. The generating chamber A, provided with openings B, a phosphorous receptacle C, and an open space U, in combination with the alkaline chamber E, and air forcing chamber F, having a water inlet G, receptacle H, tubes I, outlet N, and ozone outlet P.

No. 5435. Improvements in the Manufacture of Peat.

(*Perfectionnements dans la fabrication de la tourbe.*)

Robert A. Griffin, Montreal, Que., 30th November, 1875, (Extension of Patent No. 751), for 5 years.

Claim.—1st. The novel combination of the curers *f*₁, excavator *w*, scow *m*, with vessel *n*, vessel *n*, with elevator *n*₁, and spout *o*, waggon *G*₂, and mills *k*; 2nd. The novel arrangement of the excavator *h*, in its parts of vessel *h*₂, rollers *h*₃, and *h*₄, chains *h*₅, hangers *h*₆, buckets *h*₁, segment *i*, spout *I*, screw *l*.

No. 5436. Machine for Cutting Veneers.

(*Machine à tailler les bois de placage.*)

Samuel Wallace, Seaforth, Ont., (Assignee of J. D. McEachern), 1st December, 1875, for 5 years.

Claim.—1st. An attachment to a machine for cutting veneers for the purpose of bevelling the edges of and cutting off the sheets and consisting of the knives *c*, *d*, and *G*, held within the frames *c*, *c*, and *G*, pivoted upon the rod *d*; 2nd. The frames *C*, *C*, pivoted upon the rod *D*, in combination with the blocks *E*, *E*, and screw *F*; 3rd. The set screws *S*, *S*, operating upon the loose nuts within the blocks *E*, in combination with the screw *F*.

No. 5437. Machine for Washing Linen.

(*Machine à laver le linge.*)

Anthony Kline, Bondhead, Ont., 1st December, 1875, for 5 years.

Claim.—The frame *A*, *A*, the combination of levers *D*, *E*, *G*, and *H*, with the cross bars *F*, and *K*, and the arm *I*, *J*, in the rollers *B*, and the fluted board *C*, when used in combination with the other parts of the machine.

No. 5438. Horse Detaching Apparatus.

(*Appareil à détacher les chevaux.*)

Johusa W. Glover, Mount Savage, Ky., U. S., 1st December, 1875, for 5 years

Claim.—The spring catch bolts *A*, cord *D*, pulleys *C*, and weight *E*, combined and arranged with the whippetree of a carriage for automatically detaching the braces when the carriage turns over.

No. 5439. Railway Frogs.

(*Rails de croisement de rail-route.*)

James Cumming, Buffalo, N. Y., U. S., 1st December, 1875, for 5 years.

Claim.—1st. The combination with the intersecting track rails *B*, *B*, and combination *C*, *C*, thereof, of the chair *A*, cast complete in one piece with the guard rails *D*, *D*, and recesses *A*₁; 2nd. The combination with the rails *B*, *C*, and the chair *A*, of the detachable bridge piece *E*, constructed with bevelled sides and retained in proper position by the head of the rails; 3rd. In combination with the track rails *B*, *B*, and *C*, *C*, intersecting each other at any angle of a yielding bridge piece *E*, provided with the cushion *E*, and arranged within a recess in the chair base and held therein by the head of the rails.

No. 5440. Tea Kettle Handle. (*Anse de bouilloire.*)

William S. Potwin, Chicago, Ill., U. S., 1st December, 1875, for 5 years.

Claim.—The large hollow part at both ends and of the slender corrugated parts *C*, *C*, provided with the parts *e*, *e*, all made in one continuous piece.

No. 5441. Sash Holder. (*Support de croisée.*)

Charles E. Steller, Milwaukee, U. S., 1st December, 1875, for 5 years.

Claim.—1st. The hollow wheel integrally formed of a circular plate *A*, having at one side a peripheral rim *B*, to retain thereon a frictional band *C*; 2nd. A hollow wheel having a series of concentrically arranged holes *D*; 3rd. A hollow wheel having a removable face plate *E*.

No. 5442. Improvements on Watches.

(*Perfectionnements aux montres.*)

Albert H. Potter, Chicago, Ill., U. S., 1st December, 1875, for 10 years.

Claim.—1st. The block *A*, recessed and constructed for the reception of the works or internal operative parts of the movement of a watch or time piece; 2nd. The combination of the plate *B*, with the recessed block *A*; 3rd. The balance constructed with the auxiliary bows *B*, adjustably loaded.

No. 5443. Apparatus for Transferring the Wool from the Breaker of Custom and Feeding it to the Finisher.

(*Appareil à transporter la laine des cardes en gros et en alimenter le finisseur.*)

Hugh McKenzie, Rawdon, N. S., 1st December, 1875, for 5 years.

Claim.—1st. The combination with the breaker frame of any carding mills, the frame *B*, carrying on rollers *C*, *C*, the revolving belt *D*; 2nd. In combination with the revolving tube of any side draw apparatus the packing ring *H*; 3rd. In any side draw apparatus the arrangement with the draw rods *G*, *G*, the upper one of which is fluted, of a clearing plate *I*; 4th. In combination with the breaker and carder frames of any mill, the frame *W*, carrying on rollers *V*, *V*, the endless belt *X*, actuated as described; 5th. The combination with the carder of the frame *d*, secured to the table frame *b*, by pieces *C*; 6th. The sliding carriage *g*, *g*, mounted on the shafts *c*, and driving belt *K*; 7th. The combination with the belt *K*, of the link *n*, crank *m*, and plate *s*; 8th. The combination with the plate *L*, of the reciprocating pieces *p*, pivoted thereto actuated from the crank *m*, through the link *n*, and carrying the spindles of the rollers *q*, *q*; 9th. In combination with the plate *L*, the arm *u*, and guide box *t*, arranged and acting in combination with the rollers *q*, *q*; 10th. The combination with the rollers *w*, *w*, of the rollers *g*, *g*, all operated and working together; 11th. The combination with the sliding carriage *g*, *g*, of the rocking arm *d*, operated by the wheel *I*.

No. 5444. Improvements on Side Plaiters.

(*Perfectionnements aux plisseurs de côté.*)

James M. Cooley, Hamilton, Ont., 1st December, 1875, for 5 years.

Claim.—The combination of a perforated metal plate *B*, having two or more rows of holes *a*, *b*, the metal plates *C*, having the notches *c*, the edging *D*, having a groove *f*, as a stop to the needles; the needles or rods *E*, and the drawer *F*, with a plaiting board *A*.

No. 5445. Feed Cutter. (*Hache-paille.*)

Thomas Webb, Elyria, Ohio, U. S., 1st December, 1875, for 5 years.

Claim.—The double slotted lever *N*, fulcrumed on shaft *J*, provided with pinion *M*, and adjustable on fixed plate *Q*.

No. 5446. Combined Corset, Shoulder Brace, Spinal and Abdominal Supporter.

(*Corset, harnais et suspensoir vertébral et abdominal combinés.*)

Charles C. Robertson, Hamilton, Ont., 1st December, 1875, for 5 years.

Claim.—1st. The combination and arrangement of the backs *a*, *a*, side pieces *b*, *b*, united together by the cross lacing *e*, *e*, &c., and straps *n*, *n*, also the intermediate pieces *d*, *d*, and fronts *c*, *c*, united by cross lacing *f*, *f*; 2nd. In combination with the sides *b*, *b*, fronts *c*, *c*, and backs *a*, *a*, the abdominal supporter pad *h*, held to the sides by the straps *t*, *t*; 3rd. The combination of a corset, spinal support, shoulder brace, and abdominal supporter.

No. 5447. Liniment for Rheumatism.

(*Liniment pour les rhumatismes.*)

Louis N. Fontaine, Ottawa, Ont., 1st December, 1875, for 5 years.

Claim.—A compound composed of gall, olive oil, turpentine, brandy, cream tartar, and white vitriol and mixed in the proportion set forth.

No. 5448. Railway Pneumatic Signal.

(*Signal pneumatique de rail-route.*)

Austin Chambers, London, Eng., 1st December, 1875, for 5 years.

Claim.—1st. The combination with a hand lever *a*, or handle a pipe *e*, tube or passage charged with elastic fluid and a collapsible vessel *f*, connected to the signalling object of a compressor so constructed that as one portion of the compressor is collapsed by moving the lever or handle to move the signal another portion shall temporarily expand to receive the displaced fluid and afterwards complete the compression of fluid and move the signal *t*, by automatically resuming its original position or a position approximating thereto; 2nd. The combination with a hand lever *a*, or handle a pipe *e*, tube or passage charged with elastic fluid and a collapsible vessel *f*, connected to the signalling object *t*, of a rarefier so constructed and connected to the lever that as one portion of the rarefier is expanded or drawn out by the movement of the lever or handle to move the signal, another portion shall temporarily collapse to partially occupy the space vacated by the displaced fluid and afterwards complete the rarefaction of fluid, and move the signal as required by automatically resuming its original position or a position approximating thereto; 3rd. The mode of constructing the flexible portion of the compressors, rarefiers and collapsible vessels of pneumatic signalling apparatus for railways, by fastening together by interposed adhesive substance two or more layers of thin flexible material in such manner that the joint or junction of the inner thickness or layers of flexible material shall be covered strengthened and protected by a superposed layer, or layers, of the same material as described; 4th. The combination with a collapsible vessel or chamber *f*, connected to the signalling object *t*, a pipe *e*, tube or passage charged with elastic fluid, and apparatus for changing the pressure or density of said fluid of two gauges or indicators in juxtaposition one connected by a pipe tube or passage *l*, with a chamber *m*, communicating with the interior of the collapsible vessel or chamber by a hole or passage governed by a valve *n*, operated by a rod or projection *p*, and the other gauge or indicator communicating through a pipe tube or passage *r*, with the compressor or rarefier so as by the relative indications of the two gauges to show the position of the collapsible vessel that operates the signal; 5th. As means for controlling from a distance the moving of the signalling object the combination with an opening in a fluid containing portion of the apparatus of a valve *s*, lid or closure in conjunction with a locking or holding device operated by electricity from the point or station whence the moving of the signalling object is governed; 6th. The combination with a hand lever *a*, *a*, of a rod *b*, operating in conjunction with a tube *c*, carried by the compressor end *d*, said tube having a hole at one end of smaller diameter than the tube itself; 7th. The compressor consisting of the collapsible parts *d*₁ and *d*₂, united by a central rigid flange ring *d*, and provided with guide rods or their equivalents *e*, and *d*₅, working in tubes *d*₃ and *d*₄, carried by a plate or cross piece *d*₇; 8th. In combination with a compressor the pipe *e*, with its opening *e*, valve *s*, lever *t*, weight *l*, armature *u*, and electro magnet *u*, said pipe communicating with the collapsible vessel *f*, connected to the semaphore arm *i*; 9th. The combination of the parts comprising those marked *a*, *a*₁, *b*, *c*, *d*, *d*₁, *d*₂, *d*₃, *d*₄, *d*₅, *d*₆, *d*₇, *d*₈, *d*₉, *e*, *e*₁, *f*, *g*, *h*, *i*, *l*, *l*₁, *l*₂, *l*₃, *k*, *l*, *m*, *n*, *o*, *p*, *q*, *r*, *s*, *t*, *t*₁, *t*₂, *u*, *u*₁, *u*₂, *w*, forming the improved pneumatic signalling apparatus for railways.

No. 5449. Art of Printing with Rubber Type and Apparatus therefor.

(*Art d'imprimer avec des caractères en caoutchouc et appareil pour cet objet.*)

William L. Scott, (Assignee of S. B. Scott,) Montreal, Que., 1st December, 1875, for 5 years.

Claim.—1st. The formation of words, phrases or sentences not limited as to length by the use of alphabets of rubber types, each composed of single letter and used separately or one at a time; 2nd. A type composed of the type proper *A*, made of hardened rubber and securely fixed upon cushion made of soft rubber or other elastic substance the whole being mounted or not as desired upon a block; 3rd. A type composed of rubber secured to the face of any metal type and reproducing the figure out thereon; 4th. A type composed of a letter, figure or device, &c., &c., of rubber or other elastic material secured on the face of a metal backing or mounting; 5th. In combination

with rubber type used singly or one at a time or with a rubber stamp, a frame or guide for securing accuracy of position and correctness of impression; 6th. The combination of the bar D, vertical piece E, and clip piece F, used in combination with a rubber type; 7th. As a portable means of advertising, writing or lettering the combination within the box G, of the type A, a guide for placing same, ink and inking apparatus.

No. 5450. Improvements on Carriages.

(*Perfectionnements aux voitures.*)

Issao H. Culp and John R. Marshall, (Assignees of J. C. Heater), Clifford, Ont., 1st December, 1875, for 5 years.

Claim.—1st. In combination with a light carriage A, the four reaches or levers H, H', H'', and the pillars I, I', I'', the carriage spring K, having either the angled iron rod L, or pliable straps W, forming a yielding reach; 2nd. In combination with a light carriage A, the cross links M, journalled by toggles f, f', to the spring bars J, to keep the carriage body level with the axles E and F, when the weight is greater on one side than on the other; 3rd. In combination with a light carriage A, the cast iron bozings or fifth wheel consisting in the head block O and Q, through which the front axle revolves and works, the under plate R, the top plate U, the stirrup strap T, and bolts J, and the king bolt V, said combination dispensing with till or shaft joints.

No. 5451. Gang Plough. (*Charrue à socs multiples.*)

William P. Plant and Howard Blizard, London, Ont., 1st December, 1875, for 5 years.

Claim.—1st. The arms D, E, K, rods E, L, lever M, cross bar G, and standard H; 2nd. In combination with the first claim the axle C, tongue P, and arm N.

No. 5452. Combined Land Roller and Seeding Machine, &c.

(*Rouleau, semoir, &c., combinés.*)

James H. Holland, Aurora, Mo., U. S., 1st December, 1875, for 5 years.

Claim.—1st. The combination of the detachable wheels F, F', and roller F'', with the shaft H', and frame A; 2nd. The combination of the broad cast plate W, with a grain sower; 3rd. The combination of the tumbler S, with the roller A', and the slide R, of the grain box Q; 4th. The combination of the plough staves I, and the detachable boots H, with a sower; 5th. The combination of the plough staves I, having a collar and projections; the double pointed plough and eye bolts e, having grooves to receive the projection on the collar of the plough staves, said ploughs J, J', being secured to the plough staves by means of a nut screwed to the lower end of the plough staves with sower.

No. 5453. Improvements on Lap Robes.

(*Perfectionnements aux tabliers de voitures.*)

Frederick L. Blakely, Clinton, Iowa, U. S., 4th December, 1875, for 5 years.

Claim.—The covering D, E, of any suitable cloth and the middle piece F, of oil silk, or cloth fabric, impervious to air and water.

No. 5454. Water Supply and Ventilation of Buildings, &c.

(*Distribution de l'eau et ventilation des édifices, &c.*)

John H. Morrell, New York, U. S., 4th December, 1875, for 5 years.

Claim.—1st. The water reservoir D, constructed so as to serve as a storage reservoir as well as a distributing reservoir permitting also of ventilation; 2nd. The combination of said reservoir D, with one or more traps so that said traps will be both supplied and ventilated; 3rd. The partitioned chamber K, K'; 4th. The general arrangement of the water reservoir conducting pipes and divided or partitioned chambers; 5th. The combination with the reservoir D, or with one or more of its pipes G, of a water supply pipe F; 6th. The combination of the register valves z, h, with the reservoir D; 7th. The employment of a ventilating pipe within the water supply pipe or vice-versa, so that ventilation will be effected during the down flow of water and at all times; 8th. The combination with the entrance pipe of a ventilating pipe O; 9th. The construction of pipe H, with a partition m; 10th. The combination of the ventilating and supply pipe H, O, with the traps, water closet, or urinals; 11th. The combination with the pipes H, O, of branch distributing and ventilating pipes H, O, H', O'; 12th. The combination with the distributing pipes H, H', H'', or either of them of dividing plate n; 13th. The arrangement of the ventilating and water supply pipes H, H', H'', O, O', Orr, with the urinal K; 14th. In the water supply and ventilation of buildings and their appendances the employment of combined or double pipes one within the other or of partitioned pipes.

No. 5455. Drum heater. (*Poêle-sourd.*)

Samson H. Ghent, Hamilton, Ont., 4th December, 1875, for 5 years.

Claim.—1st. The drum heater A, having a central pipe B, perforated as set forth and a series of radial partitions C, D; 2nd. The provision of a damper G, in the pipe B.

No. 5456. Apparatus for Rendering Doors and Gates Self-closing.

(*Appareil à faire fermer les portes et barrières automatiquement.*)

Austin D. Cable and Randolph L. Moseley, Montreal, Que., 4th December, 1875, for 5 years.

Claim.—1st. The combination of the spring g, spindle h, and cam or lever L, having increasing leverage as door or gate to which it is attached closes; 2nd. The combination of the spindle h, with reversible spring g, and reversible and increasing leverage cam or arm l; 3rd. The combination of the shell e, spindle h, spring g, cam or arm L, and chain, &c., n.

No. 5457. Tube Kettle and Cooking Apparatus. (*Bouilloire et ustensile de cuisine tubulaires.*)

Benjamin Temple, Hamilton, Ont., 4th December, 1875, for 5 years.

Claim.—1st. The kettle I, with the fire tube or chamber D, fitted through the centre of it and all surrounded by the water space P, in connection with

the damper E, and the float N; 2nd. The connecting slide H, in connection with the neck G, and the stove pipe F; 3rd. The egg boiler K, and meat pan L, in connection with the kettle I, and the fire tube or chamber D, also the combination and arrangement of the several parts.

No. 5458. Sole and Heel Protector for Boots and Shoes.

(*Protecteur de semelle et de talon des chaussures.*)

Henry E. Van Benchooten, Hillsdale, N. Y., U. S., 4th December, 1875, for 10 years.

Claim.—1st. A metallic plate or die provided with notched, twisted, barbed, or arrow pointed shanks or prongs b, c, for attaching it to the bottom; 2nd. Soles and heels of boots and shoes armed with the metallic wear plate or protectors a, a', inserted in counter sunk depressions so as to be flush with the outer surface or bottom of such heels and soles, and attached hereto by means of notched, twisted, barbed, or arrow pointed shanks or prongs.

No. 5459. Lightning Rod Standard.

(*Support de paratonnerre.*)

John C. Schoonmaker, Geddes, N. Y., U. S., 4th December, 1875, for 5 years.

Claim.—1st. The combination of the tube B, and bench C, with the legs D, D, D, for the lightning rod to pass through; 2nd. The arrangement of the clips G, G, on the tube B, for glass insulators.

No. 5460. Tubular Flues for Steam Boilers.

(*Bouilleurs de chaudières à vapeur.*)

Henry Bailey, New York, U. S., 4th December, 1875, for 5 years.

Claim.—1st. The spiral sections a, within the flue tube b, in combination with the combustion chamber d, formed by the space between two of said sections; 2nd. The spiral sections a, connected by the wires or rods c; 3rd. The method of directing the heated products of combustion upon the interior of the flue tube by twisted or spiral plates introduced within such flue tube; 4th. The means for twisting the metallic flue strip consisting of the revolving mandrel and vice and movable head block and vice.

No. 5461. Improvements on Printer's Galleys.

(*Perfectionnements aux galées d'imprimerie.*)

Charles A. Scadding, Toronto, Ont., 4th December, 1875, for 5 years.

Claim.—The combination of the rolled sides B, B, and bottom A, and secured together by means of screws entering from the outside thereof.

No. 5462. Improvements in Neck Yoke Leathers. (*Perfectionnements aux cuirs des jougs.*)

Jerome B. Relyea, Hicksville, Ohio, U. S., 4th December, 1875, for 5 years.

Claim.—The combination with a neck yoke A, and leather C, the metallic clip B, placed around the yoke under said leather, and fastened to the same by a bolt or rivet a, passing through the leather and the ears of said clip.

No. 5463. Mechanism for Propelling Sleds.

(*Appareil de propulsion des traîneaux.*)

David W. DeForest, Brooklyn, N. Y., U. S., 4th December, 1875, for 5 years.

Claim.—The combination of an actuating lever A, propelling staff C, and spring D, the whole combined and arranged for operation upon a sled.

No. 5464. Hay Loader. (*Élévateur à foin.*)

Charles W. Williams, Rochelle, Ill., U. S., 4th December, 1875, for 5 years.

Claim.—In combination with the horse hay rake provided with the wheel or pulleys B, B, and with the removable draft device J, J', J, K, the elevator D, connected to the draft device and one or more chains I, I.

No. 5465. Box Coffee Mill. (*Moulin à café à tiroir.*)

Rodolphus L. Webb, New-Britain, Ct., U. S., 4th December, 1875, for 15 years.

Claim.—1st. The box A, the cover B, and the hopper C, the box constructed with the headed lugs a, and the cover with corresponding slots whereby the two parts are secured together; 2nd. The combination of the cover B and hopper c constructed with the intermediate recess F, with the runner cylinder H constructed with the flange h, and so as to interlock between and with the said hopper and cover; 3rd. In a vertical mill, the combination of the runner shaft, the notched sleeve I, and corresponding projection l, on the saddle.

No. 5466. Machine for Making Plumbers Traps. (*Machine à faire des trappes de plomberie.*)

Frederic N. DuBois, New-York, U. S., 4th December, 1875, for 5 years.

Claim.—1st. The combination of two or more plungers operated by hydraulic or other suitable power with a corresponding number of receivers connected by suitable passages with an annular die, the plungers being provided with suitable adjuncts for varying their relative speed; 2nd. The combination of two hydraulic presses arranged in the same axial line, the receivers G, G, arranged between the press cylinders and constructed with the annular die C, C', and the straining bars B, B; 3rd. The valves N, actuated by mechanism common to both and combined in relation with the hydraulic presses whereby the relative velocities of the plungers F, F, actuated by said presses may be varied.

No. 5467. Steam Governor. (*Gouverneur de vapeur.*)

Daniel La F. Chase, Boston, Mass., U. S., 4th December, 1875, for 5 years.

Claim.—1st. The combination in a steam governor of a steam chamber, having induction and ejection ports with a steam conductor or conductors disposed within said chamber and provided with steam ports and valves arranged to close such ports by direct centrifugal action; 2nd. The combination of the case A, A', provided with induction and ejection ports D, C, the driving shaft S, S', provided with hollow arms or conductor B, B, having

ports O, O, the centrifugal valves V, V, and springs E, E, E, E; 3rd. The combination of the centrifugal valves V, V, with the hollow arms or conductors B, B provided with ports O, O, and the casing A A; 4th. The combination with the steam chamber or case A, and the shaft S, Sr, of the conductor or hollow drum B; provided with ports O, O, in each of its head valves V, V, and springs E, E; 5th. The combination of the steam chamber or case A, the shaft S, springs E, balls F, F, and tube or conductor B, provided with ports O; 6th. The arrangement of a centrifugal mechanism within the steam chamber of the governor.

No. 5468. Water Wheel. (*Roue hydraulique.*)

Orange Jull, Orangeville, Ont., 4th December, 1875, for 5 years.

Claim.—1st. The combination of the guide vanes K, placed on the large band J, to receive the infowing water with the buckets F, through which the water outflows; 2nd. The combination and arrangement of the guide vanes K, to receive the infowing water with the combination and arrangements of the buckets F, through and by which the water outflows in an opposite direction and in a parallel line to the infowing water; 3rd. The combination of the buckets F, having the inclined partition E running the whole height of the cylinder of the turbine wheel B, from the lower band X and dividing all the periphery of the wheel into grooves U, with the segmental part of the buckets F, through which the water outflows; 4th. The combination of the guide vanes K, and the bands L, separating the guide vanes K, with a turbine wheel B; 5th. The combination of the inclined planes P, having slots Q, through which the pins R, move obliquely to open and close the gate O, with a turbine wheel B; 6th. The combination of the outside gate O, bearing on the large band J, the pins R, the segmental rack S and the pinion T, to open and shut the gate O, with a turbine wheel B.

No. 5469. Vehicle Seat. (*Siège de voiture.*)

Everett A. Rice, New-York, U. S., 4th December, 1875, for 5 years.

Claim.—1st. The tooth bars m, and m; and cog wheel F and F, in combination with the lever rods C and D, connecting rods q and q, bed plate K, back rest B, and seat A; 2nd. The side rods T and T, in combination with the guide plate u and u, set screw w, w, seat A, and back rest B.

No. 5470. Paint Brush Bridler.

(*Serre-pinceau.*)

Theodore Snell and John W. Charles, Toronto, Ont., 4th December, 1875, for 5 years.

Claim.—The brush bridler C, constructed of sheet metal, rubber, or any other suitable material provided with an adjustable coupling C, C, and flanged or beaded lower edge C, and attached to the brush by the shouldered and bent cleats D, or by the strip F, and plate G, or their equivalent.

No. 5471. Self-Acting Sluice Doors and Lock Gates for Canals.

(*Vannes et portes d'écluses de canaux automatiques.*)

Thomas Milette, Trois-Rivières, Que., 4th December, 1875, for 5 years.

Claim.—1st. The combination of a water wheel P, placed in the drain o and having the main cog wheel Q, on its shaft with the puppet R, R, set on the main shaft S, to give it motion; 2nd. The combination of the second puppet T, the main friction wheel X, and its spur wheel, the large cog wheel Y, the cog-wheel z, and its shaft, the spur wheel a, the rack b, the toggles G, g, the levers l, l, the groove e, of the plate f, with the lock gates M, to open or shut them; 3rd. The combination of the lever j, the pivoted square K, the lever l, the arms m, m, the lever V, and its arm, the pulley W, with the second puppet T, hung on the main shaft S, to keep the lock gates either open or shut; 4th. The combination of the third puppet p, the main friction wheel u, the spur-wheel v, the quadrant z, the shaft y, with the valve doors z, to open or shut them; 5th. The combination of the lever A, the pivoted square B, the lever C, the arms D, D, the lever r, and the pulley t, with the third puppet p, hung on the main shaft S; 6th. The combination of the sluices E, divided by the cut stone divisions F, or beams H, the battened decking I, having the spaces J, between them forming the bottom of the basins with the valve doors z, to fill or empty the basins.

No. 5472. Improvements on Mocassins.

(*Perfectionnements aux mocassins.*)

Selby Lee, Ottawa, Ont., 4th December, 1875, for 5 years.

Claim.—1st. The shoe pack A, provided with a top B, shaped as described having a free edge f, overlapping the front upper b, at the instep; 2nd. The shoe pack having the top B, the combination of the eyelets d, and hooks e, for readily lacing the boot.

No. 5473. Chain-Stopper. (*Arrête-chaîne.*)

David N. B. Coffin, jr., Newton, and Benjamin Woodward, Cambridge, Mass., U. S., 9th December, 1875, for 5 years.

Claim.—1st. A suitable yielding pawl g, in combination with a cable or chain stopper-bed provided with a spring chamber c, and a chainway b; 2nd. A traversing pawl g, having a movement in the direction parallel to or approximately parallel to the chainway b, in combination with a stationary-bed to support the chain; 3rd. The combination of a pawl having a fore and aft movement in relation to the chain bed with the spring e, and follower d.

No. 5474. Paper Bag. (*Sac en papier.*)

Albert S. Dennison and John D. Huntington, Watertown, N. Y., U. S., 9th December, 1875, for 5 years.

Claim.—A paper bag A, for tradesmen's use provided with a metallic reinforcing strip B, at the seams.

No. 5475. Waterproof Bag. (*Sac imperméable.*)

Albert S. Dennison and John D. Huntington, Watertown, N. Y., U. S., 9th December, 1875, for 5 years.

Claim.—A waterproof paper bag for tradesmen's use.

No. 5476. Improvements on Machine Guns.

(*Perfectionnements aux canons à répétition.*)

James P. Taylor, Elizabethton, and John Baxter, Knoxville, Ten., U. S., 9th December, 1875, for 5 years.

Claim.—1st. The combination of the breech block 2; one or more barrels 1 a breech frame 3, cam or cams 8, revolving thereon and one or more sliding locks or plungers 9; 2nd. The combination of the cam 8 with a concentric front portion 17 to afford a rest or dwell for firing; 3rd. The construction of the eccentric cam 8, with a concentric rear portion 18 to afford a rest or dwell for loading; 4th. The cocking cam 31 carried by the eccentric cam 8 and adjustable to regulate the stroke of the firing pins; 5th. The combination of the breech block 2; the frame 3, the longitudinal breech bars 7 of the cam-shaft 10; eccentric cams 8 and sliding plungers 9, to take up the recoil; 6th. The combination of the breech frame with removable longitudinal breech bars 7; 7th. The recesses 11, grooves 12 and switch bars 13, in combination with the plungers 9 and extractors 14, for guiding and controlling said plungers and extractors; 8th. The combination of the ledges 16 and trough-bottoms 24 for supporting the cartridges at the rear of the barrels; 9th. The sliding lock 9, carrying yokes for retracting the lock and the firing pin respectively; 10th. The combination with the sliding lock 9, of the extractor 14, with lugs 15, and the switch bars 13 to elevate and release the said extractor 14th. The top plate 35 of the plunger constituting a guiding flange and formed with a slot 36 to receive the retracting latch or arm of the hopper valve; 12th. The hopper 5 constructed with fingers 43 and throats 44 for receiving cartridge from suitable cases or holders and conducting them to the proper position above the breech of each barrel; 13th. The hopper floor 47 constructed with T-shaped apertures to support the cartridge and drop them when drawn back; 14th. The hopper valves 38 constructed with T shaped openings 45, and operating in connection with the hopper throats 44, and floors 47; 15th. The hopper 5 hinged to the frame 3 to admit of tipping it to expose the loading chambers; 16th. A set or series of valves arranged in the arc of a cylinder in combination with a revolving cam cylinder constructed with two grooves or flanges one for operating the sliding locks or plungers and the other for retracting the firing pins; 17th. The recess 57 in the cam groove 19, to permit the retracting of the plungers to a point which enables their removal; 18th. The adjustable hopper front for adapting the hopper throats to suit blank cartridges; 19th. The hopper floor adjustable to suit blank cartridges.

No. 5477. Improvements on Capstans and Windlasses.

(*Perfectionnements aux cabestans et aux guindaux.*)

David N. B. Coffin, jr., Newton, and Benjamin Woodward, Cambridge, Mass., U. S., 9th December, 1875, for 5 years.

Claim.—1st. The combination of the internal worm gear or nut-wheel a, with the screw or screws b, and barrel c, of the capstan; 2nd. The combination of the two screws b, the two gears, and shaft f, with the head of the capstan; 3rd. The pawl-holder k, hinged to the capstan; 4th. The combination of short lever socket p, its cam hinged to the screw rod q, made to turn in the deck and nut r, attached to the friction brake or strap of a windlass; 5th. The arrangement and combination of two sets of elastic cushions between and with the driving and driven parts of the actuating or impelling mechanism of a windlass; 6th. The centre bearing constructed with step and bars n, for upright shaft and the rest or bearing for the horizontal shaft; 7th. The combination of the two fixed non rotating spindles u, u, with the chain wheels or windlass barrels v, the capstan and suitable connecting gears; 8th. The combination of the two fixed non-rotating spindles u, u, the chain-wheels or windlass-barrels v, and the messenger wheel 46, with suitable connecting gears; 9th. The combination of the capstan z, and the messenger wheel 46, with suitable connecting gear; 10th. The sleeve 8, in combination with its friction grooved-plates, the chain-wheel and the friction grooved plate connected thereto and the nut wheel 24; 11th. Friction rings or sections of rings g, in combination with the grooved-friction plates; 12th. In a windlass, the arrangement of an anchor chain to engage with the chain wheel at its lower forward side, extend around aft and upward, leaving the periphery on the upper forward side for the hawse-pipe and anchor in combination with a turn around the forward side of the bit as it passes from the deck-pipe to the windlass; 13th. The upright roller 26, in combination with the windlass bit, and the arrangement of the cable or anchor-chain; 14th. The combination of the pawl 50, located forward of the windlass with the chain-wheel and its pawl-wheel or drum 43; 15th. The separate friction wheel 38, in combination with the separate chain-wheel, when the two are automatically locked to each other; 16th. The combination of the sliding lock-bolt 40, friction wheel 38, and a ratchet wheel and shaft 36 and 46; 17th. The construction of a windlass-beam with the T-section shaped connection to the links; 18th. The construction of a windlass-beam with through open sockets for levers arranged obliquely to each other; 19th. The internal ratchet wheel 36, in combination with the pawl lever or wheel 34, 35, and the windlass shaft; 20th. The double series or reversed pawls of wheels 34, in combination with the ratchet wheel 36; 21st. The construction of the chain-guard and chain-guide in one article for the double use; 22nd. The chain-wheel or barrel 29, and pawl wheel 43, constructed separately and automatically clutched together by projections and recesses or shoulders.

No. 5478. Improvements on Window Blind Fasteners. (*Perfectionnements aux arrêtes persiennes.*)

Joel Shedd, Waltham, Mass., U. S., 11th December, 1875, for 5 years.

Claim.—A wire blind fastener having a horizontal spring arm A, projecting end G, inclined or brace-arm E, intermediate spring coil E, and horizontal eye F, the same being constructed and adapted to be applied to the blind or shutter.

No. 5479. Improvements on Treadles.

(*Perfectionnements aux marches.*)

Daniel E. Lillis, Jackson, Mich., U. S., 11th December, 1875, for 5 years.

Claim.—The combination of the rock-shaft B, having a central crank provided with a foot rest C, arm D, and pitman E, with the frame A, and power wheel F, for operating the machine by a swinging motion of the foot.

No. 5480. Improvement in Making Nuts.*(Perfectionnements dans la fabrication des noix.)*

Alfred Marland, Pittsburgh, Pa., U. S., 11th December, 1875, for 5 years.

Claim.—1st. The method of making square, hexagon, octagon, or round nuts out of round, oval, square or other shaped rods by first severing the blanks transversely without materially distorting the form from rods or bars *f*, a diameter equal or about equal to that of the inscribed circle of a cross section of the nut to be made, second: in closing the same in a close die or box corresponding in transverse section to the shape of the nut to be made, third: expanding the same by end compression so as to fill the die and, fourth: punching the eye in the axial line of the blank; 2nd. The knife moving across the face of the die box and covering the box while the blank is shaped by the dies; 3rd. The die *H*, connected to the sliding cross head which is adjustable on the bars *M*; 4th. The punch adjustably connected to the main cam yoke in combination with dies *H* and *I*, and moved by means of the main cam *C*; 5th. The sliding cross head and die *H*, arranged for the purpose of pressing the nut into shape and after passing for delivering the nut out of the box; 6th. The side cams *J*, in combination with yokes *K*, bars *M*, cross-head *L*, and dies *H*, *I*, 7th. The combination of dies *H*, *I*, cutter *O* and punch *E*; 8th. The cutter arranged in combination with die *I*, to close the same and hold the blank while being pressed into shape.

No. 5481. Machine for Taking and Pumping Water out of any Vessel, Ship or Boat.*(Machine à puiser et pomper l'eau de tout vaisseau, navire ou bateau.)*

Isaac Cosgrave, Chatham, Ont., 11th December, 1875, for 5 years.

Claim.—1st. The combination of the chambers *A*, *D*, with their respective slots *I*, *L*, and openings *F*, *G*, to the siphon *H*, and their application; 2nd. The application of the siphon *H*, with the chambers *A*, *O*, for use in any vessel no matter how propelled.

No. 5482. Manufacture of certain Oxides and Sulphides.*(Fabrication de certains oxides et sulfides.)*

Henry Knight, Liverpool, Eng., 11th December, 1875, for 5 years.

Claim.—1st. The application of one or more soluble sulphides as a precipitant of zinc sulphide from solutions of zinc, in combination with the subsequent calcination of the precipitate; 2nd. The application of the washing of soda waste on a soluble sulphide of calcium as a precipitant of zinc from its solution; 3rd. The combination of the elimination of sulphuric acid from solution of zinc by means of a soluble salt of Barium together with the subsequent precipitation of the zinc by a solution containing a soluble sulphide of calcium; 4th. The mode of making an extremely comminuted form of oxide or sub-sulphide of zinc by roasting artificially precipitated zinc sulphide; 5th. The method of manufacturing oxide or sub-sulphide of zinc as described.

No. 5483. Mop-Wringer.*(Essoreuse à torchon.)*

John Lang, Arnprior, Ont., 11th December, 1875, for 5 years.

Claim.—1st. A mop wringer frame composed integrally of three sided bars *C*, helixially terminating in a perforated focus *B*, combined with a rim *A*; 2nd. In the lugs *D*, integrally combined with the rim *A*, and straddling the edge of the pail for holding the wringer.

No. 5484. Improvements in Paddle Wheels.*(Perfectionnement des roues à aubes.)*

Ross Forward, Cincinnati, Ohio, U. S., 11th December, 1875, for 10 years.

Claim.—1st. The combination in a propeller wheel, of paddles *C*, having side *e*, wider and heavier than the one *c*, with stud *c*, and shoulders *c*₃, with a slide *D*, having stud *d*; 2nd. A reversible propeller paddle *C*, pivoted loosely in wheel arms *B*, striking the water in feathered position and passing through it in an arc corresponding to that in which wheel moves until it arrives at a point within 30 to 35 degrees of the perpendicular from shaft, thence assuming a vertical position for 60 to 70 degrees, and thence moving loosely through and out of the water in the line of least resistance; 3rd. The combination of slides and reversible eccentric grooves as formed by plates *F*, and *C* in frame *A*, for the purpose of reversing and operating the wheel in their direction; 4th. The combination with studs *d*, *e*₂, *e*₃, of intermediate cam to prevent sudden impact.

No. 5485. Apparatus for Draining and Pumping Water from the Holds of Ships.*(Appareil à puiser et pomper l'eau de la cale des navires.)*

James E. Nute, John H. Nute and James Roode, New-Glasgow, N. S., 11th December, 1875, for 5 years.

Claim.—1st. The application to ships, &c., of the cylinder *B*, having the projecting port *C*, for creating a vacuum when the vessel is moving, extending through the bottom *A*, of the vessel and provided with outlet drop valve *D*, and inlet valve *E*, for expelling leakage water by gravitation when the vessel is moving a head; 2nd. In combination with cylinder *B*, having the constructive and operating features described in the preceding claim, the piston *G*, for expelling the leakage water downwardly through the bottom of the vessel when at rest, by pumping.

No. 5486. Stove-Pipe Shelf and Drier.*(Tablette-séchoir à tuyau de poêle.)*

John C. Schoonmaker, Hamilton, Ont., 11th December, 1875, for 5 years.

Claim.—The combination of the stove pipe-shelf *b*, formed of the letters "Handy stove shelf" (or their equivalent) and inner and outer circles *c*, *i*, *v*, provided with lugs *A*, *Al*, with the rods *g*, and loops *f*, forming a combined stove-pipe shelf and drier frame.

No. 5487. Tanning-Apparatus.*(Appareil de tannerie.)*

Harvey Reed, Vineland, N. J., U. S., 11th December, 1875, for 5 years.

Claim.—1st. The combination in a series of tan-vats of removable partitions and racks, for suspending the hides; 2nd. The combination of a series of tan-

vats, a series of leaches, and a propelling-wheel, the leaches and the vat provided with passages for an endless-current of the liquor to be forced around through the leaches and vats in succession; 3rd. The combination of a series of removable leaches and removable partitions; 4th. The wheel *M*, provided with internal and external projecting blades as arranged, and adapted to soften and scour hides or skins, and to keep the liquor in continuous circulation.

No. 5488. Harness Pad Press.*(Presse de bottrelieur.)*

William Dippert, Des Moines, Iowa, U. S., 11th December, 1875, for 5 years.

Claim.—In a harness pad press, the combination of the forms 1 and 2, the hinged rims *d*, *d*, and the screw press *f*, *g*, *h*, adapted to depress and hold the rims.

No. 5489. Improvements on Scale Pans.*(Perfectionnements aux plateaux des balances.)*

James McLean, St. George, N. B., 11th December, 1875, for 5 years.

Claim.—A combined scale pan, scoop and funnel constructed of the continuous or connected funnel handle, and scoop-ports *A*, *B*, *C*.

No. 5490. Machine for Making Lightning-Rods.*(Machine à faire les paratonnerres.)*

John C. Schoonmaker, Geddes, N. Y., U. S., 11th December, 1875.

Claim.—In combination with the hollow-shaft *B*, the twisting-plate *E*, having dies *e*, either inserted or formed therein, reels *g*, die *a*, and reel *J*.

No. 5491. Machine for Whitening and Buffing Leather.*(Machine à mégisser et chamoiser les peaux.)*

Joseph E. Fisk, Salem, Mass., U. S., 14th December, 1875, for 5 years.

Claim.—1st. The combination and arrangement of the rotary-cutter *C*, with the vibrating-bed *F*, and sliding frame *E*; 2nd. The combination of the lever *L*, with the clutch *j*, and friction wheel *J*, for raising and lowering the bed simultaneously with its vibrating movement.

No. 5492. Adjustable Waggon-Axle.*(Essieu de wagon mobile.)*

Joseph R. Lantz and Thomas L. Mitchell, Marrowbone, Ill., [U. S., 14th December, 1875, for 5 years.

Claim.—1st. The octagonal-shaped axle-sections *B*, in combination with the hexagonal box *A*, formed in section *a*, *ar*, and bolt or rod *e*, for tightening and clamping the sections; 2nd. The hexagonal-box *A*, composed of the sections *a*, *ar*, the latter having slot *b*, and shoulders *c*, in combination with the octagonal axle sections *B*, and set-screw *d*.

No. 5493. Improvements on Electric Telegraphs.*(Perfectionnements aux télégraphes électriques.)*

Robert K. Boyle, New York, U. S., 14th December, 1875, for 5 years.

Claim.—1st. The combination with two or more induction coils of a brush or key moving over a surface composed of alternating sections of conducting and non-conducting materials, each of the conducting sections being connected to the inner or inducing helix of one of the coils, and through this helix with one pole of a battery while all the conducting sections are connected to the other pole of said battery whereby a constant current of induced electricity of either kind can be produced; 2nd. The combination of the circuit wheel *B*, shaft *E*, disc *A*, and induction coils *C*, *D*, with each other with one or more batteries, and with the line wire of a telegraph line; 3rd. An electric telegraph apparatus whereby successive waves of one kind of induced electricity, say positive, can be produced so as to form a continuous current for the purpose of recording messages, while the induced electricity of the opposite kind, say, the negative, is thrown into form the spaces between the letters and words, and thereby tailing of the signals is prevented.

No. 5494. Cutting Bolt Nipper.*(Tenaille à couper les boulons.)*

William Ellard, Shead's Mills, Ont., 14th December, 1875, for 5 years.

Claim.—1st. The combination of box *B*, having slots *G*, *G*₁, in its upper plate *F*, and bottom plate *E*; the mortise *M*, the wedges *O*, the stationary die *N*; the movable die *R*, the die-holder *Q*; the links *P*, with the handles *A*, having eccentrics *D*, at their pivoted end *I*, to make a cutting bolt nipper; 2nd. In combination with the handles *A*, of a cutting bolt nipper, the notches *C*, and the tail *T*, having the tip end *U*.

No. 5495. Horse Overshoe.*(Couvre-fer à cheval.)*

Arthur C. Snowden, South Norwalk, Ct., U. S., 14th November, 1875, for 5 years.

Claim.—1st. The correspondingly constructed plates *A*, *B*, and *D*, *D*, attached to an ordinary shoe by means of lugs *E*, *E*, and screw *F*; 2nd. The calks *G*, constructed with steel points *H*, *H*.

No. 5496. Art of Transmitting Musical Sounds Telegraphically and Apparatus therefor.*(Art de transmettre les sons musicaux télégraphiquement et appareil pour cet objet.)*

Elisha Gray, Chicago, Ill., U. S., 14th December, 1875, for 15 years.

Claim.—Transmitting a series of tones of different pitch, provided by vibrating electro tones or automatic circuit interruptions through an electric circuit to a corresponding series of receiving instruments, each vibrating synchronously with the impulses of its respective transmitting circuit interrupter whereby each receiver reproduces its appropriate tone without interfering with the others transmitted through the same circuit; the combination of a main line, an intermittent circuit breaker adapted to throw upon the line a definite number of electrical impulses in a given time, and a key for controlling such circuit breaker; the combination of a telegraphic circuit, an automatic circuit breaker capable of producing a musical tone and an

electro-magnet receiver which reproduces the tone by being thrown into vibration by impulses generated by the circuit breaker; the combination in the receiver of the vibrating bar which reproduces a musical tone and its circuit breaking lever constructed to vibrate more slowly than the bar, whereby the circuit is interrupted without de-magnetizing the magnet; the combination of a series of transmitters, a series of receivers and a local circuit and recording mechanism, with each receiver, whereby each receiver is enabled to analyse or select and record its own notes from a number simultaneously transmitted through the same circuit; the combination in an electric circuit, of a series of vibrating electro-tones whose circuit breaking springs when in action produce tones of different pitch and a series of keys each controlling its corresponding electro-tone, whereby several tones simultaneously may be transmitted through a single circuit; the combination with a single electric circuit of a series of transmitters or circuit interrupters composed of bars or strings electrically vibrated with sufficient rapidity each to produce a tone of a pitch differing from its fellows and a series of corresponding receiving instruments likewise arranged in the circuit, and each caused to vibrate synchronously with its transmitter of corresponding pitch by impulses generated by the interruptions of the current occasioned by the vibrations of the transmitting instrument, whereby each receiver selects its own tones without interfering with others simultaneously passing through the circuit.

No. 5497. Improvements on Hydraulic Dredges and Peat Elevators.

(Perfectionnements aux dragues hydrauliques et aux élévateurs à tourbes.)

William H. Newton, Chicago, Ill., U. S., 14th December, 1875, for 5 years.
Claim.—1st. The combination of a suction pipe with an ejection pipe to be used with a dredge for disintegrating and holding earth in suspension in water and elevating the substance; 2nd. The combination of a telescopic suction pipe F, G, with rubber rings or flexible rings placed between the sections; 3rd. The reversible hood V, combined with its operating attachments H, R, S, 5, and reversible nozzle T; 4th. The telescopic suction pipe F, G, provided with a horizontal pipe 2, in combination with sleeves 3, communicating with vacuum pumps E, E; 5th. The combination of the telescopic pipe F, G, joined to the pump E, E, at 2, 3, with an ejection pipe M, N, L, and a free pump b, and conveyer pipe a, arranged with reference to a dredge scow or hull A, provided with a well hole Q**, and elevating a capstan D; 6th. The combination of the suction of a telescopic pipe F, G, with the elliptical spring H, for holding the section G, in a yielding position down to its work.

No. 5498. Improvements on Printer's Quoins.

(Perfectionnements aux biseaux d'imprimerie.)
 John Foley, Orangeville, Ont., 14th December, 1875, for 5 years.
Claim.—1st. The combination of the double bevelled side pieces A, wedges E, and screw D, having a collar c; 2nd. The combination of the wedges E, having dovetail lugs F, and side pieces A, having dovetail grooves G, for retaining the several parts of the quoin operatively together.

No. 5499. Improvements in Sheet Metal Pipe Elbows.

(Perfectionnements aux coudes de tuyaux en tôle.)
 George Lupton, Indianapolis, Ind., U. S., 14th December, 1875, for 5 years.
Claim.—1st. An un-crimped and uncut curved trough B of sheet metal; as a blank for pipe elbows, the same being smooth on its surface and of approximately uniform thickness throughout; 2nd. A curved pipe elbow, formed from a single piece, or blank of sheet metal without cutting or crimping the same, and being smooth on its surface and of approximately uniform thickness throughout.

No. 5500. Improvements on Harness Buckles.

(Perfectionnements aux boucles de harnais.)
 Joshua Challenger, Mitchell, Ont., 14th December, 1875, for 5 years.
Claim.—The combination of the snap with the buckle and the formation of the bar on which the tongue is secured, also in the formation of the buckle combined with the snap and the metallic-guard loop for holding the end of the strap behind the section of union between the buckle and snap.

No. 5501. Improvements on Hay Presses.

(Perfectionnements aux presses à foin.)
 Charles G. C. Simpson, Montreal, Que., 14th December, 1875, (Extension of Patent No. 982), for 5 years.

Claim.—1st. The frame a, box b, moveable side b1, cover c, bottom d, horizontal balks e, curved surface f, levers g, toothed ends g1, supports h, friction rollers h1, friction wheels i, pulley wheels k, hold fast l, friction roller l1, rope or chain m, friction roller n, drum o, capstan p, lever p1, capstan head p2, bolt p3, eccentric p4, arm p5, roller g, bar g1, arm g2, catch q3, doors r; rounded ends r2, eccentrically curved end r3, vertical bar r4, arm r5, catch r6, 2nd. The curved surface f, whether convex or concave, and the toothed ends g1, of lever g, meshing into each other; 3rd. The friction roller n, bolt p3, actuated by eccentric p4, and arm p5; 4th. The eccentrically curved end r3, of the rails r1; 5th. The rollers n, rope m, levers g, g, connected under the follower or support h; 6th. The levers g, g, with gear connections g1, and brackets k1, extending downwards between the timbers e, so as to apply the power below the tread of the lever rollers i.

No. 5502. Improvements in the Art of and Apparatus for Tanning Skins.

(Perfectionnements dans l'art et les appareils de tannage des peaux.)
 Horace W. Woodruff, (Assignee of G. Scoullar), New York, U. S., 14th December, 1875, (Extension of Patent No. 773), for 5 years.

Claim.—A vat A, a chamber or hollow cylinder B, sundry pipes E, G, G, H, I, K, P, R, and a vacuum gauge F, with a rack or racks D, in the chamber B, also the method, process or art for operating with the same, such consisting

of the suspension of the skins within such chamber or cylinder B, on the rack or racks D, thereof, and subsequently exhausting the chamber and skins therein of most of if not all the air contained therein and afterwards introducing the tanning liquid into the space so exhausted of air.

No. 5503. Improvements in the Art of and Apparatus for Tanning Skins.

(Perfectionnements dans l'art et les appareils de tannage des peaux.)

Horace W. Woodruff, (Assignee of G. Scoullar), New York, U. S., 15th December, 1875, (Extension of Patent No. 773), for 5 years.

No. 5504. Improvements in Refrigerators.

(Perfectionnements aux réfrigérants.)
 Daniel Y. Howell, Toledo, Ohio, U. S., and Ethelbert B. Paxton, Windsor, Ont., 16th December, 1875, for 10 years.
Claim.—The annular ice receptacle D, in combination with the box A.

No. 5505. Improvements in a Machine for Freezing Fish and Meat.

(Perfectionnements à une machine à geler le poisson et la viande.)
 Daniel Y. Howell, Toledo, Ohio, U. S., and Ethelbert B. Paxton, Windsor, Ont., 16th December, 1875, for 10 years.
Claim.—1st. The employment of sheets of metal arranged in pairs in a suitable box, in connection with a freezing mixture; 2nd. The arrangement within the box A, of the sheet metal plates B, and blocks C, D and E.

No. 5506. Dumping Platform for Railway Cars.

(Plateforme à bascule pour les wagons de railroute.)
 John W. Harrison, Niles, Mich., U. S., and Henry E. Susand, Berlin, Ont., 16th December, 1875, for 5 years.

Claim.—1st. The combination of the strip A, frame B, B, cross-pieces C, C, C, friction rollers X, X, X, bulk heads F, F, and the shaft D, having pinion wheel d, d; 2nd. The combination of the sliding floor K, cog-bar L, L, gauge bars M, M, M, pivot shaft N, and rollers n, n.

No. 5507. Apparatus for Braking and Signaling in Railway trains.

(Appareil serre-frein et télégraphique pour les convois de railroutes.)
 James Steel, Glasgow, Scot., 16th December, 1875, for 5 years.

Claim.—1st. The arrangement and construction of brake apparatus consisting of a vertical cylinder A, placed at the central part of each carriage and provided with a receiver B, either surrounding the cylinder or placed above, below, or at one side thereof into which compressed air for actuating the brakes is conducted through chambers W, and pipes Q, R, jointed by flexible couplings at each end of the carriage; 2nd. The arrangement of mechanism consisting of the pipes T, T, and valves w, whereby equilibrium of air pressure in the upper part of the cylinder and in the air vessel or receiver is effected; 3rd. The arrangement of levers C, by which the flexible couplings are connected and disconnected, and the employment thereof in connection with the arrangement of brake apparatus having the air cylinder A at the centre of the carriage or with that in which the air cylinders are placed at each end of the carriages; 4th. The arrangement by which the direct coupling of the piston of each brake cylinder to the brake blocks at both ends of the carriage is effected by means of the bell crank levers G, links H, H, and cross ties or stays I; 5th. The funicular acting mechanism I, t, t, for operating the brakes or any mere modification thereof; 6th. The packing of the piston F, consisting of cup leather h, k, springs l, and shot, and the employment thereof for purposes generally in which a moveable piston is employed; 7th. The several packings described and the employment thereof in the stuffing boxes of the brake cylinder and in stuffing boxes generally; 8th. The cock of valve z, for withdrawing the air pressure from the receiver B, and so preventing the application of the brakes when the carriages composing a train are uncoupled thereby leaving them free to be moved about; 9th. The arrangement and construction of apparatus for operating the brakes on the locomotive tender by compressed air; 10th. The employment of the reducing valve t, or of an equivalent valve as described; 11th. The use or employment of fog horns for signalling apparatus, in trains provided with brakes actuated by compressed air generally and the arrangement of signalling apparatus H, or any mere modification thereof; the passengers or guard in sounding the horns H, also apply the brakera as described.

No. 5508. Improvements in Folding Blinds.

(Perfectionnements aux persiennes pliantes.)

Alphonzo LeRoy, Syracuse, N. Y., U. S., 16th December, 1875, for 5 years.
Claim.—1st. A folding blind consisting of two side rails or their equivalents, and a series of overlapping slats pivoted thereto; 2nd. The combination of the hollow rail or body B, the rail C, and the pivoted slats A; 3rd. In combination with the rails B, C, and pivoted slats A, the sliding bar D, and links E.

No. 5509. Improvements on Whiffle-trees.

(Perfectionnements aux palonniers.)
 Stephen F. Humphrey, St. Thomas, Ont., 16th December, 1875, for 5 years.
Claim.—1st. The combination of the whiffle-tree C, tube D, spiral spring E, bolt F, and strap G; 2nd. The combination of hanger H, and roller J, J, also hook and spring J.

No. 5510. Apparatus for Raising Water, &c.

(Appareil pour élever l'eau, &c.)
 Henry Port, Stapleton, N. Y., U. S., 16th December, 1875, for 5 years.
Claim.—1st. The elevator composed of an endless band of buckets with a central tube in each through which passes the sustaining rope or links in

combination with the cog blocks C; 2nd. The combination with buckets each containing a central tube of metal links passing through such central tube and cog blocks for connecting such links together; 3rd. The endless band of buckets passing over a wheel at the upper portion of the apparatus in combination with the inclosing case trough and tubular openings through the trough.

No. 5511. Device for Indicating the Distance Travelled by Vehicles.

(Appareil pour indiquer la distance parcourue par les voitures.)
Thomas Bournann and Harrison T. Beebe, Fort Erie, Ont., 16th December, 1875, for 5 years.

Claim.—1st. A registering indicator or counter formed by the spur wheel D, operating as described, the ratchet wheel E, in combination with the index wheels F and G; 2nd. The pin a, in a wheel A, of a buggy or any other wheel in combination with the spokes B, and spur pinion c; 3rd. The pawl d, pivoted to the spur-wheel D, and acted on by the spring b, in combination with the ratchet wheel E.

No. 5512. Stove-Board. (Sous-poële.)

George F. Sawyer, Albion, N. Y., U. S., 16th December, 1875, for 5 years.

Claim.—The disc A, and the rim B, having the apertures a, a, a, for the circulation of air.

No. 5513. Coal Scuttle. (Seau à charbon.)

George F. Sawyer, Albion, N. Y., U. S., 16th December, 1875, for 5 years.

Claim.—1st. A bottom A, provided with apertures c, c, c, locked or fastened to the body of a coal-hod or other article by means of the lips d, d, d; 2nd. In the bottom, the apertures c, c, c, for the circulation of air under the hod; 3rd. A bail handle D, made from one piece of sheet metal having the ends E, E, corrugated and drawn in.

No. 5514. Fifth Wheel for Vehicles.

(Rond d'avant-train de voiture.)

LaFayette Blair, Painesville, Ohio, U. S., 16th December, 1875, for 5 years.

Claim.—1st. The plate or bearing c, provided with inner and outer spherical surfaces and means for attachment to the axle; 2nd. The plate or bearing c, provided with the lubricating chamber, upon its friction face; 3rd. The combination with the plate c, of the cylindrical or conical king-bolt K, and the elongated-slot t; 4th. The combination with the plate C, of the box A; 5th. The combination with the plate C, and box A, of the plate G, and the clips b; 6th. The combination with a hollow spherical bearing plate c, of the spherical cap-plate B, and king-bolt K, the said king-bolt starting from the under side of the plate C; 7th. The combination with the spherical cap B, of the reach box g; 8th. The combination with the plate C, and the reach box g, of the brace H, attached rigidly to the said plate and hinged to the reach box; 9th. The combination with the plate c and B, and king-bolt K, of the head block D, and shoulder h; 10th. The combination with the plates C and B, head-block D, and spring E, of the king-bolt K, starting from the underside of the plate E, and the nuts C; 11th. The combination of box A, plates C and D, reach-box G, head block D, king-bolt K, and elongated slot t.

No. 5515. Improvement in Hame Fasteners.

(Perfectionnement dans l'ajustage des attelles.)

Alfred J. Park, Virginia, Mo., U. S., 16th December, 1875, for 5 years.

Claim.—1st. The hame-fastener composed of the pieces A, B, and latch C; 2nd. The locking slide D, arranged in combination with the parts A, B, C.

No. 5516. Hay Rake and Loader.

(Râteau élévateur à foin.)

Thomas Curtis, Urbana, Ill., U. S., 16th December, 1875, for 5 years.

Claim.—1st. The inclined guard plate W, with slots W₁, the rake F, conveyor or elevator G, g, H, H, and its driving attachments b, I, h, when supported on the frames C and D, and wheels B, B.

No. 5517. Buckle for Garments (Boucle de hardes.)

William H. Barker, Pella, Iowa, U. S., 16th December, 1875, for 5 years.

Claim.—The combination of tongues A, the bows B, and the straps C.

No. 5518. Soda Cask. (Fût à soda.)

Ira N. Herrick, Chicago, Ill., U. S., 16th December, 1875, for 5 years.

Claim.—1st. The port H, in combination with the thimble G, provided with the port J, and faucet C, D, F; 2nd. The devices enumerated in combination with the removable cap E.

No. 5519. Lifting Jack. (Cric.)

David T. Welch, St. Louis, Mo., U. S., 16th December, 1875, for 5 years.

Claim.—The combination of the upright B, B, cross beam C, and yoke beam D, with the crank K, shaft F, worm W, nut N, and screw S, provided with a swivel and grapple.

No. 5520. Stove-Pipe Damper.

(Clé de tuyau de poêle.)

Samuel Selden, Erie, Pa., U. S., 16th December, 1875 for 5 years.

Claim.—1st. The spring plate or tongue D, attached to the damper, in combination with the notched or recessed spindle B; 2nd. The combination with the thimble E, of the sleeve F, arranged and operating relatively to the thimble bearing the pipe A; 3rd. The thimble or sleeve F, and spring G, applied to the spindle B, and operating in combination with the damper C, to hold the pipe with a frictional grasp.

No. 5521. Improvements on Machines for Cutting Paper Bags.

(Perfectionnements aux machines à tailler les sacs en papier.)

Thomas Gain, Hamilton, Ont., 16th December, 1875, for 5 years.

Claim.—1st. In combination with a paper cutting machine the knives G, G, constructed with a cutter projection a, at nearly right angles with the main cutting edge; 2nd. In combination with a paper cutting machine the two knife cutters having their inner ends constructed with projecting cutters a, a, rendered adjustable for cutting paper in the shape and form shown for paper bags of any size; 3rd. The adjustment of the knives G, G, to the bar E, by means of the bolts J, J, through the slot I; 4th. In combination with the cutters G, G, the holders L, L, provided with projections g, and slot c, and adjusted to bar F, by bolt d, and nut f.

No. 5522. Railway Signalling Apparatus.

(Appareil à signaux de railroutes.)

Austin Chambers, London, Eng., 16th December, 1875, for 5 years.

Claim.—1st. The application and use in combination with a collapsible compressor g, and a pipe f, tube or passage charged with elastic fluid for operating by change of pressure a semaphore arm b, or its equivalent, of a valve l, operating in connexion with an orifice i, in the end of the compressor and so arranged in relation to a stop or stud l₂, that when and so long as the compressor is in its expanded condition the valve shall be open thereby establishing and maintaining the atmospheric pressure within the compressor until the latter is again moved or compressed; 2nd. The arrangement of apparatus in which a semaphore arm b, or its equivalent, is combined with it a slotted rod d, a lever or scale beam m, and two collapsible vessels e, e', operated from independent stations or places; 3rd. The combination with a pipe f, tube or passage charged with elastic fluid, and apparatus for changing the pressure of such fluid for operating a semaphore arm, or its equivalent, of apparatus composed of two or more collapsible chambers e, e', separated by a division e₂, or divisions, each collapsible vessel being in communication by its pipe f or f', with an independent pressure changing apparatus; 4th. An apparatus designed to meet the requirements of cases in which three distinct and separate levers are to be moved over in order to move the semaphore arm or signalling body into the safety or pass position the combination of three collapsible vessels, namely, one upper vessel e, and two lower vessels e', e₂, each of the said collapsible vessels being independently governed by one of the three levers; 5th. The application and use in conjunction with a pipe f, tube or passage charged with elastic fluid and apparatus for changing the pressure of said fluid of a lever i, i, valve n, and nozzle f₁₅, having an elastic seat f₁₄, in connexion with which the valve is arranged to operate as described; 6th. The combination with a lever f₆, or its equivalent for moving railway points or switches of a pipe f, tube or passage charged with air or other elastic fluid and means for increasing or diminishing the pressure thereof above or below the external atmospheric pressure, such pipe tube or passage having branches f₁₁, f₁₂, or connexions to the respective semaphore arms or other signalling objects or bodies and being provided with a valve f₁₂, operated by the movement of the said lever or its equivalent for operating and closing communication between the main pipe tube or passage and its respective branches as well as between the latter and the external atmosphere in such manner as to ensure correct signalling according to the position for the time being of the points or switches; 7th. The combination with the levers f₆, and stud f₇, of the link f₅, rod f₄, stud f₃, slide valve f₂, pipes f, f₁₁, f₁₂, and eduction port f₁₃; 8th. The combination with a pipe f, tube or passage charged with elastic fluid, apparatus for changing the pressure of said fluid, a collapsible vessel e and a rod d, operating a semaphore arm b, of a burner c₁, fed with gas by a flexible tube c₂, and guided by a frame c₃, so as to operate in conjunction with the "safety and danger" lenses c₄, c₅, of lamp c, carried by the post a; 9th. An apparatus wherein the semaphore arm b, or its equivalent is operated by changing the pressure of elastic fluid, in a pipe f, tube or passage by means of a collapsible compressor g, the application and use in connexion with air aperture in such compressor of a valve o, arranged to open upward in such manner as during the earlier portion of the upward or expanding movement of the compressor to open by the excess of the external atmospheric pressure thus admitting air into the compressor whereby its expansion is expedited; 10th. The combination with a semaphore arm b, or its equivalent for signalling on railways of a pipe f, tube or passage charged with elastic fluid, a collapsible vessel e, or chamber operating by its movement the semaphore arm or equivalent, an air pump compressor g, or rarefier actuated by a lever t, and a valve f₂₁, or governing apparatus operated by a second lever f₆, said valve or governing apparatus being interposed between the pipe tube or passage f₂₀, leading from the air pump compressor or rarefier and the pipe tube or passage f, leading to the collapsible vessel or chamber so as to prevent the giving of a safety signal until the lever of the valve or governing apparatus has been moved from the "danger" position; 11th. The application and use for indicating to the operator that position of the signalling object or body of a valve t, arranged in connexion with a hole e₂₀, in a moving part of the collapsible vessel e, whereby the signalling body is actuated, said hole and valve being so arranged in relation to a pipe u, communicating with an indicator placed near the operator, as at the proper time to establish communication between the said indicator and the interior of the collapsible vessel, and thereby to indicate that the signal has resumed the danger position; 12th. An apparatus wherein the semaphore b, or their equivalents are operated by changing the pressure of elastic fluid in pipes f, tubes or passages combining an air pump compressor or rarefier with a series of semaphore arms or equivalent signalling object by the interposition of a main pipe f₂₀, and a corresponding series of branches f, each furnished with a valve f₂₁, or governing apparatus operated by a suitable lever s; 13th. The method of working a point lock pneumatically for securing a pair of points at a distance by combining with the lever f₆, a locking plate r, and arranging in conjunction therewith a bolt w, operated by the movements of a collapsible vessel e, actuated by changing of the pressure of elastic fluid within it.

No. 5523. Tramway for Conveying Excavated Material.

(Chemin à ornières pour transporter le déblai d'excavation.)

Jam s Canan, Port Colborne, Ont., 16th December, 1875, for 5 years.

Claim.—1st. The frame C, with sides C₁, containing the tramway H, in combination with the derrick D, and winch E; 2nd. The rack I, upon the

tramway H, in combination with the spur wheel G, arm I, and dumping cart F; 3rd. The rope or chain g, attached at one end f, to the cart F, and operated upon by some conveniently situated motor as to cause the cart F, to ascend the tramway H.

No. 5524. Railway Car-Axle.

(*Essieu de wagon de railroute.*)

Theron S. E. Dixon and George H. Wards, Chicago, Ill., U. S., 18th December, 1875, for 5 years.

Claim.—1st. The railway-car axle A, having an elevated rim or shoulder D, an inner bearing C, of greater diameter than the body of the axle, and a smaller outer bearing E; 2nd. The railway-car-axle A, having an elevated rim or shoulder D, larger-bearing C, and smaller bearing E, and provided with the oil passages G; 3rd. The combination of the loose wheel B, revolving axle A, and nut or cap F, having in connection therewith the oil passages G.

No. 5525. Oil-Tank. (*Réservoir à l'huile.*)

Newell W. Wilson and Alphonso W. Blye, (Assignes of Henry E. Wolcott) Chicago, Ill., U. S., 18th December, 1875, for 5 years.

Claim.—1st. The provision in a tank can having a fixed hood E, of a permanent dripping shelf B, having inclined corrugations or gutters b, and perforation b₁; 2nd. The combination with the dripping shelf B, of the shelf extension B₂, for the pump support D; 3rd. The combination with the dripping shelf B, of a fixed hood E, and a rim guard b₂, inclosing and forming a base-boundary for the shelf; 4th. The combination with a removable sink c, and a fixed dripping shelf B, of the extension B₂, for the pump support independent of the sink and the shelf; 5th. The cover F, constructed with the tapering end and gore sections F₁, F₂, in combination with the fixed hood E, having the inclined back e, and the rim guard b₂, over and upon which the cover is hinged to be opened and closed without binding of the overlapping parts; 6th. The combination of the hinged cover F, fixed

hood E, and the dripping shelf B, the latter being inclosed and rim bounded above the sink and serving with the pump support to form a firm and compact superstructure for the can.

No. 5526. Drying-Kiln. (*Four de sécherie.*)

Ezra Davee, William B. Baker and David B. Christy, Springfield, Ohio, U. S., 18th December, 1875, for 5 years.

Claim.—1st. A drying kiln constructed with an inner and outer wall of plank, with the space between the same filled with earth for the purpose of absorbing from the wood or other material contained therein, and in process of seasoning the moisture driven out by the heat; 2nd. The flues F, F₁, B, F₂, C and in combination with earth ex, through which the heat passes to the interior of the drying kiln; 3rd. In combination with the series of flues described, the drying kiln constructed with walls and surrounded with an envelope of earth.

No. 5527. Improvements on Lamp Chimneys.

(*Perfectionnements aux cheminées de lampes.*)

William H. Shapley and Edward L. Goold, Brantford, Ont., 18th December, 1875, for 5 years.

Claim.—1st. The mode of constructing lamp chimneys of sheet metal, with base-rings A, and F, supporting ribs C, C, and upper-rings B and f, in combination with the mica-sides D, D; 2nd. The removable cap or top G, in combination with the base ring A, and F, supporting-ribs C, C, upper rings B and f, and the mica sides D, D.

No. 5528. Oil Stove. (*Poêle à l'huile.*)

Abram Q. Allis and Hugh McConnell, Cleveland, Ohio, U. S., 18th December, 1875, for 5 years.

Claim.—The supplemental reservoir D, elevated in combination with the depressed reservoir C, connecting tube B, when the oil is kept separate from the stove.

INDEX OF INVENTIONS.

Advertising medium, E. Rawlings..... 5433
 Bale ties, J. R. Foster..... 5426
 Blind, folding, A. Le Roy..... 5508
 Boot and shoe pegging stand, A. Stone..... 5429
 Buckle for garments, W. H. Barker..... 5517
 Canal, self acting sluice door and lock gates for, T. Millette
 Capetans and Windlasses, D. N. B. Coffin, jr., and B.
 Woodward..... 5477
 Carrriage, I. H. Culp, and J. R. Marshall..... 5450
 Chain stopper, D. N. B. Coffin, jr., and B. Woodward..... 5473
 Coal Scuttle, G. F. Sawyer..... 5513
 Coffee mill box, R. L. Webb..... 5405
 Corset and supporter, C. C. Robertson..... 5446
 Cutting bolt nipper, W. Ellard..... 5404
 Distilling apparatus, W. Watt..... 5420
 Door and gate, self closing, A. D. Cable & R. L. Moseley
 Dredges, hydraulic, W. H. Newton..... 5456
 Drum heater, S. H. Ghent..... 5405
 Electric telegraph, R. K. Boyle..... 5493
 Fanning mill, L. Theobald..... 5423
 Feed cutter, T. Webb..... 5445
 Fire extinguisher, W. Dickson, jr..... 5408
 Freezing Meat, &c., D. Y. Howell, and E. B. Paxton..... 5505
 Fuel, securing combustion and using gases from, J. C.
 Ramsden..... 5422
 Furnaces, coal, H. M. Smith..... 5427
 Gas burner and regulator, J. Ellis..... 5424
 " retorts, &c., closing hermetically, H. Collinson..... 5425
 Gate and door, self closing, A. D. Cable and R. L. Moseley
 Glass crucible, A. Kenney J. N. Tarbox and E. R. Kent..... 5431
 Gun, machine, J. P. Taylor and J. Baxter..... 5478
 Hame fastener, A. J. Park..... 5516
 Harness buckles, J. Challenger..... 5500
 " pad press, W. Dippert..... 5438
 Hay loader, C. W. Williams..... 5464
 " prase, C. G. C. Simpson..... 5501
 " rake and loader, T. Curtis..... 5518
 Heel and sole protector, R. E. Van Benschoten..... 5458
 Horse detaching apparatus, J. W. Glover..... 5438
 " over shoe, A. C. Snowden..... 5495
 Jack, lifting, D. T. Welch..... 5519
 Kettle and cooking apparatus, tube, B. Temple..... 5457
 Kilns, drying, E. Davee, W. B. Baker, and D. B. Christy..... 5526
 Lamp chimney, W. H. Shapley and E. L. Goold..... 5527
 Land roller and seeding machine combined, J. H. Holland..... 5452
 Leather, whitening and buffing J. E. Fisk..... 5491
 Lightning conductor, J. C. Schoonmaker..... 5411
 " rod, J. C. Schoonmaker..... 5490
 " standard, J. C. Schoonmaker..... 5459
 Moccasins, S. Lee..... 5472
 Mop wringer, J. Lang..... 5483
 Neck yoke leathers, J. B. Relyea..... 5482
 Newspapers, machine for labelling, R. Dick..... 5421
 Nut, A. Marland..... 5480
 Oil stove, A. Q. Allis and H. McConnell..... 5528
 " tank, N. W. Wilson, and A. W. Blye..... 5525
 Oxides and sulphides, H. Knight..... 5482
 Ozone machine, R. Heneage and S. Clark..... 5434
 Paddle wheel, R. Forward..... 5484
 Paint brush bridle, T. Snell and J. W. Charles..... 5470
 Paper bag, A. S. Dennison and J. D. Huntington..... 5474
 " machine for cutting, T. Gain..... 5521
 " pulp from wood, process for making, H. H. Furbish
 Peat, manufacture of, R. A. Griffin..... 5435
 Percolator, regulating, G. McPherson..... 5418
 Pipe elbows, sheet metal, G. Lupton..... 5499
 Plough, gang, W. P. Plant and H. Blizard..... 5451
 Plumber's trap, F. N. DuBois..... 5466
 Printer's galley, C. A. Scadding..... 5461
 " quoin, J. Foley..... 5498
 Pump, I. Cosgrave..... 5481
 " J. E. and J. H. Nuts and J. Roodie..... 5485
 " H. Port..... 5510
 Railway car axle, T. & E. Dixon, and G. H. Ward..... 5524
 " " dumping platforms for, J. W. Harrison and H.
 E. Seward..... 5506
 " freight cars, A. Wilson, and J. R. Silliman..... 5413
 " frog, J. Cumming..... 5439
 " pneumatic signal, A. Chambers..... 5448
 " signalling apparatus, A. Chambers..... 5522
 " train, braking and signalling, J. Steel..... 5507
 Refrigerator, D. Y. Howell and E. B. Paxton..... 5504
 Rheumatism, liniment for, L. N. Fontaine..... 5447
 Rowing gear, W. Lyman..... 5416
 Sash holder, C. E. Steller..... 5441

Saw collars for grooving laths, P. W. Hart..... 5114
 Scale pans, J. McLean..... 5489
 Seeding machine and land roller combined, J. H. Holland..... 5452
 Shock clamp, J. R. Foster..... 5430
 Side platters, James M. Cooley..... 5444
 Sled, mechanism for propelling, D. W. De Forest..... 5463
 Sleigh lance, A. Corbett..... 5415
 " robe, F. L. Blakely..... 5453
 Soda cask, Ira N. Herrick..... 5518
 Sole and heel protector, H. E. Van Benschoten..... 5458
 Steam boiler, tubular flues for, H. Balley..... 5460
 " cocks and valves, J. Mallinson..... 5419
 " governor, D. La F. Chase..... 5467
 Stench trap, R. Garand..... 5428
 Stove board, G. F. Sawyer..... 5512
 " pipe damper, S. Selden..... 5520
 " shelf and drier, J. C. Schoonmaker..... 5486
 Street lantern, reservoir for, E. Patterson, D. A. Hut-
 chinson and J. G. Hunter..... 5432
 Sulphides and oxides, H. Knight..... 5482
 Tanning apparatus, H. Reed..... 5487
 " raw-hides, J. Angus..... 5417
 " skins, (extension), H. W. Woodruff..... 5502
 Tea kettle handle, W. S. Potwin..... 5440
 Telegraph, transmitting musical sounds by, E. Gray..... 5496
 Tinned plate, G. E. Taylor..... 5407
 Tramway, J. Canan..... 5523
 Treadle, D. E. Little..... 5479
 Truck, hand, H. H. Baltzly and L. A. Hoyt..... 5409
 Type, rubber, printing with, W. L. Scott..... 5440
 Vehicle, device for indicating the distance travelled, T.
 Bournann and H. T. Beebe..... 5511
 " fifth wheel for, La F. Blair..... 5514
 " gear, H. S. Clark..... 5406
 " seat, E. A. Rice..... 5489
 Veneer, machine for cutting, S. Wallace..... 5438
 Ventilation and water supply of buildings, &c., J. H.
 Morrell..... 5454
 Waggon axle, adjustable, J. R. Lantz and T. L. Mitchell..... 5492
 Washing machine, A. Kline..... 5437
 Watch, A. H. Potter..... 5442
 Waterproof bag, A. S. Dennison and J. D. Huntington..... 5475
 Water supply and ventilation of buildings, &c., J. H.
 Morrell..... 5454
 Wheel, water, O. Jull..... 5468
 Whiff-tree, S. F. Humphrey..... 5509
 Windlasses and capstans, D. N. B. Coffin, jr., and B.
 Woodward..... 5477
 Window blind fastener, J. Shedd..... 5478
 Wood, transferring from breaker and feeding to finisher,
 H. McKenzie..... 5443
 Wringer, A. Page..... 5412

INDEX OF PATENTEES.

Allis, Abraham Q., and H. McConnell, oil stove..... 5528
 Angus, John, tanning raw hides..... 5417
 Balley, Henry, tubular flues for steam boilers..... 5460
 Baker, William B., E. Davee and D. B. Christy, drying kiln
 Baltzly, Henry H., and L. A. Hoyt, hand truck..... 5409
 Barker, William H., buckle for garments..... 5517
 Baxter, John and J. P. Taylor, machine gun..... 5476
 Beebe, Harrison T., and T. Bournann, device indicating
 the distance travelled by vehicle..... 5511
 Blair, LaFayette, fifth wheel for vehicles..... 5514
 Blakeley, Frederick L., sleigh robe..... 5453
 Blizard, Howard, and W. P. Plant, gang plough..... 5451
 Blye, Alphonso W., and N. W. Wilson, (assignees), oil tank
 Bournann, Thomas, and H. T. Beebe, device for indicating
 the distance travelled by vehicle..... 5511
 Boyle, Robert K., electric telegraph..... 5493
 Cable, Austin D., and R. L. Moseley, rendering doors and
 gates self-closing..... 5456
 Canan, James, tramway..... 5523
 Challenger, Joshua, harness buckles..... 5500
 Chambers, Austin, railway pneumatic signal..... 5448
 " " signalling apparatus..... 5522
 Charles, John W., and T. Such, paint brush bridle..... 5470
 Chase, Daniel La F., steam governor..... 5467
 Christy, David B., E. Davee and W. B. Baker, drying kiln
 Clark, Harry S., vehicle gear..... 5406
 " Seth and R. Heneage, ozone machine..... 5434
 Coffin, David N. B., jr., and B. Woodward, chain stopper,
 " " capstans and
 windlasses..... 5477

Collinson, Henry, closing gas retorts, &c., hermetically...	5125	Millette, Thomas, self-acting sluice doors and lock gates for canal.....	5471
Cooley, James M., slide plinters.....	5144	Mitchell, Thomas L., and J. R. Lantz, adjustable waggon axle.....	5492
Corbett, Adolphe, sleigh lance.....	5415	Morrell, John H., water supply and ventilation of build- ing, &c.....	5454
Cosgrave, Isaac, pump.....	5481	Moseley, Randolph L., and A. D. Cable, rendering doors and gates self-closing.....	5456
Culp, Isaac H., and J. R. Marshall, (assignees), carriages..	5450	Newton, William H., hydraulic dredges, &c.....	5497
Cumming, James, railway frog.....	5139	Nute, James E., and John H., and J. Roodie, pump.....	5485
Curtis, Thomas, hay rake and loader.....	5516	Page, Augustus, (assignee), wringer.....	5412
Davee, Ezra, W. B. Baker and D. B. Christie, drying kiln...	6520	Park, Alfred J., hame fastener.....	5515
De Forest, David W., mechanism for propelling sleds.....	5463	Patterson, Ephraim, D. A. Hutchinson and J. G. Hunter, reservoir for street lantern.....	5482
Dennison, Albert S., and J. D. Huntington, paper bag.....	5474	Paxton, Ethelbert R., and D. Y. Howell, refrigerator.....	5504
" " " " water proof bag.....	5475	" " " " machine for freez- ing meat and fish.....	5505
Dick, Robert, machine for labelling newspapers.....	5121	Plant, William P., and H. Blizard, gang plough.....	5451
Dickson, William, Jr., fire extinguisher.....	5408	Port, Henry, pump.....	5510
Dippert, William, harness pad press.....	5488	Potter, Albert H., watch.....	5442
Dixon, Theron S. E., and G. H. Ward, railway car axle.....	5524	Potwin, William S., tea kettle handle.....	5440
Dubois, Frederick N., plumber's trap.....	5466	Ramsden, John C., securing combustion and utilizing gases from fuel.....	5422
Ellard, William, cutting bolt tipper.....	5494	Rawlings, Edward, (co-inventor and assignee), advertis- ing medium.....	5433
Ellis, John, gas burner and regulator.....	5424	Reed, Harvey, tanning apparatus.....	5487
Fisk, Joseph E., whitening and buffing leather.....	5491	Reley, Jerome B., neck yoke leathers.....	5462
Foley, John, printer's quoin.....	5398	Rice, Everett A., vehicle seat.....	5469
Fontaine, Louis N., liniment for rheumatism.....	5447	Roberts, Charles C., corset and supporter.....	5446
Forward, Ross, paddle wheel.....	5184	Roodie, James, J. E., and J. H. Nute, pump.....	5485
Foster, Jonathan R., bale ties.....	5426	Sawyer, George F., stove board.....	5512
" " " " shook clamp.....	5430	" " " " coal scuttle.....	5513
Furbish, Henry H., process of making paper pulp from wood.....	5410	Scadding, Charles A., printer's galley.....	5461
Gain, Thomas, machines for cutting paper bags.....	5521	Schoonmaker, John C., lightning conductor.....	5411
Garand, René, steuch trap.....	5428	" " " " rod standard.....	5459
Ghent, Samson H., drum heater.....	5455	" " " " stove pipe shelf and drier.....	5486
Glover, Jobusa W., horse detaching apparatus.....	5438	" " " " lightning rods.....	5490
Goold, Edward L., and W. H. Shapley, lamp chimney.....	5527	Scott, William L., (assignee), printing with rubber type...	5449
Gray, Elisha, transmitting musical sounds telegraphically	5496	Selden, Samuel, stove pipe damper.....	5520
Griffin, Robert A., manufacture of peat.....	5435	Shapley, William H., and E. L. Gould, lamp chimney.....	5527
Harrison, John W., and H. E. Susand, dumping platform for railway cars.....	5506	Silliman, James R., and J. A. Willson, freight cars.....	5413
Hart, Philo W., saw collars for grooving laths.....	5414	Shedd, Joel, window blind fastener.....	5478
Heneage, Robert and S. Clark, ozone machine.....	5434	Simpson, Charles G. C., hay press.....	5501
Herrick, Ira N., soda cask.....	5518	Smith, Horatio M., coal furnaces.....	5427
Holt, Loyall A., and H. H. Baltzly, hand truck.....	5409	Snell, Theodore and J. W. Charles, paint brush brier.....	5470
Holland, James H., combined land roller and seeding ma- chine.....	5452	Snowden, Arthur C., horse over shoe.....	5495
Howell, Daniel Y., and E. B. Paxton, refrigerator.....	5504	Steel, James, braking and signalling in railway trains...	5507
" " " " machine for freezing meat and fish.....	5505	Steller, Charles E., sash holder.....	5441
Humphrey, Stephen F., whistle-tree.....	5509	Stone, André, boot and shoe pegging stand.....	5429
Hunter, John G., E. Patterson and D. A. Hutchinson, reser- voir for street lantern.....	5432	Susand, Henry E., and S. W. Harrison, dumping platform for railway cars.....	5506
Huntington, John D., and A. S. Dennison, paper bag.....	5474	Tarbox, John N., A. Kenny and E. N. Kent, glass crucible	5431
" " " " water proof bag.....	5475	Taylor, George E., tinned plate.....	5407
Hutchinson, David A., E. Patterson and J. G. Hunter, reser- voir for street lantern.....	5432	" James P., and J. Baxter, machine gun.....	5476
Jull, Orange, water wheel.....	5468	Temple, Benjamin, tube kettle and cooking apparatus.....	5457
Kennedy, Austin, J. N. Tarbox and E. R. Kent, glass crucible	5431	Theobald, Lewis, fanning mill.....	5423
Kent, Edward R., J. N. Tarbox and A. Kenney, " " "	5431	Van Benschoten, Henry E., sole and heel protector.....	5458
Kilve, Anthony, washing machine.....	5437	Wallace, Samuel, machine for cutting veneer.....	5436
Knight, Henry, oxides and sulphides.....	5482	Ward, George H., and Theron S. E. Dixon, railway car axle.....	5524
Lang, John, mop wringer.....	5483	Watt, William, (assignee), distilling apparatus.....	5420
Lantz, Joseph R., and T. L. Mitchell, adjustable waggon axle.....	5492	Webb, Rodolphus L., box coffee mill.....	5485
Lee, Selby, moccasins.....	5472	" Thomas, feed cutter.....	5445
LeRoy, Alphonso, folding blinds.....	5508	Welch, David T., lifting jack.....	5519
Lillis, Daniel E., treadle.....	5479	Williams, Charles W., hay loader.....	5464
Lupton, George, sheet metal pipe elbows.....	5499	Willson, Alfred and J. R. Silliman, railway freight car.....	5413
Lyman, William, rowing gear.....	5416	" Newell, W., and A. W. Blye, (assignees), oil tank	5525
McConnell, Hugh and A. Q. Allis, oil stove.....	5528	Woodruff, Horace W., (assignee) tanning skins.....	5502
McKenzie, Hugh, transferring wool from breaker and feed- ing to finisher.....	5443	Woodard, Benjamin, and D. N. B. Coffin, jr., chain stopper capstans and windlasses....	5473
McLean, James, scale pans.....	5489		
McPherson, George, regulating percolators.....	5418		
Mallinson, James, steam locks and valves.....	5119		
Marland, Alfred, nut.....	5480		
Marshall, John R., and I. H. Culp, (assignees), carriage...	5450		

THE CANADIAN PATENT OFFICE RECORD.

ILLUSTRATIONS.

Vol. IV.

JANUARY, 1876.

No. I.

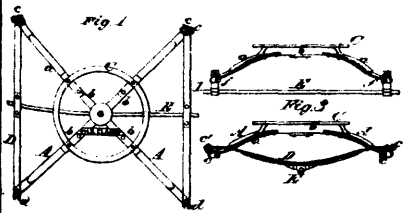

5406 Clark's Improvements on Vehicle Gears.

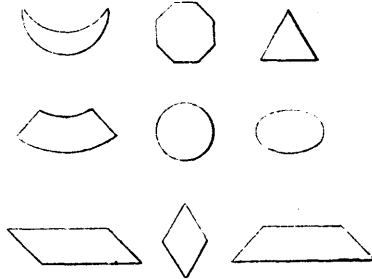

5407 Taylor's Manufacture of Tinned Plates.

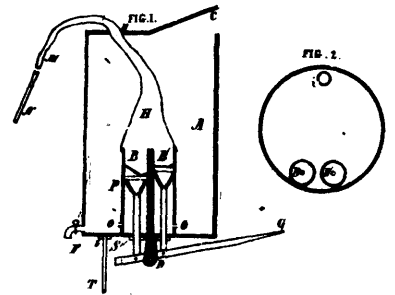

5408 Dickson's Fire Extinguisher.

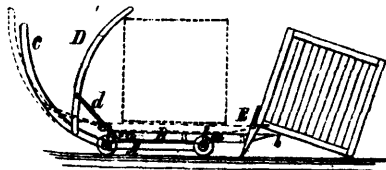

5409 Baltzly's Hand Truck.

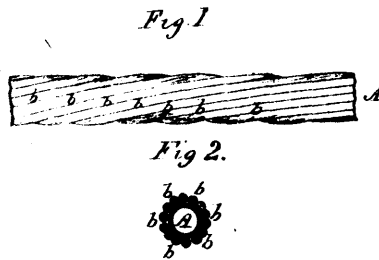

5411 Schoonmaker's Lightning Conductor.

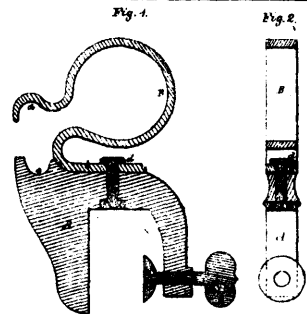

5412 Haynes' Improvements on Wringers.

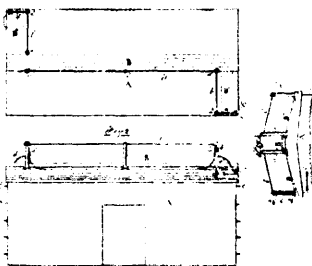

5413 Willson & Silliman's Improvements on Freight-Cars.

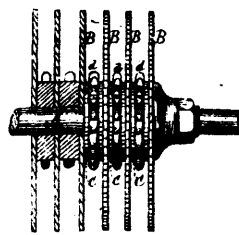

5414 Hart's Improvements on Saw-Collars for Grooving Laths.

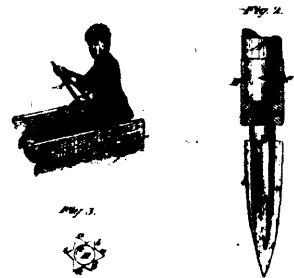

5415 Corbett's Sleigh Lance.

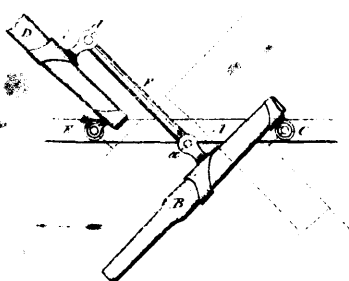

5416 Lyman's Improvements on Rowing Gear.

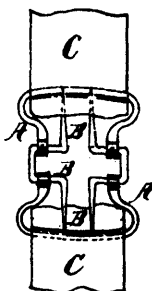

5517 Barker's Buckle for Garments.



5418 McPherson's Improvements in Regulating Percolators.

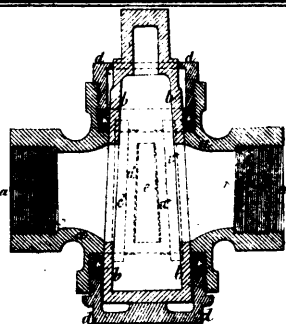

5419 Mallinson's Improvements on Steam and other Cocks and Valves.

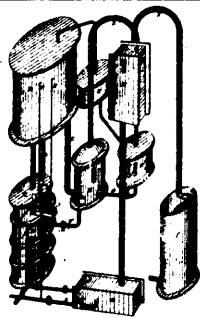

5420 Reford's Distilling Apparatus.

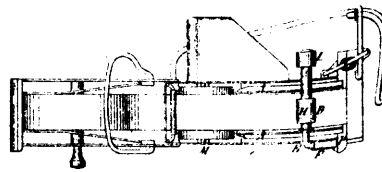

5421 Dick's Machine for Labelling Newspaper.

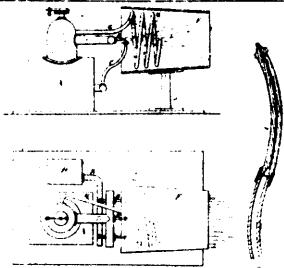

5422 Ramsden's Method of, and Apparatus for Securing the Combustion of Fuel and for the Utilization of the Gases arising therefrom.

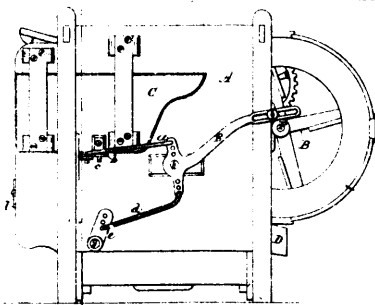

5423 Theobald's Fanning Mill.

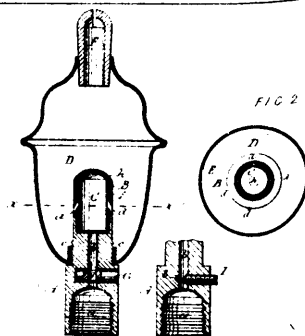

5424 Lynn's Gas Burner and Regulator.

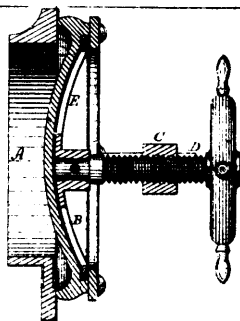

5425 Collinson's Improvements on Closing Gas Retorts and other Vessels Hermetically.



5426 Foster's Bale Ties.

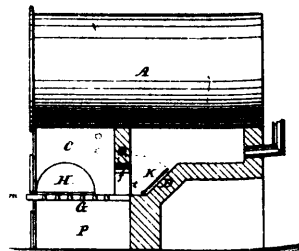

5427 Smith's Improvements on Furnaces for the Combustion of Coal.

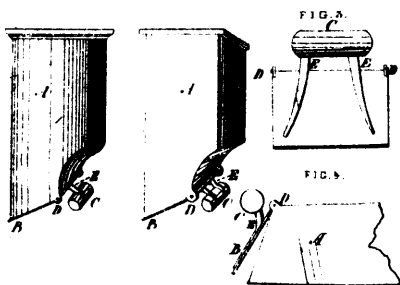

5428 Grand's Stretch Trap.

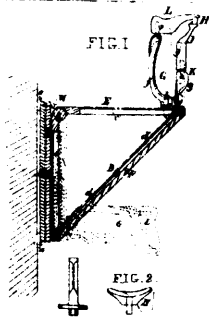

5429 Stone's Boot and Shoe Pegging Stand.

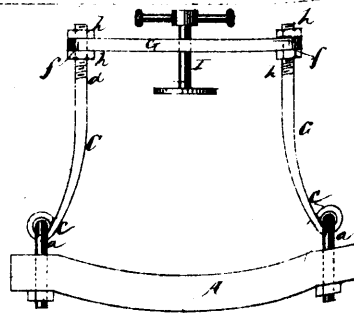

5430 Foster's Improvements in Clamps for Assembling Staves of Barrels.

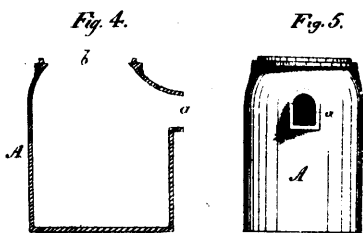

5431 Kenny, Thorbox & Keat's Glass Crucible.

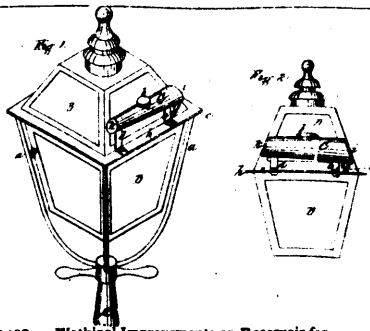

5432 Watkins' Improvements on Reservoir for Street Lantarns.



5433 Rawlings & Neave's Advertising Medium.

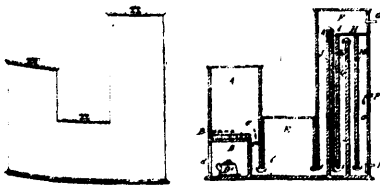

5434 Henega & Clark's Ozone Machine.

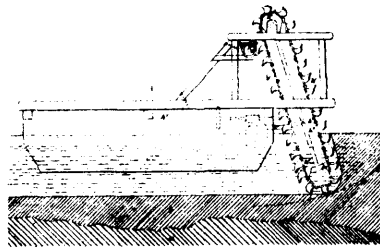

5435 Griffin's Improvements in the Manufacture of Peat,

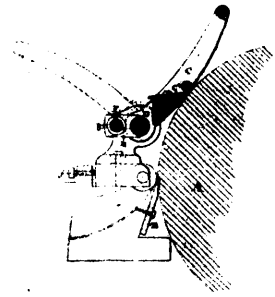

5436 McEachern's Machines for Cutting Veneers.

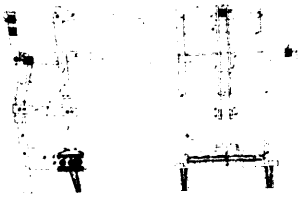

5437 Kline's Machine for Washing Linen.

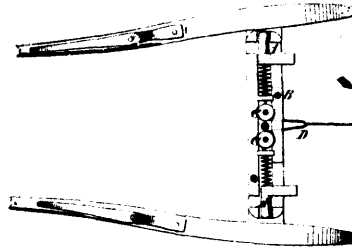

5438 Glover's Horse Detaching Apparatus.



5439 Cumming's Railway Frogs.

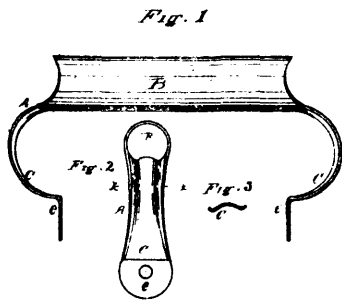

5440 Potwin's Tea Kettle Handle.

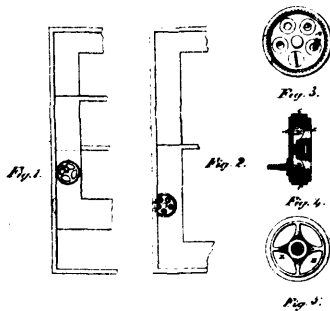

5441 Steller's Sash Holder.

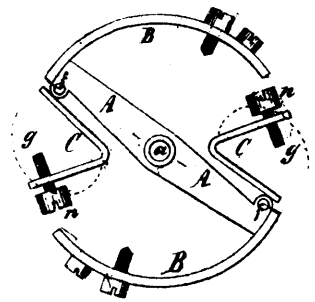

5442 Potter's Improvements on Watches.

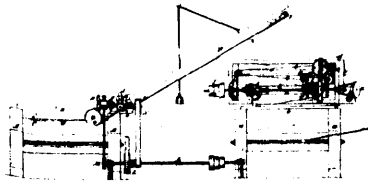

5443 McKenzie's Apparatus for Transferring the Wool from the Breaker of Custom and Feeding it to the Finisher.

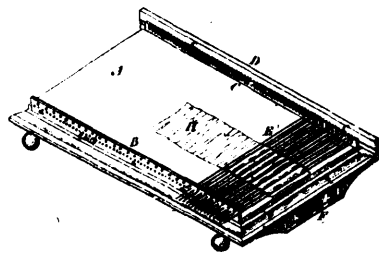

5444 Cooley's Improvements on Side Plaiters.

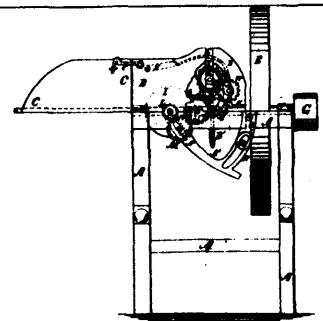

5445 Webb's Feed Cutter.

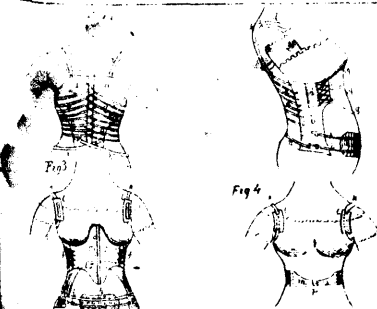

5446 Robertson's Combined Corset, Shoulder Brace, Spinal and Abdominal Supporter.



5448 Chambers' Railway Pneumatic Signal.

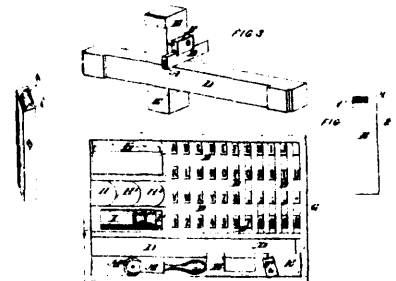

5449 Scott's Art of Printing with Rubber Type and Apparatus therefor.

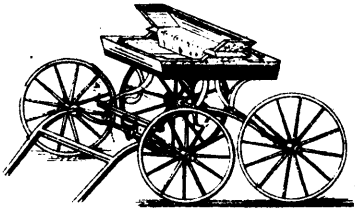

6450 Heater's Improvements on Carriages.

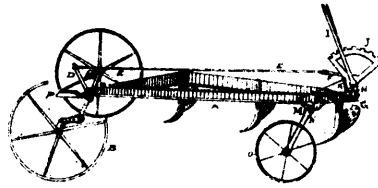

6451 Plant & Blizard's Gang Plough.

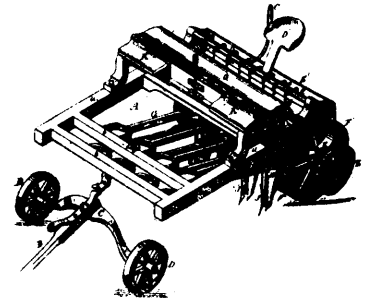

6452 Holland's Combined Land Roller and Seeding Machine, &c.

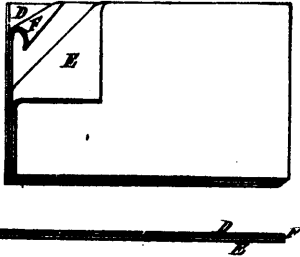

6453 Blakeley's Improvements on Lap Robes.

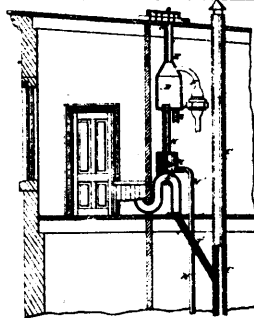

6454 Morrell's Water Supply and Ventilation of Buildings, &c.

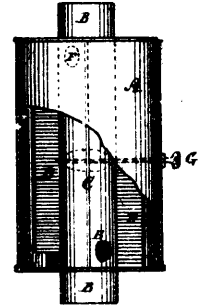

6455 Ghent's Drum Heater.

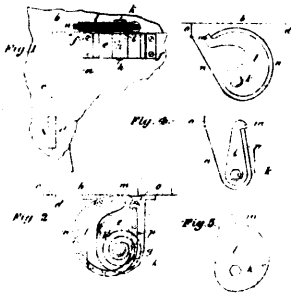

6456 Cable & Moseley's Apparatus for Rendering Doors and Gates Self-closing.

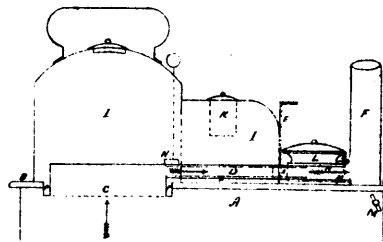

6457 Temple's Tube Kettle and Cooking Apparatus.

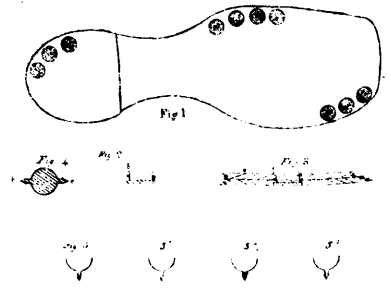

6458 Van Benchooten's Sole and Heel Protector for Boots and Shoes.

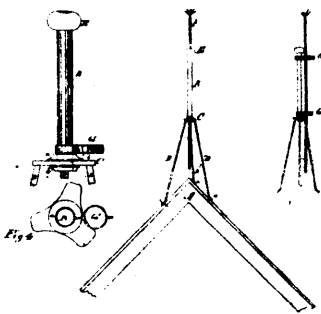

6459 Schoonmaker's Lightning Rod Standard.

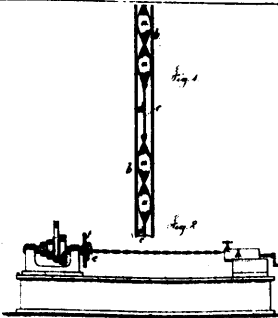

6460 Bailey's Tubular Flues for Steam Boilers.

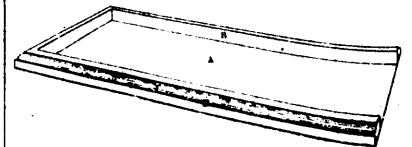

6461 Scadding's Improvements on Printer's Gallies.

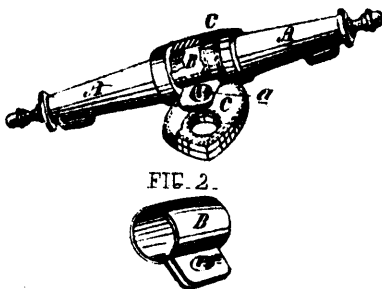

6462 Relyea's Improvements in Neck Yoke Leathers.

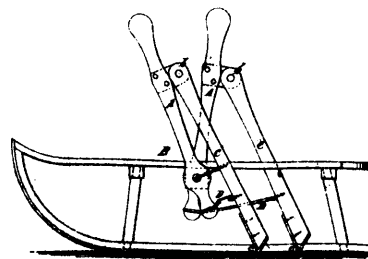

6463 De Forest's Mechanism for Propelling Sleds.

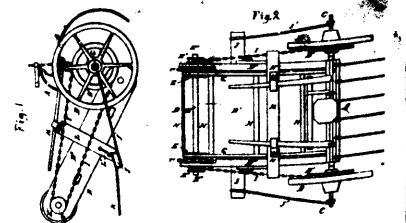

6464 Williams' Hay Loader.

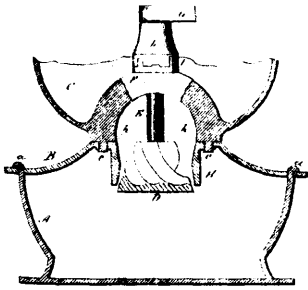

5465 Webb's Box Coffee Mill.

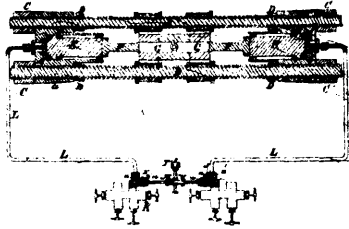

5466 Du Bois' Machine for making Plumbers Traps.

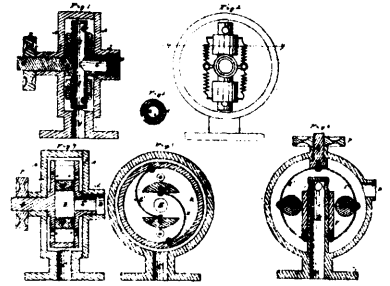

5467 Chase's Steam Governor.

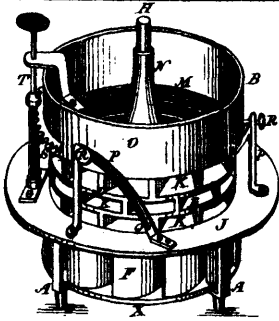

5468 Jull's Water Wheel.

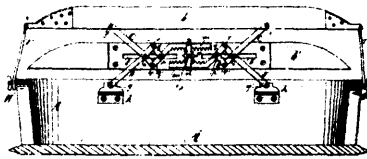

5469 Rice's Vehicle Seat.

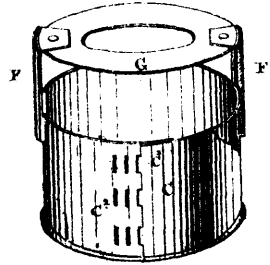

5470 Snell & Charles' Faint Brush Bridler.

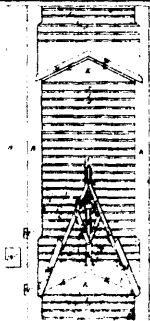

5471 Milette's Self-acting Sluice Doors and Lock Gates for Canals.



5472 Lee's Improvements on Moccasins.

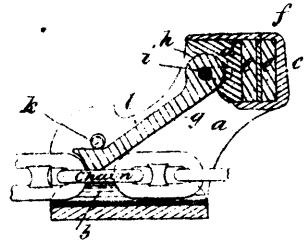

5473 Coffin & Woodward's Chain-stopper.

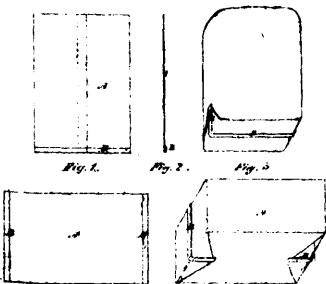

5474 Dennison & Huntington's Paper Bag.

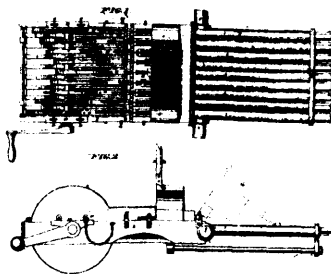

5476 Taylor & Baxter's Improvements on Machine Guns.

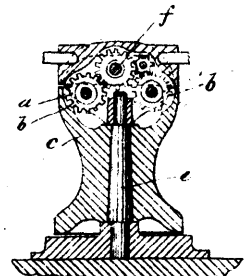

5477 Coffin & Woodward's Improvements on Capstans and Windlasses.

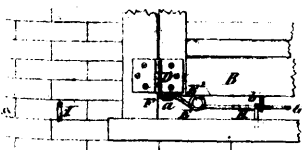

5478 Shedd's Improvements on Window Blind Fasteners.

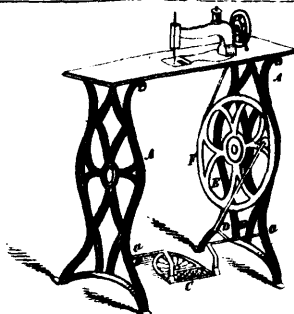

5479 Lillis' Improvements on Treadles.

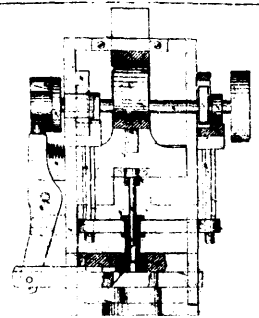

5480 Marland's Improvements in Making Nuts.

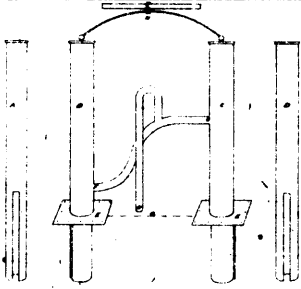

5481 Cosgrave's Machine for Taking and Pumping Water out of any Vessel, Ship or Boat.

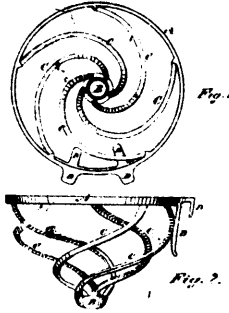

5483 Lang's Mop-wringer.

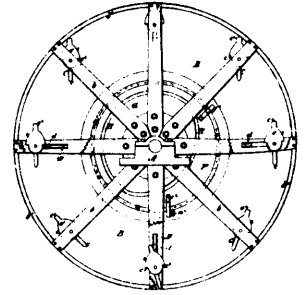

5484 Forward's Improvements in Paddle Wheels.

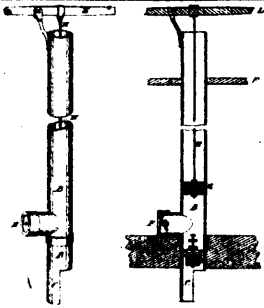

5485 Nute & Roode's Apparatus for Draining and Pumping Water from the Holds of Ships.

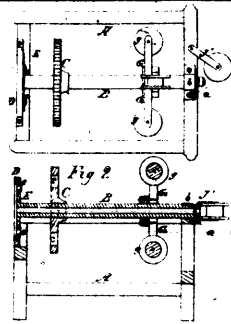

5486 Schoonmaker's Stove-pipe Shelf and Drier.

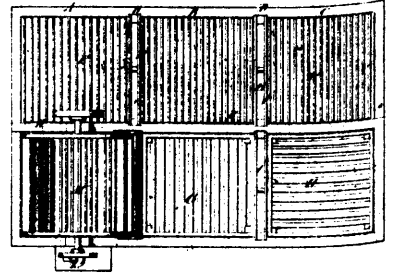

5487 Reed's Tanning Apparatus.



5488 Dippert's Harness Pad Press.

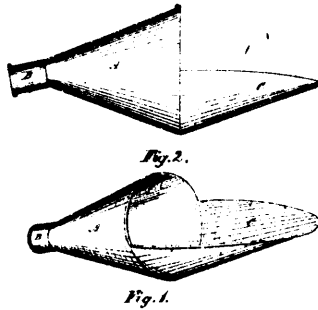

5489 McLean's Improvements on Scale Pans.

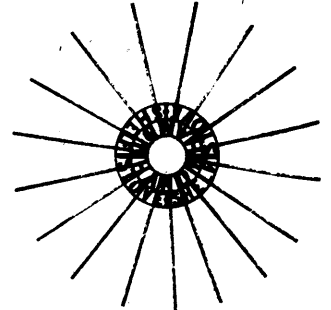

5490 Schoonmaker's Machine for making Lightning Rods.

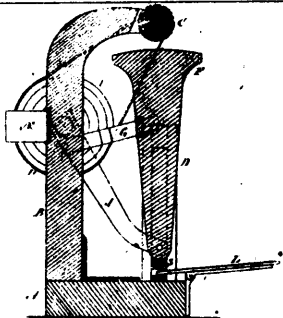

5491 Fisk's Machine for Whitening and Buffing Leather.

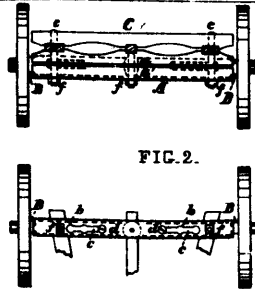

5492 Lantz & Mitchell's Adjustable Waggon Axle.

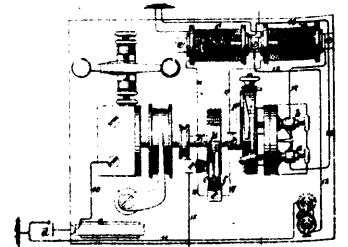

5493 Boyle's Improvements on Electric Telegraphs.

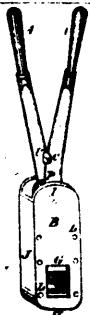

5494 Ellard's Cutting Bolt Nipper.

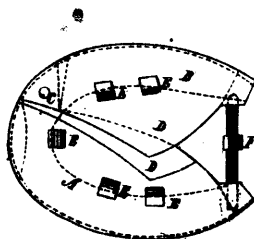

5495 Snowden's Horse Overshoe.

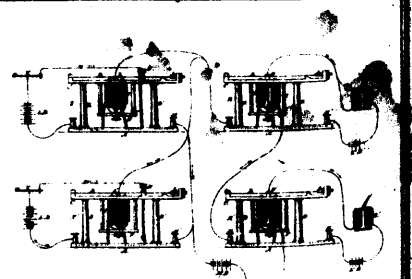

5496 Gray's Art of Transmitting Musical Sounds Telegraphically and Apparatus therefor

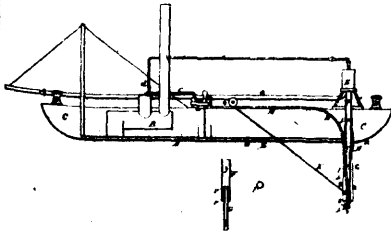

5497 Newton's Improvements on Hydraulic Dredges and Peat Elevators.

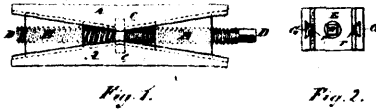

5498 Foley's Improvements on Printer's Quoins.

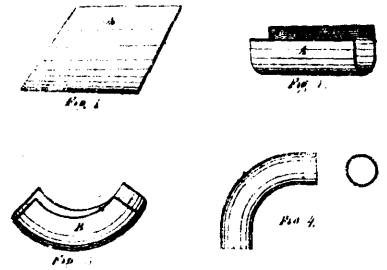

5499 Lupton's Improvements in Sheet Metal Pipe Elbows.

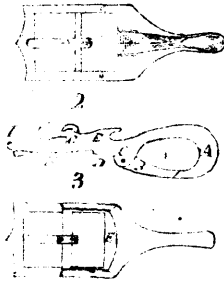

5500 Challenger's Improvements on Harness Buckles.

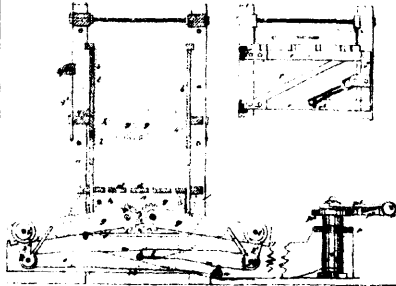

5501 Simpson's Improvements on Hay Presses.

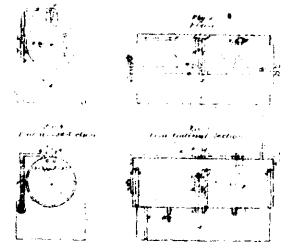

5502 Scoullar's Improvements in the Art of and Apparatus for Tanning Skins.

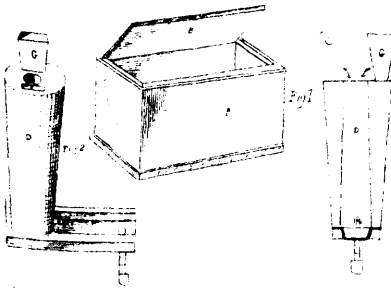

5504 Howell & Paxton's Improvements in Refrigerators.

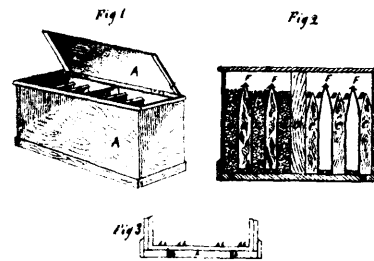

5505 Howell & Paxton's Improvements in a Machine for Freezing Fish and Meat.

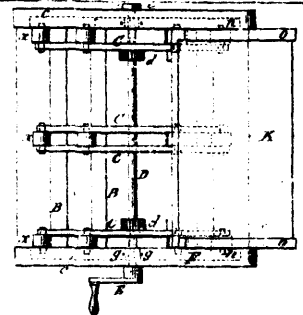

5508 Harrison & Susand's Dumping Platform for Railway Cars.

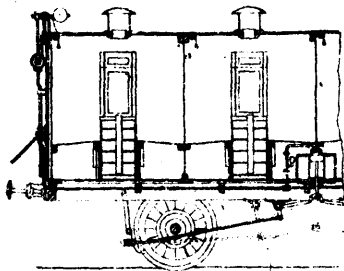

5507 Steel's Apparatus for Breaking and Signalling in Railway Trains.

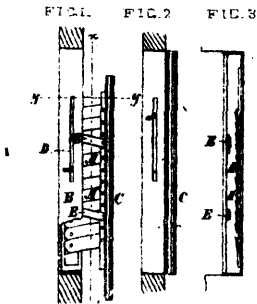

5508 Le Roy's Improvements in Folding Blinds.

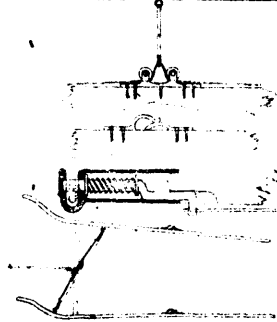

5509 Humphrey's Improvements on Whiffle-trees.

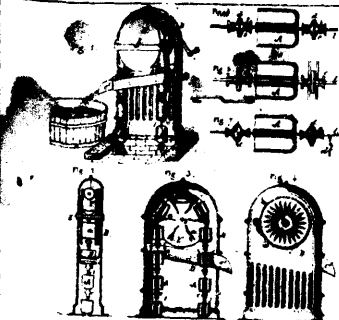

5510 Fort's Apparatus for Raising Water, &c.

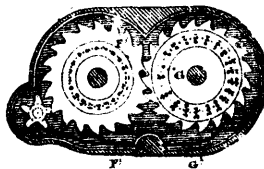

5511 Bournann & Beebe's Device for Indicating the Distance Travelled by Vehicles.

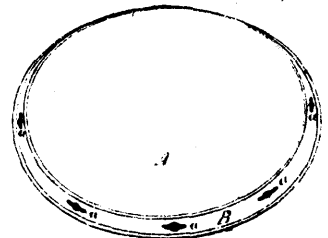

5512 Sawyer's Stove Board.

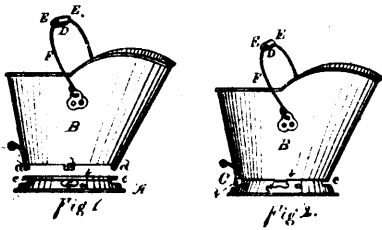

5513 Sawyer's Coal Scuttle.

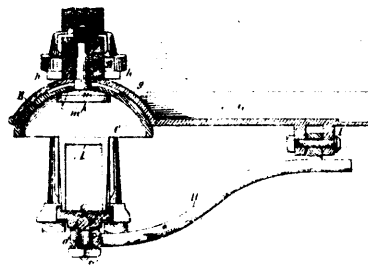

5514 La Fayette Blair's Fifth Wheel for Vehicles.

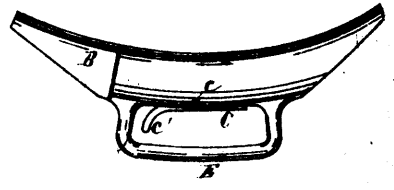

5515 Park's Improvements in Hame Fasteners.

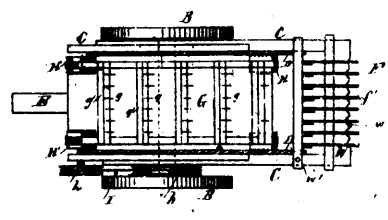

5516 Curtis' Hay Rake and Loader.

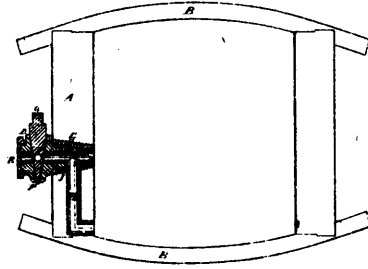

5518 Herrick's Soda Cask.

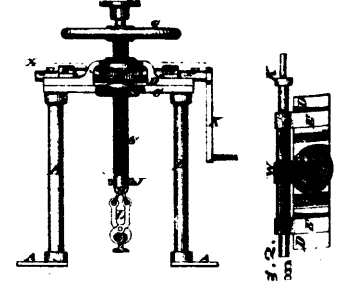

5519 Welch's Lifting Jack.

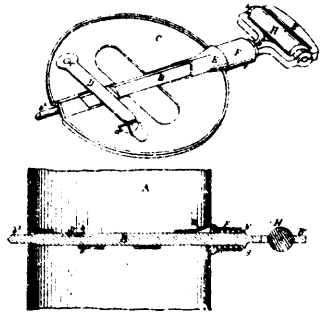

5520 Selden's Stove-pipe Damper.

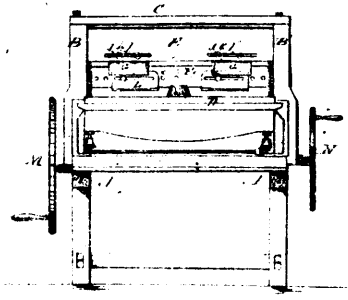

5521 Gain's Improvements on Machines for Cutting Paper Bags.

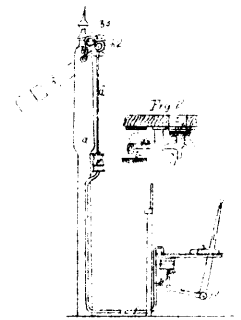

5522 Chambers' Railway Signalling Apparatus.



5523 Canan's Tramway for Conveying Excavated Material.

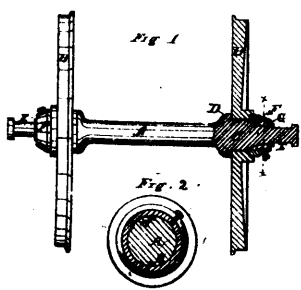

5524 Dixon & Ward's Railway Car-axle.

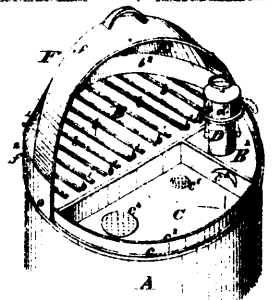

5525 Wolcott's Oil Tank.

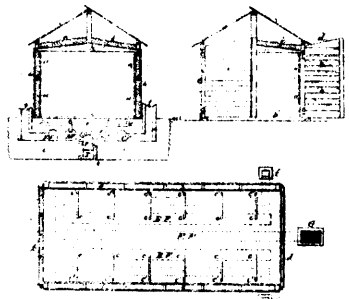

5526 Davee, Baker & Christy's Drying-kiln.

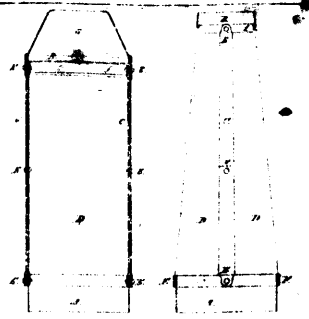

5527 Shapley & Goold's Improvements on Lamp Chimneys.

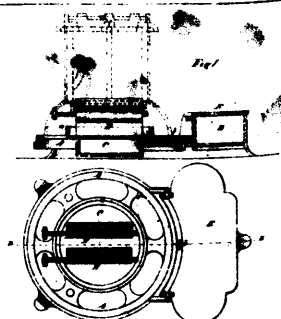

5528 Allis & McConnell's Oil Stove.