

**CIHM  
Microfiche  
Series  
(Monographs)**

**ICMH  
Collection de  
microfiches  
(monographies)**



**Canadian Institute for Historical Microreproductions / Institut canadien de microreproductions historiques**

**© 1999**

## Technical and Bibliographic Notes / Notes techniques et bibliographiques

The Institute has attempted to obtain the best original copy available for filming. Features of this copy which may be bibliographically unique, which may alter any of the Images in the reproduction, or which may significantly change the usual method of filming are checked below.

- Coloured covers / Couverture de couleur
- Covers damaged / Couverture endommagée
- Covers restored and/or laminated / Couverture restaurée et/ou pelliculée
- Cover title missing / Le titre de couverture manque
- Coloured maps / Cartes géographiques en couleur
- Coloured ink (i.e. other than blue or black) / Encre de couleur (i.e. autre que bleue ou noire)
- Coloured plates and/or illustrations / Planches et/ou illustrations en couleur
- Bound with other material / Relié avec d'autres documents
- Only edition available / Seule édition disponible
- Tight binding may cause shadows or distortion along interior margin / La reliure serrée peut causer de l'ombre ou de la distorsion le long de la marge intérieure.
- Blank leaves added during restorations may appear within the text. Whenever possible, these have been omitted from filming / Il se peut que certaines pages blanches ajoutées lors d'une restauration apparaissent dans le texte, mais, lorsque cela était possible, ces pages n'ont pas été filmées.
- Additional comments / Commentaires supplémentaires: Various pagings.

L'Institut a microfilmé le meilleur exemplaire qu'il lui a été possible de se procurer. Les détails de cet exemplaire qui sont peut-être uniques du point de vue bibliographique, qui peuvent modifier une image reproduite, ou qui peuvent exiger une modification dans la méthode normale de filmage sont indiqués ci-dessous.

- Coloured pages / Pages de couleur
- Pages damaged / Pages endommagées
- Pages restored and/or laminated / Pages restaurées et/ou pelliculées
- Pages discoloured, stained or foxed / Pages décolorées, tachetées ou piquées
- Pages detached / Pages détachées
- Showthrough / Transparence
- Quality of print varies / Qualité inégale de l'impression
- Includes supplementary material / Comprend du matériel supplémentaire
- Pages wholly or partially obscured by errata slips, tissues, etc., have been refilmed to ensure the best possible image / Les pages totalement ou partiellement obscurcies par un feuillet d'errata, une pelure, etc., ont été filmées à nouveau de façon à obtenir la meilleure image possible.
- Opposing pages with varying colouration or discolourations are filmed twice to ensure the best possible image / Les pages s'opposant ayant des colorations variables ou des décolorations sont filmées deux fois afin d'obtenir la meilleure image possible.

This item is filmed at the reduction ratio checked below /  
Ce document est filmé au taux de réduction indiqué ci-dessous.

	10x		14x		18x		22x		26x		30x	
	12x		16x		20x		24x		28x		32x	

(A checkmark is present in the box corresponding to 24x.)

The copy filmed here has been reproduced thanks to the generosity of:

Bibliothèque générale,  
Université Laval,  
Québec, Québec.

The images appearing here are the best quality possible considering the condition and legibility of the original copy and in keeping with the filming contract specifications.

Original copies in printed paper covers are filmed beginning with the front cover and ending on the last page with a printed or illustrated impression, or the back cover when appropriate. All other original copies are filmed beginning on the first page with a printed or illustrated impression, and ending on the last page with a printed or illustrated impression.

The last recorded frame on each microfiche shall contain the symbol  $\rightarrow$  (meaning "CONTINUED"), or the symbol  $\nabla$  (meaning "END"), whichever applies.

Maps, plates, charts, etc., may be filmed at different reduction ratios. Those too large to be entirely included in one exposure are filmed beginning in the upper left hand corner, left to right and top to bottom, as many frames as required. The following diagrams illustrate the method:

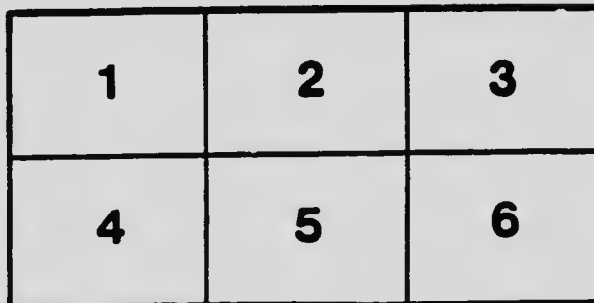
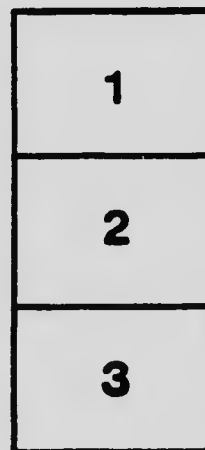

L'exemplaire filmé fut reproduit grâce à la générosité de:

Bibliothèque générale,  
Université Laval,  
Québec, Québec.

Les images suivantes ont été reproduites avec le plus grand soin, compte tenu de la condition et de la netteté de l'exemplaire filmé, et en conformité avec les conditions du contrat de filmage.

Les exemplaires originaux dont la couverture en papier est imprimée sont filmés en commençant par le premier plat et en terminant soit par la dernière page qui comporte une empreinte d'impression ou d'illustration, soit par le second plat, selon le cas. Tous les autres exemplaires originaux sont filmés en commençant par la première page qui comporte une empreinte d'impression ou d'illustration et en terminant par la dernière page qui comporte une telle empreinte.

Un des symboles suivants apparaîtra sur la dernière image de chaque microfiche, selon le cas: le symbole  $\rightarrow$  signifie "A SUIVRE", le symbole  $\nabla$  signifie "FIN".

Les cartes, planches, tableaux, etc., peuvent être filmés à des taux de réduction différents. Lorsque le document est trop grand pour être reproduit en un seul cliché, il est filmé à partir de l'angle supérieur gauche, de gauche à droite, et de haut en bas, en prenant le nombre d'images nécessaire. Les diagrammes suivants illustrent la méthode.

# MICROCOPY RESOLUTION TEST CHART

(ANSI and ISO TEST CHART No. 2)



APPLIED IMAGE Inc

1653 East Main Street  
Rochester, New York 14609 USA  
(716) 482-0300 - Phone  
(716) 288-5989 - Fax

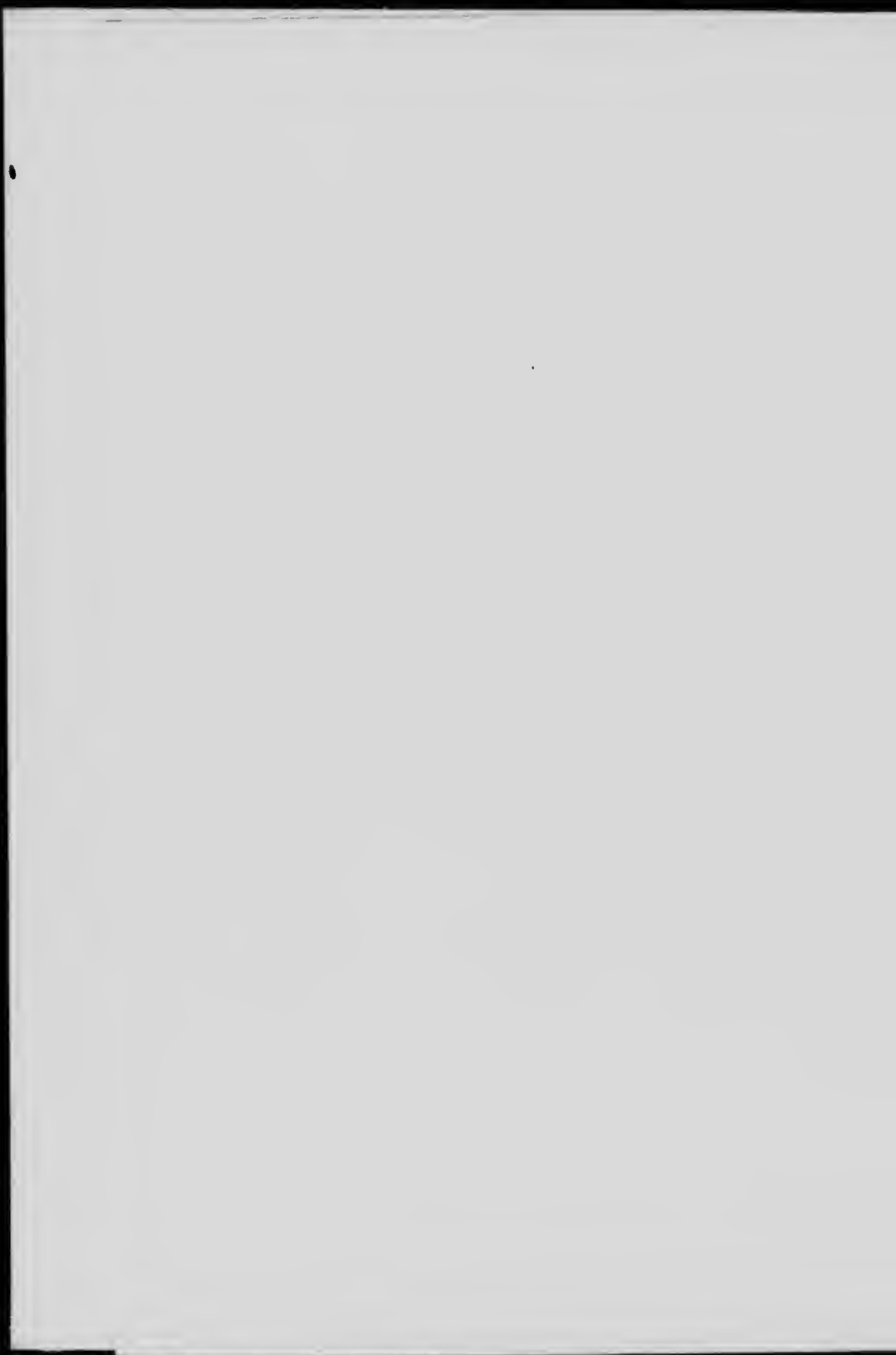

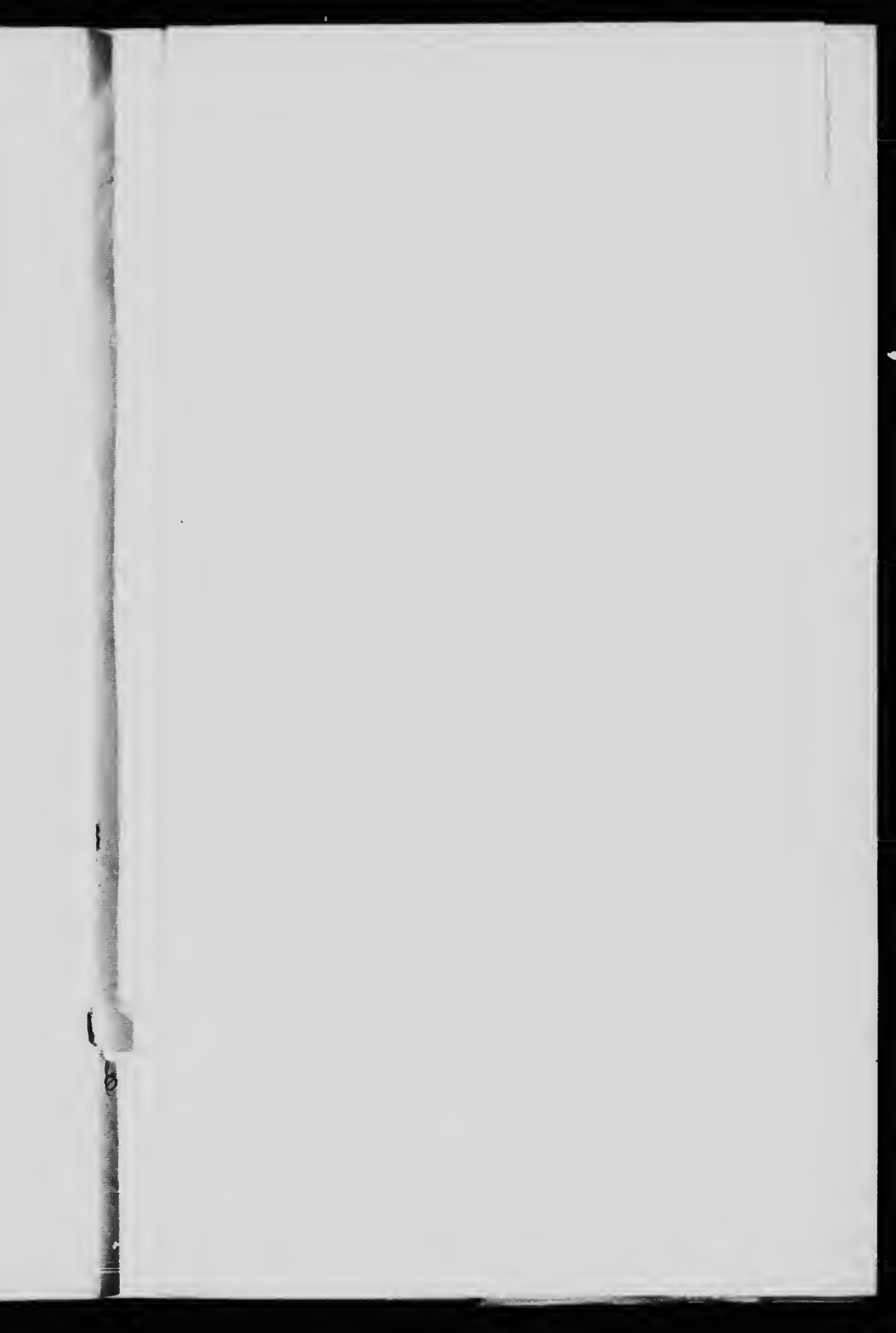

*Frontispiece.*

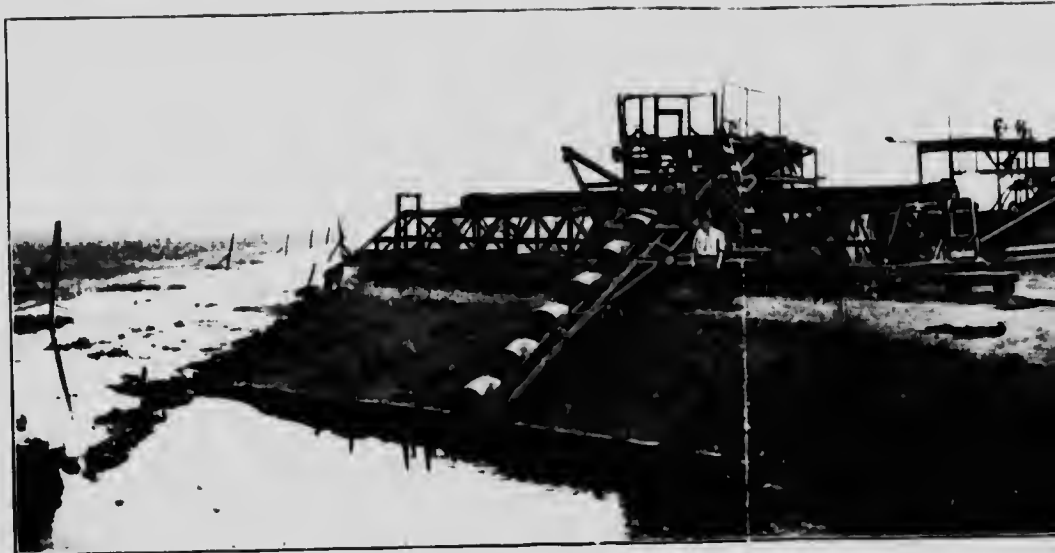

Panoramic view of the Anrep excavator, and Moore's cable d



's cable device for transportation of raw peat fuel, at the Alfred peat bog, Ontario.





at the Alfred peat bog, Ontario.

711  
840

*A. Aleni*  
*3/12/58*

**CANADA**

**DEPARTMENT OF MINES**

HON. P. E. BLONDIN, MINISTER; R. G. MCCONNELL, DEPUTY MINISTER

**MINES BRANCH**

ELGENE HAANEL, PH.D., DIRECTOR.

**BULLETIN No. 11**

**Investigation of the Peat Bogs and  
Peat Industry of Canada  
1913-14**

BY

**Aleph Anrep**



OTTAWA  
GOVERNMENT PRINTING BUREAU  
1915

No. 351

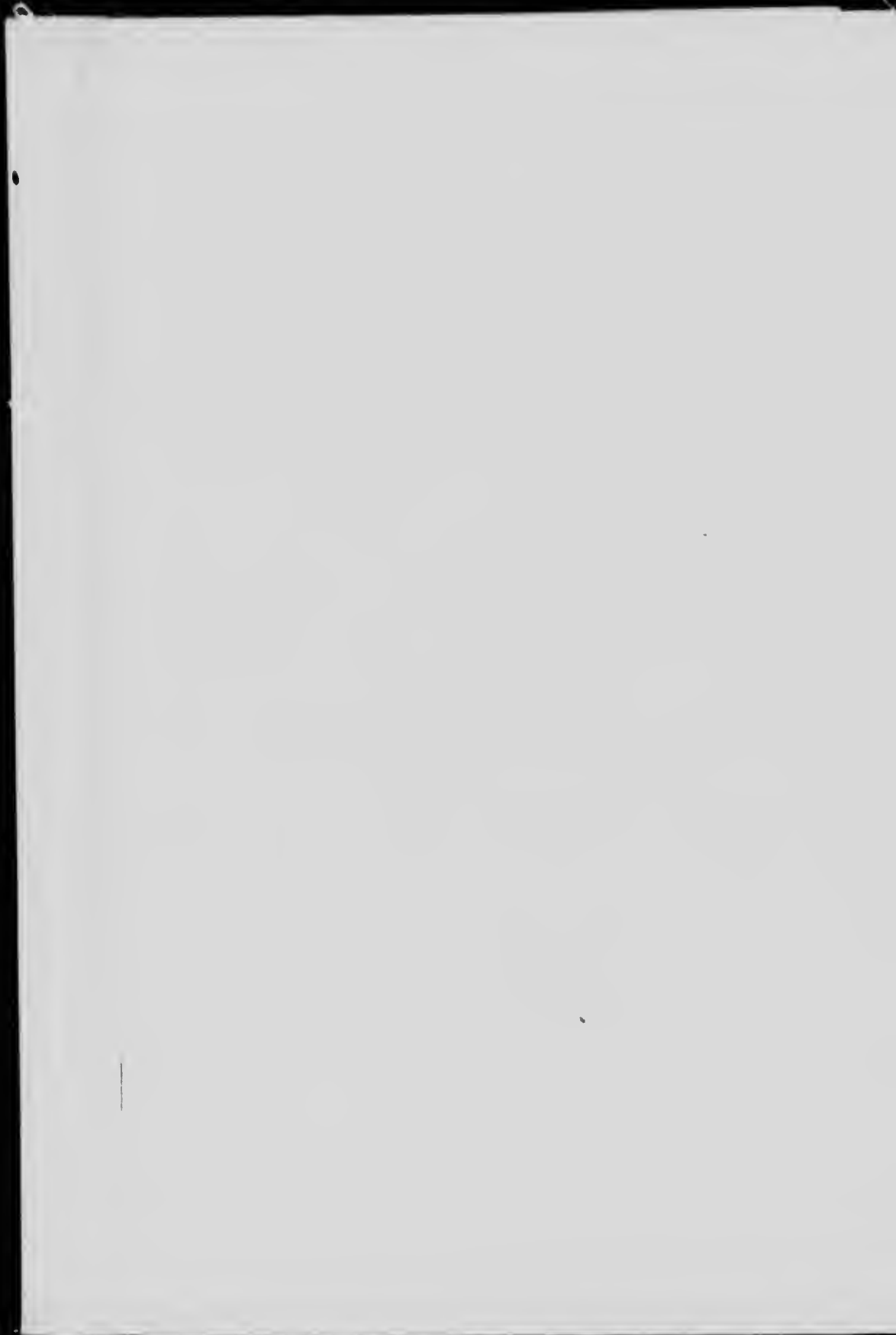

## LETTER OF TRANSMITTAL.

DR. EUGENE HAANEL,  
Director Mines Branch,  
Department of Mines,  
Ottawa.

SIR,—

I beg to submit, herewith, a report on the investigation of the peat bogs and peat industry of Canada, during 1913 and 1914.

Particulars are given of the detailed examination of ten peat bogs in the Province of Ontario; three peat bogs in the Province of Quebec; six peat bogs in the Province of Prince Edward Island; and eight peat bogs in the Province of Nova Scotia, together with a short description of a preliminary investigation of two bogs situated near Durham in the county of Grey, and one near Warton, in the county of Bruce, both in the Province of Ontario; also of one at Mount Stewart, near Charlottetown, Prince Edward Island.

In addition to the foregoing, I have included in the report over 60 photographic illustrations of botanical plants found in the bogs investigated; of which most of the bogs in the eastern provinces of Canada are composed.

A number of translations of valuable official documents on the utilization of peat, dealing with recent developments in European practice, are also included.

I have the honor to be, Sir,

Your obedient servant,

(Signed) **Aleph Anrep.**

April 30, 1915.



## CONTENTS.

	PAGE
INVESTIGATION OF CANADIAN PEAT BOGS.....	1
<b>Ontario—</b>	
Richmond peat bog .....	1
Luther peat bog .....	3
Amaranth peat bog .....	5
Durham peat bog.....	6
Eastnor peat bog.....	7
Cargill peat bog.....	7
Westover peat bog.....	7
Marsh Hill peat bog.....	9
Sunderland peat bog.....	12
Manilla peat bog .....	13
Stoco peat bog.....	14
Clairview peat bog.....	16
Marl deposits of Clairview and Stoco peat bogs.....	17
Tweed peat bog.....	18
Buller peat bog.....	18
<b>Quebec—</b>	
L'Assomption peat bog .....	20
St. Isidore peat bog .....	22
Holton peat bog.....	23
<b>Prince Edward Island—</b>	
Black Marsh peat bog.....	27
Portage peat bog.....	28
Miscouche peat bog .....	30
Muddy Creek peat litter bog.....	32
Mount Stewart peat bog.....	32
Black Banks peat litter bogs.....	32
Mermaid peat bog.....	34
<b>Nova Scotia—</b>	
Caribou peat bog.....	38
Cherryfield peat bog.....	41
Tusket peat bog.....	42
Makoke peat bog.....	44
Heath peat bog.....	45
Port Clyde peat bog.....	51
Latour peat bog.....	52
Clyde peat bog.....	54
BOTANY OF PEAT BOGS: ILLUSTRATED.....	58
<b>Ontario—</b>	
Richmond peat bog.....	58
Marsh Hill peat bog.....	58

	PAGE
<b>Quebec—</b>	
L'Assomption peat bog.....	59
St. Isidore peat bog.....	59
Holton peat bog.....	59
<b>Prince Edward Island—</b>	
Miscouche peat bog.....	59
Black Banks peat bog.....	60
<b>Nova Scotia—</b>	
Caribou peat bog.....	60
Tusket peat bog.....	60
Clyde River peat bog.....	60
Acknowledgments.....	60
<b>ALFRED PEAT PLANT, ALFRED, ONT.: LATEST DÉVELOPMENT AND CONDITION OF.....</b>	<b>61</b>
<b>NOTES ON SPECIAL APPLIANCES FOR THE MANUFACTURE OF PEAT FUEL.....</b>	<b>63</b>
Egeberg's peat fuel machines—	
(1) Hand power.....	63
(2) Horse power.....	63
(3) Electric motor power.....	64
Baumann system of peat fuel manufacture.....	64
<b>NOTES ON PEAT PRODUCTION IN FOREIGN COUNTRIES.....</b>	<b>67</b>
<b>United States—</b>	
Importation of peat moss litter, 1906-1914.....	67
<b>Sweden—</b>	
Extract from the report on peat to the Swedish government, 1911.....	67
(a) Peat powder.....	67
(b) The de Laval wet carbonizing process.....	68
(c) Loans granted by Swedish government, for the promotion of peat fuel industry, 1903-1910.....	68
Special loan for experiments on de Laval wet carbonizing process.....	69
<b>Norway—</b>	
Peat fuel manufactured at Vestfinmarken, Norway, during 1914.....	69
<b>Denmark—</b>	
Progress of peat fuel industry 1902-1913.....	70
Detailed information with regard to peat fuel manufacture—	
1913.....	70
1914.....	71
<b>Russia—</b>	
Progress of the peat fuel industry, 1909-1914.....	71

## TABLES.

PAGE		PAGE
59	Table I.—Peat bogs investigated in Ontario during 1908-09-10-11, and 1913....	9
59	" II.—Peat bogs investigated in the Province of Quebec.....	19
59	" III.—Analyses of the different peat samples collected from the bogs in the Province of Quebec.....	25
59	" IV.—Investigated peat bogs in Prince Edward Island, during 1913.....	26
60	" V.—Peat bogs investigated in Province of Nova Scotia.....	37
60	" VI.—Analyses of the different peat samples collected from bogs in the Province of Nova Scotia.....	57
60	" VII.—Peat fuel manufactured at Vestfinmarken, Norway, 1914.....	69
60	" VIII.—Peat fuel manufactured in Denmark in the years 1902-1913.....	70
60	" IX.—Total amount of peat fuel manufactured and sold in Denmark during 1913.....	71
60	" X.—Table of peat manufactured and sold in Denmark during 1914.....	71

## APPENDICES.

## COPIES OF CANADIAN PATENTS DESCRIPTIVE OF IMPROVEMENTS IN MACHINERY FOR THE HANDLING AND MANUFACTURE OF PEAT FUEL.

63	Appendix I.—Apparatus for treating peat. By A. Anrep, Helsingborg, Sweden.....	75
63	" II.—Automatic rope arrangement for transporting carriage rolling on a shiftable circular track. By A. Anrep, Helsingborg, Sweden.....	79
64	" III.—Peat moulding and spreading machine. By A. Anrep, Helsingborg, Sweden.....	83
64	" IV.—Separation of water and solid substance by application of pressure. By Horace Keeble and Cecil Keeble, Wareham, England.....	87
67	" V.—Process for drying raw peat. By Heinrich Brune, and Dr. Heinrich Horst, Frankfort-on-the-Main, Germany.....	89
67	" VI.—The getting or excavating of peat. By Thomas Rigby, Dumfries, Scotland.....	91
67	" VII.—Removal of water from wet carbonized peat. By Nils Testrup, and Olaf Söderlund, London, England.....	95
67	" VIII.—Methods of recovering peat bogs. By Bernard Granville, New York, U.S.A.....	101
68	" IX.—Peat conveyer. By Ernst August Person, Emmalunga, Sweden.....	107
68	" X.—Peat expresses. By Oscar Joseph Sigler, Mansfield, Ohio, and Jerome Jarvis, Toledo, Ohio.....	115
69	" XI.—Methods and apparatus for gathering and transporting peat. By Thomas Rigby, Dumfries, Scotland.....	121
69	" XII.—Method of desiccating peat. By Emil Hirsch, Berlin, Germany.....	123
70	" XIII.—Process for utilization of peat. By Thomas Rigby, Dumfries, Scotland, and Nils Testrup, London, England.....	125
70	" XIV.—Drying or carbonizing peat. By Edward Fox Strangways Zohrale, C.E., Baronet, Scotsvalder, Thurso, Scotland.....	129
71	" XV.—Process and apparatus for treating peat. By Josef Berglund, Eskilstuna, Sweden.....	129



	PAGE
Appendix XVI.—Improved treatment of peat for manurial and other purposes. By William Beecroft Bottomly, Kings College, London, England.....	133
„ XVII.—Machinery for treatment of peat and the like. By E. Arthur Buckle, Manchester, England.....	135
„ XVIII.—Removing roots and the like from peat. By James Sidney Whitaker, Dumfries, Scotland.....	139
„ XIX.—Peat working machine. By Constantin Zelenay, Twer, Russia.....	145
„ XX.—Apparatus for the utilization of peat. By Nils Testrup, London, England; Thomas Rigby, Dumfries, Scotland; and Olaf Söderlund, London, England.....	155
„ XXI.—Improved apparatus for the wet carbonizing of peat. By Nils Testrup, London, England.....	165
„ XXII.—Method and apparatus for removing water from peat. By T. Rigby, Dumfries, Scotland.....	169
„ XXIII.—Peat forming and spreading machinery. By E. V. Moore, Peterborough, Ontario, Canada.....	173
„ XXIV.—Peat dewatering process. By Thomas Rigby, Dumfries, Scotland.....	177
INDEX.....	181
LIST OF MINES BRANCH PUBLICATIONS.....	End

## ILLUSTRATIONS.

### *Photographs.*

Plate I.—Panoramic view of the Anrep excavator and Moore's cable device for the transportation of raw peat fuel at the Alfred peat bog, Ontario.....	Frontispiece
„ II.—Land formation surrounding Marsh Hill peat bog, Ontario.....	10
„ III.—Surface growth on Marsh Hill peat bog, Ontario.....	10
„ IV.—Wooded area representing Marsh Hill peat bog, Ontario.....	10
„ V.—Railway crossing Marsh Hill peat bog, Ontario.....	10
„ VI.—Surface growth: Stoco peat bog, Ontario.....	16
„ VII.—Surface growth on the Black Marsh peat bog, P.E.I. <i>Carex</i> and <i>eriophorum</i> dominating.....	28
„ VIII.—The Black Banks peat bog, P.E.I.: low tide.....	34
„ IX.—Black Banks peat bog, showing the floating sphagnum island, P.E.I.....	34
„ X.—Surface growth, Mermaid peat bog, P.E.I.....	36
„ XI.—Lake Macdonald, Mermaid peat bog, P.E.I.....	36
„ XII.—Clyde peat bog, Nova Scotia.....	54
„ XIII.—Clyde river into which several arms of the Clyde peat bog extend.....	54
„ XIV.—Clyde peat bog, Nova Scotia.....	56
„ XV.—Showing the elevation of the hard land on the northwest shore of the Clyde peat bog, Nova Scotia.....	56
„ XVI.— <i>Cornus Canadensis</i> (L.).....	58
„ XVII.— <i>Eriophorum viridi-carinatum</i> (Engelm.).....	58
„ XVIII.— <i>Carex exilis</i> (Dewey).....	58
„ XIX.— <i>Carex tribuloides</i> .....	58
„ XX.— <i>Carex tenella</i> (Schk.).....	58
„ XXI.— <i>Carex rostrata</i> (Stokes).....	58

PAGE		PAGE
	Plate XXII.— <i>Carex Brunnescens</i> (Poir).....	58
	" XXIII.— <i>Carex mirabilis</i> (Dewey).....	58
133	" XXIV.— <i>Carex vulpinoidea</i> (Michx).....	58
	" XXV.— <i>Dulichium spathaceum</i> (S.).....	58
135	" XXVI.— <i>Calla palustris</i> (L.).....	58
	" XXVII.— <i>Scirpus atrocinctus</i> (Fern).....	58
139	" XXVIII.— <i>Scirpus Hudsonianus</i> (Fernal).....	58
	" XXIX.— <i>Galium trifidum</i> (L.).....	58
145	" XXX.— <i>Potamogeton alpinus</i> .....	58
	" XXXI.— <i>Thalictrum dioicum</i> .....	58
	" XXXII.— <i>Calopogon pulchellus</i> (R. Br.).....	58
155	" XXXIII.— <i>Drepanocladus Kneiffii</i> (Sch.) Warnst.....	58
	" XXXIV.— <i>Mnium affine</i> , Bland, var. <i>rugicum</i> (Laur.) Br. and Sch.....	58
165	" XXXV.— <i>Climacium dendroides</i> (Dill. L.) W. and M.....	58
	" XXXVI.— <i>Calliergon cordifolium</i> (Hecl) Lindb.....	58
169	" XXXVII.— <i>Thuidium delicatulum</i> (L.) Mitt.....	58
	" XXXVIII.— <i>Amblystegium riparium</i> .....	58
173	" XXXIX.— <i>Amblystegium Juratzkanum</i> .....	58
	" XL.— <i>Drepanocladus polycaepus</i> , Bland (Warnst.).....	58
177	" XLI.—Mixture of three sterile species:	
181	Bryum bimum	
End	Tortula montana	
	Ceratodon purpureus.....	58
	" XLII.— <i>Aspidium Thelypteris</i> (Swartz).....	58
	" XLIII.— <i>Caltha palustris</i> (L.).....	58
	" XLIV.— <i>Menyanthes trifoliata</i> (L.).....	58
	" XLV.— <i>Marchantia polymorpha</i> .....	58
	" XLVI.— <i>Impatiens biflora</i> (Walt).....	58
	" XLVII.— <i>Lysimachia thysiflora</i> (L.).....	58
	" XLVIII.— <i>Onoclea sensibilis</i> (L.).....	58
	" XLIX.— <i>Sium cicutaefolium</i> , Schrank.....	58
	L.— <i>Carex gynandra</i> , Schwein.....	58
	LI.— <i>Polygonum sagittatum</i> (L.).....	58
	LII.— <i>Juncus effusus</i> , L., var. <i>compactus</i> , Lej. and Court.....	58
	LIII.— <i>Molopurus geniculatus</i> (L.).....	58
	LIV.— <i>Sium cicutaefolium</i> , Schrank; linear leaved form.....	58
	LV.— <i>Calamagrostis Langsdorffii</i> (Link.) Trin.....	58
	LVI.— <i>Chelone glabra</i> (L.).....	58
	LVII.— <i>Habenaria psychodes</i> , Gray.....	58
	LVIII.— <i>Solidago rugosa</i> , Mill.....	58
	LIX.— <i>Solidago graminifolia</i> (L.) Salisb.....	58
	LX.— <i>Solidago Canadensis</i> .....	58
	Solidago uliginosa, Nutt.....	58
	LXI.— <i>Solidago altissima</i> (L.).....	58
	LXII.— <i>Rubus Chamæmoras</i> (L.).....	60
	LXIII.— <i>Empetrum nigrum</i> (L.).....	60
	LXIV.— <i>Eriophorum Virginicum</i> (L.).....	60
	LXV.— <i>Vaccinium corymbosum</i> (L.).....	60
	LXVI.— <i>Gaultheria procumbens</i> (L.).....	60
	LXVII.— <i>Asplenium Filix-femina</i> (L.) Bernh.....	60
	LXVIII.— <i>Galium tinctorium</i> (L.).....	60
	LXIX.— <i>Adiantum pedatum</i> (L.).....	60
	LXX.— <i>Sphagnum tenellum</i> , Pers.....	60
	LXXI.— <i>Sphagnum capillaceum</i> (Weiss) Schrank.....	60

	PAGE
Plate LXXII.—Sphagnum fuscum (Sch.) Klinggr.....	60
Dark brown—	
Sphagnum capillaceum (Weiss) Schrank, var. tenellum (Schrimp) Andr.....	60
Light red—	
.. LXXIII.—Dicranum Bergeri, Blandow.....	60
.. LXXXIV.—View (seen from above) of Moore's loading hopper and Anrep's excavator, Alfred, Ontario.....	62
.. LXXXV.—The Anrep excavator, side view, Alfred, Ontario.....	62
.. LXXXVI.—Showing a clean cut of a working trench made by the Anrep excavator at Alfred, Ontario.....	62
.. LXXXVII.—Piling peat into hives, Alfred, Ontario.....	62
.. LXXXVIII.—Piling peat into hives, Alfred, Ontario.....	62
.. LXXXIX.—Peat ready for the market, Alfred, Ontario.....	62
.. LXXX.—Transportation of dry peat to the railway cars, Alfred, Ontario	62
.. LXXXI.—Moore's small gasoline transportation engine, Alfred, Ontario...	62
.. LXXXII.—Elevating system loading peat into cars, Alfred, Ontario.....	62
.. LXXXIII.—Egeberg peat pulping machine turned by hand.....	64
.. LXXXIV.—Egeberg peat pulping machine operated by horse power.....	64
.. LXXXV.—Egeberg peat pulping machine operated by electric motor with a conveyer.....	64
.. LXXXVI.—Movable macerator and forming machine operated by electrical power, Royal Bavarian peat bog, Rosenheim, Munich.....	66
.. LXXXVII.—Conveyer macerator with brick-forming machine and appar- atus for laying out the peat bricks, Royal Bavarian peat bog, Rosenheim, Munich.....	66
.. LXXXVIII.—Dumping the wet peat bricks on the field, Royal Bavarian peat bog, Rosenheim, Munich.....	66
.. LXXXIX.—Layer of the wet peat bricks during transportation, Royal Bavarian peat bog, Rosenheim, Munich.....	66
.. XC.—Laying out the rails for the spreading apparatus, Royal Bavarian peat bog, Rosenheim, Munich.....	66
.. XCI.—Anrep macerator, 1914 model, Alfred, Ontario.....	76
.. XCII.—Automatic spreading device, Alfred, Ontario.....	174

*Drawings.*

Fig. 1.—End elevation of the Anrep macerator.....	75
.. 2.—Vertical longitudinal section of the Anrep pulper.....	76
.. 3.—Fixed knife.....	76
.. 4.—Plan at the top of the Anrep pulper.....	76
.. 5.—Plan of Anrep traction system.....	80
.. 6.—Anchoring device.....	81
.. 7.—Coupling device.....	81
.. 8.—Plan of Anrep spreader.....	84
.. 9.—Side elevation of Anrep spreader.....	84
.. 10.—View of trenches for getting or excavating peat.....	92
.. 11.—Plan of Rigby's excavator, pump, and disintegrator.....	93
.. 12.—Side view of Testrup's carbonizer.....	97
.. 13.—Side view of Testrup-Söderlund air vessel.....	98
.. 14.—Plan of Bernard Granville hydraulic process.....	102
.. 15.—Conical screen for straining the peat from roots and sticks.....	104
.. 16.—Vertical section of Bernard Granville hydraulic process.....	105

PAGE		PAGE
	Fig. 17.—General plan of Persson's conveyer.....	7
60	" 18.—Station truck, Persson's system.....	108
	" 19.—Guides for supporting the wire ropes, station-truck.....	109
60	" 20.—Side view of the side frame, station-truck.....	109
	" 21.—Channel iron supported by means of a slanting stay, station-truck.....	109
60	" 22.—Roller for the wire rope, station-truck.....	110
	" 23.—Section of the idlers, station-truck.....	110
62	" 24.—Plan of the idlers, station-truck.....	110
62	" 25.—Side view of roller conveyer, Persson's system.....	111
	" 26.—Plan of roller conveyer, Persson's system.....	111
62	" 27.—Boards for receiving the peat.....	112
62	" 28.—Side view of Sigler's transportation apparatus.....	116
62	" 29.—Plan of Sigler's apparatus.....	117
62	" 30.— " " " operation of the driving shaft.....	118
62	" 31.—Perforated flights of the lower platform.....	119
62	" 32.—Plan and section of Rigby's apparatus for gathering and transporting peat	122
62	" 33.—Plan of perforator.....	124
64	" 34.—Side view of perforator.....	124
64	" 35.—Side view of Thomas Rigby's gas producer.....	126
	" 36.—Plan of Berglund's macerator.....	130
64	" 37.—Side view of Berglund's disintegrator.....	131
	" 38.—Rear elevation of Berglund's apparatus for treating peat.....	132
	" 39.—Plan of Buckle's feed tank.....	136
66	" 40.—Details of the Buckle apparatus.....	136
	" 41.—Side view of Whitaker's root removing apparatus.....	140
	" 42.—Plan of Whitaker's root removing apparatus.....	141
66	" 43.—Vertical section of Whitaker's root removing apparatus.....	142
	" 44.—Section of Whitaker's root removing apparatus.....	143
66	" 45.—Vertical section of Whitaker's peat cutting apparatus.....	146
	" 46.—Plan of Zelenay's cutting apparatus.....	147
66	" 47.—Side view of Zelenay's cutting apparatus.....	148
	" 48.—Parts of peat cutting apparatus; loosening device, screw conveyer, and motor.....	149
66	" 49.—Vertical section of screw conveyer.....	149
76	" 50.— " " loosening device.....	150
174	" 51.— " " upper part of loosening device.....	150
	" 52.—Plan of the cutters in loosening device.....	150
	" 53.—Section of Zelenay cutting apparatus.....	152
	" 54.— " " " ".....	152
	" 55.— " " " ".....	152
75	" 56.—Section of Testrup's, Rigby's, and Söderlund's wet carbonizing plant.....	156
76	" 57.—Section of Testrup's, Rigby's, and Söderlund's wet carbonizing plant.....	157
76	" 58.—Section of Testrup installation for producing briquette fuel.....	158
80	" 59.—Section of Testrup installation for producing electrical energy.....	159
81	" 60.—Section of installation of gas producer with apparatus for producing press cakes and briquettes.....	160
84	" 61.—Sectional view of Testrup's wet carbonizing apparatus.....	166
84	" 62.—Side elevation of Rigby's apparatus for removing water from peat.....	170
92	" 63.—Plan of Moore's spreader.....	174
93	" 64.—Section of Moore's spreader.....	174
97	" 65.—Side view of Moore's spreader.....	175
98	" 66.—Plan of Rigby's dewatering apparatus.....	178

Maps.

Map. No. 354.—Map of Ontario	1
" " 355.—Richmond peat bog, Ontario	2
" " 356.—Luther peat bog, Ontario	4
" " 357.—Amaranth peat bog, Ontario	6
" " 358.—Cargill peat bog, Ontario	8
" " 359.—Westover peat bog, Ontario	8
" " 360.—Marsh Hill peat bog, Ontario	10
" " 361.—Sunderland peat bog, Ontario	12
" " 362.—Manilla peat bog, Ontario	14
" " 363.—Stoco peat bog, Ontario	16
" " 364.—Clairview peat bog, Ontario	16
" " 365.—Map of Quebec	20
" " 366.—L'Assomption peat bog, Quebec	20
" " 367.—St. Isidore peat bog, Quebec	22
" " 368.—Holton peat bog, Quebec	24
" " 369.—Map of Nova Scotia and Prince Edward Island	28
" " 370.—Black Marsh peat bog, P.E.I.	28
" " 371.—Portage peat bog, P.E.I.	28
" " 372.—Miscouche peat bog, P.E.I.	30
" " 373.—Muddy Creek peat litter bog, P.E.I.	32
" " 374.—Black Banks peat bog, P.E.I.	34
" " 375.—Mermaid peat bog, P.E.I.	34
" " 376.—Caribou peat bog, Nova Scotia	38
" " 377.—Cherryfield peat bog, Nova Scotia	42
" " 378.—Tusket peat bog, Nova Scotia	42
" " 379.—Makoke peat bog, Nova Scotia	44
" " 380.—Heath peat bog, Nova Scotia	46
" " 381.—Port Clyde peat bog, Nova Scotia	52
" " 382.—Latour peat bog, Nova Scotia	52
" " 383.—Clyde peat bog, Nova Scotia	54

PAGE

1  
2  
4  
6  
8  
8  
10  
12  
14  
16  
16  
20  
20  
22  
24  
28  
28  
28  
30  
32  
34  
34  
38  
42  
42  
44  
46  
52  
52  
54

**INVESTIGATION OF CANADIAN PEAT BOGS**  
**1913-14**



H. F.  
Hase J

shal

DEPARTM

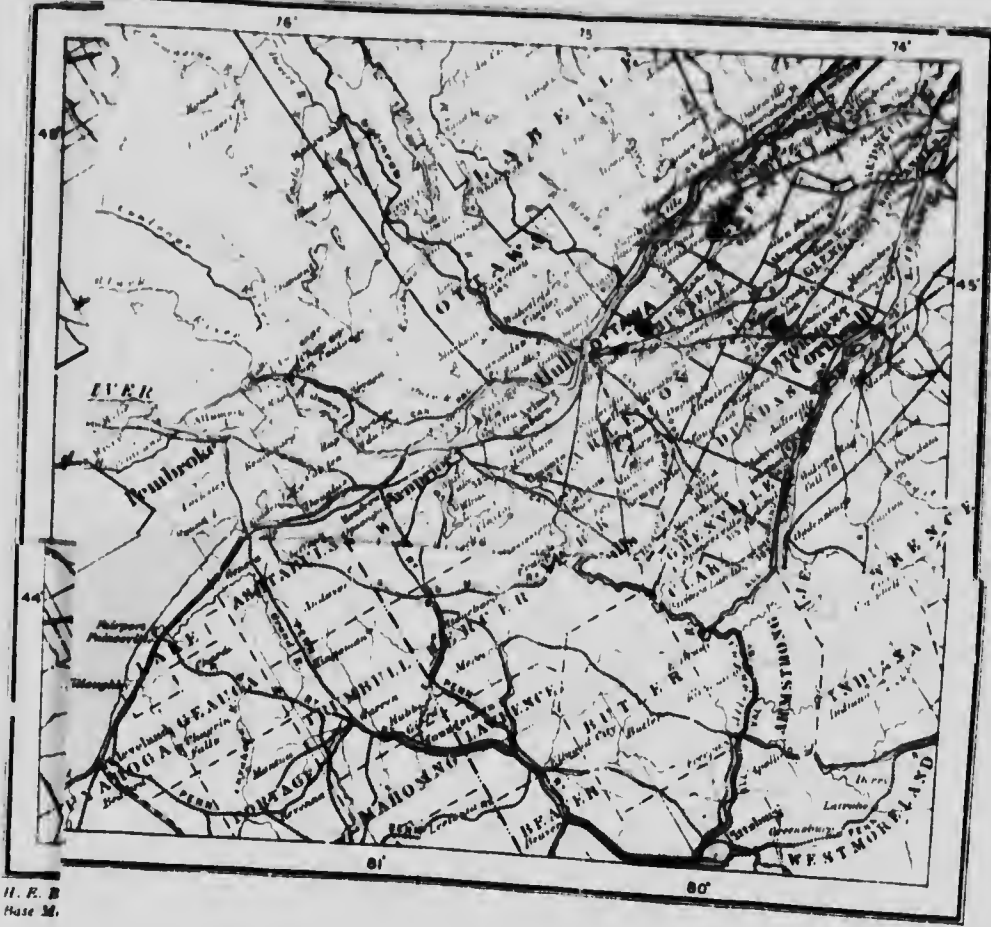

354

shallow. This part of the bog is very heavily wooded with spruce, fir,



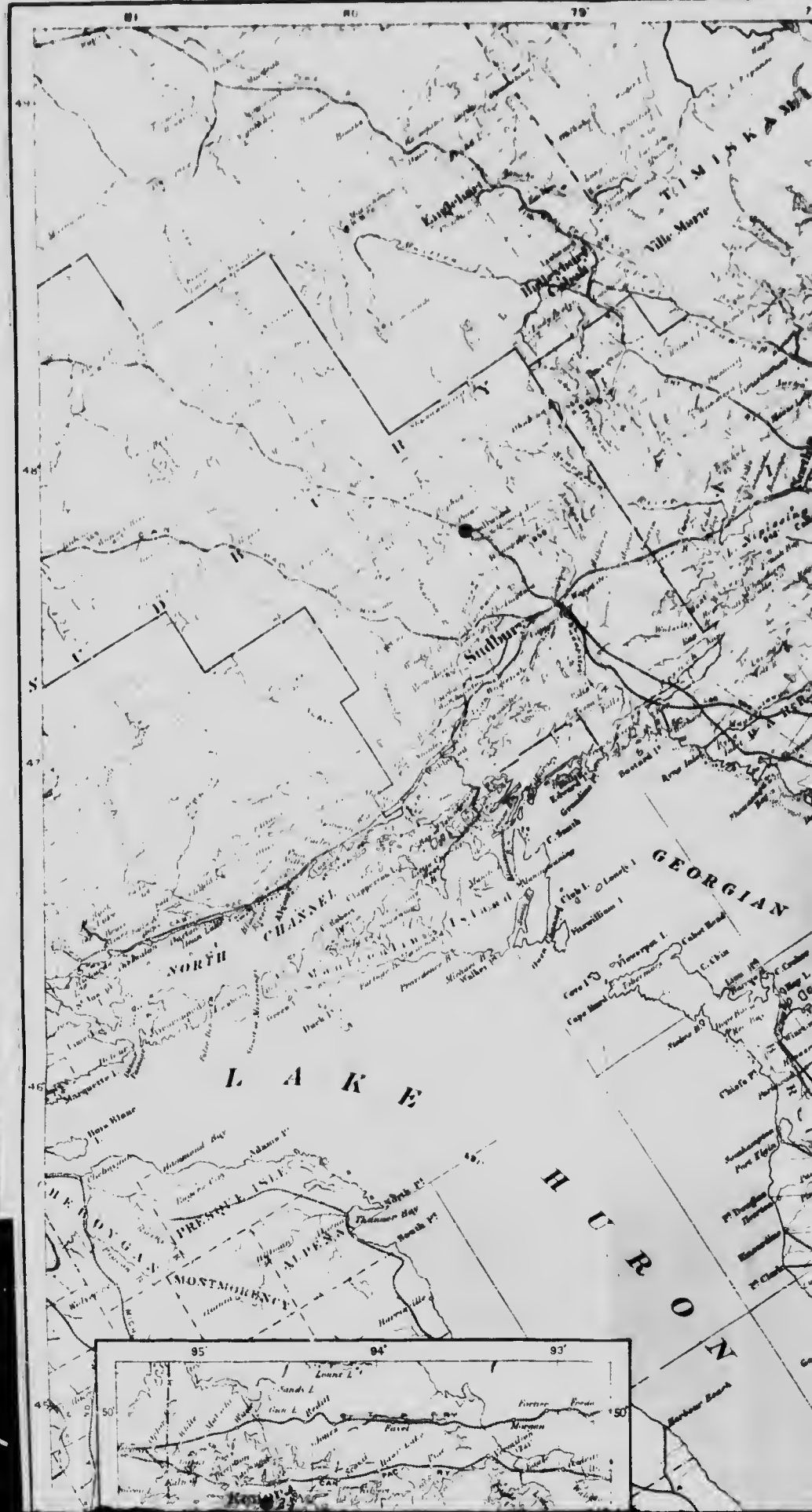



*Post Bogs*

- 1—Rondeau
- 2—Komoka
- 3—Brunner
- 4—Westover
- 5—Welland
- 6—Cargill
- 7—Luther
- 8—Amaranth
- 9—Holland
- 10—Marsh Hill
- 11—Sunderland
- 12—Manilla
- 13—Victoria Road
- 14—Stoco
- 15—Clareview
- 16—Perth
- 17—Brockville
- 18—Richmond
- 19—Mer Bleue
- 20—Newington
- 21—Alfred
- 22—Moose Mountain
- 23—Fort Frances
- 24—Kenora

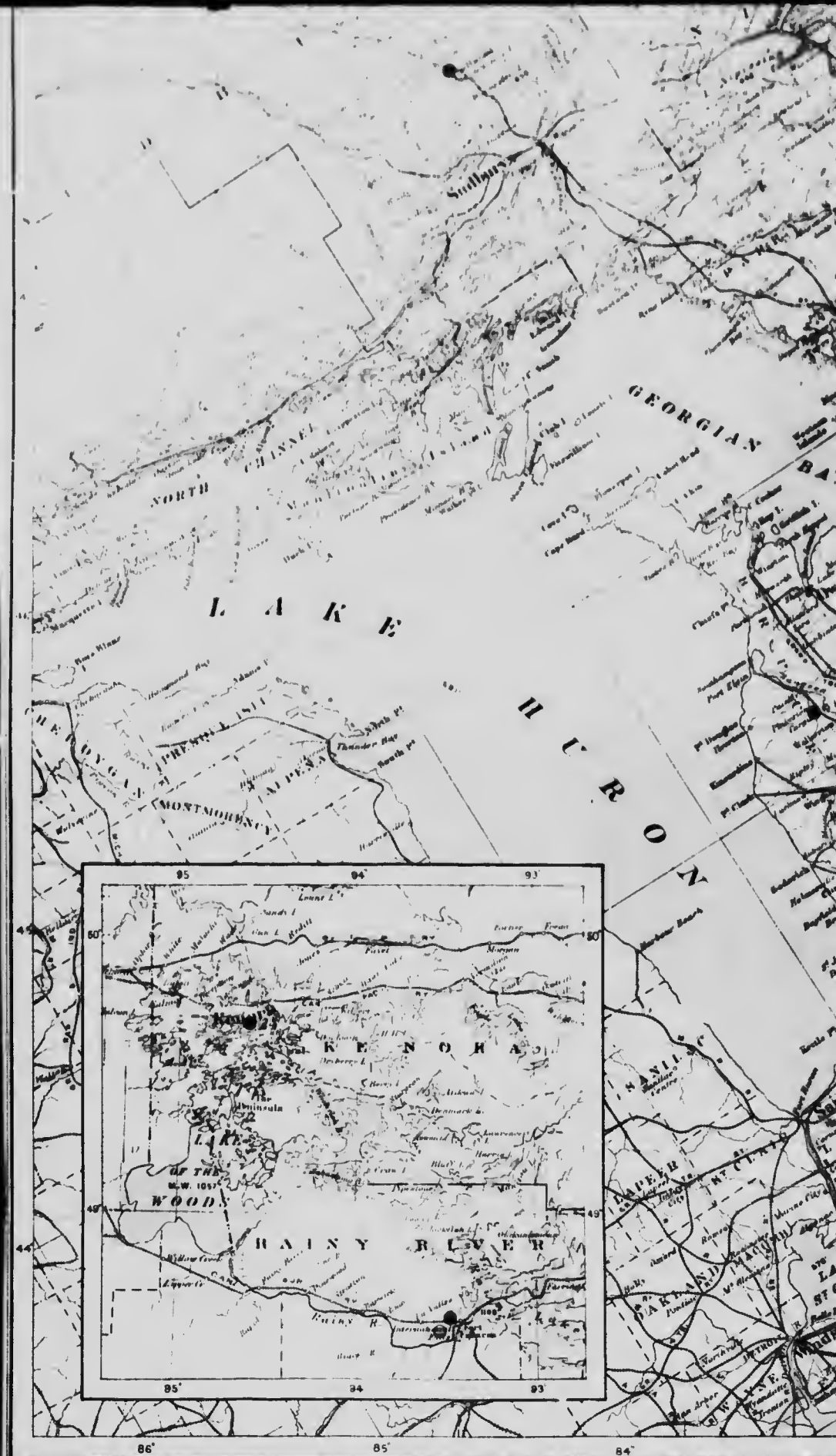

H. E. Baine, Chief Draughtsman  
Base Map, Department of the Interior.

- Peat fuel bogs
- ⊖ Peat litter bogs
- Not workable bogs

PEAT BOG



- Post Boys
- 1 - Roulet
  - 2 - Komoka
  - 3 - Brunner
  - 4 - Westover
  - 5 - Welland
  - 6 - Cargill
  - 7 - Luther
  - 8 - Amaranth
  - 9 - Holland
  - 10 - Marsh Hill
  - 11 - Sunderland
  - 12 - Mailla
  - 13 - Victoria Road
  - 14 - Steco
  - 15 - Claxview
  - 16 - Perth
  - 17 - Brockville
  - 18 - Richmond
  - 19 - Alex Blene
  - 20 - Newington
  - 21 - Alfred
  - 22 - Moose Mountain
  - 23 - Fort Frances
  - 24 - Kenora

**GREAT BOGS INVESTIGATED**  
 IN  
**ONTARIO**

Scale : 35 miles to 1 inch.



## INVESTIGATION OF CANADIAN PEAT BOGS, 1913-14.

### ONTARIO.

#### Description of the Richmond Peat Bog.

This bog is situated  $2\frac{1}{2}$  miles south of Richmond village, in the township of Goulbourn and Marlborough, county of Carleton, Ontario; and runs in a north and south direction. (See Map No. 355.) It covers more or less of:—

Lots 12-20	con. I	township of Goulbourn,
" 13-20	" II	" "
" 12-13	" VI	" Marlborough,
" 11-13	" VII	" "
" 7	" VIII	" "
" 9-14	" VIII	" "
" 6-14	" IX	" "
" 6-15	" X	" "

The total area covered by this bog is, approximately 5,500 acres. Of this area:—

Approximately, 3,340 acres have a depth of less than 5 feet with an average depth of 3 feet.

Approximately, 2,160 acres have a depth of more than 5 feet with an average depth of 7 feet.

The volume of the peat contained is:—

Approximately, 38,387,000 cub. yards in an area with a depth of less than 5 feet.

Approximately, 24,390,000 cub. yards in an area with a depth of more than 5 feet.

That portion of the bog which is situated more or less in

Lots 13-16	con. I	township of Goulbourn,
" 13-16	" II	" "
" 12-13	" VI	" Marlborough,
" 11-13	" VII	" "
" 11-13	" VIII	" "
" 11-14	" IX	" "
" 11-14	" X	" "

or the south part of the bog is fairly well suited for the manufacture of machine peat. It is well humified, and is of good depth, although rather shallow. This part of the bog is very heavily wooded with spruce, tamarack,

and cedar. Around the margin, poplar, alder, and in some parts, a heavy growth of cedar are to be found.

The peat in the remainder of the bog is very shallow. Early in the spring a large part of this portion of the bog is flooded by the river Jock, and, therefore, can not be used for the manufacture of peat fuel. If, however, the river could be lowered, and the ground properly drained, this part of the bog could be used, advantageously, for agricultural purposes.

All the samples obtained from this bog show that it is composed mainly of carex plants—*Carex mirabilis*, *C. Tribuloides*, *C. Brunnescens*, *C. utilis*, *C. Rostrata*, *C. Tenella*, *C. vulpinoidea* and several other varieties. In certain parts, the bog is intermixed with *Eriophorum viridi-carinatum*, *Scirpus hudsonianus*, *Scirpus atrocinctus*; aquatic plants are also found.

In the eastern and southern part of the bog large patches of hypnum are occasionally found.

The bottom is formed of blue clay and here and there narrow bands of sand occur. The surface of the outside edges is under cultivation, and is practically free from trees. The bog is heavily intermixed with logs, roots and stumps.

Deducting the 3,340 acres having a depth of less than 5 feet, and allowing one foot for the decrease in depth through drainage—for one foot is sufficient to allow since the bog is very compact—we have left:—

2,160 acres with an average depth, approximately, of 6 feet, and having a total volume of 20,908,000 cubic yards, approximately.

Assuming that one cubic yard of the drained bog would furnish 200 pounds of dry peat substance, the total tonnage of dry substance available would be, approximately, 2,090,000 tons (2,000 pounds), or 2,788,000 tons, approximately, of peat fuel having 25 per cent moisture.

*Analyses of Peat.*

Sample	I		II		III	
	R	D	R	D	R	D
Moisture.....	9.5		9.7		9.2	
Ash.....	10.9	12.0	9.9	11.0	10.1	11.2
Volatile matter.....	54.2	59.9	55.0	60.9	55.2	60.8
Fixed carbon (by difference).....	25.4	28.1	25.4	28.1	25.5	28.0
Sulphur.....			0.4	0.5		
Nitrogen.....	1.8	2.0	1.7	1.9	1.9	2.1
Calorific value in calories per gram, gross.....	4,400	4,860	4,230	4,680	4,270	4,710
" " in B.Th.U. per lb. gross.....	7,920	8,750	7,620	8,440	7,690	8,470
Fuel ratio, fixed carbon, volatile matter.....	0.47	0.47	0.46	0.46	0.46	0.46

Note.—Figures in column "R" refer to fuel as received, and in column "D," to fuel dried at 105°C.

The analyses were made on the fuel as received, and other results calculated therefrom.

The bog is very advantageously situated in regard to shipping facilities and market, being only 18 miles from Ottawa, and traversed on the west side by the Canadian Northern railway.

Investig. 354).

Names of the peat bogs	County	REMARKS
Mer Bieu.....	Russell.....	Principally formed of sphagnum.
Alfred.....	Prescott.....	Principally formed of sphagnum.
Welland.....	Welland.....	Formed of hypnum, eriphorum and sphagnum.
Newington.....	Stormont.....	Principally formed of sphagnum.
Perth.....	Lanark.....	Formed of hypnum, eriphorum and sphagnum.
Victoria Road....	Victoria.....	Principally formed of hypnum mixed with sphagnum.
Brunner.....	Perth.....	Principally formed of hypnum.
Vancouver.....	.....	.....

a heavy

y in the  
er Jock,  
If, how-  
ed, this  
urposes.  
l mainly  
*C. utilis*,  
ies. In  
*virinatum*,  
o found.  
hypnum

aw bands  
ion, and  
with logs,

and al-  
e foot is

et, and

nish 200  
available  
00 tons,

III

D

2	
1	11.2
2	60.8
5	28.0
9	2.1
70	4.710
90	8.470
46	0.46

uel dried  
herefrom.  
l market,  
Canadian



TABLE I.  
Investigated Peat Bogs in Ontario, during 1908-9-10-11 and -13. (See Map No. 354).

Names of the peat bogs	LOCALITY		Approximate total area, acres	Volume of workable peat			Partial analyses of absolutely dry peat				REMARKS
	County	Township		Tons of fuel with contents 25% moisture	Tons of litter with 20% moisture	Cubic yards	Fixed carbon %	Volatile matter %	Ash %	Caloric value	
Mer Bleu	Russell	Gloucester and Cumberland.	5,001	5,126,000		38,440,000	25.00	68.00	7.00	9,100	Principally formed of sphagnum.
Alfred	Prescott	Alfred and Caledonia	6,800	9,369,000		70,270,000	27.00	68.00	5.00	8,700	Principally formed of sphagnum.
Welland	Welland	Wainfleet and Humberstone.	4,900	4,106,000		30,796,000	24.00	71.00	5.00	8,700	Formed of hypnum, eriophorum and sphagnum.
Newington	Stormont	Onabruok, Roxborough and Cornwall.	3,800	6,209,000		46,566,000	26.00	67.00	7.00	8,500	Principally formed of sphagnum.
Perth	Lanark	Drummond	3,800	5,126,000		38,445,000	25.00	72.00	4.00	9,100	Formed of hypnum, eriophorum and sphagnum.
Victoria Road	Victoria	Bexley and Carden	67	54,000		400,000	25.00	70.00	5.00	8,600	Principally formed of hypnum mixed with sphagnum.
Brunner	Perth	Ellice	2,288	1,172,000		8,790,000	25.00	54.00	11.00	8,800	Principally formed of hypnum.
Komoka	Middlesex	Caradoc and Lobo	900	254,000		1,900,000	19.00	61.00	21.00	7,500	Formed of remains of sphagnum and carex.
Brockville	Leeds	Elisabethtown	1,400	1,694,000		12,705,000	22.00	67.00	12.00	8,200	Formed of remains of sphagnum and carex.
Rondeau	Kent	Harwich	1,571	1,047,000		7,856,000	23.00	61.00	16.00	7,900	Principally formed of carex.
Holland	Simcoe and York	West and East Gwillimbury and King	14,641	8,219,000		61,640,000	26.00	63.00	10.00	8,500	Principally formed of carex.
Coney Island	Coney Island	Lake of the Woods	25	32,000		240,000					Principally formed of sphagnum.
Crosier	Rainy River district	Crosier	355		518,000	6,910,000					Principally formed of sphagnum.
Fort Francis	Rainy River district	McIrvine and Crosier	1,700	891,000		6,680,000	29.0	62.0	9.0	8,900	Principally formed of sphagnum.
Richmond	Carleton	Goulbourn and Marlborough.	5,000	2,788,000		20,908,000	28.0	61.0	11.0	8,400	Composed mainly of carex.
Luther	Dufferin	W. and E. Luther	4,900	7,443,000		55,820,000	27.0	62.0	11.0	8,400	Composed mainly of sphagnum.
Amaranth	Wellington and Dufferin.	Amaranth	500	264,000		1,978,000	27.0	60.0	13.0	8,700	Composed mainly of sphagnum.
Durham	Grey	Glenelg	40								
Cargill	Bruce	Greenock	6,600				22.0	52.0	26.0	7,400	
Westover	Westworth	Beverly	1,400	306,000		2,290,000	24.0	56.0	20.0	7,900	Composed mainly of carex.
Marsh Hill	Ontario	Brock and Uxbridge	5,100	7,216,000		72,156,000	27.0	61.0	12.0	8,100	Composed mainly of carex.
Sunderland	Ontario	Brock	580	366,000		2,740,000	28.0	61.0	11.0	8,300	Composed mainly of carex.
Manilla	Ontario	Mariposa	745	399,000		2,990,000	29.0	60.0	11.0	8,100	Composed mainly of carex.
Stoco	Hastings	Hungerford	1,027	1,345,000		10,086,000	23.0	61.0	16.0	7,900	Composed mainly of carex.
Clairview	Lennox and Addington	Sheffield	280								Composed mainly of carex.
Tweed	Hastings	Hungerford	50								Composed mainly of carex.
Buller	Hastings	Hungerford	100								Composed mainly of carex.
		Total	73,570	63,416,000		500,606,000					

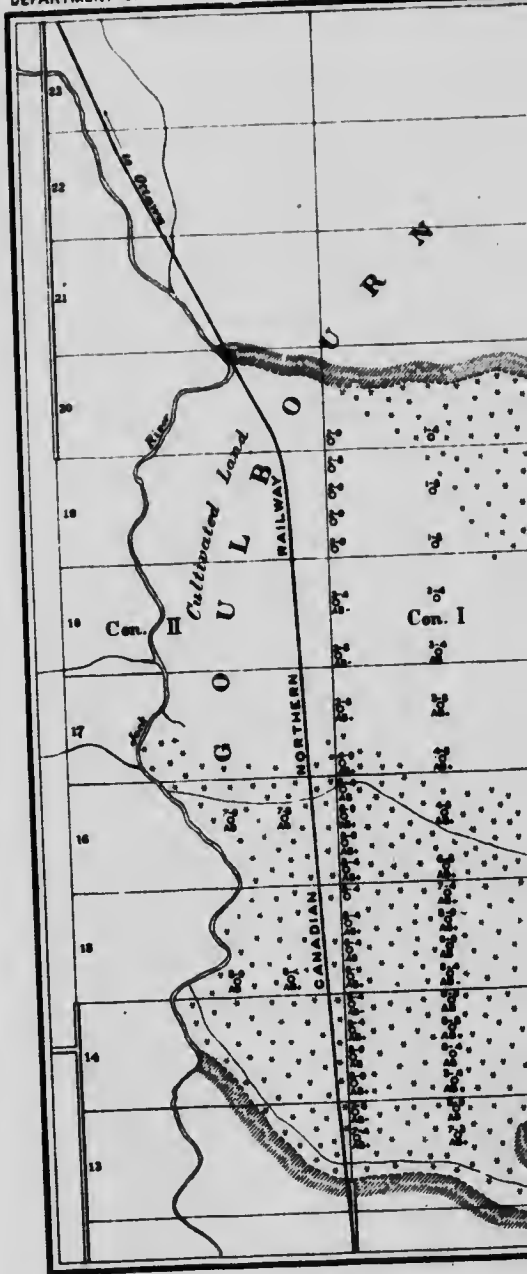

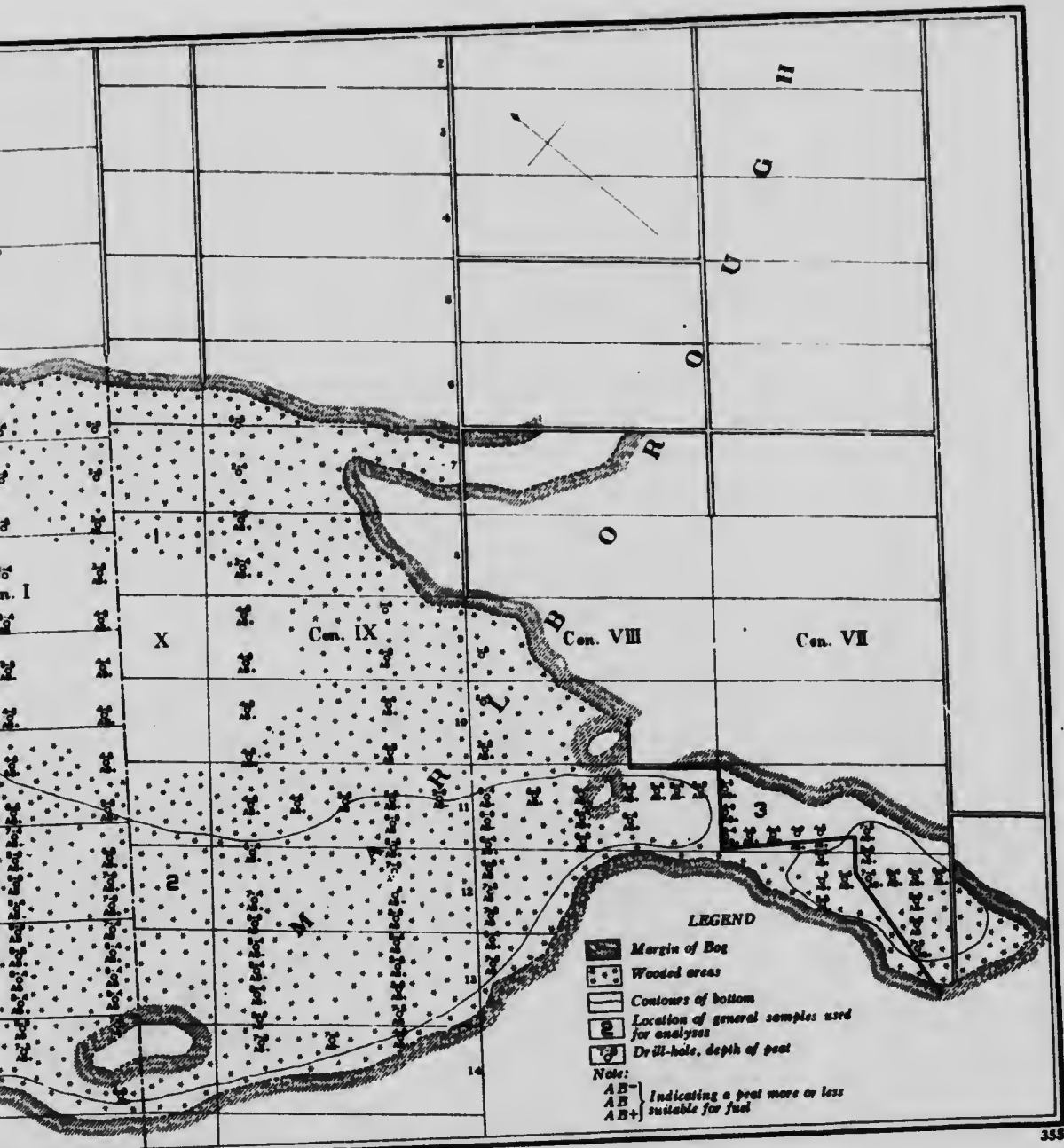

**RICHMOND PEAT BOG**

**CARLETON COUNTY**

**ONTARIO**

Scale of Feet

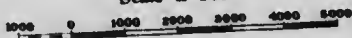



### Luther Peat Bog.

This bog is situated 7 miles west of Grand Valley, in West and East Luther townships, Dufferin and Wellington counties, Ontario, and runs in a north and south direction (see Map No. 356) covering more or less of:—

Lots	cont.	township
19-23	IV	East Luther.
" 19-21	V	" " "
" 19-21	VI	" " "
" 19	VII	" " "
" 19	VIII	" " "
" 19	IX	" " "
" 18	IV	West Luther.
" 16-18	V	" " "
" 15-18	VI	" " "
" 15-18	VII	" " "
" 15-18	VIII	" " "
" 14-18	IX	" " "
" 12-18	X	" " "
" 12-13, 15-17	XI	" " "
" 15-17	XII	" " "
" 16	XIII	" " "

The total area covered by this bog is, approximately, 4,900 acres. Of this area:—

- Approximately, 1,000 acres have a depth of less than 5 feet, average depth = 3 feet.
- Approximately, 1,650 acres have a depth of from 5 to 10 feet, average depth = 8 feet.
- Approximately, 1,700 acres have a depth of from 10 to 15 feet, average depth = 12 feet.
- Approximately, 550 acres have a depth of more than 15 feet, average depth = 16 feet.

The volume of the peat contained is, approximately:—

4,839,000	cub. yds.	in an area with depth of less than 5 feet.
21,296,000	"	" " 5 to 10 feet.
32,911,000	"	" " 10 to 15 feet.
14,097,000	"	" " more than 15 feet.

That portion of the bog lying in the township of East Luther is very well adapted to the manufacture of machine peat. It is well humified, has a considerable depth, and the surface is free from trees; but it is fringed on all sides by a margin of small willows and scrub brush. This margin varies from a few feet to about 200 feet. Beyond this margin the district is all cleared farming land under cultivation. The surrounding land rises in a short distance to an elevation of 15 to 25 feet or more above the bog.

The upper layer of the bog contains many roots and stumps. These are the result of the burning of the bog several times, which some twenty years ago was heavily wooded. A number of islands are to be found in this part of the bog—the largest of which are shown on map No. 356.

A working line over a mile in length can be obtained in the open part.

A considerable area in concessions VII and VIII, West Luther township, is also free from trees, but it is heavily overgrown with brush and bushes, principally small willows from 4 to 6 feet high.

The depth of the peat is less than in the above mentioned area, but the quality is very similar. Here also, a considerable length of working line may be secured north of a creek which runs from west to east across the bog.

The rest of the bog is heavily wooded with young spruce, tamarack and balsam, and near the margin, cedars, willows, and alders are to be found.

Most of the wooded area, with the exception of the extreme northern part lying in concessions XI and XII, if cleared, would be suitable for the manufacture of peat fuel, as the depth and quality are satisfactory.

The northern part, in concessions XI and XII, is shallow, and could not be profitably worked by machinery; but a portion could be utilized for domestic purposes by cutting the peat by hand; while the remainder could be utilized for agricultural purposes. Already, a certain amount has been put under cultivation.

The bog is formed principally of sphagnum-fuscum—with the exception of a certain small area at the northern and western part of the bog, where a variety of carex plants are to be found. In certain spots hypnum is lightly intermixed with sphagnum.

The remainder of the bog, outside of the southern part already mentioned, is comparatively free from roots and stumps. The bottom is composed of firm blue clay. It could be easily drained—the northern part east into the creek, and the southern part south, where a good fall can be obtained.

Deducting the 1,000 acres with a depth of less than 5 feet and allowing for the decrease in depth through drainage, we have left:—

1,650	acres,	with an average depth of,	approximately,	6	feet.
1,700	"	"	"	10	"
550	"	"	"	14	"

having a total volume of approximately 55,820,000 cubic yards.

Assuming that one cubic yard of the drained bog would furnish 200 pounds of dry peat substance, the total tonnage of dry substance available would be, approximately, 5,582,000 tons (2,000 pounds), or approximately 7,443,000 tons of peat fuel having 25 per cent moisture.

These  
 e twenty  
 found in  
 6.  
 en part.  
 er town-  
 rush and  
 area, but  
 working  
 ast across  
 amarack,  
 are to be  
 northern  
 ble for the  
 y.  
 and could  
 be utilized  
 remainder  
 n amount  
 exception  
 og, where  
 hypnum is  
 eady men-  
 bottom is  
 uthern part  
 fall can be  
 and a ... ng  
 et.  
 " "  
 " "  
 furnish 200  
 ce available  
 roximately,

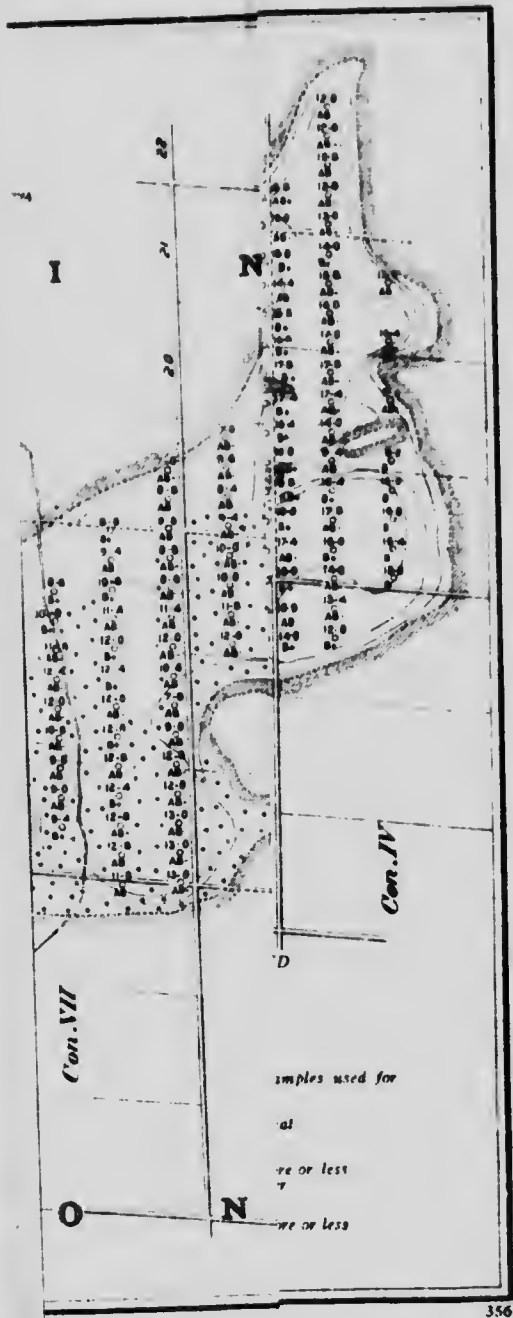

3  
 30  
 43  
 s  
 d  
 y  
 g  
 es  
 rt  
 e,  
 in  
 o.  
 of  
 th  
 d,  
 en  
 ng  
 or  
 ng  
 an

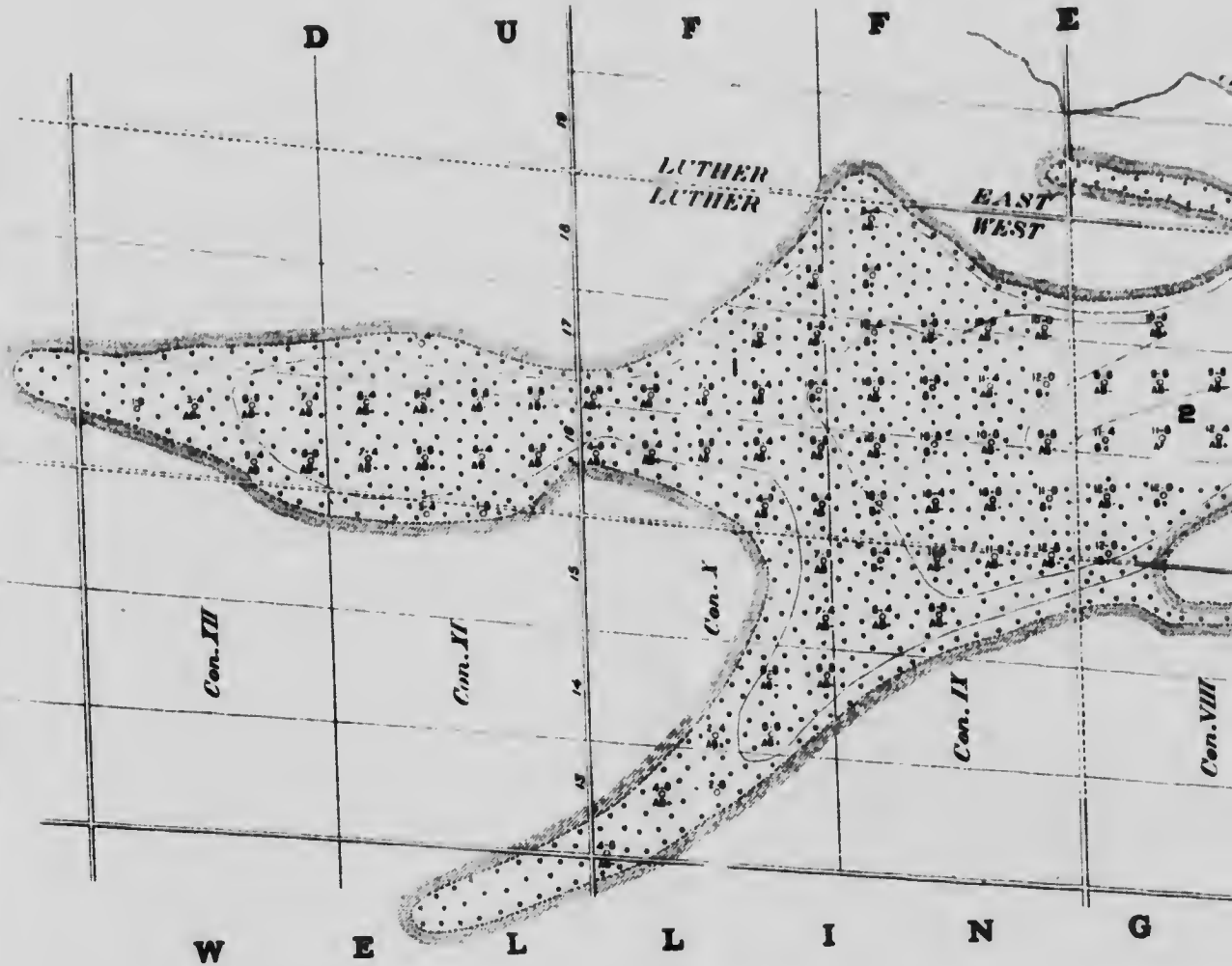

**LUTHER PEAT**

ONTARIO

Scale of Feet





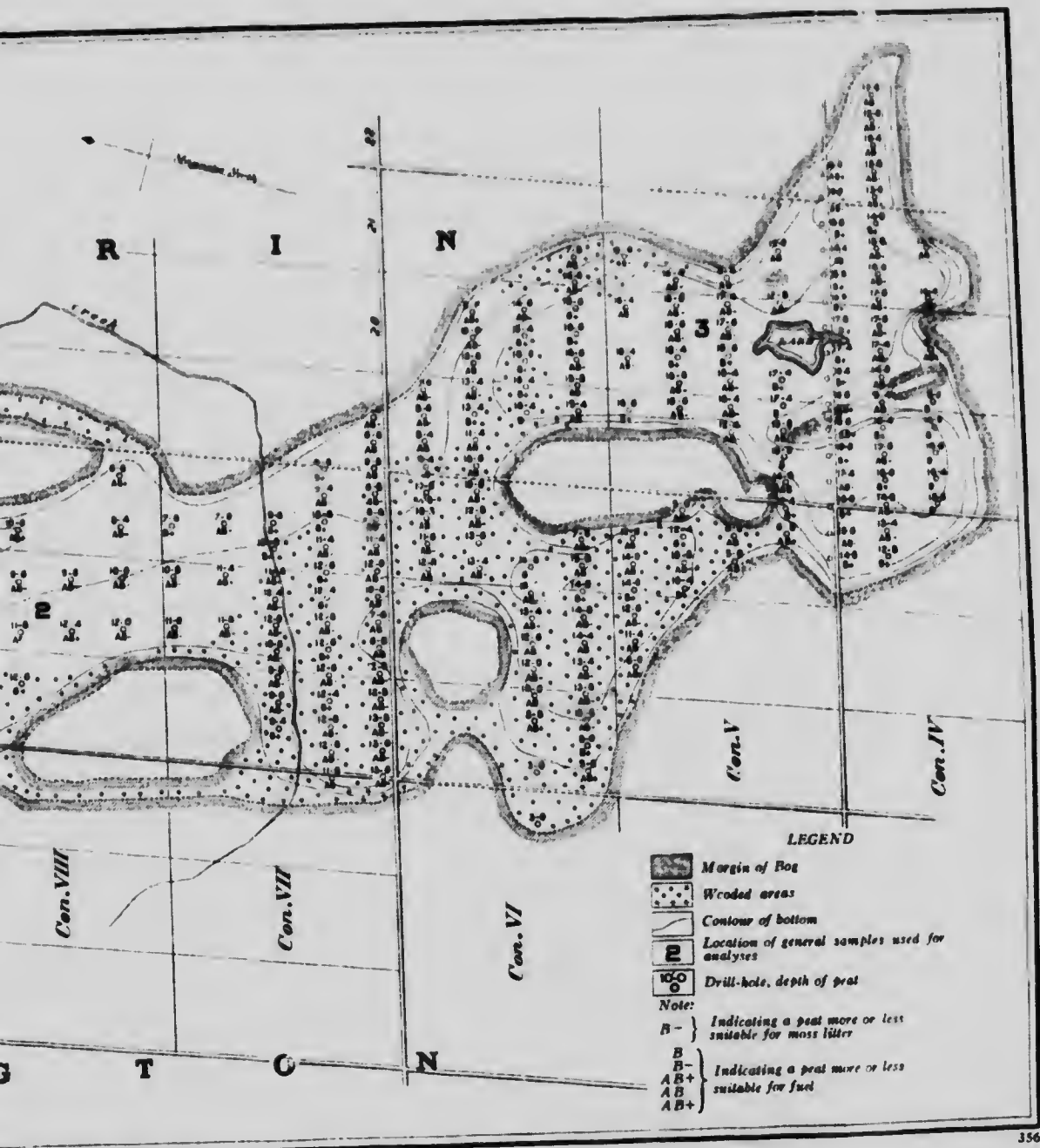

**PEAT BOG**

**ARIO**

of Feet



a:  
y:  
th

st  
b:

th  
li:  
th

ai  
fc

pa  
m

no  
fc  
cc  
h:

of  
a  
li:

ti  
cc  
ea  
o:

fc

h

p  
w  
7

*Analyses of Peat.*

Sample	I		II		III	
	R	D	R	D	R	D
Moisture.....	6.5		8.8		9.6	
Ash.....	2.5	2.7	9.9	10.9	17.0	18.8
Volatile matter.....	62.8	67.2	55.8	61.1	51.3	56.8
Fixed carbon (by difference).....	28.2	30.1	25.5	28.0	22.1	24.4
Sulphur.....			0.7	0.7		
Nitrogen.....	0.7	0.8	2.2	2.4	1.6	1.8
Calorific value, in calories per gram, gross.....	4,870	5,200	4,160	4,560	3,780	4,180
in B.Th.U. per lb. gross.....	8,760	9,360	7,480	8,200	6,810	7,530
Fuel ratio, fixed carbon, volatile matter.....	0.45	0.45	0.46	0.46	0.43	0.43

Note.—Figures in column "R" refer to fuel as received, and in column "D" to fuel dried at 105°C. These analyses were made on the fuel as received, and other results calculated therefrom.

The average content of ash is not excessive, and the calorific value satisfactory.

The bog is very well situated both as regards shipping facilities and market, being about 68 miles north from Toronto. The Canadian Pacific railway passes 2½ miles south from the southernmost part of the bog. One thousand acres of the southern part is owned by the Grand Valley Peat and Products Company, of which Mr. A. C. Steele, Aurora, Ontario, is President.

**Amaranth Peat Bog.**

This bog is situated 4 miles west from Crombie station, Canadian Pacific railway, in Amaranth township, Dufferin county (see Map No. 357) covering more or less of:—

Lots 16-19 concession IX,

    " 15-19       "       VIII.

The total area covered by this bog is, approximately, 500 acres. Of this area:—

275 acres have a depth of less than 5 feet, average depth 4 feet.

225   "       "       "       more   " 5   "       "       "       7   "

The volume of the peat contained is, approximately:—

1,770,000 cub. yds. in an area with depth of less than 5 feet.

2,540,000       "       "       "       "       "       5 to 10 feet.

This bog is principally formed of sphagnum, lightly intermixed with carex. The peat is well humified, and if thoroughly and carefully drained, would furnish a very good fuel.

The surface of the bog is comparatively free from trees, for it has been several times burned over.

The bog is fairly well situated as regards market, since the surrounding farmers have to buy their wood and coal, and pay a very high price for them.

Deducting the 275 acres with a depth of less than 5 feet, and allowing for decrease in depth through drainage, we have left:—225 acres with an

average depth of 6 feet, approximately, with a total volume of, approximately, 1,978,000 cubic yards of peat. Assuming that one cubic yard of such drained bog will furnish 200 pounds of dry peat substance, the total tonnage of dry substance available is, approximately, 198,000 tons (2,000 pounds) or, 264,000 tons of peat fuel with 25 per cent moisture.

*Analysis of Peat.*

Sample	I	
	R	D
Moisture.....	6.6	
Ash.....	12.0	12.9
Volatile matter.....	56.0	59.9
Fixed carbon (by difference).....	25.4	27.2
Sulphur.....	0.3	0.3
Nitrogen.....	1.6	1.7
Calorific value, in calories per gram, gross.....	4,520	4,840
" " in B.Th.U., per lb., gross.....	8,130	8,710
Fuel ratio, fixed carbon, volatile matter.....	0.45	0.45

Note.—Figures in column "R" refer to fuel as received, and in column "D" to fuel dried at 105°C. The analysis was made on the fuel as received, and other results calculated therefrom.

The content of ash, and the calorific value are satisfactory.

At intervals during the investigation of the bogs described above, several reconnaissances were made of the following bogs in different parts of the country around the main centres, such as Toronto and Hamilton, in the Province of Ontario.

PEAT BOGS OF WHICH PRELIMINARY INVESTIGATIONS WERE MADE.

**Durham Peat Bog.**

This bog is situated 5 miles northeast from Durham, in the township of Glenelg, county of Grey.

The total area covered by this bog is, approximately, 40 acres, with an average depth of 4 to 7 feet. The peat is fairly well humified, and is mainly composed of sphagnum plant.

As the area is comparatively small and shallow, it is not likely that it can be used for the manufacturing of machine peat fuel with the present known devices; but by systematic and careful drainage this bog could be utilized for domestic fuel, if the peat is cut by hand, or the land worked for agricultural purposes.

pprox-  
ard of  
e total  
(2,000

D

12.9  
59.9  
27.2  
0.3  
1.7  
4.840  
8.710  
0.45

ne dried  
calculated

above,  
at parts  
lton, in

MADE.

ownship

es, with  
, and is

ely that  
present  
ould be  
worked

DEPARTMENT OF MINES, MINES BRANCH.

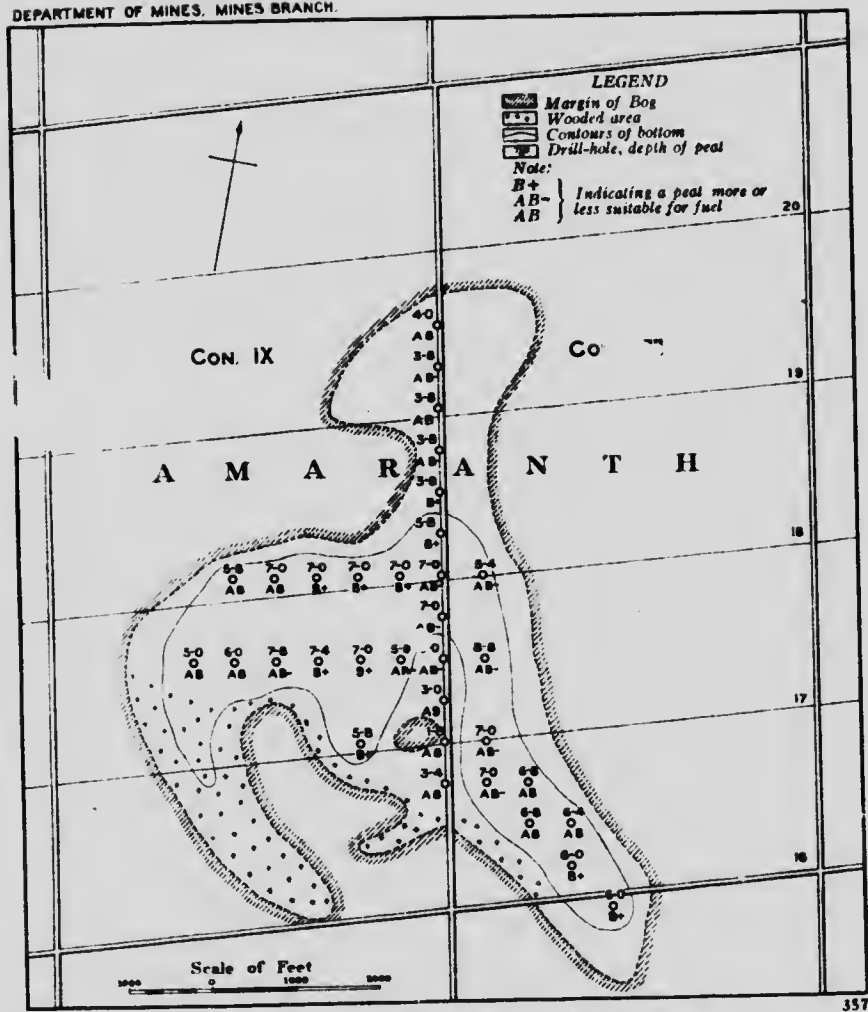

AMARANTH PEAT BOG, DUFFERIN COUNTY, ONTARIO



### Eastnor Peat Bog.

This bog is situated about 20 miles north of Warton, in the township of Eastnor, county of Bruce. It is comparatively large, but since it is situated a considerable distance from shipping facilities, or a market, it is, at present, practically valueless, hence no investigation was made.

### Cargill Peat Bog.

This bog is situated 6 miles west of Cargill station, on the Grand Trunk railway, in Greenock township, Bruce county, Ontario. (See Map No. 358).

The total area covered by this bog is, approximately, 6,600 acres, with an average depth of 2 feet.

The surface of the bog is heavily wooded.

As the bog is very shallow, it is not suitable for the manufacture of peat fuel; however, by thorough drainage, and clearing of the timber, the bog could be utilized for agricultural purposes.

A lumber company is, at present, utilizing the timber.

### Westover Peat Bog.

This bog is situated about 4 miles south of the Canadian Pacific railway, in Beverly township, Wentworth county, Ontario (see Map No. 359) covering more ss of:—

Lots 24-31, c VII township of Beverly,

" 20-31 VIII " "

The area investigated was, approximately, 1,400 acres.

Of this area:—

1,045 acres have a depth of less than 5 feet with an average depth of 3 feet.

355 acres have a depth of more than 5 feet with an average depth of 5 feet.

The volume of the peat contained is, approximately:—

5,546,000 cub. yds. in an area with depth of less than 5 feet.

2,865,000 " " " " more " 5 "

The peat is very well humified and is composed principally of carex, but around the margin the peat is heavily intermixed with hypnum, while the bottom layer is formed almost entirely of aquatic plants.

The surface is heavily wooded with spruce, tamarack, and cedar, and around the margin with pine, birch, and elm.

As this bog is comparatively shallow, and the surface heavily wooded, it is not likely that it will ever be utilized for the manufacture of machined peat; but by careful drainage, and clearing of the trees and bushes, that portion of the bog with a depth of more than 5 feet could be utilized for the manufacture of a domestic fuel by cutting the peat by hand, while the rest of the bog could be utilized for agricultural purposes.

Deducting the 1,045 acres with a depth of less than 5 feet, and allowing for the decrease in depth through drainage, we have left 345 acres with an average depth of, approximately, 4 feet, having a total volume of, approximately, 2,290,000 cubic yards.

Allowing that one cubic yard of the drained bog would furnish 200 pounds of dry peat substance, the total tonnage available would be, approximately, 229,000 tons (of 2,000 pounds) or 306,000 tons of peat fuel having 25 per cent moisture.

*Analysis of Peat.*

Sample	I	
	R	D
Moisture.....	9.0	
Ash.....	18.5	20.3
Volatile matter.....	50.6	55.6
Fixed carbon (by difference).....	21.9	24.1
Sulphur.....	1.2	1.3
Nitrogen.....	2.1	2.3
Caloric value, in calories per gram, gross.....	4,000	4,400
" " B.Th.U. per lb., gross.....	7,200	7,920
Fuel ratio, fixed carbon, volatile matter.....	0.43	0.43

Note.—Figures in column "R" refer to fuel as received, and in column "D" to fuel dried at 105°C.

The analysis was made on the fuel as received, and other results calculated therefrom.

The bottom of the bog consists of a layer of marl from 1-3 feet in depth, and lightly intermixed with blue clay.

The bogs near Dundas, Dunnville, and Port Colborne, are nothing else than flooded areas, and land insufficiently drained.

Preliminary investigations were also made of the bogs situated in the southern part of the Rainy River district, Ontario, north of the Rainy river; Pinewood, and Emo on the Canadian Northern railway.

These bogs cover a very large area and vary in depth from 5 to 14 feet. It was observed during drilling, that certain portions of these bogs were fairly well humified, hence could be utilized for the manufacture of peat fuel. They are formed, principally, of carex and sphagnum plants, and are comparatively free from roots and stumps. These bogs are situated about 150 miles east of Winnipeg, on the Canadian Northern railway.



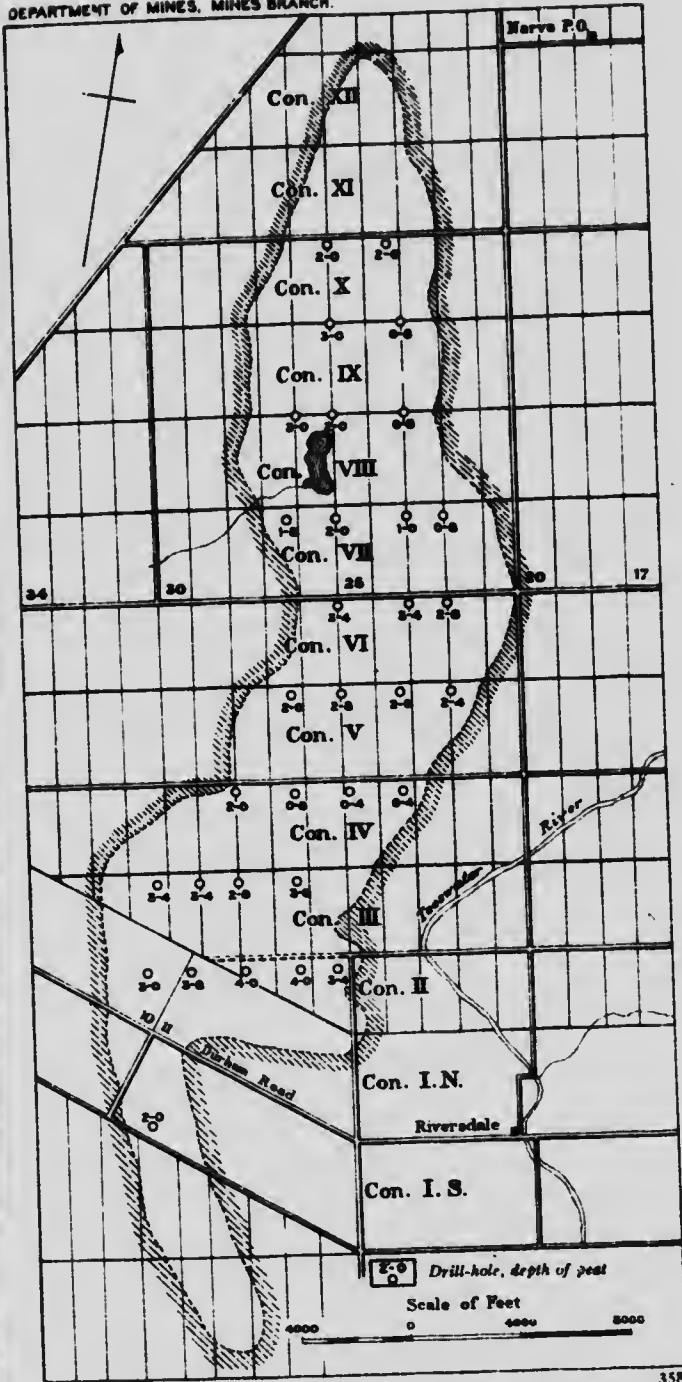

CARGILL PEAT BOG, GREENOCK TP., BRUCE COUNTY, ONTARIO



DEPARTMENT OF MINES, MINES BRANCH

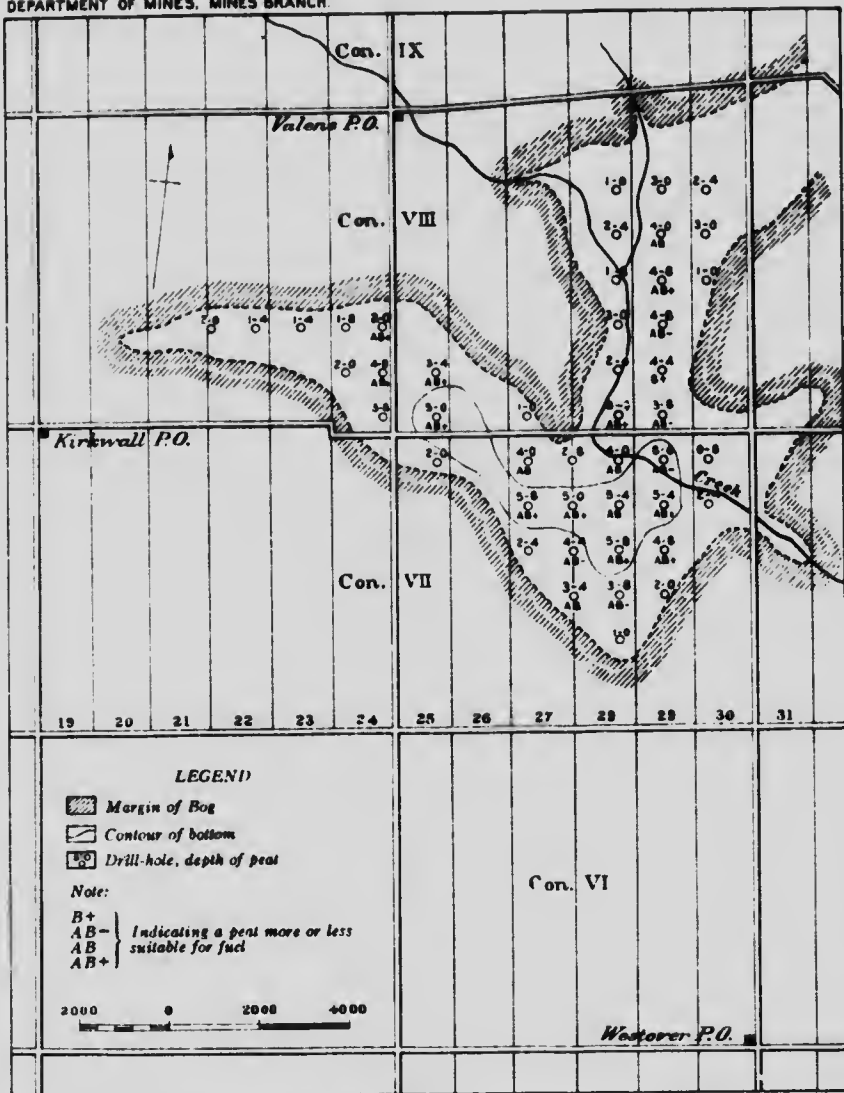

WESTOVER PEAT BOG, BEVERLY TP., WENTWORTH COUNTY, ONTARIO



### Marsh Hill Peat Bog.

This bog is situated about one mile east of Uxbridge, immediately east of Blackwater Junction and Sunderland, and 1½ mile south from Cannington, in Uxbridge, Reach, and Brock townships, Ontario county, Ontario, and runs in a north and south direction (see Map No. 360) covering more or less of:—

Lots	27-31 and 33,	con. VII	township Uxbridge,
"	1	" VIII	" Reach,
"	1-3	" IX	" "
"	1-4	" X	" "
"	1-6	" XI	" "
"	4-7	" XII	" "
"	4-7	" XIII	" "
"	6-9	" XIV	" "
"	6-10	" I	" Brock,
"	8-12	" II	" "
"	9-14	" III	" "
"	11-17	" IV	" "
"	12-13-16-18	" V	" "
"	13-15-17	" VI	" "
"	15-17	" VII	" "
"	16-19	" VIII	" "
"	17-19	" IX	" "
"	17-19	" X	" "
"	18-19	" XI	" "

The total area covered by this bog is, approximately, 5,100 acres.

Of this area:—

- 1,018 acres have a depth of less than 5 feet, with average depth of, approximately, 4 feet.
- 1,446 acres have a depth of from 5-10 feet, with average depth of, approximately, 7 feet.
- 1,267 acres have a depth of from 10-15 feet, with average depth of, approximately, 12 feet.
- 693 acres have a depth of from 15-20 feet, with average depth of, approximately, 17 feet.
- 494 acres have a depth of from 20-25 feet, with average depth of, approximately, 22 feet.
- 182 acres have a depth of more than 25 feet, with average depth of, approximately, 27 feet.

The volume of the peat contained is, approximately:—

6,569,000	cub. yds.	in an area with depth of	less than 5 feet.
16,330,000	"	"	from 5-10 feet.
24,529,000	"	"	from 10-15 feet.
18,906,000	"	"	from 15-20 feet.
17,530,000	"	"	from 20-25 feet.
7,350,000	"	"	more than 25 feet.

The southern portion of the bog, lying in the townships of Uxbridge and Reach, is especially suited for the manufacture of peat fuel on account of its great depth and long working lines, as is also the portion lying in concessions I and II, Brock township. The remainder of the bog in the township of Brock, is narrow, and has a satisfactory depth, but very short working lines. For this reason, difficulties would arise when manufacturing, if any of the present known systems were employed, which require long and wide spreading and drying fields.

The peat throughout the whole bog is very well humified, has good cohesive properties and possesses a considerable depth.

The Beaverton creek flows in a northerly direction making a winding course through the middle of the bog. On each side of the bog the land rises considerably, so that it lies in a continuous valley, which can be seen on Plate II.

The peat is composed mainly of carex and the remains of grasses which, to a certain extent—in some places—are intermixed with sphagnum and hypnum.

The bottom layers of the bog are intermixed with aquatic plants.

Fig. III illustrates the surface of the bog, showing the carex vegetation.

The surface is flooded during the larger part of the spring, and does not become dry until the middle of the summer. This flooding is due, in large part, to the fact that the Beaver creek is dammed at Cannington. In the event of the dam being removed, it would assist materially in drying the bog at an earlier date. If this were the case the shallow marginal parts could be reclaimed as valuable agricultural land.

The surface is heavily wooded with spruce, tamarack, and willows, while around the margin grow cedar, poplar, birch, elm, and alders. (See Plate IV.)

In certain parts of the bog the peat is heavily intermixed with roots, logs and stumps.

The bottom layers of the peat are, in most parts of the bog, intermixed—from 1 to 3 feet—with marl, which is composed of diatomaceous siliceous shells, insects, mussels, remains from the shores, and from the bottom flora; below this, the bottom is formed of firm sand.

Deducting the 1,018 acres with a depth of less than 5 feet, and allowing for the decrease in depth through the drainage, we have left:—

1,446	acres,	with an average depth of, approximately,	5 feet.
1,267	"	"	"
693	"	"	"
494	"	"	"
183	"	"	"
			10 "
			15 "
			20 "
			25 "

Having a total volume of, approximately, 72,156,000 cubic yards, and allowing that one cubic yard of drained bog would furnish 200 pounds of dry peat substance, the total tonnage of dry substance available would be, approximately, 7,210,000 tons (of 2,000 pounds) or 9,620,000 tons of peat fuel having 25 per cent moisture.

DEPARTMENT

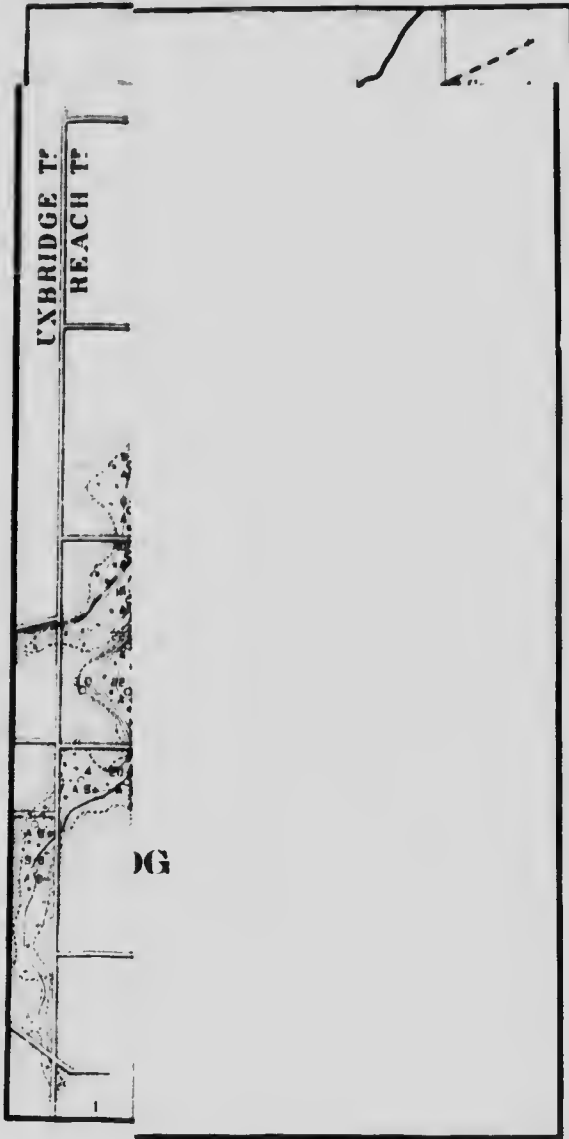

360

LATE II



LATE III



Surface growth on Marsh Hill peat bog, Ontario.

*Magnesian Quartz*

12

Sunderland Sta.

IV

III

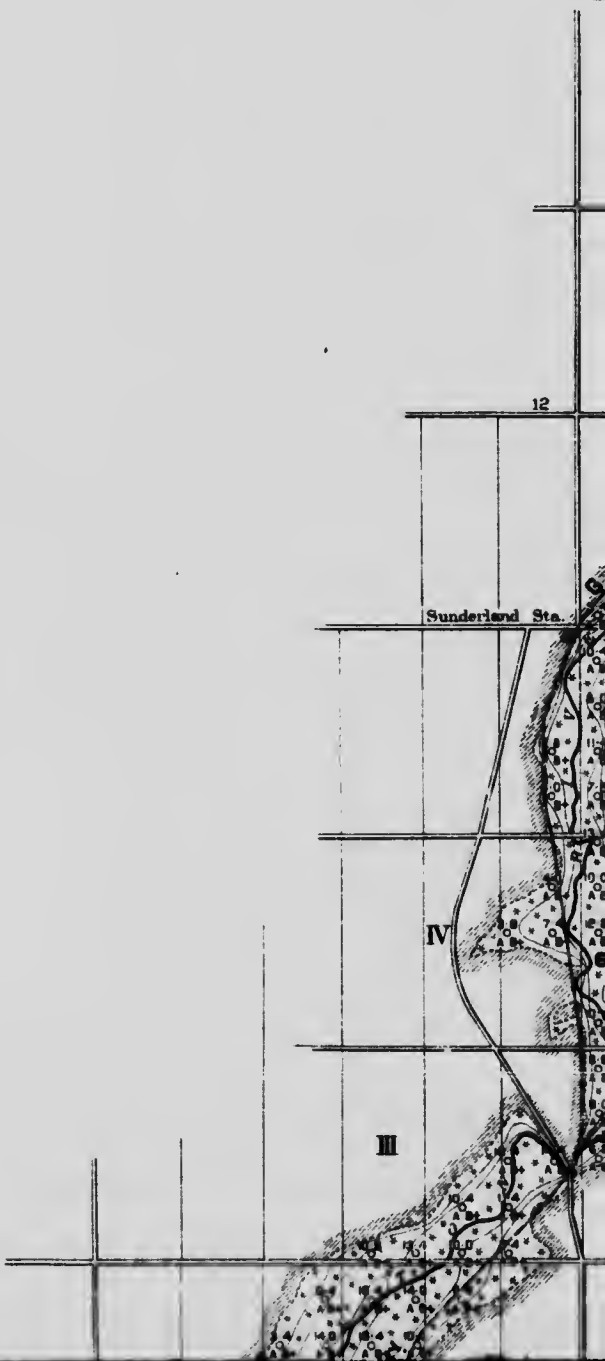





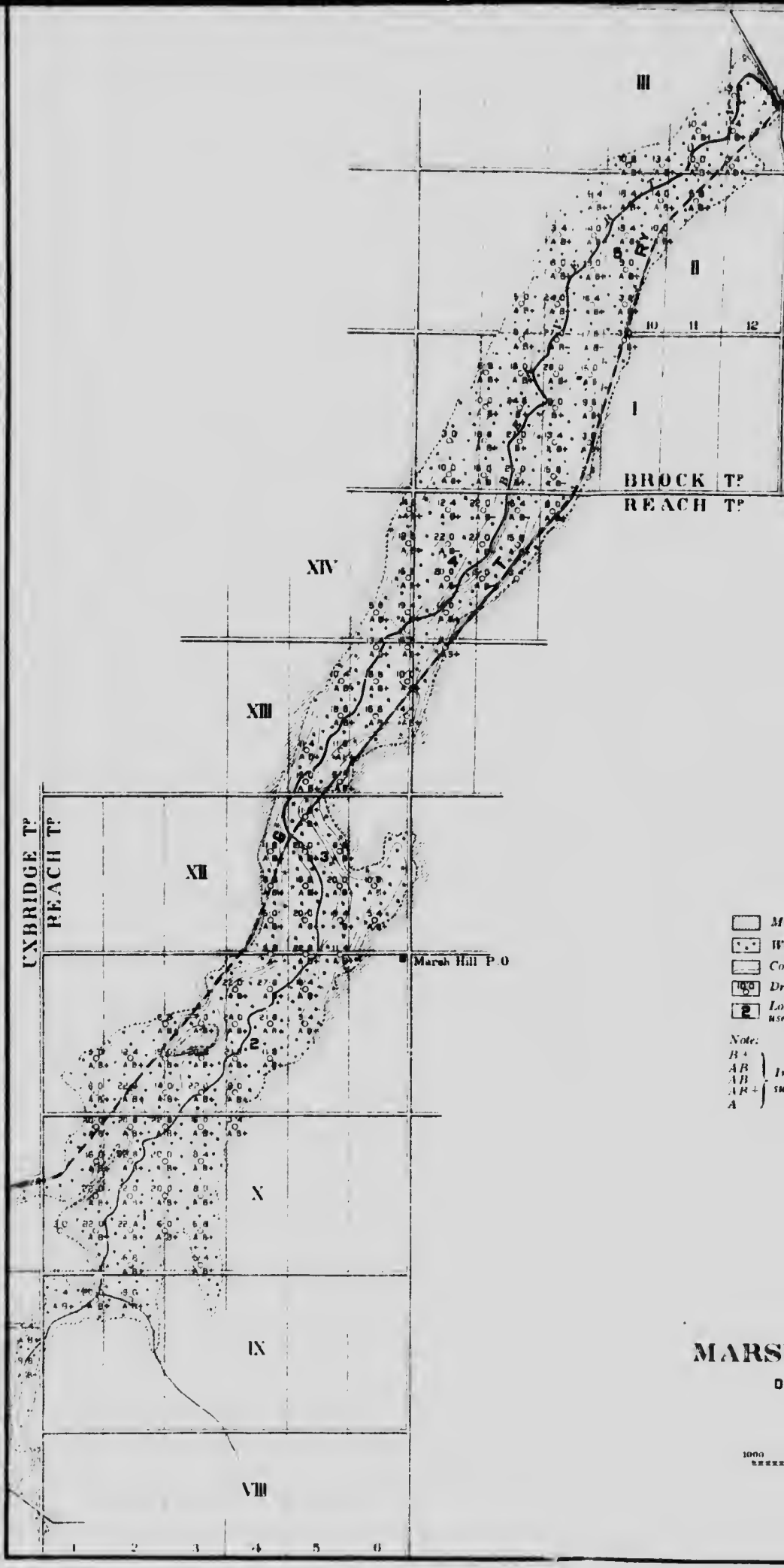

UXBRIDGE T<sup>r</sup>  
REACH T<sup>r</sup>

BROCK T<sup>r</sup>  
REACH T<sup>r</sup>

MARS<sup>r</sup>  
D

- M<sup>r</sup>
- W<sup>r</sup>
- Co<sup>r</sup>
- Dr<sup>r</sup>
- Loc<sup>r</sup>
- use<sup>r</sup>

Note:  
 B + } In  
 AB } sw  
 AB + }  
 A }

1000  
 \*\*\*\*\*

1 2 3 4 5 6

XIV

XIII

XII

X

IX

VIII

Marsh Hill P.O.

III



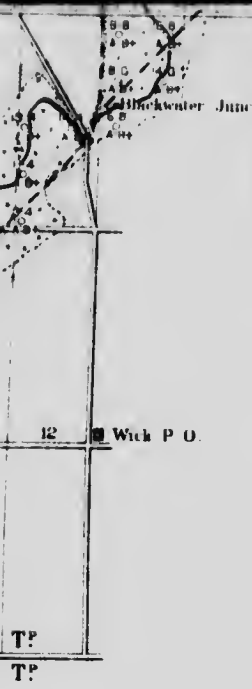

II

I

10 11 12



**LEGEND**

-  Margin of Bog
-  Wooded areas
-  Contours of bottom
-  Drill-hole, depth of peat
-  Location of general samples used for analyses

Note:  
 B+ }  
 AB } Indicating a peat more or less  
 AB } suitable for fuel  
 AB+ }  
 A }

**MARSH HILL PEAT BOG**  
**ONTARIO COUNTY**  
**ONTARIO**  
 Scale of Feet





ds  
ld  
of

PLATE II



Land formation surrounding Marsh Hill peat bog, Ontario.

PLATE III.



Surface growth on Marsh Hill peat bog, Ontario.

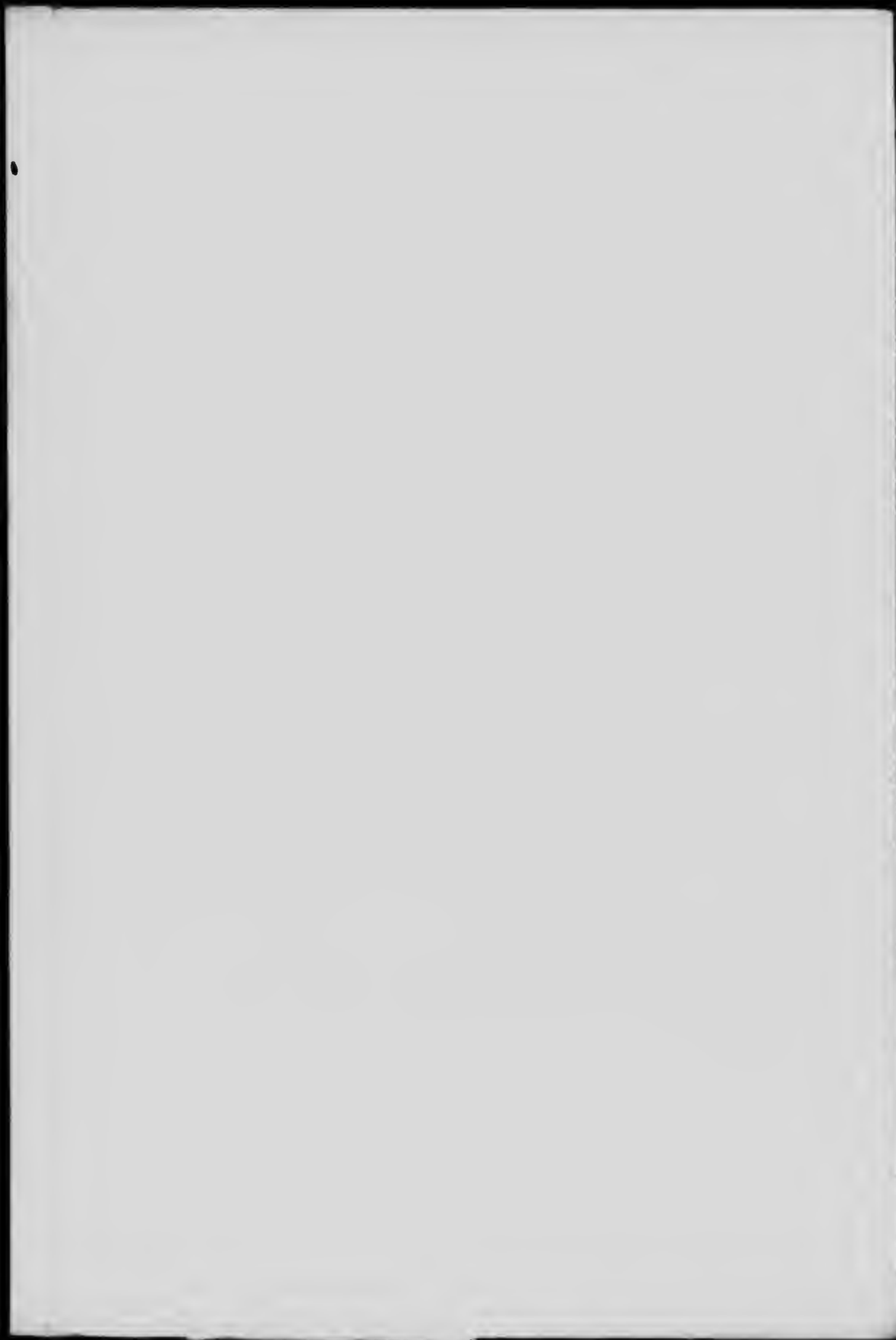

PLATE IV.



Wooded area representing Marsh Hill peat bog, Ontario.

PLATE V.



Railway crossing Marsh Hill peat bog, Ontario.

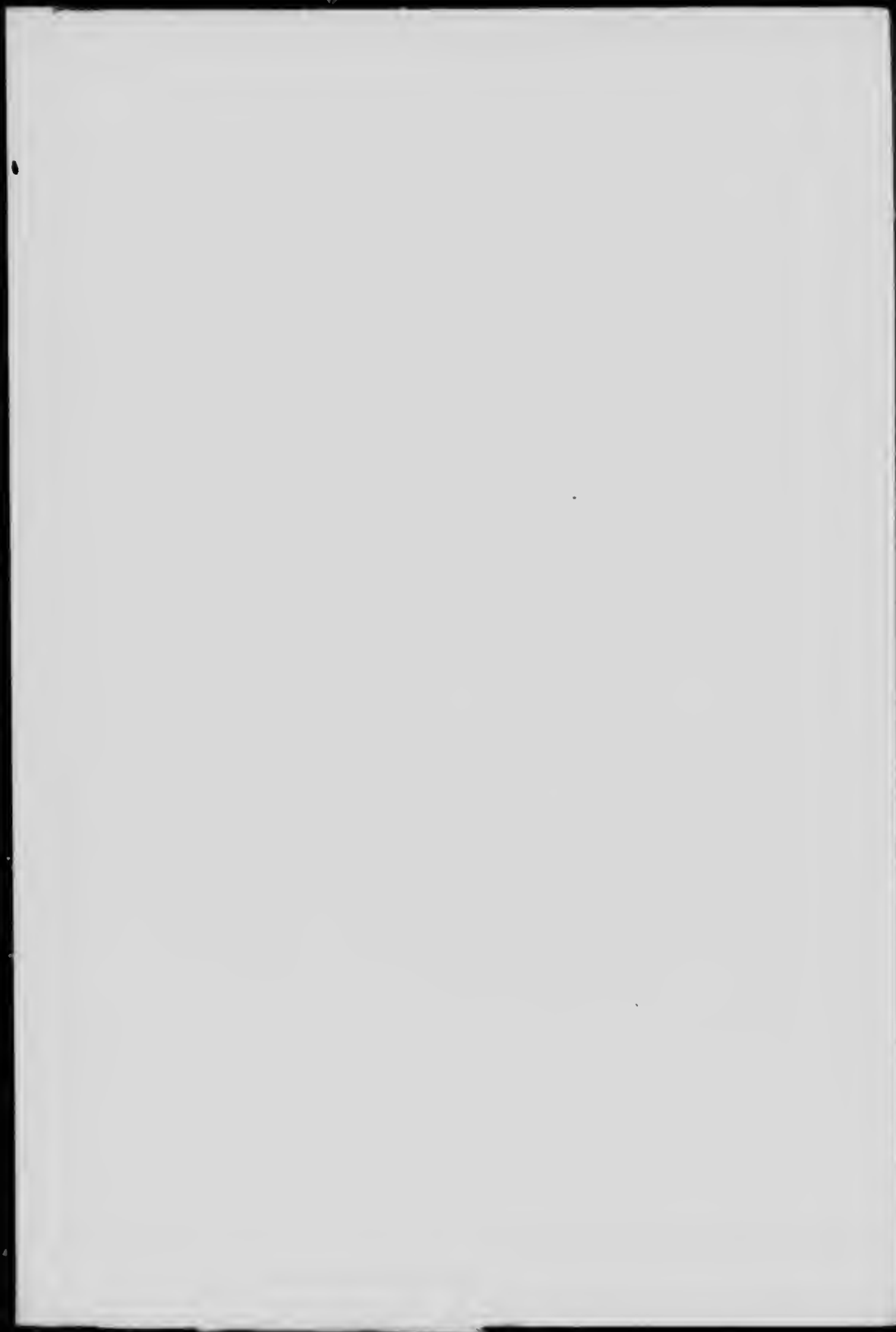



*Analyses of Peat. (Marsh Hill Peat Bog.)*

Sample	I		II		III		IV		V		VI		VII		VIII		IX		
	R	D	R	D	R	D	R	D	R	D	R	D	R	D	R	D	R	D	
	Moisture	10.0	11.1	10.2	9.2	10.3	11.5	8.3	10.0	10.9	10.1	8.2	9.9	10.8	15.3	17.0	15.7	17.4	9.0
Ash	10.0	11.1	10.2	9.2	10.3	11.5	8.3	10.0	10.9	10.1	8.2	9.9	10.8	15.3	17.0	15.7	17.4	9.0	14.2
Volatile matter	54.8	61.0	55.2	61.5	54.8	61.1	56.5	61.6	55.1	60.0	56.6	61.8	53.4	59.1	53.5	59.4	56.5	62.1	56.5
Fixed carbon (by difference)	25.2	27.9	28.3	25.4	23.6	27.4	28.2	27.5	26.6	29.0	25.1	27.4	21.5	23.9	20.9	23.2	21.6	23.7	21.6
Sulphur																			
Nitrogen	1.8	2.0	1.9	2.1	1.8	2.0	2.2	2.4	1.8	2.0	2.2	2.4	2.0	2.2	1.9	2.1	2.1	2.4	2.1
Caloric value, in calories per gram, gross	4,130	4,590	4,110	4,580	3,980	4,330	4,150	4,530	4,180	4,560	4,160	4,540	4,010	4,330	3,870	4,190	4,070	4,470	4,070
Caloric value in B.Th.U. per lb., gross	7,430	8,270	7,400	8,240	7,160	7,980	7,470	8,180	7,530	8,210	7,490	8,180	7,040	7,980	6,920	7,740	7,330	8,050	7,330
Fuel ratio, fixed carbon, volatile matter	0.46	0.46	0.46	0.46	0.45	0.45	0.45	0.45	0.48	0.48	0.44	0.44	0.40	0.40	0.39	0.39	0.38	0.38	0.38

Note.—Figures in column "R" refer to fuel as received, and in column "D" to fuel dried at 105°C. The analyses were made on the fuel as received, and other results calculated therefrom.

The bog is very advantageously situated, both as regards shipping facilities, and market, the southern end being only about 42 miles from Toronto, and the northern end about 18 miles from Lindsay, and 41 miles from Peterborough. The Grand Trunk railway follows the western margin of the bog. (See Plate V.)

### Sunderland Peat Bog.

This bog is situated about 1 mile north of Sunderland, in the township of Brock, county of Ontario, Ontario, (see Map No. 361) and covers more or less of:—

	Lot 11 con.	VI	township of Brock.
Lots 9, 11, 13	"	VII	" "
" 9 - 12	"	VIII	" "
" 11 - 12	"	IX	" "

The total area covered by this bog is, approximately, 580 acres. Of this area:—

240 acres have a depth of less than 5 feet, with an average depth of 3 feet.

340 acres have a depth of more than 5 feet, with an average depth of 7 feet.

The volume of the peat contained is:—

In an area with depth of less than 5 feet, approximately, 1,160,000 cub. yds.

In an area with depth of more than 5 feet, approximately, 3,839,000 cub. yds.

The peat is principally formed of carex, lightly mixed with sphagnum and hypnum, the bottom layer being intermixed with aquatic plants. It is very well humified, and will produce a comparatively heavy fuel. About 1 foot of the bottom layer is heavily intermixed with marl and blue clay, and below this lies a compact sand bottom.

The surface is heavily wooded, with small spruce, tamarack, and willows.

Deducting the 240 acres with a depth of less than five feet, and allowing for the decrease in depth by drainage, we have left 340 acres with an average depth of, approximately, 5 feet, with a total volume of, approximately, 2,740,000 cubic yards.

Assuming that one cubic yard of such drained bog will furnish 200 pounds of dry peat substance, the total tonnage of dry peat substance is, approximately, 274,000 tons (of 2,000 pounds) or 365,000 tons peat fuel with 25% moisture.

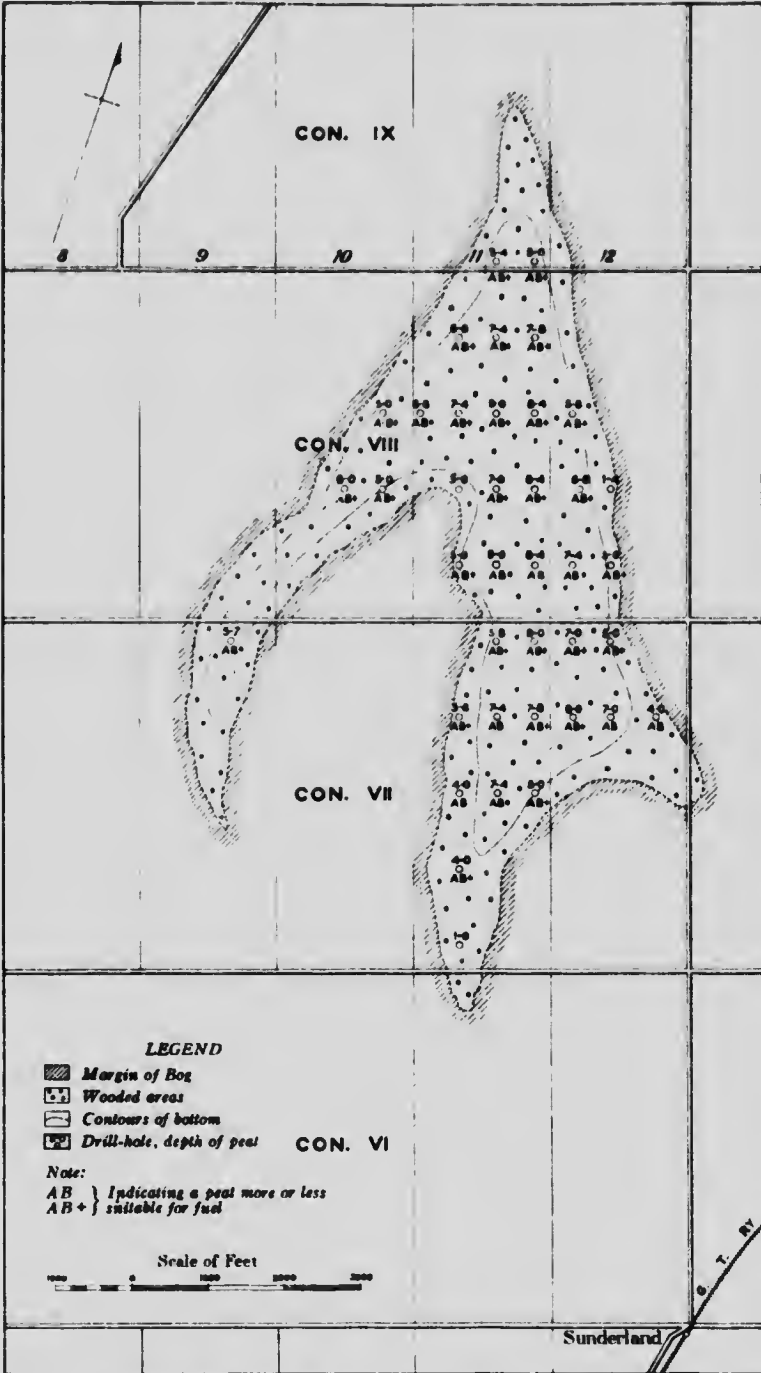

SUNDERLAND PEAT BOG, BROCK TP., ONTARIO COUNTY, ONTARIO

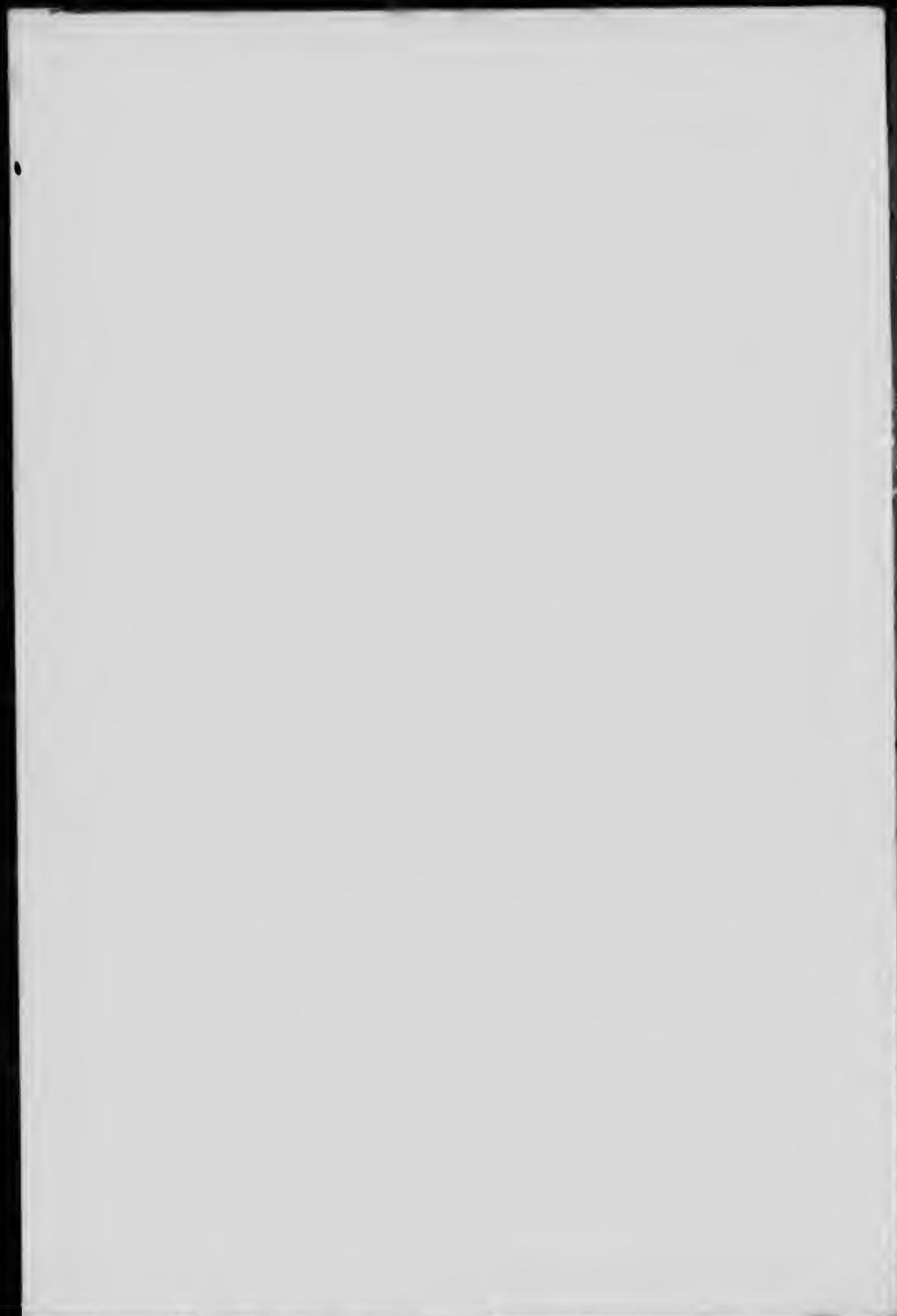

*Analysis of Peat.*

Sample	I	
	R	D
Moisture	8.6	
Ash	10.2	11.2
Volatile matter	55.4	60.5
Fixed carbon (by difference)	25.8	28.3
Sulphur	0.5	0.6
Nitrogen	1.8	2.0
Caloric value, in calories per gram, gross	4,200	4,600
" " " " B. Th. U., per lb., gross	7,560	8,280
Fuel ratio, fixed carbon, volatile matter..	0.47	0.47

Note. — Figures in column "R" refer to fuel as received, and in column "D" to fuel dried at 105°C. The analysis was made on the fuel as received, and other results calculated therefrom.

The surrounding country is of an undulating nature, causing frequent valleys in which are to be found bogs of various sizes; but as they are narrow, and heavily wooded, the expenditure necessary to make a success in manufacturing machine peat fuel would be too great.

**Manilla Peat Bog.**

This bog is situated 2 miles west of Mariposa station in Mariposa township, Victoria county, Ontario, (see Map No. 362) covering more or less of —

Lots 8 13 con. VIII township of Mariposa.

" 8 11 " IX " "

" 10 12 " X " "

The total area covered by this bog is, approximately, 745 acres. Of this area:—

380 acres have a depth of less than 5 feet, with average depth of, approximately, 4 feet.

355 acres have a depth of from 5-10 feet, with average depth of, approximately, 7 feet.

10 acres have a depth of more than 10 feet, with average depth of, approximately, 10 feet.

The volume of the peat contained is, approximately:—

2,450,000 cub. yds. in an area with depth of less than 5 feet.

4,000,000 " " " " " from 5-10 feet.

161,000 " " " " " more than 10 feet.

The peat is composed mainly of carex plants, intermixed with sphagnum, hypnum, and the bottom layers with aquatic plants. The first two feet of the surface are heavily interwoven with fallen trees, logs, and roots, and the peat is intermixed with needles, spruce cones, and leaves.

The surface is thickly wooded with spruce, tamarack, alder, and around the margin with cedar, poplar, and other softwood trees.



# MICROCOPY RESOLUTION TEST CHART

(ANSI and ISO TEST CHART No. 2)



45

50

36

32

36

40

45

50

56

63

71

80

90

100

112

125

143

160

180

200

225

250

280

315

360

400

450

500

560

630

710

800

900

1000

2.8

3.2

3.6

4.0

2.5

2.2

2.0

1.8

1.6

**APPLIED IMAGE Inc**

1653 East Main Street  
Rochester, New York 14609 USA  
(716) 482 - 0300 - Phone  
(716) 288 - 5989 - Fax



If the surface was cleared from wood this bog could be utilized, and a very good machine peat manufactured, as the peat is very well humified, and possesses good cohesive properties.

The bottom layer, from 1 to 2 feet, is heavily intermixed with marl.

Deducting 380 acres with a depth of less than 5 feet, and allowing for the decrease in depth through drainage, we have left:—

355 acres with an average depth of, approximately, 5 feet.

10 " " " " " " " 8 "

Having a total volume of, approximately, 2,990,000 cubic yards.

Allowing that one cubic yard of the drained bog would furnish 200 pounds of dry peat substance, the total tonnage of dry substance available would be, approximately, 299,000 tons (of 2,000 pounds) or 399,000 tons of peat fuel having 25 per cent moisture.

#### Analysis of Peat.

Sample	I	
	R	D
Moisture.....	10.0	
Ash.....	10.2	11.3
Volatile matter.....	53.9	59.9
Fixed carbon (by difference).....	25.9	28.8
Sulphur.....	0.5	0.6
Nitrogen.....	1.9	2.1
Calorific value, in calories, per gram, gross.....	4,050	4,500
" " B.Th.U., per lb., gross.....	7,290	8,100
Fuel ratio, fixed carbon, volatile matter.....	0.48	0.48

Note.—Figures in column "R" refer to fuel as received, and in column "D" to fuel as dried at 105°C. The analysis was made on the fuel as received, and other results calculated therefrom.

The content of ash is fairly high, but not excessive, and the calorific value satisfactory.

The bog is very well situated, both as regards shipping facilities and market, being only about 10 miles from Lindsay. The Grand Trunk railway passes about  $\frac{1}{2}$  mile south of the bog.

#### Stoco Peat Bog.

This bog is situated  $\frac{1}{2}$  mile south of Stoco station, on the Bay of Quinte railway, Hungerford township, Hastings county, Ontario. (See Map No. 363).

Lots 18-21 con. VI township Hungerford,

" 14-20 " VII " "

" 16-21 " VIII " "

The total area covered by this bog is, approximately, 1,027 acres.

Of this area:—

361 acres have a depth of less than 5 feet, with an average depth of, approximately, 3 feet.



DEPARTMENT OF MINES, MINES BRANCH.

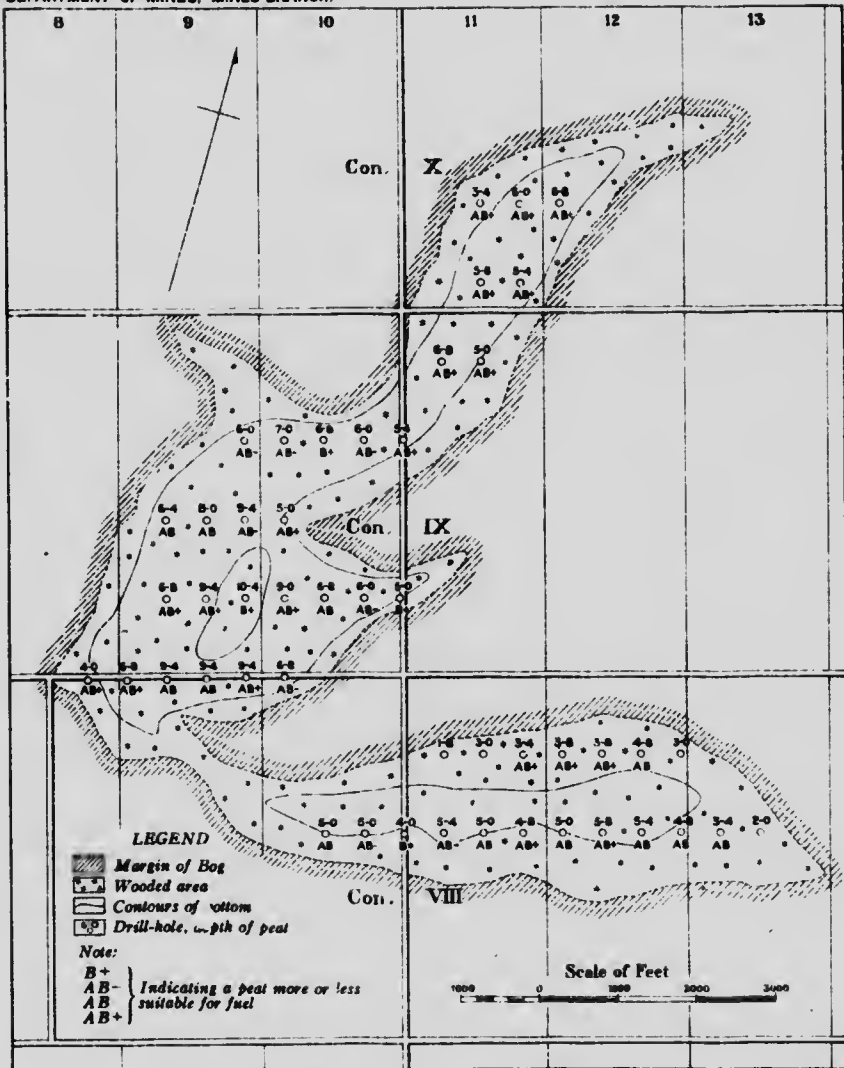

MANILLA PEAT BOG, MARIPOSA TP., VICTORIA COUNTY, ONTARIO

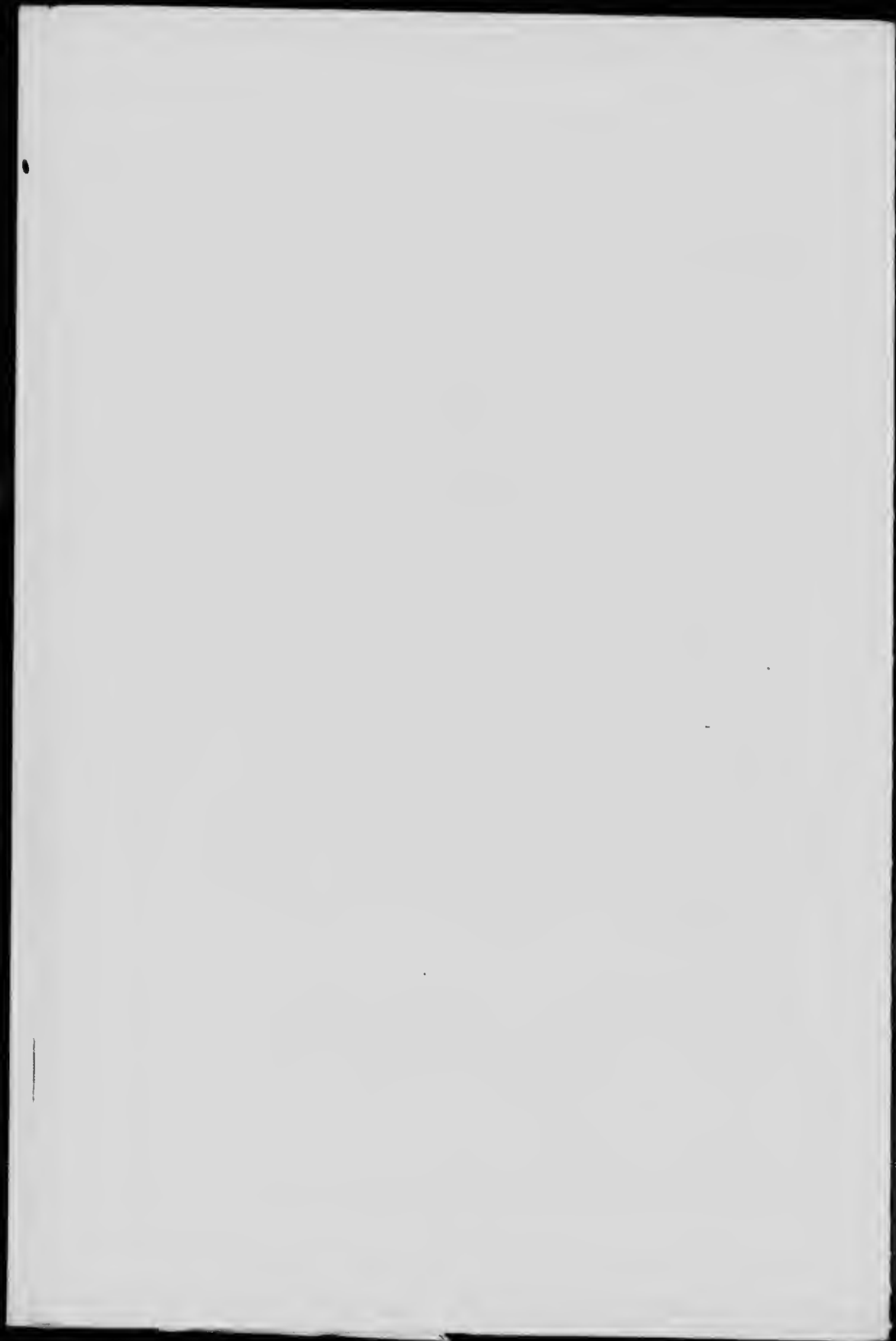

666 acres have a depth of from 5-10 feet, with an average depth of, approximately, 7 feet.

230 acres have a depth of from 10-15 feet, with an average depth of, approximately 13 feet.

28 acres have a depth of more than 15 feet, with an average depth of, approximately, 16 feet.

The volume of the peat contained is, approximately:—

1,748,000	cub. yds.,	in an area with a depth of less than 5 feet,
7,520,000	" " "	from 5-10 feet,
4,820,000	" " "	from 10-15 feet,
720,000	" " "	more than 15 feet.

The peat is composed mainly of carex plants, and in some places in the bog large sphagnum knolls are to be seen, which indicate that the present low bog, if not disturbed, will eventually develop into a high bog. In the southern part of the bog, situated in concession VI, large quantities of hypnum and aquatic plants are intermixed with carex plants.

The bottom layer of the west part of the bog is composed of blue clay 3 to 12 feet deep, and below that lie sand and stone. Through concession VII, in the eastern part of the bog, runs a marl vein of from 12 to 20 feet deep. It has a width at the south of about 10 feet, which widens out towards concession VIII, to 200 feet or more. This marl bed shows that it was formerly a river bed in which the marl was deposited gradually. (See page 18).

The part of the bog situated in the west part of concession VIII, lots 20-21, has a bottom layer of blue clay to a depth of 7 feet, which gradually shallows down to nothing towards the north.

The surface is heavily wooded with spruce, cedar, and tamarack, and around the margin with poplar, alder, elm, and other softwood trees. (See Plate VI).

If the surface was cleared from wood, this bog could be utilized, and very good machine peat fuel produced, as the peat is very well humified and possesses high cohesive properties.

Deducting 361 acres with a depth of less than 5 feet, and allowing for the decrease in depth through drainage, we have left:—

666	acres with an average depth of, approximately,	5	feet.
230	" " " "	11	"
28	" " " "	14	"

Having a total volume of, approximately, 10,086,000 cubic yards.

Supposing that one cubic yard of the drained bog would furnish 200 pounds dry peat substance, the total tonnage of dry peat available would be, approximately, 1,009,000 tons (of 2,000 pounds) or 1,345,000 tons of peat fuel having 25 per cent moisture.

## Analyses of Peat.

Sample	I		II		III	
	R	D	R	D	R	D
Moisture.....	9.8		10.1		9.0	
Ash.....	13.3	14.7	13.8	15.4	16.0	17.6
Volatile matter.....	55.1	61.1	55.4	61.6	54.8	60.2
Fixed carbon (by difference).....	21.8	24.2	20.7	23.0	20.2	22.2
Sulphur.....			1.2	1.3		
Nitrogen.....	2.0	2.2	2.0	2.2	2.5	2.7
Caloric value, in calories, per gram, gross.....	3,960	3,390	3,870	4,310	3,950	4,340
"    "    B.Th.U. per lb., gross.....	7,130	7,110	6,970	7,750	7,110	7,810
Fuel ratio, fixed carbon, volatile matter.....	0.40	0.40	0.37	0.37	0.37	0.37

Note.—Figures in column "R" refer to fuel as received, and in column "D" to fuel dried at 105°C. The analyses were made on the fuel as received, and other results calculated therefrom.

This bog is very well situated, both as regards shipping and market, as the Bay of Quinte railway crosses the bog to the south.

It is about 40 miles from Kingston, 21 miles from Napanee, and about 28 miles from Belleville.

## Clairview Peat Bog.

This bog is situated about 4 miles north of Erinsville station, Ontario, on the Bay of Quinte railway, in Sheffield township, Lennox and Addington county, (see Map No. 364) and covers more or less of

- Lot 12      concession I,  
 " 12-16      "      II.  
 " 14-15      "      III.

The total area covered by this bog is, approximately, 280 acres. The average depth being 3 feet, the volume of peat contained is 451,733 cubic yards, with a depth of less than 5 feet.

It is composed mainly of carex plants, and, in certain parts, small quantities of hypnum and sphagnum plants are to be found. The surface is heavily wooded with cedar, spruce, and tamarack, while around the margin are alders and willows. Here and there through the middle of the bog clear spaces free from wood can be found. The peat is fairly well humified, but on account of its shallowness it is not suitable for the manufacture of machine peat.

During the drilling a heavy deposit of marl was found. To acquire a knowledge of the formation of the peat, and of the geological environment, a few drillings were made in the marl bed.

DEPARTMENT

Note  
 B+  
 AB  
 AB  
 AB



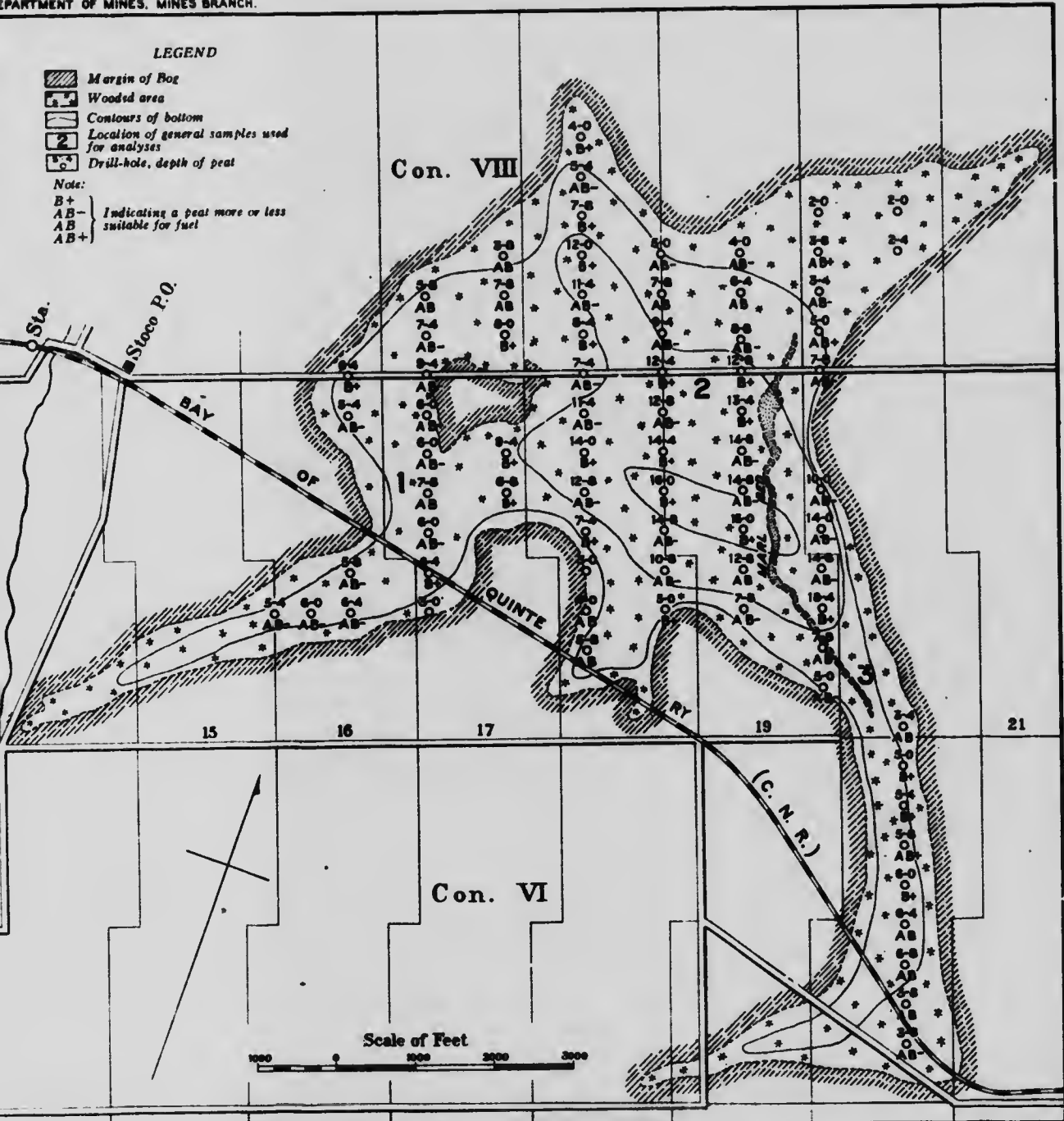

STOCO PEAT BOG, HUNGERFORD ID TP., HASTINGS COUNTY, ONTARIO

DEPARTMENT O

10

15

14

13

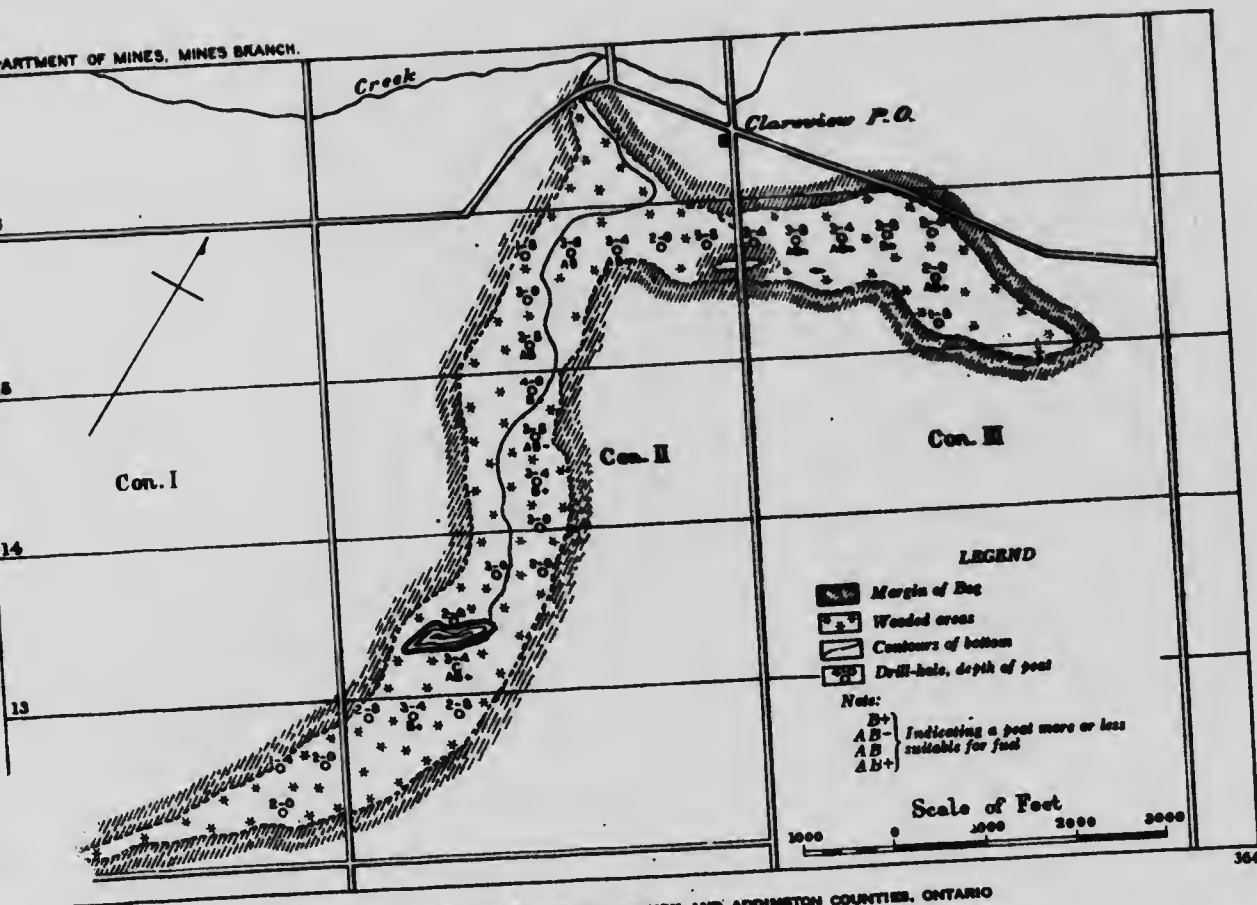

CLAREVIEW PEAT BOG, SHEFFIELD TP., LENNOX AND ADDINGTON COUNTIES, ONTARIO

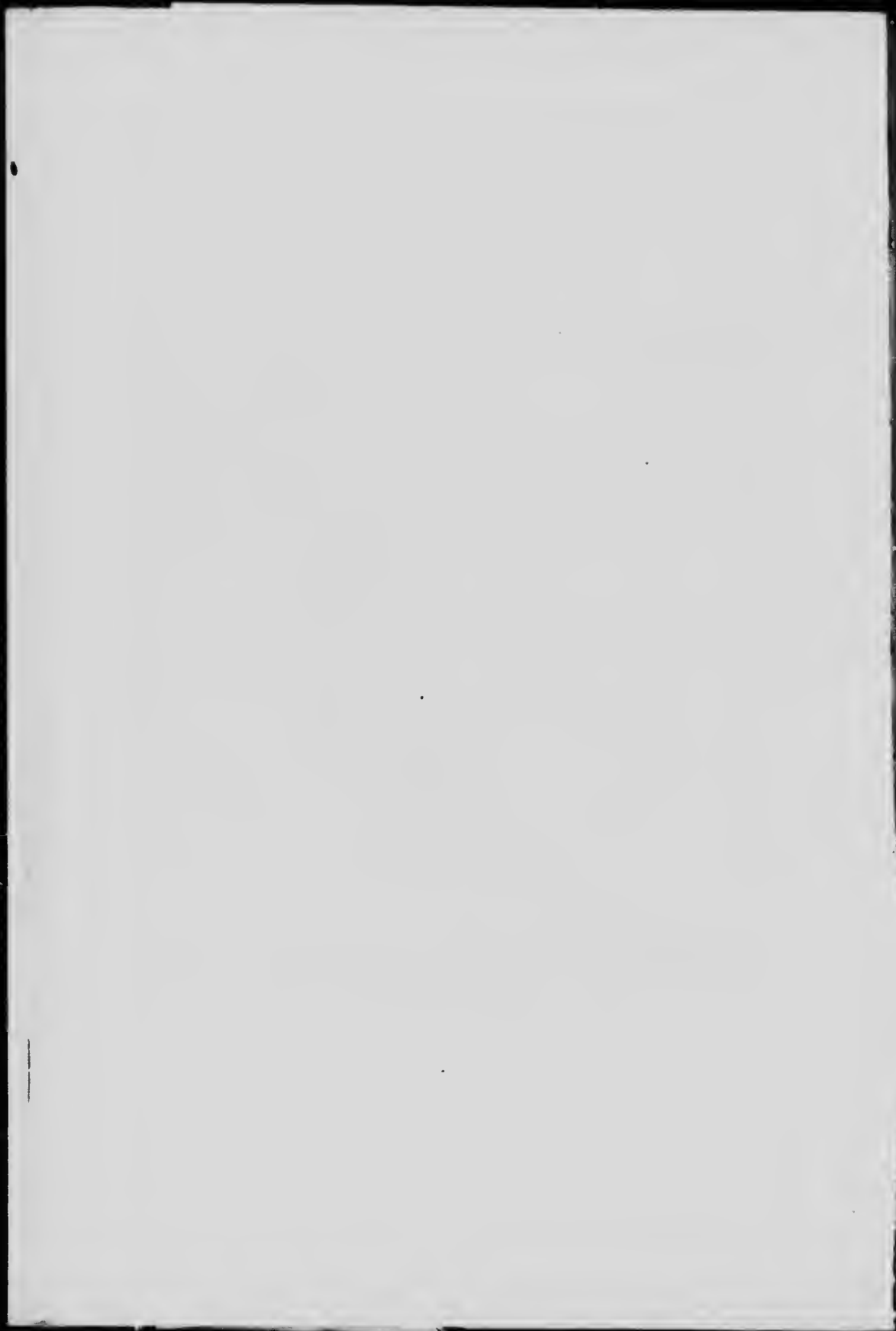
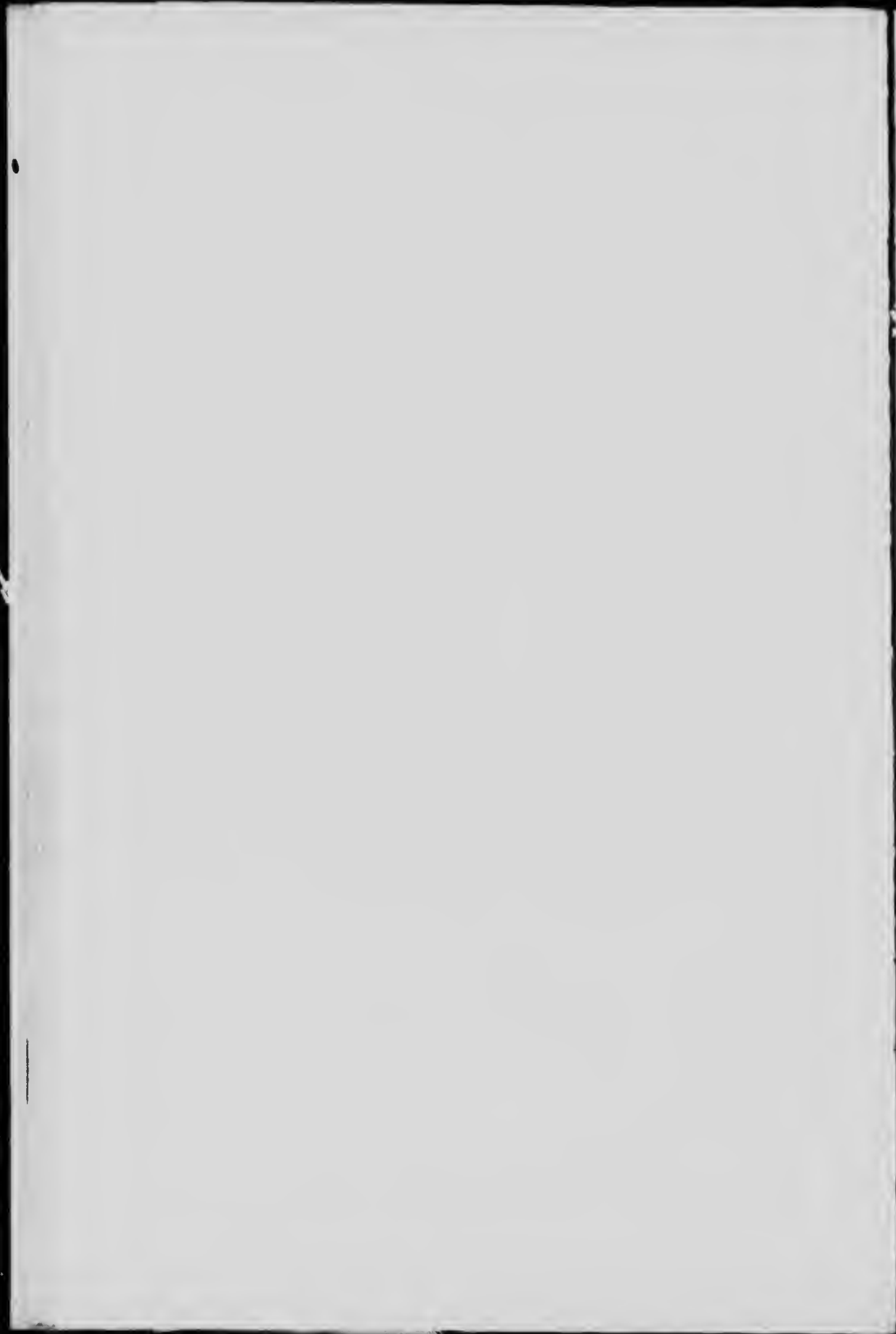



PLATE VI.



Surface growth: Stoco peat bog, Ontario.



## The Marl Deposits in Clairview and Stoco Peat Bogs.

### CLAIRVIEW MARL DEPOSIT.

This marl deposit is situated about 4 miles north of Erinsville, Ontario, on the Bay of Quinte railway, in Sheffield township, Lennox and Addington county, (see Map No. 364—Clairview peat bog) and covers more or less of:—

Lot No.	12	concession I,
"	Nos. 12-16	" II,
"	Nos. 14-15	" III.

The total area covered by this deposit is approximately 280 acres with a depth varying from 10-20 feet.

### *Analysis of Marl.*

Insoluble matter.....	0.66
Peroxide of iron and alumina.....	0.24
<sup>1</sup> Carbonate of lime.....	81.60
<sup>2</sup> "          magnesia.....	1.98
<sup>1</sup> Equivalent to lime.....	45.70
<sup>2</sup> Equivalent to magnesia.....	0.95

Contains a considerable amount of peaty matter.

This marl deposit is very well situated as regards market and shipping facilities, being only 3 miles from Erinsville station, by the short cut, and about 35 miles from Kingston; 15 miles from Napanec; and about 22 miles from Belleville.

### STOCO MARL DEPOSIT.

A very fine marl bed is deposited in the Stoco bog (See Map 363—Stoco peat bog). This bed runs through the bog in a north to south direction, following the eastern margin. The width of the bed—excepting an interval of peat 600 feet—is, approximately, 100 to 200 feet, the length about 5,000 feet, and the average depth 18 feet.

This remarkable formation shows that the bed of marl runs in an old river bed, and must have been formed by the waters of the spring highly charged with lime, as mentioned below.

### *Analysis of Marl from Stoco peat bog.*

Insoluble matter.....	0.24
Peroxide of iron and alumina.....	0.16
<sup>1</sup> Carbonate of lime.....	89.91
<sup>2</sup> "          magnesia.....	1.52
<sup>1</sup> Equivalent to lime.....	50.85
<sup>2</sup> Equivalent to magnesia.....	0.72

It is known that fresh water marl occurs usually in marshes and in shallow lakes. It is generally composed of diatomaceous siliceous shells,

insects, fresh water mollusks, mussels, washed off lime, and the remains from the shores.

The mode of occurrence and physical character of the mineral are very well described in the *Geology of Canada, 1863*, which may be quoted here:—

Although belonging to the present geological period, this marl is not always of recent formation, inasmuch as the beds of it are sometimes overlaid by peat, or by a soil supporting a growth of large trees. At other times, however, the marl covers the bottom of shallow lakes or ponds, and is evidently in the process of deposition. It appears to be formed by the waters of springs highly charged with lime, which is at first held in solution as bicarbonate, but is deposited when these waters come to the air. It is thus similar in its origin to the deposits of calcareous tufa, which occur in many places where such calcareous springs flow over the earth, rocks and vegetation, instead of falling into lakes or marshes. The presence of carbonate of lime is a necessary condition of the development of shells, and various species of mollusca abound in such waters. These by their remains, which often form a considerable portion of the deposits, give to them the name of shell-marl, which is frequently applied. This substance is white and earthy in its aspect, and, unless mingled with clay, is nearly pure carbonate of lime, which, from its finely divided state, is well adapted to serve as a dressing for such soils as are deficient in calcareous matter. When calcined, marl yields a nearly pure and very white lime, well adapted for mortar and other uses. In many parts of Vermont large quantities of lime are thus manufactured. The marl is moulded in the shape of bricks, which are dried and burned in a kiln.

For more detailed information on this subject, reference may be made to the *Report on Marl Deposits in Ontario, Quebec, New Brunswick, and Nova Scotia*, by R. W. Ells, LL.D., F.R.S.C.; also to other reports issued by the Geological Survey Branch of the Department of Mines.

#### **Tweed Peat Bog.**

A small bog of about 50 acres is situated 1 mile south of Tweed on lots 9, 10, and 11, concessions VIII and IX, Hungerford township, Hastings county, with an average depth of from 4 to 8 feet.

The peat is very well humified, and is suitable for the manufacture of peat fuel. It is composed mainly of carex plants.

#### **Buller Peat Bog.**

A bog containing little more than 100 acres is situated 1 mile south of Buller station, Canadian Pacific railway, on lots:—

1-2 cons. VII-VIII township of Hungerford, Hastings county.  
18-20   "   VII                   "                   "

This bog averages in depth from 5 to 7 feet, is well humified, and is suitable for the manufacture of peat fuel.

It is composed mainly of carex plants, lightly intermixed with hypnum and other aquatic plants.

The surface of the bog is heavily wooded with cedar, spruce, and tamarack. Around the margin grow willows, alders, elms, poplar, and other soft and hardwood trees.

If the Tweed and Buller peat bogs were properly drained the land could be utilized for agricultural purposes.

TABLE II.  
Peat Bogs Investigated in the Province of Quebec.

Names of the peat bogs.	Locality.		Approx. total area, acres	Volume of workable peat				Approx. area of peat bog, acres	REMARKS
	County	Parish or Township		Cub. yds. of peat fuel	Tons of fuel with contents 25% moisture	Cub. yds. of peat litter	Tons of litter with contents 20% moisture		
Large Tea Field	Huntingdon	Godmanchester	5,268	36,179,000	4,824,000			Princ. formed of sphagnum and remains of carex.	
Small Tea Field	Huntingdon	Godmanchester	4,190	24,866,000	3,316,000			Princ. formed of sphagnum and eriophorum.	
Lamorale	Berthier and Joliette		7,500	35,636,000	4,751,000			Princ. formed of sphagnum and remains of carex.	
St. Hyacinthe	St. Hyacinthe and Bagot		3,890	27,490,000	3,666,000			Princ. formed of sphagnum and remains of carex and eriophorum.	
Rivière du Loup	Temiscouata	Terrebois, Rivière du Loup, Parc White-worth	7,220	94,579,000	12,611,000	19,360,000	1,928,000	Princ. formed of sphagnum.	
Cacouna	Temiscouata	Lepage	845	5,370,000	716,000	8,370,000	603,000	Princ. formed of sphagnum.	
Lepage	Temiscouata	Lepage	614					Princ. formed of sphagnum.	
St. Denis	Kamouraska	Rivière Ouelle	315	21,910,000	2,921,000	6,050,000	603,000	Princ. formed of sphagnum.	
Rivière Ouelle	Kamouraska	Rivière Ouelle	4,521	13,200,000	1,760,000	36,440,000	2,624,000	Princ. formed of sphagnum.	
L'Assomption	L'Assomption	L'Assomption	1,565					Princ. formed of eriophorum, carex and sphagnum.	
St. Isidore	La Prairie, Chateaugay, Beauport, Napierville	Chateaugay, Beauport, La Salle	1,231	16,817,000	2,242,000			Princ. formed of sphagnum and remains of eriophorum.	
	Chateaugay, Napierville, Huntingdon		6,181	22,400,000	2,999,000			Princ. formed of carex and remains of sphagnum and eriophorum.	



## QUEBEC.

**L'Assomption Peat Bog.**

This bog is situated about 2 miles south of L'Epiphanie station, and approximately a mile and a half northeast of Cabane Ronde station in the seigneurie of L'Assomption, county of L'Assomption; and runs in a north-east and southwest direction (see Map No. 366) covering more or less of the seigneurie of L'Assomption, county of L'Assomption.

The total area covered by this bog is, approximately, 1,565 acres. Of this area:—

Approximately, 256 acres have a depth of less than 5 feet, with an average depth of 3 feet.

Approximately, 722 acres have a depth of more than 5 feet, with an average depth of 7 feet.

Approximately, 555 acres have a depth of more than 10 feet, with an average depth of 12 feet.

Approximately, 25 acres have a depth of more than 15 feet, with an average depth of 15 feet.

The volume of peat contained is, approximately:—

1,239,000	cub. yds. in an area with a depth of less than	5 feet.
8,230,000	" " " " more	" 5 "
6,740,000	" " " " "	" 10 "
600,000	" " " " "	" 15 "

The largest portion of the bog, from the northeast towards the southwest, is exceptionally well suited for manufacturing peat fuel. It is very well humified, contains high cohesive properties, and has considerable depth. A small portion of the southwestern part of the bog is comparatively shallow, and a certain part of this is under agriculture.

The surface of the bog has been burned over several times, which makes it fairly uniform, thereby ensuring a suitable spreading area, without incurring great expense. Here and there groups of trees occur, and there is a wooded area in the northern portion of the bog. The central parts are composed of dwarfed spruce and tamarack, poplar, alders, and a few hardwood trees cover the northern margin.

During the drilling it was noticed that the bottom layer, from two to three feet thick, was composed of aquatic plants heavily intermixed with carex. Above this, for about five feet, occurs a strong intrusion of eriophorum, slightly intermixed with sphagnum-fuscum. The upper layers are, on the other hand, mainly composed of sphagnum plants, together with eriophorum, which produces excellent fuel when humified.

The bottom of the bog is formed of sandy soil covered by a thin layer of blue clay; surrounding ridges being composed of a sand-clay mixture. Part of it, mostly toward the margin, is heavily intermixed with stumps

DEPARTMENT

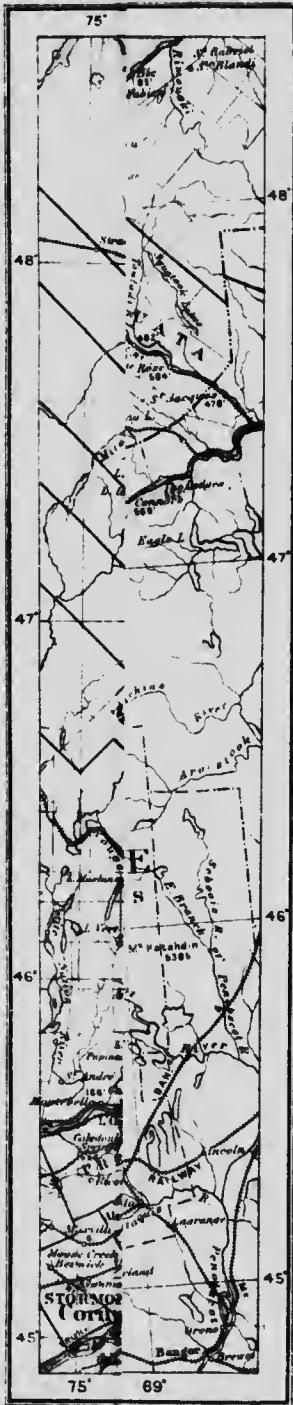

- Name of Bog
- 1 - Large Tea Field
  - 2 - Small Tea Field
  - 3 - Lanerale
  - 4 - St. Hyacinth
  - 5 - Riviere Ouelle
  - 6 - St. Denis
  - 7 - Riviere-du-Loup
  - 8 - Cucopna
  - 9 - Le Parc
  - 10 - L'Assomption
  - 11 - St. Isidore
  - 12 - Holton

H. E. Baird, C.  
Base Map, Dep.

365

366

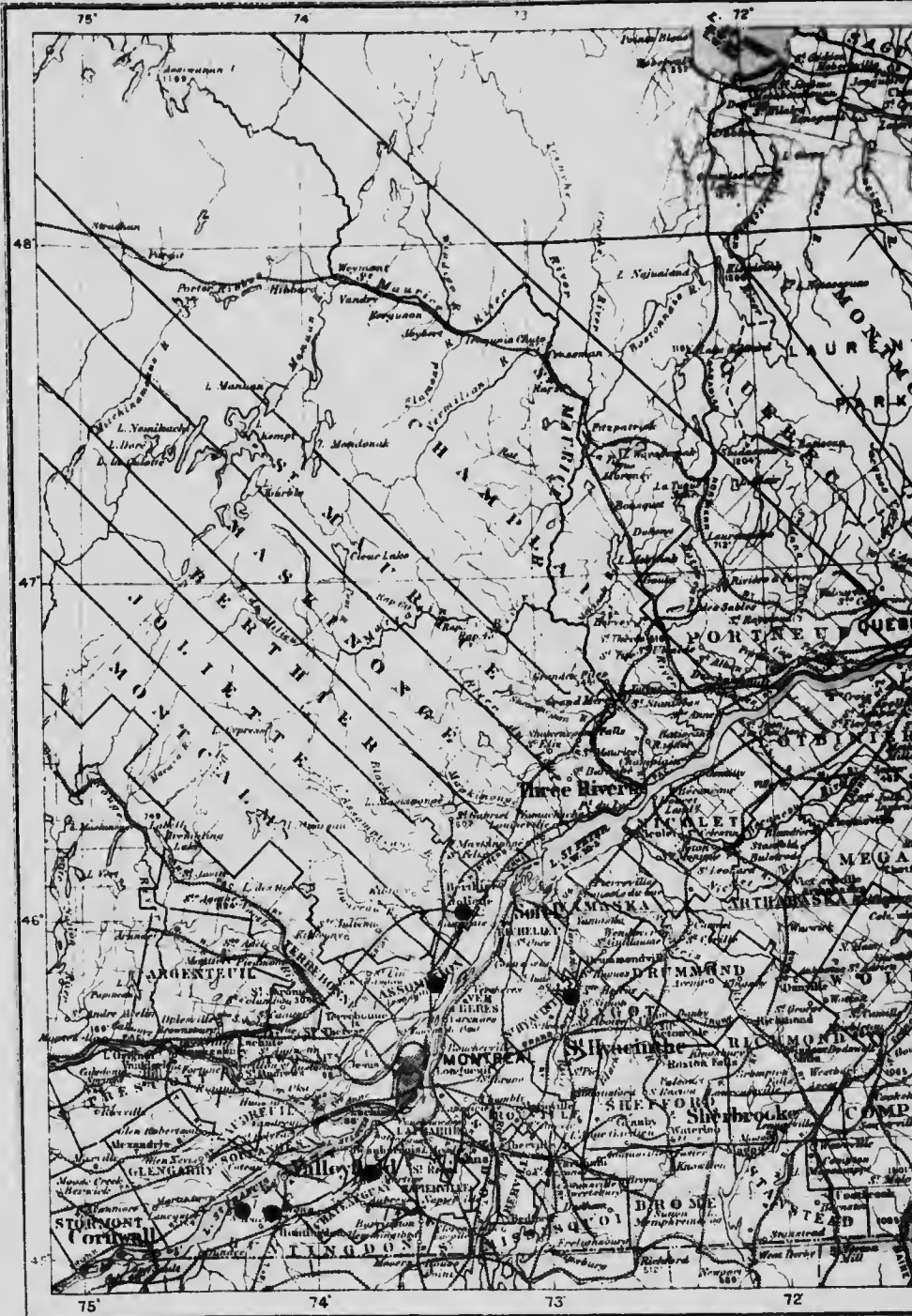

11 E. Baine, Chief Draughtsman.  
Base Map, Department of the Interior.

**PEAT BOGS INVEST  
IN  
QUEBEC**

- Peat fuel bogs
- ⊖ Peat litter bogs
- Not workable bogs

Scale: 1/35 miles to 1 inch





- Name of Bog
- 1—Large Tea Field
  - 2—Small Tea Field
  - 3—Lanorue
  - 4—St. Hyacinth
  - 5—Rivière Ouelle
  - 6—St. Denis
  - 7—Rivière-du-Loup
  - 8—Cacouna
  - 9—Le Parc
  - 10—L'Assomption
  - 11—St. Isidore
  - 12—Holtton

INVESTIGATED  
 BEBEC

365

T  
appro  
seigne  
east a  
seigne

T  
this ar  
A

A

A

A

T

T  
west, j  
well h  
depth.  
shallov



T  
makes  
incurri  
is a we  
are cor  
hardwe

D  
three f  
carex.  
phorur  
are, or  
with er

TI  
of blue  
Part o

DEPARTMENT OF MINES, MINES BRANCH

LEGEND

-  Margin of Bog
-  Contour of bottom
-  Drill-hole, depth of peat

Note:

B+ } Indicating a peat more or less  
 AB- } suitable for fuel  
 AB }  
 AR+ }

Scale of Feet

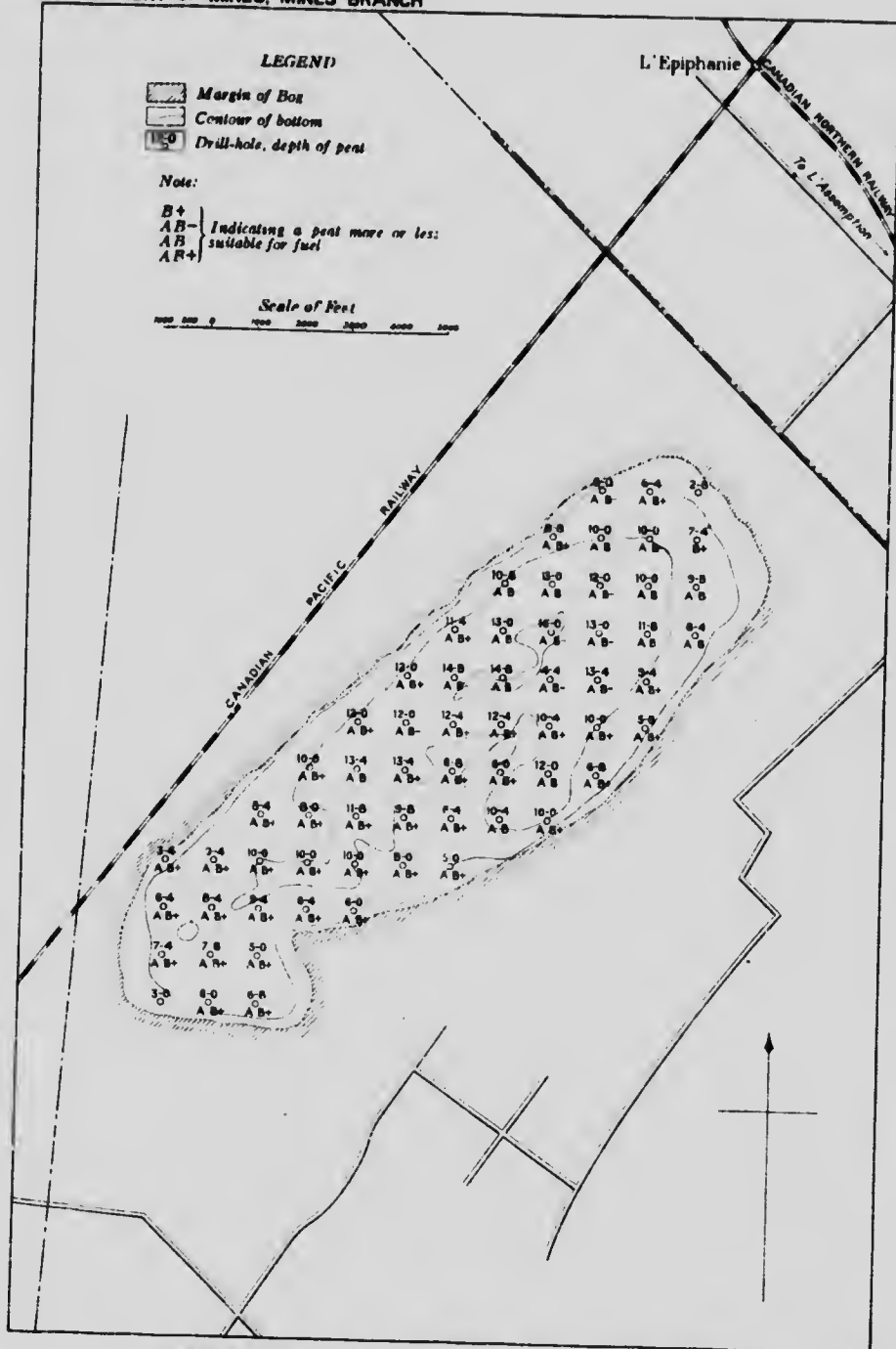

L'ASSOMPTION PEAT BOG, L'ASSOMPTION COUNTY, QUEBEC



and roots; but with this exception, the bog is fairly free from such undesirable obstructions, and would readily lend itself to the manufacture of peat fuel by modern methods.

Deducting the 256 acres having a depth of less than 5 feet, and allowing for a decrease of 12 inches in depth due to drainage, of the area of the compact bog with an average depth of 7 feet, and allowing 2 feet for the remainder of the bog, we have left:—

722 acres with an average depth of, approximately, 6 feet.

555 " " " " " " 10 "

25 " " " " " " 13 "

having a total volume of, approximately, 13,200,000 cubic yards. Allowing that one cubic yard of the drained bog furnishes 200 pounds of dry peat substance, the total tonnage of dry substance available would be, approximately, 1,320,000 tons (of 2,000 pounds) or 1,760,000 tons of peat fuel containing 25 per cent moisture.

*Analyses of Peat.*

Sample	I		II		III	
	R	D	R	D	R	D
Moisture.....	7.6		7.4		7.3	
Ash.....	4.8	5.2	3.2	3.5	4.4	4.8
Volatile matter.....	61.0	66.1	62.6	67.6	62.1	66.9
Fixed carbon (by difference).....	26.6	28.7	26.7	28.9	26.2	28.3
Sulphur*.....	0.1	0.1	0.1	0.1	0.1	0.1
Nitrogen.....	1.5	1.6	1.5	1.6	1.5	1.7
Caloric value, in calories per gram, gross.....	4,960	5,370	4,990	5,390	4,980	5,370
" " B.Th.U., per lb., gross.....	8,920	9,660	8,990	9,710	8,970	9,670
Fuel ratio, fixed carbon, volatile matter.....	0.44	0.44	0.43	0.43	0.42	0.42

\* Average of three samples from bog.

Note.—Figures in column "R" refer to fuel as received, and in column "D" to fuel dried at 105°C.

The analyses were made on fuel as received, and other results calculated therefrom.

The content of ash is comparatively low, and the calorific value highly satisfactory

The bog is very advantageously situated with regard to shipping facilities and market, being only 18 miles from Montreal; with the Canadian Pacific railway paralleling the northern side at a distance of one thousand feet to half a mile, and the Canadian Northern railway crossing at L'Epiphanie, about 2 miles east of the bog.

This bog, without doubt, is one of the most favourably situated of those so far investigated; has all the advantages for the manufacture of peat fuel, and should be used for that purpose in the near future, since domestic fuel, at high prices, is in great demand at Montreal.

### St. Isidore Peat Bog.

The bog is situated about 3 miles south of St. Isidore station, in the seigniories of

Chateauguay—La Prairie county,  
 Beauharnois—Chateauguay county,  
 La Salle—Napierville county,

and is almost circular in shape (see Map No. 367).

The total area covered by this bog is, approximately, 1,231 acres. Of this area:—

Approximately, 439 acres have a depth of less than 5 feet, with an average depth of 3 feet.

Approximately, 1,000 acres have a depth of more than 5 feet, with an average depth of 7 feet.

Approximately, 490 acres have a depth of more than 10 feet, with an average depth of 11 feet.

The volume of peat contained is, approximately:—

2,120,000	cu. yds.,	in an area with a depth of less than	5	feet.
11,340,000	"	"	more	" 5 "
8,699,000	"	"	"	" 10 "

The western portion of the bog lying in La Prairie county, and the southern part lying in Chateauguay county, are at present under cultivation. This part of the bog has a depth varying from three to eight feet, is well drained, and contains well humified peat fuel. The agricultural work is confined to the raising of potatoes, oats, cabbages, corn, etc. Some of the farmers utilize the deeper portions of this section by cutting the peat into blocks by hand, air drying it, and burning it as domestic fuel. The landscape here reminds one strongly of the boggy parts of Holland and Sweden, where the people develop their natural resources to the fullest extent.

The central portion in the counties of La Prairie and Napierville is very well humified, and is of a considerable depth. The surface is heavily wooded with small willows, poplars, alders, and as the margin is approached tamarack and spruce are encountered.

When this area has been cleared of trees and bushes, working lines of considerable length may be secured, and a modern plant for manufacturing machine peat by the air dried process could be favourably installed.

The bog is formed principally of sphagnum, lightly intermixed with other sphagnum mosses, and eriophorum plants. The bottom layer is composed strictly of aquatic plants, to a depth not exceeding one foot. In the centre of the bog large varieties of carex plants are to be found, hypnum is rarely seen, since sphagnum and carex crowd it out. The body is comparatively free from roots and stumps, is easily drained, and of a satisfactory depth. The bottom is formed of blue clay, which rises gradually from the margin into flat agricultural la

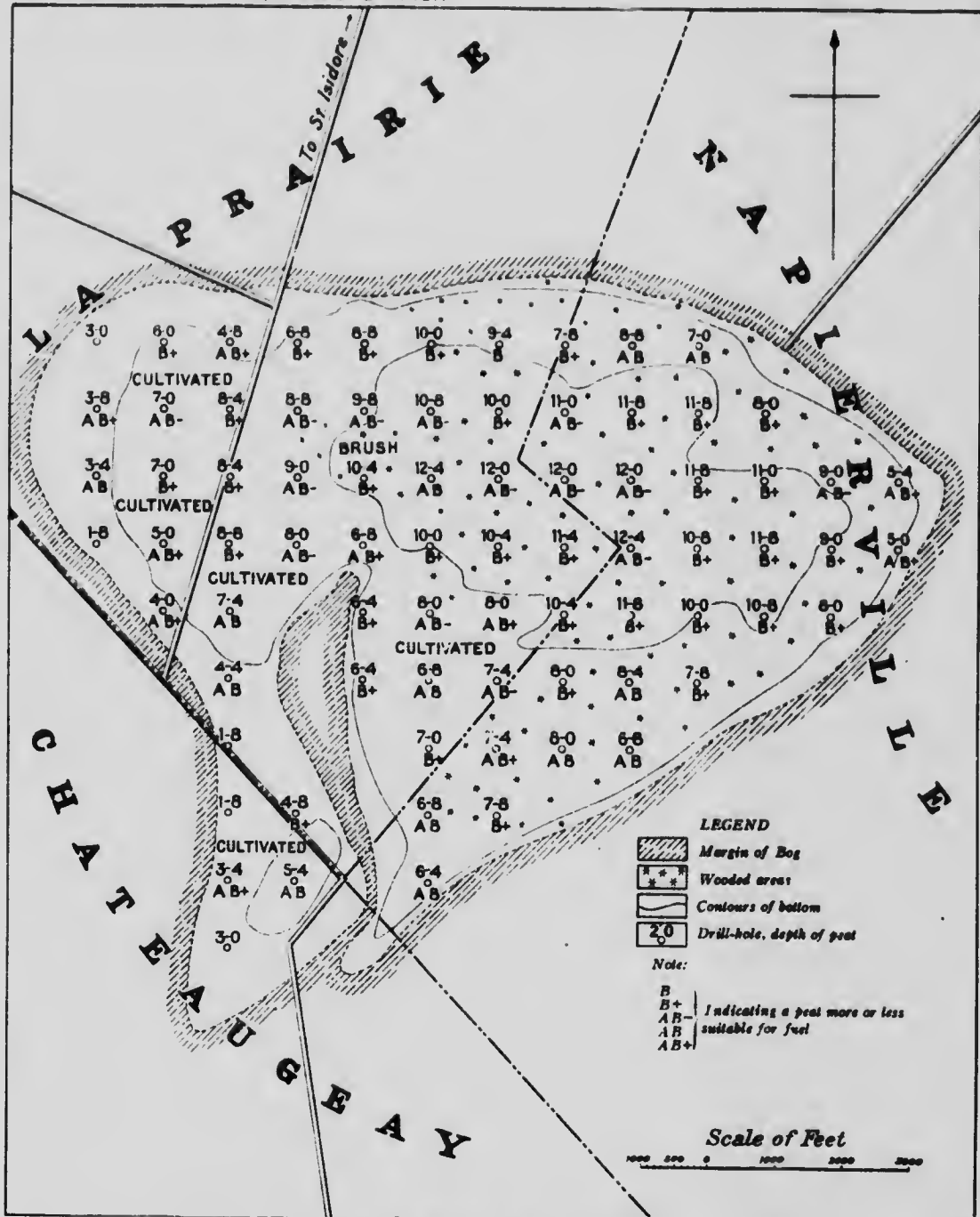

ST. ISIDORE PEAT BOG, QUEBEC





Deducting 439 acres with a depth of less than 5 feet, and allowing for a decrease in depth due to drainage of 12 inches for the area containing the compact bog of an average depth of 7 feet, and 2 feet for the remainder of the bog, we have left:—

1,002 acres with an average depth of, approximately, 6 feet.

490 " " " " " " " " 9 "  
 having a total volume of, approximately, 16,810,000 cubic yards.

Assuming that one cubic yard of the drained bog furnishes 200 pounds of dry peat substances, the total tonnage of dry peat substance available would be, approximately, 1,682,000 tons (of 2,000 pounds) or 2,242,000 tons of peat fuel containing 25 per ce : moisture.

*Analysis of Peat.*

Sample	I	
	R	D
Moisture.....	9.1	
Ash.....	6.2	6.8
Volatile matter.....	56.0	61.6
Fixed carbon (by difference).....	28.7	31.6
Sulphur.....	0.4	0.4
Nitrogen.....	1.8	2.0
Calorific value in calories, per gram, gross.....	4,510	4,960
" " B.Th.U., per lb., gross.....	8,110	8,920
Fuel ratio, fixed carbon, volatile matter.....	0.51	0.51

Note.—Figures in column "R" refer to fuels as received, and in column "D" to fuel dried at 105°C. The analysis was made on the fuel as received and other results calculated therefrom.

The content of ash is not excessive, and the calorific value satisfactory.

This bog is fairly well situated as regards market, being about 30 miles from Montreal; but somewhat too distant from the Canadian Pacific railway (3 miles), for adequate shipping facilities.

**Holton Peat Bog.**

This bog is situated about 2 miles east of Holton station, and one mile west of Barrington, in the counties of Chateauguy, Napierville, and Huntingdon, in the Province of Quebec, and runs in a north and south direction. (See Map No. 368).

The total area covered by this bog is, approximately, 6,181 acres. Of this area:—

2,704 acres have a depth of less than 5 feet, with a depth of 4 feet.

3,477 " " " " more " 5 " " " " " 6 "

The volume contained is, approximately:—

17,450,000 cub. yds. in an area with a depth of less than 5 feet.

33,600,000 " " " " " " more " 5 "

The centre of the bog, north of the Grand Trunk railway, is fairly well humidified, and is rather shallow in depth. In the event of a pronounced scarcity of fuel, this part of the bog could be utilized. The southern,

western, and northeastern portion is heavily wooded with spruce, alders, heavy underbrush, elms, a few maples, poplars, and birch.

The extreme northern part is, on the other hand, cultivated into large onion fields, and farming conditions are similar to those at St. Isidore.

The samples obtained from the bog show clearly that it is composed mainly of carex plants, occasionally interspersed with sphagnum and eriophorum; but owing to the flooding of the central portion of the bog in the spring, and subsequent drying during the summer months, the sphagnum and eriophorum species do not flourish readily.

The bottom of the bog is formed of blue clay, which, around the creek and the larger parts of the centre, is diluted with water from the surrounding limestone formation, which, together with the sediment in the creek waters, is deposited on the shores in the form of composite beds from 4 to 12 feet in thickness.

The surrounding formation is rocky, rising gradually to an elevation ten to fifty feet above the surface of the bog.

A certain portion of the bog is heavily intermixed with roots and stumps, and logs of fallen trees.

Deducting the 2,704 acres having a depth of less than 5 feet, and allowing for a 2 foot decrease in depth due to drainage, we have left 3,477 acres with an average depth of, approximately, 4 feet, having a total volume of, approximately, 22,400,000 cubic yards, and assuming that one cubic yard of the drained bog furnishes 200 pounds of dried peat substance, the total tonnage of dry substance available would be 2,240,000 tons (of 2,000 pounds), or, approximately, 2,999,000 tons of peat fuel containing 25 per cent moisture.

If this bog was thoroughly drained, large areas could be recovered for agricultural purposes, which would be of great value to the people living in the immediate vicinity of the bog, as it is only 35 miles southeast of Montreal.

#### Analysis of Peat.

Sample	I	
	R	D
Moisture.....	8.6	13.4
Ash.....	12.2	59.3
Volatile matter.....	54.2	27.3
Fixed carbon (by difference).....	25.0	1.2
Sulphur.....	1.1	2.5
Nitrogen.....	2.3	4.740
Calorific value, in calories per gram, gross.....	4,330	8,530
B.Th.U. per lb., gross.....	7,800	0.46
Fuel ratio, fixed carbon, volatile matter.....	0.46	0.46

Note.—Figures in column "R" refer to fuel as received, and in column "D" to fuel dried at 105°C. The analysis was made on fuel as received, and other results calculated therefrom.

The Grand Trunk railway traverses the southern part of the bog.

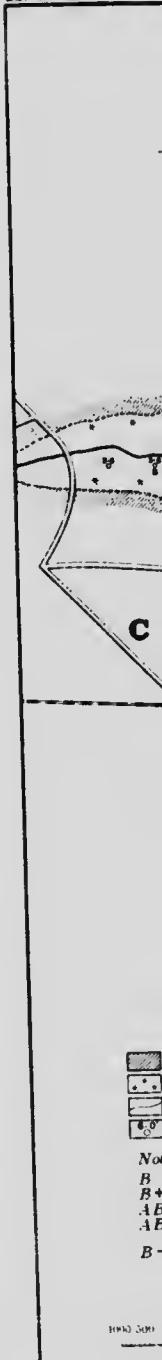

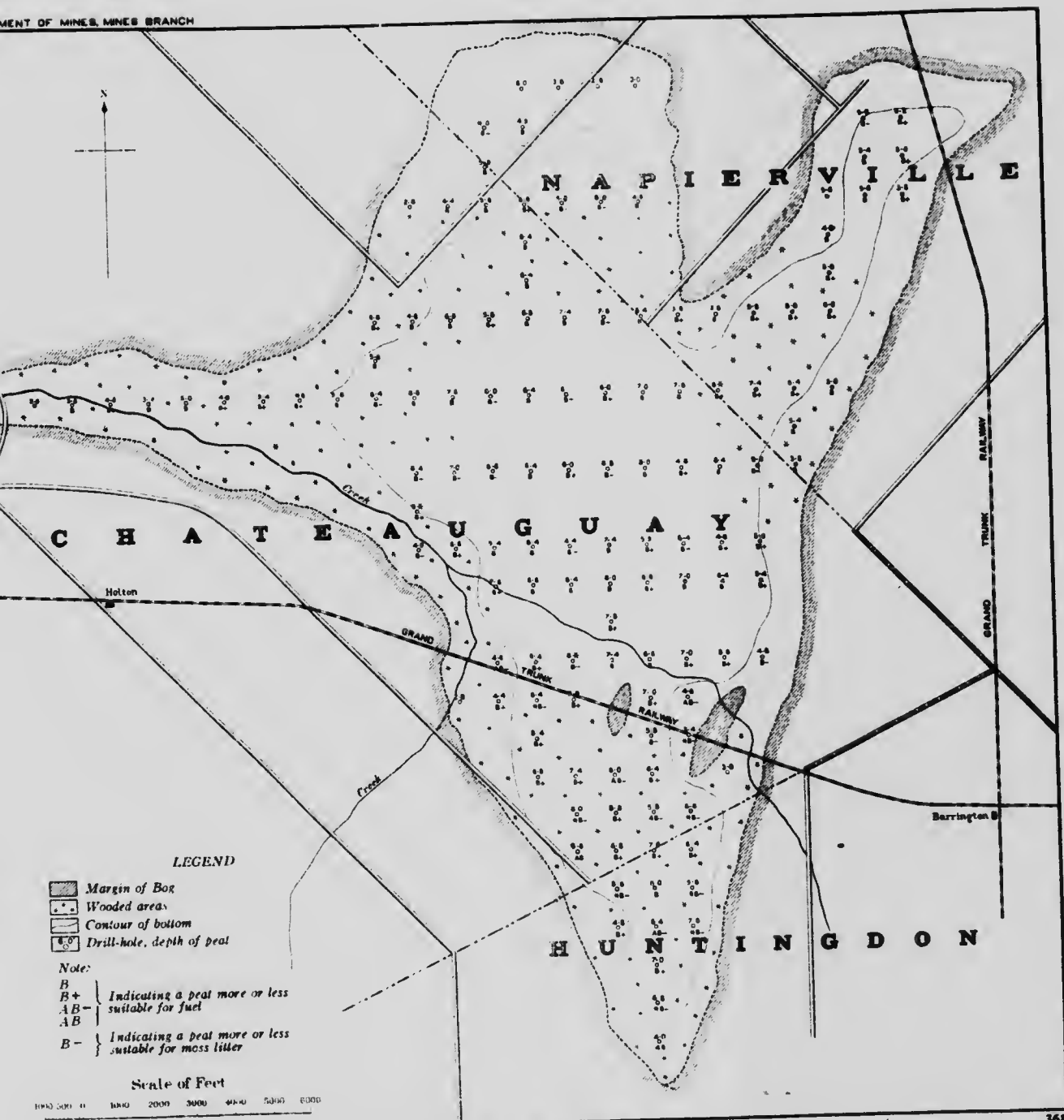

HOLTON PEAT BOG, QUEBEC

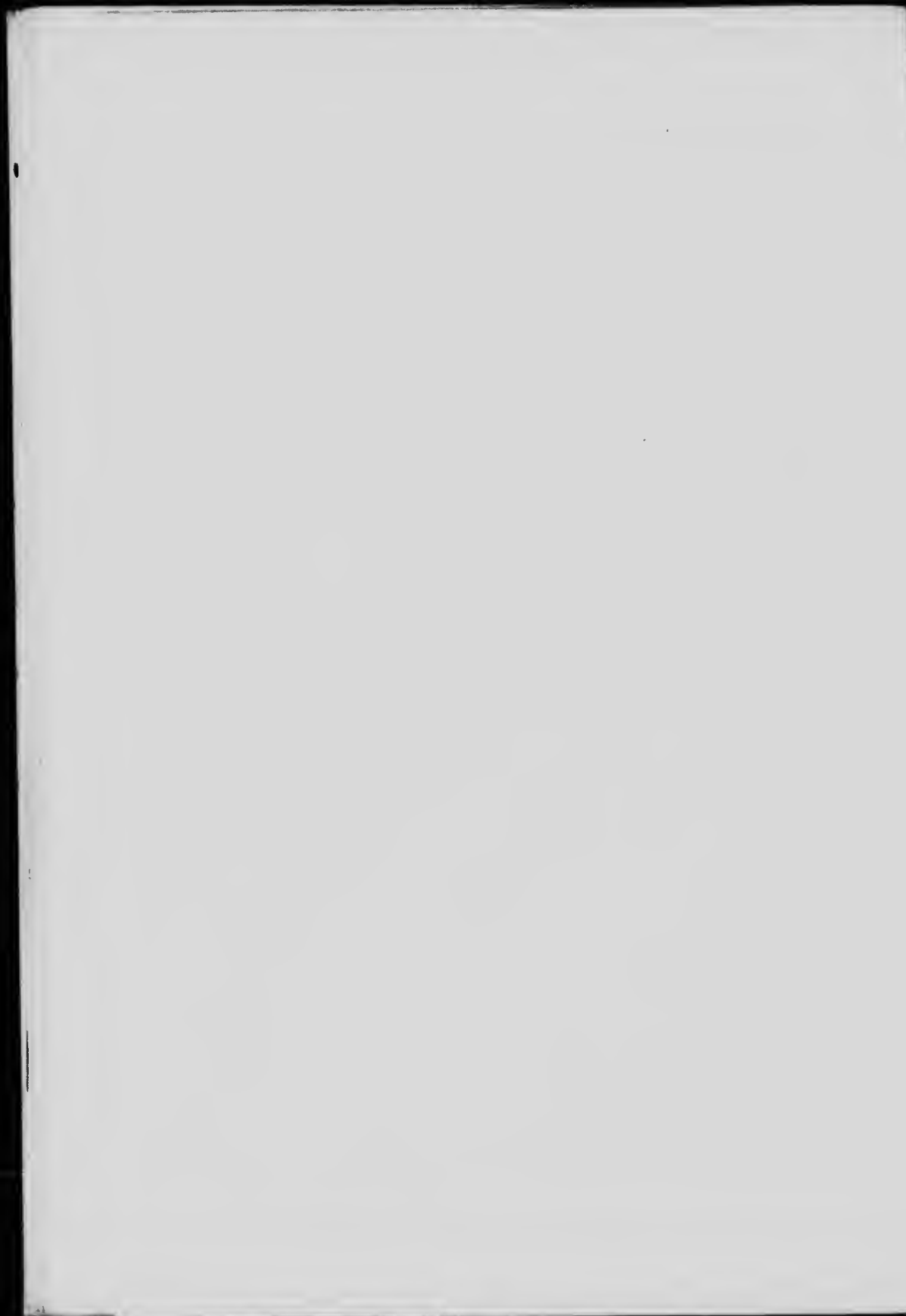

TABLE III.  
Analyses of the Different Peat Samples Collected from Bogs in the Province of Quebec.

No. of samples from each bog	LOCATION	Analyses of Peat (absolutely dry)				Calorific value		Fuel Ratio
		Fixed carbon	Volatile matter	Ash	Nitrogen	Cals.	B.Th.U. per lb.	
1	Large Tea Field.....	29.0	65.0	6.0	2.0	5,200	9,300	0.40
2	".....	20.0	66.0	5.0	2.0	5,300	9,500	0.40
1	Small Tea Field.....	30.0	65.0	5.0	2.0	5,000	8,980	0.50
1	".....	28.0	64.0	8.0	2.0	5,000	9,300	0.40
2	Lanoraie.....	26.0	64.0	9.0	2.0	4,900	8,900	0.40
1	".....	28.0	66.0	5.0	2.0	5,100	9,200	0.40
2	".....	26.0	65.0	9.0	2.0	4,980	8,800	0.50
3	".....	30.0	63.0	7.0	2.0	5,020	8,900	0.50
1	St. Hyacinthe.....	31.0	64.0	6.0	2.0	5,020	8,900	0.50
2	".....	28.0	69.0	3.0	1.0	5,000	9,100	0.40
1	Riviere du Loup.....	29.0	69.0	2.0	1.0	5,000	9,100	0.40
2	".....	28.0	70.0	2.0	1.0	5,000	8,900	0.40
3	".....	29.0	68.0	3.0	1.0	5,000	8,900	0.40
4	".....	29.0	68.0	3.0	1.0	5,000	8,900	0.40
5	".....	28.0	69.0	3.0	1.0	5,000	9,100	0.40
6	".....	28.0	70.0	2.0	1.0	4,900	8,900	0.40
7	".....	29.0	67.0	4.0	1.0	5,100	9,200	0.40
8	".....	29.0	67.0	4.0	1.0	5,400	9,680	0.40
9	".....	29.0	69.0	3.0	1.0	5,000	8,980	0.40
10	".....	28.0	69.0	3.0	1.0	5,000	9,000	0.40
1	Leparc.....	29.0	68.0	3.0	1.0	5,000	9,100	0.40
1	Riviere Ouelle.....	29.0	68.0	3.0	1.0	5,200	9,100	0.40
2	".....	29.0	66.0	5.0	2.0	5,400	9,200	0.40
1	L'Assomption.....	29.0	68.0	3.0	2.0	5,400	9,200	0.40
2	".....	28.0	67.0	5.0	2.0	5,400	9,200	0.40
3	St. Isidore.....	32.0	67.0	5.0	2.0	5,000	8,900	0.50
1	Holton.....	27.0	59.0	14.0	2.0	4,700	8,500	0.50

TABLE IV.  
**Data Relating to Peat Bogs Investigated in Prince Edward Island, during 1913.**

Name of bog	Locality		Approximate total area, acres	Volume of workable peat			Partial analyses of absolutely dry peat				Remarks
	County	Township		Tons of fuel with contents with 25% moisture	Tons of litter with 20% moisture	Cubic yards	Fixed carbon %	Volatile matter %	Ash %	Calorific value B.Th.U. per lb.	
The Black-Marsh	North		550	183,099		1,370,000	30.0	65.0	5.0	9,800	
Portage	Prince	Halifax	775	500,000	184,000	6,220,000					
Miscouche	Prince	Richmond	2,900	415,000	137,000	4,940,000	30.0	63.0	7.0	9,400	
Muddy Creek	Prince	Richmond	61			347,000					
The Black Band	Prince	Halifax	884		839,000	11,180,000	See Peat	Litter	Analyses		(Compressed mainly of sphagnum.)
Mermaid	Queens	Belford	186	115,000		860,000	20.0	67.0	4.0	9,800	(Compressed mainly of sphagnum.)
Total			5,356	1,213,000	1,160,000	24,917,000					

## PRINCE EDWARD ISLAND.

**Black Marsh Peat Bog.**

This bog is situated 6 miles north of Tignish in Prince county, Prince Edward Island, and runs in a northeast and southwest direction (see Map No. 370) covering more or less of:—

Lot I—Prince county.

The total area covered by this bog is approximately 650 acres. Of this area:—

Approximately, 430 acres have a depth of less than 5 feet, with an average depth of 3 feet.

Approximately, 170 acres have a depth of more than 5 feet, with an average depth of 6 feet.

The volume of the peat contained is, approximately:—

2,320,000 cub. yds. in an area with a depth of less than 5 feet.

1,650,000 " " " " more " 5 "

The northern part of the bog is fairly well adapted to the manufacture of machine peat, since the peat is well lumified; the depth, however, is rather shallow, but by obtaining long working lines it could be utilized by the modern system.

Serious consideration, however, should be given the matter before a plant is erected. Shipping facilities and the market would be important factors.

In this part of the bog the surface is practically free from trees, but is rough, and covered with knolls, which would involve considerable expense in levelling for spreading purposes. The rest of the bog is heavily wooded with dwarfed spruce. The trees near the margin are in a healthier condition.

The body of the bog is comparatively free from roots and stumps and the bottom is composed of sand which gradually rises slightly above the surface of the bog in the centre. The bog is principally composed of sphagnum and carex slightly intermixed with eriophorum. (See Plate VII.)

Deducting the 480 acres having a depth of less than 5 feet, and allowing for a decrease in depth of 1 foot due to drainage, we have left:—

170 acres with an average depth of approximately 5 feet.

Having a total volume of, approximately, 1,370,000 cubic yards, and assuming that one cubic yard of the drained bog furnishes 200 pounds of dry peat substance, the total tonnage of dry substance available would be, approximately, 137,000 tons (of 2,000 pounds) or 183,000 tons of peat fuel containing 25 per cent moisture.

*Analyses of Peat.*

Sample	I		II	
	R	D	R	D
Moisture.....	8.3		8.3	
Ash.....	4.0	4.4	4.9	5.3
Volatile matter.....	59.1	64.5	60.4	65.8
Fixed carbon (by difference).....	28.6	31.1	26.4	28.9
Sulphur*.....	0.3	0.3	0.3	0.3
Nitrogen*.....	0.8	0.8	0.8	0.9
Caloric value, in calories per gram, gross.....	5,030	5,480	4,990	5,440
" " B.Th.U. per lb., gross.....	9,050	9,870	8,980	9,790
Fuel ratio, fixed carbon, volatile matter.....	0.48	0.48	0.44	0.44

\*Average of two samples from bog.

Note.—Figures in column "R" refer to fuel as received, and in column "D" to fuel dried at 105°C. The analyses were made from the fuel as received, and other results calculated therefrom.

The drainage of this bog would be a very simple matter, since on its western edge it borders the sand cliff sixty feet above the sea.

### Portage Peat Bog.

This bog is situated about 1 mile east of Portage station, Halifax township, Prince co., P.E.I. (see Map No. 371), and covers more or less of lot 10, Halifax township, Prince county.

The total area covered by this bog is, approximately, 775 acres. The peat consists of two kinds: peat litter and peat fuel, which are described separately as follows:—

#### A. PEAT LITTER.

The total area covered by this portion of the bog is 148 acres. Of this area:—

110 acres have a depth of less than 15 feet, with an average depth of 11 feet.

38 acres have a depth of more than 15 feet, with an average depth of 16 feet.

The volume of the peat litter contained is:—

In an area with a depth less than 15 feet, 1,950,000 cub. yards, approximately.

In an area with a depth more than 15 feet, 980,000 cub. yards, approximately.

The peat litter in this part of the bog, especially north of the western road—as shown on the map—is practically not humified, and will produce a fairly good peat litter. The peat in the 38 acres mentioned above is comparatively free from humus, hence a high grade litter may be obtained therefrom.

Allowing 2 feet for the decrease in depth through drainage, we shall have:—





- Port Bays*
- 1 - Port George
  - 2 - Port Sydney
  - 3 - Bay of St. Lawrence
  - 4 - Mundy Bay
  - 5 - Mundy Bay
  - 6 - Mundy Bay
  - 7 - Mundy Bay
  - 8 - Mundy Bay
  - 9 - Mundy Bay
  - 10 - Mundy Bay
  - 11 - Mundy Bay
  - 12 - Port Clyde
  - 13 - Port Clyde
  - 14 - Clyde

H. F. Payne, Chief Draftsman  
Base Map, Department



H. F. Ruess, Chief Draughtsman.  
Base Map, Department of the Interior.

- Peat fuel bogs
- ⊗ Peat litter bogs
- Not workable bogs

**PEAT BOGS INVESTIGATION**  
IN  
**NOVA SCOTIA AND PRINCE EDWARD ISLAND**



- Peat Bogs*
- 1 - Black Marsh
  - 2 - Portage
  - 3 - Black Banks
  - 4 - Muddy Creek
  - 5 - Mission's
  - 6 - Marmald
  - 7 - Caribou
  - 8 - Cherryfield
  - 9 - Tusk
  - 10 - Mokoke
  - 11 - Heath
  - 12 - Port Clyde
  - 13 - Latimer
  - 14 - Clyde

INVESTIGATED  
 EDWARD ISLAND

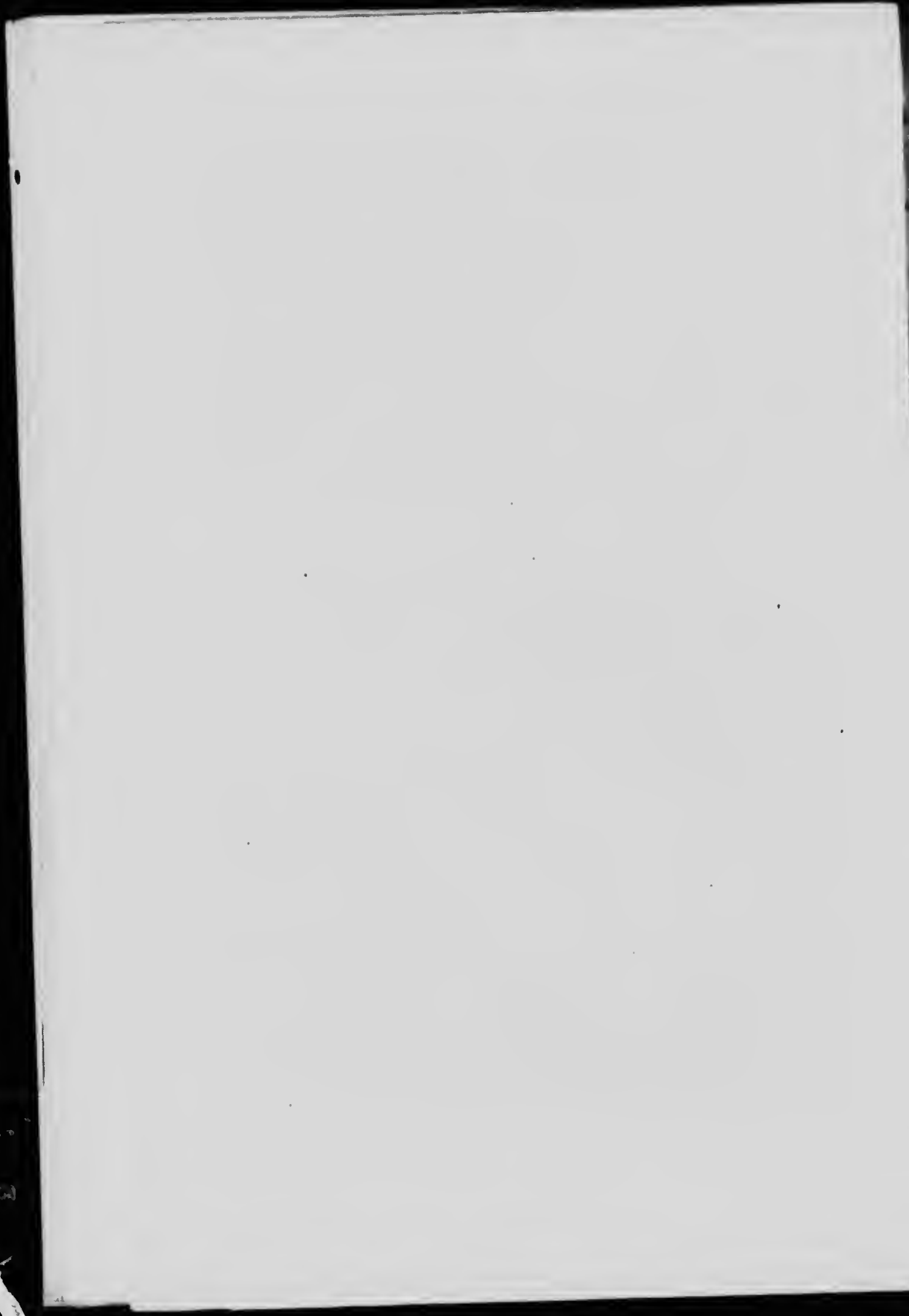

DEPARTMENT OF MINES, MINES BRANCH

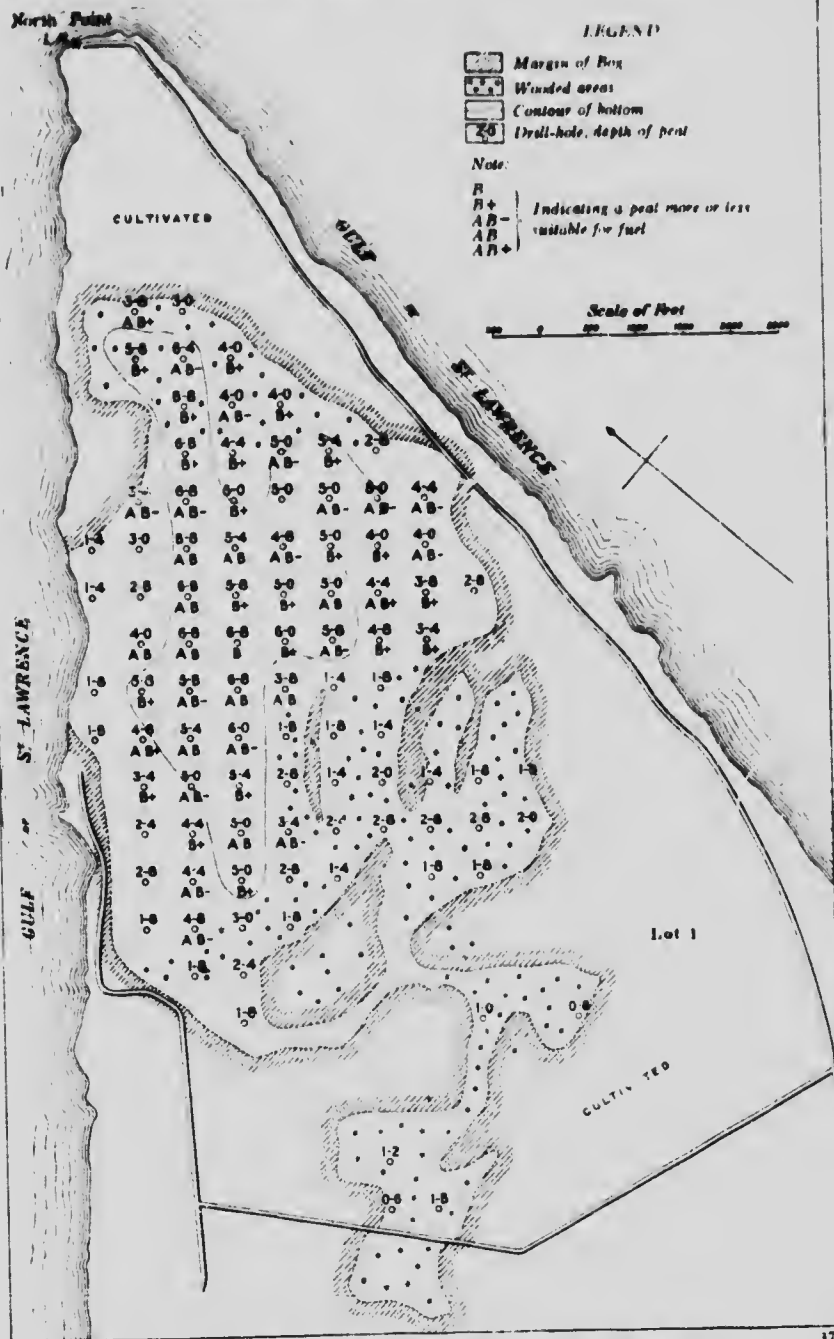

BLACK MARSH PEAT BOG, PRINCE COUNTY, PRINCE EDWARD ISLAND



DEPARTMENT OF MINES, MINES BRANCH

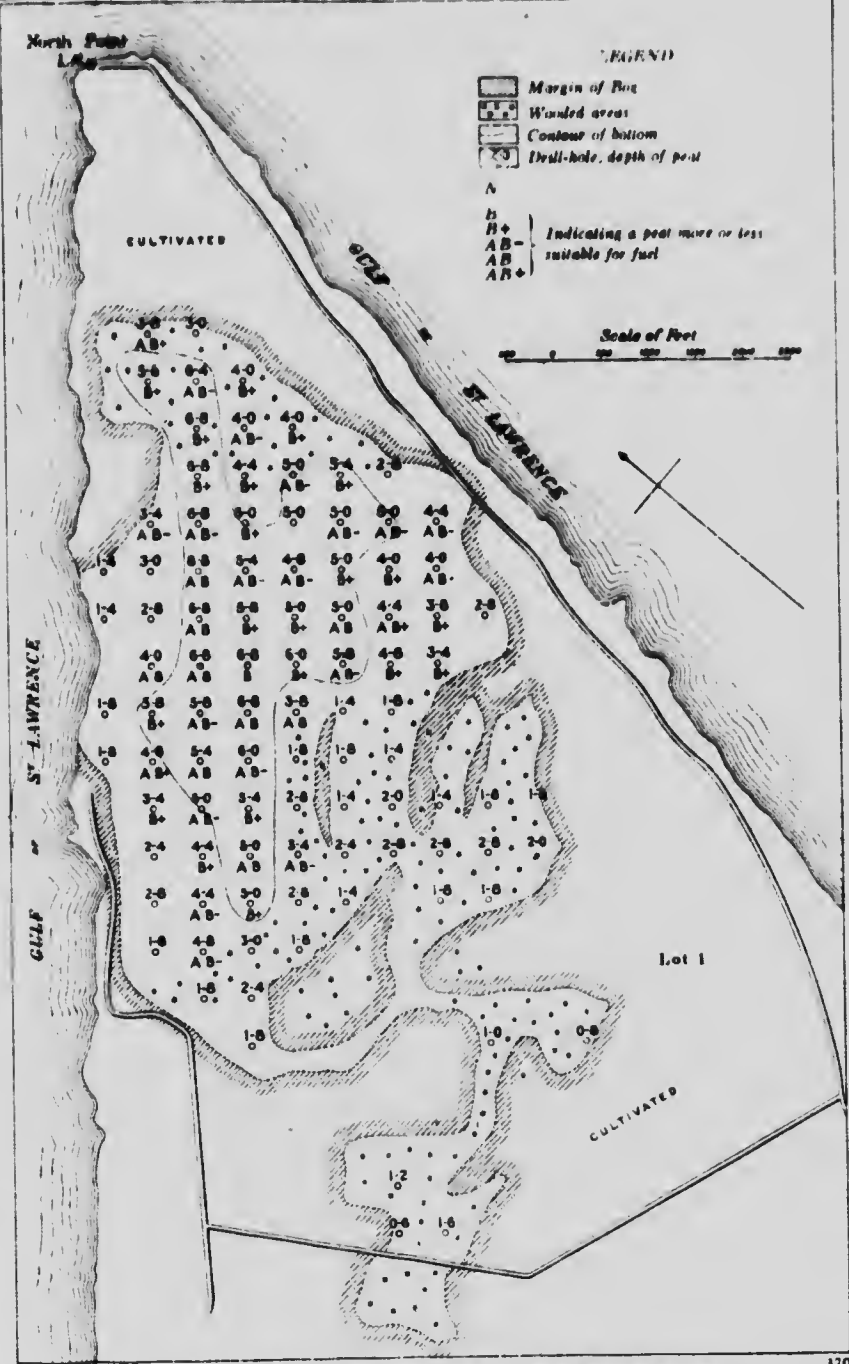

BLACK MARSH PEAT BOG, PRINCE COUNTY, PRINCE EDWARD ISLAND

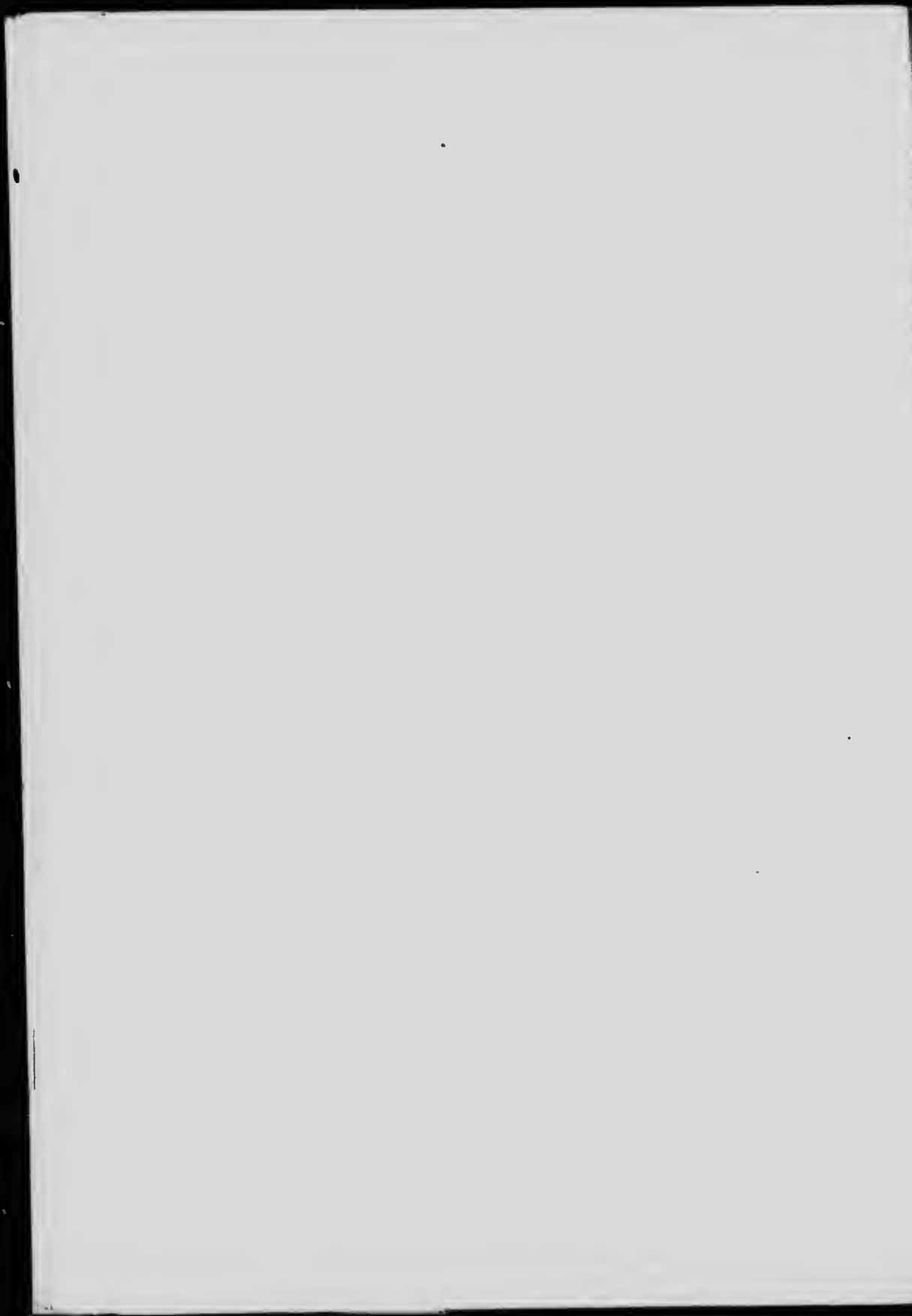



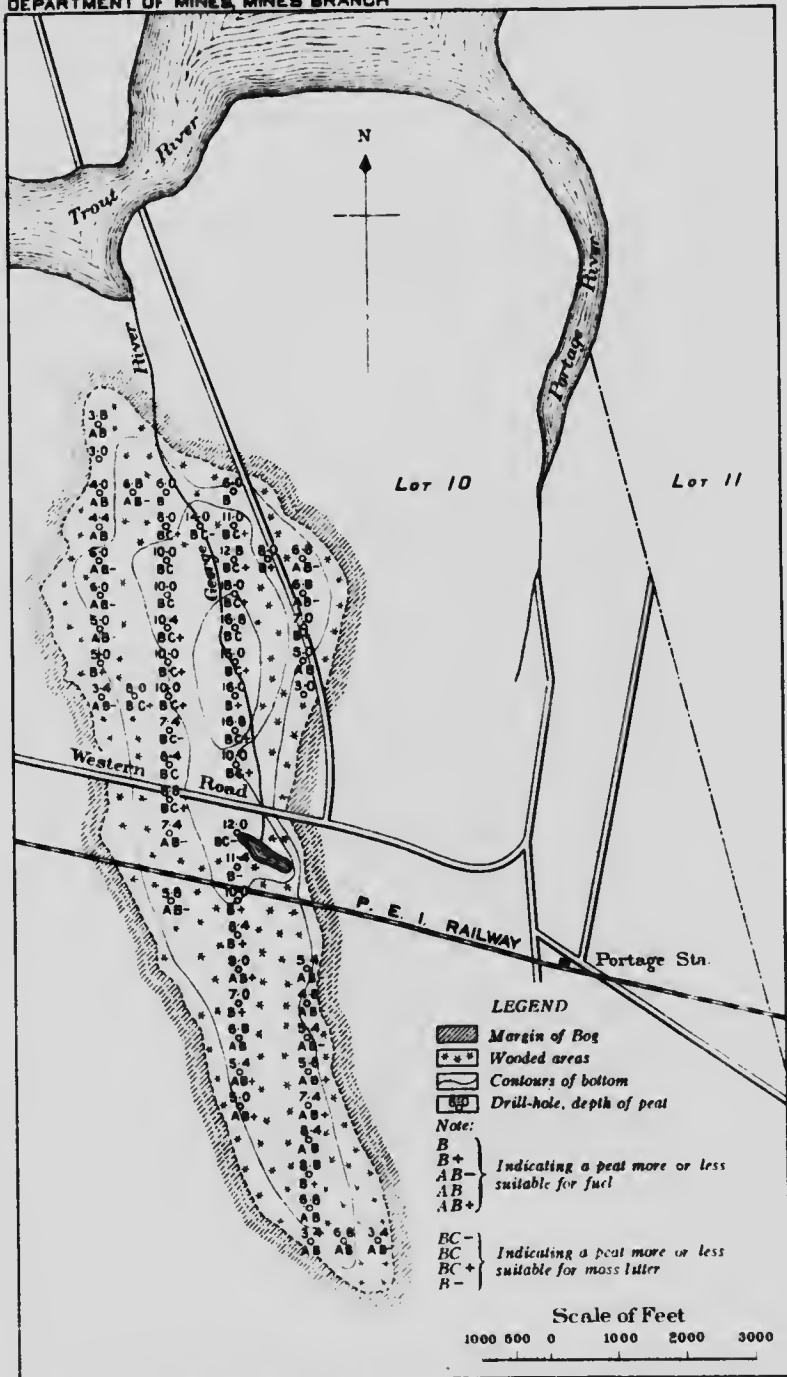

PORTAGE PEAT BOG, PRINCE COUNTY, PRINCE EDWARD ISLAND



PLATE VII.



Surface growth on the Black Marsh peat bog, Prince Edward Island:  
*Carex* and *erriophorum* dominating.

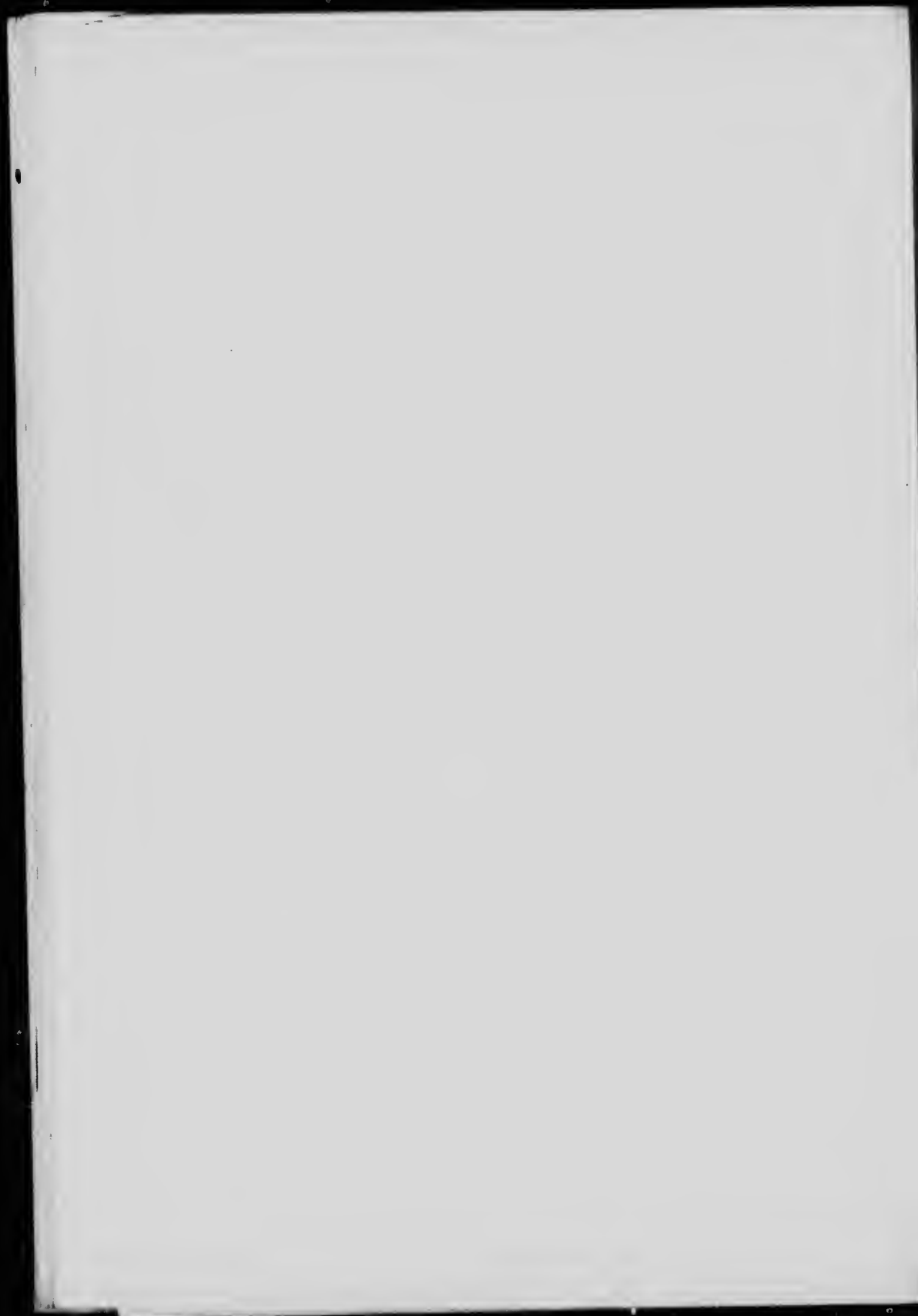

110 acres with an average depth of 9 feet,

38 " " " " " 14 "

With a total volume of, approximately, 2,460,000 cubic yards. Assuming that one cubic yard of such bog will furnish 120 pounds of dry peat substance, the total available tonnage of dry peat substance is, approximately, 147,000 tons (of 2,000 pounds) or 184,000 tons of peat litter containing 20 per cent moisture.

This part of the bog seemed to have a comparatively deep basin and, as the area is satisfactory, it is well suited for the erection of a plant for the production of peat litter. The peat is principally formed of sphagnum mosses, with the exception of the bottom layer, two feet thick, which is formed of aquatic and carex plants. Dwarfed spruce, in scattered clumps, are to be found on the surface of this part of the bog. In this portion there are no roots or trunks.

The bottom is compact red sand, and in some places rock was found.

#### *Analysis of Peat Litter.*

<sup>1</sup>Absorptive factor for moisture-free peat = 12.6; for peat with 25% water = 9.2.

#### B. PEAT FUEL.

The total area covered by this part of the bog is, approximately, 627 acres. Of this area:—

267 acres have a depth of less than 5 feet, with an average depth of 4 feet.

360 acres have a depth of more than 5 feet, with an average depth of 7 feet.

The volume of peat contained is, approximately:—

1,720,000 cub. yds. in an area with a depth of less than 5 feet.

4,069,000 " " " " " more " 5 "

The peat in this part of the bog is fairly well humified, and uniform quality can be obtained. By laying out the working field carefully, and with proper treatment and skilful labour, this part can be used for the manufacture of peat fuel on a small scale.

The surface of this part is grown over with young spruce, and the margin is encircled with alders, poplars, and heavy underbrush.

After the bog has been thoroughly drained, the peat will probably settle down about two feet. Allowing for the decrease in depth through drainage, we have:—

267 acres with an average depth of approximately, 2 feet.

360 " " " " " 5 "

having a total volume of 3,766,000 cubic yards.

<sup>1</sup> See Bulletin No. 9, page 39.

Assuming that one cubic yard of such drained bog will furnish 200 pounds of dry peat substance, the total available tonnage of dry peat substance will be, approximately, 377,000 tons (of 2,000 pounds) or, 502,000 tons containing 25% moisture.

This part of the bog is also principally formed of sphagnum intermixed with carex. It is fairly free from stumps and roots.

The whole bog is favourably situated as regards transportation and market, being traversed in the southern part by the Prince Edward Island railway, about 22 miles from Summerside.

### Miscouche Peat Bog.

This bog is situated about 1 mile from St. Nicholas station (see Map No. 372) and covers more or less of:—

Lot 16, Richmond township, Prince county.

" 17 " " " "

The total area covered is, approximately, 2,900 acres.

This bog contains two kinds of peat: peat litter and peat fuel, which are described separately as follows:—

#### PEAT LITTER.

This part of the bog is situated, practically, in the centre of the peat fuel bog, is almost circular in shape, and covers a total area, approximately, of 103 acres, with an average depth of 13 feet, and a total volume, approximately, of 2,160,000 cubic yards.

The peat in this portion of the bog is tinged with humus, but is not sufficiently humified to prevent it from being utilized as peat litter.

The upper layer of, from four to six feet, is practically free from humus, and a first-class peat litter may be obtained from it.

The bottom layers are more humified, and after the top layer is taken off, humified peat fuel can be taken out.

The surface of this portion of the bog is comparatively free from trees, and the peat free from roots and trunks.

The bottom of the bog is chiefly compact, red sand. Allowing 2 feet for the decrease in depth through drainage, we have left:—

103 acres with an average depth of 11 feet, and a total volume of 1,827,000 cubic yards of peat litter.

Calculating that one cubic yard of such drained bog will furnish about 120 pounds of dry peat substance, the total available tonnage of dry peat substance is, approximately, 109,000 tons (of 2,000 pounds) or 137,000 tons of peat litter with 20 per cent moisture.

The peat consists mainly of sphagnum mosses, with the exception of the bottom layers, in which typical aquatic and carex plants occur.

DEPARTMENT OF MINES, MINES BRANCH

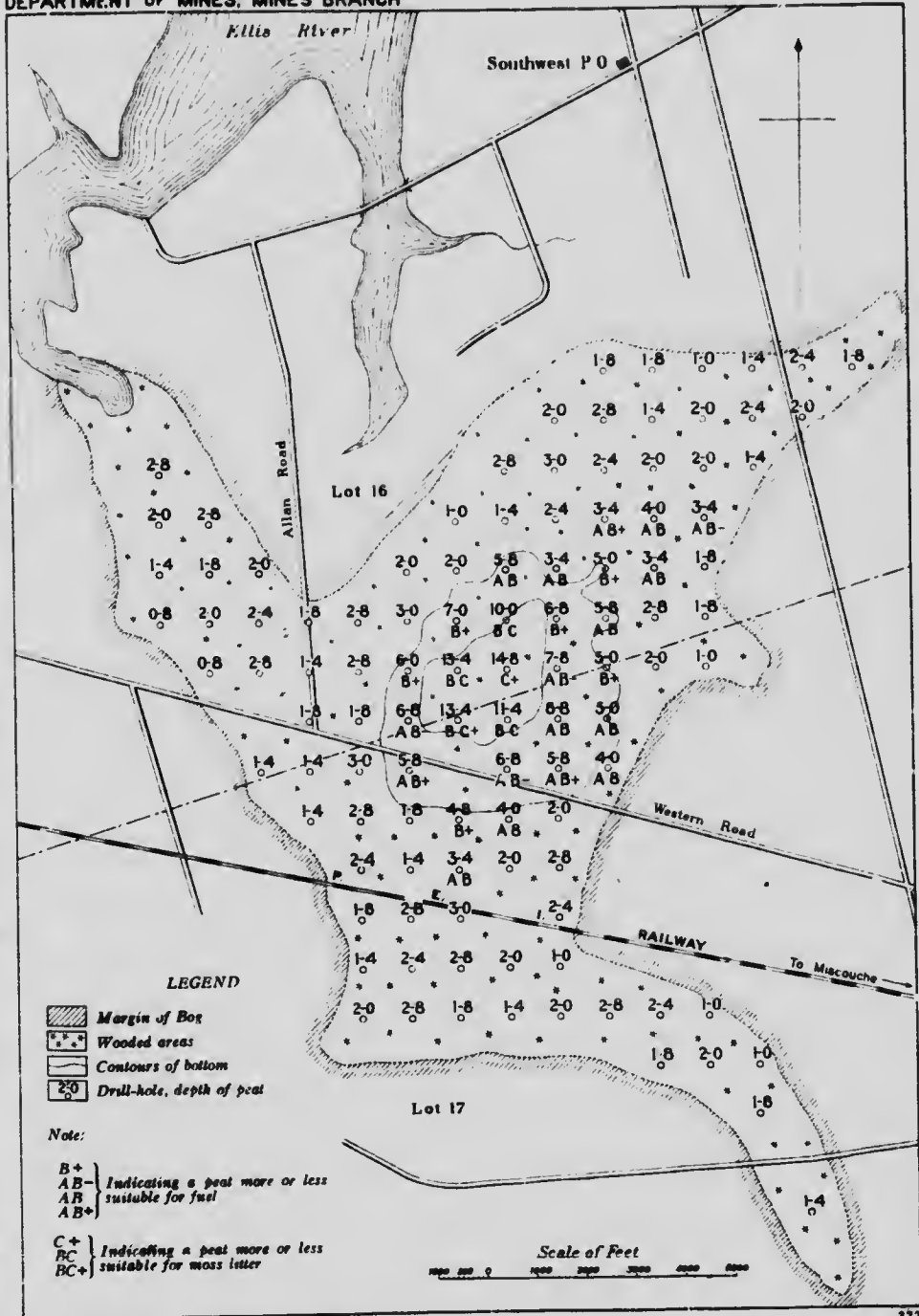

MISCOUCHE PEAT BOG, PRINCE COUNTY, PRINCE EDWARD ISLAND

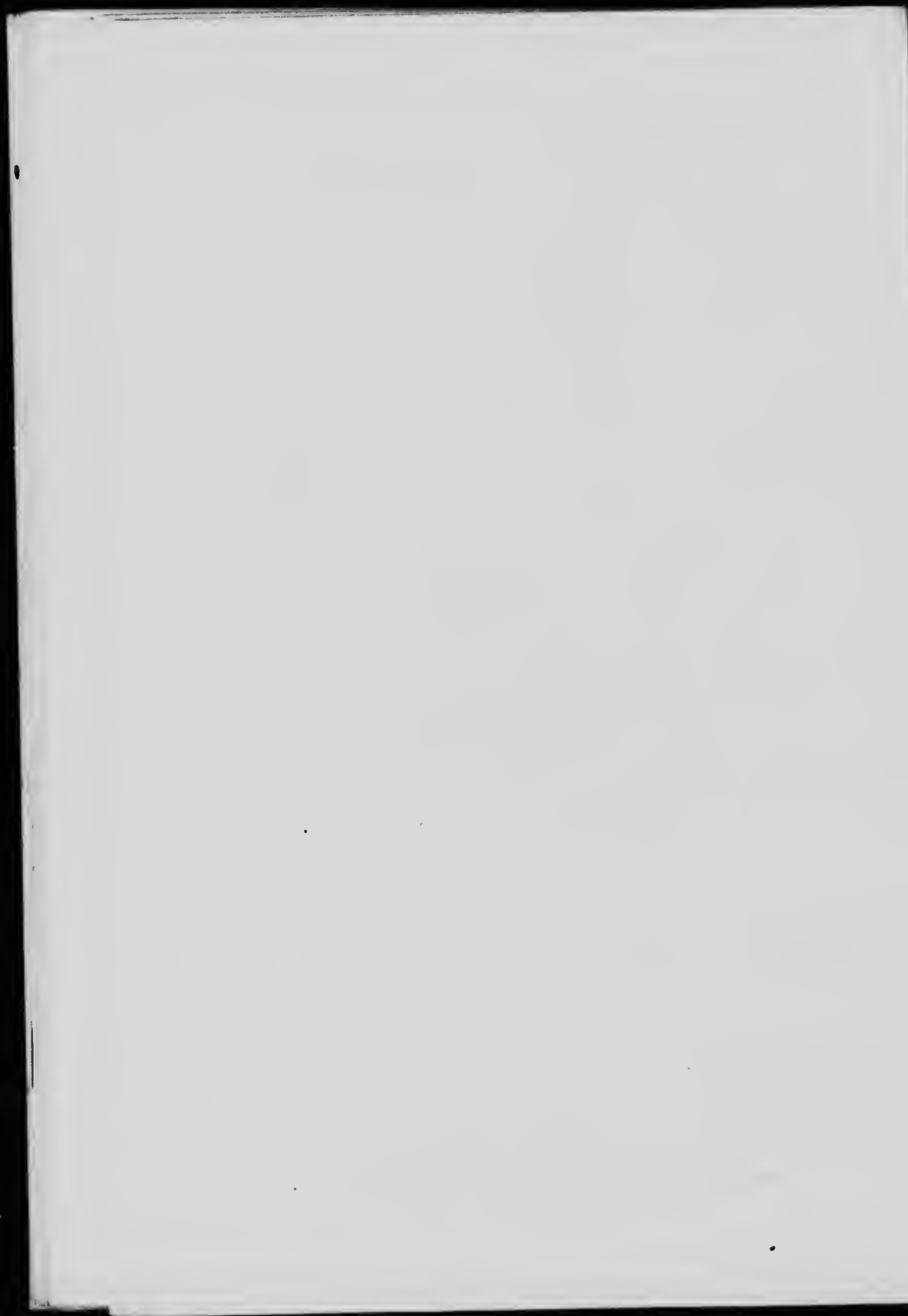



*Analysis of Peat Litter.*

<sup>1</sup>Absorptive factor for moisture-free peat = 15.6; for peat with 25% water = 11.5.

## PEAT FUEL.

The total area covered by this part of the bog is approximately 2,797 acres of which:—

2,411 acres have a depth of less than 5 feet, with an average depth of 2 feet.

386 acres have a depth of more than 5 feet, with an average depth of 7 feet.

The volume of peat contained is:—

In an area with depth less than 5 feet = 7,779,493 cub. yards.

" " " more " 5 " = 4,359,227 "

The peat in this part of the bog is well humified, and in the area of 386 acres the peat has a considerable depth. Hence by laying out the working field systematically, and using proper equipment, this part can be used for the manufacture of machine peat fuel by the air-drying process. Most of this portion is heavily wooded with young spruce and tamarack, and it is encircled around the margin with a heavy growth of alder and underbrush.

After the bog has been thoroughly drained, the peat will probably settle down 2 feet. Allowing for this decrease in depth through drainage we have:—

386 acres with an average depth of, approximately, 5 feet, having a total volume of, approximately, 3,110,000 cubic yards. Supposing that one cubic yard of such drained bog will furnish 2,000 pounds of dry peat substance, the total available tonnage of dry peat substance is, approximately, 311,000 tons (of 2,000 pounds) or 415,000 tons of peat fuel with 25 per cent moisture.

The deeper part of the bog is chiefly formed by sphagnum moss, slightly intermixed with eriophorum. The rest of the bog is heavily intermixed with carex, and there is evidence in the character of certain intermixed vegetable growths, that, at some time, this bog was affected by the tides.

<sup>1</sup> See Bulletin No. 9, page 39.

*Analyses of Peat.*

Sample	I		II	
	R	D	R	D
Moisture.....	9.9		10.6	
Ash.....	5.1	5.7	7.4	8.3
Volatile matter.....	56.6	62.8	56.1	62.7
Fixed carbon (by difference).....	28.4	31.5	25.9	29.0
Sulphur*.....	0.3	0.3	0.3	0.3
Nitrogen.....	1.2	1.3	1.3	1.4
Calorific value, in calories per gram, gross.....	4,780	5,310	4,620	5,170
"    "    in B.Th.U., per lb., gross.....	8,610	9,550	8,320	9,300
Fuel ratio, fixed carbon, volatile matter.....	0.50	0.50	0.46	0.46

\*Average of two samples from the bog.

Note.—Figures in column "R" refer to fuels as received, and in column "D" to fuel dried at 105°C. The analyses were made on fuel as received, and other results calculated therefrom.

The bog can be easily drained, and by doing so, considerable areas could be recovered and converted into valuable agricultural land.

The whole bog is favourably situated as regards transportation and market, since it is only 9 miles west of Summerside and the southern end is traversed by the Prince Edward Island railway.

### **Muddy Creek Peat Litter Bog.**

This bog is situated about 3 miles southwest of St. Nicholas station (see Map No. 373), and covers more or less of

Lot 17, Richmond township, Prince county.

The total area covered by this bog is about 61 acres, with an average depth of 3 feet, containing 347,000 cubic yards of peat litter.

As can be seen from the above, this bog is not suitable for manufacturing peat litter on a commercial scale; but farmers could cut it by hand and utilize it for stabling purposes and for sanitary conditions in closets. By taking off the upper two feet, and draining the rest, this area would be suitable for agricultural purposes.

### **Mount Stewart Peat Bog.**

This bog, which is situated on lot 35, about 1 mile south of Mount Stewart village, is mainly composed of carex, and most of the year is flooded. It is very shallow and at present marsh grass is cut on it.

If properly drained and dyked from the high tides, it could be converted into valuable agricultural land.

It is not suitable for the manufacture of any kind of machine peat.

### **Black Banks Peat Litter Bogs.**

These bogs are situated about 7 miles north of Conway, Intercolonial railway, and about 5 miles south of Alberton, Prince Edward Island, by

Muddy Creek

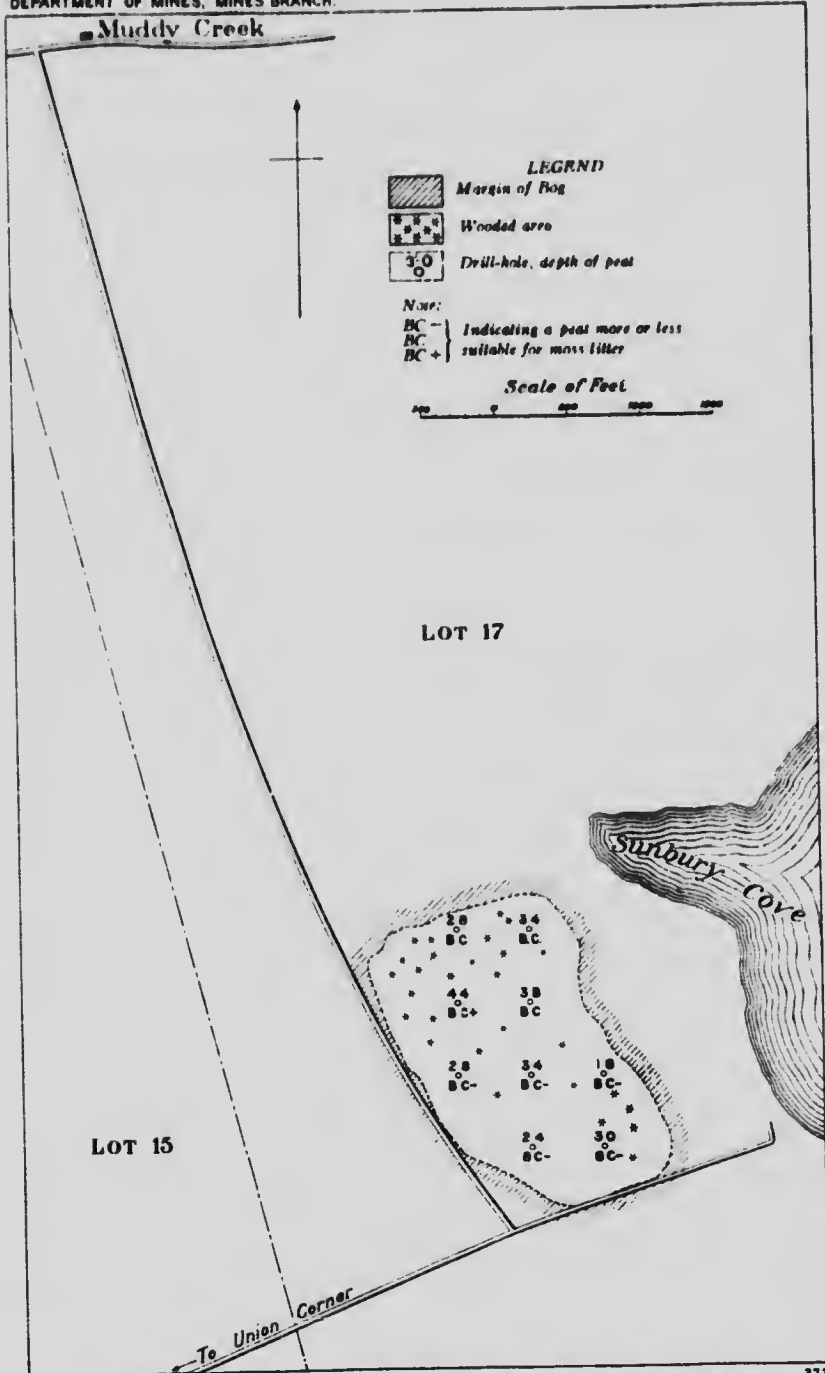

MUDDY CREEK PEAT LITTER BOG, PRINCE COUNTY, PRINCE EDWARD ISLAND

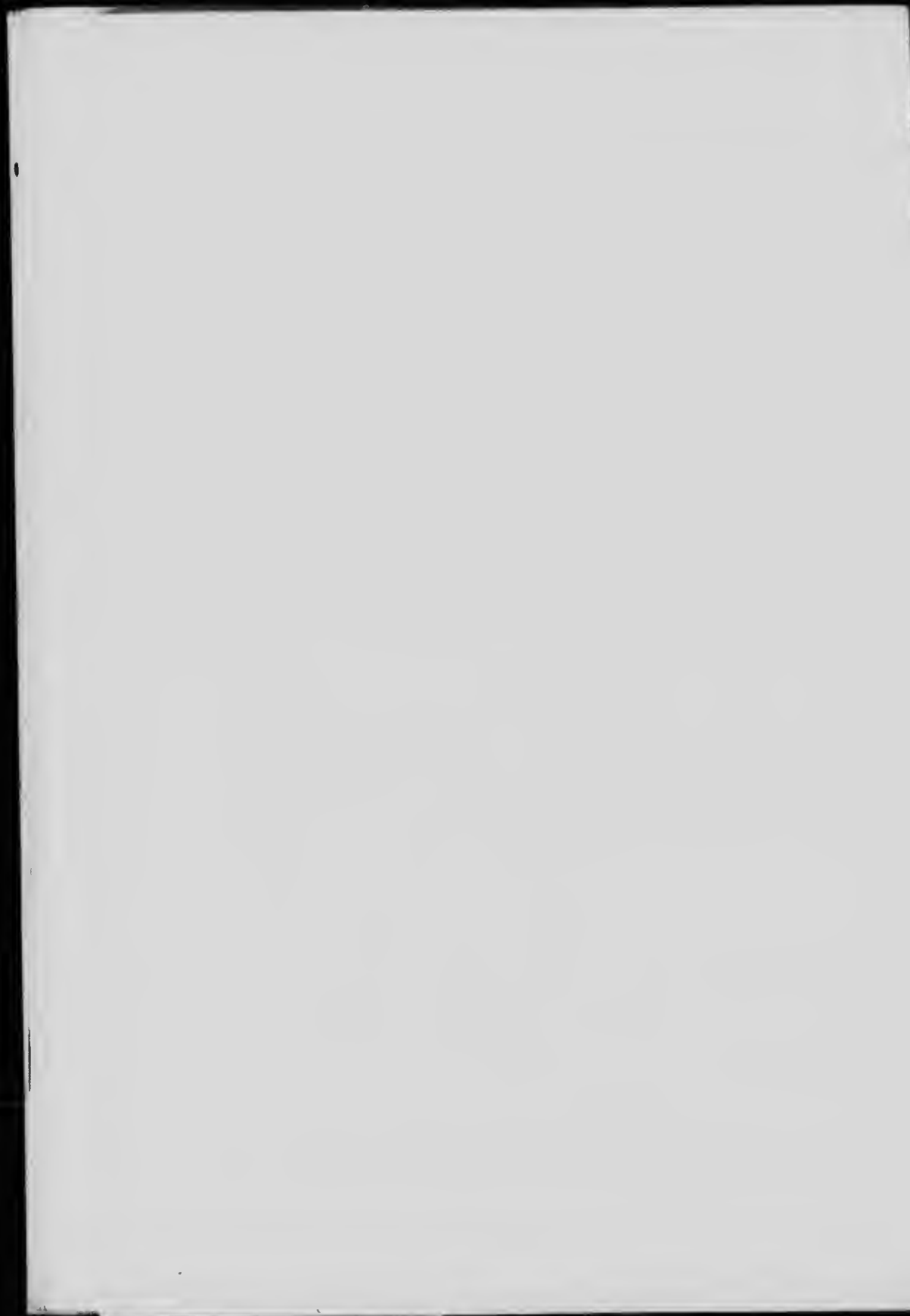

water across the Casumpeque bay (see Map No. 374) and cover more or less of the northern part of lot 11, Halifax township, Prince county.

The total area covered by these bogs is approximately 884 acres. Of this area, 60 acres which are situated in the southern part of the western bog represent fairly good peat fuel, but as the area is very small the peat cannot be commercially utilized as fuel by the methods now in use. Of the total area:—

- 255 acres have a depth of less than 5 feet, with an average depth of 3 feet.
- 179 acres have a depth of from 5-10 feet, with an average depth of 8 feet.
- 215 acres have a depth of from 10-15 feet, with an average depth of 13 feet.
- 209 acres have a depth of from 15-20 feet, with an average depth of 17 feet.
- 26 acres have a depth of more than 20 feet, with an average depth of 20 feet.

The volume of the peat contained is, approximately:—

1,230,000	cubic yards	in an area	with depth	of less than	5 feet,
2,306,000	"	"	"	"	from 5 to 10 feet,
4,509,000	"	"	"	"	from 10 to 15 feet,
5,509,000	"	"	"	"	from 15 to 20 feet,
859,000	"	"	"	"	more than 20 feet.

The peat in these two bogs, with the exception of the 60 acres which are situated in the southern part of the west bog, is not humified, and will produce a very good peat litter.

The upper layers of the above mentioned parts of the bog are comparatively free from humus, hence a first-class litter may be obtained therefrom. The bottom layer of the peat is heavily intermixed with trunks and roots. This was discovered during the drilling along the shores, where a perpendicular section sometimes of more than 10 feet can be seen. (See Plate VIII.)

The peat is formed principally of sphagnum and fuscum. Certain plants are intermixed with the sphagnum.

The bottom layer, as well as around the margin of the west and the north end of the western bog, is composed mainly of carex plants intermixed with hypnum. This part of the bog has several ponds which have a depth of 18 to 22 feet. The surface of some of these is practically grown over with sphagnum, (peat moss) which practically floats on the surface. Plate IX shows a floating sphagnum island, which in a short time will cover the pond entirely.

Eriophorum and aquatic plants were very scarce, and were noticed only rarely at the north end in the western bog.

Allowing for the decrease in depth through drainage we have:—  
179 acres with an average depth of 6 feet, approximately,

215	"	"	"	11	"	"
209	"	"	"	15	"	"
26	"	"	"	18	"	"

with a total volume of, approximately, 11,180,000 cubic yards of peat litter.

Calculating that one cubic yard of such bog will furnish about 120 pounds of dry peat substance, the total tonnage of dry peat litter substance available is, approximately, 670,000 tons (of 2,000 pounds) or 838,000 tons of peat litter with 20 per cent moisture.

The surface of the bog is comparatively free from trees, except around the margin on the northern, western, and southern parts of the west bog. These parts of the bog are partly wooded with young tamarack and spruce, and near the margin with cedar and alder.

The sand banks which rise from the sea at a distance of about 2 miles east from the bog, were at one time connected together, forming a continuous chain, which prevented the sea from flooding the land as it does now. The bog at that time was much larger, covering practically the whole western part of Cascumpeque bay. At the present time the bog is being rapidly wasted away, and it will not be long before the remaining parts of the bog—which above, are described as the East and West bog—will be completely effaced.

#### *Analysis of peat litter.*

Successive layers each one metre (39 inches) thick	Surface layer	2nd layer	3rd layer
Ash in moisture-free peat %.....	2.7	3.7	4.4
Absorptive factor for moisture-free peat.....	15.2	17.4	16.0
<sup>1</sup> Absorptive factor for peat with 25% water.....	11.1	12.9	11.8

#### **Mermaid Peat Bog.**

This bog is situated in the township of Bedford in Queens county about 5 miles northeast of Charlottetown, Prince Edward Island, and 2 miles from Mount Herbert station, Intercolonial railway. It covers more or less of the west corner of lot 48, Bedford township, Queens county. (See Map No. 375).

The total area covered by this bog is, approximately, 186 acres. Of this area:—

84 acres have a depth of less than 5 feet, with an average depth of 3 feet.

<sup>1</sup> See Bulletin No. 9, page 39.

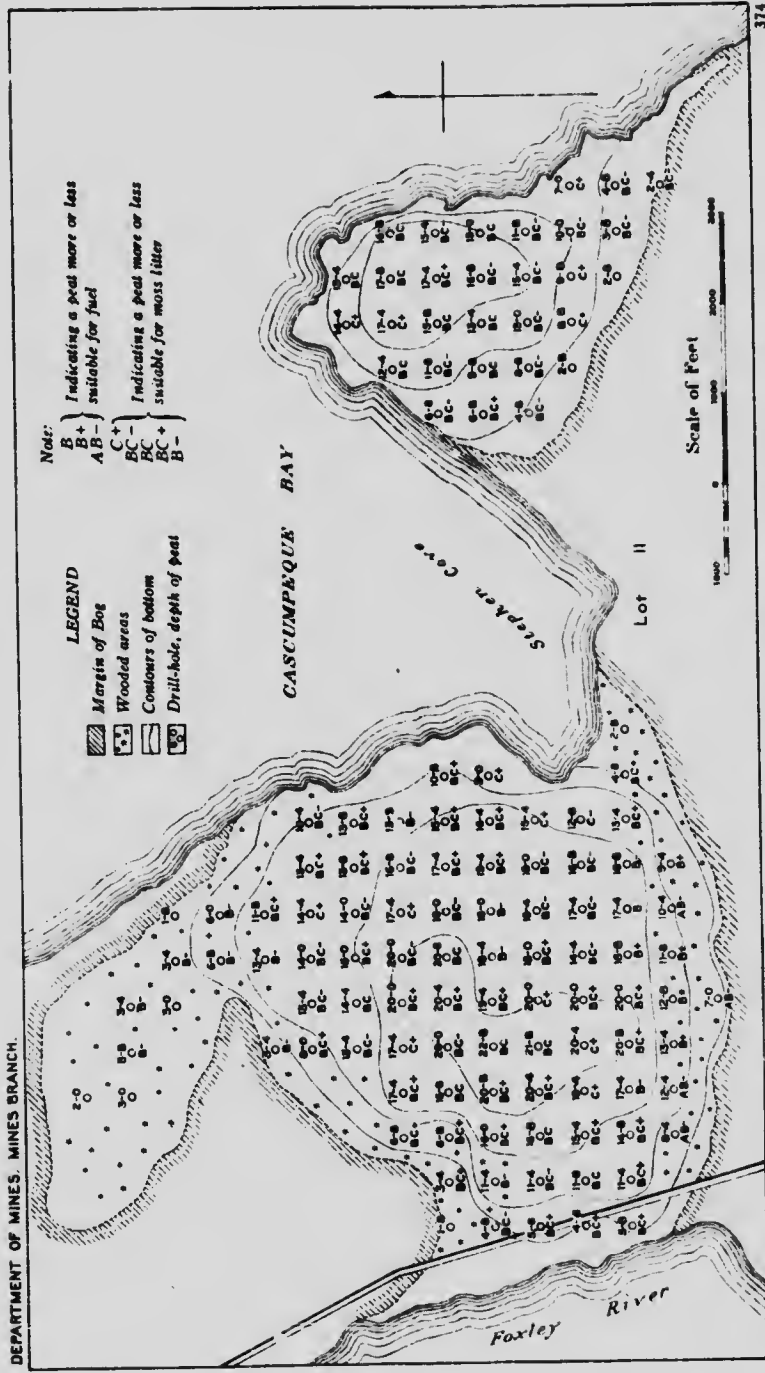





THE BLACK BANKS PEAT BOG, PRINCE EDWARD COUNTY, PRINCE EDWARD ISLAND

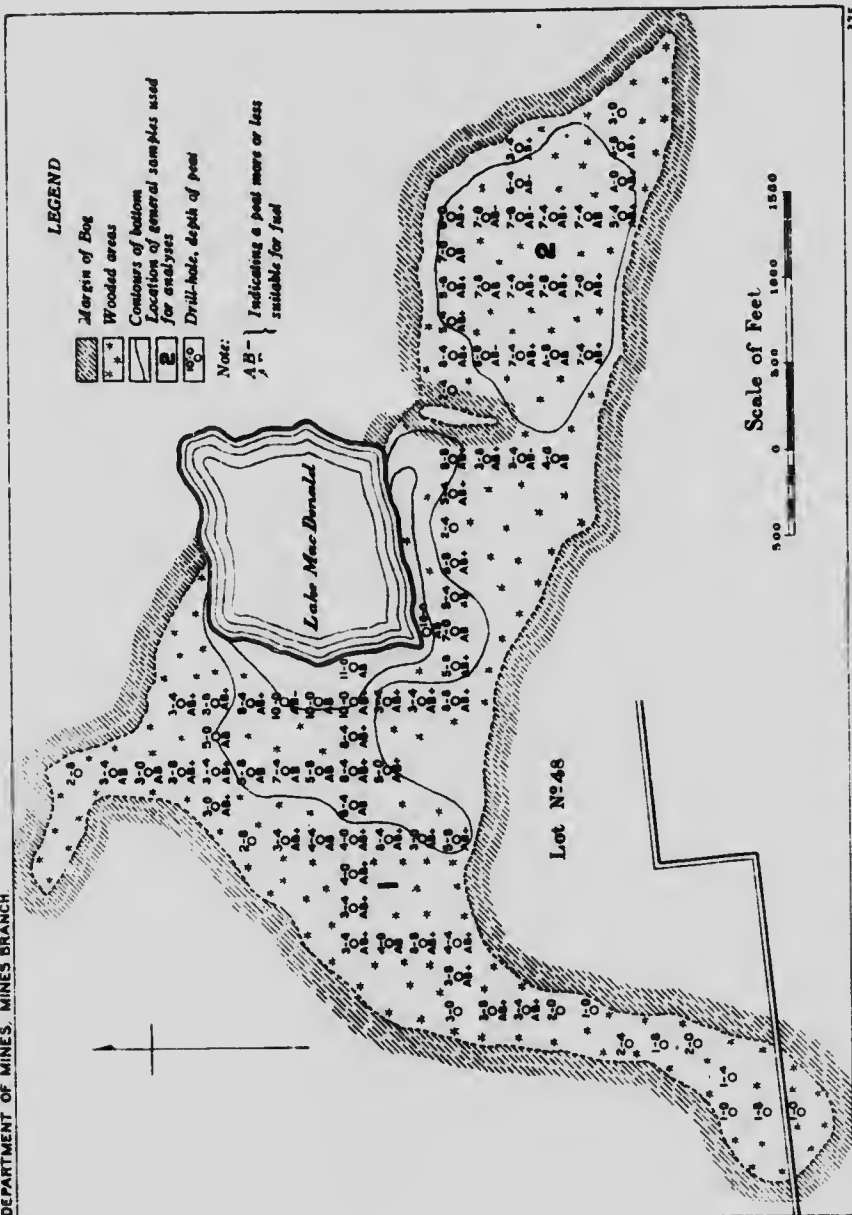





**LEGEND**

-  Margin of Bog
-  Wooded areas
-  Contours of bottom
-  Location of general samples used for analyses
-  Drill-hole, depth of peat

Note:  
 AB - } Indicating a peat more or less  
 suitable for fuel



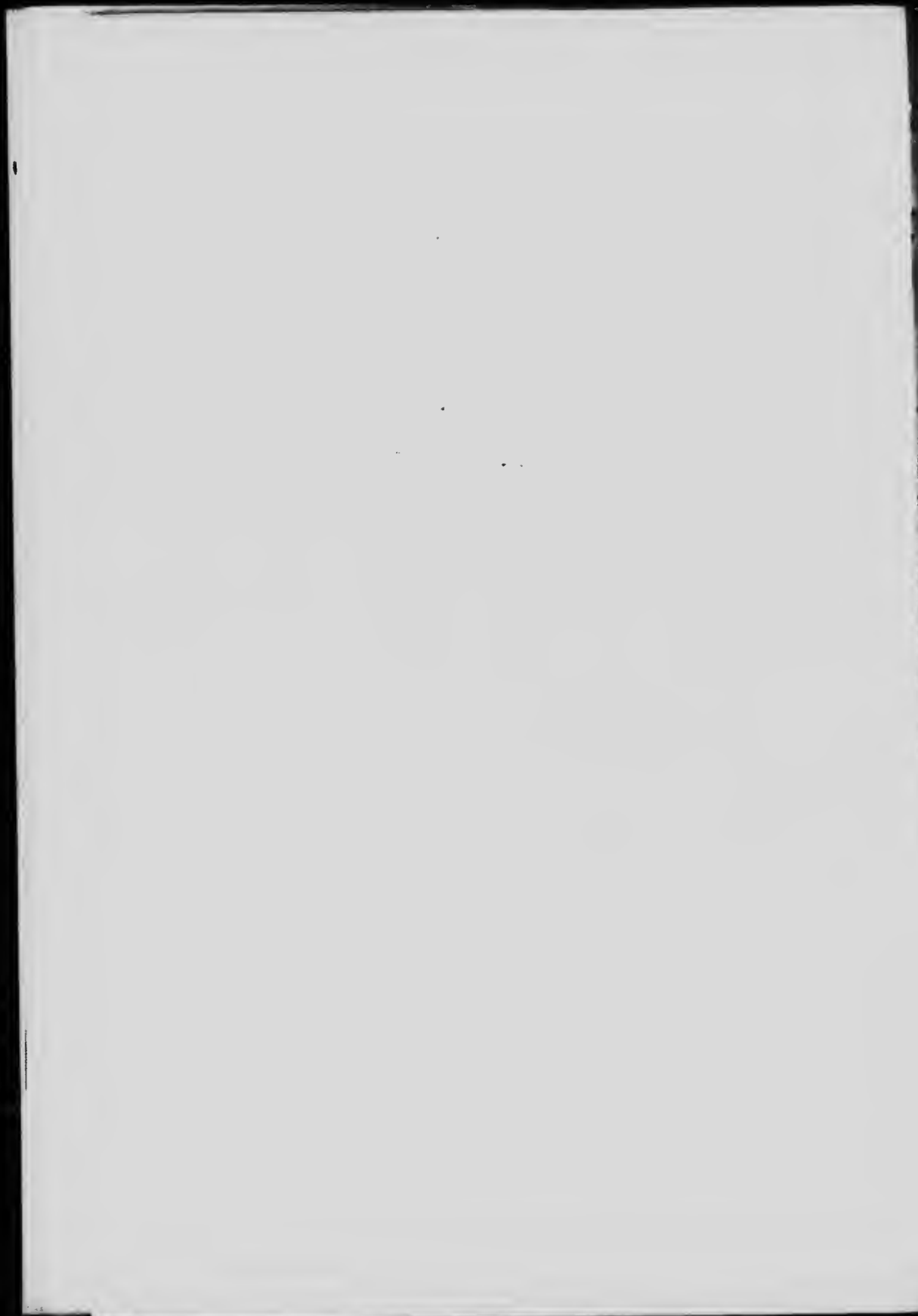

PLATE VIII.



*Photo taken by Mr. D. W. Johnson.*

The Black Banks peat bog, Prince Edward Island: low tide. Showing the abrupt elevation of peat bog. The ragged edge is due to the high tides, which wash in onto the bog.



PLATE IX.



Black Banks peat bog: showing the floating sphagnum island, Prince Edward Island.





The northeastern part of the bog runs into Lake Macdonald, which, in the centre, has a depth of 18 to 20 feet. By sinking the drill it was found that the bog followed the bottom quite a distance into the lake. If this lake is left undisturbed, the water-loving flora will spread continuously and eventually cover up the lake by growth from the bottom, and thus form a compact surface on which softwood trees and bushes will spring up. This form of development can be seen on Plate XI.



PLATE X.

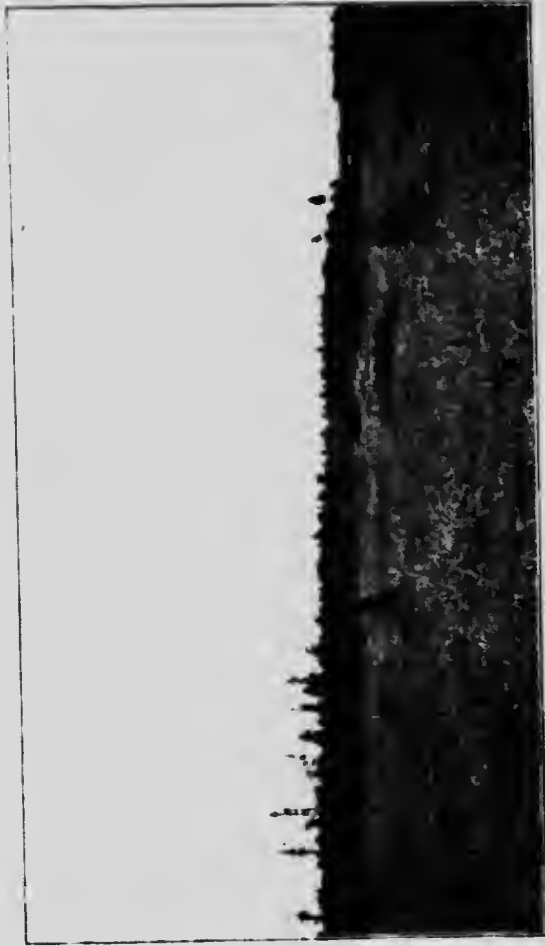

Surface growth on Mermaid peat bog, Prince Edward Island.



PLATE XI.



Lake Macdonald, Mermaid peat bog,  
Prince Edward Island.

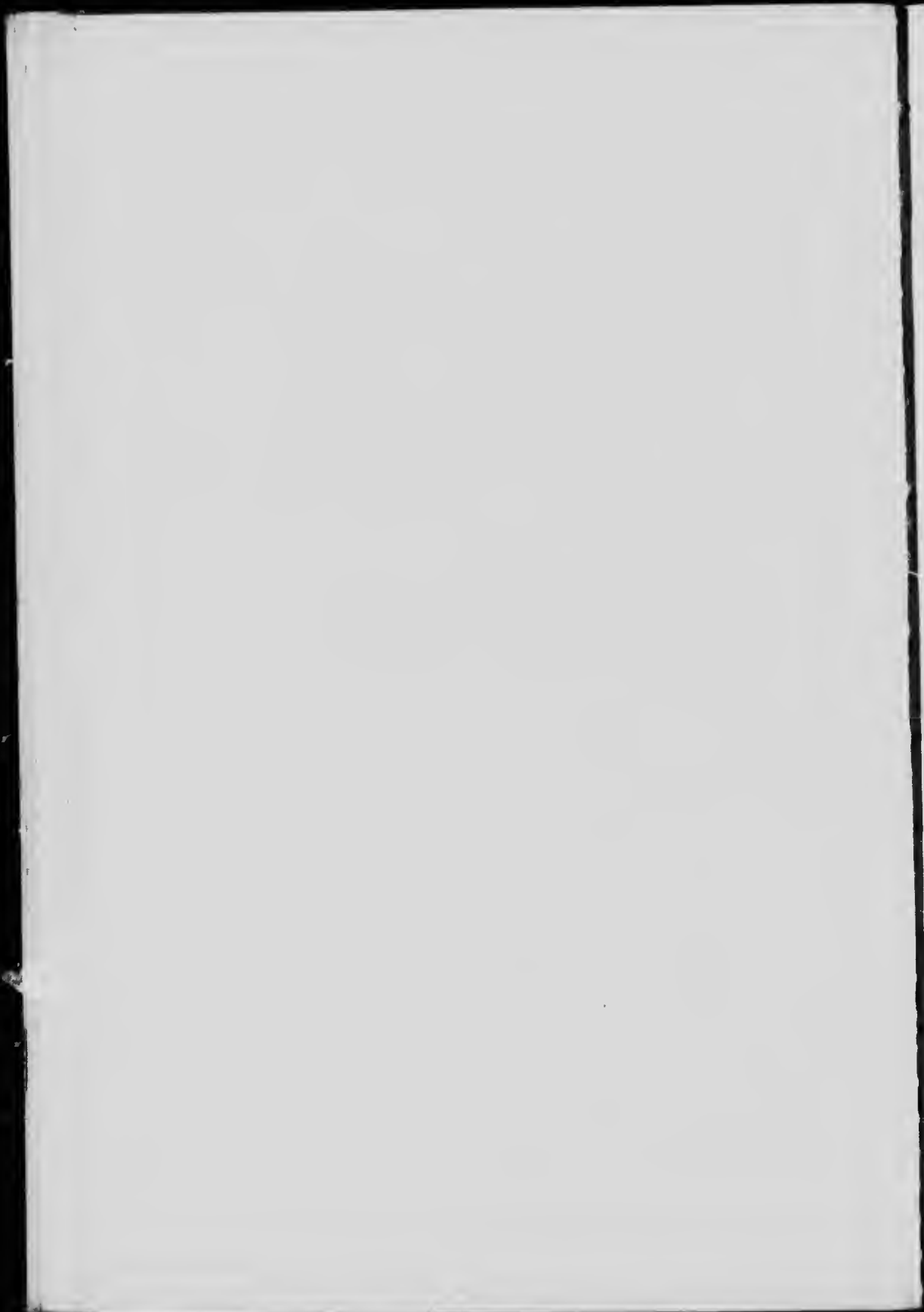

TABLE V.  
**Peat Bogs Investigated in the Province of Nova Scotia.**

(See Map No. 469.)

Name of peat bog	Locality		Approx. total area, acres	Volume of workable peat.					Approx. area of peat litter bog	REMARKS
	County			Cub. yds. of peat fuel	Tons of fuel with contents 25% moisture	Cub. yds. of peat litter	Tons of litter with contents 20% moisture			
Caribou.....	Kings.....		887	1,960,000	262,000	5,815,000	349,000	200	Prime, formed of sphagnum and remains of eriophorum.	
Cherryfield.....	Lunenburg.....		160	2,240,000	299,000				Prime, formed of sphagnum and remains of carex and eriophorum.	
Tusket.....	Yarmouth.....		235	1,936,000	258,000				Prime, formed of sphagnum and remains of carex.	
Makoko.....	Yarmouth.....		460	3,560,000	475,000				Prime, formed of sphagnum and remains of carex.	
Heath.....	Yarmouth.....		2,174	12,350,000	1,646,000	1,384,000	104,000	150	Prime, formed of eriophorum and remains of sphagnum and carex.	
Port Clyde.....	Shelburne.....		1,666	7,560,000	1,021,000				Prime, formed of sphagnum and remains of eriophorum and carex.	
Latour.....	Shelburne.....		849	5,660,000	755,000				Prime, formed of sphagnum and remains of carex.	
Clyde.....	Shelburne.....		2,240	11,595,000	2,127,000				Prime, formed of sphagnum and remains of carex and eriophorum.	

## NOVA SCOTIA.

**Caribou Peat Bog.**

This bog is situated about a mile and a half west from Berwick station, on the line of the Dominion Atlantic railway, about 2 miles west by the Post road (see Map No. 376), and is located in the northwest portion of Kings county.

The total area covered by the bog is, approximately, 887 acres.

This bog contains two kinds of peat, namely peat litter and peat fuel, which are described separately as follows:—

## PEAT LITTER.

This part of the bog occupies the centre of the whole area, and consists of, approximately, 200 acres. Of this area:—

90 acres have a depth of more than 15 feet, with an average depth of 16 feet.

75 acres have a depth of more than 20 feet, with an average depth of 22 feet.

35 acres have a depth of more than 25 feet, with an average depth of 26 feet.

The volume of peat contained is, approximately:—

In an area with a depth of more than 15 feet. 2,320,000 cub. yds.

" " " " 20 " 2,670,000 "

" " " " 25 " 1,427,000 "

The peat in this part of the bog, especially that part bounded by the Caribou lake, as shown on the map, is not humified, and will produce high-grade peat litter.

The upper layers, of from six to eight feet, are comparatively free from humus, and will produce first class peat litter.

The central portion of the litter area, as can be seen on map No. 376, has a considerable depth, and it would appear that part of the bog consists of a deep basin. This is not the case, however, as the depth at that particular point is given by the upward growth of sphagnum plants, thus forming a convex surface, which represents a high moor. (Hoch Moor).

Allowing 2 feet decrease in depth due to drainage we have:—

90 acres with an average depth of 14 feet—2,032,000 cubic yards, approximately.

75 acres with an average depth of 20 feet—2,427,000 cubic yards, approximately.



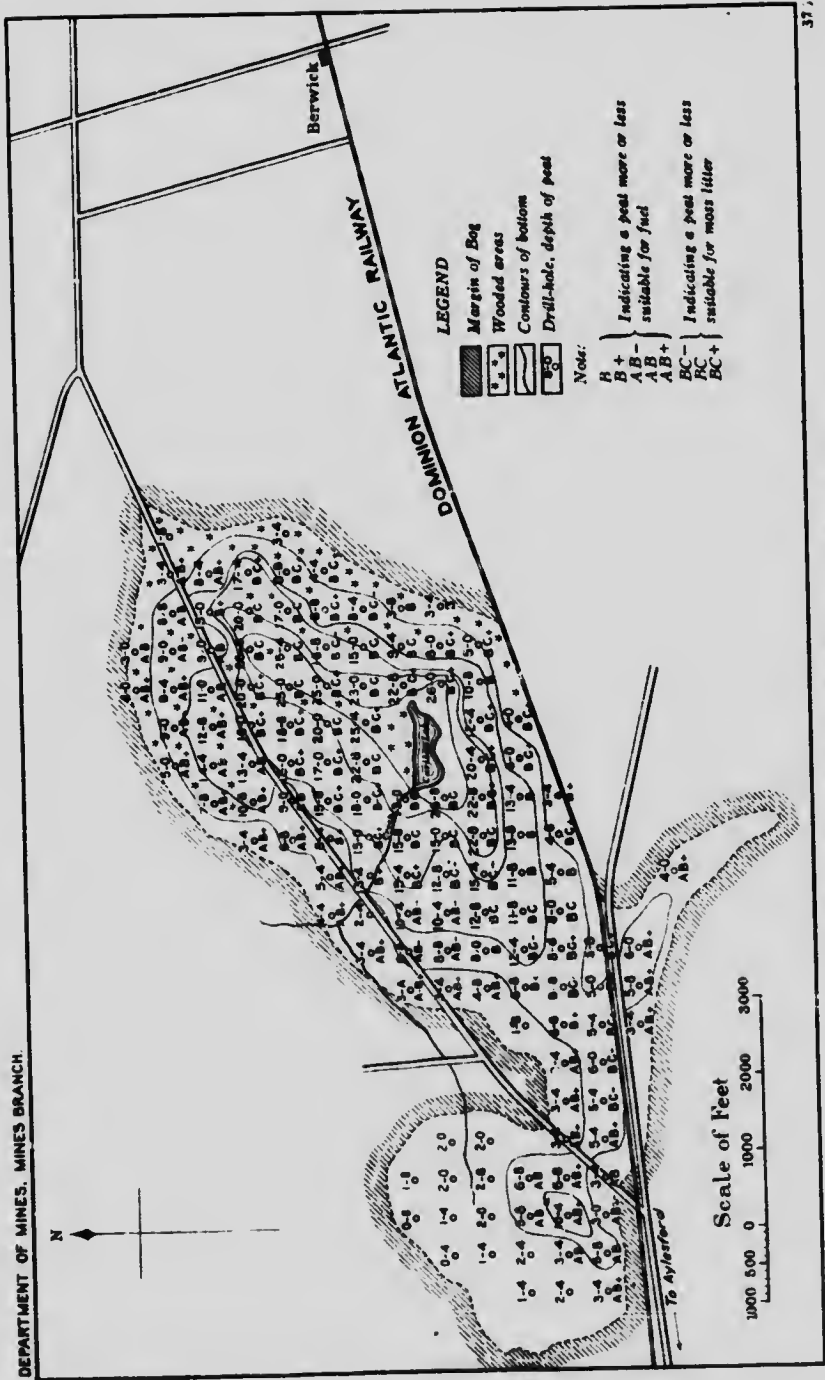

35 acres with an average depth of 24 feet—1,355,000 cubic yards, approximately.

with a total volume of 5,815,000 cubic yards of peat litter.

Calculating that one cubic yard of such drained bog will produce 120 pounds of dry peat substance, the total available tonnage of dry peat



LEGEND

-  Margin of Bog
-  Wooded areas
-  Contours of bottom
-  Drill-hole, depth of peat

Notes:

- A
  - B +
  - AB -
  - AB +
  - AB +
- Indicating a peat more or less suitable for fuel
- BC -
  - BC
  - BC +
- Indicating a peat more or less suitable for moss litter

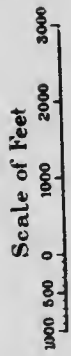

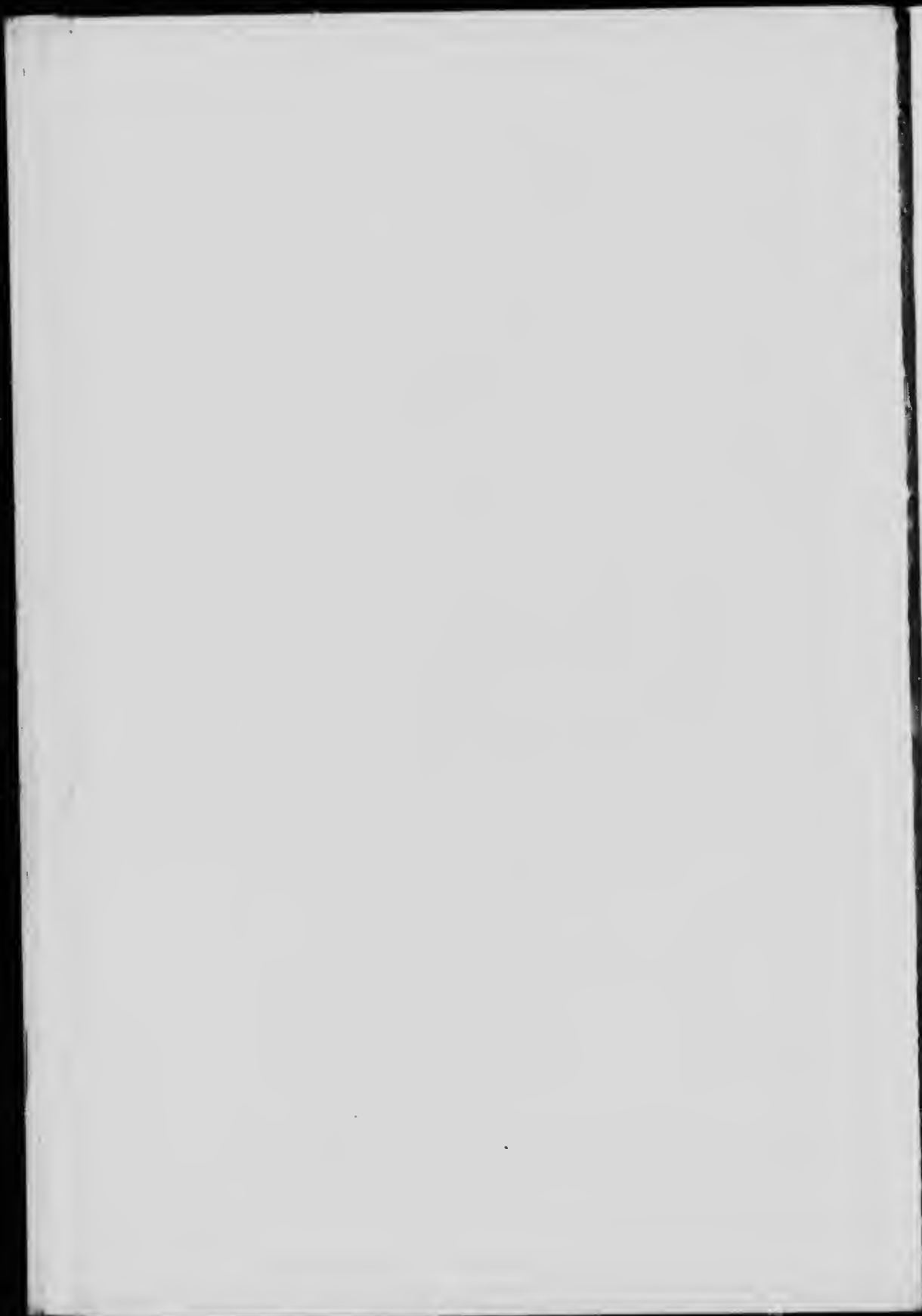



substance is, approximately, 349,000 tons (of 2,000 pounds) or 436,155 tons of peat litter 20 per cent moisture.

This peat is principally formed by sphagnum mosses, with the exception of the bottom layers in which eriophorum and carex plants are strongly in evidence.

The surface is partly wooded with dwarf spruce and tamarack.

The body of the bog is free from roots and trunks, and the bottom is chiefly compact sand, but in some cases a thin layer of composite clay is found.

Inasmuch as this peat bog has all the advantages of high grade peat litter, as described above, and is situated in a great fruit producing country, it would be of great advantage to erect thereon a peat litter plant of modern type. This should be, at once, a feasible and beneficial undertaking, as there would be an open market for fertilizer and packing substances.

#### *Analysis of Peat Litter.*

Absorptive factor for moisture-free peat .....	13.6
" " for peat with 25% water.....	9.9
The absorption capacity is about satisfactory.	

#### PEATFUEL.

The total area covered by this part of the bog is about 687 acres, of which:—

342 acres have a depth of less than 5 feet, with an average depth of 3 feet.

21<sup>5</sup> acres have a depth of more than 5 feet, with an average depth of 7 feet.

130 acres have a depth of more than 10 feet, with an average depth of 12 feet.

The volume of peat contained is, approximately:—

In an area with depth less than 5 feet, 1,666,000 cub. yards.

" " " more " 5 " 2,456,000 "

" " " " 10 " 250,000 "

The peat in this portion of the bog is well humified, and fairly uniform in quality. By laying out the working lines carefully, and by proper treatment, this part can be advantageously used for the manufacture of peat fuel.

In the northern part of the bog, the surface is heavily overgrown with young spruce and tamarack.

After the bog has been thoroughly drained, it will probably, settle down about two feet; and omitting the area having a depth of less than 5 feet, we have:—

215 acres with an average depth of, approximately, 5 feet.

130 " " " " " 10 "

giving a total volume of, approximately, 1,960,000 cubic yards of peat fuel.

<sup>5</sup> See Bulletin No 9, page 39.

Assuming that one cubic yard of such drained bog will furnish 200 pounds of dry peat substance, the total tonnage of dry peat substance is, approximately, 196,000 tons (of 2,000 pounds) or 262,000 tons of peat fuel 25 per cent moisture.

This part of the bog is principally formed of sphagnum mosses, and in certain parts is strongly intermixed with eriophorum. In the shallow parts different varieties of carex and aquatic plants can be noticed. When drilling for samples, roots and trunks were rarely encountered.

*Analyses of Peat.*

Sample	I		II		III		IV	
	R	D	R	D	R	D	R	D
Moisture.....%	8.8		8.7		8.9		8.3	
Ash.....%	7.0	7.7	4.0	4.4	2.7	2.9	1.8	2.0
Volatile matter.....%	57.1	62.6	59.1	64.7	60.7	66.7	61.9	67.5
Fixed carbon (by difference).....%	27.1	29.7	28.2	30.9	27.7	30.4	28.0	30.5
Sulphur*.....%	0.3	0.4	0.3	0.4	0.3	0.4	0.3	0.4
Nitrogen.....%	1.5	1.6	1.1	1.2	0.9	1.0	0.9	0.9
Calorific value, in calories, per gram, gross.....	4,960	5,440	4,940	5,410	4,840	5,310	4,880	5,320
Calorific value, in B.Th.U. per lb., gross.....	8,920	9,790	8,890	9,740	8,700	9,550	8,790	9,580
Fuel ratio, fixed carbon, volatile matter.....	0.47	0.47	0.48	0.48	0.46	0.46	0.45	0.45

\* Average of four samples from the bog.

Note.—Figures in column "R" refer to fuel as received, and in column "D" to fuel dried at 105°C. The analyses were made on the fuel as received, and other results calculated therefrom.

As can be seen the content of ash is comparatively low, and the calorific value satisfactory.

The whole bog is favourably situated as regards transportation and market, being traversed, at the southern end, by the Dominion Atlantic railway. This part of the country is thickly populated and as the prices for domestic fuel are as follows:—

Soft coal from \$6.00 to \$ 7.00 per ton, depending on the season.

Hard " " 8.00 to 10.00 " " " " "

Hardwood " 5.00 to 6.00 " cord, " " "

it can be seen that peat fuel could be favourably placed upon the market. By producing peat litter in the winter and manufacturing peat fuel in the summer, employment could be found for labourers the year round.

### Cherryfield Peat Bog.

This bog is situated about half a mile southeast of Cherryfield station, Lunenburg county, Nova Scotia. (See Map No. 377).

The total area is, approximately, 160 acres. Of this area:—

27 acres have a depth of less than 5 feet, with an average depth of 3 feet.

46 acres have a depth of more than 5 feet, with an average depth of 7 feet.

30 acres have a depth of more than 10 feet, with an average depth of 12 feet.

52 acres have a depth of more than 15 feet, with an average depth of 17 feet.

5 acres have a depth of more than 20 feet, with an average depth of 20 feet.

The volume of peat contained is, approximately:—

131,000	cub. yds.	in an area with a depth of less than	5 feet.
515,000	"	"	more " 5 "
590,000	"	"	" " 10 "
1,420,000	"	"	" " 15 "
140,000	"	"	" " 20 "

The peat in this bog is well humified, uniform in quality, and possesses high cohesive properties.

By laying out the working field systematically, and with great consideration, this bog can be utilized for the manufacture of machine peat on a small scale. But as it is situated a long distance from any suitable market, it would not be advisable, under present conditions, to erect a peat fuel plant.

The peat is composed mainly of sphagnum mosses, lightly intermixed with eriophorum, and, following the shores of the creek, varieties of carex plants can be found.

After the bog has been thoroughly drained it will settle down about 2 feet.

Allowing for the decrease in depth due to drainage, and omitting the 27 acres with a depth of less than 5 feet, we have:—

46	acres	with an average depth of, approximately,	5 feet.
30	"	"	" " 10 "
52	"	"	" " 15 "
5	"	"	" " 18 "

having a total volume of, approximately, 2,240,000 cubic yards.

Allowing that one cubic yard of the drained bog produces 200 pounds of dry peat substance, the total available tonnage of dry peat substance is 224,350 tons (of 2,000 pounds) or 299,000 tons with 25 per cent moisture.



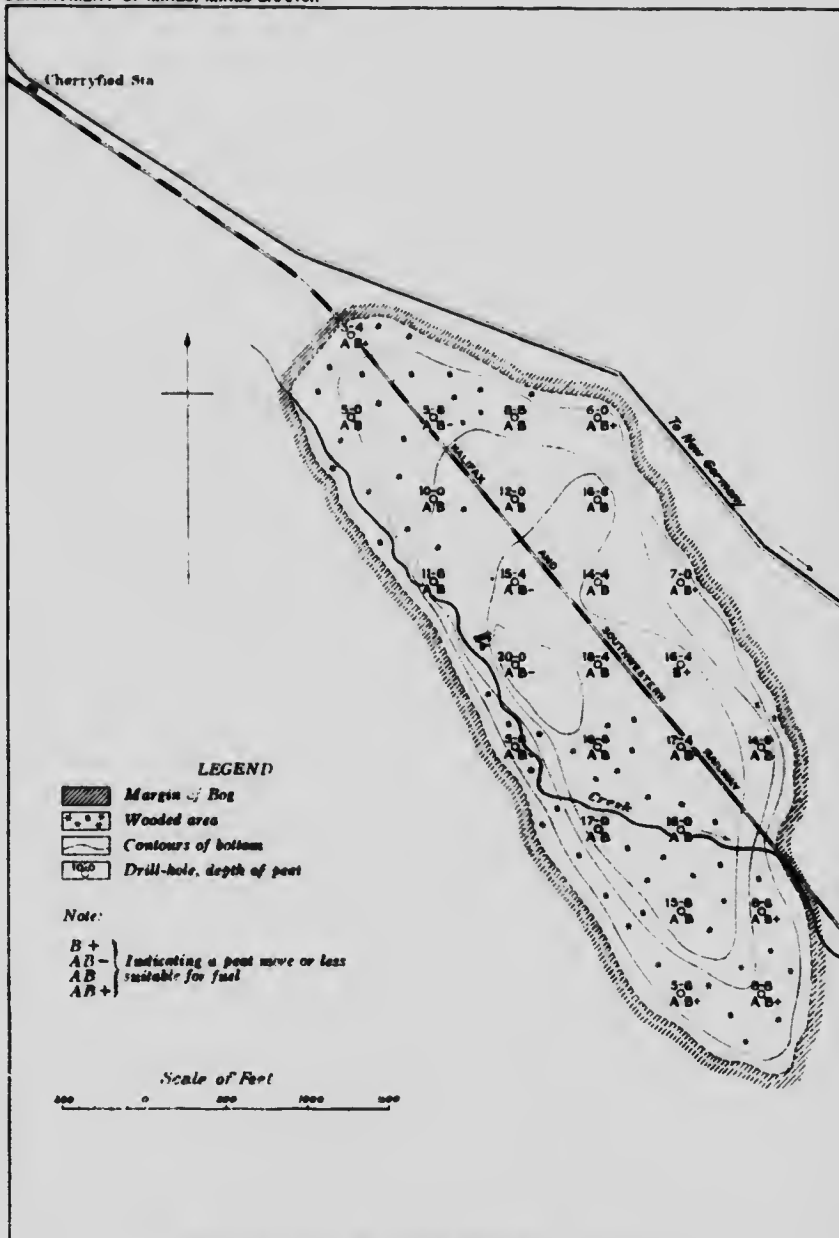

CHERRYFIELD PEAT BOG, LUNenburg COUNTY, NOVA SCOTIA

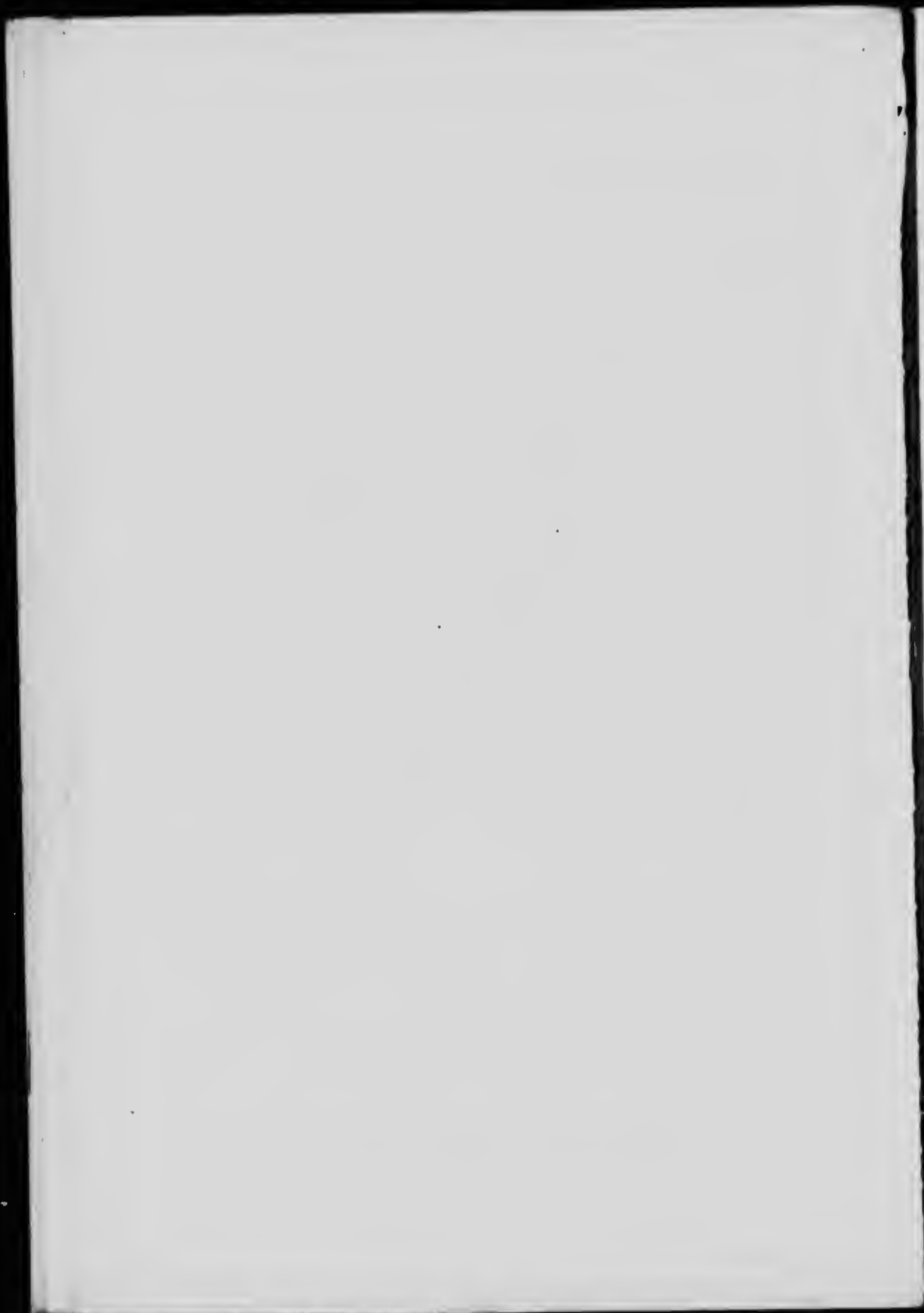

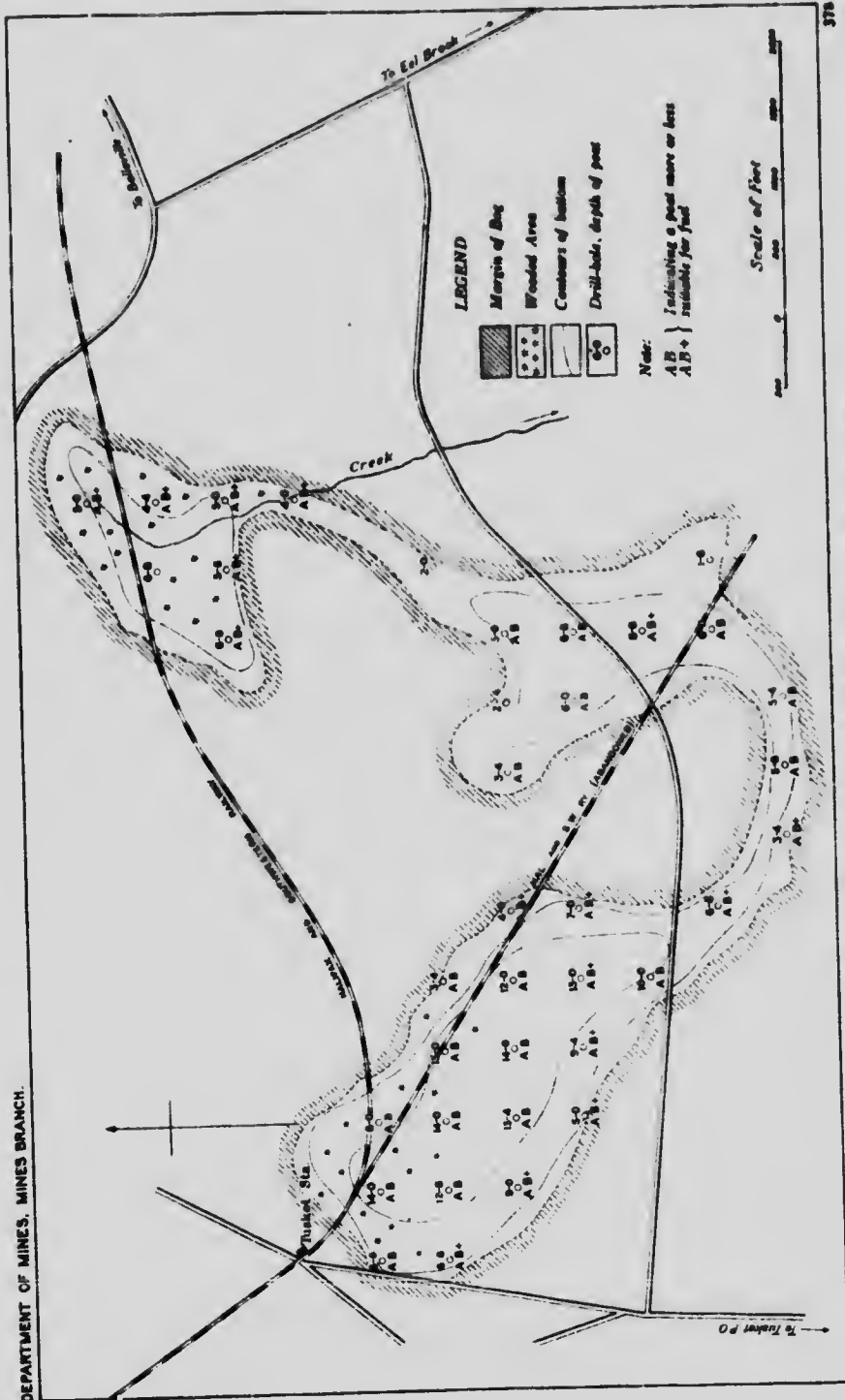

TUSKET PEAT BOG, YARMOUTH COUNTY, NOVA SCOTIA

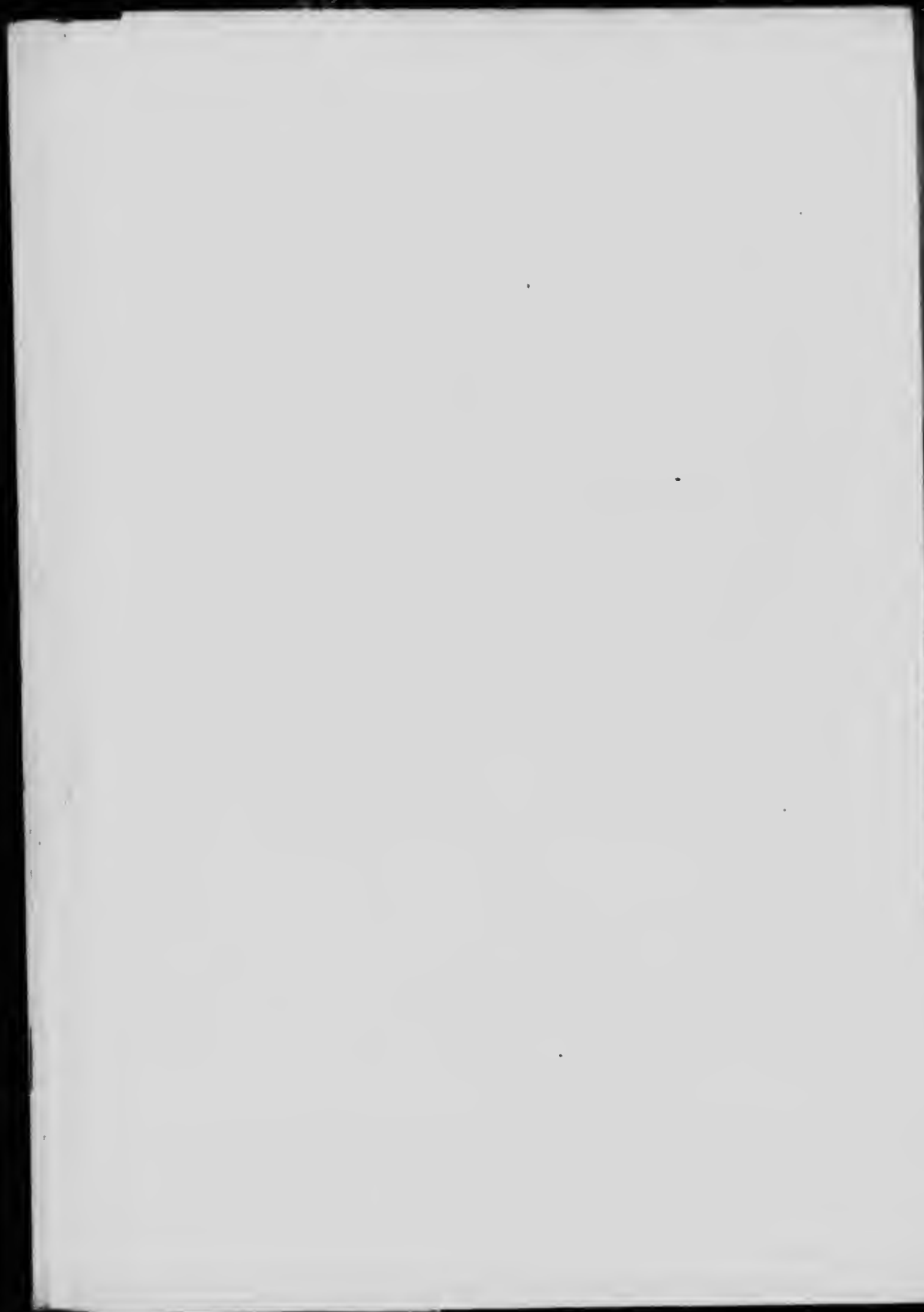





### Makoke Peat Bog.

This bog is situated about a mile and a half south of Tusket station, Yarmouth county, Nova Scotia, and has a total area of 460 acres. (See Map No. 379).

Of this area:—

120 acres have a depth of less than 5 feet, with an average depth of 4 feet.

240 acres have a depth of more than 5 feet, with an average depth of 7 feet.

100 acres have a depth of more than 10 feet, with an average depth of 12 feet.

The volume of peat contained is, approximately:—

779,000	cub. yds. in an area with a depth of less than	5 feet.
2,716,000	" " " " more	5 "
1,950,000	" " " " "	10 "

That portion of the bog, situated to the south of the road which traverses it, has a considerable depth, is very well humified, and possesses high cohesive properties. It is very suitable for manufacture into machine peat fuel. Most of the surface of this part of the bog is comparatively free from trees, with the exception of the southern and eastern points, which are heavily wooded with spruce and tamarack.

At some points the bog is 3,500 feet wide; and a 4,000-foot working line can easily be obtained. From this it can be seen that a large plant could be favourably erected. The northern part is heavily wooded with tamarack, spruce, and alders, and as its depth is comparatively shallow, it would be too costly a proposition to have the surface cleared for the purpose of manufacturing machine peat fuel.

The peat is principally composed of sphagnum fuscum, intermixed with other species of mosses, with here and there groups of eriophorum. Following the creek, carex plants are developed in profusion. A noticeable feature was that the surface of the creek was covered with groups of water-lilies.

During the drilling for samples, very few roots and stumps were encountered. The bottom seemed to be compact sand, with rocks.

After the bog is thoroughly drained, the surface will probably settle down about two feet. Allowing for this decrease in depth due to drainage, and omitting the area with a depth of less than 5 feet we have:—

240	acres with an average depth of, approximately,	5 feet.
100	" " " " " "	10 "

having a volume of, approximately, 3,560,000 cubic yards. Allowing that one cubic yard of such drained bog furnishes 200 pounds of dry peat substance, the total available tonnage of dry peat substance is, approximately, 356,000 tons (of 2,000 pounds) or 475,000 tons of peat fuel with 25% moisture.

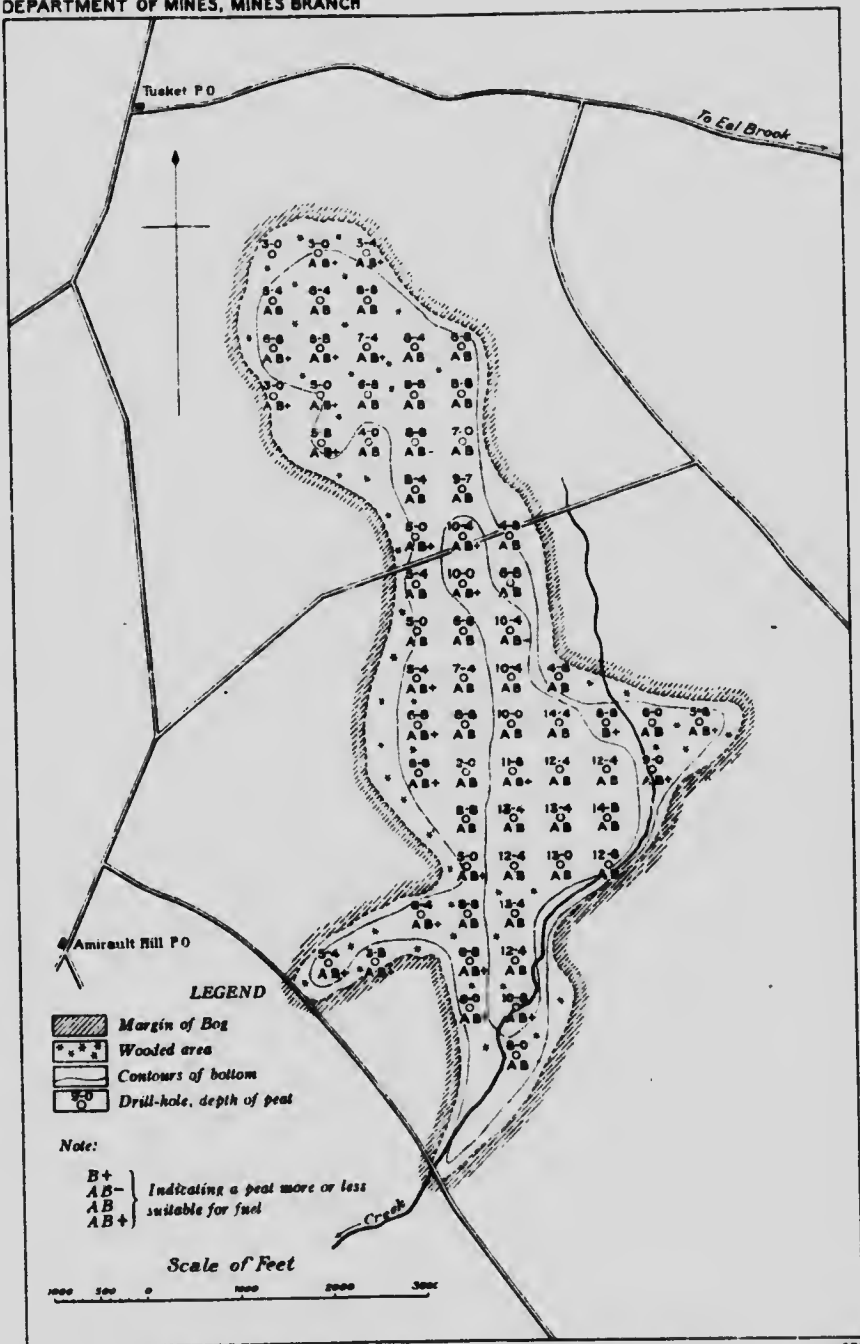

MAKOK PEAT BOG, YARMOUTH COUNTY, NOVA SCOTIA

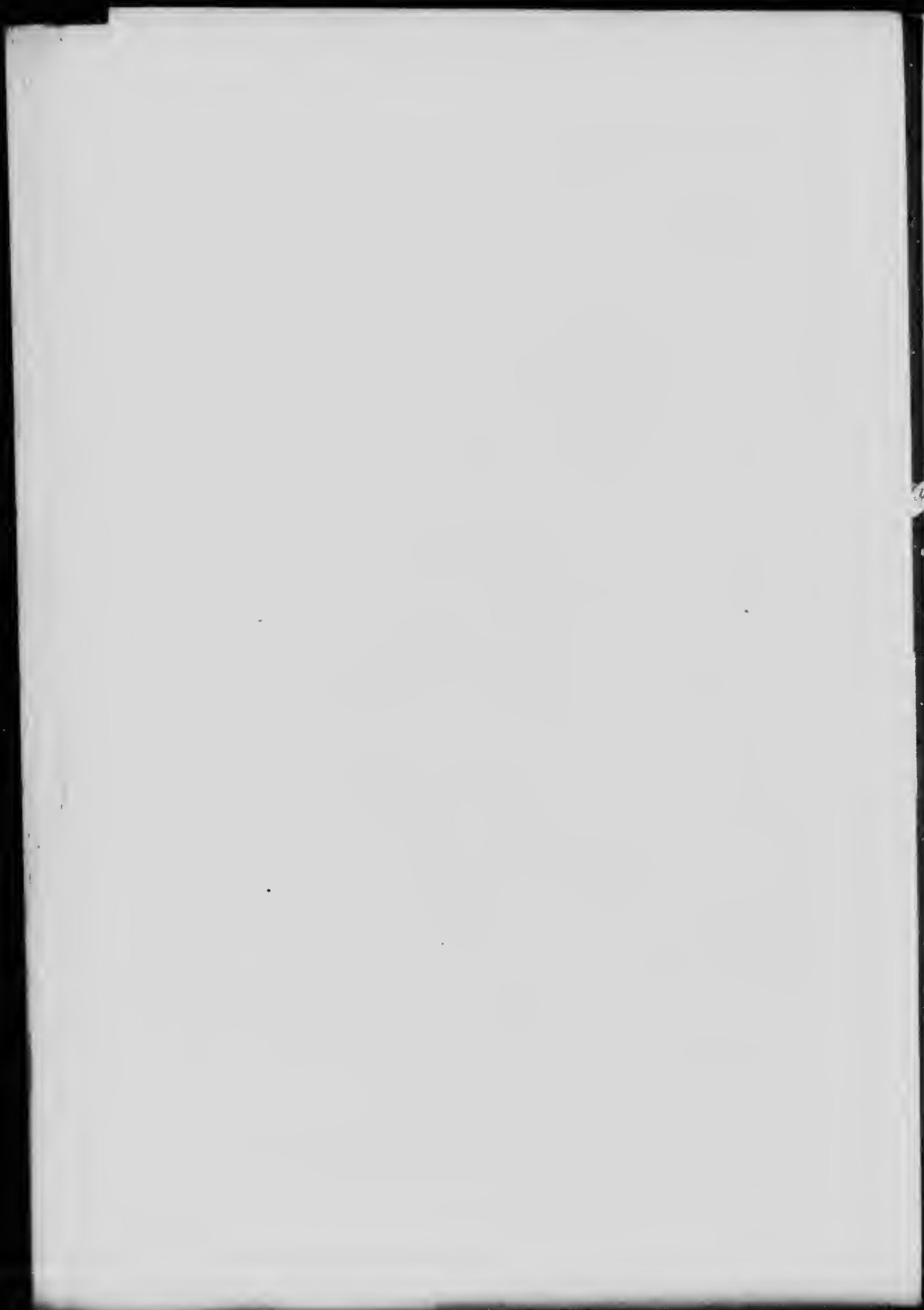

## Analyses of Peat.

Sample	I		II	
	R	D	R	D
Moisture.....	9.1		9.1	
Ash.....	5.5	6.1	3.9	4.3
Volatile matter.....	59.1	65.0	60.9	67.0
Fixed carbon (by difference).....	26.3	28.9	26.1	28.7
Sulphur*.....	0.4	0.4	0.4	0.4
Nitrogen.....	1.4	1.6	1.3	1.5
Calorific value, in calories per gram, gross.....	4,700	5,180	4,810	5,280
" " B.Th.U. per lb., gross.....	8,470	9,320	8,650	9,510
Fuel ratio, fixed carbon, volatile matter.....	0.44	0.44	0.43	0.43

\*Average of two samples from the bog.

Note.—Figures in column "R" refer to fuel as received, and column "D" to fuel dried at 107° C. The analyses were made on fuel as received, and other results calculated therefrom.

The content of ash is quite low, and the calorific value comparatively high.

The bog is very well situated with regard to shipping facilities and market, as it is only 14 miles east of Yarmouth, and a few hundred yards east of Indian Bay, which would ensure a water route to Yarmouth, where the prices of fuel are as follows:

Soft coal, \$6.00 to \$6.50 per ton, depending on the season.

Hard coal, \$8.00 to \$10.00 per ton, depending on the season.

Hardwood, \$5.50 to \$6.00 per cord, depending on the season.

### Heath Peat Bog.

This bog is situated in Yarmouth county half a mile east of Argyle head, about a mile east and west of Central Argyle station and 2 miles east of Lower Argyle.

The whole bog runs in a north and south direction, (see Map No. 380) and is divided into seven sections as follows:—

Section	1—Argyle Head	Yarmouth county.	
"	2—Ess Pond	"	"
"	3—Central Argyle	"	"
"	4—Lower Argyle	"	"
"	5—Goose Lake	"	"
"	6—South End	"	"
"	7—Great Heath	"	"

The total area covered by this bog is, approximately, 2,174 acres.

The peat consists of two kinds—peat litter and peat fuel, which are described separately as follows:—

#### PEAT FUEL.

The sections are composed entirely of peat fuel, with the exception of Great Heath, the central portion of which is peat litter.

The total area covered by this part of the bog is, approximately, 2,024 acres. Of this area:—

813 acres have a depth of less than 5 feet, with an average depth of 4 feet.

1,087 acres have a depth of from 5 to 10 feet, with an average depth of 7 feet.

120 acres have a depth of from 10 to 15 feet, with an average depth of 11 feet.

4 acres have a depth of more than 15 feet, with an average depth of 15 feet.

The volume of peat contained is, approximately:—

5,270,000 cub. yds. in an area with depth of less than 5 feet.

12,300,000 " " " " from 5 to 10 feet.

2,120,000 " " " " from 10 to 15 feet.

100,000 " " " " more than 15 feet.

For future convenience in case machinery should be installed in any of the above mentioned sections, the area and volume of each section has been separately calculated, as can be seen below:—

**Section 1 Aryle Head.**

The total area covered by this section is, approximately, 49 acres. Of this area:—

21 acres have a depth of less than 5 feet, with an average depth of 4 feet.

28 acres have a depth of more than 5 feet, with an average depth of 7 feet.

The volume of peat contained is, approximately:—

137,000 cub. yds., in an area with a depth of less than 5 feet.

310,000 " " " " more " 5 "

**Section 2—Eas Pond.**

The total area covered by this section is, approximately, 155 acres. Of this area:—

23 acres have a depth of less than 5 feet, with an average depth of 4 feet.

118 acres have a depth of from 5 to 10 feet, with an average depth of 8 feet.

14 acres have a depth of 10 feet. with an average depth of 10 feet.

The volume of peat contained is, approximately:—

149,000 cub. yds. in an area with a depth of less than 5 feet.

1,520,000 " " " " from 5 to 10 feet.

226,000 " " " " more than 10 feet.

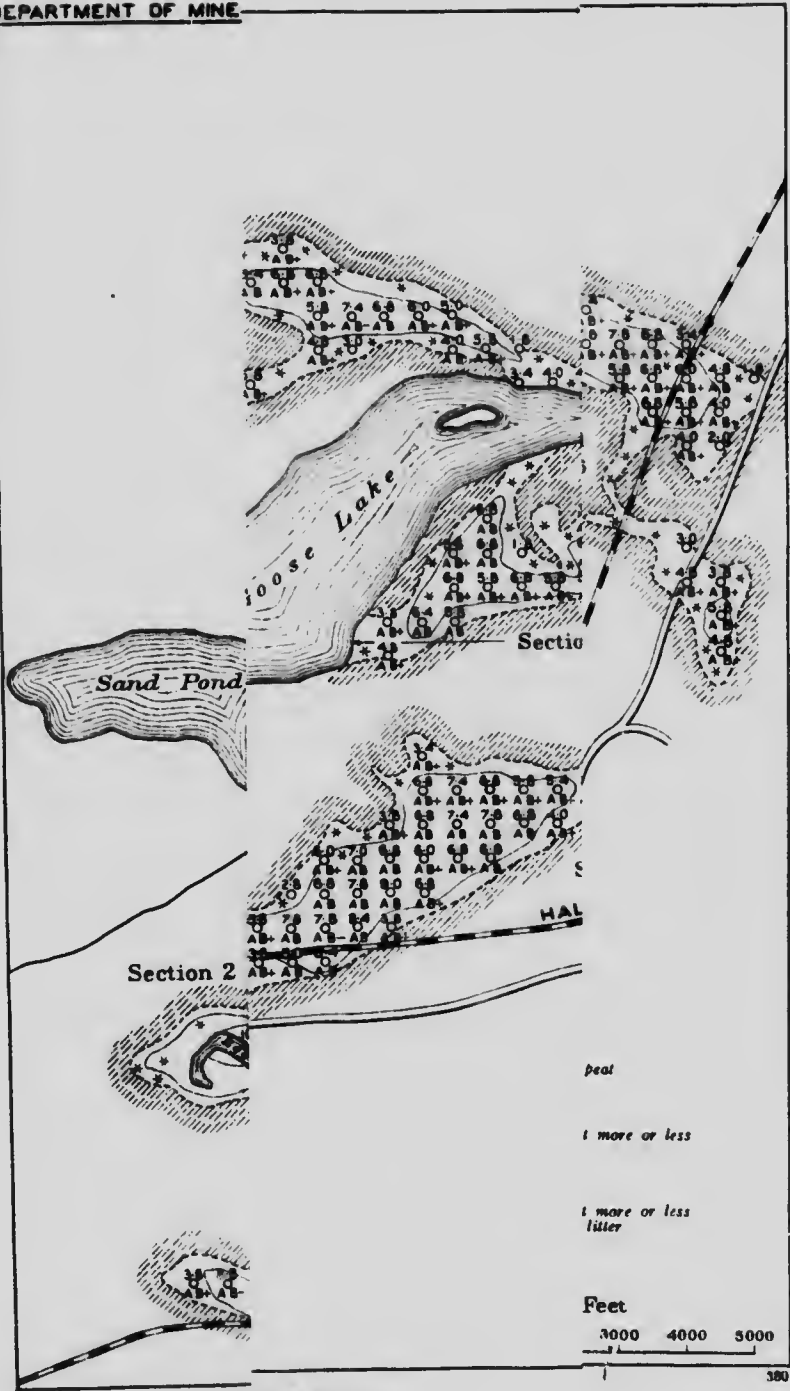











**LEGEND**

-  Margin of Bog
-  Wooded areas
-  Contours of bottom
-  Drill-hole depth of peat

*Note:*

- B
  - B+
  - AB-
  - AB
  - AB+
- } Indicating a peat more or less suitable for fuel
- BC-
  - BC
  - BC+
  - B-
- } Indicating a peat more or less suitable for moss litter

**Scale of Feet**

1000 500 0 1000 2000 3000 4000 5000



**Section 3—Central Argyll.**

The total area covered by this section is, approximately, 66 acres.  
Of this area:—

21 acres have a depth of less than 5 feet, with an average depth of 3 feet.

25 acres have a depth of from 5 to 10 feet, with an average depth of 7 feet.

16 acres have a depth of from 10 to 15 feet, with an average depth of 13 feet.

4 acres have a depth of from 15 feet, with an average depth of 15 feet.

The volume of peat contained is, approximately:—

100,000 cub. yds. in an area with a depth of less than 5 feet.

280,000 " " " " from 5 to 10 feet.

320,000 " " " " from 10 to 15 feet.

100,000 " " " " from 15 feet.

**Section 4—Lower Argyll.**

The total area covered by this section is, approximately, 265 acres.  
Of this area:—

138 acres have a depth of less than 5 feet, with an average depth of 3 feet.

127 acres have a depth of more than 5 feet, with an average depth of 7 feet.

The volume of peat contained is, approximately:—

666,000 cub. yds. in an area with a depth of less than 5 feet.

1,430,000 " " " " more " 5 "

**Section 5—Goose Lake.**

The total area covered by this section of the bog is approximately 131 acres.

Of this area:—

73 acres have a depth of less than 5 feet, with an average depth of 3 feet.

58 acres have a depth of more than 5 feet, with an average depth of 6 feet.

The volume of the peat contained is, approximately:—

350,000 cub. yds. in an area with a depth of less than 5 feet.

560,000 " " " " more " 5 "

**Section 6—South End.**

The total area covered by this section is approximately 235 acres.  
Of this area:—

121 acres have a depth of less than 5 feet, with an average depth of 3 feet.

114 acres have a depth of more than 5 feet, with an average depth of 7 feet.

The volume of peat contained is, approximately:—

587,000 cub. yds. in an area with a depth of less than 5 feet.

1,280,000 " " " " more " 5 "

**Section 7. The Great Heath.**

This section includes the Great Heath and the remainder of the bog.

The total area covered by this section is, approximately, 1,273 acres.

Of this area:

417 acres have a depth of less than 5 feet, with an average depth of 4 feet.

617 acres have a depth of from 5 to 10 feet, with an average depth of 7 feet.

104 acres have a depth of from 10 to 15 feet, with an average depth of 11 feet.

The volume of peat contained is, approximately:—

2,690,000 cub. yds. in an area with a depth of less than 5 feet.

6,960,000 " " " " from 5 to 10 feet.

2,620,000 " " " " from 10 to 15 feet.

The portion of the bog in Section I is very deep, the peat is well humified and contains high cohesive properties; but on account of its small area it is not suitable for the manufacture of machine peat fuel, on a commercial basis, but is suitable for development by hand cutting, to supply the immediate neighbourhood.

**East Pond Section.**

This part of the bog has a considerable depth and is very well humified.

In view of the good quality of peat, the area of 155 acres would be sufficient to justify the manufacture of machine peat; but on account of the precautions necessarily due to a meandering creek, the expense involved would be prohibitive.

As in the case of the previous section, it would be suitable for the manufacture of hand peat.

**Central Argyll Section.**

This section has a considerable depth, the peat is well humified, and, by using the surrounding low land for spreading purposes, could be developed suitably by a small peat plant, or very profitably by hand cutting, as the cost of fuel in this locality is, as at Tusket, very high.

**Lower Argyll Section.**

This section of the bog has a fairly good depth, the peat is very well humified, contains high cohesive properties, and is well suited for manufacturing into machine peat. It can be worked along a line about a mile in length, and over one thousand feet wide.

It is advantageously situated with regard to shipping facilities and market, as the Halifax and Southwestern railway crosses the west end of the bog, which is only 25 miles from Yarmouth.

## Goose Lake Section.

The peat in this portion of the bog is very well humified, but in view of its distance from the railway and its comparative shallowness, it would not justify the manufacture of peat fuel upon a commercial basis.

## South End.

This section of the bog is very well humified, has a fairly good depth, and by laying the working lines out carefully, the peat in this part of the bog could be utilized for the manufacture of air-dried peat fuel by modern machinery. The Halifax and Southwestern railway crossing the south-eastern end of the bog, ensures convenient shipping facilities.

## The Great Heath.

This section is fairly well humified, has considerable depth, and with proper treatment can be used for the manufacture of peat fuel on a large scale.

Towards the centre, for the first three or four feet, the peat is hardly humified enough to produce high grade fuel. As this factor has to be taken into consideration, the finished product will be comparatively light.

The surface of the bog is fairly level, and free from knolls and bushes, hence will serve as a good spreading area.

The remainder of the bog, consisting of the shallow arms connecting the various sections, could, if properly treated, be used for agricultural purposes, or for supplying the farmers in the vicinity with hand-cut peat fuel.

Considering the bog as a whole—deducting the area with a depth of less than 5 feet; allowing a 2-foot decrease in depth for depths over 10 feet; and a one-foot decrease for depths under 10 feet, due to drainage—we have:—

1,087 acres with an average depth of, approximately, 6 feet.

120 " " " " " " 9 "

4 " " " " " " 13 "

having a total volume of, approximately, 12,350,000 cubic yards.

Assuming that one cubic yard of such drained bog produces 200 pounds of dry peat substance, the total available tonnage of dry peat substance would be, approximately, 1,235,000 tons (of 2,000 pounds) or 1,646,000 tons of peat fuel 25 per cent moisture.

The peat in the Great Heath bog is principally formed of sphagnum mosses, but towards the bottom heavy layers of carex peat are to be found. Groups of eriophorum are intermixed with the upper layers of sphagnum.

The remainder of the bog has a four-foot layer of sphagnum moss, heavily intermixed with eriophorum, through the bottom layers of which can be readily seen large varieties of carex, aquatic plants, and other sea grasses. The body of the bog is remarkably free from roots and trunks. The bottom is chiefly compact sand, but in some cases rock is found.



# MICROCOPY RESOLUTION TEST CHART

(ANSI und ISO TEST CHART No. 2)

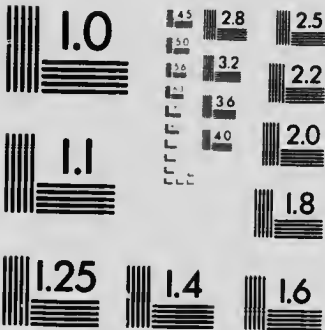

APPLIED IMAGE Inc

1653 East Main Street  
Rochester, New York 14609 USA  
(716) 482-0300 Phone  
(716) 288-5989 Fax

*Analyses of Peat.*

Sample	I		II		III		IV	
	R	D	R	D	R	D	R	D
Moisture.....%	7.5		7.7		6.9		6.8	
Ash.....%	8.2	8.9	8.9	9.6	4.2	4.5	4.6	4.9
Volatile matter.....%	56.4	60.9	58.3	63.2	61.0	65.6	62.9	67.5
Fixed carbon (by difference).....%	27.9	30.2	25.1	27.2	27.9	29.9	25.7	27.6
Sulphur*.....%	0.4	0.4	0.4	0.4	0.4	0.4	0.4	0.4
Nitrogen.....%	1.6	1.7	1.5	1.6	1.3	1.4	1.4	1.5
Calorific value, in calories per gram, gross.....	4,840	5,230	4,570	4,950	5,040	5,410	5,120	5,490
Calorific value in B.Th.U. per lb., gross.....	8,710	9,420	8,220	8,890	9,070	9,740	9,210	9,890
Fuel ratio, fixed carbon, volatile matter.....	0.50	0.50	0.43	0.43	0.46	0.46	0.41	0.41

\* Average of four samples from the bog.

Note.—Figures in column "R" refer to fuel as received, and in column "D" to fuel dried at 105°C. The analyses were made on the fuel as received, and other results calculated therefrom.

The content of ash is quite low, and the calorific value satisfactory.

## B—PEAT LITTER.

This portion of the bog is situated in the centre of the Great Heath bog, 1 mile east of Central Argyle station, and has an area of approximately 150 acres.

Of this area:—

124 acres have a depth of less than 10 feet, with an average depth of 7 feet.

14 acres have a depth of 10 feet, with an average depth of 10 feet.

12 acres have a depth of only 5 feet, and can be neglected.

The volume of peat contained is, approximately:—

In an area with a depth of less than 10 feet, 1,400,000 cub. yds.

" " " more " 10 " 229,000 "

The upper layers for about three feet in this part are comparatively little humified, and a very good litter may therefore be expected. The lower layers are partly humified, which will decrease the absorption capacity of the litter, giving a low-grade product.

Allowing one foot decrease in depth for depths less than 7 feet, and 2 feet decrease for those over 7 feet, we have:—

124 acres with an average depth of 6 feet, approximately.

14 " " " " 8 " "

with a total volume of approximately 1,380,000 cubic yards. Calculating that one cubic yard of such bog will furnish 120 pounds of dry peat substance, the total tonnage of dry peat litter substance available is, approximately, 83,000 tons (of 2,000 pounds) or 104,000 tons of peat litter 20 per cent moisture.



*Analysis of Peat Litter.*

¹Absorptive factor for moisture-free peat .....	8.2
"      "      for peat with 25% water.....	5.9

This sample did not behave like the other peat litters, but formed a kind of gelatinous mud in the wire basket, through which water ran with difficulty.

As this area is comparatively small, it would not be advisable to erect a peat litter plant on a commercial basis.

**Port Clyde Peat Bog.**

This bog is situated in Shelburne county, Nova Scotia, about 3 miles west of Port Clyde station, on the Halifax and Southwestern railway, and runs in a north and south direction.

The total area covered is approximately 1,666 acres. Of this area:—

955 acres have a depth of less than 5 feet, with an average depth of 3 feet.

552 acres have a depth of from 5 feet to 10 feet, with an average depth of 7 feet.

159 acres have a depth of more than 10 feet, with an average depth of 11 feet.

The volume of peat contained is, approximately:—

4,625,000 cub. yds. in an area with a depth of less than 5 feet.

6,240,000 " " " " from 5 to 10 feet.

2,825,000 " " " " more than 10 feet.

The portions of the bog situated north, east, and west of the belt of islands shown (see Map No. 381) are very well suited for the manufacture of machine peat. These portions have a satisfactory depth, and a fairly level and smooth surface, and the peat is well humified. Operations can be conducted along a line three or four thousand feet long. The northern and western parts have a higher average depth than the rest of the bog, and as the peat is fairly well humified throughout all the layers, they should be considered as the main areas for manufacturing peat fuel upon a large scale.

The rest of the bog is well humified, but owing to its shallowness and cut-up areas, is not suitable for the manufacture of peat fuel; but certain portions could be utilized for cutting peat by hand for domestic purposes, while the remainder could be used for agriculture.

This bog could be easily drained towards the south; but a thorough drainage would involve large expense, on account of the comparatively high ridge at the south.

The upper layers of this bog are chiefly formed of sphagnum intermixed with eriophorum, and towards the bottom layers large groups of carex, intermixed with aquatic plants, are to be found.

¹See Bulletin No. 9, page 39.

Deducting 925 acres with a depth of less than 5 feet, and allowing a decrease in depth of one foot for areas with a depth less than 10 feet, and 2 feet for depth over 10 feet, we have:—

552 acres with an average depth of, approximately, 6 feet.

159 " " " " " " " " 9 feet.

having a total volume of, approximately, 7,660,000 cubic yards. Calculating that one cubic yard of such drained bog will furnish 200 pounds of dry peat substance, the total tonnage of dry peat substance available is, approximately, 766,000 tons (of 2,000 pounds) or 1,021,000 tons of 25 per cent moisture.

*Analyses of Peat.*

Sample	I		II		III	
	R	D	R	D	R	D
Moisture.....%	7.6		7.2		7.1	
Ash.....%	2.8	3.0	3.1	3.4	3.3	3.5
Volatile matter.....%	61.5	66.6	61.7	66.5	62.3	67.1
Fixed carbon (by difference).....%	28.1	30.4	28.0	30.1	27.3	29.4
Sulphur*.....%	0.3	0.3	0.3	0.3	0.3	0.3
Nitrogen.....%	1.0	1.1	1.1	1.1	1.1	1.2
Caloric value, in calories per gram, gross.....	5,000	5,410	4,950	5,340	4,990	5,360
" " " B.Th.U. per lb., gross.....	8,990	9,730	8,920	9,610	8,970	9,660
Fuel ratio, fixed carbon, volatile matter.....	0.46	0.46	0.45	0.45	0.44	0.44

\* Average of three samples from the bog.

Note.—Figures in column "R" refer to fuel as received, and in column "D" to fuel dried at 105°C. The analyses were made on fuel as received, and other results calculated therefrom.

The content of ash is very low, and the calorific value is satisfactory.

The body of the bog is comparatively free from roots, stumps, and trunks, and the bottom is composed of rock and sand.

The bog is very well situated both as regards shipping facilities and market, being only 25 miles west of Shelburne. The Halifax and Southwestern railway crosses the northern extremity of the bog.

### Latour Peat Bog.

This bog is situated in Shelburne county, Nova Scotia, about  $1\frac{1}{2}$  mile southwest of Upper Port Latour (see Map No. 382).

The total area covered by the bog is approximately 849 acres. Of this area:—

273 acres have a depth of less than 5 feet, with an average depth of 3 feet.

419 acres have a depth of from 5 feet to 10 feet, with an average depth of 7 feet.

157 acres have a depth of more than 10 feet, with an average depth of 11 feet.

DEPARTMEN



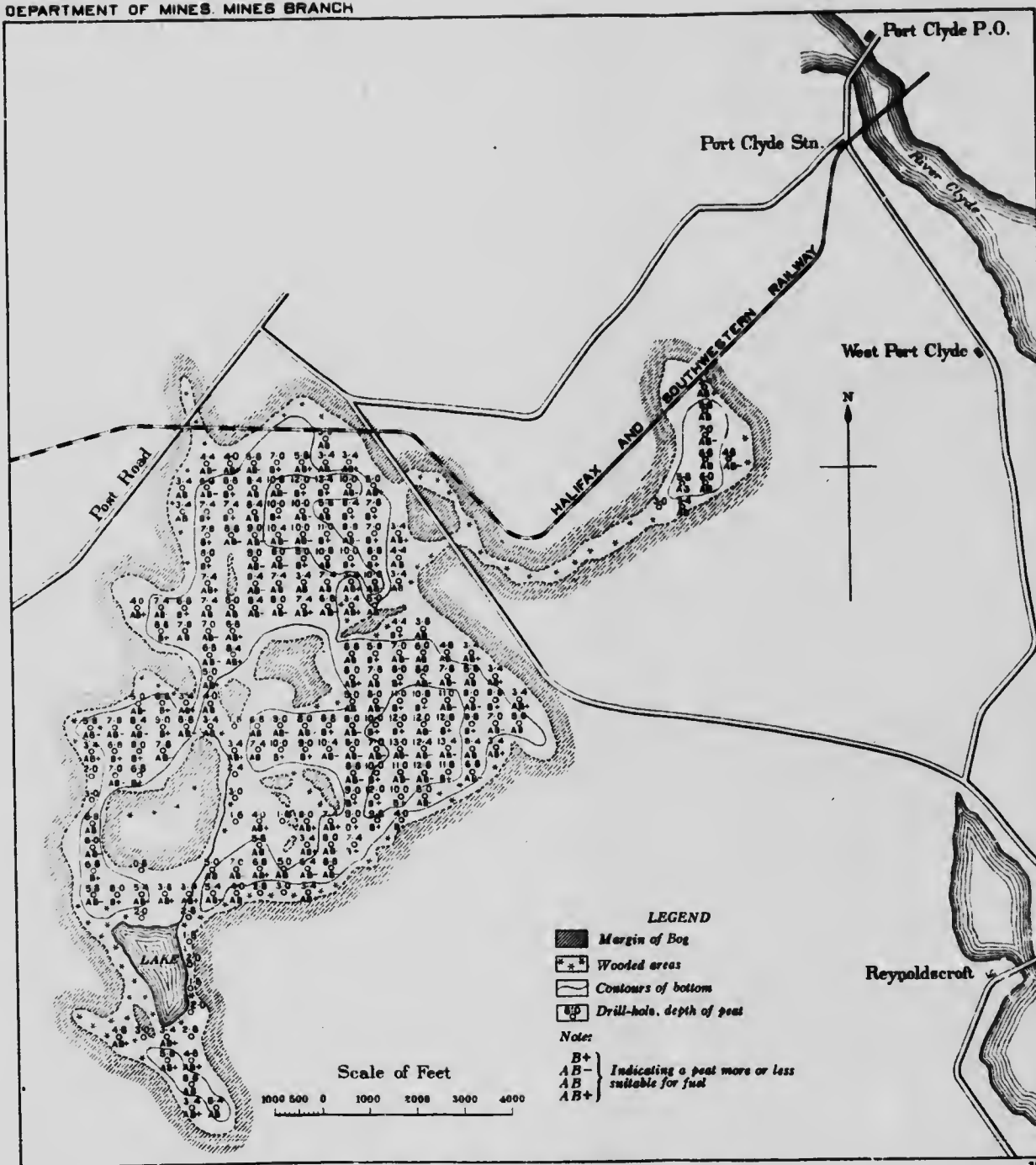

PORT CLYDE PEAT BOG, SHELBURNE COUNTY, NOVA SCOTIA



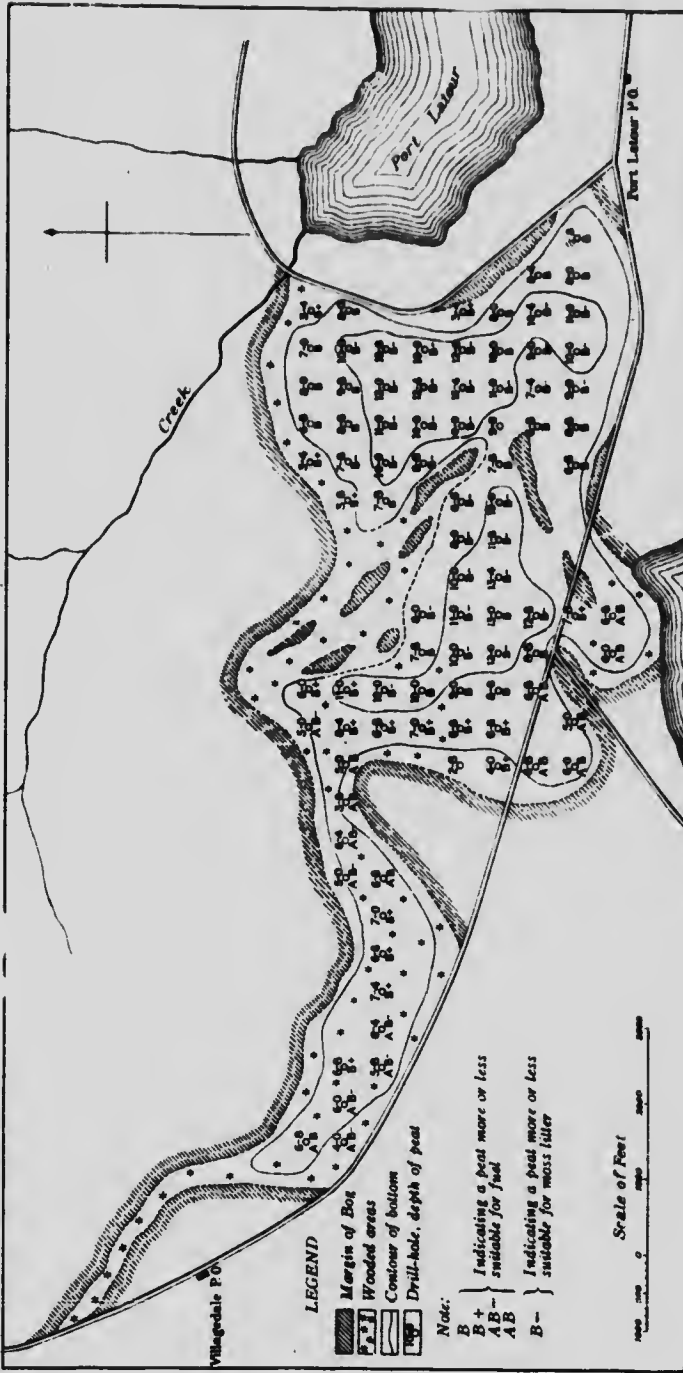

LATOUR PEAT BOG, SHELBURNE COUNTY, NOVA SCOTIA

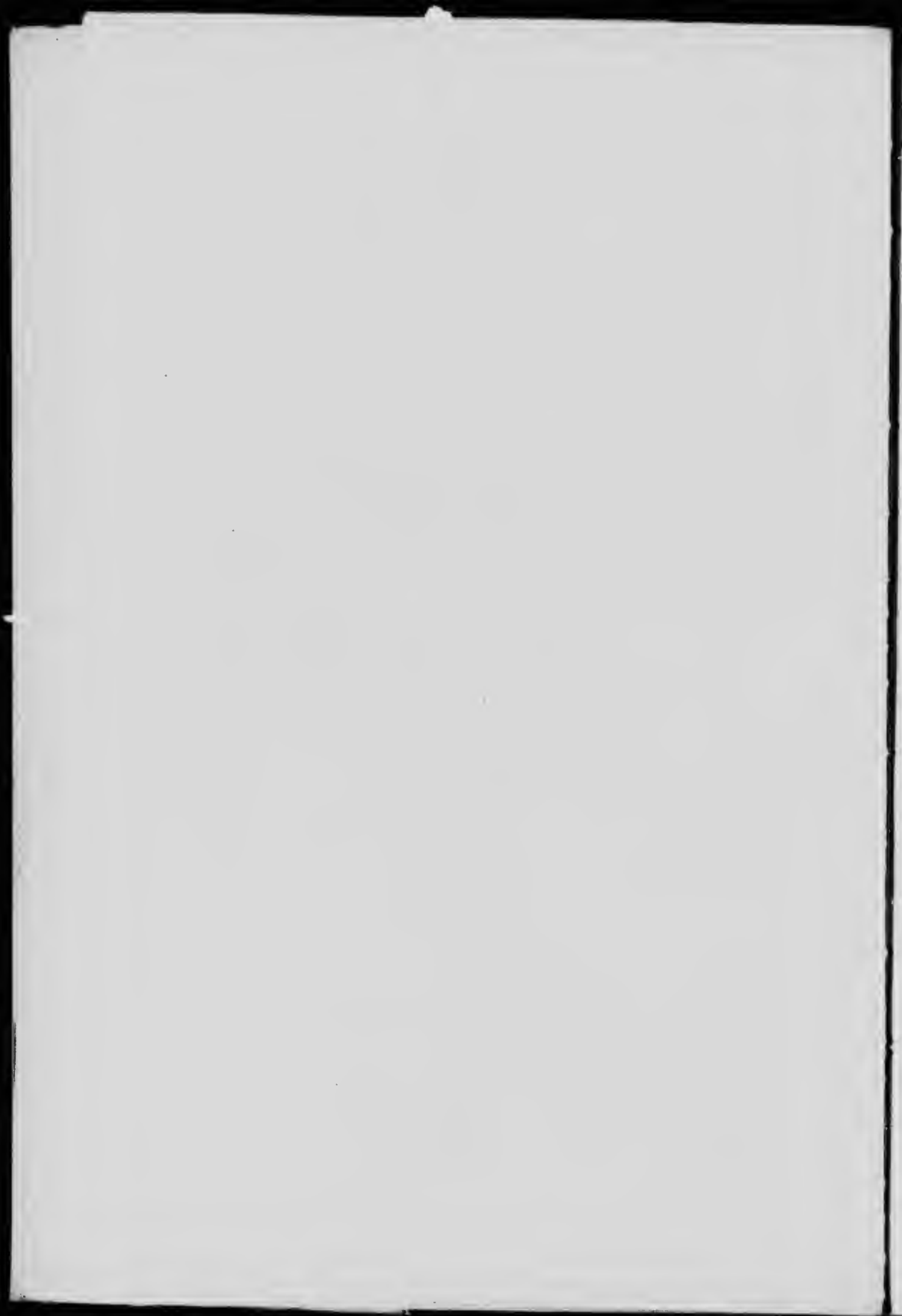

The volume of peat contained is, approximately:—

1,320,000	cub. yds.	in an area with a depth of less than 5 feet.
4,735,000	"	" " " " from 5 to 10 feet.
2,780,000	"	" " " " more than 10 feet.

The peat is principally formed by sphagnum, lightly intermixed with carex. Groups of eriophorum intermix with this sphagnum and carex on the surface. Through the largest part of the bog the peat is poorly humified, with the exception of around the margin and in the small bays, where it is fairly well humified. The centre of the bog has a considerable depth, and the rest is comparatively shallow. Judging from the general samples obtained during the drilling of the peat, this bog, at present, is not adapted to the manufacture of machine peat by the air-drying system.

As the bog is situated a rather long distance from transportation points, it would not be advisable, at the present time, to have it developed for the peat industry.

Deducting 273 acres with a depth of less than 5 feet, and allowing 2 feet for the decrease in depth due to drainage, we have left:—

419 acres with an average depth of, approximately, 5 feet.

157 " " " " " " 9 feet

having a total volume of, approximately, 5,660,000 cubic yards.

Calculating that one cubic yard of such drained bog will yield 200 pounds of dry peat substance, the total tonnage of dry peat substance available is, approximately, 566,000 tons (of 2,000 pounds), or 755,000 tons of peat fuel with 25 per cent moisture.

*Analyses of Peat.*

Sample	I		II	
	R	D	R	D
Moisture.....	7.5		7.7	
Ash.....	3.5	3.8	3.7	4.0
Volatile matter.....	62.9	68.0	62.7	67.9
Fixed carbon (by difference).....	26.1	28.2	25.6	28.1
Sulphur*.....	0.3	0.3	0.3	0.3
Nitrogen.....	1.0	1.1	1.0	1.1
Caloric value, in calories per gram, gross.....	4,770	5,160	4,770	5,170
" " B.Th.U. per lb., gross.....	8,590	9,280	8,590	9,300
Fuel ratio, fixed carbon, volatile matter.....	0.42	0.42	0.41	0.41

\* Average of two samples from the bog.

Note.—Figures in column "R" refer to fuel as received, and in column "D" to fuel dried at 105°C. The analyses were made on fuels as received, and other results computed therefrom.



### Clyde Peat Bog.

This bog is situated in Shelburne county, N. S., about  $2\frac{1}{2}$  miles northeast of Clyde River village. Two and one-half miles north of this village, the bog follows the Clyde river running in a northwest and southeast direction. (See Map No. 383).

The total area is, approximately, 2,240 acres. Of this area:—

1,390 acres have a depth of less than 5 feet, with an average depth of 2 feet.

520 acres have a depth of from 5 to 10 feet, with an average depth of 7 feet.

180 acres have a depth of from 10 to 15 feet, with an average depth of 12 feet.

140 acres have a depth of from 15 to 20 feet, with an average depth of 17 feet.

10 acres have a depth of more than 20 feet, with an average depth of 21 feet.

The volume of peat contained is, approximately:—

4,670,000 cub. yds. in an area with a depth of less than 5 feet.

5,870,000 " " " " from 5 to 10 feet.

3,480,000 " " " " from 10 to 15 feet.

3,839,000 " " " " from 15 to 20 feet.

366,000 " " " " over 20 feet.

This bog is divided into two parts by a narrow belt about 2,000 feet wide. These two portions may be designated as the Eastern and Western sections.

#### Eastern Section.

This part of the bog is situated immediately northwest of the Post road,  $2\frac{1}{2}$  miles east of Clyde River village.

It is very well suited for the manufacture of machine peat: two large modern peat plants could be easily installed, obtaining working lines of over a mile long, and more than 3,000 feet wide.

The peat is well humified, is of satisfactory depth, and the surface is comparatively smooth and level.

#### Western Section.

This part of the bog is situated on the east bank of the Clyde river,  $2\frac{1}{2}$  miles northeast of Clyde River village. It is somewhat larger in area than the eastern section, is fairly well humified, and has a higher average depth than the rest of the bog.

Three large modern peat plants, working on the air-drying system, can be operated in this portion, with working lines one mile in length, each way.

These two sections of the bog present a very curious phenomenon, as they form two separate plateaus which fall abruptly to a lower plane



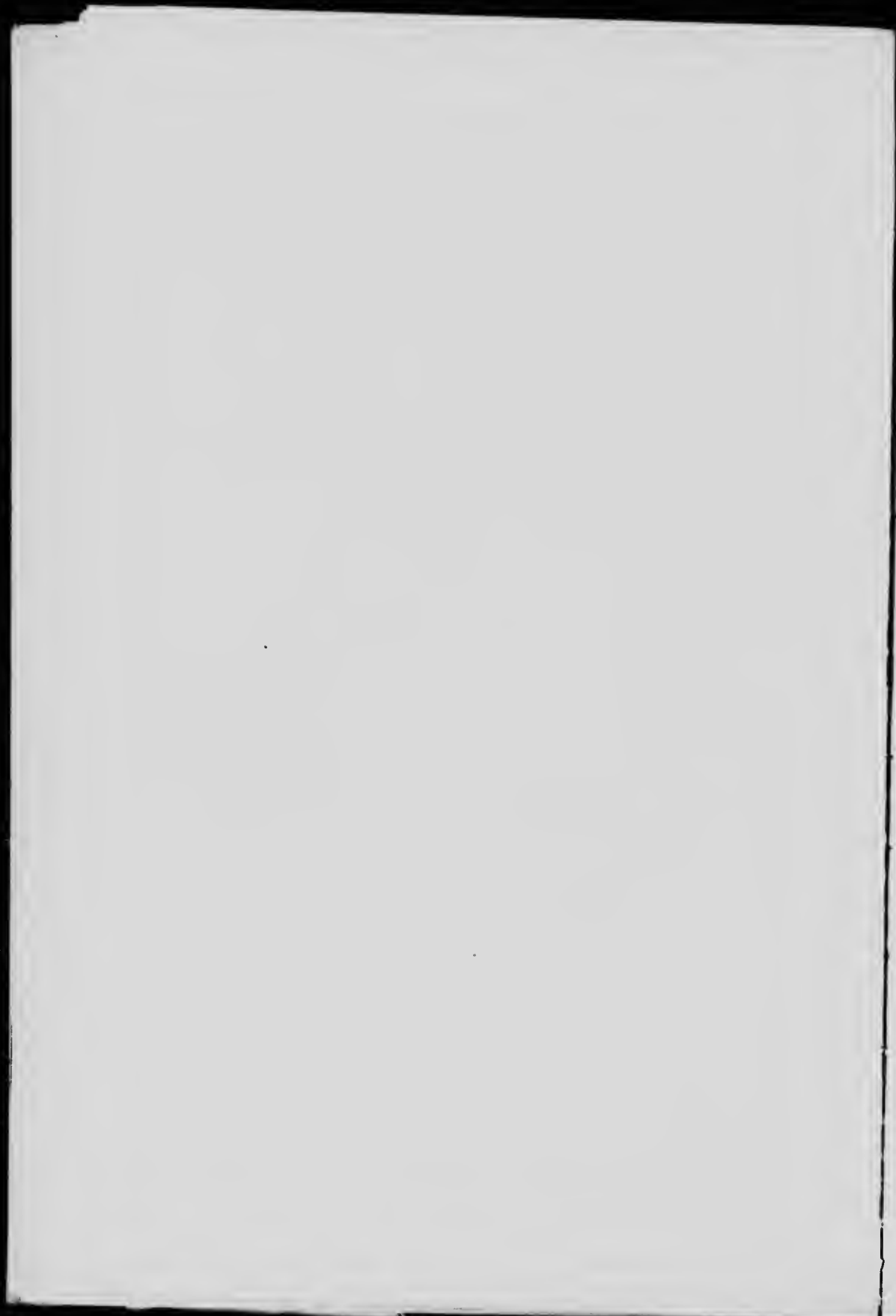

PLATE XII.



Clyde peat bog, Nova Scotia. (The white patch shows a distinct growth of eriophorum).

PLATE XIII.



Clyde river into which several arms of the Clyde peat bog extend.

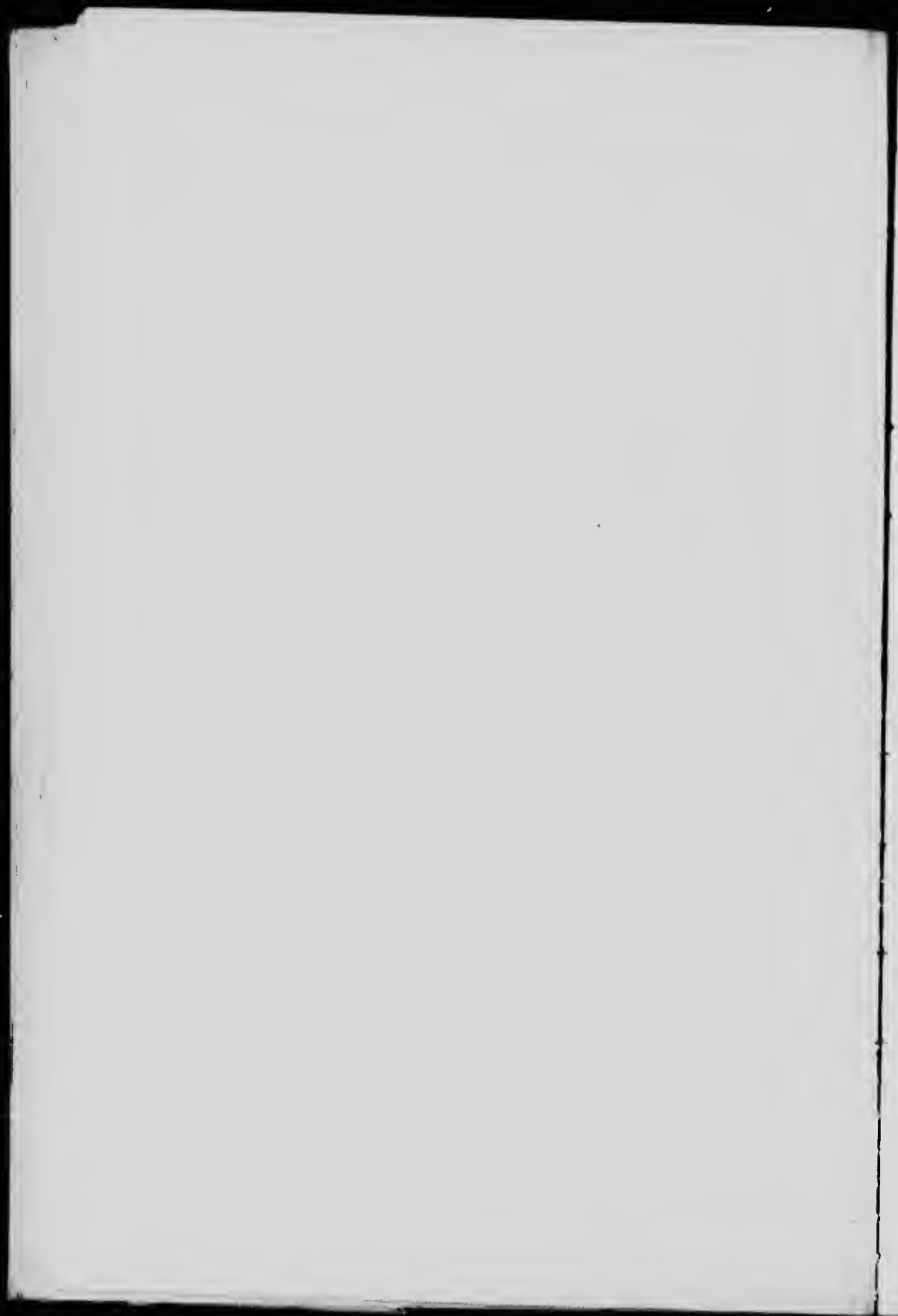

on the south, east, and west. The level height of the plateau is held to the north, where the surrounding country rises to a considerable elevation, and may be characterized as a typical "high moor". This is the first "high-moor" bog encountered during the last six years of investigation. It is humified throughout the whole area, and therefore can be considered as a valuable asset for future development of the peat industry.

The remainder of the bog, south of the Post road, and the portion to the north of the above mentioned western section, constituting, together, an area of over one thousand acres, could be converted into valuable agricultural land, as it is shallow, and can easily be drained into the Clyde river. (See Plate XII.)

The "high moors" are principally formed of sphagnum mosses, heavily intermixed with eriophorum, and towards the bottom layers carex plant dominating, which can be seen throughout the lower level of the bog.

During the drilling, it was noticed that in the deeper portions of the bog, towards the north, logs and roots occur under a layer of ten feet of well humified peat and this bed of logs becomes more dense towards the north. The bottom of the "high moor" portions is composed of sand and stone, covered with a thin composite layer of sand and clay.

Around the margin, growths of spruce and tamarack occur, and occasionally dwarfed spruce and tamarack are found on the bog. (See Plate XIII).

Deducting 1,390 acres with a depth of less than 5 feet, and allowing for drainage of one foot decrease in depth for depths less than 7 feet, and 2 feet decrease for depths of more than 7 feet, we have left:—

520 acres with an average depth of, approximately, 6 feet.

180 " " " " " " 10 "

140 " " " " " " 15 "

10 " " " " " " 19 "

having a total volume of, approximately, 11,590,000 cubic yards.

Calculating that one cubic yard of such drained bog furnishes 200 pounds of dry peat substance, the total available tonnage of dry peat substance is, approximately, 1,595,000 tons, (of 2,000 pounds) or 2,127,000 tons of peat fuel with 25 per cent moisture.

*Analyses of Peat.*

Sample	I		II		III		IV		V	
	R	D	R	D	R	D	R	D	R	D
Moisture.....%	7.1		7.7		7.7		7.5		7.7	
Ash.....%	6.5	7.0	5.0	5.4	2.9	3.2	4.5	4.9	4.0	4.3
Volatile matter %	59.5	64.0	59.8	64.8	61.3	66.4	58.1	62.8	61.2	66.4
Fixed carbon (by difference) %	26.9	29.0	27.5	29.8	28.1	30.4	29.9	32.3	27.1	29.3
Sulphur*.....%	0.3	0.3	0.3	0.3	0.3	0.3	0.3	0.3	0.3	0.3
Nitrogen.....%	1.3	1.4	1.0	1.1	1.0	1.1	1.1	1.2	1.1	1.2
Caloric value in calories per gram, gross...	4,910	5,280	4,750	5,150	4,860	5,260	5,030	5,430	4,880	5,290
Caloric value in B.Th.U. per lb., gross.....	8,840	9,510	8,550	9,270	8,740	9,460	9,060	9,780	8,790	9,510
Fuel ratio, fixed carbon, vola- tile matter...	0.45	0.45	0.46	0.46	0.46	0.46	0.52	0.52	0.44	0.44

\* Average of five samples from the bog.

Note.—Figures in column "R" refer to fuel as received, and in column "D" to fuel dried at 105°C. The analyses were made on fuel as received and other results calculated therefrom.

The content of ash is low, and calorific value highly satisfactory.

The southern extremity of the bog is about 5 miles from Port Clyde, where water and rail shipments can be conveniently made.

PLATE XIV.



Clyde peat bog, Nova Scotia. In this place a very narrow sand bank divides the bog from the river. The bank is elevated about 6 feet above the bog.



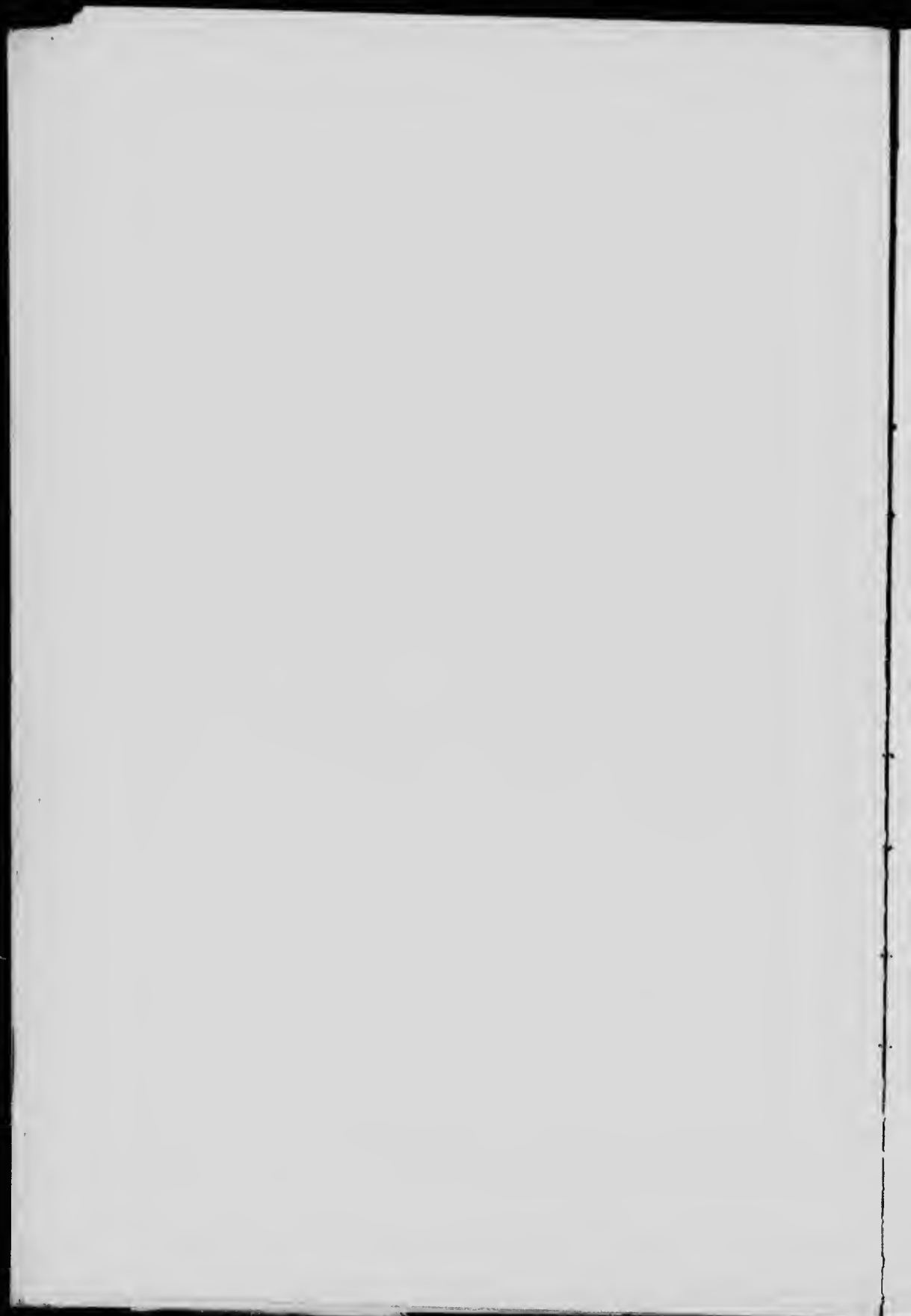

PLATE XV.



Showing the elevation of the hard land on the northwest shore of the Clyde peat bog, Nova Scotia.

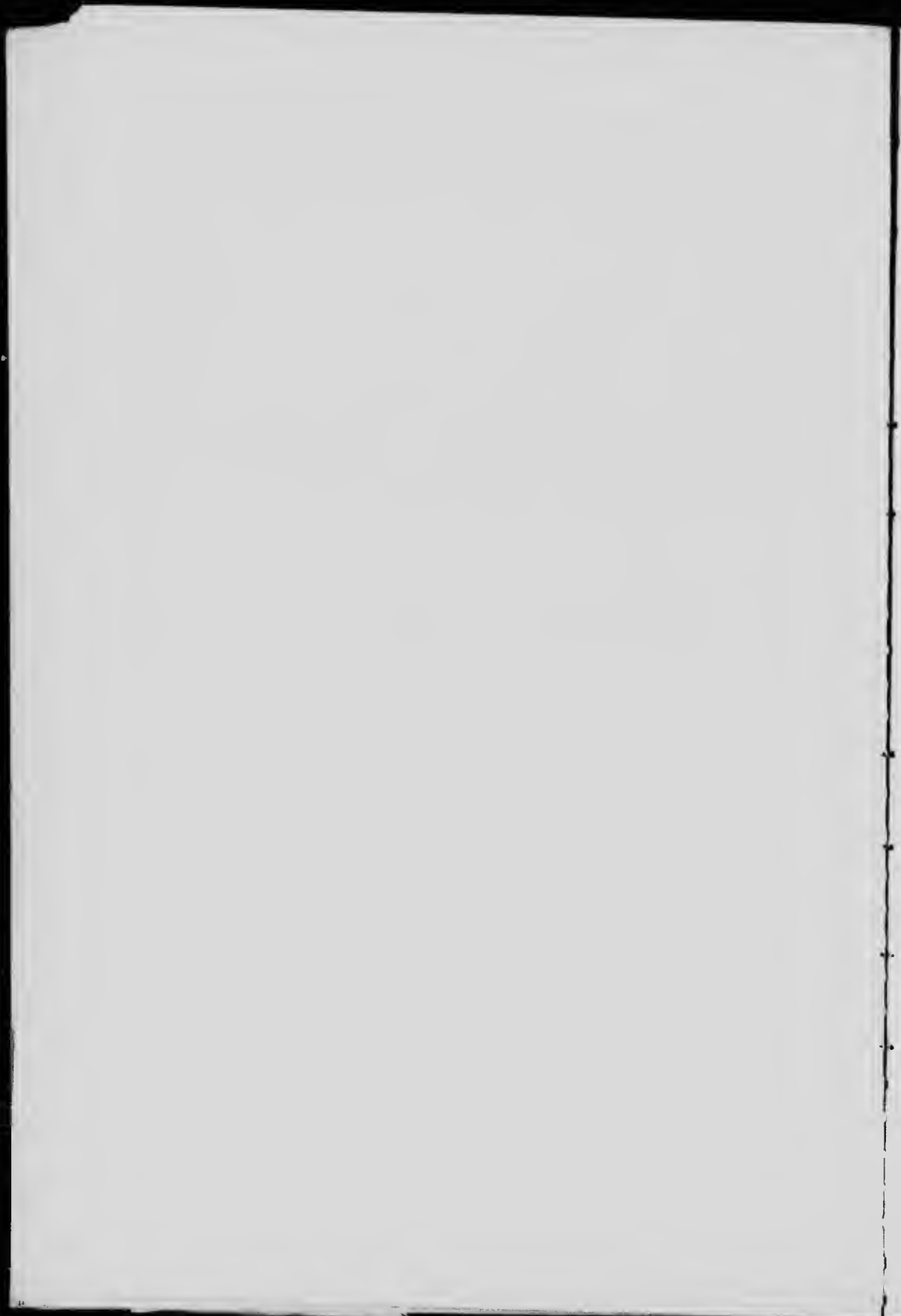

TABLE VI.  
Analyses of the Different Peat Samples Collected from Bogs in the Province of Nova Scotia.

No. of samples from each bog	LOCATION	Analyses of Peat (absolutely dry)						FUEL RATIO	
		fixed carbon %	volatile matter %	Ash %	Nitrogen %	Calorific value Cals.	B.Th.U. per lb.		
1	Caribou.....	29.7	62.6	7.7	1.6	5,440	9,790	0.47	
2	".....	30.9	64.7	4.4	1.2	5,410	9,740	0.48	
3	".....	30.4	66.7	2.9	1.0	5,310	9,580	0.46	
4	".....	30.5	67.5	2.0	0.9	5,320	9,590	0.45	
1	Cherryfield.....	29.8	64.1	6.1	1.1	5,280	9,480	0.47	
1	Tusket.....	27.8	59.5	12.7	1.8	5,270	9,470	0.47	
2	".....	28.8	61.5	6.1	1.6	5,210	9,380	0.48	
1	Maloke.....	28.7	65.0	6.1	1.6	5,180	9,320	0.44	
2	".....	30.2	60.9	4.3	1.5	5,280	9,510	0.43	
1	H.ath.....	27.2	63.2	8.9	1.7	5,230	9,430	0.50	
2	".....	29.9	65.6	9.6	1.6	4,950	8,890	0.43	
3	".....	27.6	67.5	4.5	1.4	5,410	9,740	0.46	
4	".....	30.4	66.6	4.0	1.5	5,400	9,800	0.41	
1	Port Clyde.....	30.1	66.5	3	1.1	5,310	9,730	0.46	
2	".....	29.4	67.1	3.5	1.2	5,340	9,610	0.45	
3	".....	28.2	68.0	3.8	1.1	5,360	9,660	0.44	
1	Lavour.....	28.1	67.9	4.0	1.1	5,160	9,280	0.42	
2	".....	29.0	64.0	7.0	1.4	5,170	9,300	0.41	
1	Clyde.....	29.8	64.8	5.4	1.1	5,280	9,510	0.45	
2	".....	30.4	66.4	5.4	1.1	5,180	9,270	0.46	
3	".....	32.3	62.8	4.9	1.1	5,260	9,560	0.46	
4	".....	29.3	66.4	4.9	1.2	5,290	9,510	0.44	

## BOTANY OF THE PEAT BOGS.

A series of photographs were taken of the plants found in the bogs investigated in the Provinces of Ontario, Quebec, Nova Scotia, and Prince Edward Island. Similar plants to these, organically, constitute most of the bogs in the eastern provinces of Canada.

These photographs of typical plants have been reproduced in this report (see Plates XVI to LXXIII), and will serve to show the constituent organic growths from which the peat in the respective bogs has been formed.

Nine photographic prints, illustrative of the botany of the Alfred bog, Ontario, were incorporated in Bulletin No. 8, 1910-11, namely, Plates VII to XVI; and eighteen, illustrative of the botany of the peat bogs in the Province of Quebec, were incorporated in Bulletin No. 9, 1911-12, viz., Plates II to XIX.

When a sufficient number of plants have been collected from the various Canadian peat bogs investigated, they will be properly classified, and described in a special publication.

The following is an inventory of the plants found in the various bogs:—

## ONTARIO.

## Richmond Peat Bog.

<i>Cornus Canadensis</i> (L)	Plate XVI.
<i>Eriophorum viridi-carinatum</i> (Engelm)	" XVII.
<i>Carex exilis</i> (Dewey)	" XVIII.
" <i>tribuloides</i>	" XIX.
" <i>tenella</i> (Schk)	" XX.
" <i>rostrata</i> (Stokes)	" XXI.
" <i>Brunnescens</i> (Poir)	" XXII.
" <i>mirabilis</i> (Dewey)	" XXIII.
" <i>vulpinoidea</i> (Michx)	" XXIV.
<i>Dulichium spathaceum</i> (S)	" XXV.
<i>Calla palustris</i> (L)	" XXVI.
<i>Scirpus atrocinctus</i> (Fern)	" XXVII.
" <i>Hudsonianus</i> , (Fernal)	" XXVIII.
<i>Galium trifidum</i> (L)	" XXIX.
<i>Potamogeton alpinus</i>	" XXX.
<i>Thalictrum dioicum</i>	" XXXI.
<i>Calopogon pulchellus</i> (R. Br.)	" XXXII.
<i>Drepanocladus Kneiffii</i> (Sch.) Warnst.	" XXXIII.

## Marsh Hill Peat Bog, Uxbridge, Ontario.

<i>Mnium affine</i> , Bland, var. <i>acutum</i> (Laur) Br. and Sch.	Plate XXXIV.
<i>Climacium dendroides</i> (Dill. L.) W. and M.	" XXXV.
<i>Calliergon cordifolium</i> (Hedw) Lindb.	" XXXVI.



*Cornus Canadensis* (L.).



PLATE XVII.



*Eriophorum viridi-carinatum* (Engelm).





PLATE XVIII.



*Carex exilis* (Dewey).



PLATE XIX.



*Carex tribuloides.*





*Carex tenella* (Schk).

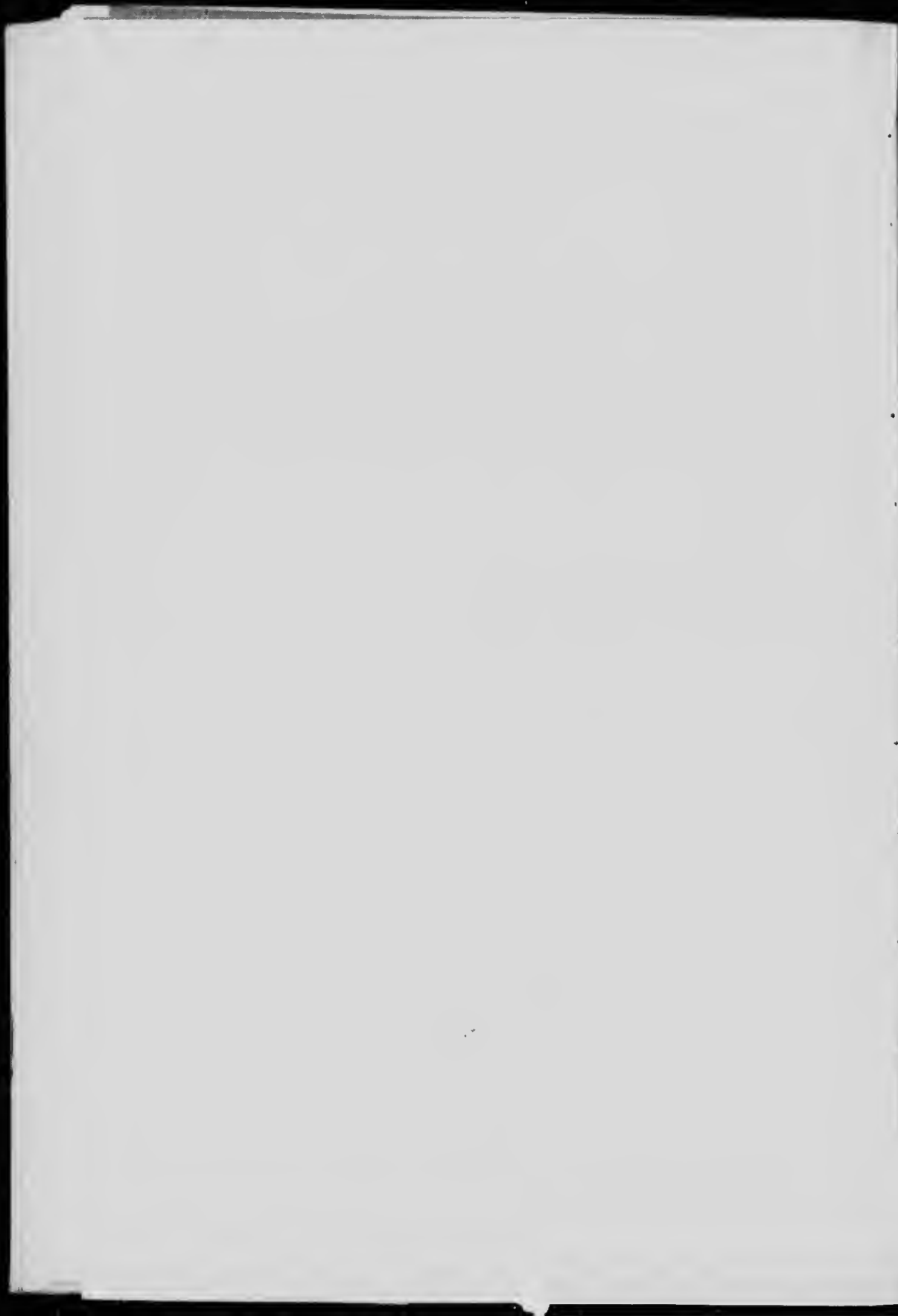

PLATE XXI.



*Carex rostrata* (Stokes).







*Carex Brunnescens* (Poir).

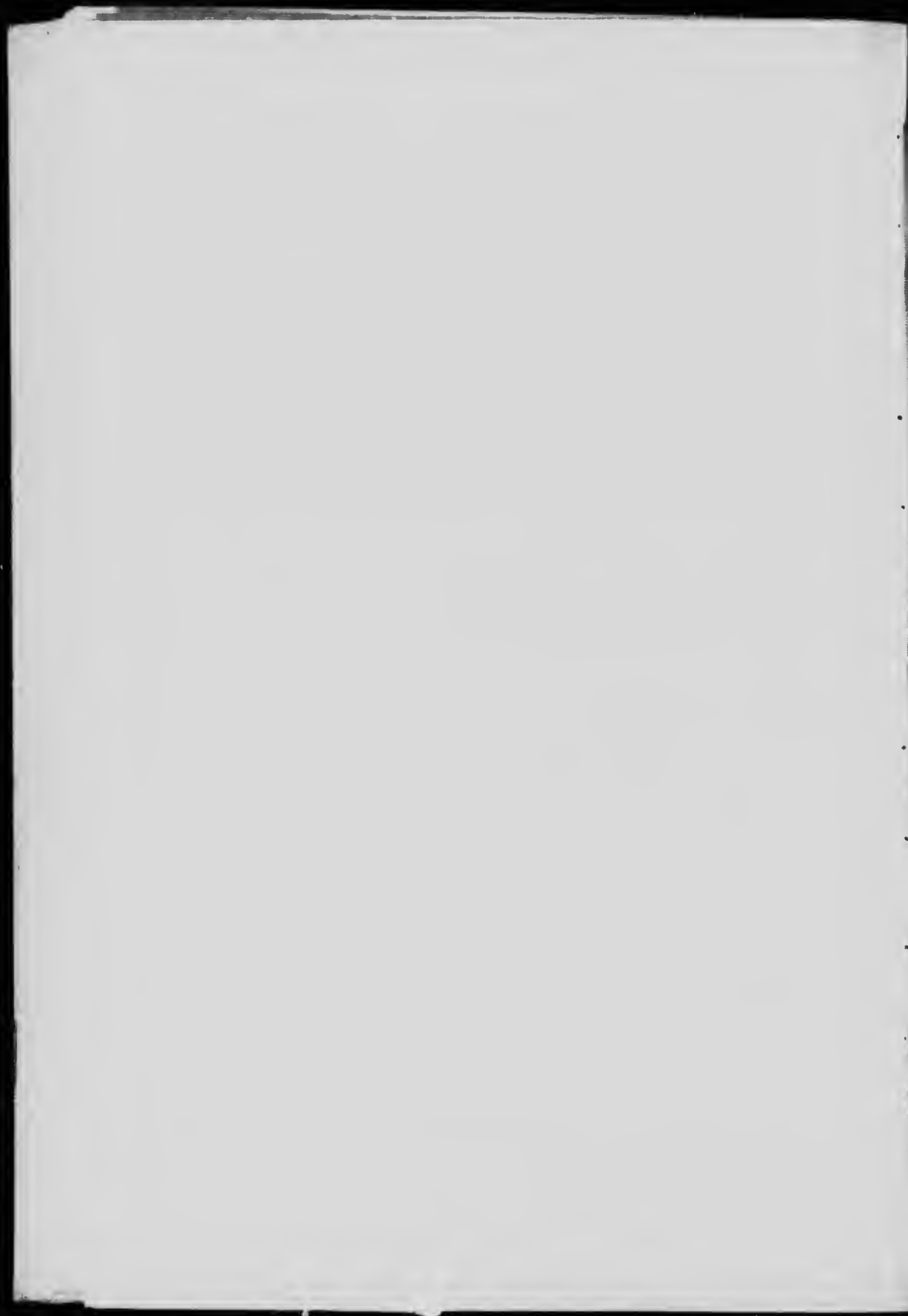

PLATE XXIII.



*Carex mirabilis* (Dewey).

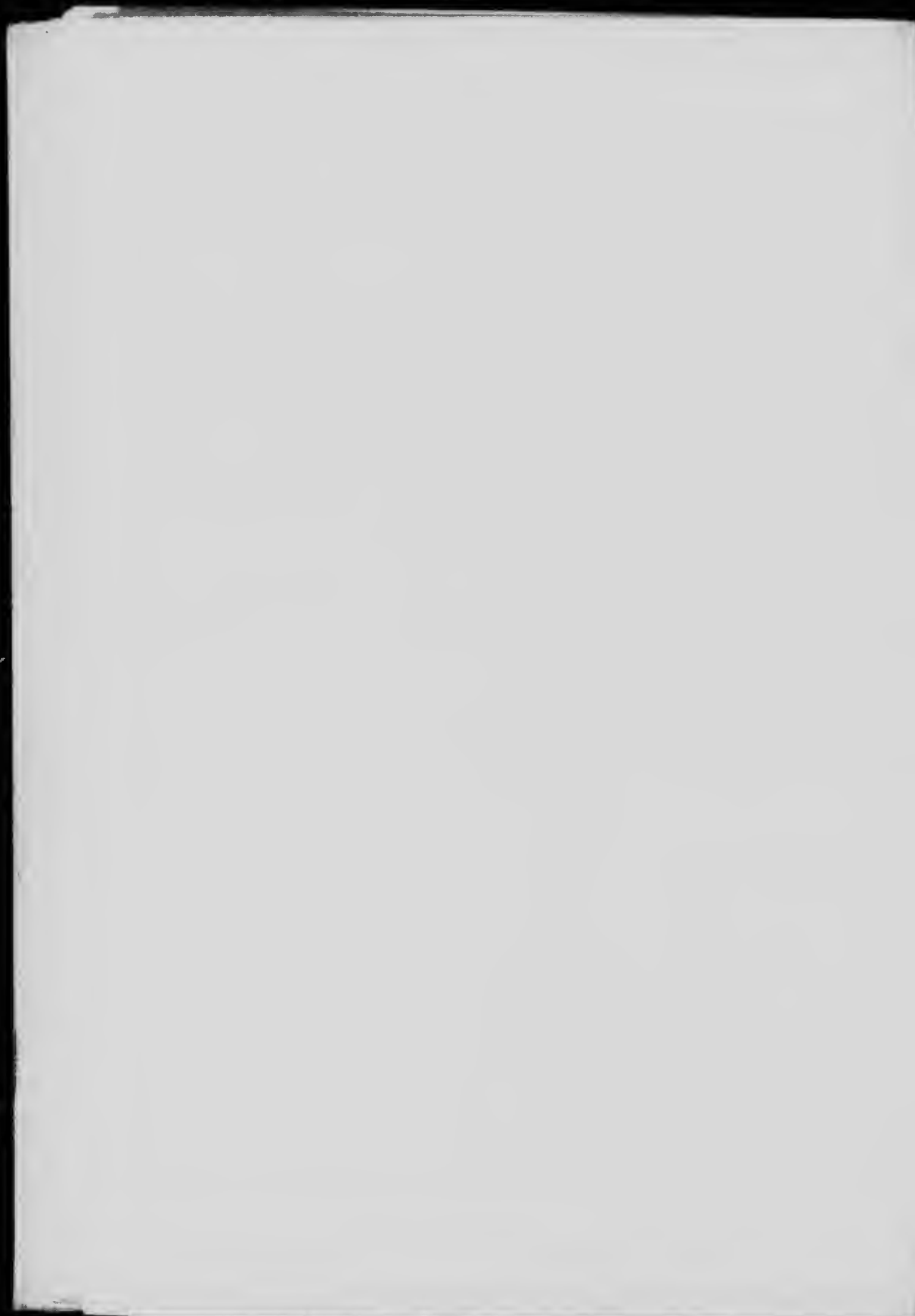
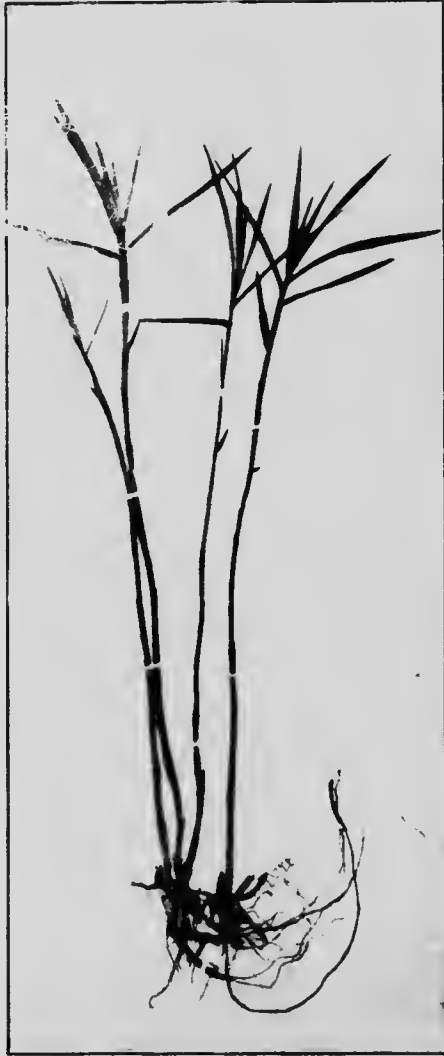

PLATE XXIV.



*Carex vulpinoidea* (Michx.).





*Dulichium spatheceum* (S).



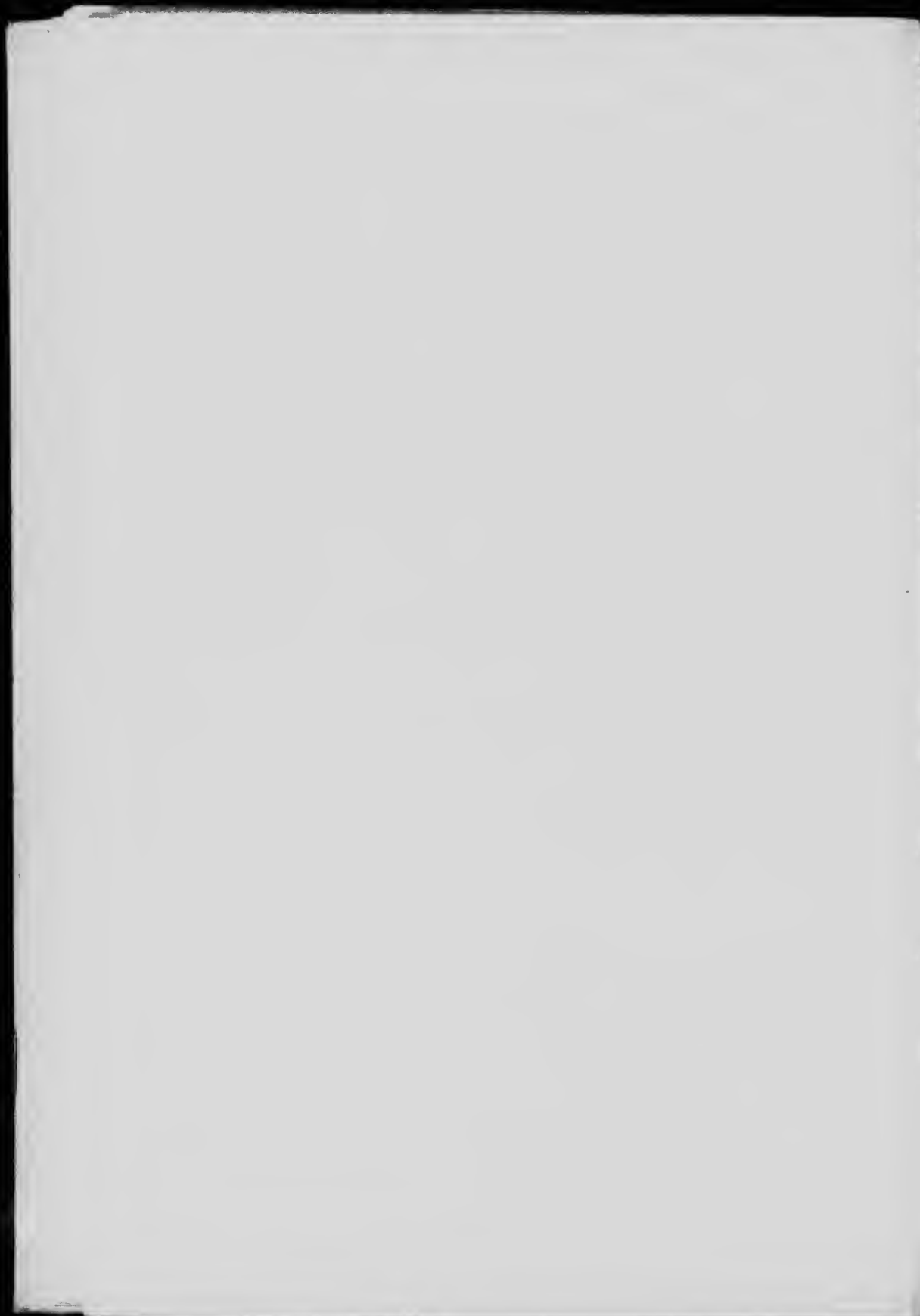



*Calla palustris* (L.).

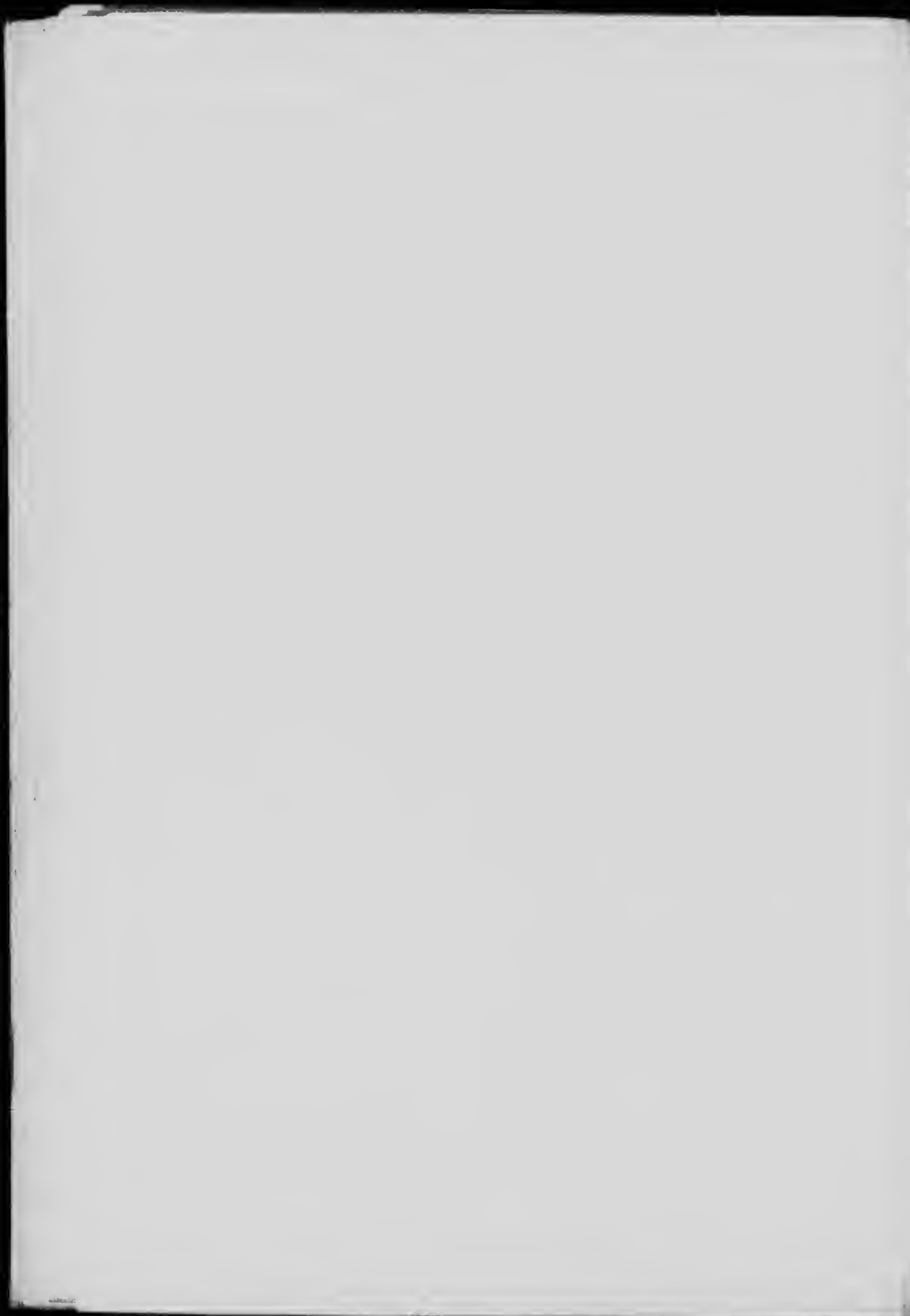
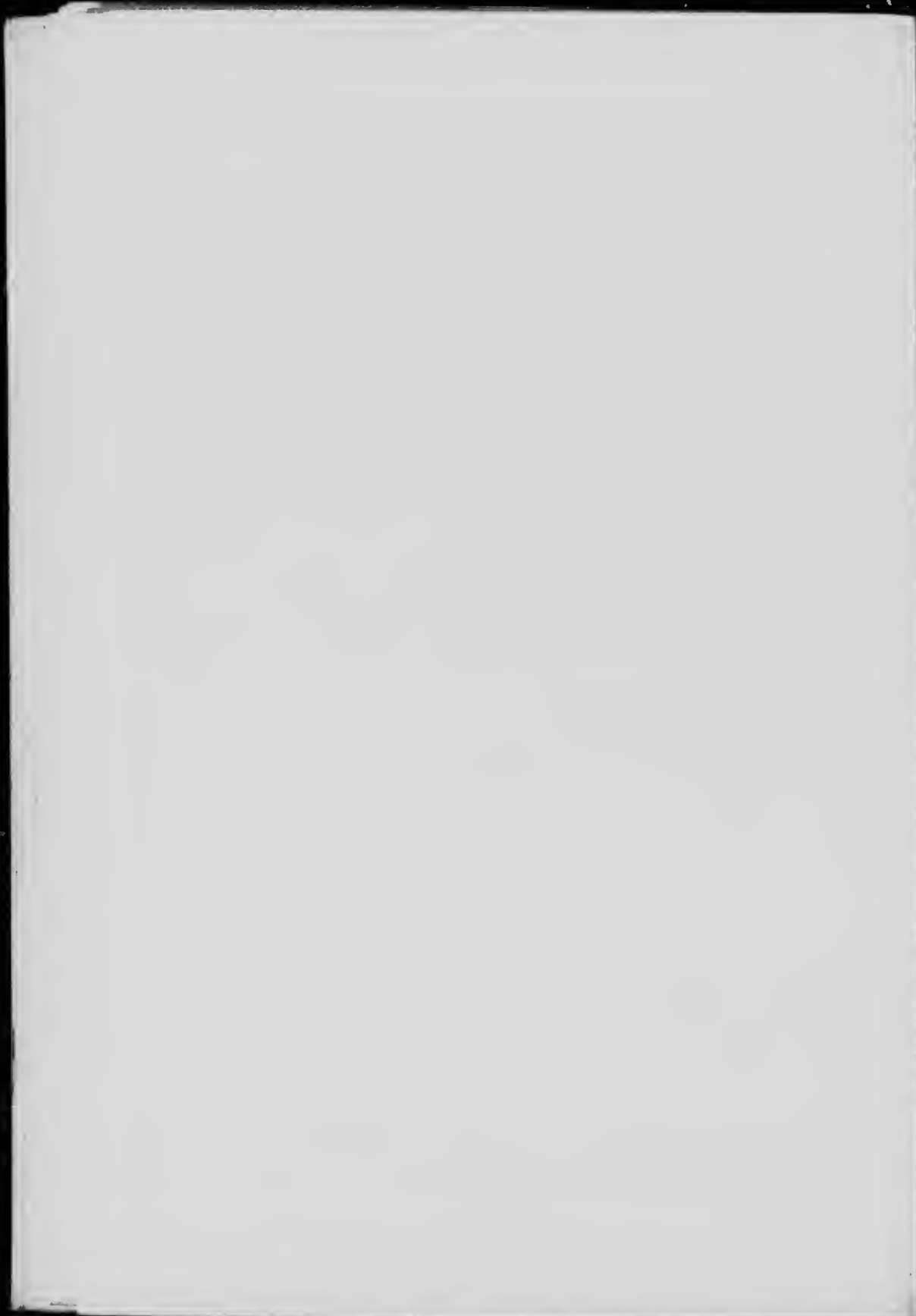

PLATE XXVII.



*Scirpus atrocinctus* (Fern).





*Scirpus Hudsonianus* (Fernal).





*Galium trifidum* (L.).



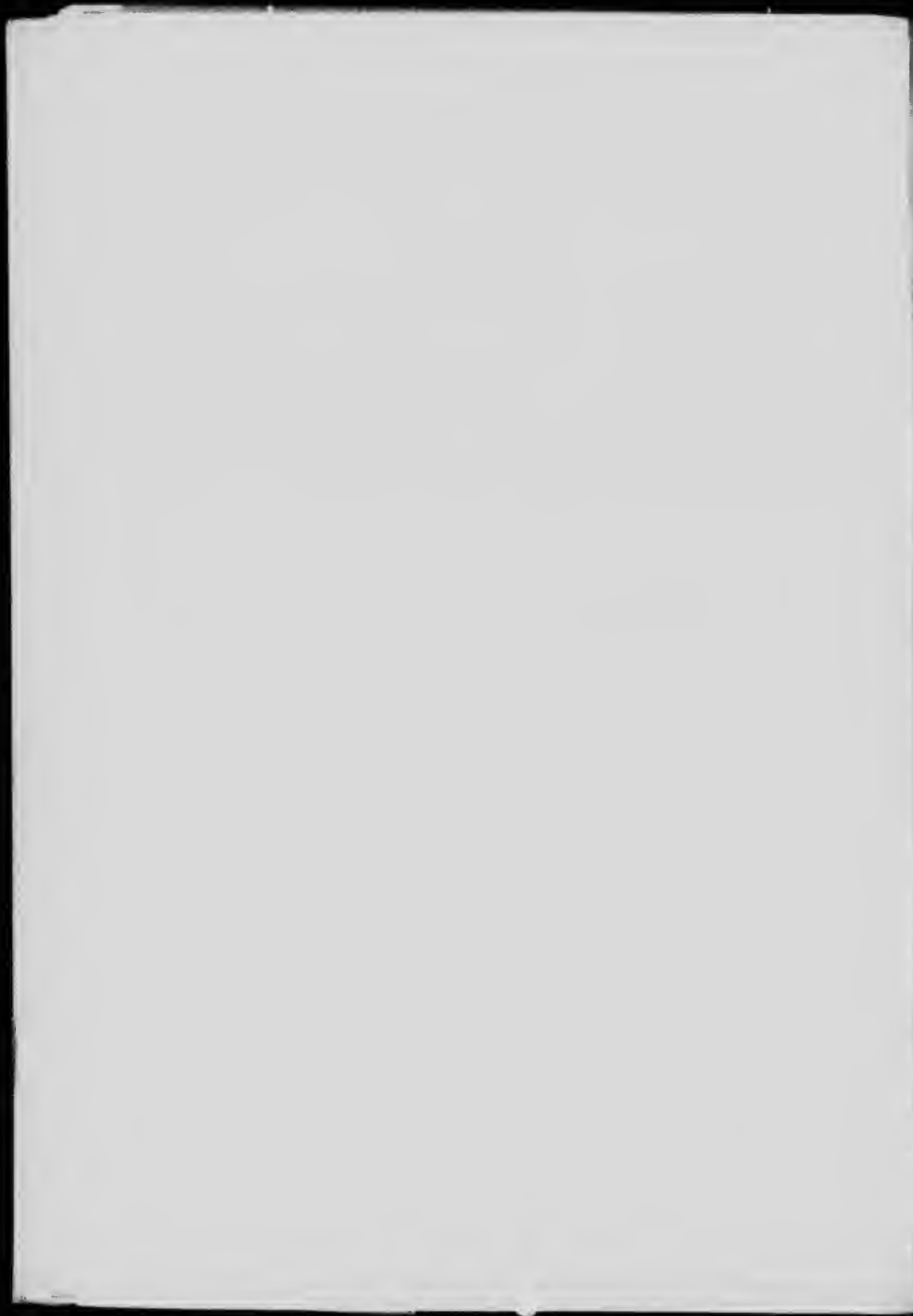



*Potamogeton alpinus.*





*Thalictrum dioicum.*

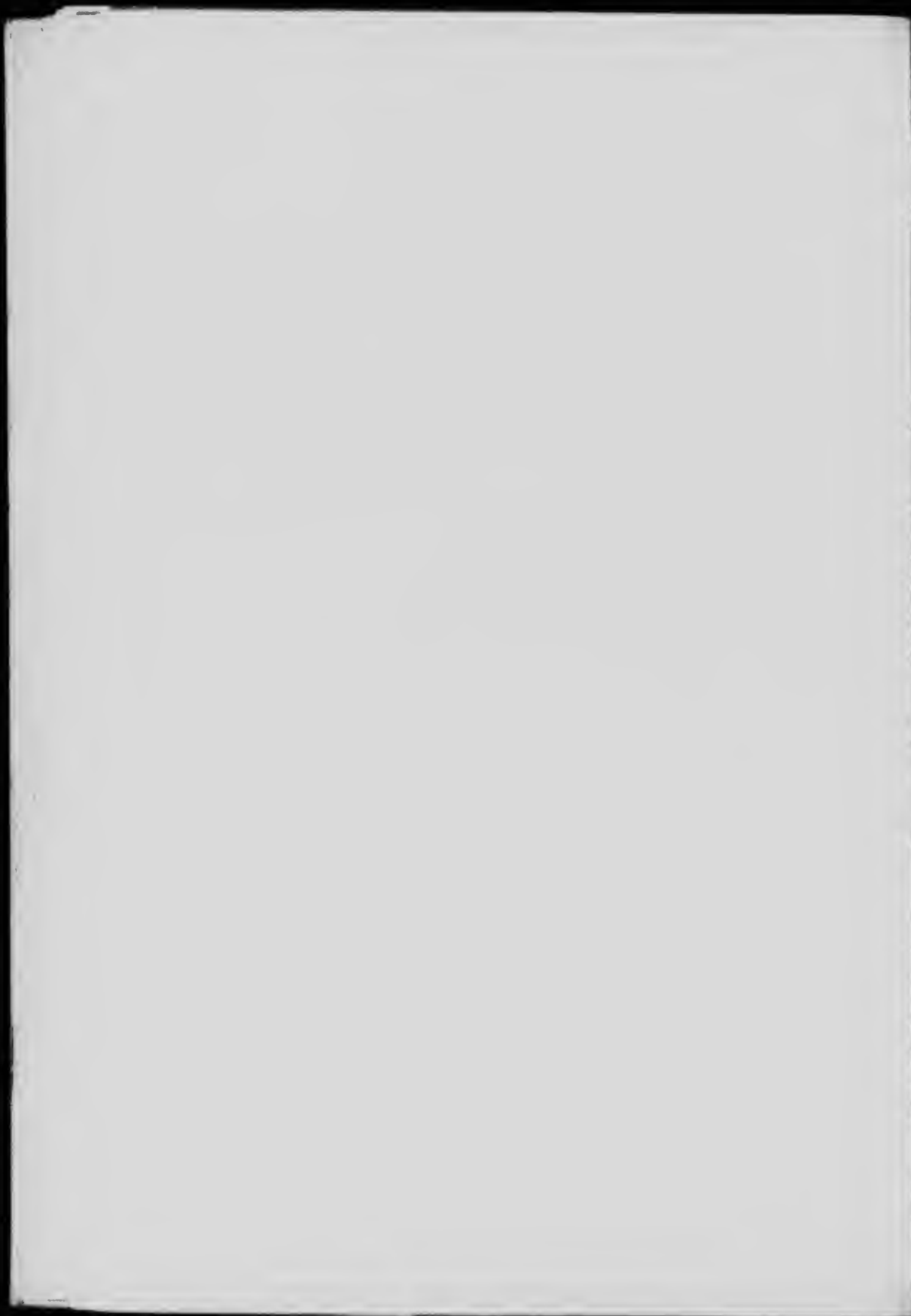



*Calopogon pulchellus* (R. Br.)





*Drepanocladus Kneiffii* (Sch.) Warnst.



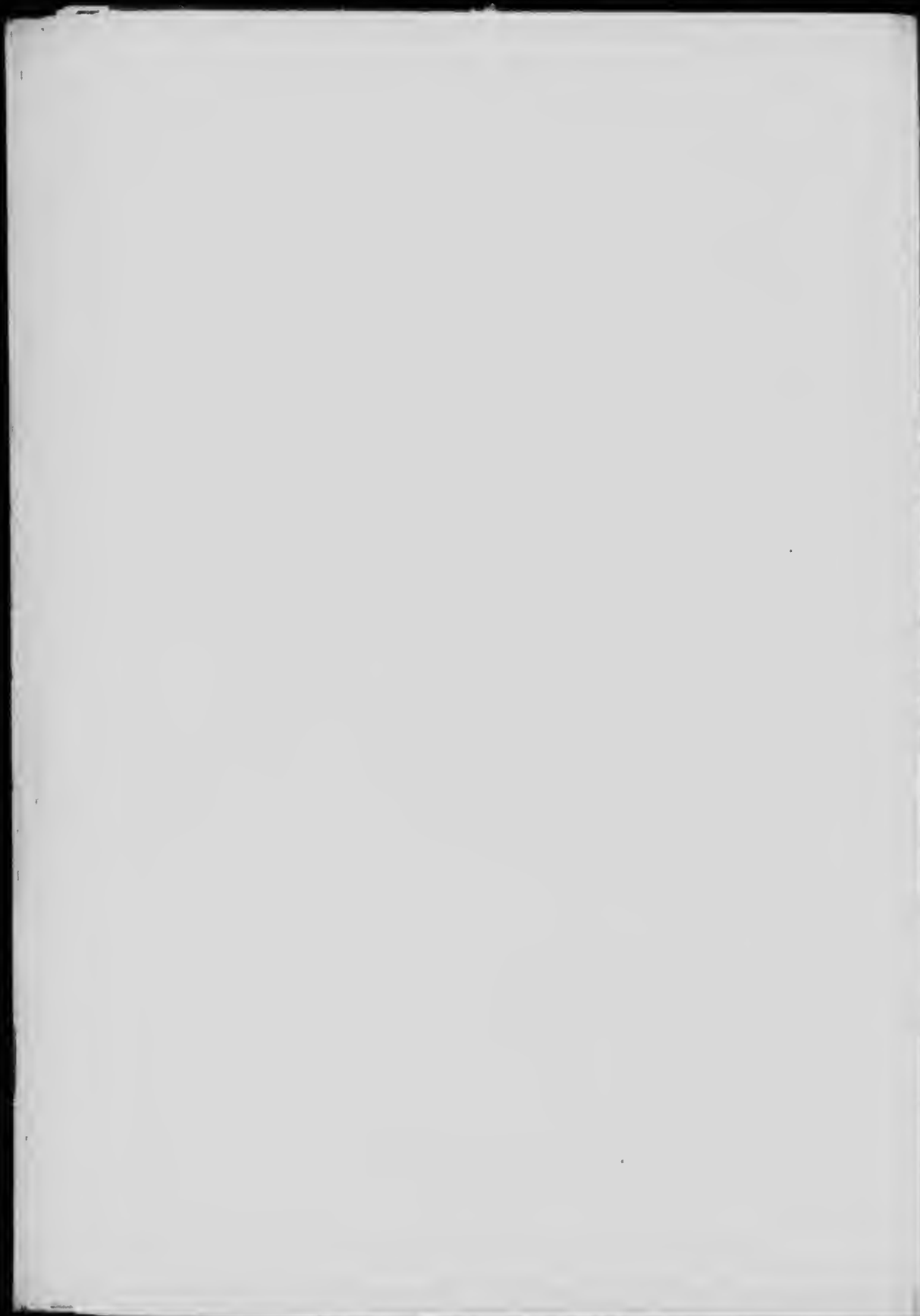



*Mniun affine*, Bland, var. *rugicum* (Laur.) Br. and Sch.

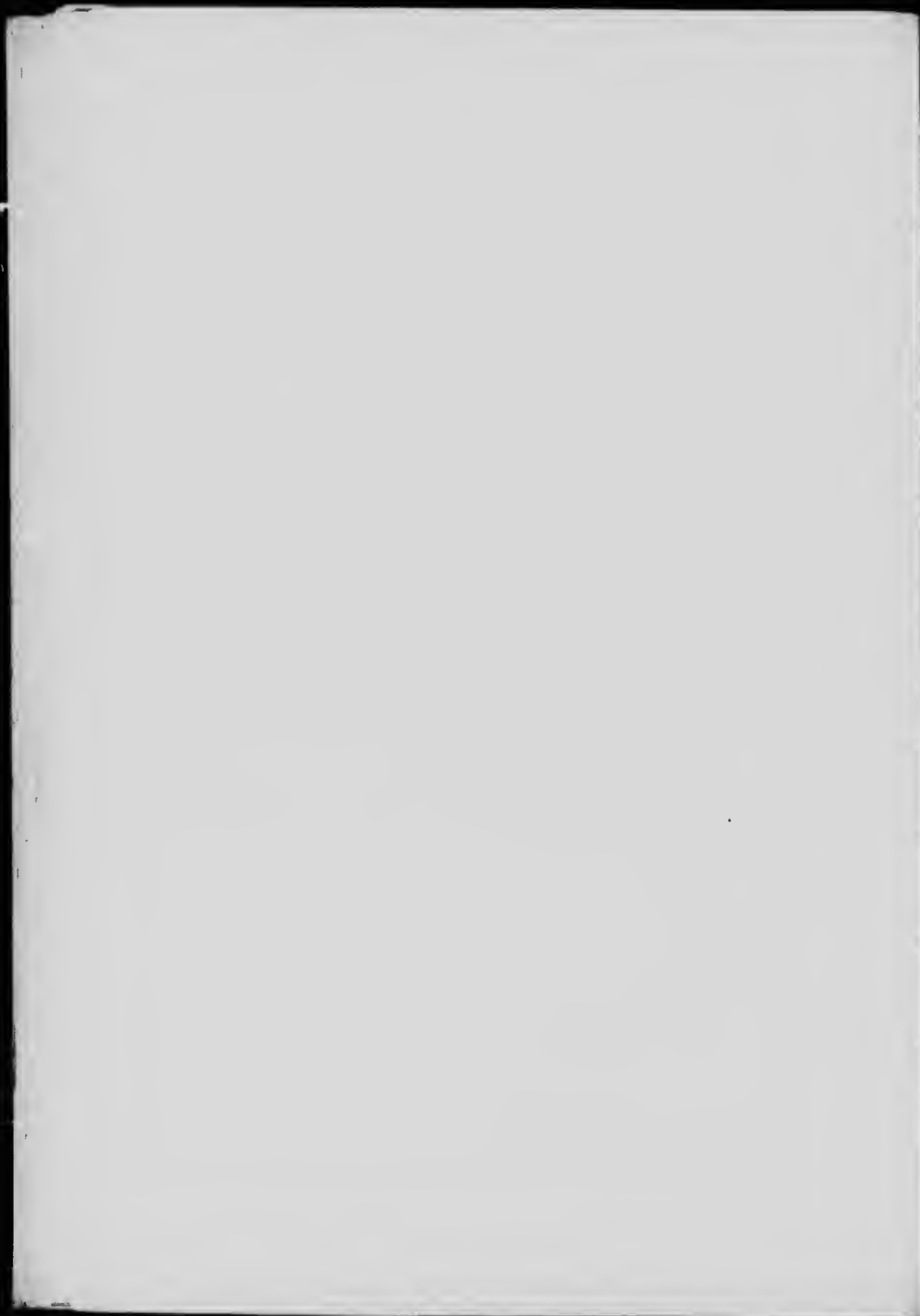



*Climacium dendroides* (Dill. L.) W. and M.

[The page contains extremely faint, illegible text, likely bleed-through from the reverse side of the document. The text is too light to be transcribed accurately.]

PLATE XXXVI.



*Calliergon cordifolium* (Hedw.) Lindb.

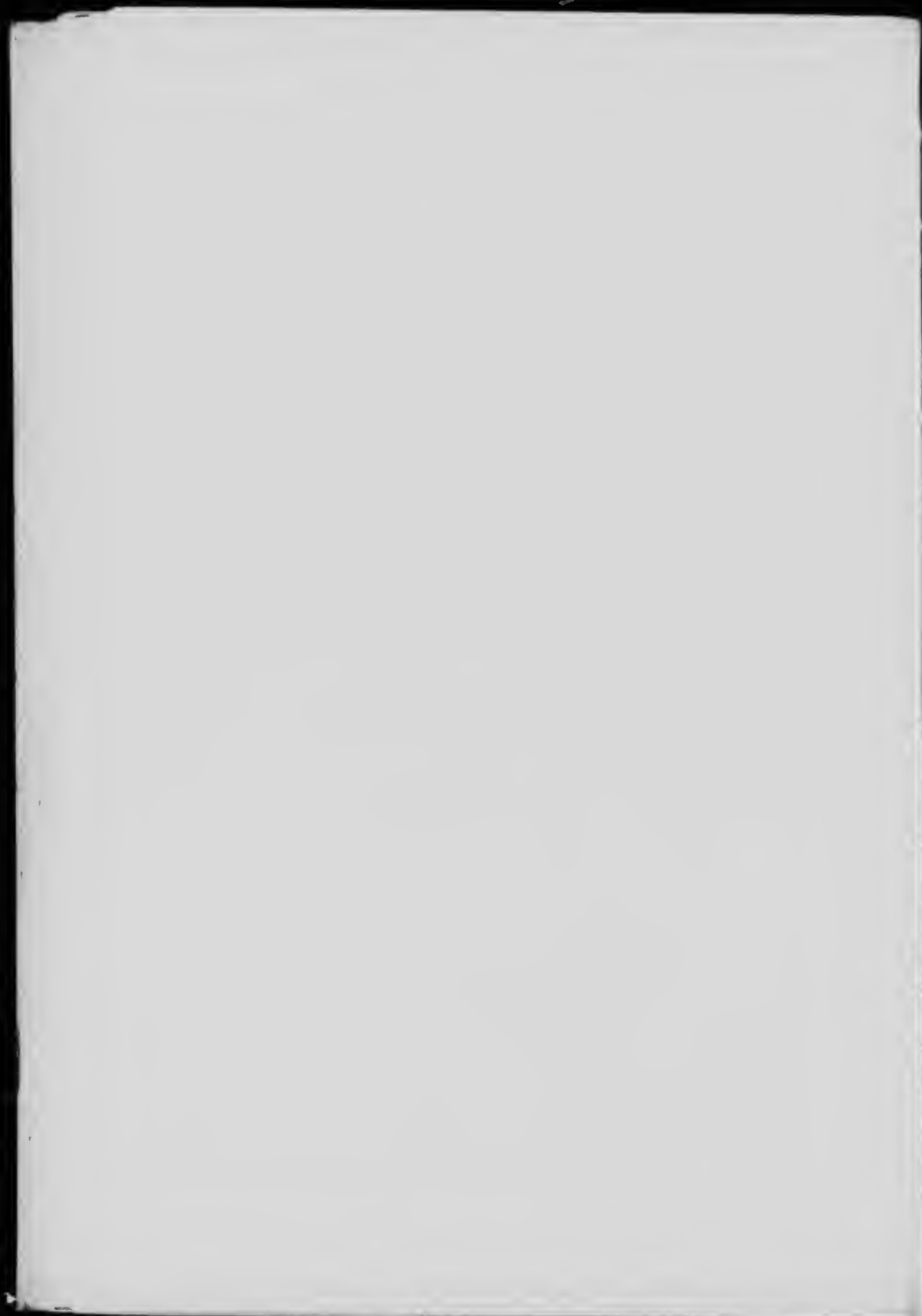

PLATE XXXVII.



*Thuidium delicatulum* (L) Mitt.







*Amblystegium riparium.*





*Amblystegium Juratzkanum.*





*Drepanocladus polycarpus*, Bland (Warnst.).

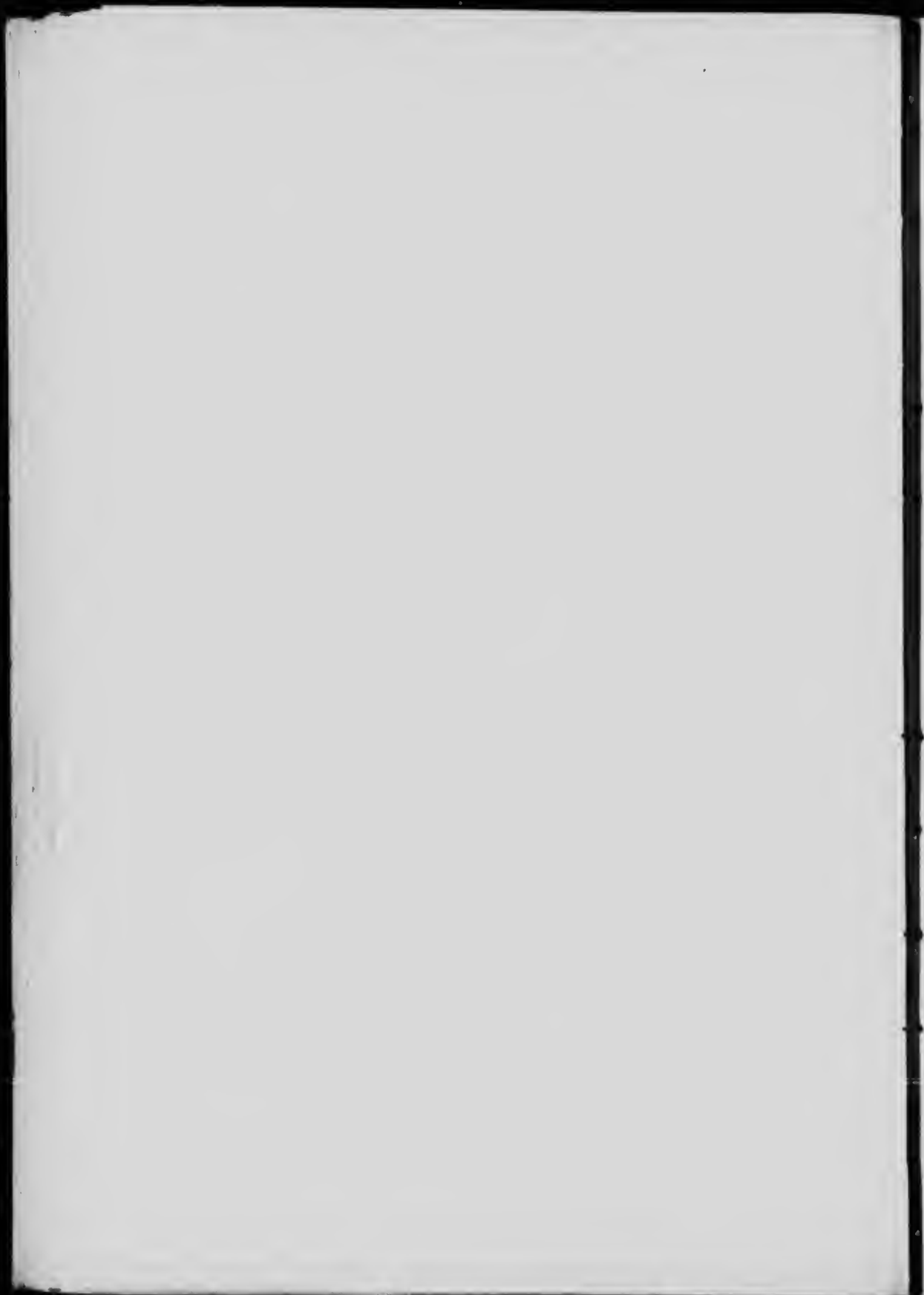



Mixture of three sterile species:—  
*Bryum bimum.*  
*Tortula montana.*  
*Ceratodon purpureus.*



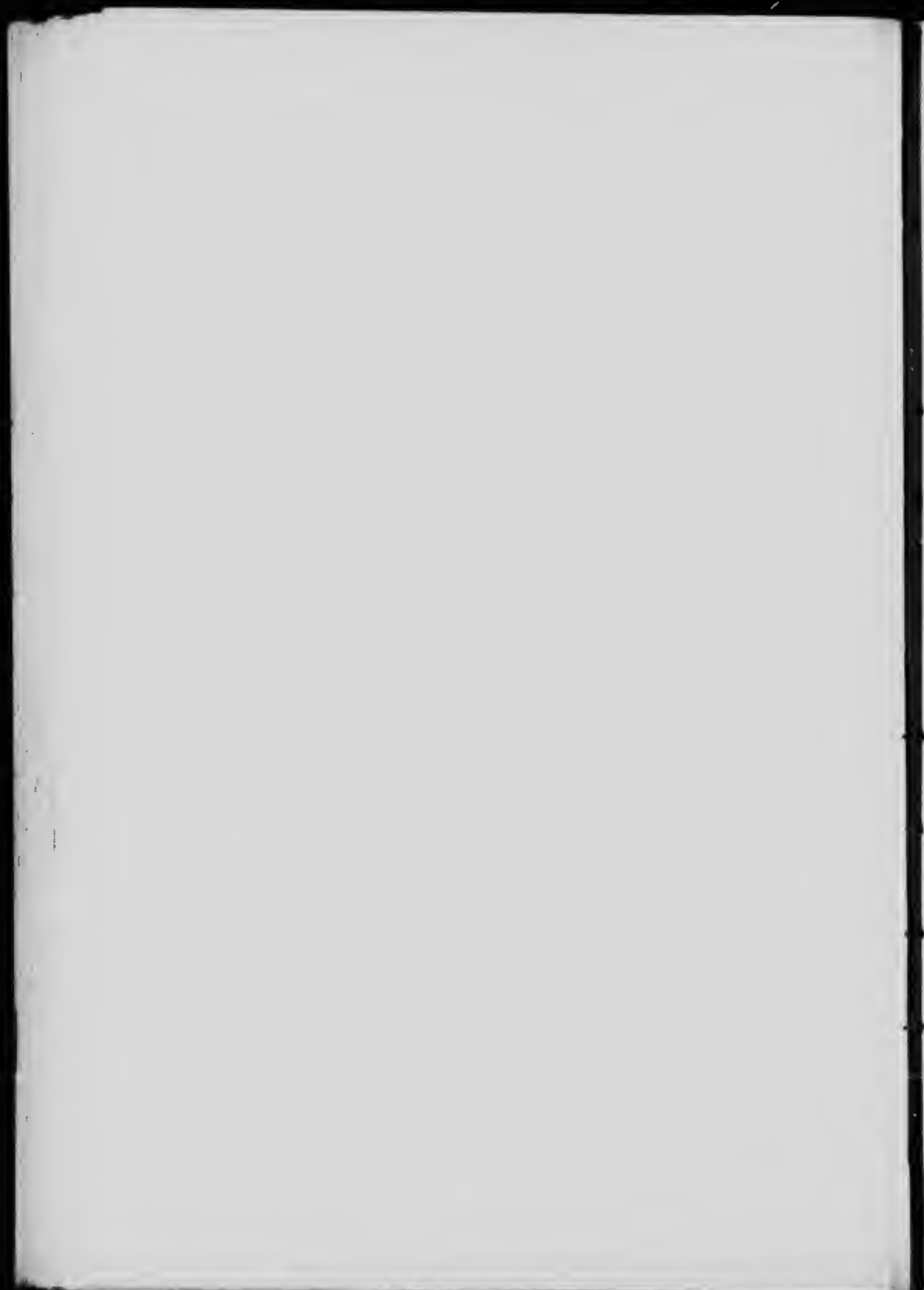



*Aspidium Thelypteris* (Swartz).





*Caltha palustris* (L.).

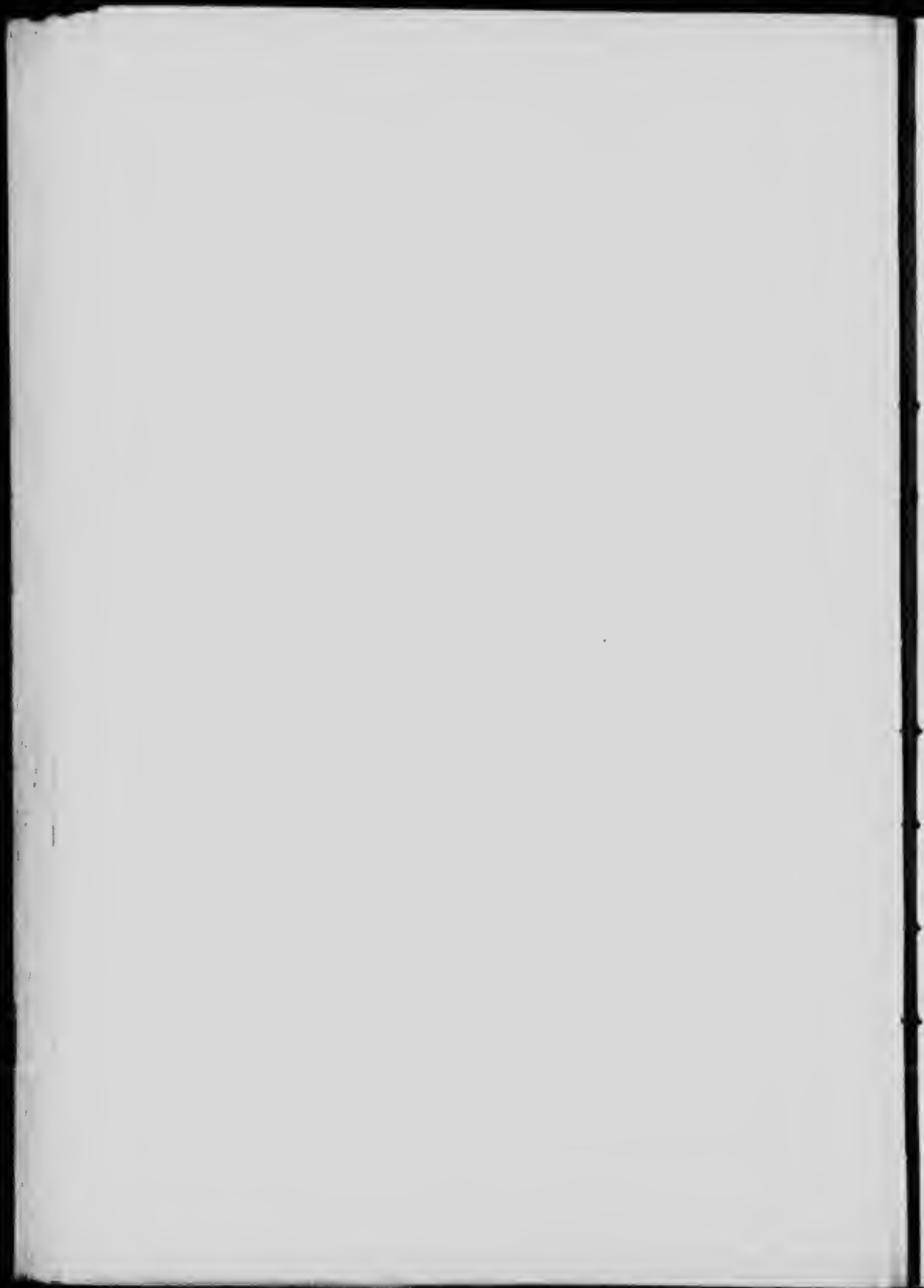



*Menyanthes trifoliata* (L.).





*Marchantia polymorpha.*



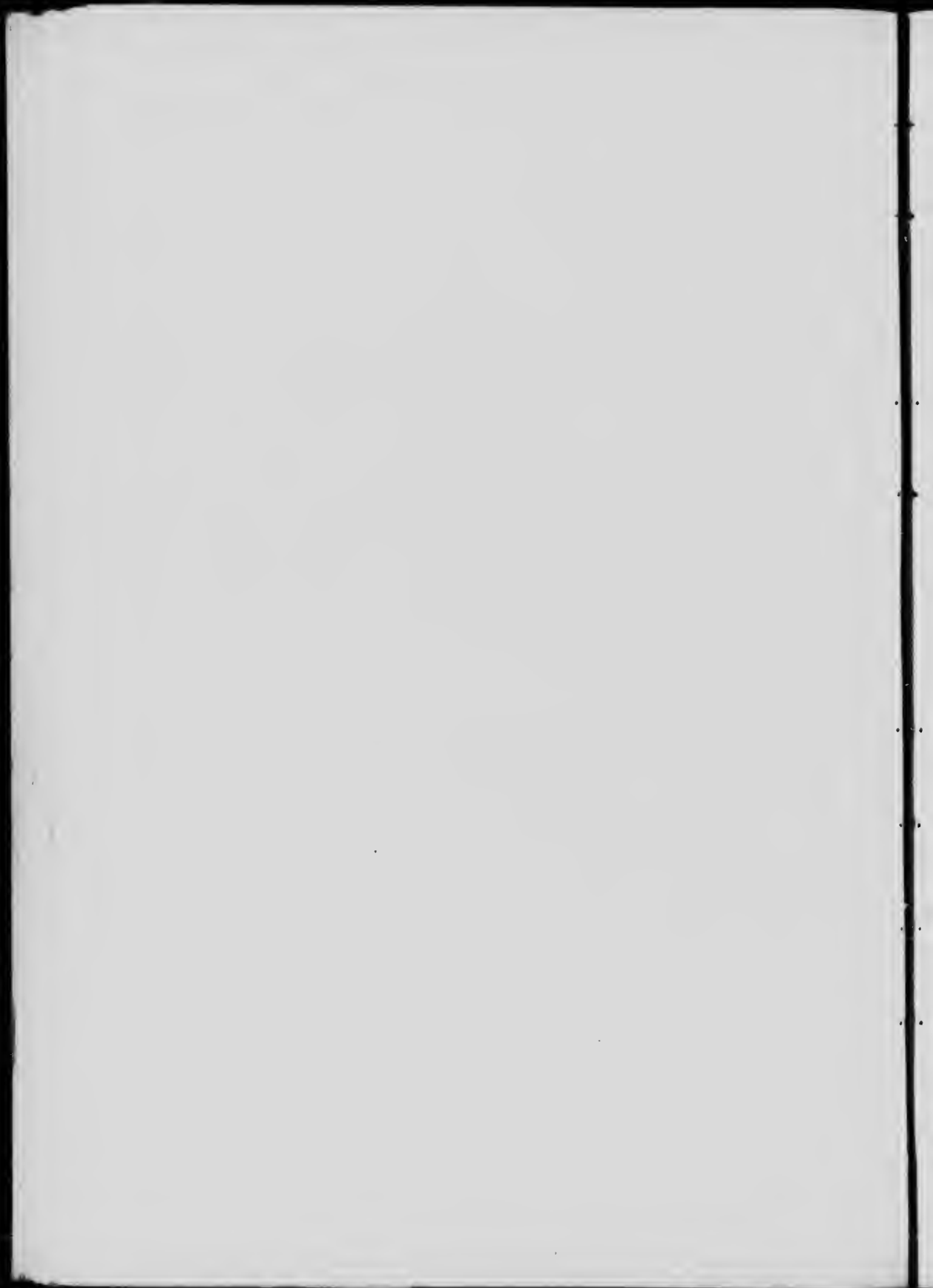
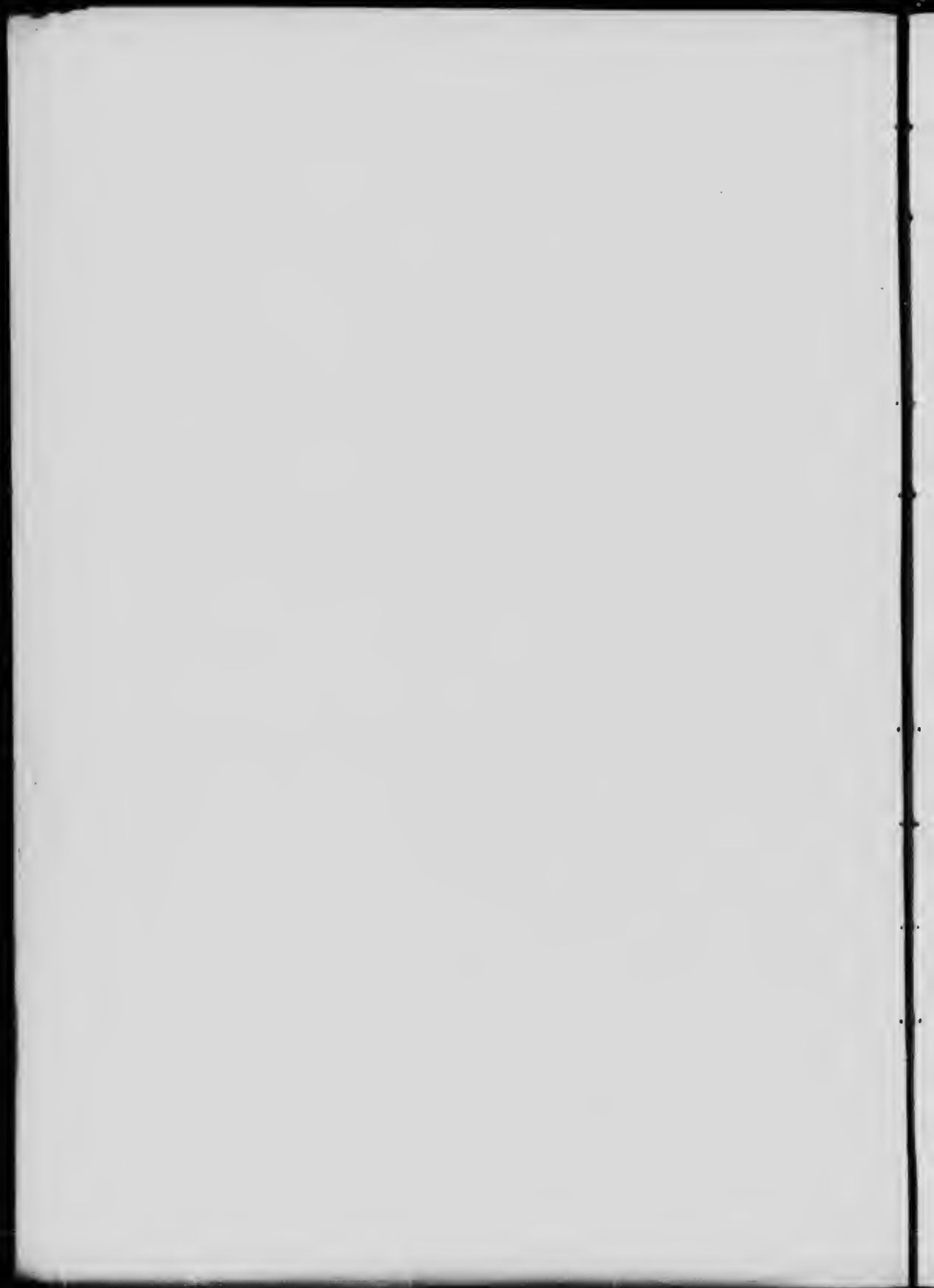

PLATE XLVI.



*Impatiens biflora* (Walt.).





*Lysimachia thrysiiflora*, (L.)

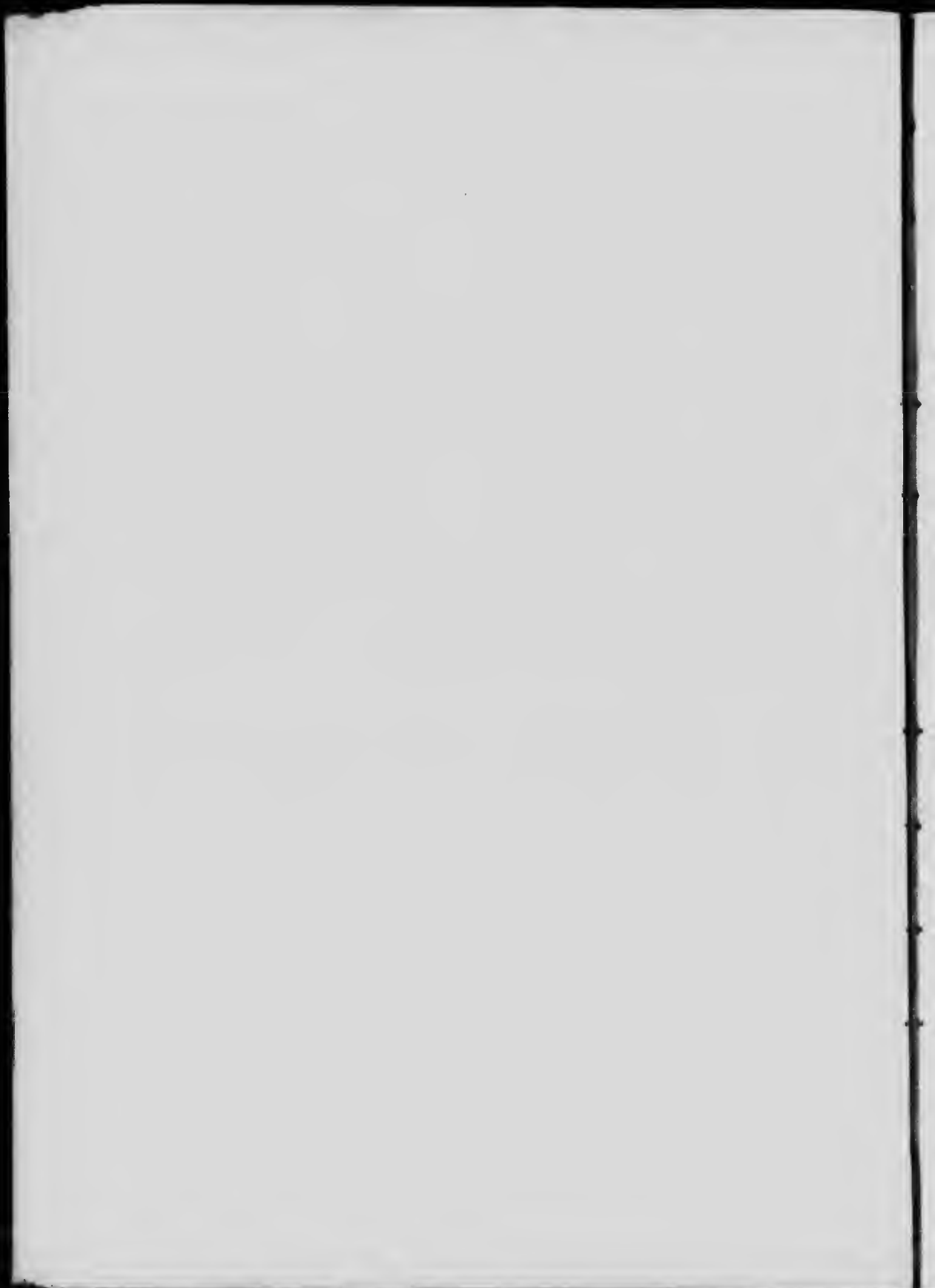



*Onoclea sensibilis*, (L.).

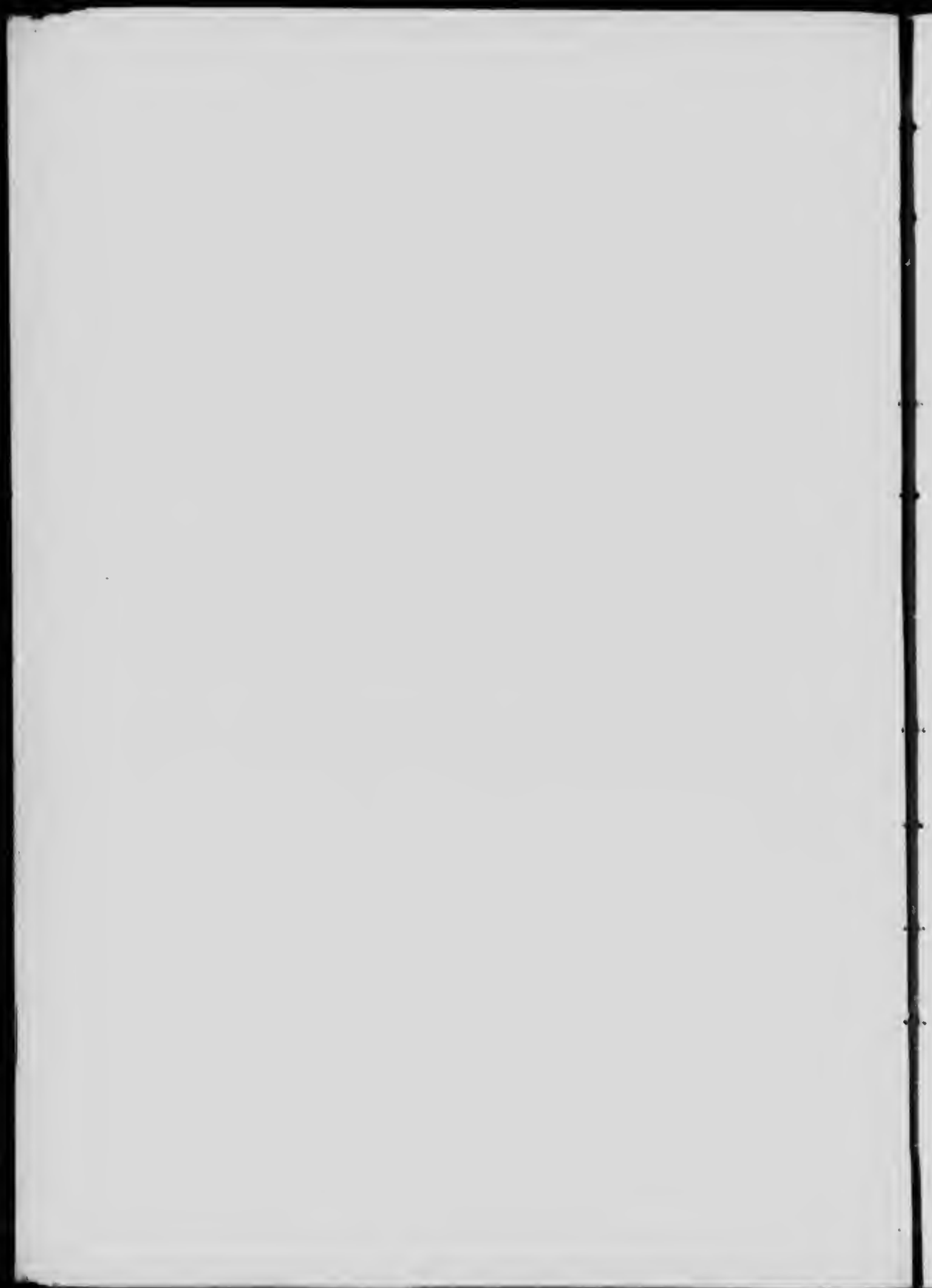



*Sium cicutaefolium*, Schrank.



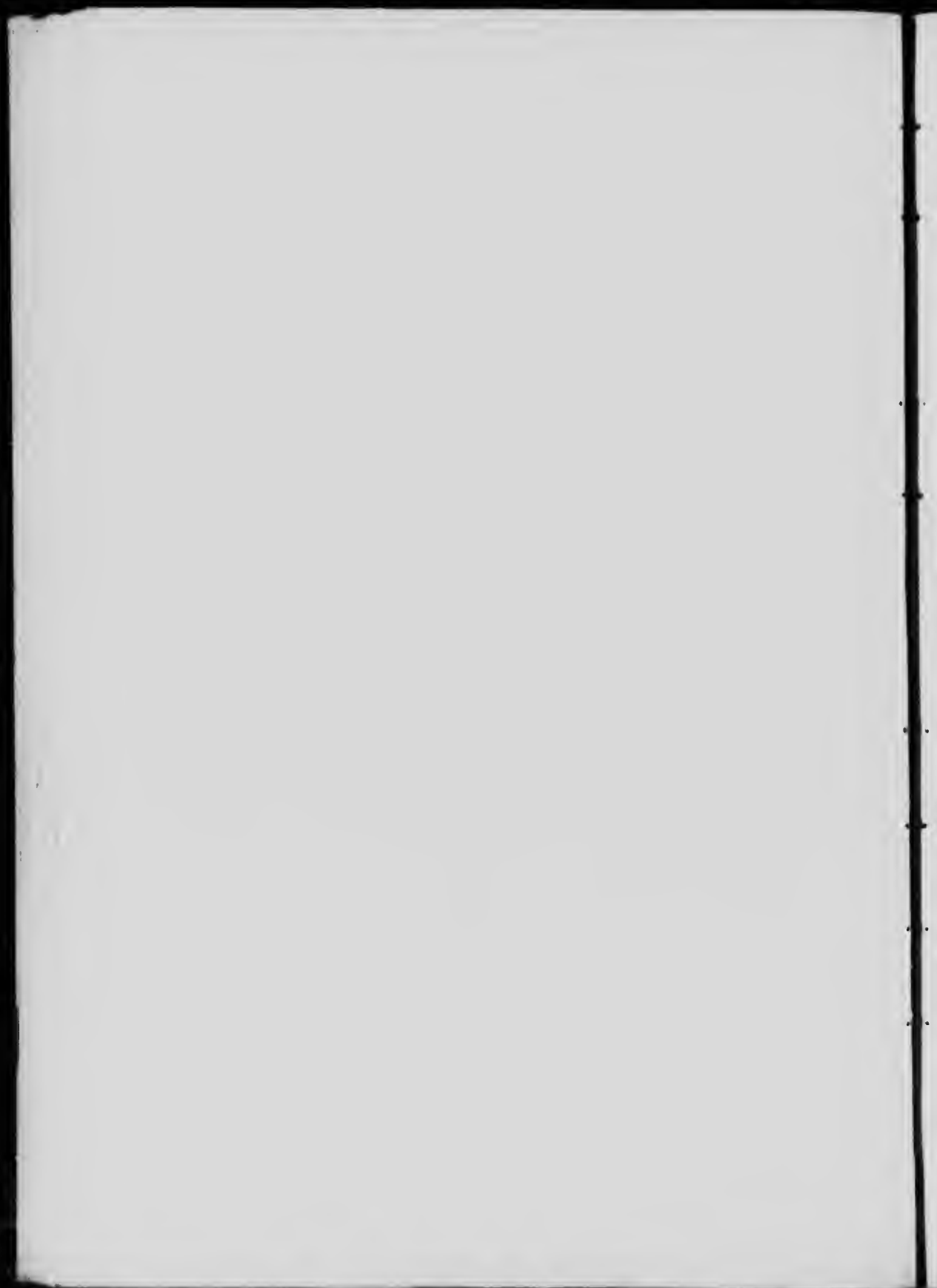



*Carex gynandra*, Schwein.

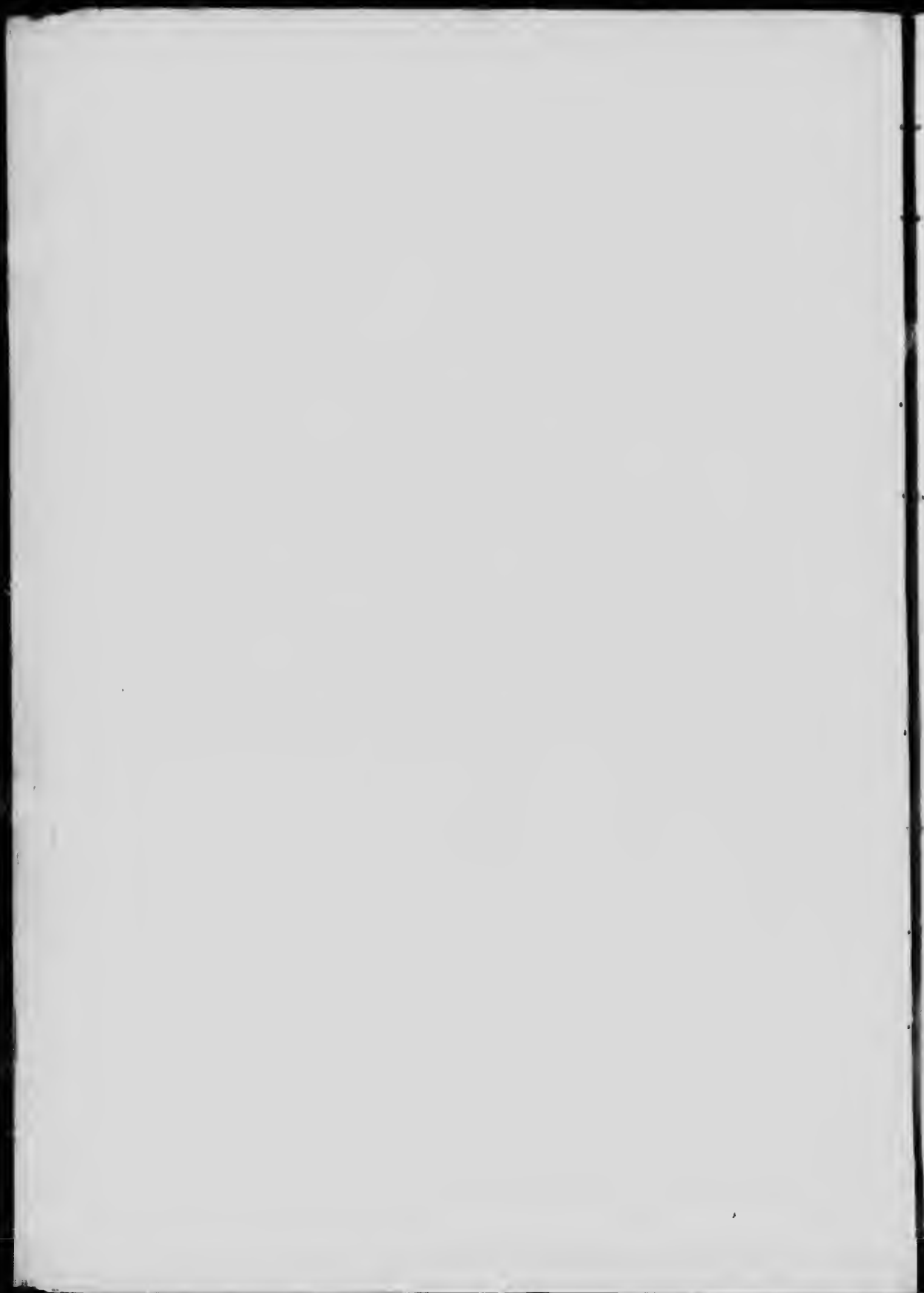



*Polygonum sagittatum*, (L.).



# MICROCOPY RESOLUTION TEST CHART

(ANSI and ISO TEST CHART No. 2)

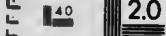
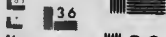

APPLIED IMAGE Inc

1655 East Main Street  
Rochester, New York 14609 USA  
(716) 482-0300 - Phone  
(716) 288-5989 - Fax

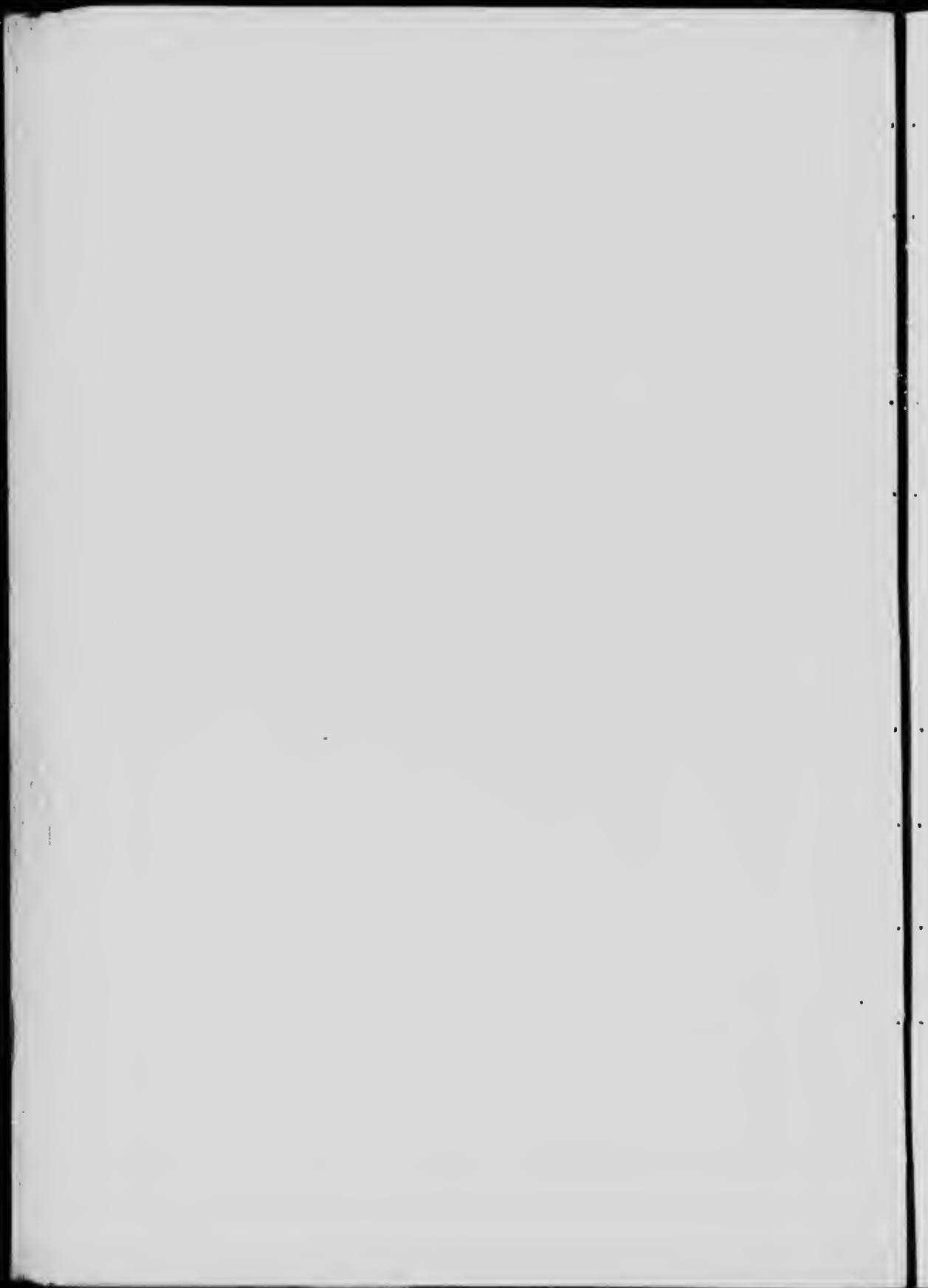



*Juncus effusus*, L., var. *compactus*, Lej. and Court.



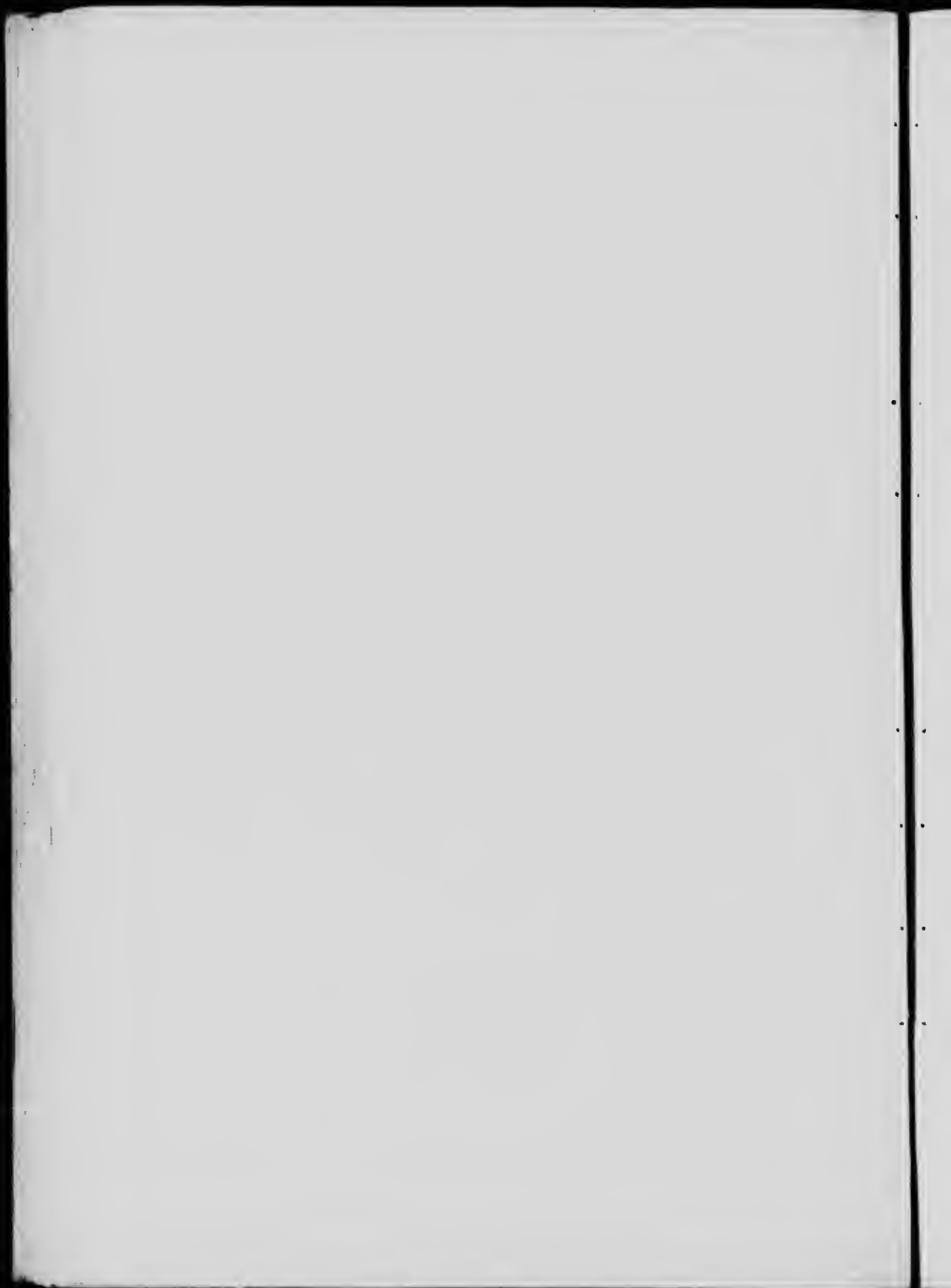



*Alopecurus geniculatus*, (L).

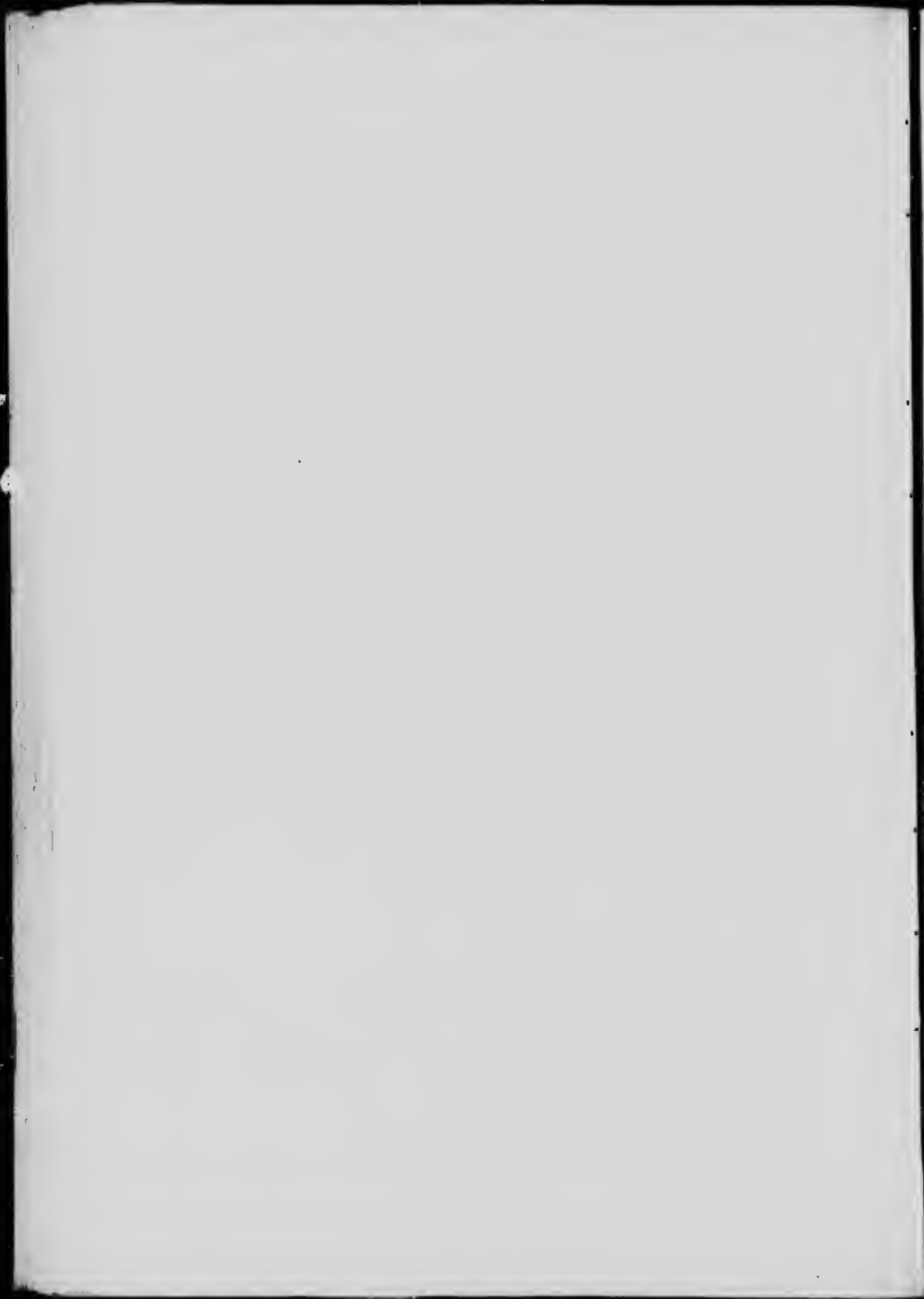



*Sium cicutaefolium*, Schrank: linear-leaved form.

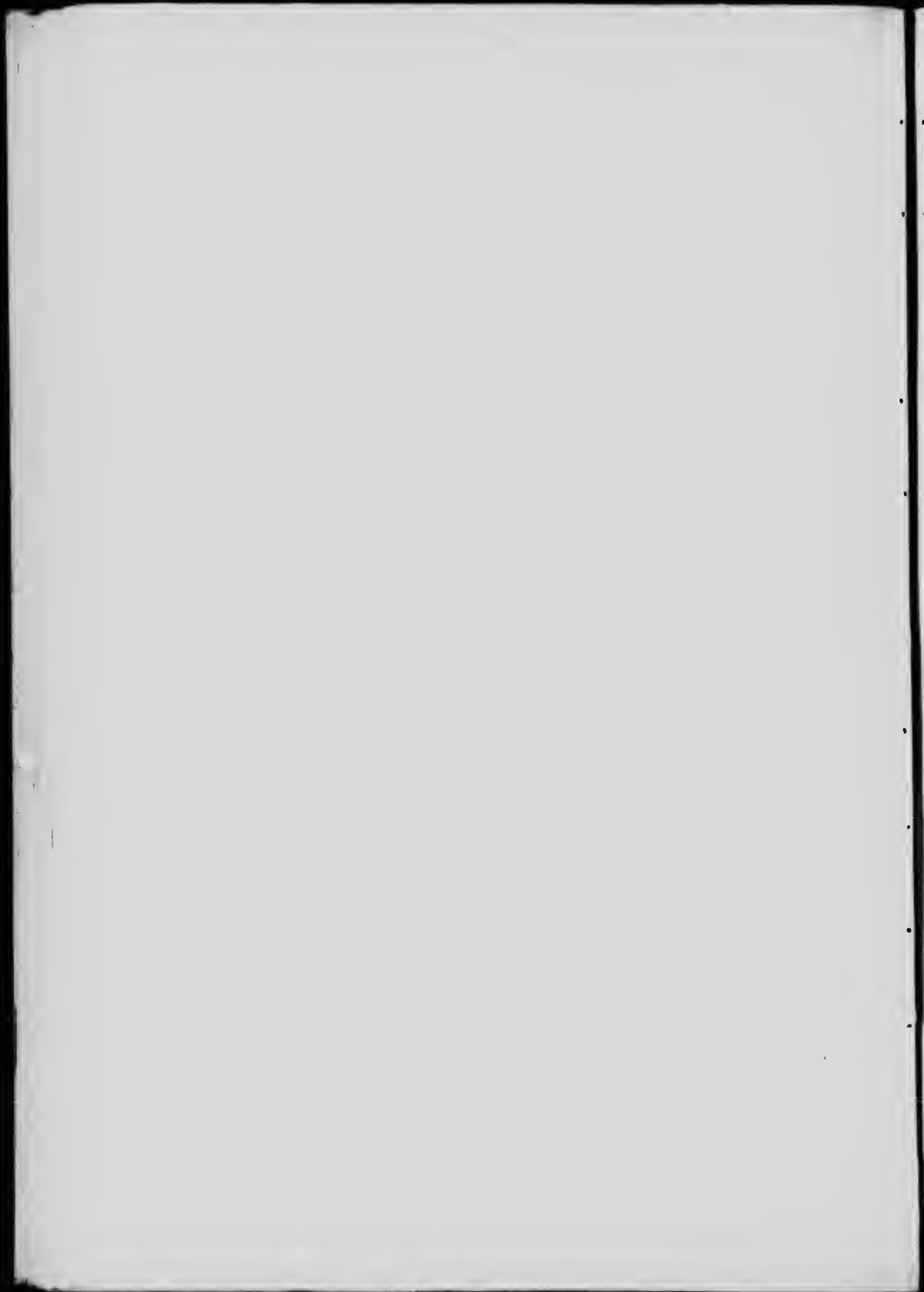



*Calamagrostis Langsdorffii*, (Link.) Trin.





*Chelone glabra*, (L.)



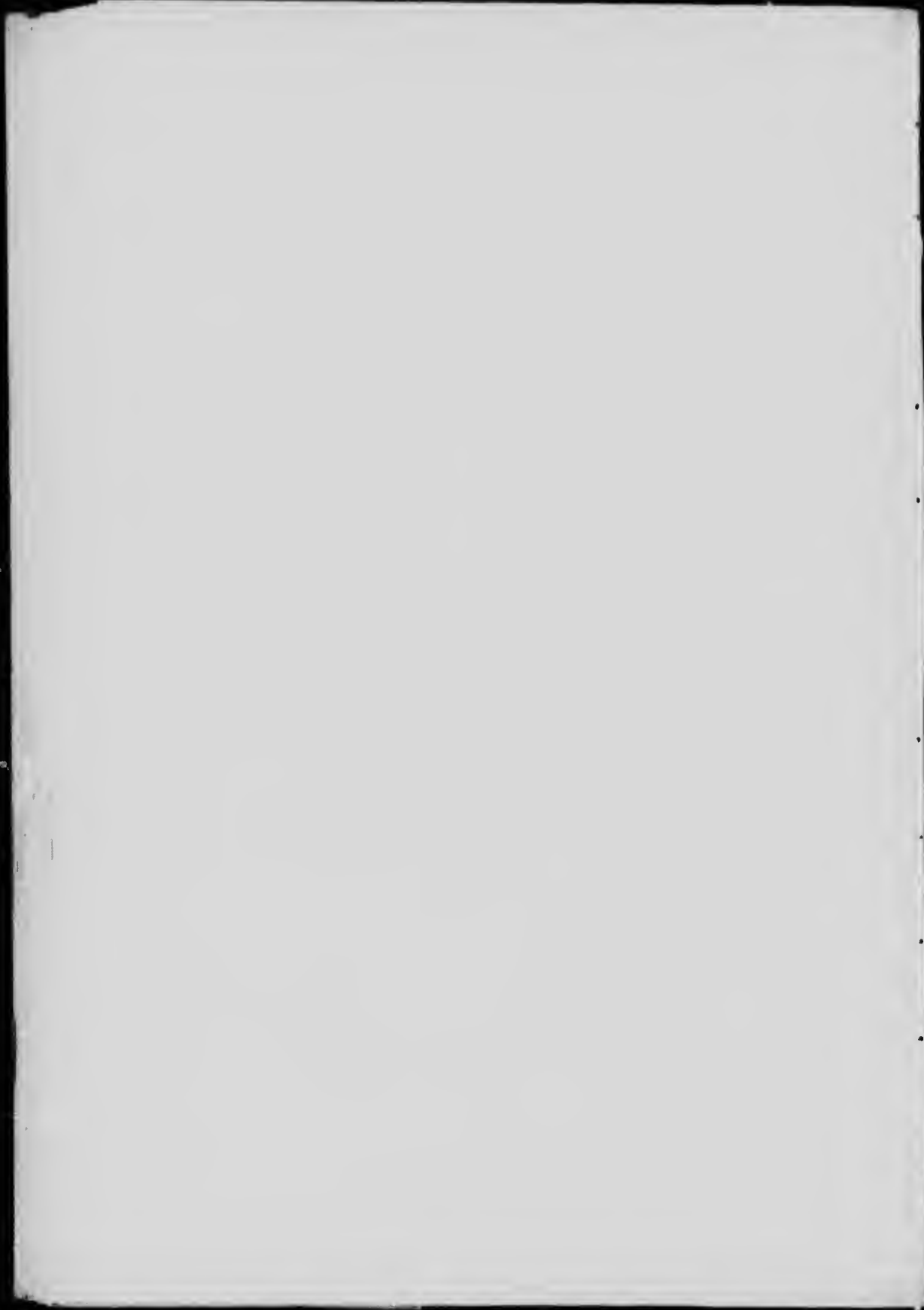



*Habenaria psycodes*, Gray.

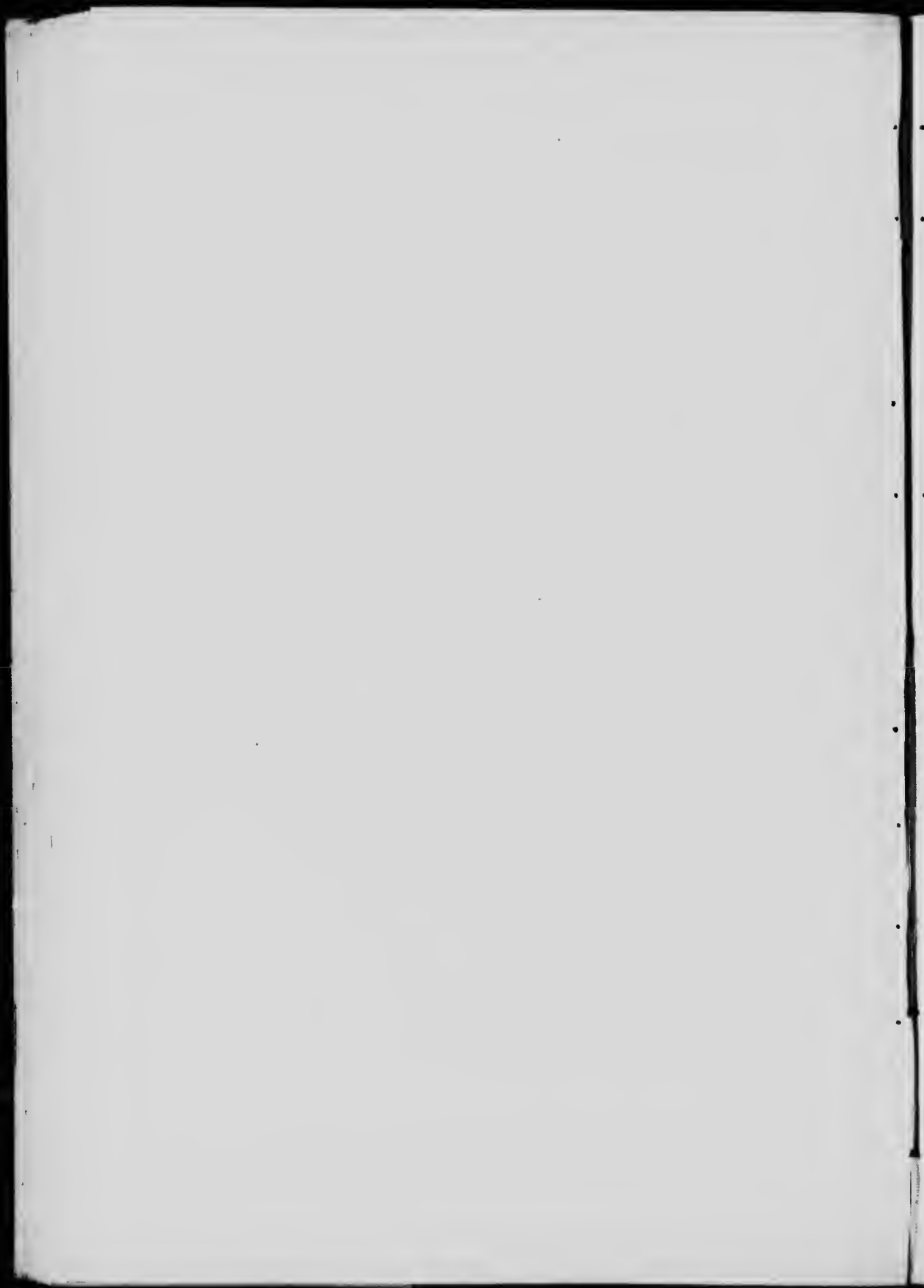



*Solidago rugosa*, Mill.

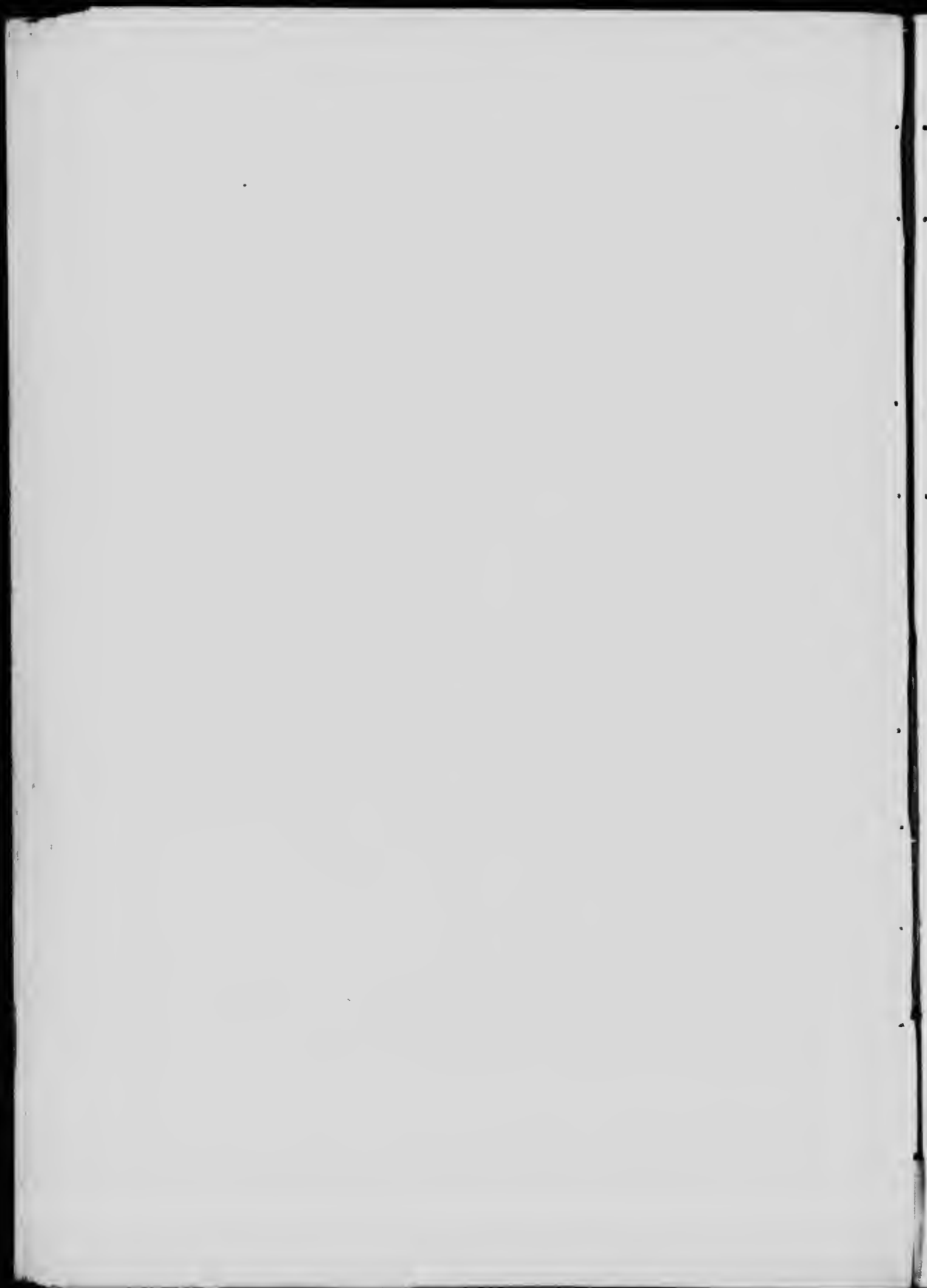



*Solidago graminifolia*. (L.) Salisb.

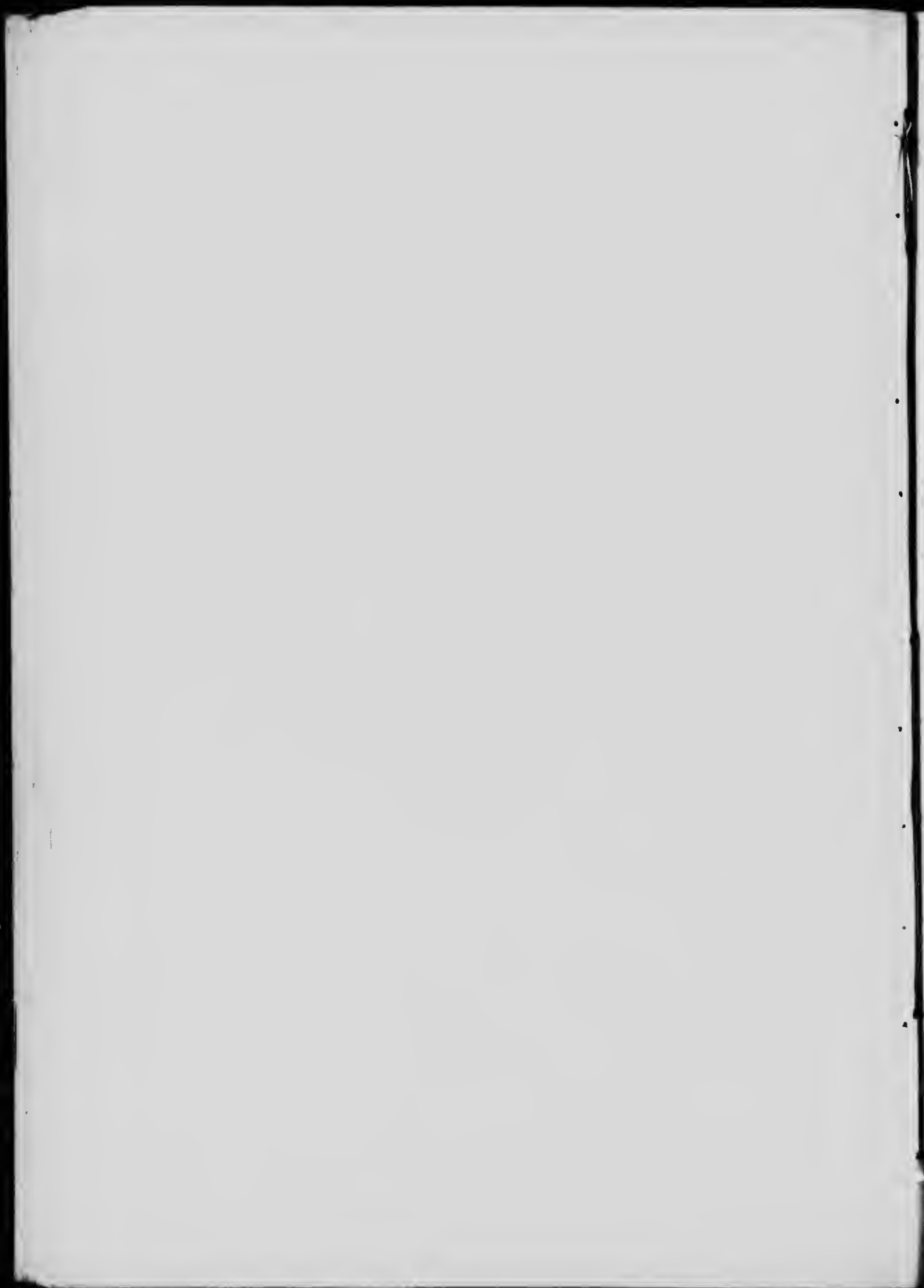



b

a

(a) *Solidago Canadensis*.  
(b) *Solidago uliginosa*, Nutt.







*Solidago altissima*, (L.).

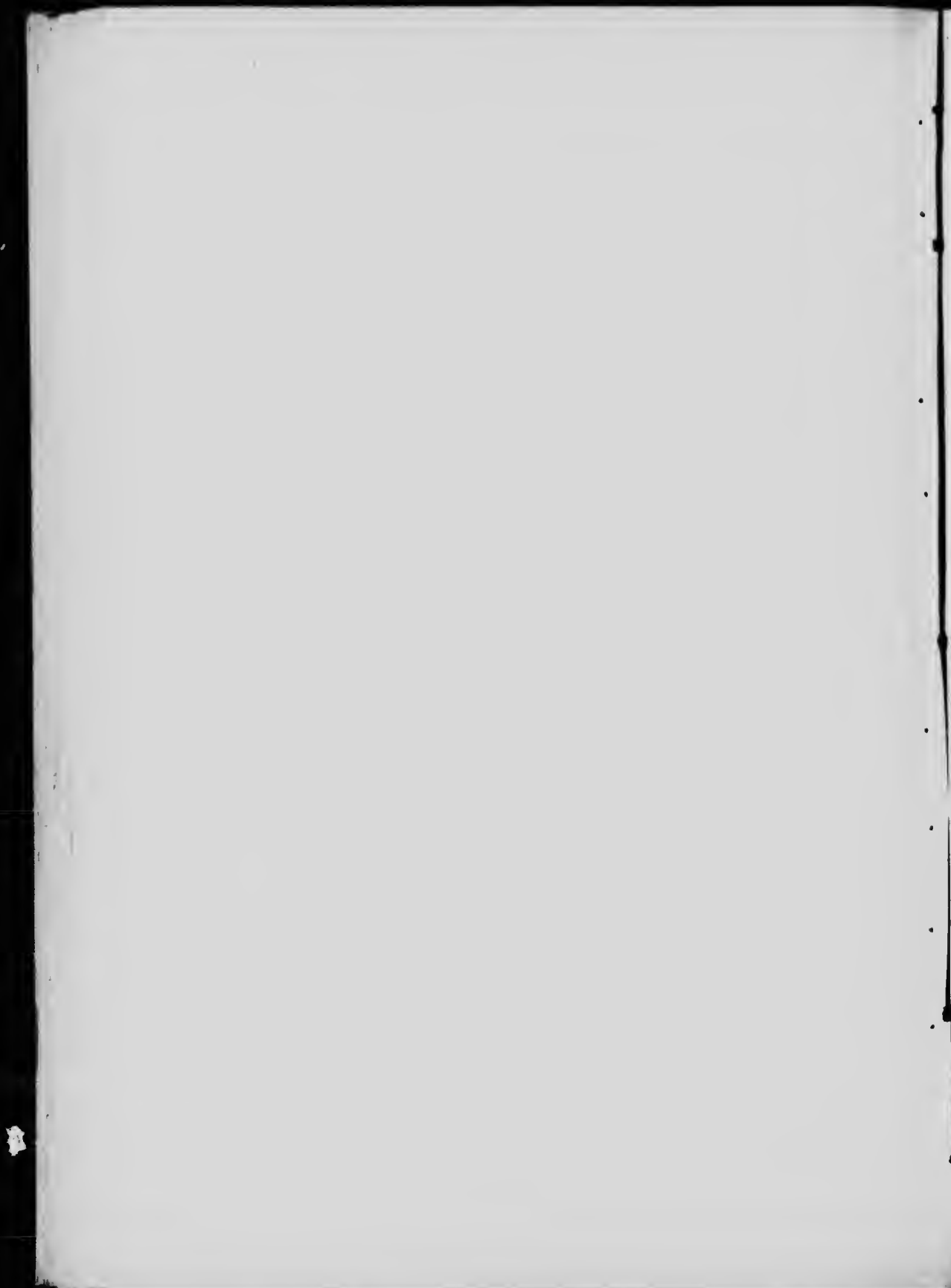

<i>Thuidium delicatulum</i> (L) Mitt.	Plate XXXVII
<i>Amblystegium riparium</i>	" XXXVIII
" <i>Juratzkanum</i>	" XXXIX
<i>Drepanocladus polycarpus</i> , Bland (Warnst)	" XL
Mixture of three sterile species:	
<i>Bryum bimum</i> , <i>Tortula montana</i> ,	
<i>Ceratodon purpureus</i>	" XLI.
<i>Aspidium Thelypteris</i> (Swartz)	" XLII.
<i>Caltha palustris</i> (L)	" XLIII.
<i>Menyanthes trifoliata</i> (L)	" XLIV.
<i>Marchantia polymorpha</i>	" XLV.
<i>Impatiens biflora</i> (Walt)	" XLVI.

## QUEBEC.

**L'Assomption Peat Bog, L'Epiphanie, Quebec.**

<i>Lysimachia thrysiflora</i> (L)	" XLVII.
<i>Onoclea sensibilis</i> (L)	" XLVIII.
<i>Sium cicutifolium</i> , Schrank	" XLIX.
<i>Carex gynandra</i> , Schwein	" L.

**St. Isidore Peat Bog, St. Isidore, Que.**

<i>Polygonum sagittatum</i> (L)	" LI.
---------------------------------	-------

**Holton Peat Bog, Holton, Que.**

<i>Juncus effusus</i> , L., var. <i>compactus</i> , Lej. and Court	" LII.
<i>Alopecurus geniculatus</i> (L)	" LIII.

## PRINCE EDWARD ISLAND.

**Miscouche Peat Bog, St. Nicholas, P.E.I.**

<i>Sium cicutifolium</i> , Schrank, linear leaved form	" LIV.
<i>Calamagrostis Langsdorffii</i> (Link) Trin.	" LV
<i>Chelone glabra</i> (L)	" LVI
<i>Habenaria psycodes</i> , Gray	" LVII.
<i>Solidago rugosa</i> , Mill	" LVIII
" <i>graminifolia</i> (L) Salisb.	" LIX.
" <i>Canadensis</i>	" LX
" <i>uliginosa</i> , Nutt.	" LX.
" <i>altissima</i> (L)	" LXI.

**Black Banks Peat Bog, Conway, P.E.I.**

<i>Rubus Chamamoras</i> (L.)	Plate LXII
<i>Empetrum nigrum</i> (L.)	" LXIII.

## NOVA SCOTIA.

**Caribou Peat Bog, Berwick, N.S.**

<i>Triophorum Virginicum</i> (L.)	" LXIV.
<i>Vaccinium corymbosum</i> (L.)	" LXV.
<i>Gaultheria procumbens</i> (L.)	" LXVI.
<i>Asplenium Filix-femina</i> (L.) Bernh.	" LXVII.

**Tusket Peat Bog, Tusket, N.S.**

<i>Galium tinctorium</i> (L.)	" LXVIII.
<i>Adiantum pedatum</i> (L.)	" LXIX.

**Clyde Peat Bog, Clyde River, N.S.**

<i>Sphagnum tenellum</i> , Pers.	" LXX.
" <i>capillaceum</i> (Weiss) Schrank	" LXXI.
" <i>fuscum</i> (Sch.) Klinggr.	" LXXII.
showing dark brown in colour, in the photograph.	
" <i>capillaceum</i> (Weiss) Schrank var. <i>tenellum</i> (Schrimp) Andr.	" LXXII.
showing light red in colour, in the photo- graph.	
<i>Dicranum Bergeri</i> , Blandow	" LXXIII.

**Acknowledgments.**

The writer desires to acknowledge his indebtedness for courteous assistance in naming the above mentioned peat plants, to Mr. John Macoun, F.L.S., F.R.S.C., naturalist of the Geological Survey Branch, Dept. of Mines; and to Mrs. E. A. Britton, botanist, New York Botanical Gardens.



*Rubus Chamaemoras* (L.).





*Empetrum nigrum* (L.).



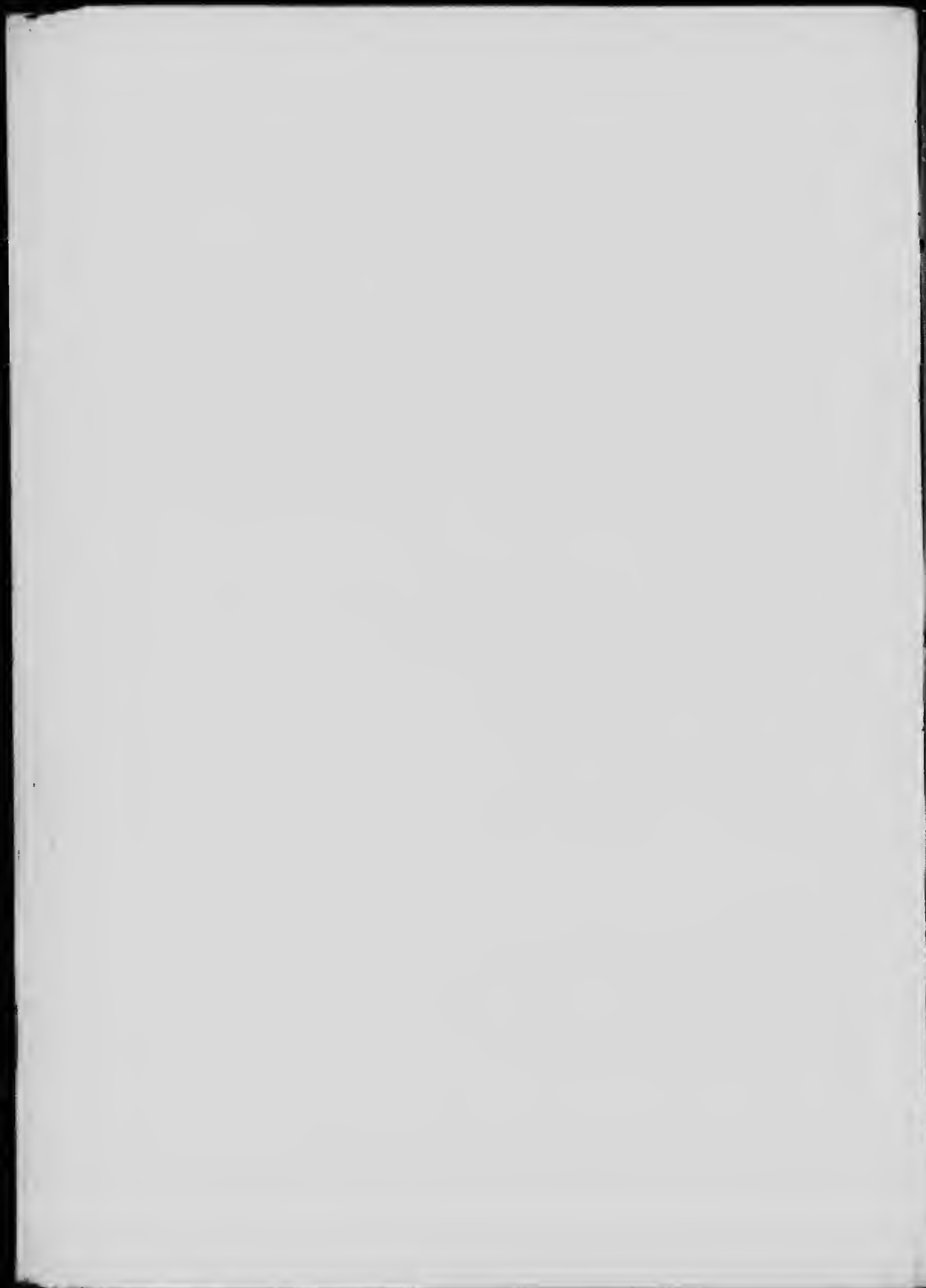



*Eriophorum Virginicum*, (L.).

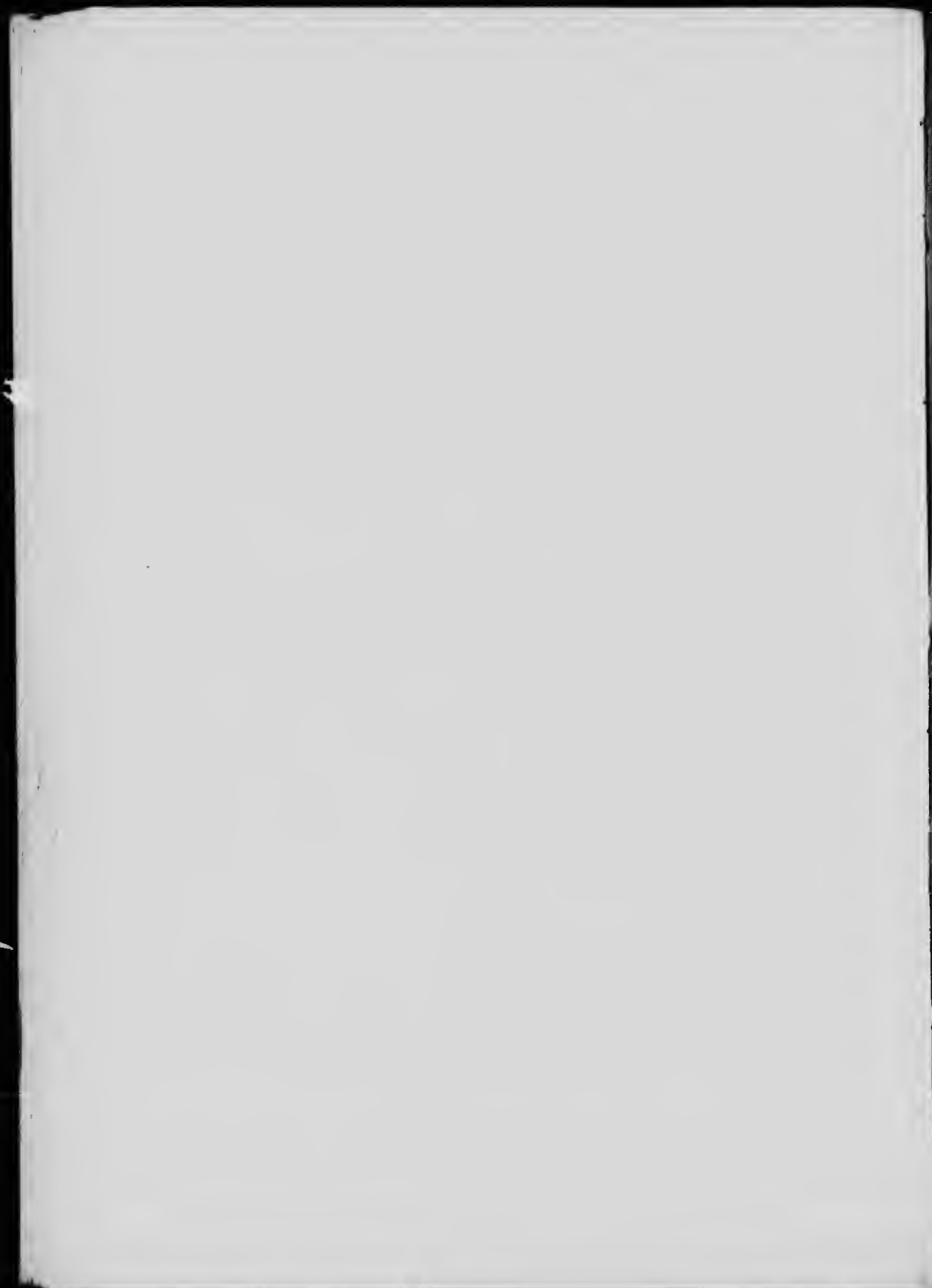



*Vaccinium corymbosum*, (L.).





*Gaultheria procumbens*, (L.).





*Asplenium Filix-femina*, (L.). Bernh.



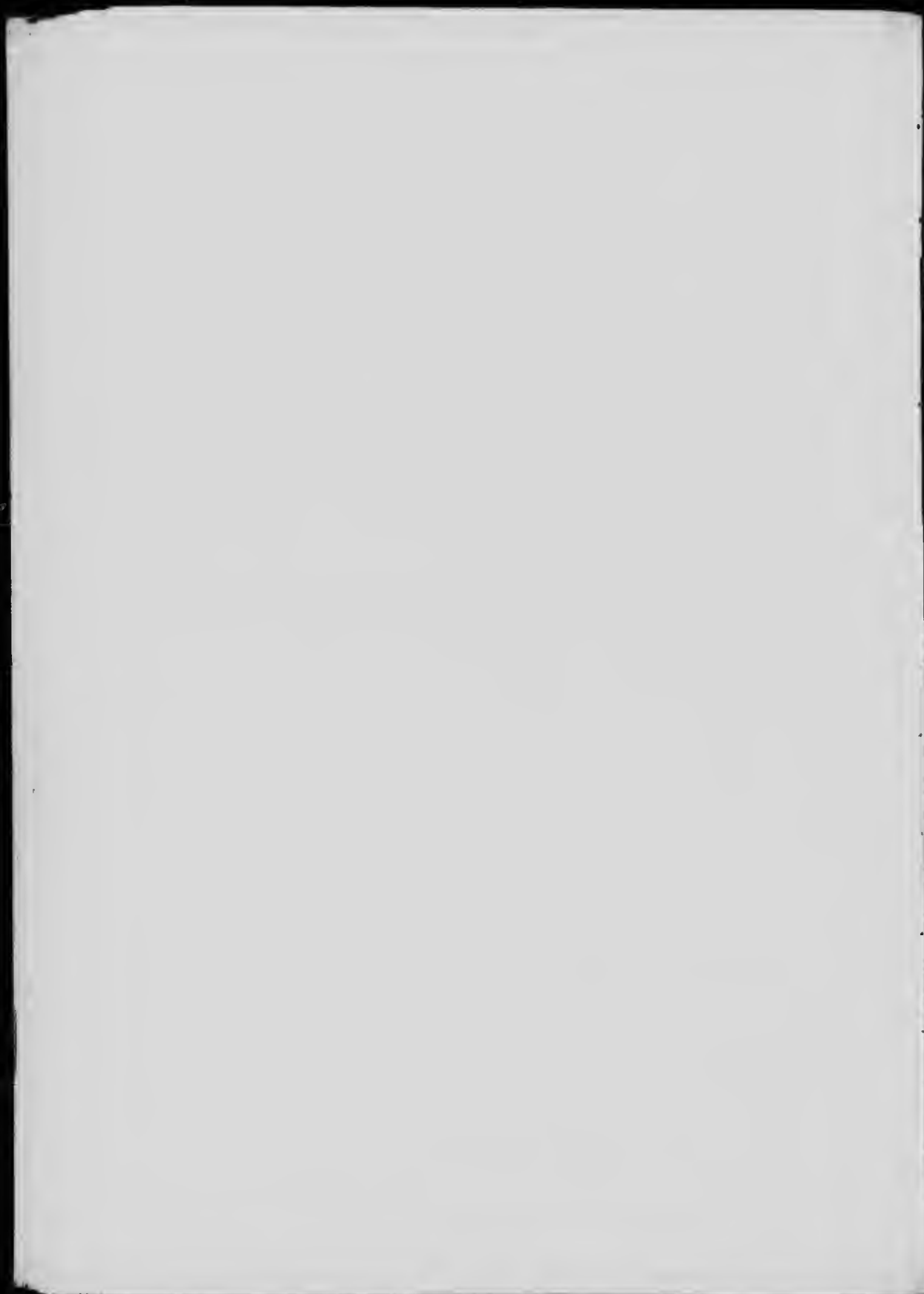



*Galium tinctorium*, (L.).





*Adiantum pedatum*, (L.)



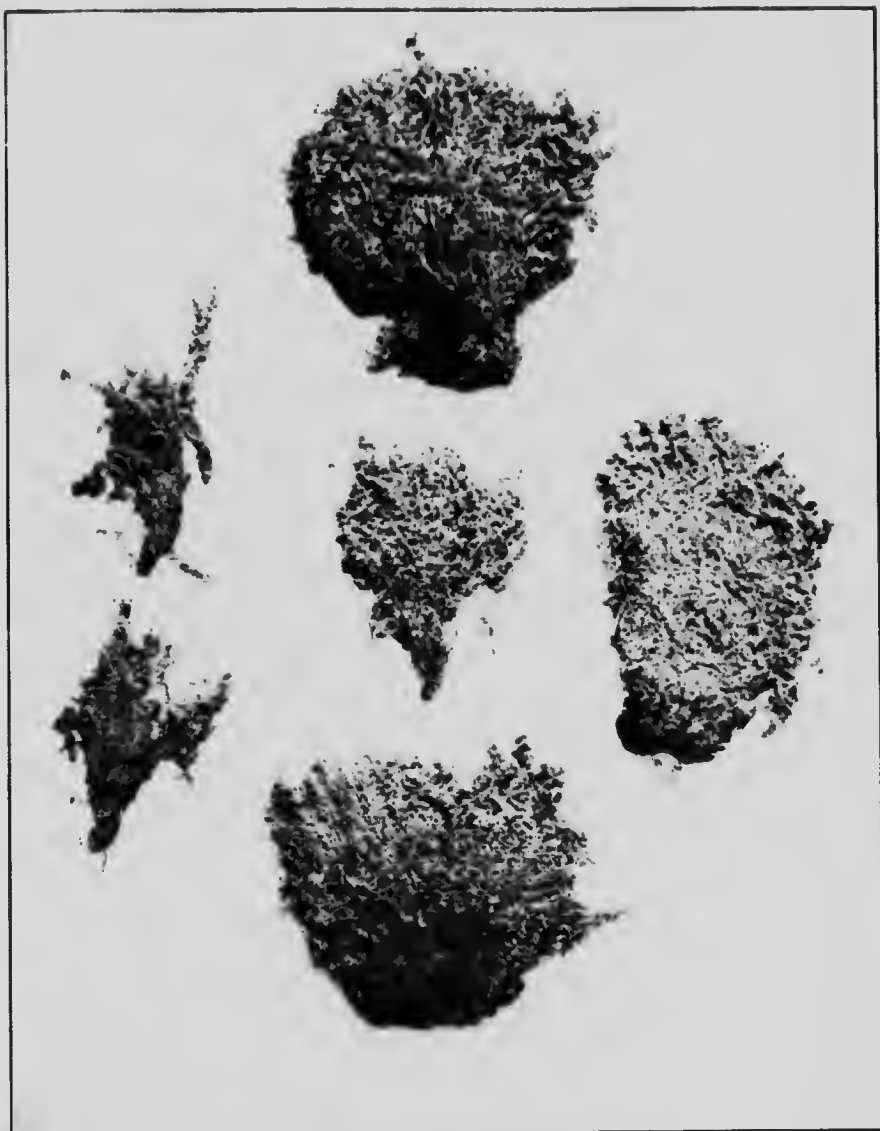

*Sphagnum tenellum*, Pers.

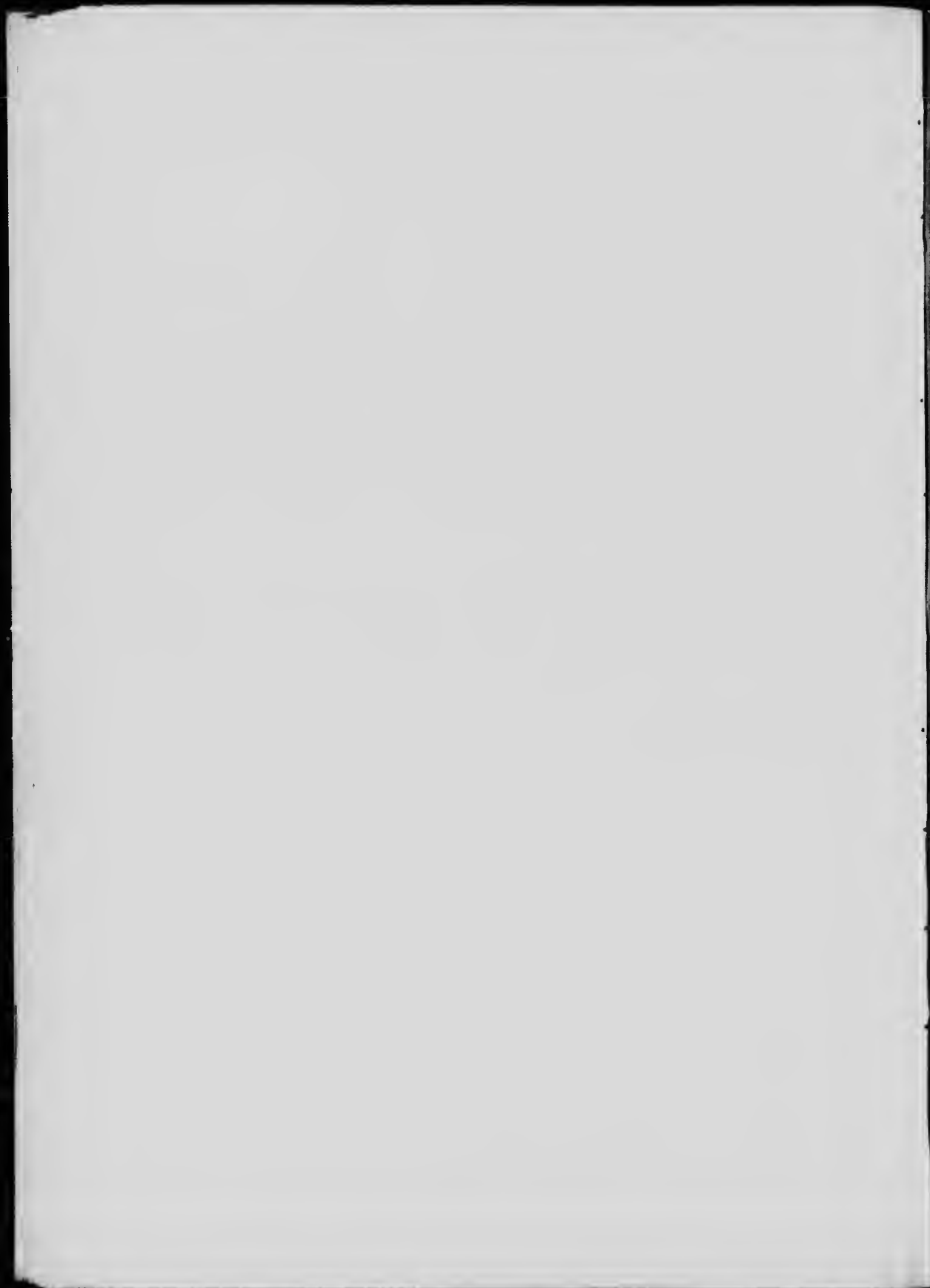



*Sphagnum capillaceum* (Weiss) Schrank.







*Sphagnum fuscum* (Sel.) Klinggr. (Dark brown.) *Sphagnum capillaceum* (Weiss) Schrank var. *tenellum* (Schrimp) Andr. (Light red).

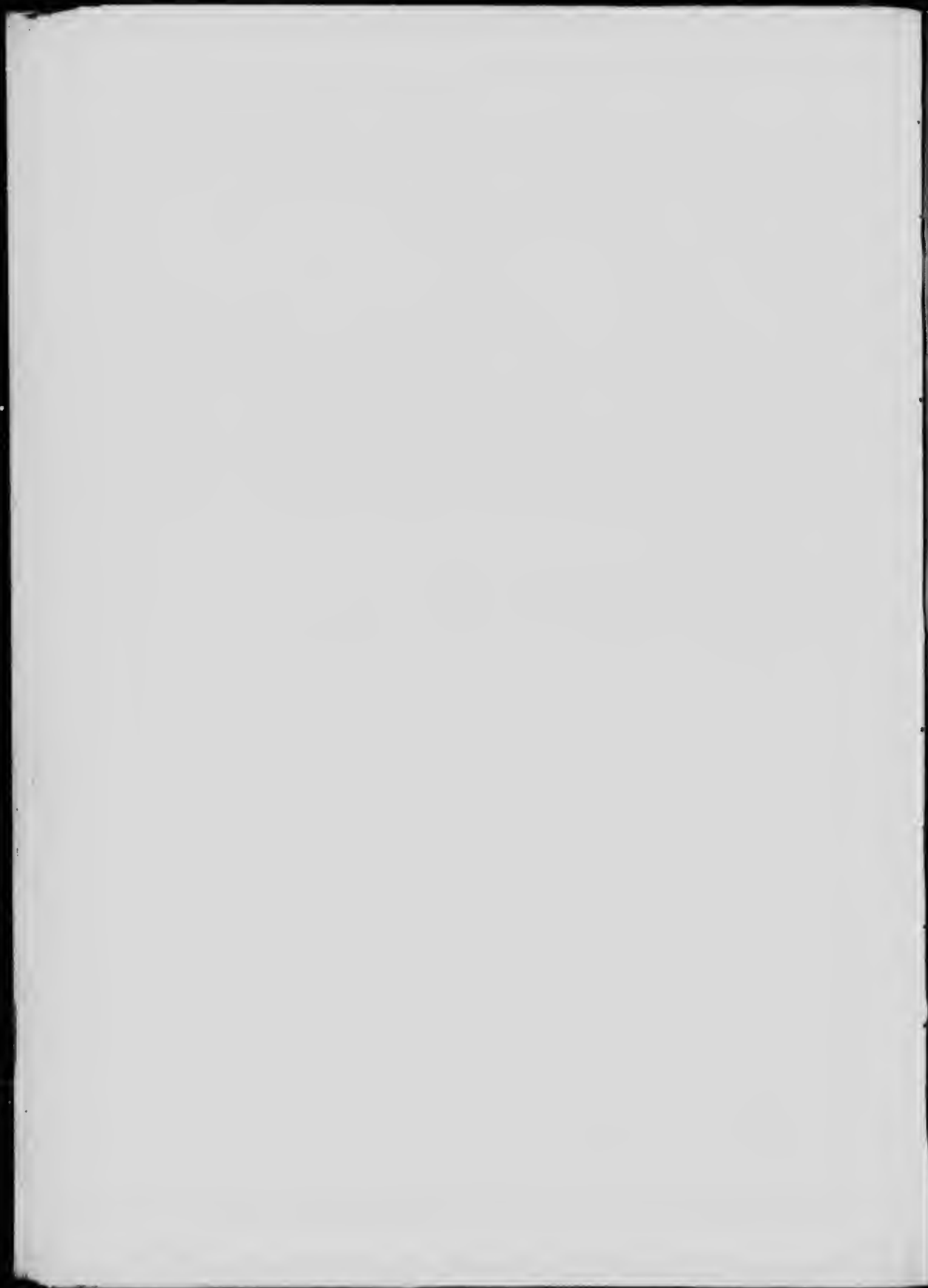



*Dicranum Bergeri*, Blandow.

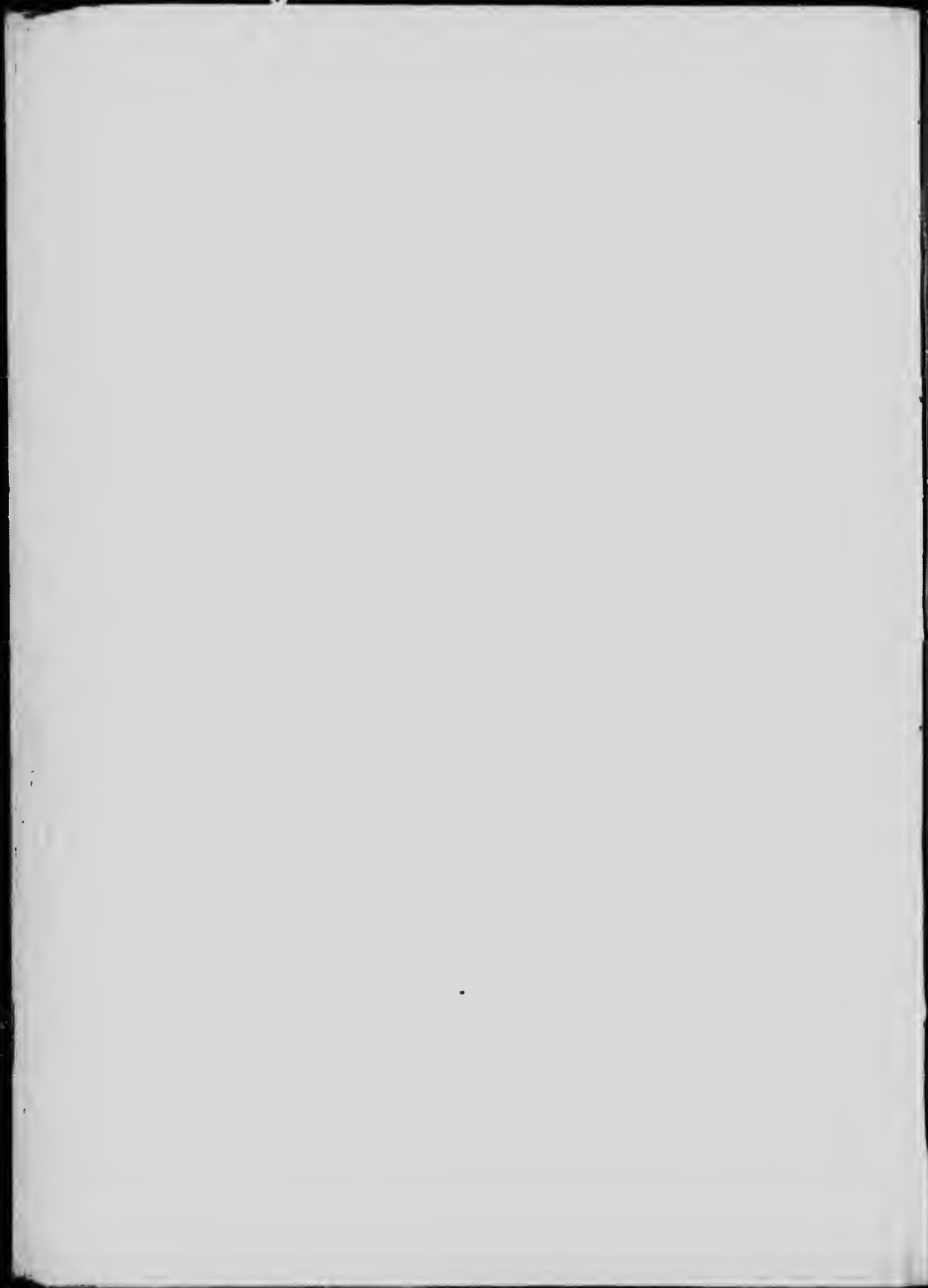

## ALFRED PEAT PLANT, ALFRED, ONTARIO.

In July, 1914, the writer visited the Alfred peat bog, and noticed that considerable improvements had been made to the plant. The wooden towers of the Moore cable device for the transportation of the raw peat from the pulping mill to the spreader were replaced by steel towers. (Full description of this device is contained in report—"Peat, Lignite and Coal," page 17). Plate I gives a panoramic view of the plant. The field press (or so-called peat forming apparatus) has also been improved. (For description of this machine see page 83).

The new Anrep pulping mill, model 1914, has been erected, tried, and found very satisfactory. This pulping mill has a larger capacity than the previous one used, and received in full measure the raw material supplied by the Anrep excavator. (For description of this pulping mill see page 75).

The writer was informed by the men, also by the manager of the plant, that the excavator worked very efficiently, and was easily managed. During the few hours of the visit, the excavator was operated by one man, and there was one man in the trench picking out the roots and stumps. It worked very evenly, without stoppages or any other inconveniences for the workmen. (See Plates LXXIV and LXXV). The digging capacity of this apparatus can be easily arranged to suit the rest of the mechanical devices on the plant. Special note was taken of the very clean bottom which was left after the excavation, as well as the even slope of the walls of the working trench. (See Plate LXXVI).

Before leaving the plant, the writer took note of the drying field, where the ready formed peat was spread, and left to be dried by sun and air. The peat had a very uniform appearance, as can be seen from Plates LXXVII and LXXVIII.

After a period of from 7 to 10 days, depending upon weather conditions, the spread peat was turned over on its side. The turning was done by young boys. As soon as the peat was sufficiently dry to be handled, it was not stacked in small cubes, as was done in 1913, (see Plate LXXVIII) but left on the ground to dry down to a content of 25% moisture, then to be shipped directly to the consumers.

This system proved unsatisfactory, and not suitable in a country where showers are frequent, especially when the surface of the bog absorbs the moisture from the air. The dampness of the surface under the peat bricks does not evaporate, hence causes the bricks to disintegrate, so that a considerable waste of material results.

A number of selected samples of dried peat, containing 25% moisture, ready to be shipped for the market, and which have been turned and stacked in small piles (cubed), can be seen in Plate LXXIX.

The finished fuel was transported on portable tracks to the storehouses, or to railway cars in dumping cars (see Plate LXXX) drawn by Moore's improvised gasoline transportation locomotive. (See Plate LXXXI).

The peat from the drying field was brought to the loading siding, dumped into a hopper, and elevated into the railway cars. This method of working decreased the labour force considerably. The loading elevator is built on the same principle as the one invented by Dolberg and operated on the peat bog at Wiesmoor. (See Plate LXXXII), described in "Peat, Lignite, and Coal," by B. F. Haanel, B. Sc., 1914, p. 171.

The manufacturing operations of the plant in 1914 were begun very late, as the beginning of the season was occupied in improving and completing the plant. Therefore, during that season, only approximately 1,000 tons of air-dried peat fuel was manufactured.

The operation of the plant has been discontinued on account of the war; but it is expected to commence again in the near future.

PLATE LXXIV.



View (seen from above) of Moore's loading hopper,  
and Anrep's excavator, Alfred, Ontario



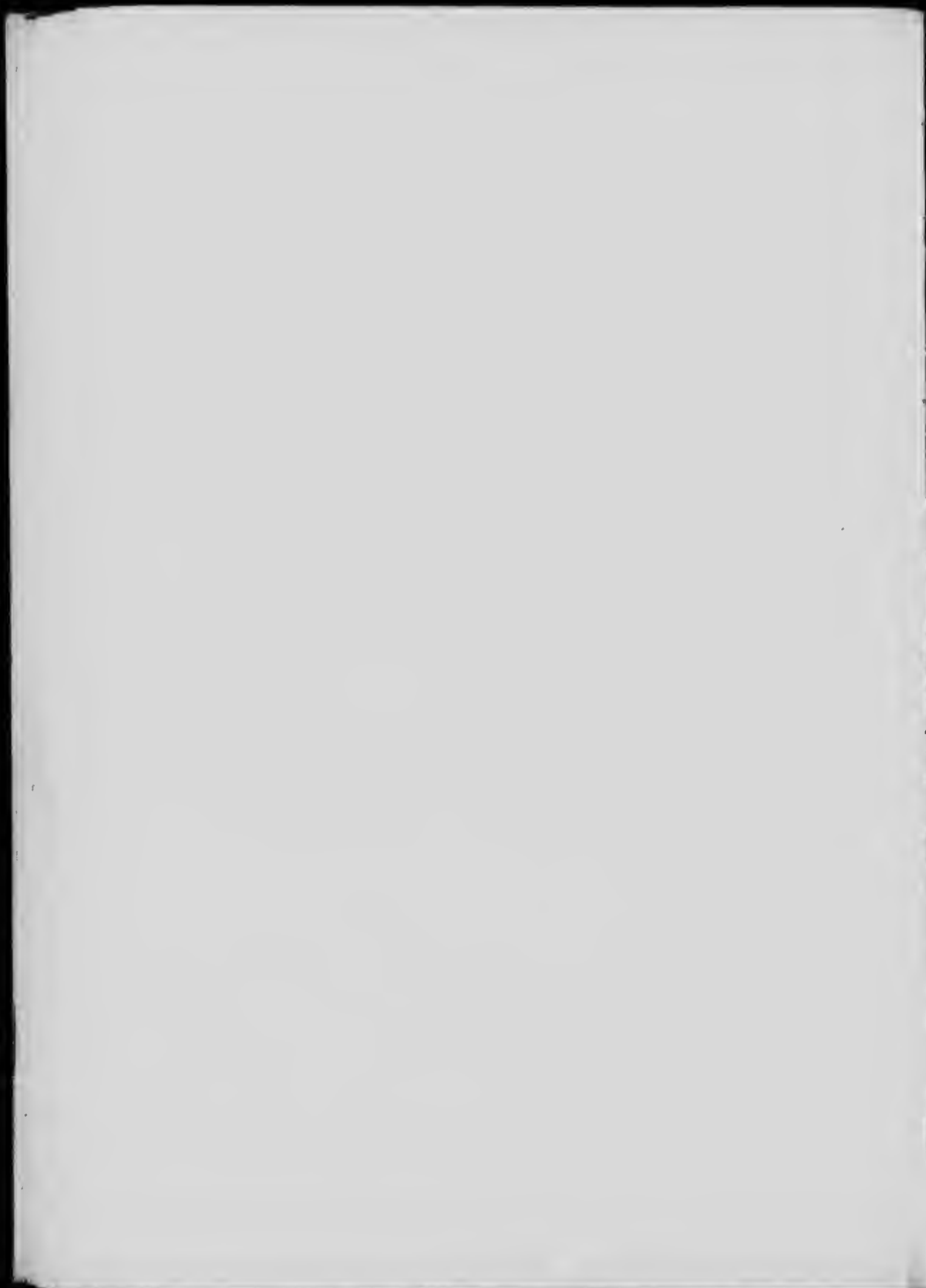
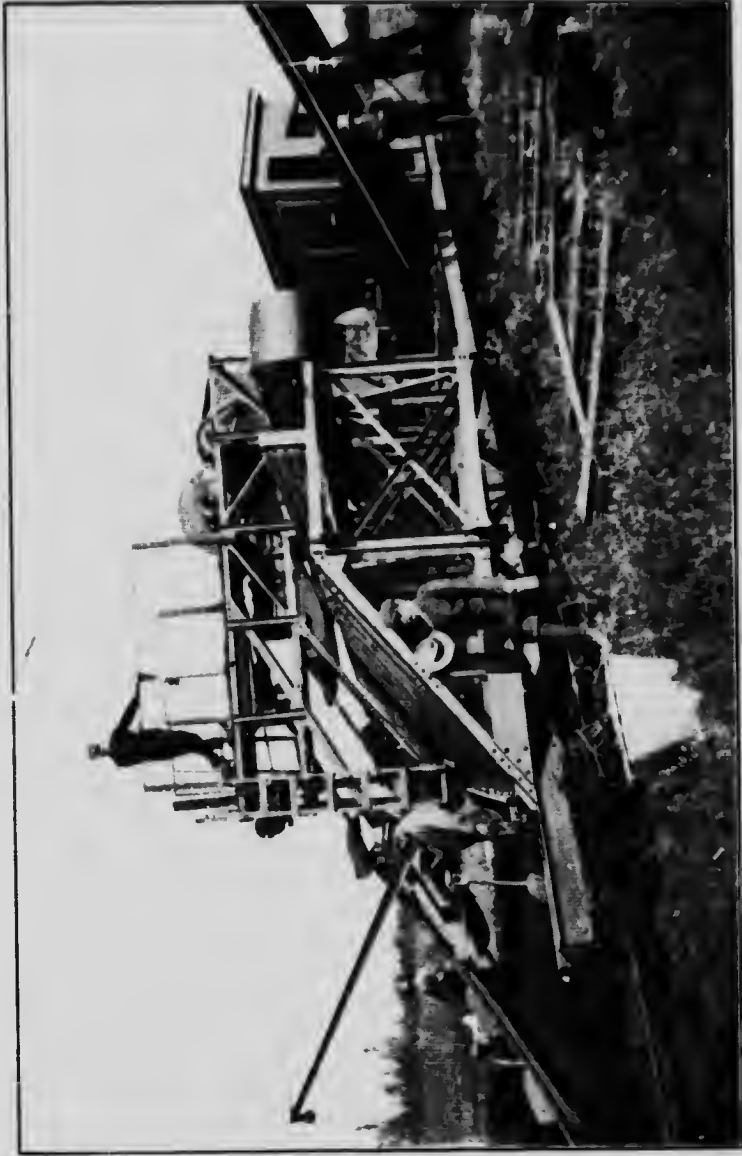

PLATE LXXV.



The Anrep excavator (side view) Alfred, Ontario.





Showing clean cut of a working trench made by the Anrep excavator at Alfred, Ontario. (Note the even slope).

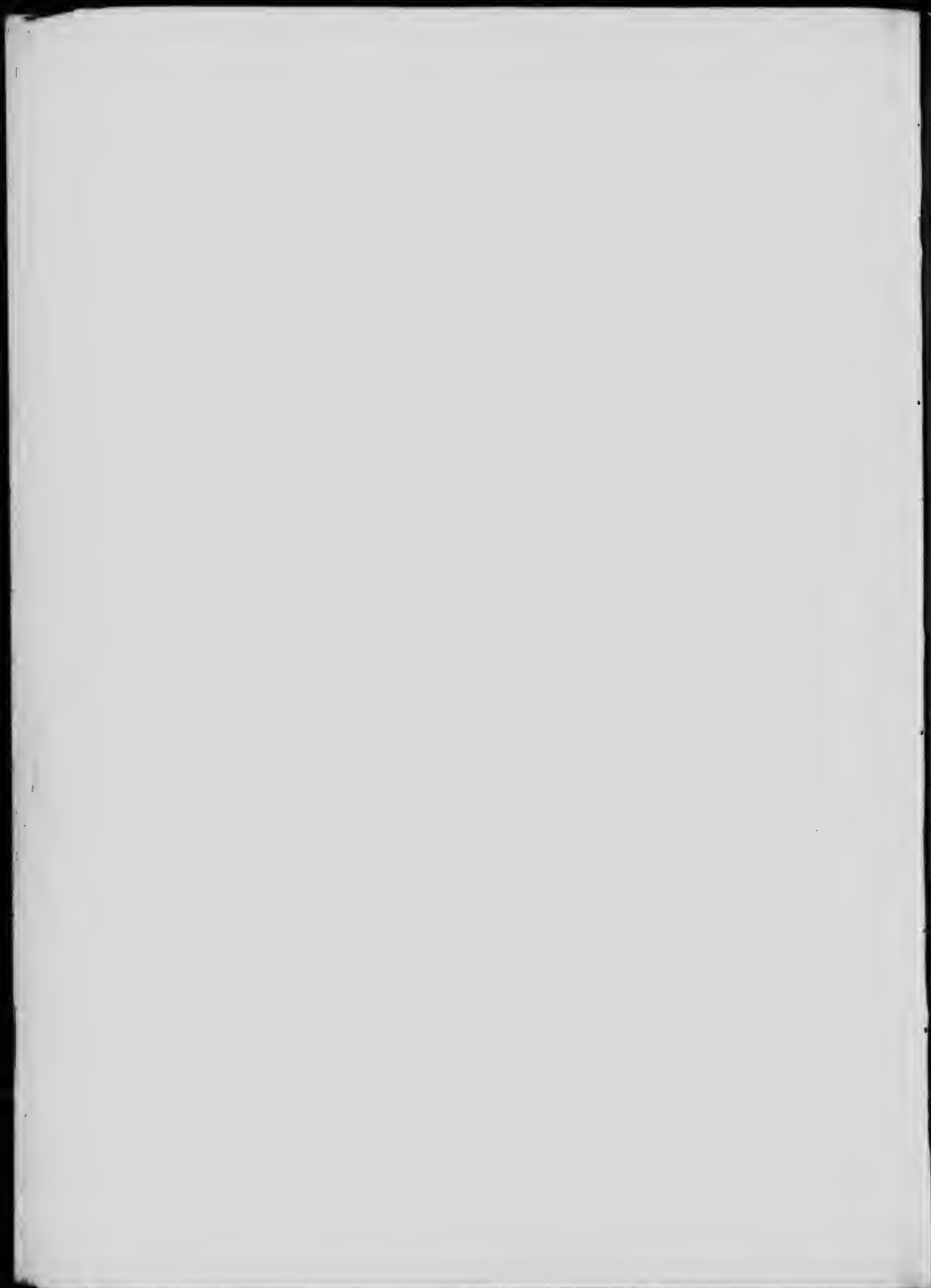

PLATE LXXVII.



Piling peat into hives (cubes). This peat has not been turned.  
Alfred, Ontario.

PLATE LXXVIII.



Piling peat into hives (cubes). This peat has not been turned.  
Alfred, Ontario.

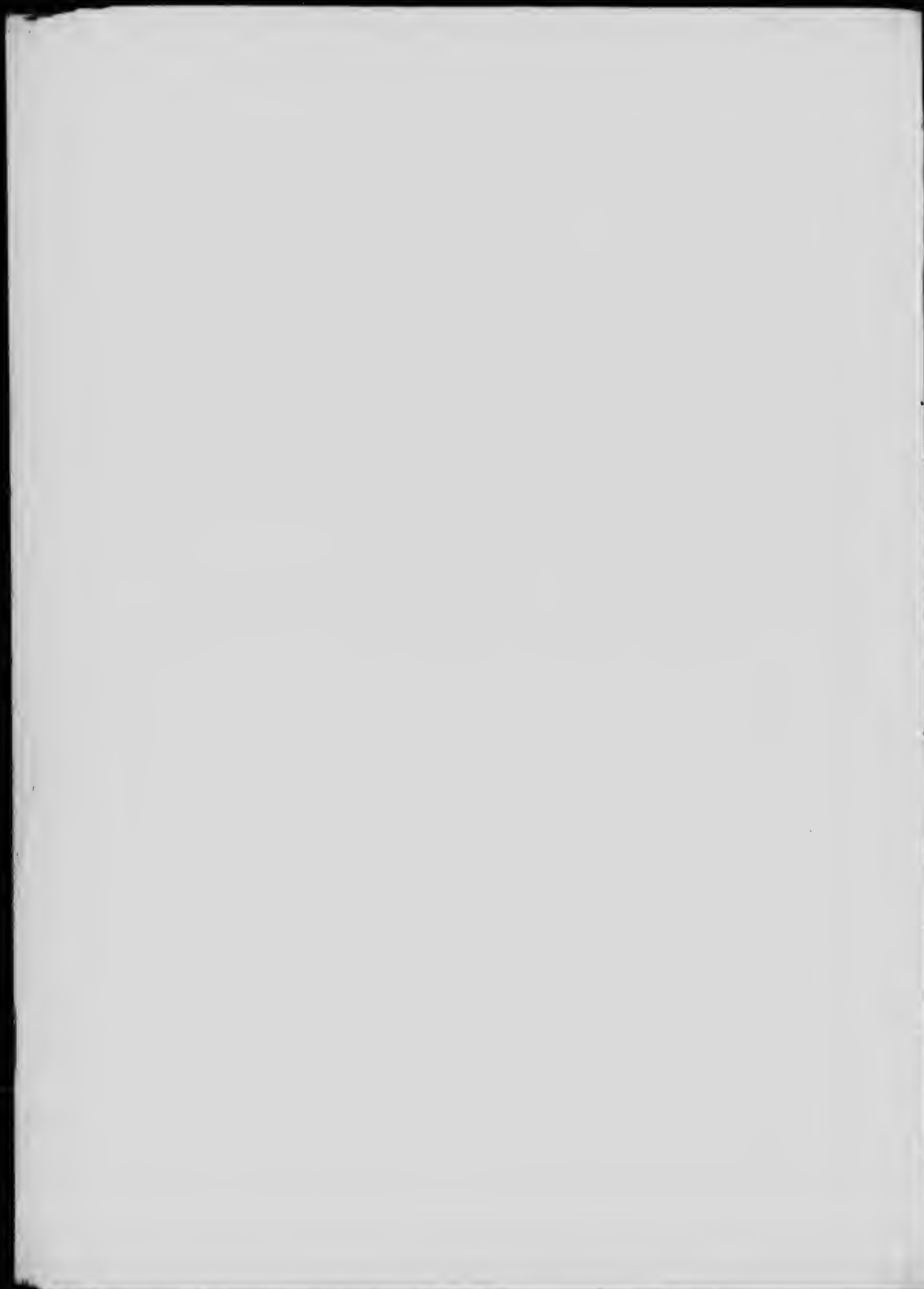

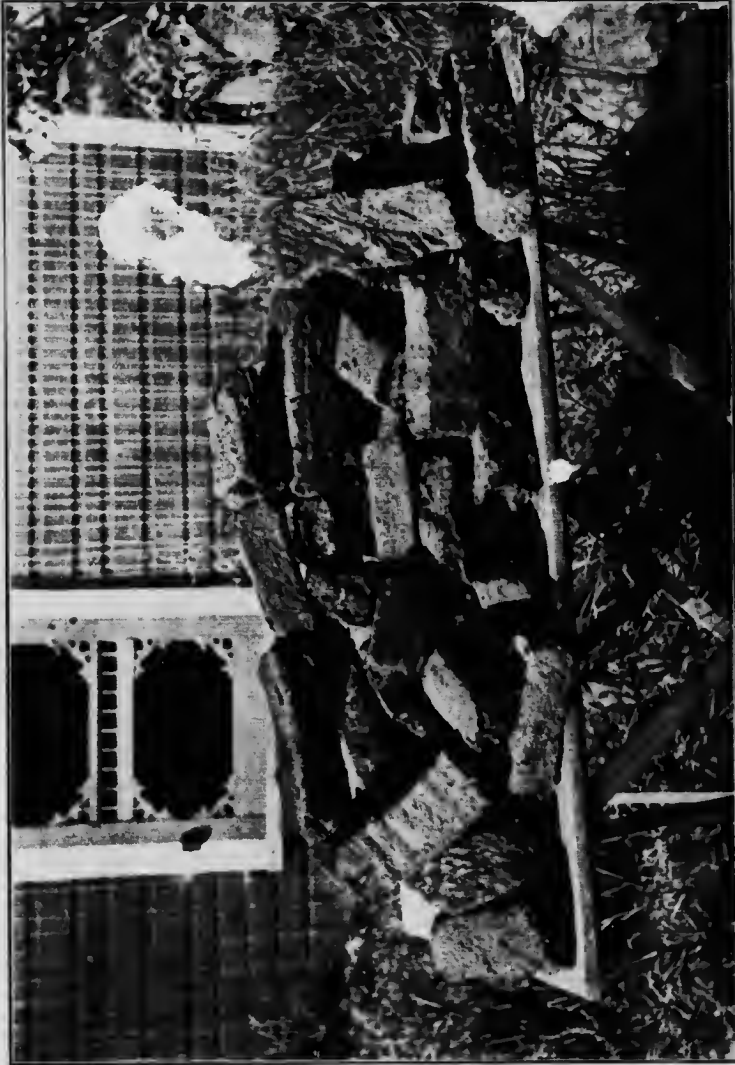

Peat ready for the market, Alfred, Ontario.





PLATE LXXX.



Transportation of dry peat to the railway cars, Alfred, Ontario.

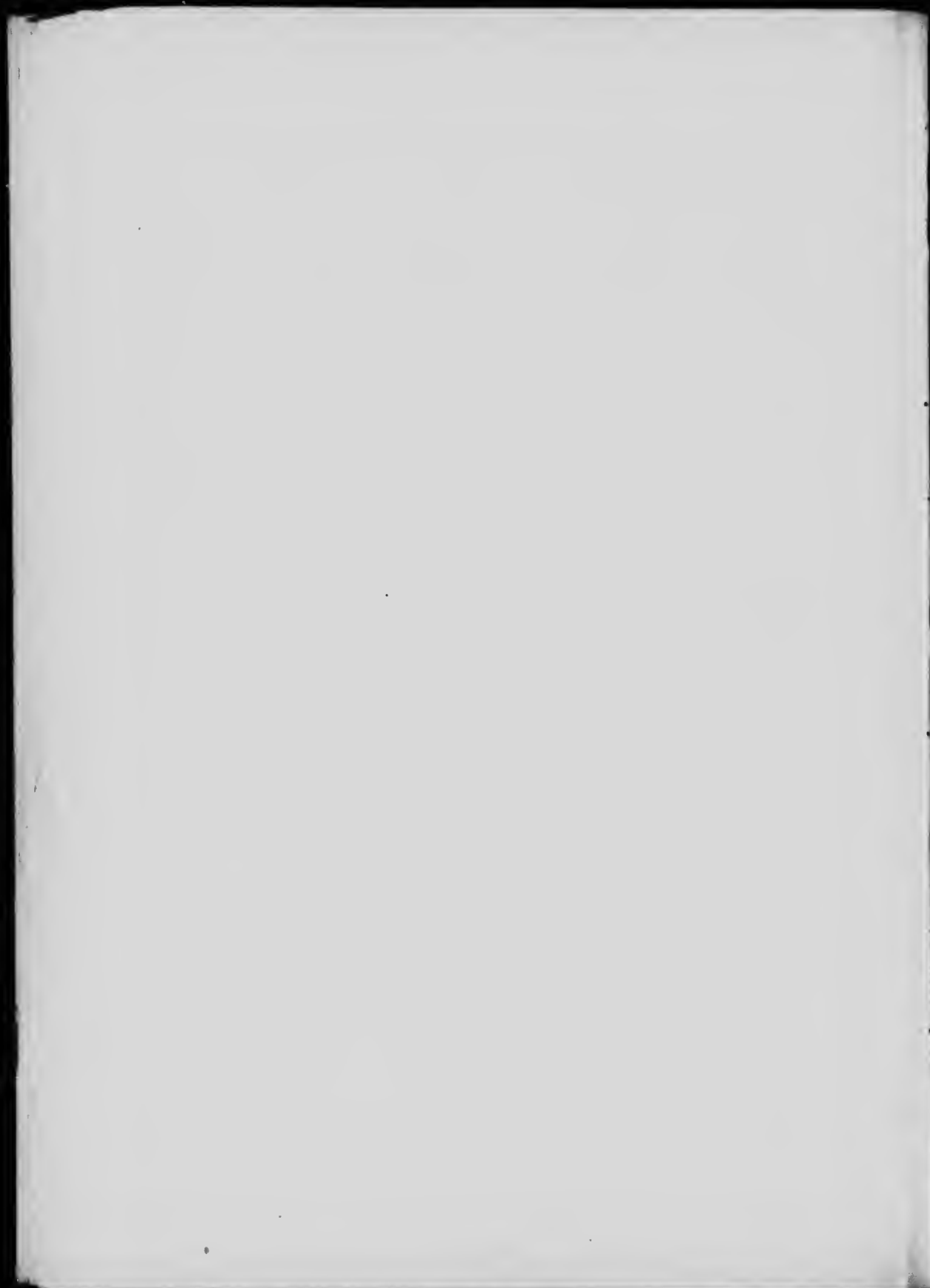
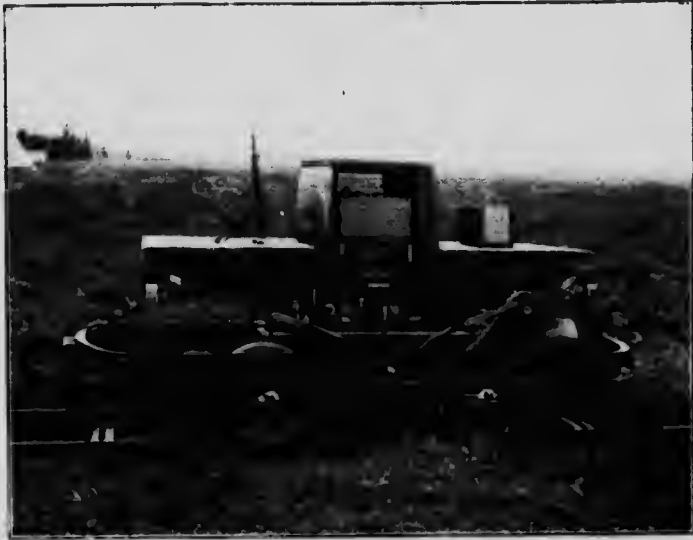

PLATE LXXXI.



Moore's small gasoline transportation engine, Alfred, Ontario.

PLATE LXXXII.



Elevating system. Loading dry peat into railway cars at Alfred, Ontario.



NOTES ON SPECIAL APPLIANCES FOR THE MANUFACTURE  
OF PEAT FUEL.

I.

M. EGEBERG'S PEAT FUEL MACHINES WORKED BY HAND, HORSE, OR  
ELECTRIC MOTOR POWER.

Three types of small peat fuel machines were exhibited by M. Egeberg at the Norwegian Jubilee Exposition, held at Christiania, Norway, 1914: respectively adapted for operation by either hand, horse, or electric power.

(1)

**Egeberg Peat Pulping Machine.**

*(Hand power)*

Plate LXXXIII shows a small machine turned by hand. This method of manufacturing peat fuel requires five men and one boy:—

Two men turning the pulper,  
One man feeding the pulper,  
" " receiving the pulped peat,  
" " spreading the peat on the field,  
" boy helping generally.

The peat is dumped into a large sized bucket, very much on the same principle as an ice cream freezer. Inside the bucket is placed a shaft with a rotating worm. The peat is pulped by hand labour; and the pulped mass is forced through an opening, near the bottom of the bucket.

(2)

**Egeberg Peat Pulping Machine.**

*(Horse power.)*

Plate LXXXIV shows the same kind of bucket, only of larger size, and driven by horse power instead of hand labour. It requires the following number of men to operate it:—

One man in the trench,  
" " delivers the peat to the machine by means of a wheel-  
barrow,  
" " feeds the machine,  
" " carries the pulped mass to the frames on the drying field,  
" " spreads the peat in the frame,  
" boy drives the horse.

---

Total = five men and one boy.

The trial of the Egeberg peat-pulping machines gave the following results:—

Time of manufacture.....	40 minutes,
Number of peat sods in the forming frame.....	50 pieces,
The dimensions of the peat sods, while wet....	235×105×75 millimetre*
The dimensions of the peat sods, while dry....	155×65×45       "
Delivered wet peat per 10 hours.....	25·2 m <sup>3</sup>
Spread peat per 10 hours.....	28·5 m <sup>3</sup>
Air dried peat with 25% moisture per 10 hours.....	3,907 metric tons.†
Spread peat sods during 10 hours.....	14,250 pieces,
Raw peat manufactured per man during 10 hours.....	4·5 m <sup>3</sup> (cubic metres)‡
Raw peat excavated by the men during 10 hours.....	25·2 m <sup>3</sup> ‡
Cost of manufacture per cubic metre raw peat (cost wages 35 öre per hour).....	76 öre‡
Cost of manufacture per ton.....	491 öre.

(3)

### Egeberg Peat Pulping Machine.

(Electric Motor Power.)

This machine is of the same type of pulping mill as in Plate LXXXIV described, with the exception that it is operated by electric motor power, and has a small supply conveyer attached to top of bucket.

This type of peat machine (Plate LXXXV) is very suitable for farmers who have only a few acres of peat bog, and where only a small quantity of fuel is required.

## II.

### Baumann System.

*Description of Peat Plant.*

The apparatus for operating the Baumann system consists of the following parts:—

1. Mechanical excavator, used as auxiliary when the bog does not contain any roots or trunks.
2. Side elevator which may be fed by the excavator or by hand labour.
3. Pulping mill and brick forming apparatus.
4. Conveyer and spreader for transporting and laying out the peat on the drying field.

The auxiliary excavator is placed next to the side elevator, and can be easily detached from, or attached to the same. It can be operated

\*1,000 m.m. = 39 inches.

†1 metric ton = 2,204 lbs.

‡1 krona = 100 öre, 1 krona = 27c.

§1 cubic metre = 35 cubic feet.

PLATE LXXXIII.



Egeberg peat pulping machine turned by hand.





PLATE LXXXIV.

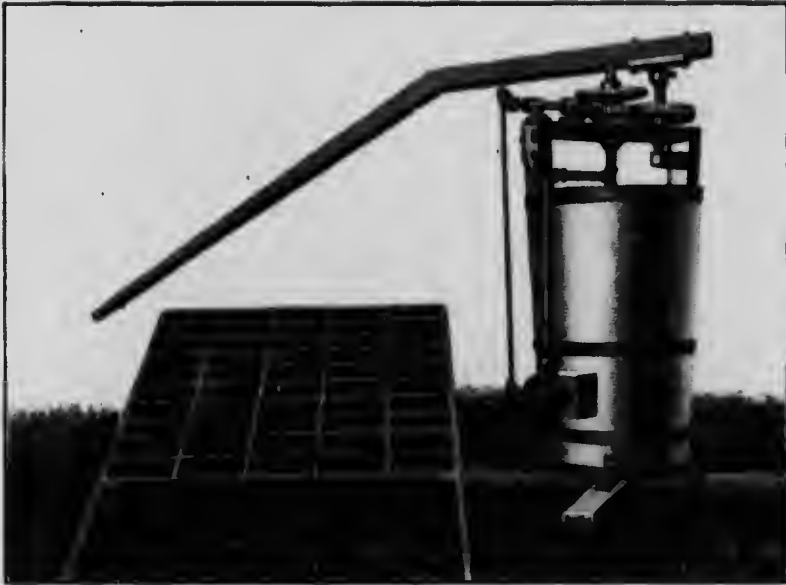

Egeberg peat pulping machine operated by horse-power.



PLATE LXXXV.

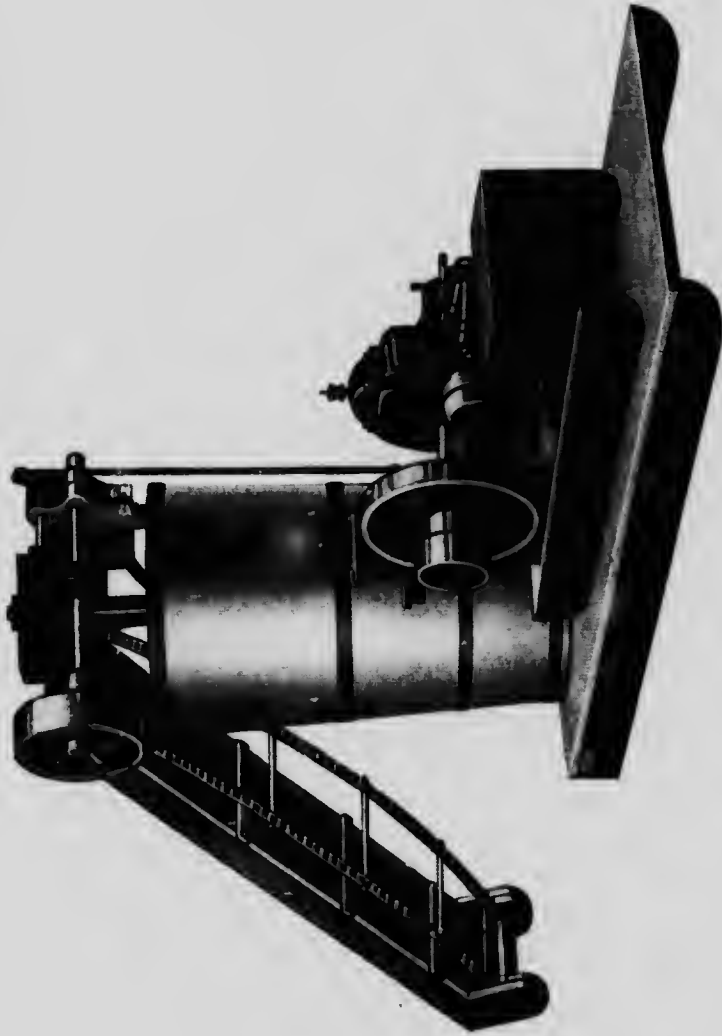

Egeberg peat pulping machine operated by electric motor, with a conveyer.



separately from the rest of the machinery. If any stoppages should occur in connexion with the pulping mill or spreading device, the excavator may be kept continuously in operation, and excavate a supply of peat ahead for the elevator and pulping mill, or if parts of the bog should contain a large number of roots and trunks, auxiliary bucket excavator is detached and discarded as it is very seldom that it can be used in such bogs.

In place of the excavator, manual labour is applied in the working trench, and the elevator is fed by hand. By this means, continuous operation may be obtained.

One man is required to operate the excavator, otherwise it requires from 4 to 6 men.

In Plate LXXXVI, the elevator is shown feeding the pulping mill through the hopper, which is placed below the elevator. The length of elevator, that is the space between the excavator or working trench and the pulping mill, may differ considerably. In later years attempts have been made to raise the peat around the stumps by means of a spoon-shaped bucket excavator.

From the elevator, the pulping mill is fed through a V-shaped hopper, and the excavated peat enters into a double cylinder which is supplied with worm screws rotating against each other. The disintegrator and peat mixer consist of an iron drum containing 12 chambers where the peat blocks are separated from each other by a radial knife and pushed forward.

Through the radial arrangement of the iron drum case, the peat sods are easily separated.

At the plant at Rosenheim very regularly shaped peat blocks were obtained, and the speed of the production was very remarkable. In one second about three blocks, each containing a volume of 298 cubic inches, and a length of 16 inches, were pushed forward.

The peat blocks from the forming apparatus place themselves on the belt of the automatic block spreader, which runs under the drum of the sod forming apparatus.

For ordinary use, the length of the spreader is from 300 to 400 feet. (See Plate LXXXVII).

The automatic spreader consists of an endless Gall's chain (chain with plates) these iron plates are tilty and rest on every two rollers of the chain. (See Plates LXXXVIII and LXXXIX).

The rollers of the chain (the upper empty and the lower charged) rest on parallel iron girders, braced with lattice work, which at certain distances are supported by specially arranged travelling trestles.

Through these trestles runs a shaft on which are placed two wide pulleys resting on triangular wooden rails. These rails can easily be handled by two men, as can be seen in Plate XC.

The chain with the plates work as a venetian blind and when the sods from the forming apparatus place themselves on these plates, and when the whole line of the spreader, from the pulping mill to the far end of the spreader, is filled with peat sods, the plates tilt and deposit the sods on the

drying field. The whole apparatus moves automatically ahead, and the operation is continued as above described.

The capacity of this machine is from 35 to 40 tons daily, of 10 hours work, employing a staff of about 5 working men.

The inventor of the apparatus described above, gives the following advantages:—

"By applying the new system, the respective companies are saving considerable quantities of rails for spreading purposes, which, in turn, require a large number of men for moving, receiving, dumping, and spreading the peat, for attendance and looking after the dumping cars. The machine has a large output per day, with a small number of labourers, obtaining high-grade peat product and consuming small amount of power. It is adaptable, practically, to any surrounding and natural condition of the bogs, noiseless and evenly working, independent of workmen, the cost of purveyance rather high, but the interest low."

This invention is the result of many years' experience in this line.

Note.—The description of the arrangement of this new spreading device sounds quite feasible, but I would consider that such an apparatus would entail considerable cost in building and maintenance and repairs. A chain, with plates used in the spreader of a length of 300 to 400 feet, is likely to get out of order very frequently and to make considerable stoppage in the work. This would lower the above mentioned output considerably. This conclusion is based on experience with other machines and not from seeing this particular machine actually in operation. (A. A.)

PLATE LXXXVI.



Movable masher and forming machine operated by electrical power: Royal Bavarian peat bog, Rosenheim, Munich.



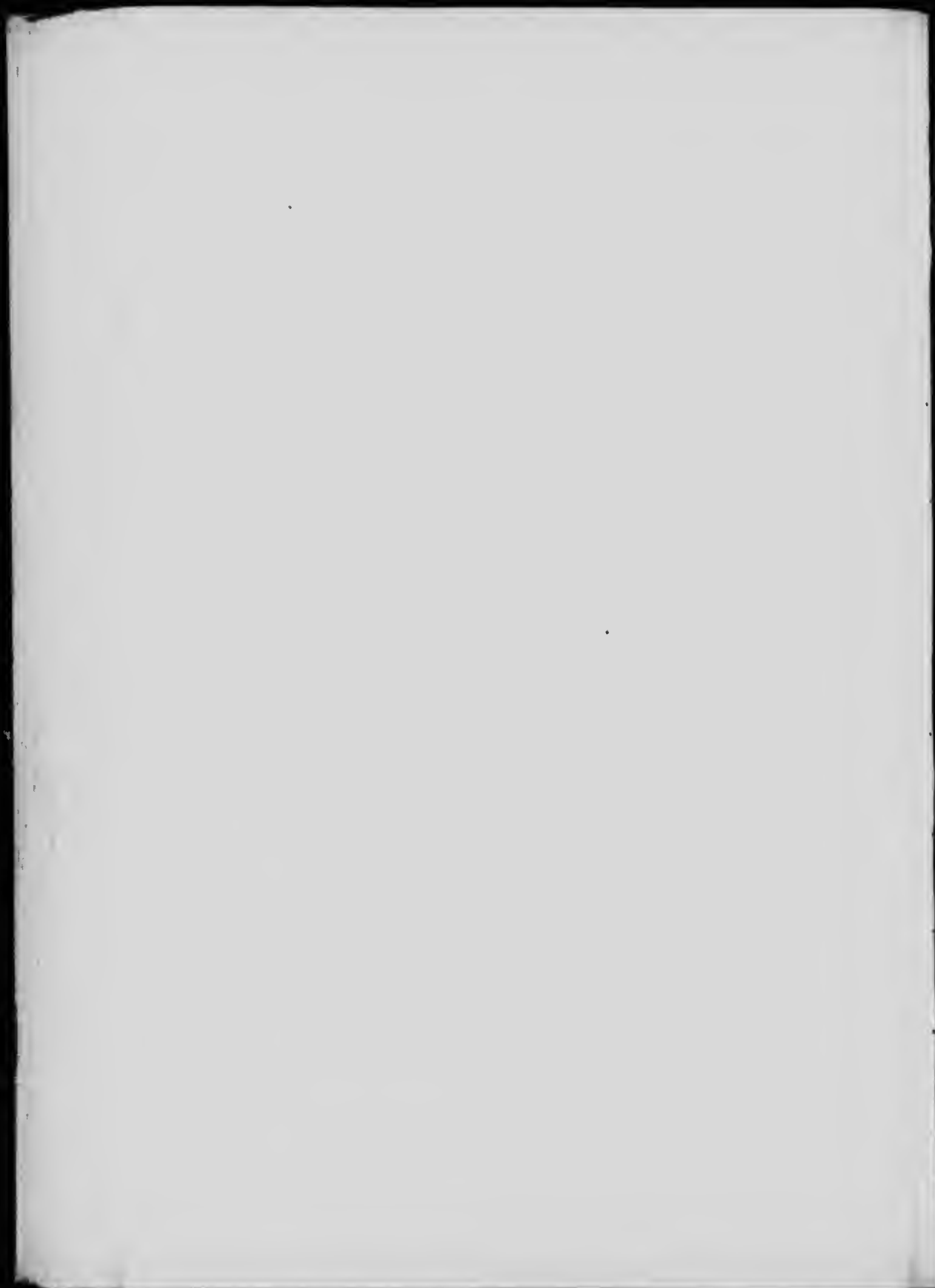
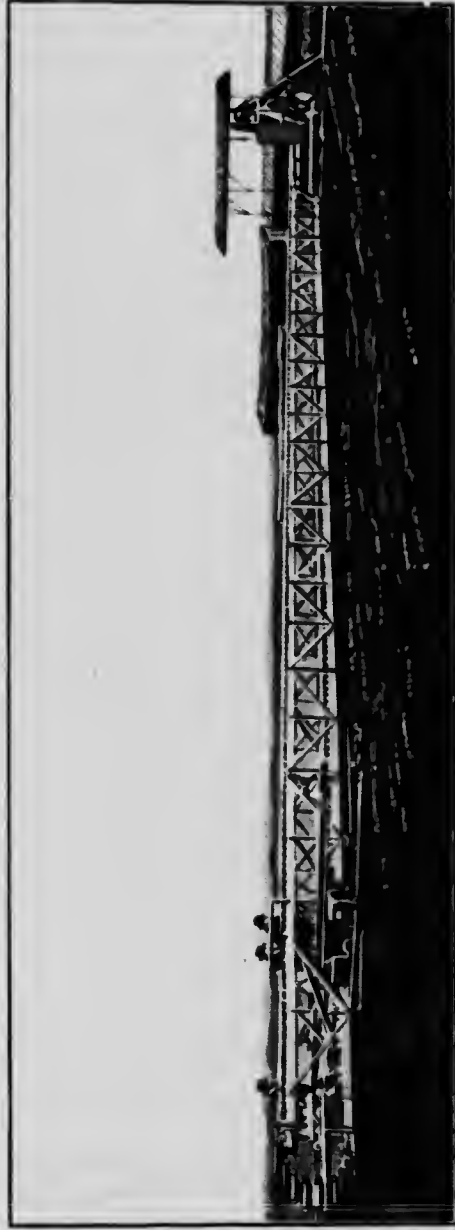

PLATE LXXXVII.



Conveyer maserator, with brick-forming machine, and apparatus for laying out the peat bricks on the Royal Bavarian peat bog, Rosenheim, Munich.



PLATE LXXXVIII.



Dumping the wet peat bricks on the field: Royal Bavarian peat bog, Rosenheim, Munich.

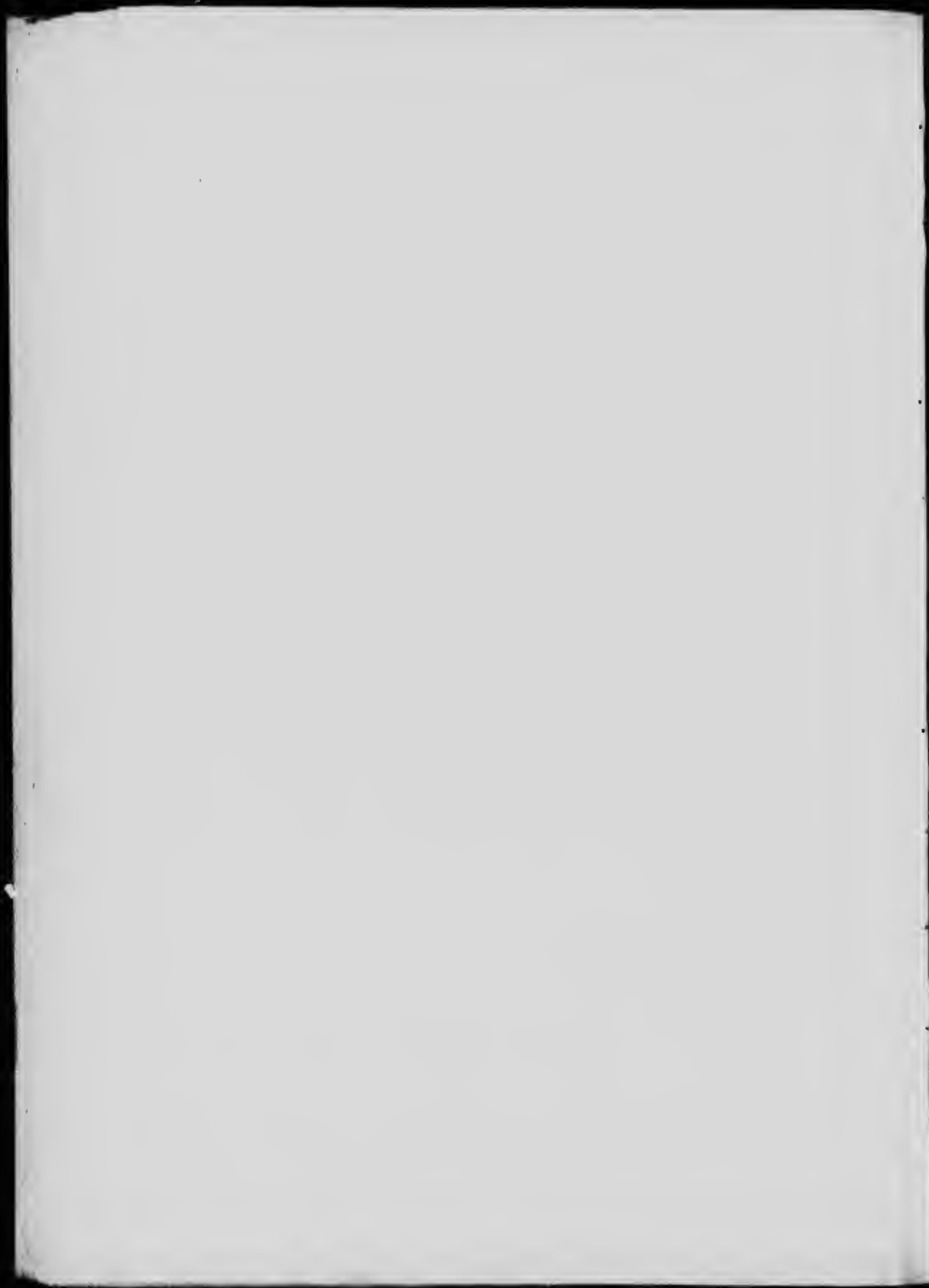
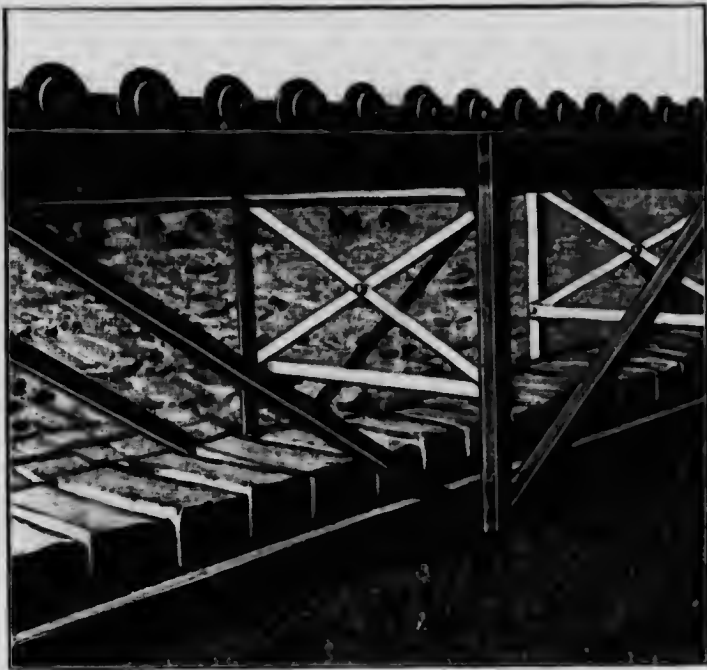
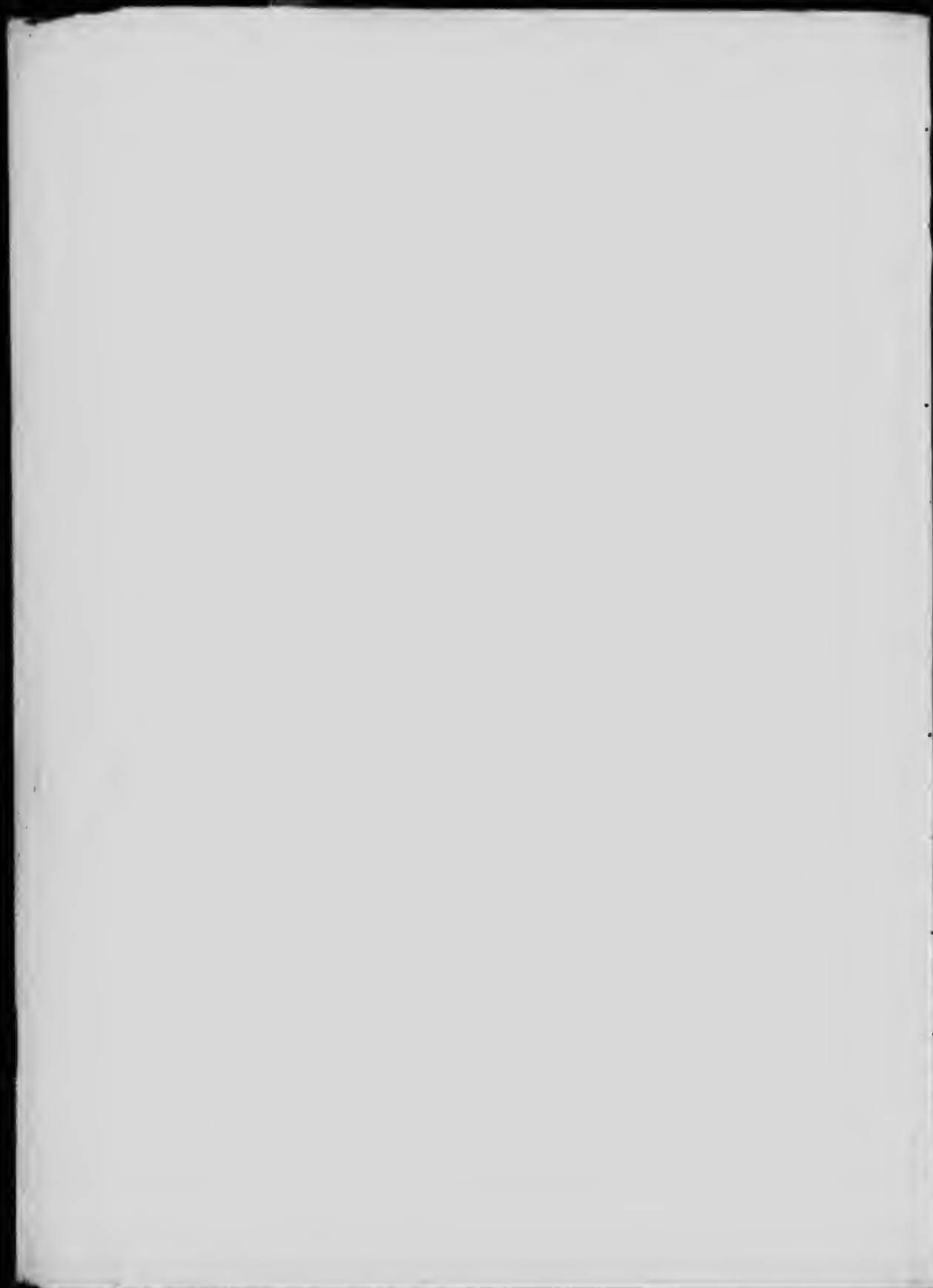
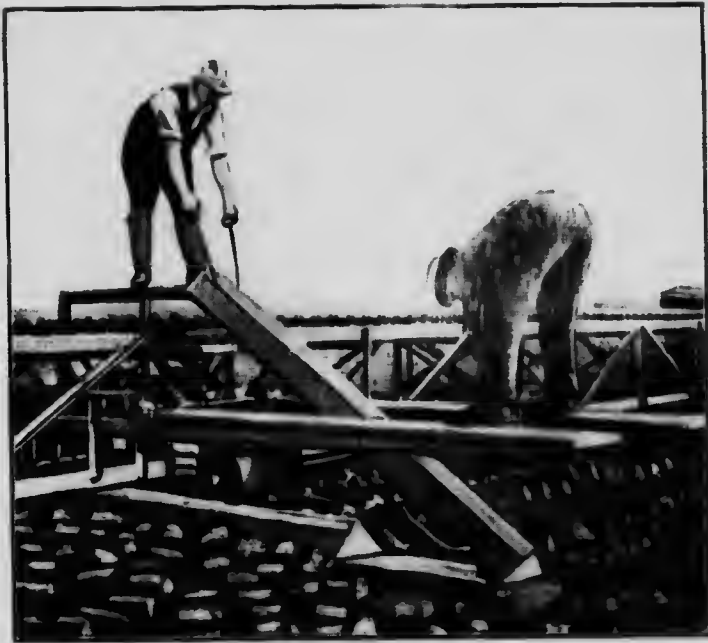

PLATE LXXXIX.



Layer of the wet peat bricks during transportation:  
Royal Bavarian peat bog, Rosenheim, Munich.





Laying out the rails for the spreading apparatus:  
Royal Bavarian peat bog, Rosenheim, Munich.





## NOTES ON PEAT PRODUCTION IN FOREIGN COUNTRIES.

## UNITED STATES.—

**Importation of Peat Moss Litter, 1906-1914.**

Statistical information received from Professor Charles A. Davis, Bureau of Mines, Washington, D.C., U.S.A., on Peat Moss Litter, imported into the United States.

	Long tons*	Valued at
1906.....	7,640	\$45,344
1907.....	7,950	46,881
1908.....	8,102	45,414
1909.....	9,408	47,227
1910.....	8,953	41,938
1911.....	8,056	39,372
1912.....	8,083	39,867
1913 Metric tons †..	9,966	55,719
1914 Long tons ....	8,858	57,542

## SWEDEN.—

**Extract from the report on Peat to the Swedish Government, 1911.**

By Captain E. Waligren, Government Peat Expert.

During the years 1910 and 1911, the peat industry in Sweden stood on the same basis as in the year 1909, except in the southern provinces, where the manufacture of hand-cut peat, which is used for domestic purposes and minor industries, has increased. During 1911, two complete peat fuel plants were erected in that part of Sweden.

The experiments with the new method of manufacturing peat fuel (peat powder, and wet carbonizing processes) have, during 1911, developed considerably.

(a)

**Peat Powder.**

In 1911, the peat powder plant expanded considerably, and plans have been drawn for another plant on a larger scale, which is expected to be in operation in the near future—in connexion with a plant for manufacturing cement.

During the same year the Swedish Steam Boiler Society executed firing tests in their boilers, with peat powder and coal. The results showed that, with peat powder 75% efficiency was obtained, and with coal 64.2%

\*Metric ton = 2,204 lbs.  
†Long ton = 2,240 lbs.

efficiency was obtained. This gives the relation between peat powder and coal with the respective effective fuel values of 4,110 calories for peat powder and 6,755 calories for coal or 1.4 of peat powder equal in fuel value to 1 of coal. This is owing to the more thorough mixture of peat powder with air, and probably to the instantaneous regulation of the amount of air and powder required for variation in steam consumption. When burned in a properly constructed furnace, a higher temperature of combustion and better efficiency is obtained per calory than from coal.

At the Bäck peat powder plant they were able to use peat from the drying field with a moisture content of 40-60% in the manufacture of peat powder. Of course, peat with lower content of moisture can be used more favourably.

(b)

#### The Wet Carbonizing Process.

The wet carbonizing process produces peat fuel in a condensed form, and is not dependent upon air-drying.

The peat is brought to the factory direct from the bog, having a moisture content of about 90%.

Dr. de Laval seems to think that the process developed considerably during the year 1911.

A government loan has been granted for carrying on the experiments with the wet carbonizing method.

Dr. de Laval was able to determine the principles of the wet carbonizing method, and showed it to be different to the Ekenberg process.

According to the statements received from Dr. de Laval in 1911, he was able, at his experimental plant, to extract water mechanically from wet carbonized and homogenized peat down to 50-60% moisture. On the strength of this statement it has been planned to erect a wet carbonizing plant according to Dr. de Laval's method on the Tyringe peat bog in the province of Skane, Sweden.

(c)

#### Loans granted by the Swedish Government.

During the period of 8 years from 1903-1910, the Swedish Government granted loans as follows:—

	Kr.*	§
Peat loans in connexion with manufacture of peat fuel and peat litter, representing a sum of	1,044,640	1,092,053
During the year 1911 8 new peat loans were granted representing a sum of	111,000	37,665
Representing a total	1,155,640	1,129,718

### Special Loan for Experiments on de Laval Wet Carbonizing Process.

(A government grant of 100,000 kronor has been recommended by Swedish experts).

Some time ago, Mr. Enar Gösling sent a petition to the Swedish Government for a grant of 100,000 kronor, to be used for erection of an experimental wet carbonizing plant, to be built according to de Laval's process, with a production of 10 metric tons of peat briquets daily. Later application was made for an additional grant of 50,000 kronor, to run the plant. The grants were to be taken from the yearly Swedish Government peat fund.

Both petitions were highly recommended by the Swedish Government peat expert, Captain Ernst Wallgren.

The Swedish Agricultural Committee and the Board of Trade of the Commercial Department have requested that the petition of the first grant be investigated by the appointed peat commission.

The Commission investigated the method, and agreed with the Swedish peat expert regarding the possibilities of the process; and they have highly recommended that Mr. Gösling should receive the grant of 100,000 kronor\* for the purpose he requested.

#### NORWAY.—

TABLE VII.

#### Peat fuel manufactured at Vestfinmarken, Norway, 1914.

From information obtained by the peat expert, Paul Sandbu, at Vestfinmark.

1.	Lerbotten	distrikt, Talvik	county,	65 families,	394,000	pieces of peat.
2.	Korsfjord	"	"	72 "	643,000	" "
3.	Lærreds-fjord	"	"	44 "	510,000	" "
4.	Rognsund	"	"	33 "	285,000	" "
5.	Langfjord	"	"	107 "	1,162,000	" "
6.	Talvik	"	"	30 "	259,000	" "
7.	Kvalsund	" Kvalsund	"	28 "	292,000	" "
8.	Rolfso	" Maaso	"	29 "	151,000	" "
9.	Ingo	"	"	21 "	80,000	" "
10.	Snefjord	"	"	9 "	34,000	" "
11.	Maaso	"	"	18 "	134,000	" "
12.	Kjelvik	" Kjelvik	"	41 "	156,000	" "
13.	Hasvik	" Hasvik	"	23 "	149,000	" "
14.	Oksfjord	" Loppen-Oksfj	"	57 "	318,000	" "
15.	Loppen	"	"	44 "	378,000	" "
16.	Sandland	"	"	47 "	435,000	" "
17.	Kjaes	" Kistrand	"	19 "	103,000	" "
18.	Smorfjord	"	"	45 "	189,000	" "

Total = 732 families, 5,772,000 pieces of peat. Valued at Kr. 57,720.00. 1 kr. = 27c.

\*1 kronor = 27c.

## DENMARK.—

(i)

The following table will show the progress of peat fuel manufactured since 1902.

TABLE VIII.  
Peat fuel manufactured in the years 1902-13.

Year	Number of peat plants	PRODUCTION.	
		Million peat bricks	Tons of peat
1902	approx. 39	approx. 93	approx. 46,760
1903	" 44	" 117	" 54,879
1904	" 47	" 129	" 56,887
1905	" 48	" 150	" 68,610
1906	" 50	" 158	" 68,278
1907	" 53	" 150	" 63,948
1908	" 56	" 156	" 68,392
1909	" 63	" 193	" 89,520
1910	" 67	" 179	" 81,865
1911	" 75	" 183	" 79,242
1912	" 90	" 190	" 84,788
1913	" 94	" 209	" 93,642

This table shows that during the last 12 years, the yearly production has more than doubled.

(ii)

### Detailed Information Regarding Peat Fuel Industry in 1913.

Information with regard to peat fuel manufacture in Denmark during the year 1913, has been received from practically all the peat plants in that country. Last year two of the old plants discontinued working.

Bedsted peat plant, whose bog at present is under cultivation; and the Aamossen peat plant at Vedde, whose bog is taken over by an English concern, intend utilizing the nitrogen for the production of ammonium sulphate.

During 1913 two new peat fuel factories were erected: namely, the Omarks, and the Noråger and Oster Teglgaaards plants, both at Viborg.

Several small peat plants have been added to some of the old factories, which also have given their manufacturing capacity: in all, 68 peat factories, with 94 peat plants.

In 1913, the conditions for peat fuel manufacture were very favourable; there was ideal drying weather, and the demand for peat fuel was very great.

		Price per 1,000 peat bricks								
		Summer		Winter						
No.		On the railway car at the plant		On the bog		On the railway car at the plant		Amount left	Delivered to industrial factories	Manufacturing of peat cut by hand
		Kr.	O.	Kr.	O.	Kr.	O.			
1	Alingsk	.....	.....	6	00	.....	.....	.....	100	200
2-8	Auning	.....	.....	.....	.....	.....	.....	.....	.....	.....
9	Bakke	4	50	.....	.....	.....	.....	.....	.....	.....
10	Birke	5	00	.....	.....	.....	.....	.....	.....	.....
11	Brand	4	00	.....	.....	4	50	500	400	.....
12	Brdr. F.	.....	.....	5	00	.....	.....	40	.....	.....
13	Boglid	used by the establishment	.....	.....	.....	.....	.....	.....	.....	.....
14	Baage	5	00	5	50	5	50	200	.....	.....
15	Elling	4	25	.....	.....	4	50	1,000	400	.....
16	Engesvi	4	50	.....	.....	.....	.....	3,500	.....	.....
17	Gander	4	25	4	00	4	50	900	.....	.....
18	Gatten	4	70	.....	.....	.....	.....	.....	.....	.....
19	Graubal	.....	.....	.....	.....	.....	.....	300	200	.....
20	Grevsk	.....	.....	.....	.....	.....	.....	.....	.....	.....
21	Heinestr	5	50	.....	.....	6	00	.....	22,000	.....
22	Holmeg	used at the glass works	.....	.....	.....	.....	.....	.....	.....	10,000
23	Hvam-l	.....	.....	5	50	.....	.....	150	.....	.....
24	Horby	4	25	3	75	.....	.....	300	.....	.....
25	Jensens	used by the establishment	.....	.....	.....	.....	.....	.....	.....	.....
26	Jorgens	.....	.....	5	50	.....	.....	.....	.....	.....
27	Kalbyg	.....	.....	6	25	.....	.....	.....	.....	.....
28	Kloster	4	25	.....	.....	4	50	.....	.....	200
29	Kaerga	4	25	.....	.....	.....	.....	.....	.....	.....
29a	Kvaerks	5	50	.....	.....	.....	.....	.....	.....	.....
30	Lammel	6	85	.....	.....	.....	.....	125	.....	.....
31	Lille Lo	.....	.....	.....	.....	.....	.....	.....	.....	.....
32	Lunders	5	00	3	75	5	00	100	.....	3,700
33	Malles	.....	.....	.....	.....	.....	.....	.....	.....	200
34	Mejerib	.....	.....	5	00	.....	.....	120	.....	.....
35	Mogens	4	25	5	00	.....	.....	150	.....	200
36	Mosbjet	4	50	4	00	5	00	500	about 150	.....
37	Mosega	5	50	.....	.....	.....	.....	.....	.....	.....
38	Mosega	.....	.....	.....	.....	.....	.....	.....	.....	.....
39	Moelua	4	50	.....	.....	.....	.....	.....	1,000	4,000
40	Nagbolg	4	50	.....	.....	.....	.....	850	.....	.....
41	Onald	4	60	5	00	5	60	350	200	.....
42	Pindstri	5	00	.....	.....	5	50	2,000	.....	200
43	Poulsen	.....	.....	.....	.....	.....	.....	.....	.....	.....
44	Rosenhe	5	00	.....	.....	.....	.....	300	.....	.....
45	Ronbjet	4	75	.....	.....	.....	.....	500	.....	.....
46	Ronbjet	4	75	.....	.....	.....	.....	1,500	300	.....
47	Raakild	3	40	.....	.....	4	00	100	.....	1,104
48	Skaerso	4	50	.....	.....	5	25	400	500	.....
49	Sparks	4	25	.....	.....	.....	.....	500	.....	200
49b	Stavns	.....	.....	.....	.....	.....	.....	.....	.....	.....
50	Stokhol	3	90	.....	.....	.....	.....	100	.....	1,000
51	Large F	.....	.....	.....	.....	.....	.....	.....	.....	.....
52	Stubber	.....	.....	.....	.....	.....	.....	.....	.....	371
53	Sobo pe	6	50	.....	.....	.....	.....	.....	.....	.....
54	Sonderg	5	00	6	00	7	00	250	.....	50
55	Tandru	.....	.....	.....	.....	.....	.....	.....	.....	.....
56	Tangaga	.....	.....	.....	.....	.....	.....	100	.....	.....
57**	Thoug	4	50	.....	.....	.....	.....	500	.....	.....
58	Tustrup	.....	.....	5	50	.....	.....	50	.....	.....
59	Tvaerbc	4	75	.....	.....	.....	.....	.....	400	.....
60	Tvaerbc	5	00	5	00	.....	.....	290	225	.....
61	Vejrholt	4	40	.....	.....	.....	.....	500	.....	400
62	Vesterg	4	50	.....	.....	.....	.....	.....	.....	.....
63	Videbae	.....	.....	4	20	.....	.....	.....	500	.....
64	Ydes pe	5	00	.....	.....	.....	.....	.....	.....	120
65	Omark	4	75	.....	.....	.....	.....	.....	.....	.....
66	Osterga	.....	.....	.....	.....	.....	.....	.....	.....	.....
67	East Fe	.....	.....	.....	.....	.....	.....	.....	.....	.....
68	Angaard	.....	.....	.....	.....	.....	.....	.....	.....	.....
1		.....	.....	.....	.....	.....	.....	16,175	26,375	22,145

400\*—Th  
 \*\*—Th  
 Th

Total Amount of Peat Fuel Manufactured

No.	NAMES OF PEAT PLANTS	Plants		Number		Drying ground Hs—Hardground surface Bs—Bog surface	Date when commenced
		No. and kind	Driven by	Workmen	Horses		
1	Allingskovgaards peat plant, Silkeborg.....	about 3 M	3 H	9	3	Bs	19/4
2-8	Auning bogs, Auning.....	about 8 M	8 H	24	8		
9	Baks peat factory, Sparkaer.....	1 S	5 HP	5	2	Ha	29/4
10	Birknaes peat factory, Ostbirk.....	1 FL	G 6 HP	5	1	Ha	5/5
11	Brandstrup peat factory, Rodkaersbro.....	2 S	G 9 HP	9	2	Ha	6/5
12	Brd. Petersend peat plant, Hvam, Kellerup.....	1 M	G 8 HP	10	2	Ha	15/5
13	Bogildgaards bog, Kellerup.....	1 M	1 H	6	about 1	Bs	21/5
14	Baagegaards peat factory, Tommerup.....	1 M	E 5 HP	10	1	Bs	20/5
15	Eiling Mosegaards peat factory, Moselund.....	1 S	S 10 HP	4	3	Ha	20/4
16	Engesvang peat factory Moselund.....	3 S	S 50 HP	50	12	Ha	14/4
17	Ganderupgaards peat factory, Doense.....	1 S	G 9 HP	7	3	Ha	3/5
18	Gatten peat factory, Gatten.....	1 S	S 5 HP	14	3	Ha	5/5
19	Grauballegaard peat factory, Silkeborg, plant	1 S	S 8 HP	14	3	Ha	29/4
20	Graubakbet Langelands peat administration.....	1 Fl	S 4 HP	11	2	Bs	26/4
21	Heinstrup peat plant, Olstykke.....	2 S	2 H	3	2	Ha & Bs	1/6
22	Holmegaards peat plant, Olstykke.....	2 S	S 24 HP	3	2	Bs	28/4
23	Hvam-Neder peat plant, Kellerup.....	1 Fl	G 7 1/2 HP	5	2	Ha	5/5
24	Horby peat factory, Hobro.....	1 S	G 9 HP	7	1	Ha	20/5
25	Jensens peat plant, Sindal.....	1 S	G 6 HP	7	3	Bs	18/5
26	Jorgensens peat plant, Tobøl.....	1 M	G 4 HP	9	3	Bs	5/5
27	Kalbygaards peat plant, Laasby.....	1 M	S 7 1/2 HP	14	3	Bs	1/5
28	Klosterlundgaards peat factory, Moselund.....	1 S	S 4 HP	5	2	Bs	4/6
29	Kaergaards peat plant, Sparkaer.....	1 S	S 12 HP	7	4	Ha	3/5
29a	Kvaerkeby peat factory, Kvaerkeby.....	1 Fl	G 6 HP	12	1	Bs	2/5
30	Lammehave peat plant, Ringe.....	1 S	E 4 HP	7	1	Ha	1/5
31	Lille Løjtvedgaards peat plant, Svebølle.....	1 S	S 3 HP	6	1	Ha	4/6
32	Lundergaards Blg., A/S, Aabybro.....	1 S	G 20 HP	9	2	Ha	3/5
33	Mælles peat plant, Sperring, Sjørring.....	1 M	2 H	10	12	Bs	15/5
34	Mejeribakkens peat factory, Ejby.....	1 Fl	G 2 HP	2	2	Bs	7/5
35	Mogensens peat plant, Hundborg, Sjørring.....	1 M	G 6 HP	11	2	Bs	3/5
36	Mosbjerg peat plant, A/S Tolne.....	1 S	S 10 HP	15	2	Ha	28/5
37	Mosegaards Resen, Struer.....	1 Fl	S 6 HP	7	2	Bs	1/5
38	Mosegaards peat factory, Trunderup.....	1 M	G 6 HP	6	2	Ha	20/4
39	Moselund peat factory, Moselund.....	4 S	S 43 HP G 8 HP	40	10	Ha	15/5
40	Nagbolgaards peat plant, Lunderskov.....	1 S	S 5 HP	12	3	Ha	2/5
41	Onsild peat plant, Onsild, and Hobro.....	1 S	S 5 HP	9	3	Ha	1/5
42	Pindstrup peat factory, Pindstrup.....	1 S	S 3 HP	9	3	Bs	5/5
43	Poulsens peat plant, Hundborg, Sjørring.....	1 M	S H 3 G 22 HP	44	11	Bs	5/5
44	Rosenholm peat factory, Hornslet.....	1 M	G 4 HP	4	1	Bs	18/4
45	Ronbjerg peat plant, Vinderup.....	1 Fl	G 8 HP	9	4	Ha	18/4
46	Ronbjerg peat factory, Ronbjerg.....	3 S	S 14 HP G 8 HP	34	9	Ha	5/5
47	Raakilde peat factory, Stovring.....	1 S	S 12 HP	21	6	Ha	5/5
48	Skaerø forest and peat Co., Ebeltoft.....	1 M	G 8 HP	4	2	Ha & Bs	18/5
49	Sparkaer peat plant, Sparkaer.....	1 S	S 6 HP	14	4	Ha & Bs	28/4
46b	Stavso peat plant, Skive and Ronbjerg.....	1 S	S 6 HP	11	3	Ha	1/5
50	Stokholm peat factory, Doense.....	1 S	S 6 HP	10	4	Ha	4/5
51	Large Flanbog peat plant, Bonnet.....	1 M	G 5 HP	5	1	Ha & Bs	10/5
52	Stubbergaard peat plant, Vinderup.....	1 M	1 H	7	4	Ha & Bs	13/5
53	Sobo peat plant, Trunderup.....	1 M	G 4 HP	4	2	Ha & Bs	18/6
54	Sondergaards peat plant, Ronbjerg.....	1 M	S 6 HP	14	2	Ha & Bs	24/4
55	Tandrup peat factory, Bedsted, T.....	1 S	S 4 HP	7	2	Bs	5/5
56	Tangsgaards peat plant, Humlum.....	1 Fl	S 4 HP	7	2	Bs	2/5
57**	Thougs & Mosega peat plant.....	1 S	G 6 HP	7	3	Bs	1/5
58	Tustrup peat plant.....	1 S	S 6 HP	10	2	Ha	20/5
59	Tvaerbog peat factories, Vinderup.....	2 S	S 20 HP	28	8	Ha	20/4
60	Tvaerbog peat factories, Vinderup.....	2 S	S 24 HP	25	7	Ha	19/4
61	Vejrholt peat factory, Arden.....	2 S	S 16 HP	10	3	Bs	25/4
62	Vestergaards peat plant, Sparkaer.....	1 S	G 9 HP	8	3	Ha	24/4
63	Vldebaek peat factory, Vldebaek.....	1 S	G 4 HP	8	2	Ha	30/4
64	Ydes peat factory, Gjernsøl, Snedsted.....	1 M	G 4 HP	10	2	Bs	13/5
65	Omark peat factory, Norager.....	1 S	G 7 1/2 HP	5	1	Ha	19/5
66	Ostergaards peat plant, Hvaeakaer, Bonnet.....	1 S	G 7 HP	8	2	Bs	1/6
67	East Tealgaards peat factory, Viborg.....	1 S	G 8 HP	7	1	Ha	1/6
68	Aagaardsholms peat plant, Roalev.....	1 S	G 9 HP	5	1	Ha	6/5
Total approximately .....		94	450 HP	763	200		

400\*—Those peat plants which have not stated the weight per peat brick, it is assumed to contain 400 grams.

\*\*—Thousgaards peat plant was not in operation in 1913.

This table was given by J. Kastrup, peat engineer, to the Danish Peat Society Journal—"Hedeselskabets Tidkrift," No.

TABLE IX.

Manufactured and Sold in Denmark during 1913.

Manufactured product					Sale price per 1,000 peat bricks												
Date when commenced	Date when finished	Per day	Total, 1913	Tons	Weight per peat brick	Summer				Winter				Amount left	Delivered to industrial factories	Manufacturing of peat cut by hand	
						On the bog	On the railway car at the plant	On the bog	On the railway car at the plant	On the bog	On the railway car at the plant	On the bog	On the railway car at the plant				
Thousands					Gram	Kr.	O.	Kr.	O.	Kr.	O.	Kr.	O.	Thousands			
19/4	22/7	30	1,400	560	400*	4	25			6	00						
29/4	6/8	28	3,300	1,320	400*										100	200	
5/5	12/7	40	2,000	1,000	500	4	00	4	50								
6/5	2/8	40	800	400	500	4	75	5	00								
15/5	5/9	33	2,200	880	400*	3	50	4	00	4	00	4	50	500	400		
21/5	14/6	12	500	188	575	4	50			5	00			40			
20/5	25/7	16	220	66	300	All peat is used by the establishm.											
20/4	10/8	40	5,000	150	250	5	00	5	00	5	00	5	50	200			
14/4	15/8	300	25,000	975	325	3	50	4	25			4	50	1,000	400		
5/5	2/8	50	3,400	1,275	575	4	50	4	50					5,500			
5/5	12/7		1,700	1,275	575	5	75	4	25	4	00	4	50	900			
29/4	9/8		3,500	1,400	500	4	00	4	70								
26/4	23/7	28.5	2,000	2,000	400*	4	30							300	200		
1/6	26/7	10	400	186	400*	7	00										
28/4	1/8	180	12,000	6,000	500	All peat is used at the glass works.				5	50	6	00	22,000			
5/5	15/7	25	700	280	400	4	50			5	50						
20/5	6/8	30	1,800	810	450	3	30	4	25	5	75			130			
18/5	28/6	45	1,530	540	400*	The peat is used by the establishm.				5	30			300			
5/5	51/7	30	2,240	896	400*	3	25			5	30						
1/5	1/8	55	2,875	1,697	625	4	75			5	6	25					
1/5	1/8	25	1,700	680	400	3	75	4	25			4	50				
2/5	9/8	65	4,715	1,767	375	4	00	4	25							200	
1/5	12/7	16.5	1,500	520	400*	5	00	5	30								
4/6	19/7	15.5	825	412	500	6	00	6	85								
5/5	9/8	100	595	158	400*	6	00							125			
15/5	15/7	28	7,830	2,956	575	5	75	5	00	3	75	5	00				
7/5	18/8		400	230	500	7	50							100		3,700	
5/5	1/8	40	5,000	1,125	375	5	00			5	00			120		200	
28/5	15/8	55	2,100	788	375	3	50	4	25	5	00			150		200	
1/5	5/8	30	2,000	1,000	500	4	30	5	30			5	00	500	about 150		
20/4	20/7	about 200	450	169	575	5	00										
15/5	1/8	50	15,000	6,000	400*												
2/5	5/8	33	5,000	1,200	400	4	25	4	50					830	1,000	4,000	
1/5	8/8		2,355	1,677	500	4	00	4	60	5	00	5	60	350	200		
5/5	1/8	16	800	400	500	4	00	5	00			5	50	2,000		200	
18/4	9/8	49	3,100	1,163	575	4	00	5	00					300			
18/4	9/8	155	13,000	5,200	400			4	75					500			
5/5	12/7	18.7	8,000	5,600	450			4	75					1,500	300		
18/5	16/8	52	1,500	750	500	2	85	5	40			4	00	100		1,104	
28/4	15/8	70	5,655	2,115	575	4	00	4	50			5	25	400	500		
1/5	1/8		2,000	1,000	500	4	00	4	25							200	
4/5	23/8	48	2,800	980	550	5	50	5	90					500			
10/5	1/8	20	600	225	575	5	50							100		1,000	
3/5	5/7							4	00								
18/6	1/7	15.7	200	75	575	6	00	6	30							371	
4/4	20/7	20	1,500	750	500	4	00	5	00	6	00	7	00	250			
5/5	28/7	30	2,900	1,450	500												
2/5	8/8		1,500	730	500	5	00									50	
1/5	14/8		2,000	1,000	500									100			
0/5	1/7	35	1,000	500	500	4	75	4	30					500			
0/4	9/8	100	10,130	4,567	430	4	25	4	75	5	50			50			
9/4	9/8	108	10,210	4,084	400	4	25	5	00	5	00			290	400		
5/4	15/7	50	2,500	1,000	400*	4	00	4	40					500	225		
4/4	4/8	45	5,465	1,755	500	4	00	4	30							400	
0/4	9/8	30	2,000	800	400*	5	65										
3/5	1/8	40	2,400	1,200	500	4	00	5	00	4	20			500			
9/5	12/8	22	1,400	635	450	4	00	4	75							120	
1/6	8/7	30	1,000	400	400*	5	50	4	75								
1/6	15/8	17	935	402	430	4	50										
5/5	24/7	18	600	300	500	4	50										
			209,515	95,642										16,175	26,375	22,145	



NAMES AND ADDRESSES OF PEAT PLANTS

	Stationary plants Movable plants
Aagaardsholm peat plant, Roslev.....	1 T
Aa peat bog A/S., Bodal pr. Vedde.....	1 FI
Ailingskovgaards peat plant, Silkeborg.....	3 T
(1)Auning Moseers peat plant, Auning.....	about 8
Backs peat plant, Spærkaer.....	1 FI
Birknaes peat plant, Ostbirk.....	1 FI
Brandstrup peat plant, Rodkaersbro.....	1 FI
Baslegaards peat plant, Tommerup.....	1 T
Delydske peat plant, Ganderup, Arden.....	1 FI
Ellingmoesgaard peat plant, Engesvang.....	1 FI
Engesvang peat plant, Engesvang.....	3 FI
Gatten peat plant, Silkeborg.....	1 FI
Grauballe peat plant, Hornum.....	1 FI
Grevsk. Langelands peat plant, Tranekaer.....	1 FI
Heinstrup peat plant, Olsykke.....	2 T
Holmegaards Glass Works peat plant, Ostrup.....	2 FI
Hvam peat plant, Kellerup.....	2 FI
Horby peat plant, Hobro.....	1 FI
Jensens peat plant, Linderumgd., Sindal.....	1 FI
Jensens peat plant, Brandstrup, Rodkaersbro.....	1 FI
Jetsmark peat plant, A/S., Kaas.....	1 FI
Kalbygaard peat plant, Laasby.....	1 T
Karup peat bogs, Karup.....	1 T
Klosterlundgd peat plant, Engesvang.....	1 FI
Kaergaards peat plant, Spærkaer.....	1 FI
Kvaerkeby peat plant, Kvaerkeby.....	1 FI
Lammehave peat plant, Ringe.....	1 FI
Landmaalergaards peat plant, Glæmsbjerg.....	1 FI
Lille Lojtvadgaards peat plant, Svebølle.....	1 FI
Lundergaards bog, A/S., Kaas.....	1 FI
Mejeribakkens peat plant, Ejby.....	1 FI
Moesens peat plant, Hundborg, Sjørring.....	1 T
Mosebjerz peat plant, A/S., Tolne.....	1 FI
Moesgaardens peat plant, Reen, Struer.....	1 FI
Moesgaard peat plant, Trunderup.....	1 FI
Moselund peat plant, pr. Engesvang.....	4 FIH
Nagbolgaards peat plant, Lunderskov.....	1 FI
Neder-Hvam peat plant, Kellerup.....	1 FI
Onsild peat plant, Hobro.....	1 FI
Pindstrup peat fuel and peat litter plant, Pindstrup.....	10 T
Raakilde peat plant, Støvring.....	1 FI
Rosenholm peat plant, Hornslet.....	1 FI
Rydbjerg peat plant, Ringkøbing.....	3 FI
Ronbjerg peat plant, Vinderup.....	1 T
Ronbjerg peat plant, Ronbjerg.....	1 T
Skaersø peat plant, Ebeltoft.....	1 FI
Spærkaer peat plant, Spærkaer.....	1 FI
Stausø peat plant, Skive.....	1 FI
Stokholm peat plant, Doense.....	1 T
Store fansmose peat plant, Bonnet.....	1 T
Stubbergaards peat plant, Vinderup.....	1 T
Sobø peat plant, Trunderup.....	1 T
Sondergaards peat plant, Ronbjerg.....	1 T
Tandrup peat plant, Bedsted.....	1 FI
Tangaards peat plant, Humlum.....	1 FI
Tustrup peat plant, Randers.....	1 FI
Tvaermose peat plant, Vinderup.....	2 FI
Tvaermose the northern peat plant, Vinderup.....	2 FI
Vejrholt peat fuel and peat litter plant, Arden.....	1 FI
Vestergaards peat plant, Spærkaer.....	1 FI
Videbæk peat plant, Videbæk.....	1 FI
Omark peat plant, Nørager.....	1 FI
Ostergaards peat plant, Hvæskaer, Bonnet.....	1 FI
Oster Teglsgaard peat plant, Viborg.....	1 FI
(2)Sjørring, Sædsted and Todboel bogs.....	4 T

Total..... 97

400 peat plants which have not given the weight have been a  
1 Kr. = 27c.  
1 Kr. = 100 ore.

This table was given by J. Rasmussen, peat engineer, to th



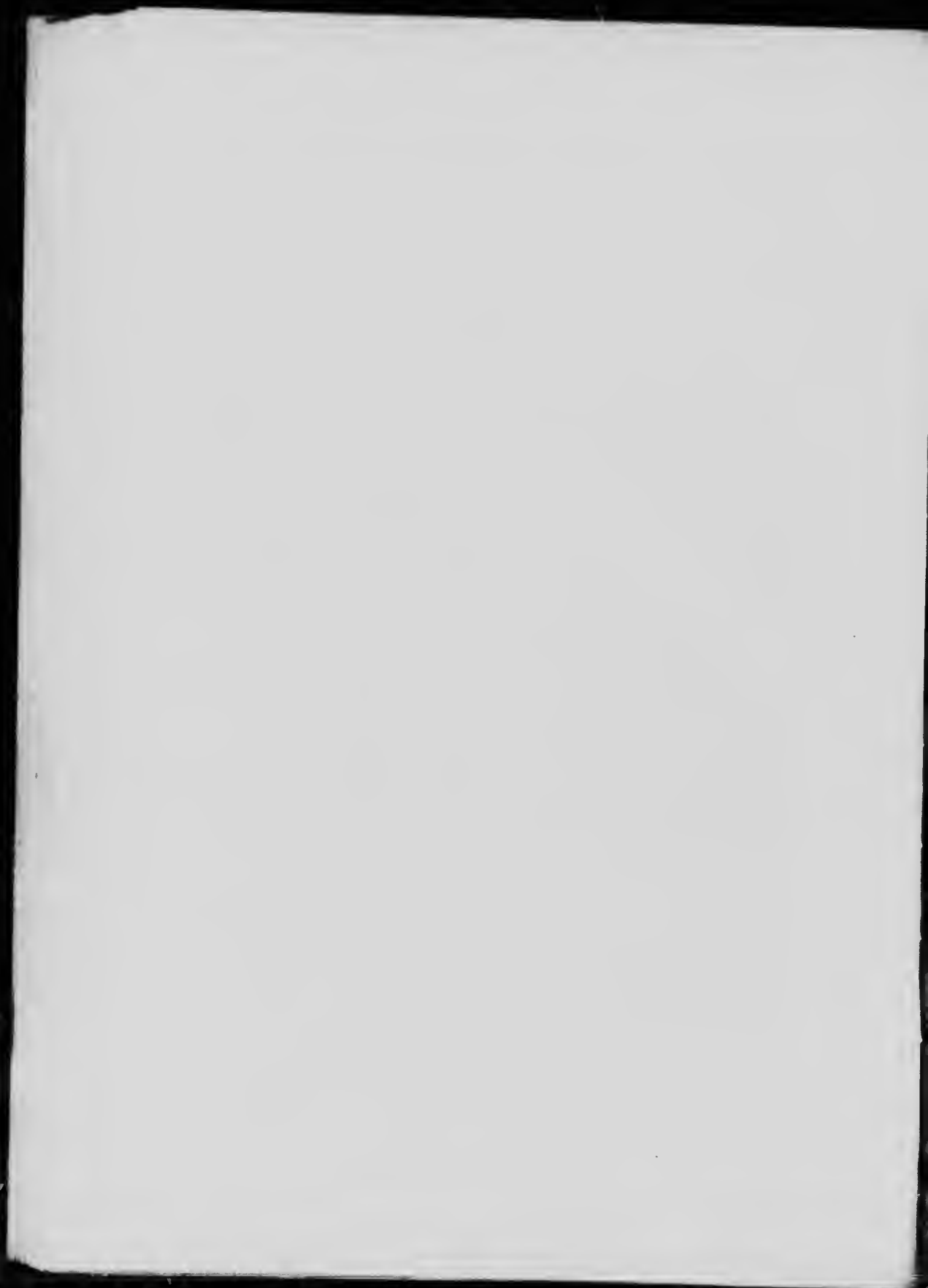

The total production of the 94 peat fuel plants in 1913 was 93,642 tons of air-dried peat fuel, which is the largest production so far obtained in Denmark.

The following Table IX, shows the amount of peat fuel manufactured and sold during 1913; together with prices, labour employed, rate of wages, etc.

(iii)

#### **Detailed Information Regarding Peat Fuel Industry, in 1914.**

The number of tons of peat fuel and peat litter manufactured during the season of 1914 were about the same as usual. The weather during the drying season was very satisfactory, and the drying of the peat was done rapidly, producing high-grade marketable fuel.

The European war has had an extraordinary effect on the peat market in Denmark. From the beginning of the war, no coal has been imported, and so the price of stored coal has increased considerably all through the country. As the prices went up the demand for peat fuel developed in gigantic proportions.

Dairies, brick manufactories, and other manufactories started to use peat fuel, and seemed to be very much satisfied in spite of the fact that in some cases the cost increased 2.00 kronor per 1,000 bricks.

The number of peat fuel plants has increased from 94 to 97 in the last year. However, the output this year is practically the same as last year, namely 206.5 Mill. (86,849 tons) this year compared to 209.3 Mill. (93,642 tons) in 1913.

The following Table X, shows the amount of peat fuel manufactured and sold during 1914; together with prices, labour employed, rate of wages, etc.

#### **RUSSIA.—**

##### **Progress of the Peat Industry in Russia, 1909-1914.**

The following statement, dated March 11, 1914, was received from Mr. A. Naumann, of the firm of Arthur Koppel, Petrograd, Russia.

During the last few years a revival of interest in the peat fuel industry of Russia can be noticed. This is shown by the fact that peat fuel takes second place in the fuel consumption of the country. In 1909, 44% of Russian crude oil, 33% of air-dried peat fuel, and 23% Donetz coal was consumed. Since then the production has increased. This development is due to the increase in the price of coal, crude oil, and wood, and it is expected that these will continue to increase in price.

During the year 1912, 11 Anrep peat machines were sold in the vicinity of Moscow, and in 1913, 41 Anrep peat machines were sold throughout the whole of European Russia. This shows an increase of 400% in one year.

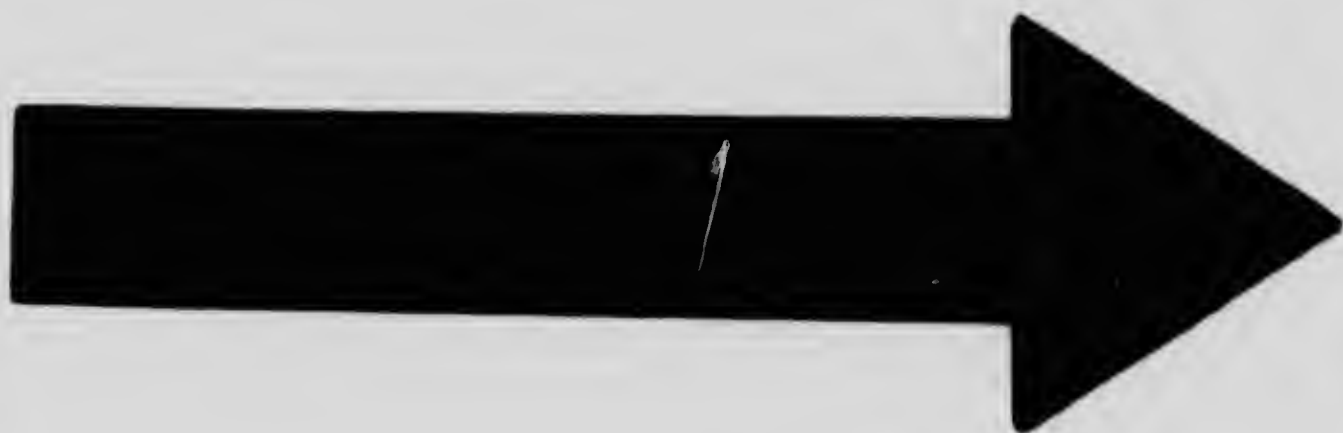

# MICROCOPY RESOLUTION TEST CHART

(ANSI and ISO TEST CHART No. 2)

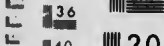
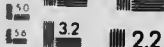

APPLIED IMAGE Inc

1653 East Main Street  
Rochester, New York 14609 USA  
(716) 482-0300 - Phone  
(716) 288-5989 - Fax

In the Teknisk Tidskrift, Stockholm, December 12, 1914, information is given by Captain Wallgren, the Swedish Government peat expert, that at present there is being manufactured in Russia, 7,000,000 metric tons of peat fuel per year: of which 5,000,000 tons are manufactured in the seven central Russian Provincial Governments.

on  
rt,  
ric  
he

**APPENDICES.**

---

**COPIES OF CANADIAN PATENTS  
DESCRIPTIVE OF  
PEAT FUEL MACHINERY**



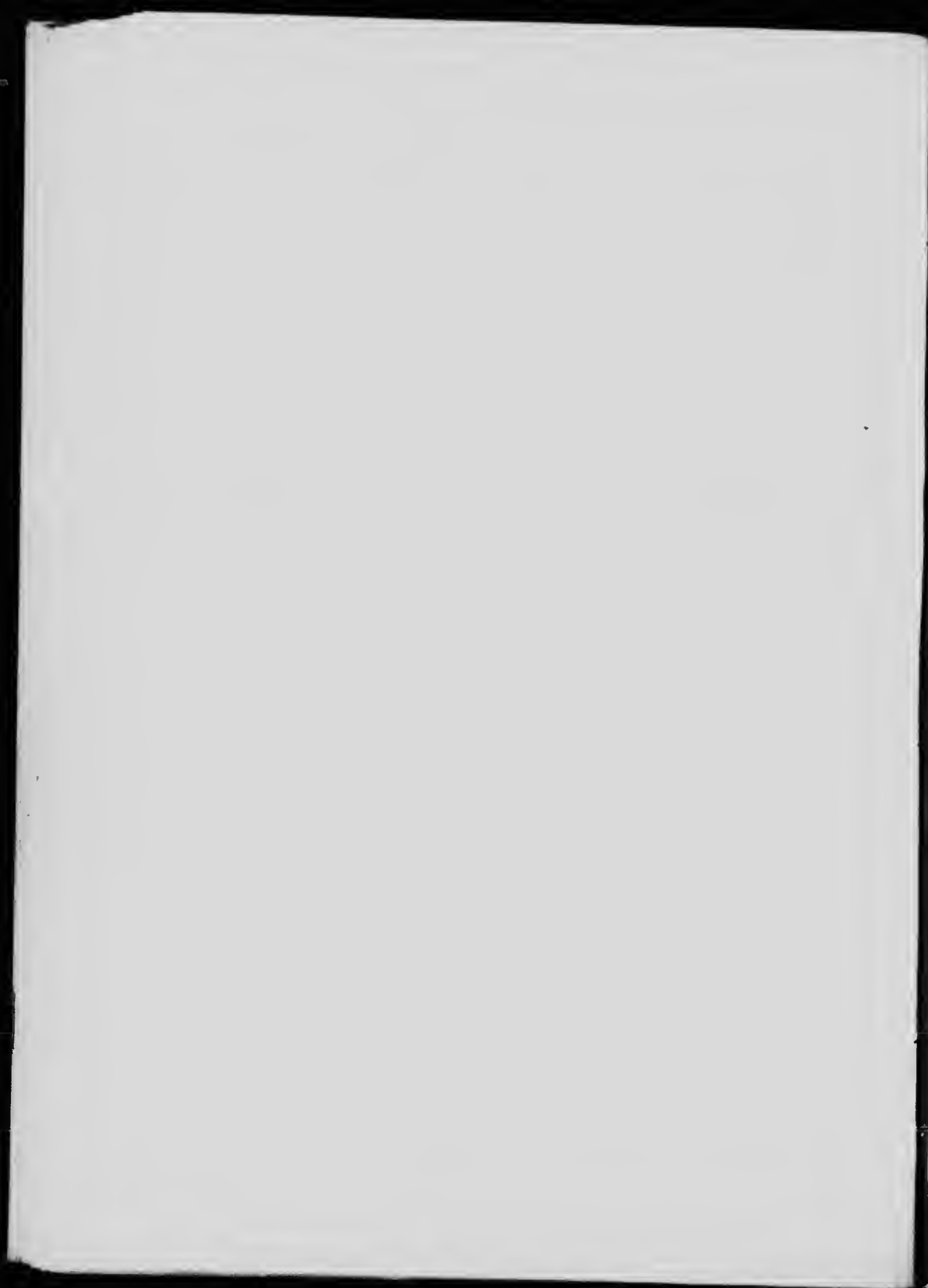

## APPENDIX I.

(Patent No. 142632)

**Improvements in Apparatus for Treating Peat.**

By

*Aleph Anrep, Helsingborg, Sweden.*

This invention relates to a process for thoroughly treating peat in continuous operation, and to a machine suitable for the execution of this process.

The process which comprises three phases of working, consists in that the peat extracted from the peat bog and having if necessary already been subjected to a tearing operation, is treated in the machine in such a manner that at the same time the roots and fibres are cut, whereby any winding up the engine shaft and clogging of the machine as well as perturbations in the work cannot occur. This peat material which has been prepared by cutting and treating is thereafter subjected to an intense cutting between movable and stationary knives and afterwards pressed through a kneading and mixing apparatus, wherein the peat material is subjected to an intense kneading and mixing whereby the raw peat is worked in the most complete and thorough manner.

By this treatment which is performed in one and the same machine, the final product acquires great uniform plastic properties whereby the uniform moulding of all kinds of peat is rendered possible whilst the contractibility of the peat during the drying operation is considerably increased whereby a relatively heavy and hard product is obtained which only gives little waste and has only very poor absorbing properties in case of rain or moist air.

The accompanying drawings show a machine for carrying out the above described process, and in this drawing:

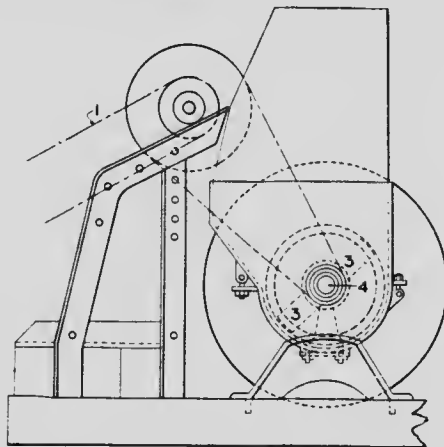

Fig. 1. Anrep macerator. End elevation.

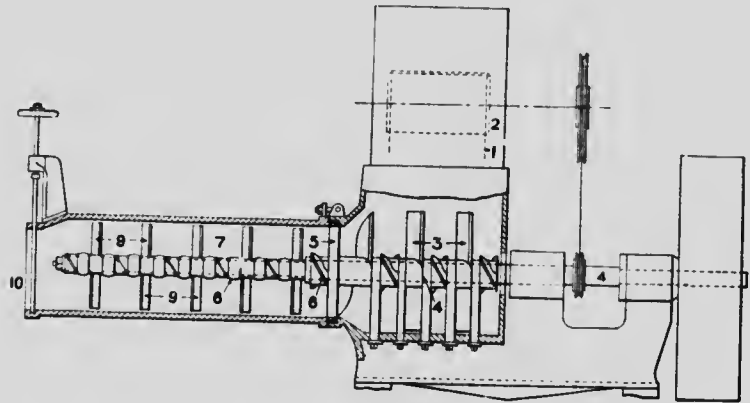

Fig. 2. Anrep macerator. Vertical longitudinal section.

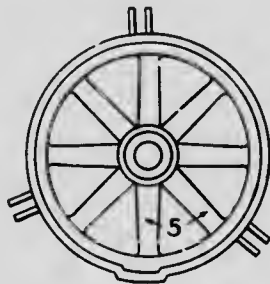

Fig. 3. Fixed knife.

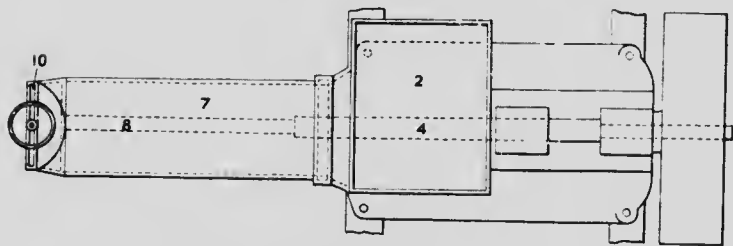

Fig. 4. Anrep macerator: plan at top.

- Fig. 1 is an end elevation view of the machine;  
 " 2 is a vertical longitudinal section of same;  
 " 3 shows the cutting device for the execution of the second working phase;  
 " 4 shows a top plan view.

PLATE XXI.



Anrep mascerator, 1914 model: Alf.ved, Ontario.



The peat is fed from above into the hopper 2 by means of an elevator 1 (see Fig. 1), or in any other suitable manner, and falls if this is thought necessary, on the cutters 3 which oscillate upward and tear the block of peat into pieces, the divided parts being then thrown on the shaft 4 which is provided with cutter (see Fig. 2) which conveys the material into the machine. The material may also be directly fed to the shaft and cutters 4, which seize and cut and treat the roots and fibres in such a manner that the clogging of the machine is avoided. The peat, which has thus been subjected to a preliminary treatment, is conveyed from this working chamber along and between the stationary knives 5, (Fig. 3) which co-operate with the cutters 6, arranged on both sides of the knives, and effect an intense cutting of the peat. The number of the stationary knives 5, depends upon the quality of the peat. The treated and finely cut peat enters, thereafter, a long drum 7, through which extends a shaft 8, provided with kneading arms 9, and which subjects the peat to a very intense after kneading, which still more effectively divides the peat mass. The completely treated peat leaves the machine through the opening 10 or another device. (See Fig. 4).

During the various phases of treatment, the peat yields more and more the water which is stored up in its cells, whereby the material becomes softer and softer, hence reduces the amount of motive power required for driving the machine. In other machines and processes the opposite is experienced, as there, the motive power required is increased in proportion as the treatment progresses, but without the same thorough treatment being entirely obtained. (See Plate XCI.)



## APPENDIX II.

*(Patent No. 130479.)***Improvements in Automatic Rope Arrangements for Transporting Carriage Rolling on a Shiftable Circular Track.**

By

*Aleph Aurep, Helsingborg, Sweden.*

This invention relates to a special arrangement of the traction rope employed in connexion with transporting carriages rolling on a shiftable circular track, such as is employed for conveying peat blocks from the peat moulding machine to the drying field. The characteristic feature of this arrangement is, that it allows the automatic lengthening or shortening of the traction rope according to the shifting which the so-called circular track employed for the transport of the peat to the drying field has to undergo, and according to the advancing motion of the peat excavator or similar plant. The arrangement also provides for the automatic tensioning of the rope.

The tractional rope 1, fig. 5, on the drawing, is placed on the inner side of the circular track, and the traction motive power is transmitted thereto by the peat extracting plant (excavator) 21, through the medium of the carriage 3, the object of rope 1 being to pull the transporting carriage 3' forward. The rope 1 forms a long loop 4, directed opposite to the advancing motion of the peat extracting device 21, and passing through the pulley 5, which is held in position by means of an anchoring device. The bent 4 contains the pulley 6' or system of pulleys which is acted upon by a counterweight 6 (See Fig. 6).

When the peat extracting plant 21 advances, more rope is required, and this supplemental length of rope is automatically supplied by the lowering of the pulley 6', which causes the counterweight 6 to rise. When the peat extracting plant 21 has advanced a distance which is equal to the width of the strip of field on which the peat blocks have been spread for drying purposes, it stops, and the curved frame 10 is dragged forward also, to a distance which is equal to the width of the said peat-spreading strip of field; this operation being carried out by means of rope 9, and the winch 11.

This shifting of the curve produces the lengthening of the traction rope, but the excess of rope is absorbed by the action of the counterweight 6, on the pulley 6'. Owing to this alternating action, and to the fact of the pulley 5 being anchored, the tension of the rope is automatically maintained until the tracks which are laid out on the field so as to form an angle with the line of working come too near to each other. The pulley 5 may, if desired, be directly acted upon by the weight, and is in this case dragged on the bottom, or in guides.



The same figure 5, shows also a somewhat modified arrangement. In the latter, the traction rope 19 is placed on the outside of the circular track, and is directly acted upon by the peat extracting device 21 in such

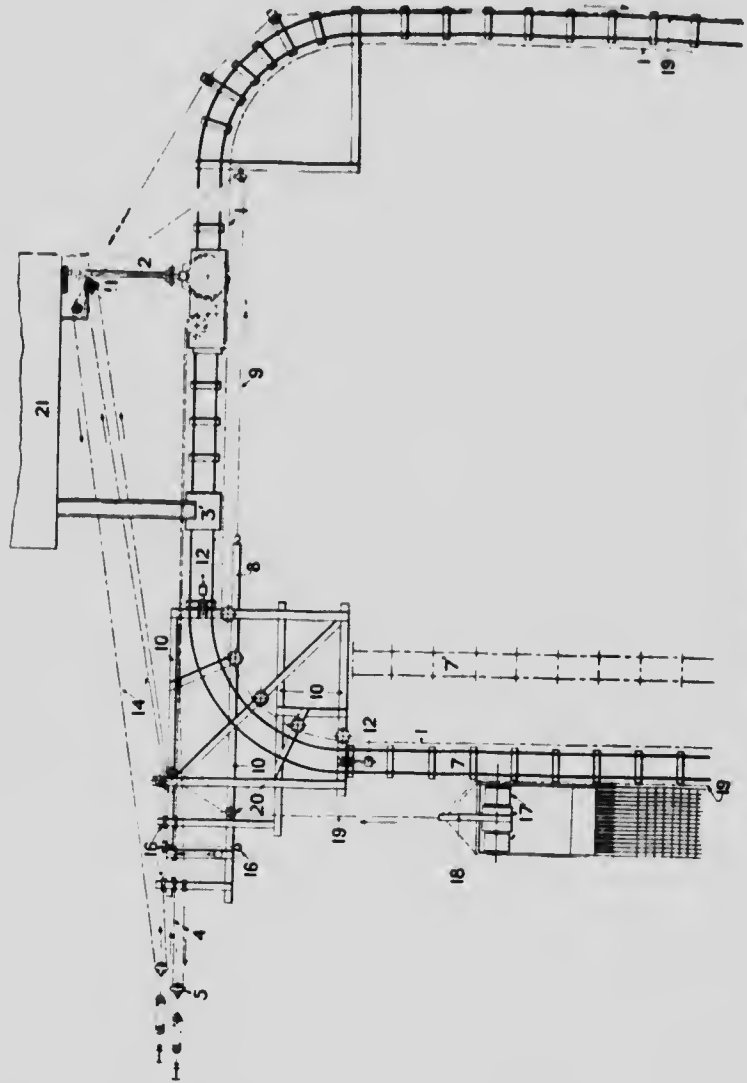

Fig. 5. Plan of Anrep tractor system.

a manner that it pulls the machine or forming the peat on the field, forward and backward along the railway, alongside which the peat blocks are spread out. The traction rope 19, which, in the instance shown, moves in the direction of the arrow, is drawn out so as to form a loop 14, and is

provided with controlling devices 16, similar to, and working in, the same alternating manner as the traction rope 1, on the inner side of the circular

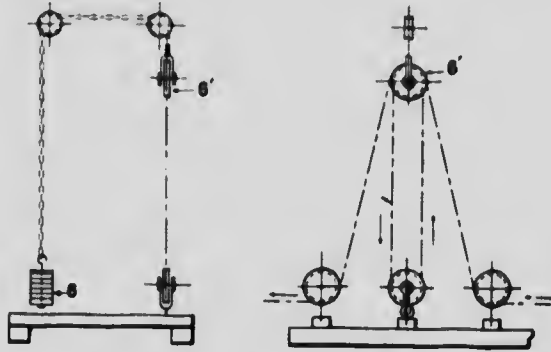

Fig. 6. Anchoring device.

track, but with this difference, that the two parts of the loop are provided with separate driving devices 15 and 15' (see Fig. 7), arranged loosely on the

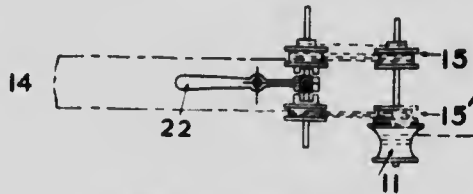

Fig. 7. Coupling device.

shaft and designed to be set going at will by means of the coupling device 22. The rope when running through the loop is crossed and works alternately forward or backward; but in both cases it is subjected to the action of the counterweight device 16.



## APPENDIX III.

*(Patent No. 141700).***Improvements in Peat Moulding and Spreading Machines.**

By

*Aleph Anrep, Helsingborg, Sweden.*

The machine comprises the filling frame 1, (see Fig. 8) into which the peat is filled in any suitable manner, and the front part of which rests on one or more rollers 2, and its rear part on the moulding frame. The latter is connected with the filling frame 1, by means of the pivot shaft or hinge 3, so as to be adapted to swing in an upward direction, and to trail on the bottom or field, when the machine is dragged forward. The mould board 4, is horizontal, or nearly horizontal; and has for its objective, the smoothing and moulding of the peat cake without dragging it or tearing it to pieces. No. 5 indicates movable dividing tongues or fingers, provided at their lower surface with knives or cutters, 6, which are intended to divide the peat cake into strings. The roller or rollers have for their objective, the compressing and levelling of the drying field, in advance of the moulding apparatus. These rollers also furnish the centres of rotation when the apparatus is turned for the return journey, the raising of the moulding frame A, being rendered easy during this operation by the action of the pole 7, carried by the bases 8, (see Fig. 9) 9. The part unnumbered represents a screw which is placed horizontally in front of the moulding frame A, and is used for dividing the mass of peat and to give it the desired thickness before it arrives under the cover 4 of the moulding frame. This arrangement is intended to provide a uniform and well moulded peat cake, or peat strings, or peat blocks. This object is attained by feeding the peat with an equal thickness into the moulding frame, which, by means of its horizontal cover, exerts a vertical pressure on the peat mass, and smoothes the peat cake, whereby a uniform and good moulding action is obtained for all kinds of peat.

An inclined cover (such as those employed in well known machines) would exert an inclined pressure, and draw the peat partly with it during the forward motion of the moulding frame, thereby injuring or deteriorating the moulded form, or even tearing the peat cake to pieces.

Owing to the fact that the moulding frame is adapted to swing vertically round its pivot shaft 3, the frame receives a part of the weight of the framework and is adapted to follow the irregularities of the drying field. If it is desired to produce not a peat cake but peat strips, the cake is divided into strips by means of the spring-controlled tongues 5, which are movably secured under the cover 4, and provided at their lower surface with knives,

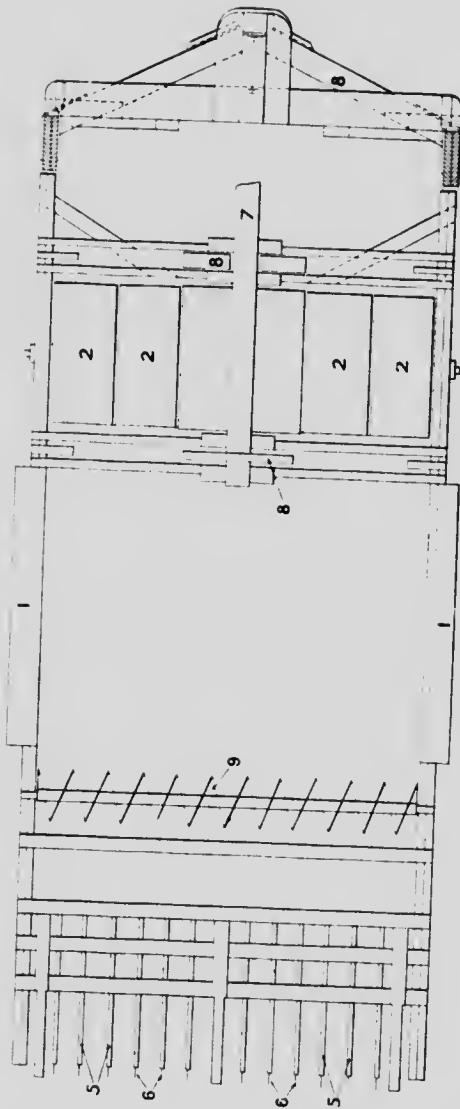

Fig. 8. Plan of Anrep spreader.

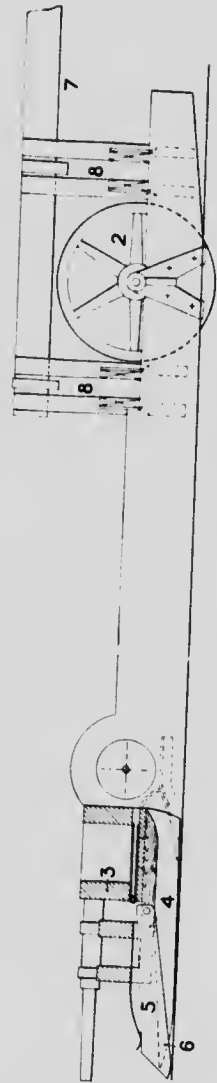

Fig. 9. Side elevation of Anrep spreader.

6. These movable tongues extend rearwards, and form, with the drying field, as small an angle as possible, whereby the exact and smooth division of the peat cake into strips is obtained without tearing. Owing to this arrangement the peat is not torn to pieces but rests quietly under the moulding press on the field. The screw 9, which is rotated by the shaft of the rollers 2, is open on its lower part, and gives the peat mass the desired thickness or height before it is allowed to enter the cover 4. The shaft 9 may be

driven from rollers 2 either by belt and pulley, chain and sprocket, or any other usual and well known transmission system. Such devices are so well known that it is not necessary to illustrate them here. The roller, or preferably a plurality of juxtaposed rollers are loose on the shaft, with the exception of the middle one which furnishes the power for driving the screw 9. These rollers compress and smooth the drying field, and serve as a centre when the apparatus is turned, during which operation no dragging takes place, as the outer rollers rotate freely on the roller shaft.



## APPENDIX IV.

(Patent No. 142519, August 27, 1912).

**Improvements Relating to Separation of Water and Solid Substance  
by the Application of Pressure.**

By

*Horace Keeble of Wareham Hall, and Cecil Keeble of White House,  
Wareham, England.*

Description of the Keeble, patent, carbonized peat, produced as described in the specifications of British Patents Nos. 10834, year 1903, and 12010, year 1909. This product contains, in association with a large amount of water, valuable constituents of the peat, which, during ordinary carbonization processes by destructive distillation, are expelled.

Hitherto, satisfactory separation of such carbonized peat and its associated water, and the conversion of the peat residue into a compressed solid with a minimum of liability to disintegration under conditions to which it is likely to be subjected, have been difficult of accomplishment.

Processes necessitating heat for evaporating the main portion of the water are expensive, whilst by reason of the finely divided and greasy condition of the carbon, attempts to separate the combined peat and water by applying pressure, have been unsatisfactory. In the case, for instance, where perforated plates are used, the material passes away with the water, whilst if fibrous material such as flannel be employed, clogging results.

We find that both these disadvantages of separation by pressure can be overcome by interposing between the material and the water exit, several layers of wire gauze maintained in close contact with one another, and held firmly between smooth metal or other hard surfaces, so that escape of expressed water must be through portion of the gauze layers gripped between such surfaces. Usually two layers of gauze suffice, suitable degrees of fineness being between the limits of say 90 to 30 holes per square inch.

The different layers of gauze may be of the same or different mesh as described.

A more detailed description may be seen in Patent No. 142519, at the Canadian Government Patent Office, Ottawa.



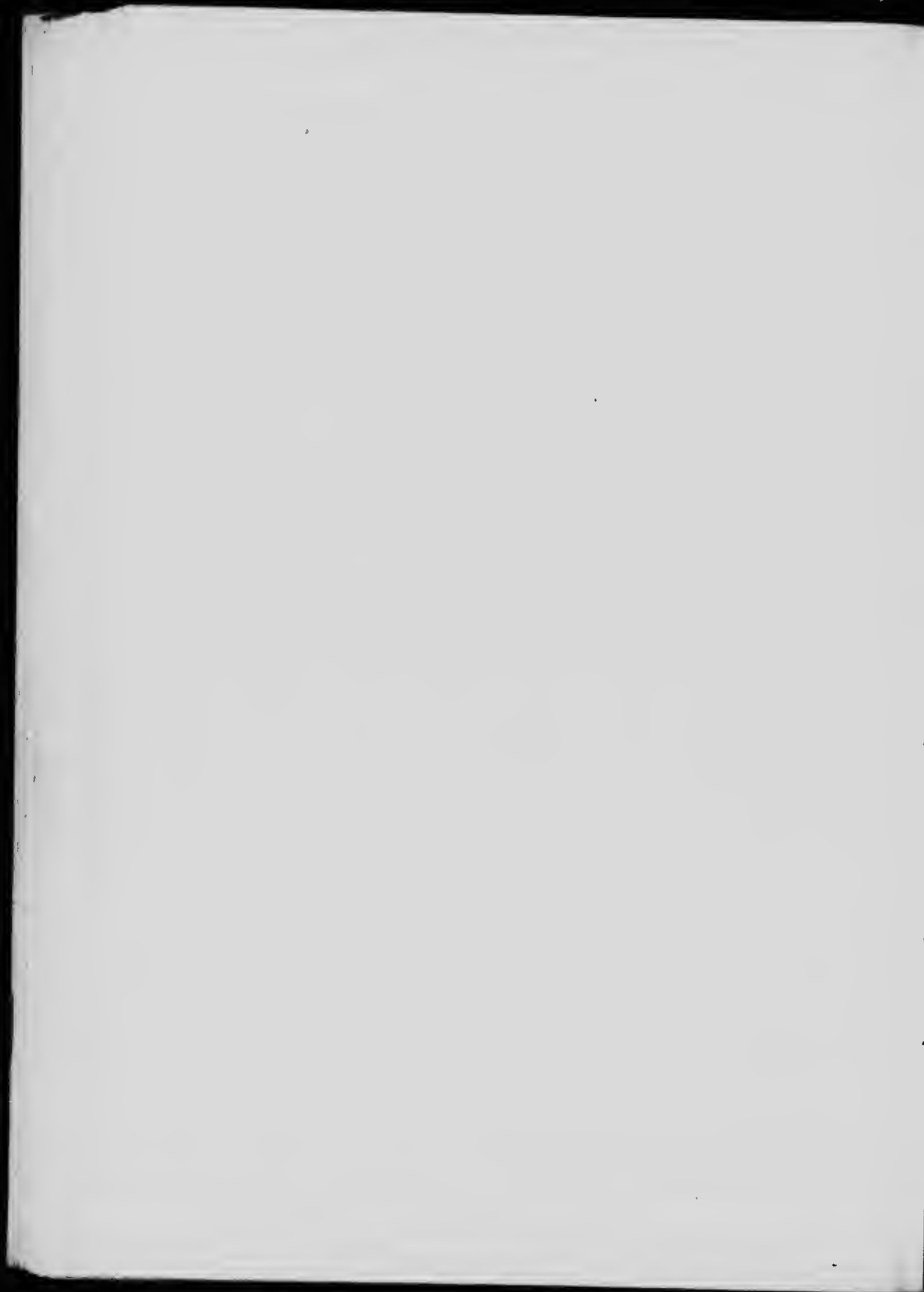

APPENDIX V.

(Patent No. 137963, January 23, 1912).

**Process for Drying Raw Peat.**

By

*Heinrich Brune and Dr. Heinrich Horst, Engineers, Frankfurt-on-the-Main,  
Germany.*

This patent consists of:—

1. A process for drying raw peat, which process consists in mixing with the raw peat, hard dried compressed peat, and pressing the mixture.
2. A process for drying raw peat, which process consists in mixing with the raw peat hard dried compressed peat and subjecting the mixture to a continuously and gradually increasing pressure.

A more detailed description will be found in Patent No. 137963, at the Canadian Government Patent Office, Ottawa.



## APPENDIX VI.

(Patent No. 144730, December 17, 1912.)

**The Getting or Excavating of Peat.**

By

*Thomas Rigby, Engineer, Dumfries, Scotland.*

This invention relates to the gathering of peat, and has for its objective, a continuous supply of peat from the bog or other deposit which is being worked, to the locality at which it is being employed in peat carbonizing apparatus situated near the bog, independently of intense winter temperatures, which often cause freezing of the bog or deposit, and generally produce periods when gathering becomes impossible and work is interrupted.

This invention consists in a method of gathering peat, in which an excavation of the bog or deposit of limited size, but of capacity to contain a supply of peat sufficient for the cold period is kept distinct from the main excavation of the bog, and is used to contain a sufficient quantity of the peat for normal working during the cold period; the excavation being of such depth that freezing cannot, under ordinary cold conditions, occur to an excessive extent.

This invention also consists of improvements in, and relating to, the gathering of peat hereinafter indicated.

In carrying this invention into effect in one form, and employing the method of gathering peat, in which the excavating implements deliver the material directly to the disintegrator or pulverizers, wherein it is converted into a watery pulp, which is then pumped through a pipe line to the desired locality—peat carbonizing installation—a certain area is first excavated in the usual way, and to such a depth that when peat is stored in it the temperatures which occur in the cold season will not be sufficient to cause more than a surface freezing. The capacity of this excavation is such as to contain a supply of the peat sufficient for six months of normal working.

The peat excavated is sent through the pipe line and employed in the usual course.

When the desired size of excavation has been reached, work is commenced on the main portion of the bog, and the pontoons bearing the excavator, disintegrator, and pump, may be floated into the main excavation by cutting away a portion of the uncut bog forming the wall between the excavations, which cutting is subsequently dammed up.

The operation of gathering is then carried on in the usual way in the main excavation, care being taken that a sufficient supply of material is kept stored in the first excavation to tide over the closed season.

It is evident, that the working capacity of the peat gathering appliances—excavator, pump, and disintegrator—will have to be greater than is necessary to supply the installation at normal working; since after a period, when the material stored in the first excavation has been drawn



Fig. 10. Section of trenches for excavating peat.

upon, peat will have to be supplied both to refill the excavation and for the supply of the factory.

It is desirable to install a permanent pumping station in the first excavation, with a peat intake situated well below the normal surface of

the peat, so that the material may be supplied with the assistance of gravity.

The freezing of a bog, even under the severest conditions, does not extend to a very great depth, (in North Britain it does not exceed 6 inches) and by making the excavation, which acts as the store, sufficiently deep,

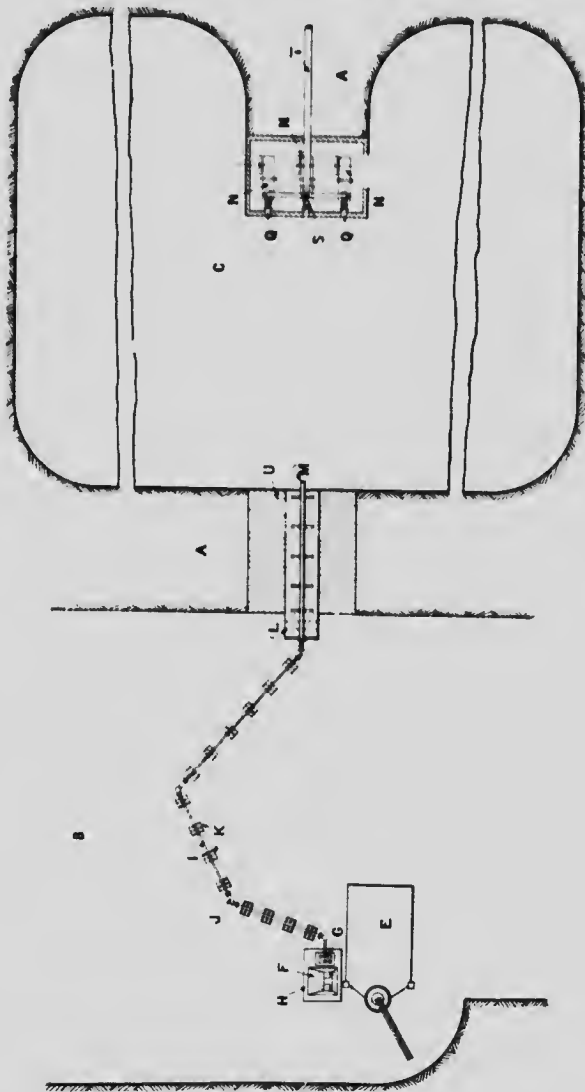

Fig. 11. Plan of Rigby excavator, pump, and disintegrator.

the greater bulk of the peat may be kept unfrozen at the submerged intake, the freezing being also retarded by the circulation which occurs in the watery disintegrated peat which the excavation contains.

See drawings—figures 10 and 11.



## APPENDIX VII.

(Patent No. 146958, April 1, 1913.)

**Improvements Relating to Removal of Water from Wet Carbonized Peat.**

By

*Nils Testrup, and Olaf Söderlund, Engineers, London, England.*

This invention relates to the removal of water from wet carbonized peat. The term wet carbonized peat employed herein, refers to peat treated according to a process such as that proposed by Ekenberg.

The removal of the water from carbonized peat presents certain difficulties. In ordinary settling tanks a reduction of 92% of water in the peat is the best obtainable. Again, by ordinary filtration, only a slight improvement results, the water being reducible to only about 90%.

Further, by employing a pressure forcing the peat into the filtering chamber, the water has been reduced only to 66% by the use of a pressure of 100 pounds per square inch, it being necessary in order to further reduce the water content, greatly to increase the pressure, but great difficulties then arise in ensuring even distribution of the pressure and in providing apparatus which shall be sufficiently strong and large to deal with these high pressures and with the large quantity of material to be handled in practice.

Unsuccessful attempts involving the use of special apparatus have been made to overcome the difficulties present in the production of pressed peat, of low moisture content from wet carbonized peat. A press of the type having a chamber formed with laminated walls and a screw feeding member therein, and having restricted orifice has been tried, but has failed, the spaces between the lamina first becoming choked, and the plug formed at the restricted orifice then being forced out and allowing free passage of the material under treatment. Similarly, an apparatus comprising a reciprocating plunger pump, with an open ended cylinder, intended to be closed by a plug of the material and filtering means around the cylinder, the peat being forced into the cylinder, has also been tried unsuccessfully, the relatively high speed of the plunger resulting, in the first place, in no filtration owing to the elasticity of the material, and the plug being then blown right out, and giving free passage to the material under treatment, similar to Patent No. 142519.

The object of this invention is, to overcome these difficulties, and to provide a practicable process and apparatus allowing of the reduction of the percentage of water to a considerably lower value than that (namely about 70%) obtainable by the means hitherto proposed.



It has been observed that when the percentage of water in the press cake in the filter press falls to about 70%, the material loses its plasticity or fluidity. Under these circumstances the pressure is highest near the inlet of the peat to the apparatus (the point of application of the pressure) and diminishes as the distance from the inlet increases, and is not, as in the case when the material is still fluid, evenly distributed throughout the same.

Increase of pressure beyond about 100 pounds per square inch, is practically useless, because it results in a rupturing of the press cake and the formation of channels therein, through which filtration proceeds without further drying action on the cake already formed. This invention is based upon these considerations.

According to this invention, externally applied, and preferably slowly applied, sustained pressure is used in the removal of the water; this treatment following a preliminary treatment in which pressure applied internally is used, namely, pressure transmitted by the fluid itself. For this purpose, the wet material may be passed into a filter press, and the water—which is readily expressible therein—removed in this way; a further quantity of water being then removed by subjecting the cake to pressure externally applied by a hand or similar press.

#### *Description of the drawings.*

The peat is carbonized in carbonizer compressing regenerative heating tubes *a*; furnace *b*; and inlet and outlet headers *c* and *d*, respectively, (see Fig. 12). No lagging or other means for preventing undue loss of heat—such as would in practice be employed—is here shown. The peat leaves the carbonizer at a high pressure, and enters the air vessel *e*, then passes through a pressure regulating valve *f*, to a receiver *g*, the connecting pipe *h* being provided with a relief valve *i* (see Fig. 13), and blow pipe *j*. The peat receiver is provided with a safety valve *k*, pressure gauge *m*, and other customary accessories. From this vessel the peat, by virtue of the pressure in the vessel, passes into a filter press *o*, the pressure of the material being used in the press to effect the filtration. A pressure of between 100 and 150 pounds per square inch is preferably employed. As it becomes, in most cases, necessary to remove the press cakes from the filter press after about 25 minutes operation at 100 pounds pressure, two or more of these devices are preferably employed, means such as suitable cocks or valves *p*, in connexion with each press being employed to allow of cutting off the supply to one for the purpose of allowing emptying of the same, while another is being used.

The material removed from the filter presses is thrown into a common bunker *q*, means such as a screw conveyer *r* at the bottom of the same conveying the material at any desired rate to a press of the hand press type, capable of giving a gradually applied and high pressure by virtue of the fact that the strong perforated endless bands, one of which is shown at *s*,

and which are carried on shafts *l* at either end, are placed closer together at one end than at the other, so that the material entering at one end is gradually more strongly squeezed between the bands as it approaches the

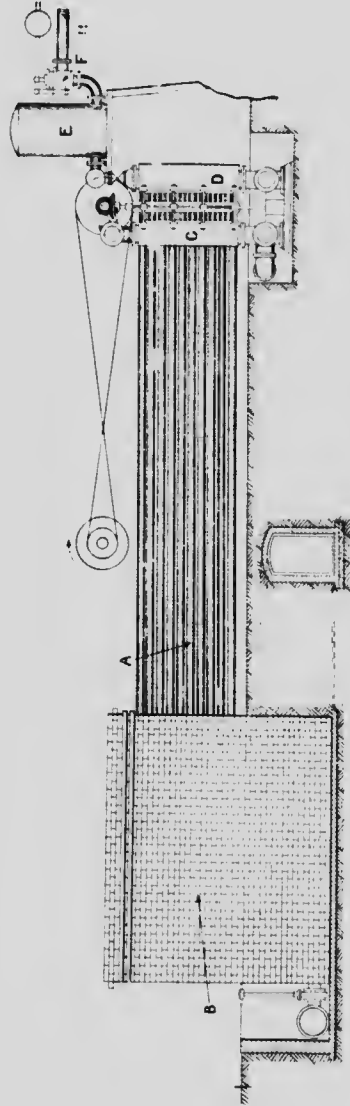

Fig. 12. Side view of Trestle carbonizer.

other end, and a further quantity of liquid therefore leaves the material, and passes away through the perforations of the links of the bands.

As many of these presses as is necessary are employed. Such a press, although unsuitable for thinly fluid masses, is particularly useful in this

case, where a slowly applied high pressure is required, and not an impact which would lead to no substantial expression of water, owing to the elasticity of the mass. The final pressure required may amount to about 600 pounds per square inch, and the hand press, therefore, should be of such a nature as to give a very high pressure without undue friction.

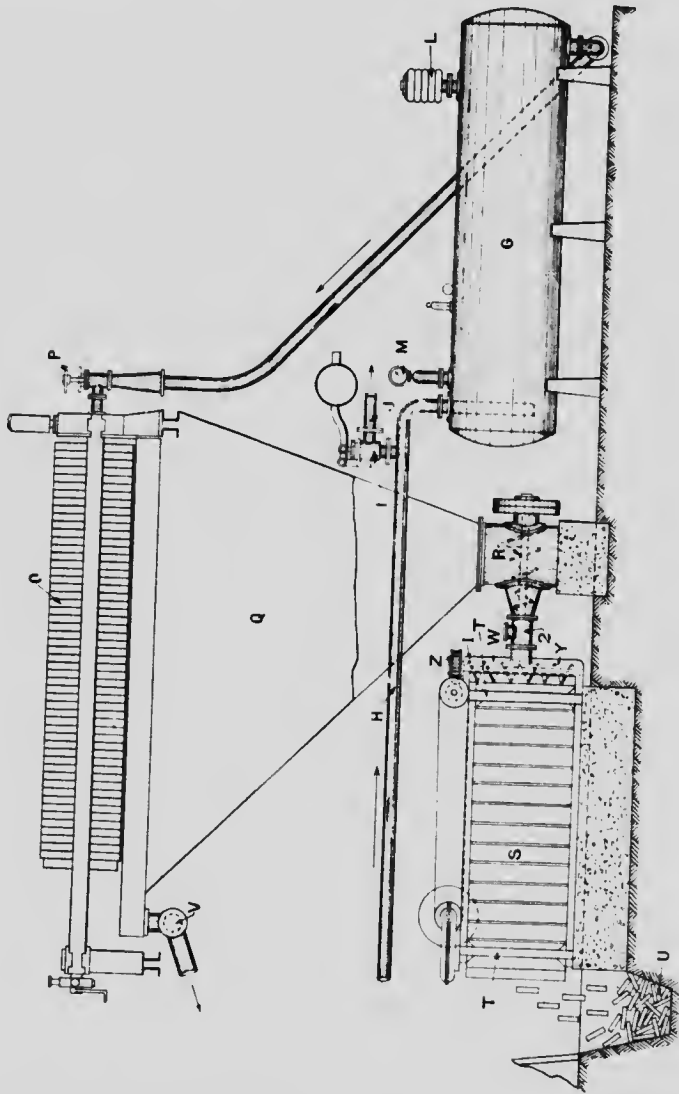

Fig. 13. Side view of Testrup-Söderlund air vessel.

This is best effected by providing roller chain bearing surfaces for the bands, so that the same can move easily and smoothly, even when the full pressure is on. The pressed material is discharged into a trough *u*, from

which it can be taken to any desired locality. The liquid matters leaving the filter press at *v*, as well as those leaving the hand press, are either passed away for utilization in any suitable manner, or may be passed to waste, for instance, by passing it back to the peat deposit. In order to feed the peat brought by the conveyer *r* more uniformly into the oblong entrance to the hand press, a double screw *w* and *y* driven from worm gear *z*, is mounted across the entrance to the press, so that the material entering chamber 1, in which the double screw is mounted, by the tube 2, is partly taken by the double screw and distributed towards each end of the press entrance.

It will thus be seen that while in the first stage (in the filter press) filtration is brought about by keeping up the pressure by pumping more fluid of constant volume into a chamber, in the second stage (in the hand press) the size of the confining chamber is reduced as the water is extracted.

The material as it now leaves the press, containing about 50% water, is quite solid, and is suitable for direct use in a producer for conversion into gaseous fuel, preferably in an ammonia recovery gas producer, for which it is particularly suitable.

On the other hand, the material may be passed into any ordinary briquetting plant, such as a lignite plant, for conversion into briquet fuel. It may, after any necessary breaking down, be passed through a rotary drier heated by steam tubes of the kind known as the Schultzer drier, and its water content reduced to about 5-15% or less, and then heated for briquetting.

In order to more clearly indicate the general method adopted in carrying the invention into effect in the form above indicated, the following detailed example is referred to.

In a factory in which 86 tons of peat, containing about 90% of water (equivalent to 8.6 tons of dry peat) were carbonized per hour, which peat was changed to such an extent in the oven that only 6.9 tons of dry peat substance remained mixed with the liquid; in order to reduce the water content of the material to the neighbourhood of 70% moisture, 7 filtering presses containing 10,000 square feet of filtering surface were required. By using these filter presses intermittently and in regular rotation, it was possible to reduce the water as low as 67% by weight when using a pressure corresponding to 120 pounds per square inch maximum on such filter presses. Twenty-five minutes, approximately, were taken to reduce the water content from 92% to 67% of water, the pressure in the interior of the filter presses being gradually increased from little or nothing (corresponding to 92% of water) to 120 pounds (when the material reached the neighbourhood of 70% water) which maximum pressure was kept on for 15 minutes, and was necessary to reduce the liquid content to about 70%, making as above mentioned 25 minutes in all for filtering. When the material had been filtered, and pressed to the neighbourhood of 70% water content, it became practically impossible to press out further water by means of the pressure of the liquid itself, and to reduce the water content from approximately 70% to about 50% by weight, external pressure was applied by

transferring the material to a hand press having 60 square feet of pressing surface. In the latter press it was necessary to have a final pressure of approximately 600 pounds per square inch, to effect the removal of the water. It will be observed that in the one case comparatively large surfaces had to be provided to filter the water away, using a moderate pressure, whereas the removal of the remainder of the water required comparatively small pressure.

The time occupied for pressing in the hand press was 42 seconds.

## APPENDIX VIII.

(Patent No. 147434, April 22, 1913).

**Improvements Relating to Methods of Recovering Peat from Peat Bogs.**

(For paper manufacturing and other articles.)

By

*Bernard Granville, New York, U.S.A.*

This invention relates to the treatment of bog peat, and has for its object the economical removal of the fibres contained in the peat as it lies in the bog, and the separation of the same from the other elements of the bog.

Heretofore, peat has been removed from the bog by mechanical devices, such as plows, rakes, spades, and dredges; and the difficulty in the utilization of the valuable fibre of the peat has been the cost of removal from the bog, and the separation of the fibre from the other constituents of the peat.

The chief purpose is to produce peat fibre as material for the manufacture of paper and other articles, and to secure economy of excavation and separation with a minimum of breaking of the fibre. The hydraulic process is used somewhat after the manner of hydraulic mining. In carrying this invention into practical effect, I direct a powerful stream upon the peat as it lies in the bog. This cuts the peat, and at the same time disintegrates it, washing the valuable fibres from the rootlets and lumps, and holding these fibres in suspension in the body of the water used in the cutting. It is better that the stream be so directed as to cut a channel leading from the point where the apparatus is situated by which the water that carries in suspension the fibre of the peat is lifted. I may cut, in this way, always against a margin of the body of peat which contains the fibre, adding constantly to this body the water of the stream, and the fibre cut and washed by the stream, and this body of water holding the fibre in suspension, forms a reservoir of material from which is drawn, by any suitable means, the material thus held in workable condition for further treatment. A natural head of water may be used if such exists conveniently near, for the force, or the water of the bog may be used, once or repeatedly.

At a point convenient to this body of water and fibre it is advisable to erect the plant for the elevation of the water and fibre, if necessary, and for separation of the fibre therefrom.

The water which is separated from the peat, in its treatment, may be collected in a suitable reservoir for re-use by returning it to the pump, which forces it to the hydraulic giant employed for cutting the peat out of the bog.

At a suitable point in the process, the fibre may be subjected, after the water is drained off, to the action of a weak alkaline solution, washed with water, and subjected to a weak acid solution and again washed, this action removing not only all dirt and mud, but most of the gelatinous matter. The acid treatment neutralizes the alkaline treatment, causing the fibre to shrink and solidify, materially adding to the strength of the fibre which

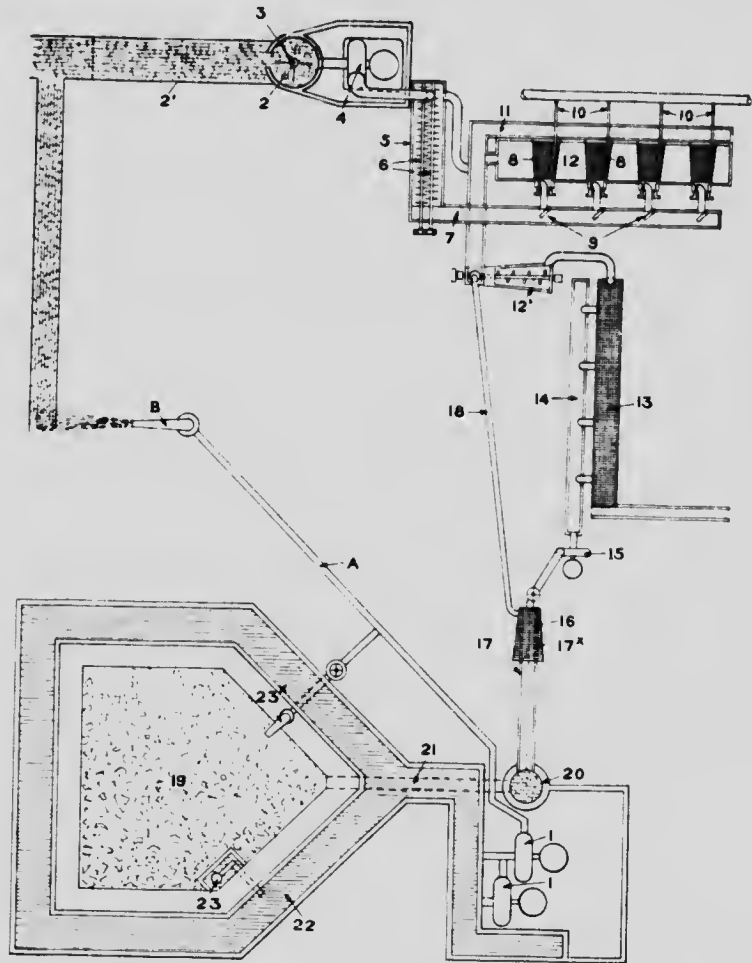

Fig. 14. Plan of Bernard Granville hydraulic process.

may then be utilized for half stuff paper making, paper boards or artificial lumber or other purposes.

Figure 14 shows a plant or system for carrying out the invention.

In carrying out the process, water from a suitable supply is dropped by gravity into a centrifugal or other pump 1 (see fig. 14) which forces the

water at a pressure of from forty to two hundred pounds through a pipe *a*, to a standard hydraulic giant *b*.

This giant is located preferably at the deepest point of the bog, and operations are commenced by cutting a channel in the peat and in the bed under the peat a distance of several hundred feet in length and forty or fifty feet wide. A suction pump is put in operation at the point where the cutting of the peat was started, so as to eject the peat onto the bog for the purpose of forming a suitable permanent well or sump 2 at or near this end of the cut. This main channel may be of any desired length, say, one-half mile or one mile, and the peat disintegrated by the giant mixed with the water passes by gravity to the pump. As the work progresses lateral cuts or channels are made by the hydraulic stream in the bog connecting with the main channel, and in these channels at suitable points grids or grizzlies 2 may be arranged which will catch sticks or logs, which may be removed in any suitable manner automatically or by hand. This sump 2 or well is made preferably circular and a vertical shaft 3 with stirring arms is constructed so as to revolve slowly for keeping the material entering the well in suspension. Pumps 4 are placed preferably at the bottom of a pit adjacent the pump so that all liquid and the material cut from the bog by the hydraulic stream will gravitate into the pumps. These pumps throw the material up into a building adjacent to the sump delivering the peat and liquid material and other substances into a log washer 5, having two shafts 6, provided with beater arms. The shafts revolve in opposite direction and lie slightly out of horizontal, the arms being so formed as to work in a helical manner, forcing the beaten up peat out of the higher end of the log washer permitting the heavier substances to gravitate and overflow at the lower end of the machine. The disintegrated peat falls from this log washer into a trough 7, which is supported adjacent to a series of rotary washers or screens 8, and above the plane thereof a swinging adjustable gate 9, being arranged opposite each rotary screen and adjustment of the gate permitting each screen to take its fullest complement of peat, and not more. The fibre falling into these rotary screens is tumbled over and over, and is washed here by sprays of water issuing from pipes 10.

This action washes out all the sediment contained in the peat, and delivers the peat from the large end of the rotary screen into a common trough 11 in a perfectly clean condition, the dirt and refuse going through the screen mesh with the water into a settling tank 12.

After the fibre has progressed beyond the rotary screens, whilst it is cleaned it may still retain a number of fine sticks and roots to be taken out. After leaving the screens, the fibre is allowed to fall from the flume 11, into a drum 12, which is a conical, imperforate barrel, arranged in a horizontal position, and having a shaft inside with a number of beater arms at an angle for forcing the fibre rapidly through the barrel, at the same time thoroughly mixing it with a large quantity of clean water which is permitted to enter the drum at the same time and place as the fibre. This water which enters the drum is preferably provided by allowing the water



used for washing the fibre in the rotary screens to fall from the screens into a settling tank 12 above mentioned, causing the sediment to fall to the bottom and the clean water to pass off at the top and overflow into the drum. After the fibre leaves the drum it is thoroughly disintegrated and mixed with the water, and passes directly on to a paper screen 13 of standard pattern, which removes all the sticks from the fibres, and permits the fibre to pass through the screen and into the trough 14, the sticks passing to the end of the screen and being thrown out automatically upon the bog by any suitable form of conveyer or cleaver. The fibre, in the finished clean condition, is preferably forced by a pump 15, from trough 14, into another rotary screen 16, which removes part of the water from the fibre, which fibre then falls from the screen into a trough 17, part of the water returning to the head of the drum by pipe 18, or head of standard paper screen if desired. The fibre is now of the right consistency to flow, if desired, by gravity to a suitable reservoir 19, adjacent to the mill; or, the process can terminate by letting the fibre, after leaving the standard paper screen, instead of being elevated pass over a series of wetbroke machines, when it is immediately ready for shipment by baling or rolling.

The clean fibre, with whatever water it contains, after leaving the flume 17, passes into a tower 20, and thence to the reservoir 19, through a tunnel 21, where it is dewatered, and the water passes thence to the outer reservoir 22, through a floating outlet 23, to be passed back through the main pumps and to the pipe line for supplying the hydraulic giant.

If wetbroke machines are used, the reservoir and flume would not be necessary.

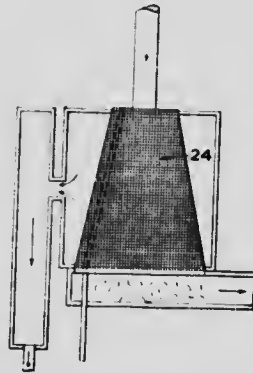

Fig. 15. Conical screen for straining the peat from roots and sticks.

When the stream from the pump giant is not being used to disintegrate or cut the peat, said stream may be directed into a return channel leading back to the reservoir.

When the mill is running the peat in liquid form can be taken from the tower into the mill, the amount of water passing through the flume 17, being regulated by a suitable gate at 17x.

When it is to be taken from the inner reservoir it is forced hydraulically by connexion with the pipe line, or by a hydraulic giant 23x, the spray from which is directed onto the bed of peat in the reservoir.

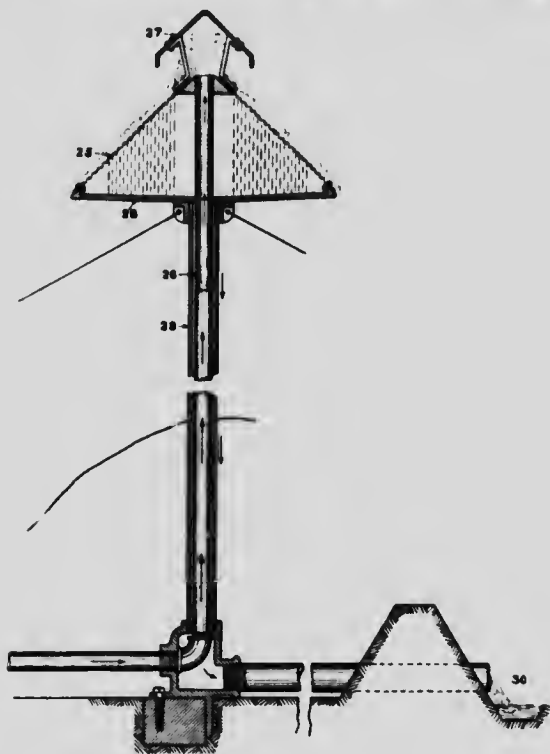
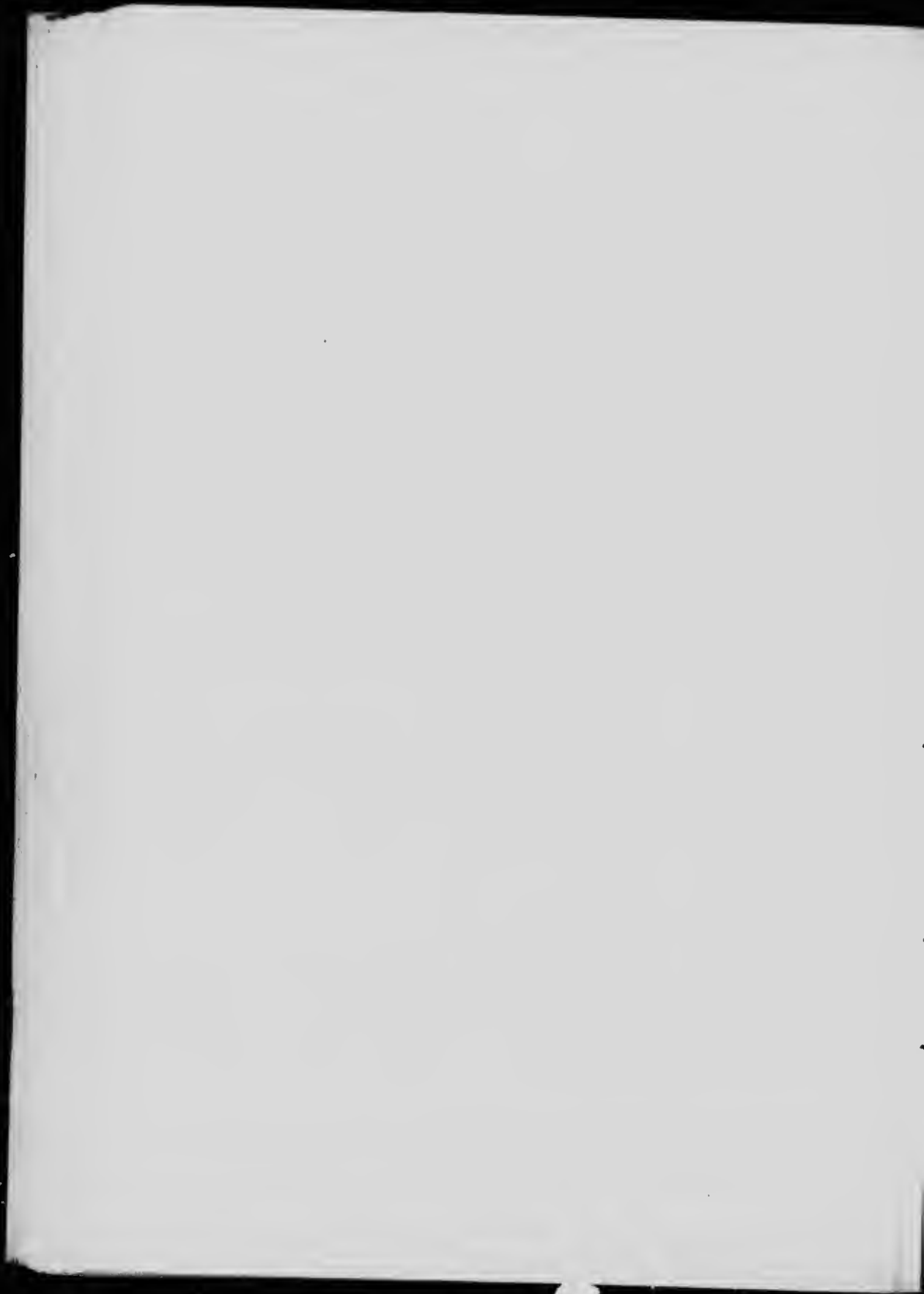

Fig. 16. Vertical section of Bernard Granville hydraulic process.

Where fibre is not required of extreme fineness, and where larger quantities are to be produced, it is preferred to use in place of standard flat paper screen 13 a large conical screen 24, (see Fig. 15), covered with a sufficiently large mesh to permit the fibres to be washed through the mesh, the sticks being retained on the inside of the screen, and falling into a trough at the end of the screen, with any suitable means for ejecting the sticks onto the bog. The peat fibre, after leaving this screen, being sent through the flume to the reservoir.

In the Figure 16, will be seen a method and means for separating the fibre from the water, and storing the fibre in a pile. For this purpose a screen 25, of conical form is mounted at the upper end of a pipe 26, through which the mixed water and fibre is conveyed, and discharged at the apex of the screen against a hood 27, from which the mixture falls onto the conical screen, the water passing through the screen and fibre passing off upon all sides of the screen to form a conical pile. The water is caught by pan 28, which directs it to a pipe 29, surrounding the pipe 26, and this water is delivered into the outer reservoir indicated in this view at 30, for re-use.



## APPENDIX IX.

(Patent No. 148778, June 17, 1913.)

**Improvements Relating to a Peat Conveyer.**

By

*Ernst August Persson, Emmaljunga, Sweden.*

This invention relates to a peat conveyer, very simple in its construction and offering a safety of working that is far greater than by using peat conveyers of hitherto known types.

The conveyer may very easily be adapted to differences in topographical conditions, as it can be moved from one place to another without any difficulty.

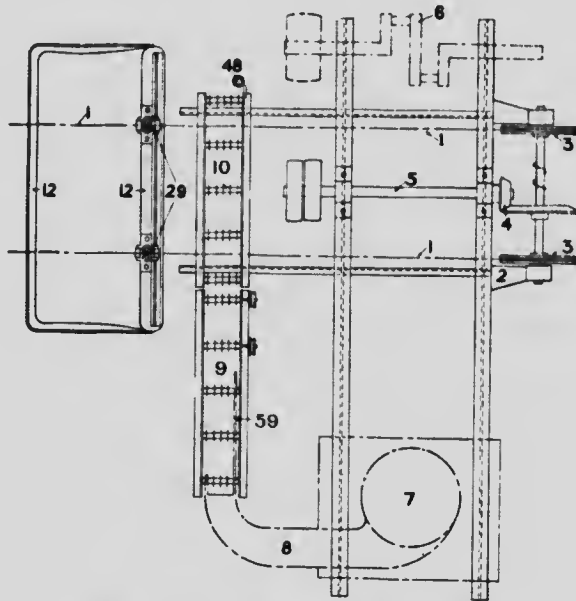

Fig. 17. General plan of Persson's conveyer.

The conveyer consists of two endless wire ropes 1, (see Fig. 17) parallel with each other and each carried over pulley 3, fastened to the frame work 2 of a portable engine or the like which is transportable on rails along the peat bog. The pulleys 3, are driven by means of a level gear system 4, which is put into rotation by means of an intermediate shaft 5, from the crank shaft 6, of the portable engine.

Such a direction of rotation is given to the wire ropes that their upper parts travel in a direction from the engine. The peat mill 7, is also arranged on the frame of the engine. The outlet 8 of the peat mill is perpendicular to the longitudinal direction of the engine, and its outer end is bent so that it is parallel with the same direction.

At this end of the outlet a stationary roller conveyer 9 of known type is arranged, and at the end of this latter, another vertically movable conveyer 10 of the same kind is arranged between the wire ropes, the following is a description of this second conveyer. The wire ropes pass from the engine over horses 11 and 12, provided with rollers or the like to a station-truck 13, movable on rails, the distance of which from the portable engine depends upon the size of the peat bog at hand, and might be as much as 200 metres to advantage.

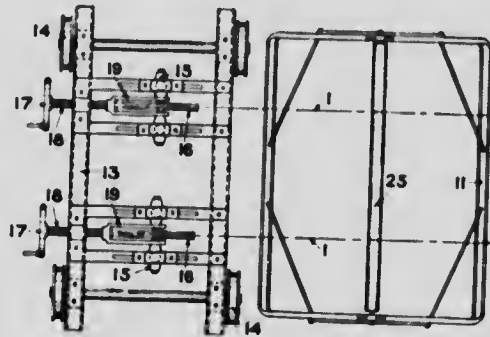

Fig. 18. Station-truck, Persson's system.

The station-truck (Fig. 18), consists of a frame resting upon wheels 14 the frame carrying two pulleys 16 in swivel bearings 15, the diameter of the pulleys is suitably the same as for the pulleys 3, over which the wire ropes run.

The swivel bearings are movable in the longitudinal direction of the wire ropes by means of hand wheels 17, provided with screws 18, that are rotatory arranged in forks 19, embracing the pulley shafts. For this purpose the foundation bolts of the bearings are longitudinally movable in slots in the frame. By this arrangement the tension of the wire ropes may be held uniform within certain limits.

The horses over which the wire ropes run are of two kinds; partly having variable height for the wire rope 11, and partly 12, with constant height. These latter serve also the purpose of guiding the wire ropes between the portable engine and the station-truck 13, so that the distance between them, laterally, may be held nearly uniform. These horses are, of course, placed promiscuously according to the topographical conditions.

The horses arranged for variable height of the wire rope (Figs. 19 and 20) consist of a frame suitably made of two bent channel irons 20 and

21, the upper parts of which are parallel with each, so as to form guides 22, between which a ladder-shaped part 23 is slidably arranged. On these parts 23, bearings 24 are rotatively arranged on the rungs, the purpose of the bearings being to carry two rollers 25 supporting the wire ropes. The

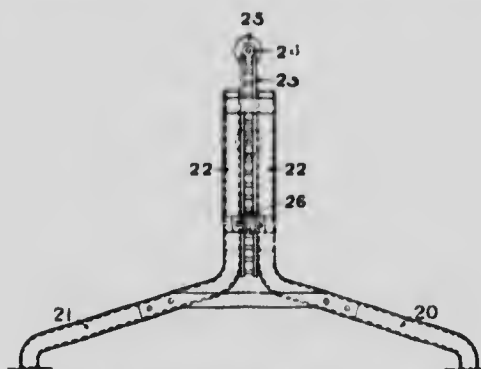

Fig. 19. Guides for supporting the wire ropes, station-truck.

ladder 23 is held in its place by means of a hook 26, that is pivoted to the frame and engaged between the rungs of the ladder. The horses are in the same way, at both ends, provided with slideable bearings both fastened to the ladder 23, and thus always able to hold both rollers of one horse at

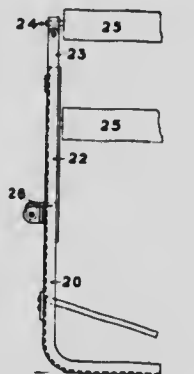

Fig. 20. Side view of the guide frame, station-truck.

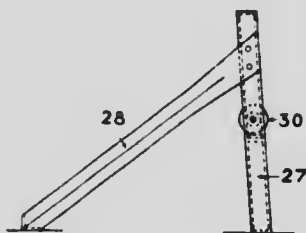

Fig. 21. Channel iron supported by means of a slanting stay, station-truck.

the same distance from each other, so that the vertical distance between the two parts of a wire rope always will be the same. The horses having a constant height (Figs. 21 and 22), consist of a channel iron 27, built into a frame and supported in vertical position by means of a slanting stay 28, suitably made of L iron, the upper part of the horse being provided with

idlers 29, for the two wire ropes (Fig. 17), and lower with a roller 30, in suitable height, the purpose of the latter being to support the lower parts of the wire ropes. The idlers 29 (Figs. 23 and 24), consist of two wheels 31,

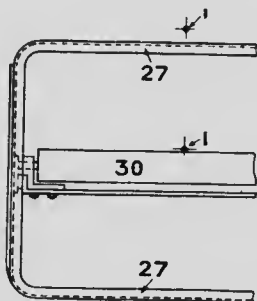

Fig. 22. Roller for the wire rope, station-truck.

placed nearly at right angles to each other and inclining towards the horizontal plane about  $45^\circ$ , and provided with grooves. The idlers are journalled in plates 32, slideable in relation to each other, the wheels 31 are

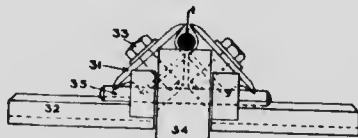

Fig. 23. Section of the idlers, station-truck.

rotatively adapted on pins 33, which are screwed into plates and threaded in such a way that they are screwed up tighter when the wire ropes put the wheels into rotation. Thus, one of the pins must have a right hand thread,

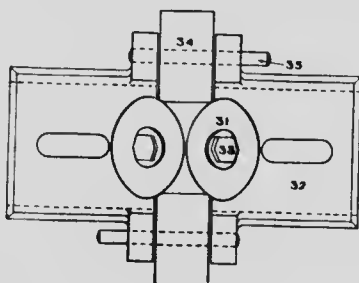

Fig. 24. Plan of the idlers, station-truck.

and the other a left hand one. The pins 33, must also be arranged in such a way that they are only to be screwed in to a certain length, so that the wheels may not be jammed up tight.

Cylindrical rollers 34, are arranged on both sides of the wheels 31; these rollers 34, being journalled on pins 35, fastened to one of the plates 32, and slideable into each other. These rollers have such a diameter and are so placed that the upper part of their circumference lies a little higher than the bottom of the grooves in the idlers 31; and when the wire rope passes over the idlers, it will, of course, rest upon the rollers 34 and it is guided sideways by the pulleys 31. The one of the rollers 34 which is located in front of the idlers counted in the direction of movement might be excluded as it is not necessary under certain conditions.

The frames of all the L-irons are built upwards at their ends, as shown, so that the horses may easily be moved over the ground when the conveyer is to be transported, according as the putting out proceeds.

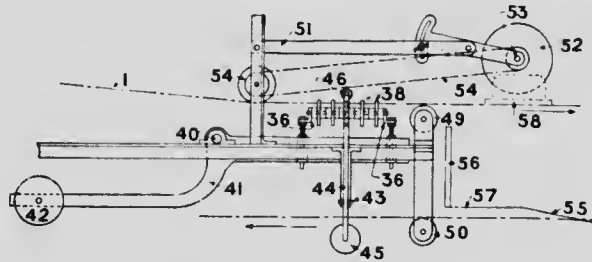

Fig. 25. Side view of roller conveyer, Persson's system.

The vertically movable roller conveyer 10 (Figs. 25 and 26), consists of two parallel L-irons 36, in which rollers 38 are journalled on axles 37, at suitable distances from each other. These rollers 38, correspond to the rollers 39, in the conveyer 9. The L-irons 36, are supported by the one arm of the levers 41, which are pivoted on an axle 40. The other arms of the levers are counterbalanced by means of weights 42.

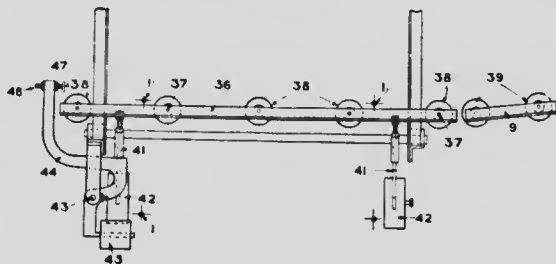

Fig. 26. Plan of roller conveyer, Persson's system.

The roller conveyer is normally held in the position shown on the drawing and is hereby supported by a bolt 44, pivoted at 43, and provided with a counterweight 45. The hold 44, has an upwardly directed arm, supporting a stopper 47 at the end of the conveyer, which stopper is adjustable by means



of a screw 46. A small wheel 48 (Fig. 18) is placed at the end of the conveyer. The wire ropes 1, are carried over and underneath the conveyer as shown in the drawings (Figs. 25 and 26), and they run over suitably arranged idlers 49 and 50. Circular knives 52, vertically adjustable, are arranged over the roller conveyer 10, on arms 51 (Fig. 25).

These cutters 52, are mounted on axles 53, and put into rotation by means of a chain gear 54, which is driven by the upper parts of the wire ropes.

An incline 55, and a bridge 57, provided with a stopper 56, and suitably resting on the ground, are placed between the lower parts of the wire ropes near the conveyer 9. A number of loose boards 58 (Fig. 27), belong also to the construction; these boards being provided with a number of half circular grooves 60, in a distance between each other corresponding to the distance between the wire ropes. The corners of the boards are rounded.

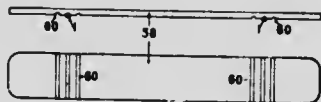

Fig. 27. Boards for receiving the peat.

When the construction is to be used for transportation of peat, all the parts are set going by the portable engine. The peat mill is also put into rotation, and it feeds a string of peat through its outlet towards the roller conveyer 9. The above mentioned boards 58, are placed at the outlet according as the peat string is fed out. The boards are placed on top of the rollers of the conveyer 9, and are thrust against a chopper 59 (Fig. 17), at the end of the outlet. The peat string then brings the boards along towards the conveyer 10, and the conveyer 9, is somewhat inclined for the purpose of making the motion easier. The last two groups of rollers nearest the conveyer 10 are also suitably driven by means of a wire rope or the like. Thus the boards carrying the lumps of peat arrive to the conveyer 10, with a somewhat increased speed, and slide to the end of the same, where-at the stopper 47 is struck by the edge of the board, so that the bolt 44 departs from the arm of the levels 41 that support the roller conveyer.

On account of the weight of the board and of the peat, the conveyer will be lowered so that the board rests on the upper parts of the wire-ropes and follows these towards the station truck over the horses. The boards are taken off the conveyer on a suitable place and sent back towards the peat mill by means of the lower parts of the wire ropes. When the empty boards arrive in the neighbourhood of the roller conveyer 10 they will slide up along the incline 55 and come to a standstill against the stopper 56 whereafter they are ready for a new transport.

The wheel 48 at the end of the conveyer serves the purpose of giving the forward end of the board a push so that it starts in the direction of the

station-truck. This is necessary while this end of the board otherwise tends to lag so that the board will lie askew on the wire ropes.

When the boards loaded with peat pass the cutters 52 the part of the string resting on the boards is cut off to a suitable length.

NOTE.—This invention is very ingenious, and is suitable in countries where cheap labour can be obtained. The trouble with the apparatus is that the handling of the pallets with the formed peat takes considerable time, and it is difficult to keep the plant clean. In Russia, two plants on this system were tried on the bogs owned by Mr. Marosoff, and on the bog owned by the Moscow Electrical Company. (A.A.)



## APPENDIX X.

(Patent No. 148809, June 24, 1913.)

**Improvement Relating to Peat Expresses.**

By

*Oscar Joseph Sigler, Mansfield, Ohio.*

and

*Jerome Jarvis, Toledo, Ohio.*

The apparatus includes a frame formed so as to have base 1 (see Fig. 28), and end upright 2, longitudinal I beams 3, are rigidly connected to the uprights 2, and are located on opposite sides of the frame. A transverse shaft 4, is journalled in bearings that are carried by the beams 3, at the front end of the frame, and a pair of spaced tooth wheels 5, are rigidly mounted on said shaft.

A transverse shaft 6, at the rear end of the frame, is journalled in bearings that are carried by beams 3, and a pair of spaced toothed wheels 7, are rigidly mounted on said shaft 6. Mitre gears 8 (see Fig. 29), are keyed to shaft 6, and mesh with similar gears 9, that are rigidly secured to the lower ends of shafts 10, the latter having squared portions 11, which project into sleeves 12, the latter being slideable on the squared portions 11.

The upper ends of the sleeves 12, are rigidly secured to shafts 13, which have the mitre gears 14, rigidly secured thereto, the said gears 14, being in mesh with mitre gears 15, which are carried by a transverse shaft 17. A pair of sprocket wheels 16, are rigidly affixed to shaft 17, the shaft 17 is journalled in bearings that are carried by upper longitudinal beams 18; the latter being mounted by means of the bolt and slot connexion 19 (see Fig. 28), so that beams 18 have an adjustable pivotal connexion at their front ends. The rear ends of the beams 18 slide in guides provided by the brackets 20. Each beam 18 has a rigid depending rod 21, affixed thereto, which is encircled by coil spring 22, the latter abutting the bracket 20 and nut 23 and rod 21. Due to the presence of the springs the free rear ends of the beams will have a yielding action and will normally be drawn downwards, the beams having the aforementioned pivotted connexion 19, at their front ends.

A drive shaft 23, has a pinion 24, (see Fig. 30), and a pulley 25, rigid thereon; the pinion meshing with a gear wheel 26. Any suitable belt may connect with pulley 25, to drive the same.

Toothed wheels 27 (see Fig. 28), are rigidly secured to a shaft 28, that is journalled in bearings carried adjacent to the front end of beams 18.



The expressing mechanism proper includes an upper and a lower endless platform, the upper platform being of less length and width than the lower platform.

Each platform consists of a series of transverse strips or flights 29, made of wood, the flights of the lower platform being perforated as indicated at 30 (see Fig. 31). Rollers 31, revolvably mounted on L-shaped brackets 32, are rigidly connected to the flights 29, on the minor faces of the latter

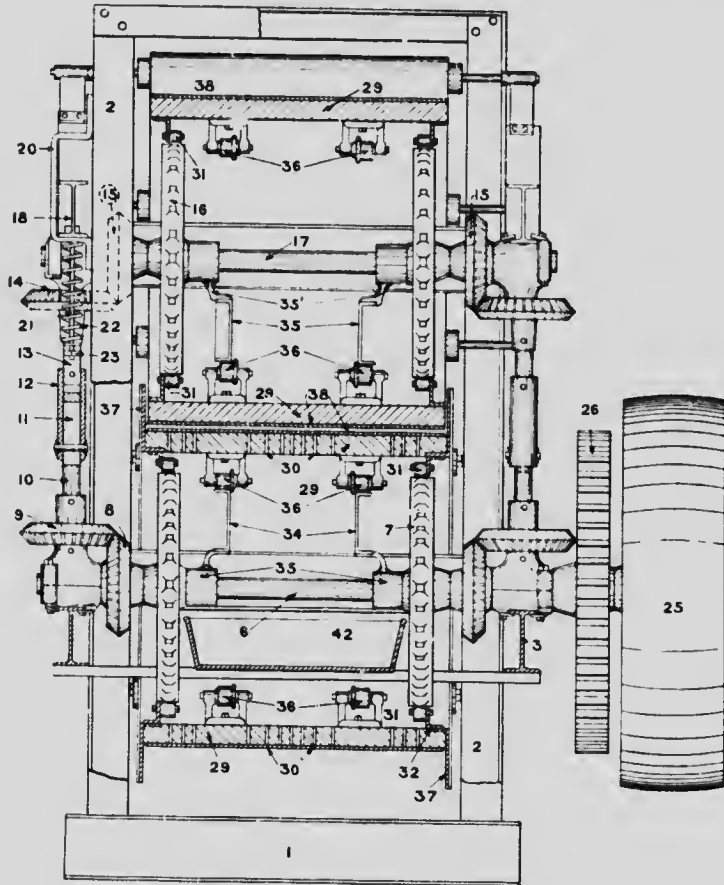

Fig. 29 Plan of Sigler apparatus.

so that the rollers will engage the toothed wheels 5, 7, and 27 and 16. The flights are connected at their ends by means of chains 33 (see Fig. 1). A pair of spaced stationary lower beams 34, are provided, and upper stationary beams 35, are likewise provided, these beams 34 and 35 being secured on brackets 35 mounted on the shafts 6 and 17 respectively, and are for engagement with anti-friction rollers 36, that are carried by the inner faces of the two platforms.

The lower platform is provided on opposite sides with overlapping pivotted side plates 37, which are secured to the individual flights thereof, and which receive the upper platform there between, as depicted in Fig. 29, of the drawings.

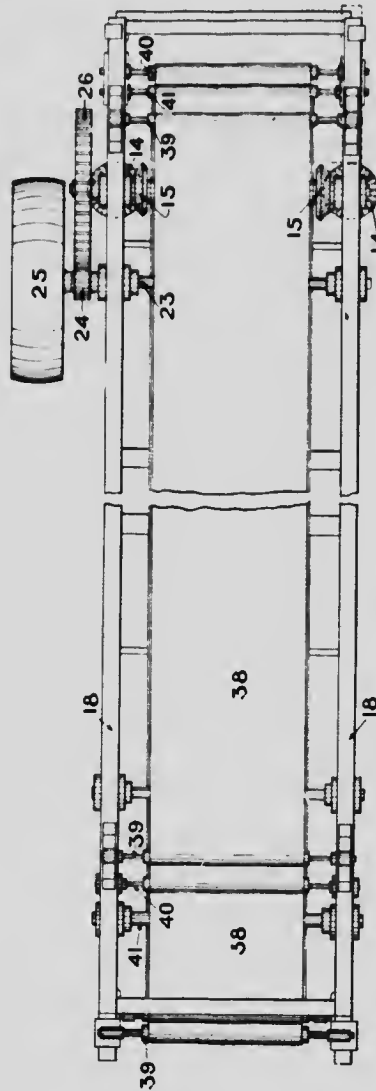

Fig. 30. Plan of Sigler apparatus. Operation of the driving shaft.

The pairs of beams 34 and 35 provide pressure rails, that is to say when anti-friction rollers 36, engage said rails, as shown in Fig. 29, they will limit the movement of the confronting portions of the platforms, and will act as abutments which hold the platform to their work, effecting the expressing action on the material, in an obvious manner.

Both platforms have their confronting portions covered with a suitable fabric, a cloth, and the liquid is forced through the foraminous lower platform by the upper platform. The cloth designated 38, is endless, and passes around end rollers 39, lower rollers 40, and intermediate rollers 41. The endless bands of cloth are driven by friction existing between the same and the material which is being carried along during the expressing thereof by the upper and lower platforms.

From the above it will be seen that the liquid is forced through the cloth of the lower platform by virtue of the pressure exerted by the upper platform, and that the upper platform is capable of having a yielding up and down movement, due to the pivotal mounting of the beams 18 which support the upper platform. It will further be seen that the endless bands of cloth by reason of being mounted on the rollers shown and described, will not interfere with the free movement of the platforms.

The solid matter remaining at the completion of the expressing operation is delivered at the rear end of the apparatus, and the liquid drops into a pan 42, that is secured on the interior of the lower of the platforms, and is

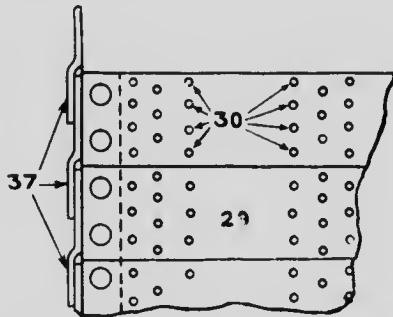

Fig. 31. Perforated flights of the lower platform.

supported by the frame in any suitable manner. The plates 37 provide side walls which are located on opposite sides of the lower platform, preventing the solid matter from escaping in an obvious manner.

The cloth further serves the purpose of preventing the solids from adhering to the platforms, and further covers the interstices between the individual flights.

In operation, the material is placed in the front end of the apparatus, between the platforms, and as the confronting faces of the platforms are forced towards one another by reason of the rollers 36, of the platforms travelling on the tracks 34 and 35, the material will be subjected to the pressure exerted by the platforms, and the liquid will be expressed from the solid matter and will drop into the pan. It will be understood that power imparted to the pulley 25 will drive the shaft 23, and therewith gear 24, the latter rotating gear 26, and therewith shaft 6, which will cause rotation of the toothed wheels 7, and thereby effect movement of the lower platform.



The rotation of shaft 6 will cause rotation of the mitre gear 8, and the latter by virtue of being in mesh with the mitre gears 9, will drive the gears 14, and therewith the gears 15, on shaft 17, effecting movement of the upper platform by reason of the toothed wheels 16 being carried by the shaft 17. Owing to the sliding connexion between the shaft 10, and the sleeve 12 of shaft 13, the beams 18 are capable of a rising and falling movement without disturbing the operation of the upper platform in an obvious manner.

## APPENDIX XI.

(Patent No. 149531, July 29, 1913.)

**Improvements Relating to Methods and Apparatus for Gathering  
and Transporting Peat.**

By

*Thomas Rigby, Dumfries, Scotland.*

A method of gathering peat, according to which the peat is excavated from the bog, and while containing about as much water as in its natural state in the bog, is subjected to maceration until reduced to a pulp of watery fluidity, whereupon it is pumped through a pipe line.

In the accompanying two sheets of drawings are illustrated an arrangement of the type indicated for cutting out a channel, say, 500 feet wide, in a peat bog, the peat being removed the full depth of the bog, which is, say, 20 feet.

In Fig. 32 is shown, in sectional elevation, a diagram of an excavator mounted on a pontoon floating in the water caused by the excavation already effected in the bog.

Figure 32 is a plan of the same showing the excavator combined with a pontoon carrying the disintegrator and pump; the pump in this second pontoon being connected by means of a movable pipe to the fixed pipe line.

A more detailed description can be obtained in the Patent Office, Ottawa, Patent No. 149531.

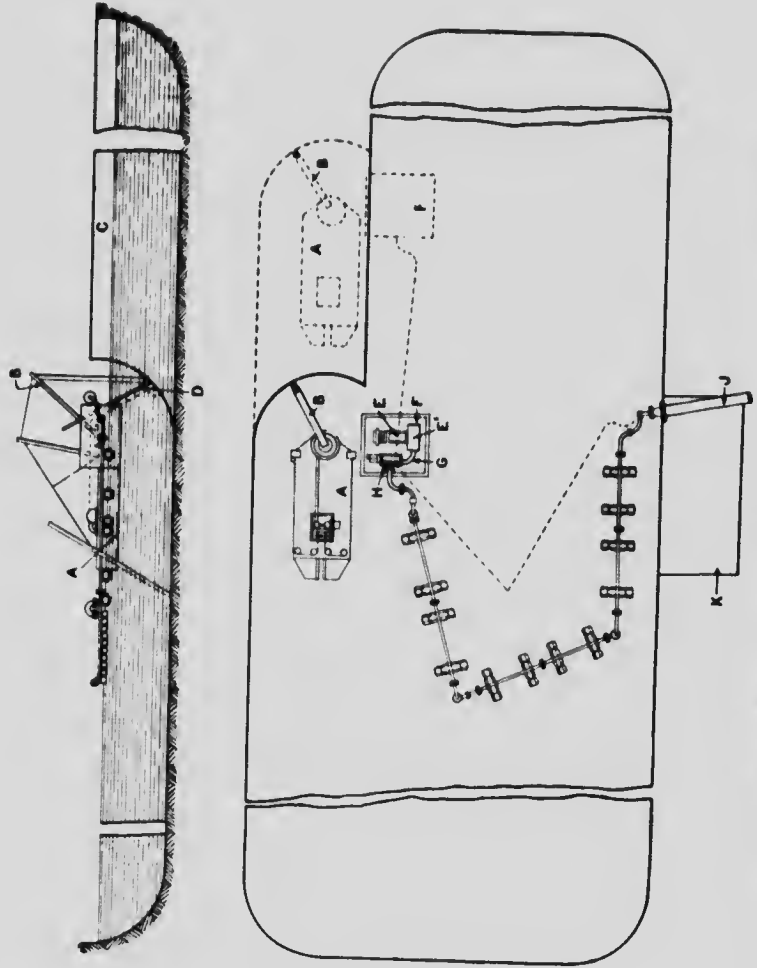

Fig. 32. Plan and section of Rigby apparatus for gathering and transporting peat.

(Patent No. 149597, July 29, 1913.)

### Improvements Relating to a Method of Desiccating Peat and the Like.

By

*Emil Hirsch, Engineer, Berlin, Germany.*

The present invention relates to a method of desiccating peat and the like, by the simultaneous application of pressure and a vacuum, or by the alternate application of pressure and a vacuum, while the pressure and the evacuation or either of these processes can be intermittently interrupted.

The methods which, hitherto, have been employed for the purpose, do not give satisfactory results, as it was found that the moisture contained in the material is not forced out of the material, even if ever so high a pressure is employed, and that it remains partly enclosed in the doubled over cells of the material.

This difficulty is obviated according to the present invention by the simultaneous pressure and the evacuation of each process by itself going down during the interruption to 0 or practically to 0. The result of this is, that any cells containing moisture which during the first compression may have been doubled over or not have been entirely opened, will on the pressure dropping to 0 or practically to 0 again assume their normal position, whereupon at the following pressure another part of them will be opened and expressed.

Obviously, the result of the new method will be more perfect the oftener the pressure is interrupted during the same period of treatment of the material.

By the action of the vacuum, that of the pressure is in so far increased, as the moisture which has been forced by the pressure out of the cells will be sucked off the more quickly, and the dropping off of the vacuum to 0 or practically to 0 will facilitate the cells returning to their normal position.

In the accompanying drawing an arrangement for carrying out the new method is exemplified.

The arrangement consists of two vessels placed the one *a* inside the other *b*, (see Fig. 33) leaving a hollow space *c*, between them. The vessel *a*, is perforated in its bottom and its sides, and is provided with tubes *d*, which are likewise perforated and extend in the direction in which the pressure acts.

These tubes *d*, communicate with the hollow space *c*, remaining between the vessels *a*, and *b*. No. *e* shows the perforated piston working in the minor vessels for producing the mechanical pressure. No. *f*, is a connecting pipe for producing the vacuum in the vessel *b*, while *g*, is a drain pipe for the water. (See Fig. 34).

The material to be treated is filled into the vessel *a*, after the lid *h* has been unscrewed.

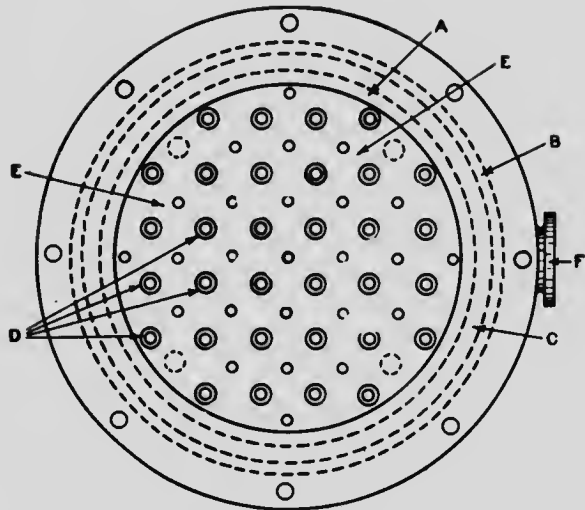

Fig. 33. Plan of perforator.

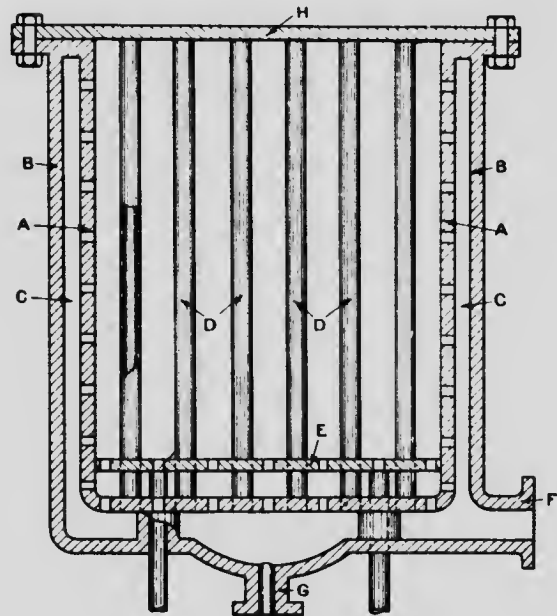

Fig. 34. Side view of perforator.

## APPENDIX XIII.

(Patent No. 149532, July 29, 1913.)

**Improvements Relating to the Process for the Utilization of Peat.**

By

*Thomas Rigby, Dumfries, Scotland, and Nils Testrup, London,  
England.*

This invention relates to the utilization of peat by gasification of the same in a gas producer adapted for by-product recovery.

Before peat can be utilized in such a way, however, it is necessary to remove water from it, and this has usually been attempted by drainage and subsequent air-drying on the bog or in drying sheds.

This method, however, suffers from serious disadvantages which have prevented its general adoption or its use in other than comparatively small installations. Thus the regularity of supply of fuel is immediately interrupted on change of weather, and consequent decrease in rate of drying, while the fuel under any circumstances is apt to be of widely varying moisture content.

It has been proposed to effect drying of peat artificially, as by exposing the peat after drainage to products of combustion but such processes have never found practical application owing to the large amount of heat required to effect drying in relation to the calorific value of the dried peat fuel obtained.

The object of the present invention is, to provide a process and installation capable of application on a large scale for utilizing peat by gasification in by-product recovery gas producers, and free of the disadvantages referred to.

The present invention consists in removing such a portion of the water of the peat as renders it suitable for disintegration, then reducing it to a finely divided condition, and exposing it for the desired period in this condition in hot products of combustion of gases generated in by-product recovery gas producers to which some or all of the treated material is supplied.

The drying is preferably carried out by passing the products of combustion through a duct leading to cyclone separators or other like means into which duct the disintegrated peat is introduced, the rate of the flow of the gases, the length of the duct and other factors being adjusted so that when the material which is carried by the gases reaches the separating means it has the desired dryness. The treated material is consolidated into cakes or briquets for gasification.

By proceeding according to the present invention, regular working is readily obtained, as no difficulty arises in obtaining weather or other conditions such as will enable the preliminary drying necessary (say to 70% water content) to be uniformly obtained.

Moreover, the fuel obtained does not require the use in the producer of so high a blast pressure, and produces less dust and consequent fouling of the tar and loss of by-products, principally ammonia, than fuel obtained by air-drying.

In carrying the invention into effect in the preferred form, the drying installation is adapted to reduce the water content of a part of the material to an intermediate value only—say to water content of 50%, and practically to dry the remainder completely, the former quantity being consolidated into cake form and the latter briquetted in any usual way, the proportions so treated being chosen to give the desired average moisture content in the fuel when they are mixed for charging into the producer. Such a mixed charge gives a mechanically strong fire, and great freedom from dust in the gases.

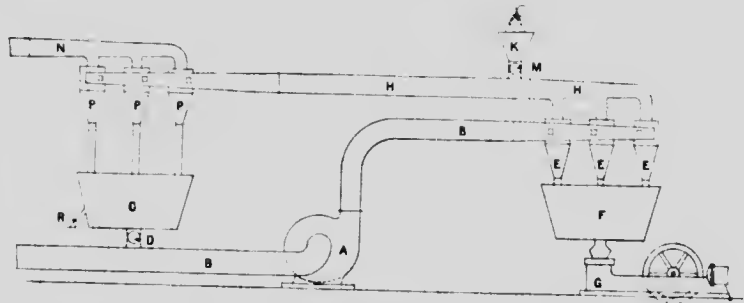

Fig. 35. Side view of Rigby gas producer.

The method may be carried out by dividing the drying into two distinct stages, the hottest products of combustion effecting the second stage of drying, and the waste gases from this stage being utilized to effect the first stage of the drying.

Thus in the arrangement illustrated in the accompanying drawings, the gases, which may be wholly or in part exhaust gases from internal combustion engines consuming producer gas and generating power, or may be obtained by combustion of the producer gas under any other suitable condition, are caused to pass by a fan *a* (see Fig. 35) through a duct *b* into which the finely divided peat already dried to some extent in the first stage is introduced through a rotary pocket valve from a hopper *c*. The material is conveyed by the dust *b* to a series of cyclone separators *e*, by which it is deposited in a hopper *f*, supplying the briquetting press *g*. As the waste gases from the separators *e* still contain a certain amount of their heat they are conducted through a duct *h* into which the raw material, which by pressing, draining, or air-drying, has had its water content slightly reduced, is introduced from hopper *k* by the rotary valve *m*.

This material is now carried forward by the gases through the duct *h*, to a further series of separators *p* by which it is deposited in the hopper *c*, already mentioned, and is supplied from the latter by the valve *d*, into the duct *b*, or if desired partly withdrawn through the opening *e*, while the gases pass through a duct *r*, to washing towers or other devices by which the remaining duct in the gear is recovered.

Either in consolidating the partly dried material, or in briquetting the more completely dried peat, any suitable binder such as tar or pitch (*e.g.*, from the by-product plant) may be used.





## APPENDIX XIV.

(Patent No. 149668, July 29, 1913.)

**Improvements Relating to Drying or Carbonizing Peat.**

By

*Edward Fox Strangways Zohrale, C.E., Baronet, Scotsclalder, Thurso,  
Scotland.*

A detailed description of this patent can be obtained in the Canadian Patent Office, Ottawa.

## APPENDIX XV.

(Patent No. 149571, July 29, 1913.)

**Improvements Relating to Process and Apparatus for Treating Peat.**

By

*Josef Berglund, Esq., Umeå, Sweden.*

The object of this invention is, to convert in an inexpensive manner, the peat as excavated from the bog into a strong and rather inhygroscopic product, having a high value as fuel.

The new process consists, briefly, in treating the raw peat mixed with large quantities of water by means of cutter rollers at any similar disintegrating device in such a manner that the small peat particles become suspended in the water, while branches, roots, and other coarse pieces, which can not be disintegrated, are separated by means of a continuously moving strainer, cleansed by means of water which is supplied to the said device, the water containing the suspended peat particles being drawn off into basins provided on the ground, in which the peat mass is left to dry.

The layer of peat remaining on the bottom of said basins, forms, after drying, a compact mass, which, on account of contraction during the drying process cracks into pieces of a size convenient to handle, and which after the drying process has been ended, has a great mechanical strength, a high fuel value, and a very low percentage of ashes, thus possessing all properties required in a good fuel.

The apparatus embodying the present invention comprises a raw peat disintegratory device provided in a water receptacle; a continuously moving strainer through which the small peat particles suspended in the water can pass, but which removes coarser particles; a sprinkling device for

cleaning the said strainer by means of water; and means for leading said water into the said water receptacle, all as will be more particularly described here below.

The main parts of the apparatus consist of a disintegrating and macerating apparatus driven by any suitable motor; a strainer for removing from the fluid peat mass solid mineral or organic pieces which are not disintegrated during the macerating process, such as stones, sand, roots, branches, and so on; and devices for supplying the water required for the macerating process, and for leading the macerated mass out to the basins. (See Fig. 36).

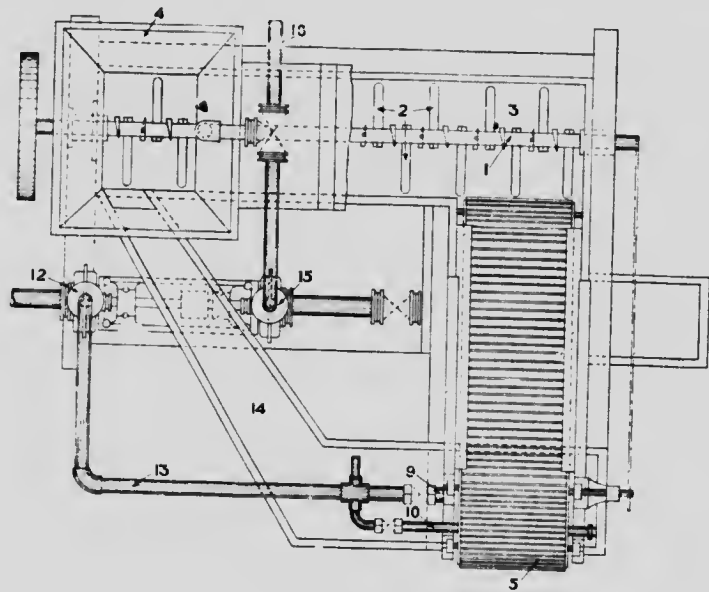

Fig. 36. Plan of Berglund macerator.

The drawing 1, indicates a rotating roller having disintegrating knives or cutters 2, and being disposed in a suitable receptacle 3, which at the one end is provided with a hopper 4, through which the raw peat, excavated by any suitable means from the bog, is introduced into the apparatus, together with the quantity of water required for the macerating process, so that the cutters act upon the raw peat in water. Instead of said roller 1, and cutters 2, one may as will be readily understood, use other well known or suitable disintegrating devices. In order to reach a continuous operation, the strainer consists of an endless, continuously moving, filtering or straining belt 5, through which the fluid peat mass can pass, while coarser pieces such as roots and the like, are retained by the strainer.

The upper portion of said belt 5, moves in the direction indicated by the arrow 6, in Fig. 37, and removes the said coarser pieces from the receptacle 3, whereupon the greater part of these pieces drops down from

the belt according as the latter passes the upper roller 7. In order to prevent the strainer from being clogged up by straws, roots and the like, which easily stick in the same, the straining belt 5, is running in an inclined position around two rollers 8, and 9, and between these rollers is provided a sprinkling device which may consist of perforated pipes 10, and 11, (see Fig. 37) extending across the belt on each side thereof. For cleansing the belt the same water is used as serves for macerating the peat, the pump 12, used for supplying water to the apparatus delivering the water through a pipe 13, to the sprinkling pipes 10 and 11, whereupon the water through a gutter 15, is led to the hopper 4, and the receptacle 3. The fluid peat mass passing through the strainer is by means of a suitable pump 15, for instance, a centrifugal pump, and a pipe or conduit 16, transported to the drying basins. The said pump 15 may be disposed with if it is possible to mount the apparatus at such a level that the macerated peat mass can

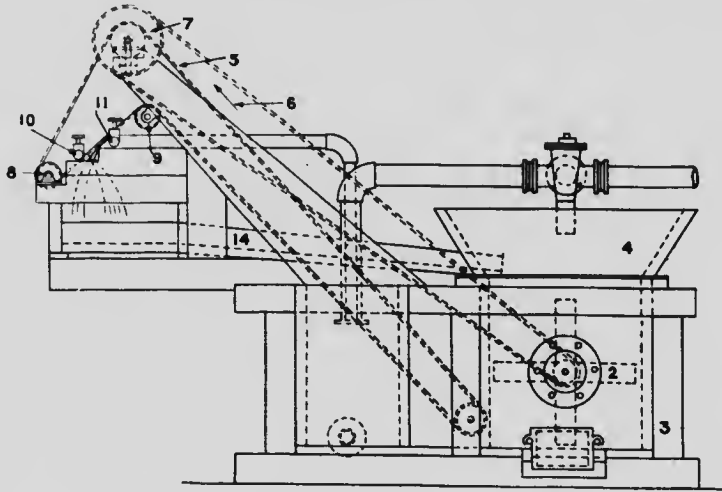

Fig. 37. Side view of Berglund disintegrator.

flow automatically through the pipe 16. Through a branch pipe 17, (see Fig. 38) a part of the peat mass may be returned into the receptacle if required for maintaining an approximately constant level of water in the receptacle 3, and for reaching the most constant proportion possible between the peat mass and the water.

The drying basins may suitably be made by surrounding horizontal fields of the bog in proximity to the place where the peat is excavated, with small banks of earth. If necessary or desired, the said basins may, however, be arranged at a distance from the bog, it being not difficult to lead the fluid peat mass hundreds of metres through pipes or conduits.

If shallow basins be used, the quantity of macerated peat mass in each basin may, for instance, be such that the dried peat layer obtains a thickness of about 10 cm. With said thickness, it is generally possible to pro-

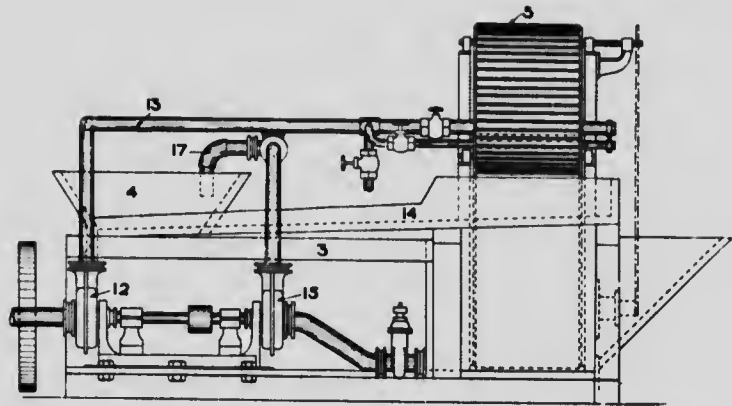

Fig. 38. Rear elevation of Berglund apparatus for treating peat.

duce three peat layers in the basins during each summer, so that the production will amount to about 30 tons air-dried peat per acre of the surface of the basins.

Of course there will be no hindrance to produce peat layers that are thicker or thinner than 10 cm. In certain cases it may be suitable to arrange very deep basins which may be built of wood and banks of earth, so that very thick peat layers are obtained. In order, in such cases, to accelerate the drying process, the basins may be provided with draining devices and with air pipes through which the air can circulate without the use of any air-propelling or heating devices for accelerating the drying process.

It may also be suitable to provide such basins with roofs in order to protect the peat mass against rain.

## APPENDIX XVI.

(Patent No. 151670, December 11, 1913.)

**Improvements Relating to "Improved Treatment of Peat for Man-  
urial and other Purposes".**

By

*William Beecroft Bottomley, King's College, County of London, England.*

According to this invention peat can be converted into an excellent manure by treating it with micro-organisms capable of producing ammonia. Such micro-organisms are obtainable by known methods from ordinary soil or from other sources such as putrefying bouillon. There are several species of them, such as *Bacillus mycoides*, *Bacillus subtilis*, *Bacterium aerogens* and *Bacterium fluorescens liquefaciens*. It is not essential to use a pure culture of any particular species or of the mixed species, since other micro-organisms may be present.

The effect of these micro-organisms on the peat is to convert the humic acid and humus bodies contained in it into compounds soluble in water and at the same time to disintegrate the peat so that it is readily distributed.

A product richer in nitrogen is obtained if nitrogen fixing organisms such as *Azotobacter* and *Bacillus radicola* are present in the mass.

In addition to its usefulness as a manure the product forms a ready source of the substances commonly classed as humic acid or humus bodies, which have lately found application in industry.

There is no difficulty in obtaining a culture of micro-organisms, containing no doubt very many species, suitable for my invention. For this purpose 10-20 grams of fertile soil may be added to a culture medium comprising 1 litre of water, 20 grams of dextrin, 1 gram of dipotassium phosphate,  $\frac{1}{2}$  gram of magnesium sulphate, 2 grams of calcium carbonate and 10 cc. of bouillon. The scum which forms on the surface of the liquid in the course of a few days is suitable for my invention. Pure culture consisting of any of the individual species that are active for the purpose or mixed cultures may, of course, be prepared, but this is not necessary so far as is at present known to me.

To the peat or peat material is added water containing the organisms and the mass is allowed to undergo the change involved, for some days. When the peat has been dried, as is the case with certain prepared peat, the amount of water added should suffice to moisten the mass thoroughly. It is not, however, necessary to dry the peat, for if this is in its natural wet condition it may be merely sprinkled with the water containing the micro-

organisms. The process is preferably hastened by adding to the mass a nitrogenous organic material, particularly a weak solution of a soluble nitrogenous organic material such as albumin, gelatine or meat extract; a solution containing say 0.25-0.5 per cent of any standard meat extract, for example will serve. Such a solution may constitute the liquid in which the micro-organisms may be contained as aforesaid. I have found that a very suitable nitrogenous extract consists of the waste liquor obtained from the boiling of bones.

It is also desirable to add a small proportion of a carbohydrate such as sugar or starch; say about 0.1 per cent of the dry weight of the original peat dissolved or suspended in a little water.

The saturated peat may be left at a temperature of 24-30° C. for three weeks or thereabouts and may then be dried. In this condition it may be applied directly as a manure. Or before it is dried it may be sterilized, such as by live steam, and then further treated with nitrogen-fixing organisms for increasing the amount of nitrogen in the mass, these organisms being capable of growing in the altered peat.

If soluble humus substances be required, the treated mass may be leached with water, and the solution used directly for any of the purposes to which humus is applied; or an acid may be added to precipitate the humic acid from the aqueous solution. The aqueous extract of the treated peat is also useful as a liquid manure.

## APPENDIX XVII.

(Patent No. 155425, May 1914.)

**Invention of Machinery for the Treatment of Peat, and the Like.**

By

*E. Arthur Buckle, Prestwich, Manchester, Eng.*

This invention relates to the treatment of peat and the like, whereby it is freed from its natural water.

It is known that when peat in an admixture with water is heated to a temperature of 180°C to 200°C, under a pressure of 20 to 25 atmospheres, the natural water of the peat is rendered expressible without any substantial decomposition of the peat taking place. It has also been proposed, with a like object, to subject peat to electro-osmosis in one instance under slight pressure, and in another case at a temperature above the normal.

The present invention is based upon investigations carried out with a view to ascertaining the most favourable conditions for the treatment of peat with a view to rendering its natural water expressible without any material decomposition of the peat. Such investigations have demonstrated that at temperatures below 85°C peat is so bad a conductor that no electro-osmotic process can be advantageously applied. At 85°C, however, the peat is conductive; and if a current is passed for a sufficiently prolonged period, the desired change in the peat ensues with more or less completeness.

According to the present invention an electric current is passed through peat heated to a temperature of at least 100°C, under a pressure sufficient to prevent the formation of steam. The electric current may be continuous or alternating but a continuous current is preferred as with it in general, a lower temperature suffices than is required with an alternating current to reproduce as good results. The voltage may vary within wide limits but a voltage of about 200 has been found to be on the whole the most economical. As stated above the temperature used is at least 100°C and the range of 100° to 120°C, with a pressure of about 10 atmospheres is preferred, but much higher temperatures with correspondingly increased pressure may be used.

If the temperature exceeds 150°C, which is the lowest at which it is believed the hydrocellulose of peat is decomposed by heating peat with water under pressure without the passage of electric current, the electric current so accelerates the decomposition as to make the process economically advantageous as compared with the case where other conditions being the same, no current is employed.

This invention may be carried out in the following manner in apparatus shown diagrammatically in Fig. 39, and in detail in Fig. 40.



Peat pulp from a disintegrator *a*, is forced by a pump *b*, at a pressure of ten atmospheres into a feed tank *c* in which are paddles *d*, mounted on a shaft *e*, having at its end a screw *f*. From the tank *c*, the peat pulp is forced through tubes *g*, preferably of elliptical cross section which tubes pass through a chimney *h*, and then through a liquid heat conducting medium

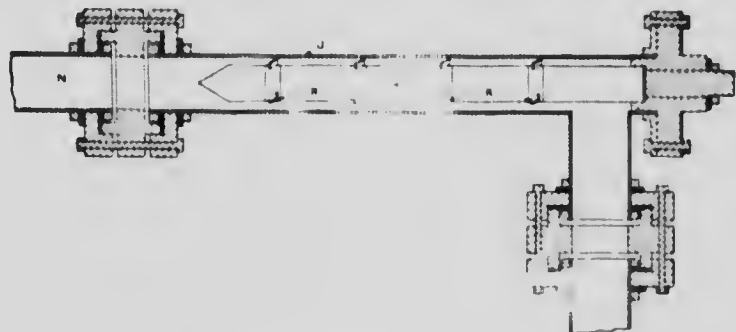

Fig. 39. Plan of Buckle apparatus.

contained in a boiler *i*, and heated to a temperature of preferably about 120°C. The peat pulp is forced under pressure of ten atmospheres through the tubes *g*, at such a rate that the temperature of the peat pulp at the

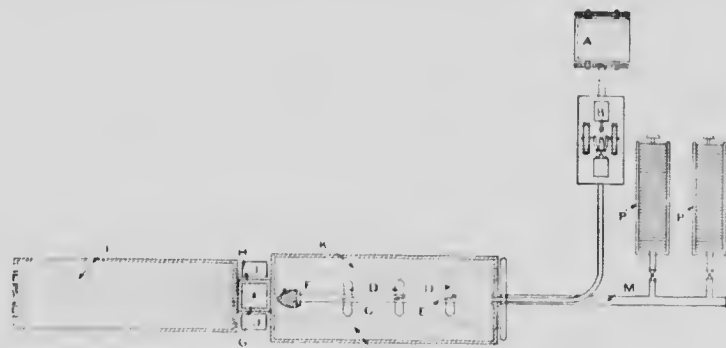

Fig. 40. Details of the Buckle apparatus.

outlet of the heating chamber is at least 100°C., if the tubes are circular their diameters would usually be from one to three inches and the boilers *i*, may be 20 feet long.

The peat pulp then passes to one or the other of the electrolyzing chambers *j*, one of which is shown in detail in Figure 39.

The chamber illustrated in this figure is designed to be part of an apparatus in which the boiler *i*, is turned at a right angle to the tank *c*. The end *n* communicates with the boiler, and the end *o* with the tank. In the chamber *j*, is an electrode *q*, consisting of a metallic rod insulated electrically from the rest of the apparatus and provided with baffle plates

*r*, so arranged that the peat pulp is forced into close contact with the electrode.

As the heated peat pulp traverses the chamber *j*, a continuous electric current of two hundred volts is passed through it, the peat pulp being thrown into a state of osmotic action, producing a rapid and complete disintegration of the cellular structure of the peat and thus allowing the decomposition of the hydrocellulose to take place. If the passage of the peat pulp between the electrodes be arrested, the electrical current automatically ceased to flow as the peat ceases to conduct electricity immediately the hydrocellulose in it is decomposed.

From the chamber *j*, the peat pulp enters tubes *k*, extending through the feed tank *c*, giving up its heat to the pulp in it. The cool peat from the tubes *k*, then enters into a main *n*, leading to filter presses *p*, in which the water is removed by the action of very slight pressure. (See Fig. 40.)

Means should be provided to change the direction of flow of the electric current, i.e. to change the polarity of the electrode and so prevent any accumulation of peat material on the positive electrode.

The peat may be used in the manufacture of producer or other gas, sulphate or ammonia being obtained as a by-product.

A proportion of lime (either as carbonate or hydrate) may be added to the peat pulp before it is treated by this process, to assist in the decomposition of the hydrocellulose, and to prevent any corrosion of the apparatus by combining with any acid produced by the reaction. If it be desired to retain the nitrogen contained in the peat, in the form of ammonia, it is advisable not to make the peat mixture alkaline.

It may be pointed out that the passage of the electric current does not heat the peat to any appreciable extent, and that the disintegration of the cellular structure of the peat allowing the decomposition of the hydrocellulose in the process, the subject of the present invention, is not due to heat generated by the electric current acting as an electrical heater.



## APPENDIX XVIII.

(*Patent No. 155554, May 1914.*)

**Apparatus for Removing Roots and the Like from Peat.**

By

*James Sidney Whitaker, Dumfries, Scotland.*

The object of this invention is to provide an apparatus by which roots and other large objects are automatically removed from peat, without being accompanied by an unduly large quantity of the latter.

The apparatus into which the excavated peat is fed is, according to this invention, provided with an element which feeds the peat through the apparatus, and with another element against which the roots or other large objects come into contact in passing through the apparatus. When this occurs, one of the elements, by continuing its movement, pushes the object until separated from the peat mass and ejected from the apparatus.

The accompanying drawings show two forms of apparatus according to this invention.

The root or like separating apparatus, illustrated in (Figs. 41, 42, and 43), comprises a hopper *a*, beneath which are arranged a series of rotatable bladed elements, which are secured upon parallel shafts *b*, and *c*, supported on a suitable framework *d*, below the hopper outlet. Each bladed element on the shaft *b*, comprises a boss *e*, of fairly large diameter, and four outwardly extending blades *f*, of T section; while interposed between each of the bladed elements on the shaft *b*, are guides *g*, attached to the hopper *a*. On the other shaft *c* the bladed elements comprise a serrated boss *h*, having projections *i*, and four outwardly extending blades *k*, which are narrower than the blades *f*, and can pass between the latter.

The shafts *b*, and *c*, are rotated in a counter clockwise direction, as indicated by the arrows, the power for this purpose being transmitted to the shaft *c*, and from the latter to the shaft *b*, by means of a toothed wheel *l*, rigidly connected to the shaft *c*, and engaging with an intermediate pinion *m*, which gears with a toothed wheel *n*, connected to the shaft *b* by a friction clutch *j*, the slipping pressure of which can be varied by adjusting the tension of a spring *o*. On the side of the shaft *c*, remote from the feeding blades *f*, guide bars *p*, are arranged between the bladed elements, while separate doors *q*, for each of said elements are pivotted at *r*, to the hopper *a*, and maintained in contact with the guide bars *p* by weighted levers *s*. Situated between the guide bars *p*, on the outside of the doors *q*, are star wheels *t*, mounted upon a shaft *u*, which is driven by a chain *v*, from the shaft *c*, for the purpose of carrying separated roots or the like from the neighbourhood of the doors *q*. Suitable scraping devices, such as a rod *w*,

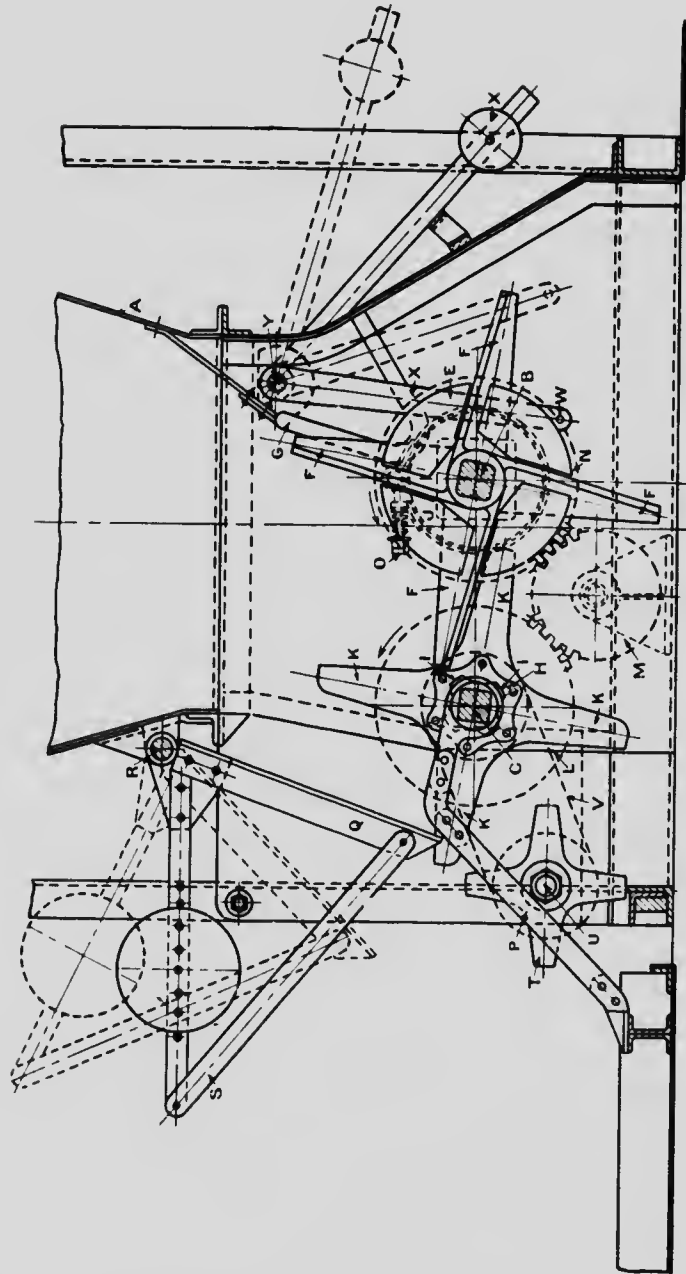

Fig. 41. Side view of Whitaker root-removing apparatus.

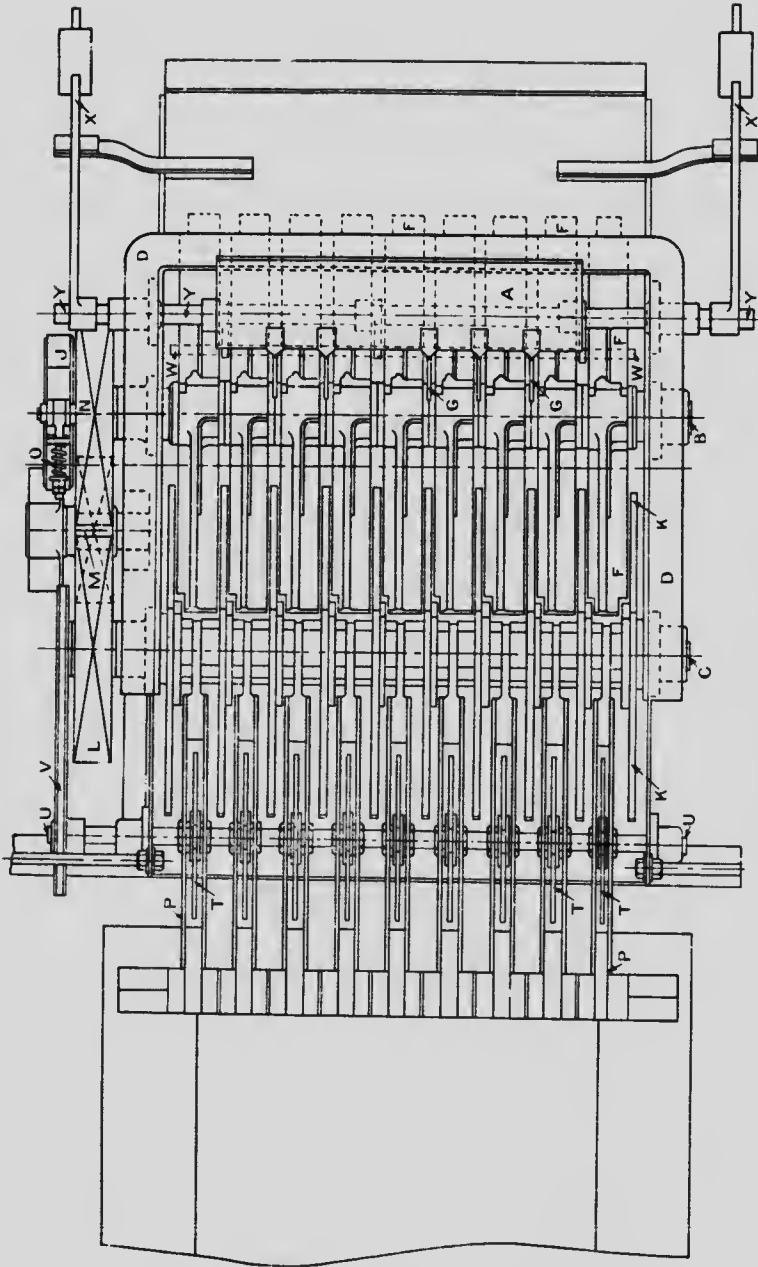

Fig. 42. Plan of Whitaker root-removing apparatus.

Copyrighted material

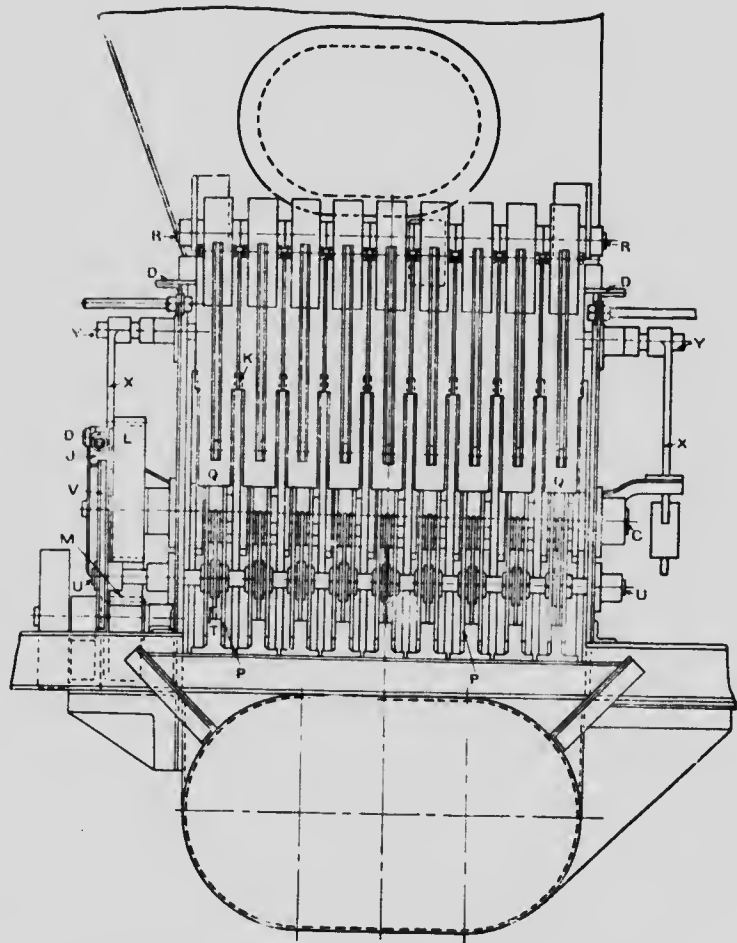

Fig. 43. Vertical section of Whitaker root-removing apparatus.

maintained in contact with the base *e*, and the blades *f*, by means of a weighted lever *x*, movable about a shaft *y*, are also provided to prevent material adhering to the blades *f*. See Fig. 44.

When the device is in operation, the peat is fed into the hopper *a*, from which it passes between the feeding blades *f*, and the blades *k*, the latter of which, in rotating in a counter clockwise direction, pass through and shear the peat. On an obstruction such as a root being encountered, the latter becomes jammed between the feeding and the shearing blades *f*, and *k*, respectively, whereupon, on the pressure at which the friction clutch *j*, has been adjusted to slip being exceeded, the feeding blades *f*, cease to rotate, and thereby permit the shearing blades *k*, in their continued movement to push the obstruction along the surface of the feeding blades

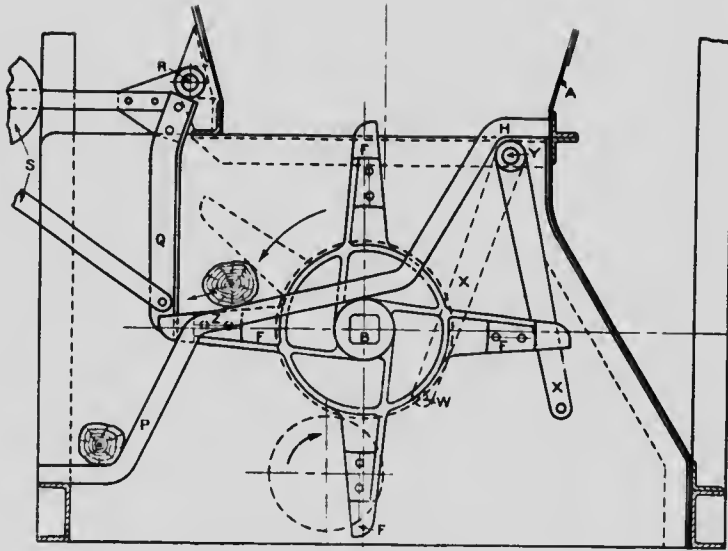

Fig. 44. Section of Whitaker root-removing apparatus.

*f*, the obstruction being thus automatically carried upwards, and thrown against the doors *q*, which open and allow the obstruction to pass down the bars *p*, and be carried away from the neighbourhood of the doors *q*, by the star-wheel *t*, after which the normal operation of the apparatus is resumed.

According to the modified form of the device illustrated in Figure 44, a plurality of elements having blades *f*, are mounted upon the shaft *b*, below the outlet of the hopper *a*. Guide bars *h* attached to the latter extend between the bladed elements, and are continued beyond the weighted doors *q*, as guide bars *p*, having the same function as those in the previously described form. The guide bars *p*, however, are connected by an intermediate part *z*, which is inclined at such an angle to the co-operating blades *f*, that the shearing strength of the root or other object is always greater than the normal pressure exerted on the bars *z*, multiplied by the co-efficient of friction between the object and the material of the bars.

When this form of the apparatus is in operation, the peat discharged from the hopper *a*, is fed downwards by the blades *f*, of the rotating elements, but on a root, for example, being encountered, the root is caught between the blades *f*, and the bars *z*, and instead of being sheared, is caused to slide along the bars *z*, until it contacts with the doors *q*, whereupon it is automatically ejected from the apparatus, and falls down the bars *p*, into a receptacle for separated roots. In this form of the device, the use of a friction clutch for driving the shaft *b*, which carries the feeding elements, is rendered unnecessary, although in some cases it may be found to be desirable.



In either form of the apparatus described above it will be understood that instead of providing a number of doors through which the roots are ejected, a single door having suitable slots to permit rotation of the adjacent bladed elements may be employed, such door or doors in all cases being arranged to open just sufficiently to permit ejection of the root or the like, but at the same time prevents escape of any of the peat.

## APPENDIX XIX.

(Patent No. 155658, May, 1914.)

**Peat Working Machine.**

By

*Constantin Zelenay, Twer, Russia.*

This invention has for its object to provide an improved combination machine for cutting peat from a drained peat bog, and treating the cut peat.

With this object the machine is mounted on a carriage adapted to travel on a railway along the peat trench, whilst the cutting devices can be moved sideways to a certain extent.

The improved machine consists substantially of a tubular cutting apparatus provided at its lower end with an apparatus for loosening and cutting up the peat, which is lifted by a worm conveyer to a mixing apparatus.

The entire machine is mounted on a carriage 1, which is moved on rails 2, along the peat trench by means of a windlass 3, and two chain drives 4 and 5. This carriage carries a railway composed of two cross beams 6, along which the movable framing 7, moves which carries the actual peat cutting apparatus and is moved by hand by means of the operating mechanism 8. (See Fig. 45). For the purpose of maintaining the equilibrium of the machine during the travel of the frame 7, the latter carries a travelling counterweight 50, which is shifted by means of ropes 51, (see Fig. 46) passing the guide pulleys 52 and 53 (see Fig. 47) and attached to the framing and counterweight in such a manner that the said framing and counterweight are simultaneously caused to move nearer to or away from the carriage 1.

The peat-cutting apparatus consists of the loosening device 9, and the screw conveyer 11, arranged inside the tube 10. The tube 10 is fixed to the plate 12, which also serves to carry the electric motor 13, the foot-steps bearing 14 and 15, of the loosening device and screw, the gear etc. (See Fig. 48). The plate 12, is suspended by means of a rope 19, and pulleys 16, and 17, and is adapted to be drawn up and down together with the tube 10, and the devices mounted on it by means of the windlass 18. (See Fig. 47.) The peat is cut from the peat bog in rows in the longitudinal and transverse directions. When a transverse row has been cut, the machine is shifted by means of the windlass 3, through a distance equal to the diameter of the tube.

The length of the tube 10, depends on the depth of the bed of peat being cut.

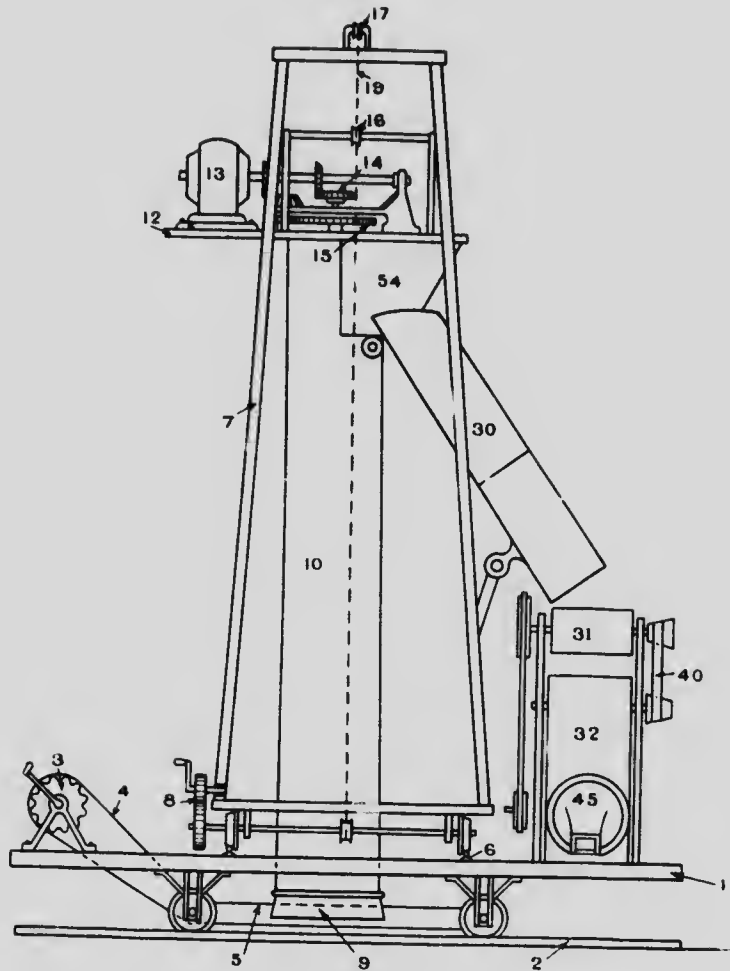

Fig. 45. Vertical section of Whitaker peat-cutting apparatus.

Inside the tube 10, is a shaft 20, on which the loosening device 9, is fixed. The shaft is surrounded by a second hollow shaft 21, which is provided with a conveyer screw 11. To the lower end of the tube 10, is fixed a cross piece 22, which are provided three ball bearings 23, 24, and 25, for the shafts 20 and 21. (See Fig. 49.) The loosening device 9, consists of a truncated conical member containing two diametrically staggered partitions 26, with screw or helical surfaces, or their equivalent, two helical apertures or passages 27. (See Fig. 50.) The lower edges of the apertures 27 are provided with broad flat cutters 28, which cut the peat or cut spirally into hard bodies such as old tree stumps.

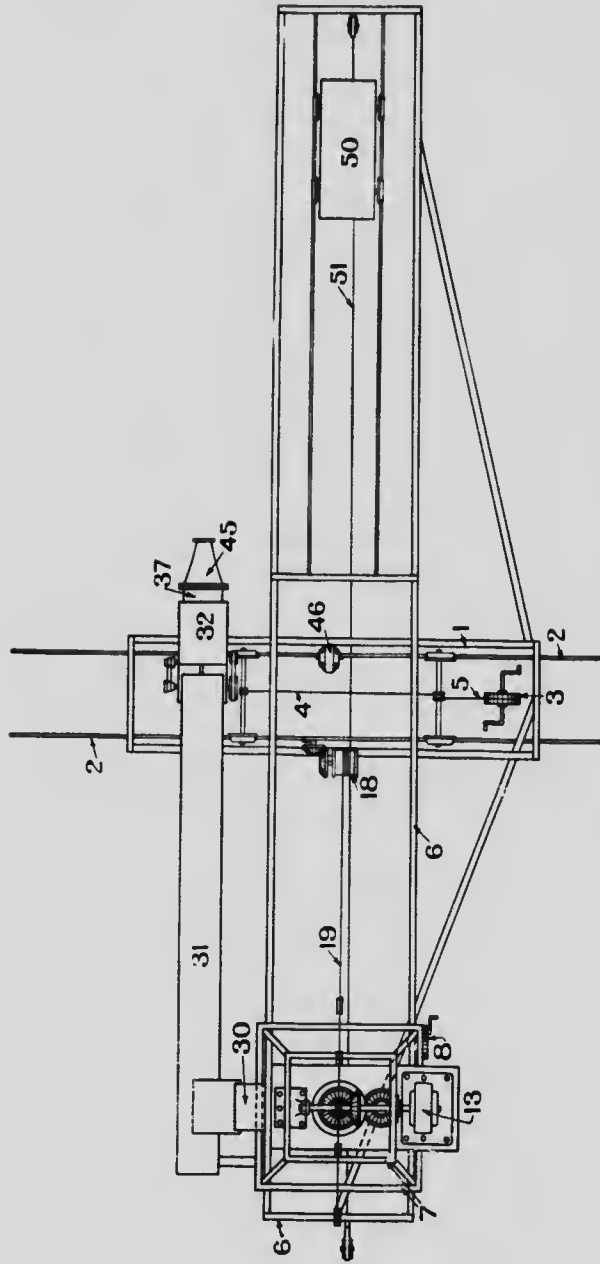

Fig. 46. Plan of Zelenay cutting apparatus.

1. 2. 3. 4. 5. 6. 7. 8. 9. 10. 11. 12. 13. 14. 15. 16. 17. 18. 19. 20. 21. 22. 23. 24. 25. 26. 27. 28. 29. 30. 31. 32. 33. 34. 35. 36. 37. 38. 39. 40. 41. 42. 43. 44. 45. 46. 47. 48. 49. 50. 51. 52. 53. 54. 55. 56. 57. 58. 59. 60. 61. 62. 63. 64. 65. 66. 67. 68. 69. 70. 71. 72. 73. 74. 75. 76. 77. 78. 79. 80. 81. 82. 83. 84. 85. 86. 87. 88. 89. 90. 91. 92. 93. 94. 95. 96. 97. 98. 99. 100.

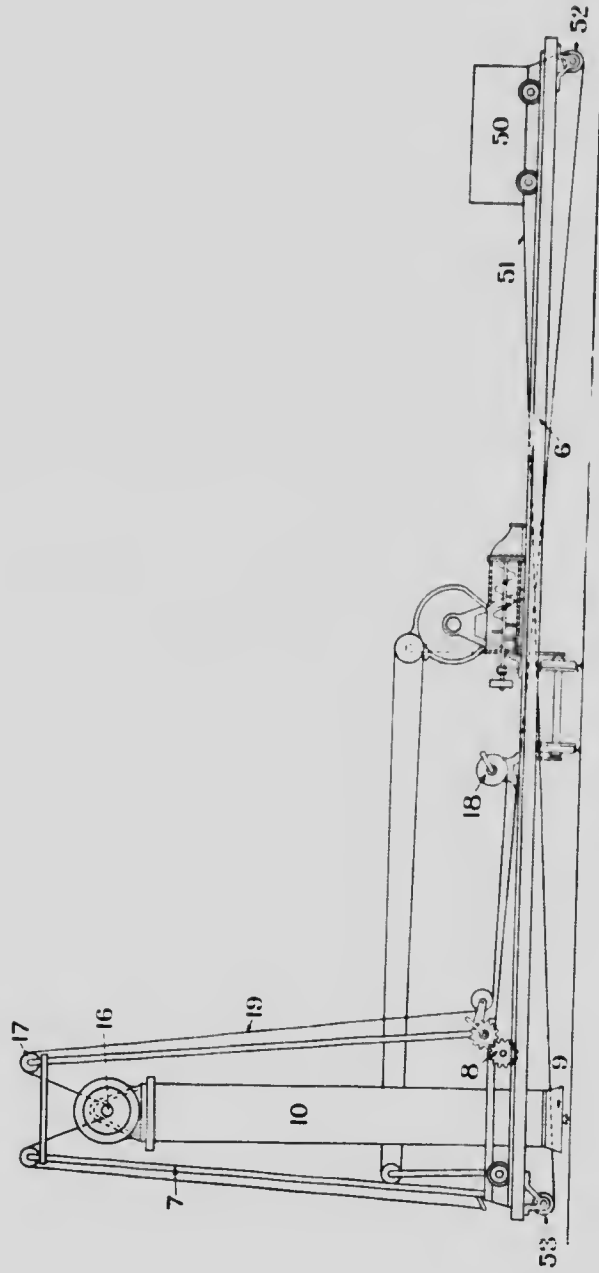

Fig. 47. Side view of Zelenay cutting apparatus.

The shaft 20, with the loosening device is rotated at a high speed, so that the cut peat is caused by its momentum to enter the loosening device 9, and pass upwards along the passage.

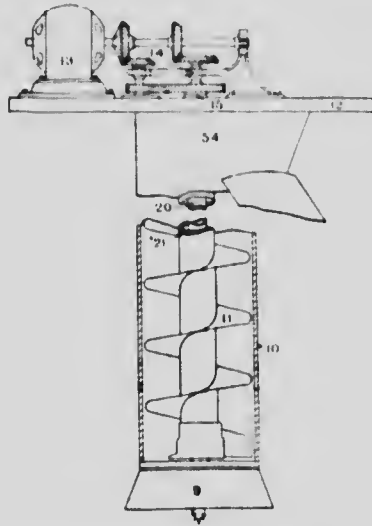

Fig. 48. Parts of peat cutting apparatus: loosening device, screw conveyor, and motor.

In order that the cut peat shall be effectively caught, the underside of the loosening device is made conical, so that any pieces of peat flying off under centrifugal action will be yet caught by the passages 27. For

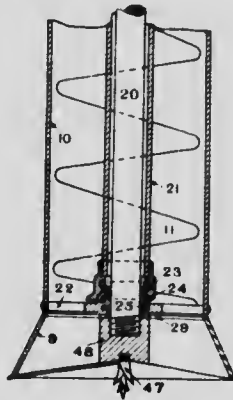

Fig. 49. Vertical section of screw conveyor.

this purpose also the cutting edge of the cutter 28, is set at an angle to the radius. In order to prevent wear of the upper edges of the cross partitions 26, the upper surfaces of the loosening device 9 are covered with correspond-

ingly recessed plate 29, of hardened steel (see Fig. 51) so that this plate forms together with the arms of the cross piece 22, a second cutting device. The outer edges of the cutters 28, extend beyond the lower diameter of the

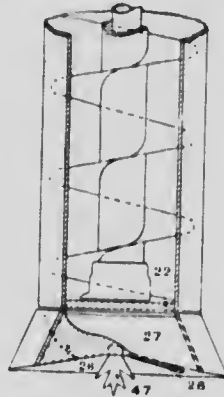

Fig. 50. Vertical section of loosening device.

loosening device for the purpose of preventing the loosening device from being braked by the peat and of facilitating the lifting cut of the cutting apparatus.

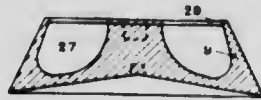

Fig. 51. Vertical section of upper part of loosening device.

In order to facilitate cutting into the peat bed, the loosening device 9, is provided at its lower part with a gradually diminishing drill 47, the greatest diameter of which is equal to the diameter of the hub 48, of the

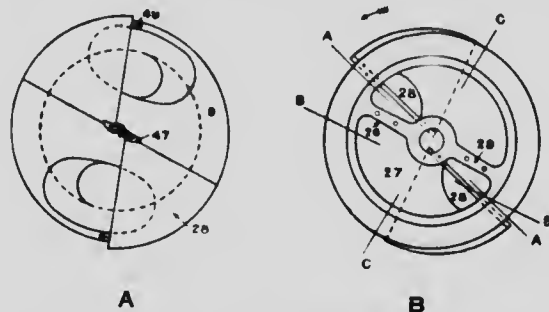

Fig. 52. Plan of the cutters in loosening device.

loosening device. Further triangular cutters 49, are fixed to the lower edge of the same in front of the cutters 28, for the purpose of preventing the accumulation of peat, stones or splinters at this part. (See Fig. 52.)

In the drawings, a loosening device is shown by the way of example with two passages; but the number of such passages may be increased to suit the section of the loosening device and the particular nature of the kind of peat being cut.

The loosened peat moving up in the tube 10, is then received by the conveyer screw 11, fixed on the shaft 21, and is conveyed to the top where it falls through the enlarged opening 54, of the tube 10, into an extensible shoot 30, and thence on to a conveyer belt 31. The shafts 20, and 21, receive their motion by means of toothed wheels from the electric motor 13.

The ends of the shoot 30 are pivotted, one end being situated directly over the conveyer belt 31, and the other end being pivotted to the upper end of the tube 10. The upper end of the shoot 30 is thus drawn down when the tube moves down so that the shoot is shortened thereby. With this object the shoot is composed of two portions telescoping one in the other.

The peat is delivered by the conveyer belt 31, into mixing apparatus which serve to mix it intimately, and which consist of two distinct apparatus: the distributing apparatus and the actual mixing apparatus. The distributing apparatus serves for effecting a provisional coarse distribution of the peat from the layers at various levels of the peat bog, whereby the further mixing effect of the actual mixing apparatus is greatly facilitated. The apparatus consists of a cylindrical shell 32, divided by a cross partition 33, into two chambers of which one remains empty, whilst the other contains a cylinder 34, which is rotatable about its horizontal axis and is open at its cylindrical surface. (See Fig. 53.) This cylinder is divided by radial walls 35, into a number of compartments. The shell 32, is provided at its lower part with a funnel 36, which delivers into the mixing apparatus or peat press 37. (See Fig. 54.) This apparatus serves the following purposes: the tube 10, in its descent penetrates various layers of peat, namely, first, the top fibrous layer, then the intermediate layer and, finally the bottom decayed peat layer. The cut peat is transferred in the same order of succession by the screw on to the conveyer belt.

In order to produce a completely uniform product, a very large mixer would be required of a capacity at least equal to, but preferably twice the capacity of the tube 10. The mixing of such large quantities of peat would, however, require considerable power. Now the above described distributing apparatus is provided, in order to avoid such large mixers and the consequent consumption of power.

When the peat falls into the shell 32, and the cylinder 34, the lower slide in the funnel 36, is at first kept shut in order to prevent the peat from entering too soon into the mixer 37. Thus the peat from the upper layers of the bog, collects at the bottom, above it comes the peat from the middle layers, and at the top above all comes the decayed peat from the deepest layers of the bog. As soon as the two cylinders, the united capacities of which are approximately equal to the capacity of the tube 10, are filled, the slide is opened to allow the peat to enter the press 37, since, however,



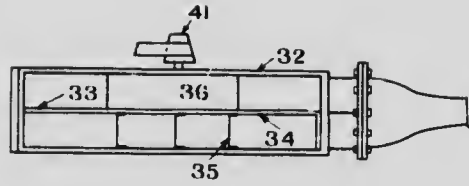

Fig. 53.

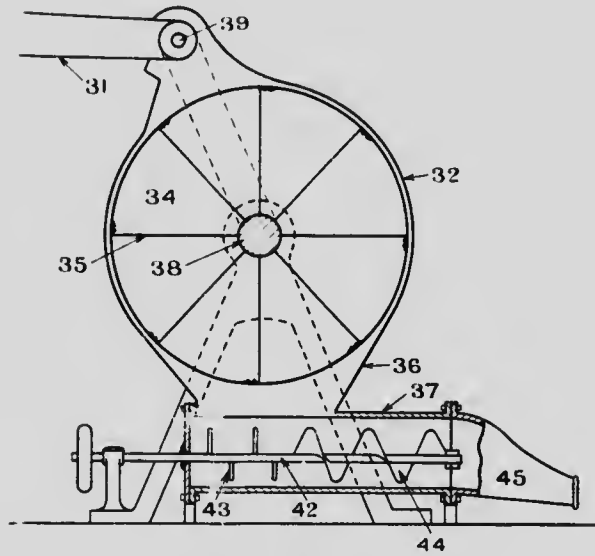

Fig. 54.

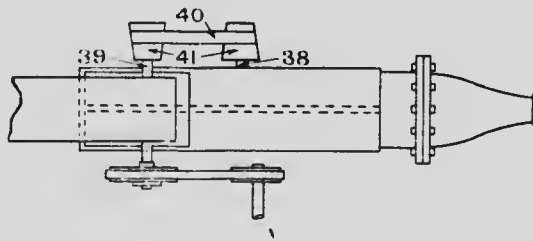

Fig. 55.

Figs. 53, 54, 55. Sections of Zelenay cutting apparatus.

the cylinder 34, rotates on its axis, its compartments become filled with peat from various layers, so that peat from various layers enters the funnel. The velocity of rotation of the cylinder 34, may be so regulated that peat cut from the upper layers of the peat bog will always come together with peat cut from the lower layers. For this purpose, the shaft 38 of the cylinder 34, and the shaft 39, of the conveyer belt pulley are provided with cone pulleys 4, connected by a belt 40. (See Fig. 55.)

The preliminary distribution of the peat enables small mixing apparatus to be used without injuriously effecting the completeness of the mixing.

The peat passes from the distributing cylinder into the mixer 37, wherein the inclined blades 43, mounted on its shaft 42, effect an intimate mixing of the peat. A conveyer screw 44, on the same shaft then forces the mixed peat from the mixer, out through a suitable mouthpiece 45, whereby a string of peat is produced which is cut up into blocks in the usual manner.

The mixer, the conveyer belt, and the lifting windlass, are driven from an electric motor 48, through ordinary power-transmitting means.

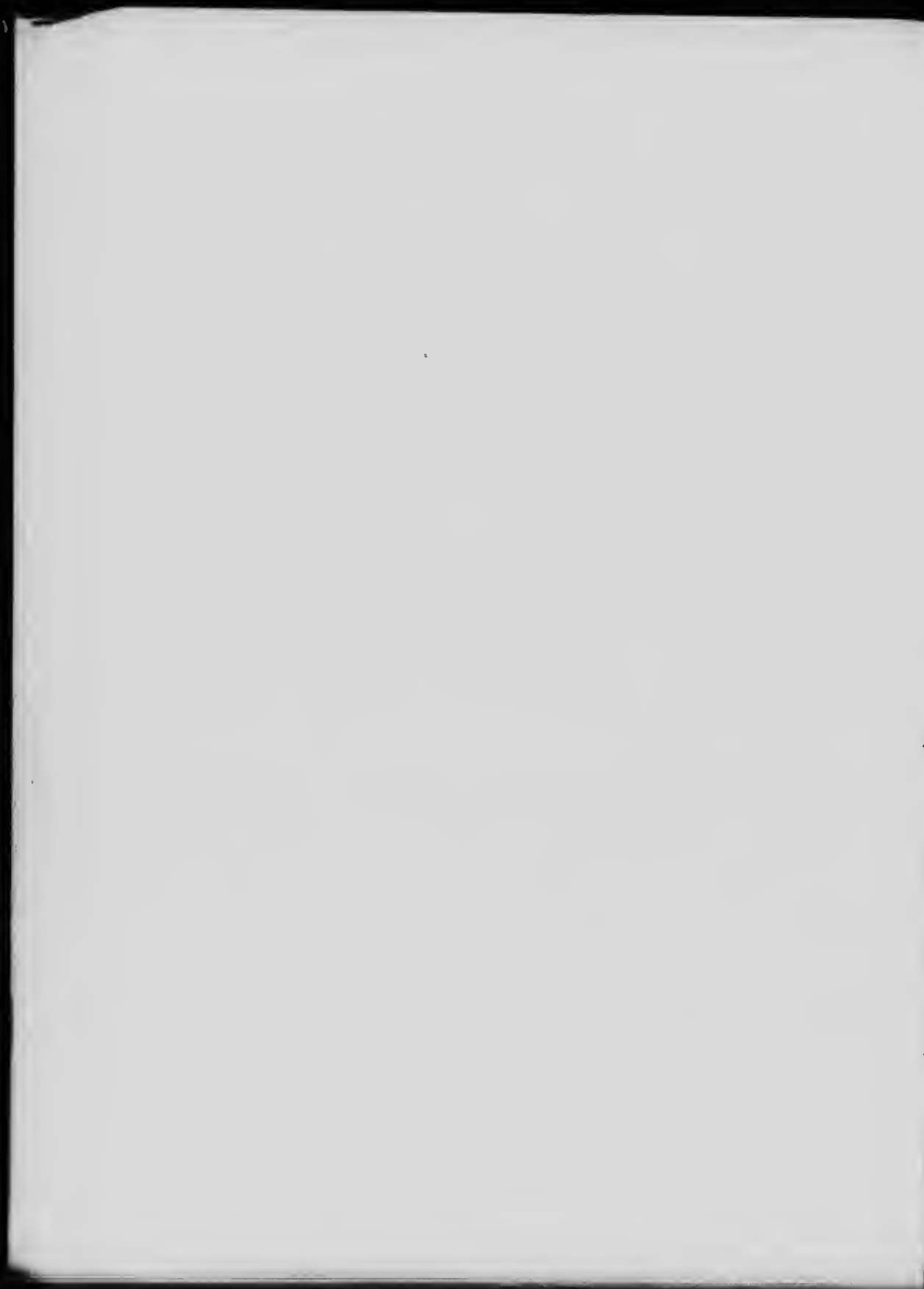

## APPENDIX XX.

(Patent No. 156544, June 1914.)

**Apparatus for Utilization of Peat.**

By

*Nils Testrup, London, England,  
Thomas Rigby, Dumfries, Scotland,  
Olaf Söderlund, London, S.W., England.*

Although the wet carbonizing process first described by Ekenberg, for rendering the water of peat more freely expressible, by heating under pressure while wet has been known for some years, its practical development has been retarded by the difficulty of effecting the subsequent water separation in an economical manner.

According to the present invention, these difficulties are removed, and in such an efficient manner that even after satisfying the needs of the process in regard to power and fuel, a substantial excess of fuel in the solid or gaseous state remain for disposal.

When the material has been wet carbonized, it has been customary to attempt removal of its water in certain special ways, based upon the supposition that dewatering could be effected by a simple operation, and to an extent sufficient, for example, to render the material suitable for gasification; but we have found that to reduce it even to the highest water content at which gasification can be conveniently carried out, say to some 50%, the dewatering must be effected in two stages, the first of which is the production as in a filter press or of a more or less solid cake from the material and the second stage the pressing of this cake, as in a hand or other mechanical press, or alternatively its drying by suspending it in a finely divided state in hot products of combustion resulting from heat, or power generation in the process.

In the installation shown in Figure 56 the peat is cut from the bog 1, by an excavator 2, mounted upon a pontoon 3, and is then introduced into a disintegrator 4, which reduces it to a pulp capable of being forced by a pump 5, at a pressure of about 28 kilogrammes per square centimetre, through a pipe line 6, to the factory reservoir 7, usually situated some distance from the excavation in the bog. By means of a pump 8, the peat pulp is withdrawn from the reservoir 7, and forced at a pressure of about 17.6 kilogrammes per square centimetre through a wet carbonizer 9, of the well-known concentric tubular type, which is heated by steam or by the combustion of producer as within a suitable furnace 10. After having been heated in the carbonizer to a temperature of about 190°C., the material is delivered into a vessel 11, having a safety valve adapted to blow off at a pressure of say, 8½ kilogrammes per square centimetre, this vessel being

for the purpose of ensuring a steady supply of material to one or more of a bank of filter presses 12, which operate at a pressure of about 7 kilogrammes per square centimetre.

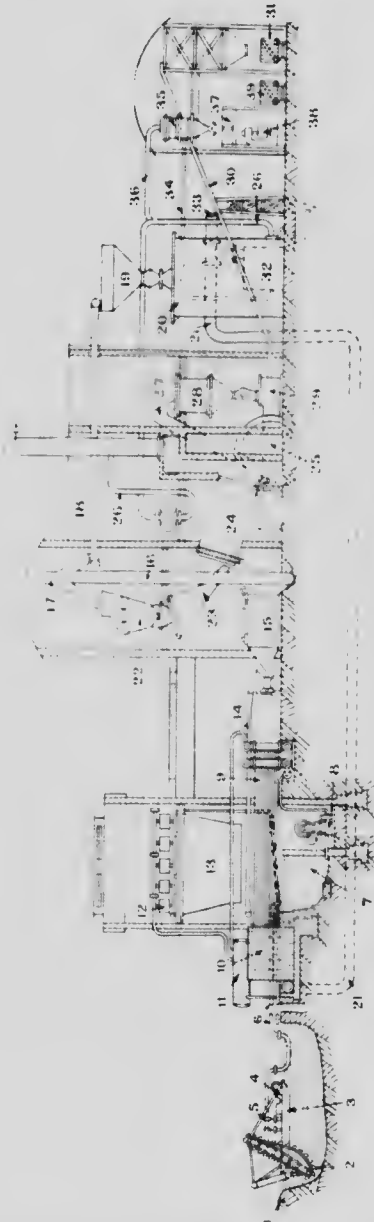

Fig. 56. Section of Testrup, Rigby, and Sælehaug wet carbonizing plant.

The filter presses 12, are situated above a hopper 13, by which the filter press cakes are deposited on a conveyer 14, which carries the cakes to a



20, the gas from which passes through a conduit 21, to the burners in the furnace 10, where it is consumed in heating the carbonizer 9. The other part of the material passes into a pulverizer 22, from which it is delivered

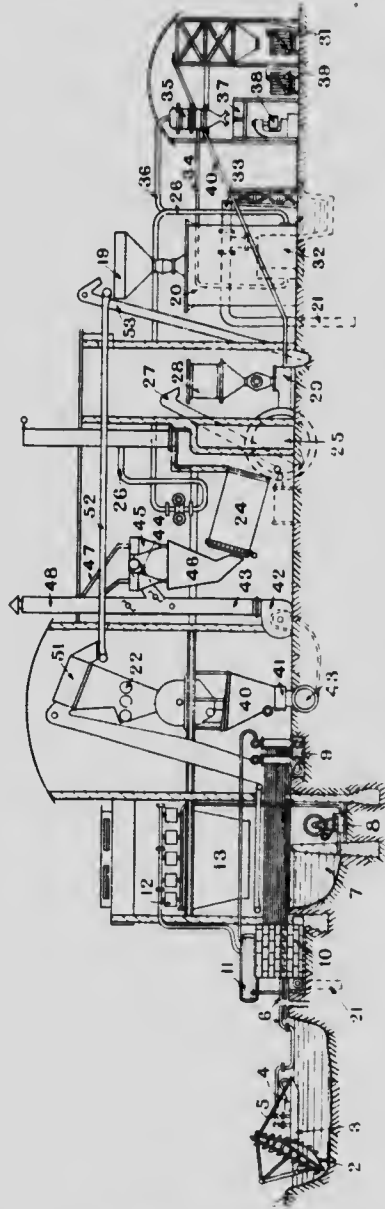

Fig. 58. Section of Te-strup installation for producing briquette fuel.

in the form of a powder to a hopper 23, which feeds the material into a rotary drier 24, of the well-known tubular type, heated by waste products

of combustion. The gases generated during drying of the material in the drier 24, pass upward through the chimney 25, from which they are usually

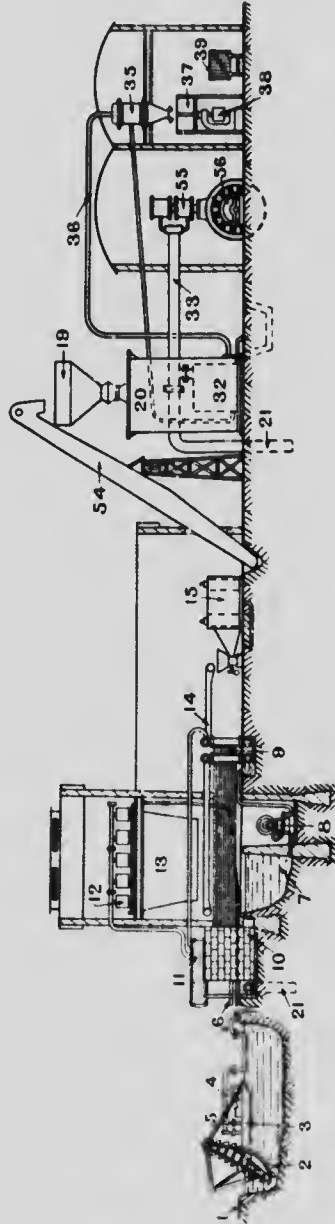

Fig. 59. Section of Testrup installation for producing electric energy.

taken by a conduit 26, to the air inlet of the gas producer to supply a large proportion of the steam necessary therefor.



The dry material from the drier 24, is carried upwards through a conveyer 27, into the hopper 28, of a briquetting press 29, from which the bri-

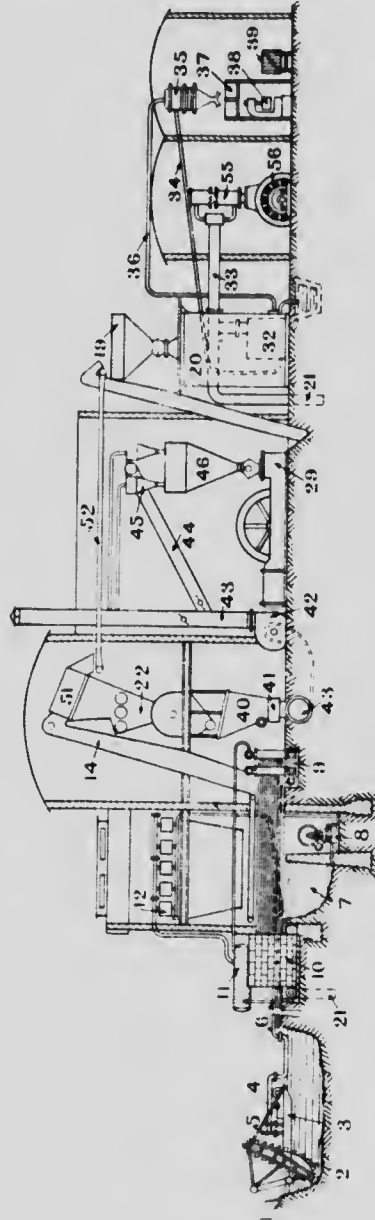

Fig. 60. Section of installation of gas producer with an apparatus for producing press cakes and briquets.

quets of peat fuel are carried by a conveyer 30, for transference to railway wagons 31.

The gas in the producer 20, is treated in washers 32, for the recovery of ammonia as ammonium sulphate, and then passed to the main gas duct 33, from which branches the carbonizer conduit 21, already mentioned. The washings from the washer 32, are conveyed by a pipe 34, to a steam-heated evaporator 35, the vapours from which are conducted to the air inlet of the producer 20, through a pipe 36 connected to the pipe 26, while the crystals of ammonium sulphate deposited in the evaporator 35, are delivered into receptacles 37, ready for drying in centrifugal driers 38, before being transferred to railway wagons 39.

In such an installation the effect of wet carbonizing the peat is to render its water so freely expressible that when the pulpy mass, of liquid consistency, is subjected to filter pressing, it is transformed into solid press cakes containing only about 68% of water, which when subjected to band pressing have their water content readily reduced to about 55%. This is sufficiently low to permit of their being gasified, and consequently, without further treatment part of the material, can, with advantage, be gasified to yield gas sufficient to meet the power and heating needs of the installation, and in addition the production of sulphate of ammonium as a by-product.

The rest of the material is pulverized and further dried, after which it is briquetted to yield briquets as a further product of the process. Thus, in the case of a peat containing 90% water, 100 parts of raw peat yield about 8 parts of dry material after wet carbonization, filter pressing and band pressing, which, if divided into equal parts, yield on the one hand 4 parts of briquets, and on the other, sulphate of ammonium and tar corresponding to the 4 parts gasified, besides any excess of producer gas not required in carrying out the process. Consequently, sulphate of ammonium, tar, and briquets are obtained without any outlay for power and fuel. In many cases, the filter press effluent, after having been utilized to preheat raw peat entering the carbonizer, is concentrated by evaporation and the solids so obtained gasified to yield by-products such as nitrogenous compounds, sugars, and acetic acid.

As large quantities of hot products of combustion are produced in carrying out a process of the above kind, that stage of water removal performed in the band press may be economically effected by direct drying of the material by such hot gases. According to a method based upon the surprising discovery that the drying can be carried out in hot gases containing a considerable percentage of free oxygen, without risk of ignition, when the material is in a stage of fine subdivision. For this purpose, the installation is modified as indicated in Figure 57 in which the press cakes from the filter presses 12, are carried upwards by the conveyer 14, directly to pulverizers 22, from which the powdered material falls into a hopper 40. From the latter it is introduced by a rotary valve 41, into a current of hot products of combustion of producer gas in the carbonizer furnace 10, which are drawn by a fan 42, through a duct 43, and thence pass by way of a branch duct 44, leading to cyclone separators 45, where the material is

separated from the hot gases and deposited in the hopper 46, the gases passing upwards through the conduits 47, to a chimney 48.

At this stage, the material is divided into two parts in passing through the hopper 46; one part being fed directly into a briquetting press 49, and delivered as briquets which are carried by a conveyer 50, to the hopper 19, of the gas producer 20. The other part of the material is, as in the process previously described further dried in a rotary drier 24, before being briquetted in the press 29, to produce the briquets which are available as products of the process.

If the filter press cakes are of such a nature that without disintegration and further drying they can be used as producer fuel, the installation is modified as shown in Figure 58, in which the press cakes from the filter presses 12, are taken by the conveyer 14, to a sieve 51, which separates the larger lumps of the material from the finer material; which latter is thereby permitted to pass into the pulverizers 22, situated below the sieve, while the larger lumps are carried by a conveyer 52, to the hopper mouth of the producer 20. At this point they are mixed with some of the finer material which, after having been disintegrated in the pulverizers 22, then further dried in the duct 42, and rotary drier 24, and briquetted in the press 29, has been delivered to the producer hopper 19, by a conveyer 53, the excess of briquets not required being, as before, delivered by the conveyer 40, to the railway wagons 31. In this way a charge of suitable average moisture content, usually about 50 to 40 per cent, can be readily obtained with the advantage that as the hard cake resulting from the briquets in the charge supports the whole of the charge and provides an open fire in the producer, the necessity of drying of the material to a much lower water content, is avoided.

The installations above described have been particularly directed to the production of briquet fuel, but when it is more advantageous to produce energy directly—say in the form of electricity, the installation is modified as shown in Figure 59, in which the whole of the material from the band press 15, is taken by a conveyer 54, directly to the hopper 19 of the gas producer 20. As a result, the producer gas, besides supplying the heating and power requirements of the installation, is now utilized to drive internal combustion engines 55, which are coupled to electric generators 56, and supplied with the gas through a conduit 33, after the gas has been treated for the recovery of ammonia in the washers 32, in the manner already indicated.

In order to obtain the benefits of supplying the gas producer with a mixture of press cakes and briquets, as in the installation described with reference to Figure 58, this method of generating electrical energy is modified by arranging the installation in the manner shown in Figure 60, in which the press cakes pass from the filter presses 12, by way of the conveyer 14, sieve 51, and conveyer 52, to the producer hopper 19, where they are mixed with the material which has passed through the sieve 51 and been pulverized, dried in the duct 42, briquetted in the press 29, and delivered as briquets by the conveyer 53.

In some cases, it may be found advantageous to heat the wet carbonizers by steam, which is either introduced directly into the peat or supplied to jackets surrounding the carbonizer tubes, this steam being generated by the combustion of producer gas under suitable steam raising boilers, and in most cases exhaust steam from prime movers supplying the necessary power for the installation.

In wet carbonizing peat pulp in the tubular type of carbonizer, difficulty sometimes arises through deposition of the pulp on the walls of the tubes. This may, however, be prevented in different ways, one of which consists in inserting a loose element such as an iron rod in the tubes, or by arranging for the dislodgment of the pulp by periodically causing a violent motion thereof in the tubes, by connecting the latter to a vessel at a lower pressure.

As an alternative to the above methods of preventing deposition of the pulp in the carbonizer tubes, the pulp is passed through the tubes at such a rate that deposition is prevented, the necessary heat transmission being effected by maintaining the pulp at or about the maximum carbonizing temperature in a vessel wherein it is subjected to the action of revolving paddles, which prevent channelling of the material, whereupon the hot material is returned to the carbonizer tubes in which it is cooled by regeneration, and the available heat utilized to warm the incoming pulp.

The method of drying the material after filter pressing by suspension thereof, when in finely divided state in hot flue gases may be carried out in such a manner, that the hot gases which have effected the final stage of the drying are utilized to effect the preliminary drying of the powdered material, which is afterwards to be more completely dried by the hottest gases. In this way, drying and heating of the material to a temperature of about 120° C before briquetting is effected by reducing the water content of the material from 70 to 65 per cent, in the preliminary drying, and to about 10 per cent or less in the final drying.

Further, the excess of solid fuel resulting from the process may be caked in by-product recovery coke ovens, in which case not only does coke result, but a further increase in the amount of nitrogen recovered from the total peat treated is obtained. The solid fuel is also suitable for use as a reducing agent in smelting operations, from which it is introduced into the smelting furnace as cakes of briquets mixed with the usual charge of coal and other materials.



# MICROCOPY RESOLUTION TEST CHART

(ANSI and ISO TEST CHART No. 2)

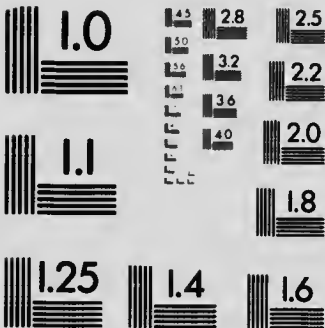

**APPLIED IMAGE Inc**

1653 East Main Street  
Rochester, New York 14609 USA  
(716) 482-0300 - Phone  
(716) 288-5989 - Fax



## APPENDIX XXI.

(Patent No. 158165, October 6, 1914.)

**Improved Apparatus for the Wet Carbonizing of Peat.**

By

*Nils Testrup, London, England.*

This invention relates to the wet-carbonization of peat according to the process proposed by Ekenberg, in which the wet peat is heated to a temperature of from 150° to 250° C. under pressure so that the jelly-like hydrocelluloses—which apparently prevent expression of the greater part of the water in the peat—are decomposed, and thereby permit such water to be more easily removed.

Hitherto, such a process has been carried out in an apparatus comprising several long double concentric tubes, through which the peat, when in a pulped condition, is forced so as to pass along one tube and back through the other, the tubes being heated over a part of their length in such a manner that after the material has been heated to a temperature of about 150° centigrade under pressure to prevent ebullition, it is cooled regeneratively in order, to preheat the incoming peat. By this means the temperature of the peat is raised above the point to which it has to be raised to render its natural water expressible without causing any substantial decomposition of the peat or distillation of the hydrocarbons. The water can be then removed by simple pressing.

It will be evident that the commercial success of such a process will depend upon the quantity of heat that must be supplied to effect the desired change.

The object of the present invention is, to reduce the amount of such heat.

It has been observed that when in carrying out this process the peat reached a temperature above 180°C, an exothermic reaction takes place within the peat, resulting in the liberation of a large quantity of heat. This observation enables us to effect increased economy in such a process by adapting the apparatus to regenerate this evolved heat, and this invention consists, therefore, in modifying the working procedure for this purpose.

In the accompanying drawing, which is a sectional view of the apparatus having two sets of double concentric tubes suitable for carrying out the above process, is diagrammatically illustrated in Fig. 61.

The inlet header *a*, of the apparatus is in communication with the outer tube *b*, which is about 52 feet in length, and is closed at its other end *c*. The inner tube *d*, is open at one end *e*, and at the other communicates with an outlet header *f*, this tube carrying a screw conveyer *g*, which,



when the tube *d*, is rotated, causes the peat to be fed from the inlet header *a*, through the annular space between the tubes *b*, and *d*, and thereafter through the inner tube *d*, to the outlet header *f*. At the closed end, the outer tube

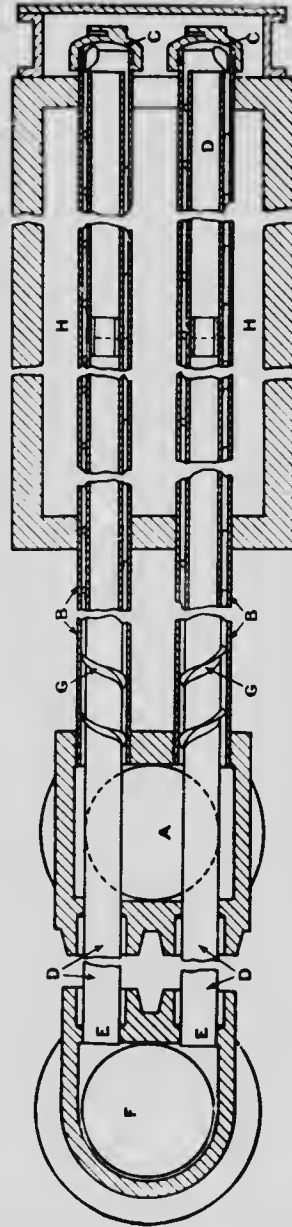

Fig. 61. Sectional view of Testrup wet carbonizing apparatus.

*b*, is situated within a steam or gas heated furnace *b*, which extends some 17 feet along the length of the tube *b*, slightly less than one-third of the

entire tube length being thus situated in the furnace, this proportion being in some cases as small as one-twelfth. In so passing through the part of the tubes situated in the furnace *h*, the peat is heated to a temperature of about 180°C.

As a result of the exothermic reaction occurring within the peat at this temperature an automatic rise of temperature takes place which is not only sufficient to complete wet carbonization, but also to enable the incoming peat to be heated regeneratively without heating the entire length of the tubes.

In this way a much smaller quantity of heat requires to be supplied from an external source in order to effect wet carbonization, and to heat the incoming raw material to the desired temperature than would otherwise be required.

This reduction in the quantity of heat necessary is therefore equivalent to a saving in the fuel consumed, and results in great economy in practice.



## APPENDIX XXII.

*(Patent No. 158166, October 1914.)***Method and Apparatus for Removing Water from Peat.**

By

*T. Rigby, Dumfries, Scotland.*

As the result of experiment, it has now been ascertained that peat, which has been wet-carbonized according to the Ekenberg process, or has been by other kindred process of heat treatment caused to undergo those changes which make the bulk of its water readily expressible, has still this property of losing water more easily and to a greater extent when pressed hot, than when pressed cold.

According to the present invention, methods of heat treatment of the kind in question are modified so as to take advantage of this property, and this, despite the necessity of recovering as far as possible the heat which has been supplied to the material.

This is effected by regenerating the heat of the hot treated peat in the usual manner, but in addition by interrupting the cooling before the temperature has fallen sufficiently low to effect appreciably the ease of pressing, whereupon the peat is pressed and the heat regeneration then continued by using the hot effluent instead of the peat, to impart heat to the cool raw material awaiting treatment.

The best temperature for pressing appears to vary considerably, but usually a temperature below 70° Centigrade is to be avoided, while on the other hand, a limit is placed on the use of higher temperatures by the inconveniently high temperature then occurring in the neighbourhood of the filter or other presses.

In applying this method for instance, to the wet carbonization of peat using concentric tubular heating and heat regenerating elements, the peat pulp is withdrawn from the regenerator when its temperature has fallen to say, 70° centigrade, and then passed to the filter presses, whereupon the expressed liquid is returned to the regenerator in the vicinity of the point of removal, where it continues to yield up its heat.

In Fig. 62 is shown a wet carbonizing installation modified on these lines.

The peat pulp is forced into the apparatus at *a*, and passes through the inner tube *b*, bend *c*, inner tube *d*, bend *e*, inner tube *f*, bend *g*, outer tube *h*, and there through the concentric tubes, *i*, and *j*, in the latter of which it is heated by the steam jacket *k*, whereupon it passes through the pipe *l*, to the vessel *m*, which is provided with stirrers *n*, and intermediate baffles *o*. On leaving the latter vessel by the pipe *p*, the peat flows through the inner

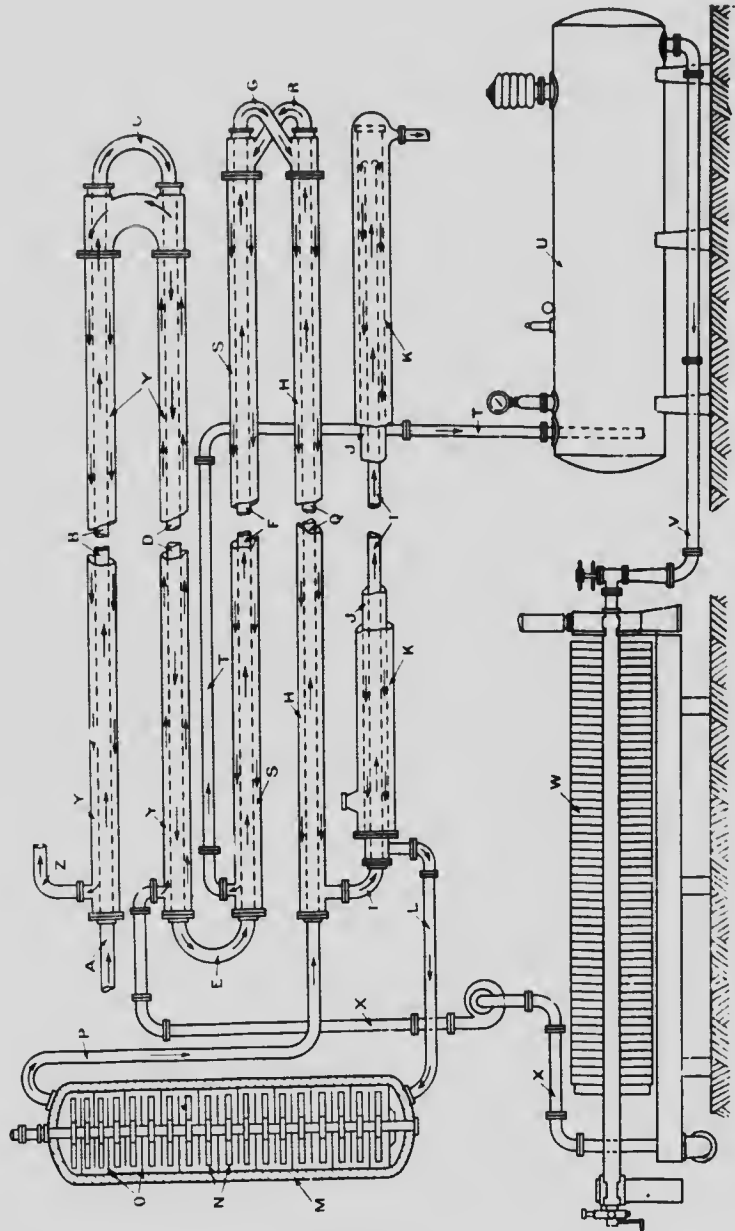
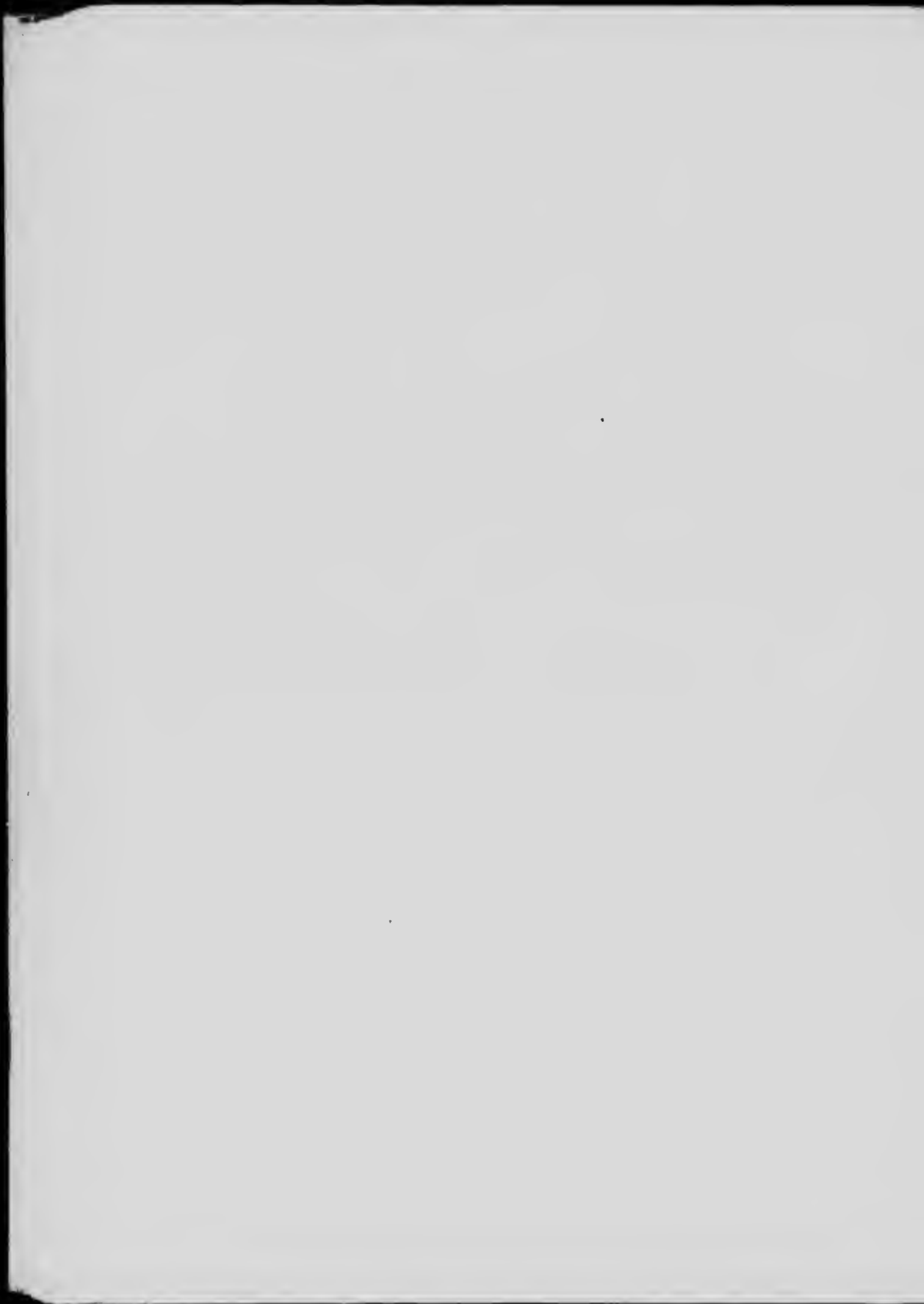

Fig. 62. Side elevation of Rigby apparatus for removing water from peat.

pipe *q*, bend *r*, and outer pipe *s*, from the latter of which it leaves the apparatus by the pipe *t*, connected to a storage reservoir *u*, from which the peat is supplied through the pipe *v*, to the filter press *w*.

From the latter, the hot expressed liquid is returned by the pipe *x*, to the regenerator part *y*, of the wet carbonizing apparatus, having lost—if the various parts have been properly lagged and all ordinary precautions taken—but little heat. After imparting heat to the raw incoming peat passing through the tubes *b*, and *d*, the peat now leaves the regenerator part *y* of the wet carbonizing apparatus at *z*.



## APPENDIX XXIII.

*(Patent No. 159843, December, 1914.)***Peat Forming and Spreading Machine.**

By

*E. V. Moores, Peterborough, Ontario, Canada.*

The object of this spreading and forming machine is, to travel along the ground and deposit the formed peat in thin layers behind it, for drying.

The device consists essentially of a framework, having at the rear a transverse trough, in which a distributing screw operates. At the rear of the trough are a number of moulds. The machine is propelled by a suitable motor, which also furnishes power to operate the forming apparatus.

The peat is transferred from the distributing trough to the moulds by a number of revolving screws or worms, which operate alternately in opposite directions and intermesh. (See Plate XCII.)

The machine consists of a frame work 11, having at each side thereof, towards the front, caterpillar treads 12. Between the treads a platform 13, is provided, on which any suitable form of motor 14, is mounted and connected to operate the caterpillars 12. A suitable arrangement of gears is provided enclosed in a case 15, and controlled by a lever 16, by means of which the caterpillars may be operated independently or one faster than the other so as to guide the machine. (See Fig. 63.)

This motor may be of the internal combustion type or of the electric type shown, in which case suitable trolleys 17, are provided to take power from overhead wires. The motor will be governed by a controller 18, of any suitable type.

Toward the rear of the machine, a transverse trough 19, is provided, having a removable cover 20, provided at one end with a hopper 21. Within the trough, a large screw or worm 22, is provided, extending from end to end of the trough and tapering away from the hopper; clearly shown in Fig. 64. On the rear side of the trough at the bottom, an outlet passage 23 is provided, extending from end to end of the trough, and opening into a plurality of rearwardly discharging moulds 24. These moulds may be tapered slightly toward the rear as shown in Fig. 65, for the purpose of concentrating the peat. In the passage 23, a number of screws or worms 25, are provided arranged at right angles to the distributing worm 22. These feeding worms 25, are located centrally in line with each mould, but are of greater diameter than the moulds as clearly shown in Fig. 63 so that the worms intermesh.



These small feeding worms 25, thus form a practically continuous feeding device from one end of the passage to the other, operating to force the peat out through the moulds. Owing to the intermeshing relation of the feeding screws, it would be necessary if all revolved in the same direction, to pitch them all in one direction. This revolution and pitch in

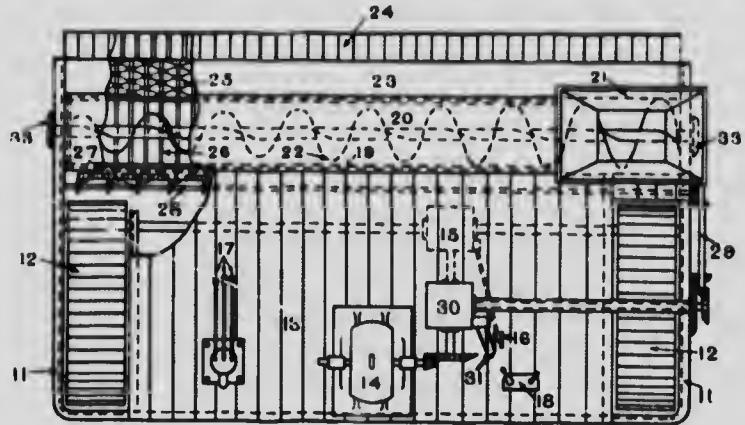

Fig. 63. Plan of Moore spreader.

uniform direction would, however, have the tendency of forcing peat along, in the passage, so that it is necessary to run alternate screws in a reverse direction to balance the stresses, maintain a uniform feed and prevent any longitudinal movement of the peat in the trough other than imparted by the distributing screw. This rotation is attained by extending the shaft 26, of the worms through the bottom of the trough and connecting them by means of gears 27, with a drive shaft 28, the gears being arranged to rotate the worm shaft 26 alternately in opposite directions, as clearly shown.

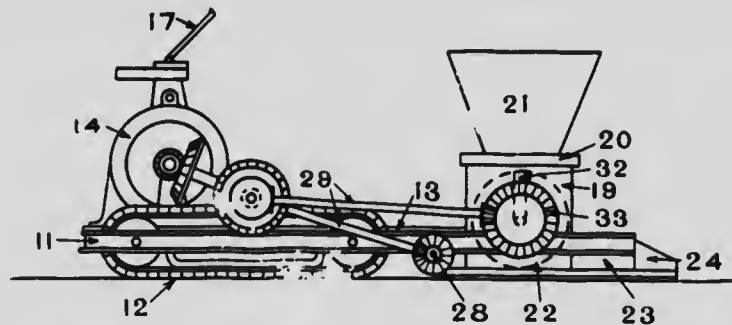

Fig. 64. Section of Moore spreader.

The shaft 28, and the distributing worm 22, are operated by suitable mechanism, designated 29, from the motor 14, a suitable gear enclosed in a casing 30, being provided to enable the distributing screw 22, and feeding

PLATE XCII.



Automatic spreading device: Alfred, Ontario.



screw 25, to be operated at variable speed and independently of each other. Suitable control levers 31, are provided adjacent to the lever 16, all three levers being convenient to the controller 18, so that one man may operate the entire machine without moving from his station on the platform.

The operation of the machine is as follows: the power is taken from overhead wires through the trolleys 17, to operate the motor, which drives the caterpillar treads 12, so that the machine is propelled over the ground, the speed and direction being controlled by the operator.

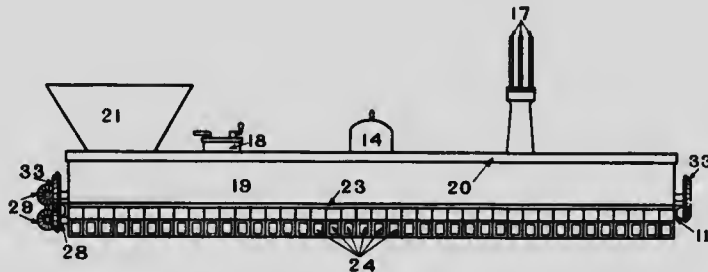

Fig. 65. Side view of Moore spreader.

The peat is dumped into the hopper 21, from a suitable conveyer, and falls onto the large end of the distributing screw. The screw carries that peat along in the trough and distributes equally throughout the entire length by reason of the decreasing size of the screw. The small feed screws 25, take the peat from the distributing screw and force it out through the moulds 24. The tapering of these moulds offers a slight resistance so that the peat is compressed into a compact mass and discharged in continuous ribbons from the rear of the machine on the ground. As each mould discharges a separate ribbon, the air has free access to three sides of each ribbon and limited access to the fourth side or underside, so that the peat will dry very rapidly. In addition to providing a more easily dried and handled product, the moulds may be made of any suitable shape, so that the ribbons of peat, and the finished peat bricks, would be rounded on the edges, corrugated, or of any other suitable form.

The distributing screw being larger at the hopper end, has a feeding capacity equal to all the moulds, while as it approaches the opposite end, the dimension of the screw decreases, and, therefore, its carrying capacity. This decrease in carrying capacity is proportional to the amount of peat already discharged or still to be carried on. If the screw was the same size from end to end, the feed would be very irregular, as the portions of the screw remote from the hopper would be only partly full, the amount of peat decreasing in proportion to the amount already discharged, so that at the fore end there would be so little peat that the screw would have no certain effect on it, and the discharge through the moulds would be very uneven.

When the end of the run has been reached, the machine is turned around, and starts back alongside its original path. The conveyer is suitably adjusted, and the cover of the trough 19, turned end for end as the opposite side of the machine now travels adjacent the conveyer. The distributing screw is also changed end for end; this change being facilitated by slots 32, in the ends of the trough for the passage of the screw spindle, permitting the screw to be lifted over and dropped back into the trough with great ease.

The screw may also be provided with a drive gear 33, at each end so that it will co-operate with the mechanism 29, without any adjustment.

While the consistency of the ribbons or briquets may be varied by regulation of the spread or feeding screws, or the speed of travel of the machine, and conversely, if the consistency of the peat supply is not uniform, the machine may be adjusted to turn out a product of uniform consistency, either by adjusting the relation between the feeding and travelling speeds, or by adjusting the relation between the distributing and feed screw speeds. The exact details of operation cannot be predicted exactly, as much depends on the nature of the peat and ground on which it is deposited for drying, and also on the weather conditions.

## APPENDIX XXIV.

(Patent No. 159904 A, January 1915.)

**Peat Dewatering Process.**

By

*Thomas Rigby, Dumfries, Scotland.*

This invention relates to the treatment of peat by processes of heating while wet, such as that known as wet carbonization, having for their object the unbinding of the water so that the same can be pressed out of the peat afterwards with relative ease.

The practical application of such processes, however, which necessitate the employment of fairly high temperatures in order that the best results may be obtained, depends upon the most rigid heat economy in the process, and, consequently, in most proposals for carrying out this process provision has been made for regenerating, from the treated peat mass, heat which has been supplied to it.

Now we have recently observed that in order to obtain the full benefits of the unbinding of the peat water effected by the heat treatment, the mass should be subjected to pressing or dewatering before it has become cooled too far, and while still, at as elevated a temperature as is convenient for working at; and, in order to enable this to be effected, we have endeavoured to cool the peat mass by regeneration only so far as is necessary to render it convenient for handling in filter presses, then to dewater it in filter presses and forthwith to return the hot liquor regenerators, and in this way apart from the easier dewatering obtained, we have found substantial benefits in reduced power for pumping through the regenerators since instead of a peat mass which is gradually cooling and becoming much more viscous only simple hot water requires forcing through the regenerator passages.

According to the present invention, however, we effect a considerable improvement even over this last proposal, in that we admit the hot effluent to such an amount as is convenient directly with the raw peat mass passing through the heating zone so that the whole of heat units contained in the heat effluent added remain in the resultant mixture without the necessity for providing tubular or other heat regenerators for this portion of the heat recovery. Moreover, the effluent in this way acts to improve the conditions for the eventual reaction, since certain matters which it contains have an accelerative reaction thereon, and simultaneously tend to lessen the proportion of the nitrogen content of the peat mass and of the solids of calorific value which pass into solution and are lost in the course of the treatment which secures unbinding of the water.

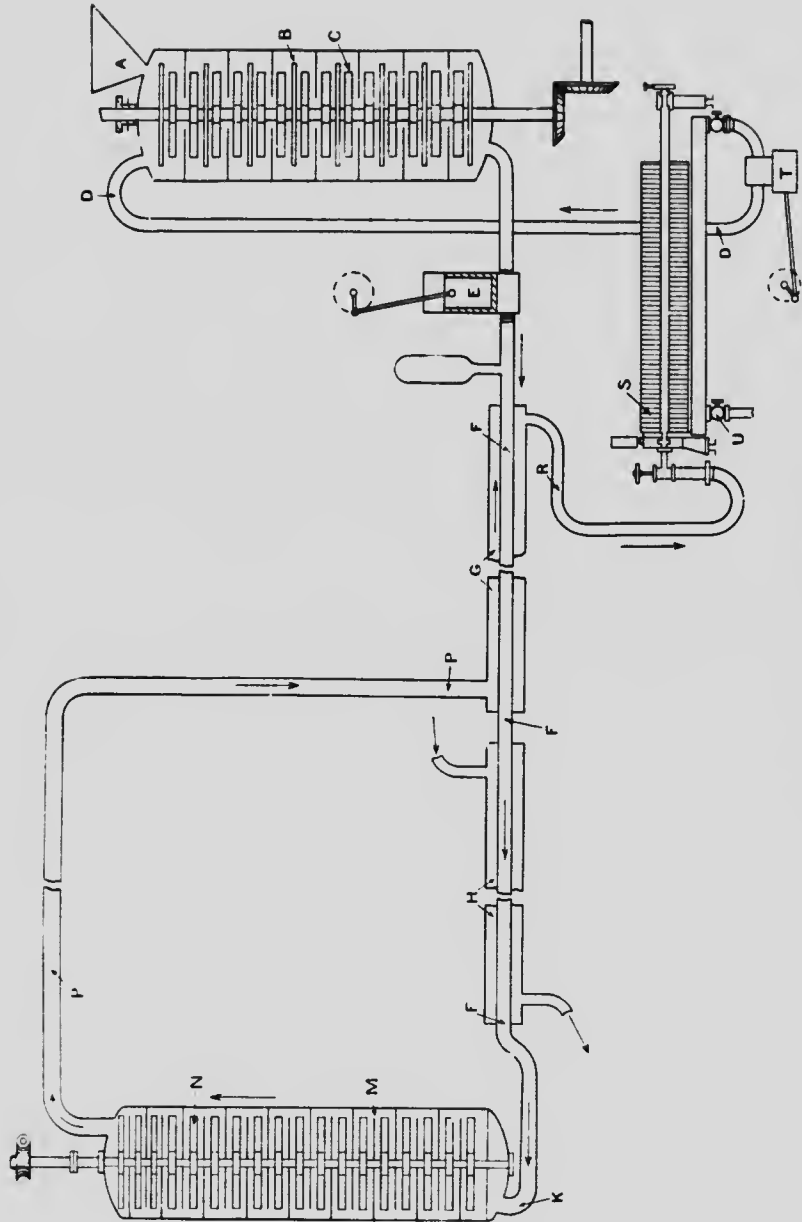

Fig. 66. Plan of Rigby dewatering apparatus.

The amount of the effluent which it is convenient to add in this way will depend largely upon the water content of the peat mass as it reaches the installation and the water content which the peat mass should have during treatment.

Thus if the peat is being excavated from a well drained deposit containing say, 87% of water, and the amount of water which it should contain is well above 90%, a large proportion of it, not the whole of the effluent, can be added directly to the peat mass to give it the desired fluidity. At the same time, even if the peat, as it reaches the factory contains a large amount of water, it may still be economical to add substantial quantities of hot effluent to it. In such circumstances it may be convenient after the admixture has taken place and the heat becomes distributed in the mixture, to subject the peat to drainage or partial dewatering, so that the excess of water is removed before the further heating operation.

In carrying out the process in the manner diagrammatically illustrated in Fig. 66, the peat is conveyed through a hopper a, into a vessel b, where it is thoroughly admixed by means of rotating paddles c, with hot effluent admitted from a pipe d. By means of a pump e, the peat is then forced through a tubular heater f, surrounded partly by a regenerator g, and partly by a team jacket h, by which the peat is heated to a maximum temperature at, or above, 100°C. On leaving the heater f, the peat passes through a pipe k, into a vessel m, in which it is maintained at or about the maximum temperature until the heat treatment has been completed to the desired extent, the peat being meanwhile agitated by revolving paddles n, it thereupon leaves the vessel m, by a pipe p, and enters the regenerator g, to be cooled in heating the peat passing through the heater f. Such cooling is continued until the peat has reached a temperature convenient for dealing with the peat in a filter press s, to which it is then passed through a pipe r. The hot effluent from the press s, while still at a temperature of about 70°C. is withdrawn in suitable quantities, and forced by a pump t, through the pipe d, leaving to the vessel b—where it is admixed with raw peat in the manner already described—any effluent not required, being withdrawn from the filter press tray through the stop-cock u.

As an instance of the influence of the re-use of the effluent on the preservation of the nitrogen contents of the peat, we may instance two cases in which a peat, wet carbonized with water in the ordinary way, lost 16.6% of its nitrogen, but only 10% when wet carbonized with effluent from previous treatment, while another peat which normally lost 21% of its nitrogen only lost 14% when treated according to the improved method.







|   | PAGE   |
|---|--------|
| Black Marsh peat bog .....  | 27     |
| Botany of the peat bogs .....   | 58     |
| Bottomley, Wm. B.—patent improved treatment of peat for manurial and other purposes ..... | 133    |
| Britton, Mrs. E. A.—peat plants named .....   | 60     |
| Brune, H. and Horst, Dr. H.—patent for process for drying raw peat .....                  | 89     |
| Buckle, E. A.—patent for machinery for treatment of peat and the like .....               | 135    |
| Buller peat bog .....   | 18     |
| <b>C</b>  |        |
| Cargill peat bog .....  | 7      |
| Caribou " .....   | 38     |
| " " botany of .....   | 60     |
| Cherryfield " .....   | 41     |
| Chairview " .....   | 16     |
| Clyde " .....   | 54     |
| " " botany of .....   | 60     |
| <b>D</b>  |        |
| de Laval, Dr.—wet carbonizing process .....   | 68     |
| " " " " special loan for experiments .....  | 69     |
| Denmark: detailed information regarding industry .....                                    | 70, 71 |
| " peat fuel manufactured 1902-13 .....  | 70     |
| Durham peat bog .....   | 6      |
| <b>E</b>  |        |
| Eastnor peat bog .....  | 7      |
| Egeberg's peat fuel machines .....  | 62     |
| <b>G</b>  |        |
| Gösling, Enar: grant for experiments by .....   | 69     |
| Cranville, Bernard: patent relating to methods of recovering peat from peat bogs ..       | 101    |
| <b>H</b>  |        |
| Heath peat bog .....  | 45     |
| "High moor," first encountered .....  | 55     |
| Hirsch, Emil: patent for method of dessicating peat and the like .....                    | 123    |
| Holton peat bog .....   | 23     |
| " " botany of .....   | 59     |
| Horst, Dr. H.—See Brune and Horst   |        |
| <b>J</b>  |        |
| Jarvis, Jerome : See Sigler and Jarvis.   |        |
| <b>K</b>  |        |
| Keeble, H. and C.—patent for separation of water and solid substances by pressure         | 87     |
| <b>L</b>  |        |
| L'Assomption peat bog .....   | 20     |
| " " botany of .....   | 59     |
| Latour peat bog .....   | 52     |
| Luther " " .....  | 3      |
| <b>M</b>  |        |
| Macconn, John: peat plants named .....  | 60     |
| Makoke peat bog .....   | 44     |

|   | PAGE       |
|---|------------|
| Manilla peat bog.....   | 13         |
| Marl beds.....  | 15, 16, 17 |
| Marsh Hill peat bog.....  | 9          |
| "    "    botany of.....  | 58         |
| Mermaid    "    .....   | 34         |
| Miscouche    "    .....   | 30         |
| "    "    botany of.....  | 59         |
| Moore, E. V.—patent for peat forming and spreading machine..... | 173        |
| Mount Stewart peat bog.....                                     | 32         |
| Muddy Creek peat litter bog.....                                | 32         |

## N

|   |    |
|---|----|
| Norway: peat fuel manufactured 1914.....    | 69 |
| Nova Scotia: peat bogs investigated in..... | 37 |

## O

|   |   |
|---|---|
| Ontario: peat bogs investigated in..... | 9 |
|---|---|

## P

|  |    |
|--|----|
| Patents relating to manufacture of peat..... | 73 |
| Peat: patents relating to treatment of.....  | 73 |
| "    production in foreign countries.....    | 65 |
| "    report on to Swedish government.....    | 67 |
| Peat bogs described: Amaranth.....           | 5  |
| Black Banks.....                             | 32 |
| Black Marsh.....                             | 27 |
| Buller.....                                  | 18 |
| Cargill.....                                 | 7  |
| Caribou.....                                 | 38 |
| Cherryfield.....                             | 41 |
| Clairview.....                               | 16 |
| Clyde.....                                   | 54 |
| Durham.....                                  | 6  |
| Eastnor.....                                 | 7  |
| Heath.....                                   | 45 |
| Holton.....                                  | 23 |
| L'Assomption.....                            | 20 |
| Latour.....                                  | 52 |
| Luther.....                                  | 3  |
| Makoke.....                                  | 44 |
| Manilla.....                                 | 13 |
| Marsh Hill.....                              | 9  |
| Mermaid.....                                 | 34 |
| Miscouche.....                               | 30 |
| Mt. Stewart.....                             | 32 |
| Muddy Creek.....                             | 32 |
| Port Clyde.....                              | 51 |
| Portage.....                                 | 28 |
| Rainy River district.....                    | 8  |
| Richmond.....                                | 1  |
| Stoco.....                                   | 14 |
| Sunderland.....                              | 12 |
| Tusket.....                                  | 42 |
| Tweed.....                                   | 18 |
| Westover.....                                | 7  |

|   | PAGE   |
|---|--------|
| Peat bogs investigated: Nova Scotia.....  | 37     |
| Ontario.....  | 9      |
| Prince Edward Id., data relating to.....  | 26     |
| Quebec.....   | 19     |
| Peat litter: Black Banks bogs.....  | 33     |
| Caribou bog.....  | 38     |
| Heath ".....  | 51     |
| Miscouche ".....  | 30     |
| Muddy Creek ".....  | 32     |
| Portage ".....  | 28     |
| United States importation of.....   | 67     |
| Peat powder: report of Capt. E. Wallgren on.....                                      | 67     |
| Persson, Ernst: patent for improvement in peat conveyer.....                          | 107    |
| Port Clyde peat bog.....  | 51     |
| Portage ".....  | 28     |
| Prince Edward Island: data relating to peat bogs investigated in.....                 | 26     |
| <b>Q</b>  |        |
| Quebec: peat bogs investigated in.....  | 19     |
| <b>R</b>  |        |
| Rainy River peat bogs.....  | 8      |
| Richmond peat bog.....  | 1      |
| " " botany of.....  | 58     |
| Rigby, Thomas: patent for apparatus for gathering and transporting.....               |        |
| peat.....   | 121    |
| " " " getting or excavating peat.....   | 91     |
| " " " method and apparatus for removing water.....                                    |        |
| from peat.....  | 169    |
| " " " peat dewatering process.....  | 177    |
| Rigby and Testrup, Nils: improvement in process for utilization of.....               |        |
| peat.....   | 125    |
| Rigby: See Testrup, Rigby, and Söderlund.   |        |
| Rosenheim: rapid <sup>2</sup> of plant at.....  | 64     |
| Russia: progress of peat industry in, 1909-11.....                                    | 71     |
| <b>S</b>  |        |
| St. Isidore peat bog.....   | 22     |
| " " botany of.....  | 59     |
| Sandbu, Paul: statistics of peat fuel, Norway.....                                    | 69     |
| Sigler, Oscar J. and Jarvis J.—patent for improvement relating to peat expresses..... | 115    |
| Söderlund, Olaf: See Testrup and Söderlund.....                                       |        |
| " " See Testrup, Rigby, and Söderlund.  |        |
| Stoco marl deposit.....   | 17     |
| " peat bog.....   | 14     |
| Sunderland peat bog.....  | 12     |
| Sweden: extract from report on peat, 1911.....  | 67     |
| Swedish Steam Boiler Society: firing tests by.....                                    | 67     |
| " government: loans granted by.....   | 68, 69 |
| <b>T</b>  |        |
| Table I. Investigated peat bogs in.....   | 9      |
| " II. Peat bogs investigated in.....  | 19     |

|   | PAGE |
|---|------|
| Table III. Analysis of samples collected from bogs in Quebec .....                            | 25   |
| " IV. Data relating to peat bogs investigated in P.E.I. during 1913.....                      | 26   |
| " V. Peat bogs investigated in Province of Nova Scotia .....                                  | 37   |
| " VI. Analysis of samples collected from bogs in Nova Scotia .....                            | 57   |
| " VII. Peat fuel manufactured at Vestfinmarken, Norway, 1914 .....                            | 69   |
| " VIII. Peat fuel manufactured 1902-13 .....  | 70   |
| " IX. Total amount of peat fuel manufactured and sold in Denmark,<br>1913 .....               | 71   |
| " X. Peat fuel manufactured and sold in Denmark, 1914.....                                    | 72   |
| Testrup, Nils: patent for improved apparatus for wet carbonization of peat.....               | 165  |
| " " and Söderlund, Olaf: patent relating to removal of water from wet<br>carbonized peat..... | 95   |
| Testrup Rigby, and Söderlund: patent for apparatus for utilization of peat .....              | 155  |
| Testrup: See Rigby and Testrup.   |      |
| Tusket peat bog.....  | 42   |
| " " botany of.....  | 60   |
| Tweed " .....   | 18   |
| <b>U</b>  |      |
| United States: importation of peat moss litter, 1906-14 .....                                 | 67   |
| <b>V</b>  |      |
| Vestfinmarken, Norway: peat fuel manufactured at .....  | 69   |
| <b>W</b>  |      |
| Wallgren, Capt. E.—report of to Swedish government.....                                       | 67   |
| Westover peat bog.....  | 7    |
| Wet carbonizing process.....  | 68   |
| " " " special loan for experiments.....   | 69   |
| Whitaker, Jas. S.—patent for apparatus for removing roots and the like from peat ..           | 139  |
| <b>Z</b>  |      |
| Zelenay, C.—patent for peat working machine.....  | 145  |
| Zohrase, E. F. S.—patent relating to drying or carbonizing peat.....                          | 129  |



**CANADA**  
**DEPARTMENT OF MINES**  
HON. P. E. BLONDIN, MINISTER; R. G. McCONNELL, DEPUTY MINISTER.

**MINES BRANCH**  
EUGENE HAANEL, PH.D., DIRECTOR.

---

REPORTS AND MAPS  
PUBLISHED BY THE  
MINES BRANCH

**REPORTS.**

- †1. Mining conditions in the Klondike, Yukon. Report on—by Eugene Haanel, Ph.D., 1902.
- †2. Great landslide at Frank, Alta. Report on—by R. G. McConnell, B.A., and R. W. Brock, M.A., 1903.
- †3. Investigation of the different electro-thermic processes for the smelting of iron ores and the making of steel, in operation in Europe. Report of Special Commission—by Eugene Haanel, Ph.D., 1904.
5. On the location and examination magnetic ore deposits by magnetometric measurements—by Eugene Haanel, Ph.D., 1904.
- †7. Limestones, and the lime industry of Manitoba. Preliminary report on—by J. W. Wells, M.A., 1905.
- †8. Clays and shales of Manitoba: their industrial value. Preliminary report on—by J. W. Wells, M.A., 1905.
- †9. Hydraulic cements (raw materials) in Manitoba: manufacture and uses of. Preliminary report on—by J. W. Wells, M.A., 1905.
- †10. Mica: its occurrence, exploitation, and uses—by Fritz Cirkel, M.E., 1905. (See No. 115.)
- †11. Asbestos: its occurrence, exploitation, and uses—by Fritz Cirkel, M.E., 1905. (See No. 69.)
- †12. Zinc resources of British Columbia and the conditions affecting their exploitation. Report of the Commission appointed to investigate—by W. R. Ingalls, M.E., 1905.
- †16. Experiments made at Sault Ste. Marie, under Government auspices in the smelting of Canadian iron ores by the electro-thermic process. Final report on—by Eugene Haanel, Ph.D., 1907.

† Publications marked thus † are out of print.



- †17. Mines of the silver-cobalt ores of the Cobalt district: their present and prospective output. Report on—by Eugene Haanel, Ph.D., 1907.
- †18. Graphite: its properties, occurrences, refining, and uses—by Fritz Cirkel, M.E., 1907.
- †19. Peat and lignite: their manufacture and uses in Europe—by Erik Nystrom, M.E., 1908.
- †20. Iron ore deposit of Nova Scotia. Report on (Part I)—by J. E. Woodman, D.Sc.
- †21. Summary report of Mines Branch, 1907-8
- †22. Iron ore deposits of Thunder Bay and Rainy River districts. Report on—by F. Hille, M.E.
- †23. Iron ore deposits along the Ottawa (Quebec side) and Gatineau rivers. Report on—by Fritz Cirkel, M.E.
24. General report on the mining and metallurgical industries of Canada, 1907-8.
- †25. The tungsten ores of Canada. Report on—by T. L. Walker, Ph.D. (Out of print.)
26. The mineral production of Canada, 1906. Annual report on—by John McLeish, B.A.
- †27. The mineral production of Canada, 1907. Preliminary report on—by John McLeish, B.A.
- †27a. The mineral production of Canada, 1908. Preliminary report on—by John McLeish, B.A.
- †28. Summary report of Mines Branch, 1908.
29. Chrome iron ore deposits of the Eastern Townships. Monograph on—by Fritz Cirkel. (Supplementary section: Experiments with chromite at McGill University—by J. B. Porter, E.M., D.Sc.)
30. Investigation of the peat bogs and peat fuel industry of Canada, 1908. Bulletin No. 1—by Erik Nystrom, M.E., and A. Anrep, Peat Expert.
32. Investigation of electric shaft furnace, Sweden. Report on—by Eugene Haanel, Ph.D.
47. Iron ore deposits of Vancouver and Texada islands. Report on—by Einar Lindeman, M.E.
- †55. The bituminous, or oil-shales of New Brunswick and Nova Scotia; also on the oil-shale industry of Scotland. Report on—by W. R. Ells, LL.D.

† Publications marked thus † are out of print.

58. The mineral production of Canada, 1907 and 1908. Annual report on—by John McLeish, B.A.

*NOTE.—The following parts were separately printed and issued in advance of the Annual Report for 1907-8.*

- †31. Production of cement in Canada, 1908.
- †42. Production of iron and steel in Canada during the calendar years 1907 and 1908.
43. Production of chromite in Canada during the calendar years 1907 and 1908.
44. Production of asbestos in Canada during the calendar years 1907 and 1908.
- †45. Production of coal, coke, and peat in Canada during the calendar years 1907 and 1908.
46. Production of natural gas and petroleum in Canada during the calendar years 1907 and 1908.

59. Chemical analyses of special economic importance made in the laboratories at the Department of Mines, 1906-7-8. Report on—by F. G. Wait, M.A., F.C.S. (With Appendix on the commercial methods and apparatus for the analyses of oil-shales—by H. A. Leverin, Ch.E.)

Schedule of charges for chemical analyses and assays.

- †62. Mineral production of Canada, 1909. Preliminary report on—by John McLeish, B.A.
63. Summary report of Mines Branch, 1909.
67. Iron deposits of the Bristol mine, Pontiac county, Quebec. Bulletin No. 2—by Einar Lindeman, M.E., and Geo. C. Mackenzie, B.Sc.
- †68. Recent advances in the construction of electric furnaces for the production of pig iron, steel, and zinc. Bulletin No. 3—by Eugene Haanel, Ph.D.
69. Chrysotile-asbestos: its occurrence, exploitation, milling, and uses. Report on—by Fritz Cirkel, M.E. (Second edition, enlarged.)
- †71. Investigation of the peat bogs and peat industry of Canada, 1909-10; to which is appended Mr. Alf. Larson's paper on Dr. M. Ekenberg's wet-carbonizing process: from *Teknisk Tidskrift*, No. 12, December 26, 1908—translation by Mr. A. Anrep, Jr.; also a translation of Lieut. Ekelund's pamphlet entitled 'A solution of the peat problem,' 1909, describing the Ekelund process for the manufacture of peat powder, by Harold A. Leverin, Ch.E. Bulletin No. 4—by A. Anrep. (Second edition, enlarged.)

† Publications marked thus † are out of print.

82. Magnetic concentration experiments. Bulletin No. 5—by Geo. C. Mackenzie, B.Sc.
83. An investigation of the coals of Canada with reference to their economic qualities: as conducted at McGill University under the authority of the Dominion Government. Report on—by J. B. Porter, E.M., D.Sc., R. J. Durley, Ma.E., and others.  
 Vol. I—Coal washing and cooking tests.  
 Vol. II—Boiler and gas producer tests.  
 †Vol. III—(Out of print.)  
     Appendix I  
         Coal washing tests and diagrams.  
 †Vol. IV—  
     Appendix II  
         Boiler tests and diagrams.  
 †Vol. V—(Out of print.)  
     Appendix III  
         Producer tests and diagrams.  
 †Vol. VI—  
     Appendix IV  
         Coking tests.  
     Appendix V  
         Chemical tests.
- †84. Gypsum deposits of the Maritime provinces of Canada—including the Magdalen islands. Report on—by W. F. Jennison, M.E. (See No. 245.)
88. The mineral production of Canada, 1909. Annual report on—by John McLeish, B.A.
- NOTE.—The following parts were separately printed and issued in advance of the Annual Report for 1909.*
- †79. Production of iron and steel in Canada during the calendar year 1909.
- †80. Production of coal and coke in Canada during the calendar year 1909.
85. Production of cement, lime, clay products, stone, and other structural materials during the calendar year 1909.
89. Proceedings of conference on explosives. (Fourth edition).
90. Reprint of presidential address delivered before the American Peat Society at Ottawa, July 25, 1910. By Eugene Haanel, Ph.D.
92. Investigation of the explosives industry in the Dominion of Canada, 1910. Report on—by Capt. Arthur Desborough. (Fourth edition.)
- †93. Molybdenum ores of Canada. Report on—by Professor T. L. Walker, Ph.D.
100. The building and ornamental stones of Canada: Building and ornamental stones of Ontario. Report on—by Professor W. A. Parks, Ph.D.
- † Publications marked thus † are out of print.

102. Mineral production of Canada, 1910. Preliminary report on—by John McLeish, B.A.
- †103. Summary report of Mines Branch, 1910.
104. Catalogue of publications of Mines Branch, from 1902 to 1911; containing tables of contents and lists of maps, etc.
105. Austin Brook iron-bearing district. Report on—by E. Lindeman, M.E.
110. Western portion of Torbrook iron ore deposits, Annapolis county, N.S. Bulletin No. 7—by Howells Frechette, M.Sc.
111. Diamond drilling at Point Mamainse, Ont. Bulletin No. 6—by A. C. Lane, Ph.D., with introductory by A. W. G. Wilson, Ph.D.
118. Mica: its occurrence, exploitation, and uses. Report on—by Hugh S. de Schmid, M.E.
142. Summary report of Mines Branch, 1911.
143. The mineral production of Canada, 1910. Annual report on—by John McLeish, B.A.

*NOTE.—The following parts were separately printed and issued in advance of the Annual Report for 1910.*

- †114. Production of cement, lime, clay products, stone, and other materials in Canada, 1910.
- †115. Production of iron and steel in Canada during the calendar year 1910.
- †116. Production of coal and coke in Canada during the calendar year 1910.
- †117. General summary of the mineral production of Canada during the calendar year 1910.
145. Magnetic iron sands of Natashkwan, Saguenay county, Que. Report on—by Geo. C. Mackenzie, B.Sc.
- †150. The mineral production of Canada, 1911. Preliminary report on—by John McLeish, B.A.
151. Investigation of the peat bogs and peat industry of Canada, 1910-11. Bulletin No. 8—by A. Anrep.
154. The utilization of peat for fuel for the production of power, being a record of experiments conducted at the Fuel Testing Station, Ottawa, 1910-11. Report on—by B. F. Haanel, B.Sc.
167. Pyrites in Canada: its occurrence, exploitation, dressing and uses. Report on—by A. W. G. Wilson, Ph.D.
170. The nickel industry: with special reference to the Sudbury region, Ont. Report on—by Professor A. P. Coleman, Ph.D.

† Publications marked thus † are out of print.

184. Magnetite occurrences along the Central Ontario railway. Report on—by E. Lindeman, M.E.
201. The mineral production of Canada during the calendar year 1911. Annual report on—by John McLeish, B.A.

*NOTE.—The following parts were separately printed and issued in advance of the Annual Report for 1911.*

181. Production of cement, lime, clay products, stone, and other structural materials in Canada during the calendar year 1911. Bulletin on—by John McLeish, B.A.
- †182. Production of iron and steel in Canada during the calendar year 1911. Bulletin on—by John McLeish, B.A.
183. General summary of the mineral production in Canada during the calendar year 1911. Bulletin on—by John McLeish, B.A.
- †199. Production of copper, gold, lead, nickel, silver, zinc, and other metals of Canada, during the calendar year 1911. Bulletin on—by C. T. Cartwright, B.Sc.
- †200. The production of coal and coke in Canada during the calendar year 1911. Bulletin on—by John McLeish, B.A.
203. Building stones of Canada—Vol. II: Building and ornamental stones of the Maritime Provinces. Report on—by W. A. Parks, Ph.D.
209. The copper smelting industry of Canada. Report on—by A. W. G. Wilson, Ph.D.
216. Mineral production of Canada, 1912. Preliminary report on—by John McLeish, B.A.
222. Lode mining in Yukon: an investigation of the quartz deposits of the Klondike division. Report on—by T. A. MacLean, B.Sc.
224. Summary report of the Mines Branch, 1912.
227. Sections of the Sydney coal fields—by J. G. S. Hudson, M.E.
- †229. Summary report of the petroleum and natural gas resources of Canada, 1912—by F. G. Clapp, A.M. (See No. 224.)
230. Economic minerals and mining industries of Canada.
245. Gypsum in Canada: its occurrence, exploitation, and technology. Report on—by L. H. Cole, B.Sc.
254. Calabogie iron-bearing district. Report on—by E. Lindeman, M.E.
259. Preparation of metallic cobalt by reduction of the oxide. Report on—by H. T. Kalmus, B.Sc., Ph.D.

† Publications marked thus † are out of print.

262. The mineral production of Canada during the calendar year 1912. Annual report on—by John McLeish, B.A.

*NOTE.—The following parts were separately printed and issued in advance of the Annual Report for 1912.*

238. General summary of the mineral production of Canada, during the calendar year 1912. Bulletin on—by John McLeish, B.A.
- †247. Production of iron and steel in Canada during the calendar year 1912. Bulletin on—by John McLeish, B.A.
- †256. Production of copper, gold, lead, nickel, silver, zinc, and other metals of Canada, during the calendar year 1912—by C. T. Cartwright, B.Sc.
257. Production of cement, lime, clay products, stone, and other structural materials during the calendar year 1912. Report on—by John McLeish, B.A.
- †258. Production of coal and coke in Canada, during the calendar year 1912. Bulletin on—by John McLeish, B.A.
266. Investigation of the peat bogs and peat industry of Canada, 1911 and 1912. Bulletin No. 9—by A. Anrep.
279. Building and ornamental stones of Canada—Vol. III: Building and ornamental stones of Quebec. Report on—by W. A. Parks, Ph.D.
281. The bituminous sands of Northern Alberta. Report on—by S. C. Ellis, M.E.
282. Mineral production of Canada, 1913. Preliminary report on—by John McLeish, B.A.
285. Summary report of the Mines Branch, 1913.
291. The petroleum and natural gas resources of Canada. Report on—by F. G. Clapp, A.M., and others:—  
Vol. I—Technology and Exploitation.  
Vol. II—Occurrence of petroleum and natural gas in Canada.  
Also separates of Vol. II, as follows:—  
Part 1, Eastern Canada.  
Part 2, Western Canada.
299. Peat, lignite, and coal: their value as fuels for the production of gas and power in the by-product recovery producer. Report on—by B. F. Haanel, B.Sc.
303. Moose Mountain iron-bearing district. Report on—by E. Lindeman, M.F.
305. The non-metallic minerals used in the Canadian manufacturing industries. Report on—by Howells Fréchette, M.Sc.
309. The physical properties of cobalt, Part II. Report on—by H. T. Kalmus, B.Sc., Ph.D.

† Publications marked thus † are out of print.

320. The mineral production of Canada during the calendar year 1913. Annual report on—by John McLeish, B.A.

*NOTE.—The following parts were separately printed and issued in advance of the Annual Report for 1913.*

315. The production of iron and steel during the calendar year 1913. Bulletin on—by John McLeish, B.A.
- †316. The production of coal and coke during the calendar year 1913. Bulletin on—by John McLeish, B.A.
317. The production of copper, gold, lead, nickel, silver, zinc, and other metals, during the calendar year 1913. Bulletin on—by C. T. Cartwright, B.Sc.
318. The production of cement, lime, clay products, and other structural materials, during the calendar year 1913. Bulletin on—by John McLeish, B.A.
319. General summary of the mineral production of Canada during the calendar year 1913. Bulletin on—by John McLeish, B.A.
322. Economic minerals and mining industries of Canada. (Revised Edition).
323. The Products and by-products of coal. Report on—by Edgar Stansfield, M.Sc., and F. E. Carter, B.Sc., Dr. Ing.
325. The salt industry of Canada. Report on—by L. H. Cole, B.Sc.
331. The investigation of six samples of Alberta lignites. Report on—by B. F. Haanel, B.Sc., and John Blizard, B.Sc.
333. The mineral production of Canada, 1914. Preliminary report on—by John McLeish, B.A.
334. Electro-plating with cobalt and its alloys. Report on—by H. T. Kalmus, B.Sc., Ph.D.
336. Notes on clay deposits near McMurray, Alberta. Bulletin No. 10—by S. C. Ellis, B.A., B.Sc.
344. Electrothermic smelting of iron ores in Sweden. Report on—by Alfred Stansfield, D.Sc., A.R.S.M., F.R.S.C.
346. Summary report of the Mines Branch for 1914.
351. Investigation of the peat bogs and the peat industry of Canada, 1913-1914. Bulletin No. 11—by A. Anrep.
384. The mineral production of Canada during the calendar year 1914. Annual Report on—by John McLeish, B.A.

*NOTE.—The following parts were separately printed and issued in advance of the Annual Report for 1914.*

348. Production of coal and coke in Canada during the calendar year, 1914. Bulletin on—by J. McLeish, B.A.
349. Production of iron and steel in Canada during the calendar year, 1914. Bulletin on—by J. McLeish, B.A.
350. Production of copper, gold, lead, nickel, silver, zinc, and other metals, during the calendar year, 1914. Bulletin on—by J. McLeish, B.A.

383. The production of cement, lime, clay products, stone and other structural materials, during the calendar year 1914. Bulletin on—by John McLeish, B.A.
385. Investigation of a reported discovery of phosphate at Banff, Alberta. Bulletin No. 12—by H. S. de Schmid, M.E., 1915.
406. Description of the laboratories of the Mines Branch of the Department of Mines, 1916. Bulletin No. 13.
408. Mineral production of Canada, 1915. Preliminary report on—by John McLeish, B.A.

*The Division of Mineral Resources and Statistics has prepared the following lists of mine, smelter, and quarry operators: Metal mines and smelters, General list of mines (except coal and metal mines), Coal mines, Stone quarry operators, Manufacturers of clay products and of cement, Manufacturers of lime, and Operators of sand and gravel deposits. Copies of the lists may be obtained on application.*

IN THE PRESS.

338. Coals of Canada: Vol. VII. Weathering of coal. Report on—by J. B. Porter, D.Sc., E.M., Ph.D.
388. The building and ornamental stones of Canada—Vol. IV: the building and ornamental stones of the western provinces. Report on—by W. A. Parks, Ph.D.
401. Feldspar in Canada. Report on—by H. S. de Schmid, M.E.
413. Magnetic properties of Cobalt and of Fe<sub>2</sub> Co. Report on—by H. T. Kalmus, B.Sc., Ph.D.



## FRENCH TRANSLATIONS

971. (26a) Rapport annuel sur les industries min. du Canada, pour l'année 1905.
- †4. Rapport de la Commission nommée pour étudier les divers procédés électro-thermiques pour la réduction des minerais de fer et la fabrication de l'acier employés en Europe—by Eugene Haanel, Ph.D. (French Edition), 1905.
- 26a. The mineral production of Canada, 1906. Annual report on—by John McLeish, B.A.
- †28a. Summary report of Mines Branch, 1908.
56. Bituminous or oil-shales of New Brunswick and Nova Scotia; also on the oil-shale industry of Scotland. Report on—by R. W. Ells, LL.D.
81. Chrysotile-asbestos, its occurrence, exploitation, milling, and uses. Report on—by Fritz Cirkel, M.E.
- 100a. The building and ornamental stones of Canada: Building and ornamental stones of Ontario. Report on—by W. A. Parks, Ph.D.
149. Magnetic iron sands of Natashkwan, Saguenay county, Que. Report on—by Geo. C. Mackenzie, B.Sc.
155. The utilization of peat fuel for the production of power, being a record of experiments conducted at the Fuel Testing Station, Ottawa, 1910-11. Report on—by B. F. Haanel, B.Sc.
- †156. The tungsten ores of Canada. Report on—by T. L. Walker, Ph.D.
169. Pyrites in Canada: its occurrences, exploitation, dressing, and uses. Report on—by A. W. G. Wilson, Ph.D.
179. The nickel industry: with special reference to the Sudbury region, Ont. Report on—by Professor A. P. Coleman, Ph.D.
180. Investigation of the peat bogs, and peat industry of Canada, 1910-11. Bulletin No. 8—by A. Anrep.
195. Magnetite occurrences along the Central Ontario railway. Report on—by E. Lindeman, M.E.
- †196. Investigation of the peat bogs and peat industry of Canada, 1909-10; to which is appended Mr. Alf. Larsen's paper on Dr. M. Ekenburg's wet-carbonizing process: from Teknisk Tidsskrift, No. 12, December 26, 1908—translation by Mr. A. Anrep; also a translation of Lieut. Ekelund's pamphlet entitled "A solution of the peat problem," 1909, describing the Ekelund process for the manufacture of peat powder, by Harold A. Leverin, Ch.E. Bulletin No. 4—by A. Anrep. (Second Edition, enlarged.)
197. Molybdenum ores of Canada. Report on—by T. L. Walker, Ph.D.
- †198. Peat and lignite: their manufacture and uses in Europe. Report on—by Erik Nystrom, M.E., 1908.

† Publications marked thus † are out of print.

202. Graphite: its properties, occurrences, refining, and uses. Report on—by Fritz Cirkel, M.E., 1907.
219. Austin Brook iron-bearing district. Report on—by E. Lindeman, M.E.
223. Lode Mining in the Yukon: an investigation of quartz deposits in the Klondike division. Report on—by T. A. MacLean, B.Sc.
- 224a. Mines Branch Summary report for 1912.
- †226. Chrome iron ore deposits of the Eastern Townships. Monograph on—by Fritz Cirkel, M.E. (Supplementary section: Experiments with chromite at McGill University—by J. B. Porter, E.M., D.Sc.)
231. Economic minerals and mining industries of Canada.
233. Gypsum deposits of the Maritime Provinces of Canada—including the Magdalen islands. Report on—by W. F. Jennison, M.E.
246. Gypsum in Canada: its occurrence, exploitation, and technology. Report on—by L. H. Cole, B.Sc.
260. The preparation of metallic cobalt by reduction of the oxide. Report on—by H. T. Kalmus, B.Sc., Ph.D.
263. Recent advances in the construction of electric furnaces for the production of pig iron, steel, and zinc. Bulletin No. 3—by Eugene Haanel, Ph.D.
- †264. Mica: its occurrence, exploitation, and uses. Report on—by Hugh S. de Schmid, M.E.
265. Annual mineral production of Canada, 1911. Report on—by John McLeish, B.A.
286. Summary Report of Mines Branch, 1913.
287. Production of iron and steel in Canada during the calendar year 1912. Bulletin on—by John McLeish, B.A.
288. Production of coal and coke in Canada, during the calendar year 1912. Bulletin on—by John McLeish, B.A.
289. Production of cement, lime, clay products, stone, and other structural materials during the calendar year 1912. Bulletin on—by John McLeish, B.A.
290. Production of copper, gold, lead, nickel, silver, zinc, and other metals of Canada during the calendar year 1912. Bulletin on—by C. T. Cartwright, B.Sc.
307. Catalogue of French publications of the Mines Branch and of the Geological Survey, up to July, 1914.
308. An investigation of the coals of Canada with reference to their economic qualities: as conducted at McGill University under the authority of the Dominion Government. Report on—by J. B. Porter, E.M., D.Sc., R. J. Durley, M.A.E., and others—  
 Vol. I—Coal washing and coking tests.  
 Vol. II—Boiler and gas producer tests.  
 Vol. III—  
 Appendix I  
 Coal washing tests and diagrams.  
 Vol. IV—  
 Appendix II  
 Boiler tests and diagrams

† Publications marked thus † are out of print.

314. Iron ore deposits, Bristol mine, Pontiac county, Quebec, Report on—  
by E. Lindeman, M.E.
321. Annual mineral production of Canada, during the calendar year  
1913. Report on—by J. McLeish, B.A.

## IN THE PRESS.

204. Building stones of Canada—Vol. II: Building and ornamental stones  
of the Maritime Provinces. Report on—by W. A. Parks, Ph.D.
200. The building and ornamental stones of Canada, Vol. III; Province  
of Quebec. Report on—by Professor W. A. Parks, Ph.D.
306. The non-metallic minerals used in the Canadian manufacturing  
industries. Report on—by Howells Fréchet, M.Sc.
310. Physical properties of the metal cobalt, Part II. Report on—by H  
T. Kalms, B. Sc., Ph.D.

## MAPS.

- †6. Magnetometric survey, vertical intensity: Calabogie mine, Bagot township, Renfrew county, Ontario—by E. Nystrom, 1904. Scale 60 feet to 1 inch. Summary report 1905. (See Map No. 249.)
- †13. Magnetometric survey of the Belmont iron mines, Belmont township, Peterborough county, Ontario—by B. F. Haanel, 1905. Scale 60 feet to 1 inch. Summary report, 1906. (See Map No. 186.)
- †14. Magnetometric survey of the Wilbur mine, Lavannt township, Lanark county, Ontario—by B. F. Haanel, 1905. Scale 60 feet to 1 inch. Summary report, 1906.
- †33. Magnetometric survey, vertical intensity: lot 1, concession VI, Mayo township, Hastings county, Ontario—by Howells Fréchet, 1909. Scale 60 feet to 1 inch. (See Maps Nos. 191 and 191A.)
- †34. Magnetometric survey, vertical intensity: lots 2 and 3, concession VI, Mayo township, Hastings county, Ontario—by Howells Fréchet, 1909. Scale 60 feet to 1 inch. (See Maps Nos. 191 and 191A.)
- †35. Magnetometric survey, vertical intensity: lots 10, 11, and 12 concession IX, and lots 11 and 12, concession V111, Mayo township, Hastings county, Ontario—by Howells Fréchet, 1909. Scale 60 feet to 1 inch. (See Maps Nos. 191 and 191A.)
- \*36. Survey of Mer Bleue peat bog, Gloucester township, Carleton county, and Cumberland township, Russell county, Ontario—by Erik Nystrom, and A. Anrep. (Accompanying report No. 30.)
- \*37. Survey of Alfred peat bog, Alfred and Caledonia townships, Prescott county, Ontario—by Erik Nystrom and A. Anrep. (Accompanying report No. 30.)
- \*38. Survey of Welland peat bog, Wainfleet and Humberstone townships, Welland county, Ontario—by Erik Nystrom and A. Anrep. (Accompanying report No. 30.)
- \*39. Survey of Newington peat bog, Osnabruck, Roxborough, and Cornwall townships, Stormont county, Ontario—by Erik Nystrom and A. Anrep. (Accompanying report No. 30.)
- \*40. Survey of Perth peat bog, Drummond township, Lanark county, Ontario—by Erik Nystrom and A. Anrep. (Accompanying report No. 30.)
- †41. Survey of Victoria Road peat bog, Bexley and Carden townships, Victoria county, Ontario—Erik Nystrom and A. Anrep. (Accompanying report No. 30.)
- \*48. Magnetometric survey of Iron Crown claim at Nimpkish (Klaanch) river, Vancouver island, B.C.—by E. Lindeman. Scale 60 feet to 1 inch. (Accompanying report No. 47.)

Note.—1. Maps marked thus \* are to be found only in reports.

2. Maps marked thus † have been printed independently of reports, hence can be procured separately by applicants.

- \*49. Magnetometric survey of Western Steel Iron claim, at Sechart, Vancouver Island, B.C.—By E. Lindeman. Scale 60 feet to 1 inch. (Accompanying report No. 47.)
- \*53. Iron ore occurrences, Ottawa and Pontiac counties, Quebec, 1908—by J. White and Fritz Cirkel. (Accompanying report No. 23.)
- \*54. Iron ore occurrences, Argenteuil county, Quebec, 1908—by Fritz Cirkel. (Accompanying report No. 23.) (Out of print.)
- †57. The productive chrome iron ore district of Quebec—by Fritz Cirkel. (Accompanying report No. 29.)
- †60. Magnetometric survey of the Bristol mine, Pontiac county, Quebec—by E. Lindeman. Scale 200 feet to 1 inch. (Accompanying report No. 67.)
- †61. Topographical map of Bristol mine, Pontiac county, Quebec—by E. Lindeman. Scale 200 feet to 1 inch. (Accompanying report No. 67.)
- †64. Index map of Nova Scotia: Gypsum—by W. F. Jennison. } (Accompanying report No. 84.)
- †65. Index map of New Brunswick: Gypsum—by W. F. Jennison. } (Accompanying report No. 84.)
- †66. Map of Magdalen islands: Gypsum—by W. F. Jennison. }
- †70. Magnetometric survey of Northeast Arm Iron range, Lake Timagami, Nipissing district, Ontario—by E. Lindeman. Scale 200 feet to 1 inch. (Accompanying report No. 63.)
- †72. Brunner peat bog, Ontario—by A. Anrep. } (Accompanying report No. 71.)
- †73. Komoko peat bog, Ontario— " " } (Accompanying report No. 71.)
- †74. Brockville peat bog, Ontario— " " } (Out of print.)
- †75. Rondeau peat bog, Ontario— " " } (Out of print.)
- †76. Alfred peat bog, Ontario— " " } (Out of print.)
- †77. Alfred peat bog, Ontario main ditch profile—by A. Anrep. }
- †78. Map of asbestos region, Province of Quebec, 1910—by Fritz Cirkel. Scale 1 mile to 1 inch. (Accompanying report No. 69.)
- †94. Map showing Cobalt, Gowganda, Shiningtree, and Porcupine districts—by L. H. Cole. (Accompanying Summary report, 1910.)
- †95. General map of Canada, showing coal fields. (Accompanying report No. 83—by Dr. J. B. Porter.)
- †96. General map of coal fields of Nova Scotia and New Brunswick. (Accompanying report No. 83—by Dr. J. B. Porter.)
- †97. General map showing coal fields in Alberta, Saskatchewan, and Manitoba. (Accompanying report No. 83—by Dr. J. B. Porter.)

Note.—1. Maps marked thus \* are to be found only in reports.

2. Maps marked thus † have been printed independently of reports, hence can be procured separately by applicants.

- †98. General map of coal fields in British Columbia. (Accompanying report No. 83—by Dr. J. B. Porter.)
- †99. General map of coal field in Yukon Territory. (Accompanying report No. 83—by Dr. J. B. Porter.)
- †106. Geological map of Austin Brook iron-bearing district, Bathurst township, Gloucester county, N. B.—by E. Lindeman. Scale 400 feet to 1 inch. (Accompanying report No. 105.)
- †107. Magnetometric survey, vertical intensity: Austin Brook iron-bearing district—by E. Lindeman. Scale 400 feet to 1 inch. (Accompanying report No. 105.)
- †108. Index map showing iron-bearing area at Austin Brook—by E. Lindeman. (Accompanying report No. 105.)
- \*112. Sketch plan showing geology of Point Maminse, Ont.—by Professor A. C. Lane. Scale 4,000 feet to 1 inch. (Accompanying report No. 111.)
- †113. Holland peat bog Ontario—by A. Anrep. (Accompanying report No. 151.)
- \*119-137. Mica: township maps, Ontario and Quebec—by Hugh S. de Schmid. (Accompanying report No. 118.)
- †138. Mica: showing location of principal mines and occurrences in the Quebec mica area—by Hugh S. de Schmid. Scale 3.95 miles to 1 inch. (Accompanying report No. 118.)
- †139. Mica: showing location of principal mines and occurrences in the Ontario mica area—by Hugh S. de Schmid. Scale 3.95 miles to 1 inch. (Accompanying report No. 118.)
- †140. Mica: showing distribution of the principal mica occurrences in the Dominion of Canada—by Hugh S. de Schmid. Scale 3.95 miles to 1 inch. (Accompanying report No. 118.)
- †141. Torbrook iron-bearing district Annapolis county, N.S.—by Howells Fréchette. Scale 400 feet to 1 inch. (Accompanying report No. 110.)
146. Distribution of iron ore sands of the iron ore deposits on the north shore of the River and Gulf of St. Lawrence, Canada—by Geo. C. Mackenzie. Scale 100 miles to 1 inch. (Accompanying report No. 145.)
- †147. Magnetic iron sand deposits in relation to Natashkwan harbour and Great Natashkwan river, Que. (Index Map)—by Geo. C. Mackenzie. Scale 40 chains to 1 inch. (Accompanying report No. 145.)
- †148. Natashkwan magnetic iron sand deposits, Saguenay county, Que.—by Geo. C. Mackenzie. Scale 1,000 feet to 1 inch. (Accompanying report No. 145.)

Note.—1. Maps marked thus \* are to be found only in reports.

2. Maps marked thus † have been printed independently of reports, hence can be procured separately by applicants.

- †152. Map showing the location of peat bogs investigated in Ontario—by A. Anrep. (See Map No. 354.)
  - †153. Map showing the location of peat bog as investigated in Manitoba—by A. Anrep.
  - †157. Lac du Bonnet peat bog, Manitoba—by A. Anrep.
  - †158. Transmission peat bog, Manitoba— " "
  - †159. Corduroy peat bog, Manitoba— " "
  - †160. Boggy Creek peat bog, Manitoba— " "
  - †161. Rice Lake peat bog, Manitoba— " "
  - †162. Mud Lake peat bog, Manitoba— " "
  - †163. Litter peat bog, Manitoba— " "
  - †164. Julius peat litter bog, Manitoba— " "
  - †165. Fort Frances peat bog, Ontario— " "
- (Accompanying report No. 151.)
- \*166. Magnetometric map of No. 3 mine, lot 7, concessions V. and VI, McKim township, Sudbury district, Ont.—by E. Lindeman. (Accompanying Summary report, 1911.)
  - †168. Map showing pyrites mines and prospects in Eastern Canada, and their relation to the United States market—by A. W. G. Wilson. Scale 125 miles to 1 inch. (Accompanying report No. 167.)
  - †171. Geological map of Sudbury nickel region, Ont.—by Prof. A. P. Coleman. Scale 1 mile to 1 inch. (Accompanying report No. 170.)
  - †172. Geological map of Victoria mine—by Prof. A. P. Coleman. } (Accompanying
  - †173. " Crean Hill mine—by Prof. A. P. Coleman. } report
  - †174. " Creighton mine—by Prof. A. P. Coleman. } No. 170.)
  - †175. " showing contact of norite and Laurentian in vicinity of Creighton mine—by Prof. A. P. Coleman. (Accompanying report No. 170.)
  - †176. " Copper Cliff offset—by Prof. A. P. Coleman. (Accompanying report No. 170.)
  - †177. " No. 3 mine—by Prof. A. P. Coleman. (Accompanying report No. 170.)
  - †178. " showing vicinity of Stobie and No. 3 mines—by Prof. A. P. Coleman. (Accompanying report No. 170.)

Note.—1. Maps marked thus \* are to be found only in reports.  
 2. Maps marked thus † have been printed independently of reports, hence can be procured separately by applicants.

- †185. Magnetometric survey, vertical intensity: Blairton iron mine, Belmont township, Peterborough county, Ontario—by E. Lindeman, 1911. Scale 200 feet to 1 inch. (Accompanying report No. 184.)
- †185a. Geological map, Blairton iron mine, Belmont township, Peterborough county, Ontario—by E. Lindeman, 1911. Scale 200 feet to 1 inch. (Accompanying report No. 184.)
- †186. Magnetometric survey, Belmont iron mine, Belmont township, Peterborough county, Ontario—by E. Lindeman, 1911. Scale 200 feet to 1 inch. (Accompanying report No. 184.)
- †186a. Geological map, Belmont iron mine, Belmont township, Peterborough county, Ontario—by E. Lindeman, 1911. Scale 200 feet to 1 inch. (Accompanying report No. 184.)
- †187. Magnetometric survey, vertical intensity: St. Charles mine, Tudor township, Hastings county, Ontario—by E. Lindeman, 1911. Scale 200 feet to 1 inch. (Accompanying report No. 184.)
- †187a. Geological map, St. Charles mine, Tudor township, Hastings county, Ontario—by E. Lindeman, 1911. Scale 200 feet to 1 inch. (Accompanying report No. 184.)
- †188. Magnetometric survey, vertical intensity: Baker mine, Tudor township, Hastings county, Ontario—by E. Lindeman, 1911. Scale 200 feet to 1 inch. (Accompanying report No. 184.)
- †188a. Geological map, Baker mine, Tudor township, Hastings county, Ontario—by E. Lindeman, 1911. Scale 200 feet to 1 inch. (Accompanying report No. 184.)
- †189. Magnetometric survey, vertical intensity: Ridge iron ore deposits, Wollaston township, Hastings county, Ontario—by E. Lindeman, 1911. Scale 200 feet to 1 inch. (Accompanying report No. 184.)
- †190. Magnetometric survey, vertical intensity: Coehill and Jenkins mines, Wollaston township, Hastings county, Ontario—by E. Lindeman, 1911. Scale 200 feet to 1 inch. (Accompanying report No. 184.)
- †190a. Geological map, Coehill and Jenkins mines, Wollaston township, Hastings county, Ontario—by E. Lindeman, 1911. Scale 200 feet to 1 inch. (Accompanying report No. 184.)
- †191. Magnetometric survey, vertical intensity: Bessemer iron ore deposits, Mayo township, Hastings county, Ontario—by E. Lindeman, 1911. Scale 200 feet to 1 inch. (Accompanying report No. 184.)
- †191a. Geological map, Bessemer iron ore deposits, Mayo township, Hastings county, Ontario—by E. Lindeman, 1911. Scale 200 feet to 1 inch. (Accompanying report No. 184.)
- †192. Magnetometric survey, vertical intensity: Rankin, Childs, and Stevens mines, Mayo township, Hastings county, Ontario—by E. Lindeman, 1911. Scale 200 feet to 1 inch. (Accompanying report No. 184.)

Note.—1. Maps marked thus \* are to be found only in reports.  
 2. Maps marked thus † have been printed independently of reports, hence be procured separately by applicants.



- †192a. Geological map, Rankin, Childs, and Stevens mines, Mayo township, Hastings county, Ontario—by E. Lindeman, 1911. Scale 200 feet to 1 inch. (Accompanying report No. 184.)
- †193. Magnetometric survey, vertical intensity: Kennedy property, Carlow township, Hastings county, Ontario—by E. Lindeman, 1911. Scale 200 feet to 1 inch. (Accompanying report No. 184.)
- †193a. Geological map, Kennedy property, Carlow township, Hastings county, Ontario—by E. Lindeman, 1911. Scale 200 feet to 1 inch. (Accompanying report No. 184.)
- †194. Magnetometric survey, vertical intensity: Bow Lake iron ore occurrences, Faraday township, Hastings county, Ontario—by E. Lindeman, 1911. Scale 200 feet to 1 inch. (Accompanying report No. 184.)
- †204. Index map, magnetite occurrences along the Central Ontario railway—by E. Lindeman, 1911. (Accompanying report No. 184.)
- †205. Magnetometric map, Moose Mountain iron-bearing district, Sudbury district, Ontario: Deposits Nos. 1, 2, 3, 4, 5, 6, and 7—by E. Lindeman, 1911. (Accompanying report No. 303.)
- †205a. Geological map, Moose Mountain iron-bearing district, Sudbury district, Ontario: Deposits Nos. 1, 2, 3, 4, 5, 6, and 7—by E. Lindeman. (Accompanying report No. 303.)
- †206. Magnetometric survey of Moose Mountain iron-bearing district, Sudbury district, Ontario: northern part of deposit No. 2—by E. Lindeman, 1912. Scale 200 feet to 1 inch. (Accompanying report No. 303.)
- †207. Magnetometric survey of Moose Mountain iron-bearing district, Sudbury district, Ontario: Deposits Nos. 8, 9, and 9A—by E. Lindeman, 1912. Scale 200 feet to 1 inch. (Accompanying report No. 303.)
- †208. Magnetometric survey of Moose Mountain iron-bearing district, Sudbury district, Ontario: Deposit No. 10—by E. Lindeman, 1912. Scale 200 feet to 1 inch. (Accompanying report No. 303.)
- †208a. Magnetometric survey, Moose Mountain iron-bearing district, Sudbury district, Ontario: eastern portion of Deposit No. 11—by E. Lindeman, 1912. Scale 200 feet to 1 inch. (Accompanying report No. 303.)
- †208b. Magnetometric survey, Moose Mountain iron-bearing district, Sudbury district, Ontario: western portion of deposit No. 11—by E. Lindeman, 1912. Scale 200 feet to 1 inch. (Accompanying report No. 303.)
- †208c. General geological map, Moose Mountain iron-bearing district, Sudbury district, Ontario—by E. Lindeman, 1912. Scale 800 feet to 1 inch. (Accompanying report No. 303.)

Note.—1. Maps marked thus \* are to be found only in reports.

2. Maps marked thus † have been printed independently of reports, hence can be procured separately by applicants.

- †210. Location of copper smelters in Canada—by A. W. G. Wilson. Scale 197.3 miles to 1 inch. (Accompanying report No. 209.)
- †215. Province of Alberta: showing properties from which samples of coal were taken for gas producer tests, Fuel Testing Division, Ottawa. (Accompanying Summary report, 1912.)
- †220. Mining districts, Yukon. Scale 35 miles to 1 inch—by T. A. MacLean (Accompanying report No. 222.)
- †221. Dawson mining district, Yukon. Scale 2 miles to 1 inch—by T. A. MacLean. (Accompanying report No. 222.)
- \*228. Index map of the Sydney coal fields, Cape Breton, N.S. (Accompanying report No. 227.)
- †232. Mineral map of Canada. Scale 100 miles to 1 inch. (Accompanying report No. 230.)
- †239. Index map of Canada showing gypsum occurrences. (Accompanying report No. 245.)
- †240. Map showing Lower Carboniferous formation in which gypsum occurs in the Maritime provinces. Scale 100 miles to 1 inch. (Accompanying report No. 345.)
- †241. Map showing relation of gypsum deposits in Northern Ontario to railway lines. Scale 100 miles to 1 inch. (Accompanying report No. 245.)
- †242. Map, Grand River gypsum deposits, Ontario. Scale 4 miles to 1 inch. (Accompanying report No. 245.)
- †243. Plan of Manitoba Gypsum Co.'s properties. (Accompanying report No. 245.)
- †244. Map showing relation of gypsum deposits in British Columbia to railway lines and market. Scale 35 miles to 1 inch. (Accompanying report No. 245.)
- †249. Magnetometric survey, Caldwell and Campbell mines, Calabogie district, Renfrew county, Ontario—by E. Lindeman, 1911. Scale 200 feet to 1 inch. (Accompanying report No. 254.)
- †250. Magnetometric survey, Black Bay or Williams mine, Calabogie district, Renfrew county, Ontario—by E. Lindeman, 1911. Scale 200 feet to 1 inch. (Accompanying report No. 254.)
- †251. Magnetometric survey, Bluff Point iron mine, Calabogie district, Renfrew county, Ontario—by E. Lindeman, 1911. Scale 200 feet to 1 inch. (Accompanying report No. 254.)
- †252. Magnetometric survey, Culhane mine, Calabogie district, Renfrew county, Ontario—by E. Lindeman, 1911. Scale 200 feet to 1 inch (Accompanying report No. 254.)

Note.—1. Maps marked thus \* are to be found only in reports.

2. Maps marked thus † have been printed independently of reports, hence can be procured separately by applicants.

- †253. Magnetometric survey, Martel or Wilson iron mine, Calabogie district, Renfrew county, Ontario—by E. Lindeman, 1911. Scale 200 feet to 1 inch. (Accompanying report No. 254.)
- †261. Magnetometric survey, Northeast Arm iron range, lot 339 E.T.W. Lake Timagami, Nipissing district, Ontario—by E. Nystrom. 1903. Scale 200 feet to 1 inch.
- †268. Map of peat bogs investigated in Quebec—by A. Anrep, 1912.
- †269. Large Tea Field peat bog, Quebec " "
- †270. Small Tea Field peat bog, Quebec " "
- †271. Lanoraie peat bog, Quebec " "
- †272. St. Hyacinthe peat bog, Quebec " "
- †273. Rivière du Loup peat bog " "
- †274. Cacouna peat bog " "
- †275. Le Parc peat bog, Quebec " "
- †276. St. Denis peat bog, Quebec " "
- †277. Rivière Ouelle peat bog, Quebec " "
- †278. Moose Mountain peat bog, Quebec " "
- †284. Map of northern portion of Alberta, showing position of outcrops of bituminous sand. Scale  $12\frac{1}{2}$  miles to 1 inch. (Accompanying report No. 281.)
- †293. Map of Dominion of Canada, showing the occurrences of oil, gas, and tar sands. Scale 197 miles to 1 inch. (Accompanying report No. 291.)
- †294. Reconnaissance map of part of Albert and Westmorland counties New Brunswick. Scale 1 mile to 1 inch. (Accompanying report No. 291.)
- †295. Sketch plan of Gaspé oil fields, Quebec, showing location of wells. Scale 2 miles to 1 inch. (Accompanying report No. 291.)
- †296. Map showing gas and oil fields and pipe-lines in southwestern Ontario. Scale 4 miles to 1 inch. (Accompanying report No. 291.)
- †297. Geological map of Alberta, Saskatchewan, and Manitoba. Scale 35 miles to 1 inch. (Accompanying report No. 291.)
- †298. Map, geology of the forty-ninth parallel, 0.9864 miles to 1 inch (Accompanying report No. 291.)

Note.—1. Maps marked thus \* are to be found only in reports.

2. Maps marked thus † have been printed independently of reports, hence can be procured separately by applicants.

- †302. Map showing location of main gas line, Bow Island, Calgary. Scale 12½ miles to 1 inch. (Accompanying report No. 291.)
- †311. Magnetometric map, McPherson mine, Barachois, Cape Breton county, Nova Scotia—by A. H. A. Robinson, 1913. Scale 200 feet to 1 inch.
- †312. Magnetometric map, iron ore deposits at Upper Glencoe, Inverness county, Nova Scotia—by E. Lindeman, 1913. Scale 200 feet to 1 inch.
- †313. Magnetometric map, iron ore deposits at Grand Mine, Cape Breton county, Nova Scotia—by A. H. A. Robinson, 1913. Scale 200 feet to 1 inch.
- †327. Map, showing location of Saline Springs and Salt Areas in the Dominion of Canada. (Accompanying Report No. 325).
- †328. Map, showing location of Saline Springs in the Maritime Provinces. Scale 100 miles to 1 inch. (Accompanying Report No. 325).
- †329. Map of Ontario-Michigan Salt Basin, showing probable limit of productive area. Scale 25 miles to 1 inch. (Accompanying Report No. 325).
- †330. Map showing location of Saline Springs in Northern Manitoba. Scale 12½ miles to 1 inch. (Accompanying Report No. 325).
- †340. Magnetometric Map of Atikokan Iron-Bearing district, Atikokan Mine and Vicinity. Claims Nos. 10E., 11E., 12E., 24E., 25E. and 26E., Rainy River district, Ontario. By A. H. A. Robinson, 1914. Scale 400 feet to 1 inch.
- †340a. Geological map of Atikokan Iron-Bearing district, Atikokan mine and vicinity. Claims Nos. 10E, 11E, 12E, 24E, 25E and 26E Rainy River district, Ontario. By A. H. A. Robinson, 1914. Scale 400 feet to 1 inch.
- †341. Magnetometric Map of Atikokan Iron-Bearing district, Sheet No. 1, Claims Nos. 400R., 401R., 402R., 112X. and 403R. Rainy River district, Ontario. By E. Lindeman, 1914. Scale 400 feet to 1 inch.
- †341a. Geological map of Atikokan Iron-Bearing district. Sheet No. 1. Claims Nos. 400R, 401R, 402R, 112X and 403R, Rainy River district, Ontario. By E. Lindeman, 1914. Scale 400 feet to 1 inch.
- †342. Magnetometric Map of Atikokan Iron-Bearing district. Sheet No. 2. Claims Nos. 403R., 404R., 138X., 139X. and 140 X. Rainy River district, Ontario. By E. Lindeman, 1914. Scale 400 feet to 1 inch.
- †342a. Geological map of Atikokan Iron-Bearing district. Sheet No. 2. Claims Nos. 403R, 404R, 138X, 139X and 140X. Rainy River district, Ontario. By E. Lindeman, 1914. Scale 400 feet to 1 inch.

† Maps marked thus † have been printed independently of reports, hence can be procured separately by applicants.

- †343. Magnetometric Map of Atikokan Iron-Bearing district. Mile Post No. 140, Canadian Northern railway, Rainy River district, Ontario. By E. Lindeman, 1914. Scale 400 feet to 1 inch.
- †343a. Geological map, Atikokan Iron-Bearing district. Mile Post No. 140, Canadian Northern railway, Rainy River district, Ontario. By E. Lindeman, 1914. Scale 400 feet to 1 inch.
- †354. Index Map, showing location of peat bogs investigated in Ontario..... by A. Anrep, 1913-14
- †355. Richmond peat bog, Carleton county, Ontario. " "
- †356. Luther peat bog, Wellington and Dufferin counties, Ontario— " "
- †357. Amaranth peat bog, Dufferin county, Ontario— " "
- †358. Cargill peat bog, Bruce county, Ontario— " "
- †359. Westover peat bog, Wentworth county, Ontario— " "
- †360. Marsh Hill peat bog, Ontario county, Ontario— " "
- †361. Sunderland peat bog, Ontario county, Ontario— " "
- †362. Manilla peat bog, Victoria county, Ontario— " "
- †363. Stoco peat bog, Hastings county, Ontario— " "
- †364. Clareview peat bog, Lennox and Addington counties, Ontario— " "
- †365. Index Map, showing location of peat bogs investigated in Quebec— " "
- †366. L'Assomption peat bog, L'Assomption county, Quebec— " "
- †367. St. Isidore peat bog, La Prairie county, Quebec— " "
- †368. Holton peat bog, Chateauguay county, Quebec— " "
- †369. Index Map, showing location of peat bogs investigated in Nova Scotia and Prince Edward Island— " "
- †370. Black Marsh peat bog, Prince county, Prince Edward Island— " "
- †371. Portage peat bog, Prince county, Prince Edward Island— " "
- †372. Miscouche peat bog, Prince county, Prince Edward Island— " "
- †373. Muddy Creek peat bog, Prince county, Prince Edward Island— " "
- †374. The Black Banks peat bog, Prince county, Prince Edward Island— " "

† Maps marked thus † have been printed independently of reports, hence can be procured separately by applicants.

- †375. Mermald peat bog, Queens county, Prince Edward Island.....by A. Anrep, 1913-1914
- †376. Caribou peat bog, Kings county, Prince Edward Island— " "
- †377. Cherryfield peat bog, Lunenburg County, Nova Scotia— " "
- †378. Tusket peat bog, Yarmouth county, Nova Scotia— " "
- †379. Makoke peat bog, Yarmouth county, Nova Scotia— " "
- †380. Heath peat bog, Yarmouth county, Nova Scotia— " "
- †381. Port Clyde peat bog, Shelburne county, Nova Scotia— " "
- †382. Latour peat bog, Shelburne county, Nova Scotia— " "
- †383. Clyde peat bog, Shelburne county, Nova Scotia— " "
- †387. Geological map Banff district, Alberta, showing location of phosphate beds. By Hugh S. deSchmid, 1915, accompanying report No. 385.
- †390. Christina river map showing outcrops of bituminous sand along Christina valley; contour intervals of 20 feet—by S. C. Ells, 1915. Scale 1,000 feet to 1 inch.
- †391. Clearwater river map, showing outcrops of bituminous sand along Clearwater valley; contour intervals of 20 feet—by S. C. Ells, 1915. Scale 1,000 feet to 1 inch.
- †392. Hangingstone-Horse rivers, showing outcrops of bituminous sand along Hangingstone and Horse River valleys; contour intervals of 20 feet—by S. C. Ells, 1915. Scale 1,000 feet to 1 inch.
- †393. Steepbank river, showing outcrops of bituminous sand along Steepbank valley; contour intervals of 20 feet—by S. C. Ells, 1915. Scale 1,000 feet to 1 inch.
- †394. McKay river, 2 sheets, showing outcrops of bituminous sand along McKay valley; contour intervals of 20 feet—by S. C. Ells, 1915. Scale 1,000 feet to 1 inch.
- †395. Moose river, showing outcrops of bituminous sand along Moose valley; contour intervals of 20 feet—by S. C. Ells, 1915. Scale 1,000 feet to 1 inch.

*Address all communications to—*

DIRECTOR MINES BRANCH,  
DEPARTMENT OF MINES,  
SUSSEX STREET, OTTAWA.

- Note.—1. Maps marked thus \* are to be found only in reports.  
2. Maps marked thus † have been printed independently of reports, hence can be procured separately by applicants.

