

Technical and Bibliographic Notes / Notes techniques et bibliographiques

The Institute has attempted to obtain the best original copy available for scanning. Features of this copy which may be bibliographically unique, which may alter any of the images in the reproduction, or which may significantly change the usual method of scanning are checked below.

L'Institut a numérisé le meilleur exemplaire qu'il lui a été possible de se procurer. Les détails de cet exemplaire qui sont peut-être uniques du point de vue bibliographique, qui peuvent modifier une image reproduite, ou qui peuvent exiger une modification dans la méthode normale de numérisation sont indiqués ci-dessous.

- Coloured covers /
Couverture de couleur
- Covers damaged /
Couverture endommagée
- Covers restored and/or laminated /
Couverture restaurée et/ou pelliculée
- Cover title missing /
Le titre de couverture manque
- Coloured maps /
Cartes géographiques en couleur
- Coloured ink (i.e. other than blue or black) /
Encre de couleur (i.e. autre que bleue ou noire)
- Coloured plates and/or illustrations /
Planches et/ou illustrations en couleur
- Bound with other material /
Relié avec d'autres documents
- Only edition available /
Seule édition disponible
- Tight binding may cause shadows or distortion
along interior margin / La reliure serrée peut
causer de l'ombre ou de la distorsion le long de la
marge intérieure.

- Coloured pages / Pages de couleur
- Pages damaged / Pages endommagées
- Pages restored and/or laminated /
Pages restaurées et/ou pelliculées
- Pages discoloured, stained or foxed/
Pages décolorées, tachetées ou piquées
- Pages detached / Pages détachées
- Showthrough / Transparence
- Quality of print varies /
Qualité inégale de l'impression
- Includes supplementary materials /
Comprend du matériel supplémentaire
- Blank leaves added during restorations may
appear within the text. Whenever possible, these
have been omitted from scanning / Il se peut que
certaines pages blanches ajoutées lors d'une
restauration apparaissent dans le texte, mais,
lorsque cela était possible, ces pages n'ont pas
été numérisées.

Additional comments /
Commentaires supplémentaires:

Continuous pagination.

The Canadian Patent Office

RECORD





Vol. XXI.—No. 11.

NOVEMBER 30th, 1893.

{ Price free by post in Canada and the United States, \$2.00.
SINGLE NUMBERS, - - - 20 Cts.

NOTICE.

All solicitors, agents or attorneys who, in circulars or advertisements, or otherwise, refer to the Commissioner or Deputy Commissioner of Patents, or to any other official of the Patent Office, for evidence of their professional standing, do so without authority.

INVENTIONS PATENTED.

NOTE.—Patents are granted for 18 years. The term of years for which the fee has been paid, is given after the date of the patent.

No. 44,595. Fifth Wheel. (*Rond d'avant-train.*)

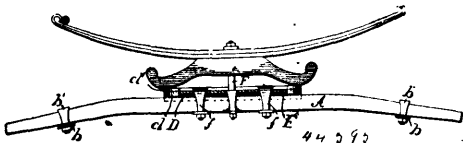

Alfred H. Worrest, Lancaster, Pennsylvania, U.S.A., 2nd November, 1893; 6 years.

Claim.—1st. The combination, with an axle, of the lower plate of a fifth wheel having a circular bar formed on the lower side thereof and engaging a recess in the top of the axle, a king bolt connected with said bar, means for retaining the bar in the recess, and thills rigidly connected with the axle, substantially as and for the purpose specified. 2nd. The combination, with an axle having a recess formed in the top thereof, of a circular bar engaging the recess and having bearings or posts thereon, the lower plate of a fifth wheel formed on or with said posts, a king post connected with the bar, means for retaining the bar in the recess, and thills rigidly connected with the axle, substantially as and for the purpose specified. 3rd. The combination, with an axle, of the lower plate of a fifth wheel having a circular bar formed on the lower side thereof and engaging a recess in the top of the axle, a king bolt connected with the bar, a cap or shield covering the hinge formed by the bar and axle and having a slot therein through which the king bolt passes, clips securing the bar and cap or shield to the axle, and thills rigidly connected with the axle, substantially as and for the purpose specified.

No. 44,596. Mordant for Plain Dyed Fabrics.

(*Mordant pour teindre les étoffes unies.*)

William T. Whitehead, of Magog, Quebec, Canada, and Henry D. Dupee, Boston, Mass., U.S.A., 2nd November, 1893; 6 years.

Claim.—1st. The process of producing cloth, having a pattern or figure thereon of a shade contrasting with the ground, which consists in printing the pattern or figure on the cloth in a resist-mordant containing zinc as the essential or active element, and thereafter dyeing the cloth a plain colour, substantially as described. 2nd. The process of producing cloth, having a pattern or figure thereon of a shade darker than the ground colour, which consists in printing the pattern or figure on the cloth in a resist-mordant containing zinc as the essential or active element, and a colour, and thereafter plain dyeing the cloth in the same colour, substantially as described. 3rd. The process of producing cloth, having a pattern or figure thereon

a colour contrasting with the ground, which consists in printing the pattern or figure on the cloth in a resist-mordant containing zinc as the essential or active element, and a colour, and thereafter dyeing the cloth in a plain contrasting colour, substantially as described. 4th. The process of producing cloth, having a pattern or figure thereon of a shade contrasting with the ground, which consists in printing the pattern or figure on the cloth in a resist-mordant containing zinc compound as the essential or active element, and thereafter dyeing the cloth a plain colour, substantially as described. 5th. The process of producing cloth, having a pattern or figure thereon of a shade darker than the ground colour, which consists in printing the pattern or figure on the cloth in a resist-mordant containing a zinc compound as the essential or active element, and a colour, and thereafter plain dyeing the cloth in the same colour, substantially as described. 6th. The process of producing cloth, having a pattern or figure thereon of a colour contrasting with the ground, which consists in printing the pattern or figure on the cloth in a resist-mordant containing a zinc compound as the essential or active element, and a colour, and thereafter dyeing the cloth in a plain contrasting colour, substantially as described.

No. 44,597. Grave Vault. (*Voûte pour tombeaux.*)

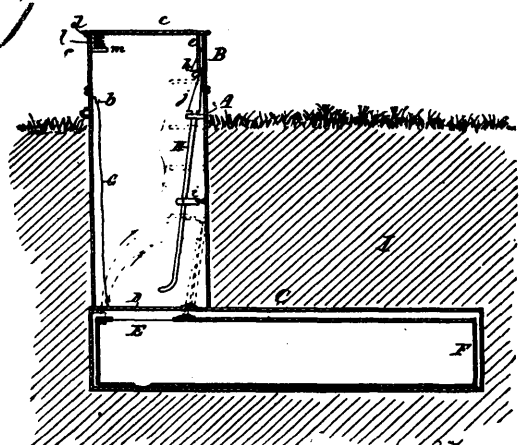

Adam Nelson Hutt and William Henry, both of Stamford, Ontario, Canada, 2nd November, 1893; 6 years.

Claim.—1st. A latent life safe or grave vault, consisting of a hollow box, preferably of non-corrosive material, placed on a hinged shell and coffin in a grave, and having a hinged cover, and a hinged lid to the cover, and devices for opening the lid by a slight upward pressure from the occupant of a grave, if buried alive in a state of coma, and having rungs or steps by which to ascend out of the grave upon return to consciousness. 2nd. A latent life safe or grave vault, consisting of a box A, having a hinged cover B, and a hinged top c, and provided with locking devices to close the lid so as to be only opened from the inside when the cover B is closed, in combination with a shell C, having a hinged lid D, and a coffin, when one is employed having a hinged lid E, so that when the lids D, E, are pushed upward, automatic devices will open the top c for the escape of the inmate of the coffin. 3rd. The combination, with a coffin F, and shell C, of a box A, of a non-corrosive material, having a hinged cover B, and a spring top c with a hinged catch plate e, having openings g, g, held down by the projections h, h, attached to the

inside of the box, entering said openings, springs *l l*, made to press upwards against the lid *c*, and a wedge-shaped headed lever *H, J*, or its equivalent, arranged to release the lid *c* by a slight upward pressure of the hinged lids *D, E*, of the shell *C*, and coffin *F*, respectively for the purpose specified. 4th. The combination of the box *A*, hinged lid *D*, of the shell *C*, and the cord *G*, for the purpose specified. 5th. The combination of the box *A*, hinged lids of shell and coffin, devices for opening the lid *c*, and rungs or steps *n* for the purpose specified.

No. 44,598. Axle Box. (Boîte à graisse.)

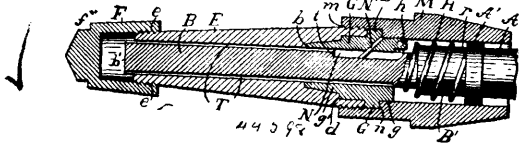

Aaron Huber Sensenig and Samuel Weaver Horst, Hummelstown, both of Pennsylvania, U.S.A., 2nd November, 1893; 6 years.

Claim.—1st. The combination, with an axle box, of a spindle, a cap connected with the end of the axle box, a sleeve on the spindle inserted in the inner end of the axle box, a collar on said sleeve engaged by the end of the axle box, and a shoulder in the cap, and a pin passing through the sleeve and entering a slot in the spindle, said slot forming a shoulder at its outer end, substantially as and for the purpose specified. 2nd. The combination, with an axle box, of a spindle having a boss formed on its inner end, a cap connected with the axle box, a sleeve on the spindle inserted in the inner end of the axle box, and adapted to engage the boss on the spindle, a collar on said sleeve engaged by the end of the axle box, and a shoulder in the cap, and a pin passing through the sleeve and entering a slot in the spindle, said slot forming a shoulder at its outer end, substantially as and for the purpose specified. 3rd. The combination, with an axle box, of a spindle having a boss formed on its inner end, a cap connected with the axle box, a sleeve inserted in the inner end of the axle box, and adapted to engage the boss on the spindle, a collar on said sleeve engaged by the end of the axle box, and a shoulder in the cap, a pin passing through the sleeve and entering a slot in the spindle, said slot forming a shoulder at its outer end, a fixed collar separating the spindle and the axle, and a spring having one end secured in said boss and the other in the sleeve, substantially as and for the purpose specified. 4th. The combination, with an axle box, of a spindle having a boss formed on its inner end, a cap connected with the axle box, a sleeve on the spindle having a conical end inserted in the inner end of the axle box, and adapted to engage the boss on the spindle, a collar on said sleeve engaged by the end of the axle box, and a shoulder in the cap, a pin passing through the sleeve and entering a slot in the spindle, said slot forming a shoulder at its outer end, a fixed collar separating the spindle and the axle, and a spring coiled about the spindle and having one end secured in said boss and the other in the sleeve, substantially as and for the purpose specified.

No. 44,599. Warming Pan. (Bassinoire.)

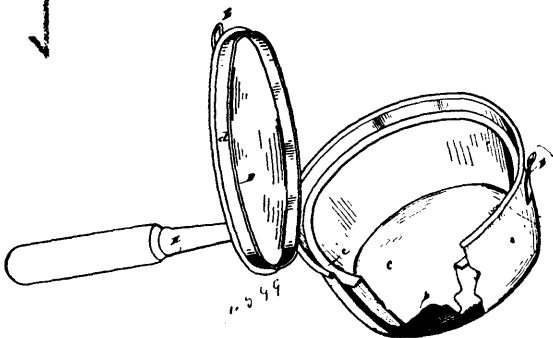

Joseph Barton, Detroit, Michigan, U.S.A., and David Edgar, Windsor, Ontario, Canada, 2nd November, 1893; 6 years.

Claim.—The combination of an outer and an inner pan separated from each other by an air space, a cover *D*, provided with a flange *d*, adapted to hold the inner pan securely in place when closed, substantially as described.

No. 44,600. Temporary Binder. (Reliure temporaire.)

Frank D. Hastings, Oscar N. Durand, Alphonse Legendre and Isaac Rochon, all of Champion, Michigan, U.S.A., 2nd November, 1893; 6 years.

Claim.—1st. In a temporary binder, a back and opposite hinged covers, in combination with pairs of opposite independent ver-

tical swivelled wire shafts having their upper ends inwardly and horizontally bent and bevelled to form joints, and near their lower ends provided with horizontally disposed crank portions or arms,

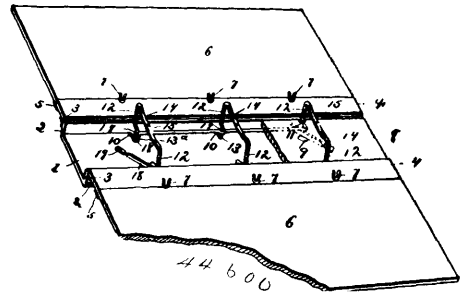

connecting rods loosely connecting the cranked portions of each series of shafts, and springs for normally closing the upper ends of the pairs of opposite shafts, substantially as specified. 2nd. In a temporary binder, the combination with the back, of the opposite series of wire shafts journaled therein and having their upper ends inwardly disposed and overlapped and near their lower ends provided with cranked portions, the springs bearing on the cranked portion of a shaft of each series, connecting rods between the shafts of the series, hinged cover sections at the sides of the back, clasps thereon, and main cover sections hinged to said cover sections beyond the clasp, substantially as specified. 3rd. In a temporary binder, the combination with the oblong back having the surrounding wall or flange, the hinged covers at the sides of the flange, and the diaphragm or plate arranged over said side walls or flanges and secured to the back, opposite bearings formed in the diaphragm or plate and bottom of the cover, wire shafts journaled in the bearings and having their upper ends inwardly bent, bevelled and meeting, and near their lower ends provided between the diaphragm and bottom of the back with cranked portions, connecting rods between said cranked portions, and flat springs obliquely and oppositely disposed and secured to the bottom of the back, and bearing against the cranked portion of a shaft of each series, substantially as specified. 4th. The support or base, and the series of independent vertical wire shafts journaled therein at each side of the support or base and adapted to swing laterally, and having their upper ends inwardly and horizontally disposed and overlapping, and horizontal cranks formed near the lower ends of the shafts, in combination with the connecting rods arranged on each side and connecting each series of shafts independently, so that the series on one side work independently of the series on the other side, and yet each series will work in unison, substantially as specified.

No. 44,601. Time Recorder. (Registre horaire.)

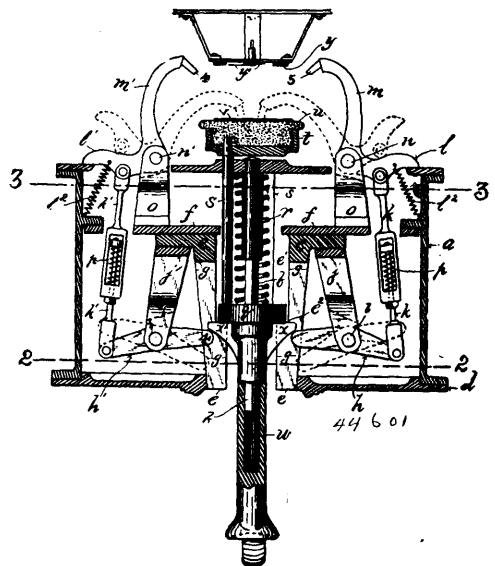

Alfonso Lee Jaynes and John Hathaway Ball, both of Buffalo, New York, U.S.A., 2nd November, 1893; 6 years.

Claim.—1st. In a recording apparatus, the combination of a key or other instrument, a tape and inking ribbon, a clock dial and a movable type, the said key or other instrument when moved in one direction forcing the tape and ribbon against the clock dial, and when moved in the other direction forcing the type against the ribbon and tape, substantially as shown and for the purpose de-

scribed. 2nd. In a recording apparatus, the combination of a key having a prong or other projection and movable along a stem or other guide, a tape and inking ribbon, and a type carried by a pivoted lever, the said lever being connected to a pivoted lever actuated by the key, substantially as shown and for the purpose described. 3rd. In a recording apparatus, the combination of a key having a prong or other projection and movable along a stem and connected to a plate carrying a tape and inking ribbon, a spring for returning the said plate and ring, a clock dial, and a type carried by a pivoted lever, the said lever being connected to a pivoted lever actuated by the key, substantially as shown and for the purpose described. 4th. In a recording apparatus, the combination of a key having a prong or other projection and a pivoted lever, which is normally held in one position by a spring, the said lever being adjustably connected to a pivoted lever actuated by the lever, substantially as shown and for the purpose described. 5th. In a recording apparatus, the combination, severally, with a series of keys, each key having a prong or prongs and movable along a central stem or other guide, of a ring or other shoulder piece preferably surrounding and movable along the stem, the said ring being connected to a plate carrying across its face a tape and inking ribbon, a clock dial having hands actuated by ordinary clockwork, a spring for returning the said plate and ring, a fixed tube or sleeve surrounding and concentric with the stem and ring, the said tube having longitudinal slots corresponding respectively to a series of pivoted levers movable at one end along the said slots and adjustably connected to a corresponding series of levers carrying types or marks and adjustably connected to a fixed part of the apparatus, substantially as shown and for the purposes described. 6th. In a recording apparatus, the combination of mechanism for moving longitudinally the tape and inking ribbon, comprising respectively the plate *t*, having oppositely projecting arms *z*, *z*¹, carrying rollers *a*¹ and intermediate pins *b*¹, pin *r*, engaging ratchet lever *q*², having pawl *q*¹, ratchet wheel *p*¹, spur wheel *f*² and pinion *f*¹ for actuating the rollers *c*¹, of tape *u*, pin *w*¹, engaging ratchet lever *v*, and having pawl *r*², and ratchet wheel *u*¹ for actuating the rollers *s*¹, of inking ribbon *v*, substantially as shown and described.

No. 44,602. Pipe Elbow. (Coude de tuyau.)

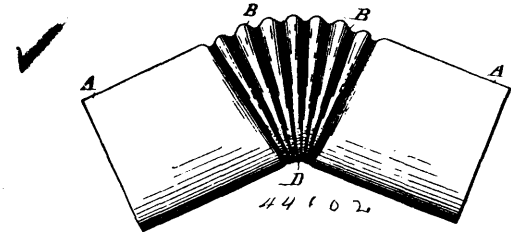

Orville H. Lawrence, Waverly, New York, U.S.A., 2nd November, 1893; 6 years.

Claim.—1st. A sheet metal elbow, formed from a tube having corrugations and bent into final shape by compressing the corrugations upon one side thereof, substantially as described. 2nd. A sheet metal elbow, provided with circumferential corrugations, the said corrugations compressed together to form the throat of the elbow, substantially as described.

No. 44,603. Pipe Bending Machine. (Machine à plier les tuyaux.)

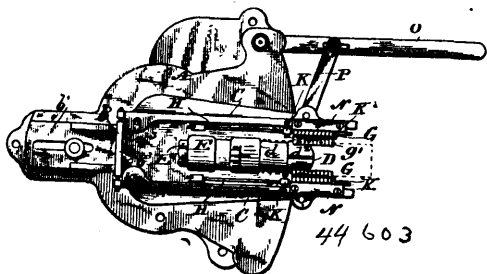

Orville H. Lawrence and Ellsworth M. Letts, both of Waverly, New York, U.S.A., 2nd November, 1893; 6 years.

Claim.—1st. In a machine for bending corrugated pipe, comprising a stationary or staking or bending tool on which the pipe to be bent is placed, a set of wings movable towards said tool, a set of gripping fingers on each wing to grip the corrugations of said pipe, a lever mechanism to move said wings, in combination with a hand staking to bend the pipe while held on the staking tool, substantially as described. 2nd. A machine for bending corrugated pipe, comprising a stationary staking or bending tool on which the pipe to be

bent is placed, a set of wings movable towards said tool, a set of gripping fingers on each wing to grip the corrugations of said pipe, a lever mechanism to move said wings and fingers against the pipe, and a spring to automatically throw open said wings, substantially as described. 3rd. In combination, with the wings and bed plate, the levers connected with said wings to close them, a latch to hold them closed, a sliding or angle bar to release said latch, and a spring connected to said levers to throw them in the opposite direction and open the wings, substantially as described. 4th. The wings, in combination with an adjustable and extensible standard *B*, provided with a plate to which said wings are hinged, and levers to operate said wings, substantially as described. 5th. The slotted tapering gripping fingers adapted to engage the corrugations of a pipe, in combination with supports for said fingers, and mechanism for moving said supports and fingers towards and on to the pipe to be gripped, substantially as described. 6th. The gripping fingers, formed and adapted to engage in corrugations in the pipe with lower ends coming collectively together, and in combination with a lifting bar and a spring to automatically operate it, the supporting wings and a lever, substantially as described. 7th. The combination of the gripping fingers, lifting bar and side supporting wings, said fingers attached to the lifting bars and having a sliding and oscillating movement on said supporting wings, substantially as described. 8th. The staking tool *D*, provided with a collar *d*, for holding the pipe on said tool, a set screw on said collar to tighten the same, a curved end to insert in the pipe, said end provided with a curved rib, and a shoulder *d*², on said tool, substantially as described.

No. 44,604. Aniline Black Discharge. (Noir d'aniline d'enlevage.)

William T. Whitehead, of Magog, Quebec, Canada, and Henry D. Dupee, Boston, Mass., U.S.A., 2nd November, 1893; 6 years.

Claim.—1st. The herein described process of producing cloth having patterns on aniline black ground, which consists in treating the cloth with a solution of aniline black colour, drying sufficiently to keep the colour from running, and printing the pattern thereon in a discharge containing zinc as its essential or active element, before oxidation of the aniline colour, substantially as described. 2nd. The herein described process of producing cloth having coloured patterns on aniline black grounds, which consists in treating the cloth with a solution of aniline black colour, drying sufficiently to keep the colour from running, and printing the pattern thereon in a discharge containing zinc as its essential or active element, and a colour, before oxidation of the aniline black colour, substantially as described. 3rd. The herein described process of producing cloth having patterns on aniline black grounds, which consists in treating the cloth with a solution of aniline black colour, drying sufficiently to keep the colour from running, and printing the pattern thereon in a discharge containing a zinc compound as its essential or active element, before oxidation of the aniline colour, substantially as described. 4th. The herein described process of producing cloth having coloured patterns on aniline black grounds, which consists in treating the cloth with a solution of aniline black colour, drying sufficiently to keep the colour from running, and printing the pattern thereon in a discharge containing a zinc compound as its essential or active element, and a colour, before oxidation of the aniline black colour, substantially as described.

No. 44,605. Aniline Black Resist. (Noir d'aniline de réseavage.)

William T. Whitehead, Magog, Quebec, Canada, and Henry D. Dupee, Boston, Massachusetts, 2nd November, 1893; 6 years.

Claim.—1st. In the herein described process of producing cloth having patterns on aniline black grounds, printing the pattern upon the cloth in a resist containing zinc as its essential or active element, suitably drying the cloth, and thereafter treating the cloth with a solution of aniline black by blotching, slop padding, or dyeing, substantially as described. 2nd. In the herein described process of producing cloth having coloured patterns on aniline black grounds, printing the pattern upon the cloth in a resist containing zinc as its essential or active element, and a colour, suitably drying the cloth, and thereafter treating the cloth with a solution of aniline black by blotching, slop padding or dyeing, substantially as described. 3rd. In the herein described process of producing cloth having patterns on aniline black grounds, printing the pattern upon the cloth in a resist containing a zinc compound as its essential or active element, suitably drying the cloth, and thereafter treating the cloth with a solution of aniline black by blotching, slop padding, or dyeing, substantially as described. 4th. In the herein described process of producing cloth having coloured patterns on aniline black grounds, printing the pattern upon the cloth in a resist containing a zinc compound as its essential or active element, and a colour, suitably drying the cloth, and thereafter treating the cloth with a solution of aniline black by blotching, slop padding or dyeing, substantially as described.

No. 44,606. Telephone. (Téléphone.)

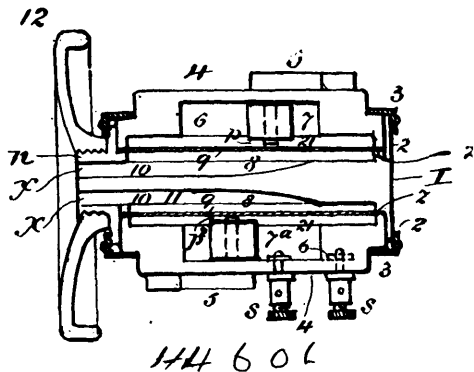

44 606

The Bell Telephone Company of Canada, Montreal, Quebec, Canada, assignees of Hammond V. Hayes, Cambridge, and Wilton L. Richards, both of Malden, Massachusetts, U.S.A., 3rd November, 1893; 6 years.

Claim.—1st. A magneto telephone for two circuits, comprising a double pole magnet and helices therefor for each circuit, the poles and helices of each magnet being arranged in a position inductively neutral to those of the other. 2nd. A compound or double circuit telephone having for each circuit an independent diaphragm and inducing helices and magnet, the poles and helices of each magnet being arranged substantially perpendicular or at right angles to the poles of the other, whereby reciprocal inductive neutrality is secured, substantially as described. 3rd. A compound or double magneto telephone provided with an independent magnet and inducing coils, and diaphragm for each circuit and having a single and common case and earpiece, each magnet having its poles and helices so relatively arranged that a straight line uniting its said poles will be substantially perpendicular to a straight line similarly uniting the poles of the other, whereby the two telephone circuits are made relatively neutral, substantially as described. 4th. In a telephone, two double pole magnets, the poles of each being fitted with inducing helices adapted for connection, respectively, in independent circuits, and each magnet being secured in such a position that each of its poles is substantially equidistant from the two poles of the other. 5th. In a compound or double circuit telephone, the combination of a central non-conducting disc having a shouldered recess on each side to form a vocalizing chamber and diaphragm seat, an earpiece secured to the periphery of said disc and connecting with the vocalizing chambers on the two sides thereof by independent sound channels, a diaphragm for each recess resting by its edges upon the shoulder thereof, closing caps or magnet holding disc for the side recesses of the said central disc adapted to inclose and clamp the edges of the diaphragms, and an independent bipolar magnet and its inducing coils for each circuit secured upon and supported by the said caps or discs, respectively, the two magnets being arranged with their poles in close proximity to their respective diaphragms, and substantially at right angles to the poles of the other, substantially as described. 6th. In a compound telephone, the combination of two separate bipolar magnets provided with pole surrounding helices, the respective helices of each being adapted for inclusion in a circuit independent of the other, with means, as indicated, for the angular displacement and adjustment of either magnet relatively to the other, for the purpose of preventing reciprocal inductive effects, as described herein.

No. 44,607. Damper Regulator for Steam Furnaces. (Régulateur de registre pour fournaies à vapeur.)

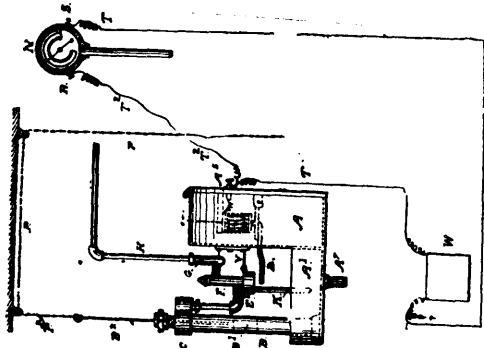

44 607

Peter St. Mary, Portland, Oregon, U.S.A., 3rd November, 1893; 6 years.

Claim.—1st. In a damper regulator of the character herein described, the combination of oppositely arranged spindle valves

operating in seats in a valve chamber provided with ports and pipe connections, a cylinder connected with said valve chamber having a piston, means connecting said piston with damper actuating mechanism, an electro magnet having an armature adapted by its movements to operate the spindle valves, and a steam pressure gauge having its expansion ring in circuit through one side of battery with one coil of the magnet, and a contact point on the pressure gauge in circuit through the other coil of the magnet with the other side of the battery, substantially as set forth. 2nd. In a damper regulator, the combination of the spindle valves, the valve chamber having ports and seats for the valves, steam pipes or ports connecting with the steam boiler and a cylinder and waste pipe, a piston holding a piston rod and chains connecting the rod to the part to be controlled, and means for operating the valves consisting of an electro magnet, an armature and an armature lever adapted to engage a circuit closer in circuit with said magnet through a battery, and actuated by the variation of the steam pressure of the boiler through the steam gauge, as set forth. 3rd. In a damper regulator, the combination of a pressure gauge connected by opposite poles to an electro magnet and electric battery, a hinged armature actuated by the said battery and engaging a valve spindle for opening and closing the ports of a valve chamber and admitting steam to a cylinder in which a piston and piston rod work, the piston rod having connection with a chain or rod attached to a damper of a steam boiler, substantially in the manner as herein set forth and specified.

No. 44,608. Rotary Press, (Presse rotative.)

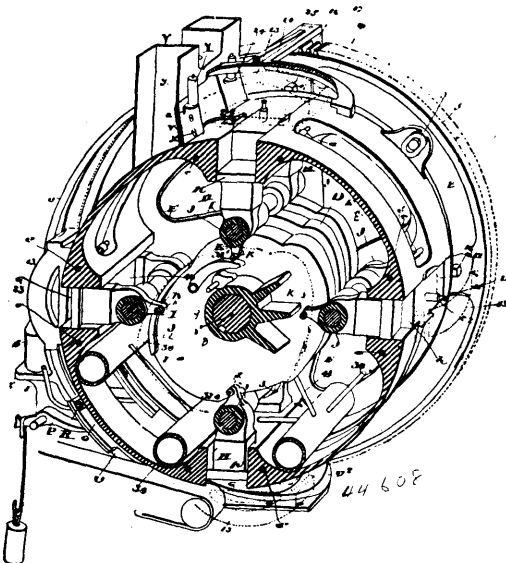

Frederick Lindley Hunt Sims, Toronto, Ontario, Canada, 3rd November, 1893; 6 years.

Claim.—1st. In a rotary press, a drum provided with a series of moulds having a corresponding number of plungers located therein and deriving a radial movement from stationary cams on the main shaft of the machine, and a pivoted door provided with plates for each pair of moulds, in combination with the eccentrically journaled gear wheels adjustably connected to and driving the drum, and a means on the gear-wheels whereby the plates of the door may be forced into the moulds so as to co-act with the radially movable plungers, as and for the purpose specified. 2nd. In a rotary press, a series of moulds rotating around the main shaft of the machine and provided with radially moving plungers, in combination with a stationary cam, the periphery of which is concentric from 1 to 2, and from 2 to 3, is provided with sudden rise for the first portion, the remaining portion being concentric to centre 9, from 3 to 4, of a gradual rise, as described, from 4 to 5, of a depression from 5 to 6, of an inclined way from the centre, from 6 to 7, of the concentric portion, and from 7 to 1, of the flange d, formed on the curve shown and for the purpose specified. 3rd. A rotary press, comprising a drum containing a series of moulds arranged in pairs, plungers reciprocating in the moulds, a transverse shaft for each pair of plungers, a divided cam and rollers carried by the transverse shafts and bearing on the periphery of the cam, substantially as described. 4th. A rotary press, comprising a drum containing a plurality of moulds arranged in pairs, plungers reciprocating in the moulds, a transverse shaft for each pair of plungers having its ends bearing in slots in the webs of the drum and allow movement at right angles to its longitudinal axis, a divided cam and a series of rollers on each transverse shaft bearing on said divided cam, substantially as described. 5th. The drum E, provided with moulds G, the plungers H, provided with a top plate h, the shaft I, provided with rollers J, and having tenoned ends moving in radial slots, and cams D, arranged to operate upon each pair of rollers as they rotate, in combination with the feed hopper V, and pivoted door 14, arranged to close the top of the moulds when the pressure is being exerted

upon the plunger by the cams D, as and for the purpose specified. 6th. A rotary press comprising a frame, a rotary drum journaled therein, provided with flat portions at intervals in its periphery, a pair of moulds at each flat portion, with plungers reciprocating in said moulds, and a pair of feed hoppers for feeding material to the moulds, having slides carried upon one side adapted to conform to the flat portion, substantially as described. 7th. A rotary press comprising a frame, a rotary drum provided with a series of flat portions, a pair of moulds at each flat portion with plungers reciprocating therein, feed hoppers having one side inclined, a slotted plate with bolts connecting the plate to the inclined sides, and weights carried by said plates for causing them to conform to the flat portions, substantially as described. 8th. The drum E, provided with moulds G, the plungers H, provided with a top plate *h*, the shaft I, provided with rollers J, and having tenoned ends moving in radial slots, and the cams D, arranged to operate upon each pair of rollers as they rotate, in combination with the feed hoppers V, secured to the channel iron U, the door 14, provided with rollers 24 and 25, and the channel iron U provided with curved ends U¹ and U¹¹, and the openings at each end of the channel iron, as and for the purpose specified. 9th. The drum E, provided with moulds G, the plungers H, provided with a top plate *h*, the shaft I, provided with rollers J, and having tenoned ends moving in radial slots, and the cams D, arranged to operate upon each pair of rollers as they rotate, in combination with the door 14, pivoted on the pins 15, which have annular grooves 22 cut in them, and pins 23 extending through the door and groove of the pin, one at each side, as and for the purpose specified. 10th. The drum E, provided with moulds G, the plungers H, provided with a top plate *h*, the shaft I, provided with rollers J, and having tenoned ends moving in radial slots, and the cams D, arranged to operate upon each pair of rollers as they rotate, in combination with the door 14, pivoted on the pins 15, which have annular grooves 22 cut in them, and pins 23 extending through the door and groove of the pin, one at each side, and the projections 20, formed on the drum and having slanting inner sides, as described and for the purpose specified. 11th. The drums E, provided with moulds G, the plungers H, provided with a top plate *h*, the shaft I, provided with rollers J, and having tenoned ends moving in radial slots, and the cams D, arranged to operate upon each pair of rollers as they rotate, in combination with the door provided with rollers 24 and 25 pivoted on the pin 15, having annular grooves and pins 23 in each groove, at each side of the pin, and the channel iron U, having an opening through which the roller 24 passes, and a curved end U¹, along which the roller 25 passes, and the straight edges u¹, as and for the purpose specified. 12th. The combination with the moulds formed in the drum and plungers deriving a radial reciprocating movement in the moulds from the cams D, of the door 14, provided with rollers 24 and 25, and adjustably held on their pivot pins, the projections 20, the channel groove U, provided with a curved end U¹, and the lugs 16, on the eccentrically journaled gear-wheels A, A¹, as and for the purpose specified. 13th. The combination with the moulds formed in the drum and plungers deriving a radial reciprocating movement in the moulds from the cams D, of the door 14, provided with rollers 24 and 25, and adjustably held on their pivot pins, the projections 20, the channel groove U, provided with a curved end U¹, and the lugs 16, and the bearing pieces 17, between which the ends of the door when closed extend, as and for the purpose specified. 14th. The combination with the moulds formed in the drum and plungers deriving a radial reciprocating movement in the moulds from the cams D, of the doors 14, provided with rollers 24 and 25, and rocking pieces 18, and adjustably held on their pivot pins, the projections 20, the channel groove U, provided with a curved end U¹, and the lugs 16, and the bearing pieces 17, beneath which the top upper ends of the door extends, as and for the purpose specified. 15th. The combination with the moulds formed in the drum and plungers deriving a radial reciprocating movement in the moulds from the cams D, of the doors 14, adjustably held on their pivot pins and having plates 21, as and for the purpose specified. 16th. In a rotary press, the combination with a series of pairs of moulds, of a single pivoted door for each pair of moulds operating to open and close both moulds of the pair, substantially as described. 17th. The doors 14, provided with plates, 21, adjustably held when closed on their pivot pins 15, above the moulds in the drum, in combination with the eccentric gear-wheels A, A¹, having inwardly extending bearing pieces 17, and lugs 16, on each wheel, between which the ends of the doors when closed extend, and the pins f¹, extending through the slots *f*, in the lugs F, secured to or forming part of the drum, as and for the purpose specified. 18th. The combination with the drum E, provided with moulds G, the plungers H, radially movable in the said moulds by the cam D, of the lifting dog M, crank N, and the rod *n*, provided with a hand wheel, as and for the purpose specified. 19th. The combination with the moulds G, formed in the drum E, of the collar 26, secured to the shaft B, and the ring 27 secured on the outer periphery of the collar, the said collar and ring having circular steam ducts 28 and 29 between them into which lead the outlet and inlet steam pipes 33 and 34, and from which lead the pipes 37 and 41, to and through the steam pipes 38 and 40, as and for the purpose specified. 20th. The combination with the moulds G, formed in the drum E, of the collar 26, secured to the shaft B, and the ring 27 secured on the outer periphery of the collar, the said collar and ring having circular steam ducts 28

and 29 between them into which lead the outlet and inlet steam pipes 33 and 34, and from which lead the pipes 37 and 41, to and through the steam pipes 38 and 40, and branch pipes 42, 43, which extend to the passageway 44, leading through the pivot pins of the doors into the branch passage ways 45, as and for the purpose specified. 21st. The combination with the moulds C, formed in the drum E, of the collar 26 secured to the shaft B, and the ring 27 secured on the outer periphery of the collar, the said collar and ring having circular steam ducts 28 and 29, between them into which lead the outlet and inlet steam pipes 33 and 34, and from which lead the pipes 37 and 41, through which the steam circulates in pipes to and into proximity to the sides of the moulds and the bottom plates of the doors which form the top of the moulds, and the face plates 30 provided with projections 31 designed to fit into the annular grooves formed in the end faces of the ring 27, and collar 26 at their point of junction, as and for the purpose specified. 22nd. In a rotary press, the drum E containing the moulds formed in two halves, the point of division being parallel with the face of the drum, and the two halves being secured together by the bolts E, which pass from the outside face into the open centre, and are connected together by the reverse threaded couplings e¹, as and for the purpose specified.

No. 44,600. Adjustable Collar Coupler.

(Joint ajustable pour Collier.)

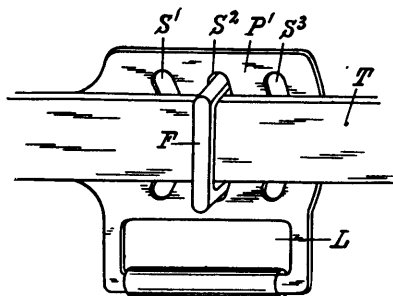

John Jones and John Sussex, London, Ontario, Canada, 3rd November, 1893; 6 years.

Claim.—1st. An adjustable coupler for separable horse collars, consisting of a plate P, provided with a flange F, in which an opening O, is formed, in combination with a plate P¹, provided with two or more slots S, and means for locking the flange F, in the slot S, substantially as set forth. 2nd. An adjustable coupler for separable horse collars, consisting of a plate P, provided with a flange F, in which an opening O, is formed, in combination with a plate P¹, provided with two or more slots S, and a loop L, and means for locking the flange F, in the slot S, substantially as set forth. 3rd. An adjustable coupler for separable horse collars, consisting of a plate P, provided with a flange F, in which an opening O, is formed, in combination with a plate P¹, provided with two or more slots S, and with a hinge K, and means for locking the flange F, in the slots S, substantially as set forth. 4th. An adjustable coupler for separable horse collars, consisting of plate P, provided with a flange F, in which an opening O, is formed, in combination with a plate P¹, provided with two or more slots S, a loop L, and with a hinge K, and means for locking the flange F, in the slot S, substantially as set forth.

No. 44,610. Machine for Slicing Fruit.

(Tranche-fruits.)

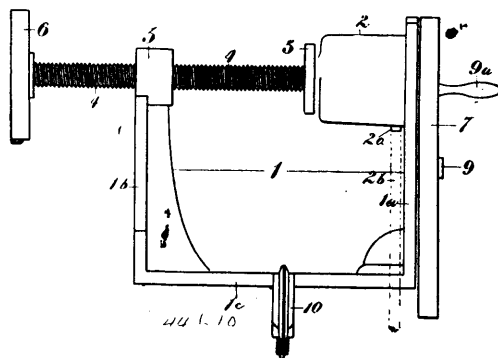

Samuel S. Arnold, Toronto, Ontario, Canada, 3rd November, 1893; 6 years.

Claim.—1st. In a machine for slicing fruit, the combination of a frame work, a feeder connected to the frame work, a series of re-

volving cutter knives, means for revolving the cutter knives and means for feeding the fruit to the cutter knives, substantially as set forth. 2nd. In a machine for slicing fruit, the combination, of a frame work, a feeder connected to the frame work, a revolving disc, a series of cutter knives secured to the revolving disc, means for revolving the disc, and means for feeding the fruit through the feeder to the cutter knives, substantially as set forth. 3rd. In a machine for slicing fruit, the combination of a frame work, a feeder connected to the frame work, a revolving disc, a series of cutter knives secured to the revolving disc, a screw having an enlarged head to feed the fruit through the feeder, the revolving disc and cutter knives, adapted to cut the fruit in the feeder, means for revolving said disc, substantially as described.

No. 44,611. Gas and Petroleum Engine.

(Machine à gaz et pétrole.)

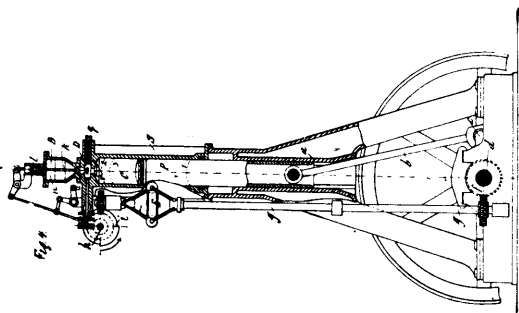

Rudolf Diesel, Berlin, Prussia, (German Empire, 3rd November, 1893; 6 years.

Claim.—The method of working combustion motors consisting in compressing in a cylinder by a working piston, pure air, or other neutral gas or vapour together with pure air, to such an extent, that the temperature hereby produced is far higher, than the burning or igniting point of the fuel to be employed, whereupon fuel is supplied at the dead centre so gradually, that on account of the outward motion of the piston and the consequent expansion of the compressed air or gas, the combustion takes place without essential increase of temperature or pressure, whereupon, after the admission of fuel has been cut off, the further expansion of the body of gas mass contained in the working cylinder takes place, substantially as described and shown in the accompanying drawings.

No. 44,612. Cover for Jars and other Vessels.

(Couvercle pour jarres ou autres ustensiles.)

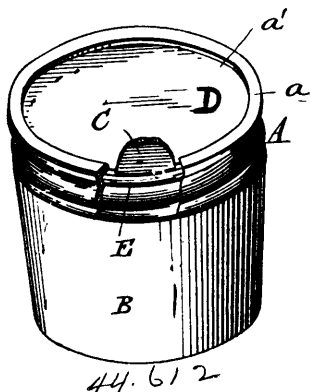

Thomas Edwin Ogram, Washington, Columbia, U.S.A., 3rd November, 1893; 6 years.

Claim.—1st. A cover or cap for a jar or like vessel having an open top, a transparent or diaphanous material, a label arranged below said transparent or diaphanous material, and a bottom or plate arranged in said cover or cap below said label, said cover or cap containing said diaphanous or transparent material, plate or bottom and label, substantially as specified. 2nd. A cover or cap for a jar or like vessel having an open top, a transparent or diaphanous material, a label arranged below said transparent or diaphanous material, a bottom or plate below said label, and a vertical flange above said plate or bottom having lugs upon its upper side adapted to be bent inwardly upon said transparent or diaphanous material, said cover or cap containing said diaphanous or transparent material, plate or bottom, and label, and forming said vertical flange with its lugs, substantially as specified.

No. 44,613. Manufacture of Matches.

(Fabrication d'allumettes.)

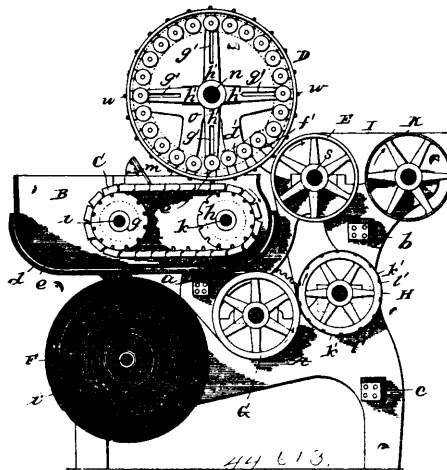

Charles M. Bowman, Lebanon, Pennsylvania, U.S.A., 3rd November, 1893; 6 years.

Claim.—1st. The method of making matches, which consists in feeding paper in a sheet, puncturing the paper longitudinally and transversely to divide the sheet into matches, and depositing fulminate in drops on the upper surface of the punctured sheet before separating the paper. 2nd. The method of making matches, which consists in feeding paper in a sheet, puncturing the paper longitudinally and transversely to form the contiguous edges and ends of the match splints, and depositing fulminate in drops on the upper surface of the punctured paper intermittently before separating the paper. 3rd. In a machine for making matches, the combination of a fulminate receptacle, means for raising, conveying and expelling fulminate in drops, and means for feeding paper. 4th. In a machine for making matches, the combination of a fulminate receptacle, a fulminate conveyer, means for raising, conveying and expelling fulminate in drops and means for feeding paper. 5th. In a machine for making matches, the combination of a fulminate receptacle, an endless conveyer in said receptacle, a drum provided with chambers and plungers for receiving, conveying and depositing fulminate, and means for feeding paper. 6th. In a machine for making matches, the combination of a fulminate receptacle, a drum provided with fulminate depositors, consisting of separate chambers and plungers, means for operating said plungers, and means for feeding paper. 7th. In a machine for making matches, the combination of a fulminate receptacle, a fulminate conveyer, a drum provided with fulminate chambers supported above said receptacle and conveyer, and a suitable support for a sheet of paper below said drum. 8th. In a machine for making matches, the combination of a fulminate receptacle, a drum provided with a plurality of fulminate chambers and plungers, arranged equidistant in the periphery of the drum, and means for feeding paper. In a machine for making matches, the combination of a fulminate receptacle, a heating chamber for said receptacle, a conveyer within the receptacle, a plurality of fulminate chambers and plungers revolvably supported above said conveyer, and means for feeding paper. 10th. In a machine for making matches, the combination of, means for puncturing paper longitudinally and transversely at the contiguous edges and ends of the matches, a fulminate receptacle, a plurality of fulminate chambers and plungers, and means for feeding paper. 11th. In a machine for making matches, the combination, of means for feeding paper, means for puncturing the paper at the contiguous edges and ends of the matches, a fulminate receptacle and a plurality of fulminate chambers provided with plungers. 12th. In a machine for making matches, the combination, of means for puncturing paper, a fulminate receptacle, a revoluble drum provided with a plurality of fulminate chambers and plungers, a revoluble support for the paper while the fulminate is being deposited thereon, and means for feeding paper. 13th. In a machine for making matches, the combination of a fulminate receptacle, means for feeding paper and chambers provided with plungers for depositing fulminate in drops upon the surface of the paper intermittently. 14th. In a machine for making matches, the combination of a fulminate receptacle, a fulminate conveyer, means for puncturing paper, a plurality of chambers provided with plungers for raising, conveying and depositing fulminate in predetermined quantities, and means for feeding paper. 15th. In a machine for making matches, the combination of a fulminate receptacle, a drum provided with a plurality of bars, having chambers therein, bars supporting plungers for said chambers and engaging grooves in the head of the drum for retracting and projecting said plungers. 16th. In a machine for making matches, the combination, of a fulminate receptacle, a revoluble drum supporting a plurality of bars provided

with chambers, bars supporting plungers for said chambers within said drum, and stationary heads for the drum provided with grooves with which the ends of said plunger bars engage. 17th. In a machine for making matches, a fulminate depositor consisting of a plurality of chambers provided with plungers, a fulminate conveyor and means for retracting the plungers to raise fulminate from the conveyor, and means for projecting the plungers to expel the fulminate. 18th. In a machine for making matches, a fulminate depositor consisting of a drum provided with a plurality of grooves, bars having chambers therein and supported in said grooves, and plungers for expelling fulminate.

No. 44,614. Magazine Firearms.

(Arme à feu à répétition.)

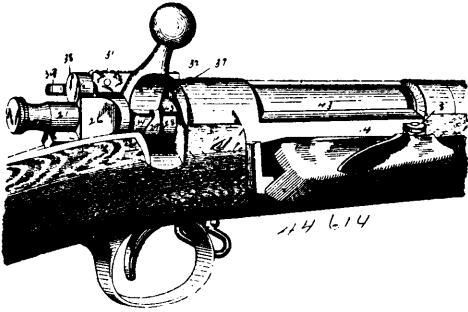

Ole Herman Johannes Krag and Erik Jørgensen Armourer, Kongsberg, Kingdom of Norway, 3rd November, 1893; 6 years.

Claim.—1st. In a breech-loading gun, the combination, with the receiver, of a horizontal magazine arranged with its inlet on one side of and below said receiver and with its outlet on the opposite side and in communication with the receiver, substantially as described. 2nd. In a breech-loading gun, the combination, with the receiver, of a horizontal magazine arranged with its inlet on one side of and below said receiver and with its outlet on the opposite side and in communication with the receiver and a spring actuated feeding device at the inlet of the magazine adapted to feed the cartridges towards or to the outlet thereof, substantially as described. 3rd. In a breech-loading magazine gun, the combination of the magazine having its feed opening on one side of the gun, a gate for closing the opening hinged to the magazine so as to swing downwardly, said gate being provided with a lug 13, with a spring actuated feed lever arranged in the magazine and engaged by said lug and moved outwardly thereby against the stress of its spring when the gate is opened, for the purposes set forth. 4th. In a breech-loading magazine gun, the combination, with the magazine having its feed opening on one side of the gun, a gate for closing the opening hinged to the magazine so as to swing downwardly, said gate being provided with a lug 13, a feed lever arranged within the magazine, a vertical pivot for said lever one end of which projects out of the magazine, said outwardly projecting end being provided with a radial arm of the convex leaf spring 11, having bearing on said radial arm and on the hinge knuckle of the grate, substantially as and for the purpose set forth. 5th. In a breech-loading magazine gun, the barrel, receiver and a magazine, open on opposite sides of said receiver, said parts being framed integral of the side wall 2, and a gate for closing said openings, said side wall and gate being detachably secured to the magazine, for the purposes set forth. 6th. In a breech-loading magazine gun, the combination, with the receiver, provided at its forward end with an annular locking recess at its rear end with a rearwardly inclined face 37, interiorly with two longitudinal bearing faces *c* and *d*, of the breech bolt provided at its forward end with two radial lugs 35 and 36, and at its rear end with a rearwardly inclined shoulder 34, a hand lever on said rear end of the bolt normally in contact with the inclined face 37, of the receiver, the firing pin provided at its rear end with a longitudinal rib 22, having full cock shoulder 23, normally in contact with the rearwardly inclined shoulder on the breech bolt and an extractor connected with the breech bolt, whereby the said breech bolt, firing pin and extractor are caused to simultaneously move rearwardly when a partial rotation is imparted to the bolt, substantially as and for the purposes set forth. 7th. In a breech-loading magazine gun, the combination with the breech bolt enlarged at its rear end, and provided in said enlarged portion with a semi cylindrical longitudinal recess, and a locking sleeve fitted in the rear end of the bolt, said sleeve being provided with a radial lug 33, adapted to engage the shoulder formed by the enlarged end of the breech bolt, and having its rear end also enlarged and provided with a longitudinal cylindrical bearing, of a locking pin seated and adapted to revolve in said bearing and extending into the recess in the breech bolt, the end of said pin that projects into said recess being semi-cylindrical, substantially as and for the purpose set forth. 8th. In a breech-loading magazine gun, the combination with the breech bolt enlarged at its rear end, and provided in said enlarged portion with a semi-cylindrical longitudinal recess, a locking sleeve fitted in the rear end of the breech bolt, said sleeve being provided with a radial lug 33, adapted to engage

the shoulder formed by the enlarged end of the breech bolt, and having its rear end also enlarged and provided with a longitudinal cylindrical bearing, the firing pin provided with the pull or knob 21, and the actuating pin of said pin having bearing on the end of the locking sleeve and on the collar on the pin respectively, of the locking pin 40, provided with a semi-cylindrical end 41, and with a head 38, having formed therein a concave recess 38^a, said pin having rotary motion in the bearing of the locking sleeve, and said semi-cylindrical end projecting into the corresponding recess in the breech bolt, substantially as and for the purpose set forth. 9th. In a breech-loading magazine gun, the combination with the receiver, the breech bolt provided at its forward end with the locking lugs 35 and 36, and the locking sleeve 29 having a forwardly projecting arm 31, under cut or recess at 45, and an extractor carrier provided with a lug fitting into said recess and with a dove-tailed longitudinal groove, of an extractor consisting of a more or less elastic plate fitted in the groove of the carrier and having an extractor hook at one end, and a curved arm projecting laterally therefrom near the hook end, said lug 36 engaging said curved arm when a partial rotation is imparted to the breech bolt in a given direction, substantially as and for the purpose set forth. 10th. In a breech-loading magazine gun, the combination with the receiver having guide bearings *d* and *c*, therein extending nearly the full length thereof, and the lateral slot *r*¹ contracted at its rear end, of the breech bolt having lugs 35 and 36 at its forward end, said lugs having bearing on and being guided by said bearings *d*, *c*, respectively when the bolt is positioned for rectilinear motion in said receiver, substantially as and for the purpose set forth. 11th. In a breech-loading magazine gun, the combination with the receiver, the breech bolt and the locking sleeve 27, having forwardly projecting arm 31, recessed at 46, of the extractor carrier consisting of a plate 43, concave convex in cross section, provided at its rear end with a lug 45 fitting loosely into recess 46, and with a longitudinal dove-tailed groove, an extractor consisting of a plate 47 having a portion thereof attenuated to give it elasticity, the body of said plate being loosely fitted in the dove-tailed groove of the carrier and extractor hook at end of the attenuated portion of the extractor, and a locking device to lock the extractor and carrier against endwise motion independently of said breech bolt when the latter is moved back into the receiver, substantially as and for the purpose set forth. 12th. In a breech-loading magazine gun, the combination with the receiver having guide bearings *d* and *c*, and breech bolt having at its forward end two lugs 35 and 36, guided by said bearings when the bolt is positioned for rectilinear motion, of the trigger *T*, and an annular arm or lever 62, the vertical branch of which projects into the receiver in the path of the lug 36 when the breech bolt is pulled rearwardly to limit the motion of said bolt, said trigger being adapted to actuate the angle lever for the purpose of withdrawing its vertical arm from the path of the lug, for the purpose set forth. 13th. The described cartridge case made of two pieces 64 and 63, fashioned to perform the function of casing and drawer respectively, the front wall 66 of the drawer being curved upwardly, for the purposes set forth.

No. 44,615. Brick Kiln. (Four à brique.)

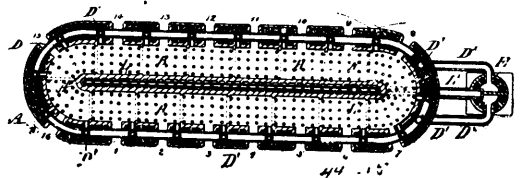

Max Alexander Theodor Boehncke, Centinela, California, U.S.A., 3rd November, 1893; 6 years.

Claim.—1st. In a brick kiln, the combination with a continuous chamber divided into a series of sub-chambers, of horizontal down-draft flues having communication with the chimney, vertical down-draft flues communicating with the respective sub-chamber and with the exterior of the kiln, the exterior openings being normally closed, said vertical flues intersecting the horizontal flues, and dampers adapted to interrupt communication between the individual vertical flues, substantially as set forth. 2nd. In a brick kiln, the combination with a burning chamber provided down-draft flues, vertical up-draft flues, and with a chimney, of main horizontal down-draft flues and a main horizontal up-draft flue, said horizontal flues each having independent communication with the chimney, substantially as and for the purpose set forth. 3rd. In a brick kiln, the combination with a chamber provided with combined feed chutes and up-draft flues arranged in rows and provided at their exterior ends with a projecting annular flange adapted to be normally inclosed by sealing caps, and a horizontal up-draft flue communicating with the chimney and provided with flanged openings in alignment with the rows of feed chutes and normally closed by caps, of a portable conductor provided at its lower side with pipes coinciding with and adapted to receive the flanges of the feed chutes and the flange of the respective opening in the up-draft flue, substantially as set forth. 4th. In a brick kiln, the combination with a chamber provided with combined feed chutes, and up-draft flues arranged in rows and provided at their exterior openings with an annular flange

surrounded by a recess adapted for the reception of a sealing medium, said openings being provided with caps normally inclosing the flanges, and a horizontal updraft flue communicating with the chimney and provided with flanged openings in alignment with the feed chutes and having a recess surrounding the flange and adapted for the reception of a sealing medium, said flanges being normally inclosed by sealing caps, of a portable conductor closed upon all sides, and provided at its under side with pipes coinciding with the feed chute, and respective horizontal flue openings, and adapted to be seated in the recesses surrounding said openings, substantially as and for the purpose set forth. 5th. In a brick kiln, the combination with a continuous chamber divided into a series of sub-chambers, main horizontal downdraft flues, and a main horizontal updraft flue, all of said flues having independent communication with a chimney, of vertical downdraft flues extending from the exterior of the kiln to the bottom of each sub-chamber and having its exterior end normally closed, said vertical flues intersecting the main downdraft flue and being provided with a damper adapted to interrupt communication with the latter, vertical updraft flues arranged in rows in the top of each sub-chamber and in alignment with openings in the main updraft flue, said flues being normally closed, and a portable conductor for connecting the vertical updraft flues with the respective opening in the main updraft flue, substantially as and for the purpose set forth.

No. 44,616. Bridle Bit. (*Mors de bride.*)

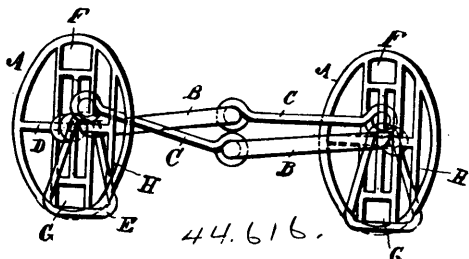

Geo. S. Parsons, Cherry Flats, Pennsylvania, U.S.A., 3rd November, 1893; 6 years.

Claim.—1st. In a bridle bit, the combination of cheek pieces, main links pivotally connected at their outer ends to the cheek pieces, and auxiliary links pivotally connected with the inner ends of the main links, and having a sliding connection with the cheek pieces at their outer ends, said main links being of larger diameter than said auxiliary links, substantially as described. 2nd. In a bridle bit, the combination of cheek pieces and separate bits or mouth pieces connected thereto, each bit piece being formed of two links pivoted together at or near the centre and one of the links of each bit being larger in diameter than the other, substantially as described.

No. 44,617. Device for Tightening Wheel Tires.

(*Appareil pour serrer les bandages de roues.*)

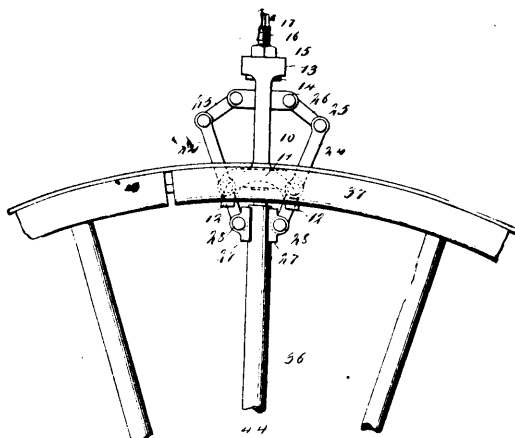

William T. Mackey, Vancouver, British Columbia, Canada, 3rd November, 1893; 6 years.

Claim.—1st. In a device of the kind described, the spoke washer, comprising two half washers with wedge-shaped members adapted to overlap to form the complete washer, substantially as described. 2nd. In a device of the kind described, the felloe wedge having a slot to receive a tenon, and parallel ribs to embed themselves in the adjacent felloe sections, substantially as described. 3rd. The herein described device for expanding wheels, which comprise a lift bar having arms to project the felloe clamping jams to engage a spoke adjacent to the felloe, toggle levers to operate the jaws, a screw for actuating the toggle levers, and an operative connection

between the screw and the lift bar, whereby the latter may be moved in relation to the jaws, substantially as described. 4th. A device for expanding wheels, comprising an adjusting screw, a lift bar operatively connected with the screw and provided with projecting arms to engage a felloe, a follower mounted on the screw, a pair of jaws to clamp a wheel spoke, toggle levers connecting the follower with the jaws, and a tie bar mounted loosely on the screw and connecting two of the toggle levers, substantially as described. 5th. A wheel expander, comprising an adjusting screw, a nut on the screw, a lifter journaled on the nut and provided with projecting arms to engage a felloe, a tie bar journaled on the lower end of the screw, a follower threaded on the screw, toggle levers connecting the follower and tie bar, two of the levers being fulcrumed on the latter, and oppositely arranged jaws carried by toggle levers and adapted to clamp the spoke, substantially as described. 6th. The combination, with the lifter and the screw mechanism for moving it, of the oppositely arranged clamping jaws adapted to be fastened to a spoke, an operative connection between said jaws and the screw which actuates the lifter, and a packing for the inner faces of the jaws, substantially as described. 7th. In a wheel expander, the oppositely arranged clamping jaws, having concave adjacent surfaces to fit a spoke, and a suitable packing for the said faces, substantially as described.

No. 44,618. Car Coupler. (*Attelage de chars.*)

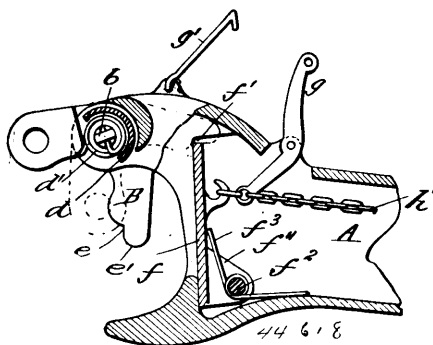

Lester B. Kenney, Dansville, New York, U.S.A., 3rd November 1893; 6 years.

Claim.—1st. The combination, of a draw-head, a coupling jaw, a non-rotatable pivot bolt therefor, a coil spring surrounding the bolt at one end and having one of its ends engaging the same and its other end bearing on an adjacent part of the jaw, a removable casing surrounding the coil spring and having one of its sides open, through which open portion one end of the coil spring works, and means for removably clamping said casing in place, substantially as described. 2nd. The combination of a draw-head, a coupling jaw and a vertical pivot pin therefor, a coil spring surrounding the pin and having one of its ends engaging the same and its other end engaging the jaw, and a casing surrounding the spring, substantially as described. 3rd. The combination of a draw-head, a swinging jaw, a locking plate pivoted on the side opposite the jaw, a spring normally closing this plate, and a horizontal lever working through the side of the draw-head and having its inner end connected to the locking plate, substantially as described. 4th. The combination of a draw-head, a swinging jaw, a locking plate pivoted on the side opposite the jaw, a spring normally closing this plate, and a horizontal lever working through the side of the draw-head and having its inner end connected to the locking plate, and means for locking this lever to hold the locking plate out of operative position, substantially as described. 5th. The combination of a draw-head, having a flanged mouth, a locking jaw provided with a shouldered locking arm, a locking plate normally bearing against the flanges around the mouth of the draw-head, ears on the end of the locking plate opposite the jaw, a vertical pin passing through said ears, and a spring normally pressing said locking plate forwardly, substantially as described.

No. 44,619. Dress Stay. (*Busc de corset.*)

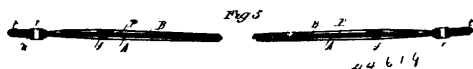

Frederick W. Lyon, Brooklyn, New York, U.S.A., 3rd November, 1893; 6 years.

Claim.—1st. A duplex dress stay composed of two flat steels fastened together at both ends and one adapted to slide or have endwise play on the other when the stay is bent or bowed, substantially as specified. 2nd. In a dress stay, the combination of a steel A, provided with notches at or near each end, a steel B, shorter than A, provided with elongated notches at or near each end and wire fasteners wrapped around the two steels and inserted in the notches to fasten the two steels together and also serve as stops to

limit the endwise motion of the steels, substantially as specified. 3rd. The combination of two steels A, B, the former longer than the latter, and provided with rivet holes and notches at each end, the steel B, provided with elongated notches, a pocket cover P, drawn over the two steels, and tips *t, t*, doubled over the ends of the steel A, and cover and secured by a rivet passed through the tips, cover and steel A, substantially as specified.

No. 44,620. Coating for Wall Paper, etc.
(*Enduit pour papier à tenture.*)

John Walker and Harry Carver, Pendleton, Lancaster, England, 3rd November, 1893; 6 years.

Claim.—1st. The process of manufacturing a substance impervious to moisture, and capable of resisting the action of strong disinfectants for coating or printing upon wall paper, calico or other fabric, or for coating walls or other structures which consists in treating or melting resin and linseed oil with caustic lime, then adding petroleum or an oily spirit to reduce it to the required consistency and mixing therewith a suitable earthy matter (such as Paris white, China clay, Oxide of Zinc or the like) to give the required body with a pigment or colouring matter, substantially as described. 2nd the process of manufacturing a substance impervious to moisture, and capable of resisting the action of strong disinfectants for coating wall paper, paper hangings, calico, walls or other fabrics or structures, which consists of mixing with melted resin a quantity of caustic lime and linseed oil, then adding petroleum, turpentine or other oily spirit to reduce it to the required consistency, treating it with a solution of soda and tartarate salts to emulsify, and then grinding with a suitable earthy matter such as described, to give the desired body thereto, with the addition of a pigment or colouring matter to give the desired colour or tint, substantially as described. 3rd. A substance for coating or printing wall papers, paper hangings, calicoes, walls or other fabrics or structures, consisting of resin treated with caustic lime, linseed oil, a reducing oil (such as petroleum or an oily spirit), with which is intimately mixed and ground a suitable earthy substance (such as Paris white, China clay or oxide of zinc), and a pigment to give the desired shade or colour. 4th. A substance for coating paper hanging, walls, or other fabrics or structures, consisting of resin and linseed oil treated with caustic lime, and a suitable reducing oil emulsified by the addition of soda and salts of tartar, with which is mixed and ground a suitable earthy substance to give body, and a pigment to give the desired shade or colour, substantially as described

No. 44,621. Process of Extracting Gold and Silver from Ores and the Like. (*Procédé pour extraire l'or et l'argent des minerais et autres.*)

John Stewart MacArthur and Charles James Ellis, both of Glasgow, Scotland, 3rd November, 1893; 6 years.

Claim.—1st. In the MacArthur-Forrest process for extracting gold and silver from ores and the like, the addition to the cyanide solution or to the ore, or to the mixture of ore and cyanide, of salts or compounds of leads, substantially as and for the purposes hereinbefore described. 2nd. In the MacArthur-Forrest process for extracting gold and silver from ores and the like, the addition to the cyanide solution or to the ore, or to the mixture of ore and cyanide, of any one or more of the metallic salts or compounds hereinbefore indicated, and capable of forming insoluble sulphides, as and for the purposes hereinbefore described.

No. 44,622. Dredging Machine. (*Cure-môle.*)

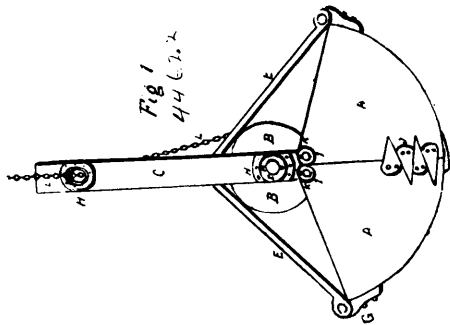

William Brooks, Liverpool, Nova Scotia, U.S.A., 3rd November, 1893; 6 years.

Claim.—1st. The combination of bucket A, A, with windlass B, B, bail C, C, plate F, rods E, E, hoisting chains L, L, opening chain M, and closing chain N, substantially as and for the purpose hereinbefore set forth. 2nd. The combination of rods O and P, with bail C, C, plate F, and bucket A, A, substantially as and for the purposes hereinbefore set forth.

No. 44,623. Apparatus for Facilitating the Opening of Oysters. (*Appareil pour aider à ouvrir les huîtres.*)

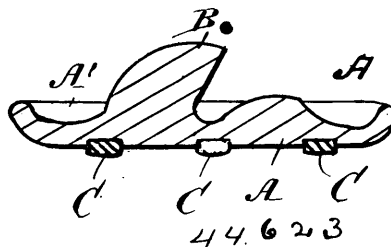

Frederic Lumb Wanklyn, Montreal, Quebec, Canada, 3rd November, 1893; 6 years.

Claim.—As a new article of manufacture, an oyster rest or holder, being a platter having circumferential depression and central boss or raised portion with transverse incline therein, for the purposes set forth.

No. 44,624. Buckle. (*Boucle.*)

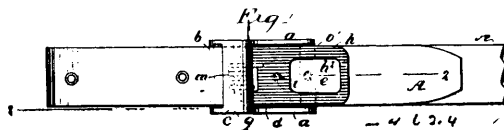

George M. Aylsworth, Collingwood, Ontario, Canada, 3rd November, 1893; 6 years.

Claim.—1st. In a buckle, the frame, comprising two side-bars and four cross-bars, constructed and arranged as herein described. 2nd. In a buckle, the frame, comprising two arched side-bars, two end cross-bars, an intermediate cross-bar and a cross-bar at the tops of the arches, substantially as described. 3rd. In a buckle, the frame, comprising two arched side-bars, two end cross-bars, an intermediate cross-bar, a locking pin on one end cross-bar, and a cross-bar, at the tops of the arches, substantially as described. 4th. In a buckle, the frame, comprising two arched side-bars, two end cross-bars, an intermediate cross-bar, locking pins on one end cross-bar, and on the intermediate cross-bar, and a cross-bar at the tops of the arches, substantially as described. 5th. In a buckle, the combination, with a frame, composed of two arched side-bars, two end cross-bars, an intermediate cross-bar, locking pins on the cross-bars, and a cross-bar at the tops of the arches on the side-bars, of a spring pressed tongue piece, and a locking stud on the lower side of said tongue piece, substantially as described.

No. 44,625. Smokeless Furnace. (*Fournaise sans fumée.*)

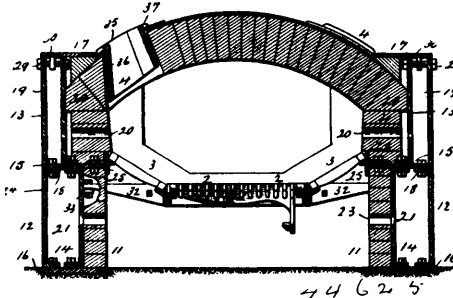

James V. Burke, Chicago, Illinois, U.S.A., 3rd November, 1893; 6 years.

Claim.—1st. The combination in an arched top furnace, of the arched top 1, and side walls composed of an inner brick lining 11, horizontal plate 15, and vertical plates 12 and 13, having air ducts 19 between them, substantially as set forth. 2nd. The combination in an arched top furnace, of the arched top 1, and the side walls composed of an inner brick lining 11, horizontal plate 15, and vertical plates 12, 13 and 14, having air ducts 19, 21 between them, substantially as set forth. 3rd. The combination in an arched top furnace, of the arched top 1, and side walls composed of an inner brick lining 11, vertical plates 12, 13 and 14, horizontal plates 15, 16 and 17, bolted together to form enclosing casings for the walls, substantially as set forth. 4th. The combination in an arched top furnace, of the arched top 1, and side walls, having horizontal plates 15, with the upper bearing bars of the inclined grates attached thereto by bolts 26, and elongated slots 27, substantially as set forth. 5th. The combination of an arched top furnace of the side walls provided with vertical plates or partitions 14, and the rear bearing bars 32,

attached to said plates, and connecting them together against lateral displacement, substantially as set forth. 6th. The combination in an arched top furnace of the side walls provided with vertical plates or partitions 14, and the bearing bars 31 and 32, of the fire grates, secured to said plates by bolt and connection 33, substantially as set forth. 7th. The combination in an arch top furnace, of the side walls provided with vertical plates or partitions 14, and the dead plate 34, and bearing bars 31 and 32, of the fire grates secured to said plates by bolt and flange connection 33, substantially as set forth. 8th. The combination in an arched top basket grate furnace, of the fuel pockets 4, at the opposite side of the furnace, removable linings 35, arranged within the fuel pockets, to form air spaces 36, and provided with top flanges or rims 37, by which they are supported in place, substantially as set forth. 9th. The combination in an arched top basket grate furnace and its side fuel pockets 4, of the front wall 5, and metal front plate 6, formed with register openings 8, with the side walls 11, having an air space 19, and air passages or orifices 20, located immediately beneath the pockets, substantially as set forth. 10th. The combination in an arched top basket grate furnace, of the front wall 5, and metal front plate 6, forming the enclosed air space 39, and the doorway lining 38, arranged within the front wall 5, so as to form air space or passage 38', between the lining and the front wall the metal front plate 6, being provided with orifices 40, in line with the air space 38', substantially as set forth. 11th. In a steam boiler furnace or setting, the combination, of the boiler 44, with the supporting posts 48, arranged within an air space in the furnace walls, substantially as set forth. 12th. In a steam boiler furnace or setting the combination of the boiler 44, with a column or post 48, arranged within an air space 51, in the furnace walls, that has communication with the outer air and with the interior of the furnace, substantially as set forth. 13th. In a steam boiler furnace or setting, the combination of the boiler 44, and its supporting brackets 45, of the supporting track 47, bearing rollers 46, jack screws 49, and removable lining piece 50, substantially as set forth. 14th. In a steam boiler furnace or setting, the combination of the boiler 44, and horizontal partition 55, forming an air chamber beneath the fire bed of the furnace, the side and rear walls of the furnace, formed with air spaces 51, open at the top of the walls, and communicating with the air chamber 54, by passages 59, through the side and end walls, and the bridge walls 62, having an air passage 61, connecting said chamber with the fire bed, substantially as set forth.

No. 44,626. Life Raft. (Radeau de sauvetage.)

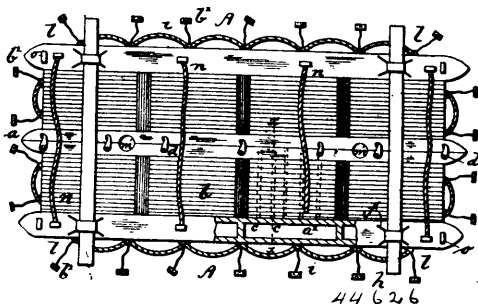

George B. Hussey, Providence, Rhode Island, U.S.A., 3rd November, 1893; 6 years.

Claim.—1st. The combination with the longitudinally arranged buoyant hollow frame divided lengthwise and jointed together and further arranged to receive a sail carrying mast, of connected sections of buoyant material, as cork, secured to said frame, an elevated detachable seat extending across each end of the frame, and one or more series of suitably disposed life lines, substantially as described. 2nd. In a life raft provided with a hollow frame or body, and having connected sections of buoyant material, as cork, secured thereto, a series of looped life lines attached to the frame and a series of similarly attached smaller lines having an end of each provided with a piece of cork, substantially as and for the purpose specified. 3rd. The life raft A, hereinbefore described, consisting of the longitudinally divided and hinged hollow buoyant frame *a*, closely connected sections *b*, of cork secured to said frame, a suitably mounted sail arranged to be fixed at either end of the raft, detachable seats *h* extending across the frame, and one or more series of suitably disposed life lines. 4th. In a life raft provided with means for sailing the same, a hollow frame portion having a series of removable airtight boxes arranged therein, connected sections of buoyant material, as cork, secured to said frame and further provided with conveniently arranged life lines, substantially as set forth.

No. 44,627. Coffee Steeper. (Appareil pour infuser le café.)

George E. Overman, Rock Island, Illinois, U.S.A., 3rd November, 1893; 6 years.

Claim.—1st. In a coffee steeper, the combination, with the hoop, having openings in its sides and a perforated bottom therein above the openings, of the perforated cone rising from the hoop and detachably connected thereto, the closed cone supported by and

around the perforated cone, and the outer cup or receptacle carried by the closed cone, as and for the purpose set forth. 2nd. In a coffee steeper, the combination, with the hoop, of the perforated cone rising from the hoop and detachably connected thereto, the closed cone supported by and around the perforated cone, and the outer cup or receptacle carried by the closed cone, as and for the purpose set forth. 3rd. In a coffee stopper, the combination, with

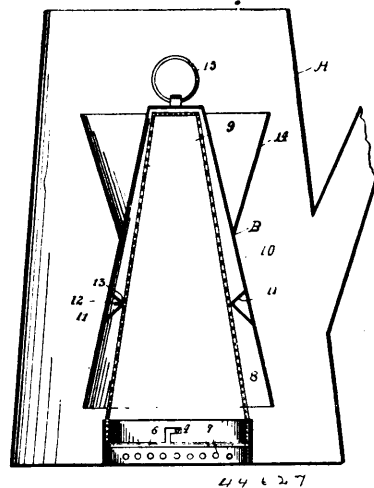

the hoop, having openings in its sides, and the perforated bottom therein above said openings, of the perforated cone rising from the hoop, a bayonet joint connection between them, the closed cone supported by and around the perforated cone, and the cup or receptacle carried by the closed one, as and for the purpose set forth. 4th. In a coffee steeper, the combination, with the hoop, having a perforated bottom, of the perforated cone rising from the hoop and detachably connected thereto, the closed cone surrounding the perforated cone, stops within the closed cone resting against the perforated cone, a pin in the latter engaging a cross slot in one of the stops, and the cup carried by the closed cone, as and for the purpose set forth.

No. 44,628. Wire Reel. (Dévidoir pour fils de fer.)

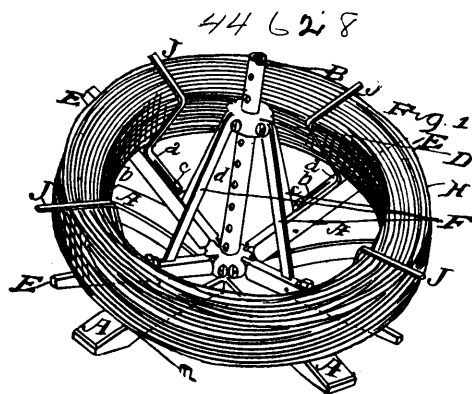

John W. Buchanan, Smithville, Ohio, U.S.A., 3rd November, 1893; 6 years.

Claim.—The combination, with a suitable support, of a rotary spindle, a head C, mounted on said spindle near one of its end portions, arms E, pivotally secured to said head to vibrate transverse thereto, brackets J, secured to the arms E, to slide thereon, sliding head D, and links F, connecting the arms with the sliding head, substantially as described.

No. 44,629. Loom Shuttle. (Navette de métier.)

Stephen M. Hamblin, New Bedford, and Edwin S. Damon, Plymouth, all in Massachusetts, U.S.A., 4th November, 1893; 6 years.

Claim.—1st. A loom shuttle having a horizontal opening in the side of its head, in line with and connecting with the delivery eye thereof, adapted to have the thread from the bobbin passed there-through by the fingers of the operator, and having a horizontal threadway in line with the spindle connecting said opening, with an opening in the side of the spindle cavity, adapted to have the thread passed through it by the fingers of the operative, substantially as and for the purpose described. 2nd. A loom shuttle having a horizontal opening in the side of its head, in line with and con-

necting with the delivery eye thereof, and having a horizontal threadway in line with the spindle, connecting said opening with an opening in the side of the spindle cavity, and having a vertical open-

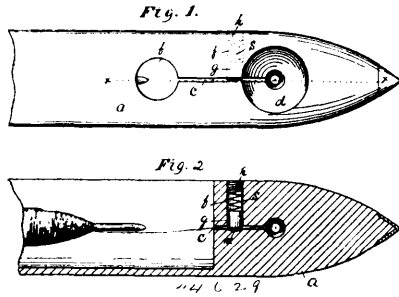

ing connecting said thread way in the track of the thread from the bobbin, a wright fitting loosely in said vertical opening and adapted to pass on said thread, a screw threaded plug adapted to close the outer end of said vertical opening, and be advanced therein at certain time, and a compressible spring interposed between said screw threaded plug and said wright, whereby when the screw threaded plug is advanced or retracted in said vertical opening the wright is caused to bear with greater or less force on the thread and then give the required tension, substantially as shown and for the purpose described.

No. 44,630. Machine for Forming Horse-shoe Blanks.
(Machine pour faire les ébauches de fers à cheval.)

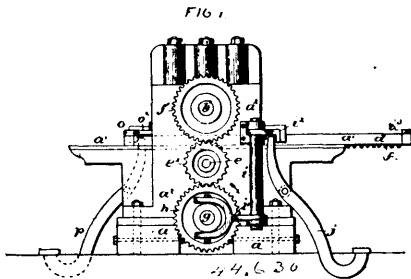

John D. Billings, New York, State of New York, James H. Ruddell and George W. Alexander, both of Detroit, Michigan, all in the U.S.A., 4th November, 1893; 6 years.

Claim.—1st. A machine for forming bars into horse-shoe blanks provided with a positively driven counter shaft having two gear-wheels, whereof one imparts motion to a rack attached to a reciprocating table provided with a die, and whereof the other drives a gear-wheel attached to a revoluble drum or cylinder provided with a die, the construction and arrangement being such that the dies are each driven by the counter shaft through separate gearing, whereby lagging of one of the dies in respect to the other is obviated, substantially as and for the purposes set forth. 2nd. A machine for forming bars into horse-shoe blanks provided with a reciprocating table having a rack and a die, a revoluble cylinder or drum having a gear-wheel and a die, a counter shaft provided with a pinion meshing with said rack, and with a gear as e^2 , meshing with the gear-wheel of the cylinder, a main shaft provided with a gear-wheel for driving the gear e^2 , and means for operating the main shaft, substantially as and for the purposes set forth. 3rd. A machine for forming bars into horse-shoe blanks provided with a reciprocating table having a rack and a die, a revoluble cylinder having a gear-wheel and a die, a counter shaft provided with a pinion meshing with said rack, and with a gear as e^2 , meshing with the gear-wheel of the cylinder, a main shaft provided with a gear-wheel as h , for driving the gear e^2 , and a friction clutch and starting lever for connecting and disconnecting the gear-wheel h , and the main shaft, substantially as and for the purposes set forth. 4th. A machine for forming bars into horse-shoe blanks provided with a reciprocating table having a die, a revoluble cylinder having a die, a main shaft, a counter shaft operated by the main shaft for driving said table forward through the intervention of a rack and pinion, and for driving said cylinder in a corresponding direction through the intervention of the gears e^2 and f^1 , a crossed belt and its complementary pulleys for imparting motion of the main shaft to said dies to drive them in a reverse direction, and friction clutches and their complementary reversing levers, substantially as and for the purposes set forth. 5th. A machine for forming metal bars into horse-shoe blanks provided with a reciprocating table having a die, a revoluble cylinder having a die, a gear-wheel e^2 , for driving said table in one direction through the

instrumentality of a rack and pinion, and for driving said cylinder in a corresponding direction through the instrumentality of a gear-wheel f^1 , a gear-wheel h , for driving the gear-wheel e^2 , a crossed belt and pulleys for driving said cylinder in a reverse direction, whereby the table is driven through the gear-wheel f^1 and e^2 in a similar direction, and tappet arms and their complementary link work and friction clutches for throwing said belt and gear h out of and into engagement with the main shaft at a predetermined point in the travel of the dies, substantially as and for the purposes set forth. 6th. A machine for forming bars into horse-shoe blanks provided with complementary reciprocating and rotating dies, a driving shaft, mechanism adapted to move the dies in one direction, and comprising gear-wheels h , e^2 , and f^1 , and a counter shaft c , a rack f , and a pinion e^1 , a crossed belt n , and pulleys m , and k , for driving said dies in a reverse direction, friction clutches for connecting and disconnecting the gear-wheel h , and the driving pulley with a positively driven main shaft, and tappet arms operated by the reciprocating die and adapted to throw the clutch of the wheel f^1 , out of action at one end of the stroke of the dies and to throw the clutch of the driving pulley out of action at the other end of the stroke, and starting levers for throwing said clutches into action, substantially as and for the purposes set forth. 7th. The combination, in a machine for forming metal bars into horse-shoe blanks, of complementary reciprocating and revoluble dies, a counter shaft, gear-wheel e^2 and f^1 , interposed between the counter shaft and revoluble die, a rack and pinion interposed between the reciprocating die and counter shaft, a main shaft provided with a loose gear-wheel meshing with the gear-wheel e^2 , and with a friction clutch for the loose gear-wheel, a driving pulley loose on the main shaft and connected by a crossed belt with the revoluble die, a friction clutch for said driving pulley, and means for operating said friction clutches, substantially as and for the purposes set forth. 8th. The combination, in a machine for forming metal bars into horse-shoe blanks, of a revoluble die cylinder provided at one extremity with a gear-wheel, and at the other extremity with a pulley, a reciprocating table provided with a rack and a die, a driving shaft provided with a loose pulley connected with the pulley on the cylinder by a crossed belt, a counter shaft provided with a pinion engaging said rack, a gear-wheel loose on the main shaft, an intermediate gear-wheel keyed to the counter shaft and meshing with the gears on the main and cylinder shafts, and means for operating said friction clutches, substantially as and for the purposes set forth. 9th. In a machine for forming bars into horse-shoe blanks, a rotating die, a reciprocating table provided with a die, a driving shaft, spur gearing for actuating the rotating die and table in one direction, a crossed belt and complementary pulleys for actuating the rotating die and table in a reverse direction, friction clutches, rock shafts provided with arms engaging said clutches and with tappet arms, tappet lugs, stops or projections at the respective extremities of the table for automatically operating the tappet arms, and starting and reversing levers, substantially as and for the purposes set forth.

No. 44,631. Spike. (Chevillette.)

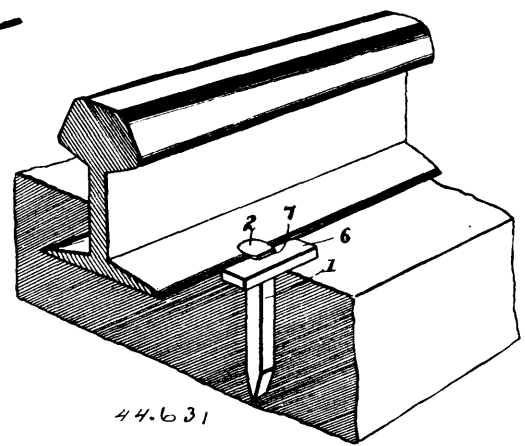

William R. Funk, of Lexington, and Lawrence Doering, Platts-mouth, Nebraska, U.S.A., 4th November, 1893; 6 years.

Claim.—1st. In combination, with a spike having an enlargement formed under the head thereof, a transverse brace provided with a side recess that is fitted over said enlargement on the outer side of the spike below the head and transversely inseparable therefrom, and extending the bearing surface of the same, substantially as described. 2nd. In combination, with a spike having an enlargement under the head thereof, with grooves in opposite edges of the same, a brace having a recess therein with inwardly projecting tongues at the mouth or entrance of said recess arranged to movably fit the said grooves in the enlargement, substantially as described.

No. 44,632. Electrodes for Arc Lamps.
(*Electrode pour lampes à arc.*)

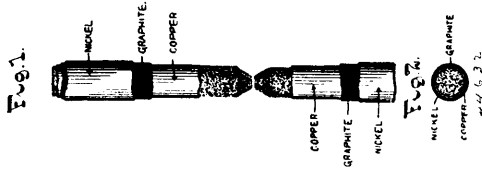

Albert C. Seibold, Mount Vernon, and Charles H. Raymond, New York, all in the State of New York, U.S.A., 4th November, 1893; 6 years.

Claim.—1st. An electrode or carbon, provided with two metallic coatings and an intermediate coating of a non-metallic refractory material, substantially as described. 2nd. An electrode or carbon, provided with two coatings of different metals and an intermediate coating of graphite, substantially as described. 3rd. An electrode or carbon provided with an inner coating of copper, a graphite coating upon said copper, and an external coating of nickel, substantially as described. 4th. An electrode or carbon, provided with a plurality of metal coatings and a non-metallic refractory coating separating the metallic coatings, substantially as described. 5th. An electrode or carbon, provided with a coating of copper, a graphite coating upon said copper, and an external coating of a different metal, substantially as described.

No. 44,633. Line Bar Rings for Harness.
(*Anneau d'attelles de harnais pour guides.*)

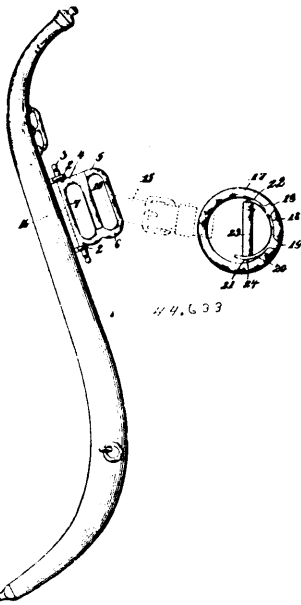

Mortimer C. Flack and Daniel Gross, both of Lake Geneva, and John G. Flack, Elkhorn, all in Wisconsin, U.S.A., 4th November, 1893; 6 years.

Claim.—1st. The herein described line guiding spreader ring, the same having at one side a reduced bearing portion and in line therewith a counter sink or seat, in combination with a tongue having an elongated slot loosely mounted on the reduced bearing portion, a spring interposed between the end of the slot and the bearing portion, and a lug on the free end of the tongue adapted to engage with the counter sink in the ring, substantially as specified. 2nd. The combination, with a hame, a pair of eye bolts extending therefrom, of a frame or ring having end trunnions engaging with the eye bolts, and an intermediate pivoted tongue adapted to close or subdivide the frame, substantially as specified. 3rd. The combination, with a hame and a pair of eye bolts projecting therefrom and in vertical alignment of a ring or frame having opposite trunnions at its inner corners, and its upper side between its ends reduced to form a bearing portion, and its lower side provided with a counter sink, a tongue having an elongated slot whose lower end is provided with a lug engaging with the counter sink, and a coiled spring seated in the slot and at its upper end bearing against the bearing portion, substantially as specified. 4th. A hames ring, comprising a frame, a spring pressed tongue yieldingly pivoted at its end to one side thereof and extending there across, and having a projection at its oppo-

site end adapted to catch in an aperture in the frame, and a spring connected to the tongue for normally holding the same in engagement with the aperture, substantially as specified. 5th. The frame, the tongue slotted at one end to loosely engage and reciprocate upon the same and extending there across, said tongue being provided at its outer free end with a lug for engaging an aperture in the frame, and a spring seated in the slot of the tongue and bearing against the frame to normally press the tongue in a yielding manner into engagement with said aperture, substantially as specified.

No. 44,634. Stringed Musical Hand Instrument.
(*Instrument de musique à cordes.*)

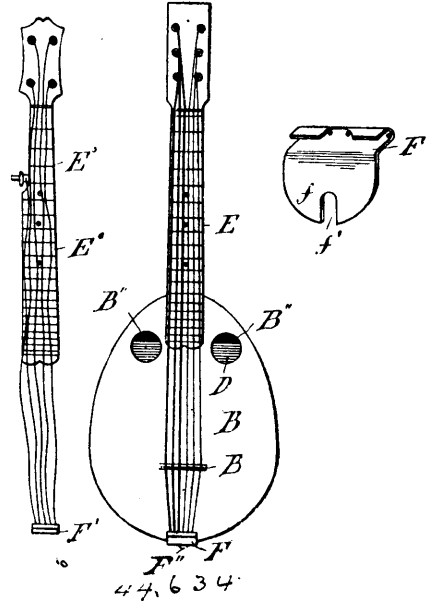

James S. Black and George L. Orme, both of Ottawa, Ontario Canada, 4th November, 1893; 6 years.

Claim.—1st. In a new stringed musical hand instrument, the combination of an oval-shaped flat-backed shell of smaller size than a guitar, with a belly B, having a raised transverse ridge b, extending longitudinally over its entire length, and provided with two sound holes near the neck, a double internal sound board D, carried by a separate internal rim D', a neck secured detachably by means of a doweled butt joint e, and an eyed plate E¹¹¹, secured to the neck end and engaging a pin E¹¹, in the cross grain of the neck joint, and a tail piece having a bent and slotted end engaging a tail pin, substantially as set forth. 2nd. In a detachable neck joint, the combination of a butt face e, having a dowel hole therein, a dowel pin E¹, inserted in the neck end of the rim, and end block adapted to engage said hole, a plate E¹¹¹, secured to the back C, and end block A¹, and having a projecting end with an eye, and a pin E¹¹, inserted in the cross grain of the neck end parallel to the butt face and projecting at the lower end and adapted to engage the eye in the said plate, substantially as set forth. 3rd. In an interchangeable neck for stringed hand instruments, the combination with the shell of a neck having a butt joint fitted against the neck end of the shell, the dowel pin E¹, inserted in the rim and engaging a dowel hole in said butt face, the plate E¹¹¹, secured to the back under the end block and having a projecting end with an eye, a pin E¹¹, inserted in the cross grain of the neck end and projecting below and engaging the eye in said plate, a tail piece having a bent end f, with a slot f', a tail pin or screw F¹¹, in the tail end of the shell adapted to engage said slot in the tail piece, and the strings secured to said tail and the head of the neck, substantially as set forth. 4th. A new stringed musical hand instrument having a shell of smaller size than a guitar and similarly constructed, but consisting of an oval shaped belly B, having a raised ridge b, extending from end to end and provided with sound holes or sound hole, flat back of similar shape joined by a flat rim A, and fitted with a guitar or banjo neck, substantially as set forth. 5th. A new stringed musical hand instrument having a shell of smaller size than a guitar and similarly constructed, but consisting of oval shaped belly and back joined by a flat rim and fitted with a guitar or banjo neck, substantially as set forth.

No. 44,635. Shoe Tip. (*Protecteur de chaussures.*)

The American Shoe Tip Company, assignees of George W. Dixon, all of Lynn, Massachusetts, U.S.A., 4th November, 1893; 6 years.

Claim.—1st. A shoe tip or toe protector having a flap extending from the edge of the upright portion thereof, said flap being turned

over against said upright portion, and having the full original thickness of the material retained in the upright portion in front of the

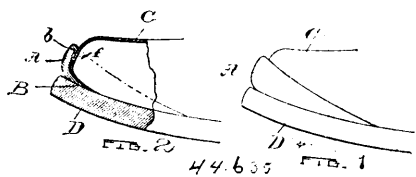

turned over flap, substantially as described. 2nd. A moulded shoe tip consisting of a strip of material which is formed with a shoulder on its rear side, and with a flap of reduced thickness extending from said shoulder to one side of the strip, said flap being turned back on the main thickness of the strip on the line of fold which is determined by the said shoulder, and the tip being moulded into shape by pressure, substantially as set forth. 3rd. The process of manufacturing shoe tips which consists in first forming a shoulder on one side of a strip of material, and skiving the said material from the said shoulder to one edge of the strip, then folding the flap of reduced thickness thus formed over the shoulders on a line which is determined by the said shoulder, and finally moulding the tip to shape under pressure, substantially as set forth.

No. 44,636. Method of Preparing Substitutes for Coffee. (*Méthode de préparer des substituts au café.*)

Henrich Trillich, Munich, Germany, 7th November, 1893; 6 years.

Claim.—1st. A process for the production of roasted cereals and malts containing coffee, consisting in preparing an aqueous extract of raw unroasted coffee substances from unroasted coffee or coffee wastes, leaves, blooms and the like, impregnating therewith the cereal or malt and then roasting said cereal or malt, substantially as set forth. 2nd. The process of producing flavoured coffee substitutes consisting of impregnating cereals or malts with an aqueous extract of unroasted cocoa rind, kolanut, matté leaves, tea and other substances containing caffeine or caffeine solutions and then roasting said cereals or malts, substantially as set forth.

No. 44,637. Process for Preserving Food.

(*Procédé pour conserver les aliments.*)

Henrich Lorenz Carl Paulsen, Hamburg, St. Pauli, Germany, 7th November, 1893; 6 years.

Claim.—1st. The hereinbefore described method for preserving articles of food, which consists in immersing them in or coating or surrounding them with a mixture of glycerine boracic acid gelatine and water prepared, substantially as set forth. 2nd. A mixture for preserving articles of food, consisting essentially of boroglycerine water and gelatine prepared, substantially as hereinbefore described.

No. 44,638. Non-Conducting Covering.

(*Couverture non-conductrice.*)

Robert H. Martin, New York, State of New York, U.S.A., 7th November, 1893; 18 years.

Claim.—1st. The method herein described of making bats or sheets, consisting in feeding to a suitable machine, the fibrous material in soft flockulent condition and simultaneously therewith distributing throughout the fibrous material, adhesive material, substantially as set forth. 2nd. The method herein described, consisting in feeding to a suitable machine asbestos fibre, and simultaneously therewith feeding cementitious material in dry and finely divided condition and subjecting the resulting bat or sheet to the action of an agency which will make the adhesive material adhesive substantially as set forth. 3rd. As a new article of manufacture, a soft, flexible, elastic and porous bat or sheet, embodying asbestos fibres, which are attached together throughout the sheet or bat at separated points of adhesion, substantially as set forth.

No. 44,639. Bicycle. (*Bicycle.*)

Friedrich Wiechard, Cassel, Prussia, German Empire, 7th November, 1893; 6 years.

Claim.—Velocipede wheel tires characterized by the use of the rubber casing *m*, adapted to be laced together over the felloe of a velocipede wheel and which casing has cast on its inner surface rubber cushions *k*, in such a manner that the round, oval or angular, etc., dome-shaped recesses *f*, arranged alternately beside each other constitute with their walls at the same time a wall of the adjacent recess, also of a number of hollow balls of celluloid and of the perforated rubber packing pieces *b*, which are recessed at each

longitudinal end in the form of a hemisphere or of bent or curved celluloid tubes *c*, closed at one end in which are inserted at certain

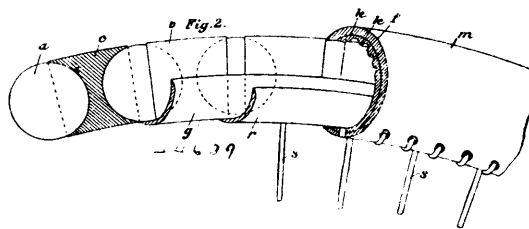

intervals of distances perforated rubber packing pieces *b*, hemispherically recessed at each longitudinal end for the purpose of constructing an inner tire.

No. 44,640. Corset. (*Corset.*)

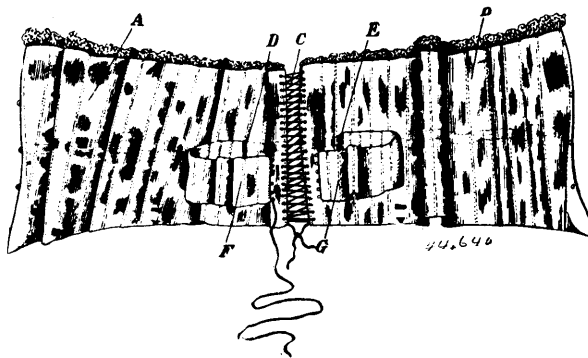

Minna Meyer, Oldenburg, Empire of Germany, 7th November, 1893; 6 years.

Claim.—In corsets, the use of an inner foundation consisting of two encased whalebone belts or bands, having their inner ends secured to the corset and their outer ends provided with eye-lets or other suitable device for the purpose of fastening the same round the body of the wearer, substantially as described and illustrated.

No. 44,641. Gas Stove for Cooking.

(*Poêle de cuisine à gaz.*)

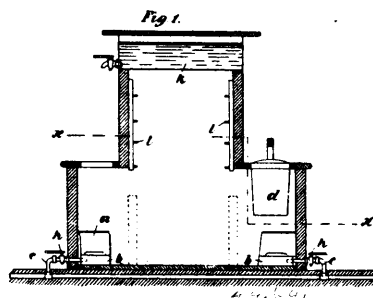

William Frederick A. Külle, Stuttgart, German Empire, 7th November, 1893; 6 years.

Claim.—1st. A gas cooking stove, having a regenerative gas hearth within a closed oven or stove arranged in such manner that the air to support combustion and introduced from the exterior, is caused to come into the contact with the sides of channels formed between the top plate of the gas mixing chamber and a covering plate, the perforated projections on the top plate of the gas chamber passing through slightly larger openings in the covering plate so as to cause the air to escape through narrow slots in order to mix with the gases for combustion, substantially as herein shown and described. 2nd. In a gas cooking stove, a gas hearth having flanges *r*¹, *r*², *r*³, so as to form, in combination with the bottom and walls of the stove, a chamber which is in communication with the outer air and causes the incoming air to be heated by contact with the hot walls of the hearth, the passages *u*, the plate *n*, of the gas collecting chamber *i*, the ribs *o*, and cover plate *v*, with ribs *p*, and to mix with the gases at the place of combustion, substantially as herein shown and described. 3rd. The arrangement of the regenerative gas hearth applied either singly or in series to gas stoves in such manner that

the air to support combustion becomes previously heated by contact with the hot walls of the hearth in the interior of vertical passages formed between the hearth and the outer walls of the stove, substantially as herein shown and described. 4th. In a gas stove, the combination of a regenerative hearth with air heating passages, substantially as herein shown and described and for the purpose stated.

No. 44,642. Holder for Animals.
(Attache pour animaux.)

Fig. 1

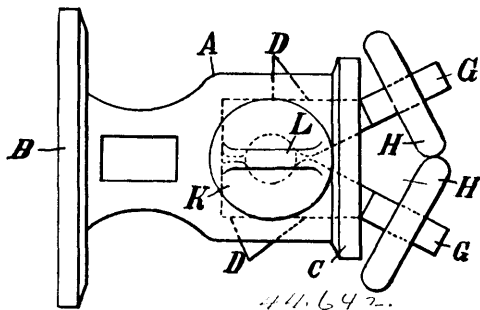

Johann W. Ziellenbach, Crefeld, German Empire, 7th November, 1893; 6 years.

Claim.—For use in securing horses or other animals in stables or other buildings, the hereinbefore described fastening or fitting consisting in connecting pieces, E, E, which are provided with rings and are capable of being placed singly or together in a cavity or opening formed in a holder A, secured in or to the wall or beam or other suitable part of the stable or other building in which the said fastening or fitting is to be employed, and of being secured in the cavity or opening in the said holder A, by means of a pin or stud F, inserted into such holder and capable of being quickly withdrawn therefrom in order to release such connecting pieces, E, E, from the holder A, in case of fire or flood or other accident or danger, substantially in the manner hereinbefore described and illustrated.

No. 44,643. Firebar. (Barreau de grille.)

Fig. 1.

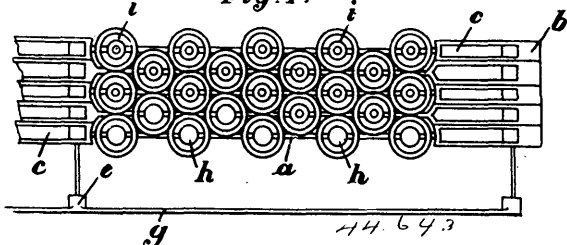

Carl Mohring, Pankow, Prussia, German Empire, 7th November, 1893; 6 years.

Claim.—1st. A firebar, the fire covered surface, of which is provided with annular cylindrical passages *h* or *i*, for air admission, and with end parts or heads *b*, having holes or passages *c*, with valves *d*, substantially as described and shown.

No. 44,644. Hook and Eye. (Crochet et œillet.)

Fig. 1.

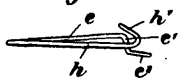
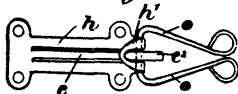

Fig. 2.



44,644

Heinrich Mentzel, Berlin, Prussia, German Empire, 7th November, 1893; 6 years.

Claim.—A hook provided with a stop spring, which is prolonged

so as to form a nose projecting outwards to the front of the base of the hook, whereby the latter can be opened directly, and in which the stop spring by the arrangement of a vertical closing surface is adapted to prevent the automatic opening, constructed and arranged, substantially as hereinbefore described.

No. 44,645. Method of and Apparatus for Producing Peat Briquettes. (Méthode et appareil pour la production de briquettes de tourbe.)

Fig. 2

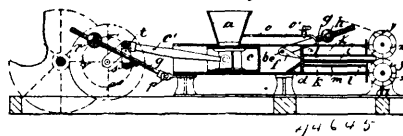

Emanuel Stauber, Hamburg, German Empire, 7th November, 1893; 6 years.

Claim.—1st. A process for the production of peat briquettes, consisting in pressing the wet peat as got from the bog for the purpose of partially freeing it from water, in moulding it into single briquettes in completely drying and hardening the briquettes in a continuous action drying oven, and finally in coking the dried briquettes away from the air in a continuous action coking furnace. 2nd. A machine for drying raw peat consisting of a chamber provided with a feed hopper, of a piston reciprocated in the chamber past the hopper opening, and of an adjustable resistance device at the opposite end of the chamber to the hopper, the whole substantially as set forth. 3rd. In a press for expressing moisture from the raw peat, the combination with perforated parts bearing on the said material, of a jute or gauze covering, substantially as described. 4th. In a press for drying raw peat, a weighted lever *g* adapted to be raised by the crank during the latter half of the back motion and first part of the forward motion to store power, and adapted in falling to act on the crank during the latter half of the forward motion and first half of the back motion, substantially as described. 5th. A machine for drying raw peat, consisting of a chamber provided with a feed hopper, of a piston reciprocated in the chamber past the hopper opening, and of a series of heating tubes situated at the end of the said chamber and through which the plastic material is forced, substantially as described for the purpose set forth. 6th. A machine for drying and moulding into blocks raw peat, consisting of a chamber provided with a feed hopper, of a piston reciprocated in the chamber past the hopper opening, and of two moulding rollers provided with corresponding recesses of the shape of the briquettes, and between which the plastic peat is formed, substantially as described for the purpose set forth. 7th. A continuous action drying oven for peat briquettes, consisting of a series of superposed drying plates, and of a series of travelling bands for carrying the briquettes over the drying plates, substantially as described. 8th. A continuous action coking furnaces for peat briquettes, consisting of a coking space, of a removable fire box underneath the fire box, of a removable damper plate separating the coking space for the fire box, of air inlet pipes to the coking space, of outlet pipes connected to exhaust ventilators from the coking space and of a winged disc arranged below the coking space, and adapted to remove the coked briquettes when the fire box is removed, the whole substantially as described.

No. 44,646. Ice Cream Freezer.

(Appareil réfrigérant pour crèmes.)

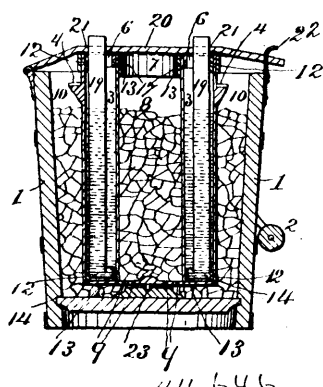

James Foster, Starkville, Mississippi, U.S.A., 7th November, 1893; 6 years.

Claim.—1st. In an ice cream freezer, the dashers and the dasher frame having its ends formed by two rings one within the other, the

two outer rings being rigidly connected together by means of two of the dashers, substantially as set forth. 2nd. The combination with an ice cream freezer, the rings forming the top and bottom of the dasher frame, the dasher rigid with the rings, the movable dashers, and the arms 15 connecting the rings, and in which the said movable dashers are pivoted, substantially as set forth. 3rd. In an ice cream freezer, the dasher frame, the journal arms 15, the movable dashers pivoted at their ends in the said arms, the cream receptacle having a central ice well, and means such as shown and described for holding the dasher frame fixed in the said receptacle, as set forth. 4th. In an ice cream freezer, the dasher frame, the movable S-shaped dashers pivoted at their ends in the journal arms of the frame, the cream receptacle, the ice well formed in the receptacle, and means such as shown and described for holding the said frame fixed in the said receptacle, for the purpose set forth. 5th. The combination with an ice cream freezer, the cream receptacle having the circular toothed flange, the central ice well formed integral with the bottom of said receptacle, and having itself a perforated bottom, the dasher frame secured in the cream receptacle, and the cap or cover 5 having slots 6, through which two of the dashers of the said frame project, substantially as and for the purpose set forth. 6th. The tub 1, the locking bar hinged to the tub and provided with slots, in combination with the cream receptacle, the central ice well having a perforated bottom and an open top, the cap or cover 5 having slots, the dasher frame having rigid and movable dashers, the said rigid dashers projecting through the cover, and means such as shown and described for revolving the said receptacle, as set forth. 7th. The tub 1, the journal bearing formed in the centre of the bottom of the tub, the locking bar hinged to the tub, and the shaft journalled upon the rim of said tub, having one end provided with a pinion, and upon the other end an operating handle, in combination with the cream receptacle provided with a toothed flange engaged by the said pinion, and having a central pivot in its bottom to rest in said bearing of the tub, the ice well, formed in the centre of the cream receptacle, the dashers, and the dasher frame, two of said dashers projecting through the locking bar so as to hold the dasher frame rigid with the tub while the cream receptacle is revolved, substantially as shown and described.

No. 44,647. Playing Cards. (*Jeu de cartes.*)

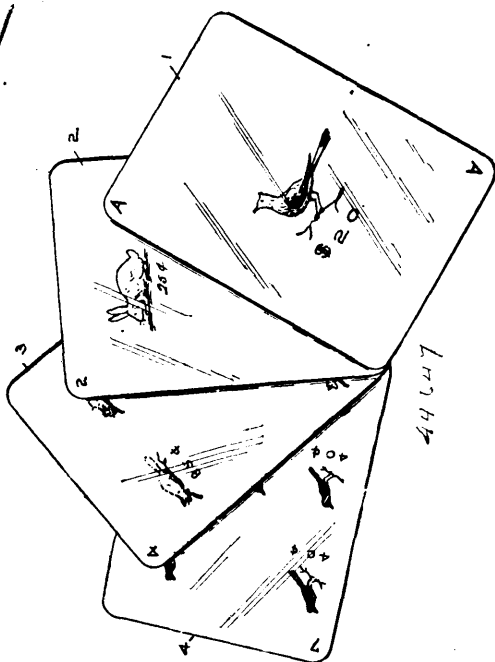

Thomas A. Cole and Josiah P. Perkins, both of Indianapolis, Indiana, and Tito M. Lash, Sacramento, California, all in the U.S.A., 8th November, 1893; 6 years.

Claim.—1st. A deck of playing cards in which the suits are indicated by illustrations of real objects or persons, substantially as shown and described. 2nd. A deck of playing cards provided with illustrations indicating the suits, and numerals placed thereon to indicate the value of the cards, substantially as shown and described. 3rd. A deck of playing cards in which the suits are indicated by illustrations of real objects or persons, and the value of the cards by numerals located under each of such illustrations, substantially as shown and described. 4th. A deck of playing cards in which the suits are indicated by illustrations of objects possessing commercial value, and the value of the cards is indicated by figures placed under each illustration, showing substantially the commercial value of the object of such illustration, substantially as shown and described.

scribed. 5th. A deck of playing cards in which the value of the face cards is indicated by representation thereon of coins, substantially as shown and described. 6th. A deck of playing cards consisting of fifty-two cards having indicated thereon their various commercial values, and a number of other cards containing lists of educational facts, substantially as shown and described.

No. 44,648. Revolving Firearms.

(*Arme à feu à cylindre roulant.*)

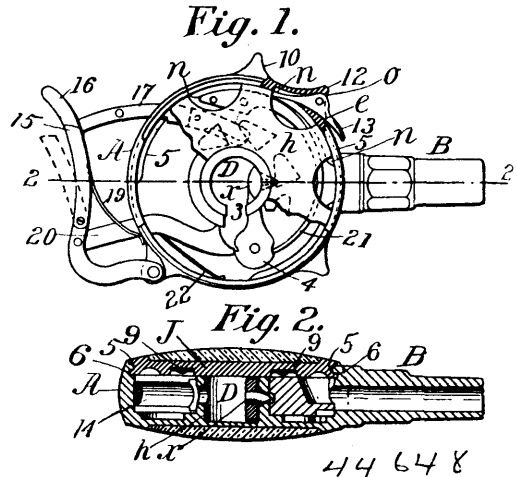

Peter Henry Finnegan, Chicago, Illinois, U.S.A., 8th November, 1893; 6 years.

Claim.—1st. In a revolving firearm of the class described, a cylindrical case, a cartridge cylinder having an intermittent rotary movement in said case and having recesses in its periphery, combined with a safety latch pivotally hung on the border of said case, one end of which passes through said border, a spring under one end of said latch operating to retain the opposite end thereof normally in engagement with any one of said recesses, substantially as set forth. 2nd. In a revolving firearm of the class described, the cylinder case having the integrally formed tubular breech block centrally located therein, said block having a slot through its side extending from its extremity to its base, whereby the nose of the hammer may be passed therethrough, substantially as set forth. 3rd. A case A, having the finger rests 10, 12, on its border, one behind the other, combined with a safety latch pivotally hung on the border of said case, and having one end opposite the forward side of said projection 12 and its opposite end extending through said border in proximity to the periphery of the cylinder h, said rear rest 10 serving as an abutment for the finger for carrying the arm, thereby leaving the outer end of said latch free, combined and operating substantially as set forth. 4th. In a revolving firearm of the class described, means for locking and removing the cover of the cylinder case, consisting of sections of inwardly extending flanges 5, 5 on the borders of said case, at the end of one of which flanges is a stop to arrest the circular movement of the case-cover, combined with a cover having sections of flanges thereon to engage under those of said case, one of said cover flanges having a cam 7 at one end to engage with one end of one of said case flanges, thereby causing the cover to be lifted from the case when turned in one direction, substantially as set forth.

No. 44,649. Apparatus for Steaming Grain.

(*Appareil pour échauder les grains.*)

Herbert S. Jewell, Brooklyn, New York, U.S.A., 8th November, 1893; 6 years.

Claim.—1st. A grain steaming apparatus having means, substantially as described, for carrying off the surplus steam and the dust from the entering grain, arranged at the upper part of the apparatus where the grain enters, whereby the formation of slime in the apparatus is prevented. 2nd. A grain steaming apparatus comprising an upright conduit having a grain inlet at its upper part, a valve controlled outlet at its lower part, a steam nozzle within the conduit, and an air exhausting mechanism connected with the upper part of said conduit for removing the surplus steam and the dust from the grain. 3rd. A grain steaming apparatus, having an automatically regulated outlet valve for the grain, said valve consisting of the hinged flaps 5, the sides 6, of flexible material secured to and connecting the flaps 5, and adjustable weights on said flaps which tend to close the valve. 4th. A grain steaming apparatus, comprising a conduit of wood or like non-heat conducting material, having an inlet for grain at its upper part, and an outlet for the same at its lower part, a steam nozzle arranged within said conduit, and means for drawing off the surplus steam and the dust at the upper part of said conduit. 5th. A grain steaming apparatus comprising a con-

duit, having a grain inlet at its upper part and a grain outlet at its lower part, a steam nozzle in said conduit, an air exhauster, a trunk

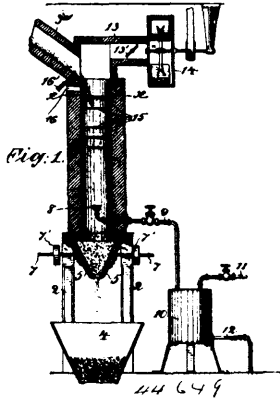

connecting said air exhauster with the upper part of said conduit, and means for regulating the force of the draft through said trunk. 6th. A grain steaming apparatus comprising a conduit having a grain inlet at its upper part, a grain outlet at its lower part, and an air inlet 16 arranged below the grain inlet, a steam nozzle arranged within said conduit, an air exhauster, and a trunk connecting said air exhauster with the upper part of said conduit, whereby the air entering at the inlet 16 is compelled to pass through the inflowing grain on its way to the air exhauster.

No. 44,650. Metallic Shingles. (Bardeau métallique.)

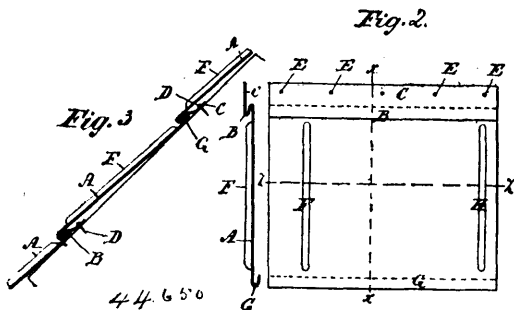

Herbert W. Kincaid, Athens, Ontario, Canada, 8th November, 1893; 6 years.

Claim.—1st. A metallic shingle or plate A, having a double turn or S-shaped fold B, and a nailing edge C, parallel thereto, a U-shaped fold G, turned downwardly and inwardly at the opposite edge of the shingle and parallel to the double fold B, a corrugation F, near to the covering line, and a corrugation H, near the weather edge, said corrugations terminating near said folds and at right angles thereto, as set forth. 2nd. A metallic shingle, having a nailing strip or portion C, along one edge, a double fold B, parallel thereto, a single fold G, parallel to said double fold, and corrugations H, F, intervening said folds and at right angles thereto, substantially as described for the purpose set forth.

No. 44,651. Machine for Raising all Kinds of Liquids. (Appareil pour pomper les liquides.)

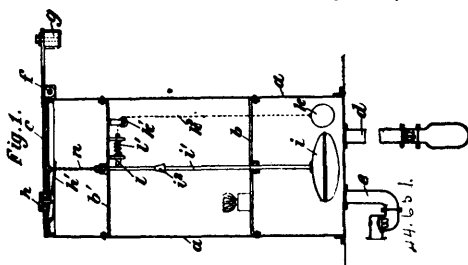

Richard Wegner, New Britz, Kingdom of Russia, 8th November, 1893; 6 years.

Claim.—1st. The improved apparatus for raising or elevating liquids, in which, owing to combustion which takes place within a vessel or chamber a, closed on all sides, a reduction of the pressure

of the air confined therein is effected, and consequently liquid is forced into the said vessel, whereupon, when communication is restored between the interior of the vessel and the external atmosphere, the liquid is allowed to run off. 2nd. The improved apparatus for raising or elevating liquids, characterized by a float i, which is raised by the liquid drawn in by suction and open the cover or lid of the vessel a, the said float being retained at the topmost limit of its upward movement by a spring-bolt l, operated by a second float k, until nearly all the liquid raised has run off, for the purpose of causing the vessel to automatically and intermittently close and open. 3rd. In an improved apparatus for raising and elevating liquids, the combination of the chamber a, and the provision therein of a constantly burning flame, which flame, after burning for a short time, diminishes to a small size in consequence of the diminution of the quantity of oxygen contained in the air, but expands again to its normal size when fresh air is re-admitted, whereby the air confined in the vessel or chamber is automatically heated to an intermittently increasing and decreasing temperature. 4th. The combination, with an apparatus for raising liquids by the alternate heating and cooling of an air chamber, of a process for rendering more complete the vacuum produced by cooling within the closed vessel or chamber, which consists in periodically introducing either certain substances capable of absorbing the products of combustion generated by the heating flame or in the periodical combustion of bodies, yielding solid products or combustion, and thereby absorbing the oxygen contained in the air. 5th. In an improved apparatus for raising and elevating liquids, a bolt l, controlled by a float k, adapted through the medium of a tappet-shaped enlargement or projection formed on the float-rod i, to temporarily retain the first or main float i, in its highest position, for the purpose of admitting a fresh supply of air for the next succeeding operation into the interior of the chamber or vessel. 6th. In an improved apparatus for raising and elevating liquids, the arrangement in storeys or floor of a number of vessels or receptacles 1, 16, 3, closed on all sides and connected by pipes and fitted with suitably arranged valves, so that as a vacuum is created in the vessel 1, liquid is conveyed or drawn in by each of the closed vessels periodically and simultaneously, the water raised from the lowest point being first delivered into an open vessel, then raised to the next storey and there again discharged, and so forth, until the water is carried to the extreme height or limit to which it is intended to be lifted.

No. 44,652. Process for Producing Basic Lead Salts and Obtaining certain Lye Products. (Procédé pour la production de sel basique de plomb et en obtenir certains produits.)

George Lunge, Zurich, Switzerland, and Cecil Henry M. Lyte, Fimborough Road, London, S. W., England, 8th November, 1893; 6 years.

Claim.—1st. The herein described process of producing a basic insoluble or sparingly soluble salt of lead, and caustic alkali, which process consists in dissolving oxide of lead in nitric acid, decomposing the nitrate of lead by a soluble salt of an alkali in the presence of some free base, so as to produce the basic salt of lead required, and a pure nitrate, then forming by double decomposition of this nitrate with ferric oxide, by means of heat, air and steam, nitric acid for use over again and a ferrite corresponding in its base to that of the soluble salt used, then decomposing this ferrite into ferric oxide for use over again, and caustic alkali. 2nd. The herein described process of producing basic lead carbonate and caustic alkali, which process consists in dissolving lead oxide in nitric acid, decomposing the lead nitrate by sodic carbonate and caustic soda, so as to form basic lead carbonate and pure sodic nitrate, then forming by double decomposition of this nitrate with ferric oxide, by means of heat, air and steam, nitric acid for use over again and ferrite of soda, and then the decomposing of this ferrite into ferrite oxide and caustic soda, as specified. 3rd. The herein described process of producing a basic insoluble or sparingly soluble salt of lead and caustic alkali conjointly with the recovery of silver as silver lead, and of nitric acid and ferric oxide for use over again, which consists in oxidizing crude pig lead, converting the lead oxide into lead nitrate, precipitating the silver from the lead nitrate with finely divided lead, forming the basic salt of lead by addition of an alkaline carbonate and some free base, decomposing the alkaline nitrate formed by means of ferric oxide, heat, air and steam, decomposing the resulting ferrite into ferric oxide and caustic alkali, as specified.

No. 44,653. Key Opening Sheet Metal Cans. (Clef pour ouvrir les boîtes métalliques.)

The National Key Opening Can Company, assignee of John Zimmerman, all of Chicago, Illinois, U.S.A., 8th November, 1893; 6 years.

Claim.—1st. The method of constructing the bodies of hermetically sealed sheet metal key opening cans of the class having a free lip or tongue which forms a prolongation of a detachable circumferential strip of the body sheet, which method consists in slitting one side edge of the sheet to form the tongue, forming a weakened line parallel with the end of the sheet and continuous with the slit, or with each slit if more than one, placing the opposite side edge of

the sheet in the slit beneath the tongue and over the remainder of the slitted edge, and finally passing a soldering tool along the super-

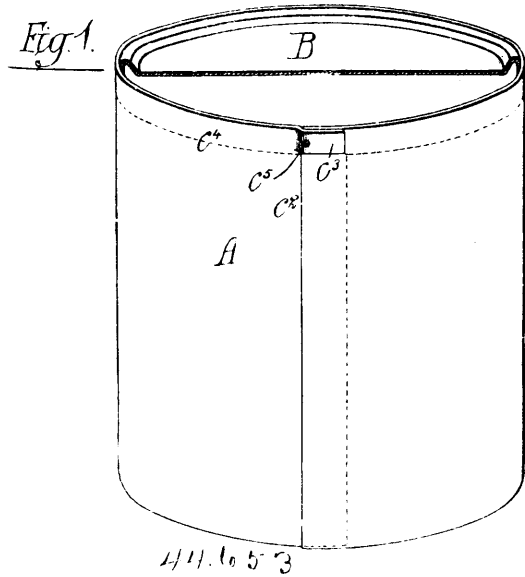

posed edge and over the base of the tongue, whereby the oppositely overlapping surfaces are soldered in a straight line from end to end of the body, leaving the end of the tongue free. 2nd. A hermetically sealed sheet metal can, having the body described, said body consisting of a sheet of single thickness throughout, which has as a part thereof a circumferential detachable strip, the extremity of which is a free tongue that is laterally disconnected from the body by a slit or slits in one margin of the sheet, the opposite margin of the sheet being beneath the tongue and elsewhere throughout superposed upon the slitted edge of the sheet to form a lapped side seam, and a straight continuous line of solder extending along the said superposed edge and beneath the base of the tongue. 3rd. A sheet metal can formed of a sheet which is lapped and soldered at its opposite margins, said sheet having a circumferential detachable strip terminating at one of the soldered margins in a free tongue, which is perforated at or near its base, and has its perforation or perforations filled with solder. 4th. A sheet metal blank for a can or other closed vessel, having a detachable strip terminating at one edge of the blank in a free tongue and provided with one or more apertures in said strip at or near the base of the tongue, substantially as set forth.

No. 44,654. Treating Compounds with Gutta Percha and Rubber. (*Traitement de composés avec du gutta percha et du caoutchouc.*)

Robert Hutchison, Springvale Mills, Cowlaers, County of Lanark, Scotland, 8th November, 1893; 12 years.

Claim.—1st. In treating or preparing gutta percha or rubber or mixtures thereof for various purposes, the combining therewith of the substance hereinbefore referred to or described as lanichol. 2nd. Forming compounds of gutta percha, or of rubber, or of gutta percha and rubber, with lanichol by boiling a mixture of the same with lanichol in a dilute solution of alkali, substantially as hereinbefore described.

No. 44,655. Plaster. (*Plâtre.*)

Rudolf Bammann, Berlin, Prussia, Germany, 8th November, 1893; 6 years.

Claim.—The employment of alkali silicate in connection with a silicate of alkaline earths or silicate of heavy metals, preferably alkali silicate with zinc, in the preparation of the plaster, for imparting thereto a marble like lustre, substantially as set forth.

No. 44,656. Mill for Cutting Grain.

(*Moulin pour moudre le grain.*)

George A. Engle, Baxter, Iowa, U.S.A., 8th November, 1893; 6 years.

Claim.—1st. In a mill for cutting grain and making flour, a skeleton frame or cylinder composed of a bottom circular plate or ring, having radial grooves in its top surface to admit the lower edges of horizontally projecting cutters, a mating top plate having corresponding grooves in its under side to admit the top edges of the same cutters, and coinciding radial arms or projections extending outwardly and rigidly connected by means of vertical bars or posts, in combination with a horizontally and vertically adjustable support and a rotating grain distributor, for the purpose stated. 2nd. In a

mill for cutting grain and making flour, a case having an annular inwardly extending flange at its bottom, a ring having radial arms adapted to overlap said flange, screws extending vertically through said flange to engage said arms, screws extended horizontally through the case to engage the same arms, and a cylinder or frame having radial cutters supported and carried by said adjustable ring, arranged and combined to operate in the manner set forth for the purpose stated. 3rd. In a mill for cutting grain and making flour,

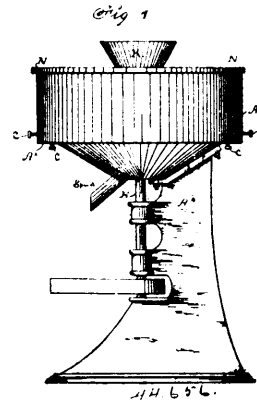

a cylindrical case having an opening in its top adapted to admit grain, and a flange extending horizontally inward at its bottom, a ring having radial arms adjustably connected with the said flange, a circular frame having cutters radially attached to the said ring, a mill spindle extending upward through the center of the case and the ring, and a grain distributor fixed to the top of the spindle, arranged and combined to operate in the manner set forth for the purposes stated. 4th. A mill for cutting grain and making flour, comprising a stand adapted to support a case having an opening at its bottom, and a mill spindle in concentric position with the case, a circular rotating grain distributor having a closed bottom, an opening in the top and vertical radial slots in its circumference, fixed to the top of the spindle, a ring adjustably connected with the bottom of the case adapted to support and carry a cylindrical frame carrying cutters, a cutter carrier consisting of a skeleton frame having radial grooves in the top face of its bottom and coinciding grooves in the bottom face of its top, cutters fitted in said grooves and detachably fastened therein, and a hopper connected with the top and center of the case, arranged and combined to operate in the manner set forth.

No. 44,657. Spindle Attachment.

(*Attache pour broches de machine à filer.*)

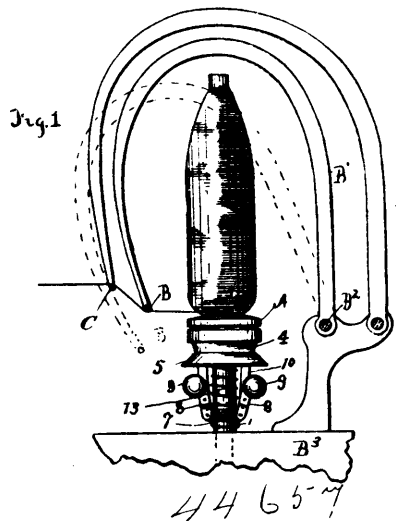

Leonard W. Huyck and Ethan Allen, both of Rochester, New York, U.S.A., 8th November, 1893; 6 years.

Claim.—1st. In a yarn holder for spindles, the combination with the separable yarn holding jaws and a spring for closing them, of an automatic device for separating said jaws by the rotation of the spindle, substantially as described. 2nd. In a yarn holder for spindles, the combination with the separable yarn holding jaws, of an automatic device for separating said jaws by the rotation of the spindle, substantially as described. 3rd. In a yarn holder for spin-

dles, the combination with the separable yarn holding jaws and a spring for holding them, of a rotary governor device connected to one of the jaws and separating them when the spindle is in motion, substantially as described. 4th. In a yarn holder for spindles, the combination with the separable yarn holding jaws and a spring for closing them, of the toggle arms connected to the spindle and operating on one of the jaws, one of the arms of each toggle being weighted, substantially as described. 5th. In a yarn holder for spindles, the combination with the separable yarn holding jaws, the ring engaging one of the jaws, and the spring for moving it, of the toggles formed by the weighted arms, and links pivoted together and also pivoted to the spindle and ring, substantially as described. 6th. As an article of manufacture, a yarn holder adapted to be applied to a spindle, consisting of a tubular body having a bobbin holding device and separable yarn holding jaws thereon, of a jaw opening device operated by the movement of the spindle operating to separate the jaws when the spindle is rotated, substantially as described. 7th. As an article of manufacture, the combination, a yarn holder adapted to be applied to a spindle, consisting of a tubular body having bobbin holding devices thereon and separable yarn holding jaws, the jaw next the bobbin being relatively smaller than the other one, and smaller than the base of the bobbin, and a spring for closing the jaws, substantially as described. 8th. As an article of manufacture, a yarn holder adapted to be applied to a spindle, consisting of a tubular body having bobbin holding devices and the lower split portion, yarn holding jaws on said body, the collar encircling the lower split portion having the securing screw, weighted toggle arms connected to the collar and operating on the movable yarn holding jaw, and the spring arranged between the collar and the yarn holding jaw for holding it closed, substantially as described. 9th. In a yarn holder, the combination with two separable jaws, the upper one relatively smaller than the lower and smaller than the base of the bobbin, and a spring for holding said jaws together, whereby the jaws may be separated and the bobbin removed by a single tool, substantially as described.

No. 44,658. Chain Coupler. (Joint de chaînes.)

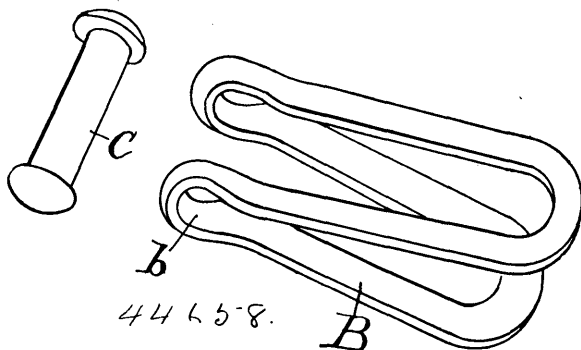

Cyrus Freeman Noble, Baldwin, Maine, U.S.A., 8th November, 1893; 6 years.

Claim.—A chain coupling composed of a link partially doubled on its centre to form an incomplete eye, combined with a double headed bolt adapted to slip laterally into said eye, substantially as described.

No. 44,659. Can Opener.

(Appareil pour ouvrir les boîtes métalliques.)

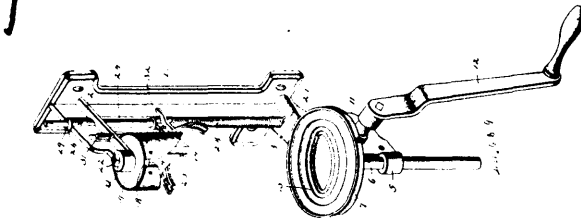

Charles Morgan, Seth H. McEuen and Liness H. Thayer, all of Latah, Washington, U.S.A., 8th November, 1893; 6 years.

Claim.—1st. In a can opener, the combination of a frame, a stationery depending knife, a vertically movable plunger provided with a rack, and having at its upper end a horizontal can support located beneath the knife, a cog-wheel mounted on the frame and meshing with the rack of the plunger, a shaft secured to the cog-wheel, and means for turning the shaft to operate the plunger, substantially as described. 2nd. In a can opener, a knife provided with tapering blades, and having an intervening space, and provided at the inner end of the space with a blade, substantially as described. 3rd. In a can opener, a knife having tapering blades

and provided with an intervening space, and having at the inner end thereof a depending cutting blade curving inward and adapted to complete the cut and to lift the severed portion of a can, substantially as and for the purpose described. 4th. In a can opener, a knife approximately cylindrical, and provided with integral tapering blades, and having an intervening Y-shaped opening forming an integral inner blade curving inward, substantially as and for the purpose described. 5th. In a can opener, the combination of a frame having arms arranged opposite each other, a knife secured to one of the arms, a plunger mounted on the other and provided with a can support, means for operating the plunger, and a spring actuated clamp mounted on the frame and arranged adjacent to the knife and having a movement longitudinal of the knife to free a can, substantially as described. 6th. In a can opener, the combination of a frame, a curved knife, a plunger carrying a can support arranged opposite the knife, means for operating plunger, and a spring actuated clamp provided with curved arms fitting around the knife and adapted to engage the top of a can, substantially as and for the purpose described. 7th. In a can opener, the combination of a frame, a knife secured to the frame, a plunger mounted on the frame and carrying a can support, means for operating the plunger, a longitudinally movable rod arranged in bearings of the frame and having a limited movement, a clamp secured to the rod and carried by the same and arranged to engage a can, and a spring for returning the clamp, substantially as described. 8th. In a can opener, the combination of a frame, a knife, a plunger carrying a can support arranged opposite the knife, means for operating the plunger, a longitudinal rod mounted in bearings of the frame and having a limited movement, a clamp secured to the rod and a spiral spring disposed on the rod and connected to the clamp and to the frame, substantially as described. 9th. In a can opener, the combination of a frame, provided with a longitudinal rib, a knife secured to the frame, a plunger mounted on the frame and carrying a can support, means for operating the plunger, a rod arranged in bearings of the frame and having a limited movement and arranged parallel with the rib, a clamp secured to the rod and provided with a recess receiving the rib, and a spring for returning the clamp, substantially as described. 10th. In a can opener, the combination of a frame, a fixed knife, a plunger carrying a can support disposed opposite the knife, means for operating the plunger, a spring actuated clamp having a movement on the frame, and an adjusting screw mounted on the frame and arranged to engage the clamp at one end of the movement of the latter to limit such movement, substantially as described. 11th. In a can opener, the combination of a frame, provided at its ends with arms and having bearings at the inner ends of the arms, said frame being provided with a longitudinal rib arranged between the arms, a knife fixed to one of the arms, a plunger mounted on the other and carrying a can support and having a rack, a shaft journaled on the frame and having a cog-wheel meshing with the rack, a cylindrical rod mounted in said bearings, a clamp secured to the rod and having a recess receiving the rib, a stop pin arranged at one end of the rod, a spiral spring disposed on the rod and connected to the frame and to the clamp, and an adjustable screw mounted on the arm having said knife and arranged to engage the clamp, substantially as described.

No. 44,660. Damper. (Registre.)

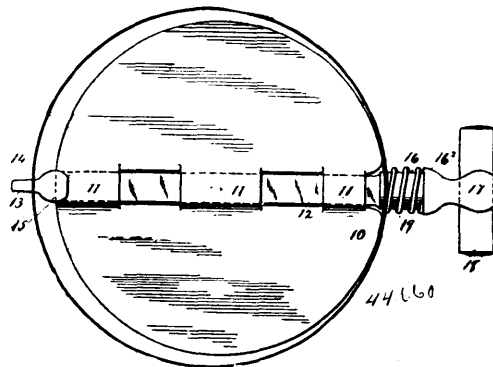

William H. Packham, Buffalo, New York, U.S.A., 8th November, 1893; 6 years.

Claim.—1st. The combination with the damper plate having a central slide way therein, of the damper shank adapted to extend through the slide way, said shank having at one end a recess to fit the damper plate and having near the opposite end a shoulder, and a spring between the shoulder and the damper plate, substantially as described. 2nd. The combination with the damper plate having oppositely arranged lugs thereon, of the damper extending through the slide way formed between the lugs, said shank having near one end a recess to receive the plate and having at the opposite end a handle, a shoulder, and a spring between the shoulder and the damper plate, substantially as described. 3rd. In a damper, the

dampner shank having one end terminating in a clasp comprising parallel arms, substantially as described. 4th. In a dampner, the dampner shank having near one end a recess to receive the dampner plate, and having the opposite end terminating in a clasp composed of parallel malleable arms, substantially as described.

No. 44,661. Seamless Leather Articles.
(Objet en cuir sans couture.)

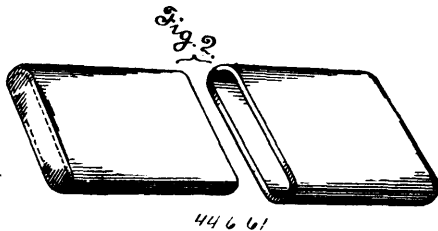

Friend Johnson Bringham, San Francisco, California, U.S.A., 8th November, 1893; 6 years.

Claim.—A seamless leather article produced by slitting a piece of leather edgewise and partially through so as to form a seamless pocket, and then forming and shaping the slitted piece or pocket into an article of the shape required.

No. 44,662. Hose Coupling. (Joint de boyau.)

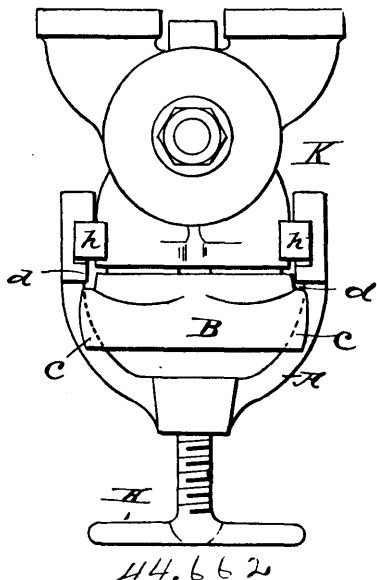

John Henry Carson, New York, assignee of Gardner Dexter Hiscox, Brooklyn, State of New York, U.S.A., 8th November, 1893; 6 years.

Claim.—1st. The combination with a plurality of pipes, of a plurality of hose, a poly-coupling head in operative connection therewith, and devices for coupling the poly-coupling head with the pipes, substantially as described. 2nd. The combination with a plurality of pipes, of a poly-coupling head, a yoke adapted to contain the same, and provided with devices for coupling with the pipes, and means for seating the poly-coupling head on the end of the pipes, substantially as described. 3rd. The combination of a plurality of pipes, a poly-coupling head adapted to seat on the ends of the pipes and provided with guides, a yoke adapted to a working fit in said guides and provided with devices for coupling on the ends of the pipes, and a screw in said yoke for actuating the coupling head, substantially as described. 4th. The combination of a plurality of pipes, provided with one member of a coupling, a coupling head having ports and seats corresponding to the number and position of the pipes and furnished with guides, a yoke adapted to a working fit in said guides and provided with the other member of said coupling, and a screw in said yoke to actuate said coupling head, substantially as described. 5th. The combination of a multi-chambered valve, provided with one member of a coupling and operatively connected with heaters in a car, a coupling head provided with seats corresponding to seats on the valve body, a guide yoke for said coupling head provided with the other member of said coupling, and a device to actuate the head against the seats on the valve body, substantially as described.

No. 44,663. Generator for Gas.

(Générateur à gaz.)

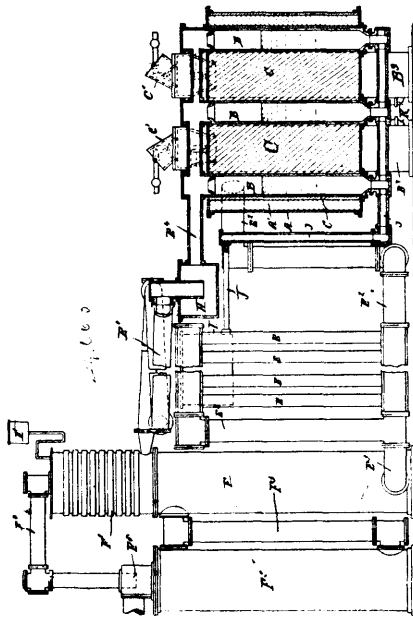

Hugh W. Williams, Victoria, British Columbia, Canada, 9th November, 1893; 6 years.

Claim.—1st. In a gas generator, the combination of a retort containing the incandescent fuel, a means for forcing steam and air through said retort, a second retort containing incandescent fuel, and a communication between said retorts whereby the gases making their exit from the first retort will be forced through the fuel in the second retort, and insert carbonic acid in the gas converted into carbonic oxide, substantially as herein described. 2nd. In a gas generator, the combination of a group of gas generator retorts containing incandescent fuel, an injector and passages whereby steam and air may be forced into the lower ends of the retorts, valves controlling said passages, adapted to independently close and open them, passages connecting the tops of said retorts and independent valves controlling said passages, whereby the gases making their exit from the top of one or more retorts of the group may be decanted into one or more of the remaining retorts and forced to pass through the fuel therein, substantially as and for the purpose described. 3rd. In a gas generator, a retort containing the incandescent fuel, a body of heated metallic fragments, a means for injecting steam and air through the fuel in the retort, and a communication from the retort to the body of metallic fragments whereby the gases issuing from the retort pass through the mass of heated metallic fragments and the steam thereby completely decomposed, substantially as herein described. 4th. In a gas generator, a shell, a gas generator retort therein containing the fuel, a mass of metallic fragments within the shell about the retort whereby they are heated by the burning fuel, a means for injecting steam and air through the fuel in the retort, and a communication from the retort to the body of metallic fragments whereby the gases issuing from the retort pass through the mass of heated metallic fragments and the steam thereby completely decomposed, substantially as herein described. 5th. In a gas generator, the combination of a group of retorts containing the fuel, a body of heated metallic fragments, independently controllable passages communicating with one end of the retorts, means for injecting steam and air therein whereby said steam and air is forced into and through one or more of the retorts, independently controllable passages communicating with the other ends of the retorts whereby the gases issuing therefrom may be decanted into and pass through the remaining retorts of the group, and independently controllable passages from the first ends of said retorts into the body of metallic fragments, whereby the gases after passing through the fuel in the retorts, are passed into the body of metallic fragments, substantially as and for the purpose described. 6th. In a gas generator, the combination of a shell, a group of gas generator retorts therein containing fuel, a mass of metallic fragments within said shell about the retorts, independently controllable passages communicating with one end of the retorts, and means for injecting steam and air therein, whereby said steam and air is forced into and through one or more of the retorts, independently controllable passages communicating with the other ends of the retorts, whereby the gases issuing therefrom may be decanted into and pass through the remaining retorts of the group, and independently controllable passages from the first end of said retorts into the body of metallic fragments, whereby the gases after passing through the fuel in the retorts, are

passed into the body of metallic fragments, substantially as and for the purpose described. 7th. A gas generator, comprising a shell, a group of gas generator retorts therein containing fuel, a mass of metallic fragments within said shell about the retorts, independently controllable passages communicating with one end of the retorts, and means for injecting steam and air therein, whereby said steam and air is forced into and through one or more of the retorts, independently controllable passages communicating with the other ends of the retorts, whereby the gases issuing therefrom may be decanted into and pass through the remaining retorts of the group, and independently controllable passages from the first ends of said retorts into the body of metallic fragments, whereby the gases after passing through the fuel in the retorts are passed into the body of metallic fragments, a condenser to which the gases are led after passing through the metallic fragments, and a water scrubber and dry charcoal scrubber through which the gases successively pass from the condenser, substantially as described. 8th. In a gas generator, the combination of an oil retort and a condenser connected therewith and arranged to permit the condensed oily matter to return by gravity to the retort, substantially as herein described. 9th. In a gas generator, the combination of an oil retort, a condenser connected therewith and an oil scrubber connected with the condenser, both scrubber and condenser being arranged to permit the condensed oily matter to return by gravity to the retort, substantially as herein described. 10th. In a gas generator, and in combination with devices for generating water or producer gas, the apparatus for enriching said gas consisting of an oil retort, a condenser connected therewith and arranged to permit the condensed oily matter separated from the oil gas to return to the retort, an oil scrubber connected with the condenser and a connection from the scrubber to a point of junction with the water or producer gas, substantially as herein described. 11th. In a gas generator, and in combination with devices for generating water or producer gas, the apparatus for enriching said gas consisting of an oil retort, a condenser, a passage between the retort and condenser, an oil trap box in said passage, an oil scrubber connected with the condenser, said scrubber and condenser being arranged to permit the condensed oily matter to return to the retort and a connection from the scrubber to a point of junction with the water or producer gas, substantially as herein described. 12th. In a gas generator, a shell and retorts therein for fuel from which the water or producer gas is formed, in combination with the enriching apparatus consisting of oil retorts in the shell and deriving heat from the fuel retorts, the successively connected condenser and oil scrubber arranged to return the condensed oily matter to the oil retorts, and a connection from said scrubber to the point of junction with the water or producer gas, substantially as herein described. 13th. A gas generator comprising a shell, a group of connected gas generator retorts therein, oil retorts within said shell, and a body of metallic fragments in the shell in the spaces between the retorts, the passages and valves described for generating the water or producer gas, the connected condenser and scrubbers for said gas, the connected condenser and scrubber for the oil gas, and arranged to permit the return of the condensed oil matter to the oil retorts, and passages for uniting the two gases, substantially as herein described.

No. 44,664. Medicinal Compound.

(Composition medicinale.)

Antoine Racicot, Montreal, Quebec, Canada, 9th November, 1893; 6 years.

Claim.—A medical compound composed of alcohol at 65 degrees, powdered capsicum, gum opium, gum camphor, powdered kino, powdered catechu, sulphuric ether, tincture of iron and oil of cojeput, in the proportions and for the purpose set forth.

No. 44,665. Screw Propeller. (Hélice de propulsion.)

Alexander D. Hall and George B. Sloan, both of San Francisco, California, U.S.A., 9th November, 1893; 6 years.

Claim.—1st. A screw propeller having the spiral continuous blades of equal diameter from end to end projecting from opposite sides of the same hub, making each a full half revolution around the propeller shaft, the rear edge of each blade and the front edge of the opposite blade terminating in a radial plane taken through the axis of the shaft and upon opposite sides thereof, substantially as herein described. 2nd. A screw propeller having spiral continuous blades of equal diameter from end to end projecting from opposite sides of the same hub and interlocking with each other to form continuous channels upon opposite sides of the hub, said blades making a half revolution around the propeller shaft, and having flanges fixed upon the outer edge of the plate projecting in each direction in a plane parallel with the axis of the propeller, substantially as herein described. 3rd. A screw propeller having spiral continuous blades of equal diameter from end to end, projecting from opposite sides of the same hub, each forming a half turn about the propeller shaft with the front edge of the blades commencing upon opposite sides of the shaft and the rear edges lying in radial planes taken through the axis, and intersecting the front edges of the opposing

blades, and flanges fixed to the peripheries of the blades projecting

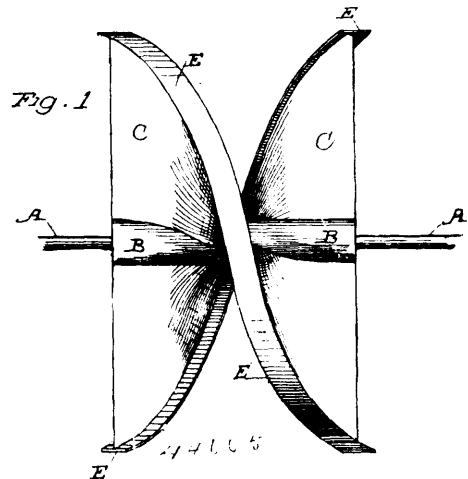

upon each side thereof parallel with the axis of the propeller, substantially as described.

No. 44,666. Car Brake. (Frein de chars.)

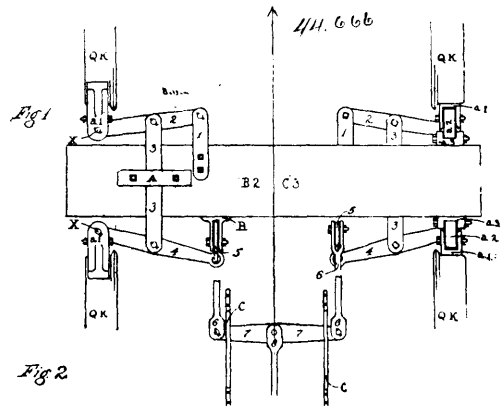

Henry Filmore Braum, Denison, Texas, U.S.A., 9th November, 1893; 6 years.

Claim.—1st. The parts 1, 2, 3, 4, 5, 6, 7, 8, 9, as arranged, substantially as hereinbefore described, constituting a car brake. 2nd. The arrangement of brake levers, attached to the brake dogs, with an equalizer connecting same, and governing their action, substantially as described. 3rd. The arrangement of independent levers 5, 5, controlled by the equalizer 7, for operating each set of brake shoes 2, 4, and 2, 4. 4th. The arrangement of the equalizer 7, for equalizing the pressure between opposite sides of the same truck. 5th. The arrangement of the main or central lever 9, with the rods 8, 8, equalizing between opposite trucks, the energy exerted at 10 or at 12. 6th. The arrangement of the levers and equalizers in such manner as to certainly impart to each and every brake-shoe exactly the same pressure, or braking power, substantially as shown and described, forming a brake lighter in construction, safer in transit and surer and more effective in operation.

No. 44,667. Roundabout. (Tourniquet.)

William Somers, Atlantic City, New Jersey, U.S.A., 9th November, 1893; 6 years.

Claim.—1st. In a roundabout, the combination of the parallel annular rims, their braces, and a peripheral series of cross ties forming suspension rods, the carriages suspended from said rods, the continuous grooves in the peripheries of said rims, and the double parallel driving cables working in said grooves, substantially as described. 2nd. In a roundabout, the combination of the parallel annular rims, the continuous grooves in the peripheral faces of said rims, the double parallel driving cables working in said grooves, and the series of carriages suspended between said rims and cables, substantially as described. 3rd. The combination with the rotary circular vertical frame arranged to turn on a horizontal axis, and having grooves in its peripheral rims, of the driving gear for said frame, said gear comprising the double driving cable working in the grooves in said peripheral rims, and actuated

by grooved wheels on the driving shaft, substantially as described. 4th. The combination, with the rotary wheel having the peripheral

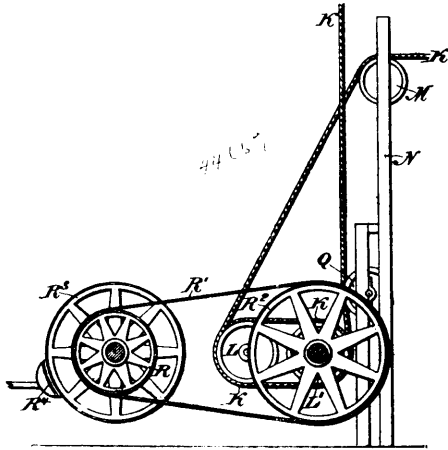

rims grooved on their outer edges, of the driving gear for said frame, said gear comprising double endless cables working in said grooves, the grooved wheels L, L', carrying said cables, one pair for each cable, and carried by a common driving shaft, the guide pulleys and tighteners for said cables, and the brake device, substantially as described. 5th. In a roundabout comprising a circular wheel having the outer parallel rims supported from the hub portion, said rims consisting each of the following parts, the annular rings S, S', secured together and composed each of a series of lapped segments, the annuli S², and the peripheral pieces S³, S³, forming the grooves for the driving cables, substantially as described.

No. 44,668. Means for Guiding Logs down Streams and Rivers. (*Moyen de guider les billots descendant les ruisseaux et rivières.*)

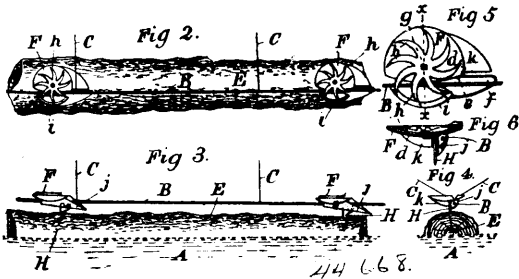

Jasper Finney and George Davidson, both of Goulding, Florida, U.S.A., 9th November, 1893; 6 years.

Claim.—1st. In combination with a cable extending along a river and secured between the banks thereof, a trolley connected to the cable and adapted to move longitudinally thereof, and suitable mechanism to attach the said trolley to a log, whereby the said log may be guided while floating down stream, substantially as specified. 2nd. The combination with a dog adapted for attachment to a log, a trolley pivoted thereto, the same consisting of a disc in separated sections connected by means of a trough, and a guard plate having arms which cross the slot or opening between the two sections of the disc, substantially as specified. 3rd. As means for guiding logs as the same are floated down a stream or river, a stream cable secured in the said river from between posts or anchors situated at the shipping point and the place of destination, guy wires attached to the said stream cable and connected to poles on the river banks, whereby the cable may be made to conform to the general direction of the river or stream, and be also deflected for the purpose of avoiding obstructions, combined with a trolley adapted for attachment to a log, said trolley having a guiding trough and a revoluble guard which prevents the lifting of the said cable from the trough and at the same time allows the guy wires to pass the trolley, substantially as described.

No. 44,669. Surgical Instrument. (*Instrument de chirurgie.*)

Alexander Dallas, New York, State of New York, U.S.A., 9th November, 1893; 6 years.

Claim.—1st. A hernia instrument provided with a head adapted for entrance to the inguinal or similar canal, said head having an

abrasive surface, substantially as and for the purpose specified. 2nd. A hernia instrument provided with a head adapted for entrance to the inguinal or similar canal, said head having an abrasive sur-

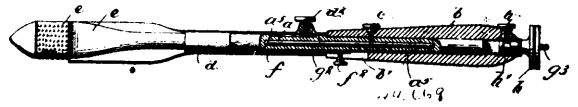

face, and a shield on the head movable to expose the abrasive surface, substantially as described. 3rd. A hernia instrument having a head adapted for entrance to the inguinal or similar canal, said head having expansible plates provided with abrasive surface, substantially as described. 4th. A hernia instrument having a head, plates at the sides of the head formed with abrasive surfaces, means for expanding said plates, and a longitudinally sliding plate, fitting between the expansible plates when the same are expanded, said sliding plate having an abrasive surface, substantially as described. 5th. A hernia instrument having a head provided with an abrasive surface, and with a guard at one side of the head for protecting the spermatic cord or femoral vein, substantially as described.

No. 44,670. Illuminating Gas. (*Gaz d'éclairage.*)

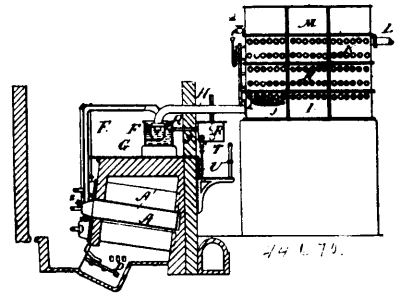

William Young and Alexander Bell, both of Peebles, Scotland, 9th November, 1893; 6 years.

Claim.—1st. The improved method of decomposing mineral oils for the production of illuminating gas, consisting in repeatedly subjecting them to the action of heat, preferably radiant heat, of a temperature so low that only a part of the oils will be decomposed each time they are passed into the retort or decomposing vessel, the rate of flow into the retort or decomposing vessel being so regulated in accordance with the externally applied temperature as to restrict the internal temperatures to those suited for the partial gasification of the particular oil being decomposed. 2nd. The improved method of fractionally effecting the decomposition of mineral oils for the production of illuminating gas by causing the oil to flow into and through the retort or decomposing vessel in an opposite direction to the outflow of the products of decomposition, so that the oil is subjected to higher temperatures and for longer times as the boiling point rises. 3rd. The improved method of washing the products resulting from the decomposition of mineral oils in the production of gas, by the oil to be subsequently decomposed and whereby the imperfectly decomposed portion is continually washed back through the condensing arrangement and hydraulic main, and down the stand pipe into the retort till the oil is completely split up into gas of the desired permanency and hard solid carbons or pitch.

No. 44,671. Petroleum or Liquid Hydrocarbon Engine. (*Machine à pétrole et hydrocarbure.*)

James Roots, High Holborn, London, England, 9th November, 1893; 6 years.

Claim.—1st. In an oil engine, the casing E, with partitions arranged as described, with intercepting channels for air, and with channel E², for oil and air, the vessel being heated by direct action of the flame, which vapourizes the oil and heats the ignition tube. 2nd. In an oil engine, the feed rod B¹, in combination with oil vapourizing vessels E², in the manner described. 3rd. In an oil engine, the oil feeder, consisting of groove B², in rod B¹, air space B³, and air pipes X and X¹, as set forth. 4th. The air heating and air and oil heating channels in the casing E, surrounding the central flame. 5th. The channels E¹, E², as described, in combination with the hand controlling and governing valves I or W, for the purpose set forth. 6th. The burner G, with an orifice G⁵, in which is a needle-shaped plug G⁴, to partially close same and form an annular passage for the vapourized oil to pass, as described. 7th. The casing

E, with an opening at its lower end with an asbestos lined tube F¹, each surrounding the ignition tube F, for the purpose described.

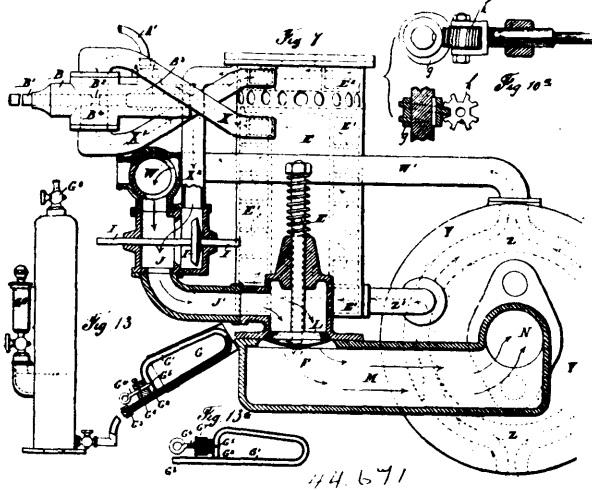

8th. As part of the piston of an oil engine and having the annular space P, the condenser P¹, as and for the purposes described.

No. 44,672. Packing Machine.
(Machine à garniture.)

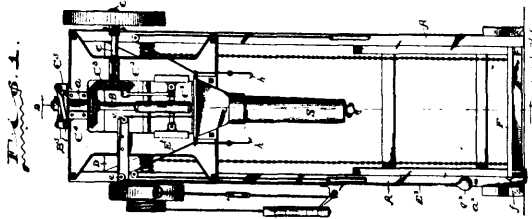

The Nordyke & Marmon Company, assignee of Evert McLellan Thompson, Indianapolis, Indiana, U.S.A., 9th November, 1893; 6 years.

Claim.—1st. The combination, with the augur of a packing machine, of a driving mechanism therefor consisting of a driven sleeve-like device surrounding said shaft but not rigid therewith, and pivoted links connecting said shaft and said device, whereby both a rotary motion is secured and a vertical movement permitted, substantially as set forth. 2nd. The combination, in a packing machine, of the auger shaft, a driving shaft at right angles therewith, a gear-wheel on said driving shaft, a gear-wheel having a sleeve-like hub surrounding the auger shaft and driven by said gear-wheel on the driving shaft, and a link connection between said sleeve-like hub and said auger shaft, substantially as shown and described. 3rd. The combination, in a packing machine, of the auger shaft, the driving shaft set at right angles therewith, a cross head attached to said auger shaft, whereby it is given a reciprocating motion and driven by a pitman from a wheel on the driving shaft, another wheel, also driven from said wheel on the driving shaft and having a sleeve-like hub surrounding the auger shaft, and a link connection between said wheel and said auger shaft, whereby both a reciprocal and rotary motion are secured, substantially as set forth. 4th. In a packing machine, a packing auger having a taper point, in combination with mechanism whereby it is given both a reciprocal and a rotary movement, substantially as and for the purposes set forth. 5th. The combination, in a packing machine, of a hopper terminating in a spout, a valve E, located at the bottom of said hopper, a rope E¹, running up through said hopper and over sheaves c c, to the side of the machine, and thence down to near the bottom, where it is provided with a weight e¹, adapted to engage with a catch, said catch a¹, on the frame work, with which said weight will engage, and the travelling platform for carrying the receptacle to be filled, having a projection f, which will come in contact with and disengage the weight from the catch, thus releasing the gate and permitting it to close, all substantially as shown and described.

No. 44,673. Confectioner's Machinery.
(Appareil pour confiseurs.)

Emma H. Van Derver, assignee of John R. Van Derver, both of New York, State of New York, assignees of Daniel Morley Holmes, Arlington, New Jersey, all in the U.S.A., 9th November, 1893; 6 years.

Claim.—1st. A confectionery coating machine, in which is comprised a coating material tank, a vertically reciprocable drop

holder, a paper reel, a carrying belt and means for imparting movement to the whole. 2nd. A confectionery coating machine, in

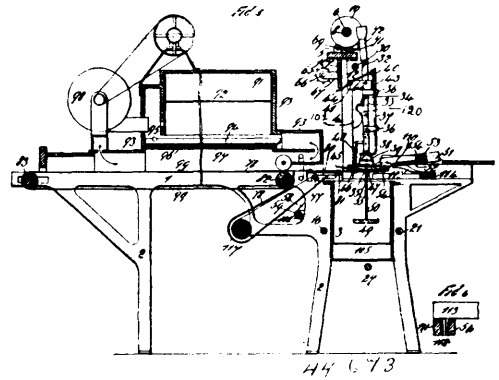

which is comprised a coating material tank, a vertically reciprocable drop holder, means for removing the surplus material from the drops after dipping, a paper reel, a carrying belt and means for imparting movement to the whole. 3rd. In a confectionery coating machine, a drop holder, consisting of a bottom support, and a movable top bearing device, in combination with drop feeding and delivering mechanism. 4th. In a confectionery coating machine, a drop dipping mechanism in combination with delivering mechanism, and a receiving shelf over which paper passes as the drops are deposited. 5th. The combination with the coating and delivering mechanism of a cooling device wherethrough the drops are carried.

No. 44,674. Safety Pocket. (Poche de sûreté.)

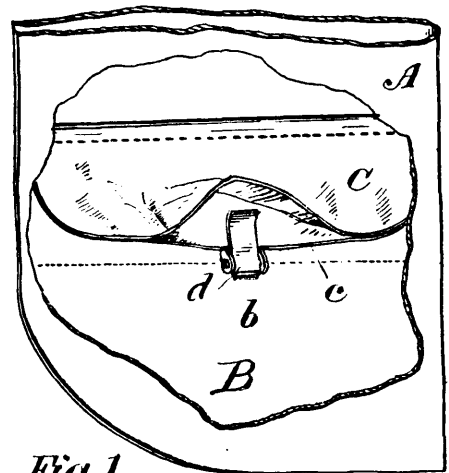

Arthur Thomas Cozens, Toronto, Ontario, Canada, 11th November, 1893; 6 years.

Claim.—1st. The combination with the pocket of a supplemental pocket provided with a suitable flap extending over the opening at the top of the supplemental pocket, as and for the purpose specified. 2nd. The combination with the pocket of a supplemental pocket provided with a suitable flap extending over the opening at the top of the supplemental pocket and a suitable fastener for securing the flap to the outside piece of the supplemental pocket, as and for the purpose specified. 3rd. The combination with the pocket of a supplemental pocket, provided with a suitable flap extending over the opening at the top of the supplemental pocket, a fly secured within the flap and a fastener designed to be brought over the fly under the flap and thereby secure the flap to the outer piece of the supplemental pocket, as and for the purpose specified. 4th. The combination with the pocket of a supplemental pocket provided with a suitable flap extending over the opening at the top of the supplemental pocket and fastener D, comprised of the parts d and d¹, the part d¹, of which is designed to be brought over the fly c, under the flap C, as and for the purpose specified.

No. 44,675. Electric Arc Lamp. (Lampe électrique à arc.)
Louis E. Howard, Plainfield, New Jersey, U.S.A., 11th November, 1893; 6 years.

Claim.—1st. An arc lamp having the electrodes around the arc enclosed in a small transparent or translucent envelope air tight at

asbestos or other fibrous material on the wire gauze electrode, drying the same, then steeping it in a solution of carbonate of soda or other suitable carbonate, and, after drying, steeping it in a solution of a silicate or phosphate. 11th. In the manufacture of a combined diaphragm and electrode for use in electrolytic apparatus, soaking the dried diaphragm in a solution of lime or any of the soluble salts of lime, or of magnesia, baryta or other suitable earthy salt, redrying the diaphragm, and subsequently soaking it in a solution of a silicate or phosphate.

No. 44,678. Printer's Lock-up.

(*Serre-forme d'imprimeur.*)

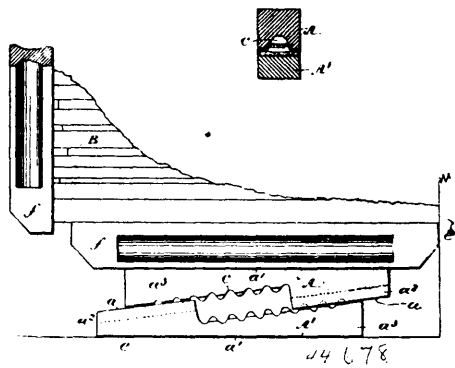

Samuel Starrett, of Londonderry, Ireland, 11th November, 1893; 6 years

Claim.—1st. The construction and use of a printer's quoin, consisting of twin parts each having a pair of operating faces, one face (designated to lie in a plane parallel to the matter or side of the chase, side-stick or other like filling in appliance) being formed flat and the other face being formed inclined in two parallel planes with a series of rack teeth arranged centrally of the one plane, and a groove centrally of the other plane, the side surface of each of which form inclined slide-ways for the inverted counterpart surface of the twin half of the quoin, in combination with a suitable key or tool having a rose or end adapted to be passed between, engaged with and cause movement to the opposed teeth upon the twin halves of the quoin, as and for the purpose hereinbefore set forth. 2nd. A printer's quoin, composed of twin halves each half quoin, having two operating faces, one composed of two inclined planes, and the other flat one of each pair of inclined faces being centrally grooved, and the other having a central projecting rack, the two halves in use being inverted so that the inclined faces are all in a parallel planes, the rack of one plane lying within the groove of the other plane whilst the sides of each inclined plane are in sliding contact with the opposed sides of the opposite half of the quoin, substantially as set forth. 3rd. The combination or arrangement and use for locking-up type or printing surfaces of the quoins composed of twin halves each half quoin having two operating faces, one composed of two inclined planes, and the other flat one of each pair of inclined faces being centrally grooved, and the other having a central projecting rack with metal side-sticks, the sides of which are squared, and part of the intermediate metal removed. 4th. The construction of manufacture and use of side-sticks of malleable iron or other suitable metal with squared sides and part of the intermediate metal removed, for the purposes set forth.

No. 44,679. Brush for Cleaning Chimneys.

(*Brosse pour ramoner les cheminées.*)

Alexander J. Fludder and Francis M. Sisson, both of Newport, Rhode Island, U.S.A., 11th November, 1893; 6 years.

Claim.—1st. In a chimney and flue cleaning brush, an elongated cylindrical hub, having a central longitudinal opening and a series of threaded openings formed in the body thereof, a series of rigid brush bristles having outer frayed ends, cylindrical exteriorly threaded band ferrules on the inner ends of said bristles and adapted to removably engage the threaded openings of the hub, and an attaching rope loosely arranged in the central longitudinal opening of the hub, and having attaching loops D, at its extremity, substantially as set forth. 2nd. In a chimney and flue cleaning brush, an elongated cylindrical hub having separate circular series or sets of threaded openings, and separate sets of rigid brush bristles, having at their inner ends threaded ferrules adapted to removably engage the threaded openings in said hub, said rigid brush bristles being also provided with outer frayed brush tip ends, and binding rings affixed thereon at the base of said frayed ends, substantially as set forth. 3rd. In a chimney and flue cleaning brush, the combination with the hub, of the brush bristles removably

attached to and radiating from said hub, said bristles comprising suitable lengths of wire rope, having frayed brush tip ends, and

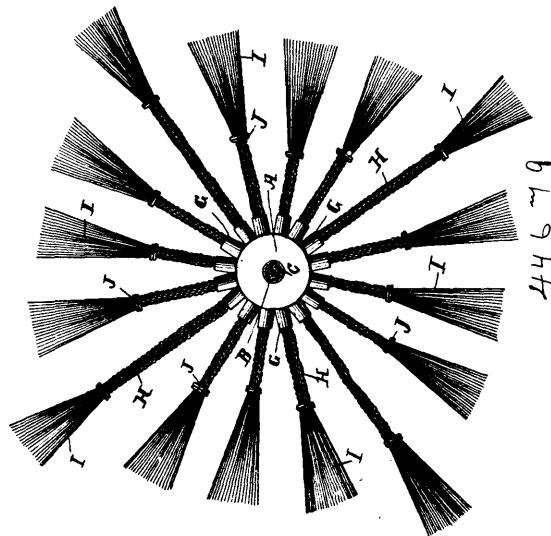

binding rings soldered thereon at the base of the frayed ends, substantially as set forth.

No. 44,680. Stock for Facilitating Horse-shoeing.

(*Appareil pour faciliter le ferrage des chevaux vicieux.*)

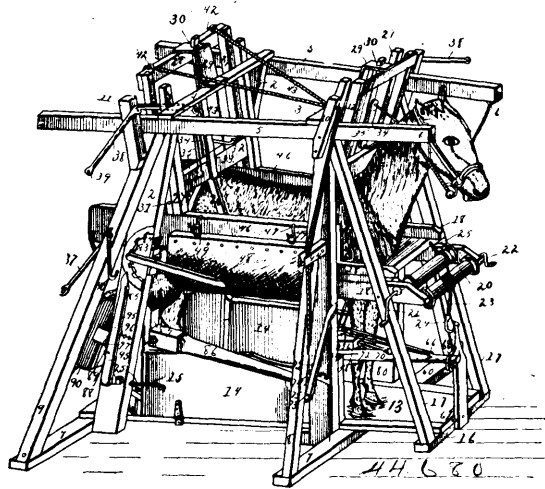

Eli B. Bradford, Munster, Illinois, U.S.A., 11th November, 1893; 6 years.

Claim.—1st. In a stock of the class described, the combination with a framework comprising opposite side-bars, of a breeching located at the rear end of the framework, a stop at the front end of the framework, means for adjusting the breeching towards the stop, and a girth connecting the opposite side-bars, substantially as specified. 2nd. In a stock of the class described, the combination with a framework, comprising opposite side-bars and a front stop, of a breeching, means for adjusting the same toward the stop, opposite hooks located upon the side-bars, and a girth terminating in eyes for engaging the hooks, substantially as specified. 3rd. In a stock of the class described, the combination with a framework, a front stop, a breeching, and means for adjusting the same toward the stop, of front and rear transverse-bars and means for raising and lowering and locking the same, substantially as specified. 4th. In a stock of the class described, the combination with a framework, a front stop, a breeching at the rear end of the framework, means for adjusting the same toward the stop, of opposite guide frame, adjusting holes located between the guides of the frames, cross-bars having their ends located in the guides, sliding bolts mounted on each of the cross-bars and adapted to engage the holes, a lever pivoted on each of the cross-bars and connected to the bolts at opposite sides of its pivot, and rods connected to the upper ends of the levers for reciprocating the bolts, substantially as specified. 5th. In a stock of the class described, the combination, with the framework, a front stop, a breeching and front and rear inclined guide frame provided intermediate the guides with holes, of adjust-

ing bars transversely disposed and mounted between the guides, standards rising therefrom, perforated guide plates for the standards, levers fulcrumed on the standards, bolts mounted on the bars, adapted to engage the holes and loosely connected at their inner ends to the levers at opposite sides of the pivots of the latter, rods connected to the levers for operating the same, and raising and lowering levers mounted on the framework and connected with said bars, substantially as specified. 6th. In a stock of the class described, the combination, with a framework, a perforated breast-bar located at the front end thereof, transverse adjustable bars arranged over the framework, and a rear breeching sling, of a windlass located in front of the breast-bar, ropes connected to the sling and passed through the perforations in the breast-bar and made fast to the windlass, and a crank for operating the windlass, substantially as specified. 7th. In a stock of the class described, the combination, with a framework, comprising upper side-bars extending beyond the framework and provided with opposite eyes for engaging the harness of a horse, of front and rear vertically adjustable bars, an adjustable breech at the rear end of the stock, substantially as specified. 8th. In a stock of the class described, the combination, of a stock frame and means for securing the animal therein, of a clenching post located in front of the frame, a winding device located above the clenching post and a rope provided with a hook and secured to the winding device, substantially as specified. 9th. In a stock of the class described, the combination, with the stock frame containing animal retaining devices, of a transverse rod connecting the front posts of the frame, opposite blocks secured to the inner faces of the posts, a wire bail suspended from the rod and movable thereon, a head block journaled in the eyes of the bail between the ends of the latter, a lower rest pivoted between the lower end of the latter, a lever for depressing the rest and connected thereto, opposite heel pieces secured to the rest, a rod secured to the lever and having its ends passed through perforations in the heel pieces and adapted to be removably connected, levers secured to said front posts, means for locking the levers, ropes secured to the levers and provided with hooks, eyes secured to the rest for removably engaging the hooks, and front hooks secured to the framework of the stock and adapted to removably engage eyes on the front end of the rest, substantially as specified. 10th. In a stock of the class described, the combination, with the stock frame, comprising animal retaining devices, of a transverse rod and a fore foot supporting device removably mounted on the rod and adapted to slide to opposite sides of the frame, substantially as specified. 11th. In a stock of the class described, the combination, with the stock frame, of a suspension bail, a rest pivoted to the suspension bail, and a cheek pivoted to the suspension rest, and a locking device for depressing and retaining the lever, substantially as specified. 12th. In a stock of the class described, the combination with the stock frame, of a suspension bail, a rest pivoted to the suspension bail, and a cheek piece pivoted to the suspension bail eccentrically with the rest, a lever for operating the rest, and a locking device for depressing and retaining the lever, substantially as specified. 13th. In a stock of the class described, the combination with the stock frame having animal retaining devices, and a suspended four foot rest, of devices for securing the foot within the rest, a block for supporting the rest, and means for drawing the rest over and upon the block. 14th. In a stock of the class described, the combination with the stock frame having animal retaining devices, of crank shafts located at the rear ends of the frame and provided with operating means, and hind foot supporting rests supported by the crank shafts, substantially as specified. 15th. In a stock of the class described, the combination with the stock frame comprising rear posts, opposite crank shafts journaled in the posts, levers for operating the crank shafts, and opposite rests suspended by the crank shafts, substantially as specified. 16th. In a stock of the class described, the combination with the stock frame comprising animal retaining devices, of opposite hind foot rests, means for supporting the same, openings formed in the lower ends of the rest, and toe supports removably mounted in the openings, substantially as specified. 17th. In a stock of the class described, the combination with the stock frame comprising animal retaining devices, of hind foot supports and pivoted guard arms located at the inner edges of the supports and adapted to extend beyond the same, substantially as specified. 18th. In a stock of the class described, the combination with the stock frame comprising animal retaining devices, of opposite adjustable blocks, and a hind foot support adapted to be supported by the blocks, substantially as specified. 19th. In a stock of the class described, the combination with a frame comprising rear posts, of opposite inclined blocks rigidly secured at the base of the posts and forming intermediate spaces, pins crossing the spaces upper inclined blocks mounted on the lower blocks, toothed flanges secured to the inner faces of said upper blocks and engaging said teeth, slotted plates secured to the inner faces of the adjusting blocks, bolts extending through the posts and engaging the slots, bearing brackets secured to the rear edges of the adjusting blocks, and bearing standards loosely connected to the upper portions of the brackets and loosely stepped in the lower portions thereof, substantially as specified. 20th. In a stock of the class described, the combination with the stock frame comprising stock retaining devices, the inclined rests, devices for raising and lowering the rests, levers connected with the rests, levers fulcrumed upon the posts of the frame, means

for locking the levers, ropes connected with the levers, hooks secured to the rests, substantially as specified.

No. 44,681. Apparatus for Removing Impurities from Smoke. (Appareil pour purifier la fumée.)

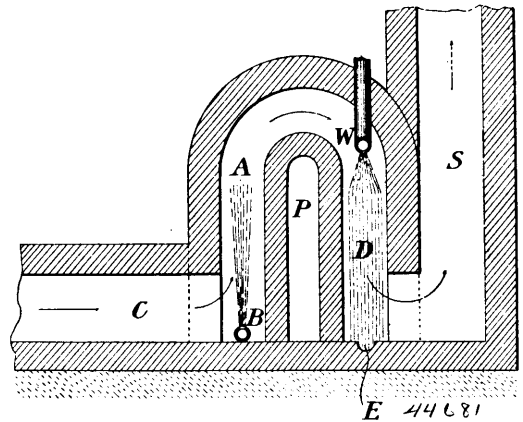

Edmund Eugene Dulier, of Chelsea, London, England, 11th November, 1893; 6 years.

Claim.—Apparatus for removing impurities from smoke, consisting of a passage for the smoke made in the form of an inverted U, and provided with steam and water pipes arranged in the limbs of the passage, substantially as described.

No. 44,682. Generator for Steam.

(Générateur à vapeur.)

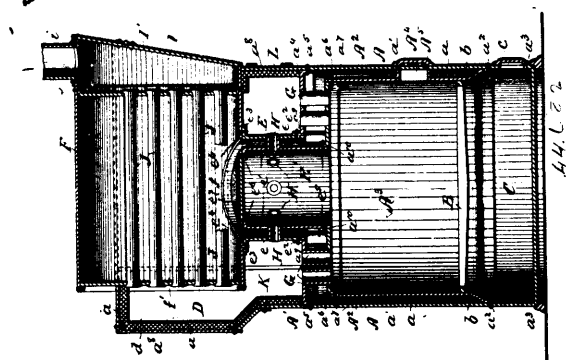

Patrick Fitzgibbon and Henry K. Eaton, both of Oswego, New York, U.S.A., 11th November, 1893; 6 years.

Claim.—1st. In a steam generator, the combination of an upright water containing shell A, formed with a contracted hollow arm B, flues G, extending upwardly through said shell, and a horizontal water containing shell F, supported upon and connected to said drum with its extremities arranged directly above said flues, substantially as and for the purpose set forth. 2nd. In a steam generator, the combination of an upright water containing shell A, having a contracted upwardly extending drum E, a horizontal water containing shell F, supported above the lower shell upon said drum and connected thereto, and flues J extending lengthwise through the latter shell, substantially as and for the purpose specified. 3rd. In a steam generator, the combination of an upright hollow water containing shell A, a horizontal water containing shell F, arranged above the former shell, an upright connection or drum E, interposed between said shells and formed with an inner chamber for receiving the products of combustion, and flues H extending through the wall of said upright connection or drum, substantially as and for the purpose set forth. 4th. In a steam generator, the combination of an upright water containing shell A, having a top wall, flues G extending through said top wall, a second substantially horizontal water containing shell F, mounted above said top wall and connected to the shell A, and having its extremities projecting above said flues G, and flues J extending through said latter shell, substantially as and for the purpose set forth. 5th. In a steam generator, the combination of an upright water containing shell A having a top wall, flues G extending through said top wall, a second substantially horizontal water containing shell F, mounted above said top wall and having its extremities projecting above said flues, flues J extending through the latter shell in substantially horizontal planes, a water connection E, between the top wall of the lower shell and the upper shell, and flues H extending through the wall of said connection, substantially as set forth.

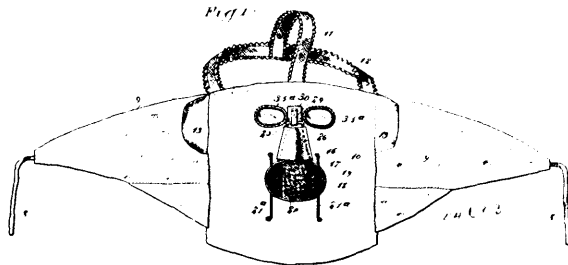
No. 44,683. Face Protector.*(Appareil pour protéger la figure.)*

Carl Gumeson, National Mine, Michigan, U.S.A., 11th November, 1893; 6 years.

Claim.—1st. In a face protector, the combination, with the mask and a suspending catch attached thereto, of the swinging nose frame and cover having a wire loop at the top, which is adapted to be detachably connected with said catch, substantially as shown and described. 2nd. A face protector, provided with a nose opening, a plate secured to the protector above the opening, a spring tongue secured to the plate and having a lower bent end, and a swinging nose case having a cross-piece extending along said bent end, substantially as described. 3rd. A face protector, provided with eye openings and horizontally swinging eye protectors hinged between the eye openings and adapted to cover the same, substantially as described. 4th. A face protector, comprising a face covering having eye and nose openings, a plate secured between the eye openings, horizontally swinging eye protectors hinged at their inner ends to the sides of the plate, and a vertically swinging nose case hinged at its upper end to the lower portion of the plate, substantially as described. 5th. A face protector, provided with a mouth opening, a frame covered with netting and yieldingly secured to the protector face so as to cover the mouth opening, and a strip of fabric extending centrally across the frame, substantially as described. 6th. The combination, with a face protector, having eye, nose and mouth protecting devices, as set forth, of the flaps and strings secured to the side edges of the protector, substantially as described.

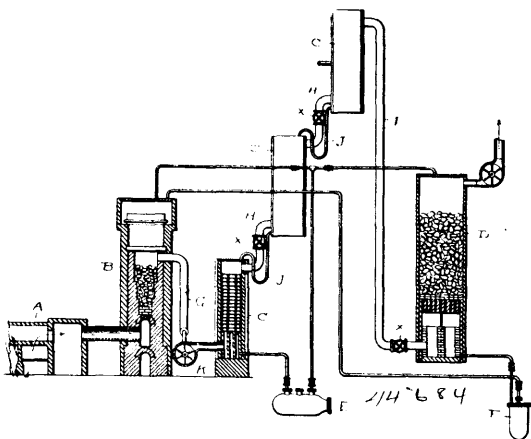
No. 44,684. Method of and Apparatus for Manufacturing Sulphuric Acid. (Méthode et appareil pour la fabrication de l'acide sulfurique.)

Frederic J. Falding, Cleveland, Ohio, U.S.A., 11th November, 1893; 6 years.

Claim.—1st. The method of manufacturing sulphuric acid, which consists in artificially forcing the fumes or vapours through a suitable apparatus in one direction and returning the acid through the same apparatus in the opposite direction, under pressure of the vapour forcing current, substantially as set forth. 2nd. In an apparatus for manufacturing sulphuric acid, the combination of a series of towers, combined and arranged, substantially as set forth, of a forcing apparatus arranged at the gas inlet to such towers, whereby the gasses are subjected to an impelling current which drives them through the apparatus in one direction, and assists in the oxidization and condensation thereof, and whereby the acid flowing through such apparatus in the opposite direction, and also the gasses, are maintained under the pressure while passing through the apparatus, substantially as set forth. 3rd. In an apparatus for manufacturing sulphuric acid, the combination of a gas producer and a suitable number of oxidizing and condensing devices, such as the series of towers herein set forth, of a forcing apparatus arranged between the gas producer and the oxidizing and condensing apparatus, and a pressure regulating device at the outlet of each such condensing apparatus, and adapted to impel the

gasses through such oxidizing and condensing apparatus in one direction while the acid flows through the same in the opposite direction, the gasses and the acid being under pressure from the forcing apparatus in their message through the oxidizing and condensing apparatus, substantially as set forth.

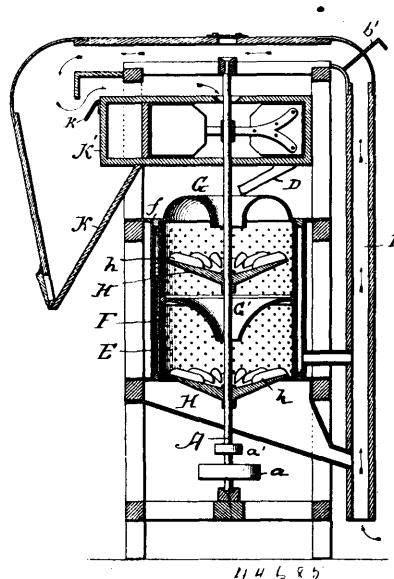
No. 44,685. Scourer for Grain.*(Nettoyeuse à grain.)*

George V. Dixon, Waits, Ohio, U.S.A., 12th November, 1893; 6 years.

Claim.—1st. In a grain scourer, the combination, of a perforated scouring case, a disc of less diameter than the scouring case provided with upwardly projecting ribs arranged tangentially to the hub thereon, and a top or dome for the scouring case curved inward to form a central funnel-shaped opening, substantially as shown and for the purpose set forth. 2nd. In a grain scourer, the combination, of a frame having a central shaft, said shaft being provided with a fan and connected with means for operating grain separating screens, a spout leading from the separator to a dome curved inward to form a central funnel-shaped opening which leads to the scouring case, a disc mounted on the shaft within the scouring case and having upwardly projecting ribs, and a cylinder surrounding the scouring case and connected with an air trunk, substantially as shown and for the purpose set forth.

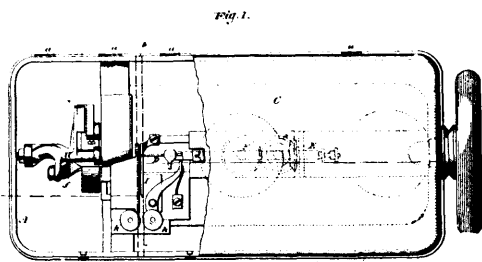
No. 44,686. Sewing Machine. (Machine à coudre.)

William Henry H. Tracy, Troy, Jeremiah A. Scrieven, New York, both of the State of New York, and Rinaldo C. Tousey, Long Hill, Connecticut, U.S.A., 12th November 1893; 6 years.

Claim.—1st. A sewing machine having the horizontally reciprocating needle D and mechanism, substantially as described, for moving the same, combined with the top plate C, said top plate being provided with the transverse slot *b*, substantially as and for the purpose herein shown and described. 2nd. A sewing machine having its entire organism housed, and covered by a slotted movable top plate or lid C, the slot of which serves to introduce the fabric into contact with the needle and thread, substantially as and for the purpose specified. 3rd. A sewing machine having the horizontally reciprocating needle D and mechanism, substantially as described, for moving the same, combined with external housing having the movable top plate C, said top plate being provided with the transverse slot *b*, substantially as and for the purpose herein shown and described.

No. 44,687. Attachment for Sewing Machines.
(*Accessoires pour machines à coudre.*)

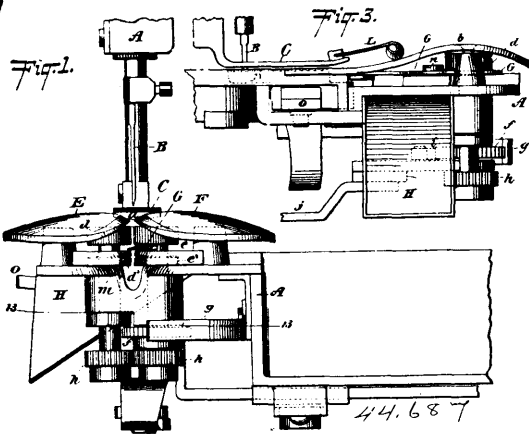

William Henry H. Tracy, Troy, Jeremiah A. Scriven, New York, both of the State of New York, and Rinaldo C. Tousey, Long Hill, Connecticut, all in the U.S.A., 12th November, 1893; 6 years.

Claim.—1st. A sewing machine having in combination with the needle and with its presser foot a feed mechanism and divided plate E, F, having slit *a*, said slit extending to the edge of the machine, substantially as and for the purpose herein shown and described. 2nd. In a sewing machine having needle, presser foot and feed mechanism, the divided plate E, F, having slit *a*, said divided plate being of bulging form to be higher forward of the needle than nearer the needle, as specified. 3rd. In a sewing machine, the combination of the presser foot C and its shank *s*, with the vibrating secondary presser foot C², and means, substantially as described, for moving said vibrating presser foot on its pivot, all as set forth. 4th. The combination of the presser foot C and its shank *s*, with the laterally movable presser foot C² and its pivoted shank *r*, and with the needle bar M, having cam *t*, all as and for the purpose specified. 5th. In a sewing machine having the ordinary horizontal feed D and suitable presser foot and needle mechanism, the combination thereof with the split plate E, F, and with the vertical feed *d e* below said plate, as and for the purpose specified. 6th. The combination of the split plate E, F, and vertical feed *d e* below the same, with the cutter mechanism G and mechanism, substantially as described, for agitating the same, all as and for the purpose specified. 7th. The combination in a sewing machine of the split plate E, F with the vertical feed *d e* below the same, cutter mechanism G *m* below said vertical feed, and scrap feed *d², e²*, as and for the purpose described. 8th. The combination in a sewing machine of the split plate E, F with the vertical feed *d e* below the same, cutter mechanism G *m* below said vertical feed, scrap feed *d², e²* and scrap outlet H, as described. 9th. In a sewing machine having divided or split plate E, F, the combination thereof with the presser foot C, and the deflector L thereon, as set forth. 10th. In a sewing machine the combination of the split plate E, F having bulging form as specified with the vertical feed in front, horizontal feed behind, presser foot above the horizontal feed, cutter below the vertical feed, and instrumentalities, substantially as described, for turning the edge of the fabric from the position in the slit of the plate E, F into a horizontal position above said plate E, F, all as described and for the purpose specified.

No. 44,688. Apparatus for and Method of Recovering Waste Alcohol from Liquor Casks, &c.
(*Appareil et méthode d'extraire les résidus d'alcool des barils de liqueur, etc.*)

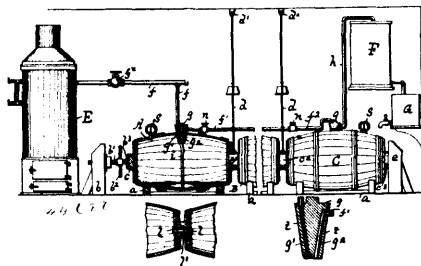

Michael Hickey, Boston, Massachusetts, U.S.A., 12th November, 1893; 6 years.

Claim.—1st. In an apparatus for recovering waste alcohol from empty liquor casks, a steam generator, a series of supports to sustain the casks to be treated, connections between the casks, and a

connection between the generator and the series of casks, combined with a condenser and a connection between it and said casks, whereby the heating medium passes from the generator through all of the casks successively to the condenser to volatilize and carry over the alcohol absorbed by the wood of said casks, substantially as described. 2nd. In an apparatus for recovering waste alcohol from empty liquor casks, a steam generator, a series of head blocks in alignment to receive the casks there between, and abutments at the ends of the series, a bung for each cask having an inlet and an outlet passage, connections between the outlet passage of one and the inlet passage of the next cask, and a connection between the generator and casks combined with a condenser connected to the end-most of the several casks and a pressure regulator carried by one of the abutments to adjust the external pressure on the heads of the casks, substantially as described. 3rd. The herein described method of recovering waste alcohol from empty liquor casks, which consists in circulating a heating medium through and in direct contact with the interior of the cask, volatilizing the contained alcohol and partially condensing the medium, withdrawing the medium and combined volatilized alcohol and condensing the same, continuing the operation until all the alcohol has been recovered, substantially as described. 4th. The herein described method of recovering waste alcohol from empty liquor casks, which consists in circulating a heating medium through successive casks of a series and simultaneously cooling their exteriors, volatilizing the contained alcohol and distilling the product, continuing the operation until no more alcohol is obtained, and recovering the water of condensation in each cask as a by product, substantially as described.

No. 44,689. Rock Drill. (*Foret de mine.*)

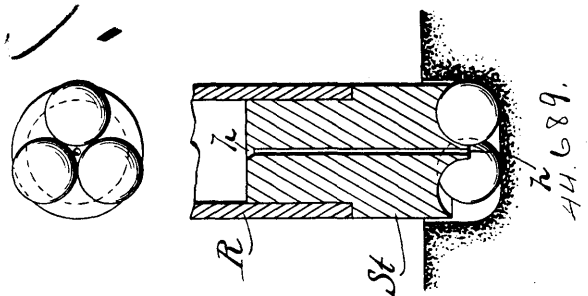

Carl Hoffmann, Charlottenburg, Germany, 12th November, 1893; 6 years.

Claim.—1st. In a rock drill, the combination, with a rotary drill-head having an annular groove in the front end thereof, of a plurality of hard metal balls suitably held in but protruding from and free to roll in said annular groove, substantially as described. 2nd. In a rock drill, the combination, with a rotating drill-head having a conduit for water therein and having an annular groove in the front end thereof, of a plurality of hard metal balls free to roll in said groove, but suitably held therein and protruding therefrom, substantially as described. 3rd. In a rock drill, the combination, with a magnetized rotating drill-head having an annular groove in the front end thereof, of a plurality of hard iron or steel balls held by magnetism in said groove, but rolling freely therein and protruding therefrom, substantially as and for the purposes described. 4th. In a rock-drill, the combination, with a magnetized rotating drill-head having a conduit for water therein and having an annular groove in the front end thereof, of a plurality of hard iron or steel balls held by magnetism in said groove, but rolling freely therein and protruding therefrom, substantially as and for the purposes described.

No. 44,690. Hook for Garments.
(*Agrafe de vêtement.*)

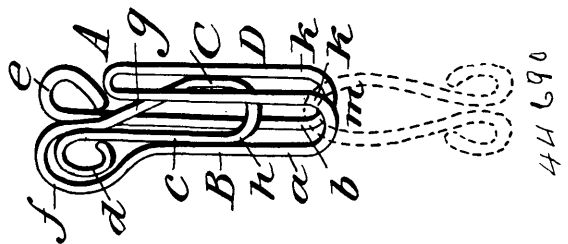

George B. Mershon, jr., and George B. Mershon, sr., Philadelphia, Pennsylvania, U.S.A., 12th November, 1893; 6 years.

Claim.—1st. A garment hook formed of front and shank portions, the shank portion consisting of side members and a central member, and the front portion consisting of side members which are continuous of the side members of the shank portion, and a forwardly projecting jaw which is continuous of the central member and one of

the side members of the shank portion, the rear end of said jaw having an eye which is enclosed in one of the eyes of the side members of the shank, said parts being combined substantially as described. 2nd. A garment hook having its shank portion formed of side members with attaching eyes, and a central member, and a central member, and a forwardly projecting jaw which is continuous of one of said side members and of said central member, and is provided with an eye which is freely enclosed in one of the eyes of the shank portion, substantially as described. 3rd. A garment hook having its shank portion provided with fastening eyes, and a forwardly projecting jaw, which latter is continuous of one of the members of said portion, and having an eye which freely occupies said first named eye, substantially as described. 4th. A garment hook formed of a shank with side members, each having an attaching eye, a central member and a front portion or hook proper continuous of said side members, said central member extending between the side of said front portion and being continuous of the attaching eye of a side member of the shank and the central member thereof, the terminus of said central member being within the attaching eye of one of the side members, said parts being combined substantially as described.

No. 44,691. Sewing Machine. (Machine à coudre.)

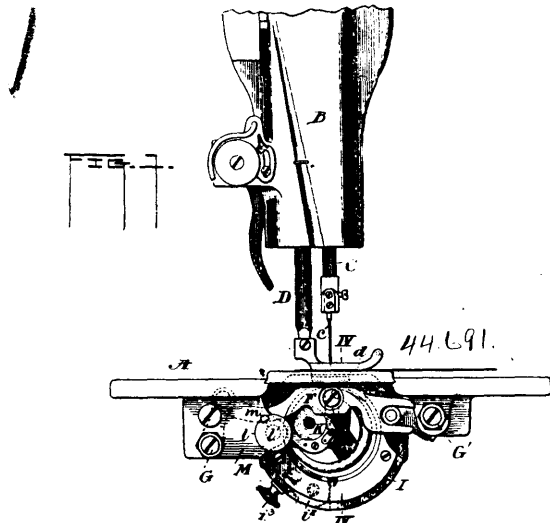

Weeks Colley Manufacturing Company, assignee of Weeks Colley, assignee of George H. Colley all of Jackson, Michigan, U.S.A., 12th November, 1893; 6 years.

Claim.—1st. In a rotating shuttle sewing Machine, the combination of a raceway casing provided with a plurality of guide grooves or shuttle races, and a supplementary race, and means for opening and closing the latter independently of the other races, so as to permit the introduction or removal of a supplementary or additional shuttle without disarranging other parts of the machine substantially as described. 2nd. In a rotating shuttle sewing machine, a multiple race comprising a rigid race way casing having a plurality of circular guide grooves or races therein to receive a fixed number of shuttles, and a sectional supplementary race and means for opening and closing the same so as to permit the interduction or removal of an additional shuttle at will, substantially as described. 3rd. In a rotating shuttle sewing machine, a multiple race comprising a raceway casing provided with a plurality of interior circular guide grooves or races and with an intermediate elongated circumferential slot, a segment fitting said slot and provided with a guide groove coinciding with an intermediate groove in the casing, so as to form a supplementary race, and means for securing said segment in said slot, substantially as described. 4th. In a rotating shuttle sewing machine, a multiple race comprising a raceway casing provided with a plurality of interior circular guide grooves or races, and with an intermediate elongated circumferential slot, a hinged segment fitting said slot and provided with a guide groove coinciding with an intermediate groove in the casing so as to form a supplementary race, and means for securing the segment within the slot, substantially as described. 5th. In a rotating shuttle sewing machine, a multiple race comprising a raceway casing provided with a plurality of interior circular guide grooves or races and with an intermediate elongated circumferential slot, a hinged segment fitting said slot and provided with a guide groove coinciding with an intermediate groove in the casing so as to form a supplementary race, and a spring pressed pin for locking said segment within the slot, substantially as described. 6th. In combination with the raceway casing provided with a plurality of interior circular guide grooves or races and an elongated circumferential open slot intercepting one of said grooves, the segment fitting said slot and having a groove therein struck on the arc of the circle described by said intercepted groove, so as to form a sectional supplementary race, the latter being

adapted to be opened and closed independently of the other races, and means for securing the segment in said slot, substantially as described. 7th. In combination, with the raceway casing provided with a plurality of interior circular side grooves or races and an elongated circumferential open slot intercepting one of said grooves, the hinged segment fitting said slot and having a groove therein struck on the arc of the circle described by said intercepted groove, so as to form a sectional supplementary race, the latter being adapted to be opened and closed independently of the other races to permit the insertion or removal of an additional shuttle, and the sliding pin adapted to lock said segment when closing said slot, substantially as described. 8th. In a rotating shuttle sewing machine, the combination of a multiple shuttle raceway casing provided with a supplementary race and means for opening and closing the latter to permit the insertion or removal of an additional shuttle, together with the needle bar and the needle holder supporting the adjustable needle sockets, and means for securing the latter in various positions whereby the number of needles employed and the spacing of the same may be varied to correspond with the number and spacing of the shuttles, substantially as described.

No. 44,692. Guitar. (Guitare.)

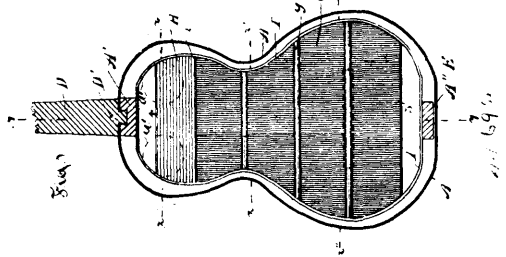

James Simpson Back and George Lewis Orme, both of Ottawa, Ontario, Canada, 14th November, 1893; 6 years.

Claim.—1st. In combination with the belly of a guitar or similar instrument, a ridge consisting of a transverse swelling extending longitudinally from end to end, substantially as set forth. 2nd. In combination with the belly of a guitar or other similar instrument, two sound holes b^1 , placed near the neck end, substantially as set forth. 3rd. The combination, with the shell of a guitar or similar instrument, a double sound board consisting of two converging parts of different lengths united at one end, the longest part shorter than the distance between the two end blocks and placed about midway between them so that the united end is nearer the tail end and about midway between the belly and the neck and the upper single end nearer the belly, and said sound boards held in a narrow rim secured to the end blocks, substantially as set forth. 4th. The combination, with the shell A, B, C, and blocks A^1 , and A^{11} , of the sound boards G and H, converging to an edge and each provided with transverse ribs, a narrow rim I, secured to the end blocks A^1 , A^{11} , and holding said sound boards, and the sound holes b^1 , in the belly B, near the neck over the open end of said sound board, substantially as set forth.

No. 44,693. Signal for Railways.

(Signal de chemin de fer.)

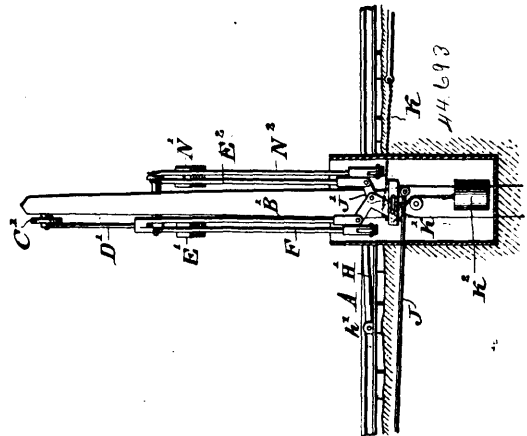

George C. Young, Washington, and George O. Willever, Phillipsburg, all of New Jersey, U.S.A., 15th November, 1893; 6 years.

Claim.—1st. A series of signal posts, bars connected with said signals and with weighted levers, rods secured to said weighted levers, and cross levers which are pivotally secured to said rods, and

are operated by a passing train, substantially as described. 2nd. A series of posts having signals, weighted levers on said posts, means for connecting said weighted levers and said signals, means for connecting the signal on one post with the signal on the next post, and cross levers having connections with said weighted levers and adapted to be operated by a passing train, substantially as described. 3rd. A series of posts having signals, weighted levers thereon, bars connecting said signals and said weighted levers, cross levers which are joined with the weighted levers and rail levers which operate said cross levers, substantially as described. 4th. A series of posts with signals, weighted levers on said posts, arms connecting said signals and levers, two sets of cross levers and two sets of rail levers which are adapted to operate said cross levers, rods connected with said cross levers and said weighted levers, and means for connecting one set of said levers with another set on the next post, whereby when one set is operated the other set is also operated all combined, substantially as described. 5th. The combination, with a series of signals arranged along the track, of two series of rail levers pivotally mounted on the rails, one series being arranged within the tread of the ordinary wheel to be operated by the engine, and the other series being arranged beyond the tread of the ordinary wheel to be operated by the passage of the rear car of the train, substantially as described. 6th. The combination, with a series of signals arranged along the track, of two series of rail levers, one series being arranged within the tread of an ordinary wheel to be operated by the engine to set the adjacent section to danger, and the other series of levers being arranged without the tread of the ordinary wheel and connected to the signal at the beginning of the block through which the train has passed to operate the signal to "safety," as the rear car of the train moves over said levers, substantially as described. 7th. The combination, with the rail, of two series of rail levers mounted on the same pivot and connected directly to the side of the rail and each having curved portions projecting above the tread of the rail and a tongue or projection extending below the flange of the rails, one of the levers of each pair being longer than the other, substantially as described. 8th. The combination, with the rail, of two series of rail levers pivotally attached directly to the rail, but at different distances therefrom, a series of signal posts arranged along the track, connections between the inner rail lever and the signal upon the post adjacent to said lever, and connections between the signal on the next preceding post and the outer lever, substantially as described. 9th. The combination, with the series of signal posts arranged along the track, of two series of rail levers pivotally connected to the track, one series being within the tread of an ordinary wheel, and the other series beyond the tread, connections between the inner lever and the signal on the adjacent post, and connections between the outer lever and the signal of the next preceding post, the respective connections being on opposite sides of the post adjacent to the levers, substantially as described. 10th. The combination, with a series of signal posts arranged along the track, of two series of rail levers pivotally connected directly to the rail, a lever G connected to the signal adjacent to the track and arranged to be operated by the inner track lever, and a lever M arranged to be operated by the outer track lever and connected to the signal on the next preceding post, the arrangement being such that the inner rail lever will be operated by the passing of an ordinary wheel, while the outer lever will be operated only upon the passing of a special wheel projecting beyond the tread of the ordinary wheel, substantially as described. 11th. The combination, with the rail, of a track lever pivotally mounted on said rail, a filling piece between said lever and the web of the rail, the lever being within the tread of an ordinary wheel, and the other track lever mounted upon the same pivot and arranged outside the tread of an ordinary wheel, and adapted to be operated by a wheel having an extended tread, substantially as described. 12th. The combination, with the signal posts carrying semaphores arranged along the track, of the track levers H and I, pivotally connected to the rail, one of the levers being longer than the other and outside the tread of the ordinary wheel, the levers G and M respectively operated by the track levers, the flexible connections between the lever M and the next preceding semaphore, and a take-up device for said flexible connections, substantially as described.

No. 44,694. Carburator. (Carburateur.)

John Clingman, Dayton, Ohio, U.S.A., 15th November, 1893; 6 years.

Claim.—1st. In a device for carburetting air, the combination, with the enclosing casing, of a carburetting chamber within said casing, so constructed as to leave a space between the two surrounding the carburetting chamber and constituting the carburetted air chamber, the said carburetting chamber having a liquid receptacle, an air chamber above said liquid receptacle, having a series of outlets for discharging air within said liquid receptacle, a hollow perforated disc for distributing the air, having outlet passages discharging into the air chamber, and means for supplying air to said air distributing disc, substantially as described. 2nd. In a device for carburetting air, the combination, with the enclosing casing, of the carburetting chamber within the same, so constructed as to leave a space between the two surrounding the carburetting chamber and forming the carburetted air chamber said carburetting chamber having a liquid receptacle, an air chamber above said liquid receptacle, a series of discharge pipes extending from said air

chamber to near the bottom of said liquid receptacle, an air distributing disc located within and having perforations discharging

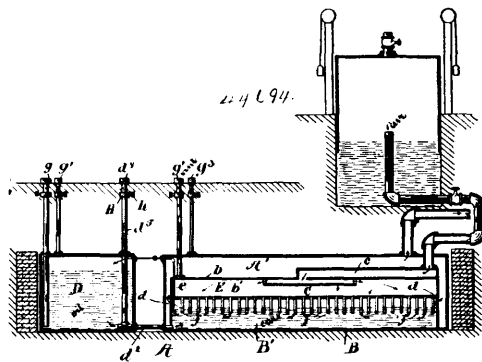

into said air chamber, an air supply pipe connected with said air distributing disc, and openings in said liquid receptacle communicating with said carburetted air chamber, substantially as described. 3rd. In a device for carburetting air, the combination, with the carburetting chamber, of a liquid supply pipe for the same, located beneath the surface of the ground, a valve located in said pipe for controlling the liquid supply, a valve stem extending from said valve to a point adjacent to the surface of the ground, an enclosing casing for said valve stem provided with a closing cap, and a construction secured to said casing to prevent its movement in the ground when the cap is removed to give access to the valve stem, substantially as described. 4th. The combination of a carburettor adapted to be placed below the surface of the ground, a pipe leading thereto provided with a screw threaded closing cap, and a device for preventing the turning of said pipe, consisting of a part constructed to rigidly engage said pipe, having laterally extending portions for engaging the surrounding earth, substantially as described.

No. 44,695. Pneumatic Tire. (Bandage pneumatique.)

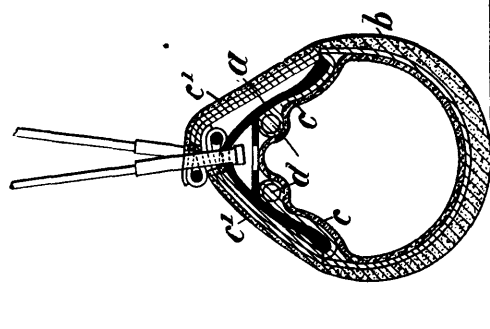

John Samuel Smith, London, England, 15th November, 1893; 6 years.

Claim.—1st. A jacket or covering for a pneumatic tire adapted to be fastened over the rim by attachment flaps and provided with bracing flaps, the edges of which are furnished with elastic cords, substantially as described. 2nd. The modification of the jacket above claimed, in which one of the bracing flaps is secured to the rim of the wheel, the other being provided with an elastic cord so as to serve the purposes hereinbefore referred to, substantially as described. 3rd. A jacket or covering, substantially of the section shown in figure 2, provided with attachment flaps such as c', and bracing flaps elastically corded, such as e, substantially as described.

No. 44,696. Electric Elevator. (Elevateur électrique.)

Alonzo Bertram See and Walter L. Tyler, both of Brooklyn, New York, U.S.A., 15th September, 1893; 6 years.

Claim.—1st. The combination, with an elevator car, and an electric motor therefor, of an electric circuit supplying current to the motor, an electro-responsive apparatus in a separate circuit and controlling the motor, a switch controlling the electro-responsive apparatus, a wheel carrying a device arranged to throw the switch, and connections from the car to the wheel whereby the latter may be turned to move the switch, substantially as described. 2nd. The combination of an elevator car, a motor therefor, a switch and rheostat in the motor circuit, a solenoid in a separate circuit, said solenoid moving the switch and rheostat, a retarding device for the solenoid, a switch in the circuit of the solenoid and mechanical connections from the car to the switch in the solenoid circuit, whereby the solenoid may be controlled. 3rd. The combination, with an elevator car and electric motor therefor, of a pole changer

in the motor circuit, an electro-responsive apparatus in a separate circuit and controlling a motor circuit, a switch controlling the

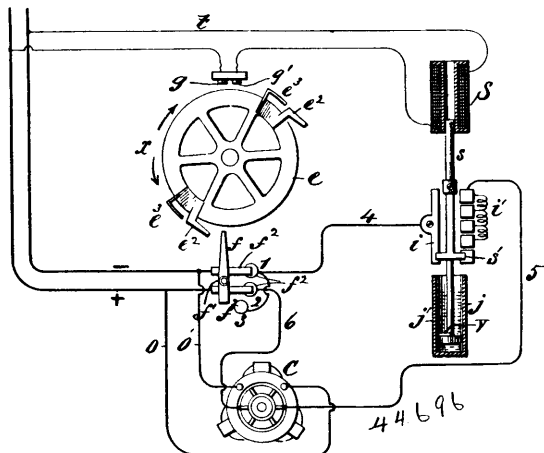

electro-responsive apparatus, and a wheel carrying two pairs of devices, one device of each pair arranged to throw the pole changer and the other device of each pair arranged to throw the switch, for the purpose set forth. 4th. The combination, of an elevator car, a motor therefor, a rheostat in the motor circuit, a solenoid in a separate circuit and operating said rheostat, a retarding device for the solenoid, a switch in the solenoid circuit, a pole changer in the motor circuit, the wheel e, and rope e', said wheel being provided with devices for operating said switch and pole changer, substantially as described.

No. 44,697. Electrolytic Apparatus.

(Appareil Electrolytique.)

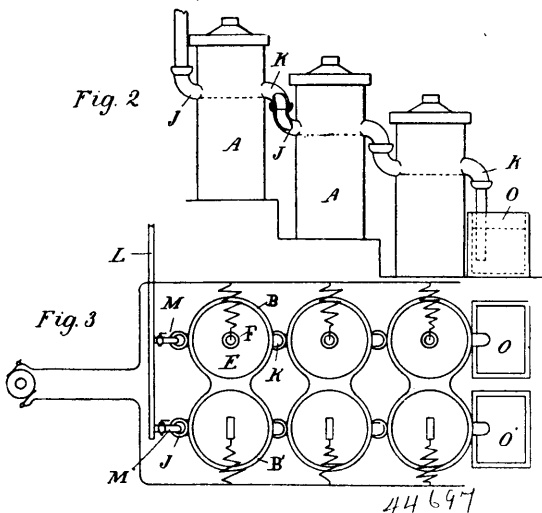

Thomas Craney, Bay City, Michigan, U.S.A., 15th November, 1893; 6 years.

Claim.—1st. In an apparatus for electrolyzing liquids, a plurality of cells, each composed of separate cathode and anode compartments electrolytically connected with each other, and an upward and a downward extending elbow connection for each compartment at a point above the space to be occupied by the liquids, whereby the joints formed in connecting the vessels are not submerged into the liquid, substantially as described. 2nd. In an apparatus for electrolyzing liquids, the combination of a plurality of cells arranged upon different planes, cathodes and anodes contained in separate compartments electrolytically connected with each other, elbow connections K, J, uniting the like compartments of the cells in series, and valve-controlled supply pipes M, M', substantially as described.

No. 44,698. Electrolysis of Metallic Salts.

(Electrolyse de sel metallique.)

Thomas Craney, Bay City, Michigan, U.S.A., 15th November, 1893; 6 years.

1st. The herein described method of electrolyzing salts in solution, consisting of subjecting the solution to the electrolytic action in separate anode and cathode compartments, in continuously feed-

ing fresh solution into the anode compartment, and in continuously discharging the product from the cathode compartment at a uniform

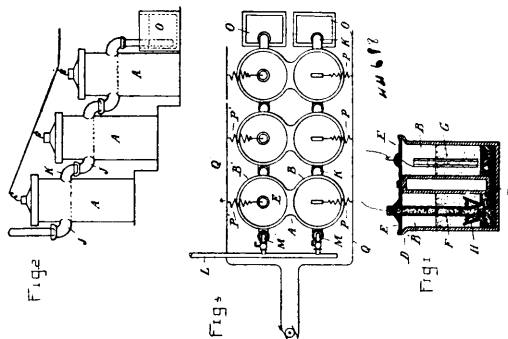

state of concentration, substantially as described. 2nd. The herein described method of electrolyzing salts in solution, consisting of subjecting the solution to the electrolytic action in cells, having separate anode and cathode compartments in which the like compartments are connected in series, supplying fresh liquid in regulated quantities into the first compartment of each series, and thereby producing a continuous flow through all the compartments, and a discharge from the last compartment of each series in a manner to maintain each cell in a uniform condition of operation. 3rd. The herein described method of electrolyzing salts in solution, the same consisting in subjecting the solution to electrolytic action in a cell having separate anode and cathode compartments, in supplying the anode compartment with fresh solution in quantity to maintain it in concentration, and in removing the product from the cathode compartment by a regulated supply of fresh liquid, substantially as described.

No. 44,699. Shirt. (Chemise.)

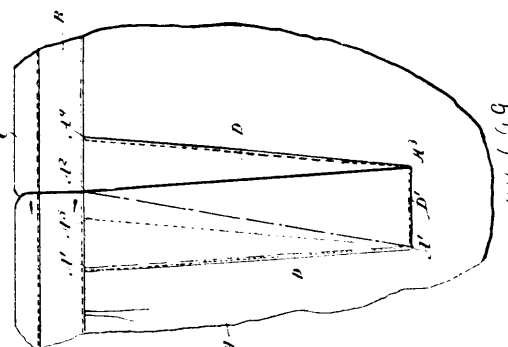

John Allan, Montreal, Quebec, Canada, 15th November, 1893; 6 years.

Claim.—1st. The combination with a shirt, of a continuous strip of fabric folded in V-form obliquely on itself and forming the edges of the opening of same. 2nd. The combination with a shirt, of a continuous strip of fabric forming the edges of the opening, folded obliquely on itself to form a V-shaped piece and sewn at the folded edge sides and ends to the shirt, as and for the purposes set forth. 3rd. In combination with a shirt opening at the back and having a V-shaped portion of such back cut out to receive it, a double continuous strip folded on itself obliquely and having its edges and the fold secured to the edges of the opening, as and for the purposes set forth.

No. 44,700. Heating, Cooling and Ventilating System. (Système de chauffage et de ventilation.)

Joseph H. Brady, Kansas City, Missouri, U.S.A., 15th November, 1893; 6 years.

Claim.—1st. A heating, cooling and ventilating system, comprising a number of vertical passageways communicating severally with the upper and lower parts of the apartments, and an air mixing and heating chamber communicating with the lower ends of said passageways, substantially as set forth. 2nd. A heating, cooling and ventilating system, comprising a number of vertical passageways communicating severally with the upper and lower parts of the apartments, an air mixing and heating chamber communicating with the lower ends of said passageways, heat radiating coils located within the air mixing and heat generator, and communicating with a suitable heat generator, and heat radiating pipes extending in pairs through the passageways and also placed in communication with a heat generator, substantially as set forth. 3rd. A heating, cooling and ventilating system, comprising a number of vertical passageways communicating severally with the upper and

lower parts of the apartments, an air heating and mixing chamber communicating with the lower parts of the passageways, and

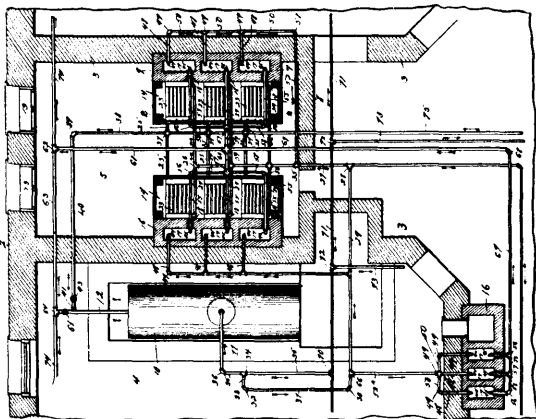

openings establishing communication between said passageways and the chamber and covered by movable gates or doors, substantially as set forth. 4th. A heating, cooling and ventilating system, comprising a number of vertical passageways leading vertically upward from the basement of the building, and communicating severally with the upper and lower apartments of the building, an air mixing and heating chamber located also in the basement and communicating with the lower ends of the passageways, a suitable heater located also in the basement, a number of heat radiating and communicating with the outlet and return of the heater, and a number of heat radiating pipes located in pairs in the passageways and connected also to the outlet and return of the heater, substantially as set forth. 5th. A method of heating, cooling and ventilating buildings, the same consisting in heating and mixing external pure air in the lower part of a building, discharging said heated and mixed air into the upper parts of the apartments of the building, discharging the contaminated air from the lower parts of the apartments of the building, and discharging the contaminated air at the top of the building, substantially as set forth.

No. 44,701. Horse Brush. (*Brosse pour cheval.*)

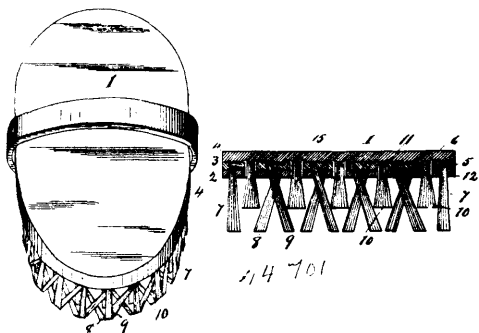

Sophia Giesecke, St. Louis, Missouri, U.S.A., 15th November, 1893; 6 years.

Claim.—1st. The improved horse brush, having tufts of brush material arranged in three separate rows, two of which have tufts of the same length arranged to form double rows of inclined tufts which cross each other, rows of bracing tufts having a less length than that of said double rows, each of said bracing tufts being constructed wide to act as a brace for two crossing tufts of said double rows, and the long tufts on the right of the double rows, being directed obliquely to the left, and those on the left of the double rows being directed obliquely to the right, so that the tufts of one of these rows wholly cross those of the other row, substantially as shown and described. 2nd. The improved horse brush, having a back 1, provided with adjacent rows of bristles 8 and 9, the tufts of one row wholly crossing those of the other row, said back having one oblong seats 11, formed therein at points adjacent said tufts, one seat between two of said tufts, and additional tufts 10, having a width in excess of the diameter of the first-mentioned tufts, and located one in each of said seats, so that one of said longer tufts stand over each of said shorter tufts, substantially as shown and described.

No. 44,702. Metallic Wagon Frames. (*Cadre pour voiture métallique.*)

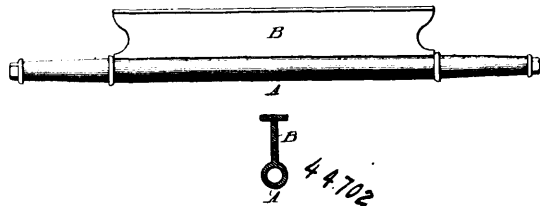

William Peter Bettendorf, Davenport, Iowa, U.S.A., 15th November, 1893; 6 years.

Claim.—1st. A metal axle and a longitudinal web or bolster thereon both formed in one piece. 2nd. A metal axle and bolster made in one piece, the cross section of the bolster being substantially T-shaped.

No. 44,703. Wind Motor. (*Moteur à vent.*)

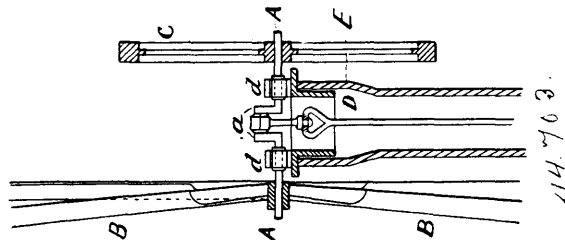

George Edward Moore, Lorette, St. Servan, Ille-et-Vilaine, France, 15th November, 1893; 6 years.

Claim.—1st. In a wind motor, the combination, with the sails and shaft of a fly wheel on the tail end of the shaft to counterbalance the sails, to equalize the rotation of the shaft and cause the sails to be automatically brought square to the wind, as specified. 2nd. In a wind motor wherein the sails are counterbalanced by a fly wheel on the opposite end of the shaft, mounting on the said shaft in bearings on a horizontal ring capable of rotary motion on a supporting pillar, as and for the purpose specified.

No. 44,704. Air Mattress. (*Matelas à air.*)

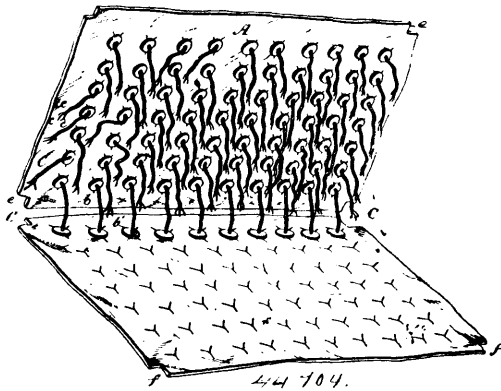

Seth Curlin, Union City, Tennessee, U.S.A., 16th November, 1893; 6 years.

Claim.—1st. In an inflatable mattress or analogous article, the transverse stays united to the walls of said mattress by discs or pieces between which the ends of said stays are confined, substantially as and for the purpose described. 2nd. An inflatable mattress or analogous article, provided with the internal stay cords having the ends thereof separated or spread and confined between discs or pieces which are united to the mattress by fastenings that pass through the cord strands, the discs, and the fabric of the mattress or other article, substantially as and for the purpose described. 3rd. In an inflatable mattress or analogous article, the combination of a stay cord having the divided strands at the end thereof, the discs or pieces between which the strands of the stay cord are arranged, and fastenings which pass through the discs, the strands and the mattress, substantially as and for the purpose described. 4th. In an inflatable mattress or analogous article, the reinforcement stays united at their ends near the corners of the mattress and having the inner ends overlapping each other and united to said mattress at the edges of the opening in the corner thereof, substantially as described. 5th.

The process of making inflatable mattresses or analogous articles, which consists in uniting a number of stay cords to a fabric sheet by sewing divided strands of each stay cord between discs or pieces, then uniting the free ends of said stay cords to a second sheet of fabric by fitting them between discs or pieces and sewing through the discs, strands and second sheet, uniting the edges of the sheets together, and fastening reinforcement stays across the openings in each corner of the mattress, substantially as and for the purpose described. 6th. The process of making inflatable water and air proof articles of textile fabric, which consists in partially making the article of textile fabric, coating the inner and outer surfaces of the textile fabric with a suitable liquid while the article is in its incomplete condition, and drying the same, then completing the article by uniting the open parts thereof, and finally introducing a quantity of free liquid which flows over the finishing seam or seams, substantially as and for the purpose described.

No. 44,705. Blast Pipe for Locomotives.

(*Tuyau d'évacuation de la vapeur dans les cheminées de locomotives.*)

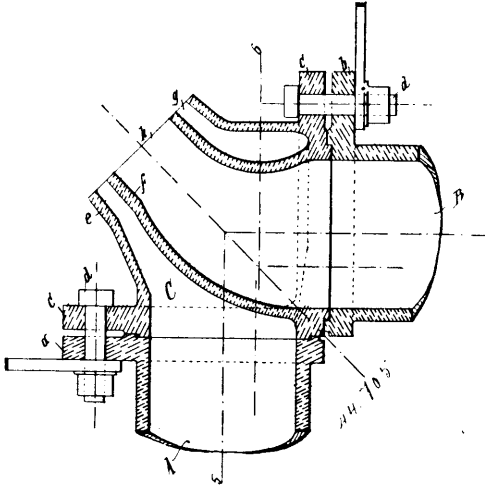

Christian Erdbrink, Paderborn, Westphalia, Prussia, 16th November, 1893; 6 years.

Claim.—1st. In a locomotive, two separate blast pipes, the end pieces of one encircling that of the other, for the purpose as described. 2nd. In a locomotive, two separate blast pipes A, B, having a common head C, the latter being composed of two concentric tubes *c f*, one tube communicating with one blast pipe, the other tube with the other blast pipe, for the purpose as described.

No. 44,706. Snow Plough. (*Charrue à neige.*)

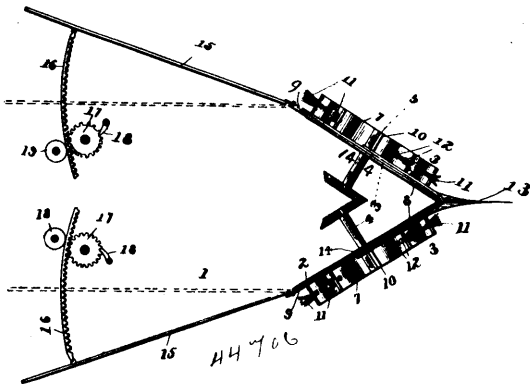

Thomas C. MacAdam, Ferndale, Pennsylvania, U.S.A., 16th November, 1893; 6 years.

Claim.—1st. In a snow-plough, the wedge-shaped head, in combination with wheels arranged parallel with the sides of said head and provided with curved brush carrying blades, substantially as specified. 2nd. The combination, with a snow-plough having a wedge-shaped head, of rotary wheels arranged parallel with the sides of said head and provided with peripheral flanges, and a prow or nose fixed to the apex of said head and provided with rearwardly divergent guard or shield plates having concave rear edges to overlap the peripheral flanges of the wheels, substantially as specified. 3rd. The combination, with a snow-plough having a wedge-shaped head, of brush carrying wheels arranged parallel with the sides of said head and comprising circular plates and curved or dish blades fixed to said plates and terminating short of their peripheries to

form flanges, and brushes secured respectively to the outer ends of the blades upon their rear sides, substantially as specified. 4th. In a snow-plough, the combination, with a wedge-shaped head, and brush carrying wheels mounted upon opposite sides of the head, of swinging wings arranged in rear of the head, and means for adjusting and locking such wings at any desired deflection, substantially as specified. 5th. In a snow-plough, the combination, with a wedge-shaped head, and brush carrying wheels arranged parallel with opposite sides thereof, of wings hinged at their front ends adjacent to the rear edges of the sides of the head, and means for adjusting and locking said wings consisting of rack bars, pinions engaging said rack bars and pawls to hold the pinions in their adjusted positions, substantially as specified.

No. 44,707. Slicing Mechanism for Bread, etc.

(*Machine pour trancher le pain, etc.*)

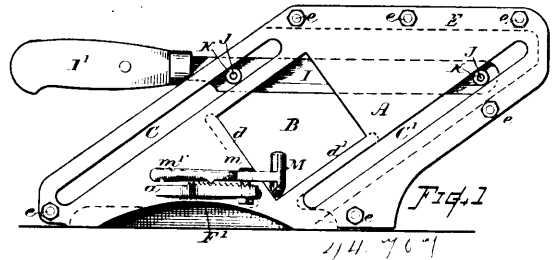

Joseph Fallows, Southbridge, Massachusetts, U.S.A., 16th November, 1893; 6 years.

Claim.—1st. In combination, substantially as described, the two upright guiding plates A A', having similar downwardly and forwardly inclined guiding slots C C', and the diagonally disposed central opening B therein, one of said plates provided with the foot A', and V-shaped feed trough D on its outer side, said plates connected together at their upper and rear edges by bolts *c* with the strip or flange E that sustain said plates with an intervening space, and the knife I movably confined within said intervening space, and provided at its opposite sides with guide studs that work in said guiding slots, and a handle I' that projects at the front of the frame, as shown for the purpose set forth. 2nd. In combination, with the plates A A' and knife I, supported and guided therein, as shown and described, the gage M consisting of a swinging handled lever pivoted upon a bracket *a* fixed to the plate A, and a notched or indented segment for retaining adjustment of said gage, substantially as set forth. 3rd. In a slicing mechanism of the character described, the plate A having at its lower edge the cut-away or recess at F', in combination with the plate A' attached thereto with the intervening space F, and the knife working and guided between said plates, said cut-away opening into said intervening space, substantially as and for the purpose set forth. 4th. The combination, with the hand-knife blade, of the removable stud having the shoulder, the rollers mounted on said stud at opposite sides of the blade, and the nut on the threaded end of said stud, substantially as and for the purpose set forth.

No. 44,708. Stall Drain. (*Drain d'étable.*)

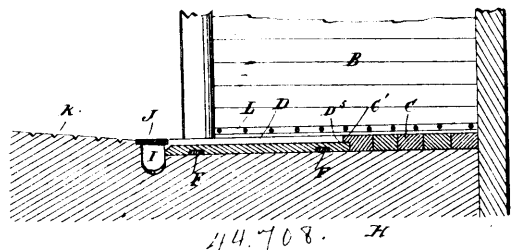

Henry Schiffer, New York, State of New-York, U.S.A., 16th November, 1893; 6 years.

Claim.—1st. A stall drain comprising a bottom made of cross-boards and longitudinal slats connected at their upper ends with the lowermost of the said cross-boards and forming top channels between adjacent slats, battens connecting the said slats with each other at the under side and angle irons adapted to be fastened to the sides of the stall and adapted to engage with their horizontal flanges the top surface of the said bottom at the sides thereof to securely hold the said bottom to the floor, as shown and described. 2nd. A stall drain provided with a bottom comprising a series of cross-boards and a drain composed of a series of longitudinal slats in alignment with the said cross-boards, each slat being formed on top and on one edge thereof with a rabbet extending throughout the length of the slat, and partly overlapped by an undercut on the next adjacent slat so as to form a longitudinal channel between each two adjacent slats and on

the top thereof, substantially as shown and described. 3rd. A stall drain comprising a bottom made of cross boards and longitudinal slats forming channels between adjacent slats, the upper ends of the slats being connected by rabbet and undercut with the end cross board, battens connecting the slats with each other at the under side, and angle irons adapted to be secured to the sides of the stall and resting with their horizontal flanges on the end slats and the sides of cross boards, substantially as shown and described. 4th. A stall drain comprising a cement floor formed with a transverse gutter, a cover for the said gutter and bottom extending from the gutter to the head of the stall, the said bottom being inclined and made of cross boards and longitudinal slats each formed on one side with a rabbet overlapped by an undercut on the next adjacent slat for forming longitudinal channels in the top of the slats and between each two adjacent slats and battens secured to the under side of the slats, substantially as shown and described. 5th. A stall drain provided with a drain made of slats placed firmly alongside one of the other, each slat being formed on top and on one edge thereof with a rabbet extending throughout the length of the slat and partly overlapped by an undercut on the next adjacent slat so as to form a longitudinal channel between each two adjacent slats and on the top thereof, substantially as shown and described.

No. 44,709. Explosive. (Explosif.)

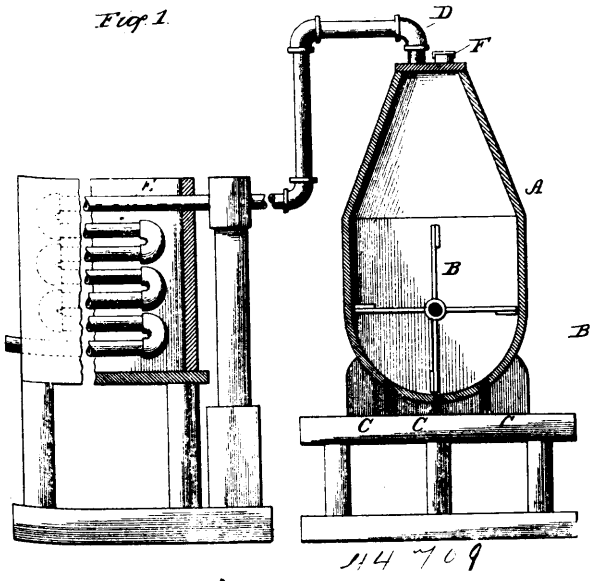

Francis G. Du Pont, Wilmington, Delaware, U.S.A., 16th November, 1893; 6 years.

Claim.—1st. The herein described process of producing a smokeless explosive, which consists in suspending nitro-cellulose in a liquid not a solvent of the same, granulating the nitro-cellulose by agitating therewith in proper proportions an emulsion of a solvent of the nitro-cellulose, which is not miscible to any great extent in the liquid used to suspend the same, in a suitable liquid in proper proportions, and solidifying the grains thus produced, substantially as described. 2nd. The herein described process of producing a smokeless explosive, which consists in suspending nitro-cellulose in a liquid not a solvent of the same, granulating the nitro-cellulose by agitating therewith in proper proportions an emulsion of a solvent of the same, which is not miscible to any great extent in the liquid used to suspend the nitro-cellulose, with water in proper proportions, and solidifying the grains thus formed, substantially as described. 3rd. The herein described process of producing a smokeless explosive, which consists in suspending nitro-cellulose in a liquid not a solvent of the same, granulating the nitro-cellulose by agitating therewith in proper proportions an emulsion of nitrobenzole, which is not miscible to any great extent in the liquid used to suspend the nitro-cellulose, with a suitable liquid in proper proportions, and solidifying the grains thus formed, substantially as described.

No. 44,710. Spring Hinge. (Charnière à ressort.)

Bommer Brothers, assignees of Lorenz Bommer, all of Brooklyn, New York, U.S.A., 16th November, 1893; 6 years.

Claim.—1st. In a double spring hinge, a three ply web connection for the barrels, made of three layers, an intermediate layer connecting the ends of the barrels and two outer overlapping layers forming extensions of the opposite ends of the barrels, the layers and barrels being made from one integral piece of sheet metal, substantially as set forth. 2nd. The combination, with the spring barrel and pintle, of a spring hinge, of a leaf having a longitudinal stop flange at its inner edge and perforated ears bent up at right angles

to the body of the leaf, pintle sockets interposed between the ears and barrel and pins connecting said ears with the pintle sockets, said pintle sockets having bushings extending into the perforations of the ears, substantially as set forth. 3rd. The combination, with the

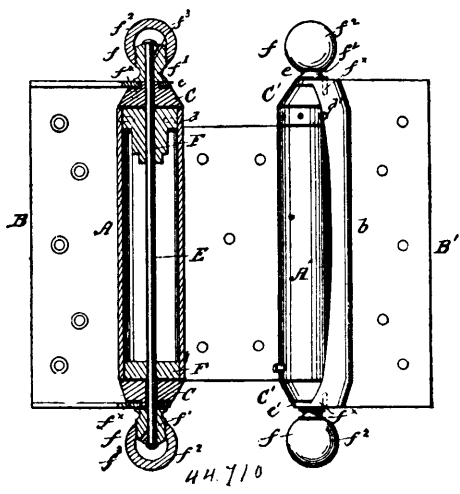

spring barrel and pintle of a spring hinge, of a leaf having perforated ears bent up at right angles to the body of the leaf, pintle sockets interposed between the ears and barrel, and pins connecting said ears with the pintle sockets, and hollow pintle tips or terminals formed of screw threaded sections or sleeves attached to the ends of the pintle and provided with inclined channels and of detachable screw caps, substantially as set forth.

No. 44,711. Machine for Making Brushes. (Machine pour fabriquer des brosses.)

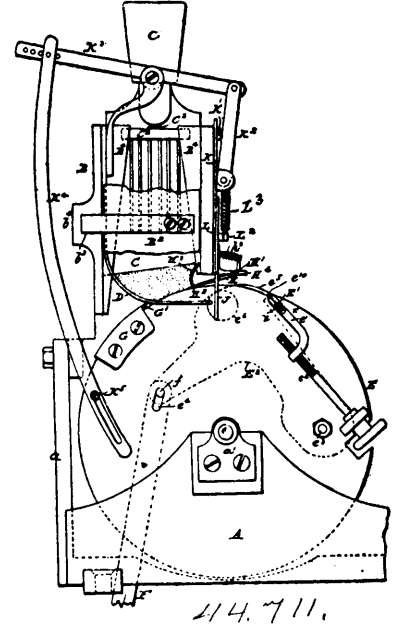

The consolidated Manufacturing Co., Philadelphia, Pennsylvania, U.S.A., assignee of Hyppolite Beeson, Hornsey, Middlesex, England, 16th November, 1893; 6 years.

Claim.—1st. In a brush machine, the combination of a hopper, a tuft gathering or notched blade or plate, movable across the mouth of the hopper, and an end plate of the hopper, movable to and fro, at right angles to the blade, or, in other words, freely adjustable lengthwise of the bristles in the hopper, as and for the purpose specified. 2nd. In a brush machine, the combination of a hopper, a tuft gathering or notched plate or blade, movable beneath the hopper, and a pair of end plates in the hopper, both of which are freely movable and adjustable in a direction crosswise of the notched plate or parallel with the length of the bristles within the hopper. 3rd. In a brush machine, the combination of a notched blade or plate, a hopper, a pair of end plates movable in a direction lengthwise of the bristles in the hopper, and means for enabling the

end plates to be moved back and forth simultaneously. 4th. In a brush machine, the combination of a notched blade or plate, a hopper, and a weighted plate or plunger therein, having serrations or grooves on its lower surface, which are transverse to the edge of the notched plate and crosswise of the bristles in the hopper. 5th. In a brush machine, the combination of a notched blade or plate, a hopper having freely movable end plates, a movable comb occupying a plane parallel with the sides of the notched blade, substantially as specified. 6th. In a brush machine, the combination of a hopper, a weighted plate in the hopper, and a vertically movable comb carried by the weighted plate. 7th. In a brush machine, the combination of a hopper, movable beater plates at opposite ends thereof, a weighted plate in the hopper carrying a vertically movable comb, and a notched plate moving beneath the hopper. 8th. In a brush machine, the combination of a hopper, a notched plate movable beneath the hopper, and a bristle feeder or compacter on the edge of the plate projecting upwardly for moving the bristles from the rear side of the hopper towards the front side, for the purpose specified. 9th. In a brush machine, the combination of a hopper, a notched plate movable beneath the hopper, a bristle collector or compacter secured to said plate, projecting therefrom, and having a forwardly projecting finger between which and the edge of the plate the bristles are collected, compacted and moved from the rear side of the hopper towards the front side. 10th. In a brush machine, the combination of a hopper, a notched plate movable beneath the hopper, and a cut-off plate, the edge or top of which intermittently occupies space between jaws at the edge of and above tuft notch in the movable plate. 11th. In a brush machine, the combination of a hopper, a notched plate movable across the mouth of the hoppers and a cut-off plate, the edge or top of which intermittently move into a slot formed in an enlargement on the plate at the outer edge of the notch. 12th. In a brush machine, the combination of a hopper, a notched plate or blade movable beneath the hopper, a cut-off plate, the edge of which co-operates with jaws at the edge of and above the notch in the movable notched plate, a pivot bolt connecting the cut-off plate with the notched plate, means for moving the cut-off plate relatively to the notched plate, and a spring washer or yielding clamp connected by a bolt with the notched blade and cut-off plate, for the purpose specified. 13th. In a brush machine, the combination of a hopper, a notched tuft carrying plate movable beneath the hopper, a cut-off plate, means for giving movement to the notched plate and to the cut-off plate, an adjustable gauge for varying the depth of the tuft notch, and an adjusting screw for giving movement to the gauge in a direction parallel with the length of the notch. 14th. In a brush machine, the combination of a hopper, a vertically moving arm bearing on the edge of the plate beneath the hopper, and having a finger projecting upwardly from the end of the arm. 15th. In a brush machine, the combination of a hopper, a tuft collecting plate or blade movable beneath the hopper, a spring actuated arm bearing on the edge of the plate beneath the hopper, and having a spring finger projecting upwardly from the end of the arm into the hopper. 16th. In a brush machine, the combination of a hopper, a tuft collecting blade movable beneath the hopper, an arm having a vertically moving outer end bearing on the edge of the plate beneath the hopper, and having also a spring arm projecting upwardly into the hopper and a collector carried by the blade for moving the bristles in the hopper toward the spring plate carried by the arm. 17th. In a brush machine, the combination of a hopper, a tuft collecting plate movable beneath the hopper, a separator blade for separating the ends of the bristles collected on the plate from those remaining in the hopper, and means for giving to the separator blade proper movements in a plane parallel with the axes of the bristles. 18th. In a brush machine, the combination of a hopper, a tuft collecting plate movable beneath the hopper, a separator blade for separating the ends of the bristles collected by the plate from those remaining in the hopper, means for giving an up-and-down or vertical movement to the separator blade, and means for moving the blade horizontally, for the purpose specified. 19th. In a brush machine, the combination of a hopper, a notched tuft collecting plate movable beneath the hopper, and a cut-off plate movable in a direction parallel or substantially parallel with the bristles lying in the notch. 20th. In a brush machine, the combination of a hopper, a notched plate reciprocating beneath the hopper, a cut-off plate, a gauge carried thereby and extending into the notch, and means for moving the gauge in a direction parallel, or substantially so, with the axis of the bristles. 21st. In a brush machine, the combination of a hopper, a notched plate moving beneath the hopper, a cut-off plate, a gauge extending into the notch, a pivoted finger having an arm projecting towards the extension of the gauge, and means for giving movement to the finger. 22nd. In a brush machine, the combination of a hopper, a slide, means for reciprocating it beneath the hopper, a notched tuft collecting blade carried by the slide, a cut-off plate carried by the slide adjacent to the notched blade, and means for automatically moving the cut-off plate laterally relatively to the notched plate. 23rd. In a brush machine, the combination of a hopper, a slide, means for reciprocating it across the mouth of the hopper, a tuft collecting plate mounted on the slide, a cut-off plate pivotally connected with the slide, an arm provided with a roller projecting from the cut-off plate, and an adjustable inclined bar with which the roller engages. 24th. In a brush machine, the combination of a hopper, a notched tuft collecting plate moving beneath the hopper,

a cut-off plate arranged above the tuft collecting plate, mounted to move vertically relatively thereto and provided with an inclined surface within the hopper.

No. 44,712. Bottle Stopper. (*Bouchon de bouteille.*)

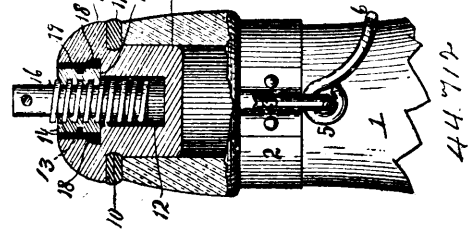

The Universal Lock and Stopper Company, assignee of Henry B. Stewart and Theodore Schwer, all of St. Louis, Missouri, 16th November, 1893; 6 years.

Claim.—1st. In a bottle stopper, in combination with the bail, lever and band, a cork having a screw connected to the bail, and having a groove 10 to receive a gasket, substantially as and for the purpose set forth. 2nd. In a bottle stopper, in combination with the bail, lever and band, a cork having a socket with an enlarged upper end, a nut fitting in the enlargement of the socket, a filler surrounding the nut, and a screw fitting in the nut and connected with said bail, substantially as and for the purpose set forth. 3rd. In a bottle stopper, in combination with the bail, lever and band, a cork having a socket with an enlarged, upper end with recesses 18, a grooved nut fitting in the enlargement of the socket, a filler surrounding the nut, and occupying said recesses and said groove, and a screw fitting in said nut and connected to said bail, substantially as and for the purpose set forth. 4th. In a bottle stopper, in combination with the bail, lever and band, a cork having a groove 10 to receive a gasket 11 and having a socket with an enlarged upper end having a groove 17 and recesses 18, a nut fitting in the enlargement of the socket and having a groove 19, a filler 19 and a screw 16 fitting in said nut and connected to said bail, substantially as and for the purpose set forth. 5th. The combination of a band adapted to encircle a bottle, a bail, a lever constructed of wire and fulcrumed on the band and having the ends of the bail pivotally connected to it, a stopper having a threaded opening, and a threaded stem adjustable in the threaded opening of the stopper and provided with a transverse opening receiving the bail, whereby the stopper is hinged to the bail, substantially as described.

No. 44,713. Machine for Weaving Cane for Chair Seats. (*Métier à tisser la canne pour sièges de chaise.*)

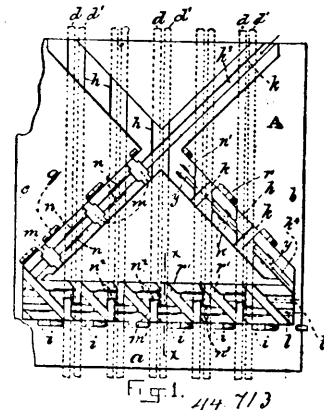

Charles W. Greenwood, South Garden, Massachusetts, U.S.A., 16th November, 1893; 6 years.

Claim.—1st. Blocks or frames provided with longitudinal grooves h, h' , and the cross grooves l, l' , at right angles to said longitudinal grooves, said blocks being provided, at suitable intervals, with projections arranged in pairs at either side of said cross grooves and with recesses opposite said projections, substantially as described. 2nd. The blocks or frames A, B, having their corresponding surfaces provided with longitudinal grooves h, h' , cross grooves l, l' , and diagonal grooves k^1, k^2 , and with plates or projections arranged at each side of said cross and diagonal grooves, in pairs, at suitable intervals apart, and with recesses opposite said plates, substantially as set forth. 3rd. The blocks or frame A, B, provided respectively, with longitudinal grooves h, h' , cross grooves at right angles thereto, projections arranged alongside of said cross grooves, recesses

opposite said projections, diagonal grooves k^1 , k^2 , the diagonal grooves of one block crossing the diagonal grooves of the other block at right angles when the corresponding faces of said blocks are brought together, substantially as described. 4th. The blocks A, B, provided respectively, with longitudinal and cross grooves crossing each other at right angles, diagonal grooves also crossing each other at right angles, and vertical plates or projections arranged at each side of said cross and diagonal grooves, in pairs, said plates or projections on one block corresponding to depressions in the opposite block, substantially as described. 5th. The blocks or frames A, B, provided respectively, with longitudinal grooves, grooves crossing the same at right angles, projections at the sides of said cross grooves at suitable intervals apart, and depressions or recesses opposite said projections, the whole so related to each other that when said blocks are brought together, face to face, a cane web may be interwoven between said blocks by passing strands of cane through or along said grooves, substantially as set forth. 6th. The blocks or frame A, B, provided with grooves, and having guides arranged in close proximity to said grooves for the purpose of guiding strands of cane into said grooves, substantially as described.

No. 44,714. Gas Heater. (*Calorifère à gaz.*)

Fig. 1. 44.714

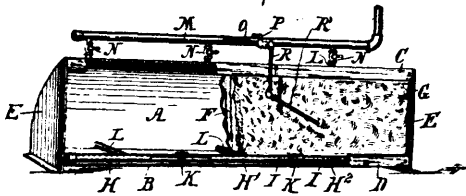

Frank P. Ziegler, Milwaukee, Wisconsin, U.S.A., 16th November, 1893; 6 years.

Claim.—A gas heater, comprising a frame or body, a vertically disposed plate therein, a batting of asbestos secured to the face of the plate, a perforated burner pipe in sections closed at their ends, located along and near to the lower edge of the asbestos batting, a main gas supply pipe, and separate pipes, each having a stop cock connecting the main pipe with the several burner sections, substantially as described.

No. 44,715. Heating Apparatus.

(*Appareil de chauffage.*)

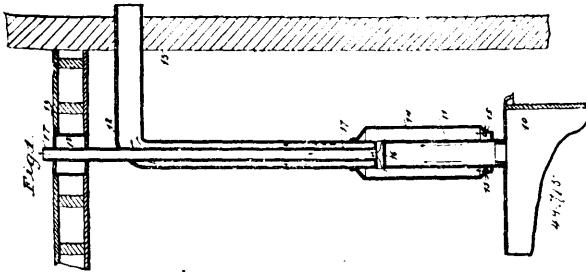

Beniah M. Dumson, Kenton, Ohio, U.S.A., 16th November, 1893; 6 years.

Claim.—The combination with a stove pipe provided with a pipe extending transversely across the same, of a hot air pipe within the stove pipe and extending from the transverse pipe out through the stove pipe, and a perforated drum surrounding the stove pipe, substantially as described.

No. 44,716. Buckle. (*Boucle.*)

George M. Aylesworth, Collingwood, Ontario, Canada, 16th November, 1893; 6 years.

Claim.—1st. A buckle, comprising a frame, having five cross-bars and locking studs on two of said cross-bars, substantially as described. 2nd. A buckle, comprising a frame having two side bars joined together by two end cross-bars, two cross-bars near the end bars, a centre cross-bar, a locking stud on one end bar, and two opposite studs on the centre-bar, substantially as described. 3rd. A buckle, comprising a frame, having two side bars that are oppositely bent edgewise near the ends of each bar, held spaced apart in parallel by two end cross bars, two cross-bars at the

crowns of the frame bar arches, and a centre cross-bar, a locking stud projected from the top face of one end cross-bar, and two

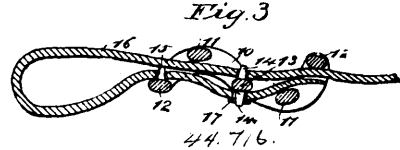
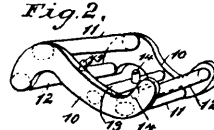

locking studs oppositely projected from top and bottom faces of the centre cross bar, substantially as described.

No. 44,717. Tire for Wheels. (*Bandage de roues.*)

Fig. 1.

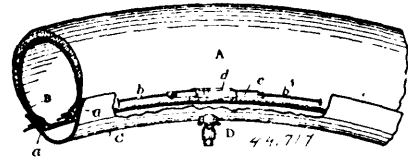

Edward Henry Seddon, Sale, Chester, England, 16th November, 1893; 6 years.

Claim.—1st. The combination with a wheel rim and a tire cover formed with a tubular edge of a wire passing partly through and partly outside of said edge and attached with its ends to an S-shaped stretcher, so that the wire ends overlap each other, substantially as described. 2nd. The combination with a wheel rim and a tire cover formed with a tubular edge of a wire passed twice round the rim partly inside and partly outside of said tubular edge the ends of which wire are connected by a coupling device. 3rd. A coupling device for the ends of a wire attaching a tire cover to a rim, said device consisting of a stretcher e , of S-shaped section hinged to one of the wire ends b , and having the other wire end b^1 , hooked upon its other end in such a manner that when said stretcher is pressed down upon the wire end b , this lies in the bottom groove and the other wire end b^1 , in the top groove of said stretcher, substantially as described and illustrated.

No. 44,718. Hermetically Sealed Bucket.

(*Vase scellé hermétiquement.*)

Fig. I.

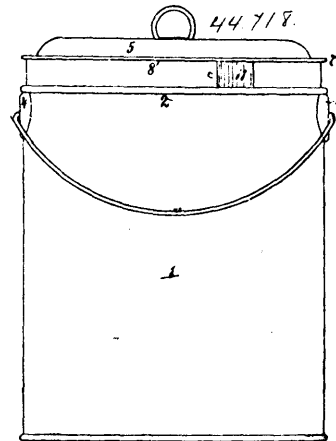

S. N. Long Syrup Company, assignee of Samuel N. Long, all of St. Louis, Missouri, U.S.A., 17th November, 1893; 6 years.

Claim.—In a hermetically sealed bucket, the combination, with the bucket, of a lid provided with a depending flange, said flange being adapted to but partially enter the bucket, a sealing strip surrounding said flange and soldered to the bucket and lid, and a packing strip interposed between said sealing strip and depending flange, substantially as described.

No. 44,719. Pneumatic Tire. (Bandage pneumatique.)

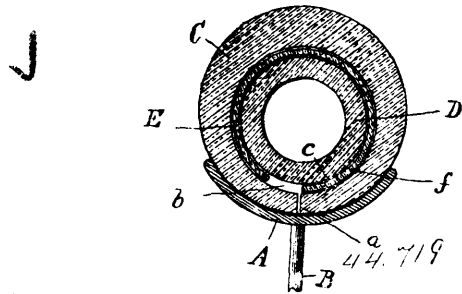

William S. Callaghan and Charles T. Holloway, both of Baltimore, Maryland, U.S.A., 17th November, 1893; 6 years.

Claim.—In a pneumatic tire, the combination of an inner elastic tube, an outer elastic tube, and an impenetrable, non-elastic cover enclosing the inner elastic tube, and having a split extending in a peripheral direction entirely around it on that side adjacent the metallic rim of the wheel, one edge only of the split being cemented or otherwise secured to one of the elastic tubes, the rest of the cover being unattached and loose, for the purpose described.

No. 44,720. Fixtures for Hanging Curtains, etc. (Ajustage des stores de fenêtres, etc.)

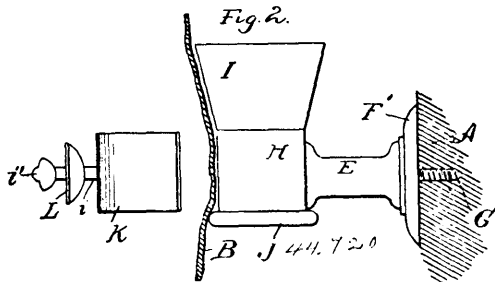

Albert W. Herr and Isaac N. Long, both of Washington, Columbia, U.S.A., 17th November, 1893; 6 years.

Claim.—1st. The herein described curtain supporting fixture comprising a suitable series of upright blocks or supports around which the curtain or drapery can be draped in plaits or folds, and means for securing or clamping the curtain or drapery to the blocks or supports, as set forth. 2nd. A curtain supporting fixture comprising, the combination of a suitable upright block and a suitable clamp adapted to clasp a curtain or drapery and form and maintain it in plaits or folds, one of said parts being provided with means for attaching it to a door or window frame, substantially as set forth. 3rd. A curtain fixture comprising, the combination of a vertical block or support from which a curtain or drapery can be draped, and a suitable clasp engaging the block or support, and adapted to clasp the curtain thereto and project into the folds of the curtain and form and maintain it in plaits or folds, substantially as and for the purposes herein set forth. 4th. A curtain fixture comprising a substantially cylindrical vertical block or support from which the curtain can be draped, and a suitable spring clamp adapted to engage the cylindrical block or support and clasp the curtain thereto, and form and maintain it in the plaits or folds, substantially as set forth. 5th. A curtain fixture, comprising a substantially cylindrical block or support, having a flaring head projecting therefrom and adapted to rest in a vertical position, in combination with a suitable spring clamp adapted to engage therewith and clasp the curtain thereon and form and maintain it in folds, substantially as set forth. 6th. A curtain supporting fixture, comprising a suitable block or support from which the curtain or drapery can be hung, a flange or beading around the bottom of said block or support for preventing the slipping of the curtain thereon, and a suitable clamp adapted to clasp the curtain to the support, as set forth. 7th. A curtain supporting bracket, formed with a substantially cylindrical portion, around which the curtain can be draped and an angular beading at the bottom of the cylindrical portion for preventing the curtain from slipping, in combination with a suitable clamp adapted to engage the cylindrical head and hold the curtain thereon, substantially as set forth. 8th. The combination of the bracket arm E, the cylindrical head secured thereto, means for securing the bracket arm to a window or door frame, and a spring clamp adapted to engage the cylindrical head, substantially as set forth. 9th. The combination of the curtain supporting bracket, comprising essentially a cylindrical head, with a spring clamp adapted to engage the cylindrical head and clasp the drapery thereto and a button attached to the spring

clamp and adapted to support an over drapery, substantially as set forth. 10th. The combination of a series of substantially cylindrical blocks or supports attached to a window or door frame in upright position, a curtain or drapery plaited or folded around said blocks or supports, and spring clamps engaging said curtain and blocks, and projecting into the folds of the curtain for maintaining the folds, substantially as described.

No. 44,721. Machine for Painting Fabric Material. (Machine pour peindre les tissus.)

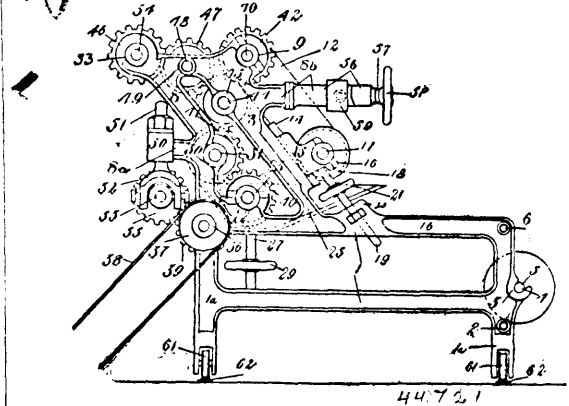

John L. Armitage, assignee of Edwin Armitage, Newark, New Jersey, U.S.A., 17th November, 1893; 6 years.

Claim.—1st. The combination of the frame 1, the web roll 5, the colour box 25, the screw threaded standards 27, for vertically adjusting the colour box, the distributing roll 24, the platen roll 32, the traversing jacket 12, the rolls 18 and 11, the screw 19, for moving the roll 18, to or away from the roll 11, the finishing knife 60, arranged at one side of the traversing jacket 12, means for moving the finishing knife to or away from the said jacket and means for imparting a rotary motion to the rolls 21, 32, 18 and 11, substantially as and for the purpose specified. 2nd. The combination of the frame 1, the web roll 5, the colour box 25, the screw threaded standards 27, for vertically adjusting the colour box, the distributing roll 24, the platen roll 32, the traversing jacket 12, the rolls 18 and 11, the screw 19, for moving the roll 18, to or away from the roll 11, the finishing knife 60, arranged at one side of the traversing jacket 12, means for moving the finishing knife respectively to or away from the jacket, the vertical adjustable roll 54, and the roll 35, and means for imparting motion to the rolls 24, 11, 32, 18, 54 and 35, substantially as and for the purpose described. 3rd. In a painting machine, the combination of the frame 1, the web roll 5, the tension rolls 6, 7 and 54, the vertically adjustable hanger 52, the colour box 25, the distributing roll 24, the platen roll 32, the traversing jacket 12, the roll 11, mounted in the top portion of the frame 1, the roll 18, mounted in guide blocks 15, sliding on guides 14, the screws 19, passing through screw threaded collars 20, formed in the frame 1, and adapted to move the guide blocks 15, on said guides in order that the roll 18 can be moved to or away from the roll 11, the finishing knife 60, arranged at one side of the traversing jacket 12, means for moving the finishing knife respectively to or away from the traversing jacket 12, the roll 35, and means for imparting motion to the machine, substantially as described.

No. 44,722. Carpet Sweeper. (Balayeuse de tapis.)

The Bissell Carpet Sweeper Company, assignee of Walter J. Drew; all of Grand Rapids, Michigan, U.S.A., 17th November, 1893; 6 years.

Claim.—1st. The combination, with a carpet sweeper case, a drive wheel, and a brush shaft, of an anti-friction roller bearing, substantially as described. 2nd. The combination, with the carpet sweeper case, a drive wheel, and a brush shaft, of an anti-friction roller, said drive wheel held away from frictional contact with the case by means of the anti-friction roller, the brush shaft, and its bearings upon the floor, substantially as described. 3rd. The combination, with a carpet sweeper case, a drive wheel, and a brush shaft, of an anti-friction roller bearing acting to force or press the drive wheel toward the brush shaft when pressure is applied to the sweeper case, substantially as described. 4th. The combination, with a carpet sweeper case, and a drive wheel, of a roller bearing acting on the drive wheel outside the wheel base and a brush shaft acted on by the drive wheel inside the wheel base, so that by pressure on the sweeper case the roller bearing forces or presses the drive wheel toward the brush shaft, substantially as described. 5th. The combination, with a carpet sweeper case and a drive wheel, of an elastic support carrying a roller bearing, substantially as described. 6th. The com-

bination, with a carpet sweeper case and a drive wheel, of an elastic support carrying a roller bearing which acts on the drive wheel out-

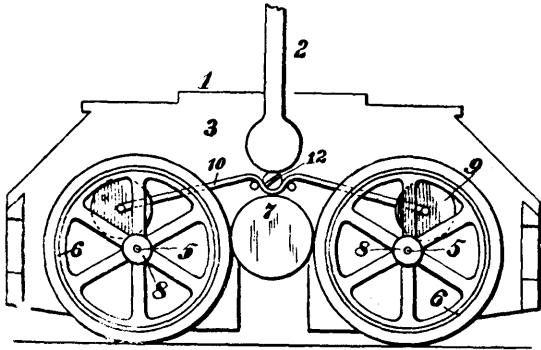

44,722

Fig. 1.

side the wheel case and brush shaft acted on by the drive wheel inside the wheel base, substantially as described.

No. 44,723. Method of Obtaining Sulphide of Nickel.
(Méthode d'obtenir du sulfure de nickel.)

The Orford Copper Company, assignee of Robert M. Thompson, all of New York, State of New York, U.S.A., 17th November, 1893; 6 years.

Claim.—1st. The hereinbefore described method of producing and separating nickel sulphide, consisting in smelting the ores or mattes containing nickel with caustic alkalies, carbonates of the alkaline bases or a mixture thereof, or other similar re-agents rich in oxygen, substantially as set forth, whereby the nickel is converted into crude metallic nickel, in allowing the crude nickel to settle and separate by gravity, in separating the crude nickel after smelting, and in resmelting the same with a sulphide of any alkaline base, substantially as set forth, whereby nickel sulphide and caustic alkali are produced, and in allowing the nickel sulphide to settle and separate by gravity and separating the same after settling. 2nd. The hereinbefore described method of producing and separating nickel sulphide, consisting in smelting the ores or mattes containing nickel, with caustic alkalies or carbonates of the alkaline bases or a mixture thereof or other similar re-agents rich in oxygen, substantially as described, whereby the nickel is converted into crude metallic nickel to settle and separate by gravity in separating the crude nickel after settling, and in resmelting the same with a sulphide of an alkaline base whereby nickel sulphide and caustic alkali are produced, in allowing the nickel sulphide to settle and separate by gravity, in separating the same after settling and subjecting it to repeated smelting with the sulphide of an alkaline base and separation by gravity, until the impurities are eliminated and a residue of commercially pure sulphide of nickel is produced. 3rd. The method of producing sulphide of nickel from "bottoms" resultant from the initial treatment of nickel ores or mattes with alkaline re-agents, substantially as hereinbefore described, consisting in smelting the same with a sulphide of any alkaline base of a mixture of any two or more of such sulphides, substantially as described, whereby nickel sulphide and caustic alkali are formed, and in allowing the former to settle and separate by gravity and removing the same after settling. 4th. The hereinbefore described method of producing crude nickel for use in the production of nickel sulphide consisting in smelting ores, mattes or other bodies containing nickel with the "tops" rich in caustic alkalies produced in previous operations by smelting crude nickel with sulphides of any alkaline base, or a mixture of any two or more of the same or other agents producing alkaline sulphides. 5th. The hereinbefore described method of producing and separating crude nickel for use in the production of sulphide of nickel consisting in smelting the ores, or mattes, containing nickel with a concentrated alkali, produced by allowing the "tops" resultant from the smelting of crude nickel with sulphides of any alkaline base or any two or more of the same in previous operations to decompose by exposure to the air, whereby the alkaline base is converted into caustic alkali. 6th. The hereinbefore described method of producing and separating sulphide of nickel, consisting in smelting the ore, mattes or other bodies containing nickel, with a suitable re-agent or flux, substantially as set forth, whereby the nickel is converted into crude metallic nickel, in allowing the crude nickel to settle and separate by gravity in separating the same after settling, and resmelting with nitre or salt cake, with an excess of carbon, substantially as set forth, whereby the nitre or salt cake is decomposed and sulphide of soda formed, which united with the crude nickel to form nickel sulphide, and in allowing the nickel sulphide to settle and separate by specific gravity, and in separating the same after settling. 7th. The hereinbefore described method of producing sulphide of soda for use in producing

nickel sulphide from crude nickel, consisting in smelting the crude nickel with commercial salt cake or nitre cake, with an excess of carbon, whereby the salt or nitre cake is decomposed, and sulphide of soda formed, which unites with nickel to form nickel sulphide. 8th. The hereinbefore described method of producing and separating sulphide of nickel from crude nickel by smelting the same with commercial nitre cake or salt cake or other similar soda salt in a furnace with an excess of carbon, whereby the soda salt is decomposed and sulphide of soda formed, which unites with the nickel to form nickel sulphide, and in allowing the latter to settle and separate by specific gravity and in separating the same after settling. 9th. The hereinbefore described method of producing sulphide of any of the alkaline bases for use in processes for producing and separating sulphide of nickel from crude nickel consisting in smelting the crude nickel in a suitable furnace with "tops" rich in sulphides of any of the alkaline bases resultant from the final separations of the sulphide of nickel in other similar operations. 10th. The hereinbefore described method of producing and separating sulphide of nickel consisting in smelting the ores, or mattes containing nickel, with suitable re-agents, substantially as described, and in allowing the crude nickel so formed to settle, in separating the same after settling in any convenient manner, and in smelting the same in a suitable furnace with "tops" rich in sulphides of any of the alkaline bases, resultant from the final separations of the sulphide of nickel in previous similar operations, and in allowing the sulphide of nickel so formed to settle and in separating the same after cooling.

No. 44,724. Table. (Table.)

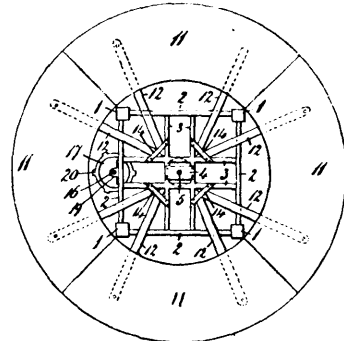

Fig. 2.

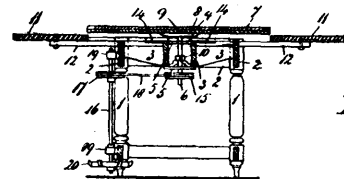

Fig. 3.

44,724

Horace Henry Bailey, Ottawa, Ontario, Canada, 17th November, 1893; 6 years.

Claim.—1st. A table having a revolving top, substantially as and for the purpose hereinbefore set forth. 2nd. A table having a revolving top, in combination with a stationary round top larger in circumference than the revolving top, substantially as and for the purpose set forth. 3rd. A table having a revolving round top in combination with extension leaves, which are removably or detachably connected to the frame of the table, substantially as and for the purpose hereinbefore set forth. 4th. A table having a round revolving top, in combination, with means for raising or lowering said top, substantially as set forth. 5th. In a table, the combination, of a round revolving top, of means for raising or lowering said top, of means for holding said top in a suspended or raised position, so that it may revolve, and of means for firmly holding said top to the table frame when lowered and resting on the table frame, substantially as and for the purpose set forth. 6th. In a table, the combination, of a round revolving top, of means for raising or lowering said top, of a stationary round table larger in diameter than the revolving top, substantially as and for the purpose hereinbefore set forth. 7th. In a table, the combination of a round revolving top, of means for raising or lowering said top, of removable extension leaves, substantially as and for the purpose set forth. 8th. In a table, the combination of a frame, of a revolving top, of means substantially as set forth, for revolving said top by the foot of a person sitting at said table, substantially as set forth. 9th. In a table, and in combination, a table frame, a revolving top having attached vertically to its centre at the under side a shaft, a grooved wheel on the lower end of said vertical pivot shaft attached to the same by a set screw, a vertical shaft attached to the outer top rail of the table frame by a box, in which its journal revolves, having near its upper end and on a level with the wheel on the

lower end of the pivot shaft, a wheel, a round or rope belt connecting the two wheels, braces from two table legs to hold in position the lower end of the vertical shaft, and a disc on the lower end of said vertical shaft and a disc on which a person may place his foot to revolve said shaft and table, substantially as and for the purpose hereinbefore set forth.

No. 44,725. Process of Tanning.

(*Procédé de tannage.*)

Edward Conlin, Delhi, Ontario, Canada, 17th November, 1893; 6 years.

Claim.—1st. In a tanning process for pelts, a steeping liquor of and in the proportion of four pounds of tanning extract, four pounds of common salt, four pounds of alum and from one to four ounces of sulphide of soda or thereabouts, and but slightly diluted, substantially as set forth. 2nd. In a tanning process for pelts, a steeping liquor composed of and in the proportion of four pounds of tanning extract, four pounds of common salt, four pounds of alum and one half to two ounces of sal soda or thereabouts, slightly diluted, substantially as set forth.

No. 44,726. Method of Chloridizing Muffle Furnaces.

(*Méthode de chlorurer les fourneaux à coupelle.*)

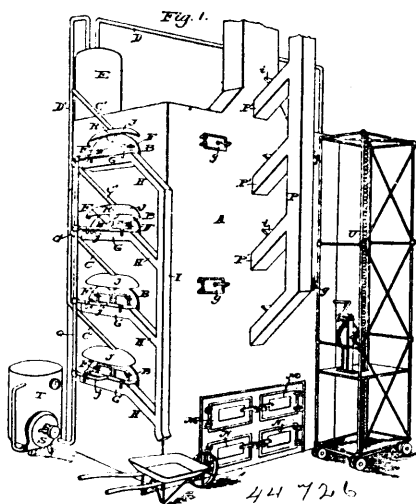

Hugh Calhoun and Prosper H. Ellsworth, both of Hot Springs, and Aron M. Beam, of Bear, all in Arkansas, U.S.A., 17th November, 1893; 6 years.

Claim.—1st. In a muffle furnace, the combination of a containing chamber and a series of muffles arranged one above another within said chamber and alternately placed in contact with opposite sides thereof, whereby a circuitous flue is formed about the muffles and a ledge is provided above each muffle upon which to burn fuel when required, and charge openings through which to introduce fuel to said ledges, substantially as described. 2nd. In combination, with chamber A, provided with zigzag flue *c*, muffles located one above another in said flue, ledges *e* at one side of each muffle, feed openings *f* above the ledge *e*, and doors or closures for said openings, substantially as described. 3rd. In combination, with chamber A, and muffles B, provided with inlet or charge openings, partition wall O, provided with chutes *h*, registering with the charge openings of the muffles, substantially as described. 4th. In combination, with a furnace chamber and with a muffle located therein and provided with doors, a hood located above the doors, a tank, and a pipe connecting the hood and the tank and serving to convey matters collected by the hood to the tank, substantially as described. 5th. In combination, with furnace chamber A, and muffles B, located in said chamber one above another, pipes Q, Q', extending into muffles, blower S, communicating with the pipe Q, and receiver T, interposed between the blower and the pipe Q, and serving to equalize the air pressure, substantially as described. 6th. The method of extracting lead from gold or silver bearing ores, which consists in first reducing the ore to granular form, heating said ore in a closed receptacle in the presence of sufficient oxygen to insure the combustion of the carbonaceous matter present, the temperature being maintained at or slightly below 600 degrees Fahrenheit, and finally removing the lead from the mass in the form of black particles, which it assumes under the treatment stated, substantially as described.

No. 44,727. Extension Ladder. (Echelle à rallonge)

James Squires Burgess, Marathon, New York, U.S.A., 17th November, 1893; 6 years.

Claim.—1st. An extension ladder, consisting of two sections connected together and braces connected thereto and provided with

intermeshing gear segments. 2nd. An extension ladder, consisting of an upper and lower section, a dog pivoted upon the lower section

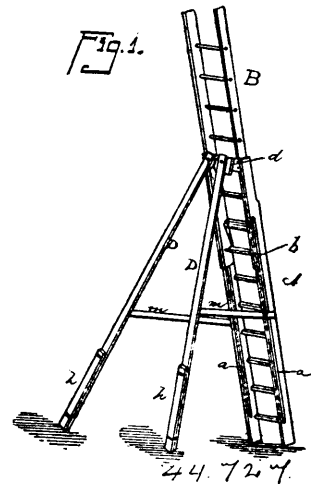

and engaging with the upper section, a board hinged to the lower section, braces pivotally connected to said board and gear segments upon said braces meshing together in combination, as set forth.

No. 44,728. Drill Press. (Machine à percer.)

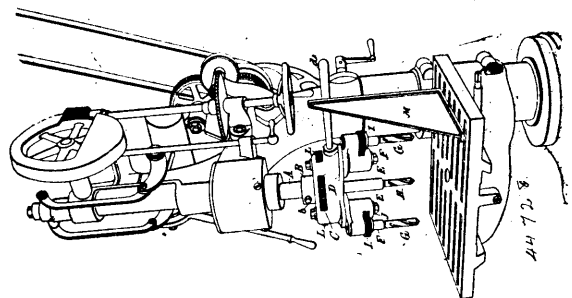

Jacob Neff Barr, Milwaukee, Wisconsin, U.S.A., 18th November, 1893; 6 years.

Claim.—1st. A multiple drilling attachment for a drill press, consisting of a portable frame, drill spindles therein, gearing to drive said spindles, and a gear operating sleeve or shank adapted for attachment to the spindle of a drill press, substantially as described. 2nd. A multiple drilling attachment for a drill press, consisting of a sleeve or shank adapted for attachment to the spindle of the press and provided with a gear, a frame in which the sleeve revolves and which is sustained thereby, secondary spindles mounted in the frame, and gears encircling said spindles and engaging with the gear of the sleeve. 3rd. In combination with a drill press, having the rotary longitudinally adjustable spindle, a frame sustained by the spindle, a stationary guide against which the frame slides to prevent its rotation, secondary drill spindles in the frame and gears in the frame connecting the secondary spindles with the main spindle. 4th. In an attachment for a drill press, a driving gear turning therein and adapted for connection with the spindle of the press, and arm adjustably pivoted to the frame, and carrying a secondary drill spindle, a pinion on the secondary spindle and intermediate pinions connecting the last named pinion with the gear. 5th. The frame D, swinging arms F, E', and spindles F, F, in combination with the sleeve B, gear C, and pinions I, J, L.

No. 44,729. Flour Bolt. (Blutoir.)

William Dickson Gray, Milwaukee, Wisconsin, U.S.A., 18th November, 1893; 6 years.

Claim.—1st. The combination, substantially as described, of the rotary reel, lifting buckets therein and an independently revolving spreader adapted to receive the material from the lifting buckets and deliver the same outward against the bolting surface. 2nd. The combination of the cylindrical reel, the internal lifting buckets connected thereto and separated at their outer edges from the bolting surfaces, the internal spreader provided with longitudinal blades to receive the material from the lifting buckets, and mechanism for rotating the spreader and the reel, the former at a higher speed than the latter. 3rd. The cylindrical reel, the longitudinal lifting buckets E, attached to and carried by the reel, their outer edges separated from the bolting cloth and their inner edges upturned, in

combination with the internal spreader, having the longitudinal blades with their faces in approximately tangential positions, and mechanism for revolving the spreader at a speed greater than that

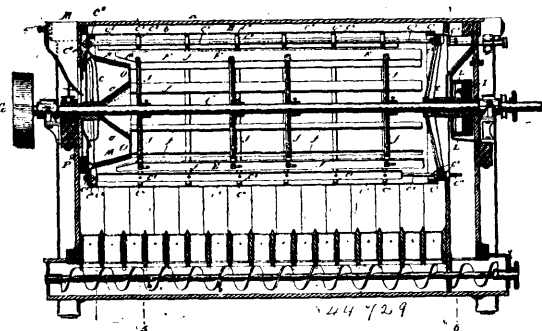

of the reel. 4th. In a flour bolt, a central shaft, the spiders fixed thereon, and the spreaders carried by the spiders, in combination with the reel spiders mounted to turn loosely on the shaft, the rods connecting the reel spiders, the bolting cloth, the lifter blades carried by the reel between the bolting cloth and the spreaders and differential gear for communicating a slow motion from the shaft to the reel. 5th. In a bolting reel, the combination of a head spider, the bolting cloth connected therewith, the tail spider, its longitudinally movably encircling hoop, having the tail end of the bolting cloth connected therewith, and adjusting screws, whereby the hoop may be adjusted axially in relation to its supporting spider. 6th. In a bolting reel, the head and tail spiders, and the longitudinal rods connecting them, in combination with the cylindrical bolting cloth connected with one spider, the longitudinal movable hoop sustained by the other spider and connected with the bolting cloth, said hoop having lugs to embrace the rods and prevent its rotation, and adjusting screws for moving the hoop in axial direction in relation to its sustaining spider. 7th. In a flour bolt, and in combination with the external casing, the reel having its head spider provided with the annular flange c^1 , as and for the purpose described. 8th. In a flour bolt, the external casing provided with the feed hopper, in combination with the internal reel, the conical screen fixed in the head of the reel to receive material from the hopper, and the plate o , substantially as described, closing the central and inner portions of the conical screen to emit the admission of air. 9th. In combination with the reel, and a hopper feeding into its head, the rotary screen located in the head of the reel and provided with internal blades, substantially as described. 10th. In combination with the external case, the central driving shaft, the reel mounted to turn loosely thereon, the differential gear connecting the shaft and reel within the casing, and the housing L , enclosing said gearing.

No. 44,730. Flour Bolt. (Blutoir.)

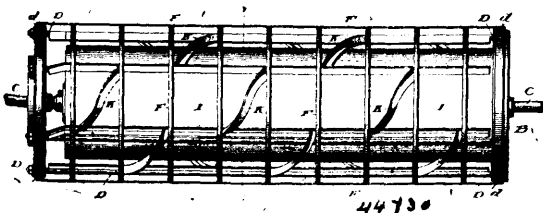

William Dickson Gray, Milwaukee, Wisconsin, U.S.A., 18th November, 1893; 6 years.

Claim.—1st. The combination, substantially as described, of a bolting reel, longitudinal lifting buckets or blades therein and obliquely arranged blades between the lifting buckets. 2nd. A cylindrical reel containing a series of lifting buckets or blades in lines substantially parallel with its axis and with a second series of blades lying at a greater angle to the axis. 3rd. A cylindrical reel, in combination with longitudinal lifting blades H , their outer edges separated from the bolting cloth and blades K arranged at a greater angle to the axis of the reel, and also separated at their outer edges from the bolting cloth. 4th. A cylindrical reel and an internal drum, in combination with lifting buckets or blades H , having their edges separated from the bolting cloth and from the drum, and the intermediate blades K , also separated from the cloth and the drum. 5th. In combination, with the cylindrical reel, the internal obliquely arranged blades K , separated from the bolting cloth, the distance between them varying at different points in the length of the blades. 6th. In combination, with a cylindrical reel and longitudinal lifting buckets or blades H therein, the intermediate blades K fixed to and carried by the blades H . 7th. In a flour bolt, the combination of a reel, internal lifting blades or buckets from which the material

gradually escapes on the upgoing side of the reel, and a secondary series of blades arranged at a sharp inclination to the axis of the reel, and in position to receive and longitudinally distribute the material falling from the first named blades. 8th. In combination, with a reel and internal lifting blades or buckets extending lengthwise thereon, intermediate obliquely arranged blades of angular cross-section separated at their outer edges from the bolting surface.

No. 44,731. Flour Bolt. (Blutoir.)

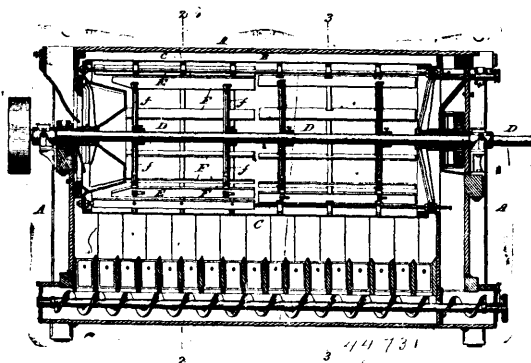

William Dickson Gray, Milwaukee, Wisconsin, U.S.A., 18th November, 1893; 6 years.

Claim.—1st. The combination, substantially as shown, of the reel lifting buckets in its head end only, rotary spreader blades inside of said buckets, rotary spreaders in the tail end of the reel, and mechanism for revolving the spreaders and the reel at different speeds. 2nd. The combination, substantially as shown, of the reel the lifting buckets in its head end, rotary spreaders inside of said buckets, rotary spreaders located in the tail with a longitudinal inclination greater than that of the head spreaders, and mechanism for rotating the reel and speeders at differential speeds. 3rd. In a flour bolt, the combination of a rotary encircling bolting cloth, internal lifting buckets to spread the material on the upgoing side, central rapidly revolving spreaders to receive the material from the lifters and deliver it against the cloth, bolting cloth to which the material passes after the above treatment, and a second series of rotary spreaders encircled thereby and acting without intervening parts to deliver the material to the cloth. 4th. A cylindrical reel in combination with internal rapidly rotating spreader blades located nearer the cloth at the tail end than at the head end of the reel. 5th. The combination with a rotary reel of two series of internal rapidly revolving spreader blades one at the head, the other at the tail, the latter arranged at a greater longitudinal inclination than the former.

44,732. Boot and Shoe. (Chaussure.)

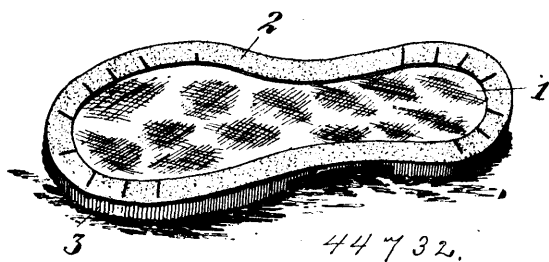

James Ferguson Sharpe, Toronto, Ontario, Canada, 18th November, 1893; 6 years.

Claim.—1st. In a boot or shoe the combination of a waterproof outer sole a flange formed integrally with the outer sole, an inner or middle sole, the said flange being turned over the edge of the inner or middle sole and secured thereto, substantially as described. 2nd. The herein described process of attaching rubber soles to boots or shoes which consists in providing the rubber sole with a flange and attaching the rubber outer sole to the middle or inner sole by means of the said flange, substantially as described. 3rd. The herein described process of attaching rubber soles to boots and shoes, which consists in first securing a rubber coated strip to the upper outer edge of the outsole, in next placing a leather middle sole on the rubber outsole and rubber coated strip and in then turning the

rubber coated strip up and over the leather middle sole and securing it firmly thereto, substantially as described. 4th. The herein described integrally formed outer sole for boots and shoes consisting of a rubber outer sole and a leather middle sole which are joined together by a rubber coated strip secured to the rubber outer sole and then turned, folded or lapped over and secured firmly to the leather middle sole and then securing the rubber outer sole and leather middle sole to the upper, substantially as described.

No. 44,733. Steam Engine. (Machine à vapeur.)

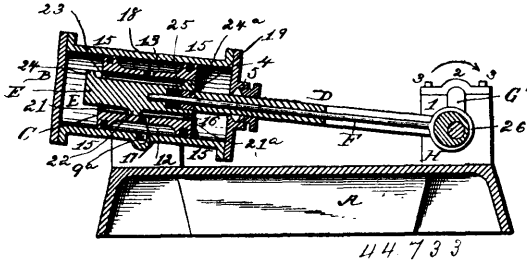

Jay Woodward Powers, Sycamore, Illinois, U.S.A., 18th November, 1893; 18 years.

Claim.—1st. The combination, in a steam engine, with the cylinder having inlet and outlet ports and passages and a longitudinally chambered piston head within said cylinder having inlet and outlet ports, of a longitudinally grooved valve operating within said piston head, and with but in advance of the same, and a shaft connected both with said piston head and valve, substantially as described, whereby both the piston head and valve will be acted upon by the steam and both transmit motion to said shaft, as specified. 2nd. The combination, in a steam engine, with the cylinder having entrance and exit ports, a tubular piston rod, and a valve operating within the chamber in said piston head and having its rod extending through said piston rod, of a crank shaft to the crank portion of which the outer end of said piston rod is connected, and an eccentric mounted on the crank portion of said crank shaft and having the outer end of the valve rod connected to it, said eccentric being mounted on said crank so as to be in lead of the throw thereof, substantially as described and for the purposes specified. 3rd. The combination, in an engine, with the oscillating cylinder having hollow trunnions, one of which forms the entrance and the other the exit port for the steam, said cylinder also having passages, one leading from the entrance port and the other to the exit port, and its inner wall pierced to form a port leading from its entrance passage to its interior, of a chambered piston head operating within said cylinder and having suitable steam passages and ports, a longitudinally grooved valve within said piston head, and a crank shaft connected with and operated by said piston and valve. 4th. The combination, in a steam engine, with the cylinder having inlet and outlet ports, of a longitudinally chambered piston head within said cylinder, said piston head having exterior steam passages always in communication with the inlet port of the cylinder, and also having entrance and exit ports, a longitudinally grooved valve within said piston head, and a shaft to which said piston head and valve are independently connected, substantially as described and for the purposes specified.

No. 44,734. Apparatus for Manufacturing Gas.

(Appareil pour la fabrication du gaz.)

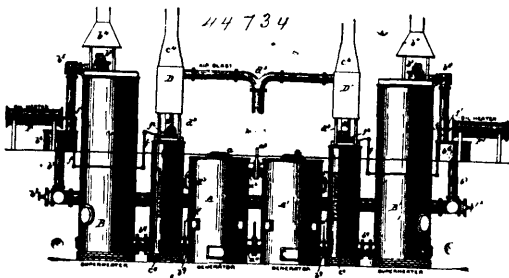

Alexander Crombie Humphreys, Philadelphia, Pennsylvania, U.S.A., 18th November, 1893; 18 years.

Claim.—1st. In a gas making apparatus, the combination substantially as hereinbefore described, of a generator and superheater having a duct or passage which connects said generator and superheater and is alternately occupied by heated products of combustion on their way from the chamber which is supplied with solid fuel, and by superheated or decomposed steam on its way to a fixing chamber, and a vertical carburetting chamber communicating at its base only, with said duct, and provided at its top with an oil supply pipe, and with an exit port provided with a valve or gate, whereby

when said exit port is opened, said chamber will be heated by a diverted portion of the products of combustion supplied by the generator passing directly through it from its base to and outward through its open top, and also whereby when said port is closed, and oil injected, the oil will be vaporized and partially gasified and merged at the base of said chamber, with decomposed or superheated steam while passing through said duct. 2nd. In a gas making apparatus, the combination substantially as hereinbefore described, of a generator, and a fixing chamber, a duct which affords the sole communication between the generator and firing chamber, and a vertical carburetter which has its top a valve guard port and an oil injecting pipe, and which communicates at its base with said duct, whereby in heating up the apparatus, all of the lot products of combustion will pass to the firer through said duct except when the top of the carburetter is opened for permitting a portion of said hot products to pass upwardly therein, and also, whereby gaseous matter delivered from said generator will pass through the same duct to the firer and be carburetted in its passage thereto. 3rd. In a gas making apparatus, the combination substantially as hereinbefore described, of a down draft generator or furnace to which solid fuel is supplied a chamber provided with a steam injection pipe and checker brick for rendering it capable of operating either as a steam superheater or as a firing chamber, through the products of combustion are mainly conducted while heating up the apparatus, and a carburetter provided with an oil injection pipe, and interposed between said generator and said chamber, communicating at its base only with the bases of both, and provided at its top with a valve guarded exit port. 4th. In a gas making apparatus, the combination substantially as hereinbefore described, of a pair of closed-down draft generators, each having an air blast port above the gate, and an exit port below said gate, and to which solid fuel is supplied, and which communicate with each other at their tops, two chambers, in both of which steam may be superheated and gas fixed, each chamber at its base connected by a duct with the base of an adjacent generator, and between each generator and its superheater or gas firer, a vertical carburetting chamber, communicating at its base with said duct, and provided at its top with a valve guarded exit port, whereby in heating up the apparatus, both carburetters may be properly heated by means of diverted portions of the products of combustion proceeding from the generators, while the main portions thereof pass to and through the superheater and gas fixing chambers, and also whereby either carburetter on being supplied with oil, will enrich gases after their passage from either superheater, through both generators, and while passing laterally through or across the interior of the carburetter near its base, on their way to the superheater, then operating as a fixing chamber. 5th. In a gas making apparatus, embodying duplicate carburetters, each provided at its top with an oil injecting pipe and a guarded port, and duplicate superheaters, each of the latter provided with a valve guarded port at its top, and with a steam injection pipe, and each capable of operating as a fixing chamber, the combination of a pair of generators which are coupled at their tops, by a duct provided with a gate, and a steam jet pipe in each generator, each of said generators being in communication with a carburetter, and with a superheater or fixing chamber, substantially as described, whereby the heating of the carburetters and the superheaters may be separately controlled, and also whereby when said generators are in open communication, steam may be superheated in either superheater, and conducted therefrom through both generators, then enriched by the contents of one carburetter, and the gases fixed in the other superheater, or by closing the said duct, enabling each generator to operate as a steam decomposing chamber, and the superheater, which is connected therewith, to operate only as a fixing chamber. 6th. In a gas making apparatus, the combination substantially as hereinbefore described, of two generators, the two superheaters, provided with steam injecting pipes and operating either for superheating steam or as fixing chambers, and two carburetters, each intervening between a superheater and a generator, and provided with oil injecting pipes, and also with steam injection pipes, whereby while either carburetter is being supplied with oil, the other may be used for superheating steam, and to co-operate with one of said superheaters. 7th. In a gas making apparatus, the combination, substantially as hereinbefore described, of a generator, to which solid fuel is supplied, a chamber, in which steam may be superheated or gas fixed, a duct connecting the bases of said generator and chamber, a carburetter provided with a steam injection pipe, and communicating at its base with said duct, and provided at its top with a valve guarded exit port, and air blast ports at the bases of said chamber and carburetter, whereby in the heating up the apparatus, appropriate portions of the heated products of combustion may be directed into and through said chamber and said carburetter, and each appropriately supplied with air for securing good combustion of gaseous matter therein. 8th. In a gas making apparatus, the combination, substantially as hereinbefore described, of the two generators or furnaces, communicating at top and bottom, valves or gates controlling said communication, a carburetter and heater communicating with each other, and with one of said generators at its base, a similar carburetter and a similar superheater communicating in like manner with the other generator, and valves or gates for controlling said communication, whereby after heating up both generators, and either carburetter, and its communicating superheater (to enable it to operate as a firing chamber) steam may

be decomposed in either or both of said generators, and delivered to the heated carburetter and superheater or firing chamber, while the other carburetter and superheater is wholly out of service. 9th. In a gas making apparatus, the combination, substantially as hereinbefore described, with a generator and a superheater and fixer, of a carburetter having at its top a valve guarded exit port, and connected at its base with a duct for directing heated products of combustion thereto, and also having said port adapted to receive either of a series of annular neck pieces or throttlers of various sizes for varying the area of said port, whereby the heated products of combustion passing through said carburetter may be graduated to its proper requirements, and obviate the wasteful diversion of heat from other portions of the apparatus, such as superheaters or fixers or both, and also whereby over heating of said carburetter may be obviated while properly heating said other portions. 10th. In a gas making apparatus, the combination, substantially as hereinbefore described, of the vertically unobstructed carburetting chamber into which oil in liquid form is delivered, and within which the oil while falling in space is vapourized for carburetting purposes, the chamber in which the carburetted gas is fixed, and an oil heater communicating with and affording a passage for hot product gas discharged from the firer, and also communicating with the top of the vertically unobstructed carburetting chamber, whereby the temperature of the product gas is reduced, and oil in its passage through said heater is not vapourized, but raised to a desirable temperature suitable for delivery in its liquid form into the carburetting chamber. 11th. In a gas making apparatus, the combination, substantially as hereinbefore described, of two generators, provided with air blast ports above their grates, and communicating with each other by way of a passage at the bottom, below the grates, a valve or gate for controlling said passage, a carburetter and a gas "fixer" both communicating with each other, and with said generators below their grates, whereby either of said generators may be wholly relied upon for co-operating with said carburetter and "fixer," or both of them made to jointly co-operate therewith.

No. 44,735. Glass Tube. (Tube en verre.)



44,735.

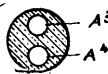

Patrick J. McElroy, Cambridge, Massachusetts, U.S.A., 20th November, 1893; 6 years.

Claim.—A continuous tube, made of glass prepared first with separated chambers or cavities open at one end and then blown and drawn simultaneously, substantially as and for the purpose herein described.

No. 44,736. Projectile. (Projectile.)

Fig. 1.

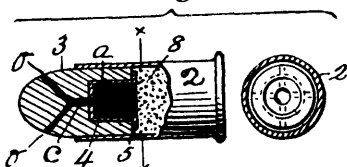

44,736

Daniel Baird Wesson, Springfield, Massachusetts, U.S.A., 20th November, 1893; 6 years.

Claim.—1st. A soft metal projectile having a chamber therein, said chamber having a lining of a hard, strong metal, and having a duct leading from the chamber to the exterior of the projectile. 2nd. A projectile having therein a chamber for a lubricant, a metal lining constituting a covering for the walls of said chamber having a flange around its open end bearing against the rear end of the projectile, and a duct leading from said chamber to the outer surface of the projectile and opening near that part of the projectile which has a bearing on the walls of the gun, substantially as set forth. 3rd. A soft metal projectile having a chamber therein, a lining of harder metal covering the walls of the said chamber, a duct leading from the chamber to the exterior of the projectile, and a movable cap covering the base of said chamber, substantially as described. 4th. A soft metal projectile having therein a chamber, a hard metal lining to said chamber, a passage leading from said chamber to the exterior of the projectile, a body of lubricant enclosed within the chamber, and a covering for the base of said chamber, all substantially as described.

No. 44,737. Rope Grip. (Grippe pour cordes.)

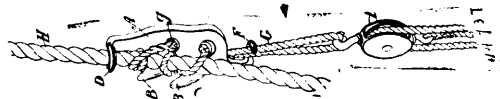

Arthur Kelly Evans, Toronto, Ontario, Canada, 20th November, 1893; 6 years.

Claim.—1st. In a rope grip, the combination, with the body plate having laterally extending hooks and a corresponding number of holes made in the body plate and a gripping rope designed to be passed over the rope to be gripped, over the hooks, through the holes and have the power applied to it as specified, of the retaining hook extending from the body nearest the portion of the rope to which the strain is to be applied as and for the purpose specified. 2nd. In a rope grip, the combination, with the body plate having laterally extending hooks and a corresponding number of holes made in the body plate and a gripping rope designed to be passed over the rope to be gripped, over the hooks, through the holes and have the power applied to it as specified, of a hook extending from the plate to form a guide for the gripping rope, as shown and for the purpose specified. 3rd. In a rope grip, the combination, with the body plate, having laterally extending hooks and a corresponding number of holes made in the body plate and a gripping rope designed to be passed over the rope to be gripped, over the hooks, through the holes and have the power applied to it, as specified, of a hook having a pulley journaled within it to form a guide for the gripping rope, as shown and for the purpose specified. 4th. In a rope grip, the combination, with the body plate, having laterally extending hooks and a corresponding number of holes made in the body plate and a gripping rope designed to be passed over the rope to be gripped, over the hooks, through the holes and have the power applied to it, as specified, of the retaining hook extending from the body nearest the portion of the rope to which the strain is to be applied and a hook extending from the plate to form a guide for the gripping rope, as shown and for the purpose specified. 5th. In a rope grip, the combination, with the body plate, having laterally extending hooks and a corresponding number of holes made in the body plate and a gripping rope designed to be passed over the rope to be gripped, over the hooks, through the holes and have the power applied to it, as specified, of the retaining hook extending from the body nearest the portion of the rope to which the strain is to be applied, and an oppositely turned retaining hook situated on the opposite end of the body of the plate, as and for the purpose specified. 6th. In a rope grip, the combination, with the body plate, having laterally extending hooks recessed and having rollers rotatably secured within such recesses and a number of holes corresponding in number to the hooks made in the body plate, and a gripping rope designed to be passed over the rope to be gripped, over the hooks, through the holes, and have the power applied to it, as specified, of the retaining hook extending from the body of the plate nearest the portion of the rope to which the strain is to be applied, as and for the purpose specified.

No. 44,738. Tag Holder. (Porte-étiquettes.)

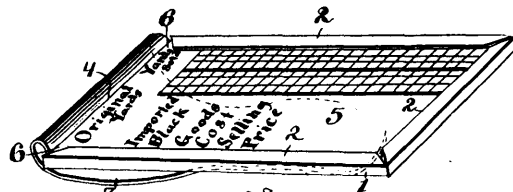

44,738

Charles E. Stowe, McAdenville, North Carolina, U.S.A., 20th November, 1893; 6 years.

Claim.—As an improved article of manufacture, a combined tag holder and clip, consisting of a back or main support with the edges turned over to form guides or retaining flanges, a spring tongue integrally formed with and extended from the top portion of the said back or support and bent downward under and adjacent to the latter, and a shoulder formed by raising the tongue in the primary bending thereof in a curved line and extending entirely across the upper end of the said back or support and located at the point where the tongue is connected, the said tongue being bent or curved in such manner as to form a secure frictional fastening when the device is applied, substantially as described.

No. 44,739. Damper for Stove Pipes.

(Registre pour tuyaux de poêles.)

Charles Treadwell Redfield, Glen Haven, New York, U.S.A., 20th November, 1893; 6 years.

Claim.—1st. The combination, with a stove pipe, of a damper smaller in diameter than the interior of the pipe, and bearings on

opposite ends of the damper-shaft compressing the pipe diametrically on the line of said shaft, whereby the pipe is made to pinch the edges of the damper adjacent to the shaft thereof, and the pipe is loosened from the edges of the damper on a line at right angles to said shaft, substantially as described and shown. 2nd. The combination, with a stovepipe and damper, of the damper-shaft passing through the pipe and having one of its protruding ends provided with a bearing on the exterior of the pipe, a spring on said shaft

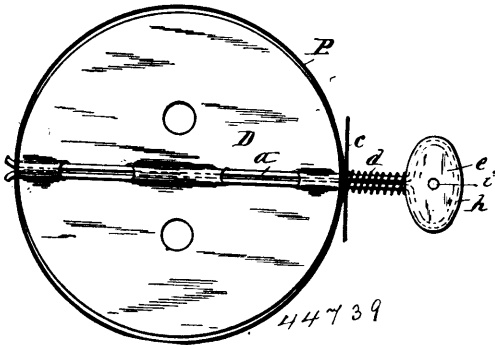

compressing the pipe, and the opposite protruding end split longitudinally and spread apart to confine the pipe diametrically compressed, as and for the purpose set forth. 3rd. The combination of the damper-shaft formed at one end with the loop *l* separate discs *cc* of wood or analogous material applied to opposite sides of said loop, and a rivet *i* passing through said discs and centre of the loop and holding the loop partly embedded in the discs, substantially in the manner set forth and shown. 4th. In combination, with the stove pipe, a damper having its shaft passing through the pipe and provided at one end with a bearing on the exterior of the pipe and the opposite end of said shaft bent into a loop, discs of wood applied to opposite sides of the loop, a rivet tying the discs to the loop, a shield mounted on the shaft, and a spiral spring on the shaft between the discs and shield and pressing said shield against the pipe and compressing the same diametrically as set forth.

No. 44,740. Glove. (Gant.)

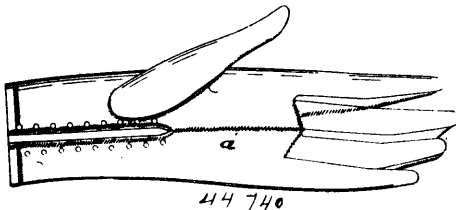

Julius Hamburger, Berlin, Prussia, German Empire, 20th November, 1893; 6 years.

Claim.—In gloves, the combination of one main piece cut to the shape of the glove and with gusset shaped additions, of two strips for the inner sides of the middle and ring fingers and of a thumb piece for insertion in a hole cut in the glove and already provided with a gusset, substantially as and for the purpose herein described with reference to the accompanying drawing.

No. 44,741. Presser Foot for Moulding Machines.

(*Pédale pour machines à mouler.*)

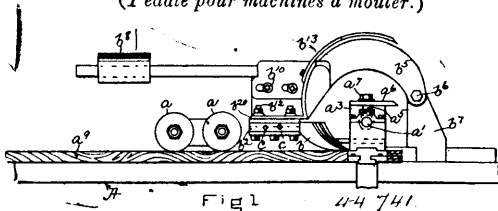

Frederick L. Creighton, Somerville, and Jesse C. Foster, Boston, both in Massachusetts, U.S.A., 21st November, 1893; 6 years.

Claim.—1st. In a moulding machine, a bed plate and a rotary cutter head supported thereon and provided with a plurality of knives arranged on the cutter head to effect cuts of varying depths in the wood or material being acted upon, combined with a presser foot carrier having a fixed or stationary position in a substantially horizontal plane above the bed plate with relation to the said cutter head and a presser foot composed of independent sections adjustable in a substantially horizontal plane toward and away from the cutter head independent of the said carrier, whereby a presser foot section co-operating with the long knife on the cutter head may be moved back away from the said cutter head and a presser foot section co-

operating with a shorter knife on the cutter head may be moved forward toward the cutter head to expose the same surface of wood to be acted on by the different knives, substantially as described. 2nd. In a moulding machine, the combination, with a bed plate and a rotary cutter head supported thereon and provided with one or more knives, of a hollow presser foot carrier secured above the bed plate in a fixed position in a horizontal plane with relation to the cutter head, and a presser foot or bar composed of independent sections secured in said hollow carrier and each consisting of a main portion or member *b*, and an arm *b*¹, extended rearwardly from the upper part of the member *b*, in a substantially horizontal plane and adjustable toward and from the cutter head independent of the cutter carrier. 3rd. In a moulding machine, the combination with a bed plate and a rotary cutter head supported thereon and provided with one or more knives, of a lever *b*², pivoted above the bed plate, a hollow presser foot carrier secured to said lever, and a presser foot or bar composed of independent sections consisting of a main portion or member *b*, and an arm *b*¹, extended rearwardly from the member *b*, and adjustably secured in the hollow presser foot carrier, substantially as described. 4th. The herein described presser foot section, consisting of the main portion or member *b*, and the arm or member *b*¹, extended rearwardly in a substantially horizontal plane from the upper part of the member *b*.

No. 44,742. Lawn Mower. (Faucheuse de pelouse.)

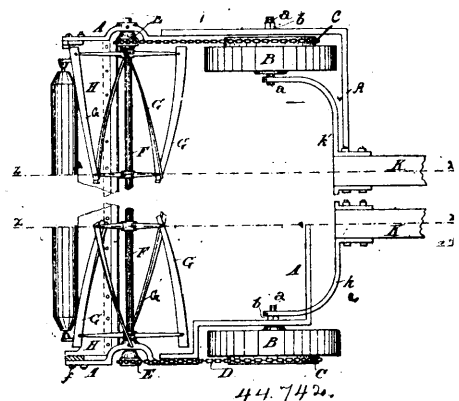

William A. Schofield and Thomas S. Linscott, both of Brantford, Ontario, Canada, 21st November, 1893; 6 years.

Claim.—1st. A main frame of wrought iron or steel, bent to suit the design as shown on sheets Nos. 1 and 2 of drawings, substantially as and for the purposes hereinbefore set forth. 2nd. A drive-wheel connected to main frame by a stud with nut, the said stud being adjusted by a dot on frame to suit chain, substantially as and for the purpose hereinbefore set forth. 3rd. A sprocket-wheel connected to same stud as drive-wheel with loose dogs working on it, said dogs working in a ratchet-wheel or geared rim on drive-wheel, and thus giving motion, this application does away entirely with springs, substantially as and for the purposes hereinbefore set forth. 4th. A cylinder driven by sprocket-chains and sprocket-wheels, as described and fully set forth. 5th. A pole connected to the machine by two spring arms on to drive-wheel studs, substantially as and for the purposes hereinbefore set forth. 6th. A knife connected to main frame by a stud or wrought iron carrier, substantially as and for the purposes hereinbefore set forth. 7th. A knife bar pivoted with two set screws and adjusted by means of two small screw bolts in slotted holes in frame, substantially as and for the purposes hereinbefore set forth. 8th. A different form of frame to suit the different arrangement of wheels as shown on figs. 2 and 3 of drawing sheet No. 1. and figs. 5 and 6 of drawing sheet No. 2, substantially as and fully, and for the purposes as set forth.

No. 44,743. Drying Device for Scrubbing Brushes.

(*Séchoir pour brosses à laver.*)

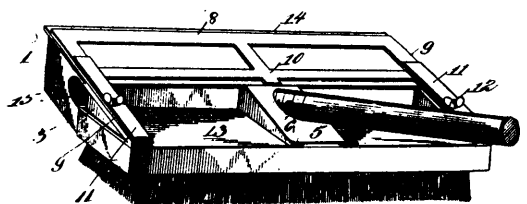

John S. McGuire, John B. Beemer and Willis P. Taft, all of East Tawas, Michigan, U.S.A., 21st November, 1893; 6 years.

Claim.—1st. The herein described attachment for scrubbing brushes, consisting of the metal box provided at its rear wall with

an oxygen electrode of lead, and a supply of zinc and mercury, substantially as described. 8th. A secondary battery cell having a hydrogen electrode consisting of a vertical conductive support inactive in the liquid, and having an affinity for, but not penetrated by mercury, a supply of mercury, and one or more sheets of amalgamated zinc forming a zinc supply, substantially as described. 9th. A secondary battery cell having a hydrogen electrode consisting of a vertical conductor perforated support inactive in the liquid, and having an affinity for, but not penetrated by mercury, and a supply of zinc and mercury, substantially as described. 10th. A secondary battery cell, having a hydrogen electrode, consisting of a series of vertical perforated conductive supports arranged in pairs, said supports being inactive in the liquid, and having an affinity for, but not penetrated by mercury, a supply of mercury, and sheets of amalgamated zinc between the pairs of supports forming a zinc supply, substantially as described. 11th. A secondary battery cell, having a hydrogen electrode consisting of a vertical copper support, and a coating of zinc and mercury on the surface of the support forming the active material, substantially as described. 12th. A secondary battery cell, having a hydrogen electrode consisting of a vertical copper support covered with a deposit of zinc, the cell containing a supply of mercury, substantially as described. 13th. A secondary battery cell, having a hydrogen electrode consisting of a series of vertical copper supports covered with a deposit of zinc, the cell containing a supply of mercury, substantially as described. 14th. A secondary battery cell, having a hydrogen electrode consisting of a series of vertical perforated copper supports covered with a deposit of zinc, the cell containing a supply of mercury, substantially as described. 15th. A secondary battery cell, having a hydrogen electrode, consisting of a series of vertical copper supports covered with a deposit of zinc, the cell containing a supply of mercury, an oxygen electrode consisting of a series of vertical plates, substantially as described. 16th. A secondary battery cell, having a hydrogen electrode consisting of a vertical copper support, an oxygen electrode of lead and a supply of zinc and mercury, substantially as described. 17th. A secondary battery cell, having a hydrogen electrode consisting of a vertical copper support, a supply of mercury and one or more sheets of amalgamated zinc forming a zinc supply, substantially as described. 18th. A secondary battery cell, having a hydrogen electrode consisting of a series of vertical perforated copper supports arranged in pairs, a supply of mercury and a sheet of amalgamated zinc between each pair of supports, substantially as described. 19th. A secondary battery cell, having a hydrogen electrode consisting of a vertical perforated conductive support inactive in the liquid and an electro deposit of zinc thereon, substantially as described. 20th. A secondary battery cell, having an element consisting of a vertical copper plate supporting electro deposited zinc, substantially as described. 21st. A secondary battery cell, having an electrode consisting of a series of connected vertical copper plates supporting electro deposited zinc, substantially as described. 22nd. A secondary battery cell, having hydrogen electrode consisting of a conductive support inactive in the liquid and not penetrated by mercury, zinc amalgam forming an active deposit thereon, and a supply of zinc consisting of one or more sheets of amalgamated zinc, substantially as described. 23rd. A secondary battery cell, having a hydrogen electrode consisting of a series of conductive supports inactive in the liquid, and arranged in pairs, zinc amalgam forming an active deposit thereon, and sheets of amalgamated zinc between said pairs of supports forming the zinc supply, substantially as described. 24th. A battery plate consisting of a series of laminae of such material as to be increased in thickness in the action of the battery, and having soluble material between the laminae, whereby space is provided for the increase in thickness of the laminae, substantially as described. 25th. An oxygen battery plate consisting of a series of laminae with soluble material between the same, whereby space is provided for increase in thickness of the laminae by oxidation, substantially as described. 26th. An oxygen battery plate consisting of a series of laminae with soluble material and conducting a material between the laminae, whereby space is provided for increase of thickness of the laminae by oxidation and the conducting of the laminae increased, substantially as described. 27th. An oxygen battery plate consisting of a series of laminae with soluble material containing zinc between the same, substantially as described. 28th. An oxygen battery plate consisting of a series of laminae with soluble material and graphite between the laminae, substantially as described. 29th. An oxygen battery plate consisting of a series of laminae with oxide of zinc and graphite between the laminae, substantially as described. 30th. The combination with a battery terminal or terminals, consisting of a core of high conductivity and a covering of conducting material, non-corrodable of the battery acids, of a connector consisting of a collar of conducting material non-corrodable by the battery acids, and constructed to receive the terminal or terminals, and a wedge of similar material for securing the terminal or terminals in the collar, said collar and wedge being constructed to engage the terminal or terminals by surfaces conforming in shape thereto, whereby large surfaces of contact are provided and a high conductivity secured, with material of low specific conductivity, substantially as described. 31st. An electric battery connector consisting of a collar of conducting material, non-corrodable by the battery acids, and constructed to receive the conductor or conductors, and a wedge of similar material for securing a

conductor or conductors in the collar, said collar and wedge being constructed to engage the conductor or conductors by surfaces conforming in shape thereto, whereby large surfaces of contact are provided and a high conductivity is secured, with material for low specific conductivity, substantially as described. 32nd. The method of making a battery plate, which consists in superposing a series of laminae with soluble material between them and dissolving out the soluble material, substantially as described. 33rd. The method of making a battery plate, which consists in superposing a series of laminae with soluble material and conductive material between them, and dissolving out the soluble material, substantially as described. 34th. The method of making a battery plate which consists in superposing a series of laminae with soluble material required in the battery between them, and dissolving out the soluble material in the battery liquid, substantially as described.

No. 44,748. Sleigh. (Traineau.)

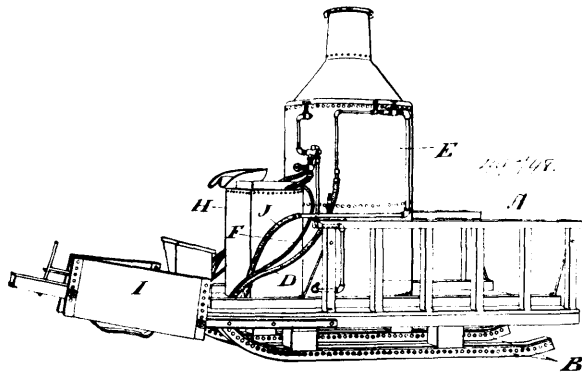

John C. West, Simcoe, Ontario, Canada, 22nd November, 1893; 6 years.

Claim.—1st. A sleigh provided with hollow runners, in combination, with means for heating the same, substantially as and for the purpose specified. 2nd. A sleigh, provided with hollow runners, in combination with a steam boiler, suitably connected with the said hollow runners, substantially as and for the purpose specified. 3rd. A sleigh provided with hollow runners, having a snow-plough connected to its forward end, in combination with a steam boiler suitably connected with the said hollow runners, substantially as and for the purpose specified. 4th. The runner B, provided with a steam chamber C, and groove *a*, in combination with the steam boiler E, and pipes D, F, and J, substantially as and for the purpose specified.

No. 44,749. Method of Treating Bast and Wood for the Purpose of Obtaining Fibre. (Méthode de traiter l'écorce intérieure et le bois pour en obtenir des fibres.)

Adolf. Forugren, Fammerfors, Finland, 22nd November, 1893; 6 years.

Claim.—1st. Removing the phosphoric acid compounds from the bast or wood, by subjecting it to the action of an acid bath, in which it is kept at a constant temperature (preferably 35° to 40° c.) for from four to six hours, after which it is washed. 2nd. Removing from the bast or wood, the encrusting substances especially the calcic sulphate by keeping it at a constant temperature (preferably 35° C) in a solution of common salt to which, if desired, an addition of sal-amoniac may be made, for about six hours, and after running off the solution washing the bast or wood, at the same time thoroughly beating it. 3rd. Dissolving out and removing the silicates by placing the bast or wood in a chlorine bath kept at a constant temperature for from 1½ to 2 hours, according to the strength of the solution. 4th. In rendering the fibre more pliable, or for removing any resin the bast or wood may still contain, thoroughly washing it with the addition of a small quantity of caustic alkali or soap with or without the addition of glycerine, this being succeeded by further treatment by breaking and heckling, as in the treatment of flax, if necessary after previous freezing, in the usual way.

No. 44,750. Combined Water Tower and Fire Escape. (Tour à eau et sauveteur d'incendie combinés.)

Frank M. Hughes, Milford, Massachusetts, U.S.A., 22nd November, 1893; 6 years.

Claim.—1st. In a telescopic tower composed of sections having sills and plates, as described, spring actuated bracket carrying posts revolvably mounted in the sills and plates of the sections intermediate the base end upper sections, whereby the brackets in one section are made to aid in the support of the section next above, substantially as described. 2nd. In a telescopic water tower, a series of fire hose extending up through the floors of the movable sections, each hose being provided with a fixed collar which rests on the floor

of the section in which it is desired the hose shall terminate, whereby the hose will be elevated in the elevation of the tower, and a

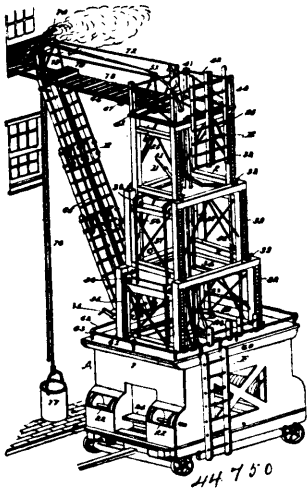

hose reel journalled in the base section, substantially as described. 3rd. The combination with a telescopic tower, of a series of fire hose suspended from the movable sections of the tower, and extension ladders pivoted at their lower ends to the base section, and carrying hooks at their upper ends which engage with the upper sections of the tower, whereby as the tower is elevated the hose will be elevated and the ladders extended. 4th. The combination with the portable tower, of two or more ladders pivoted to said tower, and a movable bridge supported at one end by the tower and at the other end by the ladder. 5th. The combination with the telescopic tower, of fire hose suspended from the movable sections of the tower, extension ladders pivoted to opposite sides of the tower, and a movable bridge supported at one end by the tower and at the other end by one set of ladders, substantially as described and for the purpose stated. 6th. The combination with the telescopic tower, of extension ladders pivoted to said tower, and a movable bridge supported at one end by the tower and at the other end by the ladders, said bridge consisting of longitudinal beams provided with means for engaging with the ladders and a folding floor. 7th. The combination with a telescopic tower and a hose reel journalled in the base section thereof, of a series of fire hose suspended from the movable sections of the tower and adapted to be wound on the reel, extension ladders pivoted to the base section of the tower on opposite sides, a knock-down bridge supported at one end by the tower and at the other end by the ladders on one side of the tower, a bucket or like receptacle, a by the ladders on one side of the tower, a bucket or like receptacle, a rope attached thereto, and a sheave attached to the bridge over which the rope is passed, substantially as described and for the purposes set forth.

No. 44,751. Metal Driving Belt. (*Courroie métallique sans fin.*)

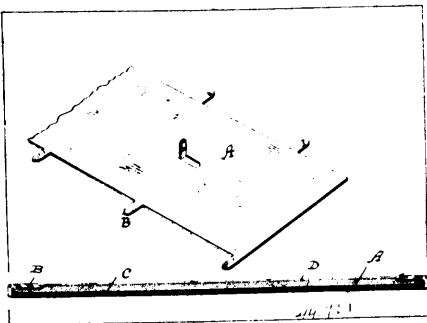

Henry Sewrey, Barrie, Ontario, Canada, 22nd November, 1893; 6 years.

Claim.—1st. As a driving belt, a band of metal having a facing of cotton, leather, rubber, paper, or other similar material connected thereto by flexible cement, substantially as and for the purpose specified. 2nd. As a driving belt, a band of metal having a facing of cotton or other webbing cemented thereto, the said webbing having a layer of rubber applied to the face coming in contact with the pulley, substantially as and for the purpose specified. 3rd. As a driving belt, a band of metal having a facing of cotton, leather, or other suitable material connected thereto in combination with

fingers formed on or connected to the metal band and turned over the facing, substantially as and for the purpose specified. 4th. As a driving belt, a band of metal having a facing of cotton or other webbing cemented thereto, the said webbing having a layer of rubber applied to the face coming in contact with the pulley in combination with the fingers formed on or connected to the metal band and turned over the facing, substantially as and for the purpose specified. 5th. As a driving belt, a band of metal having a facing of cotton, leather or other suitable material connected thereto by fingers formed on or connected to the metal band and turned over the facing, substantially as and for the purpose specified.

No. 44,752. Brake and Coupler for Railway Cars.

(*Frein et attelage de chars.*)

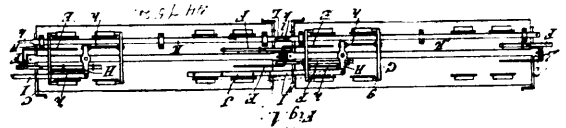

François Victor Isoire dit Provençal, Black Lake, Quebec, Canada, 22nd November, 1893; 6 years.

Claim.—1st. In a car brake, the combination, with a centrally pivoted lever linked at each end to the brake beams, of the rod I, pivoted to one end of the said lever and the buffer J, substantially as set forth. 2nd. In a car brake, the combination, with centrally pivoted levers linked at either end to the brake beams, rods I pivoted to one end of the said levers, buffers J against which the said rods abut, of the shafts K, having suitable coupling L, the arms m, operating the sliding bar N, and a stirrup O, engaging the said rod I, substantially as set forth. 3rd. In a car coupling, the combination, with a draw-head of the ordinary link and pin type, of the link lifter E, the shoe F, the shaft C, operated from the side of the car and journalled on the end thereof, a pulley c, and small chain d, attached to the said pulley and the coupling-pin, substantially as set forth.

No. 44,753. Harvester Elevator.

(*Élévateur de moissonneuses.*)

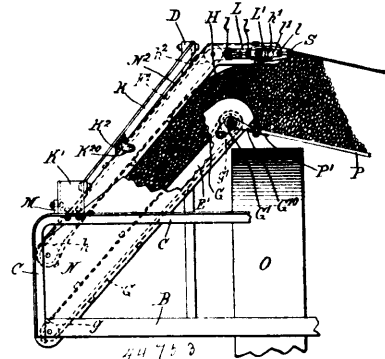

Andrew Stark, Chicago, Illinois, U.S.A., 22nd November, 1893; 6 years.

Claim.—1st. In a harvester elevator, in combination with the grain supporting element of the elevator, an endless apron carrier overhanging such element having its lower ply extending normally in a direct line oblique to the surface of said grain supporting element, and close thereto at the highest point of the latter, said carrier being provided with a guide roller for its upper ply located above a direct line between the extreme rollers, substantially as set forth. 2nd. In a harvester elevator, in combination with the lower or grain supporting element of the elevator, an overhanging endless carrier and its guide rollers, said carrier having its lower ply extending normally in a direct line close to the upper or delivery side of the grain supporting element, a third guide for the upper ply of said endless carrier located above a direct line between the extreme guide rollers, one of the guides for said upper carrier having its bearings adapted to yield under the strain of the endless carrier to afford slack to the latter when the elevator is crowded with grain, substantially as set forth. 3rd. In a harvester elevator, in combination with the binder deck and the grain supporting element of the elevator, sloping upward from opposite sides of the drive wheel to an apex higher than the wheel and grainward from its stubble side, an overhanging endless carrier having its lower ply extending normally in a direct line close to such apex, and provided with a guide for its upper ply which is located above the direct line between the extreme rollers, whereby the grain actuating ply of said overhanging carrier yielding upward toward the third guide oper-

ates upon the grain with approximately horizontal movement to advance it over said apex on to and along an immediately descending incline, substantially as set forth. 4th. In a harvester elevator, in combination with the lower or grain supporting element of the elevator, an overhanging endless carrier and its guide rollers, said carrier having its lower ply extending normally in a direct line close to the upper or delivery side of the grain supporting element, a third guide for the upper ply of said endless carrier located above a direct line between the extreme guide rollers of the same, bearings for the extreme stubbleward guideroller of said upper carrier adapted to yield under the strain of the carrier to afford slack to the latter, substantially as set forth. 5th. In a harvester elevator, in combination with the grain supporting element, an endless carrier overhanging the same, having its rear bar which affords bearings for its rollers at their rear ends suspended, whereby the elevator is made open at the rear, a bar located above the said overhanging endless carrier and from which the same is suspended, extending from near the forward stubbleward corner of the elevator obliquely rearward and grainward to a point at the rear of the rear grain vard corner of the elevator, and supported by posts extending upward from the front and rear sills at its extremities respectively, substantially as set forth. 6th. In combination, with the lower or grain supporting element of the elevator, an overhanging endless carrier having its rear roller supporting bar suspended, a bar located above the elevator and extending obliquely grainward from front to rear and supported at its extremities beyond the elevator, the seat supporting bar overhanging the grain's path at the entrance to the elevator, and suitably supported at front and rear of said path, rigid connection from the seat plank and from said oblique bar to the said rear roller-supporting bar of the overhanging carrier, whereby the latter is suspended and the elevator made rearwardly open, substantially as set forth. 7th. In a harvester elevator, in combination with the grain supporting element and an overhanging endless carrier having three guide rollers, brackets or plates secured to the side bars of such carrier, which afford movable bearings for the extreme roller thereof, said brackets or plates being extended stubbleward beyond the said roller and the over-deck or shield secured to such stubbleward extensions, substantially as set forth. 8th. In a harvester elevator, in combination with the lower grain supporting element, an overhanging endless carrier having its rear roller supporting bar suspended, whereby the elevator space is made rearwardly open, brackets or bearing plates secured to the stubbleward ends of the side bars of said overhanging carrier, said brackets projecting beyond the extreme rollers of said carrier, and a rod or bar rigidly connecting them at their extremities and the over-deck or grain shield supported by said connecting rod or bar, substantially as set forth. 9th. In a harvester elevator, an overhanging endless carrier comprising three guide rollers, in combination with the side bars of such carrier, the brackets L, bolted thereto and having the slots L², the sleeves L¹, which afford bearings for the extreme roller, having the stems L³, the ends of the side bars having sockets to receive said stem, and terminated cylindrically by the said sockets, and the springs L, coiled about said cylindrical terminals and stems respectively and reacting between the side bars, and the journal bearings to hold the latter yieldingly stubbleward, substantially as set forth. 10th. In combination, with the lower grain supporting element of the elevator, the overhanging endless carrier having side bars F, F¹, and the sheath plates N, N², the brackets L, L, secured to the side bars outside of the sheath plates and riveted to the latter beyond the ends of the side bars, and the yielding bearings for the extreme guide roller lodged and adapted to reciprocate in said brackets, substantially as set forth.

No. 44,754. Combined Shaft Support and Anti-Rattler. (*Tuteur de limonière et appareil compensateur pour armons de limonières.*)

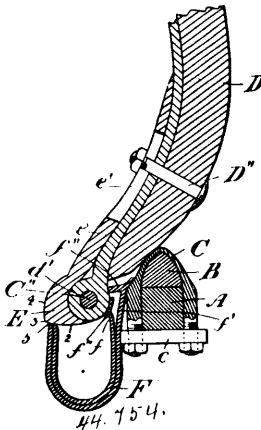

William Cavers, Owen Sound, Ontario, Canada, 22nd November, 1893; 6 years.

Claim.—1st. A shaft support, consisting of a U-shaped spring adapted to be held under the thill eye by having one limb provided

with means of supporting it between said eye and the clip and a shoulder, offset or nose on said eye, having two convex faces disposed at angle to each other, which projects forward from the said eye, so that the lower face is even with the outside of the thill eye, and is approximately horizontal when the shaft is raised and bears on the upper end of the returned limb of the spring near said angle, substantially as set forth. 2nd. A combined shaft support and anti-rattler, consisting of a U-shaped spring F, having the end of limb made longer and formed in two tongues f and f¹, of unequal length and provided with a bearing f¹¹, and head f¹², respectively, and a shoulder or nose E, having the surfaces 2 and 4 and 3, angle 3, and secured by means of a slotted extension or bracket c, to the thill iron, so as to bear with said faces on said spring when the split limb is inserted between the thill eye and clip, substantially as set forth. 3rd. In a shaft support, the combination with the thill eye of a shoulder or nose E, having a convex face 2, approximately horizontal when the shaft is in a raised position, and a convex face 4, forming an angle 3 with the face 2, and being drawn in at the top, a slotted extension or bracket c, fitting the thill iron and the bolt D¹¹, passing through said iron and the slot of said bracket, substantially as set forth. 4th. In a shaft support and anti-rattler spring, the combination of a U-bent piece, of an extended limb split in two tongues f and f¹, of unequal length, the shorter one having a bearing f¹¹, on the lower part of the thill eye, and the longer one a suspension head f¹², substantially as set forth. 5th. The combination of an axle A, thill coupling C, c, C¹¹, C¹², thill D, thill iron D¹, d¹, shoulder or nose E, on the eye of said thill iron and U-shaped spring F, having one limb split and formed with bearing and head and inserted in said coupling, substantially as set forth.

No. 44,755. Apparatus for Making Butter and Condensing Milk. (*Appareil pour la fabrication du beurre et lait condensés.*)

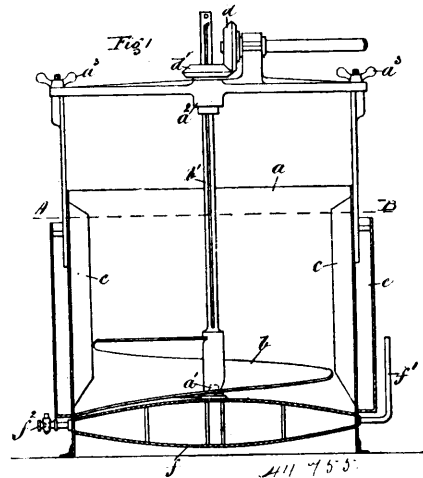

William B. Walters, Dunedin, New Zealand, 22nd November, 1893; 6 years.

Claim.—1st. In a machine for making butter or condensed milk, the vessel a, combined with screw b, substantially as set forth. 2nd. In a machine for making butter or condensed milk, the vessel a, combined with revolving screw b, and ribs c, substantially as set forth. 3rd. In a machine for making butter or condensed milk, the vessel a, combined with revolving screw b, ribs c, steam chamber f, with or without the hot water space c, substantially as set forth. 4th. The machine for making butter or condensed milk, constructed arranged and operating, substantially as set forth.

No. 44,756. Governor for Engine.

(*Gouverneur pour machines à vapeur*)

John Prentice, Lanark, Scotland, 22nd November, 1893; 6 years.

Claim.—1st. The herein described method of controlling or governing engines or prime movers, by means of a circulating fluid or mixture of fluids, substantially as set forth. 2nd. An engine governor or speed regulator, wherein a fluid or a mixture of fluids is used as the medium for producing pressure or suction in a chamber, and for operating a piston or its equivalent, said piston being connected to and operating the valve for controlling the motive fluid supply to the main engine or prime mover, substantially as hereinbefore set forth. 3rd. An engine governor or speed regulator consisting of a main fluid tank or reservoir, from which fluid is first drawn and then forced or sucked into a second chamber, having an operating piston connected to the valve controlling the supply of motive fluid to the main engines, the outflow of fluid from the second chamber being under control, substantially as hereinbefore

described. 4th. The auxiliary regulating devices, consisting of a chamber in which works a piston or diaphragm, said piston or

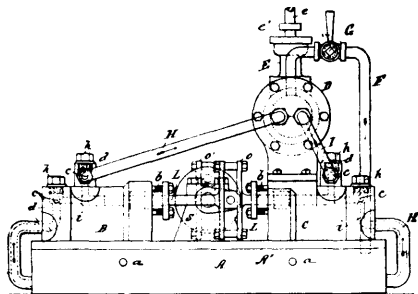

diaphragm being connected to and operating the regulating clock of the governor, substantially as and for the purpose hereinbefore set forth.

No. 44,757. Process of Treating Gold and Silver Ores and a Composition of Matter for the Same Said Process. (*Procédé pour le traitement des minerais d'or et d'argent et composition de matières à cet effet.*)

Edward D. Kendall, Brooklyn, New York, U.S.A., 22nd November, 1893; 6 years.

Claim.—1st. The method of treating gold and silver ores, which consists in mixing sodium di-oxide and a suitable cyanide and water with the ore in a finely divided condition, substantially as described. 2nd. The method of treating gold or silver ores, which consists in uniting a solution of sodium di-oxide and a solution of a suitable cyanide, and treating the finely divided ore therewith, substantially as described. 3rd. The method or process of treating gold or silver ores, which consists in uniting a solution of sodium di-oxide and a solution of a suitable cyanide, and mixing the finely divided ore therewith, then drawing the solution from the ore, and separating the metal therefrom, substantially as described. 4th. A composition of matter consisting of sodium di-oxide and a suitable cyanide in solution, to be used in treating gold and silver ores, substantially as described.

No. 44,758. Process of and Apparatus for Classing Pulverized Ores. (*Procédé et appareil pour classer les minerais pulvérisés.*)

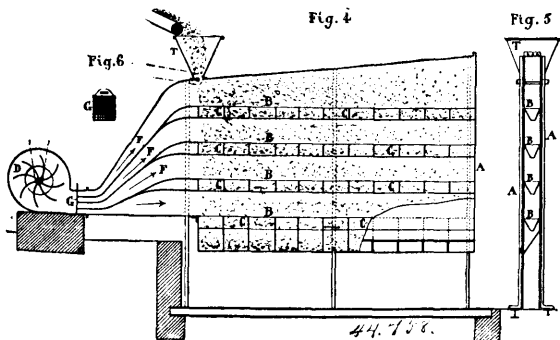

Gustav Hensch, The Gotha Mines, Germany, and Edmond Maurice Comte Exelmans, Paris, France, 22nd November, 1893; 6 years.

Claim.—1st. The herein described process for classing crushed, dried and sized ores, by subjecting them to the repeated action of air currents so as to separate the granules according to their densities. 2nd. The apparatus for conducting the said process, consisting of a casing divided into several superposed chambers, themselves divided into several compartments which discharge from one to another and finally into those of the lowest chamber, substantially as described.

No. 44,759. Ore Crusher. (*Moulin à broyer.*)

John Thomas Crawford, Warton, Ontario, Canada, 24th November, 1893; 6 years.

Claim.—1st. As an improved ore crusher, a conically shaped disc placed in the bottom of a casing and propelled by one or more cone shaped rollers, the surface of each roller coinciding with and resting upon the surface of the disc, substantially as and for the purpose specified. 2nd. As an improved ore crusher, a conically shaped disc placed in the bottom of a casing and propelled by one or more

cone shaped rollers, the surface of each roller coinciding with and resting upon the surface of the disc, sub-combinations with means

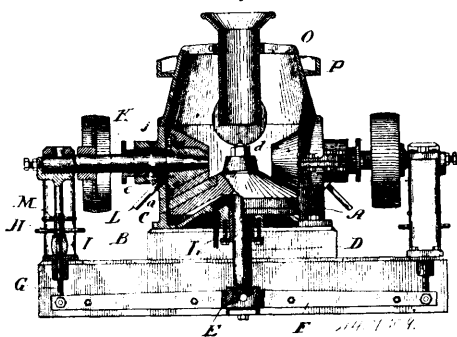

for elastically holding the face of the disc against the face of the cone shaped rollers, substantially as and for the purpose specified.

No. 44,760. Car Coupler. (*Attelage de chars.*)

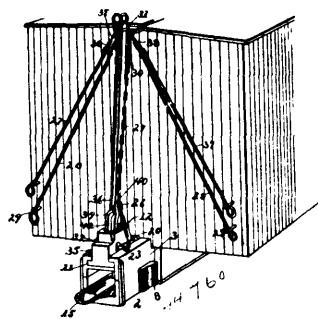

Edward B. Hyre, Elk Fork, West Virginia, U.S.A., 24th November, 1893; 6 years.

Claim.—1st. In a car coupling, the combination of a draw-head having a coupling-pin perforation, a coupling-pin, a sliding plate mounted in the draw-head and adapted to extend across the coupling pin perforation when the coupling-pin is elevated to support the latter, a rock shaft mounted on the draw-head and provided with a depending arm connected with the sliding plate to actuate the same, said rock shaft having another arm loosely connected with the coupling-pin, whereby when the latter is elevated the rock shaft will be turned, substantially as described. 2nd. In a car coupling, the combination of a draw-head having a coupling-pin perforation, a coupling-pin, a sliding plate mounted in the draw-head and adapted to extend across the coupling-pin perforation when the coupling-pin is raised to support the latter, and a rock shaft provided with a depending arm to engage and actuate the sliding plate, and having a forwardly extending resilient arm provided at its outer end with an inwardly extending portion and loosely connected with the coupling-pin, substantially as and for the purpose described. 3rd. In a car coupling, the combination of a draw-head having a coupling-pin perforation and provided in its top with a way, a slide mounted in the way and provided with a cavity arranged vertically and extending through it, a sliding plate mounted in the draw-head and arranged beneath the slide, a coupling-pin, a rock shaft journaled on the slide and having one arm engaging the sliding plate and another arm loosely connected with the coupling-pin, and means for advancing the slide when the coupling-pin is elevated, substantially as described. 4th. In a car coupling, the combination of a draw-head having a coupling-pin perforation, a slide mounted on the draw-head and provided with a vertical cavity, a sliding plate arranged beneath the slide, a coupling-pin, a rock shaft mounted on the slide and having a depending arm to engage the sliding plate and provided with a forwardly extending arm loosely connected with the coupling-pin, a bell crank lever pivoted at its angle to the slide and having one arm journaled on the draw head, and means for actuating the other arm of the lever, substantially as described. 5th. In a car coupling, the combination of a draw-head having a coupling-pin perforation, a slide mounted on the draw-head and having a vertical cavity, a sliding plate arranged beneath the slide, a coupling-pin, a rock shaft mounted on the slide and having a depending arm engaging the sliding plate and provided with a forwardly extending arm loosely connected with the coupling-pin, a bell crank lever pivoted at its angle to the slide and having one arm journaled on the draw-head, and rods and chains mounted on the end of a car and arranged at opposite sides thereof and at the top and connected with the coupling-pin and with the bell crank lever, substantially as described. 6th. In a car coupling, the combination of a draw-head provided at its top with a way and having in the bottom thereof a recess with

its rear portion enlarged to form stop shoulders, a slide mounted in the way, a sliding plate arranged in the recess and having lateral projections to engage the stop shoulder, a rock shaft mounted on the slide and engaging the sliding plate, a bell crank lever pivoted to the slide and having one arm journaled on the draw-head, a coupling-pin, and means for turning the rock shaft and actuating the lever, substantially as described. 7th. In a car coupling, the combination of a draw-head having a coupling-pin perforation, a slide mounted on the draw-head and provided at one side with a boss, a sliding plate arranged beneath the slide, a rock shaft journaled on the slide and having one arm engaging the sliding plate and provided with a forwardly extending resilient arm having its outer end bent inward to engage the boss, substantially as and for the purpose set forth. 8th. In a car coupling, the combination of a draw-head having a coupling-pin perforation, a slide mounted on the draw-head and having a coupling-pin cavity, a coupling-pin provided at its upper end with an inwardly extending curved arm and having between its ends a socket, and an upwardly extending bar having its lower end arranged in the socket and provided between its ends with an opening receiving the curved arm, substantially as described.

No. 44,761. Cultivator. (Cultivateur.)

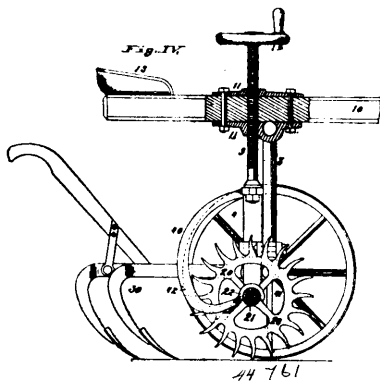

William Luedwig Meinan, and William Hieronymus, both of Mount Olive, Illinois, U.S.A., 24th November, 1893; 6 years.

Claim.—1st. The combination of an axle having an arch or bridged central portion, a frame movably secured to the axle, a threaded rod or shaft secured to said frame, and by which the frame is moved, a draft-tongue to which said axle is secured, and through which said threaded rod or shaft passes, a hand-wheel on said rod or shaft and by which it is turned to move said frame, rotary discs mounted in said frame on a rod fitting in the lower ends of the frame, distance blocks located between the discs, and stalk cutters secured by their upper ends to said frame, and resting at their lower ends upon said distance blocks, substantially as set forth. 2nd. The combination of a suitable axle, having an arch or bridged portion, ground-wheels journaled on the axle, a frame secured to the vertical arms of said axle, toothed discs supported by said frame, and shovel-ploughs secured to said axles between said ground-wheels and the vertical portions of the axles, substantially as set forth. 3rd. The combination of an axle having an arch or bridged portion, ground-wheels journaled on the axle, a frame secured to the vertical arms of the arch portion of the axle, toothed discs supported in the frame, and curved cleaners secured to the upper part of the frame, and resting at their lower ends upon the disc support, substantially as shown and described. 4th. The combination of a suitable frame, toothed discs supported in the frame, and cleaners consisting of curved bars having convex, lower, sharp edges, and having concave lower ends resting upon the disc support, substantially as and for the purpose set forth. 5th. The combination of a suitable frame, and a toothed disc mounted in said frame, so as to turn freely by contact with the ground, the teeth being formed with flat faces and with angular or convex backs, and so curved that a radial line from the centre of the disc in front of the tooth and close to its base will pass slightly back of the point, whereby in passing from vertical position and maximum penetration, the angular back of the tooth is pressed into the ground, and the point caused to pass vertically out of the ground. 6th. In a cultivator, a disc frame 4 made in three pieces 14, 17, the pieces 17 being right angles, slotted and serrated on the upper side, and the parts 16 being slotted and serrated and provided with a central hole to receive an adjusting rod, substantially as set forth.

No. 44,762. Valve for Pumps. (Soupape pour pompes.)

Oscar E. Beardsley, Trempealeau, Wisconsin, U.S.A., 24th November, 1893; 6 years.

Claim.—In a pump attachment, the combination with the pump pipe having a side drainage opening, of an attachment clamp fastened to the pump pipe above said opening and having separate off-standing pivot ears carrying a pivot pin at their outer ends, a valve lever pivoted at one end on said pivot pin and terminating at its other free end in a hook, said valve lever being further provided,

near its point of pivot, with a curved integral valve arm disposed toward the pump pipe and having a socket in its extremity, a valve plug having one end removably fitted in the socket of said valve

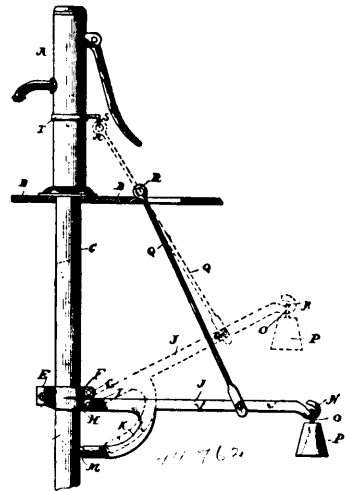

arm, a weight removably hooked on to the hook end of the valve lever, a lifting rod attached at its lower end to said valve lever, and means for holding the latter in an elevated position, substantially as set forth.

No. 44,763. Stump Extractor. (Arrache-souche.)

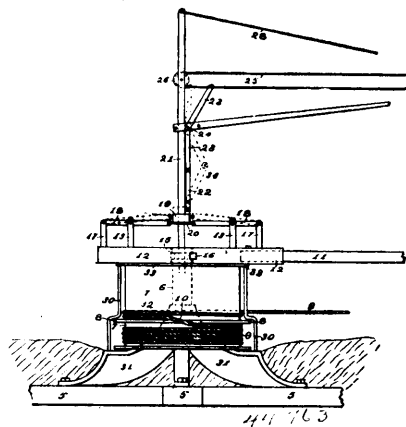

Adams C. French, Seattle, Washington, U.S.A., 24th November, 1893; 6 years.

Claim.—1st. The combination, in a stump puller, of a winding drum and means for revolving the same, the drum being provided with a circumferential flange midway its length, and a guideway extending obliquely from the body of the drum up one side of said flange to its centre and down the other side to the body of the drum, substantially as described, whereby a rope or cable may be guided from the drum at one side over the flange and down to the drum at the other side and rest upon the guideway. 2nd. A flanged winding drum having an oblique guideway extending from the body of the drum up one side of the flange to the centre of its edge and down the other side to the body of the drum across the flange, substantially as described. 3rd. The combination, in a stump puller, of a winding drum, a team pole-socket mounted thereon, clutch pins connecting the said socket and drum, pin levers pivotally mounted on the socket, a mast rising from the drum shaft, a spool fitted to slide on the mast and having a flange connection with said pin levers, a knuckle-jointed brace upon the mast and connected with the spool, and means, substantially as described, for operating the brace. 4th. The combination, in a stump puller, of a winding drum, a pole-socket, a clutch to connect them, a mast mounted on the drum shaft, a spool to slide on the mast and connected with the said clutch, a knuckle-jointed brace connected with the mast and spool, a pulley upon the mast, and a cord passing around the pulley and connected with a lever of the said knuckle-jointed brace, substantially as described, whereby a pull upon one end of the cord will close the clutch and a pull upon the other end will open it. 5th. The combination, in a stump puller, of a drum, a pole-socket, a clutch thereon, a mast upon the drum-shaft, a shifting cord connected with the clutch, and a boom sup-

ported upon the mast and extending over the team path and having a loop or eye for supporting the said core, substantially as described. 6th. The combination, in a stump-puller, of a winding drum mounted on a vertical shaft, means for rotating the drum, and a mast supporting a clutch operating device and mounted to rotate freely upon said shaft, substantially as described. 7th. The combination, in a stump-puller, of a winding drum mounted on a vertical shaft and a line carrying boom mounted to revolve freely upon the same shaft above the drum, substantially as described. 8th. The combination, in a stump-puller, of a winding drum mounted on a shaft, a team pole-socket mounted upon the same shaft, a bearing box for the socket to revolve upon the shaft and fitted to the socket with free crosswise movement, and clutch-pins to connect the socket and drum, substantially as described. 9th. The combination, in a stump puller, of a winding-drum, mounted on a shaft, a team pole-socket mounted on the same shaft and having a clutch connection with the drum, a box fitted to revolve upon the shaft and having free crosswise play in the said socket, and a key passing through the socket and box and engaging a circumferential groove in the shaft, substantially as described, whereby the socket is retained upon the shaft.

No. 44,764. Thrust Bearings for Shafts.

(Butée pour arbres.)

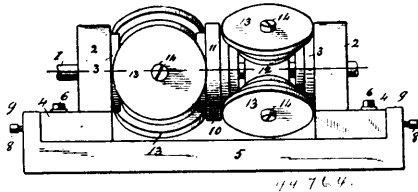

Simon Ingersoll, Glenbrook, Connecticut, U.S.A., 24th November, 1893; 6 years.

Claim.—1st. The combination, with a shaft having a collar provided with steps 11 on its faces, of bearings in which said shaft is journaled and which are provided with corresponding steps on their inner faces, and blocks which turn freely on the shaft and are provided with a series of rollers which engage the corresponding steps upon the faces of the bearings and the collar. 2nd. The combination, with the shaft, having a collar fixed thereon the faces of said collar consisting of series of steps, of bearings in which said shaft is journaled, the inner faces of said bearings consisting of series of steps corresponding with the steps on the collar, and blocks adapted to turn on said shaft and carrying series of rollers adapted to bear upon corresponding steps on the faces of the collar and the bearings. The diameter of each roller corresponding with the diameter of the steps or plane upon which it travels. 3rd. The combination, with the shaft, carrying a collar, the operative faces of which consist of series of steps, of bearings in which said shaft is journaled, the inner faces of said bearings consisting of series of steps corresponding with the steps on the collar, slotted base plates by which the bearings are carried, suitable means for locking said base plates and bearings in position after adjustment, and blocks adapted to turn on the shaft and carrying series of rollers adapted to engage corresponding steps upon the opposite faces of the collar and the inner faces of the bearings.

No. 44,765. Door Check. (Arrête-porte.)

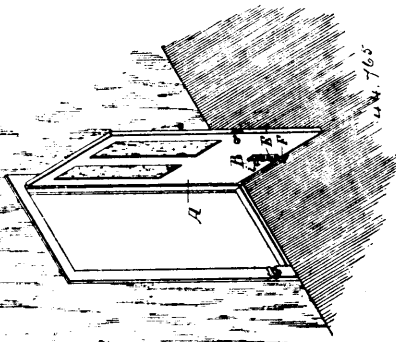

Tertullus S. Diblin, Trenton, New Jersey, U.S.A., 24th December, 1893; 6 years.

Claim.—1st. The combination, with a door check of the character described, of the brackets and its toothed loop, the slidable lever, having teeth adapted to engage the toothed loop, the cushion secured to one end of the lever, the handle formed upon the other end of the lever, and the teeth formed upon a portion of the said lever between the said two ends, substantially as and for the purpose set forth. 2nd. The combination, with a door check of the

character described, the slidable lever having teeth, the toothed loop, the spring for normally keeping the slidable lever engaged with the loop, the thumb-piece or handle formed upon the lever, and curled in one direction from the central vertical plane thereof, and the finger piece or handle curled in the opposite direction from the said central vertical plane of the said lever, substantially as and for the purpose set forth. 3rd. In a door check, the bracket, the toothed loop formed integral with the bracket, the slidable lever having teeth, the plate spring bearing against the bracket and secured to the lever, and normally keeping the teeth of the lever engaged with said toothed loop, the cushion, means for securing it to one end of the lever, and the thumb and finger handle formed upon the other end of the said lever, substantially as and for the purpose set forth.

No. 44,766. Adjuster for Railway Car Brakes.

(Appareil pour ajuster les freins de chars.)

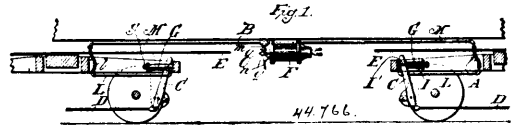

Howard Hinckley, Trenton, New Jersey, U.S.A., 24th November, 1893; 6 years.

Claim.—1st. In a slack adjuster for railway brakes, the combination of a cylinder, a keeper secured to the piston of said cylinder, the keeper forming the fulcrum of the dead lever, and a pipe connection between the cylinder and the air brake apparatus, substantially as described. 2nd. In a slack adjuster for railway brakes, the combination of a cylinder, a piston working therein, a keeper connected with the piston rod, said keeper forming the fulcrum of the dead lever, and a pipe connection between the cylinder and the brake cylinder of the air brake apparatus, substantially as described. 3rd. In a slack adjuster for railway brakes, the combination of a cylinder, a piston working therein, a stop or keeper connected with the piston rod, said keeper forming the fulcrum of the dead lever, a pipe connection between the cylinder and the brake cylinder of the air brake apparatus, and a stop to prevent the reverse movement of the keeper, substantially as described. 4th. In a slack adjuster for railway brakes, the combination of the cylinder G, a piston H, working therein, a stop or keeper I¹, forming the fulcrum of the dead lever, and an air pipe L, connecting the cylinder with the air brake apparatus, substantially as described. 5th. In a slack adjuster for railway brakes, the combination of the cylinder G, a piston H, working therein, an arm I, connected to the rod of said piston, a stop or keeper I¹, carried by said rod, said stop forming the fulcrum of the dead lever, an air pipe L, connecting the cylinder with the air brake apparatus, a fixed rack J, and a dog or tooth i, carried by the arm I, and taking into the rack, substantially as described. 6th. In a slack adjuster for railway brakes, the combination of a cylinder mounted on the truck, a piston working in said cylinder, a stop or keeper forming the fulcrum for the dead lever, said stop being connected with the piston, an air pipe forming communication between the cylinder and the brake cylinder of the air brake apparatus, and a check valve in the pipe connection, substantially as described.

No. 44,767. Pea Threshing Machine.

(Machine à battre les pois.)

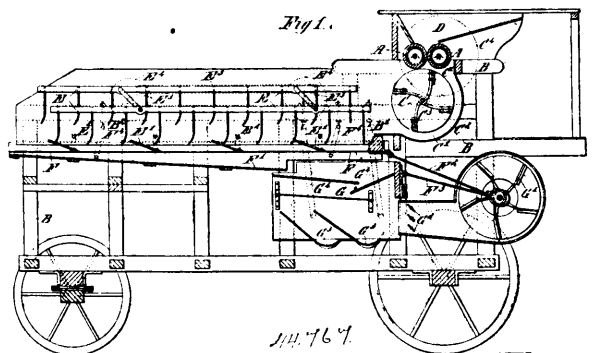

Cecil Elwin Paterson, Tooradin, Victoria, Australia, 24th November, 1893; 6 years.

Claim.—1st. In a pea threshing machine, the use of rolls having their crushing surface formed of rubber or other similar pliable material, as and for the purpose herein described and substantially as illustrated in my drawings. 2nd. In pea threshing machines, the combination, with the crushing rolls of a beater such as C, a semi-annular throat or channel such as C¹, and a semi-cylindrical

casing such as C², as and for the purpose herein described and substantially as illustrated in my drawings.

No. 44,768. Rotary Brush. (*Brosse rotatoire.*)

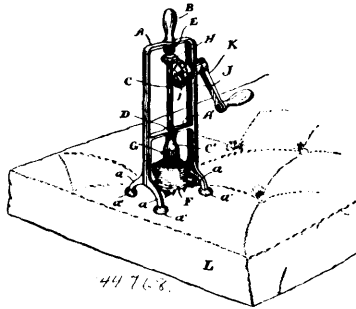

Henry G. Rockwell, Washington, District of Columbia, U.S.A., 24th November, 1893; 6 years.

Claim.—The herein described rotary brush, consisting of the vertical rectangular frame with feet at one end and a handle at the other, a shaft journaled in bearings in the frame and arranged lengthwise thereof, and carrying at its lower end a conical brush, a pinion on said shaft, a shaft at right angles to the length of the frame and provided with a crank handle, and a pinion on said shaft meshing with the other pinion, as set forth.

No. 44,769. Car Coupler. (*Attelage de chars.*)

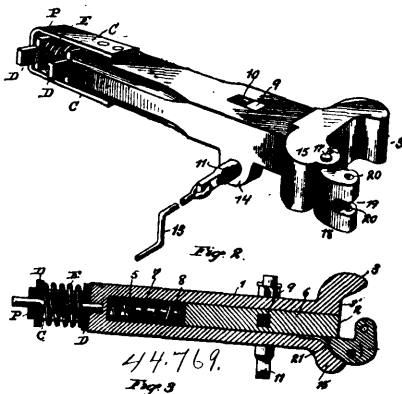

William H. Crackel, William G. Cowan, Thomas R. Cotter, Willis G. Van Auken and Aaron P. Bliss, all of Saginaw, Michigan, U.S.A., 25th November, 1893; 6 years.

Claim.—1st. In a car coupler, the combination, with a fixed jaw and a movable jaw or knuckle, of a locking bolt arranged in the draw-head, and a spring, secured within the locking bolt chamber, and bearing against the rear face of the knuckle, for throwing said knuckle open when the locking bolt is withdrawn, substantially as described. 2nd. In a car coupler, the combination, with a fixed jaw and a movable jaw or knuckle, of a locking bolt arranged in the draw-head, and a flat spring, secured within the locking bolt chamber, and bearing against the rear face of the knuckle, for throwing said knuckle open when the locking bolt is withdrawn, substantially as described. 3rd. In a car coupler, the combination, with a fixed jaw and a movable jaw or knuckle, of a locking bolt arranged in the draw-head, a projecting latch secured in said locking bolt, means for reciprocating said latch and thereby the locking bolt, and a spring secured within the locking bolt chamber, and bearing against the rear face of the knuckle, for throwing open said knuckle when the locking bolt is withdrawn, substantially as described. 4th. In a car coupler, the combination, with a fixed jaw and a movable jaw or knuckle, or a locking bolt having secured therein a projecting latch arranged in the draw-head, a slotted, revoluble bar for reciprocating said latch and thereby the locking bolt, and a spring, bearing against the rear face of the knuckle, for throwing said knuckle open when the locking bolt is withdrawn, substantially as described. 5th. In a car coupler, the combination, with a fixed jaw and a movable jaw or knuckle, of the locking bolt 6, having secured within it the projecting latch 9, arranged within the draw-head, the slotted bar 12 for reciprocating said latch and thereby the locking bolt, and the spring 21, bearing against the rear face of the knuckle, for throwing said knuckle open when the locking bolt is withdrawn, substantially as described. 6th. The combination, with a car coupler having a fixed jaw and a movable jaw or knuckle, a locking bolt having secured therein a projecting latch arranged within the

draw-head, means for reciprocating said latch and thereby normally operating the locking bolt and means for throwing said knuckle open when the locking bolt is withdrawn, of a strap, connected with the frame-work of the car, for engaging with said latch and withdrawing the locking bolt before the coupler can be torn from the car, substantially as described.

No. 44,770. Furnace. (*Fournaise.*)

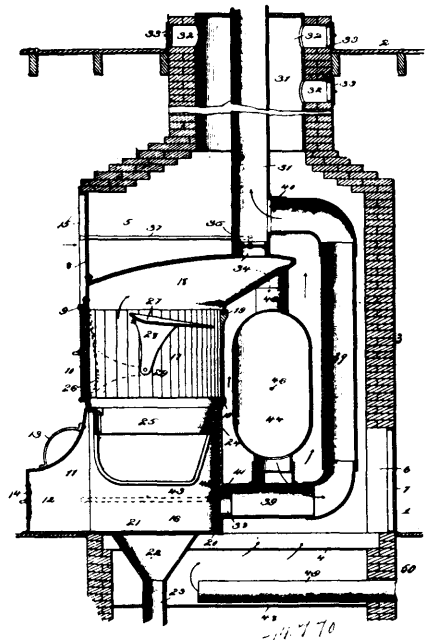

George R. Scates and Elbert S. Rogers, both of Knoxville, Tennessee, U.S.A., 25th November, 1893; 6 years.

Claim.—1st. The combination with a furnace having its dome extended beyond the line of the fire-pot and provided with two openings, and a draft pipe 30 extending upward from one of the openings, of a pipe 39 leading from the lower end of the furnace below the grate and extending up the chimney and communicating with the draft pipe above the dome, a damper 35 at the intersection of the draft pipe and dome, a damper 41 at the inner end of the pipe 39, the drum 44 directly in rear of the furnace and embraced on the opposite side by the pipe 39, and the short pipes 46 and 47, the former connecting the dome and drum and the latter the drum and pipe 39, substantially as specified. 2nd. The combination with the chimney having the lower horizontal partition arranged in the chimney, and air inlet openings for the chimney above the partition, of supporting bars arranged in the chimney, a furnace seated thereon and provided with a perforated floor, a funnel depending from the perforated floor, and a pipe extending through the partition, substantially as specified. 3rd. The fire-board having the registers 15, the ways below the registers, and the sliding doors arranged in the ways, substantially as specified. 4th. The chimney having the lower horizontal partition 48, air inlet openings 49 for the chimney above the partition, supporting bars arranged in the chimney, and a furnace seated thereon, substantially as specified. 5th. The combination with the chimney, of the fire board 8, having the register 15, the ways 9, below the registers, the sliding doors arranged in the ways, the opening below the ways, the hood having a damper arranged in front of the opening and the furnace arranged in rear of the board and damper, and terminating below the registers, substantially as specified.

No. 44,771. Method of Extracting Metals from Ores. (*Méthode pour extraire les métaux des minerais.*)

Hugh Calhoun, Hot Springs, and Aron M. Beam, Bear, all in Arkansas, U.S.A., 25th November, 1893; 6 years.

Claim.—1st. The herein described method of chlorinating ores containing gold and silver, which consists in roasting the same in the presence of carbon and muriate of ammonia, in substantially the proportions stated as set forth and described. 2nd. The herein described method of chlorinating and aggregating gold and silver from ores without a flux, which consists in subjecting the ores to heat in the presence of carbon and muriate of ammonia, or its equivalent, and maintaining the temperature between a low red heat and the fusion point of the metal or metals to be extracted until the gold and silver become chlorinated, substantially as set forth. 3rd. The herein described mode of treating ores containing precious metal, which consists in reducing the ore to a granular or pulverulent condition, mixing therewith muriate of ammonia and carbon in sub-

stantially the proportions stated, then roasting the mass in presence of air, increasing the heat as the roasting progresses, and thereby eliminating the carbon, and finally amalgamating in the usual way.

No. 44,772. Machine for uniting the Soles and Uppers of Boots and Shoes. (*Machine pour réunir les semelles et empeignes des chaussures.*)

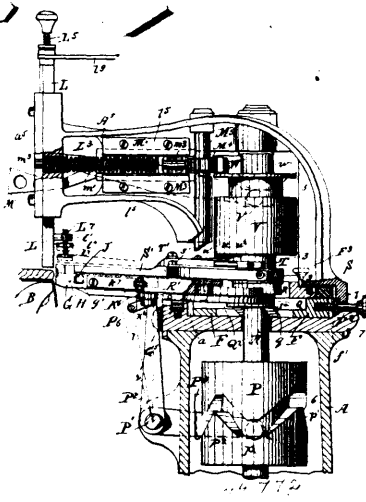

William Carey, Montreal, Quebec, Canada, 25th November, 1893; 6 years.

Claim.—1st. In a machine for uniting the soles and uppers of boots and shoes, having a work support and means for holding the work in place, a loop inserter, substantially as described, and a combined awl and nail driver arranged to work actually or approximately at right angles to each other, means for imparting reciprocating movement to same, and means for placing in the path of said nail driver, wire locking pieces, for the purpose set forth. 2nd. In a machine for uniting the soles and uppers of boots and shoes, having a work support and means for holding the work in place, a loop inserter, substantially as described, and a combined awl and nail driver, the one adapted to force a continuous thread-in loops into the substances to be united and the other to puncture one of such substances and drive short pieces of locking material into same, and means for inserting said loop inserter once into such substances and inserting the combined awl and nail driver twice into one of such substances to form a single locking toggle, as set forth. 3rd. In a machine for uniting the soles and uppers of boots and shoes, having a work support and means for holding the work in place, a loop inserter, substantially as described, and a combined awl and nail driver, and means for inserting the former once a limited distance into the substances to be united and driving the latter forward twice for different distances, for the purpose described. 4th. In a machine for uniting the soles and uppers of boots and shoes, having a work support and means for holding the work in place, the combination, with a loop inserter, substantially as described, and a combined awl and nail driver, arranged to work approximately at right angles to each other, and means of imparting reciprocating movement to same, of means for varying the extent of movement of said loop inserter and the angle at which said awl works, for the purpose described. 5th. In a machine for uniting the soles and uppers of boots and shoes, having a work support and means for holding the work in place, a loop inserter, substantially as described, and a continuous awl and nail driver, arranged and operating in such relation to the work support that the former will force a continuous thread-in loops entirely through one or more of the pieces being united together and partially through the remaining piece, and the nail driver driven inward from the edge of the latter piece short locking pieces within the loops of the continuous thread, for the purpose described. 6th. In a machine for uniting the soles and uppers of boots and shoes, having a work support, means for holding the work in place, and a combined awl and nail driver, with means for imparting reciprocating motion thereto, a loop inserter, substantially as described, located within and adapted to work in and project through said work support, and means for imparting a reciprocating motion thereto, as and for the purpose described. 7th. In a machine for uniting the soles and uppers of boots and shoes, having a swinging work supporting horn, and a loop inserter, substantially as described, carried by and working in and through the nose of same, the combination, with such loop inserter, of means for holding it laterally in position during its vertical movement. 8th. In a machine for uniting the soles and uppers of boots and shoes, having a work supporting horn, and a loop inserter, substantially as described, carried by and working in and through the nose of same, the combination, with such loop-inserter, of a disc carried in the nose of such horn, having a slot corresponding to the shape in cross-section of such

loop-inserter, which works through it, and means for preventing any movement of such disc with the horn, for the purpose described. 9th. In a machine for uniting the soles and uppers of boots and shoes, having a reciprocating loop inserter, substantially as described, and a combined awl and nail driver working approximately at right angles to each other, a hinged carrier for such awl with depressors, and a yielding support adapted to vary the angle between such loop inserter and awl, for the purpose described. 10th. In a machine for uniting the soles and uppers of boots and shoes, the combination of a loop-inserter, substantially as described, and a combined awl and nail driver working approximately at right angles to each other, a work support, presser foot bar, and means for supporting, connecting and operating the same, for the purpose described. 11th. In a machine for uniting the soles and uppers of boots and shoes, the combination of a loop inserter, substantially as described, and a combined awl and nail driver working approximately at right angles to each other, a work support, a presser foot bar adapted to be depressed to varying positions and set therein, means for supporting connecting and operating the same, and means for effecting varying depression and setting of the presser foot bar, for the purpose described. 12th. In a machine for uniting the soles and uppers of boots and shoes, the combination of a loop inserter, substantially as described, and a combined awl and nail driver, a swinging work supporting horn carrying such loop inserter, a presser foot bar in line with same, a carrier for the awl, and means for supporting, connecting and operating the whole, for the purpose described. 13th. In a machine for uniting the soles and uppers of boots and shoes, the combination of a loop inserter, substantially as described, and a combined awl and nail driver working approximately at right angles to each other, a swinging work supporting horn carrying such loop inserter, a presser foot bar adapted to be located in various working positions in line with loop inserter in horn, a carrier for the awl capable of varying the angle between the loop inserter and awl, and means for operating same and presser foot and of varying their working relation to each other, for the purpose described. 14th. The combination of horn B, having guides C², loop inserter C, cross-head C¹, geared segment d¹, pivoted to horn, connecting rods D², D³, bell crank levers D, E, and means for operating the latter, all substantially as shown and described, for the purposes set forth. 15th. The combination, with horn B, loop inserter C, carried by and working in and through the nose of same, and disc b¹, through which said loop inserter works, of disc b², intermeshing with disc b¹, and mechanism whereby upon the oscillation of the horn the disc b², is rotated and serves by such rotation to prevent any movement of disc b¹, with said horn, all substantially as shown and described, for the purpose set forth. 16th. The combination of top plate a¹, slide F, hinged carrier G, (G¹), pivoted to same, and means for adjusting such slide, all substantially as shown and described. 17th. The combination of a top plate a¹, slide F, hinged carrier G, G¹, pivoted to same, pusher G⁴, means for supporting and operating such pusher, and means for depressing such carrier, as shown and for the purpose described. 18th. The combination, with hinged slotted carrier section G, of combined awl and nail driver H, cross-head H¹, for carrying the same, bell crank lever p², link p³, and cam P, for the purpose described. 19th. The combination of carrier section G, having channel k², combined awl and nail driver H, slide J, having aperture j, lever S¹, and cam S, for giving a reciprocating movement to such slide, discs K, K¹, spring holder k⁷, spindle k⁶, ratchet K⁸, and means for rotating such ratchet, all as herein set forth and for the purposes described. 20th. The combination with the presser foot bar, the loop inserter, wedge piece M, slide M¹, having toothed rack at one end of same, and spring m¹, arranged externally of such slide for operating the same, of sliding bar D¹, screw M⁷, connections between same and loop inserter, and connections comprising pinion M⁴, shaft M⁵, pinion M⁶, rack slide M⁸, and gear teeth m¹, on screw m⁷, between said slide M¹, and such screw M⁷, for rotating the latter, all substantially as shown and described and for the purpose set forth. 21st. The combination, with head section A⁴, slide M¹, having projections m², means for holding such slide in place, and cam W, of adjustable pin m¹, and spring m², as herein set forth for the purpose described. 22nd. The combination with awl carrier G, and presser foot bar L, having a bracket l¹, of adjusting screw L⁷, and jam nut l⁴, as herein set forth for the purpose described. 23rd. The combination with the pedestal A, and shaft N³, of cam roller P, spindle P¹, carried in suitable bearings, bell crank lever P², roller P⁴, cross-head H¹, combined awl and nail driver H, and link P⁶, between said cross-head and said lever P², as herein set forth for the purpose described. 24th. The combination of shaft N³, cams T and U, carrier section G, slide J, levers T¹, and U¹, pivoted to such carrier section, and the latter having spring bolt U², pin l¹, ratchet K⁸, discs K, K¹, and combined awl and nail driver H, all as herein set forth and for the purposes described. 25th. In a machine for uniting the soles and uppers of boots and shoes, having a work support, means for holding the work in place, and stitch forming implements with their carrying parts, a separate feed foot having a four-way movement independently of any movement of said carrying parts and means for imparting such movement to same. 26th. In a machine for uniting the soles and uppers of boots and shoes, having a work support, means for holding the work in place, a loop inserter and a combined awl and nail driver, the combination therewith of a carrier for such combined awl and nail driver which is stationary during the feeding of the stock, and a feed foot

having a four-way movement, and means for imparting such movement to same. 27th. The combination of carrier G, feed foot g^2 , having a four-way movement independently of same, and cam lever and sliding bar mechanism for imparting such movement to said feed foot. 28th. The combination of carrier G, feed foot g^2 , cams R and T, levers R¹ and T¹, and sliding bar R², for the purposes set forth. 29th. In combination, with the carrier for the combined awl and nail driver, and the stationary framing of the machine at the rear of such carrier, an adjusting bolt projecting through such framing, and connected with such carrier to move same forward or backward for the purpose set forth. 30th. In combination, with the carrier for the combined awl and nail driver, and the stationary framing of the machine at the rear of such carrier, the adjusting bolt F², projecting through such framing rotatable therein but held against longitudinal movement and connected with such carrier, substantially as described and for the purposes set forth. 31st. The combination, with the stationary framing of the machine and carrier sections G G¹, of slide F and adjusting bolt F², for the purpose set forth. 32nd. The combination, with the stationary framing of the machine and carrier sections G G¹, of adjustable slide F, and set screw F³, for the purpose set forth. 33rd. The loop inserter having a perforated base and an inserting portion proper projecting up from same. 34th. The loop inserter having a perforated base, and a grooved inserting portion proper projecting up from same. 35th. The loop inserter having a perforated base, and an inserting portion proper oval in cross section and projecting up from same. 36th. The loop inserter having a perforated base and an inserting portion proper oval in cross section, grooved, and projecting up from same. 37th. The loop inserter having a perforated base and an inserting portion proper projecting up from same, one of the sides of which is in line with the perforation in the base. 38th. The loop inserter with circular base, inserting portion proper, and an opening through such base for the purpose set forth. 39th. The loop inserter with circular base having an opening through same and inserting portion proper arranged eccentrically of such base for the purpose set forth. 40th. The loop inserter with circular base having central perforation and inserting portion proper arranged eccentrically of such base for the purpose set forth. 41st. The loop inserter with circular base having an upwardly projecting loop inserting portion proper and a laterally projecting annular flange, for the purpose set forth. 42nd. The loop inserter with circular base having a central opening, an upwardly projecting loop inserting portion proper and a laterally projecting annular flange, for the purpose set forth. 43rd. The loop inserter with circular base having a central opening, a laterally projecting annular flange and an upwardly projecting loop inserting portion proper arranged eccentrically of such base. 44th. The loop inserter with inserting portion of oblong form, oval in cross section, grooved and having a circular base with central perforation, and projecting annular flange, and such inserting portion arranged eccentrically of said circular base. 45th. The loop inserter having an inserting portion proper of oblong form, oval in cross section and grooved, for the purpose set forth. 46th. The movable carrier or cross head for the loop inserter having a wall extending partially around its top surface, and such wall grooved on its inner side to accommodate the flange of the loop inserter, as set forth. 47th. The combination of the movable carrier or cross-head for the loop inserter, having a wall extending partially around its top surface, and such wall grooved on its inner side, of the loop inserter having a laterally projecting flange on its base freely fitting such groove, with means for preventing any lateral displacement of such loop inserter when in place. 48th. The combination of the movable carrier or cross-head for the loop inserter, having a wall extending partially around its top surface, and such wall grooved on its inner side of the loop inserter having a laterally projecting flange on its base freely fitting such groove, and a pin extending across the opening left in such wall, for the purposes set forth. 49th. The combination with the movable carrier or cross-head for the loop inserter, having a top supporting surface and a wall extending partially around same, the inner side of such wall having a horizontal groove therein, and a section of such groove presenting substantially the arc of a circle, of the loop inserter resting on such supporting surface, and having a laterally projecting annular flange corresponding with and freely fitting such groove, and a retaining pin extending across the opening left in such wall, for the purpose set forth. 50th. The movable carrier or cross-head, for the loop inserter, having recess d^3 in its front side to receive the oscillating terminal part of the operating devices for such cross-head. 51st. The combination of the horn having vertical guides, of the movable carrier or cross-head for the loop inserter, having ribs to fit such guides, and a recess d^3 in its front side, and the oscillating terminal part of the operating devices for such cross-head entering such recess. 52nd. In combination with the nose of the horn, adjustable guides or ways for the movable cross-head of the loop inserter, with means for adjusting same. 53rd. In combination with the nose of the horn, adjustable guides C², fitting recesses on the inner sides thereof, and adjusting screws c^7 passing through the sides of the horn and bearing against such guides, as and for the purposes set forth. 54th. The combination with the adjusting mechanism for the presser foot and loop inserter of the rack slide M⁸ suitably supported, pinion M⁶ on shaft M⁵, and teeth m^1 , on screw M⁷, for the purpose set forth. 55th. The segment d^1 hollowed on its upper surface to form a bearing for the upper end of

shaft b^5 . 56th. In combination with the presser foot bar L and a fixed part or bearing of an adjustable screw of fine pitch for regulating the adjustment of the presser foot bar as to its working length, and a second screw of greater pitch having the extent of its movement set and adapted by its rotation in opposite directions to raise or lower said presser foot a uniform distance. 57th. The combination with the presser foot bar L and slide L² carried thereby, of male adjusting screw L⁵ connected with such slide and female screw L⁶, in which such male screw is threaded, the female screw working through the upper portion of the bar L, for the purposes set forth. 58th. The combination with the presser foot bar L, and slide L², carried thereby, of male adjusting screw L⁵, connected with such slide and female screw L⁶, in which such male screw is threaded, the female screw working through the upper portion of the bar L, and the respective lock nuts 1², 1³, for the purposes set forth. 59th. The combination with the presser foot bar L, and slide L², carried thereby, of male adjusting screw L⁵, connected with such slide, female screw L⁶, in which such male screw is threaded, the female screw working through the upper portion of the bar L, and handle 1⁵, adjustably secured upon said female screw, as set forth. 60th. The combination with the presser foot bar L, and slide L², carried thereby, of male adjusting screw L⁵, connected with such slide, female screw L⁶, in which such male screw is threaded, the female screw working through the upper portion of the bar L, handle 1⁵, and jam nuts 1², 1³, 1⁴, for the purpose set forth. 61st. The combination of carrier G, shaft N³, cam Q, having downward projection q , lever g^5 , suitably pivoted, combined rack and wedge slide g^7 , g^9 , suitably supported, pusher G⁴, shaft M⁵, pinion g^1 , as and for the purposes set forth. 62nd. The combination of carrier G, a flexible pusher beneath same, and means for supporting and operating said pusher, for the purposes set forth. 63rd. The combination, with the adjustable carrier, for the combined awl and nail driver of a positive and invariable lift mechanism for same, and intermediate regulating mechanism, for the purpose set forth. 64th. The combination, with the adjustable carrier, for the combined awl and nail driver, of lifting mechanism for same, an intermediate regulating mechanism in the form of a movable wedge piece, and means for operating same. 65th. The combination of the machine head, the presser foot bar L, slide L², having opening z , lever L³, wedge piece M, wedge piece g^7 , intermediate operating connections between both wedge pieces m , pushers G⁴, carrier G, lifting lever g^5 , bearing beneath said wedge pieces g^9 , and means for operating such lever. 66th. The combination of the machine head, the presser foot bar L, slide L², having opening L, lever L³, wedge piece M, slide M¹, spring m^1 , localizing pin m^2 , rack M³, on said slide, pinion M⁴, shaft M⁵, pinion g^1 , toothed slide g^9 , and wedge piece g^7 , suitably supported pusher G⁴, awl carrier G, and means for elevating said wedge piece g^7 , and through it and said pusher, the awl carrier all combined and operating, substantially as and for the purposes set forth.

No. 44,773. Animal Trap. (Pige.)

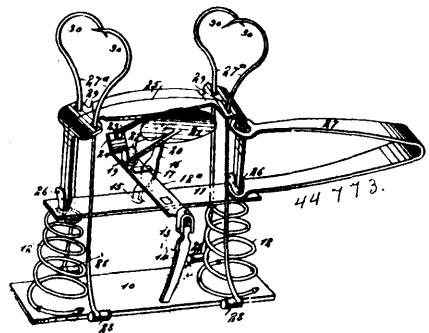

Newton Jasper Tanner and James H. Lee, both of Oviedo, Florida, U.S.A., 24th November, 1893; 6 years.

Claim.—1st. An animal trap having its spring actuated jaws pivoted upon a spring pressed plate which is released from a support and rises bodily when the trap is sprung, substantially as and for the purpose set forth. 2nd. In an animal trap, the combination of a vertically movable and spring pressed plate upon which the usual spring actuated jaws are pivoted, a jaw locking and tripping mechanism, and means for releasing the plate when the trap is sprung, to allow the plate with its jaws to rise bodily, substantially as described. 3rd. The combination with an animal trap, of springs arranged beneath the trap and adapted to lift it bodily, locking mechanism for holding the trap down and the springs compressed, and means for releasing the locking mechanism by the springing of the trap, substantially as described. 4th. In an animal trap, the combination with a support and pivoted and spring actuated jaws carried by the support, of springs arranged beneath the support, means for holding the jaws open and the springs under the support compressed, and a spring releasing mechanism operated by the springing of the trap, substantially as described. 5th. The combination with an animal trap having the usual jaws, a locking and tripping mechanism and a plate beneath the jaws, of a base plate, springs between the base

plate and the jaw supporting plate, a locking arm supported above the base plate and adapted to swing beneath the base plate, and a tripping lever supported above the base plate, said lever having one end formed into a hook to engage the locking arm and the other adapted to extend into the path of one of the open jaws, substantially as described. 6th. In an animal trap, the combination, with a base plate, and pivoted and spring actuated jaws, of hooks pivoted to the base plate and projecting through apertures in the jaws, substantially as described. 7th. The combination with an animal trap, having the usual swinging jaws and a supporting plate for the jaws, of a base plate arranged beneath the supporting plate, springs between the base plate and supporting plate, adapted to lift the trap bodily, a locking device to hold the springs in a compressed position, and means for releasing the springs by the springing of the trap, and a plurality of hooks hinged to the base plate and carried by and projecting beyond the free edges of the jaws, substantially as described.

No. 44,774. Reel for Wire Working Machines.

(Dévidoir pour fil de fer.)

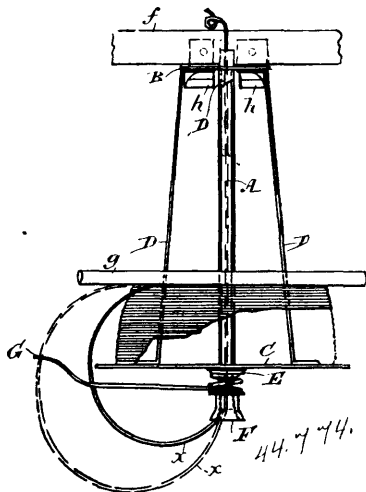

The Dominion Wire Manufacturing Company, Montreal, Quebec, Canada, assignee of Clarence Otis White and Marshall Burns Lloyd, both of Minneapolis, Minnesota, U.S.A., 25th November, 1893; 6 years.

Claim.—1st. The wire holding reel or carrier having a body with internal guideway or passage, an annular base plate and means for suspending the reel at its upper end so as to leave the base plate free for the wire to be drawn over the edge of same and up through the internal guideway or passage, as set forth. 2nd. The suspended wire holding reel or carrier having a body with internal guideway or passage therethrough and carrying the wire coil or bundle, and a rotating guide through which the wire passes on its way to the lower end of said internal guideway or passage. 3rd. The suspended wire holding reel or carrier having a body with internal guideway therethrough and carrying the wire coil or bundle, a rotating guide below the body through which the wire passes to the lower end of said internal guideway, and a sliding weight resting on said wire coil or bundle, for the purpose set forth. 4th. The suspended wire holding reel or carrier having a body with internal guideway or passage and carrying the wire coil or bundle, a rotating guiding arm below the body through which the wire passes on its way to the lower end of said internal guideway, and a sliding weight detachably secured to said body, for the purpose set forth. 5th. The wire holding reel or carrier having a body with internal guideway or passage, an annular base plate and means for suspending the reel at its upper end so as to leave the base plate free for the wire to be drawn over the edge of same and up through the internal guideway or passage, and a sliding weight resting on said wire coil or bundle, for the purpose set forth. 6th. The wire holding reel, provided with the tubular centre, and the rotating guiding arm, and arranged to feed the wire up through said tubular centre. 7th. The wire holding reel, having the tubular centre, the rotating guiding arm, and means for suspending the reel from its upper end, substantially as set forth.

No. 44,775. Cabinet. (Commode.)

The Williams Manufacturing Company, assignees of Charles Wesley Davis, and James Field, of Montreal, Quebec, Canada, 25th November, 1893; 6 years.

Claim.—1st. In a cabinet, the combination, with the hinged head section to be raised and lowered and the movable top or table portion of a pivotal lever connection between the two, for the purposes set forth. 2nd. In a cabinet, the combination, with the hinged

head section to be raised and lowered and the movable top or table portion, of a pivotal lever connection between the two and a supporting stop for the purposes set forth. 3rd. In a sewing machine cabinet, the combination, with the hinged head section to be raised and lowered and the movable top or table portion, of a pivotal lever

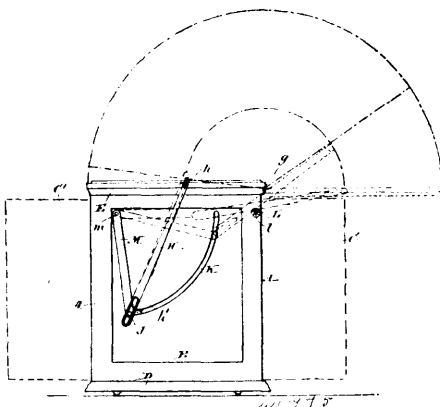

connection between the two, together with accommodating slots and arresting points acting respectively in part and together to raise and support said head section and to furnish a check against the too rapid movement of said table portion, as set forth. 4th. In a sewing machine cabinet, the combination, with the hinged head section and the movable top or table portion, of a lever having an invariable pivotal connection with said table portion and a sliding or variable pivotal connection with said hinged head section, together with a supporting stop for the purposes set forth. 5th. In a sewing machine cabinet, the combination, with the hinged head section, the movable top or table portion and the casing, having an accommodating slot, of a pivotal lever connection between said head section and table portion and a supporting stop, for the purposes set forth. 6th. In a sewing machine cabinet, the combination with the hinged head section, the movable top or table portion and the casing, having curved accommodating slot K, of lever H, having slot h', a pivotal connection between it and said table portion, and a pivot connection between it and said head section, and a supporting stop L as set forth. 7th. In a sewing machine cabinet, the combination with the hinged head section, the movable top or table portion, the casing, having an accommodating slot and a main pivotal lever connection between said head section and table portion, of an auxiliary lever or arm pivotally connected with said casing and the main lever pivotal connection, for the purpose set forth. 8th. In a sewing machine cabinet, the combination with the hinged head section, the movable top or table portion, the casing having curved accommodating slot K, lever H, and pivot connections of same with said head section and table portion, of the auxiliary lever or arm M, for the purpose set forth. 9th. In a sewing machine cabinet, the combination with the movable hinged head section and the stationary frame or casing, of an automatically operated latch or bolt carried by said head section, and a receiving socket for same, carried by said casing, with means for disengaging the bolt from the socket when desired. 10th. In a sewing machine cabinet, the combination with the movable hinged head section, the stationary frame or casing, and suitable door or doors, of a spring operated latch or bolt as P, carried by said head section, and a receiving socket for same presented by a channelled plate R, secured to said frame and containing a free bolt as r, adapted to be projected outwardly by the entrance of said bolt P, into the socket and to be forced inward to expel said bolt P, by closing a door of the cabinet, as set forth. 11th. In a sewing machine cabinet, the combination with the casing, containing an accommodating slot for a stud connection between the hinged head section, and the raising and lowering mechanism therefor, and with said raising and lowering mechanism, of a shutter for closing said slot in the form of a pivoted lever, acted upon by said stud connection in its travel to open and close said slot, as set forth. 12th. In a sewing machine cabinet, the combination with the back board of the casing, having the accommodating slot R, for a stud connection between the hinged head section and the raising and lowering mechanism, therefor and with said raising and lowering mechanism, of the lever shutter N, N', pivoted near the lower end of said slot, as shown and described.

No. 44,776. Thrust Bearing for Shafts.

(Butée pour arbres.)

Louise Jane Doty, assignee of John Doty, both of Toronto, Ontario, Canada, 25th November, 1893; 6 years.

Claim.—In a thrust bearing for propeller shafts, the combination of the propeller shaft having a screw thread at either side of the journal and extending towards the end of the shaft, and thrust clamps each having a screw thread cut on its inner face to engage

with the screw thread on its respective portion of the propellor shaft to prevent any possibility of either of the thrust clamps sliding

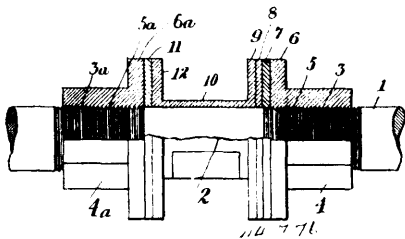

on the propellor shaft from the pressure of the thrust clamps against the thrust bearing, substantially as described.

No. 44,777. Box or Drawer. (*Boîte ou tiroir.*)

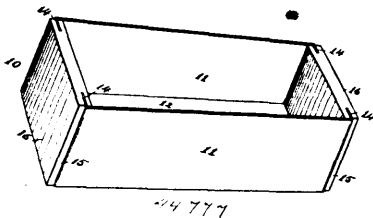

Joseph Samuel Bennett, Winnipeg, Manitoba, 25th November, 1893; 6 years.

Claim.—1st. A rectangular box, drawer or similar article, comprising suitable end pieces, and sides and bottom formed of a single piece, and having their ends bent at right angles and embedded in the end pieces, substantially as described. 2nd. An improved article of manufacture, a box, drawer or other similar article, comprising suitable end pieces having grooves in their side and bottom edges, the sides and bottom of the box being formed of a single metallic sheet, the bottom having vertical flanges at its ends, and the sides having inwardly projecting flanges at right angles to their ends, and the grooved bottom and sides of the end pieces of the box receiving said flanges, substantially as described.

No. 44,778. Milking Machine. (*Appareil pour traire les vaches.*)

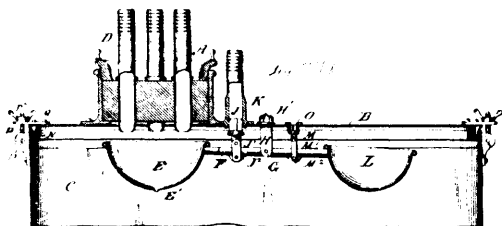

Robert Ferguson and Aaron Turner Danks, both of Melbourne, Victoria, Australia, 25th November, 1893; 6 years.

Claim.—1st. In milking machines, a centred channel, as F, forming a lever, depending from the lid of a can and supporting a cup as E at one end, and a cup as L at other end, and carrying valves as J and M, as and for the purposes described. 2nd. In milking machines, a centred lever as F¹ supporting a cup as E at one end, and a weight as L¹ at other end and carrying valves as J and M, as and for the purposes described. 3rd. In milking machines, the combination of a vacuum valve as J, with a pressure rod as J² set within a casing as K, as and for the purposes described. 4th. In milking machines, the combination and mechanical arrangement of the whole of the parts illustrated on the accompanying drawings constituting improvements in milking machines.

No. 44,779. Medicinal Compound. (*Composition médicinale.*)

William Henry Greer, Brandon, Manitoba, Canada, 27th November, 1893; 6 years.

Claim.—A cure for gonorrhœa consisting of a draught composed of bromide of potash, tincture of hyoscyamus, saltpetre, syrup of acacia, tincture of quassia and water, and an injection composed of fluid extract of golden-seal, fluid extract of belladonna, carbolic acid and water, all compounded as described and used concurrently for the purpose set forth.

No. 44,780. Smokeless Explosive.

(*Explosif sans fumée.*)

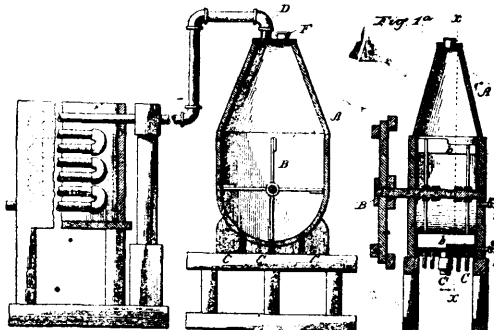

Francis G. du Pont and Pierre S. du Pont, both of Wilmington Delaware, U.S.A., 27th November, 1893; 6 years.

Claim.—1st. The herein described process of making a smokeless explosive, which consists in suspending nitro-cellulose in a liquid not a solvent of the same, granulating the nitro-cellulose by agitating therewith in proper proportions a suitable solvent not miscible to any great extent in the liquid used to suspend the nitro-cellulose, and solidifying the grains thus formed, substantially as described. 2nd. The herein described process of making smokeless explosive, which consists in suspending nitro cellulose in a liquid not a solvent of the same, granulating the nitro-cellulose by agitating therewith in proper proportions a suitable solvent not miscible to any great extent in the liquid used to suspend the nitro-cellulose, and solidifying the grains thus formed by heat, substantially as described. 3rd. The herein described process of producing a smokeless explosive, which consists in suspending nitro-cellulose in a liquid not a solvent of the same, granulating the nitro-cellulose by agitating therewith in proper proportions a suitable solvent not miscible to any great extent in the liquid used to suspend the nitro-cellulose, and solidifying the grains thus formed by agitation in an atmosphere of steam, substantially as described. 4th. The herein described process of producing a smokeless explosive, which consists of suspending nitro-cellulose in a liquid not a solvent of the same, granulating the nitro-cellulose by agitating therewith in proper proportions a suitable solvent not miscible to any great extent in the liquid used to suspend the nitro-cellulose, and solidifying the grains thus formed by rotation in an atmosphere of steam, substantially as described. 5th. The herein described process of producing a smokeless explosive, which consists in suspending nitro-cellulose in a liquid not a solvent of the same, granulating the nitro-cellulose by agitating therewith in proper proportions a suitable solvent not miscible to any great extent in the liquid used to suspend the nitro-cellulose, hardening and rounding the grains thus formed by rotation, and further solidifying the grains by rotation in an atmosphere of steam, substantially as described. 6th. The herein described process of producing a smokeless explosive, which consists in suspending nitro-cellulose in a liquid not a solvent of the same, granulating the nitro-cellulose by agitating therewith in proper proportions, accompanied by injection of steam, a suitable solvent not miscible to any great extent in the liquid used to suspend the nitro-cellulose, and solidifying the grains thus formed by agitation in an atmosphere of steam, substantially as described. 7th. The herein described process of producing a smokeless explosive, which consists in suspending nitro-cellulose in a liquid not a solvent of the same, granulating the nitro-cellulose by agitating therewith in proper proportions a suitable solvent not miscible to any great extent in the liquid used to suspend the nitro-cellulose, solidifying the grains thus formed and moderating the action of the same by the addition, during the above operation, of a suitable moderating agent, substantially as described. 8th. The herein described process of producing a smokeless explosive, which consists in suspending nitro-cellulose in a liquid not a solvent of the same, granulating the nitro-cellulose by agitating therewith in proper proportions a suitable solvent not miscible to any great extent in the liquid used to suspend the nitro-cellulose, and in which is dissolved a moderating agent, and solidifying the grains thus formed, substantially as described. 9th. The herein described process of producing a smokeless explosive, which consists in suspending nitro cellulose in a liquid, such as water, which is not a solvent of the same, and in which is dissolved a suitable salt, granulating the nitro-cellulose by agitating therewith in proper proportions a suitable solvent not miscible to any great extent in the liquid used to suspend the nitro-cellulose, and solidifying the grains thus formed, substantially as described. 10th. The herein described process of producing a smokeless explosive, which consists in suspending nitro-cellulose in a liquid not a solvent of the same, granulating the nitro-cellulose by agitating therewith in proper proportions, during injection of steam, a suitable solvent not miscible to any great extent in the liquid used to suspend the nitro-cellulose and in which is dissolved a moderating agent, and

solidifying the grains thus formed by rotation, and afterwards by rotation in an atmosphere of steam, substantially as described.

No. 44,781. Smokeless Explosive.
(Explosif sans fumée.)

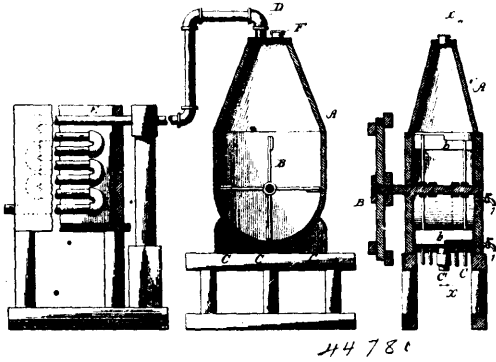

Francis G. du Pont, and Pierre S. du Pont, both of Wilmington, Delaware, U.S.A., 27th November, 1893; 6 years.

Claim.—1st. The herein described process for producing a smokeless explosive, which consists in suspending nitro-cellulose in a liquid not a solvent of the same, granulating the nitro-cellulose by agitating therewith in proper proportions a suitable solvent of the same not miscible to any great extent in the liquid used to suspend the nitro-cellulose, and solidifying the grains thus formed by subjecting the same to a heat insufficient to vaporize the solvent, but sufficient to vaporize the liquid for removal of the liquid contained in the grains, and then removing the excess of solvent, substantially as described. 2nd. The herein described process for producing a smokeless explosive, which consists in suspending nitro-cellulose in a liquid not a solvent of the same, granulating the nitro-cellulose by agitating therewith in proper proportions a suitable solvent not miscible to any great extent in the liquid used to suspend the nitro-cellulose, and solidifying the grains thus formed by subjecting the same to a heat insufficient to vaporize the solvent, but sufficient to vaporize the liquid, for removal of the liquid contained in the grains, and then to a heat sufficient to vaporize the solvent for removal of the excess of solvent, substantially as described. 3rd. The herein described process for producing a smokeless explosive, which consists in suspending nitro-cellulose in a liquid not a solvent of the same, granulating the nitro-cellulose by agitating therewith in proper proportions a suitable solvent not miscible to any great extent in the liquid used to suspend the nitro-cellulose, and solidifying the grains thus formed with removal of liquid contained in the same and excess of solvent by subjecting them to a heat ranging from 120° to 180° F. for removal of the liquid, and then boiling them for removal of excess of solvent, substantially as described. 4th. The herein described process for producing a smokeless explosive, which consists in suspending nitro-cellulose in a liquid not a solvent of the same, granulating the nitro-cellulose by agitating therewith in proper proportions a suitable solvent not miscible to any great extent in the liquid used to suspend the nitro-cellulose, and solidifying the grains thus formed by subjecting the same to a heat insufficient to vaporize the solvent, but sufficient to vaporize the liquid for removal of the liquid contained in the grains, and then to a heat sufficient to vaporize the solvent for removal of the excess of solvent, the latter operation being accompanied by agitation, substantially as described. 5th. The herein described process for producing a smokeless explosive, which consists in suspending nitro cellulose in a liquid not a solvent of the same, granulating the nitro cellulose by agitating therewith in proper proportions a suitable solvent of the same not miscible to any great extent in the liquid used to suspend the nitro-cellulose, and solidifying the grains thus formed by subjecting the same to a heat insufficient to vaporize the solvent, but sufficient to vaporize the liquid for removal of the liquid contained in the grains, and then rotating the grains in an atmosphere of steam for removal of the excess of solvent, substantially as described.

No. 44,782. Pressure Brake System.
(Système de frein à pression.)

William T. Bothwell, Jersey City, New Jersey, U.S.A., 27th November, 1893; 6 years.

Claim.—1st. In an air brake system, the combination with a brake cylinder and auxiliary cylinder and a triple valve cylinder, of a valve casing communicating with the triple valve cylinder and having a port for connection with the line pipe, a reciprocatory valve arranged in said casing and having an upper and lower seat on the inner side of the port for connection with the line pipe and also having a port for communication with the auxiliary cylinder, and a check valve arranged in this latter port, substantially as specified. 2nd. The piston cylinder, constructed as described, in combination with the check valve V, the piston valve, the exhaust

valve carried by the stem of the piston valve, the third valve casing, connected with the interior of the piston cylinder by a port or pass-

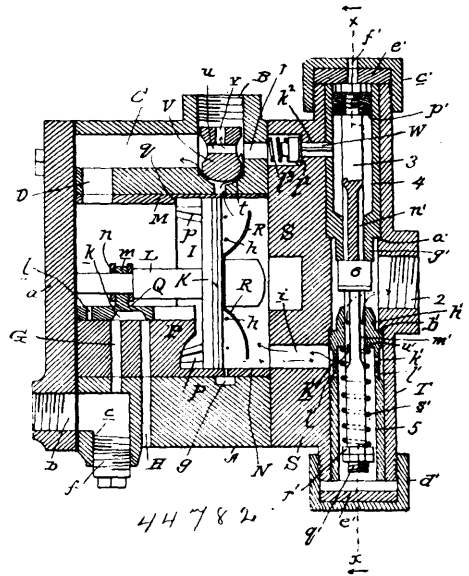

age, and also connected with the port or passage of the cylinder carrying the check valve V, and having a check valve arranged in such port, and a third valve actuated by the variable pressure in the line pipe and aided by a spring for admitting air to the piston cylinder and auxiliary reservoir or cylinder, and also allowing air from the piston cylinder to re-enter the line pipe, substantially as specified. 3rd. In an air brake system, the valve casing having a port or passage for connection with the line pipe, and also having two ports for connection with the piston cylinder and auxiliary cylinder or reservoir respectively, in combination with a check valve arranged in one of said ports, the upper and lower valve seats in said casing, the valve having the central enlargement adapted to engage said seats and also having a head at one end, and an adjustable spring surrounding the valve rod or stem at its opposite end, substantially as specified. 4th. The combination with the piston cylinder, substantially as described, of the valve casing T, the bushings 4 and 5 arranged therein at opposite sides of the train pipe port 2, and having the seats g^1, h^1 , the bushing 5 having the holes l^1 , the valve 3 having the channels m^1 and n^1 , and a central enlargement 6, and also having the head at one end and the opposite end threaded, the spring surrounding the stem within the bushing 5, and the nuts on the threaded end of the spring for regulating the tension of the spring, the whole adapted to operate and be attached to one end of the piston cylinder, substantially as specified.

No. 44,783. Brake Valve. (Soupape de frein.)

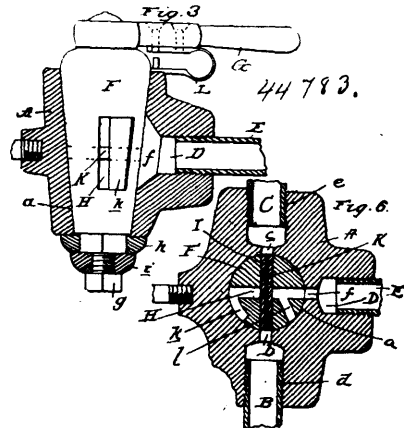

William T. Bothwell, Jersey City, New Jersey, U.S.A., 27th November, 1893; 6 years.

Claim.—1st. In an engineer's brake valve for pneumatic brake systems, the combination with a valve casing, having the three ports or passages, as described, of a plug or valve arranged in the casing, and having the main supply passage the port or passage connected with the main supply passage and also having the recess leading from the main supply passage and the port or passage free from communication with the other ports or passages of the valve, and adapted to

connect the exhaust port or passage of the valve casing with the passage which receives the train or line pipe, substantially as specified. 2nd. In an engineer's valve, for brake systems, the combination with a valve casing constructed as described, and having a conical bore, of a plug or valve arranged in said bore and carrying an operating handle, said valve having a main supply passage extending diametrically through it, and a smaller passage extending diametrically and relatively at right angles to the main passage and free from communication therewith, and also having a port or passage leading from the main supply passage, substantially as specified.

No. 44,784. Pressure Regulator.

(*Régulateur de pression.*)

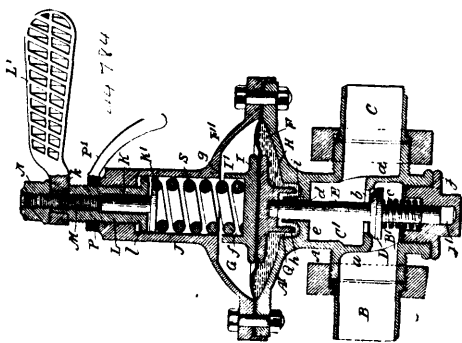

Edward Ethel Gold, New York City, New York, U.S.A., 27th November, 1893; 6 years.

Claim.—1st. In a pressure regulator, wherein the pressure is determined by a diaphragm acting upon the valve, said diaphragm arranged above the valve and receiving on one side a regulating tension and having on the other side a chamber communicating with the eduction side of the valve, the combination therewith as a means for preventing chattering, of a liquid seal beneath the diaphragm chamber and between it and the chamber or passage on the eduction side of the valve. 2nd. In a pressure regulator, wherein the pressure is determined by a diaphragm acting upon the valve, said diaphragm arranged above the valve and receiving on one side a regulating tension and having on the other side a chamber communicating with the eduction side of the valve, the combination therewith, as a means for preventing chattering, of a liquid seal *Q*, beneath the diaphragm chamber and between it and the chamber or passage on the eduction side of the valve, consisting of two parts, the one stationary and the other movable with the diaphragm, the one part being a downwardly projecting annular flange and the other part formed with the annular channel entered by said flange and adapted to hold liquid. 3rd. The combination to form a pressure regulator, of a shell *A*, divided by a partition *a*, having a valve seat *b*, into eduction and induction chambers, and formed with a portion *A*¹, for inclosing the diaphragm chamber *F*, and with an intervening partition *c*, having an opening *d*, through it for the passage of a valve stem, and an annular channel *e*, around said opening, a valve *D*, and its stem *E*, the latter passing up through said opening into said diaphragm chamber, a diaphragm *G*, having an annular flange *b*, projecting downwardly into said channel *e*, to form the liquid seal *Q*, and a spring *S*, pressing on the opposite side and tending to open the valve. 4th. A pressure regulator, comprising a casing and valve seat, a regulating valve, a diaphragm in communication with the eduction side thereof connected to the valve, a spring pressing against the diaphragm in direction tending to open the valve, a screw spindle for adjusting at will the tension of said spring to vary the pressure determined by the regulator, an interposed adjusting screw for varying the initial tension of the spring relatively to said spindle, and a stop for limiting the screwing down of the spindle, whereby the maximum pressure of fluid to which the regulator is adjustable may be determined in setting the regulator. 5th. A pressure regulator, comprising a casing and valve seat, a regulating valve, a diaphragm in communication with the eduction side thereof connected to the valve, a spring pressing against the diaphragm in direction tending to open the valve, a screw spindle for adjusting at will the tension of said spring to vary the pressure determined by the regulator, and an adjusting screw enclosed within the spindle, engaging threads therein and receiving the tension of the spring, and a lock for fixing

said adjusting screw. 7th. A pressure regulator, comprising a casing *A*, and valve seat, a regulating valve *D*, a diaphragm *G*, in communication with the eduction side thereof connected to the valve, a spring *S*, pressing against the diaphragm in direction tending to open the valve, a screw spindle *L*, having a handle by which to turn it and constructed for adjusting at will the tension of the spring to vary the pressure determined by the regulator, an interposed adjusting screw *M*, engaging threads within the spindle, and receiving the tension of the spring and transmitting said tension to the spindle, whereby the connection between the spring and spindle may be adjusted to vary the initial tension of the spring, and a fastener for fixing said adjusting screw to the spindle, whereby to maintain the adjustment of said initial tension. 8th. In a pressure regulator, wherein the pressure is determined by the tension of a spring *S*, pressing against a diaphragm *G*, for controlling the opening of a valve, and the tension of said spring is varied at will by turning a screw spindle *L*, the combination therewith of an adjusting screw *M*, which receives the pressure of said spring and communicates it to said spindle, the said screw screwing into said spindle and projecting above the top thereof, and a nut *N* screwing on said screw *M*, and tightening against the top of said spindle for locking said screw to the spindle to prevent its turning therein and impairing the adjustment. 9th. In a pressure regulator wherein the pressure is determined by the tension of a spring *S* pressing against a diaphragm *G*, for controlling the opening of a valve, and the tension of said spring is varied at will by turning a screw spindle *L*, having a handle *L*¹, fitted on its upper end, the combination therewith of an adjusting screw *M*, which receives the pressure of said spring and communicates it to said spindle, the said screw screwing into said spindle and projecting above the top thereof, and a nut *N* screwing on the projecting portion of said screw, and bearing down against said handle *L*¹, whereby it locks the screw *M* fast in the spindle, and locks the handle *L*¹ fast to the spindle. 10th. A pressure regulator comprising a casing and valve-seat, a regulating valve *D*, its stem *E*, the diaphragm *G*, the spring *S*, pressing against the diaphragm and tending to open the valve, a plunger *K*, receiving the opposite reaction of the spring, an adjusting screw spindle *L*, and an adjusting screw *M* screwing in said spindle, and receiving the thrust of said plunger, whereby the thrust of the spring is transmitted to the spindle *L*, through the plunger *K*, and screw *M*. 11th. In a pressure regulator having an imperforate diaphragm, the combination of valve casing *A*, *A*¹, and spring chamber *J*, the latter formed with a stop shoulder *g*, imperforate diaphragm *G*, a regulating valve with its stem bearing against one side of said diaphragm, a regulating spring *S* inclosed in and guided by said spring chamber, and disc *I* resting loosely against the opposite side of the diaphragm, and having a tubular portion *I*¹, arranged to abut against said shoulder *g*, after the seating of the valve to limit the further distortion of the diaphragm, and formed with a chamber *f*, receiving and fitting the lower portion of said spring, whereby the spring holds the disc *I* centrally in place against the diaphragm and its portion *I*¹ in position to engage said shoulder. 12th. In a pressure regulator, the combination with the valve casing, the imperforate diaphragm *G*, and the valve *D*, having its stem bearing against one side thereof, of a disc *I* resting loosely against the other side thereof, the helical spring *S* pressing against the diaphragm through said disc, and a cylindrical spring chamber for said spring formed partially in the casing at *J*, and partially in said disc at *f*, so that the spring by being inclosed within and engaging the walls of said chamber serves to hold the loose disc in place centrally against the diaphragm.

No. 44,785. Wire Braiding Machine.

(*Machine pour tresser le fil métallique.*)

John B. Cleveland, Indianapolis, Indiana, U.S.A., 27th November, 1893; 6 years.

Claim.—1st. In a wire braiding machine, the combination of the following instrumentalities, namely, a table, a pair of wire carriers mounted on said table and arranged to rotate thereon in a horizontal plane, a pair of wire carriers also mounted on said table and arranged to oscillate thereon in vertical planes which intersect the plane of rotation of the horizontal wire carriers, means for imparting a continuous rotary motion to said rotating wire carriers, and means for imparting an intermittent oscillating movement to said oscillating wire carriers, all substantially as and for the purposes set forth. 2nd. In a wire braiding machine, the combination of the table, the circular way mounted thereon and having in its upper surface a pair of diametrically opposed radial grooves, the centrally perforated hub secured to said table concentric with said way, the pair of wire carriers arranged to traverse said way, the wheel mounted upon said hub and arranged to rotate beneath said way, the dogs pivoted to said wheel and arranged to engage said wire carriers, and the guide arranged to disengage said dogs from said carriers while the carriers are passing the radial grooves in the way, substantially as and for the purpose set forth. 3rd. In a wire braiding machine, the combination of the table, the pair of wire carriers arranged to rotate in a horizontal plane thereto, the pair of rock shafts mounted on said table at opposite sides of the plane of rotation of said wire carriers, the plane of rotation of said rock shafts being at right angles to the plane of rotation of the wire carriers, the pair of wire carrying arms

secured to the rock shafts, the pair of rocking levers pivoted to the table so as to swing in a vertical plane thereon, the cords connecting

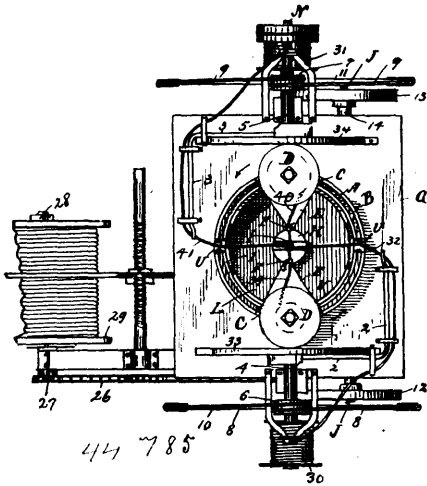

the ends of said levers and said shafts, and means, substantially as shown and described, for imparting an intermittent oscillating movement to said rocking levers, whereby said wire carrying arms are simultaneously oscillated in opposite directions, substantially as set forth.

No. 44,786. Braided Fence Wire.

(Clôture en fil de fer tressé.)

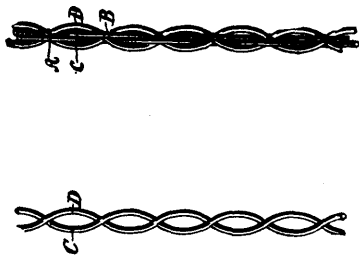

John B. Cleveland, Indianapolis, Indiana, U.S.A., 27th November, 1893; 6 years.

Claim.—The above described braided fencing wire, consisting of two strands of wire bent into serpentine form and laid side by side in parallel planes without being twisted together, but crossing each other to form a series of loops, said pair of strands being bound together by two other wire strands, which are interwoven with said loops and twisted together, passing, respectively, alternately over and under the first wires at their points of intersection, thus forming a second series of loops in a plane substantially at right angles to the plane of the loops formed by the first mentioned wires, the whole being so closely interwoven that all of the four wires composing the strand are in contact at their several points of intersection, all substantially as set forth.

No. 44,787. Shifting Device for Elevators.

(Appareil pour déplacer les élévateurs.)

James Fleming, Buffalo, New York, U.S.A., 28th November, 1893; 6 years.

Claim.—1st. In combination, the frame, the elevator-leg pivoted at its upper end to the frame, a swinging arm pivoted to the frame, its free end engaging the back of the elevator-leg, a counterweight for holding such free end up against the leg, and means, substantially as shown and described, for operating the swing arm, for the purposes set forth. 2nd. The combination, with a frame having slotted braces and an elevator-leg provided with trunnions engaging the slots in the said braces, of a pusher-arm mounted to swing and engaging the back of the said elevator-leg, and a rope and pulley mechanism for actuating the pusher, substantially as shown and described. 3rd. The combination, with a frame having slotted braces and an elevator-leg provided with trunnions engaging the slots in said braces, of a pusher-arm mounted to swing and engaging the back of the said elevator-leg, the rope and pulley mechanism for actuating the said arm, and a rope carrying a bail engaging with the said trunnions to move the elevator-leg up and down, substantially as shown and described. 4th. The combination, with a frame having slotted braces and an elevator-leg provided with trunnions engaging the slots in the said braces, of a pusher-arm mounted to

swing and engaging the back of the said elevator-leg, a rope carrying a bail engaging with the said trunnions to move the elevator-leg

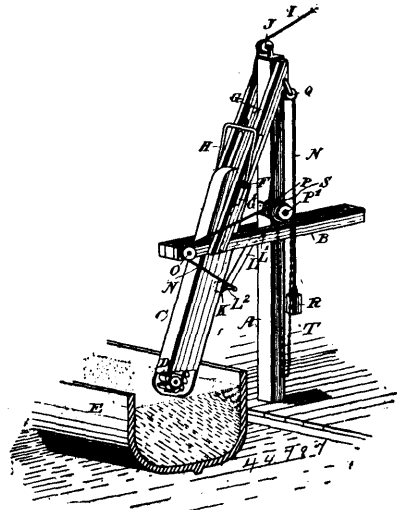

up and down, and a rope and pulley mechanism, substantially as described, and connected with the said pusher-arm to impart a swinging motion to the latter, as set forth.

No. 44,788. Carriage Axle. (Essieu de voiture.)

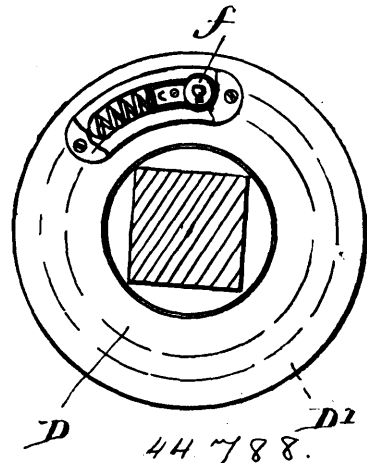

Joseph Ledoux, of Montreal, Quebec, Canada, 28th November, 1893; 6 years.

Claim.—1st. In a carriage axle, the combination with the axle box provided with points of engagement at its rear end, of the dust guard sleeve carrying a movable pin or projection to interlock with such points, for the purposes set forth. 2nd. In a carriage axle, the combination with the axle box provided with points of engagement in the face of its rear overlapping, and such points of engagement being inside the peripheral side of same, of the dust guard sleeve having a screw threaded connection with the interior periphery of such rear overlapping end and perforated to carry a movable pin or projection to interlock with such points, for the purposes set forth. 3rd. In a carriage axle, the combination with the axle provided with points of engagement in the face of its rear overlapping end, of the dust guard sleeve having a screw threaded connection with the interior periphery of such rear overlapping end correspondingly screw threaded also having a face portion adjacent to that of the rear end of said box, but out of contact therewith, and a lateral flange overlapping the rear end of said box, and adapted to be adjusted with such face portion closer to such rear end and to be locked against backward movement, with means carried by said sleeve for interlocking with said points of engagement and effecting such locking, as set forth. 4th. In a carriage axle, the combination with the axle box provided with points of engagement in its rear face of the dust guard sleeve carrying a movable pin or projection to interlock with such points, and a spring or yielding resistance device arranged laterally of such pin to hold same in its locking position, as set forth. 5th. The combination of the rear face *e'*, having the annular series of engaging points *e*, of the sleeve *D* perforated to carry the removable pin and lateral yielding resistance locking device, for the purpose set forth. 6th. In a carriage axle the combination with the axle box provided with the recesses *e* in

its rear face, of the dust guard sleeve perforated and carrying the removable pin *f* to interlock with such recesses, for the purposes set forth.

No. 44,789. Churn. (Baratte.)

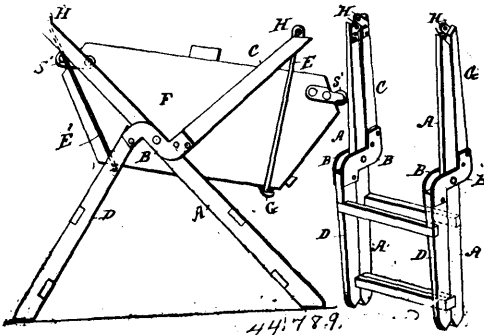

Thomas F. Hood and William G. Smith, both of Huffman, Alabama, U.S.A., 28th November, 1893; 6 years.

Claim.—1st. An improved churn supporting frame, consisting of arms A, brackets pivoted between their ends to the said arms, supports secured to the upper ends of said brackets, and legs secured to the lower ends thereof, substantially as shown and described. 2nd. An improved churn supporting frame, comprising supports A, brackets pivoted between their ends to the said supports, supports C, rigidly secured to the upper ends of said brackets, and legs pivotally secured to the lower ends of the brackets, substantially as shown and described. 3rd. An improved churn supporting bracket, comprising supports A, S-shaped brackets C, pivoted between their ends to the said supports, supports B, rigidly secured to the said brackets, and legs D, pivotally secured to the lower ends of the said brackets, substantially as shown and described.

No. 44,790. Spring Bed-bottom. (Sommier élastique.)

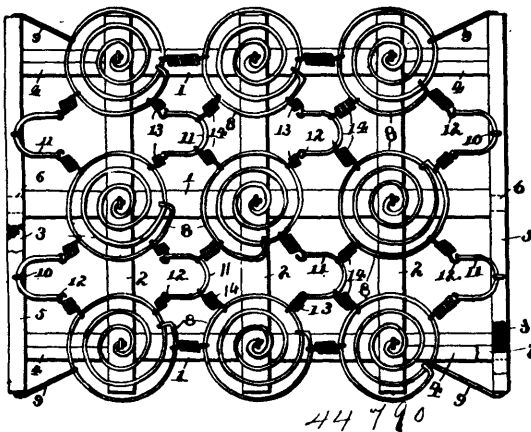

George G. Baker and John N. Wanick, both of Bloomsbury, Pennsylvania, U.S.A., 28th November, 1893; 6 years.

Claim.—In a spring bed-bottom, the combination, with the longitudinal and transverse rails and the bars constituting the frame, of a series of vertically disposed coiled springs that are fixed at their lower ends to the intersections of the rails or bars of the frame, a series of U-shaped links arranged in the horizontal plane of the upper coils of said springs with the parallel side arms thereof disposed longitudinally or parallel with the longitudinal bars of the frame and having hooked free ends, and horizontally disposed springs engaging said hooked ends and intermediate points of the links and connected to the upper coils of said vertically disposed springs, substantially as specified.

No. 44,791. Brake Attachment for Bicycle. (Attache de frein pour bicyclet)

William Sherwood Porter, Washington, Pennsylvania, U.S.A., 28th November, 1893; 6 years.

Claim.—In a brake attachment for bicycles, the combination, with the ordinary brake mechanism, of a clamp attached to the ordinary vertical brake rod, a supplemental or pendent rod screw-threaded at its upper end and adjustable in said clamp, a clamp

fitting around one of the members or tines of the steering fork and adjustable thereon, and a foot lever pivoted to said clamp and pro-

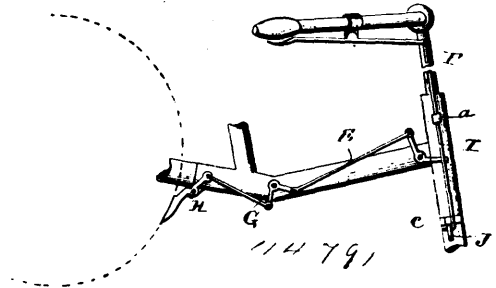

vided with a slot or oblong opening in which the lower end of the pendent rod is adjustably secured, substantially as specified.

No. 44,792. Brakes for Children's Carriage. (Freins pour voitures d'enfants.)

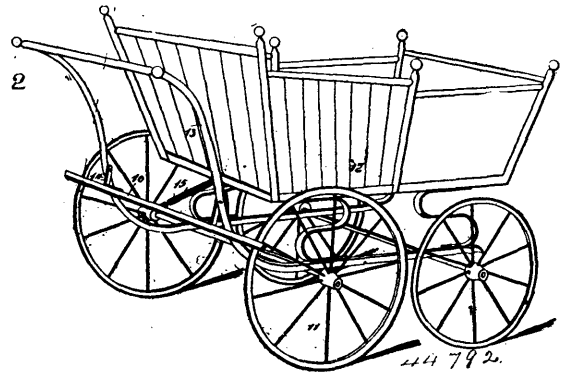

Frederick O. Boes, New York City, New York, U.S.A., 28th November, 1893; 6 years.

Claim.—1st. A brake for children's carriages, consisting of a spring controlled bar, having movable connection with a fixed support upon the carriage and adapted for engagement with the wheels of the carriage, substantially as described. 2nd. A brake bar for children's carriages, the same consisting of a bar adapted for engagement with the wheels of a carriage, arms connected with the bar and adapted for pivotal engagement with the handle bars of the carriage, and a spring connected with the bar, and adapted likewise for connection with the carriage, as and for the purpose set forth. 3rd. The combination, with a child's carriage, of a brake bar adapted for engagement with the wheels thereof, a pivotal connection between the brake bar and the handle bars of the carriage, and a spring connected with the brake bar and with a fixed support on the carriage, the point of attachment of the spring to the carriage being on a line drawn substantially about midway between the upper and the lower throw of the brake bar, as and for the purpose specified.

No. 44,793. Nut Lock. (Arrête-écrou.)

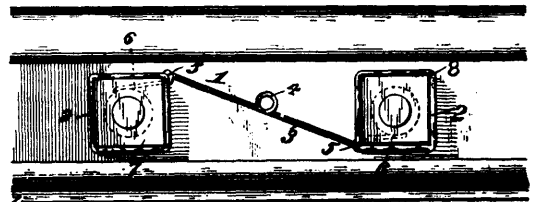

Joseph W. Hester, Citronnelle, Alabama, U.S.A., 28th November, 1893; 6 years.

Claim.—1st. A nut lock, constructed of wire and comprising a pair of nut receiving loops, and an inclined connecting portion extending from the top of one of the loops to the bottom of the other and provided with a bend imparting resiliency to the nut lock, substantially as described. 2nd. A nut lock, constructed of wire and comprising nut receiving loops, and an inclined connecting portion extending from the top of one of the loops to the bottom of the other loop, said loops terminating in eyes arranged on the inclined connecting portion, whereby the size of the loops may be varied, substantially as described. 3rd. The combination, of a rail joint, having a pair of bolts and nuts, washers of less diameter than the

No. 44,797. Automatic Flushing Apparatus.

(Appareil automatique pour laver les latrines.)

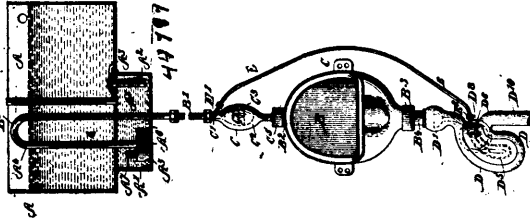

William Clark, Alexander Cameron, both of Sydney, and Charles Kirk, of North Sydney, all of New South Wales, Australia, 28th November, 1893; 6 years.

Claim.—1st. In automatic flushing urinals and other contrivances of the class set forth, the combination and arrangement with a flushing tank and a main syphon therefrom, of an open receiving vessel or basin connected to the long leg of said syphon an air-trap or water lute in said long leg of said syphon between said receiving vessel or basin, and said flushing tank, a closed chamber connected by an inverted syphon or bent pipe with the main discharge pipe from said receiving vessel or basin (or say the continuation of the long leg of the main syphon), and adapted to receive the first of any liquid supplied to said receiving vessel or basin, a by-pass pipe connecting said closed chamber with the said long leg of the main syphon, at a point above the said air-trap or water lute, and an auxiliary syphon from said closed chamber to the said main discharge pipe, adapted to set up a vacuum or partial vacuum in said closed chamber and in the said long leg of the main syphon sufficient to create syphonage in said main syphon, substantially as herein described and explained. 2nd. In automatic flushing apparatus for urinals and other contrivances of the class set forth, the combination and arrangement with a main syphon having an air-trap or water lute therein, and a break or opening or open receiving vessel or pan such as an urinal pan, also therein below said air-trap or water lute of a closed chamber connected by an inverted syphon with the discharge pipe from said break or opening and having an auxiliary syphon connecting it with the said discharge pipe, and a by-pass pipe connecting it with the said main syphon above the said air-trap or water lute, substantially as herein described and explained. 3rd. In automatic flushing apparatus for urinals and other contrivances of the class set forth, the combination and arrangement with a flushing tank having a reservoir such as A, and a measuring chamber such as A¹, a main syphon therefrom such as A⁴, B¹, and a receiving vessel or pan such as B, having a discharge pipe, and bend such as D and D¹⁰, of an air-trap or water lute such as C, an inverted syphon such as D³, a closed chamber such as D⁴, an auxiliary syphon such as D⁷, D⁸, D⁹, and a by-pass pipe such as E, substantially as herein described and explained. 4th. In automatic flushing apparatus for urinals and other contrivances of the class set forth, the combination and arrangement with the other main parts of an inverted syphon such as D³, having a perforated or grating or sieve top such as D², a closed chamber such as D⁴, within the bend D, of a plumber's trap and an auxiliary syphon formed of pipe D⁷, coil D⁸, and the pipe D⁹, substantially as herein described and explained. 5th. In automatic flushing apparatus for urinals and other contrivances of the class set forth, the combination and arrangement with the other main parts of a peculiarly constructed air-trap or water lute consisting of neck such as C¹, inner bottomless bottle-shaped chamber C², outer bottle-shaped chamber C³, connecting port or passage C⁴, and discharge socket end C⁵, substantially as herein described and explained. 6th. In automatic flushing apparatus for urinals and other contrivances of the class set forth, the combination and arrangement with other main parts of a syphon starter, consisting of box

or casing such as F, having therein catch trap formed of plates such as F⁴ and F⁵, with plug thereto such as F⁶, and divided into back and front compartments by partition as F⁷, the latter compartment forming closed chamber such as D⁴, an inverted syphon having grating such as G², long leg such as G, bend such as G³, and short leg such as G⁴, an auxiliary syphon having short leg such as H¹, coil such as H, and long leg such as H², and a by-pass pipe E, substantially as described and explained. 7th. In a syphon starter consisting of parts as set out in the preceding (6th) claim, the combination and arrangement with said parts of a weeping tank such as J, having weeping orifice such as J¹, substantially as herein described and explained.

No. 44,798. Process of Obtaining Pure Sulphide of Nickel. *(Procédé pour obtenir du sulfure de nickel pur.)*

The Oxford Copper Company, New York City, New York, assignee of John L. Thomson, City of Bayonne, New Jersey, all in U.S.A., 28th November, 1893; 6 years.

Claim.—1st. The hereinbefore described method of producing and separating sulphide of nickel, consisting in smelting ores or mattes containing nickel with a sulphide of any of the alkaline bases, or a mixture of any two or more of such sulphides, substantially as described, whereby sulphide of nickel is formed, which is of greater specific gravity than the remainder of the mass, and is precipitated to the bottom of the mass, while the copper, iron and salts of the alkaline base rise to the top and may be separated in any convenient manner. 2nd. The hereinbefore described method of producing sulphide of nickel consisting in smelting the ores, mattes or other substances containing nickel with a sulphide of any of the alkaline bases or a mixture of any two or more of such sulphides, substantially as described, in separating out the sulphide of nickel resultant from the operation, from the smelted mass, and in resmelting the bottoms rich in sulphide of nickel with the sulphide of the alkaline base, and separating the resultant sulphide of nickel from the sulphides of the other metals present, and in repeating the operation until a commercially pure residue of sulphide of nickel is obtained. 3rd. The hereinbefore described method of producing and separating sulphide of nickel, consisting in smelting the ores, mattes or other bodies containing nickel, with a sulphide of any of the alkaline bases or a mixture of any two or more of the same, substantially as described, in separating out the bottom rich in sulphide of nickel resultant from the smelting, by means of specific gravity, and in subjecting the separate sulphide of nickel to repeated smelting with the sulphide of any of the alkaline bases, and subsequent separation by specific gravity until a commercially pure residue of sulphide of nickel is obtained.

No. 44,799. Floor Mop. *(Balai à laver les planchers.)*

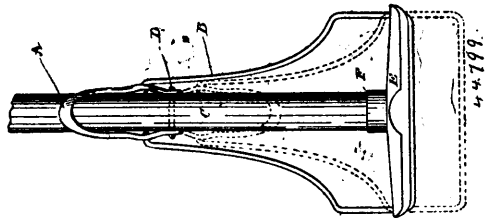

Washington T. Triphagen, Bellevue, Michigan, U.S.A., and George W. Baker, Winnipeg, Manitoba, Canada, 28th November, 1893; 6 years.

Claim.—The lever A, working on the fulcrum D, in an ordinary mop handle C, in combination with the clamp B, and the head E, with socket F, substantially as and for the purposes hereinbefore set forth.

CERTIFICATES OF THE PAYMENT OF FEES FOR FURTHER TERMS HAVE BEEN ATTACHED TO THE FOLLOWING PATENTS.

3138. ALFRED NOBEL, 2nd five years of No. 30,707, from the 5th day of February, 1894. Improvements in the Manufacture of Explosives, 2nd November, 1893.
3139. THORBIORN THORBIORNSEN, 2nd five years of No. 30,132, from the 6th day of November, 1893. Improvements in a Method of and Apparatus for Discovering Leaks in Ships and other Structures, 2nd November, 1893.
3140. CHARLES R. OTIS, 2nd five years of No. 30,099, from the 3rd day of November, 1893. Improvements in Elevating Apparatus, 2nd November, 1893.
3141. THE BOVININE COMPANY (assignees), 2nd five years of No. 30,380, from the 12th day of December, 1893. Compositions of Matter to be used as Liquid Food, 2nd November, 1893.
3142. CHARLES P. CHISHOLM and JOHN A. CHISHOLM, 2nd and 3rd five years of No. 35,389, from the 8th day of November, 1895. Improvement in the Art or Process of Hulling Peas, 3rd November, 1893.
3143. JAMES McCULLOCH, 2nd five years of No. 30,177, from the 30th day of November, 1893. Improvements Relating to Valves and Valve Gears chiefly designed for Rock Drills, 3rd November, 1893.
3144. JAMES COOPER and FREDERICK FAIRMAN, 3rd five years of No. 18,192, from the 27th day of November, 1893. Improvements on Apparatus for Coating Metals with Metal in a Melted State, 4th November, 1893.
3145. JAMES COOPER and FREDERICK FAIRMAN, 3rd five years of No. 18,318, from the 18th day of December, 1893. Improvements on Wire Wiping Apparatus, 4th November, 1893.
3146. JAMES COOPER and FREDERICK FAIRMAN, 3rd five years of No. 18,320, from the 18th day of December, 1893. Improvements on Apparatus for Feeding Wires, 4th November, 1893.
3147. JAMES COOPER and FREDERICK FAIRMAN, 3rd five years of No. 18,321, from the 18th day of December, 1893. Improvements on Apparatus for Pickling Wire, 4th November, 1893.
3148. WILLIAM B. DUNNING, 2nd five years of No. 30,159, from the 8th day of November, 1893. Improvements in Boilers for Steam or Hot Water Heating, 4th November, 1893.
3149. FERDINAND W. STARR, 2nd five years of No. 30,271, from the 24th day of November, 1893. Improvements in Fastening Devices, 4th November, 1893.
3150. STEPHEN F. MOORE, 2nd five years of No. 30,128, from the 6th day of November, 1893. Improvements in Carving Machines, 4th November, 1893.
3151. MILO COVEL, 2nd five years of No. 30,153, from the 8th day of November, 1893. Improvements in Machines for Straightening and Hammering Saws, 6th November, 1893.
3152. MILO COVEL, 2nd five years of No. 30,180, from the 13th day of November, 1893. Improvements in Devices for Holding and Dressing Saws, 6th November, 1893.
3153. GEORGE E. BAKER, 2nd five years of No. 30,205, from the 16th day of November, 1893. Wagon Lifter, 8th November, 1893.
3154. NATHAN H. GREENE, 3rd five years of No. 18,172, from the 24th day of November, 1893. Improvements in Convertible Freight Cars, 8th November, 1893.
3155. JULES PICOT, 2nd five years of No. 30,333, from the 5th day of December, 1893. Improvements in Washing or Bleaching Cakes or Powder, 8th November, 1893.
3156. JOHN YOCOM, 2nd five years of No. 30,163, from the 9th day of November, 1893. Improvements in Machines for Harvesting Beans, 9th November, 1893.
3157. HUMPHREY B. YOUNG, 2nd five years of No. 30,248, from the 22nd day of November, 1893. Improvements in Attachments to Blacksmith's Anvils, 9th November, 1893.
3158. ROBERT MARTIN and DAVID MARTIN, 2nd five years of No. 30,208, from the 17th day of November, 1893. Improved Pump Sucker, 10th November, 1893.
3159. JOHN H. R. DINSMORE, 2nd five years of No. 30,201, from 16th day of November, 1893. Improvements in the Manufacture of Gas from Coal, and apparatus employed therein, 13th November, 1893.
3160. ADELARD F. MARTEL, 2nd five years of No. 30,199, from the 14th day of November, 1893. Improvements on Switch Signals, 13th November, 1893.
3161. SPRATTS Patent (assignees), 3rd five years of No. 18,158, from the 22nd day of November, 1893. Improvement on Preparation of Food for Animals, Game and Poultry, 14th November, 1893.
3162. EBEN M. BOYNTON, 2nd five years of No. 30,306, from the 29th day of November, 1893. Improvements in Railways, 14th November, 1893.
3163. PETER HENRICHS, 3rd five years of No. 18,099, from the 17th day of November, 1893. Improvements in Sectional Show Cases, 16th November, 1893.
3164. PETER HENRICHS, 3rd five years of No. 18,100, from the 17th November, 1893. Improvements in Sectional Show Cases, 16th November, 1893.
3165. PETER HENRICHS, 3rd five years of No. 18,101, from the 17th day of November, 1893. Improvements on Sectional Show Cases, 16th November, 1893.
3166. WILLIAM TAYLOR, 2nd five years of No. 30,206, from the 16th day of November, 1893. Improvements in Dies for Holding Triangular Wire, 16th November, 1893.
3167. THOMAS PHILLIPS, 3rd five years of No. 18,107, from the 17th day of November, 1893. Improvements in Tubular Lanterns, 17th November, 1893.
3168. WARREN WEBSTER, 2nd five years of No. 30,228, from the 19th day of November, 1893. Improvements in Feed-Water Heaters and Purifiers, 17th November, 1893.
3169. LOUIS GOULLIQUOUD, 2nd five years of No. 30,680, from the 31st day of January, 1893. Improved Dust Guard for Car Axle Boxes, 20th November, 1893.
3170. THE PHOENIX ACTIEN GESELLSCHAFT FÜR BERGBAU UND HUTTENBETRIEB, (assignees), 2nd five years of No. 30,425, from the 18th day of December, 1893. Improvements in the Manufacture of Steel or Iron, 20th November, 1893.
3171. LEVI M. DEVORE AND FREDERICK W. HOEFER, 2nd five years of No. 30,510, from the 31st of December, 1893. Improvements in Spring Hinges, 20th November, 1893.
3172. LAWRENCE MANNING, 2nd five years of No. 30,255, from the 22nd day of November, 1893. Improved Brick Kiln, 21st November, 1893.
3173. DAVID L. DWINNELL, 2nd five years of No. 30,254, from the 22nd day of November, 1893. Improvements in fittings for use in Hot Water and other Heating Systems, 21st November, 1893.

3174. TIMOTHY GINGRAS, 3rd five years of No. 18,154, from the 22nd day of November, 1893. Improvements on Fly Nets, 21st November, 1893.
3175. EDWARD CARNEY, 2nd five years of No. 30,266, from the 23rd day of November, 1893. Improvements in Printing Machines, 23rd November, 1893.
3176. FRANCIS HYDE, 2nd five years of No. 30,411, from the 15th day of December, 1893. Improvements in Water Taps, 25th November, 1893.
3177. EDWARD N. HENEY, 3rd five years of No. 18,193, from the 27th day of November, 1893. Improvements on Jump Seat Carriages, 25th November, 1893.
3178. FRANK S. JACKSON, JOHN T. JACKSON, THOMAS JACKSON and ALFRED JACKSON, 2nd five years of No. 30,300, from the 29th day of November, 1893. Improvements in Mowing Machines, 25th November, 1893.
3179. EBEN M. BOYNTON, 2nd five years of No. 30,304, from the 29th day of November, 1893. Improvements in Railways, 27th November, 1893.
3180. EBEN M. BOYNTON, 2nd five years of No. 30,305, from the 29th day of November, 1893. Improvements in Railways, 27th November, 1893.
3181. GEORGE BROWNLESS, 2nd five years of No. 30,311, from the 1st day of December, 1893. Improvements in Thill Couplings, 27th November, 1893.
3182. JOHN COMBE and OLIVER W. KETCHUM, 3rd five years of No. 18,219, from the 29th day of November, 1893. Improvements on Button Fasteners, 27th November, 1893.
3183. BENJAMIN E. DONHAM, 2nd five years of No. 30,418, from the 17th day of December, 1893. Medicinal Compound, 30th November, 1893.
-

TRADE MARKS

Registered during the month of November, 1893, at the Department of Agriculture—
Copyright and Trade Mark Branch.

4773. ANGUS MacKINNON, of Alvinston, Lambton County, Ont. Medical Compound, 2nd November, 1893.
4774. JESSE ASCOUGH, of Handsworth, Stafford County, England. Soaps of all kinds, Antiseptics, Detergents, Starch, Blue, &c., 2nd November, 1893.
4775. JAMES M. AIRD, of Montreal, Quebec. Cough Drops, 2nd November, 1893.
4776. } SIGMUND BLUMENTHAL, of New York, N. Y., U.S.A. Harmonicas,
4777. } 2nd November, 1893.
4778. LINE, MacDONALD & COMPANY, of London, Ont. Cigars, 3rd November, 1893.
4779. THE MONTREAL CHEMICAL COMPANY, of Montreal, Quebec. General Trade Mark, 3rd November, 1893.
4780. SHAW STOCKING COMPANY, of Lowell, Mass., U.S.A. Hosiery, 3rd November, 1893.
4781. } ALFRED MAY ZIEGLER, of Boston, Mass., U.S.A. Suspenders and
4782. } Braces, 6th November, 1893.
4783. W. B. McALLISTER & SON, of Pembroke, Ont. Flour, 7th November, 1893.
4784. THOMAS ROBERTSON AND ALEXANDER ROBERTSON, of Toronto, Ont., trading as ROBERTSON BROTHERS. Confectionery Sugar Drops, 7th November, 1893.
4785. THE PURDUE FREDERICK COMPANY, of New York, N. Y., U.S.A. Glycerine Tonic Compound, 8th November, 1893.
4786. THE WILLIAM J. MATHESON & COMPANY, LD., of New York, N. Y., U.S.A. Dyes and Dye Stuffs, 8th November, 1893.
4787. J. B. PACE TOBACCO COMPANY, of New York, N. Y., U.S.A. Tobacco in all forms, 10th November, 1893.
4788. D. RITCHIE & COMPANY, of Montreal, Quebec. Plug and Cut Tobaccos, Cigarettes and Cigars, 10th November, 1893.
4789. } J. DUPONT & COMPANY, of Cognac, France. Cognac, 11th November,
4790. } 1893.
4791. SAMUEL MORRIS, of 148 Clare Road, Cardiff, Glamorgan County, Wales, England. General Trade Mark, 13th November, 1893.
4792. WILLIAM HENRY JUDD, of Hamilton, Ont. Soap, 13th November, 1893.
4793. JOHN COCHRANE AND HENRY ALEXANDER MUNN, of Victoria, B. C. Hospital Remedies and Medical Prescriptions, 13th November, 1893.
4794. MASSEY-HARRIS COMPANY, of Toronto, Ont. Disc Harrows and Drills and Parts thereof, 15th November, 1893.
4795. WILLIAM HANSON BOORNE, of Calgary, N. W. T. Powder and other preparations for polishing and cleaning silverware, tinware, jewelry, glassware and domestic utensils, 18th November, 1893.
4796. STAPLEY & SMITH, of 128 London Wall, London, England. Ladies' and Children's Underwear, 20th November, 1893.
4797. B. GOLDSTEIN & COMPANY, of Montreal, Quebec. Cigars, Cigarettes and Tobaccos, 22nd November, 1893.
4798. HENRY CLAY & BOCK & COMPANY, LD., of Havana, Cuba. Cigars, Cigarettes and Tobaccos, 22nd November, 1893.
799. DANIEL & ARTER, of Birmingham, England; Spoons, Forks and like table implements, 22nd November, 1893.
4800. HARDING & SMITH, of St. John, N. B. Flour, 25th November, 1893.
4801. CEYLON CO-OPERATIVE TEA GARDENS COMPANY, of Colombo, Ceylon. Teas, 29th November, 1893.
4802. WALTER H. COTTINGHAM, of Montreal, Quebec, trading as WALTER H. COTTINGHAM & CO. Paints, 29th November, 1893.
4803. } HENRY SWAIN & SON, of Montreal, Quebec. Cigars, 30th November,
4804. } 1893.

-
4805. } FRANK JOHN CHENEY, of Toledo, Ohio, U.S.A. Medical Compound,
4806. } 30th November, 1893.
4807. JESSE ASCOUGH, of Handsworth, Stafford County, England. Perfumery,
including Toilet Articles, preparations for the teeth and hair, and
perfumed soap, 30th November, 1893.
4808. GEORGE C. FRYE, of Portland, Maine, U.S.A. Medicine, 30th November
1893.

COPYRIGHTS

Entered during the month of November, 1893, at the Department of Agriculture—
Copyright and Trade Mark Branch.

7102. THE CANADIAN AND EUROPEAN EXPORT CREDIT SYSTEM COMPANY (chart). The U. S. Credit System Co., Newark, N.J., U.S.A., 2nd November, 1893.
7103. COMMERCIAL ARITHMETIC. By John C. P. Frazee, Dartmouth, N.S., 2nd November, 1893.
7104. CALENDRIER DU DIOCÈSE DE QUÉBEC, 1894. Leger Brousseau, Québec, Qué., 2 novembre, 1893.
7105. KAROO GUIDE TO HEALTH (circular). Duncan Shepperd, Toronto, Ont., 2nd November, 1893.
7106. PRIVATE TELEGRAPH CODE. The Steele, Briggs, Marcon Seed Co., Ltd., Toronto, Ont., 2nd November, 1893.
7107. ALWAYS AHEAD (Picture Chart *re* Acme Skates). The Starr Manufacturing Co., Ltd., Halifax, N.S., 3rd November, 1893.
7108. DANCE HILARITY. By Chas. Bohner. Whaley, Royce & Co., Toronto, Ont., 4th November, 1893.
7109. THE EMPIRE RYE. Music by Chas. Bohner. Dance by S. M. Early. Whaley, Royce & Co., Toronto, Ont., 4th November, 1893.
7110. OUR LAND OF PROMISE: A RUN THROUGH THE CANADIAN NORTH-WEST. By Count de Bouthillier-Chavigny, Richelieu, Que., 7th November, 1893.
7111. UNIQUE HOUSEHOLD CALENDAR, 1894. Hunter Gowan, Toronto, Ont., 7th November, 1893.
7112. FORESIGHT. (Game and Rules.) Frederick T. Butler, Toronto, Ont., 7th November, 1893.
7113. FIR GROVE WALTZ. By William Henry Firth. Point St. Charles, Montreal, Que., 7th November, 1893.
7114. PRINCESS MAY'S SLEIGH (photo.) Charles Ledoux, Montreal, Que., 8th November, 1893.
7115. DYNAMITE FOR DOUBTING CASTLE: THE NECESSITY FOR THE TIMES; OR, IS THE JESUIT RIGHT? By "Asinus." The Presbyterian Printing and Publishing Co., Ltd., Toronto, Ont., 8th November, 1893.
7116. DISCOURS DE SIR GEORGE CARTIER, BARONNET, ACCOMPAGNÉS DE NOTICES, par Joseph Tassé. Eusèbe Senécal & fils, Montreal, Qué., 8 novembre, 1893.
7117. PATRIOTIC RECITATIONS AND ARBOUR DAY EXERCISES. George W. Ross, LL.D., Minister of Education, Ontario. Warwick Brothers & Rutter, Toronto, Ont., 8th November, 1893.
7118. IF 'TIS A DREAM. Waltz adapted from Marion Manola's Song. Arranged by Edward Franz. Whaley, Royce & Co., Toronto, Ont., 8th November, 1893.
7119. MAP OF THE COUNTY OF YORK. Corrected to Date by the Clerks of the Different Municipalities. The Alexander & Cable Lithographing Co., Ltd., 9th November, 1893.
7120. DANCING STILL AT 3 A.M. Schottische. By W. E. Cadwallader. W. N. Billing, Toronto, Ont., 9th November, 1893.
7121. I HEARD THE VOICE OF JESUS SAY. Sacred Song. Words by H. Bonar. Music by Horace W. Reyner, A. C. O. I. Suckling & Sons, Toronto, Ont., 10th November, 1893.
7122. COMPTABILITÉ DES BEURRERIES ET FROMAGERIES (Carnet du Patron). J. de L. Taché, Québec, Qué., 11 novembre, 1893.
7123. COMPTES DE LAIT POUR FROMAGERIES ET BEURRERIES (Carnet). J. de L. Taché, Québec, Qué., 11 novembre, 1893.
7124. HONOURABLE SIR JOHN S. D. THOMPSON. (Lithographed photo.) William Delaney, Halifax, N.S., 11th November, 1893.

7125. SET MY HEART AT REST. Song. Words by G. P. Darnell Smith. Music by Mabel Hadrill. The Anglo-Canadian Music Publishers' Association, Ltd., London, England, 13th November, 1893.
7126. TORONTO SATURDAY NIGHT, CHRISTMAS, 1893. The Sheppard Publishing Co., Ltd., Toronto, Ont., 13th November, 1893.
7127. CHANCES OF SUCCESS. By Erastus Wiman. Frederick Reesor James, Toronto, Ont., 14th November, 1893.
7128. THE MINERAL INDICATOR. A Practical Guide to the Determination of Generally Occurring Minerals. By E. J. Chapman, Ph. D., LL.D. (Second Edition). The Copp, Clark Co., Ltd., Toronto, Ont., 14th November, 1893.
7129. A BITTER DEBT. A Tale of the Black Country. By Annie S. Swan. William Briggs (Book Steward of the Methodist Book and Publishing House), Toronto, Ont., 15th November, 1893.
7130. THE CANADIAN ALMANAC AND REPOSITORY OF USEFUL INFORMATION FOR 1894. The Copp, Clark Co., Ltd., Toronto, Ont., 16th November, 1893.
7131. COUPON INSURANCE TICKET. Allen Edward Woodcock, Toronto, Ont., 16th November, 1893.
7132. TRANSFER TICKETS. Richard Makilwaine Phipson and Byron Ladu Kennedy, Toronto, Ont., 16th November, 1893.
7133. FOR GOD AND HOME AND NATIVE LAND. Words and Music by John M. Whyte, Toronto, Ont., 16th November, 1893.
7134. THE CANADIAN ICE AGE. By Sir J. William Dawson, C.M.G., &c. William V. Dawson, Montreal, Que., 20th November, 1893.
7135. MODULATION SKETCH (as played by the Pianist "Blind Tom.") By Geo. W. Strathy. I. Suckling & Sons, Toronto, Ont., 21st November, 1893.
7136. MARY. Song by Theo. H. Northrup. Whaley, Royce & Co., Toronto, Ont., 22nd November, 1893.
7137. OLAS DEL PACIFICA (Waves of the Pacific) Waltzes for Piano, by Theo H. Northrup. Whaley, Royce & Co., Toronto, Ont., 22nd November, 1893.
7138. THE RAILROAD EMPLOYEES' COMPLETE TIME-BOOK. George M. Morrison, Toronto Junction, Ont., 22nd November, 1893.
7139. PRACTICAL MENSURATION for Colleges, Schools &c., by Christopher Alexander Fleming, Owen Sound, Ont., 22nd November, 1893.
7140. THE LIFE OF JAMES O'MALLEY, late of the 17th Leicester Royal Bengal Tigers. James O'Malley, Montreal, Que., 24th November, 1893.
- 7141 } PHOTOGRAPHIES DE Mgr. P. S. Larocque. L. A. Choquet, St. { A
7142 } Hyacinthe, 24th November, 1893. { B
7143 } { C
7144. THE CHURCH OF ENGLAND IN CANADA, 1759-1793, by H. C. Stuart, M.A., Rector of Three Rivers, Que., 24th November, 1893.
7145. THE DES BRISAY ANALYTICAL LATIN METHOD. Part I. Charles T. Des Brisay, Toronto, Ont., 25th November, 1893.
7146. THE ONTARIO REPORTS. VOLUME XXIII. The Law Society of Upper Canada, Toronto, Ont., 27th November, 1893.
7147. BLOWPIPE PRACTICE, by E. J. Chapman. Ph. D., LL.D. The Copp, Clark Co., Ltd., Toronto, Ont., 29th November, 1893.
7148. A ROMANTIC ROMANCE, by Carrie J. Harris, Wolfville, N.S., 30th November, 1893.
7149. 20 CHANSONS POPULAIRES DU CANADA, par Ach. Fortier. Edmond Hardy, Montreal, Que., 30th November, 1893.

INDEX OF INVENTIONS.

Alcohol from liquor casks. Method of and apparatus for recovering waste from. Michael Hickey	44,688	Gas. Method of making illuminating. William Young, et al.	44,670
Arc lamp. Louis E. Howard	44,675	Generator for steam. Patrick Fitzgibbons, et al.	44,682
Axle box. Aaron H. Sensenig, et al.	44,598	Glove. Julius Hamburger.	44,740
Axle for carriages. Joseph Ledoux	44,788	Gram. Apparatus for steaming. Herbert S. Jewell.	44,649
Bearing: see Thrust bearing.		Grip: see Rope grip.	
Bed-bottom. George G. Baker, et al.	44,790	Guitar. James S. Back, et al.	44,692
Bicycle. Friderich Wiehard.	44,639	Gutta percha and rubber. Method of compounding. Robert Hutchison.	44,654
Bicycle brake. William S. Porter	44,791	Harness ring. Mortimer C. Flack.	44,633
Binder: see Temporary binder.		Harvester. George W. Scott.	44,746
Boot and shoe. James F. Sharpe	44,732	Harvester elevator. Andrew Stark	44,753
Boots and shoes. Machine for uniting the soles and uppers of. William Carey	44,772	Heater: see Gas heater.	
Boring apparatus: see Rock-boring apparatus.		Heating apparatus. Beniah M. Dunson.	44,715
Box. Joseph S. Bennett.	44,777	Heating, cooling and ventilating system. Joseph H. Brady.	44,700
Brake. William T. Bothwell.	44,782	Hinge: see Spring hinge.	
Brake for children's carriages. Frederick O. Boes.	44,792	Holder for animals. John W. Ziellenbach	44,642
Brake for railway cars. Henry F. Braun	44,666	Holder for tags. Charles E. Stowe.	44,738
Bread slicing mechanism. Joseph Fallows.	44,707	Hook: see Garment hook.	
Bridle bit. George S. Parsons.	44,616	Hook and eye. Heinrich Mentzel	44,644
Brush: see Horse brush. Rotary brush.		Horse brush. Sophia Giesecke.	44,701
Brush for cleaning chimneys. Alexander J. Fludder, et al.	44,679	Horse-shoe blanks. Machine for forming. John D. Billings	44,630
Brushes. Drying attachment for scrubbing. John S. McGuire, et al.	44,743	Hose coupler. Gardner D. Hiscox	44,662
Brushes. Machine for gauging knots of bristles for. Hypolite Besson.	44,711	Ice cream freezer. James Foster	44,646
Buckle. George M. Aylsworth.	44,624	Ice velocipede. Earl E. Gould.	44,794
Butter and condensed milk. Apparatus for making. William B. Walters	44,755	Kilm. Max A. T. Boehncke	44,615
Cabinet. Charles W. Davis, et al.	44,775	Ladder. James S. Burgess.	44,727
Can. John Zimmerman	44,653	Lawn mower. William A. Schofield, et al.	44,742
Can. Samuel N. Long	44,718	Life raft. George B. Hussey	44,626
Can opener. Charles Morgan, et al.	44,659	Locomotives. Blast pipe for. Christian Erdbrink	44,705
Carburetor. John Clingman.	44,694	Logs down rivers. Means for guiding. Jasper Finney, et al.	44,668
Carpet sweeper. Walter J. Drew	44,722	Loom shuttle. Stephen M. Hamblin, et al.	44,629
Car brakes. Adjuster for railway. Howard Hinckley	44,766	Matches. Method of making. Charles M. Bowman.	44,613
Car coupler. Edward B. Hyre	44,760	Mattress. Seth Curlin	44,704
Car coupler. Lester B. Kenney	44,618	Medicinal compound. Antoine Racicot	44,664
Car coupler. William H. Crackell, et al.	44,769	Medicinal compound. William H. Greer	44,779
Car coupler and car brake. François V. Isoire.	44,752	Metals from ores. Method of extracting. Hugh Calhoun, et al.	44,771
Chain coupler. Cyrus F. Noble.	44,658	Milking machine. Robert Ferguson	44,778
Churn. Thomas F. Hood, et al.	44,789	Mill for cutting grain. George A. Engle	44,656
Coating for wall paper, &c. John Walker, et al.	44,620	Moulding machine. Presser foot for. Frederick L. Creighton, et al.	44,741
Coffee steeper. George E. Overman.	44,627	Mop. Washington T. Triphagen, et al.	44,790
Coffee. Substitute for. Heinrich Trillich.	44,636	Mordant. William T. Whitehead, et al.	44,596
Collar coupler. John Jones, et al.	44,609	Motor: see Wind motor.	
Confectioner's machine. Daniel M. Holmes.	44,673	Multiplex glass tube. Patrick J. McElroy	44,735
Corset. Minna Meyer.	44,640	Musical instrument. James S. Back, et al.	44,634
Coupler for pump rods. Frederick C. Blackwell	44,795	Non-conducting covering. Robert H. Martin.	44,638
Cover for jars. Thomas E. Ogram.	44,612	Nut lock. Joseph W. Hester	44,793
Cultivator. William L. Nieman, et al.	44,761	Ore. Apparatus for classing pulverized. Gustav Henoch, et al.	44,758
Curtain fixtures. Albert W. Herr, et al.	44,720	Ore crusher. John T. Crawford.	44,759
Damper. William H. Packham	44,660	Ores. Method of extracting gold and silver from. John S. MacArthur, et al.	44,621
Damper for furnaces. Peter St. Mary	44,607	Ores. Method of treating gold and silver. Edward D. Kendall.	44,757
Damper for stove pipes. Charles T. Redfield.	44,739	Oysters. Apparatus for opening. Frederick L. Wanklyn.	44,623
Discharge for aniline black. William T. Whitehead, et al.	44,604	Packing machine. Evert McL. Thompson.	44,672
Door check. Tertullus S. Doblin	44,765	Painting machine for fabric. John L. Armitage.	44,721
Drain for stalls. Henry Schiffer	44,708	Pea threshing machine. Cecil E. Paterson	44,767
Dredge. William Brooks.	44,622	Peat briquettes. Method of and apparatus for producing. Emanuel Stauber.	44,645
Dress stay. Frederick W. Lyon	44,619	Pipe bending machine. Orville H. Lawrence, et al.	44,603
Drill press. Jacob N. Barr	44,728	Pipe elbow. Orville H. Lawrence.	44,602
Driving belt. Henry Sewrey	44,751	Plaster. Rudolf Bammann	44,655
Electrode for arc lamps. Albert C. Siebald, et al.	44,632	Playing card. Thomas H. Cole, et al.	44,647
Electrolytic apparatus. Thomas Craney	44,697	Pneumatic tyre. John S. Smith.	44,695
Elevator. Alonzo B. See, et al.	44,696	Pneumatic tyre. Walter Sherbondy.	44,744
Elevators. Shifting device for. James Flemming.	44,787	Pocket. Arthur T. Cozens	44,674
Engine. James Roots.	44,671	Press. Frederick L. H. Sims	44,608
Engine. Rudolf Diesel.	44,611	Pressure regulator. Edward E. Gold.	44,784
Engineer's brake valve. William T. Bothwell	44,783	Printer's lock-up. Samuel Starrett.	44,678
Explosive. Francis G. Du Pont, et al.	44,781	Projectile. Daniel B. Wesson.	44,736
Face protector. Carl Gumesen	44,683	Propeller. Alexander D. Hall, et al.	44,665
Fibre from bast and wood. Method of making. Adolf Torngren.	44,749	Protioxide of copper. Method of producing. Carl Hoepfner.	44,745
Fifth wheel. Alfred H. Worrest.	44,595	Pumps. Valve attachment for. Oscar E. Beardley	44,762
Firearms. Ole H. J. Krag, et al.	44,614	Raft: see Life raft.	
Firearms. Peter H. Finnegan	44,648	Recorder for workmen's time. Alphonse L. Jaynes, et al.	44,601
Fire bar. Carl Möhring.	44,643	Reel: see Wire reel.	
Fire escape: see Water tower and fire escape.		Reel for wire working machines. Clarence O. White, et al.	44,774
Flour bolt. William D. Gray	44,729	Regulator: see Pressure regulator.	
Flushing apparatus for urinals. William Clark	44,797	Resist against aniline black. William T. Whitehead, et al.	44,605
Food. Process of preparing. Heinrich L. C. Paulsen.	44,637	Rock-boring apparatus. Carl Hoffmann.	44,689
Fruit. Machine for slicing. Samuel S. Arnold	44,610	Rope grip. Arthur K. Evans	44,737
Furnace. George R. Scates, et al.	44,770	Rotary brush. Henry G. Rockwell	44,768
Furnace. Hugh Calhoun, et al.	44,726	Roundabout. William Somers.	44,667
Furnace. James V. Burke	44,625	Salts. Electrolysis of metallic. Thomas Craney	44,698
Garment hook. George B. Mershon, et al.	44,690	Salts. Electrolysis of mineral. James Hargreaves, et al.	44,677
Gas. Apparatus for making. Alexander C. Humphreys.	44,734	Salts. Method of producing basic lead. George Lunge, et al.	44,652
Gas generator. Hugh W. Williams	44,663	Scourer for wheat. George V. Dixon	44,685
Gas heater. Frank P. Ziegler	44,714		

Seamless leather articles. Friend J. Bringham.....	44,661	Bettendorf, William P. Wagon frame.....	44,702
Secondary battery. William Main.....	44,747	Billings, John D., et al. Machine for forming horse-shoe blanks.....	44,630
Sewing machine. George H. Colley.....	44,691	Bird, Thomas, et al. Electrolysis of mineral salts.....	44,677
Sewing machine. William H. H. Tracey, et al.....	44,687	Bissell Carpet Sweeper Co. Carpet sweeper.....	44,722
Shaft support and anti-rattler. William Cavers.....	44,754	Blackwell, Frederick C. Coupler for pump rods.....	44,795
Shingle. Herbert W. Kincaid.....	44,650	Blandy, Alfred A. Substitute for india-rubber and leather.....	44,676
Shirt. John Allan.....	44,699	Bliss, Aron P., et al. Car coupler.....	44,769
Shoe tip. George W. Dixon.....	44,635	Boehnecke, Max A. T. Kiln.....	44,615
Shuttle: see Loom shuttle.		Boes, Frederick O. Brake for children's carriages.....	44,792
Signal for railways. George C. Young, et al.....	44,693	Bommer Brothers. Spring hinge.....	44,710
Siphon. Richard Wegner.....	44,651	Bommer, Lorenz. Spring hinge.....	44,710
Sleigh. John C. West.....	44,748	Bothwell, William T. Brake.....	44,782
Smoke purifier. Edward E. Dulier.....	44,681	Bothwell, William T. Engineer's brake valve.....	44,783
Snow plow. Thomas C. MacAdam.....	44,706	Bowman, Charles M. Method of making matches.....	44,613
Speed regulator for engines. John Prentice.....	44,756	Bradford, Eli B. Stock for holding horses while being shod.....	44,680
Spike. William R. Funk, et al.....	44,631	Brady, Joseph H. Heating, cooling and ventilating system.....	44,700
Spindle attachment. Leonard W. Huyck, et al.....	44,657	Braun, Henry F. Brake for railway cars.....	44,666
Spring hinge. Lorenz Bommer.....	44,710	Bringham, Friend J. Seamless leather articles.....	44,661
Steam engine. Jay W. Powers.....	44,733	Brooks, William. Dredge.....	44,622
Steeper: see Coffee steeper.		Buchanan, John W. Wire reel.....	44,628
Stock for holding horses while being shod. Eli B. Bradford.....	44,680	Burgess, James S. Ladder.....	44,727
Stopper for bottles. Harry B. Stewart, et al.....	44,712	Burke, James V. Furnace.....	44,625
Stove. William F. A. Külle.....	44,641	Calhoun, Hugh, et al. Furnace.....	44,726
Stump puller. Adams C. French.....	44,763	Calhoun, Hugh, et al. Method of extracting metals from ores.....	44,771
Substitute for india-rubber and leather. Alfred A. Blandy.....	44,676	Callaghan, William S., et al. Tire.....	44,719
Sulphide of nickel. Process of obtaining pure. John L. Thompson.....	44,798	Cameron, Alexander. Flushing apparatus for urinals.....	44,797
Sulphide of nickel. Process of obtaining pure. Robert M. Thompson.....	44,723	Carey, William. Machine for uniting the soles and uppers of boots and shoes.....	44,772
Sulphuric acid. Method of and apparatus for making. Frederick J. Falding.....	44,684	Carson, John H. Hose coupler.....	44,662
Surgical instrument. Alexander Dallas.....	44,669	Carver, Harry, et al. Coating for wall paper, &c.....	44,620
Table. Horace H. Bailey.....	44,724	Carvers, William. Shaft support and anti-rattler.....	44,754
Tanning pelts. Process of. Edward Conlin.....	44,725	Clark, William, et al. Flushing apparatus for urinals.....	44,797
Telephone. Christian H. Dorenwend.....	44,796	Cleaveland, John B. Wire.....	44,786
Telephone. Hammond V. Hayes, et al.....	44,606	Cleaveland, John B. Wire braiding machine.....	44,785
Temporary binder. Frank D. Hastings, et al.....	44,600	Clingman, John. Carburator.....	44,694
Threshing machine: see Pea threshing machine.		Cole, Thomas A., et al. Playing card.....	44,647
Thrust bearing for shafts. John Doty, et al.....	44,776	Colleg, George H. Sewing machine.....	44,691
Thrust bearing for shafts. Simon Ingersoll.....	44,764	Coulin, Edward. Process of tanning pelts.....	44,725
Trap for animals. Newton J. Tanner, et al.....	44,773	Consolidated Manufacturing Company. Machine for gauging knots of bristles for brushes.....	44,711
Tube: see Multiplex glass tube.		Cotter, Thomas R., et al. Car coupler.....	44,769
Tire. Edward H. Seddon.....	44,717	Cowan, William G., et al. Car coupler.....	44,769
Tire. William S. Callaghan, et al.....	44,719	Cozens, Arthur T. Pocket.....	44,674
Tires on wheels. Method of tightening. William T. Mackey.....	44,617	Crackel, William H., et al. Car coupler.....	44,769
Valve: see engineer's brake valve.		Craney, Thomas. Electrolytic apparatus.....	44,697
Vault. Adam N. Hutt, et al.....	44,597	Craney, Thomas. Electrolysis of metallic salts.....	44,698
Velocipede: see Ice velocipede.		Cranford, John T. Ore crusher.....	44,759
Wagon frame. William P. Bettendorf.....	44,702	Creighton, Frederick L., et al. Presser foot for molding machines.....	44,741
Warming pan. Joseph Barton, et al.....	44,599	Curlin, Seth. Mattress.....	44,704
Water tower and fire escape. Frank M. Hughes.....	44,750	Dallas, Alexander. Surgical instrument.....	44,669
Weaving machine for cane. Charles W. Greenwood.....	44,713	Damon, Edwin, et al. Loom shuttle.....	44,629
Wind motor. George E. Moore.....	44,703	Dankss, Aron T., et al. Milking machine.....	44,778
Wire. John B. Cleaveland.....	44,786	Davidson, George, et al. Means for guiding logs down rivers.....	44,668
Wire-braiding machine. John B. Cleaveland.....	44,785	Davis, Charles W., et al. Cabinet.....	44,775
Wire reel. John W. Buchanan.....	44,628	Dennis, Charles W. Telephone.....	44,796

INDEX OF PATENTEES.

Allan, John. Shirt.....	44,699	Dorenwend, Christian H. Telephone.....	44,796
Allen, Ethan, et al. Spindle attachment.....	44,657	Doty, John and Louise J. Thrust bearing for shafts.....	44,776
Alexander, George W., et al. Machine for forming horse-shoe blanks.....	44,630	Drew, Walter J. Carpet sweeper.....	44,722
American Shoe Tip Company. Shoe tip.....	44,635	Dulier, Edward E. Smoke purifier.....	44,681
Armitage, John L. Painting machine for fabric.....	44,721	Dunson, Beniah M. Heating apparatus.....	44,715
Arnold, Samuel S. Machine for slicing fruit.....	44,610	Dupee, Henry, et al. Discharge for aniline black.....	44,604
Aylsworth, George M. Buckle.....	44,624	Dupee, Henry D., et al. Mordant.....	44,596
Back, James S., et al. Guitar.....	44,692	Dupee, Henry D., et al. Resist against aniline black.....	44,605
Back, James S., et al. Musical instrument.....	44,634	Du Pont, Francis G. Explosive.....	44,709
Baker, George G., et al. Bed bottom.....	44,790	Du Pont, Francis G. and Pierre S. Explosive.....	44,780
Baker, George W., et al. Mop.....	44,799	Durand, Oscar N., et al. Temporary binder.....	44,600
Bailey, Horace H. Table.....	44,724	Eason, Henry K., et al. Generator for steam.....	44,682
Ball, John H., et al. Recorder for workmen's time.....	44,601	Edgar, David, et al. Warming pan.....	44,599
Banumann, Rudolf. Plaster.....	44,655	Ellis, Charles J., et al. Method of extracting gold and silver from ores.....	44,621
Barr, Jacob N. Drill press.....	44,728	Ellsworth, Prosper H., et al. Furnace.....	44,726
Barton, Joseph, et al. Warming pan.....	44,599	Ellsworth, Prosper H., et al. Method of extracting metals from ores.....	44,771
Beam, Aaron M., et al. Furnace.....	44,726	Engle, George A. Mill for chopping grain.....	44,656
Beam, Aaron M., et al. Method of extracting metals from ores.....	44,771	Erdbrink, Christian. Blast pipe for locomotives.....	44,705
Beardsley, Oscar E. Valve attachment for pump.....	44,762	Evans, Arthur K. Rope grip.....	44,737
Beemer, John B., et al. Drying attachment for scrubbing brushes.....	44,743	Exelmans, Edmond M. C., et al. Apparatus for classing pulverized ore.....	44,758
Bell, Alexander, et al. Method of making illuminating gas. Bell Telephone Company of Canada. Telephone.....	44,670	Falding, Frederic J. Method of and apparatus for making sulphuric acid.....	44,684
Bennett, Joseph S. Box.....	44,777	Fallows, Joseph. Bread slicing mechanism.....	44,707
Besson, Hypolite. Machine for gauging knots of bristles for brushes.....	44,711		

Ferguson, Robert, et al. Milking machine	44,778	Mohring, Carl. Firebar	44,643
Field, John, et al. Cabinet	44,775	Moore, George E. Wind Motor	44,703
Finnegan, Peter H. Firearms	44,648	Morgan, Charles, et al. Can opener	44,659
Finney, Jasper, et al. Means for guiding logs down rivers	44,668	National Key Opening Can Company. Can	44,653
Fitzgibbons, Patrick, et al. Generator for steam	44,682	Nieman, William L., et al. Cultivator	44,761
Flack, Mortimer and John G., et al. Harness ring	44,633	Noble, Cyrus F. Chain coupler	44,658
Flemming, James. Shifting device for elevators	44,787	Nordyke & Marmon Company. Packing machine	44,672
Fludder, Alexander J., et al. Brush for cleaning chimneys	44,679	Orgram, Thomas E. Cover for jars	44,612
Foster, James. Ice cream freezer	44,646	Orford Copper Company. Process of obtaining pure sulphide of nickel	44,723, 44,798
Foster, Jesse C., et al. Presser foot for moulding machine	44,741	Orme, George L., et al. Guitar	44,692
French, Adams C. Stump puller	44,763	Orme, George L., et al. Musical instrument	44,634
Funk, William R., et al. Spike	44,631	Overman, George E. Coffee steeper	44,627
Giesecke, Sophia. Horse brush	44,701	Packham, William H. Damper	44,660
Gold, Edward E. Pressure regulator	44,784	Parsons, George S. Bridle bit	44,616
Gould, Earl E. Ice velocipede	44,794	Paterson, Cecil E. Pea threshing machine	44,767
Gray, William D. Flour bolt	44,731	Paulsen, Heinrich L. C. Process of preparing food	44,637
Greenwood, Charles W. Weaving machine for cane	44,713	Perkins, Josiah P., et al. Playing card	44,647
Greer, William H. Medicinal compound	44,779	Porter, William S. Bicycle brake	44,791
Gross, Daniel, et al. Harness ring	44,633	Powers, Jay W. Steam engine	44,733
Gumeson, Carl. Face protector	44,683	Prentice, John. Speed regulator for engines	44,656
Hall, Alexander D., et al. Screw propeller	44,665	Racicot, Antoine. Medicinal compound	44,664
Hamblin, Stephen M., et al. Loom shuttle	44,629	Raymond, Charles H., et al. Electrode for arc lamps	44,632
Hamburger, Julius. Glove	44,740	Redfield, Charles T. Damper for stove pipes	44,739
Hargreaves, James, et al. Electrolysis of mineral salts	44,677	Richards, Wilton L., et al. Telephone	44,606
Hastings, Frank D., et al. Temporary binder	44,600	Rochon, Isaac, et al. Temporary binder	44,600
Hayes, Hammond V., et al. Telephone	44,606	Rockwell, Henry G. Rotary brush	44,768
Henock, Gustave, et al. Apparatus for classing pulverized ore	44,758	Rogers, Elbert S., et al. Furnace	44,770
Henry, William, et al. Vault	44,597	Roots, James. Engine	44,671
Herr, Albert W., et al. Curtain fixture	44,720	Rudell, James H., et al. Machine for forming horse-shoe blanks	44,630
Hertel, John A. Telephone	44,796	Scates, George R., et al. Furnace	44,770
Hester, Joseph W. Nut lock	44,793	Schiffer, Henry. Drain for stalls	44,708
Hickey, Michael. Method of and apparatus for recovering waste alcohol from liquor casks	44,688	Schofield, William A., et al. Lawn mower	44,742
Hieronimus, William, et al. Cultivator	44,761	Schwer, Theodore, et al. Stopper for bottles	44,712
Hinckley, Howard. Adjuster for railway car brakes	44,766	Scott, George W. Harvester	44,746
Hiscox, Gardner D. Hose coupler	44,662	Serwen, Jeremiah A., et al. Sewing machine	44,687
Hoepfner, Carl. Method of producing proloxide of copper	44,745	Seddon, Edward H. Tire	44,717
Hoffman, Carl. Rock-boring apparatus	44,689	See, Alonzo B., et al. Elevator	44,696
Holloway, Charles T., et al. Tire	44,719	Senseney, Aaron H., et al. Axle box	44,598
Holmes, Daniel M. Confectioner's machine	44,673	Sewrey, Henry. Driving belt	44,751
Hood, Thomas F., et al. Churn	44,789	Sharpe, James F. Boot and shoe	44,732
Horst, Samuel W., et al. Axle box	44,598	Sherbondy, Walter. Pneumatic tire	44,744
Howard, Louis E. Arc lamp	44,675	Siebold, Albert C., et al. Electrode for arc lamps	44,632
Hughes, Frank M. Water tower and fire escape	44,750	Sims, Frederick L. H. Press	44,608
Humphreys, Alexander C. Apparatus for making gas	44,734	Sisson, Francis M., et al. Brush for cleaning chimneys	44,679
Hussey, George B. Life raft	44,626	Sloan, George B., et al. Propeller	44,665
Hutchinson, Robert. Method of compounding gutta-percha and rubber	44,654	Smith, John S. Pneumatic tire	44,695
Hutt, Adam N., et al. Vault	44,597	Smith, William G., et al. Churn	44,789
Huyck, Leonard W., et al. Spindle attachment	44,657	Somers, William. Roundabout	44,667
Hyer, Edward B. Car coupler	44,760	Stark, Andrew. Harvester elevator	44,753
Ingersoll, Simon. Thrust bearing for shafts	44,764	Starrett, Samuel. Printer's lock-up	44,678
Isoire, François V. Car coupler and brake	44,752	Staubert, Emanuel. Method of and apparatus for producing peat briquettes	44,645
Jaynes, Alfonso L., et al. Recorder for workmen's time	44,601	Stewart, Harry B., et al. Stopper for bottles	44,712
Jewell, Herbert S. Apparatus for steaming grain	44,649	Stowe, Charles E. Holder for tags	44,738
Jones, John, et al. Collar coupler	44,609	St. Mary, Peter. Damper for furnace	44,607
Jorgensen, Erik, et al. Firearms	44,614	Sussex, John, et al. Collar coupler	44,609
Kendall, Edward D. Method of treating gold and silver ores	44,757	Taft, Willis P. Drying attachment for scrubbing brushes	44,743
Kenney, Lester B. Car coupler	44,618	Tanner, Newton J., et al. Trap for animals	44,773
Kincaid, Herbert W. Shingle	44,650	Thayer, Linus H., et al. Can opener	44,659
Kirk, Charles. Flushing apparatus for urinals	44,797	Thompson, Evert McL. Packing machine	44,672
Külle, William F. A. Stove	44,641	Thompson, Robert M. Process of obtaining pure sulphide of nickel	44,723
Kray, Ole H. J., et al. Firearms	44,614	Thompson, John L. Process of obtaining pure sulphide of nickel	44,798
Lash, Tito M., et al. Playing card	44,647	Tomgren, Adolf. Method of treating bast and wood to obtain fibre therefrom	44,749
Lawrence, Orville H. Pipe elbow	44,602	Tousey, Rinaldo C., et al. Sewing machine	44,687
Lawrence, Orville H., et al. Pipe binding machine	44,603	Tracy, William H. H., et al. Sewing machine	44,687
Ledoux, Joseph. Axle for carriages	44,788	Trillich, Heinrich. Substitute for coffee	44,636
Lee, James H., et al. Trap for animals	44,773	Triphagen, Washington T., et al. Mop	44,799
Legendre, Alphonse, et al. Temporary binder	44,600	Tyler, Walter L., et al. Elevator	44,696
Letts, Ellsworth M., et al. Pipe bending machine	44,603	Universal Lock and Stopper Company. Stopper for bottles	44,712
Lincoott, Thomas S., et al. Lawn mower	44,742	Van Auken, Willis G., et al. Car coupler	44,769
Lloyd, Marshall B., et al. Reel for wire working machines	44,774	Van Derveer, Emma H. and John R. Confectioner's machine	44,673
Long, Isaac N. Curtain fixture	44,720	Walker, John, et al. Coating for wall paper, &c	44,620
Long, Samuel N. Can	44,718	Walters, William B. Apparatus for making butter and condensed milk	44,755
Long, S. N., Syrup Company. Can	44,718	Wanich, John N., et al. Bed bottom	44,790
Lunge, George, et al. Method of producing basic lead salts	44,652	Wanklyn, Frederick L. Apparatus for opening oysters	44,623
Lyon, Frederick W. Dress stay	44,619	Weeks-Colley Manufacturing Company. Sewing machine	44,691
Lyte, Cecil H., et al. Method of producing basic lead salts	44,652	Wegner, Richard. Siphon	44,651
MacAdam, Thomas C. Snow plow	44,706	Wesson, Daniel B. Projectile	44,736
MacArthur, John S., et al. Method of extracting gold and silver from ores	44,621	West, John C. Sleigh	44,748
Mackey, William T. Method of tightening tires on wheels	44,617	White, Clarence O., et al. Reel for wire working machines	44,774
Main, William. Secondary battery	44,747	Whitehead, William T., et al. Discharge for aniline black	44,604
Martin, Robert H. Non-conducting covering	44,638	Whitehead, William T., et al. Mordant	44,596
McElroy, Patrick J. Multiplex glass tube	44,735	Whitehead, William T., et al. Resist against aniline black	44,605
McEuen, Seth H., et al. Can opener	44,659	Wichard, Friedrich. Bicycle	44,639
McGuire, John S., et al. Drying attachment for scrubbing brushes	44,743	Willever, George O. Signal for railways	44,693
Mentzel, Heinrich. Hook and eye	44,644	Williams, Hugh W. Gas generator	44,663
Mershon, George B. and George B., junr. Garment hook	44,690		
Meyer, Minna. Corset	44,640		

Williams Manufacturing Company. Cabinet.....	44,775	Ziegler, Frank P. Gas heater.....	44,714
Worrest, Alfred H. Fifth wheel.....	44,595	Ziellenback, Johann W. Holder for animals.....	44,642
Young, George C., et al. Signal for railways.....	44,693	Zimmermann, John. Can.....	44,653
Young, William, et al. Method of making illuminating gas.....	44,670		