

# THE GRAIN GROWERS' GUIDE

AND FRIEND OF LABOUR

A WEEKLY NEWS RECORD AND  
REVIEW OF EVENTS AND OPINIONS

At last the Manipulations of the Terminal Elevators have been Proven and the Manipulating Companies have been Fined. But the End is Not Yet.



**EQUITY**

"BUT CROWN HER QUEEN  
AND EQUITY SHALL USHER IN  
FOR THOSE WHO BUILD  
AND THOSE WHO SPIN  
AND THOSE THE GRAIN WHO GARNER IN  
A BRIGHTER DAY"

MAY 4th, 1910

Volume II.

## CONTENTS

Number 40

### EDITORIAL

The Terminal Elevator Investigation	5
The Chilled Meat Proposition	6

### SPECIAL ARTICLES

Canada's Pork Industry	7
Railways and Farmers, by E. J. Fream	8
Labor and Capital, by F. W. Green	9
Farmers' Party Needless, by John Kennedy	10
Millionaire Hustled and Hooted	23
A Cannon for Hail	26

### MAIL BAG

The Crisis, by W. D. Lamb	13
Criticizes Convention Resolutions, by Edwin Jacob	14
The Tariff Robbery, by R. Nourse	14
The Hudson Bay Road, by Lawrence Galt	14
Suggests a Board, by H. L. Power	14

### DEPARTMENTS

Alberta Section (Bulls Running at Large)	16-17
Saskatchewan Section (Sask. Executive and Elevator Commission)	20-21
Manitoba Section	24
Around the Fireside (What Women are Doing)	28-29
Sunshine Guild	27
Question Drawer	22
Graft in Terminal Elevators	31-32
Grain, Livestock and Produce Market	33-34

# THE CANADIAN BANK OF COMMERCE

HEAD OFFICE, TORONTO

CAPITAL, \$10,000,000 REST, \$6,000,000

B. E. WALKER, President      ALEXANDER LAIRD, General Manager  
A. H. IRELAND, Superintendent of Branches

BRANCHES IN EVERY PROVINCE OF CANADA AND IN THE UNITED STATES AND GREAT BRITAIN

### BRANCHES IN MANITOBA

BRANDON	ELKHORN	RIVERS
CARMAN	GILBERT PLAINS	SWAN RIVER
DAUPHIN	GRANDVIEW	TREHERNE
DURBAN	NEEPAWA	WINNIPEG
ELGIN	PORTAGE LA PRAIRIE	

## SAVINGS BANK DEPARTMENT

A Savings Bank Department will be found at the branches of the Bank in Canada. Deposits of \$1 and upwards are received and interest is allowed at current rates. The depositor is subject to no delay in the withdrawal of the whole or any portion of the deposit. Accounts may be opened in the names of two or more persons and withdrawals made by any one of the number or by the survivor.

**\$656,000 Subscribed Capital \$656,000**

Cash Deposits with Three Provincial Governments

## HAIL INSURANCE

It is Every Man's Privilege to carry his own risk and save the insurance premium, but why pay a premium and still carry the risk?

We Offer insurance that has been on trial for TEN YEARS in Manitoba and Saskatchewan and it shows an unbroken record of loss claims PAID IN FULL to which thousands of satisfied insurers will bear witness.

Why Experiment with something that is on record as having failed whenever put to the test of a bad hail season, or with the NEW and UNTRIED METHODS of Companies having little or no knowledge of Hail Insurance.

OURS is not cheap insurance, but an article that CAN BE DEPENDED UPON, and the price is reasonable.

THE CENTRAL CANADA INSURANCE CO. - Brandon, Man.  
THE SASKATCHEWAN INSURANCE CO. - Regina, Sask.  
THE ALBERTA-CANADIAN INSURANCE CO., Edmonton, Alta.

### INSURANCE AGENCIES LIMITED

GENERAL AGENTS - WINNIPEG, BRANDON, REGINA

LOCAL AGENTS in all districts

Will be pleased to quote rates and furnish other information

Money to Loan      Write for Prices      Fire Insurance

CEDAR :: POSTS IN CAR.  
TAMARAC      LOTS :: :

Jno. M. Chisholm, Tribune Building, Winnipeg

Do not forget to mention Paper.

# TROUT BROS.

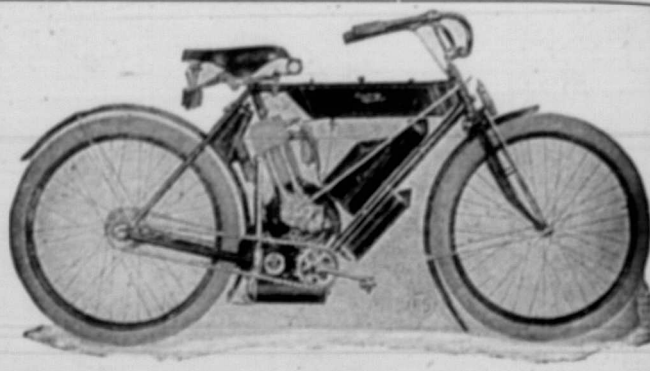

## Model 5

Reading Standard Single Cylinder 3 h.p.

Speed 5 to 50 Miles an hour      Grip control

### PRICE

With Battery Ignition - \$300  
,, Magneto (Bosch) - \$325

### Showrooms

Central Garage, Water Street

WRITE FOR 1910 CATALOGUE      Phone 286

## "GALT" STEEL SHINGLES

acknowledged the most satisfactory

## METAL ROOFING

# Why?

THEY are perfectly locked on four sides  
THEY have two nailing edges, and all nail heads are covered  
THEY have a continuous lock at bottom  
THE concealed gutter is closed at top

**DUNN BROTHERS**  
WINNIPEG      and      REGINA

The Best Sign that THE GUIDE is wanted regularly by its readers is found in the fact that, despite the present busy season, when every farmer has so much to think of, renewals of subscriptions continue to come in in large numbers daily. This is only what is right when you consider the value of the paper compared with that of a few minutes' time and a postage stamp. Don't be too busy to look after your own business, and if your renewal is due mail up the first time you are in town.

### PRUNES

All choice California Stock, medium size, running from 80 to 90 prunes to the pound. A rare value in view of last week's advance in price.

Per 25 lb. box ..... **\$1.47**

### TOMATOES

Choice goods ..... **.58**

6 Cans. .... for **.58**

### VILLAGE BISCUITS

Like an Arrowroot

6 lbs. .... for **.50**

### CATSUP

White Star ..... **.53**

Reputed Gallon Tins

### CURRENTS

Extra Fine Goods

3 lbs. .... **.25**

25 lbs. .... **\$1.95**

### SUNFLOWER SALMON

Worth 15c.

Our price ..... **.10**

Per doz. .... **\$1.15**

### TAR SOAP

Extra quality, large

cake ..... each **.5**

### SODA BISCUITS

An Exceptionally Fine

Biscuit bought in Ontario.

In view of the quantity

being limited we can allow

one box only to each cus-

tommer.

Special, per 15 lb.

box ..... **\$1.22**

### BAKING POWDER

Red Cross

1 lb. tin ..... **.18**

5 lb. tin ..... **.65**

### IMPERIAL EXTRACTS

Any Flavor

Extra special, 8 oz.

bottles ..... **.25**

### VALANCIA RAISINS

Select stock

Per lb. .... **.7**

Per 28 lbs. .... **\$1.90**

### EVAPORATED APPLES

Choice

Per lb. .... **.10**

Per 50 lbs. .... **\$4.25**

### CORN

Best Pack

Per can ..... **.09**

Per doz. cans ..... **\$1.00**

### ROLLED OATS

Per 20 lb. .... **.55**

Per 40 lbs. .... **\$1.05**

Per 80 lbs. .... **\$2.05**

# MUNRO'S

DIRECT TO YOU

## GROCCERS

614 PORTAGE AVE. WINNIPEG, MAN.

### SUGAR

A special lot of best Granulated Sugar for sale at a low price while it lasts.

Not more than 100 pounds to each customer.

Per cwt. .... **\$5.55**

## This Special Bargain List

Is a supplement to our Regular Price List which is mailed regularly to those desiring same. Every item enumerated represents the best obtainable, each one being carefully chosen from our stock and specially priced to help boost our Forced Vinegar Sale.

While we endeavor to fill all orders taken from this Bargain List, we reserve the right of cancelling orders for any lines on which our present stock is sold out, which in many cases cannot be replaced at these prices, so immediate buying is advisable.

**Tea** No. 121 Black. A line on which you can save 40% of your tea money; extra strong and well flavored and in every way equal to most 35 cent and 40 cent lines. Per lb., 25c.; 5 lbs., \$1.20; 10 lbs., \$2.30

**Vinegars** It was Vinegar, or an advance in the price of Vinegar, that caused us to publish this Bargain List.

While the manufacturers were making arrangements to put up the price on this line, we succeeded in placing an order for a great quantity of Wilson's Celebrated XXX Vinegars at the old price less a substantial discount for quantity. Then we found that we did not have sufficient storage room to accommodate this special purchase, so decided that it was absolutely necessary to sacrifice a certain part to make room for the balance.

"Wilson's" is the finest Vinegar in Canada, always demanding a higher price than other lines. During this sale you may have XXX Cider, XXX Malt or XXX White Wine in 5 gallon wax-lined pails at, per pail, \$1.80.

**Pickles** A snap in the choicest medium sour mixed pickles just at a time when you will want them is that we offer here. We guarantee the contents of each pail to be the most select vegetables in pure vinegar; in fact, we do not know of a better line on the market. In 5 gallon wax-lined pails, each \$2.83.

### Oils, Gasolines, Greases, Etc.

#### COAL OIL

A high grade Pennsylvania Oil, warranted to give a good white light and not smoke the chimney—an oil that is giving perfect satisfaction in thousands of Western homes. Per case of 10 gallon (wine measure) . \$2.50 | Per bbl. of 45 gal. (Imp. measure) . \$9.75 P.S.—Prices on Coal Oil will advance one cent per gallon June 1st.

### Engine Gasoline—Special

For Power. High Test.

This Gasoline is shipped in car lots to the following Western points, from which we can make shipment, thus causing you a saving in time and freight.

F.O.B.	Winnipeg	Brandon	Regina	Saskatoon	Calgary
Per 42 gal. bbl.	\$11.25	\$12.00	\$12.95	\$13.25	\$14.00

### Kerosene Engine Oil

For Fuel Purposes

This Engine Oil is specially recommended to users of Hart-Parr and other standard engines, being guaranteed to give 25 per cent. more power than can be derived from gasoline.

On this oil we are offering the following extremely low prices, f.o.b. any of the following points

F.O.B.	Winnipeg	Brandon	Regina	Saskatoon	Calgary
Per 42 gal. bbl.	\$7.90	\$8.80	\$9.70	\$10.00	\$10.90

Figure out the gallon price—it will surprise you. Prices quoted on all oil, excepting Kerosene, Engine Oil and Gasoline, are f.o.b. Winnipeg.

### Axle Grease

Mica, the best made, 10 lb. pail	\$.75	Diamond, splendid value, 10 lb. pail	\$.70
" " " 15 lb. pail	1.00	" " " 15 lb. pail	.80
" " " 25 lb. pail	1.50	" " " 25 lb. pail	1.15

### CHEESE

Very fine flavor ..... **.15**

Per lb. ....

### MACARONI

Domestic, per ..... **.37**

5 lb. box

### CONDENSED CREAM

Peerless

Big snap ..... **.25**

3 cans for

### MOLASSES

New Orleans

Per 10 lb. .... **.48**

Pail

### CLOTHES PINS

Good quality ..... **.01**

per doz.

### JAPAN RICE

At a Low Price

per lb. .... **.05**

Per 50 lbs. .... **\$2.25**

### EVAPORATED PEACHES

During the balance of

this month we will sell

our Choice California

Stock.

Regular price, per 25 lbs.

\$2.45 ..... at **\$2.13**

per 25 lb. case

### LAUNDRY SOAP

Palm Oil

Our leader ..... **.25**

Per 10 bars

### CORN MEAL

Steel Cut

Per 10 lbs. .... **.25**

Per 40 lbs. .... **\$1.15**

### SEEDED RAISINS

Lovely Fruit

In 12 oz. pkgs ..... **.25**

Per 4 pkgs.

### DAIRY SALT

medium ..... **.42**

Per 50 lb. sk.

### BLACK PEPPER

Usually 40c. per lb. .... **.22**

Our price

### LAUNDRY STARCH

Canada Gloss ..... **.25**

Per 3 pkgs.



### PREMIUM JAM

An excellent compound Jam in the natural fruit flavors—Strawberry, Raspberry, Black Currant and Plum.

In 7 pound sealed tins.

Worth 60c. each

Special, per tin ..... **.47**

6 tins ..... **\$2.75**

### BUTTER and EGGS

For Good Butter we are paying from 28 to 33 cents per pound; the sooner on the market the higher the price; so ship quick.

We are at present paying on Fresh Eggs 18 cents per dozen.

### FARROW'S MUSTARD

A line well known to All Old Country Folk. Worth 35 cents per lb.

Special Per lb. .... **.25**

4 lb. tin ..... **.95**



# Hail Hail Hail

Loss Claims Paid Last Year - - \$87,854.81  
 " " " " Six Years - 390,787.35

Rates of Insurance for 1910  
 from 20c. to 40c. per acre,  
 according to number of times crop has been hailed  
**\$1,500,000 Insurance**  
 in force now :: Assessable  
 Revenue on same \$70,000.00

## No Liabilities

For further information see our Agents or write

W. C. GRAHAM, Manager  
 J. H. SCHULTZ, Field Manager

### The Manitoba Farmers' Mutual Hail Insurance Company

503 McIntyre Block - - - - - WINNIPEG, Man.  
 P.O. Box 1147

*Insurance written in Manitoba only*

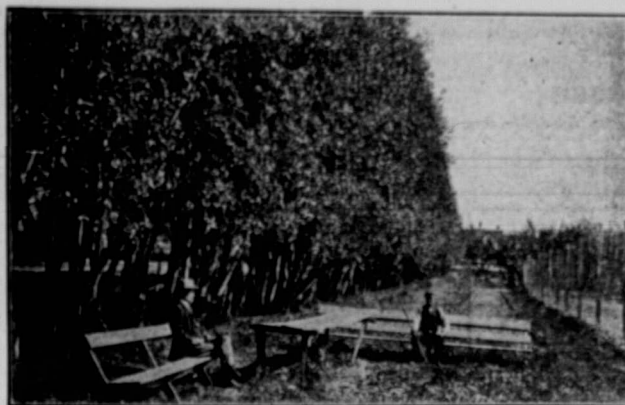

This is probably the finest break of Russian Laurel Willows between Winnipeg and the Rockies, planted by me for the Virden Town Park in 1906. I have a surplus of 100,000 Russian Laurel cuttings on hand which I will offer at \$3.50 per 1,000, express paid to any station in Manitoba, Saskatchewan or Alberta. These cuttings are better to soak in water one week before planting and can be planted up till June 1st. For all other varieties of nursery stock you have lots of time to send for my price list. I can express orders on one day's notice.

**JOHN CALDWELL**

VIRDEN NURSERIES

VIRDEN, MAN.

## Don't Waste Money On Poor Roofing

*Choose Preston Safe-Lock Shingles*



They stand the British Government acid test and are made to withstand the rigorous Western climate. They stand the heat, they stand the cold, and do not warp. They are absolutely Fire Proof, Lightning Proof, Water Proof, Storm Proof, and Rust Proof.

**Protect Your Property** by using roofing that is absolutely guaranteed.

**Preston Safe-Lock Shingles** have stood the test against storm, fire, lightning and water for years. They are heavily galvanized on both sides with the most approved galvanized material, and will last a lifetime.

**Preston Safe-Lock Shingles** lock on all four sides and, when properly put on, the heavier the strain the harder they grip. They never come off; they never rust.

Write for our "Truth About Roofing." It gives valuable information that every body who anticipates building should know

Free Booklet **WRITE TODAY—NOW**

**Clare & Brockest, Ltd.** 246E Princess Street WINNIPEG, Canada

Agents for "ACORN QUALITY" Corrugated Sheets

METAL SHINGLE & SIDING CO. LTD., Manufacturers, Preston, Ont.

## Farmer! Business Men!!



Where do you keep your Valuables, Receipts, Correspondence, Insurance Policies, Deeds, Books, etc.?

**LOST PAPERS** sometimes cost big money.

Get this Solid Steel Safe, Strong Box and Filing Cabinet, and be safe from loss forever.

Charges Prepaid anywhere.

Special Price **\$10.00**

Money back if not as represented.

The 20th CENTURY FILE complete as pictured here

A limited number at this price. Order now—today. Send P.O. Order or Draft, and get this complete safe-system outfit. Guarantee for a lifetime; fireproof, indestructible, should be in every home. Beautifully finished in green enamel with gold stripings. Keep your Valuables safe. Order today.

### THE 20th CENTURY FILING CO.

127E Higgins Avenue - - - - - WINNIPEG, Canada

Write for our Optical Catalog and be Your Own Optician

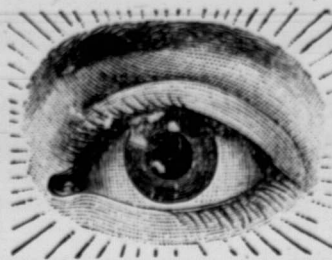

Get acquainted with our Scientific Method of Fitting Spectacles by Mail. The REFRACTOSCOPE does the work.

BRADY OPTICAL DEPT.

**ROBINSON & CO.** 400 Main St. WINNIPEG

### A STYLISH TWEED SUIT

FOR **\$9.95**

Three and four button Sack Suits cut in the newest Spring and Summer Styles. Fancy mixed patterns in brown and grey, some with threads of brighter colors. Faultlessly tailored. These suits are equal to any that custom tailors charge \$25 for.

Send measurement around chest over vest. Pant measurement around body over hip bones, over pants only, and length of inside seam from crotch to heel seam at shoe.



**F. J. KNOTT**  
 566 Main St., Winnipeg

WHEN WRITING TO ADVERTISERS MENTION THE GUIDE



# The Grain Growers' Guide

ADDRESSED TO THE FARMERS OF



Published under the auspices and employed as the Official Organ of the Manitoba Grain Growers' Association, The Saskatchewan Grain Growers' Association and the United Farmers of Alberta.

Canadian Subscriptions, \$1.00 per year in advance.  
Foreign Subscriptions, \$1.50  
Advertising Rates on Application.

Address all communications to The Grain Growers' Guide Winnipeg.

Change of copy and New Matter must be received not later than Friday noon each week to ensure insertion.

MAY 4th, 1910

## THE TERMINAL ELEVATOR INVESTIGATION

On another page of this issue of THE GUIDE, we publish the story of the recent government investigation of the terminal elevators and the results. Two of the big elevator companies, the Port Arthur Elevator Company and the Empire Elevator Company, have been convicted of sending falsified statements to the warehouse commissioner when submitting their weekly records of grain received and shipped. For these attempts to deliberately hoodwink the government officials, the three companies were fined \$5,550. The Consolidated Elevator Company also put in one false report, but claimed that it was on account of a clerical error and were given the benefit of a doubt by the court in being fined only \$50. The Canadian Pacific Elevator Company was exonerated from any attempt at graft in manipulating grades. The railway terminals have been found to be conducted properly as there is no inducement for manipulation where the warehousemen have no financial interest in the grain going through the elevator.

In brief, that is the story. It does not seem particularly startling, but we believe it will have a most far-reaching influence on the grain trade of this country. For many years back, the Grain Growers have maintained that there was graft in both the internal and terminal elevators. Many cases of the former were proven without difficulty, but the owners of the terminal elevators indignantly denied the charge that they manipulated the grades in the elevators. In fact every attempt has been made to discredit the Grain Growers by the elevator men, who even endeavored to pose as injured innocents and apostles of purity. But all this time the Grain Growers felt sure that the graft game was being carried on at the terminals. Two years ago the Manitoba Grain Act was amended, after most strenuous efforts on the part of the Grain Growers, by a clause compelling the government officials to weigh up all the grain in the terminals on August 27 of each year. This was first done last August. By having the weekly record of the amount of each grade of grain going into and out of the elevators and the amount actually in the terminals on two separate dates it is no difficult matter to ascertain if there has been manipulation. Inspector Gibbs, at Fort William, however, had suspicions, and without waiting till next August he measured the grain in several of the terminals at the close of navigation on December 10th last. This measurement natur-

ally could not be so accurate as the actual weighing of the grain, but it was near enough for practical purposes and served good ends.

The investigation that was made concerned only the three contract grades of wheat, 1 Northern, 2 Northern and 3 Northern.

According to Mr. Castle's report, the system of manipulation at the terminal elevators explains at once why the best grades of Canadian wheat have not the reputation they should have on the Liverpool market. It appears that a good deal of 1 Northern that goes into the terminal elevators is very nearly 1 Hard. Similarly, 2 Northern is very often nearly 1 Northern. By binning separately the choicest cars of these grades, manipulation is made possible. For instance, the average of all the 1 Northern in the terminal elevators might be considerably above the minimum requirements for 1 Northern grade, according to law. Now, by taking the choicest of the 2 Northern and dumping it in the choice 1 Northern bin, the whole would pass inspection as 1 Northern. Thus Mr. Castle's report shows that the Port Arthur Elevator Company shipped out 169,066 bushels more of 1 Northern wheat than they received. Also that they shipped out 116,646 bushels less of 2 Northern than they received, and 180,205 bushels less of 3 Northern, than they received. In the case of the Empire Elevator, Mr. Castle shows that the amount of 1 Northern shipped out exceeded the receipts by 437,884 bushels and that there was also a discrepancy or shortage on the 2 and 3 Northern grades.

This answers and justifies the charges made by the Grain Growers. There has been deliberate mixing done in the terminal elevators that has taken thousands of dollars from the pockets of the farmers of the west. This is easily understood when it is seen how 2 Northern is raised to 1 Northern and 3 Northern to 2 Northern, thus enhancing the value of wheat by several cents per bushel.

This is the system that has been employed to the great satisfaction of the terminal elevator owners.

All this took place at the terminal elevators despite the fact that the place is swarming with government officials. There are now seventy men in the employ of the Dominion government watching and inspecting the work of the terminal elevators, but the manipulations continue under their very eyes and they are powerless to prevent it.

A study of the figures given in Mr. Castle's report to the Department of Trade and Commerce showed that the manipulations in wheat totalled far over 1,000,000 bushels. This was during a period of less than four months and yet it must have turned over \$50,000 illegitimately into the pockets of the elevator men. What has been the history of the past? There was no possible method of discovering the manipulations prior to last year so it is fair to assume that the work has been going on merrily for years. In considering the amount of grain that has gone through the terminal elevators it is equally fair to assume that the manipulations in grades have netted the manipulators at least \$10,000,000. But the manipulation of grades is not the only illegitimate source of revenue at the terminals. The dirt is not cleaned out but is sold for the price of wheat and shipped to the Liverpool market.

It is significant that one of the offending elevator companies confessed to loaning wheat which according to Mr. Castle is not in violation of the law. If it is not against the law it should be made so at once. The admission of loaning is another proof of the charges of the Grain Growers, that it was no use for farmers to hold their wheat in the terminals elevators in the hope of bringing up the market, because the wheat which they thought they were holding had already been sold on the Liverpool market, and may have been ground into flour while the farmers thought it was in the terminals.

True to their instincts the Port Arthur and Empire Companies fought with every possible weapon to prevent the truth from

coming to light. They would not show their books or give evidence under oath before the warehouse commissioner when he was making his investigation. Mr. Castle had not the authority to enforce his demands but he secured sufficient evidence from the government employees to warrant laying information against the companies. Once the information was laid and the matter was brought into a court of law where the elevator men could be compelled to give evidence and produce their books, their attitude changed at once. They realized that their bluff was no longer good, but they did not want to show their books. Not unless they were compelled to for it is highly probable that those books show very interesting figures. So to avoid all this investigation, as soon as the case came up in a regular court of law the lawyer for the elevator companies pleaded guilty on their behalf and they were fined \$5,550. That fine was a light one, and the elevator men were highly delighted to get off so easily. If their books had been brought before the court it is highly probable that the toll would have been heavier than \$5,550. It is somewhat significant that the same lawyer acted for all the elevator companies that were fined. This lends local color to the general opinion that these three companies are simply the Peavy Company under another name. This is certain that there is an element that has come from across the line that has done no good to the Canadian grain trade. There are many honorable men in all lands but rogues also exist in all countries.

One of the most unfortunate features in the trial and conviction of the elevator companies, was the apparent intent that the proceedings should be kept from the public. We say it is unfortunate, and advisedly so, because we do not wish at the present time to use any stronger terms. Let us look at the facts. Here is one of the most important trials ever held in Winnipeg. Where was it held? In the private office of the prosecuting attorney. The public was not there and knew nothing about it for several days after. Naturally the elevator companies and their counsel would endeavor to have the matter hushed up and kept as quiet as possible. It was most regrettable that the trial was not held in open court and the public allowed to know about it. It was only by accident, and not by design, that the public knows the facts of the case at the present time. Why should there be any effort to protect men who break the law just because they happen to move in a higher social circle? Why? Why? Let justice be done to all men and justice demands the full light of publicity—especially in the case in point.

In view of all that has been learned and is now known of the manner of conducting the terminal elevators, it seems that the Dominion government should have proof enough at hand to show the need of taking over the terminal elevators. Mr. Castle, the warehouse commissioner has an opportunity now to create conditions which will work well in the interests of justice and will protect the farmers of Western Canada against the trickery of unscrupulous warehousemen. The Dominion government evidently places considerable confidence in the warehouse commissioner in giving him so much control over the grain trade of the west. We understand that Mr. Castle is recommending the registering in and out of warehouse receipts as a further protection against manipulations, which means more government control. We feel that Mr. Castle would be thoroughly justified and making a splendid move in the interests of justice should he recommend at once that the Dominion government take over the terminal elevators and operate them as a public utility under an independent commission.

It was through Mr. Castle's department that the recent investigations have brought to light the nasty mess at the terminal elevators. Great credit is certainly due to the officials who inaugurated and brought to such

a successful termination the investigations. It was one of the most important and most needed investigations that has ever been made under a department of the federal government. It has also shown that no amount of federal inspection can prevent manipulation. We hope that Mr. Castle will follow up the good work of his department and in the interest of justice recommend that terminal elevators in which the western grain is to be stored will no longer remain in the hands of private individuals.

### THE CHILLED MEAT PROPOSITION

The farmers of Alberta are very anxious that the Dominion government should take hold of the chilled meat proposition in Western Canada. They want to see a chilled meat trade established which will give the Alberta stock raiser freedom from the present monopoly which grinds him down and will not allow him to place his products on the markets of the world in a manner which will make the live stock industry remunerative. The live stock industry in Alberta is of more importance as compared with other agricultural lines than in Saskatchewan and Manitoba. It is the hope of Alberta farmers to see the Dominion government place chilled meat plants in Alberta of sufficient capacity to handle the output of live stock which would follow the inauguration of such a scheme. The live stock industry of Manitoba and Saskatchewan is continually growing, and the problem of marketing the meat is already important. The farmers of Manitoba and Saskatchewan are at present bending more of their energies towards a solution of the elevator problem. By working together the farmers of the three provinces could accomplish far more than through separate or individual action. The elevator problem in the two eastern provinces bids fair to be settled shortly, but the chilled meat problem is as far from settlement as ever. The farmers of Alberta have stood shoulder to shoulder with the farmers of the eastern provinces to secure a solution of the interior and terminal elevator problem. By reciprocating, the farmers of Saskatchewan and Manitoba will greatly assist their Alberta fellow workers in securing a solution of the chilled meat proposition. The interests of the three provinces are to a great extent identical, and by a union of forces a great deal can be accomplished. If the influences of the farmers' organizations in the three provinces is brought to bear in the proper quarters, the Dominion government will take hold of the chilled meat industry. We will then see a big plant in Alberta with probably smaller subsidiary plants and other plants in Manitoba and Saskatchewan. These, in conjunction with a refrigerator car service under the control of the federal government, would open the markets of the Old Country to the live stock raisers of Western Canada. It is a solution that must come, and, as the Alberta farmers assisted their eastern brothers, so the Saskatchewan and Manitoba farmers should reciprocate most heartily. A great deal has already been accomplished in the three provinces towards securing better conditions for the farmers, but the work has only begun. A pork packing plant in Alberta will greatly improve the conditions of the swine industry of that province, but it is probable that the pork packing plant could easily be worked in conjunction with bigger chilled meat plants under the control of the federal government and the whole industry would then be regulated from one source. Every western member of the House of Commons should be apprised of the necessity of a chilled meat industry. If the western members were all in touch with the situation they would be able to bring the matter before the federal government with the strong probability of action of the House of Commons. The Manitoba and Saskatchewan farmers are in entire sympathy with a scheme to correct the evils of the live stock

trade in the west and have expressed themselves in strong resolutions. These resolutions must be backed up and when the Canadian Council of Agriculture meets with the government in the fall, they will be able to lay before the cabinet a definite proposal for the inauguration of the chilled meat industry.

### WHAT WILL THE GRAIN EXCHANGE DO?

In view of the recent investigation of the terminal elevator manipulations and the fines imposed upon several of the elevator companies for crooked work, it is interesting to read the following from the rules and regulations of the Winnipeg Grain Exchange:

#### "By-Law No. 5. Section 1.

Should any member of the association (or any business firm of which any member shall be a partner, or any corporation which is organized by resolution of the council under the provisions of by-law 3, of which corporation any member is one of the principal officers).

- (a) Be guilty of any improper conduct of a personal character in any of the rooms of the association;
- (b) Purport to make or report any false or fictitious purchase or sale;
- (c) Fail to perform or carry out promptly any business, contract, either verbal or written;
- (d) Be guilty of any act of bad faith or of any unfair, dishonorable or dishonest conduct in his business dealings;
- (e) Be guilty of any criminal act;
- (f) Be convicted in any court of any crime;
- (g) Violate or fail to observe the constitution, by-laws, rules or regulations of the association or any of them;
- (h) Neglect or refuse to submit any matter of difference to arbitration under the by-laws of the association;
- (i) Neglect or refuse to comply promptly with the award of any board of arbitrators or board of appeal;
- (j) Do any thing or act which in the opinion of the council is contrary to the spirit which should govern the commercial transactions of members of the exchange;
- (k) Have made any false statement in his application for membership or in answer to any questions asked by the council, or any member or committee thereof when applying for membership, such member shall be liable to be fined, censured, suspended or expelled from the association.

In view of this clause the farmers of the west will eagerly watch the actions of the Grain Exchange of which the offending elevator companies are members. They are subject to the discipline of the Exchange and we presume the axe will fall in certain quarters.

### NEW AND GIGANTIC COMBINE

It is understood that the manufacturers, the wholesalers and the retailers of Canada have made an arrangement between themselves by which they will fix the prices of commodities to consumers. The passage of the bill through the House of Commons which incorporated the Retail Merchants Association, will still further aid this combine. These philanthropic gentlemen who control this new trust will now be enabled to put the screws on to the consumers more strongly than ever. The farmers of Western Canada will have to pay and pay well for the work of this amalgamated combine that is now under way. This new combine of the manufacturers, wholesalers and retailers will make a combination so strong that it will be practically impossible to control them until the House of Commons is composed of two hundred and twenty-one honest men. The possibility of having every member of the House of Commons an honest man is somewhat remote. It is, however, a splendid ideal to keep in view.

It was with the intention of preventing such a combine as this that the western members opposed the bill to incorporate the Retail Merchants' Association. Mr. Sharpe, who is a retail merchant, opposed the bill strongly, as did Dr. Roche, Mr. Neely and Mr. Turriff. Where were the rest of our western members? It would be well for their constituents to know just what action they took in regard to this bill. It will be unfortunate if the time comes when there will be a cleavage between the east and the west, but if the eastern members are going to stand behind the combines and

trusts that rob the western farmers, then it is certainly the duty of every western member to stand up in favor of their constituents. Frequently when we have pointed out the various parasites that prey upon the western farmers we have been told that it is mere imagination, and that we are merely fostering class prejudice. Every investigation that has been made into the grievances of which we have complained has proved our contentions to be correct. Further investigations that will be forced later on, will prove still further that we have been presenting the truth and nothing but the truth to our readers. This we will continue to do, even though we may enjoy the enviable position of being the only paper in Western Canada that dares to write and publish the truth. We maintain that the incorporation of the Retail Merchants' Association by the parliament of Canada was an act directly opposed to the interests of the consumers of Canada. The cost of living is high enough and another year will amply demonstrate the wisdom of our attitude.

Press dispatches tell us that the bill to incorporate the Retail Merchants' Association passed the House of Commons on May 2. Many of the western members, including Dr. Roche, W. H. Sharp, Mr. Neely, Mr. Turriff, and Mr. Smith, stood out strongly against the bill. However, the bill was against the interests of the western farmers and in favor of special privileges, and that was enough to take it through the House of Commons. If we can get the record of the vote we will publish the names for the benefit of our readers.

The farmers of the west for years have contended that they were not getting a square deal from various of the great "interests." On this account the farmers have been called unfair and accused of misrepresentation. But no investigation was ever made to prove the truth or otherwise of the farmers' claims. However, when the terminal elevators were looked into carefully, it was found that the farmers had been getting a dirty deal. Now this is but the beginning. By standing to their guns the farmers of the west will sooner or later drive special privileges from the field.

Credit is due to Dr. Schaffner, M.P., for Souris, for the manner in which he handled the terminal elevator investigation at Ottawa this week. It was due to him that Mr. Castle's report was made public. The Dominion government will thus have the summer to ponder over the matter and public opinion will also be at work. Had the report not been made public an effort would no doubt have been made to smother the whole matter.

It is rather strange that in view of the immense importance of the terminal elevators the Winnipeg daily papers have been keeping very mum on the matter. They have not endeavored to publish all the facts of the case and we do not see any of them expressing an editorial opinion. We wonder why? Is THE GUIDE the only paper that will publish the truth about a matter so vastly important to the western farmers?

Who has been right and who has been wrong? The Grain Growers seem to have hit the nail on the head in regard to the way their wheat has been handled at the terminals.

The farmers of Saskatchewan will be given an opportunity to give their views on the elevator question before the commission. This is eminently just, for without the farmers no elevators would be needed.

The farmers of the west may grow the finest wheat in the world, but by the time the elevator manipulators get through with it the farmers get a black eye by the manipulations that are made.

# The Grain Grower's Guide

Published every Wednesday at 216-277 St. Thurocke Street, Winnipeg, Canada  
Authorized by the Postmaster-General, Ottawa, Canada, for transmission as Second Class Mail Matter

Vol. II

WEDNESDAY, MAY 4th, 1910

No. 40

## Canada's Pork Industry

*The Commission appointed by the Dominion Government have Studied the Hog Question from Birth to Squeal, and have made some Important Recommendations*



In 1909 the Dominion government appointed five well known farmers and stock raisers as a commission to enquire into the swine husbandry in Great Britain and Ireland and also in Denmark and report as to the best method to improve swine husbandry in Canada. This report has just been published and may be had free for the asking from the office of the Live Stock Commissioner, House of Commons, Ottawa.

The commission was composed of W. W. Ballantyne, of Stratford, and Wm. Jones, of Zenda, from Ontario; from the province of Quebec was appointed Mr. Gedeon Garceau, of Three Rivers; Mr. Joseph Rye, of Edmonton, Alta., was named from the west; Mr. J. E. Sinclair, of Prince Edward Island, and the sixth representative was J. B. Spencer, assistant live stock commissioner, who acted in the capacity of secretary and editor.

At the conclusion of their report the commission sum up as follows:

"The commission composed of farmers residing in various provinces of Canada, who rear or market swine in greater or less numbers each year, started out with a clear understanding of the various phases of the swine rearing industry throughout the Dominion. The instructions given them to investigate and find out as far as possible the conditions responsible for the success of the industry in Denmark, Great Britain and Ireland were fully comprehended. The commission undertook this work seriously and devoted their time earnestly to the task. Every facility that could be asked was placed at their disposal. The commission is prepared to depend on the report to justify its effort.

"A careful reading of the various chapters will reveal many lessons on pork production. The time of the commission was spent among successful men and associations who revealed their methods for examination. Nowhere was there found evidence of success being attained through mysterious methods or secret processes. Intelligent management was found to be responsible for satisfactory results all along the way. This included persistency of purpose and a confidence in the system followed. Everywhere was there found a tendency to intensive methods which demand careful attention to details. Nowhere was haphazard work associated with satisfactory result. Swine rearing as examined in Europe is a highly organized branch of agriculture secondary to and always almost associated with dairy farming.

"In Ireland the rank and file of pig raisers are men of small means who have found in a pig a means of converting unsaleable products from the dairy, the potato field and other parts of the farm into a valuable product. Long experience, coupled with frugal habits and need of the returns from the fatted swine, have taught the most profitable methods of feeding. This cannot be said to be done by any special system, but rather according to the circumstances of each case and the judgment of the feeder begotten through long experience. The average Irish pig feeder is quick to detect evidence of unthriftness in his pigs, and sharp to

apply the remedy. He does not overstock, but keeps sufficient to use to best advantage the offals and by-products he has, together with as little as possible of expensive food. He keeps on day after day and year after year in raising swine, and this is perhaps the most important lesson he has for the Canadian farmer.

By this persistence he has done his part in bringing the Irish bacon trade into a profitable industry for Ireland and the individual Irish farmer.

"In England the conditions are different. All agriculture may be said to be carried on by an extensive system. While as in Ireland no suitable by-products are

consumed. The English farmer, too, is stable and consistent in his system of farming, and this has given him experience and established a reputation for his products. He has a valuable lesson for the Canadian in his consistency of purpose, application and keen business principles.

"The Scots farmer does not make a specialty of pork production. He milks cows and makes cheese and uses pigs to turn the whey to good account. He buys most of his grain food and must exercise care to get back his money with a little profit and something for the whey. He has studied how to get these,

all along the way. The top place in the bacon trade of England has been the goal in view, and the energies of the government, the pig breeder, the pig feeder, the curer and the seller, all point in the one direction. As one man all interested in the industry pull together and every branch separately works for perfection of the whole. The pig raiser only wants bacon pigs, and these as prolific and good as possible. The feeder, with his eye constantly on the grade his pigs shall ultimately reach, studies to gain this from the least outlay for feed. He does nothing by spells and spasms, but finds the road and persists in following it. Judgment born of successful experience keeps his day to day practice right, and as a pig raiser he succeeds. His conditions are not unlike those of the Canadian farmer who follows dairying, except that he has more feed to buy on account of his limited acres. He is succeeding because he will keep only such pigs as are good mothers of vigorous litters; in feeding them only



MEMBERS OF THE CANADIAN BACON COMMISSION TO DENMARK.

First row from left to right—J. B. Spencer, Assistant Live Stock Commissioner, Secretary and Editor; W. W. Ballantyne, Stratford, Chairman; Wm. Jones, Zenda, representing Ontario. Second row from left to right—J. E. Sinclair, representing the Maritime Provinces; Joseph Rye, representing Western Provinces; Gideon Garceau, representing Quebec.

allowed to waste for want of pigs. The industry goes farther than this, amounting even to an important branch of highly organized system of live stock husbandry. The keeping of pigs is carried on as a business enterprise and no chance is taken in regard to the losing of money. Much of the concentrated food used is purchased at high prices, and the books in the pig account must show a profit. There is little chance to save in the price of food, which leaves the profit to be made from the pig side. The employment of a bright, experienced feeder kept under the watchful eye of the master, is the means adopted in getting results from the foods

and follows intelligently what he has found to give best results. Having learned that sweet whey is better feed than sour, he gives it as fresh as possible, and avoids, as a principle, feeding a larger quantity than experience has taught to be economical. The feeding is done with every care and regularity, usually by the same person. The Scots feeder would teach the Canadian cheese factory patron that there is profit in the intelligent feeding of whey in sweet condition to pigs from store to finished weight.

### Denmark's Example

"The industry as conducted in Denmark has lessons for the Canadian pig raiser

on such foods and in such a manner as he knows gives greatest ultimate profit; in observing the demands of the market upon which the size of his pay cheque depends; and by his confidence in his own efforts and those in charge of the other branches of the industry.

"Everywhere the ideas of pig feeders agree with those of the most successful Canadians in regard to the best age to wean litters. Nowhere were breeders found weaning at less than six weeks, and most breeders leave the litters on the sow until two months' old.

"Both in Denmark and Ireland the

Continued on page 11

# Railways and Farmers

*The Present Law does not Protect Farmers where Stock is killed. The Railways are Protected at every turn and Farmers are Suffering all over Canada*

By EDWARD J. FREAM, Secretary, U.F.A.



FARMERS throughout the west have, since the country was settled, been troubled in every direction by having their stock killed on the railway track. Claims are put into the railway and the answers received are to the effect that the Railway Act contains

clauses which prove that the companies are not liable.

Section 294 of the Railway Act reads: "That no horses, sheep, swine or cattle shall be permitted to be at large upon the highway within half a mile of the intersection of such highway with any railway at rail level unless they are in charge of some competent person or persons, to prevent their loitering or stopping on such highway at such intersection, or straying upon the railway." The act further provides that stock so found may be impounded and that the owner will have no right of action as the stock were at large, contrary to the provisions of the act.

Section 295 provides that the owner will have no right to recover from the railways such stock killed if the gates used at farmers' crossings were not closed,

fully, a specific case is cited herewith, and some interesting letters dealing with the matter are here given.

The following is a copy of statement of Mr. W. H. Lighthart as given to a committee of the United Farmers of Alberta, said committee consisting of Messrs. Ross, Eddy and Kemmis.

Mr. Lighthart deposed as follows: On the night of January 25, 1910, on the railway crossing of the C.P.R., one mile east of Lundbrek village, and adjoining government watering reserve land on west half section 30, township 7, range 1, west of the 5th meridian, eight horses belonging to him got on the railway track, owing to the cattle guards being removed by the employees of the C.P.R. three days previously, and these horses were run down by a train some time during the night. Five were killed, two very badly injured, and one slightly injured. Mr. Lighthart next morning made complaint and claim for damages to the agent at Lundbrek and by letter to the general freight agent, Calgary, and the general claims agent, C.P.R. offices, Winnipeg, claiming damages to the amount of \$975.00. From the claims agent, Mr. D'Arcy, he received a letter, copy of which is enclosed herewith.

Mr. Lighthart is prepared to furnish

railway at public crossings, manifest a disregard for the safety of the travelling public, not to speak of the risk of damage to the company's trains."

Here, again, is the letter from the secretary, department of railways:

"I have to acknowledge the receipt of your letter of the 4th instant, enclosing a copy of a report of a committee of the Cowley union of the United Farmers of Alberta, relative to the claim of Mr. W. J. Lighthart, of Lundbrek, Alta., against the Canadian Pacific Railway for five horses killed and three injured on that railway, near that place, on or about the 25th of January last, the animals having gained access to the railway right-of-way at a public crossing, where it is alleged, the cattle guards had been removed by the company's employees, together with a copy of a letter dated 14th ultimo, to the claimant from the company's general claims agent at Winnipeg, wherein it is contended that the company is not liable, as the animals were running at large on a public highway within half a mile of the railway contrary to law. You state that you have been instructed to ascertain what steps it will be necessary to take to secure the amendment of the Railway Act, so as to protect the interests of the farmers' as well as of the railway companies.

"In reply, I have to say that the departmental solicitor advises that the Railway Act very fully protects the public in such cases, and it does not appear that further protection can be given.

"He observes that the claim in question has been declined by the company on the grounds that the animals gained access to the railway when at large upon the public highway, contrary to law, and such being the case protection of a

order to permit of the operation of snow plows, but now that the board has disapproved of the practice, the company will be governed accordingly.

"This question, however, does not enter into the matter of the company's liability for cattle killed or injured on the railway under circumstances similar to those in Mr. Lighthart's case, where the animals were admittedly at large through the wilful act of the owner, and gained access to the railway at a public crossing. It is true that the cattle guards had been removed, but the company take the view that these cattle guards are for the protection of animals lawfully on the highway within half a mile of the railway crossings; that is to say when they are in charge of some competent person or persons to keep them from loitering or stopping on the crossings or straying on the railway over the cattle guards, and are not intended for the protection of animals unlawfully at large. This, however, is a question for the courts, and I do not think the board will consider itself as called upon to settle it.

"You point out in your letter that the accident in question happened in a country which has always been open, free ranching country where there is no herd law and where the government still keep water reserves open. Now, in this connection, let me state further that under the Railway Act the obligation to fence their right-of-way is not placed on the railway company until the adjoining farmers have their own land enclosed and therefore persons who allow their stock to run at large take the risk of the animals straying upon the railway from open prairie or other unenclosed lands where the railway is not fenced, and being killed or injured by passing trains.

"In the case of Mr. Lighthart, however, the company have their right of way fenced with barbed wire and the fences were in good order and condition at the time, but the animals having been at large gained access to the railway at a public crossing. So even if the cattle guards had been in at the crossing in question the animals which were unattended were as likely to be killed on the crossing as on the railway after they got over the cattle guards, and this without negligence on the part of the company, as the accident happened when it was dark, and therefore what you have pointed out as being an open, free ranching country has no bearing on this particular case.

"Persons who allow their stock to run at large in a country where such conditions exist. I refer to the protection of the railway by proper fences, never think of the danger which this practice exposes the travelling public to, not to speak of the damage to the company's property, which an accident may result in, and I think that upon serious reflection you will agree that there is a duty cast upon the owners of live stock in such cases as well as upon the company."

These letters make very interesting reading, especially the one from the department of railways, which really looks as though the department was run for the benefit of the railways instead of for the benefit of the country at large.

From the last letter received from the C.P.R. this particular case seems to rest on the validity of the half mile regulations, and when the matter was discussed at the last meeting of Cowley union one member stated he had been paid \$100 for five head of cattle killed in this same country; another one had had a steer killed and was paid, although the fence was down at the time this case happened two years ago; and it is peculiar that if this section is so important that the company did not protest in this case.

In this case it is known that these horses referred to have run in that country close to the track for years and had only once got on the track, that time through a private gate having been left open. It looks as though the railway company were responsible through removing their cattle guards; and possibly now that this law is on the statute book the only possibility of preventing matters of this kind occurring will be to have unfair regulations removed. This is a big question and the thing is, can it be handled? We will need the united forces of every farmer in the whole Dominion to combat the powerful forces of the railway companies, but at the same time it is a matter of importance, for the law as it now reads really means that the whole of a man's property within half of a mile from a

Continued on Page 10



"Spruce Grove Farm," the property of A. H. Stenev, Eden Valley, Sask.

if they were left wilfully open, if the gates were taken down or the cattle turned within the railway enclosure or if the railway is used in any way without the consent of the company.

It is true that the owners of stock are given the power to recover in a court of competent jurisdiction unless the company establishes that such animal got at large through the negligent or wilful act or omission of the owner or his agent or of the custodian of such animal or his agent, but not one man in a thousand is in a position to stand the expense of such a suit.

If the owner places a claim against the railway he is invariably informed by the claims agent that the stock were running at large contrary to the provisions of the Railway Act, and that the company cannot, therefore, entertain the request for damages. If the owner is persistent, it will eventually mean that he might be successful in securing possibly one-tenth of the value of stock from the company, but in any event in nine cases out of ten he will be a heavy loser.

The railway companies, by a ruling of the railway commission last year, have been compelled now to fence all their tracks, the work to be completed before January 1, 1911; but in spite of this the law has been broken, and if the track is fenced in the fall a part is removed as soon as the winter comes, by the fact that the railway companies are in the habit of removing their cattle guards. To explain this matter more

affidavits as to the cattle guards being up at the time of the accident, and also to having been replaced two days afterwards, also as to the value of his stock. The committee above mentioned are of the opinion that this matter should be taken up and brought to the attention of the proper authorities, or the law or ruling quoted by Mr. D'Arcy should never apply to that section of the country. It always has been an open, free ranching country. There is no herd law, and the government still keeps water reserves open, and the C.P.R. has no right to leave their track unfenced or remove any part of their fence, and the cattle guards constitute a portion of the railway fences.

#### Letter from Claims Agent

The following is the letter from the general claims agent, C.P.R.:

"I regret to inform you that the circumstances of your claims for five horses killed and three injured on the railway, near Lundbrek, on or about the 15th of January last, do not make the company liable. It appears that the animals were running at large during the night time, and gained access to the railway at a public crossing, and the law prohibits animals running at large on public highways within half a mile of the railway crossing unless they are in charge of some competent person or persons to keep them from loitering or stopping on the crossings or straying upon the railway.

"Persons who allow their stock to run at large during the night time where they are in danger of gaining access to the

person against his own act in violation of the law is without principle."

The railway commissioner wrote as follows: "I beg to acknowledge the receipt of your letter of the 4th instant, enclosing a statement made before your committee by Mr. W. H. Lighthart, and to say that the same has been submitted to the board for consideration and that I am directed to inform you that the board has never given its approval to the removal of cattle guards and that, therefore, the company in removing the same are violating the law."

Here is a later letter from the claims agent, C.P.R.:

"I beg to acknowledge the receipt of your favor of the 22nd ulto., in reference to a claim which Mr. W. J. Lighthart, of Lundbrek, Alta., has against the company for five head of horses killed and three injured, on the railway on or about the 25th January last, near Lundbrek, and to say in reply that the matter was carefully investigated and considered before Mr. Lighthart was notified that the company did not consider themselves liable for the loss.

"I note that your association has taken the matter up with the board of railway commissioners as well as with the department of railways and canals, and that you are informed by the board that it has never given its approval of the removal of cattle guards.

"In this connection let me state that it was always customary to remove these guards for the winter season, in



# Labor and Capital

An Address given by F. W. Green, Secretary of the S.G.G.A.,  
Before the Young Peoples' Society of Zion Methodist Church,  
Moose Jaw

**I**DEAS and opinions are legion as to what relation should prevail between labor and capital under present economic conditions—what conditions ought to prevail, or in the future will prevail. The individual, family, community, tribe, class or nation—in fact, the whole world seems to advance morally, socially and economically through epochs or crises, much the same as the planetary systems revolve around the sun, or like an occasional comet, each one in its cycle or sphere being attracted by some powerful influence towards one common centre, ideal law, or truth; yet not seeming to realize the force or the wonderful magnetic power which draws it, and often seem to be resisting or fighting against this influence as it is whirled around by the all-powerful laws which underlie our moral, social and economic structure, and which, I believe, will draw until God's truth and the ideal condition for man on earth will be realized; when the principles of the man of Nazareth will conquer, and the common brotherhood of man be established.

### Records of History

In recorded history there is much of evolution, revolution and radical reform. Epochs which students can distinctly mark like stepping stones across a stream. Much progress has been made, but there is still much to accomplish. There was a time when slavery was permitted. When men could go to foreign lands and secure men, women and children by sheer force and cunning, and utilize them for their own personal gratification or aggrandizement without let or hindrance. A time when England had one hundred and ninety-two ships engaged in the slave traffic. Between 1680 and 1780 there were in British and French possession some two million, one hundred and eighty thousand slaves, and in the year 1791 over a million were held in bondage in British possessions, and it took an annual importation of fifty-eight thousand to keep up the stock. To liberate them it took a powerful agitation and expenditure of millions of money, and in America rivers of blood was shed to bring on the evolution, revolution and radical reform. Earlier slavery had been succeeded by feudalism with its concomitant evils and oppression, and as we make a study of our present condition our minds revert to the time of Cromwell and evolution, revolution and radical reform. Our present condition, I say, this age of capitalism, of industrial development, invention and competition dominated as it is by the same monopoly spirit and tyranny as made slaves of men—the same as exercised by corporations, trusts and combinations—only much more extensive and gigantic in its operations. Slavery, feudalism, monopoly, capitalism, special privilege, party entangling, ensnaring, subjecting principalities and powers, governments, political parties of all shades, churches, preachers, workers in the shop, on the railways, on the sea and on the land, in the forest and in the mine. Entangling everything that is bought or sold. All product of labor being subject to their toll or domination. In fact this spirit is more or less in every individual. The same old necessity for evolution, revolution and radical reform.

### The Powerful Ballot

The world has advanced, however, but altogether like spokes in a wheel, and labor is far better off today than in past epochs, although the relative positions are not much changed. But the workers now have in their hands an instrument which will work wonders when they have been properly trained in its use. And in our present cycle we appear to be approaching a little closer to the light which seems to be gaining in strength and intensity every day. This instrument of offense and defence will be the means of putting machine guns, sword, and spear into their proper class. Before slavery, feudalism, monopoly and special

privilege parties will fall down. Adventurers, fortune-hunting politicians, weak-kneed preachers who seek to please the rich will utterly fail and disappear before it. Strikes also will be a thing of the past when this cycle is completed and the epoch point reached, and the workers have learned to properly use this most powerful instrument—the ballot. When the laborer has learned that he has the ruling power and is a king, there will be objective bloodless evolution, revolution and radical reform.

### Enjoying Past Efforts

But the workers are getting today very much more than wages. They are today enjoying much of the labors of men that are now in their tombs—warriors, statesmen, painters, poets, musicians, historians, sculptors and results of mechanical inventing genius. Engineers have contributed with their tunnels, bridges, steamships, railways, canals; cities with their network of modern comforts, such as electric light plants, water works, sewerage systems, sidewalks, schools, colleges, universities, churches, hospitals, and street car lines. All are ours, contributing more or less to our enjoyment; so that I say labor is getting far more than wages today. But it makes me feel uneasy to think we have mortgaged all these and much of our own labor, our children and children's children, to the capitalistic combinations, who have managed somehow to get a lien on all this and compel all workers to pay tribute to them. And although the structures are here, we have bound ourselves to pay interest charges to non-workers for ages to come.

### Big Interests Valuable

But while this is so, it would appear that these large interests or concerns have a function to perform in our social education. They tell us the larger the institution the more economical it can be managed, and by the amalgamation of capital a concern similar to our Canadian Pacific Railway can be better managed and give better service, and be more profitable to its shareholders because of its magnitude. If this be so, is it not possible for such an institution to be managed in a similar manner for all the people; and to even a much greater advantage when the principle of self-help and spirit of co-operation had been planted in the heart and hand of every workman on the system; and when those who perform the labor are receiving an equitable share in the proceeds. If such a gigantic institution can be so successfully worked for a corporate few, what might we not hope for from it when all the workers have an equitable share in the wealth they create. And may we not readily believe that the present conditions is a segment of a cycle, whose ultimate result is, as a school-master to us, developing and revealing the underlying laws or truth which we shall ultimately make our own. And may we not look for a time and condition when the cause of strife between labor and capital will be removed? When divisions, strikes and wars will be over? A time when we will be able to see that the struggle we are now passing through was a necessary part of our educational training and preparation for the coming emancipation? A time when we shall have organized and educated laboring citizenship, not subjected slaves or yoked retainers of feudal lords, or blind-folded minions of monopolistic trusts whose votes were bought and sold or bribed with whisky, cigars, cash or promise of position; but educated, spirited, independent dependent men and women (for women will then vote) actuated by neither fear or favor, but a desire for equal rights for all and special favors for none (but the helpless.) A time when there will be a larger production, a frictionless exchange, an equitable distribution, a well-proportioned consumption. A time when ruthless and wasteful expenditure will be ended. A time when the millions now spent in preparation for war, and the men now

Continued on page 20

## Here Is Power You Can Depend On

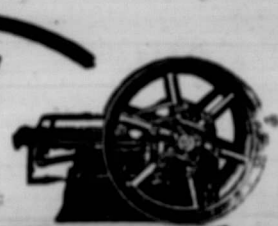

**K**EEP ahead of your work and get things done more rapidly, easily and at less cost by using an IHC gasoline engine. Until you install one of these engines you are not getting all the profit you deserve from your farming operations. It solves the "help" problem. It is the most economical worker on the farm. At any hour of any day or night it is ready to operate the cream separator, the pump, the grinder, the saw, fanning mill, sheller, huller, grindstone, washing machine, lighting system—any one of many such jobs. Thousands of farmers have come to depend on this most reliable of helpers, an **IHC Gasoline Engine**

Made in Different Styles and Sizes to Suit Every Man's Needs

The IHC line of engines is the most popular on the farm because they are so simple in construction. No previous experience is needed to operate them with complete success. Besides, they develop the greatest power possible from every gallon of gasoline.

Equip a power house at low cost. It will be the biggest paying investment you ever made. Or get a portable engine mounted on trucks or skids.

A pumping engine will solve the wind and water problem; a spraying outfit will enable you to protect your fruit from disease, worms and blight; a sawing outfit will lighten your labor, and a plowing outfit will save your time and horses. Get one, and learn its labor-saving qualities.

There are many styles and sizes, from 1 to 25-horse power—an engine for every section and every problem. Vertical and horizontal (both stationary and portable.) Also gasoline tractors—first-prize-gold-medal winners—the best all-round farm tractors.

Call and take up the matter with our local agent in your town, or write International Harvester Company of America at nearest branch house for catalogue and further information.

CANADIAN BRANCHES: Brandon, Calgary, Edmonton, Hamilton, London, Montreal, Ottawa, Regina, Saskatoon, St. John, Winnipeg, Yorkton.

**INTERNATIONAL HARVESTER COMPANY OF AMERICA**  
(INCORPORATED)  
**CHICAGO U.S.A.**

# IHC LINE

## CATER'S PUMPS

### STAR WINDMILLS

From Factory to Farmer without the middleman's profit

Cater's Wood and Iron Pumps for hand and windmill use, at reduced prices. Over 15,000 now in use in the west. Write for catalogue.

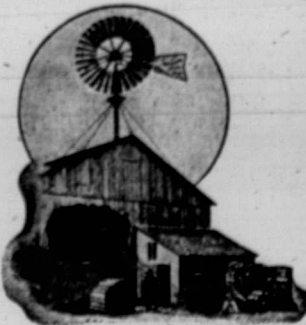

14-ft. Star Power Mill with 8-ft. Floor Grinders Only \$160

13-ft. Star Power Mill with Mast Grider. Only \$110

12-ft. Star Power Mill with mast grider. Only \$100

8-ft. Pumping Mill and 30 ft. Steel Tower Only \$60

All Power Mills are fitted with Upright Shafting, Guy Ropes and Turn Buckles, ready for erection.

**BRANDON PUMP & WINDMILL WORKS**  
Dept. 8. BRANDON, MAN



## "PARKYTE" Sanitary Chemical CLOSET

No Water, no plumbing, no excavating, no burning. Specified by Architects and endorsed by leading health inspectors and physicians throughout the Dominion. All rural districts can now have modern conveniences without sewage.

Family Size \$20.00. Hotel and School Size \$30.00

WRITE FOR CATALOGUE  
**PARKER & WHYTE**  
Inventors and Sole Manufacturers  
505 BUILDERS' EXCHANGE - WINNIPEG  
LIVE AGENTS WANTED

# Farmers' Party Needless

By JOHN KENNEDY

THE Langley and Kirkham controversy must surely bring food for thought to many minds. The little friendly battle going on between those two gentlemen must surely result in much good, as it will surely set the people thinking seriously on this all-important question—Why are we so crazy about party politics? Why should any man or any body of men support one party in preference to another? Can any man show any valid reason why one party is better than another? Can any man show that either party is above suspicion, not only in some matters, but in many matters? The man who will undertake to clear either party of such a charge, and do it skilfully, is badly needed today. Now, the two gentlemen have demonstrated this fact, that it is useless to try to improve conditions under the present form of government. Then what are we going to do about this important matter, for of all matters concerning the welfare of the Great Plain People in the last west, nothing is so necessary as that. We should have a government that will consider the necessities of all the people, rather than to pay so much attention to the few—the special privilege class. Now, to my mind, we have the solution in sight, and it is not a difficult one to bring about. That is

not do they work, neither do they spin; but they are considered the choice of the land. Who can say that this is not the doctrine that is existing today? Give us direct legislation and our representative will become the servant of the people he represents. What is he today? In many respects he is a misrepresentative of the people he represents.

Now, the point I want to make is this, that if Mr. Kirkham and Mr. Langley will give as much time in support of direct legislation as they are using in their present action, they would be a great help and factor in bringing down a blessing on the Great Plain People by giving them a government "of the people, by the people and for the people." It is a clear case of taking the road of least resistance. Trouble others as little as possible and let them vote for their own dear party. Do not ask them to go against their principles, but in this action it is simply an honest effort to improve the personnel of both parties by applying the Recall. The representative at once will realize that it will be to his best interests to study the necessities of his people, rather than spend all his time studying the doctrine of a cabinet whose amulation seems to be to support monopolies, rather than support the best interests of their country. In fact, it is said by many of the best men of the day



Farm Home of John McKague, Coulter, Man.

direct legislation—the Initiative, Referendum and the Recall. It is no new imaginary or experimental move, and it is no dream. It has been tried and not found wanting, and has proven to be a success in every place that it has been tried, and that is no small number. It has been tried for many years in several countries, and, wherever it has been tried, it is impossible to have it removed, because its good work bears investigation. It will create no political strife among the people, for it does not interfere with any man's political tendencies. It will not disturb the Liberal party, nor will it disturb the Conservative party, but it will make both parties what they ought to be. No party dare oppose it, because it is justice to all and special privileges to none. Under direct legislation the people will govern; and their representatives will be more amenable to reason when they know that for just cause they can be removed by the people who elected them. Did you ever stop to think what we really do when we elect a representative under the present government system? If we applied the same principle to our private business we would all have been out of business long ago and the police officer would be requested to keep a close watch on any persons who would conduct business in such a manner.

Just think of it. We engage our representative for a term of five years, with no alternative. He can hold his seat as long as he likes, treat us as he sees fit and he can resign at any time without consulting his employers, but we cannot discharge him, even for just cause. He can raise his salary at any time, and whether we like it or not, we have to pay just the same. He can vote for measures that takes millions out of his employers pockets and put the same into the pockets of individuals who produce nothing,

that we have nothing more or less than cabinet governments today. It is a fact not denied by many of the good and true representatives that unless a man is a member of the cabinet he is not a representative of his electors. Under direct legislation the cabinet minister will come under the same remedy as any other members and he will be subject to the Recall just in the same manner, enabling the people to remove a cabinet minister as well as any other. And, in the event of the legislation being passed, which is not in the best interests of the people, we will have 60 or 90 days to appeal before the same becomes law. Then, by the use of the Referendum, if the majority of bona-fide electors vote against such legislation, it shall not become law. Now is it not plain to all that under direct legislation we will be masters of our servants and no more allow our servants to be masters over us? And, is it plain to all that by the use of the Referendum we can undo legislation that we believe we have no right to stand for? And by the Initiative we can have enacted such legislation as we believe we are entitled to, by having a petition signed by a given number of bona-fide electors?

Now, I hope others more able than myself will go deeper into this question and give us more light. If it will not bear the real search-light, then there is something wrong with it. Can any man sit idly by and listen to what he can hear, and look at what he can see, and not realize the necessity for such a movement?

If he can, he surely must be very much married to his dear old party. If we were all married in the same way we might make up our minds that corporations would continue to rule. But thank kind Providence such is not the case, and many men have lately been aroused from their past slumbers.

## Keeps out large Animals—Keeps in the Chickens

We've put strength and stiffness into the PEERLESS JUNIOR Poultry Fence so it can stand the attacks of restless animals from the outside. We have made it close enough so small birds cannot get through. It is made of large heavy wire thick the ordinary poultry fence, well galvanized. Therefore much more durable.

### Peerless Junior the fence that saves expense

That heavy, fine, hard steel wire at top and bottom holds the fence taut and taut without the necessity of fence boards and saving more than half the usual number of posts. That means considerable saving to you. Write for our printed matter about PEERLESS Fences. We make fences and gates for every purpose.

BANWELL HOXIE WIRE FENCE CO., Limited  
Hamilton, Ont.  
Winnipeg, Man.  
Dept. 2

## THE STANDARD TRUSTS COMPANY

EXECUTOR ADMINISTRATOR TRUSTEE

We have for sale, belonging to Estates in our care, a large number of farm properties, improved and unimproved, which must be sold. If you are looking for farm property, it would pay you to write for our lists.

WM. HARVEY,

Winnipeg, Manitoba.

Managing Director.

## Ask Your Dealer for Sackett Plaster Board

and  
Empire Brands of Wall Plaster

MANITOBA GYPSUM CO. LTD., Winnipeg, Man.

### Railways and Farmers

Continued from Page 8

railway crossing is useless to him for grazing purposes, for if the cattle get onto the railway track by reason of defective fences or anything else of that kind the owner has practically no recourse whatever, as the railway company can say that the stock was at large, contrary to the provisions of the act, and it is up to the owner to prove that their contention was not correct. Is this fair?

This is a question that would be well worthy of attention from the Canadian

Council of Agriculture, and is also worthy of consideration by every local branch of all the farmers organizations throughout the country.

Woman: the Ruler. Whether they get the suffrage or not, women will rule, and always have ruled the world—indirectly. Men rule ostensibly, but women rule men, consequently women are the real rulers of the world, and many sceptics on this point would be dumbfounded did they know how far-reaching has been woman's influence in most of the great issues of the world's history.—Dowager Lady Cook in "Pearson's"

### GOOD ROAD LEVELLER

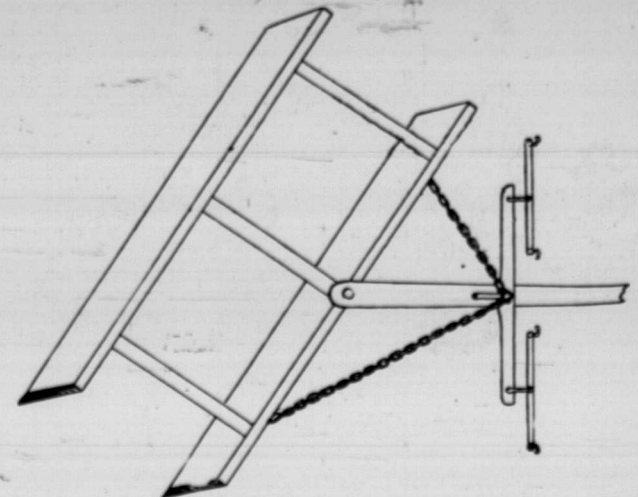

The above sketch is an improvement on the ordinary road drag, otherwise called the split log drag. The tongue is pivoted at the centre and can be swung around to any desired angle by putting the draw bolt through a link of the chain anywhere in its length. Tamarac plank 3 x 10 by 8 feet long with a strip of iron or steel on the lower cutting edge makes a very efficient road leveller.

# Canada's Pork Industry

Continued from Page 7

results of feeding experiments agree with those carried out at Canadian stations in that the cost of gain per pound increases with age and live weight. In Denmark especially it is confidently believed by feeders that hogs that are kept thrifty and growing from the time they are weaned until ready for market at five and a half to seven months old, weighing about 200 lbs., are more profitably fed than those given longer time to finish or carried to heavier weights.

"The value of milk and whey in feeding was everywhere exemplified. The commission saw very few pigs being fed without one or the other, and nowhere were these foods fed without a care for the greatest profit.

"Roughage in the form of roots or other green fodder is considered an essential part of the successful pig raiser's food supply. These, it is generally believed help materially to maintain thrift in breeding and growing stock. Nowhere can these be cheaper grown than in Canada and no pig raiser can afford to be without them.

"Another lesson gathered in each country visited is the importance of carefully grading the ration according to the age of the pig and the object in view. Everywhere young pigs were fed on easily digested food rather light in character and with only a small percentage of green food. As the pigs get older roughage is increased to cheapen the ration and strengthen and keep in tone the digestive organs. As the finishing approaches the ration is made stronger which hastens the fattening and ensures a high quality of meat. A study of the feeding throughout the report will impress this important lesson.

## The Marketing End

"The members of the commission are aware that many Canadian farmers understand well the economical production of pork. They are also familiar with the cry of a large number who claim that they cannot make pig raising profitable even at the high level at which prices of hogs have been maintained during the past two years. This, however, does not fully explain the gradual serious decline in the production of hogs that has for some time been going on, more especially in the province of Ontario, on which the export bacon trade chiefly depends. Another problem than that of feeding confronts the Canadian pig raiser. Between the feeding pen and the market there is a great gulf fixed and to bridge this most concerns the pig raisers. The commission hear it in their respective neighborhoods, the market places, the institute meetings, the winter fairs, in fact wherever farmers congregate to discuss their industry, that the bacon industry has no stability, and that the producers do not receive their share of the returns from the market. In the face of this we have the continuous high prices that have maintained, not in the summer alone when values are almost always high, but right through the autumn and into the winter even at the holiday season when so many householders are expected to be using poultry. But, say the great army who have sold their sows "What would have happened had we all continued raising hogs at the rate of 1903? allow the supply to reach a high point and the great gulf is ready to yawn at us as ugly as before. We are getting along very well without the pigs. Satisfactory help is not easy to get and our calves, feds and fowls are making very good use of the skim milk." This is the feeling that is experienced throughout the country and enables the wise, persistent hog raiser to make a fine profit from his swine.

"Then there is the grievance about buyers paying at the flat rate for all kinds light, ideal and heavy. Much pains have been taken to produce the long, fleshy singer which brings the producer no more than the cheaper fat pig that is produced in the corn belt. The packers again get the credit of reaping the fine returns from the superior hogs after purchasing them at the same rate as the less valuable kind. The packers blame the buyers and the buyers keep on as they have been doing while no concerted effort is being made to bring about a satisfactory

solution of the problem. The farmer is following his inclination but what is to become of the bacon industry?

## Working Together

"In Ireland, in England, and in Denmark, the commission compared this with the state of the industry which in those countries was found to be sailing upon a comparatively smooth sea. It is true that producers and packers in the Old World, have not always seen alike and even yet troubles and doubts arise. Each country in its own way, manages to solve these problems, not by dropping the industry but by discovering the weak points and applying what appears to be the best remedy. In some cases the packers have taken the initiative in others it has been left to the producers. In England we have examples of both. The Harris Wiltshire cures allow no grievance to grow. With the least evidence of dissatisfaction the farmers are asked to meet the packers to examine for themselves the point at issue. Such meetings are not confined to interviews in which the books are revealed to prove a theory but the whole question is threshed out until confidence and harmony are restored. The packers in this, exercise good business judgment as they know well that their success depends on the supply and kind of hogs they are able to get from week to week and from month to month. Co-operation between the two is alike good for the packer and the producer.

"In the eastern counties co-operation works out in another way. The buyer became a dominating factor and having no important business at stake he undertook to take more than his share of the returns of the industry. The impression gained foothold that an understanding between buyers had been reached but this did not drive farmers out of pig raising. The Eastern Counties Farmers' Co-operative Association engaged an experienced salesman and trusted him to find a market. This man drives an automobile up and down the roads and farmers are so well satisfied with the results that they will raise in that district more pigs than anywhere else in Great Britain.

"In Ireland the commission heard some grumbling about the buyers. The pig fair system of selling is not quite satisfactory. Buyers usually arrive at the town the evening before and it is felt that competition is not always as keen as it ought to be. Here, however, buying on merit is the rule for every bunch of pigs calls for a long discussion and the good pigs got the preference. Then the old established packing firms announce their prices for first class hogs and usually set it high enough to get most that are offered.

"Still some dissatisfaction with conditions of buying hogs prevails in Ireland and it is confidently predicted that unless co-operative curing becomes general in parts of Ireland where pigs are sold alive, that it will not be long before auction markets are operated as in England and Scotland. This it would seem should be a good solution for much of the buying difficulty in Canada. It ought to do away with the flat rate system of paying alike for all kinds, good or bad. It would do more, it would stimulate competition which is limited to a minimum in many country sections in Canada.

Co-operation is, however, the best solution as indicated in Ireland and Denmark. The members of the co-operative bacon factory at Roscrea are satisfied with their lot as pig raisers looking for full returns from their hogs. Between them and the market there is nothing to obstruct the vision and there is no one to blame but themselves if the prices received are not those quoted for the highest class.

"In Denmark the industry has grown rapidly and substantially and is thriving as a well watered tree in good soil and all on the principle of co-operation. Co-operation in Denmark had its origin in dissatisfaction with the packer and on its own success it continues to bring prosperity to the pig raiser and contentment to the farmer.

"Co-operation in Canada, can it succeed? Some say 'no, it has been tried and failed.' Was it not a poor kind of co-operation that failed? The intention of organizers was of the best, much hard work was done, farmers put in a lot of money and well equipped factories were put in operation; business connections that promised well in the Old Country were made and co-operation in the bacon



# DE LAVAL Cream Separators

## Are Guaranteed

to be as represented and to fulfil all the claims made for them, being sold subject to the guarantee of their unqualified superiority in every material feature of separator practicability, inclusive of a greater quantity of butter of value of cream and of a greater quantity of butter of better quality than is possible through the use of any imitating separator or other creaming system.

Intending purchasers are advised to ask for catalog and name of nearest De Laval agent. The latter will place a New Improved De Laval for free trial if desired.

### The DE LAVAL SEPARATOR CO.

Montreal WINNIPEG Vancouver

# THE EMPIRE—Canada's Standard Writer

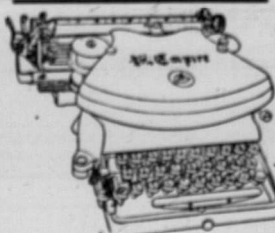

Price **\$60** Price

This machine has been adopted by The Grain Growers' Grain Co., the British Government, and the Canadian Pacific Railway. Sold on easy monthly payments, sent on trial; rented and repaired.

## Aikins & Pepler

219 McDermot Avenue - WINNIPEG

industry was launched, but it did not last. Where was the weak point? It was not in the hogs, for there were plenty and of good bacon type; it was not in the factories for these have proved their own success in the hands of proprietary firms; it could not have been the market for this has never ceased to grow for the Danes and others who send on the good bacon in regular quantities. Was the system of co-operation defective? It would seem so, at least for the disloyal members who soon commenced to bite at the dangerous bait of rival houses who received every encouragement to cast their bread upon the waters, to be gathered in larger leaves in the not too distant and very certain future. No, co-operation did not prove a success in the pig business nor could such a brand of it have succeeded in any business in which it might be tried. It would have as surely failed in Denmark with such poor staying material. The early organizers

in that country saw the rocks ahead and added a penalty clause to the rules. It required only a little patience and honor to teach the Dane that co-operation was the correct method and since then it has proved not only to the Danish but to the Canadian farmer as well, that wisely conducted co-operation is a sound principle.

"The failure of co-operative bacon curing in Canada, has valuable lessons. The success of the system in Denmark and in Ireland, has still more valuable lessons. With the instruction that these impart there should be no need of failure in every attempt at co-operative bacon raising, curing and selling, in districts of a country so well adapted as Canada for the raising of swine. A successful co-operative society requires a strong leader and a faithful membership. Unless a community is made up of such a class, who will bind themselves for a term of

Continued on page 15

We are still anxious to have our readers send us in good photographs of farm scenes. Something that will interest everybody. Do not send us any more threshing scenes as we have had a great many of them already. Send us pictures of good farm homes, or stock, or beautiful scenery, or groups of officers of farmers' associations. These are all interesting. Be sure to choose good, clear photographs and send them in flat. Do not roll them as it spoils them.

THE GRAIN GROWERS' GUIDE, WINNIPEG.

# DON'T BLAME HALLEY'S COMET

IF YOUR BUILDINGS ARE STRUCK BY LIGHTNING THIS SUMMER  
 LIGHTNING ARRESTERS WILL PREVENT IT

## TAKE TIME TO INVESTIGATE

OUR CLAIMS ARE BASED ON  
 FACTS

WE MANUFACTURE IN  
 CANADA

NO OTHER COMPANY DOES  
 THIS

SECURES YOUR PROTECTION

LOWERS YOUR INSURANCE  
 RATE

ENDORSED BY FARMERS  
 MUTUAL INS. CO.

YOU NEED OUR HELP



SAVE LIFE AND STOCK

YOUR MONEY WILL BE WELL  
 INVESTED

SECURE OUR ESTIMATES

THE WORK IS GUARANTEED

ECONOMICAL IN INSTALLA-  
 TION

MADE AND PATENTED BY  
 THE MOST EXPERIENCED  
 LIGHTNING ROD MAN IN  
 THE NORTHWEST

WRITE AT ONCE FOR BOOKLET AND COMPLETE INFORMATION RE PROTECTION

## CANADIAN LIGHTNING ARRESTER AND ELECTRIC CO. LTD.

199 MAIN STREET

WINNIPEG, MAN.

## Six Thousand Dollars in Prizes for Alfalfa Growing

Saskatchewan is clearing the floor for a great contest. The event will not be spectacular, but its effect will be greater than that of any previous movement that has taken place in the agricultural development of the west. It is no less than a provincial competition in the growing of alfalfa, a leguminous crop which will both enrich the soil in nitrogen and humus and furnish a highly nitrogenous food for all classes of live stock. This movement was inaugurated at the Agricultural Societies' Convention held at Regina in January last, when it was decided that a prize of \$1000 would be awarded for the best ten-acre field of alfalfa in Saskatchewan in 1914. The editor of a magazine at that time offered a cash prize of \$250, and others also volunteered assistance. More recently, William McKenzie, president of the Canadian Northern Railway, offered to provide the required \$1000, and needless to say his offer was accepted immediately. But the competition has outgrown the first plan; ten times \$1000 would not be more than sufficient to finance the competition as it is now planned to conduct it.

The Agricultural Societies' Convention favored the plan of having the competition conducted by a committee appointed by the minister of agriculture. The committee named by the minister consists of the dean of the college of agriculture for Saskatchewan, the superintendent of the experimental farm, Indian Head, and the president of the Grenfell agricultural society with the director of extension work in the college of agriculture, as secretary. The convener of the committee, Dean Rutherford, asked for a meeting of the committee to prepare rules to govern the contest and this was held at Indian Head on April 11th.

The approved plan provides for a division of the province into four parts. Prizes will be offered for the six best fields of alfalfa in each of the districts. The prizes will be as follows: First, \$500; second, \$400; third, \$300; fourth, \$200; fifth, \$100; sixth, \$75. The first prize

field in each of the four districts will be scored for the championship which will consist of a magnificent silver trophy.

All contestants must be paid up members of the nearest agricultural society. Entry must be made before August 1, 1913, and the crop must have been sown not later than the season of 1912. The entry fee has been fixed at the nominal sum of \$5.00 and must accompany the entry which is to be sent to the director of extension work previous to the date specified. The field of alfalfa must consist of not less than ten acres, but if the size of the plot exceeds the minimum the whole field will be scored. No artificially irrigated crop will be eligible for entry in the competition.

A full list of the rules governing the competition are being published for the guidance of interested persons and will be supplied free on application to the secretary of the committee, F. Hedley Auld, Regina. There has already been shown a marked desire on the part of the agricultural papers and others interested in agricultural development to assist in financing this great competition. The committee decided, however, that while it would gladly accept cash contributions and give due credit for such donations, it could not accept special prizes of any kind to be given for a specified purpose, as the changing of conditions would still further complicate the judging which is not an easy matter in a contest so large as this will be.

\*\*\*

## Co-operative Movement in Japan

Dr. T. Nishigaki, formerly secretary of the Japanese Central Co-operative Union, has kindly supplied us with the following information: The co-operative movement in Japan is by no means new; for generations co-operative granaries have been in existence, which have pro-

vided the poor with seed and grain, but especially with rice, in times of famine, for which they paid interest. Societies called "Ko" or "Muzin" have also been in operation for many years, and are a modest form of credit society, the members of which pay for their shares by instalments, and from which they can borrow money at a fixed rate of interest. Many thousands of such societies now exist in Japan. The chief industry of the country is agriculture, and consequently rural societies preponderate. In 1891 the first co-operative act was carried through by Count Shanagawa, Minister for Home Affairs, but this only dealt with credit societies. In 1899 the law was revised to include co-operative societies of all kinds, and came into force in September, 1900. According to this law, a co-operative society has the same legal rights as the individual, and is permitted to work on the following lines: (1) To assist its members in producing the required capital, and to help them to make the best use of their savings. (2) To sell the goods produced by its members, either as finished articles or to be worked up. (3) To purchase wholesale the raw material required by its members for the production of their wares or for consumption, and to retail to them. (4) To work up the unfinished goods made by its members, and to lend them the necessary tools for their work. A co-operative society is not limited to one of these forms of co-operation only; it is free to fulfil one or all of these functions. At the end of 1900 there were 21 Japanese societies working on the lines laid down by the new law, of which 13 were credit societies. At the end of June, 1909, there were no less than 5,149 societies, 1,864 of them being credit societies. 194 societies undertook to carry out all the above-mentioned functions, 744 were purely productive societies and the remainder united two or three lines of work. In 1903, 571 societies had a membership of 45,131; and in 1907, 1,623 societies had 151,123 members. The average number of members to each society in 1903 was 79, rising in 1907 to 93. The paid up capital amounted in 1907 to an average of about £148 per society, or 31/- per member. The reserve fund averaged £30 per society

and 3/- per member; the loans £240 or 50/-; the savings deposits about £12, or 31/- per member. 1,623 societies, with 151,123 members sent in their statistical returns in 1907, of which 141,136, or 80.2 per cent. were employed in agriculture; 10,475, or 6.9 per cent. were traders; 4.7 per cent. artisans; and 3,028 or 2 per cent. fishermen.—The Scottish Co-operators.

### We All Know 'Em

There is a man in our town, his like is hardly known,  
 He never drinks, nor smokes, nor swears,  
 and always stays at home;  
 He never chews, nor lies, nor fibs, nor does  
 a thing that's wrong.  
 That's why I write this little verse, to  
 remember him in song—  
 He's paralyzed!

There is another man in town who also  
 is all right,  
 His wife can always tell you where you'll  
 find him any night;  
 He never flirted, praised, nor fawned upon  
 a maiden fair,  
 Won't even look at beauty, nor at wealth  
 of golden hair—  
 He's blind!

There's a man who lives on Cayhill-  
 street, won't listen to a thing,  
 The gossips may keep gossiping until  
 they make things ring;  
 Won't go to hear good preaching, nor  
 music, nor the band,  
 Won't cross the street if Sembrich were  
 singing at the "Grand,"  
 He's deaf.

There also was a man in town who com-  
 bines them all above,  
 And went a step beyond them—wouldn't  
 even fall in love;  
 He was a model man for sure, as you may  
 well suspect,  
 Belonged to a peculiar class—just one of  
 the Elect—  
 He's dead.

The best way to get even with a fellow  
 is not to.

The heart makes fewer mistakes than  
 the head.



# THE MAIL BAG

## NOTICE TO CORRESPONDENTS

This department of The Guide is maintained especially for the purpose of providing a discussion ground for the readers where they may freely exchange views and derive from each other the benefits of experience and helpful suggestions. Each correspondent should remember that there are hundreds who wish to discuss a problem or offer suggestions. We cannot publish all the immense number of letters received and ask that each correspondent will keep his letter as short as possible. Every letter must be signed by the name of the writer though not necessarily for publication. The views of our correspondents are not necessarily those of The Guide. The aim is to make this department of great value to readers and no letters not of public interest will be published.

## THE CRISIS

Coming events cast their shadows before. Indications point to a general election in Manitoba before snow flies again. The Grain Growers head a movement among the masses of the people to secure wealth to those whose labor produces wealth and to prevent any from getting wealth at the expense of the industry of others. This is the "Simple Justice" among people that the "Goddess of Justice" stands for, week by week, on the front cover of THE GUIDE. Simple justice, no more, no less. And that simple justice demands, just what Christ demanded, viz.: "That each should be rewarded in proportion as his work should be." So that not only the Grain Growers but Christianity demand that those who toil produce wealth, and that those who produce not, should have not. This is the heart of the Grain Growers' problem, as well as the "chit," "core" of all religions.

This was the "nub" of the African slave problem that agitated the United States before the war, but now instead of having slave owners we have a privileged class, privileged by law, privileged to fatten off the labors of the people to a far greater extent than the slave owners of half a century ago fattened off the labor of their "black property." And the privileged classes of today hold their privileges, but escape responsibilities to the government that give them those privileges. And this legal privilege gives the holder a power to extort tribute from those who labor. The special privileges of the few, are the common rights of the many. Those who own special privileges own something that belongs to all. This is not as it should be, and it is the duty of the Grain Growers to set their faces, like flint, against special privileges without responsibility, in all its various forms. And this can be done, only by supporting candidates at the ballot-box, who openly pledge themselves to do what they can, if elected, to get "crooked laws" made straight, or to secure for the people power to make or amend their own laws, as the initiative, referendum and recall imply. It should be borne in mind that the masses are robbed by law, and that the law makers profit by such robberies. This fact is so plain that no argument is needed to establish it.

One of the means of plundering the people is, by pretending to own the spot of earth they must live on and labor on. Nearly half of Manitoba is owned by those who do not intend to labor on it. They own for the purpose of taking the crop from the people who must live on and labor the land. Surely this is a violation of justice and national right. Surely "equity" does not sanction that sort of thing. Surely the crop should belong to the man who labors for it not to the man who pretends to own the land? Surely God never made the earth to be owned for the purpose of enabling a cunning few to buy toll off the labor of the toiling many.

Now, Mr. Editor, I have already pointed out that farmers should get the increased value, that their presence and industry puts upon the vacant and non-resident land. And the Valley River G. G. A. has demanded that the government amend the Municipal Assessment Act as to authorize municipal councils to collect double the amount of taxes from vacant land than from used land. So let the Grain Growers everywhere get a pledge from candidates in writing—whisper in the ear, promises are no good—to the effect that they will both work and vote to get the act so amended as

assessment on non-resident land by \$100 each year more than that of actually used lands, so long as such vacant lands are held by non-residents. People can get this measure by their votes and influence and persistent demand. Many politicians in both parties are waxing fat, and having a jolly picnic by holding vacant lands, that settlers are making valuable. But this little change in the taxation act will spoil their fun, as the voters can win hands down, if they remain firm and press their demand. One candidate already in the field says he has nothing else now to do, but to work for the interests of the people. Put this point up to such and ask them how hard they will work to secure it.

Again the growing value of town sites is due to the industry of the people. That value belongs to the people. It is theirs. Their labors create that growing value. That value is a rapidly growing public debt upon the people if they do not secure it for themselves. The site

finds a hiding place in the pockets of town site exploiters.

This town site proposition is a very important one. The government is generally in with a railway company, and the tools of the government, the heebers and the exploiters, generally are often rewarded by the government with an interest in the town site. This is one of the ways, both grit and tory governments reward their "dogs of war." But is it now up to the voters to secure for themselves this increase in town site value? Is this not also a good point to put up to the candidates who are so anxious to do something for the people? And in this fight for justice, equity and fair play, may we not reasonably expect the Grain Growers to lead the way? The opportunity is almost here. The world is watching. Will the Grain Growers let the politicians talk to them, or will they talk to the politicians? The crucial test of the strength of any movement always manifests itself at the ballot-box.

Plumas, Man. W. D. LAMB.

## HE GOT SATISFACTION

Editor, GUIDE:—I have heard some complaints as to the manner in which The Grain Growers' Grain Company handles grain, and that they do not secure the best market price. Such reports prove a great detriment to the company, and I would like to give you my experience with them. I shipped my first car of wheat in October which graded No. 1 Nor. with instructions to sell same before expiration of free storage, to the best of their ability, which they did. On October 29 they sold it for 99 cents at Fort William, which was 3/4 cents over market quotations for that day. My second car was oats, shipped the last days of January with same instructions.



Comfort on the Farm

owners take more and more out of the people, and give back nothing in return, the more valuable the site becomes. These sites are generally owned by an active politician and the railroad company. These site owners, in many cases, claim that their site must be rated as agricultural land for taxation purposes, so long as they are the holders, but that as soon as the lot is sold to someone else, then that lot must be rated as town property. But there is one way to spoil their game, and that is to get the assessment act changed, so that the valuation of the improvements must be entered in one column, and the total assessment of lot and improvements in a third column. This is what the law requires in the case of incorporated towns and villages and the law should be amended, so that this will apply to all registered town sites, incorporated or not. This would prevent vacant lots being rated lower than used lots, and thus secure for the public treasury a nice sum of money that now

They graded 1 C.W. and sold for 38 1/2 cents at Fort William on February 14, the quotation being 36 cents on that day. Now, I think those sales go to prove the ability of the company in handling our grain. At least, I am well satisfied, and hope to ship them many cars in the future. As farmers, I think we should stick to our own company. Especially one which has done so much for us as The Grain Growers' Grain Company. J. W. HANNAH. Rouleau, Sask.

## THE GUIDE IN NEW ZEALAND

Editor, GUIDE:—Your valuable paper has been reaching me all O.K. and I am very pleased to note in the last that reached me that at least two of the governments have decided to give us government-owned elevators. I am very much interested in the matter, coming as I do from New Zealand, where I was born and raised, and where the government own all public utilities.

## FOUND GOOD VALUE

Editor, Guide:—Enclosed find One Dollar in payment of my subscription to your valuable paper. I first took it on a three months' trial, but I am well satisfied that it is worth a dollar many times over.

Hannon, Sask. FRANK WALKER.

## DON'T FORGET NAMES

We cannot publish letters that are sent in without names of the writers attached. We must know who is writing to be sure the letter is sent in good faith.

I find that I cannot do without your paper. Even while I'm travelling around I find it very interesting and take great pleasure in showing it to my friends to give them an idea what we are doing towards co-operation and fighting the combines.

I have been farming eleven years at Weyburn, Sask., and am now on a visit to my old home.

Wishing you success in further protecting the rights of the farmers and the Grain Growers' Grain Company. G. M. DAVIDSON. Tapanni, Otago, New Zealand.

## CRITICIZES CONVENTION RESOLUTIONS

Editor, GUIDE:—Please allow me the privilege to make a few remarks through THE GUIDE concerning some of the resolutions passed at the convention.

I believe in compulsory hail insurance, not allowing any one to register out.

I don't believe in the government paying full value on horses killed on account of glanders, for this reason: It will encourage neglect. The horse gets a cold, it is not taken any notice of, he gets cold upon cold until he gets in a very weak state and his blood gets in such a poisoned condition that it must break out somewhere, and it comes out in the shape of glanders. It is like the Old Country doctor, who said to his patient: "Get rid of that cold or you will get consumption."

I read the other day that at a meeting of the board of the Canadian Pacific Railway Company a dividend of two per cent. on the preference stock and three per cent. on the common stock was declared for the half year ending December last, payable on April 1 next. After payment of working expenses, fixed charges and dividends now declared, there is a surplus for the half year of £2,122,381. Such a surplus shows plainly that the C.P.R. Co. is in a position to provide ample accommodation for all kinds of goods received by them for transportation if they are called upon to do so, let it be cattle, grain or merchandise of any kind. It is the duty of the public through their members, to call upon the railway authorities to provide the necessary facilities at all stations. For this reason I say government owned elevators are not needed.

With regard to the resolution moved by F. M. Gates and seconded by E. N. Clayton, "That as the question of a contribution to the British navy is foreign to the interests of the Grain Growers as grain growers, therefore a discussion of the subject is not in order and it should not be dealt with by this convention," and carried.

I must say that there could not have been many true sons of Great Britain in that convention, or they would never

We would like to hear from a great many of our readers on the subject of Protective Tariff, and also on the Taxing of Idle Land. Write and let the other readers know what you think about it. Write now.

have allowed such a motion to be carried. To say that the subject is foreign to the interests of the Grain Growers is radically wrong, because the country will be taxed to obtain means to build and support a Canadian navy, or present the Old Country with means to strengthen her navy. Now, we all know that the tiller of the soil has to pay these taxes directly, no matter in what shape they are put onto the country. For that simple reason the convention of farmers should have dealt with this subject in a very determined way. As a true son of Great Britain, I say that Canada should present the mother country with the means to build three Dreadnoughts. It is to Great Britain that Canada must look for pro-

tection. If Canada builds a navy of her own it will neither be of use or an ornament.

Another resolution by Messrs. G. Langley and T. Conlan states, "Whereas railway companies are, at the present time, building their lines with a view to competition rather than to developing new country, be it resolved that in future aid be only granted to those companies who build with a view of developing new country."—Carriell.

Such a motion is quite contrary to what I would think a number of farmers would pass. It is competition in railways that the farmer needs, so that the rates may be lowered for carrying his produce to the markets, also the implements and other material the farmers need. If new lines are needed, let the inhabitants of that particular district petition for it. We must not kill competition. The great combines have done too much of that already. Honest competition is the life of the commercial world.

EDWIN JACOB.

Saltreata, Sask.

### THE TARIFF ROBBERY

Editor, GUIDE:—In your issue of April 6 you invite a discussion of the tariff question. I came from south of the line where they trot out the tariff every five years at election time for the purpose of dividing the farmers' vote and distracting his attention from subjects of more importance. When they reduce the tariff there, it is usually on diamonds, silks and antins, but never on articles which benefit the farmer. Now, on this side of the line the Ottawa government has just reduced the duty on about a dozen articles, not one of which is of any great benefit to the mass of the people. This was brought to my mind by a personal experience this past winter. I needed some tools and fencing, and wrote to Canadian and United States manufacturers for catalogues. While prices are a great deal less south of the line, when freight and duty are paid there is not much difference. There cannot be a great deal of difference in the cost of manufacturing as between the two places. It is evident that the Canadian manufacturers add to the price of their goods the amount of the duty on these goods, so we farmers have the duty to pay, whether we buy from Canadian or American manufacturers. It has made an absolute free-trader of me. Let the infant industries take care of themselves. I imagine that farming is somewhat of an infant industry in this western province at present. The free trade may be too radical for a new and young country like Canada, but it is the only solution I see, as the tariff is the mother of trusts and monopolies.

Stettler, Alta.

R. NOURSE.

### THE HUDSON BAY ROAD

Editor, GUIDE:—Your editorials of the 13th and 20th inst. have shown that THE GUIDE is really in earnest about the Hudson Bay Railway. The Free Press and minister of railways are hardly half in earnest, and the recent theatrical Globe-Graham-Free Press controversy is to fool the farmers.

Should all the local Grain Growers' Associations of the three prairie provinces individually and without delay convene, pass a resolution and forward one copy each to the premier, the minister of railways and their local Dominion representative and before the House has adjourned for the session, there would be something substantial done, and quickly. Indeed, so substantial is the gain to the Grain Growers that it is a matter of equal importance with the elevator problem of the three prairie provinces combined, and would even justify the cessation of seeding to get the work under way.

25 miles in 1910 is an insult to the grain growers of the west.

Saskatoon, Sask.

LAWRENCE GALT.

[Note.—This is a good scheme, but it is too late to accomplish anything at the present sitting of the House of Commons. The government has determined to make the Hudson Bay Railway a farve and nothing can be done before next session. This fall it will be wise for all associations to deal with the matter.—Ed.

### SUGGESTS A BOARD

Editor, GUIDE:—As an interested member of the Grain Growers' Association I think it is the duty of every member to interest themselves in our great movement. It may be a benefit, or it may be a failure as regards improving present conditions. If it is going to be a benefit, then let everyone interested in the welfare of this association give it very careful consideration. I would like to give expression to some of my views and would like to hear comments from others. In the first place, I would like to see forty-two Grain Growers elected the same time as the provincial elections, on the same ballot as our representative, one member from each constituency. Let those forty-two men be elected for four years and have the responsibility of electing a board for one year. This board could meet other local boards in Saskatchewan, Alberta, etc. Each member elected would take thresher reports to ascertain the amount of grain grown in that constituency, and in this way the amount grown in the province could be ascertained. When an elevator was needed in a community, the representative of the Grain Growers could bring the matter before the board, and the money could be advanced on the bond of the people of that community. There should be terminal elevators at Fort William and Winnipeg, to be owned and operated by the Dominion government. I would advise that every farmer shipping grain should retain a sample of each load and express or mail it to one of our agents giving number of the car. We would then be in a position to sell on sample. I think it would be advisable to ship only part of our grain to the market at once. I wish to impress upon every member of the association the advisability of keeping politics out of our society.

H. L. POWER.

### COMPULSORY HAIL INSURANCE

Editor, GUIDE:—As compulsory hail insurance seems to be one of the leading topics, I thought I would give you our ideas on the subject as we have discussed it pretty well at our local and I think we could agree with Mr. Ball of Strathcona, pretty well on his graduated land tax, only we don't think any land should be exempt. I do not think there is any man so poor that he could not afford to pay \$1.00 for his insurance, and as far as the ranchers are concerned, there are very few of them in this part that has over one quarter of land and some none at all, and as they are exempt from all tax on their stock, they could well afford to pay \$1.00 on their land. Nearly all of them are farming more or less, and I don't think there would be the least objection on their part. We have a live local and have got nearly every farmer in our vicinity in the local and we expect to have them all soon. Whenever we can get a man to read THE GUIDE we are sure to get him, and if I am not mistaken, you will hear from the farmers at the next election.

Prairie Center Local.  
Erskine, Alta.

B. O. WITTER.

### THE GRADING SYSTEM

Editor, GUIDE:—As an instance of how the farmers' wheat is graded by Mr. Horn's department at Winnipeg, when shipped to the Grain Growers' Grain Company, I send you the following:

I sold some wheat to the Canadian Elevator Company, at Langenburg, for 84 cents, graded No. 4. I also sold some of the same wheat to the Dominion Elevator Company, at Langenburg, and it graded No. 4 at 84 cents. I shipped some of the same wheat to The Grain Growers' Grain Company and Mr. Horn graded it No. 6, price 83 cents at Fort William. My loss will be about 13 cents per bushel. Now, what I would like to know is, does Mr. Horn grade the same for the elevator companies as he does for the farmer? There is a very strong feeling against this kind of usage among the farmers in this part of the country. By publishing this letter you will greatly oblige many of your farmer subscribers in this part.

Langenburg, Sask.

J. POLNICKY.

Worrying is a general and popular way of committing suicide.

# Foresight!

Means Provident  
Care for the Future

IS IT FORESIGHT to waste money on a flimsy Cream Separator because it is a little lower in price? It may skim for a short time, soon get out of repair and is ready for the scrap heap in a year or two. "CARE FOR THE FUTURE" means—select the strong built "Magnet" made by the Cream Separator Specialists, The Petrie Mfg. Co. Ltd., Hamilton, whose Great Success has been attained by building this Cream Separator, Superior In Every Way To All Other Separators. DO NOT TAKE our word for it, but Compare It, point by point with any or all cream separators, and you will find each part in the "Magnet" stronger and better adapted for doing the work for years than the parts of any in the others.

- 1st.—The square gear construction.
- 2nd.—The strong and rigid frame.
- 3rd.—The double supported bowl—"MAGNET" Patent.
- 4th.—The shifter in one place taken out all foreign matter leaving practically pure cream.
- 5th.—Perfect skimmer, the advertised capacity.
- 6th.—Easy turning; children operate.
- 7th.—Easy cleaning; clean within five minutes.
- 8th.—Change of capacity in the same stand for a few dollars.
- 9th.—Perfect brake; saves time; "MAGNET" Patent.
- 10th.—Safety; all parts covered.
- 11th.—Skims standing on the ground or any floor.

Our Guarantee Covers Each and Every Point. Send for Catalogue; Free to every dairyman. Department E, under the management of a Graduate, will answer all enquiries in regard to dairying. Free. Our 12 years' experience as Dairy Specialists is at your disposal. We can and will help you. :: :: :: Write

The Petrie Mfg. Co. Ltd., Hamilton, Ont.  
Head Office and Factory  
Branches: Winnipeg, Calgary, Regina, Vancouver, Montreal, St. John

### AGAINST CO-OPERATIVE PLAN

Editor, GUIDE:—In your issue of the 6th inst. James H. Fry handled a very important matter in a very masterly way. Notwithstanding the proposition of Mr. Partridge to apply the out and out principles of co-operation to the division of the profits of the Grain Growers' Grain Company, there is no doubt but that any change in the present mode of operation would be unjust to a large number of stockholders who do not ship grain. It might be asked why they do not ship? The answer is that creditors won't wait. From my own observation in this locality which is slowly being reclaimed from scrub, I have noted a few hard facts. One is that a thresher buys an outfit and has to pay fifty per cent. more than it is really worth. When threshing time comes round he naturally threshes for the biggest men first, possibly because he can get his money quicker from them. When he gets the big ones fixed up the smaller ones get their turn, and it is often late in the season before threshing operations close. By this time the machine companies have their full equipment of hired bullocks on the road, so that the small farmer is forced to follow the line of least resistance and sell to the elevator. Let Mr. Partridge reconsider his proposition. We are evidently a long way off perfection yet. Let us look to the animal world and take a lesson from the gobbling up process which is daily in evidence there.

Minitonas, Man.

D. BLAIN.

### SUPPORT WELLINGTON

The following letter has been received by the Grain Growers' Grain Company: "In reply to your favor of March 18 re taking more shares in your company. This makes me think of the time John Kennedy came to me in Swan River with a little book to put my name down for shares in the Grain Growers' Grain Company. In 1906 he said the shares were not payable but just put my name down for only \$2.50 and I would be called on later for that amount. Well, I put my name down and gave him the \$2.50, telling him that it was all I had, but it was worth \$2.50 to help a good thing along, supposing I never saw it again. Now, my share has grown to \$25.00, with only \$2.50 added to my \$2.50. I would like to take more shares in the company, but I have just pulled through

two bad years and just at present money is rather tight with me. I have always had confidence in the Grain Growers' Grain Company before it had any tail feathers and before it could crow, but by honest dealings it has become a first class bird and is licking all the older birds out of the farmers' grain bin, that were more ornament than use to the farmers. Any time that I have \$25.00 to spare it will be on our young fighting cock, although the people said it would never amount to anything. The Grain Growers' Grain Company has made a great effect on the price market since they came into existence. The farmers should support their Wellingtons and skin the selfish Napoleon who left his men on the road to die when they had no strength left to keep up to the main army, but Wellington picked those poor fellows up and cared for them and he won the battle of Waterloo, and a craven died of a broken heart, a prisoner and outcast.

Swan River, Man.

W. C. MITCHELL.

## SEYMOUR HOTEL

Farmers from the Three Provinces make it their headquarters when visiting the city. Every street car passes the City Hall, which is only a stone's throw from the hotel entrance.

JOHN BAIRD - Proprietor

Rates \$1.50 per day  
Free Bus from all Trains

### WHEN DOWN IN THE MOUTH

Remember Jonah, He Came Out Alright  
And so will you if you buy eggs for hatching from James Goring. Brown, White and Buff Leghorns, Black Minorcas, Buff Orpingtons, Houdans, 15 eggs for \$1.00. Dark Brahma, imported from England, 15 eggs \$2.00. Spout White Khoudykes, \$2.00 per 15. Golden Laced Wyandottes, \$2.00 per 15, imported from England. Moscow Duck Eggs, White \$2.00 per setting 11 eggs. My birds are all imported from the best stock that money could buy from Ontario, U.S. and England. White and Buff Leghorns and Houdan Cockerels for sale, \$1.00 up to \$3.00.  
JAMES GORING, Roden P.O., Man.

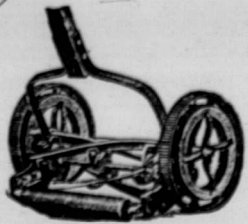
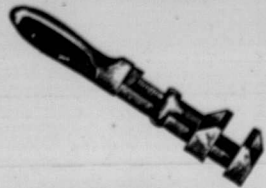

# AN Eaton Tool For Every Kind of Work

FOR every season on the farm, and for every sort of work, The Eaton Catalogue offers some tool or implement that makes the labor easier and the expense lighter.

We plan months in advance so that when the time comes we may be prepared to supply needed goods at the right price. One harvest is scarcely off the ground before we are busy making arrangements for the next season's trade. This gives us opportunity for careful selection of goods and leaves manufacturers plenty of time for thorough work.

It is this careful forethought on our part that makes The Eaton Catalogue so valuable as a ready reference for farm and home needs.

No matter where you live this Catalogue makes you neighbor to the largest stores in the British Empire, and through our Mail Order service, goods may be bought by mail with every assurance of satisfaction.

The Eaton Guarantee follows every shipment. It protects against loss or damage while goods are in transit, and after you receive the goods, our Guarantee permits the return of any unsatisfactory purchase. We pay charges both ways on returned goods, and will promptly exchange the unsatisfactory articles or refund the purchase price.

This liberal Guarantee takes all the risk and uncertainty out of Mail Order buying. It makes a Mail Order to Eaton's the simplest and most satisfactory way to buy goods.

A copy of the large Eaton Catalogue will be sent free to any address on request.

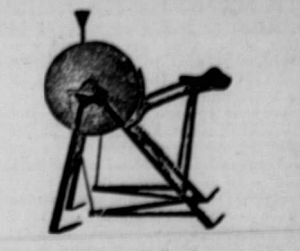
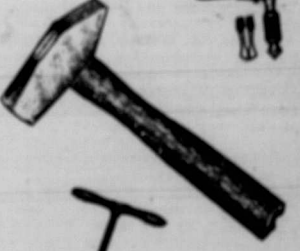
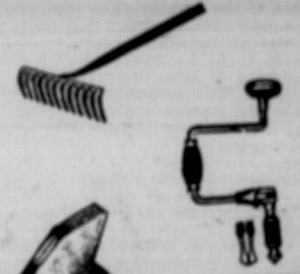

THE T. EATON CO LIMITED. WINNIPEG CANADA

! tractor time. r two. built alists, lton, 'ream. vators. point in the years ent. matter dollars. to every over all Duty Write Factory Ont. John ent money ve always Growers' l any tail crow, but me a first the older bin, that se to the ive \$25.00 ig fighting l it would The Grain s' made a since they ers should l skin the en on the o strength army, but or fellows e won the aven died d outcast. TCHELL. JR no make ime the he C112 ow from prior r day rains MOUTH Alright r batching and Bel Dyringtons Headman. l. Spuky idea Lucel from Eng- site \$2.50 l imported could buy White and s for sale. D., Man



# ALBERTA SECTION

This Section of The Guide is conducted officially for the United Farmers of Alberta by Edward J. Froom, Secretary, Innisfail, Alta.

## Bulls Running at Large

ONE of the subjects which received considerable discussion last year, also at the annual convention of the U. F. A., was the matter of bulls running at large, more especially scrub bulls. This subject was revived at the annual meeting of the Pure Bred Cattle Breeders' Association held in Calgary, and a very strong protest was registered on this subject. The complaint mentioned there was that scrub bulls, or beef bulls of another breed, break into a pasture and get pure bred yearlings into calf, thereby causing not only the loss of getting an inferior calf, but the usefulness of heifers are impaired, because in order to maintain the size and quality of a beef herd it is imperative that the females should not be bred until they are at least two years of age.

It is evident that the farmers and ranchers are practically unanimous in their opposition to having bulls running at large. Officials of the government have always been ready to give the information that it is an easy matter to secure an order granting them what they ask for and that in a great many instances the parties complaining already live in districts where bulls are prohibited from running at large, and all that is necessary is to see that the law is enforced.

But what is the law? In substance it means that every man must turn jailer and poundkeeper, for in the districts where the bulls are prohibited from running at large any person may take up a bull and can collect \$5.00 from the owner for doing so, he may also collect a fee for each and every day he has kept the animal waiting the owner's arrival to claim him. How many farmers are going to do this to their next door neighbors? The majority at least will look at the matter from the standpoint that if he enforces these conditions he has made an enemy for life, and it is not a very nice job to be living next door to someone who has it in for you. Most men see no reason why they should make policemen of themselves.

Some say this duty should fall upon the shoulders of the R. N. W. M. P.; others think it would be a good job for the brand readers, but all are unanimous that the work should be done by somebody other than themselves.

The minister of agriculture was questioned on the subject in Calgary and he told the meeting that the law authorizing the appointment of brand readers had so far worked well. This was due to two facts, that is, it is right in theory and the department has been able to secure competent men to act as brand readers. But he reminded his hearers that the majority of these readers were stockmen like themselves, that in a great many cases it required a good deal of persuasion to induce them to act as brand readers, and he felt sure that if the duty of taking up bulls was imposed upon them many of the best men would resign, and that would result in having to accept an indifferent brand reader in order to secure a man willing to take up entire animals, and he thought some other means should be devised.

A suggestion was made at the meeting that this objection might be overcome by granting the brand readers power to appoint a deputy for taking up bulls.

Mr. Stevens, the live stock commissioner, stated he had never experienced that fear of his neighbors that some of the breeders seemed to have of theirs. He said that one of the surest ways of getting a neighbor's ill will is to lead him to believe that you are afraid of it. But he added what seemed to him to be the strongest argument in favor of having this work done by an official whose duty it would be to do it, would be the moral effect of the two methods. He stated that when one farmer took up another's bull it merely cleared that vicinity, which as a rule would not mean more than half a township, but if a public officer were to take one up the news would travel fast and every bull within

a radius of ten miles would immediately be looked after and taken off the prairie.

At the close of the discussion the minister of agriculture thanked the breeders for the privilege of being present at the meeting, and stated that several ideas had been brought out that he had not previously thought of and several good suggestions had been made which, he thought, would aid him in solving the difficulties that at first appeared to stand in the way.

### OKOTOKS COMES INTO LINE

A temporary organization of the U. F. A. was formed at Okotoks on April 27, with Harold Bannister, president, and Mr. P. P. Woodbridge, secretary-treasurer. There was a fair attendance of farmers, and Mr. Bannister, in introducing Mr. W. J. Tregillus, vice-president of the association, said:

"The organization of this branch of the United Farmers of Alberta is one of the most important things for the farmers around here that has come up for a long time. The farmers must have better facilities for marketing their grain, and the time is coming when they will. The companies, especially the elevator companies, are treading on our necks and we must unite to get our rights."

Mr. Bannister read a letter from a friend in Vancouver, B. C., who has been trying to market some of his oats, in which the writer said some of his oats were worth 35 cents a bushel there now and he thought they would go higher. The writer said he had been informed by a man connected with the Vancouver Milling Company that the Alberta Pacific

and said: "We farmers want to realize our possibilities. We are the producers. Civilization follows the plow. We should realize that we are the most important factor in the commercial world. We estimate ourselves too low and others take us at our valuation. History shows that much cannot be accomplished when men do not organize, and yet farmers have always stood alone. However, I am glad to say that things are changing in this respect. We may become the best scientific farmers in the world, but we will fall down if we don't take care of the business end of our profession. We should be guided by California. There the farmers and fruit growers improved their methods of growing so much that they overstocked the market. It was one of those that are the forerunners of better things. Because of that lesson the Californians formed the most highly organized system of disposing of produce in the world. They not only found markets, but created them. We must do the same. The growers get too little; the consumers pay too much.

"The farmers are robbed daily. I heard an example at a fair held up north last fall. A farmer showed a sample of wheat he had sold for No. 3 to the provincial seed inspector, who said it was good No. 1. A number of others told the farmer the same thing. So he lost \$900 on a crop of 10,000 bushels. We should encourage the building of the pork packing plant, and trade with British Columbia. A meeting of buyers and growers is to be held in Vancouver soon to discuss this improvement of trade with Alberta and the necessary adjustment of freight rates.

"There is no reason why the farmers should not get a fair return of their labor

## UNITED FARMERS OF ALBERTA

### PRESIDENT:

JAMES BOWER - - - RED DEER

### VICE-PRESIDENT:

W. J. TREGILLUS - - - CALGARY

### SECRETARY-TREASURER:

E. J. FREEMAN - - - INNISFAIR

### DIRECTORS AT LARGE:

James Speakman, Penhold; D. W. Warner, Clover Bar; L. H. Jelliff, Spring Coulee.

### DISTRICT DIRECTORS:

T. H. Balaam, Vegreville; George Long, Nainoo; F. H. Langston, Rosenroll; E. Carwell, Penhold; J. Quinsey, Barons; E. Grisdach, Gleichen; A. Von Mieleicki, Calgary.

Mr. Hoadley also addressed the meeting and said: "I think the question of elevators should be dealt with by the government. The government was created to protect you, and if it does not, it is not carrying out its purpose. What Manitoba and Saskatchewan farmers have carried out through organization should be sufficient illustration of what you can do. And there are other important matters to be considered besides grain. Rome's achievements were due to her perfect organization. We should remember that, and still there is no use of getting together unless we stay together. I am in parliament as a representative of a constituency, 90 per cent. of which are farmers, as I have already explained on the floor of the house. My duty as I see it is to do all I can to help the tillers of the soil. Owing to the present mix up, I have had little opportunity to do so, however, up to the present time."

### GOOD STORE BUILT

The regular monthly meeting of Blackfoot Union took place at Jarrett's store, Blackfoot, on April 7th, and was well attended. We were glad to see the old faces back again after the winter's absence.

Two new members were enrolled and three shareholders secured for the local scale. Wednesday, April 13th, was set aside for putting down gopher poison, on motion of Messrs. Gordon and Tingley.

It was decided to make an effort to secure a carload of twine from the Brantford Farmers' Co-operative Company, and to this end two local unions have been written to, and all are asked to communicate if they are interested.

Mr. Jarrett's enterprise in establishing such an up-to-date store at Blackfoot is deserving of mention, and he should be complimented on his energy. The U. F. A. can claim some credit in offering encouragement to such enterprise by bringing the farmers together and trying to infuse into them the spirit of organization.

The next meeting will be held on Thursday, May 12, at Jarrett's.

JAS. STONE, Sec.

### A DIVERSITY OF OPINION

On April 9 the Cook Union held a meeting at Battle River and discussed hail insurance and the pork packing plant.

In regard to the former, the members were unanimously of the opinion that Plan No. 7 was the most suitable, but it was resolved that the question should be left to the executive to arrange a plan which would enable the association to come to some definite decision.

There was some diversity of opinion as to the pork packing plant, and it was decided that the question should be held in abeyance until the union had been visited by the live stock commissioner, by whom, it was hoped, the scheme would be thoroughly explained.

Nine new subscribers were secured for THE GUIDE and the meeting then adjourned until the first Saturday in May.

J. N. FRANKLIN, Sec.

### TOO MANY IRONS IN FIRE

The regular meeting of Great Bend Union was held on April 8, about 20 being in attendance, including visitors. The regular routine of business was proceeding with and one member reported having cows for sale. Mr. Amos Wilton was appointed on the market committee.

### THEN AND NOW



Residence of James Laird, Mountain House, Alta in 1903



Present home of James Laird, Mountain House, Alta.

Elevator Company was trying to corner the grain in Alberta, and to that end is selling grain at cost in Vancouver in order to freeze out the smaller companies. "This company is selling six cents a bushel lower than it should," reads the letter, "with the purpose of crushing competition. It made 50 to 60 per cent. on its capital last year. The quicker you people in Alberta get after it the better."

"My friend got the information from a man who is supposed to know," explained Mr. Bannister, "and if it is a fact, it is nothing less than highway robbery."

Mr. Tregillus was then called upon

and capital and the farmers help each other by organizing. In Strathmore they had a live organization of 70 men, which meets regularly for social, as well as educational purposes. Attending these meetings is better for a farmer than a business college.

In response to question Mr. Tregillus told how the U. F. A. had helped a farmer who had been sold an inferior threshing machine, and how the organization had taken up the matter of claims for prairie fire losses against the railways. He also dwelt on the importance of the question of provincial elevators and pork packing plant.



ERTA  
DEER  
LGARY  
misfall  
D. W. Jellif,  
George ngston, enhold, isbach, algary.

he meet- tion of l by the vas creat- ions not, e. What farmers nization of what ther ind besides were due re should s no use stay to a repres- per cent. e already n house. all I can Owing to had little r, up to

f Black- it's store, was extra to see the winter's

olled and the local was set r poison, d Tingley, effort to be Brant- Company, have been communi-

ublishing Blackfoot he should gy. The n offering rize by nd trying organiza-

held on E. Sec.

ION n held a discussed ing plant- members that Plan ut it was would be re a plan ation to

pinion as d it was would be nion had mmission- e scheme

cured for adjourn- lay. LIN, Sec.

ATRE at Bend about \$0. visitors- ness was reported as Wilton mmittee.

Mr. L. M. Doughty requested information in regard to woven wire fencing.

The meeting endorsed the action of the central committee in protesting against private companies soliciting hail insurance.

In regard to the pork packing contracts it was ascertained that the members in Great Bend are not producing enough pork for export at present. One member stated that he had read in the newspapers that 30,000 hogs had been secured or contracted by farmers. Is this a bluff?

The meeting endorsed the general secretary's plan on the hail insurance question.

The resolution from Roseview Union was discussed and it was unanimously decided to protest to the government against land grants and subsidies to private companies. Why not start at the foundation and subsidize the producer, the farmer, miner and farmer, if any subsidies are floating around? Our motto is equity, equal rights to all and special privileges to none.

It was thought by some members that the association was getting too many irons in the fire, but a resolution that the union was in favor of more concentrated action on the part of the executive was defeated.

Members who visited Trevenile Union and went to bed early next morning reported to the meeting very favorably on the impressions received.

The matter of securing twine was laid over till the next meeting.

C. J. NORTON, Sec.

**OPPOSES PRIVATE HAIL INSURANCE**

The regular meeting of Olds Union was held on April 21, with President Rands in the chair. After the roll call of officers and members the minutes of previous meeting were read and adopted, on motion of Messrs. Appery and Haynes. While the attendance at the meeting was not very large the interest taken was very keen and the different propositions mentioned in circular No. 3 were discussed with much interest. It was unanimously decided to support the executive in the stand taken to oppose private hail insurance companies doing business in the province, and the following resolution was adopted on motion of Messrs. Dudley and Lambert:

"That this union is opposed to any private companies doing a hail insurance business in the province and endorses the stand taken by the executive in this matter."

The secretary was instructed to procure 25 labor bureau blanks, and it is hoped to make use of the bureau in solving the labor problem.

It was decided to lay the resolution from Rose View Union, in reference to the Hudson Bay Railway, on the table till the next meeting.

All members present were of the opinion that this was the best meeting that the Olds Union had yet held.

The meeting then adjourned until May 19 next.

JOS. STAUFFER, Sec.

**FIX THE ROADS**

The second meeting of Pitcox Union was held on April 16th; there being a good attendance of members. The minutes of the previous meeting having been read and adopted, a discussion ensued on the proposed pork packing plant. The secretary was instructed to secure further information from the general secretary on this matter.

The state of the roads also came under notice, and it was decided to draw the attention of the local members in the Alberta legislature to the condition of the road between townships 38 and 38, west of the 5th meridian.

Several new members were enrolled, and the regular meeting days were set for the first and third Saturdays of the month.

FRANK A. PEARCE, Sec.

**WHEAT IS KING**

The different communications from the central association are received and discussed with much interest by the members of Spring Ridge Union. The twine question was received with enthusiasm, and we not only decided to order our twine from the farmers' co-operative company, but two of our members canvassed the district on their own expense and secured a large number of orders from people who are not yet members. Fishburn Union are going to purchase from the same

company, so that we will be able to order a full carload. We are convinced that the big combines are endeavoring to kill the farmers' company and our object is to do all in our power to make this company a success and keep it alive, and we would strongly urge other unions to assist by doing likewise.

The pork packing argument was submitted and discussed, but wheat is king in this district and the hog is therefore not in it. No one signed the contract.

This union is in a good healthy condition and is behind the central association to assist them in bringing the interests of the farmer to a successful issue.

R. J. CANTELON, Sec.

**STEWARTWYN ORGANIZED**

One of the latest unions to be organized is Stewartwyn, where the farmers met together on April 11 and listened to an address on the aims and objects of the U.F.A., which was delivered by Mr. K. J. Lincoln, of Erskine. Eleven members joined the union, which is No. 165, and the first officers elected are: President, Wm. Lynn, Stettler; secretary-treasurer, C. Kinnear, Stewartwyn.

**SUGGESTIONS FOR ELEVATOR COMMITTEE**

In further reference to the elevator question, the Fishburn Union at the last regular meeting, adopted the following resolution:

"That we are in favor of the elevator bill passed by the legislature of Manitoba, with the following amendments or additions:—

"1. Where there are no private grain buyers the commissioners shall have power to provide for the buying of street grain, the suggestion being that a man bringing a load of grain be given a storage ticket on which he could draw seventy-five per cent. at a certain bank and when the grain was shipped out the returns made to this bank and the balance credited to him.

"2. That section 21 be altered to read fifty per cent. instead of sixty per cent. and a certain area defined, taking into consideration the railway facilities and the probable extension of same, and the settlement of the country."

CHAS. H. HARVEY, Sec.

**PINCHER CREEK RE-ORGANIZED**

At a preliminary meeting of the farmers of the Pincher Creek district held a short time ago, it was decided to organize a union. There was an attendance of ten, all of whom joined, and the following officers were elected: President, A. Pelletier; vice-president, R. Mayne; secretary-treasurer, Robert Henderson.

It was decided to hold the next meeting on May 7, when it is hoped there will be a good attendance of farmers, also that some one from the central association will be present to address the meeting and explain the work the U.F.A. is doing.

ROBERT HENDERSON, Sec.

**PLOW THE ROAD ALLOWANCES**

The regular meeting of Sunnydale Union was held on April 18, with the president, G. A. Rogers, in the chair. Fifteen members were present and three new ones enrolled. Circular No. 2 was read and the hail insurance question discussed.

The purchasing of binder twine was considered and it was decided to call an extra meeting for April 30 to look into the matter more fully, and to give absent members a chance to attend.

It was proposed, seconded and carried that in view of the fact that great damage was done in the district last fall and much time lost this spring through prairie fires, that the secretary-treasurer be instructed to communicate with the local improvement district No. 24-A-4, urging upon the councillors the necessity of plowing all road allowances so that they might act as fireguards.

FRED K. WOOD, Sec.

**KEEP OUT THE STALE EGGS**

A meeting of Edwell Union was held on Wednesday, April 20, which, however, owing to seeding operations was sparsely attended.

The secretary read the tenders received for the supply of binder twine, but it was decided to call a special meeting on Wednesday, May 4, to consider them, when it is hoped all members will make an effort to attend. There is no use in being

a member of the union unless you turn up to the meetings and show your interest in affairs and help the union along.

It was proposed by F. Ellis, for consideration at a future meeting, that this union take some steps to have a picnic or outing of some description to give members' wives and daughters an opportunity to have a good time.

Mr. T. Kirton, of Edwell, was admitted a member of the union.

At a meeting held some time previous, the following resolution was also adopted, on motion of Messrs. Powell and Ellis:

"That this union views with regret and desires to place on record a protest against the importation of eggs and the like from foreign countries (Russia for example) and being sold in the markets to compete with local prices, and that such a proceeding does not tend to encourage the poultry industry in Canada."

FRED JAS. POWELL, Sec.

**ALBERTA'S CROP RETURNS**

The department of agriculture of Alberta has issued its final bulletin on the out-turn of the crop of 1909. This gives the total yield of wheat as 8,467,799 bushels, or 6,155,453 bushels of spring wheat, with an average yield of 18.97; 2,312,344 bushels of winter wheat with an average yield of 22.63. The yield of oats is placed at 24,819,661 bushels, or an average of 35.76 per acre; barley, 3,310,332 bushels, or an average of 30.72 per acre.

This shows a very much heavier return from the crop than was anticipated by the Alberta government earlier in the crop year. The figures prepared by Deputy Minister George Harcourt for the British Association in August placed the total yield of wheat at 6,790,000 bushels; oats, 19,600,000 bushels and barley, 2,500,000 bushels. It is hard to realize that the average yield of oats could have been so low as 35.76 per acre, as the crop was a very fine one, but it is probably accounted for by the fact that in preparing the figures the government appear to have left the acreage at that originally seeded, while as a matter of fact there were very heavy hail losses, and some oat fields were not cut.

**THE GREAT MOGUL**

Behold, the newspaper office. Editors, sitting at their desks, arranging copy.

Behold the floor, littered with the flotsam and jetsam of men's brains.

Reporters are coming in and going out again. Some of them are writing hurriedly.

Messenger boys obtrude themselves at occasional intervals.

Telephones.

Little lies are hiding behind manuscripts. Big lies are stalking about as if they owned the place. Sensational lies are trying on new clothes before the dingy mirror over the wash stand.

Women. Bright looking feminine faces leaning over scrawled pages. Women with semi-smart clothes, business looking women, hurried women, tired, energetic, calm, inscrutable, vivacious. All kinds.

The hum of presses in the distance. Vague, intermittent, ominous; sounds of joy, sounds of woe, sounds of hopes gone—of the jail, of the church, of the assembly, of the open street, of the interminable tangle of life. Sounds of the sea, waves thundering, men crying for help.

More lies. Trooping importantly. Bashful, hiding themselves. Lies that dodge in and about. Blatant lies, straightforward lies, happy and singing lies.

They march and countermarch, deploy, advance and retreat and come on again.

The editorial writers pass out on their way home.

The proofreaders return for their revisions.

The pressmen wait in the distance.

Hush. Lull.

Then the hum grows louder. The great press vibrates.

The news is rolling on and outward.

**Here's a Real Optimist**

(Belleville Intelligencer)

Don't grumble at the price of eggs. Be glad you don't have to buy ostrich eggs at \$175.00 per dozen.

Our idea of a hypocrite is a married man who pretends to feel sorry for a bachelor.

**COL. JAMES MASON**  
The week's events in finance throw into further prominence the name of Col. James Mason, general manager of the Home Bank of Canada—the official bank of the Grain Growers—who takes a seat on the board of directors of the Dominion Coal Company. At the meeting of the coal company, held in Montreal last Tuesday, two new directors were elected to the board, Sir William Van Horne and Col. James Mason. Sir William represents the steel interests, while Col. Mason is the representative of a group of Toronto shareholders.

Col. James Mason has had a long identity with the most solid element of finance in Toronto. As a young man he came under the notice of the late Sir Frank Smith, the millionaire senator. In 1878 Sir Frank Smith, together with Mr. Eugene O'Keefe, the present president of the Home Bank, secured a controlling interest in the Toronto Savings Bank, a then popular institution established in 1854. These gentlemen re-organized the Toronto Savings Bank and named it the Home Savings and Loan Company. James Mason, who had begun his banking career as a junior member of the staff of the Toronto Savings Bank, was made

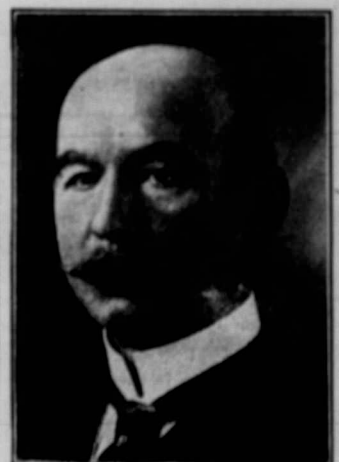

**COL. JAMES MASON**  
General Manager of the Home Bank of Canada, newly-elected Director of the Dominion Coal Company

manager of the Savings and Loan Company. From 1878 until 1903, when the Home Loan Company became the Home Bank of Canada, James Mason filled the chief executive office. Under his management the Loan Company paid a seven per cent. dividend each year, and when the final transfer of assets was accomplished, the original shareholders received a cash bonus of thirty per cent. on their holdings and \$200 in Home Bank stock for each \$100 of Loan Company stock.

Before going to the board of the Dominion Coal Company, Col. Mason was on the directorate of the Crow's Nest Pass Coal, so he comes well qualified to assume his new duties. He is also director on the board of the Manufacturers Life, and is interested in a variety of lesser financial interests. He ranks as full colonel in the Canadian militia and, with Earl Grey and Sir Thomas Shaughnessy, was recently elevated to the honor of Knight of Grace of the Order of St. John of Jerusalem in England. [ADVT.]

A unique invention has been recently put on the market by a well known Winnipeg manufacturer. It consists of a combination solid steel safe and filing cabinet and will fill a long-felt want as an household safety deposit device. It is absolutely and strongly gotten up in fire-proof and practically indestructible for filing papers, documents and important books, etc. It is really indispensable where absolute security and privacy is desired. It is especially adaptable to the farmer who heretofore has been deprived of the privilege of systematically looking after his affairs without going to a great deal of expense. The price at which this cabinet is installed is very low, hence it is a foregone conclusion that the manufacturer, The 20th Century Filing Co., of Winnipeg, will add one more to Winnipeg important concerns who have anticipated the wonderful opportunities of manufacturing and selling direct to the consumer. Their ad., with an illustration of their new invention, appears on another page of this issue.



Want, Sale and Exchange

All advertisements under this heading will be charged for at the rate of 40c per word per insertion...



Pretty Thin Soup

Numerous complaints had come before a certain public official in regard to the quality of food served to the inmates of one of the public institutions...

"Wal," said Farmer Wilkins to his city boarder, who was up early and looking round, "been out to hear the hay-cork crow, I s'pose?"

"I wish to complain," said a newly married wife, "about that flour you sold me. It was tough."

Mistress (to new servant): I must impress upon you, when you go to the dining-room, not to try to get the dirt off the "Old Master" with a wet rag...

Mistress: Do you call this sponge cake? Why, it's as hard as it can be! New Cook: Yes, mum, that's the way a sponge is before it's wet.

"Papa," wrote the sweet girl, "I have become infatuated with calisthenics." "Well, daughter," replied the old man, "if your heart's set on him I haven't a word to say; but I always did hope you'd marry a Canadian."

"As I understand it, they have lost their money, but all of the daughters are able to earn their own living save one, who is most idle and incompetent. What will become of her?" "She'll have to get married."

POULTRY AND EGGS

PLYMOUTH ROCKS AND BUFF WYANDOTTES, 14 years a wonder, eggs for setting...

FOR SALE - EGGS FOR HATCHING, FROM pure bred 54 Brown Leghorns, \$1.00 per setting...

BUFF ORPINGTON EGGS, FROM GOOD laying strain, choice birds, nothing but the best...

PURE BRED S. C. WHITE LEGHORNS, PEN selected brooders, excellent layers, headed by 1st prize...

QUALITY WHITE WYANDOTTE EGGS, ONE dollar per setting, five dollars per hundred, also Devanah chickens...

SINGLE COMB WHITE LEGHORNS, \$1.50 per setting, Barred Rocks \$1.00 E. Anderson, Fleming, Sask.

SEED GRAIN FOR SALE

FOR SALE - ABUNDANT SEED OATS grown from Galtion seed, cleaned and logged...

FOR SALE, SEED FIELD PEAS, FLAIL threshed, free from noxious weeds, \$4.00 per bush...

A QUANTITY OF MESSURY BARLEY FOR seed free from bad weeds, price in cotton bags...

POTATOES FOR SEED, THE BEST FOR the West, Early Rochester Rose and Vermont Gold...

SCRIP FOR SALE AND WANTED

SOUTH AFRICAN WARRANTS FOR SALE, Close price, prompt delivery, T. D. Thompson & Co., 41 Merchant Bank, Winnipeg

I HAVE A NUMBER OF SOUTH AFRICAN Veterans' scrip for sale cheap, write or wire orders...

FARMS FOR SALE AND WANTED

328 ACRES, WELL-IMPROVED, ONLY 28 miles from Winnipeg, one mile and a half from railway station...

FOR SALE TWO SECTIONS OF THE best wheat land in Canada, located near Hallowell...

TENDERS WANTED

WANTED, TENDERS FOR BINDER TWINE, one car, first and second grade; please send samples...

\$100 REWARD

For finding or information leading to the recovery of One Bay Horse and One Bay Mare...

Our Breeders' Directory

DO you want to buy farm stock, horses, cattle, pigs, poultry, etc? Where are you going to get them? The Breeders' Directory of The Guide aims to supply this information.

The Breeders whose cards appear in this column wisely conclude that the best means of reaching the farmer is his own paper.

In this way you will help to build up the advertising columns of your paper, and in turn we will be able to produce a better paper for you.

If you have stock which you wish to sell, evidence your faith in your own paper by advertising them in The Guide.

Mr. Mitchell, of Radisson, Saskatchewan, has the right idea. Here is his advertisement:

FOR SALE, TWO YOUNG PURE BRED Shorthorn Bulls, cheap, good pedigree. Apply to James A. Mitchell, Radisson, Sask.

It is appearing in The Guide for six weeks, and the total cost is only \$1.80.

A similar advertisement will do the work for you. The rate is 2 cents per word for one week, or 10 cents per word for six weeks.

THE GRAIN GROWERS' GUIDE Winnipeg, Manitoba

BREEDERS' DIRECTORY

Cards under this heading will be inserted weekly at the rate of \$3.00 per line, per year. No card accepted for less than six months or less space than two lines.

Under this heading should appear the names of every breeder of Live Stock in the West. Buyers and Breeders everywhere, as you are well aware, are constantly on the lookout for additions to their herds...

Consider the smallness of the cost of carrying a card in this column compared with the results that are sure to follow, and make up your mind to send us your card today.

ROSEDALE FARM BERKSHIRES - YOUNG Stock for Sale. G. A. Hoge, Wadena, Sask. A. D. McDONALD, BREEDER OF PURE BRED Yorkshire and pure-bred Shorthorn, young Stock for Sale. Sunnyside Stock Farm, Napouka, Man.

PURE BRED STOCK

FOR SALE, REGISTERED SHORTHORNS - Shorthorn dairy cows at \$30 to \$75 each, young bulls at \$25 to \$70, grade cow and steers supplied remarkably cheap.

JAN CANWELL, SASKATOON - B. H. H. Y. - Burns. Barred Rock eggs, \$1.30. Rye Grass Seed, no noxious weeds.

FOR SALE, REGISTERED SPANISH JACK, 3 years old, stands 14 1/2 hands high, a good fat getter.

ORDERS TAKEN FOR REG. BERKSHIRES, March and May farrows, and May farrow in Yorkshires.

150 Favorite Old-Time Songs WITH WORDS AND MUSIC COMPLETE



This is a splendid collection of favorite old-time songs and ballads - songs that touch the heart and recall the tenderest memories...

METALLIC CEILINGS

are everything that plaster, wood and wall paper are not. Metallic Ceilings are fire-proof, absolutely. Metallic Ceilings don't crack or crumble - don't get damp or mouldy - don't need repairs.

The Metallic Roofing Co. Limited MANUFACTURERS TORONTO AND WINNIPEG

Western Canada Factory: 797 NOTRE DAME AVENUE, WINNIPEG

"If ye please, sergeant," Punch makes the raw recruit say, "I've got a splinter in me 'and." "Wot yer been doin'?" demanded the sergeant. "Strokin' yer 'ead?"



# SASKATCHEWAN SECTION

This Section of the Guide is conducted officially for the Saskatchewan Grain Growers Association by F. W. Green, Secretary, Moose Jaw, Sask.

## Saskatchewan Executive and the Elevator Commission

*Memorandum of Proposals as to Scope of Government Enquiry is Drawn up for Presentation--Hudson Bay Railroad Discussion--Faith Expressed in Government Promises--Test Actions to be Brought Against Railway Companies Regarding Damage From Prairie Fires*

**A**N IMPORTANT meeting of the executive of the Grain Growers' Association was held in Moose Jaw, April 19. A mass of business was transacted necessitating an all day session. There were present, President F. M. Gates, of Fillmore; Vice-President J. A. Murray, of Wapella; A. G. Hawkes, of Broadview, and J. A. Maharg, of Moose Jaw.

Secretary F. W. Green took charge of the members when they arrived and conducted them on an automobile tour of the city. The schools system, exhibition grounds and the big flour mills of the Saskatchewan Flour Mills Company were visited in turn. The visitors expressed themselves as wonderfully surprised by the great development and busy scenes in evidence on every hand. Considerable information was given to them by the amiable manager of the mills, Mr. C. E. Austin.

After the pleasant trip the members of the executive met in solemn conclave to deal with the great mass of business which had accumulated since the last meeting. The most important of the business considered, perhaps, was that in connection with the elevator commission sittings which commence in Regina Tuesday, next. The advisability of presenting a memorandum to the commission and of securing a solicitor to take charge of the interests of the association during the sittings were considered. So also was the question of making presentation of the memorandum for the purpose of securing an itinerary that would be suitable to the local associations throughout the province and outlining what in their opinion should be the depth of enquiry into which the commission should go. In view of the fact that no plan could be prepared to cover the crop of the coming season, it was the opinion of the executive that every possible advantage should be taken of the opportunities offered to make a thorough investigation of all problems in connection with securing a permanent solution of the questions involved and suggested the following as the outline of what would meet their views.

(1) To gather evidence fully as to the practical methods necessary for instituting government owned and operated elevators at initial points.

(2) To secure necessary evidence and make proper representation as to the necessity of co-operation by the Dominion government in the matter of reformed facilities at terminals and in the matter of a grading system more in accordance with milling values, and of establishing a sample market; at the same time to secure evidence bearing on the question of advisability of Saskatchewan being formed into a separate inspection district.

(3) In view of the near prospect of the opening of proposed Hudson Bay route and of our wheat trade growing larger with the U.S., and the development of the Oriental trade, necessitating the routing of grain in various directions, and also building up of a large milling industry within the province; to consider whether the interests of this province and the producers of grain do not demand that the grade be determined nearer home and provision made for sample markets within the province.

(4) To enquire into the reasons causing the wide fluctuations which occur at certain seasons of the British markets in the price of Canadian wheat, exceeding the fluctuations affecting wheat grown in other countries, and also to enquire into the reasons why Minneapolis wheat should sell for more than Canadian wheat; while at the same time Canadian flour sells on the British market for the same

price as Minneapolis flour, with a view to suggesting a system of grading, storing, transportation and marketing which will ensure to the Saskatchewan grower the full value of the product.

(5) And to this end consideration be given to the matter of giving power to the permanent commission (which will operate the new system); to act as agents for the marketing of all the grain passing through the said system. In other words, that the commission of enquiry consider the advisability of applying the principle of co-operation to all grain passing through the new system as suggested in printed pamphlets as well as on the

intrinsic value of their wheat, less the cost of handling, the profits of all by-products being credited to the system in which all would share alike, both as regards profit and loss.

As regards the local itinerary the executive expressed themselves as satisfied with the proposed one published in THE GUIDE of April 13 by the secretary.

A number of other matters were considered by the executive. Communications of some length, being replies to resolutions passed by the association, in regard to a chilled meat industry and the question of dealing with glandered horses coming into the country were received from the minister of the interior. Replies were received on these questions also from nearly all western members of the Dominion house.

### The Hudson Bay Road

The Hudson Bay Railroad came in for discussion by reason of the fact that many resolutions have been pouring into the office of the association urging that steps be taken in the matter for fear that the government would not proceed

## A FERTILE VALLEY NEAR A MOUNTAIN TOP

The positions changed. Watch the Hummers!

Milden at the top with \$47.00 received for 1910.

Fertile Valley next with \$44.50

Cory running hard with \$43.00

North Battleford close behind with \$42.00

Roleau gaining speed with \$41.00

Cuper closing in with \$38.00

Saltcoats chasing with \$35.00

Wapella running well with \$32.50

Lumsden fresh with \$31.00

F. W. GREEN,  
Secretary.

draft presented by Mr. F. M. Gates, through the columns of THE GRAIN GROWERS' GUIDE in reference to quantities of less than car-load lots."

In regard to sub-section 5 of the memorandum the suggestion referred to is the following:

"That provision be made by the system for handling single loads or quantities less than car lots, and arrangements made whereby the owner of such loads may receive an advance of not less than 65 per cent. (possibly 80 per cent.) of the estimated value, if he so desires."

The executive feel that if the commission could adopt a plan in line with this clause it would be a solution of the whole vexed question. The ultimate result of such a plan would be a Saskatchewan system of initial elevators with their own terminals, the wheat being grouped as per its intrinsic values, sent direct to the world's market in direct control of the commission appointed by the people who produced the wheat, and in whose interests the whole could be managed. They would get the in-

with the construction of the road. The executive of the association felt that the most definite promises that the road would be proceeded with had been given by the government and until they had something from the government itself which would contradict these, they took the position that any action on their part was unnecessary, they having the utmost confidence that the promises made would be carried out and that construction would be started immediately.

### Test Cases Against Railways

Another important decision arrived at was that in connection with test cases being started against railroad companies for prairie fires caused by sparks from an engine, and for killing of stock on railroad lines. It was felt that many farmers were injured through these happenings, who were unable to take action against the railroad company, whose servants or engines were the prime causes of these injuries. Not only were the farmers injured, but in many cases the companies were enabled to evade



Farm House of Alfred Moffat, Frohisher, Sask.

## SASKATCHEWAN GRAIN GROWERS' ASSOCIATION

HONORARY PRESIDENT:

E. N. HOPKINS - - MOOSE JAW

PRESIDENT:

F. M. GATES - - FILLMORE

VICE-PRESIDENT:

J. A. MURRAY - - WAPELLA

SECRETARY-TREASURER:

FRED. W. GREEN - Moose Jaw

DIRECTORS AT LARGE:

E. A. Partridge, Sintaluta; George Langley, Maymont; F. W. Green, Moose Jaw; F. C. Tate, Grand Coulee; A. G. Hawkes, Percival; Wm. Noble, Oxbow.

DISTRICT DIRECTORS:

James Robinson, Walpole; J. A. Maharg, Moose Jaw; Charles Dunning, Beaverdale; John Evans, Nutana, Dr. T. Hill, Kinley; Thos. Cochrane, Melfort; Andrew Knox, Colborne; George Boerma, North Battleford.

responsibility through trailing on the ignorance of the farmer.

The secretary was instructed to take action and proceed with such cases of the kind as came under his notice and which appeared to offer a reasonable likelihood of a verdict in the farmers' favor being returned.

Other matters dealt with were those pertaining principally to the organization. The summer meeting tour, the appointment of two organizers, the securing of a solicitor for the association, and the question of preparing a memorial in reference to the amendments of the banking act of Canada were among the business transacted. In regard to the latter question, no decision was arrived at and it will be dealt with at a further meeting of the executive. Mr. George Boerma, of North Battleford, tendered his resignation from the directorate, which was accepted with regret.

The quantity of important business constantly accumulating, makes it evident that frequent regular meetings of the executive will have to be held, and it is likely that a decision on this point will be made at the next meeting.

\*\*\*

## CARNDUFF WANTS GOVERNMENT OWNERSHIP

The secretary at Carnduff writes as follows: Our directors met Saturday night and discussed the questions with regard to government acquirement of elevators. I have pleasure in reporting to you the decisions arrived at. We believe that a system of elevators to handle our grain from initial shipping points to ultimate markets should be established, but that the acquirement by the provincial government of internal elevators, without government ownership, and management of the terminals would not give satisfaction to the farmers. We think it would be unnecessary for the government to purchase all the internal elevators, as in fact there is more than is necessary now at some older points at least, that is with a reasonable supply of cars by railway companies. As there will likely be railways built paralleling and crossing present lines, we think that this should be kept in view and that it would not be necessary to buy up all the present line elevators. (It is possible some of the elevator companies may realize after awhile they have some not very good stock on their hands).

Re management: Our directors think that a board consisting of the minister of agriculture and two nominees of the Grain Growers' Association, one of the latter to seek re-appointment every third or fourth year, would be a good plan.

In regard to a sitting of the elevator commission at Carnduff, we would be highly pleased to have the commission visit us. Let us have definite information as soon as you can, and I will get into communication with the secretaries of the near associations and ask them to get representatives from their associations to meet you here. I think this would be a good plan. Should you favor us by coming would you kindly let us know as early as possible and oblige,

J. SHIER, Sec.

Carnduff.

**ALL TAKE THE GUIDE.**

Your parcel of reports of the Prince Albert Convention received, and am remitting \$1.25 for same, as per your letter.

Re THE GUIDE, I have two or three times sent in to Winnipeg the names of every farmer in this district, and I think everyone is either a steady subscriber or gets sample copies. Nearly all are steady subscribers.

The Summerberry G. G. Association held a social evening on March 16. A good crowd turned out despite the bad roads. After a short program, Dr. Elliott, M.L.A., gave a very interesting and instructive lecture on Consumption—its cause, its cure and its prevention. The doctor spoke for over an hour and was carefully listened to. A hearty vote of thanks was tendered him at the close of the meeting. Mr. Wm. Ingram presided as chairman.

R. MILLS, Sec.

**ANOTHER YOUNGSTER BORN**

Just North of Battleford at Cavalier

A number of the farmers around here were anxious to establish a branch of the G.G.A., so a meeting was called for March 5. A branch was formed, officials chosen, and the necessary business done. Eleven members have joined. I am expecting more at our next meeting.

A meeting was called for the following week for general discussion. The subject of starting a co-operative store and elevator on true co-operative principles to supply general merchandise, to purchase and handle dairy and farm produce, to handle machinery and any other branch of business affecting the farmer. Some good and valuable information was given by several of the members. Also some pamphlets read supplied by the co-operative Union of Canada. The subject of co-operating together to ship in pure bred hogs, cattle and horses to improve our flocks and herds was discussed. Also the establishing of a bureau of information where any farmer could go and enlist any article he had for sale, such as seed grain, cattle, horses, hogs, farms, etc. A buyer could also go to this bureau and enlist what he needs. Men needing employment and those that need hired help could also go to this bureau and thus bring buyer and seller into communication. No practical steps were taken, but agitation is the commencement of most things. We are busy at present seeding, with weather conditions ideal. It is proposed to hold meetings during the summer for discussion of topics of interest.

Enclosed please find \$5.50—part of subscriptions.

JOHN SMITH, Sec.

**GOING TO ATTEND TO BUSINESS**

Your letter of the 31st March came to hand some time ago, and I am sorry for the delay in answering it. The reports of the convention have also been received. With regard to the names wanted by you I may say that I have distributed the reports and as each of these contain a coupon for subscription to THE GUIDE, I am not sure how many may take advantage of it. We have not held a meeting since receiving your letter. Our first meeting is to be held on the 14th of May. We will try and push the sale of THE GUIDE at this meeting, and meantime will try to obtain ten names of men who will be likely to want THE GUIDE. Re your letter of the 13th inst., enclosing circular in reference to the elevator commission, I may state that the matter will be put before the meeting on Saturday, 14th of May, or a special meeting will be called sooner should it be found necessary. Will you please send us 25 pamphlets same as sample enclosed in your letter of the 13th. "A Glance at the History of the Grain Growers' Association," also ten constitutions. The cash for membership cards, reports, pamphlets and any overdue contributions will be paid after our meeting.

JAS. SUTHERLAND, Sec.  
Dialy G.G.A.

**BIG DAY AT STOUGHTON**

The Stoughton branch of the Grain Growers held a meeting on Saturday evening, the first we have held since the 17th March, when all correspondence was disposed of. First was your letter which was received just after our last

meeting, re the summer conventions, which I explained to the meeting. The objects of it were fully discussed and on a motion I was instructed to write you to the effect that this branch fully endorse the scheme and will do all in their power assisted by the citizens to make this the greatest day Stoughton has ever had and at the same time boom the G. G. Association, and asking you to give us the fixed date so we can begin our preparation.

The next matter taken up was your letter re the elevator commission holding a meeting here to get the views of the Grain Growers. The meeting have selected a committee to meet the commissioners and lay before them their proposition for the details of the scheme. The reports of the Prince Albert convention received all O. K., and in reply to your proposition will say first I do not know of a member of the association who does not take THE GUIDE. We have seventy trial subscribers and the greater part of the members are yearly subscribers for it with the exception of quite a number of Germans who are members of the association but who cannot read THE GUIDE in English. On Saturday I got two names as members and I asked them to subscribe for THE GUIDE. They would do so but cannot read it and they asked me would it not be possible to have at least part of the paper published in German. Our next meeting will be on the 30th of this month. Will then send you the price of reports. Please let me have the correct dates for these meetings in due time.

R. L. HAYES, Sec.

**DEAD AS SHRIMPS**

Sir:—In reply to your letter of the 13th I beg to report that our local association held no meetings during the summer—that it is practically dead for that time. There are no funds on hand so cannot send you the money for any literature.

Regarding your letter re elevator commission sittings I will report same to our president and if he wishes to take up the matter he will write you directly.

C. E. FLATT.

Tantallon, Sask.

**ROSETOWN GRAIN GROWERS' ASSOCIATION**

Enclosed you will find cheque for \$18.80, being for 34 fees and for 25 members' tickets, 25 association pamphlets, one grain act and 25 copies of the convention report all duly received from you.

Our last meeting, I'm sorry to say, was poorly attended owing to preparations for seeding operations, etc., in this district. No new members joined, but we hope to enroll more in the near future.

Mr. Noble from Tezerton was present and desired information re the formation of a branch association and I referred him to you and Mr. Tinkess, so there will probably be one more association formed and more Grain Growers come to the fold.

Allow me to congratulate you on being selected as one of the elevator commission which I trust will be the means of abolishing many of the grievances which the Grain Grower has to contend with.

RICH. STOBART, Sec.-Treas.

**HELPING THE CAUSE**

J. Alston, secretary Royal Grain Growers' Association writes:

Your favor of the 31st of March to hand, re the subscriptions to THE GRAIN GROWERS' GUIDE. I will send the names just now, and I will forward the subscriptions after our next meeting. I have sent a few extra names, and I am sure they will appreciate THE GUIDE.

**LUMSDEN SHOWING UP**

S. E. Armstrong, of Lumsden writes: I am still in Lumsden, and as Mr. Kidd had not taken over the books, I am sending you a draft for \$31.00, being the amount due the Central by Lumsden Association.

S. E. ARMSTRONG.

**THE MEMBERSHIP RACE**

Milden takes first place, \$47.00 having been received from Milden this year. Battleford comes second with \$42.00. Lumsden with \$31.00 steps in; Gaily just ahead of Cory, what do I mean? Why! Look up our report for February and March in THE GUIDE, April 13th, page 21, and keep posted.

F. W. GREEN.

**A CHILD AT FOOTE WHICH WILL SOON HAVE A VOTE**

You will find enclosed the sum of \$8.00 being the membership fee of our branch of the S. G. G. A.

The farmers of the Tynecastle P. O. district met at the Mariposa school house on the 10th of April and organized a branch of the Grain Growers' Association with a membership of sixteen. There seems to be considerable interest shown, and we expect to add more names from time to time as we become more enlightened upon the objects of the organization. You will please send plenty of reading matter that will assist us on all questions suitable for discussion at our meetings.

C. D. WHITE, Sec.-Treas.  
Foote, Sask. Tynecastle.

**THEY WILL BE ON HAND IN FORCE**

Your communication of the 13th ult. to hand. In regard to it I would say that as this is my very busiest season of the year we (the executive) do not think it advisable to call a meeting just now. As you ask for an early reply I will give you the views of this district as far as I am sure they are correct. Any points I don't touch will be discussed at the next meeting. The schedule of the elevator commission calls for a sojourn at Carlyle (our neighboring town) and you can rest assured that we will be there in force. It might be advisable to see if the association adjacent to Carlyle would send a delegate to the sitting of this commission. We favor a government monopoly because the only class a system of government storage would injure would be the middlemen and the combine. (Elevator). They are parasites pure and simple. If this elevator combine is allowed to live at all it will always be a source of trouble. We favor the three man commission subject to the will of the legislature and to be removed from office only for proved incompetence. The present commission looks good to us. This is all I can vouch for at present. As I said we will hear the discussion in Carlyle at a future date and we agree with you that the sooner the date matures the better.

C. H. BURR,  
Sec.-Treas. Manor S. G. G. A.  
Manor, Sask.

**SALTCOATS WILL SURELY BE SALTED**

The secretary at Beaverdale writes to Secretary F. W. Green, as follows:

Yours of the 8th inst. to hand and contents noted. In reference to auto trip I am pleased to have your assurance regarding Saltcoats. I have several communications lately from those interested in the scheme I proposed and shall now be able to answer them, that if the trip is taken at all Saltcoats will be included. If you could also manage to include Spring-ide, it would simplify matters for me considerably and I would guarantee a splendid turn out at both places. However, I am satisfied that the best is being done in the matter and trust that you will have definite information in the course of a short time. In re the elevator sittings I see by THE GUIDE that one

sitting is to take place at Saltcoats and I am writing them immediately urging the importance of presenting our side of the case. I realize that if the farmers do not rise to the occasion in this matter, the consequence will be entirely their own fault. In regard to life members, never fear, they will be coming along one of these days. One great drawback is the fact that many of our best men around here have held their oats over for higher prices and it looks now like they were going to get hit, and they are financially straitened just now in consequence.

CHAS. A. DUNNING.

Beaverdale, Sask.

**THEIR FIRST REPORT**

Secretary King, of Forester, writes as follows:

Please find enclosed an order for \$15.00, being the fees of thirty paid up members of the North Tisdale Association. Will you kindly forward all necessary papers, membership, tickets, etc., as we hold our next meeting on April the 29th and I should like to have them for this meeting.

T. F. KING, Sec.-Treas.  
Forester, North Tisdale.

**WHERE ON EARTH IS YETWOOD?**

T. Edwin Smith, of Yetwood, Alta., writes:

If you wish some of the propaganda literature of the Grain Growers' Association translated for use among the German speaking population, my services are at your disposal gratis. I do not speak Dutch or low German. Accept this offer as my contribution to the campaign.

Note.—We cannot find this man's post office. Saskatchewan P. O. authorities know nothing of it. Where on earth is it?

F. W. G.

**FROM VALPARAISO**

A. C. Teale, secretary-treasurer, Valparaiso, writes:

Your communication of the 31st ult., to hand, re advertising the Grain Growers' Association. I am sending the names, and the sum of one dollar for THE GUIDE. I received copies of the report of Prince Albert convention, and will remit the amount due for same presently, as we are short of funds, but I hope to increase the membership.

**WADENA REPORT**

The secretary of the Wadena branch has sent the following letter to Secretary F. W. Green:

Replying to yours of the 31st ult., re trial subscription to THE GUIDE would say, at our last meeting April 2nd, we took up a collection and voted also from the funds of the association for the purpose of having THE GUIDE sent to fifty members and non-members. I forwarded this to THE GUIDE and have their reply stating that they are sending it as requested. Re the convention reports, I will have this taken up at our next meeting, May 7th.

W. T. McPHERSON,  
Secretary Wadena Branch.

**HARNESS LIFE THE OIL FOR LEATHER**  
Goes Right Through and  
Dares the Weather



**Flackens The Harness But Not The Hands**

For sale at most first stores or sent direct L.S.B. Winnipeg for \$2.00 per gallon  
Sample size from your dealer at 25c.

**Carbon Oil Works Ltd., Winnipeg**

Manufacturers of Cowl Brand Stock Drips, Vermin Death, the bed bug annihilator, Barn Spray for disinfecting stables, etc., Cowl Brand Mange and Ringworm Cure, etc., etc.  
Write for full particulars.

## Lightning and its Actions

The electricity in the air which is commonly known as lightning, exerts annually a tremendous toll on life and property. In the United States upwards of 800 are killed annually and twice that number injured. This loss largely falls upon those who live away from the cities. The greater part of the loss of property is on farm buildings and live stock in fields. The multiplication of electrical transmission lines for light and power forms splendid protection for cities. Telephone lines are also good protectors. A lightning flash is a discharge of electricity between two electric bodies, as for instance, between a cloud and the earth. When used for economic purposes, electricity is most valuable, as it is under most perfect control. In the air, however, electricity is unchained. Hence the damage is done. All bodies do not behave alike when charged with electricity. Some bodies immediately conduct the electricity away from them as known as conductors. What is known as a "lightning conductor" means a body that will lead away a charge of electricity. Other bodies that retain the electrical charge or permit it to escape slowly are called non-conductors or insulators. Telegraph lines are insulated by glass insulators. At one time lightning rods attached to buildings were also insulated but this is not now generally done. An electrical charge falling upon a copper conductor goes straight to the earth, providing the conductor is connected with the earth. If the same charge falls upon wood it meets with great resistance usually resulting in heat, fire and damage.

Lightning conductors are made with a view of preventing the accumulation of electricity and conduct it away to the earth where it will do no damage.

There are two kinds of electricity, in nature known as "positive" and "negative." Two bodies charged with the same kind of electricity repel each other while if electrified with opposite kinds of electricity they attract one another. This produces electrical discharge or flash.

Benjamin Franklin was the first to demonstrate that an electrical field existed in the atmosphere during thunderstorms. But it has since been shown that the field existed even in fair weather. The surface of the earth is always charged with negative electricity. The exact mechanism of a thunder storm is not definitely known. Scientists have been struggling with it for centuries and many conflicting theories are advanced. Every time a drop of water breaks, a separation of electricity takes place, the water receiving a positive charge and the air a negative charge. The negative charge in the air is rapidly absorbed by the cloud particles and in time the clouds may become highly charged with negative electricity. This, of course, would occur for the most part on hot sultry days. Air currents have a very important effect upon the electricity in the air and in the clouds, and consequently a very important effect upon thunder storms. Whatever may be the origin of the electricity in the air its effect upon various earthly objects upon which it falls is well known. The intensity of the charge in lightning flashes varies greatly. All discharges are not heavy enough to take human life or even badly splinter a tree, so that it is easy to distinguish between the heaviest and lightest flashes.

When a thunderstorm develops and moves over the land the air between the under surface of the cloud and the earth's surface is able at first to resist the passage of a discharge between earth and cloud, but as the electrification increases the strain in the air becomes too great and a discharge follows. The zone of danger in a thunderstorm is, therefore, generally equal to the area of the cloud itself, sometimes extending a little to the front of the cloud. The heaviest discharge nearly always occurs simultaneously with the passage of the storm front. The reason for this can be very easily shown in the laboratory; thus it is well known that if the two poles of a charged electric machine are brought near to each other a spark will pass from one to the other. Now, in order to get the first spark, the poles of the electric machine must be

brought nearer together than is necessary after several sparks have passed. The passage of several sparks through the air separating the poles evidently electrifies it, and thus it becomes a better conductor, after the machine is used.

The area within the storm cloud is what may be called a "danger zone." Within this zone almost any upright object, especially a tree, is a better conductor than the air itself, and is consequently liable to lightning stroke. For this reason to take refuge under a tree is a dangerous proceeding. Other places to avoid are near chimneys or fireplaces and in close proximity to wire fences.

### THE BRITISH MINISTER OF AGRICULTURE ON AGRICULTURAL CO-OPERATION

By Alphonse Desjardines, Ex-M.P.

The following extract shows the high appreciation entertained by Lord Carrington, the British minister of agriculture, of the benefits that farmers can derive from co-operation. The society referred to is the Agricultural Society of England whose object is to spread the knowledge of co-operation and to help the farmers to organize such societies: "I am glad to have had an opportunity," said Lord Carrington, "of showing my entire sympathy with the practical support of the agricultural co-operative movement, and I can assure you that every member of His Majesty's cabinet hopes to see a great development of the society's work in the future."

"The objects and work of the society have my most hearty support. I hope, therefore, that all who wish well to British agriculture will support the admirable work which the Agricultural Organization Society is doing."

The organ of the society adds: "There are surely few bits of more effective ammunition than this in the locker of the speaker in favor of agricultural co-operation. In Italy our agricultural co-operative friends have been felicitating themselves on the selection of the well known co-operator, Signor Luzzatti, for the ministry of agriculture; but Signor Luzzatti will find it difficult to make a more effective deliverance on behalf of the movement than that with which Lord Carrington has aided us."—"Co-operation in Agriculture," April, 1910.

When will our parliament and legislatures realize the great advantages that Canadian farmers would derive from co-operation by passing laws authorizing the formation of such societies? If they do not, then the farmers should awake them by petitions.

# PAROID ROOFING



David Harum knew the horse business, but even David himself could never have sold you a horse on his mere say-so. You'd want to see the horse—want positive evidence of his "good points" before you'd pass over a dollar. Good horse-sense too!



Why not use common-sense and caution when it comes to buying roofing? A roof costs money. It takes time and money to apply it whether it is good, bad or indifferent. And a bad or indifferent roof will cost you a lot of money in the long run. You want wear when you want roofing. Wear is told by actual duration—not fanciful claims and slyly-worded guarantees. That's exactly why you should insist on Paroid Roofing.

More than likely your dealer can show you a Paroid Roof, or tell you where you can see one. Send us your name and address and we'll tell you where you can see a Paroid Roof if your dealer can't show you one.

Paroid Roofing is one of the famous Neponset Products. The "Little Girl" Trade Mark is your protection—a guarantee of quality and durability. We will replace any Neponset Product or refund your money if it proves defective in manufacture. Look for the "Little Girl" Trade Mark.

N.B.—Write to our Building Council Department for free information concerning any building problems you may have to solve. Give full particulars and state exact dimensions. Write for samples of Neponset Products and we will give you name and address of your nearest dealer.

F. W. BIRD & SON, 513 Lottridge Street HAMILTON, ONT.  
Established in U.S. 1796  
Western Branch—123 Bannatyne St. E., Winnipeg. Eastern Branch—144 Union St., St. John, N.E.

## Question Drawer

This department of the Guide is open to all readers, and it is hoped that they will take advantage of it. All questions relating to the problems of the farmer of Western Canada will be answered in this department. Write questions on one side of the paper only, and send only one question on one sheet of paper. Join in making this department of the greatest value.

**MUST HAVE NAMES**

Questions sent in without the name of the sender attached will not be answered. The name will not be used if not desired, but it must be sent as a guarantee of good faith.

### SASKATCHEWAN AGRICULTURAL COLLEGE

Subscriber, Sask.:—When will Saskatchewan Agricultural College, open for students?

Ans.—We referred this question to Prof. J. W. Rutherford, Dean of Saskatchewan Agricultural College and he replied as follows:

"I have yours of April 23rd in which you ask for particulars in regard to the agricultural college. We expect that ground will be broken next week and excavations started on five of the college buildings, including the main building, dormitory, farm mechanics, power house and judging pavilion and a little later the barns and residences will be started. We expect our farm mechanics building, power house, judging pavilion, barns and residences to be completed so as to enable us to open the college about the first of November of this year. We may be disappointed in this, as delays may be occasioned by unforeseen causes."

"Our course the first year will be of a very practical nature, as the classrooms and laboratories in the main building will not be ready for our use. Work will be given in the judging, feeding and management of live stock, grain selections, as well as farm mechanics including carpentry, blacksmithing, drawing plans for farm buildings; the study of farm implements including gas and steam traction engines; farm arithmetic and accounts, English, composition and literary society work. Scholarships will be granted by the department of agriculture for students who have already taken one year in any of the Canadian agricultural colleges, in order that they may be enabled to finish the two year course, as no second year course will be provided this year in the college of agriculture for Saskatchewan. It is planned to hold a short course for farmers at the college some time in January."

"For your information I may tell you also that we have four four-horse outfits at work on the farm and will have in the year about 450 acres of wheat, 120 acres of oats, 35 of barley, 25 of peas, 10 of corn, 5 of roots, 10 of alfalfa, and smaller quantities of flax, sorghum and other crops as well as about 50 acres of tame grass seeded last year."

### DIRECT LEGISLATION

Subscriber, Man.—In those states where direct legislation is in force what percentage petition is necessary for the initiative and referendum? (2) Has the initiative and referendum been used in Maine, S. Dakota, Montana and California? (3) Where can I get full information on the subject?

Ans.—We have no information concerning all the states you mention, but in South Dakota the initiative and referendum may be used by the people on a 5 per cent. petition of the voters. In Oregon the initiative requires 8 per cent. petition of the people, and in the same state the referendum may be either ordered by the legislature or secured on a 5 per cent. petition of the people. An excellent book on the subject of direct legislation is entitled "The City for the People," by the late Professor Frank Parsons, and gives the record of direct legislation up to the year 1901. It may be purchased for \$1.00 postpaid from F. J. Dixon, 200 Ellen St., Winnipeg. Papers that are devoted partially to the subject are "The Equity Series," 120 Chestnut St., Philadelphia. Another is the Twentieth Century Magazine, published in Boston, Mass., and the Public, published at Ellsworth Building, 357 Dearborn St., Chicago. We would advise all our readers who are interested in the subject to procure these books and papers above mentioned.

If you do not get your Guide regularly each week, not later than the Saturday after publication, be sure to let us know. It is an error and we will be glad to rectify it.

Wanted: Better Writers. The standard of the young men of the present day in the matter of handwriting is not so high as it used to be, and this, curiously enough, is the more marked in the case of those who have been educated in our great public schools.—Mr. F. H. Jackson.

# Millionaire Hustled and Hooted

From Lloyd's Weekly News (England), March 13

THE American wheat and cotton king, Mr. Jim Patten, who has come on a visit to England, met with a hostile reception that unpleasantly surprised him, on reaching Manchester on Friday afternoon.

He attended the Royal Exchange with a friend, but as soon as his identity was known an angry demonstration, unprecedented in the city, occurred. The millionaire speculator was hustled out of the exchange into the hands of a crowd which threatened personal violence, and he only escaped by a ruse.

This latest arrival from the states is a broad-shouldered man of fifty-eight, typically American. He wears a light grey hat of the "Trilby" shape, and a grey tweed suit, with light overcoat. Manchester's animus grew from the statements that he made his money by cornering wheat and cotton. He reaped nearly half a million from his wheat corner last year, and it cost the people more than twenty times as much. He is the son of a small farmer, of Sandwich, Illinois.

Mr. Patten landed in Liverpool on his English visit on Tuesday, but, though he visited the Cotton Exchange there, and was known, nothing occurred to lead him to expect the reception brewing for him in Manchester. It was given out that he was merely on a holiday, but a belief gained ground that his actual object was the engineering of a deal in cotton.

It leaked out that he intended to visit Manchester, but he came on Friday unannounced, and so unostentatiously that some time elapsed before it was recognized that the man in the grey overcoat was none other than the famous hero of the wheat corner. He stood there talking to his guide on the floor of the Royal Exchange, surrounded by a crowd of Manchester business men and manufacturers, too occupied with their own affairs to notice the stranger.

### An Ugly Situation

But a voice rose suddenly above the buzz of business: "Patten's here! That's him!" There was an immediate stir, and men began to press about him. Excitement in a few minutes grew, and some city spirits heckled the millionaire, whose face became excited and disturbed as he pushed his hat to the back of his head with a nervous gesture, and endeavored to answer his questioners.

There was little coherent to be heard amid the babel of sounds that so quickly arose about the American. The Manchester men encompassed him. The bulk of the members heard nothing; they saw only his expressive features working in rising excitement, whilst he harangued and answered and explained.

He lifted his hat again and again, and put it back in apparent perturbation whilst speaking. From the outskirts of the throng, then a "boo" went up. The hostile noise was carried on and the crowd pressed more uncomfortably upon the millionaire. Next came a rush, and in another moment Mr. Patten, and his friend, and his hecklers, were being rushed across the floor to the doors amid unmistakably angry shouts.

There was no more attempt at business in the building. The hundreds of men, having hustled the visitor into the streets, poured out behind him. Mr. Patten's face was deathly pale; his friend held to his arm, and looked round for rescue, while shouting men now shook their fists in the millionaire's face.

In the street the crowd looked ugly. "This is Manchester's welcome!" shouted someone in Mr. Patten's ear, and the crowd hooted and shouted opprobrious epithets. The situation was distinctly dangerous; at any time, it seemed, Mr.

Patten might be subject to assault.

At this critical moment the means of escape offered. The door of fire brigade premises stood open, and into the doorway Mr. Patten disappeared. He hastened with his friend to St. Mary's gate, and was put into a handy cab.

### "No Horns or Tail"

As an explanation of the treatment accorded to Mr. Patten it may be mentioned that short time—(on the principle of no work on Saturdays and Mondays)—has been in force in Lancashire for many months past, and bids fair to continue for several months to come. Of course, the scarcity of American cotton is one cause of this, but the high price to which it has been forced by American speculators—of whom Mr. Patten is regarded as the leader—is another.

Mr. Patten returned to Liverpool in time to visit the Corn Exchange, where there was a large assembly of members. In a few words Mr. Patten referred to his treatment at Manchester, and as a remark of their sympathy the members took off their hats and cheered lustily.

Mr. Patten's intended visit to Liverpool Cotton Exchange yesterday was abandoned because he did not desire a demonstration.

Mr. Patten stated that he went to Manchester to show them he was an ordinary man and not with horns and a tail, simply a bull on the market, and he told them so. The feeling caused in Manchester was indicated by the fact that he had received a number of letters from leading spinners regretting Friday's incident, while other spinners had visited him in Liverpool to personally express regret.

During his stay in Liverpool between 50 and 600 letters have been addressed to Mr. Patten from all parts of the country. Many contained money, which Mr. Patten was asked to speculate with on the senders' behalf, while others were begging missives, asking for assistance in developing inventions. The money sent was returned immediately.

The following cable was received by a Liverpool merchant yesterday from one of New York's merchants with reference to the incident at Manchester: "Is report treatment Patten Manchester true? England pretends friendship America. Would heathenish China be guilty this? Patten one of America's purest men."

The Liverpool merchant replied: "Liverpool resents Manchester treatment Patten. Best Manchester men ashamed. Personally feel discourtesy strongly."

Mr. Patten returned to America by the Mauretania yesterday.

### MR. PATTEN'S CAREER

Mr. "Jim" Patten retired from his wheat corner last spring with a clear profit of £400,000, his share of the £700,000 total profit to the clique of operators of which he was the most conspicuous figure.

It meant starvation to many poor people on two continents, for the corner sent the price of bread up to 6½d. per quarter. An American estimate put the loss to the public at £12,000,000, represented by increased prices to consumers. So great was the popular indignation that he hired a muscular negro to protect him on his walks abroad.

Mr. Patten's age is fifty-five, and he first made money as commission agent for farm products, founding the largest grain brokerage in the country at Evanston, of which town he was elected mayor in 1901. The prophet Dowie hailed him as Elijah the Second, but Patten caused the fire brigade to wash Dowie out of the town with the hose.

We are still anxious to have our readers send us in good photographs of farm scenes. Something that will interest everybody. Do not send us any more threshing scenes as we have had a great many of them already. Send us pictures of good farm homes, or stock, or beautiful scenery, or groups of officers of farmers' associations. These are all interesting. Be sure to choose good, clear photographs and send them in flat. Do not roll them as it spoils them.

THE GRAIN GROWERS' GUIDE, WINNIPEG.

**Make**  
**WORLD'S**  
**EXHIBITION**

**July**  
**13th - 23rd**

A double pleasure is given the occasion if you are in line for a me of the

**PRIZES FOR GRAIN EXHIBITS**

Since 1876, when samples of wheat grown at Fort Chipewyan, on the far Mackenzie, carried the Grand Prize of the First World's Fair at Philadelphia, Western Canada Grain has been the Standard of the World, and the Medal of the Winnipeg Exhibition in this Department are the Blue Ribbon trophies of the Entire Earth.

The Exhibition's Prize Money totals nearly \$50,000

For List Address  
**A. W. BELL, Secy., 1001 Union Bank, Winnipeg**

## The Price of Farm Implements

From "Industrial Canada" the Official Organ of the Canadian Manufacturers Association

A RESOLUTION recently passed by the Saskatchewan Grain Growers' Association, contained the statement that the Canadian Manufacturers were charging more for their agricultural implements in Western Canada than in England. This alleged condition was the subject of caustic criticism by the members of that organization. Since the resolution in question was brought to our attention we have made careful inquiries of manufacturers, and we are now able to state positively that the conditions complained of do not exist. It is regrettable that in the resolution passed by the above body protesting against what they maintained was an unjust discrimination against them, no specific instances were brought forward so that the fallacy of the charges would be definitely fixed. A general error, however, in comparisons of the cost of implements in the west and in the east or in other countries consists in a neglect that larger and better machines are used on the prairies than elsewhere. Six and seven foot binders are common in Saskatchewan, but are unknown even in Ontario and much more so in England. It argues no discrimination that the English farmer is charged less for his four foot implement than the western farmer for his implement almost double the size. So, too, better and stronger plows are necessary for the extensive operations carried on on the big farms of Canada, than in the cultivated gardens of England, and there what in some cases may look like a lower price is explained by a different quality. But we have the assurance of those who are selling implements, both in Canada and Great Britain, that, grade for grade, Canadian farmers get the better price. It might, however, be pointed out that there are very definite reasons why the British farmer should get a loose figure on his farm machinery.

To use but one example, it costs ten dollars less per machine to ship binders from Ontario, where the factories are located, to London, Eng., than from Ontario to Saskatoon. This same condition holds in the case of all other implements. In every case freight charges are less from Ontario to England than to western Canada. More sales are made in England on from thirty to ninety days' time, while in western Canada payments are distributed over two or three years. We feel sure that the Saskatchewan Grain Growers had not all these facts before them when they entered their criticism.

[Note.—This is the other side of the question from the manufacturers themselves. It is something for western farmers to consider and to prepare themselves to answer. There is a great deal more information to be given upon this subject and we will deal with it later on.—Ed.]

### The Truth at Last

Secretary Wilson says that much of the blame for high prices must be laid on the farmer boy, who cannot withstand the allurements of city life. It will be a great relief to a large number of people to find such a responsible place to lay this blame, which for so long has been running around fatherless. It will be a relief to the trust magnates, and they can now go abroad this summer with a clear conscience. It will be a relief to the politicians, who will not have to tinker the tariff any more, and to the editors whose daily problem is to find some place to lay blame without treading on the toes of friends.

It is a good thing the farmer boy's shoulders are broad; otherwise he might not be able to stand it.—Ex.

ing?  
it is  
you a  
ing,  
rded  
ing.  
l you  
ll tell  
one.  
Trade  
of 22y  
Look  
ing  
for  
lar.  
NT.  
in N.E.  
2771  
ay tell you  
ow outfit  
have in this  
l, 130 acres  
lease, 10 of  
and smaller  
other crops  
some grasses  
ON  
dates when  
what they  
y for the  
2) Has the  
en used in  
and Cal-  
net full in-  
nation con-  
dition, but  
and refer-  
people on a  
viders. It  
8 per cent.  
in the case  
ther ordered  
on a 3 per  
cent. An ex-  
of direct  
ity for the  
wor Frank  
of direct  
11. It may  
tpaid from  
Winnipeg  
ally to the  
"1200  
Another it  
pazine, pub-  
the Public  
ilting, 257  
ould advise  
terested in  
books and  
le regularly  
ie Saturday  
et us know  
ad to rectify  
In standard  
present day  
g is not as  
is, curiously  
in the case  
ated in our  
F. Hatt



# MANITOBA SECTION

This Section of The Guide is conducted officially for the Manitoba Grain Growers' Association by R. McKenzie, Secretary, Winnipeg, Man.

## WINNIPEG EXHIBITION PRIZE LIST

The prize list of the Winnipeg Industrial Exhibition for 1910 is now being distributed. The copy to hand shows very fine workmanship in the embossed front cover with the title of the exhibition surrounded by a wreath of anemones, the lower half of title being occupied with a photo engraving of "Revelentia's Heir," the champion Clydesdale stallion of western Canada, whilst the reverse side is occupied by a shield, surmounted with a bunch of maple leaves, containing the dates of the exhibition.

One of the features of the prize list this year is the announcing of the judges, who will make the awards in the various classes, thus giving intending exhibitors the earliest possible opportunity to know who is to act in this capacity.

A large number of special prizes is offered by the various societies, private individuals and firms, namely, Clydesdale Horse Society of Great Britain, 2 gold medals; Clydesdale Horse Society of Canada, \$225.00; Shire Horse Society of England, gold medal; P. B. Ross, Grenfell, Sask., \$45.00; Canadian Percheron Society, 2 silver cups; Percheron Society of America, 2 silver cups, 10 gold medals and cash, \$50.00; Ogilvie Flour Mills Co. Ltd., \$95.00; G. F. & J. Galt, \$50.00 and Winnipeg Business College, 2 silver cups; Suffolk Horse Society of England, silver medal; Manitoba Free Press, silver challenge cup; The English, Canadian and American Hackney Societies, six silver medals; Royal Alexandra Hotel, Winnipeg, silver cup; Frost & Wood, Massey-Harris Cockshutt Plow Co., value; Dominion Shorthorn Breeders' Association, \$300; "Canadian Farm" Toronto silver tea set; Canadian Hereford Association, \$25; Canadian Pacific Railway, \$388; Canadian Northern Railway, \$288; Zerm Disinfectant Co., 2 silver trophies; Canadian Holstein Friesian Association, \$25; Red Polled Cattle Society of England, gold medal; Empire Separator Co., \$20 and separator; American Oxford Down Record Association, \$35; the Oxford Down Breeders' Association, \$100; Western Packing Co., \$25.00; J. Y. Griffin & Co., \$25.00; all the Canadian specialty poultry clubs; De Laval Separator Co., silver cup; A. E. Druman, grain picker; Steele Briggs Seed Co., \$15; and F. W. Drewry, gold medal.

This should be a banner year in the exhibit of the Scotch breed. Other breeds of horses are well provided for possibly not so generously, whilst in Shorthorn cattle, with the two classes, one open and the other for only western Canadian owned, should bring out a record entry in the "Red and Roans," and Winnipeg fair will no doubt, this year, see its first large exhibit of Poland China swine, as many of the breeders have promised entries for the new class, provided for this popular American hog.

## NEW BRANCH AT ROSEWOOD

The farmers of the Rosewood district held a very successful meeting on April 23 and organized a branch of the Manitoba Grain Growers' Association. Notwithstanding the fact of the snowstorm, and that the roads were almost impassable there were some thirty-five of the farmers of the neighboring district assembled at the school house and two-thirds of them joined the association. R. McKenzie, provincial secretary, was present and addressed the meeting. There is every indication that this is going to be one of the most successful branches that we have in Manitoba. Up until recently no effort has been made to organize the farmers east of Winnipeg, but now they are taking hold of the movement with vigor. Meetings are to be held in the French settlements of Lorette, St. Anne and St. Pierre, immediately after the rush of seeding is over.

## PRIZE FOR MEMBERSHIP

W. J. Powell, of the Durban branch of the Manitoba Grain Growers' Association,

is presenting an easy chair as a prize to be given to the member of the association who will secure the largest number of new members. Two of the oldest members of the association have been selected as captains and the contest is now merrily on. No doubt the result will be a large increase to our membership and a lively interest taken in the work of the association in that district. This is one of the many ways that the propaganda of the Grain Growers' Association can be extended.

## MR. LANGLEY'S VISIT

Mr. George Langley, M.L.A. of Saskatchewan, paid our office a pleasant visit while in the city attending a meeting of the directors of the Grain Growers'

One by one the older peoples of the earth have taken up the warfare which science and humanity say is necessary for the well being of civilization.

Under no more favorable circumstances could this war be carried on than in the health giving, uncontaminated prairie land in western Canada. Complex difficulties have to be met in the struggle against the insidious disease among the older peoples of the world. Young as Manitoba is, however, and healthful as are the natural conditions, it is astounding the number of those within its borders who are affected with tuberculosis. Those affected are, however, in every stage of the disease. Provision has been made in Manitoba for those only of the incipient stages. Almost equally serious stages



Winter Sport of Grain Growers at Gilbert Plains, Man.

Grain Company. Mr. Langley reports a growing interest in the work of the association in his district of Saskatchewan.

## MANITOBA TAG DAY

To Establish and Maintain a Free Institution for Consumptives

The erection of a hospital for advanced cases of consumption in Manitoba has been determined on under thorough organization; Tag Day when all may participate, has been instituted.

The people of Manitoba will march into line of battle in the fight of civilization against the great white plague, tuberculosis. The 21st of May has been appointed for the first supreme effort of the banner province of the new world of the west whereon will be fired the first gun in the west against the menacing danger that threatens the health of the nation.

of the disease have not yet been provided for.

It is a moot point for humanitarians, if it is not of more consequence, the care and insolation of the more advanced consumptives than those who may be described as essentially curable. All cases are in a sense curable, but those in the latter stages are unquestionably more dangerous to others. The risk of infection is admittedly more possible.

If for no higher motive than selfish interest the patients in the advanced stages of the disease should be provided for, and provided for at a stage of the country's progress when the situation can be effectually mastered. The dominant note of the appeal for assistance in this direction, next to our common humanity, is that the young world of Western Canada shall be freed at its

## KEEP UP THE WORK.

The local secretaries throughout Manitoba are now very busy in the fields and there will be few meetings of the local branches held during the next few months. It would be unfortunate, however, to let the work die out altogether in the summer. There must be a great deal of news in connection with the local associations to report and our secretaries should see that these reports are sent regularly to the secretary at Winnipeg. The Winnipeg office is busy and is continually watching the interests of the Manitoba farmers. Will you not encourage this work by sending in reports from the field? Send along reports of any co-operative work that has been done by the local associations and what benefits have been secured through co-operative buying. Let us know what plans are laid for the future and what questions will be discussed at your next meeting. Don't let the work lag or it will be hard to arouse enthusiasm in the fall. There are scores of subjects that must eventually be discussed and settled by the farmers such as the tariff, the terminal elevator problem, the co-operative legislation at Ottawa and the Hudson Bay road. Surely one evening a month can be devoted to a meeting where these problems can be discussed. The president and secretary have been active in investigating the prosecution of the owners of the terminal elevators for manipulating grain in the terminals. This is sure to work out to the ultimate benefit of the farmers of Manitoba. Then there is the government elevator bill. The government will, no doubt, shortly appoint the elevator commission and it will be the duty of the Grain Growers to decide what action they will take towards securing a government elevator at their point. Stir up your members and keep the central office posted.

R. McKENZIE, Secretary,

## MANITOBA GRAIN GROWERS' ASSOCIATION

- HONORARY PRESIDENT:  
J. W. SCALLION - VIRDEN
- PRESIDENT:  
D. W. McCUAIG, PORTAGE LA PRAIRIE
- VICE-PRESIDENT:  
R. C. HENDERS - CULMORN
- SECRETARY-TREASURER:  
R. McKENZIE - Winnipeg
- DIRECTORS:  
Peter Wright, Myrtle; R. M. Wilson, Marringhurst; F. W. Kerr, Souris; G. H. Malcolm, Birtle; J. S. Woods, Oakville; R. J. Avison, Gilbert Plains.

beginning from the danger of infection from a terrible curse.

Regulations as to health, education and hospitals for incipient cases may be proceeded with, but as long as consumptives shall be permitted to move about in the midst of the people, absorbed as they are in homemaking and nation building, the dreadful scourge will increase year by year, and month by month. The progress of the disease will eat into the health and happiness of the nation that is to be. The necessity of isolation and sane treatment of advanced cases of tuberculosis is evident. The time for action is the beginning, now, and with the help and support of the whole province the danger will be removed in comparatively few years, a danger which threatens the whole community—the men, women and children within its several homes.

Manitoba should do its part in the war of civilization, in the crusade of the 20th century, the war on more favored ground for success than any other in the world.

Mark the 21st day of May as an eventful day for health and happiness in Western Canada.

## MANITOBA FAIRS

The managing director of agricultural societies in Manitoba has arranged for expert judges at the following summer and fall fairs.

The local fair season of 1910 promises to be the most successful yet recorded. Besides the large number of agricultural societies who have co-operated with the managing director to obtain judges and in selecting fair dates, the development of the work is made noticeable by the inauguration of three new societies, viz., Binscarth, Rosburn and Rivers. The first mentioned was organized early in January, and the organization meetings of the other two as set by the Lieutenant-Governor-in-Council will be held at Rosburn and Rivers on May 10 and 17 respectively.

Fifty-four agricultural societies have arranged with the managing director to have expert judges supplied to place the awards at their exhibitions and purpose holding these fairs as shown on the attached list. Societies who names do not appear on the list will secure judges on their own account, as it is impossible for the managing director to supply competent men to shows not connected in circuits.

## SUMMER FAIRS

Location	Date
Glenboro	July 1
Cypress River	" 5
Morden	" 5-6
Wawanesa	" 6
Springfield	" 7
Miami	" 7
Morris	" 7
Emerson	" 7-8
Carman	" 8-9
Minnedosa	" 20-21
Deloraine	" 25-29
Boissevain	" 25-30
Souris	Aug. 1-2-3
Gladstone	" 2
MacGregor	" 2
Oak Lake	" 2-3
Elkhorn	" 3
Dauphin	" 4
Sanford	" 4
Arrow River	" 4
Hartney	" 4-5
Reston	" 4-5
Treherne	" 4-5
Virden	" 5
Oak River	" 5
Pilot Mound	" 5
Melita	" 6
Cartwright	" 6
Crystal City	" 6-9



# Somerville & CO. BRANDON Monuments



A Postcard will bring you our FREE CATALOGUE, which contains numerous illustrations of monuments, showing our latest designs.

BUY BY MAIL from our Catalogue. We guarantee satisfaction and a saving of 25 per cent.

When writing address J. T. Somerville & Co. Brandon, Man.

Somerville Steam Marble & Granite Works Rosser Ave., BRANDON, Man.

Russell	AUG. 9
Harding	" 9
Swan Lake	" 9
Carberry	" 9-10
Manitow	" 9-10
Gilbert Plains	" 10
Rapid City	" 10
Shoal Lake	" 10
Roblin	" 11
Birtle	" 11
Hamiota	" 11
Binscarth	" 12
Strathclair	" 13
Headingley	Sept. 13
Kildonan	" 14-15
St. Rose du Lac	" 14
St. Laurent	" 27
Woodlands	" 28
Stonewall	" 28-29
Beausjour	Oct. 1
St. Jean Baptiste	" 4
Kellwood	" 4
St. Pierre	" 5
Meadow Lea	" 6
Plumas	" 6

### A GOOD SCHEME

An incident came to our notice within the last few days that indicates the place that the Grain Growers' Grain Company occupies in the affections of our farmers. A farmer who had rented his farm for a term of years put a provision in the lease that all grain grown on the farm during the life of the lease should be shipped to the Grain Growers' Grain Company unless in the case of some grain firm offering more than the market value at the time of sale. In any case the leasor would have to give the Grain Growers' Grain Company the usual 1 cent per bushel commission.

### PLEDGE THE CANDIDATES

I noted that the Douglas branch passed a strong resolution at their meeting on March 19, the resolution moved by Mr. Mitchell: "That we suggest that all sub-associations in the constituency shall, previous to an election, meet at some central point for the purpose of drafting the demands of the farmers and with a view of pledging the candidates, independent of party, to support the demands of the farmers."

I should like to see every branch association take this up and make it universal. I believe it to be a step in the right direction, until we are strong enough to demand direct legislation.

D. REID.

Minitonas, Man.

### IDENTICAL CONDITIONS IN THE WEST

One of the most mysterious failures of the Whitney government is that which is discouragingly obvious in the non-enforcement of the law against combines in restraint of trade. The Dominion law provides adequate penalties for this offence, but enforcement rests with the provincial authorities. When Mr. J. W. Curry, K.C., was crown prosecutor, he undertook the enforcement of the law with vigor, and made it clear that the combines could be suppressed if the authorities were honestly desirous of doing so. There is no difficulty either in regard to the collection of evidence or the preparing of cases that cannot be overcome. But with Mr. Curry's retirement from the position of crown prosecutor there came a collapse of the policy he had been carrying out. The wheels of justice stopped for no apparent cause. The formerly alarmed combiners began operations again and resumed their former boldness. As they say in New York when a corrupt administration wins and police vigilance is relaxed: "The lid was off."

The situation was strikingly depicted in the budget debate by Mr. Proudfoot, of Centre Huron, who holds a foremost place in the debating strength of the legislature. A policy of idleness and neglect, though subversive of law and order and tending toward demoralization, affords no striking or outstanding ground for attack. The law is plain and violations are everywhere apparent. Just why the crown authorities stand idly about and neglect their duty cannot be ascertained. They are open to attack for what they are daily neglecting, and their neglect is rendered especially conspicuous by the era of conscientious activity that preceded it. All kinds of explanations have been offered, from

## THE HOUSE OF STEELE, BRIGGS

Carries the distinction of having introduced the only vegetable seeds ever bred and brought out in Manitoba—WESTERN BEAUTY PEA and HONEY POD BEAN. These are INVINCIBLE Varieties.

**ORLOFF OAT** The earliest and hardiest known—the kind for the new settler on "breaking"—will succeed where all others fail—may be sown as late as June 10th and still give a crop—ahead of barley as a cleaning crop—yielded 110 bushels per acre at Brandon Experimental Farm, 1909.

**SILVER KING BARLEY** Yielded 56 bushels per acre and a good sample.

**FLAX FOR SEED** Pure and clean—don't risk anything else

"Hardy" Alfalfa "Lion" Red Clover  
"Condor" Alsike "Marten" Timothy

These grades have the biggest sale in Canada and win their way by intrinsic worth.

Write for Catalogue and Prices

*Steele, Briggs Seed Co.*  
WINNIPEG, CANADA Limited.



### ECONOMY

is not governed by the price you pay but by the VALUE you receive and the RESULTS obtained. For every dollar spent on "Great West Wire Fence" you will get a dollar's value, and be more than repaid by results.

LET US PROVE IT

Send for our Illustrated Catalogue and the name of your nearest dealer

**GREAT WEST WIRE FENCE Co., Winnipeg**

Calgary Agents: ELLIS & GROGAN Edmonton Agents: RACE & HUNT

indolence and incompetence—to timidity and questionable relationships. Whatever the cause, the neglect continues, and it renders nugatory the elaborate legislation provided for the protection of the public by the Dominion government. There seems no prospect of the enforcement, under existing conditions, so the public must depend on such protection and safeguards as the Dominion government is constitutionally able to provide.—Toronto Globe.

### SASKATCHEWAN'S EDUCATIONAL CAMPAIGN

The extension department of the Saskatchewan college of agriculture announces that preparations are now being made for an aggressive campaign in several parts of the province with a view to the extension of agricultural knowledge and the improvement of farming methods.

During February and March upwards of 100 meetings addressed by practical farmers were held at various points in Saskatchewan adjacent to lines of railway, and the meetings that will be held in June will take place in districts more or less remote from existing railway lines. The extensive tract west and south of the Soo line and the main line of the C.P.R. west of Moose Jaw will be covered as well as possible, and about twenty-five meetings will be held between Estevan and Swift Current, where two years ago there was practically no settlement. A number of meetings will be held along the Goose Lake line west of Zealanua, between that point and the Alberta boundary, and speakers will be sent into the district between Prince Albert and Battleford where an extensive settlement has sprung up within the last few years.

Experienced and capable farmers have been engaged to address these meetings

which will be practically the first of their nature held in any of the districts covered by them.

This work, conducted hitherto by the provincial department of agriculture, has been a valuable means of improving agricultural methods in the province. In future the agricultural extension work carried on by the agricultural college will increase rather than lessen the number and usefulness of such meetings as these.

That a very real need for these meetings is felt is evidenced by the fact that the demand in general from all parts of the province and where meetings have been held requests for additional ones are frequent. They are, however, most highly appreciated in the newer district where the experience of the settlers at farming is less extensive than in the older settled communities.

The meetings will number between fifty and sixty and will begin on June 13.

### NO GOOD MAN GOES HUNGRY

At a charity organization meeting in this city a few days ago a good woman said that "no good man is ever absolutely hungry," and that she didn't believe "God would let a good man go really hungry." Quite correct. Hunger is prima facie evidence of badness, and the ability to get food is evidence of goodness. Any observant person can see that. Does John D. Rockefeller or J. P. Morgan, James J. Hill or the Czar of Russia ever get hungry? Therefore, why appeal for "charity" funds with which to feed "bad" men? But children get hungry. True, but the good children are never hungry.—Frisco Star.

There is lots of fun in beginning at the bottom of the ladder and working up, but it is just as well to have the ladder stepped on one of the upper floors.

## FREE

Your Monogram Engraved Free on each article of Jewelry you order



96c. Silver-plated Collar Pin, your monogram engraved on it for 20c.

\$1.00 Silver-plated Belt Pin, your monogram engraved on it for 30c.

Solid Gold-filled Sagnet Rings, guaranteed for 5 years, your monogram engraved on it for 25c.

Sent Post-paid anywhere Your money back if not satisfied

**J. C. FENTON**

31 Queen's St. West - TORONTO, Canada

## Halley's Comet in Your Own Home

Just while they last we will send one of our "Excelsior" Telescopes, 3 1/2 feet long, with four extensions and Solar Eye Piece

For \$2.00

Remit at once to

**The EXCELSIOR SUPPLY CO.**  
8 Home Bank Building, Winnipeg

## The GOLD STANDARD HERD



Of large English Berkshires. A fine bunch of large mature sows bred for early spring litters to two of the best boars in the Province, "Command Dictator" and "Maple Lodge Roy." Roy was first in aged class and champion in 1908, at Toronto and Ottawa; and in 1909 first and champion at Edmonton, Calgary and Winnipeg. Orders solicited for spring pigs. Address: J. A. MCGILL, Neepawa, Man.

# A Cannon for Hail

Some time ago an account was given of the congress held in France to discuss the results of using cannon in fighting hail and frost. Although this congress was not unanimous in deciding that the cannon were effective, yet large tracts of country are strong in the belief that their crops have been saved by the use of the cannon. That some good has been accomplished cannot be denied.

The shooting apparatus hitherto used has been very primitive in construction. For a cannon, a mortar with a funnel-like barrel was often used. In some places



The Kanitz Weather Cannon

the funnel is fixed vertically in masonry. This method of mounting the cannon is not only crude, but also dangerous, for often enough serious accidents have occurred. In order to avoid these dangers as well as to improve the apparatus in general a Hungarian editor named Kanitz has devised a simple form of cannon which is essentially a breech-loading mortar some 30 feet in length. The mortar is journaled in a rotatable carriage, so that it can be raised and lowered and swung from side to side. The charge is a metallic cartridge of blasting powder. After the discharge a loud, shrill whistling is heard, lasting for about 14 or 15 seconds. French and Italian wine-growers insist that by means of the gun clouds are torn asunder, so that rain instead of hail falls.

The accompanying illustration of the Kanitz gun is from the Scientific American. The American consul at Lyons, France, who visited a number of stations where firing had been done, gives the following account of what he saw:

"Two long cannon were displayed in each place, almost identical in shape, but differing in the manner of firing. Each gun is in the shape of an inverted cone, the opening at the mouth being 28½ inches. It is placed upon a tripod 3 feet high. The gun itself is 6 feet 6 inches high above the tripod. It is made of thin boiler iron. At its base is a forged breech, which holds a forged iron lock. In the centre of this block is an aperture 6 inches long, about the size of a large dynamite cartridge, in which is placed a metallic cartridge containing 80 grams of blasting powder, wadded with a cork, and tapered like an ordinary miner's blast. It is discharged by a needle on a lever attached to the base of the forged iron holder.

"As many as 50 shots were fired in my presence in order that Vice Consul Browne and I might inspect the working of the guns. The detonation is very large. As soon as the lanyard is pulled flame is visible from the mouth of the gun, followed immediately by a wreath of smoke. A shrill whistling sound immediately follows the firing of the cannon and is heard for 14 seconds. At a distance this whistling is much louder than near the gun. I am told that it travels at a speed of 300 meters per second—4,620 meters in 14 seconds, which is nearly 2½ miles. During the firing a few drops of rain fell.

"I interviewed from 20 to 30 wine growers who used the cannon last summer. They were all emphatic in their belief in the efficiency of fighting hail

with gunpowder. They said if the weather were too hot and they saw the clouds forming, they prepared for a change. If the clouds were moving rapidly, their direction was changed or the movement was stopped by the firing. They were torn asunder and broken into shreds and a copious fall of rain soon followed. In localities where great losses from hail have occurred every summer, the cannon was used last summer and no hail fell. Two or three miles distant where no cannon was fired, the hail was very destructive. At Denise, in the Beaujolais, the grape growers had suffered from hail seven years out of the last decade. They think all the conditions favored hail last summer and that they were protected from its destructive ravages by their cannon. One cannon protects nearly 75 acres of land.

"The expense of equipping a shooting station is: One cannon, \$45; cabin for cannoner, \$10; ten cartridge cases, \$6; ramrod, 10 cents; horn and lantern, for signalling, \$1.50; freight, \$1.50; total, \$45. The cost of operating a gun for 500 shots, not including labor, is \$13.50. The cannoner is insured against accidents for a season for \$2.

### CO-OPERATION IN CANADA

From the Saturday Evening Post, Philadelphia

Five years ago very few people in the United States would have been able to attach any meaning whatever to the names of Alberta and Saskatchewan. Now every one who reads those names, and the name of Manitoba, immediately thinks of wheat. The tremendous rise of the Canadian Northwest as a grain producer within half a decade is a familiar story.

Perhaps within another half-decade those names will widely suggest something more than wheat. The Canadian grain growers are organizing a co-operative spirit. A rather long start in that direction has already been accomplished.

Like grain growers in this country they complained of oppression at the hands of private elevator interests that handled their product. Accordingly, at a convention in Saskatchewan last February we find them demanding not merely federal inspection but also a system of public elevators owned and controlled by the government. Also, we find a governmental representative giving official assurance that the demand would receive prompt and careful attention.

In March the Manitoba legislature passed an act for the establishment of government elevators and appropriated two million dollars for that purpose. This, of course, was in compliance with an organized, politically-effective demand by the farmers.

In the United States we find farmers rather half-heartedly and ineffectively demanding uniform federal inspection of their wheat; and some boards of trade

# EUREKA

## SANTARY CHURN

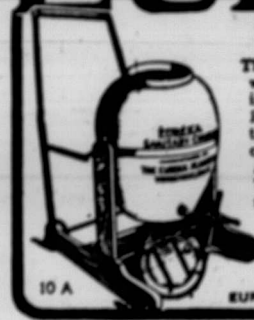

There's no comparison between the ordinary wooden churn and the "EUREKA". Barrel is stoneware—top is clear glass. Besides being absolutely sanitary, the glass top enables you to see how the churning is coming along without opening the churn. Also made with Aluminum top. The "EUREKA" is the easiest churn on the market to operate. By tilting back the frame until the weight rests on the wheels, the churn can be quickly and easily moved—while the barrel remain upright. If your dealer does not handle the "EUREKA," do not take a substitute but write us for catalogue. EUREKA PLANTER CO. LIMITED, WOODSTOCK, ONT.

vigorously opposing the demand as rank paternalism, although the Merchants' Exchange of St. Louis, at least, had the fairness and good sense to take the farmers' side.

Thanks to the initiative of the Grain Growers' Associations of the northwest provinces, a Dominion-wide organization of farmers was recently formed in Canada, with the title Canadian Council of Agriculture, concerning which we read this extraordinary statement:

"The energy of the Council will be devoted to investigating and prosecuting the trusts which have grown up under the protective tariff. Special attention will be given to those trusts which have enhanced the price of cotton, cement and wire fencing—commodities that are purchased in immense quantities by the farmers of Canada. The farmers of Ontario, working hand in hand with those of the great prairie provinces, form a power which is sufficient to overthrow any trust capital can create."

In view of which, what emotions of thankfulness must pervade the breasts of Senator Aldrich and the Steel Trust as they reflect that American farmers are not only practically unorganized for political purposes, but also have been carefully inoculated with an innocent belief that tariff-fostered high prices for the things they buy are very beneficial to them.

### SHAVING NOW A LUXURY

An ordinance has been passed by the city council and signed by the mayor, in Waterloo, Nebraska, which, among other things provides:

"It shall be unlawful for any barber in this town to eat onions between 7 o'clock a.m. and 9 p.m. No barber, while shaving a customer shall insert his thumb or finger in the said customer's mouth; shall not discuss the gossip of the town and shall not use tobacco while working over a chair; shall not insist upon a customer having his neck shaved, or his hair singed."

A violation shall subject the barber to a fine of \$5.

## The Right Spirit

The accompanying picture shows Master Norman J. Ramsay, a four-year-old Grain Grower and his daily companion and steed Fritz. Norman is the son of Mr. John Ramsay, a farmer living two miles north of Lauder. The parent is a Grain Grower, and therefore Norman has got good blood in his veins. At a grain growers' meeting in Lauder a few months ago, where President McCuaig delivered

an address, an appeal was made for new members. One of the first applicants to come forward with his dollar was Master Norman, and his name is now enrolled on the membership of the Association. Though he is not yet an active member in the transaction of the business, yet his future is promising, and he is one of the coming heavyweights in the ranks of the Grain Growers.



Master Norman Ramsay and his dog Fritz.

## CAMERA FREE

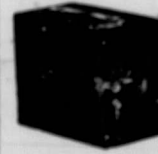

Give me Eastman Camera, with 100 feet of film. A wonderful compact little camera with nickel-plated body. High grade lens and shutter for time or instantaneous exposures. Write for catalog. Free for writing of our high grade jewelry articles at 25c each. These will be sold. Any you cannot sell we will take back. When sold send us the \$3.00 and we will forward the camera. Write now for jewelry. The CO-OPERATIVE JEWELRY Co. Desk 18 - WINNIPEG, Canada

SHIP YOUR  
**FURS AND HIDES**  
TO  
**McMILLAN FUR & WOOL CO.**  
220 KING STREET  
WINNIPEG - MANITOBA  
WRITE FOR CIRCULAR  
TRAFFIC OFFICE FREE TO TRADE  
SHIP TO US

**Imperial Hotel**  
Corner Main St. and Alexander Ave.  
The Farmers' Hotel of Winnipeg  
Centrally located - Good meals  
and warm, comfortable rooms  
**Rates, \$1.50 per day**  
ANGUS McLEOD  
JAMES MORTON, Proprietors  
**FREE BUS**

**FARMERS' ELEVATORS**  
Write for Modern Plans and all information ::  
**E. Senior ESTLIN**  
Chambers of Commerce  
**WINNIPEG**  
Elevators Built Anywhere

G. A. Elliott B. L. Deacon M. G. Macdonald  
**ELLIOTT, MACNEIL & DEACON**  
BARRISTERS, ATTORNEYS,  
SOLICITORS, &c.  
Offices: 311-316 McIntyre Block, WINNIPEG  
Phone Main 12 and 19 P. O. Box 572

**THE BEST PART OF IT.**  
"Well Bobby," said the minister pleasantly, "they tell me you are going to school now."  
"Yes Sir," said Bobby.  
"And do you like it?" asked the clergyman.  
"I like one part of it very much indeed," said Bobby.  
"Ah!" said the minister, smiling, "what part is that, my boy—arithmetic?"  
"Na-a-ah!" retorted Bobby. "The holidays."



Two Good Things For Farmers

a trouble-proof fence and a trouble-proof fencepost.

STANDARD Woven Wire Fence

is all No. 9 hard drawn steel wire, heavily galvanized—with 'The Tie That Binds', which locks on the running wire and lies smooth on both sides.

OUR NEW STEEL POSTS are best at right angles, which gives the necessary strength without the expense of solid or tubular steel.

Don't buy blindly. Learn the facts about wire fences in our book. Send five if you wish—also sample book.

The Standard Wire Fence Co. of Woodstock, Ontario, Woodstock, Ont. and Brandon, Man.



Conducted by "MARIE"

HEADQUARTERS: 201 Bon Accord Block, Winnipeg Phone, Main 9340

- Hon. President - LADY McMILLAN
Trustees: MR. R. MCKENZIE, MR. W. C. COOLEGGE, MR. FERGUSON, MR. M. LILLY, MR. NICHOLLS
Treas. - MR. W. C. COOLEGGE
State Officers: MRS. BIGGS, MRS. NICHOLLS, MRS. STRYKER, MRS. DOWNING, MISS K. YOUNG, MRS. COOLEGGE, MISS OXLEY
Organ. Secretary - E. S. LILLY
Associate membership fee, \$1.00 per year.

Irene More 25c., Josie McBurney 25c., Mrs. Torrance 50c., Blanche Torrance 50c., Ruby Torrance 55c., Mrs. Scott \$1.00.

Dear Jessie:—This is truly great work you have done. We hope to make many children happy this coming summer. This money will go to fresh air work, unless any urgent call for (child) help comes to hand and it would go to comfort the sick and needy ones.

MARIE.

MOTTO

If any little word of mine
May make a life the brighter,
If any little song of mine
May make a heart the lighter,
God help me speak that little word,
And take my bit of singing,
And drop it in some lonely vale,
To set the echoes ringing.

Dear Friends:—We have now taken a lease of the fresh air home at St. Louis, situated between Winnipeg Beach and Winnipeg on the Netley River. The cottage is built on the river bank, and the private grounds around it comprise



Mrs. Alden, the International President and a hammock full of Blind Babies at Brooklyn, N.Y.

5 1/2 acres of land: there is a lovely view. The cottage is screened in by trees, and is partly furnished, including a piano. To our great delight Mr. D. F. Burns, of Winnipeg, has kindly promised to pay \$5 per month toward the rent. This will be a great help, and we are indeed grateful for his practical sympathy. If we are willing to spend thousands on the care of the consumptive we should be more than willing to spend twice as much in the effort to give fresh air and sunshine, which the doctors agree are the chief remedies, together with nourishing food against this fell disease.

Yours lovingly, "MARIE."

FOR THE LITTLE SHUT-INS.

Dear Marie:—I am sending you the collection card with five dollars. I may send you some more later on. I hope this money will feed a good many little children. Yours truly, JESSIE SCOTT.

Underhill. The following are the subscribers to the emergency fund card forwarded by Jessie Scott. Jessie Scott 30c., Louise Scott 25c., Willie Scott 10c., Bertha Scott 5c., Miss E. Brandow \$1.00, Annie More 25c.

WHERE TO SEND SUNSHINE Master McMillan, 958 Alexander, crippled boy, would be glad of a summer home for this dear boy.

Mrs. England, 394 Harbison Ave., Elmwood.

Flossie Green, Children's Aid, Mayfair, Winnipeg, has, unfortunately, taken fits and had to be brought back to Children's Aid.

EVERY CHILD SHOULD JOIN THE SUNSHINE GUILD

Sign the form below:

Dear Marie:—I should like to become a member of your Sunshine Guild. Please send membership card. I enclose two cents stamps for its postage.

Name

Age

Address

Just Six Minutes to Wash a Tubful!

This is the greatest washer the World has ever known. So easy to run that it's almost fun to work it. Makes clothes spotlessly clean in double quick time. Six minutes finishes a tubful.



Any woman can have a 1900 GRAVITY WASHER On 30 days' free trial.

Don't send money. If you are responsible, you can try it first. Let us pay the freight. See the wonders it performs. Thousands being used. Every user delighted. They write us bushels of letters telling how it saves work and worry. Let the 1900 Washer pay for itself. Just send us 50 cents each week out of the money it saves you.

Write to-day for our Free Washer Book. It explains the 'easy payment plan'. Tell us your nearest freight station. Address me personally, G. D. BACH, Manager, The 1900 Washer Co., 357 Yonge Street, TORONTO, CANADA. The above offer is not good in Toronto or Montreal and suburbs. Special arrangements for these districts. Winnipeg Branch: 374 Portage Ave.

GRAND TRUNK RAILWAY SYSTEM THE ONLY DOUBLE TRACK LINE BETWEEN

Chicago and Eastern Canada

and the Double Track Route to NEW YORK, via Niagara Falls

THROUGH COACHES AND PULLMAN SLEEPING CARS

Steamship Tickets, Cooks Tours, Quebec S S. Co., Special Tours to the Mediterranean, Bermudas and West Indies

For rates, reservations, time tables and full information apply to A. E. DUFF, General Agent Pass. Dept., 260 Portage Ave., Winnipeg. Phone Main 7098

The Threshold of Democracy

is the Labor, Agricultural and Reform press. No other agency provides the same effective forum which generates true progress.

THE VOICE

311 RUPERT ST., WINNIPEG

is one of the best labor papers in North America. Sympathetic toward the farmers organized movement, and free from RAGE.

Does it ever occur to you that the organized farmers and wage-earners should stand together, and that you should study the viewpoints and activities of the labor men?

THE 12-PAGE WEEKLY VOICE IS \$1.00 A YEAR

Watch Us Grow GRAIN GROWERS!

Does your Watch require Cleaning or Repairs? If so mail your Watch to J. K. CALLAGHAN Expert Watchmaker and Jeweler BRANDON Man.

Why not secure

640 acres

Veteran Scrip

\$3.00 an acre

No Cash required if you have an improved farm to offer as first mortgage security. Better write us now for particulars while Scrip and land can be secured. Farm loans granted without delay.

Canada Loan and Realty Co., Ltd. Winnipeg

The Manitoba Pressed Brick

MAKERS OF FINE SAND-LIME BRICK CO. LTD. The Twentieth Century Building Material The Cheapest and Best Brick on the market. These have been used among others in the following buildings, viz.: Six large new City Schools, Fort Garry Union Station, New Customs Examining Warehouse, Somerset Block, Emmanuel Baptist Church, Residence of T. H. Johnson Esq., M.P.P., and The Grain Growers' Guide Building. Correspondence invited.

Prices and Samples on application. Bricks shipped to your nearest station. Office: 215 MCINTYRE BLOCK, WINNIPEG



THE BRUNSWICK FREE BUS MEETS ALL TRAINS Rates - \$1.50 per day

JAS. FOWLIE, Proprietor Centrally located corner Main and Rupert. Farmers' most Popular House in the West

Binary barrel

glazing in

in the frame, the red-

WKA, Singer, GWT

REE

Excellent will take you to the top of the mountain. The only watch that will keep you on the right track. The only watch that will keep you on the right track.

S S

TOOL CO. TOBA LEAD

Hotel

nder Ave. 1000000 1000000 1000000 1000000

ATORS

MAKERS OF FINE SAND-LIME BRICK

DEACON

ck, WINNIPEG

OF IT.

the minister you are going

led the clerk much indeed

smiling, an arithmetic hobby. The



## AROUND THE FIRESIDE

Conducted by "ISOBEL"

### What Women are Doing

Service League in the Free Dispensary



It is a hopeful sign of the times to find a group of busy professional men voluntarily write and pledge themselves to devote so much of medical attendance and medicines as the needy sick of a large and growing city may require; men who lead strenuous lives, men in keen competition with their fellows, but whose humanity can reach beyond a merely personal financial gain and whose compassion is of the tangible practical quality that evidences itself in bringing health to the impoverished sick—to those quite unable to pay for professional services. The financial drain upon a small handful of physicians to equip and maintain suitable premises and furnish medical supplies for the requirements of hundreds of patients (there being 396 treated during last month alone) and the number steadily increasing, will be readily appreciated, and that the inevitable attendant expense pressed heavily upon the heroic workers will also be understood.

Among their self-imposed duties, these dauntless volunteers found one department in their labor of mercy quite beyond even their practical skill—the homely, commonplace, feminine prerogative of making soups and jellies and broths to supplement or complement the gratuitous medicines. In this emergency the only reasonable and natural course lay in an appeal for aid to that class of whole-souled womanhood who never hears a just appeal unheeded. With the promptitude and effective earnestness that characterize real philanthropy a band of women resolved themselves into a service league, their avowed purpose being to aid the already organized medical staff by taking over the financial burden of furnishing and maintaining larger apartments, where more efficient treatments can be given to the unfortunate, many who must, for the present, look to the charitable for such help. In every such benevolent scheme money is the first, the imperative, requirement. This band of earnest women (and there are already ninety, though the League is but four months old) faced with immediate need of money, promptly levied upon themselves a cash deposit of \$3.00 each to form the nucleus of a fund to begin upon, and then fixed this amount as the regular annual League fee. They united in having "at homes," and "teas," and "evenings" at their several residences, where donated homemade food stuffs were sold and handsome profits realized. Subscriptions in money and donations in useful materials, dishes, and so on were solicited and obtained from appreciative sources. Committees are formed for the systematic visitation of the sick. A specialist nurse is retained whose duty is to remain in the league quarters to receive and advise applicants for League benefits and to hand over to them their respective prescriptions, whether it be broth or quinine, jelly or aloe, milk or soup.

A most worthy feature of the management is

#### The Diet Kitchen

which has for its chief object the welfare of the infant poor (this embraces not only the teaching of sanitary methods in infant care to the mothers, but also the actual daily free distribution of properly pasteurized milk to such as require it), in the hope of reducing the high death-rate among these piteous, innocent sacrifices, the direct product of corrupt legislation. Quasi statesmen may fling

their noisy tirades across a continent, deprecating the habit of race suicide in infant ranks, and Anglo-Roman churchmen plead and pray against the same entirely problematic improved decemation. Their labors end with words. The suffering, starving infants really with us, they presumably never note; always chasing shadows and fleeing from the substance lest work be entailed. The undeniable birthright of every child that enters the world is food and shelter until it is old enough to find for itself, and woe to him who defrauds the helpless. If individual parentage does not or cannot protect its progeny, the state should. Infancy should be maintained as the most precious asset of the state. But what is the state? Who can tell? At convenient seasons it seems to parade as some supreme unapproachable ogre in the dim distance, accountable to no one, responsible for nothing, a creature of its

going as it should. A gigantic carnival of breads and pastries, sweetmeats and candy is now in project for April 30th. Many of the business houses and apartment blocks of the city are giving space for tables from which volunteer saleswomen will sell to a kindly public the splendid stacks of attractive homemade foods contributed by willing Leaguers and friends of the League's work. The best wishes of all friends of the poor will go with the women of the Service League throughout their various labors, and heartfelt prayers for the early arrival of state-made conditions where no poor will be.

#### THE FORBIDDEN FRUIT

No Authority for Saying It was an Apple that Eve Ate

"What a vast amount of trouble the human race might have avoided if Eve hadn't eaten that apple," remarked the grouchy individual when something especially displeased him.

"How do you know it was an apple?" asked the accurate man.

"Why, the Bible says so, doesn't it?"

"No. It has come to be a popular belief that the fruit which was eaten by our first parents in the garden eastward in Eden, was an apple, but there is no authority for this.

"It is called simply the fruit of the tree of knowledge of good and evil. 'And when the woman saw that the tree was good for food and that it was pleasant to the eyes and a tree to be desired to make one wise she took of the fruit thereof and did eat and gave also to her husband with her, and he did eat.' What is there here about an apple?"

"A great many popular quotations



Off for an Evening Canter at Ruddell, Sask.

own creation, immune alike from friends or foe. At other equally well selected seasons it parades with hat-at-knee and hand-a-grasp, and bows and smirks and simpers and jollies itself into the easy graces of a self-deluded populace, only to retire again into its "veiled-prophet's" retreat, there to weave again the same old webs to snare the same old flies. And so the farce goes on, and meantime little children starve and die for food and care, and there is no one in the state to weave the webs with which they may be clothed. Therefore, woman, exempt from citizenship, excluded from the state, by state decree, can only kneel to succor and revive as best she can the helpless victims of a wanton state. And so these women of the Service League, not questioning the why or wherefore, if disease and want, step unostentatiously into line and cheerfully dedicate a portion of their time and substance to alleviate distress.

A systematic thoroughness marks the course of every section of the work and nothing is left to chance.

A reliable supply of pure milk is assured by the League engaging their own dairy a short distance only from the city, all the cows being tested. They have their own pasteurizing plant right in the kitchen and the milk is also modified for each particular patient by the specialist. The babies are brought daily to the kitchen for inspection and assurance that all is

attributed to the Bible when in fact they had other sources.

"God tempers the wind to the shorn lamb" is not from the Scriptures, but from 'A Sentimental Journey to Italy,' by Sterne.

"In the midst of life we are in death," which is found in the burial service, can be traced to Luther.

"From St. Paul's utterance, 'The love of money is the root of all evil,' we have twisted the saying, 'Money is the root of evil.' 'Cleanliness is next to Godliness' was uttered by John Wesley in a sermon on dress. 'The merciful man is merciful to his beast' is a popular rendering of the proverb, 'A righteous man regardeth the life of his beast.' 'The tongue is an unruly member' appears in the epistle of James as 'The tongue can no man tame; it is an unruly evil.'—Philadelphia North America.

#### OPPORTUNITY

I seek for none,  
I knock at no man's gate,  
I sit as one  
Enthroned in regal state.

Ten thousand pass  
Unheeding me and mine;  
One kneels; his glass  
I fill with magic wine.

—From the "Chicago Post."

#### Notice to Correspondents

Still the letters come in, without proper signatures. Will those wishing their letters to appear in Fireside Department, kindly remember to sign their real name in each case as well as the one designed for publication. Our readers may have gotten the idea that real names are not necessary because they are not always published, but in all cases the real name must be signed for the benefit of the publisher.

#### AN OLD-FASHIONED FARM

Somebody has to wind the clocks,  
And mend the locks,  
And tend the flocks,  
Somebody has to do the chores  
That comes by scores.  
Somebody has to spade and plough,  
And milk the cow,  
(Do you know how?)  
Somebody has to shear the sheep,  
And plant and reap,  
With little sleep—  
That's father.

Somebody has to mend the socks,  
And starch the frocks,  
And clean the crocks,  
Somebody has to wash the floors,  
And dust the doors,  
Somebody has to boil and bake,  
And make the cake,  
And fry the steak,  
Somebody has to buy things cheap,  
And wash and sweep,  
With little sleep—  
That's mother.

Somebody has to mow and to plow  
And freeze and boil,  
Somebody has to look ahead,  
Sometimes with dread,  
Somebody has to do the work  
(No chance to shirk),  
And by and by,  
With one more sigh,  
Somebody'll just lie down and die—  
That's both of them.  
—The Somerville Journal.

#### SOUND ADVICE

I have long thought of writing to the Fireside editor to let you know how much we appreciate reading THE GUIDE, and especially the "Women's Corner." It is a pleasant surprise each week to see that so many farmers' wives can take time to write to the "Fireside" on so many different subjects, and while we may not all agree on any one line of thought we can agree to differ.

I cannot say with Mrs. J. and Mrs. B. about the dower law and votes for women: "leave that kind of stuff for the other papers to discuss," for they are both such important subjects that I think they should be kept in agitation by THE GUIDE as well as other papers until the government will see fit to grant what we ask for.

As the farmers have been able to accomplish much by being united and sending large petitions to the government, so their wives and daughters will have to "go and do likewise" if they ever accomplish anything along their line of grievances.

I'm afraid our politicians will put off the evil day of granting women the ballot as long as possible for they know that when women get there, their influence will be against political corruption, and may other wrongs that need righting. We are glad to see THE GUIDE stand for all that is right and good and hope it will continue to prosper.

As this is housecleaning time, and lots of women, after they get a room cleaned and newly papered are not satisfied with the results because the furniture looks shabby, so thought I would send a recipe that has always given good satisfaction.

#### Furniture Polish

Take equal parts of turpentine, coal oil and vinegar. Keep well mixed and rub over one piece at a time—this will remove all marks. Then if there is much furniture to do, take a pint of shellac, add one-third as much turpentine and apply with a brush while the furniture is still moist. After the pieces are all gone over, finish with a coat of varnish made thin with turpentine, and you will see well repaid for your work.

FARMER'S WIFE.

Darlingford, Man.



The Piano buyer bent on getting the finest instrument to be had must inevitably choose the

# Mason and Risch Piano

No matter what your preference may have been you will detect in the Mason & Risch tone a human voice-like quality never met with in any other piano. When you have heard it you will recognize it, just as the greatest tone experts and most discerning musicians all over the world have done.

You are cordially invited to see and hear the Mason & Risch at our salesrooms.

Send for the beautiful booklet, "Inside Information." IT'S FREE.

Convenient Terms of Payment arranged.

## The Mason & Risch Piano Co. Ltd.

Factory Branch - 355 Main St., WINNIPEG

it could grow fat and sing. But they both set themselves aside and keep busy, making ready for the young ones. They do their duty and leave the responsibility to something higher than themselves.

### IF YOU WERE NOT YOURSELF WHO WOULD YOU BE?

A Prize Essay by Ethel Isabel Fowler of Chicago, Ill.

No woman is always absolutely satisfied with her own personality, no matter how much she may appreciate its advantages at some certain time in her life. There are moods in which we are bound to envy someone. As for myself, let me confess it right here, I have been known to think longingly of the lot of Eve. It would be worth something to be the first and only woman with the man you married, to be dead sure that he had not loved someone else, and then, because you happened to cross his path at the psychological moment, married you instead. It is worth something to know, when your man stayed out a bit late at night, that he was merely wandering on the outskirts of the Garden, communing with nature, instead of with some other man's wife. And to know, when you bade him goodby in the morning, and watched him start to his tilling of the soil, that evening time would surely bring him home to you, because there were no clubs, no other "fellows" he might meet for business purposes, no other women to detain him, no, nothing, in fact, but YOU.

Eve may have been a bit lonesome now and then for a gossip, she may even have tired of the monotony of her attire and sighed for a ruffle or two of some kind with which to make herself more fair in her lord's eyes, but then—the Garden of Eden was a mighty safe place for a married couple, and the life had its compensations. Then think, too, of bringing up the children there, no neighbors to boss the job. The boys could not get in disgrace in school—how could they? They could not fight with larger boys than themselves, because there were none. If they tore their clothes it was a simple matter to don another fir leaf and it saved a heap of darning. In those days the Roosevelt theory might have been all right, but for modern times—well I am of Scotch descent and, hae ma doots.

There were a few other advantages that Eve enjoyed, easily appreciated by married folk of today. Think of no relatives, no mother-in-law, no "pie like mother used to make" arguments at meal times. The only chance Adam did get to boast of his superiority was that Eve owed her life to him, and at that, he could not say he was better than she, for they were just alike. Oh, yes, methinks it must have been an ideal existence, and yet at that, the woman grew discontented. She did not know when she was well off. Her curiosity to test life a little further and to see into it a little deeper, to find some excitement to relieve the dullness of her days, possibly to do something to make Adam jealous—all this led her to eat of the fruit of the tree and lose her happiness. Since then, we have vainly sought it. Sometime we gain it for a time. Some few fortunate women perhaps, even keep it forever, but it is a brittle bubble, this happiness, and oftentimes breaks in our fingers just as we grasp it closely.

I don't particularly dislike myself, or my own lot in life, or the color of my eyes, even though my enemies do say they're green, but as stated before I do occasionally wish I'd been Eve—I don't like apples, anyway.

### HOUSEHOLD

**Lemon Cookies.**—Two cups of granulated sugar and one cup butter; add three beaten eggs and flavor with lemon juice or lemon extract. Sift into the mixture enough flour (with teaspoon baking powder) to make stiff enough to handle, roll thin, cut out and bake.

**Pancakes.**—In frying, after the first panful is cooked, add no more grease, but slice a raw potato and rub the pan each time before putting in more batter. It is said the pancakes will not stick to the pan and are much more digestible than if fried in grease.

### New Tinware

If new tinware be rubbed over with fresh lard and thoroughly heated in the oven before it is used it will never rust afterwards, no matter how much it is put in water.

For cleaning stained tinware borax produces the best results.

If the teapot or coffee pot is discolored on the inside, boil it in a strong solution of borax for a short time and all its brightness will return.

### HEMSTITCHING BY MACHINE

Mothers who do not have time to do hemstitching by hand, on their little daughters' clothes will find this method satisfactory. Draw the threads in the usual way, fold the hem over and baste the edge in the centre of the drawn threads. Loosen the tension of the machine and stitch as nearly on the edge of the hem as possible. Remove the bastings and pull the stitched edge of the hem to the bottom of the drawn threads and the work is complete. Hemstitched tucks can be made in the same way.

### Hand-Run Tucks

How to run narrow, hand-run tucks in thin material without having them of various widths is a puzzle to the woman who does her own sewing. Here is one plan that obviates the difficulty. Cut a measure double the width of the desired tuck. Lay this on the goods and draw one thread on both sides of the measure. Draw threads for all the tucks before you begin to sew. If your material is sheer, thin white goods or mull, use your finest needle and 100 thread. Fold your goods so that two thin stripes come together. Sew in this stripe where the thread has been pulled, and, after the tuck is pressed down, the drawn thread will not show. By this plan one is sure that her tucks are all of the same width. Some people complain that it takes too much time to tuck with the fingers, but after the threads are pulled one can sew just as fast as the fingers can push the needle through the goods, and it is light and pleasant work.

### ODDS AND ENDS

**The Latest Epidemic.** Presumption rather than despair, is the epidemic of today.—Bishop of Stepney.

**Religion in London.** Seventy per cent. of the people of London never enter a place of worship.—Sir Robert Perks.

**The Cup that Cheers.** It is nearly as difficult to picture the British without tea as ourselves.—The Chinese Ambassador.

**Man and His Fate.** Man is not sufficiently master of his own fate, nor does he sufficiently control his own development.—Dr. F. C. S. Schiller.

**The Great Thing.** The great thing in life is to avoid care by moderating one's desires and ambitions and one's love of worldly things.—Judge Willis.

**Matrimonial Holidays.** Every husband and wife would be better if they had a fortnight's holiday away from each other every year.—Bishop of London.

**How to Save Trouble.** What worry and trouble many people would save themselves if they would give up the ambition to be "well in" with the superior persons of their locality.—Mr. Henry Vivian, M.P.

**Absence Makes the Heart Grow Fonder.**—When you are away from people, you can realize their good points—indeed, their true character, apart from the little rubs and strains which must occur in everyday life.—Mrs. Price-Hughes.

**Our Democratic Age.**—I have frequently been struck with the eloquence of working men, who can often express themselves more clearly and logically than scholarly men, because they have not so many loose words rattling about in their brains.—Sir John Cockburn.

## SOUTH MELVILLE IS THE SPOT TO BUY

The wise investors build their faith on SOUTH MELVILLE. It is high and dry. It overlooks the lower portion of the city. It is the point of beauty which at once strikes the eye of every visitor to Melville. It is nature's own choice for the best part of Melville. Buy here. Write for Booklet, Maps, etc.

Melville Land Co. Ltd. Union Bank - - - WINNIPEG

## Queen's University and College KINGSTON ONTARIO.

ARTS EDUCATION THEOLOGY MEDICINE

### SCIENCE (Including Engineering)

The Arts course may be taken without attendance, but students desiring to graduate must attend one session. There were 1517 students registered session 1908-10.

For Calendars, write the Registrar. GEO. T. CHOWN, B. A. Kingston, Ontario.

## BRANDON CREAMERY "THE OLD RELIABLE"

### We Want Good Cream

FOR WHICH WE PAY TOP PRICE

### We Buy Eggs & Dairy Butter

Address Write for information

BRANDON CREAMERY & SUPPLY CO. Box 400 BRANDON :: :: Man.



\$18 to \$49 Free Catalogue C

FOR HIGH GRADE HAMILTON

Cream Separator

Direct. Why pay \$25 to \$75 more to a dealer

Special 30 DAY OFFER

Get Free Catalogue C, testimonials, description and prices on five sizes.

Thousands sold in Canada this Spring

## Hamiltons'

Somerset Building - - WINNIPEG

7 PER CENT. Guaranteed Investment Return. Principal absolutely safe. Established Business. American Securities Co., Toronto

ents without wishing Fireside to sign well as n. Our tea that because but in signed  
ARM ks.  
plough.  
beep.  
ks.  
rs.  
ke.  
beap.  
nd die- m.  
e Journal  
ng to the how much IDE, and ner." It ek to are can take e" on so while we e line of  
and Mrs. votes for off for the they are s that l agitation ier papers t to grant  
ble to ac- and send- government- will have they ever rir line of  
ill put of the ballot know that luence will and many iting. We and for all ope it will  
tine, coal ed and rub ill remove uch furni- s, add one- and apply ure is stin- all gone nish made u will fee  
WIFE.

# PURITY FLOUR

"MAKES MORE BREAD AND BETTER BREAD"

"ASK FOR IT"

# Labor and Capital

(Continued from Page 9)

kept for war purposes; the idle rich and their wasted millions, and the wasted earnings of the laboring class, are all put to useful occupation for the common national good and uplift. A time when right shall be the might, and not might the right.

### Standards Must be Reversed

Now, to do this, to my mind, it is of the utmost importance that a new world's ideal should be erected under an intelligent determined, deliberate, clear and far-sighted leadership. Our standards must be reversed in the public mind, viz., the world, nation, class, community, family and individual. We must demand from the collective body or body politic, what we now demand from the individual, but which the individual finds to be simply martyrdom, for he sees that for the individual to stand by our ideal, the world's best will continue to be slain by the terrific onslaught of the selfish forces which are organized around him. To be successful in this we must go to the fountain-head and shut down on the whole competitive system; from the building and arming of navies and our systems of usury, which I believe is contrary to God's ideal, and which will make slaves of one portion of the world for the benefit of the other as long as it is permitted to exist. For competition is war, and "war is hell!"

And yet the establishment and maintenance of law and order of a world's ideal, or a world's wide confederation, demands a force; a power to enforce its edicts and mandates and protect the body politic from the attacks of that which is worst; and so we will need at least one army and one navy to police the world and chastise, if need be, the unruly and wayward. Our seas and channels of commerce would need to be protected from freebooters or plunderers. But this would not necessitate a large force once the powers have agreed to a system of arbitration and re-organization under this world's new ideal.

### Canada's Opportunity

Now we, in Canada, have the greatest opportunity to lead the way—a leading voice in the galaxy of nations, a prominent factor in the most powerful empire that today exists on the earth; and a peculiar opportunity and influence that might well be used in welding the power of this whole American continent with that of the British empire. A power to make or break. An opportunity to lead off and play the game never so distinctly offered to any other people on the face of this earth; and to fail to take advantage of it is to be guilty of selling our birth-right, or abdication of our inheritance.

I cannot go further into detail. Time is limited. The question is too large, too momentous. To my mind every man should wake up. The question of the day is not Liberal vs. Conservative, Grit vs. Tory, or Labor vs. Capital. We must labor. We must have capital. And the present condition still remains. There he stands. This money God which takes by cunning device the money earned by him who digs it from the earth; and the sweat of his brow has given him a right to it against the universe which no one has a right to touch without his consent. Yet there stands this God with unlimited power. Yet cold, heartless, selfish, a God without pulse, no human feeling of pity or love. Its sole interest is gain or accumulation. It would coin dividends out of the destruction of souls. Desperate in its struggles with the rights of humanity. Striving to clutch in its iron grasp everything that ought to be free in this country. It is insatiate, deaf to the pleadings of human kind, and the question is to oppose this God and his extension of power. To resist the demands of the spirit of this God in the council chamber in parliament and out of parliament; with voice and with ballot. To refuse to be his instrument, his tool; in season and out of season. To resist this God, which grabs at the labor of every man, and refuses to work himself. Which shackles every other individual while he himself refuses to be bound. The spirit of selfishness and tyranny against unselfishness and brotherhood of man. Wrong against right.

### The Workmen Worthy

I do not know that the time will ever come that all will be equally rich or all equally poor, which will be practically

the same. Perhaps it may be necessary to have a class to perform the drudgery of life, where the lower order of intellect and little skill with vigor, docility and fidelity will find their place; and others which lead the way to further progress and refinement constitute the foundation and basis of society. But I believe there will be, and before very long, a civilization which will admire the workers for the work they do very much more than is now done for the money they gather.

But we must not, as a people, permit the past to fetter the future. The economic development of the nineteenth century has produced a solidarity of humanity which no racial or class prejudice or international hatred can destroy. Each nation is to some extent being brought to realize that it is its brother's keeper, and no nation, as we have already said, owes a greater debt or duty to civilization than Canada in the propagation of this spirit. And to fail would be a colossal crime. Our immediate channels of power are the school, church, immigration policy, extension of the franchise to women and the proper use of the ballot, together with all educational institutions which tend to raise our average intelligence.

But, in the meantime, in labor's struggles with capital, the spirit of one is likely to be as tyrannic as the other, and the burden will fall on the unorganized strata below them, and the points gained or lost are infinitely small when compared with the great problems involved and objects to be attained, and are useful only insofar as they help us to discover that a solution cannot be found along this line.

### A Harsh Alternative

What think you would happen if producers of food were as thoroughly organized and imbued with the same spirit as now dominates organized labor and capital? Farmers would demand all your cash and possessions for foods, and you city people would be offering yourselves, body and soul, for bread like the Egyptians once did to Joseph.

No, friends, competition can only in the end compel a truce and a convention to seek for the truth which shall make us free.

If we must be ruled by public opinion, we must have a public opinion so moulded that it will erect a world's tribunal. Nationalism is now too small. Class legislation nor national tariff wars will not suffice. No class or nation can live to itself, but each is radically affected by the policy of the other. A universal standard is now demanded which a world's majority will willingly respect and obey. With a force sufficiently strong to command obedience from the unruly, where the breakers of the spirit of that law which is best for all will be treated as criminals, and the keepers of it will be revered and honored; where the world's best have joined hands to control the world's worst, and are able to do it. When Burn's "Man to man the world over shall brothers be" spirit or Kipling's "There is neither east nor west, border, nor breed or birth" when two strong men meet face to face, though they come from the ends of the earth, "spirit is in control."

### We Have the Keys

Now, we need not expect a new breed of men from some other planet to come to establish this. Neither need we expect angels from heaven. We have already had one from heaven—the lowly Nazarine—who has given us the keys to the situation. We must, we must establish a new created body politic, wide enough to embrace the world. And strange as it may seem, this new creature must be generated by a new born individualism; brotherhood in the amalgamated womb of all the nations; and may I say, begotten on these broad prairies of our Canada, coming into life freed from the taint and trammels of hereditary party political systems and old world's superstitions and strife; developed in our broad prairie height environment; electrified with a sympathetic touch and world-wide vision of the human family; unified by a world's ideal and ultimate goal of the race; dedicated to the unfinished task of the ages. May I tell you that this citizenship is now being brought forth on these prairies. Sons and daughters here from every kindred and clime, the whole world represented, are being melted into one in the common struggle of pioneer life; desiring only peace and giving a living demonstration of how all the nations of the earth may live together harmoniously.



THE *Manitoba*  
FROST-PROOF  
**Gasoline Engines**  
are Simple  
Reliable  
Economical

Made right at your door. Repairs or expert advice can always be obtained without delay.

They are sold under a **POSITIVE GUARANTEE** to give satisfaction.

Made in following sizes: 2, 4 and 7 h.p. Vertical Hopper cooled; 10 h.p. Horizontal Hopper cooled, stationary or portable; 25 h.p. Portable Threshing Engines, and 45 h.p. Tractors.

We also manufacture the famous **MANITOBA WINDMILLS**, the strongest, best regulated, and most powerful mills on earth, made to suit Western conditions.

Grain Grinders, Steel Saw Frames and Wood and Iron Pumps.  
Send for Catalog G. We are manufacturers, not dealers.

**The Manitoba Windmill & Pump Co. Ltd.**  
Box 301 BRANDON, Man.

**WHY BUY FROM**  
**"BIRKS' WINNIPEG"**

**?**

**BECAUSE** your purchases will have that newness and freshness so desirable in the purchase of Jewellery, Silverware, etc.

**BECAUSE** the very fact of buying from Birks' assures the very highest quality in the articles purchased.

**BECAUSE** while you will find Birks' merchandise highest in quality, their prices are invariably the lowest.

The firm's Summer Booklet, entitled "Silver and Gold," is brimful of the very newest summer novelties and Wedding Gift Suggestions. If you have a Wedding Gift to buy it will help solve the question as to what to give. Send for a copy today.

**Henry Birks & Sons, Limited**  
Jewellers . . . . . WINNIPEG

LICENSED BONDED

**MACLENNAN BROS.**

GRAIN EXCHANGE WINNIPEG

**WHEAT: OATS: BARLEY: FLAX**

Consignments Sold to Highest Bidder. Net Bids Wired on Request

**Farmers** Patronize the independent track buyer and commission dealer and preserve competition on your market. Ship your grain by the carload. Send us your bills of lading and we will hold your grain as long as you desire, and advance you prepaid all the money you want. Write for our market card and shipping directions.

R. A. BONNAR W. H. TRUEMAN W. THORNBURN

**Bonnar, Trueman & Thornburn**  
BARRISTERS, ETC.

P. O. Box 223 Office: Suite 7 Nanton Block  
Telephone 766 WINNIPEG

ly. And beginning to discern that they have a freedom to lead in world's thought and policies.

**The Vital Force**

Simple as it may appear, this great western prairie belt has in its young rural life the vitalizing force which, if wisely stimulated and supervised under our common flag, the Union Jack, under whose folds the world's helpless and persecuted of every kindred and clime have found refuge and opportunity. Here, I say, is the force that will yet lead the world to a policy which will cut out the whole competitive system and institute in its place co-operation, which will declare we want no more war, and will establish a way to avoid it; will reserve the demagogue-like traffic in strong drink; annihilate the Goliath-like money God and the whole usury system, and prove to the world that labor is capital and capital is stored labor, to be used for the protection of the aged and infirm, and establish an edict that idlers shall not plunder; and if they will not work, neither shall they eat.

# Graft in Terminal Elevators

*Investigation Shows that Mixing has been Carried on, and that Elevator Companies have Falsified Reports. Fines of \$5,550. were Imposed upon the Elevator Companies*

IN a manner that was as sudden as it was startling, there was revealed to the public of Western Canada last week a self-confessed story of manipulations in the large terminal elevators at the head of Lake Superior which vindicated all the charges made by the Grain Growers' Association in years past, that these concerns have been habitually violating the terms of the Grain Act whereby the producers of the west have been swindled of thousands and thousands of dollars which should have rightly been returned to them.

The revelations were not only startling but the apparent attempt to hush up the prosecution of these wealthy organizations was nothing short of sensational and decidedly unusual.

On the afternoon of Friday, April 22, at a private hearing held by Magistrate T. Mayne Daly, in the private office of A. B. Hudson, lawyer of the firm of Hudson, Howell, Ormand and Marlatt, in the city of Winnipeg, the Empire Terminal Elevator Company and the Port Arthur Terminal Elevator Company were literally forced to plead guilty to six and five charges, respectively, of furnishing to the warehouse commissioner, incorrect weekly statements as to the amounts and grades of wheat in each of these elevators. The violation of the Act was flagrant, for it was found that on five and six successive weeks the elevator companies deliberately reported less of the higher grades and more of the lower. The inference was clear that there had been a constant practice of mixing wheat directly under the eyes of a staff of seventy trained government inspectors located at Fort William and Port Arthur. These two elevator companies not only admitted their culpability but conducted themselves all through the course of a long investigation in a manner that reflected fear of detection in other ways than by misrepresenting their reports. Unlike the Canadian Pacific terminals, and the Consolidated terminals, who came out into the broad light of day and offered every facility to investigators, they fought tooth and nail every attempt of the government to examine any of their past operations. They took advantage of every loop hole in the Grain Act and every technicality of law to combat the investigation.

### Hands Were Tied

Mr. Castle who conducted a long investigation previous to the prosecution, was not allowed to take evidence under oath, or to call witnesses other than those for the prosecution. During the whole course of the investigation the Empire and Port Arthur elevators refused to produce witnesses nor would they subject their books or records for examination. In this way they took refuge under the phraseology of the Grain Act which had not previously come through the white heat of the courts, so that the flaws it contained might be remedied. In this regard it might be mentioned that Mr. Castle, the warehouse commissioner, has already submitted several amendments to the Grain Act which will give him the necessary power on future occasions. For how many years the terminal elevator companies have conducted their illegitimate practices can only be conjectured, but no greater argument for government ownership has ever been brought to the attention of the federal authorities.

The Consolidated Terminal Elevator Company was found guilty on a single count of sending an incorrect report which they claimed was an error on the part of their accountants. The magistrate gave this firm the benefit of the doubt and only imposed a nominal fine of \$50. The Empire Elevator Company was fined \$500 for every offence it confessed, making a total fine of \$3,000. The Port Arthur Elevator Company was fined the same amount on its five confessed infractions making a total fine of \$2,500. It has been learned that none of the officers of these companies appeared before the court but that the matter of imposing the fine was adjusted in a few moments. Hugh Phillips, counsel for several grain firms, appeared for all three of the defendants which is in itself most significant. Mr. Castle, warehouse commissioner, who laid the charges, was present, but Mr. Hudson, who conducted the prosecution for the Dominion government, was there.

### Secrecy Was Enjoined

It was not until four days later the matter leaked out through one of the daily papers setting forth in a somewhat vague manner a few of the details of the case. THE GUIDE has learned that this paper secured its information from a most indirect source, so that it was through no effort of those connected with the prosecution that it was brought to the notice of the public. Some of the remarks of Mr. Hudson, when interviewed by THE GUIDE, would tend to show that it was the intention to keep the matter secret. When he was told that THE GUIDE was aware of where the daily press got the information he remarked in a tone that had the semblance of a sting in it, "Well, I would like to know where that information came from." THE GUIDE representative offered the conjecture that the idea of secrecy might have been simply to give the elevator companies a quiet warning and a severe scare, to which Mr. Hudson replied, "Well, that was partly the reason. They have got a scare that they will remember for a long time."

That there was an evident attempt to keep the entire matter as shady as possible is shown by the fact that President McCuaig and Secretary McKenzie, of the Manitoba Association, endeavored unsuccessfully, after the news had been made public, to obtain some of the details of the case. They visited Mr. Castle, the warehouse commissioner, Mr. Hudson and Mr. Daly, but were unable to get anything definite. Mr. Hudson, the crown prosecutor, informed THE GUIDE that the discrepancies in the reports of the terminal elevator companies indicated a clear case of mixing and he intimated that such a charge would have been preferred had not certain technical conditions made a successful prosecution doubtful.

### Long Investigation

The prosecution of these terminal elevator companies grew out of an investigation which has extended over several weeks, and which was the first of the kind ever conducted by the Department of Trade and Commerce. The charges of the Grain Growers' Association have been so insistently made year after year that the authorities were evidently brought to a realization that there was fire beneath the smoke. As a result of an amendment to the Grain Act, they were enabled, for the first time, to measure up and obtain an approximate estimate of the grain in store at the terminal elevators at the close of navigation. By the provisions of the Act, the annual inspection of the elevators takes place at the latter end of August each year. Therefore, when Mr. Gibbs, the veteran chief inspector of twenty-seven years' experience, swooped down on the elevators with his seventy assistants, on December 10, 1909, the elevators were found entirely off their guard. According to Chief Grain Inspector Horn, who was interviewed by THE GUIDE, it would have been impracticable and almost impossible to weigh up the elevators during the confusion at the close of navigation. Mr. Gibbs, however, did the next best thing and measured the elevators in the customary manner by means of a plumb bob.

Taking as a basis the actual amount of grain in the elevators when they were weighed up in August and adding and subtracting, the grain subsequently as shown by his reports received and shipped, he was enabled to ascertain the exact amount of grain which the elevators should have contained. A careful measuring up of the elevators showed him that there was a serious discrepancy between what he estimated and what they contained and he immediately brought the matter to the attention of Mr. Horn, his chief, in Winnipeg. The elevators reported by Mr. Gibbs included, in addition to the three mentioned, the C.P.R. terminal

elevators, but in this case systematic checking up showed that the mistake was purely a clerical one and consequently they were absolved from further investigation.

### Mr. Horn in Earnest

Mr. Horn was not content with merely writing to his department and making a written report, but proceeded at once to Ottawa and in person laid the full details of the matter before his minister. This was early in March and as a result, Warehouse Commissioner Castle was instructed to institute an investigation, under the powers conferred upon him in the act. This investigation, for convenience sake, was held in Winnipeg and commenced March 20. The investigation was conducted in absolute secrecy in order that the reputation of the elevator companies might not be injured in the event of their being able to prove their innocence. The report of Mr. Castle to the Department of Trade and Commerce is concise and to the point. At its conclusion he states: "In view of the action taken by the magistrate and the explanation of the elevator companies, I consider that further action should be deferred until it is practicable to weigh up the elevators and ascertain to what extent, if any, mixing has been carried on. In the event, however, of it being ascertained by the weigh up that mixing had been carried on, I would recommend that the company's license be cancelled for twelve months."

### Manipulations on Big Scale

Mr. Castle, in his report to the department, reveals discrepancies of hundreds of thousands of bushels and makes the startlingly significant statement that: "If a fair allowance were made for mistakes in the measurement it would be found that the quantity overshipped of No. 1 Northern would about balance the undershipment of No. 2 Northern and other grades."

### Mr. Castle's Report

In his report, Mr. Castle says in part as follows, according to an Ottawa despatch: "The managers of each of the elevator companies against whom discrepancies were alleged (viz., Canadian Pacific Railway, Consolidated, the Empire and the Port Arthur Elevator companies) were called in but no satisfactory explanation was given by them except in the case of the C.P.R., who immediately after seeing me had their records with those of the inspection department carefully checked over; the errors found were of a purely clerical nature so that all differences have been satisfactorily accounted for in this case."

### Port Arthur Elevator Case

Dealing with the investigation in connection with the Port Arthur Elevator Company, Mr. Castle says: "In this case the shipments of No. 1 Northern exceeded the receipts by 169,066 bushels. The stock on hand at December 11 was 303,317 bushels; average or difference, 477,383 bushels. Of No. 2 Northern, deducting shipments from receipts, there should have been on hand 291,742.20 bushels. The December 12 elevator report shows 175,096 bushels, a discrepancy or shortage of 116,646.20 bushels. Of No. 3 Northern, deducting shipments from receipts, there should have been on hand 346,460.20 bushels. The December 12 elevator report shows 166,255 bushels, a discrepancy or shortage of 180,205.20 bushels. Of No. 4, deducting shipments from receipts, there should have been on hand 36,854.40 bushels. The December elevator report shows 31,886 bushels, a discrepancy or shortage of 4,968.20 bushels."

### Outward Inspections

"From this statement submitted by Mr. Gibbs, it appears that there was

inspected out of this elevator during the week ending December 12, 106,999.50 bushels more than the total receipts sent in to me, but this might be explained by some shipment which had been omitted from the elevator receipts by mistake, and, if so, it would reduce the total overshipment of No. 1 to 370,000 bushels, and if a fair allowance were made for mistakes in the measurement, it would be found that the quantity overshipped of No. 1 Northern would about balance the undershipment of No. 2 Northern and other grades.

"Mr. Hudson advises me that a prosecution of the party making the statement for perjury would probably be very difficult to sustain; that a prosecution for the mixing of grades would also be a very difficult one to sustain, and that a magistrate might give the company the benefit of the doubt unless an actual weigh up of the grain in the elevator had been made. It would also have involved a protracted and expensive contest."

"In view of this I do not consider that any action of this nature should be taken at present, but that a weigh up of the elevator should be made as soon as it could be done practically and in the event of it then being ascertained that there is any serious discrepancy still existing in the grades, the question of cancelling the license should be considered."

"Mr. Hudson advises me that in his opinion this is the proper course—not only in this case, but also in regard to Empire and Consolidated Elevator companies."

In the Empire Elevator case, Mr. Cassels says: "In this case, the shipments of No. 1 Northern exceeded the receipts by 457,884.50 bushels."

"The stocks on hand at December 12 was 120,519 bushels, an average or difference of 558,403.50 bushels of No. 2 Northern, deducting receipts from shipments, there should have been on hand 289,159.20 bushels. The December 12 elevator report shows: 41,516 bushels, a discrepancy or shortage of 247,643.20 bushels. Of No. 3 Northern, deducting shipments from receipts, there should have been on hand 155,975.20 bushels. The December 12 elevator report shows 5,502 bushels, a discrepancy or shortage of 150,473.20 bushels of No. 4 Northern, deducting shipments from receipts there should have been on hand 47,879.40 bushels. On December 12 the elevator report shows 4,010 bushels, a discrepancy or shortage of 43,869.40 bushels."

"The same recommendation is made as in the preceding case."

In the Consolidated Elevator case, Mr. Cassels says: "According to the statement brought down by the company, showing the disposition of all No. 1 Northern wheat, both received and shipped, from August 27 to date, it would appear that the total amount of No. 1 Northern shown by the company to be on hand is equal to the total outstanding No. 1 Northern warehouse storage receipts plus an error of 36 bushels and 10 pounds which at the time of the investigation the company was unable to reconcile."

### Necessary Delay

Considering that the elevators were measured up by Mr. Gibbs on December 10, it will be considered strange by some that the investigation was not held until three months afterwards. This can be readily explained, however, from the fact that it took a prodigious amount of accounting in order to check up the contents of the elevators and to make comparison of the weekly reports submitted by the elevator companies with the reports of the inspectors. To appreciate the arduous task in the latter instance, it must be understood that the government inspector at the head of the lakes makes his reports to the warehouse commissioner at Winnipeg on the seventh, fourteenth, twenty-first, and last day of each month while the elevator companies submit their weekly reports every Friday. As there are few Fridays which come on the dates mentioned it will be seen that the work of comparing the reports and bringing them down to a common basis was a very difficult task. During the winter Mr. Gibbs was ill for a time which also delayed the work. Mr. Castle stated that

although the amendment was passed in 1908 the elevators were not checked up at the close of navigation that year for the reason that there was little time to arrange for such an inspection, and for the reason that the provisions of the amendment were new and strange and required time to familiarize before being put into actual use.

During the investigation which was held before Mr. Castle, the warehouse commissioner, the evidence transcribed in shorthand by an expert court stenographer was so voluminous that it filled 250 closely typewritten pages of foolscap. A great many sketches and blue prints were also submitted by the government and by the elevator companies. The chief witnesses examined were the government inspectors and accountants at Fort William. At times it was found necessary for all who were connected with the investigation to journey to the head of the lakes in order to examine the elevators and take evidence.

#### Many Technicalities

Mr. Phillips, the lawyer who acted for all the terminal elevator companies was able to pick holes in the case presented by the government because of the fact that the terminal elevators were measured by Mr. Gibbs and his assistants instead of being weighed. He endeavored to show the uncertainty of these measurements taken hurriedly at the close of navigation. It developed during the course of his cross-examination that grain was received at the terminal elevators until noon on Friday, December 10, while shipments were made until midnight that day. Mr. Gibbs had to produce the name of each vessel loading, the exact time at which it was loaded that afternoon, and the time of sailing, and the defence endeavored to show that he could not accurately tell the amount of grain taken from the elevators after the last receipts had been taken in at noon.

#### Working Under Difficulties

Mr. Phillips also contended that it was impossible for Mr. Gibbs and his assistants to estimate by measuring the contents of the elevators. He proved by cross examination that at the time the elevators were measured the electric light plants of these elevators were closed down, consequently it was necessary to lower lanterns into the bins in order to ascertain with the plumbob the amount of wheat they contained. He contended that it was both impossible to accurately measure the bins and to decide the grades of wheat by the light of a lantern. He showed that it would be almost impossible for Mr. Gibbs to measure the lower portion of certain concrete bins which are used partly for storage purposes, and partly as a receptacle for grain which is to be immediately shipped out. He contended further that it was impossible to accurately measure the interstices formed by the circular bins and which are formed of six sides. These interstices are used for the storage of grain. He pointed out that the grain which was dumped into the bins from the carrier belts at the top of the elevators distributed the wheat into the outside row of bins in such a manner as to leave it sloped at an acute angle with one side very much higher in wheat than the other. He thought that no man could, under such circumstances, estimate by measure the quantity of wheat these bins contained.

#### A Sharp Defence

At every stage of the evidence submitted by the inspection department objections were filed by Mr. Phillips and could he have done so, he would no doubt have cleared his clients of the charges of misrepresenting the reports, to which they finally confessed. It was because of the strong defence put up to show the uncertainties of measuring elevators to estimate their contents, especially in the manner performed by the inspectors, that it was decided not to prefer a charge of mixing wheat against the terminal elevator companies. It was thought doubtful, in view of the circumstances, whether an actual case of mixing wheat could be made out against the elevator companies, although Mr. Castle, the members of his staff, and Mr. Hudson, the prosecuting attorney, were morally certain that this had been done. In the case of the Port Arthur Elevator Company the discrepancy was over 200,000 bushels, while in the case of the Empire it was about twice that amount.

Mr. Castle, the warehouse commissioner, interviewed by THE GUIDE, stated that

within a few weeks he would have the terminal elevators properly weighed in order to determine the accuracy of Mr. Gibbs' estimate. When it was suggested by THE GUIDE that the elevators would take advantage of the lapse of time to cover up their alleged illegitimate operations, he replied: "Well, I can't help that. It will teach them a lesson at any rate and we will have the assurance that grain contained in the elevators is apportioned according to the records of what should be there."

#### Publicity Does Good

Since the prosecution of the elevator companies has been made public the Department of Trade and Commerce at Ottawa has been inundated with requests from both farmers and grain dealers of Western Canada to ascertain if these or other companies have carried the practice of mixing of grades or submitting improper returns beyond that which was made out in the cases just established. The department has made the threat that should further discrepancies be found which are in any way serious, the severest penalty under the terms of the Manitoba Grain Act will be imposed, namely, the cancellation of license. Should this be done, any of the companies thus effected would be prohibited from buying, selling, receiving for shipment, or in any way dealing in grain. Only a nominal license fee is now charged, the annual fee being but \$2. Companies operating as elevators or warehouses have also to furnish bonds, but beyond this there are no restrictions.

During the investigation it was admitted by the Consolidated Elevator Company that on a great many occasions it had loaned large quantities of grain. At the present time, according to Mr. Castle, this is not an infingement of the Grain Act, but Mr. Castle has submitted an amendment to the government which, if put into operation, will check such tactics in future.

As a result of this long investigation it was discovered that two of the largest terminal elevators at the head of the lakes were persistently falsifying their reports which the government compelled them to forward weekly to the warehouse commissioner. The charges against the Empire Elevator were for the six successive weeks from November 3, 1909, while the five charges against the Port Arthur Elevator Company were for the five weeks following November 12. Had there been but a single charge in each case or even had the various charges been spread out over a number of months there might have been some room for doubt as to whether mistakes had not occurred. But in the case of these two wealthy concerns they were "caught with the goods" and through their lawyer humbly admitted their deception and paid their fines. Every one of the charges was the same, that of making the higher grades appear less and making the lower grades appear more.

Mr. Castle, the warehouse commissioner, when asked in regard to the prosecution, said that he had preferred the charges against the companies, and that the prosecution had been postponed from day to day until Friday, April 22. He stated that he was not present when the case was heard before Magistrate Daly, and said that on the Friday evening in question, when he telephoned Mr. Hudson, the latter told him that the case had come off in his office; that two of the elevator companies had admitted the charges and all were fined on the aggregate, \$5,550. Mr. Castle said that he afterwards received a check for the proceeds of these fines from Mr. Daly. Asked if he did not think it peculiar that the case should be held in private, he said he did not think so as it was done for the convenience of Mr. Daly as the documents and evidence, blue-prints, etc., were all in Mr. Hudson's office.

#### Trial in Private

Mr. Hudson was interviewed by a representative of THE GUIDE and asked for what reason it had been found necessary to hold court in his office. He replied that the magistrate had the right to hold court wherever and whenever he pleased. He stated that it was customary in revenue cases to hold them in camera. He further explained that the charges had originally been laid before Mr. Daly at the police court, but that it had been postponed for three or four days. Mr. Daly was a busy man and it was he, himself, who suggested that the sitting be held in Mr. Hudson's office. So

far as it can be ascertained, there were just three men present, these three being Mr. Hudson, Mr. Phillips and Mr. Daly. In all probability there was also a stenographer. Mr. Hudson was asked why the prosecution was not made public, and if there had not been an attempt to keep the matter dark, to which he replied: "Well, why wasn't it made public? I don't know why. Nobody came to ask me." The GUIDE man suggested that perhaps the idea of secrecy was simply to give the elevator men a warning and a severe scare. To this Mr. Hudson replied: "Well, that was partly the reason. They have got a scare that they will remember for a long time."

Continuing, Mr. Hudson said: "The Grain Growers should be satisfied. I tried to bring the highest fine against these elevators that I could. The maximum fine was \$12,000. This case proved what the Grain Growers have been contending for years—that there was mixing going on. The Grain Growers," he said, "seemed to be suspicious that there was some collusion in this matter and I want them to know that there was nothing of the kind."

#### Federal Jurisdiction

A talk with Hon. Colin H. Campbell, the attorney general, elicited the information that the prosecution had not been conducted through his department. He said he knew nothing of it until the matter appeared in the newspapers, and that, in fact, he had not yet received the customary report on the matter. Asked if it was possible for the federal authorities to take the matters into their own hands in a case of this kind, he replied, "Yes, it is done quite often, especially in the case of prosecutions in connection with post office matters." He was further asked if it was the customary thing for a police magistrate to hold cases in private and he replied that this was often done.

Despite the contentions of all concerned, that there was no attempt at secrecy the president and secretary of the Manitoba Grain Growers' Association were unable, on the day following the publication of the news in the Winnipeg daily papers, to obtain any particulars of the case. Failing in their attempts, they wired to Dr. Schaffner, who asked on the floor of the House of Commons that the report of C. C. Castle be laid on the table and thus made public. This was subsequently done.

As an outcome of the investigation and of the prosecution, Mr. Castle invited a delegation from the exporters' association to consult with him as to changes which he proposed to be made in the Grain Act. The most important of these is that of inward and outward registration of warehouse receipts. In addition to this amendment another was submitted which would give the commissioners power to order an elevator weighed up at any time. At present the power granted is that of weighing up once a year.

#### Not Enough Proof Yet

It has been proven in a court of law that the contentions of the Grain Growers as to wheat manipulations were correct, and yet Hon. Frank Oliver, in the House of Commons, April 29, said, referring to government ownership, "The government has had the suggestion under careful consideration, but it is felt that the matter is one of such importance as to require more full and careful attention than could be given it in order to reach a satisfactory decision before the close of the present session."

Another argument in favor of government ownership is the number of government employees who are at present employed to watch the terminal elevators. If these seventy men were employed in running the elevators their services would be of more use to the country.

\*\*\*

#### AT OTTAWA

An Ottawa despatch, dated May 2, reads:

Allegations to the effect that the terminal elevator companies which were recently fined by Magistrate Daly in Winnipeg for making incorrect returns were guilty of mixing grain were contained in a letter read in the House of Commons today by Dr. Schaffner.

This letter further alleged that the elevator companies had been following this practice for years and the writer thinks it is time an example was made of the offenders.

Dr. Schaffner, of Souris, brought up the matter by reading the following

letter, dated Winnipeg, April 28, and addressed to him:

"My Dear Sir:—In further reference to the subject matter of my telegram to you, as you will no doubt know, the stock of different grades in store in terminal elevators was weighed in August of last year and immediately on the close of navigation Inspector Gibbs made an estimate of the quantity in store of each grade by measurement.

"There is a report current that this estimate showed that the amount of high grade wheat shipped out far exceeded the amount received, and as a consequence the department of trade and commerce ordered the warehouse commissioner to institute an investigation. The investigation has now been going on for some time and culminated in three of the terminal elevator companies being fined on information sworn out by Mr. Castle on the 22nd instant.

"The report has it that the solicitor representing the elevator company and the solicitor representing the department and Mr. Castle had arranged that the charges should be that of making false statements rather than the more serious charge of mixing grain. Be that report true or not, the fact remains that in place of the former being tried in the open court the solicitor for the terminal elevator companies met Mr. Daly in Mr. Hudson's office. Mr. Hudson being Mr. Castle's solicitor, and pleaded guilty, and was fined, the object apparently being to prevent the matter from coming before the public. We think this star chamber method of court should not be tolerated. If these terminal elevators are offenders against the law they should be treated as other offenders.

"It is a matter of common knowledge that practices in contravention of the law and against the best interests of the country were indulged in by those elevators for many years, and when the offenders were once brought to justice there should be no effort to endeavor to minimize the effect that would have. A simple fine is no punishment to these people, publicity is what they are afraid of.

"In the few days you have at your disposal before the house prorogues will you, in the interests of the farmers, do what you can to get Mr. Castle's report and all the correspondence brought down so the public may know what has been done. I do not think at all that the department of trade and commerce want to conceal anything and there should be no disposition on the part of anyone to protect those who are accused of tampering with our grades. Our government undertakes to deliver our grain on the world's markets according to the specifications defined by the statutes.

"Their inspectors compel the farmer to meet the requirements of the specifications and they should see that their inspectors also compel those who handle our grain to comply with the requirements of those specifications in the handling of our grain."

#### Did Not Reply

Hon. Frank Oliver did not make any remarks more than to say that he had tabled the report on Saturday.

Mr. Oliver read a letter from A. Meighen, of Portage la Prairie, referring to the fact that the minister in replying to questions put by Mr. Meighen and, based on a telegram received from the west, had mentioned only one deputation which had waited upon the government in connection with grain trade matters.

Mr. Oliver said it was quite true that the minister had been waited upon by two delegations, one representing the Manitoba Grain Growers and the other the exporters of grain. Both, however urged practically the same action and in neither case was it legislation so much as changes in administration that was mentioned. In omitting to mention the second deputation there was no intention to conceal anything.

#### FIVE PROBLEMS TO CONSIDER

In an address delivered at Springfield, Mr. S. S. McClure, the New York publisher, mentioned five great problems which he considers the most serious confronting the people of the United States. He states them as follows:

1. The better enforcement of life and property.
2. The control of the great industrial corporations.
3. Conservation of natural resources.
4. The preservation of a pure breed of men.
5. International peace.





# GRAIN, LIVE STOCK AND PRODUCE MARKET

## Market Weak

(GRAIN GROWERS' GRAIN COMPANY'S OFFICE, MAY 3RD)

Wheat—The market during the past week has been a very weak one indeed with the demand very slow. The May option has declined to as low as 98 cents since our last report. Export demand has been almost nil, and what little cash grain has been changing hands has been for the purpose of filling boat space already chartered for shipment at the opening, or the 1st half of May. However, stocks in store Fort William on account of the early opening of navigation, and the Canadian visibles of wheat is now below what it was this date last year. On the other hand, stocks back in the elevators in the country and in the farmers' hands, are reported to be much in excess of last year; but we must bear in mind that farmers who have been holding wheat since last fall, are in a position that they are not forced to sell their grain at this price, but we think will rather feel inclined to continue holding it until the price suits them, or at least until another crop is assured.

The attitude of the farmer during the rush season of marketing our crop, has had a good deal to do with keeping up prices, because he has always refrained from marketing his grain when the market declined two or three cents, rather waiting to make sale when the market had advanced to the high point. Of course everyone cannot get the highest price for his wheat, but the system of marketing followed by the farmers this season, has resulted in much higher prices being realized than otherwise would have been.

The future of prices.—This is very hard to predict. European and Continental markets are receiving enormous shipments from Russia, Austria and India. Russia especially has made record shipments in her history, and reports are that Russia supplies back in the interior are still enormous and will be coming on to the market for the next two or three months. Importing countries in the United Kingdom and on the Continent, seemed to be satisfied of the fact that they will be able to receive all the wheat they require for the next two or three months, at a lower price than they have been paying for the last 6 or 9 months. On the other hand should the American Continent not experience a good crop year, or prospects not be very bright for this season's crop, and should deterioration take place in their heavy wheat producing countries, it is possible we may see higher prices than are now prevailing. We would not advise sales on the decline, but rather waiting for good hard spots to make sales of any grain which is marketed immediately.

Oats have reached about their lowest point in the past week, and we have had a fair export demand in this grain. Farmers are almost ceasing making sales. This is not to be wondered at on account of the extremely low prices prevailing. October oats are selling at a much higher price than oats for delivery in May, and it seems to us that this grain has reached about its lowest possible level.

Barley has not been in demand; in fact, almost unsaleable, except at ridiculously low prices.

Flax has declined some with absolutely no demand; in fact sales are hard to make at anything like actual value of this grain.

## Liverpool Market Letter

By HENRY WILLIAMS & CO., LIVERPOOL, APRIL 14, 1910.

During the week wheat "futures" have ruled dull and declining in sympathy with easier American advices, to-day's prices showing a fall of 1½d. to 2d. Cargoes of white wheat from the Pacific coast of America about 6d. lower, Australians 3d. to 6d. lower, Indians 3d. lower, Russian and Black Sea cargoes 3d. lower. Argentine cargoes 3d. lower, shipments this week to Liverpool 64,500, U.K. 70,000 Continent 92,000. Orders 14,000, equalling 240,500 against 231,500 last week and 293,000 last year. Latest cables report markets weak after fair decline, weather favorable for seeding. Condition of maize continues bad and there is nothing doing in the new crop. Russia reports more favorable weather but there are still many complaints about the crop outlook in the south. Port stocks do not increase as expected and there is not much pressure to sell at present. Roumania reports very favourable weather and crop outlook most promising. Austria-Hungary reports excellent crop prospects. Italy reports wintry weather and it is feared there has been some damage to the crops. Spain reports good snowfalls which have improved the outlook somewhat. Germany reports favorable weather, crop outlook is considered excellent. France reports more favorable weather and crop reports show some improvement but the outlook on the whole is not too favorable. India reports excellently of harvest and sellers are inclined to offer more freely. Australia reports very good rains much improving the outlook for the next crop. Shipments are rather more liberal but farmers are not free sellers.

## Continental Europe Wheat Situation

Antwerp, April 15, 1910.

Wheat in America has declined by more than 3 cents on May and 2½ cents on July. The prominent feature of the week has been the publication of the Washington report, which showed a rather low condition for the whole country of winter wheat up to April 1st, viz., 80.8 against 95.8 in December and 82.2 a year ago. In 1908 it was 91.3 and in 1907, 89.9. This average condition has been so low especially on account of the small contribution of the important state of Kansas, which is estimated only at 64 per cent., against 86 per cent. a year ago, but the large increase of the acreage seeded must be taken into account and therefore, even if we make a fair allowance for the acreage abandoned—which seems to be of quite a considerable size—we might after all get a figure for the winter wheat districts not inferior to last year's.

Furthermore, we must not forget that very welcome and abundant rains have fallen since the end of March, which are believed to have considerably improved the condition, and with the very satisfactory outlook for the spring wheat, the seedings of which have been well completed, the dulness of the American markets could not surprise, the much the less so, as the big premium for May wheat Chicago has no reason any longer, since for spot the demand is so disappointing, and stocks in the interior seem to increase slowly but surely.

Great complaints are also heard about unsatisfactory sale of flour, and in Minneapolis millers are said to have greatly curtailed their production. We have already pointed out different times, that there is enough wheat in the world left to allow the consuming countries not to entertain any fears about the needs for the remainder of the season. The question would only be, how would be the dispositions of the different holders to part with this wheat. These dispositions entirely depend upon the outlook of the future crops.

India, now quite ready to begin with the shipment of her untouched crop, the Canadian spring season now approaching with celerity, and meeting the Russian shipments, the magnitude of which has not been overestimated—all that brings us to a nice quantity of wheat on the way, quite sufficient to let us go on for a good time without difficulties. But, whether this sufficiency will turn out in pressure depends entirely upon the future weather. It has always been a temerarious task, to predict the turn of prices at this time of the year, when the unknown future is a directing factor for the same. But, considering the present level, and taking into account the start generally very promising in the whole of the world's crop, there is certainly nothing to be lost by waiting. Prices are high enough to support a good deal of eventual crop damages, being given the reserves of the old crop which make the situation quite different of that of the last two years, while values are much too high, if the present promises be realized.

Roumania already begins to anticipate the situation by offering her crop new about 10 per cent. below present values and soon other countries will probably be ready to join the Danube state in this attempt to secure a relatively good price for the growing crop on the field.

Maize.—Our market ruled very quiet for every description and business is completely at a standstill with prices decidedly in buyers' favor. The fine weather prevailing in whole Europe is extremely favorable for all feeding stuffs and influenced the buyers' mind. Plate shippers are still reserved, while bear sellers are much disposed to accept less money than hitherto.

Barley.—Declining on pressing offers from Russia. Some business passing at the decline. Autumn sellers are coming out at more reasonable prices and buyers keep still reserved.

Rye and Oats.—Very quiet with poor demand.

Linseed.—The present week has been characterized by more regular offers of Duluth-Manitoba seed, October-November shipment, at prices ranging between fr. 40½ to 41½. Various sales have been completed, speculators being stimulated by the rise on linseed oil. At this opportunity we beg to point to the attempts on the part of Russia to sell Autumn seed, without much being done so far. Today the market is again weaker, on fairly large shipments from the Plate and India, and America making some concessions for October-November shipment. Oil did not resist to these depressing factors and Plate is closing about unchanged on the week, while Indian descriptions show an advance of about 3 per cent. This is not to be wondered at, considering that the latter country was too cheap against Plate, as pointed out in our last reports. Provided America does not decline, there is no danger of a serious reaction in oil crop positions so far, there being very little oil available in Europe just now, but prices could nevertheless dwindle down, if the U. S. should fail to support us further. As to autumn, everything is still mere guess work. Barring crop scares, we think present prices are hardly maintainable in the long run.

## Liverpool General Market Report

CORN TRADE NEWS, APRIL 19, 1910.

Wheat cargoes are dull and easier for Red sorts. Off coast cargoes.—39/6 (approx. \$1.17) asked for Red Walls per Duquesne. Pacific coast cargoes.—39/6 (approx. \$1.18½) asked for Red Walls and Blue Stem January, this price for 15,000 qrs. White Walls, Feb.

Australian wheat cargoes.—38/6 (approx. \$1.15½) net asked for 14,000 qrs. South Australian Jan. parcels to Liverpool from three ports for April-May are held at 37/7½ (approx. \$1.12½).

Russian wheat cargoes are dull and 3d. lower. Azoff-Black Sea, April-May offers at 38/6 (approx. \$1.15½) to 39/9 (approx. \$1.19½).

River Plate wheat cargoes.—36/6 (approx. \$1.09½) asked for 4,500 tons Rosafé 60½ lbs. afloat. 35/6 (approx. \$1.06½) asked in London for parcels of Barusso, 61½ lbs. April-May.

Canadian and U. S. A. wheat.—Parcels to Liverpool are steady with a fair demand at about unchanged rates. Parcels to London opened 3d. to 4½d. lower, but closes firm.

No. 1 Nor. Man. (incl. L'p'l.)	April	37/9	approx. \$1.13½
No. 2 Nor. Man.	April	37/1½	" 1.11½
No. 3 Nor. Man.	May	36/7½	" 1.09½
No. 1 Nor. Man. (incl. Ldn.)	Afloat	38/6	" 1.15½
No. 2 Nor. Man.	Afloat	38/-	" 1.14
No. 3 Nor. Man.	Afloat	37/6	" 1.12½

Indian wheat.—Parcels to Liverpool are dull and easier for the new crop. Choice White Kurrachee Afloat 7/9 approx. \$1.11 5-5  
No. 2 Club Calcutta March-April 7/10 " 1.12 4-5

Indian parcels to London are 3d. to 6d. lower.  
Choice White Kurrachee May-June 37/9 " 1.13½  
No. 2 Club Calcutta March-April 7/10 " 1.12 4-5

## SALES OF PARCELS (LIVERPOOL)

THURSDAY, APRIL 14.			
2,000 qrs. No. 2 Nor. Man.	March-April	38/1½	approx. \$1.14½
SATURDAY, APRIL 16.			
2,000 qrs. No. 3 Nor. Man.	May-June	36/5	" 1.08½
TUESDAY, APRIL 19.			
2,000 qrs. No. 1 Nor. Man.	May-June	37/-	" 1.11
2,000 qrs. No. 2 Nor. Man.	May-June	36/4½	" 1.09½
2,000 qrs. No. 3 Nor. Man.	May-June	36/-	" 1.08
(LONDON)			
WEDNESDAY, APRIL 13.			
1,000 qrs. No. 2 Nor. Man.	April	38/7½	approx. \$1.15½
THURSDAY, APRIL 14.			
1,000 qrs. No. 2 Nor. Man.	April	38/6	approx. 1.15½
FRIDAY, APRIL 15.			
1,000 qrs. No. 1 Nor. Man.	Afloat	39/3	approx. 1.17½
2,000 qrs. No. 2 Nor. Man.	April	38/1½	" 1.14½
SATURDAY, APRIL 16.			
1,000 qrs. No. 1 Nor. Man.	April-May	38/5	approx. 1.14½
1,000 qrs. No. 2 Nor. Man.	Afloat	38/6	" 1.15½
MONDAY, APRIL 18.			
1,000 qrs. No. 1 Nor. Man.	Afloat	38/6	approx. 1.15½
1,000 qrs. No. 2 Nor. Man.	Afloat	38/1½	" 1.14½
TUESDAY, APRIL 19.			
1,000 qrs. No. 1 Nor. Man.	May-June	37/7½	" 1.12½

Winnipeg Futures

Following are the quotations on the Winnipeg Grain Exchange during the past week for wheat, oats and flax sold for May and July delivery.

Table with columns: DATE, DELIVERY, WHEAT, OATS, FLAX. Rows include April 27, 28, 29, 30, May 1, 2, 3 for various grain types.

Liverpool Spot Cash

Table with columns: CORN TRADE NEWS, APRIL 19, 1910. Lists prices for Australian, 1 Nor. Man., 2 Nor. Man., etc.

Sample Market Prices

Table with columns: Cash Sales, Minneapolis Sample Market, April 30, 1910. Lists prices for No. 1 Hard wheat, No. 2 North wheat, etc.

Stocks in Terminals

Total wheat in store, Fort William and Port Arthur, on April 29, was 3,434,360 bushels, as against 5,690,048 last week, and 8,393,951 bushels last year.

Table with columns: No. 1 Hard, No. 1 Nor., No. 2 Nor., No. 3 Nor., No. 4, No. 5, Other grades. Lists quantities and values for 1910 and 1909.

Table with columns: STOCKS OF OATS. Lists No. 1 extra, No. 1 White, No. 2, No. 3 White with quantities and values.

Table with columns: WHEAT ON PASSAGE. Lists Wheat, Incr., Corn, Decr. with quantities and values.

Canadian Visible

(Official to Winnipeg Grain Exchange).

Table with columns: APRIL 27, WHEAT, OATS, BARLEY. Lists Tot. visible, Last week, Last year, Pt. William, Pt. Arthur, Meaford, Mid. Tiffin, Coll'wood, Owen Sd., Goderich, Sarnia, Pt. Ed., Pt. C'borne, Kingston, Prescott, Montreal, Quebec with quantities and values.

Primary Receipts and Shipments

Table with columns: WHEAT, CORN. Lists Receipts, Shipments, Total clearances of wheat and flour for LAST WEEK and LAST YEAR.

World's Shipments

Total world's shipments of wheat were 12,080,000 bushels, against 10,832,000 last week; and 8,144,000 last year.

Table with columns: LAST WEEK, PREVIOUS WEEK, LAST YEAR. Lists America, Russia, Danube, India, Argentina, Australia, Chili, N.A., Corn with quantities and values.

Comparative Visible

Table with columns: LAST WEEK, PREVIOUS WEEK, LAST YEAR. Lists Wheat, Oats with quantities and values.

Winnipeg Live Stock

There is little change in the live stock situation from last week. Choice export steers are quoted (freight assumed) at \$8, while choice hogs find a ready market at \$10.

Table with columns: Cattle, Swine, Sheep. Lists Choice export steers, Good butcher steers, Heifers, Good to choice bulls, Choice calves, Medium calves, Choice hogs, Rough sows, Stags, Choice lambs, Local sheep with prices.

Hides, Tallow and Wool

Table with columns: No., No. 1, No. 2. Lists Green salted hides, Green salted hides, branded 8c. flat, Green salted hides, bulls and oxen, Green salted veal calf, 8-15 lbs., Green salted kip, 15-25 lbs., Green salted deacons, Green salted slunks, Dry flint butcher hides, Dry rough and fallen hides, Tallow, Seneca Root, Wool with prices.

Stockyard Receipts

Table with columns: CATTLE, HOGS, SHEEP. Lists From C.P.R. points, From C.N.R. points, Total, Butchers east this week, Exporters east this week, Consumed locally, Exporters east from last week, Butchers local from last week, Butchers east held over.

Butter and Eggs

Retail merchants in Winnipeg are still paying country shippers as high as 55c. a pound for first class dairy butter, and the shortage is almost as bad as last week.

Potatoes

There is no change in the potato situation this week. The market is literally flooded with tubers, and the quotation still remains at 25c. a bushel.

QUOTATIONS IN STORE AT FORT WILLIAM FROM APRIL 27 TO MAY 3, INCLUSIVE

Table with columns: DATE, WHEAT, OATS, BARLEY, FLAX. Lists prices for various grain types from April 27 to May 3.

# GRAIN GROWERS

## WHY TAKE CHANCES ON YOUR GRADE?



**WE HAVE** established a SAMPLING AND GRADING DEPARTMENT OF OUR OWN, in order to check the Government grading of all cars CONSIGNED TO US and thus protect the interests of our shippers.

We have our own men in the railway yards to take a sample of your car as soon as it reaches Winnipeg. This sample is brought to our office and examined by our own expert, at the same time it is being examined by the Government Inspector. Should samples become mixed, or any mistake be made in the Government grading, we have a safe check, or should our expert consider that you do not receive the highest possible grade for your grain, he at once takes the matter up with the Chief Inspector, and, if it is not possible to have a satisfactory change made, we are in a position to order a reinspection at Fort William, before your car is unloaded.

THE SATISFACTION which we have given our shippers by protecting their interests in this and other ways is plainly shown in THE INCREASE OF OUR BUSINESS. We have handled up to the present time this business year about 15,500,000 BUSHELS. If you have not shipped your grain yet, we trust you will consign it to YOUR OWN COMPANY and help strengthen THE FARMERS' CAUSE.

# THE FARMERS' COMPANY

FARMERS! This is YOUR COMPANY. YOU are the only men who can hold Stock in the Grain Growers' Grain Company, and the only men who have a say in its management.

IN THE PAST FOUR YEARS this Company has saved millions of dollars for the Grain Growers of the West, and is today the largest firm of its kind in Canada. Are you not proud of what you have achieved? Send us a post card with your name and address, and we will mail you booklets telling all about Your Company and the Grain Growers' Movement.

When you are in the City, don't fail to call at our new offices, 7th floor, Keewayden Block, Portage Ave., East of Main Street.

BONDED

LICENSED

# GRAIN GROWERS' GRAIN CO. LIMITED

WINNIPEG

NOTE—Alberta Farmers will please address us to Calgary

MANITOBA

ock  
live stock  
l assume  
a ready  
high prices  
out by the  
packer  
itoba and  
live stock  
there is a  
ittle. Fat  
wage very  
as already  
and ship-  
none too  
from two  
al if warn  
  
Toronto  
its effect  
ing along  
before the  
  
n furnish  
  
5 to 85.00  
5 " 8.00  
0 " 5.75  
5 " 5.00  
5 " 4.75  
5 " 4.75  
  
... 810.00  
... 7.00  
0 to 5.00  
  
... 87.50  
... 6.50  
  
Wool  
n. Co.  
n. No.  
2  
  
c. 9jc.  
flat.  
  
flat.  
11jc.  
c. 9jc.  
  
flat.  
flat.  
k.  
to 40c.  
to 10jc.  
innipeg.  
  
pts  
umber of  
ed at the  
he week  
osition  
on ANREP  
91 275  
14 1  
95 275  
  
... 272  
... 181  
... 30  
... 787  
... 34  
... 80  
... 20  
  
g are still  
h as 55c.  
utter, and  
last week  
now, 15c.  
  
tato site  
is literally  
quotation  
  
E  
LAX  
Max. Sel

# 40 Million Square Feet of Oshawa Shingles Cover Canadian Roofs Today

A ROOFER'S square is 10 x 10 ft.—100 square feet. There are 400,000 such squares of Oshawa Steel Shingles in use to-day in

**THEY KEEP ON SELLING BECAUSE THEY MAKE GOOD**

Canada. Enough steel, that, to make a pathway a foot wide and 7,576 miles long. Almost

thrice the length of the C.P.R. tracks. Nearly enough to roof in a thousand acres of land! And the greater part of those Oshawa Shingles will be right on the job, good, weather-tight, rain-proof roofs, when your grandsons are old, old men. They are good for 100 years.

## This is the One Roofing It Pays Best to Buy

Figured by price-cost, "Oshawa" Guaranteed Steel Shingles are as cheap as the poorest wood shingles. Figured by service-cost—the length of time they will make even a passably good roof—wood shingles cost Ten Times as much; slate costs six times as much; and the stuff they call "ready roofing" costs Thirty-Three Times as much! These are facts. They can be proved to you. Proved by figures; by the experience of hundreds of other people who doubted at first, just as you perhaps doubt. Proved, absolutely! You want that proof before you roof. Get it! Send for it to-day.

## No Other Roofing Does This

Stays rain - and - snow - and - wet-proof for fully a hundred years. Absolutely fireproofs the top of the building for a hundred years. Protects the building from lightning for a hundred years. Resists the hardest winds that blow for a hundred years. Keeps the building it covers cooler in summer, warmer in winter, for a hundred years. Gathers no moisture, and never sweats on the under side for a hundred years. Needs no painting, no patching, no care nor attention for a hundred years. **WHAT MORE CAN YOU ASK OF A ROOF?**



The picture above, on the right, shows the new Spanish pattern Oshawa Galvanized Steel Shingle (Guaranteed). That on left is the standard pattern.

**O**SHAWA STEEL SHINGLES are made of 28 gauge steel, specially toughened and heavily galvanized to make them rust-proof. Thus they weigh about **seventy-eight** pounds to the square. With the box about 88 pounds to the square. When considering metal shingles always learn the **weight of metal** per square offered and be sure that the weight is of the **metal only**. Make the weight test yourself. First be sure the scales are accurate. Then unbox a square of Oshawa Shingles and weigh them. Note that the weight averages 78 pounds **without the box**. Don't go by the box weight. Some boxes weigh fourteen pounds or more.

*G. A. Pedlar*

## It Will Pay You To Pedlarize All Your Buildings

"To Pedlarize" means to sheathe your whole home with handsome, lasting and beautiful steel—ceilings, side-walls, outside, roof. It means to protect yourself against cold; against fire; against much disease; against repair-bills. Ask us and we will tell you the whole story. Just use a postcard and say: "How about Pedlarizing my house?" State whether brick or frame. Write to-day.

**A**DVERTISING alone never sold that vast area of Pedlar Shingles. Smooth salesmanship never kept them selling; nor glib talk; nor lying abuse of competing goods; nor cut price. Those things do sell shingles, right here

**THEY DO ALL WE SAY THEY WILL AND MORE TOO**

in Canada's roofing trade. But Oshawa Shingles sell, and keep on selling, for a different reason. They make good. They keep out the wet, year after year, as we say they will. They protect buildings from fire and lightning, as we say they will. They make good.

## This is the One Roofing That is Guaranteed

Some makers of "metal shingles" (ever notice how careful they are to avoid saying steel?) point with pride to roofs of theirs 25 years in service. **BUT THEY DON'T GUARANTEE** their shingles for 25 years to come. You buy Oshawa Steel Shingles—the only kind that **IS** guaranteed—upon the plain English warranty that if the roof goes back on you in the next quarter-century you get a new roof for nothing. You can read the Guarantee before you decide. Send for it. See if it isn't as fair as your own lawyer would make it on your behalf. Isn't that square?

## Book and Sample Shingle Free

Send for free book and free sample of the Oshawa Shingle itself. It will interest you to study it. You will see the actual construction. You will see that the Pedlar Improved Lock, on all four edges of the shingle, makes it certain that moisture never can get through any Oshawa-shingled roof. You will see how the Pedlar process of galvanizing drives the zinc right into the steel so it never can flake off. You will be in no doubt about which roofing after you have studied this shingle. **Send to-day for Sample Shingle and "Roofing Right" Booklet No. 26**

**GET SEVENTY-EIGHT POUNDS OF STEEL TO THE SQUARE** 310

**THE PEDLAR PEOPLE OF OSHAWA**

<b>HALIFAX</b> 16 Prince St.	<b>ST. JOHN, N.B.</b> 42-46 Prince William St.	<b>QUEBEC</b> 127 Rue de la Paix	<b>MONTREAL</b> 321-3 Craig St.	<b>OTTAWA</b> 423 Somerset St.	<b>TORONTO</b> 11-115 Bay St.	<b>LONDON</b> 86 King St.	<b>CHATHAM</b> 200 King St. W.
<b>PORT ARTHUR</b> 43 Cumberland St.	<b>WINNIPEG</b> 76 Lombard St.	<b>REGINA</b> 1901 Railway St. South	<b>CALGARY</b> 1112 First St. West	<b>VANCOUVER</b> 821 Powell St.	<b>VICTORIA</b> 434 Kingston St.		

ADDRESSES OUR NEAREST WAREHOUSE. WE WANT AGENTS IN SOME LOCALITIES. WRITE FOR DETAILS. MENTION THIS PAPER.