

# “Quanti est Sapere!”

THEN WHY NOT LEARN ABOUT

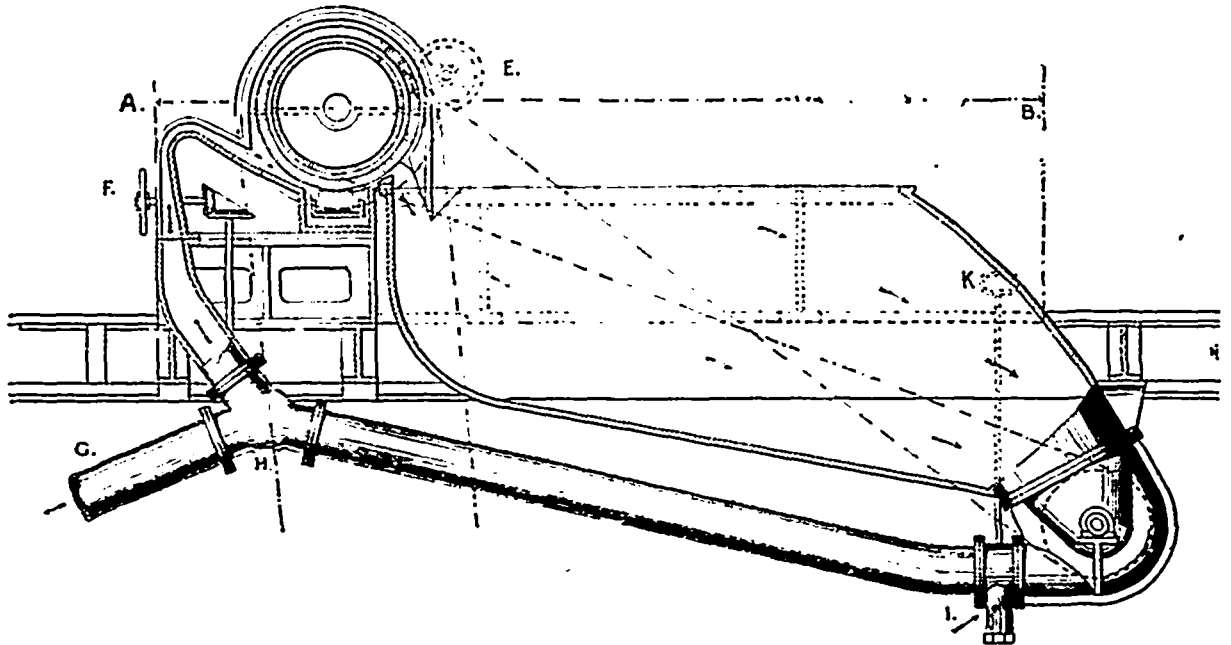

## Taylor's Beating Engine?

THE CAPACITY OF THIS ENGINE IS GREATER THAN THAT OF ANY OTHER IN THE WORLD.

And its principles of Action and Construction will commend it to every

**Practical : Paper : Maker.**

WE ARE MANUFACTURERS OF

White's Oscillating Screen,

Taylor's Beating Engine,

McCormick's HOLYOKE Turbines, Horizontal and Vertical.

**PAPER MILL MACHINERY.**

Allen's "Blue Spot" Preventive.

**SCREENS & VATS**  
For Paper Machines.

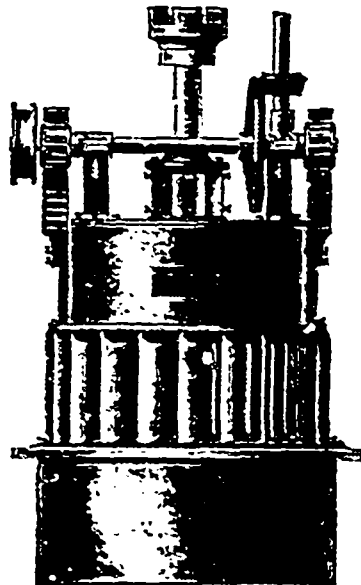

*Rag Engines and Jordan Engines*

Made and Refilled.

**BLEACH BOILERS, FAN DUSTERS,**

Ferry's Patent Star Dusters.

**PAPER CALENDAR ROLLS**

MADE AND REPAIRED.

*Chilled Rolls, Sheet, Super and Webb Calenders.*

Power Suction Pumps, Power Boiler Pumps, Suction Boxes and Plates, Palleys, Shafting, Gearing, &c.

**HAND AND POWER ELEVATORS.**

# J. & W. JOLLY,

**HOLYOKE, MASS., U.S.A.**