

TAYLOR'S PATENT

CONTRACTORS TO THE ADMIRALTY

THE ATTENTION OF ENGINEERS & OTHERS IS SOLICITED TO THE PRINCIPLES OF OUR UNIQUE PACKING, THIS PACKING CONSISTS OF METAL RINGS OBLONGS, & SQUARES, CUT FROM THIN SHEETS OF BRASS, & CORRUGATED; FOR THE PURPOSE OF BEING PLACED IN JOINTS IN THE JOINING OF METAL PIPES MAKING JOINTS STEAM & WATER-TIGHT, IN MAKING JOINT CORRUGATED; THE RING IS LAID WITH CEMENT ON INNER PART OF FLANG, CLEAR OF BOLTS, IN SCREWING UP JOINT, RIDGES OF CORRUGATIONS YIELDING TO IT WILL TAKE IMPRESSIONS OF IRREGULARITIES OF SURFACES OF FLANGES, MAKING IT IMPOSSIBLE FOR HIGH PRESSURE FROM STEAM OR WATER TO ENTER JOINT.

SOLE MAKERS **NEWTON**
TYNE DOCK CORRUGATED PACKING WORKS



METALLIC PACKING.

& SPANISH ROYAL NAVAL COMMISSION

SOME ADVANTAGES OF THIS PACKING ARE:
1-CHEAPNESS, NO CUTTING OF HOLES TO MAKE COST OF RINGS BEING A TRIFLE COMPARED WITH IMPORTANCE OF HAVING A GOOD JOINT.
2-THIS PACKING IS SUITABLE FOR HEAT PETROLEUM BOILER STAYS ETC.
3-BY USING RINGS TIGHT JOINT CAN BE MADE WITH GREAT CERTAINTY.
4-WITH THIS PACKING A CLOSE NEAT JOINT CAN BE MADE.

THESE RINGS MANUFACTURED IN BRASS COPPER CUN METAL & STEEL

& **NICHOLSON**
SOUTH SHIELDS

ANDERSON BROS.,

Engineers and Manufacturers,

Crown Smith Works, COATBRIDGE, SCOTLAND.

Iron and Steel Roofing, Coal Screening Plant,
Revolving Hutch Tipplers,
Cadzow Hand Adjustable Coal Picking Bands.

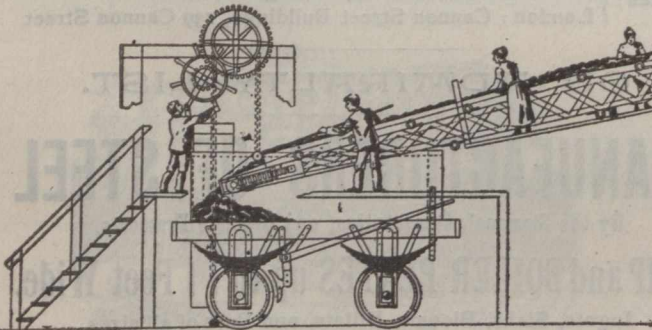
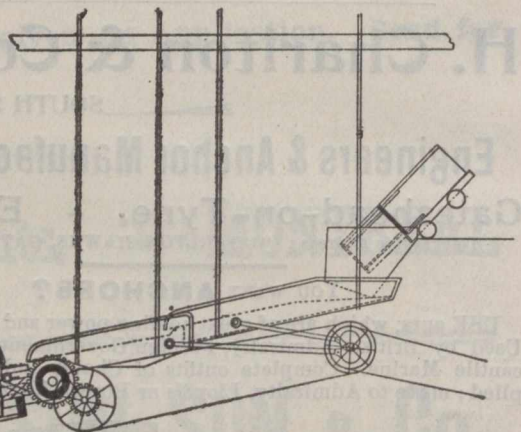

Turned Shafting,
Plummer Blocks,
Steel Pit Cages,
Smith Forgings, &c.

Sinking Kettles,
Cellar Hoists,
Steel Hutches,

L. WRIGHT & SON,

WRIGHT'S CELEBRATED NAVY BISCUITS.

These Biscuits are made from Pure Wheaten Flour, Thoroughly Kiln-Dried and specially prepared for long voyages, and are of World-Wide renown.

Established over 100 Years

Manufactory: East Holborn; Offices: Dean Street,
SOUTH SHIELDS,
ENGLAND.

AMOS COWEN,

Builder & Contractor

294 Peel Street,
MONTREAL, Que.