

tion. There is an air inlet space 7 in. wide, in a horizontal direction, between the two sections. The arrangement and shape of this air space is well shown in the cross section of the pan. While the weight of the two parts is principally held by the frames and boiler respectively they are secured together and stiffened by the plates forming the end of the pan and by two intermediate 1/4-in. stiffening plates secured to each through the medium of angles.

The doors closing the hopper openings are of swinging link type, being arranged to fit over and seat upon an extension of the hopper frame. The swinging link is so designed that the first movement of the doors is directly outward to clear this flange and then swing upward, as is shown by the dotted lines in the illustration. The operating mechanism is arranged so that the doors may be securely locked or held open at any desired point. This design of pan gives unusually large

openings for air, which is well diffused before reaching the grates, and at the same time it acts as a perfect protection against fire being blown out of the pan or otherwise escaping.

CYLINDERS.—In the design of the cylinders every opportunity has been taken for the reduction of weight where it could be done without sacrificing strength or steam economy. The 12 in. valve chambers have been set inside of the cylinders almost directly over the frames

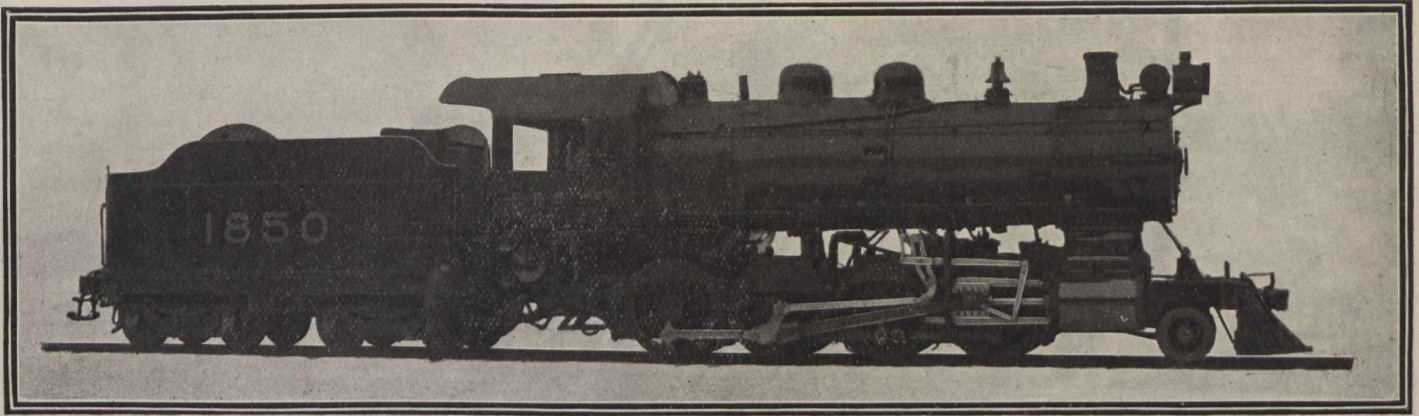

CONSOLIDATION LOCOMOTIVE, CANADIAN PACIFIC RAILWAY.

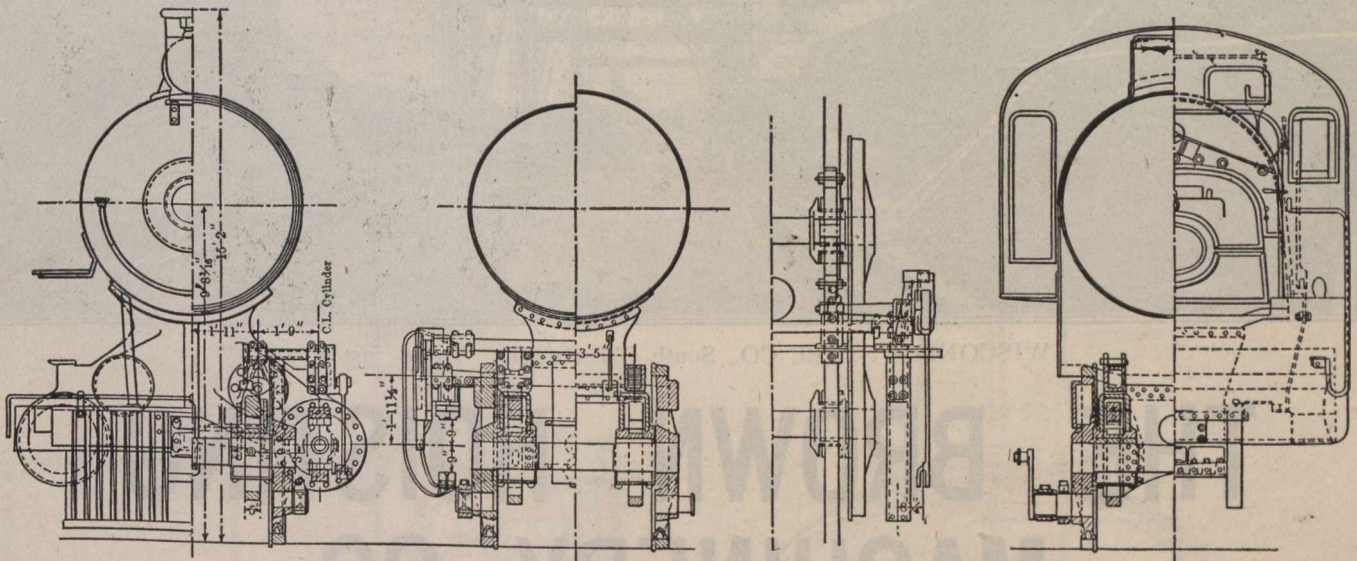

CROSS SECTIONS, CONSOLIDATION LOCOMOTIVE, CANADIAN PACIFIC RAILWAY.

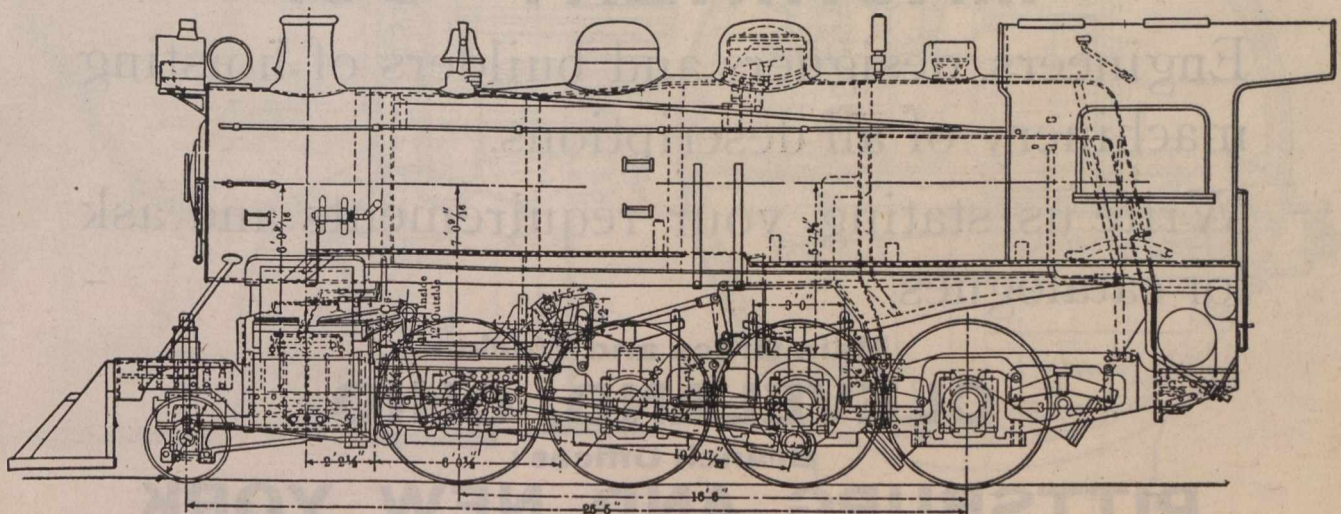

SIDE ELEVATION, CONSOLIDATION LOCOMOTIVE, CANADIAN PACIFIC RAILWAY.