

and means for adjusting the tightening pulley to correspond with the adjustment of the matcher head. 7th. In a planing machine, the combination with the machine frame, the matcher head adjustably mounted therein, the driving pulley and the matcher head belt, of a tightening pulley and means for adjusting the tightening pulley simultaneously with the corresponding adjustment of the matcher head. 8th. In a planing machine, the combination with the machine frame, the matcher head adjustably mounted therein, the driving pulley and the matcher head belt, of a tightening pulley, means for adjusting the tightening pulley to vary the tension of the belt and means for adjusting the tightening pulley to correspond with the adjustment of the matcher head. 9th. In a planing machine, the combination with the machine frame, the matcher head adjustably mounted therein, the driving pulley and the matcher head belt, of a tightening pulley, adjusting mechanism for moving the tightening pulley to correspond with the adjustment of the matcher head and independent adjustment for adjusting the tightening pulley to vary the tension of the belt. 10th. In a planing machine, the combination with the machine frame, a substantially vertical shaft and a substantially horizontal shaft journaled in said frame, a matcher head adjustably mounted on the substantially vertical shaft, a driving pulley mounted on the substantially horizontal shaft, and a matcher head belt, of a tightening pulley and means for adjusting the tightening pulley to correspond with the adjustment of the matcher head. 11th. In a planing machine, the combination with a matcher head and matcher head belt, of a tightening pulley mounted on a support and capable of lateral swinging movement thereon, an operative connection between said tightening pulley frame and the matcher head frame and means for moving the matcher head back and forth across the machine.

No. 69,599. Cooling Means for Gas Engines.
(Moyen de refroidir pour machines à gaz.)

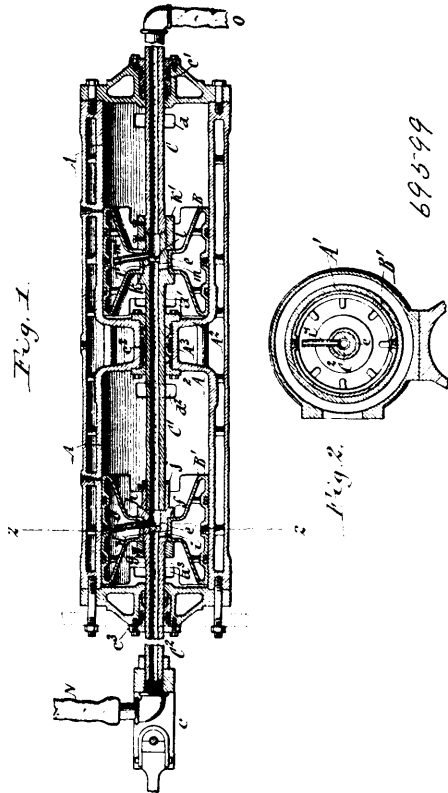

John Walter Raymond, Oil City, Pennsylvania, U.S.A., 5th December, 1900; 6 years. (Filed 16th October, 1899.)

Claim.—1st. The combination with the cylinder, of a hollow piston having its sides connected by a hollow hub and provided with inlet and outlet openings which are arranged in opposite ends of the bore of the hub, a hollow piston rod extending entirely through said hub and provided with inlet and outlet openings which coincide with the inlet and outlet openings of the hub, and a partition arranged in the piston rod between the inlet and outlet openings thereof substantially as set forth. 2nd. The combination with the cylinder, of a hollow piston having its sides connected by a hollow hub and having inlet and outlet openings which extend from opposite ends of the bore of the hub into the space within the piston, a hollow piston rod passing through said hub and provided with inlet and outlet openings which coincide with the inlet and outlet openings

of the hub, a partition bearing against an internal shoulder arranged in the bore of the piston rod between its inlet and outlet openings, a shoulder formed on the piston rod and bearing against one side of the piston, and a collar arranged on the piston rod and bearing against the opposite side of the piston, substantially as set forth. 3rd. The combination with the cylinder, of a hollow piston having its sides connected by a hollow hub and provided with inlet and outlet openings in said hub, a hollow piston rod section passing through said hub and through a stuffing box in one end of said cylinder and provided with inlet and outlet openings which coincide with the corresponding openings in said hub, another hollow piston rod section which passes through a stuffing box in the other end of said cylinder and connects with the first-mentioned piston rod section, and a partition arranged in the bore of the first-mentioned piston rod section, between the inlet and outlet openings thereof, substantially as set forth.

No. 69,600. Cellular Tire. (Bandage Cellulaire.)

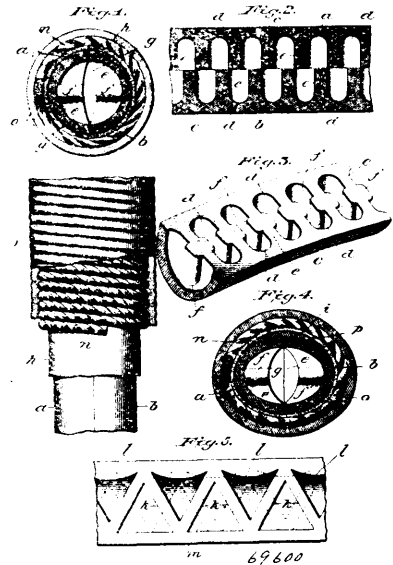

William Fessenden Beasley, Plymouth, North Carolina, U.S.A., 5th December, 1900; 6 years. (Filed 20th July, 1900.)

Claim.—1st. The hereinbefore described method of manufacturing cellular rubber tires for vehicles, consisting in forming the tire in two sections, divided in the plane of revolution of the tire, each section being molded from the raw rubber directly into an annular form, and vulcanizing the abutting faces of the two sections together while still in the moulds in which they were formed, to form the complete tire, whereby all parts of the tire are under equal tension, all substantially as set forth. 2nd. A tire comprising a plurality of separate sections, having faces abutting in the plane of revolution of the tire, each section being provided with recesses in its abutting face separated by transverse supporting walls, the circumferential portions of the said sections being connected together, and the transverse walls of the sections being unconnected, and a casing surrounding the said sections and supporting them against undue separation, all substantially as set forth. 3rd. A tire comprising a plurality of separate sections having faces abutting in the plane of revolution of the tire, each section being provided with recesses in its abutting faces separated by transverse supporting walls the circumferential portions of the said sections being connected together, and the transverse walls of the said sections being unconnected but registering with and supporting them against undue separation, all substantially as set forth. 4th. A resilient tire composed of a hollow annulus enclosing a series of transverse supporting walls, the walls extending from the rim side to the tread side of the annulus, each of the corresponding ends of each wall abutting upon the corresponding end of one of the adjoining walls, all substantially as set forth. 5th. A tire composed of two sections divided in the plane of revolution of the tire, each section being provided with transverse supporting walls, the end of each wall of each section abutting upon the corresponding end of an adjoining wall of the same section, all substantially as set forth. 6th. A cellular tire composed of two main sections divided in the plane of revolution of the tire and a tread section breaking joint with the two main sections thereof and uniting the two sections, all substantially as set forth. 7th. The combination in a tire of a resilient section, a winding therefor, composed of rope, and a tread section laid upon the rope winding and conforming to the outline of the winding, whereby a rigid tread is produced, all substantially as set forth.