

### Info Connect 2006 Kuwait

Kuwait City, Kuwait, February 4-10, 2006 > Canadian companies targeting the Kuwaiti market for latest technology products and services in the ICT industry may want to consider participating in **Info Connect 2006**, the Kuwait Information Technology and Communication Exhibition. Info Connect is the largest IT, telecommunications and Internet consumer show in Kuwait. It showcases over 3,000 product brands under one roof, making it the best place for the procurement of IT and telecommunications-related products and services in the local market.

Info Connect will focus on the wide spectrum of developments that has occurred in the ICT arena around the globe. Many international vendors and suppliers are

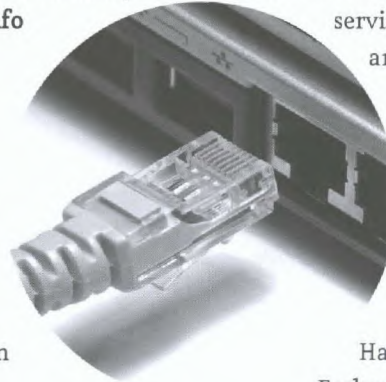

expected to present their latest technology products and services at the show, including IT equipment and systems, wireless telecommunications and networks, software services and solutions, IT services, e-government and research and development technology.

The exhibition will attract over 80,000 visitors, including IT and telecom industry professionals, decision makers and owners from companies and establishments, office and businesspeople, home users and students.

**For more information**, contact Ibtissam Hajj, Senior Commercial Officer, Canadian Embassy in Kuwait, tel.: (011-965) 256-3025, ext. 3352, fax: (011-965) 256-4167, e-mail: [ibtissam.hajj@international.gc.ca](mailto:ibtissam.hajj@international.gc.ca). Web site: [www.globalconnection.com.kw](http://www.globalconnection.com.kw).

### CeBIT: The world's biggest ICT trade fair

Hannover, Germany, March 9-15, 2006 > CeBIT Hannover is the world's largest and most influential information and communications technology (ICT) trade show. Approximately 480,000 visitors attended CeBIT in 2005—more than attended any other competing show. CeBIT allows Canadian ICT companies to tap into new market opportunities in the European Union (now a market of about 500 million people), Asia, the Middle East, and the Americas. More than 25% of the visitors that attended CeBIT 2005 came from outside Germany.

The annual event is organized by Deutsche Messe AG and takes place at the Hannover Exhibition Grounds in Germany. CeBIT 2005 ran for seven days, used over three million square feet of net display space, hosted 6,246 exhibiting companies and attracted over 10,000 journalists.

The three main display categories at CeBIT reflect all aspects of IT solutions, products and services: business processes, digital entertainment and services, and communications. The program is rounded off by a range of special highlights that will complement the expo part of the show, including banking & finance systems and the Center for Information Security (CeFIS). Specialist conferences and company presentations at CeBIT represent one of the world's biggest ICT conventions, where the latest trends and solutions are put forward to a dynamic and professional audience.

In 2005, CeBIT attracted 54 Canadian companies. Since 1986, Canadian ICT firms have exhibited, either independently, in



national stands or with European partners. ATI, Cognos, Consultronics, Hummingbird, Lava Computer MFG and Nortel have all exhibited in the past and know the value of participating in CeBIT.

A Canadian communications pavilion, organized by the Calgary Wireless City (Government of Alberta), will feature shared amenities and services within a national identity area that is open to non-Alberta exhibitors whose products fit in the communications display sector. In addition, the Ontario government will organize an Ontario software pavilion through its export development arm, Ontario Exports Inc.

**For more information** on the complete range of exhibit options at CeBIT, contact Co-Mar Management Services, tel.: 1 800 727-4183, e-mail: [info@hf-canada.com](mailto:info@hf-canada.com), Web site: [www.hf-canada.com](http://www.hf-canada.com). CeBIT Web site: [www.cebit.de](http://www.cebit.de).

### Atlanta communications firm seeks partners

Atlanta, Georgia (U.S.) > **communiqué Xpert** messaging is an application service provider based in the U.S. that offers integrated Web-based communications solutions, including electronic fax management services, voice over Internet protocol (VoIP) telephone communications, Web-based conferencing solutions and Web-based meetings. They are seeking to integrate their designed solutions with compatible software business applications. They are also seeking partners who will rebrand or resell their services as part of their integrated product offerings.

**For more information**, contact Michael Schrimsher, Executive Vice-President, **communiqué Xpert** messaging, tel.: (404) 494-0008, e-mail: [michael@communiquexpert.com](mailto:michael@communiquexpert.com), Web site: [www.communiquexpert.com](http://www.communiquexpert.com).



### On-line payment company seeks Canadian partners

Atlanta, Georgia > **Inventech, Inc.** is an Atlanta-based company that provides patent pending hardware for secured authentication of Internet transactions. The primary application of this technology is in the Internet banking and Internet payment area. The focus so far has been towards transactions executed by individuals from the home, office or other private location.

**Inventech** is actively seeking strategic partners in Canada to jointly develop products to further this technology and expand its areas of application. The two main targets of this partnership are technological development and market expansion. As such, the most important attributes in a potential Canadian partner would be technological prowess to enhance joint R&D capabilities and strong relationships with Canadian banks to enable expansion into the Canadian market.

**For more information**, contact Dipankar Sarkar, President, **Inventech, Inc.**, tel.: (678) 787-0123, fax: (775) 871-3358, e-mail: [sarkar@inventechinc.com](mailto:sarkar@inventechinc.com), Web site: [www.inventechinc.com](http://www.inventechinc.com).

### Foreign markets are crucial for Canada's high-tech manufacturing

Foreign markets are crucial for many of Canada's industries; this is even more the case for Canada's R&D-intensive industries. In 2003, Canadian R&D manufacturing industries exported 61.2% of their production on average, compared to an average of 49.5% across all manufacturing industries. The aerospace and computer industries in particular stand out, with over 80% of their products marketed abroad. The pharmaceutical industry, though exporting a percentage only around the manufacturing average, has increased that percentage from 15.3% in 1994 to 40.6% in 2003. Trade continues to be a key component in the success of these Canadian industries.

*Provided by the Trade and Economic Analysis Division  
(www.international.gc.ca/eet).*

### FACTS & FIGURES

Share of production exported: Canadian R&D-intensive manufacturing industries

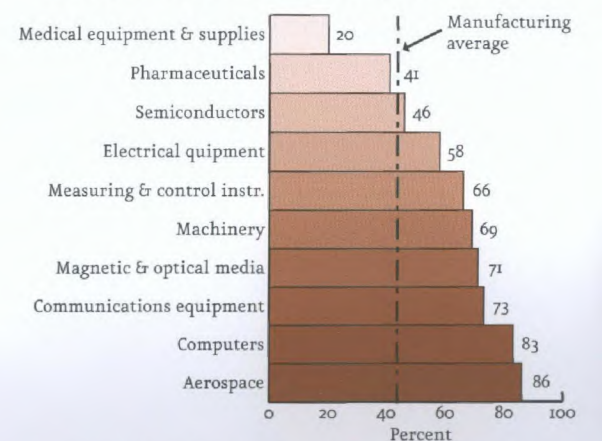

Source: ITCan calculations based on Statistics Canada data.