

system, other elements (such as heat exchanger, expansion chamber, draining mechanism) may be required.

The most important of the above elements are the collector and the storage system. These elements are described in the following paragraphs.

A solar collector consists of a black-coloured plate which is heated up when exposed to solar radiation. The heat is extracted from the plate by cooling it with a fluid which circulates in a network of tubing bonded to the plate. In order to avoid loss of some of the heat to the air, the plate is isolated from it. First, the plate is contained in a well-insulated box to prevent heat losses. Second, it is covered by one or two transparent covers which will stop heat losses due to natural convection. The glass or plastic cover allows "visible" solar radiation to enter but prevents long-wave radiation (heat) from escaping, creating a greenhouse effect. This is the general principle of a solar collector. Many variants have been designed to improve performance and cost: evacuated-tube collectors, thermo-pane collectors, concentrators, plastic collectors, and so on. Absorber plates have been built out of aluminum, copper, steel and plastic; covers using special glass have also been tried. Three of the variants are shown in Figure 6-29.

The cost of evacuated tubes is presently greater than that of the more commonly used flat-plate collectors but the excellent insulation afforded by the vacuum preserves their operating efficiency in cold weather and partially offsets their added cost. These collectors seem well suited to Canadian climatic conditions but some problems have been encountered. They lose so little heat that snow can accumulate on them, greatly reducing their efficiency. Concentrating collectors are used in applications where higher temperatures are required.

The other important component of an active solar system is the heat storage element. One of the disadvantages in using active solar heating in northern climates or in cloudy areas is the lack of sufficient sunlight to allow the system to handle the full heating load. Thus, where daily insolation in winter may not be sufficient to meet heating needs or where rain and fog can persist for days on end, a storage system becomes necessary.

Conventional heat storage systems using insulated containers of water, rocks or other materials are very bulky and gradually lose their heat to their surroundings. In order to reduce the heat losses normally encountered in small heat reservoirs, it has been suggested that huge volumes of heated water be stored underground in a confined aquifer isolated from the surface by a thick, naturally-occurring layer of impermeable clay. The idea is to withdraw many millions of gallons of water from the aquifer during the summer, pass it through solar water heaters and reinject the heated water into the aquifer through a second well. The hot water would then be

Figure 6-29: THE THREE PRINCIPAL TYPES OF SOLAR COLLECTORS

FLAT-PLATE SOLAR COLLECTOR (1)

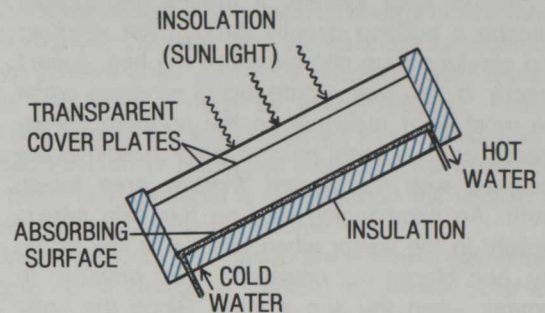

PARABOLIC-TROUGH CONCENTRATOR (1)

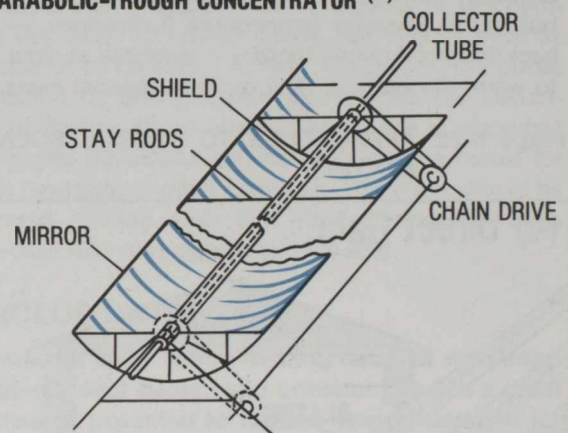

EVACUATED-TUBE COLLECTOR (2)

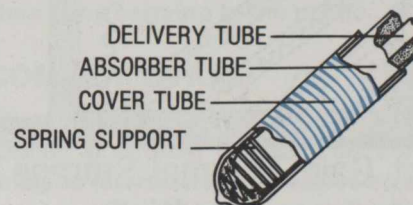

Source: (1) After Williams, 1977, p. 10, 16.
(2) Solartech Ltd., undated, p. 2.

pumped back up during the winter to heat a whole housing development. Such a storage system has been successfully tested in the U.S. and Europe where heat recapture as high as 75% has been achieved.

Chemical heat storage using hygroscopic minerals or salts can also overcome the problems encountered with small-scale water or rock storage systems. When dry, these substances store energy indefinitely in the form of a chemical potential and, when moistened, they give up heat in an exothermic or heat-releasing reaction.