

# “Quanti est Sapere!”

THEN WHY NOT LEARN ABOUT

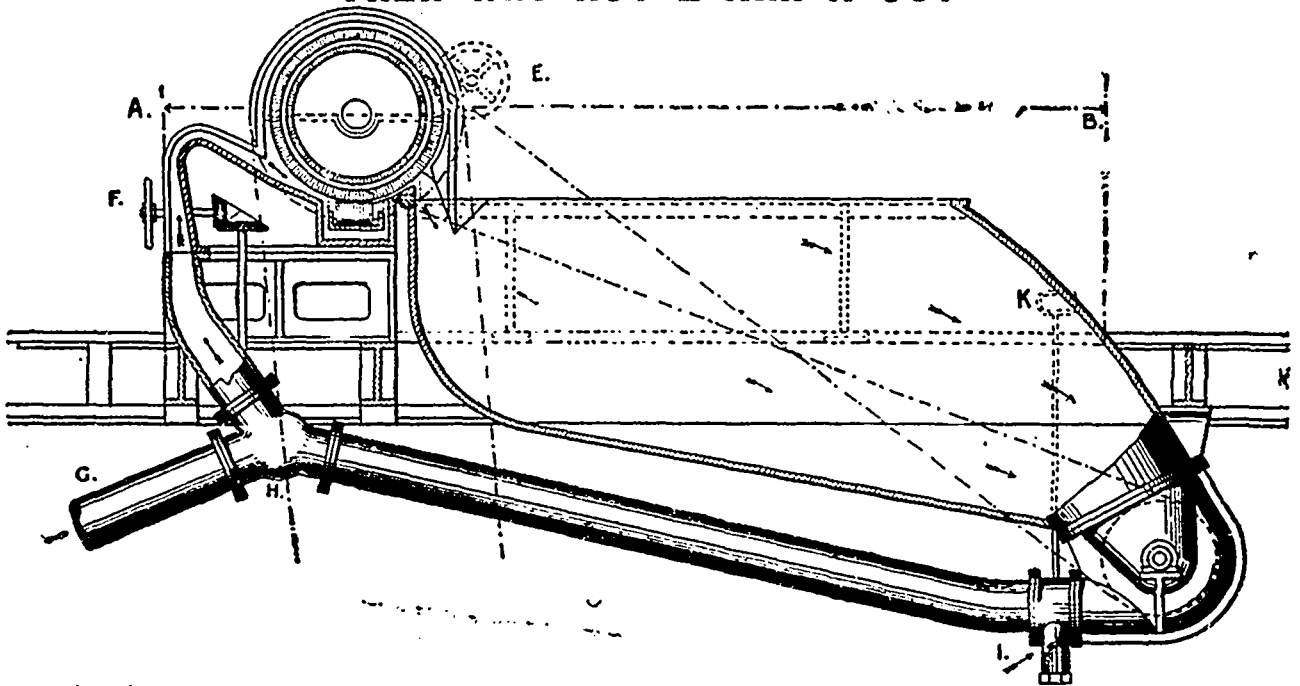

## Taylor's Beating Engine?

**THE CAPACITY OF THIS ENGINE IS GREATER THAN THAT OF ANY OTHER IN THE WORLD.**

And its principles of Action and Construction will commend it to every

**--- Practical : Paper : Maker. ---**

WE ARE MANUFACTURERS OF

White's Oscillating Screen,

Taylor's Beating Engine,

McCormick's HOLYOKE Tur-  
bines, Horizontal and Vertical.

**PAPER MILL MACHINERY.**

Allen's "Blue Spot" Preventive.

**SCREENS & VATS**  
For Paper Machines.

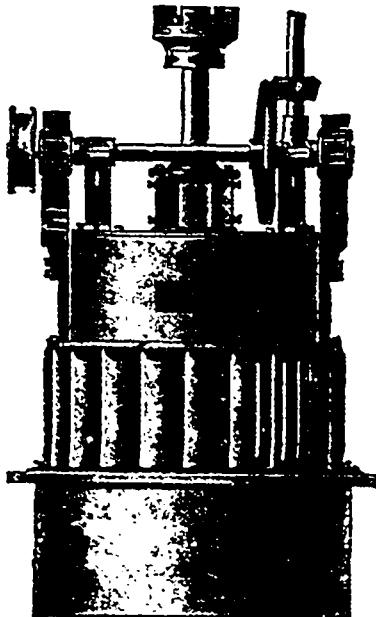

*Rag Engines and  
Jordan Engines*

Made and Refilled.

**BLEACH BOILERS,  
FAN DUSTERS,**

Ferry's Patent Star Dusters.

**PAPER CALENDAR ROLLS**

MADE AND REPAIRED.

*Chilled Rolls,  
Sheet, Super and  
Webb Calenders.*

Power Suction Pumps, Power Boiler Pumps, Suction Boxes and Plates, Pulleys, Shafting, Gearing, &c.

**HAND AND POWER ELEVATORS.**

# J. & W. JOLLY,

HOLYOKE, MASS., U.S.A.